

Water Manual for Refugee Situations (UNHCR, 1992, 160 p.)



(introduction...)



Foreword



Drinking water



1. Introduction



2. Assessment and organization



3. The need



4. Immediate response during emergencies



5. Refugee water supply systems



6. Water sources, their protection and development











7. Pumping equipment



8. Water treatment



-  **9. Water storage**
-  **10. Water distribution systems**
-  **11. Operation and maintenance of water supply systems**
-  **12. Management of emergency water supply systems**
-  **Annex A - Refugee water supply inventory forms**
-  **Annex B - Approximate daily water requirements in refugee emergency situations**
-  **Annex C - Guidelines on water quality**
-  **Annex D - Recommended format for technical specifications for water well construction**

1. Introduction

1. Safe water is essential to life and health. People can survive longer without food than without water. *Thus the provision of*

water demands immediate attention from the start of a refugee emergency. The aim is to assure availability of enough water to allow sufficient distribution and to ensure that it is safe to drink. Adequate storage and backup systems for all aspects of water supply must be assured, since interruptions in the supply may be disastrous. To avoid contamination, all sources of water used by refugees must be separated from sanitation facilities and other sources of contamination. It is important, however, to bear in mind the fact that due to difficulties in predicting the life-span of a refugee camp, the most appropriate alternative will always be the one which adapts better to a cost-effective long term service.

2. Water availability will generally be the determining factor in organizing the supply of sufficient quantities of safe water. It may be necessary to make special arrangements for the identification and development of new sources, water extraction, storage and distribution. Measures will be required to protect the water from contamination and in some circumstances treatment will be needed to make it safe to drink.

The safety of the water must be assured right through to consumption at home.

3. Water quality is always difficult to assess. Always assume that all water available during an emergency is contaminated, especially if available sources are surface water bodies (lakes, ponds, rivers, etc.). Immediate action must be taken to stop further pollution and to reduce contamination. If it is evident that available sources are inadequate (in terms of quality or quantity), arrangements must be made to find alternative sources and, if necessary, to import water to the site (by truck, barge, pipelines or any other relevant means). Where even the most basic needs for water cannot safely be met by the existing resources at the site or its surroundings, and when time is needed for further exploration and development of new sources, refugees should be moved to a more suitable location. Figure 1 shows some of the considerations in diagrammatic form.

4. Water services, sanitation and site planning are the subjects of separate manuals. Their objectives are, however, largely

interdependent; this manual should be read in conjunction with the other two.

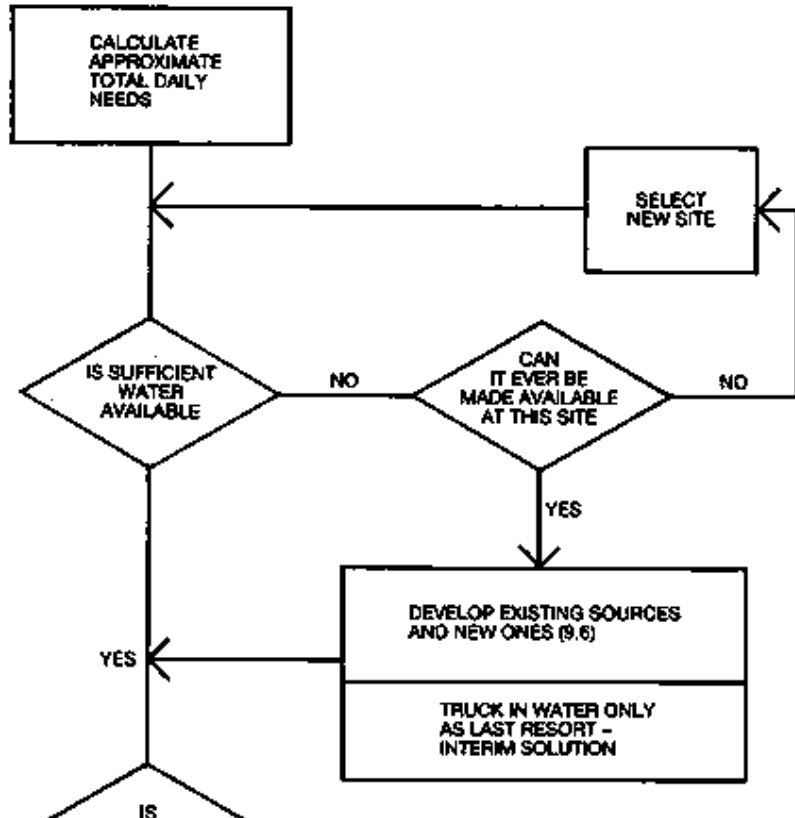

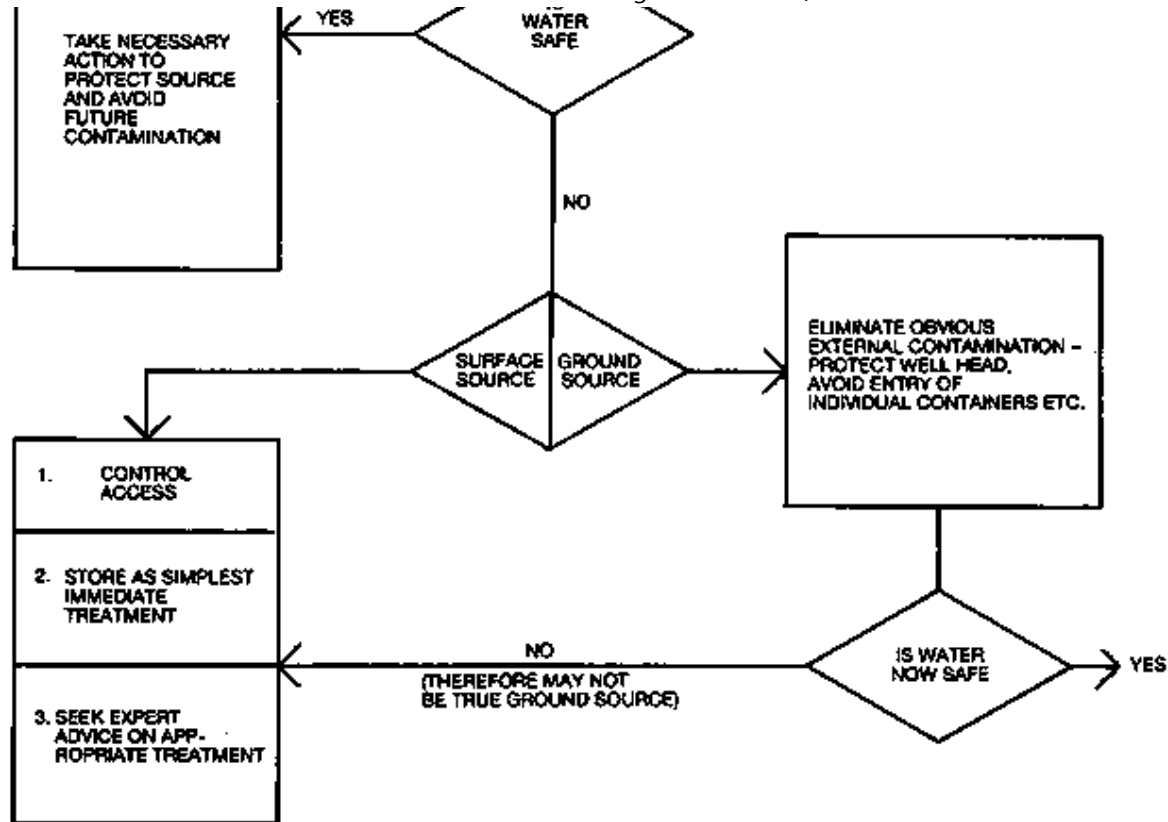
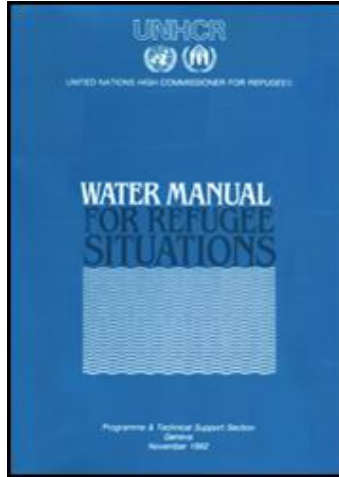

Fig. 1 General Considerations in Emergency Water Supply



[Home](#) > [ar](#).[cn](#).[de](#).[en](#).[es](#).[fr](#).[id](#).[it](#).[ph](#).[po](#).[ru](#).[sw](#)



Water Manual for Refugee Situations (UNHCR, 1992, 160 p.)

2. Assessment and organization

 **(introduction...)**

 **General**

 **Assessment**

 **Personnel and materials**

Water Manual for Refugee Situations (UNHCR, 1992, 160 p.)

2. Assessment and organization

- **An immediate, competent assessment of local water supply possibilities, involving government authorities**

and using the best possible technology is essential.

- **Although highly qualified expertise is usually required, local knowledge is most important.**
- **Involve the refugees, use their special skills and train them to operate and maintain the system.**
- **As a rule, technology and equipment for water provision should be simple, reliable, appropriate and familiar to the country.**

General

1. *An immediate on-the-spot assessment of local sources of water in relation to needs is essential.* The government's central and local authorities should be involved as much as possible in this assessment. An influx of refugees may over strain water resources used by the local population. Knowledge of the local terrain and conditions is indispensable and expertise from outside the country should be brought in only when clearly

necessary.

2. Once located, all available sources must be protected from pollution as a matter of the highest priority. Rationing of scarce water may, be needed initially in order to ensure survival of the weak and equity in distribution to the rest of the refugee population. The design and construction of a water supply system should follow an approach that will ensure a cost-effective and efficient service for the long term as well as minimal, but technologically appropriate operation and maintenance requirements. In this respect, coordination with physical planning, health and environmental sanitation sectors is most important.

Assessment

3. While estimating the need for water does not require special expertise, assessment of supply possibilities does. A distinction may be useful between *the identification* of sources on the one hand, and *their development* and exploitation on the other. Depending on the situation and camp location, sources of water

and their characteristics should be identified after consulting local technicians, neighbour community representatives and the refugees themselves. However, the assessment of water resources and of the possibilities to utilize them (the basis for decisions on the type and standards of service of the future system) require expertise in *water engineering, sanitation* and, in some cases, *logistics*. Although *water diviners* and other expertise or know-how usually available at the local level may often prove useful in assisting in the location of water resources, the most important objective of an assessment of water resources for human consumption is to ascertain the availability of water (in terms of quantity and quality) to satisfy the demand. This may only be addressed by qualified technicians, capable of interpreting regional information on water availability as obtained from specialized government departments, private consultancy firms, regional resources surveys and specialized cartography.

4. Seasonal factors must be carefully considered. Supplies that are adequate in the rainy season may dry up at other times (See

6.20).

5. Other local factors, which may only be assessed at the site itself, also determine the quantity of water available or its quality at a given place. This assessment, preferably carried out by experienced technicians, will benefit from *detailed cartographic information* on the site and its surroundings. Other specialized equipment may be helpful, depending on the circumstances, for groundwater prospection (See 6.26), for resource evaluation (flow measurements, physico-chemical or bacteriological analyses, long-term "safe yield" from springs or boreholes, See 6.38; 6.55) or for the conceptual design (See 12.2) and the analysis of alternatives (topographical surveys, borehole pumping tests).

6. The assessment of water resources will benefit from basic information gathered from the onset of an emergency operation. Annex A gives an example of the type of technical information that may prove useful during the resource assessment, design, operation and maintenance stages of water

supply service activities. This information is the basis for a technical data bank on water resources. Efforts should therefore be made to obtain, file and periodically update this information (See 11.18).

Personnel and materials

7. Local sources of information and expertise are best and may include: central and local government departments (e.g. interior, public works, health, agriculture, water resources), the UN system, especially UNICEF, bilateral aid programmes, non-governmental organizations and engineering consultants and contractors. If it becomes clear that locally available expertise will not suffice, Headquarters' assistance should be requested without delay. Outside assistance, if necessary, should be provided whenever possible in support of local experts.

8. All water supply and distribution systems established for the use of refugee communities should be conceived taking into account that their operation and maintenance requirements differ from those of a normal (local) village or town, as the

economic and social bases of refugee groupings differ from those of the host communities. This will require making special arrangements with local authorities and other implementing partners. It will also require that the technology used in the system and its long term needs (fuel, spare parts and other materials for maintenance as well as the expertise to deal with them) are locally available and within reach of the refugees (See 5.2; 11.2; 11.7).

9. The running and maintenance of refugee water supply systems by refugees themselves, with the support of local experts and specialized government agencies, must be assured before the departure of any outside expertise (See 11.11). It is for this reason that the system must be developed with the refugees and operated by them from the start, to the extent possible. The refugees may themselves have relevant skills and know-how (digging and maintenance of large diameter wells, familiarity with hand or simple motorized pumps, skills in plumbing or masonry). Refugees without prior experience should be trained as necessary (See 11.6). Basic public health

education will always prove of importance in ensuring the best use of the supplied water, in avoiding contamination and in ensuring effective communal actions for the successful operation and maintenance of the systems.

10. Whenever specialized expertise or equipment is required for the exploration of water sources in complicated hydrogeological environments or for other technically complicated activities, such as the purification of surface water, extreme care should be taken to ensure that materials and equipment to establish a water supply and distribution system are found locally, to the maximum extent possible. As a general rule, *technology should be kept simple*. It should be appropriate to the country and draw on local experience (see 12.3). Efforts should be made to standardize, as far as possible, all special equipment (including plumbing, mechanical and disinfection equipment). In this respect, its availability in local markets, as well as that of the necessary fuel and spare parts and the local familiarity with them and with their operation and maintenance should be priority considerations (See 9.11.15).

11. Both, organizational and technical aspects of the complete water supply system need to be carefully monitored. The results of this effort should be appropriately recorded in the water supply data bank (See 2.6; 11.8). The use of the system must be controlled, water wastage or contamination should be avoided and preventive maintenance should be assured to avoid, as much as possible, unexpected technical breakdowns. Any breakdowns occurring should be quickly repaired (See 11.9).



[Home](#) > [ar.cn.de.en.es.fr.id.it.ph.po.ru.sw](#)

 **Water Manual for Refugee Situations
(UNHCR, 1992, 160 p.)**

  **3. The need**

 ***(introduction...)***

 **Water demand/quantity**

 **Quality**

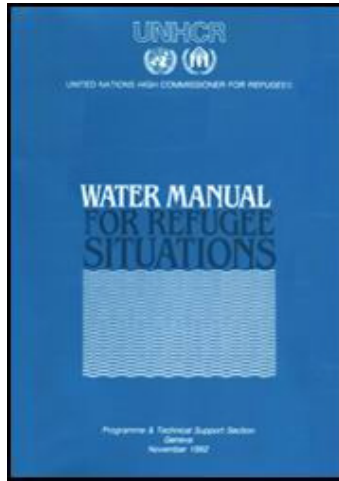

Water Manual for Refugee Situations (UNHCR, 1992, 160 p.)

3. The need

- **Water Demand: Optimum standards in most refugee emergencies call for a minimum per capita allocation of 15 litres per day plus communal needs and a spare capacity for new arrivals. When hydrogeological or logistic constraints are difficult to address, a per capita**

allocation of 7 litres per person per day should be regarded as the minimum "survival" allocation. This quantity will be raised to 15 litres per day as soon as possible.

- **Quality: To preserve public health, a large amount of *reasonably safe water* is preferable to a smaller amount of very pure water.**
- **Control: The water must nevertheless be safe: test new sources (physico-chemically as well as bacteriologically) before use and periodically thereafter, and immediately following an outbreak of a disease which might be caused by unsafe water.**

Water demand/quantity

1. The human body's basic water requirements depend on the climate, workload and other environmental factors. Minimum requirements vary between 3 and 10 litres per day. The amount of water needed for other purposes, including cooking or

hygiene, is more variable and depends on cultural habits, several other socio-economic factors and on the type of the water supply (in terms of quality, quantity, availability and convenience). Additional water requirements for livestock, sanitation facilities, other community services and irrigation may be of special importance in some emergency refugee camps.

2. Reduction in the quantity of water available to individuals directly affects their health. As supplies are reduced, clothes cannot be washed, personal hygiene suffers, cooking utensils cannot be properly cleaned, food cannot be adequately prepared and, finally, the direct personal intake becomes insufficient to replace moisture lost from the body. The reduction is reflected in increased incidence of parasitical, fungal and other skin diseases, eye infections, diarrhoeal diseases and the often fatal dehydration associated with them. Even those individuals who may have traditionally lived on less than the normally recommended amount of water (e.g. nomads), will require more in a refugee community because of crowding and other

environmental factors.

3. The needs of community services vary widely, for example from the requirements to swallow a pill or wash hands in an outpatients health post to the requirements of a health centre offering inpatient clinic facilities. Proper supplementary and therapeutic feeding programmes will be impossible unless sufficient water is available for food preparation and basic hygiene.

4. The availability of water will be a factor in deciding on a sanitation system. While pit latrine systems do not need water to function, an "aquaprivy" will require some 5 litres per user; an "Oxfam Sanitation Unit" requires up to 3000 litres per day to serve 1000 persons. The design of showers, baths or ablution facilities should always consider water availability.

5. Water will also be needed for livestock in many refugee situations. Extreme care should be taken to avoid pollution or even depletion of scarce resources by animals. Separation of human water supply points from those used by animals is a

must (See 9.11).

6. Water will probably be of little use in controlling fires on emergency refugee sites owing to a lack of sufficient quantities and pressure.

7. Annex B, which is given as a general guide, shows the approximate daily requirements in emergency refugee camps. This table should only be used as an indicative guideline on minimum requirements on which to base the planning of refugee camp facilities and to provide a monitoring tool for the appropriate-ness of service infrastructures at camp level.

8. All waterworks leak to some extent. Water wastage at refugee camps is normally large if not appropriately controlled. In most circumstances, these unaccounted for losses may be quite serious. It is impossible to reduce these losses except by inspection and constant attention to the functioning of all parts of the water system as well as to the water collection habits of the beneficiaries. Where main users are women, due to cultural practices or any other reason, female inspectors may be the

best collaborators of maintenance teams (see 11.11). Leaky pipelines may allow pollution to be incorporated into the water, especially in those camps where water is supplied intermittently through these pipes.

9. Since in many emergency refugee situations, water demand may increase as a result of additional refugee arrivals, of the need to temporarily address additional needs such as the construction of camp infrastructure (e.g. concrete structures), or in view of other socio-economic or cultural factors which had not been recognized at the beginning, plans must allow for a substantial spare capacity over initially assessed needs. However, as already pointed out (See 2.2), the resulting system should always provide an efficient but also cost-effective service.

Quality

10. Among the most important goals of assistance programmes during refugee emergencies is the one to provide an ample supply of pure and wholesome water to the beneficiaries. This,

in simple terms, means water free from:

- i) visible suspended matter;**
- ii) colour;**
- iv) taste and odour;**
- v) bacteria indicative of pollution;**
- vi) objectionable dissolved matter;**
- vii) aggressive constituents.**

Thus, the water must be fit for human consumption, i.e. potable, but it must also be palatable (aesthetically attractive).

11. The provision of potable water is the best way to control the so-called "water borne" diseases in an emergency refugee camp (mainly originated from the presence of micro-organisms in the water). However, these water borne diseases are not usually as serious or widespread as the "water washed" diseases, such as skin or eye infections or even diarrhoea, which result mainly from insufficient water for personal hygiene. Thus, *a large quantity of reasonably safe water is preferable to a smaller amount of very pure water.* The most serious threat to the

safety of a water supply system is contamination by faeces: once the water has been contaminated, it is hard to purify quickly under emergency conditions (See 8.2-5).

12. Brackish or other types of highly mineralized water may sometimes be considered for emergency water supply. Before any decision is taken on its potability, a thorough knowledge of its chemical composition (and possible variations with time, in accordance with seasons or other factors) should be obtained. Additionally, other aspects, such as the concentration of objectionable elements in absolute and relative terms (as compared to the concentrations considered "normal" in the vicinity of the camp or in the places of origin of the refugees) and the expected duration of the emergency (or exposure time of individuals to these waters) should also be taken into account. However, it is worthwhile to point out that in situations when water is very scarce, brackish, or even salt water, if available, may have to be used for domestic hygiene, and appropriate supply or distribution systems may be required.

13. New water supplies should be tested before use, and existing ones checked periodically or immediately after an outbreak of any typically water-borne disease. Normally, water should be known from the physical, chemical and bacteriological points of view. The following list is given as an indication of the most important parameters (others may be required in specific circumstances) that should be known for the complete assessment of water quality:

i) *Physical Characteristics*

Colour; Odour; Taste; Turbidity; Temperature; pH; Conductivity; Suspended and Settleable Solids (surface waters, especially from rivers or creeks).

ii) *Chemical Characteristics*

Alkalinity; Acidity; Hardness; Biological Oxygen Demand (BOD); Chemical Oxygen Demand (COD); Ammonia, Nitrite and Nitrate Nitrogen; Total Dissolved Solids (TDS); and the ionic contents of Calcium, Magnesium, Sodium, Potassium, Manganese, Iron, Chlorides,

Sulphates, Carbonates, Bicarbonates, Fluorides.

iii) *Bacteriological Characteristics*

Bacteriological counts of Total and Faecal Coliforms.

The analyses of water samples to assess these parameters and the interpretation of their results should be made by specialists. However, a quick comparison with tables or guidelines will indicate, in general terms, the potability of the water or its main constraints as a source of human water supply. Annex 9-C is one of these tables, which has been prepared based on WHO'S Guidelines for Drinking Water Quality (as published in 1984) and on UNHCR's experience.

14. Most waters have to be purified before they can be used for drinking purposes (See 1.3; 8.6). Raw water quality varies so much that there is no fixed starting point to a treatment process. Within narrower limits, there is no rigidly fixed finishing point, either. There is virtually no water that has to be considered as impossible to purify to potable standards. Some raw waters, however, are so bad as to merit rejection because

of the risk, cost and expenses involved. If a good quality source is not available, "second class" sources would have to be upgraded by treatment to first-class standards, or better water may have to be brought in from more distant sources. It is generally a matter of economics, whereby the urgency of the emergency situation and the longer-term expectations within a given refugee camp have to be taken into account.

15. The quality of the raw water may be difficult to assess. Even if many samples have been analyzed and considered before the design of a treatment process, there is always a possibility that the worst conditions have not yet been discovered. Apart from already-mentioned seasonal variations, there is always the possibility of radical long-term changes to water quality due to the development or alteration of catchment areas. River water, for example, may change its chemical and biological character if it is impounded. Increased groundwater abstractions or the overexploitation of some aquifers may cause saline water intrusions, making the raw water more saline. Groundwater sources generally produce clear water, but in many cases it may

be excessively hard, or contain iron, manganese or fluoride at levels higher than desirable.

16. Periodical control of water quality in a refugee water supply system is as important as the efforts to treat and purify it. It is the best tool to confirm the good functioning of the system as a whole and of its components. Control should be routinely carried out at watering points, although sporadic checks on the potability of water stored at individual households should be carried out to monitor the appropriateness of the water-use habits of the beneficiary population (See 8.24).



[Home](#) > [ar.cn.de.en.es.fr.id.it.ph.po.ru.sw](#)



**Water Manual for Refugee Situations
(UNHCR, 1992, 160 p.)**



**4. Immediate response during
emergencies**

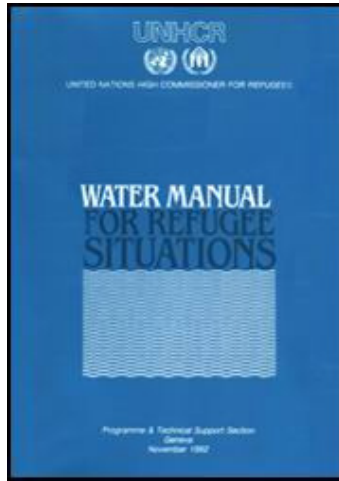

**(introduction...)
General**

Water Manual for Refugee Situations (UNHCR, 1992, 160 p.)

4. Immediate response during emergencies

- Organize as soon as possible an inventory of all water resources at the camp site and its surroundings.**
- If the minimum amount of water cannot be met by local sources, alternative arrangements should be made, either to import water from other sources (water**

tankers, barges, etc.) or to move the refugees to more suitable camp sites.

- **Whatever the water source, take immediate action to prevent its pollution by excreta.**
- **Organize a distribution system that prevents pollution of the source and ensures equity if there is insufficient water.**

General

1. Short-term emergency measures may be necessary while the long-term supply system is being developed or pending the move of refugees to more suitable sites (See 12.4). If locally available water resources are insufficient to meet the minimum requirements of the refugees, arrangements must be made to bring in water by truck (water tanker) or any other relevant means of transportation (e.g. donkey or ox carts); this type of solution will involve considerable efforts to develop adequate and cost-effective facilities for the loading or unloading of the

vehicles at the source or at distribution points (See 9.8) and it will need a well organized logistical support for the whole operation (roads, fuel or feed for animals, etc.). If this is not possible, the refugees must be moved to better campsites without delay. Often, however, the quantity of water available will meet initial minimum requirements and the immediate problem is quality: it should always be assumed that water is likely to be dangerously contaminated, unless proven otherwise by relevant water analyses (See 1.3; 8.6).

2. During the first days of an emergency, the refugees will be using surface water or, less often, groundwater from wells or springs. They will normally use whatever water is available, regardless of its quality. *Start by organizing the refugee community and by making them aware of the possibilities and dangers of existing water sources.* To do this, get immediately in contact with as many refugee community leaders as necessary or possible. Convey to them the idea of trying to prevent further pollution of these sources by excreta and the need to follow simple rules to achieve this goal, such as

drawing water in the upstream portions of flowing rivers, creeks or canals, allocating areas for laundry or body washing downstream of the drinking water intake areas, or watering animals at the extreme downstream portion of flowing water bodies. All these areas could be fenced off, if necessary, to minimize monitoring requirements and to ensure full effectiveness of these measures.

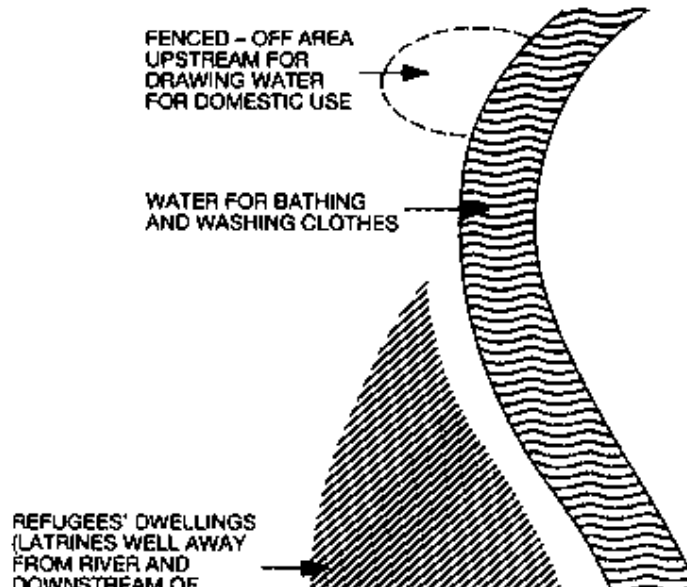

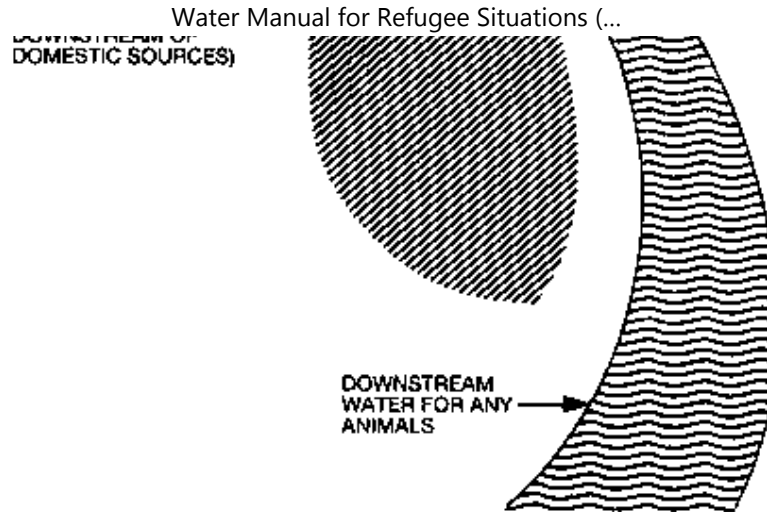

Fig. 2 Drawing Water from a River

3. If the source is a well or a spring, fence off, cover and control the source. Prevent refugees drawing water with individual containers which may contaminate the source. If possible make arrangements to store water and to distribute it at collection points away from the source. Not only does this help avoid direct contamination but storage may improve, to some extent, water quality.

4. At the same time action must be taken to increase the quantity of water available to the refugees from existing sources and to ensure the effectiveness of any distribution system.

5. From the start, families will need to be able to carry water for storage at their households. Suitable containers (10-20 litres) are essential. The type and size of these containers should be decided upon after carefully considering their immediate availability, the suitability of their design, and the most probable users (pregnant women or children are not capable of lifting very large containers full of water for long distances; larger containers may prove useful as household reservoirs). Considerable attention must be given to the need to keep these containers clean (See 10.9).

6. If the immediately available supplies of water are insufficient, action to *ration supplies and to ensure equitable distribution* must be a priority. Water rationing is difficult to organize. Firstly, access to the sources must be controlled; the

use of full-time watchmen may be necessary. The second step is to control water distribution points; uncontrolled distribution points may be abused during or after water distribution operations. These operations must be organized in accordance with strict time schedules which may be applicable on a camp-wide basis or for individual watering points, in accordance with the needs and the circumstances. Vulnerable groups may need special arrangements. Every effort must be made to increase the quantity of water available so that strict rationing is unnecessary.

7. In parallel to these steps, action must be taken to plan how the need for water may best be met in the longer term to allow the construction of a water system capable of meeting all the refugee community needs in a cost effective way for as long as necessary. The following sections outline the main considerations.



[Home](#) > [ar](#).[cn](#).[de](#).[en](#).[es](#).[fr](#).[id](#).[it](#).[ph](#).[po](#).[ru](#).[sw](#)

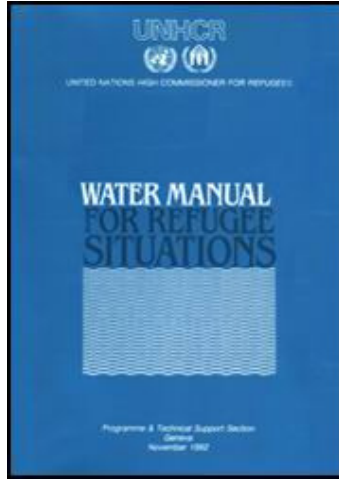

Water Manual for Refugee Situations (UNHCR, 1992, 160 p.)

5. Refugee water supply systems

 **(introduction...)**

 **General**

Water Manual for Refugee Situations (UNHCR, 1992, 160 p.)

5. Refugee water supply systems

- **A water supply system is a combination of structures (intakes, pumping sets, treatment and storage facilities, distribution pipeline networks, service points, drainage outlets) necessary for the production (collection, treatment, storage) and distribution of potable water to**

a group of people. Refugee water supply systems are usually necessary to cover the water needs of people living in camps or in village-like rural environments throughout the world.

- **To provide adequate service, the system has to be constructed in such a way that all its components are appropriate, compatible with each other and in accordance with the production capacity of the water sources and the water demand at the camp at any given time. The requirements for the operation and maintenance of this system will have to be such that they will always be easily met with locally available resources and at the lowest possible cost.**

- **To ensure an adequate service, the system will have to be planned, designed, constructed and put into operation in a short period of time (involving the refugee population as much as possible). The complexity of the task requires professional expertise which should be**

sought at the beginning of the project. Considerable attention to long term operation and maintenance requirements will also be required from the early days of a refugee water supply construction project.

- **The design of each of the components of a water supply system may also be a complex undertaking. It should solve the needs of the project in a cost-effective way. Its cost should be as low as reasonably possible, but it should also be easy to operate and maintain, and be capable of providing efficient service throughout the life-span of the system.**

General

1. As soon as the need to have an appropriate water supply system to meet the emergency needs of a refugee group is recognized, a clear idea of the paths to be followed to make the project a reality in the shortest time should be obtained. Some of these tasks and their required activities are difficult. They are frequently made more difficult by the lack of basic data or the

impossibility of obtaining other planning or design tools (cartography, hydrological data, etc.) needed for calculation or design purposes. Among these tasks, the following may be mentioned:

i) Search for adequate water sources.

ii) Preliminary surveys. Assessment of water productivity and quality. Assessment of topographic advantages (gravity) and disadvantages (pumping requirements) (See 6.1; 7.1). Collection of additional/relevant information on the refugee community (See 6.36-iii; 11.2), on other beneficiaries (if any) and on socio-economic characteristics of the local (host) community.

iii) Implementation arrangements. Responsibilities for project implementation should be clearly allocated after a conscientious analysis of the possibilities and constraints of all parties interested in the project. Issues that should be clarified at this stage include funding,

contractual procedures to be adopted (possibly a need for a Contracts Committee and therefore tendering and bidding), project supervision and monitoring mechanisms, financial reporting (See 12.5).

iv) Production of a conceptual design. Alternative solutions should be presented for consideration. The choice should be made based on implementation time requirements, technology considerations and cost-effectiveness.

v) Detailed surveys. To refine all aspects and details of the adopted conceptual design. These include further water analyses, the exploration for building material (e.g. gravel, sand iron bars, wood), further measurements of water production at sources, detailed topographical surveys of water sources, storage tanks and distribution points. Production of final designs (See 12.8-11).

vi) Organization of refugee involvement on the project.

This activity will require the organization of refugee committees and the identification of relevant skills and expertise within the community (See 6.36; 11.11).

vii) Implementation of the project. Besides the actual construction works, other inputs are required, such as the technical supervision of works to ensure that construction is carried out in accordance with approved plans and that payments for construction reflect the real value of the works accomplished (See 12.16).

viii) Organization of operation and maintenance, including the organization of a committee on which refugees and relevant assistance sectors are represented (health, sanitation, social services). Continuous engineering support should be ensured. A caretaker or a group of caretakers should be employed to carry out the operation and maintenance tasks in the best possible way. Financial matters and distribution of responsibilities for efficient operation and maintenance

of the system and its components should be regulated in advance (See 11.3).

2. In view of the fact that refugee communities throughout the world are living in conditions which may not be considered as "normal", their socio-economic base is such that they will require outside assistance to operate and maintain their camp infrastructures (See 2.8). The search for solutions to the needs of refugees should be undertaken after having seriously considered the long-term needs of the camps and their inhabitants. Although it is difficult to predict for how long a refugee or a refugee group will continue to be so (before any durable solution may be offered by their country of origin, their host country or the International Community) it is easy to foresee the problems that an ill-conceived, badly planned or wrongly constructed water supply system may generate for the refugees and for those in charge of providing them with assistance. All efforts to avoid these long-term problems will prove, with time, very valuable.



[Home](#) > [ar](#).[cn](#).[de](#).[en](#).[es](#).[fr](#).[id](#).[it](#).[ph](#).[po](#).[ru](#).[sw](#)

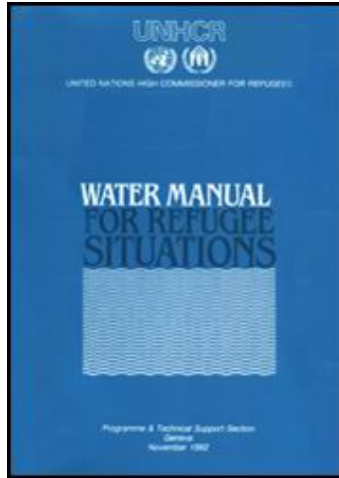

Water Manual for Refugee Situations (UNHCR, 1992, 160 p.)

6. Water sources, their protection and development

 **(introduction...)**

 **General**

 **Surface water**

 **Rainwater**

 **Groundwater**

 **Springs**

Dug wells, boreholes, infiltration galleries

 **General**

 **Dug wells**

 **Driven wells**

 **Jetted wells**

- **Boreholes**
 - 📄 **Drilling techniques**
 - 📄 **Well design and completion - Technical specifications**
 - 📄 **Borehole and aquifer yield assessment - Test pumping**
 - 📄 **Borehole maintenance**
 - 📄 **Technical specifications and contractual documents for borehole drilling contracts**
- 📄 **Infiltration galleries**
- 📄 **Municipal or private systems as source of water supply**

Water Manual for Refugee Situations (UNHCR, 1992, 160 p.)

6. Water sources, their protection and development

- **Rainwater, groundwater from springs and wells, or**

water from municipal or private systems are usually of better quality than surface water from sources such as rivers, lakes, dams or ponds and should be preferred if available.

- **Surface waters should be considered contaminated and must be treated or disinfected prior to use**
- **Physical protection of the source against pollution is essential.**
- **New or repaired source catchments and other system structures and equipment should be disinfected before use.**
- **Local knowledge and expert advice are necessary to assess most water sources and to develop new ones, especially groundwater sources.**
- **The collection of as much relevant data as possible on the region where refugees are located and on each water**

source as of the onset of a refugee emergency is important. This will allow the creation of a databank which, if later followed up, will provide useful information on the variations with time of yields and water quality, thus facilitating the tasks of the technicians in charge of planning and implementing longer-term water supply systems.

General

1. From their origin point of view, there are three main sources of natural water: surface water (streams, lakes, ponds), groundwater (wells, springs) and rainwater. From their location point of view, there are two types of water sources: those situated above consumption points (they may be preferable because they may provide *water by gravity* and will allow for the construction of systems with less operation and maintenance requirements) and those situated below consumption points (the water system will rely on *water lifting equipment*). Considerations in choosing between alternative

sources of water in an emergency include:

- i) Volume of supply (See 3.1);**
- ii) Reliability of supply (taking into account seasonal variations and, if necessary, logistics) (See 3.9);**
- iii) Water quality, risk of contamination and ease of treatment (See 3.11);**
- iv) Rights and welfare of local population (See 2.1; 5.1-ii);**
- v) Speed with which a source can be made operational;**
- vi) Simplicity of technology and ease of maintenance (See 11.15);**
- vii) Cost.**

2. Take careful account of systems and methods already in use locally. Adoption of well-proven and familiar techniques,

combined with action to improve protection against pollution, is often a sound solution.

3. In addition to organizational measures to protect the water supply, some form of treatment may be necessary. However, sources which would require treatment should be avoided if at all possible (See 8.2). The purification of unsafe water, particularly in remote areas, can be difficult and requires trained supervision to be reliable.

4. Gather as much technical information as possible on the different water sources so as to allow simple cost-benefit analysis of alternative solutions. The decision on which sources to develop and the technological approaches to be used should take into account the need for a step-like response to allow maximum use of available resources and the need to develop efficient systems to effectively cover immediate and longer-term needs (See 4.1; 12.4).

Surface water

5. Water from streams, lakes, dams, reservoirs or any other surface water body is rarely pure. Its direct use is likely to require previous treatment measures that may be complicated to plan and implement during most refugee emergencies. The immediate and long-term use of surface water may be problematic, especially in regions where water is scarce or strict water use customs or laws regulate access to water or limit its use by non-local groups.

6. The decision on using surface water as a main source for refugee water supply systems should be taken once all alternative sources have proven ineffective in providing a cost-effective base of supply. In such circumstances efforts should be made to find out as many details as possible on the quality and quantity of this water in order to assess its reliability as a source for human consumption. Hydrological techniques should be used for this purpose. The obtention of basic data, such as the size of the hydrological catchment (basin), the variation of flow with time (for the production of the catchment's hydrograph, which may be considered as the "fingerprint" of the

basin) and enough physico-chemical and bacteriological data to characterize the water's quality and its variation with time (to identify seasonal factors and the periodicity of each variation) should be pursued. This should be combined with a careful study of all possible intake sites and the structures necessary to tap this water for the use of the refugee community to allow the development of the most appropriate system to minimize operation and maintenance requirements as much as possible.

7. The design of a surface water-based system should be carried out after thorough knowledge of the quantity and quality of the water has been gained and its periodical variations (in accordance with seasons and other factors) have been assessed. These factors are most important in choosing the technology to be used in the systems; they will influence the overall effectiveness in the short and long terms, their assessment should be undertaken before the design has been finished but should continue to be monitored during the entire life-span of the system (See 11.8).

8. The possibility of locating porous materials belonging to alluvial deposits on the river bed and banks should be explored. When appropriate sediments (e.g. silts, sand, gravel) are to be found, there may be a possibility of extracting groundwater stored on these sediments. Although this groundwater may be directly recharged from the river, its quality will always be better than that of the river due to the natural process of filtration carried by the porous nature of river sediments (See 8.20). Besides, this solution is preferable as river water intakes are normally difficult to design and implement and their cost much higher than that of those structures required to tap river bed or river bank groundwater.

9. If no other suitable water source is available apart from a surface water body, and the ground is not sufficiently porous to allow extraction of enough water from wells, surface water will then be the only option. In such circumstances, emergency treatment measures, such as storage, sand filtration and chlorination will be necessary and the physical control of access to intake points will be essential (See 4.2).

10. Surface water intakes are structures specially made to tap the required amount of water from rivers, lakes, ponds or any other surface water body. Although some of these structures may be simple, their design is always determined by the source's characteristics and those of the specific site where they will be located. The structures should be adequate to minimize risks of destruction (flooding, erosion, earthquakes), loss of efficiency (siltation or other type of obstructions, changes in the course of the streams) and should be capable of collecting the total design flows at any time, the year round.

11. As a general rule, a stream flow should always be greater or equal to the one required for the system. The use of *barrages* or *dams* to retain water for storage is very seldom a sound practice. Under normal circumstances, the size and characteristics of dams capable of storing the water requirements of a regular size community or refugee camp would be such that their cost would be too high and their funding problematic. Barrages would, normally, be built to assure the collection of the required amount of water for

adequate supply. They should be perpendicular to the stream bed. Special attention should be given to the design of their foundations to guard against seepage, washouts and other problems related to leakages and erosion of the river bed and banks in the immediate vicinity of the dam or barrage. Care should also be taken in designing these structures in such a way that the overflowing water will never separate from the barrage surface even when high flows occur; this will avoid erosion at the foot of the structure. Any standing water behind the barrage must be avoided. The speed of the water flow before the barrage, in the spillway and along the side gates should be as high as possible to avoid possible sedimentation problems. Barrages should have an adequate intake structure. Although as already mentioned, the design of any intake will depend on stream and site characteristics as well as on other factors, experience has shown that the most suitable intake combinations for dams or barrages are *sidegates*. The bottom of the spillway should be low enough to allow dry season water to flow past the intake. The main water entrance gates (with removable strainers) should be at least 5 centimetres (better

more) below the low water level. The design and construction of dams or barrages are complex engineering undertakings; as such they should be entrusted to qualified people.

12. Other types of intake structures are used to tap other surface water bodies and they vary in complexity and cost in relation to the source, the site and its topographical location as compared to that of the next structure within the system where the water should be conveyed (in this case, very likely treatment facilities). UNHCR has experience in dealing with many types of these structures. Adequate advice may be obtained from the Programme and Technical Support Section in this respect. Always consult a qualified person on the technical and financial requirements of any such structure.

Rainwater

13. Reasonably pure rainwater can be collected from the roofs of buildings or tents if these are clean and suitable. This method can only be the major source of water in areas with adequate and reliable year-round rainfall; it requires suitable shelter as

well as household storage facilities. It is, therefore, not generally the solution in refugee emergencies. However, every effort should be made to collect rainwater, and small collection systems, for example using local earthenware pots under individual roofs and gutters, should be encouraged. Allow the first rainwater after a long dry spell to run off, thus cleaning the catchment of dust, etc. The supply of water which it is possible to collect by this method may be estimated as follows:

One millimetre of yearly rainfall in one square metre of roof will give 0.8 litres per year, after allowing for evaporation. Thus, if the roof measures 5 x 8 metres and the average annual rainfall is 750 mm. the amount of rainwater which can be collected in a year equals: $5 \times 8 \times 750 \times 0.8 = 24.000$ litres per year or an average of 66 litres per day (although on many days there may be none!).

14. Rainwater may be a useful supplement to general needs, for example through special collection for the community services

such as health or feeding centres, where safety of water is most important. It should also be noted that surface water is particularly likely to be contaminated in the rainy season. Thus, rainwater may be a useful source of safe water for individual use at a given time when other water is plentiful but unsafe.

Groundwater

15. Groundwater, as commonly understood, is the water occupying all the voids within rocks belonging to particular geologic strata. To be used to cover needs of human communities, livestock, agriculture or industry, groundwater should be contained in aquifers. *Aquifers* are rocks or groups of rocks capable of transmitting, storing and yielding water. Aquifers can be non-indurated sediments (silt, sand, gravel), fractured rocks or otherwise porous rock (fractured lavas, granite or sandstones), open caverns in limestones or many other geological features.

16. Specialized techniques are available to assess the potential productivity and maximum yield to be expected from any given

aquifer (See 6.55). Through them, other important characteristics of the water itself (e.g. physico-chemical and bacteriological character) may also be easily assessed. On the basis of these assessments, the best type of water intakes to be used for production purposes may be decided. Although the use of groundwater during refugee emergencies would almost always be the preferred solution (if available, groundwater usually provides the most cost-effective alternative to quickly obtain the necessary quantity and the best quality); the decision of using it to satisfy longer-term needs should be made after a good knowledge of the aquifer and all factors regulating the recharge, transmission and release of water have been determined. In most circumstances, however, groundwater exploration may be carried out simultaneously with the construction of adequate structures for its exploitation.

17. Groundwater discharge to the surface may take place in a variety of ways of which springs, artificial discharge (See 6.18) and transpiration by plants are the most important in terms of volumes of water extracted from the aquifers. Locally,

groundwater may also come to the surface as diffuse discharge (seepage) that evaporates directly from the soil surface or seeps into rivers or lakes. The quantity of water stored in an aquifer which is available for discharge depends on:

i) The recharge basin, which is defined as a physiographic unit where water is infiltrated and transported by the sub-soil to one or several interconnected aquifers.

ii) Annual rainfall and the percentage which infiltrates into the ground (this percentage depends on the permeability of the soil, topography, land cover and use and many other related environmental factors).

iii) Storage capacity of the aquifers. Aquifer size, shape, permeability and porosity as well as other hydrogeological factors determine this capacity.

18. While *springs* remain the most important and widely used natural ground-water discharge, there are many artificial ways

of extracting groundwater. Without doubt, the oldest method of groundwater recovery is a hole in the ground, with a depth well below the water table. Only a little water may be abstracted this way; *dug wells* and *boreholes* are refinements of this method. Horizontal means of groundwater extraction are called *infiltration galleries* and their forms vary from ditches open at the top to tunnels completely underground (the famous "*qanats*" or *qarrez*", commonly seen in Iran or Pakistan, are examples of infiltration galleries).

Springs

19. *Springs are the ideal source of groundwater.* Although water from a spring is usually pure at the source and can be piped to storage and distribution points, it may in general be more easily contaminated than water from properly constructed and maintained wells. Care should always be taken to check the true source of the spring water, as some apparent springs may not be related to aquifers but to possible polluted sources which have seeped or flowed into the ground a short distance

away. *It is essential that the spring water be protected against pollution* at the source by means of a simple structure from which the water would fall directly through a pipe to a tank or collection point. Care must also be taken to prevent contamination above the collection point. Subsurface sources of contamination can result from privies, septic tanks, cesspools, and livestock areas. Ordinarily, a distance of 50-100 metres will suffice (if the spring is on the "uphill" side of such sources) to provide adequate protection; many fractured-rock aquifers require particular attention as they are capable of transmitting pollution for much greater distances than loose, granular aquifers.

20. The supply of water from a spring may vary widely with the seasons and will be at its minimum right at the end of the dry seasons or just at the beginning of the rainy season (before newly recharged rainwater has reached the aquifer). Perennial springs drain extensive aquifers, whereas intermittent springs discharge only during portions of the year when sufficient groundwater is recharged to maintain flow.

21. Spring catchment structures should be constructed in simple and practical ways. Their characteristics depend on the topographical situation, the nature of the ground (including the aquifer) and the type and characteristics of the source itself. In view of this, it is important that the design and the direction of construction works to build appropriate spring catchments be the responsibility of experienced technicians. Catchment structures should never interfere with the natural conditions and the flow of the spring, as any such disturbances could mean the alteration or even the disappearance of the spring's yield, as water may try to find another route. They should always provide protection against the spring's pollution from any source; after construction, and when appropriate connections have been made to convey the water to storage or distribution facilities, the structure should be sealed off or covered. The free flow of the water away from the spring must always be guaranteed. Spring catchments have three components:

i) Collection structure. It has two parts: a permeable structure *or filter* into which the water enters and a

***barrage* to lead the water into the *supply pipe* which takes it into the *inspection chamber*. Filters should be large enough to ensure maximum flows without obstruction; a water-tight cover (preferably concrete) should be placed on their top and surface water should be drained away from them. The barrage is built on impermeable ground, to prevent water from bypassing or seeping away from it; its foundation should be cast by excavating directly into the ground to get a water tight structure. Barrages may be built in stone masonry or concrete and should be as high as the impermeable cover on top of the filters.**

ii) Water from the barrage is conveyed to the inspection chamber by the supply pipe, whose diameter should be enough to let maximum flows pass (but never smaller than 80 mm). An overflow pipe should always be installed to avoid high water levels behind the barrage which would build up pressure and force water through other ways.

iii) Inspection chamber. These structures should allow easy access to the spring. They should be large enough to allow men to work inside. They are usually calculated as small sedimentation chambers (See 8.16) and should be water tight. Manholes should not be directly above the water. They should be provided with overflows and drains to allow draining off maximum spring flows without interfering with the spring. They are usually built in stone masonry or concrete; the use of wood should be avoided for sanitary reasons.

22. The identification and development of spring catchments suitable for water supply should be undertaken by experienced technicians.

Dug wells, boreholes, infiltration galleries

General

23. If the water needs cannot be met by springs, the next best option is to raise groundwater by means of dug wells, drilled

wells or infiltration galleries. Groundwater, being naturally filtered as it flows underground, is usually microbiologically pure. The choice of method will depend on the circumstances in each case, and many factors, including the depth to the water table, yield, soil conditions and availability of expertise and equipment, will have to be taken into account when making decisions.

24. Without clear local evidence from nearby existing wells, good water resource surveys or preliminary test-drilling, there is no assurance that new wells will yield the necessary amount of water of the right quality.

25. Dug wells, boreholes and infiltration galleries are expensive engineering structures. Their location, design and quality of construction, as well as the care given to their operation and maintenance requirements, will determine, to a large extent, their cost-effectiveness and appropriateness as water sources for refugee water supply systems.

26. A *hydrogeological survey* must be undertaken before

starting any expensive drilling programme. Through it, an assessment of the hydrological parameters regulating the flow and storage of groundwater in the vicinity of the refugee site may be made. Criteria for location of groundwater bodies will be obtained. The sites for exploratory or production wells will then be chosen.

27. To extract water from an aquifer, a hole is dug (vertically in the case of wells and boreholes, horizontally in the case of infiltration galleries) into the saturated material and is then lined to prevent its collapse. Either the side lining or the bottom must be porous to allow the entrance of groundwater to the hole (intake) (See 6.28). As soon as water is extracted from a well by bucket or pump, the level of the water inside will fall, causing a difference between the internal and external water pressures and hence an inward flow through the intake. The water's entrance velocity must be controlled to avoid the erosion of the intake walls; the quantity entering must, however, be sufficient to equal the amount withdrawn. With properly designed intakes, a balance should be reached by the

water level; when water is being extracted, the level at the intake (dynamic level) is located some distance below the level of the undisturbed water table (static level); the difference in elevation between the two levels, which depends on the quantity of water being extracted, is called "*drawdown*". Deepening a well will usually increase the supply of water available from the well as a greater drawdown causes water to flow in from the aquifer at a faster rate. Making the well of greater diameter increases the area of the intake through which the water may flow:

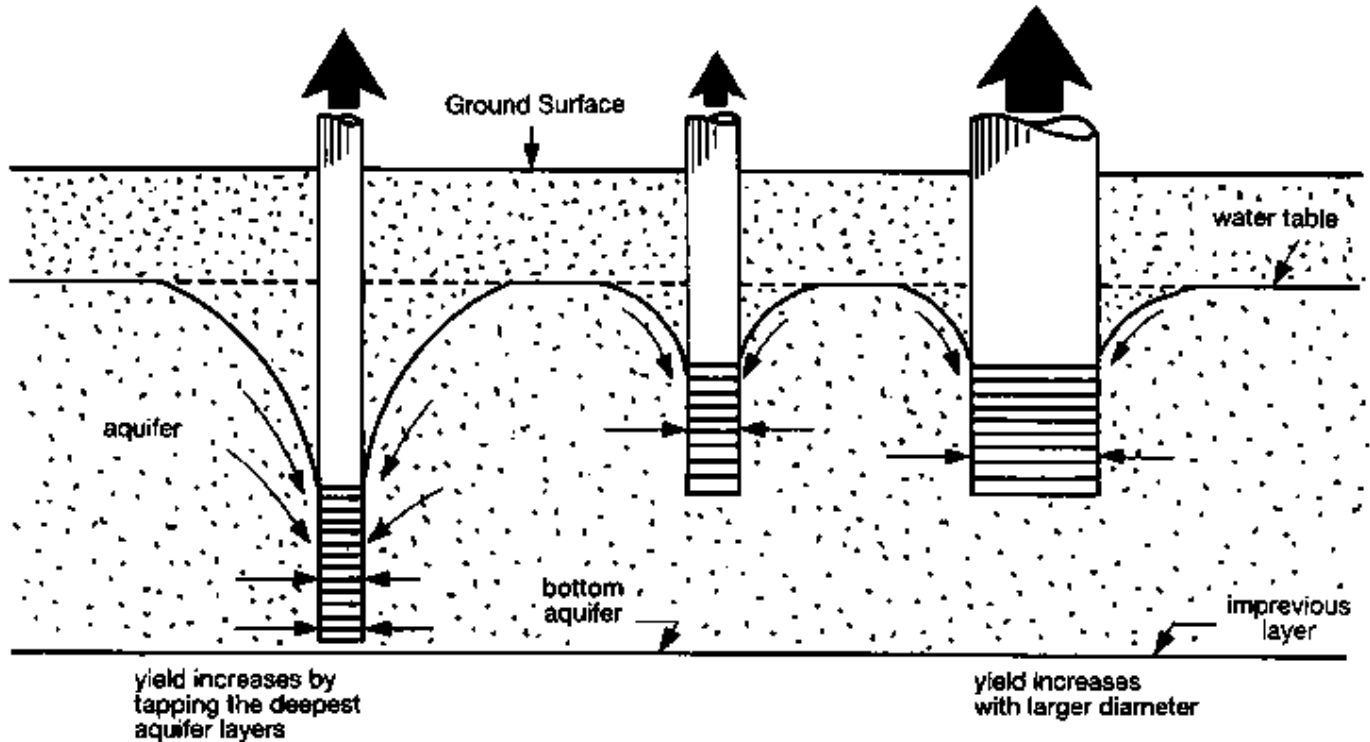

Fig. 3 Well Yields Depend on Well Characteristics

In most cases, increasing the depth of the well is a more certain

way of improving the well yield, although construction technology and the aquifer itself would place limits on the extent to which this can be done. When a number of wells are situated close together, pumping large quantities from one may affect the output of the others nearby; if the total extracted from all the wells is in excess of the capacity of the aquifer, its underground storage will be depleted and the water table throughout the area will drop (See 6.55).

28. Wells and boreholes consist of three components: the intake, the shaft and the wellhead. The *shaft* is the first component to be constructed, either by hand (dug wells) or by machine (boreholes, tube wells). This allows collection of rock samples (cuttings) whose analysis will provide clues to the nature and characteristics of the aquifer and therefore precise criteria on the design characteristics of the intake. The purpose of the *intake* is to support the exposed section of the aquifer and to permit water to flow in, while excluding solids that might enter along with it. In some geological conditions (e.g. sandstones, fissured rocks, limestones) it might be possible to

dispense with this component, but in the more usual cases, where the aquifer is made of loose sand or gravel, the intake may be considered the key of the future performance of the well. The *wellhead* is the last component to be constructed. Its design will depend on the water extraction method to be used (e.g. pump, buckets...); ideally, wellheads should be adequately sealed and impermeable to prevent insects, windblown dust, animals, refuse or dirty water from any source entering the shaft. Such wellheads are better fitted with pumps (hand, wind or mechanically operated) which, if properly placed, enable the well to remain completely hygienic throughout its life. If for financial technical or other programme or policy-related reasons, it is not possible to fit a pump, the wellhead must be designed to reduce chances of contamination to a minimum (See 9.9).

29. Like springs, wells and infiltration galleries must be protected against pollution (See 6.19). They should be located where surface water and, in particular, rain, waste or flood water will runoff away from them. They should be above, and at

least 30, preferably 50 metres from any sanitation facilities or their discharges. The wellheads must have a drainage apron, leading spilled water to a *soakaway* or *soakpit*, particularly when water distribution is carried out at the well sites (buckets, handpumps). In the case of open, large diameter wells (dug wells), the wellhead consists of a head wall which should not be so wide as to allow people to stand on it; in this case, rollers, pulleys or a windlass should be provided to avoid people leaning over the well; individual buckets must never be allowed into the well; close supervision and control is essential at least during the initial periods of the emergency, while people gets used to their "new" water supply system.

Dug wells

30. In dug wells, the shaft is of sufficient size to enable sinkers to descend and work below ground. Other manually made wells are constructed from the surface, from which a tube is drilled, jetted, driven or otherwise forced downward until the aquifer is reached, and pumps are fitted to the upper end of the tube

(*tube well*). These type of tube wells are especially suitable where plenty of water exists in shallow aquifers e.g. alongside rivers, swamps or lakes. When powered mechanical drilling equipment is available it is possible to sink boreholes to greater depths than can be penetrated by hand methods, and also to drill through hard rock which would present serious difficulties to sinkers of a hand dug well.

31. Well digging techniques vary in accordance with the nature of each site, the depth and the productivity of the aquifer. Dug wells have traditionally been constructed with either square or circular cross sections, but the advantages of economy and strength in both excavation and lining are so overwhelming with a circular shape that it is used for virtually all wells constructed nowadays. The well diameter should represent a compromise between economic and practical considerations as the cost of a lined well varies in accordance with its diameter (this takes into account the larger volume of excavation and the increased thickness of lining necessary in a larger well). The smallest practical internal diameter should give enough room

for one or two men to work inside the shaft. As a rule of thumb, 1 metre should be the smallest diameter for wells drilled by one man, while 1.3 metres should be for wells dug by two people. Experience has shown that two men working together achieve more in one day than a single man can manage in two. Effective ventilation of the shaft, an efficient size of lifting buckets and other construction equipment, additional room for concreting operations, the ability to "telescope" caisson tubes within the lining and still have enough room for a man to work within these tubes are also considerations that should be taken into account when deciding on the diameter of future dug wells. While dug wells as deep as 120 metres have been reported, about half that depth should be considered to be the limit of practical sinking by hand. This limit varies from place to place in accordance with local expertise and know-how as well as with aquifer characteristics.

32. During well digging projects, precautions should be taken to *prevent accidents*. Most of the accidents in a well are caused by:

- i) Collapse of shaft walls which are not properly lined;**
- ii) People working alone. Nobody should work alone in a well. In case of accident the workman on top should organize aid. If possible, the sinker should be secured with a rope.**
- iii) Falling into an open well. This may happen to anyone; children are more vulnerable to this sort of accidents. It may also happen in darkness, if wells or holes are not securely closed at the end of each working day.**
- iv) Sudden collapse of shaft wells due to pressure differences between the aquifer and the well. This may happen if the shaft is not lined and the water level at the well is maintained lower by pumping or bailing to allow digging under normal water table levels.**
- v) Overnight accumulations of sulfuric or carbonic gas. To avoid this, introduce an open flame e.g. a kerosene**

torch into the well; if the flame dies this would indicate the *presence of gas and danger*.

33. Dug well construction methods should always be chosen taking into consideration the characteristics of the site and the aquifer as well as the expertise available within the refugee or the host communities. Techniques used should be appropriate and should adapt to soil and aquifer characteristics; although the most cost-effective and most commonly used ones require the intervention of specialized crews, they could easily be adapted, to a large extent, to "self-help" or "refugee participation" projects within the camp (See 11.11). It is, however, important to pursue the highest technical standards possible for this type of construction project by ensuring as highly qualified and professional design, management and supervision as possible.

34. The lining of dug wells with reinforced concrete has proven to be a good method which, if appropriately used, may help during well construction and will ensure a long life-span of the

well. In soft soil conditions reinforced concrete rings may be sunk by using their own weight after excavating at their base; additional rings are mounted on top as the hole is made deeper. Once the water table has been reached and the concrete rings are secured into their final position, the lining operations stop. Concrete rings of slightly smaller diameter are "telescopically" introduced into the well (Fig 4). These rings have been previously provided with slots, holes or any other type of opening to allow water to pass from the aquifer into the well while solid materials (silt, sand, gravel) are retained. These "perforated" rings will be introduced by the same method into the saturated rock under the water table (See 6.28). To facilitate this operation and to allow sinkers to penetrate deeper under the water level, de-watering of the well is carried out. This operation may be done with buckets or with more efficient means such as motorized pumping sets. As a rule of thumb, the deeper under the water table the well intake may be positioned, the higher the finished well's yield will be (See 6.20).

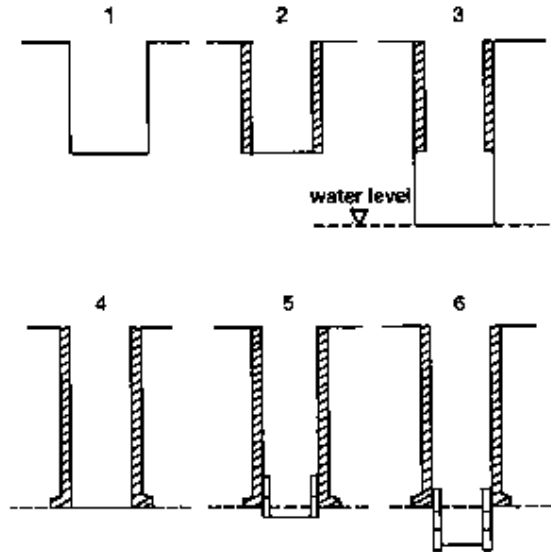

1. Digging as deep as possible, according to the soil conditions
2. Concrete lining
3. Digging as deep as possible or until the water-level is reached
4. Concrete lining
5. Lowering of caisson ring, digging continuously
6. Lowering of caisson rings, digging as deep as possible into the water. This job has to be carried out *during the driest period* of the year when the water table is at its lowest point.

Note: Taken from: Manual for Rural Water Supply.
Swiss Centre for Appropriate Technology, St. Gallen

Fig. 4 Dug Well - Reinforced Concrete Ring Lining

35. A special constraint to well sinking efforts should always be considered when planning a refugee water supply system during an emergency: it is usually very difficult to penetrate far enough into the aquifer to ensure an adequate depth of water in the well at all times in the future. Enough depth is needed to

allow for water level drawdowns during exploitation and for the seasonal variation of water table levels in most aquifers. Below a certain depth into the aquifer, water comes into the well very fast during construction. Often the available de-watering equipment would not be enough to pump out as much water as necessary for the well to be sufficiently dry for the diggers to work efficiently. As water table levels fluctuate in accordance with seasons (dry season levels are deeper than wet season ones, the magnitude of the variation depends on environment and aquifer characteristics) the difficulty of digging under water table conditions is bigger during wet seasons. As it is not always possible to arrange a well digging programme so that intake construction coincides with the lowest level of the water table, a well completed during the rainy season, and giving a good yield when new, may go dry later, when the aquifer's water level drops.

36. When planning a well digging campaign, the following points should be taken into consideration:

i) Well digging is a slow undertaking which relies to a large extent on hand labour to be accomplished. Foreseeing all project implementation constraints is a difficult, if not impossible, task. Frequently, well digging projects are negatively affected by planning underestimates of material or labour requirements.

ii) Logistics is always a big problem when several well digging crews are working simultaneously. Constraints to keep an ample supply of necessary materials at the work sites are common in refugee affected areas. To ensure the transport and shelter of digging crews is also frequently problematic. Wastage of resources (usually scarce) is difficult to avoid in many circumstances when logistic constraints are important.

iii) The willingness of the refugee community to participate in well digging projects should always be explored before decisions are taken in this respect. It may be extremely variable; it may be different at two

neighbouring camps at any given time and may also vary within the same camp within a period of time. The refugees' willingness to cooperate will be maximum during periods of water shortage, and may be reduced by the availability of alternative water sources, regardless of their quality and long-term productivity. Day-to-day occupation of the refugees will also influence on this willingness, (pastoralists will normally dedicate their full time to taking care of their livestock, agriculturalists may be more willing to participate in this type of project during dry seasons, when their occupation at their plots is reduced to a minimum; refugees in "closed camps" with no normal day-to-day occupation may welcome the idea of participating in such projects).

37. Many different dug well construction techniques may apply to individual sites, in accordance with their hydrogeological characteristics and the traditional and cultural background of the refugee and host communities. The description of these

methods may be obtained in relevant literature. Figure 5 shows the minimum construction details of a dug well.

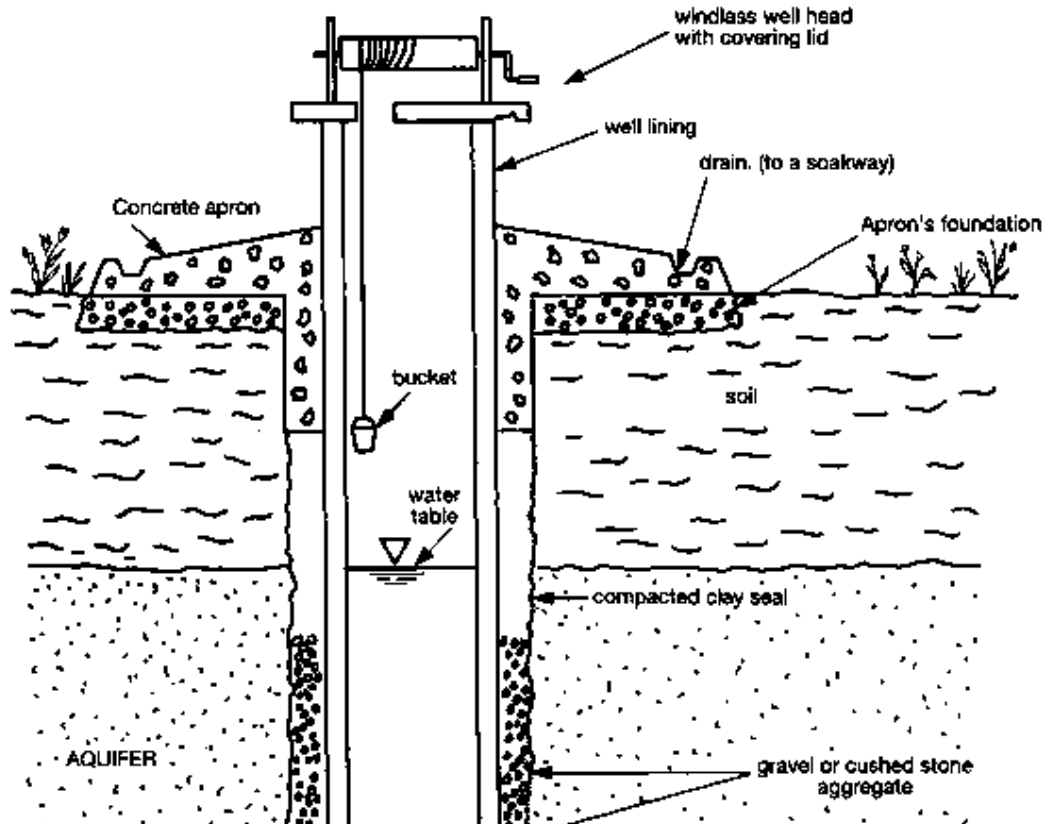

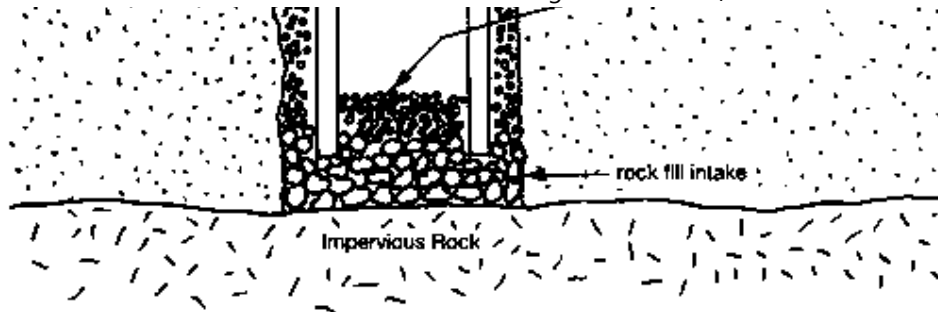

Fig. 5 Components of a Dug Well

38. The well's yield should be assessed as soon as construction and finishing works are over and the *maximum allowable drawdown* for the well may be determined (difference between the water table level and the lowest level it could reach during pumping without causing the well to dry up or the pumping equipment to suffer from lack of water). It is important to bear in mind that the aim of this assessment is not only to measure the yield at that given time, but to assess the well's long-term productivity or *safe yield*. Safe yield may be defined as the highest possible yield that it is possible to obtain from a well at the peak of dry seasons (when water level is lowest); at this

yield the drawdown at the well will be maintained (in equilibrium) at a level slightly higher than the maximum allowable drawdown.

39. The pumping test is made by extracting a given volume of water from the aquifer in a given time while measuring the evolution of the *drawdown* (drop of water levels) during the same period of time. Once pumping is finished, *recovery* levels are also recorded until the water level has reached its original level (which of course, had been previously measured). Water extraction may be carried out by whatever means available. For this purpose, buckets, bailers, compressed air pumps (if pneumatic hammers are available), hand or mechanically driven pumps may be used, provided that the total volume of water extracted during testing time may be measured with accuracy; for this purpose, mechanical pumps are the most suitable, due to their constant extraction rates and the accurate ways in which their output flows may be measured. The duration of the test is something that should be decided bearing in mind time and economic constraints as well as the hydrogeological

characteristics of the water-bearing strata; however, it is always recommendable to make this test for a minimum duration of 12 hours or to continue until at least 1 hour after the equilibrium water level has been reached (See 6.55). From the correct interpretation of the pumping test records, important ideas on the aquifer characteristics may be obtained. Only by analyzing this data, may the well's safe yield and pumping requirements be assessed. The Programme and Technical Support Section will assist you in this analysis. As a rule, *production pumping equipment for a well has to be specified and installed only after the well has been pump-tested and its safe yield assessed.*

40. As for any other engineering structure, dug wells require regular maintenance to prevent or repair damages caused by degradation, to maintain their original yields, and to ensure the longest, useful life-span possible. Periodic visits, whose findings should always be recorded in the databank (See 1.6; 11.8), should be organized to make it possible for maintenance crews to react in a timely way and repair the problems

following a *preventive maintenance* concept whereby important problems are foreseen and measures to address them are taken before their symptoms have been noticed or suffered.

41. Intakes are the most delicate component of the well and, as such, they are the most vulnerable ones; they require constant attention and maintenance. Two main problems may affect them:

i) Siltation. Whenever grain particles from the aquifer manage to pass through the filters at the intake, a deposit of these materials is formed at the bottom of the well. Outside the well a "cavern" is formed by the absence of material, sometimes so big and important that it could provoke the "sinking" of the surface surrounding the wellhead and therefore the collapse of any superstructure built nearby e.g. pump houses, wellhead apron, drainage soakaways, etc.). Little can be done to stop this problem apart from trying to place a gravel pack between the pit's wall and the outer side of

the lining; additionally, this problem will indicate the need to use smaller openings and better filtration structures in future wells.

ii) Incrustation. This problem, resulting in a gradual reduction of the well's yield (water table lowers more than normal at any given extraction rate) is due to the formation of mineral deposits in the filtration areas of the intakes, which reduce the hydraulic efficiency of these filters. These minerals are contained in suspension (clays) or in solution (carbonaceous minerals from lime-rich waters) in the aquifer's water. Different lining materials are affected by incrustation at different rates; for instance concrete rings with drilled holes used as filters suffer from incrustation at slower rates than porous concrete rings, which may be clogged up very quickly by clay or carbonaceous deposits. The solution to this problem requires agitation of the water within the well, intensive pumping and the use of chemicals to dissolve these deposits (acids, polyphosphates). This

process requires specialized expertise.

42. Maintenance of linings is simple. Actions to repair them are seldom needed. Highly expansive soils (plastic clays, black-cotton soils) may cause deterioration of lining rings by the movements related to their expansion (during wet seasons) and their contraction (during dry seasons). Cracks may appear or joints between two successive rings may be broken or otherwise displaced, thus affecting their water tightness and therefore the well's sanitary protection against pollution coming from surface sources. It will always be necessary to repair these joints and to seal-off the cracks with adequate cement mortars.

43. Well heads should also be properly and periodically maintained to ensure the impermeability of the drainage apron (to avoid surface water finding its way into the well) and to ensure the effectiveness and efficiency of drainage facilities around it. It is a common problem, especially in areas covered by soft soils, e.g. alluvial soils) that well lining rings sink

constantly at slow rates and, after a few months or years, the wellhead may be lower than the surroundings. In this case the periodical placement of additional lining rings and the necessary reconstruction of the wellheads are advisable to ensure that they will always be considerably higher than the surface of the terrain. Maintenance requirements of wellheads vary in accordance with their design and with the traffic of people in their surroundings. While less-visited wells (e.g. those equipped with pumping systems, away from distribution points) are very durable, those frequently visited by people (e.g. wells with handpumps or those very close to water distribution points and livestock troughs) will always be affected by the stagnation of spilled water (serviced water) around distribution points. In this case, adequate drainage facilities (including drainage aprons, soakaways, soakpits or any other drainage device) will have to be constructed as a part of the wellhead superstructure and will have to be maintained (cleaned, upgraded) on a regular basis to ensure their efficiency. Failure to do this on a preventive approach will cause additional problems to other wellhead components and will

negatively interfere with efforts to provide safe drinking water to the refugees.

44. If, as mentioned before, wells are affected from the combined effects of an inadequate depth to tap water-bearing aquifer layers and the periodical lowering of the water table, it will be necessary to take measures to deepen them. To take this decision, professional criteria and experience should be applied to decide between two alternatives: a) to lower existing concrete lining rings and to replace the necessary ones on top of the lining string; b) to introduce smaller diameter rings, adequate enough to expand the well's intake downwards.

45. Dug wells and the water extraction devise (bucket, pump) should be disinfected immediately after construction, repair or installation, as they may have been polluted during the work. Two or three buckets of a 2.5 % chlorine solution in water would be a suitable disinfectant (See 8.21).

Driven wells

46. Driven wells are constructed by driving a pointed screen (filter intake) with attached pipe directly into an aquifer. The point, at the lower end of the screen, is made of hard steel. Several screen designs to adapt the intake to different aquifer characteristics are available on the market. As driving proceeds and the *well point* sinks into the ground, succeeding sections of pipe are screwed on top of the screen, keeping the upper end of the casing above ground surface. Although driving can be done by hand in very soft formations (silty sands, fine sands), it is usually better to have a cable tool percussion rig or any other machine capable of hammering down the pipe string. Whatever method is used, utmost care should be exercised to deliver blows that are square and vertical as, otherwise, the pipe will bend and ultimately break. Extra heavy pipe must be used when severe driving (in hard formations) is foreseen. *These wells are mainly suitable for sandy formations* which can be easily penetrated by the well point; driven wells cannot be put in rock or heavy clay formations, hardpan, coarse gravel or boulder rich formations. Even in pure sand, the resistance to sinking increases with depth, so their application is limited to sites

where aquifers may be reached and exploited by shallow wells less than 20 to 25 metres deep. For the same reason, *their diameter is small* and varies from 5 cm. to not more than 15 cm.; a factor that limits pumping possibilities to the use of small diameter (and possibly low output) pumps. An additional restriction to those given by their depth and diameter is the fact that screen openings may become clogged with clay or similar material during construction; these obstructions will be difficult to remove from the surface. *Yields from driven wells are usually very small*, often no more than 0.1 litres per second and, therefore, large number of these wells (and pumping equipment!) would be required to satisfy a small size refugee camp.

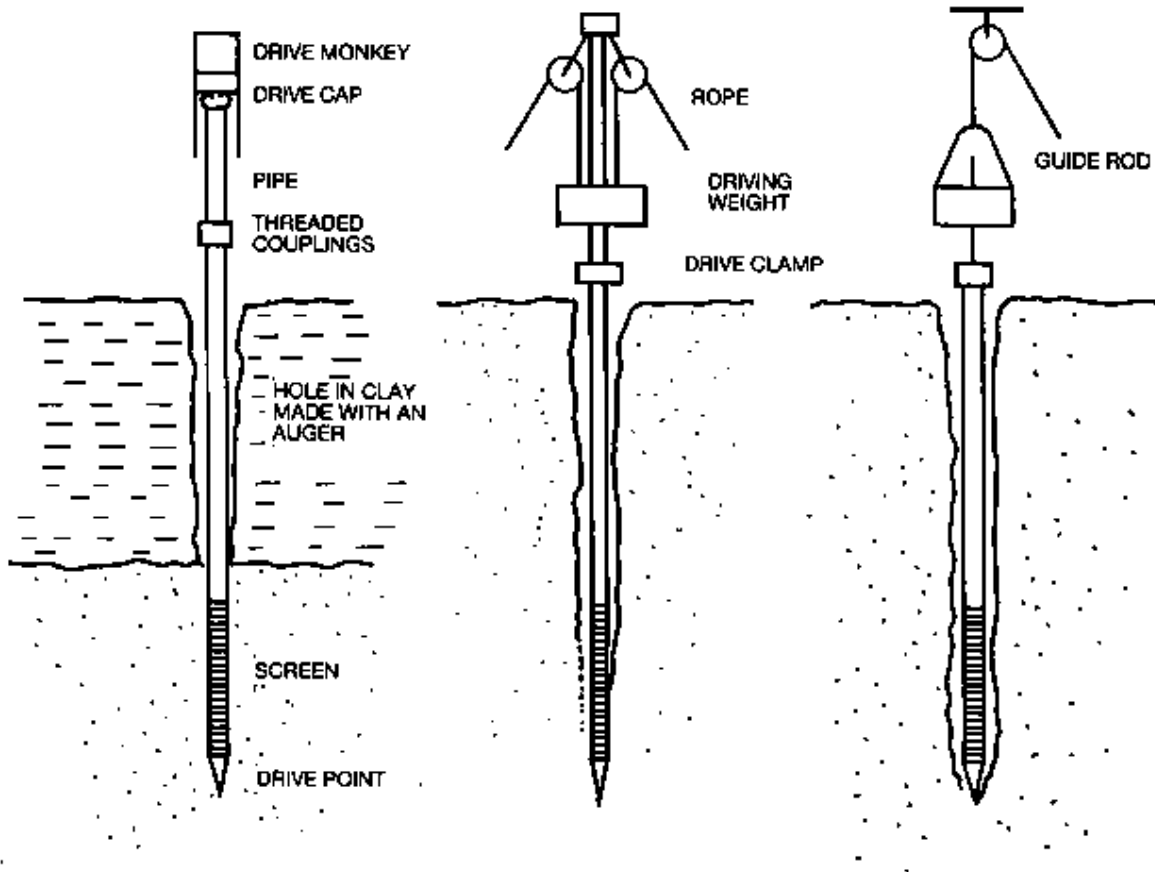

Fig. 6 Well Driving Techniques

Jetted wells

47. Jetted wells are constructed by employing the erosive action of a stream of water to cut a hole, inside which a well screen and rising pipe can be inserted after completion. The water required for this process is conveyed to the hole by a jetting pipe, of relatively small diameter as shown in Figure 7. At the top, this pipe is connected by a flexible hose to a pressure pump, while a washing nozzle at the lower end assures the outflow of water under high pressure. This water squirts at high speed against the bottom of the hole, loosens the material and carries the disintegrated fragments upwards and out of the hole; to prevent the hole from collapsing, temporary casing is commonly sunk as jetting proceeds. This type of wells may only be constructed in places where subsoil formations are soft enough to allow the technique to work; *sandy alluvial formations are among the most suitable aquifers for these wells.* Sands are easily displaced and, in such formations, wells may be constructed quicker by jetting than by any other method. The presence of clays, hardpan or coarse

gravel beds may slow down or impede drilling to continue. Well jetting requires large amounts of water, limiting its application in arid regions.

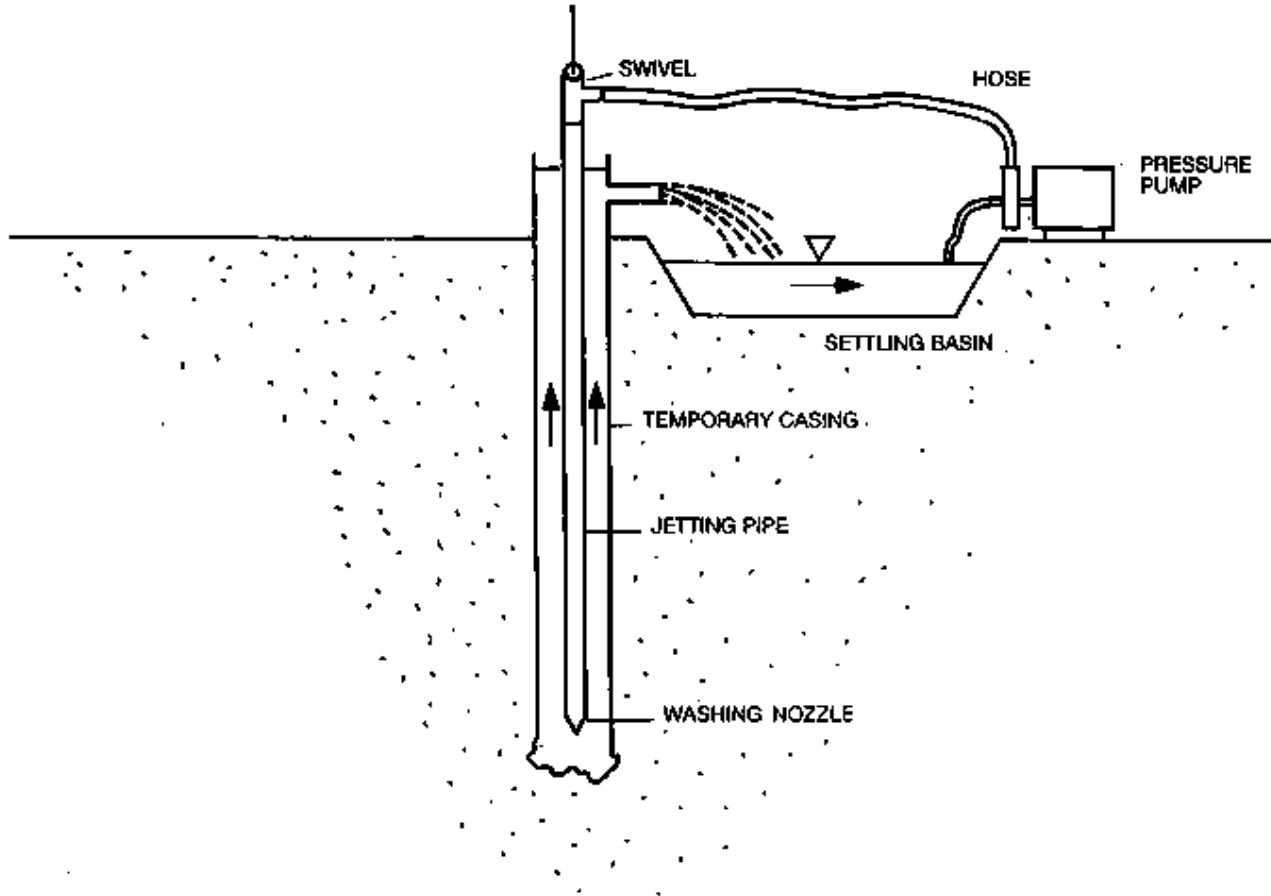

Fig. 7 Well Jetting Techniques

Boreholes

Drilling techniques

48. Boreholes are drilled by machine (rig) (See 6.28; 6.30). The purpose of drilling is to obtain a hole sufficient in size and depth, inside which *well screen* and *casing* pipes can be subsequently placed. The hole is made by cutting the formation material at the bottom and thereafter removing the disintegrated fragments to ground surface. Two main techniques are used to drill boreholes: *with percussion drilling* the cutting action is obtained by alternately raising and dropping the tools in the descending drill hole, while with *rotary drilling* this is accomplished by the rotation of suitable tools to chip and abrade the rock formation into small fragments. To remove the disintegrated material, two main methods are used: the chippings are either periodically removed with the help of a bailer or sandpump or they are continuously removed by means of a stream of water.

49. The most widely used percussion rigs are of the type known as *cable tool rigs*. The essential parts of this type of rig are shown in Figure 8. The tools are moved up and down in the well with strokes that may vary between 0.15 and 1 metres. The weight of the tools may also vary between 100 to more than 1000 kilogrammes. The hole is worked up and down until 1 to 1.5 metres of cuttings have accumulated at the bottom; the loose material is then removed with the bailer. If the formation being drilled is loose, it is necessary to advance the casing (See 6.52) as the hole progresses down, to prevent caving of the hole. In solid rock, casing may only be necessary in the first three or four metres of the hole to prevent softer soil particles from falling into it. Drilling rates with cable tool rigs vary with the type of formation being penetrated, with the depth of the hole, the type and size of the equipment and with the experience of the drilling crew operating the machine. It may be as slow as 1 to 2 metres per day in hard, dense, non-fractured rocks (granite, gneiss, lava, quartzite) or as fast as 15 to 30 metres per day in soft rocks (sandstones, sandy clay). Although slow, drilling in hard dense rocks offers no real problem to

cable tools; when the rock is fractured, however, holes tend to follow softer zones causing the borehole to crook or tools (bits, bailer) to get stuck. Unconsolidated material containing boulders is very difficult to drill, as these boulders will deflect the hole, are hard to drill and contribute to friction on the casing making the driving down of this casing more difficult. Sticky shale and clays are difficult to loosen and commonly difficult to bail. Drilling rates in clay may be between 5 to 15 metres per day. Loose, fine sand is particularly hard to penetrate because it flows into the hole almost as fast as it can be bailed; drilling rates in loose sands may be as little as 3 to 5 metres per day.

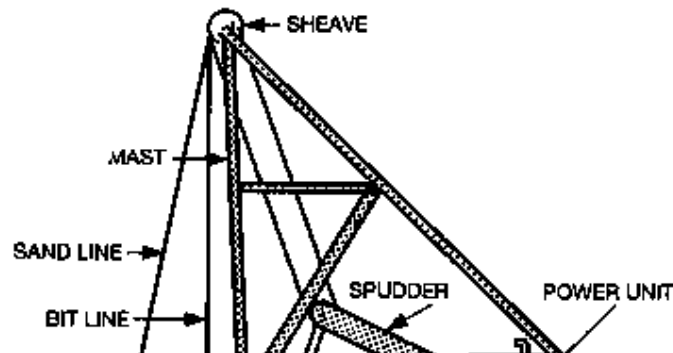

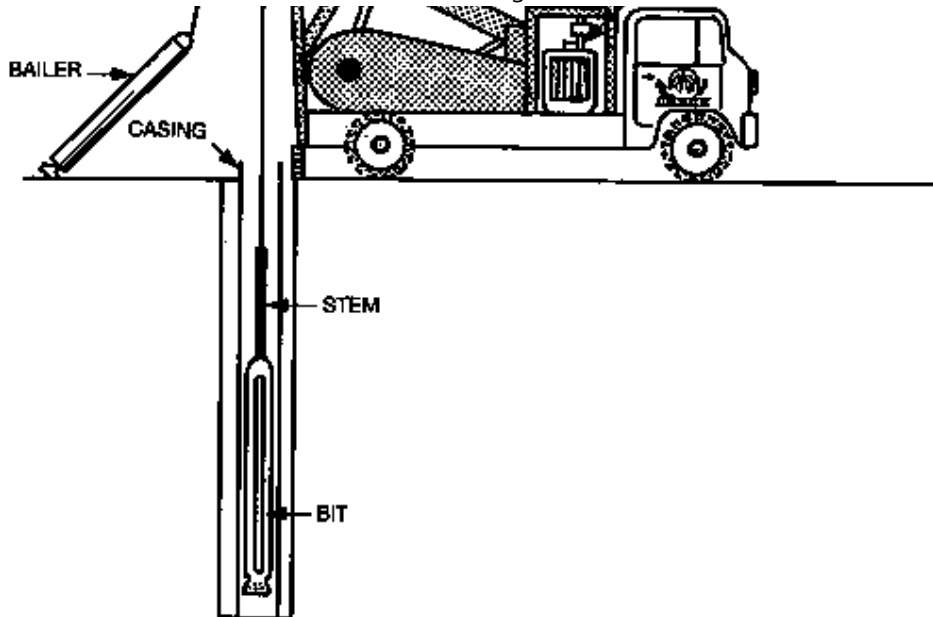
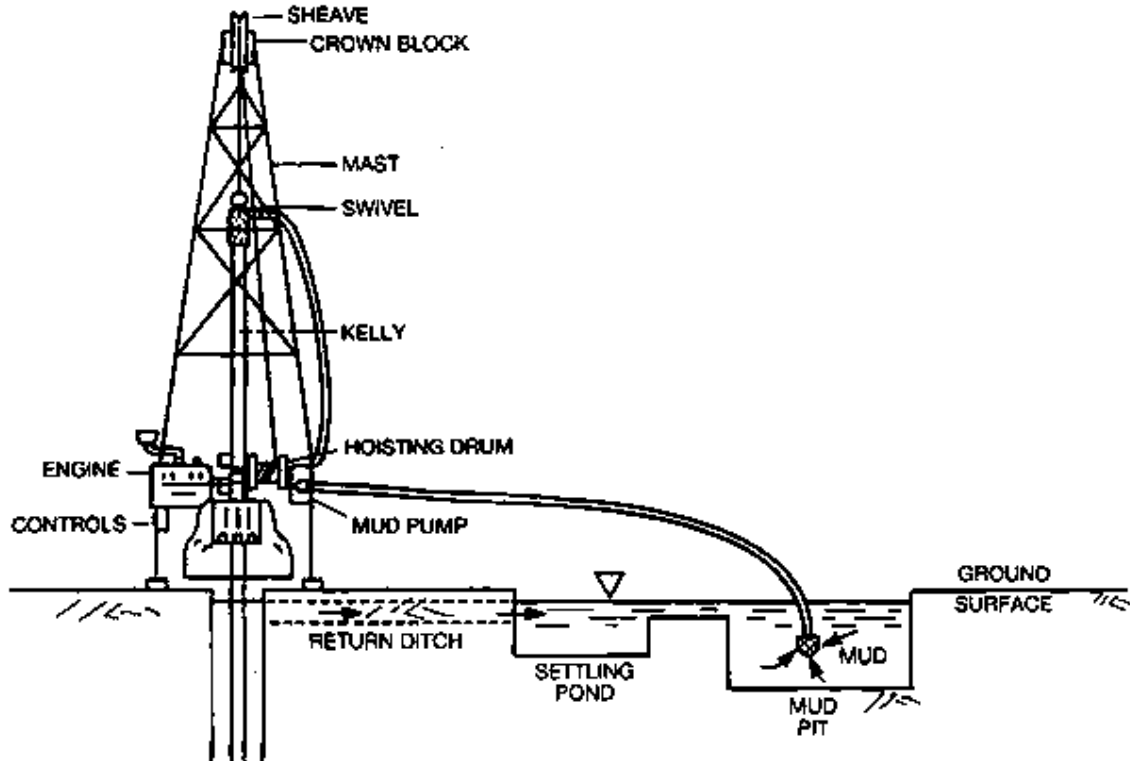

Fig. 8 Elements of a Percussion Drilling Rig

50. Rotary drilling is a popular method due to its greater drilling speed and the fact that casing is rarely needed during the drilling operation; an advantage if a low water yield in the new borehole does not justify its exploitation (the work involved in recovering casing from cable-tool drilled dry holes is difficult,

expensive and frequently impossible). The basic elements of a rotary drilling rig are shown in Figure 9. Rotating bits of various types cut the rock or sediments. Power from the engine is delivered to the bit through a rotating hollow steel. As in percussion rigs, rotary drilling rates depend on the characteristics of the rock formations being drilled, on the fracturing and degree of water saturation of these fractures and on the type and size of the equipment used. In soft unconsolidated sediments, drilling rates between 100 and 150 metres per day are possible. In consolidated rocks, these rates may vary between 10 and 20 metres per day. Rotary drilling rates are not greatly affected by depth; however some operations, such as changing bits, become lengthy and time consuming. Highly permeable rocks are the most difficult to drill, especially if their fractures are above the water table (dry); the difficulty is caused by the loss of drilling mud through these fractures, which eliminates the support the hole walls have and soft zones tend to collapse; expensive drilling bits and tools may be easily lost. When the rock material contains very hard pebbles or boulders, the bit will tend to spin on the hole

without cutting through; in this condition losing the verticality and alignment of the well may be inevitable and the hole will have to be abandoned.



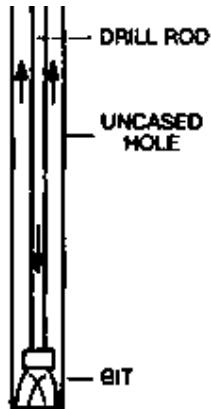

Fig. 9 Elements of a Rotary Drilling Rig

51. As a result of the fast development of *pneumatic drilling techniques* during the past 25 years a new method, usually called the *Down-the-Hole Hammer* drilling, has been introduced with very good results. A pneumatic single piston hammer (similar to the well known "road hammer") is fitted at the bottom of a string of drill pipe; a diamond or tungsten carbide bit is attached to the hammer (See Fig 10). As drilling proceeds, the bit is rotated to make it change position within the hole. While the tool is only hanging from the stem and is not touching

the bottom, the piston is "idling" on its cylinder and nearly all the air is exhausted through the bit, thus providing extra cleaning possibilities, as air (if hole is dry) or a foamy air/water emulsion (under water table levels) are at all times running into the hole and expelling cuttings to the surface. When the tools land on the bottom of the hole, the bit assembly is pushed up to meet the oscillating pneumatic piston striking with frequencies varying between 200 and 1000 blows per minute. While the bit cuts, the air cools the bit and cleans the hole. Penetration rates in hard rock have been improved by this method. Rates of 3 to 5 metres per hour through basalt are commonly reported. Down-the-Hole Hammer rigs will only operate with great difficulty in unconsolidated ground or clays; in this drilling condition, the presence of water may defeat them, as it causes the cuttings to congeal and stick to the walls (injection of special detergents into the air supply would, however, help to overcome this constraint).

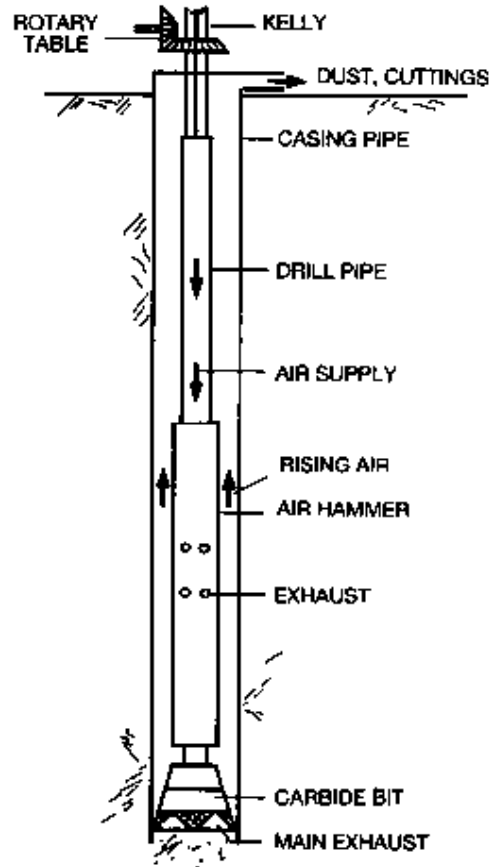
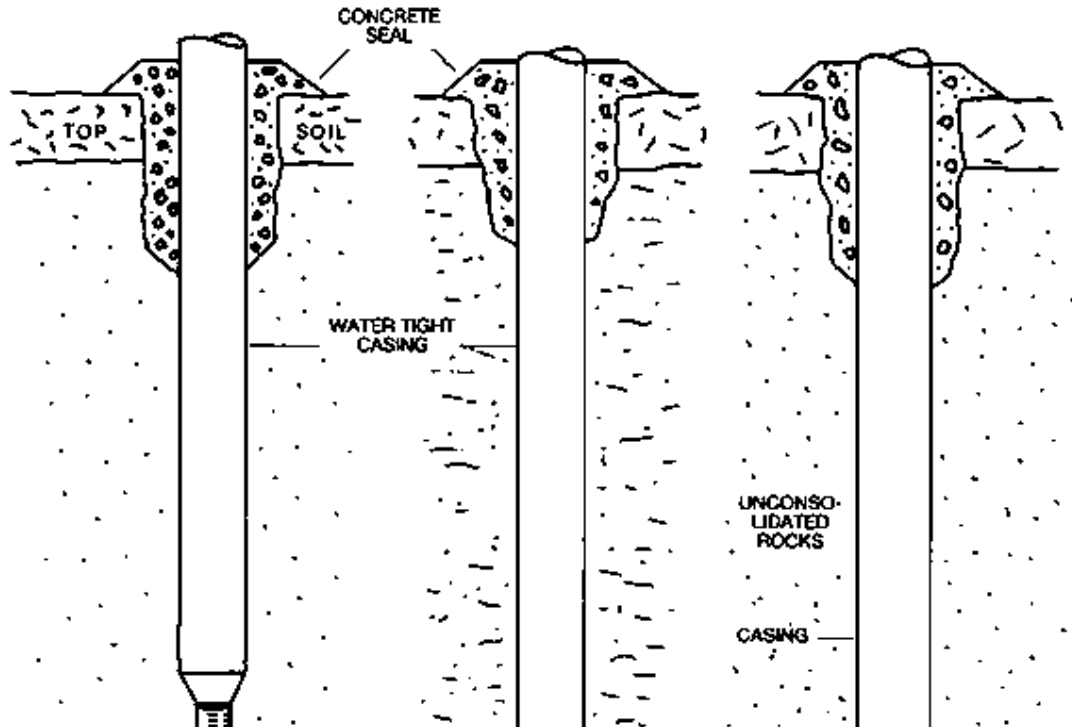

Fig. 10 Elements of a Down-the-Hole Hammer Rig

Well design and completion - Technical specifications

52. While, as mentioned before (See 6.49), a borehole drilled through hard rocks may be left unlined or will only require lining in the upper section (to avoid looser, weathered parts or soil particles falling into it), in softer rocks or unconsolidated formations the completed well must be lined over its entire depth; this lining is called *casing pipe*. In front of the aquifer, special casing is placed to act as the well's intake; it may be perforated pipe or special well *screens* (See 6.28). Sometimes, an artificial *gravel pack* is placed in the annular space between the hole wall and the outer walls of the screens (at the intakes), to provide extra protection to the intake and an increased filtration capacity to avoid solid particles being carried into the well by the incoming water during pumping (See Figure 11). Casings must be water tight, especially at the upper section, to prevent undesirable water finding its way into the hole (See 6.29). The well intake (and therefore the screen it is made from) is the "business end" of the well; its success depends on this straining device, on the care taken in collecting samples of

the drilling cuttings to identify aquifer zones for screen placement, on the skills needed to design and produce the most efficient one and on the materials used, which, in principle, should guarantee efficiency for a long time.



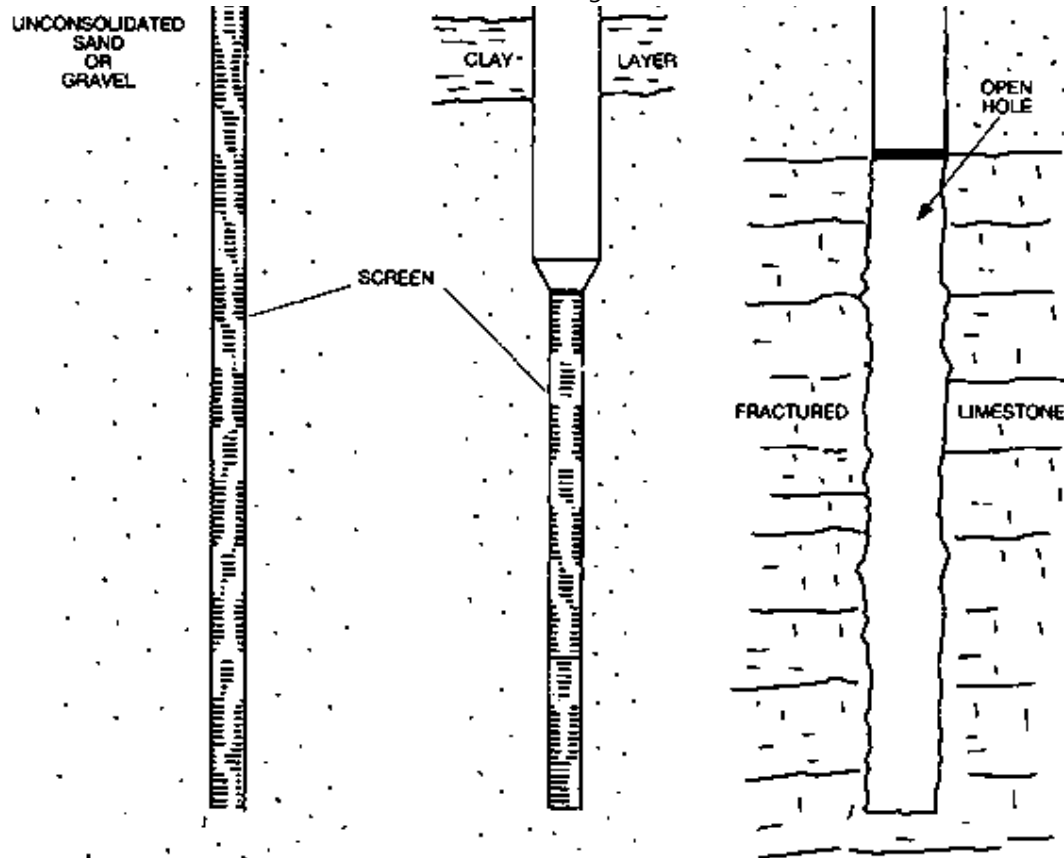

Fig. 11 Main Features of Production Boreholes

53. *Production wells must be developed for optimum yield and tested before a pump is installed; they must be properly sealed to prevent contamination from surface or subsurface sources. They need periodic maintenance and eventually, they could require rehabilitation if their yields have decreased due to corrosion or incrustation problems affecting the intake screens. All these actions can benefit from the professional assistance of experts. Geologic and hydrologic information gives positive guidance concerning the proper location and completion of production wells and optimum pumping rates. Production well location and design may also profit from the application of geophysical exploration as it may prove useful in choosing the right construction features and design; this type of survey may eliminate the need for extensive test-drilling, which is costly and should be regarded as the last resort for groundwater exploration in difficult or badly known terrains. Good and efficient final designs of production wells are dependent, to a large extent, on accurate well logs obtained during drilling operations, on the adequate collection and analysis of drilling cuttings, on the recording of water level changes during drilling*

and on the *control of water quality*.

54. The most important *well construction and design specifications* are contained in Annex D, which is presented in a format suitable for inclusion as an integral part of borehole drilling *contractual documents* (See 12.10). The completion of production wells must provide for an efficient entrance of ground-water into the well during production. If wall materials of a well are stable (hard, rocky aquifers), water may enter directly into the *uncased production well*; surface casing is required to prevent contamination and liners could be necessary to prevent caving zones from filling the borehole. Holes and casings of deep wells in consolidated rocks are often *telescoped* in diameter size to allow drilling at great depths. The design of intakes in boreholes tapping unconsolidated or soft rock aquifers is more difficult; screens or perforated casing are required to hold back the aquifer material and to allow water to enter the well without excessive *head loss* (by friction). Intake openings may vary from an open bottom of the casings and all sorts of punched, perforated or sawed slots to

sophisticated screens. Commercial screens are available in various designs, diameters, slot sizes and corrosion-resistant materials. The location within the borehole, length and slot openings of screens are decided on the basis of the study of drilling cuttings and hydrogeological conditions at the well site. There are two types of screened production wells:

i) *Natural pack* production wells, for which materials surrounding the production well are *developed* in place; development removes the finer material from the aquifer so that only the coarser material is left to surround the screen; the materials around a production well are thus made more uniform in grain size and the sand and gravel left in the aquifer are graded in such a way that the fine deposits from the aquifer cannot clog the natural pack;

ii) *Artificial pack* production wells for which materials having a coarser uniform grain size than the natural formation are artificially placed around the production well's intakes. The design of artificial gravel packs

requires expertise and should always follow criteria such as those suggested in Annex D.

Screens should be long enough to ensure their maximum hydraulic efficiency (minimum water entrance velocities and frictions). Under water table conditions (non-artesian aquifers), however, optimum production well capacity and yield may be obtained by screening the lower 33 % to 50% of the aquifer; *the pumping level must always be kept above the top of the screen*, thus, in this case, the longer the screen the less available drawdown. When choosing a screen it is necessary to take into account factors such as the *open area* per metre of screen (the larger, the better), the desired well's yield, the desired service life of the production well (See 5.2) and the funds available; the selection of the screens (quality, lengths) is often a compromise between cost and hydrogeological factors. The diameter of the well's casing should preferably be two nominal sizes larger than the outer diameter of the pump intakes to prevent pump shafts from bending, to reduce head losses and to allow *measurement of water levels in the well*.

The casing diameter may be reduced below the maximum anticipated pump setting depth. The following table suggests adequate casing diameters for various pumping rates:

Suggested Casing Diameter

Pumping Rate (litres per second)	Diameter of Well (millimetres)
up to 5	150
5-10	200
10-25	250
25-40	300

In order to install and maintain pumping equipment, *production wells should be straight and plumb* (vertical); the alignment of wells should be kept within practical limits. For this, appropriate tests are suggested in Annex D. *All production wells must be developed* to remove drilling cuttings and mud which has migrated into the well wall and into the aquifer

during drilling and to remove fine silt and sand from the aquifer around the screen to produce a coarser and more uniform gravel envelope around the production well; this may be accomplished by a variety of procedures including pumping, surging, injection of compressed air and backwashing. As mentioned before, production wells furnishing drinking water must be properly sealed to *prevent contamination from surface or subsurface sources*. To accomplish this, the annular space outside the casing must be filled with cement grout. The top of the well should contain a watertight seal. The surface around the well should be made of concrete, it should slope away from the well mouth and drainage facilities (canals, soakaways, soakpits) should be constructed to eliminate spilled water if water distribution takes place at the well or its surroundings (handpump distribution). The final step in well construction and completion is its *thorough disinfection* to kill any bacteria that may be present. A chlorine solution is the simplest effective agent for disinfection of wells, pumps, storage tanks and piping systems. Highly chlorinated water is obtained by dissolving gaseous chlorine, Calcium hypochlorite or Sodium hypochlorite

in water (See 6.45; 8.21).

Borehole and aquifer yield assessment - Test pumping

55. The assessment of water well yields is carried out by pumping water from the well at a controlled rate while the effects of this water extraction on water levels are monitored by measuring the difference of the levels before pumping starts (*static water level*) and during pumping (*dynamic water level*) at the well itself or at *observation wells* (See 6.27; 6.39). Yield and drawdown data can be used to determine the well's *specific capacity* (discharge-drawdown ratio of the well), which is a parameter to take into consideration when determining possible costs for pumping and for the selection of the most adequate pumping equipment; the specific capacity gives a measure of the effectiveness or productive capacity of the well. Pumping tests are also performed to determine the hydraulic characteristics of the aquifers (*aquifer tests*), necessary to assess the total and long-term productivity of a series of wells tapping an aquifer. These characteristics are defined by several

groups of hydrogeological parameters. An important one defines volumes of water that may be released or stored by the aquifer (*storage coefficient* or *specific yield*); another group defines flow rates that may be obtained from the aquifer (*transmissibility* and *hydraulic diffusivity*). Three main types of pumping tests are generally performed:

i) *Constant yield tests with no observation wells.* In these tests, water levels are periodically measured at the well itself while water extraction is carried out at a constant pumping rate. After pumping is stopped, water levels (*recovery water levels*) are periodically controlled until the original water table level is reached again at the well. Rough estimates of the well's specific capacity and of the aquifer's transmissibility may be obtained through the analysis of this type of test.

ii) *Constant yield tests with observation wells.* As in the case above, pumping and recovery levels are measured. Measurements are performed at one or more observation

wells whose relative location in respect' of the pumping well and the aquifer should be known as accurately as possible. These tests are usually performed as aquifer tests to obtain, from their analysis, very accurate estimates of the aquifer's transmissibility, its specific yield or storage coefficient as well as estimates of possible interference between adjacent production wells.

iii) Variable discharge tests or *step-drawdown tests* are performed by pumping the well during successive periods, usually of one hour duration, at constant fractions of its full capacity. During the test, water levels in the production well are measured at frequent intervals. Specific capacity determinations are more accurately obtained through these tests which, if properly analyzed, also provide very good estimates of the well's efficiency as a water intake structure. In simple terms, these tests provide an idea of how construction and design characteristics affect the well's capacity to produce water and may be used to assess

techniques and design.

As step-drawdown tests usually consist of four steps, they may be performed in less than 6 hours. Constant yield tests require a much longer time. Only with time will drawdown measurements reflect accurately the real conditions of the aquifer; at the beginning of the test drawdowns increase at very fast rates, but as pumping continues the well draws water from larger portions of the aquifer and the *dynamic water level* deepens at a decreasing rate with time. Stabilized conditions at the well (when the well draws water at the same rate it is being recharged to the aquifer) are obtained at the moment the water level at the well does not show any additional drawdown. Experience shows that this happens after between 15 to 36 hours of pumping. The recommended duration of this type of pumping test is, therefore 48 hours. When, for practical reasons, the duration of the tests should be lowered, the decision should take into account that economizing on the period of pumping is not justified because the costs of running the pump a few extra hours is low compared with the total

costs of the well and of the test itself; the operation and maintenance of the well and of its pumping equipment will benefit from a correct choice of specifications and from the knowledge of the aquifer and the well gained by the test. Water level measurements (at pumping or observation wells) are taken many times during the course of a pumping test, and as accurately as possible. Since water levels drop fast during the first two hours of a test, readings should be taken at brief intervals, with the time between readings being gradually increased as pumping continues. (See annex D). After the pump is shut down, water levels in the pumped well and in the observation wells will start to rise. In the first hour they will rise rapidly, but as time goes on the rate of rise decreases. These recovery levels are also measured, and the analysis of recovery data usually allows more reliable calculations of aquifer parameters. Rates of pump discharge during a pumping test should be controlled in order to keep them constant and to avoid complicated calculations during analysis. Flow rate measurements should be accurate and recorded periodically, at least once every hour, and necessary adjustments must be

made from time to time to keep the discharge rate constant; this can be done with a gate valve in the discharge pipe which is more accurate than by changing the speed of the pump. If an appropriate water meter is not available, flow may be measured with a bucket (the most simple method which, if carefully performed, may render quite accurate results), with an "orifice weir" or any other method explained in relevant literature.

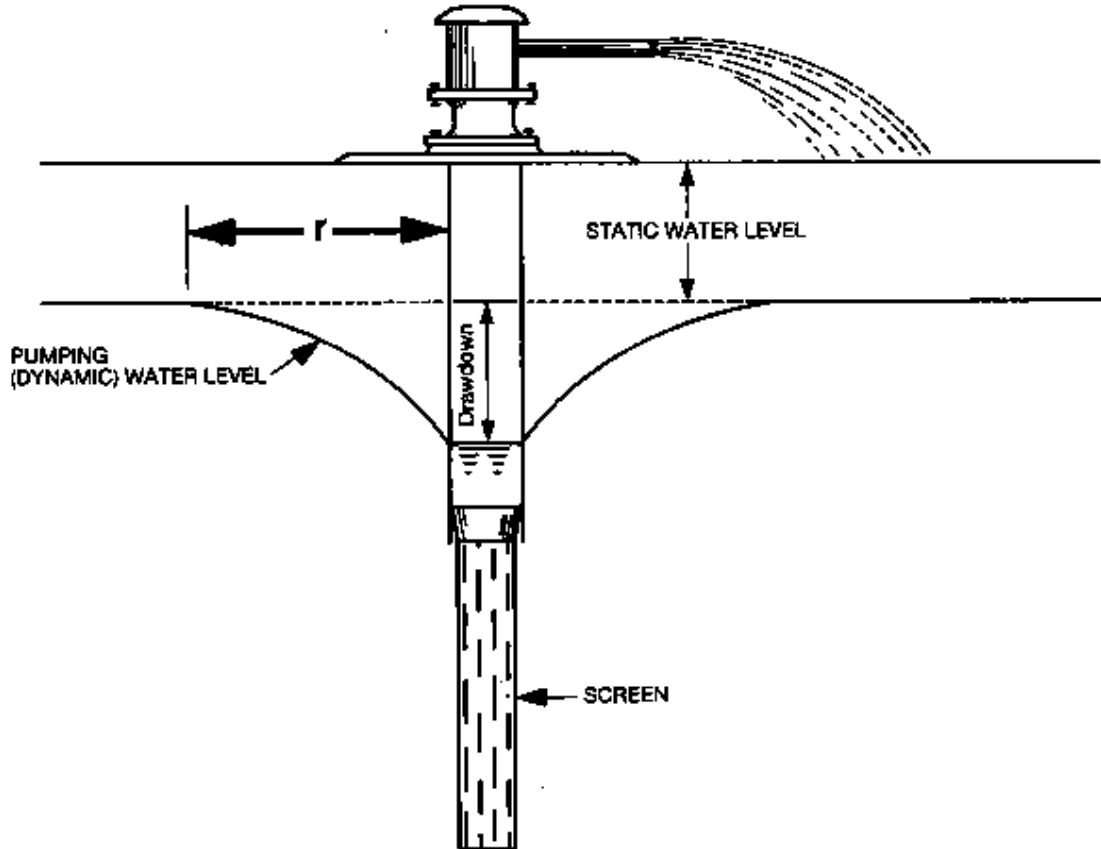

Fig. 12 Pumping Tests - Definition of Terms

Borehole maintenance

56. The life of a production well will be limited unless it is constructed in a manner which permits both, a high initial efficiency and the possibility of periodical redevelopment, and only if it is pumped at the proper design rate. Some production wells under continuous heavy pumping eventually become partially clogged. With the use of appropriate materials and with careful maintenance, a borehole may be productive for 50 years or more. Well production may decline as a response to:

- i) Lowering of water table levels;**
- ii) Inefficient pump operation caused by worn, corroded or plugged parts;**
- iii) Deposits of scale, corrosion products or micro-organism growth on the screens and casing;**
- iv) Clogging of the screens by mud, silt or sand.**

Well maintenance and rehabilitation actions help in recovering lost production if the decline is due to any of the last three causes. As important as assessing specific capacities and water

levels and drawdowns in a new well, *continuous data collection* should be a normal action when operating water supply wells in order to compile their operating history. By comparison of such data, collected over a period of time, it is possible to detect a loss of production efficiency and, in many cases, to determine the cause of such loss. With this forewarning, repair and maintenance work can be accomplished at opportune times and complete breakdowns avoided. Most groundwaters are only mildly corrosive, if at all; corrosion may be offset by using protective coatings or corrosion resistant materials for the screens and casing. Incrustation results from the deposit of extraneous material in and around the screen openings and is mainly made up of Calcium, Magnesium, Sodium, Manganese or Iron bicarbonates or sulfates; silt and clays may add to the problem as do some "iron bacteria" or "slime forming" micro-organisms. When a well is being pumped the pressure around it (static head) is reduced as an effect of the drawdown; water velocity is increased in the immediate vicinity of the well and carbon dioxide may be released as gas; water loses part of its ability to carry salts in solution and therefore minerals such as

Iron hydroxide or Calcium and Magnesium carbonates are deposited. Serious mineral deposition will occur at the top of screens which are exposed to the air due to overpumping. Slime production by iron bacteria is a result of the life cycle of these organisms, which live in groundwater by feeding on ammonia, methane and carbon dioxide; through their metabolism iron is changed to insoluble salts thus augmenting incrustation. Although there is no wholly effective safeguard against incrustation or corrosion, their effects can be retarded by periodic cleaning of the wells, by installing screens with maximum possible inlet areas to reduce water velocities and by reducing pumping rates. Once a well falls victim to incrustation or corrosion problems it needs to be *rehabilitated* or treated by mechanical, chemical or other means (surging, blasting, hydrofracturing, etc.) to recover its lost production capacity. No single treatment is suitable for all wells: as it is usually difficult (if not impossible) to pull the screens to the surface to manually clean them, the most widely used method of well rehabilitation is to treat the screens and water yielding part of the aquifer with acid or other chemicals without pulling the

screens and producing mechanical agitation within the well by surging (moving water back and forth through the screen openings with a piston or, sometimes with compressed air or dry ice). More details on well rehabilitation may be found in relevant literature.

Technical specifications and contractual documents for borehole drilling contracts

57. Water well drilling contracts are essentially the same as most other forms of contract used in civil engineering works. The specialized nature of well drilling require, however, modifications and tailor-made specifications to suit peculiarities of these works. Water well drilling should be contracted differently because:

i) Each well or group of wells can be said to be unique even though underground conditions at different sites seem to be similar;

ii) Much of the well structure cannot be inspected

visually either during drilling or after completion;

iii) Project administrators or beneficiaries are likely to be unfamiliar with well construction methods, and with the skills and techniques involved in successful drilling.

More details on contractual documents are given in 12.13. Annex D provides a guide for drawing up technical specifications for drilling contracts. They are flexible enough to be adapted to special cases or circumstances. Expert advice should always be sought when drafting these documents to guarantee smooth project implementation.

Infiltration galleries

58. Infiltration galleries are horizontal means of groundwater abstraction. They may be subdivided into three groups:

i) Open trenches, as cut in the ground, to make the aquifer and its groundwater accessible from the ground; in emergency situations and in the right hydrogeological

conditions (shallow water table) they can very quickly be developed as a source of water with the use of earth digging equipment (bulldozer). As they are easily contaminated, their use should follow the same sanitary precautions recommended for surface water sources (See 6.9); surface water should be drained away from them and access to them should be strictly limited to relevant camp staff;

ii) Buried porous conduits or drains, constructed inside the aquifer at some distance below ground level. If properly constructed, this type of infiltration gallery may provide large amounts of water when located close to, or within, medium and coarse grain (sand, gravel) river beds. Their main disadvantage is the need to construct them at the right moment, when river floods are minimal and the works may take place; sudden floods, higher than expected, have destroyed many attempts to tap groundwater for refugee camps in the past. Their construction should, however be considered as a last

resort which, if successful, may provide ample water of good quality;

iii) Tunnels of large cross-sectional areas, built in consolidated (or semi-consolidated) formations by mining methods at any depth below ground level. To this type belong the Iranian *qanats* or the Pakistani *qarrez*, which are tunnels having a low gradient towards their mouth and which, by going against the slope of the mountains, are able to reach (after many kilometers) the water table of colluvial aquifers. These qanats are very ancient; they are constantly maintained by villagers and nomads who depend on them. The use of this water (several refugee camps in Iran or Pakistan have depended on these sources during initial emergency assistance) as a source of drinking water should follow the sanitary precautions recommended for surface water sources (See 6.9).

Municipal or private systems as source of water supply

59. Existing municipal or private systems in the vicinity of the refugee sites, for example those belonging to towns or to industrial, agricultural or pastoralist establishments, may be able to meet part or all of the water needs during an emergency, and should obviously be utilized where possible before unnecessary measures are taken. A substantial increase in the yield and quality of such systems may be possible if expert advice is sought.

