

AT MICROFICHE REFERENCE LIBRARY

A project of Volunteers in Asia

Self-Help Wells

FAO Irrigation and Drainage Paper No. 30

by: R.G. Koegel

Published by:

Food and Agriculture Organization of the
United Nations
Via delle Terme di Caracalla
00100 Rome
Italy

Available from:

Food and Agriculture Organization
Distribution and Sales Section
Via delle Terme di Caracalla
00100 Rome, Italy

Reproduced by permission of the Food and
Agriculture Organization of the United Nations.

Reproduction of this microfiche document in any
form is subject to the same restrictions as those
of the original document.

self-help wells



FOOD AND AGRICULTURE ORGANIZATION
OF THE UNITED NATIONS ROME

self-help wells

by

r.g. koegel
fao consultant
university of wisconsin
madison, wisconsin. u.s.a.

The designations employed and the presentation of material in this publication do not imply the expression of any opinion whatsoever on the part of the Food and Agriculture Organization of the United Nations concerning the legal status of any country, territory, city or area or of its authorities, or concerning the delimitation of its frontiers or boundaries.

M-56

ISBN 92-5-100398-X

The copyright in this book is vested in the Food and Agriculture Organization of the United Nations. The book may not be reproduced, in whole or in part, by any method or process, without written permission from the copyright holder. Applications for such permission, with a statement of the purpose and extent of the reproduction desired, should be addressed to the Director, Publications Division, Food and Agriculture Organization of the United Nations, Via delle Terme di Caracalla, 00100 Rome, Italy.

© FAO 1977

PREFACE

The purpose of this book is to review the methods for well drilling and digging which can be done with local material and by local people. The book is intended for engineers, agronomists, health experts, etc. who may wish to help people obtain a better water supply. The book is not for highly sophisticated societies nor for those interested in the normal, capital-intensive techniques of well drilling. The aim of the book is not to provide formulae and detailed instructions for specific conditions but to provide ideas, some of which may be useful in a specific location. The emphasis is on using and building on resources which are available rather than on importing technologies.

TABLE OF CONTENTS

	Page
1. INTRODUCTION	1
2. GROUND WATER OCCURRENCE	2
3. COMPARISON OF LARGE AND SMALL DIAMETER WELLS	4
4. SMALL DIAMETER WELLS	7
4.1 Bored or Augered Wells	7
4.2 Driven Wells	13
4.3 Jetted Wells	18
4.4 Hydraulic Percussion	20
4.5 Percussion	21
4.6 Hydraulic Rotary	25
4.7 Casing and Screens	26
4.8 Methods for Obtaining Vertical Reciprocating Motion	33
4.9 Rope	38
4.10 Well Development and Finishing	39
4.11 Problem Solving	40
5. LARGE DIAMETER WELLS	43
5.1 Rationale for Construction of Large Diameter Wells	43
5.2 Dimensions for Large Diameter Wells	43
5.3 Excavation	45
5.4 Lining the Excavation	46
5.5 Equipment for Raising and Lowering Materials	54
5.6 Moulds	56
5.7 Concrete Work	58
5.8 Safety	59
5.9 Finishing Large Diameter Wells	60
6. HYBRID WELLS	61
7. NON-VERTICAL WELLS	63
8. HEALTH ASPECTS	64
9. AVAILABILITY OF SKILLS AND MATERIALS	66
REFERENCES	67
ILLUSTRATIONS OF SELF-HELP WELLS	69

LIST OF FIGURES

		Page
1.	Hydrologic cycle	2
2.	Flow into a well	3
3.	Earth augers	7
4.	Locally fabricated helical auger attached to pipe extension	8
5.	Locally fabricated cylindrical "auger" used in sticky soils	9
6.	Cylindrical auger with pipe extension and handle attached	9
7.	Auger extension and handle	10
8.	Coupling for auger extensions made from larger pipe and welded to the top of an extension	11
9.	Tripod used to support long auger extensions during drilling	11
10.	Tripod used to support long auger extensions during drilling	11
11.	Drilling with a helical auger	12
12.	Reaming blade for enlarging hole attached to top of auger	12
13.	Devices for well driving	14
14.	Drive points and screens	15
15.	Drive point fabricated from pipe	16
16.	Well jetting	19
17.	Hydraulic percussion	20
18.	4-inch diameter bamboo screen	21
19.	Bailing well with 6 cm diameter bailer	22
20.	Bailing well with manpower	22
21.	Locally forged percussion drill	23
22.	Locally fabricated bailer with heavy rubber check valve	23
23.	Percussion bits, locally fabricated	24
24.	Bailer, locally fabricated	24
25.	Coir casing	27
26.	Coir casing	27
27.	Coir casing	28
28.	Coir casing being lowered into bored hole	28
29.	Fabricating sheet metal casing	29
30.	Fabricating casing from galvanized sheet metal	29
31.	Sinking casing	31
32.	Sinking casing	32
33.	Sinking casing	32
34.	Pulling on anchored horizontal rope to obtain reciprocating motion	33
35.	Percussion drilling	34
36.	Tripod mounted pulley used to obtain reciprocating motion for percussion drilling and bailing	35

	Page
37. Using lever to obtain reciprocating motion	35
38. Spring board for obtaining reciprocating motion	37
39. Spring pole for obtaining reciprocating motion	37
40. Traditional Chinese drilling equipment	37
41. Rotating drum of "cathead" to obtain reciprocating motion or for use as a winch.	38
42. Fishing tools	42
43. Very large diameter cistern-wells with stairs for descent to the water surface	44
44. Excavating and lining large diameter well	47
45. Precast concrete caissons being set into a well excavated to the water table without lining	49
46. Well constructed by undermining precast concrete caissons starting at ground surface	50
47. Methods for attaching caisson sections	51
48. Methods for allowing water inflow through caisson walls	52
49. Caisson being lowered into well by means of overhead pulley and steel cable paid out by deep winch	54
50. Lowering a caisson using a brake post	55
51. Caisson sections made with commercially fabricated mould	56
52. Locally fabricated mould	57
53. Large diameter well with vertical casing and screen	61
54. Sinking casing and well screen into the bottom of a large diameter well to increase inflow	62
55. Large diameter well with radial well points	62
56. Ghanat	63

1. INTRODUCTION

The need for water is common to all living things. Man's health and well-being depend upon an adequate water supply to fulfil his bodily needs, to make hygiene possible and to produce the food he eats. Where water is inadequate, life is a struggle for existence?

Fresh water occurs naturally on the earth's surface in springs, streams, rivers and lakes. However, these sources of water are not uniformly distributed. Moreover, they may be intermittent and it would severely limit the locations where man could live if he had to depend solely on surface water. This constraint spurred man to learn how to sink wells to exploit underground water thousands of years ago. The ability to create a water supply which is dependable, clean and in a desired location is a skill which should be ranked second to none in the development of mankind. The social and strategic importance of wells can be learned from many historic accounts.

In addition to supplying man's own needs and those of the animals he raises, water from wells may be used to irrigate the crops which produce his food. Sometimes irrigation is the sole source of water for plants. In other cases irrigation water may be used only to start plants in seedbeds, so that they may make maximum use of natural rainfall when it becomes available. In still other cases, irrigation may be used only to supplement rainfall when it becomes insufficient. In the last two cases, relatively small quantities of water can lead to big increases in yields. Irrigation may also make it possible to have fresh fruits and vegetables in the diet when they would otherwise be unavailable.

While very sophisticated and expensive well drilling equipment has been developed, especially in response to demands of the petroleum industry, an amazing variety of simple, low-cost techniques exist. These techniques tend to be low capital labour intensive, and have been successfully used under many conditions on self-help well construction projects around the world. Since in many areas people are under-employed at some time during the year, their spare time can be used toward the improvement of their own well-being and toward an increased economic base through irrigation.

2. GROUND WATER OCCURRENCE

When precipitation falls (Figure 1) it may: (i) be evaporated from the earth's surface or from the leaves of plants (evapotranspiration) whose roots have taken up the moisture from the soil; (ii) flow along or near the surface of the earth in watercourses of ever-increasing size until it reaches the ocean; (iii) infiltrate down through the pores or crevices of the earth's mantle either at the point where it falls or at some distant point to which surface flow has carried it. Water which evaporates from the earth's surface or bodies of water is ready to start the cycle over again as precipitation.

When water is added to dry or unsaturated soil it is held in the voids between particles by capillary forces. Once the voids are saturated, however, the water is free to descend under the effect of gravity. As long as there is sufficient water to maintain saturation, the water will descend until it is stopped by some impervious layer, such as rock or highly impervious clay. The water can then flow laterally through the voids or rock crevices above the barrier. If there are significant differences in surface elevation, the water may flow out along the impervious layer at some lower point called a spring. If a hole is made vertically down into the saturated layer, water will flow into the hole. If the saturated layer has sufficient interconnected voids, water will flow through it relatively rapidly. When the saturated layer yields water in economic quantities, it is called an aquifer and the hole made into it could be developed into a well. The lack of resistance to flow through porous material is called permeability. In general, fine grained material such as clay or silt is low in permeability; sand is of medium permeability, and gravel is most permeable. Fractured rock varies in permeability depending on the degree and pattern of fracture. The quantity of water which can be stored in an aquifer is equal to the total volume of voids between the solid particles. The fraction of the total volume of an aquifer made up of voids is called porosity. If the voids are interconnected, aquifers of high porosity also tend to have high permeability.

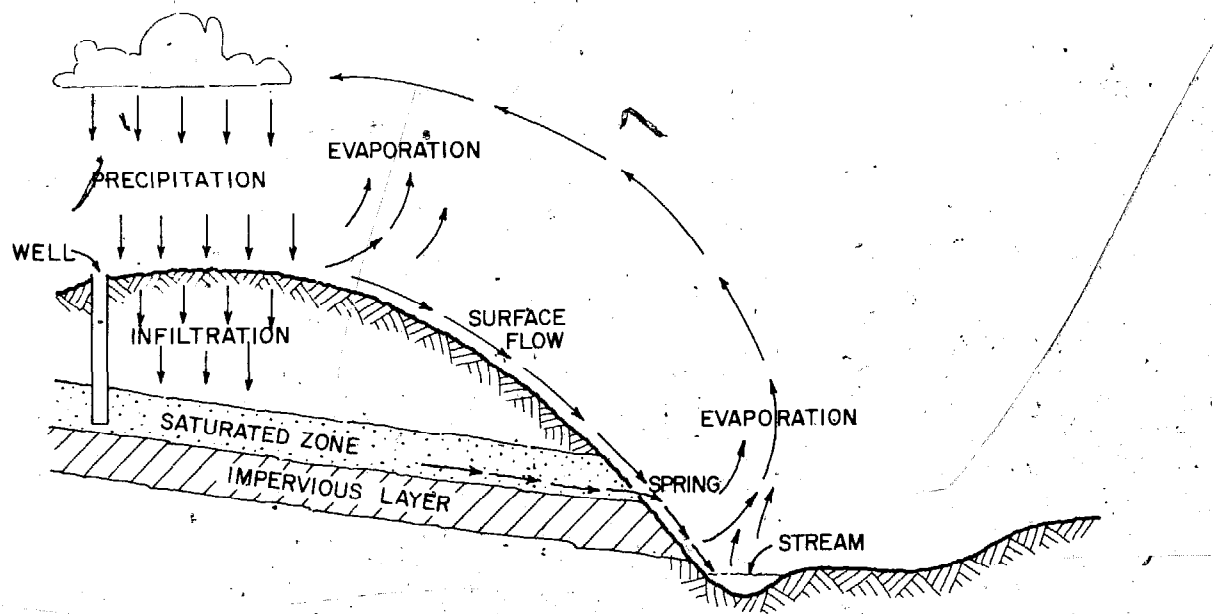

Fig. 1,

Hydrologic cycle

Sometimes groundwater is trapped under an impervious layer. An aquifer thus located is called a confined aquifer. If the inflow area to a confined aquifer is higher than the confining layer where a well penetrates it, the water will be under pressure and will rise in the well to some level above the confining layer. Such a well is referred to as artesian. If the water rises to the top of the well a "flowing well" results.

Obviously some locations offer better chances for successful wells than others. Clues which can be helpful in selecting well locations are (i) locations and depth to water of existing wells; (ii) existence of springs and/or streams; (iii) relative locations of infiltration areas and rock outcroppings which might constitute an impervious layer; and (iv) existence of known phreatophytes (plants requiring abundant water, whose roots frequently extend to the water table). In some areas of uniform geology, such as certain alluvial deposits in valleys, wells can be constructed anywhere with equal success.

In the absence of any clues or data, a test boring can be carried out by one of the methods described under small diameter wells. Such a boring can be carried out relatively quickly and cheaply and can save considerable time, money and frustration in the long run.

When a well is pumped, the water in it drops to some level below the static level (Figure 2). The water surface in the aquifer then forms a "cone of depression" as it slopes from the static level at some fairly large radius, R, to the well whose radius is r. If the well completely penetrates the aquifer with the static height of water being H and the height of water during pumping, h, then theoretical considerations give:

$$Q = \frac{\pi K(H^2 - h^2)}{\log_e (R/r)} = \frac{\pi K(H+h)(H-h)}{\log_e (R/r)}$$

where: Q = yield or rate of pumping (e.g. m³/hr, litres/sec, etc.)
K = permeability of the aquifer

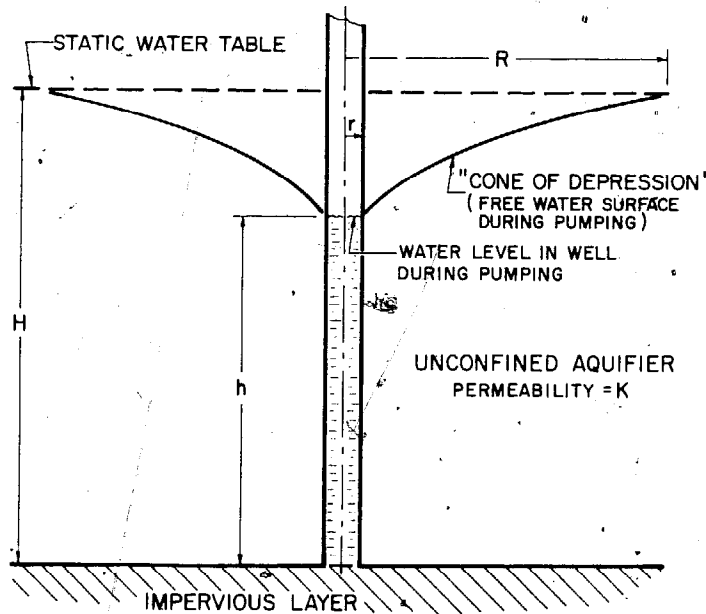

Fig. 2

Flow into a well

(H - h) is known as the "drawdown" of the well. If the drawdown is small compared to H, then the term (H + h) is approximately equal to 2H and the yield, Q, is approximately proportional to the product of H times the drawdown. This shows the importance of penetrating the aquifer to an adequate depth. By contrast, the yield, Q, is much less responsive to changes in well diameter, since it is inversely proportional to the natural log of the ratio, (R/r).

3. COMPARISON OF LARGE AND SMALL DIAMETER WELLS

Using the expression given above, the yield of a hypothetical 15 cm diameter well might be compared with that of a 150 cm diameter well, assuming that the cone of depression extends 25 m beyond the periphery of each well and that the depths of penetration are the same. Under these conditions the large diameter well will yield approximately 1.6 times as much water as the small diameter well. However, the volume of material excavated in making the larger well would be 100 times that of the small well. By contrast, increasing H from 2 m to 3 m while holding the drawdown constant at 0.5 m would make the yield 2.3 times greater for a well of a given diameter. These examples, while oversimplified, help to point out that increasing depth is frequently a more efficient way of increasing the yield of a well than is increasing the diameter.

In this paper a large diameter well is defined as one which is large enough for workers to enter for construction or maintenance. A small diameter well, on the other hand, is one which is too small to enter and is constructed from the ground surface using special tools. Table 1 lists some advantages and disadvantages of the two types of wells.

Table 2 compares various methods for drilling small diameter wells. Summing these different drilling techniques with the various methods and materials available for large diameter well construction gives a large total of options for self-help well projects. These options are compounded by the possibility of combining various techniques and/or materials in a single well.

The final choice will depend on many factors including:

- the geology of the location
- materials available and their cost
- skills available and their cost
- end use of the well.

In some cases, the most desirable type of well or construction technique may be determined only after some trial and error.

In considering whether to have a large or small diameter well, it is important to consider also whether water storage is needed, particularly in the poorly permeable rocks where wells cannot obtain large flows even in the best conditions. If storage is needed then cost of a surface reservoir or tank should be included in the small well option to compare fairly with the cost of large wells.

Table 1. RELATIVE ADVANTAGES AND DISADVANTAGES OF SMALL AND LARGE DIAMETER WELLS

	SMALL	LARGE
Equipment Required:		
(1) For Construction	(1) Specialized equipment such as augers and bailing buckets required.	(1) Little specialized equipment is absolutely necessary.
(2) For Raising Water	(2) Specialized equipment such as pumps or small diameter well buckets are necessary.	(2) Ropes and buckets are frequently used.
Cost of Construction	Lower, because relatively little material is required.	Higher, because much more material is required.
Sanitation	Potentially good, especially when a hand pump is used.	Poor, since top of well is open. Buckets and ropes which may be dirty are used in the well.
Safety	Danger during construction and use negligible.	Construction: Danger of cave-in may be eliminated by proper construction. Danger of something dropping on worker in well always possible. Use: Proper construction of top of well can minimize danger of people falling in.
Maximum Number of People Able to Use the Well Concurrently	One	Three or Four
Rate of Discharge Possible	Potentially better since well can be made almost any depth below static water level. Good possibility of putting perforated part of casing in material of high permeability.	Depth to which well may be excavated below static water level is limited by equipment. Therefore, rate of discharge is limited
Skill Required:		
(1) Well Construction	(1) Somewhat more, since tools are special and work can't be seen.	(1) Somewhat less.
(2) Water Raising Equipment	(2) More, must be able to maintain and repair pump and/or small dia. well buckets.	(2) Little required
Reliability:		
(1) Well	(1) Excellent	(1) Good only if certain precautions are taken in constructing the bottom of the well.
(2) Water Raising	(2) Frequently a problem under village use (requires trained maintenance personnel).	(2) Good.
Ability to Store Water For Hours of Peak Demand (Of Possible Importance When the Permeability of the Aquifer is Very Low).	Negligible.	May be increased by increasing the diameter and depth of well.
Limitations on When Well May Be Constructed.	None	Should be done at the time of year when the water level is at its lowest.

TABLE 2. A SUMMARY OF METHODS FOR DRILLING SMALL DIAMETER WELLS

METHOD	HOW PENETRATION IS ACCOMPLISHED	MINIMUM EQUIPMENT REQUIRED	REMOVAL OF MATERIAL FROM HOLE	ADVANTAGES/DISADVANTAGES, LIMITATIONS
AUGERED OR BORED	CUTTING LIPS OF A ROTATING AUGER SHAVE OR CUT MATERIAL LOOSE FROM THE BOTTOM OF THE HOLE.	AUGER, DETACHABLE TUBULAR EXTENSIONS, AND A HANDLE FOR ROTATING.	AUGER MUST BE REMOVED FROM THE HOLE WHENEVER IT IS FULL OF CUTTINGS. THIS NECESSITATES UNCOUPLING EXTENSIONS.	EQUIPMENT IS SIMPLE AND CAN USUALLY BE FABRICATED OR ADAPTED LOCALLY. CANNOT PENETRATE HARD FORMATIONS. UNCOUPLING EXTENSIONS SLOWS WORK AT GREATER DEPTHS. USUALLY CANNOT BE USED BELOW THE WATER TABLE.
DRIVEN	A POINT ON THE LOWER END OF A STRING OF PIPE ALLOWS THE PIPE TO PENETRATE AS IT IS DRIVEN ON THE UPPER END.	DRIVE POINT WHICH USUALLY ALSO INCLUDES A WELL SCREEN ABOVE IT, SPECIAL DRIVE PIPE WITH COUPLINGS, DRIVE CAP, AND DRIVER.	MATERIAL IS NOT REMOVED FROM THE HOLE, BUT IS FORCED OUT Laterally AS THE DRIVE POINT IS FORCED THROUGH IT.	FAST AND SIMPLE. SPECIAL WELL POINTS AND HEAVY DRIVE PIPE MAY NOT BE AVAILABLE LOCALLY. HARD FORMATIONS CANNOT BE PENETRATED. LIMITED TO SMALL DIAMETERS, BUT MULTIPLE WELL POINTS MAY BE CONNECTED TO A COMMON PUMP.
JETTED	A HIGH VELOCITY STREAM OF WATER COMING OUT OF THE BOTTOM OF A VERTICAL PIPE WASHES AWAY MATERIAL AHEAD OF IT AS IT IS LOWERED.	PIPE EQUIPPED WITH JETTING ORIFICE(S) AT LOWER END, COUPLINGS, SUITABLE PUMP (HAND OR MOTOR POWERED), FLEXIBLE CONNECTION BETWEEN PUMP AND PIPE, AND SUPPLY OF WATER.	THE WATER USED FOR DRILLING RETURNS TO THE GROUND SURFACE BY WAY OF THE ANNULAR SPACE AROUND THE JETTING PIPE CARRYING THE MATERIAL REMOVED WITH IT.	FAST. CANNOT PENETRATE HARD FORMATIONS. DIFFICULTY IN BRINGING LARGE GRAVEL OR STONE TO THE SURFACE. DRILLING EQUIPMENT CAN BE FABRICATED LOCALLY, BUT A PUMP AND A SOURCE OF WATER ARE REQUIRED.
HYDRAULIC PERCUSSION	THE HOLE IS KEPT FULL OF WATER. THE ALTERNATE RAISING AND DROPPING OF A STRING OF PIPE EQUIPPED WITH A CUTTING BIT AT THE BOTTOM ALLOWS PENETRATION BY A COMBINATION OF MECHANICAL AND HYDRAULIC ACTION.	HOLLOW DRILL BIT WITH WATER INLETS AND A CHECK VALVE, STRING OF PIPE, DEVICES TO AID RAISING AND DROPPING. A MAN'S HAND OVER THE TOP OF THE DRILL PIPE MAY BE SUBSTITUTED FOR THE CHECK VALVE.	THE RAISING AND DROPPING ACTION IN CONJUNCTION WITH THE CHECK VALVE CAUSES WATER TO BE PUMPED UP THE INSIDE OF THE DRILL PIPE CARRYING THE CUTTINGS WITH IT.	EQUIPMENT CAN BE FABRICATED LOCALLY OR PURCHASED. WATER REQUIRED. TRADITIONALLY USED IN SOME AREAS, THUS UNDERSTOOD BY LOCAL WELL DRILLERS. HARD FORMATIONS CANNOT BE PENETRATED. DIFFICULTY IN BRINGING LARGE GRAVEL OR STONES TO THE SURFACE.
CABLE TOOL PERCUSSION	A HEAVY CYLINDRICAL WEIGHT EQUIPPED WITH A CUTTING EDGE AT THE BOTTOM AND WITH A ROPE OR CABLE ATTACHED TO THE UPPER END IS ALTERNATELY RAISED AND DROPPED. IMPACT PULVERIZED MATERIAL AT THE BOTTOM OF THE HOLE.	HEAVY DRILL BIT, ROPE OR CABLE, DEVICES TO AID RAISING AND DROPPING.	THE PULVERIZED CUTTINGS ARE MIXED INTO A SLURRY WITH WATER DURING DRILLING. THESE ARE REMOVED USING A BAILER.	ALL FORMATIONS CAN BE PENETRATED AT VARYING RATES. SOME WATER REQUIRED. COMMERCIALY BUILT RIG IS EXPENSIVE AND REQUIRES CONSIDERABLE SKILL TO OPERATE, BUT A SIMPLE SET OF TOOLS CAN BE FABRICATED LOCALLY AND ADAPTED TO MAN OR MOTOR POWER.
BAIL DOWN	A LONG, CYLINDRICAL BUCKET WITH A CHECK VALVE AT THE BOTTOM AND A ROPE OR CABLE ATTACHED TO THE TOP IS ALTERNATELY RAISED AND DROPPED IN A HOLE PARTIALLY FILLED WITH WATER. PENETRATION IS ACCOMPLISHED BY A COMBINATION OF HYDRAULIC AND MECHANICAL ACTION.	BAILER, ROPE, DEVICES TO AID RAISING AND DROPPING.	SLURRY OF CUTTINGS AND WATER ENTER THE BAILER AS IT IS REPEATEDLY DROPPED. THESE ARE PREVENTED FROM LEAVING THE BUCKET BY THE CHECK VALVE. THE BUCKET IS RAISED TO THE SURFACE FOR EMPTYING.	EQUIPMENT CAN BE FABRICATED LOCALLY. FREQUENTLY USED IN CONJUNCTION WITH OTHER METHODS, SUCH AS PERCUSSION. HARD FORMATIONS CANNOT BE PENETRATED BY THE BAILER ALONE.
HYDRAULIC ROTARY	A HOLLOW DRILL BIT WITH EITHER A FIXED CUTTING EDGE OR TOOTHED ROLLERS IS ROTATED AT THE BOTTOM END OF A STRING OF PIPE. MATERIAL IS SCRAPED, ABRADED OR CHIPPED AWAY BY MECHANICAL ACTION.	DRILL BIT, DRILL PIPE, CIRCULATING PUMP, DEVICE FOR ROTATING DRILL PIPE.	WATER OR "MUD" IS PUMPED DOWN THE HOLLOW DRILL STEM TO LUBRICATE THE BIT AND TO CARRY THE CUTTINGS UP TO THE SURFACE THROUGH THE ANNULAR SPACE AROUND THE DRILL PIPE. CIRCULATION MAY ALSO BE IN THE REVERSE DIRECTION.	COMMERCIALY BUILT RIG IS EXPENSIVE AND REQUIRES CONSIDERABLE SKILL TO OPERATE. HOWEVER, SMALL ADAPTATIONS USING EITHER MAN POWER OR SMALL ENGINES HAVE BEEN DEvised. A WATER SUPPLY IS NECESSARY. IT IS DIFFICULT TO DRILL IN LOOSE FORMATIONS.

4. SMALL DIAMETER WELLS

4.1 BORED OR AUGERED WELLS

This method of excavation consists of shaving or cutting material from the bottom of the hole by the rotation of a cylindrical tool with one or more cutting lips. The process is quite analagous to boring a hole in wood or metal with an auger or drill. The excavated earth normally feeds upward and is contained in the body of the auger where it remains until the auger is emptied. The auger is both rotated and raised and lowered by means of a vertical shaft which extends upward from the auger to a convenient point above ground level from which it can be rotated. Rotation is frequently accomplished by human power applied to a handle attached to the vertical shaft. However, the auger may be driven by other power sources such as animal or engine power. In this case, the power source drives a horizontal ring gear. Two projections extending upward from the ring gear drive a bar known as a "kelly" which lies across a diameter of the ring. A square section of the auger shaft fits through a square hole at the centre of the kelly bar which causes the auger shaft to rotate with the kelly bar while allowing it vertical freedom.

Each time the auger is filled with excavated material, it must be brought out of the hole for emptying. In order to accomplish this, the auger shaft must be divided into sections which can be uncoupled and set aside.

Several types of earth augers have been used successfully for boring wells (Figure 3). The cylindrical bucket auger is a sheet metal cylinder with an attachment for the auger shaft at the top. The bottom has a helical form with a single cutting lip. It may be hinged and latched, so that it can be opened for emptying. The two-bladed auger consists of two cylindrical blades attached to the auger shaft. The blades are cut and bent at the bottom to form cutting lips. This type of auger is frequently used for boring post holes.

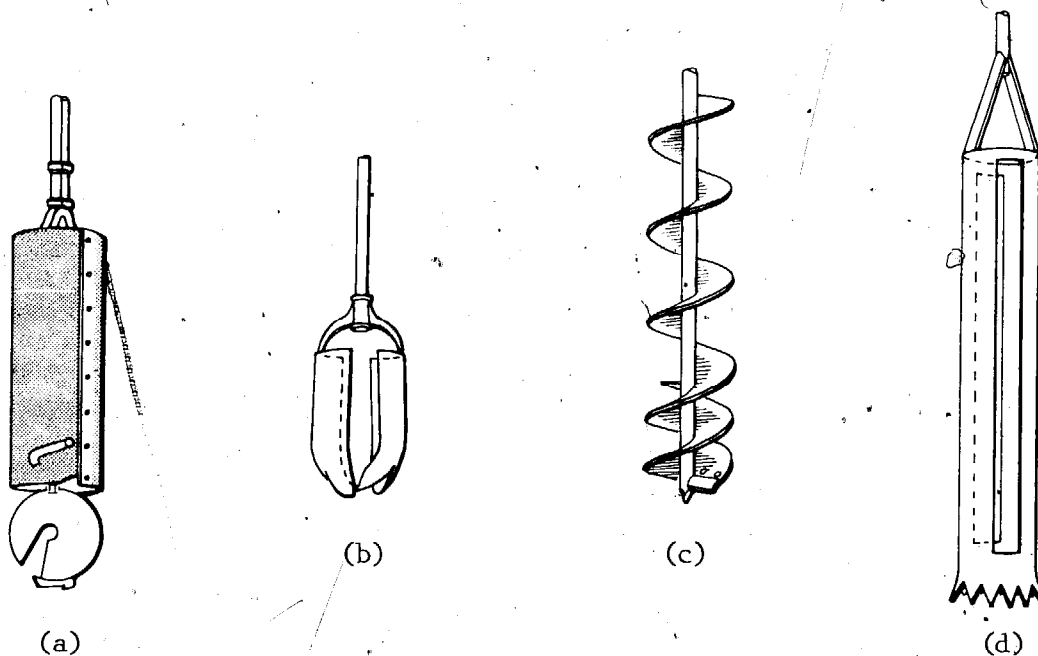

Fig. 3. Earth augers. (a) cylindrical bucket auger; (b) two-bladed auger; (c) helical auger; (d) tubular auger

A third type of earth auger (Figure 4) has a spiral of helical form. This type of auger normally has two cutting lips, one of which is mounted on the leading edge of the helix. It is sold commercially for power boring of holes or for planting trees.

A fourth type of "auger" device (Figures 5 and 6) has been used by the author in sticky or heavy clay soils where conventional augers with cutting lips did not function well. This consists of a slotted piece of tubing or pipe with the lower end cut into a tooth and flared configuration. The upper end was attached to a conventional auger shaft. This auger is alternately rammed downward and then rotated. The downward motion causes soil to be forced up inside the auger where it adheres and the rotation breaks this soil free from the bottom of the hole. A small quantity of water may be maintained at the bottom of the hole for lubrication.

Most types of augers work well on a wide variety of soils. The type used may depend largely on what can be obtained or built locally. When selecting or building an auger, several principles should be observed:

- the cutting lips or edge should cut a diameter slightly larger than the body of the auger above them, so that the auger will not drag on the sides of the hole
- the cutting lips should be angled in such a way that only the cutting edge and not the surface behind it comes into contact with the surface to be penetrated; this improves penetration and reduces drag



Fig. 4 Locally fabricated helical auger attached to pipe extension

Fig. 5 Locally fabricated cylindrical "auger" used in sticky soils

Drilling is accomplished by ramming downwards and then twisting. Auger teeth should be flared outwards to give clearance between auger and hole. Smaller tool is for cleaning compacted soil from the auger.



Fig. 6 Cylindrical auger with pipe extension and handle attached.

Tripod is used to support auger during drilling.

- as the height to diameter ratio of an auger increases, the straightness of the hole tends to increase (i.e. a tall, small diameter auger tends to bore a straighter hole than a short, large diameter auger)
- the body of the auger must be capable of holding the excavated material until the auger can be removed from the hole for emptying. Finely divided material has a tendency to flow out of the auger if openings are too large. When the water table is reached, augers cannot normally retain the cuttings and deepening of the well must be carried out by one of the other methods described.

Augers cannot normally penetrate stone. However, thin layers or small pieces of stone can sometimes be pulverized or dislodged and removed by means of a percussion bit or a spiral auger ("ram horn") made of steel rod in a form similar to a corkscrew. If the stone can be penetrated or removed, boring can be continued. If not, a different process or new location must be tried.

The necessity of emptying the auger each time it is filled places some practical limits on the depth of augered holes. Since the sections of the auger shaft must be uncoupled each time the auger is emptied, the time required for emptying increases with the depth of the hole. To minimize the number of couplings, the lengths of auger shaft or "extensions" should be made as long as practical. Frequently, auger shafts are made from lengths of water pipe which range in length from 6.1 to 6.4 metres (20-21 ft). Extensions (Figures 7 and 8) may be coupled by means of a socket attached to the top of each one. The bottom of the next extension is inserted into this coupling and held there by a pin through the socket. Normal threaded pipe couplings do not make satisfactory attachments, since they wear under prolonged use. An overhead structure of some type is needed to steady the long extensions and to ensure that they are maintained vertical during the drilling operation. It is also convenient to lean the extensions against this structure when they are uncoupled. The overhead structure for steadying and guiding the extensions might consist of a tripod with a crosspiece between two legs (Figures 9 and 10) or of two vertical posts set in the ground with a crosspiece between them. The handle or other device

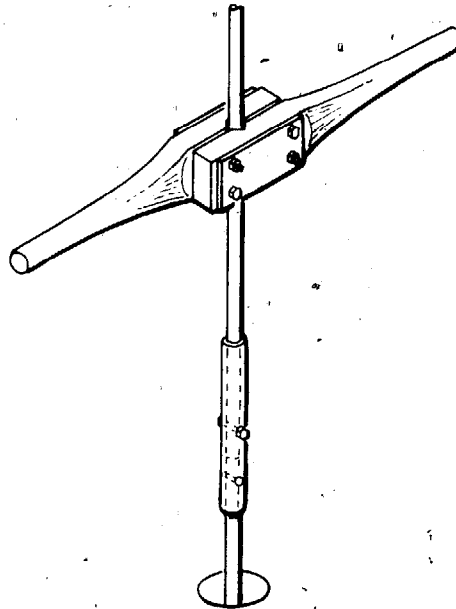

Fig. 7

Auger extension and handle

Fig. 8 Coupling for auger extensions made from larger pipe and welded to the top of an extension.

The succeeding extension is pinned in place by a 10 mm bolt. During coupling or uncoupling the bottom of the coupling is supported by the notched board. The short length of rod is inserted to prevent the extension from being accidentally dropped down the hole.

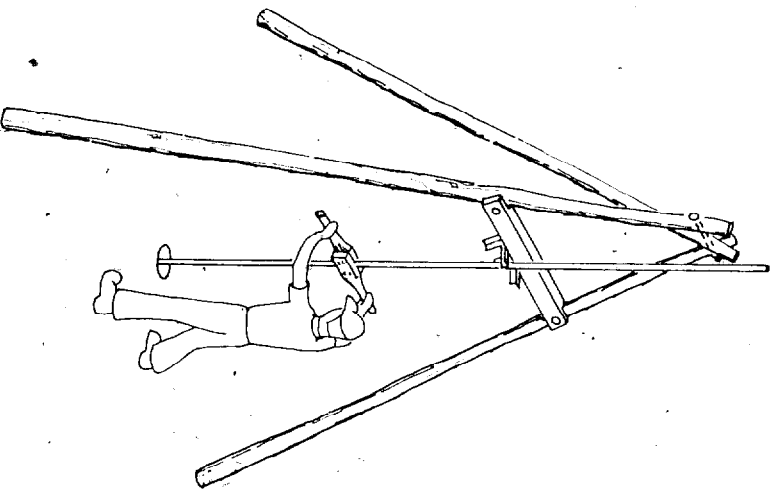

Fig. 9

Tripod used to support long auger extensions during drilling

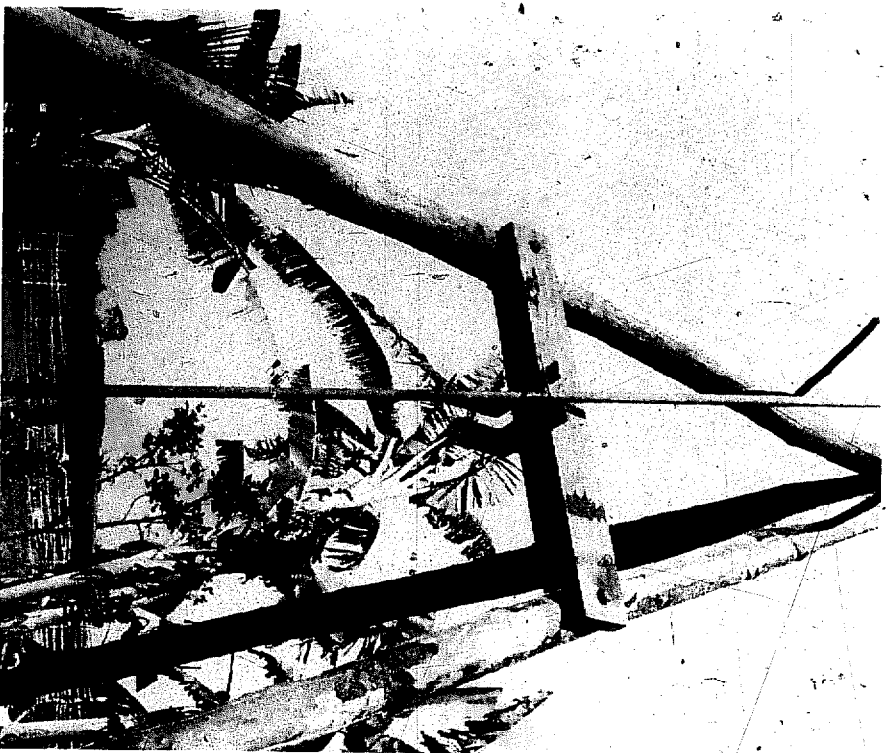

Fig. 10



Fig. 11 Drilling with a helical auger

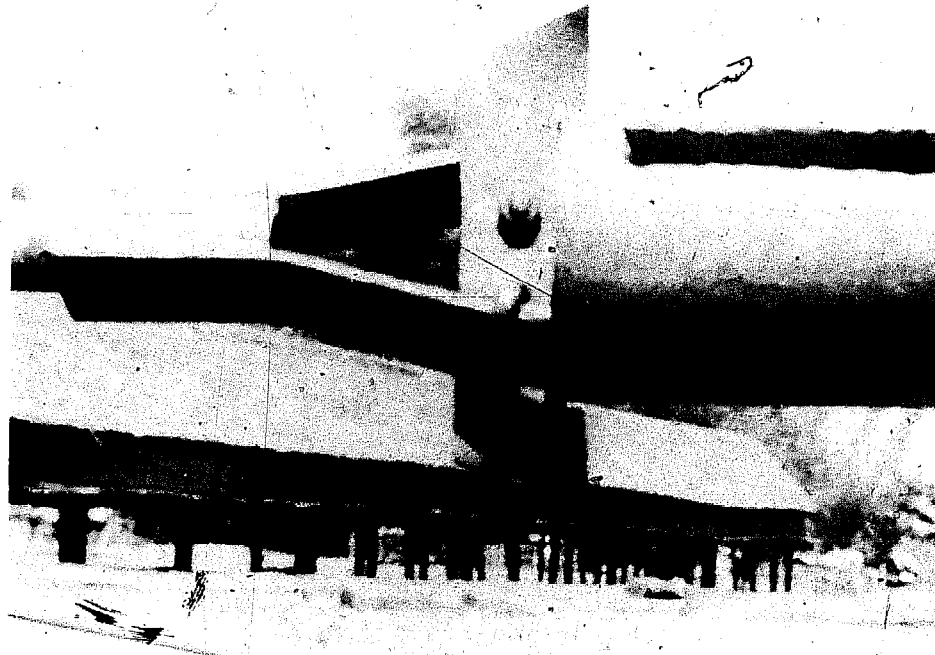

Fig. 12 Reaming blade for enlarging hole attached to top of auger

for rotating the auger shaft should be designed to mount at any point along the extensions, so that it can be maintained at a suitable working height (Figure 11).

After the approximate well location has been selected, the overhead support can be set up, and the exact location determined by hanging a plumb line from the overhead auger guide. A small starting hole for the auger can then be dug. It is important to get the auger starter as close to vertical as possible.

The deepest hand augered well known to the author is approximately 38 metres (125 feet). This well was bored by a crew of workers who were paid by the metre and was bored at a very reasonable cost. However, under other economic conditions the practical limit for hand boring may be less. When augering becomes too slow, it may be more practical to continue with a different method.

Some earth augers may be equipped with a blade for reaming to the desired well diameter (Figure 12). Boring an exploratory hole prior to digging a large diameter well may also be a good investment where conditions are uncertain.

4.2 DRIVEN WELLS

The driven well consists of a pointed perforated pipe or a pipe with a pointed well screen attached which has been driven into an aquifer. The pipe with pointed well screen is driven into place in much the same way a nail is driven into wood. Normally special pipe with thick walls and specially designed couplings are used to resist the driving forces. Under suitable conditions this method can yield a finished well in a very short time. While the well diameter is normally small and the yield relatively low, a number of driven wells may be coupled together and pumped with a single pump. Because driven wells are quick to construct, they may be used as a temporary source of water and then be pulled up when no longer needed. Driven well points may be installed and used for dewatering an excavation during construction. Unlike other well construction methods, material is merely forced aside and not excavated by the driving process. This means that little is learned about the material through which the well pipe passes. This kind of well can, however, be used for exploratory purposes to determine static water level and rate of inflow versus drawdown. Hard formations cannot be penetrated by this process. Barring impermeable strata the depth to which such a well can be driven depends on the build-up of friction between the well pipe and the material penetrated and the transmission of the force of the driver down the length of pipe. Twenty-five to thirty metres (80-100 feet) would probably be a maximum. A driven well point might be employed to finish a hole which had been excavated down to the water table by some other method such as an auger.

Driving is normally accomplished by alternately raising and dropping a weight used as a driver (Figure 13). The driver is guided on either the inside or the outside of the pipe causing it to strike squarely and accurately. If the driver is designed to strike the upper end of the pipe a driving cap is screwed onto the threads to protect them. Alternatively the driver may be designed to strike a clamp made for that purpose around the outside of the pipe. A long, thin driver which fits inside the pipe and which strikes a flat surface on the inside of the well screen point may also be used. This latter technique eliminates compressive loading on the pipe normally caused by driving and makes heavy drive pipe unnecessary.

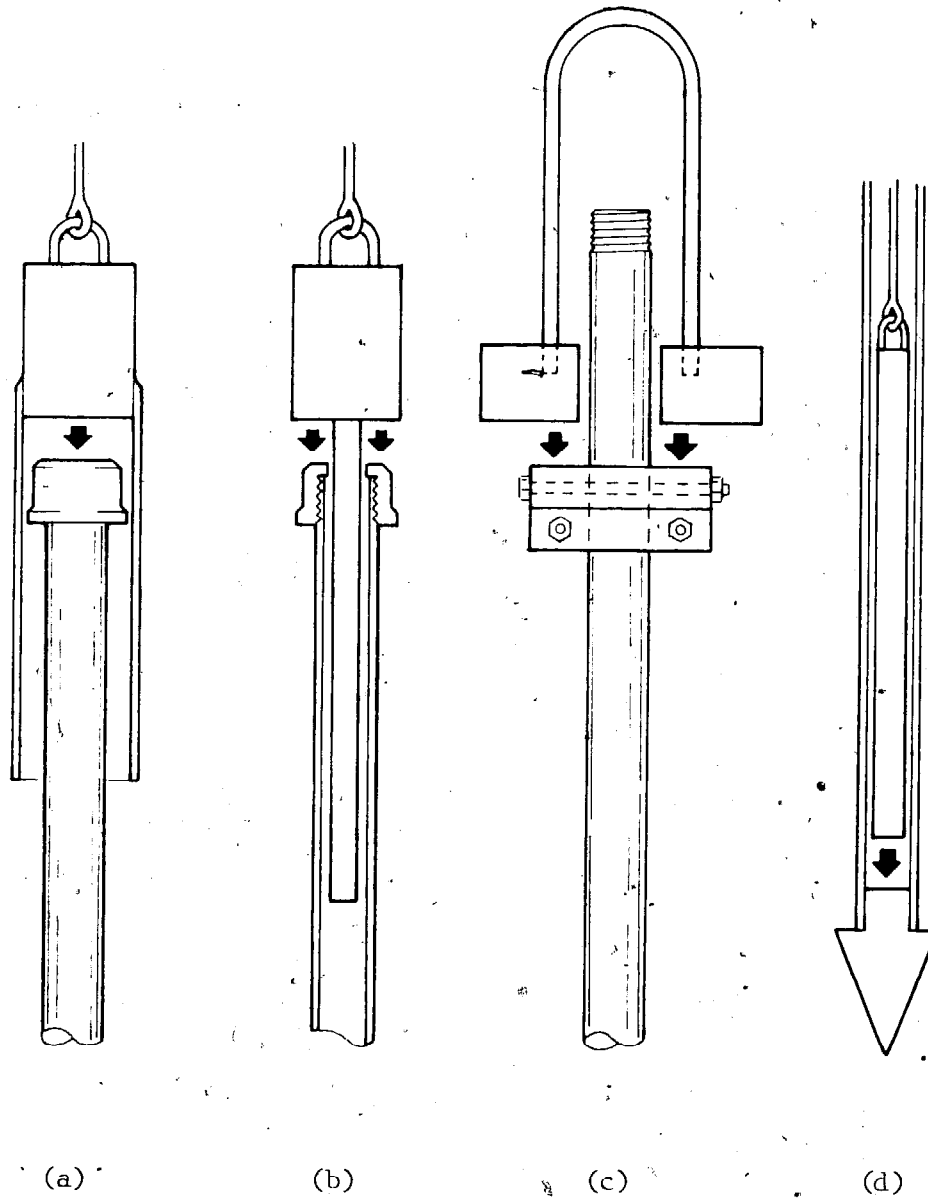

Fig. 13 Devices for well driving. (a) guided on outside of pipe; (b) guided on inside of pipe; (c) driving on clamp; (d) driving on inside of point

Well screens for driving must have sufficient strength to withstand the forces caused by the driver and the abrasion of the material through which they pass. One common type (Figure 14a) consists of a perforated drive pipe fitted with a point. The perforated section of the pipe is wrapped with a layer of brass screen of the desired fineness and the screen is protected from damage by wrapping it with a layer of perforated brass sheet. Both layers are soldered to the pipe. Another type of well screen (Figure 14b) is manufactured by wrapping trapezoidal rod in a spiral around a set of round longitudinal rods placed in a circular pattern with all intersections welded. This type of screen has the advantage of having a high percentage of open area and a slot shape which cannot become wedged full of fine sand particles.

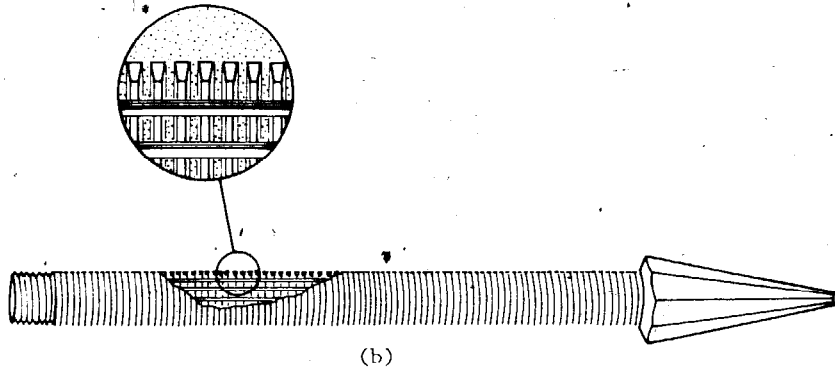
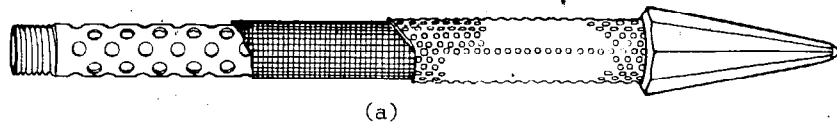
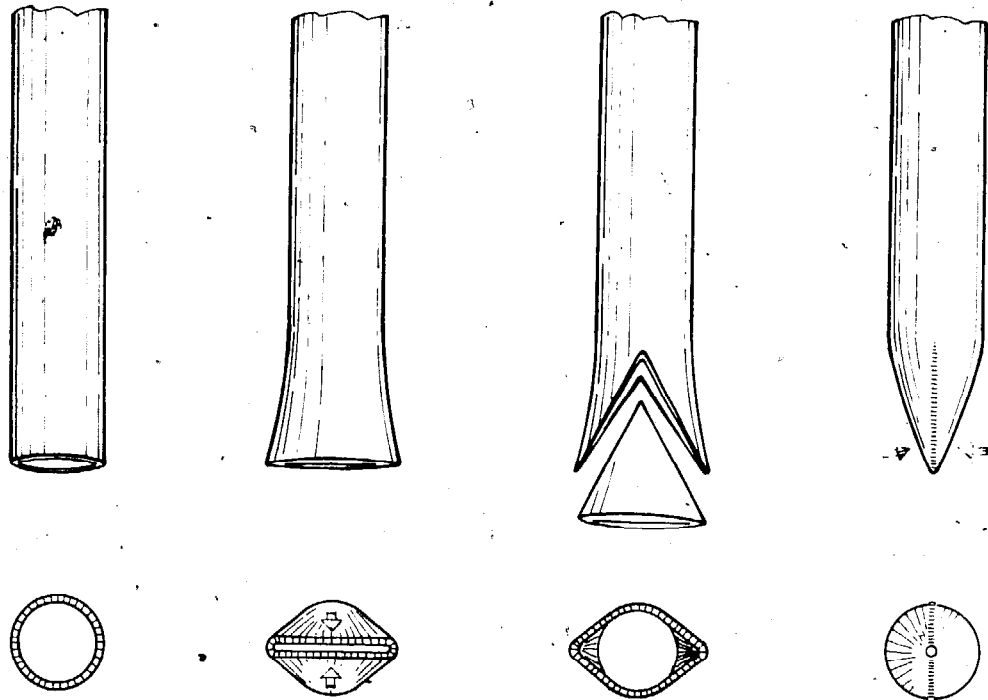
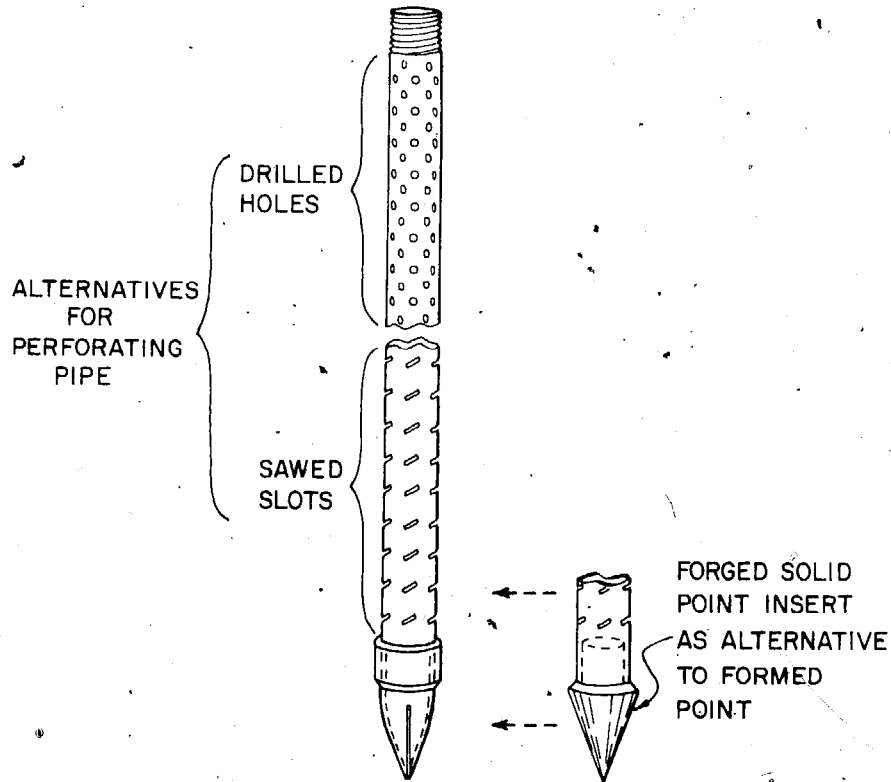

Fig. 14 Drive points and screens. (a) perforated pipe with screen; (b) spiral trapezoidal wire

A drive point can be fabricated locally from pipe (Figure 15). The point is made by: (i) flattening the end of the pipe to a gradual taper similar to the working end of a screwdriver or cold chisel; (ii) cutting out a 'V' notch from the corners of the flattened end to a point at the middle of the pipe near where the taper starts; (iii) bringing the two resulting points together to a single point; (iv) welding the two sides of the point together; and (v) filing or grinding away any irregularities to yield a smooth point. If welding equipment is not available the point can be forge-brazed or welded. A collar should be welded or riveted above the point to increase the size of the hole to a diameter slightly greater than that of the pipe couplings used. Alternatively, a point may be forged from solid steel and welded or riveted to the end of pipe. In this case care should be taken to make a shoulder on the back of the point which butts against the end of the pipe quite accurately and make the largest diameter of the point greater than that of the pipe couplings to provide clearance.



(a)



(b)

Fig. 15 Drive point fabricated from pipe. (a) forming point on end of pipe; (b) alternative perforations and points

Perforations may be made by drilling holes of the desired screen size or by making a series of short diagonal hacksaw cuts (Figure 15b). In either case enough strength must be retained in the pipe to permit driving. This can best be assured, in the case of the saw cuts, by leaving several longitudinal strips unperforated. If larger perforations are made and covered with screening of the desired mesh soldered around the pipe, the screening should be protected from being slit or stripped back by: (i) wrapping and soldering sheet metal with coarse perforations around it and (ii) having an outside diameter greater than the outside diameter of the screening either on the point or on a collar attached to the pipe below the screen.

If driving is attempted using ordinary pipe and couplings, shearing or stripping of the pipe threads or breaking of the pipe at the threads will probably occur. It should be noted that the threads on standard weight pipe cut through more than half of the wall thickness, thus greatly reducing the strength of the pipe where it is threaded. Drive pipe and couplings, in addition to being heavier than standard pipe, are designed so that the pipe ends butt together inside the coupling. This results in most of the driving force being transmitted by the ends of the pipe rather than by the threads. In addition, the couplings are frequently longer than normal couplings with a bore on each end which extends back over the non-threaded portions of the pipe to give lateral reinforcement to the weaker threaded ends.

If drive pipe and couplings are not available several techniques may be used to improve the strength of ordinary pipe. These may allow ordinary pipe to be used for driven wells if care is exercised:

- i. If a suitable well point is available, driving may be done on the inside of the well point rather than at the top of the pipe.
- ii. If driving must be done near the top of the pipe, it should be done on a clamp around the outside of the pipe rather than on the end of the pipe itself.
- iii. Stress on the threads can be decreased by one of the following:
 - running a threading die further along the pipes, so that the pipe ends may be butted together at the centre of the coupling;
 - placing a short collar inside the coupling for both pipe ends to butt against;
 - welding collars to the outside of the pipe which butt against the ends of the coupling.

4.3 JETTED WELLS

This method makes use of a high velocity stream of water to excavate the hole and to carry the excavated material out of the hole. It therefore requires some type of pump, either motor or hand-powered, of reasonable capacity, as well as a supply of water. It is possible to separate the water and the excavated material in a settling pool or tank and to reuse the water, thus minimizing the quantity required. Since this method depends on the erosive action of water, it is obvious that extremely hard materials cannot be penetrated. However, semi-hard materials may be penetrated by a combination of hydraulic and percussion effects. This is accomplished by raising and dropping a chisel-edged jetting bit. Coarse materials such as gravel require a greater water velocity to move them vertically out of the hole than do finer materials. However, very fine, hard packed materials such as clays require a high water velocity to dislodge them. Water pressure of 3 kg/cm² (40 psi) for sand and 7-11 kg/cm² (11-150 psi) for clay or gravel have been recommended. Under good conditions, drilling progress is very fast.

Two basic schemes are used:

- (1) Water is pumped down a jetting tube or pipe which is used inside a temporary or permanent casing (Figure 16a). The excavation of material by the stream of water allows the casing to descend and the excavated material is carried upward out of the well via the annular space between the jetting tube and the casing. Rotating the casing and cutting teeth on its bottom edge increases the rate of descent. If the casing sunk during the jetting operation is temporary, the final casing with screen attached is lowered inside the temporary casing, which is then jacked out of the hole. Alternatively, the permanent casing may be sunk during the jetting operation. In this case, the well screen is lowered inside the casing and the casing is then jacked up far enough to expose the well screen to the aquifer.
- (2) Jetting may be done by pumping the water down through the casing itself with the excavated material being carried up through an annular space around the outside of the casing (Figure 16b). If jetting is interrupted before the casing is sunk to the full desired depth, so that the suspended material settles around it, difficulty may be experienced in re-starting the jetting process. When an open-ended casing is used, a well screen is subsequently lowered and the casing raised slightly to expose the well screen. Alternatively a string of casing with a special self-jetting point on the end of a well screen may be used. The jetting orifice at the end of the well screen is closed by a check valve which is held against its seat either by buoyancy or by a spring when not held open by the pressure of the jetting water. In some cases a smaller string of pipe passes down through the inside of the casing and screen and is screwed into the top of the jetting point. The pipe is used to transmit the jetting water from the pump to the point, without leakage out through the screen. After the jetting operation, this pipe is unscrewed and removed.

An overhead pulley or hoist facilitates handling casing and jetting pipe. In some cases it may be desirable to drive the casing at intervals as described in other sections.

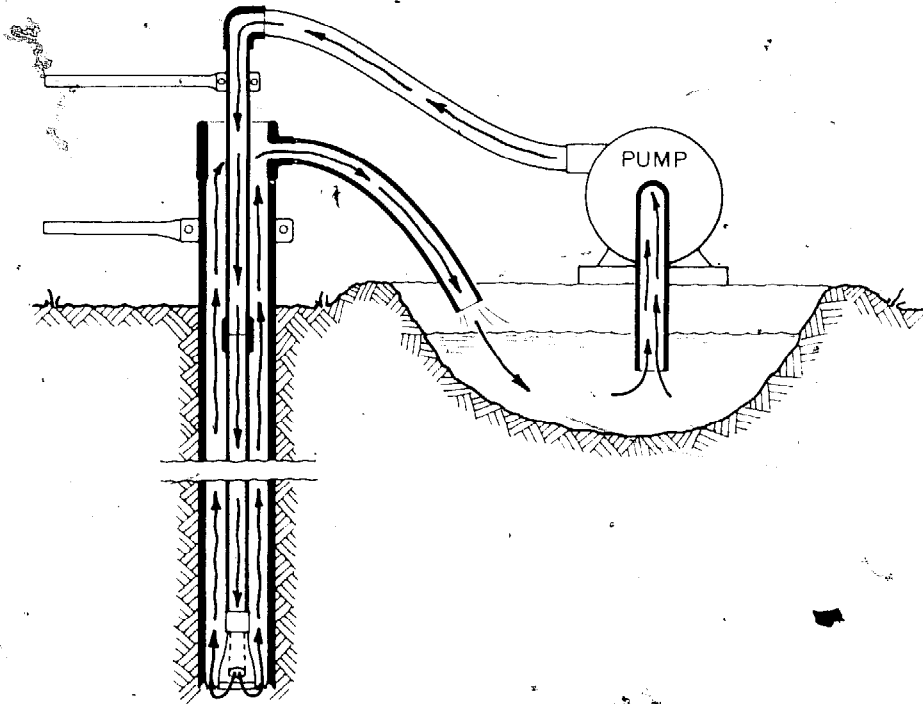

(a)

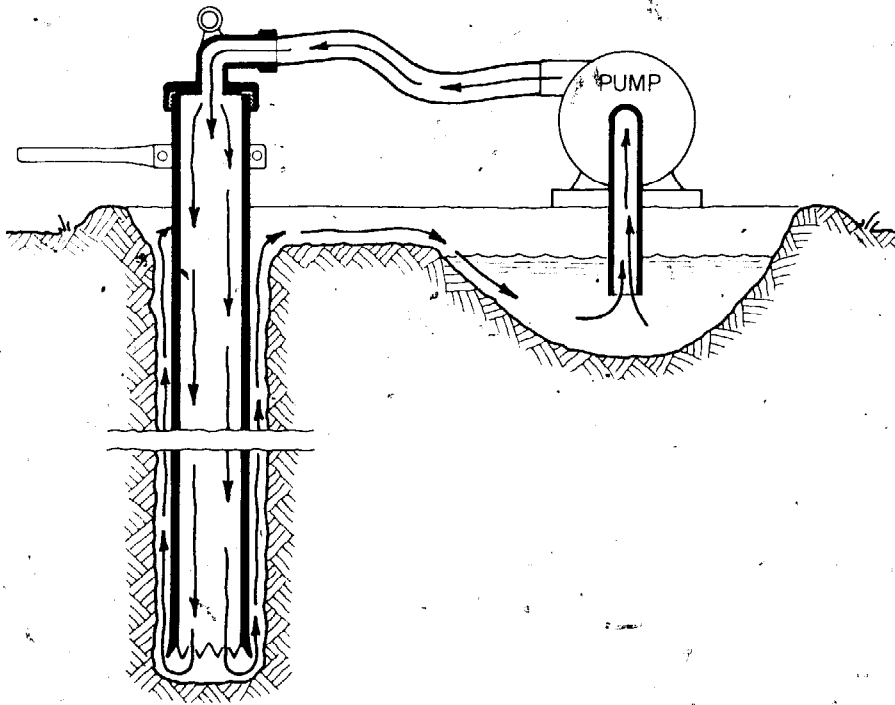

(b)

Fig. 16 Well jetting. (a) using jetting tube; (b) jetting in casing

4.2 HYDRAULIC PERCUSSION (Also Hollow Rod Method)

In this method the hole is kept full of water and a combination of mechanical and hydraulic action do the excavating (Figure 17). A chisel-edged cutting bit is attached to the bottom of a string of drill pipe. The hollow bit has inlet ports a small distance above its cutting edge. During drilling the drill pipe is alternately raised and dropped. Pressure due to the impact of the cutting bit in the bottom of the hole and the inertia of the water cause a mixture of water and cuttings to enter the inlet ports of the cutting bit. This causes the already full drill pipe to overflow. A check valve in the cutting bit prevents the mixture of water and cuttings from flowing out of the ports when the drill stem is raised. The cuttings may be settled out from the water in a pool or barrel after the mixture overflows from the drill pipe and the water can then be recycled. Hydraulic percussion is limited to drilling through relatively fine materials, since coarse materials will not rise to the surface through the drill pipe. This method has been used to depths of more than 900 metres (3 000 feet) in alluvial areas where neither hard formations nor coarse materials were encountered.

A variation of this method has been traditionally used in various parts of Asia. In the traditional method the check valve is replaced by a hand of one of the drillers who seals off the top of the pipe on the up-stroke and removes his hand on the down stroke to allow overflow. In the traditional method the hollow drill stem as well as the casing may be made of bamboo (Figure 18).

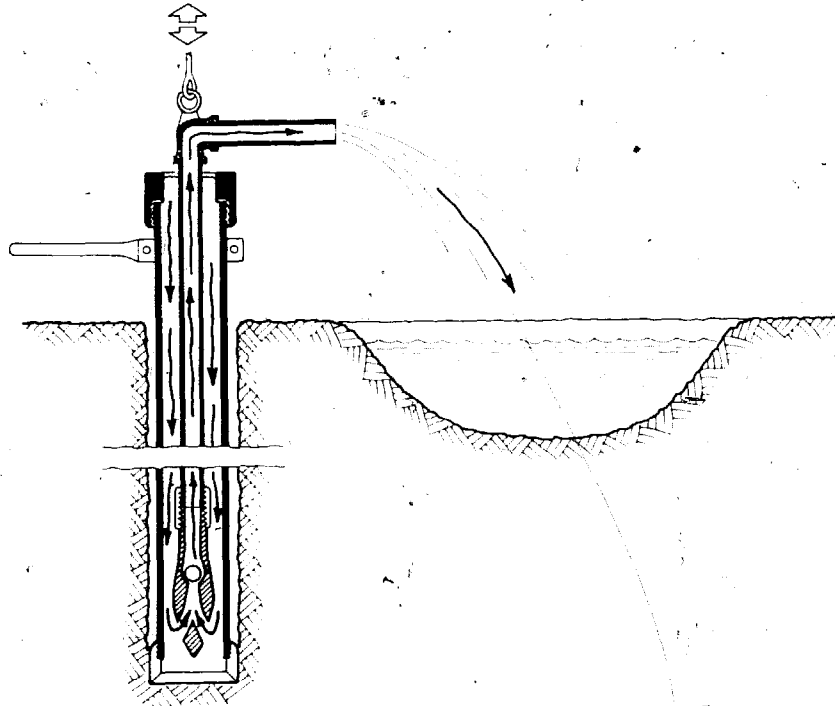

Fig. 17

Hydraulic percussion



Fig. 18 4 inch diameter bamboo screen - bamboo strips wired to metal rings, then wound with coir rope

4.5 PERCUSSION (Also Cable Tool Method)

This method consists of repeatedly raising and dropping a chisel-edged bit to break loose and pulverize material from the bottom of the hole. A small amount of water is kept in the hole, so that the excavated material will be mixed with it to form a slurry. Periodically the percussion bit is removed, and a bailer is lowered to remove the slurry containing the excavated material. The bailer or bailing bucket consists of a tube with a check valve at the bottom and a bail for attaching a cable or rope to the top. When it has been raised and dropped a number of times to fill it with the slurry it is brought to the surface for emptying. Bailing is repeated until the hole has been adequately cleaned, at which time drilling is resumed; drilling and bailing are then alternated. If the hole is unstable, casing is lowered and the driving of casing is alternated with the other two processes. In loose granular material, such as sand, bailing alone may be sufficient to remove the material from the bottom of the hole and allow the casing to be sunk. A heavy bailer with a cutting edge at its lower end, known as a "mud scow" is used for this purpose.

The percussion method is versatile, allowing all types of materials to be penetrated. However, in very hard stone, progress is slow. While this method is frequently associated with large, motorized, truck-mounted equipment, it can be successfully scaled down and used with manpower, or small engines (Figures 19 and 20). It may be used in conjunction with other methods when conditions are encountered such as hard or loose materials which make it more suitable.



Fig. 19 Bailing well with 6 cm diameter bailer



Fig. 20

Bailing well with manpower

Hand winch is being used to raise the full bailer from the bottom of the well.

Fig. 21 Locally forged percussion drill
(weight approximately 80 kg)

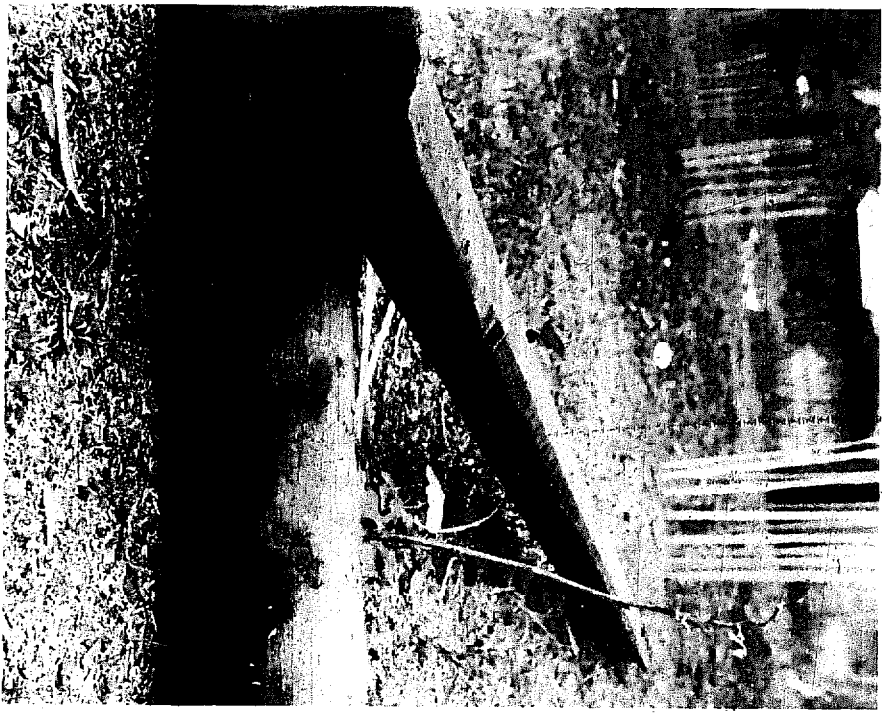
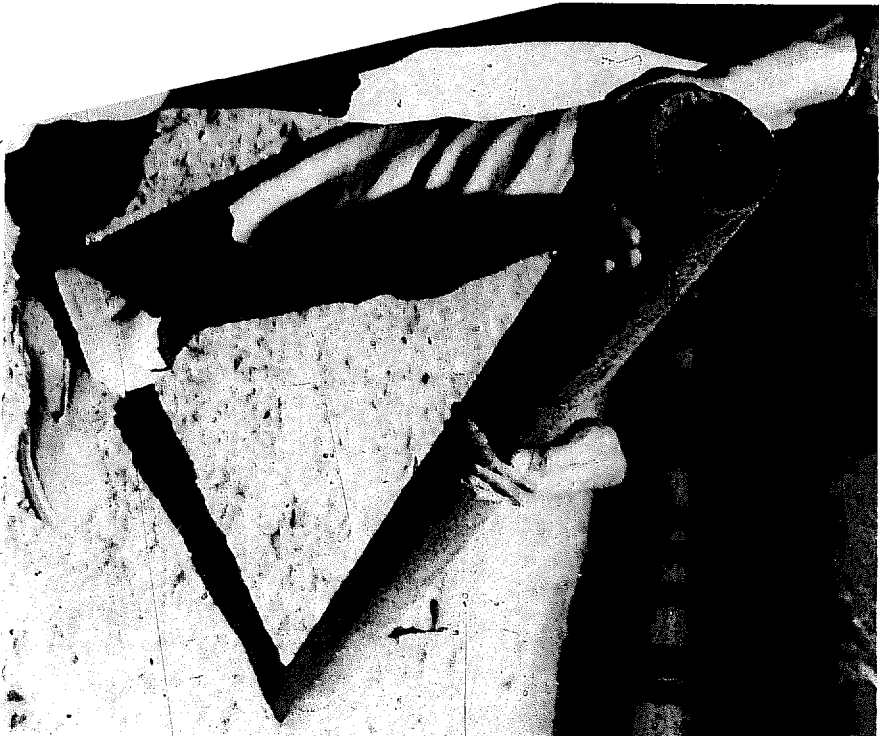

Fig. 22 Locally fabricated bailer with
heavy rubber check valve



Equipment for percussion drilling can be fabricated locally (Figures 21 and 22). A heavy leaf spring from a large truck or bus makes a good cutting edge for a percussion bit (Figure 23). It should not be heated during fabrication unless skills are available for rehardening. The leaf spring can be cut to a chisel edge (90-120° included angle) using a high-speed steel hacksaw blade. The spring steel cutting edge can be fitted into the end of a slender piece of mild steel 2-3 metres (6-10 feet) long such as an 'I' beam, two pieces of channel iron back to back, or a piece of pipe flattened at one end to fit closely around the spring steel. The spring steel should be welded or riveted in place. If possible, the upper end of the spring steel piece should butt against a notch cut into the supporting bar. This is to lessen the impact during loading on the welding or rivets during use. All transitions between the spring steel piece and the supporting bar should be bevelled, so that there are no sharp corners to catch on the side of the hole either on the upstroke or the downstroke. The cutting edge should be wider than the widest dimension of the supporting bar, so that there will be clearance around the bar in the drilled hole. The weight of the bit can be increased by adding material such as by attaching flat iron bars to the web of the I beam or channel or filling the pipe with concrete, possibly using broken pieces of cast iron as the aggregate. A starting weight of 50-60 kg (110-130 lb) might be appropriate for a 10 cm (4 inch) diameter well.

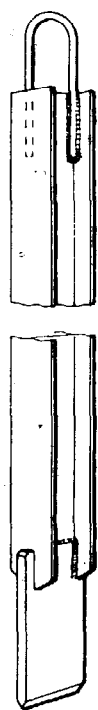

Fig. 23 Percussion bits, locally fabricated

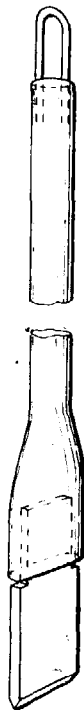

Fig. 24 Bailer, locally fabricated

A bailer can be made from a piece of steel pipe or tubing (Figure 24). A ring for the check valve seat may be forged from flat stock to fit securely into the lower end of the pipe where it is held in place by welding, rivets, or bolts. The valve consists of a disk of heavy rubber reinforced by a piece of flat metal and attached to the valve seat at one edge.

Both the bailer and the percussion bit should have a rather large bail or loop fixed at the upper end for attaching a rope or cable. The large size facilitates "fishing" or retrieval of the tool in the event that the rope or cable breaks or becomes detached.

4.6 HYDRAULIC ROTARY

This method employs a drilling bit at the bottom of a stem of rotating drill pipe. Cuttings are removed by pumping water or a mixture of water and various clays down through the drill stem. This "mud" entrains the cuttings and carries them up through the annular space between the drill pipe and the wall of the hole. When they reach ground level, the cuttings can be settled out in a small pond and the "mud" recirculated. If the reverse flow path is used ("mud" pumped to the surface through the hollow drill pipe) the system is called reverse rotary. The reverse rotary system allows larger particles of cuttings to be brought to the surface, because the upward flow velocity inside the pipe is greater than that through the annular space, due to the smaller flow cross section inside the pipe.

A second function of the drilling "mud" is to seal and stabilize the walls of the hole to prevent collapse and excessive loss of the fluid being circulated. This sealing of the walls, however, can greatly reduce or prevent the inflow of water to the well unless proper steps are taken to "develop" the well.

Two types of drilling bits are normally used: (i) a "fish tail" with two stationary blades for use in soft materials and (ii) a rotary bit with three or more gear-like rollers which roll around on hard material to crush and pulverize it.

Hydraulic rotary drilling is normally done with large engine-powered equipment. This method is used almost exclusively in oil well drilling and is also commonly used in water well drilling where wells are deep and much solid rock must be penetrated.

There are at least two exceptions to the large-scale equipment normally used for this method. The first is a system based on a small, hand-held, vertical shaft, air-cooled engine. A gear reduction unit integral with the engine has an output shaft which rotates at approximately 60 rpm. Drill pipe of 1/4 inch nominal size is attached directly to this shaft. A "tee" swivel near the top of the drill pipe allows water to be pumped down through it and return to the surface via the annular space around it. A fish-tail bit is used for penetrating soft materials. For hard materials a core drill is used. This is a tubular drill of hard, abrasive material which cuts an annular groove and leaves a cylinder of uncut material inside the drill. This uncut cylinder can be removed from the hole by wedging fine lead shot between the core and the inside of the core drill and removing it from the hole along with the drill. Alternatively, a core extractor with spring steel fingers for gripping the core may be used for removal. A second small engine is generally needed to drive a pump for circulating water.

A second system used in Bangladesh is completely hand operated, and is based on the reverse rotary system. A string of drill pipe with a cutting bit at the bottom is rotated in the hole by hand. A hand suction pump attached by means of a swivel to the top of the drill pipe is used to raise water and cuttings. Water is supplied to the annular space around the drill rod by a hand pump attached to two temporary driven wells.

Animal power has also been used to drive rotary drilling equipment.

4.7 CASING AND SCREENS

Casing serves two major functions: (i) to support the sides of the hole against collapse; and (ii) to exclude contaminated surface water. The screen, which allows the water to enter the well while preventing entry of the aquifer materials, may be a perforated section at the lower end of the casing or may be a separate structure attached to the casing.

Depending on the drilling method used and the materials penetrated, the casing may be sunk as an integral part of the drilling operation, as in the case of jetting; it may be placed after the hole is completed; or it may be placed at some intermediate point, such as when the water table is reached and the sides of the hole will collapse if not supported.

A number of different materials have been used successfully for well casing. These include wrought iron pipe or tubing, tubing rolled from sheet metal, pipe made of plastic such as polyvinylchloride (PVC) or glass reinforced plastic (GRP), asbestos-cement pipe, concrete tile, clay tile, bamboo/coir casing (made of bamboo strips attached to steel hoops and wrapped with coconut husk fibre cord and burlap), large diameter bamboo stems with the node membranes removed and split palm trunks. The type of casing used will be determined by (i) what materials are available locally; (ii) what skills are available locally; (iii) the relative costs of labour and materials; (iv) the drilling method being employed; (v) the nature of the geologic formation; and (vi) minimum acceptable life of the well.

A particularly noteworthy example of low cost, locally manufactured casing is the bamboo and coir casing developed in India (Figures 25, 26, 27 and 28). This casing consists of longitudinal strips of split bamboo riveted to hoops spaced approximately 25 centimetres apart. The assembly is then wrapped circumferentially with coir (coconut husk fibre) rope until the entire length is covered. On those sections of the casing which penetrate the aquifer the coir rope serves as a strainer or screen. On the remainder of the casing the coir rope may be covered with burlap which is coated with asphalt. Sections of casing are butted together and are attached by several longitudinal steel ties riveted to the end hoops of the respective sections.

The life of these bamboo/coir casings is said to be two or three years. At the end of this time it is necessary to bore a new well and to line it with a new casing. The use of bamboo/coir casings is an excellent example of ingenuity and local labour, and skills being used to save scarce capital and foreign exchange.

In Egypt date tree trunks are cut into one or two metre lengths, cleaned on the outside, split, and hollowed out. During hand percussion drilling with a bailer and an under reaming bit; the two halves are inserted into the hole and driven to depths of 100 to 200 metres.

Where galvanized sheet metal is readily available, casings can be made by rolling strips into tubing with a longitudinal seam (Figures 29 and 30). In one case 1 m x 2 m sheets of galvanized steel were split lengthwise into three equal strips. A single 90° bend was made along one edge and a 90° bend plus a 180° bend was made along the other edge. These were "rolled" by means of a 2 metre long wooden "V" block over which the sheet metal was laid while downward force was being applied to a length of 2 inch diameter pipe placed on top of it. By moving the sheet metal from side to side across the "V" block a reasonably round contour could be obtained. The previously bent edges were hooked together and bent over to form a seam. To accomplish the final rounding



Fig. 25

Coir casing

Split bamboo strips are spaced around steel rings and the assembly is wrapped with coir cord.



Fig. 26

Coir casing

The coir wrapping serves as the well screen at the bottom end of the casing.



Fig. 27 Coir casing
Casing which is above the
aquifer is coated with asphalt
and burlap.

Fig. 28 Coir casing being lowered
into bored hole

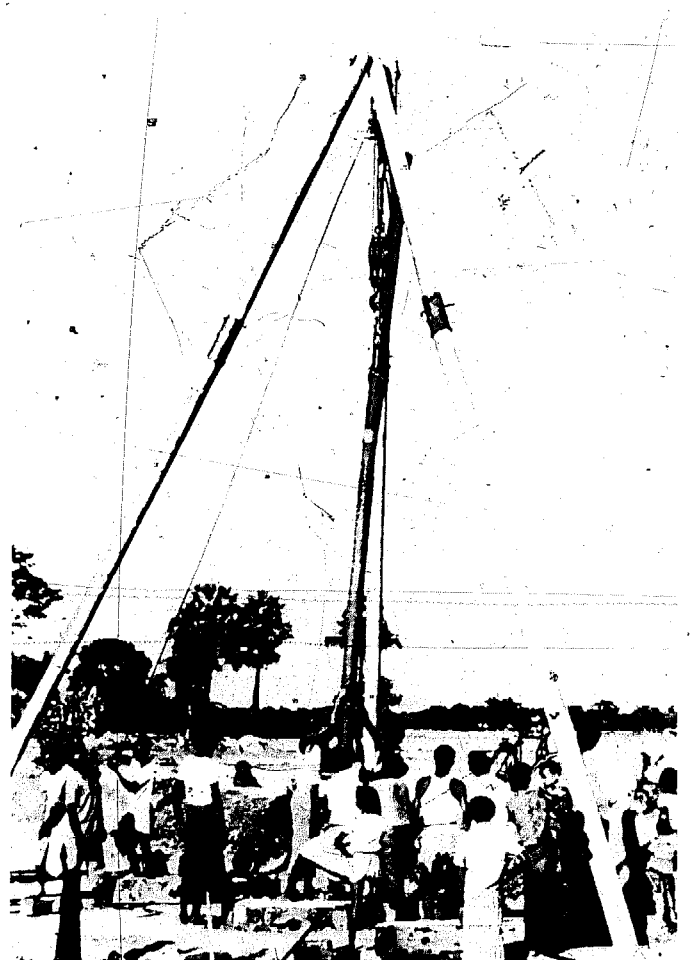

Fig. 29 Fabricating sheet metal casing

- (a) edges clamped between angle irons and bent with mallet
- (b) rolling strip with pipe and wooden "V" block
- (c) hooking edges together to form seam
- (d) crimping seam and rounding casing with pipe anvil and mallet

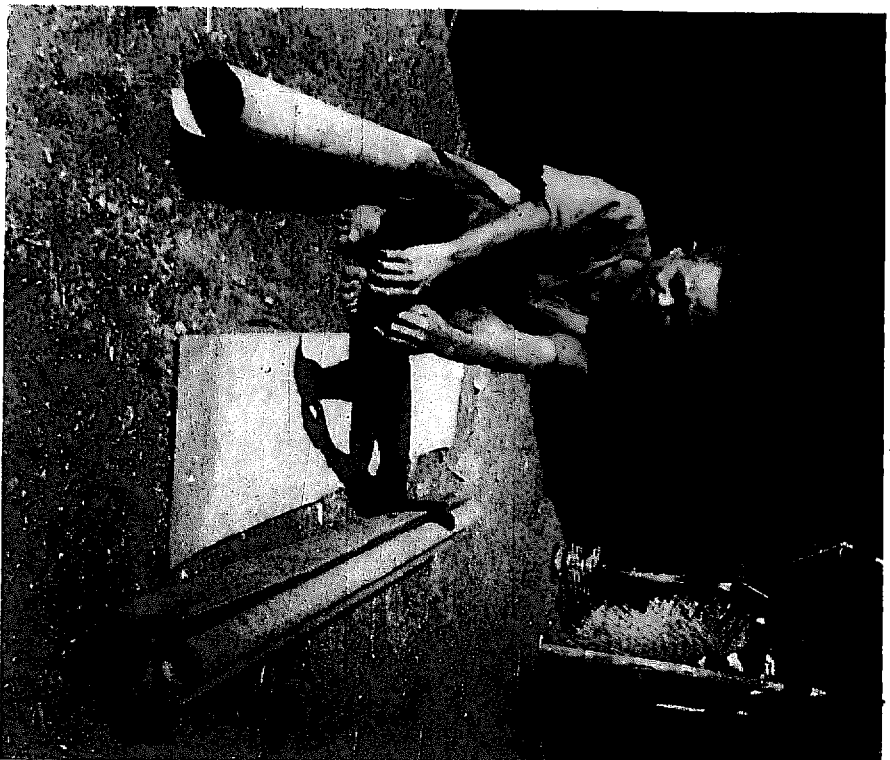
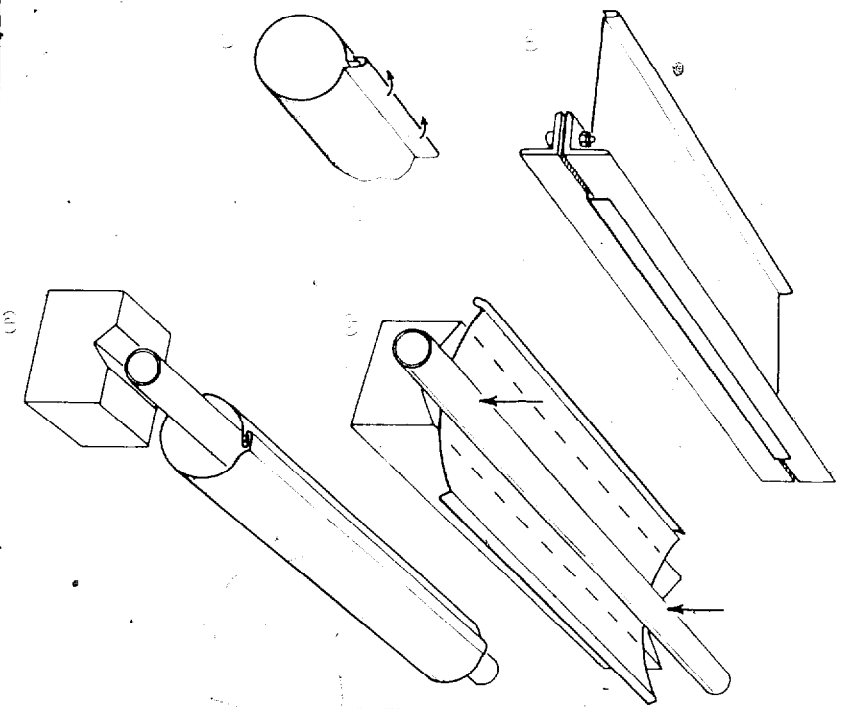

Fig. 30 Fabricating casing from
galvanized sheet metal

of the casing the piece of 2 inch pipe was supported on blocks near its ends and used as an anvil. The casing was slipped over the pipe and a mallet of wood or other relatively soft material was used to do the finish forming.

The sheet metal casing is normally joined by slipping one end inside another and then soldering the joint. Short longitudinal strips of sheet metal lapped across the joint and soldered onto both lengths of casing can be used to further strengthen the joint, and are a worthwhile practice. Ends can be made to fit together by selective assembly, by lightly crimping one end, or by intentionally making the casing slightly tapered by varying the width of the seam from end to end.

In the "California Stovepipe" method, two light sheet metal casings are used, one fitting snugly inside the other. Joints on the inside casing come at the midpoint of the outer casing sections and vice versa. The two layers are assembled and spot welded together as they are sunk, thus creating a laminated casing which is relatively stiff and resistant to buckling.

Asbestos-cement soil pipe and concrete or clay tile are frequently made with bell and spigot joints to allow one end to slip loosely into the adjoining end for a short distance. When using such pipe or tile as casing the bells point downward to minimize entry of loose material through the loose joint into the well. The lengths may be lowered into the well singly by means of a set of hooks attached to a cord. The hooks and cord fit inside the casing and hold onto the lower end of the casing until it is in place and the hooks are released by pulling on a second cord. Alternatively, if the string of casing is not too heavy, the joints may be wired together as they are assembled over the well and the casing lowered from the top end. This technique would be limited to relatively shallow wells by the weight of the string of casing.

Clay, concrete and asbestos cement tiles are relatively fragile and will break if such operations as percussion drilling or bailing are attempted inside them. If such operations are required for sinking the casing into the aquifer, it is necessary that the lowest section of casing be of some more durable material such as steel tubing or pipe.

Polyvinylchloride (PVC) tubing or pipe is the plastic material most commonly used as well casing. It is normally much less expensive than steel, lightweight, easy to cut and perforate and insert. Sections are joined by means of painting the ends with a solvent to soften them and then slipping them into a coupling where they fuse as the solvent evaporates.

Perforation of casing to allow its use as a well screen can be accomplished by drilling or by slitting with a hacksaw as was described in the section on well points.

A number of techniques have been used to help sink the casing as drilling progresses:

- i. Driving: This technique was discussed earlier in connection with sinking well points. It can be used normally only with heavy wrought iron casing using special drive couplings which allow the casing ends to butt against each other, thus protecting the threads from deformation. As pointed out earlier, driving is accomplished by raising and dropping a weight which is guided either on the inside or the outside of the casing and which strikes either on a special driving cap screwed onto the end of the casing or on a clamp around the outside of the pipe.

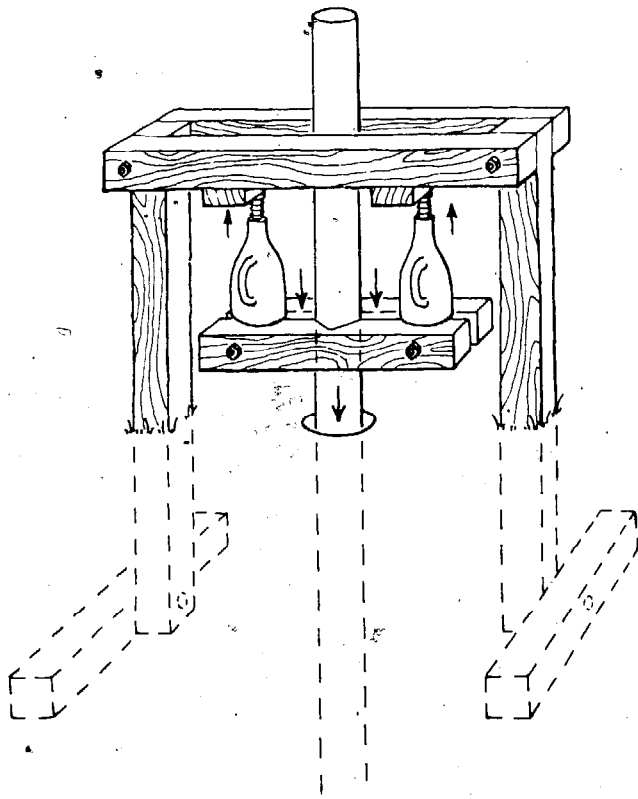

(a) with help of jacks

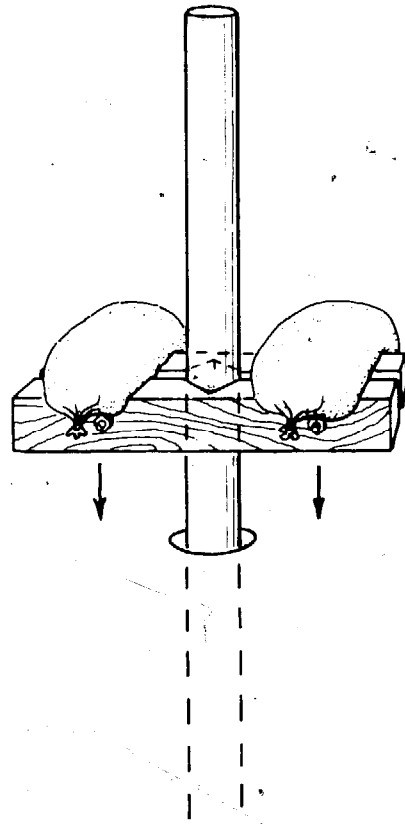

(b) weighting with sacks of soil

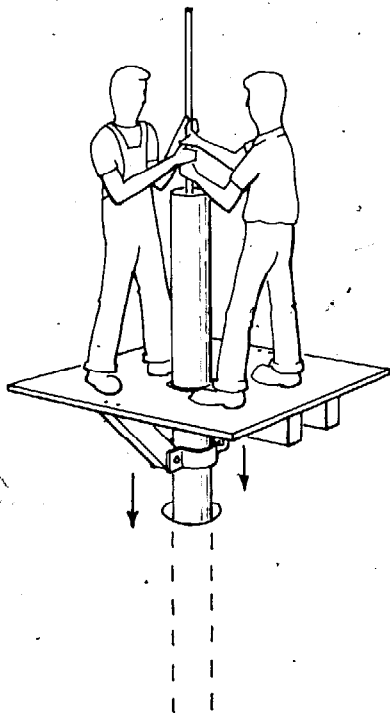

(c) using weight of drilling crew on platform

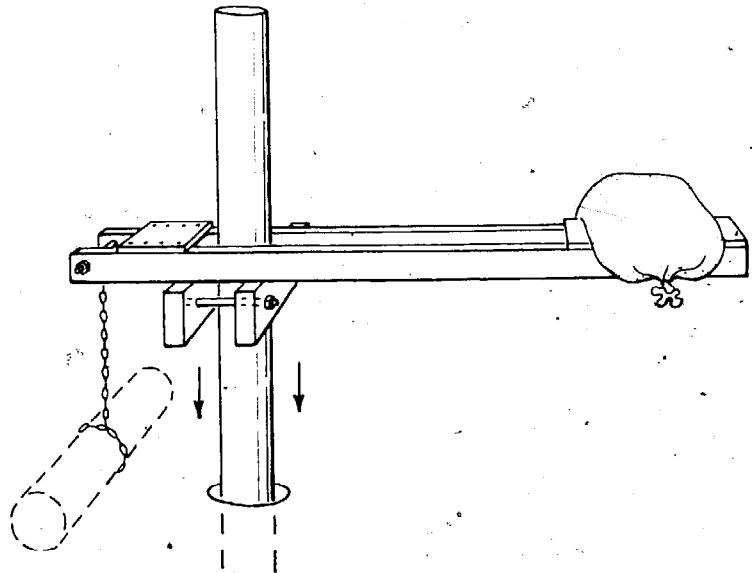

(d) using a lever and soil sacks

Fig. 31

Sinking casing



Fig. 32 Sinking casing

Two methods are being used:

- (a) Workers near casing are tightening nuts on large screws attached to timber anchors beneath the ground and to top of casing.
- (b) Note large concrete weights clamped around casing just beneath upper end. A second set of weights is located just above the ground surface.

Fig. 33 Sinking casing

Weight of drillers is being used to help sink the casing. Workers on the ground are rotating the casing as drilling proceeds.



- ii. Jacking: This technique (Figures 31a and 32) makes use of timber anchors buried alongside the well and jacks to maintain a downward force on the casing as drilling continues.
- iii. Weights (Figures 31b and 32) such as bags of soil or drums of water may be piled on a support clamped around the pipe. Alternatively, a platform on which the drillers' stand may be clamped to the casing (Figures 31c and 33).
- iv. Weights (Figure 31d) on a lever which applies force to the casing.

4.8 METHODS FOR OBTAINING VERTICAL RECIPROCATING MOTION

A number of well drilling operations require a raising and dropping motion. These include percussion drilling, bail down, hydraulic percussion and driving of casing. Large scale percussion rigs obtain such a motion by cable with one fixed end running over a pulley at the end of a pivoted arm reciprocated by a crank and connecting rod. The closest analogue to this in man-powered equipment, Figures 34, 35 and 36, consists of a rope or cable coming vertically out of the well, running over a pulley, then running parallel to the ground at about shoulder height, and finally anchored to a tree or post. To obtain the reciprocating motion a crew of 4-6 men line up facing the rope and alternately pull down and release the rope in unison.

Another device successfully used consists of a lever pivoted over a horizontal axis, Figure 37, with the drilling tools attached to the shorter end and a crew of several men applying a reciprocating motion to the longer end. Weights could be added to the longer end to counterbalance partially the drilling tools if desired.

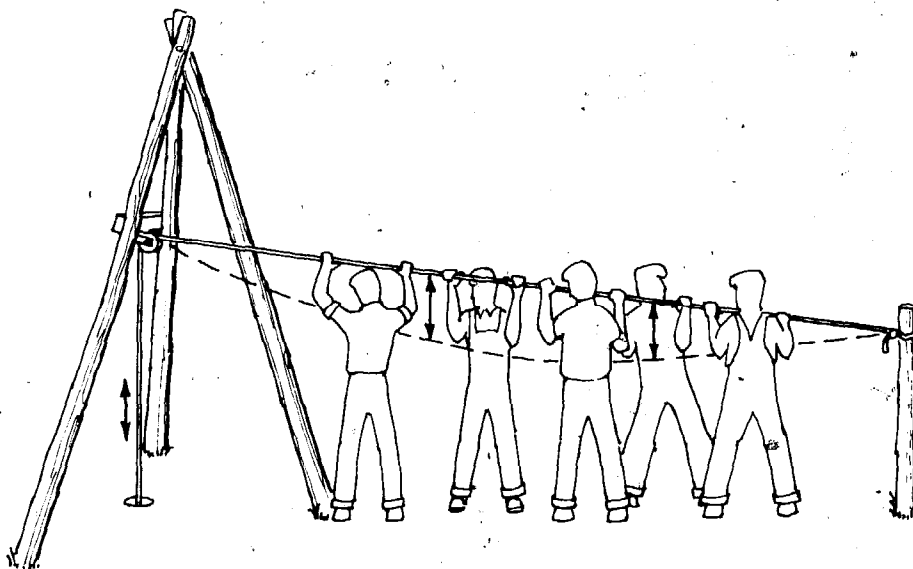

Fig. 34 Pulling on anchored horizontal rope to obtain reciprocating motion.



Fig. 35

Percussion drilling

Raising and dropping motion is obtained by pulling down on rope and releasing.

Fig. 36 Tripod mounted pulley used to obtain reciprocating motion for percussion drilling and bailing

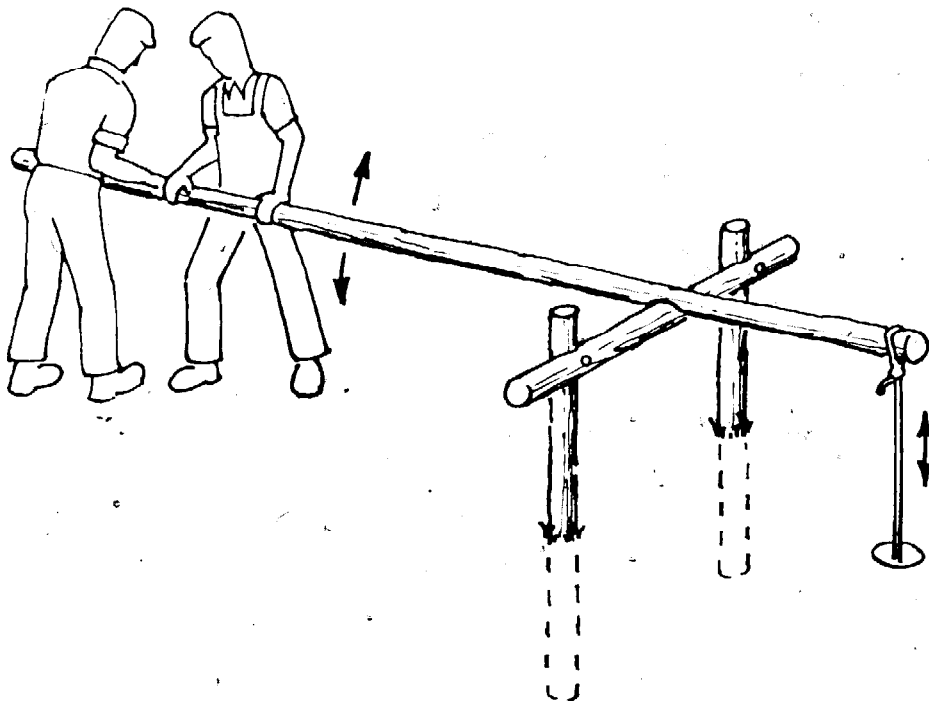
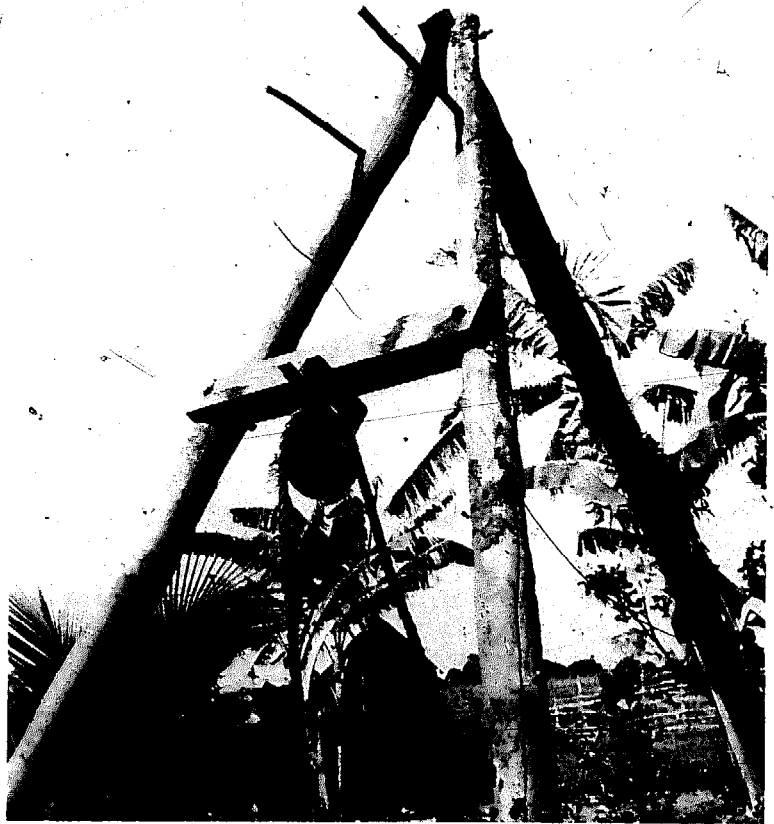

Fig. 37

Using lever to obtain reciprocating motion

There are a number of variations of the spring beam or spring pole system, Figures 38, 39 and 40. In Figure 38 the drilling line is attached to the end of a horizontal wooden cantilever beam somewhat reminiscent of a diving board. The stiffness of the beam can be adjusted either by changing the number of leaves in the spring or by changing the position of the support nearest the end of the beam where the tools are attached. Depending on the stiffness of the beam, the elasticity of the rope or other material attaching the tools to the beam, the mass of the tools, and the nature of the materials being penetrated, the system will have some natural frequency. That is, if the beam is bent and then released, the system will oscillate at a constant number of cycles per minute with a continually decreasing length of stroke until the motion is completely damped out by friction in the system. If on each downstroke a downward pull is applied, the system can be made to oscillate indefinitely with a minimum work input. In practice, a work crew stands around the line attached to the spring beam and supplies a downward force at appropriate intervals to keep the system oscillating. Alternatively, a separate rope for each can be attached to the beam. Each worker places his foot in a loop or stirrup and supplies the necessary motion with his leg and foot. This method is sometimes referred to as "kicking down a well". As the mass of tools, depth of hole and material penetrated change, the natural frequency of the system changes. This can be compensated for by adjusting the stiffness of the beam either by changing the number of leaves or the unsupported length. A greater tool mass will decrease the number of oscillations per minute while a greater beam stiffness will increase them.

Slightly less sophisticated, but widely used in North America during the first half of the 19th century is the spring pole (Figure 39). This is made from a tree 8-10 m long with a diameter tapering from approximately 20 cm at one end to 10 cm at the other. The large end is anchored to the ground possibly by piling rocks or logs on it. It is supported by a fulcrum at approximately one-third of the length from the lower end. The upper end might be at a height of 2.5-3.0 m. Stirrup ropes could be attached to the upper end for oscillating the pole.

In both the case of the spring beam and the spring pole, an overhead pulley is necessary for pulling the tools out of the hole and for bailing. This pulley would normally be supported on a separate structure such as a tripod.

Figure 40 shows a Chinese well drilling device which makes use of a large bow to obtain the oscillating motion. This general type of device goes back at least 2 600 years and has been credited with drilling to depths of 1 000 m. Such wells were used to obtain brine from which salt was made in the interior of China. The drill line is made of sections of split bamboo which are spliced together by cutting interlocking notches where ends overlap and banding the splice together with steel or hemp. Good bamboo has about the same tensile strength per unit of weight as mild steel. It is obviously not as flexible as rope or cable, however, and so the large diameter reel, shown is used to wind up the bamboo drill line. Some dimensions given for the device pictured in Figure 39 are:

Length of Bow	12 - 15 m
Diameter of Bow	20 - 25 cm
Diameter of Steel Cable for Bow String	15 - 16 mm
Diameter of Reel	4 m (approximately)

A rotating drum or "cathead" driven by any convenient power source is frequently used in well drilling operations (Figure 41). If a rope is wrapped loosely around the rotating drum, it will remain stationary while the drum rotates. When one end of the rope is pulled taut, however, friction will cause the rope to move with the drum surface and the rope and drum combination can be used as a windlass. By alternately pulling the rope taut and letting it go

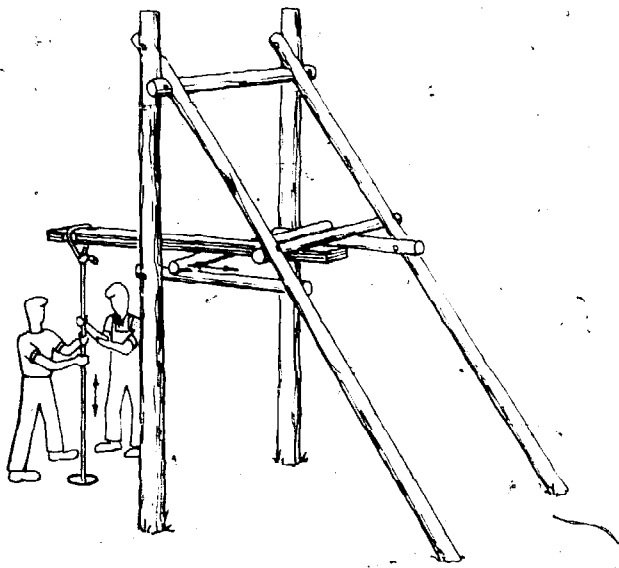

Fig. 38 Spring board for obtaining reciprocating motion

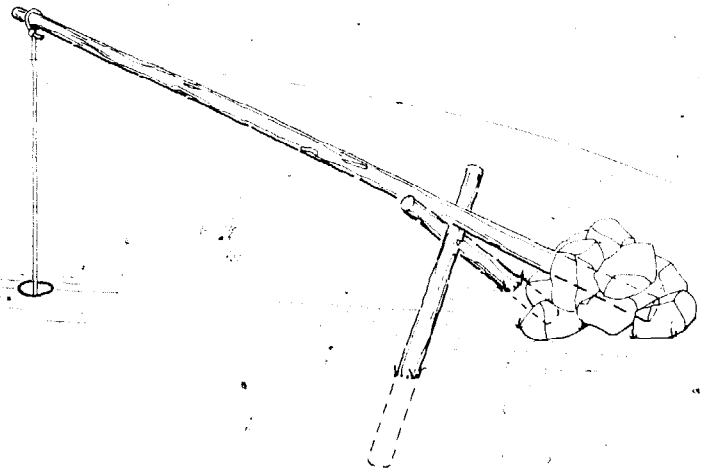

Fig. 39 Spring pole for obtaining reciprocating motion



图 1 人工架示意图
1-木架; 2-轮子; 3-弓子; 4-弓子绳; 5-立轴

(a)

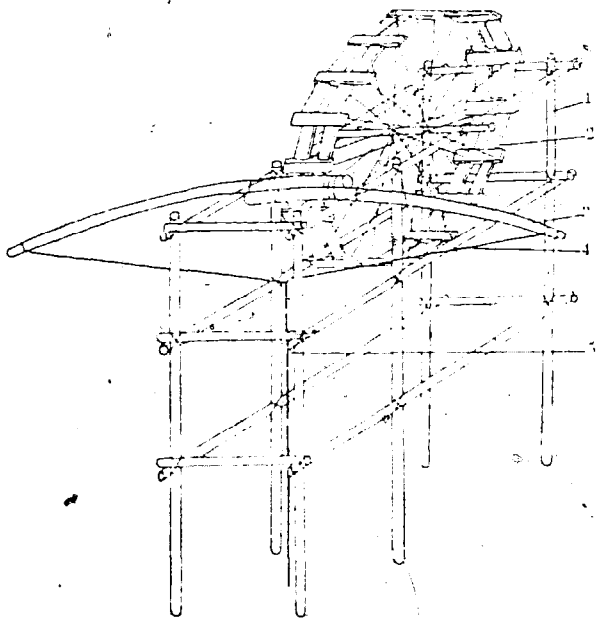

图 2 竹段接头示意图
1-竹段; 2-方木; 3-铁板

(b)



图 5-9 钻具

1-空钻; 2-实钻; 3-加重钻; 4-切准

(c)

Fig. 40 Traditional Chinese drilling equipment. (a) rig with bow for obtaining reciprocating motion and reel for bamboo drill line; (b) splice in split bamboo drill line; (c) drilling tools

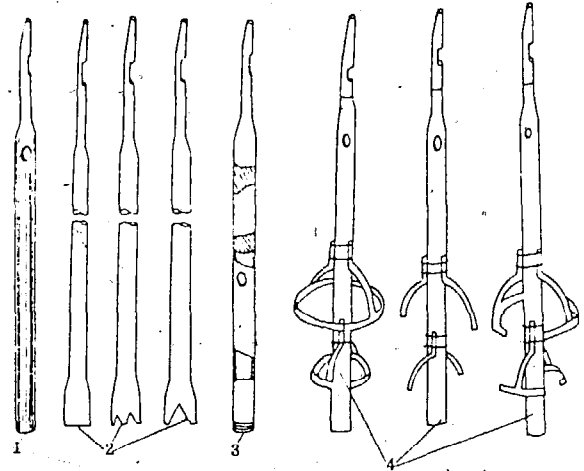
slack, it is possible to raise and drop a weight such as a percussion bit, a set of hydraulic percussion tools, or a bailing bucket. By continually keeping the end of the rope taut as it feeds off the drum, the system can also be used to pull the tools out of the well.

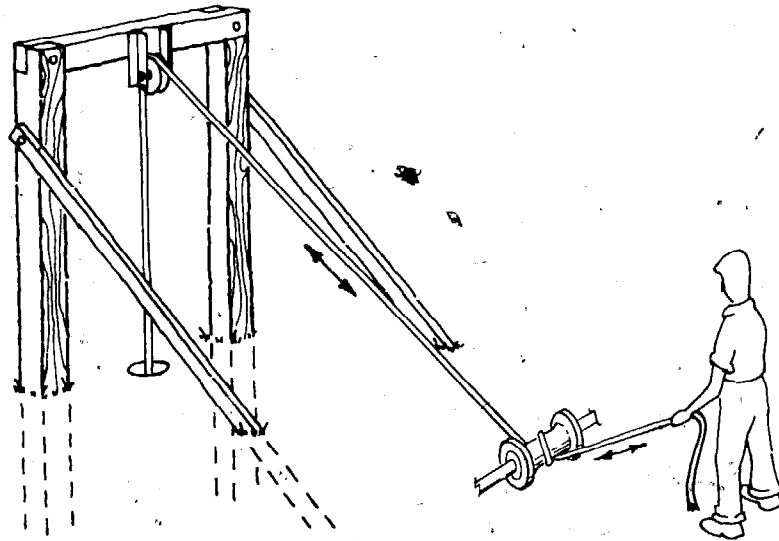

Fig. 41 Rotating drum or "cathead". to obtain reciprocating motion or for use as a winch

4.9 ROPE

Drilling systems such as augering, jetting and hydraulic percussion make use of a string of pipe or tubing to connect the actual drilling tools with the power input at or above ground level. Whenever tools must be brought up to the ground surface it is necessary to disconnect the lengths of pipe one by one and to set them aside. Returning the tools to the bottom of the hole requires a reversal of this procedure. As the hole becomes deeper, this process becomes more time consuming and progress is thus slowed. Early percussion drilling was carried out with rigid drill stems made of wooden or steel sections coupled together. These likewise had to be coupled and uncoupled every time tools were put into or taken out of the hole. In present day percussion drilling and bailing, on the other hand, the tools are normally connected flexibly to the power input by a rope or cable. This means that the tools may be quickly removed from or returned to the hole merely by pulling up or letting out the rope without any disconnecting or connecting.

Both manilla rope of 25-40 mm (1-1½ inch) diameter and steel rope or cable of approximately 10 mm (3/8 inch) diameter have been used successfully in self-help well drilling operations. To extend the life of the wire or manilla rope, the maximum practical pulley diameter should be used. Locally made ropes with short or coarse fibres, such as coir (coconut husk fibre) may be undependable and short-lived and cause delays and losses far in excess of the money saved by their use.

The drill lines of split bamboo successfully used in Asia for over 25 centuries were mentioned earlier.

4.10 WELL DEVELOPMENT AND FINISHING

The term well development refers to the process of removing the finer particles from the aquifer immediately around the well screen in order to make the aquifer more permeable and thus to decrease the resistance to flow of water into the well. This means that for a given rate of pumping the drawdown of the well and consequently the pumping height will be decreased. In order to develop a well, it is important that the openings in the well screen be chosen of the proper size. This necessitates collecting material taken from the aquifer during the process of drilling. One rule-of-thumb states that the openings should be of such a size that the smallest $\frac{2}{3}$ of the aquifer particles will pass through them.

Development is accomplished by causing the water to alternately flow into and out of the well. During inflow some small particles will be carried into the well through the screen, but other small particles will bridge between particles too large to pass through the screen. The reversal of flow will dislodge such particles and give them the opportunity to pass through the screen during the next period of inflow. The fine material entering the well is ultimately removed with the water. Removal of the fine material during development, in addition to increasing the capacity of the well, saves the pump which is later installed from abrasion.

Bailing the well is probably the simplest method of development. Each time the bailer is raised and dropped water surges into and out of the well. Fine material entering the well is trapped inside the bailer and removed from the well. The amount of fine material in the bailer indicates how far the process of development has proceeded. A special type of bailer known as a sand pump has a piston inside it. This piston is attached to the bailer line in such a way that it travels upward inside the bailer as the line goes from slack to taut. The motion of this piston has a strong surging effect on the well and helps to draw sand into the bailer.

A surge block, which acts as a piston or plunger inside the casing, can be attached to a string of pipe and made to travel up and down for the purpose of development. A surge block may consist of two or more wooden disks fastened together with rubber between them which makes contact with the inside of the casing.

Wells may also be developed by pumping water out at a high rate to create a large drawdown. Pumping is suddenly stopped and a large quantity of water which has been accumulated is allowed to run down into the well to reverse the flow through the aquifer around the screen. Compressed air may also be used to surge a well during development operations.

If an aquifer consists of fine particles without much variation in size, it may not be possible to increase the permeability around the screen adequately by the development techniques described above. In this case the capacity of the well can be increased by gravel packing, i.e. by introducing material around the screen which has a particle size greater than that found in the aquifer. Use of a gravel pack allows larger screen openings to be used, and hence gives greater percentage of inflow area. It also surrounds the screen with a layer of material of higher permeability than the aquifer itself.

One way to introduce the gravel is initially to sink a temporary casing of a diameter greater than that of the final casing and screen. The final casing and screen are lowered inside the temporary casing and are held concentric by

guides while the gravel is introduced into the annular space between the casings. The temporary casing can then be jacked out of the hole. Another method is to drill the hole somewhat larger than the casing down to the water table. The casing is then lowered and the annular space between the casing and the hole is filled with gravel. As sinking of the casing into the aquifer proceeds, some of the gravel descends with the casing. During development, more of the gravel descends to occupy the volume left by the sand passing through the screen into the well. Gravel may also be introduced around the screen through several small holes drilled for this purpose around a small circle concentric with the well.

The size and gradation of the gravel used should be such that very little of the material of the surrounding aquifer can flow into the voids between the gravel particles. If this happens, the permeability of the gravel pack may be greatly reduced. The screen opening size is selected as large as possible without allowing any of the gravel pack material to enter the well.

After the well has been developed it is usually desirable to fill in and seal the annular space between the outside of the casing and the hole. This operation known as grouting is carried out to prevent any dirty surface water from flowing directly into the well and to give the upper end of the casing firm support. A mixture of portland cement and water mixed to a fairly liquid consistency is the most commonly used grouting material. A clay-water slurry is sometimes also used at greater depths where changes in moisture will not cause shrinking and swelling of the clay.

Where the use of pumping equipment for placing the grout is not practical, it must be flowed into place by gravity. The annular space between casing and hole should probably not be less than 5 cm (2 inch). A long, slender rod can also be used to make sure the grout flows into all voids. The grout should extend from the surface to a depth of at least 6 m (20 feet) to ensure an adequate sanitary seal between casing and drilled hole.

4.11 PROBLEM SOLVING

No endeavour is without problems, but those encountered in the drilling of small diameter wells may seem more difficult since they generally occur in a location where they cannot be seen. Consequently, a high degree of "feel", deduction, reasoning and ingenuity must be developed to diagnose and to overcome problems. Well drillers have two cardinal rules concerning problems:

- (1) Prevent problems before they occur rather than trying to remedy them after they occur. This requires a great deal of alertness to sounds, feel, physical condition of tools and cuttings and continually trying to anticipate what things could possibly go wrong.
- (2) In trying to remedy a problem, do not do anything quickly or ill-considered which could make the problem more difficult or impossible to solve.

In drilling wells, particularly with labour-intensive systems, at least three types of problems arise:

- a. Small tools dropping into the hole. Any tool small enough to fit into the hole and regularly used around the hole will sooner or later get dropped in. To prevent this, all such tools should be tied to some stationary object with strong cord. Long slender objects, such as

auger extensions which are regularly coupled and uncoupled, should have a safety device, such as a piece of rod slipped through them to prevent them from sliding down the hole if dropped accidentally. "Fishing" techniques for removal of objects from the hole are discussed later.

- b. Tools stuck in the hole. While some cases of stuck tools are probably inevitable, proper design and maintenance can minimize the number of cases. The cutting edges of tools should be made and maintained so that they cut a hole large enough to allow clearance around the remainder of the equipment. Tools should be designed with reasonably smooth transitions in cross-section so that sharp shoulders do not exist which could become hooked under an irregularity in the hole or above which excavated particles could be wedged. When tools do become wedged in the hole, it is usually necessary to make use of some force-multiplying device such as a chain hoist or automotive jacks to pull them free. Since the force required to free the tool can often be considerable (even if only a small piece of gravel is wedged between the tool and the casing), equipment should be built to withstand several tons of pull. If there is concern for the rope, cable or a string of pipe breaking during hard pulling, it is usually possible to hook directly onto the stuck tool with a properly designed hook at the end of another stronger rope, cable or string of pipe. Pulling can then proceed on the latter or on both attachments. The necessity of hooking onto the tops of tools should be kept in mind when they are designed. For example, bailers and percussion bits should be made with large, easy-to-hook bails.

Commercially made percussion tools include a set of "jars". This is a heavy close fitting pair of links built into the drill system. Since the links can slide within each other, the part of the drill stem above the jars can be pulled up a short distance before the drilling bit leaves the bottom of the hole. This small relative motion and the mass of the upper drill stem and line can be used to drive a stuck drill bit upward to free it. The impact of the jars exerts a greater force than can normally be obtained by a steady pull. If the drill bit is stuck above the bottom of the hole, the jars can also be used to drive downward. The forerunner of jars was two or three heavy chain links connecting the upper and lower part of the drill stem. These, however, take a heavy beating on both the upstroke and the downstroke and are relatively short-lived.

Tools which become detached in the hole. The occurrence of this problem can be minimized by continually checking the condition of the tools and fasteners. However, when a detached or dropped tool must be removed from the hole, the process is referred to as "fishing". Frequently special tools must be fabricated to accomplish this task. This may require both considerable ingenuity and a good deal of trial and error. An impression block may be valuable in designing fishing tools. This is a shallow cylindrical container of a diameter which just fits in the hole, with an open bottom and the top attachable to a string of pipe or a bailer. The container is filled with a substance such as soap, wax or grease hard enough to hold its shape, but soft enough to take an impression. It is carefully lowered onto the object to be fished, so that the impression left on the block gives information

on the shape, location and orientation of the object which is useful in choosing the tools and strategy to be used in fishing. An impression block can be made of a thick wooden disk with a strip of sheet metal nailed around the outer edge. The wooden block can be studded with nails to anchor the impression material.

Some commonly used fishing tools are shown in Figure 42. Other tools must be devised to suit a given problem.

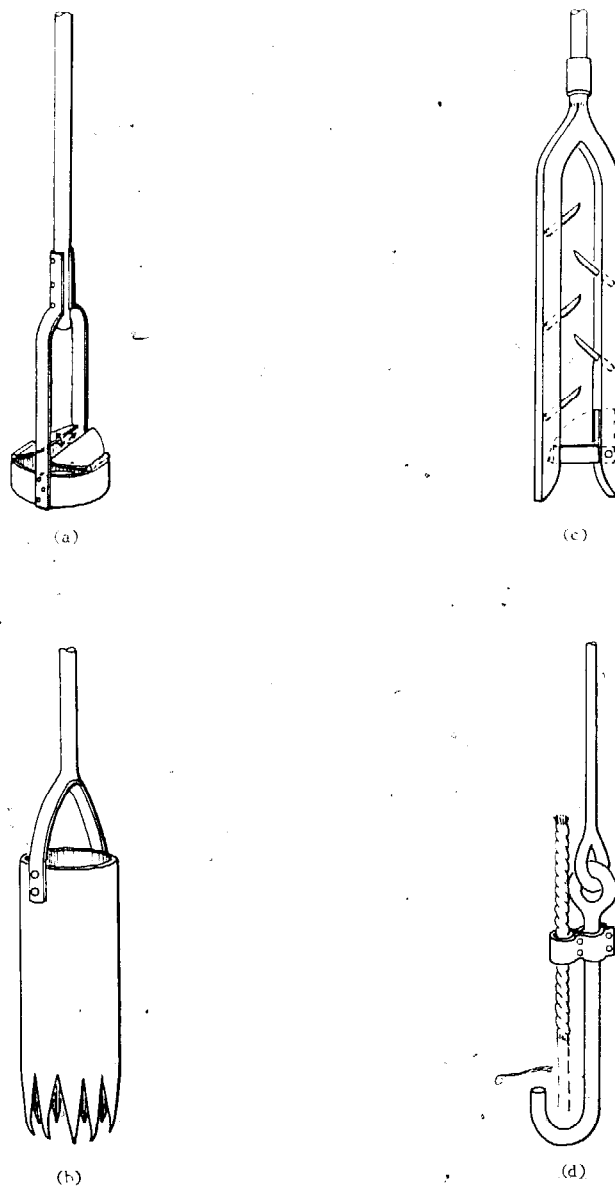

Fig. 42 Fishing tools. (a) for retrieving lengths of pipe; (b) sheet metal cylinder with teeth which bend together to close bottom for picking up small objects; (c) spear for retrieval of broken rope or cable with latch for picking up bits or bailers; (d) hook with guide for attaching supplemental line to stuck tool

5. LARGE DIAMETER WELLS

5.1 RATIONALE FOR CONSTRUCTION OF LARGE DIAMETER WELLS

As pointed out in Table 1, large diameter wells have some inherent disadvantages when compared with small diameter wells, including:

- greater effort and longer construction time
- greater safety hazards during and after construction
- difficulty in preventing contamination
- generally lower rate of inflow for the effort involved.

There are circumstances, however, which make the construction of large diameter wells necessary:

- i. inability to obtain or maintain pumps or special buckets necessary for small diameter wells
- ii. desire to use some type of water raising system requiring more space than is available in a small diameter well (e. g. continuous chain and buckets)
- iii. desire to improve or repair existing large diameter wells.
- iv. necessity of storing water where the aquifer is of extremely low permeability
- v. low cost labour is available
- vi. local skills are available.

5.2 DIMENSIONS FOR LARGE DIAMETER WELLS

Large diameter wells are almost invariably circular in horizontal cross-section. This configuration (i) makes the sides most stable during excavation; (ii) uses the least lining material for a given cross-sectional area; and (iii) makes the best use of the compressive strength of masonry linings. One possible exception might be wells in which horizontal timber cribbing is used as a lining. In this case, the horizontal cross-section would be rectangular, preferably square.

The inside diameter of hand dug wells normally ranges between one and two metres. At the lower limit the small size of the excavation tends to impede work, since there must be space for at least one worker, his tools and the bucket into which he is loading the excavated material. Furthermore, after the water table is reached, a cylindrical caisson is normally lowered inside the original shaft, thus reducing work space even more.

As the diameter is increased, certain practical limits are reached, however, since the volume of excavated material is proportional to the square of the diameter and the volume of material necessary to line the excavation is roughly proportional to the diameter. For example, the volume of material excavated from a two metre diameter well would be four times that excavated from a one meter diameter well. As a consequence, the vast majority of dug wells are found to have diameters in the range of 1.2 to 1.5 metres (4 to 5 feet). The larger size allows as many as four large well buckets to be used simultaneously if raising pulleys are properly located.

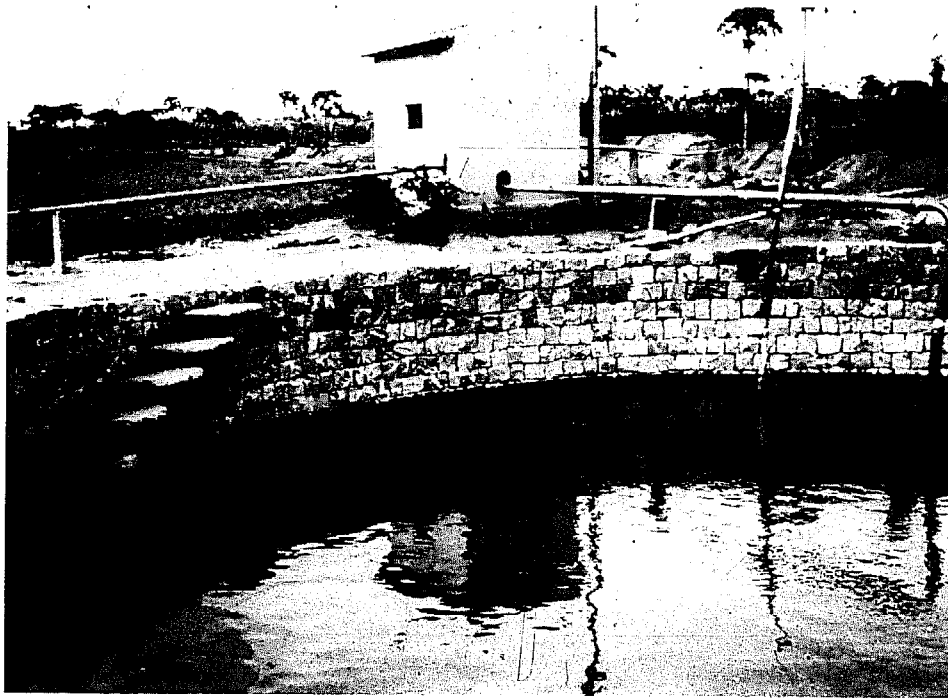

(a)

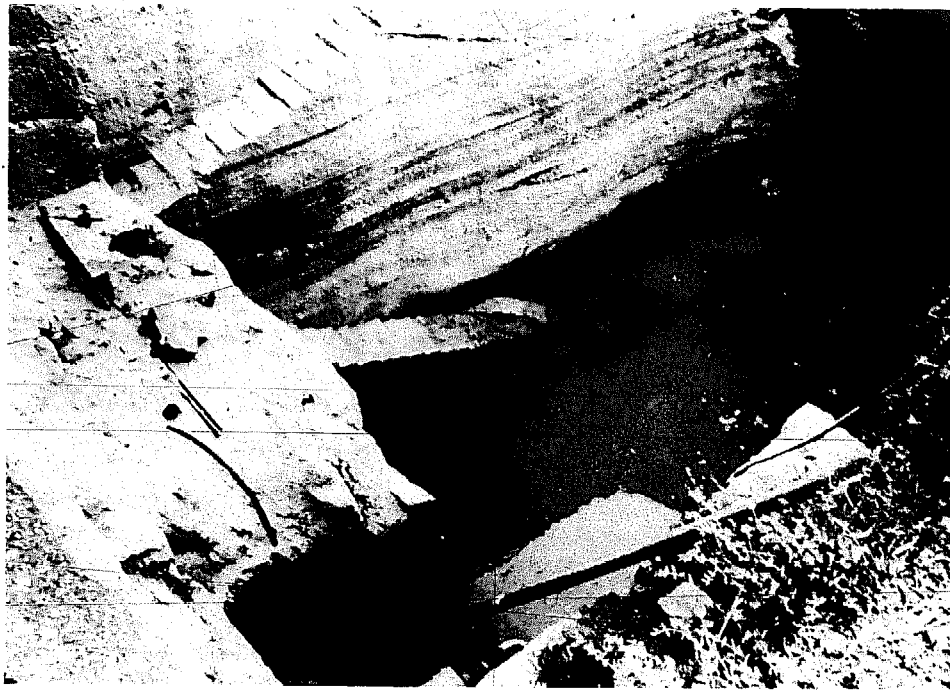

(b)

Fig. 43 Very large diameter cistern-wells with stairs for descent to the water surface. (a) with cut stone walls; (b) excavated into weathered granite

Extremely large diameter excavations serving a dual cistern-well function do exist (Figure 43). Some have stairs built into the sides allowing people to descend to the water level to dip out water. The stairs are normally used mostly during construction and maintenance, however. The construction of such structures could not be recommended, except in very special cases, due to the great effort of construction. It is obviously inefficient to lower and raise the entire body weight of the water carrier to the ground surface from the water table. Just raising the water is most efficient.

5.3 EXCAVATION

The major goal and challenge of excavation is accuracy, both locational and dimensional, i.e. the centreline or axis of the excavation must be maintained as absolutely vertical as possible while maintaining the radius of the excavation as exactly as possible about the axis. Vertical accuracy is necessary to prevent angular and offset errors between successive sections of the lining. Radial accuracy is necessary, because the excavation acts as the exterior mould for the lining. Where the radius of the excavation is too small, a thin, weak spot in the lining will occur. Where the radius is too large, a thick spot, wasteful of material will occur.

The location of the axis can be determined easily and accurately at any time or depth by means of a plumb line. The line may be attached to a special gauge stick with a hole near each end which lies along a diameter of the well at the ground surface and indexes over two steel rods securely driven into the ground on either side of the well (Figure 44a). If this stick is used to determine the centre of the well at the outset, it and the plumb line will serve to define the well axis anytime it is indexed over the two steel locating pegs. If there is danger of these pegs being knocked askew during the construction process, they should be set in concrete.

Hand tools, in local use, are normally adequate for carrying out the excavation. These might include spades, bars, picks and mattocks. Sometimes handles are shortened for use in the confined space. The hole is then excavated somewhat undersize to the desired depth keeping the bottom reasonably level. Excavated material is placed in a bucket or basket by the worker(s) doing the digging and is raised to the surface by rope and pulley by other workers who dump it some distance from the well. This distance should be great enough to prevent the pile of excavated material from becoming an obstacle, and to prevent it from being washed back into the well by rain.

After rough excavation, the hole is accurately trimmed to its finished dimension. This necessitates use of the plumb line. One method consists of accurately driving a pointed metal rod into the centre of the excavation as determined by the plumb bob, and then checking the top of the rod with the plumb bob to assure that it is vertical. The top of the rod should be at least as high as the highest point to be trimmed. Once placed, the rod can be used as a temporary axis. A gauge stick can then be used to check the radius of the excavation as trimming proceeds. Alternatively, a small scraper or mattock attached to a chain of correct length pivoted around the axis rod can be used for final trimming. Another method uses a cross whose legs are just slightly shorter than the desired diameter of the excavation. This cross is suspended from the plumb line by means of an eye at its midpoint so that its legs are both in the horizontal plane. Four vertical grooves are carefully cut in the walls of the excavation to just allow the cross to hang freely. Trimming then proceeds until the cross has the desired clearance at any position when suspended from the plumb line. The bottom of the excavation should then be carefully levelled if a mould is to be placed for lining the excavation.

5.4 LINING THE EXCAVATION

Lining the excavation serves at least three purposes:

- i. It protects the workers against cave-in during construction.
- ii. It stabilizes the sides of the well preventing sloughing off and washing in of material during use, thus extending the life of the well.
- iii. It can prevent the entry of surface water and resulting contamination where the water is for human consumption.

Three different systems of lining are in general use (Table 3). More than one system may be used in a given well depending on the conditions encountered. Several different types of lining may be used with each system.

System I (Table 3, Figure 44) consists of excavating and accurately trimming one metre of depth. A horizontal annular groove is added near the bottom of the excavation which is then lined. Another metre of depth is then excavated, trimmed and grooved which completely undermines the lining of the first metre. This lining is supported, however, by being keyed into the annular groove. Additional support may be obtained by driving short lengths of reinforcing rod radially outward into the sides of the excavation with ends protruding into the excavation prior to placing the lining. As soon as the second metre has been prepared, it is likewise lined. Alternate excavating and lining continue downward until the water table is reached. At this point another method is necessary, since the presence of water and the usual instability of the saturated material make this method unworkable.

The most common method of lining is to pour concrete into the annular space between the excavation and a cylindrical mould. Thickness of lining varies from 5 to 15 cm with dimensions about midway between the two extremes being most common. In general, the thinner the lining the more skill and care required to get an adequate result. Prior to pouring, it is important that the mould be levelled and carefully centered using the plumb line. The mould is designed so that it can be collapsed or disassembled for removal after the lining has gained sufficient strength. After the first metre, the depth of each subsequent excavation is made between five and ten centimetres greater than the height of the mould. This leaves a space between the top of the mould and the bottom of the previously cast lining through which concrete can be placed behind the mould. This space must subsequently be trowelled full of concrete. While one metre per day could theoretically be excavated and lined, this is difficult to achieve consistently, especially at greater depths.

It is important that there be continuity between successive pourings. This can be ensured by driving lengths of reinforcing rod vertically downward into the bottom of the excavation around its periphery where the lining will be placed. When the lining is poured the upper halves of the rods become part of it. The lower halves of the rods are exposed during the subsequent excavation and become part of the next section of lining. These rods provide continuity between adjacent sections of lining.

Where moulds are unavailable, a fairly fine mesh of vertical and annular reinforcing rod can be set up around the periphery of the trimmed excavation. Concrete mortar is then trowelled into the reinforcing mesh and smoothed without the aid of a mould. This method requires more man-hours, more skill and more reinforcing rod than the previous method; however, a good mason can achieve a satisfactory result.

An alternative method uses brick or stone as a lining material. It is necessary to pour a reinforced concrete sill or ring at the bottom of each level of excavation on which to lay the brick or stone lining. This ring must extend well into an annular groove around the bottom of the excavation, so that it will support the lining above it after it is undermined.

This method minimizes the quantity of concrete, reinforcing rod and mould needed, but it increases the man-hours and skill required. It is also difficult to seal out surface water with this kind of lining.

Some efforts are being made to manufacture fibreglass half rings which can be easily installed instead of using concrete. So far the fibreglass appears to be rather costly and certainly requires sophisticated manufacturing techniques not often available where self-help wells are needed.

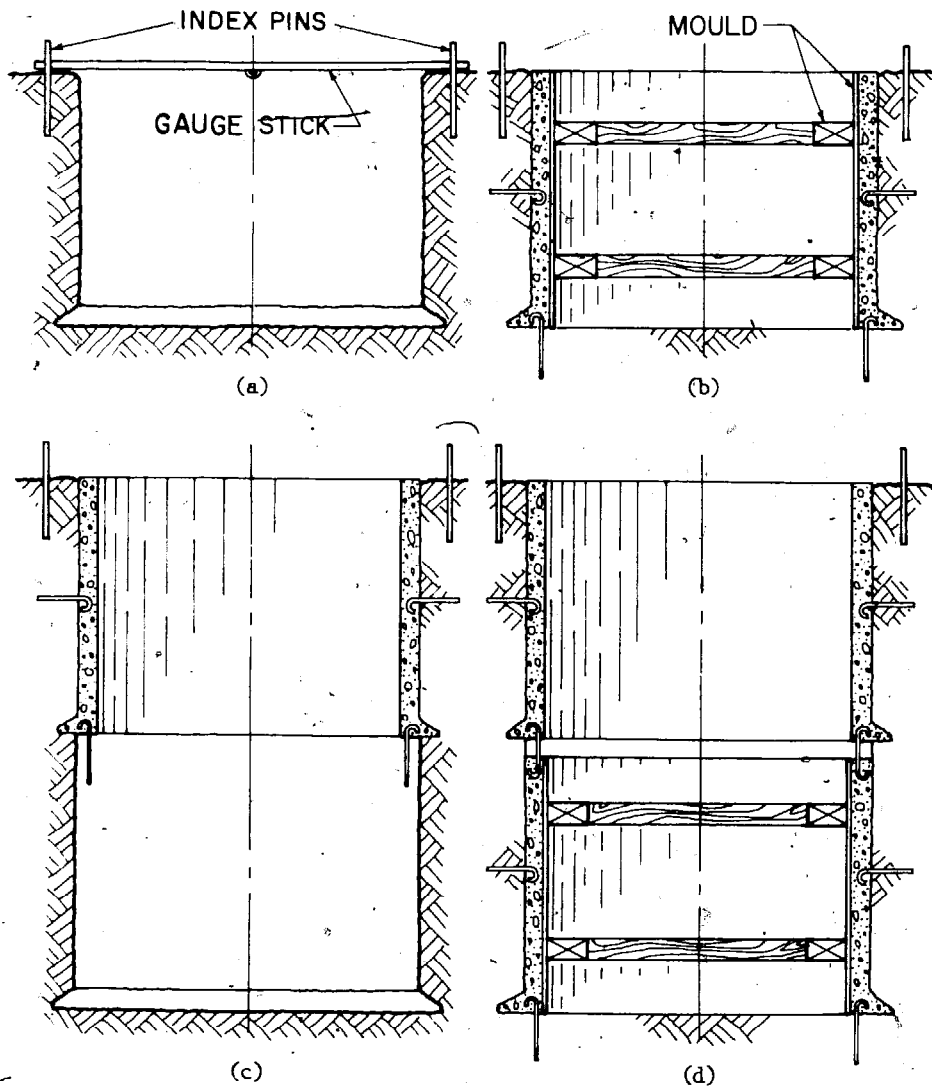

Fig. 44 Excavating and lining large diameter well. (a) excavate and trim first metre including support groove; (b) drive reinforcing rod into sides and bottom of excavation, place mould and pour concrete; (c) remove mould and excavate and trim next metre of depth; (d) drive reinforcing rod into sides and bottom of excavation, place mould and pour concrete

SYSTEM I: ALTERNATELY DEEPEN AND LINE SHAFT (approximately one metre depth is excavated and lined before repeating the process)				
General limitations and capabilities of technique	Type of lining	A. Reinforced concrete cast in place	B. Concrete trowelled into reinforcing rod grid	C. Brick or stone on concrete footing anchored into sides of excavation
Applicable above water table only, since absence of water and stability of excavation are required. Must be used in conjunction with caisson method below to finish well. Depth virtually unlimited.	1. Description	Concrete is cast in annular space formed between sides of excavation and collapsible mould.	A reasonably fine grid of vertical and annular reinforcing rod is placed around outside the excavation. Concrete mortar is trowelled into grid and smoothed without a mould.	An annular reinforced concrete ring is poured at bottom of excavation. This ring is keyed into a groove around outside of excavation and supports masonry lining laid on it.
	2. Requirements	Collapsible mould, reinforcing rod, concrete. Annular groove is cut around outside of excavation to support lining when it is subsequently undermined for further deepening.	Reinforcing rod, concrete, skilled mason. Annular grooves and/or rod driven radially into sides of excavation may be used for support during undermining.	Small mould for concrete ring, reinforcing rod, concrete, brick or stone.
	3. Advantages	Smooth, strong, uniform lining. Most commonly used method. High skill not required.	No masonry.	Quantity of concrete and reinforcing rod and size of mould minimized.
	4. Disadvantages	Cost of mould.	More manhours, skill and reinforcing rod required. Concrete will probably be less strong and dense than with mould.	More manhours, slower progress, more skill required. Lining probably not as strong as monolithic concrete. Hard to exclude surface water.

SYSTEM II: EXCAVATE TO WATER TABLE, THEN BUILD LINING UPWARD				
General limitations and capabilities of technique	Type of lining	A. Reinforced concrete cast in place	B. Brick or stone on concrete footing	C. Timber cribbing or other wood construction
Applicable above water table only, since absence of water and stability of excavation are required. Must be used in conjunction with caisson method below to finish well. Depth virtually unlimited.	1. Description	Concrete is cast in annular space between a mould and excavation. Each pour is equal to height of the mould and proceeds from bottom to surface.	An annular concrete footing is poured at bottom of excavation and lining is laid on it.	Timbers or logs laid horizontally in rectangular excavation ('log cabin' fashion). Alternatively, vertical poles with split bamboo woven horizontally around them basket fashion.
	2. Requirements	Collapsible mould, reinforcing rod, concrete.	Concrete, reinforcing rod, brick or stone.	Suitable wood.
	3. Advantages	Minimal losses of time and materials if well must be abandoned without completing. Smooth, strong uniform lining. High skill not required.	Minimal losses of time and materials if well must be abandoned without completing. Quantity of concrete and reinforcing rod is minimized.	Minimal losses of time and materials if well must be abandoned without completing. Low initial cost and manhours.
	4. Disadvantages	Unlined shaft is a safety hazard. Cost of mould.	Unlined shaft is a safety hazard. More skill and manhours required for lining. Hard to exclude surface water.	Unlined shaft is a safety hazard. Low life of living surface water not excluded.

SYSTEM III: SINK PRE-FORMED CYLINDRICAL LINING BY UNDERMINING					
General limitations and capabilities of technique	Type of lining	A. Precast reinforced concrete caisson	B. Brick or stone on reinforced concrete cutting ring	C. Prefabricated steel caisson	D. Vertical planks supported by interior horizontal rings
Applicable both above and below the water table. (Porous or perforated material used below water table to allow entry of water.) May be used exclusively or in conjunction with the above methods. Depth usually limited by friction on sides to 5-10 times the diameter.	1. Description	Cylindrical caisson has a cutting edge at bottom. It may consist of two or more sections fastened together securely or it may be monolithic, made from successive pourings.	Cutting ring is precast and lowered to bottom. Caisson is laid up on ring. Special blocks may be used so that reinforcing rod may pass through them for added strength.	Cylindrical steel with cutting edge at bottom and necessary reinforcing ribs.	Planks are sharpened on lower end and are hammered down individually as excavating proceeds.
	2. Requirements	Concrete, reinforcing rod, moulds for interior and exterior surface. Means for fastening sections together. Means for lowering caisson sections into well, if necessary.	Concrete, reinforcing rod, mould for cutting ring, brick or stone.	Cylindrical steel metal fabrication means for lowering into well.	Plank, support rings of steel or laminated wood.
	3. Advantages	Caissons may be poured at site. Does not require high skill or excessive manhours. Most commonly used method.	Quantity of concrete and reinforcing rod and size of mould minimized.	Lighter weight to lower into well. Will not crack if settling occurs. Successive sections may be bolted together.	Reasonably light pieces to lower into well. Caisson will not crack if settling occurs.
	4. Disadvantages	Moulds and lowering equipment required.	More manhours, more skill required. Caisson may crack during settling if reinforcing rod is not used.	Probably must be fabricated away from site and transported. Weight may have to be added to permit sinking.	Planks have limited life.

Table 3
CONSTRUCTION AND LINING ALTERNATIVES FOR LARGE DIAMETER WELLS

System II (Table 3, Figure 45) consists of sinking the excavation to the water table without any lining. The lining is then built from the bottom of the excavation up to the ground surface by any of the techniques described under System I.

Where potable water is not required, timber cribbing is occasionally used to line a well. This consists of horizontal timbers laid inside a rectangular shaft with the ends overlapping, "log-cabin" fashion. Where timber is abundant, this makes an inexpensive, quick lining, but one of limited life span.

Another wood lining of even more limited life consists of a number of vertical poles roughly outlining the circular excavation. These are interwoven with heavy split bamboo spiralled around horizontally to form a more or less continuous lining.

While System II is somewhat faster and easier than System I and should yield a lining with a minimum of discontinuities it cannot be recommended due to the safety hazard inherent in working at the bottom of an unlined shaft.



Fig. 45 Precast concrete caissons being set into a well excavated to the water table without lining

System III (Table 3) consists of sinking an open-ended, pre-formed cylindrical caisson by means of excavating inside it and under its edges, thus allowing it to descend under its own weight. This is the only practical system for excavating below the water table, since the sides of the excavation do not generally have enough strength to support themselves when saturated. For this reason System III is almost invariably used to finish wells which were lined by either System I or System II above the water table. In addition, a well may be

constructed by the caisson sinking system starting at ground level (5). However, in this case, the depth of the well may be limited to only ten times its diameter by the build-up of friction on the exterior of it. If a greater depth than this is desired, a second caisson which telescopes inside the first may be used. Conventionally, the part of the caisson which is below the water table is either perforated or made porous to allow the entry of water into the well. The lower edge should be bevelled inwardly to form a sharp edge to minimize its resistance to sinking. If caissons are made of steel construction, reinforcing rod should be used liberally to prevent buckling when handling, during sinking and when in place.



Well constructed by undermining precast concrete caissons starting at ground surface

Caissons are normally designed so that their height may be augmented as they progress. This helps to keep the size and weight of units which must be lifted to more manageable levels. Height augmentation can be accomplished by:

- using moulds to pour new concrete sections integrally on top of the old. In this case, there should be a continuity of vertical reinforcing rod from one section to the next;
- gradually laying up brick or stone to form a caisson of the desired height on top of a reinforced concrete cutting ring;
- adding preformed sections on top of existing sections.

In any case it is extremely important that successive sections be securely connected to prevent separation during sinking or when in use.

Several methods have been developed for connecting precast concrete sections (Figure 47):

The bottom caisson section can be cast with three or four long steel rods protruding vertically upward from it. Subsequent

sections are cast with vertical holes through them, so that they can be slid over the rods. The rods can be threaded at the upper end and nuts used to hold the stack of caisson sections together.

- (b) Three or more steel rods, straps or cables extend vertically from bottom to top along the inside surface of the caisson stack. Each is equipped with appropriate hooks to fit over the top and bottom of the stack and with a tensioning device to hold the stack together securely.

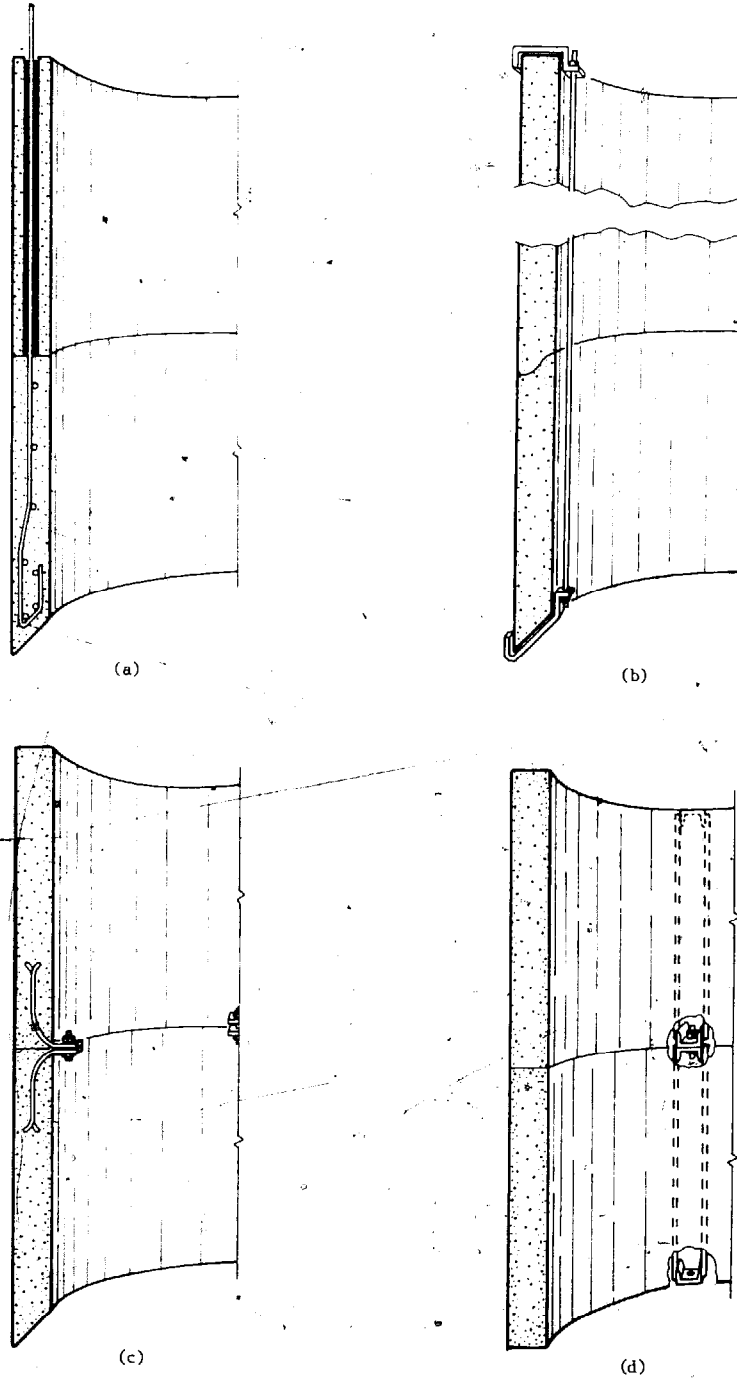

Fig. 47 Methods for attaching caisson sections. (a) caisson sections with precast holes slid over rods; (b) sections held together with rods or straps; (c) steel tabs protruding into well; (d) steel plates anchored into sections

- (c) Horizontal steel tabs at three or more locations near the top and bottom of each caisson section protrude a few centimetres into the well. The tabs at the top of a caisson section are bolted to matching tabs at the bottom of the succeeding section thus connecting them.
- (d) Small steel plates with bolt holes are set flush into the top and bottom surfaces of caisson sections. These plates are anchored into the caisson by welding them to vertical pieces of reinforcing rod prior to pouring the caisson. When the concrete for the casing is poured, a small amount is omitted around the plate. This allows a short bolt to be inserted from behind one plate. The bolt extends through the hole of a matching plate in the adjacent caisson section and a nut is used to fasten the two sections together. After all the nuts are tightened the concrete which was omitted around the fastening plates is trowelled into place. This method has a slight advantage over the previous two, since no fasteners protrude into the well.

In addition to masonry caissons, steel, plank and brick caissons are sometimes used. Steel caissons may require fabrication skills and equipment not available near the well site. Plank caissons consist of vertical planks with the lower ends sharpened and arranged around interior support rings. As excavation proceeds, the individual planks are hammered downward. The life of a plank caisson would generally be considerably less than that of a masonry casing, particularly the parts exposed to air from time to time.

The arrangement for allowing water to enter the well through the sides of the caisson (Figure 48) is probably the most crucial feature of the well and is frequently its least satisfactory feature. It sometimes becomes the "Achille's heel" of an otherwise well constructed well.

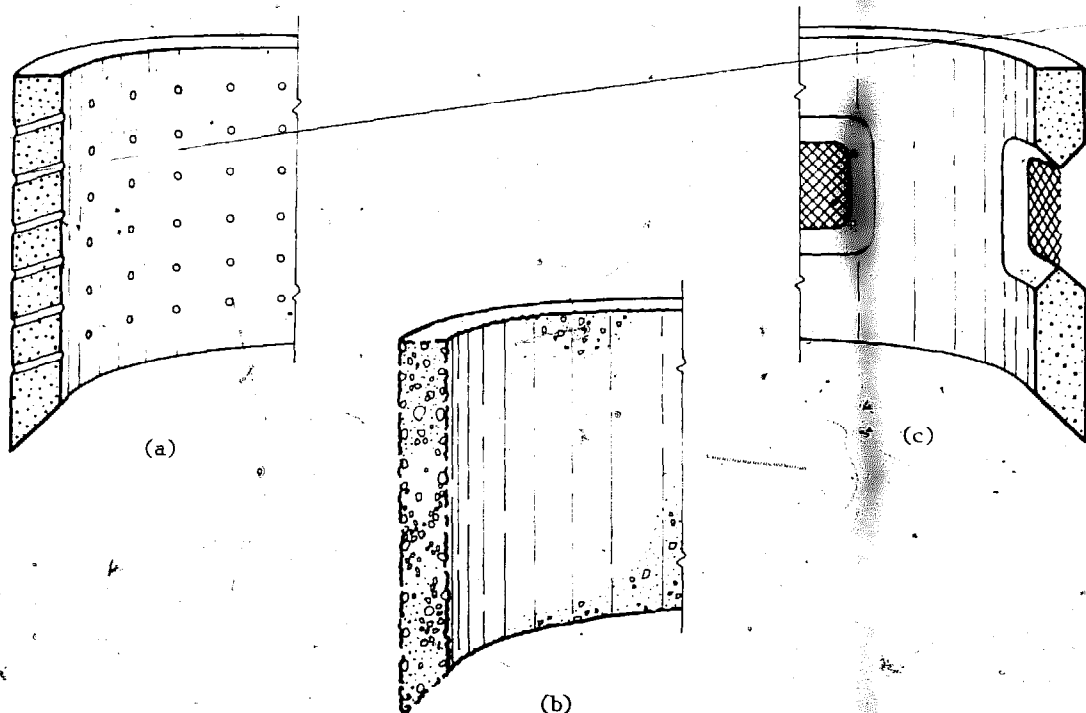

Fig. 48 Methods for allowing water inflow through caisson walls
(a) cast holes in caisson; (b) porous concrete;
(c) 'windows' of perforated stainless steel plate

Moulds for well caissons are frequently provided with holes through which pieces of small diameter rod can be inserted. These rods are withdrawn after the concrete in the mould has partially set, leaving holes through the caisson wall by which water may enter the well. Unless the aquifer is relatively coarse, however, such holes tend to be too few and too large in diameter. As a result fine material in the aquifer may be entrained with the water and carried into the well. This will necessitate removal of the fine material from the well periodically. Gradually large voids may develop in the aquifer outside the casing. Eventual collapse of these voids may also cause the bottom of the well to collapse rendering it useless. The inflow holes are sometimes inclined upward going from outside to inside to impede the entrance of fines. It is questionable how effective this technique is. Fine gravel may be introduced between the outside of the caisson and the well lining during sinking in an effort to form a gravel pack around the caisson. Such a gravel pack can improve permeability and reduce the quantity of fines entering the well.

An alternative is to make the caisson out of porous concrete. This is done by reducing the sand from the usual cement-sand-coarse aggregate mixture. A suggested ratio of cement:sand:coarse aggregate is 1:1:4. Porous concrete thus made is considerably less dense and strong than normal concrete. It should, therefore, be made with more reinforcing and be handled more carefully than conventional concrete. This method does, however, provide a large infiltration area and prevent fine material from entering the well.

A second alternative consists of making 'windows' in the caisson walls out of stainless steel plate with reasonably fine perforations. This can prevent the entrance of fines, but since the 'windows' make up a rather small percentage of the caisson area, the inflow of water may also be limited.

Other systems use an impermeable caisson and rely on water entering from the bottom of the well or through well screens sunk vertically into the well bottom or forced out radially through ports in the caisson. These will be described in more detail later.

The caisson is sunk by removing a uniform layer of material from the bottom of the well working as closely to the edge of the caisson as possible. As sinking of the caisson proceeds, it must be watched closely to assure that it is remaining vertical. If one side is sinking less rapidly than the other, excavation should be somewhat concentrated at that point in an attempt to restore the caisson to a vertical orientation. If the situation persists a chain or cable from the ground surface may be attached to the low side of the caisson and strain put on it with a winch or tackle to retard the descent at that point.

As the caisson is sunk below the water table the inflow of water to the well begins to impede further excavation. Bailing is then usually alternated with digging. This slows progress greatly, and not infrequently causes the well digging to be concluded at an inadequate depth. Constructing or deepening the well at the time of the year when the water is at a minimum level may help to alleviate this problem somewhat. Where available, motor pumps are sometimes used to keep the well drained. However, if the well is reasonably deep, centrifugal pumps may not have the lift capability required. The practice of putting a motor pump into the well, where air exchange is poor, is highly dangerous to anyone in the well due to the accumulation of carbon monoxide. The solids entrained in the water cause excessive wear in most kinds of pumps. For this reason diaphragm pumps are commonly used for draining excavations.

A better solution appears to be the development of methods allowing excavation to be carried out under water. Such methods are not generally in use. An exception is the use of conventional power cranes or drag lines with clam shell or orange peel type buckets. Analogous methods need to be developed for low

capital, labour intensive projects. Two possibilities are proposed: (i) a large, heavy bailer or mud scow, similar to those described in the section on small diameter wells. This could be actuated by workers at the ground level and guided by a worker on scaffolding near the bottom of the well; and (ii) a small orange peel or similar type of bucket. Like the bailer, this would be raised and lowered by workers on the ground level and guided by a worker near the bottom of the well.

The capability of excavating below water would allow the caisson to be sunk to the desired depth and would be an important asset in the construction of hand dug wells.

5.5 EQUIPMENT FOR RAISING AND LOWERING MATERIALS

Since all excavated material must be hoisted up out of the well and all construction material for lining, caissons, etc. must be lowered into the well, as well as workers being raised and lowered multiple times daily, a safe and adequate system for doing this must be devised (Figure 49).

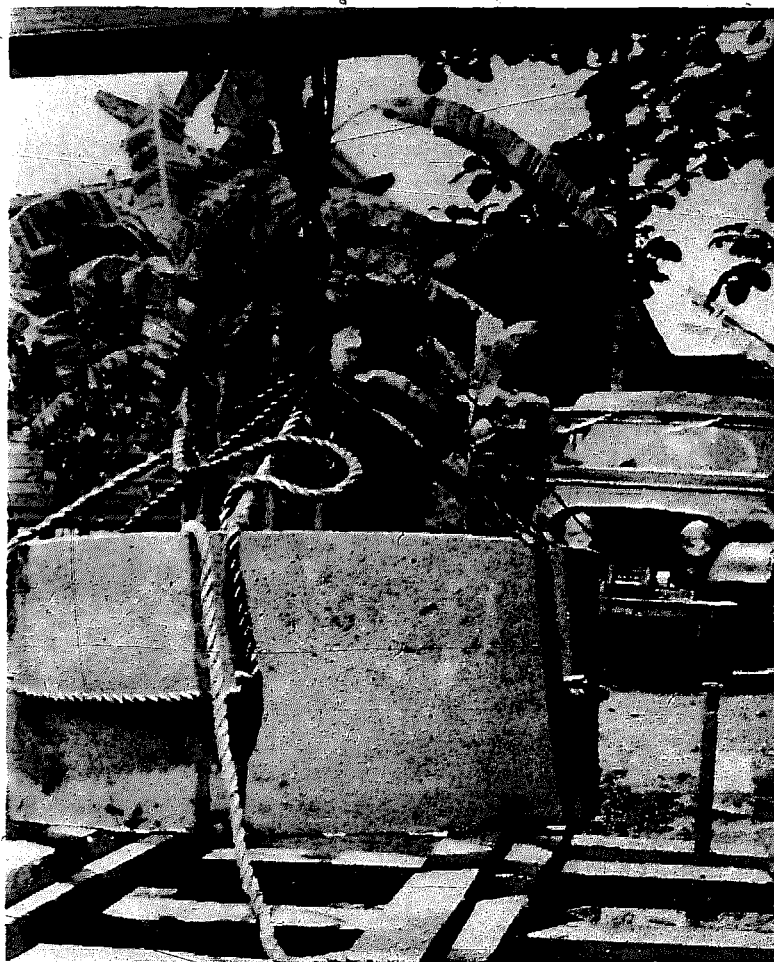

Fig. 49

Caisson being lowered into well by means of overhead pulley and steel cable paid out by jeep winch

A minimum requirement is a strong rope and pulley located quite accurately over the centre of the well at least shoulder high. It can be suspended from a tripod such as the one shown in Figure 9 or from a cross beam on vertical supports. In either case, the legs or vertical supports should be set in concrete or deeply buried to ensure stability when heavy horizontal loads are put on the rope passing through the pulley. The pulley support, pulley and rope or cable used must be capable of supporting the heaviest load encountered which will undoubtedly be the caisson sections. A reinforced caisson section one metre high, 130 cm outside diameter, and a wall thickness of 7.5 cm would weigh approximately 800 kg. Sometimes caissons are made in half metre sections to reduce the weight. This would require as a minimum a manilla hemp rope of 30 mm diameter, a pulley diameter of 20 cm and a cross timber of sound, hard wood 25 cm by 25 cm in cross section if the distance between supports is 2.5 metres. Alternatively, a steel cable of 12 mm diameter might be used. It should be emphasized that these are minimum dimensions.

Various hand winches which have hand cranks, gear reduction, cable drum, ratchets and hand brake can be purchased for use on well construction projects. The reel must be large enough to accommodate adequate cable to reach the bottom of the well. These are somewhat expensive, and while convenient, they are not absolutely necessary. Lowering heavy loads can be accomplished by wrapping the rope three or four turns around a smooth round post set securely into the ground some distance from the well (Figure 50). Enough friction is developed between the rope and the post, so that workers holding back on the free end of the rope can lower a heavy weight without difficulty. This post should be about the height of a man and its top should lean away from the well, so that there is no tendency for the rope to work off the top of the post. The heaviest load which must be raised is the weight of one man. This can be raised by 3-5 workers. The free end of the rope should be run around the brake post and kept taut by an additional worker to eliminate any possibility of the worker being dropped. The same practice should be followed when raising excavated material out of the well to protect the worker at the bottom of the well.

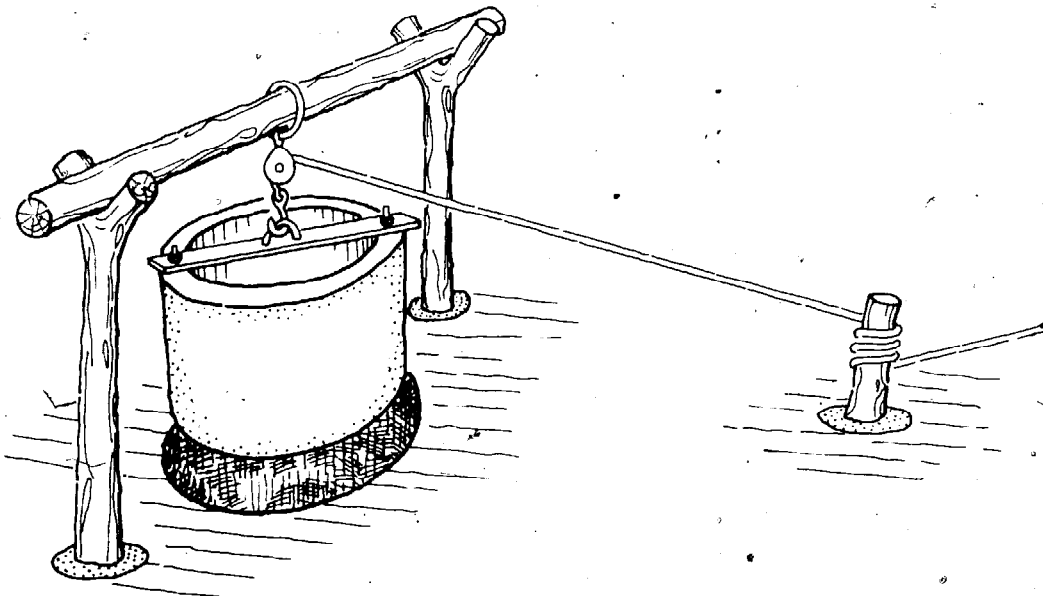

Fig. 50

Lowering a caisson using a brake post

5.6 MOULDS

Commercially manufactured moulds for well lining and for caissons are available. These can give excellent results with only a modest amount of skill and a minimum of labour (Figure 51). Such moulds, however, are relatively expensive and the decision on whether or not to buy them depends on how many wells are to be constructed, the availability of the necessary capital, available skills and the cost of labour. Less expensive moulds can be manufactured locally. These may require slightly more time and skill to obtain a good result. One such mould is shown in Figure 52. It consists of a 2 mm thick sheet metal facing which is tensioned around two wooden rings. This type of mould can be used for lining wells or for forming the interior surface of caissons. After the concrete has set, the wooden rings can be collapsed and removed. The sheet metal can then be removed.

Moulds can be made entirely of wood. In this case the facing is usually made of narrow wooden strips running parallel to the axis of curvature. These facing strips are attached to wooden ribs to make up sections of a cylinder, either exterior or interior. These sections must be joined in such a way that they can be easily disassembled for removal. In order to get a good surface finish, a mould must be thoroughly cleaned and oiled before each pouring.

The simplest lowest cost mould is one formed by carefully digging the desired shape into the earth and filling it full of concrete. This, however, requires considerable time and skill to attain dimensional accuracy and good surface finish. Caissons can be produced by carefully making a cylindrical excavation to act as the mould for the external surface. A grid of vertical and annular reinforcing rod is set up in the mould. Concrete mortar is trowelled into the reinforcing grid and is then hand smoothed. In this way the need for an internal mould is eliminated. Some means for attaching to the caissons must be provided, so that they can be lowered into the well.

Precast concrete culvert sections can be used as caissons provided a means is worked out for fastening them securely together.



Fig. 51. Caisson sections made with commercially fabricated mould
(Note perforations in surface to admit water)

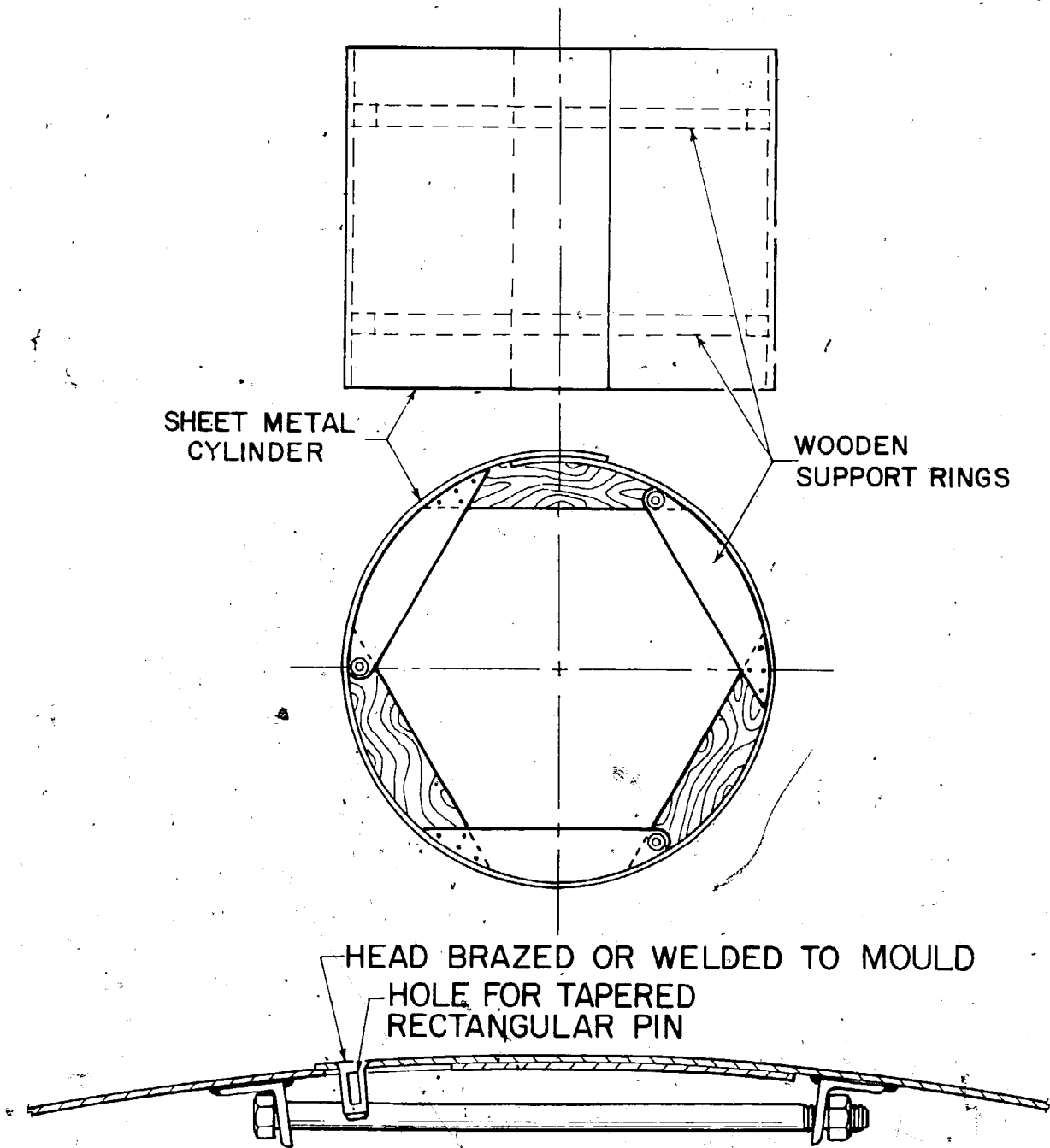

Fig. 52

Locally fabricated mould

5.7 CONCRETE WORK

Concrete frequently plays an important role in well construction. Good practice may be especially crucial to the success and useful life of large diameter wells. Many books and articles have been written on recommended practices, so only a few principles and rules of thumb will be mentioned here.

A suitable mix for use on well construction might have an approximate volumetric ratio of:

<u>Water</u>	<u>Portland Cement</u>	<u>Fine Aggregate</u> (sand)	<u>Coarse Aggregate</u> (gravel or crushed stone)
3/4	1	2 1/2	3 1/2

Water should be clean and only as much used as is necessary to make it possible to place the concrete. The smaller the quantity of water the stronger the concrete. If the sand is damp or wet, less water will be required. Both sand and gravel should be free of fine material such as silt or clay. If necessary, these fines can be washed out by spreading the aggregate on a screen and flushing water through it.

Both the sand and the coarse aggregate should have a gradation of size in their particles. The largest particles of the coarse aggregate should not be bigger than 1/3 the thickness of the piece being cast. Concrete which has partially hardened in the sack should not be pulverized and used, since it will have very low strength.

If mixing is done by hand it is customary to make a mixing platform of thin, weak concrete at least 2 metres by 2 metres. The ingredients for one batch are measured onto this platform, are thoroughly mixed dry, and then the water is added.

When the concrete is placed in moulds, voids can be eliminated by running a slender rod up and down repeatedly in the concrete and by tapping the mould with a hammer.

Concrete should be cured by keeping it moist for at least seven days and longer if possible. This will add appreciably to its strength. This can be done by keeping it covered with damp sand, soil, straw or burlap.

Concrete is strong in compression, but relatively weak in tension. The purpose of using steel reinforcing rod is to obtain adequate tensile strength without having to make the concrete too massive. Where concrete is cast in place, is very well supported by stable material and does not extend over large areas, it may not be necessary to reinforce it. However, when concrete is cast in one location, moved to another, and then has questionable support as in the case of caissons, reinforcing is a necessity. Normal practice is to use two sets of reinforcing rods at right angles to each other (e.g. vertical and annular in caissons). The two sets are bound together by light wire at intersection points to form a rigid grid. Normal practice in a caisson might be 6 mm or 8 mm reinforcing rod on 10-15 cm centres in both directions. Any dirt or rust should be cleaned from reinforcing rods before use.

5.8 SAFETY

Certain dangers are inherent in the construction of large diameter wells. Every effort should be made to minimize hazards.

The danger of cave-in can be effectively eliminated by lining each metre of excavation as it is made. Two other types of accidents can happen:

- i. The worker at the bottom of the well being struck by a falling object; either the bucket used for removing excavated material, a tool or other piece of equipment.
- ii. A worker falling into the well either when working around it or when entering it.

The first type of accident can be minimized by:

- a. having a permanent attachment between the bucket and the rope and always having the free end of the rope snubbed around the brake post;
- b. having any tools or equipment which must be used near the edge of the well attached to a securely anchored cord and keeping the ground around the well free of any debris or excavated material;
- c. providing the worker in the well with a hard hat. Needless to say, a worker should never be in the well when a heavy piece such as a caisson is being lowered.

Accidents of the second kind can be avoided by:

- a. keeping the ground around the well even and free of obstacles;
- b. keeping the free end of the rope secured at the brake post, so that it can be grabbed by anyone who loses his balance;
- c. providing an adequate bosun's chair for the person entering the well and always keeping the free end of the rope snubbed around the brake post while raising or lowering a worker. Locally made rope may not be reliable or durable. For this reason, use of manilla hemp rope is recommended as a safety precaution. Rope should be inspected frequently for damage or wear. It should also be kept as free of dirt and grit as possible.

A rope ladder may be used to enter and exit from the well, but this is quite tiring for the worker. Particularly in warm climates, the bottom of a well is a hot, stuffy place to work. After the well has reached a certain depth, consideration should be given to ventilating the well. Such devices as large blacksmith's bellows or hand-powered blowers connected to large diameter tubing have been used.

5.9 FINISHING LARGE DIAMETER WELLS

When the water in large diameter wells is drawn down considerably below its static level the pressure exerted on the material at the bottom of the well by the water in the well may be appreciably less than the pressure exerted on it by the water surrounding the well. Under these circumstances a so-called "quick" condition can occur causing the bottom material to heave or flow upward, partially filling the well. This is an indication that the caisson is not sufficiently permeable and is offering too much resistance to the inflow of water from the aquifer.

If the bottom material which flows in is repeatedly removed, a cavity can form around the outside of the caisson. The collapse of this cavity can seriously damage or destroy the well.

This problem can be remedied by weighting the bottom of the well either with a disk of porous concrete or with a layer of medium to coarse gravel or crushed stone. In either case a thickness or depth of 20-25 cm would probably be sufficient.

A better long range solution is to find methods for improving the porosity of the caisson, thus reducing its resistance to inflow.

All large diameter wells should have a parapet approximately waist high. In addition to greatly reducing the risk of children, adults and animals falling in, it also greatly reduces the amount of debris which is blown or kicked into the well.

The type of construction around the top of the well is determined by the function of the well. If it is intended for domestic water supply, a circular platform of impervious concrete should extend out from the well 2-3 metres. The platform should slope away from the well. In one case a rim around the outside of the platform was designed to collect all spilled water which was then led to a livestock watering trough. In any case, spilled water should be drained away from the well.

If the well is to be used for irrigation, the type of water raising device will determine what kind of superstructure is needed. If a hand or motor pump is used, the top of the well can be closed with a precast concrete slab, thus eliminating a source of contamination.

6. HYBRID WELLS

The difficulty of constructing large diameter wells which adequately penetrate the aquifer and which combine minimal resistance to inflow through the caisson with structural stability has led to some modifications. Two of these incorporate well screens of the type found in small diameter wells into large diameter wells. In both systems an unperforated large diameter caisson is sunk a certain distance below the water table. In the first system (Figures 53 and 54) one or more well casings with well screen are sunk vertically into the aquifer below the large diameter caisson by one of the methods described for small diameter wells. Since it is usually feasible to sink the casing to any desired depth, the possibility for placing the well screen in highly permeable material is good. The combination of increased depth and permeability can result in a well with increased yield. Since inflow is through the vertical pipe(s) the bottom of the well can be stabilized with a layer of concrete.

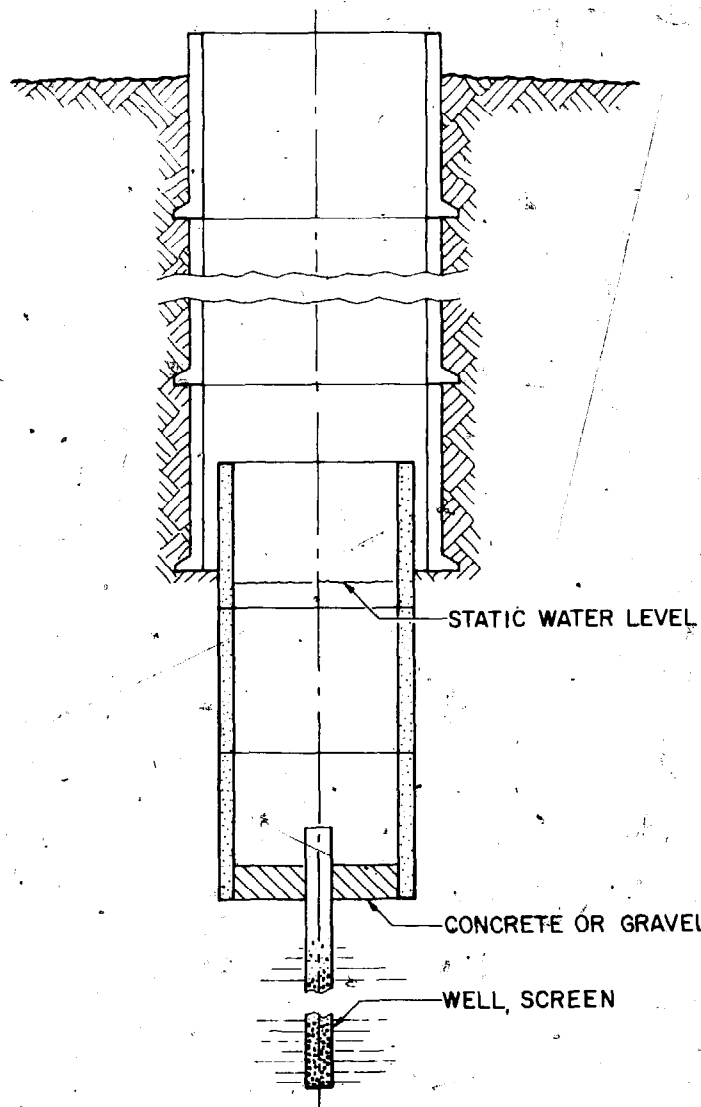

Fig. 53 Large diameter well with vertical casing and screen

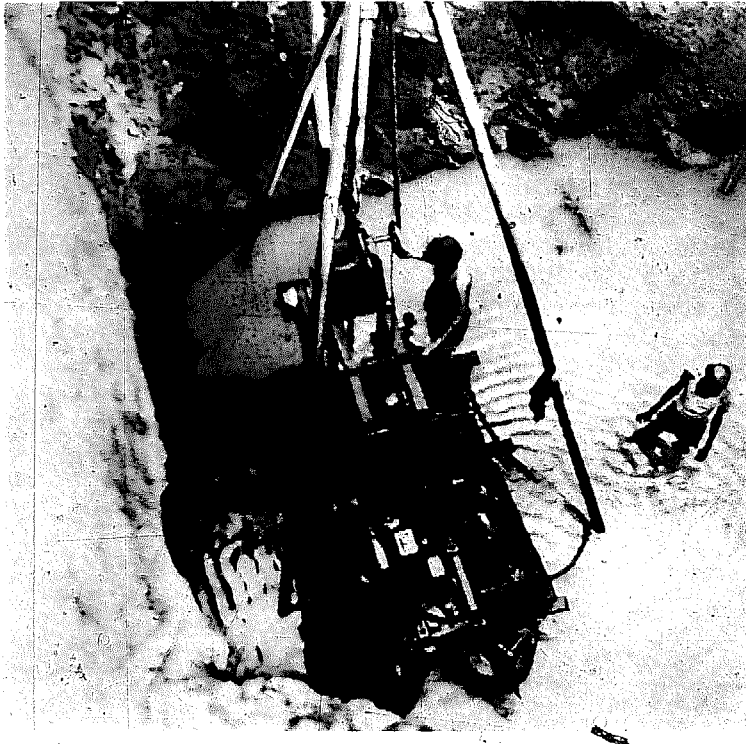

Fig. 54

Sinking a casing and well screen into the bottom of a large diameter well to increase inflow

The second system (Figure 55), sometimes called a collector well, uses well screens which extend out horizontally and radially through the wall of the caisson. These screens are similar to large drive points and are forced out into the aquifer through precast ports in the caisson by means of jacks.

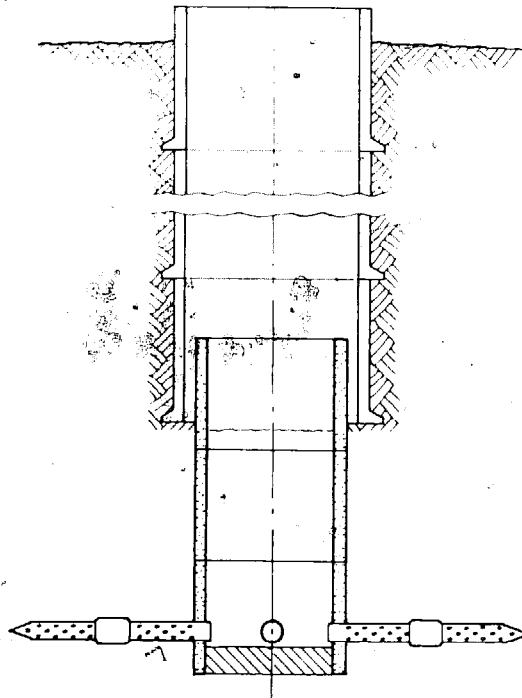

Fig. 55

Large diameter well with radial well points

7. NON-VERTICAL WELLS

The infiltration gallery is a horizontal chamber constructed below the water table. It is used where large inflow area is needed due to low permeability. It is constructed by excavating a large trench. This trench is lined with gravel and a row of precast concrete cylinders is laid along the axis of the trench to form the gallery. Joints are left open enough to permit the entry of water. The gravel pack is completed around the gallery and the trench is backfilled. Provision is made to pump water from the gallery. Where it is desired to purify unclean or silt-laden stream or river water an infiltration gallery can be constructed parallel to and a short distance from the stream.

Ghanats (also Kanats, Quanats, etc) are slightly inclined tunnels the upper end of which intersects the water table usually in alluvial material at the base of a mountain or foothill. Water flows along the floor of the tunnel until it intersects the ground surface at some location of lower elevation. Vertical shafts extend from the ceiling of the tunnel to the ground surface. These serve the dual purpose during construction of providing ventilation and as an exit for the excavated material. Ghanats have been constructed in the Middle East for the past 2 500 years. They may be several kilometres long and have been used both for irrigation and municipal water supply. Many are still in use in certain regions of Iran (Photo, page 78).

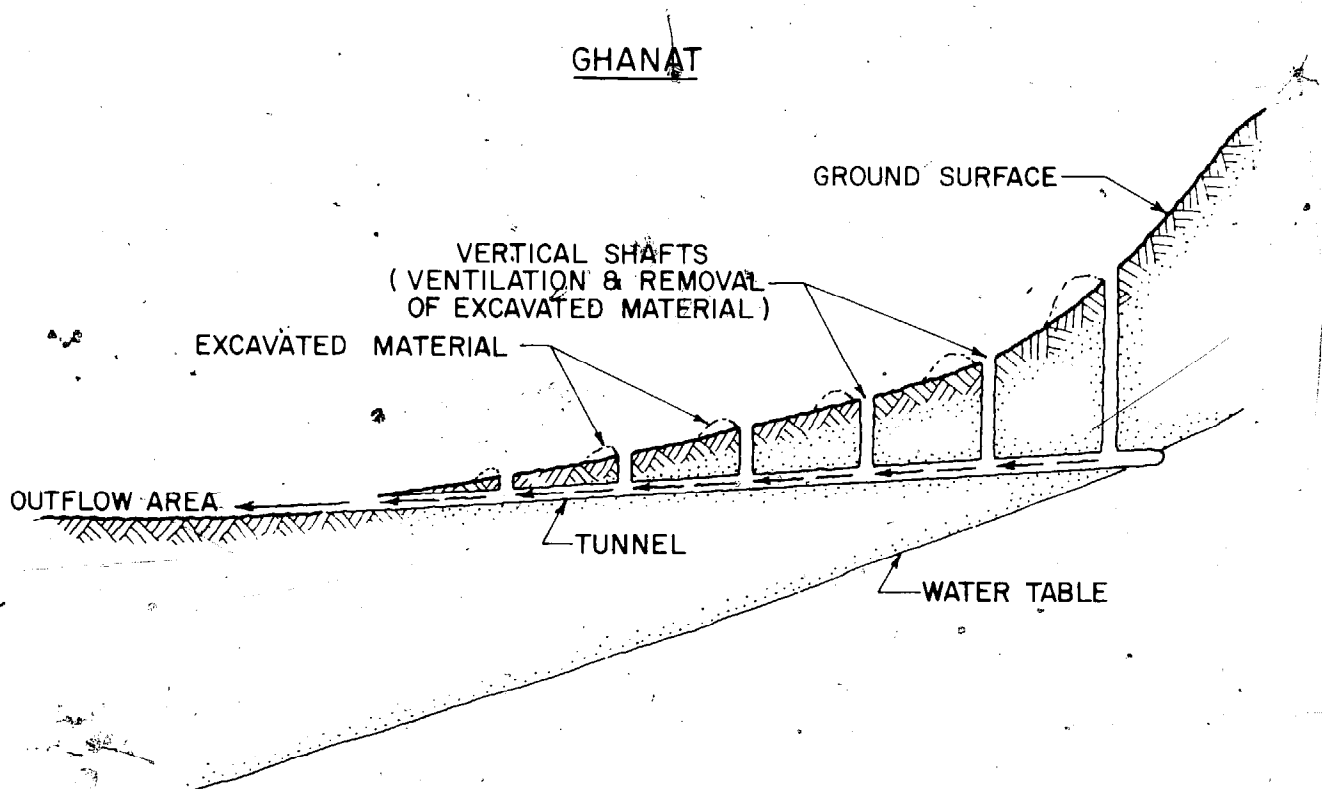

Fig. 56

Ghanat

8. HEALTH ASPECTS

Health aspects need to be considered during all phases of the well construction and operation. Such considerations include:

Avoiding areas of poor water quality

Shallow wells penetrate only the upper part of the groundwater body which characteristically is of the poorest quality. A check should be made on other wells in the area since this will give a good indication of the quality that can be expected in the new well. If a high salt content is suspected, a water sample from the new well should be sent to a laboratory to determine its usability for drinking. Deepening of such wells can sometimes improve quality. The deepening can be done with a small diameter tubewell in some cases or by using a reduced size concrete wall.

Proper location of the well to avoid contamination

A simple survey of past activity in the area will assist in well location. A well should not be constructed in a contaminated area. As a general rule a well for drinking should not be located within 50 metres of any contaminated areas such as livestock pens, old washing areas, sanitation facilities or heavily contaminated streams or channels. Even though such a facility has been removed from the area, it is possible that contamination will remain in the ground and continue to enter the groundwater for several years. In addition these types of facilities should not be built in the area of the completed well.

Proper well design to prevent contamination

The greatest source of well contamination is from water entering the well-head or from water moving down the outside of the casing. Providing a water-tight seal around the outside of the casing (concrete or other compacted material) is very effective in preventing movement of water around the casing. This seal should extend from the surface approximately one metre or more down. In addition providing a sloping concrete apron (or other suitable material) around the well will facilitate drainage of excess water away from the well. Facilities must also be provided to dispose of the drainage water such as percolating it some distance from the well or using it to irrigate vegetation in the area, or for cattle watering. In addition to the water-tight seal around the casing and the sloping apron around the well, the well-head should be constructed above ground level and precautions taken which prevent any drainage water or other contamination from entering the well.

Health safety precautions during well construction

Various types of contamination can occur during construction of the well and all efforts should be made to minimize these. All equipment should be cleaned prior to use in a new well since the soil on digging equipment that was used in another area is one source of contamination. Chemicals used in construction work should also be stored a safe distance away from the well. Hand-dug wells are especially susceptible to contamination from the workers. This risk can be reduced by simple, hygienic precautions during construction. Above all, defecation within the well or in the immediate vicinity of the well should be strictly prohibited.

Disinfection of the well prior to use

Even though precautions are taken during construction, all wells should be disinfected prior to use. Especially in the case of hand-dug wells, this should

include scrubbing the walls of the well with a suitable disinfectant. One of the most easily obtainable and effective disinfectants is common household chlorine bleach which should be diluted 1:50 (1 part chlorine bleach to 50 parts of water) to give a chlorine solution. To provide this dilution, the volume of water in the well should be estimated and the appropriate disinfectant poured in; however, the total volume of household chlorine bleach used should not exceed 3 litres. If a pump is installed on the well the well should then be pumped for a short period of time with the pumped water returning into the well. This will disinfect the pumping equipment as well as mix the well water and disinfectant. The well should then be allowed to stand for several days (2-5 days) to allow the chlorine to dissipate. Prior to use the well should be bailed out or pumped until the smell of chlorine is faint. The remaining chlorine in the well will dissipate in a few days and cause no problems in using the well. If a disinfectant other than household chlorine bleach is used, check to ensure that it will dissipate or can be removed from the well. Many disinfectants are very effective but leave a residue which may be harmful since they were never intended to be used for drinking water or they may prove to be very difficult to remove.

Health safety precautions in operating the well

When the well has been completed, the key to its continued use as a safe drinking water source will be the user. Training the local people in simple health safeguards is the most effective control measure, although simple precautions in well design will also assist. As a general rule, no washing or cooking should be permitted in the well area and proper design of the well head can discourage this practice. Defecation or urination in the well area should be prohibited. Entering the well should also be prohibited except when required for maintenance. If this is needed, after maintenance the well should again be disinfected. Animals should not be permitted in the well area and their watering facilities should be at a safe distance. The apron around the well should be kept as clean and dry as possible to prevent mud forming around the well which can be a breeding area for hookworms and other infections. Where a pump is not used, a community bucket and rope should be provided to prevent well contamination from unsanitary buckets used to draw water. Efforts should be made to prevent this community bucket from being set on the ground where it may pick up contaminated soil which is then returned to the well on the next water draw. Where pumps are used, they should be self-priming; if not, a suitable clean water supply should be provided for priming to prevent contaminated water from being used.

The methods used to prevent contamination of a constructed well will depend strongly on the local customs and habits. A quick review of these in the light of possible contamination will prove most useful in suggesting prevention measures. Public education will be the chief mechanism in implementing these prevention measures; however, this must be co-ordinated with an adequate maintenance programme. Without proper maintenance of the well all measures to prevent future contamination may fail. Sometimes two people are assigned each day to raise the drinking water for the small village and no-one else is allowed on the apron. This custom or some variety of it will be easily accepted if it is similar to existing habits.

AVAILABILITY OF SKILLS AND MATERIALS

The skills and materials available for self-help projects vary greatly, even within different localities of a given country. The methods or techniques selected will be strongly influenced by local availabilities. Any technique which relies on specialized equipment or materials imported from a distant country cannot generally be considered suitable for self-help projects. On the other hand some materials which are routinely imported and are almost always available locally may be used in limited quantities if their prices are not prohibitive (e.g. cement, pipe, etc.). In general, however, self-help projects should use indigenous materials to the greatest extent possible.

Where skills are not locally available, they can frequently be taught and the upgrading of skills might be considered as important as the finished project itself.

Table 4 shows three arbitrarily chosen levels of skills and materials available. Frequently a given country may have a relatively high level in and around population centres with lesser levels in the more remote regions. Since it is precisely in more remote regions that self-help projects are most needed, it is probably better to err in the direction of simplicity and labour intensity than in the direction of technical sophistication.

Table 4. Levels of Skills and Materials Available

LEVEL	SKILLS AND FACILITIES	MATERIALS
I	Blacksmith with traditional equipment and capability of forge welding. Carpenter with limited hand tools.	Wood, stone, steel drums, parts from discarded vehicles and machinery, locally made rope.
II	Blacksmith with traditional equipment plus hand-powered drill press, grinder, and hacksaw and oxy-acetylene welder. Carpenter with all common hand tools, sheet metal workers, stone cutter and/or brickmaker, mason.	As above plus: brick, cut stone, cement, sawed lumber, sheet metal, pipe, reinforcing rod, common structural steel (angle iron, iron channel etc), threaded fasteners, manilla rope, steel cable, chain.
III	As above, plus: machinist with metal working machines (lathe, mill etc.), arc welding equipment, sheet metal fabricating equipment. Engine mechanic.	As above plus: engines, winches, pumps, drive points and pipe, well screen, plastic pipe.

REFERENCES

- Agency for International Development. Village Technology Handbook. Department of
1963 State, Washington D.C. 20523.
- Bowman I. Well-drilling Methods. Water-Supply Paper 257. US Geological Survey,
1911 Department of the Interior.
- Brantly J.E. History of Oil Well Drilling. Gulf Publishing Company, Houston, Texas
1971 77001.
- Gibson and Singer. Small Wells Manual. Office of War on Hunger, Agency for
1969 International Development, Washington D.C. 20523.
- Giese H. A Practical Course in Concrete. Portland Cement Association, Chicago,
1948 Illinois.
- Ground Water and Wells. E.E. Johnson Inc., St. Paul, Minnesota.
1966
- Huisman L. Groundwater Recovery. Winchester Press, New York.
1972
- Johnston C.N. Irrigation Wells and Well Drilling. Circular 404, Calif. Agric. Exp.
1951 Sta., University of California.
- Koegel R.G. Equipment and techniques for the construction of self-help wells. 16(6).
1974 Transactions of Amer. Soc. Agric. Engrs., St. Joseph, Michigan.
- Meinzer O.E. The Occurrence of Groundwater in the United States. Water-Supply
1923 Paper 489. US Geological Survey, Department of the Interior (Reprint 1959).
- Peace Corps. Wells Manual. Programme and Training Journal Publication,
1975 Washington D.C.
- Preble R.E. Well drilling in Southeast Asia. New England Water Works Assoc. J.
1971 85(2).
- Rohwer C. Putting Down and Developing Wells for Irrigation. Circular 546, US
1940 Department of Agriculture, Washington D.C.
- Todd K.T. Ground Water Hydrology. John Wiley & Sons, New York.
1959
- UNICEF. Rural water supply and sanitation in the developing countries. Guide List
1975 OLGA. United Nations, New York 10017.
- US War Dept. Well Drilling. Technical Manual TM5-297.
1943
- V.I.T.A. The Construction and Maintenance of Water Wells. 3706 Rhode Island Ave.,
1969 Mt. Rainier, MD 20822.

Watt S.B. and Wood W.E. Hand Dug Wells. Intermediate Technology
1976 Development Group Ltd., London.

White A.U. and Seviour C. Rural Water Supply and Sanitation in Less-Developed
1974 Countries. (Annotated Bibliography) I.D.R.C., Box 8500, Ottawa, Canada.

NOTE:

In addition to the formal publications listed above, there are many informal reports on well construction within governmental agencies responsible for public works, public health, development and agriculture, and within voluntary agencies, both religious and secular.

ILLUSTRATIONS
OF SELF - HELP WELLS



Small diameter (10 cm) village self-help well
equipped with hand pump

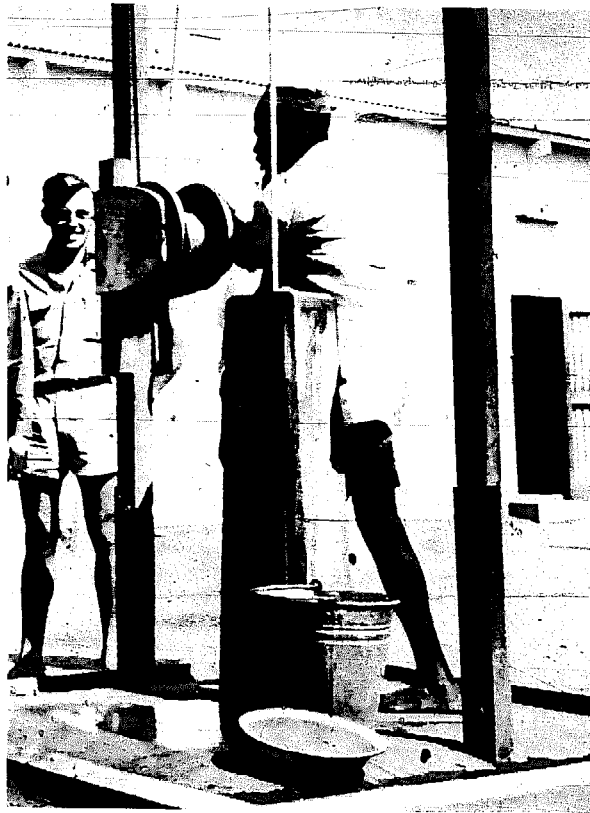

Small diameter well (10 cm) equipped with slender bucket as water supply for 70 people at an agricultural school. Note casing ends approximately one metre above the ground surface to minimize contamination

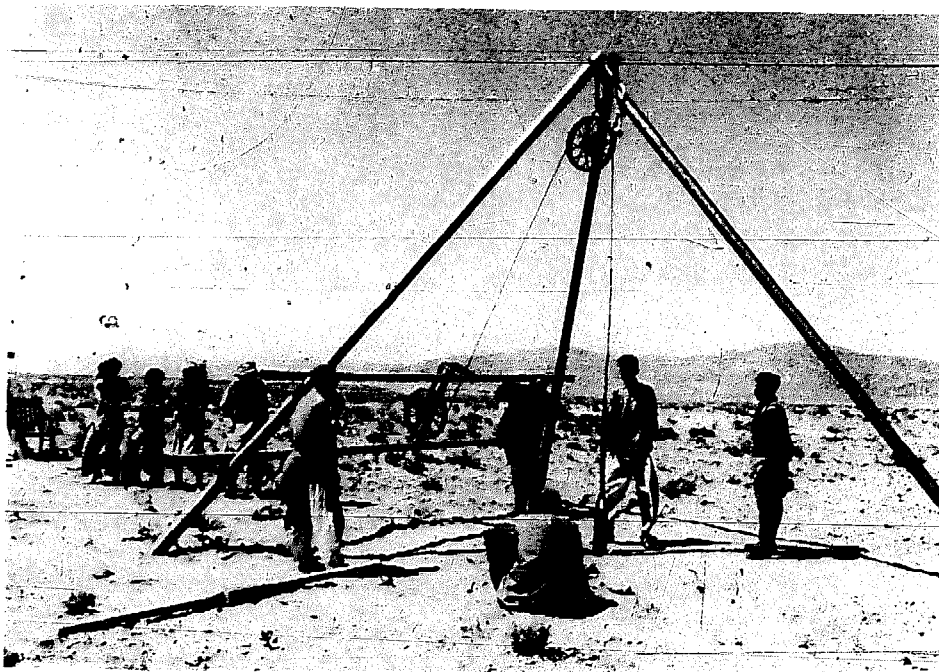

Simple drilling apparatus using motorcycle wheels and 4 inch pipes



Small diameter (10 cm) village self-help well equipped with slender well bucket



Large diameter self-help well equipped with animal-drawn skin bucket and small reservoir for irrigating vegetable crops



Large diameter village self-help well. (Note rim around platform to divert spilled water to animal watering trough.)



6 diameter well equipped with stone channel to irrigation system into
which skin buckets are emptied



Traditional animal-drawn, skin bucket on large diameter well used in irrigating orchard



Students learning to repair village well pump



Debris from vertical shafts of a Ghanat
in alluvium

FAO IRRIGATION AND DRAINAGE PAPERS

1. Irrigation practice and water management, 1971 (E* F* S*)
2. Irrigation canal lining, 1971 (E**** F**** S****)
3. Design criteria for basin irrigation systems, 1971 (E**)
4. Village irrigation programmes — a new approach in water economy, 1971 (E* F*)
5. Automated irrigation, 1971 (E* F* S**)
6. Drainage of heavy soils, 1971 (E* F* S****)
7. Salinity seminar, Baghdad, 1971 (E* F*)
8. Water and the environment, 1971 (E* F* S*)
9. Drainage materials, 1972 (E* F* S*)
10. Integrated farm water management, 1971 (E* F* S*)
11. Planning methodology seminar, Bucharest, 1972 (E* F*)
12. Farm water management seminar, Manila, 1972 (E*)
13. Water-use seminar, Damascus, 1972 (E* F*)
14. Trickle irrigation, 1973 (E* F* S*)
15. Drainage machinery, 1973 (E* F*)
16. Drainage of salty soils, 1973 (E* F* S*)
17. Man's influence on the hydrological cycle, 1973 (E* F* S**)
18. Groundwater seminar, Granada, 1973 (E* F* S**)
19. Mathematical models in hydrology, 1973 (E*)
20. Water laws in Moslem countries, Vol. 1, 1973 (E* F* A****)
Water laws in Moslem countries, Vol. 2, 1978 (E*)
21. Groundwater models, 1973 (E*)
22. Water for agriculture, 1973 (E** F** S**)
23. Simulation methods in water development, 1974 (E** F** S**)
24. Crop water requirements (Revised), 1977 (E* F* S*)
25. Effective rainfall, 1974 (E* F* S*)
26. Small hydraulic structures (Vols. 1 and 2), 1975 (E* F**** S*)
27. Agro-meteorological field stations, 1976 (E* F**** S****)
28. Drainage testing, 1976 (E* F**** S****)
29. Water quality for agriculture, 1976 (E* F* S*)
30. Self-help wells, 1977 (E*)

Availability: February 1978

E - English	* Available
F - French	** Out of print
S - Spanish	*** In preparation
A - Arabic	**** New edition in preparation in the FAO Land and Water Development Series

FAO Irrigation and Drainage Papers are available through authorized
FAO Sales Agents or directly from Distribution and Sales Section,
FAO Via delle Terme di Caracalla, 00100 Rome, Italy