

 **Disabled Village Children - A Guide for Community Health Workers, Rehabilitation Workers, and Families (Hesperian Foundation, 1999, 676 p.)**

 **PART 2: WORKING WITH THE COMMUNITY:**

 **Village Involvement in the Rehabilitation, Social Integration, and Rights of Disabled Children**

 **(introduction...)**

 **Chapter 44: Introduction to PART 2: Disabled Children in the Community**

 **Chapter 45: Starting Village-based Rehabilitation Activities**

 **Chapter 46: Playgrounds for All Children**

 **Chapter 47: CHILD-to-child: Helping Teachers and Children Understand Disabled Children**

 **Chapter 48: Popular Theater**

 **Chapter 49: Children's Workshop for Making Toys**

 **Chapter 50: Organization, Management, and Financing of a Village Rehabilitation Program**

 **Chapter 51: Adapting the Home and Community**



**Chapter 52: Love, Sex, and Social Adjustment**

**Chapter 53: Education: At Home, at School, at Work**



**Chapter 54: Work: Possibilities and Training**



**Chapter 55: Examples of Community-Directed Programs**

**Disabled Village Children - A Guide for Community Health Workers, Rehabilitation Workers, and Families (Hesperian Foundation, 1999, 676 p.)**

**PART 2: WORKING WITH THE COMMUNITY: Village Involvement in the Rehabilitation, Social Integration, and Rights of Disabled Children**



**Figure**



## Figure

### Chapter 44: Introduction to PART 2: Disabled Children in the Community

**In PART 1 of this book, we discussed ways of working with individual children according to their particular disabilities. However, a lot of what can make life better - or more difficult - for a child comes not from the child's disability itself, but from the way that people in the family and community look at and treat the child.**

**In this part of the book (PART 2) we look at ways to actively involve members of the community - disabled persons, their families, concerned adults, schoolchildren, and others - in meeting the needs of disabled children and in helping them find a meaningful place in the community.**

#### **A DISABLED CHILD GROWING UP HAS THE SAME NEEDS AS OTHER CHILDREN, FOR...**

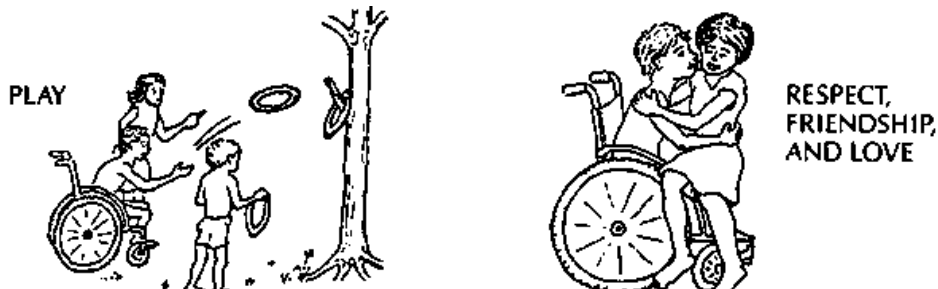

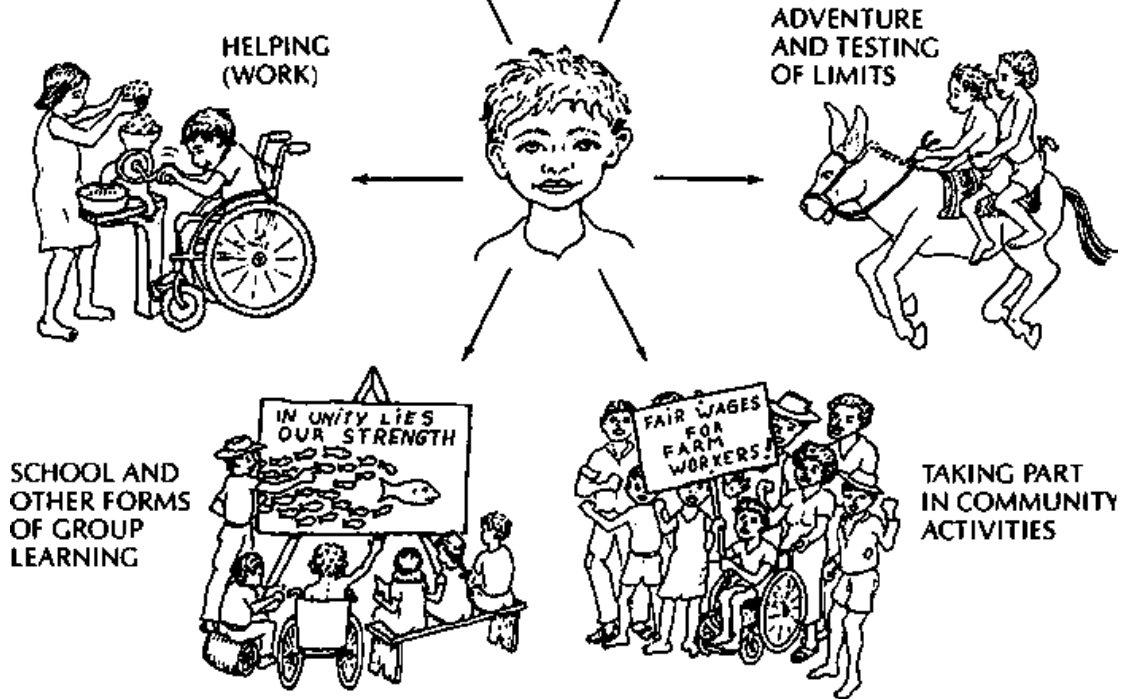

Figure

**In every society, disabled children have the same social needs as other children. They need to be loved and respected. They need to play and**

**explore their world with other children and adults. They need opportunities to develop and use their bodies and minds to their fullest ability, whatever that may be. They need to feel welcome and appreciated by their family and in their community.**

**Unfortunately, in most villages and neighborhoods, disabled persons - including children-are not given the full chance they deserve. Too often people see in them only what is wrong or different without appreciating what is right.**

### **DIFFERENT COMMUNITIES REQUIRE DIFFERENT APPROACHES**

**The way people treat disabled persons differs from family to family, community to community, and country to country.**

- Local beliefs and customs sometimes cause people to look down on disabled persons. For example, in some places, people believe that children are born disabled or deformed because their parents did something bad, or displeased the gods. Or they may believe that a child was born defective to pay for her sins in an earlier life. In such cases, parents may feel that to correct a deformity or to limit the child's suffering would be to go against the will of the gods.**
- Lack of correct information often leads to misunderstanding. For example, some people think that *paralysis* caused by polio or cerebral palsy is**

**'catching' (contagious), so they refuse to let their children go near a paralyzed child.**

- **In many societies, children who have fits or *mental* illness are said to be possessed by the devil or evil spirits. Such children may be feared, locked up, or beaten.**
- **Failure to recognize the value and possibilities of disabled persons may lead to their being neglected or abandoned. In many countries, parents give their disabled children to their grandparents to bring up. (In return, many of these children when they grow up take devoted care of their aging grandparents.)**
- **Fear of what is strange, different, or not understood explains a lot of people's negative feelings. For example, in communities where polio is common, a child who limps may be well accepted. However, in a community where few children have physical disabilities (or where most who do are kept hidden), the child with a limp may be teased cruelly or avoided by other children.**
- **How severe a disability is often influences whether or not the family or community gives the child a fair chance: In some parts of Africa, children with polio who manage to walk, even with braces or crutches, have a good chance of becoming well accepted into society. The opposite is true for children who never manage to walk. Even though most could learn**

**important skills with their hands and perhaps become self-sufficient, the majority of non-walkers die in childhood, largely from hunger or neglect.**

**• Where poverty is extreme, a child's disability may seem of small importance. When this family in Sri Lanka was asked about their disabled child, the mother said her biggest worry was that the roof of their hut leaked. The village rehabilitation workers organized neighbors to help build a new roof. Only when the basic needs of food and shelter were met, could the mother give attention to her child's disability.**



**(Photo: Philip Kgosana, UNICEF, Sri Lanka.)**

## **Overprotection**



**Certainly not all disabled children are neglected or treated cruelly. In Latin America (where this book was written) a disabled child is often treated by the family with an enormous amount of love and concern. It is common for parents to spend their last peso trying to cure their child, or to buy her vitamins or sweets, even at the cost of hardship for the other children.**

**Providing too much protection is one of the biggest problems in Latin America and elsewhere. The family does almost everything for the child, and so holds her back from developing skills and learning to care for herself. Even a child with a fairly *mild disability* is often not allowed to play with other children or go to school because her parents fear she will be teased, or unable to do as well as the others.**

**Even in Latin America, where families usually provide loving care for their disabled children, they often keep them hidden away. Seldom do you see a disabled child playing in the streets, helping in the marketplace, or working in the fields. Partly because disabled persons are given so little chance to take part in the life of the community, everyone assumes that they cannot - and should not. Disabled children often grow up as outsiders in their own village or neighborhood. They are unable to work, unable to marry and have children, unable even to move about and relate freely to others in the community. This is not because their disabilities prevent them, but because society makes it so difficult.**

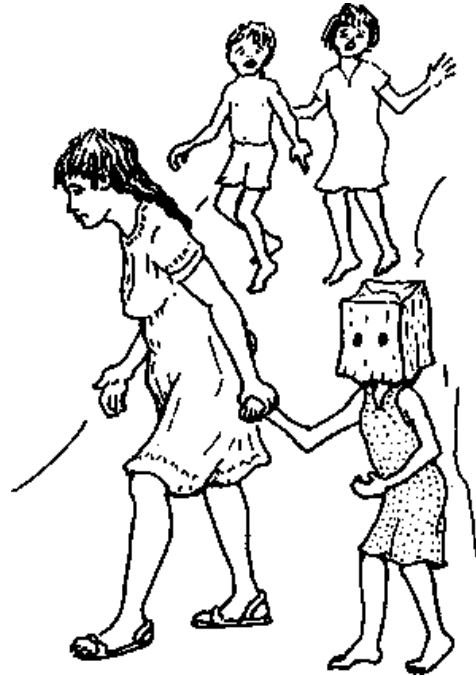

**In one Latin American border town, a mother brought her child to a clinic with her head covered by a paper bag - to hide a deformity of her mouth (cleft lip).**

**Yet things do not have to be like this. In the village of Ajoya, Mexico, people used to stare at, turn their backs on, or express their sorrow for the occasional disabled child whom they saw. But now things have changed.**

**Ajoya has become the base of a community *rehabilitation* program (PROJIMO) run mainly by disabled young people.**

**In Ajoya, disabled children and their parents are now comfortable about being seen in public. Non-disabled and disabled children play together in a 'playground for all' built by the village children with their parents' help. The community has helped build special paths and ramps so wheelchair riders can get to the stores, to the village square, in and out of some homes, and to the outdoor movie on Saturday nights.**

**Mari, a young woman who is paraplegic (paralyzed from the waist down), first came to Ajoya from a neighboring village for rehabilitation. She soon became interested in the village program and decided to stay and become a worker. Today Mari keeps the records, helps interview and advise disabled children and their families, and is learning how to make plastic leg braces. She has become one of the most important members of the PROJIMO team.**

**But Mari does not want to go back to her own village. "It's depressing there!" she says. "I never go out of the house. I don't want to. The people don't treat me like myself anymore. They don't even treat me like a person. They treat me like a cripple, a nothing. One time I tried to kill myself. But here in Ajoya it's a different world! People treat me just like anybody else. I love it here! And I feel useful."**

**Her fellow team members in the village rehabilitation center are trying to**

**convince Mari to go back sometime to her own village as a rehabilitation worker. They offer to help her change people's attitudes there, too. Mari is still uncertain. But the PROJIMO team has begun to visit Mari's village. Already the families of disabled children there have begun to organize. The village children have helped build a 'playground for all', and adults have built a small 'rehabilitation post' next to it. So, things have begun to change in Mari's village too. The 'different world' has begun to grow and spread.**



**Mari helps another spinal cord injured girl with her exercises.**

**In PART 2 of this book we look at ways to help the community respond more favorably to disabled children and their needs. Usually, of course, a village or neighborhood does not decide, on its own account, to offer greater assistance, acceptance, and opportunity to disabled persons and their families. Rather, disabled persons and their families must begin to**

**work together, to look for resources, and to re-educate both themselves and their community. Finally - when they gain enough popular understanding and support - they can insist on their rights.**

**The different chapters in PART 2 discuss various approaches and possibilities for bringing about greater understanding of the needs and possibilities of disabled children in their communities. We start by looking at what disabled persons and their families can do for themselves and each other. We look at possibilities for starting a family-based rehabilitation program, and the importance of starting community-directed rehabilitation centers run by disabled villagers themselves. We explore ways to include village families and school children. Finally, we look at specific needs of the disabled child growing up within the community - needs for group play, schooling, friendships, respect, self-reliance, social activities, ways to earn a living or to serve others; also needs for love, marriage, and family.**

### **EXAMPLES, NOT ADVICE**

**In this part of the book, which deals with community issues, we will try mostly to give examples rather than advice. When it comes to questions of attitudes, customs, and social processes, advice from any outsider to a particular community or culture can be dangerous. So as you read the experiences and examples given in these pages, do not take them as instructions for action. Use, adapt, or reject them according to the reality of**

**the people, culture, needs, and possibilities within your own village or community.**

**Each community is unique and has its own obstacles and possibilities.**

## **Chapter 45: Starting Village-based Rehabilitation Activities**

### **TOP-DOWN OR BOTTOM-UP?**

**Around the world today there are many examples of what have sometimes been called 'community-based rehabilitation programs'. Some of these programs are 'top down'; others are 'bottom up'.**

#### **Top-down: Chain of command**

**Top-down programs or activities are mostly planned, started, organized, and controlled from outside the community: by government, by an international organization, or by distant 'experts'. And the local leaders are usually persons in positions of authority, influence, or power.**



Figure

### Bottom-up: Equality in decision-making



Figure

**Bottom-up programs or activities are those that are largely started, planned, organized, and controlled locally by members of the community. Much of the leadership and direction comes from those who need and benefit most from the program's activities. In brief, the program is small, local, and 'user-organized'.**

**Community participation is important to both top-down and bottom-up programs. But it means something different to each:**

**In top-down programs, people are asked to participate only in ways that**



**have already been decided from above. For example, a decision might be made by a team of foreign specialists that certain persons in each community be selected as 'local supervisors'. The local supervisors are taught several pre-decided 'packages' of cookbook-like information. Each supervisor then instructs a given number of 'local trainers' (family members of the disabled) how they 'must train' each particular disabled person. Thus 'community participation', from the viewpoint of the experts, means 'getting people to do what we decide is good for them'.**

**In bottom-up programs, 'community participation' means something else. The program develops within a village or neighborhood, according to the needs and wishes of its members. It may take an outsider with some knowledge in rehabilitation and skill in organizing people to help get things started. But it is the people themselves, especially disabled persons and their families, who make the decisions about their own program. They can learn from other programs and from the experts. But they do not simply copy or follow others. They pick and choose from whatever advice and information they can get in order to plan activities that fit the needs and possibilities of their particular village, and their particular children.**



**In the village of Ajoja, Mexico, over 60 families participated in building a cement walkway from the rehabilitation center to the main street.**

**There are advantages and disadvantages to top-down and bottom-up. For a central government, a standardized, top-down approach is easier to introduce, administer, and *evaluate* in many communities at the same time. But in primary health care, it has become clear that top-down programs frequently fail or have serious weaknesses, mainly because they do not have enough popular leadership, understanding, and personal commitment. These are especially important for rehabilitation. Every disabled child is different and has her unique combination of needs. An imaginative, problem-solving approach is essential. If decisions and plans come pre-packaged from above, rehabilitation measures often do limited good and sometimes even harm.**

**In a bottom-up approach there is a greater sense of equality, and of**

**arriving at decisions together. People do not just follow instructions. They consider suggestions. They want to know *why*. This greatly increases the chances that exercises, aids, and activities will really fit the individual needs of the child. It also makes rehabilitation more interesting, meaningful, and valuable for all concerned. It helps both parents and children become more independent.**

**A bottom-up approach to rehabilitation has the advantage of flexibility and adaptability that comes from being organized and controlled locally. Planning is a continuous learning process that responds to the changing needs, difficulties, and possibilities within the community. Especially when disabled persons and family members play a leading role, participants at every level are likely to develop a spirit of respect, friendliness, and equality that keeps a program human and worthwhile.**

**Above all, a bottom-up program organized by those it serves, decentralizes and redistributes power: people who have been powerless begin to find strength through unity. You can never be sure where things may lead, how far people may go in terms of taking charge of their own lives or in demanding their rights.**



**On the following pages we look at community rehabilitation activities and programs from a 'bottom-up' approach in a village situation. This is where our own experience lies. For a different approach with more of the planning from above, we suggest you see the World Health Organization's *Training Disabled Persons In the Community* along with the supplementary materials. For a sharp analysis of different approaches, read Mike Miles' *Where There Is No Rehab Plan*.**

## **STARTING IN A VILLAGE-WHERE TO BEGIN?**

**Rehabilitation of disabled persons within a village or neighborhood usually has two major goals:**

- 1. To create a situation that allows each disabled person to live as fulfilling, self-reliant, and whole a life as possible, in close relation with other people,**
- 2. To help other people - family, neighbors, school children, members of the community - to accept, respect, feel comfortable with, assist (only where necessary), welcome into their lives, provide equal opportunities for, and appreciate the abilities and possibilities of disabled people.**

**One of the best ways to bring about better understanding and acceptance of disabled people is to involve both disabled and non-disabled persons in**

**shared activities. The next few chapters discuss selected community activities that can help improve people's understanding and respect for the disabled. These can be introduced either as part of a rehabilitation program, or independently by concerned persons such as parents, school teachers, or religious leaders. Some of these activities, in fact, have proved to be good ways to create interest and open discussion with local people about starting a small community-based program.**

**There are many possibilities for getting people in a village or neighborhood more actively involved. Often a good way to start is to call a meeting to bring together disabled persons and family members of the disabled. Sometimes one or more leaders in the community happen to have a child or close relative who is disabled. These persons, with a little encouragement, may take the lead in organizing other families with disabled children, or in starting a local rehabilitation program.**

**It makes sense to start where people express their biggest concern. For example, in Peshawar, Pakistan, a community program for *retarded* children was started because families of these children expressed a strong need. In Nicaragua, a group of disabled revolutionaries with *spinal cord injuries* started a program to produce low-cost wheelchairs to meet their particular needs. In Mexico, *physically disabled* village health workers started a community program for disabled children and their families. Today, these 3 programs have all expanded their coverage to include a far wider range of**

**disabilities than they started with.**

**Some children have several disabilities, so it is hard to limit attention only to certain ones. We must try to meet the needs of the whole child, within the family and within the community. However, it often works best to start in a small and fairly limited way, wherever people are ready. Let things grow and branch out from there, as new concerns arise and new people become involved.**



**In a community program everyone helps out. Here the mother of a boy with polio sews cloth to form 'stockings' for use under plaster casts.**

**Who gets things started?**

**Within a community or neighborhood there will often be persons eager to become involved in starting rehabilitation activities or even a program. All it may take is something to 'spark the idea'. This spark can be in the form of a person, a pamphlet, or even a radio program that triggers people's imaginations with ideas or basic information.**

**For example, we know of one village medic, herself disabled by polio, who received a WHO magazine with an article on "Rehabilitation for All." As a result, she began to organize the villagers to build a simple rehabilitation playground. In a similar fashion, CHILD-to-child activity sheets have sometimes inspired teachers to conduct activities that help school children to prevent certain disabilities or to behave toward disabled children in a more friendly, welcoming way.**

**Often, to get things started, it takes a person with some background in rehabilitation and in community work, to stay for a while in a village or neighborhood. Her role is to bring together people with similar needs, helping them to form a plan of action and to obtain the information and special resources they need.**

**Such a 'resource person' is sometimes called an 'agent of change'. She need not be a highly-trained professional in rehabilitation or social work. In fact, persons who have professional degrees often have the hardest time accepting that parents and disabled persons can and should be the primary**

**workers and decision makers in a community rehabilitation program.**

**What is necessary is that the agent of change be someone who respects ordinary people, and is committed to helping them join together to meet their needs and defend their rights.**

**The agent of change should be a counselor, not a boss; a provider of information and choices, not orders or decisions. Especially when such a person comes from outside the community, her role is to stay in the background, to help the people make their own decisions and run their own program. At all costs she avoids taking charge.**

**Staying in the background, however, is easier said than done, especially for an agent of change who is deeply committed. To make sure that a program is run by the people, not by outsiders, it is often a good idea that agents of change and any visiting professionals not be present all the time. Instead, they should encourage the program to continue without them. Perhaps the final test of an agent of change's success is to leave the community forever, without her absence being much noticed. These ideas are said beautifully in this old Chinese verse:**



*Go in search of Your People;  
Love Them;  
Learn from Them;  
Plan with Them;  
Serve Them;  
Begin with what They have;  
Build on what They know.*



*But of the best leaders  
when their task is  
accomplished,  
their work is done,  
The People all remark:  
"We have done it Ourselves."*

Figure

To help start a program for the disabled, it often works out better if the agent of change is also disabled. This helps make the *outsider* an *insider*.

### Disabled persons as leaders and workers in rehabilitation activities

Some of the most exciting and meaningful community rehabilitation activities in various parts of the world are those that are led and staffed by disabled persons themselves. When the leaders and workers in a program are disabled, they can be excellent role models for disabled children and their parents. When they see a team of disabled persons working together productively, doing more to help other people than most able-bodied persons do, and enjoying themselves in the process, it often gives both family and child a new vision and hope for the future. This alone is a big first step toward rehabilitation.

**Another reason for recruiting leaders and workers who are mostly disabled persons (or their relatives) is that they are more likely to work with commitment, to give of themselves. From their own experience, they understand the problems, needs, and possibilities of disabled persons. Because they, too, have often suffered rejection, misunderstanding, and unfair treatment by society, they are more likely to become leaders in the struggle for a fairer, more fully human community. Their weakness contributes to their strength.**



**Disabled workers give an example to disabled children that they can lead a helpful, full life. Polo Leyva, severely disabled by polio, has become a skilled welder and wheelchair maker.**

Examples of community rehabilitation programs run by local disabled persons are in Chapter 55.

## **Kinds and levels of village-based activities**

**There is no formula or blueprint for starting a village rehabilitation program. How things get started will depend on various factors: the size of the village, the number and nature of disabled children, the interests and talents of parents and other persons, the resources available, the distance and difficulties for getting specific rehabilitation services elsewhere. Also consider the possibilities for getting assistance (voluntary, if possible) from *physical therapists* and other rehabilitation professionals, craftspersons, health workers, schoolteachers, and others with skills that could be helpful.**

**If rehabilitation is ever to reach most of the children who need it, most rehabilitation activities must take place in the home with the family members as the primary rehabilitation workers. And even where plenty of money and professional services are available, the home and community are still the most appropriate place for most of the rehabilitation of most disabled children.**

**For home-based rehabilitation to be effective, however, parents need carefully prepared and selected information, friendly encouragement, and assistance. And at times they will need back-up services of rehabilitation and medical workers with different kinds and amounts of skills.**

**A good arrangement, perhaps, is a referral chain, starting with rehabilitation in the home with guidance from a small community center run**

**by local, modestly trained workers. If possible, the center has close links with the nearest low-cost or free *orthopedic* hospital and professionally-run rehabilitation center, to which the relatively few children with disabilities requiring surgery or complex *therapy* can be referred. Outside professionals (*orthotists, therapists, and others*) can help by making periodic teaching visits to village rehabilitation centers. They can also invite village workers to visit and apprentice with them in their city shops and clinics. (*Apprentice* means to learn by helping someone more skilled.)**

**Some villages will be too small or lack the resources to start their own community rehabilitation center. However, it has been found in several countries that once a modest center in one village opens, the word spreads. Disabled children with family members soon begin arriving from surrounding villages. In time the rehabilitation team may be able to help disabled persons and their families in neighboring villages to organize their own sub-centers. Disabled workers from these sub-centers can learn by 'apprenticing' at the original center.**

## **OUTREACH AND SUPPORT SYSTEM FOR A VILLAGE REHABILITATION CENTER**

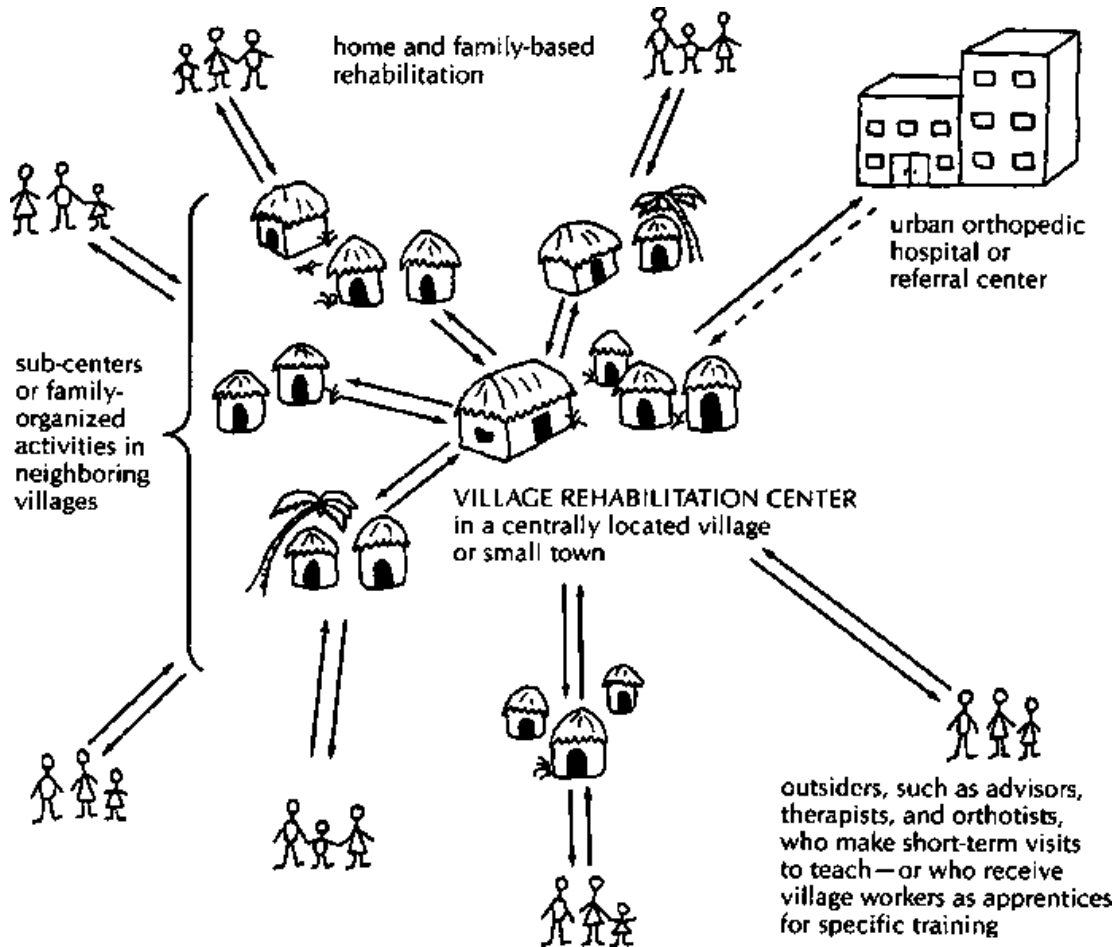

## Figure

**The above 'ideal' is more or less the way Project PROJIMO in Mexico works, although with certain difficulties and obstacles.**

### **The role of a villager-run rehabilitation center**

**Some of the most important rehabilitation activities take place with the family in the home. Others take place in the school, the marketplace, the village square, and, when necessary, in the nearest orthopedic hospital. The key to helping all this happen can be the village rehabilitation center.**

**A village rehabilitation center run by modestly trained disabled workers, together with the families of disabled children, can provide a wide range of services. These may include training and support of families, community activities, non-surgical orthopedic procedures, and making orthopedic and rehabilitation aids. The program need not try to do everything at first, but can start with what seems most important and gradually add new skills and activities as needs and opportunities arise.**

**Eventually, a community team can gain considerable skill in many areas. For example, the village team of PROJIMO is able to adequately attend the needs of about 90% of the disabled children it sees (except for blind or deaf children for whom its services are still not adequate). Only about 10% need referral to orthopedic hospitals or larger rehabilitation centers. Visiting**

**experts have found that at times the therapy or aids provided by PROJIMO are more helpful than those previously provided to the same children by professionals in the cities.**

**The chart on the following page gives an idea of possible activities and functions of a village rehabilitation center. It also lists activities of possible 'sub-centers' in neighboring villages, as well as referral and support services needed from urban orthopedic and rehabilitation centers, and outside specialists.**



**Organizing the community to build a 'playground for all children' is one of the best ways to increase participation and to integrate disabled and non-disabled children in a way that everyone enjoys.**

## POSSIBLE ACTIVITIES AND FUNCTIONS OF REHABILITATION CENTERS AT DIFFERENT LEVELS

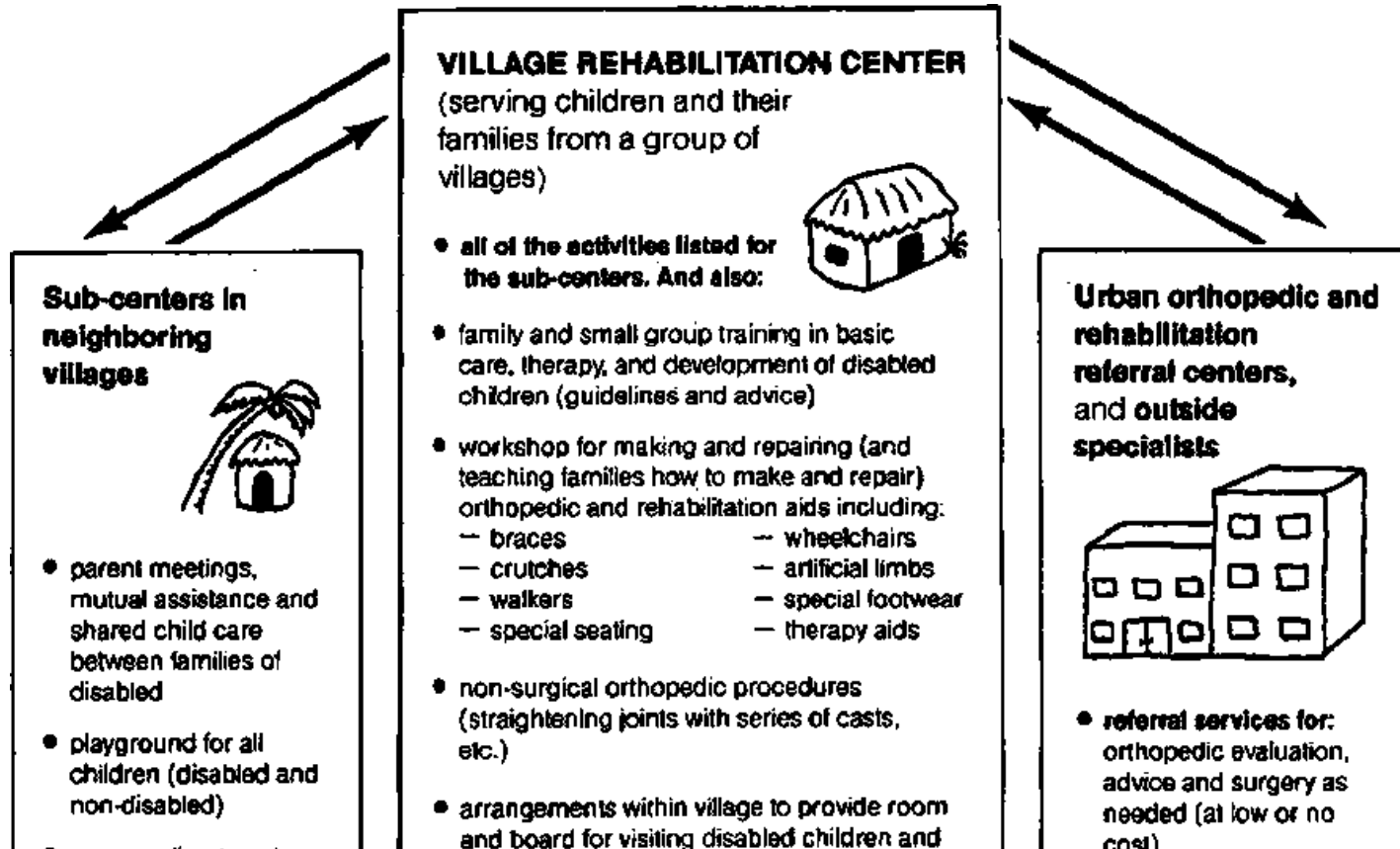



- group action to get disabled children into school
- special group activities for children who cannot attend normal school
- community awareness raising activities:
  - skits
  - CHILD-to-child
  - involving school-children and villagers in building playground, improving accessibility, making toys and equipment
- organized (group) visits to the village rehabilitation center in the neighboring village
- educational and preventive activities

family members from neighboring villages

This may include:

- village families who are willing to take in visiting families at low cost
  - a 'model home' where visiting families can stay, equipped with low-cost adaptations and equipment for better function and self-care by the disabled
  - coordination, informal training, visits and advice to parent groups or sub-programs in neighboring villages
- workshops and/or agricultural projects where disabled youth can learn income-producing skills to bring in some income to the program or family
  - prevention campaigns, for example:
    - vaccination against polio and childhood diseases, with special focus on underserved families and communities
    - education campaign against overuse and misuse of injections
  - activities to involve and include as much of the community as possible (adults and children) in the program; possibly,
    - help with therapy
    - help with play and entertainment
    - accompany disabled children on outings,

- orthopedic and rehabilitation equipment too complicated to be made at village level
- periodic visits by orthopedic surgeons to village rehabilitation center to evaluate possible surgical needs of selected children
- short teaching visits (3 days to 1 month) by visiting specialists (physical therapists, occupational therapists, special teachers, brace makers, limb makers, rehabilitation engineers, etc.) to teach and advise the village team (It is important that such visitors play a secondary, background role and not be present all the time,

<ul style="list-style-type: none"> <li>• perhaps one or more 'village rehabilitation assistants' to help with basic therapy and rehabilitation, under guidance from rehabilitation workers from the village rehabilitation center</li> </ul>	<p>help them get to school, etc.</p> <ul style="list-style-type: none"> <li>- village support committee</li> <li>- a toy-making workshop where village children make toys for disabled children and also for their little brothers and sisters</li> </ul> <ul style="list-style-type: none"> <li>• 'outreach' to help start neighboring sub-centers, with provision of training, back-up referral services, and regular visits</li> </ul>	<p>nor take charge or work independently with children.)</p> <ul style="list-style-type: none"> <li>• <b>apprenticeship opportunities:</b> learning for village workers in the centers of the different specialists</li> </ul>
--	---	--

**Figure**

## **The importance of community-run rehabilitation centers**

**In an attempt to get the focus of rehabilitation out of big institutions and into the home, some community-based rehabilitation programs have tried to manage without any kind of local rehabilitation centers. 'Local supervisors' make home visits and work directly with the families of the disabled. However, when additional assistance or aids are needed, the local supervisor often has nowhere to turn. She has to send the disabled person to professionals in the city. For reasons of distance, cost, fear, or failure of the support system, these referrals too often do not work out. As a result, rehabilitation is often incomplete, and people get discouraged.**

**Of course, referral to large city hospitals or centers will still be important for selected individuals. However, there are several strong arguments in**

**favor of setting up a small village or community-based rehabilitation center run by local concerned persons:**

- 1. It is a visible, practical, low-cost base for coordinating rehabilitation activities in the home, and for providing back-up services outside the home.**
- 2. It can produce a wide range of rehabilitation equipment and aids quickly and cheaply, using local resources, with participation of families, schoolchildren, and local craftspersons, when possible.**
- 3. It can include a 'playground for all children' and organize activities to encourage understanding and interaction with the disabled.**
- 4. It can provide meaningful work and training experience for local, otherwise often untrained and unemployed disabled persons. It gives the families of disabled children and other villagers the chance to see what a useful, helpful, and rewarding role disabled persons can have in a community.**
- 5. Although the best place for day-to-day rehabilitation is often the home, there are families for whom this may be very difficult. These include families in which one or both parents have left or are dead, or have drinking problems, or where stepparents or other family**

**members are cruel to the child, neglect her, or abuse her sexually (a fairly common problem). In many homes, the family does the best it can. But the extra work of trying to care for a *severely disabled* child may simply be too much for the family that has to work long hours just to survive. Under any of these circumstances, special care at a community center may be of enormous benefit to both the child and the family.**

**6. If many small community centers join to form a 'network', they can exchange ideas and learn from each other. Or different centers can 'specialize' in producing different supplies or equipment. For example, one village center might make wheelchairs, another toys, and another low-cost plaster bandage for casting. Then different centers or programs can supply each other at low cost.**

**Home-based rehabilitation often works much better with the help of a local, community-run center.**

**How small, local programs spread to new villages and areas**

**Bottom-up programs tend to spread through popular demand. As the news of the program travels from family to family and town to town, even a small program based in a single village can reach far in its impact. For example, Project PROJIMO is based in a village of less than 1 000 and has a staff of a**

**dozen disabled villagers. In its first 4 years, PROJIMO has attended to the needs of over 1,000 disabled children from over 100 towns and villages and the slums of several large cities. (Since roughly one child in every 100 people is moderately to severely disabled, PROJIMO is in effect serving a population of over 100,000.)**

**There are various ways that bottom-up or 'people-centered' programs tend to spread. We speak of their growth as 'organic' because they grow and spread in a living, whole sort of way, like seeds into trees.**

**In Project PROJIMO, some of the young people from neighboring communities, who first come for rehabilitation, decide to stay and to work for a while in the program. In the process they learn skills which they can use to help in the rehabilitation of other persons when they return to their own communities. In some cases, other villages and village-based health programs have sent young disabled persons to apprentice with PROJIMO for several months, in order to help start similar activities on return to their communities.**

**Another people-centered program that started small and has spread to many other towns is the Community Rehabilitation Development Program in Peshawar, Pakistan. This is discussed.**

**ACTIVITIES IN THE COMMUNITY TO WIN INTEREST AND UNDERSTANDING**

**Group activities in a village or neighborhood can help improve understanding of and interaction with the disabled children. Four types of activities that have proved especially useful are discussed in the next 4 chapters:**

- **A 'Playground for all children'**
- **CHILD-to-child activities**
- **Popular theater**
- **A children's workshop for making toys**



**Playground for all children - PROJIMO**

**Any of these activities may be used to gain people's interest and involvement when starting a community rehabilitation program. Or they can be used to increase understanding even where no special program is planned. For example, the workers in a village with a rehabilitation center**

**can visit neighboring villages and put on skits or puppet shows about disability prevention. They might also talk with school teachers, local health workers or concerned parents about developing CHILD-to-child activities, or organize local children to build a 'playground for all children'. Project PROJIMO took a truckload of school children to a neighboring village to help the children there build their own playground. Nearly 100 children and adults built the playground in one day.**

**After these 4 chapters, we will explore other aspects of social integration and opportunities for the disabled.**

## **Chapter 46: Playgrounds for All Children**

**A good way to start a village or neighborhood *rehabilitation* program is to involve the local people in building a low-cost 'rehabilitation playground'. It is important that the playground be built for use by all children - both disabled and non-disabled.**

**With a little help from adults, the local children can build most of the playground themselves. To prevent the playground from being destroyed or vandalized, you may wish to invite some of the roughest local children and 'gang leaders' to help lead the project. Or you can appoint them as 'maintenance chiefs'.**

**Building a playground 'for all children' is a good way to get enthusiastic**

**community participation. It can be built quickly as a group project at low cost using local resources and gives quick, easily seen, fun results.**



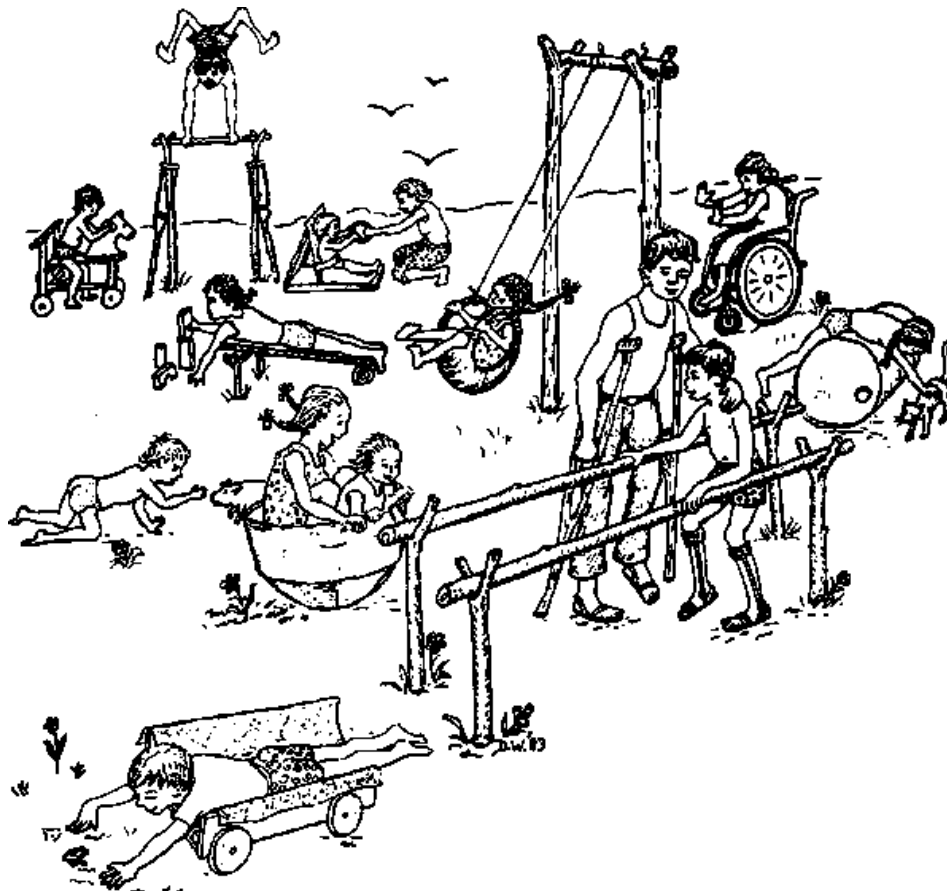

**Figure**

## **The playground brings non-disabled and disabled children together through play.**

**To build the playground, it is best to use local, low-cost materials, and simple construction. One of the playground's main purposes is to give disabled children and their parents a chance to try different playthings and exercise equipment. Whatever works for their child, a family can easily build at home, at no or low cost. For this reason, a playground made of tree limbs and poles, old tires, and other 'waste' materials is more appropriate than a fancy metal playground built by skilled craftsmen at high cost. (Also, metal gets very hot in hot, sunny climates.)**

**These pages will give you some ideas for simple playground equipment. Although most of the photos come from PROJIMO in Mexico many of the ideas shown are based on a playground in Thailand and on designs by Don Caston.**

### **A 'playground for all' built by children - PROJIMO, Mexico**

**When disabled village health workers in the small village of Ajoya decided to start a rehabilitation program for disabled children, one of the first activities was to involve the local children in building a playground.**



**1. First the children went into the forest to cut poles and vines**



**2. These they brought back to an empty lot at the edge of the village**



**3. While some children cleaned up the lot others began to build the playground equipment**



**4. They built ramps or wedges like this one which can be used in many ways for play and exercise. Here a child with cerebral palsy walks up the ramp to help improve balance and stretch his feet upwards to prevent contractures.**

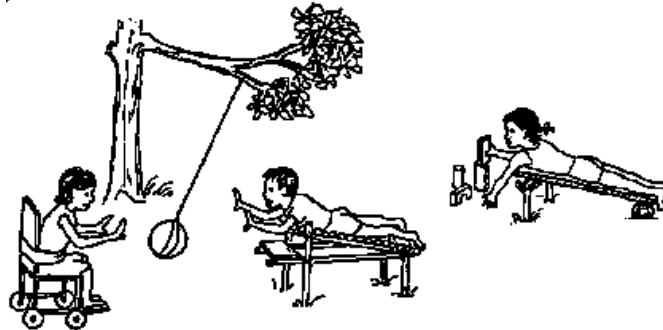

**The wedges can also be used for severely disabled children to lie on, so that they can lift their heads and play with their hands**



**Pole seats like this help a child sit who still lacks balance, or has trouble controlling his position**

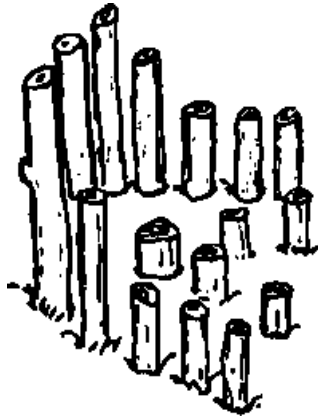

**These separators will hold apart the legs of a child whose legs pull together (spasticity)**

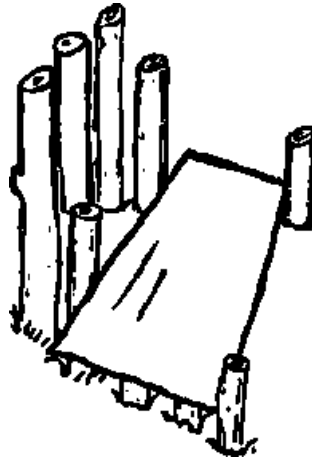

**Putting front posts the same height allows a shelf to be placed for play**

**Simple parallel bars can be used as gymnastic bars by the able-bodied children and as bars for learning to walk by disabled children**





**Figure**

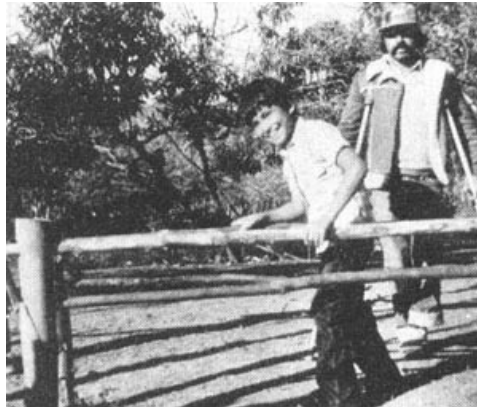

**Figure**

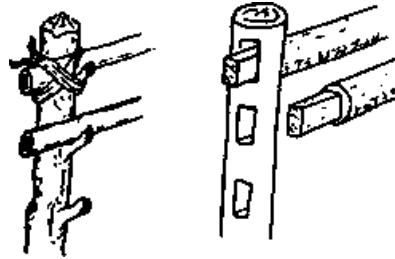

## Bars need to adjust to different heights for different children. Here are 2 simple ways

For most children, the bar should be about hip height, so that the elbows are a little bent (the same height as the handles of crutches).

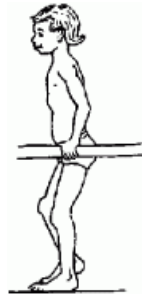

A child with very weak upper arms may find it easier to rest his forearms on the bar. The bar will need to be elbow high.



A child who tends to slump forward may be helped to stand straighter if the bar is high, so that he has to stand straighter to rest his arms on it.

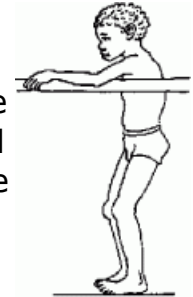

## SEPARATION OF BARS

Bars should be close enough to leave only a



Smaller children



little room on either side of the child's body. Too close, they get in the way. Too far apart makes weight bearing more difficult.



require closer bars. Therefore, put uprights so they are wider higher up.



**Simple, homemade bars, adjusted to the individual child's needs, often provide more benefit than expensive walkers or other equipment.**

## **TEETER BRIDGE**

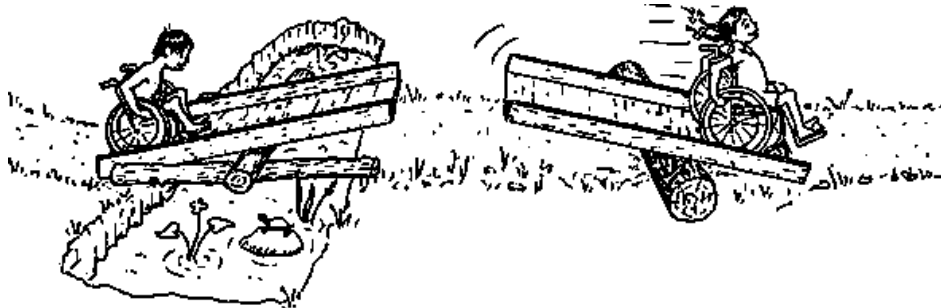

**Figure**

**This can be part of an 'obstacle course' for wheelchairs, including hills, drops, curbs, rocky ground, sand pits, and zig-zags between posts.**

**A simple seesaw or teeter-totter like this is fun and helps disabled children gain balance. The one in the photo was made by putting a pole in the crotch**

## of a mango tree.



**Figure**

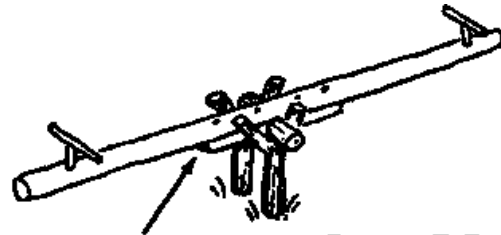

Some sort of blocking  
is needed to keep pole  
from sliding or rolling.



**Rocker supports for a seesaw can be made in many ways**

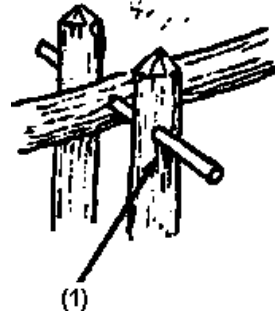

**One way to prevent rolling and rotating is to pass a metal pipe (1) thru the pole rubber crutch tips to keep from bumping head**



**One end of this seesaw has an enclosed seat for a disabled child. Space is left behind the seat for an able-bodied child to sit and protect the disabled child strap to hold in child**



**Figure**



**On the other end a wooden donkey head adds fun**

**Here are some other ideas for seesaws.**

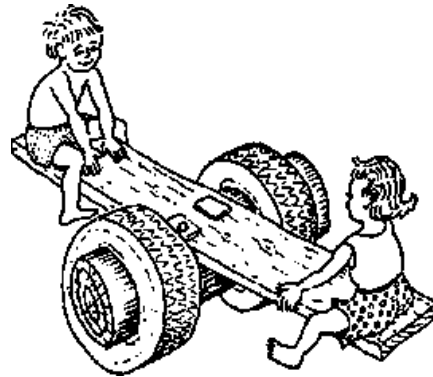

Figure

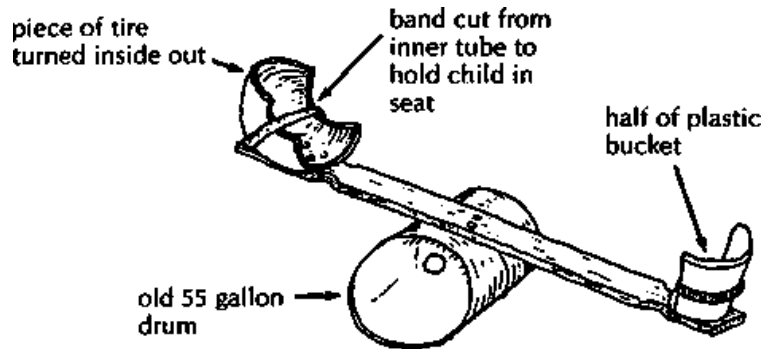

Figure

## PRECAUTIONS

**1. To avoid accidents, be sure the pole for the seesaw is strong**



**enough. Test it every few weeks by having 2 adults put their full weight on the ends of the pole**

**2. To avoid coming down too hard, put old tires under the ends of the seesaw**

**3. Make sure the seesaw will not roll lengthwise or sideways (see above)**

## **CLIMBING FRAME AND HIGH BAR**

**Children can make a simple climbing frame out of poles, by nailing them or tying them together with string.**

**The climbing frame can be used for all kinds of play, for helping disabled children pull up to sitting or standing, and for therapy exercise.**

**High bars (horizontal bars) at different levels for different children can be used for exercise and gymnastics.**



Figure

## TIRE GYM

Climbing gyms can be made out of many materials, including old tires.

Gym will be more solid if tires are bolted together.

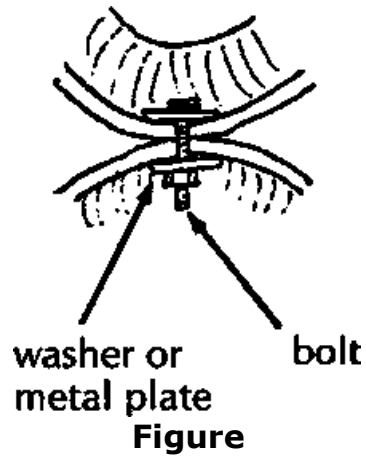

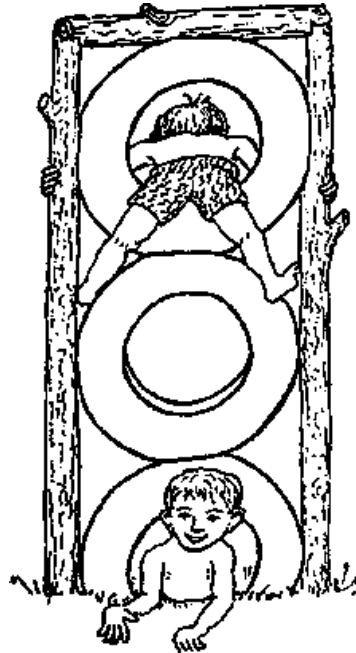

**Figure**



**The children in the village of Ajoya, Mexico helped those in a nearby town build their own rehabilitation playground. This tire climbing gym was one of the playthings they created**

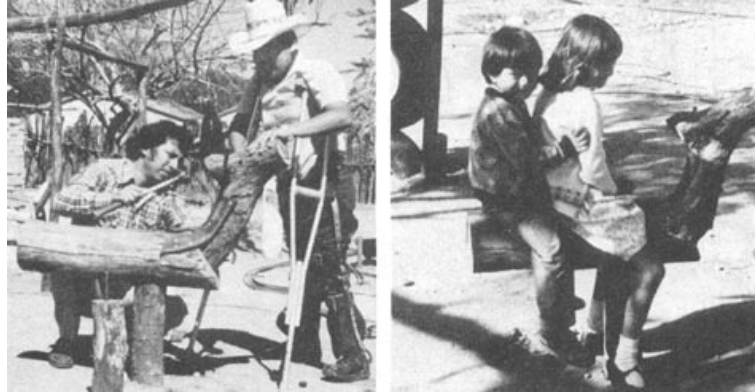

**Building and riding a rocking horse made of logs**

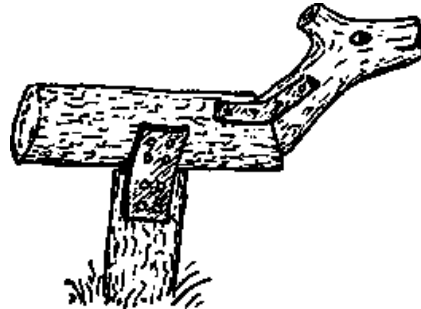

**Pieces of car tire to join logs allow horse to rock back and forth**

## **SWINGS**

**A wide variety of swings can be built out of different local materials.**

**Swinging is fun; it can help develop balance, head control, coordination, and strength. Swings with special features can be built for the needs of particular children.**



**Here children in PROJIMO make an enclosed swing.**



**This child with cerebral palsy had never had a chance to swing before. At first he was afraid ...**





**but after a while, he loved it.**



**Regular swings are placed next to special and enclosed swings, so that non-disabled and disabled children learn to play side by side.**



**Swings in the form of animals or fish add to the fun.**



**Extra wide swings allow 2 children to swing together - one assisting the other.**

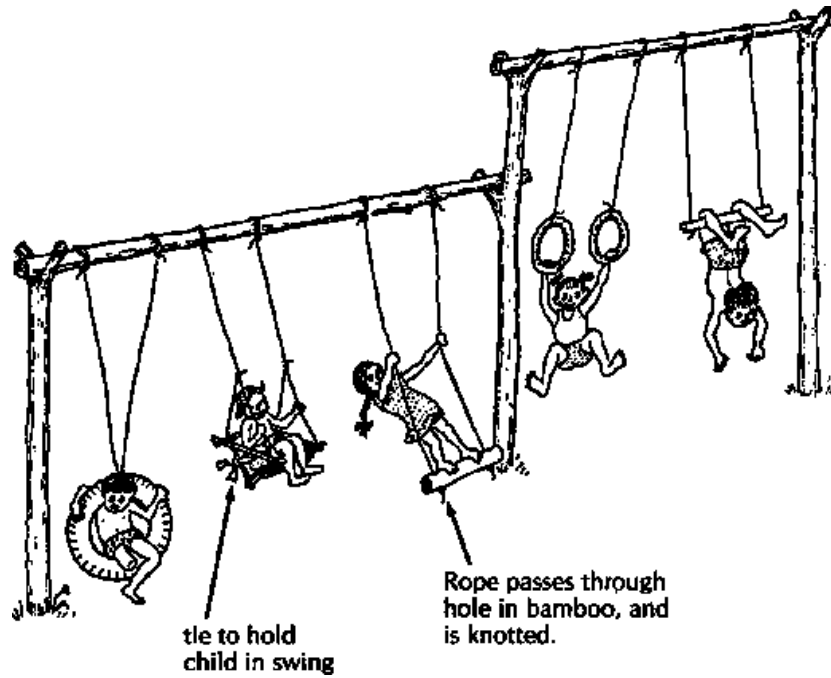

**Figure**



**Rings for swinging and many games can be made by cutting out the inner rims of old car tires.**

## **SWINGS AND PLAYTHINGS USING OLD TIRES AND TUBES**



**This swing made of an old tire is especially good for children with spasticity because it bends their backs, heads and shoulders forward.**

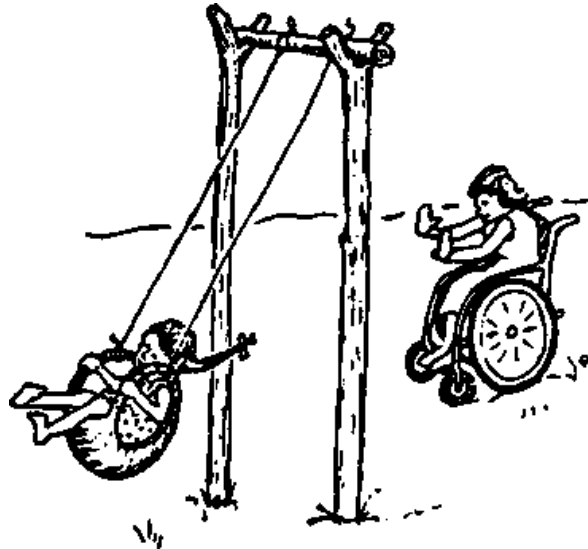

**Figure**

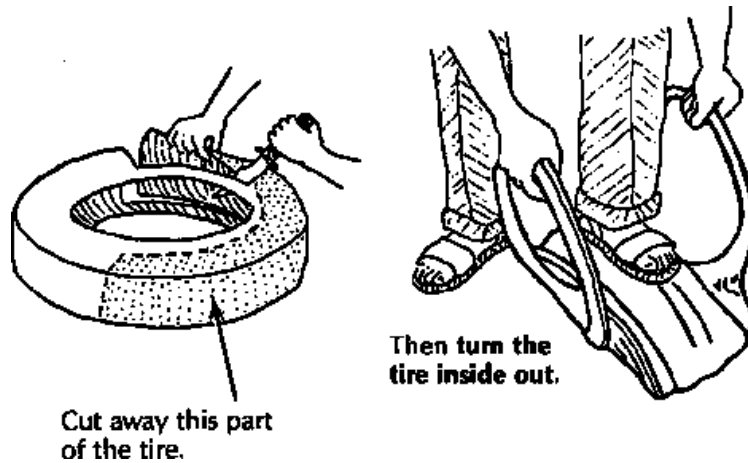

**Figure**





**In this swing, a 'floor' of sticks can be put in the tire and covered with straw or a mat**



**This flat-hanging tire swing is especially useful for the severely disabled or delayed child who is just beginning to learn to move his body. The child can lie across the tire and move this way and that by pushing the ground with his hands**

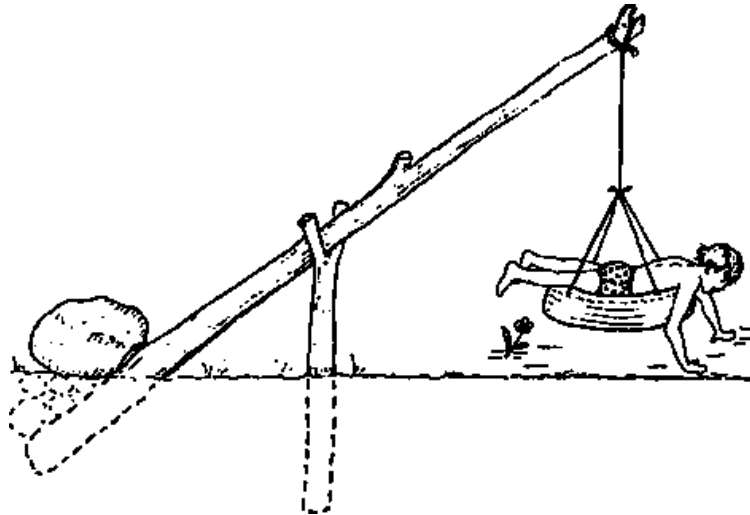

**It swings! It spins! It bounces! Fun for the able-bodied! Fun for the disabled! Several children can play on it at once!**

**Hang tire just a few centimeters from ground so the child can move with his hands**

## **WHIRLYGIG CIRCULAR SWING**



**Cross beam pivots on an iron pipe.**

**Hole in beam is soaked in old motor oil to make it turn around easier.**

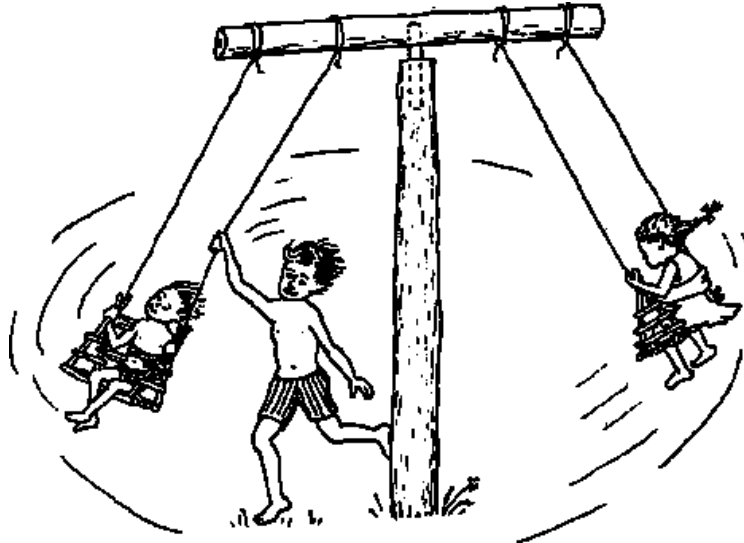

**Figure**



**Circular swing in PROJIMO rehabilitation playground. (Here the child pushing the swing has cerebral palsy. The twisting motion he uses is excellent therapy)**

***CAUTION:* Be sure both the pole and beam are of strong hard wood. Test them occasionally with adults' weight.**

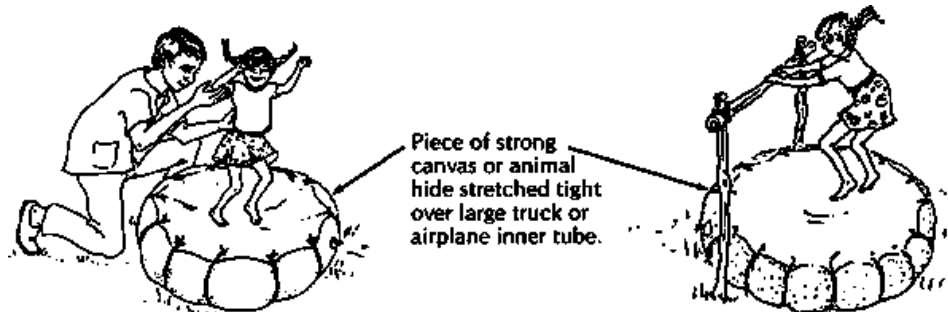

## **BOUNCING TUBE (from Low Cost Physiotherapy and Low Cost Walking Aids)**

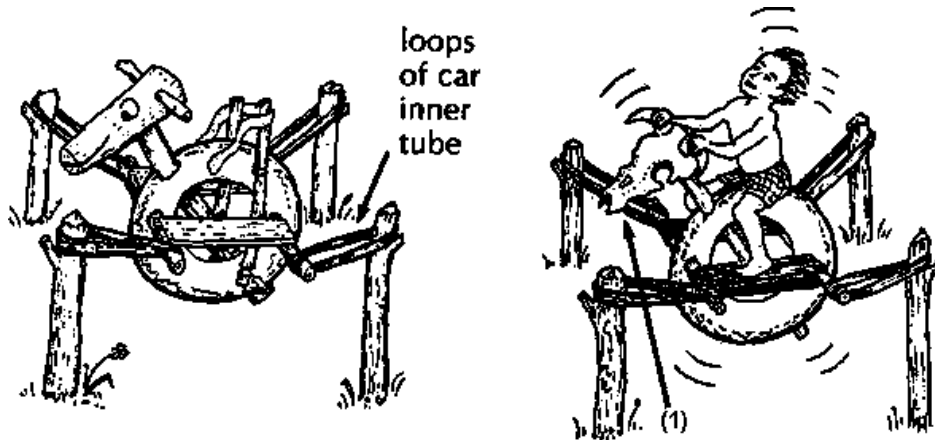

### **BOUNCING TIRE HOBBY HORSE (OR COW)**

**Be sure to notch poles and attach tubes so they do not slip.**

**A cow's skull (1) makes a good head for many playground toys. The child holds onto the horns. (Cut off the points.)**



**Figure**

***Note:* It is much easier to put holes through tires that do not have steel wire in them**

## **MAYPOLE**

**Disabled children who can sit and hang on can play with non-disabled children on the maypole. But to start turning round the circle, they may need another child to help push them.**

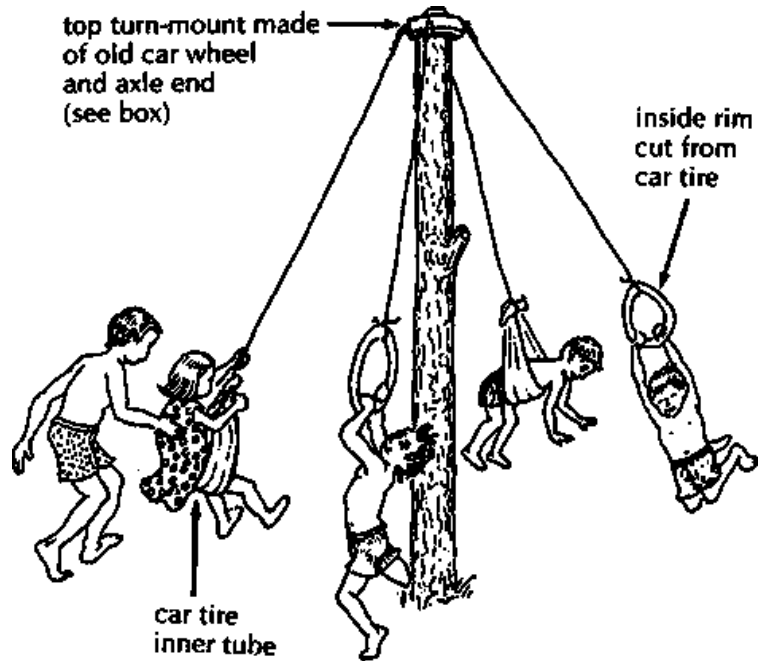

Figure

**HERE ARE 2 WAYS TO MAKE A TOP TURN-MOUNT**

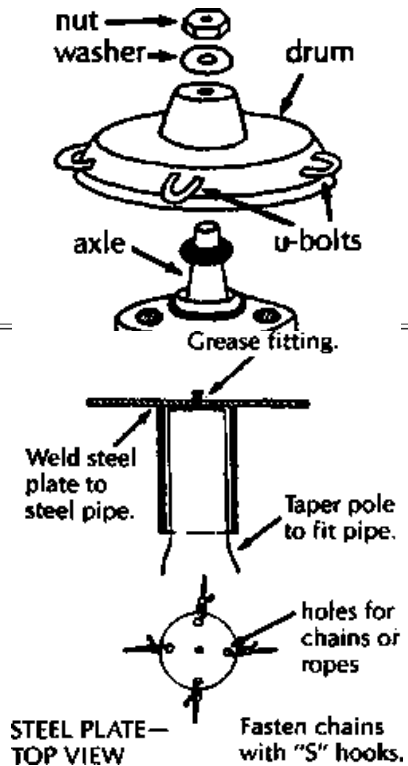
**Figure**



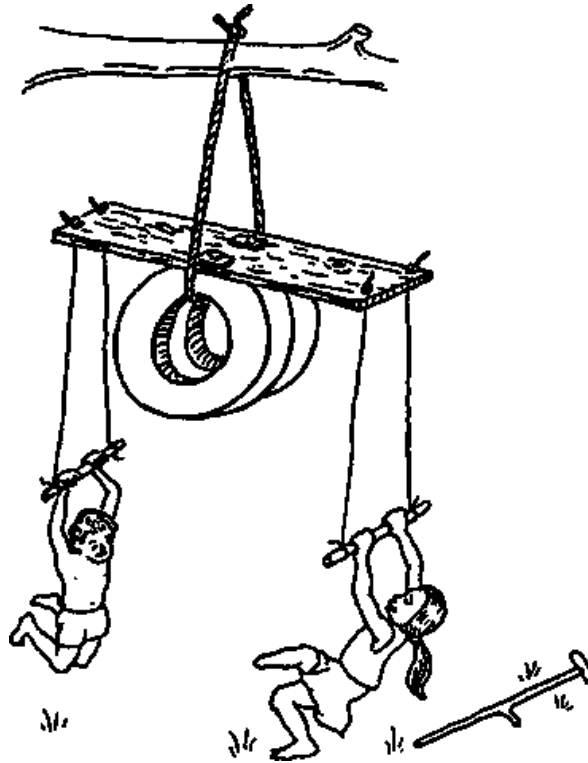

### HANGING SEESAW SWING

**The weight of the tires adds stability for smoother swinging.**



Figure

***WARNING:*** Be sure to use extra strong rope or cable in any equipment where children could be seriously hurt if the rope breaks. Adults should test rope strength regularly.

rims of old tires

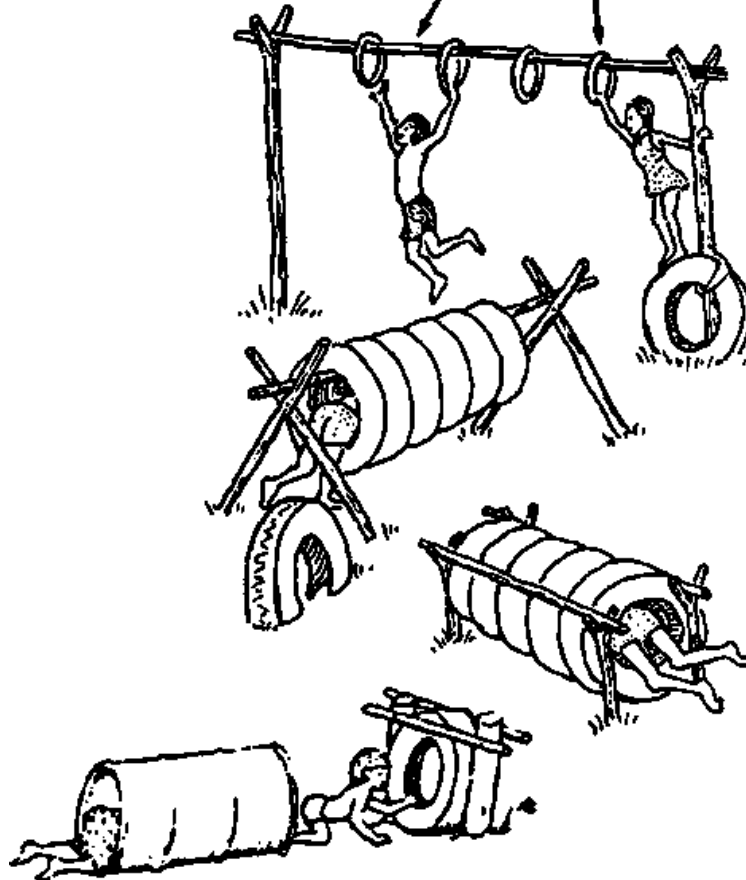

**OBSTACLE COURSE**

**Old tires and drums can be used for crawling games and obstacle courses.**

**BALANCE BOARDS**

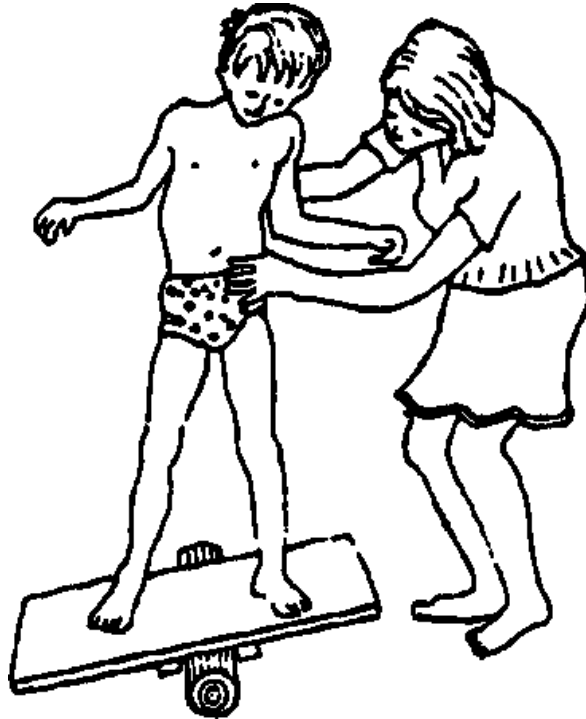

**Figure**



**Figure**



## A wider rocker base makes rocking smoother

For the rocker you can use 2 pieces of old tire.

### ROLLS



Figure



**Figure**

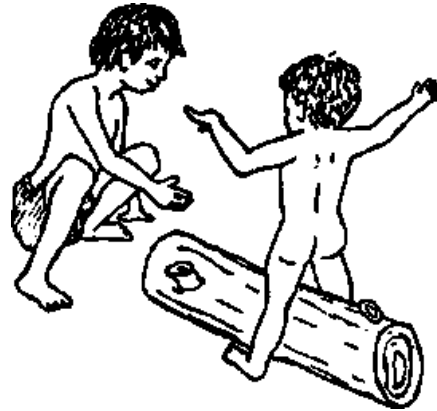

**Figure**



**A row of half buried old tires. The tires sink in when stepped on. A test of balance and great fun!**

**Old barrels, oil drums, paint cans, and logs make good playground equipment-for therapy and fun**



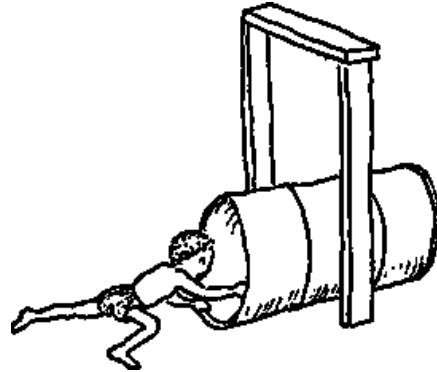

**CRAWL-THROUGH DRUMS**

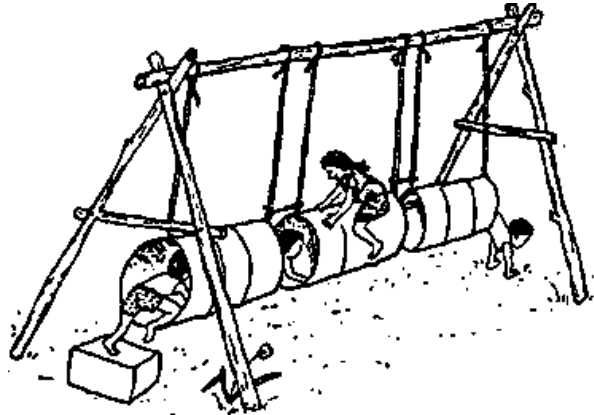

**HANGING CRAWL-THROUGH DRUMS**

**CAUTION: Hold drums apart with sticks to prevent smashed hands and**

**feet.**



rings of  
tire rims or  
anything else

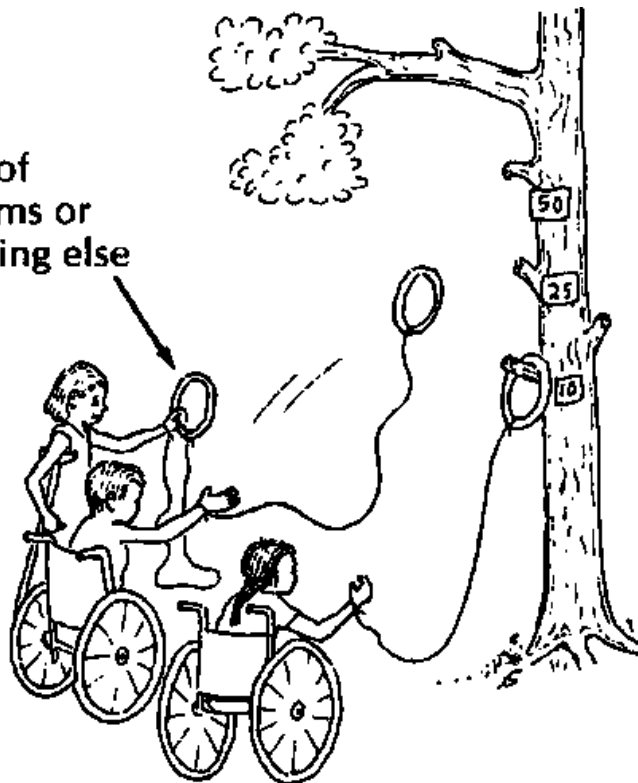

### **RING-TOSS**

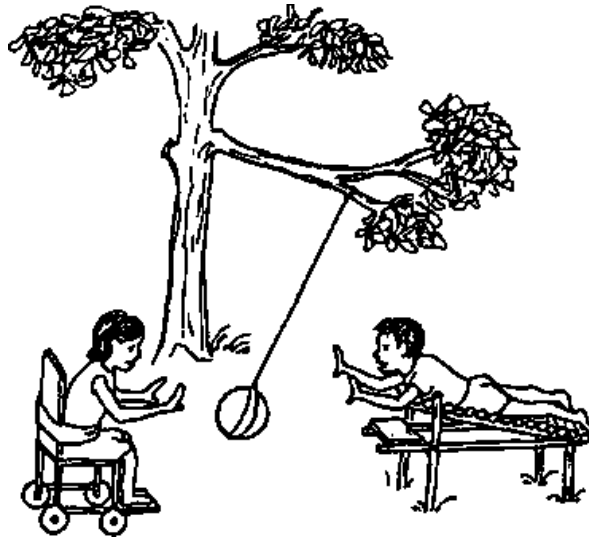

**Figure**

**For children who have trouble going after dropped balls or rings, tying a string to the toy allows the children to pull it to them**

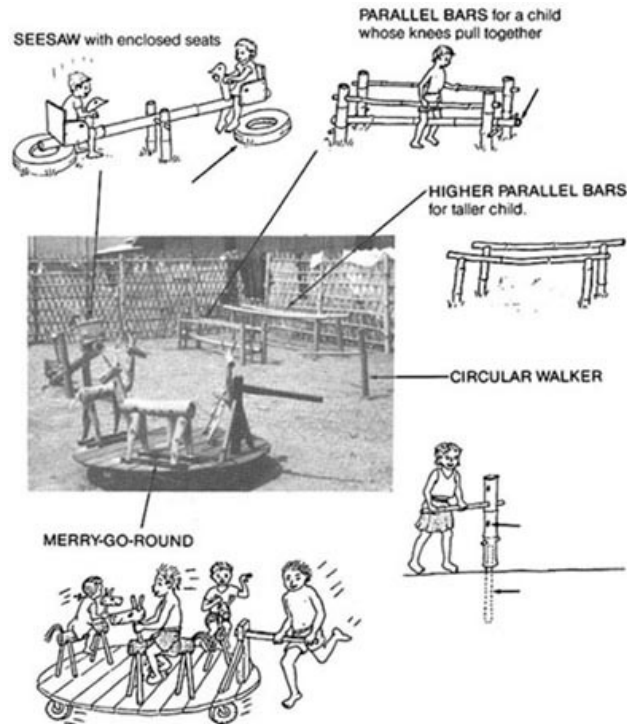

## Examples from the 'bamboo playground' in the Khao-i-dang refugee camp, Thailand

**Especially good for the child whose sudden uncontrolled movements may knock over an unfixed walker.**

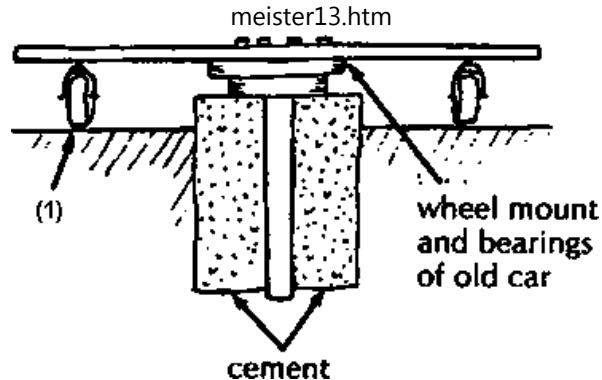

**One way to mount the platform of a merry-go-round.**

**Small wheels (1) slightly above ground level protect merry-go-round when too many children get onto one side.**

## **PRECAUTIONS AND SUGGESTIONS FOR A SUCCESSFUL ALL-CHILDREN'S PLAYGROUND**

**1. Involve as much of the community as possible in building and maintaining the playground.**

**2. Keep the playground simple and build it from local low-cost materials. Only this way can it serve as a model for families of disabled children to build the most useful equipment for their child in their own homes. Resist offers from the local mayor or politicians to build an impressive metal frame playground. This will eliminate**

**community participation and makes the equipment too costly for poor families to build at home.**

**3. For poles that are put into the ground, use a kind of wood that does not rot quickly. Or paint the posts with old motor oil, creosote, tar, copper sulfate or some other insect and fungus resistant substance.**

**If poles are used that will rot quickly, to avoid accidents, check strength of poles frequently and replace them at regular intervals- especially during the hot rainy season.**

**4. Swings can be hung from ropes or chains. Rope or vines are cheaper but may rot or wear through fairly quickly. Plastic or nylon rope will not rot in the rains, but will gradually grow brittle and weak with the sun. As with posts, to avoid accidents, check the strength of ropes frequently by having several heavy persons hang on them at one time. Replace ropes at regular intervals, before they get weak.**

**5. Regular maintenance of the playground is essential, and this will require planning and organization. Perhaps once a month the village children can take an expedition to cut new poles to replace rotting ones, to repair old equipment, and to build new. Adult coordination of such activity is usually necessary.**

**6. To boost enthusiasm, keep lists in a public place of all the children and adults who help with the playground - and put a star for each time they help.**



**Children play on a 'merry-go-round' in PROJIMO. Enclosed 'cars' protect more severely disabled children. A cow's skull provides handles for a rider.**

## **Chapter 47: CHILD-to-child: Helping Teachers and Children Understand Disabled Children**





**Children can be either very cruel or very kind to a child who is different. They may be cruel by teasing, laughing, imitating, or even doing *physical* harm. But more often they are cruel simply by not including the disabled child in their games or activities, by rejecting the child, or by pretending she does not exist.**

**Often children act in a cruel way because they fear what they do not understand. When they gain a little more understanding, children who may have been cruel or felt uncomfortable with the child who is different, can become that child's best friends and helpers.**

**It is important that children in every neighborhood or community have a chance to better understand persons who, for whatever reason, are different from themselves - in color, in dress, in beliefs, in language, in movements, or in abilities.**

**One way to help a group of children gain appreciation of the disabled child and learn ways to be helpful is through CHILD-to-child activities.**

**CHILD-to-child is a non-formal educational program in which school-aged children learn ways to protect the health and well-being of other children - especially younger children and those with special needs. The children learn simple preventive and curative measures appropriate to their own communities. They pass on what they learn to other children and their families.**

**The CHILD-to-child program began during the International Year of the Child, 1979. David Morley (author of *Paediatric Priorities in the Developing World* and *See How They Grow*) brought together a group of health workers and educators from many countries. They designed a series of 'activity sheets'-or guidelines - to be adapted by teachers and health workers for children in different countries and situations.**



**Figure**

**Six activity sheets about disabled children have been put together in a packet, together with a booklet called "*Do You Know a Handicapped Child?*" The set is available through Teaching Aids at Low Cost (TALC), P.O. Box 49,**

**St. Albans, Herts. AL1 4AX, United Kingdom. The activity sheets in the packet include:**

- ***Handicapped children***
- ***Polio: How children can help***
- ***Let's find out how well children see and hear***
- ***Looking after the eyes***
- ***Helping the severely deaf child***
- ***Understanding children's feelings***

**Other activity sheets available from TALC that include *disability* prevention are**

- ***How do we know if our children get enough food?***
- ***Healthier foods for babies and children***
- ***Care of children with diarrhea***
- ***Accidents***
- ***Our neighborhood - making it better***
- ***Playing with younger children***
- ***Toys and games for young children***
- ***A place to play***
- ***Caring for children who are sick***
- ***Better health habits***

**CHILD-to-child activities can be introduced**

- **by schoolteachers with schoolchildren,**
- **by schoolchildren (who have practiced the activities in school) with younger school-children, or with children who do not go to school,**
- **by health workers or community *rehabilitation workers*,**
- **by parent groups or any concerned persons in the community**

**The purpose of CHILD-to-child activities that relate to disability is to help children**

- **gain awareness of different disabilities and what it might be like to be disabled,**
- **learn that although a disabled person may have difficulty doing some things, she may be able to do other things extra well,**
- **think of ways that they can help disabled children feel welcome, take part in their play, schooling, and other activities, and manage to do things better,**
- **become the friends and defenders of any child who is different or has special needs**

**Rehabilitation programs in several countries have developed their own, more complete CHILD-to-child activity sheets. Here we combine versions from Kenya (Africa), the Philippines, and Mexico (where some of the original sheets were developed and tested). The 3 activities we include in this chapter are:**

**“Understanding children with special problems”**

**“Children who have difficulty understanding”**

**“Let’s find out how well children see and hear”**

From the CHILD-to-child activity sheet

### **ACCIDENTS**

Help children learn how important it is to

- Make sure that their younger brothers and sisters do not go too close to the cooking fire



**Figure**

- Keep matches out of the reach of small children (They can even make a small basket or shelf for matches to be stored high on the wall)



**Figure**

- Be sure that handles of pans are turned so that the child does not pull them



**Figure**

- Warn younger children about where snakes scorpions and bees live
- Clear grass and weeds away from paths



**Figure**



- Make sure poisons such as medicines and insecticides are kept out of reach, and that kerosene is not stored in drink bottles



**Figure**

## **CHILD-to-child ACTIVITY: UNDERSTANDING CHILDREN WITH SPECIAL PROBLEMS**

### **Group discussion**

**Encourage a class or group of children to talk about children who have some special problem or 'handicap' Ask questions like:**

- **Do you know any child who cannot walk or run or talk or play like other children?**
- **Why can't this child do everything the same as you can?**
- **Is the child to blame?**
- **How do other children treat this child? Are they kind to him? Are they mean? Do they make fun of him? Do they include him in their games?**
- **How would you feel if you had a similar problem? How would you want other children to treat you? Would you like them to laugh at you? To pay no attention to you? To feel sorry for you? To do things with you and become your friend?**

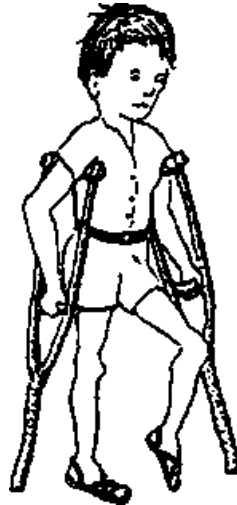

**Figure**

## **Games and role playing**

**Children will better understand the child with a special problem if they can 'put themselves in his shoes' They can play a game in which one child pretends to have a handicap.**

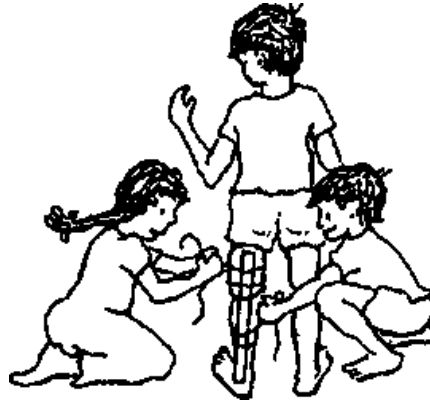

**For example tie a stick to a child's leg. Then have him run in a game or play tag**

**The other children act out different ways of behaving toward the child. Some are friendly. Some ignore him. Some make fun of him. Some help him. Some include him in their games. Let the children think up their own ideas and act them out**



**Figure**

**After several minutes, another child can pretend to have a handicap. Let several children have a turn with a handicap. Try to make the pretend handicap seem real**

**Also ask the children what they might be able to do to make things better or fairer for the disabled child. Try or 'act out' their different suggestions. For example**

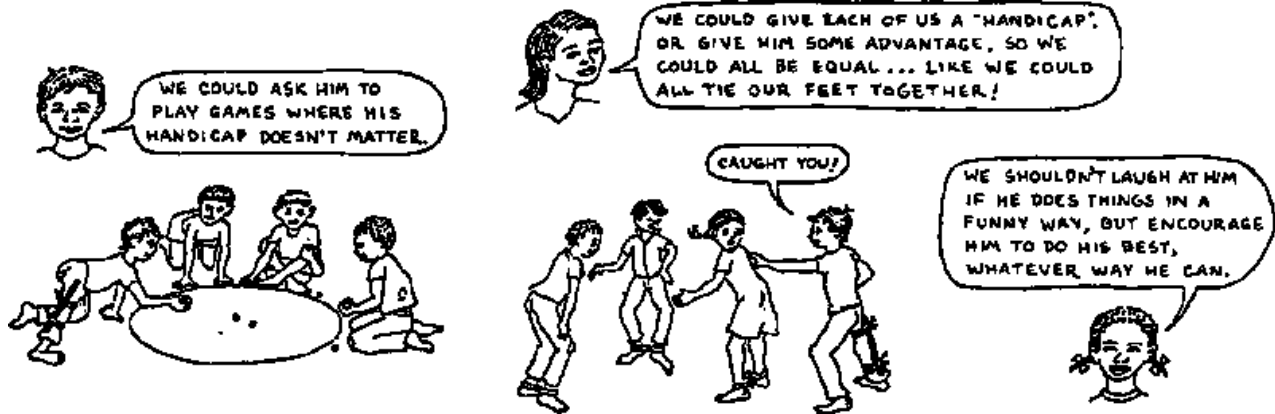

Figure

**For a more severe physical disability, the group of children can invent ways to 'find out what it is like'. For example, to learn about a child with almost no use of her legs, the children might tie the legs of one of their group together, like this.**

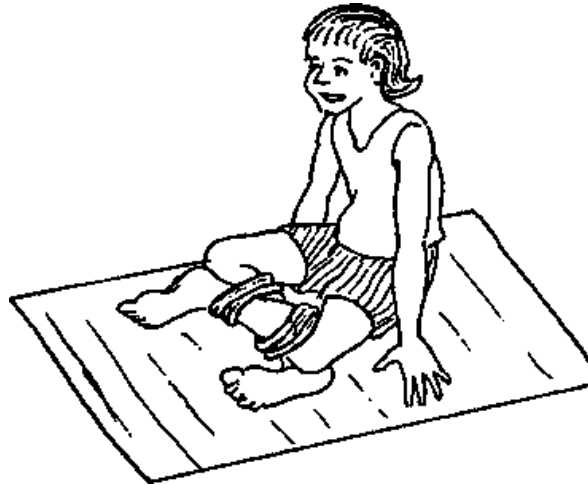

**Figure**

**Then the children can ask the child to do some of their day-to-day activities  
- like moving around the house, going to the latrine, and going to school.**



**Figure**

**After talking with the child about her difficulties, the children can try to think of ways to make it easier for her to move about.**



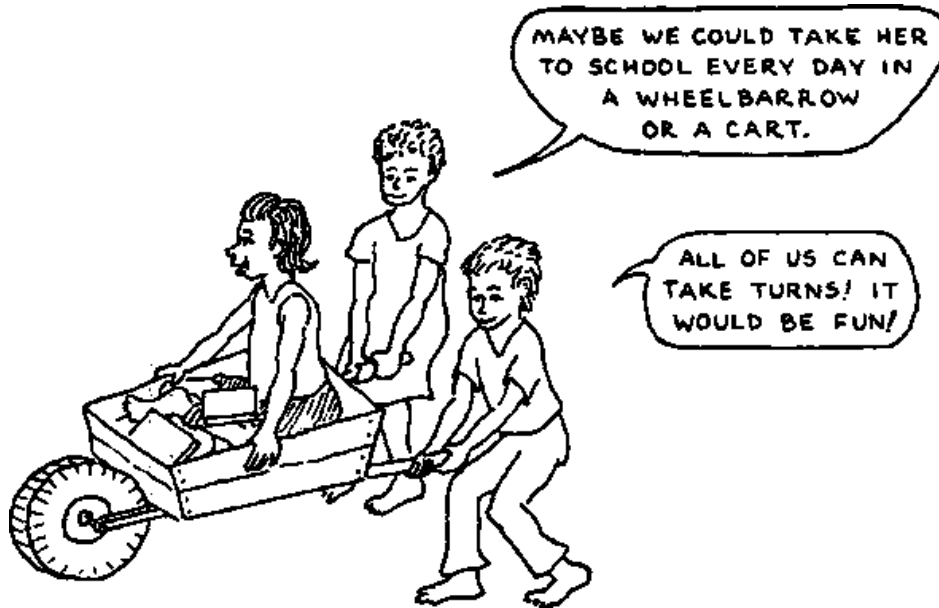

MAYBE WE COULD TAKE HER TO SCHOOL EVERY DAY IN A WHEELBARROW OR A CART.

ALL OF US CAN TAKE TURNS! IT WOULD BE FUN!

Figure

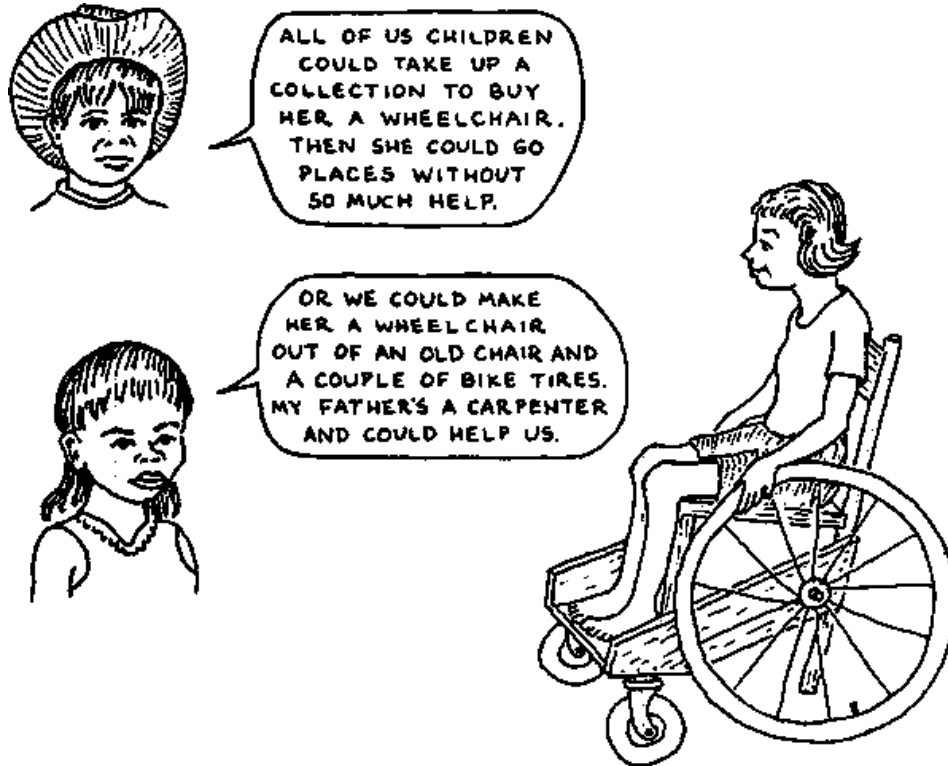

**Figure**

**Note:** With the help of their teacher or parents, children can, in fact, make simple wheelchairs and other aids for disabled children. For simple designs, see PART 3 of this book.

**REMEMBER:** Children are usually kind to a child with a very severe disability. They are often more cruel to a child with a less severe problem, such as a limp.

**Help the children gain an understanding of the particular difficulties of any disabled child in their village.**

**For example, if there is a child with spastic legs who has trouble walking because his knees press together, have a child try to walk with her knees tied together with a band of car tire inner tube.**



**Figure**

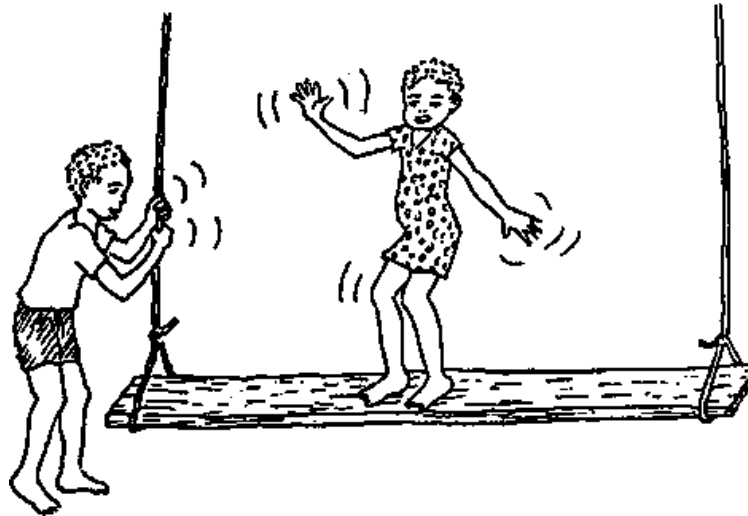

**To appreciate the problems of a child who has trouble with balance (cerebral palsy), have one of the children try to walk on a hanging board (or other moving surface).**

**If there is a child with arthritis in the village, some of the children can put small stones in their shoes or tie small stones to the bottoms of their feet. Then the other children can invite them to run and play games. Ask the children why a child with arthritis might not want to play games.**



Figure

**Ask the children, "Do you know any children who cannot use their hands like you can?" If they answer yes, help them experience the difficulties of such a child. Have the children work in pairs.**

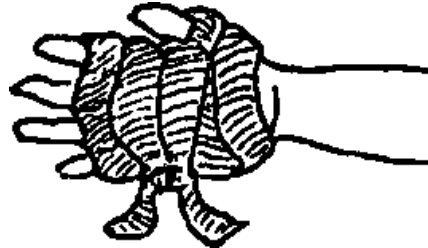

**One child can wrap a strip of cloth around the other child's hand and fingers so that he has trouble moving his fingers.**

**Now have the child try to do things like:**

- **write**
- **turn pages of a book**
- **fill a cup with water**
- **eat**
- **get something from a pocket**
- **button a shirt**



**Figure**

**Have the children try to figure out ways to make it easier. For example, wrap cloth or a piece of inner tube around a pencil or spoon, to make it easier to hold.**

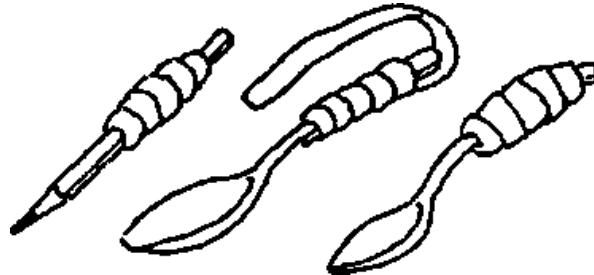

## Figure

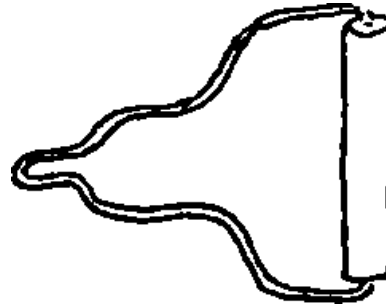

Buttoning tool

### Things that a disabled child can do well

**A disabled child cannot do everything as well as other children. But often there are some things she can do as well, or even better. Try to have the children think of examples.**



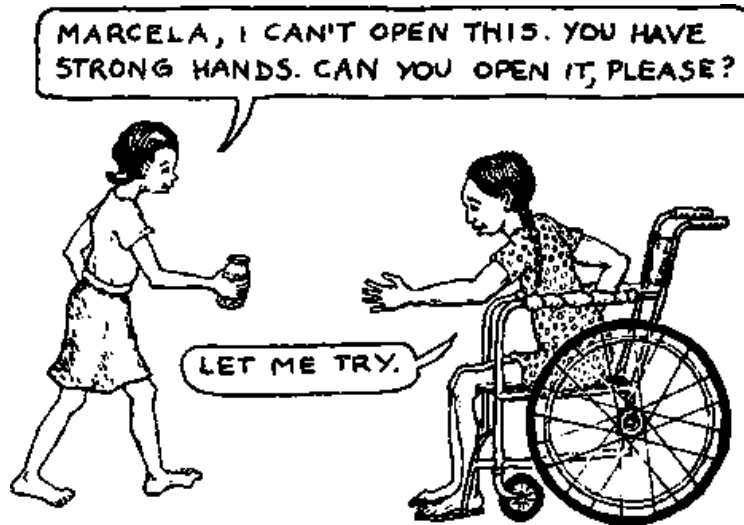

**A child with weak legs, who has to walk with crutches, often develops very strong arms and hands.**

**Or a blind child may learn to hear things extra well.**

**Rather than feel sorry for the disabled child and look only at her weaknesses, it is better to recognize and encourage her strengths.**

*A LETTER TO ALL CHILDREN*

*A handicapped child needs friends, play, and excitement - just like you. Try to*

*include the child in your games and adventures. Let him do as much for himself as he can, and help him only when he needs it. But remember, he cannot do everything you can. Protect him from danger ... but do not protect him too much! Too much protection is dangerous to any child's health. Children need adventure for their minds to grow, just as they need food for their bodies to grow.*

Thanks



## Swimming



**Many children with weak or *paralyzed* legs can learn to swim well. Their arms become unusually strong from using crutches, and in the water they easily keep up with other children. But sometimes they have trouble getting to the water, or the other children forget to invite them ...**

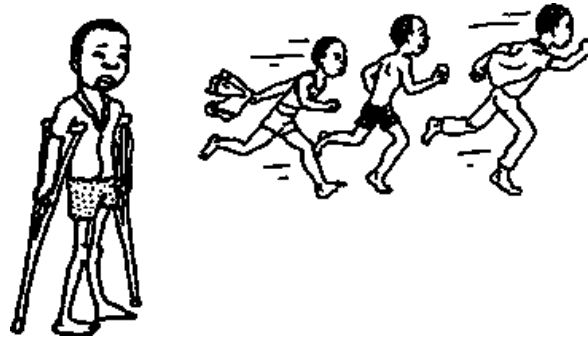

**Figure**

**A friendly word of welcome to include the child with a special problem, or a little extra time or attention given to him, can make a big difference-and can make everyone feel good.**



## Figure

### Role playing and children's theater

To help see how much it matters to include a disabled child in their fun, a group of children can act out different possibilities. For example, they might act out (or do a 'role play' of) the pictures at the bottom of the page before this one. After the role play the group can discuss which of the two alternatives made the disabled child, and the other children, feel better, and why.

### Photos from Ajoya, Mexico



Figure



**Figure**

**Or they can act out a situation in which they try to solve a particular difficulty obstacle, or challenge.**

**For example, there is a bright little girl who has no control of her arms or hands, but fairly good movement of her head and one foot. Can the children figure out a way to help her write? The class divides into 3 or 4 groups to try to solve the problem.**

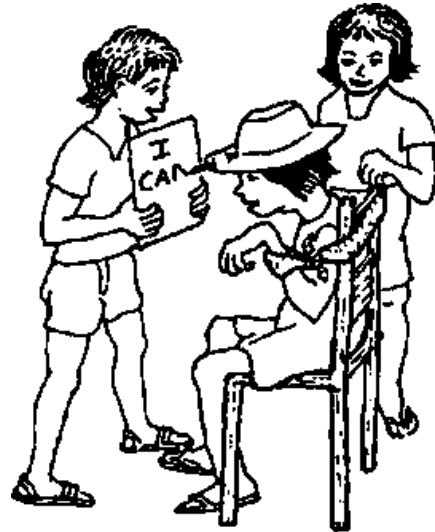

**One group might think of helping her to write with her head**



**Another, with her mouth**



**And another, with her foot**

**In these ways the children will begin to use their imaginations to help solve problems.**

**If some of the children's role plays turn out especially well, or do an extra good job at demonstrating important points, perhaps they can be developed further. Then the children can present them, in the form of skits or children's theater, to other classes, parent groups, in the health center, or perhaps to the whole village.**

**Putting our new understanding into practice**

**Once the children have developed a greater awareness of the needs and**



**possibilities of disabled children through discussion, games, role plays, and stories, they can begin to put their new understanding into practice.**

**Ask the children if they know any child in the village (or in a neighboring village) who is disabled or has special difficulties in any way.**

**Then discuss ways that the children might be able to help each disabled child become as happy, capable, and self-reliant as possible. The children can list their suggestions for each child. Later, after getting to know the child and her family better, they can change and add to their ideas.**

**If the disabled child is a brother or sister of one of the children in the learning group, starting to do things with the child and the family may be fairly easy. But if none of the children is related to the disabled child, they must be careful in the way they offer their help. Probably only two or three children should make the first visit, perhaps with the help of a teacher, health worker, or rehabilitation worker.**

**The children, with suggestions from the disabled child and her family, will need to figure out ways that they can help most. However, the following list of possibilities may give you some ideas:**

- **Become friends - one or more children can become close companions, playmates, and friends of the disabled child.**

- **Visit the child at home - regularly!**
- **Help the family by doing errands, 'babysitting' or taking the child on outings.**
- **Figure out a way to help the child get to and from school.**
- **At school, one or more children can become the 'buddies' or helpers of the disabled child, making sure her special needs are met.**
- **If it is impossible for the disabled child to go to school, children may be able to organize an after-school teaching program at the child's home. Ask the teacher to help plan this.**
- **Figure out ways to include the child in games,**
- **Make helpful toys for the child and play together with her.**



### **REMEMBER - ALWAYS BE FRIENDLY**

- **Make a 'rehabilitation playground' or 'playground for all children'. Take disabled children regularly to the playground and play together with them there.**
- **Build simple playground equipment, adapted for the particular child, at her home.**
- **With advice from a rehabilitation worker or the child's parents, learn to help with the exercises or care that the child needs.**
- **You may be able to help build special aids for the children, such as crutches, sandbags, braces, or even a simple wheelchair. Try to get advice from a rehabilitation worker. If what you need to make is too**

**difficult, perhaps the children can ask parents who are craftspersons to help. Visit them as a committee.**

- **Become 'prevention scouts' by following the suggestion, or by taking other actions to prevent disability in your village.**
- **If there is a village rehabilitation center in your village, perhaps a group of children can take turns there as volunteers after school. There are many ways you can help and much you can learn. Those who show most interest can become 'junior rehabilitation workers'.**



**A rope swing like this can help a child with weak legs teach herself to walk  
- in a way that is fun!**

## **Children with severe disabilities**

**Some children are very disabled. They cannot walk or swim or play many games. But sometimes these children can learn to play marbles, cards, or guessing games.**

**Learning is especially difficult for a child who cannot speak or think as easily as other children. This child may be very lonely. Sometimes a child who cannot speak, understands a lot more than people think he does. If there is such a child in your neighborhood, perhaps children could take turns visiting him, to talk or play with him. Let him know you care.**

## **Babies with problems**

**Sometimes a baby is slower than most to develop. Either her mind may be slow to develop, or her body, or sometimes both. The child will be later than other babies in the village to begin to sit, use her hands, crawl, walk or talk.**

**Babies who are slow to develop need special care. If possible, their parents should get advice from a rehabilitation worker or *physiotherapist*. However, there is a lot that brothers and sisters and other children can do.**

**More than almost anything else, these babies need lots of attention. They need to be played with and helped or encouraged to play. They need simple**

**toys and colorful or noisy things to attract their attention. They need to be talked to and sung to a lot. These things will help the baby develop faster. And these are all things other children can do.**

**In the next activity sheet we will talk more about helping a child whose mind develops slowly or who has difficulty understanding.**

**Helping a disabled child learn to do new things**

**There are many ways that children can help a baby or young child with a special problem to learn to do new things. Here are some ideas:**

- **Make it fun! If exercises can be turned into games, the child will learn faster and everyone will enjoy it more.**
- **Self-help. Help the disabled child only as much as he needs. Encourage him to do as much as he can for himself and by himself.**
- **Little by little. Remember, some things are especially difficult for the disabled child. Encourage her to do a little more than she already does - and then a little more. If you have her try to do too much, she may get discouraged and stop trying.**
- **Show you care. Show the child how glad you are when he learns to do new things. Praise him when he does well - and when he tries.**

- **Mind and body. Play often with the child, in ways that help her develop not only her body but also her mind. Talk with her and tell her stories. Become her friend.**



**A simple bar held by forked sticks can increase the self-reliance of a child who has difficulty squatting to shit.**

**AN EXAMPLE: Pablo is having trouble learning to crawl. Using the above suggestions, how can we help him? Perhaps his older brothers and sisters, or other children, can play 'crawling games' with him.**

**Two children can hold up part of his weight as he tries to crawl. Another**



**child encourages him to crawl by holding out a fruit or toy. Call him to crawl toward the fruit. Praise him when he tries.**

**Play the game every day. As Pablo grows stronger, less of his weight will need to be held up. In time he may be able to crawl without help.**



**Figure**

**Note:** Many more ideas of ways children can help a child who is slow to develop can be found in PART 1 of this book, especially Chapters 34 and 35.



**Children in Mexico playing a 'crawling game'.**

## **Story telling**

**Story telling is another good way to help young people understand the needs and possibilities of disabled children and what can be done to help. You can make up stories. Or better, you can base them on true events where a disabled child has achieved something outstanding, or where a group of children have succeeded in making an important difference in the life of a disabled child. The story that follows is an example.**

A Story-to be used with the CHILD-to-child activity,  
"Understanding Children with Special Problems"

## **HOW TOMS AND OTHER CHILDREN HELPED JULIA GO TO SCHOOL**

At age 7 Julia's world was so small that you could throw a stone clear across it. She had seen almost nothing of her own village. No one ever took her anywhere. The farthest she had ever crawled was to the bushes just outside the small hut where she lived with her family

Julia was the oldest of 3 children. Her family's hut was at the far edge of Bella Village. The hut was separated from the main footpath by a long, steep, rocky trail. Perhaps for this reason, Julia had missed being *vaccinated* in her first year of life, when health workers had come to the village

In the beginning, Julia had been a healthy baby and quick. At 10 months of age she was already able to stand alone for a few seconds, and to say a few words, like 'mama', 'papa', and wawa' - which meant water. Her face would light up in a big smile whenever anyone called her name. Her parents took great pride in her and spoiled her terribly



**Figure**

But at 10 months Julia got sick. It began like a bad cold, with fever and diarrhea. Julia's mother took her to a doctor in a neighboring town. The doctor gave her an injection in her left backside. A few days later Julia got worse. First her left leg began to hurt her then her back and finally both arms and legs. Soon her whole body became very weak. She could not move her left leg at all and the other leg only a little. In a few days the fever and pain went away, but the weakness stayed, especially in her legs. The doctor in town said it was polio, and that her legs would be weak all her life

Julia's mother and father were very sad. In those days there was no rehabilitation worker in the village or in the neighboring towns. So Julia's mother and father took care of her as best they could. In time, Julia learned to crawl. But she did not learn to dress or do much for herself. Her parents felt sorry for her, so they did

everything for her. She gave them a lot of work

Then, when Julia was 3 years old, a baby brother was born. This meant her parents had less time for Julia. Her little brother was a strong, happy baby, and her parents seemed to put all their hopes into the new child. They paid less attention to Julia, rarely played with her, and never took her out with them into the village. Julia had no friends or playmates-except for her baby brother. Yet sometimes, for no clear reason, Julia would pinch her baby brother and make him cry. Because of this, her parents did not let Julia hold or play with him often

Julia became more and more quiet and unhappy. Remembering how quick and friendly she had been as a baby her parents sometimes wondered if her mind, too, had been damaged by her illness. Although the doctor had explained that polio weakens only muscles, and never affects a child's mind, they still had their doubts

When Julia was 6 years old, a third child was born-a baby sister. This seemed to make Julia even more unhappy. She spent most of her time sitting outside behind the hut drawing pictures in the dirt with a broken stick. She drew chickens, donkeys, trees, and flowers. She drew houses, people, waterjugs, and devils with horns and long tails. Actually she drew remarkably well for a child her age. But no one noticed her drawings. Her mother was busier than ever with the new baby



**Figure**

Julia was 7 years old when the village school teachers, guided by a health worker from a nearby village began a CHILD-to-child program in the school. The first and second year children (who were in the same class) studied an activity sheet called Understanding children with special problems

Most of the children knew of only one seriously disabled child in their village. This was Toms. Toms walked in a jerky way with crutches. He had one hand that sometimes made strange movements. And he had difficulty speaking clearly, especially when he was excited. But Toms did not seem to need any special help-or at least not anymore. He was already in the fourth grade of school and doing well. He had lots of friends. He managed to go anywhere and do almost anything for himself, if awkwardly and nearly everyone treated him with respect. It was easy to forget he was disabled

Then one little boy remembered, "There's a girl who lives in a house at the far end of the village. She crawls around on her hands and knees, and spends a lot of time

just sitting outside. She always looks sad. I don't know her name, but she looks old enough to be in school."

"Let's invite her to come to school with us," said one of the children.

"But how," asked another, "if she can't walk?" "We could bring her in a push cart!"

"No! The path from her home is too steep and rocky"

"Then we'll carry her! If we all help, it will be easy"

"Let's go to her house this afternoon." "Good idea!"

-----

That afternoon after school, 6 of the school children, together with their teacher, visited Julia's home. Julia, who was out back, was too shy to come in. So they started talking with her mother.

"We want to be her friends," they said. "And to help her go to school."

"But she can't go to school," her mother said with surprise. "She can't even walk!"

"We can carry her," offered the children. "We'll come for her every day and bring her back in the afternoons. It's not far, really!"

"The whole class is ready to help out," said the teacher. "And so am I."

"But you don't understand," said her mother. "Julia's not like other children. They'll tease her. She is so shy she doesn't open her mouth around strangers. And besides, I don't see how school could help her."



**Figure**

The teacher tried his best to explain to the mother the great importance of school for a child like Julia. The children promised that they would all be friendly and help her in any way they could. But her mother just shook her head.

"Do you think Julia would like to go to school?" asked the teacher.

Her mother gave a tired sigh. Then she turned to Julia, who was hiding outside the



door but peeping in at the visitors. "Julia, darling, do you want to go to school?"

Julia's eyes opened wide with fear. She shook her head in a terrified NO and disappeared behind the doorway.

"There, you see!" said Julia's mother. "For Julia, school just wouldn't make sense.... Now I have a lot of work to do, please excuse me. But thank you for thinking of my poor little girl."

"Please give it more thought," said the teacher as he and the children went out the door, "And thank you for your time"

"Have a nice day" said Julia's mother, and went back to work.

-----

At school the next day the teacher met with the whole class to discuss their visit to Julia's home.

"This CHILD-to-child stuff sounds so easy and fun when we pretend," said one of the children. "But when we try to use it in real life, it ain't so easy."

"Isn't!" said the teacher.

"Still," said one little girl who had visited Julia's home, "we have to keep trying. Did you see the way Julia looked at us? She was so scared she was shaking. But she

was interested, too. I could tell. She looked so... lonely!"

"But what can we do? I don't think her mother wants us to come back"

There was a long silence. Then one little boy said, "I've got an idea! Let's talk to Toms. He's handicapped, too. But he's in school and is doing fine. Maybe he can help us."

After school, several of the first and second year students waited for Toms, who was in the fourth year. They told him about Julia, and what happened when they visited her home.

"How was it when you began school, Toms?" asked the children. "Were you afraid? Did your parents want you to go? How did the other children treat you?"

Toms laughed. "One question at a time!" He spoke slowly, with a twisted mouth and a sort of jerky speech that sometimes made him hard to understand. "Help me sit down under that tree." Toms moved forward on his crutches. The children helped him sit down. (He explained that his hips and legs wanted to stay straight when he wanted to bend them.) He sat leaning against the tree, and began to answer the children's questions.

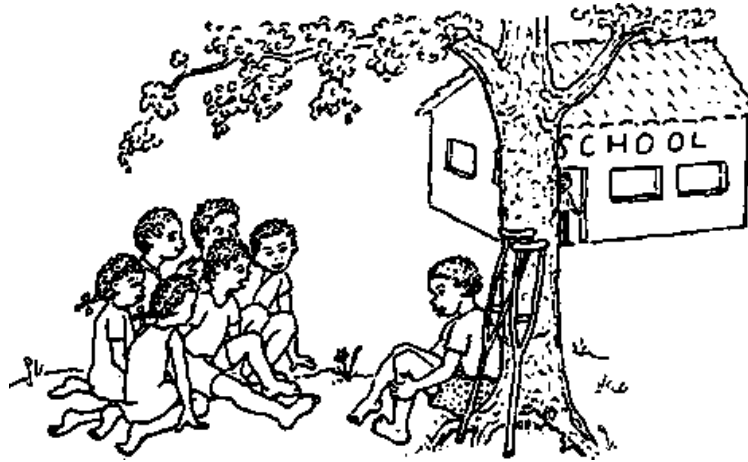

**Figure**

"Sure, I was afraid to go to school, at first," said Toms "And my mom and dad didn't want to send me. They were afraid kids would tease me or that it would be too hard for me. It was grandma who talked us all into it. She said if I couldn't earn my living behind a plow, I'd better learn to earn it using my head. And I intend to"

"What do you want to be when you grow up?" asked one boy

"Maybe a health worker," said Toms "I want to help other people"

"Did other kids tease you when you started school'?" asked the children

Toms frowned "No, not much. But they didn't know what to do with me, so usually they didn't do anything. They would stare when they thought I wasn't looking. And they would imitate the way I talk when they thought I wasn't listening. But when they thought I was looking and listening, they would pretend I wasn't there. That's what was hardest for me. They never asked me what I thought, or what I could do, or if I wanted to play with them I felt lonelier when I was with the other children than when I was by myself"

"But now you have lots of friends. You seem like one of the gang. What happened?"

"I don't know," answered Toms "The other kids just got used to me, I guess. They began to see that even though I walk and talk funny, I'm not really all that different from them I think it helps that I do well in school I like to read I read everything I can find. Sometimes when kids in my class have trouble reading or understanding something, I help them I like to do that. At first they gave me the nickname 'Crabfoot' because of how I walk. But now they call me 'Professor' because I help them with their lessons"

"The first nickname was about what's wrong with you," observed one little girl "And the second is about what's right. I guess you showed them what's most important"

Toms' mouth twisted into a smile and his legs jerked with pleasure. "Tell me more about Julia," he said

They told him all they could, and finished by saying, "We tried as hard as we could, but Julia's mother doesn't want her in school and Julia doesn't want to go either. We don't know what to do. Do you have any ideas, Toms'?"

"Maybe if I visit the family-with my parents. They can try to convince her parents, and I'll try to make friends with Julia"

The next Sunday, when Toms' father was not working in the fields, Toms asked his parents to go with him to Julia's home. They arrived in the early afternoon Julia's mother and father, together with the 2 younger children, were all sitting in the shade in front of the hut Julia's father was sharpening an ax while her mother picked lice from the children's hair. They all looked up in surprise to see the boy on crutches approaching, followed by 2 adults

The path near the hut was steep and rocky. A few meters from the hut, Toms tripped and fell. Julia's father ran forward to help

"Are you hurt?" asked Julia's father, helping him up

"Oh no," laughed Toms "I'm used to falling. I've learned to do it without hurting myself. We've come to talk to you about Julia. These are my parents"

"Come in," said Julia's father. They all exchanged greetings, and everyone went inside

While Toms' parents were talking with Julia's, Toms asked if he could speak with Julia

"She's outside," nodded her mother, pointing to the back doorway ` But she doesn't speak to strangers She's too afraid"

"She doesn't have to speak if she doesn't want to," said Toms gently, yet loudly enough so that Julia could hear, if she was listening

Toms went out and found Julia bent over a drawing in the dirt. She glanced up at him as he approached, and then looked down at her drawing, but without continuing it

There were several drawings on the ground of different animals, flowers, people, and monsters. Julia had just been drawing a tree with a big nest in it and some birds

"Did you draw all these?" asked Toms. Julia did not answer. Her small body was trembling

"You draw very well"" said Toms, admiring and commenting on each of her drawings "And with just a stick. Have you ever tried drawing with pencil and paper?" No answer. Toms continued `I bet that nobody in school can draw this well"" Julia, still staring at the dirt, trembled and said nothing. Toms also was silent for a moment. Then he said, "I wish I could draw like you do. Who taught you?"

Julia slowly lifted her head up and looked at Toms, or at least at his lower half. She looked first at his turned-in feet and the tips of his crutches. Then she looked at his knees, which had dark calluses on their inner sides where they rubbed together when he walked.

"Why do you walk with those sticks?" she asked.

"It's the only way I can," he said. "My legs don't like to do what I tell them."

Julia lifted her head and looked up into Toms' face. Toms tried to smile, but knew his mouth was twisting strangely to one side.

"And why do you talk funny?" asked Julia.

"Because my mouth and lips don't always do what I want either," said Toms. And it seemed he had even more trouble speaking clearly than usual.

Julia stared at him. "Do you really like my drawing?"

"I do," said Toms, glad to change the subject. "You have a real gift. Real talent. You should study art. I'll bet some day you could be a great artist."

"No," said Julia, shaking her head. "I'll never be anything. I can't even walk. Look!" She pointed to her small floppy legs. "They're even worse than yours!"

"But you draw with your hands, not your feet!" exclaimed Toms.

Julia laughed. "You're funny!" she said. "What's your name?"

"Toms."

"Mine's Julia. Do you really think I could be an artist? No, you're only joking. I'll never be anything. Everybody knows that!"

"But I'm not joking, Julia," said Toms. "I read in a magazine about an artist who paints birds. People come from all over the world to buy his pictures. And you know something, Julia, his arms and legs are completely paralyzed. He paints holding the brush in his mouth!"



**Figure**



"How does he get around?" asked Julia.

"I don't know," said Toms. "People help him, I guess. But he does get around. The magazine said he has been to several countries"

Julia said, "Wow! Do you really think I could become an artist?"

Toms looked again at the drawings in the dirt-and truly wished he could draw as well. "I know you could!" he answered.

"How do I start?" asked Julia, sitting up eagerly.

"First," said Toms, "you should probably go to school."

"But how?" said Julia, looking at her legs.

"That's easy" said Toms. "All the school children want to help. But you have to want to go."

"I... I'm afraid ..." said Julia. "Do you go to school, Toms?"

"Yes, of course," he answered. "Then I want to go, too!"

Inside the house, Toms' parents were trying to convince Julia's parents of the importance of sending her to school. They explained how they had had the same doubts about Toms, and how much school had helped him.

"It's not only what he is learning that's important," said Toms' mother, "but what it has done for him personally. He has more confidence-a whole new view of himself."

"And we've come to look at him differently too," said Toms' father. "He's a good student-one of the leaders in his class!"

Julia's father coughed. "Even if all you say is true, Julia doesn't want to go. She's afraid. You see, the same illness affected her..."

His sentence was cut off by Julia, who came bursting in the back doorway on hands and knees. "Mama! Papa!" she shouted. "Can I go to school? Will you let me? Pleeeeeease?"

Her father's mouth fell open for a moment. And then he smiled.

The next day Julia began school. The other children learned from Toms that Julia was ready to go, and they worked hard Sunday evening making a 'sitting stretcher' for her. One of the children had seen a similar stretcher when an injured man had been carried down from the high mountains. It was a simple wooden chair, tied firmly between two poles. The children finished making it by sunset and the next morning arrived with it at Julia's house. Toms went with them to give Julia courage. He was so excited that he fell 3 times!

Julia was so frightened when she saw the children that she almost decided not to go. But when they brought her special chair to the door, she lifted herself onto it

with her strong arms. And before she knew it, she was on her way to school!

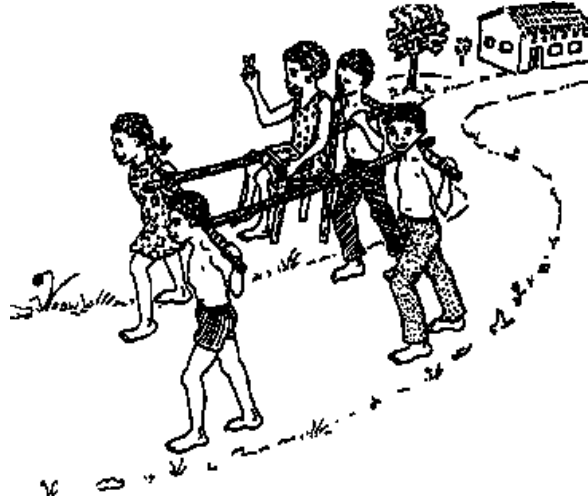

**Figure**

The first day of school went well. Everything was so new, and the children were all so friendly, that Julia almost forgot she was afraid. On the way home, she smiled and laughed as the children carried her

Six months have now passed since Julia started school. Although she began 2 months late, she is already able to read and write letters and words as well as most of her classmates. But drawing is what she likes most. The other children often ask her to draw pictures for them

Julia has made many friends. The children in her class who first looked at her as someone 'special', have now accepted her as one of their group. They include her in many games and activities, and treat her as just another child

Some problems have arisen. At first, carrying Julia to and from school each day was fun. But after awhile, many of the children got lazy and stopped helping. This meant more work for those who were left

The children got a new idea and asked their fathers for help. One Sunday a group of about 15 men and 20 children worked on improving the steep path from Julia's house to the main walkway leading to school. They made the curves wider so that the trail would be less steep, removed all rocks, leveled the surface, and pounded the dirt into a hard, smooth surface

One of the children's father had a small repair shop in the village. Another was a carpenter. With the help of their children, these 2 craftsmen made a simple wheelchair out of an old chair, 2 casters, and some bicycle wheels

Julia was excited when she saw the wheelchair. Her arms and hands were already strong, and with a little practice she learned to wheel her new chair up the long winding trail to the village

"Now you can come and go to school on your own," said Toms "How do you feel?"

"Free!" laughed Julia "I feel like writing a declaration of independence" Then she

thought a moment and frowned "I know I'm not completely independent-but that's all right. We all depend on each other in some ways. And I guess that's how it should be"

"It's being equal that counts," said Toms. "It's knowing that you're worth just as much as anybody else. Nobody's perfect"

Things also began to go better at home. As Julia's self-respect grew, so did her parents' appreciation of her. Suddenly both Julia and her mother realized that there were many things that Julia could do. She began to help with preparing meals, washing clothes, and taking care of her younger brother and sister. She treated them more lovingly and never pinched or made them cry (except, of course, when they deserved it!)

Julia's mother wondered how she had ever managed to get along without Julia's help. She missed her during the long hours she was at school. And when she realized she was going to have another baby, she thought Julia would have to stop going to school to help more at home

Julia's father shook his head "No," he said "School is more important for Julia than for any of our other children-if she is going to learn skills to make something of her life. And besides," he reminded his wife, "if we hadn't sent her to school, she would probably still be sitting outside in the dirt. It took the schoolchildren to teach *us* what a wonderful little girl we have"

Julia's mother smiled and nodded in agreement. "You're absolutely right," she said. "The schoolchildren and especially that wise little boy, Toms"

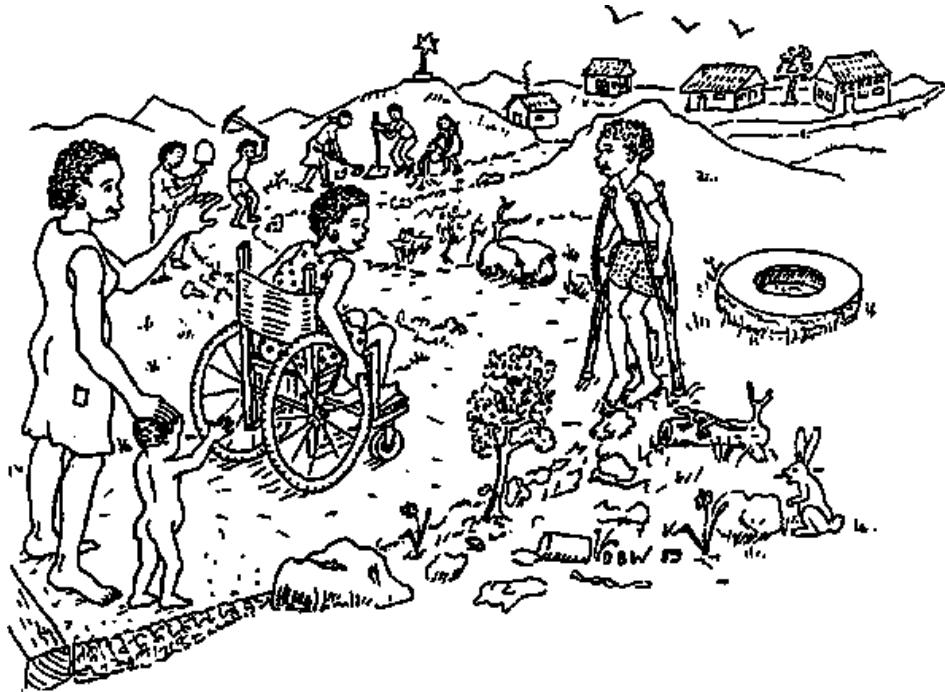

Figure

## CHILD-to-child ACTIVITY: CHILDREN WHO HAVE DIFFICULTY UNDERSTANDING

**In many communities, a child who is *mentally slow*, or *retarded*, has an especially difficult time. Other children may make fun of him for not being as quick as they are, or for not being able to understand, follow, or remember things as easily as they can. They may not realize that this child has the same need for friendship, play, and respect as they do.**

**This activity is designed to help children gain more appreciation of both the needs and possibilities of the child who is mentally slow. They will explore possible ways to help the child to feel a part of their group, and to learn new things at his or her own speed.**

**Talk with the children**

**You may want to start the activity by asking the children questions such as:**

- **Do you know a child who doesn't seem to understand or remember things as well as others her age?**
- **Does this child play much with other children?**
- **How do other children treat this child?**
- **How do you think it would feel if you had a similar difficulty?**

**Games and activities**

**Begin with games and activities that help the children discover what it may feel like to have difficulty understanding, and to be unfairly blamed for that difficulty. Then the children can look for ways to help a person learn that are easier, friendlier, and more effective.**

### **A GAME TO START WITH: 'ENGLEFLIP'**

**('Engleflip' is a nonsense word, but let us pretend that it means 'Stand up')**

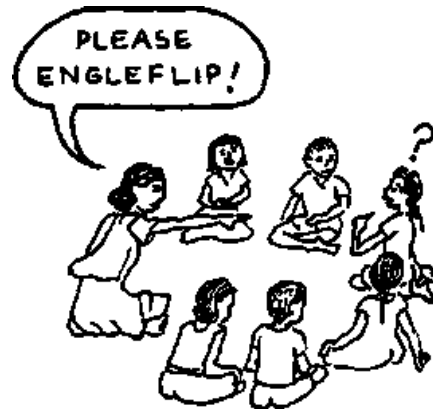

- 1. Ask one child in the group to 'engleflip'.**



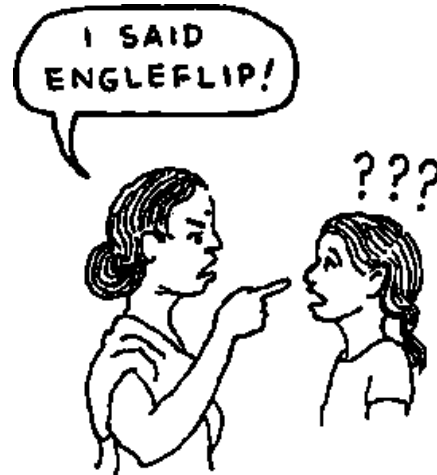

**2. Say it louder. Get angry.**

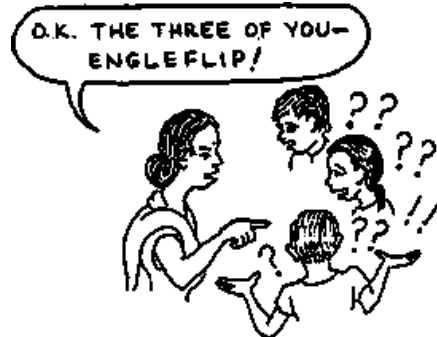

**3. Ask several other children.**

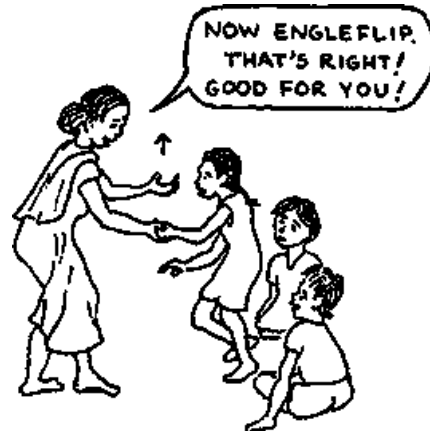

**4. Now help the children understand what you mean by showing them, assisting them, or gently explaining.**

**After the activity, discuss ...**

- **How did you feel when you could not understand the teacher?**
- **Was it right for the teacher to get angry? Did it help?**
- **Did the teacher finally do it better? In what ways?**
- **In what ways might your difficulty with 'engleflip' be similar to that of a child who has trouble understanding things?**

**Role playing**

**You can also use role plays or skits to explore the difficulties of a child who**

**does not understand, and how to help him understand. For example:**

**Ask 5 children to put on the role play.**

**They can pretend to be cleaning house. But before they start, ask one child to go out of the room. Tell the other 4 that after they have cleaned for awhile, they should turn to the 5th child and say, "Blah, blah, blah, blah." Tell the 4 children that this means, "Go get some water." But the 5th child will not know this.**

**Tell the 4 children to keep saying the words, and then to add other ways to help the 5th child understand.**

**The 5th child comes back and they begin,**

**Divide the class in groups of 5 (or more) and repeat the game. Have the children think of different situations and different meanings for "Blah, blah, blah, blah."**



**Figure**

**Afterwards, discuss with the whole class:**

- **How did the child feel who did not understand?**
- **How did the others feel?**
- **What did the others do to help the child understand?**

- **What else could they have done?**

**Follow-up activity: Write or tell a story**

**The story might begin by one child waking up one morning and not understanding anything anyone says.**

**Each child in the class writes or tells the rest of the story in his and her own way. Invite them to draw pictures with their stories.**

**Ask the children to include in their stories ideas for helping the child understand.**

**This activity could be done in a language or writing class. After they have written the stories, the children can read them to classes of younger children.**



**Figure**

## **Memory**

**It is important that the children also realize the importance of remembering things and the difficulties of a child who has an especially hard time remembering. Then they can try to find ways to help that child remember things more easily.**

### **MEMORY GAME #1**

**Ask the children to do many things, one after the other. Say the list of things in one sentence, very quickly. Do not wait for the children to do each thing before you say the next.**



**Figure**

**If the children cannot remember all the things, repeat the list louder, but just as fast.**

**Now do it differently. Say each thing slowly, and wait until they do one thing before you go on to the next.**

## **MEMORY GAME #2**

**Place 14 different things on a table where the children can see them. Let them look at them while you count to 30. Then cover them with a cloth and take 7 things away. Remove the cloth. Have the children write down the things that are missing.**



**Figure**

**Repeat the game using 6 different things and removing 3. Which is easier?**

**After the memory games:**

- **Ask the children why it was easier the second way.**
- **Explain that children who have trouble understanding are often confused when they are given too many instructions at once. Even 2**



**instructions at once may be too many for such a child. What suggestions do the children have?**

- **If the children know a child who has a hard time remembering things, they can help her improve her memory by playing these same kinds of games with her. Start with only 2 or 3 words or things, and as the child's memory begins to get better, gradually add more. Each time the child does well, praise her or give her a prize.**

### **STORY AND DISCUSSION: "I FORGOT"**

**Begin to tell a story about a little boy whose mother asks him to go to the corner store and buy some bananas. He comes back with nothing.**

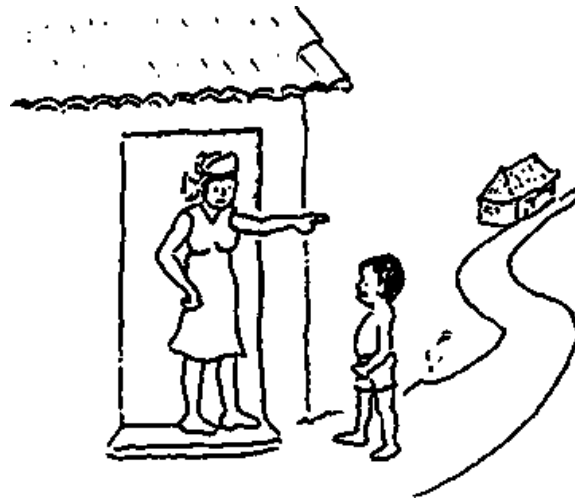

Figure



Figure

- **Why did he not bring the bananas?**

- **What might have happened?**
- **How could we help?**

**Another day the boy goes to buy bananas and comes back with matches. Why? How could we help him remember? Here are some possibilities:**

- **Another child could go with the boy - not to buy the bananas, but to help him remember, or give him 'clues'.**
- **He could take a picture to remind him - or sticks to remind him of the number.**
- **Another child could practice with him at home. Play remembering games. Start with one thing at a time.**
- **Praise or reward the boy each time he remembers and does it right. Do not praise and never punish the child when he forgets. Remember; He has difficulty remembering. It is not his fault!**

## **ROLE PLAY-GOING SHOPPING**

**The children can act out a role play something like this:**

**A mother sends her child shopping. She tells him a long list of things he must buy. He goes around the class 3 times and meets a lot of**

people who ask him a lot of questions like: "What time is it?" "Where are you going?" "Which way is the market?"

How much does the child remember when he gets to the store?



Figure

Talk with the class about what happened. How might it be made easier for the child to remember what he must buy? (Let us suppose the child cannot

**read.)**

## **PUTTING INTO PRACTICE WHAT WE LEARN**

**Do the children know any child in the village or neighborhood who has difficulty understanding or remembering?**

**Is there something they can do that might help the child to:**

- **feel he has friends who respect him and with whom he can play?**
- **remember things better?**
- **learn to do more for himself?**
- **go to school, and get the extra help he needs?**
- **enjoy himself more and fit into the community better?**

**If there are some children (or grown-ups) in town who make fun of the disabled child or treat him badly, is there anything the children can do? What? What precautions should they take? The story on the next page can give children ideas for helping a child who is mentally slow to learn basic skills. For more ideas, see Chapters 32 to 41.**

### **ZAKI AND NASIR**

A Story From Pakistan

This is the story of 2 brothers, Zaki age 9, and Nasir age 7. Their father was a

shopkeeper in Peshawar, and their mother was a teacher. They had a big brother and a big sister who were both students, living away from home. Zaki was doing well at school but Nasir had never even started school. There was something different about Nasir from other children. Nasir was mentally disabled. His brain did not work properly. He could only say a few odd words. He could not dress himself, and he made a mess at mealtimes.

Zaki felt ashamed to have such a brother. Neighborhood children made fun of Nasir. They called him nasty names and pushed him about. Nasir would get angry and try to hit them, and then fall flat on his face. Some of the grown-ups would shake their heads and say Nasir had an evil spirit inside him.

The worst of it for Zaki was that he had to take care of Nasir a lot of the time, when there was nobody else at home. It meant that he could not go out to play with his friends from school. And there was nothing to enjoy in looking after Nasir. He could not talk. He did not know how to play any games.

Zaki felt very sorry for himself, and used to hate Nasir for the times he had to stay in the house looking after him. It was so unfair! He had never done anything wrong, so why should he have to have a brother like that, who stopped him from going out and playing with his friends?

One day a visitor came by their house, looking for Zaki's father. It was his cousin, Dr. Daud. Zaki's parents were out. Only Zaki and Nasir were in the house. Dr. Daud noticed that Zaki had been crying. "What's the matter?" he asked. Zaki told

Dr. Daud all about his brother Nasir and how his own life was spoiled by having to look after him.



**Figure**

Dr. Daud listened carefully. Then he said, "Yes, you've certainly got a problem. But tell me, what are you doing about it?" "What can I do?" cried Zaki. "Nasir's just as bad now as he was 2 years ago, and he'll be twice as stupid in another 2 years time." Dr. Daud looked thoughtful. "Well, he might be," he replied. "But that depends on how clever *you* are."

“What do you mean?” asked Zaki. “I’m getting good marks at school, while he can’t even start” “Well,” said Dr. Daud, “if you’re clever enough for 2 then you could really help Nasir to change for the better. Then you’d both be happier and you’d get more free time to go out and play.” “How can I do that?” asked Zaki. Dr. Daud said,

“First, I’ll have a talk with your father and mother”

That evening Dr. Daud called again and had a long talk with Zaki’s parents. “I can’t give you any medicine for Nasir,” he said, “because there isn’t any that will cure him of mental disability. Not even the best surgeons can do anything. But you have the answer right here in your own home. If you have enough time and patience you can teach Nasir to do a lot more than he can do now.” But Zaki’s father said, “That’s just the problem! We don’t have enough time at home. I can’t have Nasir in the shop. He pulls everything off the shelves. And his mother is teaching at school and then has to get our food, and then gives private lessons. We can’t stop working, or we’ll never eat and pay the rent.”

“But Zaki has the time,” said Dr. Daud. “He could do a lot to teach Nasir. Why not try it for a month. I’ll show you where to start.”

So Zaki became Nasir’s teacher. But he also learned a lot of things himself. He started teaching Nasir to dress himself. Of course, Zaki knew how to put on a shirt. You just pick it up, and put it on! But he soon realized that there was more to it, when teaching Nasir. First you had to find which was the back and which was the



front of the shirt. Then you had to find the main hole and get the head through it. Then one arm went into the right sleeve. Then the other arm into the other sleeve. Next you pull the whole thing down over yourself.

Then there was teaching Nasir to feed himself. You would think it was obvious, how to eat! But Nasir had to find out step by step how to pick up a piece of chapati, get some curry on it, put it into his mouth and remember to chew and swallow. It took dozens of repetitions and lots of encouragement and rewards before Nasir learned each step. Zaki began to realize what Dr. Daud had meant. He needed to be clever enough for 2 in order to puzzle out how to teach Nasir. But when Nasir succeeded in some small step, they were both so delighted that it made all the effort worthwhile.

A few months later Dr. Daud was passing Zaki's house. Zaki came rushing out. "Quick, Doctor, you must come in!" Dr. Daud hurried in, thinking he would find someone at the point of death. But all he saw was Nasir, grinning broadly in his chair. "What is it? What's the matter?" demanded the doctor. Zaki was so excited he could hardly speak. "He said a whole sentence, Doctor. Nasir did. He's never said more than 2 words together before now. He just said 'Zaki give sweets to Nasir'. I've been trying for months to get him talking. He did it! He did it!"



**Figure**

Doctor Daud smiled. "I think you like your brother better than you used to," he said.

## **CHILD-to-child ACTIVITY: LET'S FIND OUT HOW WELL CHILDREN SEE AND HEAR**

### **Background discussion**

**Some children cannot see or hear as well as other children. Often we do not know about this and the child says nothing. But because the child does not hear the teacher or see the blackboard, he may not learn as quickly as others. So he may try to hide in a corner. We can help him by letting him sit close to the teacher.**

**Also, babies who cannot hear well do not learn to talk or understand as early as others.**

**In this activity, the school children try to find out which young children and babies do not see or hear well, and need help.**

### **HELPING CHILDREN UNDERSTAND THE PROBLEM**

**One way to get children thinking about these problems is to ask questions like:**

- **Do you know anybody who does not see or hear well?**
- **Do you act differently with these people? Why?**
- **How would you feel if you did not see well? Or hear well?**

**Games to help children understand *the difficulties of poor hearing***

#### **GAME: LISTEN LISTEN**

**All the children are completely silent for 3 minutes. They listen very carefully to the noises around them. Afterwards, they write down or draw everything they heard.**

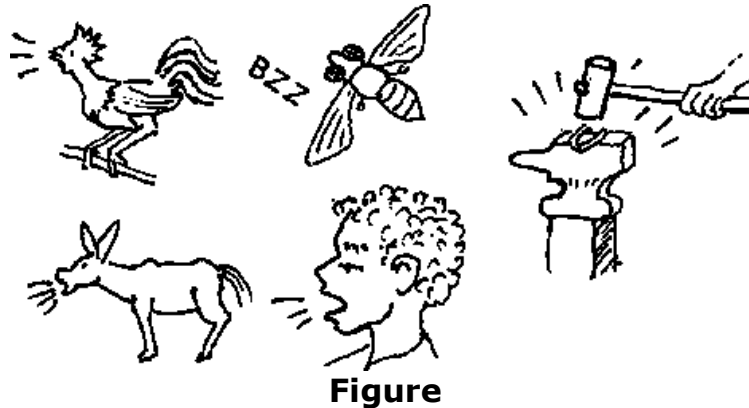

### **GAME: WHAT DID YOU SAY?**

**One child plugs his ears while another tells a funny story to the group. Then one of the children plays 'teacher' and asks everyone, including the child who had his ears plugged, to answer questions about the story. Finally, they ask him what it felt like, not being able to hear the story well.**

**Ask the children what they can do to help a child to hear better. Their suggestions might include:**

- **Have the child sit 'up front' close to the teacher.**
- **Everyone can take care to speak slow, clear, and loud (but do not shout).**

- **Use gestures or 'sign language' (if the child hears very little or not at all).**
- **Watch people's mouths and try to understand what they say. This is not easy if you do not hear the words. Have the children try it.**

## **GAME: TALKING WITHOUT WORDS**

**Children who hear very poorly or not at all often cannot speak. This is not because they are stupid, but because they need to be able to hear in order to learn how to speak. This game will help children appreciate the difficulties of a child who cannot speak, and give the children ideas of how to 'talk' without words to a child who does not hear.**



**Figure**

**Play a game where someone explains something to others through acting**

**only, without words. The others must guess what it is he is trying to say. The leader can start by acting out a simple phrase like: "I want a glass of water" The children try to guess what the leader is doing. Next have the children take turns acting out different things and ideas. Start with easy phrases like:**

- **I want to go to sleep.**
- **Give me the ball.**

**And work toward more difficult ideas like:**

- **I'm lost and can't find my house.**
- **I had a bad dream.**



**Figure**

## **Discussion after the game:**

- **Was it difficult to explain something without talking?**
- **How did you feel when no one understood you?**
- **What did the other children do to help you tell them what you wanted to?**
- **Could they have done more? What?**
- **How might you help children who cannot speak to communicate?**

**Explain to the children about sign language for the deaf. This is like the game in which children 'talk' with their hands. One form of sign language uses mostly the alphabet. Another form, which deaf persons prefer for 'talking' with each other, uses symbols for different actions and things.**

**If there is a deaf child in the school, or in the village or neighborhood, perhaps the children would be interested in finding a way to help that child learn to 'sign'. Or they may want to learn themselves, in order to be able to 'talk' with the deaf child.**

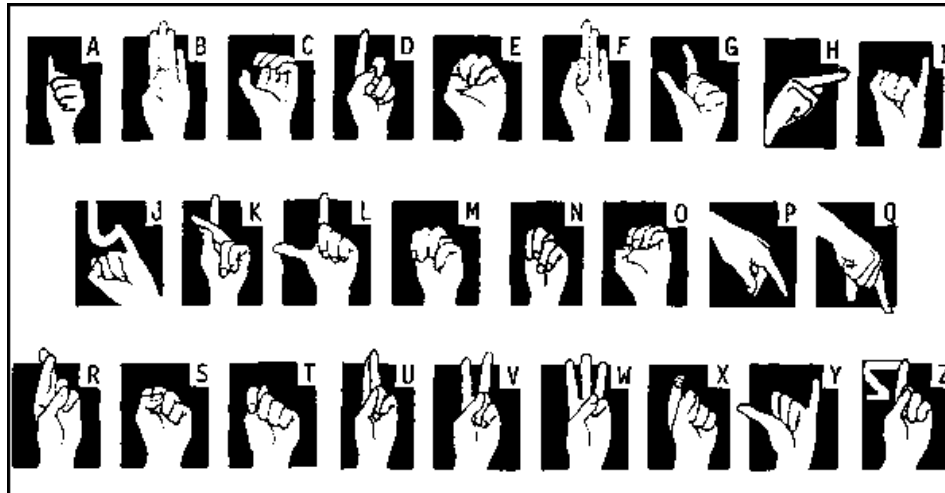

**Alphabet sign language used in the USA.**

**If 1 or 2 children in the class can learn to sign and then help translate spoken language into sign language, this can allow the deaf children to learn and take part more fully in the school and in the community. Also see Chapter 31.**

**Games to help children understand *the difficulties of poor sight***

**GAME: CATCH A THIEF**

**This game can help children understand both the importance of good**



# hearing and the difficulties of not seeing.

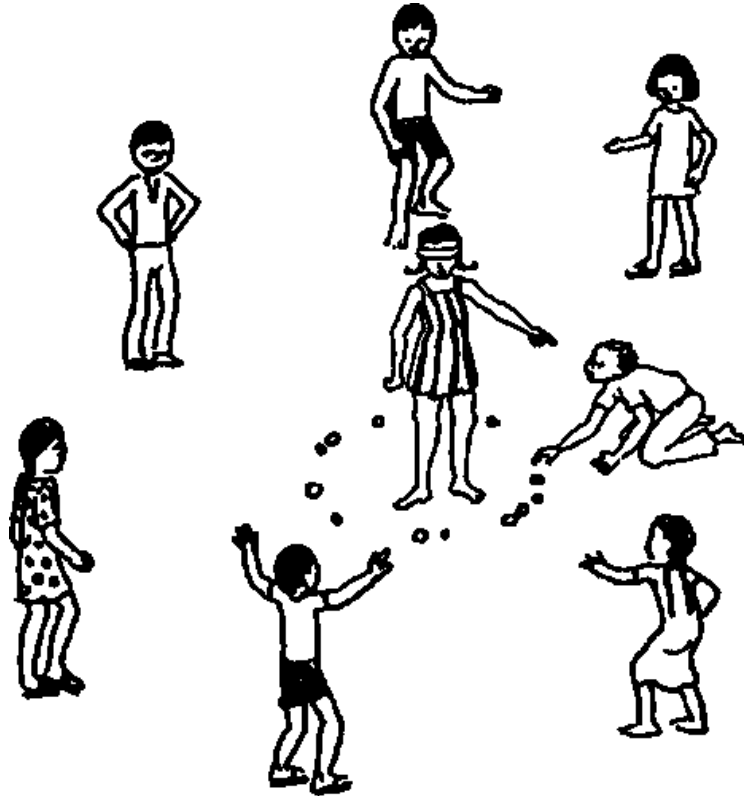

Figure

- **The children form a circle. One child stands in the middle with her eyes covered. Around her feet are small stones, nuts, or other small objects.**
- **The other children, one by one, try to creep up and steal these things.**
- **If the child in the middle hears the 'thief, she points to him and he is out of the game.**
- **The goal is to see who can steal the most objects without being heard.**

## **GAME: BLURRED VISION**

**One or more children are temporarily given poor or blurred vision in one of several ways:**



**Put somebody's powerful eyeglasses on a child who needs no glasses.**



**Or, cover his eyes with a piece of tracing paper, wax paper, or other material that you can see through slightly.**

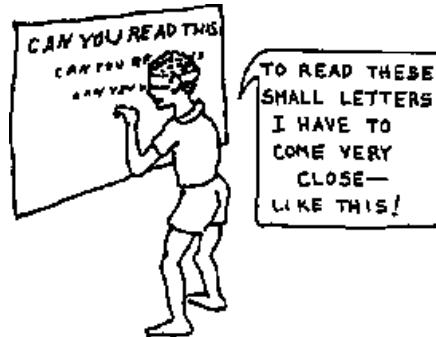

**Figure**

**Have the child try to read from a book with letters of different sizes. Do the same on the blackboard. What trouble does he have? How close does he**

**have to get? Does he read aloud from his book as well as the other children?**

### **GAME: BLINDFOLDED PARTNERS**

**The children are in pairs. One is blindfolded, the other is her guide. The guide takes the blindfolded person for a walk, letting her feel different things and taking care of her.**

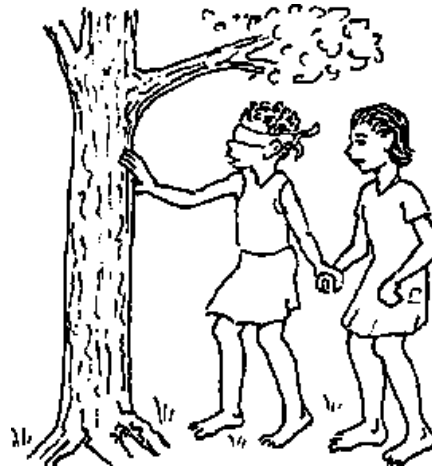

**Figure**

**After the game, discuss:**

- **How did it feel not to be able to see?**
- **What did your guide do that was helpful? Not helpful? What might she have done better?**
- **Did you trust your guide?**

### **GAME: FEEL A FRIEND**

**One child is blindfolded. He tries to recognize his friends by feeling them.**



**Figure**

**Similar feeling games can be played trying to identify different things by feeling them.**

### **GAME: WHAT'S THE SMELL?**

**Blindfold the children and have them identify things by their smell: things**

such as orange, tea leaves, banana, and local herbs.

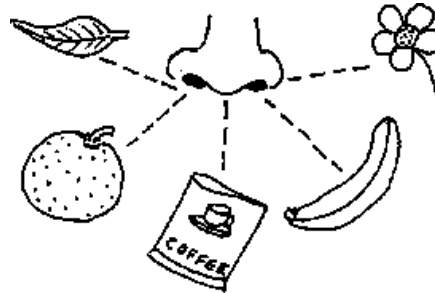

**Figure**

After the children play these different games, explain to them that because **blind people** cannot see, they **often develop outstanding ability to identify things through hearing them, feeling them, and smelling them.**

## **FINDING OUT WHICH CHILDREN HAVE PROBLEMS WITH HEARING AND SEEING**

**It is important to find out as early as possible if a child cannot hear or see well. Older children can do some simple tests with their baby brothers and sisters. A class or group of children can also test the seeing and hearing of younger children, such as those in nursery school or the first year of elementary school.**

## Testing the hearing of babies (4 months old and older)

- **Children can notice if their baby sister responds to different sounds, high and low, loud and soft. The baby may show surprise, make some movement, or turn her eyes or head toward the sound. Notice if the baby responds to her mother's voice when the baby does not see her.**



Figure

- **Or make a rattle from seeds or small stones. Creep up and shake it behind the baby's head, first on one side and then the other. See if the baby is surprised.**
- **Then call the baby's name from different places in the room. See if the baby responds.**



**Figure**

• **To test if a baby hears some kinds of sound but not others, do this. Sit at arm's length from the baby, and to one side. When she is not looking, make different kinds of sounds. Say "Ps" and "Fth" to test for high-pitched sounds, then "Oooo" for low-pitched sounds. For other high-pitched sounds, crinkle a thin, stiff piece of paper or rub a spoon inside a cup. For other low-pitched sounds, watch if the child notices the noise of a passing truck, a train whistle, a cow's 'moo', or low notes on a musical instrument or drum.**

**If the baby does not show surprise or turn her head with any of these sounds, she may have a severe hearing problem. If she responds only to certain sounds, but not to others, she has some hearing. But she may not be able to understand language well because she cannot tell certain words apart. As a result, she may not speak as early or as clearly as other children**



## and will need special help (See Chapter 31)

### Testing the hearing of young children (a game)

- An older child stands several meters from a line of younger children
- Behind each young child stands an older child with pencil and paper
- The first child says the name of an animal VERY LOUDLY

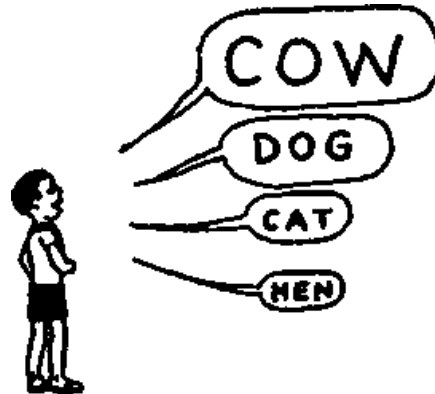

Figure

- The young children whisper the word to their older partners
- The older children write it down

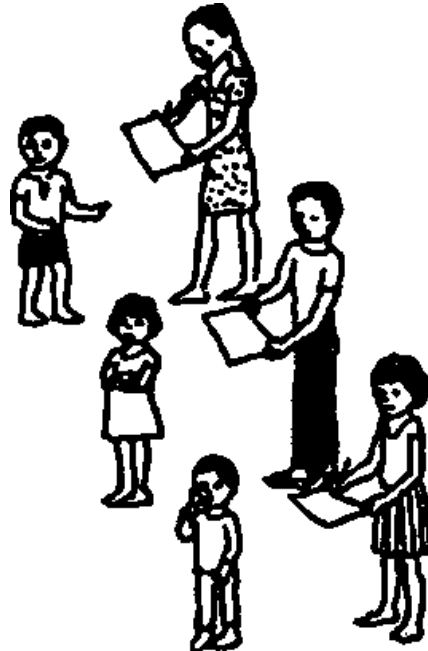

**Figure**

- Then the first child names other animals each in a softer and softer voice until he is whispering
- After about 10 animals have been named, and the words that the younger children heard have been written down, compare the different children's lists.

- Repeat this 2 or 3 times
- **Any child who has not heard as many words as the others, or has not heard them correctly, probably has a hearing problem.**

### **What to do for the child with a hearing problem**

- **Let the child sit at the front of the class where he can hear better**
- **Be sure everyone speaks clearly and loudly enough. But do not shout because shouting makes the words less clear. Check often to make sure the child understands**
- **Have one child who hears well sit next to the one who hears poorly-to repeat and explain things if necessary**
- **Always try to look at the child while you are speaking to him**
- **If possible, the child should be examined by a health worker-especially if he has pus in an ear or frequent earache**

### **HOW CAN CHILDREN HELP CARE FOR THEIR BROTHERS' AND SISTERS' EARS?**

**They can regularly look to be sure that there is no pus or small objects**

**inside. If they see anything wrong they should tell an older person, who should take the child to a health worker.**

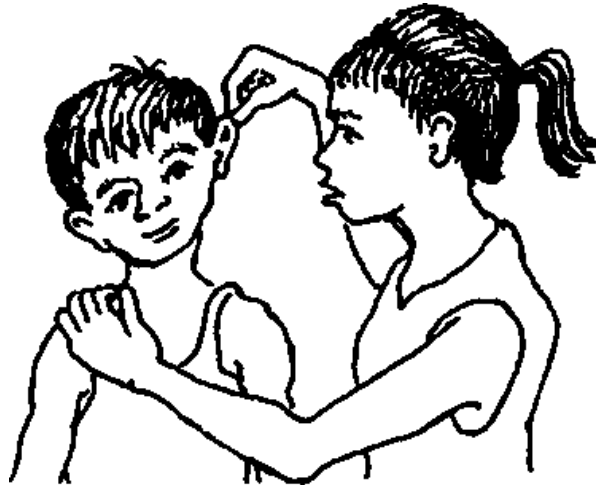

**Figure**

## **HEARING GAMES THAT CHILDREN CAN PLAY WITH BABIES**

**Most babies who are 'deaf hear something. They need help in learning to listen. The children may think of games to help babies listen and learn.**



**Figure**

**For example:**

- **Sing to babies, and teach songs to young children.**
- **Tell them stories and change voices to sound like different people**

**in the story-loud, soft, angry.**

### **Testing if a baby sees (for a child over 3 months old)**

- **Children can notice if the baby begins to look at things held in front of him, to follow them with his eyes, to smile at mother's face, and later to reach for things held out to him.**
- **Hang a bright colored object in front of the baby's face and move it from side to side. Does the baby follow with his eyes or head?**
- **If not, in a fairly dark room, move a lighted candle or torch (flashlight) in front of the child's face. Repeat 2 or 3 times.**

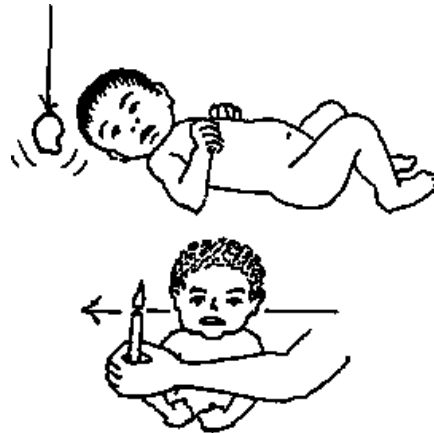

## Figure

**If the baby does not follow the object or light with his eyes or head, probably he does not see. He will need special help in learning to do things and move about without seeing. Other children can help. (See Chapter 30.)**

**Testing how well children see (4 years old and older)**

**A group of older children can make an eye chart. They can cut out black 'E's of different sizes and paste them on white cardboard.**

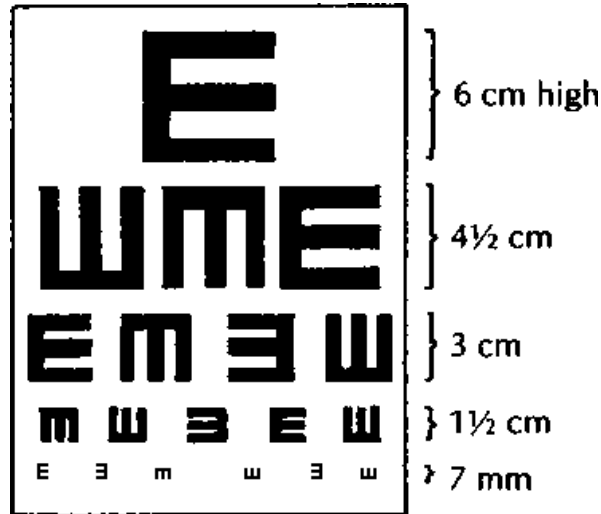

**Figure**

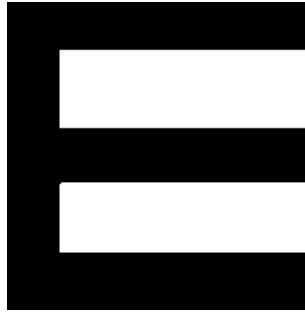

**Also make one large 'E' shape out of cardboard or other material.**



**Children making an eye chart. (Mexico)**

**First let the children test each other. Hang the chart in a place where the light is good. Then make a line about 6 meters from the chart. The child to be tested stands behind the line, holding the cut-out 'E'. Another child points at different 'E's', starting from the top.**



**Ask the child being tested to hold the cut-out 'E' so that its 'legs' point the same way as the 'E' on the chart.**



**Figure**

**If the child can easily see the 'E's' on the bottom line, he sees well. If he**

**has trouble seeing the second or third line, he sees poorly.**

- **To make the testing more fun, you can use horses in the shape of 'E's.**

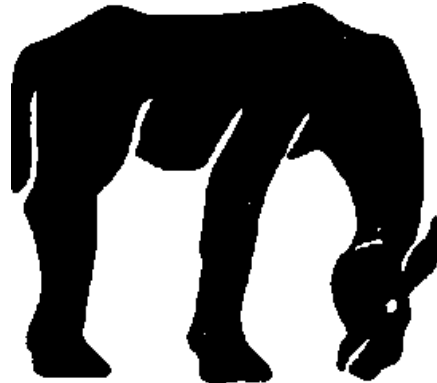

**Figure**

- **Make 5 cards using different size horses. Make the sizes the same as those shown for the letter 'E' in the chart at the top of this page.**

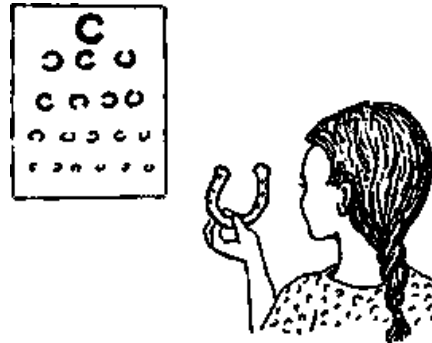

**Figure**

- **Or use a chart with 'C's. Ask the child either to hold a horse shoe in the same position as the different 'C's on the chart, or to tell you for each 'C' which way the horse shoe is going.**

**To test children who are mentally slow, deaf, or have trouble communicating, you can use pictures of different things they recognize. Hold up one picture at a time and have the child either name it or point to a similar picture - or the real object. For example, you can make a set of cards with pictures like this:**



Figure

**After the children practice testing each other, they can test the eyesight of those in the younger grades and the children who will be starting school soon.**

### **WHAT TO DO FOR THE CHILD WHO SEES POORLY**

- Be sure he sits in front, close to the blackboard.

- Write large and dark on the blackboard, and check often to make sure he can read what is there.
- If possible, the child should go to a health worker for more tests. He may need glasses.
- If he cannot get glasses, try to find a magnifying glass. This may help him read small letters.

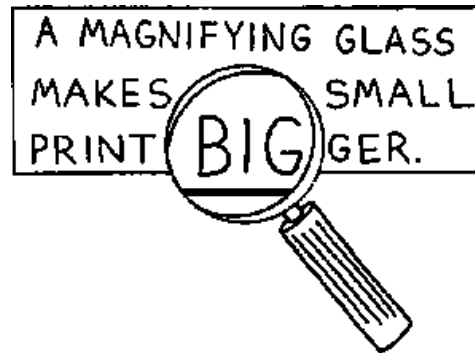

**Figure**

- If he has not learned to read and write because he does not see well, teach him with

EXTRA BIG LETTERS

- If the child still has trouble reading, have another child read his books and lessons to him aloud.

## **Looking at each other's eyes for signs of problems**

**Start with questions to get the children interested. For example:**

- **Are your eyes the same as your classmates? Shiny? Clear?**
- **How about the eyes of your younger brothers and sisters?**
- **Can you see well in the dark? Or do you often stumble at night?**
- **Do a child's eyes look dull? Are there any unusual spots or wrinkles? If so, see a health worker.**

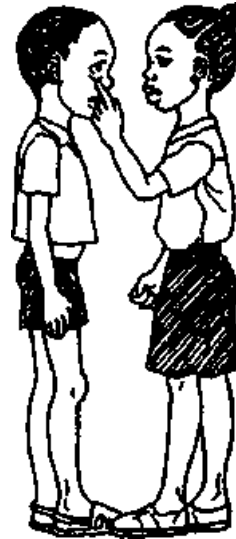

**Figure**

**Many children in different parts of the world become blind because they do not eat foods that make their eyes healthy. Eating yellow fruits or dark green leafy vegetables helps protect the eyes. Some extra cooking oil added to food also helps.**



**If children's eyes are red or sore, you can suggest that they wash them**

**often with clean water with a little salt in it (no saltier than tears). This may help eyes get better and keep the flies away. If they do not get better soon, see a health worker.**

**For more information on eye problems and blindness, see Chapter 30.**

## **Chapter 48: Popular Theater**

**Community theater can be an excellent way to raise awareness about specific needs of disabled persons or to gain greater participation of local people in a community *rehabilitation* program. It is also a good method for educating people about important preventive measures. Actors can be disabled persons, parents of disabled children, health workers, rehabilitation workers, school-children, or any combination of these.**

**No special place is needed. However, some sort of raised area is helpful, with a plain wall or curtain behind. But effective popular theater has also been carried out in the street, the village square, and the marketplace.**



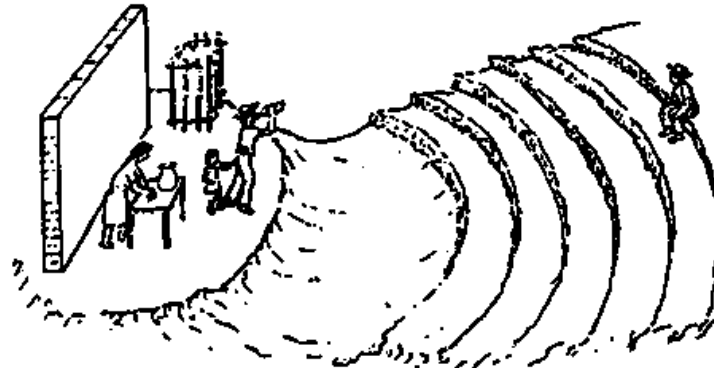
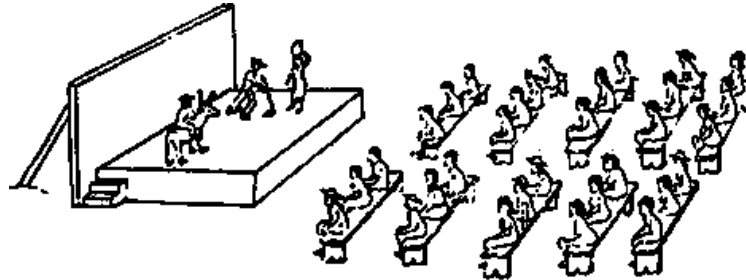

**Simple outdoor stages for popular theater.**

***For example, measles is especially dangerous to poorly nourished children, leaving many with blindness, deafness, fits, retardation, or cerebral palsy. Preventing measles helps prevent disability.***

**In Nicaragua a group of health workers and local children put on a street theater skit called '*The Measles Monster*'. Popular participation is high, for as watchers gather, the monster runs through the crowd looking for unvaccinated children. At the end of the skit, when all the children are protected by *vaccination*, the children in the audience join the children in the skit in beating-up the monster.**



**The Measles Monster street theater skit in Nicaragua. The head of the monster is a mask painted on heavy paper, glued to a cardboard carton.**



**An unvaccinated child actor (wearing a white 'happy' mask) is caught by the measles monster, who closes his huge claws around him.**



**Under the monster's claws, the child rapidly changes masks. When the monster uncovers him, he is wearing a 'sad' mask speckled with red spots. The child nearly dies.**

**The announcer of the skit asks the children in the audience why the boy was attacked. They shout back, "Because he wasn't vaccinated." At the end, after all the children are vaccinated, the loudspeaker asks, "Why can the children now overcome the monster?" They shout back, "Because we have all been vaccinated!"**

**To give another idea of what can be done through popular theater, we will show you photos from 2 theater skits organized by Project PROJIMO, the villager-run rehabilitation program based in Ajoya, Mexico.**

**In order to increase community involvement in PROJIMO and to help local people understand its activities better, the program uses popular theater. The skits were put on soon after the school children had helped build the rehabilitation playground. They tell the story of how PROJIMO began and how the playground was built and is used. The actors are local school children, disabled workers of PROJIMO, and village health workers from neighboring villages who were in town for a refresher course. The health workers' participation in the skits gave them experience working with disabled persons, and also gave them ideas for simple rehabilitation activities and aids in their own villages.**





**Figure**

The story of how Project PROJIMO got started and how village school children built a playground for disabled and non-disabled children.



**Figure**

A disabled young man (played by Marcelo) arrives at Ajoja and asks directions to the village health center (Project Piaxtla).



The health workers examine him, find he is disabled by polio and think he may need braces. But they lack the knowledge about what to do for him. So they send him away without helping him.



**Figure**



**Figure**

The health workers are concerned: "So many disabled children come to us. Most of them don't need hospitalization or surgery, but simpler things like braces or special exercises. Yet we don't have the knowledge or skills to provide these things for them. Why don't we try to get more training and start a rehabilitation program for disabled children here in our village? We can focus on what parents can do for their children in the home."

The health workers meet with villagers to discuss the new program. The villagers respond enthusiastically. Men offer to help fix up the center. Women offer to provide room and food for





**Figure**

visiting children and their families. And the schoolchildren offer to help build a rehabilitation playground - on condition that they can play there too.

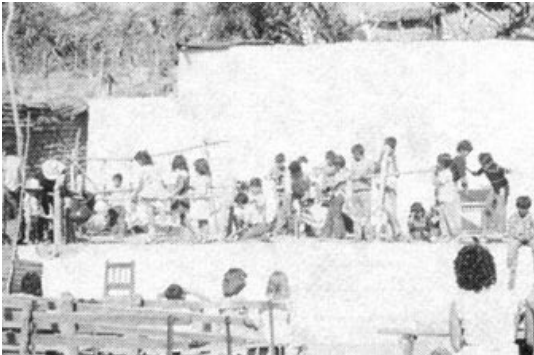

**Figure**

The schoolchildren-who had already built the actual 'playground for all children' in the village-quickly rebuild the playground on stage.

Because they had already dug the holes for the poles, and had practiced over and over again, they were able to set up the playground in about 3 minutes.





**Figure**

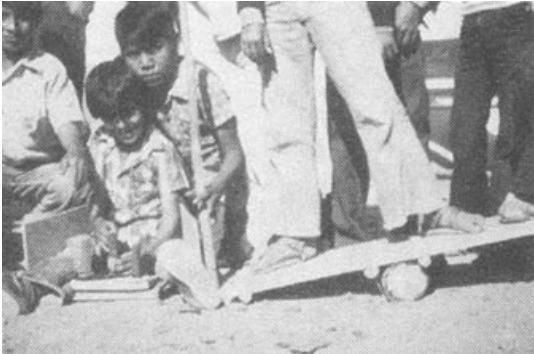

**Figure**

**The second skit is a continuation of the first.**

In this way villagers have a chance to see how different equipment in the playground is used - like this 'rocker board' to help children with balance problems, and the sitting frame to help a child with spasticity keep his legs apart while he plays with homemade educational toys.

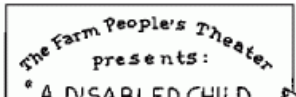



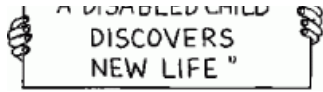

This is the disabled child, Tristn.

**Figure**

**Figure**

His role is played by Ins - one of the disabled village workers. In fact, the skit comes close to telling Ins' own story. Like Tristn in the skit, Ins is an orphan disabled by polio who was helped by PROJIMO to get braces, and then stayed on as a rehabilitation worker.



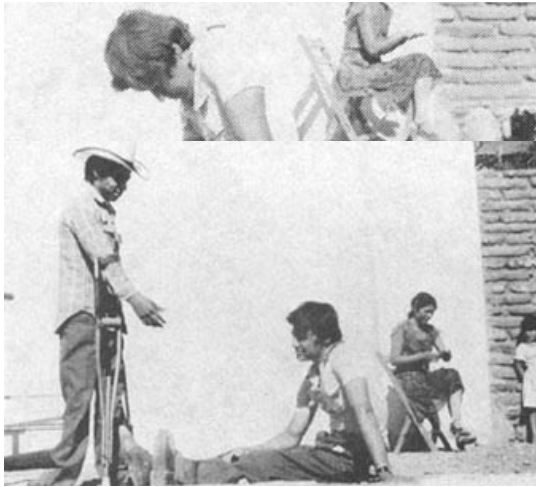

**Figure**

Marcelo, a village rehabilitation worker, finds Tristn in a village hut. The boy is unhappy because he cannot walk and has no friends. Marcelo invites Tristn to come with him to PROJIMO.



**Figure**

They arrive at PROJIMO, and Marcelo shows Tristn the playground.

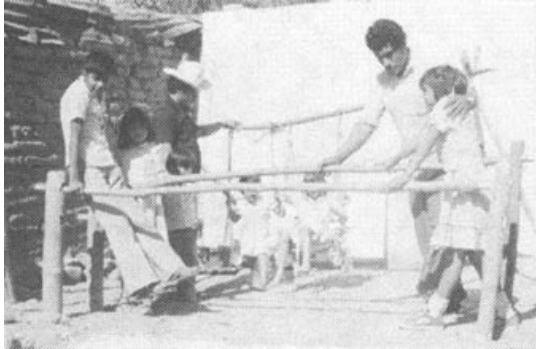

Tristn (and the audience) have a chance to see how the playground equipment is used to help disabled children learn to walk and do other things.

**Figure**



They see how the sitting frame and homemade games are used; also how a child who cannot sit lies on a sloping platform so he can lift his head and use his hands.

**Figure**



5 days later



The village rehabilitation workers have made a brace for Tristn, and here fit it onto his leg.

**Figure**



Then they help him learn to walk with the brace.

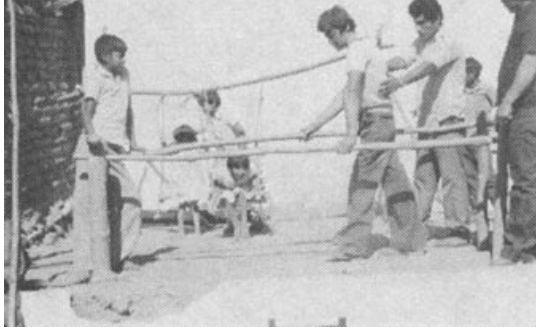

using the parallel bars.

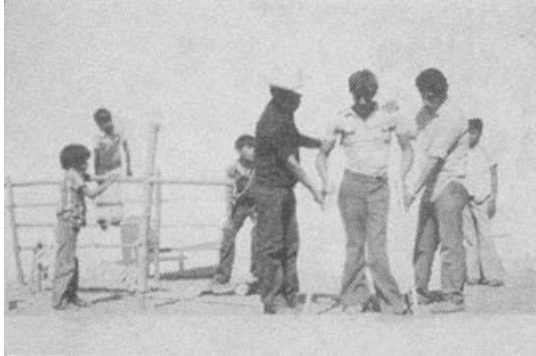

Tristin learns quickly and soon begins to walk with crutches.

**Figure**

The time comes when PROJIMO has done as much



as it can for Tristn, in terms of **physical** rehabilitation. "Where do you go from here?" they ask him. "I don't know," he answers. "I have no family to go to. I've never gone to school. Work is hard to get even for the physically fit" "Why don't you stay with us and help in the rehab program? You can learn some skills and help other children like yourself."



Tristn decides to stay, and begins to learn rehabilitation skills. Here a mother arrives with the first child for whom Tristn becomes responsible as a "rehabilitation helper".

### Figure

Together the team examines the child, who appears to have cerebral palsy affecting mainly his legs. The team believes he has a good chance of learning to walk.





Tristn shows the child's mother how she can help him learn to walk using the parallel bars.

**Figure**



**Figure**

**At last the little boy learns to walk. But just as important, he has new hope, new friends and new self-confidence. He sees other disabled persons like himself who are not only leading full lives, but who are working hard to serve others in need. As the skit ends, Tristn lifts his young friend onto his shoulders and raises his crutches in a sign of victory**

**The ending of this skit was even more impressive for the village audience because they had seen Ins (who acted as Tristn) when he first came to their village. They knew that his transformation from a very disabled, withdrawn youth to a fast-moving, capable young man was not just acted - it was real.**



**And because PROJIMO is the village's program, everyone felt proud.**



**Sets of color slides (transparencies) with written scripts of the skits "The Measles Monster," "Helping Your Neighbor," and "A Disabled Child Discovers New Life," are available from the Hesperian Foundation. Also available, although less directly related to disability prevention, are slide sets "The Importance of Breast Feeding," "Useless medicines That Sometimes Kill," "The Women Unite To Overcome Drunkenness," and "Farmworkers Unite To Overcome Exploitation."**

**Other skits are mentioned in this book.**



**Drawing by Minji Ng 6 years old of herself with her artificial arm and her friend Lupito who is missing one leg and walks with a walker**



**Disabled children together with school children at work in the toymaking shop at PROJIMO**

## **Chapter 49: Children's Workshop for Making Toys**

**If a *rehabilitation* program is to achieve a strong base in the community, it needs to involve large numbers of local children. There are many important ways in which village children of various ages can take part, playing and working together with disabled children. We have already discussed how children can help build a low-cost 'playground-for-all children'.**

**Another way that village children can contribute to a rehabilitation program is by helping to make special toys for disabled babies and children.**



**Children often design and make excellent toys. This child from Vietnam puts the last touches on his homemade truck. (Photo: UNICEF/Jacques Danois)**

**In Project PROJIMO in Mexico, village children help out in this way-and enjoy doing it. In addition to the toys that this voluntary 'labor' produces, it also brings together non-disabled and *disabled* children in a creative work-play relationship.**

**At first the children at PROJIMO made toys in the same workshop where the disabled staff was busy making braces, wheelchairs, and other *orthopedic* equipment. But soon things got too crowded. The children often played while they worked (which is natural), and a few important tools got broken or 'lost'. While there were advantages to letting the children work in the same shop with skilled disabled crafts persons, the team finally decided**

**to create a separate 'children's workshop' equipped with its own basic tools.**

**In this workshop, children are invited to make educational and useful toys - 'useful' in the sense that they help with a child's early development, providing *stimulation*, exercise, use of the senses, and learning of skills.**



**Animal puzzles, like this one made by village children, help a child learn to use his hands, and to match shapes. (PROJIMO)**

**As the children or disabled workers become more skillful at making toys,**

**some can be sold to help bring in money to the workers or program. Some of the toys and dolls made at PROJIMO are sold to visitors. In Jamaica, disabled young people run an economically successful factory, making wooden toys. Toys made at the Life Help Center for the Handicapped, Madras, India, are sold world-wide.**

**PROJIMO has an agreement with the children. The first toy they make is for the rehabilitation center or for a particular disabled child. The second toy they make they can take home for a younger brother or sister. In this way PROJIMO and the school children also contribute to the development of non-disabled children in the village.**



**School children making toys**



**Mari, one of the rehabilitation workers at PROJIMO, uses one of the child-made toys to test the ability of a girl who is developmentally delayed.**

**Another advantage to the children's workshop is that it provides experience, fun, productive activity, and skills training for visiting disabled children. Thus a child who needs to spend a few days in the village, while a brace or limb is being fitted or a joint is being straightened, can spend part of his free time in the workshop.**

**The orthopedic workshop is not strictly off-limits for the children. Occasionally a child who proves to be a responsible and serious worker will**



**be allowed to help in the 'adult workshop' - perhaps helping to make crutches, braces, special seats, and other orthopedic equipment. But to gain working privilege in the 'big persons' shop, a child must usually first prove himself in the children's workshop. This helps reduce problems. But, of course, some problems do occur-as with any community action that is worthwhile.**

**Guiding and coordinating the children's workshop (we prefer 'guiding' to 'supervising') is an important job. It can be shared by different persons: rehabilitation workers, volunteer village craftspersons, or even some of the older, more responsible children as they gain experience. What is most important for such a coordinator is (a) that she like children,(b) that she be able to provide direction and keep order effectively without being bossy and (c) that she be very patient.**

**Whether parents of visiting or local disabled children are invited as coordinators or helpers in the children's workshop can be decided depending on the particular parent and child. Some parents do a fine job. It may be an opportunity for a parent to relate to and work with his child in a completely new way. However, some parents may continue to overprotect and over-direct their own child or other children in the workshop. Many children need a chance to do and make things with other children independent of their parents' supervision or help. For such children, it may be best *not* to ask their parents to be present in the workshop.**

## **Tools and equipment for a children's workshop**

**Here are some suggestions for basic equipment. You will want to consider what tools are commonly used and least expensive in your area, and equip the shop accordingly.**

- **Workbenches.** You will probably need at least 2, at different heights. One should be just high enough for the local size of children's wheelchairs to fit under. (Unfortunately, many children are given adult-size wheelchairs with high armrests. These often do not fit under a bench at a good height for working.). Make workbenches strong enough so they do not move a lot.

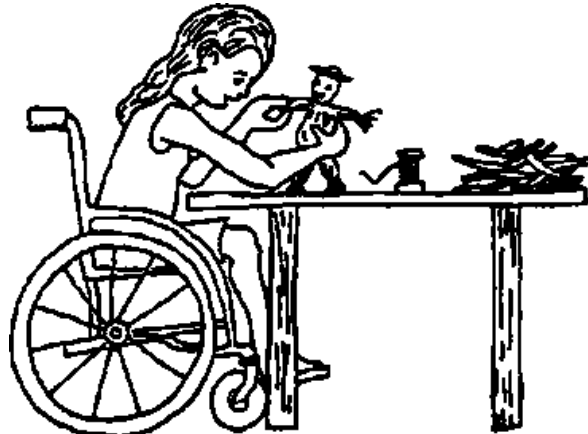

**Some children work best at a bench they can sit at in a wheelchair or stool.**

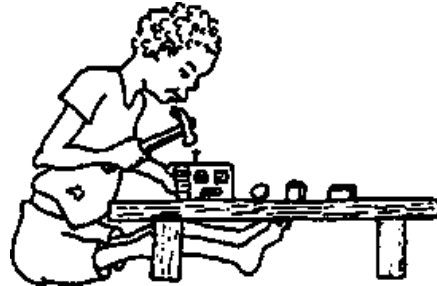

**Some children work best at a very low bench.**

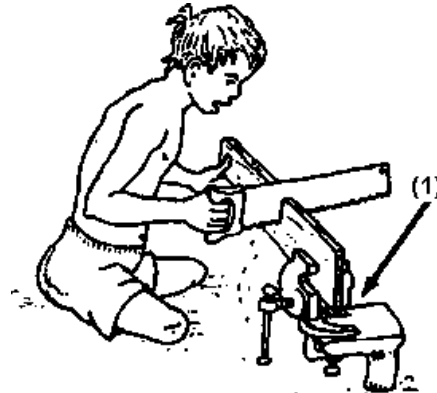

**And some children may work most easily at ground level.**

**A vise can be mounted on a post in the ground (1).**

- **vises** for holding things firmly - 2 or more



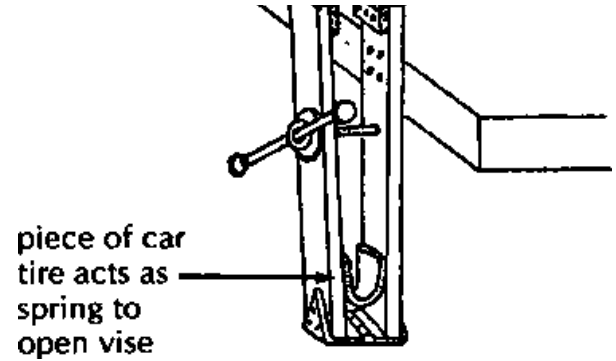

Figure

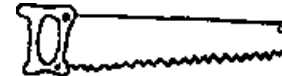

Figure



Figure

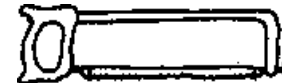

Figure



Figure

- **handsaws** at least 2
- **coping saw** (for curved cuts of thin wood)
- **hacksaw** (for cutting metal)
- **screwdrivers** (several of different sizes)
- **hammer**

- **wood-rasp**
- **metal file**
- **sharp knife**
- **sandpaper** rough and fine
- **brace and bit** or drill with bits of different sizes

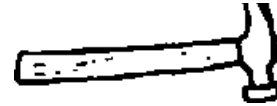

**Figure**



**Figure**



**Figure**



**Figure**



**Figure**



- 

- **square**



Figure

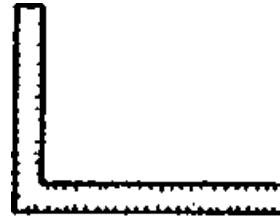

- **needles and thread**



Figure

- strong **scissors**



Figure

- **pliers** with wirecutters



Figure

### **More expensive tools**

**If electricity is available and the program or community can afford it, a few power tools will make work faster, more fun, and more productive for the children. Clearly, care must be taken to avoid highly dangerous equipment. Make sure children take the necessary precautions. Here are some examples of electrical equipment that can make work much easier and faster:**

- **an electric jigsaw** for making puzzles, wood animals, and so on

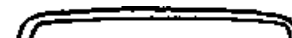

- **grinding wheel** (hand or electric)

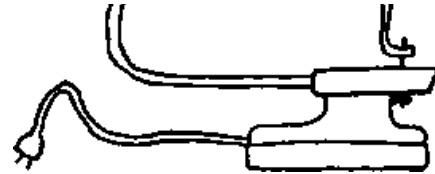

Figure

- **an electric drill** with attachments for sanding and grinding

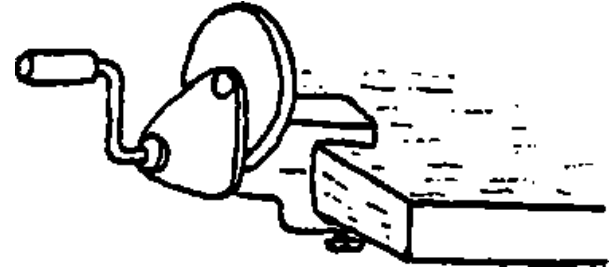

Figure

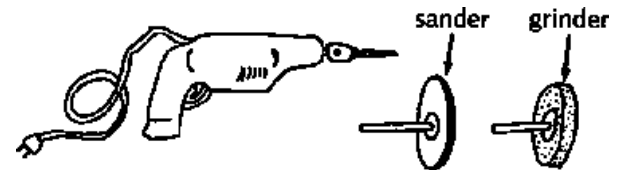

Figure

- **A sewing machine** (foot-powered or electric) will also be helpful in making many toys, dolls, and clothing. If the program can afford it, this machine can speed up sewing greatly and help children learn an important

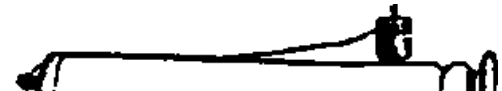



skill.

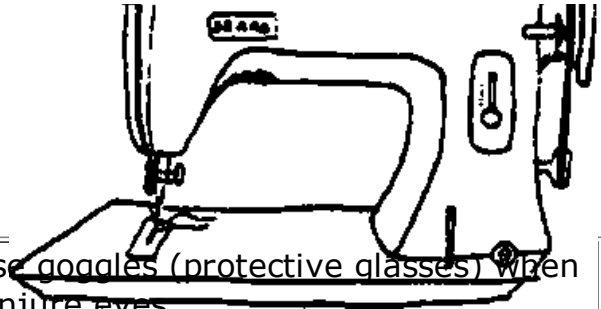

**CAUTION:** Be sure children and all workers use goggles (protective glasses) when using tools where bits of wood or metal could injure eyes.

Figure



## Gathering materials and supplies

**Explore every opportunity to obtain low- or no-cost materials and supplies for making toys. Here are a few possibilities:**

- **Many materials for making toys can be gathered from local forests - branches of trees, reeds, bamboo, wild kapok (cotton). Also various nuts, seedpods, and sea-shells can be used.**
- **Broken fruit-packing boxes often have thin wood that is excellent for toy-making. Even the nails can be pulled out, straightened and re-used.**

- **Old tubes of car and bike tires provide elastic bands for many toys,**
- **Scraps of wood, wire, and other supplies left over by lumber stores, builders, etc. will often be donated if you explain why you want them.**
- **Clothing makers and factories may have scraps of cloth left over.**
- **Cardboard cartons, especially thick ones (even if broken) provide material for making many toys. Ask in local shops.**
- **Old cans, tins, plastic bottles, thread spools, and so on are also useful.**

**Ask members of the community to look for and collect these and other supplies.**

## **TOYS CHILDREN CAN MAKE**

**In a community rehabilitation program it is essential to have lots of toys- different playthings for children at different levels of development who have different strengths, weaknesses, and interests.**



**There is an old saying ... "THEY WHO CHOP THEIR OWN FIREWOOD WARM THEMSELVES TWICE!"**



**We have a new saying ... "THE FAMILY THAT MAKES ITS OWN TOYS HAS TWICE AS MUCH FUN!" (stuffing a homemade doll with wild kapok)**

**Many of the most fun, most educational toys can be made from scrap materials by members of the family or community. Disabled children with good hands can learn skills and take pride in making toys for other disabled children. So it makes sense to make toys rather than to buy them.**



**Helping to make toys for other children can be just as educational - and fun  
- as playing with them.**



**The following pages show a number of toys that children will enjoy making in a children's workshop. Or disabled children or their families can make them at home. We start with very simple toys for babies or children at an early developmental level. Gradually, the toys become more advanced. More skills will be needed by the children who make them, and by those who play with them.**

***IMPORTANT:*** Please don't just copy the ideas for toys shown here. Be creative. And **encourage the children making the toys to be creative.** Help them use the examples shown on these pages as triggers to the imagination. Have fun!

## **TOYS TO ENCOURAGE LOOKING AND LISTENING**

small mirrors or  
pieces of tin foil  
or shiny paper

colorful objects that  
move in the air

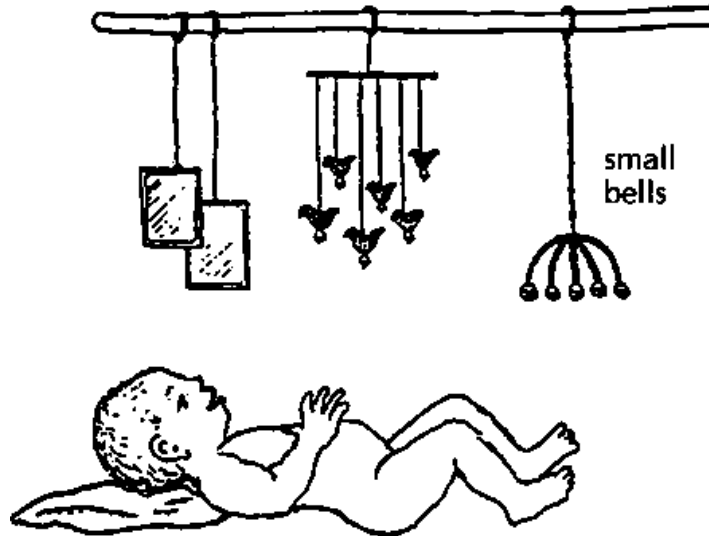

Figure

From UPKARAN manual



**For a baby, hang a 'ring of beads' where she can reach and handle it.**



**As the child develops more hand control, she can begin to make chains and necklaces by stringing the nuts on a cord.**

## TOYS THAT HELP DEVELOP USE OF HANDS AND SENSE OF TOUCH

You can make beads and chains out of wild fruits and nuts.

prickly



Figure

rough and smooth



Figure

fuzzy



Figure

wrinkled or lumpy



Figure

smooth



Figure

wiggly



Figure

**CAUTION:** Be sure not to use things that are poisonous, harmful, or that might get stuck in the child's throat, nose, or ears.





**A child can play putting the nuts and pods in and out of a container.**



**Later he can learn to sort them-first by seeing them, and then blindfolded.**

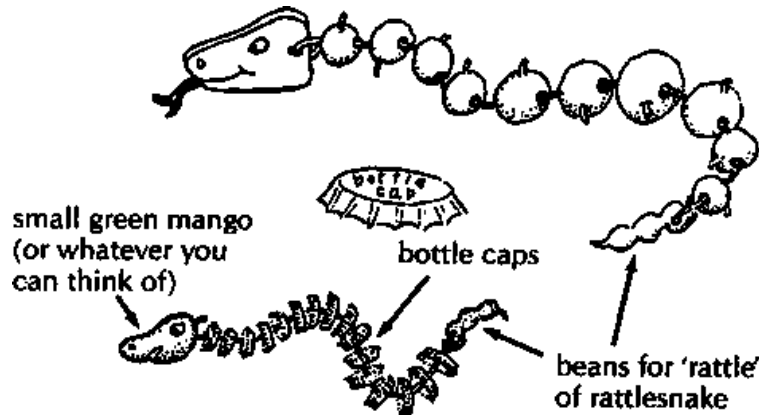

**'Snakes' can be made by stringing nuts, 'caps' of acorns, bottle caps - or any combination of things.**

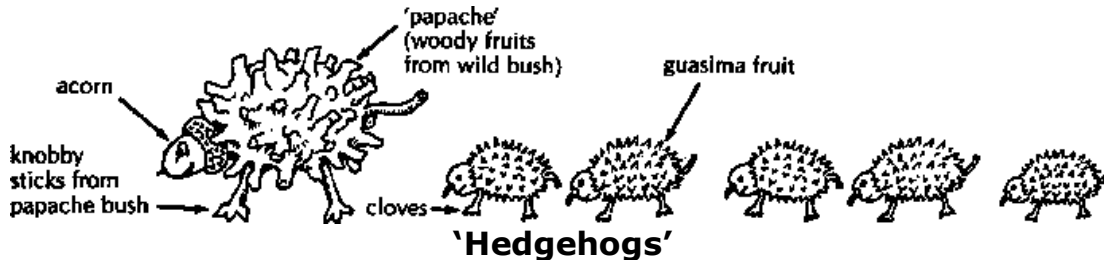

**If you use your imagination, there are all kinds of toy animals you and your children can have fun making.**

**RATTLES AND OTHER 'NOISE TOYS'**

## Gourd rattle

Find a small gourd (wild gourds or 'tree gourds' may work).



**Figure**

Cut a round hole at the stem and clean out the seeds and flesh. Let it dry out well.



**Figure**

Put 2 or 3 small rocks, nuts or other objects inside.



**Figure**

Find a stick the size of the hole. If the hole is large, thin down this part of the stick.

Glue the stick to the gourd  
To make it stronger and better looking, mix white glue and sawdust, fill in here (1), and after glue dries, sand it smooth.

To make it stronger and better looking, mix white glue and sawdust, fill in here, and after glue dries, sand it smooth.





**Figure**

**Plastic bottle rattle**



**Figure**



**Figure**

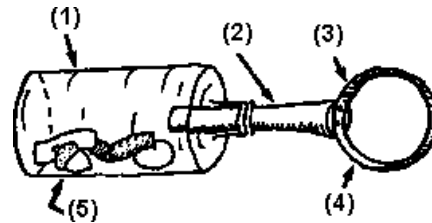

**Figure**

**(1) a see-through plastic bottle**

**(2) stick of wood**

**(3) ring cut from a plastic bottle, bamboo, or whatever**

**(4) Ring can be wrapped with strips of cloth or tire tubing for easier grip.**

**(5) strips cut from plastic bottles of different colors, colorful stones, nuts, etc.**

## **Bamboo rattle**

**SIMPLE FORM**

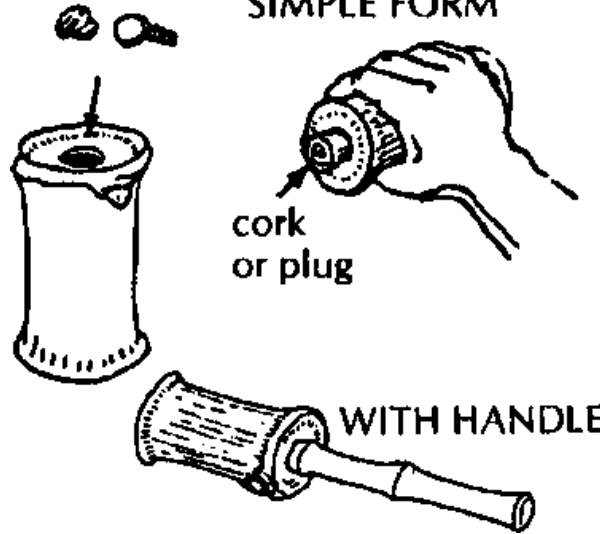

**Figure**

**Tin can rattle**

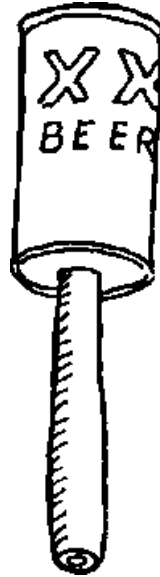

**Figure**

## **Cowhorn rattle**

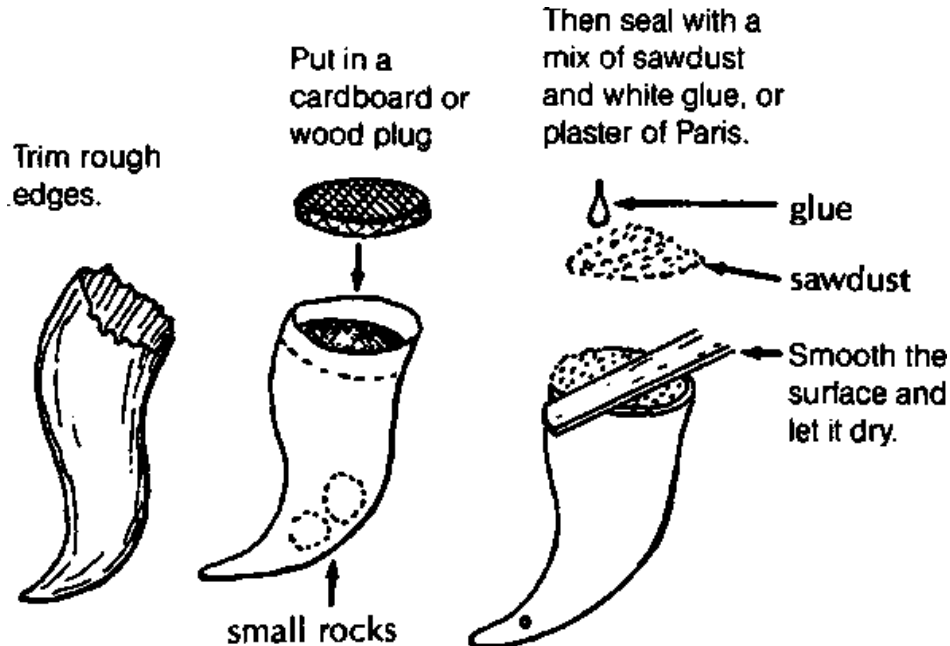

Figure



**If the child drops or throws his toys, try attaching strings and help him learn to get them back by himself.**

**IDEAS FOR HOMEMADE 'MUSIC' (from *How To Raise a Blind Child*)**



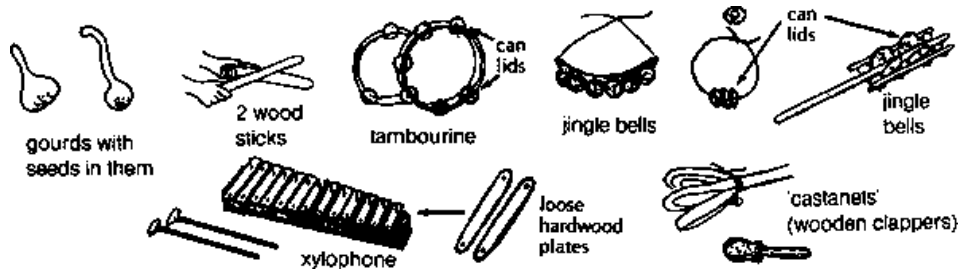

**Figure**

**Soft rattle**

Use a small can or bottle with a small stone inside, or use 2 small bells. Cut a colorful soft cloth (flannel) this shape. Place can or bells in cloth square and pack wild kapok, cotton or bits of sponge around it. Sew it shut. turn inside out.



**Figure**



**Figure**

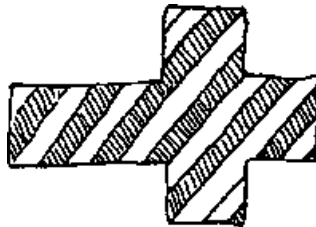

**Figure**



wild kapok

**Figure**

**Doll rattle**

Draw a doll on a 2. Sew the 2 dolls. Turn the doll inside out. Sew or draw on a

21/10/2011

Draw a doll on 2 pieces of cloth, and cut them out.

meister13.htm

Turn the doll inside out. Sew or draw on a face.

Put small bells or a rattle inside and stuff with kapok, cotton or sponge (1) and sew shut.



Figure



Figure

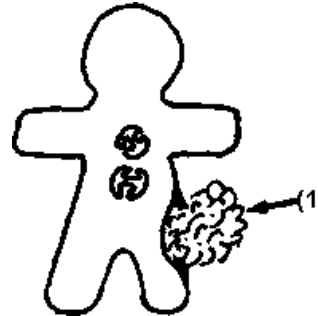

Figure



Figure

**Animal rattles can be made in the same way**

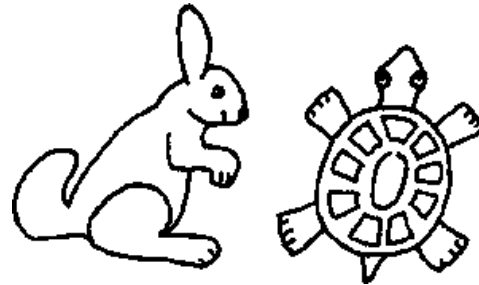

**Figure**

### **Ball rattle**

Cut 3 pieces of cloth and 3 pieces of another color of one color

Sew them together except for a small hole. Turn inside out and stuff.



**Figure**

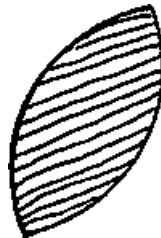

**Figure**



**Figure**

### **Push-a-long noise toy**

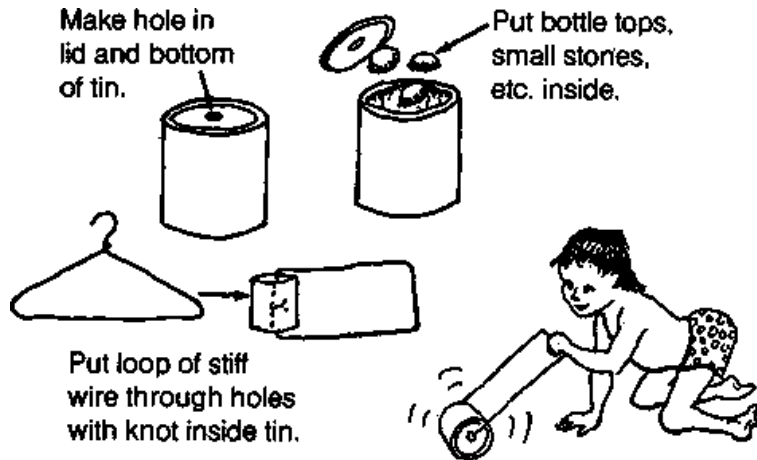

Figure

## Bamboo push-a-long

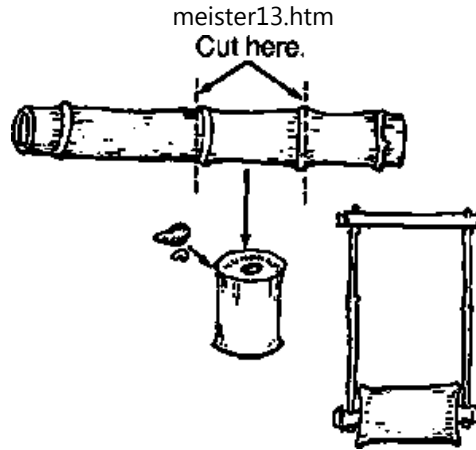

Figure

**Put loop of stiff wire through holes with knot inside tin.**

**Plastic bottle pig**

1 plastic bottle

4 corn cobs

cardboard or leather for ears (Make 2 cuts in the bottle to hold ears.)

beans, rocks, nuts or bottlecaps to put inside if you want it to rattle

hard curved acacia bean (or anything else for tail)

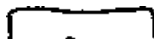

Make 4 large holes and one small hole.

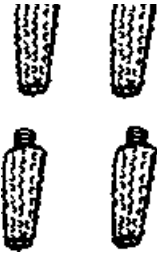
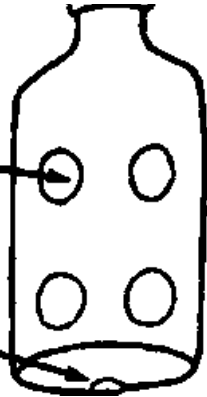

Figure



Figure

Figure  
Papier-mâché piggybank

Figure

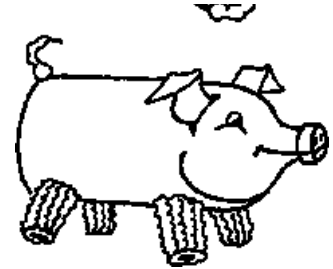

Figure

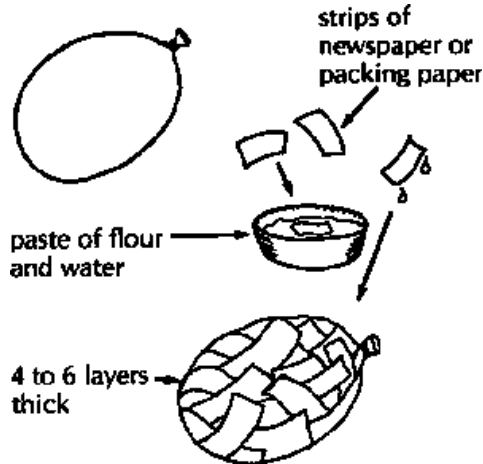

### Cover a balloon with papier-mch.



**Cut 6 lumps off a cardboard egg carton.**

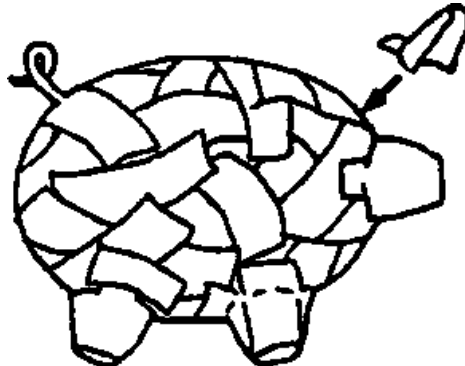

**Fasten down lumps with papier-mch.**

With a few coins inside, the pig can be used as a rattle.



After pig dries, cut a slot to drop in coins.

Decorate with paint.

Corks can be used instead of egg cartons.



Figure

**Children can improve hand control, learn to count, and learn about money**



## by playing with coins and the piggybank.

### Papier-mch frog

balloon

4 pieces of thick cardboard

cardboard tube (perhaps from old toilet roll)

Cover with papier-mch and attach 'feet' and 'hands'.

When dry, cut out mouth and paint.

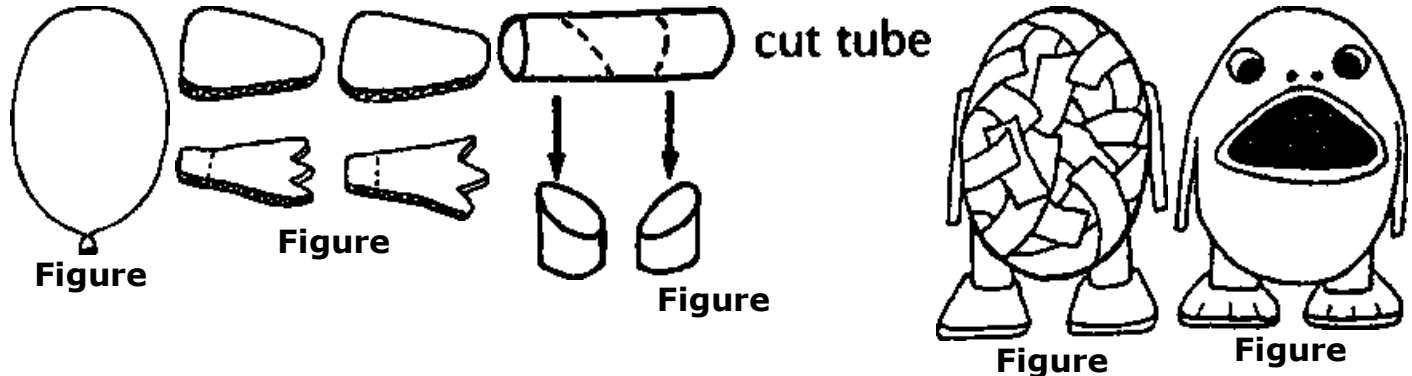

The frog can be used as a handy storage container or cookie jar.

Children who need to develop hand control can play 'feed the frog' - taking

## objects in and out.

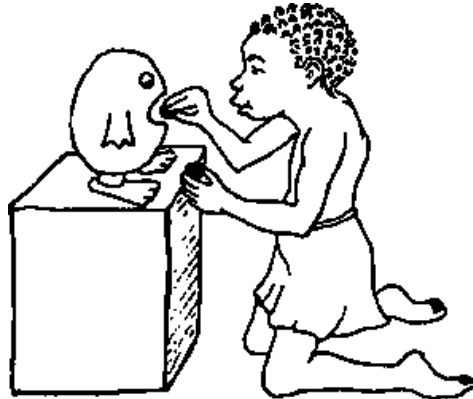

**Figure**

**Note:** For the pig and frog, you can use a large gourd instead of a balloon.



**Figure**

**Games fitting pegs or blocks into holes help develop better hand control and 'hand-eye coordination'. They also help the child learn to compare sizes, shapes, and colors.**



**Figure**

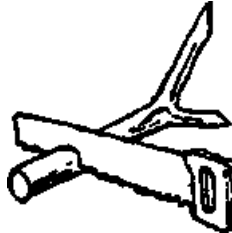

**Drill holes in a piece of wood and cut pegs from tree branches.**



**Or make a 'size box' by pouring cement, plaster of Paris, or clay into a mold. Or, make a 'plaster' box out of cow-dung or mud mixed with sand (and lime if you have it). Press pegs into the wet plaster, and remove when almost dry.**



**Or you can cut holes in a cardboard box. Glue an extra layer of tough cardboard on the top.**



**For pegs, use bottles, scraps of pipe, pieces of broom handles, bolts - or whatever.**

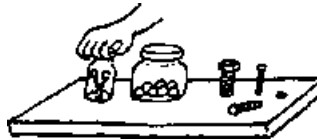

**Also, make games that help the child develop a twisting motion in her hands and wrists.**

### **Other ideas**

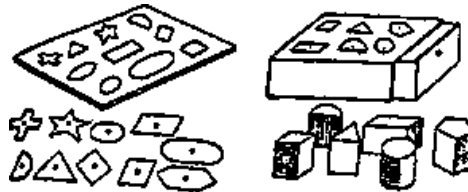

**Figure**

**Blocks for building a tower on pegs**

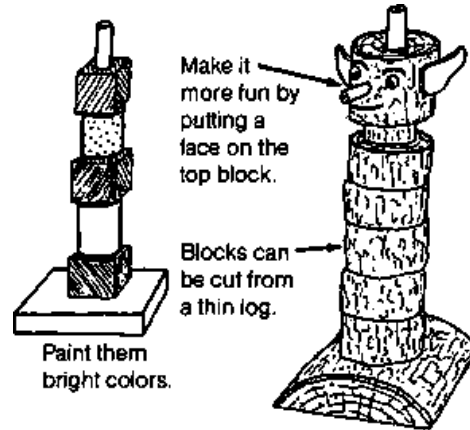

**Figure**

**'Animal stackers'**

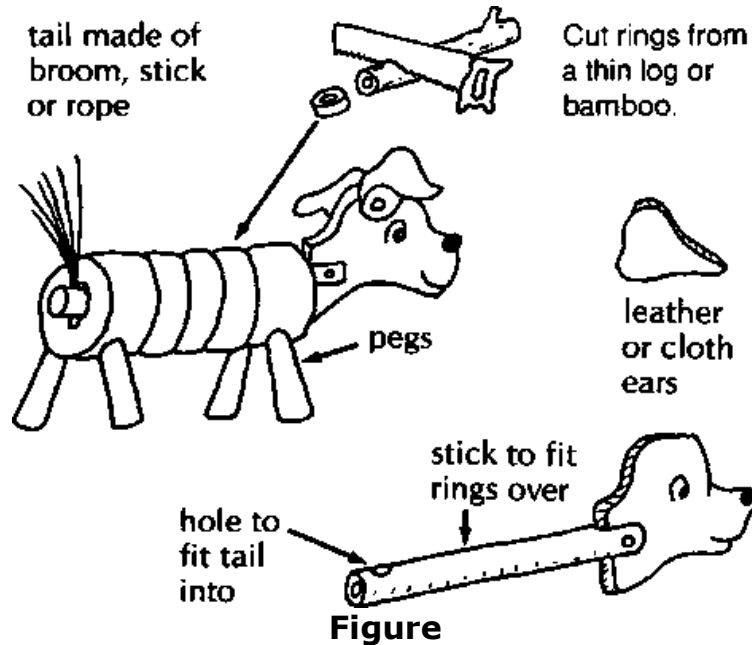

## Slide-on wire toys

To help develop fine control of hand movement, blocks, beads or animal figures can be moved along a wire. Children with poor control need only move the figure from one side to the other. Children with good control try to move the figure without touching the wire. The more bends you put in the wire, the harder it is.



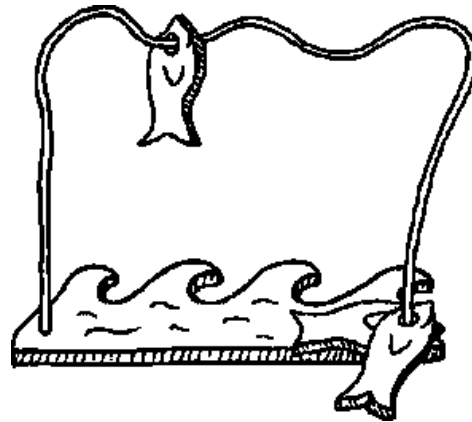

**Figure**

**To make it more interesting, match the animal figures with wooden bases in the form and colors of the place the animal lives' fish in water, squirrels in trees, birds in flowers.**

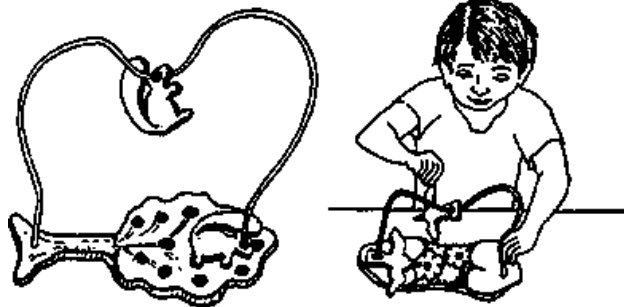

## Figure

### Gourd racing car

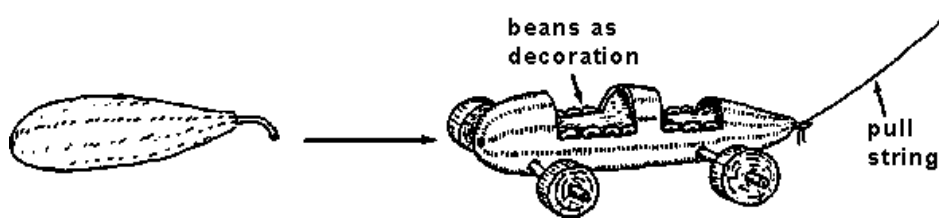

Figure

### Gourd baby

**The gourd baby is fun because it can be given drinks and then 'go to the latrine'. Thus it can be a good tool for 'toilet training' children. For other ideas and dolls for toilet training.**

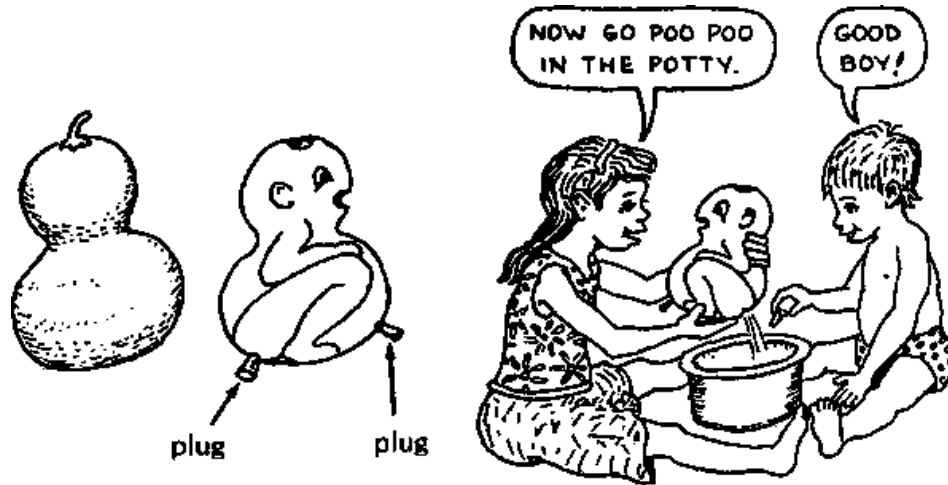

Figure

### Shapes on pegs\*

\* These are from the UPKARAN Manual.

With these, children learn about matching colors, shapes, and sizes.

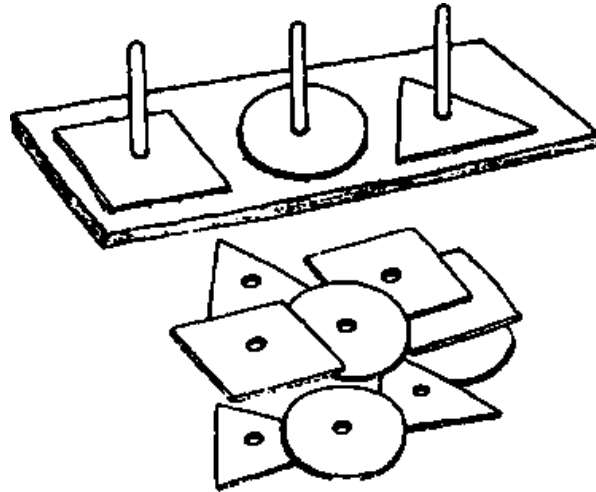

**Figure**

**Figures with posts for easy gripping\***

**\* These are from the UPKARAN Manual.**

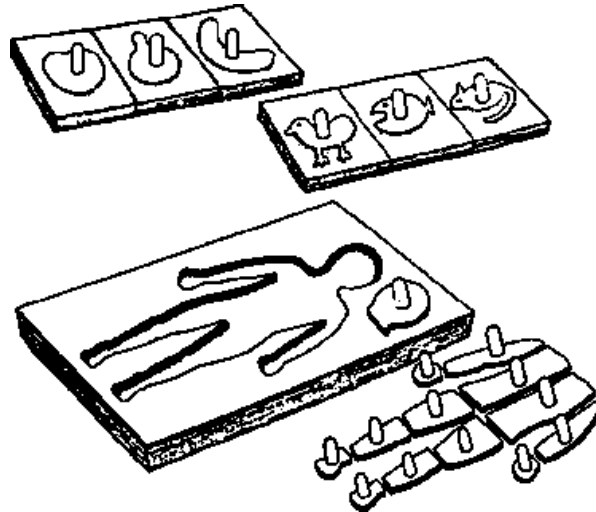

**Figure**

**Building blocks\* (of wood, clay, or layers of cardboard) cubes and sticks**

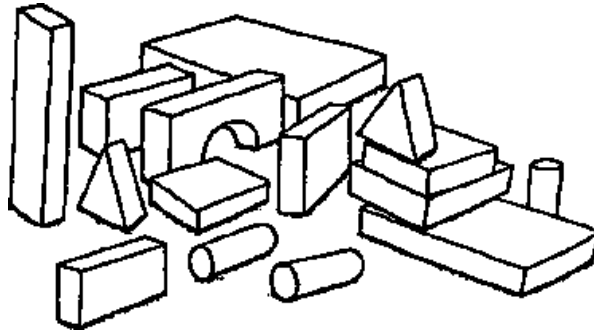

**Figure**

**\* These are from the UPKARAN Manual.**

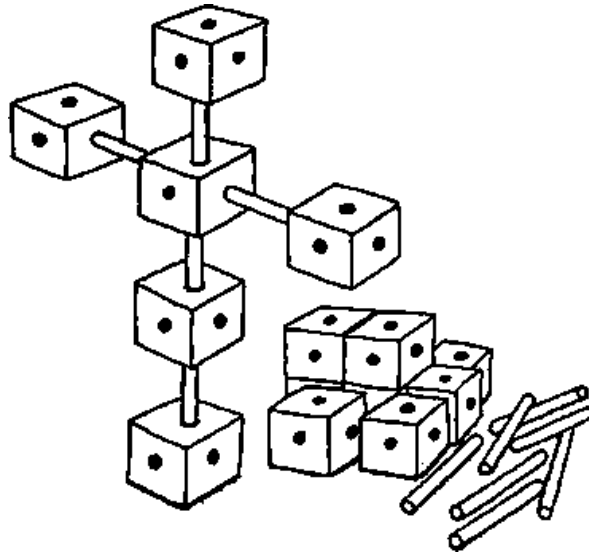

**cubes and sticks**

## **Biting donkey**

**This wooden donkey or horse with a clothes-pin head is fun to make and to play with.**

**It can also be used as a note or reminder holder. Perhaps disabled children at the rehabilitation center can make this to sell for pocket money.**

**Trace the donkey onto a piece of wood about as thick as the clothes-pin (1**

cm). Cut it out with a jig saw. Also make a base, as shown. Sand pieces smooth and glue together.

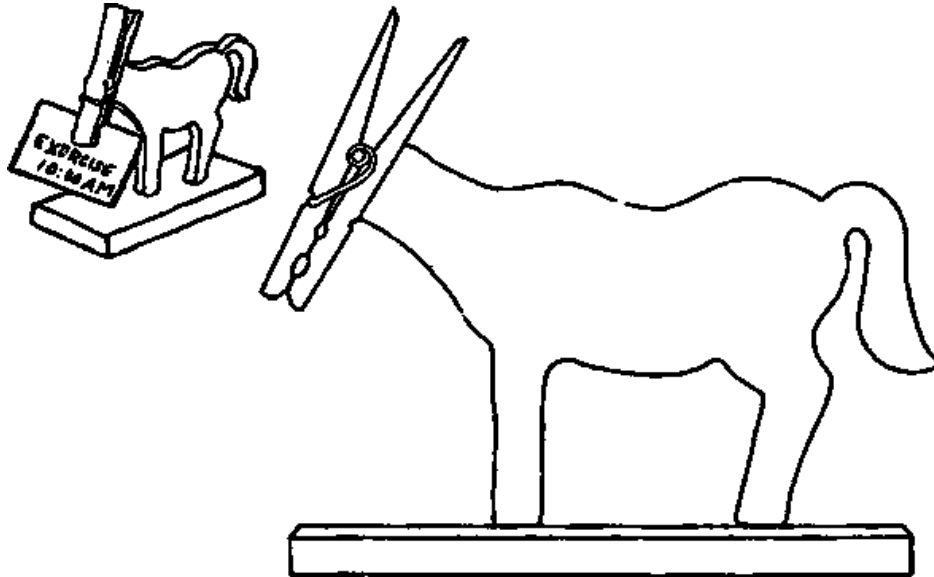

Figure

## Donkey carts



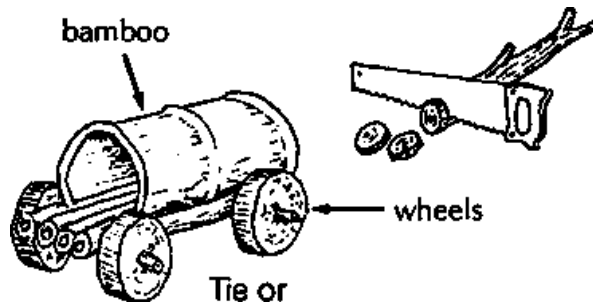

Tie or  
glue cart  
together.

**Figure**



old plastic  
bottle

**Figure**



**Figure**

## **Climbing bear**

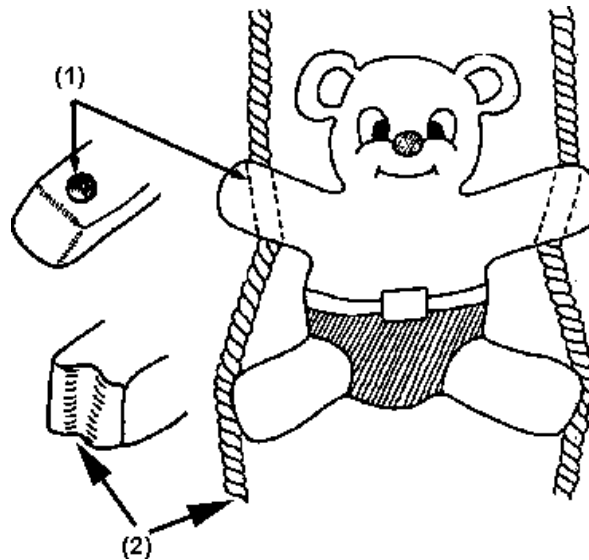

**Cut a pattern of the bear out of a wood board about 2 cm. (3/4 inch) thick.  
Drill holes through the arms at the size and angle shown here (1).  
Notch the ends of the feet so the cord can slide through the notch (2).**

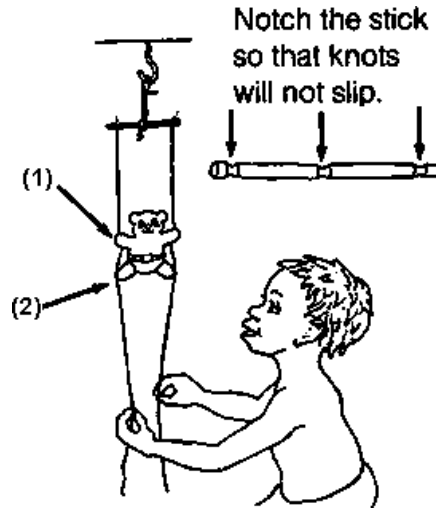

**Hang a stick from the roof or a tree limb.**

**Tie cords or leather thongs tightly to the ends of the stick and pass them through the arm holes of the bear (1).**

**Be sure the cord passes through the notches in the feet (2).**

**By pulling one cord and then the other, the bear will climb the ropes!  
Children love it!**

**Good for developing use of both hands together.**

## RUBBER BAND WIND-UP TOYS

### Steamroller

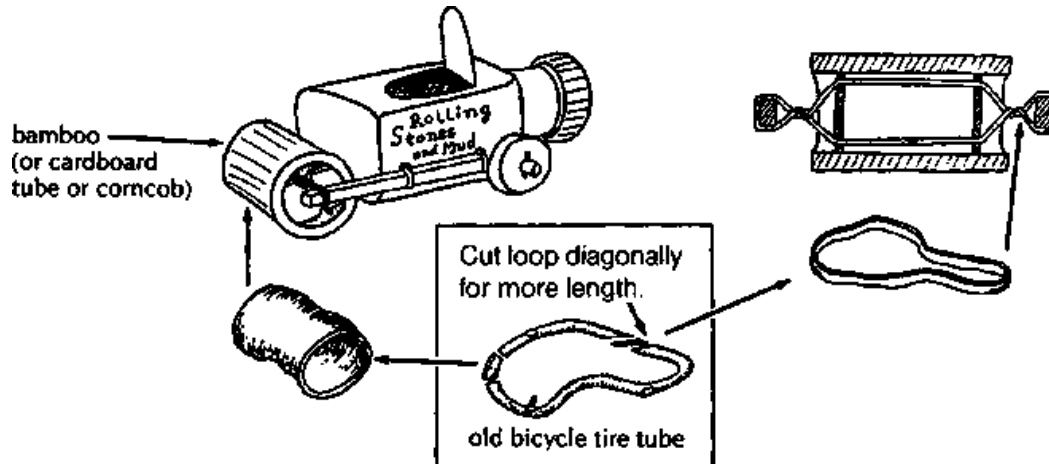

### HOW WIND-UP POWER DRIVE WORKS

To help roller pull better (not slip), cover it with rubber tire tube or sandpaper.

Instead of a rubber band, you can cut a narrow loop of inner tube.

### Paddle wheel boat

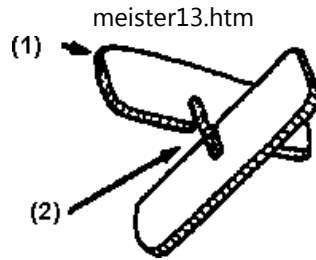

**Figure**

**Paddles from tongue depressors or pieces from an old plastic bucket, etc (1).**

**Notch the paddles and put them together like this (2).**

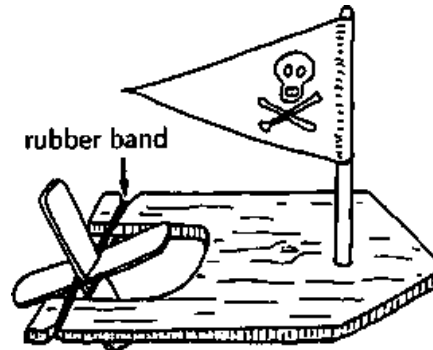

**Use it to help the child enjoy bathing, develop hand control, and even speech.**

## Corncob creeper

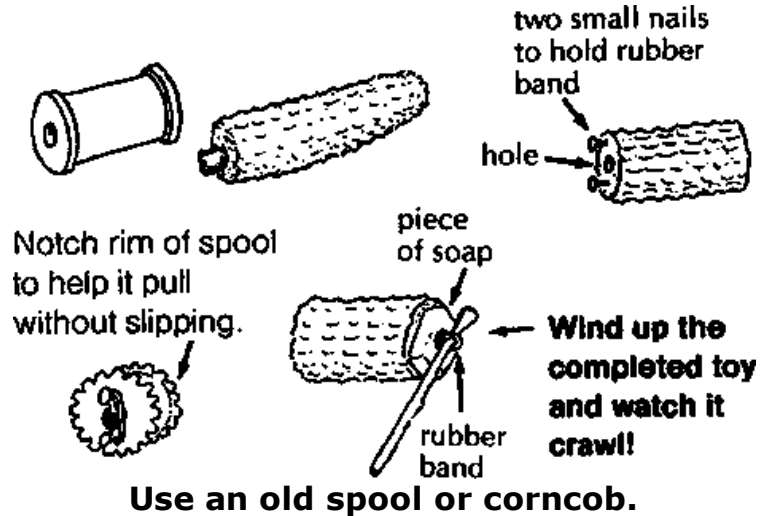



**For more fun, place a paper cone over the creeper, and decorate it to look like a person or animal.**

### **Whirlygig screech plane**

**This simple noise toy can be made completely of waste material. The pin mounted at the front scrapes against the inside of the bottlecap and the cups amplify the noise like the loud-speakers of a record player.**



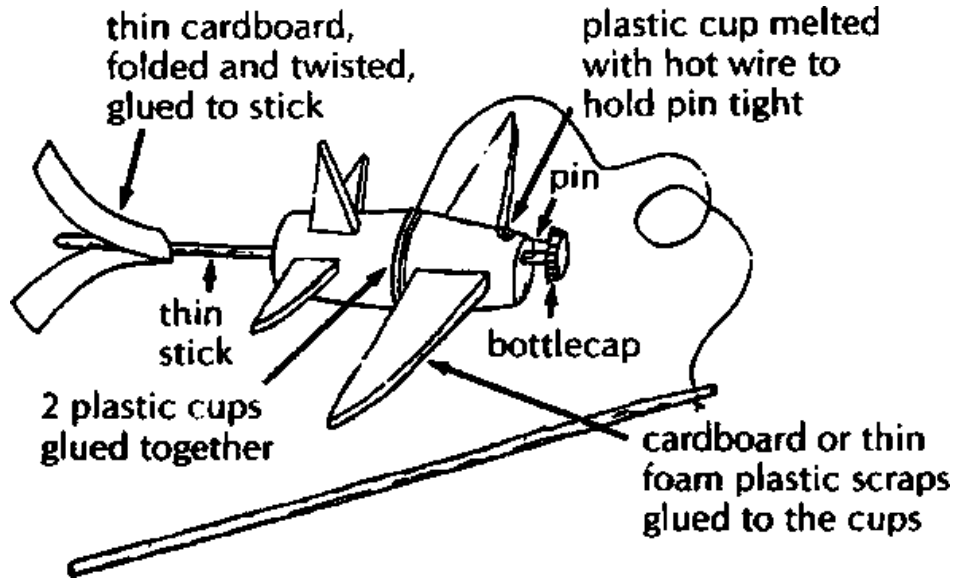

Figure



**It whirls! It squeals! It flutters!**

## **PUZZLES**

**Puzzles can help a child learn how shapes, forms, and colors fit together. Puzzles can be made by glueing a picture on cardboard, wood, plywood, or other material. Cut out the pieces with a coping saw. Puzzles can be made in various styles:**

### **Flower puzzles**

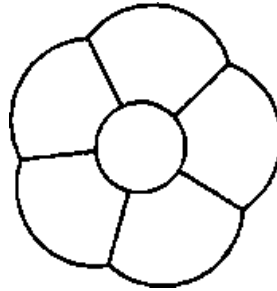

**Children can first learn to form one flower**

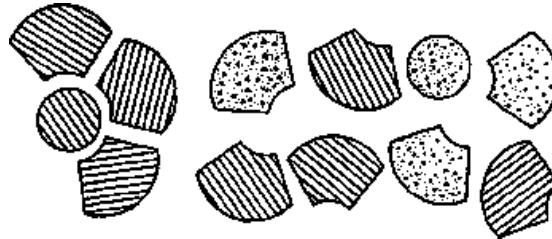

**Later, they can play "sorting games" with flowers of different colors.**

**Figure puzzles**

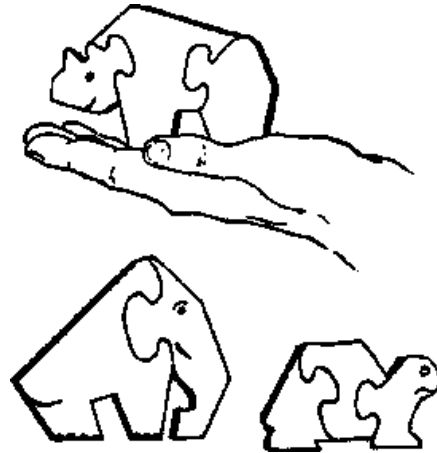

**Figure**

**Puzzles with cut-out pieces that follow the forms and lines of the drawing**

**First have the child build the main object (here, the owl) with a few pieces.  
Later, she can learn to fill in the background**

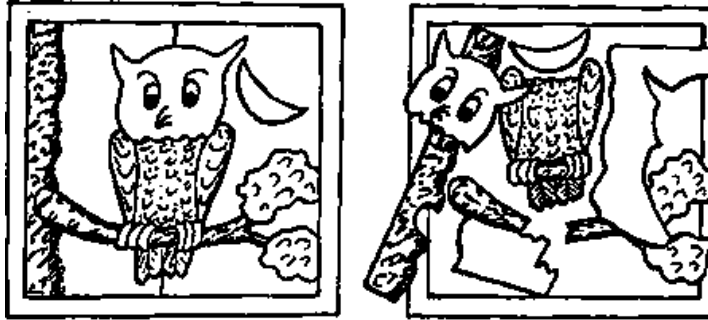

**An outer frame helps hold the pieces together**



**A retarded child in Indonesia learns to fit together a fish puzzle. (Photo: Christian Children's Fund, Carolyn Watson)**

**Puzzles with interlocking pieces**

***Suggestion:* If you have a large photo of the child or a family member, glue**

**it on cardboard and cut out the puzzle. Or use a picture from a magazine or calendar**

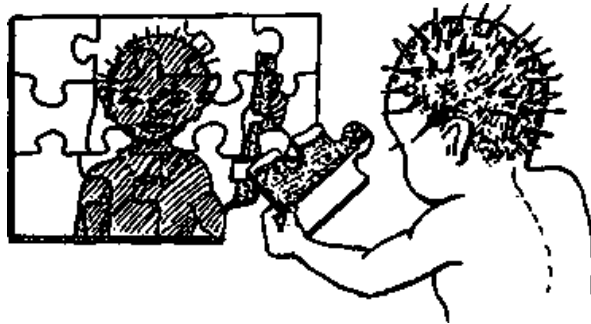

**Figure**

**Block puzzles**

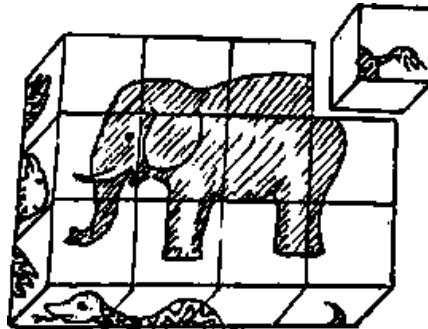

**Figure**

**Glue 6 different pictures to the sides of a thick board or sheet of foam plastic, and cut it into blocks. You can also make blocks from cubes of clay or small match boxes**

**Ideas for the toys shown in this chapter are from many sources, including books.**

## **Chapter 50: Organization, Management, and Financing of a Village Rehabilitation Program**

### **ORGANIZATION AND MANAGEMENT - A 'PEOPLE-CENTERED' APPROACH**

**In Chapter 45 we spoke of top-down and bottom-up approaches to a community program. Programs that are 'bottom-up', or begun by disabled persons, family members, and concerned members of the community, tend to be organized and managed very differently than top-down programs.**

**A sense of equality among all persons taking part in or benefiting from the program is basic to the organization of bottom-up or 'people-centered' programs:**

- Everyone is considered equal.**
- Leaders are coordinators, not bosses.**

- **Decisions are either made by the group or can be openly challenged by the group or by any of its members.**
- **Everyone has the same rights and deserves the same respect. The ideas and opinions of a *disabled* child or her parents are just as important as those of the village *rehabilitation* worker or visiting professional. All are equal and valuable members of the rehabilitation team.**



**In a people-centered program, goodwill, friendliness, and a feeling of shared pleasure in meeting each other's needs are often given more importance than polished floors, arriving on time, exact records, number of hours worked, or how many wheelchairs are produced by each worker each month. Success of the program is measured not so much by formal *evaluation* as by the 'smile factor': how good everyone - workers, parents, and children-feels about what they have put into and received from the interaction.**





**THE SMILE FACTOR**-perhaps the best measurement of a program's success  
(Photo UNICEF/T.S. Satyan)

**The PROJIMO approach: Informal organization and team management**

**We who work at PROJIMO are in no position to speak with authority about 'organization and management'. Sometimes we wonder if our achievements are due more to our disorganization. Whatever organization and management we have is informal and more or less cooperative. Not only are there no clear-cut divisions between 'managers' and 'workers', but even the division between 'workers' and 'patients' is unclear. (In fact, we avoid**

**words like 'patient' and 'client'.) Parents, children, visitors, and everyone else are invited and expected to help out in whatever way they can. Most members of the PROJIMO team are disabled young persons who first came for rehabilitation or aids. They began to help out as best they could, and finally decided to stay to learn and work. Some stay a few weeks or months, learn new skills, gain confidence, and then go on to something else. Others stay for years. Some come and go, and return again.**

**PROJIMO is like a big family, mainly of young people, growing up together. Most of the work team is made up of young persons who are themselves benefiting from rehabilitation, learning to work, and learning to relate to each other. It would be a mistake to use the same goals and measure of 'production efficiency' as you would for a shop that employs already trained and experienced workers. There is no boss to give orders. Yet the needs of the disabled children place a demand on the group to work relatively hard, and to accomplish what they can. Hours are flexible. There are quiet afternoons where half the workers suddenly decide to go swimming in the river. And there are busy days when several team members work until midnight to finish a brace or limb or wheelchair for a family that needs to return home on the morning bus. They choose to work overtime, not because someone tells them to, or because they get extra pay, but because a child's father explains that he cannot afford to miss another day's work or a mother is worried about a sick child she left at home.**

**When a situation arises that will require extra work and responsibility, the group as a whole decides if they think they can handle it. For example, one time a teenage boy named Julio arrived who was almost completely *paralyzed* (quadriplegic). He had severe pressure sores, and was totally dependent for all his daily needs. The team, which had no one specially trained in nursing care, met and discussed whether they could accept Julio in PROJIMO, since no family member was prepared to stay with him. Some argued against accepting him. Others argued in favor, pointing out that his home situation was miserable. (His stepfather resented his mother spending time with the boy.) At last the majority decided to accept Julio, even though a few team members said that they would not be willing to help in his care. It turned out, however, that some of those who had at first been unwilling became those who spent the most time with Julio. Not only did the group do an excellent job in healing his pressure sores and tending his personal needs, they became his close friends.**



**Today Julio is one of the leaders of PROJIMO. Every evening he records the work done by each member of the team**

**The team invited Julio to take part in *evaluating* the needs of other disabled children, so that he could learn history-taking and advisory skills. They also gave him the job of chief 'work checker'. His job was to keep a list of the various jobs that needed to be done each day and who was responsible for doing them. He would check to see that the jobs were getting done and speak to those who needed reminding. Since he could not get around easily, the group agreed that when Julio asked anyone to send someone to him, he or she would do so. Thus Julio, as the most severely disabled team member, was given the most power in terms of program management. This is in agreement with the politics of the program, that only through a just redistribution of power will the weak and marginalized gain a fair place and**

**voice in our society.**

**The fact that PROJIMO has no 'boss' creates certain problems while it avoids others. Individual concern, group pressure, children's urgent needs, and parents' appreciation are the main motivations to do a good job. Some team members work much harder than others. When someone is not working enough or other problems arise (such as rudeness to families) the group meets with the person. In extreme cases the person may be asked to meet the group's expectations or to leave. So far, however, those who have left have done so by their own choice.**

**Different team members are able to work at different speeds and effectiveness, depending on their *disabilities*. Therefore, the group judges a person's work not by how much he produces, but by whether or not he is doing the best he can. A person who works responsibly gets higher pay, even if unable to work fast. Within the limitations of money available, the group decides how much different team members will receive. New team members who are learning work habits and skills begin as volunteers, with only their room and food paid. Later, they earn more, depending on how responsibly and steadily they work. The group decides.**

**The team meets regularly to plan activities and to decide who will take responsibility for what jobs. Different persons take charge of different aspects of the program: consultations, record keeping, accounting and different shop activities, such as aids making or wheel-chair making. Playground maintenance, housekeeping, cooking and clean-up is usually done by turns. One person keeps track of the hours worked each day by different participants and this is used as a guide for monthly wages.**



**Members of the PROJIMO team at a weekly meeting.**

**This whole organizational approach is informal and loosely structured. It is a process of ongoing experimentation and change. In short, a group of people are learning how to work and live together as equals. Sometimes things seem to work out better than others. It is the adventure of it all that**

**keeps everyone going - the challenge to create a friendlier and fairer social order, if at first within only a small group.**

## **EVALUATION**

**An ongoing process of evaluation by the members of a community program is necessary if problems are to be corrected and improvements made.**

**Evaluation is a tool for problem-solving and planning.**

**Informal evaluation can take place often: the group sits down together once a week (or even for a few minutes once a day) to discuss successes and failures, what seems to be working well, and what does not. Together the group looks for solutions and makes plans.**

**A somewhat more formal evaluation might be done at the end of each month and each year.**

**The PROJIMO team, at the end of each month, makes an effort to fill out an evaluation form that outlines the following information:**

- numbers and names of workers involved, the responsibilities of each, hours worked, and pay received**
- number of children seen (new and returning) at the center and in**

**their homes. Also their ages, type of primary disability, and secondary disabilities.**

- **number of children who stayed at PROJIMO for more than one day for how long, and with what family members**
- **attention received by children and families: hours of instruction or *therapy*, number of braces, limbs, wheelchairs, and other aids or equipment made or provided**
- **accounting for costs of the above, including what portion was paid by each family and how much was paid by the auxiliary fund**
- **summary of financial accounts with lists of all monies gained and spent**
- **summary of evaluations of individual children by the PROJIMO team and by their parents (This includes a list of children who have made return visits, with comments on their progress and response to suggestions, home therapy, or aids.)**
- **volunteer help or participation by members of the community (children and adults)**
- **number and profession of 'special visitors' or visiting instructors**



- **new relations or interactions with other rehabilitation centers, programs, and communities**
- **feedback based on parent questionnaires, what they and their children have gained from PROJIMO, how they feel they were treated, what criticisms they have, and suggestions for improvement**
- **outstanding problems and successes in each of the main activities of PROJIMO**
- **conclusions and recommendations**

**To help in the evaluation of PROJIMO, parent questionnaires are given to each family at the end of their first visit. Another questionnaire is sent several months later, to learn more about how the child has (or has not) benefited.**

**The PROJIMO workers are still not happy with the forms and questionnaires they are using, and have revised them several times. For this reason, we do not include samples here. However, we would be glad to send our forms, such as they are, to anyone who thinks they might help in designing their own.**

**In addition to the monthly written evaluation, at the end of each year the PROJIMO team has an 'evaluation dinner'. The team invites some disabled**

**children, their parents, and some members of the community to participate. The activities of the past year are reviewed, along with problems and successes. The long-range 'vision' and direction of PROJIMO is discussed. Based on this discussion, plans, changes, new activities, and goals are outlined for the coming year.**



**When families first arrive at PROJIMO, they are given a leaflet which describes the program. It describes or lists:**

- the reason for the program
- who the workers are
- how the family can help (work that can be done)
- suggestions for donations such as blankets, wood, rope, food
- the services provided
- the disabilities that are attended

**This is the way the leaflet starts:**

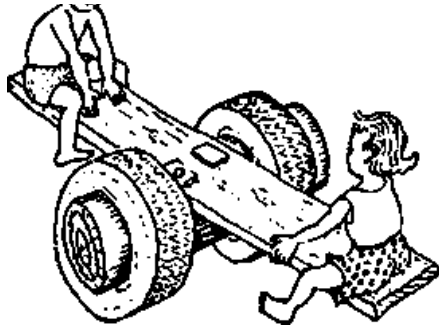

**Figure****Figure**

Most of us who work in PROJIMO are disabled villagers. We understand the difficulties disabled children face in our society, just as we understand how hard it is for many families to find adequate rehabilitation counseling and services. *Orthopedic* aids as well as physical therapy are very expensive. The few free services that do exist reach only a small fraction of the children who need them. Therefore, many disabled children, especially in rural areas, lack even basic rehabilitation services.

We formed PROJIMO to provide friendly advice, therapy and orthopedic aids to disabled children whose families could not obtain, for economic or other reasons, the services that their children need.

### **Family members as rehabilitation workers**

For most disabled children, we believe that the best place for rehabilitation is in the home, and that the best 'therapists' are those who most love and understand the child: the members of his or her own family.

**Our goal in PROJIMO is to help you, the parents and relatives, to provide the best rehabilitation and opportunities you can for your child.**

Here in PROJIMO we live together as a family. We invite you and your child to participate in our work and activities. We ask you for your suggestions and opinions. We appreciate your assistance with exercises or making aids for your child (or other children), as well as your help in the daily maintenance and work of PROJIMO.

**PLEASE HELP US TO HELP OTHERS**

## **FINANCING**

### **The myth of self-sufficiency**

**It is a goal of many community programs to become as financially self-sufficient as possible. Only when a program does not depend on outside funding, can the community and participants of the program have a full sense that "The program is ours. We run it. We control it. We make the main decisions ourselves."**

**Realistically however, for health programs in general and for rehabilitation programs in particular, economic self-sufficiency is difficult to accomplish. This is especially true if the program aims to serve mainly those who are poorest and whose needs are greatest. The poor earn barely enough to feed and clothe their children, and then sometimes not adequately. The additional expenses of trying to meet the needs of a disabled child may be too much for the poor family to bear, even when the costs are kept low.**

**The biggest obstacle to economic self-sufficiency of any community program is poverty.**

**In a country where social injustice causes widespread poverty, it is not fair to expect the poor to pay for more than a small part of the cost of rehabilitation services or aids. Nor is it fair to ask a busy rehabilitation team to try to make their program self-sufficient through separate 'income-producing activities'. (However, 'income-producing activities' can help meet some expenses and prepare disabled persons to work and earn independently. We discuss this on the next page.)**

**True self-sufficiency of a community service program may only be possible through a process of social change and fairer distribution within the whole structure of the society. Only when enough jobs are available and nearly every family earns enough to be self-sufficient in terms of meeting its basic needs, can program self-sufficiency become a realistic goal. In the**

**meantime, some sort of outside funding, government or private, is usually necessary**

**Funding - government or non-government?**

**Ideally, governments should help meet the costs of people-centered community-run service programs. Unfortunately government funding often brings with it a high degree of outside control, including pre-defined (often disabling) limitations regarding local planning and how much community workers are taught or permitted to do. The disabled and their families tend to become the objects of program objectives, to be worked upon, rather than the leaders in their own struggle for dignity and self-reliance.**

**Also, it is usually difficult for a local village or community group to ask for and obtain funding from the government. The red tape, 'preliminary investigations', restrictions, and delays are often endless. More promises are made than are kept. Thus to speak of a government-financed community-oriented program usually makes little sense.\***

**\* One exception to this is the ORD (Organization of Disabled Revolutionaries) in Nicaragua, a non-government, people-centered program for which the Sandinista government has set up a red-tape-free 'auxiliary fund' to help poor families meet costs (see next page). Such restriction-free aid may only be possible in countries where popular governments have a strong political will to serve the people**

**fairly.**

## **NON-GOVERNMENT FUNDING**

**This can come from a variety of sources, including volunteer agencies, charitable foundations, and religious charities. To permit greater independence, it is a good idea to have several sources of funding. (Some government assistance may possibly be included without sacrificing community control, if the amount is relatively small.)**

**In Pakistan, a religious (Islamic) law each year takes two and a half percent of the money people have in banks, to be used by local committees for the benefit of widows, orphans, and disabled persons. Since this law was passed in 1981, it has become a growing source of support for community rehabilitation centers.**

## **LOCAL FUNDING**

**It is also a good idea that a fair part of program costs-if possible at least half-be met within the community. Possible local sources for meeting costs include:**

- **Fees or contributions from families served: Some families will be able to pay more than others. Therefore, the fee should depend on their ability to pay. When families come from outside the**

**community, their ability to pay may be hard to judge. Project PROJIMO has tried an 'honor system' for payment of services. They ask the family to make whatever donation they can afford. So as not to shame the family who gives little, or make proud the family who gives more, each family puts whatever they can in a closed box in the corner. Only the family knows how much they gave**



**Nobody knows how much the individual family gives.**

- **Service 'in kind' or with work: The community's contribution does not have to be in money People can donate materials (sand and rock for building), do volunteer work, or provide food and lodging. All this reduces program costs.**
- **Income-producing activities: Production of things for sale is**



**another way to help meet program costs It also provides skills training for older children and temporary workers in the program. We will discuss this further on.**

**Although production of items for sale may not bring in much money, the extra income may mean that more disabled persons can be employed on the program staff. They can learn rehabilitation skills and at the same time learn income-producing skills, both of which they may put to good use then they return to their own village.**



**Weaving of chairs with plastic ribbon on a metal frame brings in income and provides skills training. (PROJIMO)**

**Some programs that are run for and by disabled persons have succeeded in meeting a large part of their costs through production**

**and sale of goods. For example, the Centre for the Rehabilitation of the Paralysed in Bangladesh creates a wide range of orthopedic and hospital equipment, much of which they sell to orthopedic hospitals. The Disabled Revolutionaries of Nicaragua has succeeded in developing a nearly profitable business out of making low-cost, rough-terrain wheelchairs. In Paraguay a group of disabled workers has also made wheelchair making a small but profitable business.**



**Sandal making produces income and teaches a skill for later self-employment. (PROJIMO)**

- **Repair services: In addition to producing items for sale, a team of disabled village rehabilitation workers can provide a wide variety of**

**repair services. The PROJIMO team in Mexico repairs plows, welds broken machinery and tools, repairs bicycles, solders holes in buckets and car radiators, re-soles boots and sandals, and sharpens axes. (They have even repaired broken plaster saints from the church!) All these services they provide using the same skills and equipment that they use in making wheelchairs and rehabilitation aids. No one else in the village provides these skilled repair services. They have therefore done a lot to increase the villagers' respect and appreciation for disabled persons in the community.**



**A PROJIMO wheelchair builder welds the broken frame of a village boy's bicycle.**

- **An 'auxiliary fund' to help poor families pay for aids and services:**

**As we have discussed, many families cannot pay for the services or aids their child needs, even though a community program provides these at low cost. Some kind of economic assistance is needed if the disabled child's needs are to be adequately met.**

**To provide such assistance, PROJIMO has arranged for an 'auxiliary fund' provided by outside donors. The fund, which is kept in a separate bank account, pays to PROJIMO the difference between what a poor family pays and the actual cost of aids or services received. Thus the workers get full payment for the services and aids they provide. In effect, the fund aids poor families, not the program directly. This allows the team to have a better measure of its accomplishments. If the team works efficiently and gains the necessary management skills, in time the program should need no more direct outside funding. The payments from the auxiliary fund, together with whatever families are able to give, should cover the cost of wages, supplies and maintenance. This will mean that the program has in a sense become self-sufficient - even though poor families still need financial aid. Project PROJIMO began to approach self-sufficiency on these terms in its third year.**

**An argument can be made for trying to obtain government financing for the 'auxiliary fund'. (This is in fact being done in Nicaragua.) The fund could even be managed by a local official (if honest) or another**

**administrator outside the rehabilitation program. At the end of each month, the team could give the administrator an accounting of the services and aids provided, their calculated value, and the amount paid by families, with receipts. Payment would be made, as if by contract.**

**Below is a form that can be used for keeping records for money to be paid by the auxiliary fund (adapted from Project PROJIMO).**

RECORD OF SERVICES, COSTS, AND PAYMENTS							Month of _____, 19__		
					Cost			Payment	
Date	Service or aid provided	By whom	To whom	Record #	Labor at \$_____ per hour	Materials cost \$_____	Total (+30% overhead) \$_____	Amount paid by family \$_____	Amount to be paid by Auxiliary Fund \$_____

## Chapter 51: Adapting the Home and Community

### ADAPTING THE HOME

The kind of *adaptations* needed in the home will partly depend on the *kind of disability* a child has, the *severity of the disability*, and the age and size of the child. Adaptations for a child who is blind are very different than those for a child who is *paralyzed* and uses a wheelchair. A child who is completely dependent will need aids and adaptations to help the family care for him and move him-especially as he gets older and heavier. However, the disabled child who can do a lot for herself may be helped by adaptations that make self-care and work in the house easier.

The kinds of adaptations needed will also depend on the local living

**situation, style of house, and customs. For example:**

**A simple ramp may work well for a wheelchair entrance to a house near ground level**

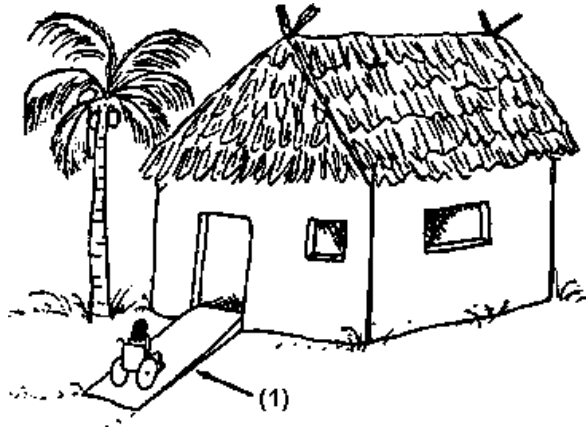

**Figure**

**Ramp can be made of wood or of dirt or rocks, perhaps covered with a thin layer of cement (1).**

**A system of ropes and pulleys may be the best way for a person with strong arms to lift herself without help to a 'house on stilts'**

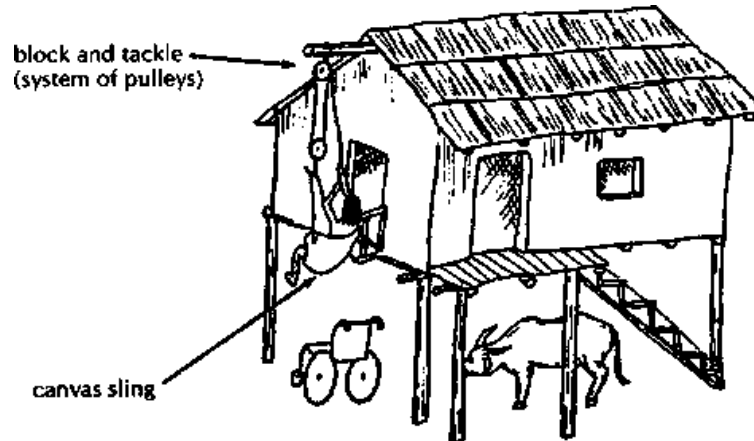

**Figure**

**The 'lift' can be made with a platform so that the whole wheelchair can be lifted. But if the house is small and people cook and eat at floor level, it may be best to leave the wheelchair outside**

**Adaptations for the child who is learning to walk and balance**

### **HAND RAILS**

**These can be fixed to the walls and furniture. If necessary, pathways with rails can be put up so that the child can walk with support almost anywhere in the house and also outside to the latrine (toilet) or garden.**



**Before attaching hand rails firmly test the child with a temporary rail at different heights to find out what works best. As the child grows you may need to place the rails higher. Or you may want to remove rails little by little to help the child improve her balance and walk more independently**

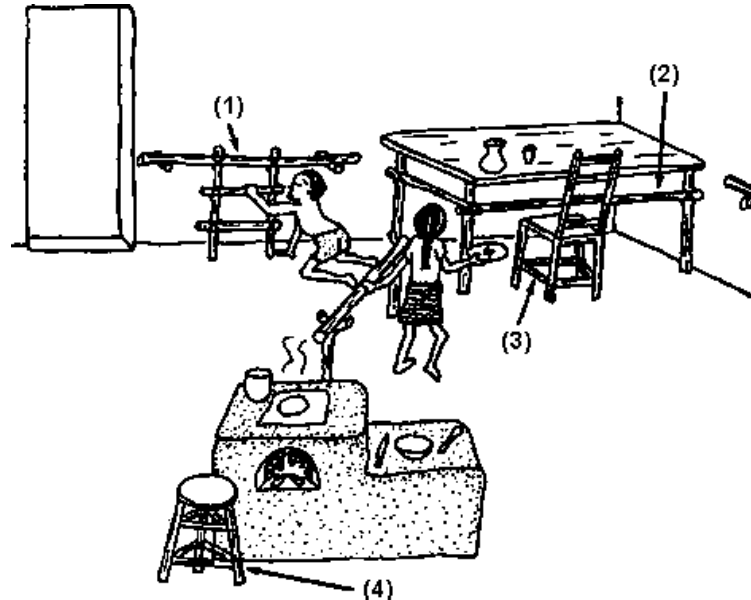

**Figure**

**Where floors are of dirt, hand rails can be mounted on upright poles. Hand rails of different height form a "ladder" on which the child can pull to**

**standing (1).**

**pole to help child stand up at table (2)**

**chair with crossbars for child to climb up on (3)**

**high stool with climb-up poles for kitchen work (4)**

**For the child who only rolls or crawls some kind of straw mat or rug will help protect her knees and skin and will help her stay cleaner (if floors are of dirt)**

## **MATS**



**Easy-to-turn door handle for child with poor hand control.**

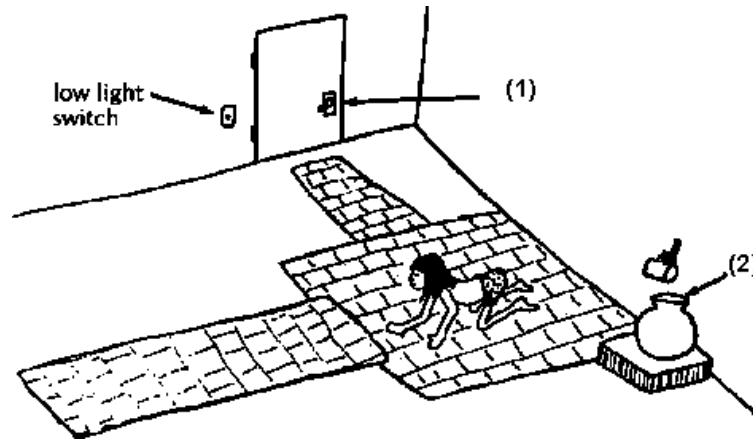

**Figure**

**Door handle at low height for crawling child (or high if you do not want her to go out alone) (1).**

**Water jug and cup near floor for older child who can only crawl (2).**

**The model home' in PROJIMO is a guesthouse. It has features that make it easier to care for a disabled person, or for a disabled person to care for herself and do housework. Visiting families can find out what is useful for their child and can adapt their own home.**



**Here PROJIMO workers split wild cane to make screens to keep out the animals**

**Home adaptations for wheelchair riders**

## **FLOORS**

**For almost any disabled person-but especially those who use wheelboards or scooters with small wheels, the floor should be as smooth and firm as possible (but not slick or slippery). Packed, smoothed clay-and-cow-dung surfaces (as used in India) work well. Cement is even better for long-lasting use of a trolley or wheelchair. Although expensive, a smooth cement floor makes getting around a lot easier.**

**NO THANKS!**

**YES PLEASE!**

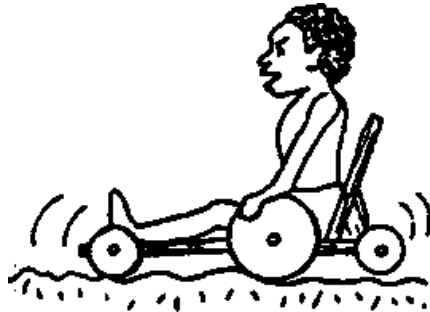

Figure

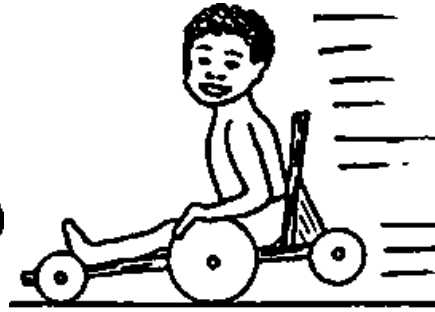

Figure

## DOORWAYS

**Make all doorways extra wide. Remember, your child will grow and may need a bigger, wider wheelchair.**

**In a house that already has very narrow doorways, be sure the wheelchair you buy or make is narrow enough to fit through easily. Most commercial chairs are much wider than necessary, especially for a child.**

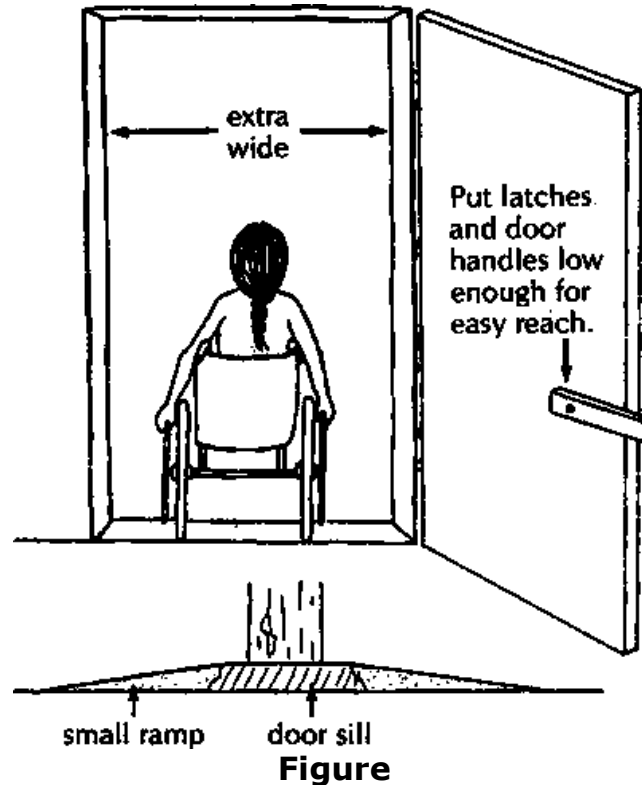

**Figure**

**Try to avoid any rise or bump at the doorway. If it already has a raised sill and you cannot remove it, build a small ramp to go over it. (This will be of special help for children with weak arms and hands.)**

## BATHROOM OR OUTHOUSE (LATRINE)

**Be sure the room is big enough for a wheelchair to turn around in easily.**

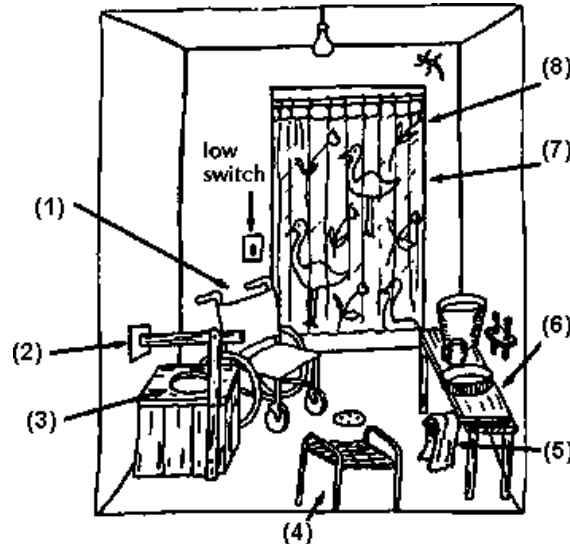

**Figure**

**A wheelchair without armrests or with a removable armrest (1) is best for transferring to the toilet.**

**(2) hand rail on far side from wheelchair**

**(3) toilet seat the same height as seat of wheelchair.**

**(4) bathing stool same height as wheelchair, with metal frame and woven plastic or rubber strips of car inner tube.**

**(5) towel on low rack**

**(6) washstand at height just above knees of wheelchair rider**

**For a wheelchair rider, a curtain (7) is often easier to open and close than a door.**

**(8) wide doorway**

## **KITCHEN AREA**

**The stove, work areas, and tables should be as low as possible, but high enough so that the legs of the wheelchair rider can fit under them**



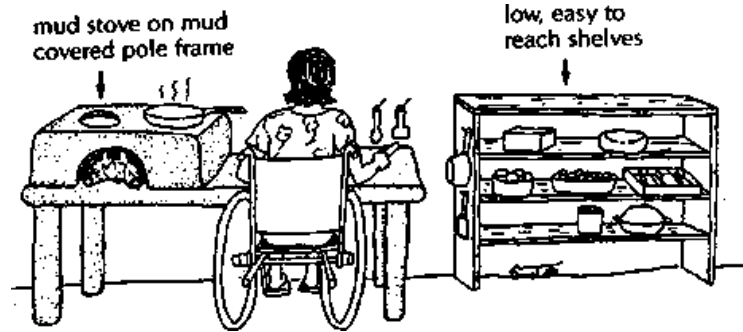

**Figure**

**CAUTION:** If the wheelchair has high fixed armrests the tables and oven will have to be higher. Or the wheelchair will have to approach from the side, in which case the table should be lower.





**The cooking and eating area in the model home at PROJIMO has a lot of adaptations**

## **BED OR COT**

**The bed or cot should be the same height as the wheelchair for easier transfer**

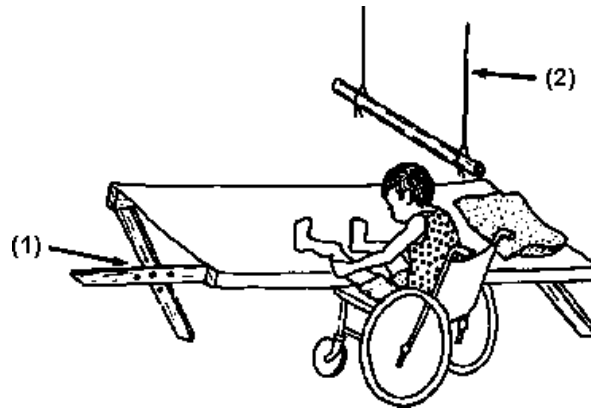

**Figure**

**Cot height can be adjusted by drilling new holes and changing the position of the bolt (1).**

**One or more hanging bars or other supports (2) may help the child to transfer or to sit up in bed.**

**WASHING AREA (outdoor)**

cement wash  
stand with  
ridged bottom

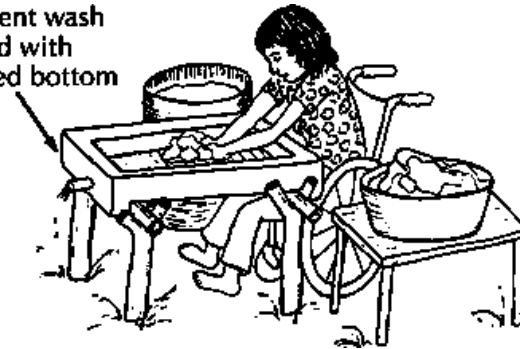

**Figure**



**Outdoor washing area at PROJIMO - designed for work from a wheelchair**

**IMPORTANT:** Before building fixed-height stoves, tables, and wash areas, **set up something temporary to figure out what works best.** Remember that the child

is growing, so try not to make things too fixed or permanent

## **ADAPTING THE COMMUNITY**

**In many villages, disabled persons have a hard time going places because streets or paths are rough, rocky, or sandy. Also, there may be high steps for getting into stores, the cinema, and even the town meeting hall, school, and health center**

**A village rehabilitation program can encourage the villagers to make it easier for disabled persons to go places and to participate in community activities**

**For example, ask storekeepers to build ramps so that wheelchairs can enter their stores. Disabled persons and their families can promise to give their business to those who cooperate in this way, and if necessary, can boycott (refuse to buy from) those who do not**



**In Ajoya, Mexico, the rehabilitation team convinced store owners to build ramps so that the wheelchair riders could enter the stores. The store owners provided the materials and local masons volunteered the labor**

## **RAMPS**

**The more gentle the slope of the ramp, the easier it is for a wheelchair rider to go up it**

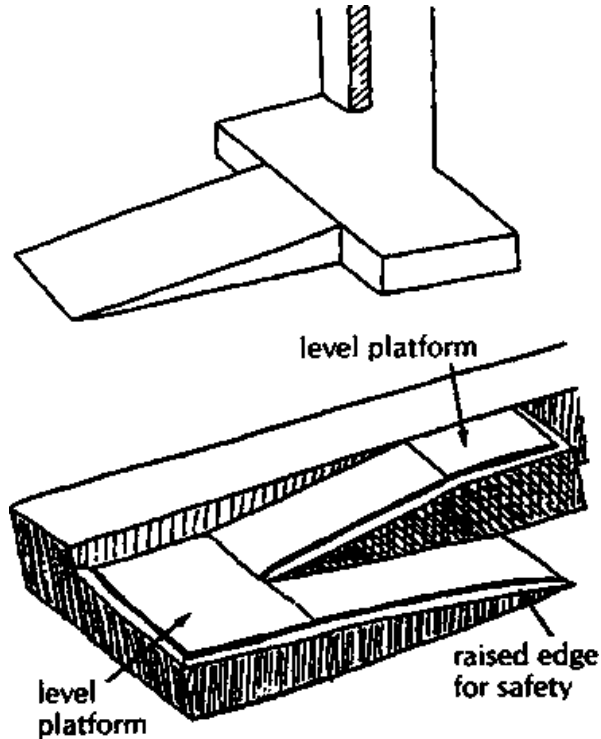

**Figure**

**One or more ramps can be put parallel to the edge of the raised area. Be sure to leave large level platforms for turning.**

**Addition of hand rails will add safety and make going up ramps easier for**

**persons who walk with difficulty**

**HOW STEEP YOU MAKE THE RAMP DEPENDS IN PART ON WHO IT IS FOR**

**Very steep slope of 1 to 6**

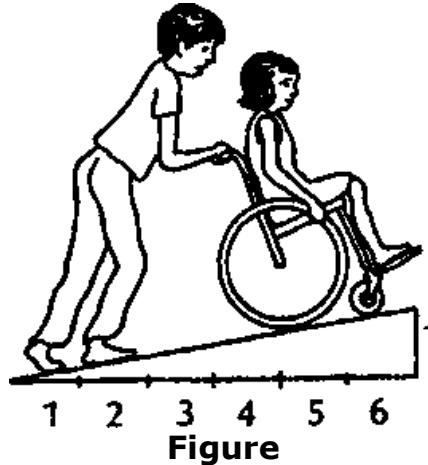

**Only possible with electric wheelchair or with help. Rarely possible for rider alone. Chair may tip backwards**

**Fairly steep slope of 1 to 10**



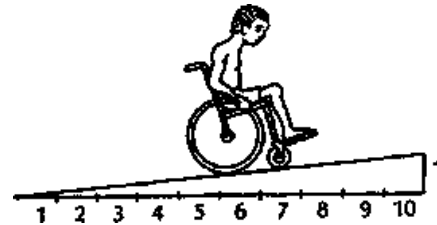

**Figure**

**Possible for riders with strong arms, strong paraplegics**

**Gentle grade slope of 1 to 14**

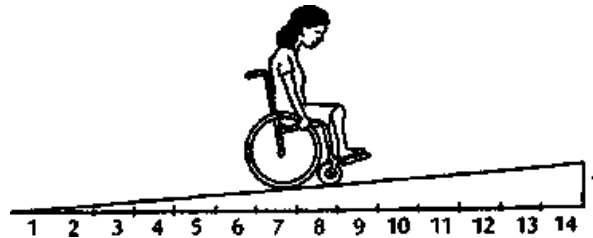

**Figure**

**Possible for average riders and strong quadriplegics. This is the best slope for public buildings and rehabilitation centers**

**Improvement of walkways and trails**

**Community work parties or groups of schoolchildren can organize to help**

**fix up smooth, hard-packed pathways through the village so that crutch users and wheelchair riders can go places more easily.**

**Also, if possible, easy-to-use pathways can be set up so that disabled children and adults can get to play areas, bathing areas, and family work areas.**

### **HAND RAILS (or ropes)**

**When placed along steep trails, these may permit children who are blind, who have balance problems, or who have difficulty walking to reach areas such as swimming or fishing holes**



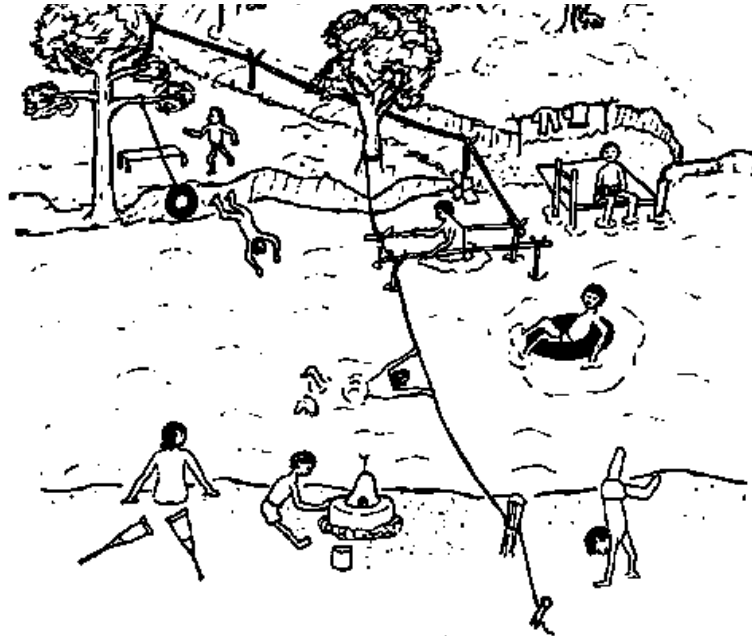

**Figure**

**In one village a rehabilitation team together with some of the village children improved the steep trail down to the river, so that disabled children would have a chance to play and swim.**



**The health workers of Project Piactla built this ramp so the wheelchair riders could come into the clinic easier. (Photo: John Fago)**



**A narrow wood ramp with sideboards lets this child pull himself up it on his skateboard.**

## **Chapter 52: Love, Sex, and Social Adjustment**

**In the village of Ajoya, the home of Project PROJIMO, disabled young men and women happily go to dances and outdoor movies together. They are not ashamed to let people know that they have a close or loving relationship. Some of the disabled young persons who have grown to know and care for each other through the Project have married and now have children.**

**All this is fairly much accepted as natural and normal and 'right' by most of the local villagers.**

**But things were not always this way. A few years ago, when PROJIMO had just begun, many people believed that a *severely* or even *moderately disabled* person should not and could not have a loving relationship, get married, or have children.**

**I remember one evening in the spring, a few years ago. An old woman watched a group of young couples listening to guitar players at the village square. One young man, who had a clubbed foot and used a cane, stood close to a young woman in a wheelchair. When the musicians started playing a romantic song, the disabled couple gently put their arms around each other. The old woman was shocked. Angrily she pointed to the pair and cried, "Isn't that disgusting! People like that have no right to behave like that! It's not natural! They're cripples!"**



**Disabled persons and their families must educate the public about their**

## **rights.**

**When PROJIMO first began, unfortunately the villagers were not the only ones who thought that disabled persons should and could not get married or have loving relationships. Many disabled young people half-believed it themselves, and in their personal lives were often depressed, frustrated, or confused. While society told them one thing, their hearts and their bodies told them another. Most believed they could never be attractive to a member of the opposite sex. Yet through adolescence, they felt increasingly attracted. Many had serious doubts about their own sexual ability. Some had discovered that they did, in fact, have fully developed feeling and functions. But they had no acceptable way to express them.**

**Some visiting advisers to PROJIMO were older disabled persons who had learned to understand their own feelings, had married, or had formed loving relationships. Slowly the disabled young people at PROJIMO began to accept their own desires, needs, and dreams. More important, they began to discover they were not so alone, not as different from other people, as they had thought. Above all, they discovered that they were attractive to other persons. Soon the romances began.**

**At first things sometimes got out of hand. The bottled-up feelings of the young people came flooding out. There were occasional mistakes and abuses. When the disabled group discovered that the rules society had set**

**for them were unfair, often their first response was to break the rules recklessly. But then, faced by the sometimes cruel results of their own hurry, passion, and inexperience, they discovered the need for a few precautions and guidelines determined by the group. They had been hurt often enough themselves not to want to cause additional hurt. And so, little by little, the PROJIMO team members have discovered their ability to live fuller lives and have more complete relationships than they had previously believed possible. Also, little by little, the local community has begun to accept this. For the first time, romances have begun to develop openly between non-disabled and disabled villagers. A new level of awareness and acceptance is slowly being achieved.**





**Conchita, who is paraplegic, was sure she could never marry. She came to PROJIMO for rehabilitation and later became one of the workers. She is now happily married to one of the able-bodied villagers**

### **The personal and sexual needs of young persons**

**Every child, whether disabled or not, has the same basic needs for food, protection, and love. The child who is treated consistently with love, respect, and understanding has a greater chance of becoming a loving, respectful, and understanding adult.**

**Every child has a need to be touched and held. Small children learn about themselves by exploring and touching different parts of their bodies. A child whose disability makes touching and exploring her body more difficult may have an even greater need than other children to be held and hugged.**

**Most societies have rules and taboos that attempt to limit and govern sexual behavior. And within most societies, young people (and old) usually find ways of getting around some of those rules, usually more or less secretly**

**The best answer to sex education may be to look for informal and unsupervised ways for disabled adolescents to spend time with and share the secrets of other adolescents.**



## **LOVING RELATIONSHIPS, MARRIAGE, AND FORMING A FAMILY**

**It is important that disabled persons and everyone else in the community realize that most disabled persons are capable of getting married and having children. Except for a few *inherited disabilities*, the children born to disabled parents have just as great a chance of being normal as do children of non-disabled parents.**

**For most disabled persons, a close, loving partnership is possible. This is true even when the disability makes having children unlikely as in some men with *spinal cord* injury. Persons who have no feeling in their sex parts can discover sexual satisfaction through meeting of lips or other parts of the body that feel. If the couple want children, perhaps they can adopt them.**

**In some societies, nearly everyone is expected and able to marry including disabled persons. But in cultures that put great importance on an 'ideal' or complete *physical* appearance, it may be difficult for the disabled person to find a partner. The biggest barrier is sometimes the feeling by the disabled person that he or she can never be attractive to anyone. To overcome those feelings, disabled persons can sometimes advise one another. Those who**

**have overcome their own fears of unacceptability and have formed loving relationships can do much to help others realize that inner beauty and gentleness of spirit can also make a person attractive.**

**Often it takes someone with a disability to see beyond the outside of another disabled person to the unique qualities inside. So it often happens that disabled persons take other disabled persons as partners - although their disabilities may be quite different. However, as disabled persons gain greater acceptance and participation in the community, loving relationships and marriage between non-disabled and disabled persons become more common.**

**Often there are not many chances for disabled young persons to get to know and become close to other young persons. Therefore, such opportunities can and should be sought or arranged. The types of opportunities and how they can be arranged will of course differ from one community to another.**

**Chances should be provided for disabled young people, even in wheelchairs, to go to ceremonies, dances, and public events that other young people attend. A community rehabilitation program can arrange games, parties, and other activities to which both disabled and non-disabled young people are invited, and in which they can participate equally**

**The need for full integration**

**It must be remembered that opportunities for a close, loving relationship are only one aspect of leading a full, accepted and participating life in the community. The more that can be done to bring about greater integration and participation of disabled persons in the life of the community the more everyone will learn to look beyond a disability and see the person. When this happens, it opens up many new possibilities.**



**A community rehabilitation program finds enjoyable ways to bring disabled**

**and non-disabled children together. Here the village children have been invited to the birthday party of a disabled child. They take turns, blindfolded, trying to break a 'piata' (a papier-mch toy filled with candy and nuts) (PROJIMO/Richard Parker)**

## **Birth control**

**Disabled girls and boys should be given the same information and opportunities to avoid unwanted pregnancy as non-disabled young people. Making such information and methods available may be of special importance for participants in a self-run community rehabilitation program. (For different methods of birth control, see *Where There Is No Doctor*, Chapter 20.)**

## **The mentally retarded child and sex**

***Mentally retarded* children, like others, as they grow up take increased interest in sex. In fact, they may take more interest in bodily experiences because opportunities for other activities are more limited.**

**Because the complex messages that the retarded child gets from other people are often confusing or contradictory, the child may develop unacceptable patterns of *behavior*. Often parents do not know how to handle this. For example, a mother may be afraid to take her retarded boy with her to the market because he tries to touch every girl he sees.**

**It is important that retarded children are helped to understand clearly what behavior is acceptable and what is not, and where. To accomplish this, a behavior approach to learning can be used. The family can consistently reward good behavior and carefully avoid giving the child special attention or in any way rewarding bad behavior. This approach is discussed in Chapter 40. In children with behavior difficulties, if possible, the family should start using a behavior approach to learning long before the child grows up sexually. The younger the better.**

**A common mistake is to pretend that retarded young people do not have a need for loving personal relationships. The need exists, and if unanswered, can lead to difficulties both for themselves and for others.**

**In most communities, it is very difficult for the retarded person to have a close, loving relationship. In some countries, programs arrange for retarded persons to live together in special homes or to come together for social activities. As a result, some of them form couples, and sometimes marry.**

**Trying to protect retarded girls against sexual abuse, and undesirable pregnancy, and at the same time respect the girls' rights, can be difficult. Some programs try to solve the problem through sex education, or by providing retarded young women with birth control methods to prevent pregnancy. Check with your local health worker to see what birth control methods are available and acceptable in your area.**



## **Marriage and family**

**In countries where the disabled have achieved greater acceptance and involvement in the community, an increasing number of disabled persons, including some with fairly severe disabilities, are getting married and having families of their own.**

**The ability of a married disabled person to bring up a family depends a lot on economics. Thus, an effort to help young disabled persons learn the skills necessary to work and earn a living or maintain a home is an important part of the preparation for marriage and family.**

## **Sex education**

**On the average, disabled children begin to mature sexually around the same age as non-disabled children. Girls may begin to have monthly bleeding (menstruate) at about age 11 or 12 (or earlier or later). Boys begin to release semen at age 12, 13, or 14 (sometimes earlier or later). Often these new bodily functions take the child by surprise, and may fill the child with confusion or even guilt unless he or she is informed about their naturalness and purpose.**

**Because disabled children often do not have the same opportunity to mix with other children in an unsupervised way, they can miss out on one of the most common forms of sex education: children's games, jokes, stories, songs, and private discussions. Therefore, older persons should make a special point to share basic 'facts of life' with these children in a relaxed, trustful way, inviting questions and answering them honestly.**

**Equally important, of course, is to make arrangements for disabled children to mix with, play with, and join in the secrets of other children.**

**The need to accept a range of social relationships**

**Disabled persons have as much right to sexual relationships as non-disabled persons. But opportunities for close relationships may not arise as often or as easily for disabled persons as for non-disabled persons. Many of the standard ways that young men and women meet may not be open.**

**It is therefore not surprising that some disabled people enter into less common types of love relationships - sometimes 2 members of the same sex, or 2 persons from different castes, races, social levels, or other social groups between which relationships are not locally approved.**

**Before condemning such a relationship, it is important to consider what benefit or harm it is providing for each of the partners. If both partners have entered the relationship willingly and seem happier and more whole**



**because of it, those concerned should perhaps be supportive - even if the relationship is not socially approved. This should be the case whether or not the persons are disabled.**

**Many groups and organizations of disabled persons are outspoken in defending the rights of persons to live in ways that are different from the norm, as long as no one is being forced or hurt. They know from personal experience that society is often cruel and unfair in its treatment of those who happen to be 'different'. So they try to take the lead in the re-education of the community toward a more flexible and accepting attitude with regard to human variation.**

**On the other hand, disabled children or young people are sometimes in a position where they can more easily be taken advantage of or abused. The very loneliness of some disabled young people or the innocence of the retarded child often makes them easy targets for abuse. Necessary precautions need to be taken.**

**What is important when 2 people live together or have a sexual relationship is not who they are, but that they truly care for and respect each other.**

## **Chapter 53: Education: At Home, at School, at Work**

**Guided learning to help a child gain skills and understanding for meeting life's needs is called 'education'. In Chapters 34 to 43 we talked about ways**

**to help disabled and delayed children learn to control and use their bodies and minds, and to master early basic skills for daily living. But as a child grows up many additional skills and knowledge are needed.**

**For nearly all children, education begins in the home. For some it continues in school; for others in the fields, in the forest, at the marketplace, on the riverbank, or in the streets.**

**In the cities of most countries, a school education has become almost a 'basic need' for getting a job or being accepted by society. In many villages and farming communities, however, 'book learning' still is much less important than the skills children learn through helping their families with daily work.**

**In some rural areas, therefore, it may be a mistake to think that 'every child' should go to school. For the child who is *physically* strong but *mentally retarded*, schooling may be a frustrating and unrewarding experience, especially if no 'special education' is available. The child may be happier and learn more skills for meeting life's needs by helping father in the fields, or mother in the marketplace, than by going to school.**



**For many children in rural areas, the most important parts of their education do not take place in school.**

**However, for some retarded children in rural areas, schooling can be important. If the teacher and other children can be helped to understand**

**the special needs of the child, treat him with respect, and give him encouragement, the slow learner may benefit greatly from school, both educationally and socially.**

**Whatever the case, it is important to consider the local situation carefully. Do not just follow the recommendations from the outside about the importance of schooling. Some school situations are better and some are worse than others. So before deciding for a particular child, look carefully at the good and the bad things about the local school and consider the other choices.\***

**\* Even non-disabled children are in some ways often damaged by school, even as in other ways they are helped. For an excellent critical analysis of public school in the social context, see *Letter to a Teacher* by the schoolboys of Barbiana. These rural Italian boys declare that "School is a war against the poor"**

**For the physically disabled child in the rural area, schooling may be especially important-more so, perhaps, than for able-bodied children. Physically disabled children often cannot do hard physical farm work as well as the able-bodied. Therefore, they need to learn skills using their minds, so that they can work or take part in community activities. It may help them to go as far in school as possible.**



**In a village, skills learned through schooling can be more important for the disabled person than the non-disabled.**

**Regular school or special schools?**

**Today, leaders in rehabilitation generally feel that disabled children should attend the same schools as other children, whenever possible.**

**For mildly or moderately disabled children this should not be a big problem, *if* the parents, school director, and teachers cooperate. In some communities, however, and especially in rural areas, parents may not even think of sending their disabled child to school. They may fear that their child will be teased or have too hard a time. And in some places, school directors or teachers refuse to accept even a moderately disabled child with a quick mind. Distance and other problems getting to school also add to the**

**difficulties.**

**Wherever possible, try to overcome these problems. Village *rehabilitation* workers can talk to teachers, parents and other schoolchildren and try to work out the best situation. At times parents may need to organize and put pressure on the schools to change their policies. In some countries, laws exist requiring government schools to accept and make special provisions for disabled children. Rehabilitation workers and parents can find out about the laws, and try to have them enforced. Or they can work to get laws passed if they do not exist.**

**Every effort should be made to make regular schooling easier and more enjoyable for the disabled child. Some possibilities that involve other schoolchildren have already been discussed in Chapter 47 (CHILD-to-child).**

**For more severely disabled children, attending regular schools often may not be possible, at least as schools exist today. Yet, sometimes if you talk with the teachers and other children, they will become more understanding and make special arrangements**

**For example, we know a boy with spina bifida who lacks *bowel* control and therefore never went to school. But after his parents talked with the teacher and schoolchildren, an agreement was reached. Now the boy goes to school. When he has an accident in his pants, he quietly gets up and goes home to bathe and change (Fortunately his house is very near the school)**



**Children with developmental delay get a 'head start' in a pre-school program near Bangalore, India**

**In cases where some disabled children cannot attend regular school, other alternatives may be possible. In cities of some countries there are 'special education' programs for children with certain *disabilities*. Such schools, if private, are usually very expensive and if public, are often overcrowded or have long waiting lists**

**In the rural areas, with rare exceptions, there are no special education programs. However, parents of disabled children may be able to organize and form their own 'special school' The group helps each child to learn at her own pace and in her own way. An example of such a school is 'Los Pargos' in Mazatlán, Mexico, described briefly. Also, the Centre for Community Rehabilitation Development in Pakistan has helped organize**

## **parent-run special education programs in many towns.**

**If no opportunity for regular or special schooling can be worked out - or even if it can - perhaps some arrangement can be made for study at home. Children who do go to school, either non-disabled or disabled, may be able to help teach the severely disabled children at home after school. A community rehabilitation program can also include a study program for disabled children and youths. Project PROJIMO has arranged at the local village school for attendance of children with special needs who have had difficulty in schools elsewhere. In addition, the disabled rehabilitation workers assist the children who need special tutoring in the evenings**



**Regular school**





**Extra help with a tutor**

**This book does not cover the details and methods of special education. It is important that the methods used be adapted to the local customs and situation - not just borrowed from Europe or the USA, as is often done. An excellent book on *Special Education For Mentally Handicapped Pupils*, by Christine Miles has been developed for the program in Pakistan, and has many ideas for adapting to the local culture.**

**Meeting the special physical needs of children at school**

**When physically disabled children are in school or studying, it is important to remember their special needs, and try to meet them.**

**For example, children who cannot get up and run around should usually *not***

**spend all day sitting in a wheelchair. This tends to lead to *contractures*, swollen feet, weak leg bones, *spinal curve*, and other deformities.**

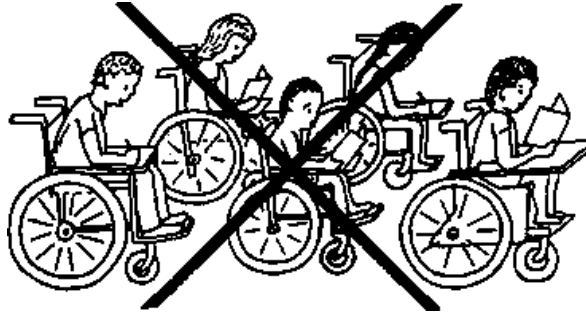

**Figure**

**So try to arrange for the children to spend at least part of the day with their bodies in a straight position.**

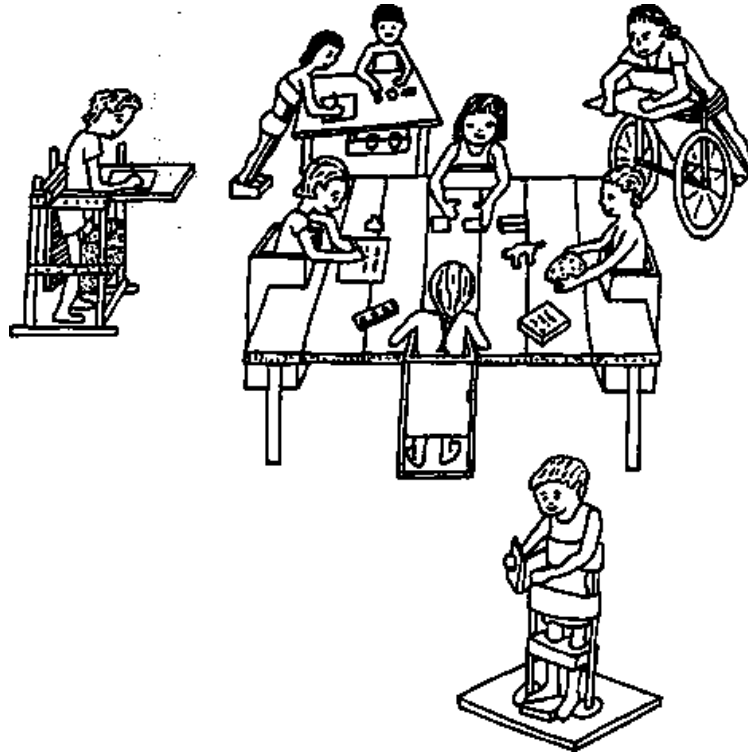

**Part of the day this can be done in standing frames (but usually not for more than half an hour at a time).**

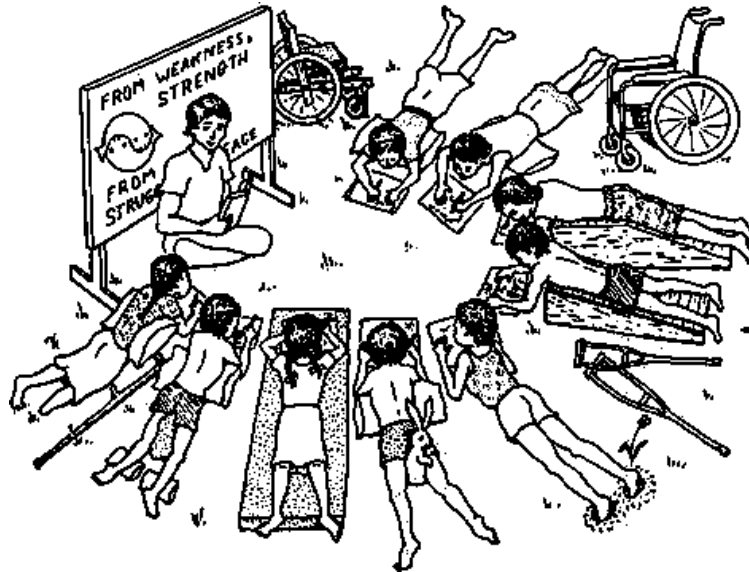

**And part of the time it can be done lying down, either on the floor, or on 'wedges' or mats that permit better positioning and use of the hands and arms.**

## **AIDS FOR READING, WRITING, AND DRAWING**

### **PENCIL HOLDER FOR A WEAK OR PARALYZED HAND**

**For children who have difficulty holding a pen, pencil, or brush, or turning the pages of a book, you can think of all sorts of *adaptations*. Here are a few**

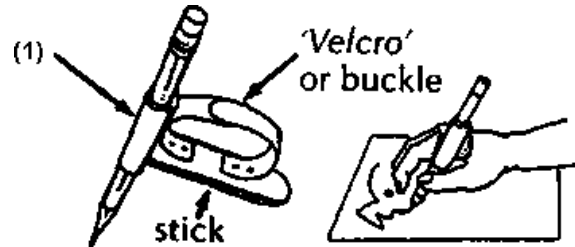
**examples:****Figure**

**(1) piece of leather or stiff cloth fastened to a stick, with space to force a pencil through the hole.**

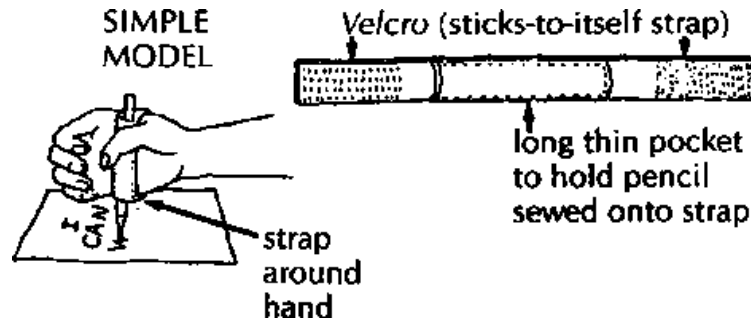
**Figure****AIDS FOR HOLDING PENCILS, PENS OR BRUSHES**

# A thick handhold gives better grip and control.

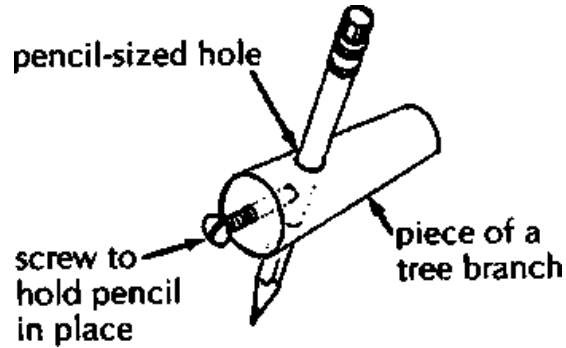

**Figure**

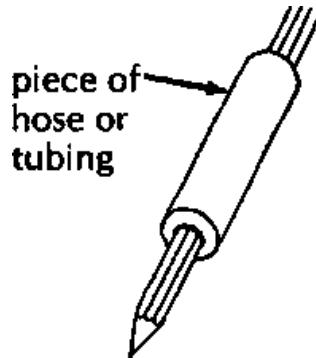

**Figure**

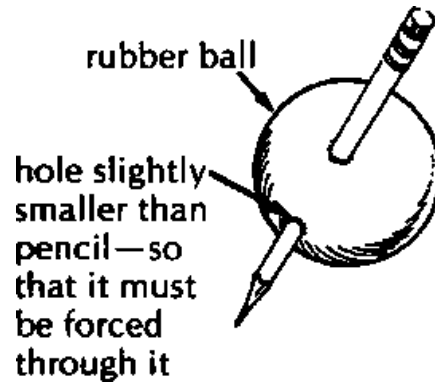

**Figure**

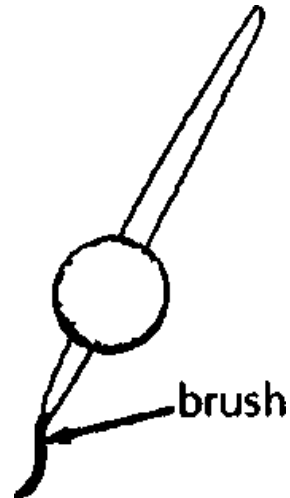

## Figure

### PAGE TURNER (Design for head)

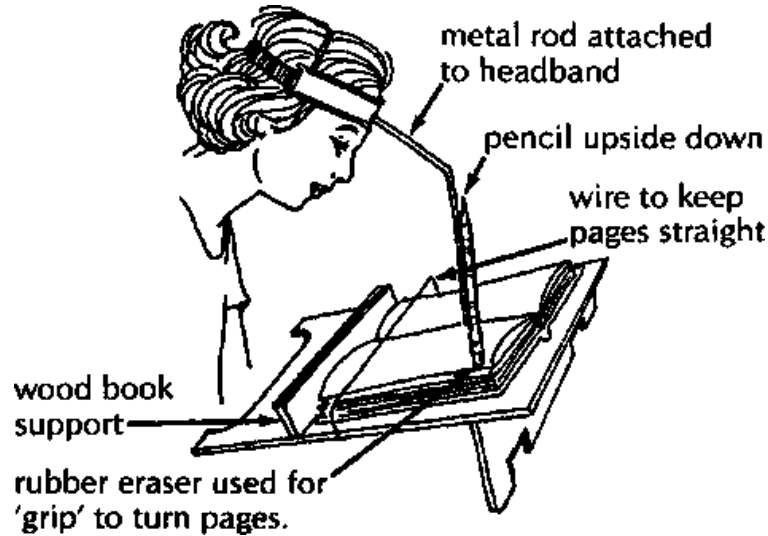

**For writing, a pencil or pen can be taped with the point down.**



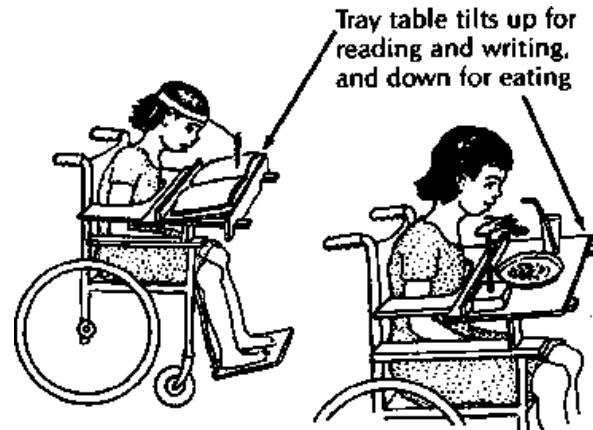

**Figure**

**Many children who have poor hand control and cannot write clearly by hand can learn to write well on a typewriter - using their hands or a stick attached to their heads. A typewriter may be a wise investment for an intelligent but severely disabled child-and may in time provide a way for her to earn money**



**Figure**

**A pocket calculator is much cheaper than a typewriter. A disabled person who is good with numbers can do many different kinds of accounting jobs.**

**For more ideas on special aids and adaptations, see Chapter 27 on amputations, Chapter 9 on cerebral palsy, and Chapter 62 on special aids.**

**Lupito's family was afraid to let him go to school. They thought the other children would tease him. Village rehabilitation workers convinced his family to let him go to school, and to also lead a CHILD-to-child activity with the schoolchildren. Lupito now attends school happily and does very well**



**Lupito at school**



**and at play**

## **Chapter 54: Work: Possibilities and Training**

**For most people, some kind of work is necessary in order to eat and have a place to live. In rural areas, the main work of many families involves farming, fishing, hunting and gathering, or other forms of food production. Equally important is the work of 'keeping house' and bringing up the family.**

**Who does most of the work within a family depends on local customs and the family's situation. In most poor rural families nearly everyone-women, men, and children - help with the work of survival. By the time they are 5 or 6 years old, children may be helping to take care of the babies, feed the chickens, herd the goats, shell and clean the grain, and to carry out other tasks so that the older members of the family are free to do other work. In many societies, children by age 8 or 10 bring in more income (food or money) than it costs their families to take care of them.**

**Work that frees people and work that makes them slaves**



**Work-whether it is done by adults or children-can be either a good or bad experience. It can help persons gain dignity and independence. Or it can take away their dignity, freedom, and health. How workers are affected depends on work conditions, on the fairness of wages, on workers' rights, and on how much respect and equality exists between workers and bosses.**

**In some situations, especially in cities, many children are forced to work**

**long, hard hours in unsafe or unhealthy work conditions for very low pay. Such 'child labor' is cruel, and may result in permanent damage to the child's body or spirit.**

**In some rural areas, children from the poorest families must also work long, hard hours under difficult conditions. But for many rural children, the opportunity to help their families with the labor of production and survival is a greater adventure than is 'play'. The chance to take care of a real baby (not just a doll) or to help grow the family food, gives many farm children a feeling of importance, self-confidence, and personal worth that is not often seen in city children.**

**As a child grows up, to be wanted and well cared for is not enough. A young person needs to feel that he or she is needed. To become 'independent' can be important. But just as important is to develop an ability to do things for and with others, to contribute toward meeting the needs of family, friends, and community.**



**Figure**

**Too often disabled children are not given the opportunity to become helpful or needed, or to learn the skills to contribute in an important way to the family or community. The family and community need to look ahead to the disabled child's future. They need to find ways to build on whatever strengths she has, so that she can have a full and meaningful role in the community.**

**A money-earning job is not the only meaningful role in society**

**In some cultures, especially in Europe and the United States, great importance is placed on work to earn money. Often it seems that a person's worth is measured by how much money he or she makes. Where such a value system exists, a standard goal of *rehabilitation* is to prepare disabled persons to work at some kind of money-earning job.**

**But caution! This goal of a paid job may not be appropriate in some parts of the world. Traditions and local values differ from place to place. Some societies are more accepting of persons who do not earn or 'produce', as long as they contribute and take part in other ways.**

**Also, we must remember that in poor countries the unemployment rate (people without work) is often very high, even for the non-disabled. It may be very difficult for a disabled person to get a job, even if well-trained.**

**There are many ways, other than by working for money, that disabled persons can contribute to their family and community. They may be able to learn skills to help with daily activities in the home. Or they may become leaders for community action. As we discussed in Chapter 45, disabled villagers who are unable to do hard physical farm work, often make outstanding health workers (paid or volunteer), rehabilitation workers, popular organizers, or defenders of human rights.**

**It is important that rehabilitation programs have a broad view of how disabled persons might work or fit into the community. Too often 'skills**

**training' prepares a *physically disabled* person to do jobs that able-bodied persons could do just as well. The challenge, whenever possible, should be to build on the unique strengths, experience, and qualities of the disabled person: help her to find a role in society that she can do better than most non-disabled persons. Disability does make a person different in certain ways, for better and for worse. Rather than pretending that the difference does not exist, it is wiser to accept the differences and look for ways that being disabled helps to deepen or strengthen the person. Help the person to have not just an ordinary role in society but one that is in some ways outstanding. Persons like Helen Keller (a blind and deaf woman who became a social leader and agent for change) can be our role models.**

**Rehabilitation programs and families should avoid planning a child's (or adult's) life work, or role in the community, for him. Rather, we should help make available as wide a range of opportunities as possible.**



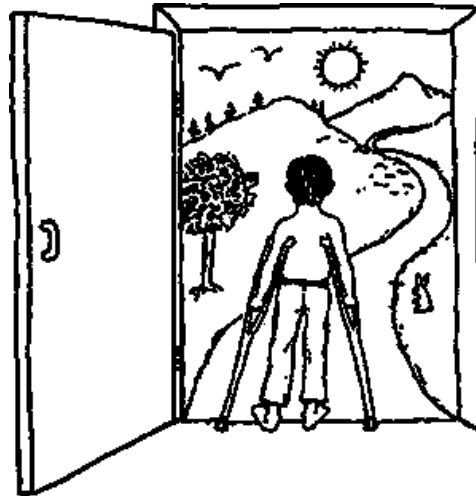

Figure

**Our goal should always be to open doors for the child, not to close them.**

**ACCEPT THE CHILD'S WEAKNESSES  
AND DEVELOP HER STRENGTHS**

**Children with certain areas of weakness or disability often also have other areas of strength or ability. When deciding what work skills a child should be helped to develop it is generally wise to pick those in areas where the child is strongest. For example:**

A child who is **mentally retarded** but physically strong...

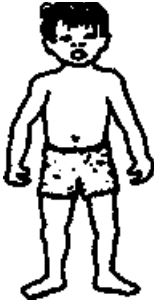

**Figure**

... may be happier and do better at learning certain physical skills...



**Figure**

.. than at spending a lot of time trying to learn mental skills.



**Figure**

He will probably make a better farm worker than a writer or bookkeeper.

A child who is physically disabled but has a quick, intelligent mind...



**Figure**

... may be happier and do better learning mental skills...



**Figure**

... than trying to learn physical skills that will always be more difficult for her.



**Figure**

She may make a better health worker or school teacher than a farmer or grain grinder

A child who has weak legs but strong



... may be happier and do better



... than trying to learn skills



He may make a better sandal

arms and hands...



**Figure**

learning manual skills...



**Figure**

that require use of his legs and feet.



**Figure**

maker or welder than a field worker.

A child who cannot see but has a good sense of hearing, touch, and rhythm...



**Figure**

may be happier and do better learning skills that depend mainly on hearing and touch...



**Figure**

than trying to learn jobs that are much more difficult without eyesight ...



**Figure**

He will probably make a better village musician than a goat herder or hunter.

**CAUTION:** It usually makes sense to help a child develop specialized work skills in the areas where she is strongest. But it is also important for her to develop self-care and daily living skills as best she can, even though this may be difficult. Thus the child who is mentally retarded needs to learn basic communication skills. The girl with *spasticity* needs to learn, if possible, how to prepare food and keep house. The weak-legged boy or blind child needs to learn how to get from place to place.

## **LEARNING SKILLS FOR AN ACTIVE OR PRODUCTIVE ROLE IN THE COMMUNITY**

### **Development of the mind**

**Learning skills that require more mental than physical activity can help the physically disabled child to gain a place in the community.**

**For development of skills such as reading, writing, and arithmetic, when possible, it is usually best that the disabled child go to school. Ideas for helping the child get to school and be accepted there are discussed in chapters 47 and 53. If the child cannot go to school, figure out ways for her to be taught at home—perhaps by school-children.**

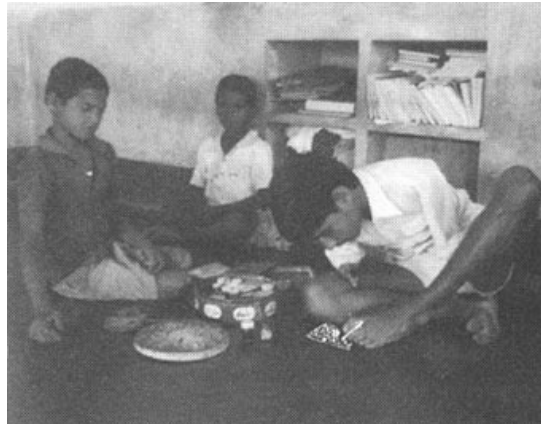

**In Melkote, India, the Janapada Seva Trust teaches disabled village children many productive skills. Here, a boy without hands uses his foot to draw greeting cards, which are later sold.**

**As soon as the child learns to read and write, try to buy or borrow simple, interesting and educational books. With these the child can develop her mind further.**

**Starting a village library is often an excellent idea. In fact, a disabled young person may be able to become the village 'librarian'-and a non-formal educator.**

To open up other possibilities, help your village recognize both the needs and value of disabled and other disadvantaged persons (such as single mothers) **When deciding who to choose for public service jobs and community responsibilities, try to make it a village policy to consider choosing persons who have disabilities or special needs.**

Although they are sometimes unable to do hard physical farm work, disabled persons can often make outstanding health workers, cooperative administrators, shop keepers, librarians, 'cultural promoters', or child care center coordinators-if they are given the chance.



**In a village, a young person who learns to read and write can become a 'librarian' and sharer of information.**

**Adaptations for farm work and gardening**

**Persons with weakness in their lower bodies but who have strong arms and**

**hands can learn a wide variety of work skills where they can sit and use their hands. (See list of skills) However, for many villagers, the growing of food is central to their lives.**

**If certain *adaptations* are made, disabled villagers can often help with farming and gardening. Here are a few suggestions.**

## **AIDS FOR CRAWLING**

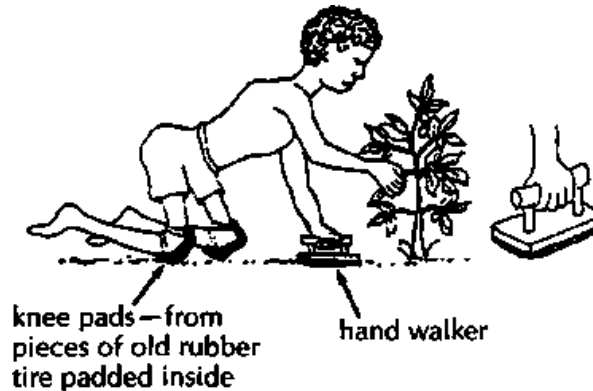

**Figure**



**hand walker attached to garden trowel**

## ELEVATED GARDENS

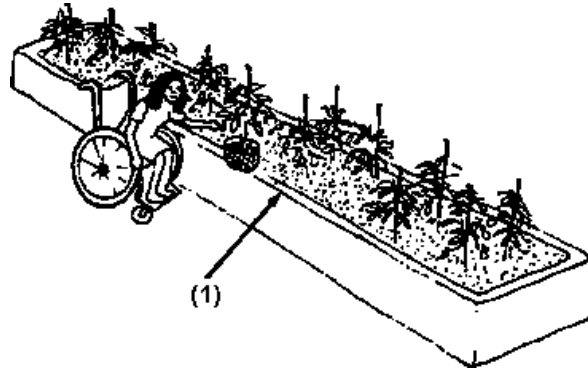

**Figure**

**(1) family garden elevated for work from wheelchair.**

## OFF-ROAD TRANSPORT

**Getting to distant fields over rough trails may be difficult for the young person who cannot walk. A simple carrying frame can be used to carry the child and also the tools and grain.**





**Figure**

## **GUIDELINES OR RAILS**

**For the child who is blind, or has difficulty with balance, hand rails may make it easier to get from the house to the garden, the latrine, and the well or water hole.**

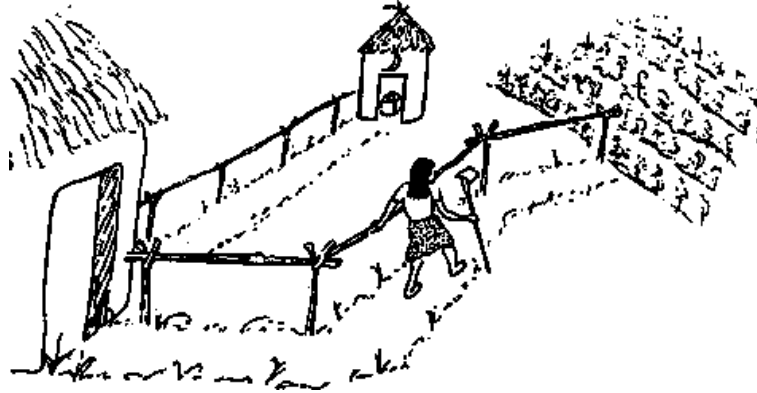

**Figure**

## **Alternatives to farm work**

**Many disabled villagers will need to learn skills other than farm work. If unemployment is high it may not be wise to train disabled persons for jobs where there is a lot of competition. In fact, any sort of paid job may be hard to get. Therefore, it often makes more sense to teach young disabled persons skills so that they can become self-employed. Or perhaps several disabled and non-disabled persons can become partners in a small 'home industry'.**

**A village-based rehabilitation center with a shop can teach young disabled persons different manual skills such as leatherwork, clothes making, woodworking or welding. While they are with the program, they can use**

**these skills to make a wide range of rehabilitation and *orthopedic* equipment. They can also make toys, chairs, leather goods, clothes, and other objects for sale. The income from the sale of these things can help cover some of the costs of the rehabilitation program and training. When the learners have gained enough skills, perhaps the community program can help them set up their own small 'shop' in their home, village, or neighborhood.**

**In several countries, organizations for the disabled have started revolving loan plans that provide the disabled craftsman with the basic equipment to start his or her own small business. The loans are paid back little by little over a reasonable time, so that the same money can be used to help another disabled person get started.**

### **SELF-EMPLOYMENT-A WISE APPROACH WHERE JOBS ARE HARD TO GET**



Helping disabled persons become craftspeople and set up their own small business in their home is one of the best approaches to employment for disabled persons with good minds and hands.

**In the West Indies, the Caribbean Council for the Blind provides a guarantee to local banks which give 'start-up' loans to disabled persons. So far, 97 percent of the disabled persons who have received loans have met their payments on time. This record is better than that of able-bodied persons. It helps convince bankers not only that disabled persons can run their own small businesses responsibly, but that they are a good investment. By involving local banks in the loan program, the public is being educated toward a new respect and appreciation for disabled persons.**



**Trash collection - a job nobody likes but everyone must help do (PROJIMO)**

**Disabled villagers can become skilled in a wide variety of manual skills.**

## **Here we list some skills that are taught in different rehabilitation programs, training programs, and special workshops**

\* skills marked with a star are sometimes taught to blind persons

☐ skills marked with a box are sometimes taught to mentally retarded persons

leatherwork ☐

sandal and shoe making and repair

metal work of a wide variety

welding

radio and television repair

electrical and mechanical repairs

weaving of cloth blankets etc \*

sewing and clothes making ☐

toymaking \*

basketweaving \* ☐

dollmaking ☐

carpentry \* ☐

cabinet and furniture making \*

hospital equipment making

making rehabilitation equipment and aids

wheelchair making

prosthetic limb making

drawing painting sculpture and design wood or ivory carving

production of simple marketplace gadgets cages utensils and nicknacks  
designing and making greeting cards  
printing and silk screening  
pottery making \*  
broom making \* □  
chalk making \* □  
candle making \*  
artificial flower making □  
typing and secretarial skills  
bookkeeping accounting  
bee keeping  
knife scissor and saw sharpening □  
gardening and vegetable raising \* □  
animal raising (chickens ducks goats rabbits pigs fish) \* □  
managing a small store or street shop \*  
cooking and restaurant management  
health work  
jewelry making  
rope and string making \* □  
landscaping grounds maintenance □  
janitorial service (cleaning and maintenance) □  
fish net making and repair \*  
teaching \*  
playing music \*

laundry work, pressing  
hair cutting, dressing  
dental work



**A blind boy in the Philippines plants a vegetable garden (Photo by Robert Jaekle for Helen Keller International)**



**This young villager in Sri Lanka became quadriplegic at age 14 The Sarvodaya CBR program helped him set up this small store in front of his home**

**The above list includes only a few of the activities that disabled persons have learned in order to run their own small business or set up shop in their home. As much as is possible, let the disabled person decide what skill or skills she wants to learn. Choices that are possible will depend on the person's combination of disability, abilities, and interest as well as on the local situation, resources, market, training opportunities, and other local factors**

**Making craft goods out of old junk - an experiment in Pakistan**



**Leaders in the Community Rehabilitation Development Project in Peshawar, Pakistan realize that in their country it is very difficult for disabled persons to 'earn a living'. Most either live by begging, are cared for by their families, or die of neglect. Since chances of employment are so limited, it is more realistic to help disabled persons learn simple craft skills for self-employment at home (if they have a home) or in the marketplace. They can make small things at low cost and sell them in the marketplace. If their small business helps the family a little or covers part of their daily expenses, something has been gained.**

**In the marketplace of Pakistan there is a variety of clever, simply made cages, tools, utensils, toys and other objects, mostly made out of very low-cost or waste materials. The Project has hired a self-taught craftsman to collect, study, and make design plans for some of these marketplace things, so that disabled persons can learn to make and sell them. To follow are a few examples. For more complete instructions, write to Mike Miles, Mental Health Centre, Mission Hospital, Peshawar, N.W.F.P. Pakistan.**

**Marketplace crafts for self-employed production by disabled persons**

**These examples and the examples on the next page are from FAMN/UNICEF Community Rehabilitation Development Project, Peshawar, Pakistan.**

**WIRE BIRD OR SMALL ANIMAL CAGE**

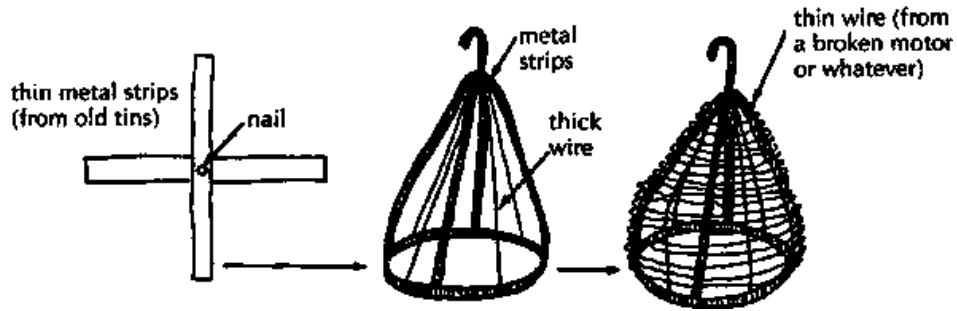

Figure



bottom

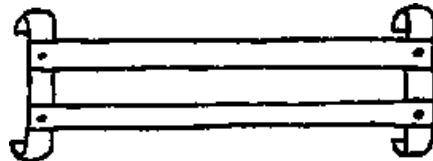

door

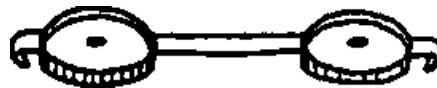

## food and water containers from old jar caps

### TIN SPOONS



Figure

Cut out the spoons with strong scissors, and hammer them to shape over a piece of iron with a hole in it.

### COCONUT SHELL SERVING SPOON

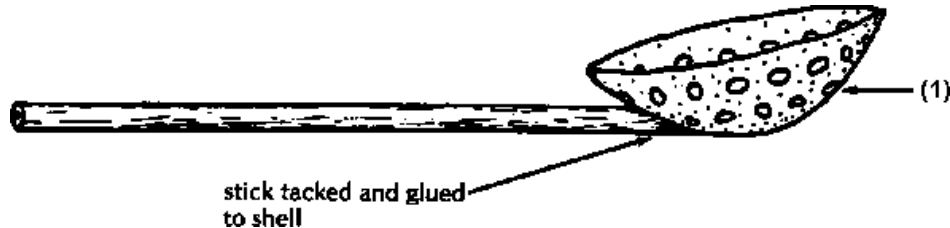

piece of coconut shell with small holes drilled (1) to drain water.

### TIN CUPS



**used beer or soda tin**

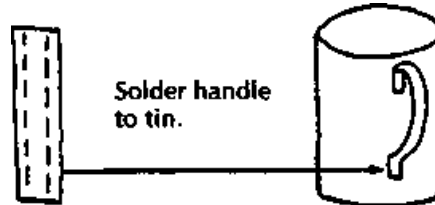

**piece of beer or coke tin**

## **BROOM**

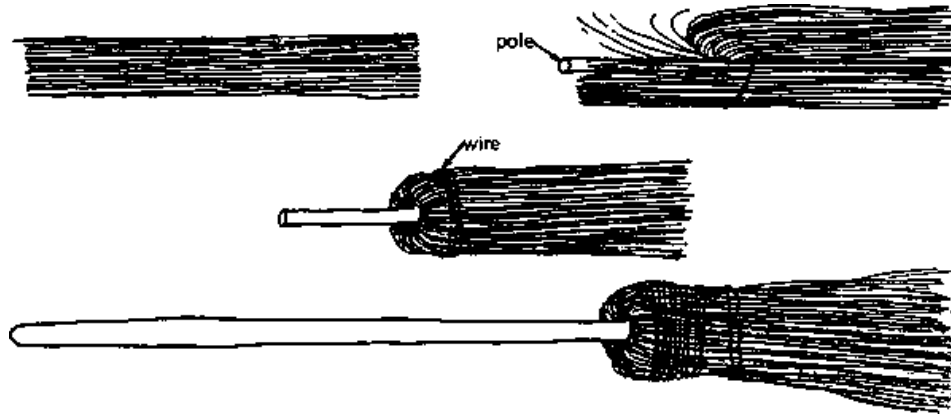

**broom straw or raffia from palm leaves**

## **PAPER BAGS**

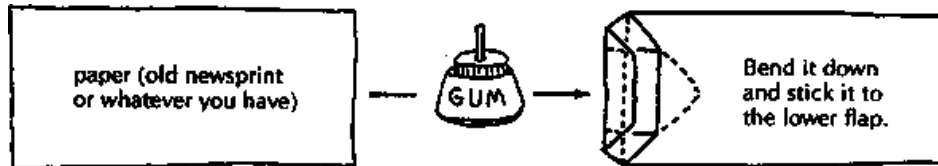

**Figure**

## **CANDLES**

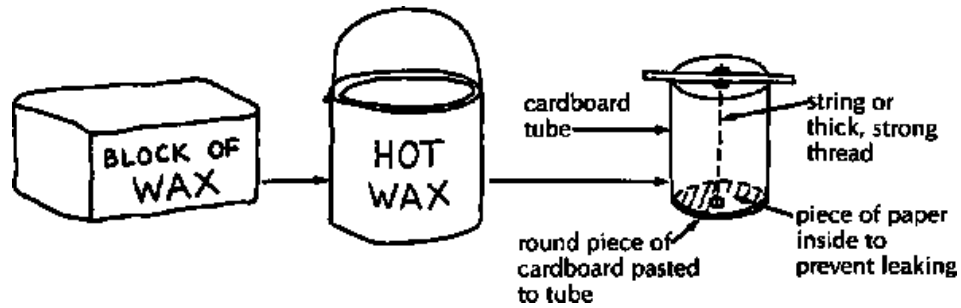

Figure



finished candle

## FLY SWATTER

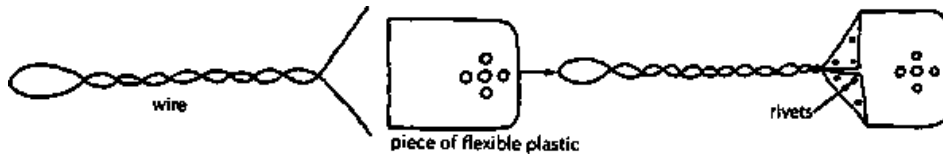

## Figure

### TRAINING

#### The integrated approach

**When possible, it is usually best that skills training for disabled persons take place together with skills training for non-disabled persons. For example:**

- **A disabled girl can go to the river to learn to wash clothes with other girls and their mothers.**
- **A disabled boy can go to the fields to help plant, weed, and harvest alongside his able-bodied brothers, sisters, and father.**
- **A disabled child can go to the same school as other children, and then go on to some specialized training course.**
- **A disabled young man or woman may enter a shop or production team as an apprentice just as non-disabled young persons often do.**

**For a *mildly or moderately disabled* child, there are many possibilities to prepare for life's work together with non-disabled children - especially if parents encourage the child and explore opportunities. A community**

**rehabilitation program can help by encouraging schoolteachers, schoolchildren, training program instructors, crafts-persons, and possible employers to be more open to giving disabled young people an equal chance.**

**For more *severely disabled* young people, opportunities for integrated education or skills training will be much more limited. Alternatives need to be looked for, or arranged, especially in communities that are still not open to giving them an equal chance.**

### **Special training possibilities**

**Different approaches have been tried to help disabled persons learn specific skills. In cities, special training centers are sometimes set up for children with similar disabilities. These include programs for deaf children, centers for retarded young persons, and programs for blind children. Each program chooses skills and activities suited to the particular limitations and abilities of the group. For example, a skills training and production program for the blind may focus on skills that depend largely on touch, such as weaving or chalk making.**

**In smaller villages, it is often not possible to bring together enough persons with the same kind of disability to create a specialized training program just for them. However, a community rehabilitation program can, in its workshop, include a variety of skills training opportunities which can be**



**adapted to persons with a wide range of disabilities.**



**This young man in Niger, Africa, learned to make leather goods together with other disabled young people. Later he can work out of his own home and sell his goods in the marketplace. (Photo: Carolyn Watson)**

## **'Sheltered workshops' - yes or no?**

**Sheltered workshops are special training and production centers for disabled persons. The idea is to provide a work opportunity and a little pay to those who would find it difficult to get training and employment 'on the outside'.**

**At best, these workshops can be a very valuable experience for participants, and may serve as a step toward greater independence. They help participants gain the technical and social skills, work habits, responsibility, and self-confidence needed for outside employment or self-employment.**

**At worst, sheltered workshops can (and often do) actually hold back the development and crush the spirit of participants. Too often they are run by persons who treat the workers like babies or slaves, giving them simple, repetitive tasks. The workers are not involved in the planning, organization, or running of the program. They are simply told what to do. They become increasingly dependent on the center and fearful of their inability to make it on their own in the outside world.**

**Perhaps the key difference between these two kinds of sheltered workshops is the question of control and equality. If the participants are involved in the direction and decision making of their own program, then they will grow and mature along with the program. Perhaps they will make more 'mistakes' than a program that is controlled and run by 'superiors'. But they**

**will learn from those mistakes. At the same time they learn crafts, they learn skills in decision-making, problem-solving and small-group democracy-essential skills for improving life in the 'real world'.**

**A community-based rehabilitation program run by disabled persons may have some features of a sheltered workshop. It may provide special training and work opportunities adjusted to the pace, abilities, and limitations of each participant. It may provide such an enjoyable 'home' and 'family' setting that some persons may choose to keep working rather than to 'move on' into the 'outside world'. But because it is a program run by disabled persons, and major decisions are made at all-group meetings, it tends to be a dignifying and liberating experience.**

**A program where disabled and non-disabled persons work side by side, sharing equally in decisions and responsibility, may be even more liberating.**



**A one-armed young man who works as a village dental worker in Project Piaxtla drills a tooth before filling it. (Mexico)**

**Children with *paralysis* in their bodies often develop strong arms and hands-and can do many kinds of work as well as anyone.**



**Here 2 boys who had polio build cane blinds for the model home at PROJIMO.**



**This boy, who is paraplegic from tuberculosis, spokes a wheel for a wheelchair. He rides a wheeled lying board because of pressure sores on his butt**

### **Combining work with therapy**

**Whenever possible, look for work that will help a disabled person fit into the life of his or her community, and that will also provide needed exercise or therapy. Here is one example from the Sarvodaya community-based rehabilitation program in Beruwala, Sri Lanka.**

**With the help of her family and a village rehabilitation volunteer, this girl with cerebral palsy learned to make rope from coconut fiber (jute). This is a common village craft, so she can work with other villagers.**



**Separating and preparing the fibers is good therapy for her spastic hands**

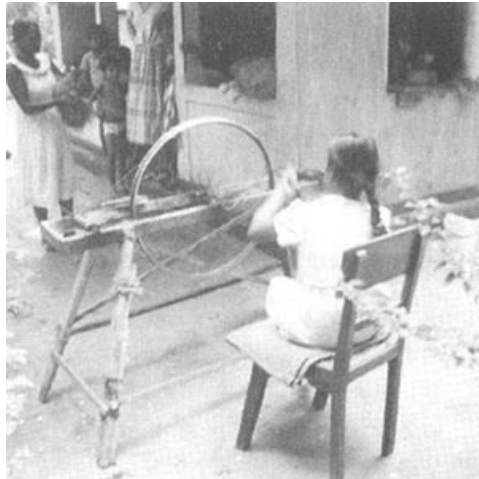

**Twisting the fiber with this wheel to make rope helps her move her stiff arms in a smooth circle - providing excellent, active therapy while she works.**

## **Chapter 55: Examples of Community-Directed Programs**

**In this chapter we give examples of 6 *rehabilitation* programs in 5 countries. Each is quite different, yet all are similar in that they are largely or completely run by *disabled* persons themselves, or by their families. Although they all work closely with the local community, each has a small 'center' of some kind where disabled persons or their families can help meet each other's needs.**



**We do not claim that the examples given here are the most outstanding or successful programs. Rather, they are the ones with which we are personally most familiar.**

**Our description of each program must be brief. We will, therefore, try to focus on their most interesting and original features, especially those that could serve as examples for other programs. Also, we describe how these have grown and spread to new communities. This kind of grassroots seeding from community to community, although slower and less orderly, may be more effective than is 'planting' of pre-designed programs from on top.**

## **1. PROJIMO-RURAL MEXICO**

**Project PROJIMO is a rural rehabilitation program in western Mexico, run by disabled villagers, to serve disabled children and their families. It was started in 1982 by disabled village health workers from an older community-based health program (Project Piaxtla).**

**PROJIMO's goal is to help disabled children and their families become more self-reliant. It aims to provide low-cost, high-quality services to poor families who cannot obtain or afford services elsewhere.**

**The PROJIMO team provides a wide range of rehabilitation activities and equipment. These include: family counseling and training, *therapy*, work**

**and skills training, brace making, artificial limbs, wheelchair making, special seating, and therapeutic aids.**

**PROJIMO is based in one small village but serves children and their families from neighboring towns and villages, and even from the closest cities (over 100 miles away). Local villagers cooperate by taking visiting disabled children and their families into their homes. Schoolchildren help make the playground-for-all-children and toys for disabled children.**



**Part of the PROJIMO team**

**PROJIMO DIFFERS FROM MANY REHABILITATION PROGRAMS IN A NUMBER OF WAYS:**

**1. Community control. Unlike many 'community-based' programs, which are**

**designed and run by outsiders, PROJIMO is run and controlled by local disabled villagers.**

**2. De-professionalization. The village team, although they have mastered many 'professional' skills, is made up of disabled persons with an average education of only 3 years of primary school. Their training has been mostly of the non-formal, learn-by-doing type. There are no titled professionals on the PROJIMO staff. However, therapists, brace makers, limb makers, and other rehabilitation professionals are invited for short visits to teach rather than to practice their skills.**

The PROJIMO team believes that only by simplifying rehabilitation knowledge and skills to make them widely available in the community, can the millions of unserved disabled children in the world receive the basic assistance they need.



**Roberto Fajardo and Mari Picos, two of the leaders of PROJIMO, evaluate a child's developmental level. Both Roberto and Mari first came for rehabilitation, then stayed in order to help others.**

**3. Equality between service providers and receivers. When asked how many 'workers' they have, the PROJIMO team has no easy answer. This is because there is no clear line between those who provide services and those who receive them. Visiting disabled young persons and their families are invited to help in whatever way they can. Most of the PROJIMO workers first came for rehabilitation themselves. They began to help in different ways, decided to stay, and gradually became team members.**

**4. Self-government through group process. The PROJIMO team has been trying to develop an approach to planning, organization, and decision-making in which all participants take part. They are trying to free themselves from the typical 'boss-servant' work relationship and form more of a 'work partnership'. The group elects its coordinators' on a one-month rotating basis so that everyone has a turn. This leads to a lot of inefficiency and confusion, but to a much more democratic group process.**



**Most of the training of the PROJIMO team members is through guided 'learning by doing'. Here, PROJIMO workers practice exercises under the guidance of a visiting physiotherapist. Parents, children, and anyone who wants to learn are welcome.**

**5. Modest earnings. The PROJIMO team believes that they should work for the same low pay as that of the farming and laboring families they serve. They can see that the high pay demanded by professionals and technicians is one reason that the children of the poor often cannot get the therapy and aids they need.**

**6. Unity with all who are marginalized. The PROJIMO team sees society's unfair attitudes toward the disabled as only one aspect of an unjust social structure. They feel that disabled persons should join in solidarity with all who are rejected, misjudged, exploited, or not treated as equals. This feeling has led the team to become more self-critical and to seek greater**

## **equality for women within their own group.**

**Thus the PROJIMO team views its role not only as one of helping disabled children and their families gain power, but as part of the larger struggle for social change and liberation of all who are 'on the bottom'.**

**7 Grassroots multiplying effect. The PROJIMO approach has been spreading in various ways. Locally, families of disabled children in a number of towns and villages have begun to organize, build playgrounds, and form their own special education programs, as more or less 'satellites' of PROJIMO. PROJIMO has also invited visitors from rehabilitation and community health programs in other parts of Mexico and Latin America to visit and take ideas back with them. Some programs have sent disabled representatives to work and learn at PROJIMO for several months so they can start similar programs in their own area.**



**The PROJIMO experience has been the basis for writing this book. Different examples or descriptions from PROJIMO are discussed in various chapters. For further references, see the Index. A 64-page report on PROJIMO with many illustrations is available from The Hesperian Foundation.**

## **2. LOS PARGOS-URBAN MEXICO**

**Los Pargos is an organization of families of disabled children in Mazatlán, a city on the west coast of Mexico. The program was started privately by Teresa Pez, a local social worker. While she was working in a public hospital, Teresa became concerned that although disabled children were given basic medical treatment, they received almost no rehabilitation. Most did not go to school because of non-acceptance by teachers, difficulties in transportation, or overprotection by parents.**

**Teresa began by bringing a group of concerned parents together, and they invited others. Today Los Pargos includes about 60 families with disabled children, and it continues to grow.**

**Los Pargos has set up its own special education program and has convinced the local university authorities to make space available in a local prep school after school hours. Some of the teachers, who are volunteers, are also disabled. This makes them good role models for the children.**



**A few of the children of Los Pargos with one of their teachers, on the left. The teacher, severely affected by cerebral palsy, has a personal understanding of the children's needs.**

**The word 'Pargos' is the name of a large, colorful fish! The children picked the name. It is perhaps appropriate, since much of the money for running the program and transporting the children comes from fish scales' On weekends the children and their parents visit the beach where fishermen dock their small boats and clean their fish for the market. The group collects the large fish scales, which they clean, bleach, color, and use to make artificial flowers. The children and parents set the flowers in attractive bouquets and designs together with small seashells, seaweed, and other dried sea life. In the tourist city of Mazatlan, selling the flowers has become a good business. When we last visited Los Pargos, parents and children were working very hard to fill a rush order for 2000 bouquets!**



**Los Pargos, located about 100 miles from PROJIMO, often takes groups of 'parguitos' (disabled children) to PROJIMO for rehabilitation services that they have trouble getting in the city. Also, their visit to PROJIMO is an adventure into the country for these city children and their parents.**



**One of the children of Los Pargos waters a young tree - part of an orchard the parents and children are planting together.**

**One of the goals of Los Pargos is to convince the government, the public schools, and society in general to accept, respect, provide opportunities,**

**and help meet the needs of disabled children. Some things are changing, but slowly. As one of the parents explains, "The best way to get something done is to do it ourselves!"**

**The idea of Los Pargos has begun to spread to other communities. Families of disabled children in Culiacn, the next biggest city to the north, are trying to organize a similar program. The key to success seems to be a few persons with energy, commitment, and an ability to get people working together**



**Four pictures of sea turtles, painted by Los Pargos children, as a part of their "Save the Turtles" campaign.**

### **3. CENTRE FOR THE REHABILITATION OF THE PARALYSED (CRP)- BANGLADESH**

**Located in the capital Dhaka, CRP is run by a local team, with the help of a British physiotherapist. Four of the staff members have spinal injuries themselves.**

**The CRP provides short- and long-term 'participatory rehabilitation' to severely *paralyzed* persons. Almost from the day of arrival, newly paralyzed persons begin to do jobs to help the Centre bring in some income. Those who must lie on stretcher trolleys (wheeled cots) work on jobs ranging from making paper bags to be sold in the local marketplace, to welding and painting of orthopedic equipment. The group produces orthopedic and hospital equipment, not only for those it serves directly, but also for sale in hospitals and in the community**



**Madhab, who is quadriplegic and who has been employed as the Centre's counselor since 1980, paints by means of a simple hand splint. Disabled workers print his paintings as greeting cards and sell them to bring in money. Madhab is responsible for the education program. He supervises those who read and write, who teach classes to those who do not.**

**CRP teaches practical skills through 'learning by doing'. The work that participants do not only brings in money for the program, but also teaches them ways to earn money after they return home. Skills learned are mostly those that will let persons have their own small home business - a roadside stand, sewing and tailoring, weaving, welding, and metalwork.**

**CRP has developed a wide range of low-cost *orthopedic* and rehabilitation equipment adapted to the needs and lifestyle of local villagers. Examples are ground level wheelchairs, or 'trolleys', for those who cook and eat on the floor, and simple metal frame beds that can be easily lowered to near ground level for easy transfer into the low trolleys.**



**Badd, who is quadriplegic, pedals a CRP-made 'exercycle' while Delwar, paralyzed by tuberculosis of the spine, practices walking.**

**Although CRP is much loved by disabled persons and their families, it has suffered attacks - sometimes physical - from opposition groups. (Many successful community-directed programs have faced similar difficulties - partly because they provide friendly, flexible, effective care that differs so much from the services provided by many large institutions.)**

**The Centre for the Rehabilitation of the Paralysed is financed mainly from outside grants and partly from the sale of its products.**



**A worker in the CRP-made wheelchair makes a bedside stand to be sold to a local hospital.**

#### **4. ORGANIZATION OF DISABLED REVOLUTIONARIES-NICARAGUA**

**The Organization of Disabled Revolutionaries (ORD) was started after Nicaragua's liberation from the Somoza dictatorship, by a group of young persons who had become paralyzed by *spinal cord* injuries. Some had been boys of 13, 14, or 15 years old when they first joined the struggle against Somoza.**



**Figure**

**ORD was begun because of concern for a common need: wheelchairs. With the increase in disabled persons from the war, the lack of a local wheelchair factory, and the difficulties of importing wheelchairs due to the United States' embargo, the shortage was severe.**

**Two young North Americans who both have spinal cord injuries, one a peer counselor for the disabled and the other a wheelchair designer and**

## **engineer, helped ORD organize and set up a small wheelchair factory**



**Figure**

**The ORD team of disabled workers now produces its own high-quality metal tubing wheelchairs, adapted for rough ground at a cost far lower than standard commercial wheelchairs.**

**Although ORD started with wheelchairs, it has grown to become a group that represents and stands up for the rights of all disabled people. It has pressured the Health Ministry to respond more to the disabled and their needs. The government-which, much more than most governments, tries to represent the people-has responded well. It has allowed ORD 'time' for**



**short educational programs on public radio and television. And it has agreed to help pay the cost of wheelchairs made by ORD for families too poor to pay. ORD is in close communication with the head of rehabilitation for the nation. In this way, the disabled organization has some voice in national policy making.**

**These are some of the advantages experienced by a community-directed program in a country with a revolutionary popular government. On the other hand, ORD suffers from the embargo and other difficulties imposed by the United States government. At times, the wheelchair production almost stops for lack of metal tubing, bearings, and other basic materials.**



## Figure

**ORD is having an increasingly far-reaching influence. It has begun to help organize groups of disabled persons in other parts of Nicaragua. Also, members have helped conduct training workshops in Central American and Caribbean countries to teach representatives from other disabled groups how to make wheelchairs.**

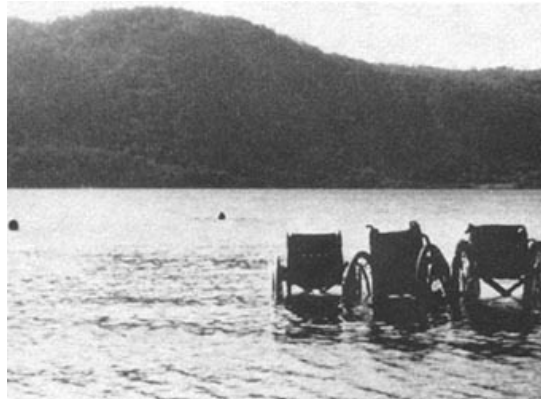

**Figure**

## **5. COMMUNITY-DIRECTED REHABILITATION DEVELOPMENT - PAKISTAN**

**The program began in Peshawar in the Northwest Frontier Province of Pakistan as a small play group for 8 *mentally* handicapped children. In 1978 the 3 Pakistani staff were joined by a Welsh special education teacher and**

**her husband. During the next 7 years the play group grew to become a community rehabilitation and resource center with daily participation of 70 physically and 40 mentally and multiply disabled children**



**Splinting a leg to straighten a knee contracture**

**Local staff persons are trained by the few professionals in special education physical therapy brace making parent counseling and planning services**

**An important part of the program is the Community Rehabilitation Development Project. The big largely rural area surrounding Peshawar is very underserved. To accomplish as much as possible with limited resources disabled children in towns were considered first. Volunteer college students went door to door to find and bring together parents and relatives of disabled children. Public meetings were held and an Association**

**was formed in each town with the aim of starting rehabilitation activities. People (sometimes young disabled persons) were chosen and sent to learn basic skills at the Peshawar center. Meanwhile the Association committee raised funds and found a place that could serve as a modest rehabilitation center**

**Although the parent program has had UNICEF and other outside funding the neighborhood rehabilitation centers have mostly been funded locally some with a government subsidy. Management is entirely in the hands of local people**

**In addition to providing daily special education and physical therapy the neighborhood centers act as a resource within their districts. They distribute advice pamphlets and books to families for home rehabilitation. Where possible going to normal schools is encouraged**

**12-minute radio broadcasts about home rehabilitation started in 1984 (The scripts for these which are excellent are available) Also the program is looking into appropriate handicrafts by which disabled young people can contribute to their family's income. A manual of these handicrafts is in preparation.**



**Helping a child begin to learn to move**

**Also available is an excellent book by Christine Miles called *Special Education for Mentally Handicapped Pupils A Teaching Manual*. It points out the importance of re-thinking special education to meet local needs and customs in developing countries.**

**Mike Miles Christine's husband has also written many excellent and critical papers on rehabilitation efforts - and problems - in developing countries.**

**The Peshawar program has succeeded in promoting community directed rehabilitation activities in much of the Northwest Frontier through organizing an already motivated group (parents of disabled children) One of**

**their keys to success is to: "Do the easy thing first!"**



**Going for a ride**

## **6. OPERATION HANDICAP INTERNATIONALE'S (OHI) ARTIFICIAL LIMB PROGRAM-THAILAND/KAMPUCHEA**

**It is estimated that in the last 8 years of the war in Kampuchea (Cambodia) more than 12 000 men women, and children have lost their legs from**

**stepping on land mines. A lot of the injured are evacuated for hospital care to a large refugee camp, called Khao-i-dang, close to the Thai border.**

**At first the hospital had no way of making or obtaining artificial *limbs*. For this reason a French relief agency (at that time SOS, or Enfants Sans Frontiers, now Opration Handicap Internationale) began making low-cost artificial legs**

**The workers in the large workshop are almost all refugee amputees. Some start learning by helping to make their own leg**

**The team (run by Frenchmen some of whom are professional limb makers) has developed different models of very low-cost limbs using local materials. The bamboo limb described is one example.**

**Bamboo is in fact the main building material for the shop itself, the rehabilitation center next door, and for most of the beds aids, and equipment. The rehabilitation playground (which served as a model for PROJIMO) is made completely of bamboo.**

**One of the most outstanding features of the program is the way it has spread to other areas. Many of the amputee workers trained in Khao-i-dang have gone back into Kampuchea and opened small artificial limb shops. The program therefore trains the amputees not only in the technology of limb making but also in basic management. Some of the 15 'satellite shops now**

**have teams of several amputees working in them. The most remote shops are run in makeshift shelters deep in the forest near the fighting**

**The spirit of hard work and friendship in shops run by amputees does much to help recent amputees accept the loss of their limbs and get back into the adventure of survival**



**Aids For Living (AHRTAG)**

**Photos from the OHI Limb Program, Thailand**





**Figure**



**Figure**



**Figure**

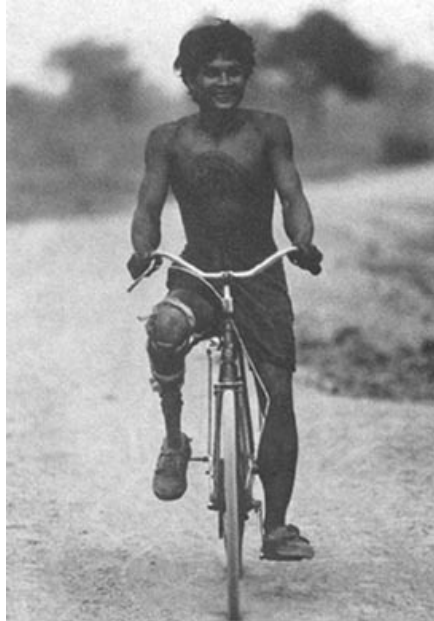

**Figure**

