

SPECTRA 70



DATA GATHERING SYSTEM

70 | 630

SYSTEM INFORMATION MANUAL



RADIO CORPORATION OF AMERICA

70-05-630
December 1967

The information contained herein is subject to change without notice. Revisions may be issued to advise of such changes and/or additions.

First Printing: December, 1967

CONTENTS

		Page	
1. INTRODUCTION	General	1	
	The Spectra 70/630 Data Gathering System (DGS)	2	
	Local System	2	
	Long Lines System	2	
	Print Back and Inquiry Response System	2	
	Summary of DGS Advantages	5	
	System Modularity	5	
	Flexibility	5	
	Speed	6	
	Accuracy and Reliability	6	
	Ease of Operation	6	
	Solid State Reliability	6	
	2. 70/630 DGS COMPONENTS	General	8
		DGS Input Station	8
		Model 6312 Transmitter	8
Standard 6312 Transmitter Features		10	
Transaction Selector		10	
Start Transmission Pushbutton		11	
Clear Pushbutton		11	
Supervisory Lock		13	
Alarm Display		13	
Equipment On Indicator		13	
Model 6311 Transmitter		13	
Optional Input Devices		16	
DGS Badge Reader Model 70/6321		16	
DGS Card Reader Model 70/6331		16	
Variable Data Reader (Keyboard) Model 70/6341		21	
Input Station Identifier		22	
Digital Readout Adapter Feature 5609		22	
DGS Buffer Model 70/725		22	
DGS Line Concentrator Models 70/6381 and 70/6382		23	
Function		23	
Operation		23	
Physical Characteristics		24	
Data Gathering Switch Unit Model 70/327-2		24	
70/780 Time Generator Buffer		25	
DGS Signal Converter Model 70/6385		25	
Function	25		
Operation	25		
Physical Characteristics	26		

CONTENTS (Cont'd)

	Page
3. DGS APPLICATIONS	
Attendance Reporting	27
Materials or Parts Receiving	27
Purchased Materials Inspection	27
Store Receipts	27
Stores Issues	27
Tool Control	27
Job Lot Inspection	27
Production Line	27
Production Line or Machine Counting and Status	28
Job Lot Production Status	28
Labor Distribution and Work Measurement	28
Calculation of Gross Pay	28
APPENDIX A	
70/630 Data Gathering System Operating Summary	A-1

1. INTRODUCTION

GENERAL

◆ The 70/630 Data Gathering System (DGS) is an on-line data gathering and communication system which provides for the transmission of fixed and variable data from a number of remote input stations. The 70/630 DGS has been designed to compress the time frame from the point of data origination to its insertion into the data processing system.

There are two ways or time frames in which data can be inserted into a processing system — in batches or as individual transactions at the time of occurrence. (See Figure 1.) By operating on an individual transaction basis, some of the efficiencies of batch operation are lost; however, the inherent disadvantages of long elapsed time from data origination to its use in file updating or in pinpointing critical exceptional situations are eliminated.

Because much of the data that is transmitted with each transaction is standard and anticipated, it can be prepared in advance by the central processing facility. Therefore, only the variable data which complements

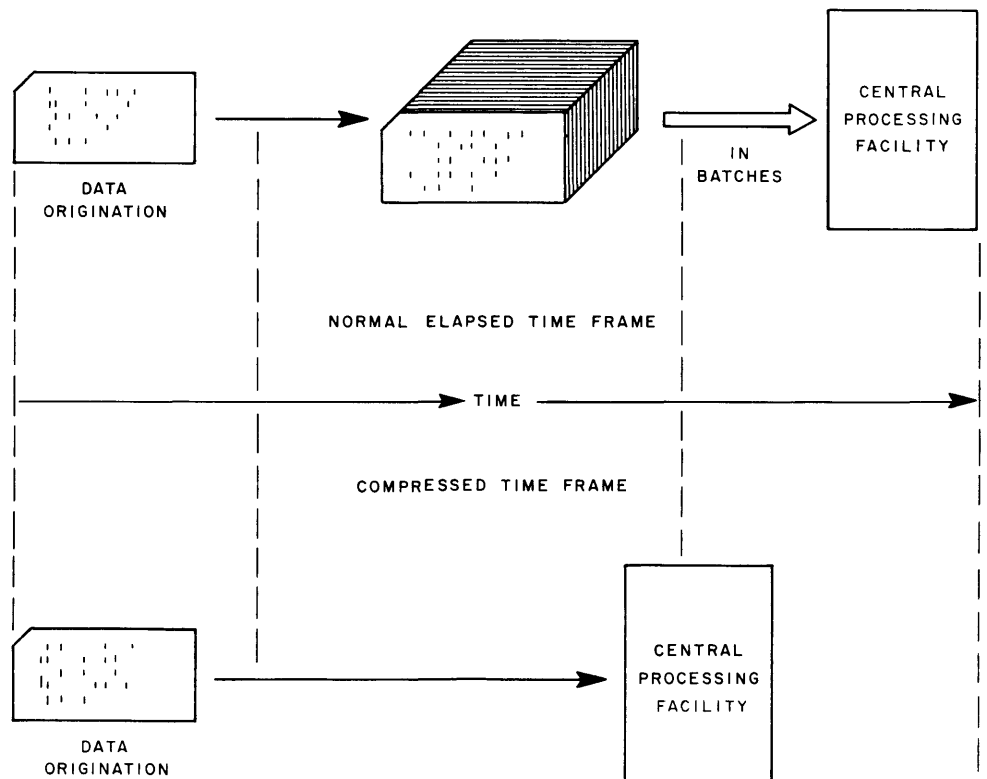

Figure 1. "There Are Two Time Frames"

GENERAL
(Cont'd)

the standard need be added at the point of transaction. Now, a second disadvantage of batch processing, transcription errors, has been minimized. Operations personnel can input source or transaction data directly to the central processing facility, minimizing the costly and redundant conventional data preparation step.

THE SPECTRA 70/630
DATA GATHERING
SYSTEM (DGS)

◆ The 70 630 DGS operates on-line to any Spectra 70 35, 45, or 55 Processor having a 65K-byte memory (with TDOS MCS)* or larger and equipped with a 70 668 Communications Controller-Multichannel. The 70 630 DGS Input Stations are located remotely at key points throughout all the user's facilities (whether within a few feet or a few thousands of miles from the central processing facility) allowing the user to enter source data accurately and rapidly into the system as the data originates. This data may be in the form of punched card, punched plastic badges, variable numerics, or digital signals converted from analogue. There are two basic DGS systems which can operate independently or in concert depending on the requirements of the user. They are the local and the long lines system.

Local System

◆ Within an intra-plant radius of 30 wire miles (from Input Station to central processing facility), the DGS operates on its own with Input Stations, DGS Line Concentrators, DGS Buffers, and Spectra 70 Communications processing equipment. To accomplish this distance transmission, simple twisted pair (two-wire) metallic voice grade lines are required.** The user has the choice of using local telephone company supplied facilities which may already exist to a large extent in his installation. Or, he may supply his own lines provided that they are equivalent to or exceed the specified line requirements. (See Figure 2.)

Long Lines System

◆ To operate the DGS over longer extra-plant distances, a DGS Signal Converter and subsets (AT&T 202D or equivalent) must be added between the DGS Line Concentrator and the receiving buffers. The DGS Buffer must also be replaced by a pair of Asynchronous Data Set (ADS) Buffers. This arrangement permits long distance operation of DGS between any desired points. (See Figure 3.)

Print Back and Inquiry
Response System

◆ Although DGS is basically a "one-way" data gathering system, provision has been made within the Spectra 70 product line to develop inquiry and remote print back systems which will operate in concert with the DGS. RCA offers the user flexibility in building his inquiry system by offering a wide range of remote inquiry/response devices which complement DGS.

As a natural outgrowth of RCA's long and unique experience in the data collection field, DGS has been designed to provide sound and useful data collection systems. Generally, the DGS offers the user: systems modularity and flexibility both in configuration and growth potential, speed, high reliability, built-in checks to ensure accuracy, ease of use, and economy.

* Tape Disc Operating System/Multichannel Communication System.

** Technical specifications for distance/line requirements will be supplied as an Appendix to this manual.

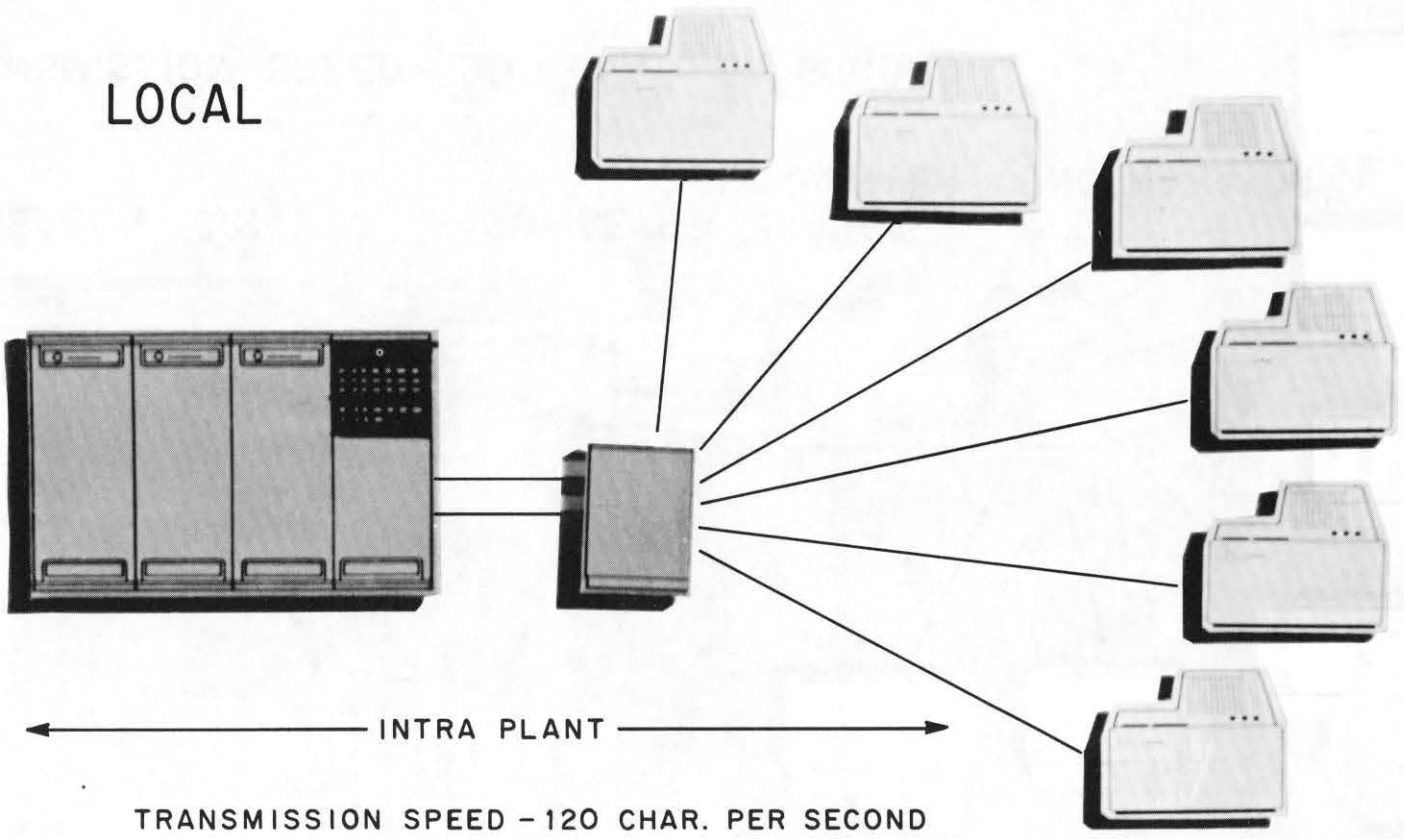
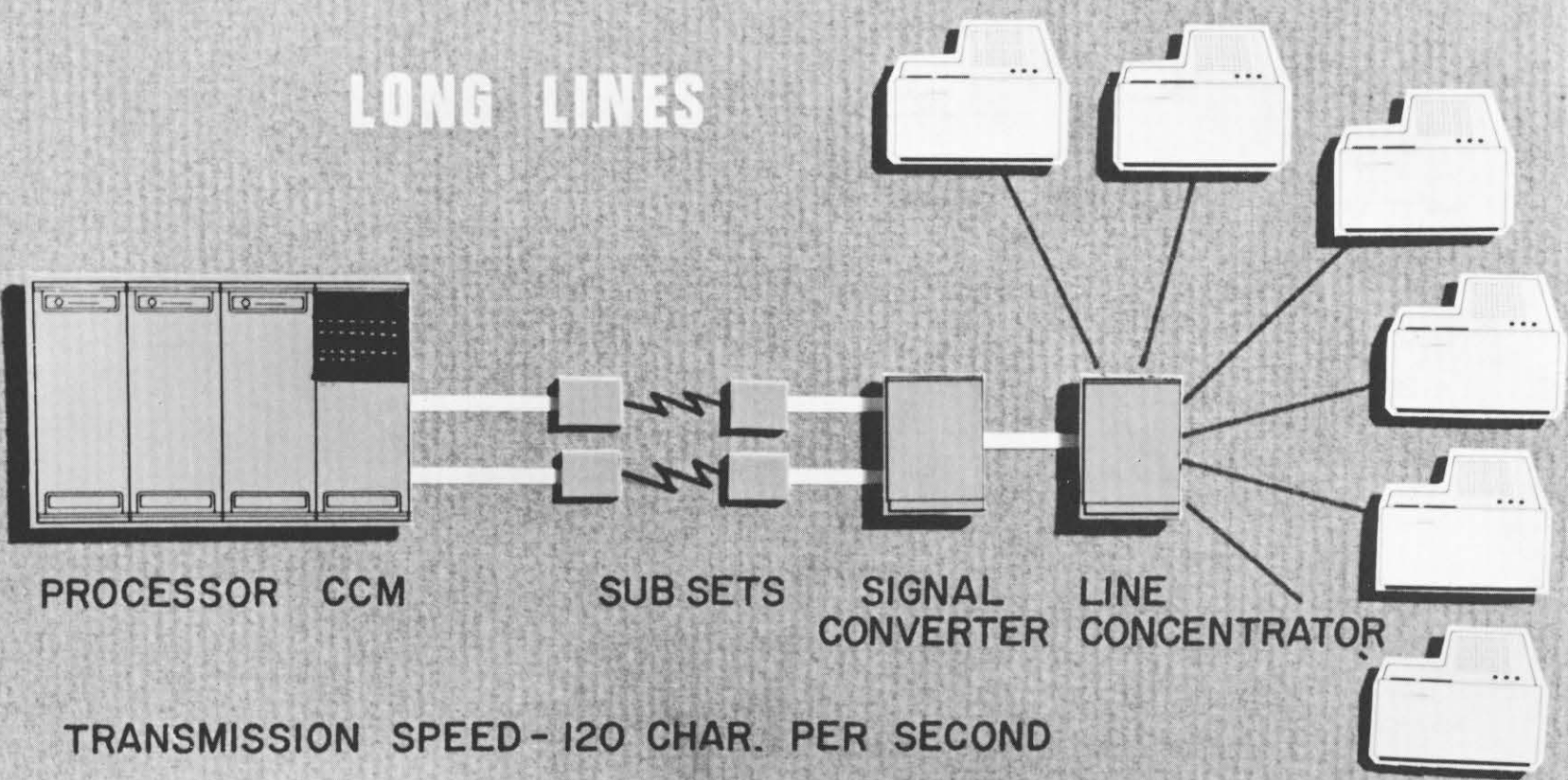

Figure 2. Data Gathering System Layout (Intra-Plant)

LONG LINES



TRANSMISSION SPEED - 120 CHAR. PER SECOND

Figure 3. Data Gathering System Layout (In Excess of 30 Wire Miles)

SUMMARY OF DGS ADVANTAGES

System Modularity

◆ The design philosophy of the third generation DGS is completely congruent with that of the entire Spectra 70 family. A complete Data Gathering System of hundreds of Input Stations is in reality a hierarchy of independent subsystems.

The user can build from a system of one or two independently connected Input Stations up to 20 or 30 in one subsystem. And he can increase the number of subsystems at will associating literally hundreds of Input Stations with a single Spectra 70/668 Communications Controller-Multi-channel. This growth can be accomplished with no disruption to the operating system.

Within each subsystem, each Input Station is also of modular design. The user initially may require Input Stations having the capability of accepting a punched plastic badge, an 80-column card or variable data input through a keyboard, or digital signals collected from a digital read-out device. He can specify any one of these media for his initial Input Station configuration or he may specify virtually any combination of these media in any one station. And as his needs grow, he can alter the original input stations at his location without interrupting other operating units in the subsystem.

Flexibility

◆ With systems modularity there is a built-in flexibility. It is this flexibility which allows the system to grow. And since all Input Stations are independently wired through to the central facility, with single twisted pair circuits, the user can rearrange the physical location of his collection network with little expense and no disruption to other system elements.

Each Input Station can be tailored to meet the needs of the user. No two DGS Input Stations in a system need to operate exactly alike; i.e., a number may be used for punched plastic badge only, others may be used for 80-character alphanumeric card and variable numeric data. The user may need other input stations which can automatically pick up and transmit piece-part count from a machine tool and read an 80-column card and an ID badge. This can be readily accomplished within a DGS.

There may also be a need for Input Stations which read multiple cards, a badge, and variable numeric data. The terminal can be conditioned to read and transmit all of these media or some of them or certain portions of each. The input message formats are specified in advance by the user.

As needs change or during growth, requirements for Input Station capability may change. The need may arise to add additional input mechanisms, possibly a second card reader or token reader. These changes can be made in the field, again, without disruption to the rest of the system.

With regard to physical proximity to the central facility, the user has the utmost range of flexibility. With an intra-plant Local DGS, he may operate Input Stations up to 30 wire miles from the central processing facility. Should he need additional distance or should he need to operate between plant facilities, this can be accomplished with the use of the Long Lines DGS. Both subsystems can be operated in the same total data collection system.

Speed ◆ Directly associated with the compression of time from data origination to its use in the central Spectra 70 Processor is the high speed transmission of a DGS. For more efficient communication channel usage, the messages from each Input Station in a subsystem are funnelled into a high speed, electronic DGS Line Concentrator — the focal point of one subsystem. Transmission from Input Station to Line Concentrator is at a rate of 120 characters per second.

Each Line Concentrator is equipped with two output trunks with each transferring data to the central facility at a rate of 120 characters per second and simultaneous servicing of two Input Stations. As subsystems are added, this speed increases in multiples of 240 characters per second.

Accuracy and Reliability ◆ Each Input Station is equipped with an instructional display to inform the operator what input he must make to complete the necessary message. He is shown not only what to include but, should he include any extraneous input, he will be instructed to withdraw it. If the operator inserts any input documents improperly, the Input Station rejects them.

Because each Input Station acts as its own buffer, instantaneous retransmission is accomplished in the event that errors beyond the control of the operator are introduced.

Basic transmission checking is accomplished via the Communications Controller-Multichannel and Data Gathering System Buffer. If the user requires more extensive checking, the Spectra 70 Processor is assigned this task.

Ease of Operation ◆ The DGS Input Station has been designed with a balance of utmost ease in operation and efficient setup and transmission time in mind. The Input Station “knows” what inputs are required for any given message. It “tells” the operator what the input requirements are through lighted displays. It also “tells” him when he has introduced too much information.

The variable keyboard is designed with full 1-inch pushbuttons — large enough to be accurately pressed by even the largest gloved hands. If necessary, the variable data once set up, can be used over and over again. The card and badge read mechanisms simply require insertion of documents in the correct orientation. Each mechanism grasps and positions the documents correctly for accurate reading.

The operator never has to identify the station in an input message. This is done for him automatically. And he does not have to press a transmit button. He can initiate transmission by simply satisfying all the input requirements. The last input document causes transmission to begin.

Solid State Reliability ◆ The DGS design employs integrated circuitry. Static reading of documents and variable keyboard is accomplished through electronic scanning. All contacts are sealed and cool lighting is employed. There is no need for a mechanical cooling system. The DGS equipment has been designed to operate under almost any common environmental conditions.

6312 TRANSMITTER



6311 TRANSMITTER

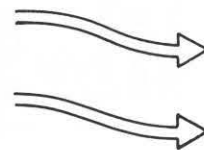
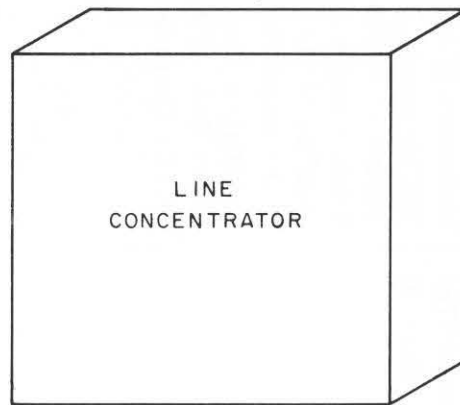
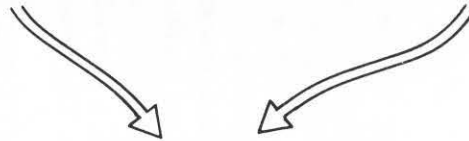

CENTRAL
PROCESSING
FACILITY

Figure 4. DGS Units

2. 70/630 DGS COMPONENTS

GENERAL

◆ The DGS permits the user to capture source or transaction data accurately, as it occurs. This data can be captured or collected where it occurs, whether a few feet from the central facility or a few thousand miles and transmitted to that facility over common voice-grade communications lines at a rate of 120 characters per second.

The components that make up the complement of required and optional DGS components are listed below.

DGS INPUT STATION

◆ The DGS Input Station provides a flexible, electronic scanner and transmitter that operates remotely from the central processing facility. Its function is to scan and transmit source or transaction data input in the form of punched plastic badges, 80-column cards, variable data through keyboard entry, and digital signals transmitted by a user-supplied digital readout device. The DGS Input Stations available are the Model 6312 Transmitter or 6311 Transmitter. (See Figure 4.)

MODEL 6312 TRANSMITTER (See Figure 5)

◆ The basic 6312 Transmitter can read and encode 124 alphanumeric characters in a single message and transmit those characters at a rate of 120 per second. Reading is bit parallel, transmission bit serial. The Input Station is equipped with a standard 10-position pushbutton Transaction Selector and a Supervisory Lock and Key. All optional input devices are attached to the basic transmitter which is table mountable. In addition to the prepunched or variable message characters the 6312 Input Station transmits a one-digit Start of Text (STX) Character, a one-digit Transaction Code (TC), a three-digit Station ID, and a one-digit End of Text (ETX) Character. The general message format is:

STX,TC,ID,n.n,ETX

where n = 118 prepunched and variable characters.

The 6312 (124 characters) and the expanded version of 188 alphanumeric characters (Feature 5608) may have any combination of input devices with only two restrictions:

1. The maximum number of characters minus the constant characters may not be exceeded in any single transmission — using the basic 6312: 118 alphanumeric characters; using the 6312 with expansion Feature 5608: 182 alphanumeric characters.
2. The transmitter can accommodate one to two badge readers or one to two card readers. However, the combination of badge readers/card readers may not exceed three (i.e., one badge, two card) with any DGS transmitter.

With these two constraints in mind, the user may specify any combination of input devices as shown in Table 1.

Figure 5. DGS Input Station — Model 6312

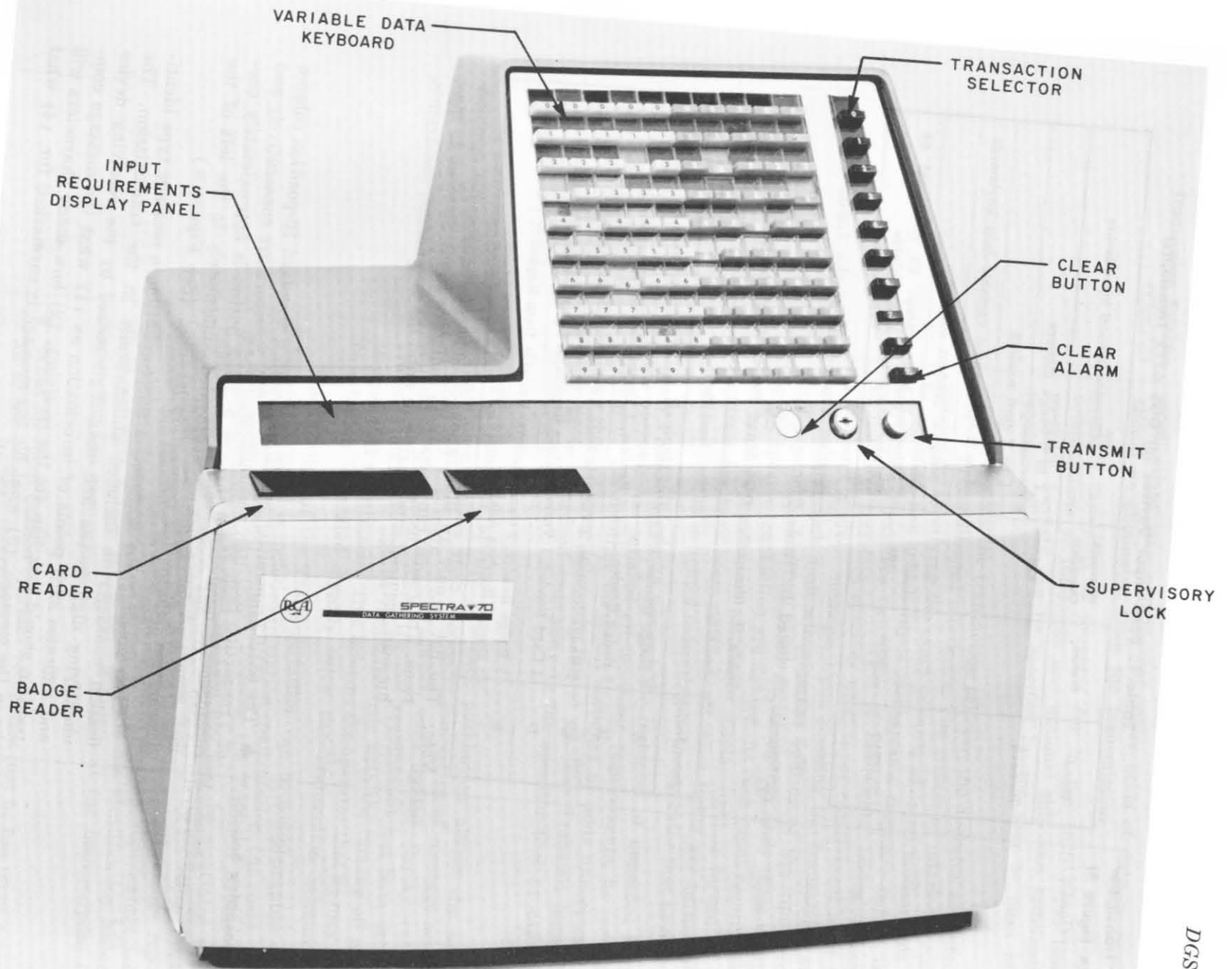

Model 6312 Transmitter
(See Figure 5)
(Cont'd)

Table 1. Basic Input Devices for DGS 6312 Transmitter

Model	Feature	Maximum Characters	Allowable Optional Input Devices
70/6312		124	1 to 2 badge readers
			1 to 2 card readers
			1 to 2 ten-position variable-data keyboards
			1 digital readout adapter
70/6312	5608	188	Same as basic except an additional 64 usable characters are available

For example, the user may require any or all of the Input Station configurations listed in Table 2.

Table 2. Illustrative DGS Input Station Configurations

Input Station	Input Units
A	1 Badge Reader, 1 Card Reader, 1 Variable Data Keyboard (10 positions)
B	1 Badge Reader, 2 Card Readers, 1 Digital Readout Adapter
C	2 Badge Readers, 2 Variable Data Keyboards (20 positions)
D	1 Card Reader, 1 Variable Data Keyboard, 1 Digital Readout Adapter
E	1 Badge Reader, 2 Card Readers, Variable Data Keyboard (20 positions), 1 Digital Readout Adapter

Note: The list is only an illustration of some of the possible combinations. The reader can proceed to configure Input Stations to meet his own requirements bearing in mind the two defined constraints.

Transaction Selector

◆ The 6312 Transmitter is equipped with a standard 10-position column of Transaction Selection pushbuttons. The Selectors are consecutively and conspicuously numbered 0 through 9. Each button is approximately one-inch square. A space has been provided immediately to the left of the Transaction Selector for transaction labeling. (See Figure 6.)

Upon pressing any transaction selector button, a message type identification character is included automatically in the transmission. The identifying digit is the first data digit sensed by the receiving device and indicates such points of information as (1) what the message composition should look like (to the receiver), (2) how many characters will be in the message, (3) what file the message is earmarked for, (4) what section of the file and so forth.

Transaction selection also indicates to the Input Station what customer specified format this message should take. Normally, the DGS scanner scans the entire 124-character positions of the message. However, many

Transaction Selector
(Cont'd)

applications may require that entire fields of data or portions of fields should be eliminated from the transmission.

This capability is provided for in the DGS Input Stations. Using combinations of interlocks and optional skip and termination features, message formats can be specified by the user to meet his particular requirements.

By pressing the transaction selector, the operator activates a combination of preconditioned interlocks. The system of interlocks controls transmission by specifying the exact quantity of input mechanisms which must be satisfied and which input mechanisms they are before transmission can begin. There are two types of interlocks: inclusive and exclusive. An inclusive interlock specifies what input requirement must be satisfied to transmit a given message. Upon pressing the transaction selector, the inclusive interlock system causes the lighting of the input requirements display panel on the face of the Input Station. Only those inputs required for the specific transaction are lighted. As each input requirement is satisfied by the operator, its associated display light is turned off. When all requirements have been satisfied, all input lights are turned off and the Transmit button is lighted indicating to the operator that he may transmit.

Exclusive interlocks prevent the inclusion of unneeded inputs. Once the operator has satisfied all the input requirements, he inserts another document (in multiple document stations) or adds unnecessary variable data; those device lights are turned on. The Transmit button remains dark or is turned off indicating to the operator that he cannot initiate transmission.*

**Start Transmission
Pushbutton**

◆ The function of the Transmit pushbutton allows the operator to initiate transmission upon successful completion of message setup. As he satisfied all the input requirements, each lighted display (of required inputs) is turned off. When the last requirement has been satisfied, the Transmit button is lighted simultaneously with the turning off of the display for that requirement. This informs the operator that he may transmit. This button is located directly below the Transaction Selector column.

The function of the Transmit button can be complemented when the trigger-trip option is included in station configuration (no cost). It causes automatic transmission without pressing the Transmit button when all input requirements have been satisfied and may be associated with any input device on the station. The trigger-trip speeds up servicing of operator queues in simple transactions. For example, in an attendance reporting application, operator queues can be serviced in a significantly reduced time frame if each operator merely inserts his identification badge. He would not have to use the Transmit button at the multipurpose Input Station for this transaction.

◆ When an Input Station operator recognizes that he has input a portion or all of his message incorrectly or the central processing unit causes an

*The Transmit button normally is dark if insufficient or excess data is entered. However, in the event that the operator has correctly stepped through a message setup until the Transmit button is lighted and then adds unneeded data, it is turned off as the display for the unneeded input is lighted.

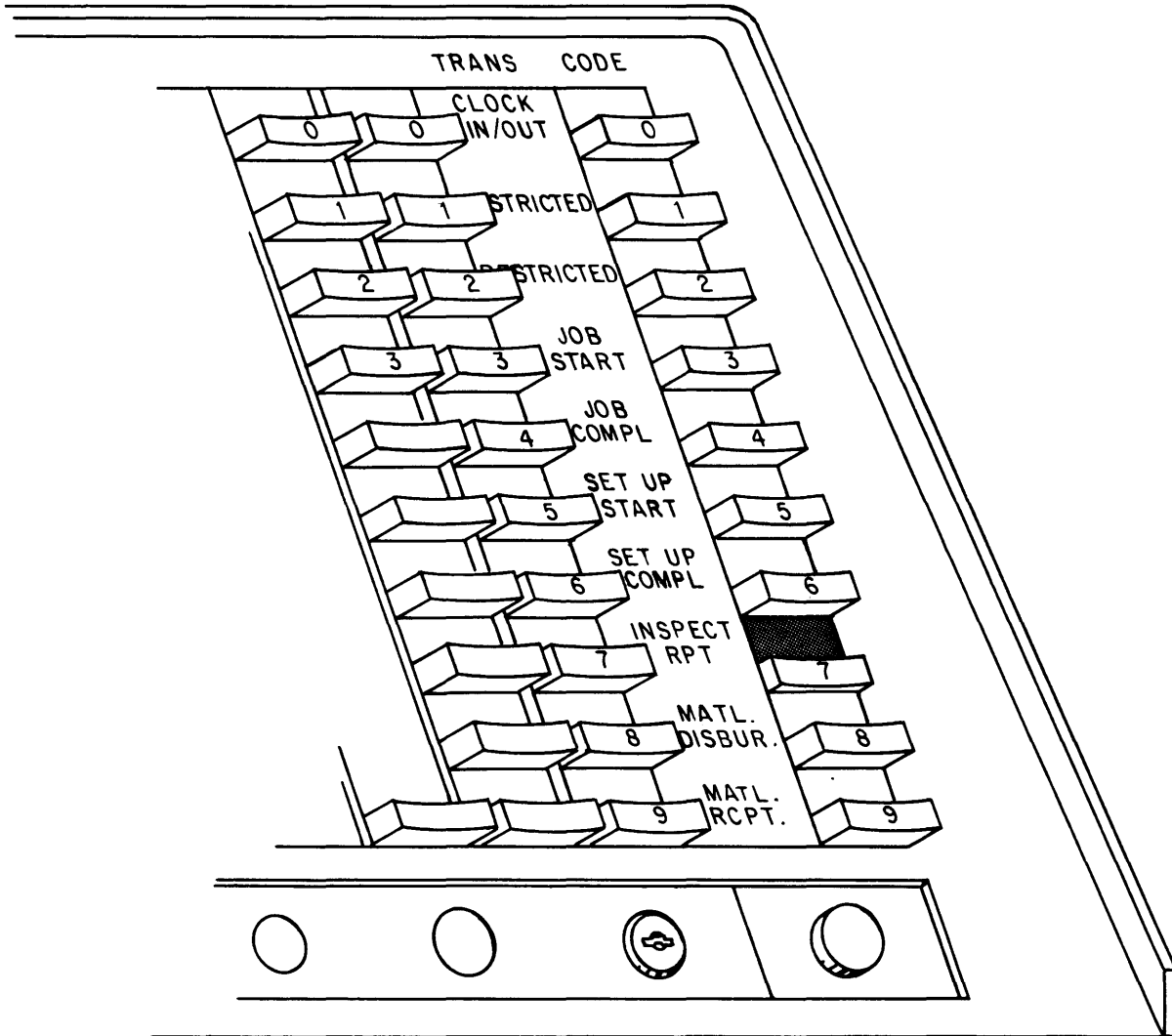

Figure 6. Transaction Selector

Clear Pushbutton
(Cont'd)

error alarm condition at the Input Station, the Clear button causes the return of all documents and all keys that were depressed. The Clear button is located directly below the Variable Data Keyboard on the input requirements display panel.

Supervisory Lock

◆ The Supervisory Lock and Key are used for restricting Input Station operation. Quite often there is a need to restrict the use of certain transactions in a commonly used Input Station. For example, if transaction number 9 were indirect labor assignment or adjustments, only authorized personnel should have the capability of operating that transaction. This can be accomplished through the use of the lock. A separate interlock preventing its use in all cases except when a key is inserted and turned is provided for with the 6312 Transmitter.

This standard feature restricts the use of any single, combination of, or all Transaction Codes at the users' discretion. It is located between the Clear and Transmit buttons on the input requirements display panel.

Alarm Display

◆ An Alarm display is located adjacent to the Clear button. Upon two successive bad messages, this display is lighted indicating to the operator that he must clear the Input Station.

Equipment On Indicator

◆ An equipment On indicator is also located on the input requirements display panel. When this indicator is lighted it indicates that power is on at the Station. It is located to the left of the Clear button in the middle of the input requirements display panel.

The approximate overall dimensions of the 6312 are: height, 22 inches; width, 26 inches; depth, 20 inches with an approximate weight of 95 pounds including a Badge Reader, Card Reader, and Variable Data Keyboard.

**MODEL 6311
TRANSMITTER
(See Figure 9)**

◆ The basic 6311 Transmitter can read, encode, and transmit up to 28 alphanumeric characters in a single message. Transmission is at a rate of 120 characters per second. The unit is wall mountable. The 6311 is capable of accommodating a punched plastic badge, or a Digital Readout Adapter, and a Station Identification Unit. The general message format is:

$$\text{STX,TC,ID,n} \dots \text{n,ETX}$$

where: n = 22 variable alphanumeric characters

Unlike the 6312, the 6311 is not equipped with a Transmit button. Transmission is automatically initiated when the plastic badge is inserted in the proper orientation. This unit has been designed primarily as a time clocking device. Model 6311 standard features are a Clear push-button which enables the operator to release his badge in the event that the error has occurred during transmission.

The approximate overall dimensions of this unit are: height, 24 inches; width, 12 inches; depth, 9 inches with an approximate weight of 40 pounds.

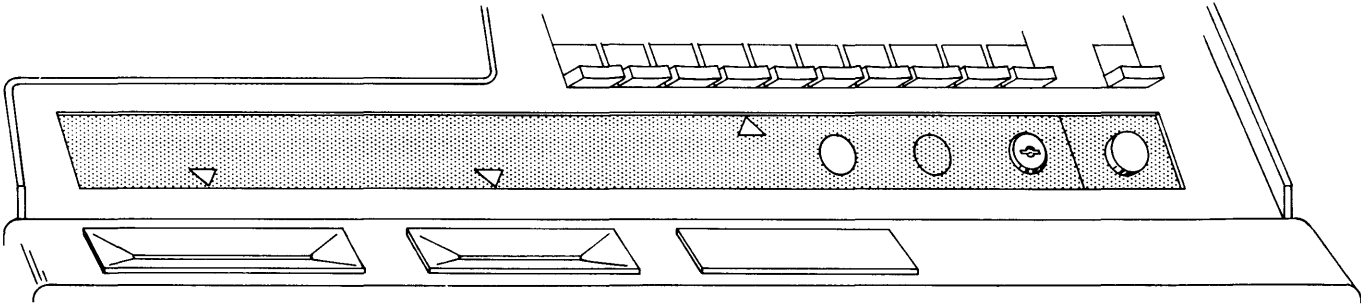

CARD BADGE AND VARIABLE REQUIRED

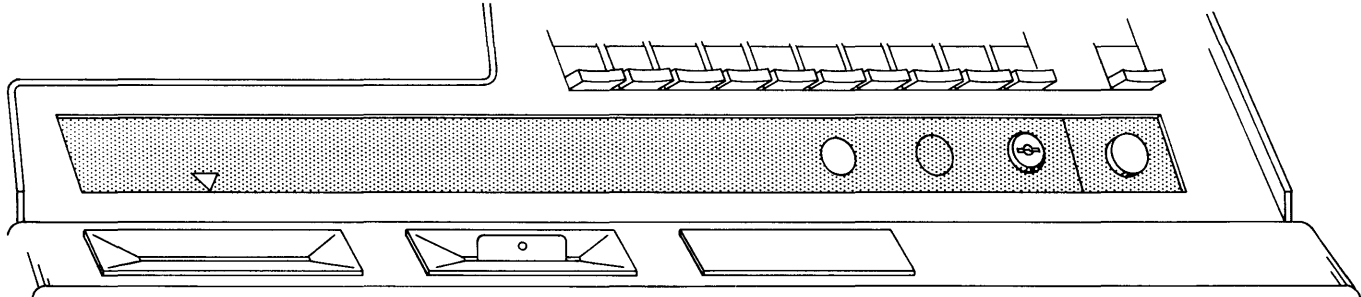

BADGE AND VARIABLE REQUIREMENTS SATISFIED

TRANSMIT BUTTON BECOMES ILLUMINATED SIMULTANEOUSLY AS LAST INPUT REQUIREMENT IS SATISFIED.

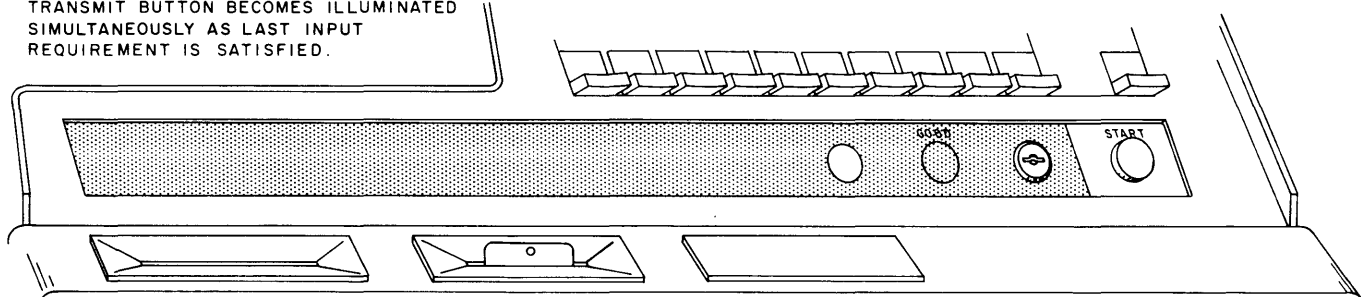

INPUT STATION IS NOW READY TO TRANSMIT.

ALL REQUIREMENTS SATISFIED

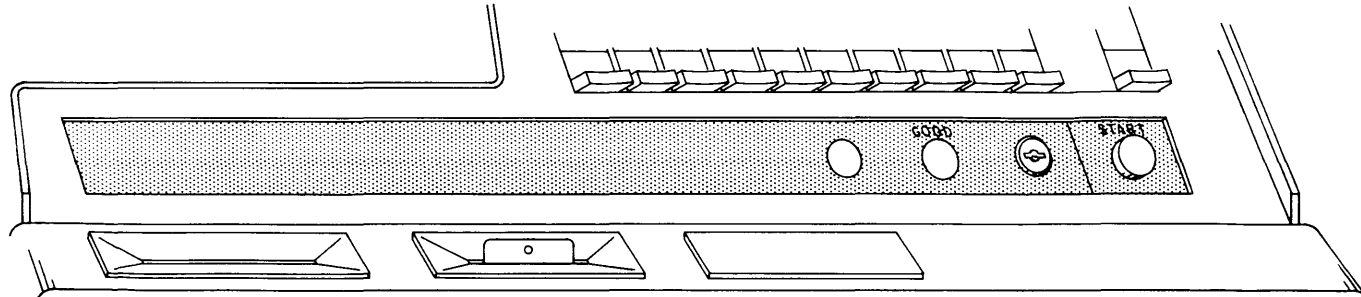

"GOOD MESSAGE" SENT

Figure 7. Input Requirements Display Panel

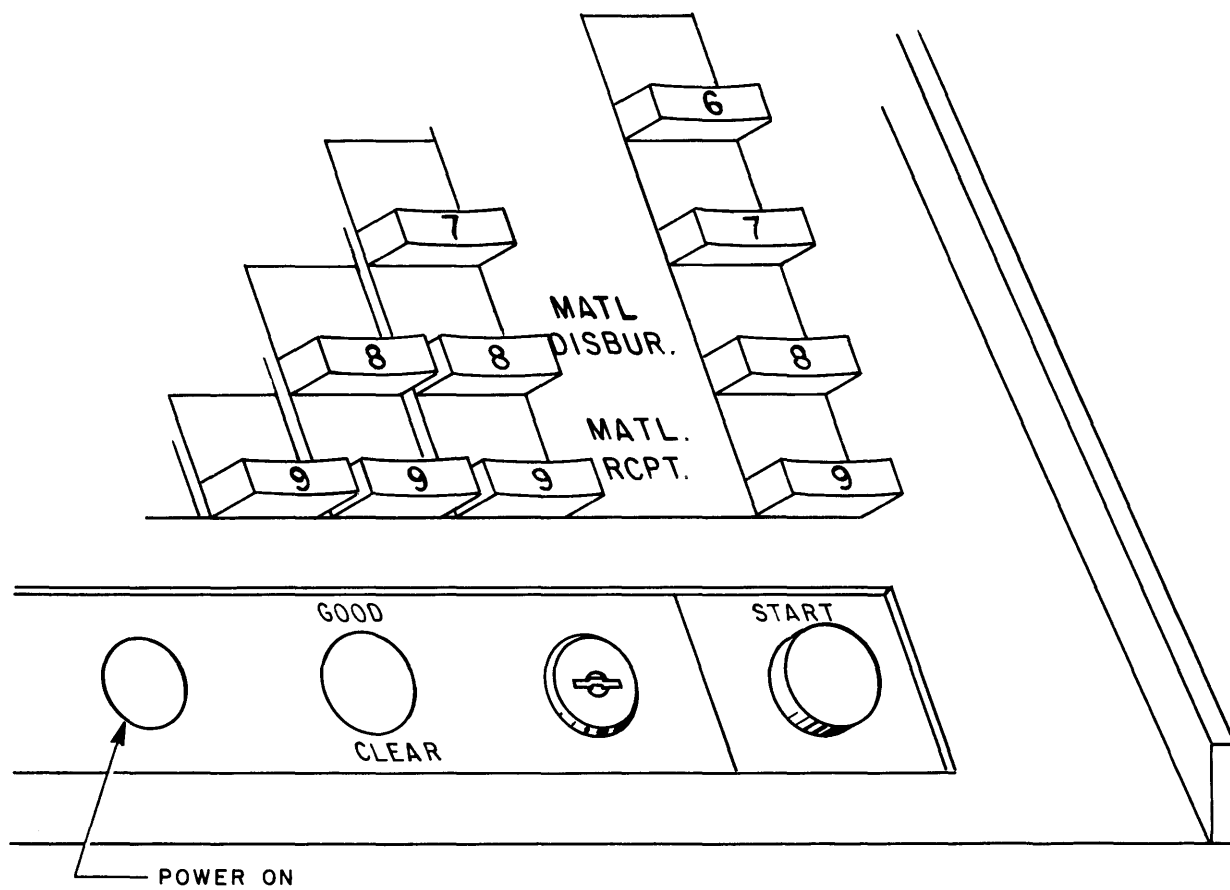

Figure 8. Clear, Supervisory Lock and Start Controls

**OPTIONAL INPUT
DEVICES****DGS Badge Reader
Model 70/6321**

◆ The DGS Badge Reader accommodates a plastic badge punched in the DGS code (see Figure 10 for DGS Badge Specifications and Table 3 for DGS Code Specifications.) The badge has been designed to function as an employee ID type document among other applications. It can be made of opaque or transparent rigid plastic and it may be laminated over printed paper inserts and/or photographs. It may also be used to identify, for example, non expendable tools, vehicles, jigs or fixtures and so forth.

The basic DGS Badge Reader can accommodate 12 alphanumeric characters. The badge is inserted into the reader face out with the locator notch down. The input mechanism then positions the badge for accurate static reading by the insertion of a pin through the badge. Should the badge be improperly inserted (i.e., backward or upside down) the mechanism will not accept it.

The Input Station/Badge Reader combination is conditioned so that it holds the badge after initial reading is complete. In this way, the Badge Reader acts as its own buffer. The Input Station waits for a message acknowledgement from the receiver. Upon receipt of a positive acknowledgement, the badge is automatically returned to the operator.

In the event that an error occurs during transmission, the Input Station receives a negative acknowledgement. Since the badge has been held in the read position, the Input Station can then retransmit automatically without a second message setup by the operator. With a successful retransmission, the Input Station receives a positive acknowledgement and the document is released. Should an error occur the second time, an alarm is displayed at the Input Station. The operator must then press the Clear button to have his badge returned.

The Badge Reader "throat" is located on the front of the Input Station directly under the input requirements display panel.

Each Badge Reader mechanism is a discrete operating unit. It can be removed and replaced or initially installed at the user site by authorized service personnel.

Optional Feature

◆ Reading capability is expandable to 18 alphanumeric characters

**DGS Card Reader
Model 70/6331**

◆ The DGS Card Reader accommodates a standard 80-column Hollerith card. The reader through a flexible formatting system can be conditioned to read the entire 80 alphanumeric columns or portions thereof.

The card is inserted into the Card Reader, column 80 down and 12 edge to the right. The card must be corner cut to trigger the positioning mechanism which ensures accurate reading. (See Figure 11.) If the operator inserts the card improperly, it is automatically rejected by the reader. Reading is done under pressure so that "dog-eared" or bent cards can be read.

The Input Station/Card Reader combination is conditioned so that it holds the card after initial reading is completed. In this way, the Card Reader acts as its own buffer. The Input Station waits for a message acknowledgement from the receiver. Upon receipt of a positive acknowledgement, the card is returned automatically to the operator.

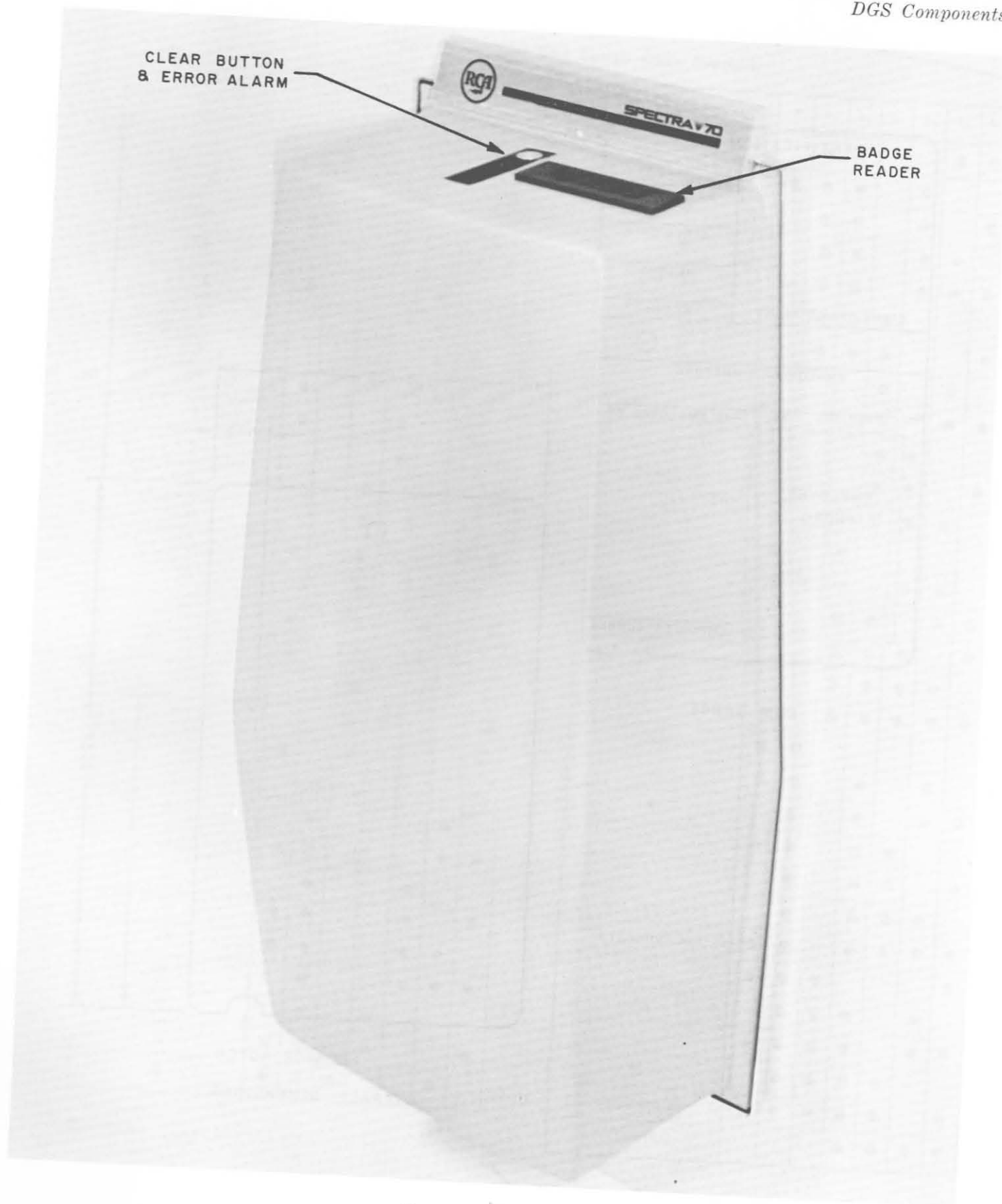
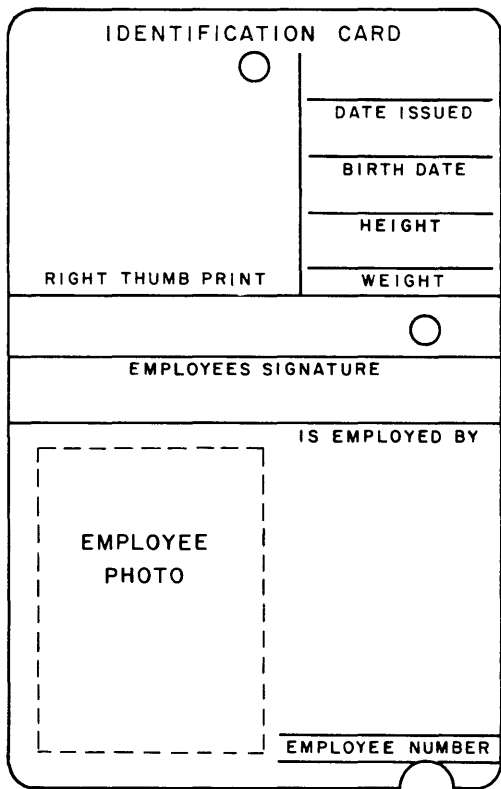
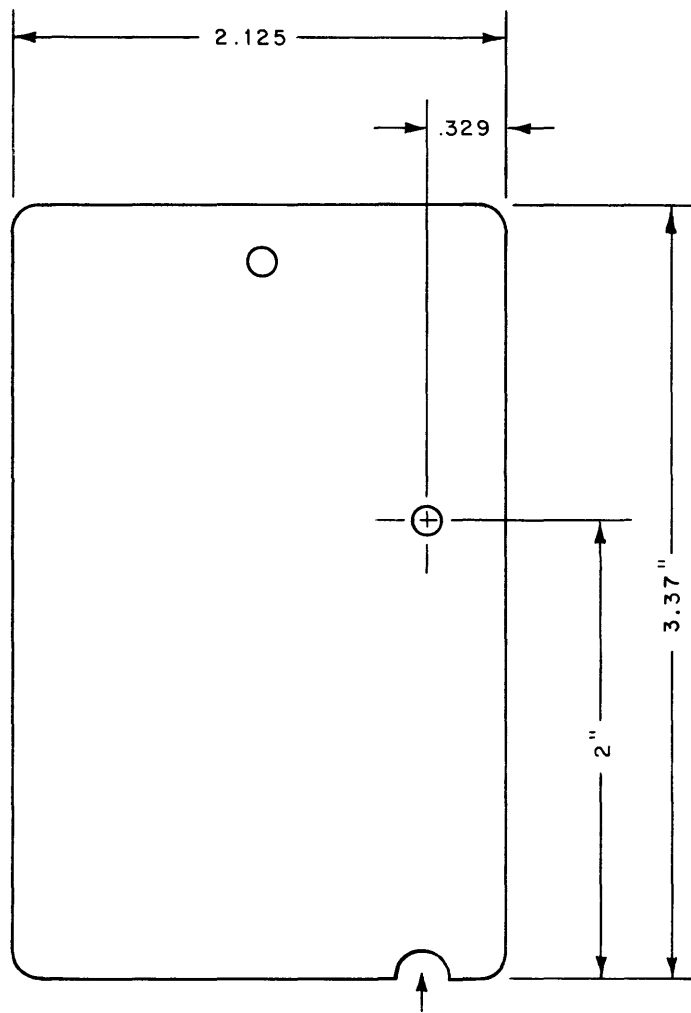

Figure 9. 6311 Transmitter



DGS BADGE



LOCATOR NOTCH
OVERALL DIMENSIONS

Figure 10. DGS Badge Specifications

Table 3. 70/630 DGS Badge Code Structure

Character	P	b ₆	b ₅	b ₄	b ₃	b ₂	b ₁
Blank							
0		●	●				
1	●						●
2	●					●	
3						●	●
4	●				●		
5					●		●
6					●	●	
7	●				●	●	●
8	●			●			
9				●			●
A			●				●
B			●			●	
C	●		●			●	●
D			●		●		
E	●		●		●		●
F	●		●		●	●	
G			●		●	●	●
H			●	●			
I	●		●	●			●
J		●					●
K		●				●	
L	●	●				●	●
M		●			●		
N	●	●			●		●
O	●	●			●	●	
P		●			●	●	●
Q		●		●			
R	●	●		●			●
S	●	●	●			●	

P = Parity.
● = Hole.

Character	P	b ₆	b ₅	b ₄	b ₃	b ₂	b ₁
T		●	●			●	●
U	●	●	●		●		
V		●	●		●		●
W		●	●		●	●	
X	●	●	●		●	●	●
Y	●	●	●	●			
Z		●	●	●			●
:				●		●	
#	●			●		●	●
@				●	●		
' (Apos.)	●			●	●		●
=	●			●	●	●	
&	●		●				
>	●	●	●	●	●	●	
•			●	●		●	●
(●	●	●		●
+			●	●	●	●	
	●		●	●	●	●	●
- (Minus)	●	●					
!	●	●		●		●	
\$		●		●		●	●
*	●	●		●	●		
)		●		●	●		●
;		●		●	●	●	
¬ (Logical Not)	●	●		●	●	●	●
/	●	●	●				●
Sp.		●	●	●		●	
,	●	●	●	●		●	●
%		●	●	●	●		
Underscore	●	●	●	●	●		●
" (Quotes)				●	●	●	●

435683 03001

ORDER NUMBER

SEQ NO.

COST CENTER

PRICE /100

SET UP PRICE

Punch indicates approval of pre price

PIECE WORKER PRICE/100

SET UP

HOURS

HOURLY FRACTION

6 NO PAY

3 DAY/BASE RATE

4 PIECE RATE

5 SPECIAL RATE

MACHINES THIS JOB

MACHINES OPERATED

QUANTITY TO PAY DATE COMPLETED

0 0 0 1 0 0 0 0 | 0 0 0 0 0 | 0 0 0 0

24 25 26 | 27 28 29 30 | 31 32 | 33 34 35 | 36 37 | 38 39

1 1 1 | 1 1 1 1 1 | 1 1 1 | 1 1 1 | 1 1 1

POINTS/100

SET UP

HOURS

CLOC NUMBER

ALTERNATE COST CENTER

2 2 2 | 2 2 2 2 2 | 2 2 2 2 2 | 2 2 2

3 3 3 | 3 3 3 3 3 | 3 3 3 3 3 | 3 3 3

DAY WORKER

HOURS

SEQUENCE NUMBER AND CAUSE CODE ARE REQUIRED ONLY WHEN A BLANK CARD IS USED FROM THE BAC OF THE PAY CARD BOOK.

4 4 4 | 4 4 4 4 4 | 4 4 4 4 4 | 4 4 4

5 5 5 | 5 5 5 5 5 | 5 5 5 5 5 | 5 5 5

SEQUENCE NUMBER

CAUSE CODE

6 6 6 | 6 6 6 6 6 | 6 6 6 6 6 | 6 6 6

7 7 7 | 7 7 7 7 7 | 7 7 7 7 7 | 7 7 7

SIZE

TOOL DESCRIPTION

OPERATION

CARD CODE

ORDER NUMBER

ITEM NUMBER

SEQUENCE NUMBER

TYPE ORDER

8 8 8 | 8 8 8 8 8 | 8 8 8 8 8 | 8 8 8 8 8

ALTERNATE PRICE/100 OR POINTS/100
ALTERNATE SET UP PRICE OR POINTS
HOURLY RATE
HOURS
M
J
M
O
COST CENTER
SERIAL NO.
DATE
CLOCK NUMBER
ALT-COST CENTER
CAUSE CODE
M
L
GANG NO.
QUANTITY

1 2 3 4 5 6 7 8 9 10 11 12 13 14 15 16 17 18 19 20 21 22 23 24 25 26 27 28 29 30 31 32 33 34 35 36 37 38 39 40 41 42 43 44 45 46 47 48 49 50 51 52 53 54 55 56 57 58 59 60 61 62 63 64 65 66 67 68 69 70 71 72 73 74 75 76 77 78 79 80

PRICE CARD NO.	INFORMATION	PRICES
BASE PRICE		
OVERALL LENGTH		
FLUTE LENGTH		
NO. OF FLUTES		
LENGTH OF CUT		
TYPE STEEL		
STOCK REMOVED		
NO. OF CUTS		
DIAM. TOL.		
LENGTH TOL.		
TIP NO.		
MISCELL.		
CHECK IF PART LOT <input type="checkbox"/>	TOTAL PRICE	

Figure 11. Punched Card Input

DGS Card Reader
Model 70/6331
(Cont'd)

In the event that an error occurs during transmission, the Input Station receives a negative acknowledgement. Since the card has been held in the read position, the Input Station can then retransmit without a second message setup by the operator. With a successful retransmission, the Input Station receives a positive acknowledgement and the document is released. Should an error occur the second time, an alarm is displayed at the Input Station. The operator must then press the Clear button to have the card returned.

The Card Reader "throat" is located on the front of the Input Station directly under the input requirement display panel.

Each Card Reader mechanism is a discrete operating unit. It can be removed and replaced or initially installed at the user site by authorized service personnel.

Variable Data
Reader (Keyboard)
Model 70/6341

◆ The DGS Variable Data Reader accepts 10 variable numeric digits as input through a 10 x 10 matrix keyboard. Each column of keys is conspicuously numbered 0 (the top most key) through 9. The keys have been designed to accommodate the largest of hands. They are approximately one inch square.

To enter variable data, such as quantities or weights, the operator keys in the proper digits in the appropriate field. As each digit is pressed, it is lighted on an otherwise dark panel. When the variable data input requirement is satisfied the respective display indicator on the input requirement display panel is turned off but the digits display remains lighted. The Input Station/Variable Data Reader combination is conditioned to hold the selected keys in the depressed (or read) position until a positive acknowledgement is returned. At this time, all keys are reset to the home position automatically.

In the event of a negative acknowledgement, since the keys are being held in the depressed position, retransmission can take place without resetting by the operator. Should a second error occur, an alarm condition is displayed at the Input Station and the operator must press the Clear pushbutton to reset the keys.

Only one key per column can be pressed. Upon recognition by the operator that he has entered an incorrect digit in any column, he can press the proper key resulting in the clearing of the erroneous one. Or the operator may reset all keys by pressing the Clear button.

The Variable Data Recorder keyboard is conspicuously located on top and right hand side of the Input Station. It is slightly inclined away from the operator to coincide with natural arm movement.

The Variable Data Reader and keyboard is a discrete operating unit. It can be removed and replaced or initially installed at the user site by authorized service personnel.

Options and Features

◆ Expansion to 20 variable numeric digits and inhibit of automatic reset (no cost) such that the same variable numeric data can be automatically repeated through successive message transmissions.

Input Station Identifier

◆ In most applications it is desirable to identify both the Input Station and its physical location, the DGS transmitters (both models) accommodate an optional three-digit Station Identification Unit. This is a pre-wired device which emits a constant three-digit station ID. It is pluggable so that in the event an Input Station is removed, it can be unplugged from that station and connected to the replacing unit. This allows a constant identification of the physical location of any particular station.

**Digital Readout Adapter
Feature 5609**

◆ As a special optional feature, both Input Station Transmitters can be conditioned to accept and transmit up to five digits (i.e., count up to 99,999) of variable information generated and transmitted by a customer supplied digital readout unit.

The digital readout unit indicates a *Ready to Send Data* condition to the digital readout adapter. The latter unit is then ready to accept data signals. A Start switch on the input station is then pressed causing the Digital Readout Adapter to read each of the five data count positions. The data is then encoded and transmitted by the DGS transmitter.

The digital readout unit is connected to the Adapter by a 10-foot cable which is supplied with the unit.

**DGS Buffer Model
70/725**

◆ The DGS Buffer allows connection of one DGS Line Concentrator to the Spectra 70/668 Communications Controller-Multichannel (CCM). It accommodates simultaneous synchronous message transmission from two Input Stations at a rate of 960 bits per second each. The buffer is in actuality, two independent sub buffers, each occupying one scan position of the CCM. Twelve DGS Buffers can be accommodated in a Type I CCM rack (maximum number restriction is a factor of CCM timing rather than physical CCM capacity). Each buffer occupies two CCM line positions. Connection between the DGS Buffer and the DGS Line Concentrator is made with twisted two-wire, metallic voice grade circuits.

Generally, exchange of control signals and data the CCM, DGS Buffer, and DGS Line Concentrator is as follows:

The CCM issues a Receive command to the DGS Buffer. Then, upon sensing a *Request to Transmit* signal via a Line Concentrator Trunk, the buffer generates and returns a *Permission to Transmit* to the Input Station. Message transmission from the Input Station then begins.

During the transfer of data bits, the buffer is conditioned to detect any interruption in the bit stream. If this condition is detected, an error condition is stored by the buffer which is then transmitted to the CCM after message transmission is complete.

After successful completion of message transmission, the buffer holds the line position for the currently transmitting Input Station and awaits a positive or negative acknowledgement from the CCM. Upon receipt of a positive acknowledgement, the Buffer transmits Acknowledge (ACK) to the Input Station and awaits transmission from the next Input Station.

If a negative acknowledgement is received by the buffer from the CCM, it transmits a Not Acknowledge (NAK) to the Input Station and waits for automatic retransmission of the message. Receipt of a

**DGS Buffer Model
70/725
(Cont'd)**

good message results in the ACK to be transmitted. A second bad message results in a second NAK and causes an error alarm to appear at the Input Station.

Malfunction reports are generated by the Buffer to the CCM as follows:

1. When a Receive command and Permission to Transmit are sensed by the buffer but transmission does not begin within 1000 ms.
2. When 1000 ms have elapsed since ACK was generated and Request to Transmit has not been removed from the line.
3. When 1000 ms have elapsed since the second NAK to the same Input Station and Request to Transmit has not been removed from the line.

An Error Message is issued, as previously stated, upon completion of transmission when the Buffer detects an interruption of the message bit transmission.

**DGS LINE
CONCENTRATOR
MODELS 70/6381
AND 70/6382**

Function

◆ The DGS Line Concentrator is an all electronic switching unit which may be thought of as the focal point of a DGS subsystem. It has been designed to assure both 1) greater data gathering systems growth potential and, 2) efficient utilization of computer communications controller scan positions. These functions are accomplished by connecting from 1 to 16 Input Stations (Model 6381) or from 1 to 32 Input Stations (Model 6382) to each Line Concentrator. Both models are equipped with two output trunks which terminate in one dual DGS Buffer.

As many as 12 DGS Line Concentrators can be associated with one Communications Controller Model 70/668-31. It is, therefore, possible to have as many as 384 DGS Input Stations associated with one CCM since up to 32 Input Stations can be connected to one Line Concentrator (32 Input Stations x 12 Line Concentrators = 384 Input Stations). Without the Line Concentrator, one CCM is capable of accommodating the traffic of only 24 DGS Input Stations.

Each Line Concentrator output trunk is independent of the other and each has a transfer rate of 120 characters per second. This results in a transfer rate of 240 characters per second and the simultaneous servicing of two Input Stations in any DGS subsystem.

Operation

◆ Upon recognition of a Request to Transmit signal from any DGS Input Station, the Line Concentrator searches to find an available output trunk and completes a connection between that trunk and the Input Station awaiting service. It then sends the Request to Transmit to the DGS buffer. When the buffer is ready to accept data, it responds with a Permission to Transmit signal which is automatically transferred to the Input Station. The Input Station completes its message and awaits a positive or negative acknowledgement which is routed through the Line Concentrator.

Operation
(Cont'd)

After receipt of a positive acknowledgement or two successive bad messages and a negative acknowledgement, the Line Concentrator drops this Input Station connection and proceeds to service the next Input Station in line. The transaction is completed within a maximum of 10 seconds, however, normally much less time is required.

The Line Concentrator is connected to its receiving buffer via two sets of twisted pair metallic voice grade lines (1 pair per trunk) conforming to the AT&T Schedule 4 Type 4A line specification or its equivalent. It may be located up to 15 wire miles from the receiving DGS buffer.

Physical Characteristics

◆ The DGS Line Concentrators consist of a single wall mountable cabinet which contains solid state control logic, power supply, control panel, and a line termination panel. An illuminated white Power On indicator and a circuit breaker are located on the front of the cabinet. The two models have the following dimensions and weight:

Model	Height (inches)	Width (inches)	Depth (inches)	Weight (lbs.)
6381	23	22	9	55
6382	23	22	9	60

Both models operate within a temperature range of 30°F and 110°F and a relative humidity range of 5% to 95%.

**DATA GATHERING
SWITCH UNIT MODEL
70/327-2**

◆ This unit is designed to facilitate switching of communication lines between alternate buffers. It operates with the Spectra 70/350 Switch Controller and the Spectra 70/356 Communications Switch Adapter.

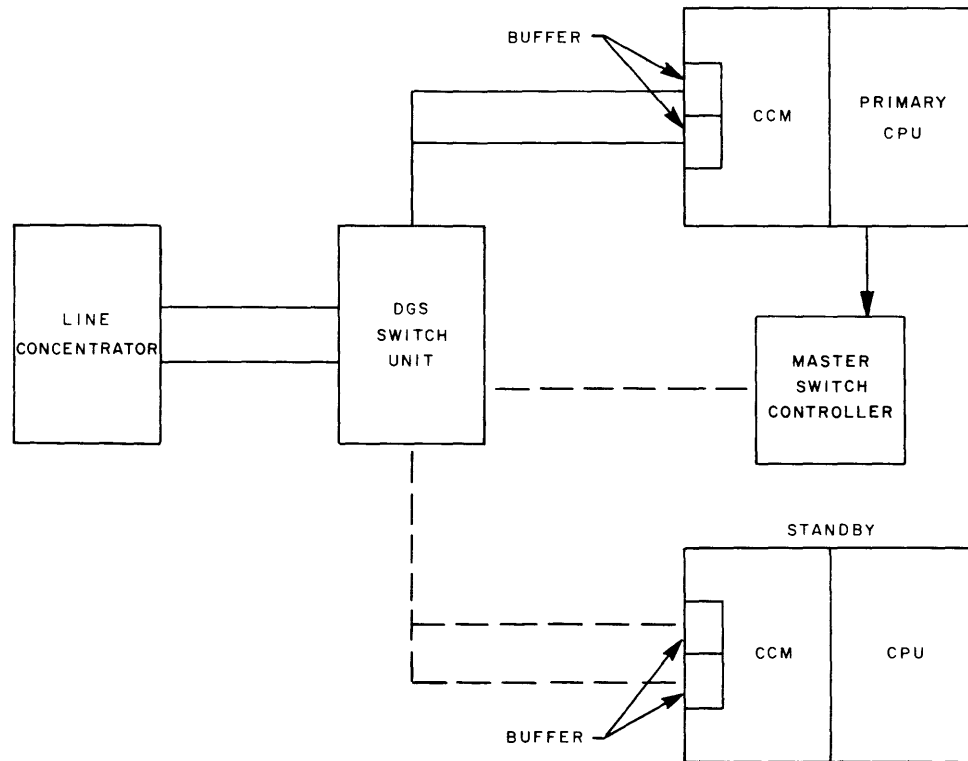

Figure 12. DGS Switch Unit for Backup

**DATA GATHERING
SWITCH UNIT MODEL
70/327-2
(Cont'd)**

One DGS Switch Unit is capable of accommodating 12 two-wire circuits (6 Line Concentrators). By ganging (or combining multiple switches in a cascading arrangement) the entire data gathering installation can be switched to the stand-by central processing unit (CPU). Switching can be done either manually, or under direct CPU control.

**70/780 TIME
GENERATOR BUFFER**

◆ In most DGS applications it is necessary to associate time of day. This is accomplished by the addition of the Spectra 70/780 Time Generator Buffer in the CCM.

This unit occupies one scan position on the CCM. It consists of an electronic clock which generates time of day (24-hour clock), a buffer which transfers records of time to the CCM, and a control panel.

The Time Generator Buffer measures time of day to the hundredths of minutes. It can be synchronized and run in direct conjunction with the user's master time system.

**DGS SIGNAL
CONVERTER
MODEL 70/6385**

Function

◆ Under long line operation — in excess of 30 wire miles, a DGS Signal Converter is required between the Line Concentrator and receivers at the central processing facility as are AT&T 202D Data Sets. The DGS 70/725 Buffer must also be replaced by two Model 70/720-22 Asynchronous Data Set (ADS) Buffers.

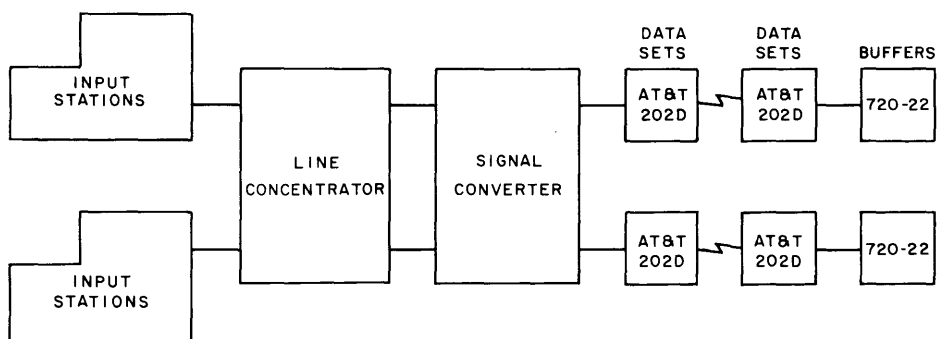

Figure 13. "Long Line" DGS Layout

Operation

◆ The Signal Converter receives the message, demodulates it, and reframes each character into a 10-bit structure by the addition of an additional start bit and one stop bit for asynchronous transmission. The character structure is ST, ST, $b_1 \dots b_n$, P, STP. Parity sense is even. Upon transmission of the last character of this message (the end of text), the Signal Converter generates and transmits a Block Check character. It then awaits a positive or negative acknowledgement signal which it converts into the tone intelligible to the input station.

Physical Characteristics

◆ The DGS Signal Converter consists of a wall mountable cabinet containing solid state controls logic, power supply, control panel, and a line termination panel. An illuminated white Power On indicator and circuit breaker are located on the front of the cabinet. The unit has the following dimensions and weight:

Model	Height (inches)	Width (inches)	Depth (inches)	Weight (lbs.)
70/6385	20	12	12	25

The Signal Converter operates within a temperature range of 30°F and 110°F, and relative humidity range of 5% to 95%.

3. DGS APPLICATIONS

ATTENDANCE REPORTING

◆ The DGS input station with badge reader can be directly substituted for the time clock and all necessary functions regarding summarization of time data can be done by the Spectra 70 Processor.

MATERIALS OR PARTS RECEIVING

◆ A prepunched card is prepared for every purchase order item and filed in receiving until material receipt. The card along with the quantity received is entered via an Input Station. The card may then be used as a route ticket, and may also be used in conjunction with a prepunched shipper identification to record C.O.D. charges.

PURCHASED MATERIALS INSPECTION

◆ A prepunched card is prepared for every purchase order item that is to be inspected, and filed at the inspection area. The items arriving for inspection cause the proper card to be pulled. The inspection card together with standard rejection and disposition cards and the quantity involved are entered via the DGS.

STORE RECEIPTS

◆ A route ticket attached at receiving or at a work station is used to record the receipt of material to stores via the DGS. The quantity received in stores can also act as a check on the quantity sent to stores. Where applicable, the storage location of the item can also be entered.

STORES ISSUES

◆ Demand issues from stores occur when a worker presents a prepunched card identifying the job, cost center and quantity required, and the item identification (and possible location). The card and the issuer's badge serve as the fixed input together with the actual quantity issued. Pre-planned issues are handled the same way except that cards are issued directly to the stores, possibly grouped by departments for ease in delivery. All issue cards are stamped to prevent reuse. Cost distribution can be done by the Spectra 70 Processor.

TOOL CONTROL

◆ Tool control consists of the control and issue of expendable tools and the maintenance and control of non-expendable tools, jigs, and fixtures. Expendable tools are issued using the employee badge and a prepunched card or badge identifying the item from the tool room file together with the quantity issued. Non-expendable tools are requisitioned exactly like stores issues except that the requesting document could be used to record its return. Tool inventory control and maintenance can be computer scheduled.

JOB LOT INSPECTION

◆ Job lot inspection is characterized by the receipt at an inspection point of a discrete group of items. It is very similar to purchased materials inspection and can be handled in a similar manner.

PRODUCTION LINE

◆ This type of inspection is characterized by a repetitive operation that is performed on each item as it moves past a fixed point. Either every item is inspected or a periodic sample measurement is taken. Both types involve the use of statistical rules to ascertain when production readjustment should occur. The direct digital readout capability can be used to provide direct input into the computer.

**PRODUCTION LINE
OR MACHINE
COUNTING AND
STATUS**

◆ Many manufacturing operations are characterized by relatively long runs resulting in produced quantities that are far in excess of practical counting. Moreover, the output of some of these machines is critical to the overall production of other machines which may be performing successive operations with little float stock. The use of the direct digital readout can effectively maintain automatic production counting and report any change in machine status for quick pin pointing of potential production stoppages.

**JOB LOT
PRODUCTION STATUS**

◆ As individual jobs proceed through successive production operations, they can be reported in and out of machine or operation centers through the use of prepunched operation cards via the DGS system. This data can be used to monitor accurately the progress of each job, prepare work center priority lists, and provide detailed data for scheduling purposes.

**LABOR DISTRIBUTION
AND WORK
MEASUREMENT**

◆ As a by-product of reporting the start and completion of each job it has processed, the DGS system automatically supplies time information for use in applying actual costs generated on each job. If operation standards are available, actual performance can be compared to these standards to provide a variety of efficiency reports.

**CALCULATION OF
GROSS PAY**

◆ In those companies where gross pay is calculated by individual and/or group incentive based on units produced, the DGS system allows economic collection of the necessary source detail data for calculation.

APPENDIX A
70/630 DATA
GATHERING
SYSTEM
OPERATING
SUMMARY

TRANSMISSION

- ◆ *Line* — 2-wire, voice grade.
Type — synchronous, bit serial.
Data Rate — 120 characters per second.
Character Size — 8 bits.
Distance — indefinite with data sets.
Input Station Capacity — up to 188 alphanumeric character per transmission.

INPUT MEDIA

- ◆ *1 or 2 Punched Plastic Badges* — up to 18 alphanumeric (credit card size).
1 or 2 Punched Cards — up to 80 columns/Hollerith card.
Keyboard — numeric 10 or 20 digits.
Digital Readout Adapter — up to 5 digits.
Reading Method — static electronic scanning.
Pluggable 3-digit Station Identifier.

DISPLAY

- ◆ 10 standard transaction selections.
Lighted step-by-step input requirements display.
Lighted Keyboard display for operator verification.
1 Automatic retransmission (in event of transmission errors).

DIMENSIONS

- ◆ *Badge only (attendance Input Station)* — Height: 28 inches, Width: 12 inches, Depth: 7 inches, Weight: approximately 45 lbs.
Combined Input Station — Height: 22 inches, Width: 25 inches, Depth: 20 inches, Weight: approximately 95 lbs.