

Adaptive Active Noise Control for Headphones Using the TMS320C30 DSP

*Application
Report*



Adaptive Active Noise Control for Headphones Using the TMS320C30 DSP

Angela Kuo Wang and Benedict Tse

Advising Professor: Wei Ren

***University of California at Berkeley
Department of Electrical Engineering and Computer Sciences
Berkeley, California 94720***

This application report consists of one of the entries in a design contest, The 1995 TI DSP Solutions Challenge. The report was designed, prepared, and tested by university students who are not employees of, or otherwise associated with, Texas Instruments. The user is solely responsible for verifying this application prior to implementation or use in products or systems.

***SPRA160
January 1997***

IMPORTANT NOTICE

Copyright ©1997, Texas Instruments Incorporated

Contents

ABSTRACT.....	1
INTRODUCTION.....	2
OUTLINE.....	2
COMMERCIALLY AVAILABLE ANC HEADPHONES.....	3
THEORY AND STRUCTURES FOR ACTIVE NOISE CONTROL.....	3
THE FILTERED-X LMS ALGORITHM.....	6
TMS320C30 IMPLEMENTATION OF AN ADAPTIVE ACTIVE NOISE CONTROL SYSTEM FOR HEADPHONES.....	9
System Components.....	9
System Identification Algorithm.....	10
Control Algorithm.....	11
Implementation of an Adaptive ANC System for Headphones.....	11
RESULTS.....	11
SUMMARY AND CONCLUSION.....	16
REFERENCES.....	17
ACKNOWLEDGMENTS.....	18

List of Illustrations

FIGURE 1. ACTIVE ACOUSTIC NOISE CONTROL FEEDFORWARD SCHEME	4
FIGURE 2. ADAPTIVE FEEDFORWARD CONTROL STRUCTURE	5
FIGURE 3. ADAPTIVE FEEDBACK CONTROL STRUCTURE	6
FIGURE 4. SYSTEM DIAGRAM OF THE FILTERED-X LMS ALGORITHM (FEEDBACK CONFIGURATION).....	9
FIGURE 5. COMPONENTS IN THE PLANT $P(q^{-1})$	10
FIGURE 6. NARROW-BAND NOISE: COMPARISON OF REDUCTION (dB VS. FREQUENCY IN HZ)	12
FIGURE 7. NARROW-BAND NOISE: A 400-HZ SINUSOID <i>WITHOUT</i> ADAPTIVE ACTIVE NOISE CONTROL ...	13
FIGURE 8. NARROW-BAND NOISE: A 400-HZ SINUSOID <i>WITH</i> ADAPTIVE ACTIVE NOISE CONTROL	14
FIGURE 9. WIDE-BAND NOISE: ADAPTIVE ANC PERFORMANCE	15
FIGURE 10. WIDE-BAND NOISE: COMMERCIAL HEADPHONES PERFORMANCE.....	16

ABSTRACT

Commercially available active noise control headphones rely on fixed analog controllers to drive "anti-noise" loudspeakers. Our design uses an adaptive controller to optimally cancel unwanted acoustic noise. This headphone would be particularly useful for workers who operate or work near heavy machinery and engines because the noise is selectively eliminated. Desired sounds, such as speech and warning signals, are left to be heard clearly.

The adaptive control algorithm is implemented on a Texas Instruments (TITM)¹ TMS320C30GEL digital signal processor (DSP), which drives a Sony CD550 headphone/microphone system. Our experiments indicate that adaptive noise control results in a dramatic improvement in performance over fixed noise control. This improvement is due to the availability of high-performance programmable DSPs and the self-optimizing and tracking capabilities of the adaptive controller in response to the surrounding noise.

¹ TI is a trademark of Texas Instruments Incorporated.

INTRODUCTION

This work addresses the problem of acoustic noise. Since prolonged exposure to excessive levels of acoustic noise can cause permanent hearing loss, safety problems, and lower worker productivity, reduction of noise is an important goal. Machinery and engines are a major source of noise, and much of this noise occurs in the low frequency range. Passive methods used to reduce noise, such as earmuffs, are not especially effective at low frequencies due to the relatively long wavelength of the sound [1]. However, active noise control (ANC) has proven to be effective at these low frequencies [2]. The underlying principle of ANC is to generate a secondary sound wave to destructively interfere with the unwanted noise, thereby reducing the net sound pressure.

Active noise control technology can be used in a wide variety of situations, including car or airplane headrests, automobile exhaust mufflers, and refrigerator fans. Headphones that employ ANC would be particularly useful for airport ramp workers, ambulance drivers, and many others who operate on or near heavy machinery. Aside from low-frequency noise control, another benefit is that the offending noise, in some cases, can be selectively eliminated, leaving desired sounds such as speech and warning signals to be heard clearly.

For the ANC technique, there are two approaches to designing the controller that drives the "anti-noise" loudspeakers: fixed and adaptive. Fixed (analog) controllers, which are easier to implement, are used in commercial ANC headphones. This paper describes the implementation of adaptive control. The self-optimizing and tracking capabilities of the adaptive controller in response to the surrounding noise suggest that improved performance over fixed controllers is achievable. Furthermore, the availability of high-performance programmable DSPs makes the implementation of computationally-intensive adaptive algorithms feasible.

OUTLINE

This paper includes:

- A brief overview of ANC headphones available on the market
- An explanation of ANC theory and structures
- One family of adaptive algorithms used for ANC: the filtered-X least-mean-square algorithm (FXLMS)

- A description of the C-language implementation of the FXLMS algorithm, including the associated system identification
- A complete TI TMS320C30 implementation of an adaptive ANC system for headphones
- A performance comparison between the 'C30-based adaptive ANC system and a commercially available ANC system for headphones

COMMERCIALLY AVAILABLE ANC HEADPHONES

There are currently three companies that sell ANC headphones: ANVT and NCT Inc., which are active noise control technology companies, and Koss Corporation, a headphone manufacturer. The ANC headphones produced by these companies use fixed analog controllers and claim to achieve a reduction of about 18 dB within the 30 Hz to 1400 Hz frequency bandwidth. However, testing of one pair of headphones shows that an average of 8–10 dB reduction is achieved for both narrow-band and wide-band noise. Because of the limitations of the fixed controller, the commercial headphones are not able to maximize the noise reduction and maintain stability for various types of noises.

THEORY AND STRUCTURES FOR ACTIVE NOISE CONTROL

Active noise control uses the principle of superposition: two sound waves combine additively. Therefore, if one can deliberately generate a sound wave to oppose the pressure fluctuations of an unwanted sound wave, then the net result is lowered sound pressure fluctuation.

As an example of an active noise control problem, consider the situation of a helicopter pilot. A headphone set mounted with actively controlled speakers, which selectively cancel the engine-induced noise, would be quite desirable. The environment would be made safer since the selectivity property means that speech and warning sounds would still be heard clearly. Moreover, such a device could be much less expensive to build than a cockpit that uses passive means to reduce noise [10].

The simplified representation of such a feedforward active noise control system is given in Figure 1, where all the signals shown are sampled signals, and q^{-1} is the unit delay operator. The goal of adapting the feedforward controller, $C(q^{-1}, k)$, is to cancel the noise at location (c), the pilot's ears. This noise originates from a source, the engine, located at point (a). A detection microphone is placed at location (a), and the signal that is picked up is

filtered through $C(q^{-1}, k)$ and fed to a loudspeaker mounted in the headphone set. The loudspeaker then emits an "anti-noise" (also referred to as secondary noise) to cancel the primary noise at location (c). The uncanceled noise is picked up by an error microphone, which is also mounted in the headphone set, and that error signal, $e(k)$, is used to tune the filter driving the loudspeaker.

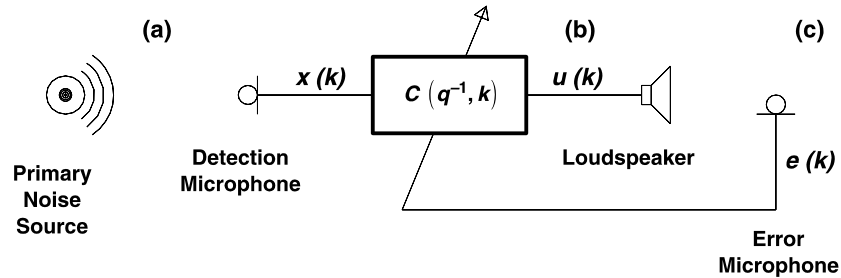

Figure 1. Active Acoustic Noise Control Feedforward Scheme [6]

The active noise control problem just described is illustrated in Figure 2 in block diagram form. The acoustical propagation dynamics are represented by $G(q^{-1})$. The loudspeaker/microphone system, referred to as the plant, is represented by $P(q^{-1})$. The signal $v(k)$ represents the noise that is unrelated to the primary noise signal $x(k)$. The goal is to find a control input to the plant, $u(k)$, so that the output of the plant matches that of the system $G(q^{-1})$, modulo a phase shift of 180° . This is done by adapting the controller parameters. The summing junction represents the superposition of the two acoustical waveforms: only the signals from the error microphone [$e(k)$] and the detection microphone [$x(k)$] are available for use in adaptation.

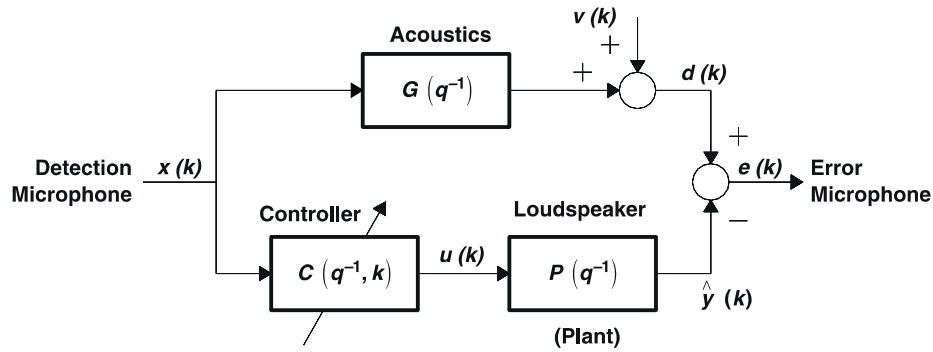

Figure 2. Adaptive Feedforward Control Structure [6]

The control of the plant $[P(q^{-1})]$ and the three-dimensional *acoustical* superposition make the problem of active noise control much more difficult than the related problems of line echo cancellation (LEC) and acoustic echo cancellation (AEC) [3]. In the LEC and AEC problems, the cancellation is done electrically and small delays are tolerable. However, for the active noise control problem, even small delays have a serious degrading effect on the performance of the system.

When the detection microphone signal is not available, as in the case with portable ANC headphones, the feedback structure developed by Morari [11] can be used. An estimate of the primary noise, $d(k)$, is obtained by introducing a mathematical model of the plant into the algorithm as shown in Figure 3. Note that if the model perfectly predicts the output of the plant, then the estimated noise, $\hat{d}(k)$, exactly matches the actual noise.

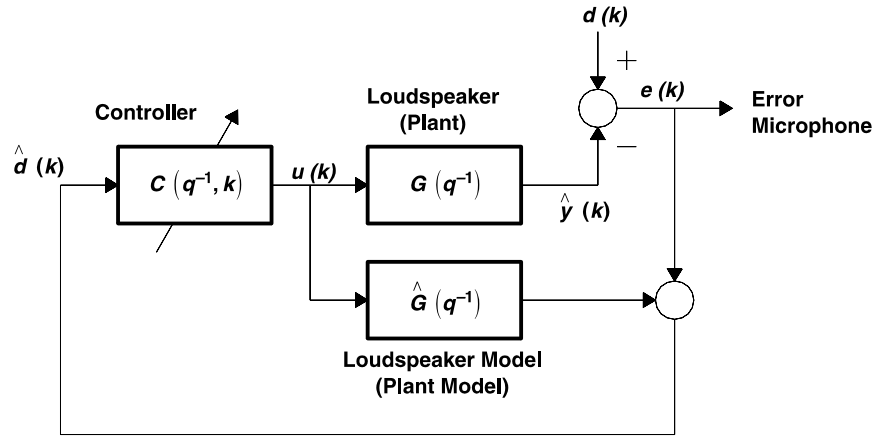

Figure 3. Adaptive Feedback Control Structure [11], [9]

THE FILTERED-X LMS ALGORITHM

The filtered-X LMS algorithm developed by Widrow [8] seeks the controller coefficients (weight vector) of $C(q^{-1}, k)$, which minimize the mean-squared error, $\xi = E[e^2(k)]$. The mean-squared error is the average power of the error microphone signal. To accomplish this task, a gradient method is used. In the feedforward configuration, the component of $e(k)$ that is correlated with $x(k)$ is removed, leaving only $v(k)$. It is this feature that allows the selectivity property in an ANC system.

The controller weight vector, $\theta_C(k) = [c_0(k), c_1(k), \dots, c_{n_C}(k)]^T$ is adjusted in the direction of the gradient

$$\nabla = \frac{\partial}{\partial \theta_C} E[e^2(k)] . \quad (1)$$

Because the exact gradient is unavailable, an estimate must be used. In the LMS algorithm, the instantaneous value of the error squared, $e^2(k)$, is used

as an estimate of the mean squared error, $\xi = E[e^2(k)]$. So, with this simple estimate of the gradient

$$\hat{\nabla} = \frac{\partial}{\partial \theta_C} e^2(k), \quad (2)$$

the adaptive algorithm becomes

$$\hat{\theta}_c(k) = \hat{\theta}_c(k-1) + \frac{\mu}{2} \cdot \hat{\nabla}(k), \quad (3)$$

where μ is the adaptation stepsize, which regulates the speed and stability of adaptation. To find an expression for $\nabla(k)$, note that

$$\hat{\nabla}(k) = \frac{\partial}{\partial \theta_C} e^2(k) = 2e(k) \frac{\partial}{\partial \theta_C} e(k)$$

and, with the parameters of the controller held constant,

$$\begin{aligned} e(k) &= d(k) - P(q^{-1})C(q^{-1}, k)x(k) \\ &= d(k) - P(q^{-1})[c_0x(k) + c_1x(k-1) + \dots + c_{n_c}x(k-n_c)] . \end{aligned}$$

Hence,

$$\frac{\partial}{\partial \theta_C} e(k) = \begin{bmatrix} \frac{\partial}{\partial \hat{\alpha}_0} e(k) \\ \frac{\partial}{\partial \hat{\alpha}_1} e(k) \\ \vdots \\ \frac{\partial}{\partial \hat{\alpha}_{n_c}} e(k) \end{bmatrix} = - \begin{bmatrix} P(q^{-1})x(k) \\ P(q^{-1})x(k-1) \\ \vdots \\ P(q^{-1})x(k-nc) \end{bmatrix} \equiv -x_{\sim_P}(k)$$

The gradient algorithm is then given as

$$\hat{\theta}_C(k) = \hat{\theta}_C(k-1) - \mu x_{\sim_P} \cdot e(k) .$$

But since the signals in the vector $x_{\sim_P}(k)$ are not directly available, the algorithm uses an estimate of the plant model so that $\hat{P}(q^{-1})x(k)$ is used instead of $P(q^{-1})x(k)$. Therefore, a filtered version of $x(k)$ is used to update the controller-weight vector—hence, the name *filtered-X LMS*. This feature is clearly illustrated in Figure 4. The complete algorithm is given as:

$$\begin{aligned} \hat{\theta}_C(k) &= \hat{\theta}_C(k-1) - \mu x_{\sim_{\hat{P}}} \cdot e(k) \\ x_{\sim_{\hat{P}}}(k) &= [x_{\hat{P}}(k), x_{\hat{P}}(k-1), \dots, x_{\hat{P}}(k-n_C)]^T \\ x(k) &= [x(k), x(k-1), \dots, x(k-n_P)]^T \\ \hat{\theta}_C(k) &= [c_0(k), c_1(k), \dots, c_{n_C}(k)]^T \\ x_{\hat{P}}(k) &= \hat{P}(q^{-1})x(k) \equiv \hat{p}_{\sim}^T x_{\sim}(k) \\ \hat{p}_{\sim}(k) &= [\hat{p}_0, \hat{p}_1, \dots, \hat{p}_{n_P}]^T \end{aligned} \tag{4}$$

The filtered-X LMS algorithm, given in equation (4), converges when the stepsize μ is sufficiently small and the plant model is sufficiently close to the true plant. See references [6] and [8] for details. Note that $\hat{d}(q^{-1})$ is used in place of $x(k)$ in Figure 4.

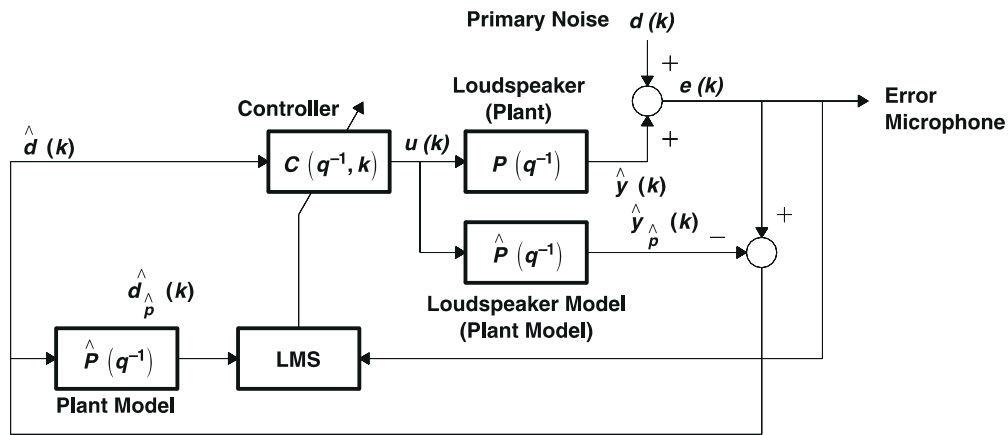

Figure 4. System Diagram of the Filtered-X LMS Algorithm (Feedback Configuration)

TMS320C30 IMPLEMENTATION OF AN ADAPTIVE ACTIVE NOISE CONTROL SYSTEM FOR HEADPHONES

System Components

The feedback control structure shown in Figure 4 was implemented using the TI TMS320C30 as the controller [14], and the components shown in Figure 5 as the plant. The loudspeakers were mounted inside the Sony model CD550 headphone set. A Radio Shack omnidirectional tie tack electret microphone was placed directly in front of the headphone speaker.

The active noise control system was first implemented using serial port 0 on the TMS320C30 Evaluation Module (EVM) and the on-board TLC32044 analog interface controller (AIC), input amplifiers and output amplifiers. See reference [13] for a description of each component. In this configuration, all components shown in Figure 5, except for the loudspeaker and microphone, were readily available on the EVM. This proved to be very convenient for the development of the ANC system.

The second phase of the implementation took advantage of serial port 1 on the EVM to interface the TMS320C30 DSP chip to external converters: Burr Brown A/Ds (102) and D/As (202). As mentioned earlier, minimizing delays is critical to performance in an ANC system and these devices have a faster conversion time specification than the AIC on the EVM. The Burr Brown converters were incorporated on a DEM-DSP 102/202 Evaluation Fixture board that included a sampling rate generator and low-pass filters. The Burr Brown interface was less convenient to use, especially since the low-pass filters had a fixed cut-off frequency of 20 kHz and amplifiers were not provided on the board. A TL074 op-amp circuit was used to provide amplification of the microphone signal, and the LM386 audio amplifier was used to provide enough current to drive the headphone loudspeakers.

In this project, the sampling rate was set to be 8 kHz, and so, in the first phase of development, the low-pass filters on the EVM were set (by adjusting the software) to have a cut-off frequency of 3 kHz.

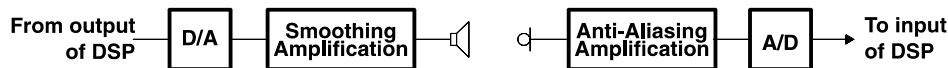

Figure 5. Components in the Plant $P(q^{-1})$ [5], [9]

System Identification Algorithm

Before the filtered-X LMS algorithm can be implemented, a model of the plant, $[\hat{P}(q^{-1})]$, is needed. Figure 5 shows the components in the plant to be identified. A linear FIR (finite impulse response) filter was chosen to model the plant because of its flexibility and ease of use.

In the system identification procedure, an excitation signal is output from the DSP. Typically, the excitation signal is pseudo-random binary noise, applied to both the plant and the plant model. An identification algorithm is used to find the parameters in the plant model.

For this project, better results were obtained by using a series of alternating positive and negative pulses as the excitation. The resulting impulse responses were averaged to obtain the final plant model, $\hat{P}(q^{-1})$. This plant model was subsequently used in the control algorithm.

Control Algorithm

The notation of Figure 4 is used to describe the program flow. After initialization, the program loops, waiting for an interrupt. When one occurs, the data at the input channel, $[e(k)]$, is read. Using this data, the noise estimate $[\hat{d}(k) = e(k) - \hat{y}_{\hat{p}}(k-1)]$ and the controller output $[u(k) = C(q^{-1}, k-1)\hat{d}(k)]$ are calculated. This new data, $[u(k)]$, is written to the headphones.

The main routine adapts the parameters (taps) of the controller $[C(q^{-1}, k)]$. First, the signal $[u(k)]$ is passed through the plant model filter $[P(q^{-1})]$ to generate the signal $\hat{y}_{\hat{p}}(k)$; then, the noise estimate $[\hat{d}(k)]$ is passed through the plant model filter to produce $[\hat{d}_{\hat{p}}(k)]$. The adaptation stepsize $[\mu]$ is then normalized [4]. Finally, the controller filter taps are updated using the error signal $[e(k)]$ from the last interrupt, the filtered data $[\hat{d}_{\hat{p}}(k)]$, and the normalized stepsize $[\mu]$ according to the algorithm given in equation (4). The program then loops and waits for the next interrupt.

Implementation of an Adaptive ANC System for Headphones

Before implementing the adaptive noise control system, extensive simulations were performed. Both computer-generated and real recorded noise were used to gain insight and predict the performance and stability limits of the actual system. Hardware, software, and electromechanical transducers were fit together to form the complete active noise control system.

RESULTS

The noise from rotating machines contains strong periodic components. Therefore, the performance of the adaptive ANC system was compared against that of a commercial ANC headphone set for a single-tone sinusoidal (narrow-band) noise. Figure 6 shows the results using the TMS320C30 EVM serial port 0 and associated on-board system components. The amount of noise reduction for each single frequency was measured in dB by feeding the microphone signal to an HP 3562A Dynamic Signal Analyzer. Clearly, the TMS320C30-based adaptive system outperformed the commercial headphones over a large range of frequencies. The reduction of the

commercial headphones is 5–10 dB in the 100 Hz to 1200 Hz frequency region. The TMS320C30-based adaptive headphone system achieves roughly 40-dB to 60-dB reduction in the 200 Hz to 1500 Hz frequency range. By adjusting the adaptation stepsize, stability was maintained throughout the frequency range shown, and reasonably fast convergence rates were obtained.

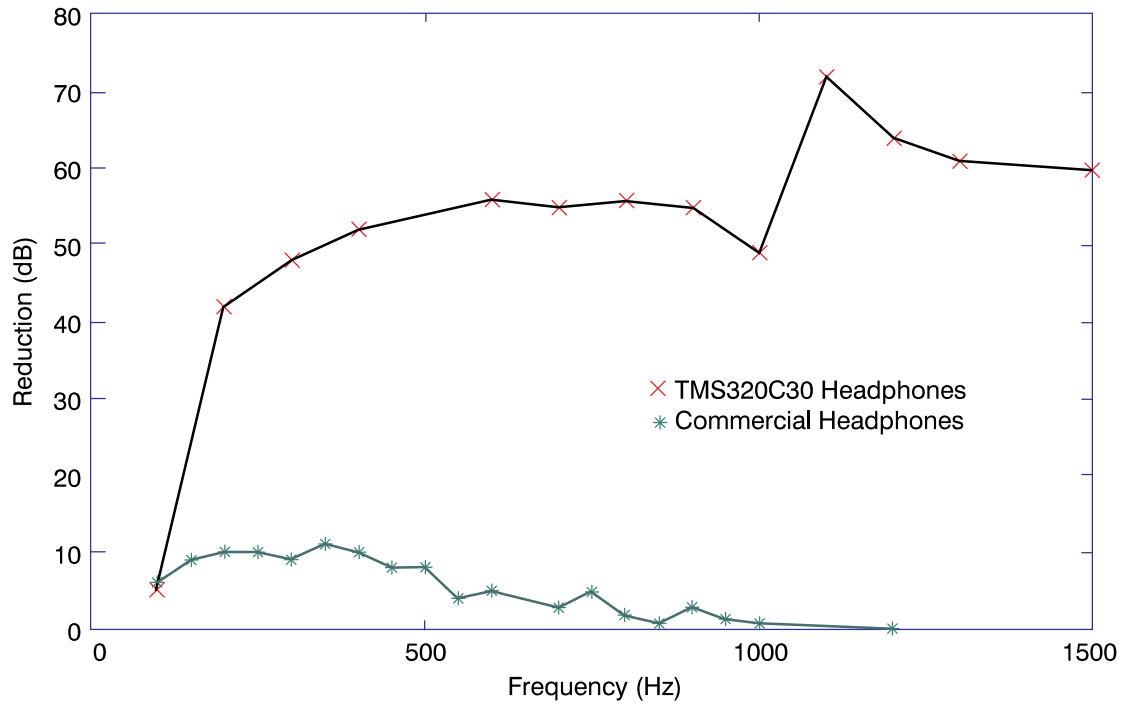

Figure 6. Narrow-Band Noise: Comparison of Reduction (dB vs. Frequency in Hz)

The results shown in Figure 6 were obtained from "before" and "after" plots shown in Figure 7 and Figure 8. In the first graph, the spectrum of a 400-Hz sinusoid is shown without any active noise control, as measured by the microphone attached inside the headphone set. With the active noise control system applied (Figure 8), a 52-dB reduction in noise is achieved.

For wide-band noise, Burr Brown converters were used. The results given in Figure 9 show that the adaptive system achieves a 5-dB to 11-dB reduction over the range from 200 Hz to 700 Hz. Roughly speaking, the adaptive system performs equally well as the commercial headphones for wide-band noise. The use of faster D/A and A/D converters (through serial port 1 of the EVM), better system identification, and more complex control structures should result in performance that exceeds the commercial headphones. Ongoing experiments also test the adaptive ANC system on wide-band non-stationary noise recorded from a moving car [12].

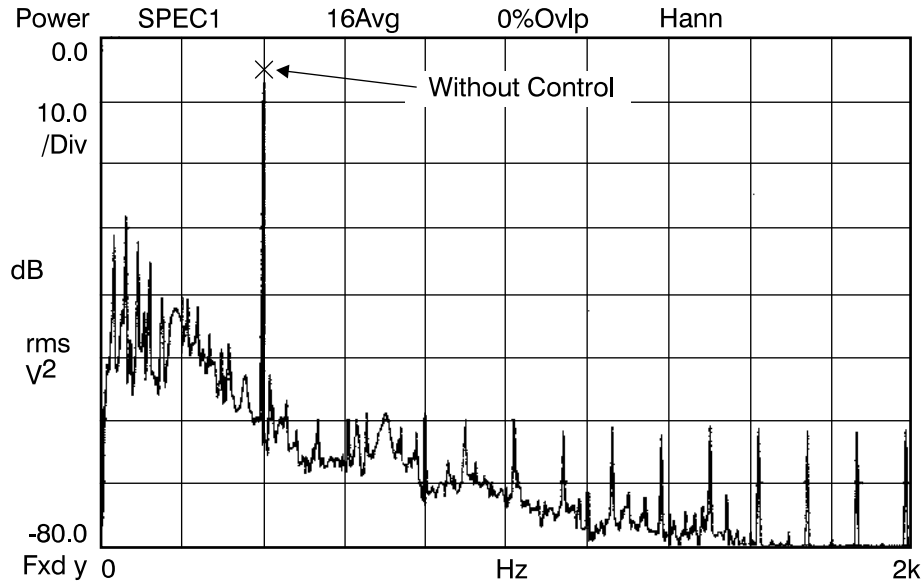

Figure 7. Narrow-Band Noise: A 400-Hz Sinusoid *Without* Adaptive Active Noise Control

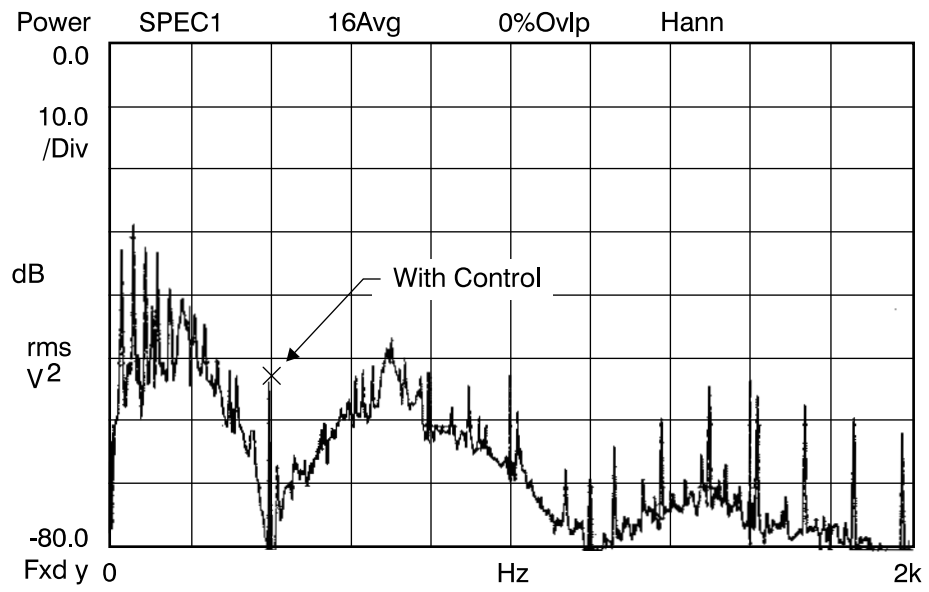

Figure 8. Narrow-Band Noise: A 400-Hz Sinusoid *with* Adaptive Active Noise Control

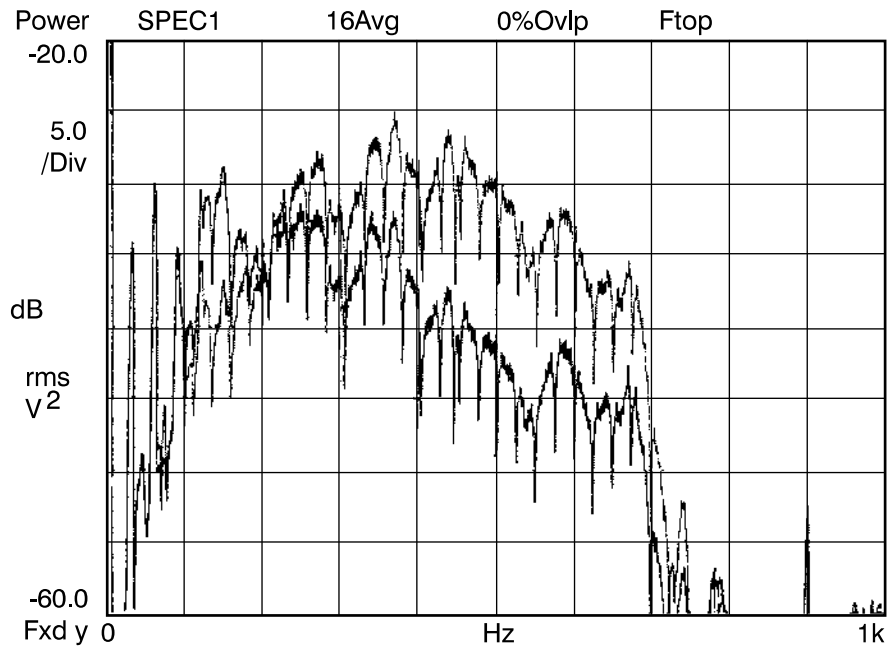

Figure 9. Wide-Band Noise: Adaptive ANC Performance

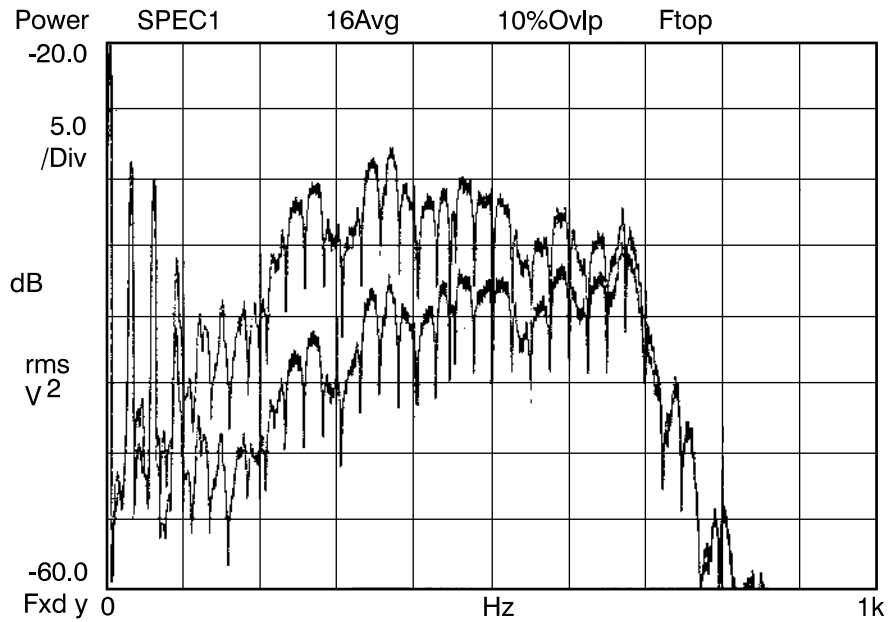

Figure 10. Wide-Band Noise: Commercial Headphones Performance

SUMMARY AND CONCLUSION

Commercially available active noise control headphones rely on fixed analog controllers to drive "anti-noise" loudspeakers. Our design uses an adaptive controller to optimally cancel unwanted acoustic noise. This headphone would be particularly useful for workers who operate or work near heavy machinery and engines because the noise is selectively eliminated. Desired sounds, such as speech and warning signals, are left to be heard clearly.

The filtered-X LMS adaptive control algorithm is implemented on a TI TMS320C30 DSP that drives a Sony CD550 headphone/microphone system. Our experiments indicate that adaptive control results in a dramatic improvement in performance over fixed control for narrow-band noise. This is achieved by the self-optimizing and tracking capabilities of the adaptive controller in response to different types of ambient noise. Further performance improvement for wide-band noise can be achieved by using more complex controller structures and faster converging algorithms.

REFERENCES

1. L. Kinsler, *Fundamentals of Acoustics*, Wiley, New York (1982).
2. P. Nelson and S. J. Elliott, *Active Control of Sound*, Academic Press Limited (1992).
3. S. Furui and M. Sondhi, eds., *Advances in Speech Signal Processing*, M. Dekker, New York (1992).
4. G. C. Goodwin and K. S. Sin, *Adaptive Filtering, Prediction and Control*, Englewood Cliffs, NJ, Prentice Hall (1984).
5. J. McWilliams, "Implementation of an Active Noise Reduction System for Headphones", Master's Report, U.C. Berkeley (1993).
6. W. Ren and P. R. Kumar, "Adaptive Active Noise Control: Structures, Algorithms and Convergence Analysis", *Proceedings Inter-noise 89*, Newport Beach, CA, pp. 435–440 (1989).
7. A. K. Wang and W. Ren, "Convergence Analysis of the Multi-Variable Filtered-X LMS Algorithm with Application to Active Noise Cancellation", *Proceedings IFAC Triennial World Congress*, San Francisco, CA (1996).
8. B. Widrow and S. D. Stearns, *Adaptive Signal Processing*, Englewood Cliffs, NJ, Prentice Hall (1985).
9. A. K. Wang, "Algorithms for Active Noise Control", Doctoral Qualifying Examination, U. C. Berkeley (1995).
10. G. B. B Chaplin and R. A. Smith, "Waveform Synthesis-The Essex Solution to Repetitive Noise and Vibration", *Proceedings Inter-noise 83*, Edinburgh, UK, pp. 399–402, (1983).
11. M. Morari, S. Skogestad, D. F. Rivera, "Implications of Internal Model Control for PID Controllers", Vol. 2, *American Control Conference*, pp. 661–666, (1984).
12. B. Kingsbury and N. Morgan, personal communication (1995).
13. *Digital Signal Processing Applications with the TMS320C30 Evaluation Module: Selected Application Notes*, literature number SPRA021, Texas Instruments (1991).
14. *TMS320C30x User's Guide*, literature number SPRU031D, Texas Instruments (1994).

ACKNOWLEDGMENTS

We thank the following individuals:

- Professor Wei Ren and John McWilliams of U. C. Berkeley, for their work in establishing this project
- Jin Namkoong, Jim Jardine, Ferenc Kovac, and Tho Nguyen of U. C. Berkeley, for their expert technical assistance
- Torrence Robinson and Russell Price, for their help in facilitating our project entry
- Texas Instruments for donating the TMS320C30 Evaluation Module, and related software and documentation

IMPORTANT NOTICE

Texas Instruments (TI) reserves the right to make changes to its products or to discontinue any semiconductor product or service without notice, and advises its customers to obtain the latest version of relevant information to verify, before placing orders, that the information being relied on is current.

TI warrants performance of its semiconductor products and related software to the specifications applicable at the time of sale in accordance with TI's standard warranty. Testing and other quality control techniques are utilized to the extent TI deems necessary to support this warranty. Specific testing of all parameters of each device is not necessarily performed, except those mandated by government requirements.

Certain applications using semiconductor products may involve potential risks of death, personal injury, or severe property or environmental damage ("Critical Applications").

TI SEMICONDUCTOR PRODUCTS ARE NOT DESIGNED, INTENDED, AUTHORIZED, OR WARRANTED TO BE SUITABLE FOR USE IN LIFE-SUPPORT APPLICATIONS, DEVICES OR SYSTEMS OR OTHER CRITICAL APPLICATIONS.

Inclusion of TI products in such applications is understood to be fully at the risk of the customer. Use of TI products in such applications requires the written approval of an appropriate TI officer. Questions concerning potential risk applications should be directed to TI through a local SC sales office.

In order to minimize risks associated with the customer's applications, adequate design and operating safeguards should be provided by the customer to minimize inherent or procedural hazards.

TI assumes no liability for applications assistance, customer product design, software performance, or infringement of patents or services described herein. Nor does TI warrant or represent that any license, either express or implied, is granted under any patent right, copyright, mask work right, or other intellectual property right of TI covering or relating to any combination, machine, or process in which such semiconductor products or services might be or are used.