

Angle (1A)

- Angles in Degree
- Angles in Radian
- Conversion between Degree and Radian
- Co-terminal Angles

Copyright (c) 2008 Young W. Lim.

Permission is granted to copy, distribute and/or modify this document under the terms of the GNU Free Documentation License, Version 1.2 or any later version published by the Free Software Foundation; with no Invariant Sections, no Front-Cover Texts, and no Back-Cover Texts. A copy of the license is included in the section entitled "GNU Free Documentation License".

Please send corrections (or suggestions) to youngwlim@hotmail.com.

This document was produced by using OpenOffice and Octave.

Angle and Arc Length

Circumference

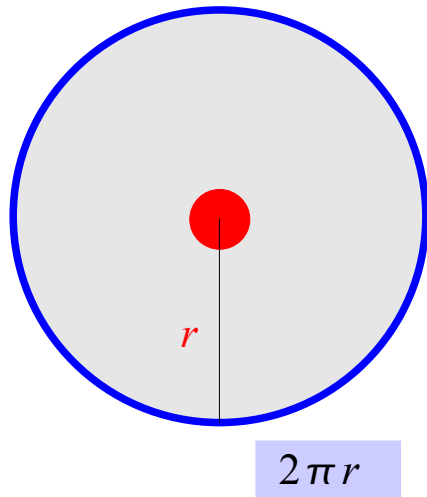

$$\text{Angle} \propto \text{Arc Length}$$
$$\left(\theta \propto \frac{l}{2\pi r} \right)$$

Arc length

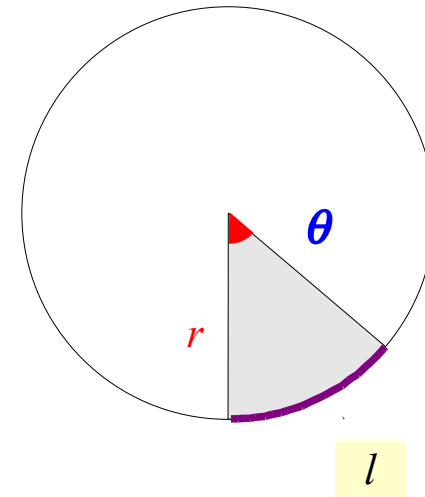

l : Arc length



$$\text{Ratio} : 0 \leq \frac{l}{2\pi r} \leq 1$$

$2\pi r$: Circumference



Arc Length Ratio

$$\theta \propto \frac{l}{2\pi r}$$

l : Arc length
 $2\pi r$: Circumference

Angle
in degree

$$0 \leq \theta_d \leq 360$$



$$0 \cdot 360 \leq \frac{l}{2\pi r} \cdot 360 \leq 1 \cdot 360$$



Ratio

$$0 \leq \frac{l}{2\pi r} \leq 1$$



Angle
in radian

$$0 \leq \theta_r \leq 2\pi$$



$$0 \cdot 2\pi \leq \frac{l}{2\pi r} \cdot 2\pi \leq 1 \cdot 2\pi$$

Degree and Radian Scales

$$\theta \propto \frac{l}{2\pi r}$$

l : Arc length

$2\pi r$: Circumference

Angle
in degree

$$0 \leq \theta_d \leq 360$$

Ratio

$$0 \leq \frac{l}{2\pi r} \leq 1$$

Angle
in radian

$$0 \leq \theta_r \leq 2\pi$$

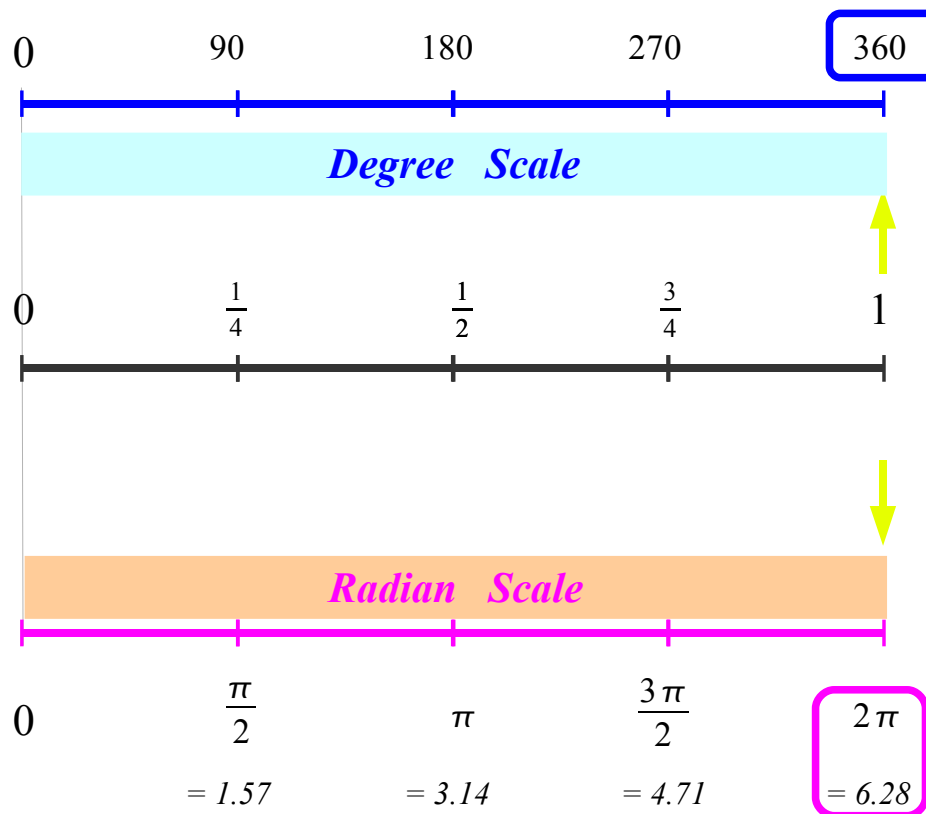

Measuring Angle in Degree

Circumference $2\pi r$

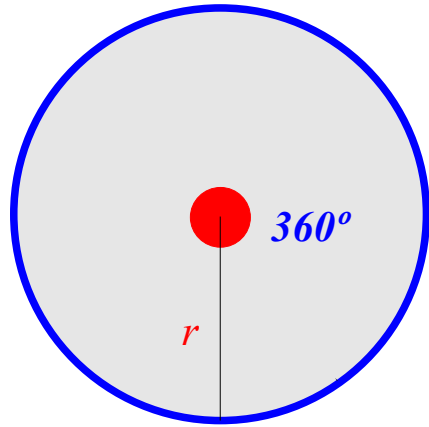

Arc length l

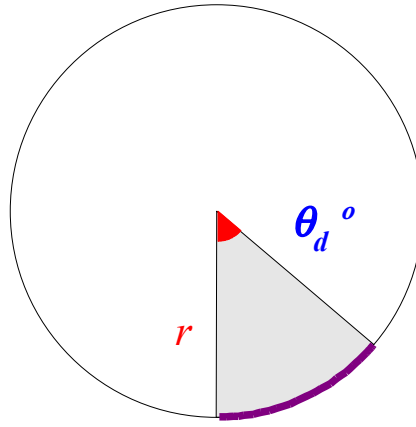

Ratio

$$0 \leq \frac{l}{2\pi r} \leq 1$$

Angle in degree

$$0 \leq \theta_d \leq 360$$



$2\pi r$

Circumference $\rightarrow 360^\circ$

l

Arc length $\rightarrow \theta$

$$2\pi r : l = 360 : \theta_d$$



$$\theta_d = \frac{l}{2\pi r} \cdot 360$$

Measuring Angle in Radian

Circumference $2\pi r$

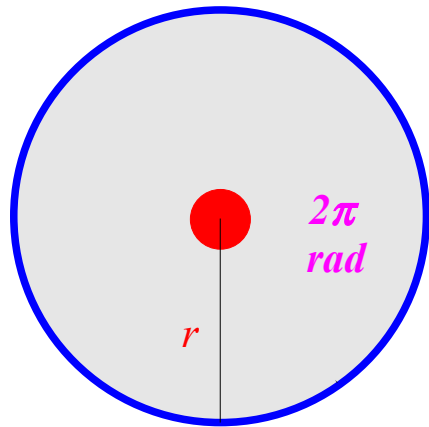

Arc length l

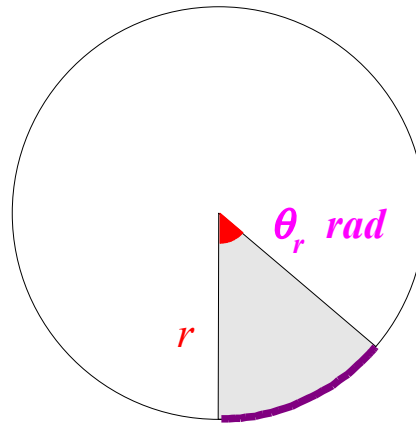

Ratio

$$0 \leq \frac{l}{2\pi r} \leq 1$$

Angle in radian

$$0 \leq \theta_r \leq 2\pi$$



$2\pi r$

Circumference $\rightarrow 2\pi$

l

Arc length $\rightarrow \theta$

$$2\pi r : l = 2\pi : \theta_r$$



$$\theta_r = \frac{l}{2\pi r} \cdot 2\pi$$

Unit Degree and Unit Radian

Unit Degree

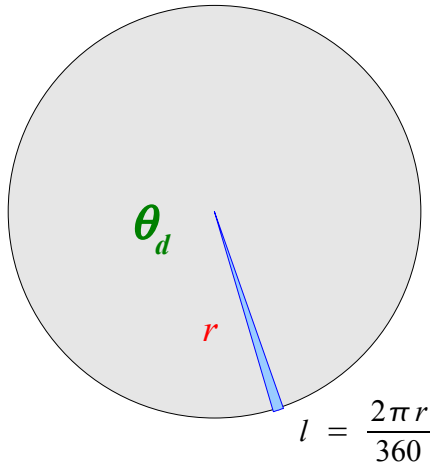

Degree

$$\theta_d \text{ deg} = \frac{l}{2\pi r} \cdot 360 \text{ deg}$$
$$= \frac{l}{r} \cdot \frac{180}{\pi} \text{ deg}$$

1 degree

If $l = (\text{circumference} / 360)$

$$l = \frac{2\pi r}{360}$$

The unit degree is represented for the sake of explanation

Unit Radian

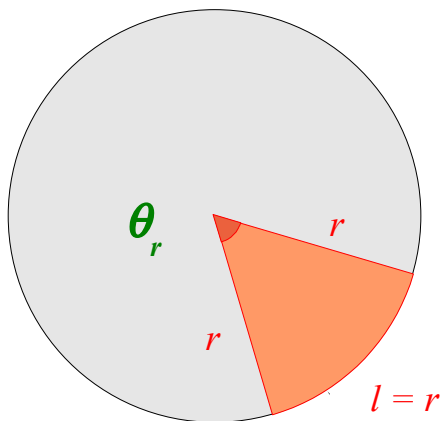

Radian

$$\theta_r \text{ rad} = \frac{l}{2\pi r} \cdot 2\pi \text{ rad}$$
$$= \frac{l}{r} \text{ rad}$$

1 radian

If $l = \text{radius}$

$$l = r$$

Degree \Rightarrow Radian

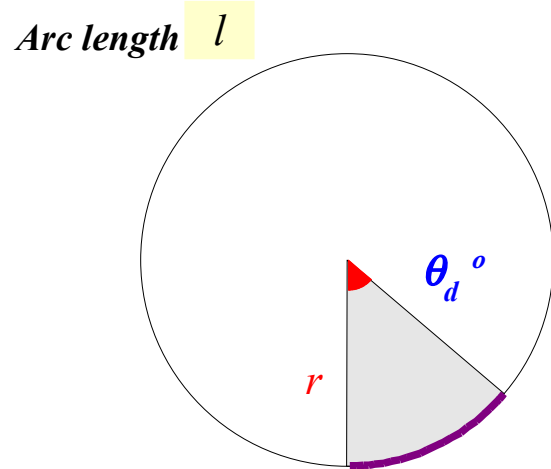
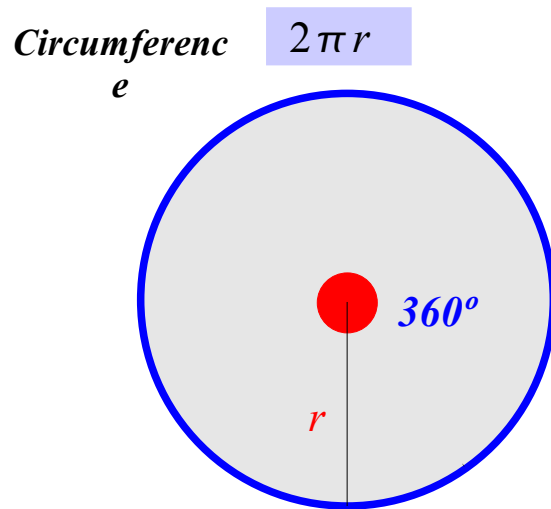

Degree

$$\theta_d \text{ deg} = \frac{l}{2\pi r} \cdot 360 \text{ deg}$$



$$\theta_d \text{ deg} \times \left(\frac{\pi}{180}\right) = \frac{l}{r} \cdot \frac{180}{\pi} \text{ deg} \times \left(\frac{\pi}{180}\right)$$



Radian

$$\theta_d \cdot \frac{\pi}{180} \text{ rad} = \frac{l}{r} \text{ rad}$$

Radian \Rightarrow Degree

Circumference $2\pi r$

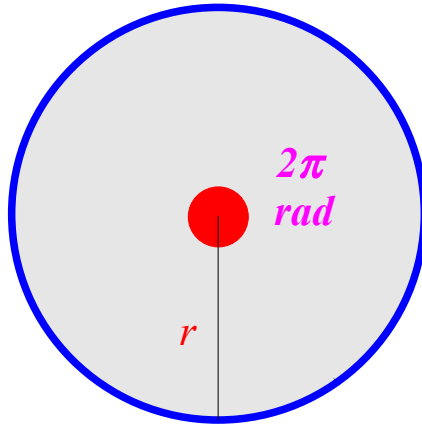

Arc length l

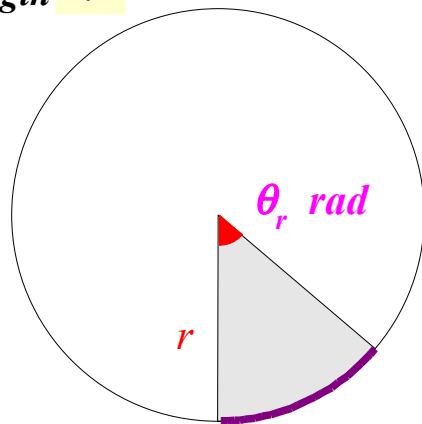

Radian

$\theta_r \text{ rad}$

$$= \frac{l}{r} \text{ rad}$$



$$\theta_r \text{ rad} \times \left(\frac{180}{\pi}\right)$$

$$= \frac{l}{r} \text{ rad} \times \left(\frac{180}{\pi}\right)$$



Degree

$$\theta_r \cdot \frac{180}{\pi} \text{ deg}$$

$$= \frac{l}{2\pi r} \cdot 360 \text{ deg}$$

Degree \Leftrightarrow Radian

The Same Angle

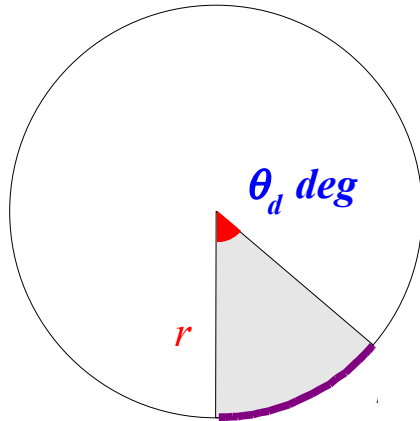

$$\theta_d \text{ deg} = \frac{l}{2\pi r} \cdot 360 \text{ deg}$$

$$\theta_r \text{ rad} = \frac{l}{2\pi r} \cdot 2\pi \text{ rad}$$

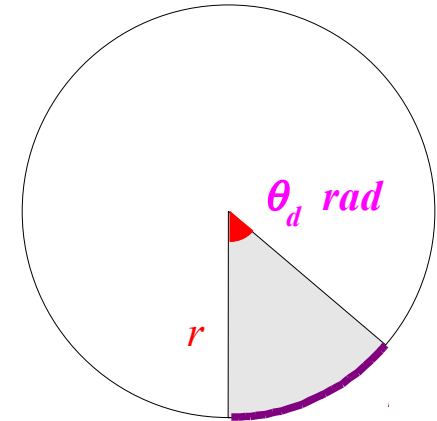

$$\theta_d \text{ degree} = \theta_r \text{ radian}$$

Degree

$$\theta_d \text{ deg}$$

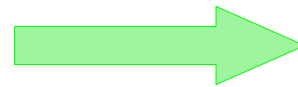

$$\theta_d \cdot \frac{\pi}{180} \text{ rad}$$

Radian

Degree

$$\theta_r \cdot \frac{180}{\pi} \text{ deg}$$



$$\theta_r \text{ rad}$$

Radian

Well-known Angles in Degree

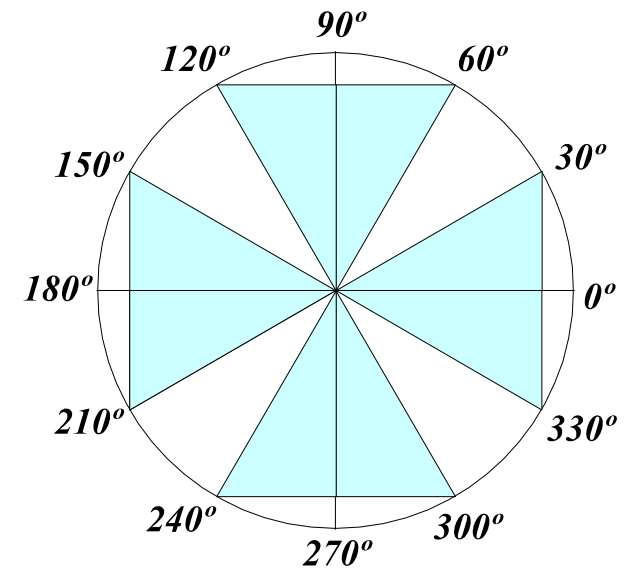
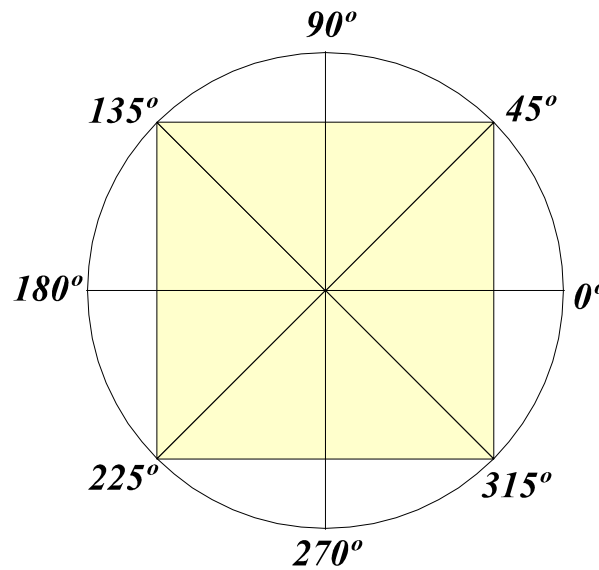
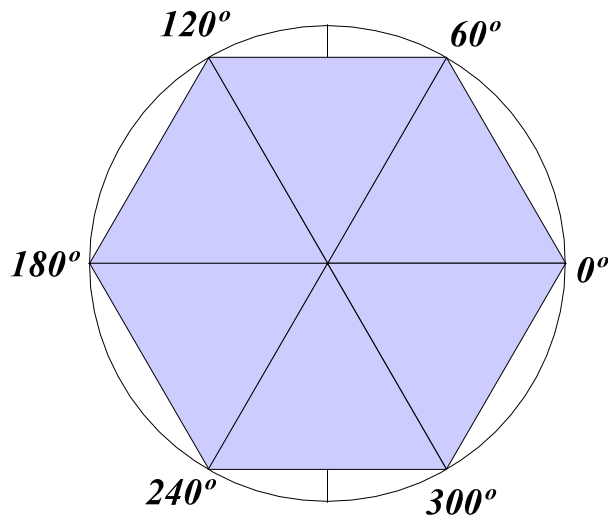
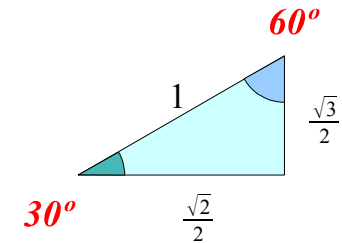
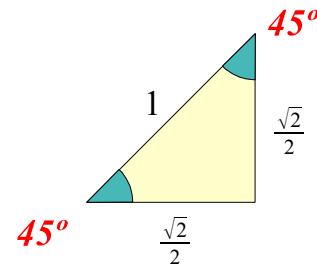
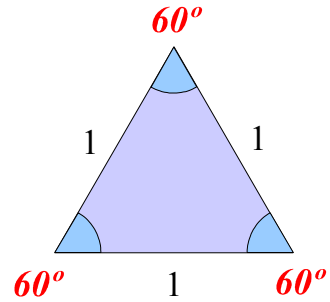

Well-known Angles in Radian

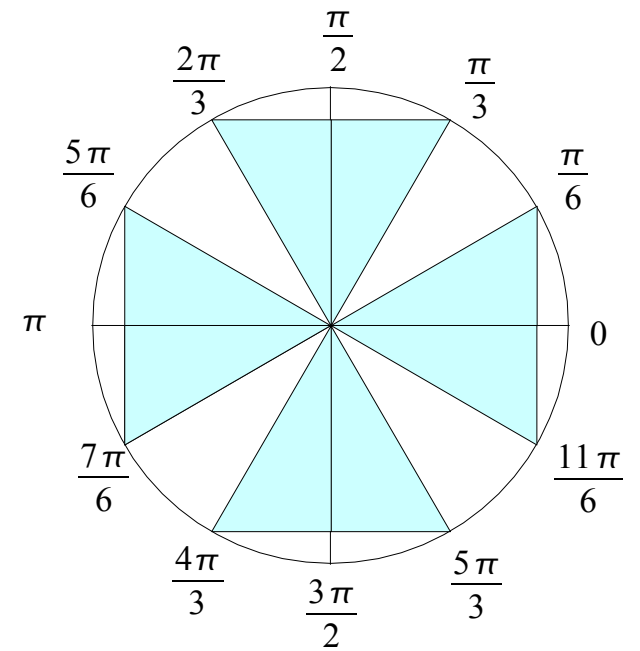
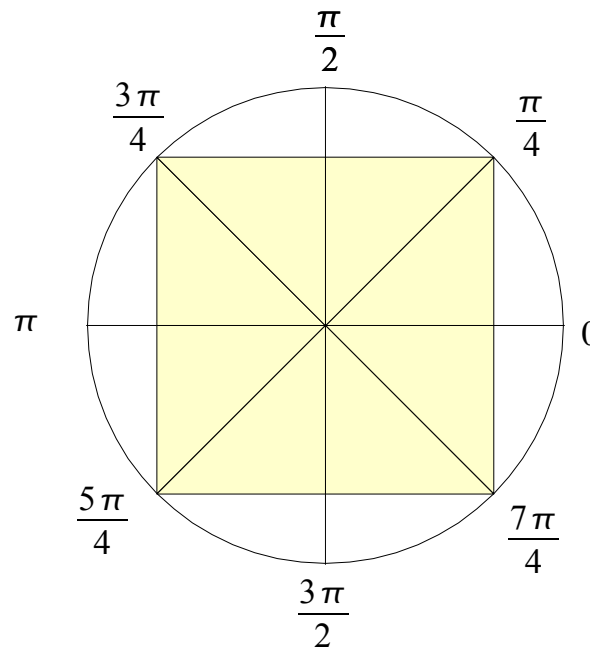
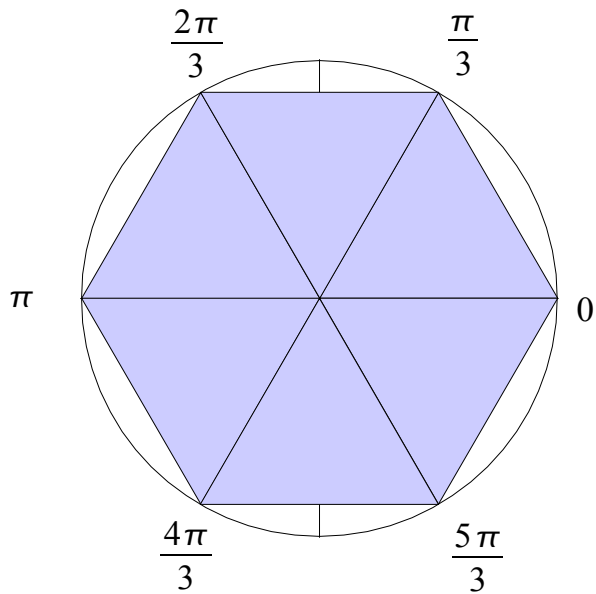
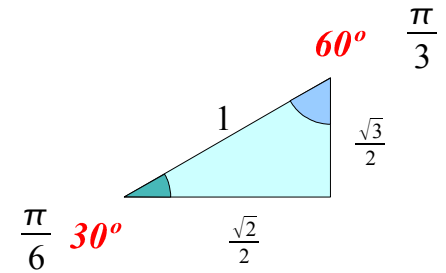
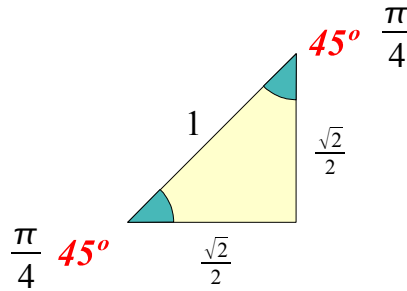
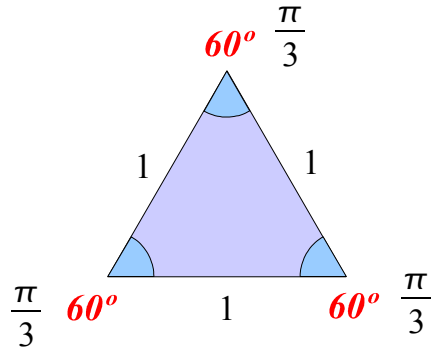

Well-known Angles (Degree → Radian)

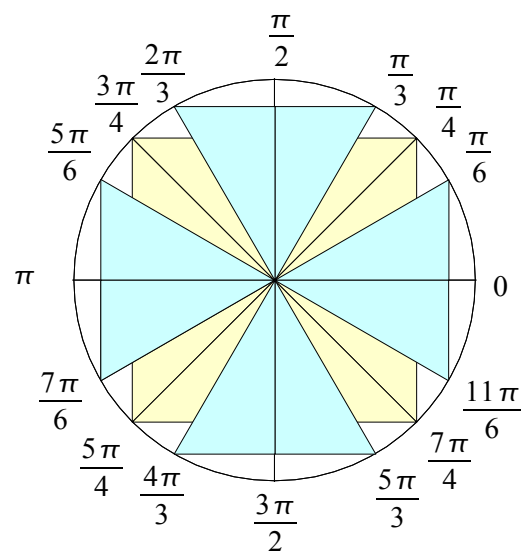
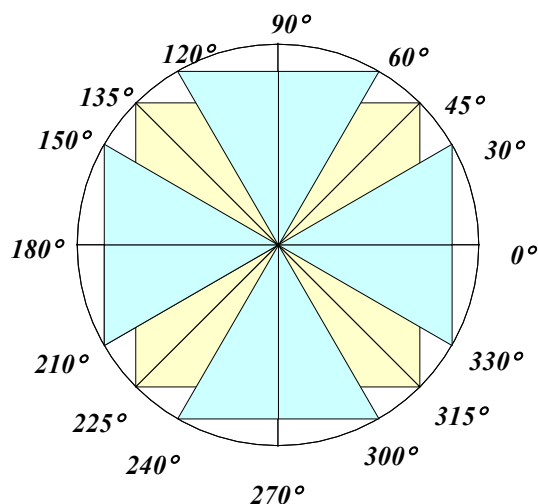

degree	radian			
0°	0	=	0	= 0.000
30°	$\pi/6$	=	$\pi/6$	= 0.524
45°	$\pi/4$	=	$\pi/4$	= 0.785
60°	$\pi/3$	=	$\pi/3$	= 1.047
90°	$\pi/2$	=	$\pi/2$	= 1.571
120°	$\pi/6 + \pi/2$	=	$2\pi/3$	= 2.094
135°	$\pi/4 + \pi/2$	=	$3\pi/4$	= 2.356
150°	$\pi/3 + \pi/2$	=	$5\pi/6$	= 2.618
180°	$\pi/2 + \pi/2$	=	π	= 3.142
210°	$\pi/6 + \pi$	=	$7\pi/6$	= 3.665
225°	$\pi/4 + \pi$	=	$5\pi/4$	= 3.927
240°	$\pi/3 + \pi$	=	$4\pi/3$	= 4.189
270°	$\pi/2 + \pi$	=	$3\pi/2$	= 4.712
300°	$\pi/6 + \pi + \pi/2$	=	$5\pi/3$	= 5.236
315°	$\pi/4 + \pi + \pi/2$	=	$7\pi/4$	= 5.498
330°	$\pi/3 + \pi + \pi/2$	=	$11\pi/6$	= 5.760
360°	$\pi/2 + \pi + \pi/2$	=	2π	= 6.283

Well-known Angles (Radian \rightarrow Degree)

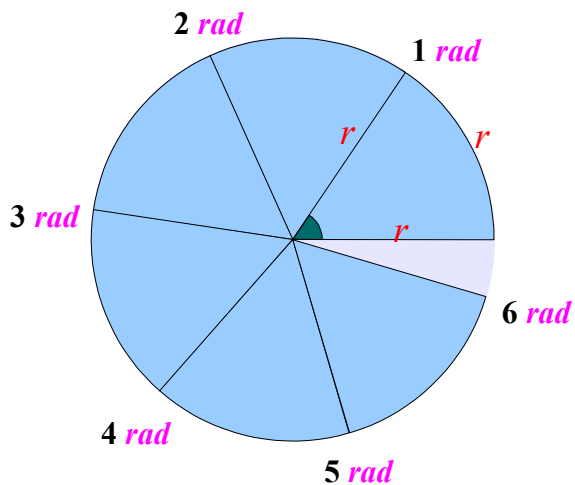
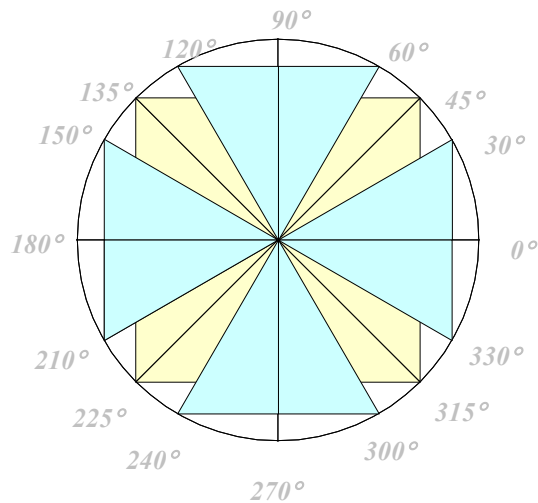

radian	degree
0	$0.0 \times 180 / \pi = 0^\circ$
1	$1.0 \times 180 / \pi = 57.3^\circ$
2	$2.0 \times 180 / \pi = 114.6^\circ$
3	$3.0 \times 180 / \pi = 171.9^\circ$
4	$4.0 \times 180 / \pi = 229.2^\circ$
5	$5.0 \times 180 / \pi = 286.5^\circ$
6	$6.0 \times 180 / \pi = 343.8^\circ$
1.57	$\pi/2 \times 180 / \pi = 90^\circ$
3.14	$\pi \times 180 / \pi = 180^\circ$
4.71	$3\pi/2 \times 180 / \pi = 270^\circ$
6.28	$2\pi \times 180 / \pi = 360^\circ$
0.79	$\pi/4 \times 180 / \pi = 45^\circ$
2.36	$3\pi/4 \times 180 / \pi = 135^\circ$
3.93	$5\pi/4 \times 180 / \pi = 225^\circ$
5.50	$7\pi/4 \times 180 / \pi = 315^\circ$

Co-terminal Angle (Multiple Rotations)

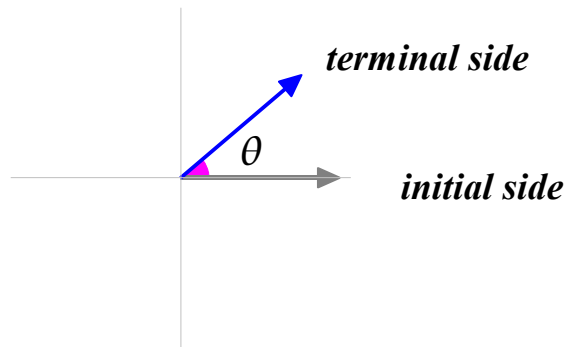

Co-terminal Angles

- the same terminal side
- the same initial side
- different rotations

$$\theta_1 = \theta$$

$$\theta_2 = 1 \text{ rotation} + \theta$$

$$\theta_3 = 2 \text{ rotations} + \theta$$

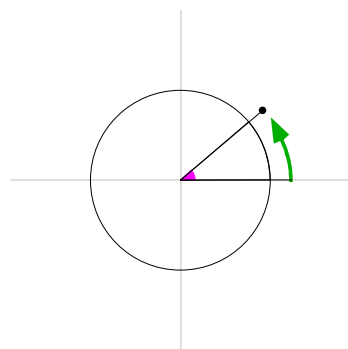

single
rotation

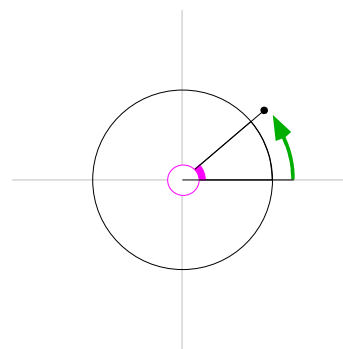

single
rotation

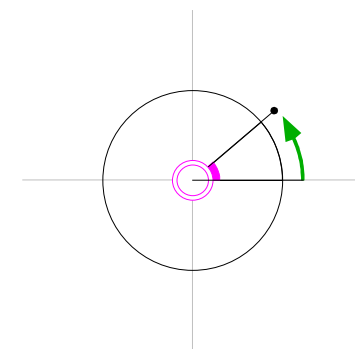

$$\theta_1 = \theta_2 = \theta_3 = \theta$$

Multiple Rotations

Allow multiple rotations

l : Arc length
 $0 \leq l \leq 2\pi r$



d : Distance traveled along circumference
 $d \geq 0$

$$\theta_1 = \theta$$

$$\theta_2 = 1 \text{ rotation} + \theta$$

$$\theta_3 = 2 \text{ rotations} + \theta$$

$$d_1 = l$$

$$d_2 = 2\pi r + l$$

$$d_3 = 2 \cdot 2\pi r + l$$

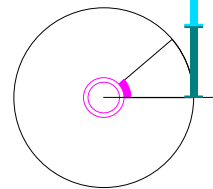
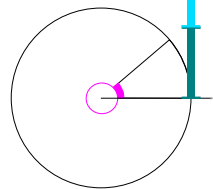
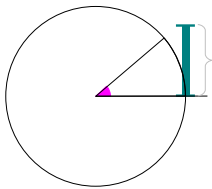

Multiple Rotations in Degree

$$\theta = \frac{l}{2\pi r} \times 360$$

$$\theta = \frac{l}{2\pi r} \times 360$$

$$\theta = \frac{l}{2\pi r} \times 360$$

$$d_1 = l$$

$$d_2 = 2\pi r + l$$

$$d_3 = 4\pi r + l$$

$$\theta_1 = \frac{d_1}{2\pi r} \times 360$$

$$\theta_2 = \frac{d_2}{2\pi r} \times 360$$

$$\theta_3 = \frac{d_3}{2\pi r} \times 360$$

$$= \frac{l}{2\pi r} \times 360$$

$$= \left(1 + \frac{l}{2\pi r}\right) \times 360$$

$$= \left(2 + \frac{l}{2\pi r}\right) \times 360$$

$$\theta_1 = \theta$$

$$\theta_2 = 360 + \theta$$

$$\theta_3 = 2 \cdot 360 + \theta$$

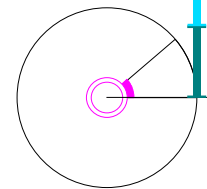
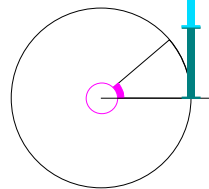
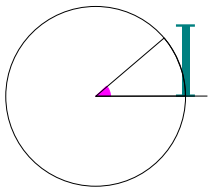

Multiple Rotations in Radian

$$\theta = \frac{l}{2\pi r} \times 2\pi$$

$$\theta = \frac{l}{2\pi r} \times 2\pi$$

$$\theta = \frac{l}{2\pi r} \times 2\pi$$

$$d_1 = l$$

$$d_2 = 2\pi r + l$$

$$d_3 = 4\pi r + l$$

$$\theta_1 = \frac{d_1}{2\pi r} \times 2\pi$$

$$\theta_2 = \frac{d_2}{2\pi r} \times 2\pi$$

$$\theta_3 = \frac{d_3}{2\pi r} \times 2\pi$$

$$= \frac{l}{2\pi r} \times 2\pi$$

$$= \left(1 + \frac{l}{2\pi r}\right) \times 2\pi$$

$$= \left(2 + \frac{l}{2\pi r}\right) \times 2\pi$$

$$\theta_1 = \theta$$

$$\theta_2 = 2\pi + \theta$$

$$\theta_3 = 2 \cdot 2\pi + \theta$$

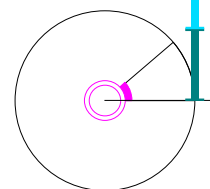
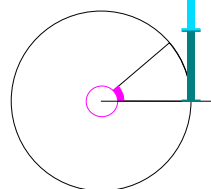
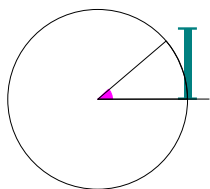

Co-terminal Angle (Reverse Rotations)

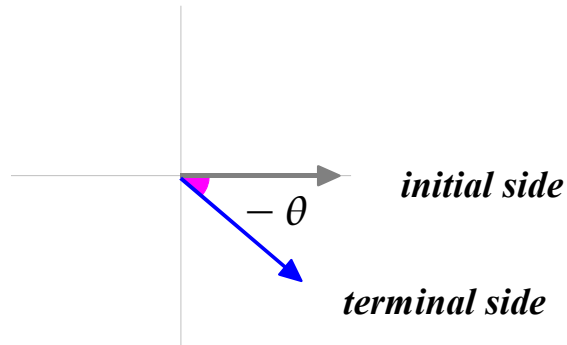

Co-terminal Angles

- the same terminal side
- the same initial side
- different rotations

$$\theta_1 = -\theta$$

$$\theta_2 = 1 \text{ rotation} - \theta$$

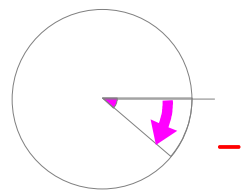

Negative Angle

clockwise



single rotation



Positive Angle

counter-clockwise

$$\theta_1 = \theta_2 = \theta$$

Reverse Rotations

Consider the direction of rotations

l : Arc length
 $0 \leq l \leq 2\pi r$



d : Displacement
 (directed distance)
 $d < 0$ or $d \geq 0$

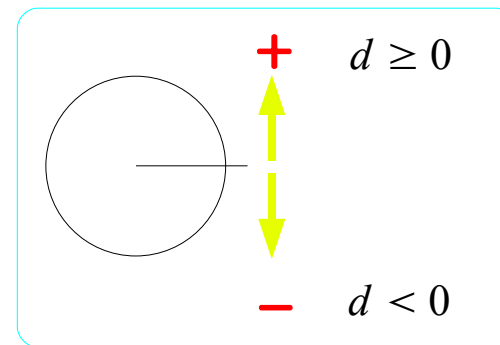

$$\theta_1 = -\theta$$

$$d_1 = -l$$

$$\theta_2 = 1 \text{ rotation} - \theta$$

$$d_2 = 2\pi r - l$$

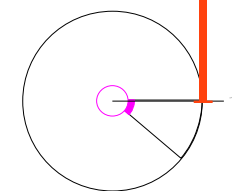
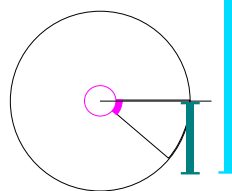
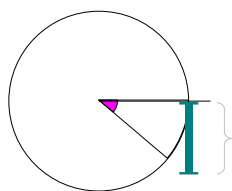

Reverse Rotations in Degree

$$\theta = \frac{l}{2\pi r} \times 360$$

$$\theta = \frac{l}{2\pi r} \times 360$$

$$d_1 = -l$$

$$\begin{aligned} \theta_1 &= \frac{d_1}{2\pi r} \times 360 \\ &= \frac{-l}{2\pi r} \times 360 \end{aligned}$$

$$\theta_1 = -\theta$$

$$d_2 = 2\pi r - l$$

$$\begin{aligned} \theta_2 &= \frac{d_2}{2\pi r} \times 360 \\ &= \left(1 - \frac{l}{2\pi r}\right) \times 360 \end{aligned}$$

$$\theta_2 = 360 - \theta$$

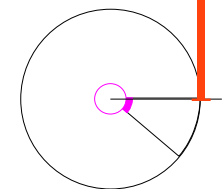
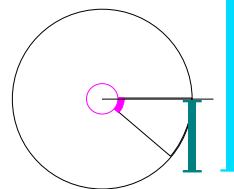
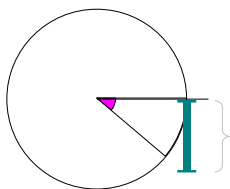

Reverse Rotations in Radian

$$\theta = \frac{l}{2\pi r} \times 2\pi$$

$$\theta = \frac{l}{2\pi r} \times 2\pi$$

$$d_1 = -l$$

$$\begin{aligned} \theta_1 &= \frac{d_1}{2\pi r} \times 2\pi \\ &= \frac{-l}{2\pi r} \times 2\pi \end{aligned}$$

$$\theta_1 = -\theta$$

$$d_2 = 2\pi r - l$$

$$\begin{aligned} \theta_2 &= \frac{d_2}{2\pi r} \times 2\pi \\ &= \left(1 - \frac{l}{2\pi r}\right) \times 2\pi \end{aligned}$$

$$\theta_2 = 2\pi - \theta$$

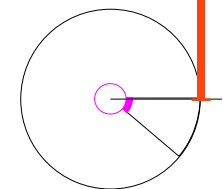
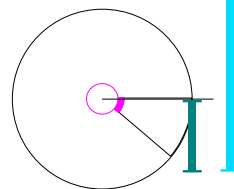
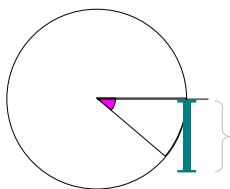

Angles in the Standard Position

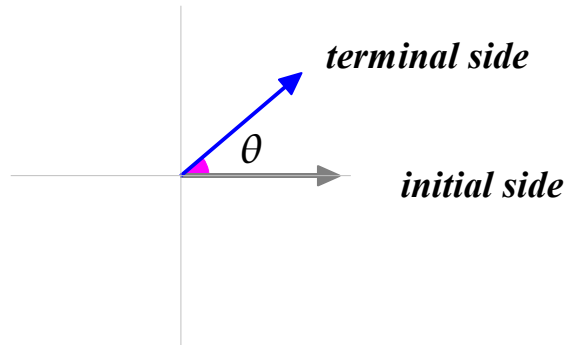

Angles in the standard position

- Vertex is in the origin of a rectangular coordinate system
- Initial side lies along the positive x-axis

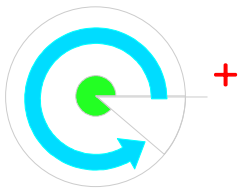

Positive Angle

$$\theta_p > 0$$

counter-clockwise

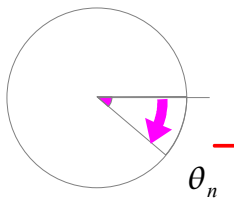

Negative Angle

$$\theta_n < 0$$

clockwise

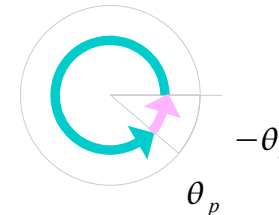

$$\theta_p - \theta_n = 360$$

$$\theta_p = \theta_n + 360 \quad (\theta_p > 0)$$

$$\theta_n = \theta_p - 360 \quad (\theta_n < 0)$$

Positive and Negative Angles

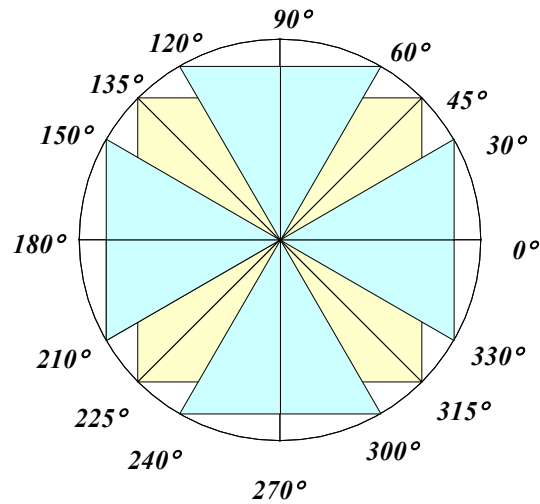

Positive Angle

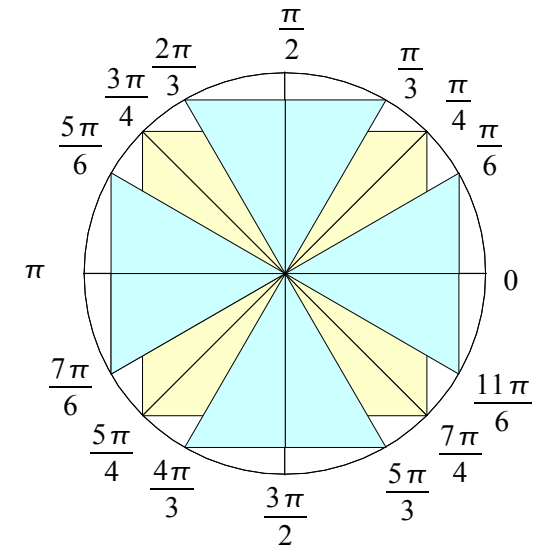
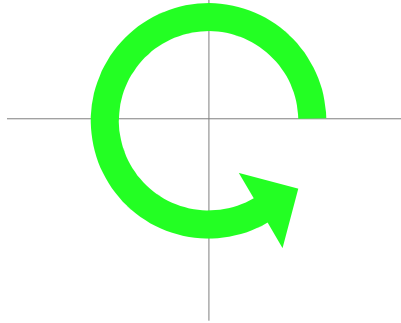

Negative Angle

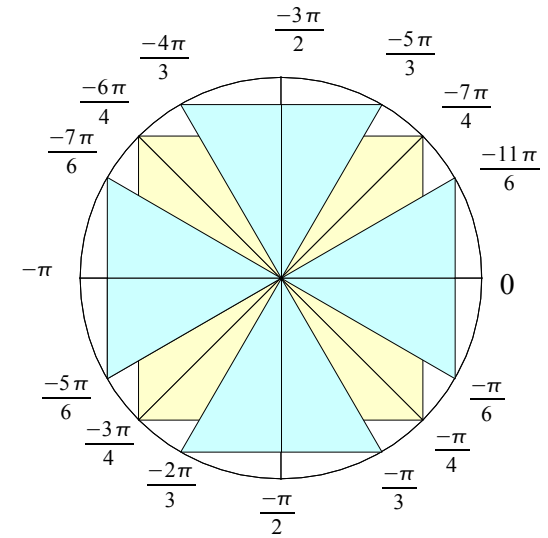
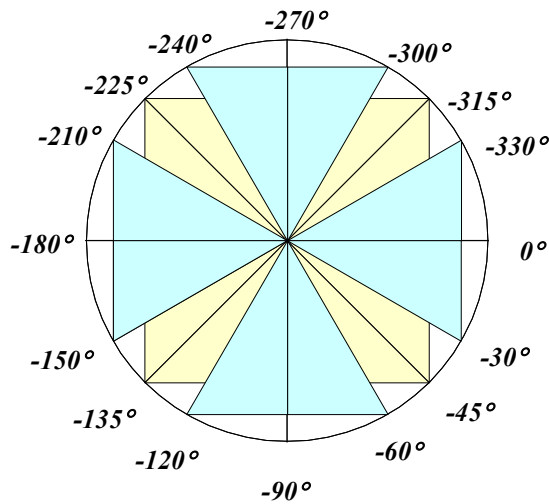
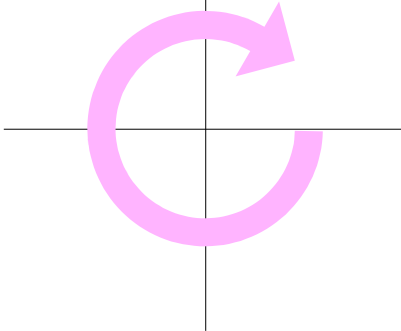

Arc Length Ratio

$$f(d_i) = \frac{d_i}{2\pi r}$$

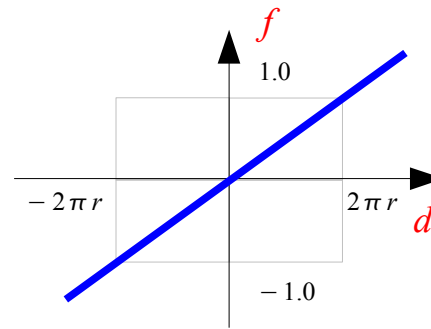
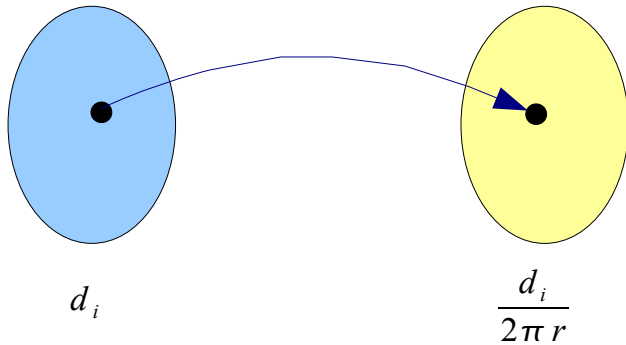

$$g(d_i) = \text{Remainder} \left(\frac{d_i}{2\pi r} \right)$$

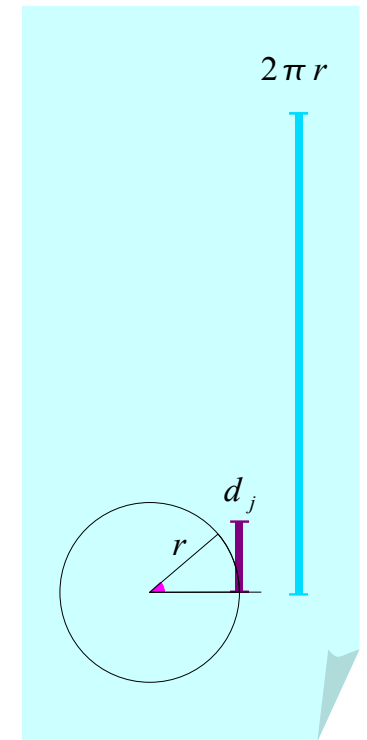
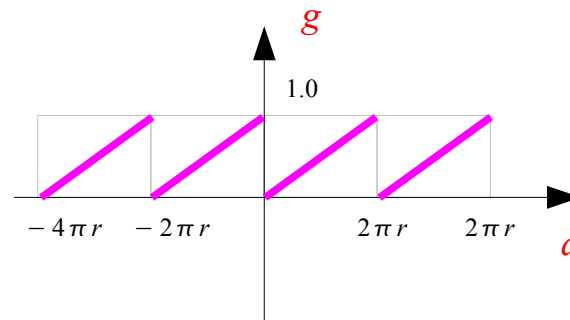
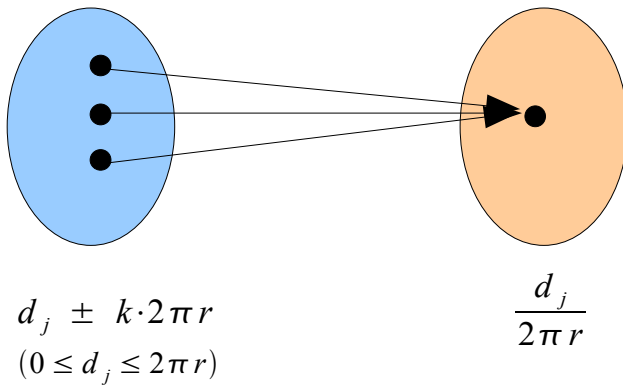

Co-terminal Angle & Arc Length Ratio

$$g(d_i) = \text{Remainder} \left(\frac{d_i}{2\pi r} \right)$$

Degree

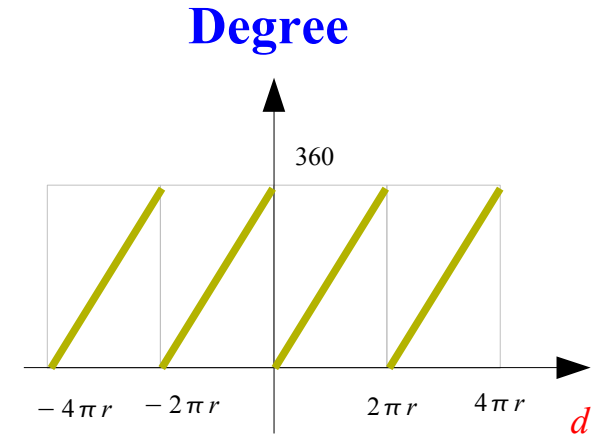
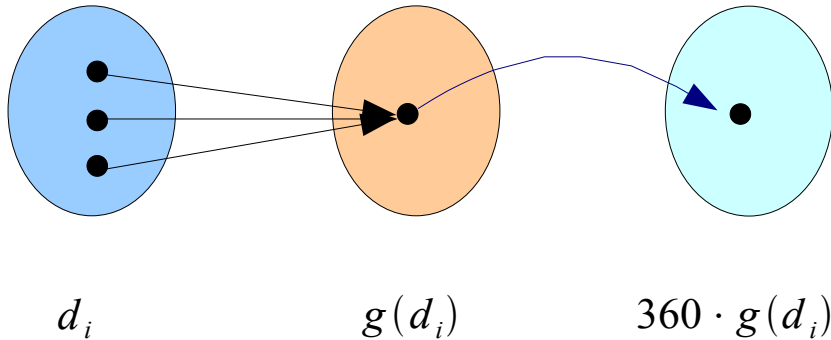

$$g(d_i) = \text{Remainder} \left(\frac{d_i}{2\pi r} \right)$$

Radian

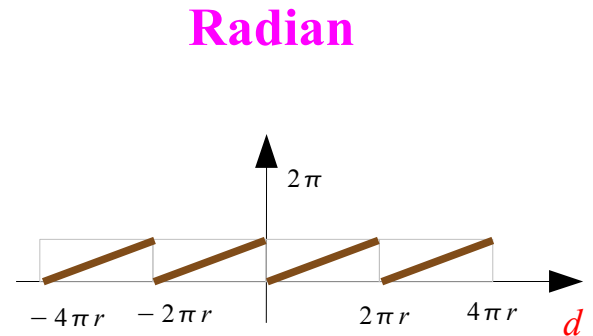
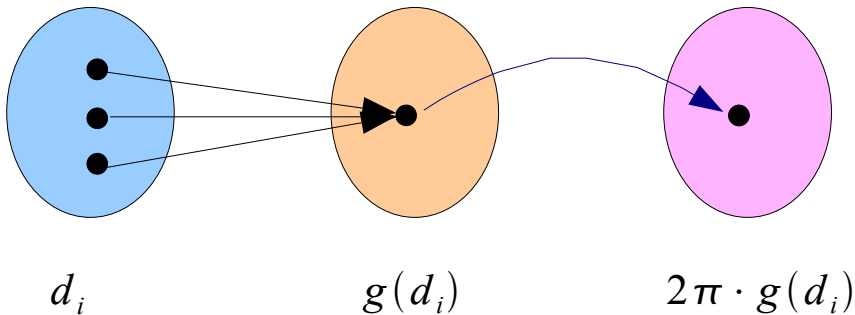

References

- [1] <http://en.wikipedia.org/>
- [2] <http://planetmath.org/>
- [3] Blitzer, R. "Algebra & Trigonometry." 3rd ed, Prentice Hall
- [4] Smith, R. T., Minton, R. B. "Calculus: Concepts & Connections," Mc Graw Hill
- [5] 홍성대, "기본/실력 수학의 정석," 성지출판