

The Popular science monthly

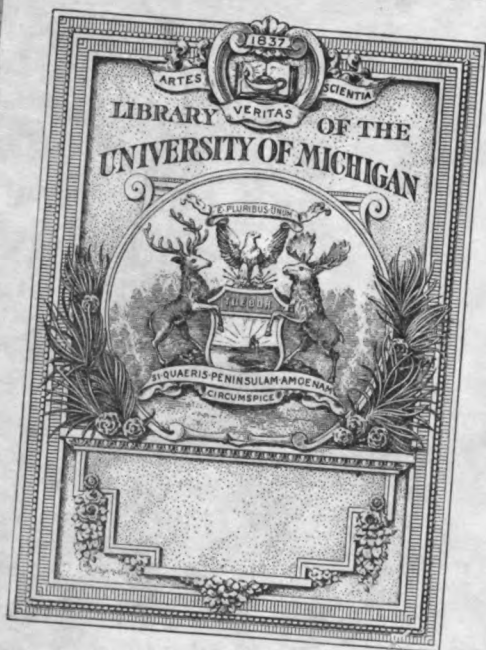



Q
-
P83



THE POPULAR SCIENCE MONTHLY

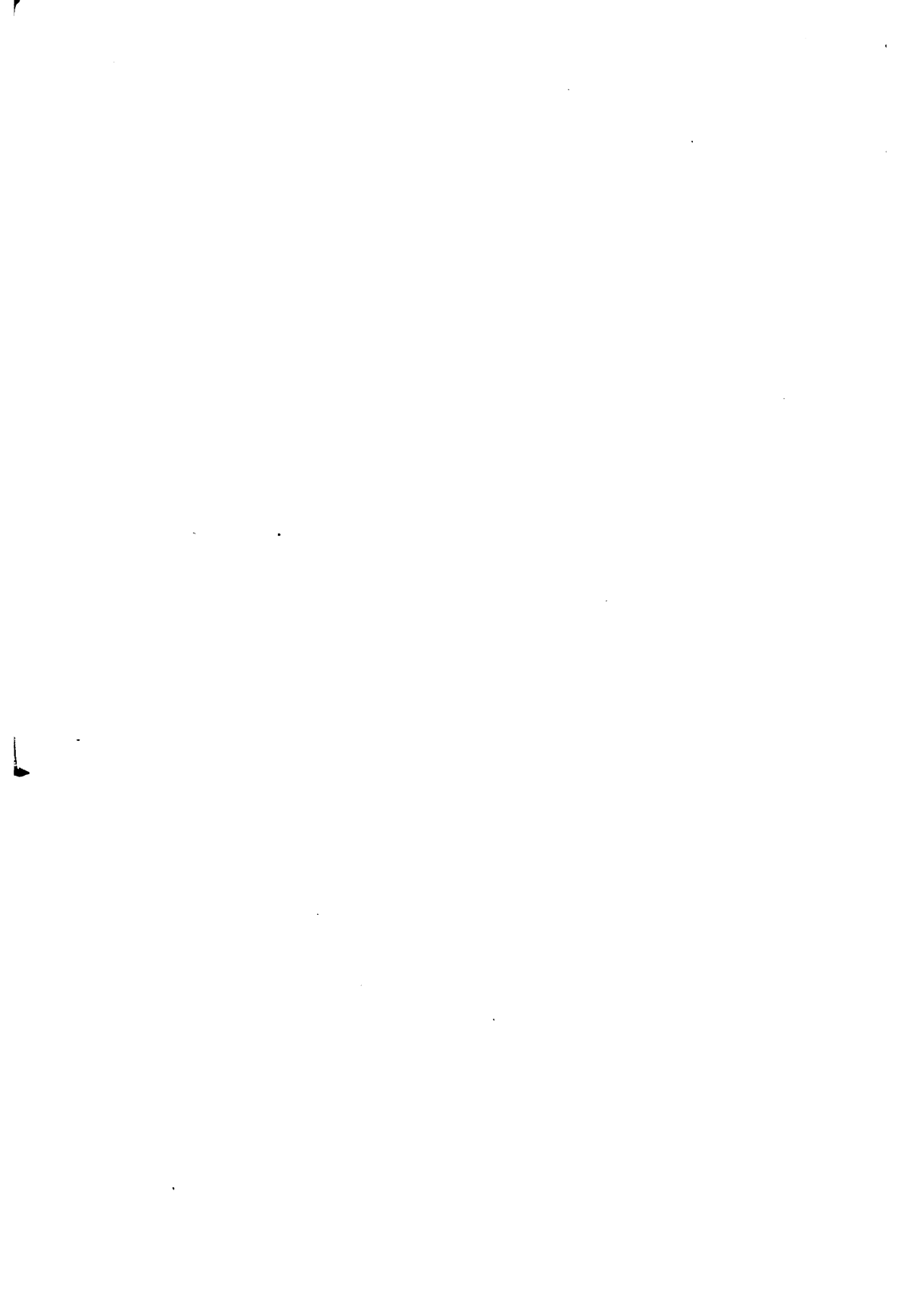

THE
POPULAR SCIENCE
MONTHLY

EDITED BY
J. MCKEEN CATTELL

VOLUME LXXV
JULY TO DECEMBER, 1909

NEW YORK
THE SCIENCE PRESS
1909

2

Copyright, 1908
THE SCIENCE PRESS

PRESS OF
THE NEW ERA PRINTING COMPANY
LANCASTER, PA.

THE POPULAR SCIENCE MONTHLY.

JULY, 1909

NATURAL RESISTANCE TO INFECTIOUS DISEASE AND ITS REINFORCEMENT.¹

BY DR. SIMON FLEXNER

ROCKEFELLER INSTITUTE FOR MEDICAL RESEARCH

COMMON observations early indicated that individuals of all animal species, and of the human species especially, were very unequally subject to disease. This elementary fact is impressed every day upon the thoughtful and has been, from the earliest times, the object of much ingenious speculation. Even to-day, and in spite of the acquisition of a wealth of new facts in physiology and pathology, we are not able to define fully the conditions that make for or against disease. However, the new knowledge which has been acquired enables us to see much more deeply and clearly into the complex mechanisms of disease than could be seen half a century ago; but unfortunately our insight has not been strengthened as regards all diseases, but almost exclusively in relation to the infectious diseases. In respect to the other class, or non-infectious or chronic diseases, among which are Bright's disease, vascular disease, malignant tumors, the gains in fundamental knowledge are far less great.

It may be axiomatic to state that all actual progress in unraveling the complicated conditions of disease depends upon precise knowledge of its underlying causes; and yet in an age in which comparative ignorance still requires that a certain amount of practise shall be empirical, it is well to bear in mind this notion, so that what is undertaken through knowledge may be kept distinct from what is adventured through ignorance. It has been to the lasting credit of the medical profession of an early period, when actual knowledge of the underlying causes of disease had not, and in the then state of development

¹ Read at the University Lectures on Public Health at Columbia University, New York City, March 1.

of the physical sciences could not, have yielded a single concrete fact, that one method—vaccination—and the most perfect one yet discovered of preventing a disease, and two drugs—quinine and mercury—specific for two other infectious diseases, should have been found and so successfully applied. But in contrast to this slow, painful and halting advance in practical means for the relief of suffering, is to be placed the body of robust facts, acquired in a quarter of a century, during the present or bacteriological era in medicine, which enables us to view in some measure the mechanisms of disease and defense against it, and which has pointed the way to efficient modes of prevention, and, in a few brilliant instances, to the production of biologically perfect means of combating certain infectious maladies. To produce a means, as has been done through the perfection of curative sera, that shall strike down myriads of living parasitic organisms, within the interior of the body, amid millions of sensitive and even sentient cells of the organs, without inflicting on them the smallest injury, is indeed a great accomplishment. And if I am successful to-day in placing before you the main facts, now revealed, of the body's manner of defense to parasitic invasion, you will, I think, come to see that it has been by imitating nature's methods and by augmentation of the natural forces of defense, that good has been achieved.

The facts laboriously acquired, on which this presentation will rest, have been drawn from the study of spontaneous disease—so-called natural disease—among man and animals, and from experimental diseases produced in animals. I need scarcely point out that there is really no unnatural form of disease any more than there is a really natural one; in all instances we are dealing with natural laws of health and disease, the difference merely being that in one case we are often ignorant of the time and manner of entrance of the infecting germs into the body, and in the other they are purposely introduced, in a pre-determined efficient manner, in a pure state into the animal body. Since we are so often ignorant of the precise manner of ingress of the germs in the non-experimental forms of disease, we conclude from the identity of the conditions present in the experimental and non-experimental forms of the disease, that in effect they are identical. This power exactly to reproduce at will, by pure bacterial cultures, infectious disease in animals has been of inestimable benefit in investigating disease.

To escape disease is not merely to remain without the zone of influence of the germs of disease. To do this in all cases is impossible, because with certain germ diseases—tuberculosis, for example—the germs are ubiquitous; and with several other diseases the germs are constant if not naturalized inhabitants of the body. Thus we carry on our skin surfaces constantly the germs of suppuration; on the mucous membranes of the nose and throat the germs of pneumonia, and sometimes those of diphtheria, tuberculosis and meningitis. The intestinal

mucous membrane supports a rich and varied bacterial flora among which are several potentially harmful species and sometimes, even under conditions of health, the bacilli of typhoid fever, of dysentery, and in regions in which cholera is endemic, or during its epidemics, of cholera bacilli.

It is obvious, therefore, that it is practically impossible to escape the dangers of bacterial infection, and withdrawal absolutely from other human beings and from all human habitations would be powerless to accomplish this result. It is equally obvious that with such constant and universal exposure to bacterial infection the body must, for the greater part, easily defend itself against this class of its enemies. It is now known that this defense is not merely by exclusion of the bacteria from the interior of the body, although in itself this is an important means of protection for which special mechanisms are provided, but that constant small escapes of bacteria into the blood are taking place from the mucous membranes chiefly, and that there rarely ensues disease from this cause.

On the other hand, there is another class of disease germs that do not regularly inhabit the body and whose influence is occasional only. Some of these germs are exquisitely infectious, as, for example, those causing small-pox, measles and scarlet fever; and others require an intermediate agency to inoculate them as in malaria, yellow fever, and possibly bubonic plague. And yet, excluding small-pox, which in ante-vaccination days overlooked few if any persons in infected regions, a great diversity of susceptibility to infection has been noted again and again among exposed persons and animals. This variability of infectivity affects difference in species, race and individuals and constitutes one of the fundamental problems of disease. Certain diseases are naturally limited to certain species and can not at all, or can only with great difficulty, be transferred to another, although related, species; other diseases appear among several species widely separated from each other; still other diseases choose by preference or are quite restricted to certain breeds of a species; and finally, individuals of a homogeneous species exhibit wide differences of susceptibility to infection. A worked-out theory of infection to and immunity from disease would include and explain, all these, and many more, diversities which have been observed. I need not offer an apology for this at present unattained ideal.

It was early apparent that bacteria must sometimes escape into the blood and yet that infection did not follow. It was observed that frequently at death the interior of the body was free of bacteria and might remain so for many hours and until signs of putrefaction began to be apparent. The deduction from this observation was to the effect that the blood and organs must protect themselves during life and for a period after death from bacterial development. The remarkable anti-bacterial power of the blood was demonstrated directly by injecting

putrescent fluids into the veins of rabbits and noting that not only might they survive the infections and remain quite normal, but that the blood drawn soon after the injection was made need not, when carefully collected, undergo putrefaction. This fundamental experiment, performed before pure cultures of bacteria were available, left no doubts that the body possesses internal means of ridding itself of large numbers of bacteria.

It is apparent that the body possesses two possible distinct ways of freeing itself of these bacteria: it might remove them through the excretory organs—the kidneys or liver; it might rid itself of them by destroying them inside the body. It was with the rise of modern bacteriology that proof was brought that the blood and certain other body fluids—peritoneal, pleural, pericardial transudates—possess a remarkable power of destroying bacteria. This power resides in shed blood, in the other fluids withdrawn from the body, and even in the fluids deprived of all their natural cellular constituents. Here was then a concrete fact: the fluids of the interior of the body are capable of killing large numbers of bacteria. It could now be shown that the bacteria introduced in large numbers into the blood of a living animal are not excreted but are destroyed within the body. This power of the blood is, however, not indefinite and is not exercised equally against all kinds of bacteria. Even with bacteria that readily succumb a very large number may exceed the blood's capacity to destroy, so that survival and multiplication would result; and certain bacterial species proved highly resistant to this blood destruction. Moreover, it was observed that the blood of all animals tested did not produce the same effects on given kinds of bacteria, that this power to destroy bacteria was lost spontaneously in a few days by the fluids removed from the body and was destroyed immediately by a temperature of 60° C. It is, therefore, a highly labile quality.

Apparently the way was opened up for the detection of the conditions which underlie infection and immunity and the various peculiarities determined by species, race and individual. Unfortunately, there proved to be no sharp relation between the bactericidal powers of shed blood and immunity from or susceptibility to infection. And important as these blood-phenomena proved to be, in accomplishing protection from infection, they do not in themselves account for all observed conditions.

The factors upon which the bactericidal properties of the blood depend have now been clearly ascertained. The chief substance has been called alexin or defensive substance, but in reality the alexin is a compound and consists of a sensitive body—complement—and a more stable substance—intermediary body. Bacteria are killed and disintegrated when the intermediate body can attach itself to them and bring them under the influence of the complement—a digestive enzymotic element, to which the intermediary body also attaches itself.

Moreover, it is now quite certain that of the two principles the intermediary body alone is a fixed, native element of the blood plasma, and the complement is subject to considerable fluctuations in quantity. The origin of the intermediary body has not been determined, while it is quite established that the complement is yielded by the white corpuscles, or leucocytes, of the blood. This matter of the origin of the complement is very important because the protective value of the blood fluid is determined by the quantity of complement available at any one time and not so much by the more constant intermediary body which is usually in excess of the complement. The complement would appear to arise from the leucocytes partly as a secretion; but the quantity derived in this way would not appear to be considerable. It also arises from leucocytes which are brought by any cause to degeneration and disintegration, and this would seem to be a richer source than the other. Leucocytes are constantly being worn out by physiological use and as constantly yielding up their complement to the blood as they go to pieces. It would appear, then, that the very essential complement which exists in the circulating blood and passes from the blood into the lymph and serous cavities, will be more or less determined in quantity by the number of blood leucocytes and the conditions to which they are exposed, and as they are brought to slower or faster degeneration; and it is extremely probable that the secretion of complement is influenced also by the nature of the stimuli to which even the living leucocytes are exposed. It has been shown beyond peradventure that the blood plasma contains less complement than blood serum, as would now be expected since the origin of complement from degenerating leucocytes has been abundantly shown, and because in the clotting of the blood the leucocytes are so greatly disintegrated. But I do not think that even the most ardent adversaries of the view that the fluids of the interior of the body do not exert direct bactericidal effects, have been able to show that the plasma contains no complement. The complement is such a labile body that doubtless it is constantly used up physiologically and must therefore as constantly be renewed, and it is highly probable that the balance between production and destruction may not always be maintained, whence a considerable fluctuation may occur even in health. Whether the fluctuations ever synchronize with intending infections in such a manner as to promote them is not really known, but is not impossible.

It is, however, patent that the naturally operative defensive mechanisms against bacterial invasion must contain other factors than these humoral ones. We are all now prepared to admit that in the phagocytes, or the devouring white corpuscles of the blood, the body possesses another defensive system of high efficiency. The motile nature of these cells and their presence in the circulating blood accord them a high degree of mobility, so that they can be quickly dispatched to any part of the body threatened by invaders, and are hardly behind the fluids of

the blood in this ability to be massed or delivered where needed. The phagocytic mechanism of defense operates through all the orders of the metazoa; and while it can hardly have been developed originally as a protective system against parasites, and doubtless represents a mechanism for disposing of effete and useless particulate matter in the body by a process of intracellular digestion, yet it has reached through evolutionary selection a high state of perfection and must have exercised no small influence in protecting from extinction certain living species.

There is good reason to believe that in the final disposal of bacteria intruded into the body the phagocytes play the terminal rôle: *i. e.*, under favorable conditions they are attracted through chemical stimuli furnished by the bacteria to which they respond to englobe them, after which the bacteria are often disintegrated. But there is equally good reason to believe that, with few exceptions, this engulfing can not take place until the bacteria have been acted on by certain plasmatic constituents that prepare the bacteria to be taken into the body of the phagocytes. The further the phenomena of bacterial destruction in the body are probed the more certain does it become that there is no single and uniform process of their disposal. The humoral doctrine of bacterial destruction contains much of fact, the phagocytic doctrine much of fact, and it is quite certain that the practical defensive activities of the body constantly imply the use of both mechanisms.

And when we push the analysis of the manner in which bacteria injure the body and enumerate the various bactericidal substances which have now been determined as existing in the plasma and in the cells, we find that this interaction must be supposed to take place. Plasmatic bactericidal action and phagocytic inclusion are cooperative functions; plasmatic antitoxic action and phagocytic detoxication are cooperative functions; plasmatic opsonization and phagocytic ingestion are complementary functions; plasmatic agglutination and phagocytic engulfing are also complementary, although less essential functions. And although in intending infections the toxic action of the bacteria to be dealt with is less a matter of great consequence, yet in principle the disposal of a few bacteria is not different from the disposal of many; and in dealing with the poison or toxic elements of bacteria, the plasma possesses distinct power of direct neutralization as the phagocytes possess distinct ability to transform poisonous into non-poisonous molecules.

I desire now to refer again to the subject of racial and species immunity for which the humoral factors of bacterial destruction afforded an imperfect explanation, in order that I may point out that the introduction of bacteria, incapable of causing infection, into immune species is followed by immediate phagocytic ingestion and destruction of the microorganisms. The rapidity and perfection of the phagocytic reaction in insusceptible animals are very impressive and might readily lead to the decision that they suffice to explain the resistance or

immunity. However, the matter does not permit of such summary disposal, since there appear to be other factors that enter into the phenomena. The frog that does not become tetanic when inoculated with tetanus bacilli or poison, develops tetanic spasms when the temperature is raised somewhat; the hen that does not respond to an anthrax inoculation develops the infection when the temperature is lowered somewhat. Even for the final ingestion of bacteria by the phagocytes of alien and insusceptible species the plasma principles are required.

Undoubtedly the phenomena of racial and species immunity are affected by phagocytosis. But our present knowledge does not justify us in disregarding other possible and contributing agencies. We are still so little informed of even the grosser features of the body's metabolism that it would be premature to deny to it influence on susceptibility to infection. Between the metabolism of birds and mammals there is such wide disparity that an influence could easily be conceived; but the metabolic disparity is less between the herbivora and carnivora, and still less between some closely related species which yet show marked differences in susceptibility to bacterial infection; and as between individuals of the same species it could only be the finer intramolecular variations that conceivably could come into play.

Although the properties of the defensive mechanisms of the blood have not been exhausted, yet they have been defined in such detail as to suffice for the moment and to permit us to turn attention, for a brief space, to some of the properties of the intending invading bacteria. It is matter of common experience, which each of us has suffered, that the elaborate mechanisms provided for our protection from bacterial infection do not always suffice, and now it becomes necessary to explain why they do not. In the first place, there are very great differences between the bacteria which seek to enter the body. Some species are never very harmful and are readily combated, excluded or destroyed; other species often possess only a moderate degree of virulence or potential power of doing injury and can also, as a rule, be overcome; while these second species sometimes acquire such highly virulent or invasive powers that the defenses prove quite inadequate to exclude or combat them. During the prevalence of great bacterial epidemics it is probable that this factor, virulence, plays a considerable rôle. Of course in epidemics the bacterial causes are by the exigencies of the situation more widely diffused than at other times, so that more individuals come under their influence; but with even such a common bacterium as the diplococcus which causes pneumonia and the bacillus which produces influenza, there arise conditions in which severe and often very extensive outbreaks, or localized epidemics, occur which are probably to be attributed to an accession in virulence of these germs, although the precise causes leading to the increase may not be discovered.

Now this quality of virulence, which is often evolved so quickly

and apparently so mysteriously is expressed biologically in various ways besides in that of greater infective power: virulent bacteria may prove incapable of being charged with opsonin so that they can not be ingested by phagocytes; they may show unusual power to resist plasma or serum destruction; they may drive away or repel or act negatively in respect to chemical attraction on the phagocytes; and being thus unopposable they tend to multiply quickly and with little restraint and thus still further to break down and render ineffective the normal defensive mechanisms, and ultimately to damage seriously the sensitive cells of the organs. This constitutes disease.

Another power resides in the body that should be regarded, namely, the power to neutralize or destroy poisons as distinct from parasites; for the body is exposed to the deleterious action of poisons generated by living parasites that do not themselves penetrate within the body. Some of these poisons are generated away from the body, as is the case with certain food poisons; some by bacteria in the intestinal canal that do not seek to invade the blood; some by bacteria, like the diphtheria bacillus, that first kill tissue, usually of the mucous membranes, and then develop in the dead tissue and send the poison into the body. And besides this every bacterial disease resolves itself ultimately into a process of poisoning—of intoxication. In typhoid fever, in pneumonia, in meningitis and in the multitude of other bacterial invasive diseases of man and the lower animals, the severe symptoms are caused by the poisons liberated through disintegration of the invading bacteria which, however, continue by multiplication to recruit their numbers.

The condition of susceptibility to poisons varies with different races and species, very much as bacterial susceptibility does. The cold-blooded animals are indifferent to poisons that are very injurious to warm-blooded animals, but not all cold-blooded animals behave alike. Tetanus toxin is alike innocuous for the frog and the alligator; but by raising the temperature artificially the frog develops tetanus, but the alligator does not. Sometimes the effects depend merely upon the mode of entrance of the poison into the body. Tetanus toxin, diphtheria toxin and snake venom have no effect on mammals when swallowed unless the intestinal epithelium has been injured. These poisons can not pass through the epithelium to reach the blood, where alone they can exert their action. The toxin of the dysentery bacillus passes readily in the rabbit from the blood into the intestine, which it injures, but can not pass from the intestine into the blood. Tetanus toxin can be injected into the circulation of the hen but does no harm. Injected into the brain it produces tetanus. Introduced into the blood it remains there for many weeks, hence the failure to act can not be due to destruction, but probably is due to inability to pass through the blood vessels in order to reach the cells of the central nervous system in a sufficient state of concentration. The physiological state of the animal also exerts an influence: certain hibernating species are sus-

ceptible to tetanus poison in the summer but not during the winter sleep. There exist, therefore, different mechanisms for excluding poisons from the sensitive and reacting cells and among them are certain quantities of neutralizing, or antitoxic substances, normally contained in the blood. We know at least one such definite antitoxin, namely, the diphtheria antitoxin, which exists in minimal quantities in the blood of man and the horse.

The absence of numerical relation between the mechanism which destroys bacteria and neutralizes poisons sometimes works sad havoc for the body. The two capacities may differ naturally or are enhanced in different degrees by artificial means. The matter is one of great importance because almost without exception all bacterial diseases are examples of poisoning. The mechanical obstructions produced by the bacterial bodies are relatively unimportant. The body is more readily defended from the invasion of bacteria, with very few exceptions, than from the effects of their poisons. The capacity to dispose of typhoid and cholera bacilli is more easily produced than the power to neutralize or otherwise render innocuous the poisons liberated by the dissolved bacilli. It is precisely because we have not yet learned how to overcome this class of bacterial poisons within the body that we have not mastered the bacterial diseases as a whole. There are, however, certain bacterial poisons for which adequate antidotes are readily produced, thus, for example, for the diphtheria, tetanus, botulism and possibly the dysentery poisons. Here the poisons can be more easily neutralized than the bacilli can be got rid of, but by neutralizing the poisons we succeed in arresting the multiplication of the bacteria and often in curing the disease.

The normal body possesses a mean resistance to bacterial invasion and to bacterial poisoning which, while somewhat fluctuant, is of high value except under certain exceptional conditions in which infection readily develops. We know that certain general states of and influences exerted on the body are associated with a rise or a fall of this mean value. But we are not equally informed of the physical basis of this rise and fall. This particular topic is peculiarly difficult because of the large numbers of factors which enter into it. We know from observation that proper clothing, wholesome food, good hygienic surroundings, avoidance of over fatigue and of depressing psychic impressions, and that physical care of the body, all contribute toward maintaining health as the reverse conditions predispose to establishing disease. In seeking the physical basis of this difference we must avoid confusing cause with effect. Good hygienic surroundings may act chiefly by excluding the sources of infection rather than by enhancing resistance. Yet there is experimental as well as observational foundation for the belief in these general influences to affect the disposition to acquire or escape infectious disease. Animals which are made to fast, to over-exercise, are made anæmic, are given excessive quantities of

alcohol and other poisons, or are exposed to abnormal cold by shaving of the skin, are more subject to certain infections than animals not so treated. If, now, it were found that the blood factors governing resistance fluctuated with these influences, became smaller and less conspicuous when the influences were bad and larger and more efficient when the influences were good, we should then have established an important concrete fact.

But the alexinic activity of the blood varies normally within such wide limits that only maximal changes could be regarded as significant, and it appears that it is only as the fatal termination of certain severe infections are reached—such as experimental anthrax and pneumococcus infections, for example—that the alexinic power falls greatly or disappears altogether. The determination of phagocytic activity outside the body has not thus far been carried out in such a manner as to indicate a functional depression which either precedes immediately or develops in the course of severe infections; although certain infections which take a severe course are characterized by a persistent reduction in the number of leucocytes in the circulating blood. This latter phenomenon must, however, probably be regarded as an effect and not as the cause of the infection. There is, however, known at least one example where paralysis of the phagocytes leads to a fatal infection under conditions in which the normal phagocytes are entirely competent to prevent infection. If to a guinea-pig a small dose of opium be administered and this is followed by the injection of a non-lethal quantity of a culture of the cholera bacillus, death will ensue because the sensitiveness of the phagocytes to the chemical stimulus exerted by the cholera poison has been diminished by the narcotic influence of the opium.

The mean phagocytic value of the blood can, however, be definitely raised by certain agencies, that are at the same time and through the rise in the number of phagocytes produced, useful in warding off and sometimes even in overcoming infection. The means employed to bring about an increase of leucocytes, or to establish a hyperleucocytosis, suffice to maintain the high value for short period relatively only, unless the stimulus is frequently repeated. A cold bath, a sun bath, the injection into the circulation of a number of simple chemical substances—peptone, albumose, nucleinic acid, spermin, pilocarpine—are all followed under physiological conditions by hyperleucocytosis and by a temporary state of increased resistance to bacterial invasion. Moreover, in certain experimental infections, at least, there can thus be aroused a heightened power to overcome established infections—those caused, for example, by the cholera, meningitis and pneumococcus germs. Perhaps the most striking example of the protective influence of hyperleucocytosis is afforded by the experimental infection described under the name of cholera peritonitis of the guinea-pig. If a fatal quantity of cholera germs be injected into the peritoneal cavity of a

guinea-pig, symptoms of poisoning quickly set in and death results in a few hours. A study of the conditions present in the peritoneal cavity shows that the bacteria have developed freely, that some have been broken up and disintegrated, and that very few preserved phagocytes can be found. Examination of the blood reveals that the number of leucocytes in the general circulation has been reduced; and all the evidences point to the conclusion that not only has phagocytosis not taken place, but that there has been a general destruction of leucocytes produced by the cholera poison. If, however, there be introduced into the peritoneal cavity of a guinea-pig twelve to twenty-four hours prior to the inoculation of the cholera bacilli, a small amount of sterile salt solution, or bouillon, or one of the other chemicals mentioned, which procedure will bring into the peritoneum a considerable number of leucocytes at the same time that it causes a rise of leucocytes in the circulating blood, then the cholera germs are quickly taken up by the phagocytes, multiplication is prevented, and the animal escapes severe illness.

The value of hyperleucocytosis as a defensive measure against infection must, probably, always remain greater than its value as a cure for established infection. There are several reasons that make this conclusion probable: the capacity of the blood is increased in the direction of destroying bacteria without being augmented at the same time in the direction of neutralizing bacterial poisons; the organism that is already severely poisoned by infection reacts less certainly to the chemical agents that provoke hyperleucocytosis than the uninfected organism. And yet we may see the operation of the benign influence of hyperleucocytosis, associated with an increased passage of alexin-containing lymph through the vessels, upon certain local infections at least, in the results of measures that determine an augmented supply of blood to a diseased part; in the mechanical hyperæmias produced through posture or superheated air; the influence (in part) of tuberculin injections; and the effects of poultices and embrocations, of counter-irritants, and of certain of the phenomena of local inflammation.

The facts at our command point to the great potential power of the normal organism to resist infection and indicate that the normal body possesses the capacity, on demand, to increase this power beyond the mean value, chiefly by opposing intending infection by hyperleucocytosis and also, probably, by the strengthening of its plasmatic defensive action through the additional soluble alexin substances thrown off by the augmented leucocytes. This defensive mechanism acts in the same manner on all bacterial invaders and is not specially adapted for any one or group of bacteria. The form of activity is strictly non-specific.

Let us now ask ourselves if in overcoming infectious disease, which luckily the organism is frequently able to accomplish, the mechanism put into operation is similar and only more intense than the one we have considered for warding off infection? The answer to this question

is that recovery from infection consists in the bringing into being of a new set of phenomena that gradually reinforce the resistance; that recovery from infection is accomplished through a process of immunization. The evidences of this condition of immunization are found in the appearance in the blood some time between the fourth or fifth to the tenth day of the disease, and somewhat later than they have appeared in the spleen and bone marrow, of chemical substances which are directed in a specific manner to the neutralization of the poisons having been and still being produced by the bacterial causes of the disease, to the destruction of the bacteria themselves either outright by the plasmatic fluid which has now been enriched by a new quantity of intermediary substance of high potency that may bring the bacteria more readily under the dissolving influence of the complement, or by the phagocytes to which they are exposed in greater measure through the production of opsonins of higher strength and stability. As recovery progresses these immunity substances continue to increase until at the termination of the disease they are present in quantities that suffice often, by a passive transfer to another individual, to protect other animals more certainly from an infection, or to terminate abruptly an infection already established in them.

When the infectious disease is the expression not of the combined effects of poison and bacteria but of the poison chiefly which enters the blood, the bacteria remaining without as in diphtheria, then the blood changes characterizing the immune state are simpler and consist in the accumulation there of antitoxins that constitute the most perfect antidote to poisons that are known. The condition of immunity produces no demonstrable change in the properties of the phagocytes through which they are better enabled to overcome the poisonous bacteria. They do become, in course of the immunization, more sensitive to positive chemotactic stimuli; but it is still an unsettled question whether they are altered qualitatively by the immunization, or whether the plasmatic changes do not really react upon them and thus increase their efficiency.

It must now be patent that between what may be termed the process of physiological resistance and what is termed the condition of immunization, a wide distinction exists. The one is non-specific in its action, the other highly specific in its effects; the one is subject to a limited augmentation, the other may be carried to a high degree of potency and perfection; the one often fails to protect the organism in which it is developed, the other suffices to protect both itself and another organism. If therefore we were to be asked in what manner can the animal organism best be reinforced against infection, we should be compelled to answer by passing safely through the infection itself. This conclusion, which has been reached by purely experimental biological methods is supported on every side by common observation and experience with

the acute infectious diseases of which one attack protects from a subsequent attack of the same disease.

It may conduce to clearness if we should enumerate the factors that have been described and assigned on the one hand to natural resistance, and on the other hand to acquired resistance or immunity. We can tabulate the factors in the following manner:

NATURAL OR PHYSIOLOGICAL RESISTANCE	INCREASED NATURAL OR PHYSIOLOGICAL RESISTANCE
Alexin { complement. intermediary body. opsonin. agglutinin.	Alexin { complement, probably increased. intermediary body. opsonin. agglutinin.
Phagocyte.	Phagocyte—increased (hyperleucocytosis).

ACQUIRED IMMUNITY

Complement—probably increased.
 Intermediary body—specific one produced.
 Opsonin—specific, stabile one produced.
 Agglutinin—specific one produced.
 Antitoxin { for exotoxin
 for endotoxin } produced.
 Phagocyte—often increased but qualitatively unchanged.

This tabulation exhibits the distinction between the physical basis of physiological resistance and of the state of immunity. There is another difference between them; any increase that can be called out beyond the mean of physiological resistance is accomplished in a few hours; and having been called out to meet a particular condition of need of the body and the effect having been exerted, it passes off very soon. It is rare that the effect of a hyperleucocytosis can be detected for more than three or four days after it has appeared. The development of the state of immunity, on the other hand, is a slow process relatively and depends upon the setting into motion of certain cell-functions, through which new substances are produced, which, being first retained within the cells producing them, eventually are passed into the blood. Hence it is that these new substances can be detected at an earlier period of the infection in the spleen than in the blood. But once they have been produced, the substances endure either for an indefinite period, or the capacity to produce new ones of the same sort is retained by the organism often for years. The blood may grow weak in the typhoid immunity principle in the course of years following an attack of typhoid fever, or a rabbit immunized with typhoid bacilli may show after a time a great diminution of the blood agglutinins for typhoid bacilli; but the typhoid immunity persists in the one, as in the other minimal quantities of typhoid bacilli will bring out, and without the original delay, a new production of agglutinin that will restore the lost amount.

The facts on immunity which I have presented to you constitute the physical basis, also, of all artificial methods which are being pursued so successfully in preventing certain infections through vaccination, and in curing them through the use of immune serum products. The facts also account in an eminently satisfactory manner for the suppression of small-pox by cow-pox vaccination. The "vaccines" so-called for bacterial diseases, which are, I might say, at present being employed chiefly in protecting animals from epidemic infectious diseases to which they are much exposed, consist for the most part of bacteria either killed outright by heat or chemicals or of bacteria whose virulence has been diminished by special methods of cultivation or treatment. In human beings this method of vaccination has been employed only when large numbers of persons have been exposed to infections from the zone or focus of which they could not be removed, or from which, owing to the peculiar circumstances surrounding the infections, they could not readily or at all be protected by the suppression of the diseased germs at their sources. Thus it has been found advantageous in a few instances to employ vaccination against cholera and bubonic plague, on those especially exposed to these epidemic diseases, and against typhoid fever on troops going in time of war into heavily infected endemic zones of that disease.

In a few instances this method of vaccination has been successfully carried out in animals with infectious diseases in which the germs causing them have not been discovered. Thus it is possible to vaccinate cattle against the destructive rinderpest of Africa, the Philippines and other tropical countries, by employing the bile of animals which have succumbed to the infection, which contains the parasite of the disease somewhat modified by certain immunity principles contained within it along with parasites. In fact, this method of conjoint vaccination with the parasite of the disease and the blood containing immunity principles is one that offers a considerable field of practical application. On the one hand, there is accomplished a passive immunization of the body that becomes operative immediately and, on the other hand, a vaccination that after the usual interval leads to the production of a state of active immunity that rises to a higher level and is far more enduring than the passive state.

Incidentally we have discovered from this process of mixed or conjoint vaccination that immune sera prepared for bacteria or other parasites which are not toxin producers in the manner of the diphtheria bacillus, but which contain endotoxin, act not especially by neutralizing toxins, or by destroying outright the bacteria, but by exercising an efficient protective control over the injury which these parasites or their poisons tend to inflict on certain sensitive body cells. For example, if cattle are inoculated on one side of the body with virulent blood from animals dying of rinderpest, and on the other side with blood serum taken from animals that have recovered from the

disease and subsequently have had their immunity intensified by injections of highly virulent blood, the cattle so vaccinated will develop rinderpest in a mild form and will subsequently on recovery be also immune; and yet during the process of immunization their blood contains highly virulent parasites so that if a little of it be introduced into non-protected and healthy cattle, they will be given rinderpest and will die of it.

The reaction of the body to the bacterial vaccines injected is out of proportion to the quantity of culture introduced. Thus two milligrams of dead cholera bacilli injected under the skin of human beings will yield enough of the specific immunity substance for these bacilli to bring about the destruction of 60,000 or more milligrams of the culture. There can be, therefore, no direct transformation of the cholera bacilli into immunity bodies, but they must exert a stimulus on certain cell-functions through which the immunity principles are produced; and the quantity of their formation depends not on the weight of crude bacilli introduced, but on the strength of the stimulus impressed upon the sensitive cells to which they react in a specific and remarkable manner.

Is it possible in the course of an established infection to reinforce the resistance of the body? I have already stated that it is not practicable to bring out at the height of an infection an efficient heightened reaction of physiological resistance; but from this it does not follow that under these conditions a special form of immunity reaction may not be elicited. The tuberculin reaction, or that part of it which is specific, may be cited as an example of this kind of reinforcement; and whatever there is of value in the treatment of infectious diseases by means of dead cultures of their specific bacteria—"vaccines" so-called—must be of the nature of an intensified immunity reaction. What is sought to be accomplished in the latter case is the formation in certain uninfected localities—in the subcutaneous tissues, for example—of immunity principles that afterwards by escaping into the blood shall assist in the termination of an infectious process situated elsewhere in the body. Such local foci of immunity as it is designed to create in the subcutaneous tissue are not unknown. The pleura can be given a local immunity to the typhoid bacilli; the subcutaneous tissue to tetanus toxin, and it is highly probable that the normal resistances exhibited by our mucous membranes to the pathogenic bacteria they harbor are examples of such local immunities.

I fear that I have carried you far afield and into somewhat devious paths of immunity to disease. You will, I know, not complain and hold it to the detriment of medical science, that these paths have not been already converted into fine open roads. But you will prefer to recall how brief is the time since where the paths now are there were only wood and tangle.

SOME PRACTICAL ASPECTS OF GYROSTATIC ACTION

BY PROFESSOR W. S. FRANKLIN

LEHIGH UNIVERSITY

THE Brennan monorail car and the Schlick device for the prevention of rolling of ships at sea have recently attracted popular attention to the gyrost, and gyrostatic action has recently become vitally interesting to a large group of men because an automobile-engine fly-wheel shows serious gyrostatic reactions when the automobile rounds a curve rapidly or rises suddenly upon a bump in the road. The following discussion will therefore be welcomed by many readers. Let no one imagine that gyrostatic action is mysterious and difficult to analyze; it is really quite simple¹ and the discussion of Fig. 10 makes this action as clear, physically, as the simple inertia reaction of a heavily loaded wagon or boat. The formula for calculating the numerical value of the torque reaction of a gyrost, as given at the end of this paper, is simple enough for any one to use.

The rotation of a wheel on an axis is called spin, and the axle upon which the wheel rotates is called the axle of spin. The spin of a wheel may be completely represented in both magnitude and direction by an arrow drawn parallel to the axle of spin, pointing in the direction in which a right-handed screw would travel if turned with the spinning wheel, and having a length which represents the number of revolutions per second of the wheel. Thus,

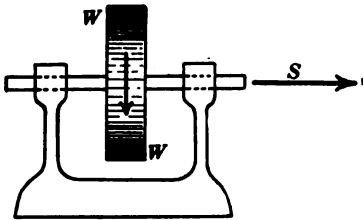

FIG. 1.

the arrow S ,² Fig. 1, represents the spin of the wheel WW .

Let the arrow S' , Fig. 2, represent the spin of a body, imagine a large turning force to act upon the body for a short time, and let the arrow S'' represent the spin which would be produced by the turning force if the body had been initially at rest. The actual resultant spin

¹ When the angular velocity of precession is small as compared with the velocity of spin and when the gyrost wheel is symmetrical with respect to its axis of spin.

² To appreciate the geometrical meaning of the arrows S , ΔS and T in the vector diagrams given in this paper, the reader should thrust his hand in the direction of the arrow head and move the hand as if turning a right-handed screw.

of the body will be represented in magnitude and in direction by the arrow R .³ That is to say, after the large turning force has acted for a short time the body will be found spinning about R as an axis, and the number of revolutions per second will be represented by the length of R . The geometrical relationship between the arrows S' , S'' , and R is completely represented in the triangle OMN of Fig. 2, which triangle is shown by itself in Fig. 3.

A turning force is usually called a torque, thus the turning or

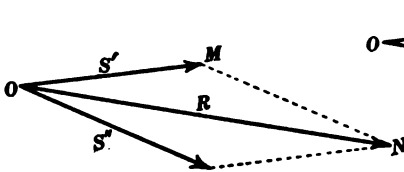

FIG. 2.

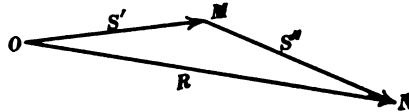

FIG. 3.

twisting force which is exerted upon a screw driver is a torque. A torque may be completely represented by an arrow drawn parallel to the axis of the torque, pointing in the direction in which a right-handed screw would travel if turned by the torque, and having a length which represents the magnitude or value Fl of the torque to scale. Thus the arrow T in Fig. 4 represents the torque due to the two forces FF .

The effect of an unbalanced torque upon a body is to produce a spin-velocity about the same axis as the torque, the amount pro-

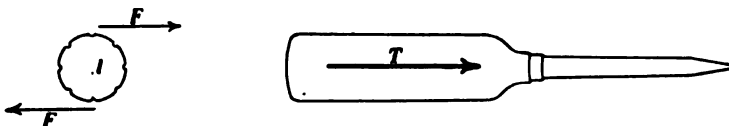

FIG. 4.

duced being proportional to the time the torque continues to act and inversely proportional to what is called the moment of inertia of the body. (a) The simplest case is where the axis of the torque is parallel to the axis of already existing spin as shown in Fig. 5, which represents a wheel and axle set spinning by pulling a cord which is wound around the axle. In this case the axle of spin remains stationary, and the magnitude of the spin increases steadily as long as the torque continues to act. (b) The general case is where the axis of the torque makes any angle whatever with the axis of the already existing spin. Thus, let the arrow S , Fig. 6, represent the already existing spin of

³This proposition is entirely correct if by spin we understand that spin-momentum is meant; the spin-velocity of a body is sometimes greatly complicated by its lack of symmetry, and these complications are ignored in the present discussion.

a body, and let the arrow T represent a torque acting upon the body. Then the arrow ΔS represents the amount of spin produced by T during a short interval of time, and the diagonal arrow S' represents the actual spin of the body after the torque T has acted for a short interval of time.

(c) The case where the axis of torque is always at right angles to the axis of spin is the most important case, and this case is exemplified in the ordinary gyrostat, which is a wheel and axle supported in a

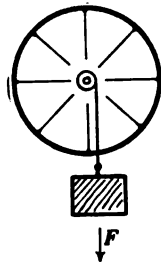

FIG. 5.

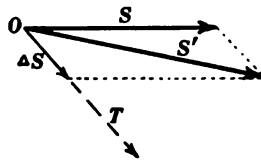

FIG. 6.

movable frame as shown in Fig. 7. By taking hold of the frame it is impossible to exert a torque upon the wheel except about an axis perpendicular to OS , friction at pivots being ignored. If the frame be suspended by a string as shown in Fig. 7 (side view), the pull of the earth combined with the pull of the string constitutes a torque as indicated by the arrow T in Fig. 7 (top view). The effect of this torque during a short interval of time is to produce a certain amount of spin, or spin-momentum, ΔS about T as an axis, and the resultant axis of spin

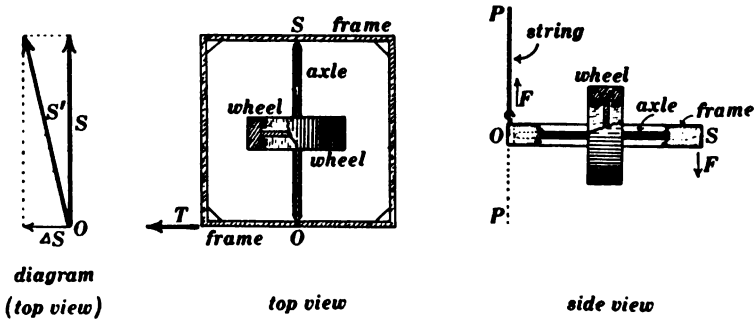

FIG. 7.

becomes S' as shown in the diagram Fig. 7. The unbalanced torque T , due to the weight of the wheel and frame in Fig. 7, causes the frame and wheel to sweep round and round in a horizontal plane about the supporting string as an axis. This kind of motion of an axis of spin due to a torque which is at each instant at right angles to the axis of spin is called *precession*, and the axis PP , Fig. 7, about which the axis of spin rotates is called the axis of precession.

A familiar form of gyrostat is shown in Fig. 8. It consists of a spinning wheel mounted in a metal ring which rests on a pivot O . The pull of the earth on the wheel and ring produces an unbalanced torque about an axis which is at right angles to the axis of spin, and this torque causes the axis of spin to sweep around the pivot O as described in connection with Fig. 7. Precessional motion is illustrated

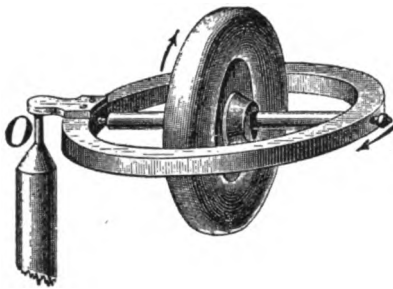

FIG. 8.

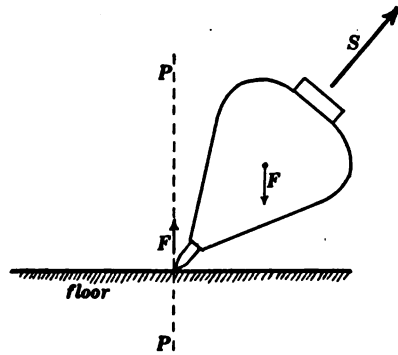

FIG. 9.

in the simplest kind of way by the ordinary top. Fig. 9 shows a top spinning about an inclined axis S . The weight of the top together with the reaction of the floor against the point of the top produces a torque the axis of which is at right angles to the plane of the paper

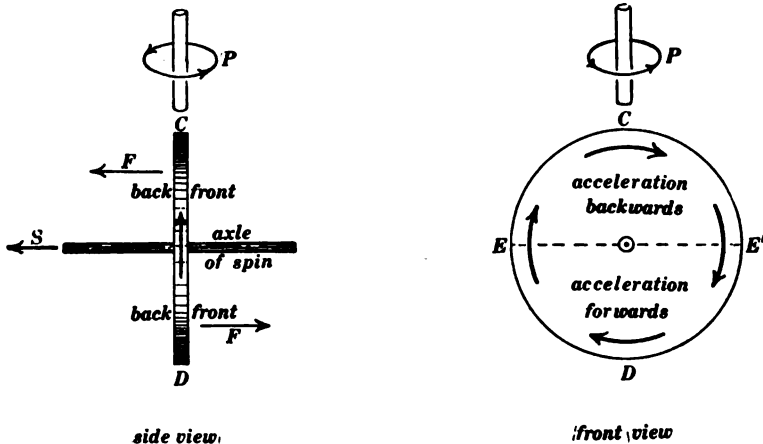

FIG. 10.

in Fig 9, and the effect of this torque is to cause the axis of spin to sweep around the vertical axis PP (the axis of precession).

The above discussion furnishes a sufficient basis for the consideration of the various practical aspects of gyrostatic action, but it is interesting to see how the precessional motion of the gyrostat in Fig.

8 (sweeping of axis of spin about a vertical axis through O) brings about inertia reactions of the various particles of the spinning wheel which keep the wheel from falling under the pull of gravity; it is only necessary to show that to produce precessional motion there must act upon the gyostat-wheel an unbalanced torque (the torque due to the pull of gravity upon the overhanging frame and wheel in Fig. 8). Fig. 10 represents a disk spinning in the direction of the curved arrows (in the front view), the spin being represented by the straight arrow S in the side view. Imagine the axle of spin to sweep slowly

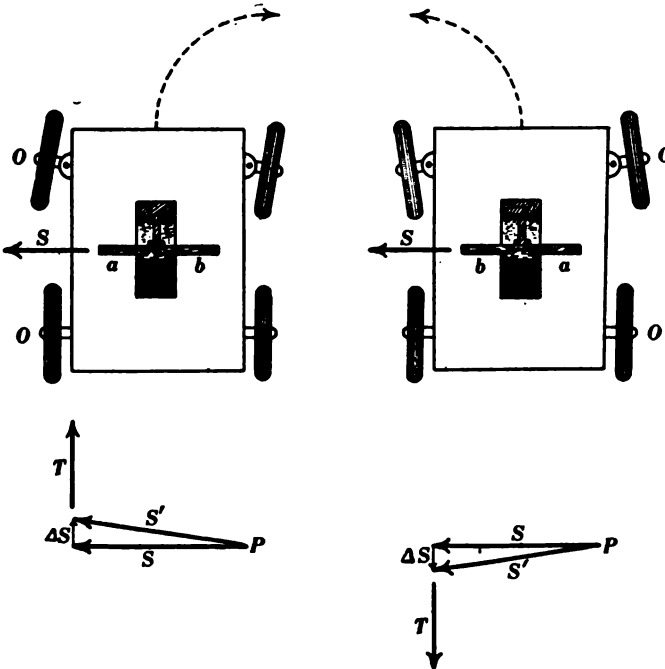

FIG. 11.

FIG. 12.

around the vertical line CD in the direction of the curved arrows PP . This sweeping of the axle of spin about the line CD constitutes precessional motion, and CD is the axis of precession. Consider the front view of the spinning disk in Fig. 10; every particle in the upper half of the disk has a component of its velocity towards the right, and every particle in the lower half of the disk has a component of its velocity towards the left. After a short interval of time the precessional motion moves the edge E of the disk forwards and the edge E' of the disk backwards in the figure, so that the velocity of every particle in the upper half of the disk is turned slightly backwards and the velocity of every particle in the lower half of the disk is turned slightly forwards, that is to say, every particle in the upper half of the

disk has received a slight backward component of velocity and every particle in the lower half of the disk has received a slight forward component of velocity. Therefore, during the short interval of time, every particle of the upper half of the disk must have been gaining velocity backwards and every particle in the lower half of the disk must have been gaining velocity forwards, so that unbalanced forces must have been pushing backwards on every particle in the upper half of the disk and pulling forwards on every particle in the lower half of the disk, or, in other words, a torque must have been acting about the line EE' as an axis as shown by the two arrows FF in the side view.

GYROSTATIC ACTION OF THE FLY-WHEEL OF THE AUTOMOBILE ENGINE

Figs. 11 and 12 show top views of an automobile, the curved dotted arrows represent the turning of the automobile around a curve, and the

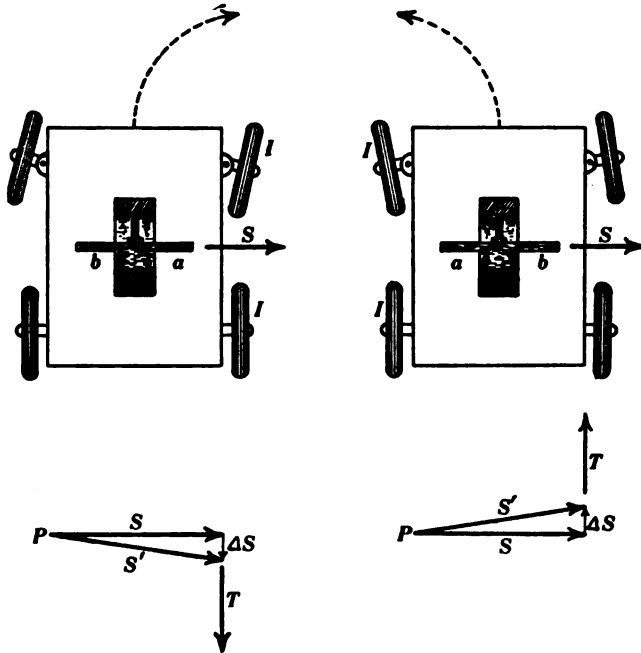

FIG. 13.

FIG. 14.

straight arrows S represent the spin of the fly-wheel shaft. The arrow S in the vector diagram of Fig. 11 or 12 represents the spin-momentum of the fly-wheel at a given instant, the arrow S' represents the spin-momentum at a later instant, ΔS represents the increment of spin-momentum, and the arrow T represents the torque which must act upon the fly-wheel shaft.

To produce this torque the bearing a must push upwards on the engine shaft and the bearing b must push downwards on the engine

shaft, or, in other words, the engine shaft must push downwards on the bearing *a* and pull upwards on the bearing *b*, so that the gyrostatic reaction of the fly-wheel causes the outer wheels *OO* of the automobile to be pushed against the ground excessively as the automobile turns round a curve.

Figs. 11 and 12 represent the case in which the top of the spinning fly-wheel is moving forwards, and Figs. 13 and 14 represent the case in which the top of the spinning fly-wheel is moving backwards. In Figs. 13 and 14 the gyrostatic action of the fly-wheel causes the inner wheels *II* of the automobile to be forced against the ground excessively, as may be seen by studying the vector diagrams in Figs. 13 and 14.

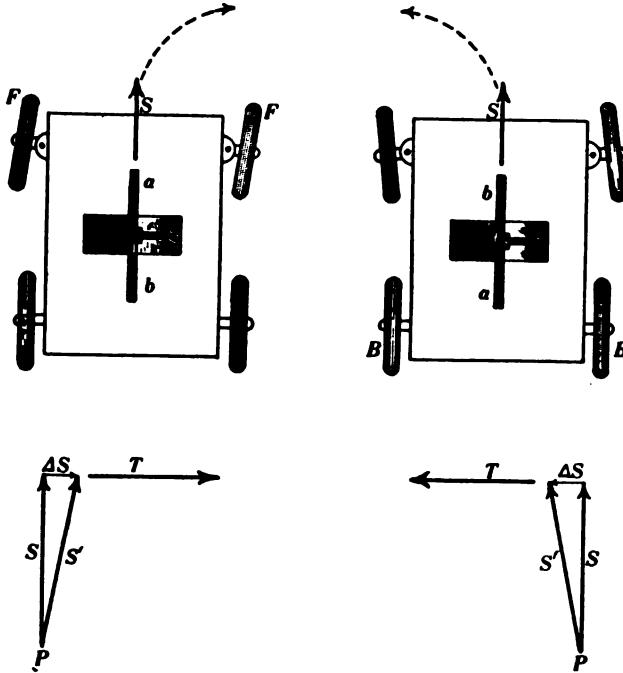

FIG. 15.

FIG. 16.

Figs. 15 and 16 represent the case in which the fly-wheel shaft is parallel to the length of the car. In Fig. 15 the car is represented as turning to the right, the arrow *S* in the vector diagram represents the spin-momentum of the fly-wheel at a given instant, *S'* represents the spin-momentum at a later instant, ΔS represents the increment of spin-momentum, and *T* represents the torque which must act upon the fly-wheel shaft. To produce the torque *T*, the bearing *a* must push upwards upon the engine shaft and the bearing *b* must push downwards on the engine shaft, or, in other words, the engine shaft must push downwards on bearing *a* and upwards on bearing *b*. Therefore the

front wheels FF of the automobile are pushed against the ground with excessive force by the gyrostatic reaction of the fly-wheel in Fig. 15. When the automobile is turning to the left, as shown in Fig. 16, the gyrostatic reaction of the fly-wheel causes the rear wheels BB of the automobile to be pushed against the ground with excessive force.

When an automobile runs over a bump in the road, no gyrostatic action is produced if the engine shaft is crosswise of the car, but very severe gyrostatic action may be produced if the engine shaft is fore and aft, as shown in Fig. 17. In the vector diagram of Fig. 17,

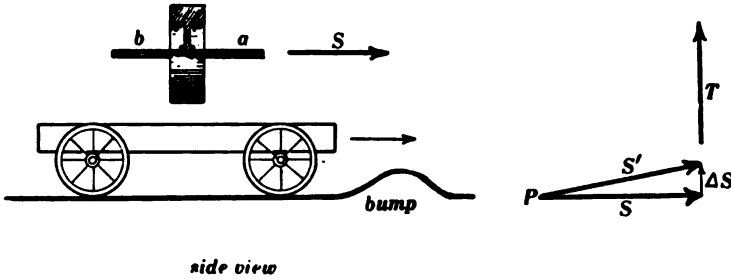

FIG. 17.

S represents the spin-momentum of the fly-wheel at a given instant, S' represents the spin-momentum at a later instant, ΔS represents the increment of spin-momentum, and the arrow T represents the torque which must act upon the fly-wheel shaft. In order to produce the torque T , the bearing a must push the front end of the engine axle to the left (with reference to the driver), and the bearing b must push the rear end of the engine axle to the right (with reference to the driver); or, in other words, the front end of the engine axle pushes to the right against the bearing a , and the rear end of the engine axle pushes to the left against the bearing b . Thus, there is a tendency for the front end of the car to be suddenly thrown to the right, when the car rises upon the bump, and the supporting springs of the car body are subjected to a skew action which is apt to break them.

There has been designed and placed upon the market an automobile in which the engine shaft is vertical. This obviates all gyrostatic action in the turning of curves, but it does not reduce the severe gyrostatic reactions when the car runs over a bump.

GYROSTATIC ACTION ON BOARD SHIP

Fig. 18 is a top view of a side-wheel steamer which is represented as turning to the right as indicated by the curved dotted arrow. The arrow S in the vector diagram represents the spin-momentum of the paddle wheels and shaft at a given instant, S' represents the spin-momentum at a later instant, ΔS represents the increment of spin-

momentum, and the arrow T represents the torque which must act upon the paddle-wheel shaft.

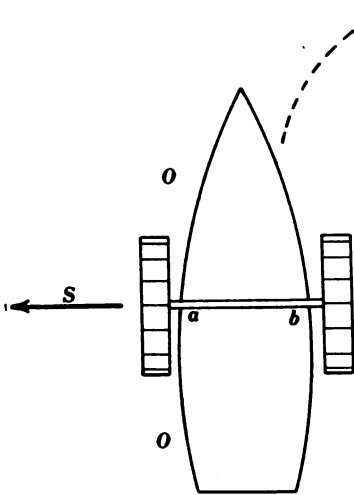

To produce this torque the bearing a must push upwards on the crank shaft, and the bearing b must push downwards on the crank shaft, or in other words, the crank shaft must push downwards on bearing a and upwards on bearing b , so that the gyrostatic reaction of the paddle wheels and crank shaft causes the boat to list, sinking the side OO of the boat deeper into the water as it turns round in the direction of the curved arrow in Fig. 18.

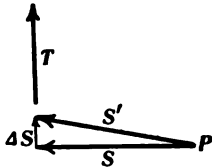

FIG. 18.

Fig. 19 is a side view of a boat driven by a steam turbine and propeller. The most serious gyrostatic action occurs in this case when the boat is pitching violently in a rough sea, and Fig. 19 is intended to represent the bow of the boat as rising as represented by the curved dotted arrow. Under these conditions the arrow S in the vector diagram represents the spin-momentum of the steam turbine and propeller shaft at a given instant, S' represents the spin-momentum

at a later

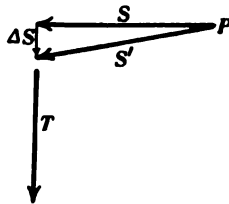
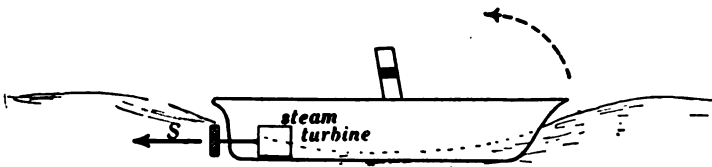

FIG. 19.

instant, ΔS represents the increment of spin-momentum, and the

arrow T represents the torque which must act on the propeller shaft. This torque is exerted upon the propeller shaft by the bearings as indicated by the arrows FF' in the top view, Fig. 20. The high speed and great weight of the rotating parts of a steam turbine represent a very great spin-momentum (arrows S and S' in Fig. 19

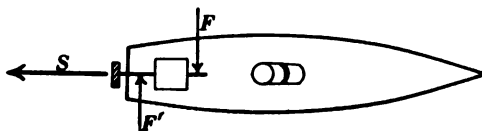

FIG. 20.

very long) so that the increment of spin-momentum ΔS which corresponds to a given angular movement of the ship is very considerable, and the torque T is great. Therefore the forces FF' in Fig. 20 may be very great. These forces are transmitted to the bearings of the propeller shaft through the hull of the vessel from the middle and forward parts of the vessel, and therefore excessive stresses may be brought into existence in the hull. It is supposed that the loss of the

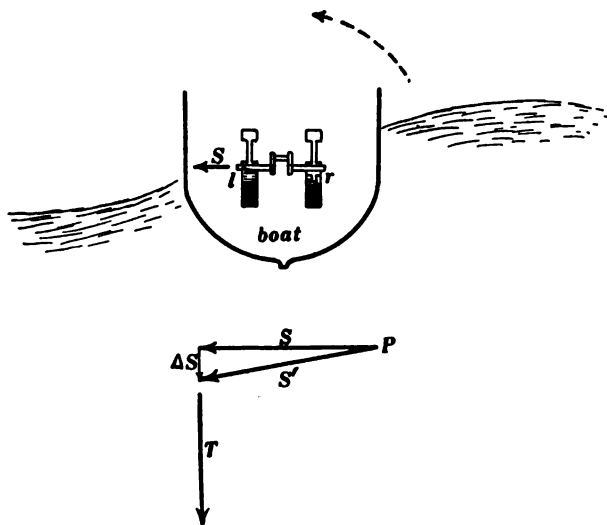

FIG. 21.

British torpedo boat *Viper* several years ago in a rough sea was due to this action.

Figs. 21 and 22 represent the details of the gyrostatic action of a high-speed steam engine, such as is used for driving dynamos on board ship, the shaft of the engine being athwartship. In Fig. 21 the ship is represented as rolling in the direction of the curved dotted arrow, and T in the vector diagram represents the torque which must act upon the engine shaft. The details of this torque action are shown in Fig.

22 where the arrows FF in the top view represent the forces with which the bearings must act upon the engine shaft to produce the torque T .

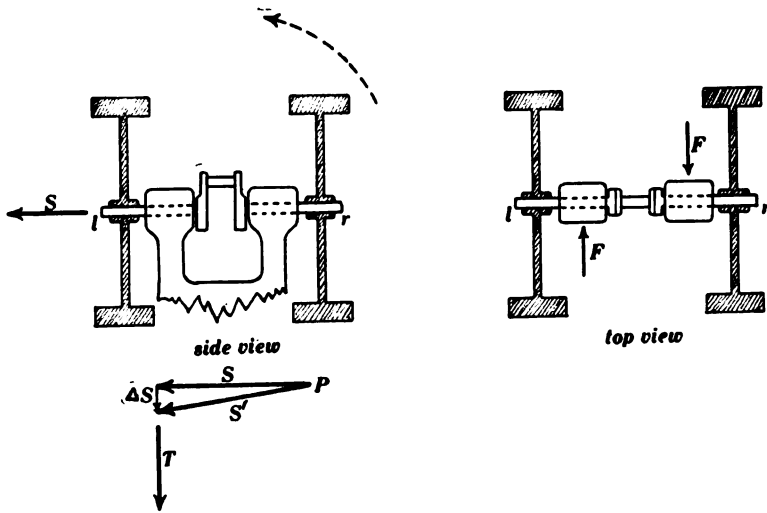

FIG. 22.

GYROSTATIC ACTION OF A ROLLING DISK

Fig. 23 represents a penny rolling along a floor. The forces FF in the side view (the tendency of the penny to fall over) constitute a torque which is represented by the arrow T in the top view. This torque produces during a short interval of time an increment of spin-

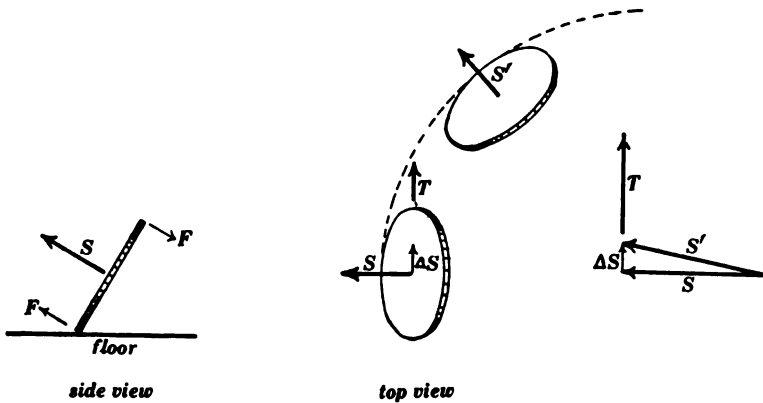

FIG. 23.

momentum ΔS which, added to the existing spin-momentum S , gives the resultant spin-momentum S' in the direction of which the axis of the penny is found to be turned. The result is that the penny rolls along a circular path as represented by the dotted curve in the top view, Fig. 23. The wheels of a bicycle exhibit a gyrostatic reaction when

the handle bar is turned, and although this gyrostatic action helps to maintain the equilibrium of the rider, it is very small in its effect as compared with the linear momentum of the rider and bicycle frame.

Fig. 24 is a top view of an axle and pair of drive wheels of a locomotive rounding a railway curve. The arrow S in the vector diagram represents the spin-momentum of the axle and drivers at a given instant, S' represents the spin-momentum at a later instant, ΔS represents the increment of spin-momentum, and T represents the torque which must act upon the axle because of its precession. To exert this torque the outer rail must push up with an excessive force against the outer driver, or, in other words, the outer driver must be forced downwards against the outer rail with more force than that which is due to the locomotive alone as it is rounding a curve.

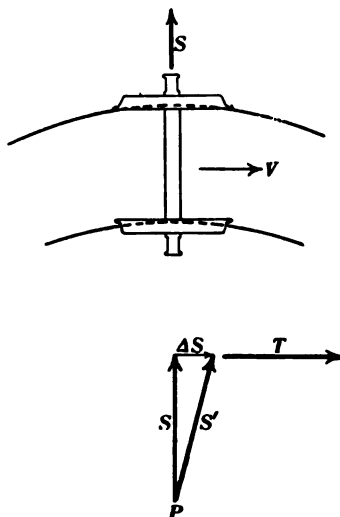

FIG. 24.

That is to say, the gyrostatic action of the drivers of a locomotive exaggerates the excess of pressure on the outer rail while the locomotive is rounding a curve.

GYROSTATIC ACTION OF THE BOOMERANG

The most familiar type of boomerang is a pair of crossed sticks twisted very slightly at the ends like the vanes of a windmill. This type of boomerang, which we will call the propeller-wheel type, is essentially similar in its action to the boomerang of the native Australians. The boomerang is thrown through the air with a spinning motion about an axis at right angles to the plane of the crossed pair of sticks, and the peculiar flight of the boomerang is due to the forces exerted upon the boomerang by the air.

Forces are exerted upon the moving boomerang very much as if it were a disk traveling approximately edgewise through the air and forces are exerted upon the boomerang by virtue of its propeller-wheel shape and because of its combined spinning and edgewise motion. The effects of these two sets of forces will be described separately and their combined action will then be made use of in explaining the actual motion of the boomerang.

A disk moving approximately edgewise through the air is in an unstable condition, if the disk starts to glance to one side or the other the air exerts a turning force or torque upon it which tends to turn

it with its side flat against the air. This may be shown by dropping a thin paper disk through the air or by blowing a blast of air against a disk which is pivoted about a diameter as an axis. Fig. 25 repre-

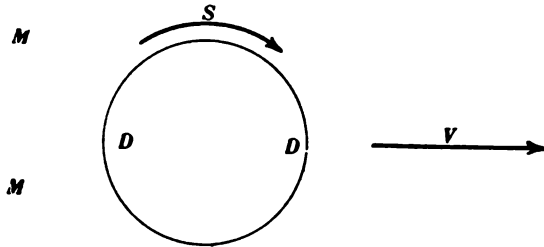
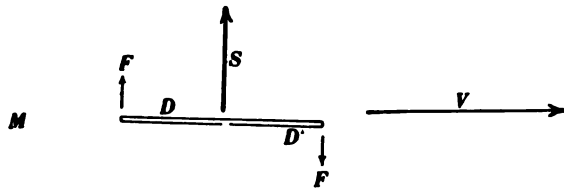

FIG. 25.

sents a thin metal disk DD which is thrown in the direction of the arrow V and at the same time set spinning in the direction of the curved arrow S , the thrower standing at MM . Figs. 26 and 27 are top views



top view

FIG. 26.

of the disk. Fig. 26 shows the disk starting to glance to the right (with reference to the thrower at M), and Fig. 27 shows the disk starting to glance to the left (with reference to the thrower at M). This glancing action of the disk causes the air to exert upon the

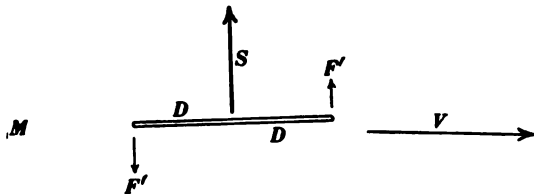

top view

FIG. 27.

disk a torque about a vertical axis in Figs. 26 and 27, which torque is represented by the forces FF in Fig. 26 and by the forces $F'F'$ in Fig. 27. This torque would turn the disk flatwise against the air if the disk were not spinning, but the effect of the torque on the spinning

disk is to cause precession, the axis of spin of the disk in Figs. 26 and 27 turns towards the vertical, bringing the right-hand side (with reference to the thrower) of the disk in Fig. 26 upwards and bringing the left-hand side of the disk in Fig. 27 upwards.

Fig. 28 represents a propeller-wheel boomerang. In the following discussion the propeller is supposed to be right-handed, that is to say, if it were set spinning in the direction of the curved arrow S in Fig. 28, it would blow air towards the reader like a desk fan. Fig. 28 represents the boomerang as it leaves the hands of the thrower, who is supposed to be standing at MM , V being the direction in which the boomerang is thrown, and the curved arrow S representing the direction in which the boomerang is set spinning. The upper vane of the

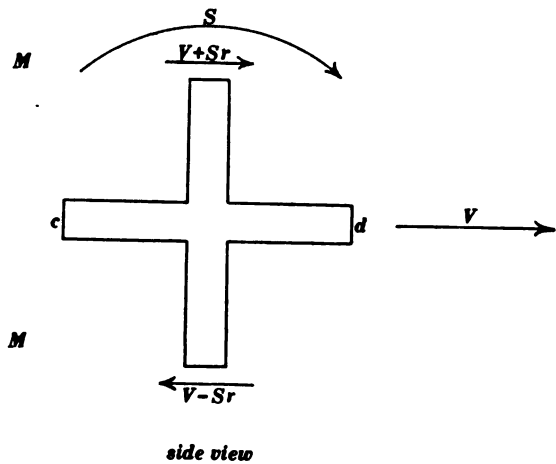

FIG. 28.

boomerang in Fig. 28 is traveling forwards at a greater velocity than the lower vane, because the forward velocity of the upper vane is the velocity of forward motion of the boomerang plus a forward velocity Sr which is due to the spinning motion of the boomerang, whereas the forward velocity of the lower vane is the forward velocity of the boomerang minus Sr . Fig. 29 is a top view of the boomerang as it leaves the hand of the thrower at M , V is the velocity of forward motion of the boomerang, and the arrow S represents the spin of the boomerang. The arrow F represents the force with which the air pushes sidewise against the upper vane because of propeller action. A force pushes sidewise in the same direction on the lower vane because of propeller action, but the sidewise force on the upper vane is the greater because of the greater velocity of the upper vane. The inequality of these forces constitutes a torque upon the boomerang, and this torque is represented by the arrow T in Fig. 29. The effect of

this torque during a short interval of time is to produce an increment of spin-momentum ΔS , and the addition of this increment of spin-momentum to the previously existing spin-momentum S gives a resultant spin-momentum S' . That is to say, the effect of the torque T is to cause the axis of spin to sweep around in the direction of the curved dotted arrow.

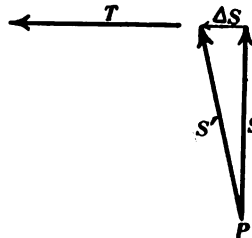
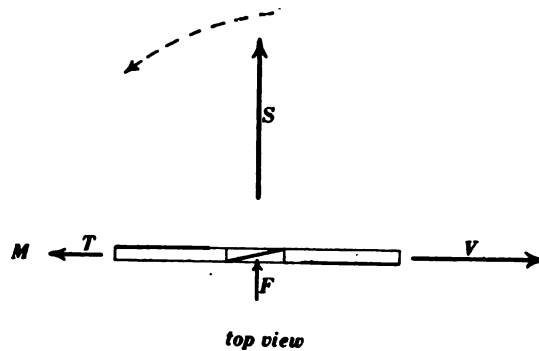

FIG. 29.

Fig. 30 shows a view as seen from above of an actual flight of the boomerang. The boomerang leaves the thrower at M with its plane approximately vertical, and the effect of the torque T of Fig. 29 is to cause the axis of spin of the boomerang to sweep about a vertical axis as represented by the curved dotted arrow in Fig. 29, thus tending to make the boomerang glance around a circular horizontal path. At the same time the boomerang acts more or less like a disk as represented in Figs. 25 and 27, and this action slowly brings the axis of spin of the boomerang into a vertical position (plane of boomerang horizontal). As the plane of the boomerang comes into an approximately horizontal position toward the end of its circular flight, the torque which is produced by propeller action (see Figs. 28 and 29) produces precessional motion which tends to raise the forward edge a and lower the backward edge b of the boomerang, thus causing the boomerang to tend to glance upwards. This tendency of the boomerang to glance upwards is helped by the propeller action of the boomerang, that is to say, the

boomerang, spinning in the direction of the arrows *SS*, Fig. 30, tends to climb upwards through the air. The result is that the curve of flight as shown in Fig. 30 is approximately a horizontal circle, the drooping of the curve of flight which would normally be produced by

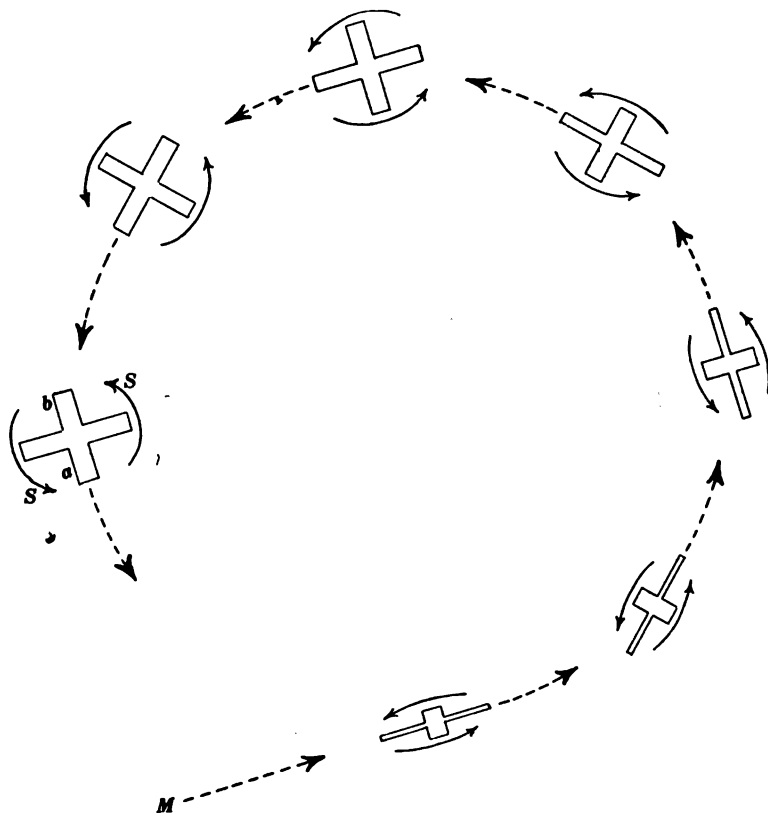

FIG. 30.

gravity being counteracted by the tendency of the boomerang to glance upwards and the tendency of the boomerang to climb upwards as specified.

THE DEVICE OF OTTO SCHLICK FOR THE PREVENTION OF ROLLING OF SHIPS AT SEA

Fig. 31 represents a spinning wheel hung upon a vertical axis from a hinge which permits the axis to swing to and fro in the plane of the keel of the ship (plane of paper in Fig. 31), the lower end of the axle being guided between two parallel bars. If the spin-momentum of the wheel were sufficiently great, all rolling motion of the ship could be eliminated, and the ship would heel over into a position for which the average heeling or rolling torque would be equal to zero; thus, the

spin-momentum produced by an unbalanced torque T' would be completely absorbed by the precessional motion of the spinning wheel as its axis of spin turns in the direction of the curved dotted arrow P' , and the spin-momentum produced by an unbalanced torque T'' would

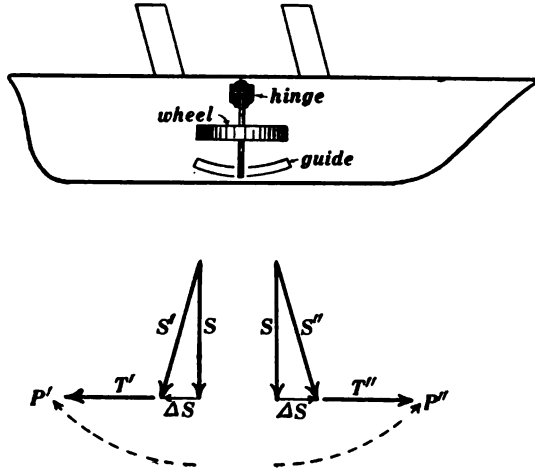

FIG. 31.

be completely absorbed by the precessional motion of the spinning wheel as its axis of spin turns in the direction of the curved dotted arrow P'' .

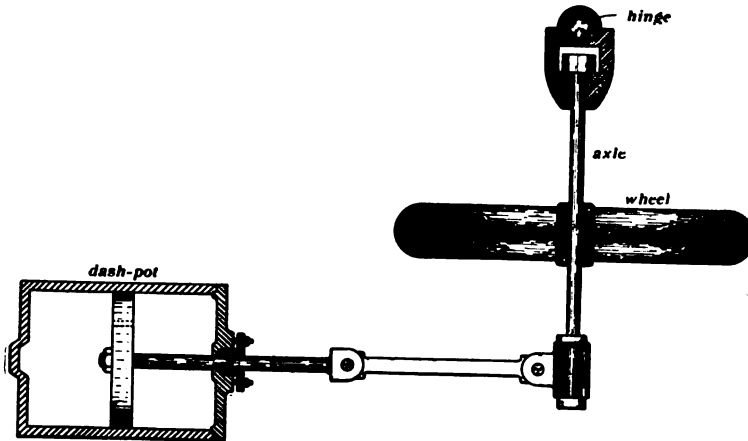

FIG. 32.

To completely hinder the rolling motion of a ship in this way would require the use of a very large wheel rotating at high speed. Thus a rolling torque (T' or T'' in Fig. 31) equivalent to 200 tons placed 10 feet to one side of the axis of the ship and continuing for only one tenth of a second would represent the whole amount of spin-momentum

contained in a solid steel disk 2 feet thick, 10 feet in diameter and rotating at a speed of 144 revolutions per minute; and therefore this amount of rolling torque continued for one tenth of a second would bring the axle of such a wheel into a horizontal position so that any further continuation of the torque would cause the ship to roll.

The rolling motion of a ship, however, is largely an oscillatory motion which is slowly built up by a succession of waves in synchronism with the proper period of rolling motion, and excessive rolling may therefore be prevented by an action which tends to hinder the oscillations by friction. A very considerable amount of frictional damping may be produced by a moderately small gyrostat arranged as shown in Fig. 32 (plane of paper in Fig. 32 is a vertical plane containing the keel of the ship). In this case the rolling motion of the ship causes the pendant wheel and axle to oscillate to and fro in the plane of the keel, and these oscillations are hindered by the motion of a piston in a dash-pot as indicated in the figure.

THE BRENNAN MONORAIL CAR

Before discussing the Brennan gyrostatic mechanism for maintaining the equilibrium of a monorail car, let us consider the action of the apparatus shown in Figs. 33 to 36, a gyrostat wheel mounted in a frame *aa* which in turn is pivoted in a larger frame *BB*, the whole

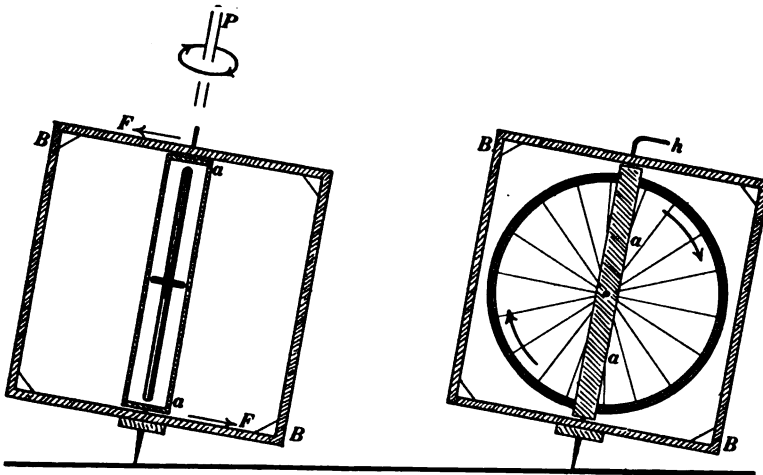

FIG. 33.

FIG. 34.

being supported upon two legs, one behind the other, as seen in the figures. Standing in the position shown in Fig. 33, the framework is acted upon by the unbalanced pull of the earth which produces a torque; the spin-momentum which is continually produced by this torque is absorbed by a precessional motion *P* of the gyrostat wheel as it

turns from the position shown in Fig. 33 to the position shown in Fig. 34, and the reaction of this precessional motion produces the two forces FF , Fig. 33, which keep the frame from falling over. When the gyrostat wheel reaches the position shown in Fig. 34, however, the precession ceases and the frame-structure falls over. Standing in the position shown in Fig. 35, the framework is acted upon by the unbalanced pull of the earth, which produces a torque, the spin-momentum which is continually produced by this torque is absorbed by the precessional motion P' of the gyrostat wheel as it turns from the position shown in Fig. 35 to the position shown in Fig. 36, and the reaction of this precessional motion produces the two forces $F'F'$, Fig. 35, which keep the frame from falling over. When the gyrostat

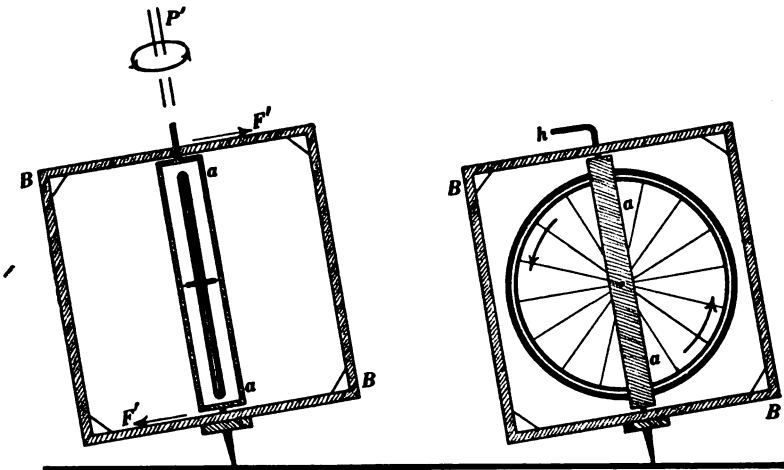

FIG. 35.

FIG. 36.

wheel reaches the position shown in Fig. 36, however, the precession ceases and the frame-structure falls over. Suppose the handle h in Figs. 33 and 34 to be forcibly turned in the direction of the precessional motion P . This hastened precession causes the reactions FF to be more than enough to hold the inclined frame in position, and the result is to bring the frame into a vertical position, or, if the precession is hastened sufficiently, to throw the frame-structure over into the reverse position as shown in Fig. 35, thus starting the reversed precession P' . This hastened precession is the essential feature of the Brennan gyrostatic mechanism and it is brought about automatically as explained in the following discussion.

The essential features of the Brennan mechanism are shown in Fig. 37. The car body BB' supports a rocker-axle O which is parallel to the rail or rope W upon which the car stands. A steel frame $FFFF$ is supported upon the rocker-axle O , and the two gyrostat wheels are

carried in two smaller frames ff and $f'f'$ which are free to turn about the precession axes P and P' . The axes of spin of the gyrostat wheels are ss and $s's'$, and these axes project as shown at A and A' . The two gyrostat wheels spin in the direction of motion of the hands of a clock as seen from the outer ends of the axes of spin A and A' , respectively. The precession axes P and P' are geared together by sectors of gear wheels G and G' . The frame $FFFF$ is hindered from turning about the rocker-axis O by the tables H, L, H' and L' ; the tables H and L' extend backwards from the plane of the paper, and the tables L and H' extend forwards from the plane of the paper.

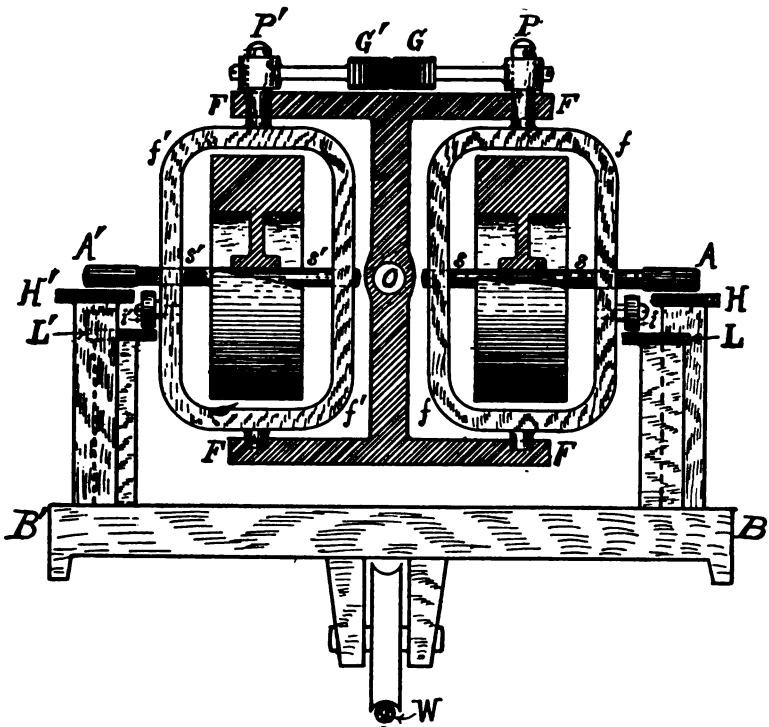

FIG. 37.

The action of this mechanism is as follows: Suppose side B' of the car body to be the heavier. The pull of gravity on this heavier side produces spin-momentum about the rail W as an axis, and this spin-momentum is absorbed by the precessional motion of the gyrostat wheels, causing both ends of the axes of spin A and A' to move away from the reader in the figure. The unbalanced car, however, in tending to tip over (side B' overloaded), brings the projecting axle A into contact with the table H , the rolling action of the axle A upon the table H hastens the precessional motion, and this hastened precession raises the side B' and lowers the side B of the car-frame, as explained

in connection with Figs. 33 to 36. This action continues until side B is heavier than side B' , when the reversed unbalanced condition of the car body causes a reversed precessional movement of the gyrostat wheels. This reversed precession continues steadily and un hastened so long as the heavy side B is balanced by the contact of the idle wheel i' with the table L' , that is, until the projecting ends of the axles of spin A and A' are brought forwards (in the figure) into the plane of the paper. Then the continuation of the reversed precession brings the axle A' upon the table H' , the reversed precessional motion is then hastened, and this hastened precession raises the side B and lowers the side B' of the car-frame, thus bringing the car-frame into its initial unbalanced condition (side B' heavier than side B). The above-described action is then repeated, and so on.

The stability of the Brennan car is due to the hastened precession which is caused by rolling action of one or the other of the projecting axles of spin upon the tables H and H' , while the axles of spin are *departing from* a line at right angles to the length of the car, and to the steady and un hastened precession, while the axles of spin are *moving towards* a line at right angles to the length of the car. The hastened precession on the one hand quickly alters the condition of balance of the car so as to limit the departure of the axles of spin from a line at right angles to the length of the car, and the steady and un hastened precession, on the other hand, insures the complete return of the axles of spin to a line at right angles to the length of the car.

The hastened precession is accomplished with great friction losses by the rolling axles A and A' in Fig. 37, and it is reported that Brennan is working upon an automatic motor-driven mechanism to produce the hastened precession without exhausting the energy of the gyrostat wheels.

Two devices like Fig. 37 with their rocker-axles at right angles to each other would hold a one-legged body in equilibrium; indeed, such a double mechanism would make it possible to use a one-wheeled car, but the wheel would have to have a deep double flange to make it roll along a rope or rail. Such a one-wheeled car, a sort of hyper-wheelbarrow car, would be of no value for practical use, and, indeed, most of us believe that Brennan's two-wheeled car is nothing more than a scientific toy.

CALCULATION OF TORQUE-REACTION DUE TO PRECESSION

Let n be the revolutions per second of a spinning wheel, P the revolutions per second (or the fraction of a revolution per second) of the axis of spin due to the precession, and K the moment of inertia of the spinning wheel in pound \times feet squared. Then the torque reaction is equal to $4\pi^2 nPK$ poundal-feet or $\frac{1}{3}\pi^2 nPK$ pound-feet.⁴

⁴ See Franklin and MacNutt's "Elements of Mechanics," p. 150.

JOSIAH WILLARD GIBBS AND HIS RELATION TO
MODERN SCIENCE. III

BY FIELDING H. GARRISON, M.D.

ASSISTANT LIBRARIAN, ARMY MEDICAL LIBRARY, WASHINGTON, D. C.

Catalysis, Colloids and Chemical Purity.—When chemical change can be produced in a system by the mere presence of small quantities of another substance which itself usually remains unchanged at the end of the process, such an effect is called catalysis and the agent employed a catalytic agent. Of the varied aspects of catalytic processes we have different examples in the decomposition of substances by the presence of finely divided metals like platinum or colloidal nickel, in the rapid evolution of oxygen from potassium chlorate when a small quantity of manganese dioxide is present, in the solution of insoluble chromic chloride through the mere presence of chromous chloride, in the inversion of cane sugar by acids, in the saponification of fats and esters, in the synthesis of indigo by oxidation of naphthalin, in the standard manufacture of sulphuric acid in the leaden chambers and the later improvements of the method through the presence of platinum or ferrous oxide, in catatypic photography without light, in the reversible physiologic and therapeutic action of the animal and vegetable ferments and enzymes, in the synthesis of nuclein during the development of the embryo, and in the pathologic effects of poisons, venoms and the toxins of disease. Many theories of catalytic action have been advanced, of which the earliest and most original is that of Leibig. Liebig supposes catalysis to be due to the fact that the catalytic agent has power, like that of a tuning fork, to set up sympathetic molecular vibrations in the substance acted upon, producing chemical change. This theory has been proscribed by Ostwald because, being a figment of the mind, it is neither capable of proof nor susceptible of refutation, leading the subject into a blind alley, from which further scientific advance is impossible.¹⁰¹ It has therefore remained, like Hamlet's father, "quietly inurned," as a beautiful, imaginative hypothesis which we can neither prove nor disprove. Of other theories of catalysis the most important is that of Ostwald himself, summed up in his famous definition: A catalytic agent is one which modifies the velocity of a chemical reaction without appearing in its final process. This statement introduces two new ideas, the notion of infinite swiftness and infinite slowness in chemical change and the fact that catalytic change may be brought about by a series of intermediate reactions. It will be seen that Ostwald's definition is elastic enough to include as

¹⁰¹ Ostwald, "Ueber Katalyse," Leipzig, 1902.

catalytic agencies such physical forces as light, electricity, extremes of heat or cold or the action of living tissues, and from this point of view the explosion of a cartridge or a charge of dynamite by percussion, the decomposition of water by electrolysis and its synthesis by the electric spark, the effects of light in photography and in healing disease, the wonderful thermodynamic effects of Henri Moissan's electric furnace, the occasional changes of food in cold storage, are further examples or analogues of catalytic action, and this is all we know of its physical nature. As to a dynamic explanation of how catalysis takes place, we have not got beyond the familiar jest of the laboratories: "Q. What is catalysis? A. Action by contact. Q. What is action by contact? A. Catalytic action." Gibbs's treatment of the subject is interesting as affording a mathematical criterion of what catalysis is and what it is not. It will be remembered that when the entropy of an isolated chemical system, say a bar of steel, has attained a maximum or its free energy a minimum value, the final state of the substance in question has been called by Gibbs a "phase of dissipated energy," implying that it has become physically and chemically inert, so that its equilibrium will not be sensibly disturbed by the presence of other substances or by such small physical agencies as an electric spark. But when the proportion of the proximate components of the substance in connection with its pressure and temperature is such that it does not constitute a phase of dissipated energy, the contact of a very small body or physical agency may produce energetic changes in its mass which do not stop short of complete dissipation. This is catalysis, and Gibbs's definition of a catalytic agent—one capable of reducing a substance to a phase of dissipated energy without limitation as to their relative proportions—is characteristic of the mathematician. A chemical system at constant temperature has several states of equilibrium corresponding to different minima of its isothermal potentials, and on the solid diagrams of Gibbs these minima are valleys at the bottoms of sloping curves. The effect of a catalytic agent on the diagram is to obliterate the ridge between two depressions representing different states of equilibrium on the free energy surface. This means that a system disturbed by a catalytic agent may pass from a higher to a lower minimum of free energy, but never from a lower to a higher unless acted upon by external forces of considerable magnitude. When the lowest minimum of free energy, indicated by the lowest depression on the diagram, has been attained, the substance can no more leave the final phase of dissipated energy than an inert body can be made to go up a hill without the intervention of external forces. On Gibbs's showing, the phase of dissipated energy is the criterion of catalytic action, the condition for which is that the substance acted upon should not have attained such a phase, while the forces operating flow, as in other mechanical, thermal, chemical or electric happenings, from higher to lower potentials. The accuracy of this reasoning is

borne out by Emil Fischer's researches in structural chemistry, which show that the intrinsic stability of chemical systems is usually such that it can not be disturbed by "intramolecular wobble," chemical change being brought about by extramolecular or catalytic influences. The mathematical treatment of catalysis gives us a deeper insight into phenomena which no one has as yet succeeded in explaining. "We have not," says Bancroft, "the first suggestion of an adequate theory of catalysis" so essential to a better understanding of chemistry and of life itself. A true theory of catalysis will enable us to solve the problem of the transmutation of the elements, of which we have already had examples in the substances derived from radium, and the recent derivation of tellurium from copper by Sir William Ramsay. The action of animal and vegetable protoplasm is probably catalytic and the chemist can now make some vegetable substances, such as indigo or alizarine, more cheaply and purely than the plants themselves do. Could we substitute inorganic catalyzers for the vegetable enzymes and ferments in all cases, we might, as Bancroft points out, duplicate everything except the plant itself. Recently Loeb has interpreted the fact that some eggs can be developed by osmotic pressure alone, while others require fertilization, by the explanation that, in the former class the nuclein synthesis, which is necessary for segmentation, is started within the nucleus as a catalytic process, one of the products of the reaction being the catalyzer itself; while eggs requiring fertilization are such that the necessary nuclein synthesis must be started by some external catalytic agency.¹⁰² Again catalysis is the key to the causes and treatment of infectious diseases, the toxins and antitoxins of which are probably colloidal catalytic agents. A few drops of such a colloid as cobra venom will rapidly reduce a living animal body to a definite phase of dissipated energy, as far as its vital activity (or "free energy") is concerned, and such catalysts as colloidal metals, which Bredig has shown to act exactly like the ferments and enzymes, can themselves be "poisoned" or rendered inert by other substances, just as toxins, venoms and poisons can be neutralized by antitoxins or other antidotes. Gibbs did not discuss colloids explicitly, because substances of such indefinite or irregular formation do not admit of mathematical treatment as such, but the physics of what we know of their intimate structure is implicit in his chapters on chemical conditions obtaining at surfaces of discontinuity. Colloids are semi-solid substances, and colloidal solutions are "pseudo-solutions," being suspensions of minute, discrete particles of matter which are not true solutions, in that they obstruct the passage of light, while neither the freezing point nor the vapor tension of the solvent can be sensibly lowered. Graham thought of colloids as dynamic phases of matter, possessing internal energy, while crystalloids are static and inert. The former include reversible colloids like gelatine which, heated with warm water, will upon cooling solidify

¹⁰² Loeb, *Science*, 1907, N. S., XXVI., 425-37.

into a "gel," and redissolve upon heating into a colloidal solution or "sol"; and irreversible colloids, which, when heated with warm water, will coagulate at once into an unchangeable precipitate. Living protoplasm, as Darwin has shown in his experiments upon *Drosera* and other plants,¹⁰⁸ acts exactly like a reversible colloid. Dead protoplasm, such as a coagulated blood clot, is an irreversible colloid consisting of a fixed network, the meshes of which contain the "sol." There is no evidence of internal structure in living protoplasm, and Hardy supposes that structure in dead protoplasm is produced by submortem or post-mortem changes associated with coagulation. Whether the phase rule can be applied to colloids is still an open question bound up with the complex nature of bodies of which we know so little. But recently Siedentopf and Zsigmony have shown that colloidal metals, organic ferments and enzymes are systems in two phases of vast surface tension consisting of suspensions of ultra-microscopic particles acted upon by chemical, thermodynamic and electric potentials. Of such suspensions animal and vegetable bodies are largely made up, protoplasm being a sort of microscopic emulsion, the physiological action of which seems to be bound up with chemical, thermal, electric and osmotic changes between its semi-permeable membranes and surfaces of discontinuity and the various surface tensions and surface energies derived from the free energy of chemical or electric change. If we conceive of colloidal solutions as made up in this way, each tiniest particle being an ultra-microscopic furnace, retort or battery in itself and carrying a definite charge of electricity, we can understand how Liebig's theory of sympathetic vibrations might be applicable to colloidal catalysis at least, and how finely divided metals, serpent venoms or the excretions of micro-organisms can produce the extraordinary effects they do. In close connection with the theory of catalysis is the nature of chemical purity and the fact that chemical changes rarely proceed directly to their final product, but usually pass through a series of intermediate stages. For a long time chemists have noticed that absolutely dry or pure substances will not interact directly upon each other, but the cooperation of a third substance is necessary for chemical change. Dried chlorine does not of itself act upon copper and other metals, but the presence of a little moisture will cause it to act upon them at once. A mixture of carbonic acid and oxygen is not explosive when thoroughly dry, but the slightest trace of steam will cause an explosion. The rapid solubility of zinc in sulphuric acid depends upon impurities in the former. Ebullition depends largely upon gaseous impurities in the boiling substance. Absolutely pure or distilled water has no digestive value, but, by its absorptive power, acts as an irritant or poison to the lining membrane of the stomach. Traces of moisture or other impurities have therefore a marked catalytic effect, a theory of catalysis which was first advanced as early as 1794 by Mrs. Fulhame in her "Essay

¹⁰⁸ Darwin, "The Power of Motion in Plants," *passim*.

on Combustion." Where water is the impurity, thermodynamic change is supposed to be due to electrolysis: the moisture being the necessary third ingredient for producing a little Voltaic circuit and the electric shock precipitating chemical action as in catalysis. The phase rule, Bancroft reminds us, has taught us to look upon an absolutely pure substance, 100 per cent. strong, as the extreme case of a two-component system, in which the concentration of the second component approaches zero as its limit. Gibbs has shown that in a system of two phases, one component of which is very small, the chemical potential of the dilute component is proportional to the logarithm of its density. As the density of the smaller component becomes less and less, its potential tends to an infinite value,¹⁰⁴ which means that, at the limit, when concentration becomes evanescent, "the removal of the last traces of any impurity would demand infinite expenditure of available energy."¹⁰⁵ From the view-point of mathematical chemistry there are many chemical substances that are relatively and approximately pure, but absolute purity of a chemical nature is, in Whetham's dictum, "more often a pious dream than an accomplished fact."¹⁰⁶

Ideal Gases and Gas-Mixtures.—It is in the physics of gases that the application of the molecular theory has proved most successful and the laws and equations relating to gaseous states are of considerable accuracy owing to the fact that practically all gases act alike. Although Gibbs made no explicit assumptions as to molecular dynamics, his treatment of gaseous states agrees so well with the kinetic theory that Boltzmann thought he must have had the latter constantly before his mind in framing his fundamental equations.¹⁰⁷ These equations are unique in that Gibbs subjected them to an unusual test of accuracy by comparing their calculated densities of gas mixtures with convertible components with the actual measurements for nitrogen peroxide, acetic and formic acids and phosphorus perchloride¹⁰⁸ by Sainte-Claire-Deville, Horstmann and others. In the case of nitrogen peroxide the difference between the observed and calculated densities scarcely exceeded .01 on the average and was not greater than .03 in any case.¹⁰⁹ The agreement between the theoretical and actual values was equally striking for the other gases, and these results are among the most accurate and satisfactory in the history of physical chemistry. Interesting features of this section of Gibbs's work are his interpretation of

¹⁰⁴ *Tr. Connect. Acad.*, III., 194-7.

¹⁰⁵ Larmor, "Encycl. Britan.," 10th ed., XXVIII., 169.

¹⁰⁶ Whetham, "The Recent Developments of Physical Science," Philadelphia, 1904.

¹⁰⁷ Aus vielen Stellen geht deutlich hervor, dass Gibbs auch diese molekular-theoretische Anschauung fortwährend vor Augen hatte, wenn er auch von den Gleichungen der Molekularmechanik keinen Gebrauch machte." Boltzmann, "Vorles. über Gastheorie," Leipzig, 1898, II., 211.

¹⁰⁸ Gibbs, *Am. J. Sc.*, 1879, 3. s., XVII., 277, 371.

¹⁰⁹ *Tr. Connect. Acad.*, II., 240.

Dalton's law as implying that "every gas is as a vacuum to every other gas,"¹¹⁰ his anticipation of van't Hoff's equation in the form of Henry's law for dilute solutions of gases in liquids¹¹¹ and his genial discussion of gas-mixtures, known in Germany as,

*The Paradox of Gibbs.*¹¹²—If two different gases which can be separated reversibly by quicklime or other process are allowed to mix, a certain definite amount of work or available energy will be gained; but if two gases, which are in every respect identical, are allowed to mix, they could not be separated by any reversible process and there would consequently be no gain of available energy in their mixing nor any dissipation of energy (increase of entropy). But if we suppose two gases which differ only infinitesimally to mix, the first condition would still obtain and there would still be a certain gain of available energy. The question arises, what will happen if we proceed to the limit? Maxwell explained this paradox by saying that our ideas of dissipation of energy depend upon the extent of our knowledge of the subject. Could we invoke Maxwell's demon and borrow his gift of molecular vision, we should perceive that when two identical gases mix there is in reality a complete dissipation of energy, which the demon's intelligence might turn into available energy if he liked; for "it is only to a being in the intermediate stage who can lay hold of some forms of energy, while others elude his grasp, that energy appears to be passing inevitably from the available to the dissipated state."¹¹³ In the reasoning of energetics, the paradox is explained by saying¹¹⁴ that the more nearly alike the gases are, the slower will be the process of diffusion, so that work or available energy might indeed be gained, but only after the lapse of indefinite or infinite time, if we have such time at our disposal.

Theory of Capillarity, Liquid Films and Interfacial Phenomena.—There are two important theories of capillary action, that of Laplace, based upon the assumption that the play of molecular forces in a liquid is only possible at insensible or ultra-micrometric distances, and that of Gauss, based upon the doctrine of energy. Gibbs's exhaustive discussion of capillarity, which takes up at least one third of his memoir, is the thermodynamic or chemical completion of the purely dynamic theory of Gauss. A capillary film or interfacial layer forms a new "phase" between the two substances on either side of it, and the mathematical condition for the formation of a new chemical substance at such an interface or "surface of discontinuity" is expressible as an algebraic relation between the surface tensions of the three layers of substance and the pressure of the three phases,¹¹⁵ the surface tensions

¹¹⁰ *Ibid.*, 218.

¹¹¹ *Ibid.*, 194-7, 225-7.

¹¹² *Ibid.*, 227-9.

¹¹³ Maxwell, "Encycl. Britan.," 9th ed., VII., 220, *sub voce* "Diffusion."

¹¹⁴ Larmor, "Encycl. Britan.," 10th ed., XXVIII., 171.

¹¹⁵ *Tr. Connect. Acad.*, III., 391-416.

being functions of the temperature and the chemical potentials. The only stable substance which can be formed between two other phases will be the one having the least surface tension.¹¹⁶ The chemical equilibrium of solids in contact with liquids, including the delicate mathematical conditions for the formation of crystals in mother liquor, is treated dynamically as a matter of stresses and strains, and this together with the theory of interfacial formations and liquid films will embrace the possible physics of colloid substances. Gibbs gives for the first time a mathematical discussion of the mode of formation of liquid films and the conditions for their stability and his dynamic explanation of the black spots on soap films¹¹⁷ was proved quantitatively in 1887 by Reinold and Rucker's micrometric data of the relations between the thickness and surface tension of these films.¹¹⁸ The importance of liquid films in biology is obvious, and this phase of Gibbs's theory, which is capable of the widest development, has as yet received the slightest attention.

Electrochemical Thermodynamics.—One of the most important features of energetics is Gibbs's theory of the galvanic cell which shows the close interrelation existing between chemical, thermal and electric energy. The earliest pioneer in this field was Lord Kelvin, and, prior to 1878, physicists had accepted the Joule-Kelvin theory that the electromotive force of a galvanic apparatus is the mechanical equivalent of the total chemical energy liberated per unit strength in unit time. But this view, which implies that all the electric energy of a chemical cell is available, did not agree entirely with the experimental data of Boscha, Raoult and others. It was corrected and modified by Gibbs, who showed that the electromotive force of the cell is in reality its free energy per electrochemical equivalent of decomposition,¹¹⁹ from which it follows that neither solidification nor fusion of the metals at the temperature of liquefaction should cause any abrupt alteration of the electromotive force. In 1882, six years later, this important theorem was rediscovered from a different view-point by Helmholtz and brilliantly developed as to experimental confirmation.¹²⁰ The Gibbs Helmholtz doctrine enables the physicist to trace out the variations in electromotive force due to chemical differences in different cells. In a letter to Professor Bancroft, now printed in the memorial edition, Gibbs connects the mathematical part of his theory of the electric cell with the fundamental principles of physical chemistry, the theories of van't Hoff and Arrhenius, Nernst's osmotic theory of the Voltaic cell

¹¹⁶ *Ibid.*, 403.

¹¹⁷ *Ibid.*, 479-81.

¹¹⁸ *Phil. Tr.*, 1887, CLXXVII., 627, 684.

¹¹⁹ "The quantities of the different substances combined in connection with the passage of a unit electricity are called the electrochemical equivalents of these substances." Bryan, "Thermodynamics," 164.

¹²⁰ Helmholtz, *Sitzungsb. d. Berl. Akad.*, 1882, 22 et seq.

and the equations of Ostwald and van der Waals.¹²¹ But perhaps his most important contributions to the theory of electricity are the two papers on electrochemical thermodynamics which he sent to the British Association in 1886 and 1888; Helmholtz, in his well-known formula for electromotive force, gives a relation such that if a cell be set up, and the reversible heat measured, the electromotive force need not be measured, but may be calculated from these data, or *vice versa*. In Gibbs's *rendement* of the perfect (or reversible) galvanic cell, both the electromotive force and the reversible heat can be predicted from his equation without the necessity of setting up any cell at all. "Production of reversible heat," says Gibbs, "is not anything incidental, superposed or separable, but belongs to the very essence of the operation."¹²² In discussing the matter in 1887, Sir Oliver Lodge raised the question whether Professor Gibbs was not regarding a galvanic cell as "too simply a heat engine" or assuming that the union of the elements in a cell primarily produces heat and secondarily propels a current.¹²³ Gibbs replied that "in supposing such a case we do not exceed the liberty usually allowed in theoretical discussions" and proceeded to show, in an ingenious demonstration, that Helmholtz's equation flows as a natural consequence from his own earlier results.¹²⁴ The accuracy of his reasoning is sustained by such developments of the subject as the "Peltier effect," in which it is demonstrated that the thermoelectric effect in systems of conductors, in which no chemical action takes place, is still proportional to the absolute temperature at any junction. In general the properties of a thermoelectric system are determined by the entropy function, and the entropy and energy in a thermoelectric network are not, as previously supposed, stored in the conductors, but, as we see in the electric transmission of motor power from a waterfall like Niagara to an engine or railway car, actually travel with the moving charge of electricity itself. In short, "entropy can be located in an electric charge."¹²⁵

Such are a few of the mathematical and physical consequences flowing from the single idea of entropy, and they are sufficient to define the position of Gibbs in the history of thermodynamics. In the establishment of the dynamical theory of heat, says Larmor, "The name of Carnot has a place by itself; in the completion of its earlier physical stage the names of Joule and Clausius and Kelvin stand out by common consent; it is, perhaps, not too much to say that, by the final adaptation of its ideas to all reversible natural operations, the name of Gibbs takes a place alongside theirs."¹²⁶

¹²¹ See Bancroft, *J. Phys. Chem.*, 1903, VII., 416-427.

¹²² "Report British Association for the Advancement of Science," 1886, 388.

¹²³ *Loc. cit.*

¹²⁴ "Report British Association for the Advancement of Science," 1888, 343-6.

¹²⁵ See Bryan, "Thermodynamics," Leipzig, 1907, 174, 198.

¹²⁶ *Proc. Roy. Soc. Lond.*, 1905, LXXV., 292.

A REVOLUTION IN DENTISTRY

BY RICHARD COLE NEWTON, M.D.

HAVE the dentists waked up? Some of them have. A new order of the "Knights of the Forceps" has been formed, called the "Orthodontists" (tooth straighteners). At last accounts there were sixty of them in America, as compared to 50,000 simple dentists. And what does it all mean? If I can compress a great deal of information into a limited space I can, perhaps, explain it and I think that it may be possible to make it clear why the movement is so important.

Dr. Osler has said that the question of preserving the teeth is more important than the liquor question. When one reflects that a great deal of intemperance is caused by dyspepsia, with its mental and physical deterioration, and that the underlying cause of much of the generally prevalent dyspepsia is the decayed and defective teeth, which preclude complete mastication of the food (even if anybody in America had the time to eat properly), the solid truth of Dr. Osler's remark begins to dawn upon us.

Now the dentists, like the doctors, have begun to realize that their true mission is not "a general repairing business," but a systematic and well-considered effort to prevent and forestall the wholesale decay and loss of human teeth. Perhaps some idea of the very general use of false teeth may be gathered from the statement that 20,000,000 of them are exported from America to England every year. When we consider that probably not more than half of the inhabitants of that country indulge in the luxury of false teeth, no matter how many "grinders" they may have lost, these figures would seem to indicate that nearly every one in England suffers from defective or missing teeth. Observations so far as they have been carried in the United States show the same deplorable state of affairs.

A great many more or less ingenious explanations have been advanced from time to time, to account for this, as well as for the fact that so few Americans have regularly disposed teeth and well-shaped jaws. Our English friends have made much sport of our "hatchet faces," "lantern jaws" and the nasal tones of our voices. We are told that such an admixture of races, as is gradually taking place in our country, is the cause of our poor teeth. Nobody seems to know why it should be so. In fact, such a result is directly opposite to nature's beneficent course in admixtures of different races and species, where

the tendency is to preserve the best and strongest features and eliminate the weak and faulty ones. I remember an elaborate article in some magazine, some years ago, which explained the great prevalence of poor teeth in America by saying, that they are caused by our habit of shaving our faces, while the orientals have sore and weak eyes because they shave their heads. The filth in which the latter live was not taken into account, nor the fact that the American women, who do not shave, have as bad teeth as the men.

A rather ingenious explanation of the marked disproportion between the size of the teeth and that of the jaw in many Americans, as for example, large teeth in small jaws, so that the former are crowded out of position and overlap one another, is that the big teeth are inherited from one parent and the small jaws from the other. This sounds plausible and since no systematic effort has, so far as I know, been made to find out the truth of the matter, it has been tentatively accepted for want of a better explanation of an exceedingly common phenomenon.

Recently some good observers, notably Dr. Sim Wallace and Dr. Harry Campbell, of England, have said that the trouble is not hereditary at all, but begins in each person's babyhood, and that our teeth are poor and irregular and our jaws contracted because we do not exercise these parts sufficiently from infancy to manhood; especially from weaning until six years of age, when the permanent teeth begin to erupt. In support of this statement they point out that the first set of teeth is practically never irregular, never overlaps and is very seldom defective. The beautiful lines of a baby's face are not distorted by irregular or protruding teeth, nor sunken by reason of the non-support of sufficiently wide jaws. The teeth of savages, Hottentots and Esquimaux are almost invariably excellent, and their jaws and tongues are wider and stronger than ours. This has been proved by the measurement of thousands of skulls as well as by observations upon the living inhabitants of the tropics and the arctic regions.

Dr. Campbell also points out that the frequent occurrence of adenoids in young children is caused by feeding them chiefly "pap." He calls this the "pap age." The good old-fashioned plan of chewing sufficiently hard and dry food to properly exercise and develop the jaws and teeth, seems to have been abandoned in our effete civilization. Instead of the honest "johnny cake" (called in the south "corn pone" or "hoe cake") upon which such sturdy characters as Andrew Jackson and Abraham Lincoln were wont to subsist—and, by the way, the American negro had good teeth and practically escaped tuberculosis so long as he lived upon simple corn bread and bacon and the vegetables and fruits from the plantation. I started to say, however, instead of corn bread and Boston brown bread and rye and "injun" bread, the breads of our grandfathers, which required mastication and insalivation

before they could be swallowed, our children now are fed on "previously cooked" breakfast foods, infant foods and other starchy viands, which may differ in name and flavor; but agree in two characteristics, viz., that they pander to lazy housekeeping, by requiring very little preparation for the table, and, secondly, require little or no mastication, before swallowing. Wetted with milk or cream they "slip down" very easily, and are landed in a stomach not prepared for a deluge of unchewed and non-insalivated starchy food. Hence the common cry of "starch indigestion." This is not wonderful because the proper digestion of starchy food must begin in the mouth, and is impossible without complete mastication. We are told in *Science* that in feeding meal to calves, "it must be spread thinly upon the bottom of the troughs so that it will be eaten slowly and insalivated." This is only one instance out of many where man's commercial instinct has taught him an invaluable truth in regard to the rearing of stock, that has a market value, but which it never seems to have occurred to him is just as important in connection with the rearing of his own children.

So far as the improper development or non-development of our teeth, jaws, tongues and lips is concerned, the trouble begins with the nursing bottle from which the infant gets its nourishment too easily and too rapidly, so that these important structures are all more or less undeveloped, and this non-development is a continuous performance up to adult life. Of course removal of adenoids, regulation of the teeth, boring out the nasal cavities and so on, are resorted to with great benefit, to obviate defects that should have been prevented by mothers nursing their babies and then making the children chew their food as nature intended them to do. If a child will not chew its food, the despised habit of chewing gum, now known to have prevailed among the Indians, should be encouraged.

Dr. Robinson, an English writer, calls attention to the development of the jaws of English boys who were taken out of the streets of London and sent into the British navy. He says "undoubtedly the most noticeable improvement in them, next to their superior stature and healthy appearance, was the total change in the shape and expression of their faces. On analyzing this, one found that it was to be mainly accounted for by the increased growth and improved angle of the lower jaw." This change was due to the rations of "hard tack" and "salt junk" upon which these lads had subsisted. A very satisfactory diet from an orthodontological point of view at least. It is plain enough that ninety per cent. of dental work might have been avoided; just as ninety per cent. of the sickness and premature death in the world is needless and could be prevented. The dentists have made the astonishing discovery that they can alter and enlarge the jaws of any child by simple means and they have found out, moreover, that the teeth

themselves and their arrangement are the pattern from which the jaw takes its shape. The teeth in different skulls differ so much, that it is extremely difficult, if not impossible, to "match" a missing tooth in one jaw with a tooth from any other one. The natural teeth then have an individuality in keeping with each particular face, and when they are in good condition and in their proper position, can not but add to the beauty, dignity and symmetry of the face. Three people out of four seem to lack in the proper development of the lower part of the face by reason of defective and misplaced teeth, and weak and ill-developed jaws. Hence we see that the "man of destiny," "the man with firm jaw, who knows his own mind," is presumably one who was made to chew properly in childhood, and was not allowed to wash down his food half chewed, or unchewed by gulps of liquid.

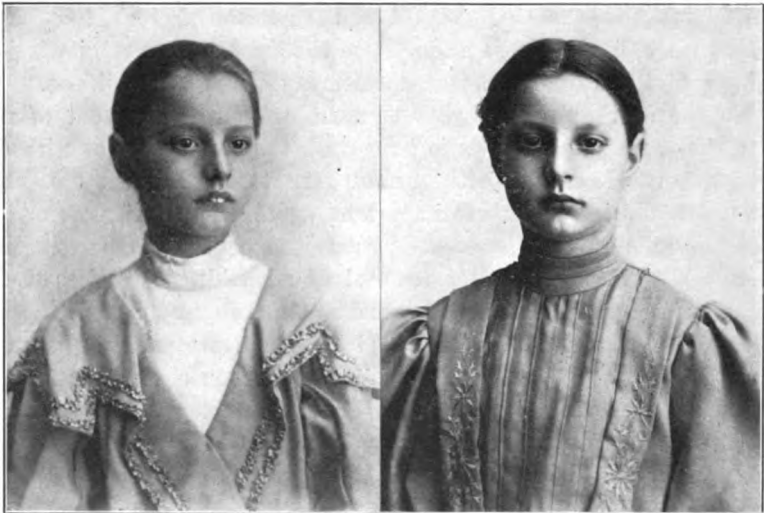

Before.

After.

It is not true, that the teeth must fit into the jaws; the reverse is true, the jaws form themselves around the teeth. The bone grows around the roots of the teeth and forms a socket like the mortar or cement around the bricks in a fire-place. This is easily demonstrated; a tooth, for example, can be completely turned round or moved from one place to another, and, as we say, it grows "fast." For that matter, teeth, as is well known, can be extracted, cleaned and put back again, or teeth from one person's mouth can be put into the place of an extracted tooth in another's mouth and become firmly imbedded and do good service for years. The part of the jaw-bone that embraces the roots of the teeth is called the alveolar process, and it continues to grow and harden for some time after the teeth have been erupted, or after

they have changed their places in the jaw. Upon this elemental truth is founded the art of orthodontia. Were the facts not as stated, it would do no good to alter the positions of teeth, since they would not retain their new positions after they had been moved into them. The fact that the jaws can be widened by spreading the teeth, taken in conjunction with the adaptability of the "alveolar" process, make the remarkable results of the orthodontist possible. The size, shape and strength of the lower jaw, or mandible, depend in great part upon the work it has to do, and furthermore, the shape of the upper jaw is determined by that of the lower. The lower permanent teeth are erupted first, and by their repeated impactions upon their opponents in the upper jaw, aided by the constant restraining and forming action of the tongue and lips gradually force the upper teeth into their proper

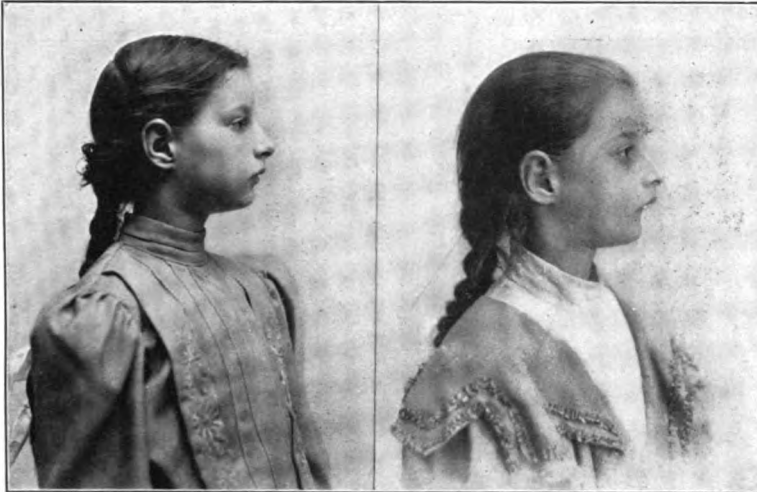

After.

Before.

places and keep them there. Provided, that the lower jaw and the tongue and lips are strong and well developed, made so by sufficient chewing, especially from the years of two to six, in a child's life. If the child's education in chewing, however, has been neglected, the dentist can and does spread the jaw as already stated, so that it will have room enough for all the teeth. In other words, orthodontia does what nature would accomplish unaided were her simple laws of development properly observed.

A full set of teeth forms a beautiful arch, no stone of which should be missing. The shape and span of this arch are greatly determined by the size and position of the four permanent first molars, "six-year-old molars," the largest and most important teeth in the head. If these teeth are properly disposed in the jaws, the regulation of the

remaining teeth is much easier than otherwise. If they are out of place, they must be brought back to where they belong, because it is essential that they should be in their proper position and serve as the guides for the regulation of all the other teeth. Then by measuring the width of one of the eye teeth and the two front teeth next to it, a diagram can be drawn which will show the exact shape and size which the jaw should have. A very simple arrangement of springs and wires, which need hardly annoy the child at all, will soon spread the jaws and give the teeth room, so that those that are out of alignment can be brought into their proper places in the arch.

In this arch, like the arch of a bridge over a stream, every tooth must bear its proper share of the pressure, and its loss can never be replaced. A moment's reflection will show the folly of extracting teeth to make room for those out of alignment, and modern dentistry has

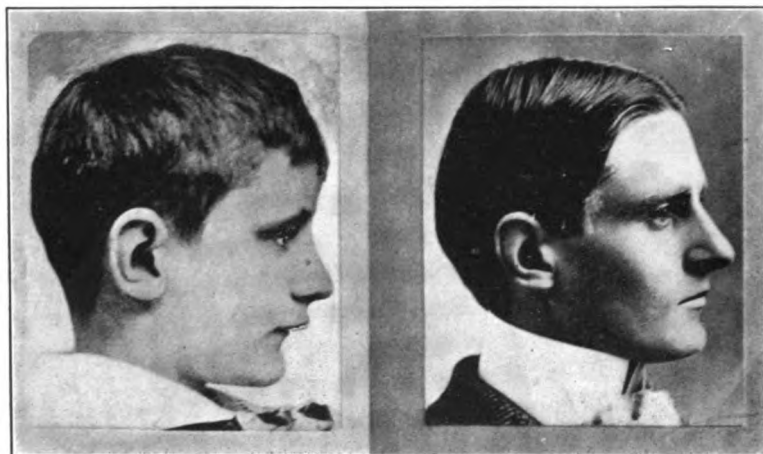

Before.

After.

proved that such extraction will defeat the object for which it is undertaken, viz., the restoration of the perfect denture. A man who will extract a tooth in regulating may be foolishly clinging to the old tradition, that was spoken of just now, that the unfortunate child had inherited large teeth from one parent, and small jaws from the other. I remember, by the way, in my own boyhood, I seriously thought that I had by mistake got somebody else's teeth, because my permanent teeth were so large and broad, that my jaws could not accommodate them, and were so crowded that several were extracted to make more room. Now I know that my "hatchet face" and "lean jaws" might easily have been prevented had some modern orthodontist, who would die before he would extract a sound tooth, given me the proper advice and care.

A little patient of my own (see photograph) was told by her dentist that her upper front teeth would have to be extracted, as they protruded so that she could not close her mouth. On hearing this, I was simply horrified. I induced the parents to consult a competent orthodontist, with the result that on meeting the child on the street about three months afterwards (see photograph), I didn't recognize her. Here are two pictures of a dentist's son "before and after taking" a course of treatment. His father regulated his teeth.

In orthodontia an inconceivably great advance has been made in preserving human beauty, health and efficiency. And the people who have been bewailing nature's inadequacy and asserting that our race is gradually deteriorating so that the coming man will be "edentulous" (toothless) are asked to take a back seat. They belong in the same category with the people in Philadelphia, who objected to opening some playgrounds to children, because the latter shouted when they played. Just as if play without shouting could be any good for young children; even in Philadelphia.

A great and beautiful truth has been taught us by these orthodontists. Every good man, every religious man, and every one who rejoices in beauty, in symmetry, in efficiency and in the comforting reflection that nature does not make mistakes—man makes the mistakes, and is sometimes blasphemous enough to lay the blame upon God—ought to rejoice at the clear proof that there was no mistake made in allotting thirty-two teeth to an adult human being. That the properly shaped jaw can hold all of these teeth, and that modern ideas of the fitness of things demand a full complement of teeth in a properly shaped jaw. That the firm well-rounded chin, the resolute jaw and symmetrical cheeks, and the appearance of decision, vigor and alertness so necessary for either male or female beauty of expression, belong by right to every American man and woman; not to mention the fact that the "laughing pearls" of perfect teeth can be possessed by any one, and some one has sinned, either the man or his parents, if the denture is defective and the jaws ill-developed.

THE ORIGIN OF THE NERVOUS SYSTEM AND ITS APPROPRIATION OF EFFECTORS

I. INDEPENDENT EFFECTORS¹

BY G. H. PARKER

PROFESSOR OF ZOOLOGY, HARVARD UNIVERSITY

THE physiological unit in the operations of the nervous system is the reflex. Broadly understood, this consists of the chain of consequences that begins with the reception of a stimulus on the surface of the animal and, leading through the central nervous organs, ends in the excitation of a reaction by some such organ as a muscle. The term reflex is made to apply nowadays to nervous operations involving conscious states as well as to those that are carried out unconsciously. In its greatest simplicity the conventional reflex involves at least two nervous cells or neurones and some form of reacting organ

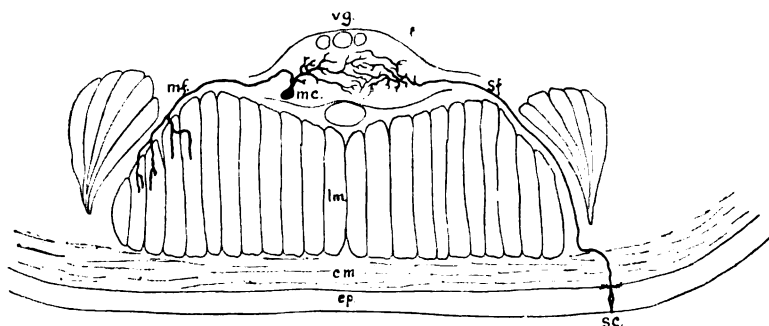

FIG. 1. TRANSVERSE SECTION OF THE VENTRAL NERVOUS CHAIN AND SURROUNDING STRUCTURES OF AN EARTHWORM (modified from Retzius). *cm*, circular muscle; *ep*, epidermis; *lm*, longitudinal muscle; *mc*, motor cell-body; *mf*, motor nerve-fiber; *sc*, sensory cell-body; *sf*, sensory nerve-fiber; *vg*, ventral ganglion.

such as a muscle-fiber. The first neurone, as exemplified in the nervous structure of such an animal as the earthworm, is often the body of a sense-cell on the surface of the animal and the sensory nerve-fiber to which this cell body gives rise and which leads to the central nervous organ. The second neurone is a nerve-cell whose body lies within the central nervous organ and whose process, a motor nerve-fiber, extends from the central organ to the muscle-cells which it con-

¹The four articles in this series represent four lectures given at the University of Illinois between March 30 and April 3, 1909.

trols. The first neurone as it enters the central organ breaks up into a large number of delicate branches which are in physiological continuity with similar branches from the second neurone. It is over these delicate branches that the nerve-impulse passes from one neurone to the other and it is the structure of this system of branches that has been a matter of so much discussion within recent years. Anatomically, then, this simplest form of central nervous organ consists of motor cell-bodies and fibrillations from these bodies and from sensory neurones. Of course most central organs include additional neurones, such for instance as association neurones, which connect one part of the central organ with another and do not participate directly as sensory or motor constituents. The simplest conceivable reflex mechanism, however, does not include these, but only the sensory and the motor neurone as described. Such a chain reaching from the periphery of the animal through its central nervous organ to and including its muscles is usually regarded as the primary type of neuromuscular mechanism.

From a physiological standpoint this simplest type of reflex mechanism falls into three parts. The first of these is the sense organ or receptor, which, as its name implies, receives the external stimulus; the receptor is also the seat of the production of the nerve-impulse. The second is the central nervous organ or, as it may be called, the adjustor, which is concerned with directing the impulse toward the appropriate end-organ and with modifying it in accordance with the particular reaction to be obtained. The third and last is the effector or organ brought into action by the impulse, such as a muscle or gland. Thus a simple reflex may be said to involve at least three special classes of mechanisms: receptors, adjustors and effectors. These mechanisms, however, do not correspond exactly to the three histological elements already named, for, though the receptive function is an activity limited entirely to the first neurone in such an animal as the earthworm, and the effector is the muscle-fiber, the adjustor is a part of the first as well as of the second neurone and is made up of at least the fine fibrillar material contributed by these two neurones to the central nervous organ. The neuromuscular mechanism even in this its simplest type has probably not sprung into being fully formed, but it has had without doubt a slow and gradual growth. It is one of the objects of these articles to trace as far as possible the steps in this growth.

It is to be noted that every reflex mechanism is in the nature of a physiologically continuous span of living substance which reaches from the receptive surface on the one hand to the effector organ on the other. At no point in this span can there be a real interruption, for a physiologically continuous thread of protoplasm must connect the two extremes. It is, therefore, conceivable that a reflex mechanism might

exist in the body of a protozoan and in fact there is experimental evidence to show that in certain infusorians the superficial protoplasm is somewhat differentiated as a receptive surface and that this protoplasm also serves as a conducting organ whereby, for instance, the activity of certain groups of specialized cilia in these animals is coordinated. These conditions, however, are found within the substance of a single cell and are so remote from those of a true nervous mechanism that, interesting and significant as they are, they had better be termed neuroid than nervous. They show at best that the protoplasm of the protozoan harbors operations that may develop in the multi-

cellular animals into reflex processes rather than that the protozoans possess these processes, and that we must look among the simplest metazoans for the beginnings of a true neuromuscular mechanism.

In making a quest for the first stages in the development of the nervous system, it is important to keep in mind the relative significance of the three physiological elements already pointed out: the receptors, the adjustors and the effectors. A little reflection will show that these three are not likely to prove all of primary significance.

A receptor or sense organ alone would be of no service whatever to an animal; it would resemble a telephone receiver disconnected from the rest of the system. In a similar way the adjustor or central organ is useless without at least some other element in the reflex apparatus.

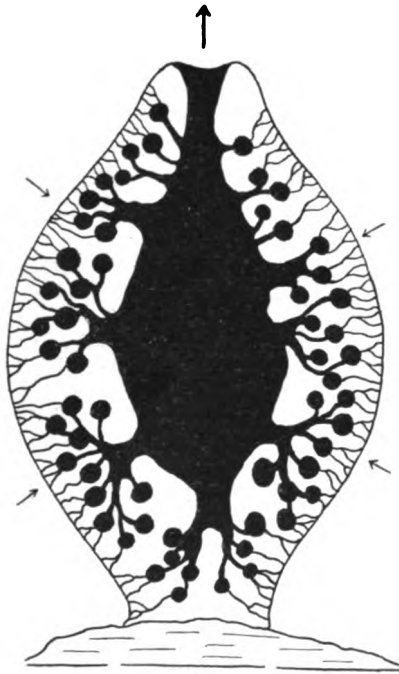

FIG. 2. DIAGRAM OF THE CANAL SYSTEM OF A CALCAREOUS SPONGE (modified from Haeckel). The lateral inlet pores receive water from the exterior, as shown by the arrows on the sides; the osculum at the apex discharges water to the exterior.

The only mechanism sufficient in itself is the effector, which, if it can be brought into action by direct stimulation, may accomplish something serviceable to the animal. It is therefore improbable that we shall find multicellular animals that possess either receptors or adjustors without effectors, but it is conceivable that primitive metazoans may have effectors without other parts of the typical neuromuscular mechanism.

In a search for the earliest traces of the neuromuscular mechanism,

we may turn first to those very primitive metazoans, the sponges. The body of one of the simpler sponges is a more or less goblet-shaped, multicellular mass, whose surface is covered with an enormous number of minute pores; these lead into tubes which in turn communicate with a relatively large central cavity that opens to the exterior by an aperture of considerable size, the osculum. In a living undisturbed sponge, water is continually passing into the lateral pores, through the tubes and central cavity, and out at the osculum. This current is produced by means of numerous cells, the choanocytes, which are provided with vibratile lashes and are variously distributed through the internal chambers and tubes of the sponge. Apparently these choanocytes work incessantly, and the current generated by them carries food, etc., to the sponge and removes waste products. Although frequent efforts have been made to show that nervous structures occur in sponges, nothing of this nature has been conclusively demonstrated and it is now generally believed that these animals are without differentiated nervous organs, either sensory or central. Nevertheless, sponges are capable of a certain amount of response. Merejkowsky (1878) observed that when he pricked with a needle the inner face of the osculum of *Rinalda*, this aperture quickly closed, not to open again for several minutes. The same reaction occurs with the lateral pores of many sponges (Vosmaer and Pekelharing, 1898). This power of closing the pores seems to be the only means by which a sponge may check the current which ordinarily flows through its canals, for, as already mentioned, the choanocytes apparently lash the water incessantly.

When a search is made for the organs concerned with the closing of the pores and oscula, they are found to consist of rings of elongated contractile cells or myocytes, which surround these apertures. These rings of cells form veritable sphincters and their action is often efficient enough to bring about a complete temporary closure of the aperture. Whether the pores and oscula open by the counteraction of radial, contractile myocytes or by the simple elasticity of the surrounding tissue does not seem to have been determined.

Since these sphincters lie very close to the epithelium that bounds the surfaces of the pores or oscula and in fact probably often form a part of this very epithelium, and since no nervous mechanism is known to be connected with them, it seems very probable that they are brought into action by direct stimulation and that the sponge is a metazoan in which there are functional effectors unassociated with receptors or adjustors. Thus the sponge would represent the first stage in the differentiation of a neuromuscular mechanism, *i. e.*, one in which the effector in the form of a primitive muscle-cell is the only element present. In my opinion it is around these contractile cells that the nervous organs of the higher metazoans have developed and I therefore

believe that these effector elements are the most primitive members in the typical neuromuscular mechanism.

That there is absolutely no trace of nervous activity in sponges is probably not true, but their extreme inertness shows that this function is certainly in a most primitive state and corresponds at best probably only to that sluggish form of reception and transmission that Kraft (1890) demonstrated for ciliated epithelium and that is probably characteristic of other epithelia. Taking all in all, the only element of the neuromuscular mechanism that is really present in sponges is the effector as represented by the sphincters of the pores and oscula.

If independent effectors occur in sponges, it is not unlikely that they may be present in the higher animals, and as possible examples of these the sphincter pupillæ of the eye in vertebrates and the heart-muscle may be considered. The sphincter pupillæ is a ring of muscle imbedded in the iris and surrounding the pupil in the eyes of most vertebrates. Its contraction would naturally reduce the size of the pupil and thereby diminish the amount of light that enters the eye. In the higher vertebrates it is well known that this reaction has the character of a simple reflex in which the retina is the receptor, with the optic nerve as its transmitting organ, and the stem of the brain is the adjustor from which the oculomotor nerve transmits peripherally to the effector, the sphincter pupillæ. In the lower vertebrates, particularly in the fishes and amphibians, it has long been known that the sphincter pupillæ will react in a characteristic way even in extirpated eyes. This fact has been explained by those who cling to the idea of a reflex as due to intraocular nervous connections between the retina and the sphincter. But Steinach (1892) demonstrated the contraction of the pupil in the extirpated eyes of lower vertebrates from which the retina had been removed and moreover he showed that when a minute beam of light was thrown on a part of the sphincter, that part contracted first and was followed later by the rest of the muscle, an observation recently confirmed by Hertel (1907) in the eyes of higher vertebrates, including man. It therefore seems quite certain that the sphincter pupillæ of the vertebrate eye, though usually controlled by nerves, is a muscle that can be directly stimulated and in this respect is an independent effector like the sphincters of the pores in sponges.

A second case of independent muscle action in the higher metazoans is the heart-muscle. This muscle for a long time past has been the occasion of much discussion. In the vertebrates it is still an open question whether the beat of the heart is primarily nervous or muscular in its origin and the neurogenic and the myogenic theories of heart action have had a lengthy history (Engelmann, 1904; Howell, 1906). To Harvey we owe not only the discovery of the circulation of the blood, but the first true ideas of the action of the heart, for he showed that

the active phase of the heart-beat was during contraction, not during expansion, as had been generally supposed, and that the heart was in reality a muscular force pump. Harvey seems likewise to have had the idea, though perhaps not very clearly expressed, that the heart-beat was dependent upon the heart-muscle and not upon some extra-cardiac mechanism. In this sense he may be regarded as the founder of the myogenic theory. Later Willis pointed out that the stomach, intestine, and heart received nerves from the brain and he believed that the movements of these parts were controlled by such nerves; he therefore may be looked upon as the originator of the neurogenic theory. To account for the fact that the heart would continue to beat for some time after its removal from the body, it was assumed by the neurogenists that the branches of the nerves left in the substance of the heart when this organ was cut from the body were sufficient to maintain the heart-beat for some time, but Haller opposed this view and declared that the heart-muscle itself was directly stimulated by the blood that coursed through it. The older form of the neurogenic theory, however, was entirely swept away by the discovery of the brothers Weber that the vagus nerve when stimulated, instead of increasing the heart-beat brought this organ to a standstill. At about this time Remak described nerve ganglia within the substance of the heart and these have been accepted by the modern neurogenists as the nervous mechanism for the heart-beat. The fact that it is practically impossible to get adult, vertebrate heart-muscle free from nerve-cells has left the problem of the heart-beat in these animals in a situation difficult for experimental approach. That the heart-muscle in vertebrates is always a continuous one, the auricles and ventricles being connected by at least a slender bridge of muscle, favors the myogenic theory, as does also the fact that the beat can be reversed in that the ventricle can be made to contract first and the auricle afterwards. In fact the general proposition, clearly expounded by Gaskell (1900), that the vertebrate heart is a muscular tube over which a myogenic wave of contraction proceeds from the posterior to the anterior end, has much in its favor and yet there are facts enough to show that the neurogenic interpretation of the action of the adult vertebrate heart is not an impossibility.

The unfavorable conditions that surround the study of the vertebrate heart have forced investigators to seek evidence concerning the nature of the heart-beat in other animals and as a result two remarkably clear sets of cases have been obtained. The first of these is the heart of the king-crab, *Limulus*. The heart of this animal, as Carlson (1904) has pointed out, possesses the unique feature of a complete anatomical separation of nervous and muscular parts. The heart itself is a long, segmented, muscular tube situated near the dorsal line of the animal. On the dorsal face of the heart is a median nerve-cord contain-

ing ganglion-cells and connected with two parallel lateral nerve-strands that lie near the sides of the heart. This whole nervous mechanism may be dissected off from the heart, leaving this organ in other respects intact.

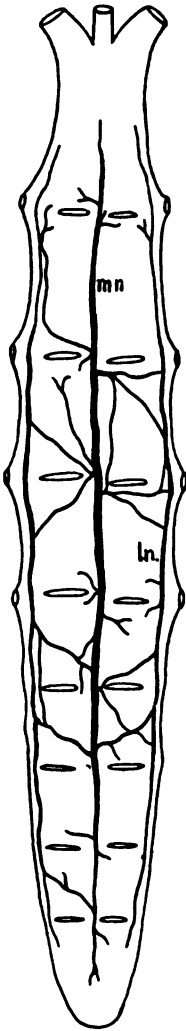

FIG. 3. DORSAL VIEW OF THE HEART OF *Limulus* (after Carlson). The anterior end is uppermost; *ln*, lateral nerve-strand; *mn*, median nerve-cord.

If a vigorous *Limulus* is opened from the dorsal side and the heart exposed, it will be seen to contract at the rate of about twenty beats per minute, and this is likely to continue under the conditions of simple exposure for some twelve to fifteen hours. If now the median nerve-cord and the lateral strands are dissected away, the heart comes to a standstill and never again shows a natural beat, though a stimulus applied directly to its substance will cause it to contract. If instead of removing the nerves, the median and lateral strands are cut through at any plane, care being taken not to injure the underlying heart-muscle, the two regions of the heart thus established beat independently and coordination of the heart as a whole is lost. If the nervous connections are left intact but the muscular heart is completely cut across in several places, the whole organ continues to beat in complete coordination. It is quite clear from these observations that the heart-beat of *Limulus* is absolutely dependent upon an extra-cardiac nervous mechanism and that this beat is carried out in exact accordance with the neurogenic theory. Since the artificial stimulation of a cardiac nerve in *Limulus* is followed by tetanus in the region of the heart under the control of this nerve, the conclusion is justified that the heart-muscle of *Limulus* is comparable rather with the skeletal muscles of this animal than with the so-called organic muscles, for skeletal muscles show tetanus when thus stimulated.

As Carlson himself remarks, however, the fact that the heart-beat of *Limulus* is neurogenic does not prove that the heart in other animals necessarily functions in a like way. In fact it is comparatively easy to point to another example in which the evidence for the myogenic beat is just as strong as that already presented for the neurogenic beat. This example is the tunicate heart. The tunicate heart, as for

instance that of *Salpa*, is a muscular tube over which peristaltic waves run from end to end. As is well known, the direction of these waves reverses from moment to moment, running for a short interval toward the visceral end of the heart, advisceral waves, and then toward the respiratory end, abvisceral waves. In *Salpa africana-maxima*, to take a single instance, according to Schultze (1901), after 16 abvisceral waves had passed over the heart in some 20 seconds, a resting period of

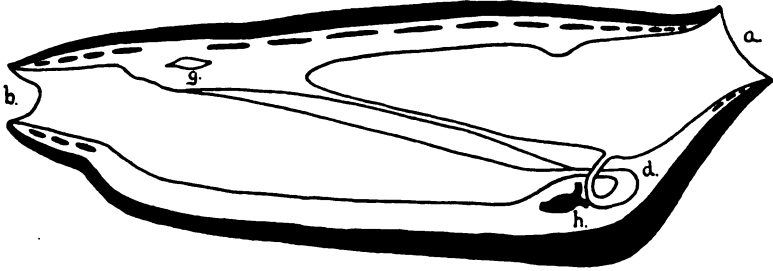

FIG. 4. SECTION OF A *Salpa* (modified from Herdman), showing the positions of the atrial aperture (a), branchial aperture (b), digestive tube (d), ganglion (g) and heart (h).

2 seconds ensued, whereupon 18 advisceral waves occupying 25 seconds preceded another resting period, etc. When the heart is removed from the body of a *Salpa*, it continues to beat with characteristic reversal. Stimulation of the central nervous ganglion of a normal *Salpa* has no effect upon the heart-beat, and though a removal of this organ is followed by a reduction in the rate, the same reduction is to be observed when other parts of the body than the central nervous organ are cut

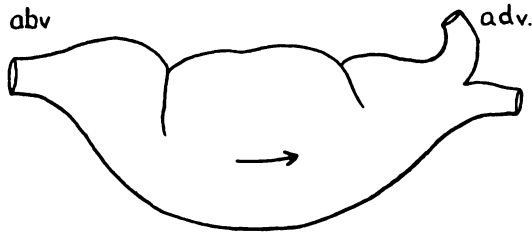

FIG. 5. HEART OF A *Salpa* (modified from Schultze), showing advisceral waves. *abv*, abvisceral end; *adv*, advisceral end.

out. Small fragments of the heart of *Salpa* also beat rhythmically when entirely isolated, a fact recently confirmed by Hunter (1903) on *Molgula*, and a most careful search of these fragments has failed to reveal nerve-cells or nerve-fibers. It seems therefore clear that the rhythmic heart-beat of the tunicates is myogenic in origin. This seems also to be true of the embryonic, vertebrate heart, for His (1891) has shown that this organ beats at a time when no trace of nervous tissue can be discovered in it.

From this general discussion it is quite evident that the cardiac muscles of different animals act in very different ways and that while some, like the heart of *Limulus*, have a neurogenic beat, others like that of the tunicates have a myogenic beat.

From this rather lengthy digression we may return to the question raised in the earlier part of this lecture, namely, the possibility of the existence of physiologically independent muscles. This I believe to have been demonstrated in part at least in the sphincter pupillæ of the lower and perhaps all vertebrates, and wholly so in the tunicate heart and the embryonic vertebrate heart. The complete freedom of such muscles from nervous control and their dependence on direct stimulation for normal action is a repetition of a process that, in my opinion, characterized all primitive muscles such as we now meet with in the sphincters of sponges. Such muscles as these sphincters I believe to represent the original and primitive elements around which the other members of the neuromuscular mechanism, the sense organs and the central nervous organs, subsequently developed. In my opinion then, effectors in the form of muscles preceded in an evolutionary sense the receptors and adjustors, and formed the centers around which these organs developed later.

REFERENCES

- CARLSON, A. J. The Nervous Origin of the Heart-beat in *Limulus*, and the Nervous Nature of Coordination or Conduction in the Heart. *Amer. Journ. Physiol.*, Vol. 12, pp. 67-74. 1904.
- ENGELMANN, T. W. Das Herz. Leipzig, 8vo, 44 pp. 1904.
- GASKELL, W. H. The Contraction of Cardiac Muscle. In E. A. Schäfer, Text-book of Physiology, Vol. 2, pp. 169-227. 1900.
- HERTEL, E. Experimenteller Beitrag zur Kenntnis der Pupillenverengung auf Lichtreize. *Graefe's Arch. Ophthalmol.*, Bd. 65, pp. 107-134. 1907.
- HIS, W., JR. Die Entwicklung des Herznervensystems bei Wirbelthieren. *Abhandl. Kgl. Sächs. Ges. Wiss., mathem.-phys. Cl.*, Bd. 18, pp. 1-64, Taf. 1-4. 1891.
- HOWELL, W. H. The Cause of the Heart Beat. *Journ. Amer. Med. Assoc.*, Vol. 46, pp. 1665-1670. 1906.
- HUNTER, G. W. Notes on the Heart Action of *Molgula manhattensis* (Verrill). *Amer. Journ. Physiol.*, Vol. 10, pp. 1-27. 1903.
- KRAFT, H. Zur Physiologie des Flimmerepithels bei Wirbelthieren. *Arch. ges. Physiol.*, Bd. 47, pp. 196-235. 1890.
- MEREJKOWSKY, C. Etudes sur les éponges de la Mer Blanche. *Mém. Acad. Imp. Sc., St. Pétersbourg*, Sér. 7, Tome 26, No. 7, 51 pp., 3 pls. 1878.
- SCHULTZE, L. S. Untersuchungen ueber den Herzschlag der Salpen. *Jena. Zeitschr. Naturwiss.*, Bd. 35, pp. 221-328, Taf. 9-11. 1901.
- STEINACH, E. Untersuchungen zur vergleichenden Physiologie der Iris. *Arch. ges. Physiol.*, Bd. 52, pp. 495-525. 1892.
- VOSMAEB, G. C. J., and PEKELHARING, C. A. Observations on Sponges. *Verh. Kon. Akad. Wetensch. Amsterdam*, Sec. 2, Deel 6, No. 3, 51 pp., 4 pls. 1898.

THE PREPARATION FOR THE STUDY OF MEDICINE

BY FREDERIC T. LEWIS, M.D.

HARVARD MEDICAL SCHOOL

Those who intend to study medicine are advised by the Medical Faculty to pay special attention to the study of Natural History, Chemistry, Physics, and the French and German languages, while in College.

This sentence of advice is contained in the catalogue of Harvard University issued in 1874. Thirty-two years later, at the dedication of the new buildings, it found more vigorous expression in the address of President Eliot.

Medical students should therefore have studied zoology and botany before beginning the study of medicine, and should have acquired some skill in the use of the scalpel and the microscope. It is absurd that anybody should begin with the human body the practise of dissection or of surgery; and, furthermore, it is wholly irrational that any young man who means to be a physician should not have mastered the elements of biology, chemistry and physics years before he enters a medical school. The mental constitution of the physician is essentially that of the naturalist; and the tastes and capacities of the naturalist reveal themselves, and, indeed, demand satisfaction long before twenty-one years of age, which is a good age for entering a medical school.

It is here assumed that these special studies form a part of the work for a bachelor's degree in arts or science, which the student has obtained before beginning his medical studies. Two groups of competent teachers of medicine dissent from this advice—those who believe that the bachelor's degree is unnecessary, since two years of special college work are sufficient; and those who consider that the degree should be required, but as a result of studies in literature, art, history and philosophy, rather than in biological science. Some physicians, therefore, send their sons to college with the advice, "Study nothing which bears upon medicine: you will have enough of that later"; and of those who have followed these directions, some have succeeded notably, both as practitioners and scientists. Because of this difference of opinion, an explanation of the relation of certain college courses to the study of medicine may be helpful to students.¹

Zoology.—It has long been recognized by the public that zoology is not medicine. When Harvey studied the circulation of the blood, "he fell mightily in his practice." "Had anatomists only been as conversant with the dissection of the lower animals as they are with

¹ In preparing this account, assistance has been received from Drs. W. B. Cannon, L. J. Henderson, W. C. Sabine, E. E. Southard and L. W. Williams.

that of the human body," he wrote in 1628, "the matters that have hitherto kept them in a perplexity of doubt would, in my opinion, have met them freed from every kind of difficulty." However, the public was unwilling to admit that this was a proper occupation for a physician, and in 1711 Addison wrote:

There are innumerable retainers to physic who, for want of other patients, amuse themselves with the stifling of cats in an air-pump, cutting up dogs alive, or impaling of insects on the point of a needle for microscopical observations; besides those that are employed in the gathering of weeds, and the chase of butterflies; not to mention the cockle-shell-merchants and spider-catchers.

Huxley admits that he really has never been able to learn exactly why a physician is expected to know zoology, and writes:

If I had to choose between two physicians—one who did not know whether a whale is a fish or not, and could not tell gentian from ginger, but did understand the applications of the institutes of medicine to his art; while the other, like Talleyrand's doctor, "knew everything, even a little physic"—with all my love for breadth of culture, I should assuredly consult the former.

This is a part of Huxley's argument for excluding comparative anatomy and botany from the curriculum of medical schools. As a preliminary training for the physician he approved of them, for later he wrote:

There can be no doubt that the future of pathology and of therapeutics, and, therefore, of practical medicine, depends upon the extent to which those who occupy themselves with these subjects are trained in the methods and impregnated with the fundamental truths of biology.

These fundamental truths are taught in college. In a general course in zoology the student should learn what an animal is, and into what great classes animals are divided. Representatives of these classes should be studied in the laboratory, and the probable relationship of one class to another, and of man to other mammals, should be considered.

The biological methods which the student should have learned in college include dissection and microscopic technic. It requires but little imagination to compare the work of two students beginning human dissection—one producing a set of instruments which he has already used, and proceeding to follow in minute detail structures similar to those which he has previously studied in the cat or rabbit; the other attempting to learn the general plan of the body and how to dissect, while he is supposed to be mastering the minutiae of human anatomy. Practise in the dissection of vertebrates and a general knowledge of their bones, muscles, nerves, vessels and organs are essential for good work in human anatomy.

Similarly in microscopic anatomy no student can afford to try to learn how to handle a microscope while his companions, by its use, are making rapid progress in the study of human tissues. The student

who has learned how to cut and stain sections for microscopic examination will be at considerable advantage. Some medical schools give courses in this "microscopic technic," but the time is better spent in studying sections than in preparing them. It has been found by Professor Waite that the better medical schools afford less time for this subject than inferior schools. A college course in which the chief tissues are prepared and studied is therefore recommended.

Embryology, which deals with the development of the body from the egg-cell to the adult organism, is divisible into two parts. That which deals with the early stages and chiefly with lower vertebrates and the invertebrates, has grown up in zoological laboratories. That which deals with the formation of the organs and the nervous, vascular and muscular systems in mammals, and with the development of the membranes in man, has been studied especially in medical schools. It is this portion of the subject which is an invaluable aid in understanding anatomy, histology and pathology, and its study should *precede* the medical school work in these subjects. Unless this is possible in the medical school which the student is to attend, college work in embryology should be considered. Thus in the Medical Department of Johns Hopkins University, where the teachers of anatomy are distinguished for their researches in *embryology*, no medical school work in this subject is required; a college course is recommended.

Special courses in the anatomy of the nervous system are given both in college and in the medical school, though generally from different standpoints. The subject is so intricate that the college work will be found of considerable assistance.

Occasionally a college announces a course on some one group of animals, such as the protozoa, insects, or worms, as desirable in preparation for medicine. The knowledge of these groups obtained from the general course should be sufficient for a practitioner. The theoretical and statistical study of variation and heredity has only a general interest for medical students, and courses in systematic zoology are of still less importance.

The value of zoological courses as a preparation for anatomy and histology is shown in the following table, based upon the marks of the class which entered the Harvard Medical School in 1907. The table shows the number of men obtaining the grades *A* to *E*, *A* being the highest (90-100 per cent.), and *E* failure to pass (less than 50 per cent.).

Students who have taken in zoology—	ANATOMY						HISTOLOGY					
	A	B	C	D	E	Av. %	A	B	C	D	E	Av. %
More than two courses	0	4	7	2	1	69	5	6	3	0	0	85
Two courses	0	1	9	7	3	53	3	6	9	2	0	77
From one half to two courses	0	0	8	8	10	49	3	4	12	5	2	68
No courses	0	0	4	4	7	45	0	2	5	2	6	52

From this table it is seen that the more zoology the student has taken the better his grade in anatomy and histology. As already stated, however, the practitioner must not specialize in anatomy, and the only college courses which it seems wise to recommend to all candidates for the medical school are as follows: General zoology, dissection of vertebrates, practise in the use of the microscope and in microscopic technic, elementary embryology.

Botany.—The study of plants is clearly less intimately related to medicine than the study of animals. The peculiar importance of the bacteria, however, makes a laboratory half-course in the morphology of plants, with special reference to the fungi, very desirable. This will give the student a more comprehensive idea of these organisms than can be obtained in a medical school; it will show their relation to yeasts, moulds and other low plants, some of which are of medical importance. At the same time the student will be trained in making accurate observations of natural phenomena and in reasoning on the basis of what he has himself observed. This ability, which may be cultivated both in botanical and zoological courses, is of the utmost value to the physician.

The study of the flowering plants was once intimately associated with medicine; and the array of drugs still used, which are derived from plants, would seem to make it important. The teacher of pharmacology, however, is not seeking students familiar with medicinal foxgloves and white poppies, but desires those well trained in chemistry. The botany of flowering plants is, therefore, not recommended.

Geology.—Geology appeals irresistibly to a "naturalist," but has little value for the physician. The air, soil and water are discussed in courses on hygiene, and in connection with drainage problems and water supplies geological knowledge is important. This, however, is not a sufficient reason for recommending geology.

Chemistry.—The study of chemistry in preparation for the work of a medical school is of great importance. Accordingly both a considerable amount of theoretical chemistry and not a little laboratory work are desirable.

General descriptive inorganic chemistry and qualitative analysis are a necessary introduction to all chemical study, and must come first in any plan of chemical training; they serve to familiarize the student with the characteristics of simple chemical processes and substances, and with the more elementary chemical theories. These courses must be followed by at least a brief course in organic chemistry, because that subject, with its unique and highly important theoretical development, is absolutely essential to an understanding of certain physiological processes; and it is of such a nature that it can be assimilated, even in its most simple form, only after a considerable period of time has been devoted to its study.

Quantitative analysis is important in another way. It gives valuable training to the hand and eye, and develops a particular form of accuracy which is required in biochemical work, and which enables the student to interpret justly the work of others.

Physical chemistry to-day contains a mass of material of the highest importance in all branches of biological science. An elementary acquaintance with it is essential for understanding such subjects as the physiology of the blood and the functional activity of the kidney and lung, since it explains the nature of solutions and the conditions governing the passage of substances through membranes.

Many medical schools require for entrance, work in general chemistry and qualitative analysis, and a few call for organic chemistry. These are essential. A half course in quantitative analysis and a half course in physical chemistry are desirable.

Physics.—Many students who are careful to take courses in biology and chemistry in preparation for medicine neglect physics entirely, or think that the elementary work done for admission to college is sufficient. A thorough college course, *with laboratory work consisting of accurate measurements*, is necessary for certain branches of medical practise and for the fundamental study, physiology. Physics is related to physiology in many ways. In studying muscular contraction the elements that constitute mechanical work and the action of levers should be known. For the study of the circulation it is necessary to understand the principles of hydraulics and the transmission of pressure in fluids; the laws of osmosis (studied in physical chemistry) aid in interpreting the diffusion of fluids between vessels and tissues. In considering the constructive and destructive changes in the body, the principle of the conservation of energy should be kept constantly in mind. To understand the maintenance of normal temperature and the changes in fever, some knowledge of the physics of heat is needed. An understanding of electricity is necessary for explaining the electrical changes produced in living tissues, and in order to stimulate tissues experimentally so that their activities may be studied. Electrical stimulation is used in treating certain diseases, and the physiological laboratory contains many pieces of electrical apparatus. The importance of the X-ray in medicine is sufficiently well known. In order to understand vision and the application of lenses to the eye, the principles of reflection and refraction must be understood. The nature of sound and its transmission through various media is similarly related to the physiology of hearing. It is a serious mistake to begin work in a modern laboratory of physiology before taking a thorough college course in general physics.

Mathematics.—The value of mathematics for medicine is indirect, since it is required chiefly in preparation for physics. The student

taking such a course in physics as has been recommended, should have had algebra, plane geometry and plane trigonometry. These courses come normally within the province of any good high school program. For advanced work in physics, solid geometry and higher mathematics are needed. For the benefit of medical students the mathematical requirement in certain special courses in physics is made as light as possible. It may be noted, however, that in the college course for future medical students outlined by Johns Hopkins University, the study of mathematics extends through two years.

Psychology.—Although psychology is a college study directly related to medicine, it appears that no medical school has yet required it for admission. A course in psychology often begins with a summary account of the nervous system and sense organs, and proceeds with the study of the states of consciousness. It discusses sensations and the nature of pain, and deals with instincts, memory, habits and the will. It gives the student a good understanding of "treatment by suggestion" and is a foundation for the study of abnormal minds, especially of hallucinations, illusions and delusions. Some knowledge of child development and an insight into sexual instincts, neurasthenia and psychasthenia are afforded by such a course. It is important for parts of physiology, pediatrics and internal medicine, and particularly for neurology and psychiatry. A half-course in psychology is therefore recommended.

French and German.—Since much of the progress of medicine is recorded in French and German publications, it is desirable, and in several schools it is required, that students should be able to read both of these languages. A beginning should be made before entering college. Courses in general literature, with practise in writing and speaking, will be found more profitable than those which are restricted to reading scientific prose. The importance of French and German in medicine is indicated by the number of periodicals in these languages for which medical libraries subscribe. The figures for the scientific libraries at the Harvard Medical School and for the Boston Medical Library, which is used largely by practitioners, are as follows:

SUBSCRIPTIONS FOR PERIODICALS			
	English	French	German
Harvard Medical Libraries.....	110	35	109
Boston Medical Library.....	88	67	161
	<u>198</u>	<u>102</u>	<u>270</u>

Since this medical literature should be at the command of students and practitioners, and is indispensable for investigators, it is necessary to be able to read both French and German.

Other Foreign Languages.—Although important medical articles

are published in Italian, and to a less extent in Spanish and other modern European languages, they are not so numerous as to justify a study of these languages. Latin is required for admission to certain medical schools, "in order to enable the student the more rapidly to master scientific and medical nomenclature." The international anatomical nomenclature is now entirely Latin and many of its terms are employed as English words. It is, therefore, very desirable that a student of medicine should have studied Latin as a part of his preparation for college. Greek is of much less importance, although it has supplied many barbarous medical terms.

English.—Although some students believe that in an examination in anatomy they should be marked upon anatomy alone, and not upon English, this is impossible. Every examiner, as well as every intelligent patient, will judge of the physician, in part at least, by his manner of expression. In a lot of examination books which had been marked in the usual way, there were a few with the grade *A*, and in none of these was there an example of strikingly bad English. The first book of low grade (60 per cent.) which was taken up, contained the following statement:

Voluntary striated muscle, developed differently, than smooth and cardiac, that coming from mesenchyma, this from somite or segments, has a definite cell membrane sarcolemma, which gives off fibers, its nucleus is found at the periphery.

It is useless to assert that clear and well-ordered anatomical knowledge exists in a mind which can not express it.

The study of English literature in college is to be recommended not only for its utilitarian value, but as a source of recreation and diversion from specialized scientific studies. There may be a few medical students who need the advice which Holmes gave to the young practitioner: "Do not linger by the enchanted streams of literature," but many more should heed the warning—"Do not let your literary life become a memory—a reminiscence." Unfortunately there are those who enter medicine with nothing on which to found a literary reminiscence.

Drawing.—The principles of drawing are taught in connection with courses in the fine arts or in architecture. Accuracy of observation may be developed in such courses, for no sooner does one begin to draw or model an object than attention is called to many details otherwise overlooked. For this reason drawing is required in studying anatomy, especially microscopic anatomy, in certain medical schools; and inability to draw seems to many students a justification for deficiencies in these subjects. To be sure, their professors are often in a similar predicament. Ruskin says:

That Professor Tyndall is unable to draw anything as seen from anywhere, I observe to be a matter of much self-congratulation to him; such inability serving farther to establish the sense of his proud position as a man of science, above us poor artists who labor under the disadvantage of being able with some accuracy to see, and with some fidelity to represent, what we wish to talk about.

If a course in art can develop this ability, it should be considered by medical students. To perceive accurately is not only a source of great enjoyment in itself, but to a certain extent it is an aid to the practising physician. One medical school in the United States recommends drawing for admission, and another provides instruction in anatomical drawing as an elective course.²

College Physiology and Hygiene.—Some colleges offer courses in physiology which are dilute presentations of medical school work. Thus, in one course, the student may be taught something of human anatomy, physiology, hygiene and medical bacteriology, all of which may be useful for those who are not intending to study medicine. It is wholly undesirable for the medical student to take time from other college work for the sake of such courses.

The Value of Research.—Some teachers believe that the original investigation of a subject in science, since it compels the student to think for himself and to depend upon his own observations, is worth several regular courses as a preparation for medical study. Certain researches, moreover, are not difficult. A study of the variation in the number of rays in the daisy, or of spinal anomalies in the salamander, might be made by an undergraduate if specially taught for this purpose. Such researches, however, are generally at the expense of fundamental education, and "researchlings" are not good students of elementary subjects.

Summary of Recommendations.—In the preceding pages it has been recommended that the medical student should have studied Latin, French, German, mathematics, physics and drawing in preparation for college; and that in college he should elect courses in zoology, botany, chemistry, physics, psychology, English, French and German, since these studies will be of direct value in connection with his work in the medical school. Between two and three years will be required for the recommended studies, but some time will be free for philosophy, history and political economy. These subjects are named since they

² Since this was written, President Eliot has referred to the advantages of studying drawing in the preparatory schools, as follows: "A university student who enters on the subject of botany or zoology is really crippled unless he can draw. He will make much slower progress; and will not have the best means of recording what he sees. And yet it is only a small percentage of the young men who now come to Harvard College that have any capacity for drawing. They have never had any opportunity to acquire any artistic skill."—Address to Graduates of the Massachusetts Normal Art School, April, 1909.

are the ones not already discussed which were formerly required for the bachelor's degree, and which are now considered by some to be an essential part of a good education. Three full years of college work which have included such courses as have been recommended, and which have led to the bachelor's degree, will be accepted as a good preparation by any medical school in the United States.

The Value of the Bachelor's Degree.—The value of the bachelor's degree for students of medicine is now generally recognized. A few medical schools require it and many recommend it. Students should, however, be warned against believing that the degree may be earned by two years of college work. This low standard, thinly disguised by the fact that the degree is not given the student until he has spent two years in the medical school, has been adopted by many colleges and is sometimes announced with considerable satisfaction, as follows:

The incalculable advantages of such a combination course must commend themselves at a glance, alike to would-be medical students who realize the value of an academic degree to the physician, and to candidates for an academic degree who contemplate a medical career and hesitate before the length of time demanded by its preparatory work.

Not only should protest be made against reducing the college work to two years, but much might be said in favor of four years, leading to the master's degree. In the Harvard Faculty of Medicine there are fifteen men who graduated from college since 1890. Two of these are doctors of philosophy; of the remaining thirteen doctors of medicine, six are masters of arts. The positions held by the six masters of arts and the seven bachelors of arts, respectively, are as follows:

	A.M.	A.B.
Professors	2	—
Assistant Professors	4	2
Demonstrators and Instructors	—	5

Since this list happens to include few practitioners, it may be noted that the college classes of '88-'90 supplied the faculty with six members, all practitioners; five of the six are masters of arts.

Not long ago, American medical schools received freely students with no college training. Scattered through the classes there were some who, without being required to do so, had obtained a college degree. The success of these men has been so notable that the requirements for admission are rapidly becoming more stringent. At Columbia University the effect of demanding one year of college work has been to eliminate that stratum of medical students described by Professor Wood as the submerged tenth.³ Most of the good schools now require two

³ Professor Wood advocates a low entrance requirement in the following remarkable statement. "The poor man, who has neither time nor money for long preparation, can enter and compete on an equal footing with the children of the rich. . . . If he does not survive the first year, well and good, no great harm has been done. . . ."

years of college work, and the student is tempted to regard this as ample preparation.⁴ The community meanwhile is seeking not younger but abler physicians. A shorter preparation than that which was obtained by many leading practitioners of the present generation is not likely to make their successors more efficient.

The Value of Scientific Preparation.—There are some physicians who believe that the preparation which has here been recommended produces scientists and not practitioners. It is clear, however, that a single course in physiology, even a very thorough one, does not make a physiologist. The professor of embryology who addressed the students who had just finished his course as “fellow embryologists” was greeted with a roar of laughter. Some of those who know that scientists are not produced by the medical school course still assert that it develops an undesirable type of scientific practitioner. A graduating class has recently been told that “At the bedside science is sometimes a hindrance.” Scientific knowledge is often contrasted with common sense and sympathetic humanity, as if they were incompatible and the patient must choose between them. The medicinal effect of a merry heart, known since the time of Solomon, has been rediscovered with great eclat, and the physician whom Holmes described as having a smile “commonly reckoned as being worth five thousand dollars a year to him” has his successors. The character of a physician is unquestionably of great importance, yet medicine is not an art of which “haply we know somewhat more than we know.” No condemnation is too severe for a physician who, without adequate knowledge of the medical sciences, attends his patient with self-confidence and a genial smile.

The college student may well be assured that the way to financial and professional success in medicine is through long and careful preparation. In this great pursuit he will not become narrow. He will develop what Dr. James Jackson long ago described as “a mind liberalized by scientific studies.” If he loses a certain breadth of culture because of specialization, still, as Cardinal Newman has said, “the advantage of the community is nearly in inverse ratio with his own.”

⁴A caution against this has recently been published by the dean of the medical courses at the University of Chicago. He says: “No device for curtailing the amount of his preparation should be sought or advised for students who can go ‘the whole road’ (that is, obtain a regular course and medical degree) within the age limit of twenty-seven or twenty-eight.” The announcement of the University of Chicago contains the italicized statement: “Every student should complete a four-years’ college course before entering the Medical School if his age and other circumstances make it possible for him to do so.”

DARWINISM IN THE THEORY OF SOCIAL EVOLUTION¹

BY FRANKLIN H. GIDDINGS, LL.D.

REVOLUTIONIZING as the life work of Charles Darwin was in the fields of biology and psychology, one may doubt if his writings disturbed the intellectual peace anywhere more profoundly than in the "Sweet Jerusalem" of pre-Darwinian social philosophy. Borrowing a shocking thought from the Rev. Thomas Robert Malthus, Mr. Darwin, in due course of time, gave it back to Malthusians and Godwinites, to Ricardians and Ruskinites, to Benthamites and Owenites, with a new and terrific voltage.

Nine years before "The Origin of Species" was published, Herbert Spencer, in the concluding chapters of "Social Statics," had offered an explanation of society in terms of a progressive human nature, adapting itself to changing conditions of life. These chapters are the germ of that inclusive conception and theory of evolution which were elaborated in the ten volumes of the "Synthetic Philosophy." Five years later, or four years before "The Origin of Species" saw the light, Mr. Spencer, in the first edition of his "Principles of Psychology," set forth an original interpretation of life, including mental and social life, as a correspondence of internal relations to external relations, initiated and directed by the external relations. Finally, in April, 1857, Mr. Spencer published, in *The Westminster Review*, his epoch-marking paper on "Progress: Its Law and Cause," in which his famous law of evolution was partially formulated, and evolution was declared to be the process of the universe and of all that it contains.

Mr. Spencer thus had seen evolution in its whole extent, as adaptation and differentiation. He had not yet mentally grasped the universal redistribution of energy and matter, wherein every finite aggregate of material units, radiating energy into surrounding space, or absorbing energy therefrom, draws itself together in order-making coherence, or distributes itself abroad in riotous disintegration. That universal equilibration, which in fact is the beginning and the end of evolution, was the aspect of the world which in thought Mr. Spencer arrived at last of all.

It is not given to any one human intellect to discover all truth, and there is more in evolution than even Mr. Spencer perceived, either at the beginning of his great work, or in the fulness of his powers. Intent upon the broader aspects of cosmic transformation, his mind did not

¹ A lecture in the course on "Charles Darwin and his Influence on Science," delivered at Columbia University, April 16, 1909.

seize upon certain implications of universal rearrangement. In the concrete world of living organisms, equilibration becomes the relentless struggle for existence, in which the weakest go to the wall. Natural selection follows. It was this intensely concrete aspect that Mr. Darwin saw, and intellectually mastered.

The distinction here indicated between evolution as a universal process, comprehensively described by Spencer, and Darwinism, or Mr. Darwin's account of one vitally important and concrete phase of that process, has often been noted, and is usually observed by careful writers. It is of particular importance in any discussion of social evolution. To indicate how far our theories of social origins, our philosophies of history and of human institutions, have become not only evolutionist, in the Spencerian sense of the word, but also Darwinian, is the purpose of my lecture this afternoon.

It was not until the publication of "The Descent of Man," in 1871, when controversy over "The Origin of Species" had raged through twelve years of intellectual tempest, that the full significance of natural selection for the doctrine of human progress was apprehended by the scientific world. Mr. Spencer saw it when "The Origin of Species" appeared. Mr. Darwin himself had perceived that he must offer a credible explanation of the paradox that a ruthless struggle for existence yields the peaceable fruits of righteousness. But it was neither Mr. Spencer, nor Mr. Darwin, who first recognized the specific phase of the life struggle in which the clue to the mystery might be sought. The gifted thinker who made that discovery was Walter Bagehot, editor of the London *Economist*, whose little book on "Physics and Politics, or Thoughts on the Application of the Principles of Natural Selection and Inheritance to Political Society," was published, first as a series of articles in *The Fortnightly Review*, beginning in November, 1867. Mr. Darwin rightly calls these articles "remarkable." Revised and put together in book form they made a volume of only two hundred and twenty-three small pages in large type, but no more original, brilliant or, as far as it goes, satisfactory examination of the deeper problems of social causation has ever been offered from that day until now. It anticipated much that is most valuable in later exposition.

In the "Social Statics," Mr. Spencer had shown that primitive man, subsisting upon inferior species and contending with them for standing room and safety, necessarily developed a human nature adapted to the task of slaughter, cruel, therefore, and unscrupulous; but that triumphant posterity, inheriting a subjugated world, and no longer bound to kill, might become sympathetic enough to cooperate successfully in peaceful activities. The exact relation, however, of this process to group formation or to the collective activity of a cooperating group when formed, Mr. Spencer at this time certainly did not see. For, incredible though it may seem, Mr. Spencer did not at this time so much

as make note of the terrific struggles for control of food-getting opportunities that occur among individuals or between groups of the same species, variety or race. Conflict among men of the same cultural attainments Mr. Spencer thought of only as prompted by surviving savage instincts, engendered by predatory habits, in the lawless youth of the race.

It was specifically the phenomena of group solidarity and of collective conflict, in distinction from a merely individual struggle for existence, which Mr. Bagehot selected for examination, and his mind penetrated directly to the essential conditions of the problem. He said :

The progress of *man* requires the cooperation of *men* for its development. . . . The first principle of the subject is that man can only make progress in "cooperative groups"; I might say tribes and nations, but I use the less common word because few people would at once see that tribes and nations *are* cooperative groups, and that it is their being so which makes their value; that unless you can make a strong cooperative bond, your society will be conquered and killed out by some other society which has such a bond; and the second principle is that the members of such a group should be similar enough to one another to cooperate easily and readily together. The cooperation in all such cases depends on a *felt union* of heart and spirit; and this is only felt when there is a great degree of real likeness in mind and feeling, however that likeness may have been attained.²

Addressing himself to the question how the necessary likeness in mind and feeling are produced, Mr. Bagehot answers: By one of the most terrible tyrannies ever known among men, namely, the authority of customary law; and in accounting for the origin and force of custom, he develops a theory of the function of imitation which anticipates much, but by no means all, of the sociological theory of Gabriel Tarde. Custom, however, tends to create a degree of similarity among social units, and an unchanging way of life, fatal to further progress. To reintroduce and to maintain certain possibilities and tendencies toward variation is, as Bagehot sees the process, one of the chief uses of conflict. Social evolution thus proceeds through the conflict of antagonistic tendencies, on the one hand toward uniformity and solidarity; on the other hand toward variation and individuality. In some groups, one of these tendencies predominates. Contending together, group with group, in the struggle for existence, those groups survive in which the balancing of these tendencies secures the greatest group efficiency. It is not too much to say that in this interpretation, Mr. Bagehot arrived at conclusions which to-day we recognize as belonging to the theoretical core of a scientific sociology.

Mr. Darwin, in those chapters of "The Descent of Man" in which he treats of the origin of social instincts and the moral faculties, adopts in substance the conclusions of Mr. Bagehot, and with his keen sense for what is essential, lays emphasis upon four facts, namely: (1) the

² "Physics and Politics," pp. 212, 213.

importance of group or tribal cohesion as a factor of success in inter-tribal struggle, (2) the importance of sympathy as a factor in group cohesion, (3) the importance of mutual fidelity and unselfish courage, and (4) the great part played by sensitiveness to praise and blame in developing both unselfish courage and fidelity. In terms of these four facts, Mr. Darwin finds an answer to the question, how, within the conditions fixed by a struggle for existence, social and moral qualities could tend slowly to advance and to be diffused throughout the world.

That the studies of both Mr. Bagehot and Mr. Darwin left much still to be said on the subject of group feeling and cooperative solidarity was shown when, in 1890, Prince Peter Alekseevich Kropotkin published in *The Nineteenth Century* his fascinating articles on "Mutual Aid among Animals," afterwards supplemented by studies of mutual aid among savages and among barbarians. These articles contained nothing essentially new in theory, but they contributed to our knowledge an immense mass of facts demonstrating how great has been the part played by sympathy and helpfulness in the struggle for existence, and how inadequate would be any interpretation of natural selection which accounted for it wholly in terms of superior strength, cruelty and cunning.

Mr. Darwin never claimed to offer an adequate explanation of the variations which natural selection preserves or rejects. He sometimes took them for granted, he sometimes spoke of them as accidental or fortuitous. He would have been the last to pretend that he had told us all that we should like to know about the beginnings of sympathy or of sensitiveness to praise or blame. But, starting from sympathy and the desire for approval as traits that may actually be observed among gregarious creatures, and that presumably have somehow had a natural origin, Darwin and Kropotkin convincingly demonstrate that groups possessing these qualities have a certain advantage in the struggle for life.

To account more fully for the origins, in distinction from the natural selection of the social qualities, was the problem that Mr. John Fiske attacked in his theory of the effects of prolonged infancy, first published in the *North American Review* of October, 1873,³ and a year later in the "Outlines of Cosmic Philosophy." Fiske discriminates between "gregariousness" and "sociality," without, however, sufficiently analyzing the one or the other, or quite defining the difference. By sociality he seems to mean a relatively high development of sympathy, affection and loyalty to kindred or comrades. He argues that sociality has its origin in small and permanent family groups. These are not necessarily monogamous at first. They may be polygamous or polyandrian, and may broaden out into clans. But they must be more enduring than matings observed in the merely gregarious herd.

³ Under the title: "The Progress from Brute to Man."

The cause of both definiteness and permanence he finds in the prolongation of infancy, necessitating a relatively long-continued parental care of offspring. The relations so established among near kindred have conserved and strengthened the feelings of affection and the sense of solidarity. Mr. Darwin recognized Mr. Fiske's theory as an important contribution to the subject. It must be said in criticism, however, that Mr. Fiske did not see all the implications of prolonged infancy, or develop his theory into all its possibilities. Admitting that the prolongation of infancy was probably a factor in the evolution of stable family relationships, and therefore played a part in strengthening the social sentiments, we must remember that the actual social life and solidarity of the gregarious group was probably a chief cause of the prolongation of infancy itself. Demanding, as it did, a relatively keen exercise of brain and nervous system in communication, imitation and cooperation, it operated to select for survival those individuals that varied in the direction of high brain power and its correlated long infancy. But this is to say that society was a factor in the evolution of man before man became a factor in the evolution of society, and the difference is important.

Moreover, Mr. Fiske's theory no more explained the actual origins of sympathy and cooperation than Bagehot's and Darwin's theories had done. Neither, for that matter, did Sutherland's account of "The Origin and Growth of the Moral Instinct,"⁴ although Sutherland got somewhat farther back when he called attention to the reaction of parental care of offspring upon the evolution of ganglia making up the sympathetic nervous system.

At this stage the Darwinian interpretation of social origins had arrived when, in 1894, there was published a work which had an almost sensational reception. Hailed as a new gospel by minds desiring above all things to find some solid ground for religious convictions that had seemingly suffered violence in the course of evolutionist warfare, this book by scientific critics was treated with scant respect. These critics, I venture to think, were in error. For, in fact, the "Social Evolution" of Benjamin Kidd raised a profoundly important question, and gave an answer to it which, while half wrong, was probably half right, and the half that was right was a real and important contribution to knowledge. Stated in the fewest possible words, Mr. Kidd's query was this:

Since natural selection saves the few and kills the many, why does not the great majority of mankind try to curb competition and put an end to progress? Thus presented, Mr. Kidd's question is the radical and fearless form of a question which socialism asks in a form that, by comparison, is conservative and half-hearted. And Mr. Kidd's answer,

⁴ Published in 1898, a worthy product of Australian scholarship, which its author described as largely a detailed expansion of the fourth and fifth chapters of "The Descent of Man."

not so much as tainted with socialism, is as fearless as his question. Progress has no rational sanction. It is irrational and, from the standpoint of reason, absurd. Man goes on multiplying, competing, fighting and making progress because he is not rational and has no desire to be. He lives not by reason, but by faith. He crucifies and kills himself to improve the race, not because he is scientific, but because he is religious.

Perhaps it was because Mr. Kidd's thesis was paradoxical, that theologians found in it something tangible and scientific men did not. It should be possible now to look back upon it without prejudice. On the face of it, it is an obvious fallacy, but back of fallacy lies a truth.

The fallacy consists in an unwarranted assumption that individuals and families marked for extermination in the struggle for existence are, in their own lifetime, aware of their impending doom. Let us suppose that, of one hundred families now flourishing, ninety will become extinct in the tenth generation, their places being filled by a corresponding number of new families branching from the one successful line. This would be natural selection at a rapid rate. Yet to maintain this rate, only ten families have to drop out in any one generation, and ten new ones to appear. This means that, at any given time, a ninety per cent. majority of all persons at the moment living have an expectation of further life, the termination of which can not be foreseen. The large majority, therefore, at any given time existing think of themselves not as the unfit that must perish, but rather as the fit selected to survive.

This way of stating the problem, however, brings us face to face with a peculiarly interesting truth, for the apprehension of which we rightly may give generous credit to Mr. Kidd. Obviously, while no family stock or race at any time existing can certainly know, or, while it remains still vigorous, find sufficient ground to believe that it is doomed to perish, neither can it certainly know that it is indefinitely to survive. It does live, struggle, plan and achieve not altogether by knowledge or by reason, but also in part by faith. It hopes, it expects to endure. It believes in its future.

This faith by which a race, a family, or an individual lives, is not anti-rational, nor yet super-rational. It is rather sub-rational or proto-rational. It is deeper, more elemental than reason—a fact of instinct and feeling. It is *faith in the possibilities of life*, born of actual survival in the struggle for existence. The question, therefore, which Mr. Kidd should have asked, and which we, reviewing his work, must ask in his stead, is this: May we identify our elemental faith in the possibilities of life with the tremendous social phenomenon of religion, which, in all the ages of man's progress, has been one of his supreme interests? Shall we perhaps find that, when reduced to its lowest terms, to its essential principle, religion is not, as has been supposed, a belief in gods, or in a supernatural, in any way conceived, but is rather

that primordial faith in the possibilities of life which was born, and generation after generation is re-born, of success in the struggle for existence; which may gather about itself all manner of supplementary beliefs, including a belief in spirits and in gods, but which will persist as the deepest and strongest motive of life after science has stripped away from it all its mystical and theological accretions? I hope to show that such is the fact. So believing, I accept as a positive contribution to the theory of human evolution Mr. Kidd's proposition that religion, a thing deeper and more elemental than reason, has been a chief factor in social evolution.

The mention of socialism, when referring to the theories of Benjamin Kidd, may serve to remind us of two further contributions to the Darwinian theory of society still to be mentioned. The Marxian socialist who has taken trouble to read Mr. William Hurrell Mallock's American lectures on socialism,⁵ will not be disposed to admit that Mr. Mallock is a competent student of social phenomena. Before passing judgment, however, he should examine Mr. Mallock's "Aristocracy and Evolution," a suggestive and really important work, published in 1898. In this book Mr. Mallock rises above his habit of literary trifling, and digs somewhat below his prejudices, to examine not only fairly, but also cogently, and with illumination, the phenomenon of personal ability as a factor of social achievement. Distinguishing between a struggle for existence merely, and a struggle for domination, he contends that progress in any legitimate sense of the word is attributable to the struggle for domination. No one, I think, can go far in sociological study without seeing that this is a significant distinction for purposes of historical interpretation.

One need not, however, draw the conclusion that democracy is necessarily antagonistic to progress, as Mr. Mallock does. He says:

The human race progresses because and when the strongest human powers and the highest human faculties lead it; such powers and faculties are embodied in and monopolized by a minority of exceptional men; these men enable the majority to progress, only on condition that the majority submit themselves to their control.*

No student of social evolution would be less likely to dispute these propositions than Mr. Francis Galton, who, in fact, in his studies of natural inheritance and hereditary genius, has done more than any other investigator to establish them on a broad inductive basis. And after Mr. Galton, no investigator has made more valuable studies in this field than Mr. Karl Pearson, and no one more unreservedly than he accepts the conclusion that superiority is necessary to social advance and that personal superiority is a fact of heredity. Yet Mr. Pearson con-

* Delivered in 1906; published 1907 as "A Critical Examination of Socialism."

* "Aristocracy and Evolution," p. 379.

tends that to add artificial advantage to natural superiority is fatal, because superiority can not be maintained unless the herd, as well as the superior individual, is carefully looked after and improved. The superiority that achieves leadership and domination is usually the power to do some particular thing exceptionally well. It is extreme individuation, and it often is purchased at the cost of race vitality. It is as necessary to maintain the one as to develop the other. Mr. Pearson therefore finds the socialistic program not incompatible with continuing progress by selection and inheritance.⁷

“To ‘wage war against natural inequality’ is clearly a *reductio ad absurdum* of the socialistic doctrine. So far as I understand the views of the more active socialists of to-day, they fully recognize that the better posts, the more lucrative and comfortable berths, must always go to the more efficient and more productive workers, and that it is for the welfare of society that it should be so. Socialists, however, propose to limit within healthy bounds the rewards of natural superiority and the advantages of *artificial* inequality. The victory of the more capable, or the more fortunate, must not involve such a defeat of the less capable, or the less fortunate, that social stability is endangered by the misery produced. At the present time a failure of the harvest in Russia and America simultaneously, or a war with a first-class European power, would probably break up our social system altogether. We should be crushed in the extra-group struggle for existence, because we have given too much play to intra-group competition, because we have proceeded on the assumption that it is better to have a few prize cattle among innumerable lean kine than a decently-bred and properly-fed herd with no expectations at Smithfield.”

From this too brief account of the applications thus far made of Darwinian theory to the problems presented by social relationships, including human institutions, we may turn to the question of further scientific possibilities in this direction. It will have been noted that the theories reviewed are not as they now stand entirely consistent with one another, and that none of them carries explanation back to the actual beginnings and causes of group formation. Perhaps if we could more adequately account, in terms of the struggle for existence, for actual social origins, and for successive stages of social evolution, the various fragments of theory which we now possess would fall into orderly correlation.

Possibly also the most promising starting point for any new attempt to achieve these ends may be found in a careful scrutiny of what is involved in the struggle for existence itself. Close readers of “The Origin of Species” know that although Mr. Darwin, when employing the phrase “a struggle for existence,” usually meant by it a struggle for subsistence, he uses it also to mean a struggle with the physical conditions of life, to which an organism that would survive must be or

⁷ “The Chances of Death,” Vol. I., pp. 112, 113. In view of the apprehensions just now so freely expressed in England, it is, I think, worth while to quote the exact words in which Mr. Pearson more than ten years ago summarized his argument:

must become adapted. "Two canine animals in a time of dearth," he remarks, "may truly be said to struggle with each other which shall get food and live. But a plant on the edge of a desert is said to struggle for life against the drought, though more properly it should be said to be dependent on the moisture."⁸ Also, "climate plays an important part in determining the average numbers of a species, and periodical seasons of extreme cold or drought seem to be the most effective of all checks."⁹ Yet further, "when we reach the Arctic regions, or snow capped summits, or absolute deserts, the struggle for life is almost exclusively with the elements."¹⁰ Again, Mr. Darwin often means, not a struggle for food or against the elements, but a struggle to avoid being converted into food. "Very frequently," he writes, "it is not the obtaining of food, but the serving as prey to other animals, which determines the average numbers of a species."¹¹ And some of his most fascinating pages deal with the variations, such as protective markings, colorings and habits, which are helpful in the mere struggle for safety. Once more, in those paragraphs in "The Descent of Man" already referred to, in which Mr. Darwin recognizes the utility of group solidarity, he, by implication, takes account of a struggle on the part of associating individuals to adjust their interests and their activities to one another in such wise that group life may be maintained.

If, then, it is legitimate to use the term, "struggle for existence," "in a large and metaphorical sense," as Mr. Darwin says his practise is,¹² the struggle itself obviously consists of four distinct and specific struggles, namely: (1) *the struggle for safety*; (2) *the struggle for subsistence*; (3) *the struggle for adaptation* by every organism to the objective conditions of its life, and, (4) *the struggle for adjustment*, by group-living individuals to one another.

And this large use of the term is legitimate in fact. Mr. Darwin's only mistake was in calling it "metaphorical." For, as Karl Pearson has pointed out, "the true measure of natural selection is a selective death rate,"¹³ and any circumstance, whether it be danger, or scarcity of food, or non-adaptation to physical conditions, or mal-adjustment of associating individuals to one another, which affects the selective death rate, is a factor in the struggle for existence.

If so much be granted, a number of difficult questions get a real illumination. What are the true relations of esthetic and economic, of ethical and social phenomena to one another, and to life in its wide inclusiveness? What, especially, is the precise point of departure of

⁸ "The Origin of Species," p. 78.

⁹ *Ibid.*, p. 84.

¹⁰ *Ibid.*, p. 85.

¹¹ *Ibid.*, p. 84.

¹² *Ibid.*, p. 78.

¹³ Essay on "Reproductive Selection" in "The Chances of Death and Other Studies in Evolution," Vol. I., p. 63.

social evolution from all that precedes it and prepares for it? And what is the precise discrimination needful of things social from things merely organic or psychological? The modes and the phases of the struggle for existence suggest intelligible answers.

Quite obviously the struggle for safety is the shaping cause of our esthetic life, the life of sensitiveness and of appreciation. On this point Mr. Darwin's data and conclusions are exhaustive. Instant reaction, if the organism is unconscious, discrimination if it is conscious, and due estimate of light and shade, of color and form, of sound and of pressure, in all their objective degrees and proportions, dissonances and harmonies—these are the readiness and the responsiveness requisite for safety from each instant of life to the next. Obviously, moreover, the esthetic life, so understood, is elemental and precedent. For an organism must in fact survive from moment to moment before it can have further need or power, even to eat.

The struggle for subsistence initiates and broadens into the economic life. The struggle for adaptation becomes the ethical life. For adaptation, in its beginnings a mere taking on or perfecting of useful characters, develops, in time, into self-control, self-direction and self-shaping.

Between adaptation and adjustment, no distinction whatever has been made by a majority of evolutionist writers. Spencer uses the word "adjustment" to include all that biologists and psychologists commonly mean by adaptation. Yet the two things are not at all the same. The struggles which they involve are not identical struggles, and, for the purposes of sociological theory, the distinction is of fundamental importance.

Adaptation—which, as it goes on, widens into and includes the ethical life, at first is a mere conforming of the organism through variation, selection and inheritance, to the physical conditions under which it happens to live; that is to say, to altitude, temperature, light or darkness, dryness or moisture, enemies, food supply, and so on. Through adaptation, and because non-adaptation means extinction, the individuals of any given species congregated and dwelling in any given region where adequate food supplies are found become increasingly alike, and the first two conditions of social life, as Mr. Bagehot rightly explained it, namely, grouping and substantial resemblance, are provided. But, since they are alike, individuals of the same variety or race, so brought together in one habitat, necessarily want the same things, and in like ways try to get them. They may compete in obtaining those things which each is able to get by his own efforts, or they may combine their efforts to obtain those things that no one could get unaided. In either case their interests and activities sooner or later must fall into adjustment. And, since any failure of adjustment may be as fatal as non-adaptation or starvation, there will be a struggle, at

first perhaps unconscious, but in course of time becoming conscious, to maintain adjustment and to perfect it. This struggle for adjustment is the beginning of social life and is the differentiating mark of all true social phenomena.

Or, to put the matter in slightly different words, while the struggle for safety develops the esthetic life, and the struggle for subsistence becomes the economic life, and the struggle for adaptation broadens into the ethical life, the struggle of resembling creatures to adjust their similar adaptations to one another, is the beginning and the continuing process of the social life.

Through success in all these struggles, and not in any one alone, there results a survival of the fit, that is, of those organisms that are so equipped with proper parts and habits that they on the whole fit into and conform to all the essential conditions of life provided by the environment in which they are forced or elect to dwell.

Holding their own in such unremitting and remorseless contests, those among them in whom consciousness has awakened, inevitably come to feel a certain sense of vital adequacy, a will and power to live, and an assurance of unexhausted opportunity. There is born in them a faith, inarticulate at first but effective, in the possibilities of life. Impelled by this faith and equipped with social instinct, man, outstripping all other creatures, presses forward into the wider conflicts of a *collective* struggle for existence.

Here a word must be said about the subjective aspect of society, which, in its objective aspect, as we have seen, is merely the struggle and process of adjustment. What is the relation of adjustment to sympathy and to understanding, to communication and to concerted purpose, to the evolution of a social constraint through which the community controls and shapes the individual, to cooperation and to social organization?

These questions are not really so difficult as some others. We have seen that adjustment arises because like creatures want the same things and in like ways try to get them. Now, wanting the same things, and trying in like ways to get them, are essentially psychological phenomena, and under analysis they resolve into one elementary phenomenon in particular, namely, like response to the same, or to similar, or to common stimulation. Responding in like ways to the same, or to common stimulation, associating individuals, acting upon one another also by suggestion and example, and imitating one another in a thousand ways, have identical feelings and develop identical or closely resembling ideas. Sympathy and understanding, as the psychologist explains, are by-products of all these things. Sympathy and understanding, supplemented by communication, and backed up by the enormous mass of common feelings and ideas, find expression in those common and usual

ways of doing things, those norms and elements of custom which Professor Sumner has so admirably named "the folkways."

Folkways, customs, mores, enforced by collective instinct and feeling, constrain the individual. They become that "most terrible of all tyrannies known to man," of which Mr. Bagehot wrote. But that tyranny, as Bagehot demonstrated, perfects the group in the unity of essential likeness, and in the consciousness of likeness, and holds it together in the bonds of solidarity. Conscious of the usefulness of solidarity, the group, as it becomes self-conscious, endeavors by definite policies so far to prescribe individual conduct as to control and limit variation from type. Society thus becomes a type-conforming group of associates, endeavoring, by self-instituted discipline, to maintain, as a type, its distinctive characteristics.

To observe the successive stages, and the complications of man's collective struggle for existence, is to examine the evolution of tribal society and to follow the history of civilization—a large undertaking. The few words that I have to offer upon these subjects at the present time will refer only to some of the relations that seem to hold between very general influences, on the one hand, and some of the larger results, on the other.

Group safety is the first consideration. It is attained through unity of action, a prerequisite of which is the sense of solidarity. To the making of solidarity, everything that we are in the habit of calling conventionality contributes. Not only the fundamentally important conventions of language, but also those of manners, of costume and of ceremonial have here an essential function.

Doubtless it is at this initial stage of the collective struggle, when life is a day by day hazard, and man's overmastering emotion is dread, that religion acquires its first intellectual coefficient. Since Edward B. Tylor developed his theory of a primitive animism, much new light has been thrown upon the earliest religious notions of the race. The new discoveries have not convinced us that animism was, indeed, the actual beginning of religion, much less have they proven that the ghost theory of Spencer's exposition was. On the contrary, research apparently has demonstrated that religion, before it was spiritistic or even animistic, was quite impersonal. It was a recognition and an ever-present dread of external power, conceived merely as strength or might. Mana, or Manitou, was not the Great Spirit of the missionary's imagination; it was merely The Great Big, The Great Mighty, The Great Dreadful, and the earlier way of establishing working relations with external might lay not through sacrifice or prayer, but through the ingenious trickery of the black art, that is to say, of magic.

But was even magic the very first mode of worship? Speaking for myself only, I doubt it. In the folkways and folklore of every people

we find, deep down in the stratum, the arts of augery, of divination, of fortune telling. In these, I suspect, we discover the earliest religious ideas and practises, as distinguished from religious feeling or faith. Before man thought of fooling, or tricking, or bribing, or importuning the powers that control his fate, he tried simply to find out what they were likely to do to him. He tried to learn whether and how far he was safe, to foresee his fate.

It has been in view of such considerations as these, and especially because of the strong probability that religion was impersonal before it became animistic, that I have thought it legitimate to identify religion in its ultimate essence or principle, with that elementary and primordial faith in the possibilities of life which springs from success in the struggle for existence.

Collective economic effort takes at first the form of a group exploitation of various natural sources of subsistence. Each horde becomes identified with a particular region or hunting-ground, and sometimes with a particular kind of food. The notion arises that the human group and its food, plant or animal, had a common origin and are now kindred. Magic is developed as the means relied on to preserve and to increase the food supply. This idea and resulting practise constitute totemism, which differentiates primitive communities into economic groups and into kinship divisions.

Within each group, the adaptation of individuals to prevailing life conditions is furthered by the folkways, imposing upon every person a common morality, and, through initiation ceremonies, or other formidable disciplines, developing in him some power of self-control. From experiences of discipline received and imparted, and of self-mastery, springs a crude theory of personal power or agency. Here, probably, is the true origin of animism as a theory of causation, and from this point religion tends to become animistic.

The ever-recurring conflicts between group and group call forth leadership, establish the simpler forms of personal government and mark out the elementary social distinctions. It is now that ideas of spirits separable from material bodies, and, as ghosts surviving bodily death, begin to take shape. Religion becomes spiritistic. The habit of making obeisance to the powerful or the clever, and of propitiating them, which has grown up step by step with leadership and personal government, is transferred to the realm of shades. Ghosts must be looked after and prayed to, or they might do mischief. Remembered, fed and honored, the kindred ghosts of a community are friendly, protecting powers. Religion becomes the bond of the living with the dead.

Through all these struggles, adaptations and adjustments, the fit that survive become in a degree socialized, and in the degree that they become social they become better assured of further survival. By the integration of small hordes of kindred into tribes, and the combination of

tribes into federations, ethnic society is evolved. The ghosts of tribal chieftains are supposed to be more powerful and important than ordinary ghosts; they enjoy, therefore, extraordinary honor and attention. They become gods. Religion becomes theistic.

The struggle for *existence* has now been won. The collective struggle for *advantage* begins. From every side confederated tribes of barbarian men press toward those regions that offer exceptional opportunities; such regions in early days were the shores and back country of the Caspian Sea, the valleys of the Euphrates and the Nile. This is the struggle for *situation*. Bringing together in one habitat a motley multitude of tribes, and fragments of shattered tribes, it grinds the tribal system to destruction. It assembles and mingles the human elements for an evolution of civil society.

When the struggle for place and opportunity has been won, and command of territory has been achieved, every energy is enlisted in the economic struggle for *abundance*. The new social order is not yet established. Miscellaneous men jostle each other, as in a mining camp. Each lives among his fellows on sufferance, or toleration. Society is merely approbational, and its interests are purely materialistic. The deities are gods of crops and generation.

This state of things, of course, can not last. The struggle for abundance begets the struggle for *efficiency*. Ideas and standards of efficiency appear. The efficient find each other out. They like each other and each other's ways. They dislike the inefficient, and begin in all possible ways to make life unpleasant for them. Efficiency and the habits that make therefor are identified with righteousness. The gods are credited with righteous impulses, and a desire to have men do right. Society has become congenial, and religion ethical.

The supreme struggle remains—the struggle for *supremacy*. To conquer, to dominate, to exploit—this alone can satisfy the state that has become strong enough to impose its yoke upon environing peoples. Armies are mustered and drilled, coercive rule and regimentation transform the domestic order. Society becomes despotic, and, since the gods of the conquerors must be worshipped by the conquered, religion becomes authoritative.

To show how despotic society breaks down, how in such frontier outposts as were the islands and shores of the Ægean Sea, intellect at last becomes dynamic, and political habit revolutionary, and how, under the hammering of these forces, society becomes contractual or constitutional, and religion rationalistic, would be to tell an enthralling story, for which no time remains. In one favored place, the Athenian city state, society became for a brief time idealistic, that is to say, its bonds were those of a common purpose, or ideal, and religion became non-theological. After two thousand years of arrest and slow recovery,

the cosmopolitan society of the western world is, possibly, once more approximating the Athenian model.

And the goal is what? If it be true, indeed, that through the ages an increasing purpose runs, is it made manifest in something that we may legitimately call progress? For progress, rightly defined, is more than evolution. It is race survival with individuation, or it is increasing individual power, capacity and happiness not entailing race extermination. Have we made sure of this? We hate to think ill of ourselves. Yet the question recurs: Has the survival of the fit become, at length, a survival of the best?

DARWIN'S INFLUENCE UPON PHILOSOPHY

BY PROFESSOR JOHN DEWEY
COLUMBIA UNIVERSITY

I

THAT the publication of the "Origin of Species" marked an epoch in the development of the natural sciences is well known to the layman. That the combination of the very words origin and species embodied an intellectual revolt and introduced a new intellectual temper is easily overlooked by the expert. The conceptions that had reigned in the philosophy of nature and knowledge for two thousand years, the conceptions that had become the familiar furniture of the mind, rested on the assumption of the superiority of the fixed and final; they rested upon treating change and origin as signs of defect and unreality. In laying hands upon the sacred ark of absolute permanency, in treating the forms that had been regarded as types of fixity and perfection as originating and passing away, the "Origin of Species" introduced a mode of thinking that in the end was bound to transform the logic of knowledge, and hence the treatment of morals, politics and religion.

No wonder then that the publication of Darwin's book, a half century ago, precipitated a crisis. The true nature of the controversy is easily concealed from us, however, by the theological clamor that attended it. The vivid and popular features of the anti-Darwinian row tended to leave the impression that the issue was between science on one side and theology on the other. Such was not the case—the issue lay primarily within science itself, as Darwin himself early recognized. The theological outcry he discounted from the start, hardly noticing it save as it bore upon the "feelings of his female relatives." But for two decades before final publication he contemplated the possibility of being put down by his scientific peers as a fool or as crazy; and he set, as the measure of his success, the degree in which he should affect three men of science: Lyell in geology, Hooker in botany and Huxley in zoology.

Religious considerations lent fervor to the controversy, but they did not provoke it. Intellectually, religious emotions are not creative but conservative. They attach themselves readily to the current view of the world and consecrate it. They steep and dye intellectual fabrics in the seething vat of emotions; they do not form their warp

and woof. There is not, I think, an instance of any large idea about the world being independently generated by religion. However much the ideas that rose up like armed men against Darwinism owed their intensity to religious associations, their origin and meaning are to be sought elsewhere.

II

Few words in our language foreshorten intellectual history as does the word species. The Greeks in initiating the intellectual life of Europe, were impressed by characteristic traits of the life of plants and animals; so impressed indeed that they made these traits the key to defining nature and to explaining mind and society. And truly life is so wonderful that a seemingly successful reading of its mystery might well lead men to believe that the key to the secrets of heaven and earth was in their hands. The Greek rendering of this mystery, the Greek formulation of the aim and standard of knowledge, was in the course of time embodied in the word species and controlled philosophy for two thousand years. To understand the intellectual face-about expressed in the phrase "Origin of Species," we must, then, understand the long dominant idea against which it was a protest.

Consider how men were impressed by the facts of life. Their eyes fell upon certain things slight in bulk, and frail in structure. To every appearance, these perceived things were inert and passive. Suddenly, under certain circumstances, these things—henceforth known as seeds or eggs or germs—begin to change, to change rapidly in size, form and qualities. Rapid and extensive changes occur, however, in many things—as when wood is touched by fire. But the changes in the living thing are orderly; they are cumulative; they tend constantly in one direction; they do not, like other changes, destroy or consume, or pass fruitless into wandering flux; they realize and fulfil. Each successive stage, no matter how unlike its predecessor, preserves its net effect and also prepares the way for a fuller activity on the part of its successor. In living beings changes do not happen as they seem to elsewhere, any which way; the earlier changes are regulated in view of later results. This progressive organization does not cease till there is achieved a true final term, a *τελός*, a completed, perfected end. This final form exercises in turn a plenitude of functions, not the least noteworthy of which is production of germs like those from which it took its own origin, germs capable of the same cycle of self-fulfilling activity.

But the whole miraculous tale is not yet told. The same drama is enacted to the same destiny in countless myriads of individuals so sundered in time, so severed in space, that they have no opportunity for mutual consultation and no means of interaction. As an old writer

quaintly said, "things of the same kind go through the same formalities"—celebrate, as it were, the same ceremonial rites.

This formal activity which operates throughout a series of changes and holds them to a single course; that subordinates their aimless flux to its own perfect manifestation; which, leaping the boundaries of space and time, keeps individuals in spite of their being distant in space and remote in time to a uniform type of structure and function: this principle seemed to give insight into the very nature of reality itself. To it Aristotle gave the name, *εἶδος*. This term the scholastics translated as *species*.

The force of this term was deepened by its application to everything in the universe that observes order in flux and manifests constancy through change. From the casual drift of daily weather, through the uneven recurrence of seasons and unequal return of seed time and harvest, up to the majestic sweep of the heavens—the image of eternity in time—and from this to the unchanging pure and contemplative intelligence beyond nature lies one unbroken fulfilment of ends. Nature, as a whole, is a progressive realization of purpose strictly comparable to the realization of purpose in any single plant or animal.

The conception of *εἶδος*, species, the fixed form and final cause, was the central principle of knowledge as well as of nature. Upon it rested the logic of science. Change as change is mere flux and lapse; it insults intelligence. Genuinely to know is to grasp a permanent end that realizes itself through changes, holding them thereby within the metes and bounds of fixed truth. Completely to know is to relate all special forms to their one single end and good: pure contemplative intelligence. Since, however, the scene of nature which directly confronts us is in change, nature as directly and practically experienced can not satisfy the conditions of knowledge. Human experience is also in flux, and hence the instrumentalities of sense-perception and of inference based upon observation are condemned in advance. Science is compelled to aim at realities lying behind and beyond the processes of nature, and to carry on its search for these realities by means of rational forms transcending ordinary modes of perception and inference.

There are, indeed, but two alternative courses. We must either find the appropriate objects and organs of knowledge in the mutual interactions of changing things; or else, to escape the infection of change, we *must* seek them in some transcendent and supernal region. The human mind, deliberately as it were, exhausted the logic of the changeless, the final and the transcendent, before it essayed adventure on the pathless wastes of generation and transformation. We dispose all too easily of the efforts of the schoolmen to interpret nature and mind in terms of real essences, hidden forms and occult faculties, forgetful of the seriousness and dignity of the ideas that lay behind. We

dispose of them by laughing at the famous gentleman who accounted for the fact that opium put people to sleep on the ground it had a dormitive faculty. But the doctrine, held in our own day, that knowledge of the plant that yields the poppy consists in referring the peculiarities of an individual to a type, to a universal form, a doctrine so firmly established that any other method of knowing was conceived to be unphilosophical and unscientific, was a survival of precisely the same logic. This identity of conception in the scholastic and anti-Darwinian theory may well suggest greater sympathy for what has become unfamiliar and greater humility regarding the further unfamiliarities that history has in store.

Darwin was not, of course, the first to question the classic philosophy of nature and of knowledge. The beginnings of the revolution are in the physical science of the sixteenth and seventeenth centuries. When Galileo said: "It is my opinion that the earth is very noble and admirable by reason of so many and so different alterations and generations which are incessantly made therein," he expressed the changed temper that was coming over the world; the transfer of interest from the permanent to the changing. When Descartes said: "The nature of physical things is much more easily conceived when they are beheld coming gradually into existence, than when they are only considered as produced at once in a finished and perfect state," the modern world became self-conscious of the logic that was henceforth to control it, the logic of which Darwin's "Origin of Species" is the latest scientific achievement. Without the methods of Copernicus, Kepler, Galileo and their successors in astronomy, physics and chemistry, Darwin would have been helpless in the organic sciences. But prior to Darwin the impact of the new scientific method upon life, mind and politics, had been arrested for the most part, because between these ideal or moral interests and the inorganic world there intervened the kingdom of plants and animals. The gates of the garden of life were barred to the new ideas while only through this garden was there access to mind and politics. The influence of Darwin upon philosophy resides in his having freed the new logic for application to mind and morals by conquering the phenomena of life. When he said of species what Galileo had said of the earth, *e pur se muove*, he emancipated once for all genetic and experimental ideas as an organon of asking questions and looking for explanations in philosophy.

III

The exact bearings upon philosophy of the new logical outlook are, of course, as yet, uncertain and inchoate. We live in the twilight of intellectual transition. One must add the rashness of the prophet to the stubbornness of the partisan to venture a systematic exposition of

the influence upon philosophy of the Darwinian method. At best, we can but inquire as to its general bearing—the effect upon mental temper and complexion, upon that body of half-conscious, half instinctive intellectual aversions and preferences which determine, after all, our more deliberate intellectual enterprises. In this vaguer inquiry there happens to exist as a kind of touchstone one problem of great historic significance that has also been much discussed in Darwinian literature. I refer to the old problem of design *versus* chance, mind *versus* matter, as the causal explanation, first and final, of things.

As we have already seen, the classic notion of species carried with it the idea of purpose. In all living forms, a specific type is present directing the earlier stages of growth to the realization of its own perfection. Since this purposive regulative principle is not visible to the senses, it follows that it must be an ideal or rational force. Since, however, the perfect form is gradually approximated through the sensible changes, it also follows that in and through a sensible realm a rational ideal force is working out its own ultimate manifestation. These two inferences were extended to nature: (a) She does nothing in vain; but all for an ulterior purpose. (b) Within natural sensible events there is therefore contained a spiritual causal force, which as spiritual escapes perception, but is apprehended by an enlightened reason. (c) The manifestation of this principle brings about a subordination of matter and sense to its own realization, and this ultimate fulfilment is the goal of nature and of man. The design argument thus operated in two directions. Purposefulness accounted for the intelligibility of nature and the possibility of science, while the absolute or cosmic character of this purposefulness gave sanction and worth to the moral and religious endeavors of man. Science was underpinned and morals authorized by one and the same principle, and their mutual agreement was eternally guaranteed.

This philosophy remained, in spite of sceptical and polemic outbursts, the official and the regnant philosophy of Europe for over two thousand years. The expulsion of fixed first and final causes from astronomy, physics and chemistry had indeed given the doctrine something of a shock. But, on the other hand, increased acquaintance with the details of plant and animal life made a counterbalance and perhaps even strengthened the argument from design. The marvellous adaptations of organisms to their environment, of organs to the organism, of unlike parts of a complex organ—like the eye—to the organ itself; the foreshadowing by lower forms of the higher; the preparation in earlier stages of growth for organs that only later had their functioning—these things were increasingly recognized with the progress of botany, zoology, paleontology and embryology. Together they added such prestige to the design argument that by the late

eighteenth century it was, as proved by the sciences of organic life, the central point of theistic and idealistic philosophy.

The Darwinian principle of natural selection cut straight under this philosophy. If all organic adaptations are due simply to constant variation and the elimination of those variations that are harmful in the struggle for existence which is brought about by excessive reproduction, there is no call for a prior intelligent causal force to plan and preordain them. Hostile critics charged Darwin with materialism and with making chance the cause of the universe.

Some naturalists, like Asa Gray, favored the Darwinian principle and attempted to reconcile it with design. Gray held to what may be called design on the instalment plan. If we conceive the "stream of variations" to be itself intended, we may suppose that each successive variation was designed from the first to be selected. In that case, variation, struggle and selection simply define the mechanism of "secondary causes" through which the "first cause" acts; and the doctrine of design is none the worse off because we know more of its *modus operandi*.

Darwin could not accept this mediating proposal. He admits or rather he asserts that it is "impossible to conceive this immense and wonderful universe including man with his capacity of looking far backwards and far into futurity as the result of blind chance or necessity."¹ But nevertheless he holds that since variations are in useless as well as useful directions, and since the latter are sifted out simply by the stress of the conditions of struggle for existence, the design argument as applied to living beings is unjustifiable; and its lack of support there deprives it of scientific value as applied to nature in general. If the variations of the pigeon, which under artificial selection give the pouter pigeon, are not preordained for the sake of the breeder, by what logic do we argue that variations resulting in natural species are pre-designed?²

IV

So much for some of the more obvious facts of the discussion of design *versus* chance as causal principles of nature and of life as a whole. We brought up this discussion, you recall, as a crucial instance. What does our touchstone indicate as to the bearing of Darwinian ideas upon philosophy? In the first place, the new logic outlaws, flanks, dismisses—what you will—one type of problems and substitutes for it another type. Philosophy forswears inquiry after absolute origins and absolute finalities in order to explore specific values and the specific conditions that generate them.

¹ "Life and Letters," Vol. I., p. 282; cf. 285.

² "Life and Letters," Vol. II., pp. 146, 170, 245; Vol. I., 283-84. See also the closing portion of his "Variations of Animals and Plants under Domestication."

Darwin concluded that the impossibility of assigning the world to chance as a whole and to design in its parts indicated the insolubility of the question. Two radically different reasons, however, may be given as to why a problem is insoluble. One reason is that the problem is too high for intelligence; the other is that the question in its very asking makes assumptions that render the question meaningless. The latter alternative is unerringly pointed to in the celebrated case of design *versus* chance. Once admit that the sole verifiable or fruitful object of knowledge is the particular set of changes that generate the object of study, together with the consequences that further flow from it, and no intelligible question can be asked about what, by assumption, lies outside. To assert—as is often asserted—that specific values of particular truths, social bonds and forms of beauty, if they can be shown to be generated by concretely knowable conditions, are meaningless and in vain; to assert that they are justified only when they and their particular causes and effects have all at once been gathered up into some inclusive first cause and some exhaustive final goal, is intellectual atavism. Such argumentation is reversion to the logic that explained the extinction of fire by water through the formal essence of aqueousness and the quenching of thirst by water through the final cause of aqueousness. Whether used in the case of the special event or in that of life as a whole, such logic only abstracts some aspect of the existing course of events in order to reduplicate it as a petrified eternal principle by which to explain the very changes of which it is the formalization.

When Henry Sidgwick casually remarked in a letter that as he grew older his interest in what or who made the world was altered into interest in what kind of a world it is anyway, his voicing of a common experience of our own day illustrates also the nature of that intellectual transformation effected by the Darwinian logic. Interest shifts from the wholesale essence back of special changes to the question of how these special changes serve and defeat concrete purposes; shifts from an intelligence that shaped things once for all to the particular intelligences which things are even now shaping; shifts from an ultimate goal of good to the direct increments of justice and happiness that intelligent administration of existent conditions may beget and that present carelessness or stupidity will destroy or forego.

In the second place, the classic type of logic inevitably set philosophy upon proving that life *must* really have certain qualities and values—no matter how experience presents the matter—because of some remote cause and eventual goal, while the logic of the new science frees philosophy from this apologetic habit and temper. The duty of wholesale justification inevitably accompanies all thinking that makes the meaning of special occurrences depend upon something that

lies once and for all behind them. The habit of derogating from present meanings and uses prevents our looking the facts of experience in the face; it prevents serious acknowledgment of the evils they present and serious concern with the goods they promise but do not yet fulfil. It turns thought to the business of finding a wholesale transcendent remedy for the one and guarantee for the other. One is reminded of the way many moralists and theologians greeted Herbert Spencer's recognition of an unknowable energy from which welled up the phenomenal physical processes without and the conscious operations without. Merely because Spencer labeled his unknowable energy "God," this faded piece of metaphysical goods was greeted as an important and grateful concession to the reality of the spiritual realm. Were it not for the deep hold of the habit of seeking justification for ideal values in the remote and transcendent, surely this reference of them to an unknowable absolute would be despised in behalf of the daily demonstrations of experience that knowable energies are daily generating about us precious values.

The displacing of this wholesale type of philosophy will doubtless not arrive by sheer logical disproof, but rather by growing recognition of its futility. Were it a thousand times true that opium produces sleep because of its dormitive energy, the inducing of sleep in the tired and the recovery to waking life of the poisoned, would not be thereby one least step forwarded. And were it a thousand times dialectically demonstrated that life as a whole is regulated by a transcendent principle to a final inclusive goal, truth and error, health and disease, good and evil, hope and fear in the concrete would remain none the less just what and where they now are. To improve our education, to ameliorate our manners, to advance our politics, we must have recourse to specific conditions of generation.

Finally, the new logic introduces responsibility into the intellectual life. To idealize and rationalize the universe at large is after all a confession of inability to master the courses of things that specifically concern us. As long as mankind suffered from this impotency, naturally it shifted a burden of responsibility which it could not carry over to the more competent shoulders of the transcendent cause. But if insight into specific conditions of value and into specific consequences of ideas is possible, philosophy must in time become a method of locating and interpreting the more serious of the conflicts that occur in life, and a method of projecting ways for dealing with them: a method of moral and political diagnosis and prognosis.

The claim to formulate *a priori* the legislative constitution of the universe is by its nature a claim that may lead into elaborate dialectic developments. But it is also one which removes these very conclusions from subjection to experimental test, for, by definition, these results

make no differences in the detailed course of events. But a philosophy that humbles its pretensions to the work of projecting hypotheses for the education and conduct of mind, individual and social, is thereby subjected to test by the way in which the ideas it propounds work out in practise. In having modesty forced upon it, philosophy also acquires responsibility.

Doubtless I may seem to have violated the implied promise of my earlier remarks and to have turned both prophet and partisan. But in anticipating the direction of the transformations in philosophy to be wrought by the Darwinian genetic and experimental logic, I do not profess to speak for any changes save those wrought in those who yield themselves consciously or unconsciously to this logic. No one can fairly deny that at present there are evident two effects of the Darwinian mode of thinking. On the one hand, there are making many sincere and vital efforts to revise our traditional philosophic conceptions in accordance with its demands. On the other hand, there is as definitely a recrudescence of absolutistic philosophies; an assertion of a type of philosophic knowing distinct from that of the sciences, which opens to us another kind of reality from that to which the sciences give access; an appeal through experience to something that radically transcends experiences. This reaction affects popular creeds and religious movements as well as technical philosophies. In other words, the very conquest of the biological sciences by the new ideas has led many to effect a more explicit and rigid separation of philosophy from science.

Old ideas give way slowly; for they are more than abstract logical forms and categories. They are habits, predispositions, deeply engrained attitudes of aversion and preference. Moreover, the conviction persists—though history shows it to be a hallucination—that all the questions that the human mind has asked are questions that can be answered in terms of the alternatives that the questions themselves present. But in fact intellectual progress usually occurs through sheer abandonment of such questions, together with both of the alternatives they assume—an abandonment that results from decreasing vitality and interest in their point of view. We do not solve them: we get over them. Old questions are solved by disappearing, evaporating, while new questions corresponding to the changed attitude of endeavor and preference take their place. Doubtless the greatest dissolvent of old questions, the greatest precipitant of new methods, new intentions, new problems, is the one effected by the scientific revolution completed in the "Origin of Species."

THE PROGRESS OF SCIENCE

THE COLLEGE AND THE STUDENT

At this commencement season university presidents and others are likely to make addresses to academic audiences and the problems of the college and of the college student are likely to be subjects for comment in the daily papers and the monthly magazines. This year two addresses have attracted special attention. Some rather incidental remarks of President Wilson, of Princeton University, are of intrinsic interest, and the Phi Beta Kappa address of President Lowell, of Harvard University, preceding his inaugural address, gives the first indication of his attitude toward questions concerning which his influence and responsibility are very great.

It is somewhat curious that the president of Princeton appears to be more modern in his point of view than the president of Harvard. President Wilson is reported as saying:

I believe in athletics. I believe in all those things which relax energy that the faculties may be at their best when the energies are not relaxed, but only so far do I believe in these diversions. When the lad leaves school he should cease to be an athlete. The modern world is an exacting one, and the things it exacts are mostly intellectual.

A danger surrounding our modern education is the danger of wealth. I am sorry for the lad who is going to inherit money. I fear that the kind of men who are to share in shaping the future are not largely exemplified in schools and colleges.

So far as the colleges go, the side-shows have swallowed up the circus, and we in the main tent do not know what is going on. And I do not know that I want to continue under those conditions as ringmaster. There are more honest occupations than teaching if you can not teach.

This is characteristically well put, but the point of view is unexpected.

It was supposed that the officers of Princeton were comparatively well satisfied with their rich boys, their professional athletics and their preceptorial system. It seems that on this occasion the president of Princeton is too iconoclastic and too pessimistic. The rich boys and the college boys will surely do more than the average in "shaping the future," even though this may be accomplished by a kind of monopoly control. The boy need not cease to be an athlete when he leaves the preparatory school; the trouble in our colleges is not that there are too many athletes, but too few, and those few over-trained and over-exploited. The college boy can do athletic stunts better than any one else can and better than he can do anything else; so there is much to be said for letting him do them. Satan can find worse mischief for idle hands.

When Mr. Wilson says that the things which the modern world exacts are mostly intellectual, he presumably refers to the kinds of things the Princeton preceptors try to teach. But what the world wants is men who will do the right thing at the right time. The boy who is to be a scholar in after life should be a scholar in college. But the average boy gains more from running the college paper or fraternity house than by writing Latin verses or even reading the innocuous literature prescribed by the College Entrance Examination Board. Certainly both college students and college teachers could be more usefully employed than they are at present; but it is odd that the president of Princeton should rub this in.

Mr. Lowell had undertaken to give the Phi Beta Kappa at Columbia before he was elected to the presidency of

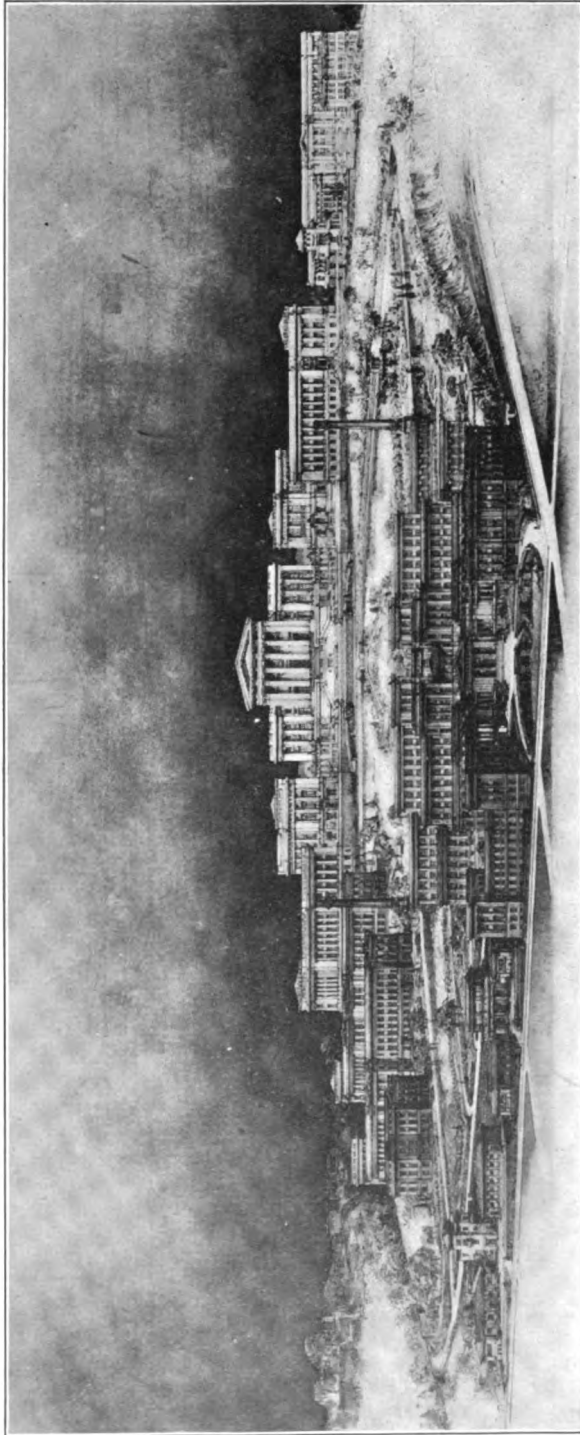

PLAN OF THE UNIVERSITY OF PITTSBURGH.

Harvard. He was reported in the daily papers to have spoken in favor of inter-collegiate athletics and against the elective system. This would indeed be a cry of "le roi est mort," and explain why one seventh of the members of the Harvard corporation did not vote with the majority in the presidential election. As a matter of fact, Mr. Lowell spoke with skill and with caution. He did, however, argue that the elective system interferes with competition in college studies, and that the cooperative competition of athletic games should be applied to the work of the class room. But he did not tell how he thought that this could be accomplished. His main argument was from the competition in the English universities. He said: "The result is that by the Isis and the Cam there is probably more hard study done in subjects not of a professional character than in any other universities in the world." This is scarcely correct. The "poll" men at Oxford and Cambridge do even less work for their degrees than the average students at Harvard and Princeton. The men in the honor courses are doing professional work of much the same character as is done in the Harvard graduate and professional schools and with much the same rewards in the way of fellowships and positions. The greater direct competition in examinations which does obtain in the English universities is not necessarily an advantage. Indeed the arrangement of men in the order of merit in the mathematical tripos has just now been abandoned at Cambridge on the ground that it led to "cramming." Scholarship is more highly esteemed in England and in Germany (where there is no class-room competition in the universities) than here. Probably as time goes on there will be an equalization due to greater respect for the scholar here and to relatively higher regard for other forms of accomplishment there. Mr. Lowell said: "Universities stand for the eternal worth of thought, for the preeminence of the

prophet and the seer." But the country can not support 80,000,000 prophets and seers.

To one hearer Mr. Lowell's address seemed somewhat naive, and left an impression of uncertainty as to how he would confront the complicated problems which the latter-day university president is expected to manage.

THE NEW BUILDINGS OF THE UNIVERSITY OF PITTSBURGH

In January, 1908, the University of Pittsburgh acquired a new location, consisting of 43 acres near the entrance to Schenley Park and within a short distance of the Carnegie Institute. The ground is partially rising and partially level, permitting an effective grouping of the buildings. Under the direction of Professor Warren P. Laird, an architects' competition was held in which sixty-six designs were submitted. The group plan accepted was that of Palmer & Hornbostel, a reproduction of which is here shown. The style of architecture is Grecian and is well adapted to the natural features of the ground. The location of the several departments of the university is determined and for the most part the exact buildings which will be erected.

The first building of the group, the School of Mines, is completed and has just been dedicated. Its cost is approximately \$200,000. The second building, costing an equal sum, is in process of erection and will be ready for occupancy in September. The state appropriation provided by the last legislature permits the erection of another building, which will belong to the medical group. The architects are working upon the plans for this building, the erection of which will be commenced on July 1, permitting the medical department to begin its work in the new location in 1910.

As rapidly as buildings can be provided the other departments, law, dentistry and pharmacy will be transferred to the new location. The university

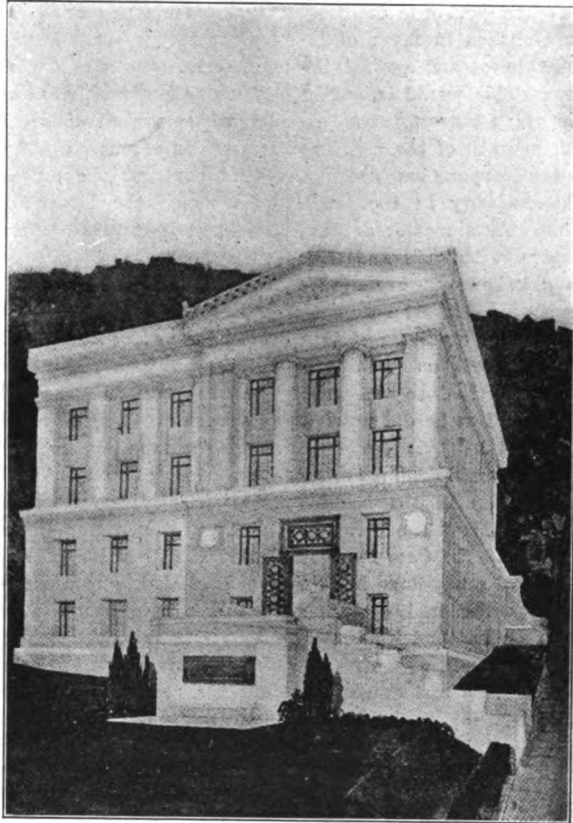

THE SCHOOL OF MINES BUILDING OF THE UNIVERSITY OF PITTSBURGH,
the first to be erected on the new site.

comprises the following departments: college, graduate, observatory, summer school, Saturday and evening classes, engineering, mining, medicine, dentistry, law and pharmacy.

The students in the regular classes during the past year have numbered 1,129. Those taking special work were 114, making a total of 1,243. The region in which the university is now located is remarkable because of the large number of fine buildings housing various educational and other institutions of the city. It bids fair to become one of the famous centers of the country.

The former buildings of the college and engineering school have been sold and the proceeds placed in the perma-

nent fund of the university. During the past year nearly \$300,000 have been raised by popular subscription. The first charter of the university was granted in 1787. The present year marks practically the first consolidation of the several departments under the absolute ownership and control of the university.

THE PERCY SLADEN MEMORIAL FUND

IN 1904 Mrs. Percy Sladen endowed with £20,000 a trust fund for the furtherance of research in the natural sciences in memory of her husband, who had died four years previously. The trustees of this fund, who are themselves men of science, are allowed

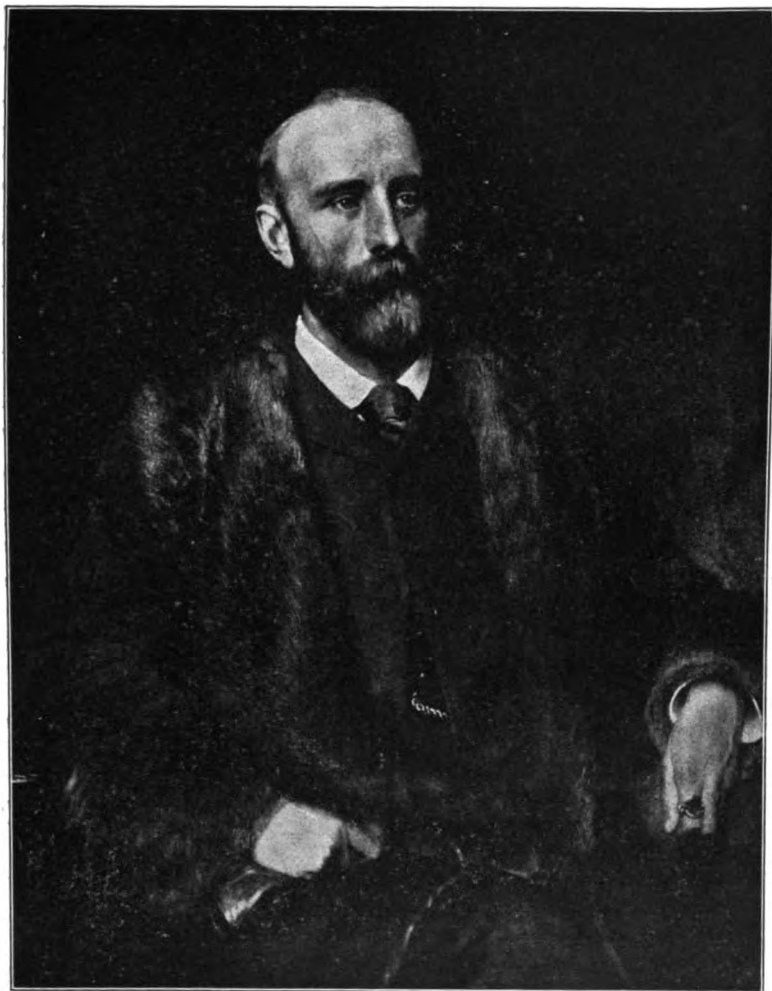

PERCY SLADEN.

wide discretion in its administration, but have adopted the policy of assisting expeditions. The first of these has been a zoological exploration of the Indian Ocean under the leadership of Mr. J. Stanley Gardiner, the results of which are now published in the *Transactions* of the Linnean Society of London. They fill a volume of 419 pages, the different groups of animals being worked over by leading specialists. The trustees of the fund are now supporting an anthropological expedition to Melanesia under the leadership of

Dr. W. H. R. Rivers, and a third expedition will be sent to study the botany of West Africa, under Professor H. H. W. Pearson.

The volume containing the account of the expedition to the Indian Ocean is prefaced by an introduction on the life and work of Sladen by Mr. Henry Bury, with a portrait here reproduced from the painting by Mr. H. T. Wells, in the possession of the Linnean Society. Born in 1849, Sladen was educated at a public school where little or no attention was paid to science and

he did not attend a university. He became interested in science through the local scientific society and museum at Halifax, and received his training through them and through his own work. He accomplished scientific work of accuracy and importance, but was an amateur in the sense that he held no scientific position. Darwin is the most notable instance of the great contributions to science made in Great Britain by those having hereditary wealth and devoting their lives to scientific work, but he is only one of a large class, including men of great eminence, such as the two last presidents of the Royal Society, Lord Rayleigh and Sir William Huggins, and many others, such as Sladen, whose work may not be widely known, but is of a high class. It is to be hoped, though scarcely to be expected, that these traditions will be maintained in Great Britain and adopted here, as the number of our wealthy families increases.

Sladen concerned himself in the main with scientific work on the starfishes. In the course of twenty years he published thirty-five papers, the most extensive being the report on the Asteroida collected by the *Challenger* which describes 184 new species. In an early paper he described an extraordinary form from a single specimen since lost which he placed in a new family intermediate between the Ophiurids and the Asterids. Another discovery of evolutionary interest was of certain "cribriform" organs in a family of starfishes. The function of these organs is not known; they appear in one family only with no indication as to how they may have been evolved, their number is fixed for each species, though it varies greatly within the family.

Though Sladen's scientific work was

narrowly limited, he was a man of public spirit and wide accomplishments. He knew Persian as well as European literatures and was an expert collector and student of old books and manuscripts. He was zoological secretary of the Linnean Society and secretary of several committees of the British Association. His biographer says of him: "Cheerful, humorous and of a remarkably even temper, Sladen presented to his many friends a singularly lovable nature, in which unselfishness, sincerity and a generous appreciation of the work of others were some of the leading characteristics."

SCIENTIFIC ITEMS

WE record with regret the deaths of Dr. Georg von Neumayer, the eminent German meteorologist; of Dr. Wilhelm Engelmann, professor of physiology at Berlin, and of Dr. F. G. Yeo, F.R.S., the physiologist.

AMONG those who will have received an honorary degree from Cambridge University on the occasion of the Darwin centenary are three Americans: Professor Jacques Loeb, of the University of California; Dr. Charles D. Walcott, secretary of the Smithsonian Institution, and Professor E. B. Wilson, of Columbia University.

DR. IRA REMSEN, president of the Johns Hopkins University, has been elected president of the Society for Chemical Industry.—Dr. E. F. Nichols, professor of experimental physics at Columbia University, has been elected president of Dartmouth College.—Mr. Lazarus Fletcher, F.R.S., the keeper of the department of mineralogy since 1880, has been appointed to the post of director of the natural history departments of the British Museum.

THE POPULAR SCIENCE MONTHLY.

AUGUST, 1909

THE FUTURE OF ASTRONOMY¹

BY PROFESSOR EDWARD C. PICKERING

HARVARD COLLEGE OBSERVATORY

IT is claimed by astronomers that their science is not only the oldest, but that it is the most highly developed of the sciences. Indeed it should be so, since no other science has ever received such support from royalty, from the state and from the private individual. However this may be, there is no doubt that in recent years astronomers have had granted to them greater opportunities for carrying on large pieces of work than have been entrusted to men in any other department of pure science. One might expect that the practical results of a science like physics would appeal to the man who has made a vast fortune through some of its applications. The telephone, the electric transmission of power, wireless telegraphy and the submarine cable are instances of immense financial returns derived from the most abstruse principles of physics. Yet there are scarcely any physical laboratories devoted to research, or endowed with independent funds for this object, except those supported by the government. The endowment of astronomical observatories devoted to research, and not including that given for teaching, is estimated to amount to half a million dollars annually. Several of the larger observatories have an annual income of fifty thousand dollars.

I once asked the wisest man I know, what was the reason for this difference. He said that it was probably because astronomy appealed to the imagination. A practical man, who has spent all his life in his counting room or mill, is sometimes deeply impressed with the vast

¹ Commencement address at Case School of Applied Science, Cleveland, May 27, 1909.

distances and grandeur of the problems of astronomy, and the very remoteness and difficulty of studying the stars attract him.

My object in calling your attention to this matter is the hope that what I have to say of the organization of astronomy may prove of use to those interested in other branches of science, and that it may lead to placing them on the footing they should hold. My arguments apply with almost equal force to physics, to chemistry, and in fact to almost every branch of physical or natural science, in which knowledge may be advanced by observation or experiment.

The practical value of astronomy in the past is easily established. Without it, international commerce on a large scale would have been impossible. Without the aid of astronomy, accurate boundaries of large tracts of land could not have been defined and standard time would have been impossible. The work of the early astronomers was eminently practical, and appealed at once to every one. This work has now been finished. We can compute the positions of the stars for years, almost for centuries, with all the accuracy needed for navigation, for determining time or for approximate boundaries of countries. The investigations now in progress at the greatest observatories have little, if any, value in dollars and cents. They appeal, however, to the far higher sense, the desire of the intellectual human being to determine the laws of nature, the construction of the material universe, and the properties of the heavenly bodies of which those known to exist far outnumber those that can be seen.

Three great advances have been made in astronomy. First, the invention of the telescope, with which we commonly associate the name of Galileo, from the wonderful results he obtained with it. At that time there was practically no science in America, and for more than two centuries we failed to add materially to this invention. Half a century ago the genius of the members of one family, Alvan Clark and his two sons, placed America in the front rank not only in the construction, but in the possession, of the largest and most perfect telescopes ever made. It is not easy to secure the world's record in any subject. The Clarks constructed successively, the 18-inch lens for Chicago, the 26-inch for Washington, the 30-inch for Pulkowa, the 36-inch for Lick and the 40-inch for Yerkes. Each in turn was the largest yet made, and each time the Clarks were called upon to surpass the world's record, which they themselves had already established. Have we at length reached the limit in size? If we include reflectors, no, since we have mirrors of 60 inches aperture at Mt. Wilson and Cambridge, and a still larger one of 100 inches has been undertaken. It is more than doubtful, however, whether a further increase in size is a great advantage. Much more depends on other conditions, especially those of climate, the kind of work to be done and, more than all,

the man behind the gun. The case is not unlike that of a battleship. Would a ship a thousand feet long always sink one of five hundred feet? It seems as if we had nearly reached the limit of size of telescopes, and as if we must hope for the next improvement in some other direction.

The second great advance in astronomy originated in America, and was in an entirely different direction, the application of photography to the study of the stars. The first photographic image of a star was obtained in 1850, by George P. Bond, with the assistance of Mr. J. A. Whipple, at the Harvard College Observatory. A daguerreotype plate was placed at the focus of the 15-inch equatorial, at that time one of the two largest refracting telescopes in the world. An image of a Lyrae was thus obtained, and for this Mr. Bond received a gold medal at the first international exhibition, that at the Crystal Palace, in London, in 1851. In 1857, Mr. Bond, then Professor Bond, director of the Harvard Observatory, again took up the matter with collodion wet plates, and in three masterly papers showed the advantages of photography in many ways. The lack of sensitiveness of the wet plate was perhaps the only reason why its use progressed but slowly. Quarter of a century later, with the introduction of the dry plate and the gelatine film, a new start was made. These photographic plates were very sensitive, were easily handled, and indefinitely long exposures could be made with them. As a result, photography has superseded visual observations, in many departments of astronomy, and is now carrying them far beyond the limits that would have been deemed possible a few years ago.

The third great advance in astronomy is in photographing the spectra of the stars. The first photograph showing the lines in a stellar spectrum was obtained by Dr. Henry Draper, of New York, in 1872. Sir William Huggins in 1863 had obtained an image of the spectrum of Sirius, on a photographic plate, but no lines were visible in it. In 1876 he again took up the subject, and, by an early publication, preceded Dr. Draper. When we consider the attention the photography of stellar spectra is receiving at the present time, in nearly all the great observatories in the world, it may well be regarded as the third great advance in astronomy.

What will be the fourth advance, and how will it be brought about? To answer this question we must consider the various ways in which astronomy, and for that matter any other science, may be advanced.

First, by educating astronomers. There are many observatories where excellent instruction in astronomy is given, either to the general student or to one who wishes to make it his profession. At almost any active observatory a student would be received as a volunteer assistant. Unfortunately, few young men can afford to accept an unpaid position, and the establishment of a number of fellowships each offering a small salary sufficient to support the student would enable him to acquire the

necessary knowledge to fill a permanent position. The number of these scholarships should not be large, lest more students should undertake the work than would be required to fill the permanent paying positions in astronomy, as they become vacant.

In Europe, a favorite method of aiding science is to offer a prize for the best memoir on a specified subject. On theoretical grounds this is extremely objectionable. Since the papers presented are anonymous and confidential, no one but the judges know how great is the effort wasted in duplication. The larger the prize, the greater the injury to science, since the greater will be the energy diverted from untried fields. It would be much wiser to invite applications, select the man most likely to produce a useful memoir, and award the prize to him if he achieved success.

The award of a medal, if of great intrinsic value, would be an unwise expenditure. The Victoria Cross is an example of a successful foundation, highly prized, but of small intrinsic value. If made of gold, it would carry no greater honor, and would be more liable to be stolen, melted down or pawned.

Honorary membership in a famous society, or honorary degrees, have great value if wisely awarded. Both are highly prized, form an excellent stimulus to continued work, and as they are both priceless, and without price, they in no way diminish the capacity for work. I recently had occasion to compare the progress in various sciences of different countries, and found that the number of persons elected as foreign associates of the seven great national societies of the world was an excellent test. Eighty-seven persons were members of two or more of these societies. Only six are residents of the United States, while an equal number come from Saxony, which has only a twentieth of the population. Of the six residents here, only three were born in the United States. Not a single mathematician, or doctor, from this country appears on the list. Only in astronomy are we well represented. Out of a total of ten astronomers, four come from England, and three from the United States. Comparing the results for the last one hundred and fifty years, we find an extraordinary growth for the German races, an equally surprising diminution for the French and other Latin races, while the proportion of Englishmen has remained unchanged.

A popular method of expending money, both by countries and by individuals, is in sending expeditions to observe solar eclipses. These appeal both to donors and recipients. The former believe that they are making a great contribution to science, while the latter enjoy a long voyage to a distant country, and in case of clouds they are not expected to make any scientific return. If the sky is clear at the time of the eclipse, the newspapers of the next day report that great results have

been secured, and after that nothing further is ever heard. Exceptions should be made of the English Eclipse Committee and the Lick Observatory, which, by long continued study and observation, are gradually solving the difficult problems which can be reached in this way only.

The gift of a large telescope to a university is of very doubtful value, unless it is accompanied, first, by a sum much greater than its cost, necessary to keep it employed in useful work, and secondly, to require that it shall be erected, not on the university grounds, but in some region, probably mountainous or desert, where results of real value can be obtained.

Having thus considered, among others, some of the ways in which astronomy is not likely to be much advanced, we proceed to those which will secure the greatest scientific return for the outlay. One of the best of these is to create a fund to be used in advancing research, subject only to the condition that results of the greatest possible value to science shall be secured. One advantage of this method is that excellent results may be obtained at once from a sum, either large or small. Whatever is at first given may later be increased indefinitely, if the results justify it. One of the wisest as well as the greatest of donors has said: "Find the particular man," but unfortunately, this plan has been actually tried only with some of the smaller funds. Any one who will read the list of researches aided by the Rumford Fund, the Elizabeth Thompson Fund or the Bruce Fund of 1890 will see that the returns are out of all proportion to the money expended. The trustees of such a fund as is here proposed should not regard themselves as patrons conferring a favor on those to whom grants are made, but as men seeking for the means of securing large scientific returns for the money entrusted to them. An astronomer who would aid them in this work, by properly expending a grant, would confer rather than receive a favor. They should search for astronomical bargains, and should try to purchase results where the money could be expended to the best advantage. They should make it their business to learn of the work of every astronomer engaged in original research. A young man who presented a paper of unusual importance at a scientific meeting, or published it in an astronomical journal, would receive a letter inviting him to submit plans to the trustees, if he desired aid in extending his work. In many cases, it would be found that, after working for years under most unfavorable conditions, he had developed a method of great value and had applied it to a few stars, but must now stop for want of means. A small appropriation would enable him to employ an assistant who, in a short time, could do equally good work. The application of this method to a hundred or a thousand stars would then be only a matter of time and money.

The American Astronomical Society met last August at a summer

resort on Lake Erie. About thirty astronomers read papers, and in a large portion of the cases the appropriation of a few hundred dollars would have permitted a great extension in these researches. A sad case is that of a brilliant student who may graduate at a college, take a doctor's degree in astronomy, and perhaps pass a year or two in study at a foreign observatory. He then returns to this country, enthusiastic and full of ideas, and considers himself fortunate in securing a position as astronomer in a little country college. He now finds himself overwhelmed with work as a teacher, without time or appliances for original work. What is worse, no one sympathizes with him in his aspirations, and after a few years he abandons hope and settles down to the dull routine of lectures, recitations and examinations. A little encouragement at the right time, aid by offering to pay for an assistant, for a suitable instrument, or for publishing results, and perhaps a word to the president of his college if the man showed real genius, might make a great astronomer, instead of a poor teacher. For several years, a small fund, yielding a few hundred dollars annually, has been disbursed at Harvard in this way, with very encouraging results.

A second method of aiding astronomy is through the large observatories. These institutions, if properly managed, have after years of careful study and trial developed elaborate systems of solving the great problems of the celestial universe. They are like great factories, which by taking elaborate precautions to save waste at every point, and by improving in every detail both processes and products, are at length obtaining results on a large scale with a perfection and economy far greater than is possible by individuals, or smaller institutions. The expenses of such an observatory are very large, and it has no pecuniary return, since astronomical products are not salable. A great portion of the original endowment has been spent on the plant, expensive buildings and instruments. Current expenditures, like library expenses, heating, lighting, etc., are independent of the output. It is like a man swimming up stream. He may struggle desperately, and yet make no progress. Any gain in power effects a real advance. This is the condition of nearly all the larger observatories. Their income is mainly used for current expenses, which would be nearly the same whatever their output. A relatively small increase in income can thus be spent to great advantage. The principal instruments are rarely used to their full capacities, and the methods employed could be greatly extended without any addition to the executive or other similar expenses. A man superintending the work of several assistants can often have their number doubled, and his output increased in nearly the same proportion, with no additional expense except the moderate one of their salaries. A single observatory could thus easily do double the work that could be accomplished if its resources were divided between two of half the size.

A third, and perhaps the best, method of making a real advance in astronomy is by securing the united work of the leading astronomers of the world. The best example of this is the work undertaken in 1870 by the *Astronomische Gesellschaft*, the great astronomical society of the world. The sky was divided into zones, and astronomers were invited to measure the positions of all the stars in these zones. The observation of two of the northern and two of the southern zones were undertaken by American observatories. The zone from $+1^\circ$ to $+5^\circ$ was undertaken by the Chicago Observatory, but was abandoned owing to the great fire of 1871, and the work was assumed and carried to completion by the Dudley Observatory at Albany. The zone from $+50^\circ$ to $+55^\circ$ was undertaken by Harvard. An observer and corps of assistants worked on this problem for a quarter of a century. The completed results now fill seven quarto volumes of our annals. Of the southern zones, that from -14° to -18° was undertaken by the Naval Observatory at Washington, and is now finished. The zone from -10° to -14° was undertaken at Harvard, and a second observer and corps of assistants have been working on it for twenty years. It is now nearly completed, and we hope to begin its publication this year. The other zones were taken by European astronomers. As a result of the whole, we have the precise positions of nearly a hundred and fifty thousand stars, which serve as a basis for the places of all the objects in the sky.

Another example of cooperative work is a plan proposed by the writer in 1906, at the celebration of the two-hundredth anniversary of the birth of Franklin. It was proposed, first to find the best place in the world for an astronomical observatory, which would probably be in South Africa, to erect there a telescope of the largest size, a reflector of seven feet aperture. This instrument should be kept at work throughout every clear night, taking photographs according to a plan recommended by an international committee of astronomers. The resulting plates should not be regarded as belonging to a single institution, but should be at the service of whoever could make the best use of them. Copies of any, or all, would be furnished at cost to any one who wished for them. As an example of their use, suppose that an astronomer at a little German University should discover a law regulating the stars in clusters. Perhaps he has only a small telescope, near the smoke and haze of a large city, and has no means of securing the photographs he needs. He would apply to the committee, and they would vote that ten photographs of twenty clusters, each with an exposure of an hour, should be taken with the large telescope. This would occupy about a tenth part of the time of the telescope for a year. After making copies, the photographs would be sent to the astronomer who would perhaps spend ten years in studying and measuring them. The committee

would have funds at their disposal to furnish him, if necessary, with suitable measuring instruments, assistants for reducing the results, and means for publication. They would thus obtain the services of the most skilful living astronomers, each in his own special line of work, and the latter would obtain in their own homes material for study, the best that the world could supply. Undoubtedly, by such a combination if properly organized, results could be obtained far better than is now possible by the best individual work, and at a relatively small expense. Many years of preparation will evidently be needed to carry out such a plan, and to save time we have taken the first step and have sent a skilful and experienced observer to South Africa to study its climate and compare it with the experience he has gained during the last twenty years from a similar study of the climate of South America and the western portion of the United States.

The next question to be considered is in what direction we may expect the greatest advance in astronomy will be made. Fortunate indeed would be the astronomer who could answer this question correctly. When Ptolemy made the first catalogue of the stars, he little expected that his observations would have any value nearly two thousand years later. The alchemists had no reason to doubt that their results were as important as those of the chemists. The astrologers were respected as much as the astronomers. Although there is a certain amount of fashion in astronomy, yet perhaps the best test is the judgment of those who have devoted their lives to that science. Thirty years ago the field was narrow. It was the era of big telescopes. Every astronomer wanted a larger telescope than his neighbors, with which to measure double stars. If he could not get such an instrument, he measured the positions of the stars with a transit circle. Then came astrophysics, including photography, spectroscopy and photometry. The study of the motion of the stars along the line of sight, by means of photographs of their spectra, is now the favorite investigation at nearly all the great observatories of the world. The study of the surfaces of the planets, while the favorite subject with the public, next to the destruction of the earth by a comet, does not seem to appeal to astronomers. Undoubtedly, the only way to advance our knowledge in this direction is by the most powerful instruments, mounted in the best possible locations. Great astronomers are very conservative, and any sensational story in the newspapers is likely to have but little support from them. Instead of aiding, it greatly injures real progress in science.

There is no doubt that, during the next half century, much time and energy will be devoted to the study of the fixed stars. The study of their motions as indicated by their change in position was pursued with great care by the older astronomers. The apparent motions were so

small that a long series of years was required and, in general, for want of early observations of the precise positions of the faint stars, this work was confined mainly to the bright stars. Photography is yearly adding a vast amount of material available for this study, but the minuteness of the quantities to be measured renders an accurate determination of their laws very difficult. Moreover, we can thus only determine the motions at right angles to the line of sight, the motion towards us or from us being entirely insensible in this way. Then came the discovery of the change in the spectrum when a body was in motion, but still this change was so small that visual observations of it proved of but little value. Attaching a carefully constructed spectroscope to one of the great telescopes of the world, photographing the spectrum of a star, and measuring it with the greatest care, provided a tool of wonderful efficiency. The motion, which sometimes amounts to several hundreds of miles a second could thus be measured to within a fraction of a mile. The discovery that the motion was variable, owing to the star's revolving around a great dark planet sometimes larger than the star, added greatly not only to the interest of these researches, but also to the labor involved. Instead of a single measure for each star, in the case of the so-called spectroscopic binaries, we must make enough measures to determine the dimensions of the orbit, its form and the period of revolution.

What has been said of the motions of the stars applies also, in general, to the determination of their distances. A vast amount of labor has been expended on this problem. When at length the distance of a single star was finally determined, the quantity to be measured was so small as to be nearly concealed by the unavoidable errors of measurement. The parallax, or one half of the change in the apparent position of the stars as the earth moves around the sun, has its largest value for the nearest stars. No case has yet been found in which this quantity is as large as a foot rule seen at a distance of fifty miles, and for comparatively few stars is it certainly appreciable. An extraordinary degree of precision has been attained in recent measures of this quantity, but for a really satisfactory solution of this problem, we must probably devise some new method, like the use of the spectroscope for determining motions. Two or three illustrations of the kind of methods which might be used to solve this problem may be of interest. There are certain indications of the presence of a selective absorbing medium in space. That is, a medium like red glass, for instance, which would cut off the blue light more than the red light. Such a medium would render the blue end of the spectrum of a distant star much fainter, as compared with the red end, than in the case of a near star. A measure of the relative intensity of the two rays would serve to measure the distance, or thickness of the absorbing medium. The effect would be the

same for all stars of the same class of spectrum. It could be tested by the stars forming a cluster, like the Pleiades, which are doubtless all at nearly the same distance from us. The spectra of stars of the tenth magnitude, or fainter, can be photographed well enough to be measured in this way, so that the relative distances of nearly a million stars could be thus determined.

Another method which would have a more limited application, would depend on the velocity of light. It has been maintained that the velocity of light in space is not the same for different colors. Certain stars, called Algol stars, vary in light at regular intervals when partially eclipsed by the interposition of a large dark satellite. Recent observations of these eclipses, through glass of different colors, show variations in the time of obscuration. Apparently, some of the rays reach the earth sooner than others, although all leave the star at the same time. As the entire time may amount to several centuries, an excessively small difference in velocity would be recognizable. A more delicate test would be to measure the intensity of different portions of the spectrum at a time when the light is changing most rapidly. The effect should be opposite according as the light is increasing or diminishing. It should also show itself in the measures of all spectroscopic binaries.

A third method of great promise depends on a remarkable investigation carried on in the physical laboratory of the Case School of Applied Science. According to the undulatory theory of light, all space is filled with a medium called ether, like air, but as much more tenuous than air as air is more tenuous than the densest metals. As the earth is moving through space at the rate of several miles a second, we should expect to feel a breeze as we rush through the ether, like that of the air when in an automobile we are moving with but one thousandth part of this velocity. The problem is one of the greatest delicacy, but a former officer of the Case School, one of the most eminent of living physicists, devised a method of solving it. The extraordinary result was reached that no breeze was perceptible. This result appeared to be so improbable that it has been tested again and again, but every time, the more delicate the instrument employed, the more certainly is the law established. If we could determine our motion with reference to the ether, we should have a fixed line of reference to which all other motions could be referred. This would give us a line of ever-increasing length from which to measure stellar distances.

Still another method depends on the motion of the sun in space. There is some evidence that this motion is not straight, but along a curved line. We see the stars, not as they are now, but as they were when the light left them. In the case of the distant stars this may have occurred centuries ago. Accordingly, if we measure the motion of the sun from them, and from near stars, a comparison with its actual mo-

tion will give us a clue to their distances. Unfortunately, all the stars appear to have large motions whose law we do not know, and therefore we have no definite starting point unless we can refer all to the ether which may be assumed to be at rest.

If the views expressed to you this morning are correct, we may expect that the future of astronomy will take the following form: There will be at least one very large observatory employing one or two hundred assistants, and maintaining three stations. Two of these will be observing stations, one in the western part of the United States, not far from latitude $+30^\circ$, the other similarly situated in the southern hemisphere, probably in South Africa, in latitude -30° . The locations will be selected wholly from their climatic conditions. They will be moderately high, from five to ten thousand feet, and in desert regions. The altitude will prevent extreme heat, and clouds or rain will be rare. The range of temperature and unsteadiness of the air will be diminished by placing them on hills a few hundred feet above the surrounding country. The equipment and work of the two stations will be substantially the same. Each will have telescopes and other instruments of the largest size, which will be kept at work throughout the whole of every clear night. The observers will do but little work in the daytime, except perhaps on the sun, and will not undertake much of the computation or reductions. This last work will be carried on at a third station, which will be near a large city where the cost of living and of intellectual labor is low. The photographs will be measured and stored at this station, and all the results will be prepared for publication, and printed there. The work of all three stations will be carefully organized so as to obtain the greatest result for a given expenditure. Every inducement will be offered to visiting astronomers who wish to do serious work at either of the stations and also to students who intend to make astronomy their profession. In the case of photographic investigations it will be best to send the photographs so that astronomers desiring them can work at home. The work of the young astronomers throughout the world will be watched carefully and large appropriations made to them if it appears that they can spend them to advantage. Similar aid will be rendered to astronomers engaged in teaching, and to any one, professional or amateur, capable of doing work of the highest grade. As a fundamental condition for success, no restrictions will be made that will interfere with the greatest scientific efficiency, and no personal or local prejudices that will restrict the work.

These plans may seem to you visionary, and too Utopian for the twentieth century. But they may be nearer fulfilment than we anticipate. The true astronomer of to-day is eminently a practical man. He does not accept plans of a sensational character. The same qualities

are needed in directing a great observatory successfully, as in managing a railroad, or factory. Any one can propose a gigantic expenditure, but to prove to a shrewd man of affairs that it is feasible and advisable is a very different matter. It is much more difficult to give away money wisely than to earn it. Many men have made great fortunes, but few have learned how to expend money wisely in advancing science, or to give it away judiciously. Many persons have given large sums to astronomy, and some day we shall find the man with broad views who will decide to have the advice and aid of the astronomers of the world, in his plans for promoting science, and who will thus expend his money, as he made it, taking the greatest care that not one dollar is wasted. Again, let us consider the next great advance, which perhaps will be a method of determining the distances of the stars. Many of us are working on this problem, the solution of which may come to some one any day. The present field is a wide one, the prospects are now very bright, and we may look forward to as great an advance in the twentieth century, as in the nineteenth. May a portion of this come to the Case School and, with your support, may its enviable record, in the past, be surpassed by its future achievements.

THE FUTURE OF MATHEMATICS

BY PROFESSOR G. A. MILLER

UNIVERSITY OF ILLINOIS

PROFESSOR A. VOSS, of the University of Munich, recently made the following statement: "Our entire present civilization, as far as it depends upon the intellectual penetration and utilization of nature, has its real foundation in the mathematical sciences."¹ He adds that this truth finds expression in the ever-increasing appreciation of the educational value of mathematics, notwithstanding the fact that it is the most unpopular of all the sciences. This unpopularity is natural since "unpopularity is an essential feature of a real science," because such a science can be comprehended only through tireless and continued efforts.

An intelligent expression as regards the future of mathematics must be based not only upon the past and present state of this science, but also upon its real essence. One of those elements which mathematics has in common with some of the other sciences, but which are more prominent in mathematics than in any of the others, is the tendency to use thought in the most economical manner. When one considers the extent to which efforts to simplify methods, theorems and formulas direct mathematical endeavor, one must admit that the statement "Mathematics is the science of saving thought" expresses a great truth, even if it is too sweeping to serve as a definition.

That mathematics is the science which is preeminently devoted to the discovery and mapping of routes along which thought may ascend securely and with the greatest ease, is supported by the fact that it has the oldest and the most extensive symbolical language. In the introduction to his classic history of mathematics, Moritz Cantor asks, "Why has mathematics, since the remotest times, found support, simplification and advancement by means of word symbols, whether these are number symbols or other mathematical symbols?" Although the oldest of these word symbols are probably relics of a very ancient picture language, yet it is of great interest that in mathematics the picture language was retained and used side by side with an alphabetic and syllabic language, while the latter displaced the former elsewhere. Even those who have mastered only the elements of algebra and the

¹ Voss, "Ueber das Wesen der Mathematik." Rede gehalten om 11. Marz, 1908, in der oeffentlichen Sitzung der k. bayerischen Akademie der Wissenschaften; Teubner, 1908, p. 4.

differential calculus are in position to appreciate the value of mathematical symbols for the purpose of centralizing and intensifying thought.

It is true that some of the roads which mathematical thought has made through great difficulties have been practically abandoned and that the popularity of many of the others has changed from time to time. Among the former we may class the results of investigations recorded at the beginning of the oldest extensive mathematical work that has been deciphered, viz., the formulas relating to unit fractions which are found in the nearly four thousand-years-old work of Ahmes. A subject which appears to have been placed at the very beginning of advanced mathematical instruction four thousand years ago is now entirely abandoned in our courses, except when the history of the development of the science is under consideration. While mathematics presents a number of other roads which are now of interest only to the historian, yet there are also many which have been known for centuries and which have been pursued with profit and pleasure by great minds in all the civilized nations. The latter class includes all the longer ones leading gradually to points of view from which the connection between many natural phenomena may be clearly discerned.

The intellectual heights reached by means of a long series of connected mathematical theorems do not always reveal their greatest lesson to the first explorers. For instance, the large body of facts relating to conic sections, developed by Apollonius and other Greek geometers, became a much greater glory to the human mind through the discovery, nearly two thousand years later, that the bodies of the solar system describe conic sections. Such experiences in the past tend to justify the fact that a large number of men are devoting their lives to the discovery of abstract results irrespective of applications, and they tend to explain why the largest prize (about twenty-five thousand dollars) ever offered for a mathematical theorem is being offered for a theorem in number theory, which is not expected to have any application to subjects outside of pure mathematics.

There seems to be a general impression abroad to the effect that mathematics and the ancient languages constituted the main parts of the curriculums of our colleges and universities a century or two ago. As regards mathematics this is quite contrary to fact, as may be seen from a few historical data. Less than two centuries ago the students in Harvard College began the study of arithmetic in their senior year. In fact, no knowledge of any mathematics was required to enter Harvard before 1803, and it was not until 1816 that the whole of arithmetic was required for entrance. In other American institutions the mathematical situation was generally worse, and in Europe the improvements were not very much earlier. It is during compara-

tively recent years that mathematics has made most of its gains towards being recognized as a fundamental science, and the study of advanced mathematics in our universities had a still later origin.

The rapid recent advances in various fields of mathematics have given rise to a very optimistic spirit as to the future. Although we still hold in high esteem the brilliant discoveries of the Greeks, we are inclined to give much more thought and attention to recent work, as may be seen from the references in the extensive German and French mathematical encyclopedias which are in the process of being published. The history of mathematics furnishes many instances of the vanishing of apparently insurmountable barriers. We need only recall the barrier created by the Greek custom of confining oneself to the rule and circle in the most acceptable geometric constructions, and the very formidable barrier furnished by the imaginary, and even by the negative and the irrational roots of a quadratic equation.

Those who fixed their attention upon these barriers in the past have naturally been led to think that the days of important advances in mathematics were about ended and that it only remained to fill in details. Such predictions had few supporters when new methods led over these barrier and turned them into steps to richer mathematical domains. As this process has been repeated so often it has gradually reduced the number of those to whom the future of mathematics looked dark. In fact, Poincaré, in his address² before the Fourth International Congress of Mathematicians, which was held at Rome, in April, 1908, said that all those who held these views are dead.

These facts seem to justify a very hopeful spirit as regards future progress, but it is necessary to examine them with great care in order to deduce from them any helpful suggestions as to the probable nature of this progress. Such prognostications clearly demand a mind that can deal with big problems as well as a thorough acquaintance with the past and the present developments in mathematics, to insure that the results obtained by a kind of extrapolation may be worthy of confidence. It is doubtful whether any living mathematician would be more generally regarded as qualified to make reliable predictions along this line than Poincaré, of Paris. The address to which we referred in the preceding paragraph was devoted to this subject and we proceed to give some of the main results.

The objects of mathematical thought are so numerous that we cannot expect to exhaust them. This appears the more evident since the mathematician creates new concepts from the elements which are presented to him by nature. Hence there must be a choice of subject matter, but who is to do the choosing? Some are inclined to think that the mathematician should confine himself to those problems which

² *Bulletin des Sciences Mathématiques*, Vol. 32 (1908), p. 168.

may be set for him by the physicist or the engineer. If he had done this in the past he would not have created the instruments necessary to solve such problems, and hence it is unreasonable to make such restrictions as to the future.

If the physicists of the eighteenth century had abandoned the study of electricity because it seemed to serve no useful end, we should not have had the many useful applications of electricity during the nineteenth century. Similarly, if the mathematician had abandoned the study of negative and imaginary numbers because they seemed to point only to impossibilities, we should not have had the many powerful instruments of thought which enable us to cope more successfully with many problems of nature. Just as the physicist is largely guided in his work by those facts which seem to point to general laws, so the mathematician is guided in his work by the desire to discover extensive relations and laws having a wide range of application. Millions of isolated facts present themselves to the investigator, some of which are of striking interest to the initiated, but they are of practically no value in the development of mathematics except that they may sometimes serve as an exercise in secondary instruction.

At a first thought the statement that "Mathematics is the art of giving the same name to different things" may appear to be entirely contrary to fact, but from a certain standpoint this statement conveys a very fundamental truth. It should be borne in mind that these different things must have in common the property to which this common name refers, and that it is the duty of the mathematician to discover and exhibit this common property. By way of illustration we may recall the use of x for various unknowns in algebra and the (1, 1) correspondence between the two series of operators. When the language has been properly chosen it is often surprising to find that the demonstrations, as regards a known object, apply immediately to a large number of new objects without even a change of name.

Just as the boundaries between the elementary subjects of mathematics—arithmetic, algebra and geometry—vanish when the knowledge of these subjects is sufficiently extended, so the boundaries between subjects in pure and applied mathematics are disappearing, and it is exactly in these bordered lands, or in this common territory of two or more subjects, where the greatest recent progress has been made and where the greatest future activity may be expected. The work in this common territory is made possible by observing similarity of form where there is dissimilarity of matter, or by observing some other common properties which admit mathematical treatment.

In Poincaré's address some of these general observations were illustrated by numerous examples chosen from various fields of higher mathematics. On the contrary, we shall confine our illustrative ex-

amples to elementary subjects. Our first effort will be directed towards exhibiting some territory which is common to each of the four subjects—arithmetic, geometry, algebra and trigonometry. By observing common properties we shall not only see a bond connecting these fundamental subjects, but we shall also be led to general methods which make it unnecessary to study the same properties in different forms. The thing to be emphasized is that these four elementary subjects have in common fundamental notions which not only connect them, but also establish contact between them and many other subjects. Such a fundamental notion is a group of order 8, known as the *octic group*. Some of the properties of this group may be easily seen by considering the possible movements of space which transform a square into itself.

The period or order of a movement represents the number of times the movement must be made in order to arrive at the identity, or at the original position. It is clear that the eight movements of the square include two of period four, five of period two, and the identity. A profound study of these eight movements would disclose many interesting facts. For instance, it would be seen that only two of them (the square of these of period four and the identity) are commutative with each one of others, while each one of the remaining six is commutative with only four of the possible eight movements. Although a profound study of this group of eight movements would be necessary to exhibit the fundamental rôle which it plays in the various subjects, it is not necessary to enter deeply into its properties in order to see that it is common to the four subjects mentioned above.

At a first thought it might appear as if these eight movements had nothing in common with trigonometry, but a very fundamental connection may be seen as follows: If the vertex of the angle A is the center of a square and the initial line of A coincides with a line of symmetry of the square, the operations of taking the complement and the supplement of A correspond to movements transforming the square into itself. Hence the eight angles which may be obtained from a given angle by a repetition of finding supplement and complement may be placed in a (1, 1) correspondence with the eight movements of the square. As these eight angles play such a fundamental rôle in elementary trigonometry, it has been suggested that our ordinary school trigonometry might appropriately be called the trigonometry of the octic group, or the trigonometry of the group of movements of the square.

Although the eight operations of the octic group do not occupy such an important place in elementary arithmetic as in geometry and trigonometry, yet these operations serve to explain some facts which present themselves in the most elementary arithmetic processes. For instance, the operations of subtracting from 2 and dividing 2 lead, in

general, to eight distinct numbers. Starting with 5, these eight numbers are

$$5, -3, \frac{2}{5}, -\frac{2}{3}, \frac{8}{5}, \frac{8}{3}, \frac{5}{4}, \frac{3}{4}.$$

No new number is obtained by dividing 2 by any of these numbers or by subtracting any of them from 2. The proof of the fact that the eight operations by means of which each one of these eight numbers may be derived from any one of them have the same properties in relation to each other as the eight movements of the square is not difficult, but it involves details which may be omitted in a popular exposition.

An instance where the octic group plays an important rôle in algebra is furnished by the three-valued function $xy + zw$, which is fundamental in the theory of the general equation of the fourth degree. On account of the existence of this function the solution of the general equation of the fourth degree may be made to depend upon the solution of the general equation of the third degree. This function is transformed into itself by eight substitutions, and we may arrange its letters separately on the vertices of a square in such a way that the eight substitutions transforming the function into itself correspond to the eight movements which transform the square into itself. Such an arrangement exhibits the intimate relations between this function and the movements of a square, and the preceding examples illustrate the fact that the octic group finds application in each of the elementary subjects—arithmetic, algebra, geometry and trigonometry, and that it forms a part of the domain common to all of these disciplines.

In a similar manner other groups could be traced through these elementary subjects of mathematics and it could be shown that the theory of these groups may be used to clarify many fundamental points and to exhibit deep-seated contact. If the common domains will furnish the most active fields of future investigations in accord with the predictions of Poincaré, and if we may expect the greatest future progress to be based upon the modeling of the less advanced science upon the one which has made the more progress, it is reasonable to expect that a subject like group theory will grow in favor, and that some of the elements of this subject will become a part of the ordinary courses in secondary mathematics. In support of this view we may quote a recent statement by Professor Bryan, President of the Mathematical Association, which is as follows: "I believe Professor Perry will get some very good material for applications out of the theory of groups, when explorers have first made their discoveries, and when the colonists have been over it and surveyed it, and discovered means for cultivating it. We do not know anything about its practical applications now."³

³ *The Mathematical Gazette*, January, 1909, p. 17.

The future of mathematics appears bright, both for the investigator and for the teacher. When a country which has such an enlightened educational system as France increased the amount of time devoted to secondary mathematics so recently as 1902 and again in 1906, it furnishes one of the strongest possible encouragements to the teacher who may have been troubled by the thought that the educational value of mathematics was not being as fully appreciated as in earlier years. Naturally we may expect that there will be local changes of view as regards the value of mathematics as an educational subject, and these changes will not always be for the better, but the civilized world, as a whole, is learning to appreciate more and more the fundamental importance of early mathematical training, so that we should not be too much perturbed by local steps backwards, but we should move ahead with the assurance that we are engaged in a work of the highest pedagogical importance.

The boundless confidence in the importance of early and extensive mathematical training should, however, not blind us to the need of changes and new adaptations. As an important function of mathematical training is the furnishing of the most useful and the most powerful tools of thought, it is evident that the choice of these tools will vary with the advancement of general knowledge. All admit that the concept of a derivative is one of the most useful elementary tools of thought, and in a number of countries this concept has been introduced into secondary mathematics and used with success. At the last International Mathematical Congress, held at Rome, M. Borel, of Paris, reported that the notion of derivative had been introduced into French secondary education in 1902 and that it had led to satisfactory results. At the same meeting M. Beke, of Budapest, stated that this notion, together with the notion of function and graph, had been introduced into the courses of secondary education in Hungary.

At the recent joint conference of the Mathematical Association and the Federated Association of London Non-Primary Teachers, the chairman remarked: "I have always thought that a mathematician was a man who when he wants to find anything out, uses his brains for that purpose, whereas a physicist, when he wants to find out anything, resorts to experiment." Although this statement is not to be construed literally, yet it does involve a great partial truth and it calls attention to elements which insure mathematical appreciation as long as there is scientific thought. "It is the mind that sees as well as the eye," and the mind sees some of the greatest truths most clearly by means of mathematical symbolism. In fact, mathematical symbols serve both as a telescope and also as a microscope for mental vision, and as long as such vision is demanded the teacher of mathematics will be appreciated.

THE "DRUID STONES" OF BRITTANY

BY PROFESSOR J. S. KINGSLEY

TUFTS COLLEGE

THE writer makes no pretense of being an archeologist, but finding a few accounts of the wonderful megalithic monuments of Brittany in English, he has written this account of his visit to them as thread on which to string a few pictures. Those huge stones erected by human hands—no one knows by whom or why or when—which are called megalithic monuments, occur throughout western Europe, from the "Huns' beds" east of the Zuider Zee, through Britain, France and Spain and into northern Africa, across the Strait of Gibraltar, but nowhere are they as numerous or striking as in Brittany. The tourist is familiar with that strange circle of standing stones at Stonehenge and, to a less extent with "Kit's Coty House" in Kent and the circle at Avebury, but Morbihan is far out of the usual track and hence is seen by comparatively few of our people.

The department of Morbihan lies on the southern shore of Brittany, three hundred miles in a straight line west of Paris, and considerably farther as the trains run. The part of it where these megaliths abound is, perhaps, twenty miles, east and west, and ten north and south. It contains no large cities—Vannes, the capital, has not twenty-five thousand inhabitants—it has no churches or art galleries starred in Bädiker; its sole attractions are its delightful inhabitants who still adhere to their ancient costumes, and the monuments.

Archeologists divide these standing stones into different categories, according to the way they are arranged, and each kind has its name derived from either the Keltic or the French. There are *menhirs* (Keltic, long stones) which stand upright in the soil, usually upon the smaller end. Menhirs may be isolated, scattered here and there through the region, or they may be arranged in lines or rows (*alignments*) stretching across the fields. In certain places the menhirs form square or semicircular enclosures called *cromlechs* (Keltic, curved stones).

Again, the megaliths have been built into chambers, the walls composed of upright stones placed close together, and roofed in by one or more large blocks of stone. These are the *dolmens*¹ (table stones), the enlarged chamber being usually reached by a narrower passage, though occasionally the entrance is in one side of the chamber. In some cases

¹ In England the dolmens are frequently called cromlechs.

instead of a true dolmen there is a narrow passage alone, an *allée couverte*. Various subdivisions of these types are recognized, but they may be ignored here.

It was to see these megaliths that we took the all-day journey (really only 148 miles) across Brittany. It was early morning when we left the wonderful rock of St. Michel's Mount and the omelettes of the now reconciled Poulards, with whose quarrels all travelers are familiar. Half an hour by tram took us to Pontorson. Why do places like Pontorson exist? Our two hours were one continual struggle with station agent, hack drivers and porters, all of whom were insistent that we should drive out to Mt. St. Michel. "One franc a person" but we knew their ways; half way there would be a demand for a *pourboire* which would make the original fare look like twenty cents. Besides, we had just come from the Mount, and why should we go back? At Dol another wait, this time long enough to get an early lunch, before we could get a cross-country train for Rennes. Up to that day Rennes had been associated in our minds with the Dreyfus trial of a few years ago. Two hours here were sufficient to assure us that Bädiker did not slander the town when he wrote that with its 75,000 inhabitants, "its spacious modern streets are generally dull, lifeless and deserted." Next a wait of an hour at Redon before taking the last train of the day—the Nantes-l'Orient express for Auray, which we reached just in time for dinner at the most comfortable and hospitable Pavilion hotel.

One may go in various ways from the railway to the monuments, but there is a best way—by carriage. There is the route from Vannes, taking a boat down through the sea of Morbihan to Locmariaquer. It is a picturesque route through a land-locked arm of the sea, studded with islands, like a miniature Casco Bay. But it is not to be depended upon, as the sailing of the steamers varies with the tides. It is cheaper to take the train from Auray to Carnac station on the little road to Quiberon, and then the little tram to Carnac village and to Erdeven. This brings one within easy walking distance of the principal alignments; but to reach the other monuments a carriage is convenient; even necessary, if one is to see the important menhirs, dolmens, etc., of Locmariaquer. Besides, the foot traveler will have to have a guide, otherwise he will waste much time and probably will miss much that he ought to see. Bädiker's map is on too small a scale to be of much assistance.

The total drive from Auray to all of the standing stones is about thirty-five miles, but by cutting out some which apparently were repetitions of others, we made our round trip about twenty-five miles. The country traversed is best described in the terms of physical geography as a *penplain* and the shore to the south as a drowned coast. It is nearly level, with no hills rising markedly above the rest of the country.

We saw the first of the monuments about six miles out of Auray and

our first glimpse was rather disappointing. A couple of hundred feet to the left of the road was the first dolmen, a dozen stones, about five feet high, standing upright in a pasture, and roofed in by two large stones lying across them. It recalled a child's house on a large scale, built out of the lichen-covered stones of the field. By its side stood a square stone monument announcing that this dolmen of Keriaval is the property of the French Republic, and that any one injuring it in any way will be prosecuted. It may be said that by each group in the entire district is a similar stone. On the other side of the road are three dolmens, close together, standing scarcely above the surrounding soil but excavated inside so that one may stand upright in the interior.

It would serve no useful purpose to give our itinerary in detail, but a clearer idea of these strange structures may be given by a general description of the monuments as a whole, specifying here and there those of more particular interest from size or other features.

Possibly the most striking of all are the alignments. Certainly they are the most difficult to explain. Of these there are several groups, each distinct from its fellows, and yet the whole series being in the same belt. Many of the stones have tumbled down and some have been utilized in building walls and houses. Thus the little church of St. Cornély at Carnac is built entirely of menhirs, broken up into blocks of convenient size, while the curious crown that surmounts its west portal was carved out of a single menhir. Le Rouzic, whom I shall often quote, says that the series of alignments once extended from a point to the west of the village of Carnac, five miles east to the Crac'h River, while other series occur further west, near Erdeven.

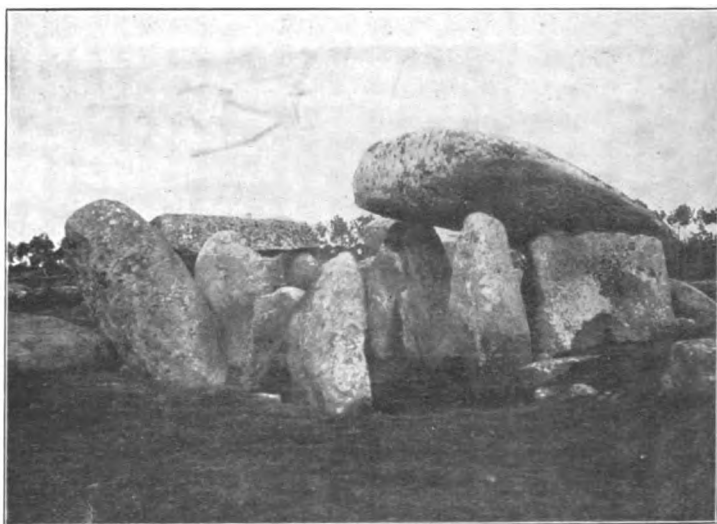

FIG. 1. DOLMEN OF KÉRIIVAL, half way between Auray and Carnac.

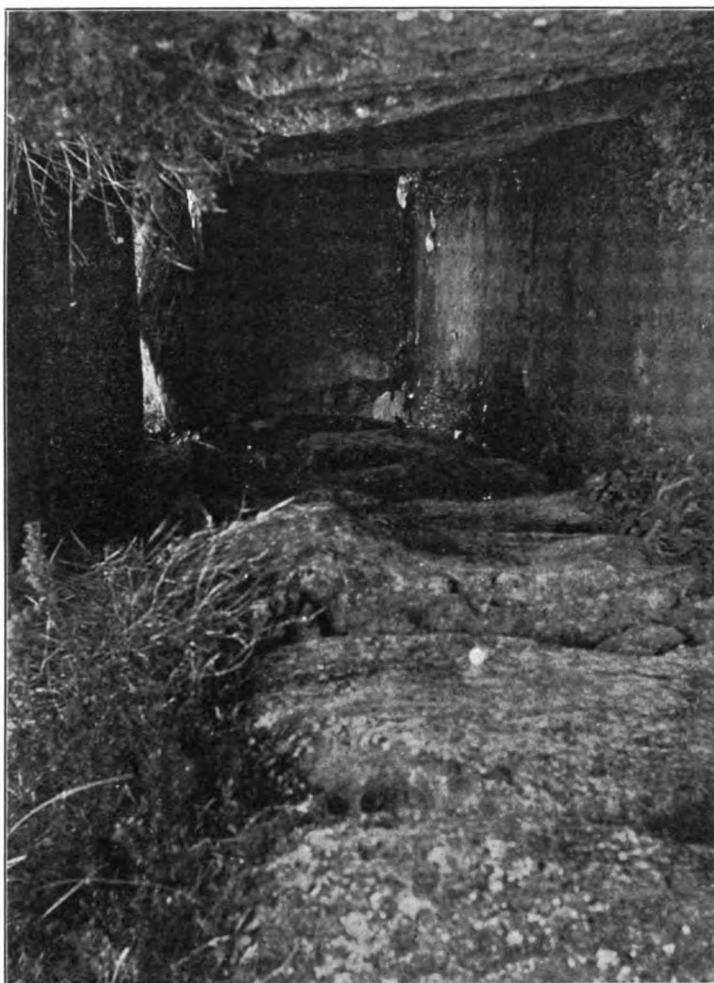

FIG. 2. INTERIOR OF THE DOLMEN OF KERIONED, across the road from Kériaval.

We visited the three alignments near Carnac—Ménec to the west, Kermario in the middle and Kerlescan to the east. Of these Ménec is the most extensive and the best preserved, but the menhirs in the others are larger. That these alignments are distinct from each other and are not parts of a single one is shown by several facts. They are separated by considerable intervals, the gap between Ménec and Kermario being a thousand feet; between Kermario and Kerlescan over a quarter of a mile. Again, the rows in the different alignments run in different directions—Ménec N. 70° E., Kermario N. 57° E., and Kerlescan S. 85° E. In each alignment the rows begin with enormous stones at the west end and gradually taper down to merely good-sized rocks at the easterly ends. Then Ménec and Kerlescan begin at the



FIG. 3. PANORAMA OF THE ALIGNMENT OF MÉNEC, near Carnac, from the westerly end. The cromlech is just behind the position of the camera, but could not be included in the view on account of a house and farm buildings. The alignment of

western ends with a cromlech, and LeRouzic is confident that there was originally a cromlech at the western end of Kermario, but that it has disappeared.

The alignment of Ménéac may be taken as typical. It lies in an undulating pasture, with farm buildings here and there, and is crossed at about the middle by a country road. Through this field, from the slight elevation at the west, down through the hollow of the road, and disappearing over the rise at the east, stretch eleven rows of menhirs, the rows being approximately parallel and about thirty feet apart, and the whole a little over three hundred feet wide while in length they extend 3,800 feet, or over two thirds of a mile. Some of the menhirs have tumbled down; here and there we note one built into the walls separating the fields but still occupying its original position. In all there are 1,099 stones still standing in Ménéac. At the eastern end they are small, rising but two or three feet above the soil, but at the western end are the giants, three or four feet in diameter and thirteen feet high.

The cromlech of Ménéac consists of 70 stones, about five feet high on the average, which sweep in a semicircle around the farm buildings at the west end of the alignment, the chord of the curve including only the southern half of the lines proper.

Only dry facts need be given concerning the other alignments we saw. In Kermario there are 982 menhirs in ten rows, extending over



Kermario is behind the woods at the farther end of the lines. At the extreme right of the view is the Mont St. Michel, a sepulchral monument or galgal, entirely artificial (see p. 134).

an area about 320 by 3,700 feet. The largest menhir, which has fallen, is 21 feet in total length, while the smallest stands but a foot and a half above the ground. In Kerlescan the cromlech of 39 stones is quadrangular in outline with rounded corners, while the alignment proper consists of 540 menhirs in thirteen rows in an area 2,700 feet long with an interruption of 600 feet where the little village of Kerlescan is situated. The largest of the stones is thirteen feet in height, the smallest only two feet above the surface of the ground.

While dolmens and isolated menhirs occur all around Carnac; the most striking of them are on the next peninsula to the east, near the little village of Locmariaquer. Here one must leave the road and go into the fields to see the monuments. Suddenly a one-armed man sprang up beside the carriage and led the way among farm outhouses, gardens and across vegetable patches, to the most remarkable of all these remains, which continually bring up the question, How could they have been erected? Largest of all is the gigantic menhir, "menhir groach," in the village itself, now fallen and broken into five pieces. According to Le Rouzic, who has measured it carefully and who has taken the specific gravity of the stone, it was originally 68 feet in length and weighed 382 tons. Le Rouzic also says that the time and cause of its fall are unknown, and cites a drawing of 1727 to show that at that time it was in its present condition. On the other hand, I have seen a little pam-



FIG. 4. ALIGNMENT OF KERMARIO.

phlet which states that it was struck by lightning, overthrown and broken in the sixteenth century. There is apparently little doubt that once this immense stone stood vertically, but the engineering problem of its erection is not easily solved. One can hardly believe, with Le Rouzic, that the lever and inclined plane were sufficient; yet what other mechanical aids could have been available?



FIG. 5. MENHIR GROACH OR GRAND MENHIR, LOCMARIAQUER.

At Locmariaquer is also the largest of the dolmens, the "dolmen des marchands." I regret that I took no measurements of its size, especially since none are given in the works at hand. I can only depend upon my memory, aided by pictures, for my estimates. At its southern end is a passage about four feet wide and high enough for a tall man to stand erect. This is walled by vertical slabs of stone and roofed in with the same material. The passage leads to a larger chamber which is at least seven feet wide and high by possibly ten or twelve in length. The end opposite the entrance is formed of a single stone, shaped like

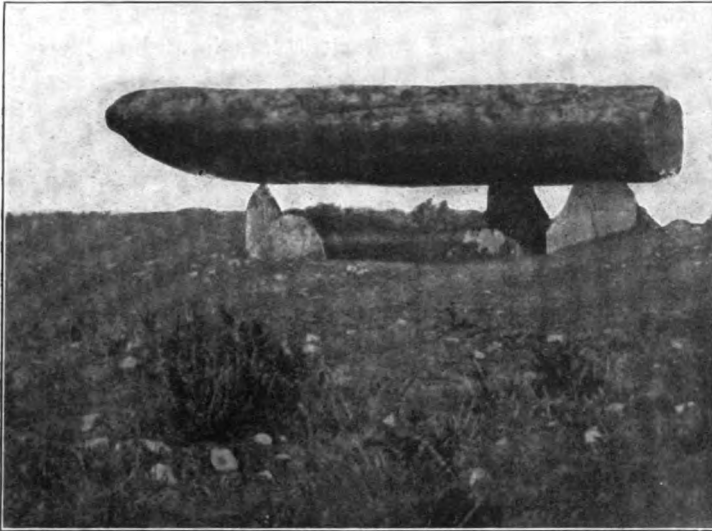

FIG. 6. DOLMEN DES MARCHANDS, LOCMARIAQUER.

the smaller end of an egg and remarkable from the fact that its surface is covered with groups of parallel curved lines, a feature found but rarely in this region. Smaller stones, about six feet high, make up the sides of the chamber, while at the opening of the passage into the chamber are a pair of seven-foot stones, like door posts. The roof is supported on these three larger stones, like an enormous three-legged table. The table top is an immense block of granite, about ten feet wide, fifteen feet long and four feet in thickness. The problem of putting this roof in position is not so difficult as that of the erection of the giant menhir just described. We may imagine the ancient workers filling all around the vertical stones of the dolmen with soil and then sliding or rolling the covering stone into position. But even this calls for an expenditure of an enormous amount of human strength.

Near this "table of the merchants" is another dolmen, "mané rétual," less perfect and less easily studied than its fellow, since it has

not been excavated. Its covering stone, however, is larger, or was before one end was broken off. Judging from the size of a man in a picture which I bought it was forty feet in length, eight in breadth and two or three in thickness.

Some of the other dolmens in the vicinity are nearly as large as these, and some vary by having lateral chambers given off, either from the main chamber or from the passage. None, however, are their equals in the size of the roofing stones, but in most instances the roof is formed of several stones. I recall measuring one roughly as it lay across the dolmen at Locmariaquer—as between eleven and twelve feet in length.

The rock of which these monuments are formed is the common granite of the region. The blocks were probably weathered out from the underlying bed rock by the elements and needed no quarrying on the part of the unknown engineers.

Speculations as to the time at which these monuments were erected, the people who put them in position and the purposes for which they were intended are numerous in the literature of the subject, some of them as fantastic and absurd as those which ascribe the antiquities of

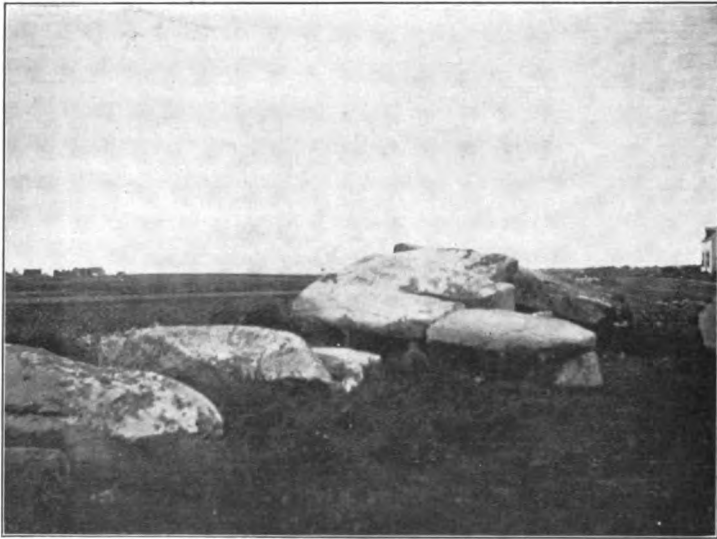

FIG. 7. DOLMEN OF MANÉ RÉTUAL, LOCMARIAQUER, foreshortened so as to include all of the roofing stones.

Yucatan to the followers of St. Thomas of apostolic times. Usually they are attributed to that mysterious people, the "Druids," whoever they may have been. Certain it is that they long antedated the conquest of Gaul by the Romans, while the relics found in connection with some of them would seem to indicate that they may date back to the second stone age, the neolithic period of the archeologist.

Human interments often occurred at the isolated menhirs and associated with these are found only simple pottery and instruments formed solely of stone and bone. Not a trace of bronze or iron, except where it was clearly of a later and intrusive character. Arrow and spear points, ceremonial stones, etc., closely resembling those of our American Indians, would point far back in the history of western Europe. Yet this is not conclusive, for these objects occur only in connection with human interments and one must make allowance for the well-known conservatism of the priestly class. Among other peoples the objects buried with the dead retained the primitive character long after the race had developed other forms in its daily life. So it may have been here. The fact that these burials were accompanied only by objects of the stone age is not conclusive proof that the people were ignorant of bronze or even of iron.

It is an interesting fact that the passages leading to the chambers of the dolmens are invariably so placed that the openings lie between the points of the rising and the setting of the sun at the summer solstice, possibly indicating that the builders were to a certain extent sun worshippers. From certain considerations of orientation the English astronomer, Lockyer, has figured out the date of the building of Stonehenge as about 1680 B.C., with a limit of probable error of two centuries either way. If his arguments be valid, there is a probability that the monuments of Carnac and Locmariaquer are at least as old.

With such a throwing back of the age of these monuments there is more and more uncertainty as to who built them. The “Druids,” who just appear on the pages of written history, were Keltish, but what evidence have we that Kelts dwelt in Brittany or Great Britain a thousand or fifteen hundred years before Christ? We know that other races dwelt in these regions before the immigrant Kelt. Did the Kelt erect these stones or did he find them where they still stand when he came? and did he simply adapt his religious rites to them? Who can say?

We are on a little more certain ground when we come to the purposes of the standing stones, or at least of some of them. As implied above, the isolated menhirs, usually placed on some spot a little above the surrounding country, have, in many cases, been found to stand near some burial, and hence it is probable that they are funeral monuments. Some may also have been boundary stones. The dolmens are also mortuary in character. Apparently every dolmen and *allée couverte* was formerly buried with earth or rocks, the whole forming a large mound—a tumulus or *galgal*. With the ages the earth in many cases has been removed, either by man or by the elements, leaving the strange “tables” as we see them. In other cases the tumulus still persists and many of these have been explored by modern archeologists, all revealing, in the interior, either a dolmen, an *allée couverte*, or smaller cairns of stones,



FIG. 8. DOLMEN OF KERVERESSE, LOCMARIAQUER.

each with human bones, frequently mingled with those of the horse and cow.

The way in which one tumulus near Carnac has been explored is interesting. This forms a large mound, over 260 feet long, oval in outline, rising fifty or sixty feet above the surrounding plain, and locally known as Mont St. Michel. On one end of the level summit is a small chapel of St. Michel while on the space in front is an interesting cross of fifteenth century workmanship. As open cuttings would have been expensive (and even impossible in the neighborhood of the chapel), the tumulus has been explored by driving small tunnels through it in every direction. These have later been walled up and roofed in with stone, so that, by the aid of a candle, one may visit all the points of interest in the interior, just as one would explore one of our Indiana or Kentucky caves, seeing all the features found—in this case two dolmens and numerous cairns—as nearly as possible in their original condition.

It would be a tedious task to enumerate, even by name, all of the objects found in these explorations, which were begun in 1862 by the Société Polymathique of Vannes, continued, for the fifteen years ending with his death in 1881, by the Scotchman, James Miln, and since that time by Le Rouzic. The material collected by Miln forms a small but very important museum which he bequeathed to the Commune of Carnac, and which must be visited in order to have a full knowledge of these strange megaliths. Le Rouzic, the present curator, is enthusiastic in his field, gladly welcoming the student, and spending much time in explaining his treasures.

In the first place these plainly show that, whether the orientation

of the dolmens has any significance or not, the tumuli were mortuary in character. Sometimes the body was buried while still in the flesh; in other instances cremation had occurred. At times there were isolated interments; at others the bones are found in large numbers, as if there were collective burials. Along with the human bones occur those of the horse and cow, while burnt clay vases, necklaces of pierced stones and stone implements—celts, arrow and spear points, etc.—accompany the remains. Some of the vessels were apparently new, while others show signs of culinary use. Many of the stone implements have a perfection of surface and edge that would imply that they were never used but were merely votive offerings, ceremonial in character. It is interesting to note that even to this day the peasants of Morbihan prize the arrow and spear points as talismans and call them "*men-garun*"—thunder stones.

But what are the alignments? Here we are in the region of speculation—pure guessing. One may pass by with mere mention the view that they, with the cromlech at the end, are gigantic phallic symbols. Le Rouzic thinks them funereal without being sepulchral in character. He thinks that they might have been connected with the religious rites. The spaces between the rows would afford passages for the faithful assembled for the celebration of the ceremonies, possibly in connection with the collective burials in the tumuli, while the cromlech was the place set apart for the priests.

Whether we can ever arrive at an exact interpretation of these monuments or not, whether we ever know when or by whom they were erected, whether we solve the problems involved in the handling of these immense stones; these thousands of rocks—originally 15,000 or 20,000 in number—scattered over the plains of Morbihan will form one of the most striking of the monuments of antiquity. Possibly we shall get nothing better or more definite, certainly nothing more poetical, than the medieval legend of Saint Cornély which I paraphrase from the version given by Le Rouzic.

Saint Cornély was Pope of Rome, from which place he was driven by the pagan soldiers, who pursued him as he fled before them, accompanied by two cows which bore his baggage and belongings when he was tired. One evening he arrived at the village of Moustoir (two miles north of Carnac). Here he fain would have stopped, but hearing a young girl there abusing her mother, he could not stay. So he went on until he came to a little hill (Mont St. Michel) where he had a view in all directions. In front was the sea, behind the soldiers in martial array. Further flight was impossible. What could he do? He stretched forth his hand and immediately the soldiers, rank and file as they stood, were changed to stone. Hence it is that one sees the long lines of standing stones to the north of the village of Carnac, and

hence it is that the village church is dedicated to St. Cornély. Pilgrims of all countries flocked to Carnac to invoke the aid of the saint for their ailing beasts, and he, mindful of the aid his cows had given him in his flight, granted their requests. To this day ghosts may be seen at night wandering among the lines of stones, the "soldiers of St. Cornély," while the image of the saint and his cows are carved on the front of the church. The query at once arises, have we here a survival from the old worship of Mithras?

THE ORIGIN OF THE NERVOUS SYSTEM AND ITS APPROPRIATION OF EFFECTORS

II. RECEPTOR-EFFECTOR SYSTEMS

By G. H. PARKER

PROFESSOR OF ZOOLOGY, HARVARD UNIVERSITY

THE second step in the development of the neuromuscular mechanism is represented by the receptor-effector system, a condition fairly realized in such cœlenterates as the sea-anemones and the jelly-fishes and probably recurring in the digestive tubes of the higher metazoans. As an introductory example we may turn to the sea-anemones.

Most sea-anemones (Fig. 1) are cylindrical animals attached to some firm object by their aboral disks and carrying on their oral disks a ring of tentacles surrounding the mouth. This aperture leads inward through a short gullet to a large, somewhat divided, digestive cavity, the gastro-vascular space, which extends throughout the whole interior of the animal even to the tips of its tentacles and is the only cavity within the sea-anemone. The body of the animal is made up of walls of extreme thinness; these walls consist of two layers of cells, an outer one next the sea water, the ectoderm, and an inner one next the gastro-vascular space, the entoderm. These two layers are separated by a tough, non-cellular sheet, the supporting lamella.

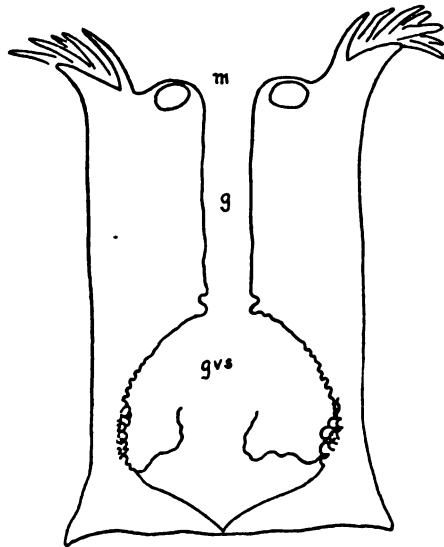

FIG. 1. LONGITUDINAL SECTION OF A SEA-ANEMONE (*Metridium*); *g*, gullet; *gvs*, gastro-vascular space; *m*, mouth; *t*, tentacles.

Unlike sponges, sea-anemones are very responsive to changes in their environment. If a fully expanded *Metridium* is disturbed by mechanical agitation, it will quickly retract its oral disk, discharge through its mouth the water contained in its gastrovascular cavity, and

finally cover its tentacles and mouth by puckering in the oral edge of its column. In this contracted state it may remain hours at a time, and when it eventually expands it does so by relaxing its muscles and refilling its body with sea water. A beam of strong sunlight, if thrown upon an expanded *Metridium* several feet under water, will usually call forth the same contraction as mechanical stimulation does.

When the exterior of a *Metridium* is tested locally, its receptiveness for certain stimuli is found to be quite diverse. The animal makes no



FIG. 2. ECTODERM FROM THE TENTACLE OF A SEA-ANEMONE (*Metridium*); e, epithelial layer; m, muscular layer; n, nervous layer; s, supporting lamella.

movements when dissolved food-substances are cautiously discharged upon the external surface of its column, though this very area is sensitive to mechanical stimulation. Precisely the reverse is true of the lips; these organs are easily stimulated by dissolved food-products, but no reaction occurs even when they are punctured by a needle. Both mechanical and chemical stimulation, however, are effective on the tentacles and vigorous responses can be called forth from even distant parts of the body by the application of either of these forms of stimuli to the tentacles. Since these reactions, as just intimated, often involve responses in very different parts of the animal from those to which the stimulus is applied, it follows that we are dealing with a process justly regarded as nervous, for transmission in this case is not accompanied with any observable motion. The surface of a sea-anemone may then be pictured as a true receptor surface partly differentiated in different regions for particular classes of stimuli, but not so far specialized that it can be described as made up of sense organs.

An examination of the structure of the ectoderm (Fig. 2) will do much to make clear the mechanism by which the reactions of sea-anemones are carried out. The ectoderm of these animals is a modified epithelium in which three definite layers can be distinguished. The outermost of these forms more than half the thickness of the total layer and is a true columnar epithelium. It contains, in addition to ordinary epithelial cells, gland-cells and nettle-cells, and, what is of more importance to us, sense-cells. These sense-cells are long, narrow bodies whose distal ends are armed with a sensory bristle which, under ordinary conditions, projects into the surrounding sea water and whose proximal ends run out into finely branched, nervous processes which intermingle with similar processes from other cells. The complex made by the interweaving of immense numbers of these processes constitutes the second layer of the ectoderm, the nervous layer, and this layer often contains in addition to the large amount of fibrillar material derived

from the sense-cells, numerous multipolar ganglion-cells whose processes add to the fibrillar material already mentioned. A careful study of this fibrillar material has recently been made with the result that a true nervous network has been demonstrated in hydroids (Wolff, 1904; Hadzi, 1909), siphonophores (Schaeppi, 1904) and sea-anemones (Wolff, 1904; Groselj, 1909). In the sea-anemones in particular this network appears to be a perfectly continuous and diffuse one, notwithstanding Havet's previous declaration (1901) to the contrary. The third layer is composed of parallel muscle-fibers that rest against the supporting lamella on one side and are in contact with the nervous network on the other side. The muscle-cells of this layer are much elongated, spindle-shaped cells. These three layers, the epithelial layer, the nervous layer and the muscular layer, constitute the structural elements in the ectodermic neuromuscular mechanism of a sea-anemone.

The nervous type of ectoderm just described covers practically the whole surface of a sea-anemone and has been designated as a diffuse nervous system in contrast to a centralized one. The fact that the nervous layer is more fully developed on the oral disk than elsewhere has given anatomical grounds for the assumption that this portion is a central nervous organ, but, as will be shown later, the physiological evidence in favor of this opinion is so slight that the designation of the nervous system as a diffuse one is more consistent with facts.

From the standpoint of our original analysis, it is quite plain that in the sea-anemones we are dealing with at least two elements of the typical neuromuscular mechanism, namely, receptors as represented by the sense-cells, and effectors as seen in the muscle-fibers. Whether the fibrillar material that intervenes between these two structures represents an adjustor or central apparatus will be discussed after the action of this nervous mechanism has been more fully described.

The feeding habits of the sea-anemones throw considerable light on the physiology of their nervous structures. If particles of meat are dropped on the tentacles of an expanded *Metridium*, they become entangled in the mucus on these organs and are quickly delivered to the mouth, where they are swallowed. If fragments of clean filter-paper soaked in sea water are similarly dropped on the tentacles, they are usually discharged from the edge of the oral disk without having been brought to the mouth. Thus the animal appears to discriminate between what is good for food and what is not. If, however, pieces of filter-paper soaked with meat juice are put on the tentacles, they are usually swallowed as though the sea-anemone had been deceived. On the basis of these simple experiments a still more striking combination can be devised. If a sea-anemone is provided alternately with pieces of meat and pieces of filter-paper soaked in meat juice it will in the beginning swallow in sequence both materials, but after ten or a dozen

trials it will regularly swallow the meat but usually discard the filter-paper. Thus it would appear that the sea-anemone had detected the deception practised on it in the beginning and had learned to circumvent the experimenter. But further observations show how erroneous this interpretation is. If the experiment just described is performed on a limited group of tentacles on one side of the oral disk and, after the animal has arrived at the stage of discriminating between meat and paper, the experiment is repeated on another and distant group of tentacles, it is found that these tentacles and the part of the mouth next them will accept both meat and paper as the first group did and the same process as was used on this group must be repeated on the second group in order to bring it to the stage of discrimination. Thus it is clear that, however we may regard these acts, *Metridium* shows no marked power of making the experience of one part of its body serve another; in other words, it shows no decided evidence of a central nervous organ.

This conclusion is in substantial accord with the recent results obtained by Fleure and Walton (1907) from experiments on *Actinia* except that they believe that the repeated trials on the tentacles of one side of the circle had in this form a slight influence on those of the other. This influence, however, was so slight that they declared that experience of this kind certainly did not become the possession of the animal as a whole.

Not only is there in these reactions absence of any strong evidence in favor of well-marked central nervous functions in anemones, but it is very doubtful if we are justified in regarding the local reaction just described as a true discrimination. Jennings (1905) has suggested that sea-anemones possess sensations of hunger and that as the experiment proceeds the animal's hunger diminishes and it finally discards when less hungry what it at first accepted. But Allabach (1905) has shown that the same so-called discrimination is arrived at if the sea-anemone is not allowed to swallow anything, but is robbed of meat and paper alike by having these materials picked out of its gullet just as they are about to be swallowed. In fact it seems quite clear that this process of apparent discrimination is in no sense due to centralized nervous functions, but is merely the result of exhaustion. At the beginning of each experiment the receptors are stimulated by the strong juices of the meat and the weaker juice of the paper. As they run down in efficiency, they come to a stage where they no longer react to the weaker stimulus of the paper and respond only to the meat. At this stage apparent discrimination takes place.

Not only do these experiments show no evidence of central nervous functions, but they indicate a decided looseness of nervous articulation. The activity of one side of the body of the sea-anemone has very little,

if any, influence on the other side. Moreover, the fact of intimate local relations between nerve and muscle, as seen in the anatomy of these animals, supports the idea of neuromuscular independence instead of centralized relations. This is well exemplified in the reactions of the tentacles. If a tentacle of *Metridium* is stimulated by food, it turns and twists irregularly and then points toward the mouth. If the same tentacle is cut off and held filled with water so that its original relations in the animal as a whole can be kept in mind, it will be found to react to food as it formerly did, in that it will finally turn toward that side which was originally next the mouth.

Hence we may conclude that the tentacle has within itself all that is necessary by way of neuromuscular mechanism for its characteristic reactions and is not dependent for these on such other parts of the sea-anemone as have been regarded as central nervous organs. Physiologically as well as anatomically the sea-anemone seems to possess a diffuse rather than a centralized nervous system, and its neuromuscular mechanism consists of receptors and effectors connected by a nervous net which is composed partly of the nervous processes of the receptor cells and partly of similar processes from ganglion cells.

The type of neuromuscular mechanism found in the sea-anemones probably also recurs in the digestive tube of vertebrates. This view is supported not only by the action of the intestine, but also by its structure (Fig. 3).

Omitting for the moment the outer serous layer and the inner mucous layer of the intestine, both of which have little or nothing directly to do with its neuromuscular mechanism, there are left the outer or longitudinal muscular layer, followed internally by a nervous layer, Auerbach's plexus, which in turn is followed by the cir-

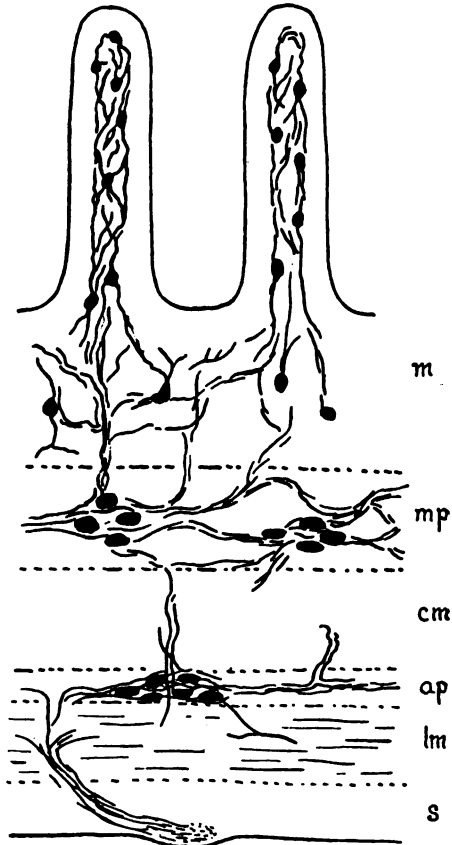

FIG. 3. LONGITUDINAL SECTION OF THE INTESTINAL WALL OF A VERTEBRATE, SHOWING THE NERVOUS AND MUSCULAR CONSTITUENTS: *ap*, Auerbach's plexus; *cm*, circular muscles; *lm*, longitudinal muscles; *m*, mucous layer; *mp*, Meissner's plexus; *s*, serous layer.

cular muscles on which rests a second nervous layer, Meissner's plexus. Each plexus, so far as is known, is a true nervous net as intimately related to the adjacent muscle fibers as is the case of the sea-anemones. In fact one of the muscle layers and the adjacent plexus in the intestine reproduce very accurately all the essentials of the neuromuscular mechanism of a sea-anemone except the epithelial sense-cells.

Not only is there this anatomical similarity between the neuromuscular mechanisms of the sea-anemone and of the vertebrate intestine, but there is also a physiological similarity as seen in the movements of the digestive tube. The essentials of these movements are well exemplified in the small intestine. In this part of the digestive tube the characteristic movements are segmentation and peristalsis. Segmentation consists in a series of temporary, ring-like constrictions in the intestinal wall that come and go in such a way that the enlarged region of the tube between any two constrictions is the site of the constriction next to appear, and so on. As a result of segmentation, the food is most thoroughly churned and mixed. Peristalsis is a wave-like movement whereby the food is carried posteriorly through the intestine. Usually these two movements go on together in such a way that the peristalsis is combined with segmentation in that the latter becomes somewhat unsymmetrical and cuts each food mass into two unequal parts the larger of which is on the posterior side of the constriction. Hence the food is not only churned but is at the same time moved posteriorly through the intestine.

The small intestine receives nerve-fibers from two extraneous sources, the vagus and the splanchnic nerves, and it might be supposed that these were essential for the movements of the intestine. But as Cannon (1906) has demonstrated, both sets of nerves may be cut, and yet after recovery from the immediate effects of the operation segmentation and peristalsis will be found to go on in the digestive tube in an essentially natural manner. It is thus clear that the vertebrate intestine, like the tentacle of a sea-anemone, contains a complete neuromuscular mechanism within its own wall, and though there is no histological evidence of the presence of receptors reaching from the mucous surfaces of the intestine to the nervous nets within, yet there are sound physiological grounds for assuming the presence of such organs. In that case the type of neuromuscular mechanism in the intestine would be practically identical with that in the sea-anemone.

A second example of a receptor-effector system in coelenterates is seen in the jellyfishes. In these animals as contrasted with the sea-anemones, locomotion is a well-developed activity, and it is the neuromuscular mechanism concerned with this function that must be considered. The structures involved in locomotion are well exemplified in *Aurelia* (Fig. 4). This common jellyfish possesses on the edge of

its bell eight clusters of sense-organs. Each cluster contains an ocellus, two sensory pits that are probably concerned with the chemical sense, and a sense-club which may be a pressure organ. The sensory portions of all these organs are modified ectoderm and from these portions nerve-fibers pass out as radiating bundles to the ectoderm of the subumbrellar surface. Here they merge into a nervous net which overlies the ectodermic musculature as in the sea-anemones. This musculature forms a circular sheet concentrically disposed with reference to the symmetry of the jellyfish. When the bell of an *Aurelia* is pulsing, the movement is carried out by the more or less general contraction of this circular band of muscle, which is brought back to its original position on relaxation by the elasticity of the gelatinous mass of the bell. The locomotor muscle, then, is a gigantic sphincter that works against an elastic resistance.

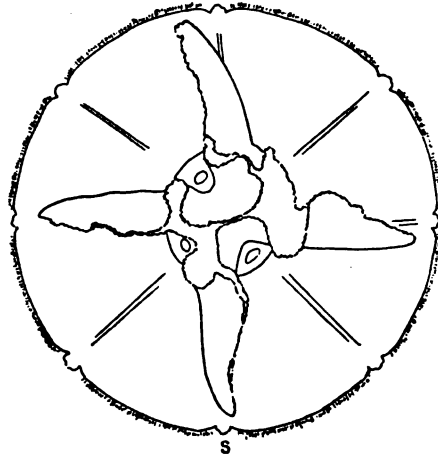

FIG. 4. *Aurelia*, subumbrellar surface; s, cluster of sense-organs.

The significance of the various parts of the neuromuscular mechanism in such an animal as *Aurelia* can be determined by experiment. If the eight sense-bodies are removed, the animal will no longer pulse spontaneously, though its muscles may be made to contract by direct stimulation. If all but one sense-body are removed, the bell will pulse with regularity and by artificially stimulating the single remaining body a wave of muscular contraction can be sent over it. It is therefore evident that the sense-bodies act like extremely delicate triggers and thus touch off the contractile mechanism. In this respect, then, the jellyfish is more highly developed than the sea-anemone, for the latter possesses no such specialized and delicate receptors.

The wave of contraction that passes over a bell when one of its sense-bodies is stimulated, may be either a purely muscular phenomenon or may be the result of nervous transmission through the nervous net whereby one region after another of the musculature is brought into action. The fact that this wave is not checked when the bell is cut even in a most irregular way provided the subumbrellar epithelium is still continuous, favors the nervous rather than the muscular interpretation. But stronger evidence on the nervous side than this has come from an entirely different direction. Mayer (1906) has shown that the subumbrellar epithelium of *Cassiopea* after removal will readily regen-

erate, and that in regeneration the nervous net forms earlier than the muscles. By taking jellyfishes at the appropriate stage in regeneration, it was found that a stimulus applied to one side of a regenerated area was followed by a muscular response on the other side of this area without any observable movement in the area itself. Hence transmission through the regenerated region must have been by nervous means, doubtless by the nervous net.

In jellyfishes the nervous net will transmit apparently in any direction and in this respect it is in strong contrast with the central nervous organs of the higher metazoans, where, especially in the vertebrates, a polarized condition generally prevails. Thus in the spinal nerves of vertebrates, it is easy to send impulses through from a dorsal root to a ventral one, but impossible to send them in the reverse direction. Apparently the cord contains some structure on its path of conduction that is valve-like and allows impulses to pass in one direction only. Such a condition does not exist in the nervous net of the jellyfishes.

The neuromuscular organs of the cœlenterates have been considered by so many investigators as the most primitive in the animal kingdom that it is not inappropriate to consider at this place the relations of some of the older views on this subject to those expressed in these articles.

The discovery by Kleinenberg (1872) of the so-called neuromuscular cells (Fig. 5) in *Hydra* led this investigator to the belief that these cells represented a complete neuromuscular apparatus in that each cell-body could be regarded as a receptor and its fibrous portion as an effector. By growth and cell division, according to Kleinenberg, separate receptors and effectors would be differentiated simultaneously from such single cells.

The simultaneous differentiation of nervous and muscular elements (Fig. 6) was also accepted by the brothers Hertwig (1878), but in their opinion the two types of tissue did not arise from a common cell as claimed by Kleinenberg, but from separate cells which became simultaneously differentiated, some to form nerve-cells (sense- and ganglion-cells) and others to form muscle-cells. This view has come to be commonly accepted by the majority of investigators.

The independent origin of the nervous system and its secondary



FIG. 5. NEUROMUSCULAR CELL (black) in place in a columnar epithelium.

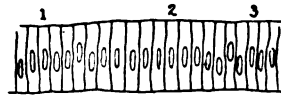

FIG. 6. DIFFERENTIATION OF NEUROMUSCULAR CONSTITUENTS FROM AN INDIFFERENT EPITHELIUM. The upper figure represents an indifferent condition containing three cells which subsequently (lower figure) differentiate into a sense-cell (1), a ganglion-cell (2), and an epithelial muscle-cell (3).

connection with the musculature has been advocated by Claus (1878) and by Chun (1880), but a nervous system without effectors is, as Samassa (1892) and Schaeppi (1904) declare, scarcely conceivable.

The opinion about the origin of nervous and muscular tissues as expressed in these articles is opposed to the various theories stated in the preceding paragraphs in that muscular tissue is regarded as the ancestral tissue and nervous tissue is supposed to have formed secondarily and as a means of bringing muscular tissue into action with greater certainty than direct stimulation would do. According to this view the primitive state of the neuromuscular mechanism is to be seen in such animals as sponges, which possess muscles but no true nervous organs; and the neuromuscular or, better, epithelial-muscular cells of the coelenterates represent these primitive effectors to which have been added a diffuse system of receptors as seen in the sea-anemones or a specialized system as in the jellyfishes. In both instances the receptors and effectors are related through a nervous net.

REFERENCES

- ALLABACH, L. F.
1905. Some Points regarding the Behavior of *Metridium*. *Biol. Bull.*, vol. 10, pp. 35-43.
- CANNON, W. B.
1906. The Motor Activities of the Stomach and Small Intestine after Splanchnic and Vagus Section. *Amer. Journ. Physiol.*, vol. 17, pp. 429-442.
- CHUN, C.
1880. Die Ctenophoren des Golfes von Neapel. *Fauna und Flora des Golfes von Neapel*, Monogr. 1, xviii + 313 pp., 18 Taf.
- CLAUS, C.
1878. Studien über Polypen und Quallen der Adria. *Denkschr. Akad. Wissensch., Wien*, Bd. 38, pp. 1-64, Taf. 1-11.
- FLEURE, H. J., and C. L. WALTON.
1907. Notes on the Habits of some Sea Anemones. *Zool. Anz.*, vol. 31, pp. 212-220.
- GEOSSELJ, P.
1909. Untersuchungen über das Nervensystem der Aktinien. *Arbeit. Zool. Inst., Wien*, Tom. 17, pp. 269-308, Taf. 1.
- HADZI, J.
1909. Ueber das Nervensystem von Hydra. *Arbeit. Zool. Inst., Wien*, Tom. 17, pp. 225-268, Taf. 1-2.
- HAVET, J.
1901. Contribution à l'étude du Système nerveux des Actinies. *La Cellule*, tome 18, pp. 385-419, pls. 1-6.
- HEETWIG, O., and R. HEETWIG.
1878. Das Nervensystem und die Sinnesorgane der Medusen. *Leipzig*, 40, x + 186 pp., 10 Taf.
- JENNINGS, H. S.
1905. Modifiability in Behavior. I. Behavior of Sea Anemones. *Journ. Exp. Zool.*, vol. 2, pp. 447-472.

KLEINENBERG, N.

1872. Hydra. Eine anatomisch-entwicklungsgeschichtliche Untersuchung. Leipzig, 40, vi + 90 pp., 4 Taf.

MAYEB, A. G.

1906. Rhythmical Pulsations in Scyphomedusae. Publ. Carnegie Inst., Washington, no. 47, 62 pp.

PARKER, G. H.

1896. The Reactions of Metridium to Food and other Substances. Bull. Mus. Comp. Zool., vol. 29, pp. 107-119.

SAMASSA, P.

1892. Zur Histologie der Ctenophoren. Arch. mik. Anat., Bd. 40, pp. 157-243, Taf. 8-12.

SCHAEFFLI, T.

1904. Ueber den Zusammenhang von Muskel und Nerv bei den Siphonophoren. Mitth. Naturwiss. Ges. Winterthur, Jahrg. 1903-04, pp. 140-167.

SHERINGTON, C. S.

1906. The Integrative Action of the Nervous System. New York, 8vo, xvi + 411 pp.

WOLFF, M.

1904. Das Nervensystem der polypoiden Hydrozoa und Scyphozoa. Zeitschr. allg. Physiol., Bd. 3, pp. 191-281, Taf. 5-9.

THE VARIATIONAL FACTOR IN HANDWRITING

BY JUNE E. DOWNEY

UNIVERSITY OF WYOMING

HANDWRITING, bearing as it does the cachet of individuality, has always interested those to whom things human make their intimate appeal. Curious observations relative to it have long been current, the existence, for instance, of national as well as family and personal chirographies; the perversions of it that take form as mirror-writing or even—it is said—as inverted writing; the whimsy shown by the bizarre characters, by the tendency to irrelevant and extravagant flourishes in the writing of those suffering from certain forms of mental disorder. Attention has been called to the similarity existing between a man's handwriting and the manner in which he walks or gesticulates. It has been claimed that age and sex and profession leave their impress upon writing, that the pencraft of the painter mirrors minutely the grace and distinction that marks the sweep of his brush across the canvas. Carried out boldly such speculations venture even the claim that the handwriting of any individual would be found to resemble the characteristic tracings shown by his pulse and respiration and fatigue curves. Nor is the interest in the variational aspect of handwriting restricted to recording the diversities in penmanship from individual to individual; it is also engaged in noting variations from day to day in the handwriting of any given person under the influence of fatigue or emotion or disease. But, however numerous, such observations and however legitimate the speculations they engender, it remains for the physiologist and the psychologist, with the aid perhaps of the sociologist, to compass the scientific study of the variational factor in handwriting.

The ground, however, has been broken. As has frequently been the case in the history of research, the claims of a pseudo-science, at once provocative and suggestive, have stimulated inquiry. In this case, graphology, the art that would find in handwriting revelations of intelligence and character, has been the direct cause of a series of investigations. On the other hand, modern psychological theory with its increasing emphasis upon behavior, upon the motor aspects of life, could not long ignore the opportunity for study presented by this most complicated and subtle act of individual expression.

Two lines of investigation have accordingly been inaugurated by the

psychologist; the one interested in the functional significance of the act of writing as the expression of individuality; the other interested in a minute analysis of this motor series, seeking to determine the laws of expression that govern this particular act. In both investigations methods of research are being worked out with the ingenuity so characteristic of scientists of to-day. Each investigation as it progresses will be found to encroach upon the other. From the two will come the future science of handwriting. A résumé of the work that has already been done has perhaps its value at the present time.

First of all it may be profitable to consider the investigations that have sought to determine under scientific control whether or not the graphologists have made good their claims. It is to France that we owe, not only the most carefully wrought-out system of graphology, but also the most carefully thought-out control of that art. In an investigation covering many months, Alfred Binet, the director of the psychological laboratory at the Sorbonne, planned and executed a series of carefully controlled experiments designed to test the ability of the graphologists to determine from handwriting the sex, the age, the intelligence and the character of the writer. Binet, who guarded carefully against all sources of error, so planned his experiments as to be able to state in figures the percentage of error in the interpretations of the graphologists and thus render possible a comparison of the graphologists' successes with those that might reasonably be expected if chance alone determined the outcome. The results showed unmistakably that the graphologist was able to determine with but a small percentage of error the sex of the writer and also, but with less certainty, the intelligence of the writer. The interpretation of age and character offered still greater difficulties. To render the tests perfectly definite and to avoid the error that might arise from the personal equation in estimation of intelligence and character, Binet in his tests upon them made use, on the one hand, of the handwriting of men famous in literature and science and, on the other hand, of specimens of the handwriting of great criminals, whose biographies were matter of legal record.

Binet's investigation, apart from his general conclusions, brought out some interesting facts. He found, for instance, that there existed not only very great differences in the skill with which different graphologists made their interpretations, but also that there were those uninitiated in the art whose readings at times even the professional graphologist might envy. An observation akin, in a way, to the common experience that some people remember and recognize handwritings, as others do faces, with extraordinary facility and accuracy. Minute differences have for them undoubtedly a value not experienced by others. Binet found, moreover, that the professional's skill in

diagnosis far outran his ability to ground his judgment on definite graphic signs. His reading was the translation into words of a general impression, somewhat similar, we may assume, to that received by the skilled reader of the human countenance. Moreover, in at least one instance, and that in the case of a non-professional, the judgments, based on intuitions, that is, non-reasoned-out impressions, were achieved in a state of passivity that we are familiar with as characteristic of automatic activities of different sorts.

Accepting these results, the investigation is obviously only well initiated, for one is next anxious to press home the question that asks the cause of such differences. It is not enough, for instance, to know that Binet's graphologists were able under highly favorable conditions to distinguish in ninety per cent. of the tests the sex of the writer; it is not enough to know that, to a certain extent, they were able to base their judgments upon the presence or absence of certain graphic signs; one would also know in detail what determines each sign of sex, whether at the last they are due, as Binet himself asks, to profound physiological or psychological causes, or, rather, are the outcome of the social environment so different in the case of the two sexes.

We are here brought face to face with the old question that has confronted all investigators of sex-differences. It is evident, however, that the question of the social environment is, in this instance, a controlling one not merely in the discussion of the revelation of sex in handwriting, but also in that of the revelation of intelligence; for there exists a peculiar environment for talent as well as for sex. Indeed, it appears that the investigation of handwriting must be socio-psychological in nature. Unconscious imitation, social suggestibility doubtless play an important, if not all-important, part in determining writing characteristics. On the whole, therefore, it is not surprising that the experts were more successful in distinguishing marked differences in intelligence than in determining the nature of the individual superiority. They perceived the class characteristic, as it were.

The overlapping of the writer's environments, social and professional, must further complicate the matter. The cases cited by Binet of writing that gave evidence of reversion of signs: the writing, for instance, of a young woman scientist that the graphologists unanimously judged to emanate from a man, or the handwriting of a man like Renan that the graphologists marked as coming from a man of inferior mental ability are of particular interest in this connection. Such cases would probably repay a detailed investigation not only of the psychology of the individual, but also of his environmental history.

It is, perhaps, because character, within certain limits, does not produce segregation of classes that the experts showed little accuracy in their judgments of moral qualities from handwriting. Their failure,

for instance, to find in the handwriting of a young woman murderer, who was of some social position, evidence of more than feminine instability and coquetry is instructive; for the case was an aggravated one of the murder, by poisoning, of three innocent victims—husband, grandmother and brother—for the sake of trifling gain.

A further control of these experiments, an attempt to diminish the masking effect of class-imitativeness, might be achieved by international work, by tests involving the discovery of similar graphic signs in the writing of individuals separated by race and training. A repetition of Binet's test as to the possibility of distinguishing sex-differences might be of value in this country where sex-segregation in education is much less pronounced than it is in France.

Other sociological aspects of handwriting might no doubt be investigated. The variation in individual chirography due to the nature of the letter written, be it of social import or a business note; the change in penmanship that comes with the change of the relation of the writer to the one addressed—all such observations, vague as they are at present, merit consideration. Most suggestive of all is the shift in style that comes when the writer addresses his own eye alone, yielding himself to the fervor of composition or the mental dissipation of being "off parade." But observations under such conditions must at best be made stealthily. A hint at the possibility of the intrusion of one's mental privacy and, conscience or vanity on the alert again, one's writing hastens to resume its conventional legibility.

The revelations of the autograph as a mental photograph, a graphic representation of social relationships, have never been fully appreciated by the sociologist, although the world at large has always accepted a famous man's autograph as secondary in interest to his photograph alone. The pretense, the dignity, the reserve, the finesse with which one faces the world finds copy in the ostentation, the simplicity, or the ambiguity with which one signs one's name. Indifferent though one may be in penmanship in general, there is something intimate and personal in the autograph that arrests one's interest, so that in the somewhat fantastic world of images, of symbols, it often happens that one adopts a mental picture of his own autograph as the official representative of himself in the counsels of thought.

In any case it is evident that there is a psychology as well as a sociology of handwriting. Tremendously complicated as the problem of diagnosis of individual traits from those tiny strokes of the pen appears, it is yet a legitimate problem of science; for the more progress psychology makes, the more evident it becomes that there is not a mode of expression which is not rooted to its finest detail in the complex psycho-physical organism. Meanwhile, it is fortunate that the task of identifying graphic signs should not be left wholly to the

intuitions of the graphologist. Experimental work that seeks to induce variation in writing through a control of outer conditions must in time correlate certain definite variations in conditions with variation in such aspects of writing as size, speed, accuracy in alignment, inequality of control and the like.

The experimental investigations, spoken of above, have attacked the problem at this point. Abandoning any attempt to deal with the more complicated aspects of chirography as an expression of individuality, they have confined themselves to an accurate analysis of such factors as speed of movement and its variations; the length and significance of writing-pauses; measurement of pressure and its variations; comparison of the accuracy of control for right and left hand; elimination of visual control; minute analysis of finger, wrist and arm movements involved in handwriting, with an assignment to each of its rôle. Such an investigation, so far as it confines itself to mere analysis, is obviously but a part of the general investigation of voluntary action. But the discovery of methods of accurately registering minute variations in writing speed, pressure, amplitude and musculature is necessarily preliminary to an accurate determination of the correlation between particular psychic traits and their expression graphically.

An illustration of what may be expected from the perfecting of the technique of registration of speed, pressure and amplitude of writing is to be found in the report of a piece of work carried out some years ago in a German laboratory, where it was discovered that increased difficulty in mental work showed itself in written expression by increased pressure or by decrease in the size of the written characters. The former way of meeting the difficulty seemed to be characteristic of men; the latter, characteristic of women.

Variation in the amplitude of written characters involves doubtless many important considerations relative to the facilitation and inhibition of movement. Writing with attention preoccupied or distracted results variously in the enlargement or dwarfing of characters, an alternative result that seems to depend upon deep-seated tendencies of the individual. If, as facts apparently show, the individual who is the more automatic in his activities responds to distraction with an increase in the size of characters used; while one less automatic, one whose attention—though sometimes in a maimed condition—is always at the helm, gives evidence of the mental difficulty by a decrease in amplitude, a decrease that bears witness to the inhibition at work, then a very simple test is at hand by means of which individuals may be grouped under the two types that have been labeled, somewhat ambiguously, motor and sensory. If it should be shown further that this difference cuts through all the mental activities of the human being, progress would have been made in the difficult matter of the classification of mental types.

Whatever more extended observations may show, the writer of this paper has found it a very simple matter to pick out individuals who will make good subjects for muscle-reading—an experiment that succeeds best with those whose movements are most automatic—by a preliminary test in which the subject, blindfolded, is required to write his name rapidly in sequence while counting aloud by a given interval, say by 13's. The writing of those individuals who would serve best in the proposed test shows a progressive enlargement and, moreover, characteristic pen-lapses.

The question may then be raised whether such difference in mental type reveals itself in normal handwriting, and an affirmative answer seems not presumptuous, although a detailed study of handwriting from this standpoint has not, so far as the writer knows, been instituted experimentally. It should be noted, however, that in the thought process which accompanies writing during composition, momentary distractions occur frequently, for thought, even in the case of rapid penmen, is apt to run ahead of the writing. Who does not number among his correspondents those whose final letters trail off into an indistinguishable scrawl; and others who end with a flourish that marks well the motor abandon? Characteristic revelations, no doubt, although interpretation as yet must be exceedingly diffident.

It is interesting to note in this connection the interpretation graphologists put upon the size of writing as indicative of individual traits. Distinction, power, frankness, honesty are held to reveal themselves by magnified writing either throughout writing as a whole or at the termination of words. Minute writing throughout or at the close of words is held to indicate, in the case of superior intelligence, artifice or preoccupation with metaphysical or other minutiae; in the case of inferior minds, miserliness. Usually, the graphologists emphasize legibility of terminal letters as highly indicative of frankness; while, on the other hand, the tendency to terminate letters in filiform fashion as evidence of a veiling of self. Mere exhibition of documents from persons of known characteristics seems, it must be said, inadequate proof of such propositions. Variations from the normal in the handwriting of any individual would under defined conditions be of more value for general interpretative purposes than would variation from one person to another. Nor can facile analogies appear worthy of serious attention until the causal relation between certain temperamental traits and the facilitation or inhibition of movement is better understood.

The attempt to study handwriting in the light of psychological analyses already in progress bids fair to help analysis, as well as to increase our knowledge of the psychology of handwriting. The relation of the inner word to the outer visible one has long interested

psychologists and pathologists, particularly in connection with the investigation of agraphia, that is, loss or impairment of the power to write. But the interest in such difficulties has centered largely in the fact that study of them might contribute to the physiological problem of the localization of cerebral function. If more than this, the interest has usually limited itself to an analysis of the situation in sensory terms; the details of the resulting expression have been but little studied. The growing interest in the psychology of lapses, both linguistic and graphic, and the development of a technique for such study is of great promise. In the case of the graphic lapse there is need not merely of the tabulation of what kind of errors are made, but also a reproduction of the writing in which the errors are found. Will such writing show characteristic variations in amplitude, pressure, and the like?

Even apart from the question as to the effect of a "hitch" in the process upon the appearance of writing, we may ask whether the general appearance and characteristics of writing are affected by the type of thought-process normal for any given individual. An intensive study of imagery types has always recognized, although with considerable divergence of opinion as to details, the varieties of the word-image. The word mentally seen or heard, spoken or written, has been found to play an important part in the complex thought-processes that underlie the consciousness of meaning and the possibility of its expression. The question of significance here is how far one sort of verbal imagery is potent in initiating the written word of any individual and whether any difference in written gesture marks off the individual who habitually indulges himself in visual imagery from the man who is more motor in type or more dependent upon auditory images.

Back even of this question lies the more deep-cutting one of the significance to the whole mental life of the predominance of the sensations, perceptions and images of a ruling sense. At what point and to what extent in the process of learning to write does the visual-motor coordination fall under the ruling sense and what effect has such subordination upon the general appearance and character of the resulting chirography? One feels certain that the handwriting of the man visually inclined must differ from that of the man preoccupied with motor details, but is unable to specify the difference. Yet the problem does not remain insoluble, for there are simple methods of determining the part played by each sense in control of the writing of any individual. Accompanying sensations such as those of sight and sound may be eliminated from the situation and the effect noted; or conflict with visual or auditory or motor images may be introduced and the results recorded. The investigation of the varieties of writing-control with the relation of each to writing-appearance offers a tempting field for work. But here speculation must wait upon the facts.

In such an investigation, however, that peculiar perversion of writing known as mirror-writing, because legible only when seen in a mirror or in transparency, may be utilized experimentally. The fact, on the one hand, that many left-handed children write in such a fashion from the first; and, on the other hand, that right-side paralytics, forced to the use of the left hand often resort spontaneously to such a form in their written communications has brought it about that the investigation of mirror-writing has been in the past largely turned over to those whose interests were either pedagogical or pathological, and has led to the conclusion that mirror-writing is either the normal writing for the left hand of all individuals or the normal writing for the left hand of the left-handed only. An examination of the evidence cited in support of these propositions or a discussion of the explanations that are used to ground them is not now in place. What is of interest is the insistence upon the need of further experimental work on induced mirror-writing with the hope of getting more light upon the relation here involved between the written characters and their visual significance. For the first question that arises is this: How can mirror-writing prove visually satisfactory, however "motorly" comfortable? And the answer to this question involves the whole problem of the relation of visual and motor control. It is probable that artificially induced mirror-writing is a simple device for determining to what extent the divorce between motor and visual control has resulted in the case of any one individual.

But the relation of handwriting to emotional temperament, as well as its relation to imagery types, merits consideration. Variation in expression under emotional disturbance has long been a special subject of experiment. Little attempt, however, has been made to compare the results so obtained with the appearance of writing under emotional tension. To be sure, the graphologists cite a tendency to elevate progressively the line of writing as an evidence of mental exaltation, of joy or ambition, while a fall in the alignment is indicative of the depressive emotions, self-distrust, sadness, melancholy. Again, a strongly marked tendency toward centrifugal or centripetal movements is held to indicate, on the one hand, ardor, simplicity, activity, uprightness, and, on the other hand, slowness, lack of spontaneity, egoism. These observations, if confirmed, need to be brought into definite correlation with the results obtained in experimental work; and in this connection the graphologists do appeal to the experimental interpretation of movements of expansion and of flexion.

Again, the observation seems in point that variations from the normal in the handwriting of any individual are, under defined conditions, of more value for general interpretative purposes than is variation from one individual to another. Some attempts to induce arti-

ficially, by means of hypnotic suggestion or provisional deceit, changes in the mood or even in the personality of a given reagent have indeed been tried in France. The results, although striking and interesting are somewhat general in nature nor is the method beyond criticism.

The dependence of style of writing upon suggestion has already been spoken of in emphasizing the rôle social suggestion plays in determining writing-types. Experimental work may investigate the influence of this factor. An incident in which a friend of the present writer, in signing the latter's name to a lecture-ticket, unconsciously imitated the writer's signature shows how extensively suggestion may operate. Reports of the character of writing during hypnosis offer material for study. Detailed reports as to the characteristic appearance of such writing are, however, wanting.

Professor Janet, of the Collège de France, urges, and with reason, that experimental graphology should begin with studies in pathological graphology, studies on the effect upon handwriting of diseases of motility and sensibility, or of specific diseases, such as those of respiration and of circulation. From the more pronounced modifications of handwriting transitions may then be made to its more delicate inflections.

This recourse to pathology bids fair to prove increasingly fruitful. Physicians have long been aware of profound modifications of handwriting through disease and have utilized such modifications in diagnosis. Considerable material has been collected and published by them in connection with their discussions of insanity, hysteria, epilepsy, paralysis and the like. Their interest has been, however, often practical rather than theoretical, and it is only with the increasing interest in the specific problem of handwriting that the full value of their documents becomes evident. Moreover, the failure to record in a particular instance specimens of the normal as well as of the perverted writing is often regrettable. Experimental work upon pathological writing has, however, already been resorted to in the attempt to determine the changes in writing induced by the use of alcohol and various other drugs.

A highly interesting case of pathological writing is that known as automatic writing, writing of which the writer is either not conscious at all or else conscious only of the movement and its result without feeling in any way responsible for the act. In connection with such automatic writing one would like to have not only an analysis of the mental state, but also detailed information of the variation from the normal in terms of speed, amplitude, alignment and pressure of writing. It is worth noting that Professor Janet has published examples of mediumistic writing, and that Dr. Prince, in his recent book on "The Dissociation of Personality," has reproduced the handwriting of a secondary personality.

Much work to-day still needs to be done in the collection, according to well-formulated plans, of material for the study of handwriting. In the matter of family resemblances in chirography, for instance, there is scarcely any material at hand, a fact not surprising since such work of collection must needs run over years. An instructive series of family autographs would be one showing handwriting at different periods of development. Any resemblance here in the handwriting at the same period of life of individuals differing considerably in age would testify directly to hereditary motor tendencies of some fineness, since suggestibility as a contributing cause would be ruled out.

Doubtless the day is far in the future when we shall be able to solve such historic enigmas as Mary, Queen of Scots, by an appeal as Tarde, the French sociologist, suggests, to her handwriting; or be proficient enough in the art of interpretation to proffer our services, as other enthusiasts predict, to the benevolent advocates of scientific match-making; but such suggestions carry with them a faith in the interpretation of this finest, subtlest of movements which time will perhaps justify. Nor will a scientific interpretation of individual chirography come merely to gratify an idle curiosity or a secret malice. It will be of immense value. All the arts remedial and educative will have need of it. Physician and educator, criminologist and sociologist, will make their appeal to it. Strange, if in time these tiny written gestures should be found to be all-revealing; if in them should be found the most intimate expression of the dramatic instinct.

JANE LATHROP STANFORD

A EULOGY¹

BY PRESIDENT DAVID STARR JORDAN
STANFORD UNIVERSITY

I AM to tell you to-day the story of a noble life, of one of the bravest, wisest, most patient, most courageous and most devout of all the women who have ever lived. I want to give to those of the university to whom its founders are but a memory some lasting picture of the woman who saved the university, which she and her honored husband founded in faith and hope, and who thus made possible the education you are receiving. I want to make my story as impersonal as I can, as though I spoke not for myself but for all of you, men and women of Stanford, with all gratitude towards the many who have helped in the great work, and with all charity towards those whose interests or whose conscientious convictions ranged them on the other side. If I am successful, you will see more clearly than ever before the lone, sad figure of the mother of the university, strong in her trust in God and in her loyalty to her husband's purposes, happy only in the belief that in carrying out her husband's plans for training the youth of California in virtue and usefulness she was acting the part to which she was assigned.

We have often said that Stanford University belongs to the Stanford students. It was the free gift of the founders, man and woman that were, to the students, the men and women that were to be. It is your university, yours and yours only, as once it was theirs.

But we must not interpret this gift too narrowly. It is not yours, you students of to-day, to have or to hold in any exclusive way. The university belongs to all the students, those who have been here, some ten thousand in all, those who are here to-day, seventeen hundred more or less, and those who are to come. Before these we count as nothing, for the students to come will number for each century about a hundred thousand. And there are many of these centuries, for the world is still very young, and a university once firmly rooted is as nearly eternal as human civilization itself can be. The university stands for the highest thought and wisest action possible for man, and the need of a university must endure so long as man exists; and that will be for a very long time. Man is bounded by the limits of space, but the race once established on this planet of ours, we see no limit of time, no prospect of a

¹ Founder's Day address at Stanford University, March 9, 1909.

twilight of gods in which the darkness shall fall on the world because universities are no longer needed. The center of gravity of Stanford University, of its student body, and of its influence on civilization, is hundreds of years, thousands of years ahead.

To the students of to-day, the professors of to-day, and the trustees of to-day, the university to-day belongs, but not as a personal possession; only as a sacred trust. It is our first duty to see that its good name and its good work are kept untarnished and unimpaired. It is for the students to see that no custom of idleness or of dissipation, no fashion of cynicism or of disloyalty ever becomes hardened into a tradition at Stanford University. It is for the professors to strengthen them in this decision, and to point out the best that men have ever thought or done, to lead the way to gentle breeding and the enthusiasm of noble thought. Now, as ever, "the university must welcome every ray of varied genius to its hospitable halls," that their combined influences may "set the heart of the youth in flame." It is for the Board of Trustees and for the university executive to act as the balance wheel, guarding jealously the funds of the institution, that the generous present may not starve the future, and to see that no neglect or perversity of student or teacher shall work any permanent harm to the university whole. For the university must ever be infinitely greater than the sum of all its parts. For its largest part is never present for our measurement, and this part we can not measure is the sum of all its future influence.

This university was founded on love in a sense which is true of no other. Its corner-stone was love—love of a boy extended to the love of the children of humanity. It was continued through love—the love of a noble woman for her husband; the faith of both in love's ideals—and as an embodiment of the power of love Stanford University stands to-day.

It is fitting that these statements should not stand as mere words. I wish that in your hearts they may become realities. Not many of you as students have seen Mrs. Stanford. The last of the freshmen classes which she knew shall graduate as seniors a few weeks hence. None of you have known Leland Stanford, broad-minded, stout-hearted, shrewd, kindly, and full of hope, a man of action ripened into a philosopher. Our university has now reached its eighteenth year. During the first two years of its history, it was the hopeful experiment of Leland Stanford. The next six years its story was that of the heart throbs of Jane Lathrop Stanford, and the ten years following, with all their vicissitudes, have been years of calmness and certainty, for the final outcome is no longer open to question.

It is my purpose this evening to tell a little of the story of the six dark years, the years from eighteen ninety-three to eighteen ninety-nine, those days in which the future of a university hung by a single

thread, but that thread the greatest thing in the world, the love of a good woman. If for an instant in all these years this good woman had wavered in her purposes, if for a moment she had yielded to fear or even to the pressure of worldly wisdom, you and I would not have been here to-day. The strain, the agony, was all hers, and hers the final victory. And so any account of these years must take the form of eulogy. Eulogy, in its old Greek meaning is speaking well, and my every word to-day must be a word of praise. It is proper, too, that I should speak these words, and even that I should give this history from my own standpoint, because there were few besides myself who knew the facts in those days. Most of these facts even it is well for all of us to forget. For the rest, the facts in issue will appear only as needed for the background, before which we may see the figure of Mrs. Stanford.

I first saw the Governor and Mrs. Stanford at Bloomington, Indiana, in March, 1891. At that time, Governor Stanford, under the advice of Andrew D. White, the President of Cornell, asked me to come to California to take charge of the new institution which he was soon to open. He told me the story of their son, of their buried hopes, of their days and nights of sorrow, and of how he had once awakened from a troubled night with these words on his lips: "The children of California shall be my children." He told me the extent of his property and of his purposes in its use. He hoped to build a university of the highest order, one which should give the best of teaching in all its departments, one which should be the center of invention and research, giving to each student the secret of success in life. No cost was to be spared, no pains to be avoided, in bringing this university to the highest possible effectiveness.

In all this Mrs. Stanford was most deeply interested, supporting his purposes, guarding his strength, alert at every point, and always in the fullest sympathy.

Mr. Stanford explained that thus far only buildings and land had been given, but that practically the whole of the common estate would go in time to the university, when the founders had passed away. If he should himself survive, the gift would be his and hers jointly, though the final giving would be left to him. If the wife should survive, the property would be hers, and in her hands would lie the final joy of giving. Mr. Stanford gave his reason for not turning over the property at once, for this might leave his wife no controlling part in the future. It was not his wish that she should sit idly by while others should create the university. So long as she lived, it was his wish that the building of the university should be her work.

This attitude of chivalry in all this needs this word of explanation, for it shaped the whole future history of the university endowment. It was the source of some of the embarrassments which followed, and perhaps as well of the final success.

The university was opened on the first day of October, 1891, a clear, bright, golden, California day, typical of California October, and full of good omen, as all days in California are likely to be. There were on the opening day 465 students, with only 15 instructors, and the first duty of the president was to telegraph for more teachers, laying tribute on many institutions in the east and in the west.

Two years followed, with their varied adventures, which I need not relate to-day. It was on the twenty-second of June, 1893, that the university community was startled by the sudden death of Leland Stanford.

It is not my purpose now to praise the founder of the university. One single incident at his funeral is firmly fixed in my memory. The clergyman, Horatio Stebbins, in his stately fashion told a story of the Greeks doing honor to a dead hero; then, turning to the pall-bearers, stalwart railway men, he said: "Gentle up your strength a little, for 'tis a man ye bear." A man, in all high senses, in that noblest of words, a man! was Leland Stanford.

After the founder's death, the estate fell into the hands of the courts. The will was in probate, the debts of the estate had to be paid, the various ramifications of business had to be disentangled, and meanwhile came on the fierce panic of 1893. All university matters stopped for the summer. Salaries could not be paid until it was found out by the courts by whom and to whom salaries were due. All incomes from business ceased. There was no such thing as income visible to any one, least of all to the great corporations.

After Governor Stanford's death, Mrs. Stanford kept to her rooms for a week or two. She had much to plan and much to consider. From every point of view of worldly wisdom, it was best to close the university until the estate was settled and in her hands, its debts paid and the panic over. Her own fortune was in the estate itself. Outside of her jewels, she had practically nothing of her own save the community estate, and this could not be hers until the payment of all debts and legacies had been completed. These debts and legacies amounted as a whole to eight millions of dollars. In normal times, there was hardly money enough in California to pay this amount; but these were not normal times, and there was no money in California to pay anything.

After these two weeks, Mrs. Stanford called me to her house to say that the die was cast. She was going ahead with the university. She would let us have whatever money she could get. We must come down to bed rock on expenses, but with the help of the Lord and the memory of her husband, the university would go ahead and fulfil its mission.

It was no easy task to do this, as one incident will show. There could be no regularity in the payment of salaries. In the eyes of the law the university professors were Mrs. Stanford's personal servants.

As such, it was finally arranged that they receive a special allowance from the estate. This allowance as household servants paid their salaries, and a registration tax of twenty dollars per year on each student had to cover all other expenses. But these two sources of income did not come at once, and the great farms run as experiment stations were centers of loss and not of income.

A single incident will make this condition vivid.

At one time in August, 1893, Mrs. Stanford received from Judge Coffey's court the sum of \$500 to be paid to her household servants. It was paid in a bag of twenty-five twenty dollar gold pieces. Mrs. Stanford called me in and said her household servants could wait; there might be some professors in need, and I might divide the money among them. I put the money under my pillow, and did not sleep that night. Money was no common thing with us then. Next morning, on Sunday, I set out to give ten professors fifty dollars apiece. I found not one who could give change for a twenty dollar gold piece, and so I made it forty dollars and sixty dollars.

The same afternoon after I had gone the rounds \$13,000 was brought down from the city for us other household servants. This sum was distributed, and then Mrs. Stanford sent word that as we had some money now perhaps we could spare her the \$500. I drew a check for the sum against a long-vanished bank account, and covered the amount in the morning with the aid of some of my associates.

This incident again will explain why for six years the professors were paid by personal checks of the president, and why these were not always issued regularly, nor for the full amounts. We were all struggling together to be able to issue them at all. There was no certainty ahead of us. Most of the property was of such a character that it could not be divided, but must go in blocks of millions, if it went at all, and no one with millions at his disposal seemed inclined to invest it anywhere. The estate held a one fourth interest in the Southern Pacific System, and of all its many ramifications. Kept together, it could maintain itself, but if any division were made the smaller part might be subject to the process known as "freezing out."

I pass by many minor incidents of struggle and economy. The farms had to be abruptly closed, and then to be made to yield an income. This required wise management and rigid economy at the same time, but for all this Mrs. Stanford proved adequate. She learned her lessons as she went along, and came to take a wholesome pleasure in the Spartan simplicity of her life. If all else failed, there were the jewels to fall back upon; and she steadily refused to consider the advice (almost unanimous) of her counsel to close the university or most of its departments until some more favorable time. In 1895 she invited the pioneer class, then graduating, to a reception in her city home, one reason being that it was the last class that could ever gradu-

ate. We had nothing to run on, save the precarious servant allowance, then fixed at \$12,500 per month, and liable to be cut to nothing at any day. Our expenses for 1893 had been nearly \$18,000 per month. Sometimes we could sell a few horses from the stock farm, but it was never clear that the stock farm belonged to the university and not to the Stanford estate, and every dollar we gained this way piled up the possibilities of litigation. All these days were brightened by the steady support of her friends and advisers, Samuel F. Leib, Timothy Hopkins and Russell Wilson. Mr. Hopkins furnished the Library of Biology and paid unasked many minor expenses, his left hand not taking receipts for what his right hand was doing. No one can tell how much the university owes to these men, who in the darkest days planned to make the future possible. Very much too the university owed to the fraternal devotion of Mrs. Stanford's brother, Mr. Charles G. Lathrop, who cared for with sympathetic hand the scanty receipts and scanty fragments of these harassed days. The warm sympathy of Thomas Welton Stanford came from across the seas. His gift of the Library Building came as a shadow of a great rock in a weary land.

At last, adjustment of one kind after another being made, there was a glimpse of daylight, when we were thrust without warning into still darker night.

The government suit for fifteen millions was brought for the purpose of tying up everything in the Stanford estate until the debts of the Central Pacific Railway were paid. It was not claimed that the university owed anything, or that the Stanford estate owed anything, or that the railway owed anything, on which payment was due, and as a matter of fact the Southern Pacific Company paid in full every dollar it owed to the government as soon as it became due, and with full interest. There was never any reason to suppose that it would not do so, and never any reason to suppose that it could not afford to pay this debt, for the power to control the line from Ogden to San Francisco, called the Central Pacific, was in itself an enormous asset, worth the value of this debt. Failure to pay this debt would have meant loss of control of the most valuable single factor in the great railroad system.

The claim of the United States was secured by a second mortgage on the Central Pacific. It was supposed that it would be sold to satisfy the first mortgage, and that it would realize no more than this sum, leaving, as a railway manager cynically expressed it, nothing but "two streaks of rust and the right of way." The government proposed, by a sort of injunction, to hold up the Stanford property, which would then be seized, in case the Southern Pacific Railway system should at some future time be found in debt. There was no warrant in law or in good policy for this suit. One United States judge spoke of it as "the crime of the century." It is not easy to work out the motives,

political or personal or what not, which inspired it. Fortunately, just now it makes no difference.

The hardest feature of the matter lay in the attitude of those jointly interested in the ownership of the Southern Pacific System. These men declined to give any assistance in the struggle for justice and for the endowment of the university. All were financially concerned in the final outcome, but they left her to make the fight alone and at her own cost.

It should be said that none of the present owners or managers of the Southern Pacific were in any way concerned in this matter. It is also fair to say that this attitude was only the business man's point of view. It seemed impossible to save the estate and the university together. All receipts of the railroads (there were no profits) were needed to continue its operations, and the outlays of the university seemed to the other owners of the railway system to involve a dangerous policy. On the other hand, to Mrs. Stanford the estate existed solely for the benefit of the university. To save the estate on these terms was to her like throwing over the passengers to lighten the ship. And as matters turned out, the university, the estate and the railway were all saved alike.

Perhaps we can get at the nature of this suit from a couple of letters written at the time. I find on our files a letter sent in November, 1894, to President Eliot of Harvard. In this letter I said:

I recognize of course that public sentiment can not be formed without a basis of knowledge. The peculiar conditions in which this university finds itself are not easily stated to the public. There are internal reasons why we can not well take the country into confidence. Some of these reasons are connected with the relations of the Stanford heirs. Others arise from our relations to our future partner, in whose power we are, until the government suit is disposed of, that is, until the settlement of the estate.

The grounds of the government suit, in brief, are these. The Central Pacific Railroad was regarded as an impossibility by most of the people of California. Its builders exhausted their funds and their credit and tried in vain to get help from every quarter, even after receiving large donations of land then worthless. The U. S. government came to their aid, whether wisely or not, . . . it does not matter at present. The road when finished bore a first mortgage, covering all that it is now worth. The government took a second mortgage upon it as security for the payment of the debt due for the bonds it had advanced in aid of the corporation. . . .

There is a law in California, by which the original stockholders in a corporation are personally liable for its debts, if suit be begun within three years after the organization of the corporation. This law was intended to check "wild-cat" speculations.

It is claimed that under this law the estates of Stanford and Huntington are still liable for the amount of the second mortgage, to come due in a few years. It is claimed that the three-years' limitation does not hold against the government. This question of liability had not been raised when the estates of the two remaining partners were distributed, and its enforcement would be possible as against the Stanford estate alone, as Mr. Huntington, being alive,

can withdraw his interests to Mexico, should the suit against Mr. Stanford be successful. Meanwhile, by the way, the question is tested for him at the expense of the Stanford estate, the railroad interests of which are in his hands as president of the road. . . .

It is believed by all jurists whom we have consulted, that the government has no case. The limitation of three years being an integral part of the statute in question, must hold against the government as against others. Furthermore, the aid extended by the government was not a debt incurred in business of the corporation.

However this may be, the courts will decide justly. Our anxiety is that they may decide speedily.

As to the various criticisms which you mention, permit me a word. In all personal matters, Mr. Stanford was perfectly truthful and just. Except in matters pertaining to the division of the earnings and bonds of the Central Pacific and the fact that its affairs were not made public, I have never heard his railroad career seriously criticized. In California, he had a very wide following among the best men, men who liked and respected him, not on account of his wealth and railroad connections, but rather in spite of them. In all the railroad war through which this state is passing, no responsible person has uttered a slur against Mr. Stanford or against the university.

It is not true that Mr. Stanford pretended to give the university a dollar more than he gave. He gave the three farms, formerly valued at \$5,000,000, in these times worth much less; all the movable stock upon them, about \$1,000,000 more; the university buildings costing \$1,250,000; and by will \$2,500,000 in cash. It was agreed by Mr. and Mrs. Stanford that each should be the residuary legatee of the other, and that whichever should survive should devote the rest of his or her life and estate to the university. The Stanford estate is therefore the university's endowment. Not in law but in fact the estate is the university. It was Mr. Stanford's feeling, and I was fully aware of it, that should his wife survive him, she should be free to endow the university and to control it as he had done. No one has ever struggled more loyally to do so than Mrs. Stanford. Since her husband died we have not received a dollar of his money, but the university has gone on without check or hindrance, though at times she has been forced to give up luxuries and to limit her expenses in every conceivable way. As a matter of fact, she has each year given me a personal bond for all she thinks that she can raise from the farms and from her own small personal property. Her devotion to the work is absolute and she is giving her life to it. When she loses, she will die.

The lands are unsalable only because the deed of gift prohibits their sale. In Mr. Stanford's lifetime they were conducted as parks. When they came into our hands, their products fell short by \$10,000 to \$20,000 per month of meeting the pay-rolls. This year under Mrs. Stanford's direction, they have yielded upwards of \$150,000 above expenses. The sale of colts is a source of revenue now that the reputation of the Palo Alto stud is made.

No cash has ever been set aside in advance, for very simple reasons. I could not ask for it. Mr. Stanford was not expecting sudden death, financial panics, nor an attack from the government. He paid in cash all salaries and all bills, placed no limits on me, and on his sudden death left no debts against the university. There are now no debts left against his estate, which is appraised at \$17,000,000, except the government claim which acts as an injunction tying everything up. It is not true that Mr. Stanford tried to "rear a personal monument by a good use of ill-gotten money." No one ever gave money in a more generous spirit, and there have not been many great givers who placed so

few restrictions on their gifts. Personal vanity does not give without restrictions in its own interest. He claimed that no man in California was the poorer for his wealth, which was true. It never occurred to him that it was "ill-gotten" or needed any apology.

I know better than any one else, except his wife, can, how genuine Mr. Stanford's interest was. He treated me, and through me, the university, with perfect truthfulness and justice. For my part and that of the faculty, we have tried to make the fund in our possession, count every dollar for a dollar to the best advancement of higher education.

As to the public at large, in time they will judge us by our fruits, if we are allowed to live to bear fruitage.

To a loyal friend of Governor Stanford, Senator Hoar of Massachusetts, I wrote this on June 20, 1894:

You will pardon me for writing to you to express my very great pleasure and that of Mrs. Stanford in the stand you have taken in defence of Senator Stanford's memory and in the effort you have made toward the protection of the university from the evil effects of prolonged litigation in which its endowment would be at stake.

You who knew Senator Stanford well know that the recent attack of Mr. Geary on his motives was without foundation in fact. The feeling of revenge at any real or supposed slight on the part of the legislature in connection with the State University, had nothing to do with his actions. He was not a man to cherish that kind of feelings. The sole basis that accusation had was this: Mr. Stanford acted for a few days as a member of the State Board of Regents. He was very much surprised to find that this board ignored the recommendations of the president of the university, and in general were disposed to treat the university chairs as personal "spoils." This led Mr. Stanford to doubt whether, if he should endow a university for California, it would be wise to place it in the hands of a political board of regents. These conditions in the State Board have now changed for the better. Mr. Stanford always spoke most kindly of the State University. He frequently consulted with its professors and it was a great pleasure for him to know that the new institution has in every way helped the old one. The friendly rivalry has been most salutary to both. Instead of 450 college students in one school as in 1890, there are now 1,700 students in the two, besides the professional classes.

As a matter of fact, Mr. and Mrs. Stanford founded the university with the sole purpose of putting their fortune to the best use of their country. I know Mr. Stanford's motives in this regard as well as one man can know the motives of another, and I know that no feeling of revenge and no selfish feeling entered into these motives.

The university has now safely passed every other serious difficulty. Mrs. Stanford has no other purpose in life than that of carrying out every detail of her husband's purposes. Her devotion has shown itself in maintaining the work of the university unimpaired during this period of hard times, while the estates are in probate, and therefore not available for university purposes.

It would, I believe, be a great national calamity if this great fund were lost to higher education. It would be almost as great a calamity if it were exposed to the delay and loss of prolonged litigation.

I assure you that the great majority of the self-respecting people of California are very grateful to you for what you have done towards the protection of the university endowment.

The story of the passing of the great suit is known to all the old students of the university.

It was brought to trial in San Francisco in the United States District Court, and the university side of the question had the strong support of the great jurist, John Garber.

The decision of Judge Ross was against the claim of the government. It was appealed and came before Judges Morrow, Gilbert and Hawley, who again found no merit in the government contention. It was appealed to the Supreme Court of the United States, and here our case seemed hopeless. The Supreme Court moves slowly, and our lifeblood was ebbing fast. It takes money to run a university, and our money was almost gone. To delay the matter was to destroy us, and no one but ourselves had any interest in pushing along the decision.

Finally Mrs. Stanford went to Washington to appeal to President Cleveland. She told him our story, and beseeched him to use his influence for a speedy settlement. Once for all, let us know the future and we will stand by it. At last, President Cleveland saw his duty, and through his influence the Stanford case was placed on the calendar of the United States Supreme Court for speedy trial. Joseph Choate, whose name every Stanford man should hold in grateful memory, supplemented the work of John Garber. The case came to trial, and by a unanimous decision, the work of Justice Harlan, Stanford University was again free!

The boys celebrated the victory as Stanford boys can. The United States Postoffice on the campus, a wooden shack now removed, was painted cardinal red, to its great improvement in appearance, and once for all and forever the future of the university was assured.

This was the end of the dark days, but not of the days that were difficult. There were still eight millions of dollars to be paid. There was still the uncertainty as to whether Mrs. Stanford could survive to pay it, and the estate must come into her hands before she could give it to the university. She made many attempts to facilitate this transfer. At one time, we have the pathetic figure of the good woman going to the Queen's Jubilee in London, with all her own possessions, half a million of dollars worth of jewels, in a suit case carried in her hand. She hoped to sell these to advantage, when all the world was gathered in London. But the market was not good, and three fourths of them she brought back to California again.

And this seems the appropriate place for the story of the jewel fund. It is told in an address made at the foundation of the Library Building, and again and finally in a resolution of the Board of Trustees.

On May 15, 1905, I said:

There was once a man—a real man, vigorous, wealthy and powerful. He loved his wife greatly, for she, wise, loyal, devoted, was worthy of such love. And because among all the crystals in all the world the diamond is the hardest

and sparkles the brightest, and because the ruby is most charming, and the emerald gentlest—the man bought gifts of these all for his wife.

As the years passed a great sorrow came to them; their only child died in the glory of his youth. In their loneliness there came to these two the longing to help other children, to use their wealth and power to aid the youth of future generations to better and stronger life. They lived in California and they loved California; and because California loved them, as she loves all her children, this man said, "The children of California shall be my children." To make this true in very fact he built for them a beautiful "Castle in Spain," with cloisters and towers, and "red tiled roofs against the azure sky"—for "skies are bluest in the heart of Spain." This castle, the Castle of Hope, which they called the university, they dedicated to all who might enter its gates, and it became to them the fulfilment of the dream of years—a dream of love and hope, of faith in God and good will toward men.

In the course of time the man died. The power he bore vanished; his wealth passed to other hands; the work he had begun seemed likely to fail. But the woman rose from her second great sorrow and set herself bravely to the task of completing the work as her husband had planned it. "The children of California shall be my children"—that thought once spoken could never be unsaid. The doors of the castle once opened could never be closed. To those who helped her in these days she said: "We may lose the farms, the railways, the bonds, but still the jewels remain. The university can be kept alive by these till the skies clear and the money which was destined for the future shall come into the future's hands. The university shall be kept open. When there is no other way, there are still the jewels."

Because there always remained this last resource, the woman never knew defeat. No one can who strives for no selfish end. "God's errands never fail," and her errand was one of good will and mercy. And when the days were darkest, the time came when it seemed the jewels must be sold. Across the sea to the great city this sorrowful, heroic woman journeyed alone with the bag of jewels in her hand that she might sell them to the money changers that flocked to the Queen's Jubilee. Sad, pathetic mission, fruitless, in the end, but full of all promise for the future of the university, founded in faith and hope and love—the trinity, St. Paul says, of things that abide.

But the jewels were not sold, save only a few of them, and these served a useful purpose in beginning anew the work of building the university. Better times came. The money of the estate, freed from litigation, became available for its destined use. The jewels found their way back to California to be held in reserve against another time of need.

A noble church was erected—one of the noblest in the land, a fitting part of the beautiful dream castle, the university. It needed to make it perfect the warmth of ornamentation, the glory of the old masters, who wrought "when art was still religion." To this end the jewels were dedicated. It was an appropriate use, but the need again passed. Other resources were found to adorn the church—to fill its windows with beautiful pictures, to spread upon its walls exquisite mosaics like those of St. Mark, rivaling even the precious stones of Venice.

In the course of time the woman died also. She had the satisfaction of seeing the buildings of the university completed, the cherished plans of her husband, to which she had devoted anxious years, fully carried out. Death came to her in a foreign land, but in a message written before her departure to be read at the laying of the corner-stone of the great library, she made known

the final destiny of the jewels. She directed that they should be sold and their value made a permanent endowment of the library of the university.

And so the jewels have at least come to be the enduring possession of all the university—of all who may tread these fields or enter these corridors. In the memory of the earlier students they stand for the Quadrangle, whose doors they kept open, and for the adornment of the church, which shall be to all generations of students a source of joy and rest, a refining and uplifting influence. To the students who are to come in future days the message of the jewels will be read in the books they study within these walls and the waves of their influence spreading out shall touch the uttermost parts of the earth.

They say there is a language of precious stones, but I know that they speak in diverse tongues. Some diamonds tell strange tales, but not these diamonds. In the language of the jewels of Stanford may be read the lessons of faith, of hope and good will. They tell how Stanford was founded in love of the things that abide.

It was resolved by the Board of Trustees on May 29, 1908, as follows:

WHEREAS, it was a cherished plan of Mrs. Jane L. Stanford that all jewels left by her should be sold after her death, and that the proceeds (estimated by her at more than five hundred thousand dollars) should be invested as a permanent fund, of which the income should be used exclusively for the purchase of books for the Library of the Leland Stanford Junior University; and

WHEREAS, the pressing financial needs of the university compelled her temporarily to forego said plan, and to sell many of said jewels in her lifetime in order to raise money to maintain the university; and

WHEREAS, by communication delivered to this board at its meeting, held February 22, 1905, Mrs. Stanford declared:

“In view of the facts and of my interest in the future development of the University Library, I now request the trustees to establish and maintain a library fund, and upon the sale of said jewels, after my departure from this life, I desire that the proceeds therefrom be paid into such fund and be preserved intact, and invested in bonds or real estate as a part of the capital of the endowment, and that the income therefrom be used exclusively for the purchase of books and other publications. I desire that the fund be known and designated as the “Jewel Fund.” I have created and selected a Library Committee of the Board of Trustees, under supervision of which all such purchases should be made.”

Now, THEREFORE, in order to carry out said plan of Mrs. Stanford and to establish and maintain an adequate library fund, and to perform the promise made by this board to her, it is

Resolved, that a fund of five hundred thousand dollars, to be known and designated as the “Jewel Fund” is hereby created and established, which fund shall be preserved intact, and shall be separately invested and kept invested in bonds or real estate by the Board of Trustees, and the income of said fund shall be used exclusively in the purchase of books and other publications for the Library of the Leland Stanford Junior University, under the supervision and direction of the Library Committee of this Board of Trustees.

It was in these dark days that I was asked by President Cleveland through Mr. Charles S. Hamlin, to go to Bering Sea to help settle the fur seal disputes.

Before I started, in 1896, Mrs. Stanford said: “Now that our af-

fairs are looking so much better, do you not think that I might afford to bring back my housekeeper?" Her servants then were her secretary, her Chinese cook, and an old man, a servant of other days, who served as butler, without salary.

It was in these days, too, that Mrs. Stanford, going to Washington to settle up the household affairs of the mansion occupied while Mr. Stanford was senator, took four hundred dollars with her, lived in the private car owned by the Governor, attended to the packing of her goods, and the rental of her house to a senator from New York, and brought back \$340 of the amount, which she turned over to me, to be used for the university. I have given this and other details private and personal, but full of meaning as showing her devotion to the university, and her utter unselfishness in carrying out the plans made by herself and her husband for the welfare of the men and women of the coming generations of California and of the world. While matters inside the faculty and the details of instruction were left to those supposed to be experts in these lines, for this was her husband's wish, she had always before her his purposes. "What would Mr. Stanford do under these conditions?" was always her first question; and in almost every instance this question led to a wise decision.

To outside suggestions as to this or that, she used to reply: "I will never concern myself with the religion, the politics or the love affairs of any professor in Stanford University." And this resolution she religiously kept.

With the passing of the government suit, conditions looked brighter. The payment of the eight millions went on very slowly, because the railway holdings could not be broken and must be sold as a whole if at all. The taxes on properties yielding no income became an intolerable burden. Besides, it was apparent that the original enabling act under which the Board of Trustees was organized contained grave defects, which might invalidate the actions of this Board. For this reason, mainly, the Board of Trustees existed in name only, Mrs. Stanford being in fact the sole trustee.

In 1899 the railroad holdings were sold, to good advantage, thanks to the good offices of a well-known German banker whose name I am glad to speak, James Speyer, and the estate at once passed out of debt. Finally, piece by piece, it passed into Mrs. Stanford's hands, and each piece was at once deeded to the Board of Trustees. The Board of Trustees was legalized by a change in the State Constitution. The university was by the same means relieved of part of the burden of its taxes. At the earliest possible moment, Mrs. Stanford again and in full transferred the whole estate to the board, reserving for herself a relatively small sum "to play with" as she said, but in fact to give her occupation and means to carry out in her own way other plans of strengthening the university and of helping mankind. The Board of

Trustees was then organized as a working body. Mrs. Stanford became its president, and this history passes over into the bright days of the dawn of the twentieth century.

Mrs. Stanford then left the university for a trip around the world by way of Australia and Ceylon. This was not that she wanted to see the world, or to be absent from her beloved Palo Alto, but that she wished to give to the Board of Trustees absolute freedom in taking up their great responsibilities. She wished them to handle the accumulated funds on their own initiative, without suggestion from herself.

The rest of the story can be told by others, for it is an open record. The whole may be summed up in these words of Mrs. Stanford in a letter written to me September 3, 1898:

Every dollar I can rightfully call mine is sacredly laid on the altar of my love for the university, and thus it ever shall be.

That all this may seem more real, I venture to quote a few paragraphs from personal letters of Mrs. Stanford written in the dark days from 1893 to 1899.

On November 24, 1895, Mrs. Stanford wrote from the university:

It has been my policy to say as little about my financial affairs to the outside world as possible, but I feel sure that I am doing myself and our blessed work injustice by allowing the impression among all classes to feel certain there is plenty of money, at my command, the future is assured, the battle fought and won. . . . I only ask righteous justice. I ask not for myself, but that I may be able to discharge my duty and loyalty to the one who trusted me, and loved me, and loves me still. I am so poor myself that I can not this year give to any charity; not even do I give this festive season to any of my family. I do not tell you this, kind friend, in a complaining way, for when one has pleasant surroundings, all we want to eat and wear, added to this have those in their lives we can count on as friends, it would be sinful to complain. I repeat it only that you my friend may know, I ask only justice, to the dear ones gone from earth life and the living one left.

I am willing you should speak plainly to any one who may question as to the university or myself. I have many devoted and true loyal friends in Washington, and I am sure did they know I was kept from my rights, they would speak their sentiments openly, and when it was known a public sentiment was in my favor and against their unfairness, it would cause a different course to be pursued toward me. I shall henceforth speak plainly, and I desire you to do so. You will meet our good President, Mr. Cleveland, my good and true friend Secretary Carlisle, Mr. John Foster and many others, and you . . . can do our blessed work good and God will bless the act, and bring fruit to bear from the seeds sown. I have kept myself and my affairs in the background. It has been an inspiration from the source from which all good comes, from my Father God—I trust Him to lead me all along the rest of the journey of life. He has led me thus far through the deep waters, and joy will come, for He never deserts the widow, the childless, the orphan. I have His promise "blessed are those who mourn, for they shall be comforted."

On the same day she said:

Everything is going on smoothly as far as I know at the university. The

boys are wild over the game to be played. I hope they will win because my boys will be happy if they win.

On July 20, 1896, she wrote to a candidate for a professorship:

The university still is restricted and limited in its ambitions and its aims, because of my inability to increase the number of students or the number of professors. The gift of \$2,500,000 in bonds which I have by the grace of God been enabled to give to the trustees for the present and future maintenance of the university brings in a monthly income of \$10,000, while the actual expenses for the faculty and the president and the necessary matters bring the sum total of expenses per month to \$19,000. This \$9,000 I am obliged to furnish myself, through the strictest economy and the husbanding of resources; consequently I am not increasing expenses but on the contrary shall retrench in the future.

On December 28, 1895, she said:

I must confess to a feeling of great pride in our entire body of students, both male and female, and I think we are all in a way under obligations to them for their uniformly good conduct, and a desire, as my dear husband once expressed it, to be ladies and gentlemen.

On July 29, 1895, she wrote:

I send a precious letter from Mr. Andrew White for you to read. I read it with a heart running over with various emotions. Mr. Stanford esteemed him so highly I could not but feel like asking God to let my loved ones in heaven know the contents of this letter. I prize this letter beyond my ability to express. It lifted my soul from its heaviness. My heart is one unceasing prayer to the Allwise, All Merciful one, that all will be well for the future of the good work under your care. When the end of our troubles is over, all (these letters) will be placed in your hands for future reading by our students, a story for them when I have passed into peace.

Soon after, she wrote:

I return herewith Mr. Choate's kind letter. God bless him, for he was a friend indeed.

After the decision of Judge Ross (July 6, 1895), she wrote:

I dare not let my soul rejoice over the future. It must be more sure than it is now. I hope and pray that the final decision will be as sure as the first. It means more to me than you or the world have dreamed. It means an unsullied, untarnished name as a blessed heritage to the university. My husband often used to say: "A good name is better than riches." God can not but be touched by my constant pleading, and this first decision by Judge Ross makes me humble that I so unworthy should have received the smallest attention.

From Paris, August 30, 1897, she wrote:

I wish the rest of my responsibilities caused me as little care as does the internal working of the good work. I am only anxious to furnish you the funds to pay the needs required. I could live on bread and water to do this, my part, and would feel that God and my loved ones in the life beyond this smiled on the efforts to ensure the future of my dear husband's work to better humanity.

Again, in 1897, she writes to her trusted solicitor, Russell Wilson:

I stand almost alone in this blessed work left to my care, and I want and

need the president's support and his helpfulness in this work as far as he can support me. There are plenty who are interested in the affairs of the estate with me, but few in the university.

In July, 1898, she said :

If I am able to keep the university in the condition it is now, I shall be more than thankful. \$15,000 a month is a great expenditure, and exhausts my ingenuity and resources to such an extent that had I not the university so close to my heart I would relieve myself of this enormous burden and take rest and recreation for the next year. But I prefer to see the good work going on in its present condition, and I am not promising myself anything further for the future until the skies are brighter than they are now.

On December 14, 1900, she repeats :

I could lay down my life for the university. Not for any pride in its perpetuating the names of our dear son and ourselves, its founders, but for the sincere hope I cherish in its sending forth to the world grand men and women who will aid in developing the best there is to be found in human nature.

These extracts, largely from business letters, will show better than any words of mine her spirit and her faith. These must justify and make live the words I used on February 28, 1905, the date of Mrs. Stanford's sudden death in Honolulu.

The sudden death of Mrs. Stanford has come as a great shock to all of us. She has been so brave and strong that we hoped for her return well rested, and that her last look on earth might be on her beloved Palo Alto. But it was a joy to her to have been spared so long; to have lived to see the work of her husband's life and hers firmly and fully established.

Hers has been a life of the most perfect devotion both to her own and her husband's ideals. If in the years we knew her she ever had a selfish feeling, no one ever detected it. All her thoughts were of the university and of the way to make it effective for wisdom and righteousness.

No one outside of the university can understand the difficulties in her way in the final establishment of the university, and her patient deeds of self-sacrifice can be known only to those who saw them from day to day. Some day the world may understand a part of this. It will then know her for the wisest, as well as the most generous, friend of learning in our time. It will know her as the most loyal and most devoted of wives. What she did was always the best she could do. Wise, devoted, steadfast, prudent, patient and just—every good word we can use was hers by right. The men and women of the university feel the loss not alone of the most generous of helpers, but of the nearest of friends.

To these words spoken when the shock of the death of the mother of the university first came to her children, I added later a single thought as to Mrs. Stanford's conception of the future development of the university.

It should be above all other things, sound and good, using its forces not for mental development alone, but for physical, moral and spiritual growth and strength. It should make not only scholars, but men and women, alert, fearless, wise, God-fearing, skilled in "team work" and eager to "get into the game," whatever the struggle into which they may be thrown. To this end she would

have the university not large but choice. There should be no more students than could be well taken care of, no more departments than could be placed in master hands, no teachers to whom the students could not look up as to men whose work and life should be an inspiration to them. The buildings should be beautiful, for to see beautiful things in a land of beauty is one of the greatest elements in the refinement of clean men and women. Great libraries and great collections the university should have, but libraries and collections should be chosen for their fitness in the training of men. And with all the activities of athletics, of scholarly research, of the applications of science to engineering, the spirit of "self-devotion and of self-restraint," by which lives have been "made beautiful and sweet" through all the centuries should rise above all else, dominating the lower aspirations and activities as the great church towers above the red tiles of the lower buildings. But for all this, the Church should exist for men—for the actual men who enter its actual doors—not men for the Church. For this reason, any special alliance with any of the historic churches of Christendom is forever forbidden.

We do not yet see all these things. Rome was not built in a day, nor Stanford in a century. But as the old pioneers returning now behold in solid stone the dream-castles of their college days, so shall you, Stanford men and women, find here as you come back to future reunions, the university of your dreams, the university of great libraries and noble teachers, the university of the perfect democracy of literature and science, "of self-devotion and of self-restraint," the university in which earnest men and women find the best possible preparation for work in life, the university which sends out men who will make the future of the republic worthy of the glories of its past, the university of the plans and hopes of Leland Stanford, the university of the faith and work and prayer of Jane Lathrop Stanford.

LIFE FROM THE BIOLOGIST'S STANDPOINT¹

BY PROFESSOR WILLIAM E. RITTER

MARINE BIOLOGICAL STATION OF SAN DIEGO, CALIFORNIA

THE data of biology are living plants and animals. These are what nature presents. To these we must always go in order to make a beginning at any investigation. Is one interested in ganglionic cells, or germ cells, or liver secretions, or degenerate organs? He must find some kind of animal that has, or produces, or can yield such things. In making a successful quest for "material," it always turns out that a particular individual plant or animal, one or more, furnishes it. One may not be able to tell exactly what he means by an individual tree or man, but he must have one before he can study it or any part of it. Definitions of natural objects come at the end, rather than at the beginning, of our knowledge of them.

We biologists frequently speak of the principle of life, or the germs of life, and of many other particular manifestations of organisms, as though they were something really existent independently of particular organisms. Such questions as: Which came first, or is more fundamental, the chick or the egg; structure or function; life or organization? are frequently asked with more or less seriousness. Herbert Spencer devotes considerable space to the inquiry as to whether life or organization appeared first. He writes:

It may be argued that on the hypothesis of Evolution, Life necessarily comes before organisation. On this hypothesis, organic matter in a state of homogeneous aggregation must precede organic matter in a state of heterogeneous aggregation. But since the passing from a structureless state to a structural state is itself a vital process, it follows that vital activity must have existed while there was yet no structure: structure could not else arise. That function takes precedence of structure seems also implied in the definition of Life.

He continues:

If Life is shown by inner actions so adjusted as to balance outer actions

¹ During the academic year 1908-9 the program of the Philosophical Union of the University of California consisted of a series of discussions led by speakers representing various departments of biology and framed in a spirit compatible with the broad aims of such an association. This was the concluding paper of the year.

Wir denken heute durchweg more biologico. . . .

. . . dass die Biologie selbst heute noch im Zustand des gärenden Werdens, der tastenden Unsicherheit sich befindet, also für eine Grundlegung der sichersten aller Wissenschaften, der formel Logik, noch keine Eignung besitzt, begehrt der Pragmatismus denselben Circulus vitiosus dem auch Hume nicht zu entrinnen vermochte. . . .—*Ludwig Stein.*

...; then may we not say that the actions to be formed must come before that which forms them . . . that the continuous change which is the basis of function, must come before the structure that brings function into shape? ²

Greatly to Mr. Spencer's credit he tells us in another connection (p. 197), that "in truth this question is not determinable by any evidence now accessible." We must go a long way beyond this position and recognize that not only is the question not determinable "by any evidence now accessible," but that there is not the slightest indication that such evidence ever will be accessible. What we have to see is that all such discussions are utterly futile for science; indeed, that they have no legitimate place in inductive science.

Has anybody ever seen an egg that was not produced by some organism; some function without structure, or *vice versa*; some life without organization, or organization independent of life? Surely not. Then equally surely you can make no assumption that involves the disjunction of either member of one of these couples from the other, without attempting to transcend experience—without becoming in so far an *a priorist* pure and simple.

Now you may perhaps have the privilege of being an *a priorist* pure and simple, if you want it, but in case you choose thus you can not have a seat in the temple of physical science for one instant. On the basis of experience science can project itself far in advance of experience, but only on that basis can it thus project itself.

So much for the data, the starting places of biology. They are *individual animals and plants, living in nature*. It is wholesome for any domain of science to stop now and then and ask what its original data are. Such inquiry not only yields enlightenment, interesting and useful of itself, but it is further illuminating as to the way a science deals, and *must* deal, with its raw material—its "givens."

Notice the procedure in a special case. Observe how oceanography proceeds in studying the Pacific Ocean. Of what is that vast sea composed? First of all of water, H₂O. No doubt about that. Dissolved in this are various mineral salts, chlorides of sodium and magnesium, particularly, and the gases O, N and CO₂. These with perhaps a few other elements and the ocean is chemically accounted for. Yet how far have we gone toward a knowledge of the Pacific Ocean when we have found that it is thus constituted? Even though we should have ascertained the total quantity of water, salts and gases in the entire Pacific, we should have scarcely made a beginning on the oceanography of this body of water. Its form and boundaries; its connections with other oceans; the character of its bottom; its islands, continental and oceanic; its currents; its tides; the up-welling waters on its eastern margins; its temperature in general, and in particular parts, and dozens of other matters, are quite over and beyond anything

²"Principles of Biology," Vol. I., p. 210.

that strict chemical knowledge can reach. Oceanography as now understood is quite impossible without chemistry, but it by no means follows that chemistry is the whole of oceanography. Physics is as essential as chemistry; and geology and astronomy are in turn as essential as physics.

So with the other inorganic sciences. Spectroscopy, a department of chemistry, has been largely the making of modern stellar astronomy. Yet is not such a problem as that of the variable stars, something over and above spectroscopy? Is it conceivable that spectroscopy alone would ever have *discovered* variable stars, and formulated the many interesting questions about them that astronomy is now asking?

Do not the same principles of constitution, and study of constitution, hold when we enter the domain of living objects? They surely do. Organisms have their own special qualities and so present their own problems, exactly as do oceans and stars. Biology depends upon, but at the same time transcends, chemistry and physics, in exactly the same way that astronomy rests upon but transcends chemistry and physics. We are here on the threshold of one of the oldest, in many of its aspects one of the most familiar scientific and philosophic puzzles; namely, that of the relation of a whole to the elements which compose it.

Alas for the proneness of humankind to go all awry with itself and nature from not duly heeding the commonest, most familiar things! Hear this dialogue that comes to us across a stretch of two thousand years:

Socrates—"Suppose one were to ask you a question about the first syllable in the name Socrates, and say 'Theætetus, tell me what SO is,' what would you answer?"

Theætetus—"That it is S and O."

S.—"Well, have you not there the reasoned statement of the syllable?"

T.—"Yes, certainly."

S.—"Proceed then and give me in the same way the reasoned statement of S."

T.—"But how can one give the elements of an element? For indeed, Socrates, S is one of the voiceless letters, a mere sound, as it were a whistling of the tongue. . . ."

S.—"But stay, I wonder if we are right in laying it down that while the element is not knowable the combination is? . . ."

T.—"That would be strange beyond all reason, Socrates. . . ."

S.—"Perhaps we ought to have taken the combination to be not the sum of the elements, but a single form resulting from them, with an individual shape of its own, and differing from the elements."

T.—"Certainly, very possibly this view is more correct than the other. . . ."

S.—"Then let the combination be, as we now put it, a single form, alike in letters and in everything else, resulting from the conjunction of harmonious elements in each case."¹

¹"The Theætetus and Philebus of Plato," translated by H. F. Carlill, in "New Classical Library."

As long as the mind of the interpreter is human, the whole truth of a complex natural object or proposition can never be ascertained from knowledge of its components alone. Or varying this statement, you can never give a full account of any whole in terms of its elements.

In spite of the ocean and the stars as illustrating the truth thus formulated, the statement sounds dogmatic. We must examine it farther.

The presumption that biological phenomena may be adequately treated in terms of chemistry and physics takes care of itself so far as strict science is concerned, since its utter futility becomes apparent almost immediately it is put to rigid experimental test. For one thing, it results in constant effort to extend generalizations far beyond where later study will permit them to stand. It leads inevitably to a forcing of evidence, which process sooner or later comes to grief.

One aspect of this forcing is almost certain betrayal into an illegitimate use of the analogical mode of reasoning. For instance, an analogy is often drawn between the so-called reversed actions in chemistry, and what is spoken of as a return of certain animals—certain worms—to the egg state. As a matter of fact the earlier speaker who drew this analogy might have used the "second-childhood" of the old man as well as the supposed second egg state of the worm. One has as much in common as the other with the chemical process for which correspondence was claimed.

You must not understand by this that I condemn, wholly, comparison and analogy in reasoning. On the contrary, I attach great importance to these, as would become clear were this discussion to be carried into regions where it is not possible for it to go now. In so far as there is resemblance between reversed chemical action and growing old, the fact is illuminating, and to have discovered it is good. My criticism is directed not against pointing out the resemblance, but against not pointing out the difference at the same time, thus leaving the inference that one process accounts for or explains the other.

It is in its wider bearings, its bearings beyond strict specialties in science, that the influence of the theory of physical-chemical adequacy in the treatment of life phenomena is most unfortunate. Only when regarded from this larger standpoint does its withering effect on the scientific spirit and method generally, and on man's attitude toward nature, become apparent.

The subject is, according to my view, so vital that I must ask you to look into it more closely. This we can not do without running a little into what these walls are accustomed to hear about under the term theory of knowledge, or epistemology. Most of us would agree that we have to use both our senses and our minds in science. Most would agree too that that workman is the most efficient who uses his instruments the most intelligently—who is not a mere rule-of-thumb

workman. How then do our minds and our senses work while we do science? Are there general principles of operation, to know which would enable us to use them more smoothly, more surely, more productively? Let us watch them while they work at some problem of chemistry, say. To be as objective as possible we will use common table salt. We began with a general acquaintance with the article. How do we become thus acquainted? Surely in no other way than by examining it. We touch our tongues to it, it dissolves readily and has a characteristic taste. Examining this dissolving propensity minutely, we find that in distilled water at a definite temperature, a definite quantity will be taken up. Its *solubility* is thus determined.

The moment we handle it in considerable amount we note that it is rather heavy. In water it sinks quickly. This property we examine more closely and find that a *specific gravity* characterizes it.

In a pulverized state it is pure white. If, however, we let it evaporate slowly, we get cubical crystals, not white but transparent.

We may suppose now we have examined all the *physical* properties of salt. But surely our knowledge is not yet complete. We know nothing of its composition. Before beginning on this chemical extension of our knowledge, let us take due note of the fact that table salt is a definite thing to us; we can use it in a hundred ways and rely implicitly upon it, on the basis of this physical knowledge alone. We do not have to know whether it is simple or compound in order to get its benefits *as salt*. *Physical* knowledge of it we must have before we can use it in any way. *Chemical* knowledge, understanding by this knowledge of constituents, we need not have.

But since we started out to know salt through and through, we must become salt chemists. We must decompose the substance, if it turns out to be compound, and examine its constituents as carefully as we examined the substance itself. To make the story short we get sodium and chlorine. But we must not so shorten the story as to fail to see what we do in examining these constituents. What is it that we do? We proceed exactly as we did in examining the salt. We determine their physical properties. The sodium is opaque, and bright metallic in color. Ordinarily it is amorphous and waxy. Instead of dissolving in water as does the salt, it decomposes water. Instead of sinking quickly, it floats. It melts at $95^{\circ}.6$ C., while 776° of heat are required to melt salt.

The chlorine, a gas at any temperature we can readily command, is greenish-yellow in color. Its odor is characteristically disagreeable, and it irritates our noses and throats. Like the salt it is soluble in water, but while the salt is more soluble in hot water than cold, chlorine is more soluble in cold water. It is heavier than air, though much lighter than water.

What is the net result of our examination of the constituents of

salt? First and foremost an interesting lot of entirely new knowledge. Our understanding of salt has been broadened and deepened. Salt is a much more complex thing to us now than it was before. Instead of simplifying salt by reducing it to its elements, we have greatly complicated it. But notice this particularly: The new knowledge has not enhanced by one jot our knowledge of the *physical properties* of salt. There is nothing whatever in the properties of the sodium or the chlorine that gives us any clue to the properties of the salt. We might, so far as the best cunning in observation we now possess promises anything, examine the sodium and the chlorine till doomsday and never suspect that together they might produce salt, unless we happened to put them together and note that salt actually did result.

This is a threadbare, school-book story. Why revamp it here? Because it is part, though an essential part, of a much larger story, the whole of which is rarely if ever told. Before we can reach the heart of the matter we must stop a moment with another fact so familiar as likewise to seem stale. Our physical examination of the salt, the sodium and the chlorine, were applications of the general principle that the first step in all knowledge of external objects is the determination of their physical qualities. The familiar expression is, "we know an object only by its properties, or qualities." Let us take this statement from its pigeon-hole of mere habit, and look at it reflectively. Does it mean that there are no natural objects in all the universe about which we can get knowledge in no way other than through their physical properties? Those of you who say "yes, that is what it means," I agree with, and with you might go on at once with the discussion. But some will, I suspect, hesitate to reply thus. To you who hesitate, I say that if there be objects which we may know by other means than through their physical properties, they must be namable, otherwise you could not claim for them a place in the physical world; so I demand that you mention examples. You will probably name the atoms of the chemist and the ether of space. You are then, in so far as concerns the atoms, committed to the conception of propertyless atoms, are you not? I ask you to tell me then exactly what it was that John Dalton and the other founders of modern chemistry actually did. Certainly there were atomic theories of the constitution of matter long before these men lived. Democritus and Newton, to say nothing of others, made much of such atoms. Why did the pre-Daltonian atoms signify nothing, or almost nothing for physical science? *Because they were propertyless atoms.* To attach to these old purely speculative, and hence scientifically useless atoms, *one property* of the particular substance to which they belong, was exactly what these chemists did. The property so attached was that of *combining with other substances in definite ways.*

Analyze the atomic theory of modern chemistry and you will find

that all that makes it significant for chemical practise is expressible in this way: If any two substances unite with each other chemically, they do so in such a manner that there are no particles of them so small as not to follow the same law of combination that holds for the substances in bulk.

Atoms in modern chemistry are small bodies imagined to constitute visible substances, and they are imagined for the purpose of incarnating, if you will, the observed trait that substances have of combining with one another according to known rules. As to most of the other properties of atoms, their shape, color, hardness, etc., if atoms are conceived to be anything else than little particles of the substances, science knows no more to-day than did Newton and Democritus.

The purpose of this little excursion into the atomic doctrine, that border-land of physical science, is to bring home something of the mighty power there is in the properties of things, and in sense experience. It is not too much to say that the modern science of chemistry was born then and there, when one property that substances have, viz., that of definite combination with other substances, was attached to the hitherto purely speculative, more or less mystical atoms of those substances.

I ask you now to recall what was said about the way we deal with the salt, sodium and chlorine. Substantially the statement was that we have to treat them all on exactly the same basis, so far as the process of knowing is concerned. That is, we have to treat each one on the basis of *its own properties*. We can not touch sodium with our knowledge of the properties of chlorine, nor *vice versa*. Similarly, we can not touch sodium with our knowledge of the properties of salt, nor salt with our knowledge of the properties of sodium, except, mark you, as we may say that one property of sodium is its power to unite with chlorine to produce salt. My familiar expression for this is that the external world and our minds are so constituted, are so articulated with each other, that every object in that world must be treated *on its own merits*. Now notice that since these substances must be treated, each on its own merits, and since the sodium and chlorine have the power of combining with each other in such a remarkable way that they wholly lose their original properties, at least temporarily, and merge into another substance, salt, with properties wholly *its own*, we must recognize that the properties of substances manifest something of transitoriness and relativity.

Thus are we led to the notion which I have ventured to speak of as the *standardization of reality*. The expression is suggested by the chemist's process of standardizing solutions; the process, that is, of using a solution of known composition and concentration as a unit of value to which to refer various reactions and processes. The meaning is that whatever criterion of reality you apply to any natural object,

that same criterion you must apply to all other natural objects, no matter whether some of these be constituents of others, or stand in some other relation to one another.

Making the statement specific for the case of objects that are composed of other objects or substances, it runs thus: Whatever criterion of reality you apply as the test of the elements of a complex body or substance, exactly that same criterion you must apply as a test of the reality of the complex body itself.

It follows from this, that with the question of a fundamental essence or substance behind properties, we are, as students of objective nature, in no wise concerned. As to whether there is or is not a real essence of sodium, or of salt, to which the sensible properties of these substances adhere, is no affair of ours. Physical science can not even raise the question of an absolute reality or realities behind the objects with which it deals.

Now let us carry these considerations of the nature of objects and of minds, and the relation existing between them, up into the realm of objects that we call living. The formulary will run thus: In whatever sense you predicate reality, or fundamentality, or ultimateness to the germ or any part of an organism, in exactly the same sense you must predicate reality, or fundamentality, or ultimateness to the completed and whole organism.

If you have been accustomed to look upon living nature with the conception that somewhere deeply hidden in the plants and animals you daily meet there is something more real than the organisms themselves, something possessed of a potency wholly unique and mysterious as contrasted with that possessed by the visible beings; or, if you have regarded living beings as objects of your own consciousness—if, I say, you have been wont to thus regard organisms, grasp fully this conception of reality and of measuring reality and you will find, I believe, that it will transform your world. It will increase your interest in every developed organism as contrasted with your interest in its germ, or any portion of the organism physical or psychical in almost direct proportion as the sensible complexity of the organism as a whole exceeds the sensible complexity of the germ or any part of the organism.

Here is the epistemological necessity for the conception of an "organism as a whole," the biological compulsion of which we speak later. The point is simply this: Every object in nature has some nature of its own. That is just what makes it belong to nature. Consequently there must be something about it which can not be fully accounted for by referring it to something else in nature. For if you could thus dispose of every natural object, nature would consume itself in explanation. You would have the case of the Kilkenny

cats psychologized. We come here, I imagine, upon what virile truth there is in the "Ding an Sich," the "Thing in Itself."

I can not restrain my interest from going where I believe reality to be. Contrariwise, I can not send it where I believe reality is not. Interest and attention, like natural forces generally, take the direction of least resistance; and the places of greatest belief in reality are those of least resistance for attention. With this psychological basis to go on, illustration will carry us forward more surely and steadily than further argument.

The very heart of that school of biology known as materialistic, or mechanistic, is its effort to interpret living beings by ascribing to invisible substances or bodies, located somewhere within the germ-cells and other cells of the body, reality and essentiality of a sort quite unique as contrasted with the visible substances, and the organisms themselves. Examine the program of this school attentively and you will see that it proposes to "*explain*" or "*express*" those parts of animate nature about which we know most, observationally, in terms of those parts about which we know least, observationally. It is undoubtedly a quasi-inductive, semi-mystical program.

The chemical materialist conceives certain compounds, never well-known ones mark you, enzymes for example, to be thus supremely endowed. The biological materialist on the other hand, ascribes this exalted rôle to imaginary, invisible living bodies hidden deep within the germ and other cells. Biology of the last three decades has bestowed mighty powers upon such bodies under the designation "determinants." Only those familiar with the technical literature of the science during this time can have any notion of the influence these bodies have had. What have been, and what are the effects of such conceptions on biological theory and practise? I mention only a few of these.

Nothing is more characteristic of the biological thought in highest repute to-day than its disposition to look down upon all those kinds of research not aimed at the elements of organisms—at "ultimate problems," as the expression goes. Most of those who labor in the biological vineyard but are not elementalists of some sort, will appreciate what I mean, for they will have personally felt the ban placed upon them by the dominant school. A few years ago one of our best known American zoologists, speaking from a position of national preferment in his science, reviewed comprehensively the present range of zoology, and did not hesitate to pass upon the labors of description and classification of animals as hardly worth while. In other words, he pronounced as not worth doing, the very things which an examination of the nature of the knowledge-getting process shows to be absolutely fundamental steps toward an understanding of living nature.

This zoologist, it is hardly necessary to say, is an elementalist at heart. Plants and animals, as nature presents them, are for him real in a way. They are of course what our naked, crass senses come in contact with, but the real essence of them, the thing we want to get at, lies far away in the germ-cells, in the chromosomes, in protoplasm. *There* is reality. There is the pole-star by which our compass should be set, according to his views.

The consistent elementalist can not care much for description and classification, for these depend in the first instance on "mere qualities," while he is concerned with essences. The elementalist's problems, like the pure intellectualist's, are always ultimate problems. For both anything this side of the absolute is only appearance.

There is prevalent among many influential biologists, unfortunately for practical ends, a tendency to esteem what are called "gross" anatomy and physiology as of no great scientific value. To the elementalist this is bound to be so. The structures and the activities of your bodies, as the anatomist and physiologist of the ordinary kind sees them, are not their fundamentally real structures and activities. These are deep hidden in the uttermost recesses of your members. They are "probably" your proteid compounds, especially your enzymes.

One of the best characterization-marks of elementalist biology is the expression "nothing but." What is the human brain? It is "nothing but" a vast multitude of ganglionic cells (9,200,000,000 in the cortex alone), if the answer comes from a cellular elementalist; or it is "nothing but" a still greater number of chromosomes, if the elementalist be of the consistently orthodox chromosomal persuasion.

And what are the so-called emotions of the human breast? In last analysis they are "nothing but" chemical substances in unstable equilibrium, or in some other state.

Ernst Mach, that prince of modern elementalists, quotes Litchenberg approvingly as follows: "We should say *It thinks*, just as we say *It lightens*. It is going too far to say *cogito* if we translate *cogito* by *I think*. The assumption, or postulation, of the ego is a mere practical necessity." What sort of necessity, if not practical necessity, do these people believe in? Seemingly it is theoretical or impractical necessity, or both.

The answer to those who hold such views is obvious: If you want to call yourself "It" why, go ahead. But I propose to call myself "I" and no power in heaven or on earth can compel me to call myself "It." I may not be able fully to define my "I." Surely I am not, for full definition comes at the end and not at the beginning of experiential knowledge. But however incomplete my definition be, here I am. "The proof of the pudding is the eating."

Why do the elementalists pin their faith to the invisible constituents of things rather than to the things themselves? Can it be that they

deliberately deceive themselves as to the place where reality is located? Surely this can not be so. Some misguiding agent or agents there must be, and they must be subtle, otherwise they could not succeed as well as they do with so many earnest people.

Let us see if we can detect any of these subtle misleaders. In order to walk sure footed, we must remain on the platform of objectivity. Let us go back to salt and its elements. If the properties of salt are not derived from the sodium and the chlorine, where do they come from? Does something wholly extraneous to the elements while they exist apart, come in at the instant of their union that bestows upon the salt its peculiar properties? In other words, is there a mystical somewhat in chemical affinity? Those of you who know anything of the history of biological theory will recognize that this brings us to the threshold of the vitalistic school. If the completed organism does not lie as potency and promise in the germ and its natural environment, then where does it abide? If the qualities of the organism are not thus derived, then indeed is there something in man not derived from nature, just as a time-honored school of philosophy asserts. But for biology this would be vitalism, and vitalism means a walled city with the gates locked and the keys lost beyond recovery.

Have we reached a city surrounded by such a wall? A wonderful city indeed we have come to, for in truth is it an eternal city. By no means, though, are its gates locked against us. We may enter with perfect freedom and wander through its streets and palaces as long as we live, even to the latest generations of those who follow us, always there to find that which is more interesting, more beautiful, more marvelous.

Being primarily a man of science and only incidentally an artist, I am privileged to be a bad artist, so may interpret my metaphor.

What I mean is, that while we can not see how the properties of the salt are potentially in the chlorine and the sodium; and how the qualities of the man are potentially in the germ-cells, we still have no grounds for supposing they are not there. If our knowledge of the chemical elements and of the germs were full enough, we should see how they produce the results which flow from them. Now here is the crucial point—if our knowledge were *full enough* we should see. But how full would “full enough” be? So far as the knowledge we now have enables us to answer, only *unlimited knowledge would be full enough*. If we are privileged to suppose we shall sometime be possessed of infinite knowledge; shall be, in other words, infinite beings, then but not till then, shall we understand how chlorine and sodium produce common salt, how the germ-cells produce a common man.⁴

⁴ Readers acquainted with Hume's teachings about the relation of cause and

Nature is through and through infinite in her forms and processes, so it seems from the experiential knowledge thus far gained.

In just what ways science is being driven to the conclusion that nature is thus constituted is too long and hard a story to tell here. We can only glance at a few of its specially striking features. The atomic theory of modern chemistry contains several of these. By modern chemistry is meant chemistry since Dalton, Lavoisier and Avogadro; and especially since Lorentz and the electron idea came into it.

The special thing about the atomic theory that I call your attention to in this connection is the conception of change of valence of atoms now being discussed by some of the foremost chemists. According to this conception, the same atom may have different combining values under different circumstances. Do you not see without further comment what this suggests as to unrevealed potentialities of atoms? If the known facts of carbon-chemistry are such as to drive the chemist to suppose the atom of carbon changes from bivalency to quadrivalency and *vice versa*, what sober chemist will venture to place any limitation on the possibilities for further change of like nature not only in this but in other atoms?

Since we know absolutely nothing about the relation of the atoms in *living* substance, would it not be a reasonable hypothesis to say that the nature of that marvelous process called metabolism is due to just the fact that the atoms of carbon, nitrogen, hydrogen, oxygen, etc., are undergoing perpetual change of valence? I see no reason why we may not legitimately imagine even consciousness due to such a process.

Were such a hypothesis to be seriously taken, it would seem to follow that consciousness would have its roots wherever metabolism is going on. What an excellent starting point this would make for dealing with the perennial puzzle of how it is that the "mind influences the body"! The mind would then be part of the body.⁵

Another fruitful idea recently introduced into chemistry, and significant for the present point, is what is known as mass action. The essence of this, as my colleague Professor F. W. Cottrell expresses it, effect will recognize that at this point I part company with the keen-minded Scotchman. It is not necessary, however, to go into the matter here.

⁵Since preparing this essay my attention has been called to the writings of Henri Bergson. From what I gather by reading a number of reviews of his works and from a glance through his "*Matière et Mémoire*," it seems certain that many of my positions are close akin to his, though our starting points have been so very different. Among other things, this suggestion as to the chemical foundation of consciousness would seem to fall in admirably with the views held not only by M. Bergson but also by Avenarius, that not the brain alone but the whole body is the seat of conscious life. (See "*Subjectivism and Realism in Modern Philosophy*," by Norman Smith, *The Philosophical Review*, Vol. 17, 1908, p. 138.)

is that the more opportunity for chemical action the particles of a substance have, the more they act; that is, the particles improve their opportunity, so to speak.

See again how pregnant of meaning this is for the potentialities of atoms. It means that they have capacities to act that are revealed only when conditions for them to act are presented. This reminds one strongly of the unused energies of men that Professor James has recently written about so luminously.

The one other phase of science to which allusion will be made under this head, belongs to the biological realm. It is the conception of the "organism as a whole" that for a number of years has been working its way into biology by sheer force of its own weight. The facts are such as to compel admission even though they are wholly inexplicable on the basis of current elementalist doctrines, and so are frequently ignored or scouted by biologists of that school.

An expression which, though extreme, still rightly presents the idea comes from the German botanist de Bary. He said "Die Pflanze bildet Zellen, nicht die Zelle bildet Pflanzen" (The plant produces cells, not the cells produce the plant). This is an over statement but is true in so far as it expresses the unescapable fact that the whole organism at any given moment, as well as its elements, is concerned in determining what it shall be in the next succeeding moment. A more exact expression of a particular phase of the idea is due to our foremost American student of the cell, Professor E. B. Wilson. He writes: "*We can not comprehend the form of cleavage (cell-division) without reference to the end-result.*"

Let us look at an instance of the working of this principle in the realm of political organization, where it is more openly displayed. The original thirteen colonies of our pre-national period, united into a compact under what was known as the articles of confederation. A corner stone of the union was that each state should keep inviolate its original powers and privileges. Under the governmental fiction of this compact, the Congress, it has been said, could recommend everything but could enforce nothing. The experiment was naturally a failure. After a period of "Strang und Gang" our nation with the federal constitution as its basis was founded.

Now recall some of the striking things that happened in this transition time. First of all, the hitherto individual, sovereign states had to give up some of both their powers and their possessions. The "western lands" claimed by the states, had been one of the most serious obstacles in the way of a closer union. First New York, then Virginia, yielded their claims to congress for certain guarantees to them in return. The other states followed. Afterward the congress erected new states in the territory thus acquired, and the old states modified their organic laws to conform to the new conditions. Shall

we say that the new creation, the United States, contained something underived from the original states and their conditions? Shall we deny that our republic was contained potentially in the thirteen original states? Surely not. But the processes of gestation and parturition by which the nation came forth profoundly modified the elements, the states. Only a wisdom practically infinite could have foreseen exactly what those modifications would be.*

Growth and organization everywhere in living nature work inward as well as outward. The processes turn back upon themselves and produce changes in the contributing elements. What the new creation will be, what modifications the elements will undergo, one can see beforehand partly, but never fully. Only infinite wisdom could see altogether. Notice under what conditions one's wisdom would enable him to predict the future absolutely. Would not these two conditions be essential: That his knowledge of *the past* should be absolute, and that the course of events, that is the laws of nature, should be absolutely trustworthy?

Observation with our senses, of law-abiding operations, performed by objects cognizable only through their own properties, is one way of

*The criticism has been made that in using the origin of the United States as an illustration of the centripetal action of the developmental process, I am resorting to the analogical mode of reasoning, the very thing I have objected to in another connection. Attention must be called to the fact that it was not the use but the illegitimate use of this method to which objection was made. I am not pretending that the reciprocating action as it takes place in either the animal body or the nation explains the process *in the other*. My point is that in both cases the developmental process manifests this peculiarity. There is a common element in the two developments. That is all I am insisting on. But this must be taken in connection with the principle insisted on with equal emphasis elsewhere, that each natural object has *its own* qualities and properties. The man and the nation have something in common as to their mode of development, but they also have something of difference. To ascertain the *differences* and the *traits-in-common* all along the line is exactly what the business of developmental biology is.

Those biologists whose creed is that explanation of nature consists in reducing her to a few simple principles will make wry faces if nothing worse at this. But until such biologists can be more successful than they have been so far, in preventing organic chemists from finding new compounds day by day, and in suppressing systematic botanists and zoologists who persist in hunting up new kinds of plants and animals, and new characteristics and varieties of old ones, I see no prospect of these wry faces changing to expressions of good cheer.

It may be unfortunate that the living world is so complex, was not constructed on "a few simple principles." But one thing seems well established: Nature can not be made simple by treating her on the theory that she ought to be so when as a matter of fact she is not. To say that a few principles can be found that are common to very wide domains of nature, and to deny that there are numberless other principles not so widely prevalent are very different propositions.

describing our knowledge of nature. But we should fall woefully short were we to be satisfied with such an account of it. We can reach the kernel of a more adequate account by way of that indispensable aid to scientific discovery known as hypothesis-making.

A few, only a few, men of science have proposed to eliminate hypotheses from science altogether. The best known of these eliminators is Wilhelm Ostwald. In the place of the hypothesis Ostwald would install what he calls the *protothesis*. And what is that? It is a "vorläufige Annahme." There you have it! A protothesis is a taking of something by running on ahead. Ostwald wants to get rid of hypotheses altogether and rely wholly on "Arbeit," on work, to make conquests in science. But see what his proposal comes to, taking his own words. He is going to do part of to-morrow's work to-day, even at this very instant. The mind forecasts. It outstrips its past and present experiences. That is the vital fact, and why quibble about how it shall be named?

All generalization is hypothesis, says M. Poincaré. Think about it and you will see the eminent Frenchman is right. Think about it further and you will see you can not move ahead in real science one inch without generalization. But for it you might possibly have co-ordinated experiences which by courtesy might be called knowledge. But such knowledge would be wholly without motive, and what rational being would care a snap for such knowledge!

We must not fail to notice how radically at variance this way of interpreting the mind's work is from Kant's way of interpreting it. Kantians speak of that which the "mind itself puts into nature." If something is really put into nature, that something must have been previously outside of nature. You can not put water into a dish that is already in the dish. What is that outside something? Where is the outside source whence it comes? Ask the unfortunate mortals of whom Laura Bridgman was an instance, who are deprived from tender infancy of their sense organs, whether they know of some source of knowledge wholly outside nature. These cases furnish indubitable evidence, so far as they go, that consciousness has no content till sense perception gives it some.

No, the mind does not put something into nature that was previously outside it. This however, it does do: It takes something from one part of nature and puts it into another part. We must allow that the mind really does put something into *any particular situation* that was not in that situation before. But that is quite different from allowing that it puts something into *nature as a whole* that was not before somewhere in *nature as a whole*. This brings us back to our standardized, or tested, or relative reality.

If we ask how or by virtue of what quality or force the mind does this running ahead, this transferring of something from one part of

nature to another, no answer is forthcoming any more than there is to the question as to how or by virtue of what quality or force it senses at all; or to the question as to how or by virtue of what quality the properties of salt are produced by the sodium and the chlorine. It may be galling to find that we must accept many things as by free grace, so to speak; but this does not alter the fact.

It is the penalty we pay for belonging to nature at all. If one is galled by the fact and so tries to escape it, the course open to him is that taken by the oriental occultist who sees the natural order as a clog to the nobler but invisible real order and hence as a thing to be got rid of as soon as possible.

At a few places in this discussion it has seemed as though the course we were on would drag our physical science back to the primal chaos of mere sensations and facts from which it seems to have come. In truth, though, now that we can look at the whole situation as from a hilltop, how thoroughly familiar, how reassuring, how in accord with the best, most fruitful endeavor of all the ages of human history it is seen to be. "Nur in der Erfahrung ist Wahrheit" (only in experience is truth), said Kant. Modify this to the extent of making it say "Ohne Erfahrung ist keine Wahrheit" (without experience is no truth), and can any but a sophisticated mind doubt its truthfulness?

If nature is as true to herself and to man as she seems; if the body of evidence gathered by centuries of laborious science to the effect that law and order do prevail throughout the universe; and if the universe is as inexhaustible in variety and power as experience indicates, then how securely we stand on the truth that struggled to expression in Saint Paul's prophetic words: "Faith is the substance of things not seen"!

There seems to be no question about what experience *alone* can do since there is no such thing so far as we can see. Nor is there any question about what faith *alone* can do since there is no such thing. Experience appears to exist because of or through faith, and faith to exist because of or through experience. So far as production has reference to the fact that something exists now that did not exist previously, experience and faith must, it would seem, be said to be generative inter se. We have no ground whatever for saying that either preceded the other in time. Even the simplest sensation, the starting point of experience, can not be conceived in any intelligible terminology that does not recognize it as belonging to some organism. What sane person would talk of a sensation absolutely independent of an organism? But an organism of the simplest imaginable sort⁷ must still have some measure of fidelity, of faithfulness to

⁷ This remark need not be interpreted to mean that the simplest conceivable organisms actually did begin in time. For my part, I am of opinion that biology has reached the point where the suggestions of such cosmically-minded men

itself; must have, for example, some measure of persistence or constancy in time. I am unable to imagine an organism existing but for a single instant.

The moment a living being appeared on earth that could *respond more than once in the same way to the same stimulus*, at that moment appeared simultaneously the germs of all human knowledge and faith. The moment a human being comes to know that his experiential knowledge must be incomplete knowledge, from the very conditions of its being knowledge at all, at that moment does he touch the highest level of knowledge and faith attainable by living beings. Agnosticism, mere disclaimer of absolute knowledge, can not be the loftiest attainable mental attitude. This must consist in knowing, partly at least, how and why your highest knowledge is limited and seemingly must ever remain so.

In conclusion, life from the biologist's standpoint is the sum total of the phenomena exhibited by myriads of natural objects called living because they present these phenomena. To understand any organism it must be studied *as a whole* and in all its relations. Taking man as a type, his life must be studied throughout the whole cycle of its existence on earth and in its relations to all other lives and things. Not only must the germ-cells, the chromosomes and all the rest be subjected to investigation as to their forms, vital activities and chemico-physical composition, but the whole gamut of his experiences, physical, intellectual and spiritual, must be likewise searched out, so far as it is possible for human minds to search.

No biologist can do much by working at the whole of biology thus viewed. But—and here is one of the centers of our position—he can toil in his particular corner with a mind full-illuminated by the recognition that someone else must do the things he can not do because all must be done. He does not need to suppose the thing he is not doing is hardly worth doing.

of science as Lord Kelvin and Professor Arrhenius, that life like matter and force is eternal, must be taken hold of seriously as the best working hypothesis that can be made on the basis of the biological data available. This hypothesis will surely involve enormous difficulties, but some of the most difficult, one can foresee, will at least have the merit of being open to observational inquiry. Among the great difficulties will be that by "life" we must understand "organisms." We have no observational ground for postulating "organic substance" as anything else than the substance of which living beings are constituted.

This being so, the hypothesis would have to face at once the question, How numerous must the primal, eternally existent organisms be conceived to have been? But I am not adopting the hypothesis, not now, at any rate. I merely want to point out what seems a clearly possible alternative for the hypothesis of an actual beginning of life in time, which hypothesis seems to be growing less and less fruitful with the advance of experiential knowledge.

JOSIAH WILLARD GIBBS AND HIS RELATION TO
MODERN SCIENCE. IV

By FIELDING H. GARRISON, M.D.

ASSISTANT LIBRARIAN, ARMY MEDICAL LIBRARY, WASHINGTON, D. C.

The third stage of thermodynamics has for its point of departure Maxwell's observation that the second law is not a mathematical but an empirical or statistical truth, and his prediction that any attempt to deduce it from dynamic principles, such as Hamilton's principle, without introducing some element of probability, is foredoomed to failure.¹²⁷ "We have reason to believe of the second law," says Maxwell, "that though true, its truth is not of the same order as that of the first law," being an empirical generalization from the facts of nature in the first instance, while the molecular theory shows it to be "of the nature of a strong probability which, though it falls short of certainty by less than any assignable quantity, is not an absolute certainty." This statement of Maxwell's not only resumes the knowledge of his time, but has not been improved upon by later investigators, whose work shows that the truth of the second law is certain to the limit of human probability only. The theory of probabilities itself is exact as far as human observation goes. In 6,000 throws of dice, a particular facet will not necessarily turn up 1,000 times, but the probability of its doing so will be more nearly one sixth, the greater the number of throws. In the vital statistics of a great city the data of births, deaths, illegitimacy, etc., will be more nearly the same from week to week, the greater the population of the city; even the introduction of new dynamic factors, as seasonal change, epidemics, vaccination, antitoxin, etc., may alter particular effects but will not change the general tendency towards uniformity. Maxwell has observed that everything irregular, even the motion of a bit of paper falling to the ground, tends, in the long run, to become regular, and this is the rationale of testing the second law with respect to gases. In the kinetic theory of gases, the first scientific statement of which is due to Clausius, we assume a gas to be an assemblage of elastic spheres or molecules, flying in straight lines in all directions, with swift haphazard collisions and repulsions, like so many billiard balls. These, by Maxwell's calculations, will, if enclosed and left to themselves, gradually tend to an ultimate steady condition of perfectly equalized and permanently distributed velocities (*i. e.*, uniform temperature or thermal equilibrium) called "Maxwell's state." "This possible form of the final partition of

¹²⁷ *Nature*, 1877-8, XVII., 280.

energies," Maxwell claims, "is also the only form." At this point the work of Boltzmann becomes of central importance, especially on account of its profound influence on the later works of Gibbs. In Boltzmann's application of probabilities to Maxwell's problem, the starting point or initial stage of any sequence of events is called a "highly improbable one," because its certainty decreases the more the events proceed to some final or "most probable" state. For example, the blowing up of the *Maine* is to us a moral or mathematical certainty, but it may not be so æons hence, while its predisposing or exciting causes are even now "highly improbable" in that we know nothing positive about them. When a gas is brought into a new physical state, its initial stage is, in Boltzmann's argument, a highly improbable one from which the system of molecules will continually hasten towards successive states of greater probability until it finally attains the most probable one, or Maxwell's state of equilibrated partition of energy and thermal equilibrium. Maxwell's law of final distribution of velocities as determined by Boltzmann's probability coefficient is, therefore, a sufficient condition for thermal equilibrium, and Boltzmann found that the entropy of any state of gas molecules is proportional to the logarithm of the probability of its occurrence; or as Larmor puts it, the principle that the trend of an isolated system is towards states for which the entropy continually increases is analogous to the principle that the general trend of a system of molecules is through a succession of states whose intrinsic probability of occurrence continually increases. As a measure of the degree of variation of the gas molecules from Maxwell's state, Boltzmann introduces a function H such that, as the distribution of molecular velocities constantly tends toward the most probable distribution, H varies with the time and is found to be constantly diminishing in value. The necessary condition for thermal equilibrium is, therefore, that H should irreversibly attain a minimum value. Thus Boltzmann's "minimum theorem" becomes, like the Clausius doctrine of maximum entropy, a theorem of extreme probability,¹²⁸ or to quote the aphorism of Gibbs which Boltzmann chose as a motto for his *Gastheorie*: "The impossibility of an uncompensated decrease of entropy seems to be reduced to an improbability."¹²⁹ Applying similar reasoning to the material universe, Boltzmann finds that the following assumptions are possible: either the whole universe is in a highly improbable (*i. e.* initial) state, or, as the facts of physical astronomy would seem to indicate, the part of it known to us is in a state of thermal equilibrium, with certain districts, such as the earth we live

¹²⁸ "It can never be proved from the equations of motions alone, that the minimum function H must always decrease. It can only be deduced from the laws of probability, that if the initial state is not specially arranged for a certain purpose, but haphazard governs freely the probability that H decreases is always greater than it increases." Boltzmann, *Nature*, 1894-5, LI., 414.

¹²⁹ *Tr. Connect. Acad.*, III., 229.

on, noticeably removed from this condition. The probability of the latter state of affairs is smaller, the further such a state is removed from thermal equilibrium, but it can be made as great as we please to assume the universe to be great. But there is necessary and sufficient probability that our earth as we know it is in its present state. By the second law (irreversible increase of entropy in natural processes) there is still greater probability that it tends to a final state of thermal equilibrium or death; and since the universe itself is so great, there is sufficient probability that other worlds than ours may deviate from thermal equilibrium. As a graphic exposition of this theory, which shows the vast scope of the second law of thermodynamics, a curve can be plotted with the variables H and the time as coordinates, to visualize what takes place in the universe. The H curve is shaped like a succession of inverted trees, the summits of which represent "the worlds where visible motion and life exist."¹³⁰ Physicists have found that the Maxwell-Boltzmann distribution of velocities is satisfactory for gases whose molecules move independently and at random; but when the molecules are supposed to be subject to one another's influence, it does not account for certain facts of nature such as the measured specific heats of gases or individual peculiarities of their spectra. In monatomic gases like argon, helium and mercury, the ratio of the specific heats will account for the three degrees of molecular freedom ascribed to them by the mathematical theory, but in the case of diatomic gases, like hydrogen or oxygen, the theory calls for six degrees of freedom, while experiment will account for only five. Boltzmann met these objections with frank or ironical admissions as to the ultimate inadequacy of all human hypotheses,¹³¹ and although his theory is to some extent invalidated by facts like the above,¹³² his subtle handling of molecular thermodynamics gives the physicist deeper insight into

¹³⁰ "Almost all these trees are extremely low, and have branches very nearly horizontal. Here H has nearly the minimum value. Only very few trees are higher, and have branches inclined to the axis of abscissæ, and the improbability of such a tree increases enormously with its height." Boltzmann, *Nature*, 1894-5, LI., 581.

¹³¹ "Neither the theory of Gases nor any other physical theory can be quite a congruent account of facts, and I can not hope with Mr. Burbury that Mr. Bryan will be able to deduce all the phenomena of spectroscopy from the electromagnetic theory of light. Certainly, therefore, Hertz is right when he says: 'The rigour of science requires that we distinguish well the undraped figure of Nature itself from the gay-coloured vesture with which we clothe it at our pleasure.' But I think the predilection for nudity would be carried too far if we were to forego every hypothesis. Only we must not demand too much from hypotheses." Boltzmann, *Ibid.*, 413.

¹³² The principal opponent of the Maxwell-Boltzmann partition of energies was Lord Kelvin in his "Nineteenth Century Clouds over the Dynamical Theory of Heat and Light." When asked what he had against it, he replied point-blank: "I don't think there is a single thing about it that is right" (*Science*, Jan. 3, 1908, p. 6).

such unusual phases of matter as radiation in rarefied gases, where the system has no temperature at all, because its internal motions have not settled down to a definite average. Helmholtz's dynamic proof of the second law assumes the existence of cyclic systems with reversible circular motions, like those of the gyroscope or the governor of a steam engine, in other words it assumes matter to be made of rotational or gyrostatic stresses in the ether. Gibbs's "Elementary Principles of Statical Mechanics" (1903)¹³³ is based upon no assumptions whatever except that the systems involved are mechanical, obeying the equations of motion of Lagrange and Hamilton. "One is building on insecure foundations," he says, "who rests his work on hypotheses concerning the constitution of matter," and his statistics deal, not with the behavior of gas molecules in isolated systems, but with large averages of vast ensembles of systems of the same kind (solid, liquid or gas), "differing in the configurations and velocities which they have at any given instant, and differing not merely infinitesimally, but it may be so as to embrace every conceivable combination of configuration and velocities." The problem is, given the distribution of these ensembles in phase (*i. e.*, in regard to configuration and velocities) at some one time, to find their distribution at any required time. To solve this problem Gibbs establishes a fundamental equation of statistical mechanics, which gives the rate of change of the systems in regard to distribution in phase. A particular case of this equation gives the condition for statistical equilibrium or permanent distribution in phase. Integration of the equation in the general case gives certain constants relating to the extent, density and probability of distribution of the systems in phase, which Gibbs interprets as the principles of conservation of "extension in phase," of "density in phase," and of "probability in phase." Boltzmann found that when the gas molecules have more than two degrees of freedom, the equations can not be integrated and further progress is impossible. He got around this difficulty by using Jacobi's "method of the last multiplier," which integrates the equations of motion. Gibbs found that the principle of "conservation of extension-in-phase," supplies such a Jacobian multiplier, "if we have the skill or good fortune (he says) to perceive that the multiplier will make the first member of the equation an exact differential." Boltzmann's probability coefficient is used as the index of the canonical distribution of ensembles, and when the exponent of this coefficient is zero, the latter becomes unity, producing a distribution in phase called "micro-canonical," in which all the systems in the ensemble have the same energy, as in Maxwell's "state." After demonstrating the possibility of irreversible phenomena in the various ensembles, and after a careful study of their behavior when isolated, subjected to external forces or to

¹³³ "Yale Bicentennial Publications," 1903. Translated into German by Ernst Zermelo, Leipzig, 1905.

the spheres of one another's influence, Gibbs finds that the processes of statistical mechanics are to all human perception analogous to those of thermodynamics, the familiar formulæ of which appear, as Bumstead puts it, "almost spontaneously, as it seems from the consideration of purely mechanical systems." The differential equation relating to average values in the ensemble is found to correspond with the fundamental equation of thermodynamics; the modulus of distribution of ensembles turns out to be analogous to the temperature, while the average index of probability in phase is the analogue of the entropy with reversed sign, and being a minus quantity, is found to decrease just as entropy increases. Most of the objections filed against Gibbs's statistical demonstration, turn upon the fact that it is difficult, perhaps impossible, to apply the reversible dynamics of ideal, frictionless systems to the spontaneous irreversible phenomena of nature without making some physical assumptions. "Entropy," Burbury objects,¹³⁴ "may, for all that appears, either increase or diminish in a system which is dynamically reversible. This then can not be strictly applied to an irreversible process." Gibbs has met these objections fairly. "Our mathematical fictions,"¹³⁵ he says, to quote Burbury's paraphrase of his argument, "give us no information whether the distribution of phases is towards uniformity or away from it. Our experience with the real world, however, teaches us that it is towards uniformity." All actual mechanical systems are, as Gibbs pointed out long before, in reality thermodynamic,¹³⁶ and it seems odd that the critics who rejected Boltzmann's proof, because it did not agree with the facts of nature, should now, for a logical quibble, take exception to Gibbs's because it does. It has been predicted that future truth in physical science will often be found in the sixth place of decimals, for not everything in nature works out according to specifications. We can, if we choose, regard mathematics as a metaphysical diversion or employ it practically as a means of interpreting the physical facts of nature, empirically ascertained by man. In these matters, says Gibbs elsewhere, "Nature herself takes us by the hand and leads us along by easy steps as a mother teaches her child to walk,"¹³⁷ and he would have agreed with Langley that man may put questions to nature if he will, but is in no position to dictate her answers to them.¹³⁸ Nature seems *très femme* in this respect, especially in regard to mathematical fictions, that is, ideal or limiting cases devised by the finite mind of man.¹³⁹ Like any other human

¹³⁴ *Phil. Mag.*, 1904, 6. s., VIII., 44.

¹³⁵ *Ibid.*, 45.

¹³⁶ *Tr. Connect. Acad.*, III., 108.

¹³⁷ *Proc. Am. Ass. Adv. Sc.*, 1886, Salem, 1887, XXXV., 62.

¹³⁸ "Let us read Bacon again, and agree with him that we understand only what we have observed." S. P. Langley, *Science*, 1902, XV., p. 927.

¹³⁹ "Physical chemistry is not yet a quantitative science; it is a pseudo-quantitative science. There are all the outward signs of a quantitative science.

instrument of precision, our mathematical methods are but an approximation to the subtler aspects of nature, and it is only by eternal vigilance in regard to sources of human error that workers in physical science have put aside personal equation and infallibility and thus avoided what Rowland calls the "discontinuity" of the ordinary legal or cultivated mind.¹⁴⁰ "Gibbs has not sought to give a mechanical explanation of heat," says Professor Bumstead, "but has limited his task to demonstrating that such an explanation is possible. And this achievement forms a fitting culmination of his life's work."¹⁴¹

The naturalist Haeckel has explicitly denied the doctrine of universal increase of entropy¹⁴² because, pointing as it does to the ultimate thermal death of different worlds, it conflicts with his monistic conception of the universe as a *perpetuum mobile*, consisting of infinite substance in eternal motion, without beginning and without end. Yet the cosmogony of Kant and Laplace, which Haeckel accepts, points to the same conclusion as well as to formative periods in the history of the solar and sidereal systems, in which entropy decreases, and energy, instead of dissipating, tends, after a maximum of degradation, to concentrate. Even possibilities of this kind put the second law on a lower plane of probability than the first as far as man is concerned, unless it be that the irreversible processes of nature are in reality cyclic, in which case we should have Nietzsche's "eternal return" of all things. But as Bumstead has so admirably said, "It is nearer the truth to base the doctrine of entropy upon the finite character of our perceptions than upon infinity of time."

In connection with the validity of the second law arises the important question of the extent of its application to animate nature and whether it is capable of reversal in vital processes. "The first law (conservation of energy) has been proven," says Ostwald, "with an exactness of 1:1,000 even for physiological combustion (including mechanical and psychical work performed)." The second law, whether in the Clausius form of increase of entropy, the Kelvin form of dissi-

We have formulas and tables; we make use of thermodynamics and the differential calculus; but this is for the most part a vain show. Long before we reach the point where the formula is to be tested experimentally we slip in a simplifying assumption: that the concentration of one component may be considered as a constant; that the heat of dilution is zero; that the solute may be treated in all cases as though it were an indifferent gas; that the concentration of the dissociated portion of a salt may be substituted for the total concentration; etc., etc. The result is that our calculations apply at best only to limiting or ideal cases, where an error in deducing the formula may be masked by errors in observation. Helmholtz did not do this, but Helmholtz is considered old-fashioned." W. D. Bancroft, *J. Phys. Chem.*, 1899, III., 604.

¹⁴⁰ H. A. Rowland, *Am. J. Sc.*, 1899, 4. s., VIII., 409.

¹⁴¹ Bumstead, *Am. J. Sc.*, 1903, 4. s., XLI., 199.

¹⁴² Haeckel, "The Riddle of The Universe." New York, 1900, 246-248.

pation of available energy, or the Gibbs-Helmholtz form of decrease of free energy, is assumed by recent physiologists to be characteristic of all spontaneous or metabolic processes, but both Helmholtz¹⁴³ and Kelvin¹⁴⁴ have doubted whether it is either necessary or sufficient for their production, while Maxwell¹⁴⁵ and Boltzmann¹⁴⁶ have asserted, what Gibbs's statistical researches seem to prove, that it is sometimes possible for entropy to decrease, that is for small isolated temporary violations of the second law to occur in any real body. Has animal or vegetable protoplasm ever the power ascribed to Maxwell's demon of reversing the thermodynamic order of nature, and directing physico-chemical forces? Such a demon, according to Lord Kelvin, might, through his superior intelligence or motor activity, render one half of a bar of metal glowing hot, while the other half remained icy cold. We have something analogous to this in certain diseases, as gangrene, aphasia, various forms of paralysis, the curious vasomotor and trophic disorders of the nervous system. Are these phenomena then of a thermodynamic nature? The animal body, Lord Kelvin thought, does not act like a thermodynamic engine, but "in a manner more nearly analogous to that of an electric motor working in virtue of energy supplied to it by a voltaic battery." Here, as Gibbs has shown in his theory of the chemical cells, the electromotive force would be identical with the free energy upon which the surface energies of the body must ultimately depend. Beyond these speculations we know nothing. Gibbs himself avowed his express disinclination to "explain the mysteries of nature," while Lord Kelvin, although affirming that physicists are bound "by the everlasting law of honor," to explain everything material upon physical principles, mystified friends and opponents alike by falling back upon a "vital principle" with "creative power" behind it as the *causa causans* of biological happenings. But the business of physics is with the material facts of the universe, and the invocation of creative power explains nothing and is subversive of determinism, or the relation of cause and effect in science. It may be that "man was born too late to ascertain final causes": he can only interpret the physical facts of his experience as he finds them and with the means at his disposal. An interesting attempt to explain the relation of life and mind to matter is found in the *energetische Weltanschauung*

¹⁴³ Helmholtz, *J. f. Math.*, v. 100, 137. Auerback, "Kanon der Physik.," 414.

¹⁴⁴ Kelvin, "Pop. Lect.," II., 199, 463, 464. See, also, the discussion in *Science*, 1903, N. S., XVIII., 138-146.

¹⁴⁵ Maxwell, *Nature*, 1877-8, XVII., 280.

¹⁴⁶ Der grosse Meister, dem auch diese Zeilen huldigen möchten, hat einst den Gedanken ausgesprochen, dass es in der Welt vielleicht Stellen giebt, wo die Entropie nicht wächst, sondern zunimmt," O. Chwolson. Boltzmann, "Festschr.," 1904, 33.

or energetic philosophy of Ostwald, which confessedly derives¹⁴⁷ from the thermodynamic argument of Gibbs, but should not be confused with the latter. Gibbs was concerned only with applying the laws of mechanics to physical chemistry. Compared with the case of nature, he says, thermodynamic systems are "of an ideal simplicity." To Ostwald, however, mind and matter are but forms of energy, which is the only thing eternal and immortal. "We can deal with measurable things, never with the unknown heart of nature," says Ostwald, yet his basic principle, energy, is to all intents and purposes identical with the eternal infinite substance of Spinoza, Goethe and Haeckel, "sive Deus, sive Natura naturans, sive Anima mundi appelletur." Matter, in Ostwald's scheme, is a group of energies in space; thought becomes a mode of energy involving evolution of heat, and "the problem of the connection between body and spirit belongs to the same series as the connection between chemical and electrical energy, which is treated in the theory of voltaic chains."¹⁴⁸ Falling in love, listening to a Beethoven symphony, identifying oneself with nature, are to Ostwald instances of dissipation of energy like any other.¹⁴⁹ Philosophy of this kind does not clear up the mystery of the relation of mind and matter. Descartes assumed that mind and matter exist apart as parallels, having no causal connection with each other. Spinoza held that neither can exist apart; indeed, he sometimes asserts their practical identity as different modes of the same eternal substance. But however intimately they may be associated, no scientist or philosopher has yet proven, whether in the body of man or in the origin of the universe, that one is either the cause or the effect of the other.

Assuming matter in mass to be ultimately made up of rotational, vortical or gyrostatic stresses or of energies, whether kinetic or potential, we encounter the formidable objection of Boltzmann, that it seems illogical, not to say unmechanical, to postulate motion as the primary idea with the moving thing as the derived one. Motion of what? we have a right to ask, since Ostwald disdains the ether of the physicists.¹⁵⁰ Matter, in the words of Sir Oliver Lodge, may be physically resolved

¹⁴⁷ "Wir wollen daher den Versuch wagen, eine Weltansicht ohne die Benutzung des Begriffs der Materie ausschliesslich aus energetischem Material aufzubauen . . . In der für die neuere Chemie grundlegenden Abhandlung von Willard Gibbs ist sogar dies Postulat praktisch in weitestem Umfange durchgeführt worden, allerdings ohne dass es ausdrücklich aufgestellt worden wäre." W. Ostwald, "Vorles. über Naturphilosophie," 165.

¹⁴⁸ *Monist*, 1907.

¹⁴⁹ W. Ostwald, "Individuality and Immortality," 44-46.

¹⁵⁰ "What the atom of each element is, whether it is a movement or a thing, or a vortex, or a point having inertia, all these questions are surrounded by profound darkness. I dare not use any less pedantic word than entity to designate the ether, for it would be an exaggeration of our knowledge to speak of it as a body, or even a substance," Lord Salisbury, "Rep. Brit. Ass. Adv. Sc.," 1894, 8.

“perhaps, into electricity, and that into some hitherto unimagined mode of motion of the ether,” but no dynamic theory of the ether can resolve the ether into nothing. Assuming thought to be a mode of energy, the metaphysical argument that mind is at the bottom of motion seems more likely, in the last analysis, than that motion should be the cause of mind, for we can not conceive of a thing moving unless something moves it. Mind seems almost like an assemblage or complex of causes in itself, and is probably related to the brain as music to the violin. Destroy the violin and there will be an end of its music, but it needs other coefficients than the violin itself to get music out of it. Ostwald has himself admitted the force of Leibnitz’s argument, that no mechanical explanation of cerebral action will ever account for the genesis of thought or the nature of consciousness: “Nihil in intellectu quod non prius in sensu, nisi intellectus ipse.” Individual thinking may be the result of physico-chemical differences of structure or substance in the brain, but apart from the evidence of mind in the evolution and structure of the universe, different aspects of mind, as ideas, sensations and sentiments, seem to have an individual life of their own so far as man is concerned, and are “things” in the sense that, like external forces, they have profoundly influenced and determined the actions of individuals and of entire races. Human thought as a function of the human brain may disappear with man himself, but this does not annul the possibility of mind existing in manifold ways elsewhere in the universe. The electric waves of wireless telegraphy undoubtedly existed as motions in the air before man discovered and labeled them and may continue to exist and be apprehended in other spheres of thought when man is gone.

Man’s capacity for error in these matters is determined by his anthropomorphic tendencies and by the fact that his intelligence is finite. Of the possibly infinite number of attributes of eternal substance postulated by Spinoza, the human mind can apprehend only two—thought and extension, and even here thought and sensation are the fundamental facts, while “all else is an inference and is probably essentially unlike what it appears to our senses.” It seems impossible to break down the fact that there is no absolute causal connection between the two primary categories of Spinoza, who has anticipated most of modern psychology. For this reason such subjects as spiritualism, phrenology, faith-healing, telepathy have remained in the limbo of pseudo-science, although each has undoubtedly a shadowy reason for existence. It is as fair as any other hypothesis, then, to assume that man, in his higher mental or psychical activities, may, under certain conditions, be “freed from the galling yoke of space and time,” or, in other words, released from the thralldom of the second law. Yet such an assumption, even if made by a Kelvin, would be, in our present state of knowledge, an expression of individual personal

belief, a literary or humane analogy, a leaning in the direction of the "fair humanities of old religion," but not a scientific fact. To fix our ideas for the material world we may accept the expanded statement of the second law which Ostwald gave in his Ingersoll lecture in 1906:¹⁵¹ "Every known physical fact leads to the conclusion that diffusion or a homogeneous distribution of energy is the general aim of all happenings. . . . A partial concentration may be brought in a system, but only at the expense of greater dissipation, and the sum total is always an increase in dissipation."¹⁵² Through the labors of Joule and Kelvin, Maxwell and Boltzmann, Gibbs and Helmholtz, Carnot's simple generalization about heat engines has been elevated to the dignity of an irrevocable law of nature, a principle of scientific determinism, giving one of the most complete and satisfactory answers that man can furnish to the great question: How does any event in the material universe come to pass? In Darwin's picture of nature the quiet woods and waters, so calm and peaceful on the surface, are in reality centers of "strange and cruel life," the struggle and turmoil of creatures continually preying upon each other, even trees and plants and the tiniest particles of animate bodies taking part in a definite, never-ending war for existence. But the stern law of life, whereby the strong war down the weak, loses all moral or human significance when seen as due, in the last analysis, to an inevitable tendency to dissipation of energy or as the resultant of a play of complex forces, which, through some principle of "least action," must inexorably flow from higher to lower potentials. As Spinoza pointed out long ago, Nature could not change these laws which flow from its very being, without ceasing to be itself, and the conclusion of physics and biology that Nature is never on the side of the weak becomes, as far as man is related to the material universe, identical with Spinoza's denial of final causes.

Apart from his work in mathematical physics, Gibbs made several important contributions to pure mathematics, notably in his theory of "dyadics," a variety of the multiple or matricular algebras which Benjamin Peirce classified as "linear associative." The tendency of his mind was always toward broad, general views and the simplifications that go with such an outlook, and here mention should be made of his charming address on multiple algebra and his innovation of vector analysis, a calculus designed to give the student of physics a clearer

¹⁵¹ W. Ostwald, "Individuality and Immortality," Boston, 1906, 42.

¹⁵² As a fundamental formula for all material happenings, analogous to the "world-formula" of Laplace, J. G. Vogt proposes the following (*Polit. Anthropol. Rev.*, Leipzig, 1907-8, VI., 573): If Pe represent the positive or dissipational potential (*emissives Potential*) and Pr the negative or concentrational potential (*rezeptives Potential*) of any given set of forces, then $Pe + Pr = 0$ or $\int_n dPe + \int_0^n dPr = 0$. This is, however, only another restatement of Newton's Third Law of Motion, that action and reaction are equal and in opposite directions.

insight into such space relations as strains, twists, spins and rotational or irrotational movements in general. Maxwell, who once declared that he had been striving all his life to be freed from the yoke of the Cartesian coordinates, had already found such an instrument in the Hamiltonian quaternions, the application of which he brilliantly demonstrated in his great treatise on electricity and magnetism. Quaternions are elegant, consistent, concise and uniquely adapted to Euclidean space, but physicists have latterly found them artificial and unnatural to their science, because the square of the quaternionic vector becomes a negative quantity.¹⁵³ The Gibbsian vectors obviate this difficulty, and while seemingly uncouth, furnish a mode of attack more simple and direct and adaptable to space of any dimensions. Their capacity for interpreting space relations was amply tested by Gibbs in his five papers on the electromagnetic theory of light and his application of vectors to the calculation of orbits, since incorporated in recent German treatises on astronomy. The fact that vectors tend to displace the quaternionic analysis of Sir William Rowan Hamilton involved our author in a lengthy controversy with Hamilton's best interpreter, the ingenious and versatile Tait,¹⁵⁴ who looked upon Gibbs as "one of the retarders of quaternionic progress," defining his system as "a sort of hermaphrodite monster compounded of the notations of Hamilton and Grassmann." But Gibbs did not regard his method as strictly original; he was only concerned with its application in the task of teaching students; and when, after testing it by twenty years' experience in the class-room, he reluctantly consented to the publication of his lectures in full, the task was confided to one of his pupils, our author declining, with a characteristic touch of conscience, to have the work appear under his name or even to read the proof. In the controversy with Tait there is, as in most controversies, an amusing element of human nature. The name of Hamilton is undoubtedly one of the most illustrious in the history of science, and Tait and his adherents seemed to regard it as an impertinence and a desecration of his memory that any other

¹⁵³ "I have the highest admiration for the notion of a quaternion; but . . . as I consider the full moon far more beautiful than any moonlit view, so I regard the notion of a quaternion as far more beautiful than any of its applications. . . . I compare a quaternion formula to a pocket-map—a capital thing to put in one's pocket, but which for use must be unfolded: The formula, to be understood, must be translated into coordinates." Arthur Cayley, *Proc. Roy. Soc. Edinb.*, 1892-5, XX., 271. At the Southport meeting of the British Association in 1903, Professor Larmor, while admitting the extreme usefulness of the different methods of vector analysis, argued that their slow progress in physics was due to the lack of uniformity in definitions and notations, requiring that each system must be mastered separately before it can be applied. To which Professor Boltzmann not inaptly replied that the confusion might have been avoided, if Hamilton had adopted the notations of Grassmann in the first instance.

¹⁵⁴ *Nature*, 1891-3, *passim*.

system than quaternions should be proposed. "The ideas which flashed into the mind of Hamilton at the classic Brougham Bridge" became the occasion of a joined battle between the perfervid clan-loyalty of the Celt and the cool individualism of the Saxon; on one side,

"The broad Scots tongue that flatters, scolds defies,
The thick Scots wit that fells you like a mace,"

and on the other, the overconscientious, ethical arguments of a supersensitive spirit, obviously nettled at certain rough pleasantries which were understood but not appreciated. In 1893 Heaviside, an English vectorist, reports "confusion in the quaternionic citadel: alarms and excursions and hurling of stones and pouring of water upon the invading hosts."¹⁵⁵ The vectorists were denounced as a "clique" and ridiculed especially for their lack of elegance, their alleged intellectual dishonesty and the fact that their pupils were "spoon-fed" upon mathematico-physical pap. But some of the notations held up to ridicule turned out to be things like Poisson's theorem or the difficult hydrodynamic problem "given the spin in a case of liquid motion to find the motion," which Helmholtz solved with one of his strokes of genius, and which Gibbs showed could be understood and interpreted by the average student without genius by a simple application of vectorial methods. The real point at issue in the controversy, the fundamental difference in the ideals of European and American education, lies here. Both have their relative advantages and defects, but the object of one has been to bring the best to the highest development, while the other is concerned with increasing the efficiency of the average man. One has been exclusive, aiming at the survival of the fittest; the other is democratic and inclusive, and aims, in Huxley's words, to make the greatest number fit to survive. The merits of the case are well summed up in Gibbs's final statement: "The notions which we use in vector analysis are those which he who reads between the lines will meet on every page of the greatest masters of analysis, or of those who have probed deepest the secrets of nature, the only difference being that the vector analyst, having regard for the weakness of the human intellect, does as the early painters who wrote beneath their pictures 'This is a tree.' 'This is a horse.'"¹⁵⁶ This view is in perfect accord with the recent trend of mathematical teaching, European or American, which is to emphasize the meaning and interpretation of equations and formulæ rather than their demonstrations or manipulation; in short, to substitute visualizing methods, the art of thinking straight and seeing clear, for what is conventional and scholastic. A Harvard professor is said to have told his students that the demonstration of a theorem is no evidence that it is understood, but the intelligent use of it is; and the object of such teaching as Gibbs's was to enable the

¹⁵⁵ *Ibid.*, 1892-3, XLVII., 534.

¹⁵⁶ *Ibid.*, 464.

student to see physical phenomena with the "clarity of vision" which Tait himself thought characteristic of the truly mathematical mind, and of which a good criterion is afforded in Helmholtz's unforgettable statement about Michael Faraday: "With wonderful sagacity and intellectual precision, Faraday performed on his brain the work of a great mathematician without using a single mathematical formula."¹⁵⁷

At Yale Gibbs was esteemed an ideal teacher of physics, cordial, quick, helpful, willing to devote unlimited time to assist plodders and giving his students ample opportunity to learn "what may be regarded as known, what is guessed at, what a proof is and how far it goes." Of the qualities that make for distinction of mind and character he had the impersonal gift, "le don d'être né essentiellement impersonnel," which Renan thought highest of all, and which, fortunately for the advance of real knowledge, has been characteristic of most of the great leaders of science. He could build no wall of personal egotism between himself and the external facts, and "few could come in contact with this serene and impartial mind without feeling profoundly its influence in all his future studies of nature."¹⁵⁸ We know little of his life beyond the fact that he was a man of stoic fiber, who lived and worked alone. The countenance in the portraits expresses the Puritan austerity with lines that tell of mental stress and struggles with illness, but the man himself was "unassuming in manner, genial and kindly in his intercourse with his fellow men." "In the minds of those who knew him," concludes his biographer, "the greatness of his intellectual achievements will never overshadow the beauty and dignity of his life."¹⁵⁹

American contributions to physics, from Franklin to Michelson, have been characterized by originality of invention and experiment. The work of Gibbs has a place apart as that of a mathematical theorist whose ideas have found wide application in the main current of modern thought, and his true position is best described in his own often-quoted estimate of his great predecessor, Clausius. "Such work as that of Clausius," he says, "is not measured by counting titles or pages. His true monument lies not on the shelves of libraries, but in the thoughts of men and the history of more than one science."¹⁶⁰ The general scientific reputation of Gibbs is of this kind, while in his chosen field of activity, the austere region of physics in which Newton and Lagrange, Hamilton and Jacobi are the leaders, his is assuredly the most distinguished American name.

¹⁵⁷ Helmholtz, Faraday Lecture, 1881.

¹⁵⁸ Bumstead, *Am. J. Sc.*, 1903, 4. s., XLI., 201.

¹⁵⁹ Bumstead, *loc. cit.*

¹⁶⁰ Gibbs, *Proc. Am. Acad. Arts and Sc.*, 1889, N. S., XVI., 465.

THE PROGRESS OF SCIENCE

THE DEATH OF SIMON NEWCOMB

WE have not had in America a great period of scientific productivity such as formed part of the Victorian era in Great Britain or followed the renaissance of the universities in Germany. Perhaps only in one science have we been in the position of leaders. In astronomy, thanks it may be to the endowment of observatories where research was not crowded by elementary teaching, we have done our share, or more than our share, for the advancement of science. Our great astronomer, who gave distinction to science in America, is now dead, and we mourn the loss of one whose place can not be filled.

Simon Newcomb was born on March 12, 1835, in a village of Nova Scotia, but was of New England descent from five generations of Simon Newcombs, as well as on the side of his mother. In his "Reminiscences of an Astronomer," published six years ago, there is an interesting account of his early life. His father was a school teacher who moved from village to village in accordance with the custom of the time. The child was apt at figures and had done arithmetic through cube root at the age of six and a half. He read with avidity the few books that came within reach, especially those concerned with science, but had no regular schooling or education in the ordinary sense. At the age of fourteen he was apprenticed as a boy of all work to an irregular practitioner in the hope that he might pick up some knowledge of medicine. This result not following, he ran away, worked his passage to Massachusetts in a sailing boat and found himself teaching in a country school in Maryland at the age of eighteen. A couple of years later, he became

acquainted with Secretary Henry of the Smithsonian Institution, it may be through borrowing from the institution a copy of Laplace's "Mechanique Celeste," a knowledge of which he regarded as necessary for a computer. Such a position he soon afterwards obtained on the "Nautical Almanac," then conducted at Cambridge. He was at the same time able to enter Harvard University, where he studied under Professor Peirce and read in earnest the works of Laplace and La Grange.

Henceforth Newcomb's scientific career is a long record of sound and brilliant achievement. Beginning with work on the orbits of the asteroids he extended it to Uranus and Neptune and to other planets and to the moon. The mathematical genius required for work of this kind is of the highest type; many would regard Laplace as the greatest intellect that the world has produced, and in America he has had worthy successors in Newcomb and in Hill.

In 1861 Newcomb was appointed professor of mathematics in the navy, and in 1877 superintendent of the Nautical Almanac Office, a position which he held till he was relieved in 1897 at the age limit with the relative rank of rear-admiral. An appropriation to enable him to continue his work was made by the congress and later it was carried forward under the auspices of the Carnegie Institution to be ended only with his death. He declined the directorship of the Harvard Observatory, but accepted a professorship in the Johns Hopkins University in conjunction with his work at Washington.

In addition to his great work in celestial mechanics, Newcomb performed important services for astronomy and for science in many directions. One of

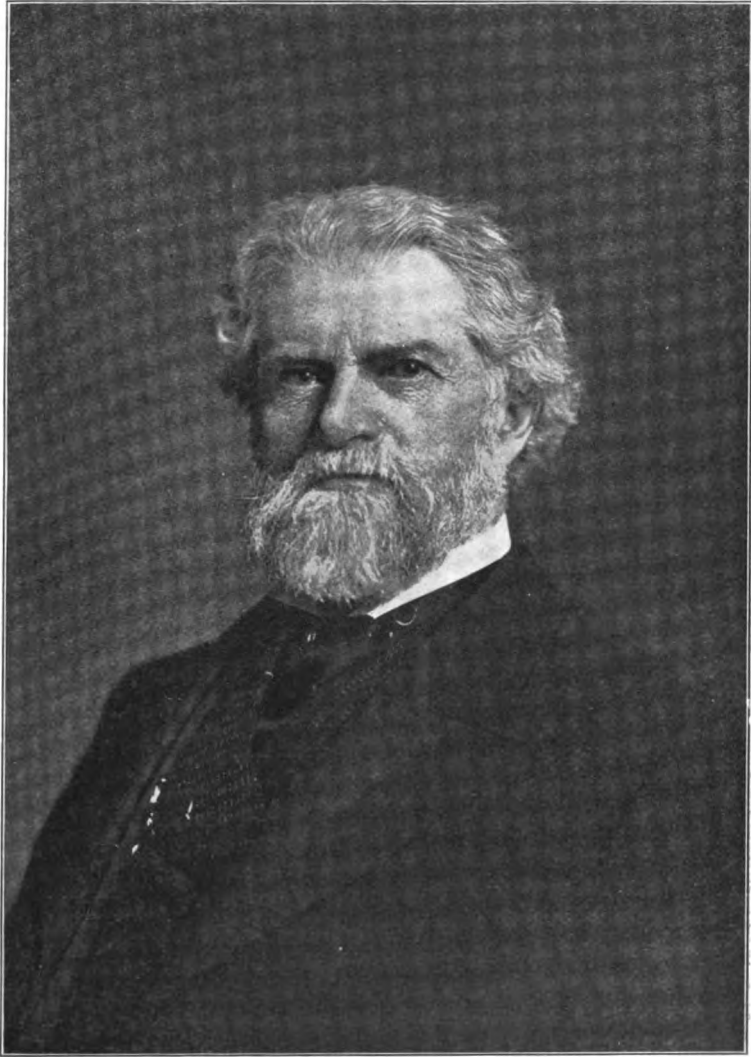

Simon Newcomb

these was in administration, and the national government owes much to his skill and wisdom. Another is in his numerous popular works and text-books. He was a master of clear thinking and good English—witness, for example, the series of papers on "The Stars," published in this journal in 1900. He was also the author of standard works on political economy and of a great number of articles, addresses and papers dealing with the problems of science over a very wide range.

It is needless to tell here of the honors conferred upon Newcomb. He was elected president of the American Association for the Advancement of Science at an early age. Honorary degrees and honorary membership in academies were heaped upon him. To be one of the eight foreign associates of the Paris Academy of Sciences is perhaps the highest recognition that can be given in the scientific world. It had not been awarded to an American since Franklin.

THE DARWIN COMMEMORATION AT CAMBRIDGE

THE centenary of the birth of Charles Darwin coinciding with the fiftieth

anniversary of the publication of "The Origin of Species," has been adequately celebrated in the United States, as recounted in the April issue of this journal, which was itself a Darwin memorial number. It is, however, fitting that the principal commemoration should be held in Great Britain and at the University of Cambridge. Darwin, it is true, held no academic position and was not greatly influenced by his work as an undergraduate at Cambridge. He said later that his "time was wasted as far as his academic studies were concerned"; but he could also say: "the three years I spent at Cambridge were the most joyful of my happy life." The part often played by a college in the future life of a student through the friends and associations there formed is well illustrated in the case of Darwin. He became interested in collecting beetles through his cousin, W. Darwin Fox, also a student of Christ's College, and through Henslow, the eminent botanist, and it was through the latter that he was led to undertake the voyage on the *Beagle*. This was Darwin's true university course, and it is difficult to imagine just what he would have done in the world had it not been for the circum-



THE SECOND COURT OF CHRIST'S COLLEGE, in which were the rooms of Charles Darwin.

stances, which may be regarded as accidental, leading to this voyage. When we remember that his contemporaries, Huxley, Wallace and Hooker, were also led to their scientific work by a voyage of exploration, we must regard it as more than a mere incident in their lives.

It is truly remarkable that Christ's College, smaller than the average of our six hundred colleges and with no higher standards as far as the requirements of the curriculum go, can celebrate the tercentenary of the birth of Milton as well as the centenary of the birth of Darwin; that Tennyson and Darwin should have been fellow students, and that Newton, perhaps Darwin's only rival for scientific preeminence, should have been a member of the same university. Darwin's grandfather, Erasmus, was also a Cambridge student, and three of his sons are intimately connected with the university. Cambridge may well be proud of its great men and England of its great university; and this feeling we may share, remembering the descent of our academic institutions from the new Cambridge in New England.

An English university is certainly the place where a ceremonial such as the Darwin centenary has the most fit setting. To it came delegates from all parts of the world, some 230 in number, leaders in all departments of science and especially in the biological and evolutionary sciences. Lord Rayleigh, formerly professor of physics and now chancellor of the university, welcomed the guests to the Fitzwilliam Museum on the evening of June 22. On the following day, there was a presentation of addresses by the delegates in the Senate House. After the address of the chancellor speeches were made by Professor Oscar Hertwig, of Berlin; Professor Elié Metchnikoff, of Paris; Dr. Henry F. Osborn, of New York, and Sir E. Ray Lankester, of London. In concluding his remarks Dr. Osborn said that they, the delegates, naturalists and friends, desired to present to

Christ's College, as a memorial of their visit, a portrait of Charles Darwin in bronze, the work of their countryman, William Couper, "a portrait which they trusted would convey to this and future generations of Cambridge students, some impression of the rugged simplicity as well as of the intellectual grandeur of the man they revered and honored."

On Wednesday evening the delegates and guests were entertained at a banquet held in the New Examination Hall, which was used for the first time for a public purpose. Among the speakers were the Right Hon. A. J. Balfour, Dr. Svante Arrhenius, Professor E. B. Poulton and Mr. William Erasmus Darwin, eldest son of Charles Darwin. On Thursday, the Rede lecture was given by Sir Archibald Geikie, president of the Royal Society, and honorary degrees were conferred on a number of delegates, including from America Professor Jacques Loeb, of the University of California; Secretary Charles D. Walcott, of the Smithsonian Institution and Professor Edmund B. Wilson, of Columbia University. During the celebration there was an exhibition held in Christ's College of pictures, books, manuscripts and other objects connected with Darwin, including the portraits by Richmand, Collier and Oules, and the bronze bust by William Couper, of New York, which the American delegates presented to Christ's College.

THE WINNIPEG MEETING OF THE BRITISH ASSOCIATION

THE British Association for the Advancement of Science takes seriously its imperial functions. Four years ago it migrated to South Africa, and now, for the third time, it is about to hold a Canadian meeting and in the very center of the great dominion. The British Association has maintained its usefulness and prestige along the lines in which it was originally established. It is a great factor in the diffusion as well as in the advancement of science.

Its meetings are attended by the leading professional men of science and at the same time by large numbers of amateurs. The local members at each meeting are likely to exceed a thousand, and excellent arrangements are made for their instruction and entertainment. The social features are emphasized, so that there is opportunity for forming personal acquaintances and for those who are only interested in science to meet those most actively engaged in its advancement.

The Winnipeg meeting, which opens on August 25, will be presided over by the eminent Cambridge physicist, Professor J. J. Thomson, who succeeds Mr. Francis Darwin. Addresses of general interest will be given by the president and the presidents of the sections, and by Professor Herdman, Professor Tutton, Professor Dixon, Professor Poynting and others, and the sectional meetings are certain to have attractive programs. There will also be the usual extensive arrangements for garden parties, receptions and excursions. A visit to the Pacific coast, including Alaska and the Seattle Exposition, should be of unusual interest.

The Canadian railways offer a single fare, so the return trip from Montreal or Quebec to Winnipeg costs only thirty-six dollars. The council of the British Association has courteously voted to admit all members of the American Association for the Advancement of Science to membership for the meeting, waiving the entrance fee, and the American Association will hold no meeting this summer. A large number of Americans will doubtless take advantage of the generous invitation of their British colleagues and attend the

Winnipeg meeting. It is a rare privilege that should be taken advantage of by all who find it possible.

SCIENTIFIC ITEMS

WE record with regret the death of Professor J. D. Cunningham, the anatomist of the University of Edinburgh, and of Dr. M. A. Brezina, the mineralogist of Vienna.

AMONG the honors awarded on the birthday of King Edward are knight-hoods to Mr. Francis Galton, Professor J. Larmor, Mr. R. H. I. Palgrave and Professor T. E. Thorpe.—Mr. Orville Wright and Mr. Wilbur Wright were presented on June 19 with the gold medal authorized by congress, a medal on behalf of the state of Ohio and a medal on behalf of the city of Dayton.

DR. WILLIAM H. WELCH, professor of pathology in the Johns Hopkins University, has been elected president of the American Medical Association.—Professor E. W. Morley has been elected honorary president and Dr. W. H. Nichols acting president of the Seventh International Congress of Applied Chemistry, which has accepted the invitation extended by the congress through the president and the secretary of state, to meet in this country in 1912.

MR. JOHN D. ROCKEFELLER has made a further gift of \$10,000,000 to the General Education Board. Its endowment is now \$53,000,000. Mr. Rockefeller has authorized the board to distribute the principal as well as the income for educational purposes, should this at any future time appear to be advisable.

THE POPULAR SCIENCE MONTHLY.

SEPTEMBER, 1909

CAPACITY OF THE UNITED STATES FOR POPULATION

BY PROFESSOR ALBERT PERRY BRIGHAM
COLGATE UNIVERSITY

IF any reader of these pages thinks, with a recent writer, that "population is a vast and wandering theme," we shall have no quarrel with him. No doubt the problem has a keener interest in such a country as Great Britain or France, where population approaches capacity or is perhaps beyond the permanent limit of resources. But we are maturing, the frontier stage is past, our land is filling and fertile quarter sections are no more free. We have thus our own social problems, sharpening their quest for solution, and, moreover, being Americans, we now and then become enthusiastic and break into prophecy.

We may well sober our inquiry with the preliminary question—is a great population desirable? Not so, surely, for us, from the military point of view. We have men enough to send to the front and men enough to keep in the shop and field, to meet any emergency of war which lies within the horizon of reasonable conjecture. Perhaps, in view of our general influence in the world, we might be glad to have several hundred millions of people, but only if we are so conditioned that our influence would be a boon to other lands. This indeed in itself implies a limit, for we must not be too many to live with freedom and with worthy standards.

We may take ourselves out of the ranks of the enthusiast with a second preliminary question—is a great population probable? Our list of prophets is distinguished. Mr. O. P. Austin thinks there is no good reason for our failing of three hundred million people in the year 2000. Mr. James J. Hill expects an increase to two hundred million in less than fifty years, and Mr. Andrew Carnegie a few years ago thought five hundred million a proper figure. Mr. Justin Winsor allows two hundred million for the Mississippi Valley. Mr. F. A. Ogg raises the figure

by fifty million, and Professor A. B. Hart does not hesitate to go up to three hundred and fifty million. We are by no means disposed to dispute all of these figures, but there are considerations which point in the other direction, as for example that the percentage of increase went down in the decades between 1860 and 1900.

We have also the check of advancing civilization. That voluntary restriction follows a higher scale of needs is shown in France, in lesser degree in Great Britain and probably in all lands of advancing culture. Thus there is color for the view that France with her disturbing birth rate has only arrived first at the condition to which all cultivated peoples are moving. Motives of economy and of opportunity for self and children press more strongly as standards rise, and it has recently been urged that even Ireland, with new land laws and with peasant proprietorship, will become more restrictive of population. It seems to be as true with man as in the general field of natural history, that the higher the type the fewer the progeny.

Perhaps also this tendency will fall in with the natural limit of food production. Indeed, the latter will have a controlling causal effect on the former, following the ever-operative law that higher prices or approaching scarcity is accompanied by restriction of population. That which is temporary in the latter case may well be found permanent in the other.

To the present time immigration has been one of the chief sources of our growth. We are already seeing a check of the inflowing current, and this may well become permanent in future years. The restrictive measures of the government count for something. The narrowing of opportunities, as for free land, is another and more powerful factor, and a further consideration of unknown significance is rising in our view, namely, the improvement of conditions and the triumphs of democratic aspiration in the lands from which the foreigner comes. In proportion as life in the old countries becomes endurable, not to say attractive, the fountains of immigration will begin to go dry.

On the other hand, there is a source of increase upon which we may look with full content, reasons, applicable alike to us, which a European authority has assigned, for the increase of European population during the last half century. These reasons are in relation to the lowering of the death rate by diminution of war, by the elimination of epidemics and by better hygiene. These advances would seem to mean more than a lower death rate. Not only are people kept alive, but they are made more productive workers and reasonably, it would seem, may become more prolific as well as better conditioned. Whatever our views of population or progress, it would hardly be prudent to disagree with Mr. Mackaye's proposition that it is not so important to get nitrogen into the soil and raise more food as to make right use of the food we have. We should, he thinks, avoid undue increase of our population,

raise our wealth per capita, and not "cause two unhappy human beings to live where one lived before."

It is proposed here to attend more to the means of approaching the problem, than to the study of figures, which last in writings on population, are usually guesses supported by vague and inapplicable comparisons with China. As the writer has said elsewhere, it is not of interest to know how many Chinese could exist on American soil, but how many occidental citizens could live here in comfort and progress.

The largest single element in our problem must always be food. Other things are important, but for simplicity we take this singly, in relation to the resources of our own domain. There are several ways in which our food supply can be increased, and first of all, without raising the sum of products, they can be enlarged in their availability. No one familiar with culinary matters can avoid the belief that there is great loss through misuse and positive waste. Unskilled treatment alone is responsible for much loss of nutritive values and prodigality is to be found on private tables, while consumption in public places is attended oftentimes with destruction that is well-nigh criminal. The rise of industrial and domestic science will in part correct the evil, and any ultimate approach to a narrow margin between food and mouths would be felt in resulting economies.

No one doubts that our food supply could be much increased by more scientific and intensive cultivation of lands which are now actually under the plow. Here indeed we are already beginning a cheerful and significant era of hope and achievement. The farmer is becoming a wiser man and many things are helping him in his unfolding. This came home to us recently in the story of a farmer in western New York, who started poor four years ago, has paid for a large farm property with four crops, and expects out of the fifth to build a mansion for his family.

The American farmer is learning to adapt his crop to his soil and to his market. This is the teaching of the United States Bureau of Soil Survey, in its field work and in its reports. It is the burden of the agricultural college and of the experiment station, and the agricultural explorer of the department in Washington is searching widely in aid of something fit and good to fill every arable American acre. Adaptation will increase the product of food, as will also the more intelligent and energetic use of fertilizers. Intelligence will find the fertilizer and put it where it will do the greatest good, and will stimulate the energy in its use which is now sadly lacking. Let any man traverse the country regions in the eastern states and he will pass innumerable poor and hungry farms, and the greater the natural leanness of the soil, the more sure is he to see the manure-heap leaching, often for the second year, in the farm yard.

In like degree are our resources now wasted through the prevalent

methods of sewage disposal. No treachery to the land can be so great as that which sends out into the sea the highly concentrated nitrogenous products which have with toil been wrung from a soil which is becoming poor in capacity for crops. In this primitive riddance of valuable matter we accomplish a further loss by polluting the waters and if we do not thus endanger human life, we destroy the fields in which a certain important amount of aquatic food can be produced.

A further gain can be had on soils already in use by expert management in the direction of proper succession of crops and a thoroughness of occupation and tillage often seen in Italy, France or Belgium, but only exceptionally found as yet in our own land. We need not only better directed labor, but more labor on the same soil. In the regions of sufficient rainfall, which comprise nearly the eastern half of the United States, we shall find, or did find in 1900, seven men per average square mile, tilling the soil, or one to each lot of 91.4 acres. Making generous allowance for ground not in tillage, we still find the working force far too small to bring maximum quantities of food out of the ground. We need also on much plow land and meadow east of the arid belt supplementary irrigation for many seasons and for some crops, and with abundant water resources, there is no good reason why nature should not thus be helped to her best. Some areas, many, it would doubtless be better to say, would be doubled in productive worth by more effective drainage than has yet been applied. The barest inspection of crop averages per acre, or of half the ripening harvests that fall under the eye of the traveler, supports the belief that a vast increment of food can be won from lands that are not now given a full chance.

Further inquiry leads us to lands not now cultivated, which might and will be made productive. Here some of our largest reserves appear. Lands of an arid or semi-arid character embrace about two fifths of our territory. In these great fields, and in small patches now improved, crops can not be expected unless water is applied by man. There is doubtless force in the claim that these soils are potentially marked by exceptional richness, due not only to the fact that they are virgin soils as related to man, but because they have not suffered the leaching and waste of important elements which have affected soils in lands of large rainfall. It is cited by Hilgard that Nile lands have for centuries supported an average population of more than one and one half persons per square acre, which means a density of about 1,000 per square mile. Without questioning the accuracy of this claim, it may be urged that we do not know whether flooding by the Cordilleran irrigator would be as favorable to fertility as the flooding of the Nile. Nor may we forget comparative standards of living any more than in the case of China.

We must also keep in sight the inevitable condition that there is water enough in the west to make fertile but a small fraction of the dry area. If we accept this at one fifteenth and receive without discount

the figures for the Nile, applying them boldly to Arizona, Colorado, Nevada and the other arid states, we shall arrive at a population of eighty million for the arid regions. The eastern man will incline to think this conclusion savors of fancy, and the Cordilleran enthusiast will in like manner think it sober and sensible prophecy. All will agree, however, that the food production of the country will rise by a marked increase when reclamation work has been carried toward its maximum. Whether many millions or several tens of millions will thus be added to our numbers is not important to our present purpose. That the growth will be large none denies.

A further great gain will be made in the drainage of our marsh lands, both of the marine and of the fresh-water type. That this is in no way theoretical appears in the vast European areas, which, though now densely peopled, were more or less covered by water a millennium ago. Professor Shaler counted that the area of swamp lands rises to more than 100,000 square miles, reckoning only such marshes as would be considered reclaimable in northern Europe, and he believes that they would be equal in production to the three states on the north bank of the Ohio River, Ohio, Indiana and Illinois. When one remembers the quality of a drained swamp, and that the area of available marshes is about three fourths as great as these combined states, he will have no difficulty with this conclusion.

The importance of this reserve has recently been accented by the proposal of Senator H. C. Hansbrough, to make these marshes also subject to reclamation by federal action. Further emphasis is warranted by the easy proximity of many of these lands to great eastern markets, and by their adaptation to the intensive culture of many crops.

We may be challenged in the statement that forest lands of some extent may yet be spared for tillage. The writer yields to no one in loyal conviction of the importance of forest conservation, or in condemnation of congressional delay and inaction. Ultimate adaptation will control in forest conservation, and some lands will be cleared for needful and effective tillage, and their loss will be counterbalanced by the foresting of other areas where unfitness for the plow is now evident.

We shall also replace forest products in a more extended use of underground materials for buildings and implements. As in Europe the clay pit and the quarry will afford means of curtailing the forest. Likewise the use of the fibers of grain plants for the making of paper will release timber for other uses or timber land for other crops. We need also to remember that the remaining forests will be properly conserved and made largely and permanently productive. When, forty years ago, the Irish laborer planted his potato patch by the railway track, or when to-day the Italian immigrant raises his vegetables in waste corners, it has not been recognized that he is the pioneer of the future. It is the traveler in such foreign lands as Belgium, Norway or Italy, who becomes able to appreciate the waste of American soils.

Beyond the plowed fields of the present, the arid and wet lands and the superfluous forests, are no inconsiderable reserves of food from lands deemed useless. We may consider potential gardens along more than two hundred thousand miles of railway, the fruit that might grow by millions of miles of highway, the steep and immature slopes that are more capable of terracing than those of Capri or Amalfi, or ancient Palestine, and finally those rugged areas of glacial hillside or mountain slope, where nut-bearing trees might produce no inconsiderable amount of highly nutritious food. The possible production of food substances in the laboratory is at present so far from the geographer's domain that it would be profitless to dwell upon it.

It is plain that the whole circle of conservation problems applies here, not only by directly increasing food, as in irrigation, but in cheapening the cost of transportation, in saving land by forest conservation and in utilizing power of every kind to the full, thus releasing time and energy for the free use of opportunity and the complete employment of all our resources. Thus a well ordered civilization would sustain the greatest number at good standards, as a well-managed household may maintain a large family on a lesser sum than is required by a neighboring small household.

Population capacity would afford a less baffling inquiry if food alone were needed. Mere questions of mouths, bushels and pounds might involve simple ratios, easily determined, but we must at once include clothing, of vegetable fibers, animal fibers, furs and skins, nearly all requiring land for their production. Man must have shelter and a long catalogue of objects of domestic utility, for the household and for the tillage of the soil. These things may become chiefly derivable from subterranean sources with the single exception of a minimum demand on the forest. Many rocks and mineral substances would far outrun any possible use of them, but it seems certain that we could not for many generations supply iron for as many millions as we can feed. It may be doubtful whether our ultimate expansion will receive its first effective check above or below the surface of the earth.

We must include also a wide range of objects of public utility, such as roads and all appliances of transportation and manufacture, and public structures for education, worship, government, health and charity, adding instruments of knowledge and pleasure such as books, music, ornaments and all works of art.

Almost as fundamental as food is the requirement of power. Here, however, the supply seems ample and permanent. Long before the stores of buried fuel are exhausted, other natural forces, particularly that of moving water, will meet the needs of any population which we can feed. The maximum of population therefore for the whole world hinges upon the supply of material substances derived from the atmosphere, the water, the soil and the rocks.

For a given country the problem is complicated by exchange. The exchange values, however, must be won on the home ground. England has, for example, a far greater population than she can feed, but her coal and iron have enabled her to manufacture and to carry for other nations. But England is now to a considerable extent using foreign supplies of the ores of iron. For a period she may do this and maintain her industry, through inertia, but imported raw materials and fuel could not permanently afford a basis for British industry, and for the present population of the United Kingdom. In that future, whenever it may come, the islands will contain the people whom they can feed, clothe and shelter, and no more.

Total resources, therefore, rather than total food production, determine how many people a given country can support, but in the world aspect total food marks an absolute limit, since we can not bring in food from Mars, even if Mr. Percival Lowell should convince us that she had a surplus.

It would be interesting to consider the United States in the light of the principles that have been suggested, but the story would be too long. We might simplify it by adopting the interesting and pleasant belief that our extraordinary range of resources would enable us to get on with little exchange, but this, as we have seen, would hardly change the result as to population. Mr. O. P. Austin supports our hopes of three hundred million people by the comfortable assurance that we can grow all our sugar, all our rice, wine, tea, silk fibers, tobacco and most tropical fruits. Probably we could get on without diamonds and there are those who think our civilization might survive without coffee. But it would really make little difference whether we raised coffee or bought it with the proceeds of wheat. Or we might, indifferently, raise our silk, or sell farm machinery and buy silk, since either sort of production at present requires trees, and trees require land.

We have ventured the belief that we are sure of power. We may further include hopefully the resources of the underworld of the rocks, considering new reductions and uses of metals and many mineral substances. When the use of wood has come down to the minimum, the chief remaining demands on the soil, may, after all, be for food and clothing.

If we further suppose war and heavy armaments eliminated and all government honestly and economically administered, we shall cover a vast present waste. Thus to arrive at maximum population we must somewhat approach millennial conditions. Then, in high degree a self-sufficient nation, we could keep as many people as our own soil could feed and clothe. With wise timidity we have been deferring those large transactions in figures which the reader has been expecting, and we might with good show of reason, confess that inquiry for precise results is absurd and drop the attempt to forecast. Nevertheless, the next patriotic speech will marshal before us our future hundreds of millions,

sole progeny of buoyant national pride. Perhaps, therefore, any sober argument on this inevitable theme is better than none.

Probably the safest approach is by comparison, for thus we avail ourselves of such experience as has come to our race in different parts of the world. But let us avoid China and Java, even though they seem such available examples of a great population, of high density, with small percentage of exchange and hence almost self-sufficient. But their standards of living—could we, even with our superior skill and progressiveness, take the same resources and support an equal number of people up to American standards of comfort and efficiency? We do not know those resources well enough to tell, hence we dismiss oriental nations and turn to people more like ourselves.

We have elsewhere made a brief comparison between England and that part of the United States which lies east of the Dakotas, Kansas and Texas. It was suggested that this region, about two fifths of the chief continental area of the United States, averages in resources of every sort as well as England, and it was shown that if we could in these 1,200,000 square miles reach the present density of England, we should have, east of the meridian of Omaha, 742,000,000 people. To have put this in print should at once, it would seem, shatter all pretension to soberness. We are quite willing to scale down the figure, while taking refuge under the fact that these computations were not offered as prophecy. With such an enormous population, we, like England, could not feed half our mouths, and should have to exchange other products for food. But other lands might not have the surplus in those days, to send to us. And our underground resources might be seriously reduced, if not exhausted, and we could not produce the exchange values. We thus see how fascinating and how futile is the hundred-million tendency. Let us divide our total by three, and arrive at a population which we might hope to feed from our own soil, a little under 250,000,000. It will be seen that in this estimate we leave the Great Plains and Cordilleras to be peopled according to the dictates of a cold conservatism, or of a lively enthusiasm.

An instructive comparison can be made with Italy, whose area is 110,550 square miles, and whose population is reckoned to have been, on January 1, 1907, 33,640,710. The density was 304.3, not far from half that of England or Belgium, and about twelve times as great as that exhibited by the United States in 1900.

We may first take the comparative density of agricultural workers. In Italy, of persons, male and female, over nine years of age, there were at work in the fields, in 1900, 9,611,003. In our own country in 1900 there were, over ten years of age, 10,438,219. When we remember that the smaller country contained a little more than 30,000,000 people at that time and we had 76,000,000, the figures show their meaning. This comes out with force if we look at the ratio of workers to a given surface of production. In the United States east of the arid regions there was

one worker to each 91.4 acres, counting the entire territory. In Italy there was one to each 5.07 acres, counting only the productive lands. But as these are there reckoned at more than two thirds of the whole, the comparison stands almost at full force. Including all of Italy, we should find one worker for each plot of eight acres or a little less.

Making all due allowance for primitive methods and smaller individual efficiency, we still see how much more intensive is the care of the lands. And we must not forget that in Lombardy and some other parts of the Mediterranean kingdom, modern methods are gaining ground. Indeed that nearly two thirds of the country is worked as productive soil is in itself significant to one who knows the ruggedness of much of the realm. The stretches of bare Apennine slope seem to be endless, and one is sometimes inclined to say that Italy is fertile only in spots. It has been called a "gray rather than a green country," a designation which must stand true except for idealizing imaginations which require Italy to unroll fields of endless verdure. One must traverse the Val d'Arno, or cross and recross the plains of the Po, find the fertile corners of south Italy and Sicily, and then explore the terraced mountainsides and secluded Apennine valleys, to learn how the little kingdom feeds so many people. If we are reminded that the people are poor and the comforts of life small, we recognize the fact, often sad and depressing, but even here, when considering capacity for population, we remember that Italy has lost by long use of her soils, and by much injury through deforestation, no small measure of her ancient capacity for food production. We, on the other hand, have a virgin country and on the whole our spirit of conservation has arisen in time to save us from fatal losses.

The value of Italian products, as reported, for tillage, animals and forest, is annually about \$1,000,000,000. This figure, however, does not include the items of poultry, eggs or vegetables. These, and especially the last, are no doubt far more important relatively than in our own country. The above figure gives a little less than \$30 in value for each person in the kingdom. This indeed would seem a starvation figure, but for the vegetables, whose rapid succession of crops and large consumption, must be a large factor in maintaining so great a density.

The comparison turns greatly in our favor when we consider underground resources, and here her paucity makes Italy instructive for population study. Gold and silver are so small as to be negligible, and yet she must acquire her reasonable sum of these metals. Sulphur is far in the lead, but amounts annually to but little more than \$7,000,000. Zinc follows with \$4,000,000, lead with a little more than one and one half million and all the others fall below the last figure. Iron gives an annual value of \$1,371,155, and employs but 1,790 workers. Mineral fuel stands at \$838,375, a small fraction of the mineral fuel output of the single state of Iowa. Coal and coke are imported to the extent of about \$40,000,000, and boilers and machinery cross the fron-

tier to the value of \$32,600,000. The total annual mineral output of Italy is about \$20,000,000.

When we remember that Italy imports much of her food as well as iron, coal and other things, we are pressed with the question—where does she get her exchange values? Five of her imports pass the hundred million lire mark. These are wheat, raw cotton, coal and coke, boilers and machinery and raw silk. But one export passes this mark, viz., raw silk, rising, however, to nearly 600,000,000 lire. There are, indeed, many exports of smaller value, but these are more than offset by minor imports, so that, as a whole, her imports exceed her exports by nearly 600,000,000 lire, or by about 33 per cent. It is not easy to see how Italy maintains her people. Certain reliefs suggest themselves. It is admitted that many Italians exist rather than live; but this must not be said of Rome or Tuscany or the valley of the Po. We allow something for a genial climate which at once gives quick returns from the soil and reduces the need of clothing and fuel. And we may not forget the great sums brought into Italy by travelers and foreign residents, for the winning of whose money Italian arrangements sometimes seem peculiarly effective. However difficult it is for one not trained in economic studies to see how this thing is done, it is done, and conditions are improving. We are thus warranted in looking to this middle kingdom of the Mediterranean for lessons concerning ourselves.

As has been already intimated, 70.6 per cent. of Italy is registered as productive, the rest being barren or negligible. Let us consider the territory of the United States east of the arid regions. We will (let us hope to be forgiven) eliminate New England, the Appalachian Mountain belt, the Appalachian Plateau, the interior timbered region and the Ozark Hills. The lands thus thrown out as relatively poor contain 28 per cent. of the area under consideration, which it will be seen is not far from the 29.4 per cent. rejected in Italy. And they contain 30,000,000 people, which is not far from the population of Italy. We have left a vast expanse of prairie, alluvial and lacustrine lowland, and of coastal plain. We may at least please our fancy by giving these selected lands the density of Italy. The resulting population is about 334,000,000. Adding the present population of the rejected areas, we have a total east of the arid belt, of 364,000,000. If we allow half the density of Italy for this entire area, we have a total population east of the arid belt, of 230,000,000.

We have just referred to a classification of lands which is comparatively new. For some years physiographers have seen that new categories were needed in the description of continental surfaces. The forms of the land have been taken into account, in respect both to their origin and to their present characteristics. A plain is more than a plain for it may be of a variety of origins and types, with its peculiar phases of structure, relief, soil, climate and vegetation. Similar statements

may be made of plateaux and mountain regions. In the census of 1900, this classification was taken up in a brief and supplementary way, and the area, population and density of the several physiographic regions were computed and are placed before the reader. The areas are not exact, for the boundaries had to be determined by the nearest available county lines, but the error can hardly be of disturbing proportions.

It is not here possible to exhibit or discuss the interesting facts brought out by this new departure of the census. It marks, however, a step of progress in understanding the adjustment of our people to their environment. Under the designation of New England Hills are included New England, the Adirondacks and the foothill country east of the Hudson in the state of New York. The density for this region is the highest in the United States, 124.1. How strongly population turns on other factors than soil, thus appears, and the result becomes astonishing when we put down in comparison the present density of the prairie region, viz., 29.2.

Using the new land classification, we may approach again the possible or probable population east of the great plains, or in the well-watered eastern section of the United States. Leaving out the New England Hills, which already exceed the density we are about to propose, and omitting the Appalachian Plateau and the Ozark Hills, it would seem reasonable to expect an average density of 100 for the remaining territory of the east. This is about the density of Europe. The territory for which we propose it includes the coastal plains and lowlands, the Appalachian Valley, the piedmont and lake regions, the Mississippi alluvial region, the interior timbered region and the prairies. One need not apologize for thinking this aggregate physically as good as average Europe. Two of the regions, the Appalachian Valley and the piedmont, already have more than three fourths of the density proposed, and the interior timbered region, so far from being the wilderness implied by its name, has a density of 68.7. Raising the whole to 100, we pass from the present 53,800,000 to 127,600,000. If to this total we add the present population of the New England Hills, the Appalachian Plateau and the Ozark Hills, we bring our total to 145,000,000. If we allow reasonably for the growth of these three regions we place the figure at 150,000,000.

A density of 100, however, seems a low expectation for the prairies, and also for the lake region, which last already has 55.2 persons per square mile. Considering the soil, climate, minerals and transportation facilities of the lake borders, their population must largely increase. Give these two regions the present density of France or of Austria-Hungary, we must add to the total already reached, 40,000,000 for the prairies and 15,000,000 for the lakes, bringing our total east of the great plains to 205,000,000.

Iowa is a typical prairie state and has 55,475 square miles, not counting a few hundred miles of water surface. This state has about

two and one fourth million of people, and with the density of France would have more than four times as many, or nearly ten and one half million. Iowa now has 13.39 acres of improved farm land for each one of her population. With the greater density she would have about three acres for each person, while France now has two and one third acres. In general fertility the odds are probably in favor of Iowa.

The mineral output of France is now relatively much greater than that of the prairie state, but it is by no means certain that the ratio would be maintained under full development of the new region, whose building stones, clays and gypsum are but in their commercial beginnings. In that prime necessity, coal, Iowa has quite the advantage, for she mines annually $2\frac{1}{4}$ tons for each resident, against $\frac{1}{3}$ ton in France. The latter people imports much fuel, while the vast resources of Iowa for the most part lie still beneath the surface. Not many are probably aware that Iowa has 7,000 square miles of forest, more than at any previous time within the ken of the white man. She has, indeed, nearly as much forest for the proposed ten million people, as France now has for an equal number. It seems reasonable, therefore, to forecast for the prairies an occupation as dense as that of France or Austria.

It would be fatal to the peace of any student to omit the west in such a discussion as this. The writer recently made before the International Geographic Congress at Geneva what seemed to him the moderate and innocent assertion, that the center of our population would always remain some distance east of the geographic center of the United States. He was sharply reminded by a fellow American that such sentiments openly expressed on the Pacific Coast would make him the subject of a lynching excursion. As he is at present at a safe distance he retains his view, but is willing to accept tentatively a generous prophecy for the Cordilleras. Suppose we take seventy-five per cent. of the figure already hazarded for the areas of reclamation, or 60,000,000. And that we may not seem to be dominated by cramped eastern notions, let us concede, since no data are available, that when the arid lands are turned into paradise and a full trade established up and down the Pacific and across its wide waters, that the coast and its cities, the wet belt of the border, the mining centers, mountain valleys and arid pastures will harbor an additional 40,000,000 people. This allows 100,000,000 people west of the prairies, a region that in 1900 had a population of 4,654,818 and a density of 3.5. Here is an increase of twenty-one and a half times, a proposal which can hardly be charged with parsimony, and raises our total for the whole country to 305,000,000. If we think the Cordilleran estimate out of bounds, it would yet be easy on the basis of European comparisons to find place for compensating millions in some of the geographic regions east of the Mississippi River.

PEALE'S MUSEUM

BY HAROLD SELLERS COLTON, PH.D.

UNIVERSITY OF PENNSYLVANIA

AN almost neglected chapter in the history of the natural sciences in this country is that dealing with Peale's Museum.¹ Of the accounts of the museum that have appeared from time to time, one alone is worthy of consideration, being written from a scientific point of view. The work referred to is by Mr. Witmer Stone² and considers the ornithological collections alone.

Through the great kindness of Mr. Horace Wells Sellers, access has been had to the diaries, letter books and unpublished autobiography of Charles Willson Peale. With the material thus furnished by Mr. Sellers, to whom the writer is deeply indebted, and much other material from the Pennsylvania Historical Society and the Philadelphia Library, very little of which has been referred to by biographers, many clouds enveloping the history of Peale's Museum have been cleared away. As this history is so intimately connected with the life of the founder, a better beginning can not be made than by reviewing briefly his career.

His life was a long one—eighty-six years. It divides itself very naturally into four periods—of about equal length—twenty to twenty-four years: the period of youth, the period of the prime of life, the period of middle age, and the period of old age. The first period begins with his birth in Queen Anne County, Maryland, April 15, 1741.

His progenitors were English. In the paternal line, they were for several generations rectors of the parish of Edith Weston in Rutlandshire. Charles Peale, his father, although educated in turn for the church at Cambridge, did not take a degree, but came to this country and became headmaster of the Kent County Free School in Maryland. Although the school was popular and patronized by the best families of Kent County, yet he, at times, had great difficulty in making both ends meet; and died when his eldest son Charles Willson Peale was nine years old. His widow, being left with very little to provide for a large family, removed to Annapolis, and, by dressmaking, maintained herself and her children.

¹The official name was "The Philadelphia Museum," but must not be confused with the now existing "Philadelphia Museum," which was founded forty-five years after the former ceased to exist.

²*Auk*, April, 1899, Vol. XVI., pp. 166-177.

Charles was now put to school; but, after he had learned writing and arithmetic, etc., he was apprenticed, at the age of thirteen, to a saddler. Working out his apprenticeship, when he was twenty-one he married into an influential family; and, with the assistance of a life-long friend of his father, James Tilghman, set up in business for himself.

The saddlery business did not prove a success; and it was about this time that he, on seeing a poorly executed painting and having had from childhood a taste for drawing, thought that he could paint as well. With some borrowed colors and by the aid of a looking glass, he painted a portrait of himself with such good results that some of his friends advised him to study painting seriously. Thus, at the age of twenty-four, he began the second period of his life—that of a painter.

Peale, the Portrait Painter

After studying under the best available talent in Maryland and in Virginia, he went to Boston and took a few lessons under Copley and shortly afterward was engaged to paint several portraits. Returning to Annapolis, his work soon became noticed. John Beale Bordley and several of his fellow members of the Governor's Council of Maryland made up a purse and sent Peale to London to study under Benjamin West. Returning to Maryland two years later, his ability was soon recognized and for the next twenty years he was the leading portrait painter of Pennsylvania and the south.

His many engagements in Philadelphia caused him to move to that city in 1774 and to make it his permanent home. Being an ardent patriot, he offered his services to the American cause at the beginning of the Revolution, being made lieutenant and later captain in a company of Philadelphia militia. He was in action in the battles of Germantown, Trenton and Princeton. At Valley Forge in the winter of 1777 he found occupation in painting portraits of his fellow officers. Many of his portraits painted during the war were subsequently placed in his "painting room" to form a nucleus of what he hoped would become a national portrait gallery. During this period, his interest in public affairs led him into various activities and public positions in connection with the British evacuation of Philadelphia.

As soon as opportunity offered, he established himself in a house at Third and Lombard streets and resumed with his former energy the practise of his portrait painting. In connection with this house he built a long room to hold his pictures and to use as a studio. As curiosities Dr. Morgan gave him some bones of a mammoth from Ohio; Professor Robt. Patterson, of the College of Philadelphia, presented him with a paddle fish from the Allegheny River; Dr. Franklin gave him an Angora cat from France, which was soon lost for want

of proper means to preserve it; with these as a nucleus, it was suggested to Peale that he start a museum of natural history.

The Museum

At the age of forty-four the third period of Peale's life may be said to begin. Acting on the suggestion that he form a museum of natural history, he at once referred to books to discover the means to preserve reptiles, quadrupeds and birds. At the end of the second summer those preserved were all eaten up by dermestoes and moths. After a great deal of experimenting, a method was devised that fills many pages of his autobiography. The basis of this method was the use of arsenic and alum. Although it had a very serious effect on his health for awhile, yet he was obliged to use it. "The many difficulties I had encountered in this new business," said he in his autobiography, "had made me often repent that I had undertaken so arduous a task, yet . . . the idea of handing down to posterity a work, that if judiciously managed might become equal to any undertaking of the like kind in Europe"—this was a stimulus to his exertions. Although, by the neglect of his portrait painting, he found it difficult, at times, to meet the expenses not only of his family, but of taxes, ground rents and other unavoidable expenses of his establishment, yet his enthusiasm, perseverance and ingenuity enabled him to conquer the difficulties, but not without the aid of his talents as a painter. Finally, after placing his museum on a self-supporting basis he retired in 1808 to his country place, "Belfield," in Germantown.

In the midst of the active period of museum development he made trips when his funds were low into all the neighboring states to paint. During his trips he never lost an opportunity to gather specimens or further the interests of his museum. On a trip to Maryland he met a Rev. Mr. Kerby who was a collector of beetles. His account, in his diary, of the effect of this meeting shows the enthusiasm that was instilled into his collecting. Said he:

Some collectors, like myself, have only looked for subjects large and striking to the sight, but now I declare that I find equal pleasure in seeking for an acquaintance with those little animals whose life, perhaps, is spent on a single leaf, or at most on a single bush. It is diverting to watch a flower as you approach and see the little being watching you. It turns around a twig or part of a flower to avoid your sight, and in an instant drawing in its legs rolls off, sometimes falling from leaf to leaf to get a passage to the ground.

Yesterday morning I set out to walk several miles before dinner. . . . But in the first meadow I found myself examining the bushes attentively and there I found so much amusement that several hours passed away before I could think of leaving those bewitching animals. Looking at my watch, I found it was almost dinner time, when I scarcely thought I had begun my pursuit.

The museum grew rapidly and soon he was obliged to seek for other quarters. Being a member of the Philosophical Society, some of his

friends suggested that he rent Philosophical Hall. This the society allowed him to do, making him curator and librarian. In describing the moving of the collection he writes:

To take advantage of public curiosity, I contrived to make a very considerable parade of the articles, especially those which were large. As boys are generally very fond of parade, I collected all the boys of the neighborhood. At the head of the parade was carried on men's shoulders, the American buffalo, the panthers, tiger cats; and a long string of animals carried by the boys. The parade from Lombard Street to the Hall brought all the inhabitants to their doors and windows to see the cavalcade. It was fine fun for the boys. They were willing to work in such a novel removal and saved me some expense in moving the delicate articles.

Governor Mifflin allowed Peale to fence in part of the State House Garden so as to make a place to keep living animals. Speaking of this, Peale said:

The cages and animals kept in the yard amused the public much, but was supported with some expense; yet it was a necessary appendage to the museum, as animals that had not come to their full growth are not fit subjects to be preserved, except when some of the young are to be placed with their parents to form family groups, as pictures of the manners of animals.

Notwithstanding legends to the contrary, this was the only zoological garden that Peale ever attempted to form, it being but a temporary expedient.

It was not Peale's practise to sell his duplicate specimens; but wherever opportunity offered he would exchange. In this way he was soon in communication with the various museums of Europe and from his letters I find that he sent many specimens to the Museum d'Histoire Naturelle, to the British Museum, to the Royal Society of Sweden, and many others scattered over Europe.

It must be remembered that during much of this time Europe was at war. Privateers scoured the seas, which made many letters go astray and caused many cases of specimens to be lost. Notwithstanding these troubles he mentions receiving an orang-outang and a "Platipus," and many other beasts from all over the world.

"Now to show all these things to advantage," said Peale, "required judgment as well as a tasteful disposition of them to be pleasing to the eye as well as useful to enquiring visitors." In classifying animals he followed Linnæus. In fact he was such an admirer of Linnæus that he named one of his children after the great Swede. He used Buffon's work to identify the specimens. However, as one would expect in a new country that had been visited by but few naturalists, much of the material gathered by Peale would be classed as "non-descriptis." To these Peale gave a common name but did not describe. It fell to the labors of Wilson, Say and other Philadelphia naturalists who followed to describe those animals. As arranged in the cases each animal had on it a label that gave the English, French and (when one had been given to it) Latin name.



CHARLES WILLSON PEALE.

With respect to the arrangement of the specimens on the shelves Peale says:

It is not customary in Europe, it is said, to paint skies and landscapes in their cases of birds and other animals, and it may have a neat and clean appearance to line them only with white paper, but on the other hand it is not only pleasing to see a sketch of a landscape, but by showing the nest, hollow, cave or a particular view of the country from which they came, some instances of the habits may be given.

This idea is interesting because it is the one that is growing in favor in the museums of Europe and America at the present time.

Peale and His Contemporaries

In 1792 Peale writes:

Having exerted myself to my utmost ability to collect and preserve articles for the museum and believing I could get men of distinction to form a board of visitors and obtain legislative aid for the further improvement of it so that at last it might become a great national institution, I waited on several gentlemen.

As a result of this, a board of visitors or directors was formed of twenty-five individuals. Thomas Jefferson was elected president, and among the others present were Alexander Hamilton, James Madison, Thos. Mifflin, Robert Morris, David Rittenhouse and Dr. Caspar Wistar. In the registration book of season ticket holders for the year 1794, the first signature is that of George Washington, who signed for four tickets. Then follow the names of John Adams, Munroe, etc. The fact that he was able to procure the aid of such men and the fact that he was allowed the use of Independence Hall rent free for a time and later for a nominal rental, all show that the museum was recognized as a valuable institution.

The decades 1790-1810, during which Peale was most active, composed part of the period of American zoology called by Brown Goode² the period of Jefferson. The influence that the great statesman exerted Goode compared to that of Agassiz in a later period. Among the medical profession of the country were a few men interested in natural history. These centered about the newly founded medical school of the University of Pennsylvania. The ones only that might be placed in a class with Jefferson were Caspar Wistar and Benjamin Smith Barton. Later may be mentioned the names of Wilson, Ord and Rafinesque.

At this time the pure sciences centered around the American Philosophical Society. The minute books of the society show that from the time that Peale was elected a member in 1786, he was rarely absent from a meeting. Renting, as he did, a large part of the hall and being librarian and curator, he was for many years closely identified with it.

In 1804, Baron Humboldt, Bompland, the botanist, and a Peruvian gentleman, Montrefar, arrived in Philadelphia from the famous trip to South America. Peale was a member of an informal committee from the Philosophical Society to see to their reception. The committee went with the travelers to Washington, where they were entertained by President Jefferson. Of this journey Peale writes to his brother-in-law in New York:

However, I have been richly repaid for the expense and trouble of a journey, by the agreeable conversation of Baron Humboldt, who is, without exception, the most extraordinary traveler I have ever met with; he is a fountain of knowledge that flows in copious streams; to drop this metaphore, he is a great luminary diffusing light in every branch of science, I say diffusing because he is so communicative of his knowledge, which has been treasured up in his travels of upward of nineteen years.

The Baron sat before Peale for his portrait and on sailing for France Peale presented him with a mounted specimen of an alligator. This

²G. Brown Goode, "Beginnings of American Science," *Proc. Bio. Sci. Wash.*, Vol. IV., 85.

later was presented on the Baron's return to France to the National Museum.⁴

With the Museum d'Histoire Naturelle, Peale had more intercourse than with any other institution in Europe. This began when the museum in Philadelphia was very young, by the arrival in Philadelphia of the naturalist, Baron Palisot de Beauvois, a refugee from the terrible massacre at St. Domingo. For the short time that he was in Philadelphia, Beauvois aided Peale in many ways. Not only did he help Peale in identifying the specimens,⁵ but he also wrote the French edition of the catalogue; and Peale in turn aided him by furnishing him with many letters of introduction whenever he went on collecting trips into other states. A personal friendship sprang up which lasted till Beauvois' death in 1820, and it is in Peale's letters to Beauvois after the latter's return to France that one finds the best account of what was going on in Philadelphia. With respect to the museum, Peale was in correspondence with Geffroy St. Hilaire and with Cuvier, also receiving letters from Lamarck. With all these connections joining the museum to France it was not strange that the French influence was strong.

The Mastodon

The feat which was Peale's greatest achievement in connection with the museum was the recovery and reconstruction of the skeleton of a mastodon. In the spring of 1801, receiving information from a scientific correspondent in the state of New York that the bones of a mammoth had been found in digging a marl pit near Newburg, Peale hastened to the spot; and, after bargaining with Mr. Masten, who owned the farm on which the bones were found, he finally paid \$300 for those bones that had already been procured and the right to drain and excavate the morass to recover if possible the rest of the skeleton. On Mr. Masten showing Peale the spot where the bones were found, which was a spacious hole filled with water, he wrote in his autobiography:

The pleasure which I felt at seeing the place, where I supposed my great treasure lay, almost tempted me to strip off my clothes and dive to the bottom and try to feel for bones. The hope, however, of returning soon with the means of emptying the pond satisfied me.

He went at once to New York. Through President Jefferson he was able to borrow pumps from the Navy Department and other things from the War Office. The Philosophical Society advanced him \$500 without interest, with his house in Philadelphia as security. He then returned to the scene of operation with his son Rembrandt. After

⁴Hamy, E. T., "Alexandre de Humboldt et le Museum D'Histoire Naturelle," *Nou. Achhis. Du Mus.*, 4e series, Vol. VIII., p. 10.

⁵Cuvier, "Eloge de M. de Beauvois," *Mem. Paris Acad. Sci.*, IV., 1819-20, p. 318.



INDEPENDENCE HALL, Philadelphia, which contained Peale's Museum.

hard work they were rewarded with grand success and were able to ship to Philadelphia one skeleton that lacked principally the lower jaw and the top of the head. What was lacking in this skeleton was found in another from a nearby bog. The bones of the two animals were not mixed. When the skeletons were set up the missing parts were carved out of wood, so that there were finished two complete skeletons. "Although putting these skeletons together," to return again to the autobiography, "was a long and arduous work; yet the novelty of the subject, the producing the form, and, as it would seem a second creation, was delightful; and every day's work brought forth its pleasure."

Up to this time many scattered bones and teeth of the mastodon had been found in this country. They had been described as belonging to a race of gigantic man, to the fathers of cattle, to hippopotomi, etc. In a letter to Geoffroy Saint-Hilaire describing his find Peale states that this animal should be called the carnivorous elephant of the north, but should not be confounded with the Siberian mammoth. Cuvier in his memoir "Le Grand Mastodonte" writes:

Mais pendant que nous travaillions ainsi en Europe sur quelques fragmens de cet animal, M. Peale continuait à en recueillir les os, et il avait été assez heureux pour en obtenir deux squelettes presque complets qui ont décidé la question pour toujours (p. 261).

The Museum in the State House

In 1802 the state legislature moved to Lancaster. This left the State House (Independence Hall) vacant. Peale petitioned the legis-

lature and was allowed to occupy the building as long as he allowed persons to pass through the hall into the State House Garden. His son Rembrandt used the east room on the first floor as his studio, while the entire second floor and tower was given up to the use of the museum.

The best picture that we have of the museum in Independence Hall is found in a letter written by the late George Escol Sellers, of Chattanooga, Tenn., a grandson of Peale, who as a boy and a young man spent much of his time in the museum, and who subsequently became one of its trustees. The period referred to in this letter is about 1820-1824, twelve years or more after Charles Willson Peale ceased to take an active part in the management, Mr. Rubens Peale being in control. There is very little evidence that much of scientific value was added after the father retired, except, perhaps, the collections of Major Long's expedition to the Rocky Mountains, and Dr. Harlan's anatomical and craniological preparations.

Mr. Sellers, in describing the arrangement of the hall writes:

I will go with you up the stairs and try to lead you through the Museum rooms. At the top of the stairs is a small window where tickets to the Museum are sold. We enter a great door from the landing and find ourselves in what was called the hall lecture room. The bench seats rose all around at such an angle that the two or three upper seats crossed the passage into the Quadruped Room at sufficient height to give headway under them. To the right is a door that is worthy of consideration. (This door leads into the Quadruped Room, the south-west Room of the State House.) On the west end of the room, the

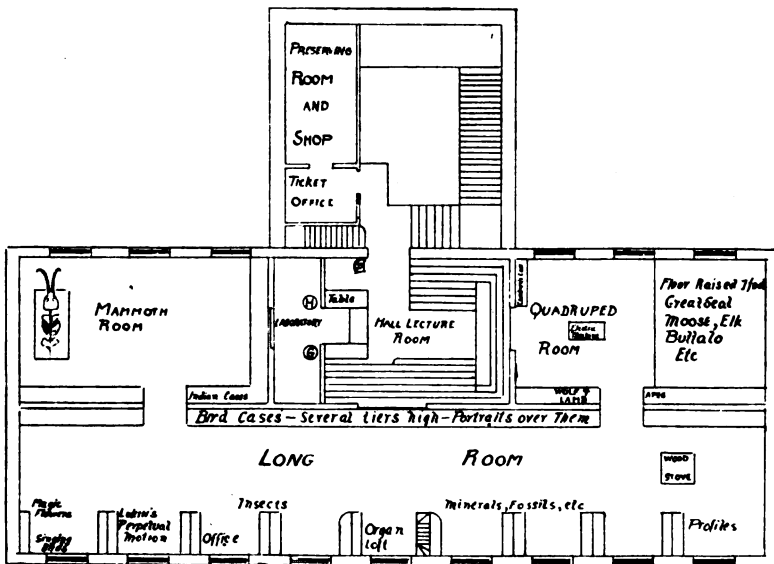

GROUND PLAN OF PEALE'S MUSEUM IN INDEPENDENCE HALL ABOUT 1821 TO 1826. From a diagram drawn by Mr. George Escol Sellers, from memory.

floor was raised about 1 foot and on it stood the great seal, Buffalo, Elk, Moose, Bears, etc., but most attractive to country folk was a 5 legged cow giving milk to a 2 headed calf. As we turn to the passage into the long room, the great case at our right hand is the wolf case. The great gray wolf with bloody fangs is rending a lamb, whose papier-mache entrails from the skilled and realistic hands of Uncle Rubens bulge out so naturally that they appear living and in motion. The opposite case was of particular interest to children. Smaller animals crowd the cases that fill this room.

Of the Long Room Peale himself has perhaps given us the best account.⁶ He writes:

For instruction to those who wish to know the Linnean classification of Birds on the side of the door entering the Long Room, is a large frame containing the several orders and genera of Birds with the characters of each. This Long Room has an elegant appearance. Its length is 100 feet. It is handsome because of its regularity of the numerous glass cases, which are neat without being gaudy and the catalogue in the frames makes a beautiful division covering each of the shelves extending from end to end of the room. There are 9 windows opposite, between them projecting are partitions to hold the cases of insects and also cases for minerals and fossils.

Over the center window is a neat well tuned organ for the use of such visitors that understand music. Under the orchestra are microscopes for showing Insects and other subjects to advantage.

Over the Bird cases are two rows of portraits of Distinguished Personages in gilt frames extending almost the whole length of the room. They are original portraits painted from life by C. W. Peale and his son Remb^t. At each end of the room are also some portraits. The most conspicuous being those of General Washington and his lady, which are the last they sat for C. W. Peale.

To complete the description of the museum we return to Mr. Sellers' letter:

If the day be chilly, the settees are around the great six plate wood burning stove. This was a very attractive feature. This Long Room was a promenade to show off finery, gay bonnets and cashmere shawls. Most of the more modern paintings and the portraits painted by Uncle Rembrandt when in Europe for the Museum were in the Mammoth Room.

On entering this room in the corner case was a wax figure of Col. Lewis or Clark, I do not remember which, in a complete Indian costume. The cases of Indians and their dresses and implements were very attractive. Back of the skeleton of the Mammoth at the end of the room was a large, what might be called, historical painting showing the tread wheels and other appliances that were used to pump out the morass while the bones were being exhumed. In fact this and a smaller painting gave a graphic history.

The marine room, up the lobby stairs, better known as the anatomical room was really a gruesome room in spite of its end cases of Monkeys at work. There was shown the smith, the carpenter, the cooper and even the shoe maker, a shoe between his knees, his arms akimbo as if drawing tight his waxed ends, a grin from ear to ear. The side cases were shallow and filled with snakes long and coiled. One snake was charming a stuffed bird with its bead eyes. One was in the act of swallowing a toad or frog with the hind quarters projecting from the mouth. There were also lizards big and little. Among the various cases was one filled with real anatomical preparations, including a

⁶ See footnote, p. 231.

ghastly tattooed head, a manufactured South American Mermaid—half fish and half hairless dried monkey—, innumerable alcoholic preparations, also an embryo shelf with animal and human fœtuses.

In 1805 Peale started to write a book called "A Walk with a Friend to the Philadelphia Museum."⁷ This seems never to have been finished and was never published. A comparison of the above account of Mr. Sellers with that of Peale shows that on the whole the same specimens were on exhibition as in the days that Mr. Sellers recorded; nevertheless there was a lack of sensational attractions in 1805. As an instance of this may be mentioned the fact that the monkeys at work were not added until 1809, a year after Peale retired to his Germantown farm. The two-headed calf was not added for some years after that.

In "A Walk with a Friend" Peale writes about the quadruped room, and it is of interest in relation to modern methods of taxidermy:

The door opens to us and behold a multitude of animals fills the room on every side. They seem to be in characteristic attitudes; the Lama of South America is rearing up in the act of spitting through the fissure of his upper lip. . . .

The muscles of this as well as many of these quadrupeds are so well represented that painters might take them for models and all is so well preserved that no insects can destroy them; a thing too generally the case in other museums.

The Proprietor has invented a mode of mounting them which I believe was never practised before. As the muscles can not be preserved to keep their natural plumpness nor can it be expected that the most careful operator can stuff skins in the common way to preserve perfectly the true form more especially of animals that have not an abundance of hair or fur—the limbs of these have been carved in wood; closely imitating the form after the skins had been taken off; giving swell to the muscles proportional to their action so that, in fact, they are statues of animals with the real skin to cover them—a stupendous labour originating from and effected by an enthusiastic desire of exhibiting a series of real forms as they exist in nature. . . .

Besides the methods of taxidermy as practised by Peale, there was another equally striking innovation. We have seen that there was a large frame illustrating Linnæus's classification of birds. To aid the inquiring visitor much information of general interest was contained in similar frames. In the Mammoth Room on the wall beside the skeleton of the Mastodon, Rembrandt Peale's "Historical Disquisition on the Mammoth" was framed page by page. By reading this account and by referring to the skeleton and to the paintings Peale intended that his visitors should have the opportunity of becoming well informed. These were points the importance of which were emphasized by Brown Goode⁸ many years afterward.

⁷ Manuscript in the Pennsylvania Historical Society.

⁸ See Brown Goode, "Museum History and Museums of History," 1889, p. 267.

As an attraction, one winter when the attendance was low, Peale installed in one corner of the hall a man to cut silhouettes by a new method. In one year 8,880 people carried away likenesses of themselves. After he retired, but particularly after his death, under the direction of his sons this precedent that Peale himself established of having attractions was increased, so that in its last years the institution became little more than a dime museum.

In the library of the Pennsylvania Historical Society there is a large blank book bound in whole calf entitled "Memoranda of the Philadelphia Museum." This book contains a record of the donations, accessions and exchanges between the years 1803 and 1837. An impression that one gets from reviewing its pages is that of the enormous amount of valueless material presented by travelers from Europe and from farmers up in the state. This, however, is a common feature of all museums; nothing offered must be refused, but, if of no value, will find its way to the official rubbish heap.

The library of the museum must have been of exceeding value. Every page records books bought or books received in exchange. As an exchange for specimens sent to France the museum received Buffon's works in five volumes. The following is a sample page showing the type of entry:

PAGE 12

- 1806 A Tropic Bird, 2 Frigates, 3 Eels which are said to wound very severe
Feb. 17. and to attack people. Ship Geo. "Washington by Capt." Farris.
The natural history of British Insects with colored plates Vol. 1st
—octavo,—John Armond.
19. Fossil shell from Kentucky, they are found from 1 foot to 50 feet
below the surface of the earth in limestone. W. Chambers.
2 pieces hog skin, one inch and $\frac{1}{2}$ in thickness, from the shoulder.
It was shot on the banks of the Ohio, in the spring of 1793—William
Chambers.
21. The head of the Petrel F. V. Riviere.
21. Phæton Athireus or tropic bird, female, F. V. Riviere.
Lacerta Chamæon, Chameleon, Isle of France—Cap.ⁿ Farris.
21. Skeleton of a Porcellaria Petrel. Samuel Coates.
22. The Trumpet Fish from S. America—Peter Solee
An Experimental Dissertation on the Rhus Vernix, Rhus Rodicans
and Rhus Globrum commonly known in Penn^a by the names Poison
ash, Poison-vine, and common Sumach by Tho^s Horsfield.
An Inaugural Dissertation on the warm Bath by Hen. Wil^m Lockette.
24. Viverra nasua Coata Mondî (alive) from South America Joseph
Baker.

His Last Years

Peale's early training and natural ingenuity enabled him to turn his hand to anything; this quality has been exaggerated by his biographers and mere incidents pointed to as periods in his career.

Peale's period of senescence may be said to date from the time he

resigned the active management of the museum and moved to his "Belfield" place, at Germantown. With him old age was robbed of its infirmities. Temperate habits, outdoor exercise and constant employment of mind and body, were responsible, according to his own theories,⁹ for the vigor that he enjoyed at eighty. He was eighty-three when he painted without his glasses a full-length portrait of himself by order of the trustees of the museum. This is the portrait that now hangs in the Academy of Fine Arts in Philadelphia, an institution of which he was the chief founder. These latter years of his life were not marked by reduced activities, but by more varied occupations. His attempts to make porcelain teeth and similar undertakings have been unduly emphasized. Undoubtedly it is the memory of this period that has led many of his biographers to refer to him as a "jack of all trades."

Later History of Museum

It may be interesting to outline briefly the later history of the museum and the fate of its collections.

In the first decade of the nineteenth century the value of the collections was from an educational point of view equal to those of the famous museums of Europe. At this time, with a view to its preservation and to carry out a cherished hope, Peale offered it to the government at Washington to form the nucleus of a National Museum. According to Jeffersonian simplicity it was not in the province of the government to father institutions not directly connected with government, so the offer was refused.

In 1816 the city purchased the State House from the state; and, at once, raised the rent on Peale from \$400 to \$2,000. As Peale could not pay so much, a compromise was made for \$1,200. The museum was run at a loss for three years, at the end of which time Peale induced councils to lower the rent to \$600. About this time Peale offered the museum to the city on condition that they would agree to house, add to it, and promise not to sell any part of it except duplications. The city refused to accept the gift.

In 1821 the museum took another lease of life, and its aged proprietor, still fearing that it would become divided on his death, had it incorporated with five trustees, all, except one, members of his family. As organized, four professors were appointed to give lectures in Natural History, viz.:

In mineralogy,	Dr. Gerard Troost.
In zoology,	Thomas Say.
In comparative anatomy,	Dr. Richard Harlan.
In physiology,	Dr. John Godman.
Conservator in zoology,	Titian Peale.

⁹ "An Epistle to a Friend on the Means of Preserving Health, Promoting Happiness, etc.," 8vo, Philadelphia, 1803, 48 pp., by C. W. Peale.

The publishing of a journal was undertaken which perished after the appearance of the first number.

In 1827 Charles Willson Peale died and the next year the museum moved into the Arcade on Chestnut Street above Sixth Street., on the north side. In 1835, the stock of the company was increased from \$100,000 to \$400,000 and a magnificent building was started at Ninth and Sansom on the site of the present Continental Hotel. Three years later the collections were moved from the Arcade into their new home.

Up to this time the museum had been very prosperous financially and had become largely a money-making concern. In 1841 the failure of the United States Bank carried down the Museum Company. The receivers of the bank foreclosed on the building, which was soon sold at auction. By paying rent the Museum Company was allowed by the new owner to occupy the building. In the hard times that followed, the Museum Company attempted to keep its head above water by vaudeville attractions and concerts. Thus the museum was thrown into direct competition with the dime museum as typified by Barnum's Museums. The directors of the company were not equal to competition with the trained showman. When, in 1846, the end came, the collections were sold at auction, the pictures going all over the country; yet one third subsequently came back to Independence Hall.

An attempt was made to keep the Natural History collections together; and until 1850 they were exhibited at Masonic Hall, but not by the Peales. At that time they were sold by the sheriff and bought for five or six thousand dollars by P. T. Barnum and his associate, Moses Kimball. They were divided, half going to the Boston Museum and half going to Barnum's American Museum, in New York.¹⁰ Legend has it that the mastodon went to this latter place and was destroyed when, in 1865, the American Museum burned. Since its whereabouts¹¹ was not known in 1852 when Warren wrote his monograph, it is possible that it was burned in the fire that destroyed, in 1851, Barnum's Philadelphia Museum. If this be the case it would seem to indicate that Barnum did not take all his share of the specimens to New York as he said he did. In either case it was destroyed.

In 1900 the Boston Museum broke up, and the specimens were presented to the Boston Society of Natural History, where about 1,300 of the birds now are. There is nothing to indicate that any specimens were added to the collections after they were removed from the Philadelphia Museum.

¹⁰ P. T. Barnum, "How I Made Millions"; the life of P. T. Barnum, written by himself.

¹¹ The bones mentioned by Warren as being exhibited in Paris belong, I judge, to a mass of bones of several animals which were found at Big Bone Lick. An attempt was made to sell them to Peale. As they were from several animals he refused to buy them. Cf. "The Navigator," Pittsburg, 1811, 7th edition, p. 117.

The second mastodon found in 1801 has had a more varied history. In 1803 Rembrandt Peale and his brother Rubens carried it to England. It was exhibited before the Royal Society. While in London, Rembrandt Peale wrote his "Historical Disquisition on the Mammoth." An attempt to sell the skeleton to Napoleon was undertaken, but war broke out with England which prevented the deal being completed. Peale's sons brought it back to this country and they made a southern trip, exhibiting the mastodon as far south as Charleston. Later, in 1813, Rembrandt started a museum in Baltimore¹² on similar lines to that of his father's in Philadelphia. In this museum the mastodon found a home. This became later the Baltimore Museum, from which in 1846 it was purchased by Dr. Warren and taken to Boston for comparison with his very perfect skeleton and placed in the Warren Museum on Beacon Hill. With Warren's mastodon it was bought from the Warren estate by J. P. Morgan and is now in the American Museum of Natural History in New York, and is called the Baltimore mastodon. This is all that is known of the fate of the collections of Peale's Museum.

A point that has been particularly confusing to historians is the fact that Peale's Museums were located in both New York and Baltimore. In this connection it will become necessary to refer briefly to Peale's sons.

In the last decade of the eighteenth century Rubens Peale and his brother Rembrandt attempted to found in Baltimore a museum with some duplicate specimens given them by their father. This museum was discontinued after one year.

In 1813, however, Rembrandt Peale, who was a better artist than his father, but was less of a naturalist, moved to Baltimore and in the following year opened a museum and art gallery on Holliday Street in a building that afterward became the Baltimore City Hall. The museum finally passed out of his hands, becoming the Baltimore Museum, which was bought by Barnum in 1845. In the early twenties Rembrandt opened a museum in New York, on Broadway, opposite the City Hall. This museum passed out of his hands into that of a stock company, which, after trying to compete with Barnum's American Museum, was obliged to sell out to the great showman in 1842.

When Charles Willson Peale retired, he placed his son Rubens in his place as director of the Philadelphia Museum with the secret hope that with the opportunities at his disposal he would become a naturalist of world-wide reputation. However, Reubens was apparently not much of a naturalist, but during the years that he was director he devoted himself to making the museum self-supporting rather than increasing the value of its collections. For a while, it would seem about 1841, at

¹² Scharf, "History of Baltimore."

the call of the directors of the New York Museum, he became manager of it.

The sons of Peale who had real tastes in zoology were both of the name of Titian. Titian Peale, by Charles Willson's first wife, was becoming a naturalist of great promise and of great help to his father, when he died at the age of eighteen. In memory of this son Peale named a child by his second wife Titian. This Titian became an ornithologist¹³ of some distinction, and was conservator of the collections of the Philadelphia Museum for many years.

Peale as a Museum Director

As we have seen, Charles Willson Peale was an enthusiastic collector. The object of these collections was the education of the public. Peale's ideas as to the function of museums are best illustrated by some extracts from a lecture introductory to a series of forty that he delivered in the winter of 1800-1801.¹⁴ He wrote that a museum should teach the economic use of animals and plants. Says Peale:

A farmer ought to know what reptiles best aid and protect the fruit of his labors, and not through ignorance destroy such as feed on animals more destructive to his grain and fruits; nor possess antipathies to those that he ought to cherish.

A museum should exert a moral influence in the community. Said the lecturer:

An instance of this is in the memory of many of my hearers. The chiefs of several nations of Indians who had an hereditary enmity, happened to meet unexpectedly in the museum in 1796; they regarded themselves with considerable emotion which in some degree subsided when, by their interpreters, they were informed, that each party, ignorant of the intention of the other, had come merely to view the museum. Never having met before, but in the field of battle, . . . now for the first time finding themselves at peace surrounded by a scene calculated to inspire the most perfect harmony, the first suggestion was that as men, they were of the same species and ought forever to bury the hatchet of war. After leaving the museum they formed a treaty. At the request of the Secretary of War, I supplied them with a room. They heard a speech written by General Washington recommending peace. Their orators spoke, and they departed friends.

After giving a brief account of the history of the museums in the world, from the time of Ptolemy Philadelphus, he describes his ideal museum. Says he:

First let us suppose we have before us a spacious building . . . in which are arranged all the various animals of this vast continent and all other countries. Let us suppose them classically arranged so that the mind may not be confused and distracted in viewing and studying such a vast multitude of objects. Here should be no duplicates and only the varieties of each species, all

¹³ See Stone, Witmer. *Auck*, 1899, Vol. XVI., pp. 166-177.

¹⁴ See "Discourse Introductory to a Course of Lectures, etc.," 1800, C. W. Peale.

placed in the most conspicuous point of light to be seen to the best advantage, without being handled. Besides a classical catalogue descriptive of every article in so extensive a museum, there ought also to be a library consisting of the writings of the best authors on natural history from Aristotle down to the present time. A few persons well acquainted with the methods of preserving subjects should be continually employed. Gentlemen of talent should be allowed to deliver lectures in the several branches of natural history. . . . It would readily be conceived that some person should have the superintendence of the museum, under whose directions every addition should be made and the care of everything should rest with him. . . .

Parts of this lecture and the one delivered in the previous winter in "the hall of the University of Pennsylvania," as an introduction to a course of twenty-seven,¹⁵ remind one amazingly of certain portions of the addresses of Sir William Flower¹⁶ and Brown Goode.¹⁷

Some of the characteristic features of Peale's Museum might be summarized as follows:

1. Its collections were educational rather than scientific.
2. The idea of indicating the natural environment with the mounted specimen, the idea of framing the pages of books (recommended also by Brown Goode), the idea of having diagrams and popular descriptions of the specimens beside the specimens themselves, and the idea of placing those of the 4,000 insects that were too small to be easily observed by the naked eye under permanent simple and compound microscopes, and his methods of taxidermy, all of which approach the arrangement of modern museums of natural history.
3. Although Peale was not the first to give lectures in natural history in this country, yet he was the first to give lectures illustrated by specimens.

The Influence of the Museum

The influence of the museum was wide-spread, but lay not in the direction that the founder had hoped. A perusal of the newspapers of the first decade of the nineteenth century will show that by this time there were a number of museums in every city. They show also that these museums were copied from Peale's Museum, in that they nearly always had a gallery of portraits of heroes in connection with a collection of curiosities. By the first quarter of the century, all had added concerts as an additional attraction. It was not long before the concert developed into a variety theater, although in the case of the Boston Museum legitimate drama was given. In the middle of the century these museums reached their greatest development, such as it was, while Peale's Museum became but a memory. Barnum's American Museum

¹⁵ "Introduction to a Course of Lectures in Natural History," Philadelphia, 1800.

¹⁶ Flower, William Henry, "Essays on Museums," 1898.

¹⁷ Brown Goode, "Museum History and the Museums of History," American Historical Association, 1888, p. 63.

marked the climax. When in 1902 the Boston Museum ceased to exist, this event marked the end of the last museum that obviously was suggested by the Peale Museum, although there are a few dime museums of later date that have managed to survive.

The cause of the fall of these museums lies in the fact that their place has been filled by natural history museums and zoological gardens which teach true natural history in place of the fake natural history of the dime museum. Although Peale's Museum seems to us to-day a very primitive affair, yet, considering the time when it was founded, the institution must be looked upon in a different light. Then there was no other collection of any kind in the country that could be called a museum. Not having any precedent of museum arrangement, the whole evolution was independent.

The museums of Europe exerted some influence, of course, on its development, but they were so far away that the problems that cropped up from time to time had to be solved independently. This accounts of course, for the many original features that were presented.

The importance of Peale's Museum has been largely discredited, owing to the impression left of its latter days, long after its founder's death. One forgets its positive value and influence when it was directed by his energy and intelligent effort. In the decade of 1800-1810 travelers compare the quality of its collections with the museums on the other side of the ocean. After Peale's retirement from its active direction, the museum ceased practically to grow, while those founded much later began their wonderful development.

Although Peale helped but little to advance our scientific knowledge by the collection of facts, yet to him should be given the credit of organizing what was for awhile a great museum and enabling thousands of people to become acquainted with the appearance and the habits of many animals of this and other countries.

THE THEORY OF INDIVIDUAL DEVELOPMENT¹

BY PROFESSOR FRANK R. LILLIE

UNIVERSITY OF CHICAGO

ORGANIC development presents two aspects: that of the individual and that of the race, ontogeny and phylogeny (evolution). These are not two separate and distinct series of phenomena; on the one hand, the individual development is to a certain extent a record of the past history of the race, and the promise of future racial development; on the other hand, evolution is not a series of completed individuals but a series of individual life, histories; for the only road from one generation to the next is by way of a complete life history. Individual development is, therefore, not something distinct from evolution; it is a part of the process of evolution itself; the development of the individual is a chapter in the history of the race.

The development of the individual may be pictured as a steadily broadening stream that takes its source in the fertilized ovum and flows on until death. In this analogy the individual would be represented as a cross-section of the stream at whatever stage we were examining. Though such an analogy limps, inasmuch as individual development is never before us as a unit, as a stream may be conceived to be, and can indeed be said to exist only as the successive cross-sections (its past having disappeared and its future yet unborn), nevertheless, it represents very well the steady, unbroken progress of development from the ovum to old age. There may be crises in the development of the individual, as, for instance, when the chick leaves the egg or the pullet lays its first egg, but there are no breaks in its continuity. Successive generations may be pictured as new streams, each taking its source from a particle—a germ cell—from some cross-section of the preceding generation; and evolution may be represented by placing the new source at a different level than the original. For evolution studies we compare cross-sections of different developmental streams (generations) at comparable distances from the sources, and for evolutionary explanation we must examine the entire series of processes involved in the origin of the new source and in the conditions and inherent character of the new developmental stream.

We can not be said to have actual experience of any other form of development than individual development; evolution or racial de-

¹One of the series of Darwin Anniversary addresses given under the auspices of the Biological Club of the University of Chicago, February 1 to March 18, 1909.

velopment is an inference from innumerable facts and series of phenomena, all of which are bound up together and rendered intelligible by the theory of common descent. We therefore find that the founders of theories of evolution turn to individual development as the court of last resort, as the place where evolution may be detected in actual process. For here is found the link that binds successive generations, here variations arise, whether they be mutations or of the ordinary fluctuating kind, whether they be germinal or acquired; here in the individual life history the Lamarckian must look for the reflection of the experiences of the individual back upon the germ; here the adherents of orthogenesis must find their crucial evidence.

In his theory of natural selection Darwin accepted as given the data of individual development. But he saw clearly that the fundamental phenomena of heredity and variation had their seat in the individual development, and he experienced the need of framing a conception that would bind together the phenomena of hybridization, the various forms of variation, atavism, telegony, regeneration, inheritance of acquired characters and the like; and in his volumes on "Animals and Plants under Domestication" he framed the provisional hypothesis of *pangenes* to include them all. I shall not attempt to present the details of this theory, but I may be permitted to say that, as a matter of logical arrangement of the assumed data, under the circumstances of existing biological conceptions and of the state of knowledge of the time, the theory was well worthy of its illustrious founder. In its way, it was as original as the theory of natural selection, though some of its fundamental ideas had certainly been anticipated by previous writers.

Nor shall I attempt a critical estimate of the value of the theory in the history of science; but I may be permitted to call attention to certain features. In the first place, the theory was overburdened with certain unnecessary conceptions such as inheritance of acquired characters, atavism and telegony. The elimination of these conceptions immensely simplifies the theory of individual development. In the second place, it rested upon a fundamental conception, that of representative particles, which amounts to a denial of the reality of individual development. And in the third place, it assumed certain biological processes—the existence of specific vital particles of ultramicroscopic dimensions, their radiation from parent cells, and their aggregation in other specific cells in a definite architectural pattern—for which there is not only entire absence of evidence, but which are wholly inconsistent with the known facts of cellular physiology. For these reasons the theory had only provisional importance, as indeed Darwin recognized in naming it the provisional hypothesis of *pangenes*.

The determinant hypothesis of Weismann, contained in his theory

of the germ-plasm, includes the assumptions of the pangenesis hypothesis, with those eliminated that were made necessary by the conception of the inheritance of acquired characters. For Weismann's gemmules, or determinants, the assumption of somatic origin was unnecessary, and thus, as Professor Whitman states, the entire centripetal migration of Darwin's theory was eliminated, but the entire centrifugal process was retained. The origin of every character of the individual was explained in the Weismannian theory, as in the Darwinian theory, by the unfolding (it can not be called development) of representative particles. Nevertheless, the theory of the germ-plasm played an important rôle in the development of biological knowledge, for it framed a set of ideas in a manner sufficiently logical and definite to serve as veritable working hypotheses or bases of attack. The immense effect of Weismann's writings on the theory of individual development should not be underestimated.

PHYSIOLOGY OF DEVELOPMENT

The theories of individual development that we have mentioned bear all the marks of provisional or formal hypotheses. Although extremely ingenious and logical, they are based only in small part on analysis of the actual processes and they offer no real explanation of the phenomena themselves; for they really include all the elemental phenomena and merely sum them up; they are definitions that include the matter to be defined; they amount to a denial of the reality of individual development as truly as did the preformation theories of the eighteenth century.

As a series of processes occurring in nature and accessible to experience, the development of the individual is capable of resolution into simpler biological processes, and these presumably into physico-chemical events in the usual sense. All attempts to make such analyses come under the head of Physiology of Development; and this plan of attack on the problems of individual development, known in Germany as developmental mechanics, is one of the most actively pursued lines of biological investigation at the present time. Physiology of Development deals primarily with specific problems, and the results constitute a critical basis for the appreciation of general theories of both individual and racial development. We shall examine some results and principles of these studies, and consider their application to some theories of heredity and evolution.

1. *Embryonic Primordia and the Law of Genetic Restriction.*—In the course of development the most general features of organization arise first, and those that are successively less general in the order of their specialization. Thus the directions of symmetry of the future organism—the oral and aboral surfaces, right and left sides, anterior

and posterior ends—are the earliest recognizable features of organization of bilateral animals, and they appear while the germ is still unicellular. The distinction between outer, intermediate and internal organs next makes its appearance, each at first as a single tissue. The outer tissue then separates into an epidermal and a nervous tissue, the inner tissue into the intestinal and yolk-sac epithelium, the middle tissue into muscle-forming tissue, connective tissue, skeleton-forming tissue, blood-forming tissue, excretory tissue, peritoneal tissue, etc.

For every structure, therefore, there is a period of emergence from something more general. The earliest discernible germ of any part or organ may be called its *primordium*. In this sense the ovum is the primordium of the individual, the primitive outer tissue the primordium of all structures of the skin and nervous system, the primitive inner layer of the intestine and all structures connected with it, etc. Primordia are, therefore, of all grades, and each arises from a primordium of a higher grade of generality.

The emergence of a primordium involves a limitation in two directions: (1) it is itself limited in a positive fashion by being restricted to a definite line of differentiation more special than the primordium from which it sprang, and (2) the latter is limited in a negative way by losing the capacity for producing another primordium of exactly the same sort. The advance of differentiation sets a limit, in the manners indicated, to subsequent differentiation, a principle that has been designated by Minot the law of genetic restriction. This in a merely descriptive way is one of the general laws of individual development, and in it is involved the explanation of many important data in the fields of physiology and pathology.

But, though primordia are thus restricted, they nevertheless have the very important property of subdivision, in many cases at least, each part retaining the qualities of the whole. Thus, for instance, in some animals two or several complete embryos may arise from parts of one ovum. Similarly, two or more limbs may be produced in some forms by subdividing a limb bud. Thus frogs with six hind legs have been produced by Gustav Tornier by the simple process of dividing the primordia of the hind legs with a snip of the scissors, in which case he found that on each side one part of the primordium produced a complete pair of legs and the other the normal leg of that side. This capacity for subdivision of primordia explains large classes of pathological facts—at the same time it furnishes a problem to the student of the physiology of development which has proved a serious stumbling block.

2. *Principle of Organization.*—I have already indicated the existence of direction and localization in the primordial germ of the individual, the unsegmented ovum; the ovum, as we say, is polarized,

and, not only so, but, in bilateral animals, it is bilaterally symmetrical. This is not usually indicated in the form of the ovum, which is typically spherical, but in the disposition and developmental value of its parts. Here we have one of the most fundamental and least comprehended facts in embryology. It has, moreover, been shown that this property of direction and localization resides in the homogeneous, transparent, semifluid matrix that suspends all the visible particles of the protoplasm of the egg. It is probable that primordia of all grades possess similar properties, and, if this is so, we have a principle that goes far to explain the orderly localization of processes in morphogenesis.

This principle is not farther analyzable at present; but, as it may be found intact in parts of primordia no less than in the whole, it probably rests on a molecular basis. The most ready analogy in simpler phenomena is that of crystallization. The study of fluid crystals has furnished us examples of inorganic molecular aggregates in which direction and localization are given in the whole and also reappear rapidly in the parts when the whole is subdivided.

3. *The Rôle of Cell-division in Development.*—The individual organism begins as a single cell, from which all cells of the developed organism trace their lineage by the process of cell-division. This has been regarded as one of the most fundamental factors of the individual development in the theories of Weismann, Hertwig and others. But important as the process of cell-division undoubtedly is in development, I believe that it is impossible to ascribe to it in principle more than an indirect effect: Considerable complexity of development is possible among Protozoa, whose body is unicellular, and some ova may carry out under experimental conditions a considerable part of the early development without a single cell-division. Moreover, the same kind of differentiated structure may be composed of one cell or of many, or of variable numbers of cells.

The physiological value of cell-division is no different in principle in developing than in functioning tissues (using these terms in the usual sense). The general law of relative reduction of surface in proportion to increasing mass imposes a size limit on cells, which can be regulated only by cell-division; an internal principle of regulation of cell-size has also been stated by R. Hertwig and Boveri, viz., a certain relationship characteristic of each species between the amounts of nuclear and cytoplasmic matters, so that increase of initial volume of the former involves increase of the latter, and *vice versa*. Corresponding to these principles, we find that individuals of different sizes of the same species vary not in the size, but in the number of the cells; and this is regulated by variation in the number of cell-divisions in different individuals.

Cell-division must necessarily, therefore, have an immense func-

tional significance in development, owing to the principle of relation of functional area to mass. It has also another very important function as an isolating factor. The localizations that arise, owing to the organization process of which we have spoken, are rendered relatively stable and permanent by the formation of cell-walls. Thus the elements of the mosaic are isolated, and each isolated part has the opportunity to grow into a new mosaic. Cell-division is thus an important factor in progressive differentiation, not as a cause, but as a means.

4. *Environment.*—Environment must be conceived in a somewhat broader sense than usual in considering the individual development. The developing embryo has an environment in the usual sense, consisting of all those external conditions that surround it, some of which enter into its development. But in addition to this *extra-organic* environment there is an *intra-organic* one; the developing embryo is not merely a unit on which an extra-organic environment operates, but it is a living mosaic, each element of which may conceivably enter into the development of any other in the sense of being a factor in the process. Each part of the embryo, therefore, has an intra-organic environment consisting of all the other parts, some of which constitute relatively immediate environmental factors, others relatively remote ones.

To illustrate: nerves arise in the embryo from certain centers and grow out in the embryonic tissues, much as roots grow out in the soil; the muscles arise separately and the nerves grow to them and make the proper connections. Is this due to an innate tendency of each nerve to grow in particular paths and branch according to definite laws, or, on the other hand, is it due to a directive stimulus exerted on the growing nerve by developing muscle tissue? The answer can be given only by a suitable experiment: If an abnormal innervation area were brought into the field of growth of a developing nerve, would the nerve entering the abnormal area follow its normal mode of branching, or the one characteristic of the normal nerves of the transposed area? To be specific: the bud of a leg of a tadpole that has as yet no nerves may be transplanted to any region of the body (Braus and Harrison), and it develops as a leg; but it receives its innervation from the nerves of the region to which it has been transplanted, and the mode of branching of the nerve is that of the leg nerves. We may generalize this statement by saying that any nerve may be made to depart from its normal mode of branching and to branch like leg nerves, by bringing a leg bud into its innervation area at the time that the nerve is still growing.

It will be seen that if this is generally true, the constancy of distribution of peripheral nerves is not due to the transmission of nerve-branching determinants from generation to generation, but is a function of the intra-organic environment in each generation.

The case of the determination of nerve-branching by intra-organic relations does not by any means stand alone. The same principle undoubtedly holds for the development of the blood-vessels, which grow along paths determined by the arrangement of organs and tissues and not according to a predetermined law given in the blood-vessels themselves. Color patterns have been shown in some cases to be determined by intra-organic variable relations, as in Loeb's experiments on the determination of the color pattern of the yolk-sac of a fish, which he demonstrated to be due to the positive attraction of the circulating blood for migratory cells that bear pigment. The development of any color pattern was therefore dependent upon blood-circulation, and the form of the pattern upon the pattern of the blood-vessels. The primordia of the eye or the ear transplanted to strange locations in the embryo induce formations in surrounding tissues that are strange to them and characteristic of the normal eye and ear environment. The origin and growth of motor nerve cells has been shown in my laboratory by Miss Shorey to be dependent in the chick on normal muscle development; so that the anatomy of the central nervous system, no less than the peripheral system, is dependent to some extent on the environment. Regeneration of lost parts is dependent for its completion to some degree on innervation, and the normal development of muscle tissue beyond a certain stage is likewise so dependent. These examples might be increased by others, which, taken together, would show that an immense part of what we call inheritance is inheritance of environment only, that is, repetition of similar developmental processes under similar conditions. The bearing of all this on the doctrine of determinants, that characters of the adult are represented by germs of a lesser order in the germ of the entire organism, is obvious.

Many of the problems of heredity, so-called, are not capable at present of such resolution. We may note some instances of this kind and then attempt to analyze the whole matter briefly. The example cited of transplantation of a leg-bud is of this kind: the transplanted leg-bud does not develop into an arm if it be transplanted to the region of the arm, but into a right or left leg, as the case may be, and this is true no matter how early the stage at which the transplantation may be made. It is not possible to change the specificity of such a primordium by any means yet employed. Moreover, there are many other experiments which show that the primordia of a great many structures are definitely specified even before they can be detected by any method of pure observation. Thus if a portion of the medullary plate of a frog embryo be cut out so as to include in the cut part the region that would form an eye in the course of time, and if then this piece be replaced inverted, it is found that the subsequent development of this area is inverted, not restored to the normal, although no trace of organs

was present at the time of the operation (Spemann). In this case, then, the eye appears in an abnormal position.

Correlative Differentiation.—We have cited a series of cases that illustrate two apparently contradictory principles known as the principles of correlative differentiation and of self-differentiation. The part that these play in embryonic development should be analyzed. The data of correlative differentiation may be placed in two categories, one of *behavior* and one of *metabolic relations*. Considering these separately:

Behavior.—Any case of behavior involves a stimulus, and a response; these imply irritability and reaction capacity. To take a simple case, for instance, the contraction of a muscle, the stimulus may be of a variety of kinds, nervous, chemical, electrical, thermic, mechanical; in any case the response is contraction. The nature of the response is given in the system and is limited by its reaction capacity. The muscle cell does not contract for one kind of stimulus and secrete in response to another.

This principle is elementary in physiology and psychology and it must apply also in the physiology of development. It appears to me that it has not been sufficiently borne in mind by students of the subject. Herbst, for instance, divides developmental stimuli into directive, trophic and formative. The first kind of stimulus determines the direction of growth or migration, and so plays an important part in development, a really great part illustrated in two of the cases cited, viz., the mode of branching of nerves, and the direction of migration of wandering cells. Trophic stimuli are those that affect the rate or amount of growth without altering its specific character.

The conception of formative stimuli implies, if it has any meaning whatever, that the nature of a developmental process is determined by the nature of a stimulus. A case often cited is as follows: the two most fundamental parts of the eye, lens and retina, develop from two entirely distinct primordia, the retina from the embryonic brain and the lens from the epidermis. The retina first grows out from the wall of the brain and reaches the epidermis to which it becomes fused. The latter then produces a lens. Now it was shown for some amphibia, that, if the retina fails to reach the epidermis, no lens forms; therefore, it was argued that the production of the lens is due to a formative stimulus exercised by the retina on the epidermis. But in some other cases the lens forms even if the retina be absent; which does not prove that it arises without stimulus, only that this *specific* stimulus is not needed. And the fact that transplanted optic vesicles stimulate lens formation in strange localities from the epidermis merely shows that this form of reaction of embryonic epidermis is widespread at this stage of development.

The instance is valuable as proving that stimuli are important in

development, but useless as an example of a formative stimulus. Morphogenetic behavior, like behavior in other fields, is not a function of the stimulus as to its specificity, but it is prescribed and limited by the reaction capacity of the system. One example is as good as many. We shall not find this principle contradicted by any of the known data of the physiology of development.²

Metabolic Relations.—When we consider to what an extent the nature of every biological character is given in its chemical composition, it can be readily understood that, to some authors, physiological chemistry should seem the complete basis of heredity. The characters of every tissue of the body are absolutely dependent on their chemical composition, and even slight variations in chemical composition may completely alter function, appearance or form. For such a statement examples are entirely unnecessary.

The development of characters in the individual is dependent upon the occurrence of definite chemical reactions, upon their rate and upon their degree of completion. It has been shown that the law of acceleration of embryonic development in correspondence with rise of temperature is the same in principle as the law of acceleration of chemical reactions by temperature increase. Numerous experiments have been made on the character of development in the absence of one or other or combinations of the elements normal to protoplasm, with the aim of determining their rôle in development. Herbst, for instance, has made a series of experiments on the development of larvæ of the sea urchin in artificial sea waters, in the composition of which definite elements are wanting. He shows, for instance, that in sea water made up without calcium the skeleton fails to develop, and that the form of the larva resulting is profoundly modified from the normal. In other experiments the potassium or sulphur, or iron, etc., is omitted from the solution, and the effect on the development noted. Other experimenters have maintained that the presence of specific chemical elements in excess has definite morphological consequences.

As regards complex substances and their rôle in morphogenesis, but little is actually known. Recent results indicate that the egg contains substances of complex chemical composition which are essential for the development of specific parts or tissues. Thus certain experiments consist in the removal of definite parts of the egg containing specific materials; and in the subsequent development specific parts of the embryo are wanting. In other experiments, by Conklin, the transference of definite substances from their normal location by means of centrifugal force is followed by the development of corresponding

²Stimuli in the sense in which we use the word involve merely the impinging of energies on the stimulated system; if substantive additions are involved we have more than a mere stimulus, to the extent that substances are added to the system.

specific structures in the abnormal location. These experiments strongly suggest, even if they do not rigorously prove, that such substances are essential ingredients in definite developmental processes.

I am indebted to Dr. Riddle for the following illustration: The various colors of mammals, such as black, brown, red, yellow, are due to chemical substances known as melanins. The chemistry of these substances starts out from a simple colorless base or chromogen, from which the series of colors, yellow, red, brown, black, is derived as successive stages of oxidation. The chromogen base is found in all mammals; the color then would appear to be due to the varying powers of the cells of different individuals to oxidize the given base. Tornier has shown in his experiments on the coloration of Amphibia that the particular color developed is a function of nutrition, varying in the order of oxidation value (as was later ascertained) according to the degree of nutrition. The development or inheritance of color, therefore, can certainly not be due to the presence of black or brown or red or yellow determinants in the germ, assumed for theoretical purposes by some students of heredity, but to a specific power of oxidation of the protoplasm. This faculty in its turn is no doubt capable of resolution into other physiological terms.

We are only at the beginning of the study of correlations of embryonic metabolism. The rôle that the internal secretions of the embryo may play in the processes of development is practically unknown; but we may expect to find here biological reactions of fundamental significance, especially when we consider such phenomena of the adult as the influence of pregnancy on the organism, the possibility of inducing lactation, with all that this implies, by injection of foetal tissues; the relations between the sex organs and secondary sexual characteristics and indeed the entire habitus of the organism; the influence of a small gland like the thyroid, or the pituitary body, etc. Biochemical reaction runs through every phase of development and is unquestionably the decisive factor in the appearance of many characters of the organism.

Self-differentiation.—The conception of self-differentiation in morphogenesis is a vague and unsatisfactory one. In a sense it is a contradiction in biological terms, for assuredly environment enters into every biological process. On the one hand, the term covers the fact of the specificity of primordia, which means only a certain stability of metabolism and reaction capacity; on the other hand, it may have specific meaning in one large class of developmental phenomena, viz., polarization and localization. If, for instance, the term self-differentiation might be applied to the appearance of definite axes, angles, points and faces of a crystal, it would with equal propriety be applicable to the appearance of polarity, bilaterality, etc., the axes of embryonic development. But if the term should come to hold simply this restricted meaning, then all reason for its maintenance would be gone.

It is not at all certain that it will be possible to reduce all the problems of the physiology of development to such categories as we have mentioned. The subject is full of unsolved problems, but so far as I can see no one has shown any real reason for assuming ultra-physical agencies in any of the events, and there is the same pragmatic reason for refusing to assent to such suggestions, which are made all too frequently, that there is in other fields of science. If we will be consistent, we are driven to the conclusion that the apparent simplicity of the germ is real, that the germ contains no gemmules, or determinants or other representative particles; that development is truly epigenetic, a natural series of events that succeed one another according to physico-chemical and physiological laws; the explanation of the sequence consists simply in the discovery of each of its steps.

APPLICATIONS

The problems of heredity and variation are included in a true physiological conception of the individual development; but some biological conceptions that have more or less status and reputation are inconsistent with it. Such are the inheritance of acquired characters, atavism, and the theory of unit characters. The first is a familiar problem that I shall not argue anew; the second logically implies the presence of ancestral representative particles in the germ, which is inconsistent with a physiological theory of development. But it is obvious that the facts united under the name of atavism or reversion take their place naturally in a physiological theory of development, as arrests of development, or modification of environment, or in other ways.

The theory of unit characters deserves more attention for it is essentially a modern theory, and counts numerous adherents. This conception has been most sharply formulated by De Vries in his *Mutationstheorie*. He says:

The properties of the organism are constructed of units which are sharply distinguished from one another. These units may be united in groups, and in related species the same units and groups occur. Intermediates between the units, such as the external forms of plants and animals exhibit so abundantly, are not found any more than between the molecules of chemistry.

Bateson's allelomorphs constitute a similar conception. Such hypothetical elements of organization must be conceived as distinct from the germ on. They can be shuffled about from one generation to another, and can, therefore, be introduced, removed or replaced in the germ cells.

It must be admitted that these conceptions fit certain facts of inheritance in many hybrids fairly well, but the progress of discovery has made necessary the installation of subsidiary hypotheses, so that the most recent conceptions of unit characters are becoming extremely

complex, and it would seem as though the system would soon fall of its own weight. The entire value of the hypothesis consists in the formal approximate expression of certain facts; when it is found that the hypothesis begins to fail even for the classes of facts for which it was originally intended, and that most of the known facts of development can not possibly be expressed in its terms, the entire conception is put on trial.

The weakness in the theory of unit characters is in the use and conception of the term "character." The term has been prescribed to us by the systematic zoologists and botanists engaged in describing the differences between species; so that "character" really means any definable feature of an anatomical kind that differentiates species; by extension it also means any other differentiating features that can be defined. In the study of evolution and heredity, it is usually only anatomical characters that are in question. Now the study of the physiology of development teaches us that whatever else "characters" may be, they are not units; *they simply represent the sum of all physiological processes coming to expression in definable areas or ways*, and they may thus represent a particular stage of a chemical process, or a mode of reaction of some part. "Character" is essentially a static morphological term; in the study of heredity and development we are dealing with biological *processes*. To adapt a phrase of Huxley's: "characters" are like shells cast up on the beach by the ebb and flow of the vital tides; they have a more or less adventitious quality. To give them representation in the germ is equivalent to a denial of uniformity in biological phenomena.

Just as the exact position of each shell on a beach might be fully explained if we knew its full history, so each character has a certain kind of inner necessity as the result of a sequence of developmental processes. And just as in the history of the position of the shell on the beach we should certainly ascribe great importance to the tides and winds, so in the quality of each individual character we should find corresponding vital tides and winds, as regular and lawful as those of the ocean. We do not yet know the secrets of the vital tides; we maintain only that they are the moving forces in development and heredity, just as in physiology and pathology; and every fundamental contribution to the physiology of protoplasm is at the same time, and to the same extent, a contribution to heredity and the physiology of development.

But if these principles are accepted, how are we to explain the facts on which the theory of unit characters depends? The main difficulty lies not in the facts of mutation, for the physiology of this phenomenon already begins to appear from the experiments of Tower and MacDougal, who show that mutations may result from action of

environment directly on the germ cells. The most fundamental phenomena in the unit character theory are unquestionably the segregations of characters that appear in the offspring of hybrids in so-called Mendelian inheritance. In the most typical cases, grandparental characters reappear in definite proportions of the progeny of the hybrid generation. The interpretation, according to the theory of unit characters, is in the hypothesis of purity of the germ cells of the hybrid generation with respect to the segregated characters; which means that the germ cells of the hybrid generation are pure with reference to the contrasting characters united in the soma; in other words, that corresponding contrasted characters can not both remain in the same germ cell, but are segregated in different ones and may thus appear pure in the descendants of a hybrid generation.³

We may well doubt that absolute purity of grandparental characters in the offspring of the hybrid generation occurs, and the results unquestionably vary with the environment; but I believe that we have to admit the general principle of segregation. However, the theory of segregation of unit characters in the germ cells is in no way necessary to explain the results; it is in fact inconsistent with the highly variable result; if unit characters were segregated in the germ, we should expect very definite constant results.

If we take our stand on the epigenetic basis and regard the germ cells as no more complex than *direct* investigation would lead us to suppose, then we have to admit that segregation in the germ cells can involve only constituents of the germ cells themselves. But any variation thus induced in the germ cells would be a factor in each process of the development, and would hence tend to influence every character that appears. Such a hypothesis involves the conception that germ cells contain elements capable of segregation; and this is so. Even if the principle of segregation of characters in inheritance had never been discovered, the principle of segregation of germ-cell elements would still hold, for the two discoveries were made absolutely independently.

I refer to the work of Guyer and Montgomery on the chromosomes, which has been followed by a long series of very exact studies. These studies certainly suggest segregation of parental chromosomes in varying proportions in different germ cells. Indeed, I know of no other interpretation of chromosome behavior that is consistent with the facts. Whatever value we may attribute to the chromosomes in cellular physiology, the variable relations established by their differential segregations, even if only quantitative differences are concerned, must involve endless secondary effects in the long series of cell generations that make

³ Recent modifications of the theory of purity of the germ-cells do not essentially modify the argument.

up the individual life history.⁴ It is not impossible that other segregations than those of the chromosomes form part of the germ-cell behavior, but of this we know nothing as yet. In any event, the principle of segregation of actual visible elements of the germ cells has a firm anatomical basis.

It must not be forgotten that the germ is the entire organism and that it passes through development as the same individual; *continuity of individuality is preserved throughout development*. Therefore, if we discard determinant hypotheses and take our stand on a strictly physiological theory of development, it follows of necessity that the transmitted factors of heredity included in the organization of the germ cells must be factors in the development of the entire organism. The so-called Mendelian factors must therefore be of this character, as I have argued elsewhere. That is to say, the segregated factors must be general constitutional conditions effective as factors in the development of every part of the organism. It can readily be seen that specific intensity of metabolism, or of reactivity, and variation in constitutional size of cells may be such conditions. Others no doubt exist, of which sex may be one. The essential thing to recognize is that the heritable and segregable factors, being conditions of the germ cells at the start, can never be anything less than factors of the entire organism at all stages.

Our conclusion is that the theory of individual development must more and more come to be regarded as a branch of physiology proper. The theory of representative particles must be relegated to the class of formal hypotheses whose usefulness is largely outlived. While it may still play a part in speculations on heredity, I believe that it will come to be generally recognized by those who use it as a mere matter of convenience of terminology, and not as an explanation of the phenomena described in its terms, in the sense of being a verifiable part of the sequence of processes in development.

⁴This general argument would stand even if the chromosomes be regarded merely as indices of organization. They at least give us a clue as to what "the organism" is doing at the time in question. This is indeed all we can say of any characters at any period if we consider the matter in a strictly logical sense.

THE ORIGIN OF THE NERVOUS SYSTEM AND ITS APPROPRIATION OF EFFECTORS

By G. H. PARKER

PROFESSOR OF ZOOLOGY, HARVARD UNIVERSITY

III. CENTRAL NERVOUS ORGANS

IN dealing with the differentiation of nervous organs, the earthworm affords a good example of a simple type of well-centralized nervous system. The central nervous organs in this animal (Fig. 1) consist of a brain or cerebral ganglion situated anteriorly and dorsal to the buccal cavity, right and left oesophageal connectives extending from the brain ventrally to the ventral nerve-cord which stretches as a segmented organ from near the anterior end of the worm over its ventral line posteriorly to the tail. The segments in the ventral cord agree in

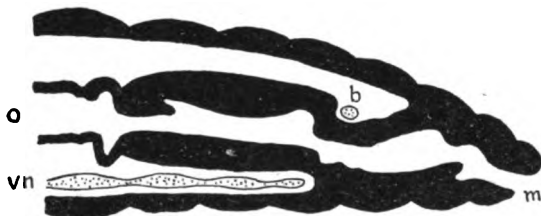

FIG. 1. HEAD OF AN EARTHWORM IN LONGITUDINAL SECTION. *b*, brain; *m*, mouth; *o*, oesophagus; *vn*, ventral nerve-cord.

number and position with those of the worm's body and from each segment three pairs of nerves pass out to the integument and muscles of the adjacent region.

The essential nervous elements of the ventral cord can be made out in transverse sections (Fig. 2). In such sections the integument will be seen to be filled with sense-cells, each of which ends peripherally in a sensory bristle and gives rise centrally, in addition to a few subepithelial processes, to a single nerve-fiber which passes inward between the muscles and enters the ventral ganglion by one of its three nerves; finally this fiber spreads out in the fibrillar substance or neuropile of the ganglion. This cell-body in the integument with its processes including the nerve-fiber constitutes a primary sensory neurone. These neurones usually do not spread beyond the ganglion with which they are directly connected, but in exceptional cases they may extend into the ganglion anterior or posterior to this one.

In the ventral and lateral portions of each ganglion are numerous large nerve-cells from which coarse processes extend through the neuro-

pile, fibrillating as they pass to terminate as motor nerve-fibers in the muscles of the adjacent part of the body. These cells with their processes constitute the primary motor neurones of the earthworm and, like the sensory neurones, they may be present in any one of the three nerves of a segment. Their longitudinal extent is probably not much beyond a single segment.

The primary sensory and motor neurones not only give rise to the nerves of the earthworm, but they contribute a larger part of the sub-

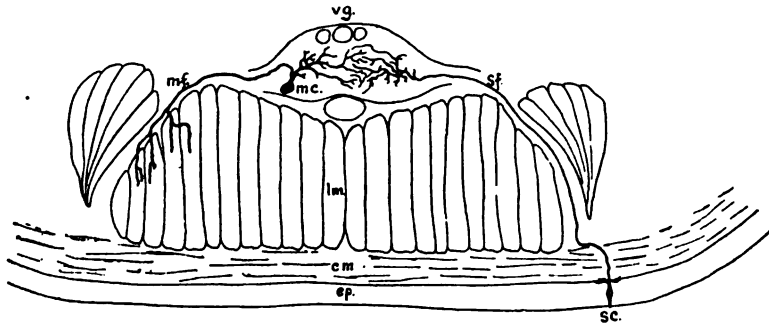

FIG. 2. TRANSVERSE SECTION OF THE VENTRAL NERVOUS CHAIN AND SURROUNDING STRUCTURES OF AN EARTHWORM. *cm*, circular muscles; *ep*, epidermis; *lm*, longitudinal muscles; *mc*, motor cell-body; *mf*, motor nerve-fiber; *sc*, sensory cell-body; *sf*, sensory nerve-fiber; *vg*, ventral ganglion.

stance of each ganglion. As stated in the first article, they form when together the necessary elements for the simplest, conventional reflex-arc. How they are related to one another in the neuropile is not conclusively settled, but, judging from the work of Apáthy (1897) and others, the connection here as in the nervous net is one of direct continuity.

Besides the motor and sensory neurones, the central nervous organs of the earthworm contain a considerable number of so-called association neurones. These are nerve-cells with longer or shorter processes that connect parts within the same ganglion or run from one ganglion to another. They give rise to no fibers that extend into the nerves and hence they are strictly limited to the central nervous organs. Their longitudinal extent is seldom over more than one or two segments.

Since the sensory, motor, and association neurones thus far described make up the bulk of the ventral nerve-cord of the earthworm and since none of these have a longitudinal extent of more than a few segments, it follows that the cord must be conceived as made up of an immense number of overlapping short neurones which in this collective way stretch over its hundred and twenty or more segments. But the nerve-cord of the earthworm is not composed exclusively of short neurones. In its dorsal portion are three giant fibers which, though their nature has been even recently disputed, are without much doubt nervous

organs. The middle and largest of these fibers extends almost the whole length of the ventral cord and, according to Friedländer (1894), has unquestionable connections with ganglion-cells. The two lateral fibers, though smaller, have much the same extent as the median one and are also directly connected with cells. Both sets of fibers connect by branches with the neuropile of the successive segments. Thus the ventral cord of the earthworm may be described as composed of three long neurones and an immense number of overlapping short neurones.

This peculiarity in the structure of the cord makes itself manifest in the movements of the worm. Undoubtedly the slow waves of muscular activity that move over the worm from head to tail as it creeps along are dependent upon the interlocked short neurones, whereas the

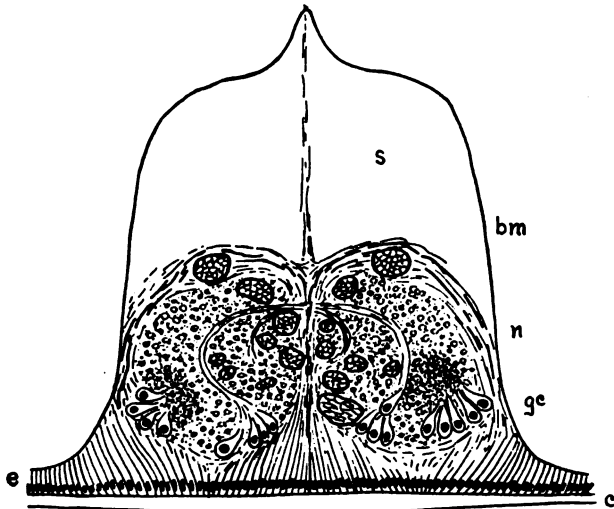

FIG. 8. TRANSVERSE SECTION OF THE VENTRAL NERVOUS CORD OF *Segalton* (modified from Hatschek). *bm*, basement membrane; *c*, cuticula; *e*, epidermis; *gc*, ganglion-cells; *n*, nerve-fibers and neuropile; *s*, space occupied by vacuolated supporting tissue.

sudden drawing together of the worm as a whole, when it is vigorously stimulated, is very probably the result of impulses spread through the long neurones.

The absence of degenerated fiber-tracts in the ventral cords of earthworms that have been cut in two and the rapidity with which nervous regeneration takes place in these worms are conditions that very likely depend upon the almost entire formation of the cord from systems of short neurones.

At first sight the central nervous apparatus of the earthworm seems to be widely different from the neuromuscular mechanism of the cœlenterates, but the difference in reality is not so pronounced. To begin with, the whole nervous mechanism of the cœlenterate is within an

epithelial layer, whereas the central nervous organs of the earthworm are solid masses of nerve-cells, fibers, and neuropile entirely distinct from any epithelium. But this condition is apparently a recent acquisition on the part of the earthworm, for in another annelid, *Sagalion*, the ventral cord (Fig. 3) and the brain are still a part of the superficial

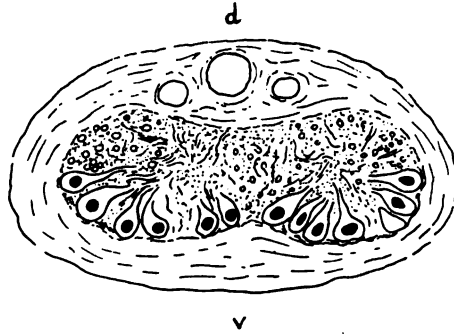

FIG. 4. TRANSVERSE SECTION OF THE VENTRAL NERVOUS CORD OF AN EARTHWORM, showing the ganglion-cells on the ventral side (*v*) and the nerve-fibers and neuropile on the dorsal side (*d*).

ectoderm and differ from the condition in the coelenterates only in that they represent a concentration of nervous elements in certain regions instead of a diffuse condition as in the sea-anemones, etc. In *Nereis* the brain is epithelial, but the cord by a process of delamination has broken away from the integument, and in the earthworm the whole central nervous system, brain as well as cord, has delaminated. It is chiefly this concentration and separation of the nervous organs from the skin that justifies, in my opinion, the statement that an earthworm has central nervous organs and a sea-anemone has not.

The fact, however, that the central nervous system of the earthworm has developed on the lines of the coelenterate, has left its mark in the distribution of nervous materials in the ventral cord of this animal. In the ectoderm of the coelenterate the cell-bodies of the nervous mechanism are nearer the exterior of the animal than are their processes, the fibrillar mass, and the same is true in the ventral ganglia of the earthworm (Fig. 4); here the cell-bodies are on the ventral side of the ganglion, *i. e.*, next the integumentary epithelium, and the neuropile and nerve-fibers are on the opposite or dorsal side of the ganglion. This peculiarity in the distribution of nervous materials is apparently true for most higher metazoans.

Another point of comparison between the nervous mechanism in coelenterates and in the earthworm is the presence of nerves in the latter and their absence in the former. As already pointed out, the nerves in the earthworm are bundles of independent fibers which course more or less together between their end-organs and the central apparatus.

The fibers in a nerve have no necessary functional relations one with another, but are brought together chiefly by convenience of passage. They are characteristic of those animals in which sense organs and muscles have become well differentiated and widely separated from the central organs, and are not to be confused with elongated bundles of nervous elements such as are to be met with in some coelenterates and many echinoderms, for though these may represent early steps in the evolution of nerves, they still retain so many evidences of functional interrelation among their elements that they are to be classed rather with nervous nets than with nerves.

The differentiation of nerves as thus defined implies an increased interrelation of neurones in the central apparatus as compared with the condition in the more primitive nervous net. The nature of this growing interrelation has been well expressed by Sherrington (1906) in his principle of the common path. This principle implies that each sense organ may be connected through the central organ with every effector and conversely any effector may receive through the central organ impulses from any sense-organ. In consequence the central organ must contain many common paths which are momentarily used, now for this, now for that combination of particular receptors and effectors. This condition without doubt obtains in earthworms as it does in higher animals, and is a feature that can hardly be said to exist in the nervous nets of the coelenterates.

It is also probable that the nervous mechanism in coelenterates differs from that in the earthworm in its capacity as a nervous transmitter. Attention has already been called to the fact that transmission in the nervous net of a coelenterate may occur in almost any direction and that in the central nervous organs of vertebrates it is very definitely limited and may in fact flow in only one of two apparently possible directions. So definite a restriction can not be asserted for the earthworm but, as Norman (1900) has shown, significant differences do obtain. If an earthworm that is creeping forward over a smooth surface is suddenly cut in two near the middle, the anterior portion will move onward without much disturbance whereas the posterior part will wriggle as though in convulsions. This reaction, which can be repeatedly obtained on even fragments of worms, shows that a single cut involves a stimulation which in a posterior direction gives rise to a wholly different form of response to what it does anteriorly; in other words, transmission in the nerve-cord of the worm is specialized as compared with transmission in the nervous net of the coelenterate.

There is good reason to believe that the cerebral ganglion or brain of the earthworm is in a measure degenerate. Certainly if we turn to such an annelid as *Nereis* we find in place of the small mass of ganglionic cells and fibers that represent the brain in the earthworm a much

more extensive organ connected with a considerable number of sense organs none of which are present in the earthworm. Eight peristomial tentacles, a pair of palps, a pair of antennæ and, two pairs of eyes are found connected by nerves with the brain of *Nereis* and represent a condition in strong contrast with the unspecialized state in the earthworm. Yet both the earthworm and *Nereis* show much the same traits when deprived of their brains (Loeb, 1894). Each worm is immensely reduced in activity somewhat as a jellyfish is after the removal of its sense-bodies, and one is justified in concluding that the head of even the earthworm is an especially sensitive region through which many slight environmental influences that might not be able to affect other parts of the body gain access at this point to the neuromuscular mechanism. That such a condition should obtain at the anterior end of a bilateral animal has long been recognized as appropriate, for this is the part of the animal that in normal locomotion first reaches the new environment. But I am not acquainted with any discussion as to the mutual relations of the nervous parts at the anterior end of an animal so far as their origins are concerned. If what has been said in these lectures is true, namely, that sense-organs in general precede central nervous organs in evolution, then the brain of the worm has developed at its anterior end because the chief sense-organs were originally there, and not *vice versa*, a statement that I believe to hold for the growth of the brain in all animals. Intricate and marvelous as the brain of the higher animals is, it is, in my opinion, the product of a group of sense-organs that in evolution preceded it in point of time.

The annelids then possess a neuromuscular mechanism in which there are not only primary organs such as muscles, and secondary organs, the sense-organs, but also tertiary organs, central nervous organs. These central organs intervene in position between the receptors and effectors and in the annelids are composed almost exclusively of short overlapping neurones. It is probable that in the sea-anemone these neurones are represented by the so-called ganglion-cells of the nervous layer, but I would not go as far as Havet (1901) and designate these cells in coelenterates as motor cells, for though some of them undoubtedly connect with the muscle-fibers, others may be purely association neurones. I believe further that in the sea-anemones the fibrils from many sense-cells connect directly with muscle-fibers without the intervention of ganglion-cells.

As an example of a central nervous system built upon the annelid type but with increased complication, we may turn to the arthropods. The central nervous system of these animals, like that of the annelids, consists of a dorsal brain, œsophageal connectives, and a ventral, segmented cord. These organs have been formed by a process of delamination as in the earthworm and exhibit the same fundamental arrange-

ment of cellular elements as is seen in this animal, *i. e.*, the ganglion-cells are on the side of the cord next the exterior, and the neuropile and nerve-fibers next the interior.

The chief fundamental point of difference in the nervous systems of the annelids and arthropods consists in the great number of long neurones in the latter as compared with the former. In the crab, as demonstrated by Bethe (1897), many of the primary sensory neurones extend over half the length of the ventral cord instead of being limited to a few segments as in the earthworm, and the same is true of the primary motor neurones. Moreover, the association neurones have shown an extensive growth. Although in the crab there are some neurones limited to one or two segments, as is the rule in the earthworm, the great majority extend over many segments and often through the whole length of the nervous system. In this way the central nervous organs of these animals are locked together much more closely than are those in the worm and exhibit consequently in their physiology a unity that the worms do not possess. This nervous unity, moreover, has developed to such a degree in the higher arthropods that we may with reason ascribe to such animals as the insects a primitive form of intellectual life not unlike that found in the vertebrates. The structural basis for this seems to me to be foreshadowed in the few long neurones of the worm which, as I have just pointed out, come to be the common type in the arthropods. The type of central nervous system with long neurones also characterizes the other higher invertebrates such as the mollusks, etc.

The central nervous system of the vertebrates and of certain other closely allied forms like the tunicates, is usually put in strong contrast with that of the higher invertebrates. The most striking feature in this contrast is the fact that the vertebrate nervous system is tubular and the invertebrate solid. As is well known, the central nervous organs in vertebrates develop from an ectodermic tube that has been infolded from the median dorsal surface of the animal. This simple nerve-tube with nervous connections, but otherwise almost unmodified, exists to-day in that primitive vertebrate amphioxus. In the higher vertebrates the posterior portion of this tube becomes uniformly thickened and forms the spinal cord, the central canal of which gives evidence of its tubular nature. The anterior portion undergoes still more profound changes than the posterior part in that its wall thickens very differently in different regions and expands in several lobe-like outgrowths, giving rise thus to the brain whose ventricles represent the original cavity of the nerve-tube.

Notwithstanding the striking difference between the central nervous organs of vertebrates and invertebrates, they show certain fundamental similarities and the first of these has to do with the distribution of

nervous materials. Since the nerve-tube from which the central nervous organs in vertebrates are developed is infolded ectoderm, it follows that the inner surface of the tube represents a portion of the outer surface of the animal. This inner surface even in the adult central nervous system is always covered by an epithelium as the exterior of the animal is, and the nervous materials which surround it are related to this epithelium in a characteristic way. This relation can be most easily seen in any transverse section of the spinal cord. Beginning at the central canal of such a section (Fig. 5) and proceed-

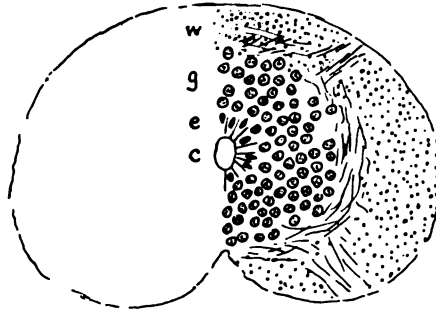

FIG. 5. TRANSVERSE SECTION OF THE SPINAL CORD OF A VERTEBRATE (SALAMANDER). *c*, central canal; *e*, epidermis; *g*, gray substance composed of ganglion-cells and neuropile; *w*, white substance or nerve-fibers.

ing through the substance of the cord to the opposite face, one passes first an epithelial layer, then gray substances composed of nerve-cells, neuropile, etc., and finally white substance made up of nerve-fibers. Precisely this sequence is met with in the central nervous system of any primitive invertebrate such as *Segalion*, where, as already pointed out, in passing through the thickness of the central nervous organ from the exterior to the interior one meets first external epithelium, then ganglion-cells and fibrillæ corresponding to the gray substance of vertebrates, and finally nerve-fibers corresponding to the white substance of these animals. Thus the nervous materials of the vertebrate spinal cord are distributed through that structure on a plan similar to that found in invertebrates, and this plan, though considerably modified, also holds good for the vertebrate brain. So far as these particulars are concerned, the vertebrate central nervous system differs from that of the higher invertebrates chiefly in that in separating from the integument it has carried with it its epithelial mother-tissue instead of leaving this tissue behind.

Not only are the materials of the vertebrate central organs distributed on a plan that is best understood from the standpoint of the invertebrates, but the primary neurones of vertebrates are also most clearly interpreted from this point of view. The primary motor neurones of

vertebrates (Fig. 6) resemble very closely those of invertebrates, for their cell-bodies are within the central nervous mass and their neurites extend as motor nerve-fibers to the skeletal muscles. The primary sensory neurones also agree with those of the invertebrates except that their cell-bodies instead of being in or near the integument, as in most invertebrates, have migrated centrally and thus form the dorsal ganglia. At least this appears to have occurred in all vertebrate sensory nerves except the olfactory, which still retains the usual invertebrate condition.

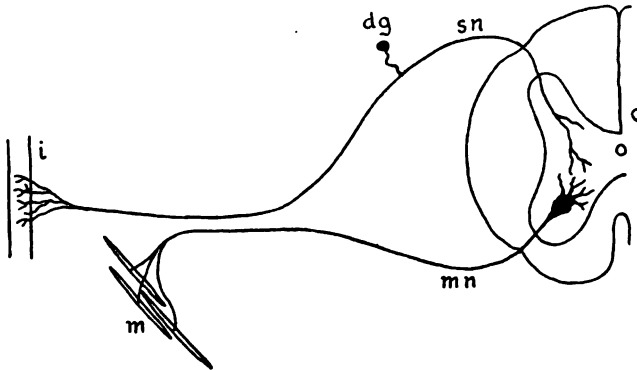

FIG. 6. DIAGRAM OF THE PRIMARY NEURONES OF THE VERTEBRATE NERVOUS SYSTEM AS SEEN IN TRANSVERSE SECTION. *c*, spinal cord; *dg*, dorsal ganglion; *i*, integument; *m*, muscle; *mn*, motor neurone; *sn*, sensory neurone.

Association neurones, which were met with in the invertebrates, are abundantly present in the vertebrates.

How the neurones in vertebrates are related to one another has been a matter of much dispute. Whether the gray substance of the central organs in these animals contains a true nervous net as seems to be the case in many invertebrates or whether their neurones retain greater individuality and are related morphologically only through contact, is not yet settled. That many embryonic neurones, or neurocytes, are in the beginning widely separated from others with which they are ultimately closely related is true and gives color to the belief that they may never fuse anatomically, though physiologically they do become continuous. The fact that nervous transmission through central organs in adult vertebrates is slow, open to exhaustion, and restricted to one direction as contrasted with transmission through nerve-fibers, is strong physiological evidence of a special central mechanism of interrelation between neurones such as Sherrington (1906) has pictured in the synapse. That no special anatomical condition has thus far been discovered that answers to this physiological requirement can in no sense be taken as an objection to it. That the vertebrate central nervous system is in many of its parts a synaptic organ can not be doubted, but that all its parts are synaptic is not yet proved. Possibly this is a

feature characteristic of only the more specialized parts of the vertebrate central organs and entirely absent from the invertebrate, but whether this difference really exists or not must remain for future investigation.

Although it can not be said at present that a synaptic nervous system is the peculiar possession of the vertebrates, there are two important features in which the central organs of these animals differ from those of the invertebrates. In the first place, the central organs of vertebrates exhibit a large preponderance of long neurones over short ones, and in the second place, they show an enormous increase in the number of association neurones. In an earthworm there are only three long neurones and the rest are short ones; in a crab the long and short neurones are perhaps about equally abundant; but in a vertebrate the long neurones certainly far outnumber the short ones. In any transverse section of the spinal cord of one of the higher animals almost all of the white substance in view excepting a thin layer surrounding the ventral horn is made up of systems of long neurones. In this respect the condition in the vertebrates seems to be almost the reverse of that in worms and in consequence transection of their central nervous organs results in profound and extensive degeneration such as is never met with in animals like worms. For this reason the central nervous system of the vertebrate, though giving much evidence of segmentation in its early stages of growth, is finally a physiological unit such as is realized in no other group of animals, a condition well evidenced by the fact that some of its most recent phylogenetic acquisitions, like the pyramidal tracts of the mammals, may consist of neurones that reach almost from one end of the system to the other.

The second feature that distinguishes the central nervous organs of vertebrates from those of invertebrates is the enormous development of association neurones. These neurones are present in worms, are numerous in arthropods, but are overwhelmingly abundant in vertebrates. Of the white substance seen in the transverse section of the spinal cord almost all except the dorsal columns represent association neurones. Judged from this standpoint there are certainly many more association neurones in the cord than all other kinds taken together. But the association neurones are not only the most numerous in the vertebrates; they also constitute the basis of the most significant evolution. The central nervous organs that show the most conspicuous progressive changes in the vertebrates are the cerebellum and the cerebrum, particularly their cortical portions, and when it is remembered that few or no primary sensory or motor neurones contribute to these two organs, but that they are made up of association neurones almost exclusively, it will be seen how enormously important these neurones become. The association neurones in the vertebrates are not only the organs of intricate nervous exchange, but in the region of the cerebral cortex they

afford the material basis of the intellectual life. Thus in the vertebrates the primary sensory and motor neurones in number and importance are outstripped by the association neurones.

As thus sketched the development of the adjustor or central nervous element of the neuromuscular mechanism takes place in the region between the receptors and the effectors and in time after these two sets of organs have appeared. Its primary function is undoubtedly transmission involving the principle of the common path; secondarily it comes to be a repository of the effects of nervous stimulation whereby its principal function as a modifier of impulses is made possible.

REFERENCES

APÁTHY, S.

1897. Das leitende Element des Nervensystems und seine topographischen Beziehungen zu den Zellen. *Mitth. zool. Stat., Neapel*, Bd. 12, pp. 495-748, Taf. 23-32.

BETHE, A.

1897. Das Nervensystem von *Carcinus Mænas*. *Arch. mik. Anat.*, Bd. 50, pp. 460-546, Taf. 25-30.

FRIEDLÄNDER, B.

1894. Altes und Neues zur Histologie des Bauchstranges des Regenwurms. *Zeitschr. wiss. Zool.*, Bd. 58, pp. 661-693, Taf. 40.

HAVET, J.

1901. Contribution à l'étude du Système nerveux des Actinies. *La Cellule*, tome 18, pp. 385-419, pls. 1-6.

LOEB, J.

1894. Beiträge zur Gehirnphysiologie der Würmer. *Arch. ges. Physiol.*, Bd. 56, pp. 247-269.

NORMAN, W. W.

1900. Do the Reactions of the Lower Animals against Injury indicate Pain Sensations? *Amer. Journ. Physiol.*, vol. 3, pp. 271-284.

SHERBINGTON, C. S.

1906. *The Integrative Action of the Nervous System*. New York, 8vo, xvi + 411 pp.

ANOTHER MODE OF SPECIES FORMING¹

BY LUTHER BURBANK,

SANTA ROSA, CAL.

THE more usual concept of the formation of species is by slow variations so well known as the Darwinian theory, which though attacked from every point, still is and must always in the main be accepted, for without question it gives the fundamental principles of evolution as had never been done before. Yet the boundless amount of research along these lines during the last half century has developed strong new sidelights which illuminate, and in some cases compel a slightly different view of, some of the suggestions of *the master, Darwin*.

During the period of forty years that I have been experimenting with plant life both in bleak New England and in sunny California, extensively operating on much more than four thousand five hundred distinct species of plants, including all known economic and ornamental plant forms which are grown in the open air in temperate and semi-tropic climates, as well as many of those commonly grown in greenhouses and numerous absolutely new ones not before domesticated and on a scale never before attempted by any individual or body of individuals, numerous general principles have pressed themselves forward for discussion and observation. Only one of these can be discussed at this time, and this briefly, more as a text for further observations and experiments than as anything like a full view of this highly interesting mode of species formation.

In the first place, let me say that our so-called species are only tentative bundles of plants, no two individuals of which are exactly alike, but nearly all of which quite closely resemble each other in general outside appearances and in hereditary tendencies. Yet no one can tell just what the result will be when combinations of these inherent tendencies are crossed or subjected to any other disturbing factor or factors. Like the chemist who has new elements to work with, we may predict with some degree of accuracy what the general results will be, but any definite knowledge of the results of these combinations is far more difficult, even impossible, as the life forces of plants and animals act in infinitely more new directions than can any ordinary number of combinations of chemicals.

Only a few years ago, it was generally supposed that by crossing two somewhat different species or varieties a mongrel might be produced which might, or more likely might not, surpass its parents.

¹ Read at the annual meeting of the American Breeders' Association, at Columbia, Mo., January 5 to 8, 1909.

The fact that crossing was *only the first step* and that *selection from the numerous variations secured in the second and a few succeeding generations was the real work* of new plant creation had never been appreciated; and to-day its significance is not fully understood either by breeders or even by many scientific investigators along these very lines. Old tailings are constantly being worked over at great expense of time and with small profit, while the mother lode is repudiated and neglected.

Plant breeding to be successful must be conducted like architecture. Definite plans must be carefully laid for the proposed creation; suitable materials selected with judgment, and these must be securely placed in their proper order and position. No occupation requires more accuracy, foresight and skill than does scientific plant or animal breeding.

As before noted, the first generation after a cross has been made is *usually* a more or less complete blend of all the characteristics of both parents; not only the visible characters, but *an infinite number of invisible ones* are inherent and will shape the future character and destiny of the descendants, often producing otherwise unaccountable so-called mutations, saltations or sports, the selection and perpetuation of which give to new plant creations their unique forms and often priceless values, like the Burbank potato produced thirty-six years ago and which is now grown on this western coast almost to the exclusion of all others (fourteen millions of bushels per annum, besides the vast amount grown in the eastern United States and other countries), or the Bartlett pear, Baldwin apple and navel oranges, all of which are variations selected by some keen observer. Millions of others are forever buried in oblivion for the lack of such an observer.

But in this paper I wish to call attention to a not unusual result of crossing quite distinct wild species which deserves the most careful analysis, as it seems to promise a new text for scientific investigation, especially on biometric lines. The subject was most forcibly brought to my attention twenty years ago by the singular behavior of the second-generation seedlings of raspberry-blackberry hybrids. By crossing the Siberian raspberry (*Rubus crataegifolius*) with our native trailing blackberry (*Rubus vitifolius*), a thoroughly fixed new species was summarily produced. The seedlings of this composite *Rubus* (named *Primus*), though a most perfect blend of both parents but resembling neither, never reverted either way; all the seedlings coming much more exactly like the new type than do the seedlings of any ordinary wild rubus. Many thousand plants have been raised generation after generation, all repeating themselves after the new and unique type. No botanist on earth could do otherwise than classify it if found wild as a valid new species, which it truly is, though so summarily produced by crossing.

Since the *Primus* species was originated, numerous similar cases have attracted attention, such as my now popular Phenomenal produced by crossing the Cuthbert raspberry with our native Pacific coast blackberry, and the Logan berry, both of which, though a complete blend of two such distinct species, yet reproduce from seed as truly as any wild rubus species.

I have had also growing on my grounds for some fifteen years or more hybrids of *Rubus idæus* and *Rubus villosus*, both red and yellow varieties. All are exactly intermediate between these two very widely different species, yet both always come true intermediates from seed, generation after generation, never reverting either way.

By crossing the great African "stubble berry" (*Solanum guinense*) with our Pacific coast "rabbit weed" (*Solanum villosum*) an absolutely new species has also been produced, the fruit of which resembles in almost every particular the common blueberry (*Vaccinium Pennsylvanicum*), and while the fruit of neither parent species is edible, the fruit of the newly created one is most delicious and most abundantly produced, and the seedlings, generation after generation though produced by the million, still, all come as true to the new type as do either parent species to their normal type.

Still another example of this mode may be found in my experiments with opuntias. By crossing *O. tuna* with *O. vulgaris*, thousands of seedlings have been produced, all of which, in the first, second and third generations, though a well-balanced blend of the two natural species, still come as true to the newly created species as do either parent species to their own natural types.

Not only does this new mode hold true under cultivation but species are also summarily produced in a wild state by natural crossing.

The western blackcap (*Rubus occidentalis*) and the eastern red raspberry (*Rubus strigosus*) when growing contiguous, as they very commonly do in Central British America, often cross, forming an intermediate new species which sometimes sorely crowds both of the parent species, and when brought under cultivation still firmly maintains its intermediate characters, no matter how often reproduced from seed. And still further, our common "tarweed" (*Madia elegans*) with its beautiful large blossoms often crosses with *M. saliva* with its insignificant pale yellow flowers, producing a complete intermediate. I have not yet determined whether the intermediate will reproduce true from seed, but confidently expect it to do so. Similar results among wild evergreens and deciduous trees and shrubs and herbaceous plants have been frequently and forcefully brought to my attention, leaving little doubt in my own mind that the evolution of species is by more modes than some are inclined to admit.

HENRI POINCARÉ AND THE FRENCH ACADEMY¹

BY M. FRÉDÉRIC MASSON

PARIS ACADEMY OF SCIENCES

THE Académie Française is primarily a literary organization, and its special work is the preparation of a dictionary. But even in this enterprise it is desirable, as M. Masson points out in the document of which I propose to translate a part, to have expert assistance at hand in the matter of the meaning and use of scientific terms. It is probably for this reason that Henri Poincaré, already a member of thirty-five academies, was this year called to membership in the most celebrated of all academies.

The great mathematician entered the august body with a eulogy of his predecessor, the poet Sully-Prudhomme—which task was not as strange to him as might seem at first glance, since Sully-Prudhomme was educated for a scientist and all of his work shows a scientific turn—and was received, with the customary biographical welcome, by the historian Frédéric Masson. A study by a layman and for the ears of laymen, M. Masson's address is a thoroughly popular effort; but it has a great deal that is pleasing, and not a little that is suggestive. I quote, with considerable abbreviation, from the part which deals most directly with the new academician's life and work.

You were born, a little more than half a century ago, in that dear and glorious Lorraine which has furnished this body so many men remarkable in lines of activity so diverse; so soon after we have been cruelly touched by the death of Theuriet, of Gebhart and of Cardinal Mathieu, you appear, attesting, by the exercise of a totally different genius, the inexhaustible fecundity of your native province.

You come of an old race long established at Neufchâteau, and located at Nancy for a century. Of your name—*Pontcaré* (square bridge), rather than *Poincaré* (square point), for, as you have said, one might conceive a square bridge, but scarcely a square point—there have been magistrates, savants, lawyers, soldiers like the Commandant Poincaré, your great-uncle, whose tenderness for his wife and whose sad adventures M. Chuquet has narrated—like that other Poincaré, also an officer, who died for the republic in the year IX., whose son the first consul himself recommended to the ministry of war for a place in their offices, since, a corporal in the Seventh Hussars, "he had lost a leg and a thigh in one of the last battles which adorned the last campaign on the Rhine."

¹ Translated, with an introduction, by Professor Roy Temple House.

Your grandfather was a pharmacist; it was at Nancy, in his house, opposite the ducal palace, that you came into the world; and this house, solid, massive and without ornament, is entered through an almost monumental portal whose worm-eaten posts support a broken pediment bearing the semblance of a boiling pot. Some found a bit of symbolism: the portal is poetry; the house is prose; it gives an impression of bourgeois simplicity and of settled living which is by no means trivial. Your father, a physician, was a conscientious student, a distinguished practitioner; and the faculty of Nancy, where he took his course, considered him a master of whom they were justly proud, at the same time that the working population saluted in him their benefactor. He was one of those men who, having been led by a noble curiosity into the most emotional and uncertain of professions, practise it with admirable disinterestedness and hold themselves amply repaid if they are so fortunate as to save a human life now and then. For the honor of the nation, there are many of the sort in France; but few have been able, like Dr. Poincaré, to discharge the duties of so absorbing a profession, to work in the laboratory, to teach assiduously, and at the same time to travel extensively over Europe.

Your mother was one of those alert, active women, always in motion and always busy, whose spirit of order, organization and command rules a household. She also was a native of Lorraine, of an old local family, home-loving, attached and riveted to the soil; the boys, no matter how brilliantly they had begun life, were never easy till they had returned to the home-nest to live, hunting on their estates or supervising their cultivation; two of your great-uncles joined to their rural tastes an inclination for geometry. Your mother wasted no time on such matters, finding enough to busy her in those occupations which are duties, and which, cheerfully accepted as such, become pleasures. Ah! what admirable sources of vital energy are these Frenchwomen, honest and shrewd, economical and judicious, sovereign in their own domain and disdainful of the other conquests, constantly busy at reforming the national virtue and transmitting intelligent patriotism to their children! . . . In your home you found an uncle recently graduated from the *École Polytechnique*. What a prestige surrounds these young men who, by a mental effort which is sometimes excessive, succeed in obtaining the first places in their generation, and to how many mistaken choices of vocation does their example lead! But with you, sir, the vocation had nothing to do with example; you were predestined to mathematics! This aptitude, in your paternal and maternal family, is transmitted in collateral lines like the throne in the House of Osman, and yourself twice heir of avuncular gifts, I am told that you have selected one of your own nephews for the precious succession.

You did not wait long to reveal your vocation, and you are justly

cited as the most precocious of infant prodigies. You were nine months old when you first saw the sky at night. You saw a star come out. You obstinately pointed out the shining spot to your mother, who was also your nurse. You discovered a second, with the same astonishment. You greeted the third, the fourth, with the same cry of joy and the same enthusiasm; it was necessary to put you to bed, you were so excited by your new occupation of star-finding. That evening brought your first contact with infinity and your first lesson in astronomy; you were the youngest professor known.

I have been told that you were a delicate, alert, charming child, spoiled and adored by your parents; a terrible illness suffered at the age of five years, as a result of which it was feared that you would never be able to speak again, left you more delicate, timid and somewhat awkward, so that you were afraid of the noisy games of the boys and preferred the society of your little sister. I do not imagine that violent sports ever tempted you, or that you ever became skilful in them. Nevertheless, you learned to hunt very large game. As soon as you learned to read, your curiosity was excited by those books of popular science which have replaced fairy stories in realistic schemes of education. You found extreme pleasure in them, and you experienced a grandiose horror in witnessing cosmic upheavals and battling with antediluvian animals. It was formerly the fashion to run after Prince Charming and awaken Sleeping Beauties. Now the child is no longer expected to make the acquaintance of those trivial personages; he must content himself with those whose skeletons have been discovered. Let me ask you: Between creatures which have really lived and of which we know nothing and never shall know anything, except that they lived, and beings which have lived only in the dreams of humanity, but which in the course of the ages have gratified us with so much beauty, grace and poetry, which are the more real, which bring more of light, of consolation, of joy? But you were not made to sit in the arm-chair of Charles Perrault.

It was in your father's house that you received from a retired teacher, a friend of your family, your first notions of things; he did not require written exercises from you; he conversed with you, talking of everything at haphazard; this encyclopedic instruction was so appropriate to your nature that when you entered the *collège* you at once took the first place; but this sort of work would be injurious to children of different endowment. Your memory was and still is more auditory than visual. Pronounced words engrave themselves on it. When you come back from a journey, no matter how long, you can recite the names of all the stations you have passed, if you heard them cried before your car. More than this—a character presents itself to your mind like a sound. In the evening, you can recite the numbers of

all the coaches you have met in the course of the day, but you hear them, you do not see the figures. This is one of the most remarkable peculiarities of your brain, and I venture to note it because I have the unanimous testimony for it of those who know you most intimately.

At the *lycée* of Nancy, you were superior to your comrades in every branch, and you seemed so well endowed for literary studies that one of your teachers, who is one of our best historians, would have been glad to attract you to our speciality; but when, in the fourth grade, you opened a text on geometry, the work was done. Your astonished teacher rushed to your mother and said to her: "Madam, your son will be a mathematician." And she was not particularly frightened. Mathematics, as soon as you made her acquaintance, seized you and held you. She is a tenacious mistress, with this peculiarity, that she fires all her lovers with the same impulse: the mathematician is a peripatetic. Pedestrian exercise seems necessary to him in order to stimulate thought, and, as he walks, certain mechanical gestures with which he occupies his fingers seem the indispensable auxiliaries of an intellectual labor that leaves him indifferent to the exterior world and even unconscious of it. One day, when promenading, you suddenly discovered that you were carrying in your hand a wicker cage. You were prodigiously surprised. When, where, how had your hand plucked this cage, which was new and fortunately empty? You had no idea, and retracing your steps, you walked until you found on the sidewalk the stock of a basket-maker whom you had innocently despoiled. Such phenomena are very common with you; they will become, if they are not already so, as celebrated as those attributed to Lagrange, to Kant, to Ampère. You might be in worse company.

You were, nevertheless, at times, a child who liked pleasure and games, but you invented your own amusements. You played at railroad or *diligence* with a map or a guide in reach, and thus you learned geography. You put history into dramas and comedies; at sixteen years you had written a five-act tragedy in verse, and you would not have been a son of Lorraine if the heroine had not been Joan of Arc. Even charades had a charm for you. Are they not problems?

The war interrupted these games. You were sixteen years old; your age and your health prevented your mingling with the combatants, but you tried to make yourself useful; every day you accompanied your father to the hospital and served as his secretary; you were so eager to learn the news that, in order to read them in the only papers that were accessible to you, you learned German. The war must have matured you; it certainly left its trace upon you; but it did not change your life. To the men of the generation preceding yours, it brought a definite conversion with introspection. You have read Sully-Prudhomme's verses entitled "Repentance." In them he confesses the error into which the generosity of his heart had drawn him and in which the fal-

lacious discourses of the rhetoricians had maintained him ; in order to carry out designs which were unworthy and shameful, these gentry resort to sonorous words to lull a careless people to security ; and when the nation awakens and finds herself rolling into the abyss, she cries out treason but is unable to distinguish the traitors. So Sully-Prudhomme had detested war and shown himself rather disdainful of soldiers. Then he learned from his own experience that any one who chooses can not be a soldier, that it is one thing to deliver philosophic harangues and another to submit one's physical and moral being to monotonous regulations and entire self-effacement ; he learned—and the lesson cost him dear—that in order to possess the right to think, one must have conquered first the right to live ; that it is folly which would be ridiculous if it did not bring such despair to profess humanitarianism when all of Europe is under arms ; and that, however inelegant the solution may appear, there is but one, if a people intends to maintain its nationality, guard its independence, continue its race, possess its territory, speak its language—and the solution is to be strong enough to defend them.

You lived your life, sir, under the yoke of the victorious enemy. It was in a city occupied by the Germans that you resumed and continued your studies. You were thoroughly successful in them ; but the joy was doubled for you by the fact that your public success coincided with the evacuation of Nancy. As our dear late colleague Émile Gebhart has told us, it was in a hall filled with the joy of deliverance that you received your last scholastic honors. You held the first rank, a native of the city and ten times a prize-winner. You carried off the prize in mathematics from all your rivals, from Paris and the departments ; it depended on you alone to enter the School of Forestry second on the list of appointees ; this would have been another glory for Nancy, but you refused to go further with the school than to leave your visiting-card ; you were distrustful of the fallacious dryads who delight in troubling the absent-minded.

The next year you presented yourself as a candidate at the *École Polytechnique* and at the same time at the *École Normale* ; for the latter you stood number five, for the former number one. Which of the two great schools would you choose ? That which decided your choice, more even than the familiar memories, than the temptation of the uniform and the glory of the sergeant-major's chevrons, was it not, tell us, the groaning of the mutilated fatherland ? But you never reached the point of entering upon a military career. Your scientific bent showed itself so brilliantly at the school that there was no question of another sort of glory ; your residence there is a matter of piously transmitted tradition. It is related that you attended your classes, at least in mathematics, without taking a note, without reading or even collecting the mimeographed sheets which reproduce the professor's lecture. Your method

was to classify the results established, to study their connections, with no care for the demonstrations, sure of finding others, if you happened to forget the ones which they had employed; at the time of your entrance examination, did you not find a new solution for a problem which had been set you? When you worked, you did not remain in your room, but gave your brain a promenade through the corridors, and in place of a pen, a pencil or a piece of chalk, your hand was busy with a bunch of keys—your opener of ideas.

Your superiority in mathematics was so decided that, in spite of your inaptitude for anything practical—manipulations, linear design, imitative design—you were, at the closing examination, placed second, and admitted to the School of Mines. There you found life pleasant for more than one reason. In the first place, in the Latin Quarter, you lodged with one of your cousins, who was taking a literary and law course. . . . With him, in the practise of peripatetism—which was, perhaps, less a philosophical school than a physical peculiarity of philosophers and mathematicians—you followed those studious rounds in the course of which you discussed philosophic themes, already indissolubly associated in your mind, as in those of the ancients, with mathematical theories.

In 1880, the Academy of Sciences had set as the subject of the mathematical great prize, the theory of differential equations. When the illustrious M. Hermite presented his report, he mentioned a discussion bearing the motto: *Non inultus premor*, whose anonymous author he invited to persevere in a work which promised to produce results. The motto was that of Nancy; you were the author; but your paper was only a first sketch; you presented at that time only the results which you were soon to obtain and which, in the month of February, 1881, burst forth—it is the only exact phrase, says one of your admirers—in the report of the Academy of Sciences. From week to week, with the notes which you sent out regularly, your discovery increased in precision and amplitude for a period of nearly two years. Your contribution was the “the crowning of the work of Cauchy and Riemann, the representation of the coordinates of any algebraic curve in uniform functions, the integration of linear differential equations with algebraic coefficients—it was a new and immense perspective opened to view.”

This discovery was a great victory for French science. For some years the German geometers had been roving about the house without finding the door. You located it and opened it.

From there I need not follow you in your career: Professor in the University of Paris and the Ecole Polytechnique, your lessons have had an unequaled vogue; and if, among your auditors, many were not able to follow you, all agreed in proclaiming your astonishing superiority; at thirty-two years you were elected a member of the Academy of

Sciences, you have been called into the majority of the scientific societies of two hemispheres; you have received all the honors that a legitimate ambition could crave. Your name, going out beyond the narrow circle where your work can be appreciated, has become illustrious and added to a nation's glory, and this fame you owe only to yourself; it is the gift of no one, you have followed no master, you belong to no school, you are yourself—and that is enough.

Similarly, when you undertake a criticism of science, you make it a personal matter, and without adopting any tradition, without bowing to any formula, you walk on in your independence and because you choose to. You run indeed, and so fast, with such bounds, that in order to follow you it is necessary to leap ditches and fill in gaps; but you are built so. Original in mathematics, you remain so in this branch of philosophy; you apply to it, at the same time, a highly-developed interest in psychology, a rare aptitude for observing physiological phenomena in your own person, and that mathematical habit which organizes precision and with refined subtlety binds arguments together with chains that seem impossible to break. Restrained by nothing which you place confidence in or accept *a priori*, you build up your doubt against official science and sound its nothingness. So your work is double: in mathematics you erect to scientific truth a temple accessible only to the few initiates; and with your philosophic artillery you hurl into the air the chapels about which throng the crowds of rationalists and free-thinkers who by a common school certificate have acquired the right to believe in nothing which is not proved to them, to celebrate the mysteries of a pretended religion of science. Ah, sir, what havoc you are making in these demonstrations! Nothing would survive the rudeness of the blows you are dealing if you did not stop from time to time to banter your victims, or if, seized with a sort of remorse, you did not amuse yourself by gluing together again the members you have broken. The axioms which seemed established by the wisdom of the ages are no longer more than definitions when you have passed; the laws become hypotheses; and at the same time that you prove the essential rôle of these hypotheses, you show their merely temporary utility—you make it evident that these definitions are convenient but ephemeral. What remains? Nothing, or little more than nothing, and the most precious idols of primary religion go to join the dead stars in the depopulated heavens.

Does this mean, sir, that you doubt science more than truth? Neither the one nor the other; but the latter gives way constantly before the advance of the former, and, as man proceeds one step farther, the space he must cross withdraws before him; beyond the steppe whose extent his eye embraces, others await him, and still others, for he only is assured of reaching the end who stopped with the rudiments—and learned them by heart. . . .

COLLECTING AND CAMPING AFOOT

BY A. S. HITCHCOCK

SYSTEMATIC AGROSTOLOGIST, U. S. DEPARTMENT OF AGRICULTURE

EVERY naturalist wishes to spend a part of his time in the field, observing, taking notes and making collections. It often happens that such field work can be done best by camping. Methods employed by field naturalists while camping vary according to the character of the country and according to the objects to be attained.

It is the purpose here to give a few hints concerning traveling on foot, and carrying a light camp outfit on the back as a pack. These hints are based upon considerable experience with this method of camping in various parts of the United States, and are given with the hope that others may find them an aid in planning similar trips. This kind of camping can be of service only when the necessary collecting outfit and specimens collected are comparatively light in weight and when the area of the region to be covered is considerable. In my own work I can use this method because I am collecting only grasses which are easily prepared, and because I wish to cover in a single season a wide area, usually several states. I wish to travel quickly by railroad or other regular transportation, from one locality to another, often two or three hundred miles apart, spending one to five days in each place. It does not pay to outfit with wagon or pack animals for so short a time and one is not sufficiently mobile when stopping at hotels. With a light outfit one can start into the field as soon as he arrives at a station, thus saving much time. If more than five days is required for a given excursion, I am in the habit of taking a pack animal to carry my outfit, as I can not conveniently carry in a pack provisions for more than that number of days.

In calculating the details of an outfit one must first determine the weight he is able or willing to carry. If the weight carried is too great the mobility is too much reduced. Yet enough in the way of food, clothing and bedding must be carried to prevent too much risk to the health from short rations and exposure. The problem before us is to adjust the factors so that the result may represent a maximum efficiency. I endeavor to keep the total weight of my outfit within fifty pounds and we may assume in general that a man should limit his pack to a third of his own weight. With this weight I count on walking fifteen to twenty miles a day over ordinary roads or trails that do

not include over two thousand feet of total climbing. In climbing one can count on one thousand feet an hour, without a pack if the trail is steep. With a fifty-pound pack the time is about doubled. If one finds it necessary to carry more than the weight indicated, the distance traveled is correspondingly reduced. From the total weight one must subtract the weight of the collecting outfit. My own outfit consists of a wood slat press with straps, twenty-five light-weight driers, one hundred sheets of inner papers, a few ounces of cardboard slips for fastening over the bends in specimens, and my plant digger. The total weight is not over five pounds. The weight of the specimens gathered is not likely to be, on a single trip, more than five pounds, which increase in weight is, however, offset by the decrease in weight of supplies. We have then forty-five pounds for the remainder of the pack.

The outfit may be considered conveniently under the following heads: clothing, bedding, cooking utensils, provisions, miscellaneous. The exact selection depends upon the length of the trip, the character of the country, climate, accessibility of supply stations and many other conditions which can not here be foreseen. It is clear that in the high Sierras more bedding is necessary than in Florida, that more provisions must be carried in a wilderness than in a settled country, and that rain or mosquitoes must be provided against where these occur. Therefore in discussing the requisites for an outfit I shall not make a definite selection, but shall offer suggestions as to such selection based upon my own experience.

In my own work I travel from place to place with the usual baggage allowance of one hundred and fifty pounds aside from my hand baggage. In this baggage I carry such articles as I am likely to need at hotels where I may stop, and also a selection of camp equipment, and extra driers and other collecting supplies. Sometimes I go first to a hotel, where I leave my baggage while I make an excursion of a few days on foot. Sometimes I travel in camp clothes and pack, in which case I can leave my baggage at the depot and go at once into the country.

Concerning clothes for camping, I can say little except that it is very necessary that the foot covering, whatever its other qualities, should be well fitted and well "broken in," for it is absolutely essential in a walking trip that the feet should be kept in good condition. As to other articles, I prefer heavy socks, wide-brimmed cowboy hat, and, in the mountains, woolen underwear. I usually go without a coat, but carry a sweater. The extra clothes may be reduced to an extra suit of underwear, an extra pair of socks, two large handkerchiefs and a pair of moccasins. The latter I use chiefly at night.

The bedding may be reduced to a single blanket of moderate weight or two of light weight. I also carry a waterproof poncho. This is a protection against rain, dew or damp ground at night and can be used

as a cape in the daytime in case of showers. I carry in my baggage a light, so-called balloon silk A tent for use in regions where one may expect rain at night. This has a ridge rope by which it is suspended and weighs six pounds. In mountain regions where the nights are cold I depend for warmth on keeping a fire during the night, rather than on carrying extra bedding. But in my baggage I carry a waterproof sleeping bag for use on longer trips with a pack animal. Where mosquitoes abound one must be provided with a cheese-cloth tent, or at least with a head veil.

The cooking utensils may be reduced to a very few pieces, but in this aluminum age one may add a few luxuries. While one can with patience cook over a small fire between stones, this method has its disadvantages. There may be no stones; but even when these are present it is not easy to find them of the proper size and shape for the small vessels used by one person, such as a pail four inches in diameter. I therefore usually carry a "stove" or grate. This consists of three pieces of strap iron about fifteen inches long, fastened by four cross strips. This can be set across stones or small logs and is certainly a great convenience. It is strong enough to hold in the middle a quart of water. When packed it is placed in a cloth sack to prevent the soot from soiling other articles. Two or three dishes may be cooking at the same time by this means. The cooking utensils consist of a straight-sided coffee pot, a pail in which this fits, both of aluminum, all with the parts riveted, not soldered, and finally a small frying pan of iron. I have not found aluminum so satisfactory for the latter article, as foods cooked in it seem to burn more easily. A second small pail is a convenience, in fact I often use in an emergency a tin fruit can with the top melted off and a wire bail attached. Each utensil used over the fire should be packed in a light cloth bag to prevent the soot from soiling the other articles. One can not take time to remove soot after each meal. In addition might be mentioned a plate and two bowls of aluminum, a drinking cup of tin (aluminum gets too hot), knife, fork and dessert spoon. I must not fail to mention the canvas bucket. This is light and collapsible, and is very convenient to bring a supply of water from a distance. One can not always camp in the immediate vicinity of water. The best matches are the old-fashioned sulphur kind that come in blocks. These should be kept in a waterproof box. In a recent work on camping I saw mentioned a handy contrivance for blowing the fire. It consists merely of a rubber tube with a short metal tube at the end. When cooking with such a small outfit it is necessary to use a small fire, frequently replenished. The blower serves a useful purpose for bringing the fire quickly into action. I have used this article during the last season and can heartily recommend it to others. In describing my outfit I mentioned a plant digger. For this purpose

I use an "intrenching tool," an implement in use in the army. This is a broad-bladed knife of good steel which fits in a scabbard carried at the belt. It is an excellent thing with which to dig plants, but it can be used for several other purposes, the most important of which is to cut fire-wood and incidentally to make friends with vicious dogs. This tool may be obtained of Francis Bannerman, 549 Broadway, New York.

In choosing the food for such a trip as described one is limited by the available supply and is governed by one's tastes and by the necessity of reducing the total weight to a minimum. It is essential that the ration be fairly well balanced. The following is given only as a suggestion, as tastes and conditions are so variable. It is also to be remembered that the supplies must be obtained from ordinary sources as found in the region visited. A few kinds of food, such as erbswurst and dried egg, I may provide at the beginning of the trip, as these can not be purchased at village grocery stores. For drinking I carry cocoa, as coffee is more bulky and tea I do not care for. If cold water of good quality can be obtained I drink the cocoa only at breakfast. To the cocoa I often add a little arrowroot. To avoid lumps the sugar may be mixed with the dry cocoa before the hot water is added. Milk I carry in condensed form. Dried milk is not so satisfactory, as it does not mix well for cooking, but it has the advantage of light weight. Since a can of condensed milk will last one or two days, according to size, it is necessary to protect an opened can or there will be a fine mess in one's baggage. I keep the can in a closed tin can just large enough to hold it. The milk can is opened by driving two small wire nails in the top at opposite sides. When not in use the nails remain in as stoppers. The foods may be classified into carbohydrates, fats, nitrogenous foods, fruits and condiments. Of the first may be mentioned sugar, which with me is an important article of diet, as I eat half a pound a day. The starchy foods present considerable variety. Bread heads the list, but not infrequently one is unable to obtain this at a supply station. Furthermore, on a walking trip one can scarcely count on carrying bread sufficient for more than two days. Flour is likely to be the staple. I have found self-rising pancake flour the most convenient, as this comes in small packages all ready for use. One can carry but a few pounds of flour and it is difficult to obtain so small a quantity of the ordinary sort at a store. Other starchy foods that I often use are grape nuts, cream of wheat (or similar breakfast food) and rice. This last, however, I do not much relish, though it is improved by cooking with raisins or dried fruit. When possible I add potatoes and onions, but both are bulky and can be carried only in small quantity. The fats are supplied usually by bacon. Butter can be carried only in the mountains where the climate is cool, otherwise it turns to oil. The nitrogen may be supplied by canned meats, which are heavy; by canned beans,

which are also heavy; by dry beans, which take too long to cook to suit me, or by dried egg. I depend largely upon this last. It comes in convenient-sized cans and has proved very satisfactory. One can make omelette or scrambled eggs, or it can be mixed with the flour for cakes. I use the last method frequently, putting into the flour the equivalent of two eggs. Fruit is an essential in camping. I prefer dried cherries, but if these can not be obtained, I use prunes, dried peaches, apples or whatever is available. A package of raisins is a good thing to have. Of the condiments I carry only salt, as I do not care for pepper, vinegar and so on, which are inconvenient and superfluous articles for a pack. There are various kinds of concentrated soup packages on the market only one of which I have found worth carrying. That is erbswurst, sold by Abercrombie & Fitch Co., of New York. It is put up in pound, half-pound and quarter-pound packages and consists of a meal ground from peas, vegetables and meat, seasoned, ready for use by adding water. It is a balanced ration easy to prepare and very concentrated. On a forced march one could subsist upon this alone.

The miscellaneous portion of the outfit includes a few toilet articles, a pocket dissecting outfit, together with bandages, carbolated vaseline, etc., for patching myself in case of accident, needle, thread, twine, safety-pins and similar small articles. For packing these and the food not contained in the original cases I use small cloth bags. The sugar, dried fruit, rice or even the flour or cream of wheat, is transferred to a cloth sack, as paper sack or pasteboard boxes will not withstand close packing.

The greater part of the outfit is carried in a pack upon the back. If the bulk is small an ordinary soldier's knapsack is satisfactory. When it is necessary to carry more the outfit may be placed in two waterproof duffle bags and these carried in a strap pack. The most satisfactory pack that I have tried is the Merriam pack by which a portion of the weight is supported at the hips.

In a trip of three to five days from a station, the outfit consists, then, of the Merriam pack in which is placed every thing except the poncho and blanket which are folded in a roll on the outside, the plant digger carried at the belt and the plant press carried in the hand. I carry in addition a haversack for overflow articles. I try to start with two loaves of bread, which being too bulky for the pack I place in the haversack. In this I carry also my note book and drinking cup.

Having decided upon a route for a short trip, which should be arranged if possible so that no portion is traveled over twice, I carry my pack to a favorable locality for collecting and unload. After exhausting the collecting I move on to another place. Occasional plants are dug up without removing the pack but this is somewhat of a strain and should not be done regularly. One is obliged to rest every two or three

miles, and by selecting the proper localities, these halts can be used for collecting. The pack can be removed by unfastening a single clasp. If long side trips are to be made, such as climbing a mountain, the outfit can be cached until the return.

An average day in the field, thus equipped, would be about as follows: Supposing that I have arrived in the forenoon at the terminus of a branch railway line in the mountains, I obtain such supplies as may be necessary and start at once toward what appears to be the most favorable collecting ground. At noon I eat a light lunch such as grape-nuts, usually not going to the trouble of making a fire. About five o'clock in the afternoon I begin to watch for a favorable camping spot. The requisites are good water, firewood in abundance and a comfortable location for my camp. As I carry no axe it is necessary that the firewood be in shape for use without chopping. At altitudes where the temperature sinks to 40° F., it is necessary to keep a fire all night, as the bedding carried is not sufficient to keep one comfortably warm. A level spot is selected and freed from stones, sticks and cones. It is an advantage if one can place his bed by a large rock or log and build the fire a short distance in front as the heat is then reflected and the wind is kept off. It is scarcely safe to build a fire against a large log or stump, as it may start a forest fire or it may at least be troublesome to put out the next morning. A supply of firewood should be placed near at hand and the fire replenished as needed, which is at intervals of about two hours during the night. There is no advantage in making a larger fire as one is driven farther away and gets cold just as soon when the fire dies out, and furthermore there is more danger from sparks falling on the blanket. It may be remarked that the falling temperature always wakes one up in time to replenish the fire if the nights are cold. Having gathered the firewood one prepares for supper. I do not utilize the large fire for cooking, but build a small fire near-by, under the grate previously described. The small fire can be controlled to suit the requirements. As one sits near the stove while cooking, the fire must not be too large. The supper is with me the important meal of the day. There is time to cook such articles as need prolonged boiling. At this meal I have pancakes, bacon, potatoes, onions, fruit or whatever my supplies will furnish. As the cooking utensils are limited to a frying pan, coffee pot, pail and tin can, the amount of cooking that can be carried on at one time is limited. Enough dried fruit is made into sauce to last for the breakfast and possibly the lunch following. Cream of wheat will also be cooked for the following breakfast. If potatoes are carried enough are boiled at night to give a small surplus for frying the next morning. As a matter of fact when one is alone it is necessary to limit the variety of food at any one meal, since it is not convenient to carry in a pack the surplus from a meal, especially if in liquid form.

Supper over I go to bed at once. The bed consists of the poncho and blanket doubled on the ground near the fire. I never take the trouble to collect boughs or otherwise prepare a bed, except to remove obstructions. If soft turf is present so much the better, but this does not often happen. Usually I sleep on the bare ground as bunch grass is not comfortable. As explained before I carry an extra suit of underwear and a pair of socks. At night I remove the clothes worn during the day, put on dry underwear and socks, and if the weather demands, put on the other suit of underwear over the first, and finally the sweater and moccasins, and am ready to fold myself in my blanket. To do this I spread the blanket and poncho over me, roll first to one side, then to the other until the slack is taken up on each side. In this way the two edges are lapped beneath and I can roll to either side, the blanket remaining tight. For a pillow I use the bag in which I carry my clothes, filling it with leaves. I arise at dawn and retire soon after dark, for there is little to do when alone by a campfire.

As partially indicated above the breakfast consists of cocoa and cream of wheat or other breakfast food cooked the night before, and if I am hungry enough, other food left from supper. The utensils are now cleaned and packed for the day.

The plant driers are changed once or twice a day. As I usually carry only twenty-five driers, it is necessary to remove the plants and dry the driers in the sun, or if the weather is damp, before a campfire. Ordinarily in sunny weather I attend to the drying about 10 A.M. and 2 P.M., most grasses being dry in twenty-four hours. In this way I can prepare about twenty-five specimens each day. But if the collecting is particularly good I can double the number by drying before the campfire at night.

With the outfit I have described one can travel safely, that is, without subjecting himself to exposure, but the work is not easy. Of course if two persons arrange to travel in company the trip would be more pleasant and a few additional comforts might be included. One advantage in traveling afoot is the mobility. Little time is lost in getting to the collecting ground and one is not confined to roads or trails as when traveling with pack animals. One can cross a mountain range or from one railroad to another. The available range with full complement of supplies is as much as one hundred miles.

The traveler should be provided with good maps and a compass. Topographic sheets of a considerable portion of the country can be purchased from the United States Geological Survey.

The above suggestions are offered for the purpose of aiding any who propose making natural history collections. I should not advise this method for those who are going for pleasure only, as it is hard work and the necessary drudgery is only balanced by the increased opportunity for collecting and observing.

THE NECESSITY FOR AN INTERNATIONAL LANGUAGE

BY IVY KELLERMAN, Ph.D.

CHICAGO

IT was urged by a certain Greek philosopher that in ignorance alone lay the real reason of wrong-doing, and that none who truly understood the right could thereafter be guilty of wrong. Ignorance in a narrower sense has been offered as the explanation for misunderstanding and consequent trouble of a more or less serious nature between nations and races as well as between individuals. Ignorance of one another's civilization, lack of appreciation of each other's character and ideals, failure to comprehend the motives of essentially simple actions—all these are at fault when great nations disagree. No other interpretation is indeed possible, since longing for power, love of conquest, lust to slay, can hardly be suggested in calm seriousness as motivating the actions of nations who are followers of the gentle Jesus, the kindly Buddha, the wise Confucius, in a supposedly civilized century.

It seems strange at first that there should be room for such lack of mutual understanding and sympathy, in view of the vaunted increase of international intercourse, due to the many opportunities of communication by mail and by wire, to the great interchange of commodities made possible by commercial progress, and to the growing facilities for international travel. It seems strange, also, when we recollect that in the employ of every nation there are numerous persons skilled in the language of every other nation of political or commercial importance, to serve the one as interpreters of the thoughts and words of the other, and to translate the ideas and ideals of these peoples for each other in any emergency that may arise. Such experts are found likewise in all great educational centers. There is not a university without its corps of trained linguists, while its leaders in all of the various departments must possess a fair degree of familiarity with numerous foreign tongues. Even the students are becoming slightly cosmopolitan. A few Americans and Englishmen and Orientals are found at every European university of note, while in America are scattered students from Europe, from the far east and from South America.

Therefore we may claim to have interpreters. They are few indeed, in proportion to the number needed, as has been forcibly pointed out, with the plea that "governments, universities, churches, chambers of commerce, should have some definite plan of raising up a body of sympathetic scholars, who shall be first-hand interpreters of one nation to the other."¹

But in this very claim lies the explanation of the puzzle. As long

¹ Document 15 of the American Association for International Conciliation: "American Ignorance of Oriental Languages," by J. H. DeForest, D.D., page 12.

as interpreters are needed, as long as the ability to interpret rests only with the officials of the government, the faculties of the universities, and the small proportion of citizens and students who have opportunity of extended residence in at least one country besides the native one, just so long is perfect understanding impossible. For perfect understanding between two nations results from an understanding between a majority of the citizens of these two nations, not from even the most perfect understanding and appreciation of one by but a small minority in the other. This is true even if the minority happens to be the political body in control. For in one way or another the people rule, and public opinion and desire, however faulty, exert a mighty influence.

Accordingly, if international sympathy and agreement rest upon adequate mutual understanding attained through the complete comprehension of more languages than the mother-tongue among the general public—whether these languages be spoken, printed in newspapers, pamphlets and books, or written in letters amicably exchanged—the immediate solution suggesting itself is this: Let all or a majority of the citizens of each nation learn thoroughly the language of each other nation. Then will the barrier to intercommunication disappear. Each individual may read at will and at once the publications of every other; may express his ideas and have his questions answered, orally or by correspondence, with citizens of any nation; and may feel himself linguistically at home in any country of the world, without the present need of guidebooks, couriers and interpreters, ever provocative of mutual distrust.

Such a proposition is, however, utterly futile from a practical point of view. Persons in comfortable financial circumstances may learn several languages besides their own, business men stationed in foreign countries may do so to some extent, and peasant immigrants may do the same in limited degree; but the possessor of more than a moderate familiarity with two or three languages is called a linguist, and placed in a class apart, as differing by that very fact from the majority of mankind. Genuine admiration is accorded any person who has completely mastered three or four languages in addition to his mother-tongue, and speaks and writes all of them with equal fluency, exactness and elegance. Nor is any one surprised to hear that such an expert spends many years and much care in acquiring these three or four languages with a reasonable perfection of pronunciation, syntax and style, or that teaching this is in itself a profession worthy of remuneration.

Yet to be truly a polyglot one must be familiar with not only French and German, English, Spanish, Italian, Russian, each difficult of mastery, and the Scandinavian languages, but also Dutch, Flemish, Portuguese, Roumanian, Catalonian, Greek and the many languages allied to Russian, such as Bohemian, Polish, Servian, Bulgarian, Lithuanian, etc., and also the non-Aryan tongues of Europe, such as Hungarian and

Finnish and the scattered Yiddish. Not even with this may he be content, although it demand the work of a lifetime and more, but must turn to the east, with its Persian, Armenian, Arabic, Turkish and numerous Hindoo tongues, and then pass on to China and Japan, and even to Korea.

Who can boast of all this? Yet who will deny that not one nor many, but in truth each and every one, of the intelligent citizens of every nation should have the power of overcoming these linguistic barriers? This is one of the great needs of the civilized world, as urged in the Prime Minister's address at the Seventeenth Universal Peace Congress held in London, July, 1908: "I have said it before, but I would say it again, *the main thing is that nations should get to know and understand one another.*" This is profoundly true. Not only the future but the present of these various-tongued races and nations is intertwined to such an extent that the power of free intercommunication is an imperious necessity. But if this direly needed intercourse is so impossible of universal or even fairly general attainment under existing circumstances, another solution must be sought.

The solution that presents itself next is, that some one of these languages be chosen for universal international use. Next after the mother-tongue, this should be learned by every inhabitant of the civilized world, and all publications of any importance whatever should be published directly or in duplicate in this international medium. All international correspondence should be thus conducted, and the language likewise used in all international assemblies and conventions. To learn one language besides the native tongue would not be so absolutely impossible as the absurd idea of learning many or all of them. The proposal is good, and the selection of this language at once becomes a problem worthy of attention, for that one language should serve all nations of the world in international dealings is eminently reasonable.

The place of a semi-common language among the educated classes was held by Latin in the middle ages, and the mind at once reverts to this, with speculations as to the possibility of its revival. But Latin can not serve this purpose. Its vocabulary is too limited and too unsuitable for discussion of modern themes, since even a bicycle or an umbrella demands circumlocution in Latin, while the introduction of new and modern words would destroy its purity, and make it but a barbarous hodge-podge of Latin forms. Moreover, the difficulties of Latin grammar and syntax prevent this language from being easily mastered. Only at the expense of much time and effort can the modern mind completely assimilate the ancient ways of word-inflection and sentence construction. Any one may admire the purity and severe elegance of Ciceronian Latin, but not every one is able to imitate it. Yet Ciceronian Latin would unhesitatingly be chosen as the standard for a revivification of this tongue. The silver Latinity and that of the

middle ages are as out of the question as the "modern" Latin which for want of a better medium is forced to serve in a multitude of scientific classifications and descriptions of the present day. This too is in regard to Latin as a written language. Speaking it is a still more difficult problem, one before which even the Latin specialist is ill at ease. It is evident that the idea of bringing Latin in any shape into real use as an auxiliary language in the busy modern world is absolutely hopeless.

What is true of Latin is equally true of Greek, with its own peculiar alphabet, used by no other language, and its even greater remoteness from present European tongues, in spite of the many derivatives from it in modern vocabularies, especially in technical terminology, and in spite of the fact that the idiom developed from ancient Greek is a spoken language to-day. The languages of the past can not serve the peoples of the present in any immediate and practical capacity.

The next alternative is the consideration of the modern and living languages. For French was the accepted language of European courts, in times not yet remote, as well as the language of diplomacy and of polite literature; although, as in the case of Latin, this language too was semi-universal among chiefly the educated and politically powerful classes. Is it feasible to restore French to that high estate from which it has now fallen? Hardly so, with English a powerful competitor, and German vying with both. From this very competition it is clear that neither French nor any other national speech can to-day or to-morrow become the accepted auxiliary language. This idea, untenable now, may find acceptance in the far future, *after* the establishment of international unity and understanding, and after the forgetting of international jealousies and struggles for political preferment and commercial supremacy. But at present it is plainly Utopian. No nation of to-day will yield to any one other nation the immense commercial and political advantage given by permitting the mother-tongue of that nation to become the accepted medium for international dealings. No American or Englishman would consent to an attempt to have German used exclusively, in his intercourse with Spanish-speaking peoples, or any other peoples, nor would he consent to French for such a sole medium. No German would accept French in this capacity, or English; nor would the Frenchman be a whit more generous. This same feeling, intermingled with a host of ancient grudges, would extend to the lesser nations whose languages meet with still less consideration in such theorizing.

In days of old, that nation politically most powerful might sometimes thrust its language upon conquered peoples, by sheer force of arms. This method is rather impracticable to-day, although a hint of it remains in the ineffectual struggles of the Poles to retain their own idiom in spite of the "official" tongues established among them, or of the Boers against the "official" English. Clinging to the native

tongue overbalances practical and economic considerations, and hence the Flemish, Celtic and similar "revivals."

The proportion of those speaking a certain language is no less impracticable a basis for the choice of an international auxiliary medium. Leaving out the question of Asiatic tongues, in spite of their superiority in this regard, the selection is among those same reciprocally jealous nations, namely, Russian, French, English and German. Moreover, this method would be unfair to multitudes among nations speaking other languages. For even French (in France, Belgium and Switzerland) is spoken by only about forty-five millions among the three hundred and fifty millions of Europeans, English by about forty millions, and so on. If the calculation be made upon a wider basis, and the new world and the far east included, the additional figure for English would be more than neutralized by the additional figure for Spanish tongues and the entrance of the multitudinous non-Aryan as well as Aryan languages.

Let still a different basis for the selection be offered: Let that language be chosen which is the easiest of acquirement for all peoples to whom some other language than this is the native tongue. This is even more perplexing. The people of each nation, accustomed to the national language from infancy, are unconscious of its peculiarities and irregularities, its difficulties of pronunciation, inflection and syntax, and its various idiomatic expressions. Not aware that these are difficulties, they unhesitatingly declare their own language the easiest of all. Yet English-speaking people would debar German from the choice because its mastery takes far too long, and is woefully hampered by the umlaut vowels, the three categories of grammatical gender, the complicated verb and the troublesome word-order. Similar objections exist for the Scandinavian languages, while against Russian are its additional vowels and additional consonant combinations, its perfective verbs, its seven-case substantive, with changing declensions for noun, adjective and pronoun, and three classes of formal gender, its alphabet which like Greek and German would need transliteration into the more universal and therefore also more economical Roman characters. French would be dismissed because of the "French u," the nasals, the varying verbal forms, the grammatical gender, quite as annoying as the gender of three categories in the previously mentioned languages, inasmuch as the assignment of those categories is entirely arbitrary in each from the point of view of the others, and the irregular plurals, and the many fine distinctions which make complete mastery all but hopeless. Of Spanish and Italian much the same may be said. English is quite as much out of the question as any other language. A smattering of it, as of the others, is obtainable without great difficulty, but to learn it well, to overcome all of its difficulties, is another matter. English contains three consonant sounds peculiar to English alone, the *w*, the sound

represented by *th* in *with*, and the surd represented by the same digraph in *pith*. The accentuation is irregular and perplexing, while the orthography is hopeless. A half-dozen sounds may be represented by one letter or combination of letters, or one sound may be represented by as many varying signs.²

There are irregular verbs, about 175 in number, numerous irregular and defective plurals, and a want of clearness due to the fact that nouns, particles, adjectives, adverbs and verbs may have the same form, and that different tenses of the verb may be identical in form, whether or not identical in sound. There is also a more or less stereotyped and yet elusive word-order.

Any and all of the national languages are then out of the question, first because none can yet secure adoption even if it were suitable, and second, because none is suitable. To be capable of truly international use a language must be possible of complete acquirement by all, whether linguistically gifted or not, and must be possible of such acquirement in such short space of time as can be devoted to this by the majority of the busy citizens of the world. Its acquirement must be an incidental preparation for one's profession or business, not an end in itself, or a matter of higher culture for the few.

Hence the thought of modifying some one of these languages, or combining them, or in some way forming a neutral language, objectionable to none on political or sentimental grounds, easily mastered by all, and therefore recognized by all nations and races as the accepted medium for international communication. That it must appeal to all sufficiently to be thus accepted is an important item, for, as has been previously intimated, nothing of this kind can be forced into use. It must be such a language that every intelligent citizen of each nation can and will learn it, as the first language to be mastered after his mother-tongue, to be able to read it, speak it and write it, in his capacity as a citizen of the world, and as an intelligent citizen of his own nation.

Since the days of Descartes this dream has haunted one and another, and plans for such a tongue have been proposed, necessarily crude at first, gaining in value as time went on, and as each author of such a plan profited by the faults in the projects of his predecessors. The earliest attempts were to create a language of philosophical or *a priori* nature, in which words are reduced to mere formulæ, a certain letter of the alphabet indicating the concrete, another vegetable life, another animal life and so on. The idea, although wholly impracticable, has not yet entirely disappeared, and *a priori* schemes are still occasionally promulgated. One project, for example, has the following

² Note for example the different signs for the one consonant sound in *gash*, *fashion*, *mission*, *conscious*, *fetich*, *nation*, *vicious*, etc., the different signs for the same sound in *raze*, *raise*, *rays*, *tael*, *gaol*, *gauge*, *great*, *fete*, *matinee*, *eh*, *eight*, *they*; the different sounds given to *ch* in *charm*, *chasm*, *chandelier*; the interchange of *s* and *z* sounds in *lose*, *loose*, *azure*, *leisure*, *raze*, *race*, *erase*, etc.

formations upon the letter *m*: *mab*, "mankind"; *mac*, "monkey"; *mad*, "cat"; *maf*, "dog"; *mag*, "bear"; *mas*, "horse"; *me*, "bird"; *mi*, "reptile"; *mo*, "fish," etc. Quite the opposite of these are the *a posteriori* languages, based upon the principle of borrowing, selecting and simplifying from already existing languages. This latter method, with a negligible admixture of the *a priori*, proves the only sound one, and all projects meeting with the slightest favor have been of this class. Among the numerous languages proposed, two alone have succeeded in obtaining any prominence or general publicity. The first of these was Volapük, published in 1880. Societies for its propaganda were organized, some instruction books and several magazines published. The success of the language, in spite of its crudities and too great difficulty, afforded proof that an international language was desired. But dissensions arose, chiefly as to whether numerous proposed changes should be introduced, with or without the consent of the author, who had assumed an unfortunate attitude of ownership of the language. By giving attention to discussion of such matters instead of to propaganda work, the Volapükists lost all they had gained.

Their bitter experience taught a lesson to the promulgators of the only other important project for an international language, the only one which to-day receives general attention. When overzealous theorists proposed changes in Esperanto, and insisted upon the adoption of their "improvements" the great majority of Esperantists refused to countenance any sudden or radical changes, declaring instead for a unity and stability. Their action was the more decisive in that the proposed improvements appealed to them as simply the marring of a language already proved satisfactory and practicable, and already existing as a living language, in which any changes should come gradually and systematically. The smaller restless and theorizing element attempted to create a schism through the use of various publications attacking Esperanto or Esperantists, and arrived at a somewhat unstable idiom of their own, which was called simplified Esperanto by some and a new language by others, among its advocates. A certain amount of newspaper notoriety was obtained in both Europe and America, but no definite or serious results.

The wisdom of the Esperantists as a whole is apparent in the progress due to their steadfastness and united effort. Those who know more or less of the language are reckoned by hundreds of thousands, judging by the number of text-books sold by responsible publishing houses, but the number of persons announced as being in the actual propaganda movement consists only of those who are registered and paying members of some official organization, such as the national associations, British, French, German, Japanese, American,³ and various international or-

³ Esperanto Association of North America, headquarters, 3981 Langley Avenue, Chicago.

ganizations, such as those of Esperantist physicians, scientists, pacifists, and many others. Propagated steadily but unobtrusively in all quarters of the world, the international language idea, represented by Esperanto, has loomed large and become a reality, even in this short space of time since its presentation to the world. Doubtless one reason is that the unbounded possibilities of the practical side of the language have only as yet begun to develop, while the insistence upon the ideals of "Esperantism" has been emphasized. This word Esperantism has come to stand for a spirit of tolerance and conciliation which is distinctly worthy of note, and which materially aids in paving the way for ultimate complete understanding and "the federation of the world."

It is a significant fact that the two nations which may be said to hold the linguistic balance of power, since their decision for the international language and their refusal to continue struggling with the manifold tongues of Europe, except for cultural purposes, would have great and well-nigh decisive weight, namely, the United States and Japan, were the two countries to send official *government* representatives to the last (fourth) International Esperanto Congress, held in Dresden, August, 1908.⁴ For these two nations whose more and more intimate relations demand better mutual understanding and appreciation, as forcibly pointed out in the document previously mentioned, the most immediate and practicable method of obtaining such general and immediate intercourse lies ready at hand. The Esperanto movement, strongest in Europe, has found favorable reception in Japan, whose minister of foreign affairs is president of the Japanese Esperanto Association. In the United States the present propaganda association is less than a year old, yet the number and quality of persons interested in the idea and movement is such that European Esperantists expect to be invited to the United States for the Sixth Annual International Esperanto Congress, in 1910. It is to be hoped that this will come to pass, and that some educational institution of note will open its doors for the occasion, as did Cambridge University for the Congress in England in 1907. In the meantime, it certainly behooves every one who approves of the wide-spread international acquaintance, understanding and conciliation, to examine this language which offers such great possibilities, since it has proved itself fully worthy of consideration in the brief time that it has existed as a living language. It behooves every one to examine it, and to aid its promulgation as best he may, by advocating it, by urging its introduction into schools and publishing in it, entire or in abstract, at least some of the writings which he now offers to the reading public in English or some other national idiom only. For Esperanto is solving the problem of an international language, which is "An attempt to save the greatest amount of labor, and open the widest fields of thought and action to the greatest number."

⁴ Cf. the report made by the U. S. delegate, Major P. F. Straub, of the U. S. Medical Corps, published in the *Army and Navy Register*, January 16, 1909.

WHAT IS A LIVING ANIMAL? HOW MUCH OF
IT IS ALIVE?

BY DR. A. F. A. KING

WASHINGTON, D. C.

CONSIDERING the second question first, the reply to it will depend a good deal upon education. An extremely ignorant person might answer that all parts of a living body are alive except the bones. It required some education before we medical men learned to realize, without surprise, that crude metallic bodies—bullets, pins, needles, wire sutures buried in our internal organs, nails driven into our fractured bones by surgeons, finger rings, scissors, forceps, spectacles, etc., left in the peritoneal cavity by careless operators—could remain in a human body without any immediate danger to life.

We had to learn also that large crystalline masses—the various forms of calculi—and dead fœtuses; lithopodians; even dead children at full term, both intra- and extra-uterine—could remain in a living body for several decades without any immediate danger to life. Thus we learn from these crude examples that living bodies may contain dead bodies, and dead substances of various kinds. Numerous other instances will now be considered.

The protective shells of some animals, the epidermal appendages (horns, tusks, hoofs, claws, nails, hair, wool, etc.), of others, are only alive at their proximal ends—their “roots” so-called. Their distal extremities are not living. They are products of life, but so are our coal beds, chalk cliffs, coral reefs and tortoise shell combs, but they are not alive.

If we ask, Where is the line of division between the dead and living in a cow's horn, or an elephant's tusk, we must reply, there is no such line. The transition from living to dead tissue is a gradational one. And this simple example should help to dispel the common error that everything in this world *must* be either *dead or alive*. Not so. It may be between the two: neither one or the other. Here, if anywhere, the old truism, *Natura non facit saltem*, deserves special recognition.

We must certainly realize that the gases, foodstuffs and excrementitious matters in the alimentary canal and the contents of the urinary bladder are not alive. Is the bile living? Bile is an excrement from the hepatic cells, the histological units of the liver, which find it necessary to discharge their toxic excreta into those minute drains, the bile ducts, and thence into the main sewer of the intestine. In thus maintaining their own normal metabolism, they save us from hepatic toxæmia. Bile is not alive.

Is milk a living substance? It is a saline solution, containing sugar and albumen. Microscopically we find it swarming with the *post-mortem* débris of epithelium cells that have undergone fatty degeneration. It is the fatty dust into which these dead cells have crumbled that rises to the surface as cream and when amassed in the churn constitutes the butter of commerce. Milk is emphatically a dead material.

What of that milky emulsion we call chyle? We can not say it is alive in the intestine; nor does it become so in the thoracic duct, nor in the subclavian vein. Neither does mingling with the blood give it life. It is dead.

What of the blood itself? Commonly we speak of it as being "warm with life." Not so in cold-blooded animals. Again, it is referred to as the "vital fluid," the "life-blood"; and we say: "the blood is the life thereof." So it is, in the sense that we can not live without it, and if we lose it by hemorrhage we die. Nevertheless, the blood is *not* alive. Its corpuscles are, but the plasma in which they float is not living. This plasma is the natural *habitat* of the living corpuscle (much in the same way as a pond of water is the natural *habitat* of *Amæba proteus*), but it is not alive.

Can our blood corpuscles live in a dead plasma? It is not very long ago that in cases of hemorrhage we injected into the blood vessels large quantities of cow's milk; now-a-days we inject salt solution. In some cases we inject so much of these dead fluids that the quantity may exceed that of the normal blood plasma left behind after the hemorrhage. Hence we know by actual experiment, in these cases, that the larger part of the blood plasma mixture is not alive.

Furthermore, human leucocytes have been kept alive in normal salt solution outside of the body for many hours, retaining all their amœboid and phagocytic properties; and recently in a properly prepared solution containing 3 per cent. of sodium citrate and 1 per cent. of sodium chloride, R. C. Ross has kept human leucocytes three days alive and has caused them to protrude and retract the most remarkably long pseudopodia so that they actually resembled squids, or tarantulas.¹ Thus we see a living plasma is not necessary for the blood corpuscles: they flourish in a dead one. The blood plasma is not alive.

In the days of venesection we were taught that the last *act of vitality* in blood when drawn from the body was its coagulation, but is this really any more a vital process than the clotting of sour milk? I think not.

In the same category with milk and blood plasma, we must place lymph, the fluids in the pleura, pericardium, peritoneum and synovial sacs, and also the cerebro-spinal fluid; none of them is alive.

It might be supposed that the delicate structures of our central

¹ London *Lancet*, January 30, 1909, p. 314.

nervous system must at least be protected from contact with *dead* fluids. Not so. In cases of cerebro-spinal meningitis, we draw off the cerebro-spinal fluid and inject into the cerebro-spinal canal a curative antimeningitic serum that has stood on the shelves of its manufacturer, cold and dead, for half a year or more before being used.

In this line of thought we have reached the conclusion that the crystalline masses, gases and *fluids* in an animal body are none of them truly alive.

What have we left? What parts of the body *do live*? The histological units—the individual cells: these are the living inhabitants, in that great organic community, which constitutes a living animal.

The fluids of the body are inert plasmata designed for the maintenance, nourishment and functional integrity of these living units. The cells of the body are alive, but nothing else in it can be truly said to live.

Let us now ask: When an animal dies how much of it is dead? An ignorant person would reply: "All of it." Not so. The cells of a corpse remain alive some considerable time after the man has ceased to breathe. The cells of the liver continue their glycogenic function. Active spermatozoa have been found in the testicle, and living leucocytes in the cavities of the heart, many hours after death. The skin of a recent corpse can be successfully transplanted into a living person, as may also some of the internal organs, bones and joints. Recently one of our surgeons² has transplanted an entire knee joint (a healthy one) from the body of a corpse into the limb of a person from whom a diseased knee joint had been just previously removed. The case is progressing favorably.³

In the retrogressive phenomena of death as in the evolution of living from dead matter, the old saying of nature not making leaps, again asserts itself, and the prevalent error that everything must be either dead or alive, with no intermediate gradations, becomes pronouncedly manifest.

We now come to the question: What is a living animal? The one most marked characteristic of things that are truly alive is motion, especially locomotive auto-mobility, to which must be added growth and reproduction.

It is now generally admitted that the basis of life is electricity. The power that produces muscular motion, cell-movement, cell-division, cell union (as in fecundation), and embryological growth, is essentially a form of electro-magnetic energy, this energy being generated by the successive chemical decompositions and syntheses—the electrolytic asso-

² Dr. Tully S. Vaughn, of Washington, D. C.

³ It is now six weeks since the operation. There have been a few similar cases in Germany.

ciations and dissociations of atoms and molecules—of anions and cations—in the complex phenomena of metabolism throughout the body. No nutritive change, even in a single cell, can take place without a disturbance of electric equilibrium and the development of an electric current, be it ever so diminutive. Nerve force, electricity and “vital force” are identical in so far as they are all manifestations of electromagnetic energy. Every histological unit in an animal body is a diminutive battery in which such energy is evolved. This, I think, is common knowledge, that has passed beyond the realm of theory.

Perhaps the crudest and most evident illustration of the production of electricity by animal metabolism is exhibited in the electric fishes: the torpedo, the *Gymnotus* (electric eel), the *Malapterurus* (electric catfish), the skate and others. In these forms, it is true, we find a special electric apparatus, consisting of some hundreds of columns made up of millions of superimposed plates or discs, arranged transversely to the length of the columns and separated from one another by an albuminous liquid, thus resembling a voltaic pile. The distribution, or discharge of this electric energy is controlled by nerves emanating from the medulla oblongata. Thus the animal, at will, can shock and capture its prey, and even emit charges, in some instances, sufficient to injure, and perhaps kill, even men and horses.

A more delicate method of demonstrating the identity of nerve force and electricity was shown at the last meeting of the International Congress of Electrology and Radiology held in the University of Amsterdam,⁴ when Professor Salomonson, by using Einthoven's string-galvanometer (a sort of electric microscope), was able to measure, and render visible on a photographic plate, the electric current producing one contraction of a single muscle, for example, that of the quadriceps femoris during the patellary reflex. Even currents producing contractions in the cardiac muscles were exhibited. He presented on the screen a cardiogram, by which, he remarks: “Each muscular fiber of the heart has written its own sign-manual on the photographic plate.” By means of this device he was able to exhibit visibly events successively occurring at intervals of one one-hundredth of a second, and electric nerve currents so small as the one ten-thousandth part of a single volt.

Now if every living animal, and every cell within it, be really an electrical machine—a generator of electro-magnetic energy—it is evident that in order to secure and use the power thus produced the apparatus must be *insulated* from its surroundings, otherwise the electricity would instantly escape back into the earth whence it came. All our electric machines and batteries are thus insulated.

Are animal bodies provided with this electric insulation? They are.

⁴ *Proceedings of the Royal Society of Medicine*, November, 1908.

The insulatory resistance of the bare human skin varies from 1,000 to 6,000 ohms. In many animals the insulation is increased by non-conducting hair, wool, fur, etc. And naked man finds it expedient to reinforce his own insulation by clothing of silk, satin, hair, wool, flannel and other non-conducting materials. We are exhilarated by a dry atmosphere: depressed by a damp one, because the moist air, being a conductor, carries off some of our electricity to the earth, while dry air is a more complete insulator and prevents this leakage.

Besides contact with the air, the *feet* of animals are in actual contact with the earth itself, and accordingly ought to be endowed with a specially good insulation.

Finding no data on this point, I submitted to the U. S. Bureau of Standards some specimens of a horse's hoof, to have their insulation tested. The director, Professor S. W. Stratton, wrote me⁵ that the resistance of the first specimen, when dry, was 4,700 million ohms. This was a part of the "frog" of the foot. A second specimen, taken from the peripheral margin of the hoof was tested, of which the bureau reported⁶ that "by the direct-deflection method, using 120 volts and a very sensitive galvanometer, the deflection was so small that it could not be read." "The resistance was equal to or greater than 22 billion ohms. This corresponds to a specific resistance of about 16.5×10^{10} ohms per centimeter cube." Professor Stratton adds: "Of course the actual resistance may be much higher, as it was too high to determine with any accuracy by this means."

Subsequently, Professor Chas. W. Mortimer, of the George Washington University, by using his Wheatstone Bridge apparatus, kindly tested for me, altogether, 67 specimens of animal and some vegetable structures, as to the insulating power of their external coverings. The specimens included the feet, claws and bills of sheep, rabbits and chickens; the fresh human umbilical cord, foetal membranes and placenta; the shell of an egg; the external coverings of fruits (oranges, apples, nuts, etc.) and of vegetables (turnips, onions, etc.).

In no instance did the external covering fail to exhibit a relatively greater resistance than the internal structure. In most of the specimens the resistance hovered about 10,000,000 ohms, some more, some less. In one instance, that of a green pea pod, the resistance of the unbroken pod was 500,000 ohms, while the external surface of the green pea itself was 10,000,000 ohms.

I did not test any cereal grains, but Mr. Lyman J. Briggs, of the Bureau of Plant Industry, U. S. Department of Agriculture, has recently ascertained that the resistance of wheat grains, varying with

⁵ Official letter, October 23, 1903.

⁶ Official letter, January 21, 1904.

temperature and moisture, is somewhere between 2 million and 10,000 million ohms.⁷

It is conceivable that the grains of wheat exhumed with Egyptian mummies would scarcely have retained their germinating power after so many centuries had not nature clothed them with their insulating shells, and passing from these diminutive little lives of eggs, grains and cells, it is conceivable that this globe that we inhabit would itself become a moving sepulchre, devoid of all molecular transformations of energy, were it not for the external envelope of insulating atmosphere with which it is clothed. Without this insulation the energy of solar light and heat would no longer be transformed into things of beauty and life; but would at once be dissipated into the abysses of space and our earth would probably become as dead as the moon, which has no insulating covering, and, consequently, upon whose face, within the memory of man, no single change of feature has been observed.

In the foregoing discussion my purpose has been to lay the foundation for a modified definition of life. Every one is familiar with Spencer's definition, viz:

Life is the definite combination of heterogeneous changes, both simultaneous and successive, in correspondence with external coexistences and sequences.⁸

Never, perhaps, did human language attempt to express so much in so few words. In fact it is so condensed as to be difficult of comprehension. If the definition had been given first, few of us would ever guess that life was the thing it intended to define.

On page 80, Spencer says:

The broadest and most complete definition of life will be: the continuous adjustment of internal relations with external relations.

De Blainville said:

Life is the twofold internal movement of composition and decomposition at once general and continuous.

Criticizing this definition, Spencer remarks:

It describes not only the integrating and disintegrating processes going on in a living body, but it equally well describes those going on in a galvanic battery which *also* exhibits a two-fold internal movement of composition and decomposition at once general and continuous.⁹

At the time Spencer wrote (1866), biology was not sufficiently advanced for him to realize that every cell in the body really *was* a minute electric battery, and that the coordinate and simultaneous action of millions of these batteries made up together the living body of a complete animal.

⁷ *Science*, December 4, 1908, p. 812, and Bulletin 99, 1907, Bureau of Plant Industry, U. S. Department of Agriculture.

⁸ "Principles of Biology," p. 74.

⁹ "Principles of Biology," p. 60.

With these preliminaries, I submit the following definition of a living being. It is this: A living body, whether a simple cell or a fully developed mammal, consists of a temporary aggregation of a limited number of material particles, call them what we may—molecules, atoms, ions, electrons—whose actions and reactions between each other, and between themselves and their environing conditions (light, temperature, air, water, food, terrestrial magnetism, gravitation, etc.) are of such a kind as to generate electro-magnetic energy, which energy *is* and necessarily *must* be secured to the use of the individual producing it, by a semi-porous limiting external envelope which provides the individual with *electric insulation* from its surroundings.

It is upon this *external electric insulation* that I desire to insist as a necessary part of everything that can truly be said to “live, move and have its being.” Vain and useless indeed would be the energy generated in living bodies by the successive compositions and decompositions, the integrations and disintegrations, the electrolytic associations and disassociations of ions and electrons resulting from animal metabolism, if no arrangement had been provided by which the energy developed could be secured to the use of the individual producing it, instead of instantly flashing back to the earth whence it came, which it inevitably would do, in the absence of such insulation.

That this insulatory covering really exists, in the case of animals, eggs, seeds, etc., has been shown by the experiments before mentioned.

That the individual cells of the body—the histological units—are also provided with the same electric insulation, may be more difficult to demonstrate. But such demonstration is not altogether wanting. The red corpuscles of the blood are, in a measure, insulated from the serum in which they float. “The intact red corpuscles,” writes Stewart, “have an electric conductivity so many times less than that of serum that they may, in comparison, be looked upon as non-conductors.”¹⁰ Among other explanations he suggests that this may be because the envelope of the corpuscles refuses passage to the electric charge produced by the dissociation of ions within them.

In the developing ovum, according to this view, the ectoderm ought to be an insulator. I can give no proof of this, but it is significantly suggestive that the cerebro-spinal axis of the embryo (which we should think ought to receive a specially good insulation) is clothed on its outside by an investment from the ectodermic layer, produced by an invagination of that structure to form the medullary groove and canal in which the central nervous system pursues its development.

Finally, is the protoplasm of animal organisms a really living substance? The answer will depend upon our definition of the word

¹⁰ “Human Physiology,” p. 35, 3d ed., 1899.

“living.” Properly speaking, protoplasm is neither dead nor alive: it is between the two.

If we could get together an ounce or a ton of it, we should say it was a substance or mass exhibiting *some of the properties* of living matter. We could not say it was a living individual. It is simply matter occupying a very high plane in those ascending gradational transformations between the dead and the living: between the simple inorganic constituents of the earth, and those more complex segregations of chemical atoms which finally become surrounded by a limiting insulatory envelope and thus constitute “physiological units,” or living beings. But until this formation of units—this individualism—of the mass, protoplasm can not be said to live.

Of course, the *direct* transformation of *inorganic* matter into living *animal* matter is impossible. There must always occur the intermediate phenomenon of vegetable life. Vegetables *can* transform the inorganic chemical materials of the air and earth into their own structure, but the animal must either feed upon the products produced by the vegetable or upon other animals that have been so fed. No single definition of life, therefore, can include both animal and vegetable life, since the vegetable is an intermediate product between minerals and animals. The evolution of life is a gradational process. Things are *not* “either dead or alive.” Some things, like protoplasm, are between the two.

ABANDONED CANALS OF THE STATE OF NEW YORK

By ELY VAN DE WARKER

THOSE who have only a partial knowledge of the subject, regard the present time as the age of canals. They overlook the generations of time and the vast sums of money expended by other people who have held to the idea of the canal with a national fixity of purpose that has produced astonishing results. The amount of money expended so exceeds the sums spent in the United States, including the Isthmian Canal, that they appear like trivial things.

France has 3,045 miles of artificial waterways and 4,665 miles of canalized rivers, aggregating nearly 8,000 miles. These cost in the last thirty years five hundred million dollars. Belgium has one mile of canal navigation to eight miles of territory. Germany has spent, since 1900, eighty million dollars and has just authorized the expenditure of eighty-five million dollars more. Austria-Hungary within a few years has expended fifty-three million dollars and is yet pushing the work. The canals of Holland and some of those of southern France were built centuries ago.



FISH CREEK, OPENING OF WOOD CREEK, which will be a part of the Barge Canal.



WOOD CREEK, THE OLD CANAL, 1795.

These countries are achieving commercial supremacy along lines that parallel the development of their canal systems. One of the most interesting features of international political economy is the great value one nation will place upon a thing that another people will throw away. What makes the canals of France of such value to the people is their contentment in saving money. The Frenchman has a keen sense of the value of a dollar saved. So long as he can get the product of his acres and the output of his factories at their final destination at the lowest freight cost, without time as an important factor, he is content with canal transportation. He realized that a dollar so saved is to be totaled among his profits and not credited to his savings.

The American, working on the credit system, is obliged to earn the quick dollar, and yet feels the attrition of the nether millstone that gives to the corporate trusts the money that belongs to the small producer. He thus abandons canals that in France would pay the individual as well as the state. The American has but one standard, Do the canals pay? He demands immediate returns, not prospective. Canals have their good and bad years. With such a criticism no canal, as a tax earner, is always successful. This, in brief, was the history of the abandonment of the central New York canals. It is interesting to trace this cause in the profligate dereliction of the lateral canals.

The state engineer's report shows the abandonment of 221 miles of canals with their locks and feeders. To this, add a littoral of lakes and rivers of 300 miles and we have abandoned waterways of 521 miles. This covers a region which, in the course of thirty years, has increased 1,500,000 in population and its manufactured products have more than trebled.

The American voter is not the wise man that he thinks he is. He fails to grasp the primary idea of statecraft. He bends an obedient knee to the moloch of the lobby. He obeyed the behest of his party and sold his birthright for something as impalpable as moonlight. When he sold the right of way of the Chemung Canal for \$100, he saw neither wrong to himself nor injustice to his posterity. A few dollars of annual tax was worth more than millions in prospective.

For years it was a vexed question in politics, with the democrats on one side and the republicans on the other. The fatal blow was given in the republican stronghold, central New York, by the people who had the most at stake in preserving the canals.

The republican legislature of 1873 officially abandoned them. The results were quickly shown. The year before the abandonment gave a loss in tons of 308,588, while two railways connecting Lake Erie with New York showed an excess in tons of freight over that of 1872 of 1,877,187. This was a direct loss to the farmer and the small producer of \$96,693 to save the small sum of \$34,000 divided among sixteen counties. A more complete demonstration of the canals as a freight regulator it would be impossible to find.

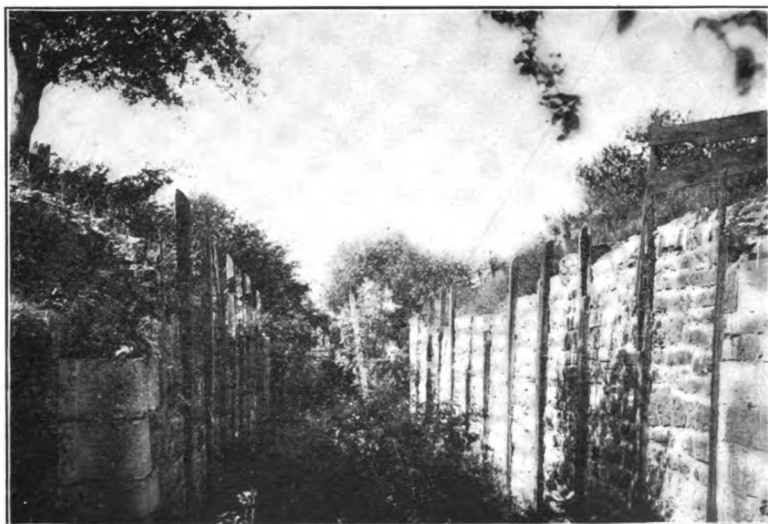

ONEIDA LAKE CANAL LOCKS.

The result to the farmers was a harder blow to bear. Real estate value shrank to less than was paid for land forty years before. Central New York was the great wheat-growing region of the state, but by the rapidly moving freight of the railways they were unable to compete with the western wheat. This lost crop was so nearly total that they ceased to grow enough for their own mills. It appears as though they ought to have had business foresight to realize the value of the lateral canals as coal carriers. It was for this purpose that these canals were built.

They awoke from their dream of small economy to find themselves in the grasp of the great octopus of the coal roads, which for thirty-five years has been growing more exacting and oppressive. Throughout this region these roads are not only drawing the coal, but by their own agents they are delivering it at the door of the consumer.

We have been laying this upon the farmer and the people directly interested in maintaining these canals, and justly. There never was a moment when the mass of voters in this republican stronghold could not have dominated the situation. It was the old time-worn adage of a fool and his folly. He has not the negative merit of holding his tongue after he has committed the error. Utica, which could have saved the Shenango Canal, petitioned the state engineer's office and the canal board for the rebuilding of the canal as a coal carrier only a year ago. It was a childish effort and they awoke from the calm repose to find that their fair city was simply reduced to a state of mind and the real Utica was the Lackawanna road.

Before the Erie Canal was a practical waterway the people were keenly alive to the value of the lakes as commercial waterways. The earliest steamboat navigation as a well-developed enterprise upon inland waters was opened in the New York lake region. Upon three of the lakes—Cayuga, Seneca and Keuka—steam navigation appeared in 1820. The people were roused to enthusiasm. The first boats made their landings amid the shouts of the multitude, volleys of musketry and salvos of cannon. Gradually the steamboat service was extended until in 1827 steamboats were a general thing upon the lakes. Many years previous to this sloop navigation was resorted to for both freight and passengers. The first began regular trading trips in 1795 and gradually this form of navigation was extended over all the lakes.

The Erie Canal found abundant supplies of freight and passengers waiting when it passed through this region of the lateral canals. As a method of commercial interchange they never paid; whatever we may think about the ethics of the state making money off the people's enterprise, there was no question about its rights as late as 1873. Neither was any money lost until the people followed like a flock

of sheep the bell wether, the political factotum of the countryside, and surrendered its rights to the railways. The face of the country withered, as though stricken by a famine, under their remorseless demands. The fact that makes canal navigation not alone possible but profitable is that speed represents cost.

That which constitutes a profitable canal is not a dividend on the investment, but in augmenting the volume of trade. The profit that accrues is prospective, not immediate, and belongs to the people; a theory of public utilities that the state of New York never adopted.

Let us see what this meant to the farmer and the manufacturer. The manufactured product was of coarsest character, hoops, staves, shingles and sawed lumber, material that could not afford to pay a higher tariff for transportation. This was practically cut out. Farm produce was of a like character; potatoes, cabbage, onions and apples demanded a moderate price for carriage if they were to make a living return to the grower. These were no longer seen by the boatload except within wheeling distance of the Erie; a small supply was received from the Cayuga and Seneca canals. The wheat crop, as already noticed, had disappeared. Barley and oats, in the cheap days of 1870, represented little money to the grower, and hay at six and seven dollars a ton, including the cost of baling, was impossible as freight. It was reasonable to expect that the roads would not work against these products an impossible tariff. The way station received but little notice. It was the fatal long haul, that has caused so many crimes against commerce, that was at fault. It cost more to stop and side-track than to make the continuous trip.

In 1872 the amount carried was 156,999 tons. This did not represent much in commercial value. But, this was only a minor part of its true worth. Imagine the condition had the slight sacrifice been made of maintaining the lateral canals for the past thirty-five years, with over 1,500,000 population added. These derelict canals would have been a treasure-trove to the inhabitants. An English author upon the subject expresses the idea perfectly when he states "that where canals do not pay, they pay by increasing the volume of trade."

The coal transported by lateral canals was 411,918 tons, sufficient to compel the roads to meet the cheap water rate. An instance on the Black River Canal, now used as a feeder to the Erie, illustrates what happened to the people of the lake region. The last station on the canal paid at retail three dollars a ton for coal; the town above, served by the railroad, paid five and a half per ton. The saving on freight, in thirty-five years, had the canals been the rate maker, would have amounted to more than a million and a half dollars yearly.

The waterways of the Iroquois were, from the nature of their distribution, natural waterways; while the Erie connected two termini.

The freighting was the natural product of its own littoral. The demand for canals was so urgent that as early as 1768 it was designed to connect Oneida Lake and the Mohawk by the improvement of Wood Creek. In 1792 the legislature passed the act. To this day old wooden locks may be found upon Wood Creek. Central New York was the first stimulus to the canal system of the state. It paid even at that early date. It reduced the cost of transportation from \$32 to \$16 per ton on the cargo. This great reduction in price "actually doubled the intrinsic value of the lands and produce around our lakes."¹ If the reader were able to see the insignificance of the little ditch of Wood Creek he could not realize the grand total of the result.

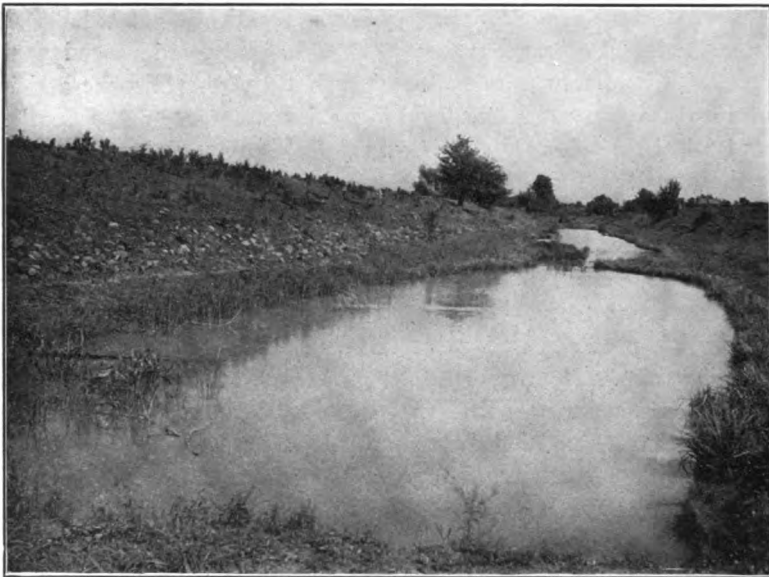

OLD ONEIDA LAKE, WOODEN LOCKS.

X A few details will prove that the cheapening of carriage and the earning capacity of the canal was under- rather than over-estimated. The toll on a barrel of flour passing 100 miles was 52 cents and for a ton of goods passing the same distance was \$5.75. The rapidity with which its earning capacity increased is not less remarkable. The capital stock of the western company was \$232,000, which paid to the stockholders a dividend of 3 per cent. in 1798, 3.5 in 1813, 4.5 in 1815 and 8 per cent. in 1816.

The rights of this company were acquired by the state in 1820, for \$151,000. The middle division cost \$1,125,983. If we add to this double the amount for enlargement, the sum of \$2,570,000 was

¹ State Engineer's Report, 1862.

abandoned by the state, the result of an ignorant and weak constituency and an aggressive lobby who represented the powerful railways behind the movement. These canals will be rebuilt on a grander scale commensurate with the magnitude of the barge canal. Already some of the great inland lakes have applied for a renewal of the canals. The history of the lateral canals will insure a favorable response. Even then they will not be money-makers. They will make money for the state only in proportion to the trade developed.

It is doubtful if the history of the country can parallel such useless destruction. From the amount of money squandered and the human



ONEIDA CANAL.

interests involved, it stands alone, not as an object of public plunder, but, worse than that, a colossal blunder.

In going over these old canals it appears among the marvels of time, how quickly they are disappearing. Stones of monolithic size are lying in heaps. Canals, like the Chemung, are simply weed-grown ditches. Wooden locks have left scarcely a trace; ruin, measured by the hundreds of miles, disfigures and encumbers the earth.

The Genesee Valley was one of the most important of the subsidiary canals. During the year previous to its official abandonment the total movement of goods amounted to 96,000 tons, in a total of nearly a half million. In 1873, 132 tons of wheat and 245 tons of



CHEMUNG CANAL.

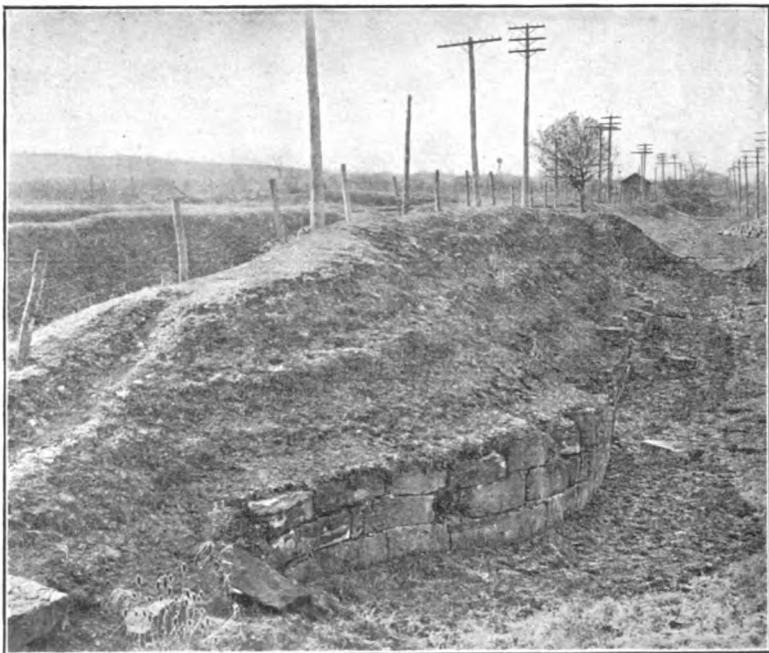

CHEMUNG CANAL EXTENSION.

flour moved in the direction of tide water. The total of tolls in the last year of its official life was over 20,000 dollars. The story of the coal moved is better told in the amount carried by the Cayuga and Seneca Lakes Canal, and partly distributed by the Genesee Valley, which was 400,000 tons, now reduced to a few boatloads to accommodate the railroads and not the public. There could not possibly have been serious loss to the state from the Genesee Valley Canal and yet it passed the way of the other waterways. This canal offers the most picturesque ruins. A railway runs along the bottom for a part of the way. The remains of the works at Dansville have a kind of melancholy grandeur; a sad evidence of the greed and folly of man.

It is only a matter of time when the subsidiary canals will be rebuilt. With the increased value of material and labor, it will cost hundreds of thousands while the original represented thousands. It will not be a question of money. It will be an overmastering impulse to equal the best in canal structure. France, Germany, Belgium, Holland will be the criteria. There appears every prospect that the roads will take their normal place as freight carriers.

It is planned to build a canal from the great lakes to Pittsburg, thence to the Gulf. Such a waterway, if constructed with a view of paying interest on the investment, will never be built. As a check to the greed of the railways, as a plan to place them in normal accord with the transportation interests of the country, it will prove an unalloyed blessing. Of more value than all else will be the vast tide of traffic that will seek the cheap route of the canals. Seen from this point the canals will always pay. The lateral waterways of New York, in their darkest hour, paid the people manifold. The sin of the abandoned canals rests to-day upon this charming region. The fleets of steamers, sloops and barges have disappeared and the lakes have drifted back to primeval solitude.

THE PROGRESS OF SCIENCE

TENNYSON AND THE SCIENCE OF THE NINETEENTH CENTURY

THE hundred years which began with the births of Darwin, Tennyson and Gladstone, and closes with the deaths of Meredith and Swinburne, has been a notable period in English history. Its two chief movements—the growth of science and the growth of democracy—are adequately represented by Darwin and Gladstone. Tennyson was the most widely read and perhaps the greatest poet of the period. The scientific man may be permitted to moralize over the world-wide extension and permanence of Darwin's contribution as compared with Tennyson's. Fifty years ago Darwin's name was almost unknown, whereas Tennyson's was a household word in England. A little later a man was not thought to have made himself ridiculous by saying that he sided with God against Darwin and the devil. Now Tennyson's reputation is being defended; no one would think of defending Darwin. The University of Cambridge lavishes its academic ceremonial on the man of science rather than on the poet. Tennyson wrote:

The man of science himself is fonder of
glory, and vain,
An eye well practised in nature, a spirit
bounded and poor.

But Darwin's personality and character are comparable with his services to science.

We may place the science of the nineteenth century before its poetry and Darwin before Tennyson; but to do so it is not needful to depreciate the poetry or the poet laureate. Indeed a scientific journal may well call attention to the fact that Tennyson was largely influenced by the science of his period and permitted it to become part of his poetry. Poetry based

on the classical tradition can not make a wide or deep appeal to a world in which it is no longer living; the future of poetry depends on the possibility of its adjusting itself to science and modern life, and Tennyson should receive honor for his efforts to this end.

The well-known verses of "In Memoriam" were printed nine years before the "Origin of Species." The geology may have come from Lyell, but it was twenty years before Lyell would have been willing to accept the last verse of the stanza:

The solid earth whereon we tread
In tracts of fluent heat began,
And grew to seeming random forms,
The seeming prey of cyclic storms,
Till at the last arose the man.

The doctrine of evolution is frequently used, as in "Maud," where the first verse is scarcely less significant than the second in the couplet:

As nine months go to the shaping an
infant ripe for his birth,
So many a million of ages have gone to
the making of man.

There will also be found in Tennyson an adequate conception of physical science and an attempt to put even its practical achievements into poetical form. Thus the age is told to
Rift the hills, and roll the waters, flash
the lightnings, weigh the sun,
and we even hear of

The nations' airy navies grappling in the
central blue.

Scientific knowledge is assumed or taught continually in the pages of Tennyson from the first lines of the "Lady of Shalott," which reawakened the spirit of English poetry—

On either side the river lie
Long fields of barley and of rye . . .
Willows whiten, aspens quiver
Little breezes dusk and shiver.

to his last poem with

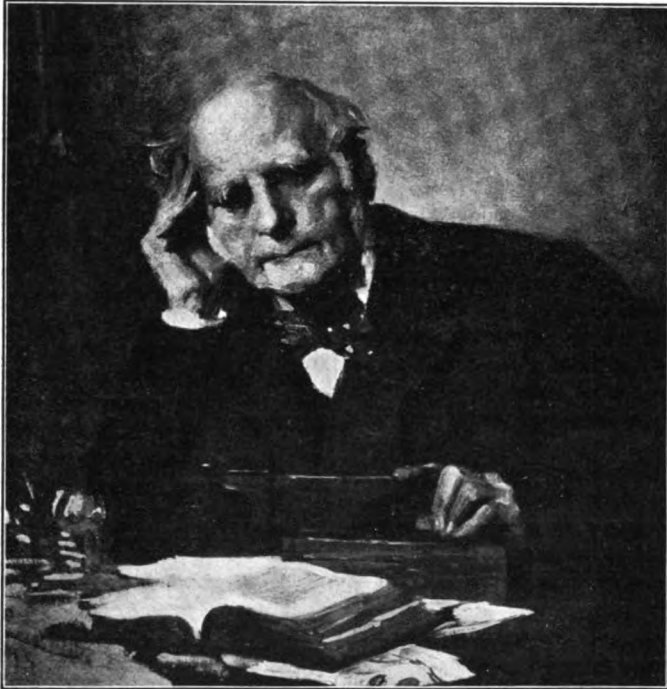

From a painting by C. W. Furze, A.R.A.

*Young Jastrowell
Francis Galton*

the kindly sphere
That once had rolled you round and round
the sun.

Medievalism and modern life, classical reference and scientific simile are curiously commingled in Tennyson's poems. As one turns back to them "the tender grace of a day that is dead" does not fully return. They are not like science universal; but for their own epoch they were not only great poems, but also rendered a not insignificant service in the diffusion of the scientific spirit.

THE REMINISCENCES OF SIR FRANCIS GALTON

THE greatness of the Victorian era is now represented among the living by men of science—Hooker, Wallace, Averbury, Lister, Huggins, Galton—all past eighty years of age. Sir Francis Galton—the "sir" is a tardy recognition on the king's recent birthday—now in his eighty-eighth year has done well to prepare the reminiscences which have been published under the title "Memories of my Life." He is typical of the great period in which he has lived and to the preeminence of which he has contributed his share. Like his cousin, Charles Darwin, he has had no profession, but with sufficient private means he has devoted his life to the advancement of science. There are certain marked resemblances in intellect and character between the two kinsmen—scientific curiosity reaching from obscure details to broad theories, patience combined with daring, royal simplicity and directness—which might be used to illustrate the theories of heredity in which both have been interested. Galton, like Darwin, studied medicine and like him was a student at Cambridge; but, unlike Darwin, he has lived in London and has taken an active part in the social and scientific activities of the time. He has been in intimate personal relations with the scientific and other leaders and a helpful friend to many at the beginning of their scientific work. The writer of

the present note is one of a large company that owes him an unpayable debt for personal kindness and intellectual stimulation.

Galton—the Sir Francis does not come naturally—gives rather full details, as is becoming, of his parentage and early life. On both sides he was of quaker stock. He traces to inheritance his taste for science, for poetry and for statistics, and his endurance of physical fatigue. His formal schooling was not profitable. He says (it was before going to Cambridge): "In the spring of 1840 a passion for travel seized me as if I had been a migratory bird." He made a somewhat adventurous trip to the near east, and his travels were continued more seriously on completing his studies. He made two trips of exploration in Africa, in the second conducting an expedition of some 1,700 miles through unknown regions in the southwest. For this he was awarded one of the gold medals of the Royal Geographical Society in 1854, and was elected a fellow of the Royal Society two years later.

In 1853 Galton married a daughter of the dean of Peterborough, the father of a gifted family, and thenceforth residing in London carried out the investigations and published the long series of important memoirs and volumes, the contents of which are all too briefly reviewed in the reminiscences. First appeared works on travel, then serious attention was given to meteorology and the Kew Observatory. In 1865 were published two papers on "Heredity Talent and Character"; and these were followed by the studies on variation and individual differences which are largely summarized in "Human Faculty." The work on anthropometry, on association and on imagery opened up new fields for psychology; the composite portraits and the study of finger prints are known to all. Nearly every one of the 183 publications contains a new idea or an ingenious application. The work on

heredity and its application to eugenics, beginning before the publication of the volume on "Hereditary Genius" in 1869 and continuing to the present time, is of vast importance. Numerous articles on these subjects by Galton himself and by others who have received their inspiration from him have been published in this journal, and it is of course out of the question to give a summary in a brief note. There are no other problems so important as those to which Galton has given the name eugenics, and there is no one else who has done so much toward making straight the way for their solution.

THE EUGENICS LABORATORY OF THE UNIVERSITY OF LONDON

AMONG Sir Francis Galton's unnumbered services to science has been the establishment of a laboratory for the study of national eugenics at the University of London. In cooperation with the biometric laboratory and the department of applied mathematics, also under the direction of Professor Karl Pearson, it is leading the way in a movement likely to become dominant in the course of the present century. National eugenics is officially described as "the study of agencies under social control that may improve or impair the racial qualities of future generations, either physically or mentally." It is further stated that it is intended that the laboratory shall serve as a storehouse of statistical material bearing on the mental and physical conditions in man, and the relation of these conditions to inheritance and environment, as a center for the publication or other form of distribution of information concerning national eugenics, and as a school for training and assisting students in special problems in eugenics.

The general scope of the work which has been undertaken may be gathered from an enumeration of the publications for which the laboratories of the University of London are responsible.

Biometrika is a journal for the statistical study of the biological sciences published about four times a year and now in the seventh volume. It is a storehouse of materials and methods, dominated naturally by the interests of the editor. In some ways it is an advantage and in some ways a drawback that Professor Pearson is a mathematician. The need of applying mathematical methods to variation and heredity should be emphasized and stress on the method has permitted the treatment and unification of varied material. But it is also true that so long as there are but few biologists who are mathematicians, there is danger that certain methods may become prematurely crystallized and these special methods may be regarded as an end rather than as a tool. In addition to *Biometrika* there has been established this year a *Treasury of Human Inheritance*, devoted to family histories, including diseases, physical traits and mental qualities. Then there are two series of memoirs, one entitled *Biometric Series*, the other *Studies in National Deterioration*, published at the expense of the Drapers' Company. The first of these contains chiefly Professor Pearson's more recent mathematical contributions to the theory of evolution, while the second includes so far three studies, one on the relation of fertility in men to social status and two on inheritance and infection in tuberculosis. Lastly, there is a lecture series, of which but one has been issued, and a memoir series from the eugenics laboratory. The memoirs include a study of the inheritance of ability from the Oxford class lists and of the relation between success in examinations and in after life; inheritance of insanity, the resemblance of first cousins and the inheritance of vision.

THE INHERITANCE OF VISION

THE recently issued monograph from the Eugenics Laboratory on the in-

heritance of vision, which is by Miss Amy Barrington and Professor Karl Pearson, is of special interest, as it is one of the first attempts to determine the relative influence of heredity and environment, and announces the unexpected conclusion that there is no definite evidence that schools have a deleterious effect on the eyesight of children. Other results are that keenness of vision is an inherited character, that there is some relation between intelligence and good eyesight, but none between this and poverty or shiftless parentage.

The authors have not obtained data of their own, but work over results that have already been published. For heredity they discuss the work of Steiger, which has the drawback that the material is not a random selection from the population, but starts with abnormal cases. Allowing for this, they conclude that heredity is as strong in the case of astigmatism as for other physical traits, such as height or eye color.

For environment the authors depend largely on a study of 1,400 school children made by the Edinburgh Charity

Organization Society. These children show a high degree of fraternal resemblance. The conditions of eyesight are reproduced in the accompanying diagram. It appears that emmetropia—which the authors regard as synonymous with normal vision, though there are good grounds for regarding the hypermetropic eye as normal—actually increases from the age of six to ten, while astigmatism decreases. There is no appreciable change in myopia. Myopia, or near-sightedness, does increase from the age of ten to fourteen, though only to 6.5 per cent. of the children.

These figures do not agree with those of Cohen, Erismann, Risley and other investigators. Cohen, for example, found the percentage of myopics to be: in village schools 1.4 per cent., in elementary schools 6.7 per cent., in intermediate schools 10.3 per cent., in the gymnasium 26.2 per cent. and in the university 59.5 per cent. The fact is that the Edinburgh children, being from the poorest classes, probably did not greatly strain their eyes with reading and school work. The authors say: "The persistent use by the Ger-

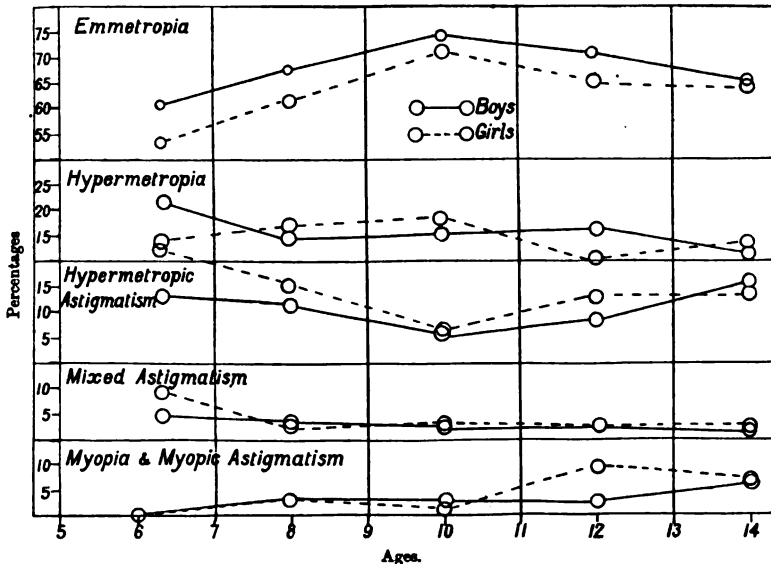

THE DISTRIBUTION OF EYESIGHT AMONG EDINBURGH CHILDREN.



DR. ERNEST FOX NICHOLS

President of Dartmouth College, lately Professor of Physics
in Columbia University.

mans of non-hygienic characters for their type . . . renders all comparisons of English and German conditions unprofitable." One might suppose, on the contrary, that this comparison would indicate that progressive myopia is due to environment rather than to heredity. Cohen indeed found that of 1,000 near-sighted children only 2.7 per cent. had a near-sighted father or mother.

Professor Pearson may be correct in urging that "the first thing is good stock, and the second thing is good stock, and the third thing is good stock," but it does not appear that this conclusion can be deduced from what is known in regard to defective eyesight. There is danger that an attitude such as Professor Pearson's may lead to neglect of those factors of the environment which we can improve. When he says: "Pay attention to breeding, and the environmental element will not upset your projects," he rather neglects to emphasize the fact that paying attention to breeding does not under what Galton calls "the existing conditions of law and sentiment" give us much chance to improve the racial stock in man. We can not breed a race immune to myopia, but we can refrain from producing a generation of myopic school children.

SCIENTIFIC ITEMS

WE regret to record the death of Dr. R. E. C. Stearns, of Los Angeles, known for his work on the Mollusca; of John Morse Ordway, until recently professor of metallurgy at Tulane University; of Mr. Lefferts Buck, a leading New York engineer; of Dr. T. W. Bridge, professor of zoology at Birmingham, and of Dr. V. R. Matteucci, director of the Observatory on Mt. Vesuvius.

PROFESSOR R. C. ALLEN, of the University of Michigan, has been appointed state geologist of Michigan, to succeed Dr. A. C. Lane, who has become professor of geology in Tufts College.—Dr. C. Gordon Hewitt, lecturer in economic zoology in the University of Manchester, has been appointed entomologist to the Dominion of Canada in succession to the late Dr. James Fletcher.

SIR JOSEPH DALTON HOOKER celebrated his ninety-second birthday on June 30. His scientific career began seventy years ago, when he went out as surgeon and naturalist with Sir James Ross's Antarctic expedition.—Dr. C. Lloyd Morgan, F.R.S., known for his contributions to comparative psychology, has resigned the office of vice-chancellor of the University of Bristol.

THE French Association for the Advancement of Science will meet this year at Lille on August 2-7, under the presidency of Professor Landouzy, dean of the faculty of medicine in the University of Paris. The gold medal of the association, which was instituted last year, is to be awarded to Professor H. Poincaré, who will deliver a lecture during the course of the meeting.

THE heirs of the late Herr Heinrich Lanz, head of the Mannheim engineering firm, have given a million Marks for the establishment of an academy of science at Heidelberg.—M. Henry Deutsch has given 500,000 francs, and promises in addition an annual grant of 15,000 francs, towards the creation of an aerotechnical institute in the University of Paris. M. Basil Zakaroff has given 700,000 francs for the foundation of a chair of aviation in the faculty of sciences of the university.

THE POPULAR SCIENCE MONTHLY.

OCTOBER, 1909

THE HUDSON-FULTON CELEBRATION OF 1909

BY DR. GEORGE FREDERICK KUNZ

NEW YORK CITY

SINCE the London Exhibition of 1851, and the first Paris Exposition of 1855, there have been probably one hundred exhibitions in various parts of the world. Generally they have been held in commemoration of some historic event or anniversary, and each one, large or small, has usually had some special distinctive feature. The great exposition at Chicago had its White City and its illuminations; the Buffalo Exposition had its architecture, its illuminations and the added advantage of its striking environment, and the various French expositions have each possessed peculiar points to mark their individuality. All of them have been held for six months or more, but in a great many cases from one third to one half of that time elapsed before all the departments were completed and opened to the public. In this way public interest was checked at the beginning, and when the exposition was finally completed, a good part of the allotted time had passed, and the enthusiasm always excited by these affairs had begun to flag.

New York in itself is not only the greatest exposition, perhaps, in the world, because of its geographic features and its wonderful resources, but its various lines of transit—surface cars, elevated railways and subways—facilitate the handling of great crowds. In addition to this New York lies between two rivers, and is as easily reached by boat as by rail, to say nothing of the attractive physical advantages this location gives it.

The writer, in an article published in the *North American Review* for September, 1902, and entitled "The Management and Uses of Expositions," strongly urged the holding of an exposition to mark the tercentenary of Henry Hudson's arrival at the mouth of the river which bears his name. The forecast of the present advantages of our city



HENRY HUDSON (ideal). No artist's name attached.

given in this article has been almost literally fulfilled, and the writer realizes more than ever that he was correct in saying that the museums and institutions of our city would "furnish a greater display to the visitor than any exposition yet held on the continent."

New York, with its great variety of public buildings, its miles of waterways, its dozens of museums, its many civic buildings, its great system of parks, stands alone as a prominent and fitting exposition ground. Why erect a city of staff, wood and other inflammable material to hold costly objects? Whoever contributed his much-prized works of art to such shelter, awaited, with fear and trembling, their safe return, and few of the finest things were ever loaned except in Paris, where they were shown in permanent structures such as the artistic Nouveau Salon, and its dainty neighbor, the Petit Salon, to the right of which is the magnificent Pont Alexandre II.

Although not so named, this Hudson-Fulton Celebration really presents the features of a great exposition, for when all the resources

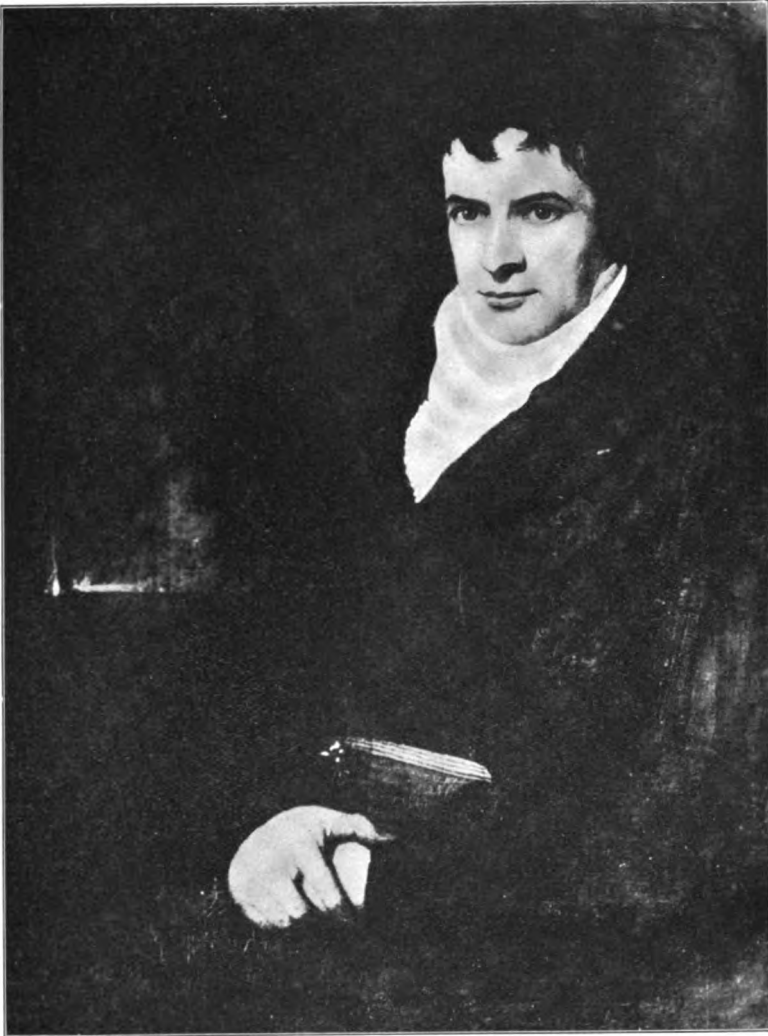

ROBERT FULTON, by Benjamin West. Fulton as a youth went to Europe to study art. West was his teacher. This portrait of Fulton is said to represent West's best style. Hudson-Fulton Celebration Commission.

of New York are presented as they will be on this occasion, and given a brilliant and attractive setting, it will be found that no exposition ever organized on this continent has offered a greater variety of interest. To apply the standard of monetary value may seem a trifle vulgar when we are treating of the triumphs of art in all its forms, and yet this standard merely expresses the worth of antiquities and artistic creations in a more exact way than by using superlatives of speech. A reasonable estimate of the value of the attractions that our city offers to its visitors would be rather in excess of \$2,000,000,000 than below that figure, and

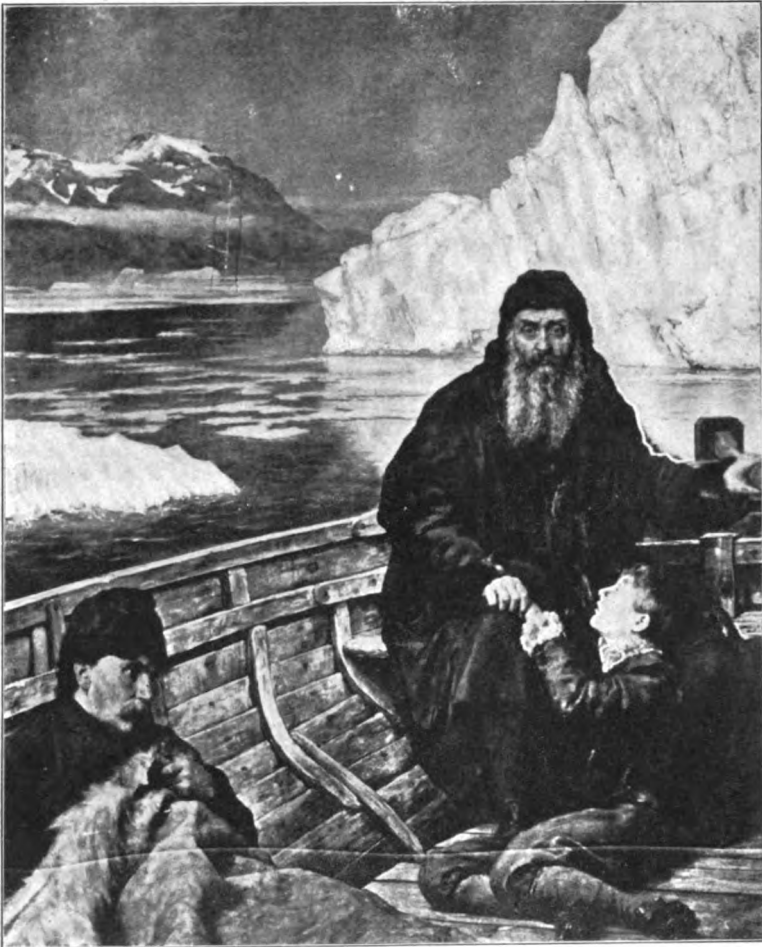

LAST DAYS OF HENRY HUDSON, by Sir John Collier. Original in Tate Gallery, London.
 On his last voyage (in the *Adriatic*) Hudson was set adrift in a small boat
 by his mutinous crew and nothing was later heard of him.
 Hudson-Fulton Celebration Commission.

yet, where the great expositions of the past have cost from \$10,000,000 to \$20,000,000 or more for their organization, all the treasures and beauties of New York can be displayed at an expense of only \$1,000,000. A single building, the Metropolitan Museum of Art, with the objects it will hold, would not be over-valued at from \$30,000,000 to \$40,000,000.

At an exposition the public is called upon to pay fifty cents admission each time to enter the gates and an additional fee for each special exhibition. The great New York celebration will be free for all, even for those who have no car fare to enable them to ride. The demonstrations are in the heart of the city itself. They do not take place in some suburb, or barren, out-of-the-way spot. They are not encompassed

within a temporary city built like that at Coney Island, or held away out in the Bronx, on the Palisades or at Staten Island; neither is the celebration instituted or furthered to boom any special piece of real estate, or to sustain the selling of a quantity of traction stock or railroad stock that might be affected by an unusual traffic for the time being.

The celebration is designed to cover a very wide field, and the aim of the commission has not been confined to honoring the explorer of the Hudson River and the man who made steam navigation a permanent success; in addition to this the occasion has been utilized to illustrate and emphasize the development and greatness of New York City, the metropolis of the western hemisphere. Those who can understand the true significance of this celebration, and who are able to forecast the future, will see the vision of a still greater and more magnificent city, worthy of being called a world metropolis.

Although the naval parade owes its greatness to the presence of the American and international war fleet, and to the immense aggregation of vessels of all kinds and denominations assembled for the occasion, the place of honor is fittingly assigned to the replicas of the two small vessels which helped to make the names of Hudson and Fulton famous. The reproduction of the *Half Moon*, generously offered by the government of the Netherlands, is a craft of but 80 tons burden and is only 74½ feet long and 17 feet wide. The *Half Moon* will be under the command of Commander Lam, who will be costumed to impersonate Henry Hudson; the crew will also wear the dress of sailors of Hudson's time. A comparison with the *Celtic* shows in a striking manner the wonderful progress in naval construction, the giant liner being 700 feet long and 75 feet wide, while its tonnage is 20,904. The historic *Clermont*, which, in 1807, made its memorable trip up the Hudson, thus inaugurating steam navigation on the river, has been carefully reproduced. This craft, while larger than the *Half Moon*, is still small and insignificant in comparison with the magnificent steamers of to-day. It is only 150 feet long and 18 feet wide.

The reproductions of the *Half Moon* and the *Clermont* constitute the central point, the very focus, of the celebration, and this has been fully recognized by the commission. Hence the opening day, Saturday, September 25, will be devoted to a grand naval parade, perhaps the greatest naval pageant ever seen. The eighty warships, American and foreign, form the most imposing array of naval forces assembled at any time in the new world, and we may safely say that, with one or two possible exceptions, no fleet of equal might and numbers was ever brought together.

The United States will be represented by 16 battleships, 12 torpedo-boats, 4 submarines, 2 supply ships, 1 repair ship, 1 torpedo vessel, 1 tug and 7 colliers: 53 vessels in all, the battleships constituting the

most powerful fleet ever assembled except on a few occasions in the English Channel. Rear-Admiral Seaton Schroeder, U.S.N., is in command.

From the Netherlands comes the cruiser *Utrecht*, commanded by Captain G. P. van Heeking Colenbrander, R.N.N., and the replica of the *Half Moon*. Germany sends the cruisers *Dresden*, *Hertha*, *Viktoria Luisa* and *Bremen*, under the command of Grand Admiral H. L. R. von Köster, retired, of the Imperial Navy. The English squadron will con-



THE PURCHASE OF MANHATTAN ISLAND.

sist of the cruisers *Inflexible*, *Drake*, *Argyll* and *Duke of Edinburgh*, commanded by Admiral Sir Edward Seymour, of the Royal Navy. France will be represented by two battleships, the *Liberté* and the *Justice*, under the command of Vice Admiral Le Pord. From Italy come the cruiser *Etruria* and the schoolship *Etna*, on board of which will be the cadets of the Royal Naval Academy—the future officers of the Italian navy.

Latin America will also participate in the parade, Mexico being represented by the gun-boat *Bravo*, commanded by Captain Manuel E. Izaguirre; Cuba, by the revenue-cutter *Hatuey*; the Argentine Republic, by the warship *Presidente Sarmiento*, and Guatemala, by a coast-patrol boat.

An immense fleet of seagoing and coastwise merchant vessels, steam-boats, ferryboats, steam yachts, motor boats, tugs and steam lighters, sailing crafts, police boats, wrecking boats, fire boats, hospital boats, naval-militia vessels, steam cutters and launches, United States revenue-cutters and other craft, including the *Clermont* and *Half Moon*, will assemble in ten squadrons in the Harbor, in the vicinity of the Brooklyn,



A GENERAL PEACE.

NEW-YORK, March 25, 1783.

LATE last Night, an EXPRESS from New-Jersey, brought the following Account.

THAT on Sunday last, the Twenty-Third Instant, a Vessel arrived at Philadelphia, in Thirty-five Days from Cadiz, with Dispatches to the *Continental Congress*, informing them, that on Monday the Twentieth Day of January, the PRELIMINARIES TO

A GENERAL PEACE,

Between *Great-Britain, France, Spain, Holland,* and the *United States of America*, were SIGNED at Paris, by all the Commissioners from those Powers; in consequence of which, Hostilities, by Sea and Land, were to cease in Europe, on Wednesday the Twentieth Day of February; and in America, on Thursday the Twentieth Day of March, in the present Year One Thousand Seven Hundred and Eighty-Three.

THIS very important Intelligence was last Night announced by the Firing of Cannon, and great Rejoicings at Elizabeth-Town.—Respecting the Particulars of this truly interesting Event no more are yet received, but they are hourly expected.

Published by James Rivington, Printer to the King's Most Excellent Majesty.

The foregoing "Broadside" has been compared with the original, in the Senate House, Kingston, N. Y., and found correct.

JULIUS SCHOONMAKER, Custodian.

Submitted and sworn to before me, this 15th day of October, 1861.
C. HUMB. Notary Public.

Staten Island and New Jersey shores. An object of interest for all will be the historic *Roosevelt*, used by Commander Peary in his successful trip to the North Pole. Staten Island has contributed a reproduction of Commodore Vanderbilt's periagua, the forerunner of the Vanderbilt ferryboats between Staten Island and Manhattan. The warships will also rendezvous in the harbor, and at 1:30 P.M. the parade will begin, the warships in the lead. The whole array of vessels, at least seven miles in length, will advance, slowly and majestically, up

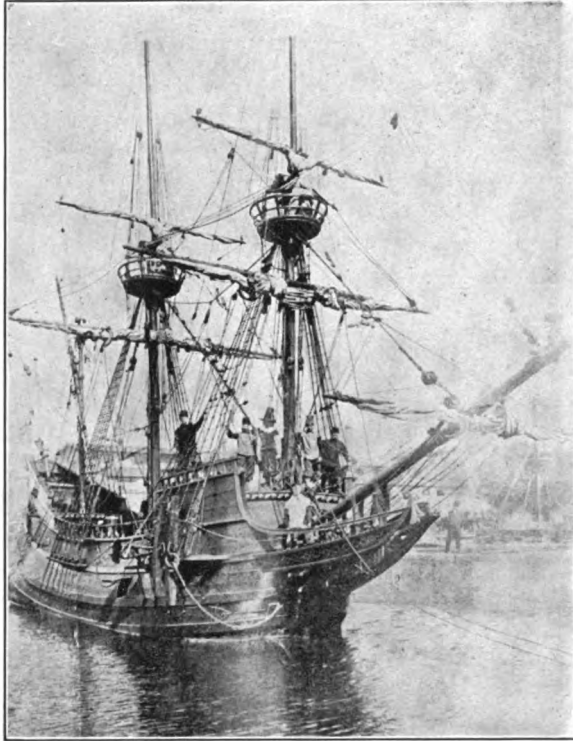

THE HALF MOON. An exact photograph of the replica of the *Half Moon*, in which Hudson sailed under the auspices of the Dutch East India Company, built by patriotic citizens of Holland and to be presented to the Commission. Hudson-Fulton Celebration Commission.

the Hudson River. When the head of the column reaches Forty-second Street, the two leading warships will swing out of line and cast anchor opposite each other; a little further on the second pair will then perform the same evolutions, to be succeeded in turn by all the other warships, the line finally extending from Forty-second Street to 175th Street. The civic fleet will continue on its way, passing to the left of the warships until the head of the line is reached, when the vessels will cross over and move down the river between the warships and the Manhattan shore, to 110th Street.

In the meanwhile the replicas of the *Half Moon* and the *Clermont*, accompanied by their more immediate escort, will pass up between the lines of warships to 110th Street and will be greeted by a salute in passing. Arriving at 110th Street, the formal presentation of the two vessels will be made, the exercises taking place on a landing stage constructed at that point.

The parade of the civic fleet will be repeated in the evening, starting at 7:30 P.M., and will make a very brilliant spectacle, for the moving vessels as well as the warships will be illuminated with electric lamps, which will outline their form with a tracery of fire.

On Wednesday, September 29, about 9:30 A.M., the *Half Moon* and the *Clermont* will leave their anchorages at 110th Street and will proceed up the river, stopping for a time at Yonkers, Tarrytown, Ossining, Peekskill and Cornwall. On Friday, October 1, these vessels will arrive at Newburgh, where they will meet the Upper and Lower Hudson fleets. The latter fleet will leave New York on the morning of October 1, and will consist of the submarine *Costine* (the first submarine), twelve torpedo boats and a large number of other ships, divided into six squadrons.

There can be no question that the naval parade with which the Hudson-Fulton Celebration begins, represents the central idea of the whole festival. The spectators, in gazing upon the immense fleet of modern vessels, may find it difficult to realize that the tiny ships, the *Half Moon* and the *Clermont*, so faithfully reproduced for this occasion, occupy a more important place in the world's history than will all the gigantic vessels that are assembled to honor the two remarkable men who accomplished so much with such scant resources.

This lesson is especially important in our time, for the tendency of our day is to lay undue stress upon mere magnitude, and to believe that larger ships, larger buildings and larger cities necessarily mark a real progress in civilization. No sane person will deny the fact that the conditions of life have changed and are changing for the better—slowly, it is true—but there can be as little question that the rate of progress would be greatly accelerated if the essentials of civilization



THE HALF MOON.

were more regarded than the development of mere material greatness.

The first of the land parades, the great historical pageant, will take place on Tuesday, September 28, and will consist of 54 cars, or "floats," bearing groups of figures and accessories illustrating scenes from the history of the city or state of New York. These floats will be accompanied by marching bodies from various civic societies, American and foreign. The one which will head the procession has been named "The New York Title Car" and will bear a seated figure of the God-

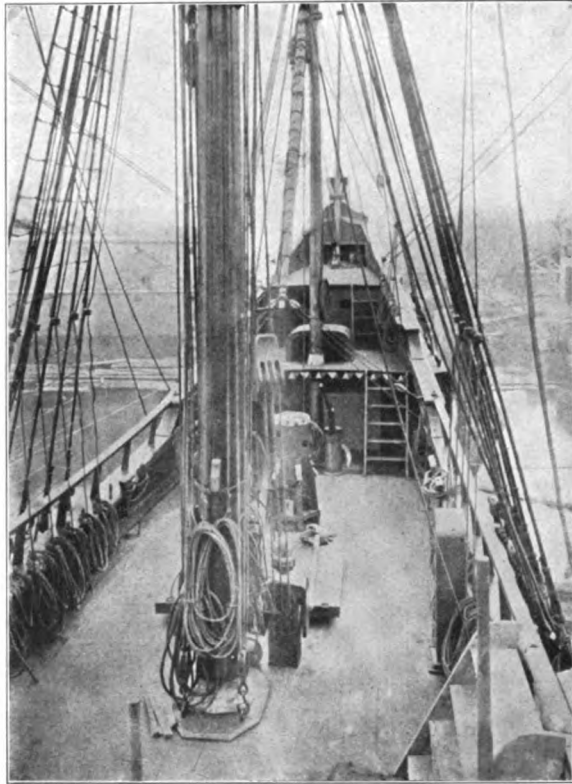

THE HALF MOON.

dess of Liberty; two owls, the birds of Minerva, are perched upon the high back of the chair on which the goddess sits, signifying that wisdom has guided her in her progress. The contrast between the primitive conditions of Henry Hudson's time and those of the present day is strikingly presented by the model of an Indian canoe alongside of that of an ocean liner, and by representations, in due proportions, of a "skyscraper" and of an Indian wigwam.

The parade will be divided into four divisions, devoted, respectively, to the Indian, the Dutch, the Colonial and the Revolutionary periods, each division being preceded by a car bearing a group which epitomizes

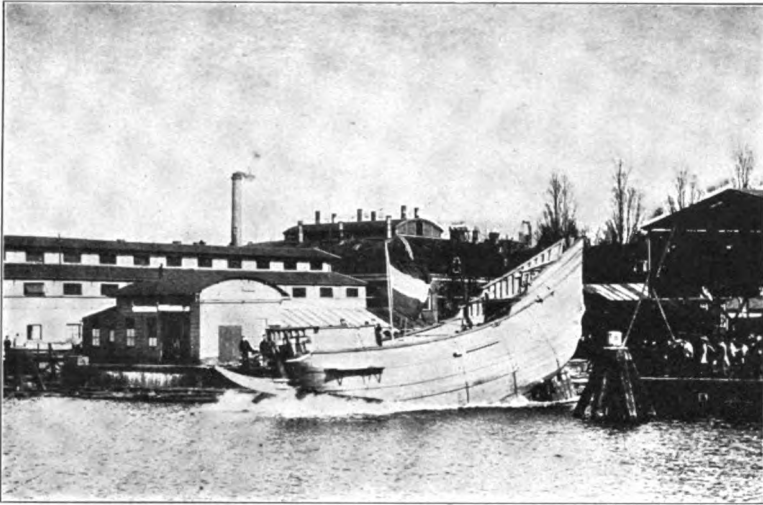

LAUNCHING OF THE HALF MOON AT AMSTERDAM.

the leading characteristics of the period. The last car typifies the hospitality of our city, a gigantic figure of Old Father Knickerbocker standing upon it with hands outstretched and extending a hearty welcome to all the nations of the earth. In order to add to the verisimilitude of the different groups, Iroquois Indians have been secured to man the Indian floats; members of the various Holland societies to represent

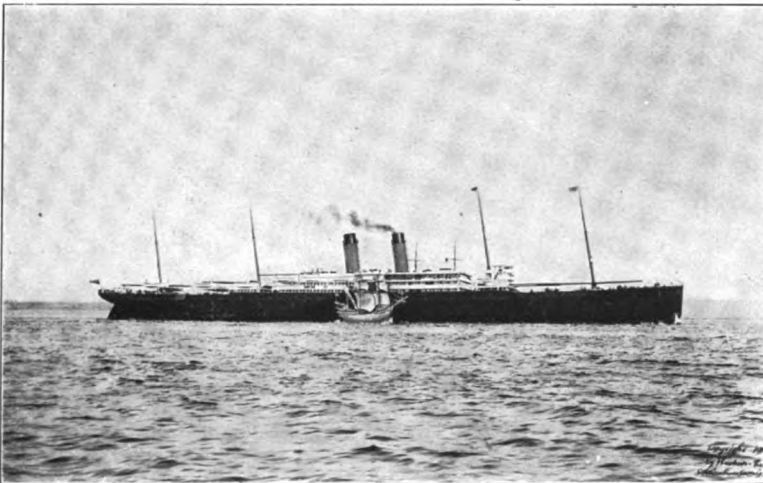

COMPARATIVE PICTURE. "CELTIC" AND "HALF MOON." *Celtic* (1909)—length 700 feet, beam 75 feet, depth 49 feet, displacement 37,870 tons, tonnage 20,904 tons, horsepower 13,000. *Half Moon* (1609)—length 74.54 feet, beam 16.94 feet, depth 10.08 feet, tonnage 80 tons. The *Celtic* crosses the Atlantic in a little less than eight days. The *Half Moon* crossed the Atlantic in fifty-nine days.

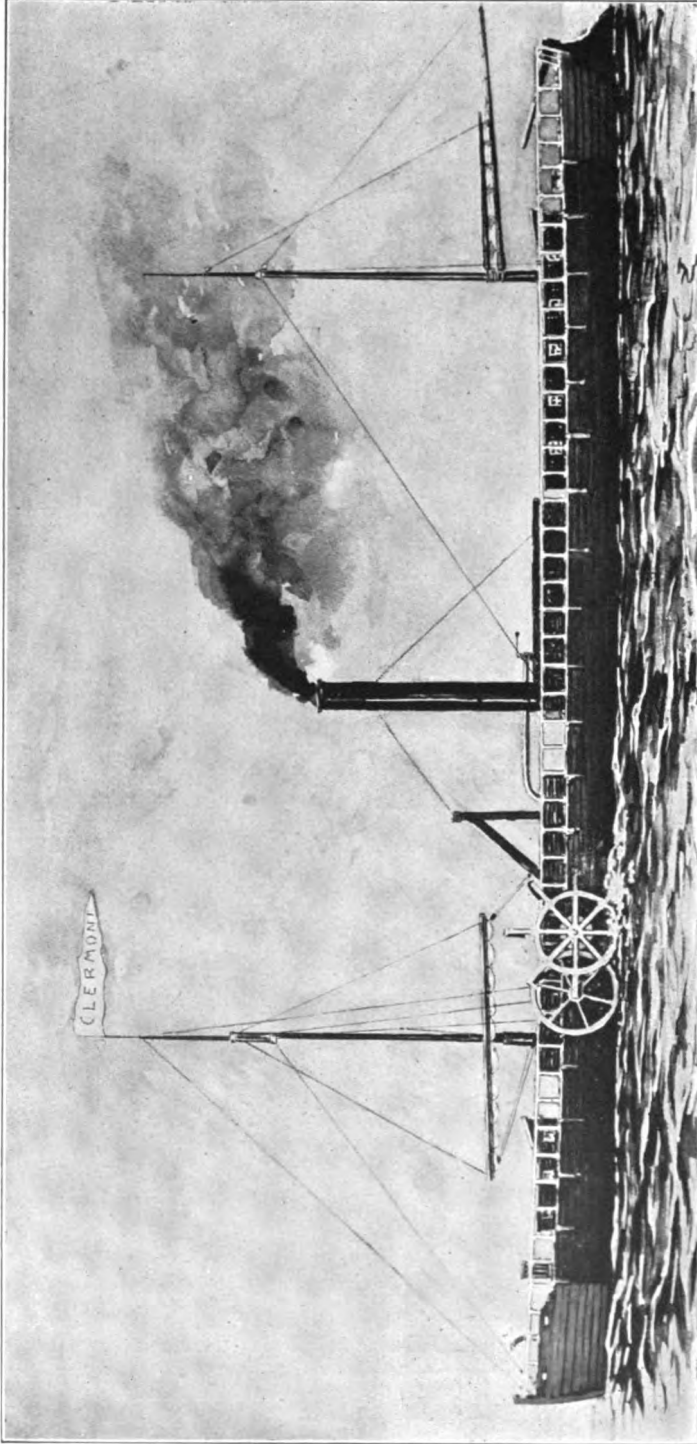

THE CLERMONT.
Copyrighted, 1909, by Hudson-Fulton Celebration Commission.

the characters on the Dutch floats, and descendants of the old Colonial families, members of the Society of Colonial Wars, Sons of the Revolution, etc., to perform the same service on the Colonial floats. The float showing the capture of Major André will be manned by descendants of John Paulding, one of André's captors.

The parade will begin at 110th Street and Central Park West and will proceed down Central Park West to 59th Street, through that street to Fifth Avenue, and down Fifth Avenue to Washington Square.

This parade will be repeated in Brooklyn on Friday, October 1, proceeding from the Memorial Arch at the entrance to Prospect Park by way of the Eastern Parkway to Buffalo Avenue. Richmond Borough will also have its historical parade, on a smaller scale, it is true. This will take place on Monday, September 27, and will traverse the Amboy Road, between New Dorp and Oakwood. The ceremonies on the site of the first church on Staten Island, founded by the Waldensians, will commemorate the first permanent settlement on the island.

The military parade will take place on Thursday, passing over the route followed by the historical pageant. It will be composed of the Federal Troops of the Department of the East, the National Guard of the State of New York within the limits of New York city, the United States Navy and Marine Corps, the Naval Reserve, the veteran organizations, and marines and sailors from foreign warships. It is estimated that 25,000 men will be in line.

The carnival parade on Saturday evening, October 2, will traverse the route followed by the historical parade and the military parade. This will unquestionably be one of the most interesting and probably the most brilliant feature of the celebration. It will be under the care of the German societies of New York, and the Germans have always displayed a remarkable aptitude for organizing and designing pageants of this kind. The fifty cars composing the parade will be artistically illuminated, and many thousands of torch-bearers will precede and follow the emblematic groups. These will represent music, art and literature, and the wide field of German legend, song and history will furnish most of the themes. The streets along the route of the parade will be made as light as day by festoons of electric lamps. This pageant will be repeated in Brooklyn on the evening of Saturday, October 9, and will pass along the Eastern Parkway.

The general illumination of the city every night during the festival period will offer the most brilliant spectacle ever seen in this country. All the municipal buildings, as well as thousands of private buildings, will be lighted up by tens of thousands of electric lights. The four bridges spanning the East River will be radiant with rows of lights, 14,000 being placed on the Queensboro Bridge, 13,000 on the Brooklyn Bridge, 11,000 on the Williamsburg Bridge and the same number on



the Manhattan Bridge. As seen from any point on the East River, these bridges will be outlined against the dark background of the night, so as to appear like structures of flame, evoked by a magician's hand. On the other side of the island, both shores of the Hudson River from Forty-second Street to Spuyten Duyvil will be ablaze with light. At 110th Street there will be a battery of twelve searchlights, aggregating 1,700,000 candle power; these lights will be directed up, down and across the river, illuminating an immense radius. Another battery of searchlights, four in number and aggregating 400,000 candle power, will cast its rays upon Grant's Tomb, which will be thrown into striking relief by the dazzling light.

The historical parade and all the other pageants of the week will

arouse in the minds of the beholders a more lively understanding of the history and development of our city, and, while delighting the eye, will convey an important lesson in the very best and most effective way—that is, unconsciously. A population like ours is greatly in need of some powerful stimulation of this kind to weld together all its heterogeneous elements. But let it not be supposed that this is the only end to be attained; such brilliant spectacles are a good in themselves and none will appreciate this more thoroughly than those whose life is merely a sad and monotonous struggle for their daily bread. On this occasion the poorest and the richest will share equally in the enjoyment of the various splendid and artistic spectacles.

Of the special exhibitions which have been organized by the Art and Historical Exhibits Committee, the most important is the magnificent collection of masterpieces by Dutch painters which will be seen in the Metropolitan Museum of Art, at Fifth Avenue and Eighty-second Street. Never before have so many splendid examples of Dutch art been gathered together in the United States; indeed, the exhibition as a whole has never been rivaled even in Europe. Here may be seen no less than thirty-five Rembrandts, a larger number than exist in any permanent collection, except that of the Hermitage in St. Petersburg. Then there are nineteen portraits by Franz Hals, who is only inferior to Rembrandt among the Dutch portraitists, and five specimens of the work of Vermeer van Delft, whose pictures are extremely rare, there being only thirty authentic examples extant. Besides the works of these artists there are fine and characteristic pictures by Jacob and Salomon Ruysdael, Cuyp, Hobbema, Metsu, Van Ostade and many others who were contemporaries of Henry Hudson. These works come from the finest private collections in the United States and many years will pass before an equally favorable opportunity will be afforded for the study of Dutch pictorial art.

The special exhibition also embraces a large and valuable collection of furniture, silver, pewter, porcelain and glass, produced in this country between 1625 and 1815, the year of Fulton's death; and there is also a fine collection of paintings by American artists born before 1800, including pictures by Woolaston, Copley, West, Allston, Peale, Stuart, Trumbull, Fulton, Doughty, etc.

We have all read of the Indians who were settled on Manhattan Island before the arrival of Henry Hudson, but few realize how many relics of these aborigines have been found here, especially at the upper end of the island. A large and valuable collection of these relics may be seen in the American Museum of Natural History, at Central Park West and Seventy-seventh Street, and a classic monograph, written by Dr. Clark Wissler, can be obtained at the same place, and will enable the visitor to understand the significance of the various relics. The

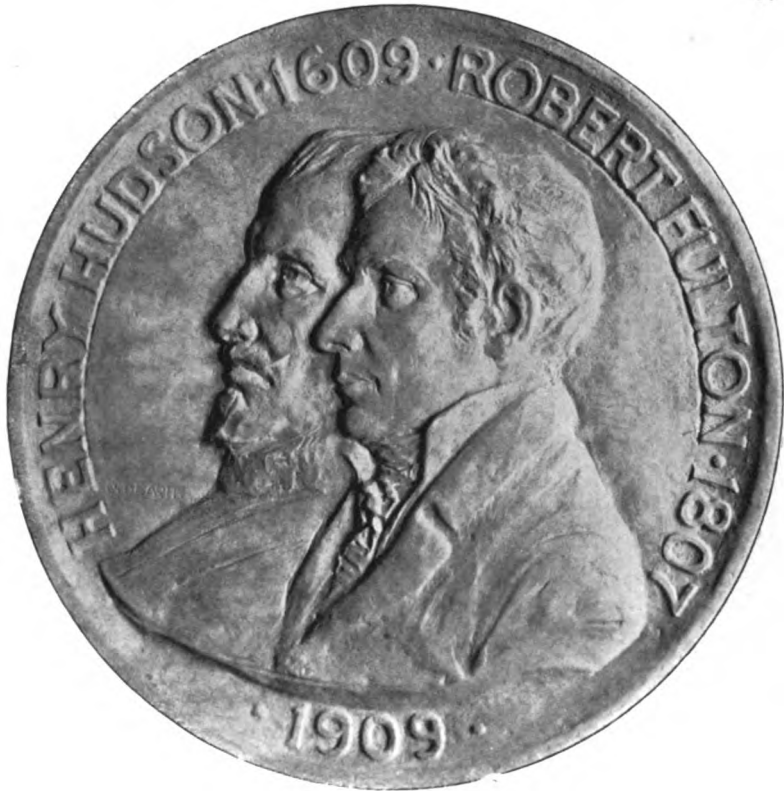

manners and customs of the Indians of Long Island are represented by an important exhibit in the Brooklyn Institute. Independent of any museum, and of ethnological interest, will be the 125 Indians, men, women and children, from New York reservations, who will participate in the landing of the *Half Moon*, and in several of the parades.

The early history of New York and the beginnings of steam navigation will be illustrated by an exhibition of views, paintings, manuscripts, books, etc., shown in the Lenox branch of the New York Public Library, detailed information in regard to the exhibits being offered in a special catalogue. The New York Historical Society, in its new building, on Central Park West, corner of Seventy-seventh Street, just below the American Museum of Natural History, exhibits many interesting pictures and relics relating to Robert Fulton. At the National Arts Club, No. 15 Gramercy Park, the special collection is entitled "Three Hundred Years of New York," and the visitor will see a large number of pictures and other objects illustrating the development of the city and its rapid and marvelous growth. A collection of oil paintings and old manuscripts concerning the early history of New York is exhibited by the Genealogical and Biographical



Society, No. 226 West Fifty-seventh Street, and rare manuscripts and books on the same subject may be seen at the College of the City of New York, St. Nicholas Avenue and 138th Street.

As is the case with all great inventions, steam navigation was not the work of one man alone, although Robert Fulton was the first to apply it consequently and permanently. Epoch-making inventions have usually been the work of a group of men pursuing the same end, often independently of each other, but the credit and glory of success is reserved for that one of them who possesses the energy and persistence requisite for ultimate triumph. Before Fulton built the *Clermont*, John Fitch had constructed a boat operated and propelled by steam, and John Stevens had already sailed a steamboat, his *Phoenix* being undoubtedly the first steamboat to sail on the ocean; but Fulton applied the ideas of Fitch and improved upon them to such an extent that he is rightly regarded as the parent of steam navigation. Aided by the advice of Chancellor Livingston, he secured a sort of monopoly in steamship building and his name will always be remembered among those of the great benefactors of humanity.

The portrait of Fulton by Benjamin West is justly regarded as one
VOL. LXXV.—22.



GENERAL STEWART L. WOODFORD,
President of the Hudson-Fulton Celebration
Commission.

us something not to be found in other portraits, namely, the idea, or perhaps we should rather say the ideal, the artist has formed of himself.



HENRY W. SACKETT,
Secretary of the Hudson-Fulton Celebration
Commission.

²In Brooklyn Institute exhibit.
Published by his permission.

of the best works of our American painter, who became president of the Royal Academy in London. Fulton himself was an artist of considerable ability, and pursued his art studies in London under West's direction. Among his works is a most interesting portrait of himself, which can be seen in the Brooklyn Institute. Although this does not equal West's portrait in artistic merit, like other attempts of artists to portray their own features it gives



HERMANN RIDDER,
Vice-president of the Hudson-Fulton
Celebration Commission.

One of the most interesting of the printed documents referring to the Revolution is an old "Broad-side" printed in New York, March 25, 1783.² We are here given a vivid idea of the time required for the transmission of news in that day, for this sheet tells us that the first news of the signing of the preliminaries to the treaty of peace at Paris

Loaned by Colonel Henry T. Chapman.

on January 20, 1783, reached Philadelphia, by way of Cadiz, Spain, on the twenty-seventh of March.

The flora of Manhattan Island and its vicinity, in the time of Henry Hudson, is shown in the New York Botanical Garden, where these specimens are indicated by the letter "H," and in the parks of Brooklyn and Queens boroughs, a special sign in this case indicating the trees and shrubs which grew here in 1609. It is difficult for those who see this city of stone, brick and concrete to imagine its appearance in Henry Hudson's time, when stretches of meadow land alternated with groves or small forests of trees, over the greater part of the territory, while the upper part of Manhattan Island was traversed with rocky ridges rising in some cases to a considerable height above tide-water. Except in the outlying portions of the city, all these irregularities have been effaced, but the large parks, especially Morningside Park and a portion of Central Park above 100th Street, still show much of the primitive conditions.

Such a transformation makes the old pictures of Manhattan Island seem unreal, nevertheless it should be a consolation for the present landowners to know that the land was duly and legally acquired by the first Dutch settlers, and although Peter Minuit may have made a good bargain, the title is clear and without stain.

Those who wish to form some idea of the fauna of this region at the time of Hudson's arrival should visit the New York Zoological Garden, where the specimens in question are marked by the flag of the Hudson-Fulton Celebration. In the New York Aquarium appropriate signs have also been placed on the tanks containing fish indigenous to the Hudson River and the waters surrounding New York.

For many special exhibitions catalogues have been prepared at considerable expense. The price at which they are sold scarcely covers the cost of printing them from the plates. A first edition of 5,000 to 10,000 copies has been printed, but when this supply is exhausted new editions of, say, 2,000 copies will be issued from time to time as occasion requires.

One of the leading features of the celebration will be a grand banquet of 2,000 persons in the magnificent new dining-hall of the Hotel Astor. This will be the greatest fine banquet ever given in this country, and the use of the hall has been held back to have this the initial banquet. It is true that in point of size it can not be compared with the dinner given to 22,000 *maires* of the French communes, at the opening of the Paris Exposition in 1889. Some idea of the gigantic proportions of this function may be given by the fact that the plates used in serving the dinner, if placed on top of each other, would have made a pile two miles in height. However, this was merely a dinner, while the function in the Hotel Astor is a grand banquet faultless in every detail.

In Brooklyn the social side of the celebration will find expression in

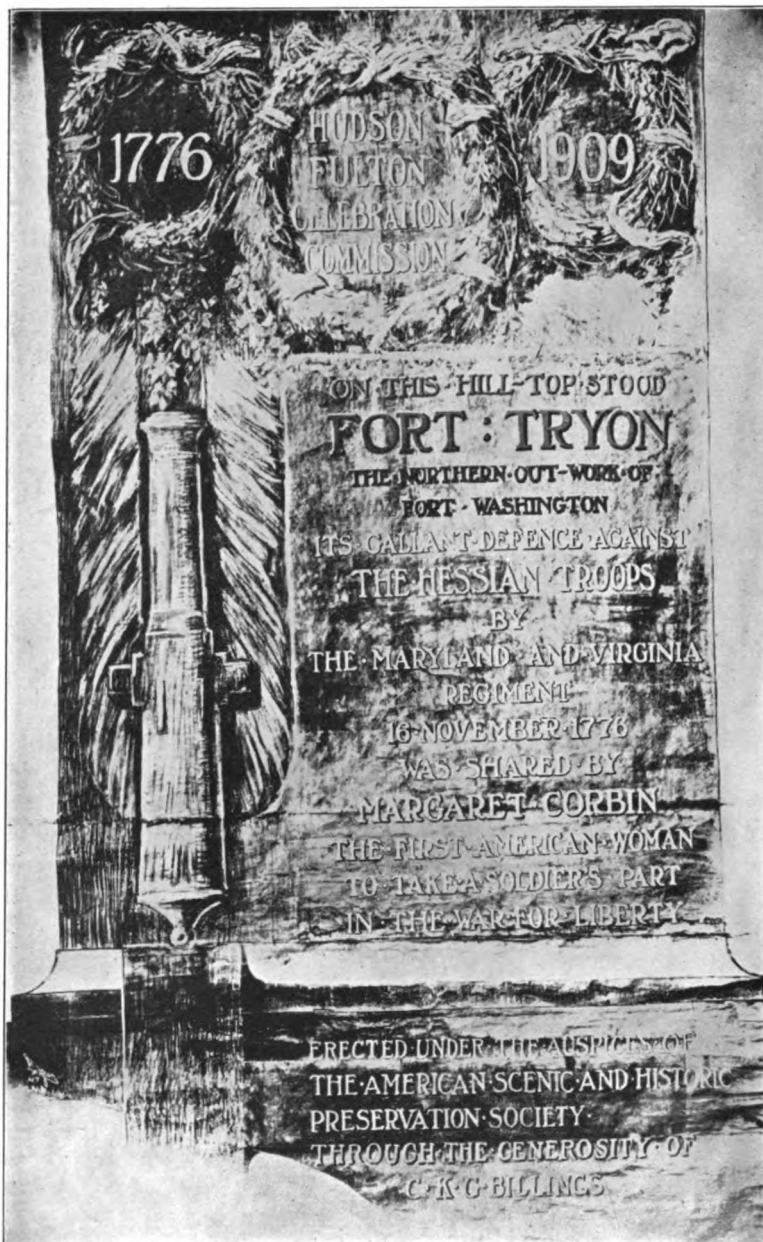

a ball to be given at the Brooklyn Academy of Music. Invitations have been extended to the officers of the American and International fleets, the diplomatic representatives of foreign nations, and many other distinguished guests, and the ball will undoubtedly be a brilliant and imposing affair.

Lovers of good music will have ample opportunity to gratify their

tastes. On Sunday evening, September 26, the masterpieces of Irish music and song will be rendered in Carnegie Hall by Irish citizens of New York, many of the songs being given in both English and Gaelic. In the Hippodrome, on the same evening, there will be a concert by the United German Singers of the Northeast District of New York.

On Monday evening, September 27, the Hudson-Fulton official ceremonies will open with a reception to the distinguished visiting guests at the Metropolitan Opera House, when all the distinguished foreign guests will present their addresses, after an official welcome by the Hudson-Fulton Celebration Commission, Gen. Stewart L. Woodford, Charles E. Hughes, Governor of the state of New York, Mayor George B. McClellan, and Mrs. Julia Ward Howe, over ninety years old, author of the "Battle Hymn of the Republic," will recite a poem.

On Tuesday evening, September 28, there will be a musical festival by the German Liederkrantz in the Metropolitan Opera House, and on Thursday evening, September 30, a concert will be given by the New York Festival Chorus in Carnegie Hall. Lastly, there will be a sacred concert at Carnegie Hall by the People's Choral Union, under the leadership of Walter Damrosch, on Sunday, the third of October.

Educational exercises, dealing with subjects appropriate to the celebration, and designed to be participated in by universities, colleges, schools, museums and learned and patriotic societies throughout the state, will be held on Wednesday, September 29. In New York City, the following lectures will be delivered in various rooms of the New York University: "Literature of the First Two Centuries of New York City," by Professor Francis H. Stoddard; "Conditions Determining the Greatness of New York City as a Commercial and Financial Center," by Professor Joseph F. Johnson; "The Political History of New Netherland," by Professor Marshall S. Brown; "History of Education in New York," by Professor Herman H. Horne; "Fulton and Other Promoters of Steam Navigation," by Professor Daniel W. Hering; "History of Steam Navigation," by Professor Charles E. Houghton; "A Comparison of the Steam Engine Before 1809 with Fulton's Steam Engine," by Professor Collins P. Bliss; "The Physiographic Development of the Hudson River Valley," by Professor Joseph E. Woodman. There will also be exercises in connection with the university's schools in Washington Square. In Brooklyn Borough there will be literary exercises on Tuesday evening, September 28, at the Brooklyn Academy of Music.

Commemorative services will take place throughout the city and state on Saturday, September 28. On this day the Reformed Protestant Dutch Church of the City of New York, organized in 1628 and representing the earliest religious organization in New York, will hold special commemorative services at 11 A.M. and 8 P.M., in its churches at Second

Avenue and Seventh Street, Fifth Avenue and Twenty-ninth Street, Fifth Avenue and Forty-eighth Street and West End Avenue and Seventy-seventh Street.

The Henry Hudson Monument on Spuyten Duyvil Hill will be dedicated on Monday, September 27, and is so placed as to form a prominent landmark. From a base ornamented with bas-reliefs springs a fluted Doric column, surmounted by a pedestal supporting the statue of Hudson. This monument, by Karl Bitter and Schrady, is a chaste and beautiful work of art. It is 110 feet high, and, being set upon an

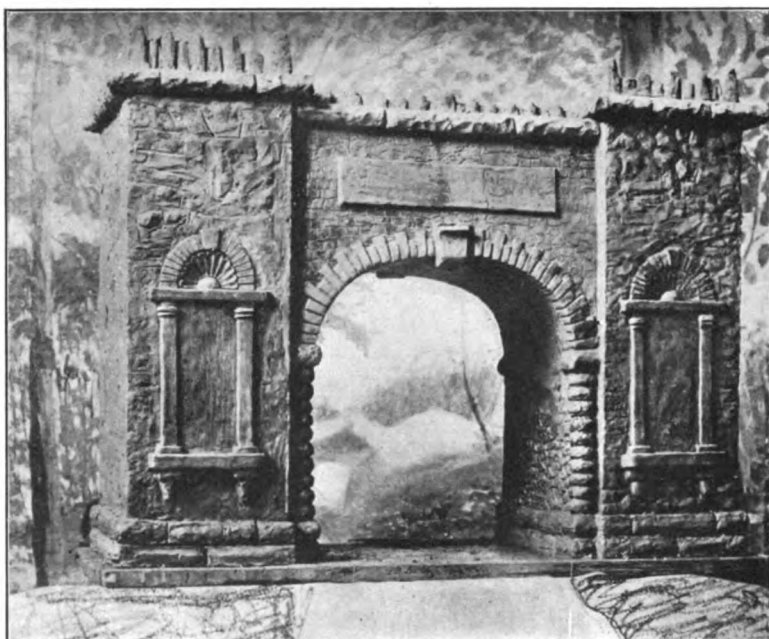

GATEWAY ERECTED ON STONY POINT BATTLEFIELD BY DAUGHTERS OF THE REVOLUTION (New York State) and to be dedicated during Hudson-Fulton Celebration—September 25 to October 9, 1909—as part of the official program. Hudson-Fulton Celebration Commission.

elevation 200 feet above tide-water, it can be seen from a distance of several miles up and down the Hudson River, and even from the waters of Long Island Sound; the sum required for its erection was supplied by private subscription. The monument rests on the site of the Indian village of Nipinichsen, whence, on October 2, 1609, an attack was made upon the *Half Moon*.

The last scene of Hudson's life makes a gloomy picture. Set adrift in a small boat by the mutinous crew of his ship *Adriatic*, he passed away out of the sight of men and was never heard of again. In the dreary hours of aimless drifting over the tossing waves, and face to face with death, Hudson had not even the consolation of knowing that his

name would be handed down to posterity, and that nearly three centuries after his death millions of his race and speech would assemble to do him honor.

Land is so valuable on Manhattan Island that but few remain of the old buildings associated with the early history of the city. For this very reason a visit to four of these historic buildings which have been preserved from destruction will be of interest. Fraunces' Tavern, situated near the corner of Pearl and Broad Streets, is famous as the place where Washington bade farewell to his officers, December 4, 1783. The collection of old pictures and historic relics gathered here will gain in interest by the associations connected with the place.

Another building dating from colonial times is that formerly known as the Morris Mansion, or the Jumel Mansion. This fine old residence was built about 1760 and it was here that Washington established his headquarters during the military operations on the upper part of Manhattan Island. The building is now the property of the City of New York, and is under the care of the Daughters of the American Revolution (State of New York), who have brought together a very interesting collection of mementoes of the Revolution.

The Van Cortlandt Mansion, erected about 1748, is a fine and characteristic specimen of the colonial style of architecture, and will contain a valuable collection of portraits of men who played a leading part in the Revolution. This building is cared for by the Colonial Dames of the State of New York.

The Aquarium building in Battery Park was originally erected, in 1807, as a fort, and was named Fort Clinton in 1812. Many years later it was transformed into a theater and concert hall, under the name of Castle Garden. There are some still living who can recall the wild enthusiasm evoked by the "Swedish nightingale," Jenny Lind, when she made her first appearance before an American audience in this building. In 1855 a new use was found for Castle Garden and it became the goal of an immense host of immigrants, 7,690,606 passing through its portals in the period from 1855 to 1890.

One of the interesting exercises connected with the celebration will be the dedication of the Memorial Arch erected by the Daughters of the American Revolution in the Stony Point Battlefield State Reservation. The ceremonies will take place on Saturday, October 2. The governor of the state and many prominent citizens, as well as a number of military and civic organizations, will be present. The National Scenic Preservation Society, the official custodian of the reservation, will cooperate in the formal exercises.

On Wednesday, September 29, at 4 P.M., the American Scenic and Historic Preservation Society will dedicate the tablet erected through the generosity of Mr. Cornelius K. G. Billings, on the site of Fort Tryon,

on Fort Washington Avenue. This fort was gallantly defended on November 16, 1776, by the Maryland and Virginia Regiment, against the attack of the Hessian troops.

The following dedications have also been officially recognized by the commission: On Wednesday, September 29, the City Wall Bastion Tablet, at No. 48 Wall Street, New York, marking the site of a bastion in the old city wall to be dedicated by the Society of Colonial Wars in the State of New York; the Fort Amsterdam Tablet placed on the United States Custom House in New York City, marking the site of Fort Amsterdam, dedicated by the New York Society of the Founders and Patriots of America. On Monday, September 27, the Palisades Interstate Park, extending for thirty miles along the western shore of the Hudson River, from Fort Lee, N. Y., to Piermont, N. Y., will be dedicated by the commissioners of the Interstate Palisades Park. The date for the dedication of the bust of Verrazzano, the Italian navigator who visited New York Harbor in 1524, has not yet been selected by the Italian societies which have donated it to the city.

Aquatic sports will be the order of the day on Wednesday, September 29, when boat races will be held on the Hudson River, the boats being manned from the crews of the foreign and American warships. There will also be interstate contests between members of the Naval Reserves from different states, canoe races and motor-boat races. At Yonkers, on the same day, high-power motor-boats will compete, and there will be boat races between various amateur crews from clubs.

The astonishing progress in aeronautics during the past year has excited public interest to the highest pitch, and the celebration commission is making every effort to assure the presence of some of the leading aeronauts and aviators. While the arrangements for this branch of the celebration are not fully completed at the time of writing, the public will certainly be given an opportunity to see many types of dirigibles and aeroplanes, and some sensational flights will be made. If the weather conditions are favorable, the aeronautical exhibitions will begin on Monday, September 27.

In organizing the various parades and exercises, the celebration commission has not forgotten the children of our city, for whom special festivals will be held, on Saturday, October 2, at fifty different centers. There will be games, historical plays, folk-dances, etc., given by thousands of children from the public schools, and accommodations will be provided for a half million children to witness the spectacles.

The close of the celebration in all its phases will be marked by a chain of immense beacon-fires lighted on mountain tops and heights from Staten Island to the head of navigation on Saturday evening, October 9. All these beacons will be connected by electric wires and will be lighted simultaneously by President Taft. The beacons are made of peat with chemicals, so that they will burn even if it rains.

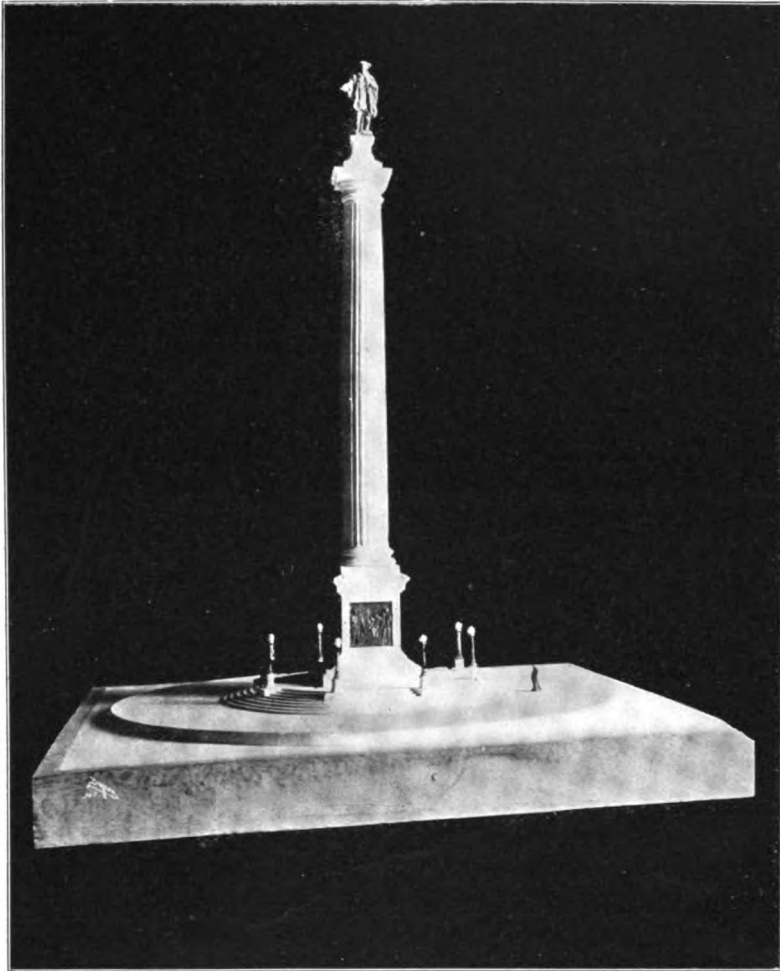

HENRY HUDSON MONUMENT. To be erected on Spuyten Duyvil by popular subscription at a cost of \$100,000, and to be dedicated as a part of the official program of the Hudson-Fulton Celebration. This monument is by Karl Bitter and Schrady, is 110 feet high and will stand on an elevation of two hundred feet above the water, being visible for many miles above the Hudson River and from Long Island Sound.

A special two-cent stamp to commemorate the Hudson-Fulton Celebration has been issued by the Post Office Department. The background of the design shows the Palisades, with the *Half Moon* sailing up the Hudson River, and the *Clermont* steaming in the opposite direction; in the foreground is an Indian in a canoe, and another canoe manned by four Indians can just be discerned in the distance. The commission has to thank Congressman Bennett and his colleagues, Congressmen Parsons and Olcott, for their successful efforts in securing the consent of the Postmaster General to the issue of these stamps, of which fifty million will be printed.

THE ORIGIN OF THE NERVOUS SYSTEM AND ITS
APPROPRIATION OF EFFECTORS

By G. H. PARKER

PROFESSOR OF ZOOLOGY, HARVARD UNIVERSITY

IV. THE APPROPRIATION OF EFFECTORS

IN the preceding articles in this series the origin and development of the neuromuscular mechanism has been broadly sketched in a succession of representative stages. The first stage was that of the independent effector, the muscle which was brought into action by the direct influence of environmental changes as seen in the pore sphincters of sponges. The second stage was that of the combined receptor and effector in which the receptors, in the form of diffuse sensory epithelia or specialized sense-organs, served as delicate triggers to set the muscles in action and thereby render the effectors responsive to a wider range of stimuli than they would be under independent stimulation. Finally, the third stage is seen in the complete neuromuscular mechanism in which a central nervous organ or adjustor has developed between the receptors and the effectors. This adjustor serves as a switchboard for nervous transmission and a repository for the effects of nervous activities.

This line of progressive differentiation from the muscle to the complete nervous system is complicated by the fact that in the more complete examples of the third stage the nervous system is found connected not only with such effectors as muscles, but with electric organs, chromatophores, glands, luminous organs, etc. If the history of the growth of the neuromuscular mechanism as it has been sketched in these articles is a correct one, the effectors just named must be regarded in the light of relatively recent acquisitions and in my opinion they illustrate an invasion and appropriation on the part of the nervous system of territory that was not originally under its control. This principle of appropriation results not only in the acquisition of totally new forms of effectors such as glands, etc., but also in gaining control over independently and newly developed muscles. Examples of this kind will be taken up first in discussing this question of nervous appropriation.

The differentiation of the central nervous organs is in large part a process that goes on hand in hand with the differentiation of the muscles. This is well seen not only in the higher invertebrates, but also in the vertebrates. The differentiation of a single muscle into a group of muscles and the consequent and corresponding changes in the nerv-

ous relations, both central and peripheral, are too well known to require comment. To this process must be added, I believe, the appropriation of totally new muscles. There is good reason to assume that the heart-beat in tunicates is of myogenic origin and the fact that the embryonic vertebrate heart pulses before it contains any nervous elements is strong evidence in favor of the view that the cardiac muscle of the primitive vertebrate was a muscle developed independently of nervous control. That that muscle in modern adult vertebrates is under a certain amount of nervous control is unquestionable, but this control is not of the kind usually seen in other neuromuscular combinations. The nerves that enter the heart are probably not ordinarily directly concerned with its beat, for, as already pointed out, this continues after they are cut. The function of these nerves seems to be that of modifying this beat and in this respect two classes of fibers may be distinguished: augmentors which increase the beat, and inhibitors which retard or even check it. This whole nervous mechanism has the appearance of having been superimposed upon a muscle that was originally non-nervously active, and I therefore regard the vertebrate heart as an example of an originally independent muscle secondarily brought under the influence of central nervous organs. Many other muscles, like the sphincter pupillæ, etc., have doubtless had a like history, but as they have not been investigated from this standpoint, the question of their exact relations to nervous control must remain for the present somewhat open.

In the vertebrates at least, nervous effectors include not only muscles, but also electric organs. These organs occur not infrequently among the fishes. They are best represented in the South American electric eel, the electric catfish of Africa and the torpedoes of the Mediterranean Sea and the Atlantic and Indian Oceans. They also occur less fully developed in certain skates, mormyres and the star-gazer. These organs are usually imbedded in a mass of the fish's muscle or they occupy such positions that they clearly replace muscles. Their histogenesis, as worked out particularly in the skates by Ewart (1888), shows conclusively that each electric plate is a modified muscle-fiber and in fact there seems to be good reason to conclude that all known electric organs, excepting possibly those of the electric catfish, are modified muscles. This is entirely consistent with what is known of the physiology of these two kinds of effectors, for muscles not only move parts, but generate through their activity a certain amount of electricity, while the electric organs have lost the power of producing molar movements and have enormously increased that of producing electricity. Electric organs, though often described as a special class of effectors, are in reality merely modified muscles and therefore can not be regarded properly as a new appropriation of the nervous system.

The chromatophores, on the other hand, are effectors which are in no sense derived from muscles. These organs enable many animals to make relatively sudden changes in their external coloration, and though they are present in many animals, they are most perfectly developed in the arthropods, mollusks and vertebrates. They are also present in

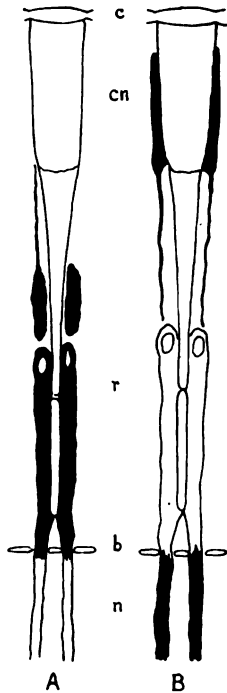

FIG. 1. TWO ELEMENTS FROM THE COMPOUND EYE OF A SHRIMP, showing the distribution of pigment in the light (A) and in the dark (B). b, basement membrane; c, cuticula; cn, cone; n, nerve-fiber; r, reticular cell.

the more complex types of eyes, where their movements serve to protect the receptive elements from exposure to excessive light or to open them to the full effects of dim light. The investigation of these organs dates from comparatively recent times and van Rynberk (1906), who has recently summarized our information about them, has shown that the accounts already given are in many respects contradictory. Hence what I shall have to say I shall draw mostly from those fields with which I am somewhat acquainted at first hand.

That some chromatophores are completely independent of nervous control even though they are most intimately associated with nervous mechanisms is well attested. The deeper part of the compound eye in the shrimp, *Palaemonetes*, contains a layer of cells, the reticular cells (Fig. 1), which though they carry rhabdomes and end proximally in nerve-fibers and are therefore unquestionably sensory cells, contain many dark pigment-granules which change positions in accordance with the illumination. From this standpoint these cells are true chromatophores. In an eye exposed to the light the pigment-granules occupy distal positions in these cells; in one in the dark they come to lie in proximal positions. The place occupied by the pigment in a given eye is entirely determined by the presence or absence of light in that eye, for the two eyes have no sympathetic relations. Moreover if a persistent shadow is cast on part of one eye, the condition characteristic for the dark is assumed by that part even though the pigment in the rest of the eye is in the position characteristic for light. These observations show the physiological independence of the chromatophores in different parts of the eye. These organs, though connected by nerve-fibers with the central nervous organs, are also in their action independent of such parts, for the movements of their pigment from the dark to the light position and the reverse go on in an essentially normal way even after these connections have been cut. Chromatophores then may carry out under direct stimulation somewhat complicated pigment-migrations in

intimate relations to the successful action of such an organ as an eye, and yet with complete independence of central-nervous control.

Other chromatophores, like those in the skin of lizards, can be as clearly demonstrated to be under the control of nerves as those in the eyes of *Palæmonetes* have been shown to be free from this control. The integumentary color changes in lizards are often extremely complicated processes, especially in such forms as the chameleon, but they include as a fundamental principle the inward and outward migration of dark pigment-granules within certain large unicellular chromatophores (Fig. 2). When these pigment-granules pass out into the processes of the chromatophores, they give to the surface of the lizard a dark or even black aspect. When they migrate inward to the body of the chro-

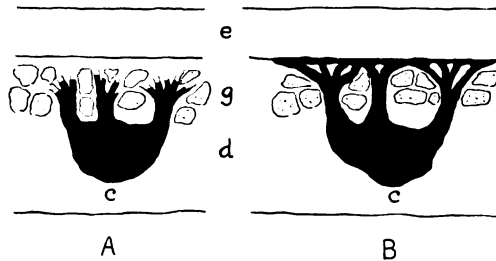

FIG. 2. TWO CHROMATOPIORES FROM THE SKIN OF A LIZARD, showing the condition due to the dark (A) and to the light (B). c, chromatophore; d, derma; e, epidermis; g, irregular masses of ground color.

matophore, which is often hidden in pigment masses of some particular color, they thus allow the ground-color behind them to assert itself. By this simple inward and outward migration of the pigment, the chief change in the color differences of the lizard's skin is accomplished. The question that we have to consider is to what extent these changes are controlled by the central nervous organs.

The inward and outward migration of the pigment of the chromatophores is well seen in the skin of the so-called Florida chameleon, *Anolis*. According to Carlton (1903), who has studied this animal with care, the passive state in its chromatophores is that in which their pigment is gathered together in the cell-bodies. This state is brought about when the lizard is removed from the stimulating effect of light, when the blood and nerve supply of a given region are cut off, when the animal is etherized, or when it dies. In fact any change that might be expected to interfere with nervous activity calls forth this condition. Since nicotine is a poison for the sympathetic nervous system, rendering it temporarily inactive, and since the inward migration of the chromatophoral pigment is immediately produced on injecting a very small amount of nicotine into the *Anolis*, it is probable that the reverse process, the outward migration, is dependent upon the normal action of

these poisoned parts, the sympathetic nerves. For these reasons I believe that in *Anolis* the inward migration is a process which is ordinarily under the control of the chromatophore itself and that the outward migration, which takes place all over the animal when even only a small spot in the skin is illuminated (Parker and Starratt, 1905), is dependent upon the action of sympathetic nerves.

In the true *Chameleon*, as Brücke (1852) and many others have demonstrated, precisely the reverse is true; the outward migration is independent of nerves and the inward migration is produced by them. Moreover, judging from the results of experiments on the spinal cord, the nerves which in *Chameleon* are concerned with these changes are not sympathetic nerves, but spinal nerves.

These differences between *Anolis* and *Chameleon* I believe to be well founded. In my opinion both animals have descended from a stock in which the chromatophores were entirely independent of nervous control and in the process of descent the chromatophores of different lines became separately appropriated as effectors of the nervous system. In the ancestors of *Anolis* the sympathetic nervous system became related to the outward migration of pigment; and in those of the *Chameleon* the spinal system associated itself with the inward migration. The fact that *Chameleon* and *Anolis* belong not only to separate families, but to separate suborders of lizards, rather emphasizes this view than otherwise.

Such instances as the independent retinal chromatophores of *Palæmonetes* and the nervously dependent chromatophores of *Chameleon* and *Anolis* lead me to believe that chromatophores are effectors evolved independently of nervous control, but in some cases secondarily appropriated as nervous end-organs.

What has been said of chromatophores so far as their relation to nerves is concerned is probably also true of glands. The majority of glands are unquestionably independent of direct nervous control. In almost all instances a blood supply is essential to the action of a gland, and as this can be controlled by nerves there is thus an indirect influence of the nervous system on the action of the gland, but this nervous control over the blood supply is very different from a direct nervous control over secretion. I know of no good reason to assume that nerves have any direct influence on the secretions of the kidneys, the liver or even the pancreas. The pancreatic juice which appears with such precision on the arrival of food in the small intestine has been shown by Bayliss and Starling (1904) to be secreted not through the action of nerves on the gland, but through the action of a substance, secretin, produced by the food in the intestine and carried by the blood to the gland. If into the blood of a fasting animal whose nerves to the pancreas have been cut a small amount of secretin is injected, the pancreas will begin to produce its characteristic secretion.

Although most glands are not under direct nervous control, some are as completely under this control as the majority of muscles are. The best examples of this condition are the sweat glands and the salivary glands. The fact that when the nerves supplied to the salivary gland are stimulated, secretion may take place at a pressure higher than that of the blood supplied to the gland shows conclusively that the production of saliva is not a simple organic filtration process, but is dependent upon action called forth in the secretory cells by a nervous impulse. This view gains additional support from the fact that in the salivary glands nerve fibers have been found to end in connection with the secretory cells. There is therefore every reason to believe that the salivary glands, and the same may be said of the sweat glands, are organs whose secretions are directly controlled by nerves.

As these several examples show, some glands are completely under the control of nerves and others are not. In my opinion the latter represent the primitive state of this form of effector and the former the condition after such organs have been appropriated by the developing nervous system.

Luminous or phosphorescent organs afford another class of effectors which have probably originated independently and fallen secondarily under the influence of the nervous system. These organs, however, have been studied so imperfectly that it is at present difficult if not impossible to get satisfactory evidence as to their exact condition. Some animals have been supposed to possess phosphorescent organs when in reality their luminosity was due entirely to reflection; others like certain earthworms were found to be phosphorescent because their slime contained photogenic bacteria. But aside from these spurious cases there is an abundant range of truly phosphorescent animals, examples of which occur from protozoans to vertebrates. One peculiarity in their distribution is that true phosphorescent animals are not found in fresh water; they are either marine or air-inhabiting.

In all cases where animal phosphorescence has been examined with care, it seems to be dependent upon the production of a special substance by the light-producing cells. This substance is not in the nature of a living, structurally organized material like muscle, for it can be crushed into a paste and still show light. Moreover, Bongardt (1903) dried the phosphorescent organ of a common firefly over calcium chloride and then kept it in a sealed tube from July 16, 1901, till August 3, 1902, a period of over a year. After this the tube was opened and the organ wet with distilled water; in twelve minutes it glowed so that it could be seen at a distance of two meters. Evidence of this kind supports the view that the phosphorescent substance is not living but rather formed material, such as a secretion, and resembles in this respect pepsin or trypsin.

If phosphorescent organs produce a substance essentially a secretion to which their characteristic activity is due, they might without impropriety be classed as glands, but if they are thus classed, it must be remembered that the majority of them are so placed that they have no access to cavities or the exterior; hence they would be in the nature of ductless glands. In one respect, however, they differ even from ductless glands; the substance that they produce is not carried away from them even by the blood-stream but is used locally for the production of light. Hence though phosphorescent organs may be in many important respects like glands, they differ in certain ways from all ordinary glands.

Whether phosphorescent organs are under the control of nerves or not is a question of some uncertainty. The fact that many highly specialized phosphorescent organs have a rich innervation indicates that they are under nervous influence, but even this may be of the indirect kind such as has already been indicated for glands and not a direct control. In *ctenophores* Peters (1905) has shown that a few paddle-plates will glow on mechanical stimulation precisely as the rows of plates in the normal animals do. He has also shown that the primitive nervous system of these animals plays no direct part in this phosphorescence. This instance seems to me to be a perfectly clear case of phosphorescence not under the control of nerves, though in an animal with a nervous mechanism.

In the common firefly the relations are not so well understood. Thus Bongardt (1903), though he describes an intimate nervous plexus in the luminous organ of this animal, believes that its rhythmic photogenic activity is not under even indirect nervous control. He maintains, on what, however, is not really strong experimental evidence, that the firefly can not extinguish its light through nervous action and he believes that the phosphorescent rhythm is due to totally different factors. This case merely shows the fragmentary nature of our knowledge of this phenomenon even in so well-known an example as the firefly.

As a good instance of nervous control over phosphorescence the brittlestar, *Ophiopsila*, recently studied by Mangold (1907), may be quoted. On mechanical stimulation the ventral surfaces of the arms of this animal glow for a short time. The phosphorescence begins in the stimulated part and, if this be an arm, it may spread over this arm to the disk and thence to the other arms. The course that it follows is that of the radial and circular nerve-strands. If any of these are interrupted by being cut, the phosphorescence does not pass beyond the cut, thus showing that it is probably controlled by the nerve.

These instances, few and confessedly fragmentary as they are, indicate that phosphorescent organs, though in many important respects like glands, are in reality a separate class of effectors and that in some

instances their action is independent of nervous control, while in others it is under this control. In my opinion the instances of independent action represent a primitive state; the others a condition brought about through the appropriation of these organs as end-organs by a developing nervous system.

If what has been stated in this article is correct, we must picture to ourselves as steps in the evolution of the nervous system not only the independent origin of muscle around which the nervous organs subsequently develop, but also the independent origin of other effectors such as chromatophores, glands and phosphorescent organs and the secondary appropriation of many of these by a developing nervous system. This principle of appropriation I believe to be as significant in elucidating the present condition of the nervous system and its appendages, as the principle of evolutionary sequence of parts, muscle, sense organ, and central nervous organ, as given in the first three articles.

REFERENCES

- BAYLISS, W. M., and E. H. STARLING.
1904. The Chemical Regulation of the Secretory Process. *Proc. Roy. Soc.*, London, vol. 73, pp. 310-322.
- BONGARDT, J.
1903. Beiträge zur Kenntnis der Leuchtorgane einheimischer Lampyriden. *Zeitschr. wiss. Zool.*, Bd. 65, pp. 1-45, 3 Taf.
- BRÜCKE, E.
1852. Untersuchungen ueber den Farbenwechsel des afrikanischen Chamaeleons. *Denkschr. Akad. Wiss., Wien, math.-naturw. Cl.*, Bd. 4, 34 pp., 1 Taf.
- CARLTON, F. C.
1903. The Color Changes in the Skin of the so-called Florida Chameleon, *Anolis carolinensis* Cuv. *Proc. Amer. Acad. Arts and Sci.*, vol. 39, pp. 259-276, 1 pl.
- EWART, J. C.
1888. The Electric Organs of the Skate. On the Development of the Electric Organs of *Raja batis*. *Phil. Trans. Roy. Soc.*, London, B, vol. 179, pp. 399-416, pls. 66-68.
- MANGOLD, E.
1907. Leuchtende Schlangensterne und die Flimmerbewegung bei *Ophiopsila*. *Arch. ges. Physiol.*, Bd. 118, pp. 613-640.
- PARKER, G. H.
1897. Photomechanical Changes in the Retinal Pigment Cells of *Palæmonetes*, and their Relation to the Central Nervous System. *Bull. Mus. Comp. Zool.*, vol. 30, pp. 275-300, 1 pl.
- PARKER, G. H., and S. A. STABBATT.
1905. Color Changes in *Anolis*. *Science*, n. ser., vol. 21, p. 381.
- PETERS, A. W.
1905. Phosphorescence in Ctenophores. *Journ. Exp. Zool.*, vol. 2, p. 103-116.
- VAN RYNBERG, G.
1906. Ueber den durch Chromatophoren bedingten Farbenwechsel der Tiere. *Ergeb. Physiol.*, Jahrg. 5, Abt. 1 and 2, pp. 347-571.

THE SERVICE OF ZOOLOGY TO INTELLECTUAL PROGRESS¹

BY PROFESSOR WILLIAM A. LOCY
NORTHWESTERN UNIVERSITY

UNDOUBTEDLY the progress of zoology has played an important part in the intellectual development of civilized mankind, but the way in which it has moulded thought is but vaguely appreciated by most people. On that account it is my purpose to discuss the question of the service of zoology to intellectual progress.

We speak of the intellectual development of civilized mankind, meaning thereby the general level of mental development that any people has attained; and we observe that the circumstance that chiefly sets one people on a pinnacle higher than another people is their degree of intellectual development.

There is nothing that affects us all more closely than that our young people should learn to think straight, and that they should ally themselves with the thought of their time, and take part in it, because this mental life of ours is remaking for us our ideas of the universe in which we live. It is not peopling it with phantasies and dreams so much as with realities. There was never a time before when realities were so carefully sought after.

If we look into history we shall see that there has been a ruling power in the mental life of different peoples characteristic of every age, such as the mental devotion of the Romans to law and government, of the Greeks to art and philosophical disquisitions, of the people of the middle ages to mystical metaphysics and theological dogma, and so on.

Let us now ask: "What is the dominant note in intellectual life to-day?" Is it not a greater care to determine the truth? Is it not the investigating spirit? Is it not that spirit which we may designate generically as the scientific spirit? Perhaps great material prosperity is the most evident aspect of life to-day, but in the mental sphere there is certainly a disposition to analyze, to experiment and to arrive at conclusions by the method of observation and reasoning.

This situation is very different from the one from which the civilized world has recently emerged. A former state prevailed in which authority was declared to be the source of knowledge. In the sixteenth century, and earlier, men believed things not because they could be shown to be true, but because some one had said they were true. In order to crush out dissent the authority for a certain statement was quoted, and the authority cited was usually one of the ancient writers.

¹The annual address before the Iowa State Academy of Science, April 30, 1909.

The Revival of Learning.—But the human mind, ever restive to discover the relation between causes and effects in the production of natural phenomena, would not permanently brook this restraint. The minds of the more energetic and independent thinkers revolted against the reign of authority, and, under the leadership of such minds, there began a reform that is known to us all under the title of the revival of learning, a reform of wide extent and of great importance to the human race. I wish to take a few minutes to point out that the essence of this reform consisted in a change in the method of the pursuit of knowledge.

This so-called revival of learning affords a striking illustration of how a change in mental interests may have great consequences for those who engage in it. Let us first picture to ourselves the fruits of the mental life of the middle ages, and then contrast this with the results of the changed method of ascertaining truth introduced at the time of the revival of learning.

It is an old, oft-repeated story, how with the overthrow of ancient civilization the torch of learning was nearly extinguished. Not only was there a complete political revolution; there was also a complete change in the mental interests of mankind. The situation was complex, and it is true that there were many influences at work, but the extinction of all scientific activity which occurred at this time was due to a complete arrest of inquiry into the phenomena of nature. The physicist no longer experimented, the naturalist no longer sought for relation and causes in living beings.

One circumstance that played a considerable part in the cessation of scientific investigation at this time was the rise of the christian church and the dominance of the priesthood in intellectual as well as in spiritual life. The world-shunning spirit, so scrupulously cultivated by the early christians, promoted a spirit that was hostile to observation. The behest to shun the world was acted upon too literally. The eyes were closed to nature and the mind was directed towards spiritual matters, which truly seemed of higher importance. Presently the observation of nature came to be looked upon as proceeding from a prying and impious curiosity—as an attempt to search out the concealments of the Almighty.

Books were scarce, schools of philosophy were reduced, and any general dissemination of learning ceased. The priests who had access to the books assumed the direction of intellectual life. But they were largely employed with the analysis of the supernatural, and without the wholesome checks of observation and experiment, mystical explanations were invented for natural phenomena, while metaphysical speculation became the dominant form of mental activity.

Authority declared the Source of Knowledge.—In this atmosphere free inquiry could not live, controversies over trivial points were en-

gendered and the ancient writings were quoted as sustaining one side or the other. All this led to referring questions as to their truth or error to authority as the source of knowledge, and resulted in a complete eclipse of the reason.

This was a barren period, not only for science, but also, curiously enough, for those studies which were especially engaged in. Notwithstanding the fact that for more than a thousand years all the new works were written by theologians, there was no substantial advance in their field of learning, and the reflection comes to us that the reciprocal action of free inquiry is an essential condition for the growth of any department of learning.

We should remember that the mental life of the Middle Ages was active. It is a mistake to suppose that men of those times differed much in their mental powers from those of to-day. The medieval philosophers were masters of the metaphysical method of argument, and their ingenuity and mental alertness were great. The principal thing that held progress in check was the method of setting about to ascertain truth.

Renewal of Observation.—It was an epoch of great importance, therefore, when men began again to observe, and to attempt, even in an unskilful way, hampered by intellectual inheritance and habit, to unravel the mysteries of nature and to trace the relation between causes and effects in the universe. The new movement was, as previously said, a revolt of the intellect against existing conditions. In this movement were embraced all the benefits that have resulted from the development of modern science. The invention of printing, the voyages of mariners, the growth of universities, all helped in a general way, but just as the pause in science a thousand years or more earlier had been owing to the turning away from nature and to new mental interests, so the revival was a return to nature and to the method of science.

The Widening Horizon.—The reign of authority in intellectual matters lasted for twelve centuries, and then gave way gradually to the reign of observation and reason. Under the influence of the new method we have been moving generation by generation into a state of clearer discernment and into an intellectual atmosphere of wider horizon.

There is an inspiration in this ever-widening horizon. We must recognize, I think, that there has been a reconstructive force accompanying scientific progress. Wherever traditional opinion has been uprooted something more helpful to humanity has been planted. When rightly understood, we see that this freer life of thought has been constructive and helpful, not merely iconoclastic. Man has once again taken his high place in the world as the interpreter of nature, and as investigation widens his comprehension of the laws of natural phe-

nomena, he is extending his control in the sphere of nature and turning natural forces to his advantage.

The Study of Nature.—I now turn to another phase of the subject, viz. : to a consideration of the effect upon mental life of advances in the knowledge of natural phenomena. Let us, if possible, catch a glimpse of the edifice that has been built upon the foundation since the early naturalists broke ground and began operations.

One of the most notable things of the last half century has been the mental evolution produced by the great extension of knowledge of organic nature. This more intimate acquaintance with natural phenomena, and of living nature in particular, has altered our way of looking at the world, and especially of our relation to it. The whole fabric of thinking has been so profoundly changed by the biological advances to which I refer that all educated people ought to make themselves acquainted with the generalizations of biology and with the foundations upon which they rest. This science is not a remote branch of learning; it touches every-day life at many points, and affects our well-being more closely than is generally realized.

The study of nature and the explanation of natural phenomena possess an inherent interest to which most minds respond. The physicist and chemist have for their territory the field of inorganic nature, but the biologist has the advantage of dealing with the living world. There is, in reality, nothing in the sphere of knowledge more fascinating than the study of life. Any reference to the part that bacteria play in the world awakens a responsive interest. References to the doctrine of evolution, and the light it throws on the origin of the human body as well as on the races of animals, arouse attention. The teachings of science in reference to the life of the globe have awakened wonder, sometimes dissent, but always interest.

Zoology the Central Subject.—Now the kind of knowledge to which I am referring belongs to the domain of biology, and in that domain zoology is the central subject. Many people think of zoology as it was in the time of Linnæus, or, at best, as it was in the early part of the nineteenth century, when the spiritless activity of species-making was its prominent feature. It is no longer merely a mass of knowledge that enables its devotees to name animals and to arrange systematically a cabinet. Zoology of to-day is vastly different; it has become one of the leading departments of science. While dealing with the structure, the development and the evolution of animal life, it at the same time brings one into contact with those changes in human opinion for which its own advances have been largely responsible.

From the group of the natural sciences there emerges into prominent place the princely science of zoology. As was said before, it is the central subject in all that advance in the knowledge of organic nature to which reference has been made. It is best fitted, it seems to me, to give

to the students in our colleges and universities an idea of the results of the activity of the nature seekers. Its sister science, botany, which runs parallel to it, deals with similar phenomena in plants. Still, it is only among animals that we find nervous responses tolerably well developed. The presence of a nervous system in animals in connection with a highly developed state of other organs affords a more comprehensive picture of vital activity. If I seem, in this statement, to show bias, it should be set down to the circumstance that my activities for some years have been taken up mainly with the study of animal life.

The observations in zoology, as carried on to-day, are so illuminating and have such important bearings that we can see why it is that all over the civilized world it has been given such a prominent place in universities and colleges. We begin to understand why great buildings are constructed for its laboratories, and why a number of men in one faculty represent different phases of zoological investigation. This is why in the State University of Iowa, as in other similar institutions, zoology has come to occupy a prominent and an honored place in the curriculum of studies.

It is the ideas of this science woven into the fabric of human thought which I have in mind, rather than merely its details. Dis-jointed fragments of knowledge are of little worth; they must be combined into a unity before they have much meaning. Isolated facts should be treated as merely specific illustrations of broad truths. The study of one stone in an edifice as to its chemical analysis, its resistance to strain and crushing weight, and its microscopic structure, will not give us an idea of the edifice as a whole. Thus it is that after our students have observed and experimented in the laboratory they must, under the guidance of the lecturer, be brought to see the relation of their specific observations to zoology as a science.

It is owing largely to advances in zoology that we are enabled to formulate theories about the world, the history of living beings on it, and the part they play in the scheme of nature. It is owing to the intellectual progress that zoology has chiefly promoted that we have been able to comprehend the structure of the human body and thereby to discern the means of promoting its well being and assisting in its care.

It is owing chiefly to the advances supplied by the study of zoology that one can adequately appreciate the soliloquy that Shakespeare puts in the mouth of Hamlet: "What a piece of work is man! how noble in reason! how infinite in faculty! in form and moving how express and admirable! in action how like an angel! in apprehension how like a god! the beauty of the world! the paragon of animals!"

His structure and his development excite in the mind of the anatomist the same measure of admiration and wonder. And we observe in passing that the most discerning anatomists are the comparative anatomists of zoology.

The Growth of Zoology.—Let us now look at some general phases in the growth of zoology. In its first stages of growth we find a period devoted to descriptions. In the time of Linnæus, for illustration, emphasis was placed on collecting, describing and systematically arranging all the different kinds of animals. This resulted in giving naturalists a knowledge of the form and appearance of the chief animals that inhabit the globe, and formed the basis upon which further progress could be made.

We can not, however, reach general conclusions without the examination of many facts, and there was naturally a long period devoted merely to the accumulation of facts about animals.

The next great step in advance was that of comparison. The contrast between description and comparison is brought out so clearly by I. P. Whipple in his essay on Louis Agassiz that I quote from it. He says:

My first impression of the genius of Agassiz was gained when he was in the full vigor of his mental and physical powers. Some thirty-five years ago (now sixty-five years), at a meeting of a literary and scientific club of which I happened to be a member, a discussion sprang up concerning Dr. Hitchcock's book on fossil "Bird-tracks," and plates were exhibited representing his geological discoveries. After much time had been consumed in describing the bird-tracks as isolated phenomena, and in lavishing compliments on Dr. Hitchcock, a man suddenly rose, who, in five minutes, dominated the whole assembly. He was, he said, much interested in the specimens before them, and he would add that he thought highly of Dr. Hitchcock's book, as far as it accurately described the curious and interesting facts he had unearthed; but, he added, the defect in Dr. Hitchcock's volume is this, that it is "dees-creep-teeve," and not "com-par-a-teeve." It was evident throughout that the native language of the critic was French, and that he found some difficulty in forcing his thoughts into English words, but I can never forget the intense emphasis he put on the words "descriptive" and "comparative," and by this emphasis flashing into the minds of the whole company the difference between an enumeration of strange, unexplained facts and the same facts as interpreted and put into relation with other facts more generally known.

The moment he contrasted "dees-creep-teeve" with "com-par-a-teeve" one felt the vast gulf that yawned between mere scientific observation and scientific intelligence, between eyesight and insight, between minds that doggedly perceive and describe and minds that instinctively compare and combine.

The descriptive and comparative stages in zoology, of course, overlapped. It was in the early part of the nineteenth century that Cuvier, the great French zoologist and legislator, founded the science of comparative anatomy, and this brought the comparative method into the study of zoology. The beneficent results of this were notable, and zoological knowledge broadened and deepened.

In the last part of the nineteenth century zoologists added another method to the investigation of animal life; they began to study processes by the experimental method. This was not merely the extension of physiology into zoology. The new method involved experiments upon

the development of the embryo and sought to trace the modifications resulting from changes in the conditions of growth and development. It opened the way to those extensive experiments on regulation that have been engaged in by some of our American zoologists. Experiments were further extended to the study of heredity and evolution.

Thus description, comparison and experiment, came to mark different phases in the progress of zoology. Certain other nineteenth century advances can be merely alluded to. Those that had the greatest influence on the progress of zoology were the establishment of the cell theory, the discovery of protoplasm and the acceptance of the doctrine of organic evolution. If time permitted, a fuller consideration of these great events in the history of zoological science might be profitable, but I must hasten to another division of the subject.

The Idea of Service.—In these days we have come to estimate the worth of achievements in the terms of service. We hear on every hand the inquiry, How is this man or that man fitted to serve his time and generation? When inquiries come to the universities regarding one of their graduates seeking place in the world, the chief inquiry is, what is his promise of service? We do not always mean by this the narrow idea of direct utility—the faculty to make something that will sell—but more often that capacity for usefulness to the state and to society that depends on broad education, on discernment of essentials, that has been gained by freeing the mind from hereditary hindrances and from those grosser misunderstandings of natural phenomena that we class as superstitions. The university is a place where such basal training is carried on. The activity of the university is a crusade not only against ignorance, but also against superstition.

It is this kind of service for which the progress of science is especially conspicuous, and this brings us naturally to the consideration of the service of one science in particular. I wish to maintain that for the past century the progress of zoology has exercised a strong and wholesome influence upon the intellectual development of the race. The date of a century is an arbitrary limit, but the event I have in mind is the publication in 1809 of Lamarck's "Philosophie Zoologique," that contained the first comprehensive theory of organic evolution that has survived to the present day.

Very likely the idea is a novel one to many that the influence of zoology upon intellectual progress has been considerable. While one may not dissent from the proposition, he might very well wish to have it supported by specific illustrations.

Influence of Zoology on General Enlightenment.—Let us consider first the part this science has played in general enlightenment. Its influence has been great in clearing the atmosphere of thought, in dispelling clouds and in freeing the mind from the bonds of inherited prejudice and traditional superstition. At the beginning of the revival

of learning there were fantastic and grotesque misconceptions. The idea of the resurrection bone was one of these—the belief that in the body there was an indestructible bone that formed the nucleus of the resurrection body. This view was demonstrated to be untenable by Vesalius, the reformer of anatomy in the sixteenth century and the forerunner of the morphologists of zoology. Other points about the structure of man and animals, equally fantastic, were upheld, and against one who ventured to disbelieve in them the cry of heretic was raised. We may at first sight think that crude misunderstandings are harmless vagaries, but when viewed as to their consequences we see that this class of superstitions has led to intolerance and persecutions. As illustrations there come to mind the horrors of the inquisition, the cruel and harmful ideas of witchcraft, the brutal and wicked persecution of men and women for holding saner views than the majority of mankind of the part played by the Almighty in his universe. It is one of the blessings of progress that mankind has been relatively freed from persecutions of this nature. These grotesque beliefs and superstitions were dispelled by advances in the knowledge of the organization of animals. Wherever investigation in this territory prospered, it shed light and dispelled error.

From one point of view the fossil remains of extinct animals belong to the sphere of the zoologist, for the fossil animals were the ancestors of the living ones. It was two zoologists, Cuvier and Lamarck, that founded the science of paleontology, one that of the vertebrate series, and the other that of the invertebrate. When fossil bones were first unearthed they excited stupid wonder and amazement, and the most fantastic theories were proposed to account for them. They were regarded as bones of giants, as remains deposited by the deluge, etc., but finally were accepted as the remains of former races of animals and were turned to account as supplying an index to the past history of the earth. The constantly increasing collections of fossil remains of animals are enabling us to understand something of the momentous changes that have passed over the succession of animal forms that have lived upon the globe. The accounts of the discoveries of prehuman remains, connecting by gradations with races now living, are extending into remote periods our conception of the antiquity of man. These matters arouse interest and discussion, and the sweep of all these discoveries brings with it a widening of the horizon of human understanding. The historical relations of fossils have been established by a great number of talented observers. Without any disparagement to other men who have done notable work in this field, I mention but one, Henry F. Osborn, of New York, who is one of our most distinguished American zoologists. With the enormous collections at his disposal he has devoted himself with marked success to making out the relations of

fossil forms to living forms and he has succeeded in tracing the remote ancestry of a number of living races of mammals.

The Constancy of Nature.—As one great result of the investigations of the nature seekers, there was established a belief in the constancy of nature, and from the work of the zoologists in particular came the idea that all animal life is the result of one orderly progress. Animal organization leads up to the structure of the human body, and on this account there has always been a tender point in discussing the evidences as to man's place in nature.

This belief in the constancy of nature was a great step in intellectual development. In its broad application it means that the entire universe and all on it is the result of an orderly and well-directed progress. It leaves no room for the idea of chance. Remote ancestral man did not rise by chance from the animal series. The gill-clefts in the human embryo are not there by chance. Their presence has some significance, if haply we may find it. The great service of establishing the idea of orderly progress in nature is part of the heritage of work already done. The idea, in so far as it involves living and fossil forms of animals, is owing to the progress of zoology.

Some Practical Applications.—Let us now consider secondly some of the applications of zoological advances to the benefit of mankind. It was owing to the cooperation of botany and zoology that the germ theory of disease was established. The bacteria are, of course, plants. The method of studying their action on animals is zoological. There are also diseases produced by minute animal organisms, such as malaria or common fever and ague. As has long been known, this disease is due to an animal parasite that infects the red blood corpuscles. It is only within recent years, however, that the entire life history of these animal parasites has been made out. As you all know, part of their life cycle is passed in a certain kind of mosquito. The disease itself has been shown to be owing to bites of these mosquitoes, and this fact pointed out the way of avoiding malaria. The ingenious methods by means of which the propagation of mosquitoes is prevented has freed many malarious districts from pestilence. These discoveries opened the entire question of the transmission of disease by insects, and now, thanks to those brilliant observations and experiments in which some men sacrificed their lives, we know the entire life history of the microbe of yellow fever. We know it is transmitted by mosquito bites, and that disease can now be controlled. The Roman fever, once much dreaded by travelers, and the fever of the Campagna may be avoided. Thanks also to zoological studies, these diseases no longer strike in the dark. We can recognize their approach and avoid inoculation. The scourge of the sleeping sickness that attacks the people of the Congo district is due to an animal parasite. The terrible scourge of syphilis has recently been traced to a minute organism that is probably

animal. The recognition of these facts is the first step towards gaining control of the disease.

There are other larger animal parasites like trichina, the tape worm, the filaria of the blood, etc., the life history of which is due to zoologists. Some of us recollect that the most comprehensive treatment of these is due to Leuckart, a zoologist. His "Die Menschlichen Parasiten" is a piece of research in pure science. The phagocyte theory, with all its implications, was given to the world by a zoologist—Metchnikoff.

The study of cancer, trypanosomes, opsonins, etc., are being studied by zoologists as well as by medical men, and the work of the medical men with these subjects is chiefly by zoological methods.

Studies of animal behavior, so extensively carried on by zoologists, are reacting on psychology and lighting the way to new advances in that science. Those zoological studies on the wonderful architecture of the nervous system (to which some of your men in the state university have contributed) are bringing a knowledge of the mechanism of the brain, and throwing light on its normal processes and its disorders. Leading up through these studies and the inferences to be drawn from them, we arrive at the science of comparative psychology. Furthermore the study of localization of function in definite areas of the brain substance has opened the way to brain surgery.

The studies of heredity in animals embrace many practical hints to stock breeders and to medical men.

But we can not make a comprehensive list of the large number of practical applications that come from zoological investigation. The illustrations already given are sufficient to indicate that studies in pure science often become of the highest practical value. The practical applications will follow fast enough upon the heels of advancing knowledge. The essential thing, as well as the difficult thing, is, by research, to uncover the facts and to make the first demonstrations.

Encouragement of Scientific Research.—I wish to speak just a word in appreciation of the men who extend the boundaries of knowledge, and a word in favor of the encouragement of pure research. The investigators are necessarily somewhat removed from their fellows and, therefore, often misunderstood. Theirs is a career of intense application and sacrifice. Scientific knowledge is not advanced by happy guesses in moments of inspiration, but only by continuous and well directed effort. He who would wrest from nature her secrets must prepare for the struggle by long training and must follow his calling with intense devotion. Often must he forego the pleasure of social relaxation in order that the discoveries that he is nursing into being may not suffer. When his work is reaching a climax he leads a lonely existence.

The spirit that still animates men of this type is that so long ago exemplified by Agassiz. As Whipple says:

From him came the most notable of all the maxims which illustrate the disinterestedness of the chivalry of science. At the time he was absorbed in some minute investigations in a difficult department of zoology, he received a letter from the president of a lyceum at the West, offering him a large sum for a course of popular lectures on natural history. His answer was: "I can not afford to waste my time in making money." The words deserve to be printed in capitals; but Agassiz was innocently surprised that a sentiment very natural to him should have excited so much comment. He knew that scores of his brother scientists, American and European, would have used the words "afford" and "waste" in the same sense, had they been similarly interrupted in an investigation which promised to yield them a new fact or principle. Still the announcement from such an authority that there was a body of men in the United States who could not "*afford to waste time*" in making money had an immense effect. It convinced thousands of intelligent and opulent men of business, who had never before thought a moment of time devoted to the making of money could be wasted, that science meant something; and it made them liberal of their money when it was asked for scientific purposes. It did even more than this—it made them honor the men who were placed above the motives by which they themselves were ordinarily influenced.

Men of proved capacity who are willing to devote themselves to research will enter upon it with no selfish motives. They should be classed among the benefactors of mankind, engaged in a useful service. They should be encouraged by men of wealth, by state legislatures and by the establishment of endowments to provide the means of carrying on their researches. There are men of this kind in the State University of Iowa; to the citizens of the state I would say: "These men are a valuable asset to the state," and to the university authorities I would say: "Honor these men and encourage the pursuit of graduate studies under their direction." To any in the rising generation of students who have the internal leading to follow a career devoted to scientific investigation, if they are gifted and energetic, let them without hesitation enter upon this career. The compensations will be chiefly internal. Those who enter upon scientific investigation as a life work must forego certain material prizes in the world that await equally well-directed efforts in other lines of activity, but they will have other kinds of compensations—in living close to great truths, and realizing in their discoveries that thrill of the searcher when he has found, and after long years feeling the uplift of their occupation. Nevertheless, they must learn to renounce and not be embittered as Robert Louis Stevenson wrote in that little gem of composition on the attributes of men.

To be honest, to be kind, to earn a little and to spend a little less, to make upon the whole a family happier by his presence, to renounce when that shall be necessary and not be embittered, to keep a few friends, but these without capitulation, above all, on the same grim condition to keep friends with himself—here is a task for all that a man has of fortitude and delicacy.

The Doctrine of Organic Evolution.—The crowning service of zoology in extending the boundaries of human understanding is found, perhaps, in the doctrine of evolution. The great sweep of this doctrine

makes it one of the greatest acquisitions of human knowledge. There has been no point of intellectual vantage reached which is more inspiring. It is so comprehensive that it enters into all realms of thought. Weismann, as you all know one of its great representatives, expresses the opinion that "the theory of descent is the most progressive step that has been taken in the development of human knowledge" and he says further that this position "is justified, it seems to me, even by this fact alone: that the evolution idea is not merely a new light on the special region of the biological sciences, zoology and botany, but is of quite general importance. The conception of an evolution of life upon the earth reaches far beyond the bounds of any single science, and influences our whole realm of thought."

Its applications are helping man in the knowledge of himself and his destiny. Anything that throws light on man's history and his capabilities affects the question of his duty and his destiny. A prominent theologian (Bishop Creighton, of London) has said: "Religion means the knowledge of our destiny and the means of fulfilling it." I shall not attempt to qualify the statement, as I am not a theologian, but I will point out that progress in zoology has extended the knowledge of the history of man, and has thereby influenced our conception of his relation to the universe. I think these advances are helpful, and are supplying a safer and better basis for our education, our system of morals and our religion. For all these matters of so much importance must be brought into relation with the state of knowledge at different periods of the history of our race. This condition is necessary, it seems to me, to men who think, who read or who investigate.

There is still too often a disposition shown by platform and pulpit speakers to qualify, to antagonize and to belittle scientific advances. But let us open our hearts freely, without fear, to the extensions of truth and let us continue in the belief that the knowledge gained by investigation of nature will be helpful to all departments of human endeavor and aspiration. It is to be expected that the views first of the scholars and then of the great mass of humanity will be modified and will become harmonious with all present and all future advances in knowledge.

The present results of these advances will appeal differently to people according to their temperament and experience, but to many scientific men, like Darwin and Huxley, as well as to those of smaller place, the contemplation of it all is uplifting. We may well be drawn into sympathy with the great nature psalm and feel the beauty and force of those lines of poetry in which all nature is called upon to unite in praise of the Ruling Power that directs the forces of the universe. Inanimate nature, as well as all that is alive:

Mountains and all hills; fruitful trees and all cedars; beasts and all cattle; creeping things and flying fowls; kings of the earth and all people; princes and all judges of the earth; both young men and maidens, old men and children.

THE EMMANUEL MOVEMENT FROM A MEDICAL
VIEW-POINT

BY DR. HOMER GAGE

WORCESTER, MASS.

IN matters pertaining to the preservation of health, and the cure of disease, it is a fact of common observation that people in general, and educated people in particular, are very apt to seize eagerly upon every new theory or practise that is confidently announced as able to dispel their ills; and all the more eagerly if, in disregard of science and experience, it is strongly flavored with the mystical and miraculous.

The most remarkable modern instance is the extraordinary growth and acceptance of Eddyism, or so-called christian science, and so confident are its claims and so long its list of undisputed victories that they overshadow, and actually seem to make us forget, the real progress of medical science, which continues uninterruptedly, but without any such flourish of trumpets and beating of drums.

Let us remind ourselves for the moment that scientific investigation has established the presence in the world of certain poisons, whose effects on man have been carefully studied and can be confidently predicted, like strychnia, prussic acid, arsenic and opium; that it has furthermore discovered certain other poisons in the animal world, like the bacillus of tuberculosis, of anthrax, of cholera, of diphtheria, the plasmodium of malaria and the spirochæte of syphilis, equally poisonous to man with the mineral and vegetable poisons, and capable of producing equally definite and specific effects.

It may not have been part of the intent of creation that man should be harassed by the latter any more than by the former; but the conditions of life and of civilization have made us very vulnerable through our appetites. Intended or not, these specific causes of disease are here; and medical science has not only demonstrated their existence, but has further proved beyond cavil that by their isolation and exclusion the diseases which they cause may be limited, and even be prevented from spreading from person to person.

Scientific medicine has further shown that the vital parts of our bodies are subject to certain degenerative changes induced by exposure, by imprudent habits of eating and drinking, by unnatural modes of living, by inheritance, or simply by age itself. Such are the degenerations of the brain, the heart and blood vessels, the liver, pancreas and kidneys; conditions which are accompanied by demonstrable changes

in the structure of these organs, are often progressive in character, and usually incapable of repair.

There is, however, a third class of diseases, which medical science has thus far been unable to classify with the infections or the degenerations; nevertheless, very real and very common, to which it has applied the term functional disorders. These present no demonstrable organic lesion, and very many of them seem to have their origin in psychic rather than in physical causes.

It is from this latter class that the superstition and quackery of all ages have largely derived their support. To be sure, science is gradually invading even this field, and finding a physical basis for conditions which it has been hitherto unable to classify.

It is clear, however, to scientific men that there is a large class for which no physical basis is likely to be found, which will always be the subject of much philosophical speculation and mysticism. Of late, a most interesting attempt has been made to employ science, religion and hypnotic suggestion, under the guise of psychotherapy, in the study and treatment of these cases, and I thought that perhaps it would be interesting to look for a few moments at the so-called Emmanuel movement from a medical viewpoint.

The underlying principle of mind or faith healing is by no means new; it is probably as old as the race. It is the same principle that underlay the sacrificial offering of the ancients, and that underlies the pilgrimages to Lourdes, and the shrine of St. Anne de Beaupré. One of the earliest analogous movements, to that of which we now hear so much, was that of Mesmer in the latter part of the eighteenth century.

“By the discovery of a universal fluid, in which life originates, and by which it is preserved, and by the power of regulating the operations of this fluid”—he claimed to be able to cure the most intractable diseases; and although a scientific commission, including our own Benjamin Franklin, was appointed to investigate his claims, and reported that they could find no evidence of any such fluid or special agency emanating from him or his baquet, while, if blindfolded, his patients proved susceptible to its influence only when they believed that they were within its influence, whether they really were or not; still it had for many years an astonishing vogue and following.

In the hands of his pupils animal magnetism, or mesmerism, as it was called, was found to be capable of producing a state of profound insensibility in some individuals and a state akin to somnambulism in others. The subjects were made to do all sorts of unnatural things, and to endure the severest pain without flinching. A number of surgical operations were performed upon patients, who were placed under its influence, and it was the subject of much medical speculation and discussion.

But so thoroughly tainted with fraud was it found to be, in the extravagant and unwarranted claims of its practitioners, that it soon fell into the hands of charlatans and traveling showmen, and thus into general discredit.

It had, however, a great influence in the development of spiritualism and also of hypnotism, although the latter did not obtain its first scientific recognition until many years later, through the work of the eminent French neurologist, Charcot.

This same doctrine of the susceptibility of the individual will to the influence of suggestion or authority is the very foundation of christian science. It underlies the time-honored and well-nigh universal use of the placebo by the medical profession, like the historical brown-bread pill of Dr. Jacob Bigelow, and is the curative agent in most of the well-known proprietary medicines. It is reflected in that old French saying that medicine sometimes cures, often relieves and always comforts.

Physicians have always made use of it, and especially the now much-neglected family doctor. His intimate knowledge of the heredity, habits, social and domestic life of his patients gave him a peculiar advantage in discriminating between their mental and their physical ailments; while the confidence, nay, almost reverence with which his families regarded him gave an authority to his counsel that was seldom questioned.

"His father was here before him," Mrs. Macfadyen used to explain, "atween them, they've had the countyside for weel on tae a century; if MacLure disna understand oor constitutions, wha dis a'wud like tae ask?"

And this simple faith has given the country doctor his one opportunity through all the world, and for many hundreds of years, to practise what we now call psychotherapy. Perhaps he did it unconsciously and in an amateurish sort of way, as Dr. Cabot says, but he did it, is doing it and has done it with great success.

The use of psychotherapy, or mind cure, in a purely scientific way, in the practise of medicine has been tried with conspicuous success for many years by Dubois, in Berne, and Bramwell, in England. "Our endeavor," says the former, "is to raise up these patients, to give them confidence in themselves, and to dissipate their fears and autosuggestions." They do this by making a direct appeal to the patient's reason, by trying to train his will, by trying to make the dominating idea of his ego one of health and strength, not of weakness.

Another factor in the development of this new movement is the renewed interest in the old command, to love thy neighbor as thyself; the awakening of a sense of responsibility of the more fortunate for the less fortunate, in the world they both live in.

One of the striking features of our economic development is the disappearance of the small community and the small business, with the personal interest of each in all, employer and employed; and in its place we see the herding together of great masses of people in our large cities, each class by itself; the corporation taking the place of the individual owner, and the growth of vast business enterprises, with its inevitable loss of personal interest and sense of personal responsibility.

The old relation of the physician to his patient has also changed; partly because of the growth of the specialties, partly from the growth of the hospital and dispensary, where the great number of patients makes an investigation into each one's individual circumstances and surroundings easier to neglect than to follow up; but more largely still, to that want of intimate acquaintance and the mutual confidence bred of intimate acquaintance incident to life in a large community.

To meet this problem and to help the less fortunate, who, as a class, suffer most from this change, we have the growth of settlement work, of personal service, the better administration of charities, the getting closer to the personal life of the unfortunates, with a better knowledge of their trials, hopes and disappointments, giving more advice, counsel, sympathy and practical help and less alms.

We have, of course, a class of nervous invalids, whose condition is the result of the strain of business and pleasure; but another, and much larger class, whose condition is due to ignorance, misfortune and actual hardship. Hospital men are beginning to recognize that simply a thorough physical examination with a prescription for some medicine and a few hurried words of advice are not enough; that much of our effort and of our hospital endowment has been wasted, because we did not know anything about the conditions under which our patients lived; did not know whether our advice could be followed or not and, even if it could, did not follow them up, see that they understood it and that the instructions were carried out.

To order for one patient a diet that he cannot possibly procure; for the next, a vacation that he is too poor to take; to forbid the third to worry, when the necessary cause of worry remains unchanged; to give the fourth directions for an outdoor life, which you are morally certain he will not carry out; to try to teach the fifth (a Jewish mother) how to modify milk for her baby, when she understands perhaps half what you say and forgets most of that half;—this makes a morning's work not very satisfactory in the retrospect to anybody.

We see at once the necessity of getting back to the old idea of the physician, as the friend, adviser and guide of his patients; to a closer personal relation between physician and patient, and where, as in a large hospital clinic, this is impossible, an organization which, under his direction, shall follow his patients to their homes, see what is

possible to be done in the way of carrying out his instructions, how it may be best accomplished, and see that it is accomplished.

In this line, the work of the social service department of the Massachusetts General Hospital, under Dr. Cabot's direction, is a conspicuous example of how these reforms may be brought about.

We have referred now to two separate movements; each of which has exerted a large influence in the development of this Emmanuel movement, so-called. First, the development of a healthy suggestion from without or within, with the education of the will, by an appeal to reason, and the cultivation of a right attitude toward life and especially toward health; and, secondly, the attempt to get closer to those who, by ignorance, misfortune, heredity or wrong doing, have become victims of distorted ideas about health and disease, and are unable to extricate themselves without help.

These very real, very active movements have appealed to many churchmen as offering opportunities in which they could be useful to their fellow men; while, at the same time, they would be extending the influence of their church. The first attempt on a large scale and with a complete organization to enlist in this service was by Rev. Elwood Worcester, of the Emmanuel Church, Boston.

He began three years ago with a tuberculosis class under the personal direction of Dr. J. H. Pratt. "The treatment consisted of the approved, modern method of combating consumption, plus discipline, friendship, encouragement and hope; in short, a combination of physical and moral elements." It was like a regular hospital clinic under the direction and charge of a hospital physician, but having its headquarters not at the hospital, but at the church; and the church cooperated with its visitors and helpers.

The only new thing about it was its connection with the church organization and the opportunity thus given immediately to strengthen the moral and religious character as well as the physical constitution; there was no mysticism, nothing but rational help—and the class was very successful.

So successful was it that Dr. Worcester says:

It convinced us, that the church has an important mission to perform to the sick, and that the physician and the clergyman can work together to the benefit of the community. Accordingly, in the autumn of 1906, we determined to begin a similar work among the nervously and morally diseased.

Our single desire is to give each patient the best opportunity of life and health which our means allow. We believe in the power of the mind over the body, and we believe also in medicine, in good habits, and in a wholesome and well-regulated life.

In the treatment of functional nervous disorders we make free use of moral and psychical agencies, but we do not believe in overtaxing these valuable aids by expecting the mind to attain results which can be effected more easily through physical instrumentalities. Accordingly, we have gladly availed our-

selves of the services of skilled medical and surgical specialists, who have offered to cooperate with us.

All patients are referred to these specialists first, and only those found to be suffering from the purely functional nervous disorders are admitted to the classes; this is done to avoid the objection that the employment of psychotherapy "in diseases which obviously require physical interference, may result in death through neglect"; but especially because "disorders of this nature are peculiarly associated with the moral life"—and "moral maladies require moral treatment."

The philosophy of the movement is simple; the fundamental idea is the existence in each of us of a subconscious or subliminal mind, which is a normal part of our spiritual nature and is responsible for our unconscious and automatic movements, thoughts and motives. It is this subconscious mind which responds to hypnotic suggestion, after the conscious mind has been put to sleep; but even without resort to hypnotism, one of the most important characteristics is its suggestibility, its subjection to moral influence and direction.

The functional disorders of the nervous system such as neurasthenia, psychasthenia, hysteria, hypochondria and the like, are believed to be diseases of the subconscious; caused by a dissociation of consciousness, *i. e.*, by certain portions of consciousness having become detached from the main stream.

By "psychic reeducation, utilization of reserve energy, suggestions given in hypnosis or in states of deep abstraction, there follows a re-association, a synthesis of the dissociated state, and a return to a state of healthy mindedness." And the susceptibility of the subconscious mind to suggestion is believed to afford the means of accomplishing this.

How this is actually applied in the clinic will be understood better perhaps, if I quote directly from Mr. Powell, one of Dr. Worcester's earliest pupils and imitators.

After the discussion and the prescription of good books the patient is seated in the comfortable morris chair before the fire, which I take care by this time to have burning low—is taught by rhythmic breathing and by visual imagery to relax the muscles, and is led into the silence of the mind by tranquilizing suggestion. Then in terms of the spirit, the power of the mind over the body is impressed upon the patient's consciousness, and soothing suggestions are given for the relief of the specific ills.

In addition to the clinic at which individual treatments are thus given, there is, at Emmanuel Church, a mid-week meeting, at which, after singing and Bible reading, requests for prayer are read and answered, a short, practical address, applying the teachings of Christ to human ills, followed by an hour of social intercourse in the social room of the church. For the benefit of the doctors, ministers, social workers and others who desired to study the movement, a course of

lectures was given last summer extending over three weeks, for which a small fee was charged.

Such is, in brief, the theory of the practise of the Emmanuel movement, so-called. It attempts to relieve certain disorders, which have a mental or moral origin, by the use of suggestion, reinforced by an appeal to the patient's religious faith, and it invokes the aid of medical science to eliminate those disorders which have a purely physical organic basis. Except for this appeal for the help of science and the recognition of science which it contains, there is absolutely nothing in the movement that is new.

In the first place, these so-called functional diseases do really exist; although it is true that the class has been growing constantly smaller under the influence of scientific investigation and discovery. Still, it is also true, now, as in the middle of the eighteenth century when Dr. John Atkins wrote, that "many distempers, especially of women that are ill all over, or know not what they ail, have been cured, I am apt to think, more by a fancy to the physician than his prescription."

Every doctor is familiar with the patient whose physical ailments are quite insignificant when compared with the exaggerated importance with which his mind or imagination has invested them. Every medical man recognizes how little physical basis there is for the worry, fear, doubt and melancholy with which so many of his patients are obsessed. We all appreciate how often that symptom-complex, which goes to make up what we call the neurotic temperament, is found in cases in which the most rigid physical examination fails to reveal any indication of organic disease.

In this class we find kindred conditions, which have at different times borne a great variety of names, such as nervous prostration, neurasthenia, psychasthenia, hysteria, hypochondria, or melancholia, while in other cases we are content with the simpler definition of disturbed mental equilibrium or deviation.

It seems impossible to classify these cases accurately, because there is no really scientific basis upon which a classification can be made; and the invention of new names to define certain types is not as important or as progressive as it seems.

In speaking of these names, Dubois says: "The name neurasthenia is on everybody's lips; it is the fashionable disease. But I am mistaken, the disease is not new, it is the name by which it is known that is changed. We now designate by this name, a combination of symptoms known through all time." What we must not lose sight of is that there are diseases of the mind, or imagination, or nervous system, in which no physical deviation from the normal can be found, but which are none the less real, none the less distressing, and that they tax the skill, resources and patience of the attending physician almost to the breaking point.

Furthermore, it must be observed that these are the cases in which psychotherapy, whether practised by means of the placebo, or through the agency of christian science, or the Emmanuel movement, is pre-eminently successful.

In the second place, if we study carefully the causes of these conditions, we shall find them in the two great classes into which Charcot has divided them. "The neuroses," he says, "arise from two factors, the one essential and invariable, neuropathic heredity; the other, contingent and polymorphic, the provoking agent."

In the latter belong our doubts and fears and worries, as well as the other more easily controlled factors in the causation of these purely functional nervous disorders. But even in the case of heredity, it is more the unstable nervous equilibrium that is transmitted than the specific form in which it is manifested in any individual case; and this unstable equilibrium is capable, in no small degree, of being influenced by reeducation along the lines of which we have been speaking.

"In neurasthenia," says Dubois, "we find general debility; sometimes it is physical, sometimes intellectual, but above all it is moral." In other words, it is a wrong view-point, a weakness of the will power of the individual, an inability to throw off the unduly insistent habit, or thought, or motive.

In a few words, Carpenter explains the long list of epidemic delusions of history, the form of which has changed from time to time, although many of their characteristics have been common to all; such as mesmerism, magnetism, spiritualism and the like, by saying that "The condition which underlies them all is the subjection of the mind to a dominant idea."

The trouble is that in the case of these delusions, as well as in the case of the neurasthenic, the dominant idea is pointed in the wrong direction; and the Emmanuel movement simply aims by a process of reeducation through suggestion, autosuggestion or, if necessary, hypnosis, to change this direction.

In the treatment of these cases of functional disorder of the nervous system, doctors, psychologists and Emmanuelists, all agree in attempting to continue the subjection of the mind to a dominant idea; but try, each in his own way, to make that idea stand for health, for right living and right thinking, for cheerfulness, in a word, so to direct it that it shall always look for the doughnut, not the hole.

But, while agreeing thus far, a fundamental difference of opinion is disclosed, as soon as we take up the question as to by whom this work can best be done; by the doctor or by the clergyman. The lines, however, are not strictly drawn between the two professions, because some medical men see no impropriety in asking and encouraging the assistance of the church, while many churchmen deprecate the entrance

of the church, as an organized body, into new and untried and disputed fields of activity.

One thing should be clear at the outset, and it is emphatically set forth in the introduction to Dr. Worcester's book.

The church should not undertake this work without the cooperation and assistance of the best possible medical advisers. It is a scientific work, based on the knowledge derived from the study of medicine and psychology, and its favorable results are not miracles, to be exploited for the glory of religion. They can be obtained only in cases in which no organic pathology is found to exist, in cases carefully selected, after rigid and strictly scientific examinations.

Remember that the goal is reeducation into right habits of thinking and living; and in this process of reeducation, judged by their results, there is little to choose, between the efficiency of the agnostic Dubois and the ecclesiastical Worcester.

That this process of reeducation can not be accomplished by hypnotic suggestion is the firm belief of the medical profession, especially the neurologists. That a state of hypnotic susceptibility can be induced in most people by a will that is stronger than their own is not doubted; but that it is safe, or that its results justify its use as a therapeutic measure, is stoutly denied.

Hypnotism has been known since Braid in 1842, and every now and then it rises up on a new wave of interest and popularity, often in a new guise; but so far as its therapeutic value is concerned, we have as yet derived from it no safe practical assistance.

If not by hypnotism, then how shall we seek to accomplish this reeducation—shall it be by an appeal to reason, or to faith? Unless by faith is meant religious faith, it has been and will always be done by medical men, acting through both agencies; by strong men, confident in their own powers, and able to impress others with the same confidence and faith in the truth, sincerity and accuracy of their opinions.

Examples of this use of psycho-therapeutics have been common enough in the practise of every successful physician. That he has been working at an increasing disadvantage is probably true; due partly to the growth of specialism, and also to the complexity of modern life, which, as has been already indicated, means the loss of that personal relation and sympathy between patient and physician which used to be common; but to an even greater extent is this disadvantage the result of the extraordinary development of the more material and scientific side of disease.

For example, Dr. Cabot complains, and with too much reason, that the psychological side of tuberculosis has been largely disregarded. "We have tried to have our patients live almost by bread alone—actually by milk and eggs alone, in some cases.

The effect of idleness upon the will, of a discouraging and unlovely health resort on the spirits, of an empty outlook for the future—all these have been largely disregarded. Put him in the open air, and fatten him up, we say,—so far, so good. But he has a mind, as well as a body; a future, as well as a present—and neither element can be neglected.”

Then, too, the study of the treatment and means of prevention of the infections and degenerations, and the brilliancy of its results, have tended to make us impatient with the less prompt response of the neurotic. We medical men have been tempted to speak sternly, as did the King in Alice in Wonderland, who told the poor hatter, who was trembling before the throne: “Don’t be nervous, or I’ll have you executed on the spot.” So we have been tempted to say to the unduly nervous patient: “You are not sick; don’t be nervous, or you’ll make yourself sick”—good advice, but, like much that we have to listen to, badly given.

We must look deeper into the causes of the nervousness, and suggest something to take their place. The profession is already awakening to this defect in its practise, and one of the benefits of christian science and the later movement is the stimulus which it has given the medical profession, to take up again, in its new light, a work which it always used to do, and which still is a part of its duty; a part of its very *raison d’être*.

A recent editorial in the *Boston Medical and Surgical Journal* says:

That the profession at large needs instruction in the practise of psychotherapy we are willing to admit; we believe that such instruction should be given at medical schools, to the end that the limitations as well as the possibilities of mental treatment should be laid down, so far as our present knowledge permits.

The University of Wisconsin has already established a chair of psychology and medicine; the Phipps fund of \$500,000 will soon be available for a similar course in the Johns Hopkins University, and Dr. Morton Prince offers a course in psychotherapy this winter at the Tufts Medical School. In the great field of hospital and dispensary practise much has been accomplished in the same direction by the introduction of the social-service department, as at the Johns Hopkins, the New York Post-graduate and the Massachusetts General Hospitals.

From these considerations I think there can be no doubt but that the doctor has, can and ought to do this work; the next question is, in how far it can and ought to be done by the church. We all agree that the underlying causes in very many of these functional nervous disorders are moral causes. We all recognize the strong religious side in human nature. We have all seen in our own experience, or that of some of our friends, the peace and satisfaction of mind to be derived from a strong religious faith.

It is a powerful force for the uplifting of man, mentally and morally.

This appeal to religious faith is, however, but one of our means of reaching nervous invalids; it is not always the most promising, nor is it always applicable; but it is the only one which affords any excuse for the entrance of the church into the fields of psychotherapy.

If, as has been said by one of its stoutest medical defenders, the aim of the Emmanuel Church work is only "to educate the religious faith, and to train the moral capacities of nervous invalids, sent to it by the physicians of the community for that very purpose," there would be much less room for criticism. The work would then be done in the same quiet, unobtrusive way that the medical profession believes that all such work should be done.

But when it comes to lecturing weekly, to hundreds of laymen and women at the church, and to going about from city to city explaining to lay audiences the nature of the work and encouraging imitation, as is being done by the projectors of this Emmanuel idea, the medical profession at large views with alarm the superficial manner in which a complex medical problem is presented, and sees in it strong elements of quackery and charlatanism, and the danger of great harm from its practise.

Education of the reason and strengthening of the will would seem to be more promising means of securing a nervous equilibrium than an appeal to the emotions. Even though this work has been, and is being done by the general practitioner, as we have already seen, it is probably true that in many cases, at least, it is a work in which he would welcome the assistance and advice of a specialist. But how much better fitted to give that help is the expert in diseases of the brain and nervous system who has studied psychology, than he who has studied psychology alone, or taken it up as a side issue to his study of theology and of church administration.

On this point there would seem to be little chance for disagreement. The safest counselor in all medical matters is he who has first grounded himself in normal and abnormal anatomy, in normal and pathological physiology and in the theory and practise of medicine as a whole, and then upon this foundation has made a thorough and exhaustive study of his special department; not the man who has followed a post-graduate course of lectures for a few weeks, or even months, nor the man whose psychological study has been incidental to his ecclesiastical training.

To quote again from the *Boston Medical and Surgical Journal*:

The only knowledge which is of value in the field of abnormal psychology and mental therapeutics has been gained from the laborious investigations of psychologists and physicians. This, all are free to use; but that its use is best safeguarded, and likely to be productive of the best results, in the hands of men with a general medical training will not generally be denied.

In sympathy with this feeling the best medical opinion is already alienated, and it is apparent that the movement must get along without the very cooperation upon which its originators laid such emphasis; yet it is doubtful if they will recognize this, for they seem disposed to show the same lack of discrimination in the selection of their medical authorities that is manifested by the opponents of vivisection.

It ill becomes a medical man to undertake to say what the effect of this movement may be on the church itself. It is entering a field that has always been occupied by medical men in an empirical way; and with the advancing knowledge of psychology and psychotherapy, they have demonstrated their ability and willingness successfully to cultivate it, wholly independent of church and religion. It is certainly not desirable that this independence should be too complete; but neither is it at all desirable, for the reasons above given, that the medical and scientific part of the work should be incidental and secondary to the religious.

The point which Dr. Worcester seems to me to miss is this: That these disorders, though not accompanied by any structural lesion, are, nevertheless, deviations from the normal brain function, and, as such, are to be studied and treated by those who have a thorough knowledge of the normal anatomy and physiology, and the pathological anatomy and physiology of the brain; and that the assistance of religion in this work, great and invaluable as that often is, should be strictly subordinate, just as it is subordinate, though very helpful and often necessary, in the conduct of the tuberculosis clinic, in his own church.

It is difficult to see where the church has any material advantage in the competition, and as the movement spreads into the hands of those with few qualifications and with greater independence of sound medical counsel, it seems not unreasonable to predict its ultimate failure and general discredit.

However, the Emmanuel movement has done good, just as the popular interest in hypnotism and christian science has done good. They emphasize and make clear the value of mental therapeutics, and spur the doctor and psychologist to renewed study of its nature, limitations and practical application. It will also serve, perhaps, to recall the practising physician from too cold a materialism; and to prevent a dehumanized scientist from taking the place of the doctor of the old school.

It is undoubtedly true that there has been a strong tendency to give undue attention and attribute undue importance to the interesting pathological problem presented in each case, and too little attention to its humanitarian aspect. We must not let the scientist push to one side the samaritan. Such is the lesson to be learned—more real human sympathy and help from the doctor, but not a “medicalized clergy.”

THE ATLANTIC FOREST REGION OF NORTH AMERICA

BY SPENCER TROTTER

SWARTHMORE COLLEGE

A STUDY OF INFLUENCES

I

RATZEL in his illuminating work on "The History of Mankind," remarking upon the influence of the ocean on the life of primitive peoples, says:

The wide gap which the Atlantic Ocean opens in the zone of habitation has the effect of producing "fringe"-lands. Although a brisk intercourse from north to south, together with thickly-peopled regions at the back, and more favorable climates, have rendered these far less ethnographically destitute than the regions towards the poles, we still find that in Africa the highest development has been reached on the east coast, in America on the west, that is, on the *inner* sides or those farthest from the Atlantic.

In contrast with this "gap in the belt of human habitation" the island-dotted Pacific, with its narrowing shore lines to the north, is a habitable area. Its island clusters have ever been the homes of men, and its watery waste the highway of primitive navigators. Dwellers on the fringe-lands of the continents looked out upon the Atlantic as upon a great void, and it was not until the first thousand years of the present era had passed that Scandinavian peoples penetrated its gloomy mists and founded colonies in Iceland and the Faroes. This movement of the Northmen was an expression of that migratory impulse that earlier had brought the rude peoples of Europe to the confines of the land. Five hundred years passed before the "wide gap" was again crossed.

Such a forbidding "fringe," on the farther verge of the known world, was the landfall of the first voyagers, who, steering westward, solved the mystery of the western ocean. In their wake followed successive waves of migrating peoples from the shores of Europe, who sought to found colonies on these strange coasts. Whatever fanciful Eldorados they may have pictured were rudely dispelled by the wild solitudes of an unknown forest that, sphinx-like, stretched its front along the indented coast from the St. Lawrence to Florida. Between these peoples and the world of civilization lay the dissociating Atlantic. Once landed, they had set foot on the threshold of a new home. To the natural features of this threshold—forest, mountain, river, shore-line and climate—and its aboriginal life, we must look for those influences that went so largely to the making of a new type of civilized men.

II

The natural condition of eastern North America is that of a forest-covered land. Wherever the primeval woodland has been cleared there springs up, unless thwarted by persistent tillage, a sturdy "second growth" which in time, and if allowed to spread, would restore the face of the country to something of its former appearance. We are familiar enough with such tracts, abandoned by men as unprofitable for cultivation and left to the genial influence of birds and winds and the chemistry of humus soils—nature's way of getting back to original conditions. These delectable places are the "woods," scattered in patches of greater or less extent throughout the farming districts, covering the slopes of hills and the windings of valley streams—places of little value in the economic eye save for a few cords of firewood or as a trifling source of timber, but rich withal in youthful associations.

The primitive Atlantic forest was, for a space of three hundred years after the discovery, a dominant feature in the history of the country. For a long period its impenetrable solitudes limited the spread of settlement to a narrow seaboard margin; only the more intrepid of the newcomers plunged into its depths to meet with strange adventures. The valleys of the larger rivers formed natural highways into the interior of this forest region and the broad tracts of rich bottom-land gradually became, in favorable situations, the sites of settlement, widely scattered at first, but advancing farther and farther inland as population increased.

It is hard for us, dwelling in the long-settled land, to appreciate the attitude of the early colonists toward the forest. Fear mingled with curiosity was undoubtedly the chief state of mind of the first comers. Clearing the land had a twofold purpose—for planting ("plantation" was the word used in all early writings concerning the colonies) and to satisfy a feeling of domesticity that was ingrained in the European mind—an inherited instinct to civilize. To these people the forest was a dreadful reality (some early writers speak of it as a "Desert"), full of unknown terrors, and, especially to the Puritan and Jesuit, a haunt of the Powers of Darkness. On the whole the French settlers took more kindly to the forest than did the Anglo-Saxon peoples, who from the outset evinced a ruthless determination to clear the land. The ancient wood steadily receded, slowly at first, then rapidly as the planted country widened its borders, forest everywhere giving way to field, and with it vanished much that was aboriginal.

III

"Pine-tree State" and "Pine-tree Shilling" were terms of no empty meaning in the region where they originated. In northern New England the white pine is still the most characteristic tree over wide areas of unimproved land, and a well-defined "pine belt" reaches

from the coast westward to beyond the Great Lakes. A goodly number of other trees mingle with the pines in this northern portion of the Atlantic forest—basswood, elm, birch, sugar maple and ash among the broad-leaved species, and the black spruce, hemlock and cedar among conifers, but the pine everywhere gives the broadest and most pronounced feature to the woodland. This northern pine forest follows the highest ridges of the Alleghanies quite to their southern limits, conspicuous in the mountain landscape as an evergreen belt—the hemlock (or what is left of its once grand forests after the axe of the lumberman and “bark-peeler”) predominating in certain districts.

Somewhere in the mid-New England region, and in New York along the watershed of the St. Lawrence, one who travels with an eye for trees will notice the ever-increasing number and variety of broad-leaved species toward the south. Among the scattered pines appears the massy leafage of oaks, hickories, chestnuts, beeches and other hardwoods, which denotes a borderland in tree life—the northern edge of that vast deciduous forest the summer canopy of which, in aboriginal times, covered the Ohio and Mississippi basins and the Piedmont land of the Atlantic seaboard to beyond the valley of the Delaware. Even to-day there are wide areas still covered by remnants of this magnificent interior forest of the continent. And what a wealth of species! Nowhere in the temperate zone may we find such an assemblage of splendid tree forms save possibly in eastern Asia. The tall tulip tree with its gorgeous blossoms and broad leaves of shining green; the array of magnolias, rivaled in beauty and variety only in the Chinese region; the gums (both tupelos and liquidambar); the flowering dogwood; the buckeyes, locusts, catalpas, beeches, plane trees, chestnuts, ashes, elms, cherries, a great variety of hawthorns, the hackberry, persimmon and sassafras; the hickories, walnuts and butternuts; the basswood, maple and sourwood; the hornbeams, and upwards of twenty species of oaks, not to mention a host of other less familiar trees and underwoods. This is the forest that nature would spread over the land again should the white man cease in his toilsome civilization. Those of us born with a love for the woods can only regret the loss and cling the more tenaciously to every woodland tract that happily we may still have the right to protect.

On the coast plain of the southern Atlantic region another form of tree-life gives character to the forest. Here the long-leaf pine and other allied species find a congenial home, the monotonous “piney woods” covering wide tracts of level, sandy country. From the earliest times tar and turpentine have given local color to the commerce of the region where this pine abounds. In low-lying swamp districts and along river shores the bald cypress, with its curious “knees” lifted above the submerging flood, is a conspicuous tree in the landscape and entirely peculiar to this Atlantic coast region.

The existence of a forest on the Atlantic side of North America is a result of several natural conditions, chief among which is a copious rainfall. The average yearly precipitation east of the Mississippi Valley amounts to some fifty or sixty inches, increasing towards the coast and the Gulf border. This insures an abundant water supply in the subsoil—the stratum into which the roots of forest trees delve in their search for moisture. Soils, too, play their part in the foresting of a land. An underlying layer of clay holds the water, which collects above it in the permeable sands and loam of the subsoil where the tree roots interlace in a vast network. The varied nature of soils over wide regions determines, within certain limits of temperature, the character of tree growth. This explains in part the preponderance of pines on a sandy soil where the water passes more or less rapidly through the root area. Pines are physiologically dry trees as compared with the broad-leaved, deciduous species; their tough and narrow needle-like leaves do not so readily favor the transpiration process—the freeing of the water which has ascended through their vessels from the roots. What ground water enters the transpiration current is, therefore, not too easily lost to the tree through its leaves. The case of the broad-leaved trees is different, for their roots tap soils more or less constantly moist and the ascending transpiration current is quickly relieved by the broad expanse of leafage which they present to the air.

Temperature is unquestionably the controlling feature in the northward and southward distribution of trees. Along the Atlantic seaboard the effective temperatures in tree dispersal are related, in a general way, to the “lay of the land.” In the same latitude various species belonging to a more northern habitat appear in the highland districts, while many southern forms are more or less abundant in the lowlands. Along its inland border the coastal plain, in many places, ends in a low rise of land, or “upland terrace,” from the top of which one sees the flat expanse of the plain over many miles. Back of the observer lies the rolling country of the Piedmont district (the “uplands” of the early settlers and farming people), a landscape of hills and valleys stretching away to the eastern border of the Blue Ridge. South of the valley of the Delaware this terrace feature marks, in a very general way, the limits of certain northern and southern trees. The sweet gum or liquidambar of the southern region is abundant on the coastal plain in southeastern Pennsylvania, but is of rare occurrence on the uplands. The sheltered nature and rich alluvial soils of river bottoms extend the ranges of some of the more southern trees beyond this limit, and the same sweet gum is found growing in the valley of the Connecticut. In like manner the valleys of the Hudson, the Delaware and the Susquehanna are each tinged with a more southern tree life than are the surrounding uplands along their course. As a reverse of this picture, certain trees of a more northerly distribu-

tion, like the hemlock, are found growing along the higher land and in cool ravines as far south as the Lower Delaware Valley.

The more familiar trees, however, mingle over a wide area of country—southern New England and the Middle Atlantic district—a transition region that lies between the northern coniferous forest and the broad-leaved, summer-green forest of the great interior valley and south Atlantic slope.

Something besides temperature appears to control the distribution of certain trees. Since the settlement of the country numerous species, the natural habitats of which are far to the south, have been planted and grown successfully in more northern localities. The catalpa, the sourwood and the several species of magnolia are illustrations of this. Just what is the determining factor in preventing such trees from spreading northward (or others from spreading southward) it is difficult to say. Possibly some subtle condition in the balance of nature—some item in the struggle for existence, has helped or hindered the spread of certain trees, excluding some from localities already occupied by others. It is well known that where pines have been cut off certain species of oaks will spring up and occupy the land. The oak seedlings must have been abundantly scattered over the soil for a long period of time. Only a comparatively few species are enabled to hold their own through some superior advantage in adaptation and grow up to form a forest. A vast number must of necessity lie dormant in the soil for centuries. In Denmark, since glacial times, there has evidently been a succession of forests—oak following fir and beech following oak through a period of many thousands of years. The varied relations of the different species of trees to light, heat, moisture and soils, to animals, and to other trees and plants, are involved in slow, deep-seated processes, the expression of which is the forest as we see it. Our point of view, however, is but momentary in the vast events of nature—a fleeting glimpse, merely, of one picture in an endless biograph.

The question of the succession of forests suggests another question—that of the origin of the present Atlantic forest and its relation to other forests in different parts of the world. In a general survey of the forest trees of eastern North America there appears a large number of types which are common also to Europe. With the exception of the bald cypress and the hemlocks all the other coniferous types—pines, spruces, firs and larches—are represented in Europe by closely allied species. This is true also of a number of the deciduous trees—the oak, beech, chestnut, elm, willow, birch, aspen, walnut, ash, maple, plane tree, linden or basswood, and others are represented on both sides of the Atlantic by more or less nearly related forms. This is not surprising when we come to consider that all of the above-named trees are decidedly northern in their distribution, and exist under very similar climatic conditions. This is especially true of the coniferous

trees and the birches which form a characteristic boreal forest zone of similar features throughout the entire land area of the cold temperate region from Kamschatka to Alaska. Farther south, as the land masses diverge, the forest types show a decreasing likeness—yet the broad-leaved woodlands of oak, beech and others are readily recognized as such in both the old and the new worlds.

A number of American trees, however, and these characteristic of the more southern portion of the Atlantic forest, have no European counterparts. We look in vain through the forests of Europe for such familiar forms as the hemlock, the hickories, the tulip tree, the magnolias, the sassafras, the tupelo gums, the witchhazel, the Kentucky coffee tree, the yellow-wood, the locusts, the catalpa and the liquidambar. Strange as it may appear, nearly all of these eastern American forms occur nowhere else in the world save in eastern Asia, in the more temperate parts of China and Japan, where the same or very nearly related species are to be found. What is even still more striking is the contrast between the Atlantic and Pacific sides of North America. Excepting along the mountain crests where the more or less world-wide boreal plants find a congenial environment, the vegetation of the California region is related mainly to the dry plateau lands of Mexico and South America. So far as the trees are concerned a native of the eastern United States would find himself in much more homelike surroundings in the woodlands of temperate China and Japan than on the Pacific slope of his own country. A tulip tree, very similar to the one at home, almost if not the identical species of sassafras, numerous closely related magnolias, a near relative of the southern yellow-wood, the liquidambar, the catalpa, the coffee tree, the hemlock, and other forms appear as familiar trees in the landscape of China and Japan. This likeness between the two widely separated regions is not confined to the trees alone. The flora at large presents many features in common. The fox grape, the poison ivy, the hydrangeas, the wistaria, the blue cohosh, the may-apple, the twin-leaf, the trailing arbutus or may-flower, and the creeping snowberry have each a more or less closely related form in eastern North America and eastern Asia, but are found in no other part of the world.

This likeness between the forest types of eastern North America and eastern Asia dates from a period far back in the history of northern lands. The tertiary deposits of Greenland and Spitzbergen have yielded numerous fossil remains of trees, among them a magnolia, a tulip tree, a sassafras and a liquidambar, quite similar, if not, in some cases, identical with the species now living. Besides these forms that are peculiar to the regions above named, the remains of other trees of more wide-spread distribution have been found in Greenland—a bass-wood, a plane tree, a persimmon, also several kinds of beeches, birches,

poplars and oaks—all of which are nearly related to the modern types.¹

This ancient circumpolar forest flourished at a time when the climate of the Arctic regions was almost warm temperate in its character and capable of supporting a rich and varied tree-life throughout an immensely long period of time. Toward the close of this period the increasing cold which culminated in a glacial epoch caused a gradual change in the forest conditions. The more northerly portion of this wide-spread forest was not able to survive the change, its species were forced out of the region, finding more suitable conditions in lands farther to the south, where some, undoubtedly, had already established themselves. A large number of species, like the oaks and beeches and some of the conifers easily adapted themselves to a varied environment and spread widely around the north temperate zone. Others, however, found suitable conditions of life only in certain localities, often widely apart, but with similar climatic features. Here we have a solution of the similarity of tree forms in forests so widely separated geographically as those of eastern North America and eastern Asia. In every other portion of the wide region into which the trees of this polar forest migrated a certain number of species failed to occupy the soil through some adverse conditions in climate or life relations. Cut off from their center of development in the polar area, they spread to the south, but only in two localities did they succeed in establishing themselves—on the eastern side of the two great northern land masses, where almost similar climatic influences prevail.

It is of more than passing interest to thus trace back the history of our forests. As with men so with trees. Countless generations succeed one another, occupying the soil in which the remains of older generations lie buried, each new generation springing from the one before it and bearing the marks of an inheritance that allies its individual members with other men and trees in far distant lands, and that carries them back through a seemingly endless chain of life to a remote antiquity.

With the retreat of the ice at the close of the last glacial epoch, and the gradual assumption of the present climate and physical features of eastern North America, the more hardy coniferous trees, and some of the broad-leaved species that had adapted themselves to low temperatures along the edge of the ice sheet, began to occupy the newly uncovered land as a northern belt of pine forest. This expansion of tree life toward the north must have relieved the long overcrowded southern area and permitted a fuller development of the summer-green, broad-leaved forest with its great variety of forms. The deciduous habit of this summer-green forest is clearly an adaptation to a low winter

¹ "The Relations of North American to North East Asian and Tertiary Vegetation"—being portion of an address by Dr. Asa Gray, published as Article V. in "Darwiniana."

temperature, the falling away of the leaves temporarily drying out the tree by checking the transpiration current and thus preventing the disastrous effects of freezing. Along the warmer Gulf borders certain deciduous types, as the live oaks, have either never acquired the habit or have lost it since glacial times.

IV

A glamour of romance brooded over this forest land and cast its spell on the mind of western Europe. From Raleigh, dreaming of colonies beyond the sea, down to the days of the great exodus of European peoples there was a pervading sense of wonder concerning the new country. History has dealt at length with the motives that prompted whole bodies of people to leave a long-familiar and civilized homeland for an unknown and untried wilderness. No matter what the varied motives may have been—whether from religious or political oppression, or for the betterment of home and fortune—each and all were expressions of that migratory impulse that from a remote period had been working out the destiny of the race.

The English stock that colonized the Atlantic slope of North America was made up of two strains of blood that had mingled to some extent in the mother country, but which was destined to a far wider and more complete fusion in the new world. From an ethnological point of view the Welsh, the Irish and the Highland Scot or Gael have come to be regarded as the modern representatives of an ancient Celtic people that once occupied Britain and that were driven into remote corners of the land by the invading Angle and his allies. As applied to this people and its speech and literature the word "Celtic" has come to stand for a certain kind of temperament—imaginative and emotional in its nature, poetic and inclined to mysticism, a man on the edge of things, elated or cast down, and capable of great bursts of energy. The reverse of this picture is called up by the word "Teutonic"—the opposite strain of blood that has mingled so largely with the Celtic element in the moulding of an American type. In point of fact the Teutonic is the dominant strain in most of us to-day; the Celtic being more of a local infusion here and there, like the occasional brook flowing into the main stream of a river. The New England Puritans were almost wholly English Teutons and the same was true of the Virginia colonists. The Teutonic Swede and Hollander held for a time the middle region—the Hudson and the lower valley of the Delaware—and left an infusion of their blood in the dominant English population which may still be traced in certain family names. The Quakers that settled Pennsylvania were, like the Puritans, of Teutonic English stock. The Scotch-Irish peoples, likewise largely Teutonic, settled the Carolina seaboard. The main German migration spread through the middle region—in the Delaware and Susquehanna water-

sheds—and together with the Scotch-Irish settled the frontier valleys of the Blue Ridge. These were the peoples—Teutonic with a Celtic infusion—that traversed the wide gap of the Atlantic and planted a civilization on its farther fringe.

It was what these people brought with them, as qualities of mind, traditions and habits of life, and the way they looked at things, that interest us most. There could be no adaptation to a wilderness life like that of the aboriginal inhabitants of this fringe-land. Here were men and women, the product of centuries of civilization, suddenly confronted with the bare fact of existence on the edge of an inhospitable and unknown forest. This transit of civilized peoples is one of the amazing events of history. Tillers of the land for generations, they brought with them the old-world grains and food plants, their household goods, farm implements and cattle, and with these a bundle of curious ideas and superstitions which had a deep and widespread rootage in the ancestral soil of Europe. The forest held nothing for them save fuel and material for shelter. Fish, flesh and fowl were to be had in abundance, but of the wild food-plants that were indigenous to the soil and which the native peoples had used for ages these immigrants from civilization knew little or nothing. Dependent from a remote antiquity upon agriculture, it is scarcely to be wondered at that the first comers to the new land were at times sorely put to it for food, as the early records relate.

The effect of this fringe-land upon its native inhabitants was apparent in the low state of their culture. The aboriginal Atlantic tribes were unacquainted with the use of iron, which, as Ratzel has remarked, is a characteristic of all fringe-land peoples. Their agriculture was of the rudest sort—the planting of maize, squashes and tobacco, with little or no tillage, hunting and fishing producing their chief food supply. The very primitive condition of these Indian peoples was further evinced by such customs as mother-right and other ancient forms of the social state. The Atlantic fringe-land as a whole was thinly populated. Where many millions of Europeans now dwell on a sound basis of agriculture, the aboriginal population seemed barely able to hold its own, living as it were from hand to mouth. This failure to advance culturally and increase numerically through intelligent use of the soil is the underlying fact in all backward peoples, and their backwardness is, in large measure, the result of environment. Undoubtedly one of the factors in this environment is isolation, through many generations, in a forest region, though we must also remember those inherent racial traits that tend to depress whole bodies of people, relegating them to the less desirable regions—overwhelming forests, unfertile tracts and fringe-lands. A non-agricultural people can not wrest a civilization out of the wilderness. It can only be accomplished by agricultural peoples with a well developed instinct to clear

the land. The forest and the ocean set limitations to the aboriginal American. The Atlantic once crossed by the agricultural Europeans, though it served to hold them to their new home, became their highway of communication with the world. To them it was no longer "a gap in the belt of human habitation."

The Teutonic blood evinced its trait of dogged persistence in the settlement of the land. Acre after acre of the primeval woodland was cleared and planted. Of the species indigenous to the new country only maize and tobacco became rivals of the old-world culture plants. We can picture to ourselves the rude farm lands of the first period of settlement, with stumps scattered through the fields, charred and blackened in many places by the firing of the fallen growth, with the maize and the English grain springing up; the kitchen-garden of old-world vegetables and herbs; the dooryard blooms—wallflower, daffodil, marigold, larkspur, and other sweet, homely flowers brought from across the sea; the young orchards with their seedling fruit trees or newly set-out transplantings of peach, apple, plum and pear. Most of the houses at this period were built of rough-hewn logs or sawed planks, while some of the more pretentious were of stone or brick. Peter Kalm, the Swedish traveler, has left us a picture of the countryside about the Delaware in the middle of the eighteenth century, after three quarters of a century of settlement. Speaking of the farms near Philadelphia, he says in one place:

As we went on in the wood, we continually saw at moderate distances little fields, which had been cleared of the wood. Each of these was a farm. These farms were commonly very pretty, and a walk of trees frequently led from them to the highroad. The houses were all built of brick, or of the stone which is here everywhere to be met with. Every countryman, even though he were the poorest peasant, had an orchard with apples, peaches, chestnuts, walnuts, cherries, quinces and such fruits, and sometimes we saw the vines climbing along them. The valleys were frequently provided with little brooks which contained a crystal stream. The corn on the sides of the road, was almost all mown, and no other grain besides maize and buckwheat was standing. The former was to be met with near each farm, in greater or lesser quantities; it grew very well and to a great length, the stalks being from six to ten feet high, and covered with fine green leaves. Buckwheat likewise was not very uncommon, and in some places the people were beginning to reap it.

A month later (in October) he writes:

Wheat was now sown everywhere. In some places it was already green, having been sown four weeks before. The wheat fields were made in the *English* manner, having no ditches in them, but numerous furrows for draining the water, at the distance of four or six feet from one another. Great stumps of the trees which had been cut down, are everywhere seen on the fields, and this shews that the country has been but lately cultivated.

The "worm fence" appears to have been a feature of the farm lands in Kalm's time, at least in the middle and southern regions. He comments at some length on the wastefulness of wood in the construction of these worm fences.

Considering how much more wood the *worm fences* require (since they run in bendings) than other inclosures which go in straight lines, and that they are so soon useless, one may imagine how the forests will be consumed, and what sort of an appearance the country will have forty or fifty years hence, in case no alteration is made; especially as wood is really squandered away in immense quantities, day and night all the winter, or nearly one-half of the year, for fewel.

These rude forefathers of ours evidently had small concern for future posterity. Wood they had in abundance and they burned it without stint. The smell of the hearth smoke must have gone deep into their veins and its subtle influence still evokes a sense of homeliness in those of us who perchance have inherited some ancestral response that makes for happiness quite as much as acres of standing timber.

In New England the mantle of drift, that had been strewn over the land by the melting of an ancient glacier, afforded abundant material for the building of "stone fences." These old walls, beset with weeds and briars, became the retreat of many of the smaller wild animals that had been driven from their forest stronghold by the clearing of the land. The fox still finds a friendly road in the cover of these boundaries, and the woodchuck, ensconced within some sheltering cranny, whistles his shrill note of defiance against the harassing boy and dog.

The surroundings of a homestead very often reflect certain local conditions. The picturesque "well-sweep" still survives here and there in rural New England and its origin may possibly be traced to the long pine pole of the region. The well-sweep also appears in the pine wood tracts of the coastal plain in Delaware, and probably elsewhere. In the middle Atlantic region the "spring-house" was an early adjunct of the dairy. Many old spring-houses still linger throughout this land, with crumbling roofs and weathered walls falling slowly into decay while the rill trickles through, reminiscent of a time when pans of creamy milk and bowls of yellow butter stood cooling in its water. Ofttimes, in near-by spots, these rills and springs are choked with a growth of the pungent water-cress. Modern separator machinery has dispossessed the spring-house—only on some remote farm does it still do service. Its passing is not altogether to be regretted, for many women-folk fell early victims to the crippling rheumatism that its damp walls engendered. Occasionally some poor family makes a home in one of these abandoned structures, and this recalls a still more interesting abode which one now and then happens upon in some out-of-the-way district—an old log-house that has lingered on through the changing years, a quaint reminder of the past. I know of several such houses not many miles from Philadelphia. The spring-house appears to be altogether local in its origin; the abundant springs and rills along the hillside borders of wide meadow pastures inviting the

building of such contrivances for keeping dairy products through the hot spells of summer.

Many curious old-world customs and beliefs, into which various natural objects entered, took root in the new soils though in a somewhat altered form to suit the changed conditions. Much of folk-lore has always been concerned with the weather. Besides the ember-days there was Candlemas with its superstition regarding the sunshine on that day as a prognostication of the remainder of winter. In Germany, if the badger saw his shadow it was an old belief that hard weather would follow for some time. No badger appearing on the Atlantic slope, the rôle of weather prophet was conferred upon the ubiquitous woodchuck or ground-hog whose honors are still fairly even with the weather bureau. So prominent a bird in European folk-lore as the cuckoo appears to have had no representative in this country to take its place, though we might regard the term "rain-crow," bestowed upon its American congener, as a somewhat vague recognition of kindred qualities. The art of the divining-rod in locating underground water migrated across the sea with these early settlers, and for this purpose a forked branch of the witch-hazel was used with as sure results, when held by a gifted hand, as that of the elm, the hazel or the willow of the old world. Unfortunately we can not trace the "witch" part of the name back to any certain source in the craft of the broomstick, and "hazel" is but a borrowed title. The shrub has much about it that is peculiar. Among our American underwoods its late autumnal bloom, at the fall of the leaf, and the ripening of its fruit in the next summer are conspicuous and may have appealed to the mystery-loving mind of the seventeenth century.

Superstition gathered about the strange whippoorwill and its weird twilight call. The Indian peoples, too, seem to have regarded this bird as one of omen and Catesby in his "Natural History of Carolina" quotes a piece of aboriginal folk-lore to the effect that the bird was unknown to them until after a certain battle when a great many of their people were slain by the Europeans, and that now the birds heard calling in the dusk are the souls of their ancestors. Many fragments of nature folk-lore sprang up in the new world from an old-world transplanting, as to the belief that swallows spent the winter in the mud of ponds and river, and other beliefs quite as curious which have gone into the limbo of the forgotten past.

In parts of the country, notably in the middle Atlantic region, the planting of plane trees (the sycamore or buttonwood) in the immediate vicinity of farm houses appears to have been a wide-spread custom under the belief that the tree warded off lightning. Whatever may have been the reason for its planting, this tree, with its huge bowl uplifting a crown of branches, and the striking color of its bark—white,

brown and gray in streaks and blotches—is one of the most conspicuous features about the grounds of many old homesteads.

V.

Adventurous men who wandered beyond the Appalachian Mountains into the Ohio country found, west of the Wabash River, the forest giving place to open grassland or “prairies.” These were great meadows with little or no tree growth, save along the bottomlands of rivers. The edge of the broad-leaved forest along this prairie border thinned out into those scattered, open woods known to the early pioneers as “oak openings.” It may have been that this prairie country was at one time more extensively wooded and its later deforested condition a result of the persistent burning of the undergrowth by the hunting tribes of Indians to increase the pasture area for the vast herds of bison that roamed over the grass country of the Mississippi Basin. The late Professor Shaler advanced this view some years ago, stating that it was his belief that had the discovery of the continent been delayed for another five centuries much of the original forest to the east would probably have been burnt off in this way and the land changed into a prairie country. This burning of the woods seems to have been a wide-spread custom in aboriginal times. William Wood, in his “New England’s Prospects,” speaks of it as follows:

For the *Indians* burning it [the ground] to suppress the Underwood, which else would grow all over the Countrey, the Snow falling not long after, keeps the ground warme, and with his melting conveighs the ashes into the pores of the earth, which doth fatten it.

Mention is also made of this custom by numerous writers at a later period. Richard Smith,² of Burlington, New Jersey, who made a survey about the headwaters of the Susquehanna and the Delaware, in the spring of 1769, speaks of the appearance of these burnt tracts, and I have been told on reliable authority that in the lower Delaware region the Indians burned the tops and slopes of the hills, leaving the land along the river bottoms untouched.

The clearing of land in the progress of settlement had the same effect as the burning off of the forest—it virtually converted a wide area of primitive forest-covered country into prairie, though interspersed with tracts of woodland. Our pastures are in reality prairies so far, at least, as their faunal and floral features are concerned. This fact suggests a very interesting question. When the country was almost entirely forest-covered, as in the period before settlement, what was the manner of life of such plants and animals as now inhabit our fields and meadow pastures? Were they originally forest-dwellers which have altered their habits to meet the new conditions, or are they migrants from the western prairie country? In the case of certain birds I think that the last view embodies what has actually taken place. A large

²“Journal of Richard Smith,” edited by F. W. Halsey.

number of plant species, however, which are characteristic of our pastures and fallow fields, involves another point of view as to their former distribution.

The aboriginal flora of the Atlantic slope was unquestionably composed of shade-loving species. Kalm, in a very interesting and suggestive paragraph in his "Travels," noted this fact as early as the year 1748. Save along the river marshes and seacoast, or in widely scattered glades and beaver meadows throughout the forest region, there was little encouragement to the growth of meadow plants as we know them to-day. A striking fact in the distribution of our eastern flora is the comparatively large numbers of species that have found their way across the ocean from the shores of Europe and have become naturalized in our fields. These immigrants are for the most part "weeds" which everywhere find congenial surroundings throughout our cultivated lands, and like the human immigrants thrive apace. They are rank growers of great fecundity and have gained an ill reputation among the farmers. Some of them, as the big white daisy and the buttercups, in out-of-the-way districts where the standard of farming is low, form the chief hay crop, and the daisy is said, by way of extenuation, to possess milk-making qualities. The names of these intruders are familiar to most of us, possibly more familiar to many than those of native growth. Daisy, buttercup, toad-flax, mullein, burdock, cockle-bur, dandelion, the common St. John's wort, self-heal, lamb's quarters, field-sorrel, smartweed, and many more are among the throng that early made a new home for themselves in the cleared land. It is hardly likely that these same plants would have gained a foothold had the land remained in its primitive forest-covered state, for they are all light-loving species, thriving in the open expanse of fields. Many indigenous species, as the Joe-Pye weeds or thoroughworts and the tick-seeds and others of more or less moist habitats have undoubtedly greatly increased their range since the days of settlement, spreading out from river borders into the low meadow lands. One interesting plant is unquestionably a rather recent migrant from the prairie country. This is the Black-eyed Susan or cone flower which has found its way into eastern fields with clover seed brought from the west.

Doubtless it was in some such manner that the host of European species that now adorn this land found a means of transit, for much grass seed and grain was brought over by the colonists. Nearly all the grasses of our fields belong to European species that have become naturalized. The native grasses appear, for the most part, to have been annual species that grew in the woods, at least in certain districts. Kalm has an interesting observation on this point. While staying with the Swedes at their village on the Delaware in the autumn of 1748 one of the old inhabitants told Kalm that in his youth "there was grass in the woods which grew very close, and was everywhere two feet high,"

but being an annual it was rapidly destroyed by the cattle, that were turned into the woods by the settlers, before it had time to seed itself. Kalm further remarks:

However careful economists have got seeds of perennial grasses from *England*, and other *European* States and sowed it in their meadows, where they seem to thrive exceedingly well.

From the same writer it appears that the woods about this Delaware region originally had a scant undergrowth, for he speaks of their open character—"so that one could ride on horseback without inconvenience . . . and even with a cart in most places."

It is a significant fact that most of the native wild flowers of our Atlantic region, excepting those that grow along the river banks and in wet meadows, are woodland species. We go to the woods to find our early spring flowers—hepatica, bloodroot, the anemones, the may-flower, dogstooth violet, saxifrage, bluets and spring-beauty. These species probably acquired the habit of vernal blooming as a necessity imposed by their forest life—unfolding their blossoms in the sunshine of bare woods before the leafage cast its heavy shade. It is possible also that the habit may be, in part, an inheritance from the glacial time, the then short summer period of vegetative activity corresponding with our present spring.* In certain groups of plants which are eminently characteristic of eastern North America the larger number of species are of woodland distribution. This is the case with the golden-rods and asters. In glancing over these two groups one is struck by the preponderance of species that are found in woods or along wood borders. Those that grow in the more open lands, as in fields, are for the most part either of northern or western distribution or are inhabitants of moist soil districts, such as meadows and swampy glades.

Every boy who has indulged a natural propensity to haunt the wild and delectable spots of his neighborhood, to pursue shy birds and pry into the secrets of their nests, knows that there are some birds that dwell in the woods and others that make their homes in the fields. A student of ornithology, likewise, soon learns that certain species of birds are peculiar either to the woods or to the fields, and that the structure and habits of life in each are in accordance with the nature of the surroundings. Among eastern North American birds there are several species of sparrows, as the vesper sparrow or grass finch, the savanna and grasshopper sparrows, that are strictly grassland birds. The same is also true of the meadow lark, the bob-white, the cowbird, the red-winged blackbird, and the bobolink. These are all birds of open grassland country.⁴

* "The Origin of our Vernal Flora," Harshberger. *Science*, Vol. I., p. 92. New Series.

⁴ These remarks on the origin of our field birds appeared in an article by the present writer under the title "Birds of the Grasslands," in the *POPULAR SCIENCE MONTHLY*, February, 1893.

The question naturally arises—When the region was one unbroken forest, as in aboriginal times, where were the birds that to-day are found only in our fields? Two answers appear possible to this question. There may have been a radical change in the habits of these birds since the first clearing of the land, or they may have come from the western prairie region. This latter view, is, I think, the more probable from the fact that all of the above-mentioned birds are found throughout the prairies and on the Great Plains, or are represented there by varieties which differ only in slight shades of color. The three sparrows are widely distributed over the country, though the savanna sparrow in its choice of localities is not so entirely an upland bird as are the other two species, haunting marshes along the coasts and river valleys as well as the higher open country. The familiar meadow lark of our eastern fields is abundant throughout the prairie region and is replaced on the drier western plains by a closely related form. The cowbird is another species that is widely spread over the continent and its habit of associating with cattle for the purpose of feeding upon the flies that swarm about them suggests the question—whether this habit was acquired since the settlement of the country, or did these birds haunt the bison herds on the plains and begin to straggle eastward after the cattle were introduced. The bobolink may have been a bird of the river marshes throughout the Atlantic region long before the discoverer set foot upon these shores, though from its wide range over the interior valleys and prairie lands we might infer that it had come east after the opening of the country. Similar conclusions could be adduced concerning the red-winged blackbird, but it is a bird more of marshland than of upland fields. Certain shore birds seem also to have taken advantage of the clearing of the country, as the killdeer and the grass plover, both being frequenters of plowed and fallow land.

A remarkably interesting case is that of the black-throated bunting or dicksissel. This bird is an abundant species in the glasslands of the middle prairie region. In the time of the ornithologist Wilson, and as late as the year 1880, it was not uncommon in certain localities in the east. Since this latter date it seems to have entirely disappeared from the Atlantic seaboard. For several years previous to that time I knew of a few pairs of these birds which nested each spring in certain fields of timothy and clover in the vicinity of Philadelphia. Their disappearance from these localities was remarkably sudden and apparently without reason, unless, as was suggested, it was due to the mowing of the fields and the destruction of nests and young birds. The evidence seems clear, however, that a part of the dicksissel population spread early into the newly opened fields of the east and abandoned them later, returning to their original prairie home.

In old, settled lands, as in England and the countries of western Europe, bird life has in large measure adapted itself to the human

population. Its background is the domestic landscape—village, hedge-row and park; no wide tracts of uncultivated land or of wilderness to lure birds away. In America vast numbers of birds still sequester themselves in wilderness solitudes undisturbed by men, and even in the settled districts many of the more shy species find congenial haunts in the depths of undergrowth some distance from habitations. On the other hand, there are some like the grackle or crow blackbird, the robin and the bluebird, the catbird, the chipping and song sparrows that seem to prefer to dwell about the homes of men. Indeed, it is quite true, that many of our native birds have found a certain advantage in this affiliation with the human population, at least so far as the food problem is concerned. The blackbird flocks that swarm over the corn lands in early autumn have certainly not diminished, rather have they increased, since the first days of settlement. The bobolink has probably widened its range with the increased area of cultivation. The crow, though a wary tenant of the farm lands, nesting and roosting away from the haunts of men, is still a prominent figure in the landscape of agricultural districts. Many sparrows are gleaners in the shorn fields and pastures, and about the barns and door-yards. Orchards have become a favorite resort, affording an abundance of food for numerous bird families. Great numbers of migrating birds, especially wood warblers, follow the bloom of the fruit trees from south to north in the spring to feed on the insects that infest the buds and blossoms. Not so many years ago, before the larger cities had entirely outgrown their earlier village character, the Baltimore oriole wove its hanging nest here and there in some shade tree along a busy street or in some city square or old town garden. Its rich warble and brilliant color were truly a refreshing sound and sight in the June days, a touch of the woodland life now rarely if ever to be met with in the great overgrown centers of trade.

In England one is impressed with the abundance of individuals among birds which have become dependent upon man and his work. In America a process of adjustment is going on which will unquestionably bring about a similar status in the bird population as more and more of the wild land is cleared and cultivated. In the human history of progress and discovery many delicately adjusted points in the balance of nature are disturbed, entailing often complex and widespread changes in the life and habits of the native fauna. Such changes as we have pictured are small fragments in the history of a country, but they possess great interest as showing how remotely and by what strange means causes and effects operate. Man appears in a new land, clears its face of timber and builds his home. By and by birds from the distant prairie lands find their way into his fields. The swift forsakes the hollow tree to build in the settler's chimney, and the swallow leaves the overhanging tree-trunk and rocky ledge for the shelter of the eaves

and barn. The robin nests within handreach of the door-sill, and the wren and martin, leaving their old homes in the forest to some wood-pecker more lazy than his fellows, scold and quarrel for the possession of any hole or box so long as it is near the dwelling places of men.

The effect of forest clearing and settlement on the larger wild animals of the region was even more striking, since it caused their rapid disappearance from the vicinity of cultivated land. The wild animal life of the larger sort is always in inverse proportion to the increase of an agricultural population. The indigenous fauna increases in a land of aboriginal hunting folk of low culture, but decreases swiftly and surely in contact with civilized men. Aboriginal man is part of the fauna of a region. As a species he has struck a balance with other indigenous species of animals and as such is a "natural race." Like the lower animals the native man also vanishes from the region of settlement.

Of the lower mammals which inhabited the Atlantic forest region in aboriginal times the gray timber wolf was conspicuous, as all early records relate. It has not entirely disappeared from the wilder tracts, especially in the remote northern forest, even at this late day. The bear still lingers in more or less security on the outskirts of settlement, his vegetarian tendencies rendering him a far less formidable animal than some of his former neighbors. Of these last the cougar, variously known as puma, panther or "painter," was a desperate character and has been hunted out even from the more remote wilderness. His relative, the bay lynx or wild cat, may still be met with in deep mountain woods. Of the deer tribe, the common or Virginian deer ("buck" in the colloquial tongue) is fairly numerous in many parts of the wild country, largely as a result of protection. The case of the wapiti or "elk," however, is different. This great deer at one time dwelt along the wooded ranges of the Appalachians, probably in some parts extending its migrations to tide-water (upper Chesapeake Rivers) as witnessed by various local place names. The deep wilderness of coniferous forest to the north, remote and little disturbed by European invasion, is inhabited by two species of deer—the moose and the caribou—which are still fairly numerous. A difference in habits, as well as in aboriginal distribution, may account for the persistence of these two deer, as compared with the elk, in the Atlantic region. The elk is gregarious by nature and in the early history of the country was found in large herds, sometimes a hundred or more individuals, frequenting the open beaver meadows and the timber of river bottoms throughout the Appalachians. The moose and the caribou, on the other hand, rarely associate in any considerable numbers and frequent more inaccessible places, as tamarack thickets and the heavy growth of spruce and birch woods.

At the time of the discovery, and possibly long before, the bison

or buffalo had extended its range eastward into the region about the headstreams of the Ohio and Tennessee and there is evidence that an occasional straggler had even reached the upper valleys of streams flowing into the Atlantic. Remains of the animal found in caves and deposits in several localities testify to this eastward extension of its range in pre-Columbian times. The word "buffalo," occurring as it does in certain place-names of an early date throughout the middle Atlantic region, offers further evidence as to the one time presence of the animal in these localities, and there is at least one well-authenticated notice of its having been killed in central Pennsylvania as late as 1790.⁵

Of the smaller animals many, like the beaver and the otter, have disappeared, though the latter animal is still rarely seen here and there on remote streams, even in the settled districts. The beaver formerly built its dams and lodges in many of the streams throughout the forest region and traces of its occupancy may still be found in certain woodland meadows as well as in various place-names. Other species seem to have suffered little if any diminution, as the fox, skunk, mink, woodchuck, musk-rat, the raccoon and opossum, while rabbits and squirrels multiply apace. These have all in part adjusted themselves to the new conditions, many of them thriving at the expense of the agriculturist.

VI

A tract published in London in the year 1634 under the title "New England's Prospects," by William Wood, contains among other interesting and curious observations the following concerning the American weather:

The North-West wind coming over the Land is a cause of extreme cold weather. . . . But as it is an Axiome in Nature, *Nullum violentum est perpetuum*, No extremes lasting long, so this cold winde blowes seldome above three days together, after which the weather is more tolerable, the Aire being nothing so sharpe, but peradventure in foure or five dayes after this cold messenger will blow afresh, commanding every man to his house, forbidding any to outface him without prejudice to their noses.

This is a capital description of the average winter climate of eastern North America, dominated as it is by the constant succession of high and low pressure areas moving eastward across the country. William Penn in like manner writing from Pennsylvania says—"the weather often changeth without notice, and is constant almost in its inconstancy"—which, as John Fiske remarks, is "an excellent description of nearly all weather in the United States, except on the coast of California."

Many of these early tracts on the colonies were what might be

⁵ Rhoads, "The Mammals of Pennsylvania and New Jersey," page 47. Also *Proceedings of the Academy of Natural Sciences of Philadelphia*, 1895, p. 224; and 1897, p. 207.

styled in the slang of to-day "land boomers." "New England's Prospects" was one of these, and it drew a comparison at the expense of the Virginia region with the hope, no doubt, of inducing families to come over and settle. Wood says:

Virginia having no winter to speak of, but extreame hot Summers, hath dried up much *English* blood, and by pestiferous diseases swept away many lusty bodies changing their complexion, not into swarthinness, but into paleness: so that when as they come for trading into our parts, wee can know many of them by their faces. . . . In *New England* both men and women keep their natural complexions, insomuch as seamen wonder when they arrive in those parts, to see their country-men so fresh and ruddy.

In another place the same writer says:

The hard Winters are commonly the fore-runners of pleasant Spring-times and fertile Summers, being judged likewise to make much for the health of our *English* bodies.

There has been considerable speculation on the subject of climatic influence in the moulding of an "American type." The moist climate of England presents a marked contrast with the drier continental winds of the region east of the Rocky Mountains, and a certain change in the physical type, since the settlement of the country is undoubtedly a fact. Unfortunately, however, there are no exact data and we are still left in the lurch with only our theories. No doubt the American atmosphere by virtue of the "cold wave" possesses a higher electrical potential and a more drying effect upon the tissues than does the atmosphere of Great Britain and western Europe. This may increase nerve tension, though it is by no means clear in just what way the American climate has altered the European type. The different effect of landscape, which is largely a matter of atmosphere, must have influenced the European mind in some degree, at least in accentuating the idea of greater expanse. The contrast between the sky of England and that of America assuredly is most striking. The English sky has the appearance of being less wind-swept, and the sunshine has the quality of having been sifted through cloudy vapors much more obviously than the sky in America. This has the effect of softening or toning down the outlines of the typical English landscape, at the same time making the sky seem more imminent. In the American sky there is less of this apparent nearness; more of what Lowell would call the "emancipating spaces." These landscape and sky effects, at the same time exist largely in the eye of the beholder. It seems to be a habit of mind to interpret the facts of nature in terms of one's own sense impressions—to see things, as it were, through temperamental glasses.

The early settlers found spring invading this new land—creeping up river valleys, touching the meadows and woods with its young green—and the farmer still finds spring invading this homeland of the Atlantic slope through the valleys of the Susquehanna, Delaware,

Hudson and Connecticut. Spring is always appreciably earlier in such places. It spreads later over the uplands. We are apt to think of our rivers as flowing eastward to the ocean, when in reality they flow almost directly southward. This is true, at least, of the more northerly rivers—the Connecticut, Hudson, Delaware and Susquehanna, and of the larger rivers flowing into the Gulf of Maine, as the Kennebec and the Penobscot. South of the Chesapeake the rivers do come more directly from the west.

The physical basis of this advent of spring is the northward movement of a definite line of heat (the isotherm of 43.8 degrees F.) that calls into germinal life the slumbering forces of vegetation, awakens the hibernating animal and urges the migratory bird to seek its northern nesting place. An expanding zone of green marks this creeping of the vanguard of spring up river valleys, over hill country and along mountain slopes until all the land is invaded and the frost giant driven back to his hyperborean realm. In woods almost the first touch of spring is seen when the branches of the spice-bush break out in yellow blossoms. In fields, at this time, the plow is turning over the fallow and the air is redolent of earthy smells. In gardens the sod-breaking crocus and daffodil appear along the squalid, unkempt borders. From meadow pools comes the piping chorus of cricket frogs. Crows are brooding in remote woodlands, and the grackle flocks and robins have returned. This is spring as we know it on the Atlantic slope to-day and as our fathers knew it after the first planting of the wilderness.

Spring waxes into summer and summer wanes into autumn and after the gorgeous pageant of the leaf has passed there steals over this land a time of strange stillness. A haze, like the farthest waftings of some distant forest smoke, broods over the landscape, veiling its features and filling the responsive mind with a vague sense of mystery. There is a mellowness of sight and sound; all that was harsh and discordant seems now blended into one harmonious tone by the enchanted haze. All too soon these few delightful days are dispelled and we stand upon the threshold of winter. This charming period, coming in November, has been called the Indian Summer. The reason for its name is not obvious. It suggests remoteness, like some old Celtic tale, and there are those of us who would fain think of it as a heritage from the aboriginal past. Students who have investigated the matter will scarcely credit such vain imaginings, but however the name may have come, it is surely most happily associated with a dreamy spell of weather in the late days of the American autumn.⁶

VII

The influence which this threshold of the new land had upon the mind and character of the people is perhaps more apparent than are its

⁶ "The Term Indian Summer," a pamphlet by Albert Matthews, Boston.

purely physical effects upon the tissues. It is reflected in many characteristics. As a matter mainly of feeling it finds expression in literature; as a motor response, in the working out of ideals and in material progress.

A sense of spaciousness, of being untrammelled by close-set boundaries, had worked upon the imagination of the people. More than anything else was the idea of expanse in the vast extent of territory that lay to the west. The motor response to this feeling found expression in that great westward movement of population into the rich bottomlands and fertile prairies of the Mississippi Basin. Men had caught the inspiration on the threshold, amid the homely farm-lands and clearings, and in the growing towns with their semblance of European culture. Here on the threshold they felt the stir of a new life and moved under its impulse. Daniel Boone, standing on the bluff edge of Muldraugh's Hill and gazing out over the vast primeval forest that lay at his feet, is the prophetic figure of that time; a figure with its face ever turned toward the west.

The earliest feeling for the natural objects and scenery of the American land that found expression in literature appears in the stories, essay and verse of such writers as Cooper, Irving, Bryant and Thoreau, and in the journals of travelers and naturalists. In the "Episodes" which Audubon interspersed through his "Ornithological Biography," and often, indeed, in the descriptions of various birds, we find portrayed many scenes of the early American background. Thoreau was steeped in the natural features of New England and the fascination of his books is largely in the local color which he reflects through his peculiar personality. To a less extent both Emerson and Lowell have reflected this home environment of the Atlantic slope. Cooper's "Novels" emphasize the frontier life as it existed on the western edge of the threshold—the typical "backwoods" period in central New York and the northern Appalachian region. Washington Irving, for all his indebtedness to a long residence in England and to Addisonian sources, found the inspiration for much of his best work in the Hudson Valley and the Catskills. English poets and writers had set the nightingale, the skylark and the cuckoo forever singing in the hearts of men. Irving, harking back to his boyhood days, immortalized the bobolink, "the happiest bird of our spring." William Cullen Bryant, in like manner, gave literary value to many objects of native growth. To lovers of that English literature that found expression in the new homeland the "Fringed Gentian" and the "Yellow Violet" will hold an equal place in the heart with the "rathe primrose" and "daffodils that come before the swallow dares." Bryant was under the spell of the aboriginal spirit of the land, and the haunting mood of the ancient wilderness appears in many of his verses. In his poem, "The Prairies," he has given voice to that sense of dis-

tance, of vast stretches that lay "twice twenty leagues beyond remotest smoke of hunter's camp," far beyond those prairies that he was traversing and where he found the bison's "ancient footprints stamped beside the pool." Whittier, too, has left us pictures of the land—the farm life of a New England winter in "Snow Bound," and the bracing air of an upland road with its late summer bloom of golden-rod in "Among the Hills."

The most sympathetic verse of our native poets is in these touches of nature; that nature that wrought upon their childhood on hillside farms, in the woods and fields, and by the streams of the land that their fathers first set foot upon—the threshold of a new home.

LATIN VS. GERMAN

BY PROFESSOR RALPH H. MCKEE, PH.D.

LAKE FOREST COLLEGE

CERTAIN arguments have from time to time been presented favoring a rule requiring all students to present Latin for entrance to college, rather than to place the ancient and modern languages on an equal footing. The following very suggestive data were obtained from the records of Lake Forest College, Lake Forest, Ill., and presented to the faculty of that institution. In the thought that others might be interested they are now publicly presented, though with some hesitation, owing to the comparative smallness of the number of students under observation, the class entering each year being ordinarily about fifty-five.

Greek and French being but rarely given in the high schools of Illinois and the adjoining states, the question actually comes to a question of German *vs.* Latin. It was thought that, by a study of the data available from the college records, evidence of the comparative value of the two languages, as now taught in the high schools, might be obtained. The statistics have given an answer showing that German is unquestionably as desirable as Latin as a requirement for entrance to college.

1. It has been claimed that the student with Latin preparation for college does better work in college than the student whose high-school language preparation has been German.

The records of Lake Forest College show that in so far as grades indicate the quality of work done in the various departments and that is the purpose of giving grades they show that the student, whose language preparation for entrance has been German presents work of *fully* as good quality as that of the student whose language preparation has been Latin.

If Latin were really better than German for preparation for college entrance, then the students of Group 1 would have the highest grades, the students of 2A higher than 2B and 2C, and the students of 3A higher than 3B and 3C. The facts are exactly contrary to the above, the students whose language preparation has been German proving to be better students than those who have presented Latin for college entrance.

2. It has been claimed that the study of Latin is particularly valuable as a preparation for work in English, far better than the modern languages.

TABLE I
ENTRANCE RECORDS AND GRADES FOR ALL STUDIES FOR THE YEARS 1903-07

Group	Years at Entrance	No. Students	Percentage of Each Grade Obtained				
			A	B	C	D	E
1.	4 Latin and 0, 1, 2, 3, 4 other language.....	102	34.6	42.7	21.0	1.0	0.6
2A.	3 Latin and 0, 1, 2, 3 other language.....	31	33.2	38.5	26.5	1.1	0.7
2B.	3 German and 0, 1, 2, 3, 4 other language.....	20	33.1	43.4	23.1	0.4	—
2C.	3 German and 0, 1, 2, 3 other language.....	10	41.2	43.2	15.5	—	—
3A.	2 Latin and 0, 1, 2, 3 other language.....	46	25.4	45.5	24.9	2.3	1.9
3B.	2 German and 0, 1, 2, 3, 4 other language.....	57	39.1	37.3	20.7	1.4	1.5
3C.	2 German and 0, 1, 2, 3 other language.....	29	39.2	34.1	23.0	1.9	1.9

TABLE II
GRADES OBTAINED IN THE DEPARTMENT OF ENGLISH (1903-07)

At Entrance	Percentage of Each Grade Obtained				
	A	B	C	D	E
4 Years, Single Language					
4 Latin.....	31.4	45.9	18.5	1.4	2.8
4 German. ¹	25.0	41.6	25.0	8.3	—
4 Years, Two Languages					
3 Latin and 1 German.....	12.5	12.5	62.5	12.5	—
2 Latin and 2 German.....	22.2	37.5	32.5	5.0	2.5
1 Latin and 3 German.....	No students				
5 Years, Two Languages					
4 Latin and 1 German.....	30.2	39.5	23.3	7.0	—
2 or 3 Latin and 3 or 2 German.....	43.5	43.5	13.0	—	—
6 Years, Two Languages					
4 Latin and 2 German.....	47.1	40.0	12.9	—	—
3 Latin and 3 German ¹	60.0	20.0	20.0	—	—
2 Latin and 4 German.....	No students				

TABLE III

Group	Years at Entrance	No. Students	Percentage of Each Grade Obtained				
			A	B	C	D	E
1A.	4 Latin and 0, 1, 2 or 3 German...	93	34.6	42.5	19.6	2.3	1.0
1B.	4 German and 0 Latin ¹	2	25.0	41.7	25.0	8.3	—
2A.	3 Latin and 0, 1, 2 or 3 German...	26	26.0	42.0	28.0	2.0	2.0
2B.	3 German and 0, 1, 2, 3 Latin ...	20	25.0	42.3	30.8	1.9	—
3A.	2 Latin and 0, 1, 2, 3 German ...	38	20.2	45.2	31.0	2.4	1.2
3B.	2 German and 0, 1, 2, 3, 4 Latin ...	54	31.0	45.1	20.4	1.8	1.8
3C.	2 German and 0, 1, 2, 3 Latin ...	26	29.3	39.7	24.1	3.4	3.4

¹ There were only two students in each of these three groups, so they should be omitted in any generalization. However, it may be noted that in their effects they balance each other.

It is thus seen that with an increase of language preparation there is an increase in the quality of the work in English, but that in so far as there is shown a difference between the value of German and Latin the advantage is with German.

Grouping the students' grades in English (1903-1907) after the method used when the grades of all departments were considered (Table I.) we have:

It might be questioned whether in group 3B the considerable number of students who have had 2 years' German and 4 years' Latin might not be responsible for the higher English grades. Omitting those with 2 German and 4 Latin we have group 3C in which it is seen that the percentage of high grades is changed but little and is still far better than the corresponding Latin group 3A.

It is thus plain that, in so far as our experience gives light, and contrary to the old superstition, a year's German helps a student's work in English more than a year's Latin.

3. Is the student whose language preparation for college is German as likely to persevere until graduation as the student whose language preparation has been Latin?

The classes of 1907 and 1908, as given in the last catalogue, were taken for study. Of these students the entrance records of 45 were available, the others having entered from other colleges, etc. At entrance these two classes numbered 95.

CLASSES OF 1907 AND 1908

	Years at Entrance. Average per Student	Years at Graduation. Average per Student	Per Cent. Increase
Latin.....	2.83	3.04	7.4
German.....	1.04	1.31	26.0

From Lake Forest's experience we must conclude that the student whose high-school language preparation has been German is more likely to stay through the college course than the one whose language preparation has been Latin.

4. It has been claimed that the students from the better class of families study Latin rather than German. It is hard to characterize just what is meant by "better class of families." Perhaps the financial condition represents this as correctly as any one criterion that may be used for measurement.

The scholarship lists for last year and this year include a total of 80 names, duplicates not counted.

	Latin	German
Average entrance credits, scholarship students	2.96	1.04
Average entrance credits, all students last five years ..	2.91	1.16

In other words, the more Latin and the less German a student has the more likely he is to need financial assistance.

6. It has been claimed that there are not enough students in the high schools studying German, who are not studying Latin, to distinctly increase the number of possible college students.

The Lake Forest records show that the amount of Latin per student is not increasing, but that the amount of German is steadily increasing.

Students Entering Lake Forest	Total Number	Average Latin per Student	Average German per Student
1903-4	53	2.93	1.01
1904-5	42	2.69	1.15
1905-6	57	3.21	1.33
1906-7	59	2.97	1.19
1907-8	58	2.65	1.47

The United States Commissioner of Education's Reports show that the proportion of students taking Latin is not increasing while the proportion taking German is increasing faster than that taking any other subject.

Letters of inquiry to the high schools in the larger towns of Illinois and the adjoining states show that with them the proportion studying German rather than Latin is even larger than is given in the United States Commissioner of Education's Report for those states, the small high schools being included in the Report as well as the larger ones.

Letters from other colleges where the languages are placed on an equal footing for entrance show that a considerable proportion of their students, particularly men, enter without Latin. (The colleges where the languages are placed on an equal footing are nearly all in the north central states.)

President Hughes, of Ripon College:

We have eighty freshmen. Thirty-six offered Latin for entrance requirements. Forty-four did not offer Latin.

President Plantz, of Lawrence University:

This year we have 173 freshmen, of whom 63 presented Latin as an entrance credit. I think the number presenting Latin is steadily decreasing.

Registrar Densmore, of Beloit College:

Of the class entering in September, seventy-eight had Latin credits and sixteen were without Latin credits; of the latter the large majority were men. In general, a large proportion of the men enter without Latin. I do not think that we feel that the policy of taking in these men has lowered the standard of the institution.

Registrar Hiestand, of the University of Wisconsin:

I think I may safely place the number of students with part or full Latin preparation, entering the College of Letters and Science, as between 60 and 70 per cent.

Registrar Pierce, of the University of Minnesota:

We have 548 freshmen in the College of Science, Literature and the Arts, and 131 did not present Latin for admission.

Lake Forest, while nominally requiring four years of language, two of which must be Latin, has actually not attempted to enforce the requirement of Latin, but instead has, for a number of years, placed the ancient and modern languages on a parity. By this action of its entrance board in allowing students to enter with other languages in place of Latin the above comparisons have been made possible. It is possible, though quite improbable, that the students under observation at Lake Forest were exceptional and that conclusions drawn from their records are not capable of general application. It would be very valuable, if in a community where a modern language is taught in the high school to an extent approximating that of Latin (for French, Massachusetts or New Hampshire; for German, Wisconsin, Minnesota, Pennsylvania or New York), a large institution, where the languages are on a parity regarding entrance, would present similar records.

THE LAST CENSUS AND ITS BEARING ON CRIME

BY THE REV. AUGUST DRAHMS

CHAPLAIN OF THE STATE PRISON, SAN QUENTIN, CAL.

THE latest published report of the criminal census of the United States, recently issued, gives an aggregate prison population of 81,772, five hundred and fifty-seven less than a like report for the previous decade ending with the year 1890.

By states the figures present an equally exceptional showing, unexplainable upon the basis of any known law of criminal variation. Thus, among the foremost states that have shown an actual increase in the number of offenders, we have Kansas, 58.2; West Virginia, 50.6; Florida, 40.7, and Washington, 26.6. Twenty of the states, many of them under similar civic, social, climatic and economic conditions, register a marked falling off in the number of such defalcants, notably, New York leading with an actual decrease of 1,606; followed successively by North Carolina, 848; Illinois, 756; Arkansas, 589; Tennessee, 454; Alabama, 450; Arizona, 359; Missouri, 40, and California, 43 prisoners.

The above showing as a whole, would seem to indicate upon the surface a healthy diminution in crime within the last ten years, especially when we consider the fact that the general population of the country has increased during the same period 29.84 per cent. and the criminal status had grown steadily during every previous decade, as set forth by those reports successively, that of 1880, for instance, showing an increase of 78.14 per cent. over that of the previous report; while that of 1890 gives us 40.47 per cent. over that of 1880.

The cause assigned for this apparent falling off in crime, however, is set forth in the body of the report as due to the introduction and spread of the probationary system by which the more youthful, and first offenders, are placed under suspended sentences dependent upon good behavior under proper supervisory care appointed by the court, a wise tentative measure, not without its faults, but infinitely superior to the unconditional detention of this class of offenders at the risk of a still greater immurement in crime at the most impressionable period of their existence.

As to the actual number thus passing under probationary methods we have no way of knowing save from the records of the courts themselves, but they must necessarily be considerable and help to swell materially the general criminal record.

Moreover, a large number of offenders are now sent to the juvenile reformatories who were heretofore included in the jail and penitentiary population, the number in 1890 being 14,846, while in 1904 they had grown to 32,034, an increase of 55 per cent.

These both represent decided movements in advance in the penological systems of the land, approaching more nearly a rational process in the line of treatment and certainly more in accord with the best thought in tentative methods. At least it has this advantage over the old process in that it *may* cure while the latter is *sure* to solidify irrevocably into criminal characterization.

A curious study in the variation of the criminal psychological wave that sweeps over the land, is afforded in tracing the rise and fall of the various grades of offences throughout the different geographical divisions of the United States. A wide divergence in the ratio of the same offences is thus presented with apparently slight differentiation in the social, climatic or economic conditions as manifestly operating causes.

Commencing with grand larceny, which may be considered as a representative type of crime as standing for attack upon property, and we have a wide divergence in the criminal barometer. That form of offence constitutes about 16.8 per cent. of the general bulk of offences in the United States. It finds its lowest manifestation at 12.4 per cent. in the North Atlantic Division, reaching its highest point at 27.1 per cent. in the South Central, and its medium at 15.9 per cent. in the extreme Western Division. In the report of ten years previous it found its maximum in the Western at 61.7 per cent., and its minimum (as at present) in the North Atlantic Division at 24 per cent.

Assault, which may stand for the primitive (atavistic) form of crime in attack upon the person, and we have the lowest in the North Atlantic (5.5 per cent.), and its highest in the South Atlantic at 14.9 per cent. Burglary seems to be the least frequent in the North Atlantic (3.0 per cent.) and most rife in the South Central, where it reaches 11 per cent.

Robbery, the more aggressive form of mixed offenses, contrary to general acceptance, is least rife in the Western Division (1.2 per cent.), and most prevalent in the South Central (18 per cent.); otherwise maintaining a remarkable uniformity throughout the other geographical divisions. In the report of the previous census it reached its climax (13.6 per cent.) in the Western Division. The same may be said of forgery and rape, the latter reaching its apogee in the South Central Division (1.0 per cent.), as against a lesser showing (.05 and .03 per cent., respectively), in the other divisions.

Homicide, the atavistic element in the criminal test, runs its en-

sanguined thread through the North Atlantic Division at the rate of .04 per cent.; in the South Atlantic, 4.3 per cent.; in the North Central, 1.4 per cent., and 9.2 per cent. in the South Central, while the "wild and woolly west," contrary to the generally accepted reputation, gives us but 1.5 per cent. of homicides. It has improved in this respect since the date of the previous census (1890) which assigns to that section 27.8 per cent. and to the South Central 22.7 per cent. against its present 4.3 per cent.—a marked veering in the mercurial tendency accountable upon no known law in criminal anthropology.

PERCENTAGE OF CRIMES TO POPULATION BY GEOGRAPHICAL DIVISION.

	CRIME	N. ATLANTIC	S ATLANTIC	N. CENTRAL	S CENTRAL	WESTERN
	HOMICIDE	.04	4.3	1.4	9.2	1.5
	ASSAULT	7.3	5.4	4.4	8.1	4.7
	ROBBERY	.08	1.6	1.2	1.5	1.8
	RAPE	0.4	0.3	0.2	.1	0.6
	BURGLARY	0.8	.6	.3	.1	1.2
	LARCENY	10.0	10.0	10.0	10.0	10.0
	FORGERY	0.7	2.2	1.2	0.4	1.0
	DRUNKENNESS	32.3	5.0	21.6	3.8	6.3

The total number of homicides in the United States for the year 1904 is given at 10,744, as against 7,351 in 1890, an increase of over 20 per cent. during that period.

As a general rule, the excess of given offences in the southerly divisions is due to the preponderance of the negro element, 67 per cent. of minor offences being attributable to whites, and 83.8 per cent. to the negro race.

Among minor offences drunkenness adds its quota of interest to the general perturbation, oscillating from 5.0 per cent. in the South Atlantic to fever line in the North Atlantic Division at 32.3 per cent., and falling to blood heat at 21.6 per cent. in the North Central, thence to 3.8 per cent. in the South Central and gradually tapering off the mathematical debauch in 6.3 per cent. accredited to the Western Division.

The variation in crime in this respect is no indication of the frequency of the offence, however; it rather reflects the public policy of the given section as expressed in the manner and form of the punishment for this particular offence. There is no special table of the existing habits of the prisoners enumerated, hence no way of reaching

any approximate conclusion upon the basis of facts. The census of 1890 gives 23.38 per cent. drunkards among its aggregate prison population, after deducting the number whose habits are "not stated."

Drunkenness is the prevailing habit of criminal offenders, fully 50 per cent. of crimes being due to that habit in this and European countries, perhaps 20 per cent. of the crime in this country being actually committed in the saloons themselves, which are the hotbeds of the criminal propaganda.

The great bulk of crime in the United States, proportionately, is upon the side of the foreign-born population. Succinctly stated, the 13 per cent. of the whole population, representing the foreign-born element, commit 23 per cent. of the crimes in the United States. Precisely the same ratio was reported by the census of 1890. The parentage of this foreign-born element aggregates 29.8 per cent., with a mixed parentage of 6.9 per cent. as against 63.3 per cent. of native-born. The leading nationalities thus represented are Ireland, 36.2 per cent. out of a representation of 15 per cent.; Germany, 12.3 per cent. out of 25 per cent.; Canada, 10.1 per cent. out of 11.4 per cent., and England and Wales, 9.2 per cent. out of 9.10 per cent., of the whole population. As to the more recent arrivals, the Italians furnish 6.1 per cent., with 3.5 per cent. of Russians, and 3 per cent. of Poles. This foreign element is not indigenous to the soil, but belongs to old world criminalism, a form of accretion that does not help swell, but diminishes, proportionately, the list of the country whence it comes. It is characteristic of no other country in making up the criminal consensus.

A careful study of the statistics of the various states show unequivocally the vital relation crime sustains to the two great negative centers of the social disease, viz., ignorance and want. As to illiteracy, that relation is not so apparent in the present as is usually shown by the reports of local institutions. Of the 144,597 committals for the year 1904, 83 per cent. were literates, and 12.6 per cent. were given as illiterates, and 4.3 per cent. not stated. The total percentage of illiterates in the United States was 10.7 per cent.

The occupation of the prisoner is more suggestive. Over 47 per cent. of the white offenders belonged to the laboring classes and servants, and but 3.5 per cent. to the professional and clerical order, while 27 per cent. were credited to the manufacturing and mechanical trades. Among these, it is observable, the professional (to the extent of 2.1 per cent.), and the agricultural portion (to the number of 23.4 per cent.), were more addicted to major than to minor offences, while the laboring classes and servants were more prone to the lesser than to the graver forms, the temptations to the latter being much less in rural districts than in the cities. The largest proportion of offences

against the person is found in the rural sections (34.2 per cent.), while those against property predominate in the professional (40.9 per cent.) and the clerical and official (49.8 per cent.) ranks.

These figures present material for the politico-social and economic philosophers, with whom it is left to discover the true points of causal relations and to trace the relative virulence of the social disease as it approaches those great active centers where the struggle for existence grows constantly more intense. In short, the want line focuses the brunt of battle, and here, whatever specific form it assumes, the overt act (that constitutes crime) is most pronounced whether manifested under the world-old principles of greed against need, or in the more purely sporadic form, in either case the burden of the attack may be said to be committed by those who stand nearer the want end of the economic problem, hence the solution must fall more largely to the social and economic phases of the question.

No clear understanding of the criminological problem from either a concrete or academic standpoint is possible without a table of recidivists. This has been omitted from the twelfth census. It renders it valueless to the student of crime. The recidivist table is a method by which we may roughly measure (approximately) the bulk of the criminal aggression and presents the only stable criterion upon which anything like a reliable estimate of the force of the criminal disease may be based with any degree of certainty. Upon its figures alone both the protective and corrective agencies may be said to operate with perfect safety. The repeater has earned his place in the criminal category by inherent right. Recidivism is the classification in the rough by which he is assigned *sui generis*. The generalization may be crude and not always fair, but it presents the only rule possible under the circumstances. The subtler psychological conditions that underlie human conduct escape utterly any and every analytical process. Every attempted classification upon the basis of accredited conduct must of necessity be but crudely inductive, but it is the only feasible method whereby to differentiate the true criminal from the offender by circumstance.

The latter may not repeat the same act under similar conditions, his inhibitory powers coming to the rescue, the former is almost certain to do so, owing to their lack, or total absence. It is the demarcation between the instinctive and accidental malfasant. The separation may waste some gold in the process, but in the main the method is correct. At any rate, it is necessary to a complete understanding of the criminal problem and the tentativeness of criminal and corrective measures. It clarifies the former and helps to simplify the latter. The first offender represents an invasion upon the healthy social tissue; the recidivist stands for the already diseased, hence their

treatment implies essentially different methods; to the one proper remedial initiatives under wise supervisory care; to the latter a simple process of sequestration under practical life detention.

The latter cuts off at a single blow the fountain of criminal propagandism, protects both society and the offender himself, and is the sole remedial dispensation against the infection. If for no other reason than this, tables that present the problem in clear numerical proportion are a great gain from both a theoretical and a practical standpoint, and its omission is at the expense of both. A marshalling of figures is like the marshalling of an army, it contains the potentialities of victory or defeat, though in the absolute these may be determined by subtler factors.

SIMPLE LESSONS FROM COMMON THINGS

BY PROFESSOR FRANCIS E. NIPHER
WASHINGTON UNIVERSITY

THERE has long been a feeling which is still more or less strongly pronounced, that matter is not worthy of very serious attention from mind. Some have had the feeling that matter was the source of all our woes. Although all conscious beings are embodied in masses of matter, it was thought to be a prison-house which served mainly to quench those higher feelings to which we should aspire. The world, the flesh and the devil were all put in one class, and we were advised to have as little as possible to do with any of them.

In the meantime there have been many who have given their undivided attention to the study of the material things which surround us, and with which we must deal. The chemist and the physicist have undertaken to study the structure and the composition of matter. And the more minutely it has been studied, the more wonderful does it seem when it is considered as a specimen of engineering and architectural construction. We were formerly told that the varied forms of matter which surround us were composed of a comparatively few elementary substances, each of which was composed of particles called atoms; that these atoms were all alike for the same substance, and that they exist everywhere as far as the astronomer can penetrate, into the infinite space which the stellar systems occupy. To give some idea of the size of these atoms as determined by the army of men who in various ways have indirectly measured their dimensions, Lord Kelvin made this illustration. If a rain drop were increased in volume, until its volume equaled that of the earth, the molecules of the substance being proportionately enlarged, the water molecules would then be larger than fine shot, and not larger than cricket balls.

But during the last decade another great step has been taken. A study of radioactive substances has shown that the atom itself is a structure of wonderful complexity. A radioactive substance is one whose atoms explode into their more elementary constituents. There are a number of substances which do this, radium being the most conspicuous of the group. Each of these substances yields one kind of corpuscle or particle which is common to them all. Each atom is composed in part of minute particles having a mass of about one thousandth that of the hydrogen atom. These particles have apparently been identified as negative electricity. They constitute what Franklin called the

electric fluid. They are a component of every atom of every kind of matter. We have only to rub any two unlike pieces of matter together, and one of them takes this negative fluid from the other. The piece of matter which has lost the electric fluid is said to be positively electrified. One question before us to-day is this: Should not this positively electrified matter be called positive electricity? It seems certain that there is no positive electrical fluid, and that there is no positive electrical current. What we have been calling the negative current is then the real current. It flows through our trolley wires and lights our cities. In other words, it seems very probable that all matter is composed of a combination of positive and negative electrical particles.

It is also certain that the positive and negative electrons are by no means simple in their structure. They are in some way linked with each other through the agency of the ether of space, and can act upon each other at a distance.

This may seem very complex and it may seem to be a complete overturning of the atomic theory of matter. In fact it is not in any sense an overturning of any theory of matter. The chemist still deals with atoms and combining ratios, and he will continue to do so.

If a house builder should suddenly learn that the bricks which he uses are not the final elements in his houses, it would in no way disturb him. The fact that his bricks are composed of molecules, and these molecules of atoms, and these atoms of negative and positive electricity, would in no way change his professional practise in the design of houses. The fact that we now find that every atom of any kind of matter is normally the abiding place of a certain definite number of negative electrons, each having a mass of about the one thousandth of that of the hydrogen atom, does not make these atoms behave differently from what they did before.

The fact that atoms of certain substances are exploding and giving off energy is no more remarkable than the fact that nitroglycerin and limestone behave differently. It is no more remarkable than the fact that some houses fall to pieces and give off energy. And it is in no way unexpected that an advance in our knowledge of matter has vastly increased the complexity of our conceptions of its structure. The phenomena around us with which we are in a certain sense familiar are by no means simple. For example, let us assume that some stranger from the regions which Dante described should now visit our earth, after an absence of thousands of years. When he was here before he dwelt in a cave. He sees our houses and he observes that empty houses attract homeless families. He tries to explain how this attraction is to be accounted for. He becomes acquainted with Newton's law of gravitation and he at first thinks that this is the clue which he is seeking. He soon learns that the size of the house has little to do with the attraction

which makes a family move into it. He is satisfied that houses do gravitationally attract people, but this is not in any way the attraction which produces the observed motion. He finally learns that it is the architectural features and the internal arrangement of the houses, and the landscape features immediately about the houses, which appeal to the minds of the people. Being a philosopher, he straightway forms an explanation which involves the existence of a mental field of force, emanating from these conscious beings, and laying hold of these architectural and other characteristics of the houses. Next he finds that ether waves are involved in the phenomenon. The people must see the houses before the attraction begins. This involves the existence of an all-pervading ether through which waves due to molecular agitation on the sun may pass. These waves, which we call light waves, fall upon these houses. From thence they pass into the eyes of the people, where they form images of the houses. The people do not see these images in the same sense that they see the houses, but in some unknown way these images make it possible for them to become conscious of those things, which determine for them the attractiveness of these houses.

It is through this complex train of machinery that the mental action is aroused, which results in this mental attraction. But this is not all. There must be involved in this transaction a transfer of the value equivalent of a certain number of foot-pounds of mechanical work previously done. The value equivalent of this work is produced by the family about to move into the house, and is delivered to the former owner who has moved out. This value equivalent of work is delivered in the form of a definite quantity of some valuable substance, as gold. He next finds that this transfer may also be made, by means of written entries on the books of two banks, through the agency of a check, which passes through the clearing house. By this means a credit to one customer at one bank is transferred to another customer at another bank. This value equivalent of work previously done exists potentially in the form of credit at a bank, and its quantity may be increased or drawn upon, as energy itself may be stored in a pond of water, which may be drawn upon to drive a mill.

The average citizen will tell you that we do not know what electricity is, and that the sending of wireless messages, and the driving of our street-cars, are operations which are full of mystery. But it never occurs to him that there is anything mysterious about the attraction which empty houses have for homeless families. He would think it wonderful that a balloon could be controlled by wireless methods, from a station on the earth, but it would never occur to him that there was anything remarkable about one conscious being influencing the outward action of another conscious being, by talking to him or by looking at him. We are surrounded on every hand by phenomena which we think

too commonplace to deserve a moment of our attention, and which we are, nevertheless, utterly unable to understand. In a crude way we can understand the machinery of sound waves. We can see the action of the vocal organs, by means of which they are produced. We can learn something of the nerve fibers of the ear upon which these sound waves fall. But what else is there at the two ends of this line of action? What is there within these two masses of matter, which enables either one of them to hold wireless communication with the other?

Let us assume that we are wholly familiar with the motion of each molecule of air involved in the sound waves; that we are able to make drawings of all the delicate modulations of muscular motion which are involved when the organs of speech produce these sound waves. Our drawings are to show precisely how these motions of the vocal organs are different, when English words are spoken with Irish and with German accent. Our knowledge is to be similarly complete concerning the receiving apparatus at the hearing end of the line. We trace these motions finally along nerves leading to two brains at opposite ends of the line. We may assume that we know all of these structures and their motions in the most minute detail. What do we then know of the phenomenon that one conscious being, embodied in a mass of matter, may determine or influence the thoughts and actions of another conscious being, by formulating thoughts in words, and delivering them to him through the air? How are we to explain the fact that he can plan and deliver a sentence, which will, unknown to the receiver, change the frequency of his heart beats?

He may even do this by sending to him through the mails a sheet of paper upon which he has made certain marks in ink. On the enclosing wrapper are certain other marks, images of which, by means of ether waves, are formed on the retinal membranes of clerks in the post office. By such means the muscular motions of these clerks are determined. The letter is delivered to the particular person whom the sender had in mind.

When the receiver of this paper has also allowed ether waves from these ink marks and the paper which bears them, to fall upon the nerves of his retinal membranes, he knows the mental attitude of the man who sent that paper. He makes some computations. He does some thinking. And, by the way, what is doing some thinking? He makes a response to the wireless message. The result is a mental agreement between two minds. A check and a deed of transfer of title to property are drawn, and are exchanged, and a family moves from one house to another.

What would the former cave dweller think of these amazing phenomena? I venture to assert that this transaction is vastly more complex than any electrical action. The man who talks of the mysteries of

electricity and who can not discover anything mysterious about the operations on the floor of a business exchange is in need of a mental shaking.

It is useless for us to attempt to answer such questions as, what is electricity? Or, what is a conscious being? Or, what is hydrogen? We can only answer such questions in unknown terms. But we have learned much about all of these things. Whether we consider matter in the minutest details of its structure or in the larger fields into which the telescope and the spectroscope have led us, we find the same array of wonders. How many of those who talk to us of the work of the Creator have the faintest idea of what those words mean? Have all of these electrons, and atoms and molecules and worlds and stars and stellar systems been created?

We are dependent on molecular vibrations on the sun for the conditions which make life possible. That heat energy which we receive from our sun will finally fail. The sun will become cold. The earth will freeze. Our atmosphere will become liquid and finally solid. The stars are also going through the same history. Their heat is also being continually radiated into space. The operation is like that of a clock which has been wound up and is running down. There must have been a beginning, and there will be an end, in cold and universal night. Now and then two dead stars may collide and vaporize into a nebula. This nebula may finally become a planetary system which may become the habitation of conscious beings; but it will go through the same history. And the number of bodies capable of colliding and forming world systems will have been reduced by one. To be sure, the probability of the occurrence of such collision happening during a given time interval will diminish continually, but there will evidently be an end of the present order of things. The results of recent work on the phenomena of radioactive bodies make it probable that the beginning of life on this earth may be much farther back in time than was formerly supposed. The heat which has been radiated from our earth has been in part supplied by the energy of these atomic explosions. It may be that the temperature of our sun may be thus maintained for a longer time than was formerly thought possible. But such considerations do not in any way change our ideas concerning the nature of the operations which are going on. Here also, in these radioactive bodies we find a store of energy which is being continually drawn upon. It is manifesting itself finally as heat which is being continually radiated into space. It may be that we must place a higher estimate than was formerly thought necessary upon the vast store of energy which the visible universes of to-day have possessed in the remote past. It may be that the work of creation was greater than we have supposed. It may be that the end is more remote than we now think. But even if we assent to the

conclusion that in theory the end is in the infinite future, it seems certain that so far as the possibilities of human life are concerned there will be an end. When a battery circuit is closed, the equations show that the current never reaches the value which Ohm's law demands, although it continually approaches that value. Practically it reaches that limiting value in a very small fraction of a second, and this result is also in exact harmony with the equations.

Consider the mechanical work that would be required, to take the stellar universes of to-day, as raw material, in the condition to which they are tending, and put them in the condition in which they now are.

To take a minute sample of this work of creation: let us assume that the moon were in tangential contact with our earth. How much work would be required to separate them to their present distance from each other? A very simple calculation shows that to do this amount of work would require a million steam engines, of a thousand horse-power each, working continuously for between fifteen and sixteen million centuries.

Each molecule of matter is composed of a swarm of minute particles and the chemist has never been able to detect any variations in the composition of molecules of the same material. Each molecule is a complete closed system, vastly more complex than our planetary system. What shall we think of the work which is involved in the creation of a system of stellar universes, so vast that the human eye can never hope to see any limit to its extension in space, and composed of particles existing in endless duplication, which are so small that the human eye can not hope to see them?

And we must add to these wonders of the material world, the still greater mysteries which are involved in life and consciousness. We may devote a lifetime to the study of these things, and we shall then feel how insignificant is our knowledge of these revelations which we are continually receiving. And we are more and more impressed with the feeling that a being capable of producing such results, must differ in many respects from an oriental despot. We may become more and more inspired with a feeling of profound admiration and wonder, as we think on these things which our eyes behold. But we can not feel that such a being is anxiously seeking for flattery and praise. If we were to seek by such means to secure from him personal favors which we do not deserve, we should be paying him a very doubtful compliment. Such methods are not even considered proper at our city hall.

The highest type of man of which we can conceive is one who does not deserve any credit for shunning iniquity or for doing the works of righteousness. He does not refrain from murder in order to escape the gallows and the lake that burns with fire and brimstone. He never feels any temptation to commit murder. He does not murder and he

does not steal, because he is neither a murderer nor a thief. Society does not need to surround him with policemen in order that he may be led to conclude with some reluctance and regret that honesty is the best policy! And when he goes about doing good, when he helps the fatherless and the widow in their affliction, he is not doing such deeds in order that he may secure to himself personal advantages in the nature of titles to valuable celestial properties. He thinks not of himself when his brother calls for help. He has within him the instincts of a gentleman. They were born in him. They have been bred into his very bones. These instincts prompt him to respect the rights and property of others, and to lend a hand when others need his help. He is ready to do his part in providing the children who are living amid brutal surroundings, with those influences which will inspire them with admiration for that which is pure and good and manly.

The highest type of man of which we can conceive deserves no more credit for being what he is, morally, than he deserves credit for having a white skin. It is precisely this which makes him a man of the highest type. He does not need to waste his strength in resisting temptation to do wrong. When we come to consider the character of the Creator of these wonders, which so far as we know find their highest expression in the human race, on this little insignificant earth, we can not think of him as claiming or deserving any credit for being what he is, or for doing what he has done.

We can not think of him as having been sorely tempted to do wrong and having resisted the temptation. We can not think of him as having struggled into his present position, under adverse and discouraging conditions, in a manner which entitles him to praise. We can not think of him as an oriental despot, who demands praise of his creatures, most of whom have never studied physics or astronomy or chemistry or biology, and who are therefore unable to properly appreciate the wonders which surround them on every hand.

We have, however, made progress, and we can all see that the possession of such knowledge as we possess, by the masses of the people, during those dark and brutal periods of religious intolerance, would have made impossible those bloody quarrels over questions to which we give not the slightest thought.

THE PROGRESS OF SCIENCE

**THE WINNIPEG MEETING OF THE
BRITISH ASSOCIATION FOR THE
ADVANCEMENT OF SCIENCE**

THE British Association has in recent years taken seriously its imperial duties. Twenty-five years ago it first met outside the British Islands. The step was not taken without long consideration and considerable opposition, but the meeting in Montreal in 1884 proved remarkably successful, no fewer than 910 members crossing the sea. In 1897 the association met in Toronto, and after an intervening meeting in South Africa in 1905, it has now for the third time visited Canada. The registration of members at Winnipeg was about 1,400, of whom about 500 crossed the Atlantic and about 150 came from the United States. The attendance at meetings of the British

Association is always greatly increased by local and visiting associate members who join for the year from interest in the general and social events or from public spirit. The meetings of the British and American associations are of about the same size, but there is a noticeable difference in the composition of the membership. In the case of the British Association there are a large number of amateurs dominated by a few leaders, whereas at the annual meeting of our association and the affiliated societies the average working man of science is the main factor. This appears to represent a typical difference between an aristocracy and a democracy, for though Great Britain may be in its government more democratic than the United States it retains its social aristocracy.



DR. A. E. SHIPLEY,
of Cambridge University, President of
the Zoological Section.



DR. ARTHUR SMITH WOODWARD,
of the British Museum (Natural History),
President of the Geological
Section.

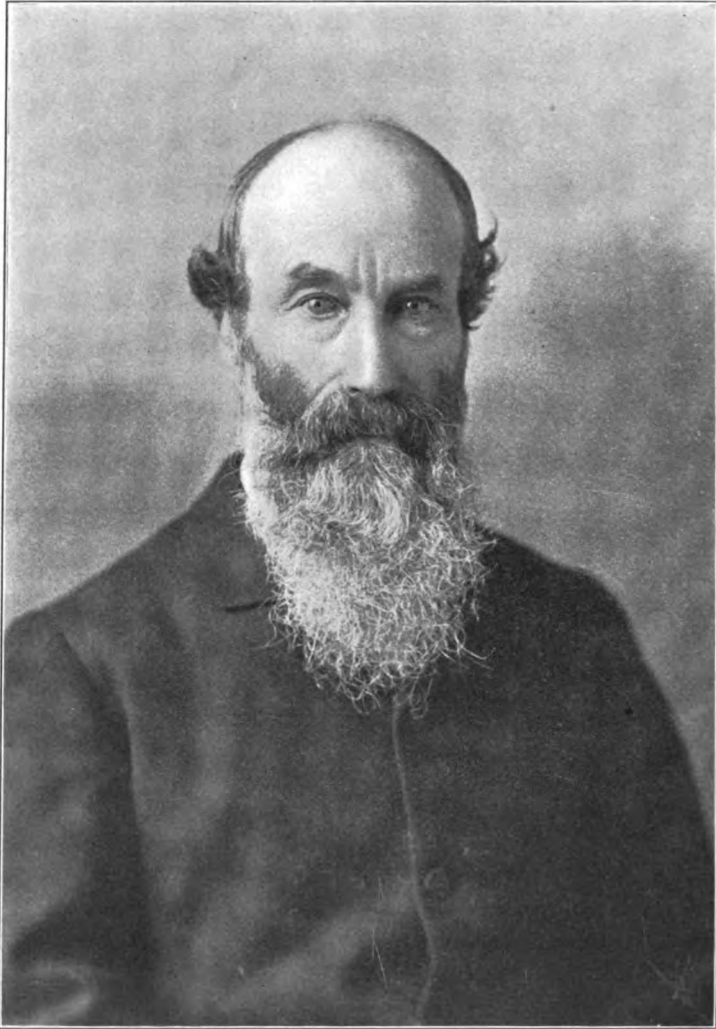

DR. T. G. BONNEY,
Professor Emeritus of Geology, University College, London, President of the
British Association for the Advancement of Science.



DR. E. H. STARLING,
of the University of London, President
of the Physiological Section.

It is certainly a remarkable fact that with a much smaller number of working men of science than Germany or the United States, Great Britain is able to produce so many great leaders. Lord Rayleigh was president of the Montreal meeting twenty-five years ago and Lord Kelvin president of the section for mathematics and physics. It might be supposed that Great Britain could not again furnish two physicists of the same class, but at Winnipeg Sir J. J. Thomson presided over the association and Professor Rutherford over the section, both recipients of Nobel prizes and commanding the course of modern physics.

In his address Professor Thomson referred first to the local conditions of the meeting and the great development of Manitoba, reminding his hearers that even the enterprise and energy of the people and the richness of the country could not have accomplished this without the resources coming from the labors of men of science. After discussing certain educational problems, including the dangers from the

examination system and early specialization, the speaker reviewed the more recent developments of physics and the new conception of physical processes with which he himself has been so intimately concerned. As he aptly said in his concluding sentences: "The new discoveries made in physics in the last few years, and the ideas and potentialities suggested by them, have had an effect upon the workers in that subject akin to that produced in literature by the Renaissance. Enthusiasm has been quickened, and there is a hopeful, youthful, perhaps exuberant, spirit abroad which leads men to make with confidence experiments which would have been thought fantastic twenty years ago."

Professor Rutherford naturally chose for discussion one of the subjects in the newer physics with which his own work—largely carried on in a Canadian university—has been concerned, namely, the present position of the atomic theory and the values of certain fundamental atomic magnitudes. Before the



SIR WILLIAM HENRY WHITE,
formerly Director of Naval Construction
of the British Navy. President of
the Engineering Section.

chemical section Professor Armstrong covered a wide range of topics. He charges Ostwald with filling his test tubes with ink; but he himself writes some 35,000 words, going at times considerably beyond the ascertained facts of science, as in discussing "the revolt of women against their womanhood." Dr. A. S. Woodward before the geological section treated paleontological topics and the old age of races largely in the light of American discoveries. Professor A. E. Shipley opened with some references to Charles Darwin, discussed methods of organizing zoology, with its 600,000 known species, and concluded with a discussion of international oceanic research. Sir W. H. White treated the engineering enterprises and commerce of Canada and Great Britain. Professor E. H. Starling applied physiology and biology to sociological questions. Addresses of equal interest were given before the other sections and at four general meetings, the speakers in practically all cases emphasizing those aspects of science which are likely to hold the attention and affect the conduct of those who are not professionally engaged in scientific work.

As always, the excursions and social events were arranged in a way that it does not seem possible to rival in this country. The Canadian government appropriated \$25,000 and the city of Winnipeg \$5,000 toward the expenses. It is only necessary to mention the excursion to the Rocky Mountains and the Pacific coast with 150 invited guests. When the association met at Montreal 300 English members attended the Boston meeting of the American Association, but there does not appear to have been this year any concerted effort to bring the foreign men of science south of the Canadian border.

The Rev. T. G. Bonney, the eminent geologist, professor emeritus in University College, London, was elected president of the association for the meeting to be held next year at Sheffield.

SCIENCE AND ADVENTURE

REACHING the North Pole and flying across the British Channel are sporting events of the first magnitude. They stir the imagination and unite the whole world in healthy interests and generous enthusiasms. They may also be regarded as achievements of applied science. Thousands of workers in the laboratory and in the field have made possible the adventures whose culmination fills the daily papers. To "nail the stars and stripes to the pole," as Commander Peary cabled, or to win for France "imperishable glory" by a flight from Calais to Dover is not in itself a serious contribution to science. But these achievements exhibit in dramatic form the conquest of nature by man which science has accomplished. Perhaps the only facts of considerable scientific interest so far announced in the case of the "dashes" to the pole are Dr. Cook's statement that he discovered land in the extreme north and Commander Peary's sounding which proved that the sea at the pole is over 1,500 fathoms deep. In the main the appeal is to the imagination and it is unfortunate that patriotic enthusiasm has been checked by a certain amount of skepticism in regard to Dr. Cook's exploit. It is certainly unfortunate that Commander Peary should have so expressed himself. From the time of Herodotus it has been the fate of travelers to have their stories questioned. It is to be hoped that Dr. Cook's records may prove entirely definite, so that all doubts may be cleared up. In any case the pole has been reached, and the way has been cleared for scientific exploration in the arctic and antarctic regions.

THE POSSIBLE POPULATION OF THE UNITED STATES

IN the last issue of the MONTHLY Professor A. P. Brigham discusses the capacity of the United States for population and places the maximum number of people that can be supported by our resources at 305,000,000. In an

earlier volume of the MONTHLY (November, 1900) President Henry S. Pritchett predicted, a population of over a billion two hundred years hence and of about twelve billion six hundred years hence. We may agree with Professor Brigham that "population is a vast and wandering theme." It is, however, fascinating and not without practical interest. Emigration laws and even birth rates are not unaffected by such guesses as may be made.

The population of a country is in the main limited by the food supply. Man does not live by bread alone, but his higher needs are increasingly supplied by an increasing population. With a given stock and a given environment the number of men of genius who add to the social heritage is proportional to the population. Material supplies other than food are needed, but they are not likely to become exhausted. Metals and clays are inexhaustible; the increasing difficulty of obtaining them will surely be met by improved methods. Metals—also wood and even the materials of clothing—can be used over and over again should this become desirable. Fuel, like food, is consumed, but the sun's energy is boundless and means are already at hand to obtain all that may be needed. It is safe to say that the population of the earth is limited only by its food supply.

The area of continental United States apart from Alaska is, in round numbers, two billion acres, of which one half is in farm lands and one fourth under cultivation. Probably three fourths of the total area could be brought under intensive cultivation and made to give fifty bushels of corn per acre or its equivalent. The food value of a bushel of corn is sufficient to support a man for nearly a month, and the product of an acre would about support four men for one year. If one half of the grain were turned into animal food for human consumption, two men per acre could be fed and the country would support a population of 3,000,000,000. Apart from the possible

synthetic manufacture of food, it may be regarded as probable that improved agricultural methods will in the course of a century double the present maximum productivity. It should also be remembered that tropical lands are far more productive and under an ideal civilization would export food and import manufactures. The maximum population that might be supported in the United States may, a century hence, consequently be placed at about ten billions.

Such a maximum figure compares with a probable figure somewhat as the theoretically possible efficiency of a steam engine compares with its actual efficiency. But a population of one billion could be supported comfortably. Our present food supply feeds about a hundred million. Better methods would double the production from the area at present under cultivation and less wasteful methods would halve the consumption. If the area under cultivation were increased from 25 per cent. to 62.5 per cent. there would be food for a billion people. Allowing for a reasonable exchange with tropical countries and an ever-increasing efficiency in production such a population would have an ample food supply with a reasonable amount of meat and fruit and even as much alcohol, tobacco and coffee as may be desirable for health. Such a population would not mean in any sense living under the conditions of the Asiatics. The more dense the population within the limits stated, the greater would be the per capita wealth. Nor will the country be crowded. Doubtless most of the people would prefer to live in villages or cities and for the quarter that might prefer the country there would be thirty acres for each family.

What the actual population of the United States will be a hundred years hence is a very different question. In a state of nature the number of a species may be reduced by enemies or disease, but as a rule they are limited only by the food supply. But with

man a change more significant than any other in history has taken place within the last fifty years. Thanks to the applications of science, the food supply is ever increasing; but the supply of children decreases in an ominous manner. The population of a country is no longer limited by the food supply, but by a conflict between instinct and rationalism, and by physiological fertility under the conditions of modern civilization. It is not likely that the population of any country will ever again be so large as its food supply would support.

SCIENTIFIC ITEMS

WE record with regret the deaths of Professor Emil Hansen, the eminent physiological botanist of Copenhagen, and Dr. Otto von Bollinger, professor of pathology at Munich.

DR. C. M. GABRIEL, professor of medical physics at Paris, has been elected president of the French Association for the Advancement of Science for the meeting to be held next year at Toulouse.—At the celebration of the fifth centenary of the University of Leipzig some ninety honorary degrees were conferred, including a doctorate of medicine on Professor E. B. Wilson, of Columbia University, and doctorates of philosophy on Professor Jacques Loeb, of the University of California, and Professor A. A. Michelson, of the University of Chicago.—At its recent celebration the University of Geneva conferred one hundred and fifty honorary doctorates. Among the men of science included were Lord Lister, Professor Haeckel, Professor Ostwald and Professor Engler.

PROFESSOR R. C. ALLEN, of the University of Michigan, has been elected state geologist to succeed Mr. A. C. Lane, who resigned to accept a chair in Tufts College.—Dr. Juan Guitaras has consented to remain director of sanitation and chairman of the National Board of Health for Cuba, in

view of the fact that the government has now appropriated sufficient funds for the work of the department of sanitation.—Dr. E. D. Durand, the director of the census, has announced the appointment of experts in statistics, economics, agriculture and manufactures to cooperate with him in the formulation of the census schedules on which the enumerators will enter the information they obtain next April. The conferees on the agricultural schedule are: Dr. J. L. Coulter, instructor in agricultural economics in the University of Minnesota; Dr. H. C. Taylor, professor of agricultural economics in the University of Wisconsin; Dr. C. F. Warren, Jr., professor of farm management in Cornell University, and Dr. T. M. Carver, professor of economics in Harvard University. The conferees for manufactures and on population are leading experts, being in most cases university professors.

WHILE the British are reorganizing the College of Medicine and the Technical Institute at Hong Kong into a university, the Germans have established a school of university grade at Kiao-chau. It is said that the German government has appropriated \$160,000 for its establishment and will contribute \$50,000 annually for the support of the institution.—The assembly of Iceland has decided to establish a university at Reikjavik, with four faculties and sixteen professors and lecturers.

By the will of Cornelius C. Cuyler, the New York banker and a trustee of Princeton University, \$100,000 is bequeathed to Princeton University. The residue of the estate, which is said to be very large, will go to the university after the death of Mrs. Cuyler.—The council of the city of Cincinnati has appropriated the sum of \$576,000 to erect three new buildings for the University of Cincinnati.

THE POPULAR SCIENCE MONTHLY.

NOVEMBER, 1909

THE SHIFTING OF THE EARTH'S AXIS

By DR. SIDNEY DEAN TOWNLEY

STANFORD UNIVERSITY

THE earth has two principal motions, one of revolution about the sun, the other of rotation upon an axis. The revolution about the sun is accomplished in $365\frac{1}{4}$ days at an average speed of nineteen miles per second, or thirty-three times the speed of the swiftest modern projectile. The rotation upon its axis is accomplished in twenty-four sidereal hours, and since the equatorial circumference of the earth is nearly 25,000 miles, a point on the earth's equator has a speed of rotation of over one thousand miles per hour.

In form the earth is an oblate spheroid, a flattened sphere, and the axis about which it rotates coincides very nearly with the shortest axis of the body. If a plane be passed through the center of the earth perpendicular to the *axis upon which it rotates*, not perpendicular to the shortest axis, this plane will cut the surface in a circle which is known as the equator. One of the two coordinates by which the location of a place on the earth's surface is designated is its distance north or south of the equator—measured in degrees, not in miles—and this coordinate is called latitude.

Let the small circle at the center of Fig. 1 represent a section of the earth through the plane of any meridian and the large circle the line in which this plane extended cuts the celestial sphere, supposedly at an infinite distance, PP' being the direction of the axis upon which the earth rotates and CE the line in which the plane of the equator cuts the given plane. Let O be the place of observation and NS the line in which a plane through the center of the earth parallel to the horizon plane at O cuts the plane of the meridian. According to the definition the arc EO is the latitude of the place O and it is easily seen from the figure that this arc is equal to the corresponding arc on the sky $E'Z$,

minute changes of latitude were taking place, but it is only during the last quarter century that the methods of observation and calculation have reached that degree of refinement necessary to detect these small changes.

In 1884 and 1885 Dr. Küstner, astronomer at the Royal Observatory of Berlin, made a series of observations upon certain stars for the purpose of determining the constant of aberration—the maximum apparent displacement of a star due to the finite ratio between the speed of the earth in its orbit and the velocity of light. One of the quantities used in the reduction of these observations is the latitude of the place of observation. Dr. Küstner found his results to be discordant, much more so than he had good reason to believe that they should be from the known care and precision with which the observations were made. Upon investigation it was found that these discrepancies could be almost entirely explained away by assuming a change in the latitude. Dr. Küstner, therefore, in 1888, made the bold announcement that the latitude of the Berlin Observatory had changed during the period over which his observations extended.

This announcement aroused wide-spread interest and steps were immediately taken by the International Geodetic Association¹ to test the reality of the announced variation. Through the cooperation of the observatories at Berlin, Potsdam, Prague and Strassburg, observations for latitude were begun in 1889 and carried on continuously for over a year. These observations agreed in showing a minute but appreciable change in the latitude. In order to test the matter still further, an expedition was sent in 1891–2 to Honolulu, and observations for latitude were made there simultaneously with others made at the observatories just named. As Honolulu is on the opposite side of the earth from Europe, it is seen at once, from Fig. 1, that if the latitude were increasing at the European observatories a corresponding decrease should be shown at the Honolulu station. The results came out as expected and this was generally accepted as a complete demonstration of the reality of this phenomenon. Fig. 2 gives a graphical representation of the results, time being measured along the horizontal and latitude along the vertical line.

The observations thus far made showed that the changes in latitude were periodic in character, that is, the latitude of any place would increase for a certain length of time and then decrease to a minimum value and so on, continuing to oscillate between certain limits. It is easily seen that such changes in the latitude of any place may be

¹ The International Geodetic Association has its headquarters at Potsdam, Germany, and is supported by the principal governments of Europe, the United States, the Argentine Republic and Japan. It carries out pieces of geodetic and astronomical work which are international in their scope.

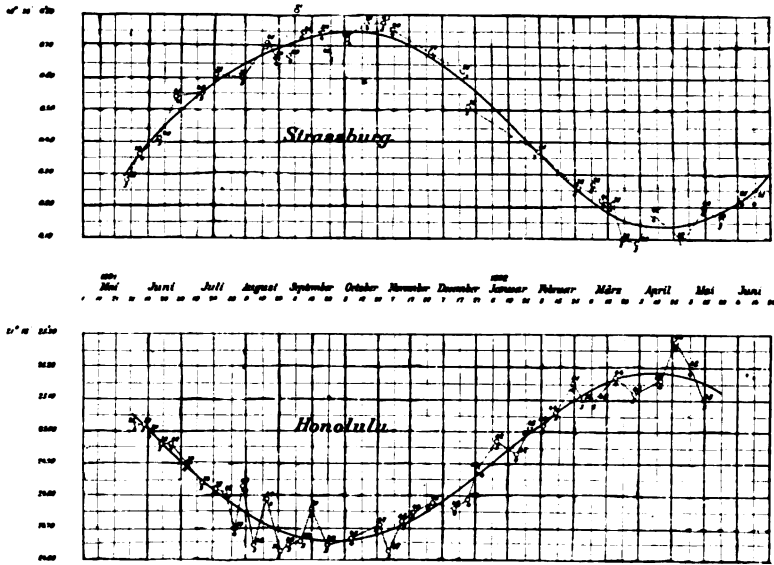

FIG. 2. The upper figures denote the number of stars observed, the lower figures, the number of days on which observations were made.

explained through the assumption of a revolution of the axis of rotation about the shortest axis of the earth, or the axis of figure as it is called.² In Fig. 3 let PP_1 be the axis of figure and $P'P_1'$ the position of the axis of rotation at a time when P and P' lie in the meridian of the place of observation O , and let $E'E_1'$ be the line in which the plane of the equator cuts the meridian plane of this place. If now the axis of rotation is given a motion of revolution about the axis of figure, then when one half a revolution has been completed the axis of rotation will be in the position $P''P_1''$, the equator line will have shifted to $E''E_1''$, and the latitude of the place O will have changed from $E'O$ to $E''O$, the whole change in the latitude, $E'E''$ being $2i$, or twice the angle between the axis of figure and the axis of rotation. After a complete revolution of the axis has been accomplished the latitude of the place O will again be $E'O$ and it will oscillate between the maximum value $E'O$ and the minimum value $E''O$. The reader should bear in mind that the figure is grossly exaggerated, the actual value of the angle i being less than one half of a second of arc. If the angle i remains constant and the axis of rotation revolves about the axis of figure with a uniform speed then the place of observation will apparently swing back and forth in its meridian through an arc equal to $2i$. If the

² The usual statement of the problem is the converse of that just given, that is, that the axis of figure revolves about the axis of rotation, but the effect is the same, provided the distance from O to the end of the shortest axis remains constant, and for purposes of illustration the above statement of the problem seems simpler. The direction of the axis in space remains nearly fixed, but its position within the earth is not fixed.

values of the latitude be plotted along a vertical line and time along the horizontal, we shall obtain the representation of a simple harmonic motion, the crest of the wave corresponding to a maximum value of the latitude and the trough of the wave to the minimum value.

About the time of the expedition to Honolulu, Dr. Seth C. Chandler, of Cambridge, Mass., one of America's foremost astronomers, took up the subject of the variation of latitude and through a brilliant series of

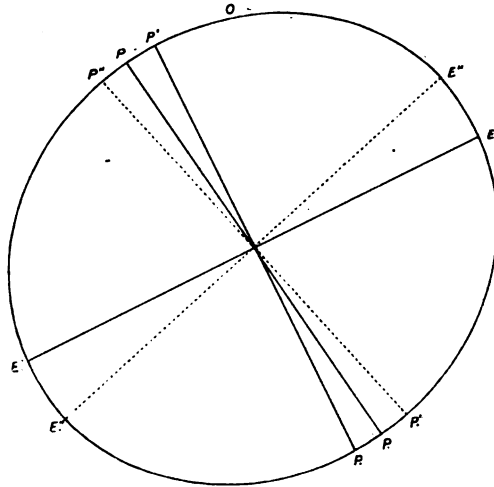

FIG. 3.

researches, published in the *Astronomical Journal*, succeeded in setting forth a number of very interesting results. Dr. Chandler examined all the astronomical observations made with transit instruments, meridian circles, zenith tubes and allied forms of instruments, which were at all suitable for throwing light upon the subject. The first and most interesting result obtained by Dr. Chandler was that the period of the latitude variation was about 427 days. He showed that the observations of the eighties and nineties could be represented very well by assuming that the axis of figure of the earth revolves about the axis of rotation in a circle of thirty feet radius in a period of 427 days.

Dr. Chandler's investigations of earlier observations, which run back as far as Bradley's classic observations for the determination of the constants of precession and nutation made with a zenith tube in the early part of the eighteenth century, seem to show that the period of variation was formerly considerably shorter than at present, the observations of the eighteenth century seeming to demand a period of about 370 days. Later observations showed also that the *amplitude* of the change is not constant, so that the change in latitude can not be accurately represented by assuming that one axis revolves about the other in a circle of thirty feet radius. Chandler's later conclusion is that

the motion of the earth's pole may be conveniently separated into two motions, one an annual revolution in a narrow ellipse about thirty feet long and eight feet wide, but varying in form and position, the other a revolution in a circle about twenty-six feet in diameter with a period of 427 days; both motions being counter clockwise. The resultant of these two motions is quite irregular, as may be seen by referring to Fig. 6, which will be explained later.

From Dr. Chandler's investigations and from the observations for latitude made during the early nineties, it became evident that the movement of the earth's pole was a very complicated one and that an accurate determination of its motion could be obtained only through continuous observations of the latitude at various places on the earth's surface. In 1896 a plan was promulgated by the International Geodetic Association whereby it was proposed to establish stations for the express purpose of observing the latitude. For reasons to be stated later these observatories were all to be located on the same parallel of latitude and in selecting them, social, hygienic, seismological and meteorological, as well as mathematical, conditions were considered, the prime requisite being, of course, that all of the stations have a fair proportion of clear nights at all seasons of the year. Seventeen different combinations of stations lying between latitudes $+36^{\circ}48'$ and $+44^{\circ}50'$, and including two combinations in the southern hemisphere on parallels $-33^{\circ}54'$ and $-33^{\circ}27'$, were considered. The parallel of $+39^{\circ}8'$ was finally chosen with the stations located in Japan, in Italy and the eastern and western parts of the United States. Two other stations were subsequently added, one in Central Asia and the other in the central part of North America, at Cincinnati.

The preliminary work of establishing the stations occupied about three years and observations were begun at all of them in the fall of 1899. The Japanese station is situated very close to the city of Mizusawa (10,000 inhabitants), which lies in a fertile valley 290 miles north of Tokio. The valley is nearly enclosed by two ranges of mountains, having a general northerly and southerly direction, the highest peak of which is 6,700 feet above sea-level. The meteorological conditions at this station are not especially favorable. There is a large range between summer and winter temperatures and the percentage of cloudiness is greater than at any other station. Nevertheless, the two observers, Dr. H. Kimura, director, and Dr. T. Nakano, observer, who have served continuously since the observatory was established, have obtained a most excellent series of results. The number of earthquakes at Mizusawa is large, but the locality is not affected by these disturbances as much as some other portions of Japan. Since the observatory was established there has been none of sufficient intensity to seriously affect the observations.

The Central Asian station is located in the Russian possessions east

of the southern end of the Caspian Sea, six miles northwest of the city of Tschardjui and two miles from the left bank of the Amu Daria, or River Oxus. The observatory is located on an oasis in a sand-waste traversed by many canals. There is a greater range in the annual temperature at this station than at any of the others. Tschardjui is affected by very few earthquakes. The observations at this station are made by a single observer, several having taken part thus far, all of them officers of the Russian army.

The Italian station is very picturesquely located on an old tower, San Vittorio, close to the city of Carloforte, on the island of San Pietro, which lies west of the southern end of the island of Sardinia. The tower is located on a peninsula on the east side of the island, so that the meridian of the observatory lies almost entirely over the Mediterranean Sea, and anomalies in refraction would seem to be absolutely excluded. The island is free from mountains, the highest point being some 650 feet above sea-level. Carloforte has 8,000 inhabitants and can be reached from Cagliari, the chief city of Sardinia, in eight hours. The meteorological conditions at Carloforte are very favorable. The annual variation of temperature is less than at any other station and over 70 per cent. of the nights are clear, a condition which prevails, I believe, in no other section of the world than that surrounding the Mediterranean Sea. The island is free from earthquakes, there having been only four in nearly four hundred years of any considerable intensity, and none of these destructive. The observations at this station are made by two observers, who alternate with the nights. Several changes in the staff have taken place thus far, but all its members have been Italian astronomers.

The station in the eastern part of the United States is located half a mile south of the village of Gaithersburg, Maryland, twenty-one miles northwest of the city of Washington. The surrounding country is hilly, the observatory has an altitude of 540 feet above sea level and the meteorological conditions are fairly favorable. Mr. Edwin Smith, of the Coast and Geodetic Survey, made the observations at this station during the first year; Dr. Herman S. Davis during the succeeding five years. The work is now in charge of Dr. Frank E. Ross.

After the parallel of $39^{\circ} 8'$ had been selected for the location of the latitude observatories it was found that this parallel passed through the grounds of the Observatory of the University of Cincinnati, and Professor J. G. Porter, director of the observatory, volunteered to carry on observations if he were provided with an instrument. The observatory is located on a hill, five miles northeast of the city, and one mile east of the Ohio River. The altitude of the observatory is 800 feet above sea-level and the meteorological conditions are fairly favorable. Thus far all of the observations, except a few during the summer months, have been made by Professor Porter.

The sixth station is situated in California, 112 miles north of San Francisco, one mile south of the city of Ukiah, the county seat of Mendocino County. The observatory is located toward the western edge of one of the numerous small valleys in the Coast Range of mountains. The valley, which is traversed by the Russian River, is about ten miles long and from two to three miles wide, and surrounded by mountains of an average height of about 1,300 feet above the floor of the valley. The altitude of the observatory is 700 feet above sea-level. The meteorological conditions at this station are very favorable, standing next to those of Carloforte in this respect. Snow seldom falls and, although

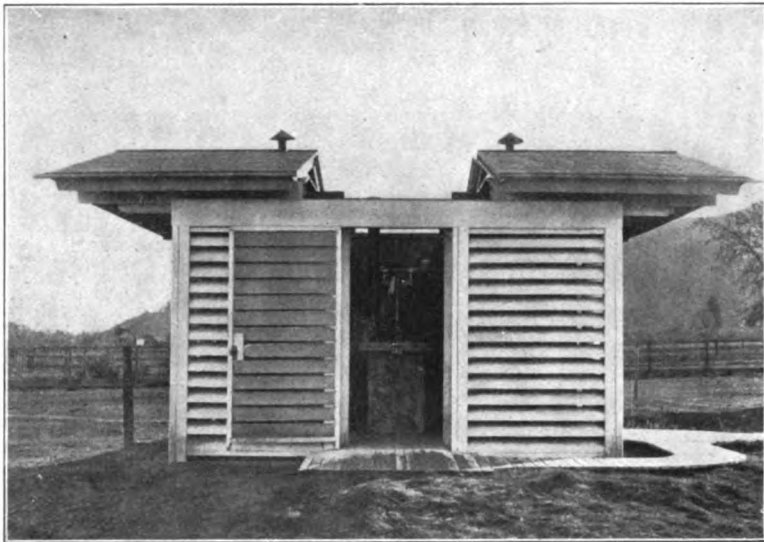

INTERNATIONAL LATITUDE OBSERVATORY, UKIAH, CALIFORNIA. (Looking South.)

the summer temperatures are sometimes extreme, the nights are always cool, which adds much to the comfort of the observer if not to the accuracy of the observations. Up to May, 1903, the observations at this station were made by Dr. Frank Schlesinger, now director of the Allegheny Observatory; from that time until September, 1907, the observations were made by the writer of this article. The work is now in charge of Dr. James D. Maddrill.

From a seismological point of view, all the American stations are favorably located. Although the Pacific Coast of the Americas is well recognized as a region of seismic activity, yet the mountainous nature of the country surrounding Ukiah seems to afford a measure of protection from these disturbances. No earthquake since the observatory was established, not even the great shock of April 18, 1906, has been of sufficient intensity to interfere in any way with the progress of observations.

The four stations first established, Mizusawa, Carloforte, Gaithersburg and Ukiah, are provided with zenith telescopes of exactly the same pattern, and constructed especially for this work of observing latitudes by the Talcott method.³

These instruments, illustrated in Fig. 4, were made by Wanschaff, of Berlin, and have objectives of $4\frac{1}{4}$ inches aperture and focal lengths of fifty-one inches. The instruments at Tschardjui and Cincinnati are of similar design by the same maker, but smaller. From the figure it may be seen that the telescope is fixed perpendicular to the end of a horizontal axis. By placing this axis in an east and west direction the telescope will move only in the plane of the meridian as the horizontal axis is rotated in its supports. The whole instrument may be revolved about the vertical axis, *m*, and by properly adjusted stops on the base-piece the amount of rotation may be limited to 180° , thus giving two east and west positions for the horizontal axis, one, telescope east, the other, telescope west. It is readily seen that if the telescope is set to point say 10° north of the zenith when east of the vertical axis, then, without disturbing the setting of the telescope, if the whole instrument be revolved about the vertical axis, the telescope will, when it comes into the position west of the axis, be pointed 10° south of the zenith. It is thus possible to measure the *difference* of zenith distance of two stars,

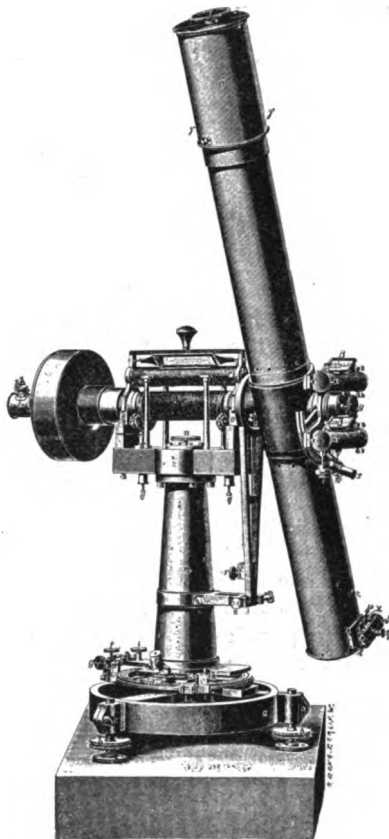

FIG. 4.

³ Descriptions of this method may be found in any work on practical astronomy. The following statements concerning the method may be of help to those who are not familiar with its details. In order to make a determination of the latitude by this method it is necessary to measure, by means of an eye-piece micrometer attached to the zenith-telescope, the *difference* of zenith distance of two stars of known declination which culminate at nearly equal zenith-distances, one north of and the other south of the zenith. The telescope is set at the mean of the zenith-distances of the two stars and the first to culminate will pass a little above or below the middle of the field of view. The distance from the

one of which culminates on one side of the zenith and the other at nearly the same distance on the opposite side of the zenith, by means of an eye-piece micrometer rather than a graduated circle, and herein lies the chief advantage of the Talcott method over all others, the micrometer being a much more delicate and accurate instrument than the graduated circle.

The program of work calls for sixteen determinations of the latitude each night, which means the observation of sixteen pairs of stars. Particular stars have been chosen in such a way as to give convenient intervals between the culmination times of each and the work consumes four hours of time each night. As the stations are all located on the same parallel of latitude the zenith of each observatory will traverse the same path in the sky and the same stars may therefore be observed at each station. Exactly the same program of work, weather and other conditions permitting, is carried out at each station every night of the year. About 12,000 determinations of the latitude are obtained each year, the total to the beginning of 1908 being 99,313. The greatest number of observations are obtained at the Italian station, the next greatest at Ukiah,* as may be seen from the following table:

TOTAL OF LATITUDE OBSERVATIONS UP TO 1908

Mizusawa	13,561	Cincinnati	12,190
Tschardjui	14,901	Ukiah	18,676
Carloforte	25,302	Total	99,313
Gaithersburg	14,683		

middle is measured by means of the micrometer. The instrument is then reversed about its vertical axis, without disturbing the setting, and the telescope will then point as far south as it did north of the zenith before reversal, or *vice versa*. The second star will then pass through the field of view as far below or above as the first star was above or below the center, and this distance from the center is again measured by means of the micrometer. The proper combination of the micrometer settings on the two stars gives the actual difference of their zenith-distances, which may be turned into arc measure, provided the value of one revolution of the micrometer-screw be known. The latitude, ϕ , of the place of observation is computed by means of the formula,

$$\phi = \frac{1}{2}(\delta_n + \delta_s) + \frac{1}{2}(m_n - m_s)R + \frac{1}{2}(l_n + l_s) + \frac{1}{2}(r_n - r_s),$$

in which the first term of the right-hand member of the equation represents one half the sum of the declinations of the two stars of the pair observed; the second term one half the difference of the zenith-distances of the two stars as measured by means of the micrometer; the third term a small correction for any change in the pointing of the telescope after reversal, detected by means of two very delicate levels attached to the telescope; and the last term a small correction for the *difference* in the atmospheric refraction affecting the rays of light coming from the two stars. It might be noticed that if the two stars are at *exactly* the same zenith-distance, and the instrument is reversed without disturbing the pointing, then the second, third and fourth terms each become zero in the equation above, and the latitude is simply the mean of the declinations of the two stars, or the declination of the zenith, as may be seen by referring to Fig. 1.

The percentage of nights upon which observations were obtained, during the first five years at the various stations, is given in the following table:

PERCENTAGE OF OBSERVING NIGHTS			
	Per Cent.		Per Cent.
Mizusawa	50	Gaithersburg	42
Tschardjui	35	Cincinnati	32
Carloforte	72	Ukiah	48

The conditions at Carloforte, in the Mediterranean Sea, must be almost ideal from an astronomical standpoint, still the above tabulation can not be taken as a true index of the weather at the stations. At Carloforte and at Mizusawa two observers are constantly employed, and probably nearly every favorable night is utilized. At the other stations, where all the observations are made by a single observer, some favorable nights must of necessity be allowed to pass. At Ukiah, for instance, the percentage could be increased by at least ten, perhaps fifteen, if two observers were employed. In considering the above table, the further fact should be taken into consideration that Professor Porter, who makes the observations at Cincinnati, has many other duties in connection with his position as director of the Cincinnati Observatory and professor of astronomy in the University of Cincinnati. We should also consider the still further fact that at some stations—for instance, Mizusawa—many nights are rendered incomplete by fog or clouds, and a night upon which only one pair is obtained enters into the above tabulation with the same weight as a complete night of sixteen pairs.

On account of the uncertainties of the weather it seldom happens that observations are obtained at all the stations on the same night—and a complete set of sixteen determinations at all stations on the same night is indeed a rare event. During the first five years that observations were made, there were but nineteen nights upon which *some* observations were obtained at all the stations, and not a single night on which a complete set of sixteen determinations was obtained at every station.

This seems a little strange at first thought, but a simple computation according to the principles of probability shows that such a result should be expected. Let us ask, first, What is the probability of obtaining at least some observations at each station on the same night? If we assume that observations are made on the average on fifty per cent. of the nights, then the probability of obtaining observations at any one station on any particular night will be one half, and manifestly the probability of obtaining observations at two stations on the same night will be $\frac{1}{2} \times \frac{1}{2}$, or $\frac{1}{4}$, and the probability of obtaining observations at three stations on the same night $\frac{1}{2} \times \frac{1}{2} \times \frac{1}{2}$, and the probability of obtaining observations at six stations $(\frac{1}{2})^6 = \frac{1}{64}$.

Observations would therefore be made at all six stations on the same night on an average of once in every sixty-four nights. The assumption, however, that observations are made upon fifty per cent. of the nights is somewhat in error, the true percentage being almost exactly 46.5. The probability of this event occurring would be therefore ($\frac{465}{1000}$),⁶ which equals $\frac{1}{99}$. The event would occur on an average therefore of once in every ninety-nine days, or nineteen times during the five years under consideration. This result is in exact agreement with the observed number.⁴

Let us now ask, What is the probability of obtaining a complete night's work at all six stations on any particular night? The ratio between the number of complete nights and the total of nights is not given in the published results, but is probably not far from one half. At Ukiah about sixty per cent. of the nights upon which observations are made are complete, but the percentage is known to be less at some of the other stations. If now we assume that observations are made upon fifty per cent. of the nights, and fifty per cent. of these are complete, then a process of reasoning similar to that just used will bring us to the result that the probability of the occurrence of the event under consideration is $(\frac{1}{64})^2 = \frac{1}{4096}$. That is to say, a complete night's work will be obtained at all six stations on an average, in round numbers, of once in every 4,000 nights, or once in about eleven years, so that it is not at all surprising that this rare event did not occur at all during the first five years of observations.⁵

The observations made during the first five years after the international latitude stations were established, and the results deduced from them, have been published in two quarto volumes.⁶ These observations show periodic changes in the latitude similar to those found from earlier observations. The results obtained at the various stations, from the beginning of 1902 to the end of 1905, are represented graphically in Fig. 5, taken from the second volume just mentioned. All the observations obtained at each station during a certain period, about a month, are combined into an average value, these mean results are plotted, and represented in the figure by the small circles. The small figures standing adjacent to the circles indicate the number of

⁴The exact method of computing this probability is, of course, to take the product of the six separate probabilities rather than the sixth power of the average probability. The result comes out sixteen rather than nineteen.

⁵If more exact figures were used in this computation it is certain that the probability of this event would be much reduced, perhaps by nearly one half, so that the event would not occur more than once in twenty years.

⁶*Resultate des Internationalen Breitendienstes*. Band I. (1903), von Th. Albrecht. Band II. (1906), von Th. Albrecht und B. Wanach. *Centralbureau der Internationalen Erdmessung*; neue Folge der Veröffentlichungen, Nos. 8 und 13. A review of these volumes was published by the writer in *Publications of the Astronomical Society of the Pacific*, Vol. 19, pp. 139-58.

observations entering into each average. The small circles are connected by straight lines. The smooth curves in each case are obtained by combining, by means of a mathematical analysis, the results at all

Verlauf der Polhöhe auf den einzelnen Stationen.

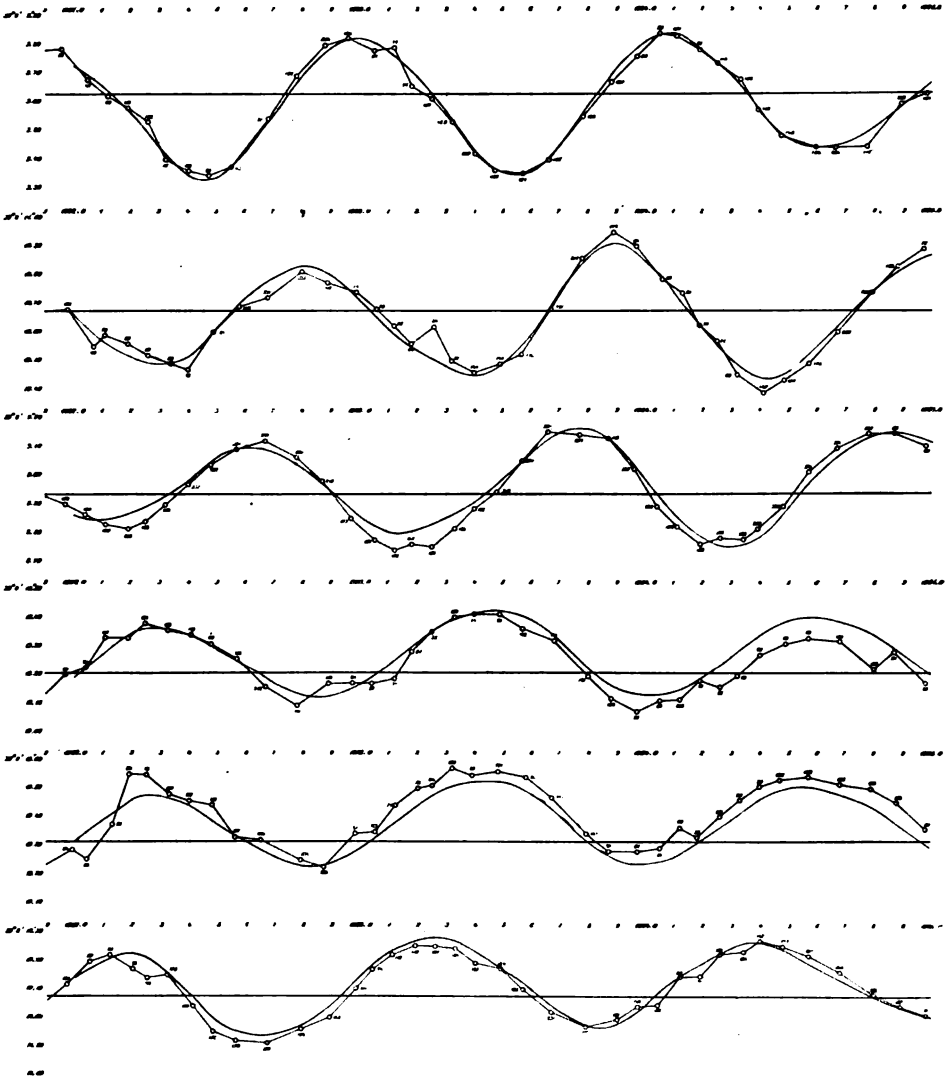

FIG. 5. Observations taken at Mizusawa, Tschardjul, Carloforte, Galthersburg, Cincinnati, Ukiah. (Reading from the top, down.)

of the stations into a general result, and then from this general result computing the variation of the latitude for each individual station. The vertical distance between any small circle and the smooth curve will be, very nearly, the actual error of the average result represented

by the circle. The station where these vertical distances are the smallest will, in general, have obtained the most accurate results. An inspection of the figure shows that the best agreement was obtained at Mizusawa. It is rather significant that at Carleforte, where more than twice as many observations are obtained than at some of the other stations, and the meteorological conditions are exceptionally fine, yet the agreement between the observed and the computed curves is not so close as at some other stations. This is a good illustration of the precept that, in general, little or nothing is to be gained by increasing beyond a certain moderate amount the number of observations made with the same instrument under similar circumstances. In fact it is quite possible that just as good results could be obtained by limiting the number of observations taken at each station to a monthly average of a hundred or thereabouts.

As Tschardjui and Ukiah are separated by nearly 180° of longitude, the curve of the one is almost the counterpart of the other. It may be seen from Fig. 5 that the maximum change in the latitude, during the time represented, is less than 0".5, which corresponds to about fifty feet on the surface of the earth. The observatory then apparently swings back and forth in the meridian to a distance of twenty-five feet on either side of the mean position.

Having now the actual observed variations in the latitude at six different stations, separated widely in longitude, it is a comparatively simple problem in mathematical analysis to compute what the actual motion of the pole, with respect to its mean position, must be in order to produce the observed changes in the latitudes. If the difference between an instantaneous value of the latitude and the mean value be represented by $\Delta\phi$; the rectangular coordinates of the instantaneous pole, with respect to the mean position of the pole, by x and y ; and the longitude of the observing station by λ ; then the following equation, the derivation of which is given in the review mentioned above, may be written,

$$\Delta\phi = x \cos \lambda + y \sin \lambda.$$

Early investigations showed that the observations were not represented to the highest degree of accuracy by this equation and Dr. Kimura, the Japanese astronomer, suggested the addition to the equation of a third term, z , independent of the longitude. The observations are satisfied much better by an equation of this form, and z turns out to be a small variable quantity of an annual period. No satisfactory physical explanation of this term has as yet been given. Several have been suggested, one of which is that perhaps there is a small annual shift in the position of the center of gravity of the earth.

In order to solve the problem connected with this term, two additional latitude stations were established in the southern hemisphere in

1906. They are both located in south latitude $31^{\circ} 55'$ —one at Bayswater, near Perth, West Australia, and the other at Oncativo, in the Argentine Republic, about forty-five miles from the National Observatory at Cordoba.⁷ Definite results from these observations have not yet been obtained, but Dr. Albrecht has recently published a short note stating that a provisional reduction of the observations obtained at the two southern stations shows that z has the *same sign* at the south parallel as at the north, and probably the same magnitude. If this is true the hypothesis of a shift in the center of gravity of the earth must be abandoned. This term is zero about ten days before the equinoxes and reaches its maximum values, $-0''.048$ and $+0''.044$, about ten days before the summer and winter solstices, respectively. These facts would seem to favor the meteorological explanation of origin of this term.

The motion of the earth's north pole, from the time the International Latitude Stations were established in the fall of 1899 to the be-

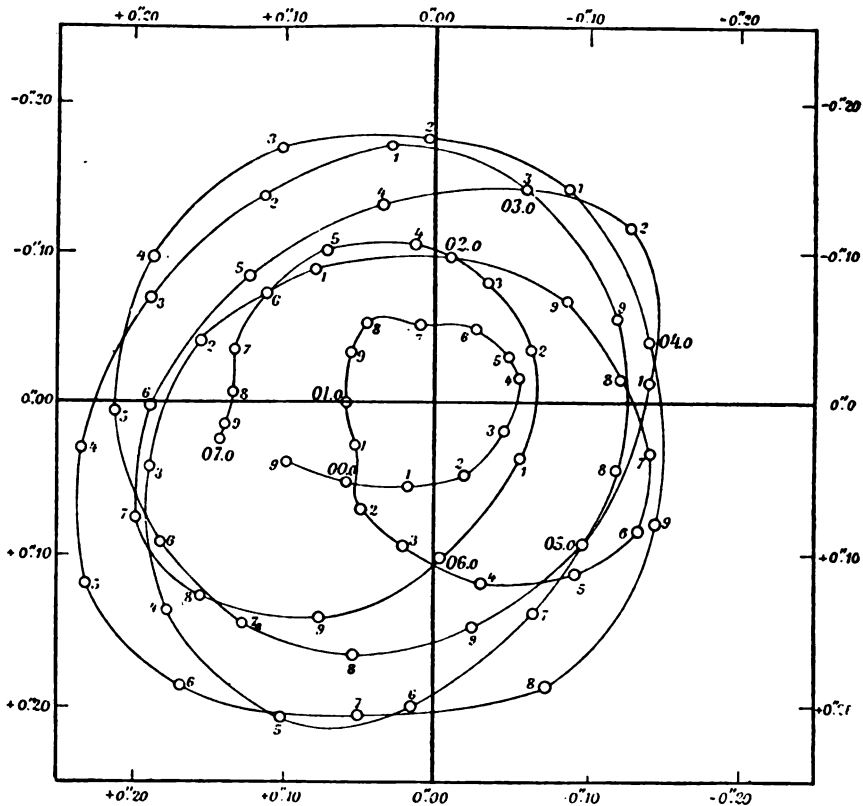

FIG. 6.

⁷ In addition to these eight stations under the International Geodetic Association regular observations for latitude are made at Poulkova, Russia, in latitude $+59^{\circ} 46'$; at Leiden, $+52^{\circ} 9'$; and at Tokio, $+35^{\circ} 39'$.

ginning of 1907 is represented in Fig. 6 taken from the *Astronomische Nachrichten*, No. 4187. The large square represents a piece of ground fifty feet on a side. The small circles represent the position of the pole for each tenth of a year beginning with 1899.9 and ending with 1907.0. By starting at the beginning and following out the motion of the pole a roughly spiral path is found with a clearly marked period of about seven years, the position of the pole at the beginning of 1907 almost coinciding with the initial position, 1899.9.

The observations made at the International Latitude Observatories have determined the motion of the pole with a degree of refinement and continuity never before attained, and it is now found that the laws deduced by Chandler fifteen years ago are no longer sufficient to accurately represent the observed motion. Dr. Kimura has recently made a harmonic analysis of the variation of latitude and finds, in addition to the two principal motions of periods of fourteen months and one year found by Chandler, two smaller motions with periods of 0.75 and 0.6 of a year. Kimura also finds that the principal motion of fourteen months is in an ellipse and not in a circle as found by Chandler, the interpretation of which would be, that the equator is an ellipse and not a circle, if we assume the earth to be made up of homogeneous layers, or, in technical language, that the equatorial moments of inertia are unequal.

The change of latitude being so very small is, of course, of no consequence whatever to the navigator who has to determine his position at sea. It is, however, of great interest and importance from a scientific standpoint, and it is hoped that the work at the various stations may be carried on long enough to make a definitive determination of the laws of the polar motion possible, so that a mathematical formula may be constructed from which the position of the pole, or the latitude of any place, may be computed for any time past or future.

One way in which the variation of latitude might have political or commercial significance is in cases where a certain parallel is designated as the boundary line between two countries, states or counties. For instance, the forty-ninth parallel is, for a portion of the distance, the boundary line between the United States and the Dominion of Canada. If any question should be raised, however, a court of arbitration would probably decide that, inasmuch as the actual line shifts its position, the one already established, if not egregiously in error, should continue to be considered the boundary line. A case similar to this has recently been decided by the courts of California. The boundary line between Mendocino and Trinity counties is defined as being the fortieth parallel of latitude. When the counties were first established a surveyor was employed to locate this line, but some score or so of years afterward other surveyors found that the established line lay about two miles too far south. Thereupon Mendocino County brought suit against Trinity

County to have this two-mile strip taken from the latter and added to the former. After dragging through the courts for a number of years the matter was finally decided in favor of Trinity County, the argument being that, inasmuch as it is impossible, by ordinary processes of surveying, to locate the parallel with absolute accuracy, the original survey, made by due process of law and accepted by both counties, although admittedly largely in error, should remain the official boundary line. The amount of territory, mountainous and sparsely settled, is a comparatively small part of either county, Mendocino County being nearly as large as the state of Connecticut. The question was, however, of considerable importance to the property owners of the two-mile strip. After the land was claimed by Mendocino County, it was assessed and taxed by both counties, and the taxpayers who cast their lot with Mendocino County now have several years of back taxes to pay in Trinity County.

Doubtless most of the readers of this article have already wondered what may be the cause of the shifting of the earth's axis. In 1765, Euler, a famous Swiss mathematician, demonstrated, as a proposition in dynamics, that if a free rigid oblate spheroid rotates about an axis which differs slightly from the axis of figure, or shortest axis, then the axis of figure will revolve about the axis of rotation in a period the length of which will depend upon several factors. He computed that, if the assumed conditions obtained for the earth, then the period of revolution of the axis of figure about the axis of rotation would be 306 days. Obviously, however, the earth is not rigid; the oceans are quite plastic and the ground itself is possessed of some elasticity. Professor Newcomb computed some years ago that, if we assume the earth as a whole to possess the rigidity of steel, then the period of revolution of the one axis about the other would be 441 days, as against 306 days found by Euler on the assumption that the earth is perfectly rigid. The actual observed period is fourteen months, or 427 days, and the legitimate conclusion to be drawn is that the earth as a whole is somewhat more rigid than steel—a conclusion that agrees with that derived by Lord Kelvin and others from entirely different considerations.

Now the question arises, Why does the earth not rotate upon its shortest axis? The explanation is simple. If the earth ever did rotate upon its shortest axis it could not continue to do so because of the shifting of matter upon and within the surface. Winds, rains, rivers and ocean currents are ceaselessly transporting matter from point to point, and during the winter great masses of snow and ice accumulate in the temperate and frigid zones only to disappear again in the summer. Although these effects will, to a large extent, neutralize each other, the sum total can not be other than to produce at least a theoretical lop-sidedness to the earth; and as soon as this takes place there must be a shifting of the axis of rotation. The time of revolution of

the one axis about the other could be accurately computed if the exact form of the earth, the structure of the earth's interior and its coefficient of elasticity were known.

In addition there are other phenomena, namely, volcanoes and earthquakes, through which considerable quantities of matter may be displaced. That the amplitude of the polar motion might be affected by earthquakes was pointed out by Professor Milne ten or fifteen years ago and a French scientist has more recently compiled a table showing the number of severe earthquakes each year and the amplitude of the polar displacement. A rough proportionality between the two seems to exist, that is, the greater the number of earthquakes each year the greater the amplitude of the polar displacement. Such results, however, are to be taken with several grains of allowance. The term "severe earthquakes" is rather indefinite and by modifying its definition quite a variety of results may be obtained from the given data. It might be pointed out that in 1906, the year of the great earthquakes in California and Chile, the amplitude of the polar displacement was small.

We have then a rational explanation of the phenomenon of the variation of latitude. The axis upon which the earth rotates is not in exact coincidence with the shortest axis; such being the case, according to the principles of dynamics, the axis of figure must revolve around the axis of rotation giving rise to the changes of latitude. But on account of the changes incessantly taking place in the distribution of matter upon the earth's surface, and perhaps also within the surface, the amplitude of the polar displacement, and perhaps the principal period of revolution of the one axis about the other, are changeable, the changes taking place in a rather complicated way according to laws as yet not fully determined.

In connection with this explanation we should not lose sight of the fact that all the material moved through meteorological, volcanic and seismic agencies is probably almost infinitesimal as compared with the total mass of the earth, and no one, so far as I know, has as yet shown that the shifting masses are sufficient in magnitude to properly account for the observed annual and other unexplained components of the polar motion.

Indeed, if one desires to follow the path of least resistance, he might abandon the above explanation altogether and adopt the one given by a colored preacher living in the oil region of Texas, who met some brethren at the corner grocery one day and delivered himself of the following explanation of this puzzling scientific phenomenon:

Ah see by de papers dat de urf's axis am a wobbling an' dey dunno wat fo'. But ah know wat makes de urf's axis wobble. Do you see all dis oil dese men am a takin' out of de urf? Well wat do you spose de good Lord put dat oil in dere fo'? Wy to grease de axis wif, of couse, an' when dey take it all out, wat else can de axis do but to wobble an' to squeak?

DESERT SCENES IN ZACATECAS

BY PROFESSOR J. E. KIRKWOOD
UNIVERSITY OF MONTANA

ABOUT 400,000 square miles of desert lie south and west of the Rio Grande. Much of this vast area occupies the great tableland, bounded east and west by long mountain ranges and reaching southward several hundred miles, where it becomes broken by more fertile areas; all this being, in fact, a continuation of the great southwestern desert region of the United States which prevails from Texas to California. The aspects of its southern extension vary with local conditions within certain limits, and with its lowering latitude new elements enter into its composition, but on the other hand many of the features characteristic of a Texas or an Arizona landscape are conspicuous in its geological formations, its fauna and its flora. This region has, however, certain significant peculiarities which give the central Mexican plateau a character of its own.

Typically representative of the conditions on much of this great plateau is the northern part of the state of Zacatecas. Traversed by fragmentary mountain ranges with a general trend from northwest to southeast, only in a few places do its plains stretch level to the horizon. On every hand the skyline is formed by the heaving back of some ridge or group of mountains whose summits rise from 1,000 to 4,000 feet above the plain. The plain itself is 6,000 feet elevation, more or less, and the mountains appear as if almost submerged in it. Here and there are lower ranges whose heads are scarcely lifted above the plain and whose softly rounded outlines show that leveling forces have long been at work upon them, or that their softer materials have more readily yielded to eroding forces. Other peaks rise higher and a few of these are rugged and sharp with steep declivities, but for the most part the evenly rounded outline prevails.

The more or less isolated ranges, the Sierras of the Potrero, the Zuloaga, Zapoca, Guadalupe, Oratorio, Ramirez, Chivo, Caballos, etc., are all on an area some sixty by seventy miles in extent, which constitutes the Hacienda de Cedros, a corner of which the Mexican Central Railroad crosses southeast of Torreon between Rivas and Carlos. This Hacienda, which lies mostly to the east of the sun-baked village of Camacho, extends also to the west fully twenty miles. An interesting estate and sufficiently large from an American standpoint it is, but one of many of its kind in Mexico, managed in a feudal way. It is to this particular region that the accompanying discussion pertains.

Looking westward, far across the broad Camacho plain, standing

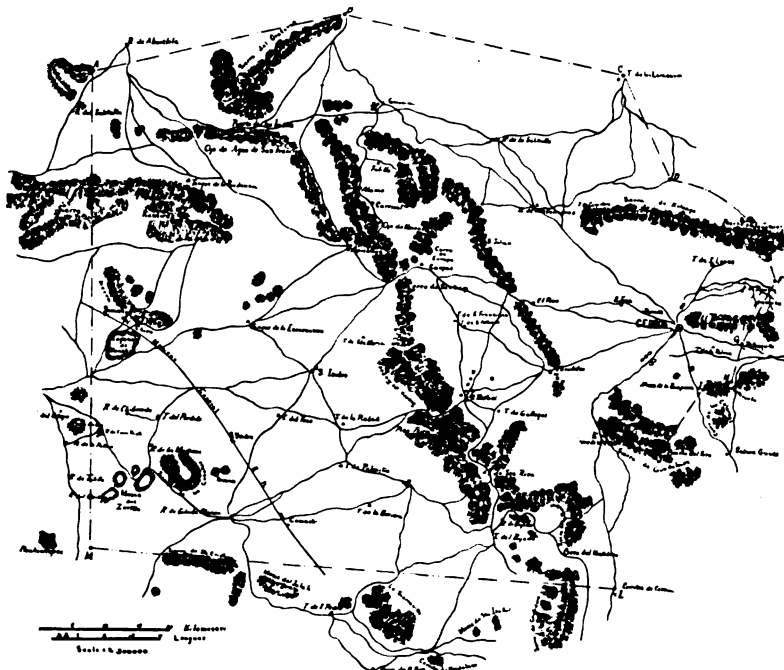

MAP OF THE HACIENDA DE CEDROS, a private estate of over two million acres, on which dwell some two thousand people.

well up on the horizon are the high Mesas del Zorillo. Their broad level tops lie in the same plane, at their borders a sheer descent is visible to the point where the talus slope begins and slants off in graceful lines to the rolling lands below. But such configurations are rare in that region. Here and there what is left of that stratum which forms the high floor of these Mesas may be visible, but only as vestiges, for they have mostly disappeared.

Standing at the edge of one of these wide plains and looking across, one may survey at a glance twenty to forty miles of mountain barrier along the opposite side, thirty to fifty miles away. Deep scalloped with cañons and ravines which divide and subdivide into successively smaller branches as we follow their course upwards, they are ultimately lost in the rounded brow of the mountain. Below the steeper slopes the low-lying, far-outreaching butresses of the range finally sink into the plain. At the mouths of the cañons, broad fans of silt, gravel and other detritus from the heights above, spread out and meet their neighbors on the right and left until a long, slightly undulating footslope is formed, and gradually merge into the floor of the valley. Thus the wide valley is gradually being made wider by the building up of its floor, which is the accumulation of ages of the wash from the mountains; the nature of the process is obvious. Where a deep arroyo cuts down through the land a section of the deposit shows

in places stratification of clay, sand and gravel. Here and there a well is bored and the same story is told. Every valley between these mountain ranges presents the same features, a gentle slope for miles from either side, so gentle that in walking over it one hardly realizes that it is not level, and in the center is—not a stream—but a shallow basin, frequently lined with salty incrustation. Such is the character of the Bolsón, as it is called, which is also a marked feature in the physiography of southern Arizona.

Into these basins the arroyos pour the floods from the mountains. One finds the arroyo in the higher parts of the plain nearer the mountain where the steeper incline gives more velocity and erosive force to the stream. Lateral valleys which lie between high slopes usually develop the arroyo to a marked degree. The deep basin between the ridges, filled with the detrital wash from the slopes, is readily eroded by the swift streams which are produced frequently by the torrential rains of these regions. Running lengthwise through the midst of an apparently level valley floor, these arroyos are often invisible a few feet away, and the traveler may be entirely unconscious of the presence of a ditch thirty feet deep and possibly fifty wide, with perpendicular walls, hardly fifty paces away. The walls of these arroyos are being constantly undermined, and the materials, caving into the channel, are carried out with the rest of the wash; at the same time the head of the arroyo is receding toward the higher land and the channel becomes more and more shallow as the underlying rock comes nearer the surface. As the arroyo extends out into the plain its fall becomes less, the power of erosion by the water decreases and the channel is finally lost on the lower slope.

Thus the composition of the mountains is responsible for the composition of the valley floor. Limestone is the predominating material. Rocks of igneous origin are less conspicuous, but are present, and mineral-bearing veins are plentiful. Occasionally heavy formations of calcareous tufa may be found where springs issue from the hills, as at the village of Cedros, situated at the end of a short range. In deep and sheltered ditches salts collect on the clay and hang in slender glistening crystals to its surface. The ooze of calcium solutions is everywhere visible in the formation of caliche, which forms a hard, impervious and impenetrable layer on or near the surface of the ground. Here and there it cements together stones and gravel in a solid mass, resistant to weathering and erosion.

But few springs are found and these usually at the foot of the higher slopes. At the western end of a small range, the Sierra del Potrero, water comes to the surface in numbers of strong springs, and on this oasis is built the village of Cedros, the administrative seat of the Hacienda of the Cedars. From the limestone rock, cropping out on the toe of the range, the springs issue forth. One at least of these is warm.



SOTOL ON THE HACIENDA DE SANTA INEZ. Photo by F. E. Lloyd.

the others cold; some feed a small rivulet, across which one might step with ease, that passes through a series of reservoirs and is used in irrigating the gardens, some supply the baths, and others the troughs where the cattle come to drink.

But this wealth of water, for wealth it is in such a country, is not general. One would go far to find so splendid a supply as feeds the industries of this place. Here and there wells are sunk in the valleys and water is found at a depth of forty feet more or less, but often drilling goes much deeper without finding any.

The sites of these springs are here, as everywhere else in deserts, oases of fertility, visible sometimes a day's journey across the broad valleys, and marked in the broad expanse of desert landscape by dark tops of huge cottonwoods, and the light reflected from the white-washed walls of adobe houses. The number and quality of the springs determine the size of the hamlet and sometimes the nature of its operations. Upon arrival we may find also ash and pepper trees, pecans, avocados, figs, pomegranates, apples and grapes, rows of magueys and hedges of tuna-bearing nopáls. Onions, garlies and

chilis are the principal garden crops, and flowers (poppies, asters, roses, etc.) in pots or beds in the patios or dooryards of nearly all dwellings, however humble. Fields of corn and barley, with *calabasas* (squashes), are scattered about the plain not far away, where crops are matured in the short season of the summer rains. Their corn planted in July is harvested in October, its growth hastened by irrigation of a primitive sort; running a ditch along the face of the slope, the *ranchero* collects the run-off from the rains and directs it on to his field. On some of these fields corn grows to the height of ten feet with a degree of luxuriance that would gladden the heart of a northern farmer.

Although no permanent streams of any consequence exist, yet the rapid drainage of the land makes feasible a mode of existence otherwise impossible. The herdsman pushes out away from walls and springs and establishes himself in the midst of the desert. Choosing a place where the land lies to form a basin or wide valley, he throws a dam across the mouth and collects the run-off from a large area. For this purpose a gently sloping drainage basin is preferred, else the labor of building the dam will come to naught in a few years by the reservoir's becoming filled with silt and drift; moreover, the rushing torrent may cut through the embankment and drain the tank dry. I have seen old tanks which had been filled to a depth of fifteen feet or more, and as the earthen dam was finally cut through, the later floods had sluiced down an arroyo through the flat sedimentary plain above. So the tanks in such situations are short lived, but where fed by the gentle drainage of a gravelly plain they may last indefinitely and supply water the year round to large herds. Frequently these tanks hold water covering several acres at the height of the dry season, and when at its deepest it may assume the proportions of a small lake. Some of the dams are strong and well-built structures of stone masonry a half mile or more in length and ten to twenty feet in height. To the "tanques" come the horses, the mules, the burros, the sheep, the goats and every other animal of the desert; they drink the turbid liquid, they wade in it, they bathe in it, they discharge into it, and all around the margin is a fringe of greenish drift and scum, but it is water in a thirsty land and man is grateful for it. It is the objective camping point in the day's travels and at noonday the cool shade on its banks is the favorite resting-place for man and beast.

From one to two and a half feet of rain falls on this land in a year, depending partly on the altitude and local conditions. Records of rainfall at Chihuahua and San Luis Potosi show 10.86 and 10.41 inches, respectively, for one year (1901), and at the city of Zacatecas the average for ten years (1897-1907) was thirty-one and a half inches. The precipitation at Cedros for one year (1907-8) was about eighteen inches.

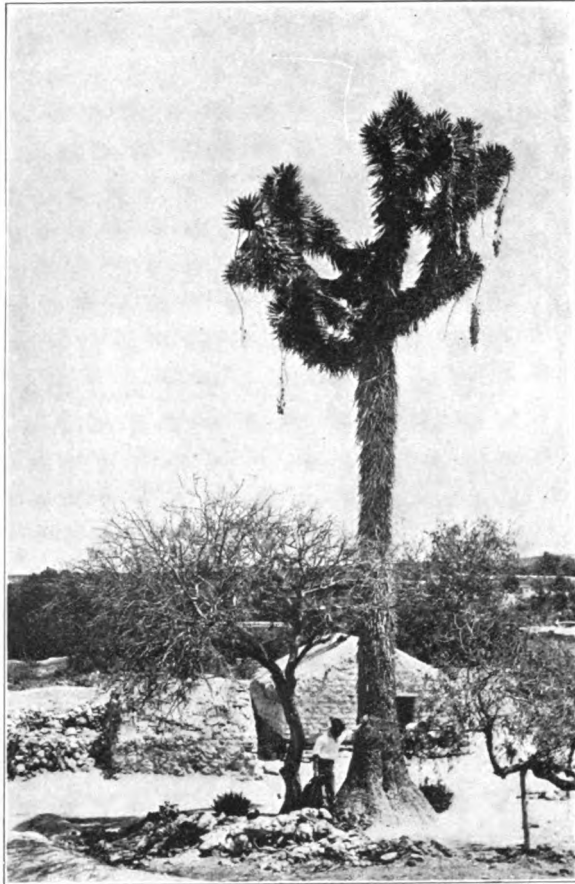

PALMA CHINA (*Yucca australis*) IN THE VILLAGE OF CEDROS. Photo by E. A. Crane.

The heavy rains, sometimes as much as an inch in a few hours, run off with great rapidity through the drainage channels and twenty-four hours later the sides of the mountains and the footslopes appear as if not having known a rain in six months. Here and there in the bottoms of the cañons a pocket in the rock holds a gallon or two of sweet pure water, and out upon the plain pools may linger for a few days on the clay.

Here the summer months are the months of rain, but in most months of the year a little rain may be had. As springtime advances clouds may be seen along the distant slopes and among the peaks with a trailing haze of rain beneath. Though in the summer-time the rain clouds are partial to the highlands, yet more often do they wander out across the plain. Scarce a day of summer passes but showers may be seen falling on some part of the landscape, but the amount falling on any particular area is relatively small.

The isolation of these places is intense. The light of midday dazzles the eyes as it is reflected from the walls of the houses, the dust of the road, or the whitish soil of hill or valley. Heat is a liberal accompaniment of the fierce glare of light, as blistered lips may abundantly testify after a few hours riding across the desert. The Mexican knows the value of his broad-brimmed sombrero and is seldom to be found without it, if indeed we may induce him to leave the shade of the tree or the dark interior of his adobe dwelling at the middle of the day. But the shade, even the thin shade of the mesquite, is a place of comfort, affording some shelter from the direct rays of the sun. Even alongside a thermometer registering over 100° in the shade, no discomfort may be felt in the thin and relatively dry air of this climate.

The most suggestive feature of the desert is its vegetation and the variety of the plants which it supports. The great number of species which by some peculiar fitness of their own are able to maintain themselves in the midst of seemingly impossible conditions, must certainly impress one accustomed to the abundant vegetation of the green fields and woodlands of the better-watered sections of the country, though the number of individuals of a race may be considerably less. This is not true of all species, but the fact is quite patent to any one who has seen even a little of desert vegetation, having in mind the almost impenetrable vegetation of some of our northern woodlands. Across the desert of Zacatecas one may ride in any direction, limited only by the perpendicular banks of arroyos, or mountain barriers. The floor of the desert here also is bare and clean for the most part, which means a paucity of herbaceous plants. Such herbaceous forms as do exist are found usually in shaded situations, under the shelter of woody perennials.

The vegetation of this region as it appears to one at a casual glance seems to be composed of Yuccas, shrubs and small trees, Agaves and cacti and these constitute the predominant features of the plant life in varied arrangements and conditions.

The most conspicuous element in this vegetation is the palma, so called, which may be seen on every hand. Two kinds are usually met with; one a straight-stemmed plant, six to ten feet in height, with a crown of stiff radiating sword-like leaves, much prized for the fiber or ixtli which it yields. This plant, *Samuela carnerosana*, which the native calls palma zamandoca, grows in great abundance on the higher lands, from the upper footslopes a thousand feet up the mountainside. On the high rolling land south of Saltillo, from Carneros to Fraile and beyond, thousands of acres are covered with this splendid plant. In March and April they are in full bloom and one may go far to find a more pleasing picture than these tall plants with their erect panicles of creamy-white flowers, two or three feet in height. This plant grows so



A GOOD COLLECTION OF DESERT PLANTS: VEGETATION OF THE PLAIN.
Photo by F. E. Lloyd.

slowly that the increment of one season can not be marked without precise measurements, but year by year the lower leaves of the foliage crown die and add to the thatch of dry leaves that cover the trunk below. The trunk itself is six inches to a foot in diameter, a mass of spongy tissue with a more dense outer rind. Of these stems the peon makes fences, or sets them palisade-like for the walls of his hut, or hollows them out for bee-hives. The leaves of the plant make the most convenient thatch for his hut, and from the fibers of its leaves he makes ropes and sundry other articles of convenience. Palma china, as the native calls it, known to botany as *Yucca australis*, is a close relative of the preceding and often occurs in the same situations. Usually, however, this plant does not ascend to the heights attained by its neighbor, but is a native of the wide valley lands, where it often occurs in great profusion as at Palmas Grandes, a few miles west of Mazapil, and again on the footslopes some twenty miles east of Camacho. This *Yucca* is the most striking of all the plants seen on this desert. Reaching a height of 35 to 40 feet, and having a trunk diameter of two to three feet, its upper portion is divided into straggling branches clothed for a foot or two from the tip with rigid outstanding leaves a foot and a half long. The branching of palma china is never symmetrical, but usually both trunk and branches are contorted and arched in various directions. Occasionally one is found straight and tall and beautiful,

such as grew by a peon's hut in the village of Cedros, and one which was found on the plain near Symón was as grand a tree as an oak of two centuries and probably not much younger. This magnificent palma must have been close to forty feet in height, with a hundred branches which filled out the hemispherical top with symmetry and beauty. The trunk of this palma was near three feet in diameter four feet from the ground, and its thickened base below was not far from six feet across. The flower cluster of this plant is about three feet long and the creamy flowers which abound in June are much prized by the people as food. This plant also yields fiber, which, however, is not so generally used as that of its neighbor, owing doubtless to the abundance of the latter, which has longer and more accessible leaves. Some of the other desert plants less conspicuous than the Yuccas are hardly less interesting. In numbers the Maguey and its family outrank almost everything else. From *Agave americana* down to *A. lechuguilla* and *Hechtia* they are everywhere abundant. While the huge pulque maguey is found in this region at least only in cultivation, its lesser relatives are on a thousand hills, sometimes leaving little room for anything else to grow. Three species of *Agave* are abundant. Two of these, *A. lechuguilla* and *A. falcata*, are never found on the level plain, but as soon as one begins the ascent of the low ridges which rise but little above the valley he is almost sure to encounter *A. lechuguilla*. We may say encounter advisedly, for their leaves are as so many daggers set at all angles to impale the unwary. The rigid leaves about a foot long are armed with terminal spines as sharp as needles and as strong as nails. These in places, especially on the low limestone ridges, are so numerous that one with difficulty can make his way through. In June this plant is at the height of its flowering season and over large areas the flowering shoots, ten to twelve feet tall, are everywhere conspicuous. The stems of last year have fallen, and the new ones soon ripen their seed and terminate the life of the plant. The leaves of this plant are especially valuable for fiber and it is one of the most important of native Mexican plants. From it the native also obtains amole, the short stem and leaf bases, which, when crushed, has marked saponaceous properties, and seems to justify the esteem in which it is held, if one may judge by results. *A. falcata* occupies the slopes of the ridges, but is rare as compared with *A. lechuguilla*. Its flower stalk is smaller on the whole than that of its neighbor and its flowers much darker colored. Its sickle-shaped leaves are pointed inward and it is, therefore, not nearly so unpleasant to meet as *Lechuguilla*. But its fiber is little used, probably owing to the scarcity of the plant and the great abundance of the other species which is more easily worked.

Agave asperima is one of the plants which the traveler first notices in the desert of Zacatecas. Its bluish-green leaves are usually less than three feet in length as it grows in the desert, but are sharply armed



PEON HABITATIONS IN THE DESERT. Photo by F. E. Lloyd.

with stout spines both terminal and lateral, which make them formidable objects to meet. These plants spread by stolons and form impenetrable masses where they monopolize the ground. This agave grows in greatest abundance on the plain, where it frequently impedes the progress of a horseman quite effectually. It also spreads upward on the ridges and in the cañons to points a thousand feet above the plain. Its flowering season is in June, though it loiters along in this business through the whole summer. The flowering shoot is similar to that of *A. americana*, but hardly exceeds fifteen feet in height. But these great flowering shoots are of great interest in their strength and beauty, looming up against the sky on the crest of some ridge, and not the least in the fact that this huge inflorescence represents the culminating vital activity of the whole life of the plant. Slowly through the years the materials have been gathering for this particular task, and finally in a few short weeks of summer the supreme work is consummated, and the great candelabrum of branches stands forth with its hundreds of seed capsules, while the erstwhile luxuriant leaves are sere and withered, their substance, as indeed the whole life of the plant, sacrificed to this one supreme effort toward the propagation of its kind. When in bloom the inflorescence is surrounded by myriads of flies and other insects attracted by the abundant nectar which the flowers secrete. These flowers in press, if not killed, continue for days to produce the viscid sweetish fluid which the natives collect and call *miél* or honey. When the seeds are ripe the pod splits down from above

and spreads apart slightly, so that a few seeds are easily shaken out by a gust of wind. The inflorescence, though dead, may stand for a year or more, and the seeds that it bears may be scattered over a wide area.

Before this plant comes into bloom the tender apex of the short stem is often used as food. Out in isolated places among the mountains one may come upon a rude circle of heavy stones bordering a shallow pit. The Mexican would say that here they were preparing *quiote* by taking the hearts of the magueys and roasting them in the pit. Upon further inquiry he will say that these morsels are covered with earth and stones and the fire built over them and kept for some hours. The older leaves yield a fiber for cordage, though this plant to a less degree than its larger relative, *A. americana*. Many uses are found for the maguey; in fact hardly any other plant of Mexico serves the people in so many ways as this one. It provides food and drink, it yields fine strong fibers for ropes, fabrics and other articles. It has served in the manufacture of paper and enters into the construction of fences and buildings. It formerly found use in religious rites and was part of the material of weapons.

As ornamental plants the cultivated magueys are hard to beat. During its fifteen years' or more life it produces relatively few leaves, but towards the close of its span of years one hundred or more of these may be in evidence, each somewhat narrow, six to ten feet in length and often weighing as much as one hundred pounds. Most of them are a dull dark green, some are margined with yellow or yellowish green. They are often planted as hedges or borders, and as such they are very attractive to look at. The short stem which in all the years has not attained a height of two feet now suddenly shoots up to thirty feet, its outstanding branches in symmetrical order enhancing its dignity and beauty beyond that of most other plants.

On the slopes of many foothills that rise from the edge of the desert plain and often on the higher slopes in great profusion, one finds a stately plant which is always conspicuous and always beautiful. Something about the sotól makes it especially attractive, with its pale green leaves an inch wide and a yard long, the tips of which often overtop a man's head. But these leaves, though beautiful to look upon, are well armed against any invader by means of many forward set teeth along their margins. In fact, a leaf of *Dasyllirion* is like a piece of double-edged band saw.

Under the hot sun of May and June the flower stalk ascends from the center of the crown of leaves and carries its topmost flowers to twice the height of the horseman riding by. These flowers, unlike those of the maguey, are small and borne on a long and slender, though compact panicle; they are monœcious, therefore not all the tall stems



PICO TEIRA FROM TANQUE DE LA PIEDÁD. Photo by F. E. Lloyd.

are destined to bear the small triangular fruits that often remain the following winter on the stalk that bore them.

This plant, besides being one of the most attractive of the whole desert flora, is not without its uses, both legitimate and otherwise. From the leaves of sotol the natives weave mats and various other articles of utility. They split the long leaves into narrow strips which they weave into hats. But this plant, like the maguey, also furnishes food and drink. The central cabbage-like bud is cooked and eaten. This central bud, and the thick top of the stem below it, are used much in the manufacture of a fiery liquor called Sotól, of rank intoxicating power.

While the plants above cited are striking and characteristic features of this desert vegetation, yet even more common and more characteristic of deserts in general are the cacti, which abound in species and individuals. *Cactus*, *Echinocactus*, *Cereus*, *Echinocereus*, *Mamillaria* and *Opuntias* of both divisions are everywhere. Down on the open plain the nopáls (*Platopuntias*) abound, as one soon discovers who tries to ride across country. The broad flat joints of these plants are everywhere. Here and there a cluster of bisnaga colorada (*Echinocactus pilosus*) shows the top of its cylindrical body bristling with red spines above the low bushes, for this bisnaga, as the native calls it, does not grow very tall, five feet being about its maximum. It blooms in June and successions of yellow fruits follow the flowers. These lemon-yellow fruits about the size of a lime are possessed also of the lime's acid

properties. But this plant is not content with the lowlands, but climbs to the top of the mountain above, where I saw some of the largest of its kind.

Echinocactus ingens, like nearly all of the cacti of this desert, prefers the hills, and there its thick trunk, bristling with long straight spines, grows to a diameter of a barrel and as much as five feet in height. This bears its flowers in a furrow across the top. The pulp of this plant is said by the peons to be sweet, but one who has tasted other cacti which they eat, may be content to leave the appraisal of this delicacy to others.

The opuntias which cover the plain and mountain are of abundant interest in their variety and numbers. The cylindropuntias abound in forms of cholla, cardencia and tazajillo, according to native terminology, with spines long and sharp and barbed, which penetrate with ease thick leather leggings, and where they stick they stay. In this the tazajillo, which grows as high as a horse's back, is especially to be dreaded, with its stiff slender spines; it separates its joints at a touch and sends them along with the passer-by. Under and around these plants scores of these joints are busy taking root, though one seldom finds thickets of tazajillo. Few of these young plants really have a future before them, though there are enough of them as it is. But the cardencias, arborescent opuntias like the species *mammilata*, *spinosior*, etc., of the Arizona desert, are not so savage as the cholla, nor so unexpectedly met with as their more slender and less conspicuous relatives, the tazajillos, as above described. In its varied forms the nopál, or flat-jointed *Opuntia*, is of more interest to the native than all the other cactus forms. This is about the only kind of cactus that may serve as fodder for cattle, and it is a common sight to behold some hundreds of pounds of one of these species carried on passing ox-carts. At the last camp where these travelers rested one could probably find the remains of a fire where they had burned off the spines of a number of nopáls, which indeed is the principal diet of their oxen.

Some of these nopáls are of imposing size and aspect, but mostly they are low procumbent forms, branching out in all directions, pushing forth segment after segment from the lower forward margin of the laterally compressed joint. Along the upper margin occur the flowers and the succession of fruits in varying shades of yellow and red. Here and there at higher altitudes are forms which produce edible fruits not unlike the edible tunas which are produced under cultivation. It seems quite possible that these may be the forerunners of some of the cultivated varieties, inasmuch as the preponderance of evidence points to Mexican origin for the tuna-bearing nopáls. Again we find on the hills a small and compact species which has little to recommend it. This, *Opuntia microdasys*, has branches closely set with coarse spicules which are easily detached and are said to be a frequent cause of blindness

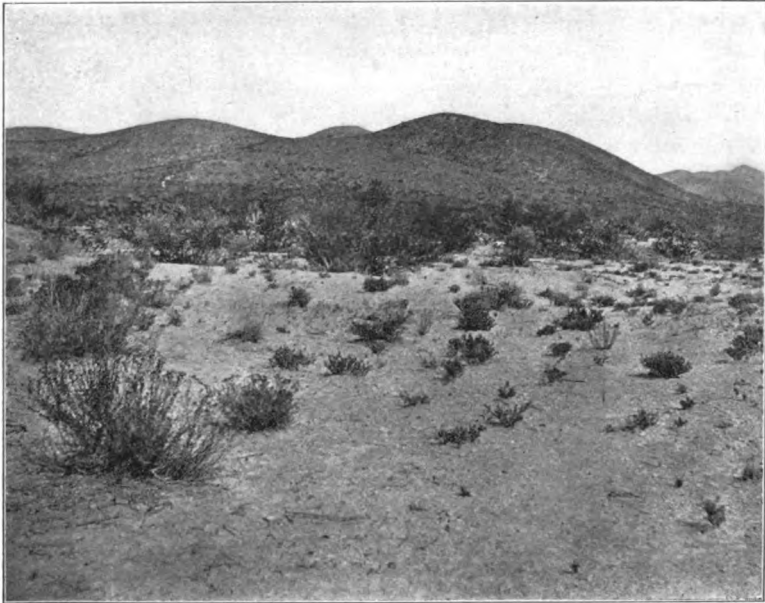

A DESERT LANDSCAPE IN ZACATECAS. Photo by F. E. Lloyd.

among horses and cattle. The animals nosing about among the branches of this plant for some tuft of grass or other morsel, dislodge the glochids and get them in their eyes. Every well-appointed doorway or garden has one or more species of the cultivated cactus which produces edible fruits of which the Mexican is very fond. These are of many varieties, differing in the characters of the branches and the fruits, the latter varying in color from the deepest red to lemon color and in form entirely distinct. They form a very important item in the short list of foods upon which the poorer classes live.

In this desert region one can not but be impressed with the number and variety of the woody plants, shrubs and small trees, which are to be seen on every hand. Many of these are common in our own southwest—mezquite, ocotillo, creosote bush, *Ephedra*, *Condalia*, *Koeberlinia*, species of *Atriplex* and *Acacia* are among the most conspicuous, some are the same species and others different, and the less obvious things are, *Lippia*, *Buddleia*, *Mortonia* and many others. In all these the families of the Leguminosæ, Labiatae and Compositæ are especially prominent, as they are elsewhere in desert regions. The shrubby growth gives color to the landscape, and in many places its whole aspect and character is due to these plants more than to the yuccas, agaves or cacti. Very few trees in this desert are more than fifteen feet high and the majority of them are much less, so that in no sense does the country seem wooded, except upon the highest ranges where pines and oaks occur.

Among these desert shrubs are some of unusual beauty. There is

Cassia wislizeni, quite common, a tall graceful bush with large panicles of orange-colored flowers, a plant which might well be valued by horticulturists of the north. All through July and August these delight the eye and stand out in conspicuous contrast with the surrounding vegetation. Pinacate they call it, though the reason is not obvious. Again if we walk out over the lower slopes not far from the banks of some arroyo we may come upon the beautiful "huisache," *Acacia farnesiana*, in full bloom if the time is summer. This plant with its small delicate leaves, its white spines, its little balls of yellow flowers scattered in profusion along the younger branches, is a beauty to behold, but the casual passer-by, if insensible to the beauty of the flowers, may perchance be attracted by their sweet and delicate perfume. Farther along in a shallow wash where the waters occasionally take their way from the higher land, appears *Chilopsis saligna* in slender graceful form, swaying to every breeze. Its clusters of red flowers need not be seen to be aware of their presence, for their sweet fragrance is borne on the breezes far beyond that of most flowers. There are few desert flowers equally conspicuous in color and perfume, and few as well supplied with either as the desert willow. But where the way leads down into the bottom of the arroyo, almost hidden under the overhanging bank, one comes unexpectedly upon the beautiful "tronadora," to use its Spanish name. Few plants of the desert are more striking in their beauty than this, with its dark, deeply compound leaves and its conspicuous cluster of orange-colored flowers, which reminds one in their form and attitude of those of the trumpet-creeper, and well it may, for it is *Tecoma stans*, a member of the same genus. If we thread along still further through the tangle of "charnís" (*Forrestiera*) with its load of mistletoe, and "junco" (*Holacantha*) and "huisache," with lacy trimmings of the vine, *Nissolia*, where the dry stream bed is flanked by *Trixis*, and sometimes Tatalencho (*Gymnosperma*) on upward to where the steep banks of the arroyo give way to less precipitous rocky slopes and into the deeper cañon beyond, *Asclepias linaria* springs from the sandy wash at our feet with its sheaf of slender stems, each capped by its umbel of white flowers. Now just to the right where a limestone cliff faces the north and receives little light from the sun that scorches the ground just beyond, is a patch of resurrection plants with their star-like forms expanded to full view by the moisture acquired from the recent shower. The day before when we passed this same way these plants had coiled themselves together into compact balls and were hardly visible in the crevices of the rock. But with the drenching shower came the resurrection to renewed activity. Near at hand some shrubs are covered with a furry growth of grayish grassy-looking plants, which upon nearer approach are seen to be a dense growth of *Tillandsia recurvata*, a sort of Florida moss, which finds in the moister air of the cañon floor or the

mountain top the conditions favorable to its growth and it attaches indiscriminately to any woody plant that furnishes a convenient hold.

But of the many things that we brush by in this ramble we have not the time to tell, but in this narrow space of moisture between zones of perennial drought, occur ferns of the genera *Pellaea*, *Notholaena* and *Cheilanthes*. Under the neighboring rocks their prothallia are growing, and young sporophytes of all ages are coming on. Climbing out of the bed of the cañon in a few steps we find ourselves again among the ocotillos and the agaves and the cacti.

Among the shrubby plants none are so important as the guayule, the native name for *Parthenium argentatum*. It is one of the most abundant of all the desert plants, especially on the limestone slopes, and its grayish color gives a distinct character to the landscape where it abounds. A small shrub or dwarf tree, it seldom exceeds four feet in height or a stem diameter of four inches. Its leaves are covered with silvery hairs and its flowers are in inconspicuous heads of composite structure not over one fourth inch across. Its light seeds—one hundred would not fill half an ordinary thimble—are supplied with a papery bract by the aid of which they are driven easily by the wind. Maturing in late summer and autumn, the seeds are dropped to the ground beneath the parent plant, or by some strong gust of wind are borne to a distance, where some find lodgment in a sheltered spot—a crevice of the rock or the cover of some friendly shrub. Here, when the rain comes, it is kept moist for time enough to send down a long, slender, thread-like root before drought again overtakes it. After the fitful showers of summer have passed a long dry season awaits the young plant, so it behooves it to make as much root as possible while the growing conditions are favorable. These slender roots will make a growth of six inches in about a week, before the first true leaf has appeared lifted on the short stem half an inch high, and in six weeks the tap root has been observed fifteen inches long. Thus the plant insures itself against the dry season, and by hardening its stem and leaves, makes still further provision against the vicissitudes that await it.

And this example serves, doubtless, for many other desert plants. We find that the seedlings spring up in abundance under the shelter of bushes and cacti and other perennials. In fact, elsewhere there is almost no chance for the survival of a tender seedling, since the hot sun dissipates so quickly the moisture of even a heavy rain that the surface of the soil is again dry in less than a day. The chances of survival of a seedling are exceedingly remote, and considering the great number of seeds produced and distributed, probably only a very small fraction of one per cent. even germinate.

But interest in this guayule which covers the desert slopes is not alone in relation to its environment, but in the *hule* or gum which it produces, forming no small part of the rubber production of Mex-

ico. Two and a quarter millions of dollars' worth of this product came from one district in one year recently and much more is following. Back in the middle of the eighteenth century it was discovered that the source of the rubber in the balls with which the Indians were wont to amuse themselves, was this guayule. As the Indians formerly did, so one now may extract this rubber in the same crude way by chewing the bark and rejecting the fiber until sufficient gum for the purpose has been accumulated.

That this gum is a by-product in the physiological processes of the plant and stored in its tissues in the form of granules, is not the least of its interesting features, for most of the rubber-bearing plants known to the public are trees yielding a milky fluid from which the rubber is obtained by coagulation. But in this case the rubber is not obtained by tapping, but by the immediate destruction of the plant.

Besides the mesquite and the greasewood and other shrubs that clothe the valleys and lower slopes, the steeper acclivities abound in *Jatropha*, *Buddleia*, *Salvia*, *Bahia*, *Ephedra* and many other woody plants, members of other genera to the number of a hundred or more, are scattered among the agaves, the palmas and the cacti up and down the mountainside.

One who has not sought these plants where they grow can have little idea of their number and variety, nor of their varied structural and physiological attributes which make for complete fitness in the stern environment of the desert. Here they grow and flourish where it would seem there is no chance for life. But they thrive in these barren wastes—league on league of plain and mountain, where there is neither spring nor pool nor forest shade, blistering heat and glare above and hot dry stones beneath, and find it sufficient.

THE WORLD OF LIFE AS VISUALIZED AND INTERPRETED
BY DARWINISM¹

By ALFRED RUSSEL WALLACE, Esq., O.M., D.C.L., LL.D., F.R.S.

THE lecturer began by stating, that, although the theory of Darwinism is one of the most simple of comprehension in the whole range of science, there is none that is so widely and persistently misunderstood. This is the more remarkable, on account of its being founded upon common and universally admitted facts of nature, more or less familiar to all who take any interest in living things; and this misunderstanding is not confined to the ignorant or unscientific, but prevails among the educated classes, and is even found among eminent students and professors of various departments of biology.

Darwinism is almost entirely based upon these external facts of nature, the close observation and description of which constituted the old-fashioned "naturalists," and it is the specialization in modern science that has led to the misunderstanding referred to. Those who have devoted years to the almost exclusive study of anatomy, physiology or embryology, and that equally large class, who make the lower forms of life (mostly aquatic) the subject of microscopical investigation, are naturally disposed to think that a theory which can dispense with all their work (though often strikingly supported by it), can not be so important and far-reaching as it is found to be.

NUMBERS, VARIETY AND INTERMINGLING OF LIFE-FORMS

Coming to the first great group of facts upon which Darwinism rests, the lecturer calls attention to the great number of distinct species both of vegetable and animal life found even in our own very limited and rather impoverished islands, as compared with the more extensive areas. Great Britain possessed somewhat less than 2,000 species of flowering plants while many equal areas on the continent of Europe have twice the number. The whole of Europe contains 9,000 species, and the world 136,000 species already described; but the total number, if the whole earth were as well known as Europe, would be almost certainly more than double that number or about a quarter of a million species. The following table, showing how much more crowded are the species in small than in large areas, was exhibited on the wall. It affords an excellent illustration of the fact of the great intermingling of species, so that large numbers are able to live in close contact with other, usually very distinct, species.

¹ Abstract of a lecture before the Royal Institution of Great Britain.

· NUMBERS OF FLOWERING PLANTS²

	Square Miles.	Species.
The County of Surrey	760	840
A portion containing	60	660
A portion containing	10	600
A portion containing	1	400

The above figures were given by the late Mr. H. C. Watson, one of our most eminent British botanists, and as he lived most of his life in the country, they are probably the results of his personal observation, and are therefore quite trustworthy.

Continuing the above enquiry to still smaller areas, one perch equalling $\frac{1}{160}$ acre, or less than the $\frac{1}{100000}$ of a square mile, has been found to have about forty distinct species, while on a patch 4 feet by 3 feet in Kent (or about $\frac{1}{2500000}$ of a square mile) Mr. Darwin found twenty species.

The same law of increase of numbers in proportion to areas applies to the animal world, if we count all the species that visit a garden or field during the year, though those that can continuously live there are not perhaps so numerous in very small areas.

THE INCREASE OF PLANTS AND ANIMALS

The powers of increase of plants and animals were next discussed, and were shown to be enormously great. An oak tree may produce some millions of acorns in a good year, but only one of these becomes a tree in several hundred years, to replace the parent. Kerner states that a common weed, *Sisymbrium Sophia*, produces about three quarters of a million of seeds; and if all these grew and multiplied for three years, the plants produced would cover the whole land surface of the globe.

Equally striking is the possible increase in the animal world. Darwin calculated that the slowest breeding of all animals, the elephant, would in 750 years from a single pair produce nineteen millions. Rabbits, which have several litters a year would produce a million from a single pair in four or five years, as they have probably done in Australia, where they have become a national calamity. As illustrative of this part of the subject, the lecturer referred at some length to the cases of the bison and the passenger pigeon in North America, and the lemmings of Scandinavia. In the insect tribes still more rapid powers of increase exist. The common flesh-fly goes through its complete transformations from egg to perfect insect in two weeks; and Linnæus estimated that three of these flies could eat up a dead horse as quickly as a lion.

² Other tables illustrating similar facts in other parts of the world were prepared, but not exhibited, as being likely to distract attention from the lecture itself.

It is these enormous powers of rapid increase that have ensured the continuance of the various types of existing life from the earliest geological ages in unbroken succession; while it has also been an important factor in the production of new forms which have successively occupied every vacant station with specially adapted species.

INHERITANCE AND VARIATION

The vitally important facts of inheritance with variation was next discussed, and their exact nature and universal application pointed out. The laws of the *frequency* and the *amount* of variations, and their occurrence in all the various parts and external organs of the higher animals, was illustrated by a series of diagrams. These showed the actual facts of variation in adult animals of the same sex obtained at the same time and place, which had been carefully measured in numbers varying from twenty to several thousand individuals.

The general result deduced from hundreds of such measurements and comparisons, was, that the individuals of all species varied around a mean value—that the numbers became less and less as we receded from that mean, and that the limit of variation in each direction was soon reached. Thus, when the heights of 2,600 men, taken at random, were measured, those about 5 feet 8 inches in height were found to be far the most numerous. About half the total number had heights between 5 feet 6 inches and 5 feet 10 inches, while only ten reached 6 feet 6 inches, or were so little as 4 feet 10 inches, and at 6 feet 8 inches and 4 feet 8 inches there were only one of each.

The diagrams from the measurements of various species of birds and mammals were shown to agree exactly in general character; and the further fact was exhibited by all of them, that the parts and organs varied more or less independently, so that the wings, tails, toes or bills of birds were often very long, while the body, or some other part was very short, a point of extreme importance, as supplying ample materials for adaptation through natural selection.

THE LAW OF NATURAL SELECTION

The next subject discussed was the nature and mode of action of natural selection. It was pointed out that since the glacial epoch no decided change of species had occurred. This showed us that the adaptation of every existing species to its environment was not only special but general. The seasons changed from year to year, but the extremes of change only occurred at long intervals, perhaps of many centuries, with lesser, but still very considerable variations twice or thrice in a century. It was by the action of these seasons of extreme severity at long intervals, whether of arctic winters, or summer droughts, that the very existence of species was endangered;

and it was at such times that the enormous population of most species and their wide range over the whole continents, always secured the preservation of considerable numbers of the best adapted in the most favored localities. Then the rapidity of multiplication came into play, so that in two or three years the population of each species became as great as ever; while, as all the least favorable variations had been destroyed, the species as a whole had become better adapted to its environment than before the almost catastrophic destruction of such a large proportion of them.

It is the fact of the adaptation of almost all existing species to a continually fluctuating environment—fluctuating between periodical extremes of great severity—that has produced an amount of adaptation that in ordinary seasons is superfluously complete. This is shown by the well-known fact that large numbers of adult animals that have not only reached maturity but have also produced offspring and successfully reared them, continue to live and breed for many years in succession, although varying considerably from the mean, while almost the whole of the inexperienced young fall victims to the various causes of destruction that surround them.

THE NATURE OF ADAPTATION

The next subject discussed was the complex nature of adaptations in many cases, and probably in all; a subject of great extent and difficulty. The lecturer directed special attention to the relations between the superabundance of vegetation in spring and summer, the enormous, but, to us, mostly invisible, hosts of the insect tribes which devour this vegetation, and the great multitudes of our smaller birds whose young are fed almost exclusively on these insects. Without these hosts of insects the birds would soon become extinct; while without the birds, the insects would increase so enormously as to destroy a considerable amount of vegetable life, which would, in its turn, lead to the destruction of much of the insect, and even of the highest animal groups, leaving the world greatly impoverished in its forms of life.

The vast numbers of insects required daily and hourly to feed each brood of young birds was next referred to, and the wonderful adaptation of each kind of parent bird which enables it to discover and to capture a sufficient quantity immediately around its nest, in competition with many others engaged in the same task in every copse and garden, was next pointed out. The facts were shown to involve specialities of structure, agility of motions, and acuteness of the senses, which could only have been attained by the preservation of each successive slight variation of a beneficial character throughout geological time; while the emotions of parental love must also have

been continuously increased, this being the great motive power of the strenuous activity exhibited by these charming little creatures.

LORD SALISBURY ON NATURAL SELECTION

As illustrating the strange and almost incredible misconceptions prevailing as to the mode of action of natural selection, the lecturer quoted the following passage from the late Lord Salisbury's presidential address to the British Association at Oxford in 1894. After describing how the diverse races of domestic animals have been produced by artificial selection, Lord Salisbury continued thus:

But in natural selection, who is to supply the breeder's place? Unless the crossing is properly arranged the new breed will never come into being. What is to secure that the two individuals of opposite sexes in the primeval forest, who have been both accidentally blessed with the same advantageous variation, shall meet, and transmit by inheritance that variation to their successors? Unless this step is made good the modification will never get a start; and yet there is nothing to ensure that step but pure chance. The law of chance takes the place of the cattle-breeder or the pigeon-fancier. The biologists do well to ask for an immeasurable expanse of time, if the occasional meetings of advantageously varied couples, from age to age, are to provide the pedigree of modifications which unite us to our ancestors, the jelly-fish.

Here we have the extraordinary misconception presented to a scientific audience as actual fact, that advantageous variations occur singly, at long intervals, and remote from each other; each statement being, as is well known, the absolute reverse of what is really the case. It totally ignores the fact, that every abundant species consists of tens or hundreds of millions of individuals, and that as regards any faculty or quality whatever, this vast host may be divided into two portions—the *less* and the *more* adapted—not very unequal in amount. It follows that at any given time, in any given country, the advantageous variations always present are not to be counted by ones and twos, as stated by Lord Salisbury, but by scores of millions; and not in individuals widely apart from each other, but constituting in every locality or country, somewhere about one half of the whole population of the species.

The facts of nature being what they are, it is impossible to imagine any slow change of environment to which the more populous species would not become automatically adjusted under the laws of multiplication, variation and survival of the fittest. Almost every objection that has been made to Darwinism assumes conditions of nature very unlike those which actually exist, and which must, under the same general laws of life, always have existed.

PROTECTIVE COLOR AND MIMICRY

The phenomena of protective coloration and mimicry were very briefly alluded to, both because they are comparatively well known and

had formed the subject of previous lectures; while they are very easily explained on the general principles now set forth. The explanation is the more easy and complete, because of all the characters of living organisms, color is that which varies most, is most distinctive of the different species, and is almost universally utilized for concealment, for warning or for recognition. And further, its useful results are clear and unmistakable, and have never been attempted to be accounted for in detail by any other theory than that of the continuous selection of beneficial variations.

THE DISPERSAL OF SEEDS

The subject of the dispersal of seeds through the agency of the wind, or of carriage by birds or mammals in a variety of ways, and often by most curious and varied arrangements, of hooks, spines or sticky exudations almost infinitely varied in the different species, was also briefly treated, since they are all readily explicable by the laws of variation and selection, while no other rational explanation of their formation has ever been given.

CONCLUSION

In concluding, the lecturer called attention to a series of cases which had shown us the actual working of natural selection at the present time. He also explained that these cases were at present few in number, first, because they had not been searched for; but perhaps mainly, because they only occur on a large scale at rather long intervals, when some great and rather rapid modification of the environment is taking place.

In the following paragraph he endeavored to summarize the entire problem and its solution:

It is only by continually keeping in our minds all the facts of nature which I have endeavored, however imperfectly to set before you, that we can possibly realize and comprehend the great problems presented by the "World of Life"—its persistence in ever-changing but unchecked development throughout the geological ages, the exact adaptations of every species to its actual environment both inorganic and organic, and the exquisite forms of beauty and harmony in flower and fruit, in mammal and bird, in mollusc and in the infinitude of the insect-tribes; all of which have been brought into existence through the unknown but supremely marvelous powers of life, in strict relation to that great law of usefulness, which constitutes the fundamental principle of Darwinism.

MENTAL INHERITANCE¹

BY DR. MADISON BENTLEY
CORNELL UNIVERSITY

OUR chapter of Sigma Xi has recently invited to its membership some two score persons who have shown themselves to be possessed of such talents and aspirations as the society honors and rewards. Of these new members many have finished their preparatory studies, and are entering upon the independent work of science. It is therefore suitable upon this occasion that we should consider some one of those qualities that distinguish the person who is engaged in the scholarly pursuit of knowledge. The quality which I have selected is the possession of temporal or historical perspective; and I propose to use, by way of illustration, the subject of mental inheritance.

Nothing is easier than to exalt beyond its due the present moment. The present is so vivid, so impressive, so intimate, so important for action, as to compel attention; and current means of communication succeed so well in bringing distant lands and deeds within our field of vision that the whole world contributes to the fascination of the passing scene. We all realize this fascination, however much we may set our faces against the vulgar homage paid to the latest mode, the most recent invention, or the last political experiment. We realize it, and, if we are wise, we perceive that the philistine passion for being "up-to-date" (as the street-phrase has it) contains an element of great value—the element of enthusiasm. Scholarly work demands enthusiasm, and every epoch of science has, and, I suppose, will have, its sanctions and its rewards for enthusiastic endeavor. In this regard our own time certainly is not wanting. At a period when the constitution of matter and its elementary forms have, by the discovery of new facts, been brought to the focus of attention; when the development of living forms through their various stages of growth is observed by methods undreamed of by the earlier historians of nature; when the study of evolution has advanced to the stage of analysis and experiment; when the earth is revealing significant traces of primitive man and his works; when psychology proposes new methods for the study of thought and action and for a comparison of the human with the animal mind; when, finally, philosophy rests less upon the authority of great names and systems than upon the immediate data of experience, no ardent novice in science can complain that fate has thrown him upon an age of

¹ An address delivered before the Cornell Chapter of Sigma Xi, June 9, 1909.

platitude and dogma, or has denied to him the opportunity of spending his energies in the cultivation of a land of promise.

The kindling enthusiasm of the man of science must not, however, be confused with the philistine's boast that history is a wreck from which only he and his time have been saved. Opportunity which inspires the scholar inflates the time-server and intoxicates the anarchist. The difference between these persons rests at last upon temporal perspective, or the want of it; for it is the apprehension of new opportunities and new needs in the light of old accomplishments that leads to profitable reconstruction of human knowledge. In mechanical invention, the new model may cause the old to be cast upon the rubbish-heap; but in man's interpretation of the world, old theories and old points of view which have served their generation are never discarded; they still mark the stages of human acquisition and take their place in the development of science. Without a knowledge of them, and of their relation to present problems, no man, however ingenious or fertile, should hope to do more than a journeyman's work in the free advancement of learning.

But even when we know the general history of thought and the special histories of our own small divisions of human knowledge, we are apt to overlook the fact that, in a large sense, civilization itself is a matter of the moment, which may be viewed in the light of a broader perspective. Civilization we measure by hundreds and thousands of years. For example, we trace the Mediterranean cultures eight or ten or twelve thousand years, and then we lose the thread; but the whole history of man we reckon in geological epochs. We find his footprints stamped everywhere upon the Quaternary earth, and we find what appear to be vestiges of him in the deeper deposits of the Tertiary. Throughout the brief day of his written history we study him in a long series of related disciplines which we call "the humanities"; while we hand over the unmeasured period of his whole antecedent career to the single science of anthropology. We glance with admiration at his morning work in iron and bronze and brass, his noontime of Athenian culture, his late hours of reflection and invention, and we seek however feebly to illumine the night of his future; but we tend to overlook the antiquity of man, the record of other days and years, and to avoid the question whether civilization is not, after all, still in the experimental stage—whether we ourselves are not next-door neighbors to the barbarian.

When we regard the rapid accumulations of a few thousand years of culture, we realize that civilization lays upon the human mind a staggering load of traditional knowledge and traditional duty. In "Darwinism and Politics" the late Professor Ritchie has defined civilization as "the sum of human contrivances which enable human beings

to advance independently of heredity." Contrast man and other animals. The animal carries over from his parents and from his racial stock the physical equipment and the functional tendencies which enable him to fight the battle of life precisely as his ancestors fought it. If his type varies under natural conditions, it varies so slowly that, as a rule, many generations are required to disclose the change. With man all this is different. As I just now observed, nurture is cumulative. Each succeeding generation takes up its heritage, not where the preceding generation began, but where it left off. Each has to advance by first absorbing the new attainments of its immediate ancestors. In a real sense, therefore, because he has language and books and institutions and traditions, man is

the heir of all the ages.

Notice, however, that man comes into his social heritage only by acquisition during his individual life, by his own individual efforts. Is he, now, as a conscious being, better and better endowed as time goes on for the process of absorption? Does talent grow as knowledge grows? Does mental capacity keep pace with social accumulation? May we not suppose that the men and women of some distant glacial age, who dwelt upon the ice, wore the skin of the seal, and ate raw fish, had as much brain and as generous a measure of talent as have their remote descendents who wear sealskins, and eat ices and caviare? We can not say that they had not. On the contrary, our records, so far as they go, indicate that the social heritage has outstripped the hereditary growth of mind—that, as regards mental endowment, we begin very much as our distant forbears began; only, we proceed at once to burden ourselves with information and obligation which for them did not exist. To compass languages and sciences and histories and arts, and a complicated social and political régime, we are supplied with virtually the same minds that primitive man used for his primitive wants. Is it any wonder, then, that education is the central problem of an advanced civilization?

The question has been raised, however, whether it is not time to look beyond education to the possibility of improving the human stock; whether education is, after all, the only way of civilizing the individual. When the garden vegetable or the domestic animal fails to meet our needs, we improve its breed—so the argument runs; we breed for size, for strength, for flavor, for color, for endurance, for speed, or for general service. When we find that the part of our human stock which is best fitted to carry the cumulative load of civilization is weak, or degenerate, or inclined to sterility, why do we not look to the improvement of those strains that are mentally fittest and to the elimination of the bad? The argument, you observe, assumes that mental endowment and mental capacity are heritable possessions. Is the as-

sumption warranted? We can not say until we have examined the present status of the problem of inheritance; but whether or not we are pessimistic as regards the future of the race, we must agree that the sudden and increasing burden which culture places upon the human mind raises this problem to the first rank of importance.

Suppose that we look, then, at the grounds of belief in the hereditary transmission of mind. The belief itself stands among the fixed convictions of common sense. In our every-day thinking we take it for granted. The child, we maintain, inherits its father's bad temper just as it inherits its mother's good looks. We consider twice before we adopt the foundling, which may be of dull or vicious parentage. We shake our heads over the wayward son, remembering that his father "sowed his wild oats," and we observe "like father like son," or "blood will tell." We expect to find talent in the children of the gifted, thrift or dwarfed intellect or high purpose, according as these qualities are "bred in the bone." The folk-tale of paupered prince or stolen princess who never, though reared as swineherd or scullion, loses regal bearing and courtly demeanor, the wide respect for royal blood, and the easy belief in the "born criminal," alike testify to the common and venerable persuasion that minds, and even morals, are subject to hereditary transmission.

It is only when we stop to inquire precisely *what* is inherited in all these instances, and how it is conceivable that mind should pass from parent to offspring, that we leave the highway of common sense and enter the more difficult path of critical observation and induction. It is obvious that a clear statement of the problem and a forecast of method are of the first importance.

Inasmuch as the notion of "inheritance" involves both the process and the products of transmission, the *inheriting* and the *thing inherited*, a choice of methods is at once suggested. Shall we—that is to say—seek to describe the mechanism of inheritance, or to discover the like qualities that have actually appeared in successive generations of blood-relatives? It is quite impossible to state the alternatives without adverting to the fact that biology has, for a half-century, been absorbed in the parallel investigation of physical inheritance. Nor are we likely to forget, in the midst of our commemoration of Darwin's birth and of "The Origin of Species," that the whole doctrine of organic evolution rests upon the facts of heredity. Whatever the factors that determine racial descent—fluctuating variation, or the sudden change of type, use and disuse, natural, artificial, sexual or organic selection—both continuity in the process of bionomic change and maintenance of the change once produced, demand the conception of a hereditary likeness. Without inheritance the establishment of a stock would be impossible, and without a stock, variations and mutations

would be chaotic and without significance. Thus, ever since Darwin's own attempt at a theory of heredity, we find the students of organic evolution and the breeders of plant and animal races alike devoting themselves to the problems of racial and individual inheritance.

Now it is plainly futile for the psychologist to pretend to first-hand knowledge in a field which is not his own; but, on the other hand, it is equally foolish for him to proceed to the question of mental inheritance without a conception of the methods used, and of the general progress made, by the biological sciences in like inquiries. He must at least bear in mind that the days of pangenesis were followed by the days when Weismann challenged the Lamarckian doctrine of use and disuse, these by the days of rapid development in cytology (the science of the cell and its development), and these days, in turn, by the establishment of the science of genetics and of a revised, if tentative, doctrine of heredity. He must also keep in view the general march of events that led up to the rediscovery of Mendel, the attempt to establish "unit characters" and to segregate the elementary factors in descent, the exploitation of sudden or discontinuous variation at the expense of fluctuation, and the wide use of Quetelet's discovery that individual variation follows the law of probability.

But what, you may ask, has psychology to learn from the doctrine of physical inheritance, when bionomic orthodoxy is overgrown with speculation, when evolutionists themselves are asking, fifty years after Darwin, whether the time is yet ripe for a discussion of the origin of species, when they are raising the doubt whether there has yet fallen from the tree of knowledge the apple that shall suggest the discovery of the universal law of inheritance; when Strassburger affirms that the doctrine of heredity must rest upon the study of the cell, and Bateson replies that the student of evolution is "still, as a rule, quite unable to connect cytological changes with any genetic sequence," and that the direct examination of parent and offspring, not of the germinating cell, is the present key to the problem? What can the psychologist hope to learn about method when the biometrician and the follower of Mendel stand at sword's points; the one fighting for measurements, and schemes of distribution, and coefficients of correlation, and the other for segregation, unit characters and laws of dominance and recession?

My reply is, first, that, in spite of his keen enjoyment of the battle, even the observer from the outside can appreciate the invention and application of clever and useful methods and the advancement of knowledge through conflict; and, secondly, that the student of mental inheritance must get at least half of his equipment from the antecedent studies of biology. To be sure, he finds his material within psychology; but he sees that the strict dependence of mental upon physical derivation calls for an alliance with both the biometrician and the student of physiological genetics.

Let us be more concrete in this matter. If I catch the drift of biological discussion (a hazardous assumption, it may be, for the layman in biology to make), no current and generally accepted doctrine of heredity is able to trace in an unbroken series of structures or events the details of the parental organism through the stages of reproduction to the corresponding details of the offspring. The nuclear and non-nuclear substances that are supposed to represent the "vehicle" of heredity do not, I think (except, perhaps, in a few cases) show variations that represent and correspond to the likeness or difference in given characters as these appear in parent and offspring (*e. g.*, differences in height, in shape of leaf, or in color of hair). If, at some future time, these variations are discovered, then they will, I suppose, represent or correspond to mental as well as physical likeness and difference. At present, however, degree of likeness in blood-relations must be derived from description or measurement of corresponding characters or qualities to be observed in succeeding generations. And the point at which we are here aiming is this: the establishment of inheritance of these qualities, whether physical or mental, must, in principle, rest upon one and the same basis. The inheritance of eye-color and the inheritance of memory-type, the inheritance of an "athletic build" and the inheritance of a bad temper are facts of the same order, and similar methods may be laid under prescription for their establishment.

The great difficulty lies here: how are the characters, mental and physical, to be conceived? and how are they to be described and measured?

We have just seen that upon this question of analysis and measurement, quite apart from the problem of mechanism, the schools of evolution show wide differences of opinion, the biometrician basing his method upon the doctrine of probabilities and proceeding quantitatively, the Mendelian basing his method upon the doctrine of unit characters and segregation and proceeding analytically and by distinction of qualities.

Which of these methods, if either, is psychology to adopt? It happens that psychology has already made a provisional choice; or rather, a choice has been made for her. Biometry has been predominantly concerned with human, Mendelism with non-human, inheritance. It is scarcely an accident, then, that biometrical methods were the first to exploit the mind of man. As you know, biometry's inspiration came from Francis Galton, traveler, explorer, geographer, anthropologist, student of evolution, psychology and sociology. The grandson of Erasmus Darwin, a representative therefore of one of the highly gifted strains of English blood, Galton has devoted himself to a quantitative study of the inheritance of talent and intellect, and to practical measures for purifying and improving the race. His interests revolve

about the central theme of human ability and its dependence upon the stock. In a study of three hundred eminent English families, Galton found the descent of great mental capacity to be far more intensive than in less eminent families; and found, further, that the closer the blood-relationship, the greater was the number of eminent individuals. Later studies, for example, Galton's own recent inquiry into the family history of Fellows of the Royal Society, have likewise shown that the person of superior mind is much more likely than the average to possess superior ancestors and descendants. These facts are justly interpreted as an indication that mental endowment depends in large measure upon direct inheritance.

This kind of inquiry then—the kind that takes human beings in the mass and applies a rough unit of measurement—reveals in a striking way the importance of the hereditary factor in mental ability. However, the method does not constitute a science of heredity. No evolutionist would be satisfied to know that large horses beget large horses, and small horses small horses. It is the degree of likeness of some particular organ, or quality, or function, or peculiarity that the student of heredity now attempts to state, and to state often in numerical terms.

So the present psychological problem of heredity comes back to the question of mental characters and of the best methods for their description and measurement. The psychologist may answer this question in either one of two ways. First, he may fall back upon the distinctions of every-day or popular psychology and say that "a good memory," "sound judgment," "conscientiousness," "affability," "sentimentality" and "industry" are mental characters, and that the way to calculate their heritability is to take a large number of persons, related and not related, estimate the eminence of these qualities in each, note their distribution and derive laws of resemblance. If you find that a good memory, or affability, or industry "runs in families," and is not to be attributed to a common environment, you may conclude that the characteristic in question is heritable. As a matter of fact, this is the method that, for the most part, has been employed within the last ten years; and it has been used either by biometricians themselves, or by the psychologist who has followed their initiative.

Let me cite two or three instances. Professor Karl Pearson, of the University of London, the leader of the biometrical school, collected from teachers data regarding some four thousand children. Color of hair and eyes and cephalic index were among the physical characters graded, and conscientiousness, temper and assertiveness among the mental traits. The degree of likeness between brothers and sisters was found to be substantially the same for physical and mental qualities; in Pearson's terms, each showed a correlation of about 0.5. Again.

Professor Thorndike, of Columbia University, in a study of fifty pairs of twins, by the use of tests and measurements, derived nearly the same degree of correlation (just exceeding .75) for mental and physical characters—a much higher degree of resemblance, by the way, than he found in brothers and sisters *not* twins. The result is noteworthy, even though we may doubt the full validity of the method. The most extensive and painstaking investigation of this order was recently made by two Dutch psychologists, Heymans and Wiersma, of the University of Groningen. Some four hundred physicians responded to a questionnaire, each giving the results of his intimate acquaintance with a single family. The questions asked pertained to the ardor, impulsiveness, resolution, persistence, generosity, temperance, wit, patience, industry, etc.—about ninety topics in all—of each member of the family selected. The results when thrown into tabular form indicate a high degree of resemblance between parent and child—a higher resemblance between father and son, mother and daughter, than between father and daughter and mother and son. Even after allowance had been made for cultural influences, the degree of likeness was about the same as the inheritance of bodily stature, and the result seems, moreover, to stand in close agreement with Galton's law of ancestral inheritance, which accords to the average parent one quarter the heritage of the offspring.

It is, now, a matter of interest that these studies and others that might be brought under survey suggest that our mental traits and capabilities are derived, very much as are our bodily characteristics, from hereditary endowment. You must, however, have been struck by the grossness of the method of collecting facts. What is the scientific value, you may have asked yourselves, of a teacher's or physician's opinion that *A* is more vivacious or less generous than *B*? Well, the outcome does show, I think, that careful mathematical treatment of extensive data thus collected will yield noteworthy and valuable results. But the more important the results, the greater the demand for refinement of method. Can the method be improved? I think that it can. The biometrician having shown that the problem is capable of solution, let us see if his arch-enemy, the follower of Mendel, can not suggest the improvement in procedure. The improvement that I find suggested is this: the exclusive inheritance of Mendel lays emphasis upon the analysis and separate treatment of individual characters. Now without presuming to decide whether inheritance takes place in all cases, or even as a rule, through the recombination of "unit characters," mental or physical, psychology may profit by the Mendelian principles so far as to insist that inheritance be studied, not in the gross, but in terms of definite and measurable mental structures and functions.

This insistence involves the substitution of a doctrine of mental characters for the popular conception of vague and indefinite traits and peculiarities. How is this doctrine to be derived? Obviously from psychology itself. Neither biometry nor biology nor common sense can furnish the materials.

Look with me for a moment, if you will, to see what psychology has to offer. It is evident that the general psychology of the average normal mind will not suffice when the matter is one of defining *differences* among minds of the same class. Just as physical inheritance must take account of arrays and schemes of distribution, and not of averages, so must mental qualities and magnitudes be arranged with respect to definite individual variations within the class.

A psychology of individual differences is thus invoked; and a psychology of individual differences does exist; or rather, it is in process. The way of scientific description is first to reveal uniformities hidden in the mass, and afterward to seek the rule of variation from the average. General psychology, taken in this sense, is accordingly the older branch of the science—the psychology of what is common to all minds—individual psychology, the newer. So it happens that although the older branch of the science has a well-developed metrical technique, established at almost the same moment that “The Origin of Species” appeared, its quantitative determinations are determinations of psychophysical *constants* and not laws of individual variation. These laws can not then be used (at least not directly) for the statistical study of inheritance. What is needed is a psychology of typical differences, and this it is that individual psychology is by way of supplying. Let me, in a word, indicate its method. It proceeds by experiment to take the dimensions of mind as regards variable functions, *e. g.*, the maximal amount read in a given time and under given conditions, or the number of words remembered or of figures added. The first results show typical differences as between mind and mind. The experimenter next proceeds to factor the performance into elementary processes and functions. By drawing his conditions closer and closer he discovers that the capacity for reading depends upon such simple factors as the range of consciousness, the degree of attention, and the temporal rate of visual processes, factors all capable of measurement and exact description. He discovers that remembrance depends upon the employment of visual or auditory or kinesthetic processes, *i. e.*, that in one observer an eye-mind, in another an ear-mind and in a third a muscle-mind is employed. Of these factors, he can predicate heritability. It is as if “criminality” were reduced to a lack of motor control plus an abnormally intensive passion or lust. “Criminality” would then never be inherited, but the constituent factors might very well be. The method of individual psychology, however, goes farther. After

having reduced a conscious experience to simpler terms, the process of reconstruction begins. The functions and processes that have been reduced to numerical terms are recombined in their several amounts and the integration when complete represents an individual in so far as that individual is typical. With the absolute and exhaustive description of the individual as such, science is not concerned. Typical minds thus derived are, so to say, minds of different length and breadth and thickness. They are analogous to the variable organs and functions of the body. Their scientific description differs from the crude characterizations which we pass upon our friends and enemies as the law of falling bodies differs from an observer's account of a balloonist's accident.

The steps, then, in the procedure of individual psychology are (1) the measurement of a group of mental processes or functions, (2) analysis for the discovery of elementary or fundamental differences, (3) integration of these differential factors, and (4) a classification of types; measurement, analysis, integration, description, a common and justified sequence in the general methodology of science. Compare with this procedure the instances taken a few moments ago from the psychology of common sense—the method employed, let us say, by Pearson. The first and the last steps are combined (“conscientiousness” or “assertiveness” represents the type), analysis and integration are omitted, and an offhand estimate is substituted for careful measurement.

I fear that I have been tedious and that I have perplexed you overmuch with matters remote from your primary interests. My excuse is that I have given you in part a program for the future, and that methods in the making are notoriously self-conscious and awkward of expression. If it were ten years later doubtless I could display more product and vex you less with the process. I could, I have reason to believe, show you this psychological problem of ours, which already at the early stage of crude quantification has proved itself extremely fertile, in a much more mature and fruitful state.

Now that you have before you, in outline, the problem of mental inheritance, its debt to biology, and the present necessity—if the problem is to advance—for the analytical treatment of traits by a science of individual differences, let me in closing return to my earlier remarks touching the import of inheritance in human history. I urged that human knowledge and human obligation have grown out of proportion to human talent. So far as we can tell, the child of to-day possesses the same nervous system, the same sense organs, evinces the same instinctive tendencies, in short, develops with the same physical and mental equipment as the child of unnumbered generations ago. If, so far as education went, the primitive boy was ready for man's estate at

twelve or fifteen, can we wonder that at present the candidate for an advanced university degree has often passed his thirtieth birthday? We should rather marvel at the elasticity of the mind's response to new needs. We know that Quaternary man sometimes possessed artistic ability—perhaps as great ability as the modern European; but what a difference in the product. We can not conceive a medieval musician—to go no further back—producing or comprehending our operas and symphonies; but who would say that native ability in music has grown in the meantime? Are we not then driven to the admission that no principle of selection has for a long time been sufficiently active to raise the level of mental endowment? We live on capital gathered and hoarded by the race. Suppose that we turn spendthrift! Francis Galton reckons that England at its best falls two grades below the highest intellect of Athens; that England produces one man of supreme eminence where the older culture produced two hundred. Suppose that by improving the breed our mental endowment should recover those two grades. The effect, direct and indirect, upon the race is not easily estimated. It is conceivable that it should give to every generation a Homer or a Dante or a Shakespeare, and to each of the European states and America a dozen Newtons and Darwins. Eugenics rests upon a scientific basis and it proposes a well-considered program for future activity. Whatever differences of opinion we may hold regarding the probable success of its methods, we must agree that civilized man may not indolently regard himself as “God's domestic animal”; that he will, on the contrary, do well to examine and to estimate the hereditary factor in his own mental development and to seek to combine for his improvement the conjoint forces of nature and nurture.

ASTRONOMICAL SUPERSTITIONS

BY JOHN CANDEE DEAN

INDIANAPOLIS, IND.

THE great majority of our superstitions had their birth in attempts to interpret natural phenomena from erroneous ideas which consist of fancies suggested by the imagination. In other words, most superstitions are attempted short cuts to explain phenomena while omitting natural causation. The average man loves superstition, loves the fictitious, both loves and fears the supernatural and is fascinated by the incomprehensible. From the infancy of the human race men have attempted to explain things according to their external appearances, and whatever was strange or vast, especially if it had visible motion, impressed the beholder with the fear of invisible powers.

During September, 1908, a score of people called the writer by telephone to ask about a brilliant star that had appeared in the eastern morning sky. They had been informed that it was the star of Bethlehem, which appears only once every 300 years. They generally seemed disappointed when told that it was not the star of Bethlehem, but the planet Venus, which instead of becoming visible only once in 300 years, regularly appears twice in a period of 584 days. On attempting to impart further information it soon became evident that their interest was in the *mystery* of the star of Bethlehem and not in any *facts* relating to Venus.

Fashionable society will enthusiastically discuss telepathy, astrology, christian science, psychic force, palmistry, spiritualism, etc., but if one should introduce a subject relating to astronomy or physics, he would be regarded as a pedantic bore. Du Maurier illustrated the indifference of society to science by a drawing in *Punch* entitled "Science and Music at an Evening Party." The scene was in a large London drawing room. In the foreground was a professor earnestly talking to a gentleman, while at the back of the room all the rest of the company were eagerly crowding around a piano. Chesterfield wrote to his son:

Pocket all your knowledge with your watch and never pull it out in company unless desired; the producing of one unasked, implies that you are weary of the company, and production of the other will make the company weary of you.

While it is true that there is but a small circle of people interested in what is called physical science, yet that science now rules the world and is nearly as despotic as nature herself. Human progress is almost entirely scientific and even our industrial progress is based on applied science.

Even before man essayed to group the stars into constellations he naturally raised the question of the origin, and the manner of the production of the world itself. He then believed it to be flat and immovable, and its seagirt disk supported the sapphire vault above. Gods, men, monsters and heroes familiarly associated and acted their parts, before man had learned to judge by evidence and to place a limit on probability. The sun, the moon and the earth were living beings filled with demons, and sorcery governed belief. Under these conditions there arose no astronomical or geographical difficulties, for where superstition rules evidence becomes useless.

The astronomical ideas of primitive people have been similar the world over. The cosmogony of the Mahometans, as presented in the Koran, is so puerile as to be unworthy of serious consideration. It teaches that the earth is flat and floats in the sea. It is kept in balance by the mountains, and the sky is supported above by a huge dome so perfect that it is impossible to discover a crack in it. Above are the seven heavens, ranged one over the other, the uppermost being the abode of God, which does not rest on the earth, but is supported by winged animals. Meteors are red-hot stones thrown by angels at bad spirits, when they approach too near the seventh heaven. Of the many creation myths, the Jewish story is the one most familiar to us. According to this narrative the universe was miraculously created in six days. The earth is the fixed center enclosed in a great hemisphere called the firmament, which divides the seas above it from those below. More space is devoted to describing the creation of the firmament—now known to be an optical illusion—than to the creation of man himself. The sun, moon and stars were made “to give light upon the earth,” and the whole universe was purely anthropocentric, that is, man was the preordained center and aim of all creation. This anthropocentric dogma is closely connected with all three of the great Mediterranean religions, Mosaic, Mohammedan and Christian, hence it has for centuries dominated the beliefs of the greater part of the civilized world.

Many of the most charming legends of Greek and Roman mythology were drawn from astronomical subjects. There is no more beautiful illustration of Roman superstition than that shown in Guido's familiar fresco of “Aurora.” Why this picture is called Aurora and not Apollo is difficult to explain. The noble sun god is the most important figure of the picture, and he dominates all the rest. He is surrounded by the light tripping Hours, each a very queen of loveliness. Aurora, the goddess of the dawn, leads the throng. From the crown of her beautiful head to the soles of her rosy feet, she is grace incarnate. As she flies she scatters flowers and dew from her hands upon the verdant fields below.

The Roman child was taught that the sun was the actual wheel of Apollo's chariot. In the morning this god arose from the eastern sea

driving his four wonderful horses across the heavens; in the evening he descended into the western sea; at night he slept in a golden boat which was borne along the northern edge of the earth to the rising place in the east. The moon was the abode of the lovely goddess Luna, sister of Apollo, who guided its course in the heavens.

Thus mythology explained astronomical phenomena; the sun, moon, planets, clouds, dawn, and night with its black mantle bespangled with stars, became animated things. The sun, when setting in the brilliant evening clouds, then became Hercules in the fiery pile.

While mythology obstructed scientific progress by finding sacred explanations for every natural event, there were a few gifted, inquisitive minds among the Greeks that sought for knowledge behind the painted curtain of superstition. Thales of the sixth century B.C., was the father of Greek astronomy. He taught that the earth is spherical and that the moon receives her light from the sun. Anaxagoras ascribed eclipses of the moon to natural causes and taught the existence of a creative intelligence. He fell a victim to the superstitions of his age. Sentence of death was passed on him and his family, which required all the eloquence of his friend Pericles to commute to banishment.

Pythagoras of the fourth century B.C. was a most assiduous enquirer. He is said to have been the first to propose the system of a globular earth and of planets, revolving around the sun. When the Church condemned the theory of Copernicus the indictment was that it was heathenism and Pythagorean.

Modern astronomy may be said to have arisen in the third century B.C., under the patronage of the first king of the Greek dynasty, at Alexandria, Egypt. Euclid, Eratosthenes, Hipparchus and Ptolemy were among the illustrious astronomers of the Alexandrian era. It was in the second century A.D. that Ptolemy published his great work on astronomy called the "Almagest," which during the following four-

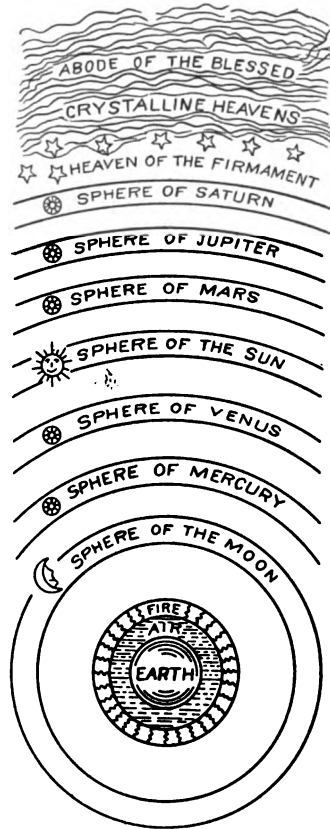

ANCIENT THEORY OF THE UNIVERSE

teen centuries was universally regarded as a kind of astronomical bible.

One of the curious astronomical superstitions that originated with the Chaldeans, and which persisted almost to our own times, was that of the crystalline spheres. The idea of a spherical universe was a very natural one. It was difficult to see how thousands of bodies could revolve around the earth for generations, without change in their relative positions, unless there was something to retain them in their places. It was believed that the planets and stars were set in a series of concentric orbs or spheres, each so perfectly transparent that bodies in the outer ones were visible through all the intervening ones. The drawing shows the order of the spheres and the system of the universe according to Ptolemy. The earth is in the center enclosed by the sphere of the moon, beyond are the concentric spheres of Mercury, Venus, the sun, Mars, Jupiter and Saturn. Outside of all are the crystalline heavens and the abode of the blessed.

The revolution of the spheres was supposed to produce the most exquisite music which filled all celestial space, but such was its refined quality that it was inaudible to mortal ears. One of the most sublime passages of Shakespeare describes this music:

Sit, Jessica. Look how the floor of heaven
Is thick inlaid with patines of bright gold.
There is not the smallest orb which thou beholdest
But in his motion like an angel sings,
Still quiring to the young-eyed cherubims:
Such harmony is in immortal souls;
But while this muddy vesture of decay
Doth grossly close it in, *we* can not hear it.

The following parallel lines are from Milton's "Arcades":

In deep of night when drowsiness
Hath lock'd up mortal sense, then listen I
To the celestial Sirens harmony,
That sits upon the nine infolded spheres.
Such sweet compulsion doth in music lie,
To lull the daughter of Necessity
And keep unsteady Nature to her law,
And the low world in measured motion draw
After the heavenly tune which none can hear
Of human mould, with gross unpurged ear.

Astronomy has always been the favorite science of the poets. The frame-work of Dante's "Paradise" is constructed on the Ptolemaic system. His ten heavens are arranged in the exact order of those shown in the drawing. The crystal orbs are rotated by angels. He says:

The virtue and motion of the sacred orbs,
As mallet by the workman's hand must needs
By blessed movers be inspired.

It may be said that during the Christian era, up to the thirteenth

century in which Dante lived, there had been no progress in scientific knowledge. He still held to the four elements of the Greeks:

Thou sayest, the air, the fire I see,
The earth and water, and all things of them
Compounded, to corruption turn and soon
Dissolve.

Although Shakespeare was not born until twenty years after the death of Copernicus, all allusions made by him to the heavens are either astrological or Ptolemaic.

The tendency of a superstition to persist even after closely allied phenomena have been explained on a purely natural basis, is illustrated in the belief that planetary motion was due to "blessed movers." Although Copernicus discovered that the planets revolve around the sun instead of the earth, he still believed that their motion was controlled by guiding spirits. Galileo conclusively confirmed the correctness of the heliocentric theory, but faith in the supernatural motion of the planets was undisturbed. Not until the genius of Newton had discovered and formulated the law of universal gravitation and provided a mathematical foundation for Kepler's laws, were these conducting spirits dismissed. It required the discoveries of three men of genius and two centuries of time to overthrow the foolish superstition of mediocre man.

From the end of the fourth to the beginning of the fifteenth century superstition had given to society a form that prevented the man of genius from being heard. Buckle says that from the sixth to the tenth century there were not in all Europe more than three men who dared to think for themselves, and through fear of punishment even they were obliged to veil their meaning in mystical language. The remaining part of society was sunk in degrading ignorance. Progress became possible only when science essayed to explain observed phenomena by depending on natural causation.

For ages the superstitions of astrology ruled the world by the terror that they inspired. The figure of a man, with entrails exposed, in the front of the family almanac is a survival of Egyptian astrology. Around the figure are the twelve signs of the zodiac with lines extending to the parts of the body supposed to be influenced by the celestial signs. Aries the head, Leo the heart, Capricornus the knees, Pisces the feet, etc. Faith in the influence of the signs of the zodiac remained unshaken in spite of knowledge that the inconstant stars were shifting from one sign to another by the precession of the equinoxes. When the pyramids were built, what is now known as the pole star was so far from the celestial pole that the Egyptians saw it rise and set in the Mediterranean. The Southern Cross was then visible not only in northern Egypt but throughout Europe as far north as London.

Coincidences have ever been mistaken for causes. Owing to the

unparalleled brilliancy of the Dog Star, astrologists assigned to it powerful influences, and because it rose just before the sun, at the season when the Nile overflowed, it was supposed to be the mystic cause of the inundation. They gave it the name of Sirius, from the river Nile, which was called Siris in their hieroglyphics. They also called it the Dog Star because, like a faithful watch-dog, it warned them of the approaching overflow, and they waited for its appearance with deep solicitude, for on the overflow of the river depended agricultural prosperity or blighting drought. They computed the length of the year from the heliacal rising of the Dog Star and this is still known as the *Canicular year*. The Romans were equally solicitous and were accustomed to sacrifice a dog to Sirius, to render his influence beneficent to agriculture. Virgil says:

Parched was the grass, and blighted was the corn:
Nor 'scaped the beasts; for Sirius from on high,
With pestilential heat infects the sky.

The time of the year when the Dog Star rose with the sun and appeared to combine its influence with the solar heat they gave the name "dog days" (*dies canicularis*) which began August 4 and ended September 14. Owing to the displacement of the constellations by precession, the time of the heliacal rising of the Dog Star is continually accelerated, hence modern dog days have no connection with this star, and furthermore, recent study of rabies proves that more dogs go mad in winter or early spring than in summer time.

A favorite prediction of astrologers was of cataclysms that would destroy all mankind. Such a catastrophe was foretold to occur in 1186, and a universal deluge was predicted for the year 1542. In the latter year there was to be a conjunction of three planets in the watery sign of the "Fishes." The prophecy was generally believed and the terror was wide-spread. A Noah's ark was built at Toulouse, but the year was distinguished for its drought.

Ridicule is sometimes more efficacious than argument in overthrowing false theories. A skit by Dean Swift discredited astrology, in England, more than all the evidence of science. Swift published a satirical pamphlet under the title of "Predictions for the Year 1708, by Isaac Bickerstaff, Esq.," in which he predicted the death of a well-known astrologer and almanac maker by the name of Partridge. He claimed to have consulted the stars and calculated the exact hour of the astrologer's demise. This was followed by a letter to a man of rank, giving complete particulars of Partridge's death on the day and almost at the very hour foretold. The angry astrologer denounced the pamphleteer, employed a literary friend to write up proofs of his existence and published his almanac for the year 1709. Swift answered all of the arguments, claiming that the denial of death was spurious, and that the deceased was a gentleman who would never have used the

abusive language employed; as for the almanac, everybody knew that almanacs were frequently published under the names of people who had long been dead.

An adequate account of the superstitions of astrology would make a volume, and it would be easy to compile a list of one hundred lunar superstitions that still govern the actions of the uninformed. For example, the new moon if first seen over the right shoulder will bring good luck. If seen over the left shoulder, bad luck. Meat killed when the moon is waning shrinks in the pot. Whatever grows above ground must be planted when the moon is waxing. Whatever grows underground must be planted when the moon is waning. One of the commonest lunar superstitions is that the changes of the moon, at the quarter, affect the weather, and many of our almanacs still publish so-called "Herschel's weather tables," for foretelling changes of the weather, not only throughout all the lunations of the year, but for all future time. We are assured by the almanac makers that the tables are the result of careful consideration of the attractions of the sun and the moon "and so near the truth as to seldom or never fail." Belief in the moon's influence over terrestrial conditions is a mild lunacy by no means wholly confined to the ignorant. A tabulated meteorological record, kept at Greenwich running back for forty years, shows that there are no constant relations between the moon's columns and those recording the readings of the instruments. In other words, lunar meteorological influences are almost inappreciable. Idle fancies are still cherished that the mind and body are affected by the light of the moon, that the rays sometimes produce blindness by shining on the sleeper's eyes, and that death occurs at the time of the changes of tide.

When Copernicus published his work on the "Revolutions of the Heavenly bodies," in 1543, he was already on his deathbed. A few men of learning read it, the doctors of the church rejected it, and it received but little attention until the time of Bruno, Galileo and Kepler, half a century later. During the previous thirteen hundred years the astronomical system of Ptolemy had been regarded with superstitious reverence. It was natural that a geocentric and anthropocentric universe should be drawn, because these errors were conducive to man's interests, pleasing to his extreme egotism, and resulted in the apotheosis of himself. The anthropocentric dogma culminated in the belief that *man* was the preordained center and aim of all creation, while the new heliocentric mechanism of the planetary system relegated both the earth and man to subordinate positions.

In 1610 Galileo ascended the tall campanile of St. Mark's, in Venice, and with his newly devised telescope showed the assembled noblemen and senators that Venus was a crescent, Jupiter the center of a miniature Copernican system, the moon had tall mountains casting dark shadows across her surface, that the star cluster of the Pleiades

contained not seven stars but thirty-six and that the milky way was powdered with stars. In reward for his discoveries the Venetian Senate doubled his salary of professor at Padua, and secured that position to him for life. He was made philosopher extraordinary to the grand-duke of Tuscany, and the next year visited Rome, where he exhibited the wonders of the heavens to the eminent personages of the Pope's court.

But war on Galileo soon flamed forth. The spiritual authorities saw that established dogmas were endangered. He was accused of heresy and atheism. The story of his summons before the inquisition, his trial, conviction and suffering, has been told too often to be repeated here. The triumph of superstition over his astronomical discoveries was for the time complete. This great genius lived to see his works expelled from all the universities of Europe, their publication prohibited, and he knew that he was doomed to face all posterity as one who had committed perjury to escape torture.

Sixteen years previous to Galileo's first summons to Rome, poor Giordano Bruno was burned in that city. In his wanderings to escape persecution Bruno had visited England and while there published his exposition of the Copernican system. Prudence frequently obliged him to change his place of residence and it is not strange that he finally drifted to Venice. Here greater religious liberty was permitted than in other Italian cities, and here the stake had never been erected. It was at the Palazzo Mocenigo, on the Grand Canal, that emissaries of the inquisition finally ran him to earth. The first indictment of the inquisition charged him with teaching that there were innumerable worlds. He was burned to death in the Piazza Campo di Fiore in the year 1600. Galileo's greatest contemporary was Kepler, who discovered the laws of planetary motion which paved the way to the greater discoveries of Newton. Kepler was abused, imprisoned and warned that he must bring his theories into harmony with the scriptures. Astronomy was then so poorly patronized that to increase his meager income he was obliged to pay homage to the astrological superstitions of Rudolph II. and Wallenstein.

One of Kepler's most terrible experiences arose from the prevailing superstition of sorcery. His aunt and his mother were charged with being witches and sentenced to be burned alive. Through Kepler's indefatigable efforts, and the influence of powerful friends, his mother was saved, but the suffering which she endured during more than a year's imprisonment resulted in her death a few months later. Kepler's aunt was burned at the stake.

The writings of all ages up to the eighteenth century show that comets were believed to be dire messengers of woe. Stars and meteors were generally thought to foretell happy events, especially the birth of heroes and great rulers. Eclipses expressed the distress of nature over terrestrial calamities, while comets portended greater woes than all the

other celestial signs combined. Those who did not recognize them as warnings from God were stigmatized as atheists and Epicureans. John Knox believed them to be tokens of the wrath of heaven, others saw in them warnings to the king to extirpate the Papists. Luther declared them to be the work of the devil and called them harlot stars. Milton says that the comet "from its horrid hair shakes pestilence and war." Whole nations from the king down to the lowest peasant were frequently plunged into the direst alarm by the appearance of these messengers of misery. The comet that appeared the year after the assassination of Cæsar was supposed to be his metamorphosed soul armed with fire and vengeance. It is said that the comet of 1556 had a powerful influence in causing the Emperor Charles V. to abdicate and retire to the monastery of San Yuste. Queen Elizabeth, in 1580, issued an order of prayers to avert God's wrath, and referred to comets, eclipses and heavy falls of snow as evidences of His great displeasure. The periodic comet known as *Halley's* probably caused more consternation than any other within historic times. One of its early appearances was the year of the Norman Conquest and it was supposed to presage the defeat of the Saxons and the death of Harold. At the South Kensington Museum is a copy of the Bayeux Tapestry on which may be seen the comet of 1066. Its return in 1456 spread a wider terror than was ever known before. The belief was general that the judgment day was at hand. People gave up all hope and prepared for their doom. Again in 1607 it alarmed the world by its appearance and the churches filled with terror-stricken multitudes. Kepler, who was then imperial astronomer at Prague, quietly traced its course and discovered that it was outside of the moon's orbit. Tycho had made the same observation respecting a bright comet that appeared thirty years earlier. The announcement of Kepler's discovery caused a great outcry because it attacked the very foundations of the cometary superstitions. It also assailed the dogma of the crystalline spheres, because the motion of a superlunar comet would send it crashing through the spheres. It was hard for superstitious man to give up the "signs of the heavens" that had so long misguided him. As late as the latter part of the seventeenth century a book was published by Father De Angelis, of the Clementine College, Rome, in defense of the old cometary faith. He claimed that comets originate in our atmosphere below the moon. Everything heavenly is eternal. We see the beginning and ending of comets, hence they are not heavenly bodies. They are emanations of dry, fatty matter from the air and may be ignited by sparks from heaven or by lightning. Every one knows that they cause war, pestilence and famine. He had observed a comet at Naples which was so close that its tail almost touched Vesuvius, and it would have destroyed Naples but for the blood of the martyr Januarius.

People were so wedded to ancient errors that it required one hundred years of telescopic work to bring the Copernican system out of

the realms of hypothesis. For generations the universities taught both the geocentric and the heliocentric systems, leaving the student to decide which was right. During more than a thousand years previous to Galileo's discoveries, *superstition* and *unreason* had prevented all human progress. They were the source of untold mischief and suffering and are still man's greatest enemy, while science and reason are his greatest friends. Modern superstitions are often the best comment on ancient astronomical errors.

Newton's astrophysical discoveries placed the solar system on a mechanical basis and dispensed with the planetary guiding angels. Empirical science has since shown that every phenomenon has its mechanical cause, while Darwin's "Descent of Man" has shattered the dogma of anthropocentricism. In the operation of cosmic forces it may now be said that events occur by mechanical necessity regardless of man's interests. During the latter half of the nineteenth century, by the telescopic study of the vast and the microscopic study of the small, a splendid record of accumulated truths was attained. The discoveries of the laws of the indestructibility of force and matter, the unity of nature, the mechanical theory of heat; inorganic and organic evolution and the universality of law, have explained many mysterious phenomena, and forced them out of the darkness of the supernatural to the light of the natural. It has been said that mystery has now been driven from the universe. Belief in the miraculous and the transcendental rests on the assumption that outside and beyond the natural world active forces exist that have no material basis, and of which we can learn nothing by experience, or by any natural means. Such dualistic beliefs are purely idealistic and are evolved from the activity of the brain called emotion. Emotion has nothing to do with the attainment of truth and all doctrines, or opinions, are to be suspected, that are favored by our passions.

Philosophy is the science of which all others are but branches, hence philosophy lies in the province of physical science and not in that of letters. Haeckel says: "All true natural science is philosophy and all true philosophy is natural science." The astronomical errors of the past have arisen from attempts to explain the cosmos out of the inner consciousness, rejecting all scientific methods and substituting faith. While faith may supplement observation in the search for truth, we must not confuse supernatural faith with the natural faith of science. Mark Twain has defined the former as "believing something that you know is not true." The natural faith of science and of practical life is drawn from experience. Kant, Hume, Huxley and Haeckel agree that all knowledge of the reality of phenomena is limited to that revealed to us by experience. Belief must rest on evidence. That belief which is not founded on evidence is both illogical and immoral.

GEOGRAPHIC INFLUENCES IN THE DEVELOPMENT
OF OHIO

BY PROFESSOR FRANK CARNEY

DENISON UNIVERSITY

OHIO leads the states in its clay products, and its workable clays are practically inexhaustible. Ohio leads also in the number of presidents furnished the union, with unimpaired prospects for the future. Both ratings are consequences of geographic causes, as will appear in later discussion.

This state lies between $38^{\circ} 27'$, and $41^{\circ} 57'$ north latitude; it is bounded by the meridians reading $80^{\circ} 34'$ and $84^{\circ} 49'$. For its width in latitude and its lack of great range in altitude, it has a marked range in mean annual temperature; in southern Ohio the mean annual range is 54° , while in northern Ohio it is 49° ; its range in average temperature is about 40° . Lake Erie exerts an appreciable influence on climatic conditions for the northern part of the state.

The Ohio River bounds the state for 436 miles, and the lake shore gives it 230 miles more of natural boundary. About one half of the state line is artificial.

A rock section of the state gives in its lower half a predominance of limestone and shale formations; above this are wide-spread horizons of sandstone and conglomerate. These more resistant formations, belonging to the late Mississippian and early Pennsylvanian periods, are registered in the relief by a mild escarpment or cuesta sweeping to the south and west from the northeastern corner of the state. The northern and western parts consist of shale and limestone formations. There is slight relief particularly in the shale areas. The region of the limestone extends across the western portion of the state coinciding in longer axis with the orientation of the Cincinnati anticline. The drainage pattern resulting from this arching has given the west and southwest part of the state much more relief than would be the case with more horizontal strata.

The general dip of these formations is to the south and east. It is probable that the original consequent streams flowed in this direction. It would be futile, however, at the present time to attempt to sketch the drainage history of Ohio from the Pennsylvanian period, since which time the area has been continuously subject to stream work. Diastrophic movements have introduced some complexity. Several erosion cycles have been inaugurated, but there is evidence that few were

normally terminated. The distribution of the Pennsylvanian formations coincides with the most irregular topography of the state. The average altitude is about 770 feet, and the range in altitude is approximately 1,100 feet.

✓ The present watershed crosses the state from east to west, trending slightly to the south, at an altitude of about 1,100 feet. Drainage lines have divided the upland portion into north-south trending blocks progressively more widely spaced towards the west. These low tracts have been used by the canals and railroads connecting Lake Erie and Ohio River.

The larger part of Ohio is an almost completely severed portion of the Allegheny plateau, extending westward from the northwestern part of Pennsylvania like a great spit into the Mississippi lowlands; the broad valley of the Ohio resembles a bay between this spit and the western slopes of the Appalachians. This somewhat peculiar relationship of topography is the combined result of drainage adjustments due to stratigraphy, and slight diastrophic movements.

Using natural boundary lines, it would be difficult to divide North America into many states. Where such lines do exist, they have not always been utilized. Lake and river, however, form over half the border of Ohio. In general, a water boundary is an asset to a commonwealth; it may be a protection from disputes, and a transit to trade. The reaction varies with other natural boundaries: high altitudes, sometimes barriers, may impose aloofness, or almost complete isolation, whereas water boundaries invite commercial relations.

Geographically Ohio is the back door of the middle and north Atlantic states. This relationship has been of reciprocal value to both areas; as population became more and more dense in the early settlements, and knowledge of the broad lands across the Appalachians spread, a movement in that direction was natural. The easiest route for the more northern of the Atlantic states was through New York via the Mohawk valley, out and along Lake Erie; for the more southern states, through passes in the mountains. Possibly on account of the narrow coastal lands to the south, or possibly because of the greater enterprise there in watching the movements of the French, the southern routes were first explored, and the earliest movements into the Ohio valley came either by way of Pittsburg or by the course of the Cumberland road.

A gross classification of the factors in the development of any region is (1) internal and (2) external. The external include the boundary itself in case the region is a natural one; but geographic situation is frequently very important. When avenues of travel and traffic converge and pass through a state benefit follows. Advantage always comes from proximity to great centers of business or culture

whence energy radiates. Contiguity to activity is an incentive to endeavor. We can scarcely find an area of the earth so void of possibilities as not to experience some stimulation from without. The internal factors in this development are generally obvious. Mineral wealth, energy-producing waterfalls, broad rich fields, varied uplands, a gently blending topography, constant rivers, and a range of climate, make a state self-assertive. Ohio has never been conspicuous for mineral resources: in the early days relative importance might be granted its output of iron ore; the annual production of bituminous coal, while of great advantage to the state, has never been very large, and even now its rank is fourth; natural gas and petroleum have been of much importance to the state, but these resources are always temporary; the supply of clay was great enough even under partial exploitation to stimulate the manufacture of clay products in which the state will be apt to hold a permanent position; in the coarser abrasives, as grindstones and pulpstones, Ohio has always been a foremost producer; with the increasing use of concrete for structural work, greater importance will be given still other natural resources.

But the human responses to natural resources and to geographic environment vary with the people. The same inorganic conditions have elicited a variety of reactions under shifting populations; this variation may after all be the best testimony of geographic influences. Move a people into a different physiography and for some time they will still be the children of their former surroundings. Adaptation is slow, but the law is relentless.

When population becomes too dense for the economic development of a people, the more sturdy among them are the first to emigrate. With few exceptions the earlier settlers in the Ohio area represented the very best colonizing material of the seaboard states. These hardy volunteers in a contest with unbroken lands and unfriendly Indians led to the foundation of one of our most important commonwealths. Among them were not only yeomen, but the enlarged outlook of the land between the lake and the river attracted many of the best schoolmen of the thickly-settled parts. These pioneers not only cherished and perpetuated the place names of New England, but transplanted also the New England zeal for education. In testimony of this spirit among its founders, Ohio possesses more institutions of higher learning than any other state of the union. There was a time in the development of our frontiers when many centers of higher education were needed. Travel was difficult, money was scarce and barter to quite an extent entered into financing these primitive college courses; the colleges and seminaries in Ohio were once even more numerous than now. Advanced standards in education, by a process akin to natural selection, have eliminated many. But the cumulative results of about a century of opportunity for gen-

eral culture must be reckoned among the assets of this state; its dozens of small colleges made it possible for thousands to obtain a training they otherwise would not have received. This inheritance of the better eastern culture, which was stimulated and nurtured by the natural advantages of the region their ancestors were geographically guided into for settlement, accounts for the position won by Ohioans in public life as well as in arts and letters.

The geographical development of any state is usually a complicated problem. Some light, however, is generally thrown on the question by accounting for its particular city that leads all other centers of population. Sometimes the metropolis shifts; if so, a geographic law is always involved. For several decades Ohio was an agricultural community, pure and simple. Wealth increased slowly because there were no ready markets for disposing of products. The first important outlet for farm products came with the introduction of steamboats on the Ohio River in 1810. Naturally the river town that was the most accessible to the agricultural areas became the shipping port. Cincinnati was the earliest clearing house for products that Ohio had to sell. Buying and selling are correlative transactions. A ready market stimulated a desire for things that were counted luxuries in the primitive days, consequently Cincinnati became a manufacturing town, and ever since it has been the leading manufacturing city of Ohio.

Until recent years there has never been any doubt as to which city was the metropolis of Ohio. In the vicinity of what is now Cincinnati a settlement, the second in the state, was made in November, 1788; the next month another handful of men built their cabins on the north bank of the Ohio opposite the mouth of the Licking; this became Cincinnati, whose location assured its growth; on the river, the shipping facilities were considered excellent, and, buttressed by the river flats, the farming lands of the Miami valleys, their development into a city of trade and manufacturing, was speedy and permanent. Before the middle of last century it was stated that:

The trade of Cincinnati embraces the country from the Ohio to the lake, north and south; and from the Scioto to the Wabash, east and west. The Ohio River line, in Kentucky for fifty miles down, and as far up as the Virginia line, make their purchases here. Its manufactures are sent into the upper and lower Mississippi country.³

Cincinnati attained city rank in 1820; during the next decade it became the eighth city in size in the union; from 1830 to 1850 it ranked sixth; by 1880 it had dropped again to eighth place, and at the last census to the tenth place.

The greatness of Cincinnati and the assurance of even marvelous progress in the years to come was prophesied by the editor of the *Toledo Blade*, in 1841:

³ Henry Howe, "Historical Collections of Ohio," Cincinnati, 1847, p. 221.

I venture the prediction that within one hundred years from this time, Cincinnati will be the greatest city in America; and by the year of our Lord, 2000, the greatest city in the world.³

This thought now sounds extravagant, but at that time there was ample reason for feeling sanguine about the future of Cincinnati. No one dreamed that railroads to Baltimore, Philadelphia and New York would in a few years handle the commodities then passing through Cincinnati. Sir Charles Lyell visited this metropolis of Ohio in May, 1842; his explanation of the commercial basis of the city, and its culture is worth repeating:

The pork aristocracy of Cincinnati does not mean those innumerable pigs which walk at large about the streets, as if they owned the town, but a class of rich merchants, who have made their fortunes by killing annually, salting, and exporting, about 200,000 swine. There are, besides these, other wealthy proprietors, who have speculated successfully in land, which often rises rapidly as the population increases. The general civilization and refinement of the citizens is far greater than might have been looked for in a state founded so recently, owing to the great number of families which have come directly from the highly educated part of New England, and have settled there.⁴

✓ However great may be the commercial initiative of frontier peoples, as an asset of the nation their value is largely contingent upon the means of trade and social intercourse. The construction of highways by governments was an old idea in Europe though not widely practised. In this country its advantages to the seaboard states appeared at once upon the drift of population into the trans-Appalachian region. After long agitation the federal government undertook the construction of a roadway westward from Cumberland on the Potomac River; the Chesapeake and Ohio canal later reached this point, and the road became a traffic-feeder to the canal. On the other side of the Ohio River, the government continued this highway across Ohio; this is known as the "national road." Its advantages were obvious, and were duly appreciated. Commodities that had usually passed down the Ohio River were seen on the wharves at Baltimore. News traveled more rapidly along this highway; residents along or near it were envied; the towns it passed through were enlivened; the equipages of aristocracy took this route through the state. Cambridge, Zanesville, Columbus and Springfield each owed something of their rating in that day to the advantages of their location on the national road.

The canal-digging fever struck Ohio shortly after its outbreak in Atlantic states. In 1817 its legislature considered the matter of constructing waterways; the subject came up regularly in the following years, culminating in 1825 in a law that commenced operations. In this same year Clinton's "ditch" tapped Lake Erie. The Ohioans,

³J. W. Scott, quoted in Howe's "Historical Collections of Ohio," 1847, p. 221.

⁴"Travels in North America," New York, 1845, Vol. II., p. 61.

therefore, did not wait for proof positive of the advantages of improved waterways. The evidence was forthcoming had it been necessary, for at once after the Erie canal had wedded the lake and the ocean northern Ohio felt a new throb of commercial life. Lake trade was stimulated, harbors were improved, wharves and warehouses constructed; and prices advanced on all commodities that could be conveniently reached. The Ohio legislature had taken the initiative without these evidences. In seven years the Ohio canal, connecting Portsmouth on the river at the mouth of the Scioto with Cleveland on the lake, 306 miles long, was completed. The Miami canal joining Cincinnati and Toledo was commenced in the same year, reached Dayton in 1830,⁵ but was not completed to the lake till 1845. Along either canal route trade activity shortly developed the sleepy villages into thrifty towns and cities. Later adjustments have left some of these places only a retrospect; the canal period was their heyday. Others, however, as Newark, Coshocton, Massillon, Akron, Hamilton, Troy and Defiance, have continued to prosper under the conditions incident to the transfer of shipping from the canals to railroads.

The Ohio canal, the course of which was controlled by other considerations than merely joining the river and the lake, makes an ascent of almost 500 feet. Its construction, relative to its length, was much more expensive than the Erie canal which ascends only 445 feet. The maintenance of the Ohio canal also involved greater expense. For this reason, with the extension of railroad lines in the state, we find that by 1856 the canals of Ohio ceased to earn running expenses.⁶ During about twenty years, however, these canals were of great commercial importance to the contiguous parts of the state. Even upon the opening of the canal from Dresden to Cleveland the price of wheat advanced from \$.25 to \$1.00 per bushel.⁷

When we speak of railroads to-day we at once think of one or another of the great through lines. In the early days of railroad construction no one dreamed of even a trans-state road. Until recent years a through line always meant the consolidation of short independently owned segments. Local interest in railroad building in Ohio was lively from the start. Thrifty commercial relations emphasized the inadequacy of boating facilities. The efficiency of the Lake Erie and Erie canal route was not questioned, but there were few canals in Ohio to give access to the lake. The first steam road to operate in the state (1836) had one terminus on the lake at Toledo, the other being at Adrian, Mich. Sandusky had no canal, but by 1839 it com-

⁵ *The Ohio Gazetteer*, Columbus, 1839, p. 528.

⁶ Poor's "Manual of the Railways of the United States," 1881, p. xvii.

⁷ Henry Howe, "Historical Collections of Ohio," Columbus, Vol. II., 1891, p. 325.

pleted several miles of a railroad, "The Mad River and Lake Erie," towards Dayton, which point it reached in 1844. Ohio capital and enthusiasm for railway construction were abundant, as shown by the fact that in 1837 forty-three railroad companies were organized by state charters.⁸ Many of these roads were never built, but some of them have become the best lines in the state. By 1846 a road was completed from Cincinnati to Springfield, and by 1848 through steam connection was made between Cincinnati and Sandusky.⁹ Columbus and Cleveland were connected in 1851, and during the same year a railroad was finished between Cleveland and Cincinnati.¹⁰ The next year a line was opened from Cleveland to Pittsburg.

Geographically Ohio needed transverse railroads; the lake and the river were its natural thoroughfares to markets; the wide, fertile major valleys of the state trend north-south, and its products move almost by gravity to one outlet or the other. Ohioans, except the immigrant ancestors, never gave further thought to the "Appalachian Barrier"; their commercial friends on the seaboard looked after building the east-west lines.

The rivalry of the Atlantic ports in establishing through railroad transportation to the Mississippi basin was thus an advantage to Ohio. The Hudson-Mohawk valley made the construction of a line a child's task for New York, but the Appalachians imposed on Baltimore and Philadelphia a herculean undertaking; the former city early recognized the limitations of canals. A citizen of Baltimore in urging the undertaking said:

Baltimore lies two hundred miles nearer to the navigable waters of the West than New York, and about one hundred miles nearer to them than Philadelphia; to which may be added the important fact, that the easiest and by far the most practicable route through the ridge of mountains, which divides the Atlantic from the western waters, is along the depression formed by the Potomac in its passage through them.¹¹

In 1828 construction was commenced at Baltimore on a line headed for the Ohio valley, but twenty-five years elapsed before this destination was reached by the Baltimore and Ohio Railroad, the difficulties of construction having been underestimated.

The next year, 1854, the Pennsylvania line reached Pittsburg, with which city Cleveland had been joined the preceding year. In 1852 a road was opened from Buffalo to Cleveland; the same year, one from Toledo to Chicago; and the next year through traffic was made possible

⁸ *Ohio Gazetteer*, Columbus, 1839, pp. 531-33.

⁹ *Ohio Archeological and Historical Society Publications*, Vol. IX., 1901, p. 190.

¹⁰ *Ibid.*, p. 190.

¹¹ Philip E. Thomas, quoted in *Johns Hopkins University Studies in Historical and Political Science*, Third Series (1885), p. 99.

from Buffalo to Chicago. In 1857 a road across southern Ohio and on to St. Louis was completed; this was practically a continuation of the Baltimore and Ohio Railroad. By 1860 Ohio had what was considered in that day very ample railway facilities, a condition that contributed largely to the position the state at once took in manufacturing.

Ohio ranks fifth among the states in the gross value of its manufactured products. The state has always been quick in appreciating the demands of its trade environment. Its waterways, natural and artificial, before the period of steam roads, gave it an advantage. No state responded more promptly and effectively to the era of railroad construction. A study of the evolution of railways in this country shows that the network pattern first appeared in Ohio. Manufacturing is invariably stimulated by shipping facilities. Excellent transportation service for decades has been available for producers in this state. Furthermore, the geographic center of population, now in Indiana, has been in and near Ohio for sixty years. Convenience of raw material, accessibility of markets through shipping facilities for finished products, and stability in the supply of labor insured by a normal equilibrium between wages and the cost of reasonable living are essential conditions to a state's maintaining its rank in manufacturing.

The first blast furnace in Ohio was built in 1804 in Mahoning County. The number of furnaces gradually increased throughout the area of the Logan and Pottsville formations which contain the meager iron ore. Limestone is also quite liberally distributed in this same region. Charcoal was used in these furnaces for over two decades, after which coal slowly supplanted wood. Local demands for cooking stoves and other simple necessities stimulated the initial working of these ores. To some extent, the finished product was shipped outside the state. Ohio, ever since these early days, has continued to give an annual output of iron ore, but the supply ceased years ago to be of relative importance.

✓ While fertility of soil insuring a cheap food-supply, and easy topography inviting modern transportation methods, and mobility of labor sustaining manufactories, are of prime importance to industrial growth, nevertheless environment has had much to do in the development of states. The environment here referred to involves the extent to which adjacent commonwealths have either responded to their physiography or have made progress in spite of it. Up to the present time, however, Ohio owes but little of its development to mere geographic situation. ✓ But extraneous influences will be of increasing importance in the commercial future of the state. I refer especially to the midway position that Ohio's lake ports occupy in reference to its own and the Appalachian coal fields, and the Superior iron areas. At the present time Ohio stands second only to Pennsylvania in its annual output of steel and

iron products. If physiography is the arbiter, the southern shore of Lake Erie, before many years, will be the center of steel and iron production in this country.¹² The Pennsylvania center of this industry has a momentum and a capital investment that will enable it to stand out long against the logic of geography. Allied with this conservatism are the artificial combinations which tend always to restrain the development of new manufacturing centers. But such commercial egoism will in time recognize the greater advantage in conforming to geographic laws. In reference to a particular nation it is probable that ultimate stability will be reached in the industries concerned largely with the inorganic. After the resources of a country have been thoroughly exploited, equilibrium should come, and be disturbed only by responses made to world-wide influences of commerce. But in this country we are still far from stability in the localization of industries; for example, the center of shoe manufacturing has steadily progressed westward; flour milling left Baltimore for Rochester, and moved later to Minneapolis whence it promises to shift again before many years; slaughtering and meat packing, once centered at Cincinnati, later at Chicago, probably now centers west of the Mississippi.

But an almost equally important factor in the shifting of the steel industry is associated with shipping facilities for the finished products. In this respect, northern Ohio has even now an advantage. With the insured growth of New Orleans as a transfer port for marine cargoes a larger relative proportion of finished steel products will go southward.

The earliest effort in this country to facilitate transportation found expression, as already described, in highway construction. This movement was side-tracked when attention was given to canals and later to railroads. These larger needs, involving the final and longest haul for agricultural products, at least, so monopolized thought that we forgot the first step in the route between the farmer and consumer. Early last century Ohio was given an object lesson in highway construction when the national road from Wheeling, W. Va., crossed the central part of the state. Ohio should have excellent roadways. The state now ranks first in the annual production of road-making limestone. This fact should exert an important influence in the future agricultural progress of the state.

The pasture lands of Ohio have always been important and even at the present time they constitute about one third of the area of the tilled lands. The eastern and southeastern parts of the state, the portion encompassed by the Pennsylvanian formations, contain relatively a larger amount of pasture lands. For several decades Ohio was the

¹² W. M. Gregory, "The Industries of Cleveland, Ohio," *Journal of Geography*, Vol. VI. (1908), pp. 183-87, gives data on the magnitude of the steel industry at this one lake port.

leading state in the production of wool. At the present time it still leads among the states outside of the ranching regions. Its rank is ninth in neat cattle, seventh in swine, and sixth in horses. Associated with its standing in live stock is the corollary fact that in Ohio slaughtering and meat packing is still the fourth industry, while in the whole country it ranks ninth in dairy products, and in the gross value of agricultural products it is third in the union.

The trend of scientific agriculture arising from the work of our colleges and from the federal department of agriculture indicates that there will be greater diversity in products as well as more stability in yield. The present marvelous output of the Mississippi basin is bound to be greatly increased. With the prospect of new markets through shorter hauls made possible by the Panama Canal route, and the improvement of waterways, supplementing the inadequate railroad facilities to New Orleans and other gulf ports, the Ohio River states will be stimulated as never before. The probable diversion of trade from the present great shipping ports on the Atlantic does not necessarily imply shrinkage in their business; it means a compliance with physiographic conditions that naturally divides the output of this great agricultural region, between the gulf and the ocean. A large part of the great interior looks to the gulf; geographically, it is a mediterranean country; such was its geologic origin. Its natural affiliations were aborted when the French were supplanted by the British. The history of commerce, the world over, shows how adjustments are inevitable so long as scientific progress is made in farming and manufacturing, and in transportation itself.

From the standpoint of agriculture, however, still another factor will be conspicuously influential before many years. Immigrants to this country in recent times have largely increased our urban population where employment without capital is found, chiefly in the manufacturing centers. A large percentage of these immigrants are farmers in training, and, as they accumulate money, they gravitate to the country. In the east especially these provident foreigners find no trouble in acquiring land because the natives are glad to get out of the country and into villages or cities, preferring to take their chances on earning as good a living there as they were accustomed to on the farm. The deserted farms in the east do not attest a serious impairment of the soil; they indicate an incapacity on the part of the original farmer to adjust himself to changing conditions in agriculture.

In nearly all parts of Ohio one may find holdings which afforded the original farmers a very doubtful living now yielding a constant profit under the tillage of immigrants. European methods of agriculture combined with ability to reef expenses to the vacillations of income make them successful. During the decade 1890-1900 the average

size of a farm in Ohio was decreased 29.3 + per cent. Particularly in the northern part of the state, throughout the lake-plain belt, specialized and intensive agriculture is now common.

I believe that farming will continue to be one of Ohio's chief sources of wealth. Two thirds of its surface bears glacial soil which contains an abundant and various plant diet. Improved methods of preparing foods for distant markets, and the promise of these markets becoming more accessible through the River-Gulf-Panama Canal route will stimulate cultivation. The advantages of the Ohio River as a means of transportation elicited an early response. In 1794 regular trips, one in four weeks by keel sailboats, were begun between Cincinnati and Pittsburgh;¹³ this was only six years after the former city was founded. In 1801 a one-hundred-ton vessel for sea trade, built at Marietta, made its first trip down the river, loaded with produce;¹⁴ this was the logical shipping route for the surplus products of southern Ohio.

As early as 1746, six hundred barrels of flour were shipped southward from the Wabash country.¹⁵ French affiliation then dominated the Mississippi valley. The French observed the geography of this interior country in approaching it from either the St. Lawrence or the gulf. New Orleans should be a great port. Logically it is the doorway to nearly half of North America. The aggressive Briton built firmly to the north along the Atlantic; he built so well that it would have been folly to rearrange his structure upon falling heir to the rest of the continent. In extending the commercial structure inland he has not neglected even the slightest natural advantage. But after all, physiographically, the structure is somewhat awkward, and its maintenance expensive. In the organic world, man alone on occasion ignores physiography, but in time he finds it to his highest advantage to comply with the principles of topography. The gulf is the natural outlet of a large part of the Mississippi basin.

¹³ Henry Howe, "Historical Collections of Ohio," Cincinnati, 1847, p. 215.

¹⁴ *Ibid.*

¹⁵ B. A. Hinsdale, "The Old Northwest," 1889, p. 50.

THE DECIMAL SYSTEM OF NUMBERS

BY DR. L. C. KARPINSKI
UNIVERSITY OF MICHIGAN

IS there a limitation placed upon our thought by the language which we use? Do the Germans take to philosophy more easily than other people because of some peculiarly philosophical bias of their language? These are speculative questions which can never be satisfactorily answered. It may, however, safely be asserted that the literature of a language is immediately dependent upon the written alphabet. It is impossible to conceive of a novel having been written in Babylonian cuneiform characters or in Egyptian hieroglyphics. Romance was the same, in its larger outlines, then as now, but writing was too serious a matter to be undertaken for such fleeting fancies. With a difficult alphabet and lack of facilities for writing, general culture was impossible. The Chinese, in modern times, furnish a striking illustration of the deadening effect of a difficult alphabet.

As literature and general culture are related to the alphabet and written language, so scientific advancement is related to the number system in use and to the system of writing numbers. A slight study of the Roman numerals gives the clue to the reason why the advancement along scientific lines lagged so far behind the general advancement achieved by the Roman peoples. The Greeks had a peculiar genius for arithmetical research; but with them long division was a difficult operation, on account of the symbols. Only an Archimedes could overcome the clumsiness of an unscientific method, and even he could solve but comparatively simple problems.

In order to comprehend the essence of our own number system, it is necessary to distinguish between a number system and a place system. A ten system involves having symbols for 1, 2, 3, 4, 5, 6, 7, 8, 9 and 10 groups of objects, respectively, and beyond that separate symbols for the successive powers of 10—100, 1,000, 10,000, 100,000. . . . A five system would involve separate symbols for 1, 2, 3 and 4 groups of objects and further symbols for 5 and for the successive powers of 5—25, 125, 625, 3,125, 15,625. . . . A logically complete 5 system has not been developed among any people of the earth. In fact no other complete system, than a decimal system has ever been developed. Among the Mayas of Central America a 20 system was partially developed. Among the Babylonians there was in use a sixty system interwoven with a decimal system.

A decimal place system involves symbols for 1, 2, 3, 4, 5, 6, 7, 8, 9 and 0. The ideas of 10, 100, 1,000 and successive powers of ten are

involved, but the symbols are given by combination of the symbols for 1 to 9, with the symbol for zero. As our development will show the symbol for nothing was the great stumbling block in the development of a scientific method of writing the numerals. A place system to the base five would require only the addition of a symbol for zero to the symbols for 1, 2, 3 and 4. Leibnitz occupied himself with the binary system, as this required only two characters, one for unity and one for non-entity. To illustrate a binary place system the numbers from 1 to 16 are written, using only 1 and 0.

Three written as 11, means one, two and one unit. Nine written as 1001 represents one cube of two, no squares of two, no first powers of

1	1	$\frac{1}{2}$.1
2	10		
3	11	$\frac{1}{4}$.01 repeating
4	100		
5	101	$\frac{1}{8}$.01
6	110		
7	111	$\frac{1}{16}$.0011 repeating
8	1,000		
9	1,001		
10	1,010	$\frac{1}{32}$.001
11	1,011		
12	1,100	Multiply 8 \times 9	
13	1,101	1,000	
14	1,110	1,001	
15	1,111	$\overline{1,001,000}$	annex three ciphers.
16	10,000		

two, and one unit. The construction of the arithmetic universe out of the single unit afforded Leibnitz some philosophical satisfaction in connection with his system of monads. All the operations of ordinary arithmetic are possible in this system. We catch a glimpse of our slight comprehension of the infinite totality of numbers in noting that any number that can be expressed with our ordinary ten digits can also be expressed with these two digits, and that even though we used a thousand digits we could add no new numbers. Doubtless it would afford Leibnitz some gratification to know that his binary system is used in modern mathematical analysis in certain delicate proofs. The study of these number systems is not wholly foreign to the history of the decimal system, as traces of the binary and quinary systems appear among primitive peoples.

Among the South Australian tribes the binary system of numeration is almost universal. This is undoubtedly due to the fact that the hands and feet and eyes and ears occur in groups of two in each normal individual. These tribes are not advanced enough to have a system of symbols; such a development would imply a degree of intelligence which would proceed to a higher and more convenient number base. The system is seen in their words; three is given as two and one,

four as two and two, five as two and two and one, and six as two, two, two. This system is found also among South American tribes. The quinary system is the most frequent of all the systems occurring in the numerals of American languages, although the twenty system is common along the Pacific. A study of the words of various American Indian tribes reveals traces of a five system in the formation of the words for six, seven and eight which are given as five and one, five and two, and five and three. The higher numbers, however, are formed on the decimal scale. The word for twenty signifies two tens and the higher tens are similarly constructed. Among some of the African tribes a partial five system is in use. Other tribes of northern Africa have borrowed the decimal notation from their civilized neighbors.

Without a single exception the ancient civilized peoples of all the world—Egyptians, Babylonians, Hebrews, Chinese, Greeks, Romans, Hindus—all used the decimal systems. Such striking uniformity among all the races of the earth requires a natural origin for the decimal number base. As Herodotus first suggested, man counts by tens because he has ten fingers. While there may be logical grounds for the advocates of a duo-decimal system, the ten system is too deep-rooted to be dislodged. Were we to acquire numbers as adults with mature minds, a duo-decimal system might be possible, but with children the acquisition of a twelve system may be said to be almost a psychological impossibility.

Among the Babylonians existed a sixty system mixed with a decimal system. Separate symbols and words are found for 60, 3,600 and 21,600 (60 , 60^2 , 60^3) and also for 10, 600 and 1,000 and 36,000.

The ingenious hypothesis is advanced by M. Aures that the Babylonians having originally a decimal system, gradually changed from that system of numeration to the duo-decimal and then to the sexagesimal in order to make the number system accord with their systems of measurements. This is the reciprocal movement to that which is taking place with us to-day and that which was effected for France by the French Revolution, the change from duo-decimal and what not else systems of measurements to a decimal system in conformity with our number system. The hypothesis of Aures is justified by the existence of the special symbols and names for 10, 100 and 1,000, and many other curious mixtures of decimal, duo-decimal and sexagesimal systems in the Babylonian measures. There is some comfort to be found in the reflection that ours is not the first civilization to struggle with diverse systems of notation and measurement.

The most striking fact of Babylonian mathematics is that they were in possession of a sixty place system. The famous tablets of Senkereh, discovered by the English geologist, W. K. Loftus, give tables of square and cubic numbers in cuneiform characters. In these tables the numbers proceed regularly up to 8^2 , which is given as 1.4, 9^2 is given as

1.21, $\overline{10^2}$ as 1.36, $\overline{20^2}$ as 6.40—naturally all in cuneiform characters. The only possible interpretation of this is that the 1 in the left hand place stands for 60. The table of cubic numbers bears out this interpretation as $30^3 = 27,000$ is given as 7.30, meaning $7 \times 3,600$ or $7 \times \overline{60^2} + 30 \times 60 = 25,200 + 1,800$ which makes the total of 27,000. Up to date no documents have been found which show the presence of the zero in this system. Even though a zero, and with it thus a full place system, had existed the unwieldiness of the large base would have operated against a universal adoption of the system; a number system must be adapted to child mind.

Our division of the day into 24 hours is probably a heritage from the Babylonians; the division of the hour and minute into sixty parts is certainly a survival from this hoary system. So also the division of the arc of the circle into 360° and the further subdivisions have come to us from this extinct civilization. Greek astronomers and through them all European astronomers borrowed much from the same source, and for over fifteen hundred years of the Christian era sexagesimal fractions were used in all arithmetical computation. The first tables of trigonometric functions were on the basis of a radius of 600,000, later 6,000,000, finally to be discarded by Regiomontanus in 1470 for the base 10^6 , later for 10^{15} , and then by the great Vieta, in 1579, for the base one with decimal values.

It is entirely within the bounds of possibility that the first development of the Hindu, commonly called Arabic, place system was due to some oriental scholar who was familiar with the writings of these ancient Babylonians. Abundant testimony exists tending to prove the communication between Europe and the east. Having special symbols, such as existed in India for 1, 2, 3, 4, 5, 6, 7, 8 and 9 as early as the second century, acquaintance with this advancement of the Babylonians may have suggested the step to a decimal place system and the innovation of a zero. The existence of a Babylonian zero symbol would strengthen this hypothesis; even a blank space may have been the first symbol.

The Egyptians were in possession of a complete decimal system, with separate symbols for 1, 10, 100, 1,000, 10,000 and higher powers of 10. The famous Papyrus Rhind of the British Museum gives us a practically complete Egyptian arithmetic. The striking peculiarity of their arithmetic consisted in the work in fractions which was confined almost entirely to unit fractions. The Ahmes Papyrus of date about 1700 B.C. gives a table for a conversion of fractions from $\frac{2}{3}$ to $\frac{2}{99}$ into unit fractions. The tremendous inertia of even the clumsiest system once established is seen in the fact that Greek manuscripts of date 700 A.D., at least 2,200 years later, contain this same bungling system of fractions. Aside from this malign influence European arithmetic was not affected by the Egyptian.

Among the ancient Semitic peoples we find separate symbols for 1, 10, 20 and 100. Noteworthy is the use of twenty in forming the higher powers of ten; sixty is written as three twenties. The use of twenty as a unit of higher order goes back to primitive counting on fingers and toes, which operation still exists among Pacific coast tribes of Indians, Mexicans and Esquimaux. Persistence of the unit twenty is seen in our word for score; more markedly in the French *quatre-vingt* for 80.0.

Some time before the Christian era, the Phoenicians changed to an alphabet system of numbers. The first nine letters of their alphabet were given the number values 1 to 9; to the second nine attach the values 10—90; and similarly with the hundreds. From the Phoenicians this method was taken by the Hebrews and the Greeks. In any numerical work the order hundreds, tens, units is strictly observed. Nevertheless, as to each word there was a definite number value the Hebrews indulged in secret writing by giving one name with the hint to the wise to substitute some other well-known name with the same number value. This near-punning occurs in the Book of the Revelations, "the number of the Beast is 666," referring to the Roman Emperor whose name written in Hebrew letters had the numerical value, 666.

A different type is presented by the Attic system of numbers in use among the ancient Greeks, in which the symbols are the first letters of the corresponding Greek words.

$$\begin{aligned}
 1 &= \text{I.} \\
 5 &= \text{II or } \Gamma \text{ from } \piέντε \text{ for five.} \\
 10 &= \Delta \text{ from } δέκα \text{ for ten.} \\
 100 &= \text{H from } εκατον \text{ for hundred.} \\
 1,000 &= \text{X from } χίλιοι \text{ for one thousand.} \\
 10,000 &= \text{M from } μυρίαι \text{ for ten-thousand.}
 \end{aligned}$$

Combinations Γ^{Δ} , Γ^{H} , Γ^{X} , Γ^{M} were used for 50, 500, 5,000 and 50,000. The advantage in numerical computation of this system over the alphabet system is great as the connection between 50, 500 and 5,000 is brought out by the symbols. Deceived by the apparent simplicity of the alphabet system, the Greeks abandoned the Attic in favor of the alphabet form.

$$\begin{array}{ll}
 \gamma + \delta = \zeta, & 3 + 4 = 7, \\
 \lambda + \mu = \sigma, & 30 + 40 = 70, \\
 \tau + \upsilon = \psi, & 300 + 400 = 700,
 \end{array}$$

are apparently simple, but they fail to show any trace of the underlying decimal system.

$$\begin{array}{ll}
 \text{III} + \text{III} = \text{VII.} & 3 + 4 = 7. \\
 \Delta\Delta\Delta + \Delta\Delta\Delta\Delta = \Gamma^{\Delta}\Delta\Delta. & 30 + 40 = 70. \\
 \text{HHH} + \text{HHHH} = \Gamma^{\text{H}}\text{HH.} & 300 + 400 = 700.
 \end{array}$$

These second forms are organically connected, whereas the first forms exhibit no connection.

During the first thousand years of the Christian era, the alphabet system held full sway; then for a period of nearly five hundred years the Roman and the Greek systems vied with each other for popular favor among European arithmeticians.

The origin of the Roman numerals is lost in obscurity. Undoubtedly the symbols are from Etruscan sources changed gradually into the similar Roman letters. It is to be noted that such changes in the forms of letters were most easily effected by copyists previous to the invention of printing. Just as the Babylonians operated with the common denominator sixty, so the Romans confined themselves to the denominator 12 (and powers of 12). The twelfth represented at first a definite concrete unit of weight or length, the uncus, which later acquired a numerical sense.

LIST OF ROMAN 12THS

Name	Value	Symbol	
as	1	I	There were further names and symbols for $\frac{1}{2}$, $\frac{1}{3}$, $\frac{1}{4}$ or $\frac{1}{2}$, $\frac{1}{3}$, $\frac{1}{4}$.
bes	$\frac{2}{3} = \frac{1}{2}$	S =	
semis	$\frac{1}{2} = \frac{1}{2}$	S	$\frac{1}{2}$ or $\frac{1}{3}$, $\frac{1}{4}$ or $\frac{1}{12}$, $\frac{1}{24}$, $\frac{1}{36}$, $\frac{1}{48}$, $\frac{1}{72}$, $\frac{1}{96}$.
quadrans	$\frac{1}{4} = \frac{1}{2}$	= —	These were used to apply to any measurements.
uncia	$\frac{1}{12}$	—	
sextula	$\frac{1}{24}$	—	

The connection between the uncia and our inches and ounces is evident.

The Roman numerals like their prototypes in the Attic system of Greece and the more ancient semitic systems, left no traces upon our current arithmetic. However, the Roman system of calculating upon a reckoning table was one of the vital factors in the development of the decimal place system. This system was not peculiarly Roman, as ancient Greek reckoning tables are found in several continental museums. The Chinese suan-pan, in popular use in Chinese laundries, is familiar to most readers. A similar instrument is found in Russian elementary schools.

A series of parallel grooved spaces and a goodly number of pebbles constitute the simplest form of one of these primitive calculating machines. Any right-hand column is chosen as the units column and the successive columns to the left are designated by the symbols for the successive powers of ten. Ten pebbles in any one column are replaced by one pebble in the next column to the left. Addition and subtraction are simple operations and even multiplication with small integers is not a difficult operation. Division was an accomplishment which only masters achieved; the complicated rules given by some medieval writers on the subject lead one to suspect that the writers were concealing ignorance in obscurity. On the Roman abacus the extreme right-hand column represented twelfths (uncia) and three smaller columns

denoted 24ths, 48ths and 36ths respectively. On the Greek abacus also the right-hand columns were of mixed systems which serve to make the calculating more difficult.

A late development of the same nature was the reckoning on lines which continued into the sixteenth century. The essentials are similar.

A glance at the accompanying diagram explains the connection between this system and the decimal place system. The upper part represents the number 4,063, the lower part the number 3,251. It seems such a slight step, after acquiring special symbols for the groups of one

M	C	X	I
0		0	0
0		0	0
0		0	0
0		0	
		0	
		0	
		0	
0		0	
0	0	0	
0	0	0	0

to nine to construct a symbol to indicate a blank space, but that step took centuries to achieve.

Of all ancient peoples the Hindus occupied themselves most deeply with numbers. To some of their scholars came the conception of a connection between the infinite of the universe and the infinite of numbers. This longing for the infinite found expression in the construction of ever increasing numbers. Buddha calculates the number of grains of sand in a mile and shows how to compute the number in a sphere whose radius is the distance to one of the fixed stars. Not content with this, the Buddha goes on to show how even greater numbers may be expressed, arriving at the equivalent in modern exponential notation of $10^{(7+9 \cdot 4^9)} = 10^{421}$. The numerals of the ancient Tamils, who, like the mountaineers of Appalachian America, conserve the traditions of a more remote civilization, show us that the Hindu peoples originally had special symbols not only for the first nine units, but also for the nine tens, the nine hundreds and even the nine thousands. The formation of the sequences of large numbers revealed the futility of having separate signs for the mixed tens and hundreds, with the consequent result that they dropped the separate symbols for 20 to 90, 200 to 900, and used the pure decimal units in connection with the symbols for one to nine. A similar development took place in quite early times—pre-Christian—among the Chinese but their clumsy notation obscured the realization of the possibility of a simpler place system.

The reading of a large number in Hindu style reveals how close their nomenclature brought them to the place system.

- In modern notation, 8,443,682,155, 8 billion, 443 million, 682 thousand, 155.
- In Hindu, 8 padmas, 4 vyarbondas, 4 kôtis, 3 prayoutas, 6 lakchas, 8 ayoutas, 2 sahasra, 1 çata 5 daçan 5.
- In Arabic and in later German, eight thousand thousand thousand and four hundred thousand thousand and forty-three thousand thousand and six hundred thousand and eighty-two thousand and one hundred fifty-five.
- In Greek, eighty-four myriads of myriads and four thousand three hundred sixty-eight myriads and two thousand one hundred fifty-five.

It is well established that in different parts of India the names for some of the higher powers took different forms, even the order was interchanged. However, as the significance of the name was further given by the order in reading, the variations did not lead to error. Indeed, the variation itself may have necessitated the introduction of a word to signify a vacant place or a lacking unit, with the ultimate introduction of a zero symbol for the word. The use of a special word to indicate absence of a unit is not hypothesis, but is found in verses in the ancient Indian book on astronomy, the *Sourya-Siddhanta*, and in numerous other ancient Hindu writings.

Brockhaus has well said that if there was any invention for which the Hindus by all their philosophy and religion were well fitted it was the invention of a symbol for zero. This making of nothingness the crux of a tremendous achievement was a step in complete harmony with the genius of the Hindu. The exact date of the birth of the zero symbol is not known, doubtless never will be known. The burden of proof points to a use of this symbol towards the beginning of the fifth century of our era. Wide-spread use in India did not occur until towards the ninth century. With nations as with individuals, the complete significance of great idea is not achieved in a moment; even as this idea itself in its unfolding required the labor of master minds of many centuries, so the appreciation and application of this advance required centuries for its completion.

The intellectual awakening of the Arabs beginning about the middle of the eighth century, manifested itself in the appearance of numerous translations of Greek, Syrian and Hindu works. Barbarians as they undoubtedly were at the period of their first conquests, the Arabs distinguished themselves by their desire for the further conquests of the science and literature of the subjugated peoples. The Persian invasion brought them close to the civilization of the Hindus and here the scholars went further than the flag. Hindu astronomy and astrology accompanied by the Hindu arithmetic were given to the scientific public in translations made at the command of one of the first great Mahome-

tan patrons of learning, the Caliph Almansur, who reigned during the second half of the eighth century.

For a period of five hundred years the intellectual activity of the Mediterranean countries was well nigh confined to the Arabs. With what extraordinary diligence the pursuit of foreign learning was made by these erstwhile wanderers is evidenced by the thousands upon thousands of Arabic manuscripts. The library of Hakam at Cordova in Spain contained 400,000 manuscripts; the catalogue alone is in 44 volumes. Original work in science and mathematics did not come from Arabic hands, but the debt of civilization is none the less great as they were long the conservors of the learning of the Greeks and Hindus. The revival of Euclid was brought about by translations made from the Arabic; indeed many important Greek works in all the sciences have come to us only from Arabic sources.

The points of contact of Europeans and the Ottomans were numerous. From Asia Minor at the east to Greece was a well-traveled route; Sicily, Sardinia and Africa were in constant communication with Italy. Moorish Spain was for centuries a meeting place of English, French, Polish and German scholars.

The church played an important rôle in the spread of the Hindu numerals over Europe, and at the beginning of the thirteenth century in England, France, Germany, Italy and Poland, the arithmetic of the far east was explained by churchmen who had learned of Moorish teachers. However, it remained for a commercial traveler (line he handled is not known) to write the epoch-making work explaining the new doctrine. Leonard of Pisa traveled for business purposes in Africa, Syria, Egypt, Greece and Sicily and incidentally he acquired enough mathematics to make him the greatest mathematician since Archimedes. His *Liber Abaci*, or book of the abacus, first edition written in 1202, gave the first masterful exposition of the better way to reckon. It was for four centuries the great work of reference in this field.

With the knowledge of the Hindu method spread over all Europe at the beginning of the thirteenth century the acceptance of the improvement might be presupposed, but as late as 1520 arithmetics were published entirely in Roman numerals. The logically self-evident step to the right, to decimal fractions, required further centuries for its completion. The step up, to exponents to base ten, was made rather quickly, but has not yet taken its proper place in commercial work.

It is not too much to say that the present development of modern science would be impossible without our number system, yet how slow the world was to accept the reform. Is not the same story being repeated in the United States and England with the decimal system of weights and measures? But the optimistic soul regards chiefly the final acceptance with the comfortable assurance that the forward movement is as sure as it is slow.

THE ARGUMENT FOR ORGANIC EVOLUTION BEFORE
"THE ORIGIN OF SPECIES"BY PROFESSOR ARTHUR O. LOVEJOY
THE UNIVERSITY OF MISSOURI

I

IN this year of the Darwin centenary it is worth while to raise two questions which have, in the mass of literature elicited by the occasion, received less consideration than they merit. At what date can the evidence in favor of the theory of organic evolution—as distinct from the hypothesis of natural selection—be said to have been fairly complete: in other words, how early were the facts and principles from which the truth of that theory is now ordinarily inferred sufficiently known to all competent men of science, to require the inference, even though it was not, in fact, generally made? And by what English writer was a logically cogent argument for the theory first brought together and put before the public? The interest attaching to these questions is much more than merely historical. The answer to them will afford a sort of object-lesson in the logic of scientific reasoning. Here is a doctrine now accepted by all naturalists: at what point, in the century-long accumulation, through half a dozen separate sciences, of the evidences inclining to that doctrine, ought we to say that the balance of logical probability turned decisively in its favor? The inquiry will also be found, I think, to throw a somewhat instructive light upon the psychology of belief, and to show how far, even in the minds of acute and professedly unprejudiced men of science, the emotion of conviction may lag behind the presentation of proof.

By this time, no doubt—though it has not long been so—every schoolboy knows that Darwin did not invent the theory of evolution. The Darwin centenary itself has served to remind the public of the names and works of at least some of the earlier protagonists of the doctrine: of the elder Darwin, namely, of Lamarck, of Geoffroy St. Hilaire, of the author of the "Vestiges of the Natural History of Creation," and of Herbert Spencer. It is less commonly remembered, but perhaps not universally forgotten, that among English-speaking naturalists, the theory was a commonplace topic of discussion for two or three decades before 1859, and especially after the publication and immense circulation of the successive editions of Robert Chambers's "Vestiges," of which the first appeared in 1844. Geological text-books of the period referred to the "theory of transmutation of species" as

a matter of course, though usually only to reject it as an exploded hypothesis. Thus the "Elements of Geology," of Alonzo Gray and C. B. Adams, 1852, enumerates three theories which have been advanced respecting the origin of animal species: (1) Successive special creations; (2) "transmutation, which supposes that beings of the most simple organization having somehow come into existence, the more complex and the higher orders of animals have originated in them by a gradual increase in the complexity of their structures";¹ (3) *generatio æquivoca* of individuals and species. The first is adopted, but the second is discussed at greatest length; on it the authors remark that "those who have adopted the theory of transmutation have generally detached it from Lamarck's theory of appetency, and not attempted to explain *how* the process of transmutation goes on." The argument for evolution is similarly discussed and "refuted" in "Geological Science," a popular text-book by D. T. Ansted, F.R.S., 1854. To this refutation, indeed, the greatest of English geologists had devoted three chapters of his "Principles of Geology"² before 1835.

But though such facts as these are, as I have said, now fairly familiar, the notion still widely prevails, even among biologists, that no serious *proof* of evolution either existed or had been published before the appearance of the "Origin of Species"—or at all events, before the late 1850's.³ Professor Joseph Le Conte, indeed, in his "Evolution and Its Relation to Religious Thought,"⁴ made it a reproach against both Lamarck and Chambers that they had unscientifically embraced the hypothesis before the evidence for it was ripe; and considered it fortunate for science that their notions died still-born, under the weight of the great authority of Cuvier and Agassiz. "I know," wrote Le Conte, "that many think with Haeckel that biology was kept back half a century by the baleful influence of Agassiz and Cuvier; but I can not think so. The hypothesis was contrary to the facts of science, *as then known and understood*. It was conceived in the spirit of baseless speculation, rather than of cautious induction; of skilful elabora-

¹ I quote from the reprint of 1854, p. 87.

² The writer's copy of Lyell's "Principles" is the first American from the fifth London edition, 1837.

³ This opinion has, for example, been expressed by Poulton in his "Charles Darwin and the Theory of Natural Selection." "The paramount importance of Darwin's contributions to the evidences of organic evolution are [*sic*] often forgotten in the brilliant theory which he believed to supply the motive cause of descent with modification. Organic evolution had been held to be true by certain thinkers during many centuries; but not only were its adherents entirely without a sufficient motive cause, but their evidences of the process itself were erroneous or extremely scanty. It was Darwin who first brought together a great body of scientific evidence which placed the process of evolution beyond dispute, whatever the causes of evolution may have been" (p. 100).

⁴ Second edition, 1905, pp. 33-35.

tion, rather than of earnest truth-seeking. Its general acceptance would have debauched the true spirit of science. . . . The ground must first be cleared . . . and an insuperable obstacle to hearty rational acceptance must first be removed, and an inductive basis laid." This last, Le Conte goes on to argue, was largely the work of Agassiz, opponent of evolutionism though he was. Now, it is, of course, undeniable that the premature adoption of a hypothesis is a sin against the scientific spirit, and that the chance acceptance by some enthusiast of a truth in which, at the time, he has no sound reason for believing, by no means entitles him to any place of honor in the history of science. But what constitutes prematurity in this particular matter? And *was* the evolutionary hypothesis "contrary to the facts of science, as known and understood" at any time after 1840?

The prevalent belief that it was is chiefly due to two things. The first is the fact that before 1859 few English naturalists of high standing accepted, and almost none publicly avowed, the theory of descent; whereas, after the publication of the "Origin," such notable names as Huxley, Lyell, Hooker and Asa Gray were speedily numbered among the disciples of the doctrine, and in the ensuing five years it was well upon its way towards its eventual complete triumph. The other source of the supposition that Darwin presented the first adequate grounds for believing in evolution is the express testimony of Huxley, whose paper on the reception of the "Origin of Species"⁵ has come to be the principal source of information on its subject. In that article, and in several letters and other writings, Huxley takes credit to himself for his rejection of the transformation-theory until he became acquainted with Darwin's work; and he never expressed any sentiment far short of contempt for Chambers's "Vestiges." He wrote in 1887:

I must have read the "Vestiges" . . . before 1846; but if I did, the book made very little impression on me, and I was not brought into serious contact with the "species" question until after 1850. . . . It seemed to me then, as now, that "creation," in the ordinary sense of the word, is perfectly conceivable. . . . I had not then, and have not now, the smallest *a priori* objection to raise to the account of the creation of plants and animals given in "Paradise Lost." . . . Far be it from me to say that it is untrue because it is impossible. I confine myself to what must be regarded as a modest and reasonable request—for some particle of evidence that the existing species of animals and plants did originate in that way, as a condition of my belief in a statement which appears to me highly improbable. And, by way of being perfectly fair, I had exactly the same answer to give to the evolutionists of 1851-58. . . . The only person known to me whose knowledge and capacity compelled respect, and who was, at the same time, a thorough-going evolutionist, was Mr. Herbert Spencer. . . . But even my friend's rare dialectic skill and copiousness of apt illustration could not drive me from my agnostic position. I took my stand upon two grounds: Firstly, that at the time the evidence in favor of transmutation was wholly insufficient; secondly, that no suggestion respecting the causes of the

⁵ Published as Ch. XIV. of "The Life and Letters of Charles Darwin."

transmutation assumed, which had been made, was in any way adequate to explain the phenomena. Looking back at the state of knowledge at the time, I really do not see that any other conclusion was justifiable. . . . As for the "Vestiges," I confess the book simply irritated me by the prodigious ignorance and thoroughly unscientific habit of mind manifested by the writer. If it had any influence at all, it set me against evolution. . . . Thus, looking back into the past, it seems to me that my own position of critical expectancy was just and reasonable. . . . So I took refuge in that *tätige Skepsis* which Goethe has so well defined; and, reversing the apostolic precept to be all things to all men, I usually defended the tenability of received doctrines, when I had to do with the transmutationists; and stood up for the possibility of transmutation, among the orthodox.

In this matter Huxley is assuredly a witness whose testimony should not lightly be set aside; for to his attainments as a naturalist he ordinarily joined singular logical acumen and rare openness of mind. Yet I think it possible to show that the passage just quoted gives a thoroughly misleading view of the logical status of the argument for evolution, as it existed in the light of the science of the period; that the attitude which Huxley assumed from 1850 to 1858 was contrary to all sound ideas of scientific method; and that he does the reputations of both Spencer and Chambers serious injustice. I shall attempt to establish these conclusions mainly by showing that the arguments and facts chiefly relied upon by Huxley himself and other early champions of transformism were entirely familiar and well authenticated from fifteen to twenty years before 1859, and had virtually all been clearly noted and pertinently used in the published evolutionary reasonings of Chambers or of Spencer. The truth is—as the evidence to be adduced will make clear—that Huxley's strongly emotional and highly pugnacious nature was held back by certain wholly non-logical influences from accepting an hypothesis for which the evidence was practically as potent for over a decade before he accepted it as it was at the time of his conversion. These influences did not in Huxley's case, as they did in so many others, proceed from religious tradition or temperamental conservatism. But Huxley had unquestionably been strongly repelled by the "Vestiges." The book was written in a somewhat exuberant and rhetorical style; with all its religious heterodoxy, it was characterized by a certain pious and edifying tone, and was given to abrupt transitions from scientific reasoning to mystical sentiment; it contained numerous blunders in matters of biological and geological detail; and its author inclined to believe, on the basis of some rather absurd experimental evidence, in the possibility of spontaneous generation. All these things were offensive to the professional standards of an enthusiastic young naturalist, scrupulous about the rigor of the game, intolerant of vagueness and of any mixture of the romantic imagination with scientific inquiry, a little the victim, perhaps, of the current scientific cant about "Baconian induction," and quite incapable of

taking, towards any doctrine or movement, any attitude intermediate between contemptuous hostility and ardent partizanship. Full advantage, moreover, had been taken, by the eminent scientists who were also champions of religious orthodoxy, of the faults of Chambers's book; they contrived very successfully to put about the impression that to be a "Vestigiarian" was to be "unscientific" and sentimental and absurd. These were three qualities which Huxley would have been peculiarly averse to being charged with. Finally, he seems to have been exasperated most of all by a single loose piece of phraseology that now and then recurs in the "Vestiges." Chambers, namely, was prone to speak of "laws" as if they were causes and, more particularly, as if they were secondary causes to which the "Divine Will" delegated its agency and control. To Huxley, from the beginning of his career, this hypostatizing fashion of referring to "laws of nature" was a *bête noire*; and in 1887 we still find him pursuing the author of the "Vestiges" with ridicule because of his "pseudo-scientific realism."⁶ He, therefore,⁷ in 1854, almost outdid the *Edinburgh Review* in the ferocity of his onslaught upon the layman who had ventured to put forward sweeping generalizations upon biological questions while

* "Science and Pseudo-science," 1887. Huxley's criticisms are curiously beside the mark. He argues that, whether you suppose that the Creator operates uniformly but directly "according to such rules as he thinks fit to lay down for himself," or that "he made the cosmical machine and then left it to itself," in either case his "personal responsibility is involved" in every result into which this uniform operation works out. But Chambers, so far from denying this, was especially anxious to insist upon it. What he equally insisted upon, however, was the uniformity of this agency. When he spoke of the Creator as working "through" law, the expression, doubtless, was infelicitous; but his essential idea was plain and unexceptionable, viz., that neither organic nor inorganic phenomena "result from capricious exertions of creative power; but that they have taken place in a definite order, the statement of which order is what men of science term a natural law." These last words are Huxley's own, uttered in 1862, in an address before the Geological Society. It is, he added, logically possible to regard such a law as "simply the statement of the manner in which a supernatural power has thought fit to act"; the main thing is that "the existence of the law and the possibility of its discovery by the human intellect" be recognized. This was exactly the essence of the view for which Chambers was contending. Huxley was so unduly enraged by a bit of unscientific looseness of language that he actually overlooked the important idea which that language was manifestly intended to express.

⁷ I have not had access to this article, published in the *Medical and Chirurgical Review*; but its character is sufficiently indicated in the correspondence of Huxley and Darwin. The former speaks of it as "the only review I ever have qualms of conscience about, on the ground of needless savagery." Darwin thought it "rather hard on the poor author"; and added a curiously mild intimation of his own belief: "I am perhaps no fair judge; for I am almost as unorthodox about species as the 'Vestiges' itself, though I hope not quite so unphilosophical" ("More Letters of Charles Darwin," I., 75).

capable of errors upon particular points which were palpable to every competent specialist.

Yet the layman was, after all, sound in his main thesis; and, what is far more significant, his thesis was based upon sound and sensible arguments, substantially the same arguments that Huxley was destined before long to use in the same cause, though with far superior skill as a debater. It will, I think, appear impossible to acquit the young Huxley of a certain measure of scientific Pharisaism in this episode. He was so shocked by minor breaches of scientific propriety, in the "Vestiges," that he forgot the weightier matters of the law of scientific method. In his irritation at Chambers's incidental slips in zoology, he became blind to the importance and suggestiveness of the general outline of that writer's reasoning. Quite other was Alfred Russel Wallace's reaction upon the little book. As early as 1845 he wrote:

I have rather a more favorable opinion of the "Vestiges" than you appear to have. I do not consider it a hasty generalization, but rather as an ingenious hypothesis, strongly supported by some striking facts and analogies, but which remains to be proved by more facts and the additional light which more research may throw upon the problem. It furnishes a subject for every observer of nature to attend to; every fact he observes will make either for or against it.*

By 1847 Wallace had become thoroughly convinced of the truth of transformism; and from that time forward his mind was occupied with the problem of explaining the cause and *modus operandi* of evolution. At this time, he writes:

The great problem of the origin of species was already distinctly formulated in my mind. . . . I believed the conception of evolution through natural law, so clearly formulated in the "Vestiges," to be, so far as it went, a true one; and I firmly believed a full and careful study of the facts of nature would ultimately lead to the solution of the mystery.

Wallace thus escaped the fatal error in logical procedure into which Huxley fell. For Huxley, in the passage already cited, gives as one of his two reasons for refusing to accept, even provisionally, the evolutionary hypothesis, the fact that "no adequate suggestion respecting the causes of the transmutation assumed" had then been made. But, that no causal explanation of a fact is at hand, is not good reason for denying the fact, if serious evidence of its reality is presented. Wallace properly discriminated the two issues; becoming first convinced that there was an established balance of scientific probability in favor of the fact, he then set himself upon the quest of a hypothesis that would explain it. He verily had his reward; a decade later he appeared, with Darwin, as joint author of the doctrine of natural selection.

*Wallace, "My Life," I., 254. Writing sixty years after, Dr. Wallace adds his final judgment of the "Vestiges," "a book which, in my opinion, has always been undervalued, and which, when it first appeared, was almost as much abused, and for much the same reasons, as was Darwin's 'Origin of Species' fifteen years later" (*ibid.*).

It is time to proceed to the proof of the contentions of this paper. In presenting it, I shall first recall to the reader passages—some of them, doubtless, already familiar—from Huxley or other post-Darwinian defenders of the evolution theory, and then exhibit the parallel arguments found in Chambers, Spencer and other pre-Darwinians. Since, in such a case, textual precision is of some importance, it is hardly needful to apologize for copious citation of the *ipsissima verba* of the authors in question. The arguments for evolution will be taken up in the order of their generality or of their logical interconnection.

It is necessary first of all, however, to remind the reader of the general outlines of the situation in the science of the time. It was a situation essentially different from that in which Lamarck had carried on the propaganda of transformism. The difference was due to two changes that had taken place in the intervening period. First, the science of geology had gone through a brilliant development, and had fought and won its battle against religious orthodoxy; and in England, though not all geologists were consistent uniformitarians, all geology had been profoundly influenced by the principles and the methods of Hutton and Lyell. Second, the two allied subsidiary sciences of paleontology and stratigraphic geology had been created, through the work of Cuvier and of William Smith. One result was that the recognized age of the planet had been vastly extended; enough time was thus granted for the evolutionary process. A still more significant result was that the Mosaic cosmogony had been entirely abandoned by even the most orthodox of men of science. The doctrine of creation which such men defended against the hypothesis of development no longer bore any close resemblance to the narratives of Genesis; it was no longer a question of a single, original creation of all things, but of a large number of repeated acts of "special creation," separated from one another by wide intervals of time, and confined to the production of organisms. Meanwhile, it was assumed, in the organic realm things were going on in an orderly and normal manner, in accordance with natural laws of geologic change; even the Cuvierian "catastrophes" were "natural" phenomena. The effect, in short, of the triumph of geology had been, curiously enough, to *increase* the resort to supernatural agency in the current accounts of the genesis of the existing order of nature. In place of one great, obscure miracle at the origination of the universe, the revised version of the doctrine of creation assumed a large number of petty and definite miracles; it supposed, in Chambers's words, "an immediate exertion of the creative power, at one time to produce zoophytes, at another time to add a few marine mollusks, another to bring in one or two crustacea, again to produce crustaceous fishes, again perfect fishes, and so on to the end."⁹ Creationism, to conform to the accepted principles and accumulated knowledge of geological science, had been

⁹ Chambers, "Vestiges," 1844, Ch. XI.

compelled, like the Ptolemaic astronomy before it, to interpolate some very singular epicycles in its hypothesis. And while all these miraculous interpositions were taking place in order to keep the organic kingdom in a going condition, the Creator was not for a moment allowed by the orthodox geologists to interfere in a similar manner in their own particular domain of the inorganic processes. Their attitude was like that of the French authorities who, a century earlier, suppressed the "miraculous cures" of the Jansenist abbé at the church of St. Médard in Paris, and, in a famous lampoon, were represented as posting the following proclamation on the church doors:

De par le roi, défense à Dieu
De faire miracle en ce lieu.¹⁰

So, in the ruling science of 1830-60, the only officially licensed place (outside of Palestine) in which miracles might be performed by the Creator was the domain of organic phenomena. Here, as a measure of compensation, the number of miracles scientifically sanctioned had been materially increased.¹¹

It was a further consequence of these changes in the scientific situation that the men who, in the name of orthodoxy but under the mantle of science, attacked the pioneers of evolutionism, themselves taught doctrines no less completely at variance with the usual—and with any natural—interpretation of Scripture. Accommodations and forced interpretations had, indeed, been devised in abundance, to "harmonize" the new science with theology; but if these could be invented to justify geology, others could as well be, as they since have been, invented to justify evolutionary biology. Any consistent scriptural believer could make out as good a case of heresy against Cuvier, Owen, Sedgwick, Agassiz, or Hugh Miller, as against the author of the "Vestiges" or Herbert Spencer. These writers, therefore, occupied a position of a strange and rather damaging incongruity, as Chambers did not fail to point out:

Strange to say, those who every day give views of physical cosmogony altogether discrepant in appearance with that of Moses, apply hard names to my book for suggesting an organic cosmogony in the same way liable to inconsiderate odium. . . . The views which I gave of this history of organization stand exactly upon the same ground upon which the geological doctrines stood, fifty years ago. . . . If the men newly emerged from the odium which was thrown upon Newton's theory of the planetary motions, had rushed forward to turn that odium upon the patrons of the dawning science of geology, they would have been prefiguring the conduct of several of my critics, hardly escaped from

"By the king's order, God is hereby forbidden to perform miracles in this place."

¹¹ The reader will find amusing examples of this inconsistency in President Hitchcock's "The Religion of Geology," 1852, pp. 164-165, 339-340. Cf. also Gray and Adams, "Elements of Geology," 1854, pp. 16 and 89.

the rude hands of the narrow-minded, yet eager to join the rabble against a new and equally unfriended stranger, as if that were the best way of purchasing immunity for themselves. The public must soon see that if a literal interpretation of scripture is an insufficient argument against the true geognostic history of our earth, so also must it be against all associated phenomena, supposing they are presented on good evidence.¹²

In view of this situation, the arguments for evolution, in 1844 or 1859, were primarily significant, not as direct evidences in favor of one hypothesis, but as touchstones for deciding between the claims of two—the only two—rival hypotheses: that of the ready-made production of species, with their known characteristics and relations, by repeated special acts of creation; and that of their production through the gradual modification, in the course of natural descent, of earlier and simpler forms. Huxley, it is true, refused to face the alternative, and cried, “a plague o’ both your houses!” Nothing can be said, however, in justification of such a position on the part of a man of science. *Hypotheses non fingo* has never been a sound or serviceable maxim; it had certainly not been by following it that the sciences of astronomy and geology had developed.¹³ Now, if other hypotheses, beyond the two in question, were conceivable in 1844, certainly no others were seriously advanced. The first concern of a biologist of the period should, then, have been to compare the two hypotheses of the origin of species, in the light of the then known principles and facts, hereafter to be enumerated. This comparison, if made honestly, by a logically competent mind, must necessarily have led, at almost any time after 1840, to the conclusion to which Spencer tells us that he found himself forced somewhere about 1850. By this time, he says:

The belief in organic evolution had taken deep root [in my mind] and drawn to itself a large amount of evidence—evidence not derived from numerous special instances, but derived from the general aspects of organic nature and from the necessity of accepting the hypothesis of evolution when the hypothesis of special creation had been rejected. The special creation belief had dropped out of my mind many years before, and I could not remain in a suspended state; acceptance of the only possible alternative was imperative.¹⁴

After these preliminaries, the reader is prepared for viewing the arguments for evolutionism, now to be recalled in a more detailed manner, in their proper historical and logical perspective.

1. *Argument from the General Presumption of Science against “Supernatural” Explanations of Phenomena.*—In his “Belfast Address,” 1874, Tyndall pointed out that the main argument for evolu-

¹² Chambers, “Explanations,” 1846, p. 120.

¹³ Huxley later expressed this general truth forcibly enough; *e. g.*, “The Progress of Science,” 1887. “Physical science rests on verified or uncontradicted hypotheses; and, such being the case, it is not surprising that a great condition of its progress has been the invention of verifiable hypotheses” (“Method and Results,” 1902, pp. 61-62).

¹⁴ Duncan, “Life and Letters of Herbert Spencer,” 1908, II., 317.

tion lay in the superior congruency of the hypothesis—as contrasted with the special creation doctrine—with the methodological presuppositions of modern science and with the general view of nature which in most of the other provinces of science had already been accepted.

The basis of the doctrine of evolution consists, not in an experimental demonstration—for the subject is hardly accessible to this mode of proof—but in its general harmony with scientific thought. From contrast, moreover, it derives enormous relative strength. On the one side we have a theory which converts the Power whose garment is seen in the visible universe into an artificer, fashioned after the human model, and acting by broken effects, as man is seen to act. On the other side, we have the conception that all we see around us and feel within us—the phenomena of physical nature as well as those of the human mind—have their unsearchable roots in a cosmical life, . . . an infinitesimal span of which is offered to the investigation of man. Among thinking people, in my opinion, this last conception has a higher ethical value than that of a personal artificer.

Reviewing the past triumphs of the scientific method over supernaturalism, he concludes:

We claim, and we shall wrest, from theology the entire domain of cosmological theory. All schemes and systems which thus infringe upon the domain of science must, in so far as they do this, submit to its control. . . . Acting otherwise proved always disastrous in the past, and it is simply fatuous to-day.

Similarly Romanes put in the fore-front of the arguments for evolution

The fact that it is in full accordance with what is known as the principle of continuity—by which is meant the uniformity of nature, in virtue of which the many and varied processes going on in nature are due to the same kind of method, *i. e.*, the method of natural causation. . . . The explanations of . . . phenomena which are at first given are nearly always of the supernatural kind. . . . Now, in our own day there are very few of these strongholds of the miraculous left. . . . No one ever thinks of resorting to supernaturalism, except in the comparatively few cases where science has not yet been able to explore the most obscure regions of causation. . . . We are now in possession of so many of these historical analogies, that all minds with any instincts of science in their composition have grown to distrust on merely antecedent grounds, any explanation which embodies a miraculous element. . . . Now, it must be obvious to any mind which has adopted this attitude of thought, that the scientific theory of natural descent is recommended by an overwhelming weight of antecedent presumption.

This “overwhelming weight of antecedent presumption” against special creation, and in favor of evolution, was pointed out by Chambers with entire clearness; his arguments present in part an almost verbal parallel to the passages I have quoted from Tyndall and Romanes. In the already established results of geology and astronomy, he writes in the “*Vestigis*”:

We have seen powerful evidence that the construction of the globe and its associates was the result, not of any immediate or personal exertion on the part of the Deity, but of natural laws which are expressions of his Will. What is to hinder our supposing that the organic creation is also the result of natural

laws, which are in like manner the expression of his Will? . . . The fact of the cosmical arrangements being an effect of natural law, is a powerful argument for the organic arrangements being so likewise; for how can we suppose that the august Being who brought all these countless worlds into form by the simple establishment of a natural principle flowing from his mind, was to interfere personally whenever a new shell-fish or reptile was to be introduced in one of these worlds? Surely this idea is too ridiculous to be for a moment entertained. This would certainly be to take a very mean view of the Creative Power—in short to anthropomorphize it.

In his "Explanations,"¹⁵ 1846, he puts the considerations urged by Romanes far more tellingly than Romanes put them forty years later. Chambers wrote:

The whole question stands thus: For the theory of universal order—that is, order as presiding both in the origin and administration of the world—we have the testimony of a vast number of facts in nature, and this one in addition—that whatever is reft from the domain of ignorance and made undoubted matter of science, forms a new support to the same doctrine. The opposite view, once predominant, has been shrinking for ages into lesser space, and now maintains a footing only in a few departments of nature which happen to be less liable than others to a clear investigation. The chief of these, if not the only one, is the origin of the organic kingdoms. So long as that remains obscure the supernatural will have a certain hold upon enlightened persons. . . . One after another the phenomena of nature, like so many revolted principalities, have fallen under the dominion of order and law; but here is one little province still faithful to the Bœotian government; and as it is nearly the last, no wonder it is so vigorously defended. As in the political world, however, men do not trust in the endurance of a dynasty which is reduced to a single city or nook of its dominions, so we may expect a speedy extinction to a doctrine which has been driven from every portion of nature but one or two limited fields.

Huxley, it is true, seems in his pre-Darwinian period to have disapproved of this type of argument; creation being "perfectly conceivable . . . the so-called *a priori* arguments against the possibility of creative acts" appeared to him "to be devoid of reasonable foundation." This, of course, was a perverse misapprehension of the issue. It was not a question of conceivability, but of the relative probability of the only two available hypotheses. And the first criterion of probability in such a case must be the agreement of any proposed hypothesis with the general type of hypothetical explanations which the whole previous experience of men of science has found to be capable of fruitful application, and of the sort of verification which comes through fruitful application. By such a criterion, no hesitation between the two hypotheses was admissible. "Special acts of creative volition" had never been found by science to be a *vera causa* at all; the hypothesis was vague, sterile, impossible of verification, contrary to all the principles of method by the use of which the past successes of science had been achieved; "gradual development through natural descent" was, as a

¹⁵ This supplement to the "Vestiges" seems to be little known; it is in many respects superior to the original volume.

working theory, definite, suggestive of precisely formulable problems to which inductive tests could be applied, harmonious with the initial assumptions through which several other disciplines had already been converted from mere masses of information into sciences. Huxley later saw this clearly enough, and expressed it forcibly, though he never seems to have confessed the unreasonableness of his earlier position. The publication of Lyell's "Principles of Geology" in 1830, wrote Huxley¹⁶ in 1887, "constituted an epoch in the modern history of the doctrine of evolution, by raising in the mind of every intelligent reader this question: If natural causation is competent to account for the not-living part of our globe, why should it not also account for the living part?" If every intelligent reader had this question in his mind after 1830, it is a little singular that Huxley himself, and almost every other naturalist of the period, saw no importance whatever in the reasonings of Chambers, Spencer, Baden Powell, and a few others, who were the only *writers* of the time to press the question home.

2. *The Argument from Uniformitarianism in Geology.*—Huxley, indeed, from the time of his conversion to Darwin's views, always set great store by the argument from the presumptions of scientific method; but usually in a more specialized and less philosophical form of it. Geology was, in England, the dominant and the most brilliantly successful science of the first half of the century; and Lyell had made it a working principle of geological reasoning that past phenomena, not directly open to experiment, were, so far as possible, always to be referred to the operation of "causes" similar to those now at work. Whether the uniformitarian doctrine was not, as some contemporary geologists hold, a good deal overstrained by Lyell, it does not lie within the purpose of this paper to ask; at all events, the doctrine was accepted by Huxley and most of the men of science of that time. And in uniformitarianism evolutionism seemed to Huxley—after 1858—to be directly implied. We find him writing Lyell in June, 1859:

I by no means believe that the transmutation hypothesis is proven, or anything like it. But I view it as a powerful instrument of research. Follow it out, and it will lead us somewhere; while the other notion is, like all the other modifications of "final causation," a barren virgin. . . . I would very strongly urge upon you that it is the logical development of uniformitarianism.

In the self-same paper in which we saw Huxley justifying his refusal for some twelve years to adopt the doctrine of transformation, even as a working hypothesis, there is also to be found the following passage:

I have recently read afresh the first edition of the "Principles of Geology"; and when I consider that for nearly thirty years this remarkable book had been in everybody's hands, and that it brings home to every reader of ordinary intelligence a great principle and a great fact—the principle that the past must be

¹⁶ "Method and Results," "The Progress of Science," p. 99.

explained by the present unless good cause can be shown to the contrary; and the fact that, so far as our knowledge of the past history of life on our globe goes, no such cause can be shown—I can not but believe that Lyell was, for others, as for myself, the chief agent in smoothing the road for Darwin. For consistent uniformitarianism postulates evolution as much in the organic as the inorganic world. The origin of a new species by other than ordinary agencies would be a vastly greater “catastrophe” than any of those which Lyell successfully eliminated from sober geological speculation.”

But however much Lyell may have “smoothed the road,” Huxley, and most of the biologists of those thirty years, declined to go in thereat. It remained for an anonymous amateur, whom they thereupon with one accord fell to abusing, to point out the practicability of that highway. In the “*Vestiges*” and the “*Explanations*” Chambers urged the presumption from geological uniformitarianism with an effective use of concrete examples.¹⁸

If there is anything more than another impressed on our minds by the course of geological history, it is that the same laws and conditions of nature now apparent to us have existed throughout the whole time. Admitting that we do not now see any such fact as the production of new species, we at least know that, while such facts were occurring upon earth, there were associated phenomena of a perfectly ordinary character. For example, when the earth received its first fishes, sandstone and limestone were forming in the manner exemplified a few years ago in the ingenious experiments of Sir James Hall. . . . It was about the time of the first mammals that the forest of the Dirt Bed was sinking in natural ruin amidst the sea sludges, as the forests of the Plantagenets have been doing for several centuries upon the coast of England. In short, *all the common operations* of the physical world were going on in their usual simplicity, obeying the laws which we now see governing them; while the supposed extraordinary causes were in requisition for the development of the animal and vegetable kingdoms. There surely hence arises a strong presumption against any such causes.

It is a curious circumstance, however, that the argument from uniformitarianism cut both ways. As Wallace says:

One of the greatest, or perhaps we may say the greatest, of all the difficulties in the way of accepting the theory of natural selection as a complete explanation of the origin of species, has been the remarkable difference between varieties and species with respect to fertility when crossed.”

This difference, as Darwin said in the “*Origin*,” seemed, on the face of it, “to make a broad and clear distinction between varieties and species.” And the apparent existence of such a radical distinction between the varieties produced under domestication and true physiological species was an objection, not only against natural selection, but also against evolution itself; for it meant that we do *not* see now, nor within the limits of human observation, organisms actually getting

¹⁸ “*Life and Letters of Charles Darwin*,” Ch. XIV. The letter to Lyell is in “*Life and Letters of Thomas Henry Huxley*,” I., 174.

¹⁹ “*Vestiges*,” reprint in “*Morley’s Universal Library*,” 1890, p. 114.

²⁰ “*Darwinism*,” p. 152.

transformed, through the accumulation of variations, into new species differing from their progenitors by the final test of specificity of character. In the 1850's such a radical distinction seemed to hold; even by the sixth edition of the "Origin," dated 1872, Darwin was able to point to only four somewhat debatable instances, in plants, of the infertility of varieties when intercrossed. If this difficulty appeared to Huxley and other zoologists an insuperable objection to evolutionism before 1858, it was not, in Huxley's opinion, removed after that date. Yet he no longer found the difficulty insuperable; it was purely a negative argument, *e silentio*, and he had faith to believe that by further investigation it would be removed. In his Edinburgh lectures of 1862, "he warned his audience of the one missing link in the chain of evidence—the fact that selective breeding has not yet produced species sterile to one another. But it is to be accepted as a working hypothesis, like other scientific generalizations, 'subject to the production of proof that physiological species may be produced by selective breeding.'" In the same year Huxley wrote Darwin:

I have told my students that I entertain no doubt whatever that twenty years' experiments on pigeons, conducted by a skilled physiologist, instead of by a mere breeder, would give us physiological species sterile *inter se* from a common stock, . . . and I have told them that when these experiments have been performed I shall consider your views to have a complete physical basis.*

It is certainly interesting thus to observe that, as Huxley, before his conversion, saw no potency in arguments which afterwards seemed to him conclusive, so also he was able, in his second phase, to pass over by an act of faith one of the most serious of the pre-Darwinian objections to evolutionism. This provisional disregard of the "missing link" in an argument otherwise impressively well concatenated was, under the circumstances, far from unreasonable. But it would have been equally reasonable in 1846 or in 1851.

Leaving these antecedent considerations in favor of evolutionism drawn from the general principles of scientific method, I turn to the more specific facts which—when illumined by those principles—provide the now usual and familiar arguments for the theory. All the more essential of these facts were known before 1844; and attention was duly called to their bearings by the neglected prophets of evolutionism during the fifteen years preceding the publication of the "Origin of Species." In speaking of these "facts," it is well to explain what is meant, in this connection, by the expression. The theory of evolution does not rest immediately upon an induction of individual phenomena; and the evidence for it did not increase by a slow arithmetical progression, through the accumulation of observations of individual phenomena. It is a generalization established inferentially, by

* Huxley's "Life and Letters," I., 193, 195.

virtue of the fact that it unifies and explains a number of lesser generalizations, themselves for the most part established by direct induction, in several special sciences. When, in these separate sciences, the subsidiary generalizations underlying the theory of the transformation of species were well established, and generally accepted by specialists, the evidence for evolution must be said to have been logically complete. This does not mean that more facts were not subsequently added; it does mean that the argument was adequate without them, and that no one who found the original evidence unconvincing had any logical ground for being convinced by any of the considerations adduced in the "Origin of Species" or in Huxley's earlier evolutionary writings.

3. *Argument from the Homologies in Vertebrates.*—This argument was, by 1844, already so old and even hackneyed a one, that it may, in a consideration of the status of the evolutionary argument at that special period, be passed over very briefly. The facts upon which the argument rests had been in the possession of zoologists ever since Buffon and Daubenton had laid the foundations of the science of comparative anatomy (1749). These facts chiefly had, before the end of the eighteenth century, made evolutionists of Diderot,²¹ of Kant, and (but for perfunctory reservations in favor of religious orthodoxy) of Buffon himself. It can, therefore, scarcely be necessary to cite evidence to show that the argument was familiar a quarter of a century after the whole conception of homologous organs had been clearly elaborated by E. Geoffroy St. Hilaire.²² Nor, for the purposes of the present paper, is it necessary to estimate the precise logical weight of this argument when it stands alone. At the time with which this inquiry is concerned, it did not stand alone, but had been complemented by a number of considerations more recently brought to light by scientific discovery.

4. *Argument from the Variability of Existing Species.*—Not less old than the last-mentioned was the argument from the fact that existing—and, especially, domesticated—species have a marked tendency to variation, exhibit an extensive diversity of form, and are capable of transmitting variations to their descendants. It was mainly this group of facts that had caused Maupertuis²³ to embrace the evolutionary hypothesis before 1751. The same argument, with that from the homologies, is set down by Erasmus Darwin in the "Zoonomia," 1794, as among the principal reasons for believing in the transformation of species. We are led to such a belief, wrote the grandfather of the author of the "Origin,"

When we think of the great changes introduced into various animals by artificial or accidental cultivation, as in horses, . . . or in dogs, . . . or in the

²¹ Cf. Lovejoy, "Some Eighteenth Century Evolutionists," THE POPULAR SCIENCE MONTHLY, August, 1904, pp. 323-327.

²² In his "Philosophie Anatomique," 1818.

²³ Cf. Lovejoy in THE POPULAR SCIENCE MONTHLY, July, 1904.

changes of form in cattle. Add to these the differences we daily see produced in smaller animals by our domestication of them, as rabbits or pigeons, or from the differences of climate or even of seasons. . . . Add to these the various changes produced in the forms of mankind by their early modes of exertion, or the diseases occasioned by their habits of life, both of which become hereditary, and that through many generations.²⁴

The argument had often been repeated in the nineteenth century; and in the period under consideration we find Spencer observing that

The supporters of the Development Hypothesis . . . can show that the degrees of difference so produced [through structural changes under altered conditions] are often, as in dogs, greater than those on which distinctions of species are in other cases founded. They can show that it is a matter of dispute whether some of these modified forms *are* varieties or separate species.²⁵

This argument, it is true, if taken by itself, suffered from two serious limitations. One has already been adverted to, in another connection: the absence of evidence that variation can produce varieties sterile *inter se*, as species are sterile. But we have already seen that this difficulty, upon the testimony of Huxley himself, was not removed in 1859. The other limitation of the argument was that, before the promulgation of the hypothesis of natural selection, it was commonly associated with a belief in the inheritance of acquired characters. But this association was not logically necessary; and in any case, the wholesale denial of such inheritance is a doctrine of neo-Darwinism unknown to the pre-Darwinian period and to Darwin himself; and was in that period, therefore, not a ground of difficulty.

In a subsequent instalment of this inquiry it will remain to consider, somewhat more minutely, four more of the principal general arguments for evolutionism, three of these being, in 1844, of a much less venerable age than the two last mentioned.

(To be concluded)

²⁴ "Zoonomia," 1794, pp. 500-501. The elder Darwin, it will be noted, believed in the inheritance of acquired characters; he might be called an eo-Lamarckian.

²⁵ "The Development Hypothesis," 1852.

THE PROGRESS OF SCIENCE

LORD KELVIN

THE two great advances of modern science, perhaps the two most notable human achievements, are the doctrine of organic evolution and the doctrine of the conservation of energy. All the world has this year been celebrating the hundredth anniversary of Darwin's birth. William Thomson, born fifteen years later, occupies in the physical sciences a position almost equal to that of Darwin in the biological sciences. It is a striking fact that Great Britain should have produced these two great men in the same rank with Newton, by whom, and near Darwin, Kelvin nearly two years ago was buried in Westminster Abbey.

Thomson, like Darwin, appears to have been impressed with hereditary genius; his father was professor of mathematics and his brother professor of engineering. Unlike Darwin, typifying a distinction which seems to obtain between the mathematical sciences and the sciences of observation, Thomson was precocious. He matriculated at Glasgow University at the age of ten and attended his father's classes in mathematics. He published a mathematical paper of consequence before going to Cambridge as a student at the age of seventeen, and during his years as an undergraduate at Peterhouse, he published a number of papers on mathematical physics, which fully represented the direction and characteristics of the work which was continued for more than sixty years. He became professor of natural philosophy at the University of Glasgow at the age of twenty-two. At Cambridge Thomson rowed on his college boat and won the Calquhoun sculls, one of the chief athletic competitions of the university. He was one of the founders

of the musical society of the university and played at its concerts.

This vigorous versatility was maintained to the end of his long life. The laying of the Atlantic cable, the fixing of units on which electrical engineering is largely based, the invention of electrical and other instruments, many of which were patented and produced a large fortune, seem almost incompatible with his theoretical work in mathematical physics, though it is true that his mathematical analyses were kept in close touch with actual facts. It seems odd to an American that he should have changed the name that had become familiar and famous, if indeed the peerage itself is worth while when there are no heirs to whom it can be bequeathed. Darwin, to whom no peerage was offered but who bequeathed his name and a large measure of his scientific genius to his sons, seems in this respect to have enjoyed the better fortune. Kelvin visited this country three times and is associated with it both by his work on the Atlantic cable and by the fact that some of his most important theoretical deductions were made known in the form of lectures at the Johns Hopkins University.

An admirable account of Kelvin's scientific work has been contributed to the *Proceedings* of the Royal Society by Sir Joseph Larmor. From this monograph we reproduce three portraits—the two earlier ones on a reduced scale. It would be fortunate if it were possible to reproduce the lucid exposition of the development of Kelvin's contributions to science and their relations to the work of his predecessors and contemporaries.

In 1848 it was possible for Thomson to maintain the view that heat is a substance which may produce energy

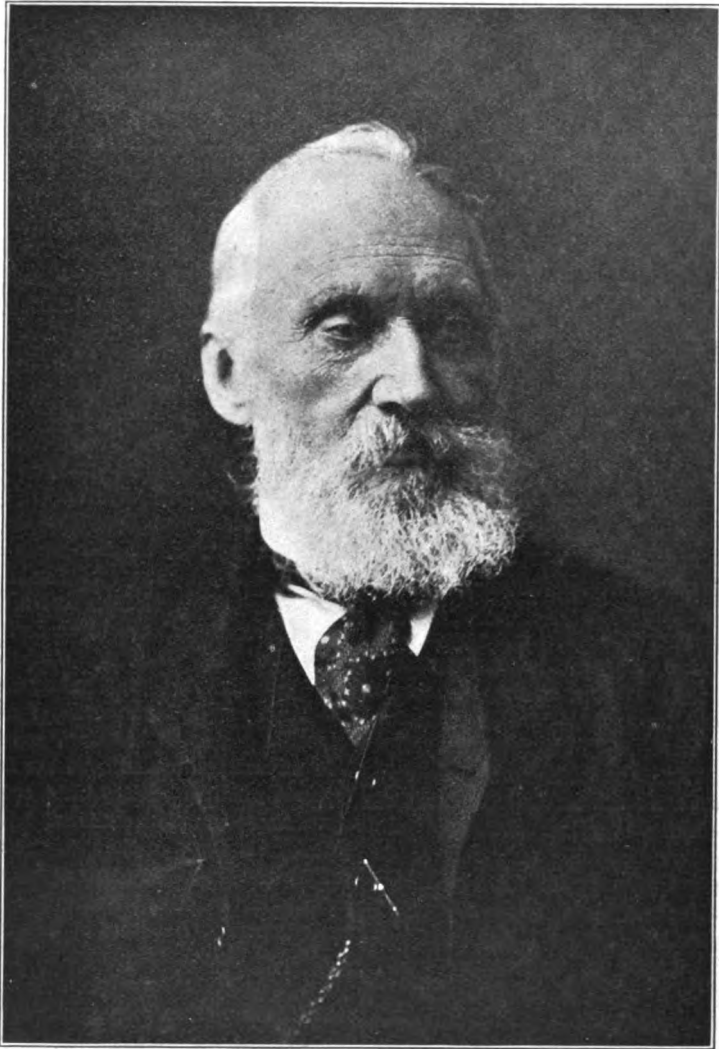

Yours very truly
Kelvin



WILLIAM THOMSON
in 1854.

in falling to a lower temperature or may diffuse passively. But in 1844 Joule had made known his experiments establishing the transformation of heat into work, and in 1847 Helmholtz had published his classical memoir on the conservation of energy. Mayer's earlier paper was first brought to general notice by Joule in 1849. Maxwell published his first paper in 1856, but did not reach the electric theory of light until eight years later. Clausius presented his paper on the motive power of heat to the Berlin Academy in 1850. It was indeed a marvelous period in the history of physics. Among the giants of those days, Thomson stands almost or quite preeminent. His great paper on the dynamical theory of heat was published in 1851, and laid firmly the foundations of the scientific treatment of energy.

In 1849 Thomson published his memoir on the mathematical theory of magnetism, on which subject he had already written four years earlier. This was followed by his remarkable contributions to the theory of electricity and light. In later years his attention was directed to the structure of the ether and of matter. His limitation of the age of the earth gave much concern

to geologists and biologists, which the more recent advances of physics has again relieved, though the episode was probably of advantage to the natural sciences.

Even in the briefest note, reference should be made to Thomson and Tait's "Treatise on Natural Philosophy," an epoch-making text, which Helmholtz translated into German, and to the admirable popular lectures which fill three volumes. The contributions to electrical engineering have already been mentioned. Thomson was the leader in the advances by which steam is being supplanted by electricity.

An adequate appreciation of Kelvin's personality is quoted by Sir Joseph Larmor from the address of Lord Roseberry when installed as Kelvin's successor in the chancellorship of the University of Glasgow: "In my personal intercourse with Lord Kelvin, what struck me was his tenacity, his laboriousness, his indefatigable humility. In him was visible none of the superciliousness or scorn which sometimes embarrass the strongest intellects. Without condescension, he placed himself at once on a level with his

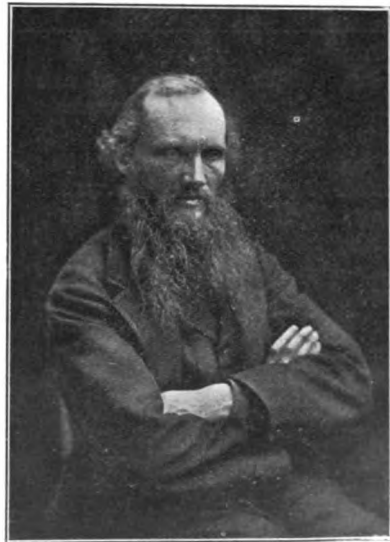

WILLIAM THOMSON
in 1877.

companion. That has seemed to me a characteristic of such great men of science as I have chanced to meet. They are always face to face with the transcendent mysteries of nature. . . . Such labours produce a sublime calm, and it was that which seemed always to pervade Lord Kelvin. Surely in an age fertile in distinction, but not lavish of greatness, he was truly great."

A PHOTOGRAPH OF HALLEY'S COMET

EDMUND HALLEY, born in 1656, Savilian professor of geometry at Oxford and later Flamsteed's successor as astronomer royal, made notable contributions to astronomy and cosmical physics. He was the first to catalogue the stars of the southern sky; he studied the orbits of Jupiter and Saturn; he detected the acceleration of the moon's mean motion; he used the transit of Venus to determine the solar parallax; he discovered the proper motion of the fixed stars; he suggested the magnetic origin of the aurora borealis; he studied terrestrial magnetism and located magnetic poles; he surveyed the tides and coasts of the British Channel; he cooperated with Newton in the publication of the "Principia."

But outside the circle of astronomers, Halley's name is known because it is attached to a comet whose orbit he calculated and whose return he predicted. This was in 1682, when Halley computed its parabolic orbit, and comparing this with the imperfect observations of comets which had appeared in 1456, 1531 and 1607, concluded that each was the same body returning from the outer region of the solar system beyond the furthest known planet. He wrote: "Wherefore, if it should return according to our predictions about the year 1758, impartial posterity will not refuse to acknowledge that this was first discovered by an Englishman."

This was not only a great advance in astronomy and important in its

relation to the theory of gravitation, but was a forward movement in the conception of the orderliness of the universe. Comets had been portents of war, pestilence and famine. It was indeed Halley's comet which appeared in 1066 at the time of the invasion of William the Conqueror and again in 1456 when Constantinople was besieged by the Turks and the crescent-shaped tail was a mighty omen.

Halley's comet duly appeared in 1759, somewhat retarded by the attraction of Jupiter and Saturn, its perturbations having been accurately calculated by the French astronomer, Clairaut. It appeared again in 1835 and is now once more rapidly approaching the earth and the sun, having passed the orbit of Jupiter in April last. It has been observed by Professor Max Wolf, of Heidelberg, and we are able to give here photographs taken by Mr. Oliver J. Lee with a two-foot reflector at the Yerkes Observatory. These are printed by the courtesy of Dr. Edwin B. Frost, director of the observatory and editor of the *Astrophysical Journal*, where they are also printed.

The plate of September 16 was taken with an exposure of 180 minutes, standard central time of mid-exposure being 14^h 45^m (2:45 A.M. Sept. 17). The comet's position, as measured on the plate, was R.A. 6^h 18^m 56^s, Dec. + 17° 9' 23". The plate of September 17 was exposed for 130 minutes, mid-exposure at (central standard time) 14^h 10^m (2:10 A.M. Sept. 18). The right ascension had increased by 4", and the declination had decreased by 23". The arrows indicate the position, and also the components of the direction of the comet's motion.

The original negatives are magnified about ten times, and the scale of the pictures here is about 8".5 to the millimeter, or 3.5 minutes of arc to the inch; in other words, the width of each picture is about one seventh of a degree. The new Lumière "Sigma" plates were used, a fresh and clean

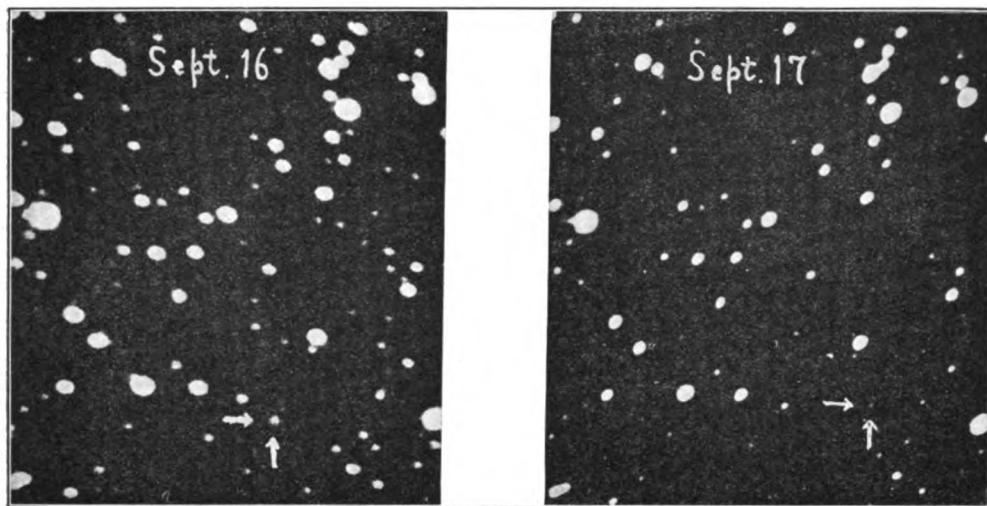

IN THESE PHOTOGRAPHS HALLEY'S COMET IS INDICATED BY THE ARROWS.

emulsion having been provided by the manufacturers. The faintness of the comet on the plate of September 17 was due to the poor sky, and not to any change in the comet's brightness. The brightest star shown in the pictures, near the left-hand edge, slightly above the center, is of magnitude 8.7, or about ten times fainter than the limit of naked-eye visibility. Stars at least as faint as the seventeenth magnitude, or twenty-five thousand times fainter than naked-eye visibility, are shown on the original negatives, and the comet's brightness must have been considerably less than this, more accurate determinations being now in progress at the hands of Mr. Parkhurst.

The comet was first observed visually by Professor Burnham, with the forty-inch telescope, on September 15. It was also observed visually by Professor Barnard on September 17 and several subsequent nights. Professor Barnard's visual estimate of the comet's brightness at his last observation before the moonlight interfered, on the early morning of September 27, was that it was of magnitude 14 or 14.5. His measures indicated a diameter of about 10", but the object was without definite boundary.

The comet will be visible to the naked eye early next year and will attain its greatest brightness in the month of May.

SCIENTIFIC ITEMS

WE record with regret the death of Dr. Washington Irving Stringham, professor of mathematics in the University of California; of Dr. Leonard Pearson, dean of the Veterinary School of the University of Pennsylvania, and of Professor Anton Dohrn, the eminent zoologist, founder and director of the Naples Zoological Station.

DR. A. LAWRENCE LOWELL was installed as president of Harvard University on October 6, and Dr. Ernest Fox Nichols was installed as president of Dartmouth College on October 14. The inaugural addresses, which are devoted to the condition of the American college, are printed in *Science* for October 15.

DR. EDMUND C. SANFORD, A.B. (California, '83), Ph.D. (Johns Hopkins, '88), professor of experimental psychology in Clark University, has been elected president of Clark College to succeed the late Carroll D. Wright.—Dr. J. F. Anderson has been appointed

director of the Hygienic Laboratory, Washington, D. C., to succeed Dr. M. J. Rosenau, who retires from the Public Health Service to accept a professorship of preventive medicine and hygiene at Harvard University.

DR. IRA REMSEN, president of the National Academy of Sciences, has consented, at the request of Dr. H. F. Osborn, president of the American Museum of Natural History, and Mr. Archer Huntington, president of the American Geographical Society, to appoint a scientific commission to examine the records of Lieutenant Peary and Dr. Cook, in case they are ready to present them to such a commission. Lieutenant Peary has accepted the suggestion.

PROFESSOR GEORG LUNGE, the eminent chemist of Zurich, was presented on September 19 with a gold medal bearing his portrait and the sum of 40,000 francs to celebrate his seventieth birthday and the jubilee of his doctorate. Chemists were present from many countries and addresses were delivered by a number of delegates. Professor Lunge in his reply announced his intention of giving the money to the Polytechnic Institute for the aid of students of chemistry.—On the occasion of the recent Leipzig celebration Dr. Wilhelm Wundt, the eminent psy-

chologist, who made the principal address, was given the title of excellency. He was also made an honorary citizen of the city of Leipzig.

At the meeting of the Chemists' Club, New York, held on October 8, it was announced that a Chemists' Building Company had been organized, for the purpose of acquiring a plot of ground and erecting thereon a large scientific building, the lower floors of which are to be rented to the Chemists' Club on a long lease, to contain scientific meeting rooms, a library and a museum, as well as the ordinary facilities required by a social organization, including sleeping apartments for its members. The upper floors of the building are to be leased for scientific offices and laboratories.

YALE UNIVERSITY has received from Mr. William D. Sloane and Mr. Henry T. Sloane the sum of \$475,000 to build, equip and endow a physical laboratory.—The University of Pennsylvania proposes to erect during the coming year a building for its graduate school, costing \$250,000.—The Pratt Institute of Brooklyn has received the sum of \$1,750,000 from Mr. Charles M. Pratt, son of the founder and now its president, and from his five brothers and his sister, Mrs. E. B. Dane.

THE POPULAR SCIENCE MONTHLY

DECEMBER, 1909

THE PLANET VENUS¹

BY DR. PERCIVAL LOWELL

FLAGSTAFF, ARIZ.

THE special object of the observatory which I have the honor to represent is the study of planets of our solar system, beginning with their present state and passing thence to their evolutionary history. So extended to-day is the astronomic field that to do good work one must specialize his endeavor, restricting himself to one particular branch of it and incidentally refraining, we may add, from discussing that of which he has not expert knowledge. Now research on the planets constitutes one such division, making as it were an entity in itself. For diverse as the planets are to-day, they are all the result of one particular evolutionary process and knowledge of each member throws light upon the development, past or present, of the others.

It is popularly imagined that our gaze is concentrated on Mars, to the exclusion of much else, and that we are particularly concerned with its habitability. That this is a popular fallacy I shall show you to-night. For we shall contemplate together another planet in the light that study of the past thirteen years at the Lowell Observatory casts upon it, and we shall see not only that such a study has indicated it not to be habitable, but that the question of habitability has not in the least affected our research. In short, to us habitation by organic life or non-habitation is merely an incident in the study of a planet's history, which we view with as strict scientific impartiality as we do the presence or absence of water-vapor in its air. We are concerned solely with the facts, a romantic enough revelation in themselves.

Venus, I need not remind you, is the planet which stands orbitally next inside the earth in the solar family. To us she is by far the most brilliant star in the firmament, excelling Sirius some sixteenfold and

¹ An evening lecture at the vicennial of Clark University.

paling Jupiter when seen near him by almost the like amount. Her incomparable splendor is partly the result of propinquity; nearness to ourselves and nearness to the sun. Relatively so close is she to both bodies that to show she does not need the abetting background of the night, but without waiting for the sun's withdrawal may nearly always be seen in the daytime in clear air if one knows where in the sky to look. Situate about seven tenths of our own distance from our common giver of light and heat, she gets about double the amount of solar radiation that falls to our lot, so that her surface is proportionately brilliantly illuminated. Being also relatively near us, she displays a correspondingly large disk.

Nevertheless, until recently astronomic inquiry regarding her has proved singularly baffling. The beauty of her face was equaled only by the blankness of her expression. Hers proved one of those countenances that dazzle on a first glance, to tell you nothing on a second. From the time when Galileo first saw her phases, little was learned of her for two centuries and a half, and even the little she seemed to show proved misleading. The few traits thought to be discerned there were so faint and fugitive that, while some observers deemed them substantial, others ascribed them in whole or part to cloud. A cloud-en-shrouded planet Venus in consequence was considered to be; a covering not so much for her own sins of commission as for the sins of omission of observers to see.

It was not until Schiaparelli attacked the subject that any real light was shed on her who reflected so much. Through a new departure, by choosing daylight for his observation time, that most eminent observer first solved one riddle she had read astronomers so long, the length of her day. Hitherto she had been scanned chiefly for a few moments at twilight and the recurrent aspect her disk presented on successive days had been for much in imputing to her a rotation not differing substantially from the earth's in length. Schiaparelli's method allowed of repeated scanning during several hours at a stretch and in this manner he learned that the periodic punctuality of the same features night after night was not because they managed so nearly to keep pace with our own, but because they failed to move at all in the meantime. In other words, her day must be immensely long. He then critically examined the older observations and found that they could all be thus explained. Six years later he repeated his observations and with the like result.

In 1896 the subject was taken up at Flagstaff. Very soon it became evident that markings existed on the disk, most noticeable as fingerlike streaks pointing in from the terminator, faint but unmistakable from the positional identity of their successive presentation. A projection near the south cusp was also clearly discernible, as well as two others, one in mid-terminator, one near the northern cusp. Other dark mark-

ings also came out, developing into a sort of collar round the southern pole. Spots, too, small, not large, stood blotched upon the disk. In this investigation not only was care taken to guard against illusion, but no regard at the time was paid to any previous observations.

The configurations thus disclosed proved permanent in place. By watching them assiduously it was possible to note that no change in position occurred in them upon the face the planet showed, first through an interval of five hours, then through one of days, then of weeks. It thus became evident that they bore always the same relation to the illuminated portion of the disk. This illuminated part, then, never changed. In other words, the planet turned always the same face to the sun. The fact lay beyond a doubt, though of course not beyond a doubter. The fundamental importance of this primary fact upon the world of Venus we shall note as we proceed.

In character these markings were peculiar and distinctive. In addition to some of more ordinary form were a set of spoke-like dark rays which started from the planet's periphery and ran inwards to a point not very distant from the center. The spokes began well-defined and broad at the edge, dwindling and growing fainter as they proceeded, requiring the best of definition for their following to their central hub. They were most noticeable on the edge of the disk which marked the boundary of light and shade, the sunrise line the terminator, as it is called; less so on that which the sky cut off, called the limb.

From so much of the planet as was then presented earthwards, it was possible to make a map giving the chief features of Venus's globe. In addition to demonstrating the durational identity of the axial rotation and the orbital revolution, the markings showed the planet's poles to be practically perpendicular to the orbital plane. Thus the central equatorial longitude lay in perpetuity directly under the sun.

The difficulty in seeing these tell-tale marks lies in their faintness. A very good reason for such astronomic concealment on the part of Venus will appear as we go on. In consequence, the contrast must be intensified as much as possible and to secure it a small aperture and low powers are best. It is only in very good air that these helps to definition can be disregarded.

Corroboration of these markings has been obtained at Flagstaff in the years that have since elapsed. In 1903 a bulletin giving drawings of that year was published, showing confirmation, and in 1907 and 1909 other drawings afforded like witness to their actuality. Markings have been seen by almost every member of the staff and independent observations made on identical dates show remarkable agreement.

But the most telling testimony is the concordance in results between different methods of investigation. The first of these we shall mention is the spectroscope.

The spectroscope is primarily an instrument for analyzing light.

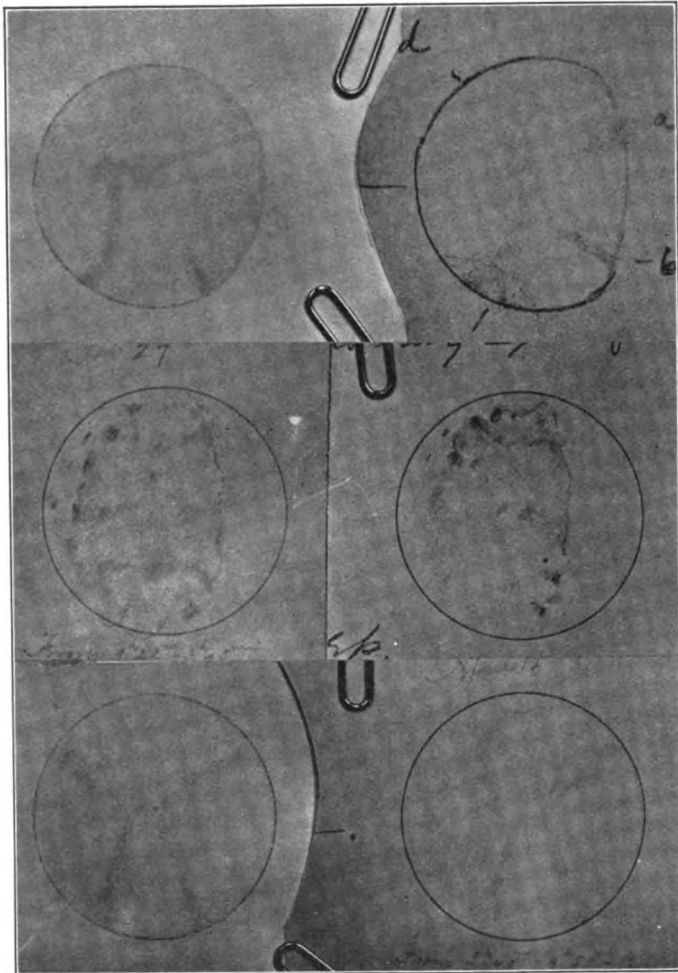

SKETCHES OF THE PLANET VENUS.

The sketches at the top were made on November 1, 1907, by Dr. Lowell (on the left), and on November 2, 1907, by V. M. Slipher (on the right). The sketches in the middle were made by V. M. Slipher and E. C. Slipher, on February 27, 1909. The sketches at the bottom by Dr. Lowell and E. C. Slipher, on April 12, 1909.

Light is due to wave-motion of the ether, and ordinary light consists of a mixture of light of various wave-lengths. By means of a prism or grating these are refracted differently and so sifted into a colored ribbon or band, the longer waves lying at the red end of the spectrum, as the ribbon is called, the shorter at the violet. Now the spectroscope is such a prism or grating placed between the image and the observer, by means of which a series of colored images of the object are produced. In order that these may not overlap and so confuse one another, the light is allowed to enter the prism only through a narrow slit placed across the telescopic image of the object to be examined. Thus suc-

cessive images of what is contained by the slit are presented arranged according to their wave-lengths. In practise the rays of light from the slit enter a small telescope called the collimator, and are there rendered

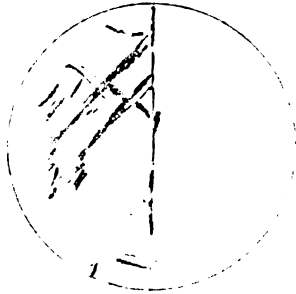

Drawn by Percival Lowell.
 $4^{\circ} 6''$

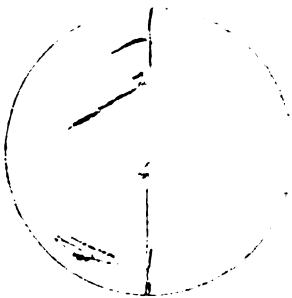

Drawn by A. Anguiano.
 $4^{\circ} 55''$ by $5^{\circ} 5''$



Drawn by F. Valle.
 $5^{\circ} 10''$



Drawn by T. J. J. See.
 $5^{\circ} 15''$

SKETCHES OF THE PLANET VENUS.

Sketches of different observers showing agreement, made at Tacubaya, Mexico, on February 7, 1897.

each according to its kind, into a spectral image band which may then be viewed by the eye or caught upon a photographic plate.

One of the interesting applications of the spectroscope lies in its ability to detect motion in the line of sight, or in just the direction in which the eye can not.

It was reasoned by Doppler in 1842 that if an object be coming toward the observer emitting light as it does so, each wave-length of its spectrum should be shortened in proportion to the relative speed of its approach as compared with the speed of light, because each new wave is given out nearer the observer than would otherwise be the case and its wave-length thus seemingly decreased. Reversely it will be lengthened if the object be receding from the observer or he from it. This would change the color of each wave-length and so of the object, were it not that while each hue moves into the place of the next, like the guests at Alice's tea-party in Wonderland, some red rays pass off the visible spectrum, but new violet rays come up from the infra violet and the spectrum is as complete as before. This unfortunate infecundity of his principle in Doppler's own hands was remedied in 1848 by Fizeau, who pointed out that the dark lines in the spectra can be used as measures of the shift. In all spectra are gaps where individual wave-lengths are absorbed or omitted and these, the lines in the spectrum, tell the tale.

This principle is applicable not only to a body moving as a whole, but to differing motions of its parts if the body be large enough to show a disk. Now, if a body be rotating, one side of it will be approaching the observer, while the opposite side is receding from him, and if the slit be placed perpendicular to the axis about which the spin takes place, each spectral line will appear not straight across the spectrum of the object, but skewed, the approaching side being tilted to the violet end, the receding side to the red.

This principle was put in practise by one of the observatory staff, Dr. Slipher, to determine spectrographically the rotation of Venus. By placing the slit parallel to the ecliptic or, more properly, to the orbit of Venus, which is practically the same thing, it would find itself along what we have reason to suppose the equator of the planet and thus by its tilt give evidence of the rotation period capable of measurement. Even a considerable error in the position of the equator would make little difference in the rotational result. In order that there might be no question of illusion or personal bias, photographs instead of eye observations of the spectrum were made.

Dr. Slipher began by considering the take off before he jumped. His sagacity greatly influenced the result. It might seem as if the best time to examine the planet for rotation were when it is farthest from the sun and is best seen. This indeed was the time selected by Belopolsky, who examined Venus spectrographically between the time

of the inception of the investigation at Flagstaff and its execution and thought he had detected a short rotation for it.

Belopolski made his attempt at elongation in spite of knowing what I shall now explain. For elongation, although the time when the planet is easiest seen, is not that in which it is best examined spectrographically for rotation.

In the case of a body reflecting light, the shift varies from what it is if the body be emitting it, from twice as much in some positions to nothing at all in others. This is because the reflecting surface itself moves to or from the waves. Thus if a planet be on the side of the sun away from the earth, the rim of it which is approaching the earth advances to meet each new wave and so shortens it by just the amount

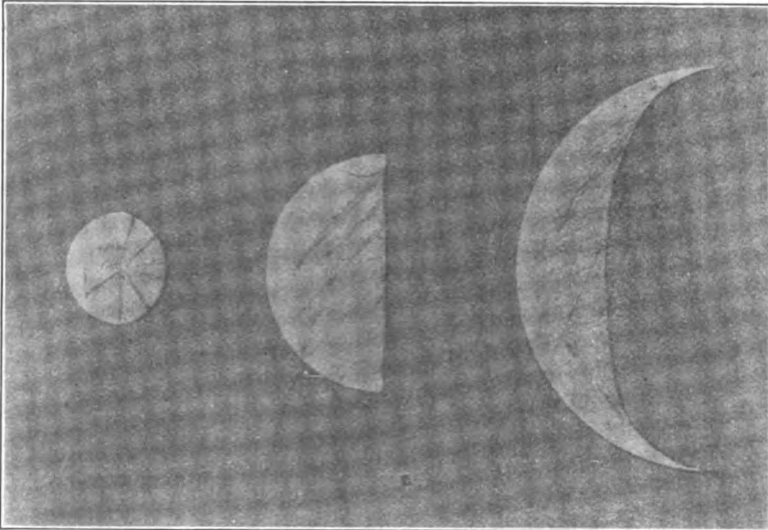

THE PLANET VENUS.

October 15, 1896.

February 12, 1897.

March 26, 1897.

of its own advance, thus doubling the shortage which would result if it emitted the waves itself. The receding side in the same manner doubles the recession. If the planet be at right angles to the sun the waves are affected as if they were emitted and we have a single shortening or lengthening, as the case may be. If the planet be between us and the sun, the rim is running from the sun at just the speed it is approaching us and the total effect is nil.

Thus in the case of Venus, the evidence of tilt obtained depends entirely on where you take her. Superior conjunction or when she lies beyond the sun is the best time spectrographically and it was this that Dr. Slipher chose. He caught the planet just as she was coming out from behind the sun as evening star. In this he was abetted by the clear and steady air of Flagstaff, which enabled him to get her while she was still not far from the sun himself.

Venus

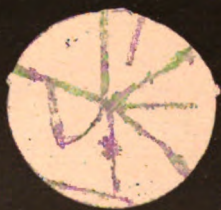

1866 Oct. 9
7^h 15^m

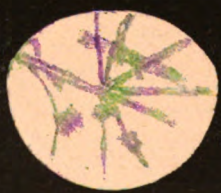

Oct. 29
3^h 10^m

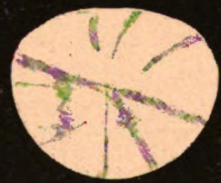

Nov. 7
4^h 45^m



1897 Feb. 19
2^h 30^m



Feb. 22
2^h 40^m



Apr. 2
23^h 55^m

Rotation 225 days

R

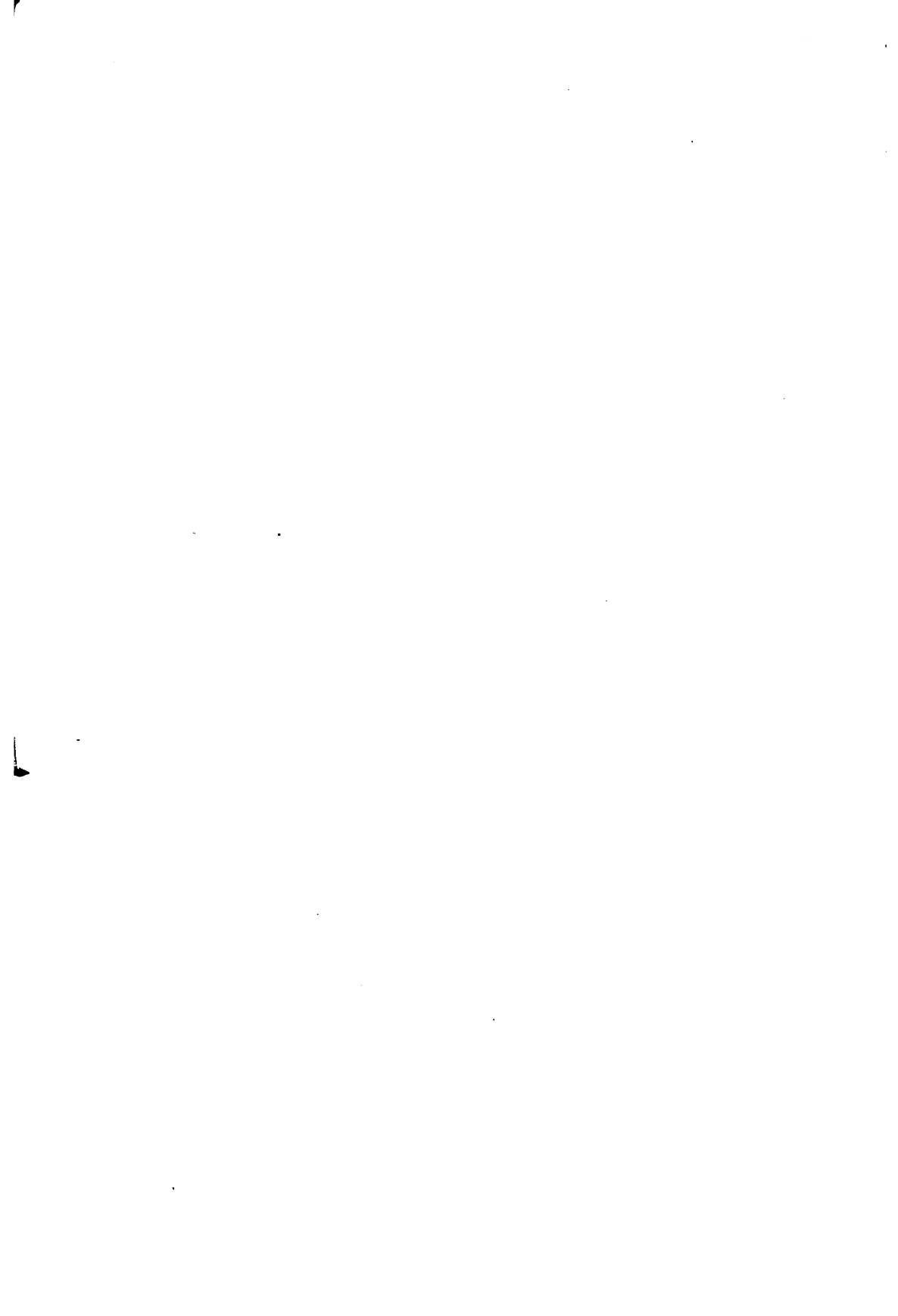

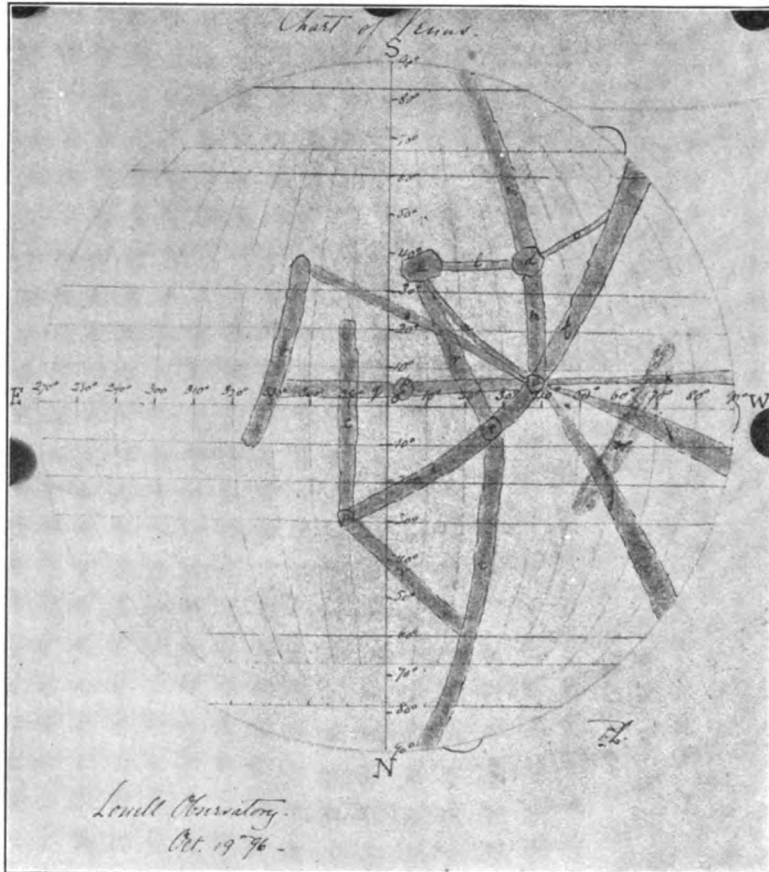
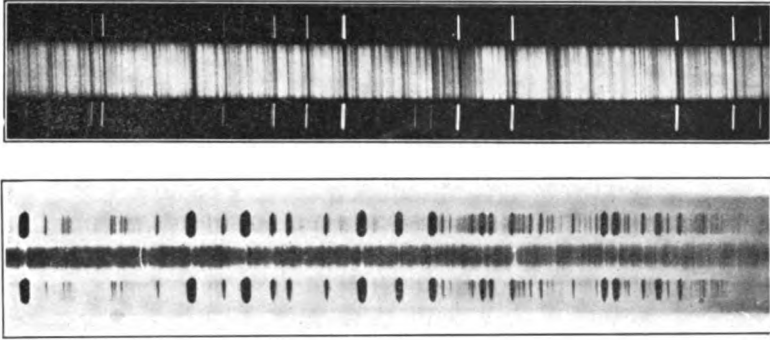

CHART OF THE PLANET VENUS.

plates were made in like manner on that planet. Now Mars is an object which by reason of its smaller size is twice as difficult a test for rotation in twenty-four hours as Venus. The plates too did not happen to be so good. Nevertheless, on measurement they yielded a result within a twenty-fourth part of what we know to be the Mars day. For we know this time to within the hundredth of a second. Now in consequence of the smaller quantity to be measured an error of 55 minutes in the case of Mars corresponds to one of 31 minutes on Venus. To this precision, then, the day of Venus would have been determined had it been of twenty-four hours' duration.

Another test of like character was forthcoming in Dr. Slipher's spectrograms of the rotation time of Jupiter. Inasmuch as Jupiter's day at the equator is 9 hours 50.4 minutes long, while Jupiter's diameter is some twelve times that of Venus, the precision possible is here thirty times as great. Thirty-one minutes' error on Venus would mean about one minute for Jupiter. The spectrograms did even better than this. The known speed of rotation at Jupiter's equator is 12.63 km.; Dr. Slipher's spectrograms gave 12.62 km., or within half a minute of



SPECTROGRAM OF JUPITER ABOVE AND OF VENUS BELOW, SHOWING IRON COMPARISON.

the true rotation period. This means that they would have shown Venus's to within 14 minutes if the conditions were as good. As Jupiter's spectrograms are easier to measure than Venus's, while Mars's are more difficult, we may take 25 minutes for the mean of the two criteria. I need perhaps not tell you that no previous spectrograms of Jupiter for rotation had come up to this precision.

From these two determinations on Jupiter and Mars we may determine the utmost period of rotation for Venus which the spectroscope could disclose. This would be the period for which the probable error was just equal to the quantity to be measured. From Mars we have for a 24-hour period on Venus a probable error of 31 minutes. This is one forty-eighth of the quantity measured on the supposition of a day's period. One of 48 days, therefore, would have its probable error equal to the quantity itself. From Jupiter we get in the same way 96 days. Thus from two to three months would be the limit of leisureliness the spectroscope could be got to note, and it was just this quantity that the investigations on Venus themselves expressed.

The spectroscope, therefore, definitely asserts that the rotation of Venus does not take place in anything approaching twenty-four hours, and by negating any period up to two or three months long corroborates to the limit of its ability that shown by eye observation, one of 225 days.

The care at Flagstaff with which the possibility of error was sought to be excluded in this investigation of the length of Venus's day and the concordant precision in the results are worthy of notice. For it is by thus being particular and systematic that the accuracy of the determinations made there in other lines besides this has been secured.

Now a certain peculiarity of Venus's appearance of a totally different kind from those so far spoken of, here comes in to corroborate both of the previous determinations: the perfect roundness of her figure. For this very rondure has something to disclose. If Venus rotated in anything like twenty-four hours her disk should be perceptibly flattened at the poles, her figure becoming squat in consequence of her spin. For though as rigid as steel to sudden impulses she would be like putty at

the hands of long-continued ones. We can calculate about how much that flattening would be. That of the earth is $\frac{1}{293}$, that of Mars $\frac{1}{190}$, and both planets rotate in approximately twenty-four hours. That of Venus for a like spin would lie between the two figure, because in mass and density she falls between the earth and Mars. Let us say $\frac{1}{275}$ for it, which would be close to the truth.

Now Venus on occasion offers peculiar opportunity to measure any such flattening if it existed. For at times she passes in transit across the sun's face. At that moment she presents an absolute absence of phase and in consequence any correction due to asymmetrical illumination is self-eliminated. Furthermore, she then shows the largest of all planetary disks, one of 60 seconds in diameter. A flattening of $\frac{1}{275}$ would amount therefore in her case to $0''.22$. Such a quantity could not possibly miss of detection. For that of Mars, which is only half as much and is not so well displayed, has nevertheless been measured. Yet no divergence from perfect sphericity has ever been found in the globe of Venus, though diameters at all azimuths have been carefully taken when she is seen silhouetted in transit against the sun.

I may have seemed to dwell at unnecessary length upon the time that Venus takes to turn. But there is cause. The rotation time of Venus, the determination, that is, of the planet's day, is one of the fundamental astronomical acquisitions of recent years. It is not a question of academic accuracy merely, of a little more or a little less in actual duration, but one which carries in its train a completely new outlook on Venus and sheds a valuable sidelight upon the history of our whole planetary system. For upon it turns our whole knowledge of the planet's physical condition. More than this, it adds something which must be reckoned with in the framing of any cosmogony.

To this we shall now proceed and if the deductions and the phenomena which corroborate them appear almost romantically strange it is in the facts themselves that the romance exists.

In the first place such isochronism gives us a glimpse into the planet's past. That the day should coincide with the year means that it has been brought to this condition. For that it can always have been so is mechanically highly improbable. On the other hand, there is a cause continually tending to bring about such a result; tidal friction. Under the immense forces at work the planetary masses behave as if they were plastic. In consequence tides of the whole substance are set up in them if they rotate, and these tides act as a brake upon the rotation until they finally retard it to coincidence with the orbital revolution.

That Venus now turns the same face in perpetuity to the sun, lets us look down a long vista in her career, and gives us a very instant idea of a phase in a planet's history: that long slow change by which a day is lengthened to infinity. That Venus should have suffered such action is in keeping with theory, though it could not have been predicted in the absence of facts. For Venus falls exactly on debatable ground, on

the line as it were. Tidal action depends, for the time necessary to produce a given result, on the square of the radius of the body acted on and as the sixth power of its distance from the exciting cause. In consequence for solar action the nearer planets would show its effect first. Now Mercury already turns the same face always to the sun; the earth, as we know, does not. Venus comes between the two in distance and might therefore *a priori* do either, depending upon how long the action has been going on. That she agrees with Mercury in continuously staring at the sun thus affords valuable evidence on the general evolution of the solar system.

Interesting as this information is, it is second to what we learn in consequence about the body itself. To have the same hemisphere exposed everlastingly to sunlight while the other is in perpetuity turned away, must cause a state of things of which we can form but faint conception from what we know on earth. Baked for æons without let-up and still baking, the sunward face must, if unshielded, be a Tophet surpassing our powers adequately to portray. And unshielded it must be, as we shall presently see. Reversely, the other must be a hyperborean expanse to which our polar regions are temperate abodes. For upon one whole hemisphere of Venus the sun never shines, never so much as peeps above the star-studded horizon. Night eternal reigns over half of her globe! The thought would appall the most intrepid of our arctic explorers, and prevent at least everybody from going to the pole; or rather what here replaces it "through the dark continent."

Deduction from our known premises enables us to go further in sketching the picture of Venus's globe. Venus we know has an atmosphere. The effects of it are patent at the times when she passes between, or nearly between, us and the sun. She is then seen haloed by a rim of light due, as Wilson has shown, to reflection chiefly, not to refraction as was formerly supposed, from an atmosphere about her. Now the intense heating to which the center of her sunward side is exposed must necessarily expand the air there, causing it to rise funnel-wise up in a world-wide western cyclone. To fill the space thus depleted currents must set in toward the center from all points of the compass, continuing out to the lighted rim. Their place in turn would be occupied by surface indraughts from the dark side. Meanwhile the heated air would spread like an umbrella round into the cold hemisphere there to descend and replace the outgoing superficial current back to the sunlit face. A regular aerial round of travel is thus started, which is the same forces that began it must keep up. The course is surface-wise from the dark to the illuminated hemisphere; aloft from the sunlit to the night one.

Now this simple, regular and reliable meteorological service explains a feature of the visual observations which has deterred many timid souls from crediting their reality. One of the most striking features of Venus's disk are the tongues of shading that make in from all parts of

the lighted rim toward the center. They are the beginnings of those spoke-like markings the methodical oddity of which makes their actuality so difficult of belief. They seem a thought too peripherally positioned to be other than optically evolved. Their recurrent showing in the same places marks them as facts, however, and as such we must regard them. Now when we consider them in the light of Venus's meteorology their cause at once suggests itself. And with this index-finger to guide us we perceive that far from being surprising they are just the phenomena we ought to expect. For consider the surface indraught along the bounding rim of constant sun-exposure. With the immense temperature gradient which exists between the day and the night side of Venus, the power of these winds must be enormous. Being essentially surface ones, they must sweep the face of the planet with irresistible force and, what is more, having once found a pathway of preference, must from the general unchangeableness of the conditions continue to follow it perpetually. For the only thing to alter their direction, the libration, is from the circularity of Venus's orbit negligibly small. Sweeping in originally through valleys or mountain passes, the points offering the easiest access, they must eventually have polished the surfaces over which they passed to a differentiation of appearance visible even across millions of miles of intervening space. Essentially surface currents at the rim, they would become less and less so as they neared the center of the lighted side and furthermore would converge as they approached it. They would seem to us to narrow and become at the same time less salient as they advanced. This is just what their spoke-like character shows. Thus the peculiar look of the Venusian markings proves to be in exact keeping with what the conditions demand, and by so doing bears testimony that those conditions actually exist.

Not less strange on its face and equally interesting for its disclosure is another phenomenon connected with the planet which also has been deemed incredible—the exceeding brightness of Venus's disk. Her great luster is, as we saw above, in part attributable to her proximity first to the sun and secondly to us. But this is not the sole cause of it. Though a part of her splendor is due to her position, a part is her own. Her intrinsic brightness, her albedo, as it is called, has been found by Müller, of Potsdam, who has made the last and most authoritative determination of it, to reach the excessive figure of .92 of absolute reflection. This figure has seemed to many impossible, but we shall see from consideration that it simply reflects the conditions.

The rising currents on the sunward side must from their great heat be capable of holding much water-vapor in suspension. This they would take over with them in large part to the night side and becoming chilled there deposit it as snow. Being cold on their return they would reenter the warm side relatively dry and thus be fitted to act again as water-carriers from that side to the other. This process of depletion

on the one and accumulation on the opposite hemisphere must end in taking the whole supply, surface or aerial, from the day side to pile it up in perpetual ice upon the night one. Dry air more or less laden with dust must therefore constitute now the atmospheric covering of the sunward hemisphere. Now this is what gives Venus her excessive luster—an atmosphere devoid of cloud. It is precisely because she is not cloud-covered that her luster is so great. She “clothes herself with light as with a garment” in consequence of a physical fact of some interest. As becomes the Mother of Loves, this drapery is gauze of the most attenuated character, and yet on that very account is a great heightener of effect. For it is a well-known property of matter that a substance when comminuted reflects much more light than when massed as a solid or an opaque cloud. Now an atmosphere is itself such a comminuted affair and especially is made lucent by the dust of one sort and another which it holds in suspension. This would particularly be true of Venus for the reasons we have exposed and thus stands explained her albedo of .92 which were she cloud-covered could not exceed .72, the albedo of cloud. This brightening character of an atmosphere stands corroborated by what we perceive of the other planets. Mercury and the moon, which are airless bodies, have an albedo of only .17; Mars, which has some air but not much, one of .27; while Venus, whose sky is clear, one of .92.

Another phenomenon which has greatly puzzled astronomers stands accounted for by what we have learned latterly of the world of Venus. For years by one observer or another a sort of faint phosphorescent shine has been reported of the unilluminated part of her disk; the ashen light, it has been called. The side of her which should be dark has appeared ghostly lighted up. The phenomenon has seemed the weirder for the difficulty of explaining it. It is like what dimly reveals the old moon in the new moon's arms. With the moon this is earth-shine; the moon-shine the earth herself lends her satellite. But Venus has no neighbor to act as mirror near her, though such be her astronomic symbol. The earth is too far off and the stars inadequate to the occasion. But the state of things we have sketched furnishes an explanation. If the night side of Venus be a vast stretch of polar ice, here is just the surface to reflect the starlight with something approaching a phosphorescent shine. Nor would this necessarily be dimmed by the dust of ages because of a slow process of glacier rejuvenation constantly in progress, due partly to the winds, partly to a slow sinking of the débris to the bottom.

Such are some of the peculiar phenomena presented by the planet. When we thus reason about them—and even in science reasoning is not so much to be despised as some mechanical souls would have us believe—we see that they lose their oddity, becoming the very pattern and prototype of what we should expect.

Logical deductions from well-established fact has led us to explana-

tion of what had seemed inexplicable or untrue. Our several results check one another. For, in conclusion, we may note how full of significance it is that the outcomes of such various investigation should fit into one another to an articulated whole. Their dove-tailing at times is indeed surprising, so diverse the character of the converging lines of research. Thus that the planet's albedo should have anything to say about the length of its day, should actually come forward in corroboration of the markings' own forthright showing, would hardly have been supposed. Or that the ashen light of the dark side should find interpretation in the same axial rotation through a long chain of concatenated circumstance was not to be anticipated. Still less would one have divined that the cycle would stand complete and that the very markings which enable us to determine the duration of the Venusian day should have had their peculiar features determined by it.

The force that such agreement to a common end imparts to the chain of argument needs no comment. It speaks for itself.

The picture of Venus thus presented to our gaze may seem forbidding—one hemisphere a torrid desert, the other deserted ice. Which side strikes us as the worse is matter of personal predilection. But the portrait has its grand features for all that; features which give us a new conception of what exists in the universe and lure our thought afield in space with all the greater insistence for being drawn not from fancy but from fact.

Not less of interest is the way in which our knowledge has been obtained; for it has been acquired by research along very different lines, and then by reasoning upon the results of that research to their necessary conclusions. That these conclusions lead to a consistent conception assures us of their truth. Two things are suggested to us by such procedure: first, the pregnancy of considering a subject from many points of view, and secondly, the importance of reasoning upon facts after they have been acquired.

The fact-gatherer has his uses, but they are not those of the highest class. It is not enough to have a thing on our plates, we must know that we have it there and interrogate it for meaning if we would extract from it the knowledge it is capable of yielding and so most truly add to the advance of our day.

In the case before us the result is of special interest because it exemplifies the eventual effects of a force in astronomical mechanics, the importance of which is only beginning to be appreciated: tidal friction. It has brought Venus as a world to the deathly pass we have contemplated together. Starting merely as a brake upon her rotation, it has ended by destroying all those physical conditions which enable our own world to be what it is. Night and day, summer and winter, heat and cold, are vital vicissitudes unknown now upon our sister orb. There nothing changes while the centuries pass. An eternity of deadly deathlessness is Venus's statuesque lot.

THE ARGUMENT FOR ORGANIC EVOLUTION BEFORE
"THE ORIGIN OF SPECIES"

BY PROFESSOR ARTHUR O. LOVEJOY

THE UNIVERSITY OF MISSOURI

II

IN the former part of this historical inquiry, it was shown that four of the arguments which rapidly made converts to the theory of evolution after 1859 rested upon principles of scientific method and facts of anatomy and physiology which were entirely familiar much more than fifteen years before that date. A similar examination must now be made of four more of the most important "evidences of evolution." Here again it will appear that the facts were known at least as early as 1844, and that their evolutionary implications were pointed out by Robert Chambers, Herbert Spencer or other pre-Darwinian writers. It will also appear that the flaws and gaps in the evidence which could be plausibly exhibited by the opponents of the theory during those fifteen years were, for the most part, not removed by the "Origin of Species," nor for a number of years subsequent to its publication. Substantially, whatever force the arguments for the transformist conception of the origin of the specific characters of organisms had after 1859, they had before; and whatever weaknesses they had before that memorable year, they still had after it. In presenting proof of this I shall, as before, indicate by direct citations the manner in which the arguments were used by the early Darwinians, and then point out the parallel reasonings in the evolutionists of the earlier period.

5. *The Argument from the Sequence of Types in Paleontology.*—The nature of this argument is, of course, too familiar to need exposition. The value which Huxley attached to it in 1863 is shown by a passage in his "Lectures on the Phenomena of Organic Nature":

If you regard the whole series of stratified rocks . . . constituting the only record we have of a most prodigious lapse of time;—if you observe in these successive strata of rocks successive groups of animals arising and dying out, a constant succession giving you the same kind of impression, as you travel from one group of strata to another as you would have in travelling from one country to another; . . . when you look at this wonderful history and ask what it means, it is only a paltering with words if you are offered the reply, "They were so created." But if, on the other hand, you look on all forms of organized beings as the results of the gradual modification of a primitive type, the facts receive a meaning and you see that these older conditions are the necessary predecessors of the present. Viewed in this light the facts of pale-

ontology receive a meaning—upon any other hypothesis I am unable to see, in the slightest degree, what knowledge or signification we are to draw from them. Again, note . . . the singular likeness which obtains between the successive faunæ and floræ, whose remains are preserved in the rocks; you never find any great and enormous difference between them, unless you have reason to believe that there has also been a great lapse of time or a great change of conditions.

Just so did Chambers argue in his "Explanations," 1846:

Fifty years ago science possessed no facts regarding the origin of organic creatures upon earth. . . . Within that time, by researches in the crust of the earth, we have obtained a bold outline of the history of the globe. . . . It is shown on powerful evidence that during this time strata of various thicknesses were deposited in seas; . . . volcanic agency broke up the strata, etc. . . . The remains and traces of plants and animals found in the succession of strata show that while these operations were going on the earth gradually became the theatre of organic being, simple forms appearing first and more complicated afterwards. . . . This is a wonderful revelation to have come upon the men of our time, and one which the philosophers of the age of Newton could never have expected to be vouchsafed. The great fact established by it is that the organic creation, as we now see it, was not placed upon the earth at once:—it observed a progress.* . . . There is also the fact of an ascertained historical progress of plants and animals in the order of their organization. . . . In an arbitrary system we had surely no reason to expect mammals after reptiles; yet in this order they came.†

Thus the *general* fact of the gradual appearance of higher types in the course of geological time, and the existence of a broad parallelism between antiquity of strata and relative simplicity of the contained organic forms, was by this time thoroughly established and universally familiar. True it is, however, that the evidence from paleontology, when more minutely scrutinized, proved to be by no means so favorable to the development hypothesis. This was so far the case that the orthodox geologists were able, with some real plausibility, to turn this weapon against the evolutionists. One of the only two really serious reasons that could be advanced after 1840 for rejecting the hypothesis lay in the observation that the facts of stratigraphic geology, as then known, failed to exhibit, with any consistency, fulness or precision, the sequences that the hypothesis required. The principal fighting, between the time of the "Vestiges" and that of the "Origin," took place around this issue; and the battle-ground was well chosen for the conservatives. For the weakest side of the theory of development then was its paleontological side. But this continued to be its weakest side in the 1860's; and it is a side not wholly without weak points even at the present day, especially when to the theory of development is added the theory of natural selection.

The chief objections raised by the paleontologists were five in number. There was, first, the general difficulty about the "missing links" in the chain of past organisms. Secondly, there was the fact of the

* *Op. cit.*, p. 21.

† *Op. cit.*, p. 106.

apparently sudden appearance of groups of allied, and by no means absolutely primordial, species in the lowest fossiliferous strata then known. Thirdly, there was the sudden disappearance of whole groups of species at the end of certain geological periods, and their sudden replacement in the next period by species different in type from the former, and closely allied to one another. These two points—the second and third—were the especial contribution of the Cuvierian school to the controversy. Out of Cuvier's doctrine of the abrupt extinction of faunas at the successive "revolutions of the globe," his disciples had elaborated the theory of the radical and world-wide discontinuity of the faunas and floras of the successive great periods, and had hence inferred the actual necessity of assuming a definite number of special creations of fresh organic worlds *en bloc*. D'Orbigny knew exactly how many such creations there had been:

The first creation shows itself in the Silurian stage. After its annihilation through some geological cause or other, a second creation took place a considerable time after, in the Devonian stage; and twenty-seven times in succession *distinct creations* have come to repeople the whole earth with its plants and animals, after each of the geological disturbances which destroyed everything in living nature. Such is the fact, certain but incomprehensible, which we confine ourselves to stating, without endeavoring to solve the superhuman mystery which envelops it.²⁸

Fourthly—to continue the enumeration of the paleontological difficulties—it was objected that, especially within the limits of single great geological formations, the arrangement of fossils in the strata did not exhibit the required order of progression from lower to higher types, but sometimes even reversed that order. This was Sedgwick's principal point in his *Edinburgh Review* article, as it was that of Hugh Miller in his "Footprints of the Creator," 1849, the most widely circulated of the replies to the "Vestiges." Miller's argument may be summarized in his own words.²⁹ The latest discoveries in the Silurian and Cambrian series, he declared, do not show the

sort of arrangement demanded by the exigencies of the development hypotheses. A true wood at the base of the old red sandstone, or a true Placoid in the limestones of Bala, very considerably beneath the base of the Lower Silurian system, are untoward misplacements for the purposes of the Lamarckian; and who that has watched the progress of discovery for the last twenty years and seen the place of the earliest ichthyolite transferred from the Carboniferous to the Cambrian system, and that of the earliest exogenous lignite from the Lias to the Lower Devonian, will now venture to say that fossil wood may not yet be detected as low in the scale as any vegetable organism whatever, or fossil fish as low as the remains of any animal? But though the response of the earlier geologic systems be thus unfavorable to the development hypothesis, may not

²⁸ D'Orbigny, "Cours élémentaire de Paléontologie Stratigraphique," 1849, II., 251; cited in Depéret, "The Transformations of the Animal World," 1909, pp. 18-19.

²⁹ Quoted from the American edition, 27th thousand, 1875, pp. 227-8; the edition has a eulogistic preface by Agassiz, 1851.

men such as the author of the "Vestiges" urge that the geologic evidence, taken as a whole, and in its bearing upon groups and periods, establishes the general fact that the lower plants and animals preceded the higher, . . . that the fish preceded the reptile, that the reptile preceded the bird, that the bird preceded the mammiferous quadruped and that the mammiferous quadruped and the quadruped preceded man? Assuredly yes! They may and do urge that geology furnishes evidence of such a succession of existences; and the arrangement seems at once a very wonderful and very beautiful one. Of that great and imposing procession of which this world has been the scene, the programme has been admirably marshalled. But the order of the arrangement by no means justifies the inference based upon it by the Lamarckian.

The reason why, according to Miller, it does not, constitutes the fifth objection urged against evolutionism from the side of paleontology; "superposition," as Miller put it, "does not mean parental relation," any more than the presence of gradually accumulated vegetable and animal refuse in a farmer's ditch means that the creatures whose remains lie at the bottom of the ditch begot those whose remains are found higher up.

The last argument does not call, and never did call, for serious consideration; it is a begging of the precise question at issue, concealed by a specious but lame analogy. The other four arguments depended, with respect to their logical weight, upon the way in which they were applied. If it were assumed that the burden of offering specific proofs rested upon the transformationist, and that the paleontological evidence was put forward by him as a proof, the objections of the orthodox geologists were perfectly sound: the paleontological evidence was not clear nor complete—though it assuredly pointed toward the probability of the hypothesis. If, again, transformism were regarded as an hypothesis which implied the existence of certain geologic facts, then, also, the objections enumerated were pertinent—with one all-important and extremely obvious qualification: the implied facts in stratigraphic geology had *not* been verified—so far as inquiry into a record that will always and necessarily remain fragmentary had then extended. If, lastly, the objections were advanced as a positive disproof of the transformation of species, they were entirely incompetent, by reason of the necessity of adding the qualification last mentioned. The record being notoriously incomplete, it was impossible to infer from mere breaches of continuity, and from an occasional failure in the general parallelism of geological antiquity with simplicity of organic type, that the order of appearance of species had not in fact been progressive, and the result of gradual modification through natural descent. The difficulties raised by the conservative paleontologists logically justified, at the utmost, only a Scotch verdict of "not proven"—so far as this part of the testimony is concerned.

This continued to be the logical situation in 1859 and for a number of years thereafter. Darwin wrote to Quatrefages:

My views spread slowly in England and America; and I am much surprised to find them most commonly accepted by geologists, next by botanists, and least by zoologists; . . . for the arguments from geology have always seemed strongest against me.

That the objection from the general absence of intermediate links between species was a pertinent one he acknowledged with characteristic candor.

Geology assuredly does not reveal any such finely graduated organic chain; and this is perhaps the most obvious and serious objection which can be urged against the theory.

He recognized that, so far as geological knowledge then went, whole groups of species sometimes seemed to make their appearance abruptly; though he argued that the increase of such knowledge had steadily tended to diminish this semblance of abruptness. Wholly eliminated these sharp transitions have never been, to this day; the latest authoritative expositor of the general results of paleontology says of d'Orbigny that, though "his ideas" were "too absolute, his observations remain none the less exact in their broad lines, and the sudden replacing of marine faunas, when passing from one stage to another, or even from zone to zone, must be considered almost a general rule." The same writer,²⁰ who is, of course, a convinced evolutionist, observes:

After all we can not forget that there exists an immense number of creatures without intermediate links, and that the relations of the great divisions of the animal or vegetable kingdom are much less strict than the theory demands. . . . The keenest partisan of the descent theory must admit that the fossil links between the classes and orders of the two kingdoms exist in infinitesimally small numbers.

The second argument of the paleontological opponents of the theory Darwin regarded as still more deserving of serious consideration.

The sudden manner in which several groups of species first appear in our European formations, the almost entire absence, as at present known, of formations rich in fossils beneath the Cambrian strata, are all undoubtedly of the most serious nature. The difficulty of assigning any good reason for the absence of vast piles of strata rich in fossils beneath the Cambrian system is very great. . . . The case at present must remain inexplicable, and may be truly urged as a valid argument against the views here entertained.²¹

To all these objections, as to that drawn from the absence of a uniformly progressive sequence in the superposition of species of certain classes, Darwin opposed a single reply: "the imperfection of the geological record"—an imperfection due not only to the inadequacy of geological exploration but to the inevitable absence of many chapters from the rock-history itself. Paleontology thus offered to neither side materials for a decisive proof of its case. Darwin's ninth chapter pre-

²⁰ Depéret, "The Transformations of the Animal World," 1909, p. 22; the following passage, p. 113.

²¹ Citations are from "Origin of Species," sixth edition, ch. X., *passim*; this was ch. IX. of the first edition.

sented these considerations in a masterly manner. But there was no time in the history of paleontology when they were not extremely obvious and familiar considerations. Chambers, in replying to his critics, had fallen back upon the argument from the inconclusiveness of negative evidence. Even Hugh Miller, without greatly profiting by his own precept, had pointed out "how unsafe it is for the geologist to base positive conclusions on merely negative data."³² And Spencer, in a brilliant article written in 1858,³³ and published in the *Universal Review*³⁴ in July, 1859, had urged that "along with continuity of life on the earth's surface, there not only *may* be, but *must* be, great gaps in the series of fossils;" and that "hence these gaps are no evidence against the doctrine of evolution." He concluded:

It must be admitted that the facts of Palæontology can never suffice either to prove or disprove the Development Hypothesis; but that the most they can do is, to show whether the last few pages of the Earth's biologic history are or are not in harmony with this hypothesis.

In its later development, it is true, paleontology has been able to produce some striking supplementary evidences of evolution. In a limited number of cases, approximately complete and closely graduated series of forms of single orders or families can be exhibited in due stratigraphic superposition. But all the elaborate and impressive "form-series" have been worked out since 1859. Darwin himself made no original discoveries in this field; and as late as the sixth edition of the "Origin" the best evidence of the sort he presented from other writers is, I believe, summed up in these two sentences:

Several cases are on record of the same species presenting varieties in the upper and lower parts of the same formation. Thus Trautschold gives a number of instances with Ammonites, and Hilgendorf has described a most curious case of ten graduated forms of *Planorbis multiformis* in the successive beds of a fresh-water formation in Switzerland.

Of the two instances cited the first is vague—the great studies of Waagen (1869) and of Neumayr (1871–5) in the Ammonites were still to come; and the observations of Hilgendorf seem already, by the time the sixth edition of the "Origin" was prepared for the press, to have been shown to be erroneous.³⁵ The best known example, to English readers, of a form-series is that of the Equidæ. But Rüttimeyer's "Beiträge zur Kenntnis der fossilen Pferde" appeared only in 1863; and Huxley's researches in this field, which were the consequence, not the cause, of his acceptance of the theory of descent, were first presented to the public in his presidential address before the Geological Society in 1870.

6. *The Argument from Persistent Types*.—If good cases of gradu-

³² "Footsteps of the Creator," p. 32.

³³ "Life and Letters of Herbert Spencer," II., 332.

³⁴ Reprinted in "Illustrations of Universal Progress," 1868, pp. 361, 376.

³⁵ Cf. O. Schmidt, "Descent and Darwinism," 1873, English tr., 1896, p. 96.

ated form-series were not available at the time of the "Origin" or before, the evolutionist of the period could still find in paleontology one sort of evidence decidedly unfavorable to the chief hypothesis then opposed to his own—that of extensive "revolutions of the globe," wholesale obliterations of faunas, and thorough-going new creations of the entire organic world. This evidence lay in the persistence of many orders and certain species through more than one geological epoch. The classic of the special creation doctrine was the introduction to the third edition of Cuvier's "*Récherches sur les ossements fossiles*"; and the principal argument of that work was, in the words of one of Cuvier's disciples,³⁶ to the effect that "no fossil species, at least among the two classes of *mammalia* and *reptilia*, has any analogue among living species, or, in other words, that every fossil species is extinct." If this could be shown by positive evidence not to be the case, one of the principal supports of the special creation hypothesis was taken away from it. Huxley made much of this line of attack in a paper of 1859 and in his address before the Geological Society in 1862. He pointed out, for example, that *lingula* and certain *mollusca* "have persisted from the Silurian epoch to the present day, with so little change that competent malacologists are sometimes puzzled to distinguish the ancient from the modern species." He noted that the "group of *crocodilia* was represented at the beginning of the Mesozoic age, if not earlier, by species identical in the character of their organization with those now living"; and that, probably, even certain types of the ancient mammalian fauna, such as that of the *marsupialia*, have persisted with no greater change throughout as vast a lapse of time."

But the argument Huxley here used had not newly become available. Cuvier's generalization had gone far beyond any evidence which he had offered, or which could, in the nature of the case, be offered. The proposition was, indeed, insusceptible of proof, save by a sort of reasoning in a circle. For when the special creationists denied the survival of species from one epoch to another, they were using the word "species" in a sense different from that in which *they*, at least, usually employed it. In their zoology, the final test of specific difference between two forms was the sterility of the hybrid. But extinct forms can not be subjected to this test. In paleontology, therefore, differences of species had to be determined solely on grounds of morphological dissimilarity; while it was, at the same time, recognized that in living animals an immense range of such dissimilarity might be consistent with identity of physiological species. If the pug dog and the greyhound had been extinct, it is at least questionable whether paleontologists would have assigned them to the same species—especially if their remains had been found at different geological horizons. Under such

³⁶ Flourens, "*Analyse raisonnée des travaux de G. Cuvier*," 1841.

circumstances, it was open to the paleontologist to multiply species almost *ad libitum*; if he had adopted a theory which required that no species found in one stratum should be found in another, it was easy to make the most of slight variations of form. Differentiations of species thus made, however, were essentially subjective; all that could conceivably have been proven objectively was that no *form* remained the same through successive geological periods. Yet even of this no proof was forthcoming; the geologic record was not the sort of document that could furnish proof for a universal negative. It furnished, in fact, evidence on the other side. Even Cuvier's eulogist had been obliged (1841) to limit the generalization by adding "at least among mammals and reptiles"—and then to make further exception of two orders of mammals. And Hitchcock in his "The Religion of Geology" (1852), while exaggerating the discontinuity of then known types, could say no more than that, "of the thirty thousand species of animals and plants found in the rocks, *very few* living species can be detected." But a few were as good as a multitude as witnesses to the fact that there had been no such complete, simultaneous extinctions of faunas, and radical alterations of terrestrial conditions, as the Cuvierian theory supposed.⁸⁷ And we find Chambers, in 1844, citing specific examples of persistency, as Huxley was to do fifteen years later.

There is a badger of the Miocene which can not be distinguished from the badger of the present day. Our existing *Meles taxus* is therefore acknowledged by Mr. Owen to be "the oldest known species of mammal on the face of the earth." It is in like manner impossible to discover any difference between the existing wild cat and that which lived in the bone caves with the hyæna, rhinoceros and tiger of the ante-drift era, all of which are said to be extinct species. . . . There is a persistency of certain shells since the beginning of the tertiaries. . . . Several shells of the secondary formation straggling into the tertiaries are not less conclusive, in rigid reasoning, that all the tertiary species were descended from the secondary, though the wide unrepresented interval at that point allowed a greater transition of forms. In short, the whole of the divisions constructed by geologists upon the supposition of extensive introductions of totally new vehicles of life must give way before the application of this rule, and it must be seen that what they call new species are but variations of the old.⁸⁸

7. *The Argument from the Recapitulation Theory.*—In charging Chambers with prematurity in his acceptance of evolutionism, Professor Le Conte urged that "the foundation, the only solid foundation, of a true theory of evolution" is to be had solely in "the method of

⁸⁷ It was, indeed, possible to restate the special creation theory so as to avoid this difficulty; extinctions and fresh productions of species, one at a time, might be supposed to have taken place continuously, without any general or widespread "revolutions of the globe." Such a conception was put forward by Bronn in 1857. But when thus amended the theory was pretty manifestly in a state of hopeless overstrain. It now made miraculous interpositions a matter of, so to say, almost daily occurrence in the geologic history.

⁸⁸ "Explanations," 1846, p. 108 f.

comparison of the phylogenic and the embryonic succession," and in the resultant principle that "the laws of embryonic development (ontogeny) are also the laws of geologic succession." This method and this principle Le Conte represented as "added" to biology by Agassiz. Holding such views of the importance and the date of origin of the recapitulation theory, Le Conte concluded that no one was reasonably entitled to believe in the transformation of species prior to the publication of the work of Agassiz; and hence that Chambers's evolutionism was a "baseless speculation."³⁹ Le Conte's popular book has done much to form current ideas on this subject. But its author was misled by piety towards the memory of his greatest teacher into a serious neglect of chronology, in a matter where chronology is of the essence of the question at issue. Even if Agassiz be regarded as the originator of the doctrine of recapitulation, it must be remembered that he announced his evidences for that doctrine in his "Poissons du vieux grès rouge," 1842-44, and repeated them in popular form in his Lowell Lectures of 1848.⁴⁰ And in point of fact, the doctrine and an important mass of evidence for it had then long been familiar; so that one finds Lyell, before 1835, arguing against the use of it as a proof of evolution. In the "Principles of Geology,"⁴¹ he wrote:

There is yet another department of anatomical discovery to which I must allude, because it has appeared to some persons to afford a distant analogy, at least, to that progressive development by which some of the inferior animals may have gradually been perfected into those of more complex organization. Tiedemann found, and his discoveries have been most fully confirmed and elucidated by M. Serres, that the brain of the fœtus assumes, in succession, forms analogous to those which belong to fishes, birds and reptiles before it acquires the additions and modifications peculiar to the mammiferous tribe. So that in the passage from the embryo to the perfect mammifer, there is a typical representation, as it were, of all those transformations which the primitive species are supposed to have undergone, during a long series of generations, between the present period and the remotest geological era.

Lyell's reply to this argument was brief and dogmatic: he fully admitted the facts, but denied the inference.

It will be observed that these curious phenomena disclose, in a highly interesting manner, the unity of plan that runs through the organization of the whole series of vertebrated animals; but they lend no support whatever to the notion of a gradual transmutation of one species into another; least of all, of the passage, in the course of many generations, from an animal of a more simple to one of a more complex structure.

To the mind of Darwin the same sort of data presented a very different import.

³⁹ Le Conte, "Evolution in its Relation to Religious Thought," 2d ed., 1905, ch. II.: The Relation of Louis Agassiz to the Theory of Evolution.

⁴⁰ Cf. Agassiz's own words, cited in Marcou, "Louis Agassiz," I., 230; and Morgan, "Evolution and Adaptation," p. 61.

⁴¹ First American edition, 1837, I., 526.

As it seems to me, the leading facts in embryology, which are second to none in importance, are explained on the principle of variations in the many descendants from some one ancient progenitor, having appeared at a not very early period in life, and having been inherited at a corresponding period. Embryology rises greatly in interest, when we look at the embryo as a picture, more or less obscured, of the progenitor, either in its adult or larval state, of all the members of the same great class.⁴²

Yet poor Chambers is reproached for "baseless speculation" because, looking upon facts accepted by all the competent embryologists of his time, he saw in them the meaning that Darwin afterwards saw, and that so great a mind as Lyell's had been unable to see. In the third edition of the "Vestiges," 1845, he wrote:

First surmised by the illustrious Harvey, afterwards illustrated by Hunter in his wondrous collection at the Royal College of Surgeons, finally advanced to mature conclusions by Tiedemann, St. Hilaire and Serres, embryotic development is now a science. Its primary positions are . . . (2) that the embryos of all animals pass through a series of phases of development, each of which is the type or analogue of the permanent configuration of tribes inferior to it in the scale.

And in this Chambers found one of his chief evidences of transformation of species. Elsewhere in this edition he devotes several pages to the elaboration of the argument from recapitulation in the case of the brain. "Taking as a basis the scale of animated nature as presented in Dr. Fletcher's 'Rudiments of Physiology,'" he points out "the wonderful parity observed in the progress of creation, as presented to our observation in the succession of fossils, and also in the foetal progress of one of the principal human organs."⁴³

8. *The Argument from Rudimentary Organs.*—In his "Lectures on the Phenomena of Organic Nature," 1863, Huxley mentions as illustrations of this type of evidence the foetal teeth of the whalebone whale, the rudimentary toes in the horse's leg, the rudimentary teeth in the upper jaw of the calf. He concludes:

Upon any hypothesis of special creation, facts of this kind appear to me entirely unaccountable and inexplicable; but they cease to be so if you accept Mr. Darwin's hypothesis, and see reason for believing that the whalebone whale and the whale with teeth in its mouth, both sprang from a whale that had teeth, and that the teeth of the foetal whale are merely remnants—recollections if we may so say—of the extinct whale. . . . The existence of identical structural roots, if I may so term them, entering into the composition of widely different animals, is striking evidence in favor of the descent of those animals from a common original.

But from the same facts Chambers had argued to the same conclusion nearly a score of years earlier.

The baleen of the whale and the teeth of the land mammals are different organs. The whale in embryo shows the rudiments of teeth; but these not being wanted, are not developed, and the baleen is brought forward instead.

⁴² "Origin of Species," sixth edition, ch. XIV.

⁴³ "Vestiges," third edition, 1845.

He mentions also the existence of rudimentary toes in the horse, the rudimentary feet of serpents, the undeveloped wings of the ostrich, the teats of male mammals, the *os coccygis* in man. "The single fact of the existence of abortive or rudimentary organs condemns" the "idea of a separate creation for each organic form; . . . for these, on such a supposition could be regarded in no other light than as blemishes or blunders." Such a thing was "most irreconcilable with that idea of Almighty Perfection" which the special creationists were at least as anxious as the author of the "Vestiges" to maintain. Chambers gave the argument, here, a pious turn which did not increase its logical force. But he made the main point plain enough. The special creation theory could make nothing of rudimentary organs; viewed in the light of the theory of development, as incidental to natural descent with gradual modification, they appeared normal, intelligible and instructive.

It is worth while, perhaps, before concluding, to bring the last six arguments together, in a single general view of their logical bearings. No one of them, nor all of them collectively, ever amounted to more than "circumstantial evidence" of the transformation of species; none of them actually exhibits any species *in flagrante delicto* of transmutation. These arguments got their force from the fact that, when taken together, they fitted with striking nicety into the requirements of one of the two possible hypotheses about the origin of species—a hypothesis already recommended on general grounds of scientific method; while they reduced the rival hypothesis to a grotesque absurdity. "Conceivable" that other hypothesis still remained, as Huxley contended. It was, and is, possible, by making a sufficient number of supplementary suppositions, to give to the special creation doctrine a form in which it is neither explicitly self-contradictory nor explicitly in conflict with any fact established by pure induction. But when thus fitted out with the epicycles required by the facts already known to the science of 1840, the doctrine certainly presented a singularly odd and whimsical appearance. It implied that the Creator had produced the different types of organisms by fits and starts, strewing them at irregular intervals along the vast reaches of geologic time. Precisely what happened on one of these interesting occasions, the hypothesis left in a baffling obscurity; after a somewhat extensive reading in the literature of the period, I can not recall that any special creationist replied to Spencer's request for particulars on this point. Spencer wrote in 1852:

Let them tell us how a new species is constructed and how it makes its appearance. Is it thrown down from the clouds? or must we hold to the notion that it struggles up out of the ground? Do its limbs and viscera rush together

"Vestiges," American (=third) edition, 1845, pp. 145-149. Chambers unluckily adds: "The land animals, we may be sure, have the rudiments of baleen in their organization."

from all points of the compass? Or must we receive the old Hebrew idea that God takes clay and molds a new creature?

On these matters the theory remained judiciously non-committal. But it maintained, at all events, that the vast majority of species, however created, were destined to be in turn destroyed—and destroyed by the operation of natural forces. The Great Artificer could fashion, but he was either unable or unwilling to protect, the creatures his imagination had devised. When ordinary physical processes were too much for them, sweeping them off by groups, or even, according to the favorite variant of the theory, obliterating them altogether, he was obliged to start afresh; whether this happened four or twelve or twenty-seven or thirty thousand times was a detail about which the partisans of the doctrine could not agree. The forms thus later produced did not always differ markedly for the better from their unfortunate precursors; many primitive and rather unsuccessful models continued to be repeated. But in general, as time went on, the Creator brought both more diverse and more complicated beings into existence. In doing so, he behaved after the manner of a lazy and incompetent architect, who, instead of “studying” each problem afresh, with reference to the special uses and situation of the edifice to be erected, is content to make a few minor alterations in a single conventionalized plan. The “unity of type” of organisms destined to the most dissimilar modes of existence was generally dilated upon with devout enthusiasm by the special creationists. They seem to have regarded it as an agreeable mannerism of the Creator’s personal style. But it is the kind of mannerism which, in a human designer, is commonly ascribed to indolence or limited intelligence. Indeed, the parallel of the lazy architect was inadequate to represent the whole singularity of the Creator’s mode of construction. He not only used as few general models as possible, but he also—when, with a cleared field, he created a fresh group of organisms—reproduced in them organs and members which had been functional and useful in their predecessors, but were with the new species useless, meaningless, and even disadvantageous—like the proverbial Chinese tailor, who laboriously imitates all the rents and stains in the discarded European garment given him as a model. Finally, the Creator was supposed to have implanted in all organisms the senseless habit of mimicking, in the embryonic stages of the individual’s development, the forms of other and extinct organisms to which that individual bore no relation of kinship.

Such—with the details absolutely required by the accepted scientific knowledge of the time—was the hypothesis tenaciously held by most men of science for at least twenty years before 1859. With the greater number of them the motives for holding it were primarily theological; yet the thing that now impresses us in the theory is its extraordinarily irreligious, not to say blasphemous, character. Science

might conceivably, after some fashion, have made shift with a hypothesis of this kind; but it is hard to see how any one could suppose it in any degree advantageous to religion. It had not even the poor merit of being anthropomorphic. For no man out of a madhouse ever behaved in such a manner as that in which, by this hypothesis, the Creator of the universe was supposed to have behaved. Ascribing to him both the ability and the disposition to intervene with absolute freedom in natural—or, at least, in organic—phenomena, the theory also represented him as incapable of intervening intelligently or effectually.

That men of great abilities were unable to see the true character of the hypothesis which great numbers of them so long embraced, is certainly an interesting, if not an encouraging, fact in the history of the human intellect. But the capacity of theological prepossessions and religious feeling to retard and confuse intellectual processes is an old story. More remarkable, perhaps, is the failure, for an equally long period, of a number of men *not* impeded by theological prepossessions—men who were capable of seeing the absurdities of the special creation hypothesis—to recognize the methodological superiority and the promise of scientific fruitfulness inhering in the other hypothesis, or even to recognize the logical obligation to choose between the only two hypotheses available. Men of science of the present generation have perhaps little to learn from a consideration of the reasons which prevented a Cuvier, a Miller, a Sedgwick or an Agassiz from accepting the theory of evolution. But there may still be for us profitable matter for reflection in a consideration of the reasons which prevented a Huxley from finding, in 1846, anything of value in facts and reasonings which thirteen years later he was, with unequalled vigor and skill, proclaiming from the housetops.

The only historian of English thought known to me who has quite truly stated what I believe to be the fact about this episode in the history of scientific opinion, is Mr. A. W. Benn. In his "Modern England"⁴⁵ he observes concerning the "Vestiges":

Hardly any advance has since been made on Chambers' general arguments, which at the time they appeared would have been accepted as convincing, but for theological truculence and scientific timidity. And Chambers himself only gave unity to thoughts already in wide circulation. . . . Chambers was not a scientific expert, nor altogether an original thinker, but he had studied scientific literature to better purpose than any professor. . . . The considerations that now recommend evolution to popular audiences are no other than those urged in the "Vestiges."

The truth of this is, I think, by no means sufficiently recognized by biologists or by historians of science. I hope that the present study may somewhat contribute to the more general acknowledgment of the correctness of Mr. Benn's statement.

⁴⁵ 1908, II., 307, I., 238.

AN ARRAIGNMENT OF THE THEORIES OF MIMICRY
AND WARNING COLORS

BY ABBOTT H. THAYER

There is every reason to believe that all animals' eyes see upon one principle, an eye being a machine for receiving what we call light vibrations, so that to receive from any object *more* of these vibrations is to have it look lighter, and to receive from it *less* of them is to have it look *darker*.

IN the last few years, naturalists have received from outside their ranks, the first scientific analysis of the use of animal's colors that has ever been made.

They have been shown the effacing power of the universal counter-shading in animals' costumes, and later, they have seen with their own eyes the equally perfect effacing power of the patterns which up to that moment they had believed to be factors of conspicuousness.¹ They have thus been forced to perceive that all their own theories prove to have been built in ignorance. These were made before the world had perceived the universal importance of employing specialists, and even Darwin and Wallace failed to realize that in view of nature's infinity, one study like their own was all that they could hope to be faithful to. The laws of *visibility* reach, like all others, into infinity, and could not constitute part of the zoologist's field, while in the science of the painter, these laws are the very pith of his study.

The following demonstration of the fallacy of the badge and warning-color theories is not, in the same sense, an attack upon mimicry, although it inevitably calls attention to the fact that the latter can not survive the demise of these other theories. It does not imply that there is no case possible of protective resemblance of one animal by another, but contents itself with bringing forward conclusive evidence that the great mass of what is now called mimicry is nothing of the kind, but is, in every respect, the same common concealing coloration everywhere to be found where there are common habits and environment. This fact escaped naturalists, simply because it lay out of their special field, *i. e.*, in optics rather than in zoology, and once off the track, they have been driven step by step into the erection of a wholly fictitious fabric, where no fabric at all was required.

¹ I have shown, both to the naturalists at Woods Hole, Mass., and in London, the wonderful concealing power of various representative "conspicuous" costumes, from white patterned birds seen against the sky, to the bright red-black-and-yellow coral snake, supposed to be one of the most conspicuous animals in nature.

The universal tendency of common habits and environment to be accompanied by common form and appearance has long been a familiar fact, and no one would have conceived of a vast gap in this tendency but that naturalists thought themselves forced to accept the evidence that such a gap existed, and set themselves to work to fill it as best they could. Now, however, the obstacle to their discovering the wholly concealing character of the whole array of costumes that had puzzled them vanishes, and no power can withhold this array from taking its place in the ranks of universal procrystic coloration.

The following pages demonstrate that all diversification of the colors of animals' costumes tends wholly and unmixedly to conceal them. This should set the believers in conspicuous species reflecting that while they are making their records of cases of momentary conspicuousness of individuals of one species or another, they are making no investigation whatever of the possibility that all the while a large number of individuals of this same species are, through some magic of their costume, escaping their sight and making no impression on their minds. It is precisely to such an investigation as this that I here invite the reader.

Any out-of-door naturalist knows that if he walk through a sunny field of fairly profuse vegetation, after first studying it, say, from an upper window, he will flush an immensely greater amount of so-called conspicuous aerial life than he had detected from the window, and he will believe that much of this life was all the time within the field of his vision.

These plates have been prepared with the especial purpose of exposing the weakness of the optical hypotheses upon which the theories of "warning-colors," "recognition," "mimicry," etc., so largely rest. They show that these hypotheses would never have lived a day had their originators begun by testing them. Darwin's erroneous supposition that a conspicuous mark on an object makes the object itself conspicuous has been built on and rebuilt on by the leaders of zoological research, even down to the present day. Entomologists, especially, make much of the supposed power of sharp and strong patterns to render conspicuous that particular part of the insect which they occupy. We now discover that the effect of these patterns is the very opposite. In the illustrations of this article we see the actual effect of such marks in several typical situations. Fig. 1 shows two butterflies and several letters, all of one color, and against one background. On each butterfly and on several of the letters bright spots or patterns have been painted. As the spectator recedes, those parts of the butterflies nearest the bright patterns fade, until, at a short distance, they are invisible, while the rest of the insect is clearly distinguishable up to a much greater dis-

tance.² The same thing is true of the letters, the unmarked ones being legible much farther than the others. Fig. 2 shows exactly the same effect with reversed colors. That part of the gray butterfly next the black ocellus fades, as one recedes, until it becomes pure white like the background, leaving the rest of the butterfly to continue visible at a much greater distance. In both these cases the effect of conspicuous pattern proves to be the exact reverse of the old hypothesis on which the Bates and Wallace theories so largely rest. Figs. 3 and 4 will, I think, still more surprise the many writers who, from Darwin and Wallace down to the present time, are accustomed to say of one or another brilliantly pied species, that its patterns are so conspicuous that one can see it a hundred yards off. It is here shown that it can not be the brilliancy or conspicuousness of the animal's patterns that enables them thus to see him from afar, since these very characters here produce the opposite effect. The reader will discover, in looking from a greater and greater distance, that it is the normally colored, strongly pied butterfly and skunk, respectively, that *fade first*, and that all of the remaining six figures can be seen further. (These can be tested not only by distance, but by decreased illumination, and, especially for the latter means, a still more satisfactory test of the skunk can be made by using life-size figures and turning down the lights in a hall, or studying them out of doors as night comes on.) He will discover that the supposed white blazon actually serves to efface the black animal on a nearer view (especially if seen through the leaves). He can not fail, either, to perceive that an all-white skunk, being exempt from the risk of giving an impression of *two different things*, a black one, and a white one, would in the long run, be, also, the more *recognizable* when seen against any ground, except snow.^{2a} It is not yet generally perceived that in the scenery about us every spot means to a casual observer *one thing*, and it follows that two different color-patches, as of the skunk, amidst the million color-patches in sight, tend, especially when more or less eclipsed by vegetation, to mean, not one pied *animal*, but *two different elements of the scene*. It must be remembered that the skunk's scene is a night scene, commonly abounding, in wild places, in black shadow masses relieved here and there by light spots made by bleached twigs, fragments of fallen birches, shining wet spots, etc., and, what is by far the most essential fact, with all visibility whatsoever at the minimum. In fact the whole "warning-color" theory in the case of these nocturnal species smacks of the laboratory. For instance, although skunks abound all

² In most butterflies, the body itself is wonderfully effaced by having its color blent off into the wing; yet it profits greatly by the effacing-power of the strong pattern to right and left.

^{2a} To learn the superiority of monochrome for identification, paint a uniform tone over a chiselled inscription that has become hard to read because of weather-stains, and instantly it is as legible as when it was first cut.



FIG. 1

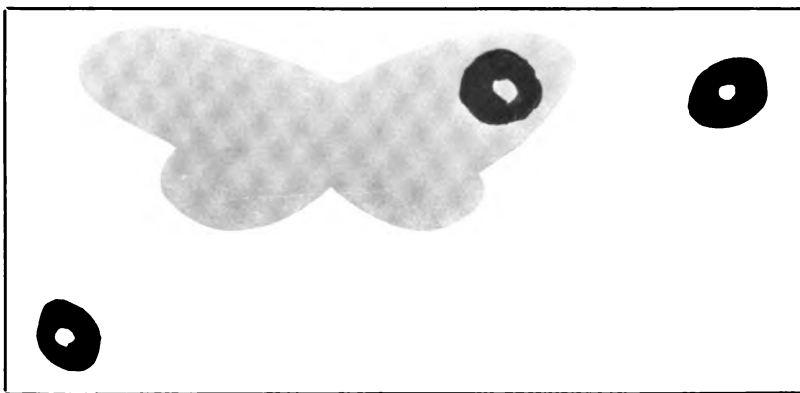

FIG. 2

FIGS. 1 and 2 show that bright sharp pattern obliterates, instead of rendering conspicuous, the form on which it is painted; and that its details are left to seem to be part of the similar details of the background. Test these facts by receding from the picture.

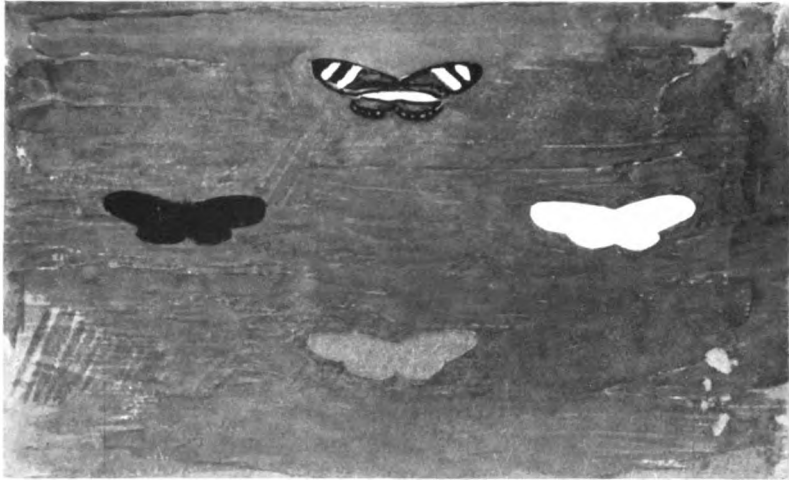

FIG. 3

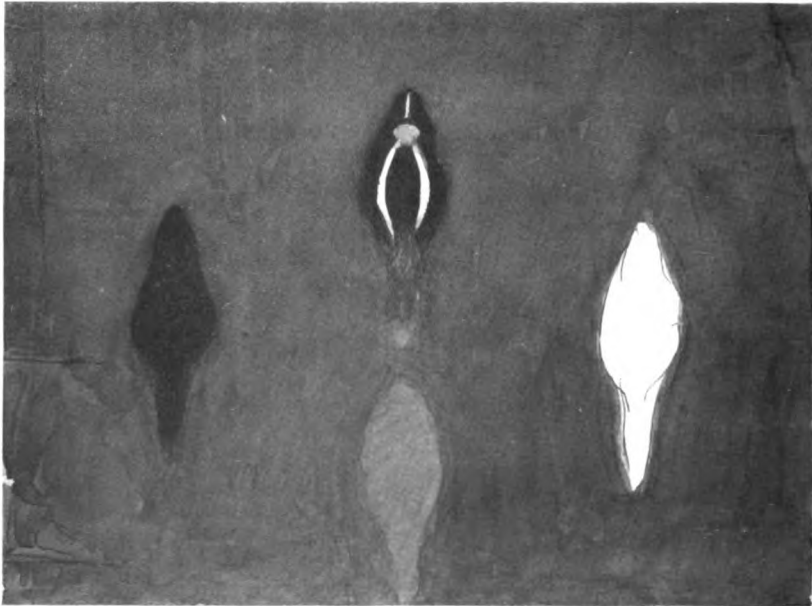

FIG. 4

FIGS. 3 AND 4. Here the spectator will find, as he recedes or turns down the light, that all the monochrome figures, even the dimmest, can be seen further, or in a less illumination, than the two normally and brightly patterned ones. These latter fade first. They show how contrasted juxtaposed color-notes destroy each other, so that, contrary to the current theories, monochrome is far better both for revealing the wearer, and also for proclaiming his identity amidst the innumerable details of wild places.

over the premises of American country folk, it is very rare to see one of them, except by encountering him in the hen-house. This is the more significant in view of their well-known temerity and disinclination to get out of one's way. Their white pattern, if seen at all, and even when observed to move, is easily mistaken for some inanimate detail of the scene, some shifting shine on a wet leaf, or other of the above-mentioned light-colored details of the place. There seldom pass many minutes without some breeze to set in motion the many more or less white details of the shrubbery, so that the disembodied light patch of this little hunter's coat may move, even within the short visibility-range that we have discovered it to possess, yet by no means commonly attract our attention. It is certainly the universal experience of American country dwellers that although in their domestic duties they must frequently pass within a few feet of skunks, yet the whole family together scarcely see one a year. Under shrubbery, moonlight, which might be expected to reveal these animals, adds, on the contrary, to the scene hundreds of white patterns, and these often all in motion, so that what was before a comparatively negative form of concealment becomes a most brilliant and positive illusion. The skunk's pattern so absolutely reproduces the hundred surrounding ones, often all shifting in a thousand directions, that even when the animal is near enough to be seen, he is almost sure to escape detection. Dr. Merriam first called my attention to this, and also to a very clear statement of it by Verrill. Merriam says that spilogales amidst cactus shadows in moonlight are practically impossible to follow with the eye. It is easy to see that this must apply to the appearance of all the other top-patterned species under similar circumstances. This is one more instance of increased illumination producing increased procrryptic effect, such as we also see in the operation of counter-shading.

These simple diagrams, then, prove that it is not the diversification into brilliantly contrasted pattern that makes its wearer conspicuous, or that is the most efficacious way to make him *recognizable*. It is the very juxtaposition of the skunk's black that makes his white fade out of sight at a short distance, and in a nearer view, amidst the many light spots likely to be in sight, one more has often no significance to a spectator; but if this light color took the full shape of a *skunk*, then, of course, it would make him recognizable. In the next plates we shall see what is the main cause of the frequent conspicuousness, during motion, of all aerial species, or of any that by virtue of being taller than others, are, to these lower-level observers, practically the same as aerial, because of looming against their sky.

But let us turn aside to notice the circumstances of the species already recognized by naturalists as procrryptically colored. These are merely such species as live, or *rest by day*, in actual contact with their

background, and, as now proves to be the case with practically the whole animal kingdom, *wear its colors* (or some of them).

Bark moths, terrestrial animals in general, terrestrial habited birds, etc., all such species, when thus in actual contact with their backgrounds, share its varying illumination from minute to minute. The patch of sunlight that falls on the squatting woodcock illumines also



FIG. 5 shows the revealing-effect of being seen against a contrasting background, and illustrates the fact that no aerial creature can go about at all without constantly passing across both revealing and concealing backgrounds.

the surrounding ground, so that the bird continues to seem a part of it; and the same is of course true of the rest of this great class of animal. But a very different fate attends the life of aerial species destined constantly to appear against more or less distant backgrounds which do not share their particular momentary illumination, and which constantly show, now light, when the flying bird or butterfly is dark, and the next instant dark when he is light. This fate causes all aerial species, in a very vital sense, to be conspicuous. Fig. 5 illustrates this. On the white of the sky a white butterfly has been pasted, which, of course, does not show. In the same way, a black one has been placed upon the darkest part of the tree's shadow, and a ground-colored one on the ground. Both of these, like the white one, are, of course, practically invisible, and, could they be always seen against these same backgrounds, they might be classed as cryptic. But their habits preclude the possibility of this, their own changes of position, not to speak of those of the spectator, bringing them, as they fly about, across, often in a single second, the whole gamut of backgrounds, from brightest sky to deepest tree-shadow, and back. And against every one, except the single one which they match, they are clearly visible. The black one shows against the sky, the ground, etc., the white one against the various

darks, and so forth. Nor is it only their varying background that dooms them to visibility. Their flight carries them with equal speed through a series of metamorphoses of their own aspect. Now, for an instant of their passage, they are themselves practically black, because of being in deep shadow, and are perhaps seen against a bright sky-space. The next has brought them out into full sunlight, and they blaze bright against a new background of perhaps inky darkness. The principle of the inevitable visibility produced by this swift succession of *visible moments*, though alternating with *repeated vanishings*, is well illustrated by the complete visibility of landscape through the cracks in



A B

FIG. 6. In this figure the two inconspicuous butterflies in the middle show the effacing-power of pattern when it repeats the background. At the left a butterfly of the same costume is represented passing through a moment of illumination too great to admit of its patterns' still cutting it apart into notes of the background. At the right a butterfly of the same pattern is going through the reverse experience, being for an instant too much in shadow for its pattern to save it from appearing as one single dark form against the light space beyond. This illustration reminds one how perpetually such vicissitudes must succeed each other in the life of such species.

a board fence, to the eyes of any one passing swiftly by. The view recurs again and again to the retina, in time to keep up the image. This is why the average observer thinks he sees these butterflies through all their course. This plate only goes so far as to show how fatal to invisibility it is to have the wrong background. Fig. 6 illustrates the above explanation of that perpetual disharmony between flying species and their background which *plays fast and loose, part of every second, with all their patterns' power to cut their forms into deceptive shapes*, by making them, so constantly, first so bright against dark that *all* parts, even the blackest, fall into one light silhouette, and then so dark in shadow, against bright light, that even their white parts join the rest in one dark silhouette. These two climaxes of visibility, first one and then the other, occur in the flight of a bird or butterfly often at the rate of several a second, while, during the rest of the second, the creature is *effaced* by passing a background that his costume matches, and by

being, as in the case of the butterflies A and B, midway between the extremes, favored by the momentary illumination's being neither too great nor too small. Even in the climaxes of conspicuousness his patterns still perpetually *lessen his visibility* in direct ratio to their strength. And when he is chased by an enemy every instant of confusion as to where he leaves off and the background begins must often save him, so that the brighter his light marks and the deeper his dark ones, the greater the range of background he can meet without silhouetting as an entirety, and being for the instant conspicuous. One advantage which patterns do certainly sacrifice in purchasing the above advantages is that, although their wearer is never seen *entire* until the background is too dark for his black, or too light for his white, yet it is true that, on the other hand, some note of a pied costume is always to be detected moving when the wearer moves. In this respect, monotone, whenever at rare moments it exactly matches its background, has the advantage. This fact additionally condemns the aerial animal to detection when he moves, yet it is often rather his *motion* than his *form* that becomes noticeable, because each of his patterns still has the chance of passing for something beyond him.

Fig. 7 shows one of the cardinal effects of patterns. C is a bird patterned in white, black and gray. Seen against the sky he loses his white part—against the dark he loses his dark part—and against the gray, his gray part.

Now when we find that pattern works always for concealment in direct ratio to its own conspicuousness and elaboration, there remains no vestige of evidence that the specific *recognizability* of the of course *constant* pattern of each species has had, even to the slightest degree, a hand in the evolution of such pattern. And those who would still claim for conspicuous patterns any other reason for being than concealment of their wearer must first show *what* patterns could in the slightest degree better serve procryptic ends, under the circumstances, than the very ones now in use; and also what ones would less aid identification.³

There are two groups of supposed warningly-colored animals that seem particularly to lend themselves to the exposure of the weakness of

³ Naturalists confound identification with mere detection. Our *identification* of familiar objects depends, fundamentally, upon unvaryingness of their appearance. We know the mink just as well by his slim form and sleek dark monochrome as the skunk by his fatter form and bushy black and white. The skunk, by the way, varies in appearance far more than the mink, ranging from nearly all black to half white, and this is another evidence that his pattern is not for identification. Naturalists' assertion that patterns serve equally both purposes is like two men claiming the same dog. The wise judge puts it to the test as to which man the dog will obey *against the commands of the other*. If we call animals' costumes the dog, we find that he *always* obeys Master Concealment, but obeys Master Warning-color *only* when Master Concealment has commanded the same thing.

these theories. These are the carnivora which bear anal stink-glands, and, among insects, those armed with stings at their rear end. In the first place, very few of these species wear the so-called badge conspicu-

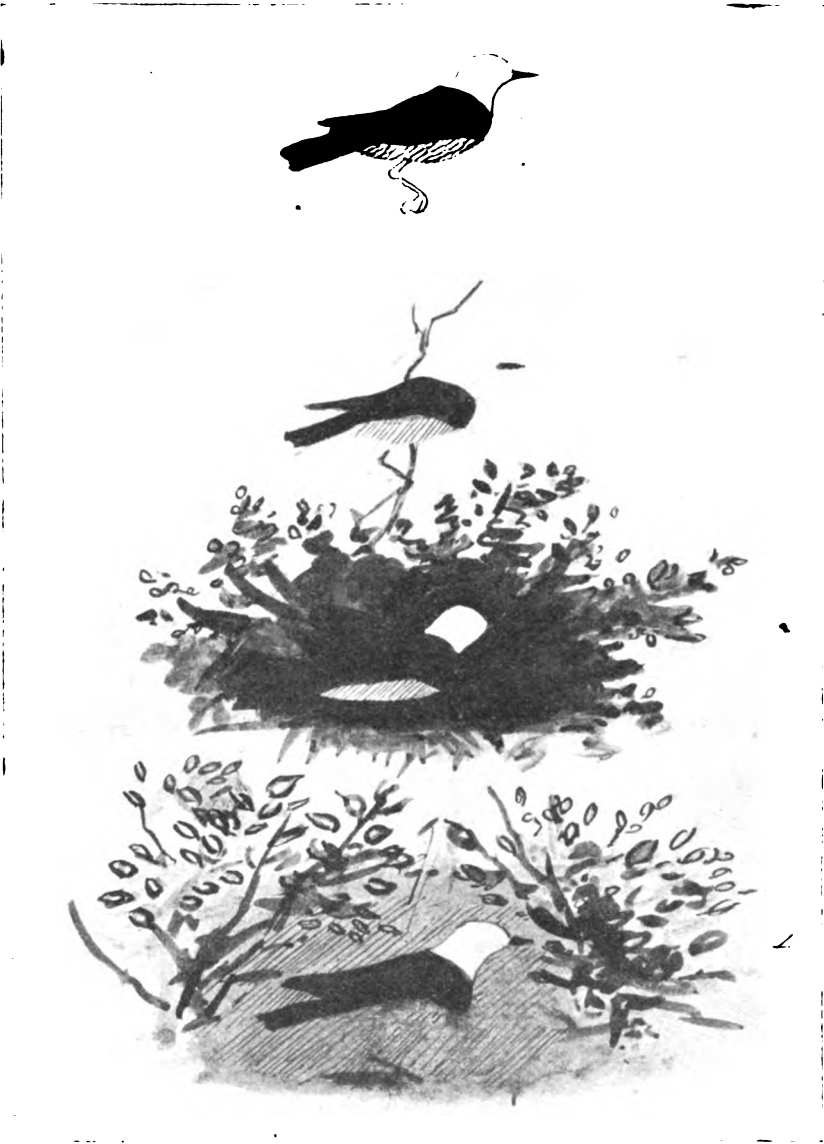

FIG. 7 shows the fundamental optically disruptive effect of pattern. Against each background the bird loses that part of its form which matches it.

ously near their weapon, or anywhere that would call attention to the situation of such weapon. (Entomologists have been keen to cite any

supposed cases of the contrary arrangement, any apparent association of "badge" and armament.) In the second place, the coloration of all the members of these groups proves to be the most perfect imaginable concealing coloration, picturing the details in the most exquisitely true colors of the very background against which it is most dangerous for their wearer to be detected (commonly that of their feeding ground). While, on the other hand, apparently no brilliant colors at all are found in any branch of the world of above-ground animal life, either in air or water, where no such colors are typical of any of the animal's backgrounds, no matter how much these animals may need advertising.

The famous black and gold, the supposed blazon of offensiveness, so characteristic of the wasp and bee family, is the utmost picture of the sunlit vegetation which they haunt, with the golden stamens of flowers, the yellow of fruit, and the dark interstices. Were this coloration really such a blazon, why does nature deny it to the hordes of *stinging* ants that often swarm within a few feet of the wasps, but wear only the comparatively dull tones that match the bark and earth surfaces to which their general lack of wings condemns their lives? (Such red as is found in ants' costumes is a universal detail of the forest débris.)

So ingrained is the time-honored conception that such a creature as a golden-patterned wasp, as he bustles among the flowers, owes his conspicuousness at least in part to his costume, that only actual personal experiment with the laws herein shown can dispel it. Not till naturalists give up collecting records of cases of conspicuousness, and begin to inquire by experiment whether any more procryptic coloration could, under the animal's circumstances, be devised, will they have begun at all the study of this subject. One day's investigation of this kind would greatly astonish them, and they would end by discovering that it is unequivocally the wasp's *actions* that condemn it to so much visibility, and this *in spite* of its wearing, as far as they can discover, every available form of concealment-coloration.

As to the supposed warningly colored carnivores, the light-colored marks that are considered as badges are often prominently concentrated upon the animal's face and front top, and in no case equally prominently arranged near his rear. Being always on the creature's sky-lit surfaces, they obliterate him to the eyes of beholders from a lower level, such as the seeing portion of his small terrestrial victims. In doing this they fall into the universal class of concealing coloration. Fig. 12 illustrates this function, and the previous illustrations have shown that this same white, so perfect an auxiliary of the animal's feeding operations, is not, in other views, unfavorable to its concealment.

Let us now find out what traits and habits in these groups *do* constantly go together. We find among the stench-bearing carnivores, just as among the above insects, that the bright patterns are only found on

such species as have, in their background, colors that these patterns match, to the eyes of certain other animals whose sight they need to avoid. They are found on skunks, civets, badgers, teledus, ratels, for instance, and the animal life devoured by these carnivores is said to consist largely of worms, insects and mice, most of which are presumably either caught on the surface or dug out of the turf, *i. e.*, procured on a lower level than the predator's head. Such of this list of



FIG. 8.

FIG. 8 shows that a monochrome figure will continue distinguishable, because of its continuity of color, even when largely eclipsed by interposed forms.



FIG. 9.

FIG. 9 shows how much less distinguishable an animal would be in the same situation if his head, feet and tail were light colored.



FIG. 10.

In FIG. 10 we see simply the skunk's reproduction of the other light-colored details which partly form the animal's background, and partly mask his form, so that both his darks and his lights tend, as it were, to dissolve their partnership and ally themselves to their counterparts in the surroundings.



FIG. 11

FIG. 11. Here we see a skunk whose patterns are experiencing exactly the same over-darkening as that of the right-hand butterfly in Fig. 6. This sketch and that of the butterfly illustrate one of the greatest uses of pattern in forest species in combatting the silhouetting propensity universal to animals observed in a dim forest illumination against lighter regions beyond them.

victims as can see would certainly have much more chance to escape, were not what would be a dark-looming predator's head converted, by its white sky-counterfeiting, into a deceptive imitation of mere sky. Now let us see whether such stench-gland bearers as hunt in a bolder way wear the white "badges." We find at once that minks, martens and most weasels, though well-armed with the same glands, have no top-white, and, instead of hunting along the earth's surface or putting

merely their heads into holes for their prey, go boldly under ground and attack such prey as hares and marmots, or fasten upon fowls much larger than they themselves. From all such prey their foreheads have nothing to gain by being white, since in the hole all is dark, and in the case of these large victims attacked above ground, the attacker, if it be a weasel, is looked *down at*, not seen against the sky, while the mar-



FIG. 12 shows the animal's white top performing its perhaps cardinal function, viz., that of effacing his top contour against the sky to the eyes of inhabitants of the turf.

This is the only function of the skunk's white top that is practically unceasing as long as the animal is above ground. We have already seen that his white and black cause each other, especially at night, to fade from sight at a short distance, and even at a near view, confuse themselves with forest details. But the obliterating power of night itself largely suffices to render all devices for concealment unnecessary. The great development of the ears of nocturnal animals attests their difficulty in seeing at this time. On the other hand, the night is scarcely ever so dark but that a solid form within a foot of one's eye would show dark against the sky or the light parts of the forest ceiling, and surely this must be the reason why skunks and the other grubbers of small surface life wear this wonderful counterfelt of sky on their foreheads. By its aid, they must constantly come close to many kinds of small surface-life on which they so largely feed, which would evade them if they could see them. This must be especially obvious to any one who has often tried in vain to creep within catching-distance of grass-hoppers. A single night's out-of-door experimenting will convince students of the importance of the white top to such an animal as a skunk.⁴

tens, arboreal, acrobatic, swift and bloodthirsty, catch doubtless much after the bold manner of the small weasels, and obviously would not seem to have so much use for concealment from any particular viewpoint. The pine marten, however, is enough light-foreheaded to save his head from too much silhouetting in his above-ground forest operations against small terrestrial life.

In tall grass, to catch small terrestrial prey like mice, cats creep low, and fling themselves high in air, dropping flat outspread upon the dazed victim. Foxes vary this by coming down head-first upon it. In neither case would top-white help them—and they haven't it.

The one thing which all these sting and stink bearers have constantly and in common, with perhaps no exception, even including the dogs and hyenas which have also anal glands (cats *lack* such glands and also lack the habit of digging) is this: In pursuit of food, or in storing it, they all either go bodily into holes, as bees and wasps into flowers and fruit cavities, or ants into their galleries, and as do the weasel family after burrowing mammals, or like the grubbing species above mentioned, and foxes, stick their *heads* into holes for similar purposes. In all these cases these rear-armed species have a common need to be so armed, being totally helpless to defend themselves while thus immersed. Of all animal adaptations this stink apparatus was the thing most to be expected in a part of the animal so entirely defenseless.

Picture a bee deep in a flower, or a badger with his head jammed deep in a mouse hole—what a chance for his enemy! But these hind ends have taken care of themselves. Now notice the thing that seems to bring final ridicule on the “badge” theory. Take, for instance, the grison, Patagonian weasel, bridled weasel, the badgers and the skunk, species whose white pattern is worn upon the head (the skunk’s tail is normally a mixture of black and white hairs—like a gray cloud); the moment when these animals most need to advertise the offensiveness of their armament would be when they were most defenseless, and this is, of course, when their heads are in holes, and at such a moment their “badges,” being on their heads, are concealed! The apparent reason for the white patterns’ extending so often along the back nearly to the tail is very simple. The act of digging or of stepping down into a hole tends to bring the fore part of an animal lower than his rear, and this, to eyes upon the turf, brings the whole of his back against the sky, and an erect white tail (like the upturned plumes of the egret) additionally blends the wearer into the sky.

To realize how inevitable was the development of special rear protectors a man has only to conceive what an anxious sensation he himself would experience if in a jungle he had to spend much time with his head down a hole, and the rest of his body a tempting bait for tigers.

In fine, we find upon certain species of carnivora that we know to be more or less scavengers and catchers of small fry such as require rather to be picked up than stalked or chased, and on others that we *suspect* of having the same habit, the same sky-picturing patterns that, from the eye-level of their prey, efface the top contours of most other slow walking feeders-on-small-life, in all branches of the animal kingdom. We find, on the other hand, a large number of Mustelidæ, as well as a number of other carnivora, well armed with stink-glands, but, as if because of not feeding in the same manner, entirely *without top-white patterns*.

Among the genera that move erect without crouching in the vicinity of their prey, and catch it upon surfaces below their level, and which are commonly effaced as to their top contours, by white in their costume, are herons, cranes, pelicans and the omnivorous swans, geese and ducks. And a similar use of white effaces the *rear view* of an immense number of widely separated members of the animal kingdom which tend to be seen by their *pursuers* against the sky. Among these are hares, deer and antelopes, ground-nesting birds that commonly *spring on wing* from the nest on being flushed, such as waders, ducks and geese, many passerines, and such hawks as nest on the ground. These all wear some white rump or tail pattern, which obliterates them in the most magical way, against the sky, exactly while, in getting under way, they are for a fateful instant within springing reach of the cougar, lynx or fox that, with head close to the ground, has crept up to them. White patterns abound on aerial passerines in general, but even white wing bars are lacking from such as keep so close to the ground that no enemy sees them against the sky. And among small rodents none has top-white unless, like the jerboa, he jumps high enough to be seen by his pursuer against the sky.

Now, while these white top patterns seem to be universally employed wherever they can be of the above service, on the other hand, they are conspicuously *lacking* from the rears of such ground-nesters as habitually *run*, instead of *flying* from the nest, and thereby avoid showing against the sky, to terrestrial eyes. Such are gallinaceous birds, tinamou, rails and many other sedge-haunting species. (Gallinules whose upturned tails present, as they fly, a white sky-picture, probably keep their tails down when they *slink* from their nest.)

The white patterns on the breasts of several kinds of bear, which Mr. Pocock has classed as warning colors, serve perfectly the same obliterative purpose that we find in all the rest of upward-facing white patterns. (These patterns face upward when the bear stands erect, *i. e.*, face upward to the degree necessary for catching top light.) Now, we find that for recognition a monochrome silhouette, especially in a thicket, is far superior to a patterned one (see Fig. 8), and also we have small grounds for thinking that such bears, when standing erect in the jungle, have need to be afraid of being attacked by mistake by any of their neighbors that would avoid them if they recognized them. On the other hand, be the bear's object, in thus assuming man's attitude, either aggression or defense, he gets the same general advantage out of escaping detection, and the chance of enjoying this boon is, as we now realize, greatly increased by the chance of this light patch being, at the right moment, just sufficiently illuminated to pass for a sky-hole through the dark mass of shrubbery of which the erect bear forms the dark center. All woodsmen know that when one has followed with the eye some bird

or arboreal beast, and lost it in the trees, the eye searches every mass of foliage silhouetted against the sky, scarcely counting on discerning the creature's outline, so much as on noting some mass of unbroken dark—dark without any sky-hole through it—sufficiently extensive to contain the animal itself. Into this mass, if one wish to kill the animal, one shoots, at a venture, and very often with success. In such cases, a single white mark on the concealed animal has a great chance of showing through the foliage, and saving the creature's life by passing for sky, making the hunter think he can see through the clump as if there were no opaque animal in it.

This wonderful universal function of top-white will only begin to have vitality in the minds of students of natural history, when they begin to take the trouble to spend hours, lying flat on the ground, studying terrestrial life from the true point of view. They will at last realize that the terms "cryptic" and "conspicuous" can refer only to the relation of objects to their background, and that a hare is as conspicuous, dark outlined against the sky, to the little mouse at his side, as the white heron looked at on the ground by man; while to the mouse, this same heron, now seen against the sky, is the perfection of pro-cryptic coloration, just as is the hare seen from the level of a man's or hawk's eyes.

There is one more point that particularly bears on the skunk matter. There is not, through all his range, any mammal, unless one counts the porcupine (an animal to resemble which would be a protection) with which any other creature could possibly confuse him, except when he is very dimly seen, either by virtue of darkness or of interposed forms, and in either of these situations, as this article has shown, the light pattern only diminishes his recognizability. Do we not, in fact, forget the evidence that the wild animals know each other by far more subtle means than we might suppose? The dog, even after all these centuries of domestication, still keeps the power to recognize his master, not merely by his scent, but by his foot-fall, when he can not see him. And the kind of faculty implied by this is even strong in the wild races of man.

Many naturalists think that such circumstances in the life of a race as are of only occasional occurrence have no part in its evolution. History seems to demonstrate the opposite. It is the stresses that are formative, and are the weeders-out of weak elements. The men of a village, regardless, for instance, of whether all of them could swim, might go yearly all summer to their meadows, and all come home at night, till once when some sudden deluge swept their valley, only the strong swimmers would escape, and thenceforth that village would comprise only strong swimmers. How often do we hear some one tell of a small and half forgotten faculty having saved his life. This seems equally to

apply to the evolution of all animals. Their races are, in the long run, subject to great fluctuation of prosperity, many of them coming, occasionally, near to extermination in some part of their range. This, according to universal belief, is oftenest through famine, and in that case, plainly, those individuals best able to accommodate themselves to new food, and to *new methods of procuring it*, would be most apt to survive. For this reason it does not signify whether badgers, etc., eat a larger or a smaller proportion of *seeing* food, since those individuals best fitted to catch it will ultimately constitute the race, because, while a white-topped animal would be no worse than a plain one *at eating turnips*, he would excel him at catching mice and crickets when turnips chanced to fail; and, as this article shows, his white does not in any way increase his conspicuousness.*

Patterns of animals are like scars of ordeals, recording what their wearers have been through. Those hares and antelopes and deer which, by virtue of a white sky-imitation on their rears, were not too fatally good a target against the night sky for the stalking feline that flushed them, have survived to propagate their race. The same record of how they escaped the eyes of prey or enemy is found on the costumes of most of the animal kingdom.

Let us try to get a vivid view of the whole field of the world's animals; over the whole earth, all species, of all orders (that ever prey or are preyed on), wear, regardless of all possible needs of badge or mimicry, such colors, and nothing but such colors, as are to be found in certain of their backgrounds. Nothing but failure to perceive this broad fact has made it possible for all these rootless theories to gain a foothold. The two most recent theories, Professor Gadow's, and that of several experimenters, that humidity is the cause of patterns, both these are invalidated by the same general arguments. Dr. Gadow, who believes that it is shadows flickering over a lizard's back that cause his patterns, ignores the unmistakable fact that lizards, like all other terrestrial species, are colored and patterned to match the ground on which they live, no matter whether there be vegetation over head to cast shadows, or, as on sea-beaches and bare rocks, nothing but air and sunlight. The humidity theory has the same defect. It believes that the increased richness in the colors of a species as one traces it from the arid part of its habitat to such a region as the moist-aired gulf-state forests, arises from the increased humidity, not noticing that with the increase of

*This applies to all such cases as the objection that seated butterflies are apt to have their wings closed, and therefore need no concealment-colors on their upper sides, and that flamingoes seldom prey on animal food that can see, and therefore have little need to match the sky against which they loom. The butterfly's fitness for opening his wings in safety, when he needs to do so, and the flamingo's, for eating *seeing*-food when he *must*, are distinct advantages.

humidity goes always a corresponding enriching of the vegetation which forms the species' background. Let these investigators push through the mangroves that border this sultry aired forest against the bare sands of the gulf, and they will find, two steps out upon the beach, in a saturated ocean atmosphere, a beach and ocean fauna of the purest beach and ocean colors, palest gray and pearl.

Black-and-gold is as truly the background color of the flower haunting black-and-gold wasp, as is stone-weed-and-sand color of the stone-and-weed-and-sand colored sandpiper. Scarlet and yellow fruit colors, sky-blue and green leaf colors, on the macaw, are as absolutely the picture of this bird's background while he is dangerously absorbed in feeding in a tropical fruit tree, as is the little terrestrial mammal's brown the picture of the universal earth-brown on which he lives. The thousands of species of open ocean fish, the bare sand-dwellers and the ocean-air-fliers, all wear only the colors that characterize their backgrounds, often adding for the breeding season bits of the scenery of their nesting place, as in the case of puffins, whose gaudy breeding-season-bill on guard at the mouth of the burrow, obliterates the dark hole itself, and at the same time substitutes a semblance of flowers to complete the deception. The moment these domestic duties are over, and the puffin back in the open sea, we behold him dressed again in the universal ocean-and-rock colors of his habitat. (To show that no physiological difficulty prohibits fish, for instance, from wearing gaudy colors, we find such colors upon them wherever they live amidst brilliant corals and brilliant water-plants.)

To complete the above argument, notice that, as my illustrations show, it is in the midst of vegetation, or other confusing and more or less eclipsing surroundings, that monochrome is far the best costume for *identification*, while out in the open spaces, the air, the beach, and the sea, there, where no twigs or other forest details threaten to confuse the identity of pattern, striking devices of all kinds would have their fullest chance to effect the identification for which they have been supposed to exist. And what do we find? We find nature foregoing, from end to end of the world, every chance to make use of this obvious opportunity.

Furthermore, to show that it is not a matter of regions, notice, as I have pointed out, the gilded wasps living within a few feet of earth-colored ants, and little earth-colored rodents swarming on the brown forest floor, two feet below bright dressed inhabitants of the bright dressed overhanging foliage. Why do not these rodents, forever preyed upon, in fact the stand-by diet of carnivora in every order, why do they not develop unpalatability and badges? All attainable unpalatability they must possess, after their immeasurable period of being picked from, but why not the badges? The truth appears to be that all advantageous attributes have, in every animal, *grown side by side*, and that the cul-

minations, for instance, of concealing coloration, such as the transparency of a group of the supposed mimetics, have gone on, in this group, hand-in-hand with that of unpalatability. Now that we see that all procryptic coloration (except, of course, the facsimile kind, such as that of geometers) produces its effect by making the observer seem to see through the place where the colors are, it follows that *actual* transparency, as in these "mimetics," must, in ever so many situations, be wonderfully potent for obliteration. It is, of course, the only scheme for succeeding equally against both the light and the shadow, tending both to escape showing light against dark backgrounds and dark against light ones. Here are Bates's own remarks about the degree of conspicuousness of a transparent butterfly. In "A Naturalist on the Amazons," on page 39, he writes:

Some have wings transparent as glass; one of these clear-wings is especially beautiful, namely, the *Hetaera Esmeralda*; it has one spot only of opaque coloring on its wings, which is of a violet and rose hue; this is the only part visible when the insect is flying low over dead leaves, in the gloomy shades where alone it is found, and it there looks like the wandering petal of a flower.⁵

As a few hours' experimenting in obliteration by juxtaposition of patterns will prove to any student, the optical laws which govern it are so absolute that one is not surprised to find that the whole world's butterflies have scarcely three different schemes of pattern. The principle of pattern arrangement in these famous "mimetic" groups (shown in Fig. 6) is out and away the predominant one over the whole globe. If this is the case, is it strange that in each most swarmingly populated seat of butterfly life there prove to be a number of species which, living in the very same station, and with seemingly identical habits, have, in obedience to this great pattern-law, practically identical patterns and form? We see in the ocean, for instance, even mammals wearing the shape and color of fishes?

The question, now, is, at most, merely why they have the same station and habits.

Let us dwell a moment upon the significance of this finding of the greatest cryptic coloration in the very midst of the so-called mimetics. First we must remember that all men agree that it is only persecution that can have engendered any form at all of protection. It is, as I have said, inconceivable that any forever preyed-on and picked-from race should not have acquired all possible unpalatability. And it is equally inconceivable that any race that either preys or is preyed on should not during the same periods have become, also, as nearly as possible either invisible, or at least unrecognizable as any form of animal life. Such a boon incomparably surpasses any advantage from passing for some other at the best not wholly inedible animal. Therefore one would

⁵The deepest forest shades seem to be, everywhere, the typical home of these transparent species. In Trinidad they bear a popular name that alludes to this characteristic.

have expected to find all species of the classes above referred to proving to be by one means or another at the minimum of recognizability as animals, and at the same time, at a corresponding minimum of palatability; and behold, that is just what we find! We find in the very ranks of the supposed mimetics (a term which asserts a protection involving *conspicuousness* of the protected individual) the actual climax of invisibility, as Bates practically testifies in the above extract, and as I too, and all others who have studied these insects in their homes, must testify. (In deep forest shades the actual illumination is faint, and objects show most when they come between the beholder and regions of more lighted foliage beyond or up nearer the forest's top. In these circumstances all rank patterns are potent to thwart the revealing-power of silhouette, and behold, here we find the very prince of silhouette-thwarters—transparency itself!)

As to the impression that "flaunting flight" (*i. e.*, slow or weak flight), gaudy costume and unpalatability keep together, they do not do this to any very impressive degree, as the accompanying table will remind the student. Entomologists will see that this table is sufficiently correct for my purpose.

ACME OF RESPECTIVE TRAITS

Of Strength and Speed of Flight.	Of Gaudiness of Costume.	Of Slowness.	Of Dulness of Costume.	Of Alleged Unpalatability.
<i>Morpho.</i> <i>Papilio.</i>	<i>Morpho.</i> <i>Papilio.</i> <i>Heliconius.</i>	<i>Heliconius.</i>	The whole "mimetic" group proper.	<i>Heliconius.</i> The whole "mimetic" group.

In fact, one finds, as one would have expected, that every butterfly has the gait best suited to the kind of place that he lives in. *Heliconius*, one of the very slowest genera on our continent, is particularly at home while flying through the densest copses. It is perfectly natural that such a butterfly as a grapta, matched to the colors of the ground, should hurry, in flying from one safe spot on the ground to another, but the case of *Heliconius* is very different. He *lives* in cover, the very kind of cover to which small birds fly from a hawk, and through this he sails and flits in the only conceivable manner, threading its minute alleys with short wing beats, and at times almost seeming to stop and crawl through the narrowest places. This is, at least, true of *charitonus*, *sara* and *melpomene*, in the West Indies and Trinidad, where I have seen them. As is characteristic of all nature, these insects overflow from the situations that most nurture them into less favorable places.

Yet it is almost a sufficient answer to the natural question why they are not there preyed upon, to point out afresh that on the American continent, at least, no kind of butterfly at all appears often to be attacked on the wing. In Trinidad, one of the keenest of that remark-

able family of born naturalists, the Carrs, told me that he had never seen a bird catch a butterfly, and this has almost or quite been my experience too. In Trinidad, for instance, one may see flycatchers catching slow fliers like beetles, by the hour, any day, but never see them pay the slightest attention to any butterfly whatever. I reiterate this here, merely for what it is worth, and am nowise averse to believing that *Heliconius* is more than ordinarily unpalatable. If it be true that feeding among red or orange flowers has now or formerly so predominated in the life of the red and yellow spotted species, as to make this dress do them more good than harm, it is equally logical that, as in the case of the digging and burrowing animals that I have referred to, with their corresponding rear armaments, butterflies particularly subject to dangerous absorption while feeding, should have been in the whole period of their existence bred to an excessive degree of inedibility. As to the flight of such butterflies as on the one hand, papilios and morphos, and on the other, the "mimetic" groups proper, the former two families comprise between them, the strongest and swiftest of American butterfly flight, and an unsurpassed brilliancy of costume, bright colors not proving, in their case, to be accompanied either by slow flight, or by *equally* notable unpalatability. On the other hand, the American so-called mimetic groups proper have a middle-class flight apparently well suited to the by no means open under-brush of the forest, where they go about much in the manner of the genus *Hipparchia* in the north.

Now to glance for a moment at the significance ascribed by entomologists to the injuries which are found along the borders of butterflies' wings.

Perhaps the most highly artificial and strained hypothesis that has been released from duty by the discovery of the use of patterns is the conception that after a million years' experience birds would not *inevitably* know what part of a butterfly is edible and instinctively seek it, rather than try to eat the tissue-paper pictures of background painted along its wing-borders. This is entirely contrary to the stern rectitude of nature. One might as well hope to fool a ship about her center of gravity, and induce her to float at an angle that did not defer to it, as induce a million-year-long race of eaters of butterflies' bodies to waste energy over these patterns.

A butterfly has, of course, a fairly tough body, and wings that begin tough next to the body, but become mere tissue-paper at the lateral borders. Now, every slightest contact is perilous to the entirety of these borders, and, at the same time every circumstance of the butterfly's life threatens contact to them. Even the wind may blow things against them, and when the butterfly is pursued by an aerial enemy, his own efforts to escape must often bring them into collision with vegetation. Again, if the pursuer be a bird, his swoops bring him into

almost inevitable collision with these outstretched wing-borders. To lunge at a thing and miss it is inevitably to be carried on, the next instant, close past it. To put it from the insect's point of view, barely to dodge an onrushing foe, is, as we all know, to have him almost inevitably brush against us, to say the least, as his impetus carries him forward. It would be absurd to doubt the very great likelihood of mutilation to the butterfly's wing-borders at such a moment. Again; a bird struggling, against difficulties, to seize such a thing as a zigzagging butterfly, inevitably tries for the *mass* of the target, the most visible part. Now, although the wings do, certainly, more or less wag the body up and down, nevertheless the body is the axis of the mill-wheel of which the wing-borders are the floats, so that even if the bird *tried* for the body, unless the attack came exactly from behind, the flapping wings would tend to protect it by constantly getting in the way of the bird's beak, but this would be at the expense of these delicate fabrics, which would smash themselves against it. So much for the immensely greater risk of every sort to this delicate border than to the body itself.

Now as to the supposition that birds prefer to seize this border region, rather than the body. One simple fact suffices to show us that we have not the slightest evidence that they do so. It is this. A butterfly seized by his body can not escape (unless, of course, he chance to be cut nearly through by the beak that seized him) while one seized by the wing-border is no more detained by being thus seized than by receiving at this point any of the merely accidental injuries above referred to. Now if a butterfly seized by the *body*, is generally *eaten*, while on the other hand every butterfly injured as to its *border*, *escapes*, what possible significance has our finding, as we do, mainly border injuries?

Now, although it seems scarcely necessary to finish the argument, to consider for a moment the supposed selection by the bird, of special points along these borders, the reader has been sufficiently reminded how very far the bird is, in one of these chases, from being in a position to *select* a point of attack.

We find that the whole subject of animals' coloration has been handled with very loose thinking, as if the old time disrespect of natural history still haunted men's minds and dissuaded them from real study. This cloud that enveloped natural history in former centuries has been steadily thinning, but it is certainly accountable for many loosenesses even up to the present time.

For instance, it is perfectly plain to-day that nature would not ask a coral snake to get along with a costume which, while it often served to warn off his enemies, proved, at other times, a disadvantage to him by identifying him to the animals which he wished to eat. The writings upon these subjects, down to the present day, teem with just this kind

of weakness. Also, being falsely based, they have needed props and dikes at one point after another, and these have naturally proved to be out of harmony with each other. Here it has been assumed that animals need badges for mutual recognition, and there, as in the "mimetic" groups, a theory has obtained which assumed that they need nothing of the kind. Individuals of each species of these groups have been expected to know each other amidst a crowd of close imitations (and doubtless they could do so).

The much insisted upon significance of the *superficiality* of the *resemblances* among the "mimetic" groups vanishes upon our discovery of a full blown use, of the most direct and primitive character, for all these colorations. From that moment, these resemblant costumes are seen to be, as I have pointed out, on one basis with the many other resemblances among species of widely different origin that have long enough had the same habits and environment. All these, and they are to be found in many orders of the animal kingdom, are only superficial resemblances, yet it is perfectly plain that they have been acquired for a *use*. The proof that they are only superficial is that the anatomist can discover the real pedigree of the disguised species by an examination of the elements of its structure. Good examples of this fact are the whales and seals, with their hind legs more or less arranged into a fish-tail, yet perfectly recognizable by the zoologist. (I assume the truth of natural selection.)

In fine to imagine that the forest population, living side by side, in perpetual need of knowing each other, would be in any way helped by badges, is as if some person, newly arrived in a long-established community, supposed, because he could only distinguish its members by prominent superficial marks, the red hair of one, the pock marks of another, etc., that this was how the members themselves knew each other, after lifelong familiarity.

The truth, however, is, that were he to cite these distinguishing marks, in speaking of one member to another, he would find that the mutual familiarity of these members had become so subtle, had, so to speak, sunk in so deep, that they had almost forgotten the existence of such marks at all, except where men's names commemorated these.

Lifelong members of a community, all reacting upon each other in a hundred ways, know each other by innumerable means, all communicating with their subliminal consciousness. To this consciousness, the movements, for instance, of a mink in the bushes, probably announce his identity to all his neighbors, who hear him, just as plainly as if they saw him, and the least glimpse of him would, upon the same principle, be as good as a full view. Habitual woodsmen generally tend to believe this, because of finding that they themselves tend to this intuitive method of identifying their wild neighbors in the forest.

WHAT PRAGMATISM IS, AS I UNDERSTAND IT

BY THOMAS MITCHELL SHACKLEFORD

TALLAHASSEE, FLORIDA

ONE who undertakes to tell what pragmatism is has a hard task to perform. Before he gets through with it, he may find himself in a like plight with old Kaspar in trying to tell his grandchildren of the battle of Blenheim. You will remember that in response to little Peterkin's request, "Now tell us what 'twas all about," and to his question, "And what good came of it at last?" Kaspar could only declare "That 'twas a famous victory."

To begin with, not only has no history of the origin, rise and spread of pragmatism yet been written, but no full, complete, systematic statement of what it really is, what it does and what it may be expected to do is to be found anywhere. A systematic exposition of this "new philosophy" remains an unfulfilled want. We can not be said to have anything like an adequate treatise. Dr. Schiller's "Humanism" and "Studies in Humanism" consist of a number of detached essays, largely controversial in character, written at different times between the years 1892 and 1907, on various occasions and for special purposes. Professor Dewey's "Studies in Logical Theory" also consists of detached essays from himself and seven of his co-workers, and Professor James's "Pragmatism" is made up of eight popular lectures, published in the same form in which they were delivered, without notes and without revision. All of these are most excellent books, well written, entertaining and bearing directly upon the new philosophical movement, only they are not, and do not pretend to be, what most of the critics seem to have rather hastily assumed—full or complete expositions or treatises. Much other literature upon the subject may be found scattered through the various philosophical periodicals. In fact, so voluminous has this literature grown of late years and the movement has evoked so much hostile criticism, that the uninformed reader would be justifiable in thinking "pragmatism a complete system set forth for centuries in hundreds of ponderous volumes."

However, for all practical purposes, it still remains as true as in 1905, when Professor James wrote concerning the movement:

It suffers badly at present from incomplete definition. Its most systematic advocates, Schiller and Dewey, have published fragmentary programs only.

So, a few months later, an able and somewhat sympathetic reviewer complained:

Its defenders have not come before the world with a ready-made and fully-developed doctrine, thought out into all its consequences and tested in all its applications. It is just the tentative and provisional nature of many expositions of pragmatism which makes it hard to grasp its meaning unequivocally. It seems to change Proteus-like, under our hands, just when we think we have held it fast and pinned it down. The very formulations of its doctrines are perplexingly numerous, and not always, on the face of them, consistent with each other.

There is undoubtedly some truth in this accusation, but the reason why such a condition exists is not far to seek.

It is well known to all who have ever attempted to make them that definitions and rules in any science or branch of study are always exceedingly difficult to frame. Though studied first by the student, they are necessarily formulated last. Dr. Schiller says:

Real definitions are a standing difficulty for all who have to deal with them, whether as logicians or as scientists. . . . For a real definition, to be adequate, really involves a complete knowledge of the thing defined. And of what subject of scientific interest can we flatter ourselves to have complete knowledge?

Only a moment's reflection will convince us that this is true. Definitions must necessarily delimit and restrict, consequently with the growth of knowledge they become insufficient and obsolete. The discovery of one new fact may invalidate and completely overthrow a definition that may have passed current and remained unchallenged for years. In other words, "new facts burst old rules" and definitions, both are man-made products, so it should never be forgotten that definitions and "rules are made for man, not man for rules" and definitions. No science is finished, none can be called exact, all are in the process of formation. To illustrate. Who can define matter, or ether, or electricity? Of how much value now are many of the definitions in physics or chemistry of ten, or even five, years ago? All definitions, then, at least along scientific lines or in any living, growing branch of study, should be regarded as provisional only, true only up to date, and, like railroad schedules, subject to change without notice to the public. They should be treated as useful working tools, but liable any day to be superseded by better instruments. All this applies with especial force to a "new philosophy," still in the embryonic or chrysalis state. Since "the pragmatic movement,—so-called," according to Professor James, "seems to have rather suddenly precipitated itself out of the air," it ought not to be a matter of surprise that there is not entire agreement even among the pragmatists themselves. It would be an easy task to set forth various points of difference, as well as apparent, if not real, contradictions, among those who have grasped their pens, even if they can not be said to have drawn their swords, and hastened to do battle in its defense. In doing this, however, we should only be following in the wake of the

hostile critics who have emphasized these points to the exclusion of any real merits which the movement may possess.

We all remember what Emerson said long ago about ideas announcing truth being in the air, seeking to gain entrance to different minds in different parts of the world at the same time, and "the most impressionable brain will announce it first, but all will announce it a few minutes later." But it is not to be expected that all minds will be impressed in the same way or to a like degree, or that all would have equal power of utterance. So we are further told by Professor James:

A number of tendencies that have always existed in philosophy have all at once become conscious of themselves collectively, and of their combined mission; and this has occurred in so many countries, and from so many different points of view, that much unconcerted statement has resulted.

Before the movement was fairly launched, or an opportunity had been afforded its leaders of getting together and comparing notes as to their common message and unifying it, if possible, the critics had attacked it on all sides and from every quarter. This caused a rush of both friends and foes, professionals and tenderfeet, to this newly discovered philosophical Klondike, which has been productive of much confusion and misunderstanding. Reconciling these conflicting statements is simply out of the question, and I shall not attempt the impossible.

Disclaiming right at the outset all intention of speaking as one clothed with authority, fully realizing that what I may say is binding upon no one, my mission is simply to set forth what pragmatism is, as I understand it. Even this I venture upon with diffidence. As an excuse for my seeming rashness, if such be needed, I would repeat what the protagonist of pragmatism himself has said:

Whoever will contribute any touch of sharpness will help us to make sure of what's what and who is who. Any one can contribute such a definition, and, without it, no one knows exactly where he stands.

My purpose, however, is not to add another to the many existing definitions, but rather to weigh and compare some of those already current. In other words, I merely propose to examine the history of the movement with the intention of ascertaining, if possible, what pragmatism is, and I shall throw this layman's contribution into the bubbling vat of publicity where, jostled by rivals and torn by critics, it will eventually either disappear from notice, or else, if better luck befall it, quietly subside to the profundities, and serve as possible ferment of new growths or a nucleus of new crystallizations.

It is easy enough to tell of the origin of the word and that it is "derived from the same Greek word *πράγμα*, meaning action, from which our words 'practise' and 'practical' come." Now this not only does not tell us much, but has actually proved misleading and is

responsible for some of the current misunderstandings. But it is too late now to rectify this most unfortunate selection of a name. It has been married to the movement for so many years that they must be taken together "for better for worse." As Dr. Schiller has well said:

The name in this case does even less than usual to explain the meaning.

Elsewhere he has said:

In the end we *never* find out "what a thing really is" by asking "what it was in the beginning." . . . The true nature of a thing is to be found in its validity, which, however, must be *connected* rather than *contrasted* with its origin. "What a thing really is" appears from what it *does*, and so we must study its whole career. We study its past to foretell its future, and to find out what it is really "driving at."

The first person to use the word pragmatism in print was Professor James, in his California address in 1898, wherein he sets forth the principle as follows, with the prefatory statement that

it may be expressed in a variety of ways, all of them very simple: The soul and meaning of thought can never be made to direct itself towards anything but the production of belief, belief being the demicadence which closes a musical phrase in the symphony of our intellectual life. Thought in movement has thus for its only possible motive the attainment of thought at rest. But when our thought about an object has found its rest in belief, then our action on the subject can firmly and safely begin. Beliefs, in short, are really rules for action; and the whole function in thinking is but one step in the production of habits of action. If there were any part of a thought that made no difference in the thought's practical consequences, then that part would be no proper element of the thought's significance. Thus the same thought may be clad in different words; but if the different words suggest no different conduct, they are mere outer accretions, and have part in the thought's meaning. If, however, they determine conduct differently, they are essential elements of the significance. "Please open the door," and "*veuillez ouvrir la porte*," in French, mean just the same thing; but "D—n you, open the door," although in English, means something very different. Thus to develop a thought's meaning we need only determine what conduct it is fitted to produce; that conduct is for us its sole significance. And the tangible fact at the root of all our thought-distinctions, however subtle, is that there is no one of them so fine as to consist in anything but a possible difference of practise. To attain perfect clearness in our thoughts of an object, then, we need only consider what effects of a conceivably practical kind the object may involve—what sensations we are to expect from it, and what reactions we must prepare. Our conception of these effects, then, is for us the whole of our conception of the object, so far as that conception has positive significance at all.

He goes on to say:

This is the principle of Peirce, the principle of pragmatism. I think myself that it should be expressed more broadly than Mr. Peirce expresses it. The ultimate test for us of what a truth means is indeed the conduct it dictates or inspires. But it inspires that conduct because it first foretells some particular turn to our experience which shall call for just that conduct from us. And I should prefer for our purposes this evening to express Peirce's principle by saying that the effective meaning of any philosophic proposition can always be brought down to some particular consequence, in our future practical experience, whether

active or passive; the point lying rather in the fact that the experience must be particular, than in the fact that it must be active.

All this seems to be perfectly plain and simple, but, in view of the misunderstandings that are still current concerning the principle, due largely to flagrant, if not wilful misrepresentations, and as this is the beginning point of the "new philosophy," I trust that you will pardon still further extracts. The gifted lecturer tells us that "to take in the importance of this principle, one must get accustomed to applying it to concrete cases," and the entire address is devoted to such applications along religious and philosophical lines. He says:

This is one of its first consequences. Suppose there are two different philosophical definitions, or propositions, or maxims, or what not, which seem to contradict each other, and about which men dispute. If, by supposing the truth of the one, you can see no conceivable practical consequences to anybody at any time or place, which is different from what you would foresee if you supposed the truth of the other, why then the difference between the two propositions is no difference,—it is only a specious and verbal difference, unworthy of further contention. Both formulas mean radically the same thing, although they may say it in such different words. It is astonishing to see how many philosophical disputes collapse into insignificance the moment you subject them to this simple test. There can be no difference which doesn't make a difference—no difference in abstract truth which does not express itself in a difference of concrete fact, and of conduct consequent upon the fact, imposed on somebody, somehow, somewhere, and somewhen.

After stating that "it is the English-speaking philosophers who first introduced the custom of interpreting the meaning of conceptions by asking what difference they make for life," he adds:

Mr. Peirce has only expressed in the form of an explicit maxim what their sense for reality led them all instinctively to do. The great English way of investigating a conception is to ask yourself right off, What is it *known as*? In what facts does it result? What is its *cash-value*, in terms of particular experience? And what special difference would come into the world according as it were true or false?

Finally, he says:

For what seriousness can possibly remain in debating philosophic propositions that will never make an appreciable difference to us in action? And what matters it, when all propositions are practically meaningless, which of them be called true or false?

Expressed in these different ways but all meaning the same thing, it would seem that Dr. Schiller was right in saying that the principle ought to be regarded as the greatest truism, if it had not pleased intellectualists to take it as the greatest paradox.

After all that has been written on the subject, a writer has quite recently said:

Ninety-five per cent., and a little more, of all who have rallied so valiantly to the pragmatic banner totally misunderstand the new philosophy. And it is even nearer the truth to say that one hundred per cent. of all the critics who to their own satisfaction have completely demolished the pragmatic structure have fired their shots at the wrong target.

Even if this contains only a half-truth, it behooves us to try to get our bearings, although philosophical orientation be fraught with all the difficulties that have been claimed. In any event, it is of the utmost importance to get the right point of beginning, so I have thought it advisable to set forth Professor James's exact words when he first announced the principle.

So far as I have been able to discover, the next time he announced it was in his "Varieties of Religious Experience," where he condensed it. I quote only one sentence:

To attain perfect clearness in our thoughts of an object, we need then only consider what sensations, immediate or remote, we are conceivably to expect from it, and what conduct we must prepare in case the object should be true.

I should like you to note especially the added words, "immediate or remote." I would also call attention to the fact that none but a pragmatist could have written this truly delightful book. The eighteenth chapter, bearing the title "Philosophy," is simply a clearly wrought-out application of the principle in the philosophy of religion.

In Baldwin's "Dictionary of Philosophy," Professor James defines the principle as follows:

The doctrine that the whole "meaning" of a conception expresses itself in practical consequences, consequences either in the shape of conduct to be recommended, or in that of experience to be expected, if the conception be true; which consequences would be different if it were untrue, and must be different from the consequences by which the meaning of other conceptions is in turn expressed. If a second conception should not appear to have other consequences, then it must really be only the first conception under a different name. In methodology it is certain that to trace and compare their respective consequences is an admirable way of establishing the different meanings of different definitions.

In an article entitled "Humanism and Truth," published in *Mind* for October, 1904, he says:

First, as to the word "pragmatism." I myself have only used the term to indicate a method of carrying on an abstract discussion. The serious meaning of a concept, says Mr. Peirce, lies in the concrete difference to some one which its being true will make. Strive to bring all debated conceptions to that "pragmatic" test, and you will escape vain wrangling: if it can make no practical difference which of two statements be true, then they are really one statement in two verbal forms; if it can make no practical difference whether a statement be true or false, then the statement has no real meaning. In neither case is there anything fit to quarrel about: we may save our breadth, and pass to more important things.

All that the pragmatic method implies, then, is that truths should *have* practical consequences. In England the word has been used more broadly to cover the notion that the truth of any statement *consists* in the consequences, and particularly in their being good consequences. Here we get beyond affairs of method altogether; and since my pragmatism and this wider pragmatism are so different, and both are important enough to have different names, I think that Mr. Schiller's proposal to call the wider pragmatism by the name

of "Humanism" is excellent and ought to be adopted. The narrower pragmatism may still be spoken of as the "pragmatic method."

Before proceeding further or attempting to set forth what the movement has seemed to mean to others who have written upon the subject, whether favorably or otherwise, it may be advisable for us to pause and ask ourselves if we are certain that *we* understand what its brilliant protagonist means. Is the language in which he has couched it so vague, obscure, ambiguous, uncertain or contradictory as to warrant the different constructions that have been placed thereon? I ask this question advisedly, since Professor James himself, in his *Pragmatism*, has said:

On all hands we find the "pragmatic movement" spoken of, sometimes with respect, sometimes with contumely, seldom with clear understanding.

It would seem that it ought to be well worth our while to try to get at the reason for this.

It may be that in so doing we can derive some assistance from the rules applied by the courts in the interpretation and construction of constitutions, statutes, contracts, deeds, wills and other written instruments. Some of these rules are so well settled that they are regarded as almost axiomatic and pass unquestioned. They are even applied to the construction of charges and instructions given by trial judges to juries to aid them in reaching correct verdicts in the trial of contested cases, whether human life, liberty or property is involved. If it be practicable and safe to apply them in the settlement of such vital questions, surely they may be used profitably and safely, even pragmatically, if you will, in abstract discussions along philosophical or religious lines. Of course, there are some points of difference in the application of these rules by the courts to the different kinds or classes of instruments, but such points are of minor importance and may be treated as negligible for our present purposes. In setting forth some of these cardinal rules, I shall divest them of all legal technicalities, as far as may be, and clothe them in plain, simple language.

1. When the language of a writing is plain and unequivocal, there is neither occasion nor opportunity for interpretation. When the words used admit of but one meaning, to put another upon them is not to construe or interpret a writing, but to alter it.

2. Words are presumed to be used in their plain, ordinary sense; technical terms are to be understood in their technical sense; all words are to be understood according to their meaning at the time and place of writing them.

3. The grammatical and ordinary sense of words is to be adhered to, unless that would lead to some absurdity, or some repugnance or inconsistency with the rest of the instrument, in which case the gram-

matical and ordinary sense of the words must be modified, so as to avoid that absurdity or inconsistency, but no further.

4. In construing any part of a writing, regard should be had to the entire instrument. Other portions may throw much light upon the one under special investigation or consideration, and greatly modify the meaning which it would bear as an independent clause. Every part of a writing should be brought into action in order to collect from the whole one uniform and consistent purpose, if that is possible. Accordingly, if one construction will give reasonable effect to every part of an instrument, while another would require the rejection of a part, the former will be preferred.

These rules will probably prove sufficient for our present purposes. In order, however, to make it plain to you, perhaps, it may be well for me to give a concrete instance of their application by the courts. I shall select the giving of charges or instructions to juries. In passing upon a single instruction or charge it should be considered in connection with all the other instructions and charges bearing on the same subject, and if, when thus considered, the law appears to have been fairly and impartially presented to the jury, an assignment of error predicated upon the giving of such instruction or charge must fail, unless, under all the peculiar circumstances of the case, the appellate court is of the opinion that such instruction or charge was calculated to confuse, mislead or prejudice the jury. In determining the correctness of charges and instructions, they should be considered as a whole, and, if as a whole they are free from error, an assignment predicated on isolated paragraphs or portions, which, standing alone, might be misleading, must fail. Again, where an instruction, as far as it goes, states a correct proposition of law, but is defective because it fails to qualify or explain the proposition it lays down in consonance with the facts of the case, such defect is cured if subsequent instructions are given containing the required qualifications or exceptions. It is not required that a single instruction should contain all the law relating to the particular subject treated therein.

I believe that these are all the legal propositions to which I wish to call your attention. I might add that the object of judicial interpretation of instruments is not to discover the intention of the maker or writer by the use of any and every legitimate means, but rather to take the instrument itself and determine such intention from the words used therein.

It would really seem that the rules of grammar and the laws of language would be all that we should need in order to determine what Professor James meant in the quoted passages, but even if we should apply these legal rules in all their strictness I do not believe that we should be left in any state of doubt or uncertainty. But we are not

called upon to so narrow and restrict our investigation. It is well known that every writer of marked individuality or originality acquires a style peculiarly his own and easily recognizable. Their writings come to have a certain hall-mark, so to speak, which there is no mistaking. It is further true that a writer, especially along philosophical or theological lines, either forms a school or system of his own, which he is likely to do if he is a genius, or else joins or connects himself with one of the already existing schools. In either case he becomes identified with certain doctrines. He presents those aspects of the truth, as he has conceived it to be, which have most strongly appealed to him and which he considers of supreme importance. Upon these he will dwell and lay special emphasis, reiterating them, presenting them from different points of view, until his readers grow to expect his utterances to be along those chosen lines and in his own individual way. In this way schools and systems are founded and followers and adherents gained. Such a writer is entitled in all fairness to have whatever he writes taken and judged in connection with his other utterance along similar lines; otherwise, in order to avoid misunderstandings, he would be forced to continually repeat himself, which would be intolerable.

Professor James has written much along both psychological and philosophical lines, and the particular doctrines which he holds are well known. His style has long been noted for its lucidity and has become both the marvel and despair of other writers. Hitherto he seems to have experienced no difficulty in making himself understood. Is it conceivable, then, that, all at once, when he began expounding the principle of pragmatism, he should have lapsed or fallen into vague and obscure expressions? In all candor, I ask you to turn back to the quoted passages, and taking them just as they are, torn from their contexts and settings, apply to them any or all of the rules and tests that I have mentioned, and then ask yourself whether or not you have any difficulty in grasping their meaning. If not, why have the critics found it so hard to understand them?

And yet, the most diverse and contradictory constructions have been placed thereon as well as upon his "Pragmatism," which entire book is devoted to elucidating what the principle is and wherein it may be applied. In fact, to such an extent has this prevailed that he felt impelled to write "a final brief reply" to his critics, which he entitled "The Pragmatist Account of Truth and Its Misunderstanders" and published in *The Philosophical Review* for January, 1908. It should further be borne in mind that the critics also had access to all of his other writings and were presumably familiar with them. Again I ask the pertinent question, how such a condition of affairs could exist? Making all due allowances for the imperfections and

uncertainties of language and the limitations of human thought and understanding will not serve to explain it. It could not really have been asked or expected that the entire essence of the principle should have been compressed into one concise definition or even into one formal or rigid statement. As its protagonist himself has said in an article entitled "Humanism and Truth Once More," published in *Mind* for April, 1905:

As I apprehend the movement toward humanism, it is based on no particular discovery or principle that can be driven into one precise formula which thereupon can be impaled upon a logical skewer. It is much more like one of those secular changes that come upon public opinion over-night, as it were, borne upon tides "too full for sound or foam," that survive all the crudities and extravagances of their advocates, that you can pin to no one absolutely essential statement, nor kill by any one decisive stab.

In the same article he says:

The one condition of understanding humanism is to become inductive-minded oneself, to drop rigorous definitions, and follow lines of least resistance "on the whole."

It would seem that this was expecting entirely too much. He had also said in *The Journal of Philosophy* for March 2, 1905:

It is not a single hypothesis or theorem, and it dwells on no new facts. It is rather a slow shifting in the philosophic perspective, making things appear as from a new center of interest or point of sight. Some writers are strongly conscious of the shifting, others half unconscious, even though their own vision may have undergone much change. The result is no small confusion in debate, the half-conscious humanists taking part against the radical ones, as if they wished to count upon the other side.

I am inclined to think that its very simplicity has been the chief barrier in the way of its acceptance. "Unto the Jews a stumbling block, and unto the Greeks foolishness." Has it not ever been so in both the philosophical and religious worlds? Would it not find more ready acceptance if it required "some great things"? Perhaps, one barrier in the way of those who have "seriously tried to comprehend what the pragmatic movement may intelligibly mean" is mental myopia, which prevents them from assuming the proper attitude in order to gain the right point of view. They are too wedded to their idols of dogma and authority to experience that change of heart which would enable them to break the shackles which bind them to "absolutistic hopes" and acquire the freedom which would permit them to enter into such "conditions of belief." Dr. Schiller has said:

Concerning any considerable novelty of thought the prediction may be made that hardly any one above thirty will be psychologically capable of adopting it, unless he had previously been looking for just such a solution.

Whether this be true or not, many have failed to understand it simply for the reason that they have not really tried to do so. They "have boggled at every word they could boggle at, and refused to

take the spirit rather than the letter" of what was said. In violation of every rule of interpretation, common-sense or legal, they have ignored the context and pounced upon single words and isolated sentences. Truly, in philosophy as elsewhere, "none are so blind as those who will not see." We are all familiar with "the proof-text method" of argument, much in vogue among theological disputants some years ago, but now happily fallen into a state of "innocuous desuetude." Surely it is not being revived in philosophy. The reasons for the attitude of this class of critics are plain. If the pragmatic method should prove to be true or valid, it would necessarily require "much restatement of traditional notions." If it should prevail, the existing systems of philosophy would be unsettled, if not overthrown, and many of the past, not to mention current, philosophical treatises would thereby become obsolete and subject to relegation to "that 'Museum of Curios' which Professor James has so delightfully instituted for the clumsy devices of an antiquated philosophy." Did not Demetrius, a silversmith, and his followers raise a great uproar at Ephesus against St. Paul for like reasons?

Our Harvard pragmatist has further said:

A pragmatist turns his back resolutely and once for all upon a lot of inveterate habits dear to professional philosophers. He turns away from abstractions and insufficiency, from verbal solutions, from bad *a priori* reasons, from fixed principles, closed systems and pretended absolutes and origins. He turns towards concreteness and adequacy, towards facts, towards action and towards power. That means the empirical temper regnant and the rationalist temper sincerely given up. It means the open air and possibilities of nature, as against dogma, artificiality, and the pretence of finality in truth. At the same time, it does not stand for any special results. It is a method only. But the general triumph of that method would mean an enormous change in what I called in my last lecture the "temperament of philosophy." Teachers of the ultra-rationalistic type would be frozen out, much as the courtier type is frozen out in republics, as the ultramontane type of priest is frozen out in protestant lands.

Yet once more:

No particular results then so far, but only an attitude of orientation, is what the pragmatic method means. *The attitude of looking away from first things, principles, "categories," supposed necessities; and of looking towards last things, fruits, consequences, facts.*

All this affords some explanation of the flutter and consternation which pragmatism has caused in the philosophic dove-cotes and why it has even been productive of ruffled feelings and bad temper. Doubtless some felt deeply incensed that "proud Philosophy," that celestial goddess, long acclaimed "*Scientia Scientiarum*," should be dragged down from her empyrean heights into this work-a-day world, reduced to the menial position, so to speak, of a hewer of wood and drawer of water. Surely this was desecration, if not rank sacrilege. Perhaps,

a still further explanation may be found in the fact that pragmatism undertook to act as a mediator and reconciler between the contending systems and, in consequence thereof, has suffered the proverbial fate of the peacemaker.

Whether or not I have been successful in pointing out the true causes which have induced the fierce onslaughts which have been made against the movement, it must be admitted that they have signally failed to check it, and that it is growing, in spite of all the hostile criticisms and gross misrepresentations. It would seem that it has come into the world to stay. It might well be that its critics would have fared better from the beginning if they had remembered that "good humor is a philosophic state of mind," even if it be not true "that one should always talk of philosophy with a smile." It undoubtedly would have been more in unison with the true philosophic spirit, and, perhaps, attended with better results, if they had set to work in good earnest to refute the arguments advanced by Professor James and the other leaders, instead of contenting themselves with giving pragmatism a bad name and bestowing upon it abuse and opprobrious epithets. If they were simply following the old maxim, "give a dog a bad name and it will hang him," they were on a false trail.

As I have said, entire harmony has not existed in pragmatist ranks, of which fact the critics have made the most. Even so, such differences furnish no justification for the failure of the professional philosophers to understand the lucid statements of Professor James, or of the other two leaders, Dr. Schiller and Professor Dewey, as some of them seem to have done. The points of divergence among them are easily discernible by those who really try to see and understand the movement.

However, pragmatism, being what its protagonist says it is, ought not to be expected to mean the same thing or to make a like appeal to different minds. Evidently, it was with deep design that Professor James began the first lecture in his "Pragmatism" with that paradoxical quotation from Mr. Chesterton's "Heretics," as to the most important thing about a man being his philosophy. It contains a greater modicum of truth than most paradoxes, for as a man's philosophy is, so will be "his view of the universe," and, as that view is, so will be his life. From this paradox our pragmatist proceeds to develop the thesis that "the history of philosophy is to a great extent that of a certain clash of human temperaments," and to show us how temperament "loads the evidence" not only for philosophers, but for all of us. In this he follows Fichte, who has said somewhere, "what system of philosophy you hold depends wholly upon what manner of man you are." So Dr. Schiller has said, "the fit of a man's philosophy is (and ought to be) as individual as the fit of his clothes." All this

must naturally follow if we agree with Mr. R. R. Marett, who has said :

There is at least a half-truth at the back of the view that a man is born either a Platonist or an Aristotelian, a Stoic or an Epicurean, an intuitionist or a utilitarian, an idealist or a materialist. We are spiritually-minded or worldly-minded, believers or sceptics, romanticists or realists, and so forth, primarily at least in virtue of a certain fundamental endowment of massive sentiment.

Our "great student of the human soul" has said, this particular difference in temperament "has counted in literature, art, government and manners as well as in philosophy." He should have added religion, for in no other department of life has temperament played a most important rôle, as he himself has superbly exemplified in his "Varieties." This furnishes the key to the explanation of why "God has two families of children on this earth, the once-born and the twice-born," to use Francis W. Newman's significant phrase. There is no escaping it. By shaping our faith for us it largely "divides us into possibility men and anti-possibility men" and explains why "each of us dichotomizes the Kosmos in a different place," thereby each making for himself the world in which he lives. We have certain rules by which we can calculate with approximate correctness the variation of the magnetic needle from the true North and South line, but, most unfortunately, we have no rule for computing temperamental variation.

Pragmatism, therefore, being primarily a method of thought, "an attitude of orientation," neither designates nor leads to any "specific philosophic creed"; and is not a system or a metaphysic. Dr. Schiller has cogently said that it is "an epistemological method which really describes the facts of actual knowing." That it should somewhat definitely point to a metaphysic and also prove to be "a genetic theory of what is meant by truth" should prove no surprise to us, but, as important as all this is, it must be considered as secondary. One of its chief beauties and attractions is that it leaves each one of us perfectly free to develop his own particular "ideals and over-beliefs, the most interesting and valuable things about a man." Thus it has led Professor James to "radical empiricism," Mr. Peirce to "pragmaticism," Professor Dewey to "instrumentalism" or "immediate empiricism," Dr. Schiller to "humanism," and others to "the thirteen pragmatisms," of which we have been hearing so much of late. All this is as it should be and is greatly to its credit. But these different terms should not be confounded with each other, used interchangeably as though they were synonymous, or identified with pragmatism, as has been done by some friends and many foes of the movement. At all hazards, the *pragmatic method* must not be permitted to become identified with any one of them. That would be only the first step towards its crystallization into a creed or petrification into a dogma. That would be but to follow blindly in the footsteps of those teachers who

have so treated the Christian religion, thereby creating schisms, sectarianism, and that intolerant party spirit "which blights and cankers the truth itself." Whatever Christianity may be now, primarily it was a method of living, a principle of life—not a creed or dogma.

For us, in this day and time, to repeat this blunder would simply be indefensible and unpardonable. However desirable unity may be, it should never be purchased at the expense of truth and freedom. Dr. Schiller says:

Two men, therefore, with different temperaments, *ought not* to arrive at the same metaphysic, nor can they do so honestly; each should react *individually* on the food for thought which his *personal life* affords, and the resulting differences *ought not* to be set aside as void of ultimate significance. . . . No two men ever think (and still less feel) alike, even when they profess allegiance to the self-same formulas.

Consequently, the pragmatic method will not prevent the formation of different systems of philosophy, which may be expected to "abound as before, and be as various as ever." They will still "have their day and cease to be," in the future as in the past, being necessarily only "broken lights," but pragmatism will not fall with them, for the reason that it will be "more than they" and, therefore, not identified with any of them.

That pragmatism should have encountered bitter opposition was what might have been expected. Has it not been so with every great movement in human thought from the time of Protagoras, with his famous dictum, "man is the measure of all things," down to the present time? It seems inevitable that all must run the gauntlet of criticism. Perhaps, this helps to determine "the survival of the fittest." Professor James R. Angell has recently said:

Signs are not wanting that the asperity of its critics is already softening—especially those who come out from behind the screen of anonymous reviews.

This would seem to be true, since even Mr. Bradley has said of Professor James's last book:

While reading the lectures on Pragmatism, I, doubtless like others, am led to ask myself, "Am I and have I been always myself a Pragmatist?" This question I still find myself unable to answer.

However, the distinguished author of "Appearance and Reality" may have made this statement in a Pickwickian sense. If it be true, as has been somewhat sneeringly said, that pragmatism has made comparatively few converts among the professional philosophers, but has made its strongest appeal to the men in the street, it may be fittingly replied that this has been likewise true of the greatest movements in the world's history. That the common people have heard its teachers gladly may prove to be, not its reproach, but its honor and its glory. Again and again it has happened that "not many wise men after the

flesh, not many mighty, not many noble, are called," but rather those who have become as little children, single-minded and simple-hearted.

We are still passing through one of those great transitional eras of human thought which recur at somewhat irregular intervals. It may be said to have begun some fifty years ago with the launching of the evolutionary hypothesis, but when or what the end may be no one can say. Whatever the result may be, whether for good or ill, things will never be just the same again.

But neither heat, nor frost, nor thunder,
Shall wholly do away, I ween,
The marks of that which once hath been.

There is a spirit of unrest in the air which has invaded and seriously affected, not only philosophy and science, but religion and government. In fact, it would seem that all things are being called in question, and that "there is a general reaction against uncritical acceptance of the authority of tradition along all lines of thought." What may ultimately survive or what may perish we cannot tell. Some of us believe that the pragmatic movement is one of the contributing causes, perhaps the most important, toward bringing about this condition of affairs. We think that it has already accomplished a most salutary work in philosophy and religion, which is far from being finished, and we look for it to make its presence strongly felt along educational and governmental lines. We believe that it is destined to invade our law-making bodies and courts of justice, where it must be admitted that it is sorely needed. In fine, we believe that the days of blind authority and antiquated precedents are numbered, and that the principle of pragmatism will perform a like mission in the world to that of the woman's leaven in the three measures of meal. It has been ironically spoken of as "a new gospel in philosophy." To some of us it has proved to be a veritable gospel indeed—a gospel of freedom, an evangel of hope.

IMMIGRATION AND THE FUTURE AMERICAN RACE

BY DR. ALBERT ALLEMANN

ARMY MEDICAL MUSEUM, WASHINGTON, D. C.

THE people of the thirteen colonies, the builders of the American Union, were almost exclusively of the Anglo-Saxon race. The immigration which set in after the war of independence and continued during the greater part of the nineteenth century, was composed of people not dissimilar from those early colonists. They came from the British Isles, Scandinavia, Germany and the smaller Teutonic countries. But during the last twenty-five years the number of immigrants from those regions has steadily decreased and has now sunk to very small numbers, while the immigration from Italy, Hungary, Greece and Russia has increased from year to year during the same period of time, and, of late years, has assumed truly enormous proportions. Thus while the earlier immigrants were of a reasonably homogeneous race, almost entirely of Anglo-Saxon or Teutonic origin, just enough leavened with Celtic elements to quicken the phlegmatic pulse of that cold northern race, the majority of the immigrants that landed on our shores during the last quarter of a century, are quite dissimilar in their origin, language, customs and religion from the original settlers of the American Union.

It is claimed by some writers that all these various races, which are now forming the population of the United States, will, in the course of time, fuse together and produce a new and superior type of people. Other writers go still farther; they assert that the immense numbers of this later immigration will overwhelm this country and, in the course of a few generations, supplant the original stock of Anglo-Saxon and Teutonic settlers.¹ Both these views are erroneous. It is impossible, as we shall see, that a general intermixture throughout this mighty empire can take place, much less will the later immigrants be able to supplant the descendants of those sturdy pioneers who first settled the vast prairies and fertile valleys of this great republic.

There are so many and so varied types among these later immigrants, and they are generally so much inferior to the native American

¹ "The awful tragedy, forever repeating itself, of hero nations building lordly palaces in which servant races will some day pitch their gipsy camps, will also set in in America, and the descendants of the sturdy Old English and Teutonic pioneers, a race that is said to possess the finest long-heads and the heaviest brains, will have only worked for Magyars, Slavs, Italians and Negroes." Kraus, *Polit.-Anthrop. Rev.*, Leipz., 1906-7, V., 695.

population, that such a mixture would not be desirable. Herbert Spencer, Gobineau and others have pointed out that a mixture of races, very dissimilar, produces an inferior type of people. History bears out this view. The modern peoples that dwell in the Mediterranean basin present to-day a greater mixture of dissimilar races than any country on the globe, yet these regions, once the center of civilization, have certainly not produced a superior type of humanity. If the mixture of two races of equal vigor, energy and civilization, but very dissimilar in their racial make-up, produces an inferior people, much less can the fusion of several races, some of which are of a very inferior civilization, produce a fair type of humanity.² It is the purpose of this article to show that no general mixture of the original Anglo-Saxon and Teutonic stock with the various heterogeneous elements of the later immigration will take place. We shall see that these later arrivals settle almost entirely in the large cities, and that they will there, in the course of a few generations, be eliminated in the great struggle of modern industrial and commercial life. But first we must get acquainted with the history and character of the various races which form the present population of the United States.

Broadly speaking, we have two great classes of immigrants, those that came before about the year 1885 and those that came after that year. The native home of the former was northwestern Europe and the bulk of them belongs to the so-called Teutonic, or Scandinavian, or northern blond race; the latter came from the Mediterranean basin and eastern Europe, and present a number of racial types.

The Scandinavian or Teutonic race was divided into a number of barbarian tribes when the Romans first made their acquaintance. These tribes lived in Scandinavia, northern Germany and on the islands of the Baltic Sea. Full of vigor and countless in numbers, they began to make invasions into the territories of the Roman Empire, and though frequently defeated by Roman science and discipline, they never gave up until, during the fifth century, they overran all the western provinces of the great empire and founded new states and new nations in the regions they conquered. All the modern nations of western Europe are more or less a mixture of the original Celto-Roman inhabitants with these northern conquerors; but as the latter were far in the minority, the Teutonic blood has, in the course of many centuries, been more or less eliminated; only the aristocracies of these countries, avoiding intermarriage with the subject races, preserve to this day the characteristics of their northern forefathers. This race exists

² Macchioro ascribes the decline of the Roman empire to the great intermixture of the many dissimilar races within its borders, and especially on the Italian peninsula. The greater part of the population of Rome during Imperial times consisted of foreigners. Rome presented a similar picture to New York to-day. *Polit.-Anthrop. Rev.*, Leipz., 1906-7, V., 557 et seq.

to-day in its greatest purity only in Scandinavia, in northwestern Germany and in England.³ Its chief physical characteristics are blond hair, a fair complexion, tall stature and especially a distinctly dolichocephalic shape of the head. Now as Ripley justly remarks,⁴ this long-headedness does not *ipso facto* imply a strong character, or superior mental power. The negroes, the Spaniards, the Sicilians are dolichocephalic without showing any intellectual superiority.⁵ But this particular long-headed northern race excelled and still excels by great mental qualities. It is the dominating race of modern times. It forms the ruling and predominating element in the three most powerful nations of the present day, England, Germany and the United States. Through the Anglo-Saxons, its most vigorous branch, it carried European civilization to the uttermost parts of the earth. The higher classes and the dynasties of the modern European nations belong to this northern race. Lapouge found that most of the great Frenchmen are of this type and are the descendants of the early Teutonic invaders.⁶ The majority of the great Italians who, during the Renaissance, made northern Italy the most enlightened country in the world, were the descendants of the northern conquerors, who during the great migration settled in that part of Europe.⁷ Likewise a close inquiry would probably show that the great thinkers and writers of middle and southern Germany, where the brachycephalic Alpine race forms the bulk of the population, are the descendants of the long-headed Teutons who settled among them. These northern peoples surpass all others in vigor, energy and self-control; they are aristocratic in their nature, domineering, oppressive to inferior races; but they are liberty-loving, have an innate love for law and order, and are above all other races capable of self-government; and it is certainly not accidental that all the branches of this race are protestants.

It is of descendants of this long-headed northern race that the great majority of the agricultural population of the United States is made up, and it is its very best elements that settled the American states. The people that founded the thirteen colonies belonged to the most energetic and most independent elements of old England. Only men of an indomitable courage and superior intellect would dare to brave the dangers of a distant and unknown country. Many left their homes

³ Green, in his "History of the English People," holds that the Saxon invaders almost entirely destroyed or drove out the Celto-Roman inhabitants, and the ethnographical study of the modern English people certainly sustains him.

⁴ Ripley, "Races of Europe," New York, 1899, 43.

⁵ Some of the greatest men of history were brachycephalic. The hats of Napoleon I., which are still preserved, are almost circular.

⁶ *Rev. d'anthrop.*, Paris, 1887, XVI., 76.

⁷ Woltman, *Polit.-anthrop. Rev.*, Leipzig, 1905-6, IV., 197, and 1906-7, V., 244.

on account of religious or political persecution; they stood above their fellow men in independence of thought and love of freedom. Thus by a process of natural selection only the best people of Old England came to settle the American colonies and to form the solid nucleus around which the great American nation was to form.⁸ Of these early settlers only the most vigorous, the most intelligent, again survived; the weaker elements succumbing to the new conditions, the climate, the dangers of a new country.

After the war of independence came the Irish, the Germans, the Scandinavians, the Austrians, the Swiss. The Celtic colonists, coming from Ireland, Wales and parts of Scotland, mixed with the Anglo-Saxon and Teutonic settlers. They have undoubtedly greatly modified the character of the American people. The American is less stolid, less phlegmatic than the Englishman; he is quicker, more nervous; in vivacity he approaches the mercurial Frenchman. The character of the American people was much less affected by the people who came from middle and southern Germany, from Austria and Switzerland, because these peoples are themselves the product of a mixture between the Teutonic conquerors and the brachycephalic Alpine race and were thus a less heterogeneous element than the Celtic immigrants. Here, too, a selective process was at work. It was still the days of the sailing vessel and the prairie schooner. Only the strongest, most energetic, most independent would undertake such a long, tedious and dangerous voyage. Ammon, in his most interesting study on the population of South-German cities, has shown that it is mostly the long-headed as the most energetic people who move from the rural districts to the cities. From this we may infer that the countries just mentioned sent principally this class of people across the ocean to mingle their blood with a kindred race.

The greater part of this earlier immigration belonged to the agricultural classes. Large numbers of families came from the rural districts of northern and central Europe in quest of new homes, where they might enjoy greater freedom and have larger opportunities, and where they might be enabled to leave their children a goodly inheritance. Only

⁸ England has for centuries sent out her best elements to colonize foreign regions, and if there is any truth in the assertion of some modern English writers that the British people is declining physically and intellectually, the fact that that wonderful country has for centuries been drained of its most valuable blood, would certainly not be one of its least causes. While her nearest relatives, the Germans, spent their best powers in fruitless internecine wars, England sent her best people into the most distant regions as the carriers of intellectual culture and Anglo-Saxon civilization; and should her power ever decline the famous boast of Macaulay will prove true. England's glory will never perish, her very spirit is taking a new birth in America, Australia and South Africa. These mighty colonies will bear witness of England's greatness in all future centuries.

a comparatively small portion of these people established themselves in the large cities; the great bulk of them went west and settled, side by side with the pioneers from the eastern states, the broad and fertile prairies of the Mississippi Valley and the sunny slopes of the Pacific Coast. It is true, a general intermixture of the various branches of this northern race did not take place equably throughout the country. There are large territories in many states where certain nationalities established distinct and separate settlements. Extensive tracts in Pennsylvania, Illinois, Missouri, Iowa, Texas and other states were settled by Germans alone. The Swedes and Norwegians established their new homes mostly in the northwest. The purest Anglo-Saxon blood we find in the southern states. The Celtic immigrants formed nowhere large separate settlements; they are scattered equably all over the union. One important fact must be noted here. A very large portion of the people of Celtic origin did not settle in the rural districts, but established themselves in the great cities, in New York, Boston, Chicago, St. Louis, etc., where, as we shall see later, they will disappear in the course of a few generations.

About the middle of the ninth decade of the last century an entirely new immigration began to set in. The new arrivals came from southern and eastern Europe, from Italy, Greece, Hungary, Bohemia, Russia. Hailing from an entirely different region of Europe, they differ completely in their racial characteristics from the earlier immigration. Considering only the head form, some of these people would show no marked difference from the Anglo-Saxon or Teuton. The Sicilians, the Neapolitans, the Greeks, are more or less dolichocephalic. But some anthropologists lay entirely too much stress on the headform. It is evident that purity of race is of far greater importance than the shape of the head. But these Mediterranean countries have probably the most mixed population of any region on the globe. This manifold intermixture began during the later periods of the Roman republic. The numerous prisoners taken in the many and frequent wars were sold as slaves in Italy and the provinces bordering on the Mediterranean Sea. Mommsen estimates the slave population of the Italian peninsula in the times of Sulla at twelve to fourteen millions, twice as numerous as the free population.⁹ These slaves came from the most distant regions, and were mostly barbarians, in every respect dissimilar from the Roman people.

The island of Sicily presents perhaps the best example of this manifold intermixture of the Mediterranean peoples. In the earliest cen-

⁹Mommsen, "Röm. Gesch.," 1857, II., 396. During the later times of the Republic the aristocratic classes acquired immense estates throughout Italy. They bought out or drove out the small landed proprietor and worked the land with slaves. The disappearance of the great middle class, the small landholders, was one of the chief causes of the downfall of the great empire.

differ from the long-headed northern race, which occupies to-day the rural districts of the American Union. Not one of them has reached a high degree of civilization. They have not proved their capability of self-government. They are illiterate and differ in their religious beliefs, their languages and customs, from the Teutonic peoples. They are vivacious, restless, turbulent, and do not possess that respect for law and a well-regulated government which is inborn in the northern race. They bring rarely whole families with them.¹³ No process of selection is now at work as in former days. A modern sea voyage has not the dangers and terrors of earlier times. The better and best people stay now at home and only the lower classes emigrate. A mixture of these races with the earlier immigrants could not possibly produce a superior people, as we sometimes read in newspaper articles; it would vitiate and deteriorate the American race, and might prepare for this nation the fate of the Roman empire.¹⁴

At the time when the immigrants from the south and east of Europe began to arrive in larger numbers on the American shore the vast tracts of public lands had, as we have seen, been occupied by the Anglo-Saxons and the other Teutonic peoples, mingled with considerable numbers of Celts. There were no large territories left where any great numbers of these newcomers could have settled. But these later immigrants are not agriculturally inclined; they would not settle in the country even if public lands were still accessible to them. They belong to the poorest classes, were mostly brought up in cities, and are not adapted to the cultivation of the soil. With the exception, perhaps, of the Poles an exceedingly small number of these later immigrants settle in the country.¹⁵ The Russian Jew is a city dweller; the Greek and the Syrian stay in the cities; the Hungarian and the Slav take to mining; the Italians who do not follow mining or railroading prefer the large cities. Ripley asserts that four fifths of our foreign-born citizens live in the twelve principal cities of the country.¹⁶ It is quite certain that the greater number of these are of the later immigration.

We have thus shown that the Anglo-Saxon and Teutonic stock,

¹³ Ripley, *Atlantic Monthly*, December, 1908. About 70 per cent. of these immigrants are males.

¹⁴ To withstand and counteract the steadily growing power of the yellow races the American nation requires all the strength and unity of a homogeneous people.

¹⁵ How few of these immigrants settle on public lands may be seen from a late announcement of the Chamber of Commerce of Spokane, Wash. (April, 1909). It shows that during fourteen months 106,000 new settlers established themselves in the states of Washington, Idaho, Oregon and Montana. Of this number only 10,000 were immigrants from Europe and almost all of these came from Great Britain and the Teutonic countries.

¹⁶ *Atlantic Monthly*, December, 1908. More than 800,000 Jews live in New York alone; most of them came to this

mixed with Celtic elements, forms the rural population of the United States, while the greater portion of the population of the larger and largest cities is composed of the new immigration. It is a bold assumption that the United States is a "melting-pot" in which all the races of Europe are fused to a new race. A general intermixture of the old and the new immigrants can take place only in the large cities while the rural population, the backbone of the nation, will not be appreciably affected. This mixed city population will not persist for any length of time. It is a generally recognized fact that city populations have much less vitality than the agricultural classes. But the surprisingly rapid rate at which families in the cities die out was not known until the remarkable observations of Hansen, Ammon and others were made public.

In modern times the causes which contribute to the rapid destruction of the city population are much more potent than in the past. The cities are generally much larger and it is certain that the healthfulness of a city decreases as its size increases. It is true that sanitary measures are much more efficient than in former times, but it is also true that the destructive influences have grown in strength and new ones have appeared. The modern factory work, the poor housing conditions of the lower classes, tend to destroy life and weaken vitality. Race suicide is practised especially in the cities, while it is almost unknown among the country population. The struggle for existence is much severer in the cities; marriages are fewer; the mortality of children is greater. Prostitution, the curse of large cities, is an enemy to marriage and tends to shorten and destroy life by transmitting and spreading venereal diseases. To all this we must add the attractions of city life, the chase after pleasure, the constant excitement, the nervous strain, which are all hostile to the vitality of families.¹⁷ Another cause of the rapid extinction of the city population lies in the very mixture of so many races. There is a biological law that hybrids do not tend to reproduce their kind. The fecundity of such a mixed population is appreciably lower than that of a pure race. Lapouge found that in those regions of France where the brachycephalic Alpine race has preserved a comparative purity the birth rate is much higher than in the districts where the race is greatly mixed with Teutonic blood. In the latter regions the birth rate is actually decreasing.¹⁸

It is evident that the lower classes, living under less favorable conditions than the well-to-do, are more subject to rapid extinction. But

¹⁷ The U. S. Census of 1900 shows that the death rate in the cities of Massachusetts, New York, New Jersey, Connecticut, New Hampshire, Michigan, Maine and Vermont was 18.6 per thousand of population, while in the rural districts it was only 15.4 per thousand. Baker, *Quart. Publ. Am. Statist. Ass.*, Boston, 1908, XI., 133.

¹⁸ *Rev. d'anthrop.*, Paris, 1887, XVI., pp. 74 and 526.

the higher classes are not exempt from this iron law. Various causes are mentioned for this fact. Marriages are contracted much later in life among the wealthy, and, as a rule, they have fewer children; the intellectual life seems to be unfavorable to the fecundity of women. Race suicide is more common among the higher classes.¹⁹ It is hardly necessary to mention that families of an extremely healthy stock, and living under the most favorable conditions, are able to continue their existence a much longer time. The remarkable vitality of the British aristocracy is due to their athletic habits and to the fact that they spend the greater part of the year on their estates in the country. Ammon holds that the aristocratic classes of the continent "have favorable prospects to perpetuate their family names only if they live on their estates and devote themselves to agriculture and the chase."²⁰

The Jews seem to form an exception to what has just been said. They have been city dwellers from the time they left Palestine and began to overrun the countries of the earth. There can be no doubt that they are a very healthy race. In the struggle for existence, during the endless persecutions they had to undergo in every country and at all ages, only the strongest individuals survived. A process of natural selection thus produced a vigorous race. The frugal and sober habits and the faithful application of the sanitary precepts of the Mosaic code also contributed greatly to produce a healthy people. But these influences are much less at work in modern times. The vitality of the Jew will be greatly affected by modern city life as we find it in the city of New York, where the great bulk of the Jewish population in this country lives. Tuberculosis, the scourge of the white race, used to be rare among the Jews, but the unsanitary life in the "sweat-shops" of New York is also increasing its victims among this people.²¹

The rate at which city populations die out is much more rapid than one would ordinarily suppose. Recent researches have thrown much light on this process of elimination. Ammon, in his researches on the population of Carlsruhe and Freiburg (two comparatively small cities) established the fact that the city-born population decreases in the course of two generations from 100 per cent. to 29 and 15 per cent. He supposes that on an average the families who move from the country to a city die out in the course of two generations.²² Hansen found that one half of the population of the German cities consists at all times of immigrants from the country districts, and he concludes from this fact that the city population renews itself completely in the course of two generations.²³ We may safely apply these results, which have been

¹⁹ Ammon, "Natürl. Ausl.," p. 297.

²⁰ *Ibid.*, p. 302.

²¹ Jerusalem, *Med. Blätter*, Wien, 1909, XXXII., 181.

²² Ammon, "Natürl. Ausl.," p. 300.

²³ Hansen, "Drei Bevölkerungsstufen," 1889, p. 27.

obtained for the German cities, to the great industrial and commercial centers of America, for conditions here are not more favorable to the maintenance of human life. We may assume, therefore, that the families that are now living in our large cities will, with few exceptions, die out in the course of two or three generations. It is only through the constant supply which the cities draw from the country that they are able to maintain and increase their population. If a modern city had to rely solely on its own natural increase, its population would steadily decline and finally shrink to an insignificant number. But if the disappearing portion of the American city population were constantly replenished by new immigration from Europe there would be no change in the actual conditions. However, the time is near at hand when the government of the United States will be compelled, for economic reasons, to close the gates to the great mass of poor immigrants from Europe. When that time comes the cities will have to rely exclusively on the country to replenish their dwindling population. Then the unceasing stream of people, which even now is constantly flowing from the country towards the towns, will reconquer the cities from that alien population which now holds them.²⁴ It is clear that the longer this process of conquering the cities by the rural population is going on the more thorough will be the elimination of the alien races. A few elements of the new immigration will doubtless persist and form a permanent part of the future American race, but they will be a desirable acquisition, for by the law of the survival of the fittest they must be considered a superior type of humanity.

We have thus shown that no general intermixture of the old with the new immigration will take place, and that instead of the Anglo-Saxon and Teutonic settlers "are working for inferior races," who will some day displace them, the reverse is true. There is no doubt that these later immigrants, as laborers, have performed and are performing an important part in this country; they have contributed not a small part to the wealth of this nation.²⁵

It was not the purpose of this article to minimize the disadvantages and dangers of this later immigration. The presence, in our large cities, of great numbers of these illiterate strangers, who neither understand nor sympathize with the political institutions of this country, is an impediment to municipal reform. So many of these heterogeneous

²⁴This is what one of the orators at the last Congress of Catholic Missionaries had in mind when he said that if the Catholics did not make headway in the country districts, the time was coming when their churches in the great cities would be empty. It is well known that most of the adherents of that denomination live in the great cities.

²⁵Emerson, who certainly spoke with no cynical or mocking motive, did not hesitate to affirm that these laboring emigrants "have a good deal of guano in their destiny."

people are now among us that it would be to the best interests of the country if congress, by suitable legislation, restricted immigration in such a manner as only to admit a small number and only the best elements of these heterogeneous races.

The negro, more dissimilar from the Anglo-Saxon than any other race, has purposely been omitted in this study. Though the negroes form a considerable portion of the agricultural population of a large section of the union, a mixture between the two races, as is the case in Latin America, will never take place. The Anglo-Saxon is too proud and too much bent on the preservation of his racial purity to admit of any such intermixture. He even rejects the mulatto who shows the slightest traces of black blood. The negro is physically and intellectually inferior to the white man; he is several thousand years behind the white race in his intellectual development and, as Huxley observed, will never be the equal of the white man. In the great struggle for existence which, in future centuries, will grow in intensity, the negro will be eliminated, "he will melt away before the breath of the white man as snow melts under a hot wind."²⁶ This is the probable solution of the negro problem in the United States. One of the chief means by which this process of elimination is hastened, is the marked tendency of the negro to leave the rural districts and to settle in the large cities, where he has much less chance of survival than the more energetic and thrifty white man.

²⁶ Ammon, "Natürl. Ausl.," p. 325.

ENVIRONMENT AND PRODUCTIVE SCHOLARSHIP

BY DR. W. J. HUMPHREYS

WASHINGTON, D. C.

TO say that ours is the best age the world has ever known is to state a simple truth. Even though we can claim for literature no living Homer, nor Dante, nor Shakespeare; for art no Phidias, nor Michel Angelo, nor Rubens; for moral suasion no Confucius, nor Zoroaster, nor Mahomet, still the statement is true. True because for the west as well as for the far east this is the age of Meiji—the age of enlightenment. True because man to-day has more knowledge than ever before of the laws of the universe in which he is placed, and because this knowledge is power; the power by which he brings inanimate nature to his aid; the power that determines his efficiency and fixes his place on the scale of civilization. It is this knowledge, slowly gained through the ages, and his ability to use it, that raises man above the plane of the mere animal and gives him dominion over all the earth and its creatures.

He alone has discovered even so simple a thing as how, by putting the half burned logs closer together and by adding fresh fuel, to keep burning the fire that, like himself, many an animal enjoys but knows not how to obtain; a discovery that has been of incalculable benefit to him and will be. And so too each additional discovery, by the fuller knowledge and wider control of nature it brings, marks a gain in the struggle for life and for happiness. It lays broader and deeper the foundation upon which our arts and our civilization are based, and stamps, therefore, the discoverer as a benefactor of the human race.

There is no intention here to imply that people without originality are necessarily useless. In fact, they are very far from being so, for the practise of the arts is the end of science, and for this one does not need in the least to be original. Nevertheless, all material progress does depend absolutely upon the investigator and the inventor; upon that rare man, the genius that discovers the secrets of nature, and upon that host of skillful men who cleverly use these discoveries in devising mechanical and other means of meeting every-day needs.

Science, as just implied, is not an end within itself, at least not an important one, for it is the bringing of nature's forces to our service, the application of her laws to the development of useful arts, and not the abstract knowledge of the laws themselves, that chiefly concerns mankind; and, therefore, being cognizant of only its mediate benefactors, the public gives its laurels and its material rewards to the inventor and the manufacturer, rather than to the investigator and the scholar. But in this, as in so many other things, the decision of the majority is

wrong and the judgment of the public not to be trusted. Some praise may very well be given to the manufacturer and a great deal more to the inventor, for the work of each is essential to the good of the public; but, after all, the real honor is due the investigator who, by patient research and keenness of insight, discovered the laws that made possible the invention and its uses. Only let some genius discover electrical waves and in time there will be devised many systems of wireless telegraphy, or let the mysterious X-ray and how to produce it be revealed and soon there will be hundreds of clever devices for its practical use. And so it is through all the arts and all the sciences, where there is one to lead and discover there are many to follow and apply, and countless millions to enjoy. A Newton, a Darwin, a Pasteur, rarely is found, but wherever he may be there are, besides himself, many others who can and who do perform the necessary, but always secondary, function of turning his discoveries to every-day uses so that all mankind, as long thereafter as the race may last, can live more securely and more happily.

It is man's power of investigation and of discovery that enables him to bring the forces of nature to his aid, without which help he would perish wholly or at best live only as the beasts of the forest. It is science that makes two blades of grass grow where but one grew before, and this is basic, for by it we conquer in the struggle for existence. It is basic because self-preservation is everywhere and always the first law of nature, and because whatever else happens, and before any higher development is possible, our physical needs must be provided for.

The author fully concurs in every claim that can be made for the intellectual and the moral uplift due to the beautiful and the artistic, whether in literature, music, painting or any other form whatsoever in which they can find expression; but these are apart from his present discussion which concerns the knowledge of nature's laws and their application to human affairs. Neither is he unmindful of nor without appreciation for the great good, other than material, that follows in the wake of scientific study and investigation. He believes that the declaration: "The truth shall make you free," is as applicable and as necessary to things intellectual as to things spiritual; but he also holds that those truths of nature that aid in providing for our daily needs are just as effective as any others in freeing the human mind from the bondages of fear and of superstition, and that therefore only those truths that offer definite applications, and those essential to a better understanding of nature and a fuller control of her forces, are really worthy to be sought after patiently and diligently.

However, the possible usefulness of an investigation is a point to be considered, if ever at all, in determining what question to take up and how to attack it, for the scientific genius investigates, as the poet writes, along any line that appeals to him. In a sense he can not help it, for to him research and experiment are life and happiness; he is still

a boy who has never outgrown young life's curiosity and the joy of seeing new things, nor has he outgrown the stimulus of companionship, the necessity for playmates. He obeys instinctively that best of advice given and followed by Rowland of experimental fame: "Do something to it, man, do something to it and something will happen," and therefore once his investigation is begun he seldom stops to consider of what use the results may be; nor is this often to be regretted since whatever his discoveries, it is practically certain that some day they will have many and unsuspected applications. It was Helmholtz who, to satisfy his own apparently idle curiosity, determined why a cat's eye glows, or as we say, looks green in the dark. But out of this investigation, which to the practical man would appear utterly trivial and useless, came not only knowledge that shattered certain superstitious fears, but even the ophthalmoscope that every year helps to save the sight of thousands of human beings.

This beautiful illustration of the unsuspected results of scientific work is scarcely more than typical, for however keen the zest of investigation, however glorious the hour of discovery, these joys of the few are as nothing in comparison with the sum total of the peace of intellectual freedom and of the pleasures of physical comfort their labors provide for the multitudes of every living nation and of all future generations. And therefore it would seem that, of all people, those who, by their persistent labors and by the keenness of their intellect, make the world more fruitful and nature more the servant of man, would be honored and encouraged; that they would be sought after and put in those positions that would enable them to do their work best, and where they could exert the greatest influence upon others by inspiring as many as possible to emulate their example. And indeed this in some measure is the happy state of affairs in the cultured centers of the old world; and it is there that nearly all the power that comes of knowledge had its origin.

That which makes human progress possible, that which has given us our present civilization, and points the way to a higher, should command our unqualified admiration and our every encouragement. And in so far as they depend upon our knowledge of the laws of the universe in which we are placed and from which we can not escape, in so far as they depend upon our luxuries and upon the means of providing our necessities, of protecting ourselves from plague and from pestilence—in so far as they depend upon making the world more fruitful and therefore the abode of a more numerous and happier people—so far as civilization and progress depend upon all these things, just so far they depend absolutely upon the labors of the creative scholar, upon the work of the investigator, the seeker after and the discover of nature's truths and nature's laws. It matters not how firmly the man of affairs establishes some new and important industry, nor how readily the public accepts what he has to offer, whether the convenience of modern lighting,

the facilities of wireless and of other methods of communication, or any of the thousands of things that steam and electricity can supply, every one traces back beyond the artisan and the financier to the oft forgotten investigator but for whose labors there would be occasion for neither, and even kings could not have as a luxury that which all the world now deems a necessity.

It is absolutely essential to our future progress, nor can this be emphasized too strongly, that we appreciate the inestimable value of pure research; that we realize the futility without it of every effort to advance, and the certainty with it of the creation of new industries, the finding of new comforts and the improvement of man's every condition: and it is equally essential that on realizing this we have the courage to act according to our convictions.

Let us then humbly and honestly inquire what part we Americans as individuals, as communities and as a nation are taking in this the chief labor of the human race for its existence and for its betterment. The average individual, if he is honest with himself, is not likely to feel very proud of his own achievements or of those of his community, nor even satisfied with the earnestness of his efforts; and therefore as a nation we are not able to point with pride to the part we have taken in scientific investigations. Good work has been done and is being done in an increasingly large amount, but on the whole, as a nation, we are not doing our duty in this respect, for our productiveness, relative to our numbers, falls far short of that of most of our mother countries, such as England, France, Germany and Holland, and besides many of the more important discoveries that we claim were made by men of foreign birth.

It is not very agreeable to have to admit this state of affairs, but only the ignorant fail to see their own faults, and only the coward refuses to admit them. The wise thing to do is to admit them frankly—at least to one's self—and the courageous thing is to begin promptly and persistently to do one's full duty as he sees it.

It would be well if possible to learn the cause of this generally admitted rarity of American discoveries, so that as in the case of a disease a remedy can be intelligently sought for. It can not be attributed to race difference, since we are of the same stock that produces so much more on the other side of the ocean. Nor can it be attributed to lack of means, for we boast of the greatest wealth of any nation of this or of any past age, and to our universities we make gifts whose princely magnificence astounds the world. Neither is it due to our mad rush in business, our striving after wealth, for in general our greatest business centers, our wealthiest cities, are the principal sources of our original contributions to knowledge; while that very part of our country which has always boasted its superiority to the sordid things of mammon, to the littleness of business strife, and prided itself upon its intelligence,

upon its scholarship, its leisure and its devotion to the greatest good of its own people, is the least productive of creative work—in some of the more important sciences even practically sterile.

Here then, in the south, that cause, whatever it is, has its greatest influence, and can therefore the more certainly be determined. Surely though, this mortifying, this deplorable state of affairs does not have to exist, for the south long ago showed her ability in meeting and mastering great political, military, and judicial problems, and she has to-day as splendid a class of people, as earnest, as capable, as sensitive and as self sacrificing as has any country on the face of the earth, the very qualities essential to scientific achievements. Why then do her people accomplish so little of this kind of work, and why have they no voice in the councils of our national scientific societies?

But first to show that these statements are true. In *Science* for December 18, 1908, is given the names of the presidents and secretaries for the Baltimore meetings of a number of scientific organizations—the American Association for the Advancement of Science, its several sections, and twenty-four other societies—in all, seventy-eight names, and just one is from south of the Potomac and the Ohio. Even the Southern Society for Philosophy and Psychology was officered by men from north of the Potomac. Surely then the voice of the south is faint in the councils of our scientific organizations; nor has she even a single representative in the whole of the National Academy. But this is not intended in the least as a criticism of any of these societies or of the excellent men they have chosen to represent them. It is a simple statement of the facts, so astonishing, however, that if generally realized they could not help arousing that healthy determination that leads to better things.

During the past twelve years the author has had the pleasure of attending many of the meetings of the American Association for the Advancement of Science, sections A and B, of the American Physical Society and of the Astronomical and Astrophysical Society of America, but in all this time, except for an occasional contribution from one university, rarely ever heard a paper that was written in what are known as the southern states. He has repeatedly heard papers, often excellent ones, written at northern universities by men of southern birth, but seldom, if ever, a paper by a northern man in a southern university.

This great inequality, even when the men are the same, in productive scholarship between the northern and the southern parts of our country can have but one explanation—*difference in environment*; and it explains too the inferior part we as a nation are taking in preparing the way for any real advance in civilization.

It is the stimulus of his environment, as every creative scholar knows, that is chiefly responsible for the quantity and even in large

measure for the quality of all the original work he does, and as our educational institutions, equipped with their splendid libraries, museums and laboratories, are the only places where men are supposed to give their entire time to knowing things and to training others to know, therefore the tone, as we say, of its universities, their attitude towards science, is the chief determining cause of the part any nation takes in adding to the sum of human knowledge and of human power; and therefore too it is properly expected of them that they shall seek the highest type of scholarship, and constantly maintain that peculiar environment that stimulates to creative work. The spirit of its community of course has more or less influence on the work of every university, but it is never of first importance, for each takes the institution in its midst for a model, and as no one rises to the level of his ideal, so too no community equals even in sterile scholarship, much less productive, that of its university. In the main this spirit of the community is but that of its own college reflected in a modified and enfeebled form. Of course there are good and bad reflectors, but everywhere the important thing is the quality and intensity of the central light. In fact the public, whose business is the making of money and the getting of bonds, can not be expected to be so enthusiastic about these higher things as are educational institutions whose very existence is for the development of brains and the training of hands, and therefore for some time to come the university is likely to remain, as it has been in the past, the source of much the greater part of all original knowledge, in spite of the fact that at present there is an increasing amount coming from governmental and from business laboratories, for both these latter, necessarily, are greatly restricted in their fields of operation. Business men wish conducted investigations that promise immediate financial returns to themselves, and investigators that do this class of work have something of the same restrictions thrown about them that hedge in the advertising poet whose inspiration is a special brand of soap; and mighty little of a first class order has ever come from either source. Government institutions, though allowing a greater latitude than do business firms in the investigations selected, often feel compelled to have for their object immediate returns that will encourage congress and the country to continue their support, and only too frequently does this lead to insistent calls for "copy," as though the investigator could submit at stated intervals original ideas and finished results with the same regularity that the farmer can raise a new crop of pumpkins.

There remain the special laboratories of the Carnegie Institution that are an inspiration to all the world, but even here the investigator is not so free as is the university professor to follow whithersoever his tastes and his talents may lead, and, besides, even these laboratories have not the opportunity that the university has of fixing the lives of men, of molding public opinion and of determining the destiny of our country.

Wherever then any country is to blame for its barrenness in scientific ideas and results, this blame attaches to her universities. If a community in which a university is situated is without interest in matters of a scientific nature it is because the university itself cares but little for such things and does less.

As stated above, the south is the least productive of original work of any part of our country, and the fault lies at the doors of the southern universities—as the following several illustrations will make clear—the institutions whose duty it is to train by precept and by example.

A good instance emphasizing this point is the case of a certain southern man whose name is well known to the scientific world because of his investigations while in the north. On finally accepting, after much hesitation, a position in one of the oldest and best of the southern universities he remarked pathetically in regard to his scientific career—“I am going now to be laid upon the shelf for the rest of my life.” And, while he is an ornament to the faculty of which he is a member, as he would be to any other, he fully understood and correctly judged the lethal effect on all scientific aspirations of his boyhood environment,

Where the mocking bird calls to dreams of fair women,
And the soul drifts on in a somnolent ease.

But lest this be regarded as a mere isolated case, due to the peculiarities of a single individual, it may be well to describe the attitude towards creative work maintained by the heads of certain institutions.

One of these, the president of one of the largest institutions in the south, has more than once assured the writer that he regarded investigation on the part of professors as a thing which took just that much time from the students, and that therefore it should not be encouraged—a fallacy that once obtained, but outgrown more than a century ago, at one of the great northern colleges. And the pity of it is this man's opinion clearly is having an influence on his institution, for in certain of the sciences it is about as much heard of as is the Imperial University of Timbuctoo.

The president of another institution of almost boundless claims (this applies to both), when he was on the point of closing a contract with a really capable man, so runs the information from this man himself, invited him to take part in a prayer meeting. This was declined on the ground that, while a regular church attendant, he was not an active church worker. He was then informed that this particular institution raised up christian young men (by implication others did not), and that he, the president, regarded active work in the Young Men's Christian Association on the part of a professor as of more importance than his teaching.

From a certain standpoint this view of the situation may be logical enough; at any rate, the Young Men's Christian Association, in its moral uplift of college life, has a noble function to perform and per-

forms it well; but still there is good authority for rendering unto Cæsar the things that are Cæsar's, and if the chief purpose of a secular college is to train the intellect, then surely the main duty of its professors is to know their own specialities, to work in them and to teach them.

So delicately sensitive a thing as the creative instinct, the uncompromising devotion to truth, even though it conflict with fond notions, seldom thrives in a sectarian college, whether honestly sectarian, sectarian everywhere except in the catalogue, or only sectarian for advertising purposes. The open-minded investigator would be wholly out of place, even miserable, in such an environment, and often, as in this particular case, is informed that his services are not wanted. Such institutions are of but little credit to any church and less to real scholarship. Science and religion are not on the same plane; they deal with totally different things by entirely different methods, and therefore can no more conflict or agree than mathematics can conflict with morals. Consequently any attempt to unite the two is wholly illogical and can lead to nothing but utter confusion. A man of course may be both religious and scientific, but science is no part of his religion, however much the life he lives may be better and more useful because of his science.

One more illustration; probably the best of all for showing the deplorable state of affairs at perhaps many an institution in all sections of the country, for there are echoes of it from every quarter. Not long ago the president of a leading southern university was charged with the troublesome duty of finding several new men for his faculty, and in the course of his inquiries let it be understood that a man with research aspirations and first-class attainments was not desired, and made the astonishing statement, in support of his position, that a research man is seldom ever a teacher. What he really wanted, he said, was men that would mix with the boys and with the people of the state—a clever shoe drummer might have met these conditions.

As mixing with the people suggested a kind of missionary work for the purpose of winning popular favor, he was asked if he was not limited by public sentiment to draw his faculty from his own state. No, he said, fortunately not, as his state furnished no men of sufficient scholarship.

Now right here are brought together the cause we are looking for and its effect. This university does not wish men of first-class attainments given to original work. Its environment must therefore be stifling to every creative effort; and this is the cause that produces such a disastrous effect upon the state that it can furnish no men sufficiently trained (and note that high attainments are not required) to fill the chairs in its own institutions. In the name of reason how can it be expected to? And so long as this condition continues what possible hope is there that it will ever be able to do any better?

The writer does not advocate exclusive use of home talent. On the contrary, he urges very general exchange, but when a state has nothing suitable for its own use exchange is impossible—it can only import.

If scholarship is worth while, if knowledge is of any value, and research productive of good, then this condition of affairs is utterly intolerable. The change to a better simply must and will be made, for no community high-minded, sensitive and capable as the south is will do anything other than welcome an honest description of things as they are, and then wherever not creditable set about to correct them.

In this case the task is a difficult one, but the need of it more than manifest, and the task weighs first and heaviest upon the presidents of the universities. Power implies duty, and theirs in the main is the power to shape the destiny of their institutions, and through them of the communities, the states and the nation of which they are a vital part.

Wherever the president of an institution gives no hearty encouragement to first-class attainments, wherever creative ability is held to disqualify a man for a position in a university rather than to be the first essential, at that place is stagnation and death in all that stimulates the scholar to his noblest efforts, and at best only a lot of weary task-masters driving to their unwilling grinds so many human phonographs that give back just what they have taken down of another.

It may not be the university president of the south that is to blame for the origin of the sterile condition of scholarship in his section, but it is to him we must look for the needed change. He may find the labor difficult, but it is possible and that is sufficient. He can not claim that his students are without the ability to follow the leadership of a master, for in the north and in Europe, wherever they have the chance, they do follow masters, and follow them to a purpose. Nor can paucity of material equipment any longer be claimed, since many of the southern institutions are equipped far beyond the extent indicated by the results turned out, and have been for a long while. Indeed for many kinds of creative work the necessary equipment is not great, and besides there are a number of sources from which the capable and the active often can secure substantial aid. Then, too, cooperation with one or another of the various scientific bureaus of the national government is eminently practical and because of the many mutual benefits earnestly to be desired. The physicist, for instance, if so inclined, can with but small expense take up the studies of atmospheric electricity, sky polarization, insolation, or any one or more of the many other interesting meteorological phenomena that are always with him, but which are not yet fully understood. In no other way could he add more to the advancement of his own subject, while at the same time he would be enriching the science of meteorology and thereby improving the art of forecasting. This is only one of many possible suggestions for even the physicist, and similar ones could be made in connection with other branches of

science. No man need believe there is nothing for him to do, nor no one to appreciate and help him—provided only that he will make it evident by his works that he deserves encouragement and would profitably use any material assistance.

For some lines of investigation, as every one knows, an expensive equipment is needed, but, as just explained, there are other things one may do, and besides that state is poor indeed that can not afford support to its university. Note what Germany did for her universities at the close of the Napoleonic wars, and what in turn the universities have done for her. Consider too the attitude of Japan when fighting the greatest battles of all history. Even the emperor's palace was without heat the whole winter long, but the Imperial University and every school of the empire was fully supported. It was when Port Arthur was still resisting stubbornly and all the issues of the war were unsettled that the eminent Kitazato, in company with many American scientists, first saw exhibited a certain new and important piece of research apparatus. The Americans expressed an admiration of and a desire for the apparatus, but each said that his department could not afford it. Kitazato, however, saw its value and recognized that an institution active in his specialty could not afford to do without it, and therefore ordered it at once and insisted upon the earliest possible delivery.

This is the spirit that within thirty years has made the University of Tokio one of the world's greatest centers of learning and of productive scholarship, and this is the spirit the absence of which has permitted that drowsy, contented introspection that is bringing Nirvana to many an American institution; and especially to those of the south.

O wad some power the giftie gie us
To see oursel's as others see us!

The critic is frequently assured that his is an easy task, and told that if he wishes things different he must at least state clearly what he does want, and show how to get it. Now it is not desired that this article shall be taken as a criticism chiefly, but rather as an appeal for a larger quantity of high-class creative work, especially at our universities of every section. Nevertheless, a few suggestions, which the author knows to be practicable will be made.

But before suggesting what, in the author's opinion, are some of the things best to do to render our scholarship more profound and more productive it may be worth while, though it is humiliating to admit it, emphatically to call attention to a few things not to do. Don't merit contempt by cheaply exploiting the scholar's noblest work. Don't set unprepared young men to doing worthless pieces of drudgery—counting the hairs on the end of a white kitten's tail it may be—and then, after cheating them of their time, try to humbug them into believing that they have been profitably engaged upon important investigations. Don't

let research flourish for advertising purposes in the catalogue when there is nothing of it in the laboratory. Dishonesty and humbugery in scholarship and in education probably are the meanest, because the most injurious, of all forms of rascality; and yet, though there should be none of it, who can be found willing to say that it is even uncommon?

America, as already stated, is not doing her share of creative work, and this inexcusable negligence is far more pronounced in the southern states than it is anywhere else, though no section is free from blame—no institution can claim to be ideal. This is not due to racial peculiarities, to want of material equipment, nor to an inordinate struggle for wealth, but chiefly to the atmosphere of the university, to the environment in which the university professor is placed and upon which he must depend for his daily intellectual stimulus.

For schools, academies and colleges that confine themselves strictly to elementary work, creative scholarship on the part of the teachers is not so imperative, but, as the reputation of every institution is that of the work it does and no more, therefore, in the case of those that wish to justify their claims to the title of university, let every important chair, irrespective of the present or prospective quantity of graduate work, be filled only by a man who has contributed something to the advancement of his subject, and who is likely to continue doing so. Such a man, because of his love for his specialty, and because of his thoroughness, usually is an enthusiastic teacher and often an inspiring one—the highest qualification. He who is not a research man seldom induces the love of knowledge in others—blood doesn't come from turnips.

In the name of civilization and of human progress let no position that presupposes scholarship and offers the sacred privilege of doing work be filled save by him who recognizes that in this case opportunity means duty. The ideal man is one who has a sympathetic appreciation for all sciences and a minute knowledge of his own specialty—one who knows something about everything and everything about something, for nothing short of this can give that accuracy and that resourcefulness essential to the solution of difficult problems, nor that alertness and breadth of view so necessary to the detection and to the understanding of new phenomena. To be sure, the ideal man seldom is found, but it is better to hunt long for the ideally good, than, as sometimes seems to be the case, quickly to secure the ideally bad.

This, then, the careful selection of his faculty, selection and promotion according to their productive ability (for by their fruits ye shall know them), is the president's first and greatest obligation. Nor is this impracticable, for it is the avowed and fruitful policy of the president of one of our leading universities, a policy fully approved by his board, and supported by the legislature to which he is responsible.

Another important thing the president can do—and one of our best

college presidents did it for years—is to keep himself constantly informed, in a general way, of every investigation that is going on in his institution, and to encourage those who are doing this work, publicly and privately. This sort of encouragement costs but little, but, coming from him whose position and whose judgment command his highest respect, is of incalculable help to the weary, sensitive investigator. He needs to be cheered on by the knowledge that what he is doing is meeting, not indifference, but active encouragement by those to whom he is most responsible for what he does. The writer has known capable men to be timidly engaged on investigations about which it was almost impossible to get them to say anything at all. They acted as though nature was a huge bungle for which they were responsible and of which they therefore were heartily ashamed, or as if they were on the point of making some wonderful discovery which if suddenly revealed in its perfected form would startle the civilized world.

This frame of mind, harmful alike to the man himself and to his associates, is most unwholesome, and one from which the president, more than any one else, can help to free him, since it often originates in the real or supposed isolation of the victim in his work; a condition, as every scholar knows, inimical to creative activity, whether it be the isolation of positive loneliness, or that worse form, the isolation of uncongenial surroundings. And in this connection it should be remembered that because of the intensity and exhausting nature of his work, the research man needs pleasant surroundings and frequent diversions; conditions over which the president unfortunately has but little control, and which therefore should be given all the more careful consideration, if possible, in the original selection of the institution's location. The faculty of an isolated institution is itself in great measure isolated, and commonly the creative work one does in a desert, under the oppression of ennui, bears but little relation to what he can do when agreeably situated and surrounded by things intellectually stimulating. The investigator, imaginative like the poet, nervous and often overwrought, is sensitive, and, while easily elated, just as easily depressed; and therefore when no one takes an obvious interest in what he is doing, and there are no ready means of diversion, he tends to become morose, and keeps his thoughts to himself, where they are likely to find anything but cheerful company.

However, under all conditions let the investigator be encouraged to talk, let him join with his colleagues in the formation of a local science club for the free exchange of ideas, and there let him talk often and talk freely. It will aid greatly to clear up his own ideas—this explaining of things to others—and will help to keep him enthusiastic. In this way his light will not be hid under a bushel, but shine, as it were, from a hilltop where it will be of the greatest help to his neighbors. Because of this sort of encouragement and this sort of united effort and material

support the creative work of every department and of every scholar in the entire institution will be greater in volume and better in quality.

The proper distribution of routine duties and responsibilities at any institution is an important question, and there is a numerical ratio, not a large one, either, between professors and students beyond which nothing can be properly done; but as far as possible let the research man be relieved of routine drudgery and worry of every type. Of course, however, if at the head of his department, he must have something to do with executive work, but this should be only of the most general nature and at infrequent intervals. The routine and the details of it should be left to others. Some one else can do this class of things as well and commonly better, for the mind that is in tune with the one is out of harmony with the other.

Finally let the professors be encouraged to attend the principal meetings of those societies to which they belong, or should belong, and not only to attend but whenever practicable to take with them suitable communications. They are certain to hear at these meetings many papers of interest, and their own communications will receive all that attention and respect they deserve. But far better than the information they will get from the papers heard, or from the discussion of their own, will be the enthusiasm inspired by the association thus secured, even though temporary, with the productive scholars of the entire country; an enthusiasm that welcomes difficulties and leads, through persistent attack, to their ultimate solution.

It can not be emphasized too strongly that quality of work depends upon efficiency of equipment, and that therefore as the professor is the most essential part of the university's equipment he at least must be kept free from rust and from corrosion. He must attend the meetings of scholars in his own line, where friendly mental friction will give him that alertness and enthusiasm that will increase the quantity of his work and improve the quality of every thing he does.

It may not be practicable for many institutions to follow the lead of a certain excellent college—one that deserves the name university—and set aside a sum of money to help pay the expenses of its representatives at these meetings; but those who can do it will find this an investment that will repay an hundredfold, in enthusiasm, in efficiency and in productiveness.

Frankly, as a nation, and especially in certain sections, we Americans have not been, and are not now, doing our share of original work; not taking our part in the creation of new arts and the promotion of civilization. But the case for us is far from hopeless; already here and there are signs of a true awakening, a realization that opportunity means duty. The past is not creditable, but the present bids us look confidently to the future when soon the sincere and capable alone will achieve success and recognition.

MEDIEVAL CREATION MYTHS

BY PROFESSOR B. K. EMERSON

AMHERST COLLEGE

THERE is perhaps more reserve than formerly in assuming the westward wandering of great hordes out of Asia, but, whether the peoples have or have not migrated, the myths certainly have, and all through western Asia and southern Europe the old biblical stories are strongly blended with dualistic traits that have all the ear marks of Iran. As the light conquers the darkness and ushers in the day, so the darkness conquers the light and ushers in the night. Thus Ormuzd and Ahriman are equal to the confines of eternity and God and Satanael become equal in the blended stories.

Of the many variations of these creation myths which have taken root especially among Slavic peoples in the Caucasus, across southern Russia and the Balkans, I have wilfully chosen those parts which have a geological flavor, and illustrate or parody, in quaint and naïve manner, many earth forms or earth-forming processes.

I owe most of this material to Oscar Dähnhardt,¹ who has collected many medieval stories of the creation of curious interest. In north and west Russia, in the fifteenth and sixteenth centuries the "Roll of the Divine Books" tells how, while there was still neither heaven nor earth, the Sea of Tiberias existed, solitary and alone, and it was shoreless.

The story is continued thus in Ukraine (p. 55) :

As God would create the world, he spoke to the oldest of his angels, Satanael, with whom he wandered over the sea, and bade him dive to the bottom and bring him up a handful of sand. As he grasped the sand he should say, "I seize thee, Earth, in the name of the Lord!" But as Satanael came to the bottom the wicked thought came to him, and he said, "In the Lord's and in my name!" But as he arose again the sand ran out of his hand and he brought up nothing.

The Lord, who noticed what had happened, bade him dive again and forbade him to use his own name. He did this, nevertheless, and again brought up nothing. Only the third time he left out his own name and brought up sand in his open hand. God took it; went out over the sea and scattered it upon the waters and it became land.

But Satanael licked his hand and said, "I will keep back just a little and also make land." And God asked him if he had any sand and he answered, "No!"

Now God blessed the earth in all four directions and it began to grow. But the earth that Satanael had in his mouth began to grow also and became so great that his lips stretched apart.

¹"Sagen zum Alten Testament."

And God said, "Spit it out, Satanael." And he began to sputter and spat it all out, and wherever it fell cliffs and mountains grew up. Therefore is our earth greatly uneven.

"Wherefore hast thou made such mountains?" asked the Lord, "That man should weary himself in climbing them?"

"O Lord it is good that it is so hard," answered the Devil, "For now will man think of you and also not forget me. When he climbs up breathless he will say, 'Help, Lord!' When he descends the mountains he will think of me also, and say, 'The Devil has tempted me up on to this mountain, here one can break his neck only too easily.'"

Among the Philippon of the flat plains of Ost Preusen the story has this curious turn:

Then the earth grew in the mouth of the angel, he screamed and called on God for help, and spat out the earth at God's command, and there grew therefrom tobacco and hops.

We may continue the story as it is told among the Moguls (p. 67):

The earth grew continuously. As it had reached a large compass God and Satanael descended from the clouds and began to dwell upon the earth. From this time on, they used the clouds only for long journeys and when they wished to rise to the heavens.

To increase the number of the living upon the earth, God took two stones and struck them together. On the first stroke the Archangel Michael came forth and on the second the Archangel Gavril. Satanael envied God and wanted also to create servants. So he took two stones and began to strike them together. With every blow there came forth a devil. As he kept on striking a great throng of devils appeared. And God was angry that his companion knew no bounds in creating his kind, and forbade him the further creation of devils. Satanael stopped only when, after long labor, he found his stones no longer produced devils.

In Transcaucasia they say:

The archangel followed him and they came on a blue stone (or gold stone) which they raised up. But Satanael was under it and he sprang up, grabbed God by the throat, and nearly throttled him. God called on the archangels for help, but they could not free him. There was nothing left but to beg Satanael. "Ask what you will of me, only let me free." And Satanael said, "I ask nothing except that we be brothers. And God promised this, whereupon Satanael let him go and went his way.

In a Greisinian variant (p. 32):

Michael and Gabriel wander through the earth, and the crust of the earth was so thin that they sank to the knees, although they wore snowshoes. Always a round stone rolled on before these angels, and God said, "We are tired of this stone." And in spite of the angels' warning, God shattered the stone with his foot, and lo, Satanael was in the stone.

In the Swanetic narrative:

God and his angels wandered through the world on their wonderful horses, and came on a great white stone. But the angels led God another way. Again they came on the stone and again the angels led God another way. "Some cheating is the cause," said God to the angels, "that we do not come upon this stone; otherwise we should have reached it already." The angels answered, "All right, we will bring you to the white stone, but we believe it will do you

harm." They went to it and God broke the stone with his whip. Then the devil sprang out of it and grabbed God's horse. The devil said to God, "I and you were both in the same stone. I and you are of the same origin. I am the heart of the stone like you, so give me part of the world." While God chose for himself men and animals, the devil chose the souls. But the angels said to him: "Rejoice not overmuch. Know that the souls will remain in your hand only until a Son of God is born, who will free the dead from thy kingdom." The devil answered: "That will be a long time hence."

God placed himself and his archangels upon the cloud, raised himself high over the earth and created the heavens. Satanael made, with his devils, a second heaven that was higher than God's. God would not live below Satanael and raised himself higher and made a third heaven. In this way, vying with each other, they created nine heavens, one above the other, and Satanael began to build a tenth heaven still higher. Then God lost his patience and commanded his angels that they throw Satanael and his devils down from heaven.

Satanael and his angels fell down upon the earth. Each took his name from the place where he fell. He who fell in the wood became a wood devil, he that fell upon the water became a water devil.

In the Balkans they describe this fall of the angels thus:

As the angels under the earth mourn and complain we feel it as an earthquake, when they weep on the earth their tears are so hot that long drought follows, when floating among the stars they shed tears and we see them fall upon the earth as shooting stars.

We may continue the story as it is told by the Bulgarians:

As now Satan saw the great broad earth, he hit upon the deceitful plan of putting God to sleep and then throwing him in the water; taking possession of the earth himself and claiming honor as creator of the earth. God of course knew Satan's plan, but laid him down as if to sleep. Satan then seized God and carried him to the great water to throw him in. As he came to the shore the land began to grow rapidly so that he could in no wise reach the water. He turned back to the opposite shore, but for the same reason could not reach that. And as he could not reach the water from the third side because of the growth of the land before him, he let God slide down on the ground, and sank down beside him. After he had slept awhile he took God up again and carried him in the fourth direction to the water. As the land began immediately to grow in this direction also, so in this direction also he failed to reach the water.

He then waked God up, saying, "Arise, God, let us bless the earth! Lo, how it is grown while we slept." God answered him, "As you have carried me in four directions, to throw me in the water, and thus with my body described a cross, I have blessed the earth already, that it grow and flourish." This made Satan wroth and he left God. God remained alone, and the earth grew continuously, so that it could no longer be covered by the sun's light. Then God created out of his spirit angels and sent the war angel to ask Satanael what he should do to stop the earth's growing.

In the meantime the devil had made him a goat, and he came to God riding on the back of the goat, for which he had made a beard of earth. Since that time goats have beards to the present day. As the angels saw the devil riding toward them they laughed at him; he was wroth and rode back. On the instant God created a bee and said: "Fly quickly to Satan and listen to his speech. Return and inform me." The bee then flew to Satan and perched on his shoulder as he spoke to himself, "Oh, this foolish God (O dieser dumme Gott), he knows not that he needs only to take a stick and mark the earth with a cross

and say: 'This much earth is enough.' He just doesn't know what to do!" Then God blessed the bee and commanded that its wax should serve to illumine weddings and funerals and its honey should heal the sick.

In the Rumanian Sage the bee goes to the wise hedgehog for advice and the hedgehog says:

"Plainly God does not know that he must create mountains and valleys to make room for the waters."

The Setts say (p. 128):

As the earth was created it did not fit under the arch of heaven. Where shall one put such a great disk? Just then the hedgehog came along and asked what the trouble was. "Verily the earth is done, but we can not get it under the arch of heaven and it would not do to break a piece off." "That's nothing," said the hedgehog, "You must squeeze the disk together a little and then it will go." Good: God quickly pressed the disk together and it was easy to stick it under the heaven.

Now there appeared here and there, by the pressure, wrinkles which are the present mountains and valleys. God gave the hedgehog, for his shrewd head, an excellent coat, all of needles, so that no enemy can get near him.

THE PROGRESS OF SCIENCE

THE MEDICAL SCHOOL AND THE COLLEGE

THE marble palaces which American millionaires have built for the Medical School of Harvard University are justified by their beauty. They will house part of the meetings of the American Association for the Advancement of Science and the affiliated societies during convocation week at the end of the present month, and it would be worth while for scientific men from a distance to attend the meetings if their only object were to see these beautiful and stately halls. But these buildings have not solved the complicated problems of medical education; they have, to a certain extent, fossilized the system of sequestering the medical school from the university. Reinforced cement at Cambridge might have accomplished more for training and research in the medical sciences than marble on the Boston fens.

President Eliot appears to be in large measure responsible for separating the medical school from the university both in space and time. Shortly before his retirement, he appointed a dean of the school who to a certain extent shares his views. Dean Christian, in his address at the dedication of the Medical Department of Stanford University, said that the institutions which have adopted a combined academic and medical course "have succeeded in rendering the A.B. degree of less value and significance than formerly and have sacrificed one or two years of college work while seeking to conceal this fact by the award of the two degrees, A.B. and M.D."

President Lowell, who does not hesitate to express educational theories at variance with those of his predecessor,

agrees with him in wanting to base the professional schools on the college, and apparently would have the professional schools so ordered that "every college graduate ought to be equipped to enter any professional school." In his inaugural address he says: "Our law school lays great stress upon native ability and scholarly aptitude, and comparatively little upon the particular branches of learning a student has pursued in college. . . . Many professors of medicine, on the other hand, feel strongly that a student should enter their school with at least a rudimentary knowledge of those sciences, like chemistry, biology and physiology, which are interwoven with medical studies; and they appear to attach greater weight to this than to his natural capacity or general attainments."

It may be doubted whether in the Harvard Medical School or elsewhere there are professors who attach greater weight to rudimentary knowledge of certain sciences than to natural capacity and general attainments. But there are those in the Harvard Medical School, as appears from an extended article filling half the *Harvard Bulletin* for November 3, who do not approve the attitude of the administration in determining the relation between the college and the medical school. It is there argued that students in the college should be permitted to study in the college the sciences required by the medical student, as they now can the sciences preliminary to engineering, and that it should be possible for the student to complete both his college work and his medical course in six years.

President Lowell apparently wants a four-year college course, followed by

a medical course which can not count on any special knowledge on the part of the student—it should in this case be five years—and this must be followed by a year or two in the hospital. Students are on the average over eighteen years old when they enter Harvard, and the physician would not begin to practise medicine and to learn what can only be taught by practise until he is nearly thirty. To this late start in life there are serious objections both educational and economic.

It may be that the local separation of the medical school from the rest of the university which obtains at Harvard and also elsewhere, as at Columbia and the Johns Hopkins, may ultimately lead to greater independence on the part of the medical school. In this country we find that medical schools were usually started as independent institutions which later became parts of universities. This was a great advance, for the medical schools were largely proprietary institutions whose standards were lower than in the university. But it is perhaps now true that the spirit of scholarship and research is more advanced in the medical school than in the college. When a medical school is sufficiently well endowed and its professors are men devoted to research, it is probable that it would be best for it to take charge of the education of students after they leave the high school, whether their period of instruction is to be four years or ten. The resources of the college and the graduate schools could be fully used, but men engaged in medical practise, teaching and investigation should be responsible for the education required by physicians and by those preparing to undertake research work in the medical sciences.

KAKICHI MITSUKURI, 1858-1909

IN Tokyo on September 16, after a long illness, died Kakichi Mitsukuri, professor of zoology in the Imperial University, dean of the college of sci-

ence, and the foremost zoologist of Japan.

Any one might safely have predicted that Mitsukuri would succeed. For he came from stock which was both intellectual and energetic. For generations his family had produced prominent scholars, especially physicians, and I recall that one of his forefathers had learned the Dutch language and was translating works in surgery and anatomy in the days of the early Tokugawas, when such exotic studies were punishable with death. And it came to pass that this family with its tradition of western learning pushed to the front in the enlightened upheaval of the restoration. And that of its youngest members Mitsukuri and two of his brothers were among the scholars who sought the training of foreign universities. They were better by one than *par nobile fratrum*, those young Mitsukuri, and if they could have looked from their ship into the waters of the future they would have seen themselves high in the counsels of a new and national university, one of them a dean of a college, another a peer, a minister of education, and a president of a university.

Mitsukuri Kakichi, as he is known in Japan, owed his training largely to the United States. He received his first foreign education in Hartford—he was then but a boy and was in the care of the Misses Goldthwaite, to whom his gratitude was ever almost filial. In 1875 he entered the Sheffield Scientific School, and took his degree of Ph.B. in 1879. The same year he matriculated at Johns Hopkins and studied with Brooks and Newell Martin for four years. In 1881 he became fellow in biology and he took his degree (Ph.D.) in 1883. It may be mentioned that his thesis "On the Gills of *Nucula*" has not fallen into the limbo of forgotten dissertations. In his Hopkins days he was an enthusiastic frequenter of the Chesapeake laboratory, and was an intimate of his fellow students, Fessenden Clark, Sedgwick and Wilson.

After this he traveled in Europe, visited universities, English and continental, and thence returned to Japan. There he arrived at an opportune moment: the department of zoology which had been organized by Morse and given a second bent by Whitman, was in a state of upheaval. Japan in general was then beginning to assert her intellectual rights: from the imported foreigners it had learned nearly all it felt the need of, and in this instance there seemed no reason why one branch of the educational work should not be carried on entirely by Japanese. Mitsukuri entered into the work with his new training, and with a knowledge of Japanese diplomacy and breeding and obligations which no foreigner, at least in those days, had mastered. So it came about that the department of zoology began a new development, and in this work Mitsukuri would be the first to testify how much he owed to his trusted associate, Professor Iijima, and his other colleagues.

Mitsukuri devoted much of his life in Japan to his numerous pupils, sacrificing to no little degree his research work. He was tireless in his attendance at the university, accessible at all times, and with an affectionate friendliness which no one appreciates more keenly than a Japanese. "I feel I have lost a parent," writes Dr. M—. And this is the common sentiment among his pupils. His attitude was ideal: he was frank, inspiring, uncompromising when a question involved accuracy or scientific purpose. "How different," he would say, "is the training of the diplomat and the scientist—the one studies to dress up the truth, the other to expose it naked." In spite of his long years of foreign training "*because of it,*" he would perhaps have said), Mitsukuri was intensely Japanese—patriotic to his finger-tips, alert to point out the advantages of his country's ways, but like Okakura, so skilful in his dissection of the failings of his foreign friends that they never minded the pain. None the less,

I have still the feeling that the Japanese looked upon him as somewhat *too progressive*. He admitted foreigners among his most intimate friends, he had rooms in his house in foreign style, and his family took its place in social gatherings in the same informal way as in America or Europe. And he could think as a foreigner, and he certainly could write as one, for his English never betrayed him. And he had a wide circle of correspondents for whom he was constantly doing, and with the greatest courtesy, troublesome favors.

For zoology in Japan Mitsukuri did these things: He directed the upbuilding of the zoological and, to a certain degree (as dean of the science college), the scientific work of the university; he organized zoology in Japan, making his department its focus, not only in technical matters but popular and semi-popular as well; he was the moving spirit in sending zoological expeditions throughout Japan from Sagahalin to the Liu Chiu islands—even to Tai Wan; he was conspicuous in founding and developing the Misaki Biological Station; he was potent in building up a fisheries bureau, officered it with his pupils and contributed to its publications; he gave an important stimulus to the pearl industry in Japan and furnished numerous ideas to the culturists who sought to produce natural pearls by artificial means; and last of all he lifted up the position of zoology throughout the country by means of his many-sided teachings and by means of the influence exerted in his behalf by many friends in all stations. In this regard it has often been said he had not a few personal attributes of our own Professor Baird.

His researches cover many branches of zoology. At the time of his death he was completing a monograph of the holothurians of Japan. "We must do systematic work," he said in mock apology, "for you know that nearly everything we find here is new, and it



KAKICHI MITSUKURI.

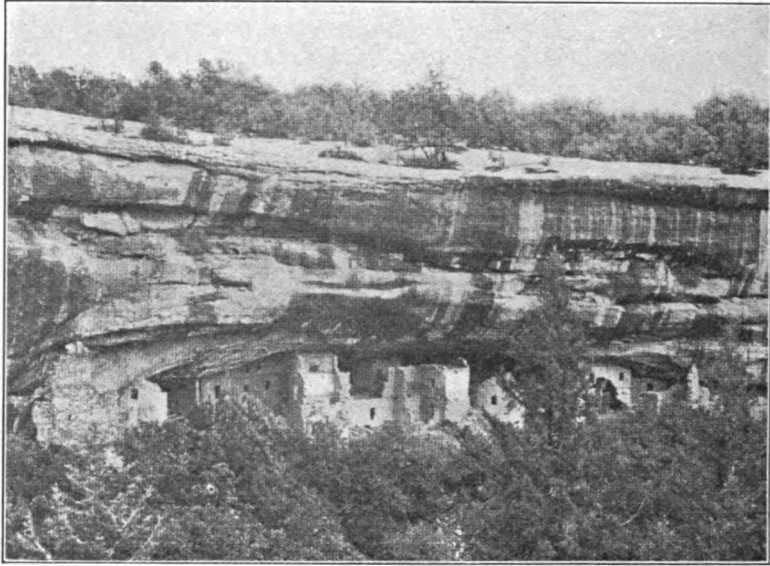

THE SPRUCE TREE HOUSE.

will be decades before we outgrow the zoological age of Linné." But his great work was undoubtedly reptilian embryology—indeed his papers on the gastrulation and embryonic membranes of turtles have long become classic. Here, for example, he first gave the correct interpretation of the primitive streak, discovering the rudiment of the yolk plug and enabled comparisons, on the one hand, with the amphibian, on the other, with avian and mammalian types. Here, also, he gave the first satisfactory explanation of the relation of the archenteric to the sub-germinal cavity, and the peculiar growth of the sero-amniotic canal, which, by the way, one of his pupils afterwards demonstrated in the chick. It is in a manner the test of the big-ness of Mitsukūri that with the keen interest in his purely morphological work he did not fear loss of dignity by contributing to economic subjects. A delightful little paper is his report on Japanese oyster culture, quite after the fashion of his old teacher, Professor Brooks.

*THE SPRUCE TREE HOUSE OF
THE MESA VERDE NATIONAL
PARK*

DR. J. W. FEWKES has performed a useful service in exploring and restoring one of the great aboriginal monuments of the country, and the Bureau of Ethnology has now printed a description of the ruin. The Spruce Tree House and the Cliff Palace, the largest of the ruins of the Mesa Verde Park, were discovered by native cattle herders, and were first adequately described by Baron Gustav Nordenskiöld in 1893. The imposing ruin shown in the illustrations extends 216 feet under the over-hanging cliff. It contains about 120 rooms and probably housed some 350 people.

The buildings are divided by an alley into two sections, the northern being the larger and the older. There are in all eight subterranean rooms, which were used for ceremonial purposes and are known as kivas. Above these are plazas used for dancing and other ceremonies, and about the plazas are the living and other rooms, some-



KIVA D, FROM THE NORTH.



NORTH END OF THE RUIN, SHOWING MASONRY PILLAR.

times in three tiers. These rooms are small and usually dark, the only entrance being often a small doorway which served also for window and chimney.

The kivas, one of which is shown in the illustration, are curious structures, probably survivals of pit-houses of an antecedent people. Two walls enclose the circular room, on the inner of which rest six pedestals which support the roof beams consisting of cedar logs cut with stone axes. The fire-place is in the floor and there is a second depression which is a symbolic opening into the under-world. In addition to the kivas there are two other circular rooms and several rectangular rooms, which were probably used for ceremonial purposes. There is also a mortuary room, in which several skeletons have been found.

The culture was apparently self-centered; the people were farmers, timid, industrious and superstitious; they seem never to have ventured far from home and seldom met strangers; the language they spoke is unknown.

SCIENTIFIC ITEMS

WE regret to record the death of Dr. William Torry Harris, for many years U. S. Commissioner of Education and eminent for his contributions to education and philosophy.

THE Copley medal of the Royal Society has been awarded to Dr. G. W. Hill, the eminent American astronomer.—Dr. Theodore W. Richards, professor of chemistry at Harvard University, has been elected a corresponding member of the Berlin Academy of Sciences.—Professor J. H. Van Amringe, head of the department of mathematics in Columbia University, and dean of the college, will retire from active service at the end of the present academic year, when he will have completed fifty years of service for the institution and reached his seventy-fifth birthday.

MR. JOHN D. ROCKEFELLER has given the sum of \$1,000,000 to combat the hookworm disease and has selected a commission to administer the fund which includes Dr. William H. Welch, professor of pathology in Johns Hopkins University; Dr. Simon Flexner, director of Rockefeller Institute for Medical Research, and Dr. Ch. Wardell Stiles, chief of the division of zoology, United States Public Health and Marine Hospital Service, discoverer of the prevalence of the disease in America.

By the will of John Stewart Kennedy, the banker of New York City, who died on October 31, in his eightieth year, bequests are made for public purposes amounting to some \$30,000,000. The bequests depend on the size of the estate and the amounts are conservative estimates. They include seven bequests of \$2,225,000 each, respectively, for Columbia University, the New York Public Library, the Metropolitan Museum of Art, the Presbyterian Hospital in New York City, and to three of the boards of the Presbyterian Church; of \$1,500,000 to Robert College, Constantinople, and to the United Charities of New York; \$750,000 to New York University and the Charity Organization Society of New York for its School of Philanthropy; \$100,000 to the University of Glasgow, Yale University, Amherst College, Williams College, Dartmouth College, Bowdoin College, Hamilton College, the Protestant College at Beirut, the Tuskegee Institute and Hampden Institute; \$50,000 to Lafayette College, Oberlin College, Wellesley College, Barnard College (Columbia University), Teachers College (Columbia University), Elmira College, Northfield Seminary, Berea College, Mt. Hermon Boys' School and Anatolia College, Turkey; \$25,000 to Lake Forest University and Center College; \$20,000 to Cooper Union. There are also a number of other bequests to hospitals and charities.

INDEX

NAMES OF CONTRIBUTORS ARE PRINTED IN SMALL CAPITALS

- Adventure and Science, 414
ALLEMAN, ALBERT, Immigration and the Future American Race, 586
 Animal, Living, How Much of it is Alive? **A. F. A. KING**, 289
 Arraignment of the Theories of Mimicry and Warning Colors, **ABBOTT H. THAYER**, 550
 Astronomical Superstitions, **JOHN CANDEE DEAN**, 469
 Astronomy, The Future of, **EDWARD C. PICKERING**, 105
 Atlantic Forest Region of North America, **SPENCER TROTTER**, 370
 Axis, Earth's, Shifting of the, **SIDNEY D. TOWNLEY**, 417
- BENTLEY, MADISON**, Mental Inheritance, 458
 Biologist's Standpoint, Life from the, **WILLIAM E. RITTER**, 174
 British Association for the Advancement of Science, the Winnipeg Meeting of, 207, 411
 Brittany, the "Druid Stones" of, **J. S. KINGSLEY**, 124
BURBANK, LUTHER, Another Mode of Species Forming, 264
- Cambridge, Darwin Commemoration at, 206
 Camping and Collecting Afoot, **A. S. HITCHCOCK**, 274
 Canals, Abandoned, of the State of New York, **ELY VAN DE WARKEB**, 297
 Capacity of the United States for Population, **ALBERT PERRY BRIGHAM**, 209
CARNEY, FRANK, Geographical Influences in the Development of Ohio, 479
 Census, The Last, and its Bearing on Crime, **AUGUST DRAHMS**, 398
 Collecting and Camping Afoot, **A. S. HITCHCOCK**, 274
 College, and the Student, 99; and the Medical School, 614
 Colors, Warning, and Mimicry, Arraignment of the Theories of, **ABBOTT H. THAYER**, 550
COLTON, HAROLD SELLERS, Peale's Museum, 221
 Commemoration, Darwin, at Cambridge, 206
 Creation Myths, Medieval, **B. K. EMERSON**, 610
- Crime, The Last Census and its Bearing on, **AUGUST DRAHMS**, 398
- Darwin Commemoration at Cambridge, 206
 Darwinism, in the Theory of Social Evolution, **FRANKLIN H. GIDDINGS**, 75; The World of Life as Visualized and Interpreted by, **ALFRED RUSSEL WALLACE**, 452
 Darwin's Influence upon Philosophy, **JOHN DEWEY**, 90
DEAN, JOHN CANDEE, Astronomical Superstitions, 469
 Decimal System of Numbers, **L. C. KARPINSKI**, 490
 Dentistry, A Revolution in, **RICHARD COLE NEWTON**, 49
 Desert Scenes in Zacatecas, **J. E. KIRKWOOD**, 435
 Development, Individual, The Theory of, **FRANK R. LILLIE**, 239
DEWEY, JOHN, Darwin's Influence upon Philosophy, 90
 Diseases, Infectious, Natural Resistance to, and its Reinforcement, **SIMON FLEXNER**, 5
DOWNY, JUNE E., The Variational Factor in Handwriting, 147
DRAHMS, AUGUST, The Last Census and its Bearing on Crime, 398
 Druid Stones of Brittany, **J. S. KINGSLEY**, 124
- Earth's Axis, Shifting of the, **SIDNEY D. TOWNLEY**, 417
 Effectors, Appropriation of by the Nervous System, **G. H. PARKER**, 65, 137, 253, 338
EMERSON, B. K., Medieval Creation Myths, 610
 Emmanuel Movement from a Medical View-point, **HOMER GAGE**, 358
 Environment and Productive Scholarship, **W. J. HUMPHREYS**, 587, 577
 Eugenics Laboratory of the University of London, 309
 Evolution, Social, Darwinism in the Theory of, **FRANKLIN H. GIDDINGS**, 90; Organic. The Argument for, before "The Origin of Species," **ARTHUR O. LOVEJOY**, 499, 537
- FLEXNER, SIMON**, Natural Resistance to Infectious Diseases and its Reinforcement, 5

- Forest, Atlantic, of North America, SPENCER TROTTER, 370
- FRANKLIN, W. S., Some Practical Aspects of Gyrostatic Action, 20
- French Academy and Henri Poincaré, FRÉDÉRIC MASSON, 267
- GAGE, HOMER, The Emmanuel Movement from a Medical View-point, 358
- Galton, Sir Francis, Reminiscences of, 308
- GARRISON, FIELDING H., Josiah Willard Gibbs and his Relation to Modern Science, 41, 191
- Geographic Influences in the Development of Ohio, FRANK CARNEY, 479
- German, vs. Latin, RALPH H. MCKEE, 393
- Gibbs, Josiah Willard, and his Relation to Modern Science, FIELDING H. GARRISON, 41, 191
- GIDDINGS, FRANKLIN H., Darwinism in the Theory of Social Evolution, 75
- Gyrostatic Action, Some Practical Aspects of, W. S. FRANKLIN, 20
- Halley's Comet, A Photograph of, 518
- Handwriting, The Variational Factor in, JUNE E. DOWNEY, 147
- HITCHCOCK, A. S., Collecting and Camping Afoot, 274
- Hudson-Fulton Celebration of 1909, GEORGE FREDERICK KUNZ, 313
- HUMPHREYS, W. J., Environment and Productive Scholarship, 587
- Immigration and the Future American Race, ALBERT ALLEMAN, 586
- Individual Development, The Theory of, FRANK R. LILLIE, 239
- Infectious Diseases, Natural Resistance to, and its Reinforcement, SIMON FLENNER, 5
- Inheritance, of Vision, 309; Mental, MADISON BENTLEY, 458
- Intellectual Progress, Zoology in the Service of, WILLIAM A. LOCY, 346
- International Language, The Necessity for an, IVY KELLERMAN, 281
- JORDAN, DAVID STARR, Jane Lathrop Stanford, 157
- KARPINSKI, L. C., The Decimal System of Numbers, 490
- KELLERMAN, IVY, The Necessity for an International Language, 281
- Kelvin, Lord, 515
- KING, A. F. A., What is a Living Animal? How Much of it is Alive? 289
- KINGSLEY, J. S., The "Druid Stones" of Brittany, 124
- KIRKWOOD, J. E., Desert Scenes in Zacatecas, 435
- KUNZ, GEORGE FREDERICK, The Hudson-Fulton Celebration of 1909, 313
- Language, An International, The Necessity for, IVY KELLERMAN, 281
- Latin vs. German, RALPH H. MCKEE, 393
- LEWIS, FREDERIC T., Preparation for the Study of Medicine, 65
- Life, from the Biologist's Standpoint, WILLIAM E. RITTER, 174; The World of, as Visualized and Interpreted by Darwinism, ALFRED RUSSEL WALLACE, 452
- LILLIE, FRANK R., The Theory of Individual Development, 239
- Living Animal, What is a. How Much of it is Alive? A. F. A. KING, 289
- LOCY, WILLIAM A., Zoology in the Service of Intellectual Progress, 346
- London, University of, Eugenics Laboratory, 309
- LOVEJOY, ARTHUR O., The Argument for Organic Evolution, before "The Origin of Species," 499, 537
- LOWELL, PERCIVAL, The Planet Venus, 521
- MCKEE, RALPH H., Latin vs. German, 393
- MASSON, FRÉDÉRIC, Henri Poincaré and the French Academy, 267
- Mathematics, The Future of, G. A. MILLER, 117
- Medical, View-point, The Emmanuel Movement from a, HOMER GAGE, 358; School and the College, 614
- Medicine, Preparation for the Study of, FREDERIC T. LEWIS, 65
- Medieval Creation Myths, B. K. EMERSON, 610
- Mental Inheritance, MADISON BENTLEY, 458
- Mesa Verde National Park and the Spruce Tree House, 618
- MILLER, G. A., The Future of Mathematics, 117
- Mimicry and Warning Colors, Arraignment of the Theories of, ABBOTT H. THAYER, 550
- Mitsukuri, Kakichi, 615
- Nervous System, The Origin of, and its Appropriation of Effectors, G. H. PARKER, 65, 137, 253, 338
- Newcomb, Simon, The Death of, 204
- NEWTON, RICHARD COLE, A Revolution in Dentistry, 49
- Nichols, Ernest Fox, 311
- Nineteenth Century, Tennyson and the Science of the, 306
- NIPHEE, FRANCIS E., Simple Lessons in Common Things, 404
- Numbers, Decimal System of, L. C. KARPINSKI, 490
- Ohio, the Development of, Geographic Influences in, FRANK CARNEY, 470

- Organic Evolution, the Argument for, before "The Origin of Species," ARTHUR O. LOVEJOY, 499, 537
- PARKER, G. H., The Origin of the Nervous System and its Appropriation of Effectors, 65, 137, 253, 338
- Peale's Museum, HAROLD SELLERS COLTON, 221
- Philosophy, Darwin's Influence upon, JOHN DEWEY, 90
- PICKERING, EDWARD C., The Future of Astronomy, 105
- Pittsburgh, University of, New Buildings, 101
- Planet Venus, PERCIVAL LOWELL, 521
- Poincaré, Henri, and the French Academy, FRÉDÉRIC MASSON, 267
- Population, Capacity of the United States for, ALBERT PERRY BRIGHAM, 209; Possible, of the United States, 414
- Preparation for the Study of Medicine, FREDERIC T. LEWIS, 65
- Productive Scholarship and Environment, W. J. HUMPHREYS, 587
- Progress of Science, 99, 204, 306, 411, 515, 614
- Race, Future American, Immigration and, ALBERT ALLEMAN, 586
- Resistance, Natural, to Infectious Diseases, and its Reinforcement, SIMON FLEXNER, 5
- Revolution in Dentistry, RICHARD COLE NEWTON, 49
- RITTER, WILLIAM E., Life from the Biologist's Standpoint, 174
- Scholarship, Productive, Environment and, W. J. HUMPHREYS, 587
- Science and Adventure, 414
- Scientific Items, 104, 208, 312, 416, 519, 620
- Shifting of the Earth's Axis, SIDNEY D. TOWNLEY, 417
- Simple Lessons in Common Things, FRANCIS E. NIPHER, 404
- Sladen, Percy, Memorial Fund, 102
- Social Evolution, Darwinism in the Theory of, FRANKLIN H. GIDDINGS, 75
- Species Forming, Another Mode of, LUTHUR BURBANK, 264
- Spruce Tree House of the Mesa Verde National Park, 618
- Stanford, Jane Lathrop, DAVID STABB JORDAN, 157
- Stones, Druid, of Brittany, J. S. KINGSLEY, 124
- Student and the College, 99
- Superstitions, Astronomical, JOHN CANDEE DEAN, 469
- Tennyson and the Science of the Nineteenth Century, 306
- THAYER, ABBOTT H., Arraignment of the Theories of Mimicry and Warning Colors, 550
- TOWNLEY, SIDNEY D., Shifting of the Earth's Axis, 417
- TROTTER, SPENCER, The Atlantic Forest Region of North America, 370
- Variational Factor in Handwriting, JUNE E. DOWNEY, 147
- Venus, The Planet, PERCIVAL LOWELL, 521
- Vision, Inheritance of, 309
- WALLACE, ALFRED RUSSEL, The World of Life as Visualized and Interpreted by Darwinism, 452
- VAN DE WARKER, ELY, Abandoned Canals of the State of New York, 297
- Winnipeg Meeting of the British Association for the Advancement of Science, 207, 411
- Zacatecas, Desert Scenes in, J. E. KIRKWOOD, 435
- Zoology, the Service of, to Intellectual Progress, WILLIAM A. LOCY, 346

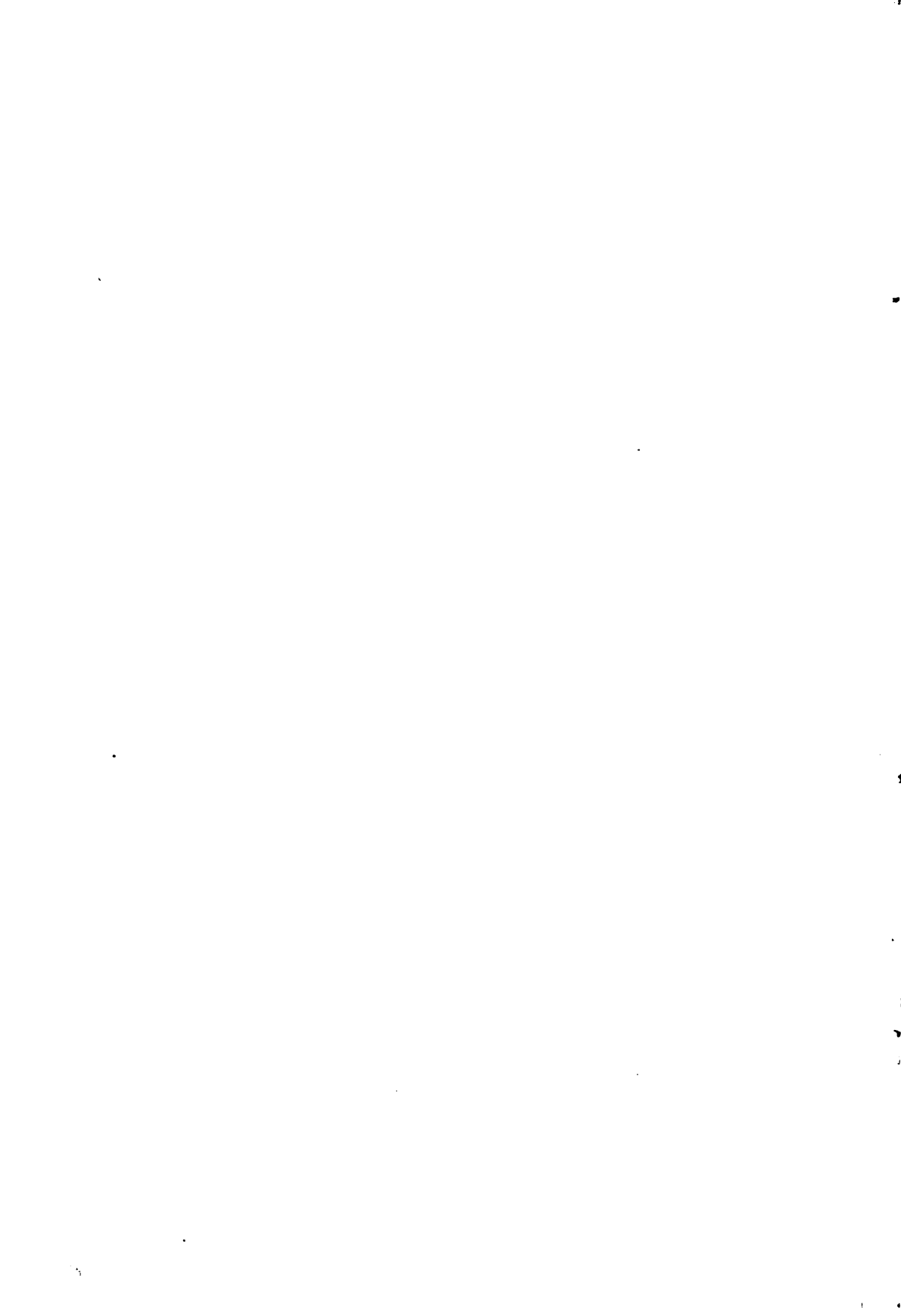

LIBRARY
UNIV. OF MICH.
OCT 25 1909

THE POPULAR SCIENCE MONTHLY

EDITED BY J. McKEEN CATTELL

CONTENTS

The Shifting of the Earth's Axis. Dr. SIDNEY D. TOWNLEY 417

Desert Scenes in Zacatecas. Professor J. E. KIRKWOOD 435

The World of Life as Visualized and Interpreted by Darwinism. Dr.
ALFRED RUSSEL WALLACE 452

Mental Inheritance. Dr. MADISON BENTLEY 458

Astronomical Superstitions. JOHN CANDEE DEAN 469

Geographic Influences in the Development of Ohio. Professor FRANK
CARNEY 479

The Decimal System of Numbers. Dr. L. C. KARPINSKI 490

The Argument for Organic Evolution before "The Origin of Species."
Professor ARTHUR O. LOVEJOY 499

The Progress of Science :
Lord Kelvin ; A Photograph of Halley's Comet ; Scientific Items . 515

THE SCIENCE PRESS

LANCASTER, PA.

GARRISON, N. Y.

NEW YORK: SUB-STATION 84

SINGLE NUMBER, 30 CENTS

YEARLY SUBSCRIPTION, \$3.00

BOOKS OF PERMANENT, ALL-THE-YEAR-ROUND VALUE
SEVEN GREAT WORKS OF REFERENCE

NOW READY

Cyclopedia of American Agriculture

Edited by L. H. BAILEY. Complete in Four Royal Octavo Volumes, with about 8,000 illustrations in the text and 100 Full-page Plates. Price of the set, cloth, \$20 net; half morocco, \$32 net.

Dictionary of Philosophy and Psychology

Written by many hands and Edited by J. MARK BALDWIN, LL.D., with the co-operation of an International Board of Consulting Editors, and Bibliographies by DR. RAND.

In three volumes: Volume I, \$8; Volume II, \$8; Volume III, (in two parts) \$10 net. Volume III contains the "Bibliography of Philosophy, Psychology, and Cognate Subjects," by Benjamin Rand, of Harvard University, in two parts.

Bryan's Dictionary of Painters and Engravers

A new edition of a work which has no rival for completeness and trustworthiness. Thoroughly revised, with over 1200 new biographies and more than 4000 alterations necessitated by modern research.

Five volumes, fully illustrated. Each \$6.00 net.

Encyclopedia Biblica

Edited by The Rev. T. K. CHEYNE, D.D., and J. SUTHERLAND BLACK, LL.D., Assisted by many Contributors in Great Britain, Europe and America. Cloth, \$20 net; half-morocco, \$30 net.

Cyclopedia of American Horticulture

Edited by L. H. BAILEY, assisted by WILHELM MILLER and others. 2,000 pages, with 2,800 illustrations and 50 full-page plates. Four volumes, cloth, \$20 net; half morocco, \$32 net.

A Dictionary of Architecture and Building

By RUSSELL STURGIS, Fellow of American Inst. of Architecture, Author of "European Architecture," etc., and many Architects, Painters, Engineers and other Expert Writers, American and Foreign. With Bibliographies, and over 1,500 illustrations. Three vols. Cloth, \$18 net; half-mor., \$30 net.

Dictionary of Music and Musicians

By Sir GEORGE GROVE. Revised and greatly enlarged Edition, in Five Volumes. Each volume illustrated with a photogravure and twenty-four full-page half-tone plates, besides many pictures in the text. Cloth, 8vo. Volumes I. and II. now ready. Each \$5.00 net, on orders for sets only.

Sold by subscription only. For full particulars as to special cash or instalment offers address

THE MACMILLAN COMPANY, 64-66 FIFTH AVE,
NEW YORK

Neurological Technique

By IRVING HARDESTY

196 pages, 8vo, cloth ; net \$1.75, postpaid \$1.87

INTENDED to serve as an introduction and laboratory guide to the study of the architecture of the nervous system, containing a succinct account of methods which have stood the test of practical application.

"The instructions are thoroughly practical."—*British Medical Journal*.

"The descriptions are clear."—*Philadelphia Medical Journal*.

"We know of no similar book which will be as valuable to the student of neurological technique."—*American Journal of Insanity*.

"The book bears the indorsement of Henry Donaldson, which is sufficient guarantee for its widespread acceptance."—*Northwestern Lancet*.

Laboratory Outlines for the Study of the Embryology of the Chick and the Pig

By FRANK R. LILLIE

60 pages, 12mo, paper ; net 25 cents, postpaid 27 cents

WILL be found a valuable contribution toward the establishment of a standard of embryological work for students generally, and for others desiring a convenient guide to the order of study of this subject.

Quantitative Classification of Igneous Rocks

Based on Chemical and Mineral Characters, with a Systematic Nomenclature

By WHITMAN CROSS, JOSEPH P. IDDINGS, LOUIS V. PIRSSON
and HENRY S. WASHINGTON

286 pages, 8vo, cloth ; net \$1.75, postpaid \$1.91

AN entirely new system for the classification and nomenclature of igneous rocks according to chemico-mineralogical principles, accompanied by a complete original nomenclature adapted to the system. Of value to all geologists and petrologists.

The Rôle of Diffusion and Osmotic Pressure in Plants

By BURTON EDWARD LIVINGSTON

160 pages, 8vo, cloth ; net \$1.50, postpaid \$1.62

THE important part played by the phenomena connected with diffusion and osmotic pressure in the life-process has here for the first time found full and adequate treatment.

Address Dept. 33

THE UNIVERSITY OF CHICAGO PRESS
CHICAGO AND NEW YORK

LIBRARY OF PHILOSOPHY, PSYCHOLOGY AND SCIENTIFIC METHODS

THE VALUE OF SCIENCE

By M. HENRI POINCARÉ, Member of the Institute of France; lately President of the Paris Academy of Sciences; Professor of Mathematical Astronomy in the University of Paris and at the Ecole Polytechnique. Translated from the French with an introduction by Professor GEORGE BRUCE HALSTED and a special preface by the author.

Pages vi + 147. Large Octavo. \$1.25 net.

M. Poincaré having attained the highest eminence from his researches in pure mathematics, mathematical physics and celestial mechanics, has recently directed his keen intellect to the consideration of questions concerned with the methods, the meaning and the value of science. Readers of *THE POPULAR SCIENCE MONTHLY*, who from month to month have had the advantage of reading chapters from this work will be glad to have it in book form. It appears to be in France that fundamental ideas are most likely to be treated with clearness and in an attractive literary style, and M. Poincaré is at the same time the leading French man of science, and one of their greatest men of letters. The clearness and admirable style has been maintained in the translation which was made with the cooperation of the author and is introduced with a preface by him.

SCIENCE AND HYPOTHESIS

By M. HENRI POINCARÉ. Translated from the French by PROFESSOR GEORGE BRUCE HALSTED, with a preface by the author and an introduction by PROFESSOR JOSIAH ROYCE, of Harvard University.

Pages xxxii + 196. Large Octavo. \$1.50 net.

This book displays the same understanding of fundamental scientific and philosophical problems and the same literary skill as the volume on the *Value of Science*. The original French and the present translation have been highly praised. The terminology is untechnical, and the style of the author and his thought are so clear that the work will prove of interest to those who have not had a technical training, while it is at the same time an important contribution to the philosophy of mathematics and the exact sciences. It is an excellent text-book for classes in philosophy.

EDUCATIONAL PSYCHOLOGY

By EDWARD L. THORNDIKE, Ph. D., Professor of Genetic Psychology in Teachers College, Columbia University.

Pages viii + 177. Large Octavo. \$1.50 net.

In this book Professor Thorndike applies to a number of social, and especially educational problems, the methods of exact science. The topics are treated in the light of the most recent researches and with the aid of modern technique. The book thus provides those interested in education as a profession or as a feature of American life with a sample of scientific method in this special field as well as with important information which has hitherto been inaccessible. The attitude of the author, who is the head of the department of educational psychology in Teachers College, Columbia University, and the author of numerous original contributions to dynamic psychology, is that of a candid and painstaking student of the work that has been done in this field and upholds rigorous ideals of scientific accuracy and logic. The book is so written and illustrated as to be readable and teachable.

AN INTRODUCTION TO THE THEORY OF MENTAL AND SOCIAL MEASUREMENTS

By PROFESSOR EDWARD L. THORNDIKE

Pages xii + 212. Large Octavo. \$1.50 net.

This book is valuable, in fact indispensable . . . written in an attractive style.—PROFESSOR E. F. BUCHNER, of the University of Alabama, in *The Educational Review*.

The best introduction to statistical theory yet published, and a text-book that ought to mark an important departure in college training. If I had the making of the list of required studies in an American college course, I should put into it a term's drill in this book of Professor Thorndike's, whatever mathematical requirement I had to throw out to make place for it. Or, if necessary, I would substitute it for the required work in political economy; for it is a book that opens up, as nothing else ever has opened, the whole realm of scientific ideas and scientific methods in the so-called, but not really, inexact sciences.—PROFESSOR FRANKLIN H. GIDDINGS, of Columbia University, in the *Journal of Philosophy*.

THE SCIENCE PRESS

Sub-Station 84

NEW YORK

HOTEL MAJESTIC

West 72d Street at Central Park
NEW YORK



One of the Finest, Most Palatial
in the World

Residential and Transient. Contains 800 Rooms.
Thoroughly Fireproof. Cuisine and Service Unexcelled.
Prices Reasonable. Illustrated Booklet on Request.

American Men of Science

A BIOGRAPHICAL DIRECTORY

Edited by

J. McKEEN CATTELL

A new edition of the Biographical Directory of American Men of Science is in course of preparation and will be published early in 1910. The first edition, published early in 1906, is a volume of importance for the history of science in America. Libraries and those wishing to own the volume should order it before the remaining copies of the first edition are exhausted.

Price, \$5.00 net, postage paid

THE SCIENCE PRESS

GARRISON, N. Y. LANCASTER, PA.

Sub-Station 84: NEW YORK

Science

A weekly journal, established in 1883, devoted to the advancement of the natural and exact sciences, the official organ of the American Association for the Advancement of Science, publishing original articles and notes on the progress of the different branches of science, the proceedings of scientific societies and academies, reviews of scientific books and articles, preliminary accounts of researches and full discussion and news on all subjects concerning scientific men and scientific and educational institutions.

Annual subscription \$5.00. Single numbers 15 cents

The American Naturalist

A monthly journal, established in 1867, devoted to the biological sciences with special reference to the factors of organic evolution.

Annual subscription \$4.00. Single numbers, 55 cents.

** To new subscribers mentioning this advertisement and enclosing one dollar, SCIENCE will be sent for three months, THE AMERICAN NATURALIST for four months or THE POPULAR SCIENCE MONTHLY for six months.

THE SCIENCE PRESS

Garrison, N. Y.

Lancaster, Pa.

Sub-Station 84, New York

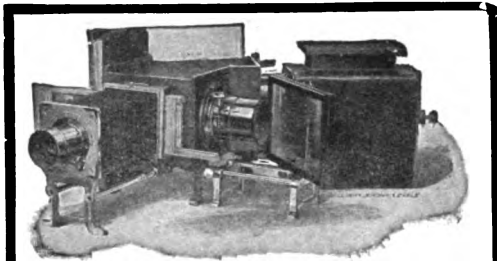

The Reflecting Lantern

or Post-card Projector, in its various forms, is doubtless the most universally useful projection instrument ever invented. With it a collection of post-cards or engravings becomes a source of endless amusement and instruction. With it also natural specimens such as

**Flowers, Leaves, Minerals,
Butterflies, etc.,**
are shown in All the Colors of Nature

We manufacture our Projectors to show

**Opaque Pictures and Objects
Lantern and Microscopic Slides**

We offer thirty different styles covering every possible requirement and ranging in price from

\$4.50 to \$200.00

We also make Magic Lanterns, Cinematographs, and have 40,000 Lantern Slides for sale or rent. Lists free.

Manufacturers and Patentees

WILLIAMS, BROWN & EARLE,
918 Chestnut St., Dept. N., Philadelphia, Pa.

LEARN TO BE A WATCHMAKER

BRADLEY POLYTECHNIC INSTITUTE

Horological Department

Peoria, Illinois

Formerly Parsons Horological Inst.

Largest and Best Watch

School in America . . .

We teach Watch Work, Jewelry, Engraving, Clock Work, Optics. Tuition reasonable. Board and rooms near school at moderate rates. Send for Catalog of Information.



This entire building used exclusively as a watch school.

Michigan College of Mines

F. W. McNAIR, President

Located in Lake Superior district, Mines and Mills accessible for college work. For Year Book and Record of Graduates apply to **PRESIDENT or SECRETARY,** Houghton, Michigan.

BEFORE DECIDING

WHERE TO ATTEND SCHOOL

Send for Catalog of **Valparaiso University, Valparaiso, Indiana**

One of the Largest Universities and Training Schools in the United States

25 Departments **Excellent Equipments** **165 Instructors**

Expenses less than at any other school. Catalogue mailed free. Address

H. B. BROWN, President.
or O. P. KINSEY, Vice Pres.

Our thirty-fifth year will open September 3, 1907.

FOR SALE

Rare pre-historic stone and bronze implements, weapons of savage tribes, birds' skins and eggs, butterflies' shells, fossils. List for stamp.

'THE BULLETIN'

4, Duke Street, Adelphi, London, W. C. England

MENDELISM

By **R. C. PUNNETT, Caius College, Cambridge**

The last word on Evolution, Mutation, Heredity and Mendelism

50 cents Postpaid

WILSHIRE BOOK COMPANY

200 WILLIAM ST., NEW YORK

If Any Readers of This Magazine

have in their possession, or know of the whereabouts of any of the **Works, Magazine Articles, Manuscripts or Letters,** written by the late Dr. George Miller Beard, will they kindly communicate with his daughter, **MISS GRACE ALD N BEARD?** Address, 675 Flatbush Ave., Brooklyn, New York.



WANTED to purchase Collections or Single Specimens of fine **OLD SAVAGE CURIOS** from Polynesia and America (especially New Zealand and British Columbia); Carved Specimens, Weapons, Carvings, Ornaments, Idols, &c., &c. High prices given for fine and rare pieces. References: Deposit.—**W. O. OLDMAN,** Hamilton House, Brixton Hill, London, England.



ROMEIKE'S

PRESS CLIPPINGS

are now an absolute necessity for every scientific man. By methodical searching through the most important papers and periodicals published in this country and abroad we are able to supply you at short notice with information on any subject which perhaps you would be unable to find yourself in libraries or reference books after spending days or even weeks at such a task. Write for further information.

HENRY ROMEIKE, Inc.

110-112 West 26th St., New York City

Georgetown University School of Medicine and Dental Department

The Fifty-ninth Session will begin September 28, 1908, and continue eight and one-half months. Practical laboratory work under special instructors, in Anatomy, Physiology, Chemistry, Histology, Pathology and Bacteriology. Ample facilities for clinical experience and practical work in hospitals of city and in the University Hospital, containing in all over 3000 beds. For particulars address

GEO. M. KOBER, M.D.

Dean School of Medicine, 1819 Q Street,

WM. N. COGAN, D.D.S.

Dean Dental Department, "The Sherman," Washington, D. C.

SCIENTIFIC BOOKS

MODERN THOUGHT AND THE CRISIS IN BELIEF

By DR. R. M. WENLEY, *Professor of Philosophy, in the University of Michigan.*

Eight lectures delivered at the University of Michigan, being the Baldwin Lectures for 1909, founded "for the Establishment and Defence of Christian Truth." Pp. xviii + 364.

The Macmillan Company, New York City

LECTURES ON THE ELEMENTARY PSYCHOLOGY OF FEELING AND ATTENTION

By PROFESSOR EDWARD BRADFORD TITCHENER, *Cornell University.*

Eight lectures, delivered as non-resident lecturer in Psychology at Columbia University in February, 1908. Pp. ix + 404

The Macmillan Company, New York

CONDITIONS OF LIFE IN THE SEA

By JAMES JOHNSTONE, *Fisheries Laboratory, University of Liverpool.*

A short account of quantitative marine biological research, and of the related results of hydrography and oceanography. Pp. xiv + 382.

The University Press, Cambridge, England

FISH STORIES ALLEGED AND EXPERIENCED WITH A LITTLE HISTORY NATURAL AND UNNATURAL

By CHARLES FREDERICK HOLDER and PRESIDENT DAVID STARR JORDAN.

Pp. vii + 330.

Henry Holt & Company, New York City

ECONOMIC ZOOLOGY

By HERBERT OSBORN, *Professor of Zoology and Entomology in the Ohio State University.*

An introductory text-book in zoology, with special reference to applications in agriculture, commerce and medicine.

It is hoped that this book may be of service to that ever-increasing body of citizens who wish to familiarize themselves with present state of knowledge regarding the animal kingdom. Pp. xv + 490.

The Macmillan Company, New York

RADIO-TELEGRAPHY

By C. C. F. MONCKYON

It is hoped that this book may serve a useful purpose in enabling readers to become acquainted with the principles and practise of telegraphy. Pp. xvii + 272. \$2.00.

The D. Van Nostrand Company, New York

DEVELOPMENT OF THE CHICK An Introduction to Embryology

By FRANK R. LILLIE, *Professor in the University of Chicago.*

This is in all regards the most complete and satisfactory work on this subject which has yet appeared. Prof. E. G. CONKLIN, *Professor in Princeton University.*

xi + 472 pp. 8vo. \$4.00.

Henry Holt & Company, New York

THE PROBLEM OF AGE, GROWTH AND DEATH

By CHARLES S. MINOT, LL.D., D.Sc., *James Stillman Professor of Comparative Anatomy in the Harvard Medical School.*

This book is the outcome of an attempt to learn something as to the essential character and the cause of the gradual loss of the functional powers of the organism. Pp. xxii + 280.

G. P. Putnam's Sons, New York and London

FOODS AND THEIR ADULTERATION

By HARVEY W. WILEY, M.D., Ph.D., *Chief of the Bureau of Chemistry.*

This manual aims to give as thoroughly and intelligibly as possible an account of the various food products in common use in their natural and manufactured conditions, with the usual adulterations that have been found therein. Pp. xli + 626, with eleven colored plates and 86 other illustrations.

P. Blakiston's Son and Co., Philadelphia

BIRDS OF THE WORLD

By FRANK H. KNOWLTON, *United States National Museum.*

A work of this scope is of necessity very largely compilation, but the author has sought in every instance to give the latest authentic information regarding the distribution and life history of the forms treated. Pp. xlv + 872. \$7.00.

Henry Holt & Company, New York

ELEMENTS OF PSYCHOLOGY

By EDWARD L. THORNDIKE, *Professor of Educational Psychology in Teachers College, Columbia University.*

I defy any teacher or student to go through this book as it is written, and not to carry away an absolutely first-hand acquaintance with the workings of the human mind and with the realities as distinguished from the pedantries and artificialities of psychology.—Professor William James in the Introduction.

A. G. Seller, New York

DARWIN AND MODERN SCIENCE

Edited by A. C. SEWARD, *Professor of Botany in Cambridge University, for the Cambridge Philosophical Society and the syndics of the University Press.*

Essays in commemoration of the centenary of the birth of Charles Darwin and of the fiftieth anniversary of the publication of *The Origin of Species*. Pp. xvii + 595.

Cambridge University Press

ESSAYS ON EVOLUTION

By EDWARD BAGNALL POULTON, D.Sc., *Hope Professor of Zoology in the University of Oxford.*

These essays were delivered as addresses or published on various occasions and at very different dates, but are the expression of a continuous line of thought and therefore fall together as naturally as if they had been written at one time, for the purposes of the present volume. Pp. xlviii + 479.

The Clarendon Press, Oxford

BOTANY AND PHARMACOGNOSY

By DR. HENRY KRAEMER, *Professor of Botany and Pharmacognosy in the Philadelphia College of Pharmacy.*

Intended as a guide in the microscopic study and analysis of drugs, foods, spices, and other products of vegetable origin. 850 large octavo pages. New Revised Edition. Profusely illustrated. Pp. vii + 850. Price \$5.00.

J. B. Lippincott Company, Philadelphia, Pa.

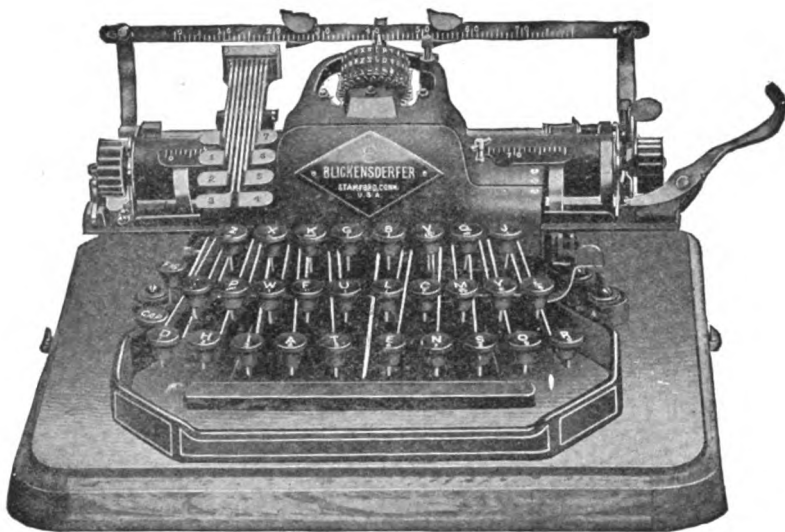

THE BLICKENSDERFER TYPEWRITERS

are used very extensively in Scientific Work. They are easy to operate, light in weight, and convenient to carry about. More than 150,000 users can testify to their value.

Write for catalogue and mention the Popular Science Monthly.

No. 5, \$40.00; No. 7, \$50.00;
and the model No. 8, \$60.00.

THE BLICKENSDERFER MFG. CO.

240 Broadway, New York

FAY BICYCLE

FOR BOYS AND GIRLS

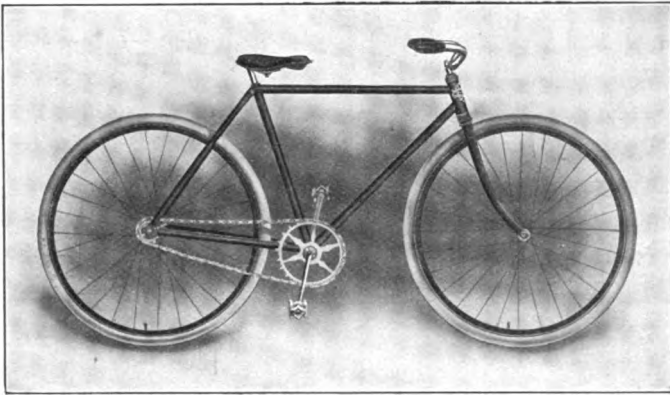

**Every Boy and Girl would prefer a Bicycle for a
Christmas Present ahead of anything else**

Of all the varied forms of recreation for children none appeals more strongly to the average boy and girl than the many delights of cycling, and no gift is so acceptable to them as a bicycle. It is a sport of which they never tire, and while they are enjoying themselves they are building up a sturdy constitution.

SEND FOR ILLUSTRATED FAY CATALOGUE,
1910 MODELS NOW READY

**THE POPE MANUFACTURING CO.,
HARTFORD, CONN.**

Simplicity

in a typewriter secures durability, ease and efficiency of operation, and increases the speed and accuracy of the work : the

UNDERWOOD

STANDARD

Typewriter

is a
Marvel
of
Simplicity



Originated—Writing-in-Sight Construction.

Built-in Tabulators and

Modern Bookkeeping Appliances.

There is nothing hidden about the Underwood. The type-bars lying when at rest in a compact segment ; the patented guide—all the parts which permit the visible writing—which help, not bother, the operator will be shown you, explained also if you like ; but really you'll see for yourself why the Underwood *does* endure and why its operation is so easy, quick and accurate.

“The Machine You Will Eventually Buy”

UNDERWOOD TYPEWRITER COMPANY, Inc.

ANYWHERE

The Popular Science Monthly

Entered in the Post Office in Lancaster, Pa., as second-class matter.

CONTENTS OF OCTOBER NUMBER

- The Hudson-Fulton Celebration of 1909. Dr. GEORGE FREDERICK KUNZ.
- The Origin of the Nervous System and its Appropriation of Effectors. Professor G. H. PARKER.
- The Service of Zoology to Intellectual Progress. Professor WILLIAM A. LOCKY.
- The Emmanuel Movement from a Medical View-point. Dr. HOMER GAGE.
- The Atlantic Forest Region of North America. SPENCER TROTTER.
- Latin vs. German. Professor RALPH H. MCKEE.
- The Last Census and its Bearing on Crime. The Rev. AUGUST DRAHMA.
- Simple Lessons from Common Things. Professor FRANCIS E. NIPHER.
- The Progress of Science:
The Winnipeg Meeting of the British Association for the Advancement of Science; Science and Adventure; The Population of the United States; Scientific Items.

CONTENTS OF NOVEMBER NUMBER

- The Shifting of the Earth's Axis. Dr. SIDNEY D. TOWNLEY.
- Desert Scenes in Zacatecas. Professor J. E. KIRKWOOD.
- The World of Life as Visualized and Interpreted by Darwinism. Dr. ALFRED RUSSEL WALLACE.
- Mental Inheritance. Dr. MADISON BENTLEY.
- Astronomical Superstitions. JOHN CANDER DEAN.
- Geographic Influences in the Development of Ohio. Professor FRANK CARNEY.
- The Decimal System of Numbers. Dr. L. C. KARPINSKI.
- The Argument for Organic Evolution before "The Origin of Species." Professor ARTHUR O. LOVEJOY.
- The Progress of Science:
Lord Kelvin; A Photograph of Halley's Comet; Scientific Items.

 The MONTHLY will be sent to new subscribers for six months for One Dollar.

SUBSCRIPTION ORDER

To THE SCIENCE PRESS,
Publishers of THE POPULAR SCIENCE MONTHLY,
Sub-Station 84, New York City.

Please find enclosed check or money order for three dollars, subscription to THE POPULAR SCIENCE MONTHLY for one year, beginning December, 1909.

Please find enclosed from a new subscriber one dollar (sent at your risk), subscription for six months to THE POPULAR SCIENCE MONTHLY, beginning December, 1909.

Name.....

Address.....

Single Numbers 30 Cents

Yearly Subscription, \$3.00

THE SCIENCE PRESS

Garrison-on-Hudson, N. Y.

41 North Queen St., Lancaster, Pa.

Sub-Station 84; NEW YORK

Bausch & Lomb BH Microscope

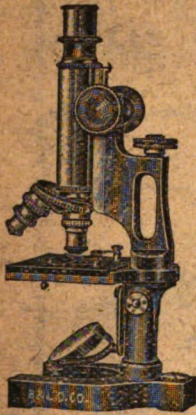

is the result of many years of thought and experiment to produce a really efficient scientific instrument suitable to place in the hands of young students, that should be at the same time durable and low enough in price to commend it to schools with limited means.

¶ Many schools are being equipped with these microscopes.

¶ Price complete with 16 and 4 mm. objectives, 25 mm. eyepiece, \$24.50; with double nosepiece, \$28.50.

¶ We shall be glad to send you descriptive literature on request.

¶ PRISM — Copy A and D.



Our Name on a Photographic Lens, Microscope, Field Glass, Laboratory Apparatus, Engineering or any other Scientific Instrument is our Guarantee.

Bausch & Lomb Optical Co.

NEW YORK WASHINGTON CHICAGO SAN FRANCISCO
LONDON ROCHESTER, N.Y. FRANKFORT



Regarding Cocoa Beans

Cocoa Beans are classed among the most highly nourishing Products of the Plant Kingdom.

Cocoa Beans contain all that is needed for the perfect development of the human body.

The daily use of the Cocoa Bean in some form is therefore highly recommended to

Old and Young.

WHY NOT GET THE BEST?

Naylor's Cocoa and Chocolates



From Bean to Cup
WITHOUT ADULTERATION



FOR EATING. DRINKING AND COOKING.
UNSURPASSED FOR
PURITY AND DELICIOUSNESS OF FLAVOR.
SOLD BY SHOPKEEPERS EVERYWHERE.

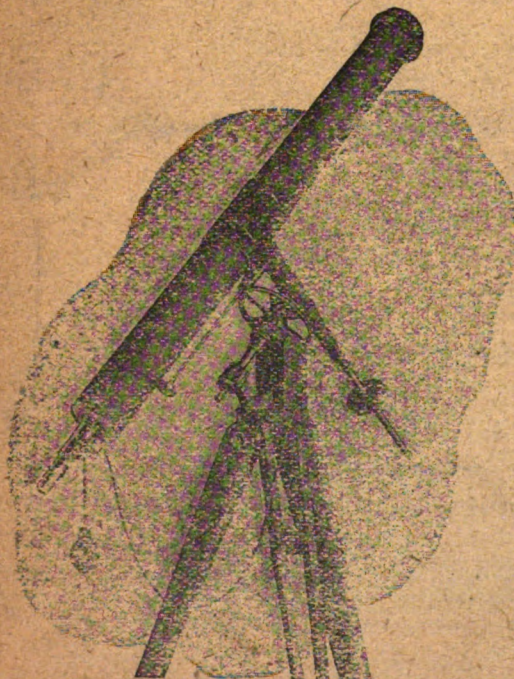

Illustration shows 5-in. with pneumatic clock.

Refracting and Reflecting Astronomical Telescopes

Standard and Portable

Visual and Photographic

OBJECTIVES

Computed by our associate

DR. F. R. MOULTON

(Chicago University)

OBSERVATORIES

Specula, Planes, Eyepieces, etc.

Photographs and Circulars on request

LOHMANN BROS.

GREENVILLE, OHIO :: :: U. S. A.

BOUND IN LEATHER

DEC 21 1911

UNIVERSITY OF MICHIGAN

3 9015 03668 6593

