

AN ACCOUNT
OF THE
CONSTRUCTION OF THE
SELF-RECORDING MAGNETOGRAPHS

AT PRESENT IN OPERATION

AT THE

KEW OBSERVATORY OF THE BRITISH ASSOCIATION.

BY

BALFOUR STEWART, M.A.,

*From the Report of the British Association for the Advancement
of Science for 1859.*

LONDON:
PRINTED BY TAYLOR AND FRANCIS,
RED LION COURT, FLEET STREET.
1860.

superior definition and finish of the lines leaves hardly anything to be desired. Mr. Beckley, the engineer attached to the observatory, very skilfully devised the mechanical details in conformity with Mr. Welsh's plan, and prepared a working drawing of the instruments*.

Mr. Chambers (magnetical assistant at Kew Observatory) assisted in overcoming certain photographic difficulties that arose. He has since been in charge of the instruments, and has performed his task in a very efficient manner.

This Report is divided into five sections. In the first section a general and preliminary description is given of the principles of construction of the magnetographs. In the second, a detailed account is given of each of the instruments. In the third section the photographic process is described. In the fourth, the method of ascertaining the instrumental coefficients, and of tabulating from the curves, &c., is detailed; and in the fifth section certain improvements[†] are mentioned which have been made on a set of magnetographs since constructed of the same kind as those described.

Section I. PRELIMINARY DESCRIPTION.

The room in which the instruments are placed is one of the lower rooms of the observatory, the roof of which is not much above the level of the ground outside. It is well protected from damp by a vault which goes round the observatory, and is subject to very small changes of temperature, the mean daily range being within 1° Fahr., and the annual range about 20° , the thermometer varying from 50° Fahr. in winter to 70° Fahr. in summer. In shape the room is an octagon, of about 22 feet in diameter, with a height of about 17 feet. Daylight is only admitted through panes of orange-coloured glass, which have the effect of excluding the actinic rays.

Four pillars, A, B, C, D (see Plate 3. fig. 1), made of Portland stone, are firmly fixed into the floor. The centres of the pillars B, C, D are in a line perpendicular to the magnetic meridian, while the centres of pillars A and D are in the line of that meridian. The pillars A, B, and C support the three magnetographs, while the pillar D supports the recording cylinders and clockwork.

In Plate 3. fig. 1, we have a ground-plan of the instruments, and in fig. 2 an elevation of the same.

Referring to the Declination Magnetograph (Plate 3. fig. 1), *a* denotes the gas-flame which is the source of light; *b* is a bull's-eye lens, the object of which is to condense the light on a narrow vertical slit at *c*. The bull's-eye therefore enables the light to be nearly as effective as it would be if placed immediately behind the slit *c*, although in reality it is at a convenient distance from it.

After having passed the slit *c*, the light is conveyed through a covered tube until it reaches the plano-convex achromatic lens set vertically at *d*, having passed through which, it next falls on two semicircular mirrors which have their centre at *e*. The faces of these mirrors are exhibited in Plate 4. fig. 3, from which it will be seen that the lower mirror is firmly fixed to a marble slab, while the upper one, which is nearly, but not quite in contact with the lower, is attached to a delicately suspended magnet, and consequently moves with it. The light, after leaving the mirrors, is reflected in the direction *ef* through a piece of plane glass at *f*, and through a covered tube until it reaches a cylinder *h*, the axis of which is horizontal, and which is covered with sensitive paper.

The focal length of the lens *d* is such, that the point *h*, where the rays

* The drawings for the Plates attached to this Report were also made by Mr. Beckley.

EARLY in 1857 the Government Grant Committee of the Royal Society voted £150 towards the expense of a set of Self-recording Magnetographs to be erected at the Kew Observatory of the British Association; the sum of £250 having been previously granted out of the Wollaston fund for the purpose of lighting the observatory with gas.

The late Mr. Welsh thereupon applied himself with much zeal to the task of constructing these magnetographs, and devised a plan which was transmitted to Mr. Adie, optician, 395 Strand, who undertook to make the instruments.

These were completed by Mr. Adie in a satisfactory manner, and were in operation in July 1857; by the beginning of 1858 all difficulties, whether of a mechanical or photographic nature, had been overcome, and since that date a continuous register of the magnetic elements has been obtained. With regard to the plan devised by Mr. Welsh, the best proof of its excellence is the nature of the results obtained, which may be judged of from an average specimen of the curves appended to this Report. Indeed, the

strike the cylinder, is the conjugate focus to the slit c ; we should therefore have an image of the slit c exhibited on the sensitive paper. As, however, our object is to produce a *dot* and not a *slit* of light, a hemicylindrical lens, having its axis horizontal and focus at the cylinder, is placed at g , so that the rays passing through it have the vertical slit of light which they would otherwise have formed on the cylinder compressed into a dot; in which state therefore the light falls upon the sensitive paper. But it is only when both the mirrors, the fixed and the moveable, are in *one* plane that we shall have *one* dot upon the cylinder. For if the plane of the one mirror is inclined at an angle to that of the other, the ray from the first mirror will not be reflected in the same direction as that from the second, and will consequently fall upon a different part of the cylinder. Two slits of light will in this case reach the hemicylindrical lens, and two corresponding dots of light will appear upon the sensitive paper which covers the cylinder. The distance between these two dots will be a measure of the angle between the two mirrors, and will consequently (the lower mirror being fixed, and the upper one moving with the magnet) indicate the position of the magnet from time to time.

The cylinder round which the sensitive paper is wrapped is moved round by clockwork once in every twenty-four hours, so that the dot belonging to the fixed mirror generates a straight line, while that belonging to the moveable mirror will describe a line corresponding to the movement of the magnet.

The arrangements of the horizontal-force instrument are in all respects similar to those of the declination magnetograph which has just been described, with this exception, that in the latter the magnet is in its natural direction, viz. perpendicular to ef , while in the former it is twisted into a direction at right angles to its natural position, and is now in the line ef .

The only difference which it is necessary here to notice between the vertical-force magnetograph and those which we have now described, is that in the vertical-force magnetograph the slit c is horizontal and the hemicylindrical lens and cylinder vertical, while the axis on which the moveable semicircular mirror, attached to the magnet, turns, is horizontal. The mirror of this magnetograph is exhibited in Plate 4. fig. 5. One piece of clockwork is made to drive all the cylinders.

The principle of construction which we have now described seems to possess the following advantages:—

1st. The optical arrangements are such as to secure an exceedingly well-defined dot of light, and by means of suitable photographic appliances, an unexceptionable curve and base-line.

2nd. Should anything occur to change the position of the slit c , both the curve and the base-line will be equally displaced, so that the distance between them (with which only we are concerned) will remain precisely the same as before.

Thus too, by slightly altering the position of the slit each day, we may put two or even three days' curves on the same sheet.

3rd. The stone piers, &c. secure perfect steadiness to the apparatus, and the central arrangement presents the advantage that one piece of clockwork drives all the cylinders.

Section II. DETAILED DESCRIPTION OF THE INSTRUMENTS.

1. Declination Magnetograph.

The flame used is that of gas, the supply of which is kept constant by

means of a water-regulator. The burner consists of a narrow slit about three-quarters of an inch long, and one-hundredth of an inch in breadth. It is placed endwise with respect to the lens, in consequence of which position, the light (coming from a stratum of flame three-quarters of an inch in depth) has its brilliancy greatly increased (see Plate 4. fig. 10 A).

The shape of the burner and the arrangement for supplying the flame with air, are in all respects similar to those used in a paraffin lamp, their application to gas having been suggested by Mr. Beckley. The burner is fitted with a glass chimney, the presence of which intensifies the light—it must not, however, fit too tightly.

The bull's-eye lens used for condensing the light of the gas upon the slit is that known as the double condenser.

Having passed the bull's-eye lens, the light falls upon the slit c . The breadth of this slit is about $\frac{1}{100}$ th of an inch; a front view of it is given in Plate 4. fig. 10 a.

By means of an adjustment, the distance between the gas-flame and the bull's-eye lens may be altered until the slit is in focus for the gas-flame.

The light having passed the slit, goes through a covered tube until it reaches the plano-convex achromatic lens before mentioned. By means of an adjustment, the gas-flame, the bull's-eye, and the slit may be moved together until the slit be at that distance from the lens which is the conjugate focus of the sensitive paper. There is also an arrangement by which gas, bull's-eye, and slit may be moved a little to one side of the central line of the lens, so that the two dots may be made to assume a different position on the sensitive paper.

The distance between the slit and the lens is 17.7 inches. This lens is fitted into a glass shade which covers the magnet, as represented in Plate 4. fig. 2.

This glass shade stands upon a circular marble slab, diameter 20 inches, thickness 1.2 inch, which is cemented to the top of a solid pillar of Portland stone 4 feet high.

There are two holes cut in this glass shade, each about 3 inches in diameter (see Plate 4. figs. 1 & 6), the one to contain the lens above mentioned, through which the rays of light pass on their way from the slit to the mirror; and the other to contain a piece of plane glass through which the same rays pass on their way from the mirror to the cylinder. The glass shade is gilded inside nearly to the top. This gilding serves the double purpose of reflecting back any heat associated with light which may strike it from the outside, and (being a bad radiator) of diminishing as much as possible the currents of air which changes of temperature are apt to produce. The portion of the shade which is not gilded is covered outside with a cloth cap, removable at pleasure. A vessel containing chloride of calcium is put inside to absorb all moisture. A curved arm of brass (Plate 4. figs. 3 & 4) carries the suspension roller A, and torsion circle C (see also fig. 14) reading to minutes. The suspension thread is a silk fibre slightly rubbed with bees-wax, in order to render it less susceptible to hygrometric influences.

The magnet (D) is a rectangular bar about 5.4 inches long, 0.8 inch broad, and 0.1 inch thick. The semicircular mirrors, already alluded to, are also represented in figs. 3 & 4. Their diameter is 3 inches; and great care has been taken that the glass surfaces should be accurately plane and parallel to each other. G is a copper damper, the object of which is to check the oscillations of the magnet, and bring it to rest speedily. The angle aef (Plate 3. fig. 1) being $=30^\circ$ and ef being perpendicular to the magnetic meridian, it follows that the plane of the mirror must be inclined at an angle of 15° to the axis of the magnet, in order that the ray dc may be reflected in the direction ef .

The semicircular mirrors must likewise be placed so that their centre shall be on a level with the centre of the lens. The distance from the lens to the centre of the mirror is 8.1 inches. Having been reflected by the mirror, the light passes through a zinc tube fixed to a slate, which connects the declination pillar with the central pillar (see Plate 3. fig. 2), and so reaches the hemicylindrical lens and sensitive paper already described. The distance from the centre of the mirror to the sensitive paper is $6\frac{1}{2}$ feet. Hence we have

Distance between lens and mirror = 8.1 inches.

Distance between mirror and cylinder . . = 78.0 inches.

Total distance between lens and cylinder = 86.1 inches.

And since the distance between the slit and the lens is 17.7 inches, we find that the focal distance of the lens for parallel actinic rays is nearly 14.7 inches*.

Before falling on the sensitive paper, the light passes through a hemicylindrical plano-convex lens (see Plate 3. fig. 1). The radius of the second surface of this lens, is about 0.6 inch, and consequently the distance between this surface and the sensitive paper (in order that the latter may be in focus) is nearly 1.2 inch.

2. Horizontal-force Magnetograph.

This instrument is exhibited in Plate 4. figs. 1 & 2. The magnet, mirror, lens, shade, adjustments of light and slit, &c., are in all respects similar to those of the declination magnetograph already described. The peculiarity of the instrument consists in the mode of suspension. A grooved wheel, E (Plate 4. figs. 1 & 2), about 0.3 in. in diameter, has its axle attached to the stirrup which carries the magnet, the plane of the wheel being in the direction of the magnet's length.

The suspension thread, consisting of steel wire (steel being considered little liable to stretch), is carried round the wheel, and the two ends fixed to the suspension roller A (see also fig. 13). A little below the suspension roller the two threads pass over a screw at B, the screw being right-handed where it meets the one thread, and left-handed where it meets the other. Consequently by turning the screw-head, we can vary the distance between the wires until it becomes equal to the diameter of the wheel, and the wires will now be at the same distance from one another throughout their entire length. Let us suppose that the magnet is in the direction of the magnetic meridian. Turn round the torsion circle C (precisely similar to that already described) until the magnet assumes a position at right angles to the magnetic meridian. It is clear that, in order to do this, we shall have to turn the torsion circle through an angle greater than 90° , and consequently that the plane of the wires at their lower extremity will be different from that at their upper. This difference is at present = $35^\circ 56'$ nearly. The suspension thread is about 11.6 inches long.

As the light which falls upon the mirror in the direction *de* (see Plate 3. fig. 1) must be reflected in the direction *ef* (*def* being 30° as before), it follows that the plane of the mirror must make an angle of 75° with the magnetic axis of the magnet.

The distance between the slit and the lens is 17.7 inches, and that between

* The focal length of the lens is determined rather by convenience of shape of the instrument than by optical considerations. In the declination magnetograph, for instance, if the distance between the slit and the lens were much greater than 17.7 inches, the light, bull's-eye, and slit could not well be supported by an arm of the slate which is attached to the declination pillar, but would require a separate pillar for themselves.

the lens and the mirror 8.1 inches, these being the same as in the declination magnetograph; but the distance between the centre of the mirror and the cylinder is different, being here 4.885 feet.

Hence the focal length of the lens for parallel actinic rays is about 14 inches. The hemicylindrical lens is in all respects similar to that already described.

3. Vertical-force Magnetograph.

This instrument is exhibited in Plate 4. figs. 5, 6 & 7.

The vertical-force magnet is of the same size as the others, and is balanced by means of a steel knife-edge upon an agate-plane. It is provided (see Plate 4. fig. 7) at one side with a brass screw working horizontally, and at the other with a similar screw working vertically. By means of these the centre of gravity may be thrown to either side of the centre of suspension, or it may be raised or lowered, and the sensibility of the magnet, when balanced, thereby increased or diminished.

These screws are arranged so that there is a preponderance of weight towards the south side of the magnet. This is neutralized partly by the magnetic force tending to pull the north end down, and partly by a slip of brass (H) standing out horizontally towards the north side. Let us suppose the system to be in equilibrium at a certain temperature; if the temperature rise (since brass expands more than steel), the leverage of the weight at the north side will increase more rapidly than that of the weight at the south. There will therefore be a slight preponderance towards the north, and this may be arranged so as to neutralize to a great extent the decrease in the magnetic moment which an increase of temperature produces.

The plane of the magnet is 15° out of the magnetic meridian (see Plate 3. fig. 1), for the following reason. Had the magnet been in the magnetic meridian, it would have been necessary to have placed the mirror inclined at an angle of 15° to the axis of motion of the magnet. This was tried, but it was found that in this position of the mirror, the correction for temperature was so excessive that the instrument became a thermometer, and not a magnetometer. The mirror was therefore put in a plane passing through the axis of motion of the needle, the needle being made to move in a plane inclined 15° to the magnetic meridian. Its temperature correction is at present very small.

The mirror of this instrument is exhibited in Plate 4. fig. 5, one half moving with the magnet, and the other half being fixed to a stand; I is a lifter which may be inserted from without the glass shade, and which, by raising three Vs to catch the needle, may remove it from its position of balance when necessary.

A thermometer is inserted within the glass shade of this instrument, by means of which the temperature both of the horizontal and the vertical-force magnets may be determined with sufficient accuracy.

In the vertical-force magnetograph, the slit for the light is horizontal, while the hemicylindrical lens and the cylinder are vertical.

It might be thought that with a horizontal slit the style of burner already described would prove unsuitable, as we here require a horizontal and not a vertical light; but by using a burner twice as large every way as those of the other magnetographs, we obtain a light that is found to answer in practice extremely well.

The adjustments for regulating the distance between the light and the slit, and between the slit and the lens, are similar to those for the declination and bifilar magnetographs. There is also an adjustment, by means of which the

light, bull's-eye, and slit may be pushed vertically (not horizontally as in the others) a little to one side of the central line of the lens, so that the dots may assume a different position on the sensitive paper.

The distance between the slit and the lens is 17.6 inches, that between the lens and the mirror is 8.1 inches, while the distance between the mirror and the cylinder is 6 feet.

Hence the focal length of the lens for actinic parallel rays is about 14.4 inches.

4. Registering Cylinder and Clockwork.

These are exhibited in Plate 4. figs. 8 & 9. The cylinders are each $6\frac{1}{2}$ inches long, and 6 inches in diameter. They consist of brass silvered over. The method of connecting them with the clockwork was devised and executed by Mr. Beckley. The toothed wheel *k* is driven by the clockwork, and drives the two pinions *l*. These pinions, when in gear, drive the two horizontal cylinders by means of teeth attached to the circumference of the latter. Two radial arms, to which the pinions *l* are attached, enable these to be put out of gear when it is necessary to remove the cylinders. The position of the pinions in this case is indicated in the figure by dotted lines. The vertical cylinder has a toothed rim attached to its lower extremity, which is driven by the crown wheel *m*. By removing a screw, the cylinder may, when necessary, be detached from its toothed rim, leaving the latter behind.

Section III. DESCRIPTION OF THE PHOTOGRAPHIC PROCESS.

The process employed is that known as the waxed-paper process, and is thus described by Mr. Crookes.

Description of the Wax-paper Photographic Process employed for the Photo-meteorographic Registrations at the Radcliffe Observatory. By W. CROOKES, Esq.

1. Before attempting to select from the numerous Photographic processes the one best adapted to the requirements of Meteorology, it was necessary to take into consideration a number of circumstances comparatively unimportant in ordinary operations.

To be of any value, the records must go on unceasingly and continuously :

First. Therefore, the process adopted must be one combining sharpness of definition, with extreme sensitiveness, in order to mark accurately the minute and oftentimes sudden variations of the instruments.

Second. To avoid all hurry and confusion, it is of the utmost importance that the prepared paper or other medium be of a kind capable of retaining its sensitiveness for several days.

Third. The contraction which paper undergoes during the numerous operations to which it is subject in most processes (in general rather an advantage than otherwise), is here a serious objection ; for this reason, the experiment first tried, of transferring to paper the image received on collodion preserved sensitive by the nitrate of magnesia process, was a failure.

Fourth. Strong contrast of light and shade, and absence of half-tint, unfortunately so common amongst ordinary photographic pictures, is in this case no objection.

Fifth. It is essential to preserve the original results in an accessible form ; and for this reason, the Daguerreotype process, admirably as it seems to answer other requisites, is obviously not the one best suited to our purpose.

Lastly, the whole operation should, if possible, be so easily reducible to

practice, that with a very small share of manipulatory skill, the loss of even a day's record would be impossible.

2. Bearing these conditions in mind, on looking over the photographic processes with which I was acquainted, that known as the wax-paper process, first described by M. Le-Gray, seemed peculiarly applicable. In sharpness it might be made to rival collodion ; and although generally stated to be slow in its action, I had no doubt that its sensitiveness could be easily increased to the required degree.

Of all paper processes, I believed it to be the one most free from contraction, either during the time it is undergoing the action of the light, or in any subsequent stage. Its chief superiority, however, consisted in its capability of remaining sensitive for so long a time, that it is of little consequence whether the sensitive sheets be a day or a week old. Then the comparative slowness of the development, which has always been looked upon as one of its weak points, would be in this case a positive advantage, as dispensing with that care and attention which must always be bestowed on a quickly developing picture.

In addition to all these recommendations, it was a process to which I had paid particular attention, and consequently the one in which I might naturally hope to meet with the greatest amount of success.

3. The general outline of the process does not differ materially from that which I published some years back in 'Notes and Queries,' vol. vi. p. 443 ; but as that account was written for practical photographers, the details of the manipulation were brief. It has therefore been thought advisable, that while describing again the whole process, with the addition of such modifications as the end in view requires, I should also give such fuller description of the manipulation, as may render it more serviceable to those who have not hitherto paid attention to photography in its practical details. This must be my excuse, if to some I seem unnecessarily prolix. None but a practical photographer can appreciate upon what apparently trivial and unimportant points success in any branch of the art may depend.

It may not be without service, if, before entering into the practical details of the process, I say a few words respecting the most advantageous way of arranging a photographic laboratory, together with the apparatus, chemicals, &c. which are of most frequent use.

Among those requisites, which may be almost called absolute necessities, are gas, and a plentiful supply of good water, as soft as can be procured.

4. The windows and shutters of the room should be so contrived as either to allow of their being thrown wide open for purposes of ventilation, or of being closed sufficiently well to exclude every gleam of daylight ; and the arrangement should admit of the transition from one to the other being made with as little trouble as possible.

5. A piece of very deep orange-coloured glass, about 2 feet square, should be put in the window, and the shutter ought to be constructed so as to allow of the room being perfectly darkened, or illuminated, either by ordinary daylight, or daylight which has been deprived of its photographic rays, by filtering through the orange glass. The absorbing power of this glass will be found to vary very considerably in different specimens, and I know of no rule but experience to find out the quality of any particular sample ; the best plan is to select from a good stock one of as dark a colour as possible. The proper colour is opaque to the rays of the solar spectrum above the fixed line E.

6. The best source of heat is unquestionably gas. It will be as well, however, to have a fire-place in the room, as, in some cases, a gas-stove will be

inapplicable. There should be gas-burners in different parts of the room for illumination at night; and also an arrangement for placing a screen of orange glass in front of each.

Several rough deal benches should be put up in different parts of the room, with shelves, drawers, cupboards, &c. The arrangement of these matters must of course depend upon the capabilities of the room.

7. The following apparatus is required. The quantities are those that we have found necessary in this Observatory:—

Eight dishes.	Six funnels.
Eight mill-board covers.	One funnel stand.
Three brushes for cleaning dishes.	Pint, half-pint, one ounce, and
A vessel for melting wax.	one drachm measures.
Two gauze burners.	Three glass flasks.
One box, iron.	Boxes for holding paper.
Filtering paper.	Scales and weights.
A still for water.	Sponge, glass rods, stoppered
One platinum, and three bone spatulas (flat paper-knives).	bottles, &c.

8. The dishes may be made of glass, porcelain, or gutta percha. Glass and porcelain are certainly cleaner than gutta percha; but for general use the latter is far preferable, as with it there is no risk of breakage, and the bottom of the dish can be made perfectly flat, which is a great advantage. These dishes should be made of sufficient length to allow of a margin of about half an inch at each end when the paper is in; and the shape should be made as nearly square as possible, by arranging them to take two or three sheets side by side.

The gutta percha should be of a good thickness, otherwise it will bend and give way, if it be moved when full of liquid. The depth must depend upon the size of the dish, and the purpose for which it is intended. The dishes in use here accommodate three sheets of paper side by side; they are fifteen inches square, and one inch and a half deep. I think, however, for some purposes, where they are not wanted to be moved about much (*i. e.* those for holding the bath of hyposulphite of soda for fixing), the depth might be advantageously increased to two inches and a half. Each dish ought to be reserved for a particular solution, and should have a piece of millboard a little larger than itself for a cover.

9. The brushes for cleaning the dishes are of two sorts; a common scrubbing brush will be found the best for all parts but the corners, and for these another kind must be used, having a handle about a foot long, at the end of which are tufts of stiff bristles, projecting about three-quarters of an inch, and radiating on all sides, forming a ball about two inches and a half in diameter. Hardly any dirt will be found capable of resisting this brush if it be pressed into a corner, and twisted round several times. The dishes ought always to be put away clean, as the dirt is much more difficult to remove if allowed to dry on.

10. When a dish is to be cleaned, if it be of glass or porcelain, strong nitric acid must be poured into it; if of gutta percha, it should be filled with a strong solution of cyanide of potassium. After soaking for half an hour or an hour, according to the state of the dish, the liquid is to be returned into the bottle (both the nitric acid and the cyanide can be used several times), the dish rinsed out with water, and then well scrubbed in every part with the brushes; afterwards it is to be washed several times in common water, once with distilled water, and then placed in a slanting position against a wall, face downwards, to drain on clean blotting-paper.

11. The vessel in which the wax is melted, must be contrived so as never to allow of its reaching a higher temperature than 212° Fahr., or decomposition of the wax might ensue. I have found the most convenient apparatus to be, a tin vessel 15 inches square and 4 inches deep, having a tray which holds the wax fitting into it about 1 inch deep. The under vessel is to be half filled with water, and by keeping this just at the boiling temperature, the wax above will soon become liquid.

12. The best source of heat is that known as the gauze gas-burner, it being free from smoke or dust, and not liable to blacken anything placed over it. It consists of a common argand burner fixed on a rather low and heavy iron stand, which is surmounted by a copper or brass cylinder 5 inches in height and 2 inches wide, having a piece of wire gauze of 900 meshes to the square inch fastened over the top. By connecting this burner by means of vulcanized india-rubber tubing to the gas-pipe, it can be moved about the table to any convenient position. The mixture of gas and air, formed inside the cylinder, is to be lighted above the wire gauze; it burns over this with a large and nearly colourless but intensely hot flame.

13. The most convenient form of iron is the ordinary box iron, made hot by heaters inside; perhaps it might be improved in shape by having the end not quite so pointed, but this is not of much consequence. Some operators recommend facing the bottom with a plate of silver; this is very expensive, and seems to me to be attended with no advantage whatever.

14. For the purpose of absorbing the excess of wax from the surface of the sheet, I should recommend the ordinary white wove blotting-paper, medium thickness. But this is not sufficiently free from impurities to serve either for drying the sensitive sheets, or for filtering; for this purpose, the fine filtering paper (not the Swedish) employed in quantitative chemical operations is the best.

15. The distilled water being one of those substances upon the purity of which success will in a great measure depend, it will be found much safer to distil it on the premises, especially as the quantity required is trifling. A convenient size for the still is about two gallons; it may be procured ready made, with worm, &c. complete, of any large dealer in chemical apparatus. It will be found far more economical, both in time and trouble, to heat the water over a charcoal or coke fire, in preference to using gas for this purpose.

16. A platinum spatula is a most necessary instrument in almost every operation; the best size is 4 inches long, $\frac{1}{2}$ an inch wide at one end, and $\frac{3}{4}$ at the other, the corners being rounded off; it should be of a sufficient substance to prevent its being easily bent. Its chief use is to raise one corner of the sheets to allow of their being held between the finger and thumb, for the purpose of removing from one dish to another, as, previous to fixing, none of the solutions should come in contact with the fingers.

During the fixing and subsequent washing, bone spatulas will be found very useful; but after having been in contact with hyposulphite of soda, they must be carefully kept away from any of the previous baths, or black stains will infallibly ensue.

17. The funnels may be either of glass or porcelain; it will be found useful to have several of different sizes, from 2 inches diameter, up to 6 inches. A convenient stand for them may be made of a piece of flat board, with circular holes, about half the diameter of the funnels employed, drilled into it, and supported upon four legs about 8 inches high. The paper used for filtering should be the finest of the two sorts of blotting-paper mentioned above (14). The filters can either be cut from the sheet as wanted, or they may be obtained ready cut in packets.

The measures should be of glass, graduated, the pint and half pint into ounces, the ounce measure into drachms, and the drachm measure into minims; they should be rather long in proportion to their width.

The Florence oil-flasks, which can be obtained for a trifle at any oil warehouse, will be found to answer every purpose, nearly as well as the more expensive German flasks. They must be cleansed thoroughly from the adhering oil; this may be done by boiling in them, over the gauze gas-burner, a strong solution of ordinary washing soda, and afterwards well rinsing out with water.

18. It will be found indispensable, where there are many operations going on at the same time, and many different sheets of paper in various stages of progress, to have a separate box or division to hold the paper in each of its stages. The plan I have found most convenient, is to obtain several mill-board boxes, the fronts of which will fall flat when the lid is lifted up, similar to those used by stationers for holding letter paper, &c.: they can be made to hold two or three piles of sheets side by side. They may be obtained from M. Rousseau, 352 Strand, London.

The scales and weights need not be of any great accuracy. A 6-inch beam capable of turning to half a grain, when loaded with 500 grains in each pan, will be all that is requisite: the pans must be of glass, and the weights should consist of a set of grain and a set of drachm weights.

A sponge will be found useful for wiping up any of the solutions that may have been spilt on the bench. Solid glass stirring rods of about the thickness of a quill, and six or eight inches long, and a small Wedgewood pestle and mortar, are of great service in many of the operations.

Stoppered bottles should be employed for all the solutions; and too much care cannot be taken to label each bottle accurately and distinctly.

19. Besides the above apparatus, the following materials and chemicals are requisite. A rough estimate is also given of their relative consumption in three months:—Photographic paper, 270 sheets, or 112 square feet; four pounds of wax; three ounces of iodide of potassium; three ounces of bromide of potassium; four ounces of nitrate of silver; two ounces of glacial acetic acid; four ounces of gallic acid; one pint of alcohol; seven pounds of hyposulphite of soda; half a pound of cyanide of potassium; half a pint of concentrated nitric acid; eighteen gallons of distilled water.

20. The selection of a good sample of paper for the basis on which the sensitive material is to be formed is of great importance, as any imperfection will be a source of annoyance in every stage of the process, and will hardly fail to show itself on the finished picture. The paper, which from numerous experiments I have found to be superior to any other, is that known as Canson's thin photographic paper. This is manufactured with care, and is in general very uniform in quality.

It will be found by far the most advantageous plan, when used on a scale like the present, to order it of some wholesale stationer cut to the requisite dimensions. The size of the sheets in use here is $4\frac{5}{8}$ inches by $12\frac{1}{2}$ inches*. Hitherto Messrs. Hallifax and Co., 319 Oxford Street, have supplied us with the paper of this size.

21. I am indebted to Mr. Barclay of Regent Street, wax bleacher, for much valuable information concerning wax and its adulterations, and for

* This is a most inconvenient size, as it involves the cutting of more than one-third of the paper to waste. The admirably ingenious arrangement of Mr. Ronalds was not made with the view of employing Canson's paper, or it would doubtless have been contrived to accommodate sheets of a size which could be cut with less waste, such as $4\frac{1}{4}$ by 13 inches or $4\frac{3}{8}$ by $11\frac{1}{4}$ inches.

an extensive assortment of waxes of all kinds, and in every degree of purity; also to Mr. Maskelyne, for a valuable series of the chemical bodies of which the various waxes are composed; by means of these I have been enabled to examine the effect produced by saturating the paper with bees-wax from different countries, Myrica wax, Canauba wax, China wax, spermaceti, ethal, stearic acid, stearin, palmitic acid, palmitin, paraffin, and various oils.

22. I find that the action of the wax is purely mechanical, almost the only difference of effect produced by any of the above bodies, widely as they vary in their chemical nature, arising from a difference in their physical properties.

Stearin, palmitin, and most of the oils, are too greasy in their nature to be advantageously employed. The fatty acids do not make the paper in the least greasy, but they injure the transparency. China wax has almost too high a melting-point, and gives a crystalline structure to the paper. Spermaceti also is too crystalline. Paraffin, ethal, and the waxes, produce very good results; of these bees-wax is the only one that would be practically available for this purpose. It should be free from stearin, stearic acid, tallow, &c.; the presence of a little spermaceti does not much interfere, but as its price does not differ very much from that of pure wax, it is not so common an adulteration as the other cheaper substances.

23. It will be unsafe to use the wax in the form of round thin tablets, about 4 inches in diameter, in which it is usually met with, as in this state it is generally adulterated to the extent of at least 50 per cent.

As an article of commerce, it is next to impossible to obtain small quantities of wax sufficiently pure to be relied upon. The only way I can recommend is to apply to one of the well-known large bleachers, and trust to them for supplying the article in a state of purity. Whenever I have found it necessary to make such applications, my request has always been acceded to in the most cordial manner, and every information has been given with the utmost readiness.

24. The other chemicals (with the exception of the strong nitric acid, which any retail druggist will supply, and the water, which had best be distilled on the premises) should be ordered direct from some manufacturing chemist, as otherwise, unless the operator have a sufficient knowledge of chemistry to be able to detect any inferiority, there is danger of not having the articles sufficiently pure.

The iodide and bromide of potassium should be ordered *purified*.

The nitrate of silver should be crystallized, not in sticks; it ought to be perfectly dry, and have no smell, acid or otherwise.

There are usually two varieties of glacial acetic acid to be met with; the purest must be used; it should be perfectly free from any empyreumatic odour, and must cause no turbidity when mixed with a solution of nitrate of silver, *e. g.* in making the exciting bath (42).

The gallic acid should be as nearly white in colour as possible.

Especial care should be taken to have the alcohol good; it should be 60° over proof, and of specific gravity 0.83. On evaporating a few drops on the palm of the hand, no smell should be left behind, nor should it, under the same circumstances, leave any stain on a sheet of white paper.

25. The hyposulphite of soda will be found one of the articles most difficult to obtain pure; there is a large quantity at present in the market, having little else of this salt but the name, and being of course totally unfit for use; if there be the least doubt about its purity, it should be tested in the following manner:—

Weigh out accurately 10 grains of nitrate of silver, dissolve this in half an ounce of distilled water; then add 4 grains of chloride of sodium (common salt), also dissolved in water. On mixing these two solutions together, a white curdy precipitate of chloride of silver will fall down. Next add 22 grains of the hyposulphite of soda, and allow it to stand for about ten minutes, stirring occasionally with a glass rod. If at the end of that time the chloride of silver has dissolved, the hyposulphite of soda may be considered as pure. A greater or less amount of residue will indicate roughly the degree of impurity.

26. The cyanide of potassium is usually met with in the form of hard white lumps; they will be found quite pure enough. It is very useful in removing stains formed by nitrate of silver on the fingers, &c.; but the greatest care must be taken in its employment, as it is a most energetic poison; its use in cleaning the dishes from silver stains has been pointed out above (10).

27. The first operation to be performed is to make a slight pencil mark on that side of the photographic paper which is to receive the sensitive coating. If a sheet of Canson's paper be examined in a good light, one of the sides will be found to present a finely reticulated appearance, while the other will be perfectly smooth; this latter is the one that should be marked. Fifty or a hundred sheets may be marked at once, by holding a pile of them firmly by one end, and then bending the packet round, until the loose ends separate one from another like a fan; generally all the sheets lie in the same direction, therefore it is only necessary to ascertain that the smooth side of one of them is uppermost, and then draw a pencil once or twice along the exposed edges.

28. The paper has now to be saturated with white wax. The apparatus for this purpose has been previously described (11). The wax is to be made perfectly liquid, and then the sheets of paper, taken up singly and held by one end, are gradually lowered on to the fluid. As soon as the wax is absorbed, which takes place almost directly, they are to be lifted up with rather a quick movement, held by one corner and allowed to drain until the wax, ceasing to run off, congeals on the surface. When the sheets are first taken up for this operation, they should be briefly examined, and such as show the water-mark, contain any black spots*, or have anything unusual about their appearance, should be rejected.

29. The paper in this stage will contain far more wax than necessary; the excess may be removed by placing the sheets singly between blotting-paper (14), and ironing them; but this is wasteful, and the loss may be avoided by placing on each side of the waxed sheet two or three sheets of unwaxed photographic paper, and then ironing the whole between blotting-paper; there will generally be enough wax on the centre sheet to saturate fully those next to it on each side, and partially, if not entirely, the others. Those that are imperfectly waxed may be made the outer sheets of the succeeding set. Finally, each sheet must be separately ironed between blotting-paper until the glistening patches of wax are absorbed.

30. It is of the utmost consequence that the temperature of the iron should not exceed that of boiling water. Before using, I always dip it into water until the hissing entirely ceases. This is one of the most important points in the whole process, but one which it is very difficult to make beginners properly appreciate. The disadvantages of having too hot an iron, are not

* These spots have been analysed by Mr. Malone; he finds them to consist, not of iron, as is generally supposed, but of small pieces of brass. I have also examined them myself with a like result.

apparent until an after stage, while the saving of time and trouble is a great temptation to beginners. It is to a neglect of this point that I am inclined to attribute most of the faults so commonly laid to the charge of this beautiful process; such as gravelly appearance, or want of smoothness in the lights, and quick decomposition in the developing solution.

31. A well-waxed sheet of paper, when viewed by obliquely reflected light, ought to present a perfectly uniform glazed appearance on one side, while the other should be rather duller; there must be no shining patches on any part of the surface, nor should any irregularities be observed on examining the paper with a black ground placed behind; seen by transmitted light, it will appear opalescent, but there should be no approach to a granular structure. The colour of a pile of waxed sheets is slightly bluish.

32. The paper, having undergone this preparatory operation, is ready for *iodizing*; this is effected by completely immersing it in an aqueous solution of an alkaline iodide, either pure or mixed with some analogous salt.

One would think that in no part of the photographic operation would greater unanimity exist, than on the composition of the iodizing bath; but on this subject, strangely enough, no two persons seem to think alike. The formulæ for this bath are nearly as numerous as the operators themselves; and some of them show not a little ingenuity in the manner in which substances apparently the most unphotographic have been pressed into service.

33. The results of numerous experiments, which I need not mention here, had convinced me, that for ordinary purposes, iodide of silver *per se* was the best sensitive surface for receiving an image in the camera; but on making use of that body in these operations (by employing pure iodide of potassium in the bath), I was surprised to meet with results for which I was at first unable to account. A little consideration, however, showed me the direction in which I was to look for a remedy. The experiments which had led me to prefer iodide of silver as a sensitive surface, had all been performed with sunlight, either direct, or more frequently in the form of diffused daylight. In this case, however, coal-gas was the source of light; and if, as was very probable, there were any great difference in the quality of the light from these two sources, the superiority of iodide over the bromide or chloride of silver would still be a matter for experiment.

34. A comparison of the spectra of the two kinds of light showed a very marked difference; while in sunlight the spectral rays which are around and above the fixed line G (the indigo and higher rays) are so intense and numerous, as completely to overpower the small space between and about F and G (the blue and upper portion of the green), a part of the spectrum which affects bromide more than iodide of silver; in gaslight the case was quite different. The great bulk of photographic rays was found to lie within the limits of the visible spectrum, and consequently the photographic action of this light was likely to be far more energetic on bromide than on iodide of silver. These suppositions were fully borne out by experiment; on introducing a little bromide of potassium into the iodizing bath, the change was very apparent. It requires a certain proportion to be observed between the two to obtain the best results. If the iodide of potassium be in excess, the resulting silver salt will be wanting in sensitiveness, requiring a comparatively long development to render an image visible; while, if the bromide be in excess, there will be a great want of vigour in the impression, the picture being red and transparent. When the proportion between the two is properly adjusted, the paper will be extremely sensitive, the picture presenting a vigorous black appearance, without the least approach to red. The addition of a chloride was found to produce a somewhat similar effect to that

of a bromide, but in a less marked degree. As no particular advantage could be traced to it, it was not employed.

35. I have also tried most of the different forms of organic matter which it is customary to add to this bath, but I cannot recommend them; the most that can be said is, that some of them do no harm. At first I thought a little isinglass might be an improvement, as it instantly removes the greasiness from the surface of the paper, and allows the iodide of potassium to penetrate more readily. Unfortunately, however, it interferes with the most important property of this process, that of remaining sensitive for a long time.

36. I think the best results are obtained when the iodide and bromide are mixed in the proportion of their atomic weights; the strength being as follows:—

Iodide of potassium	582·5 grains.
Bromide of potassium	417·5 grains.
Distilled water	40 ounces*.

When the two salts have dissolved in the water, the mixture should be filtered; the bath will then be fit for use.

37. At first a slight difficulty will be felt in immersing the waxed sheets in the liquid without enclosing air-bubbles, the greasy nature of the surface causing the solution to run off. The best way is to hold the paper by one end, and gradually to bring it down on to the liquid, commencing at the other end; the paper ought not to slant towards the surface of the bath, or there will be danger of enclosing air-bubbles; but while it is being laid down, the part out of the liquid should be kept as nearly as possible perpendicular to the surface of the liquid; any curling up of the sheet, when first laid down, may be prevented by breathing on it gently. In about ten minutes the sheet ought to be lifted up by one corner, and turned over in the same manner; a slight agitation of the dish will then throw the liquid entirely over that sheet, and another can be treated in like manner.

38. The sheets must remain soaking in this bath for about three hours; several times during that interval (and especially if there be many sheets in the same bath) they ought to be moved about and turned over singly, to allow of the liquid penetrating between them, and coming perfectly in contact with every part of the surface. After they have soaked for a sufficient time, the sheets should be taken out and hung up to dry; this is conveniently effected by stretching a string across the room, and hooking the papers on to this by means of a pin bent into the shape of the letter S. After a sheet has been hung up for a few minutes, a piece of blotting-paper, about one inch square, should be stuck to the bottom corner to absorb the drop, and prevent its drying on the sheet, or it would cause a stain in the picture.

39. While the sheets are drying, they should be looked at occasionally, and the way in which the liquid on the surface dries, noticed; if it collect in drops all over the surface, it is a sign that the sheets have not been sufficiently acted on by the iodizing bath, owing to their having been removed from the latter too soon. The sheets will usually during drying assume a dirty pink appearance, owing probably to the liberation of iodine by ozone in the air, and its subsequent combination with the starch and wax in the paper. This is by no means a bad sign, if the colour be at all uniform; but if it appear in patches and spots, it shows that there has been some irregular

* While giving the above as the calculated quantities, I do not wish to insist upon their being adhered to with any extreme accuracy. An error of a few grains on either side would, I believe, be without any perceptible effect on the result.

absorption of the wax, or defect in the iodizing, and it will be as well to reject sheets so marked.

40. As soon as the sheets are quite dry, they can be put aside in a box for use at a future time. There is a great deal of uncertainty as regards the length of time the sheets may be kept in this state without spoiling; I can speak from experience as to there being no sensible deterioration after a lapse of ten months, but further than this I have not tried.

Up to this stage it is immaterial whether the operations have been performed by daylight or not; but the subsequent treatment, until the fixing of the picture, must be done by yellow light (5).

41. The next step consists in rendering the iodized paper sensitive to light. Although, when extreme care is taken in this operation, it is hardly of any consequence when this is performed, yet in practice it will not be found convenient to *excite* the paper earlier than about a fortnight before its being required for use. The materials for the exciting bath are nitrate of silver, glacial acetic acid, and water. Some operators replace the acetic acid by tartaric acid; but as I cannot perceive the effect of this change except in a diminution of sensitiveness, I have not adopted it. It is of little importance what be the strength of the solution of nitrate of silver; the disadvantages of a weak solution are, that the sheets require to remain in contact with it for a considerable time before the decomposition is effected, and the bath requires oftener renewing; while with a bath which is too strong, time is equally lost in the long-continued washing requisite to enable the paper to keep good for any length of time. The quantity of acetic acid is also of little consequence.

42. In the following bath, I have endeavoured so to adjust the proportion of nitrate of silver, as to avoid as much as possible both the inconveniences mentioned above:—

Nitrate of silver	300 grains.
Glacial acetic acid	2 drachms.
Distilled water	20 ounces.

The nitrate of silver and acetic acid are to be added to the water, and when dissolved, filtered into a clean dish (10), taking care that the bottom of the dish be flat, and that the liquid cover it to the depth of at least half an inch all over; by the side of this, two similar dishes must be placed, each containing distilled water.

43. A sheet of iodized paper is to be taken by one end and gradually lowered, the marked side downwards, on to the exciting solution, taking care that no liquid gets on to the back, and no air-bubbles are enclosed.

It will be necessary for the sheet to remain on this bath from five to ten minutes; but it can generally be known when the operation is completed by the change in appearance, the pink colour entirely disappearing, and the sheet assuming a pure homogeneous straw colour. When this is the case, one corner of it must be raised up by the platinum spatula, lifted out of the dish with rather a quick movement, allowed to drain for about half a minute, and then floated on the surface of the water in the second dish, while another iodized sheet is placed on the nitrate of silver solution; when this has remained on for a sufficient time, it must be in like manner transferred to the dish of distilled water, having removed the previous sheet to the next dish.

44. A third iodized sheet can now be excited, and when this is completed, the one first excited must be rubbed perfectly dry between folds of clean blotting-paper (14), wrapped up in clean paper, and preserved in a portfolio until required for use; and the others can be transferred a dish forward,

as before, taking care that each sheet be washed twice in distilled water, and that at every fourth sheet the dishes of washing water be emptied, and replenished with clean distilled water: this water should not be thrown away, but preserved in a bottle for a subsequent operation (49).

45. The above quantity of the exciting bath will be found quite enough to excite about fifty sheets of the size here employed, or 3000 square inches of paper. After the bulk has been exhausted for this purpose, it should be kept, like the washing waters, for the subsequent operation of developing (49).

Of course these sensitive sheets must be kept in perfect darkness. Generally sufficient attention is not paid to this point. It should be borne in mind, that an amount of white light, quite harmless if the paper were only exposed to its action for a few minutes, will infallibly destroy it if allowed to have access to it for any length of time; therefore, the longer the sheets are required to be kept, the more carefully must the light, even from gas, be excluded; they must likewise be kept away from any fumes or vapour.

46. Experience alone can tell the proper time to expose the sensitive paper to the action of light, in order to obtain the best effects. However, it will be useful to remember that it is almost always possible, however short the time of exposure, to obtain some trace of effect by prolonged development. Varying the time of exposure, within certain limits, makes very little difference on the finished picture; its principal effect being to shorten or prolong the time of development.

Unless the exposure to light has been extremely long (much longer than can take place under the circumstances we are contemplating), nothing will be visible on the sheet after its removal from the instrument, more than there was previous to exposure; the action of the light merely producing a latent impression, which requires to be developed to render it visible.

47. The developing solution in nearly every case consists of an aqueous solution of gallic acid, with the addition, more or less, of a solution of nitrate of silver.

An improvement on the ordinary method of developing with gallic acid, formed the subject of a communication to the Philosophical Magazine for March 1855, where I recommend the employment of a strong alcoholic solution of gallic acid, to be diluted with water when required for use, as being more economical both of time and trouble than the preparation of a great quantity of an aqueous solution for each operation.

48. The solution is thus made: put two ounces of crystallized gallic acid into a dry flask with a narrow neck; over this pour six ounces of good alcohol (60° over proof), and place the flask in hot water until the acid is dissolved, or nearly so. This will not take long, especially if it be well shaken once or twice. Allow it to cool, then add half a drachm of glacial acetic acid, and filter the whole into a stoppered bottle.

49. The developing solution which I employ for one set of sheets, or 180 square inches, is prepared by mixing together ten ounces of the water that has been previously used for washing the excited papers (44), and four drachms of the exhausted exciting bath (45); the mixture is then filtered into a perfectly clean dish, and half a drachm of the above alcoholic solution of gallic acid poured into it. The dish must be shaken about until the greasy appearance has quite gone from the surface; and then the sheets of paper may be laid down on the solution in the ordinary manner with the marked side downwards, taking particular care that none of the solution gets on the back of the paper, or it will cause a stain. Should this happen, either dry it with blotting-paper, or immerse the sheet entirely in the liquid.

50. If the paper has been exposed to a moderate light, the picture will

begin to appear within five minutes of its being laid on the solution, and will be finished in a few hours. It may, however, sometimes be requisite, if the light has been feeble, to prolong the development for a day or more. If the dish be perfectly clean, the developing solution will remain active for the whole of this time, and when used only for a few hours, will be quite clear and colourless, or with the faintest tinge of brown; a darker appearance indicates the presence of dirt. The progress of the development may be watched, by gently raising one corner with the platinum spatula, and lifting the sheet up by the fingers. This should not be done too often, as there is always a risk of producing stains on the surface of the picture. I prefer allowing the development to go on until the black is rather more intense than ultimately required, as it is generally toned down in the fixing bath.

51. As soon as the picture is judged to be sufficiently intense, it must be removed from the gallo-nitrate, and laid on a dish of water (not necessarily distilled). In this state it may remain until the final operation of fixing, which need not be performed immediately, if inconvenient. After being washed once or twice, and dried between clean blotting-paper, the picture will remain unharmed for weeks, if kept in a dark place.

52. The *fixing bath* is composed of a saturated solution of hyposulphite of soda diluted with its own bulk of water. Into this the sheets are to be completely immersed, until the whole of the yellow iodide of silver has been dissolved out. This operation need not be performed by yellow light; day-light is much better for showing whether the picture be entirely fixed. This will take from a quarter of an hour to two hours, according to the time the bath has been in use.

It will be well not to put too many sheets into the bath at once, in order to avoid the necessity of turning them over to allow the liquid to penetrate every part.

When fixed, the sheet, if held up between the light and the eye, will present a pure transparent appearance in the white parts.

The fixing bath gradually becomes less and less active by use, and then its action is very energetic on the dark parts of the picture, attacking and dissolving them equally with the unchanged iodide. When this is the case it should be put on one side (not thrown away), and a fresh bath made.

53. After removal from the fixing bath, the sheets must be well-washed. In this operation, the effect depends more upon the quantity of water used than upon the duration of the immersion. When practicable, it is a good plan to allow water from a tap to flow over the sheets for a minute or two, and having thus got rid of the hyposulphite of soda from the surface, to allow them to soak for about ten minutes in a large dish of hot water.

54. They are then to be dried by hanging up by a crooked pin, as after iodizing. When dry, they will present a very rough and granular appearance in the transparent parts; this is removed by melting the wax, either before a fire, or, what is far better, by placing them between blotting-paper, and passing a warm iron over them; by this means the white parts will recover their original transparency.

55. The picture, arrived at this stage, may be considered finished, as far as is requisite for the purposes of measurement and registration; sometimes, however, it may be necessary to multiply copies, for the purpose of transmitting to other Meteorological Observatories facsimiles of the records, or at least of those containing any remarkable phenomena. I will therefore now detail the method of printing photographic positives from these negatives, premising that the process does not differ materially from that usually adopted.

56. The only extra piece of apparatus required, is a *pressure frame*; which consists essentially of a stout piece of plate glass in a frame, with an arrangement for screwing a flat board, the size of the glass, tight against it. Though apparently very simple, some care is required, when the frame is a large one, in arranging the screw and board at the back, so as to obtain an equal pressure all over the surface; unless this is done, the glass will be very liable to break. The pressure frames supplied to us by Messrs. Newman and Murray, 122 Regent Street, are unexceptionable in this respect. The board should of course be well-padded with velvet, and the lateral dimensions of the glass should be the same as those of the gutta-percha dishes (8).

57. The extra chemicals required for this process are chloride of sodium and chloride of gold. Generally speaking, for the former, common table-salt will be found quite pure enough; but as the quantity required is but small, it will perhaps be found better to obtain some of the recrystallized salt along with the other chemicals.

The chloride of gold is merely required for an artistic effect. Many persons object to the reddish-brown appearance of ordinary photographic positives; the addition of a little chloride of gold to the fixing bath converts this into a rich brown or black; the trifling quantity required removes any objection to its use on the score of expense.

58. I prefer using the same kind of paper for positives as for negatives (20). Messrs. Canson manufacture a thicker paper, which is generally called positive paper, but I think the thin is far preferable; the surface is smoother, and the various solutions penetrate much better.

59. The first operation which the paper has to undergo is *saltin*; the bath for this purpose consists of

Chloride of sodium.....	100 grains.
Distilled water	40 ounces.

Filter this into a clean dish, and completely immerse the sheets, marked as directed (27). This is best done by laying them gently on the surface of the liquid, and then pressing them under by passing a glass rod over them; as many sheets as the dish will hold may be thus immersed one after the other. Allow them to soak for about ten minutes, then lift and turn them over in a body; afterwards they may be hung up to dry (38), commencing with the sheet which was first put in. When dry, they may be taken down and put aside for use at any future time. The sheets in drying generally curl up very much; it will therefore be found convenient in the next process, if the salted sheets, before being put away, have been allowed to remain in the pressure frame, screwed tight, for about twenty-four hours. This makes them perfectly flat.

60. The exciting bath is composed of

Nitrate of silver.....	150 grains.
Distilled water	10 ounces.

After filtering, pour the solution into a clean dish; and then lay the sheets, salted as above, on the surface, face downwards, gently breathing on the back, if it be necessary, to counteract the tendency to curl up; let them remain on this bath for about ten minutes, and then hang up to dry (38).

61. This exciting bath will serve for nearly one hundred sheets; it will then be better to put it on one side (64), and make a new bath. It is not advisable to excite more positive sheets than will be likely to be required in the course of a week, for they gradually turn brown by keeping, even in the dark, and lose sensitiveness. They will, however, keep much better if pressed tight in the pressure frame, and thus protected from the air.

62. When a positive is to be printed from a negative, let the glass of the pressure frame be perfectly cleaned and freed from dust on both sides, then lay the negative on it, with its back to the glass. On it place a sheet of positive paper, with its sensitive side down. Then, having placed over, as a pad, several sheets of blotting-paper, screw the back down with sufficient force to press the two sheets into close contact, but of course not so as to endanger the glass. Now place the frame in the sun, so that the light can fall perpendicularly on the glass, and allow it to remain there until it is judged to have been exposed long enough.

63. No rule can be laid down for the proper time of exposure; it will depend upon the quality of the light and intensity of the negative; some pictures being completed in a few minutes, others requiring upwards of half an hour. The printing should always go on until the picture is several shades darker than ultimately required. A very little experience will enable the operator to judge so well of the quality of the light, as hardly ever to have a failure. If the two sheets of paper be stuck together in two or three places at the edges with small pieces of gummed paper, the frame can be removed to the dark room, and the progress of the sheets examined; but this is always attended with some danger, for unless they are replaced without having been shifted one from the other, there will be a double image.

64. As soon as the picture is considered to be printed sufficiently deep, it has to be fixed.

The fixing bath consists of

Saturated solution of hyposulphite of soda	10 ounces.
Water	30 ounces.

This bath will be found to fix the pictures perfectly, but they will generally be of a reddish tint; if it be thought desirable to obtain the pictures of some shade of dark brown or black, it will be necessary to employ a bath made as follows:—

Saturated solution of hyposulphite of soda	10 ounces.
Water	10 ounces.
Exhausted positive exciting solution (61)	10 ounces.

Mix these together, and then add the following:—

Water	10 ounces.
Chloride of gold	20 grains.

taking care in mixing to pour the solution of gold into the solution of hyposulphite, and not the latter into the former, or another decomposition will be produced.

Pour this mixture into a dish, and lay the positive carefully on it, face downwards. As soon as it is thoroughly damp (which may be known by its becoming perfectly flat after having curled up), immerse it totally in the liquid.

65. The pictures should not be too crowded in the bath, as they are very apt to become irregularly coloured in places where the hyposulphite has not had free access during the whole of the time. When first put in, the colour will change to a light brown, and in the course of some time, varying from ten minutes to two or three hours, it will pass through the different shades of brown to black and purple, gradually fading in intensity during the time. It will be necessary to allow the picture to remain in this bath for ten minutes *at least*, in order that it may be perfectly fixed. After this time, its stay

need only be prolonged until it has become of the desired tone and colour; always remembering, that during the subsequent operation of drying, &c. it will become of a somewhat darker tint than when taken out of the fixing bath.

66. On removal from this bath, the pictures must be allowed to soak in a large quantity of cold water for ten or twelve hours. There must not be very many in the dish at a time, and the water must be changed at least three times during that interval; they must then have boiling water poured over them (of course in a *porcelain* dish) two or three times, and lastly be pressed dry between sheets of clean blotting-paper (14) (these may be used several times, if dried), and then allowed to dry spontaneously in the air. When the pressure frame is not in use, a pile of these finished positives may be put in, and kept tightly screwed up all night; by this means they will be rendered perfectly flat and smooth.

67. The picture is now complete. It must be borne in mind, however, that the light and shade are reversed by this operation, the track of the luminous image along the paper being represented by a *white* instead of by a *black* band, as in the original negative. Should it be desired to produce exact facsimiles of the negatives, it can be done by employing one of these positives as a negative, and printing other positives from it; in this way, the light and shade, having been twice reversed, will be the same as in the original negative.

68. In some cases it may happen that, owing to a partial failure of gas, or imperfection in the sensitive sheet, an image may be so faint as to render it impossible to print a distinct positive. The gap that this would produce in a set of pictures may be obviated, and with very slight sacrifice of accuracy, by forming an artificial or *secondary* negative in the following manner:—

69. Print a copy on positive paper, of any intensity which will show the most distinct impression; then without fixing, and with a pair of sharp scissors, accurately and carefully cut out the part corresponding to the impressed portion of the negative. Expose this piece to the light until it has become perfectly opaque, and then it can either be cemented over the imperfect original sheet, or on a clean sheet of paper, and used as an ordinary negative.

It is astonishing what accuracy and quickness in cutting out even the most intricate pictures, may be obtained with a little practice; the error of the scissors is generally within the error of measurement.

Supplementary Notes to the above description, embodying some slight changes in the process made at Kew. By C. CHAMBERS.

1. After reaching the stage described in art. 28, a pile of paper is to be made up, in which eight plain (unwaxed) sheets alternate with one waxed sheet, and in this state is to be placed between hot plates and subjected to high pressure for several hours, when the mass of paper will be found to be completely permeated by the wax. The operation is to be repeated four or five times, and the sheets, being separated after cooling, will be ready for iodizing.

The operation of pressing is best accomplished with the paper *not* folded, and of the full size as received from the maker, so that the edges which retain superfluous wax may be cut off and rejected, and the sheets then cut into pieces of the required shape. Piles half an inch in thickness may be done at once in this way, and using several series of hot plates, any quantity of paper may

be put through the press in one night. The hot-pressing apparatus is used by the paper-makers, and by some of the wholesale stationers.

2. The iodizing bath, which should be kept in the dark when not in use, consists of—

Iodide of potassium.	582 $\frac{1}{2}$ grains.
Bromide of potassium.	417 $\frac{1}{2}$ grains.
Distilled water	40 ozs.
Iodine—sufficient to give the solution a decidedly red tinge.	

With every fresh batch of paper, a small quantity of iodine should be added to restore the red tone of the bath.

The paper is to be hung up to dry in a dark cupboard, and, when dry, it should be of a light reddish-brown colour; if a deep red or purple, it will want sensitiveness; if nearly white, it will want keeping properties, and will become discoloured during development.

3. The exciting bath contains,—

Nitrate of silver	750 grs.
Distilled water	30 ozs.
Acetic acid.	3 drms.

A strong solution of nitrate of silver (100 grs. to 1 oz. of water) is kept in a separate bottle for replenishing the exciting bath, which loses by use both in quantity and strength. 2 drms. of this solution with $\frac{1}{4}$ drm. of acetic acid, is added after exciting every three sheets (300 square inches) of paper. The addition of acetic acid prevents discoloration during development, but at the same time slightly diminishes the sensitiveness, and, if added in excess, the intensity of the image is much weakened. When the bath is more than a fortnight old, it is necessary to filter before using. With a weak and old exciting bath the iodide of silver is apt to fall from the sheet in flakes while in the bath, and the portions of the sheet so deprived of silver are no longer sensitive to light: however, there need be no fear of this occurring while the strength of the bath is maintained as above directed. The same exciting solution has been used as long as three months with satisfactory results (1000 square inches of paper being sensitized weekly).

4. (Art. 44.) Instead of drying the sheets between blotting-paper, it has been found to give cleaner and more uniform pictures to hang them up to dry in a dark cupboard; about an inch is cut off each end of the sheet and rejected where the fingers have touched it, and where the fluid has accumulated in dripping.

5. It is very desirable that the exciting and fixing operations should be performed at different times; for if, after fixing, the hands have not been carefully washed, the least remnant of fixing solution left upon the fingers is communicated to the edge and dispersed over the moist surface of the newly sensitized sheet, producing a stain which appears on developing. If a series of black spots, proceeding from one corner of the sheet, show themselves while developing, the cause should probably be looked for in the exciting operation—a drop of the solution accidentally got on the upper side of the floating sheet having trickled down when the sheet was held vertically: when this occurs, it is better (instead of merely floating) to immerse the sheet in the two washing dishes (see art. 43).

6. A sheet of plate-glass, 20 inches by 18 inches, ground at the edges to prevent the solution from flowing off, is used for developing. This was proposed by Mr. Welsh, and it is found to answer extremely well: it rests upon

a wooden cross-piece which fits into a large earthenware dish, and is capable of being roughly levelled by means of screws which support the dish.

It is raised about an inch above the bottom of the dish. A solution consisting of—

Distilled water	8 ozs.
Acetic acid	1 drm.
Old exciting bath	4 drms. (or 1 drm. of solution of nitrate of silver 100 grs. to 1 oz.)
Gallic acid solution	1½ drm. (see art. 48)

is poured upon the plate, and the exposed sheets floated side by side upon it. The time required for this operation varies from two hours in summer to six or eight hours in winter.

Note.—In dull weather, the sensitive paper above described may be used with advantage for printing copies of the curves—requiring an exposure of only a few seconds to diffused daylight.

Section IV. ON THE METHOD OF ASCERTAINING THE INSTRUMENTAL COEFFICIENTS, TABULATING FROM THE CURVES, ETC.

1. Declination Magnetograph.

In this instrument the distance between the centre of the mirror and the registering cylinder is 6.5 feet, and consequently a change in the position of the dot of light on the sensitive paper, equal to one inch, denotes a change of 22'18 in the position of the magnet.

The mirrors are so arranged that the moveable dot is north of the fixed dot on the cylinder (see Plate 3. fig. 1); an increase of declination therefore will bring the two dots nearer together, while a decrease of declination will have the opposite effect.

Should the suspension thread be without torsion altogether, or should its torsion remain constant, the same distance between the two dots of light will always denote the same absolute declination; so that if by any means we know the absolute declination corresponding to a given distance between the dots, we shall be able to tell what it is for any other distance, or, in fact, for any moment of time.

The comparability with one another of the various tracings afforded by the instrument, depends on the constancy of the torsion; should this vary, the curves are no longer absolutely comparable. Great attention should therefore be paid to secure, if not an entire absence of torsion, at least a constancy in the little that remains.

The thread should be well freed from torsion when the magnet is suspended: by slightly rubbing it with bees-wax, or by some other similar process, it should be rendered less susceptible to hygrometric influences, and a dish of chloride of calcium should be kept under the glass shade to absorb all moisture. When the magnet is in perfect adjustment, there can be no objection to seal the shade to the marble slab all round with bees-wax, at least if an ordinary loosely fitting shade be used.

Besides all this, it is necessary to make at least every month at some spot free from the influence of iron, observations of absolute declination, noting the precise moment at which each observation is made. The distance between the two dots of light, that is to say between the curve and the baseline of the declination magnetograph, at the moments of observation, will

afford us corrections, which, when applied to our monthly absolute determinations, should bring them all to the same value: in other words, the self-recording magnetograph affords us the means of eliminating the changes that are constantly taking place in the value of the magnetic declination. Should, however, the torsion of the suspension thread of the declination magnetograph have become changed to any extent, our corrected monthly determinations will no longer have the same value.

We are thus presented with a test, by means of which we may ascertain whether change of torsion in the suspension thread, or some other circumstance, such as the change in position of some neighbouring mass of iron, has affected our magnetograph. The following results show that the magnetograph herein described has stood this test in a very satisfactory manner:—

Time of observation of absolute declination.	Declination reduced by magnetograph to Jan. 1858.
1858 January	21° 56' 27"
February	21 54 47
March	21 56 2
April	21 56 59
May	21 56 33
August	21 55 38
September	21 57 1
October	21 55 4
1859 October	21 57 7
November	21 56 38
December	21 54 53

Before concluding this part of the subject, I may remark that the magnetographs are merely intended to serve as differential instruments; so that, in addition to their employment, absolute values of the magnetic elements require to be taken from time to time. On this account also, although it is very desirable to have, if possible, no torsion in the thread of the declination magnetograph, and no iron in its neighbourhood, yet the value of the result does not depend so much on the entire absence of these sources of error as in the constancy of the effects which they produce. The greatest caution should therefore be exercised in excluding any hygrometric influence which might change the torsion, and the greatest pains taken to prevent any *shifting* of iron in the neighbourhood of the instruments.

2. Horizontal-force Magnetograph.

We have in this case two things to determine, viz. the temperature correction, and the value of one inch on the cylinder in parts of force. With regard to the first of these, the most trustworthy method is to make the observations themselves determine their own temperature correction by means of comparing together two periods, for which the average temperature is different, while the average horizontal force is known to be the same for both. It is, however, advisable that the temperature correction of the horizontal-force magnet should be well determined in the ordinary manner before mounting it. With regard to the scale coefficient, or value of 1 inch in parts of force, it may be well to exhibit in detail the process by which the scale coefficient of the present horizontal-force magnetograph has been determined.

There are two methods by which the scale coefficient is determined. In the first of these, let v denote the angle which the plane of the upper extremities of the wire makes with that of the lower; δv the change, in parts of

radius, which is occasioned on v by the moveable dot traversing the sensitive paper one inch; k the scale coefficient, or value of one inch in parts of force; then $k = \cot v \delta v$.

By this formula, k , or the scale coefficient, may be determined when v is known. Let us determine v accurately when the magnet is mounted, that is, let us find accurately the angle which the plane of the upper extremities of the wire makes with that of the lower for a certain distance between the fixed and the moveable dot of light upon the cylinder, then we can always find the value of v . Loss of magnetism in the magnet may have widened the distance between the dots on the cylinder since we first determined v^* , but knowing the angular value of one inch we can make allowance for this, and thereby determine the present value of v , which will be somewhat less than the first. The loss of magnetism may even have obliged us to turn the torsion circle, in order to bring the dots of light nearer to one another, and of course an accurate account must be taken of this, and allowance made for it in calculating for the future the values of v .

Taking these circumstances into account, viz. the amount of change of the torsion circle, and the distance between the dots, v may always be determined, and, consequently, by the above formula, the scale coefficient may be known.

But as there is some doubt of the rigorous truth of the conditions which the above formula assumes, another method of determining the scale coefficient has been proposed which does not seem open to any such objection.

Let a deflection bar be arranged as in Plate 3. fig. 4 A, 4 a, so as to support a magnet horizontally placed, with its axis in the magnetic meridian, and so that if prolonged it would pass through the centre of the bifilar magnet.

Let the centre of the two magnets be at the distance r from one another. The presence of the deflecting magnet will of course have changed the position of the moveable dot upon the cylinder. Bring the bifilar magnet speedily to rest, and allow the deflecting magnet to remain in its position for about five minutes: this time will sufficiently enable us to procure a photographic impression of the position of the bifilar magnet when deflected; and having its position before and after, we shall thus be enabled to estimate the amount of deflection. Let this be n inches.

Take the same deflecting magnet and place it in a similar position with respect to the declination magnet, and also at the distance r . Here it is obvious that the axis of the deflecting magnet is at right angles to the magnetic meridian. Determine photographically, as before, the angle of deflection which it has caused; let this be u ; then k , or the value of one inch

in parts of force for the bifilar magnetograph = $\frac{\tan u}{n}$.

Example. On April 30, 1858, the deflecting magnet having been applied as above to the bifilar magnetograph, the deflection produced was = 2.887 in.

The same magnet being applied in a similar manner, and at the same distance, to the declination magnet, the deflection was = 3.560 inches = 78' 58".

Hence $k = \frac{\tan 78' 58''}{2.887} = .00796$.

A similar observation having been performed at the distances 2.5 and 3.0 feet, we find as a mean result on that date,

$$k = .00800.$$

* In the declination magnetograph a decrease of distance between the dots denotes an increase of westerly declination, while in the bifilar and vertical-force magnetographs it denotes an increase of horizontal and vertical force respectively.

On December 2, 1859, a similar set of observations gave

$$k = .01004.$$

These may be taken as the correct values of k at their respective dates, but we wish to obtain the values of k for intermediate dates. In order to do this, let us make use of the other formula,

$$k = \cot v \delta v.$$

On April 30, 1858, v was nearly = 43° 13'; hence

$$k = \cot 43^\circ 13' \times \frac{1}{117.24} = .009078.$$

On December 2, 1859, $v = 35^\circ 56'$; hence

$$k = \cot 35^\circ 56' \times \frac{1}{117.24} = .011769.$$

By the first or more correct formula we find the change that had taken place in the value of k between the two dates to be .00204, while by the latter formula the change is .002691. We cannot go far wrong in supposing that the real change upon k is equal to that given by the formula ($k = \cot v \delta v$) multiplied by the fraction $\frac{.00204}{.002691}$. Hence to find the real value of k for any value of v , we have

$$k = \frac{.00204}{.002691} \{ \cot v \delta v - .009078 \} + .00800.$$

In these instruments it is of great importance to have magnets which lose their magnetism very slowly; for it is the loss of magnetism, rather than any other cause, which renders it necessary to turn the torsion circle, and occasions changes in the value of the scale coefficient. In connexion with this magnetograph, it is necessary to make frequent observations of absolute horizontal force, noting the precise times at which the observations are made. Such observations will serve to eliminate from the results of the horizontal-force magnetograph those changes which are occasioned by loss of magnetism and stretching of the suspension thread. It is particularly desirable to make absolute observations immediately before and after turning the torsion circle.

3. Vertical-force Magnetograph.

The temperature correction of this instrument, if fitted with a slip of brass, as in the present instance, will have to be determined by the observations themselves. It is well, however, as a measure of precaution, to determine the temperature coefficient of the magnet before it is mounted.

With regard to the value of one inch in parts of force, there are two methods by which this may be determined, viz. the method of vibrations, and that of deflections.

With respect to the former of these—

Let T denote the time of vibration of the magnet in a vertical plane;

T' the time of vibration of the magnet in a horizontal plane*;

Θ the magnetic dip;

Y the vertical component of the earth's force;

which suppose to become $Y + \delta Y$, occasioning a change in the angular position of the magnet represented by $\delta \epsilon$; then it may be shown that

$$\frac{\delta Y}{Y} = \frac{T'^2}{T^2} \cot \Theta \delta \epsilon.$$

* Suspended so as to have the same moment of inertia which it has in the vertical plane.

Again, since the normal to the mirror is inclined at an angle of 15° to the incident ray, and since the sensitive cylinder is 5.965 feet, or 71.58 inches distant from the mirror, it may be shown that the vertical space of one inch traversed by the luminous dot upon the cylinder, represents an angular change in the position of the magnet

$$= \frac{1}{143.16 \times \cos 15^\circ};$$

hence the value of 1 inch in parts of force

$$= \frac{T^2}{T^2} \frac{\cot \Theta}{143.16 \cos 15^\circ}$$

The second method, by which the value of one inch in parts of force may be determined, is that of deflections. Let a suitable apparatus (see Plate 3, figs. 5A, 5a) be contrived, by means of which a deflection magnet, m , may be placed vertically with its centre at a given distance, r , from that of the vertical-force magnet and in continuation of the magnetic axis of the latter magnet, when horizontal. Let the change of position of the luminous dot upon the cylinder be registered photographically as before; let this be $=n$ inches.

Let the deflecting magnet be now placed with its centre at the distance r from that of the declination magnet, and in continuation of the magnetic axis of the latter magnet; also let the magnetic axis of the deflecting magnet be perpendicular to the magnetic meridian; and, finally, let the angle through which the declination magnet is deflected be determined photographically. Call this angle u ; then it may be shown that the value of one inch in parts of force for the vertical-force magnet is found from the following expression:—

$$\text{Value of one inch} = \frac{\tan u}{n \tan \Theta}.$$

By the method of vibrations the value of one inch was determined on February 27th, 1858, to be $=.00221$ in parts of force, while by the method of deflections (mean of three distances) its value was found to be $=.00211$ in parts of force. There is thus a very satisfactory agreement between the results of the two processes.

On April 18th, 1860, the value of one inch was determined by the method of deflections to be $=.00249$ in parts of force. There is thus a change $=.00038$ which has taken place in the value of one inch during the course of about two years. This has no doubt been occasioned by loss of magnetism of the magnet widening the distance between the dots and rendering it necessary to alter the balance of the magnet by means of the horizontal screw from time to time.

A proper method of interpolation will enable us to determine with sufficient accuracy the value of 1 inch in parts of force for any period between February 27th, 1858, and April 18th, 1860.

It is perhaps a safe rule to determine the value of the scale coefficients of bifilar and vertical-force magnetographs, by the method of deflections, once a year.

Monthly observations of dip are made at Kew, which, combined with the monthly determinations of absolute horizontal force, will enable us to determine the absolute vertical force, and thus to eliminate from the vertical-force curves the changes that have been occasioned by loss of magnetism from time to time.

Method of tabulating from the curves.—By pushing the dots of light forward a little, two days' curves are recorded on each sheet of sensitive

paper. These sheets are therefore only changed every second day. This change is made a little after 10 A.M., and the time occupied in making it is about ten minutes, while that occupied in pushing forward the dots is only about three minutes. There is thus every day a loss of ten and of three minutes alternately, so that the curves never record precisely the whole of the twenty-four hours, but generally something less by a few minutes. The precise moment (Kew mean time) of stopping the pendulum and of setting it going again is noted, so that the length of time for which any curve is a record is known and is attached to the curve in writing. (See curves appended to this Report, Plate 5.)

The instrument for tabulating from the curves is represented in Plate 3, fig. 3 A: ab is a time-scale commencing and ending with 22^h . This scale is moveable round a as a centre, and the centre a is also moveable in a horizontal direction. Part of the instrument, $d f g$, is moveable in a vertical direction by means of h , the head of a pinion which works into the rack i ; d serves as a vernier for the scale e . The piece $c d e f g$ is moveable in a horizontal direction by means of a slide which fits into the slot kl ; f and g are two tubes through which the eye looks at lines on a piece of glass (exhibited separately at full size in fig. 3 a). These are two sets of double lines which are etched on glass, the sets being exactly two inches apart. The distance between the tubes f and g is also two inches, so that when the upper pair of lines is placed under f , the lower pair is under g . The glass is firmly attached in this position to the moveable piece $d f g$, so that the double lines remain exactly under the tubes in whatever manner $d f g$ is moved. The breadth between the two lines (which together constitute a double line) on the piece of glass is a little greater than the breadth of the curve or zero-line on the photographic paper.

In order to measure the distance between the curve and zero-line, the photographic paper is set between two pieces of plate-glass, and so adjusted, that when the tube g is set over the zero-line, it may continue to be approximately over it in any part of its horizontal range.

Suppose now that $c d e f g$ is at the extreme left, the vertical line of the piece of glass lying along the commencement of the curve and that of the zero-line. Set the time-scale ab so that the edge of the index e may touch that hour on the time-scale which corresponds to the commencement of the curve. Adjust the vertical height of b , the extremity of the time-scale, so that when $c d e f g$ is carried to the other or right-hand extremity of the curve, the index e may touch that division of the time-scale which corresponds to the termination of the curve. Were the same length of base-line always to denote the same space of time, there would be no need of altering the inclination of ab ; but the rate of the clock may vary a little, or the paper may fit more or less loosely to the cylinder, so that an inch of the base-line will not always denote precisely the same space of time. Having thus adjusted the time-scale, in order to find the distance between the base-line and the curve for any hour, set the index e to the required time, move the pinion head h until the upper pair of etched lines at f are over the curve-line, and read off the height on the scale e by means of the vernier d . Next move the pinion head h until the lower pair of etched lines at g are over the base-line, and read off by means of the vernier as before. The difference between the readings for the curve and the base-line plus two inches, gives the distance between these lines.

In case any shifting should take place, it is best to read the curve and its corresponding base-line consecutively, instead of reading first a number of points of the curve together, and then the corresponding points of the base-

line together also. Occasionally the presence of iron for a short time may cause an abrupt rise and fall of small size in the curve, the one motion being due to the approach of the iron, and the other to its removal. These must be taken into account in tabulating from the curves. An instance of this occurs in the curves appended to this Report.

Section V. IMPROVEMENTS IN THE CONSTRUCTION OF A SET OF SELF-RECORDING MAGNETOGRAPHS SINCE MADE.

Magnetographs very similar to those here described have been lately set up in a house constructed to receive them about 70 yards from the Kew Observatory.

The following improvements were made in their construction :—

1. Instead of one large glass shade standing upon the marble slab, each magnetograph has a gun-metal cylinder, which stands upon the slab, and is surmounted by a glass shade of comparatively small size. An opening is cut in the side of the cylinder, in which there is inserted a piece of perfectly plane glass; this glass covers that space which in the old arrangement would have been occupied by the two round holes already described. The lens is apart from the cylinder, and has an adjustment to admit of its distance from the mirror being altered if necessary.

This arrangement permits the shades to be removed without disturbing the lenses. It also renders the working of the instrument less liable to interruption in case of any accident happening to the shade.

There is also a tube inserted through the marble, which may be connected with an air-pump and the interior of the cylinder and shade exhausted, if this be thought necessary.

2. The second improvement consists in having reading telescopes with ivory or other scales mounted on pillars, and so placed that the light from the divisions of the scale falling upon the moveable mirror attached to the magnet is reflected into the telescope. In consequence of this, the motion of the mirror will cause an apparent motion of the scale in the field of view of the telescope. The position of the magnet will therefore be known by observing what division of the scale is in contact with the vertical wire of the telescope.

We may thus combine the photographic record with eye observations. The advantage of the latter is that we see what is taking place at the very moment of its occurrence, whereas we only obtain the photographic record a couple of days after the changes to which it relates have happened.

Should a disturbance take place, we are thus not only made aware of it at the time of its occurrence, but we may, by having a telescope scale of greater range than the recording cylinder, obtain eye observations, when owing to excessive disturbance the dot of light has altogether left the sensitive paper.

Fig 3 a.

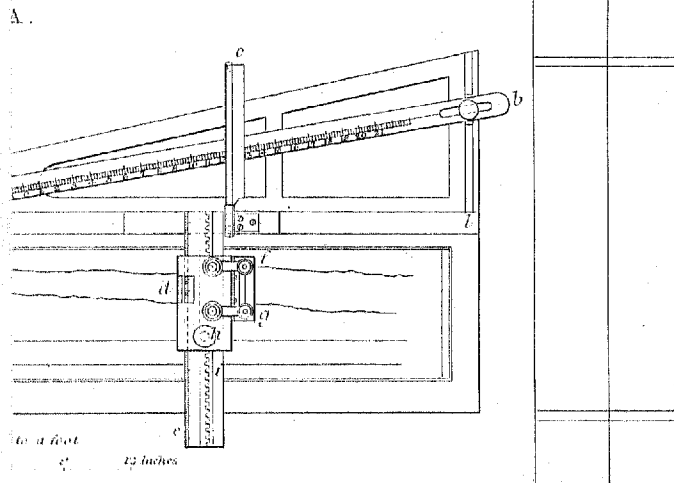

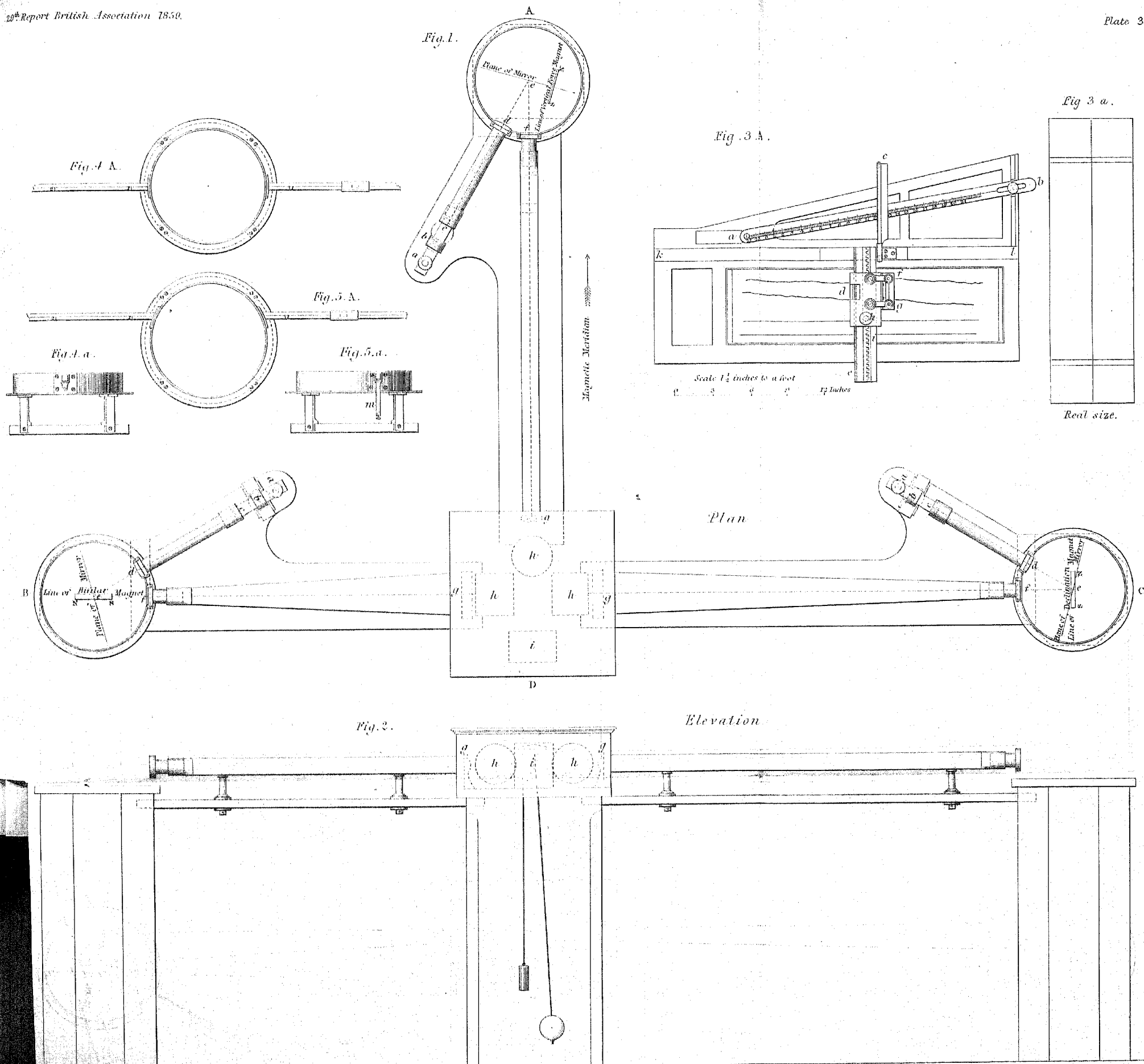

Scale 1 1/2 inches to a foot to all figures except Fig. 7.
Inches 1 2 3 4 5 6 7 8 9 10 11 12

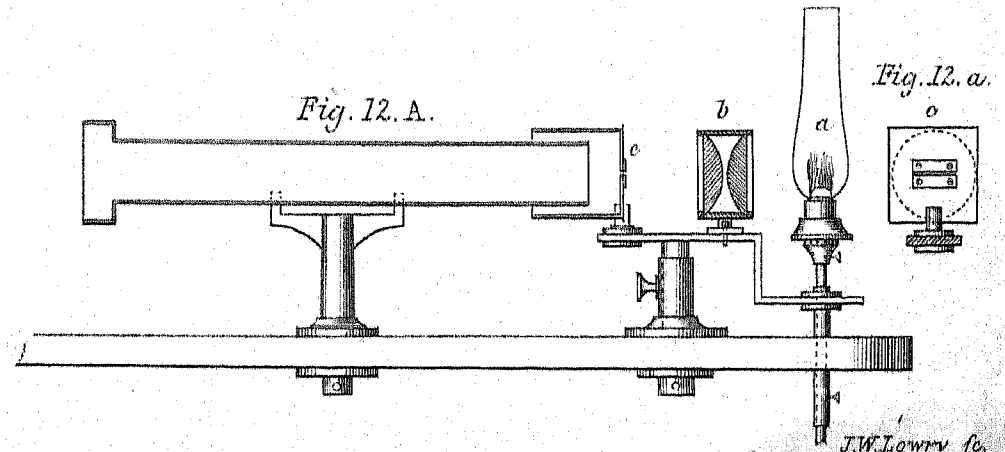
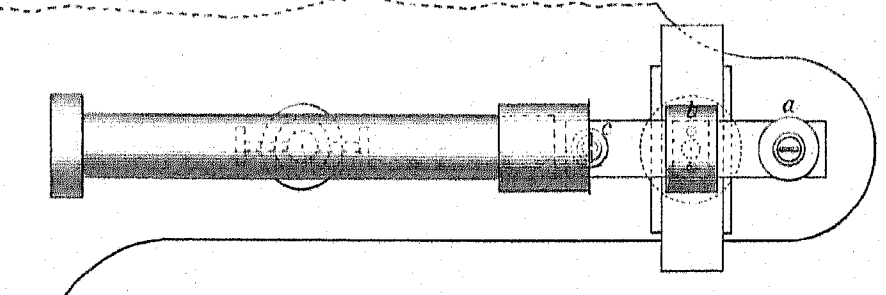
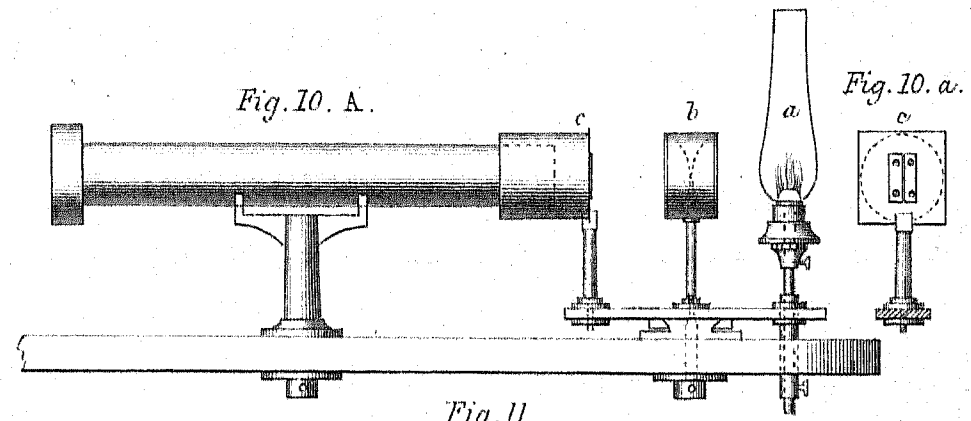
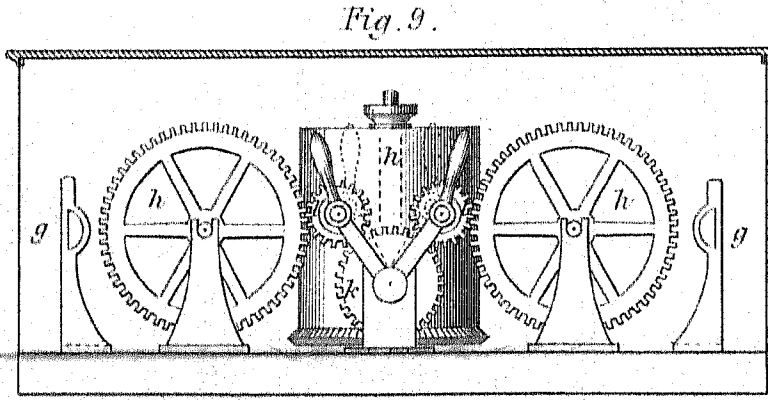
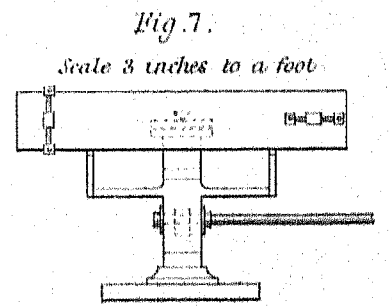
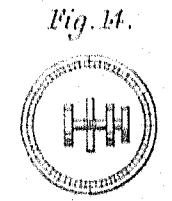
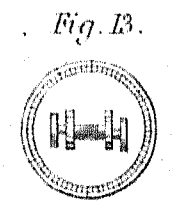
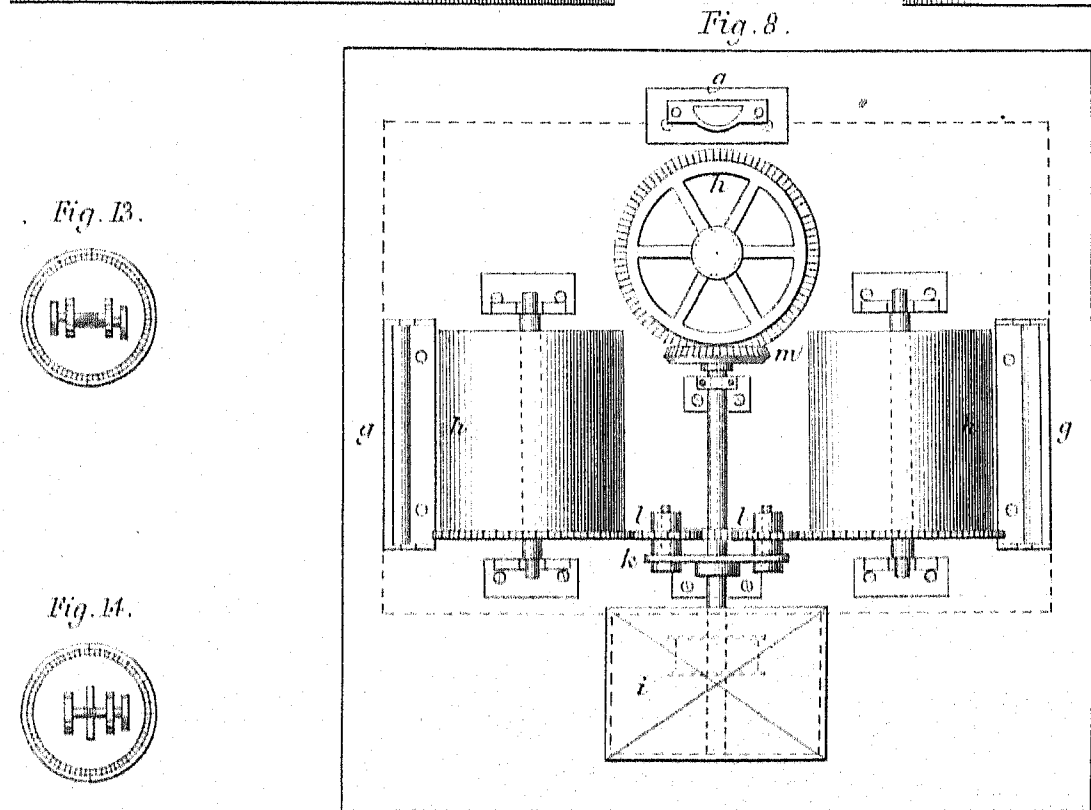
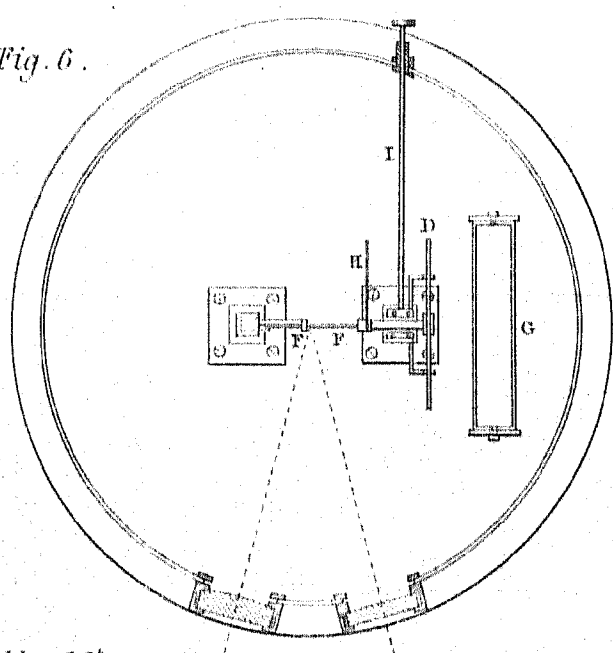
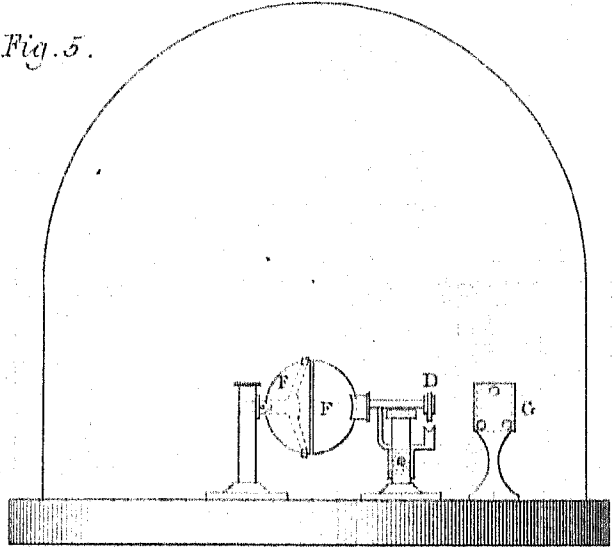
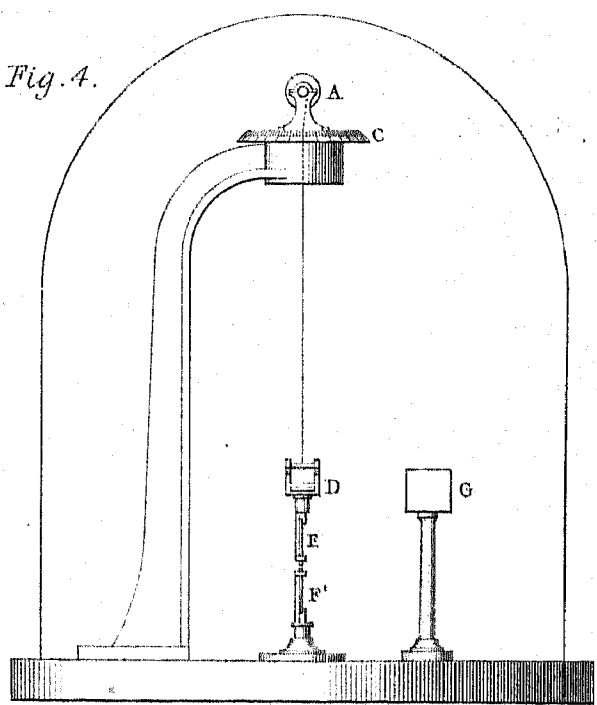
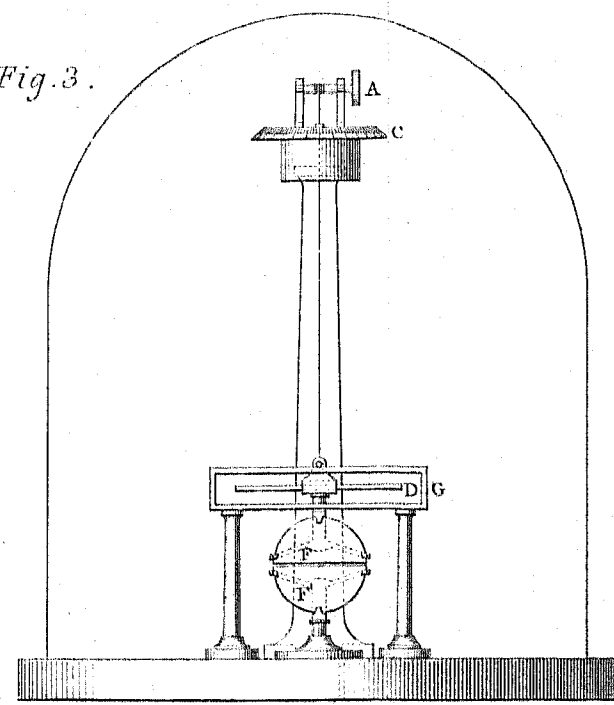
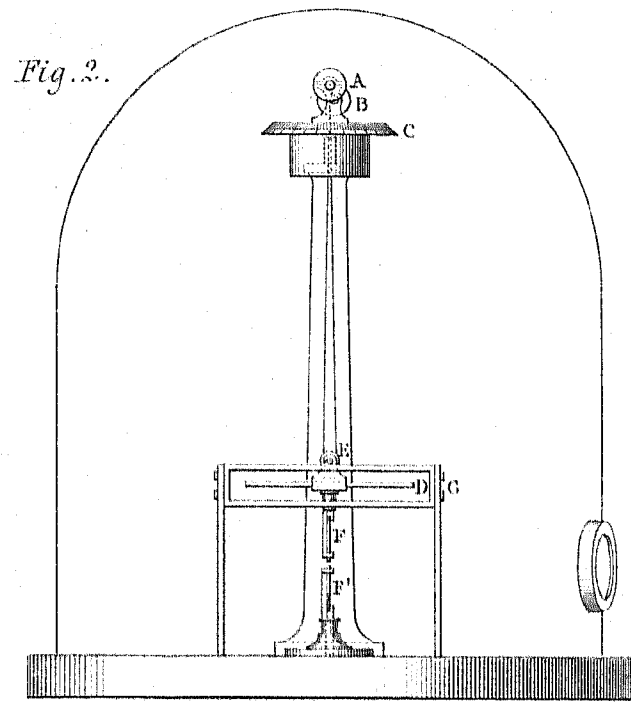
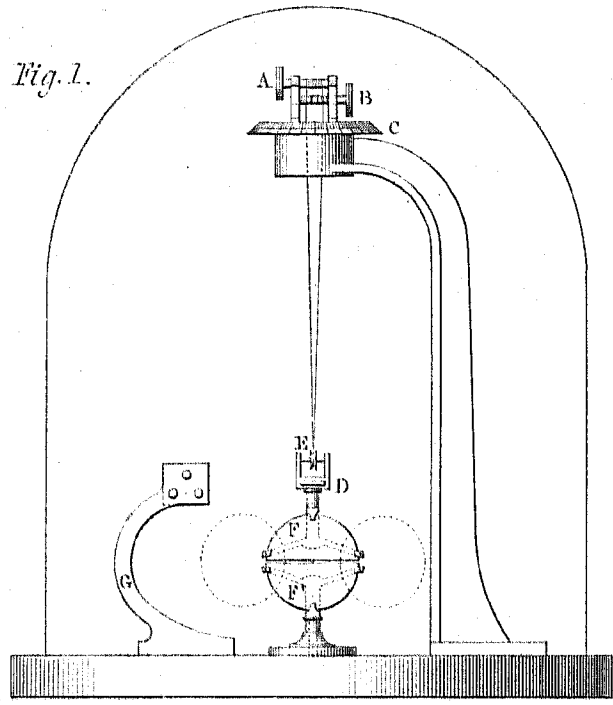

FAC-SIMILES OF THE PHOTOGRAPHIC IMPRESSIONS produced by the MAGNETOGRAPHS AT KEW OBSERVATORY.

DECLINATION.

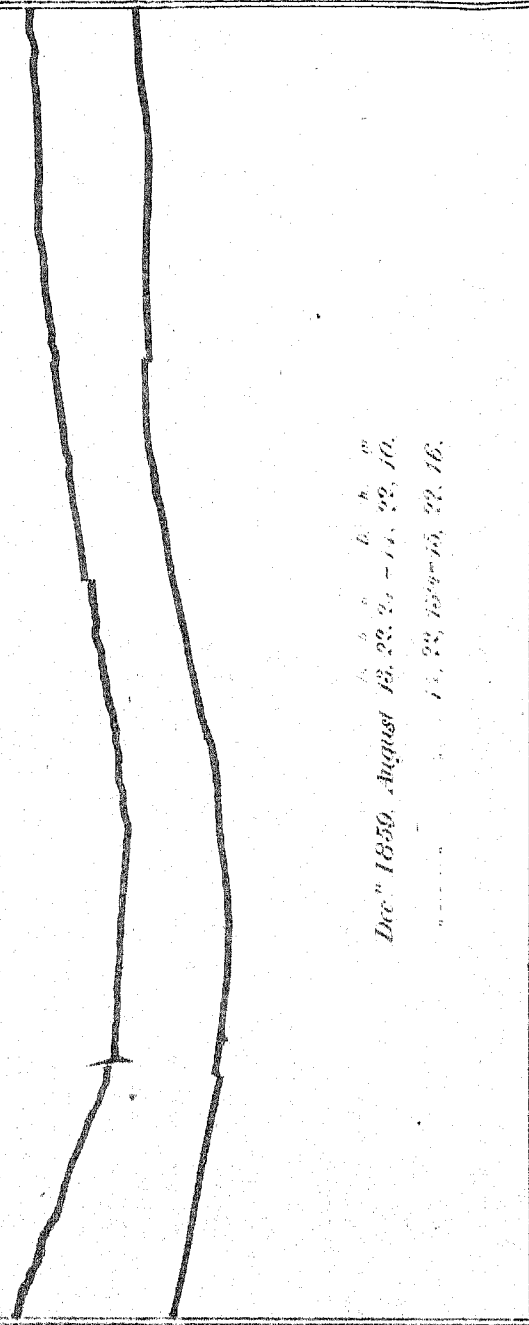

HORIZONTAL FORCE.

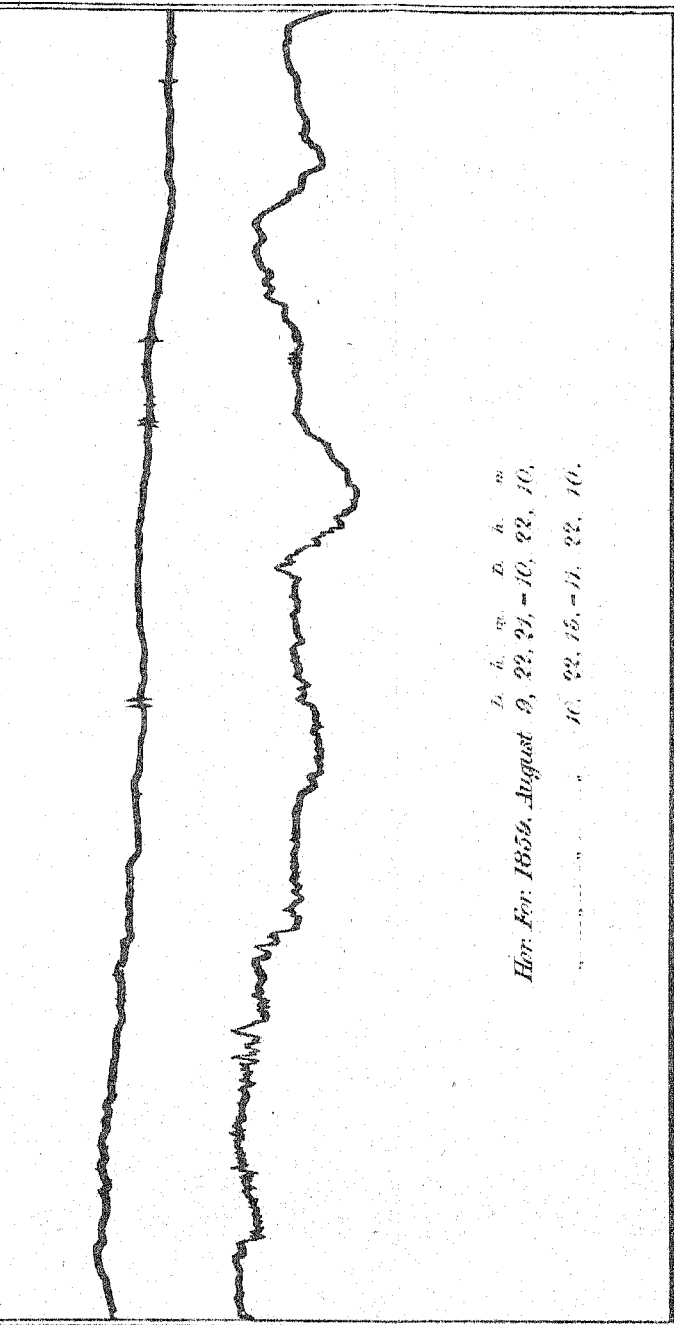

VERTICAL FORCE.

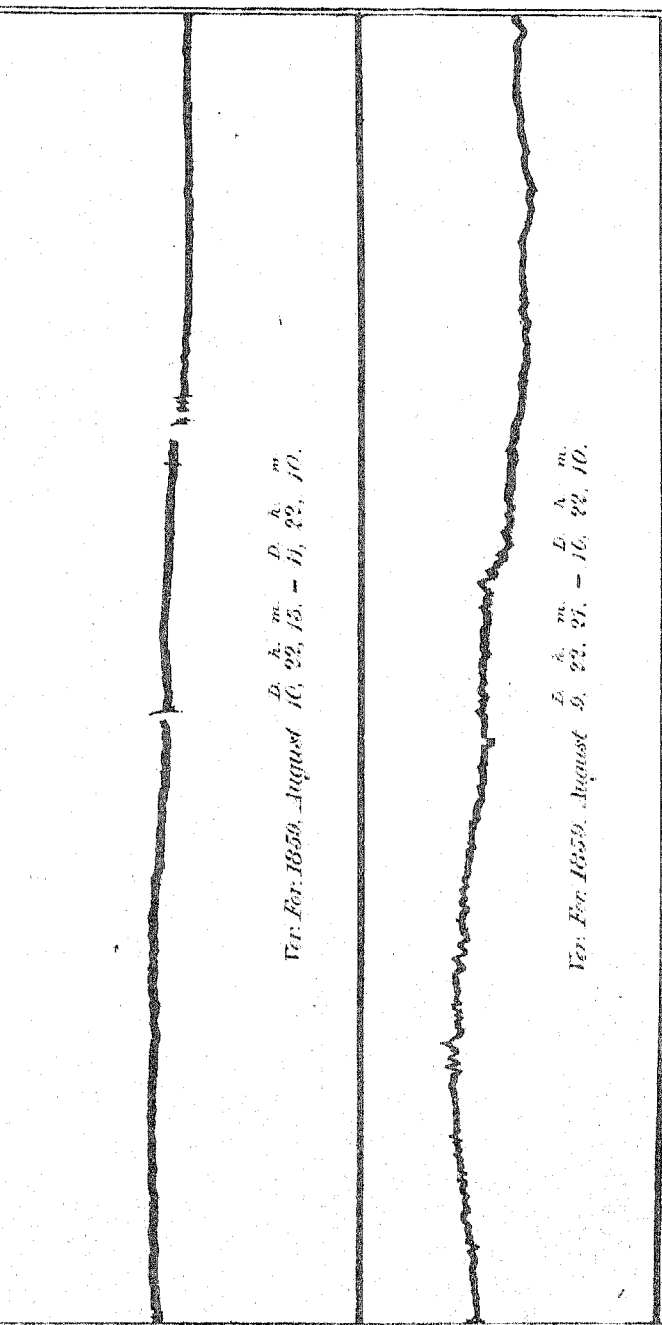

NOTE. The total length of these Lines in the Original is 15 Inches.