



US 20100126053A1

(19) **United States**

(12) **Patent Application Publication**
Fitzpatrick et al.

(10) **Pub. No.: US 2010/0126053 A1**

(43) **Pub. Date: May 27, 2010**

(54) **AMMUNITION MAGAZINE WITH FOUR AMMUNITION STACKS**

Related U.S. Application Data

(75) Inventors: **Richard M. Fitzpatrick**,
Longmont, CO (US); **Michael T. Mayberry**,
Denver, CO (US); **Michael Morgan**,
Windsor, CO (US); **Eric C. Burt**,
Broomfield, CO (US); **Eric S. Nakayama**,
Broomfield, CO (US)

(60) Provisional application No. 61/082,819, filed on Jul. 22, 2008.

Publication Classification

(51) **Int. Cl.**
F41A 9/69 (2006.01)
(52) **U.S. Cl.** **42/50**

Correspondence Address:
GEOFFREY E. DOBBIN, PATENT ATTORNEY
4278 SOUTH 6220 WEST
WEST VALLEY CITY, UT 84128-6501 (US)

(57) **ABSTRACT**

The present invention is a high capacity, non-drum magazine. The high capacity magazine comprises a broad general storage area capable of holding four staggered stacks of ammunition, a unified follower on a spring system biasing the follower and associated ammunition, a central partition a barrier separating two dual staggered round stacks and around which the follower will pass, and a transition area between the feed end of the magazine and the storage area. The spring may be a composite spring system, made of two springs joined in series, or a single, variable constant, spring.

(73) Assignee: **MAGPUL INDUSTRIES CORP.**,
Boulder, CO (US)

(21) Appl. No.: **12/505,419**

(22) Filed: **Jul. 17, 2009**

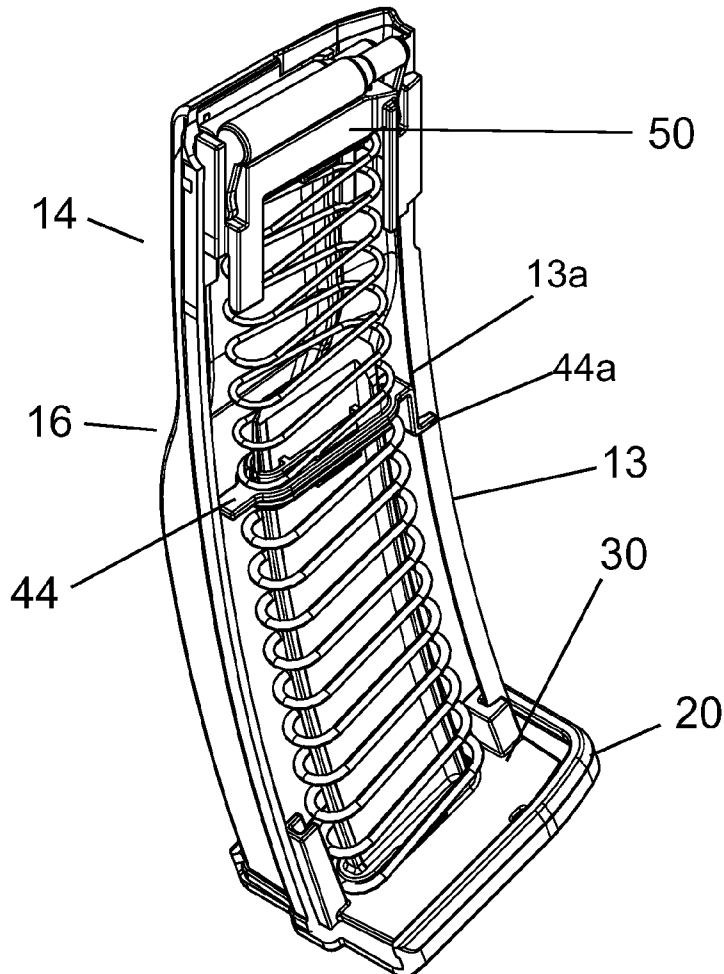

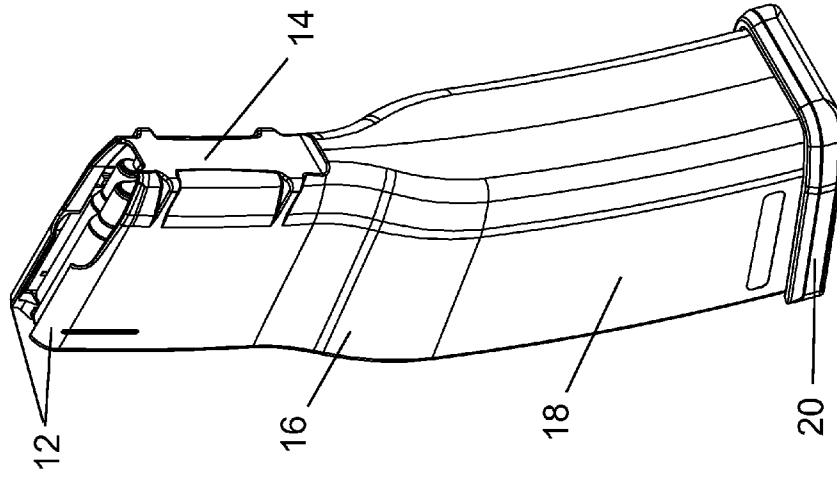

FIG. 3

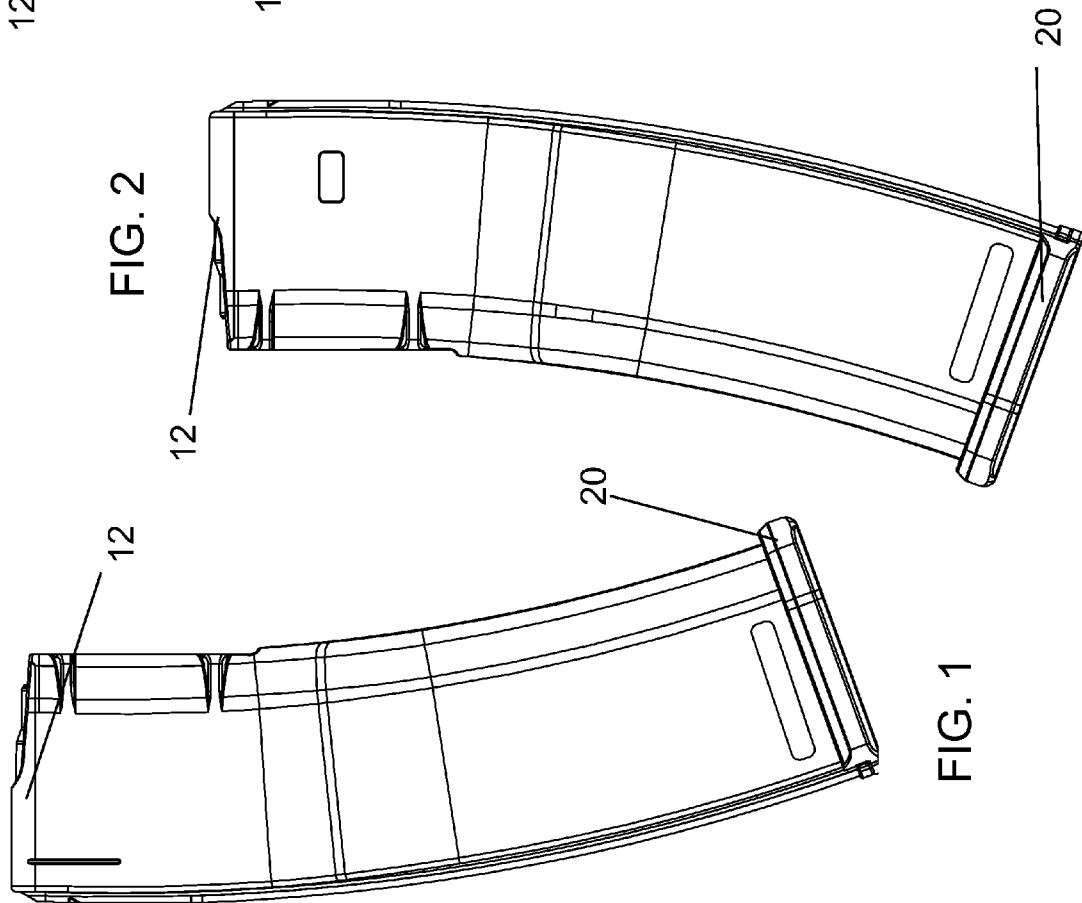

FIG. 2

FIG. 1

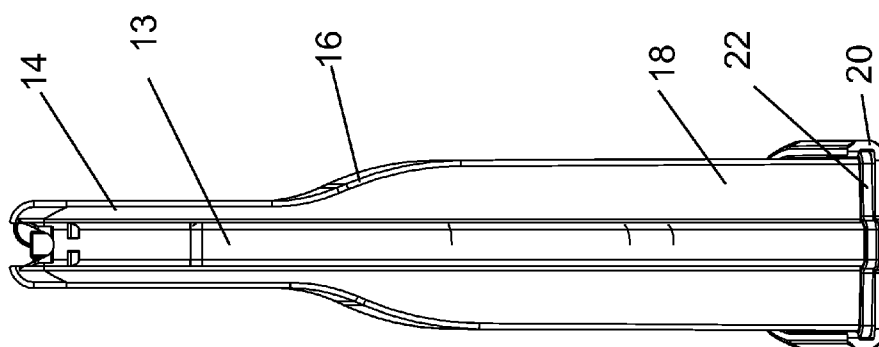

FIG. 5

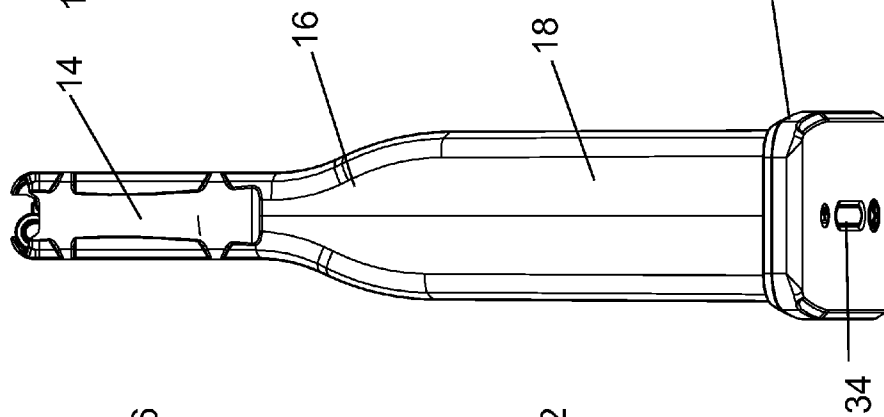

FIG. 4

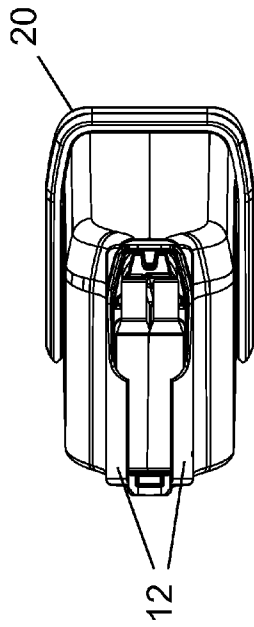

FIG. 6

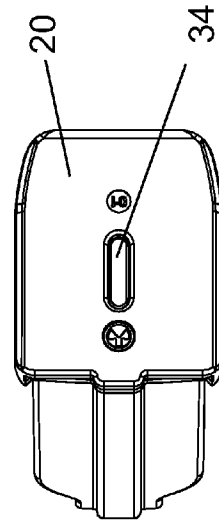

FIG. 7

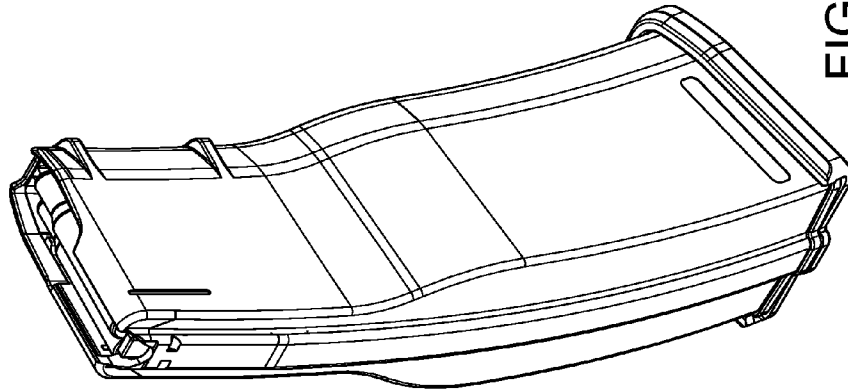

FIG. 9

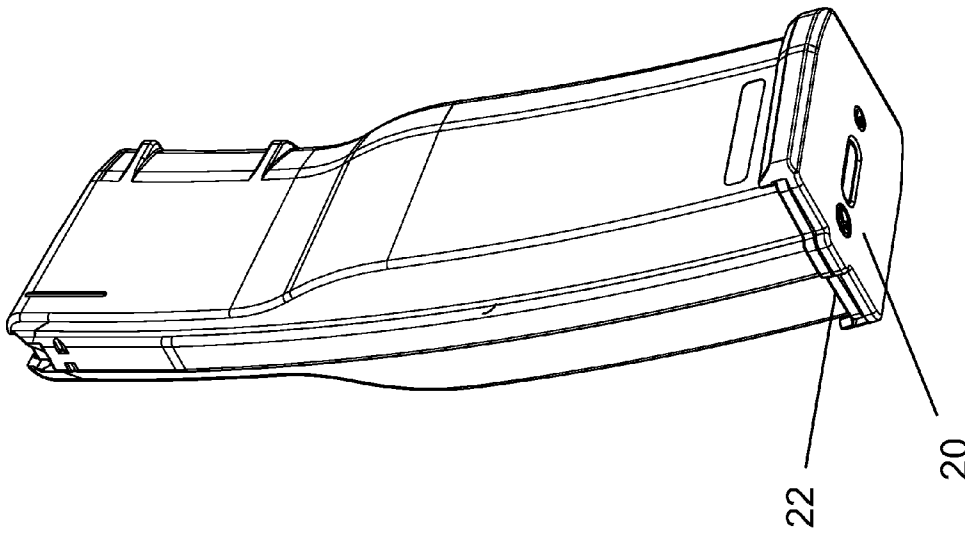

FIG. 8

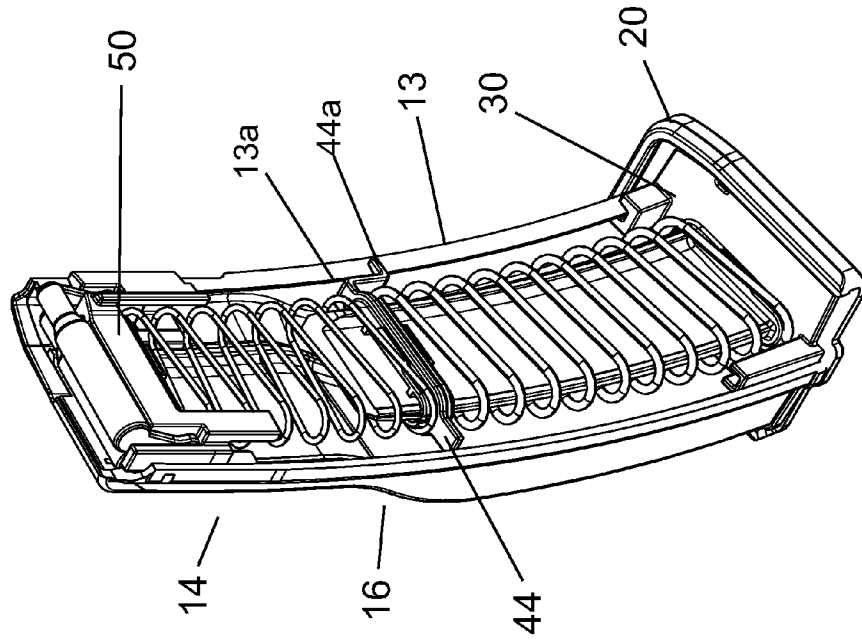

FIG. 11

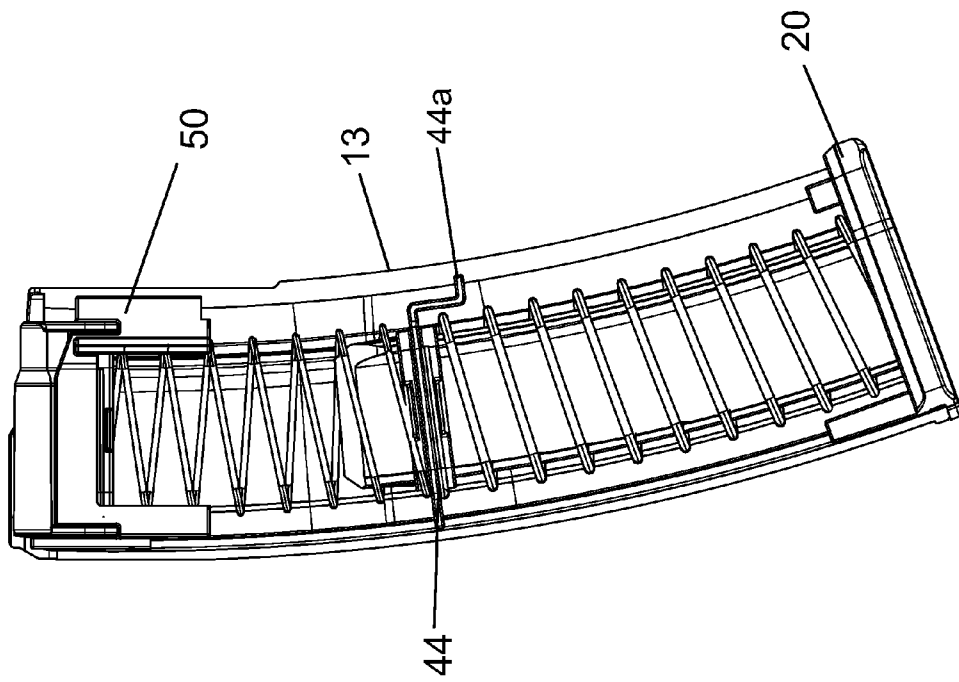

FIG. 10

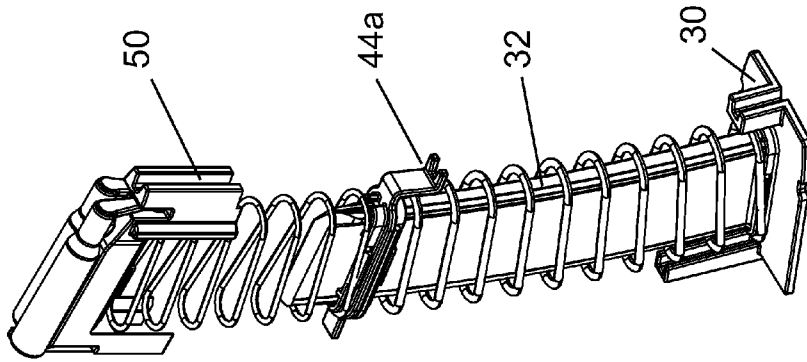

FIG. 14

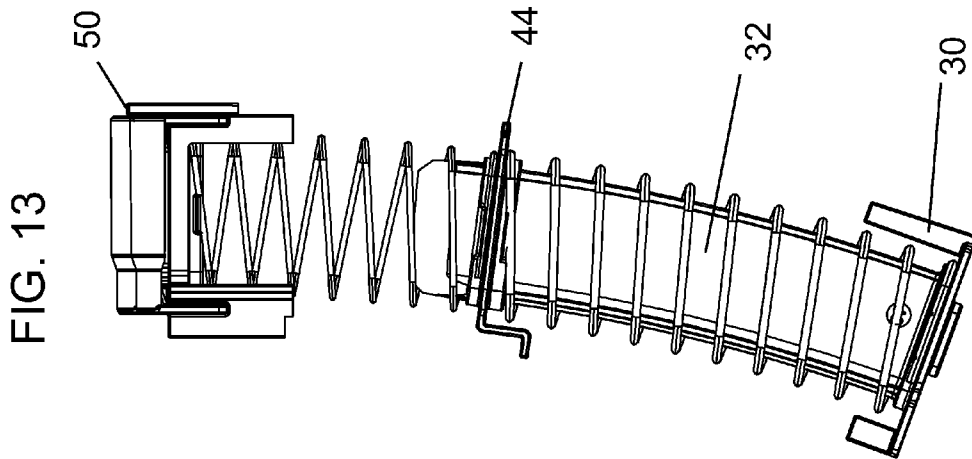

FIG. 13

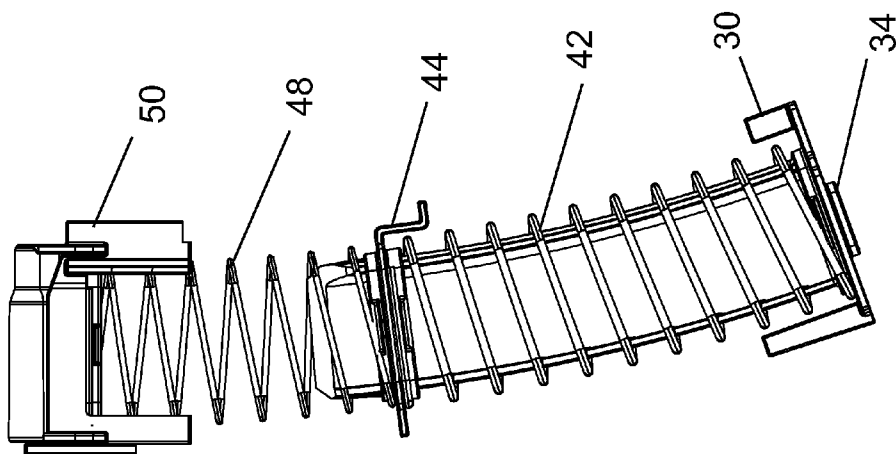
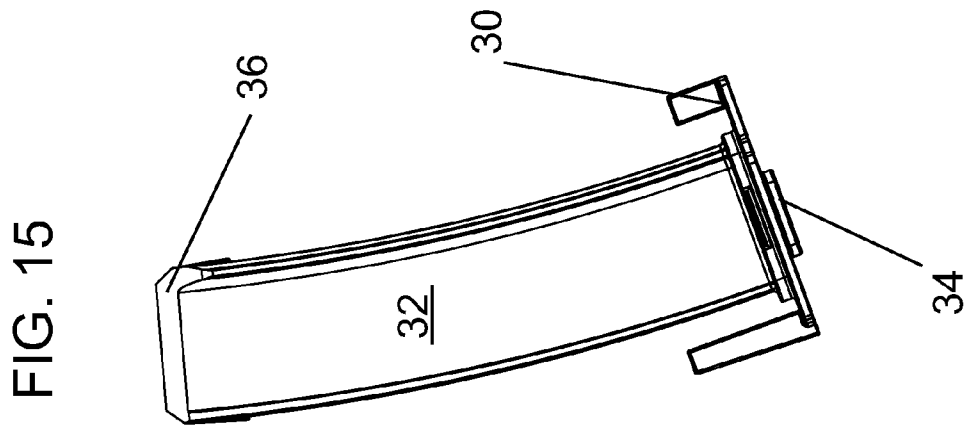
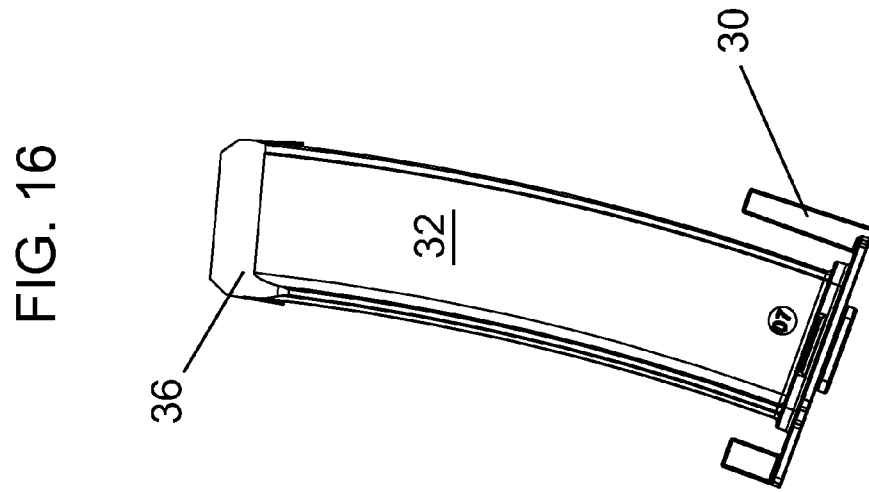
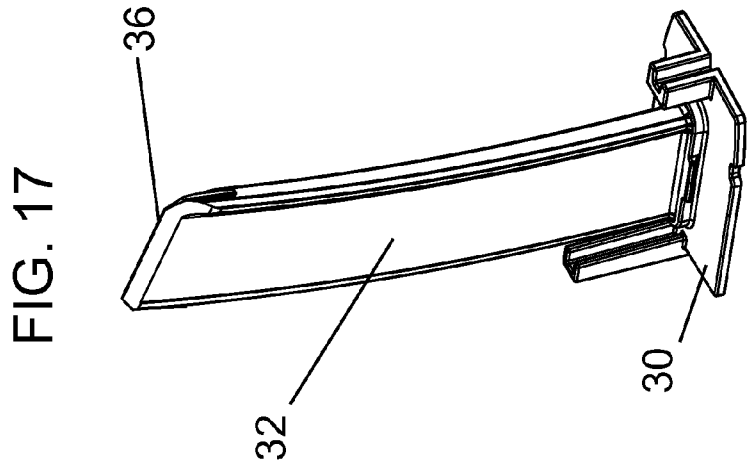
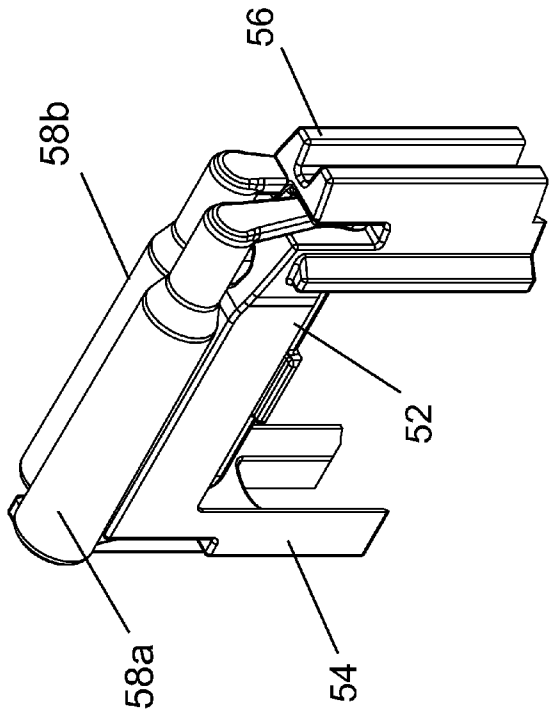

FIG. 12





50

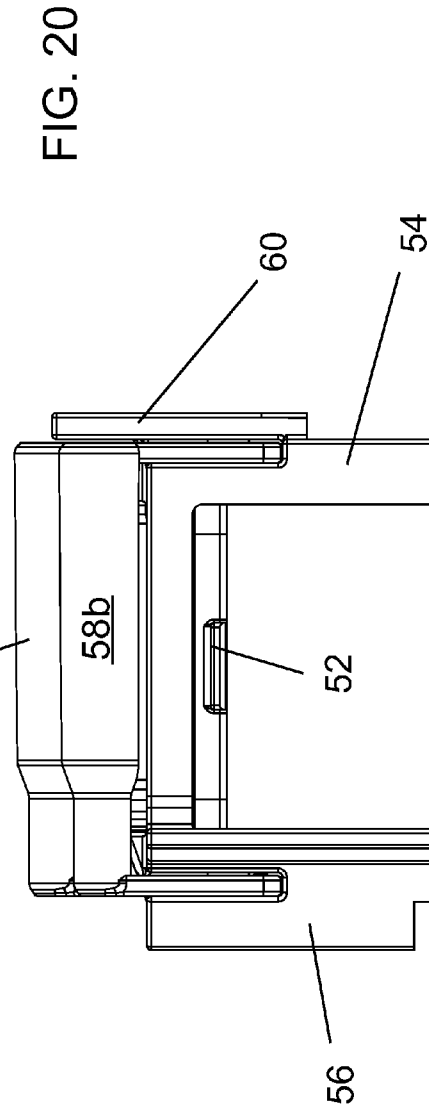
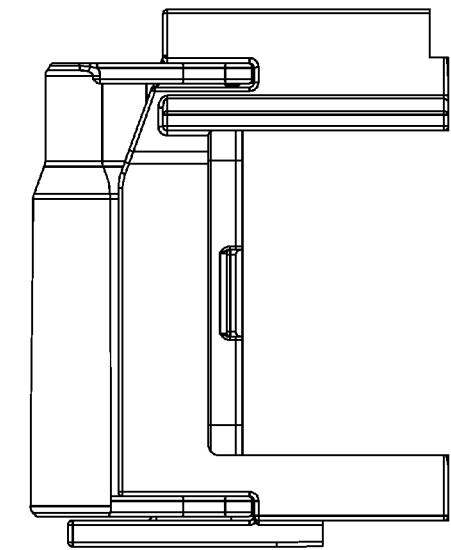

FIG. 20



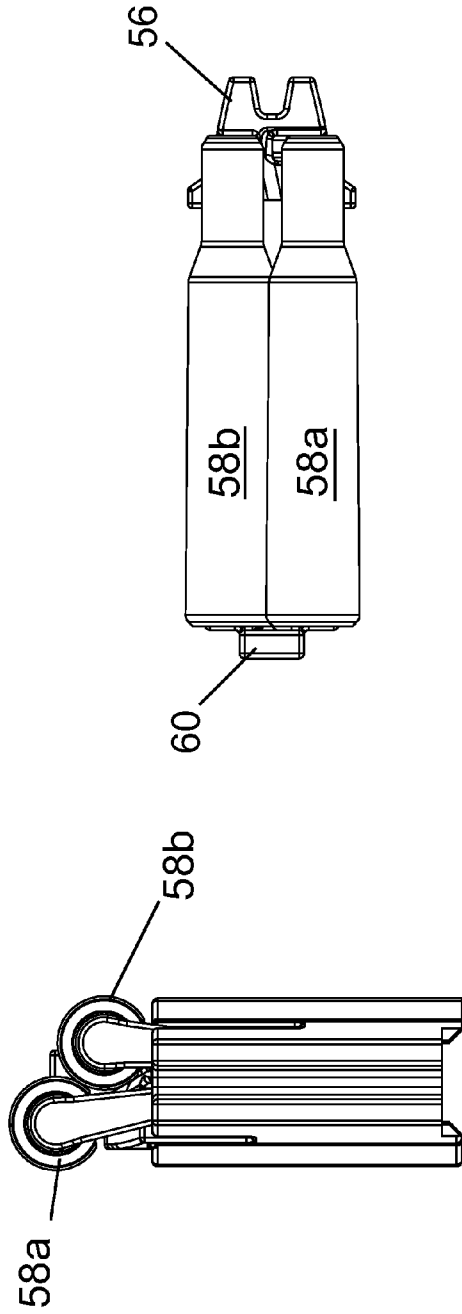

FIG. 21

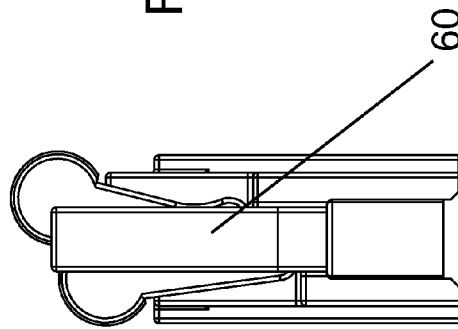

FIG. 22

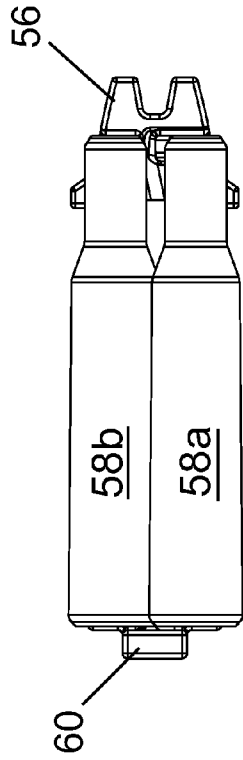

FIG. 23

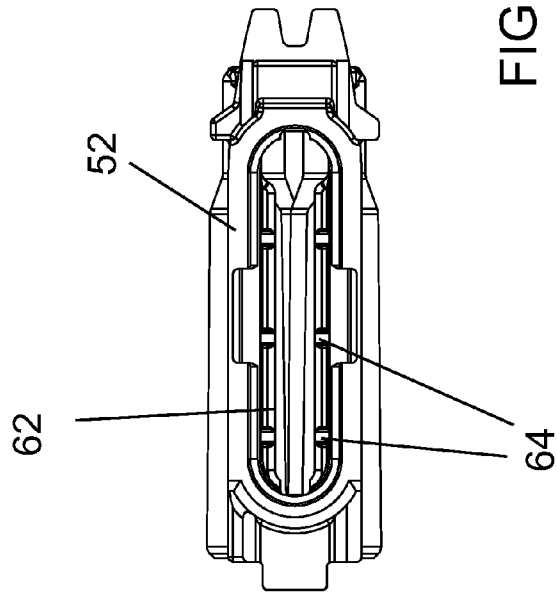

FIG. 24

AMMUNITION MAGAZINE WITH FOUR AMMUNITION STACKS

CROSS-REFERENCES TO RELATED APPLICATIONS

[0001] This application claims priority as a perfection of prior filed U.S. Provisional Application No. 61/082,819, filed Jul. 22, 2008 and incorporates the same by reference in its entirety herein.

FIELD OF THE INVENTION

[0002] The present invention relates to the field of firearms and more particularly relates to a large capacity ammunition magazine utilizing four varied stacks of ammunition.

BACKGROUND OF THE INVENTION

[0003] The present invention is a high capacity magazine utilizing four staggered stacks of ammunition with a single follower and it represents a departure from the prior art in that the high capacity magazine of the present invention allows for four staggered stacks of ammunition to be simultaneously fed through the magazine as each round is sequentially loaded into the firearm. Most high capacity magazines in the prior art are "drum" magazines, where the ammunition is stored in a round chamber. Others are made of a number of pieces that require assembly before use. The present invention also utilizes a simple spring drive system, similar to lower capacity magazines, where other prior art high capacity magazines tend to utilize more complicated systems

SUMMARY OF THE INVENTION

[0004] In view of the foregoing disadvantages inherent in the known types of firearm magazines, this invention provides a four round stack ammunition magazine that is compatible with current firearm platforms. As such, the present invention's general purpose is to provide a new and improved magazine that utilizes a single unified follower to move four staggered stacks of ammunition from a storage area, through a transition area and into the weapon as needed.

[0005] To accomplish these objectives, the high capacity magazine comprises a broad general storage area capable of holding four staggered stacks of ammunition, a unified follower on a spring system biasing the follower and associated ammunition, a dividing wall to provide a barrier separating two dual staggered round stacks, and a transition area between the feed end of the magazine and the storage area.

[0006] The more important features of the invention have thus been outlined in order that the more detailed description that follows may be better understood and in order that the present contribution to the art may better be appreciated. Additional features of the invention will be described hereinafter and will form the subject matter of the claims that follow.

[0007] Many objects of this invention will appear from the following description and appended claims, reference being made to the accompanying drawings forming a part of this specification wherein like reference characters designate corresponding parts in the several views.

[0008] Before explaining at least one embodiment of the invention in detail, it is to be understood that the invention is not limited in its application to the details of construction and the arrangements of the components set forth in the following description or illustrated in the drawings. The invention is

capable of other embodiments and of being practiced and carried out in various ways. Also it is to be understood that the phraseology and terminology employed herein are for the purpose of description and should not be regarded as limiting.

[0009] As such, those skilled in the art will appreciate that the conception, upon which this disclosure is based, may readily be utilized as a basis for the designing of other structures, methods and systems for carrying out the several purposes of the present invention. It is important, therefore, that the claims be regarded as including such equivalent constructions insofar as they do not depart from the spirit and scope of the present invention.

BRIEF DESCRIPTION OF THE DRAWINGS

[0010] FIG. 1 is a right plan view of an ammunition magazine according to the present invention.

[0011] FIG. 2 is a left plan view of the magazine of FIG. 1.

[0012] FIG. 3 is a top front perspective view of the magazine of FIG. 1.

[0013] FIG. 4 is a rear plan view of the magazine of FIG. 1

[0014] FIG. 5 is a front plan view of the magazine of FIG. 1

[0015] FIG. 6 is a top plan view of the magazine of FIG. 1.

[0016] FIG. 7 is a bottom plan view of the magazine of FIG. 1.

[0017] FIG. 8 is a bottom perspective view of the magazine of FIG. 1.

[0018] FIG. 9 is a top rear perspective view of the magazine of FIG. 1.

[0019] FIG. 10 is a partial cut-away view of the magazine in the same orientation of FIG. 1.

[0020] FIG. 11 is a partial cut-away view of the magazine in the same orientation of FIG. 9.

[0021] FIG. 12 is right plan view of the internal assembly of the magazine of FIG. 1.

[0022] FIG. 13 is a left plan view of the internal assembly of FIG. 12.

[0023] FIG. 14 is a perspective view of the internal assembly of FIG. 12.

[0024] FIG. 15 is a right plan view of a lock plate according to the present invention.

[0025] FIG. 16 is a left plan view of the lock plate of FIG. 15.

[0026] FIG. 17 is a perspective view of the lock plate of FIG. 15.

[0027] FIG. 18 is a right plan view of a magazine follower according to the present invention.

[0028] FIG. 19 is a left plan view of the follower of FIG. 18

[0029] FIG. 20 is a perspective view of the follower of FIG. 18.

[0030] FIG. 21 is a rear plan view of the follower of FIG. 18.

[0031] FIG. 22 is a front plan view of the follower of FIG. 18.

[0032] FIG. 23 is a top plan view of the follower of FIG. 18.

[0033] FIG. 24 is a bottom plan view of the follower of FIG. 18.

DETAILED DESCRIPTION OF THE PREFERRED EMBODIMENT

[0034] With reference now to the drawings, the preferred embodiment of the . . . is herein described. It should be noted

that the articles “a”, “an”, and “the”, as used in this specification, include plural referents unless the content clearly dictates otherwise.

[0035] With reference to FIGS. 1-9, the magazine comprises three regions, the feed region 14, the flared transition region 16, and the wider storage region 18. The feed region 14 is designed to interface with a desired weapon platform, such as the AR15/M16, and ejects rounds of ammunition into the weapon system as needed to reload the weapon. Feed lips 12 are present at the opening of the magazine feed region 14 so as to control feeding of the ammunition. The storage region comprises the “floor end” of the magazine and presents a ridge 22 upon which floor plate 20 slides to seal the components of the magazine inside and to provide a force platform for the follower spring system. Floor plate 20 interfaces with tab 34 of the lock plate to stay in position.

[0036] One of the important features of the magazine body itself is that it is in one piece, rather than a number of pieces as is found with the prior art, and presents a constant internal curve to lessen disadvantageous follower tilt. It also provides guides for the use of “stripper clips” in order to reload the magazine. The transition region 16 is also asymmetrical, accounting for variations in the round stacks as they travel through the transition region 16. The transition region 16 is also lower on the magazine (relative the feed lips 12) than other high capacity magazines, which allows the magazine to be backwards compatible with common weapon systems currently in use, which includes the ability to drop the magazine out of the weapon without manipulation.

[0037] The internal structure of the magazine is simple. As with most magazines and as shown in FIGS. 10 and 11, the present invention utilizes a follower 50 and spring system to incrementally move stacks of ammunition through the transition region 16 and into the feed region 14. The preferred embodiment utilizes a lock plate 30 residing within the magazine to provide a base for the spring system and to project a tab 34 through the floor plate 20 and so lock it in place as the lock plate is continually biased outward from the spring and into the floor plate 20 (FIG. 7). This biasing prevents the tab 34 from being removed from the floor plate 20 and arrests lateral motion of the floor plate, thereby keeping it in position. The internal pieces are more clearly depicted in FIGS. 12-14. The preferred spring system is a dual series spring system. Base spring 42 is heavier than top spring 48 and has a larger spring constant. Top spring 48 interfaces with follower 50 while base spring 42 interfaces with lock plate 30. They are joined at spring splicer 44. Spring splicer 44 has a travel guide 44a that follows the inside 13a of the spine of the magazine 13 (FIG. 11) when inserted into the magazine. The structure of the spring system provides maximum power to move ammunition through the magazine at the lower regions and through the transition, where it is most needed. It also provides a less powerful spring in the feed region 14, where a more powerful spring could disrupt the feeding cycle. Alternatively, a parallel spring system may be utilized, or a combination of parallel and serial springs, or a single, variable constant spring could be utilized.

[0038] The lock plate, shown in FIGS. 15-17, provides a base for the spring system. A long dividing partition 32 extends upwards and centrally from the lock plate 30. The partition 32 provides support in the storage region for the ammunition by dividing the storage region into two sections and provides a wall upon which two sets of ammunition stacks may rest. At the top of the partition is a blade 36 that

parts the round stacks into two sets of two stacks as the magazine is loaded and also provides a slope for travel of the stacks during deployment. The spring system also encompasses the partition 32 as it uncoils, so the partition also supports the springs, particularly the upper spring 48 when the spring system is compressed into the storage region 18.

[0039] The follower 50 (FIGS. 18-24) is unitary and specially constructed with a platform 52 having two leg extensions 54, 56 depending there from. Two pivoting bails 58a, 58b provide support for the ammunition stacks. The bails 58a, 58b pivot at the follower 50 travels up and down along the interior of the magazine and part when the follower contacts blade 36 of the lock plate 30. Normally, bails 58a, 58b are spring biased together to better enable supporting ammunition stacks. Platform 52 has an orifice 62 through which the partition 32 may pass and a rim 64 whereby it may rest on the top spring 48. Rear leg 54 also presents a bolt block 60 so that the bolt of the firearm will not interact with the bails 58a, 58b when the magazine is empty. Bolt block 60 also interfaces with the spine of the magazine 13 as the follower 50 travels through the magazine. Both legs 54, 56 are configured to maximize interface with the interior of the magazine.

[0040] Although the present invention has been described with reference to preferred embodiments, numerous modifications and variations can be made and still the result will come within the scope of the invention. No limitation with respect to the specific embodiments disclosed herein is intended or should be inferred.

What is claimed is:

1. An ammunition magazine comprising:
 - a. A casing, further comprised of:
 - i. a lower storage section with a cross-sectional area;
 - ii. an upper feed section with a cross-sectional area narrower than that of the lower storage section; and
 - iii. a medial transitional area with a variable and asymmetrical cross-sectional area gradually decreasing from the cross-sectional area of the storage section to the cross-sectional area of the feed section
 - b. a floor plate, capable of interface about an orifice of the storage section;
 - c. a locking plate, residing internal of an orifice of the storage section and being capable of secure interface with the floor plate while also further comprising a partition extending from the lock plate into an interior of the storage section of the casing;
 - d. a follower spring; and
 - e. a follower having a slit such that it is capable of straddling the partition.
2. The magazine of claim 1, the follower having at least one pivotable bail.
3. The magazine of claim 1, the follower spring being a composite spring comprising a plurality of springs, representing at least two different spring constant, connected in series to each other.
4. The magazine of claim 3, the follower having at least one pivotable bail.
5. The magazine of claim 3, the plurality of springs being joined by a spring splicing apparatus, said apparatus having a guide to interface with a trough located internally along a narrow side of the casing.
6. The magazine of claim 5, the follower having at least one pivotable bail.
7. The magazine of claim 1, the casing being of one piece, having no separable parts.

8. The magazine of claim 7, the follower having at least one pivotable bail.

9. The magazine of claim 7, the follower spring being a composite spring comprising a plurality of springs, representing at least two different spring constant, connected in series to each other.

10. The magazine of claim 9, the follower having at least one pivotable bail.

11. The magazine of claim 9, the plurality of springs being joined by a spring splicing apparatus, said apparatus having a guide to interface with a trough located internally along a narrow side of the casing.

12. The magazine of claim 11, the follower having at least one pivotable bail.

13. The magazine of claim 7, the casing having a constant internal curve.

* * * * *