

**Department of Mechanical Engineering
The University of Hong Kong**

**Foundations of Engineering Mechanics
ENGG1010 (2008 – 2009)**

"Mechanics of Fluids"

Lecturer: Dr. C.O. Ng (office: HW7-1; phone: 28592622; email: cong@hku.hk)

Required Text: *Fundamentals of Fluid Mechanics* 5th Ed., B.R. Munson, D.F. Young & T.H. Okiishi, Wiley Asia Student Edition.

References: 1) *Fluid Mechanics: Fundamentals and Applications*, Y.A. Cengel & J.M. Cimbala, McGraw-Hill. Highly recommended.
2) *Fluid Mechanics* 6th Ed., F.M.White, McGraw-Hill.

Assessment: In-course continuous assessment 10%
- mid-term quiz (details to be announced in due course)
Examination 90%

Topics Covered:

1. Properties of fluids
 - Definition of a fluid
 - Density
 - Viscosity
 - Surface tension
 - Compressibility
2. Hydrostatics
 - Hydrostatic pressure distribution
 - Pressure measuring devices (manometers)
 - Hydrostatic force acting on submerged plane and curved surfaces
 - Equilibrium of a hydraulic structure under hydrostatic and applied forces
3. Fluid in Motion
 - Continuity equation (conservation of mass)
 - Bernoulli's equation (conservation of mechanical energy)
 - Momentum equation (force and rate of change of momentum)
 - Applications
 - Velocity measurement with a Pitot tube
 - Jet issuing from an orifice
 - Flow-rate measurement with a Venturi-meter
 - Impact force by a jet on a flat plate
 - Impact force on a pipe bend

(I) INTRODUCTION

What is Fluid Mechanics?

First, what is a *fluid*?

- Three common states of matter are solid, liquid, and gas.
- A *fluid* is either a *liquid* or a *gas*.
- If surface effects are not present, flow behaves similarly in all common fluids, whether gases or liquids.
- Formal definition of a fluid - A *fluid* is a substance which *deforms* continuously under the application of a *shear stress*.
 - Definition of **stress** - A stress is defined as a force per unit area, acting on an infinitesimal surface element.
 - Stresses have both **magnitude** (force per unit area) and **direction**, and the direction is relative to the **surface** on which the stress acts.
 - There are *normal* stresses and *tangential* stresses.

$$\text{normal stress} = \frac{F_n}{dA}$$

$$\text{shear stress} = \frac{F_t}{dA}$$

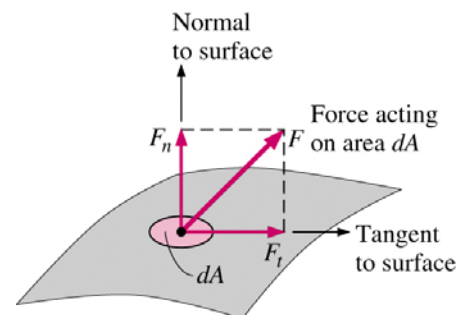

- *Pressure* is an example of a *normal* stress, and acts inward, toward the surface, and perpendicular to the surface.
- A *shear* stress is an example of a *tangential* stress, i.e. it acts along the surface, parallel to the surface. Friction due to fluid viscosity is the primary source of shear stresses in a fluid.
- One can construct a free body diagram of a little fluid particle to visualize both the normal and shear stresses acting on the body:

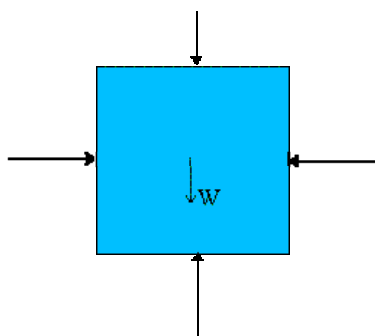

Free body diagram for a fluid particle at rest.

Consider a tiny fluid element (a very small chunk of the fluid) in a case where the fluid is at rest (or moving at constant speed in a straight line). A fluid at rest can have only normal stresses, since a fluid at rest cannot resist a shear stress. In this case, the sum of all the forces must balance the weight of the fluid element. This condition is known as hydrostatics. Here, pressure is the only normal stress which exists. Pressure always acts positively inward. Obviously, the pressure at the bottom of the fluid element must be slightly larger than that at the top, in order for the total pressure force to balance the weight of the element. Meanwhile, the pressure at the right face must be equal to that on the left face, so that the sum of forces in the horizontal direction is zero. [Note: This diagram is two-dimensional, but an actual fluid element is three-dimensional. Hence, the pressure on the front face must also balance that on the back face.]

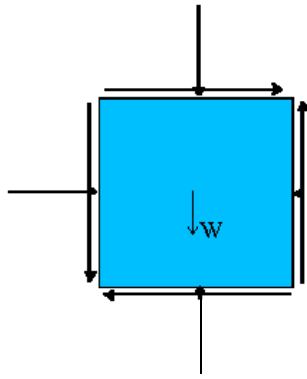

Free body diagram for a fluid particle in motion.

Consider a tiny fluid element (a very small chunk of the fluid) that is moving around in some flow field. Since the fluid is in motion, it can have both normal and shear stresses, as shown by the free body diagram. The vector sum of all forces acting on the fluid element must equal the mass of the element times its acceleration (Newton's second law). Likewise, the net moment about the center of the body can be obtained by summing the forces due to each shear stress times its moment arm. [Note: To obtain force, one must multiply each stress by the surface area on which it acts, since stress is defined as force per unit area.]

- **Fluids at rest cannot resist a shear stress**; in other words, when a shear stress is applied to a fluid at rest, the fluid will not remain at rest, but will move because of the shear stress.
- For a good illustration of this, consider the comparison of a fluid and a solid under application of a shear stress: A fluid can easily be distinguished from a solid by application of a shear stress, since, by definition, a fluid at rest cannot resist a shear stress. If a shear stress is applied to the surface of a solid, the solid will deform a little, and then remain at rest (in its new distorted shape). One can say that the solid (at rest) is able to resist the shear stress. Now consider a fluid (in a container). When a shear stress is applied to the surface of the fluid, the fluid will continuously deform, i.e. it will set up some kind of flow pattern inside the container. In other words, one can say that the fluid (at rest) is unable to resist the shear stress. That is to say, it cannot remain at rest under application of a shear stress.

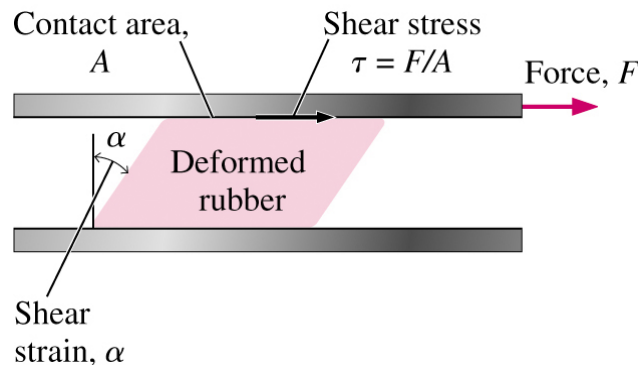

Next, what is *mechanics*?

- Mechanics is essentially the application of the laws of force and motion. Conventionally, it is divided into two branches, statics and dynamics.

So, putting it all together, there are two branches of fluid mechanics:

- *Fluid statics* or *hydrostatics* is the study of fluids *at rest*. The main equation required for this is Newton's second law for non-accelerating bodies, i.e. $\sum \vec{F} = 0$.
- *Fluid dynamics* is the study of fluids *in motion*. The main equation required for this is Newton's second law for accelerating bodies, i.e. $\sum \vec{F} = m\vec{a}$.

(II) PROPERTIES OF FLUIDS

A. Density, Specific Weight, Relative Density

Density (ρ) = mass per unit volume of substance = $\delta m / \delta v$; $[\rho] = [ML^{-3}]$.

Specific weight (γ) = force exerted by the earth's gravity upon a unit volume of the substance = ρg ; $[\gamma] = [ML^{-2}T^{-2}]$.

Relative density (specific gravity) = ratio of mass density of the substance to that of water at a standard temperature and pressure = ρ / ρ_w (non-dimensional).

B. Viscosity

Viscosity is a measure of the importance of friction in fluid flow. Consider, for example, a fluid in two-dimensional steady shear between two parallel plates, as shown below. The bottom plate is fixed, while the upper plate is moving at a steady speed of U .

It turns out (we will prove this at a later date) that the velocity profile, $u(y)$ is linear, i.e. $u(y) = Uy / b$. Also notice that the velocity of the fluid matches that of the wall at both the top and bottom walls. This is known as the no slip condition.

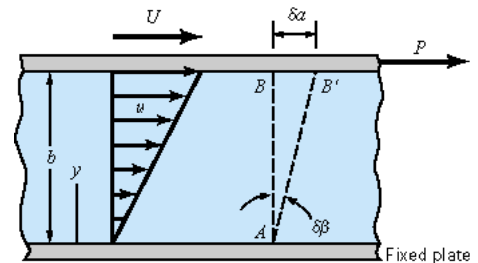

The top plate will experience a friction force to the left, since it is doing work trying to drag the fluid along with it to the right.

The fluid at the top of the channel will experience an equal and opposite force (i.e. to the right).

Similarly the bottom plate will experience a friction force to the right, since the fluid is trying to pull the plate along with it to the right. The fluid at the bottom of the channel will feel an equal and opposite force, i.e. to the left. In fluid mechanics, shear stress, defined as a tangential force per unit area, is used rather than force itself, and is commonly denoted by τ (Greek letter "tau").

In simple shear flow such as this, the shear stress is directly proportional to the rate of deformation of the fluid, which in this case is equal to the slope of the velocity profile $\tau \propto U / b$.

Introducing the **constant of proportionality** μ (Greek letter "mu"), which is called **the coefficient of viscosity**, the Newton's equation of viscosity states that:

$$\tau = \mu \frac{du}{dy}$$

Fluids that follow the above relation are called **Newtonian** fluids. The coefficient of viscosity is also known as **dynamic viscosity**; its dimensions are $[\mu] = [ML^{-1}T^{-1}]$ while its SI units are Pa-s. An **ideal** fluid is one which has zero viscosity, i.e., **inviscid** or non-viscous.

Sometimes, it is more convenient to use **kinematic viscosity**, denoted by Greek letter "nu", which is simply defined as the viscosity divided by density, i.e.

$$\nu = \frac{\mu}{\rho}$$

Kinematic viscosity has the dimensions $[\nu] = [L^2T^{-1}]$, and its SI units are m^2/s .

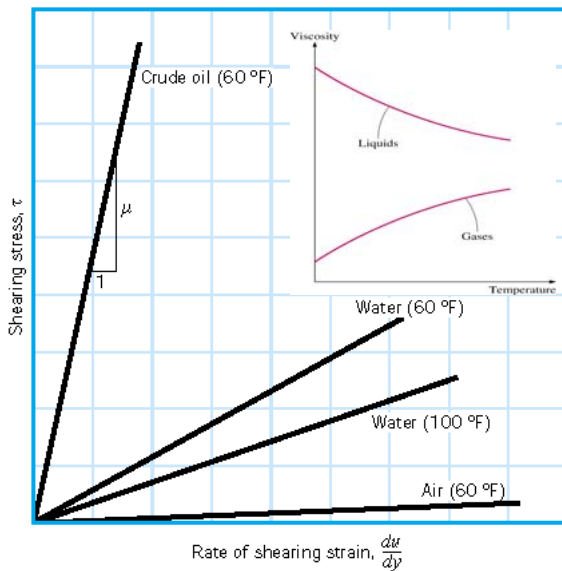

Typically, as temperature increases, the viscosity will decrease for a liquid, but will increase for a gas.

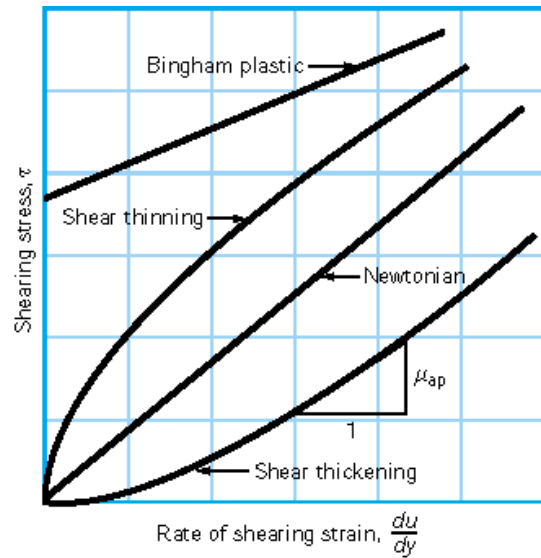

The fluid is **non-Newtonian** if the relation between shear stress and shear strain rate is **non-linear**.

C. Surface Tension and Capillarity

Surface tension is a property of liquids which is felt at the interface between the liquid and another fluid (typically a gas). Surface tension has dimensions of **force per unit length**, and always acts parallel to the interface. Surface molecules are subject to an attractive force from nearby surface molecules so that the surface is in a state of tension. A soap bubble is a good example to illustrate the effects of surface tension. How does a soap bubble remain spherical in shape? The answer is that there is a higher pressure inside the bubble than outside, much like a balloon. In fact, surface tension in the soap film acts much the same as the tension in the skin of a balloon.

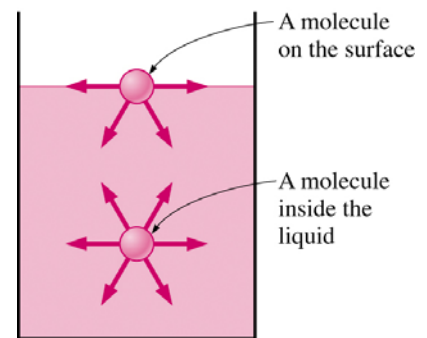

Consider a soap bubble of radius R with internal pressure p_{in} and external (atmospheric) pressure p_{out} . The excess pressure $\Delta P_{bubble} = P_{in} - P_{out}$ can be found by considering the free-body diagram of half a bubble. Note that surface tension acts along the circumference (resulting from cutting across the two interfaces) and the pressure acts on the area of the half-bubble. By statics (to be explained later), the net force due to the pressure is equal to the pressure times the projected area. Hence, balancing the forces due to surface tension and pressure difference:

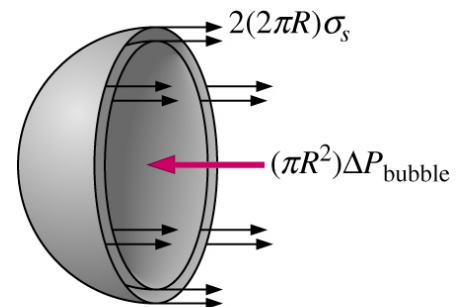

$$2(2\pi R)\sigma_s = (\pi R^2)\Delta P_{bubble}$$

$$\Rightarrow \Delta P_{bubble} = 4\sigma_s / R$$

(b) Half a bubble

where σ_s is the surface tension of the fluid in air.

You may repeat this exercise for a droplet, and show that $\Delta P_{droplet} = 2\sigma_s / R$.

Surface tension is also important at the interface between a liquid, a gas, and a solid. For example, a meniscus occurs when the surface of a liquid touches a solid wall, as most readily noticed when a capillary tube is placed in a liquid. Consider a glass capillary tube inserted into a liquid, such as water. The water will rise up the tube to a height h , because surface tension pulls the surface of the water towards the glass, as shown. The meniscus is the curved surface at the top of the water column.

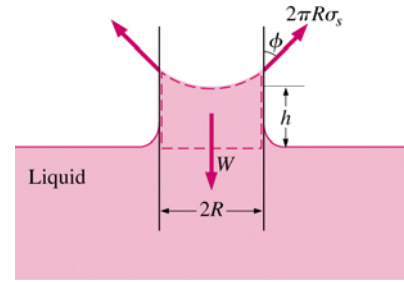

The height of the water column can be found by summing all forces acting on the water column as a free body diagram. (This is a statics problem since there is no acceleration.) The downward force is due to gravity, i.e. the weight of the water column. The only upward force available to balance the weight is that caused by surface tension (pressure forces all cancel out, as will be explained in a later lecture). Column height h can be determined as follows:

$$\begin{aligned} \text{weight of fluid column} &= \text{surface tension pulling force} \\ \Rightarrow \rho g (\pi R^2 h) &= 2\pi R \sigma_s \cos \phi \\ \Rightarrow h &= \frac{2\sigma_s \cos \phi}{\rho g R} \end{aligned}$$

The contact angle is defined as the angle between the liquid and solid surface, as shown in the sketch. Contact angle depends on both the liquid and the solid. If ϕ is less than 90° , the liquid is said to "wet" the solid. However, if ϕ is greater than 90° , the liquid is repelled by the solid, and tries not to "wet" it. For example, water wets glass, but not wax. Mercury on the other hand does not wet glass.

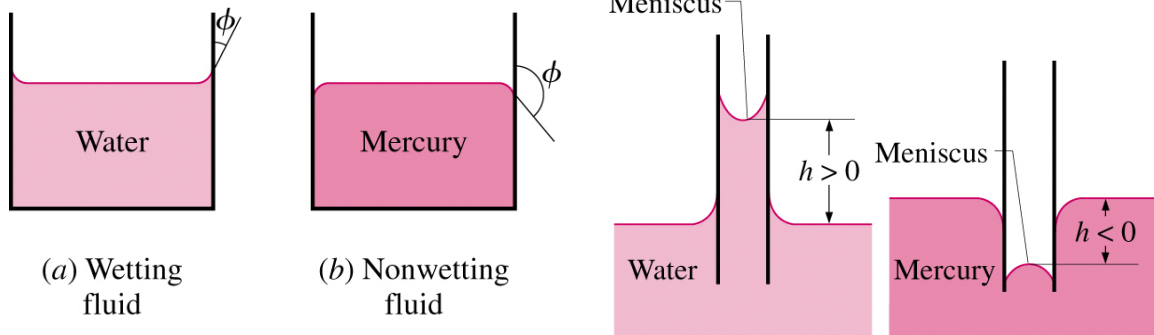

D. Vapor Pressure

Vapor pressure is defined as the pressure at which a liquid will boil (vaporize). Vapor pressure rises as temperature rises. For example, suppose you are camping on a high mountain (10,000 ft. or roughly 3,000 m in altitude). From Table A.6 of *Fluid Mechanics* by Frank White, the atmospheric pressure at this elevation is about 70 kPa. From Table A.5 it is seen that at a temperature of around 90°C , the vapor pressure of water is also around 70 kPa. From this it can be stated that at 10,000 ft. of elevation, water boils at around 90°C , rather than the common 100°C at standard sea level pressure. This has consequences for cooking. For example, eggs have to be cooked longer at elevation to become hard-boiled since they cook at a lower temperature. A pressure cooker has the opposite effect. Namely, the tight lid on a pressure cooker causes the pressure to increase above the normal atmospheric value. This causes water to boil at a temperature even greater than 100°C ; eggs can be cooked a lot faster in a pressure cooker!

Vapor pressure is important to fluid flows because, in general, pressure in a flow decreases as velocity increases. This can lead to **cavitation**, which is generally destructive and undesirable. In particular, at high speeds the local pressure of a liquid sometimes drops below the vapor pressure of the liquid. In such a case, **cavitation** occurs. In other words, a "cavity" or bubble of vapor appears because the liquid vaporizes or boils at the location where the pressure dips below the local vapor pressure. Cavitation is not desirable for several reasons. First, it causes noise (as the cavitation bubbles collapse when they migrate into regions of higher pressure). Second, it can lead to inefficiencies and reduction of heat transfer in pumps and turbines (turbomachines). Finally, the collapse of these cavitation bubbles causes pitting and corrosion of blades and other surfaces nearby. The left figure below shows a cavitating propeller in a water tunnel, and the right figure shows cavitation damage on a blade.

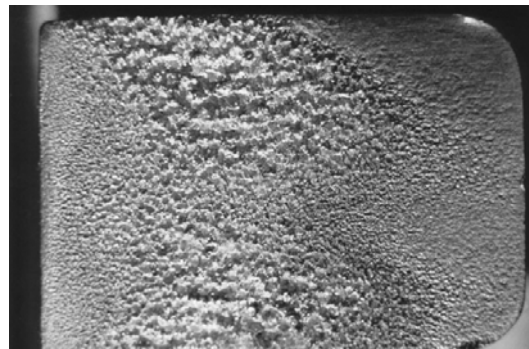
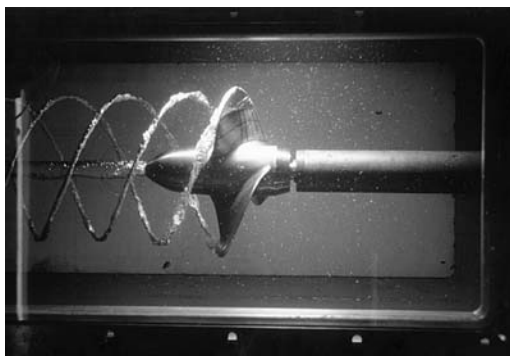

E. Compressibility

All fluids are compressible under the application of external forces. The compressibility of a fluid is expressed by its **bulk modulus of elasticity E** , which is the ratio of the change in unit pressure to the corresponding volume change per unit volume.

$$E = \frac{\Delta P}{-\Delta V / V} = \frac{\Delta P}{\Delta \rho / \rho}$$

Note that the bulk modulus of elasticity has the same dimensions as pressure: $[E] = [ML^{-1}T^{-2}]$.

For water at room temperature, E is approximately $2.2 \times 10^9 \text{ N/m}^2$, while for air at atmospheric pressure the isentropic bulk modulus of elasticity is approximately $1.4 \times 10^5 \text{ N/m}^2$. That is, air is typically four orders of magnitude more compressible than water.

For most practical purposes liquids may be regarded as incompressible. However, there are certain cases, such as unsteady flow in pipes (e.g., water hammer), where the compressibility should be taken into account. Gases may also be treated as incompressible if the change in density is very small (typically less than 3%).

An ideal fluid is an incompressible fluid.

Pressure disturbances imposed on a fluid move in waves. These pressure waves move at a velocity equal to that of sound through the fluid. The velocity, or celerity, c , is given by

$$c = \sqrt{E / \rho}$$

F. Perfect Gas Law

Very often we have fluid flows of gases at, or near, atmospheric pressure. In these cases, the changes in pressure p , density ρ and absolute temperature T of a gas particle may be related accurately to each other by the perfect (or ideal) gas law:

$$p = \rho RT, \quad \text{where } R = R_g / M_g$$

where R is called the perfect gas constant, R_g is the Universal gas constant and M_g is the gas molecular weight.

The universal gas constant is $R_g \cong 8.31 \text{ J/mol} \cdot \text{K} \cong 0.082 \text{ L} \cdot \text{atm/mol} \cdot \text{K}$.

The perfect gas law alone is insufficient to explain how the properties of a gas change as it moves. In addition, the laws of thermodynamics must be invoked. Compressible flows are inherently complicated because the laws of thermodynamics, as well as the laws of fluid mechanics, operate simultaneously.

G. Concluding Remarks

Fluid mechanics represents that branch of applied mechanics dealing with the behavior of fluids at rest and in motion. In the development of the principles of fluid mechanics, some fluid properties play principal roles, other only minor roles or no roles at all for a particular problem. In fluid statics, weight is the important property, whereas in fluid flow, density and viscosity are predominant properties. Where appreciable compressibility occurs, principles of thermodynamics must be considered. Vapor pressure becomes important when low gauge pressures are involved, and surface tension affects static and flow conditions in small passages.

(III) FLUID STATICS

Hydrostatics is the study of pressures throughout a fluid at rest and the pressure forces on finite surfaces. As the fluid is at rest, there are no shear stresses in it. Hence the pressure at a point on a plane surface always acts normal to the surface, and all forces are independent of viscosity. **The pressure variation is due only to the weight of the fluid.** As a result, the controlling laws are relatively simple, and analysis is based on a straightforward application of the mechanical principles of force and moment. Solutions are exact and there is no need to have recourse to experiment.

A. Introduction to Pressure

Pressure always acts **inward normal** to any surface (even imaginary surfaces as in a control volume).

Pressure is a normal stress, and hence has dimensions of force per unit area, or $[ML^{-1}T^{-2}]$. In the English system of units, pressure is expressed as "psi" or lbf/in^2 . In the Metric system of units, pressure is expressed as "pascals" (Pa) or N/m^2 .

Standard atmospheric pressure is 101.3 kPa or 14.69 psi.

Pressure is formally defined to be

$$p = \lim_{\Delta A \rightarrow 0} \frac{\Delta F_n}{\Delta A}$$

where ΔF_n is the normal compressive force acting on an infinitesimal area ΔA .

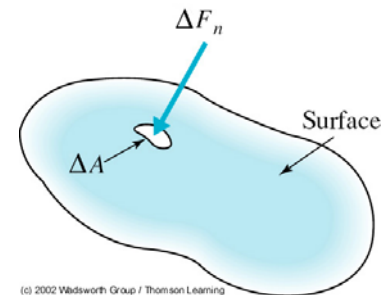
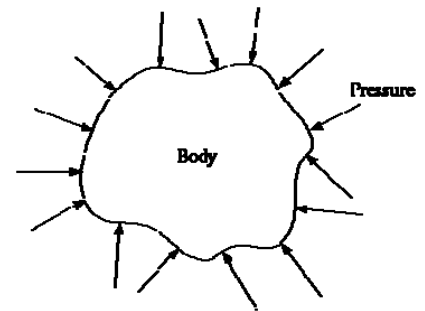

(c) 2002 Wileys Group / Thomson Learning

B. Pressure at a Point

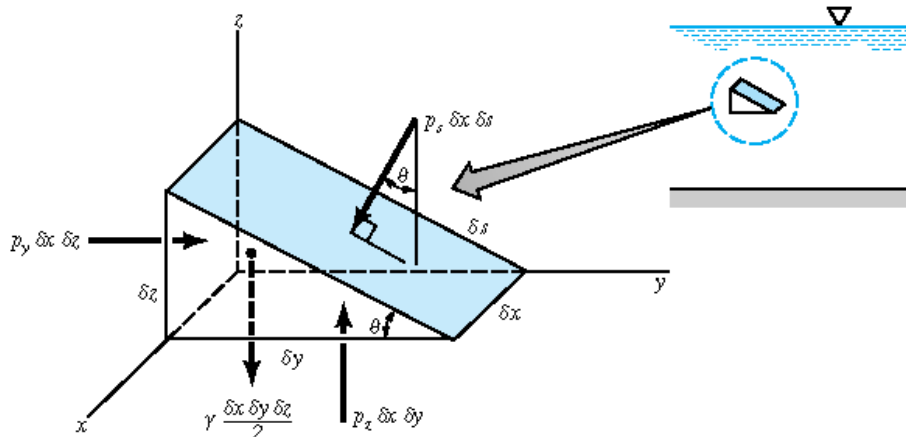

By considering the equilibrium of a small triangular wedge of fluid extracted from a static fluid body, one can show that for *any* wedge angle θ , the pressures on the three faces of the wedge are equal in magnitude:

$$p_s = p_y = p_x \quad \text{independent of } \theta$$

This result is known as **Pascal's law**, which states that the pressure at a point in a fluid at rest, or in motion, is independent of direction as long as there are no shear stresses present.

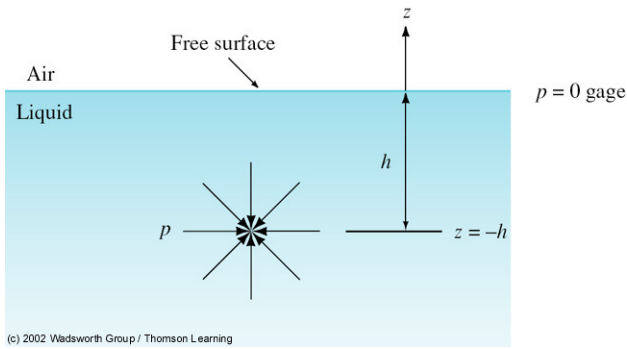

Pressure at a point has the same magnitude in all directions, and is called **isotropic**.

C. Pressure Variation with Depth

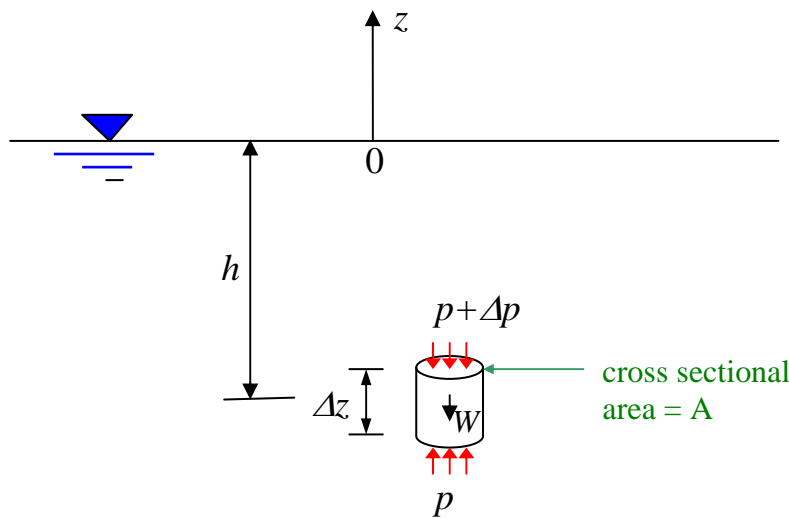

Consider a small vertical cylinder of fluid in equilibrium, where *positive z is pointing vertically upward*. Suppose the origin $z = 0$ is set at the free surface of the fluid. Then the pressure variation at a depth $z = -h$ below the free surface is governed by

$$\begin{aligned}
 (p + \Delta p)A + W &= pA \\
 \Rightarrow \Delta pA + \rho g A \Delta z &= 0 \\
 \Rightarrow \Delta p &= -\rho g \Delta z \\
 \Rightarrow \frac{dp}{dz} &= -\rho g \quad \text{or} \quad \frac{dp}{dz} = -\gamma \quad (\text{as } \Delta z \rightarrow 0)
 \end{aligned}$$

Therefore, the hydrostatic pressure increases linearly with depth at the rate of the specific weight $\gamma \equiv \rho g$ of the fluid.

Homogeneous fluid: ρ is constant

By simply integrating the above equation:

$$\int dp = -\int \rho g dz \quad \Rightarrow \quad p = -\rho g z + C$$

where C is an integration constant. When $z = 0$ (on the free surface), $p = C = p_0$ (the atmospheric pressure). Hence,

$$p = -\rho g z + p_0$$

Pressure given by this equation is called **ABSOLUTE PRESSURE**, i.e., measured above perfect vacuum.

However, for engineering purposes, it is more convenient to measure the pressure above a datum pressure at atmospheric pressure. By setting $p_0 = 0$,

$$p = -\rho gz = \rho gh$$

Pressure given by this equation is called **GAUGE (GAGE) PRESSURE**.

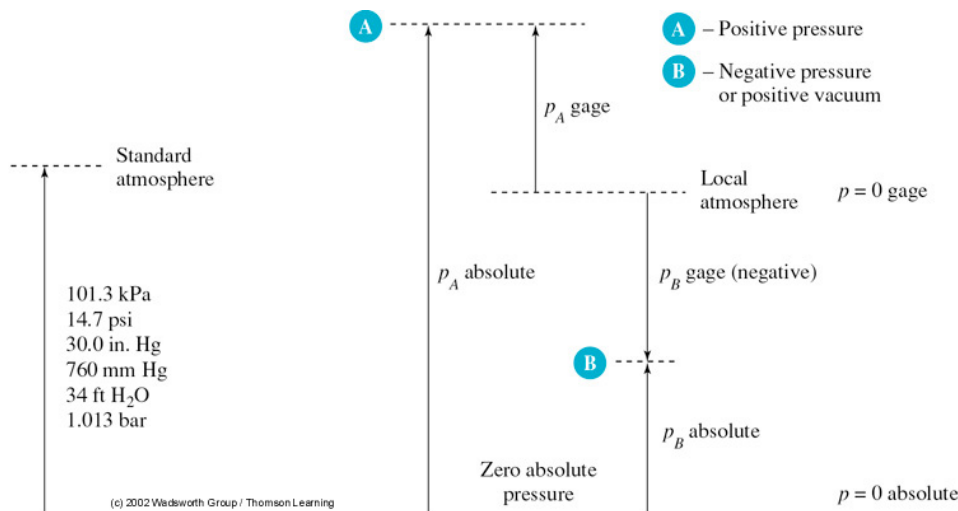

The equation derived above shows that when the density is constant, **the pressure in a liquid at rest increases linearly with depth from the free surface.**

Consequently, the distribution of pressure acting on a submerged flat surface is always trapezoidal (or triangular if the surface pierces through the free surface of the liquid and the pressure is gauge pressure).

Also, the pressure is the same at all points with the same depth from the free surface regardless of geometry, provided that the points are interconnected by the same fluid. However, the thrust due to pressure is perpendicular to the surface on which the pressure acts, and hence its direction depends on the geometry.

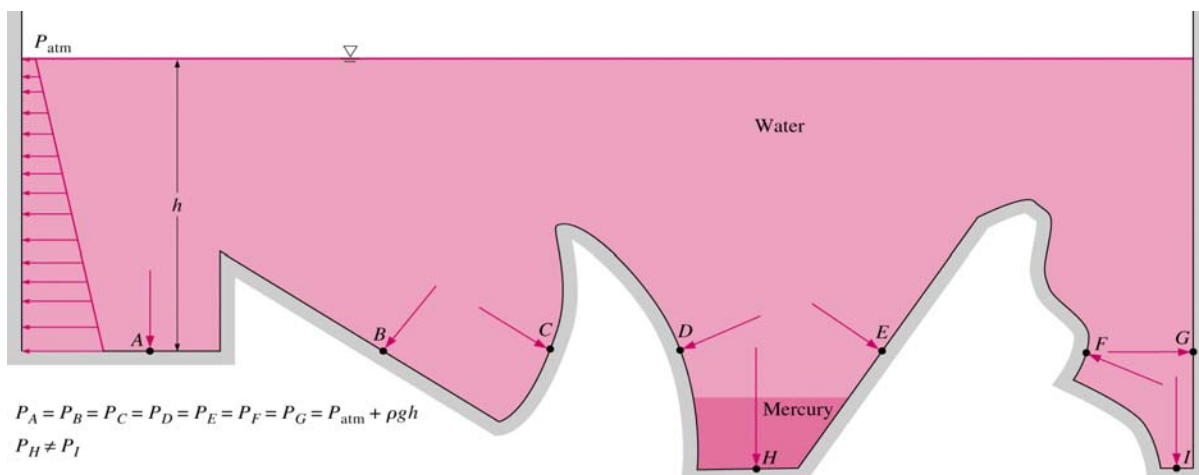
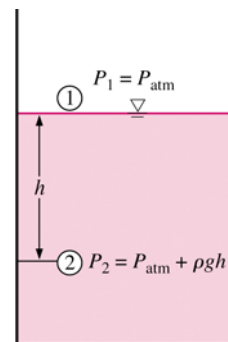

Compressible fluid: ρ varies with depth

Example: Find the relationship between pressure and altitude in the atmosphere near the Earth's surface. For simplicity, neglect the vertical temperature gradient. Let temperature $T = 288 \text{ K}$ (15°C) and pressure $p_0 = 1 \text{ atm}$ at the surface. The average molecular weight of air is $M_g = 28.8 \text{ g/mol}$. The Universal gas constant is $R_g = 8.3 \text{ J/mol} \cdot \text{K}$.

Solution: Let the altitude above the Earth's surface be denoted by z , then

$$\frac{dp}{dz} = -\rho g$$

Assume that air is a perfect gas, its density varies with pressure according to

$$\rho = P \frac{M_g}{R_g T}$$

Combining the above two equations, and integrate:

$$\begin{aligned} \frac{dp}{dz} &= -p \frac{M_g g}{R_g T} \quad \Rightarrow \quad \frac{dp}{p} = -\frac{M_g g}{R_g T} dz \\ &\Rightarrow \int_{p_0}^p \frac{dp}{p} = -\int_0^z \frac{M_g g}{R_g T} dz \\ &\Rightarrow \ln \frac{p}{p_0} = -\frac{M_g g}{R_g T} z \\ &\Rightarrow p = p_0 \exp \left[-\left(\frac{M_g g}{R_g T} \right) z \right] \end{aligned}$$

Neglecting temperature variation, the exponential decay rate for pressure with height is,

$$\frac{M_g g}{R_g T} = \frac{28.8 \times 10^{-3} \times 9.81}{8.3 \times 288} = 1.18 \times 10^{-4} \text{ per meter of rise}$$

Say, at 2000 ft or 610 m above the Earth's surface, the pressure is

$$p = (1 \text{ atm}) \exp \left[-1.18 \times 10^{-4} \times 610 \right] = 0.93 \text{ atm}$$

That is, for such a high elevation, the pressure drops only by 7%. (Note that temperature cannot be considered constant if this calculation is performed for large altitude differences.)

In most practical problems where the change in elevation is not extremely large, atmospheric pressure can be assumed to be constant.

D. Hydrostatic Pressure Difference Between Two Points

For a fluid with constant density,

$$p_{\text{below}} = p_{\text{above}} + \rho g |\Delta z|$$

It is easily remembered by thinking about scuba diving. As a diver goes down, the pressure on his ears increases. So, the pressure "below" is greater than the pressure "above."

There are several "rules" or comments which directly result from the above equation:

- **If you can draw a continuous line through the same fluid from point 1 to point 2, then $p_1 = p_2$ if $z_1 = z_2$.**

For example, consider the oddly shaped container:

By this rule, $p_1 = p_2$ and $p_4 = p_5$ since these points are at the same elevation in the same fluid. However, p_2 does not equal p_3 even though they are at the same elevation, because one cannot draw a line connecting these points through the same fluid. In fact, p_2 is less than p_3 since mercury is denser than water.

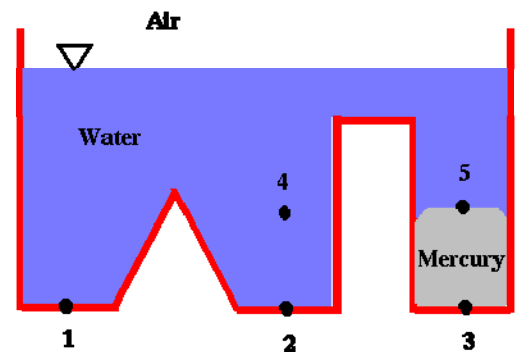

- **Any free surface open to the atmosphere has atmospheric pressure, p_0 .**

(This rule holds not only for hydrostatics, but for any free surface exposed to the atmosphere, whether the surface is moving, stationary, flat, or mildly curved.) Consider the hydrostatics example of a container of water:

The little upside-down triangle indicates a free surface, and means that the pressure there is atmospheric pressure, p_0 . In other words, in this example, $p_1 = p_0$. To find the pressure at point 2, our hydrostatics equation is used: $p_2 = p_0 + \rho gh$ (absolute pressure) or $p_2 = \rho gh$ (gauge pressure).

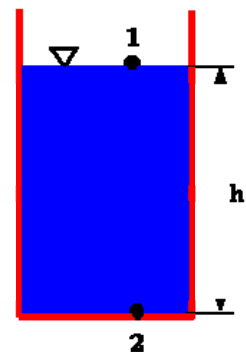

- **The shape of a container does not matter in hydrostatics.**

(Except of course for very small diameter tubes, where surface tension becomes important.)

Consider the three containers in the figure below:

At first glance, it may seem that the pressure at point 3 would be greater than that at point 1 or 2, since the weight of the water is more "concentrated" on the small area at the bottom, but in reality, all three pressures are identical. Use of our hydrostatics equation confirms this conclusion, i.e.

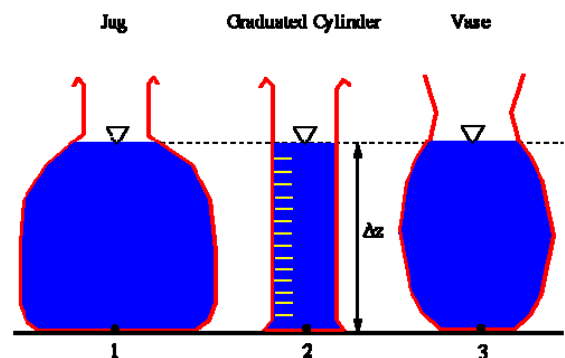

$$p_{\text{below}} = p_{\text{above}} + \rho g |\Delta z| \Rightarrow p_1 = p_2 = p_3 = p_0 + \rho g \Delta z$$

• **Pressure in layered fluid.**

For example, consider the container in the figure below, which is partially filled with mercury, and partially with water:

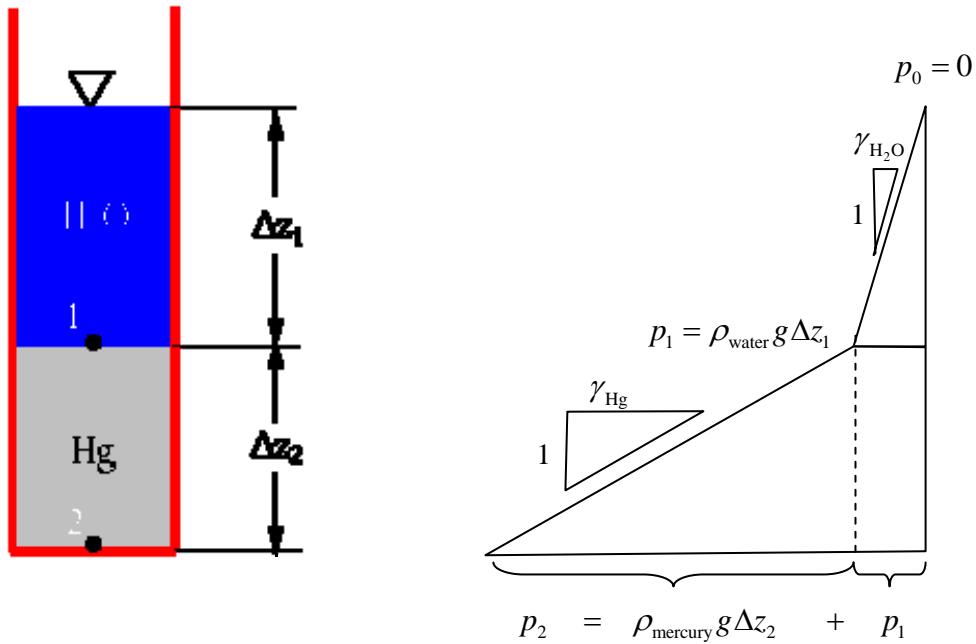

In this case, our hydrostatics equation must be used twice, once in each of the liquids

$$p_{\text{below}} = p_{\text{above}} + \rho g |\Delta z|$$

$$\Rightarrow p_1 = p_0 + \rho_{\text{water}} g \Delta z_1 \quad \text{and} \quad p_2 = p_1 + \rho_{\text{mercury}} g \Delta z_2$$

Combining,

$$p_2 = p_0 + \rho_{\text{water}} g \Delta z_1 + \rho_{\text{mercury}} g \Delta z_2$$

Shown on the right side of the above figure is the distribution of pressure with depth across the two layers of fluids, where the atmospheric pressure is taken to be zero $p_0 = 0$. Note that:

- The pressure is continuous at the interface between water and mercury. Therefore, p_1 , which is the pressure at the bottom of the water column, is the starting pressure at the top of the mercury column. The pressure p_1 can also be regarded as the water surcharge pressure superimposed onto (uniformly transmitted to, and felt at any depth by) the mercury below.
- The vertical gradient of the pressure distribution is equal to the specific weight of the fluid γ . Therefore, the pressure in mercury increases with depth at a rate 13.6 times faster than that in water since $\gamma_{\text{mercury}} / \gamma_{\text{water}} = 13.6$.

The fact that the *pressure (or known as surcharge) applied to a confined fluid increases the pressure throughout the fluid by the same amount* has important applications, such as in the hydraulic lifting of heavy objects:

$$P_1 = P_2 \Rightarrow \frac{F_1}{A_1} = \frac{F_2}{A_2} \Rightarrow \frac{F_1}{F_2} = \frac{A_1}{A_2} \ll 1$$

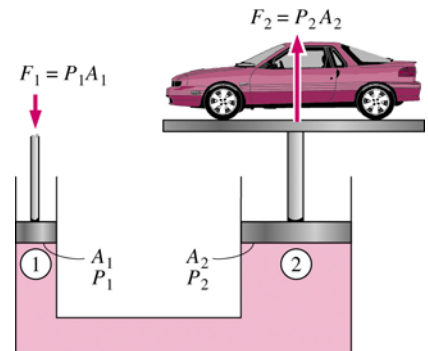

E. Pressure Measurement and Manometers

• Piezometer tube

The simplest manometer is a tube, open at the top, which is attached to a vessel or a pipe containing liquid at a pressure (higher than atmospheric) to be measured. This simple device is known as a piezometer tube. As the tube is open to the atmosphere the pressure measured is relative to atmospheric so is **gauge** pressure: $p_A = \gamma_1 h_1$

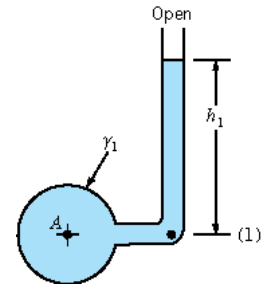

This method can only be used for liquids (i.e. not for gases) and only when the liquid height is convenient to measure. It must not be too small or too large and pressure changes must be detectable.

• U-tube manometer

This device consists of a glass tube bent into the shape of a "U", and is used to measure some unknown pressure. For example, consider a U-tube manometer that is used to measure pressure p_A in some kind of tank or machine.

Again, the equation for hydrostatics is used to calculate the unknown pressure. Consider the left side and the right side of the manometer separately:

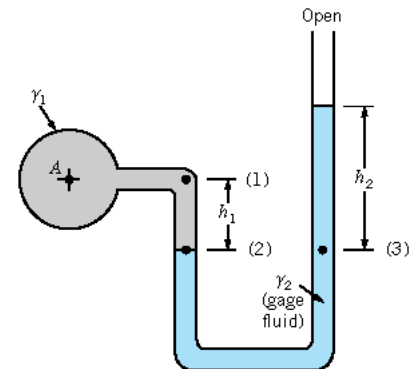

$$p_2 = p_1 + \gamma_1 h_1 = p_A + \gamma_1 h_1$$

$$p_3 = \gamma_2 h_2$$

Since points labeled (2) and (3) in the figure are at the same elevation in the same fluid, they are at equivalent pressures, and the two equations above can be equated to give

$$p_A = \gamma_2 h_2 - \gamma_1 h_1$$

Finally, note that in many cases (such as with air pressure being measured by a mercury manometer), the density of manometer fluid 2 is much greater than that of fluid 1. In such cases, the last term on the right is sometimes neglected.

• Differential manometer

A differential manometer can be used to measure the difference in pressure between two containers or two points in the same system. Again, on equating the pressures at points labeled (2) and (3), we may get an expression for the pressure difference between A and B:

$$p_A - p_B = \gamma_2 h_2 + \gamma_3 h_3 - \gamma_1 h_1$$

In the common case when A and B are at the same elevation ($h_1 = h_2 + h_3$) and the fluids in the two containers are the same ($\gamma_1 = \gamma_3$), one may show that the pressure difference registered by a differential manometer is given by

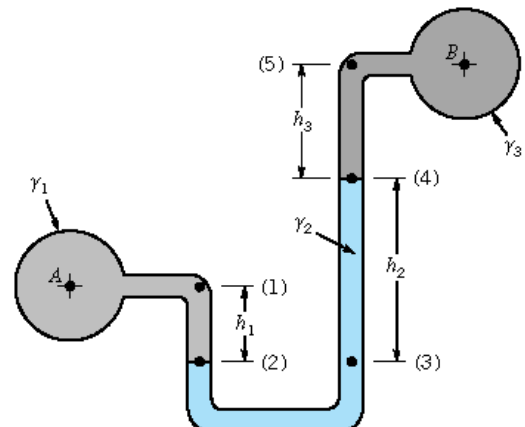

$$\Delta p = \left(\frac{\rho_m}{\rho} - 1 \right) \rho g h$$

where ρ_m is the density of the manometer fluid, ρ is the density of the fluid in the system, and h is the manometer differential reading.

• **Inclined-tube manometer**

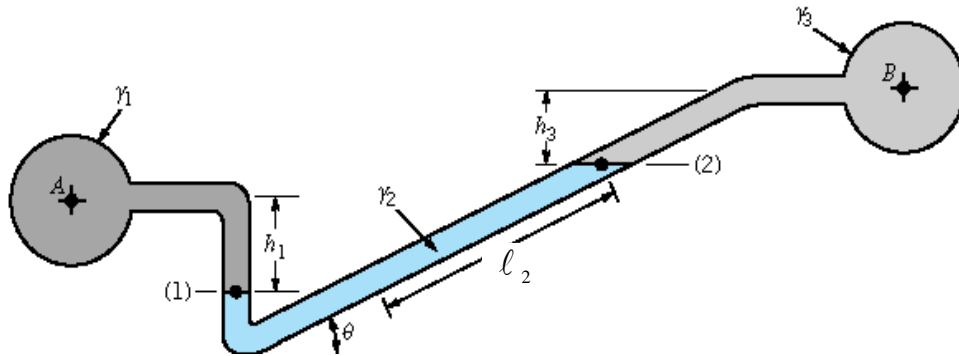

As shown above, the differential reading is proportional to the pressure difference. If the pressure difference is very small, the reading may be too small to be measured with good accuracy. To increase the sensitivity of the differential reading, one leg of the manometer can be inclined at an angle θ , and the differential reading is measured along the inclined tube. As shown above, $h_2 = l_2 \sin \theta$, and hence

$$p_A - p_B = \gamma_2 l_2 \sin \theta + \gamma_3 h_3 - \gamma_1 h_1$$

Obviously, the smaller the angle θ , the more the reading l_2 is magnified.

• **Multifluid manometer**

The pressure in a pressurized tank is measured by a multifluid manometer, as is shown in the figure. Show that the air pressure in the tank is given by

$$P_{\text{air}} = P_{\text{atm}} + g (\rho_{\text{mercury}} h_3 - \rho_{\text{oil}} h_2 - \rho_{\text{water}} h_1)$$

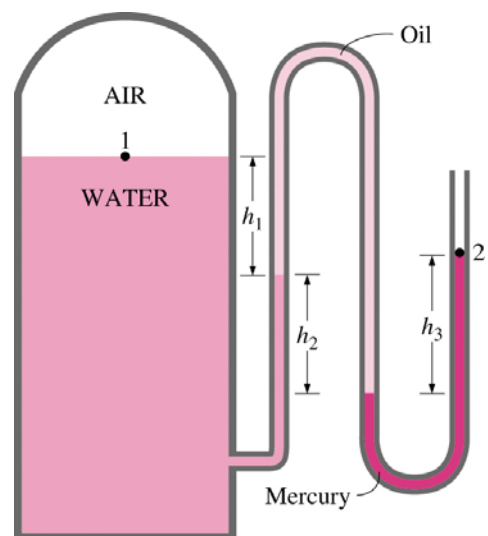

F. Pressure Distributions

• Flat Surfaces

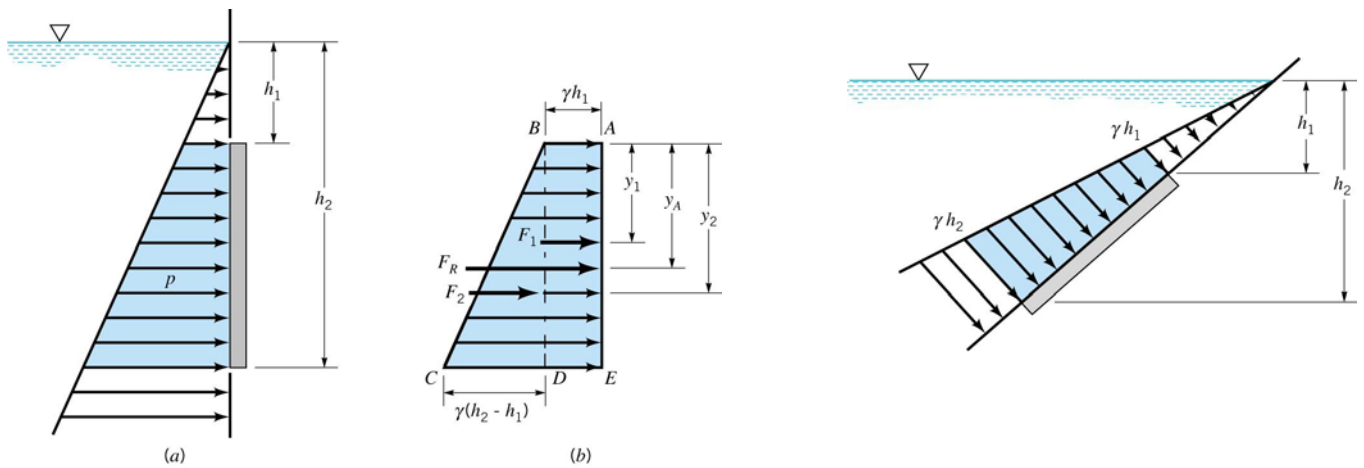
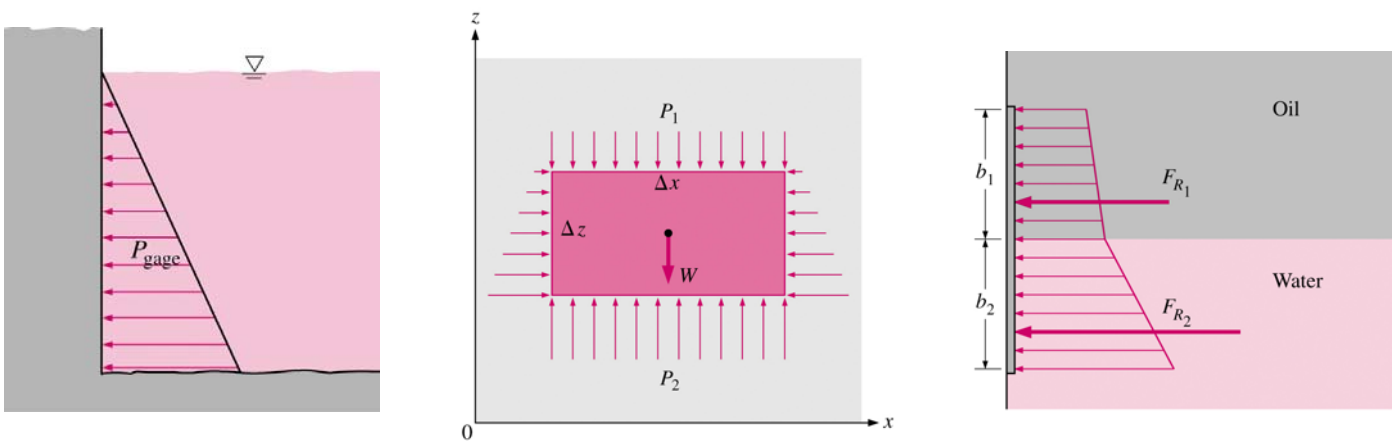

• Curved Surfaces

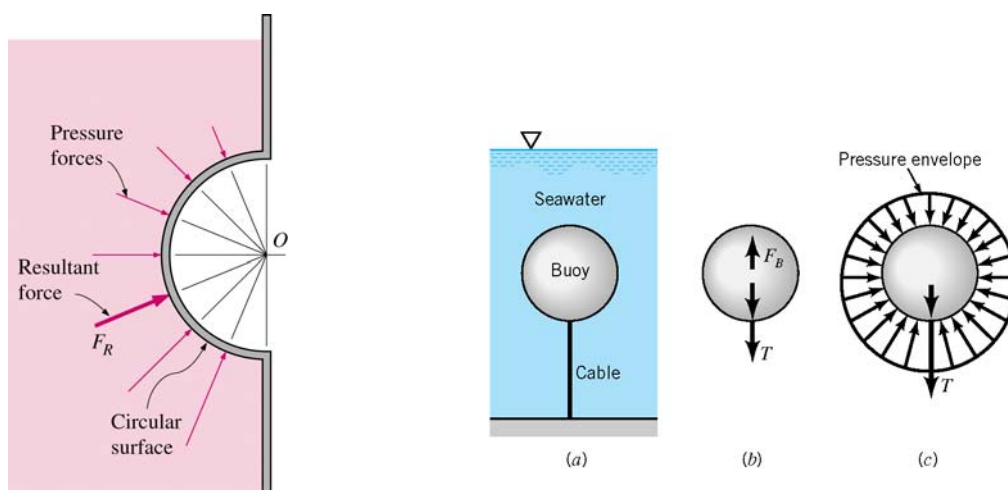

When the curved surface is a *circular arc* (full circle or any part of it), the resultant hydrostatic force acting on the surface always passes through the center of the circle. This is because the elemental pressure forces are normal to the surface, and by the well-known geometrical property all lines normal to the surface of a circle must pass through the center of the circle.

G. Hydrostatic Force on a Plane Surface

Suppose a *submerged* plane surface is inclined at an angle θ to the free surface of a liquid

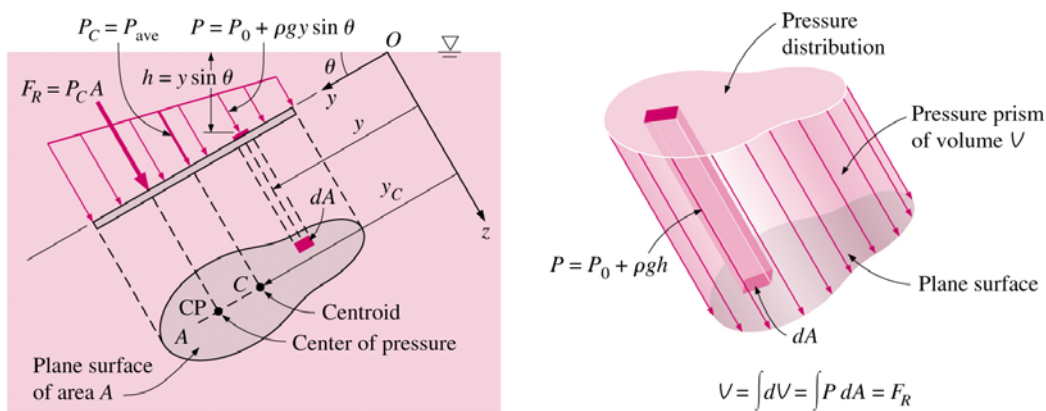
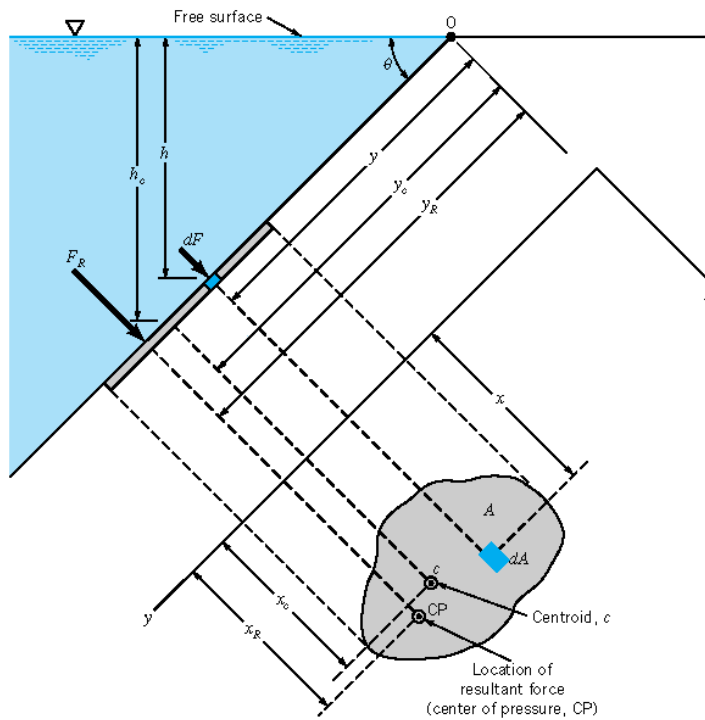

Notation:-

- A - area of the plane surface
- O - the line where the plane in which the surface lies intersects the free surface,
- C - centroid (or centre of area) of the plane surface,
- CP - center of pressure (point of application of the resultant force on the plane surface),
- F_R - magnitude of the resultant force on the plane surface (acting normally),
- h_c - vertical depth of the centroid C ,
- h_R - vertical depth of the center of pressure CP ,
- y_c - inclined distance from O to C ,
- y_R - inclined distance from O to CP .

Find magnitude of resultant force:

The resultant force is found by integrating the force due to hydrostatic pressure on an element dA at a depth h over the whole surface:

$$F_R = \int_A dF = \int_A \rho g h dA = \rho g \sin \theta \int_A y dA$$

where by the first moment of area

$$\int_A y dA = y_c A$$

Hence,

$$F_R = \rho g (y_c \sin \theta) A = \rho g h_c A$$

The resultant force on one side of any plane submerged surface in a uniform fluid is therefore equal to the pressure at the centroid of the surface times the area of the surface, independent of the shape of the plane or the angle θ at which it is slanted.

Find location of centre of pressure:

Taking moment about O ,

$$F_R y_R = \int_A y dF \Rightarrow (\rho g y_c \sin \theta A) y_R = \int_A y (\rho g y \sin \theta dA) \Rightarrow (y_c A) y_R = \int_A y^2 dA$$

But

$$\int_A y^2 dA = I_O = I_c + Ay_c^2 \quad \text{by parallel axis theorem}$$

where I_O = second moment of area (or moment of inertia) of the surface about O ,

I_c = second moment of area (or moment of inertia) about an axis through the centroid and parallel to the axis through O (depends on the geometry of the surface, see below for the values for some common figures).

Therefore, on substituting,

$$(y_c A) y_R = Ay_c^2 + I_c$$

$$\Rightarrow y_R = y_c + \frac{I_c}{y_c A} \quad \text{or} \quad h_R = h_c + \frac{I_c \sin^2 \theta}{h_c A}$$

Now, the depth of the center of pressure depends on the shape of the surface and the angle of inclination, and is always below the depth of the centroid of the plane surface.

For a flat surface that pierces through the free surface, and hence triangular pressure

distribution: $A = HB$, $h_c = \frac{1}{2} H \sin \theta$, $h_R = \frac{2}{3} H \sin \theta$, $F = \frac{1}{2} \rho g H^2 B \sin \theta$

(c) 2002 Wadsworth Group / Thomson Learning

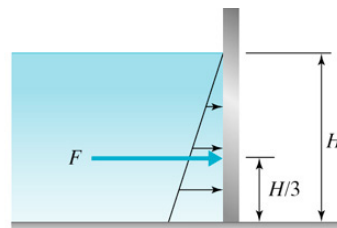
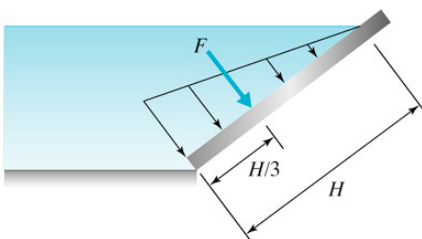

Properties for some Common sectional areas

GG is an axis passing through the centroid and parallel to the base of the figure.

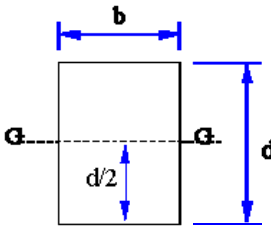
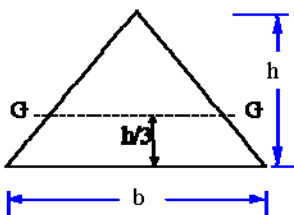
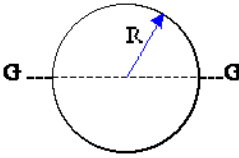
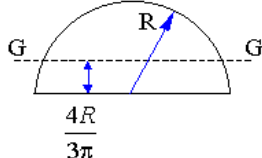
Shape	Dimensions	Area	I_c (moment of inertia about GG)
Rectangle		bd	$\frac{bd^3}{12}$
Triangle		$\frac{bh}{2}$	$\frac{bh^3}{36}$
Circle		πR^2	$\frac{\pi R^4}{4}$
Semi-Circle		$\frac{\pi R^2}{2}$	$0.11R^4$

Some Additional Notes on Second Moment of Area

For a plane surface of arbitrary shape, we may define the n^{th} ($n = 0, 1, 2, 3, \dots$) moment of area about an axis GG by the integral

$$\int_A y^n dA,$$

Then,

- the zeroth moment of area = total area of the surface,
- the first moment of area = 0, if GG passes through the centroid of the surface,
- the second moment of area gives the variance of the distribution of area about the axis.

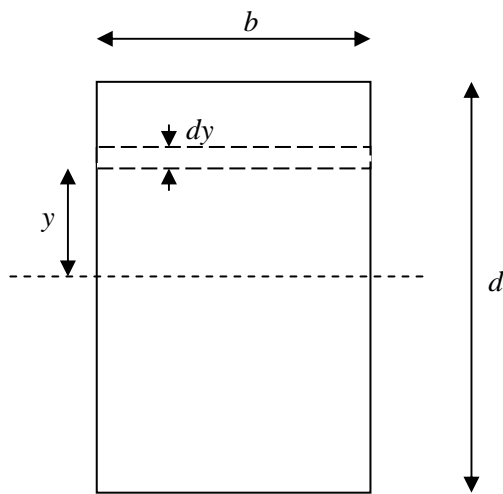
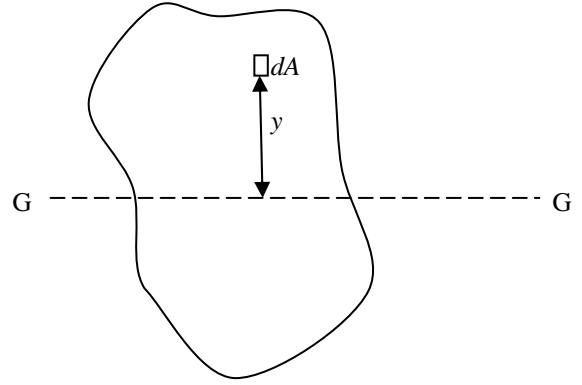

For example, for a rectangular surface, the second moment of area about the axis that passes through the centroid is

$$\begin{aligned} I_c &= \int_A y^2 dA \\ &= \int_{-d/2}^{d/2} y^2 (bdy) \\ &= \left[\frac{by^3}{3} \right]_{-d/2}^{d/2} \\ &= \frac{bd^3}{12} \end{aligned}$$

Parallel Axis Theorem

If OO is an axis that is parallel to the axis GG, which passes through the centroid of the surface, then the second moment of area about OO is equal to that about GG plus the square of the distance between the two axes times the total area:

$$\begin{aligned} I_o &= \int_A y'^2 dA \\ &= \int_A (y_c - y)^2 dA \\ &= \int_A (y_c^2 - 2y_c y + y^2) dA \\ &= y_c^2 A - 2y_c \underbrace{\int_A y dA}_0 + \underbrace{\int_A y^2 dA}_{I_c} \\ &= y_c^2 A + I_c \end{aligned}$$

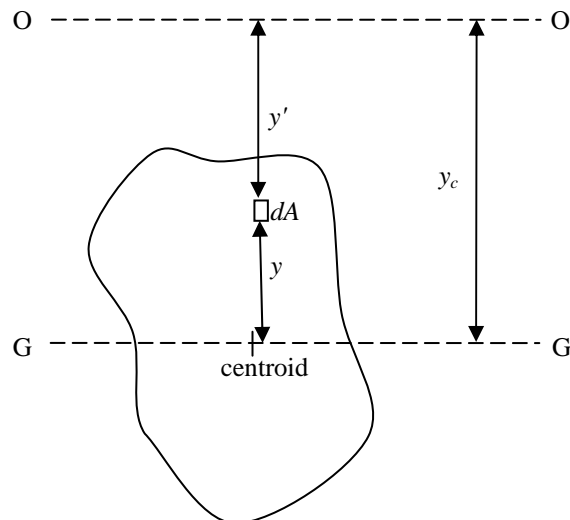

H. Hydrostatic Force on Submerged Curved Surfaces

1) Liquid above surface

Suppose we are required to find the force acting on the upper side of the curved surface AC.

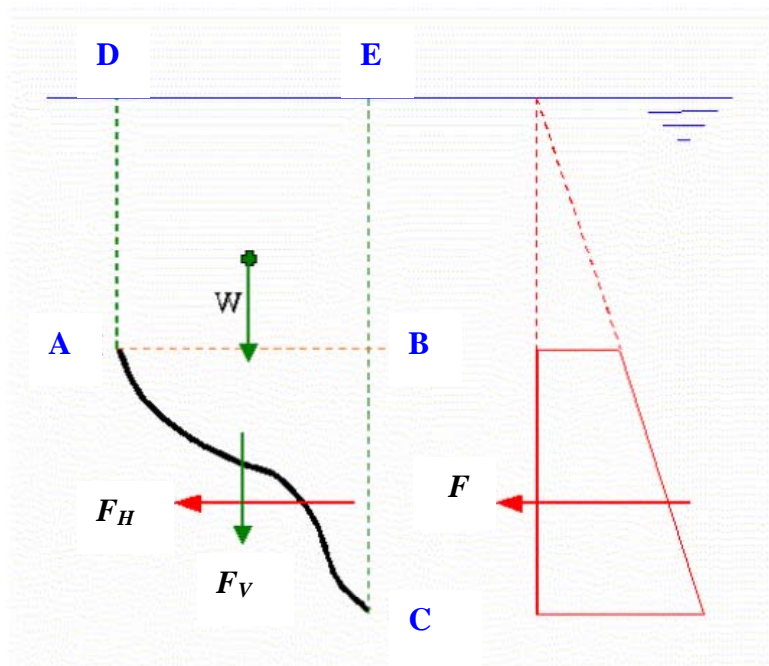
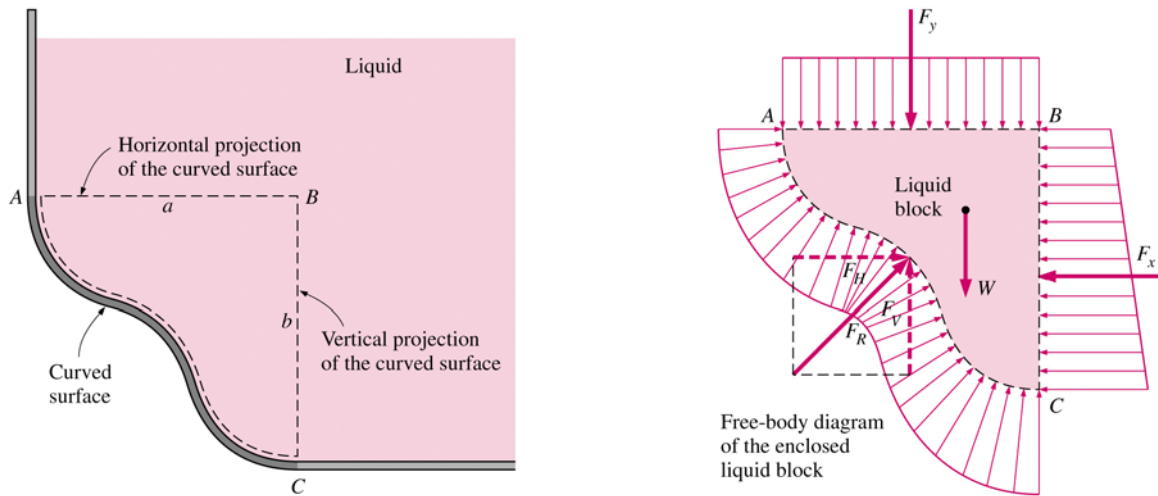

Horizontal component of force on surface:

By considering the equilibrium of the liquid mass contained in ABC, we get

$F_H = F$ = resultant force of liquid acting on vertically projected area (BC) and acting through the centre of pressure of F .

Vertical component of force on surface

By considering the equilibrium of the liquid mass contained in ADEC, we get

$F_V = W$ = weight of liquid vertically above the surface (ADEC) and through the centre of gravity of the liquid mass.

Resultant force

$$F_R = \sqrt{F_H^2 + F_V^2},$$

pointing downward, and making an angle $\alpha = \tan^{-1}(F_V / F_H)$ with the horizontal.

2) Liquid below surface

Suppose we are required to find the force acting on the underside of the curved surface AB. The space above the surface ADCB may be empty or contain other fluid.

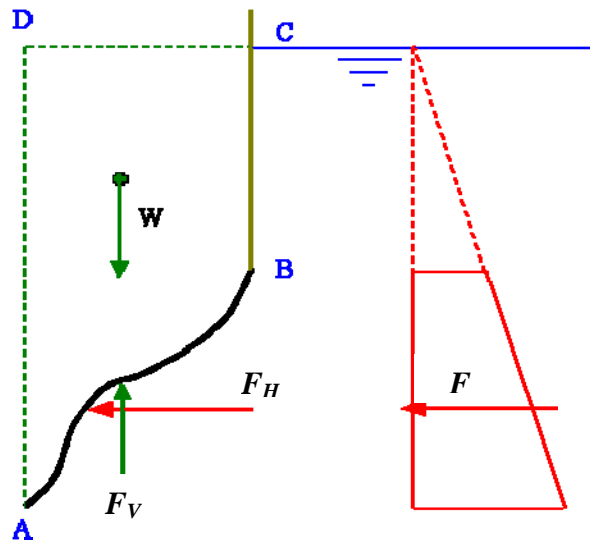

Imagine that the space (ADCB) vertically above the curved surface is occupied with the same fluid as that below it (disregard what actually is filling that space). Then the surface AB could be removed without disrupting the equilibrium of the fluid. That means, the force acting on the underside of the surface would be balanced by that acting on the upper side under this imaginary condition. Therefore we may use the same arguments as in the preceding case:

Horizontal component of force on surface:

$F_H = F =$ resultant force of liquid acting on vertically projected area (AB) and acting through the centre of pressure of F.

Vertical component of force on surface

$F_V = W =$ weight of imaginary liquid (i.e., same liquid as on the other side of the surface) vertically above the surface (ADCB) and through the centre of gravity of the liquid mass.

Resultant force

$$F_R = \sqrt{F_H^2 + F_V^2},$$

which points upward, and makes an angle $\alpha = \tan^{-1}(F_V / F_H)$ with the horizontal.

I. Solutions to Problems Selected from the Textbook

1.10R

1.10R (Viscosity) A large movable plate is located between two large fixed plates as shown in Fig. P1.10R. Two Newtonian fluids having the viscosities indicated are contained between the plates. Determine the magnitude and direction of the shearing stresses that act on the fixed walls when the moving plate has a velocity of 4 m/s as shown. Assume that the velocity distribution between the plates is linear.

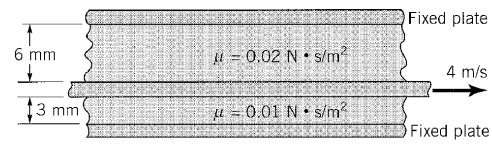

FIGURE P1.10R

$$\tau = \mu \frac{du}{dy} = \mu \frac{U}{b} \text{ so that}$$

$$\tau_1 = \mu_1 \frac{U}{b_1} = (0.02 \frac{\text{N}\cdot\text{s}}{\text{m}^2}) \left(\frac{4 \frac{\text{m}}{\text{s}}}{0.006 \text{m}} \right)$$

$$= \underline{\underline{13.3 \frac{\text{N}}{\text{m}^2}}}$$

$$\tau_2 = \mu_2 \frac{U}{b_2} = (0.01 \frac{\text{N}\cdot\text{s}}{\text{m}^2}) \left(\frac{4 \frac{\text{m}}{\text{s}}}{0.003 \text{m}} \right)$$

$$= \underline{\underline{13.3 \frac{\text{N}}{\text{m}^2}}}$$

Stresses act on fixed walls in direction of moving plate.

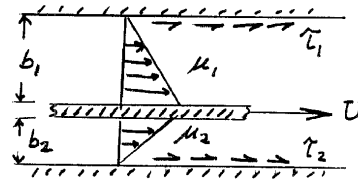

2.1R

2.1R (Pressure head) Compare the column heights of water, carbon tetrachloride, and mercury corresponding to a pressure of 50 kPa. Express your answer in meters.

$$p = \gamma h$$

For water: $h = \frac{50 \times 10^3 \frac{\text{N}}{\text{m}^2}}{9.80 \times 10^3 \frac{\text{N}}{\text{m}^3}} = \underline{\underline{5.10 \text{ m}}}$

For carbon tetrachloride: $h = \frac{50 \times 10^3 \frac{\text{N}}{\text{m}^2}}{15.6 \times 10^3 \frac{\text{N}}{\text{m}^3}} = \underline{\underline{3.21 \text{ m}}}$

For mercury: $h = \frac{50 \times 10^3 \frac{\text{N}}{\text{m}^2}}{133 \times 10^3 \frac{\text{N}}{\text{m}^3}} = \underline{\underline{0.376 \text{ m}}}$



2.4R

2.4R (Manometer) A tank is constructed of a series of cylinders having diameters of 0.30, 0.25, and 0.15 m as shown in Fig. P2.4R. The tank contains oil, water, and glycerin and a mercury manometer is attached to the bottom as illustrated. Calculate the manometer reading, h .

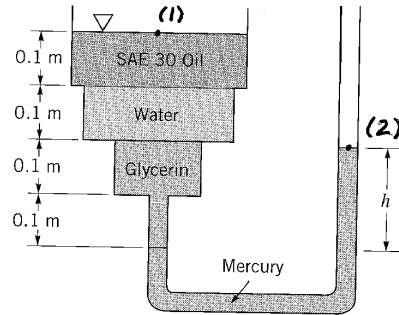

Figure P2.4R

$$P_1 + \gamma_{oil} (0.1\text{m}) + \gamma_{H_2O} (0.1\text{m}) + \gamma_{gly} (0.2\text{m}) - \gamma_{Hg} h = P_2$$

Thus, with $P_1 = P_2 = 0$,

$$h = \frac{(8.95 \frac{\text{kN}}{\text{m}^3})(0.1\text{m}) + (9.80 \frac{\text{kN}}{\text{m}^3})(0.1\text{m}) + (12.4 \frac{\text{kN}}{\text{m}^3})(0.2\text{m})}{133 \frac{\text{kN}}{\text{m}^3}}$$

$$= \underline{\underline{0.0327 \text{ m}}}$$

2.7R

2.7R (Force on plane surface) A swimming pool is 18 m long and 7 m wide. Determine the magnitude and location of the resultant force of the water on the vertical end of the pool where the depth is 2.5 m.

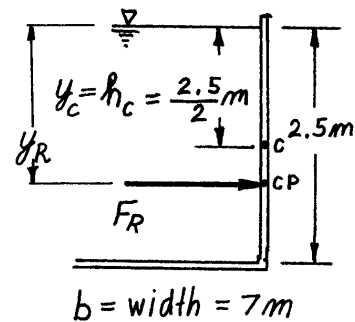

$$F_R = \gamma h_c A = (9.80 \frac{\text{kN}}{\text{m}^3}) (\frac{2.5\text{m}}{2}) (7\text{m} \times 2.5\text{m}) = \underline{\underline{214 \text{ kN}}}$$

$$y_R = \frac{I_{xc}}{y_c A} + y_c \quad \text{where } I_{xc} = \frac{1}{12} (7\text{m})(2.5\text{m})^3$$

$$\text{Thus, } y_R = \frac{\frac{1}{12} (7\text{m})(2.5\text{m})^3}{(\frac{2.5\text{m}}{2}) (7\text{m} \times 2.5\text{m})} + \frac{2.5\text{m}}{2} = \underline{\underline{1.67 \text{ m}}}$$

The force of 214 kN acts 1.67 m below surface along vertical centerline of end.

2.8R

2.8R (Force on plane surface) The vertical cross section of a 7-m-long closed storage tank is shown in Fig. P2.8R. The tank contains ethyl alcohol and the air pressure is 40 kPa. Determine the magnitude of the resultant fluid force acting on one end of the tank.

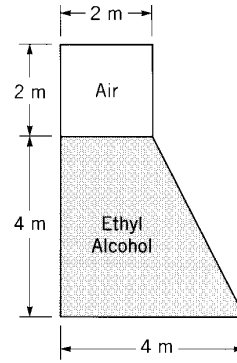

FIGURE P2.8R

Break area into three parts as shown in figure.

For area 1 :

$$F_{R1} = p_{air} A_1 = \left(40 \frac{kN}{m^2}\right) (2m \times 2m) = 160 \text{ kN}$$

For area 2: (From Table 1.6 $\gamma_{ethyl\ alcohol} = 7.74 \frac{kN}{m^3}$)

$$\begin{aligned} F_{R2} &= p_{air} A_2 + \gamma h_{c2} A_2 \\ &= \left(40 \frac{kN}{m^2}\right) (2m \times 4m) + \left(7.74 \frac{kN}{m^3}\right) \left(\frac{4m}{2}\right) (2m \times 4m) \\ &= 444 \text{ kN} \end{aligned}$$

For area 3:

$$\begin{aligned} F_{R3} &= p_{air} A_3 + \gamma h_{c3} A_3 \\ &= \left(40 \frac{kN}{m^2}\right) \left(\frac{1}{2}\right) (2m \times 4m) + \left(7.74 \frac{kN}{m^3}\right) \left(\frac{2}{3}\right) (4m) \left(\frac{1}{2}\right) (2m \times 4m) \\ &= 243 \text{ kN} \end{aligned}$$

Thus,

$$\begin{aligned} F_R &= F_{R1} + F_{R2} + F_{R3} \\ &= 160 \text{ kN} + 444 \text{ kN} + 243 \text{ kN} = \underline{\underline{847 \text{ kN}}} \end{aligned}$$

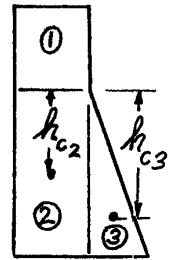

2.11R

2.11R (Force on plane surface) The rectangular gate CD of Fig P2.11R is 1.8 m wide and 2.0 m long. Assuming the material of the gate to be homogeneous and neglecting friction at the hinge C , determine the weight of the gate necessary to keep it shut until the water level rises to 2.0 m above the hinge.

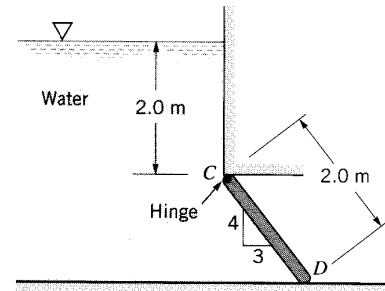

FIGURE P2.11R

$$F_R = \rho h_c A$$

$$\text{Where } h_c = 2\text{ m} + \frac{1}{2} \left[\left(\frac{4}{5} \right) (2\text{ m}) \right] = 2.8\text{ m}$$

Thus,

$$F_R = (9.80 \frac{\text{kN}}{\text{m}^3}) (2.8\text{ m}) (1.8\text{ m} \times 2\text{ m})$$

$$= 98.8\text{ kN}$$

Also,

$$y_R = \frac{I_{xc}}{y_c A} + y_c \quad \text{where } y_c = \frac{2\text{ m}}{\left(\frac{4}{5} \right)} + 1\text{ m} = 3.5\text{ m}$$

so that

$$y_R = \frac{\left(\frac{1}{12} \right) (1.8\text{ m}) (2\text{ m})^3}{(3.5\text{ m}) (1.8\text{ m} \times 2\text{ m})} + 3.5\text{ m} = 3.595\text{ m}$$

For equilibrium,

$$\sum M_o = 0 \quad (\text{Note: Set } F_D = 0 \text{ to obtain minimum weight})$$

and

$$W \left(\frac{1}{2} \right) \left[\left(\frac{3}{5} \right) (2\text{ m}) \right] - F_R \left(y_R - \frac{2\text{ m}}{\left(\frac{4}{5} \right)} \right) = 0$$

or

$$W = \frac{(98.8\text{ kN}) (3.595\text{ m} - 2.5\text{ m})}{\left(\frac{1}{2} \right) \left[\left(\frac{3}{5} \right) (2\text{ m}) \right]} = \underline{\underline{180\text{ kN}}}$$

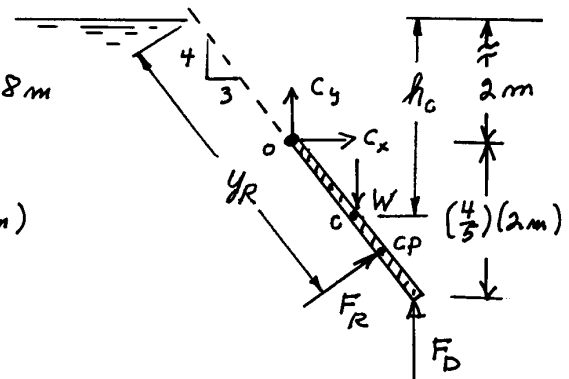

2.7

2.7 For the great depths that may be encountered in the ocean the compressibility of seawater may become an important consideration. (a) Assume that the bulk modulus for seawater is constant and derive a relationship between pressure and depth which takes into account the change in fluid density with depth. (b) Make use

of part (a) to determine the pressure at a depth of 6 km assuming seawater has a bulk modulus of 2.3×10^9 Pa, and a density of 1030 kg/m^3 at the surface. Compare this result with that obtained by assuming a constant density of 1030 kg/m^3 .

(a)

$$\frac{dp}{dz} = -\gamma = -\rho g \quad (\text{Eq. 2.4})$$

Thus,
$$\frac{dp}{\rho} = -g dz \quad (1)$$

If ρ is a function of p , we must determine $\rho = f(p)$ before integrating Eq.(1). Since,

$$E_v = \frac{dp}{d\rho/\rho} \quad (\text{Eq. 1.13})$$

then
$$\int_{p_0}^p dp = E_v \int_{\rho_0}^{\rho} \frac{d\rho}{\rho}$$

so that
$$p = E_v \ln \frac{\rho}{\rho_0}$$

Thus,
$$\rho = \rho_0 e^{\frac{p}{E_v}} \quad \text{where } \rho = \rho_0 \text{ at } p = 0$$

From Eq.(1)

$$\int_{p_1}^0 \frac{dp}{\rho_0 e^{\frac{p}{E_v}}} = -g \int_{z_1}^{z_0} dz$$

or
$$\int_{p_1}^0 e^{-\frac{p}{E_v}} dp = -\rho_0 g \int_{z_1}^{z_0} dz$$

so that

$$p = -E_v \ln \left(1 - \frac{\rho_0 g h}{E_v} \right) \quad \text{where } h = z_0 - z_1, \text{ the depth below surface}$$

(cont)

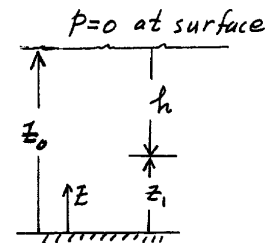

2-4

2.7 (cont)

(b) From part (a),

$$p = -E_v \ln \left(1 - \frac{\rho_0 g h}{E_v} \right)$$

so that at $h = 6 \text{ km}$

$$p = - \left(2.3 \times 10^9 \frac{\text{N}}{\text{m}^2} \right) \ln \left[1 - \frac{(1.03 \times 10^3 \frac{\text{kg}}{\text{m}^3})(9.81 \frac{\text{m}}{\text{s}^2})(6 \times 10^3 \text{m})}{2.3 \times 10^9 \frac{\text{N}}{\text{m}^2}} \right]$$

$$= 6.14 \times 10^7 \frac{\text{N}}{\text{m}^2} = \underline{\underline{61.4 \text{ MPa}}}$$

(c) For constant density

$$p = \gamma h = \rho g h = (1.03 \times 10^3 \frac{\text{kg}}{\text{m}^3})(9.81 \frac{\text{m}}{\text{s}^2})(6 \times 10^3 \text{m})$$

$$= \underline{\underline{60.6 \text{ MPa}}}$$

2.8

2.8 Blood pressure is commonly measured with a cuff placed around the arm, with the cuff pressure (which is a measure of the arterial blood pressure) indicated with a mercury manometer (see Video 2.1). A typical value for the maximum value of blood pressure (systolic pressure) is 120 mm Hg. Why wouldn't it be simpler, and cheaper, to use water in the manometer rather than mercury? Explain and support your answer with the necessary calculations.

$$p = \gamma h$$

For 120 mm Hg :

$$p = \gamma h$$

$$= (133 \times 10^3 \frac{\text{N}}{\text{m}^3})(0.120 \text{m})$$

$$= 16.0 \text{ kPa}$$

To obtain this pressure with a water column

$$h_{\text{H}_2\text{O}} = \frac{16.0 \times 10^3 \frac{\text{N}}{\text{m}^2}}{9.80 \times 10^3 \frac{\text{N}}{\text{m}^3}} = 1.63 \text{ m (or 5.35 ft)}$$

Thus, if water were used in the manometer the required column heights would be too high and impractical. No.

2.34

2.34 Small differences in gas pressures are commonly measured with a *micromanometer* of the type illustrated in Fig. P2.34. This device consists of two large reservoirs each having a cross-sectional area, A_r , which are filled with a liquid having a specific weight, γ_1 , and connected by a U-tube of cross-sectional area, A_t , containing a liquid of specific weight, γ_2 . When a differential gas pressure, $p_1 - p_2$, is applied a differential reading, h , develops. It is desired to have this reading sufficiently large (so that it can be easily read) for small pressure differentials. Determine the relationship between h and $p_1 - p_2$ when the area ratio A_t/A_r is small, and show that the differential reading, h , can be magnified by making the difference in specific weights, $\gamma_2 - \gamma_1$, small. Assume that initially (with $p_1 = p_2$) the fluid levels in the two reservoirs are equal.

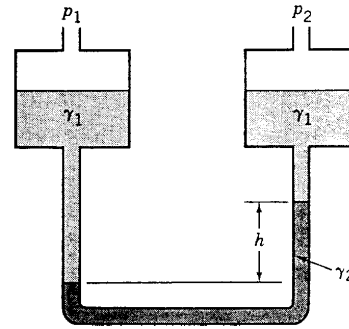
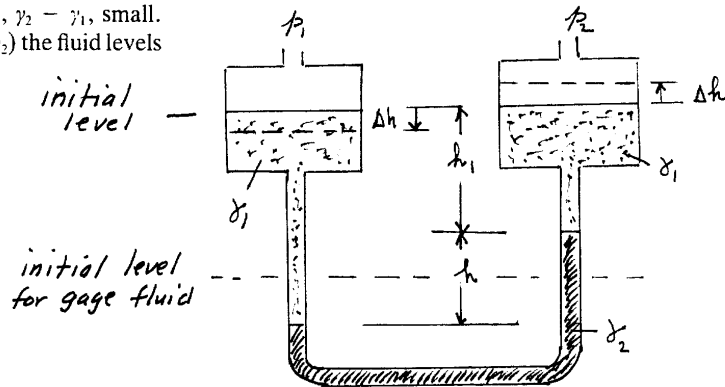

FIGURE P2.34



When a differential pressure, $p_1 - p_2$, is applied we assume that level in left reservoir drops by a distance, Δh , and right level rises by Δh . Thus, the manometer equation becomes

$$p_1 + \gamma_1 (h_1 + h - \Delta h) - \gamma_2 h - \gamma_1 (h_1 + \Delta h) = p_2$$

or

$$p_1 - p_2 = \gamma_2 h - \gamma_1 h + \gamma_1 (2 \Delta h) \quad (1)$$

Since the liquids in the manometer are incompressible,

$$\Delta h A_r = \frac{h}{2} A_t \quad \text{or} \quad \frac{2 \Delta h}{h} = \frac{A_t}{A_r}$$

and if $\frac{A_t}{A_r}$ is small then $2 \Delta h \ll h$ and last term in Eq.(1) can be neglected. Thus,

$$p_1 - p_2 = (\gamma_2 - \gamma_1) h$$

or

$$h = \frac{p_1 - p_2}{\gamma_2 - \gamma_1}$$

and large values of h can be obtained for small pressure differentials if $\gamma_2 - \gamma_1$ is small.

2.35

2.35 The cylindrical tank with hemispherical ends shown in Fig. P2.35 contains a volatile liquid and its vapor. The liquid density is 800 kg/m^3 , and its vapor density is negligible. The pressure in the vapor is 120 kPa (abs) , and the atmospheric pressure is 101 kPa (abs) . Determine: (a) the gage pressure reading on the pressure gage; and (b) the height, h , of the mercury manometer.

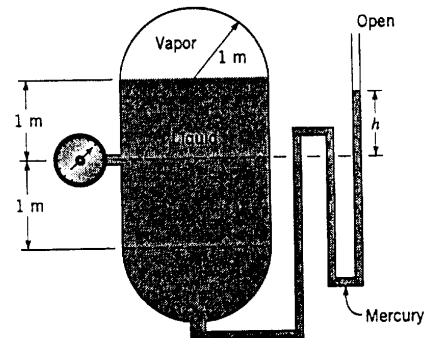

■ FIGURE P2.35

$$(a) \text{ Let } \gamma_l = \text{sp. wt. of liquid} = \left(800 \frac{\text{kg}}{\text{m}^3}\right) \left(9.81 \frac{\text{m}}{\text{s}^2}\right) = 7850 \frac{\text{N}}{\text{m}^3}$$

and

$$p_{\text{vapor (gage)}} = 120 \text{ kPa (abs)} - 101 \text{ kPa (abs)} = 19 \text{ kPa}$$

Thus,

$$\begin{aligned} p_{\text{gage}} &= p_{\text{vapor}} + \gamma_l (1 \text{ m}) \\ &= 19 \times 10^3 \frac{\text{N}}{\text{m}^2} + \left(7850 \frac{\text{N}}{\text{m}^3}\right) (1 \text{ m}) \\ &= \underline{\underline{26.9 \text{ kPa}}} \end{aligned}$$

$$(b) p_{\text{vapor (gage)}} + \gamma_l (1 \text{ m}) - \gamma_{\text{Hg}} (h) = 0$$

$$19 \times 10^3 \frac{\text{N}}{\text{m}^2} + \left(7850 \frac{\text{N}}{\text{m}^3}\right) (1 \text{ m}) - \left(133 \times 10^3 \frac{\text{N}}{\text{m}^3}\right) (h) = 0$$

$$h = \underline{\underline{0.202 \text{ m}}}$$

2-29

2.45

2.45 Determine the new differential reading along the inclined leg of the mercury manometer of Fig. P2.45, if the pressure in pipe A is decreased 10 kPa and the pressure in pipe B remains unchanged. The fluid in A has a specific gravity of 0.9 and the fluid in B is water.

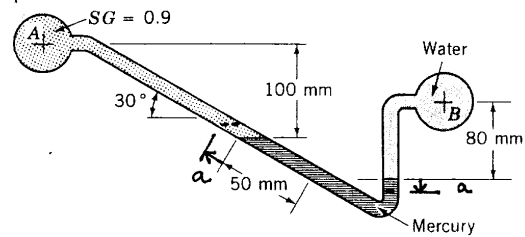

FIGURE P2.45

For the initial configuration :

$$p_A + \gamma_A (0.1) + \gamma_{Hg} (0.05 \sin 30^\circ) - \gamma_{H_2O} (0.08) = p_B \quad (1)$$

where all lengths are in m. When p_A decreases left column moves up a distance, a , and right column moves down a distance, a , as shown in figure. For the final configuration:

$$p'_A + \gamma_A (0.1 - a \sin 30^\circ) + \gamma_{Hg} (a \sin 30^\circ + 0.05 \sin 30^\circ + a) - \gamma_{H_2O} (0.08 + a) = p_B \quad (2)$$

where p'_A is the new pressure in pipe A.

Subtract Eq. (2) from Eq. (1) to obtain

$$p_A - p'_A + \gamma_A (a \sin 30^\circ) - \gamma_{Hg} a (\sin 30^\circ + 1) + \gamma_{H_2O} (a) = 0$$

Thus,

$$a = \frac{-(p_A - p'_A)}{\gamma_A \sin 30^\circ - \gamma_{Hg} (\sin 30^\circ + 1) + \gamma_{H_2O}}$$

For $p_A - p'_A = 10 \text{ kPa}$

$$a = \frac{-10 \frac{\text{kN}}{\text{m}^2}}{(0.9)(9.81 \frac{\text{kN}}{\text{m}^3})(0.5) - (133 \frac{\text{kN}}{\text{m}^3})(0.5 + 1) + 9.80 \frac{\text{kN}}{\text{m}^3}}$$

$$= 0.0540 \text{ m}$$

New differential reading, Δh , measured along inclined tube is equal to

$$\Delta h = \frac{a}{\sin 30^\circ} + 0.05 + a$$

$$= \frac{0.0540 \text{ m}}{0.5} + 0.05 \text{ m} + 0.0540 \text{ m} = \underline{\underline{0.212 \text{ m}}}$$

2-40

2.57

2.57 Two square gates close two openings in a conduit connected to an open tank of water as shown in Fig. P2.57. When the water depth, h , reaches 5 m it is desired that both gates open at the same time. Determine the weight of the homogeneous horizontal gate and the horizontal force, R , acting on the vertical gate that is required to keep the gates closed until this depth is reached. The weight of the vertical gate is negligible, and both gates are hinged at one end as shown. Friction in the hinges is negligible.

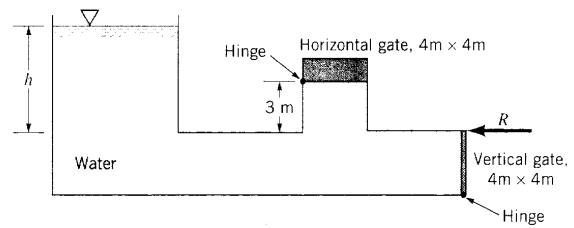

For horizontal gate,

$$\sum M_H = 0$$

so that

$$W = pA \quad \text{where } p \text{ is the water pressure on the bottom surface.}$$

Thus, $p = \gamma_{H_2O} (2m)$

so that

$$W = (9800 \frac{N}{m^3}) (2m) (4m \times 4m) = \underline{\underline{314 \text{ kN}}}$$

For vertical gate,

$$F_R = \gamma h_c A \quad \text{where } h_c = 7m$$

so that

$$F_R = (9800 \frac{N}{m^3}) (7m) (4m \times 4m) = 1100 \text{ kN}$$

To locate F_R

$$y_R = \frac{I_{xc}}{y_c A} + y_c = \frac{\frac{1}{12} (4m) (4m)^3}{(7m) (4m \times 4m)} + 7m = 7.191m$$

For equilibrium

$$\sum M_H = 0 \quad \text{so that}$$

$$R = \frac{(1100 \text{ kN})(9m - 7.191m)}{4m} = \underline{\underline{497 \text{ kN}}}$$

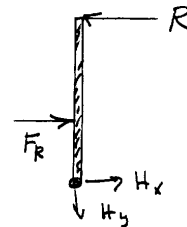
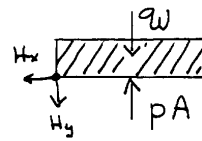

2.58

2.58 The rigid gate, OAB , of Fig. P2.58 is hinged at O and rests against a rigid support at B . What minimum horizontal force, P , is required to hold the gate closed if its width is 3 m? Neglect the weight of the gate and friction in the hinge. The back of the gate is exposed to the atmosphere.

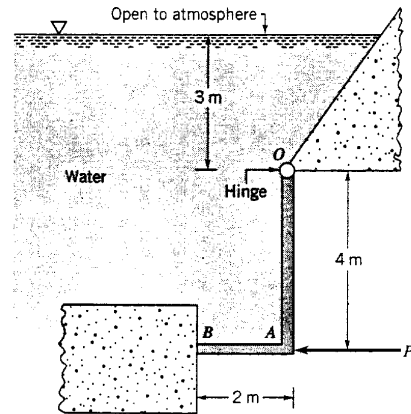
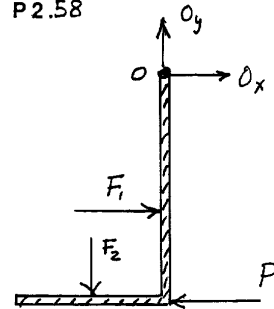

FIGURE P2.58



$$F_1 = \gamma h_{c_1} A_1 \quad \text{where } h_{c_1} = 5 \text{ m}$$

Thus,

$$F_1 = (9800 \frac{\text{N}}{\text{m}^3})(5 \text{ m})(4 \text{ m} \times 3 \text{ m})$$

$$= 5.88 \times 10^5 \text{ N}$$

$$F_2 = \gamma h_{c_2} A_2 \quad \text{where } h_{c_2} = 7 \text{ m}$$

so that

$$F_2 = (9800 \frac{\text{N}}{\text{m}^3})(7 \text{ m})(2 \text{ m} \times 3 \text{ m})$$

$$= 4.12 \times 10^5 \text{ N}$$

To locate F_1 ,

$$y_{R_1} = \frac{I_{xc}}{y_{c_1} A_1} + y_{c_1} = \frac{\frac{1}{12}(3 \text{ m})(4 \text{ m})^3}{(5 \text{ m})(4 \text{ m} \times 3 \text{ m})} + 5 \text{ m} = 5.267 \text{ m}$$

The force F_2 acts at the center of the AB section. Thus,

$$\sum M_O = 0$$

and

$$F_1 (5.267 \text{ m} - 3 \text{ m}) + F_2 (1 \text{ m}) = P (4 \text{ m})$$

so that

$$P = \frac{(5.88 \times 10^5 \text{ N})(2.267 \text{ m}) + (4.12 \times 10^5 \text{ N})(1 \text{ m})}{4 \text{ m}}$$

$$= \underline{\underline{436 \text{ kN}}}$$

2-53

2.62

2.62 A gate having the shape shown in Fig. P2.62 is located in the vertical side of an open tank containing water. The gate is mounted on a horizontal shaft. (a) When the water level is at the top of the gate, determine the magnitude of the fluid force on the rectangular portion of the gate above the shaft and the magnitude of the fluid force on the semicircular portion of the gate below the shaft. (b) For this same fluid depth determine the moment of the force acting on the semicircular portion of the gate with respect to an axis which coincides with the shaft.

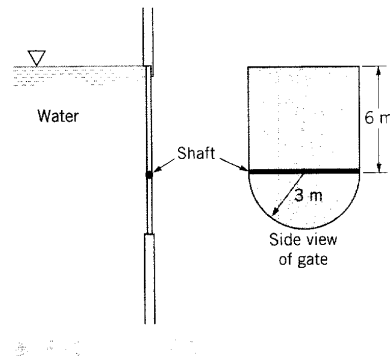

(a) For rectangular portion,

$$(F_R)_r = \gamma h_c A \quad \text{Where } h_c = 3 \text{ m}$$

So that

$$(F_R)_r = (9800 \frac{\text{N}}{\text{m}^3})(3 \text{ m})(6 \text{ m} \times 6 \text{ m}) = \underline{1060 \text{ kN}}$$

For semi-circular portion,

$$(F_R)_{sc} = \gamma h_c A \quad \text{Where } h_c = 6 \text{ m} + \frac{4R}{3\pi} \quad (\text{See Fig. 2.13})$$

$$= 6 \text{ m} + \frac{4(3 \text{ m})}{3\pi} = 7.27 \text{ m}$$

so that

$$(F_R)_{sc} = (9800 \frac{\text{N}}{\text{m}^3})(7.27 \text{ m})(\frac{\pi}{2}(3 \text{ m})^2) = \underline{1010 \text{ kN}}$$

(b) For semi-circular portion

$$y_R = \frac{I_{xc}}{y_c A} + y_c = \frac{0.1098 R^4}{(7.27 \text{ m})(\frac{\pi}{2}) R^2} + 7.27 \text{ m}$$

$$= \frac{0.1098 (3 \text{ m})^4}{(7.27 \text{ m})(\frac{\pi}{2})(3 \text{ m})^2} + 7.27 \text{ m} = 7.36 \text{ m}$$

Thus, moment with respect to shaft, M ,

$$M = (F_R)_{sc} \times (7.36 \text{ m} - 6.00 \text{ m})$$

$$= (1010 \times 10^3 \text{ N})(1.36 \text{ m})$$

$$= \underline{1.37 \times 10^6 \text{ N}\cdot\text{m}}$$

2-60

2.70

2.70 A 4-m-long curved gate is located in the side of a reservoir containing water as shown in Fig. P2.70. Determine the magnitude of the horizontal and vertical components of the force of the water on the gate. Will this force pass through point A? Explain.

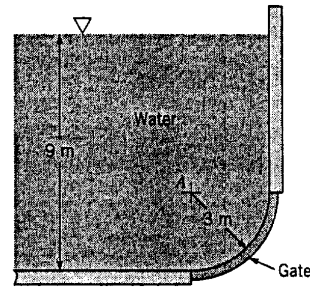

FIGURE P2.70

For equilibrium,
 $\Sigma F_x = 0$
 or $F_H = F_2 = \gamma h_{c2} A_2 = \gamma (6\text{ m} + 1.5\text{ m})(3\text{ m} \times 4\text{ m})$
 so that $F_H = (9.80 \frac{\text{kN}}{\text{m}^3})(7.5\text{ m})(12\text{ m}^2) = \underline{882\text{ kN}}$

Similarly,
 $\Sigma F_y = 0$

$$F_V = F_1 + q_W \quad \text{where:}$$

$$F_1 = [\gamma (6\text{ m})](3\text{ m} \times 4\text{ m}) = (9.80 \frac{\text{kN}}{\text{m}^3})(6\text{ m})(12\text{ m}^2)$$

$$q_W = \gamma V = (9.80 \frac{\text{kN}}{\text{m}^3})(9\pi\text{ m}^3)$$

$$\text{Thus, } F_V = (9.80 \frac{\text{kN}}{\text{m}^3}) [72\text{ m}^3 + 9\pi\text{ m}^3] = \underline{983\text{ kN}}$$

(Note: Force of water on gate will be opposite in direction to that shown on figure.)

The direction of all differential forces acting on the curved surface is perpendicular to surface, and therefore, the resultant must pass through the intersection of all these forces which is at point A. Yes.

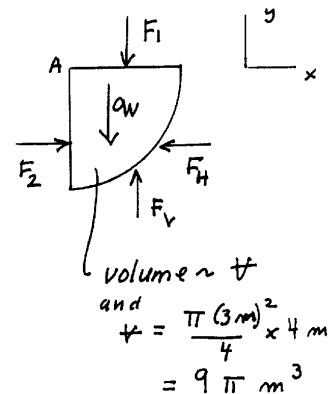

2.81

2.81 Three gates of negligible weight are used to hold back water in a channel of width b as shown in Fig. P2.81. The force of the gate against the block for gate (b) is R . Determine (in terms of R) the force against the blocks for the other two gates.

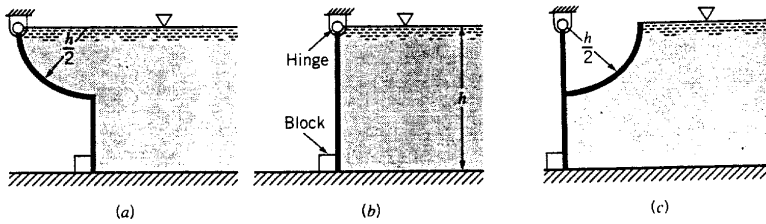

■ FIGURE P2.81

For case (b)

$$F_R = \gamma h_c A = \gamma \left(\frac{h}{2}\right) (h \times b) = \frac{\gamma h^2 b}{2}$$

$$\text{and } y_R = \frac{2}{3} h$$

Thus,

$$\text{so that } \sum M_H = 0$$

$$h R = \left(\frac{2}{3} h\right) F_R$$

$$h R = \left(\frac{2}{3} h\right) \left(\frac{\gamma h^2 b}{2}\right)$$

$$R = \frac{\gamma h^2 b}{3} \quad (1)$$

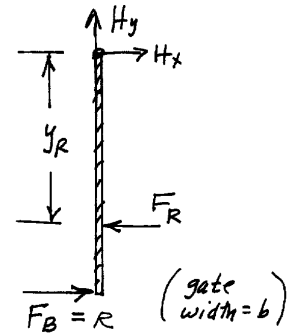

For case (a) on free-body diagram shown

$$F_R = \frac{\gamma h^2 b}{2} \quad (\text{from above}) \quad \text{and}$$

$$y_R = \frac{2}{3} h$$

and

$$\begin{aligned} W &= \gamma \times \text{Vol} \\ &= \gamma \left[\frac{\pi \left(\frac{h}{2}\right)^2}{4} (b) \right] \\ &= \frac{\pi \gamma h^2 b}{16} \end{aligned}$$

$$\text{Thus, } \sum M_H = 0$$

$$\text{so that } W \left(\frac{h}{2} - \frac{4h}{6\pi}\right) + F_R \left(\frac{2}{3} h\right) = F_B h$$

$$\text{and } \frac{\pi \gamma h^2 b}{16} \left(\frac{h}{2} - \frac{4h}{6\pi}\right) + \frac{\gamma h^2 b}{2} \left(\frac{2}{3} h\right) = F_B h$$

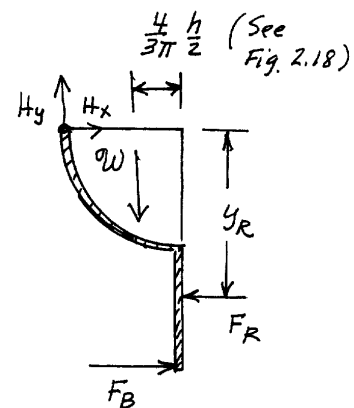

(Cont)

2.81 (cont)

It follows that

$$F_B = \gamma h^2 b (0.390)$$

From Eq. (1) $\gamma h^2 b = 3R$, thus

$$F_B = \underline{\underline{1.17R}}$$

For case (c), for the free-body diagram shown, the force F_{R_1} on the curved section passes through the hinge and therefore does not contribute to the moment around H. On bottom part of gate

$$F_{R_2} = \gamma h_c A = \gamma \left(\frac{3h}{4}\right) \left(\frac{h}{2} \times b\right) = \frac{3}{8} \gamma h^2 b$$

and

$$y_{R_2} = \frac{I_{xc}}{y_c A} + y_c = \frac{\frac{1}{12}(b)\left(\frac{h}{2}\right)^3}{\left(\frac{3h}{4}\right)\left(\frac{h}{2} \times b\right)} + \frac{3h}{4}$$

$$= \frac{28}{36} h$$

Thus, $\sum M_H = 0$

so that

$$F_{R_2} \left(\frac{28}{36} h\right) = F_B h$$

or

$$F_B = \left(\frac{3}{8} \gamma h^2 b\right) \left(\frac{28}{36}\right) = \frac{7}{24} \gamma h^2 b$$

From Eq. (1) $\gamma h^2 b = 3R$, thus

$$F_B = \frac{7}{8} R = \underline{\underline{0.875R}}$$

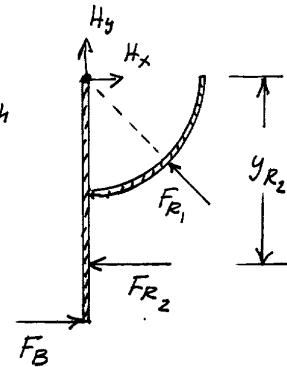

(IV) FLUIDS IN MOTION

Fluid motions manifest themselves in many different ways. Some can be described very easily, while others require a thorough understanding of physical laws. In engineering applications, it is important to describe the fluid motions as simply as can be justified. It is the engineer's responsibility to know which simplifying assumptions (e.g., one-dimensional, steady-state, inviscid, incompressible, etc) can be made.

A. Classification of Fluid Flows

1) Uniform flow; steady flow

If we look at a fluid flowing under normal circumstances - a river for example - the conditions (e.g. velocity, pressure) at one point will vary from those at another point, then we have non-uniform flow. If the conditions at one point vary as time passes, then we have unsteady flow.

Under some circumstances the flow will not be as changeable as this. The following terms describe the states which are used to classify fluid flow:

Uniform flow: If the flow velocity is the same magnitude and direction at every point in the flow it is said to be uniform. That is, the flow conditions DO NOT change with **position**.

Non-uniform: If at a given instant, the velocity is not the same at every point the flow is non-uniform.

Steady: A steady flow is one in which the conditions (velocity, pressure and cross-section) may differ from point to point but DO NOT change with **time**.

Unsteady: If at any point in the fluid, the conditions change with time, the flow is described as unsteady.

Combining the above we can classify any flow in to one of four types:

- **Steady uniform flow.** Conditions do not change with position in the stream or with time. An example is the flow of water in a pipe of constant diameter at constant velocity.
- **Steady non-uniform flow.** Conditions change from point to point in the stream but do not change with time. An example is flow in a tapering pipe with constant velocity at the inlet - velocity will change as you move along the length of the pipe toward the exit.
- **Unsteady uniform flow.** At a given instant in time the conditions at every point are the same, but will change with time. An example is a pipe of constant diameter connected to a pump pumping at a constant rate which is then switched off.
- **Unsteady non-uniform flow.** Every condition of the flow may change from point to point and with time at every point. An example is surface waves in an open channel.

You may imagine that one class is more complex than another – *steady uniform* flow is by far the most simple of the four.

2) One-, two-, and three-dimensional flows

A fluid flow is in general a three-dimensional, spatial and time dependent phenomenon:-

$$\mathbf{V} = \mathbf{V}(\vec{r}, t) = u(\vec{r}, t)\vec{i} + v(\vec{r}, t)\vec{j} + w(\vec{r}, t)\vec{k}$$

where $\vec{r} = (x, y, z)$ is the position vector, $(\vec{i}, \vec{j}, \vec{k})$ are the unit vectors in the Cartesian coordinates, and (u, v, w) are the velocity components in these directions. As defined above, the flow will be uniform if the velocity components are independent of spatial position (x, y, z) , and will be steady if the velocity components are independent of time t .

Accordingly, a fluid flow is called three-dimensional if all three velocity components are equally important. Intrinsically, a three-dimensional flow problem will have the most complex characters and is the most difficult to solve.

Fortunately, in many engineering applications, the flow can be considered as *two-dimensional*. In such a situation, one of the velocity components (say, w) is either identically zero or much smaller than the other two components, and the flow conditions vary essentially only in two directions (say, x and y). Hence, the velocity is reduced to $\vec{V} = u\vec{i} + v\vec{j}$ where (u, v) are functions of (x, y) (and possibly t). This reduction in the velocity component and spatial dimension will greatly simplify the analysis. Examples of two-dimensional flow typically involve flow past a long structure (with the axis of structure being perpendicular to the flow):

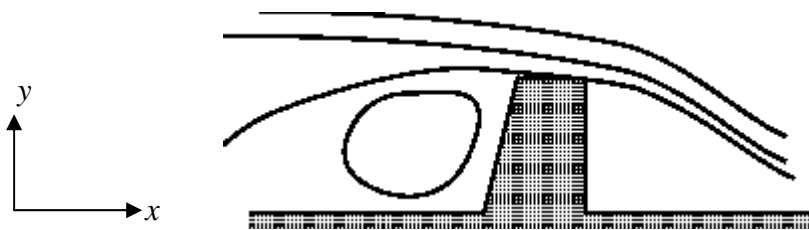
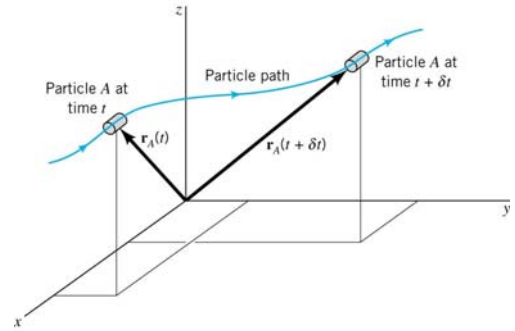

Two-dimensional flow over a long weir.



Flow past a car antenna is approximately two-dimensional, except near the top and bottom of the antenna.

It is sometimes possible to further simplify a flow analysis by assuming that two of the velocity components are negligible, leaving the velocity field to be approximated as a *one-dimensional* flow field. That is, $\vec{V} = u\vec{i}$ where the velocity u may vary across the section of flow. Typical examples are fully-developed flows in long uniform pipes and open-channels. One-dimensional flow problems will require only elementary analysis, and can be solved analytically in most cases.

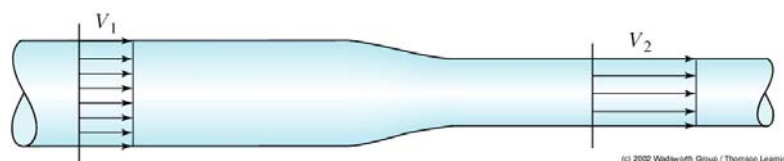

One-dimensional **ideal** flow along a pipe, where the velocity is uniform across the pipe section.

3) Viscous and inviscid flows

An **inviscid flow** is one in which viscous effects do not significantly influence the flow and are thus neglected. In a **viscous flow** the effects of viscosity are important and cannot be ignored.

To model an inviscid flow *analytically*, we can simply let the viscosity be zero; this will obviously make all viscous effects zero. It is more difficult to create an inviscid flow *experimentally*, because all fluids of interest (such as water and air) have viscosity. The question then becomes: are there flows of interest in which the viscous effects are negligibly small? The answer is "yes, if the shear stresses in the flow are small and act over such small areas that they do not significantly affect the flow field." The statement is very general, of course, and it will take considerable analysis to justify the inviscid flow assumption.

Based on experience, it has been found that the primary class of flows, which can be modeled as inviscid flows, is **external flows**, that is, flows of an unbounded fluid which exist exterior to a body. Inviscid flows are of primary importance in flows around *streamlined* bodies, such as flow around an airfoil (see the sketch below) or a hydrofoil. Any viscous effects that may exist are confined to a thin layer, called a **boundary layer**, which is attached to the boundary, such as that shown in the figure; the velocity in a boundary layer is always zero at a fixed wall, a result of viscosity. For many flow situations, boundary layers are so thin that they can simply be ignored when studying the gross features of a flow around a streamlined body. For example, the inviscid flow solution provides an excellent prediction to the flow around the airfoil, except possibly near the trailing edge where **flow separation** may occur. However the boundary layers must be accounted for when the skin friction force on the body is to be calculated.

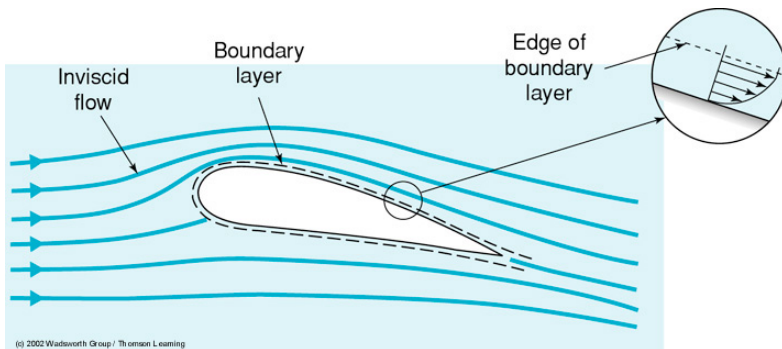

External flow around an airfoil.

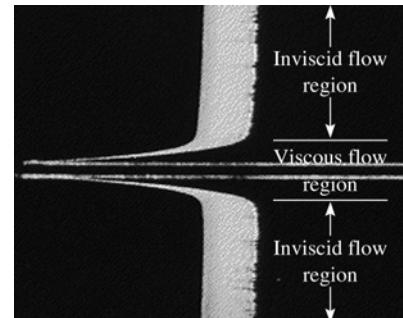

Viscous flow in a boundary layer.

Viscous flows include the broad class of **internal flows**, such as flows in pipes, hydraulic machines, and conduits and in open channels. In such flows viscous effects cause substantial "losses" and account for the huge amounts of energy that must be used to transport oil and gas in pipelines. The no-slip condition resulting in zero velocity at the wall, and the resulting shear stresses, lead directly to these losses.

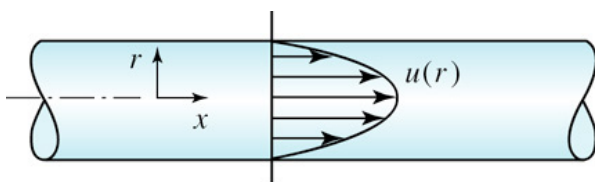

(c) 2002 Wadsworth Group / Thomson Learning (a)

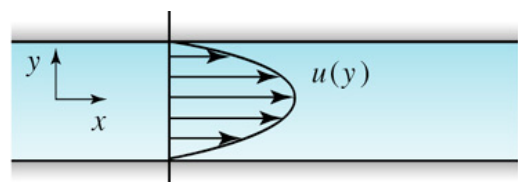

(b)

Viscous internal flow: (a) in a pipe; (b) between two parallel plates.

4) Incompressible and compressible flows

All fluids are compressible - even water - their density will change as pressure changes. Under steady conditions, and provided that the changes in pressure are small, it is usually possible to simplify analysis of the flow by assuming it is incompressible and has constant density. As you will appreciate, liquids are quite difficult to compress – so under most steady conditions they are treated as incompressible. In some unsteady conditions very high pressure differences can occur and it is necessary to take these into account - even for liquids. Gases, on the contrary, are very easily compressed, it is essential in cases of high-speed flow to treat these as compressible, taking changes in pressure into account.

More formally an **incompressible flow** is defined as one in which the density of each fluid particle remains relatively constant as it moves through the flow field. This however does not demand that the density is everywhere constant. If the density is spatially constant, then obviously the flow is incompressible, but that would be a more restrictive condition. Atmospheric flow, in which $\rho = \rho(z)$, where z is vertical, and flows that involve adjacent layers of fresh and salt water, as happens when rivers enter the ocean, are examples of incompressible flows in which the density varies.

Low-speed gas flows, such as the atmospheric flow referred to above, are also considered to be incompressible flows. The **Mach number** is defined as

$$M = \frac{V}{c}$$

where V is the gas speed and c is the speed of sound. The Mach number is useful in deciding whether a particular gas flow can be studied as an incompressible flow. If $M < 0.3$, density variations are at most 3% and the flow is assumed to be incompressible; for standard air this corresponds to a velocity below about 100 m/s. If $M > 0.3$, the density variations influence the flow and compressibility effects should be accounted for. Compressible flows include the aerodynamics of high-speed aircraft, airflow through jet engines, steam flow through the turbine in a power plant, airflow in a compressor, and the flow of the air-gas mixture in an internal combustion engine.

5) Laminar and turbulent flows

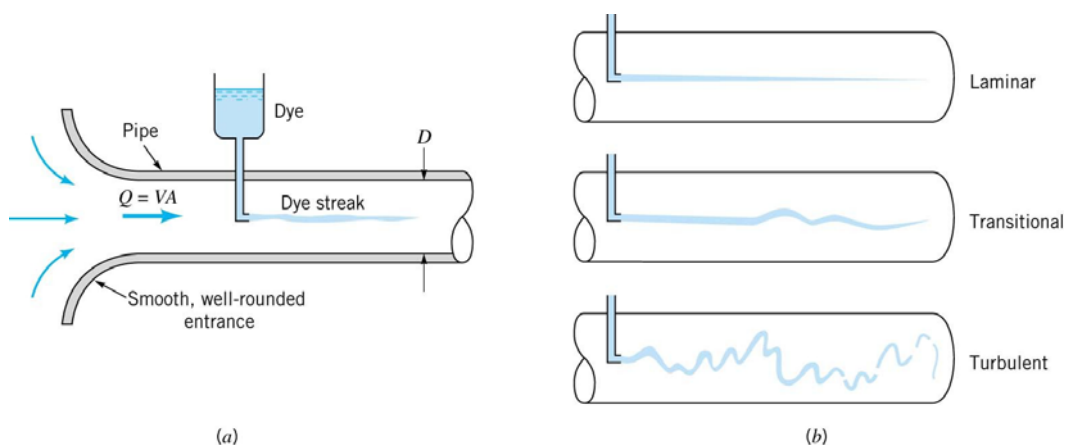

In the experiment shown above, a dye is injected into the middle of pipe flow of water. The dye streaks will vary, as shown in (b), depending on the flow rate in the pipe. The top situation is called **laminar flow**, and the lower is **turbulent flow**, occurring when the flow is sufficiently slow and fast, respectively. In laminar flow the motion of the fluid particles is very orderly with all particles moving in straight lines parallel to the pipe wall. There is essentially no mixing of neighboring fluid particles. In sharp contrast, mixing is very significant in turbulent flow, in which fluid particles

move haphazardly in all directions. It is therefore impossible to trace motion of individual particles in turbulent flow. The flow may be characterized by an unsteady fluctuating (i.e., random and 3-D) velocity components superimposed on a temporal steady mean (i.e., along the pipe) velocity.

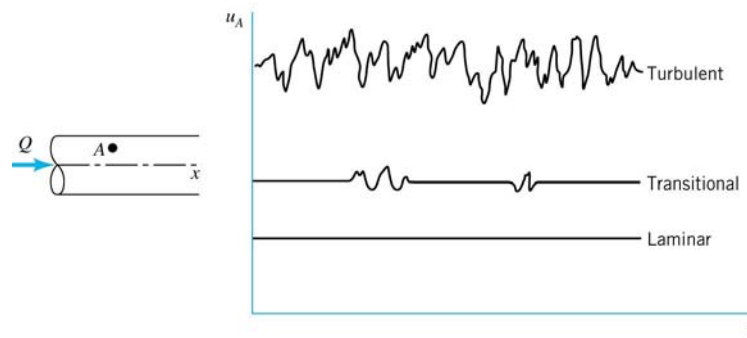

Time dependence of fluid velocity at a point.

Whether the flow is laminar or not depends on the Reynolds number,

$$Re \equiv \frac{\rho \bar{V} d}{\mu} \quad \rho = \text{density}, \quad \mu = \text{viscosity}, \quad \bar{V} = \text{section-mean velocity}, \quad d = \text{diameter of pipe}$$

and it has been demonstrated experimentally that

{	$< 2,000$	laminar flow
	between 2,000 and 4,000	transitional flow
	$> 4,000$	turbulent flow

B. Flow Visualization

There are four different types of flow lines that may help to describe a flow field.

1) Streamline

A **streamline** is a line that is everywhere tangent to the velocity vector at a given instant of time. A streamline is hence an instantaneous pattern.

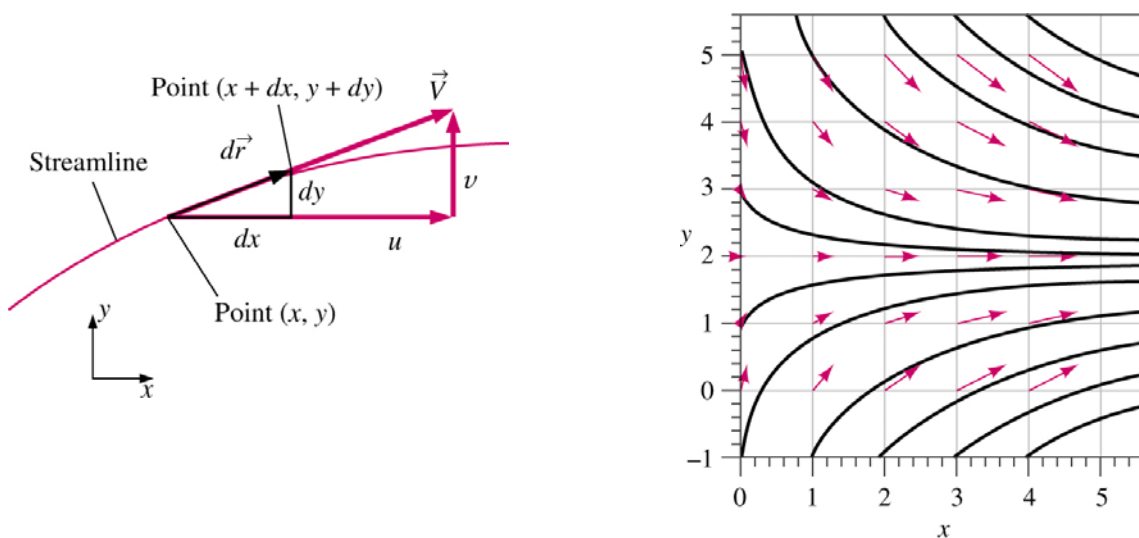

Equation for a streamline

$$\frac{|d\vec{r}|}{|\vec{V}|} = \frac{dx}{u} = \frac{dy}{v} = \frac{dz}{w}$$

Streamlines are very useful to help visualize the flow pattern. Another example of the streamlines around a cross-section of an airfoil has been shown earlier on page 41.

When fluid is flowing past a solid boundary, e.g., the surface of an aerofoil or the wall of a pipe, fluid obviously does not flow into or out of the surface. So very close to a boundary wall the flow direction must be parallel to the boundary. In fact, the boundary wall itself is also a streamline by definition.

It is also important to recognize that the position of streamlines can change with time - this is the case in unsteady flow. In steady flow, the streamlines do not change.

Some further remarks about streamlines

- Because the fluid is moving in the same direction as the streamlines, fluid cannot cross a streamline.
- Streamlines cannot cross each other. If they were to cross, this would indicate two different velocities at the same point. This is not physically possible.
- The above point implies that any particles of fluid starting on one streamline will stay on that same streamline throughout the fluid.
- The mathematical expression of a streamline can also be obtained from

$$\vec{V} \times d\vec{r} = 0$$

where \vec{V} is the fluid velocity vector and $d\vec{r}$ is a tangential vector along the streamline. The above cross product is zero since the two vectors are in the same direction.

- A useful technique in fluid flow analysis is to consider only a part of the total fluid in isolation from the rest. This can be done by imagining a tubular surface formed by streamlines along which the fluid flows. This tubular surface is known as a **streamtube**, which is a tube whose walls are streamlines. Since the velocity is tangent to a streamline, no fluid can cross the walls of a streamtube.

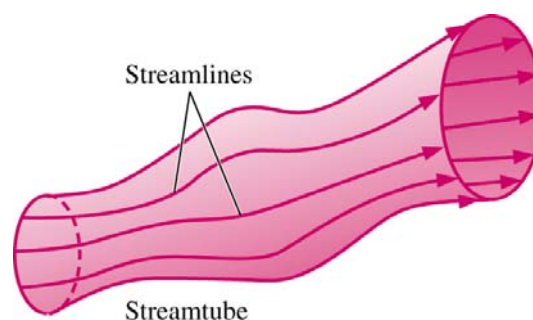

2) Streakline

A **streakline** is an instantaneous line whose points are occupied by particles which have earlier passed through a prescribed point in space. A streakline is hence an integrated pattern. A streakline can be formed by injecting dye continuously into the fluid at a fixed point in space. As time marches on, the streakline gets longer and longer, and represents an integrated history of the dye streak.

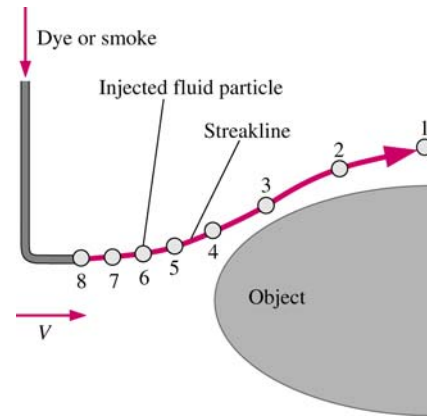

3) Pathline

A **pathline** is the actual path traversed by a given (marked) fluid particle. A pathline is hence also an integrated pattern. A pathline represents an integrated history of where a fluid particle has been.

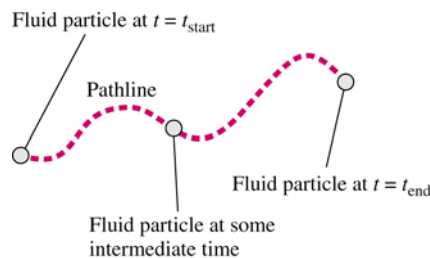

4) Timeline

A **timeline** is a set of fluid particles that form a line segment at a given instant of time. A timeline is also an integrated pattern. For example, consider simple shear flow between parallel plates. A timeline follows the location of a line of fluid particles, which can be a straight line initially. Timelines of later time are composed of the same particles, and will continually distort with time, as shown in the sketch. Notice the no-slip condition in action. The top and the bottom of the timelines stay in the same location at all times, because the boundaries are not moving.

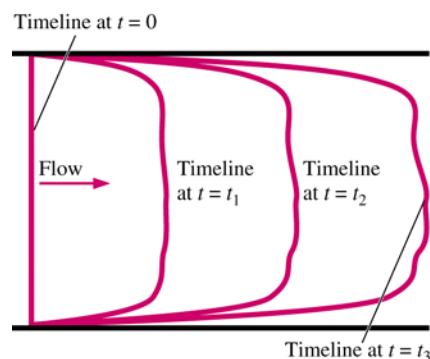

Note: For steady flow, streamlines, streaklines, and pathlines are all identical. However, for unsteady flow, these three flow patterns can be quite different. In a steady flow, all particles passing a given point will continue to trace out the same path since nothing changes with time; hence the pathlines and streaklines coincide. In addition, the velocity vector of a particle at a given point will be tangent to the line that the particle is moving along; thus the line is also a streamline.

C. Elementary Equations of Motion

In analyzing fluid motion, we might take one of two approaches: (1) seeking to describe the detailed flow pattern at every point (x,y,z) in the field, or (2) working with a finite region, making a balance of *flow in* versus *flow out*, and determining gross flow effects such as the force, or torque on a body, or the total energy exchange. The second approach is the "**control-volume**" method and is the subject of this section. The first approach is the "**differential**" approach and will be covered in a higher level fluid mechanics course.

We shall derive the three basic control-volume relations in fluid mechanics:

- the principle of conservation of mass, from which the continuity equation is developed;
- the principle of conservation of energy, from which the energy equation is derived;
- the principle of conservation of linear momentum, from which equations evaluating dynamic forces exerted by flowing fluids may be established.

1) Control volume

- A control volume is a finite region, chosen carefully by the analyst for a particular problem, with open boundaries through which mass, momentum, and energy are allowed to cross. The analyst makes a budget, or balance, between the incoming and outgoing fluid and the resultant changes within the control volume. Therefore one can calculate the gross properties (net force, total power output, total heat transfer, etc.) with this method.
- With this method, however, we do not care about the details inside the control volume (In other words we can treat the control volume as a "black box.")
- For the sake of the present analysis, let us consider a control volume that can be a tank, reservoir or a compartment inside a system, and consists of some definite *one-dimensional* inlets and outlets, like the one shown below:



Let us denote for each of the inlets and outlets:-

V = velocity of fluid in a stream

A = sectional area of a stream

p = pressure of the fluid in a stream

ρ = density of the fluid

Then, the **volume flow rate**, or **discharge** (volume of flow crossing a section per unit time) is given by

$$Q = VA$$

Similarly, the **mass flow rate** (mass of flow crossing a section per unit time) is given by

$$\dot{m} = \rho VA = \rho Q$$

Then, the **momentum flux**, defined as the momentum of flow crossing a section per unit time, is given by $\dot{m}V$.

- For simplicity, we shall from here on consider **steady** and **incompressible** flows only.

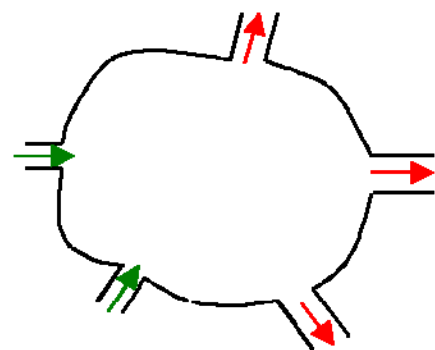

2) Continuity equation

By steadiness, the total mass of fluid contained in the control volume must be invariant with time. Therefore there must be an exact balance between the total rate of flow into the control volume and that out of the control volume:

$$\text{Total Mass Outflow} = \text{Total Mass Inflow}$$

which translates into the following mathematical relation

$$\sum_{i=1}^M (\rho_i V_i A_i)_{\text{in}} = \sum_{i=1}^N (\rho_i V_i A_i)_{\text{out}}$$

where M is the number of inlets, and N is the number of outlets. If the density of fluid is constant, conservation of mass also implies conservation of volume. Hence for a control volume with only one-dimensional inlets and outlets,

$$\sum_{i=1}^M (V_i A_i)_{\text{in}} = \sum_{i=1}^N (V_i A_i)_{\text{out}} \quad \text{or} \quad \sum_{i=1}^M (Q_i)_{\text{in}} = \sum_{i=1}^N (Q_i)_{\text{out}}$$

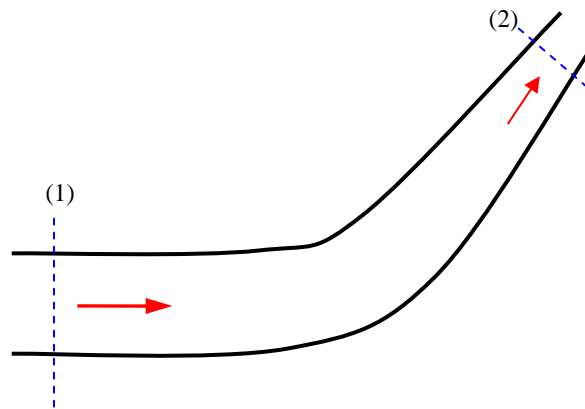

For example, in a pipe of varying cross sectional area, the continuity equation requires that, if the density is constant, between any two sections 1 and 2 along the pipe

$$Q = V_1 A_1 = V_2 A_2 = \text{constant}$$

Another example involving two inlets and one outlet is shown below.

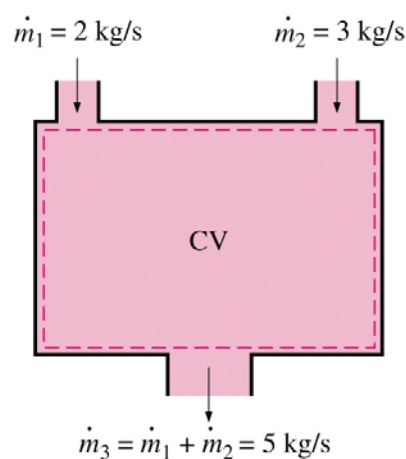

3) Bernoulli and energy equations

Let us first derive the *Bernoulli* equation, which is one of the most well-known equations of motion in fluid mechanics, and yet is often misused. It is thus important to understand its limitations, and the assumptions made in the derivation.

The assumptions can be summarized as follows:

- Inviscid flow (ideal fluid, frictionless)
- Steady flow (unsteady Bernoulli equation will not be discussed in this course)
- Along a streamline
- Constant density (incompressible flow)
- No shaft work or heat transfer

The Bernoulli equation is based on the application of Newton's law of motion to a fluid element on a streamline.

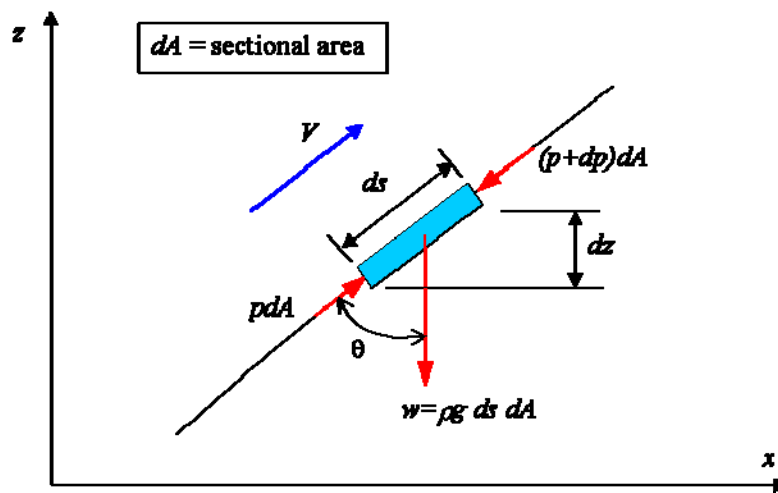

Let us consider the motion of a fluid element of length ds and cross-sectional area dA moving at a local speed V , and x is a horizontal axis and z is pointing vertically upward. The forces acting on the element are the pressure forces $p dA$ and $(p + dp) dA$, and the weight w as shown. Summing forces in the direction of motion, the s -direction, there results

$$p dA - (p + dp) dA - \rho g ds dA \cos \theta = \rho ds dA a_s$$

where a_s is the acceleration of the element in the s -direction. Since the flow is steady, only convective acceleration exists

$$a_s = V \frac{dV}{ds}$$

Also, it is easy to see that $\cos \theta = dz / ds$. On substituting and dividing the equation by $\rho g dA$, we can obtain **Euler's equation**:

$$\frac{dp}{\rho g} + dz + \frac{V}{g} dV = 0$$

Note that Euler's equation is valid also for compressible flow.

Now if we further assume that the flow is incompressible so that the density is constant, we may integrate Euler's equation to get

$$\frac{p}{\rho g} + z + \frac{V^2}{2g} = \text{constant}$$

This is the Bernoulli equation, consisting of three **energy heads**

$\frac{p}{\rho g}$	Pressure head, which is the work done to move fluid against pressure
z	Elevation head, representing the potential energy; z can be measured above any reference datum
$\frac{V^2}{2g}$	Velocity head, representing the kinetic energy

- A **head** corresponds to **energy per unit weight of flow** and has dimensions of **length**.
- **Piezometric head** = **pressure head** + **elevation head**, which is the level registered by a piezometer connected to that point in a pipeline.
- **Total head** = **piezometric head** + **velocity head**.

It follows that for ideal steady flow the total energy head is constant along a streamline, but the constant may differ in different streamlines. (For the particular case of irrotational flow, the Bernoulli constant is universal throughout the entire flow field.)

Applying the Bernoulli equation to any two points on the same streamline, we have

$$\frac{p_1}{\rho g} + z_1 + \frac{V_1^2}{2g} = \frac{p_2}{\rho g} + z_2 + \frac{V_2^2}{2g}$$

There is similarity in form between the Bernoulli equation and the energy equation that can be derived directly from the first law of thermodynamics. Without getting into the derivation, the energy equation for a control volume with only one inlet (section 1) and one outlet (section 2) can be written as

$$\frac{p_1}{\rho g} + z_1 + \frac{V_1^2}{2g} = \frac{p_2}{\rho g} + z_2 + \frac{V_2^2}{2g} + \dot{W}_s + h_L$$

where \dot{W}_s is the **shaft work**, or the rate of work transmitted by rotation shafts (such as that of a pump or turbine; positive if output to a turbine, negative if input by a pump) that are cut by the control surface, and h_L , called the **head loss**, is the sum of energy losses required to overcome viscous forces in the fluid (dissipated in the form of thermal energy) and the heat transfer rate. In the absence of these two terms, the energy equation is identical to the Bernoulli equation. We must remember however that the Bernoulli equation is a momentum equation applicable to a streamline and the energy equation above is applied between two sections of a flow. The energy equation is more general than the Bernoulli equation, because it allows for (1) friction, (2) heat transfer, (3) shaft work, and (4) viscous work (another frictional effect).

4) Momentum equation

On applying Newton's second law of motion to the control volume shown on page 46, we get

$$\begin{aligned}\sum \vec{F} &= \sum_{i=1}^M (\rho_i V_i A_i \vec{V}_i)_{\text{out}} - \sum_{i=1}^N (\rho_i V_i A_i \vec{V}_i)_{\text{in}} \\ &= \sum_{i=1}^M (\dot{m}_i \vec{V}_i)_{\text{out}} - \sum_{i=1}^N (\dot{m}_i \vec{V}_i)_{\text{in}}\end{aligned}$$

Note that this equation

- follows from the principle of conservation of linear momentum: resultant force on the control volume is balanced by the net rate of momentum flux (i.e., $\dot{m}\vec{V}$) out through the control surface.
- is a vector equation. **Components** of the forces and the velocities need to be considered.
- can be used to calculate the magnitude and direction of the impact force exerted on the control volume by its solid boundary.

Further consider a steady-flow situation in which there is only one entrance (section 1) and one exit (section 2) across which uniform profiles can be assumed (see the figure on page 47). By continuity

$$\dot{m}_1 = \dot{m}_2 = \rho Q = \text{mass flow rate}$$

The momentum equation now reduces to $\sum \vec{F} = \rho Q (\vec{V}_2 - \vec{V}_1)$

or in terms of their components in (x, y, z) coordinates

$$\begin{aligned}\sum F_x &= \rho Q [(V_x)_2 - (V_x)_1] \\ \sum F_y &= \rho Q [(V_y)_2 - (V_y)_1] \\ \sum F_z &= \rho Q [(V_z)_2 - (V_z)_1]\end{aligned}$$

where $(V_x)_1$ is the x -component of the velocity at section 1, and so on.

On applying the momentum equation, one needs to pay attention to the following two aspects.

Forces

$\sum \vec{F}$ represents **all forces acting on the control volume**, including

- Surface forces resulting from the surrounding acting on the control volume:
 - Impact force, which is usually the unknown to be found, on the control surface in contact with a solid boundary
 - Pressure force on the control surface which cuts a flow inlet or exit. Remember that the pressure force is always a compressive force.
- Body force that results from gravity.

Sign of the vector variables

When plugging into the equations, one should be careful about the sign of the force and velocity components. These quantities should carry a positive (negative) sign when they are in the same (opposite) sense as that of the corresponding coordinate.

D. Applications of the Bernoulli and Momentum Equations

1) Pitot tube

If a stream of uniform velocity flows into a blunt body, the streamlines take a pattern similar to this:

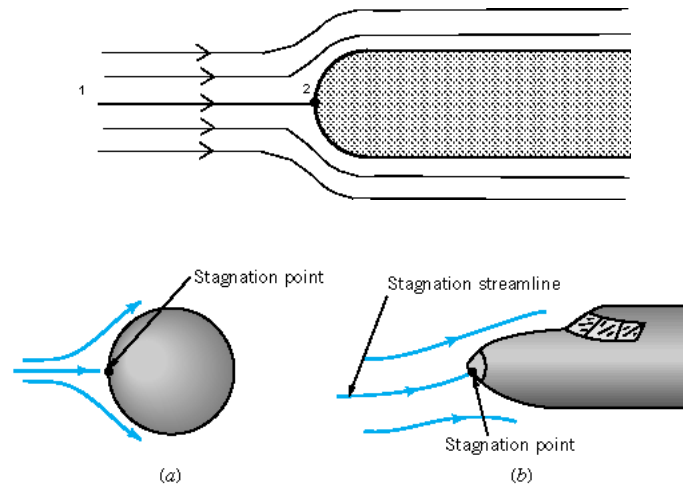

Streamlines around blunt bodies

Note how some move to the left and some to the right. But one, in the centre, goes to the tip of the blunt body and stops. It stops because at this point the velocity is zero - the fluid does not move at this one point. This point is known as the **stagnation point**.

From the Bernoulli equation we can calculate the pressure at this point. Apply Bernoulli equation along the central streamline from a point upstream where the velocity is V_1 and the pressure p_1 to the stagnation point of the blunt body where the velocity is zero, $V_2 = 0$. Also $z_1 = z_2$.

$$\frac{p_1}{\rho g} + \cancel{z_1} + \frac{V_1^2}{2g} = \frac{p_2}{\rho g} + \cancel{z_2} + \frac{V_2^2}{2g} \Rightarrow p_2 = p_1 + \frac{1}{2} \rho V_1^2$$

This increase in pressure, which brings the fluid to rest, is called the *dynamic pressure*.

$$\begin{aligned} \text{Dynamic pressure} &= \rho V_1^2 / 2 \\ \text{or converting this to head (using } h &= p / \rho g) \\ \text{Dynamic head} &= V_1^2 / 2g \end{aligned}$$

The total pressure is known as the *stagnation pressure (or total pressure)*

$$\begin{aligned} \text{Stagnation pressure} &= p_1 + \rho V_1^2 / 2 \\ \text{or in terms of head,} \\ \text{Stagnation head} &= p_1 / \rho g + V_1^2 / 2g \end{aligned}$$

The blunt body stopping the fluid does not have to be a solid. It could be a static column of fluid. Two piezometers, one as normal and one as a Pitot tube within the pipe can be used in an arrangement shown below to measure velocity of flow.

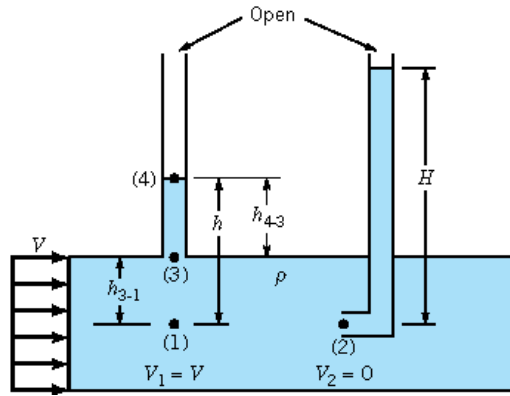

A Piezometer and a Pitot tube.

Using the above theory, we have the equation for p_2 ,

$$p_2 = p_1 + \frac{1}{2} \rho V_1^2 \Rightarrow \rho g H = \rho g h + \frac{1}{2} \rho V^2 \Rightarrow V = \sqrt{2g(H-h)}$$

which is an expression for velocity obtained from two pressure measurements and the application of the Bernoulli equation. This equation is for ideal flow only. To account for real fluid effects, the equation can be modified into $V = C_v \sqrt{2g(H-h)}$, where C_v is the coefficient of velocity to be determined empirically.



A Pitot tube used to measure velocity of flow in a channel.



A Pitot tube underneath the wing of an aircraft.

2) Pitot static tube

The necessity of one piezometer and one Pitot tube and thus two readings make this arrangement a little awkward. Connecting the two tubes to a manometer would simplify things but there are still two tubes. The **Pitot static tube** combines the tubes, and they can then be easily connected to a differential manometer. A Pitot static tube is shown here. The holes on the side of the tube connect to one side of a manometer and register the *static head*, (h_1), while the central hole is connected to the other side of the manometer to register, as before, the *stagnation head* (h_2). The difference of the two heads, being the *dynamic head*, is now measured directly by the differential manometer.

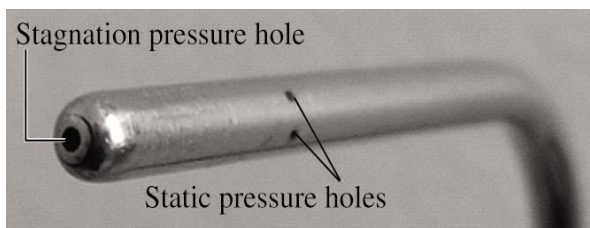
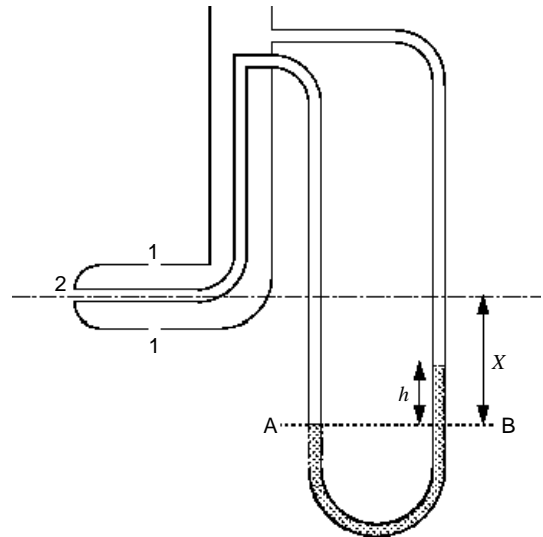

Close-up of a Pitot static tube.

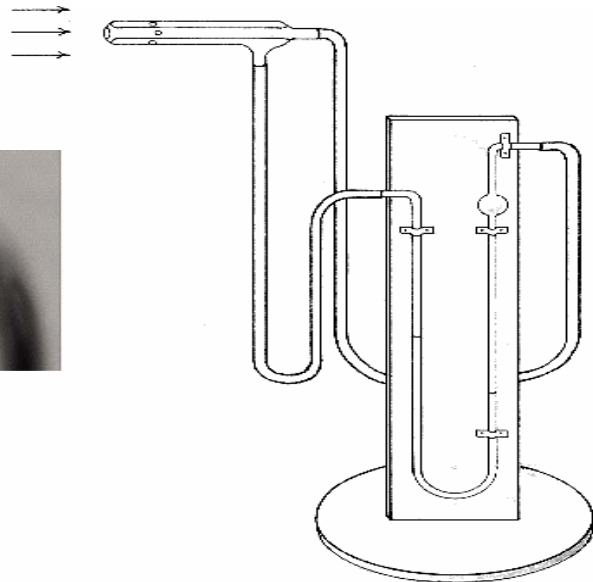

Consider the pressures on the level of the centre line of the Pitot static tube and using the theory of the manometer,

$$p_A = p_2 + \rho gX$$

$$p_B = p_1 + \rho g(X - h) + \rho_{man} gh$$

But $p_A = p_B$

or $p_2 = p_1 + (\rho_{man} - \rho) gh$

We also know that $p_2 = p_1 + \rho V^2 / 2$. Hence

$$V_{ideal} = \sqrt{\frac{2gh(\rho_{man} - \rho)}{\rho}} \quad \text{and} \quad V_{actual} = C_v V_{ideal}$$

The Pitot/Pitot-static tubes give velocities at points in the flow. It does not give the overall discharge of the stream, which is often what is wanted. It also has the drawback that it is liable to block easily, particularly if there is significant debris in the flow.

3) Orifice and vena contracta

We are to consider the flow from a tank through a hole in the side close to the base. The general arrangement and a close-up of the hole and streamlines are shown in the figure below

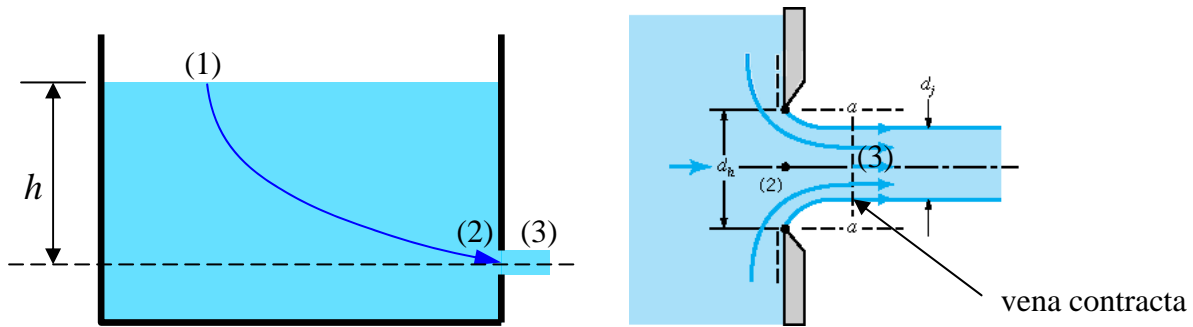

Tank and streamlines of flow out of a sharp-edged orifice

The shape of the holes edges are as they are (sharp) to minimize frictional losses by minimizing the contact between the hole and the liquid - the only contact is the very edge.

Looking at the streamlines you can see how they contract after the orifice to a minimum cross section where they all become parallel, at this point, the velocity and pressure are uniform across the jet. This convergence is called the **vena contracta** (from the Latin 'contracted vein'). It is necessary to know the amount of contraction to allow us to calculate the flow.

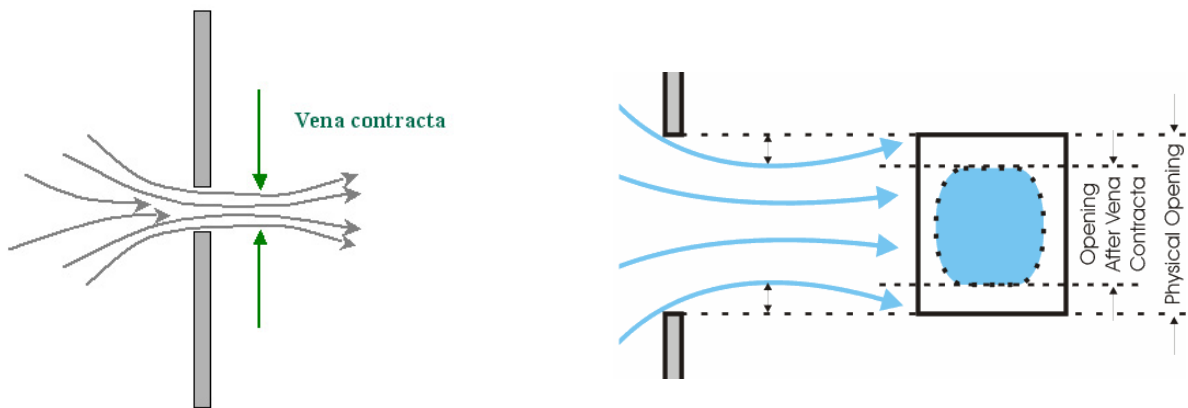

We can predict the velocity at the orifice using the Bernoulli equation. Apply it along the streamline joining point 1 on the surface to point 3 at the centre of the vena contracta.

At the surface velocity is negligible ($V_1 = 0$) and the pressure atmospheric ($p_1 = 0$). Outside the orifice the jet is open to the air so again the pressure is atmospheric ($p_3 = 0$). If we take the datum line through the orifice then $z_1 = h$ and $z_3 = 0$, leaving

$$h = \frac{V_3^2}{2g} \quad \Rightarrow \quad V_3 = V_{\text{ideal}} = \sqrt{2gh}$$

This is the theoretical value of velocity. Unfortunately it will be an over-estimate of the real velocity because friction losses have not been taken into account. To incorporate friction we use the coefficient of velocity to correct the theoretical velocity,

$$V_{\text{actual}} = C_v V_{\text{ideal}}$$

Each orifice has its own coefficient of velocity C_v , which usually lies in the range (0.97 - 0.99).

To calculate the discharge through the orifice we multiply the area of the jet by the velocity. The actual area of the jet is the area of the **vena contracta** not the area of the orifice. We obtain this area by using a coefficient of contraction C_c for the orifice:

$$A_{\text{actual}} = C_c A_{\text{orifice}}$$

So the discharge through the orifice is given by

$$Q = AV$$

$$\Rightarrow Q_{\text{actual}} = A_{\text{actual}} V_{\text{actual}} = C_c C_v A_{\text{orifice}} V_{\text{ideal}} = C_d A_{\text{orifice}} \sqrt{2gh}$$

where C_d is the coefficient of discharge, and $C_d = C_c C_v$.

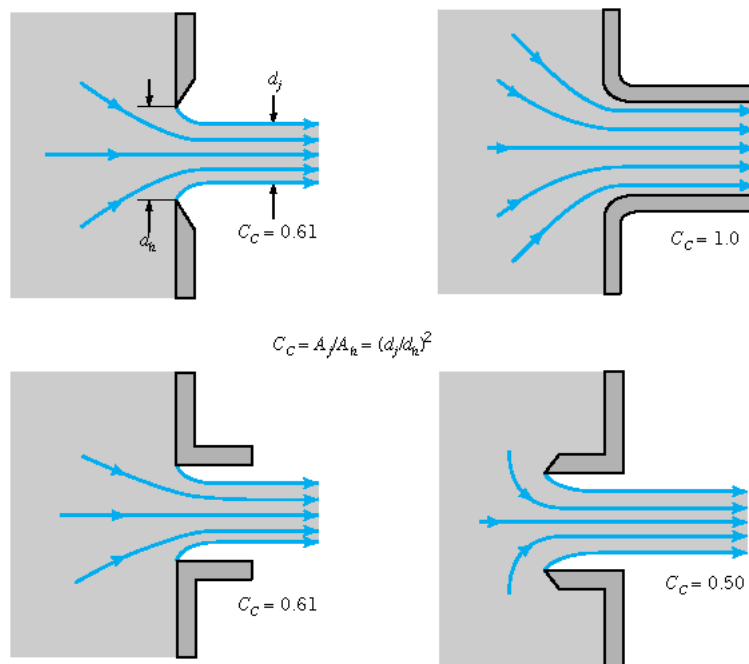

Typical flow patterns and contraction coefficients for various round exit configurations

4) Venturi, nozzle and orifice meters

The Venturi-, nozzle- and orifice-meters are three similar types of devices for measuring discharge in a pipe. The Venturi meter consists of a rapidly converging section, which increases the velocity of flow and hence reduces the pressure. It then returns to the original dimensions of the pipe by a gently diverging 'diffuser' section. By measuring the pressure differences the discharge can be calculated. This is a particularly accurate method of flow measurement as energy losses are very small.

The nozzle meter or flow nozzle is essentially a Venturi meter with the convergent part replaced by a nozzle installed inside the pipe and the divergent part omitted. The orifice meter is a still simpler and cheaper arrangement by which a sharp-edged orifice is fitted concentrically in the pipe.

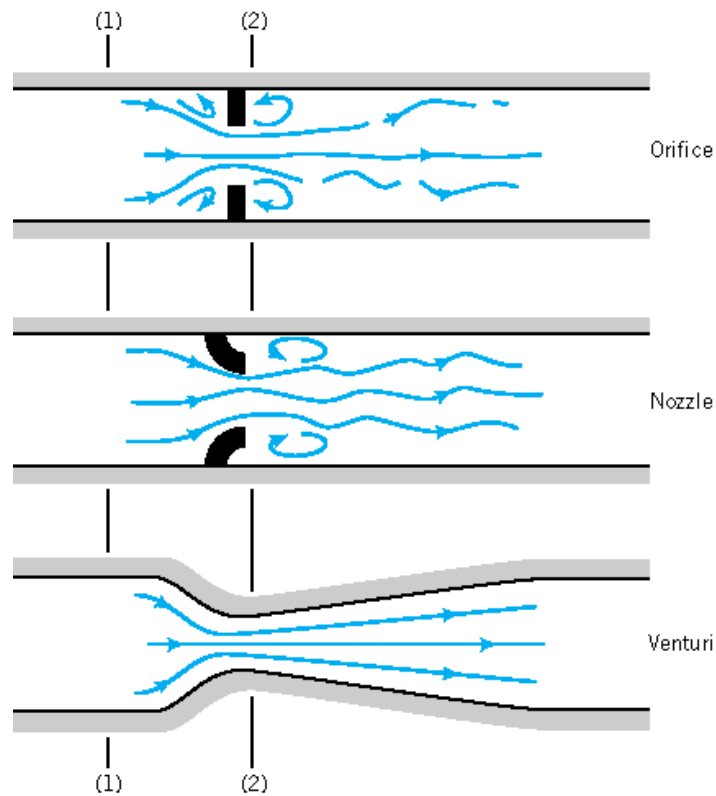

Schematic arrangements for three types of devices measuring flow-rate in a pipe

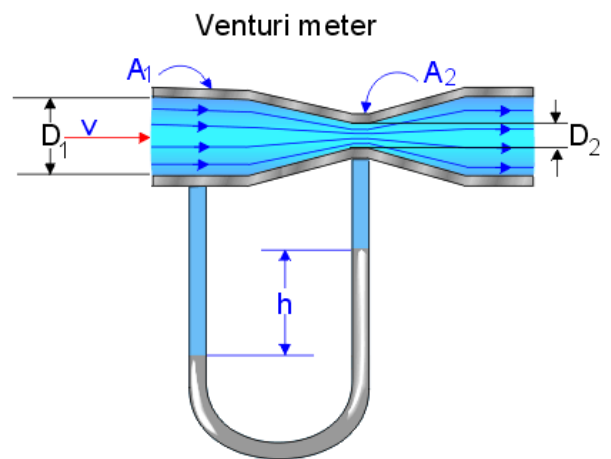
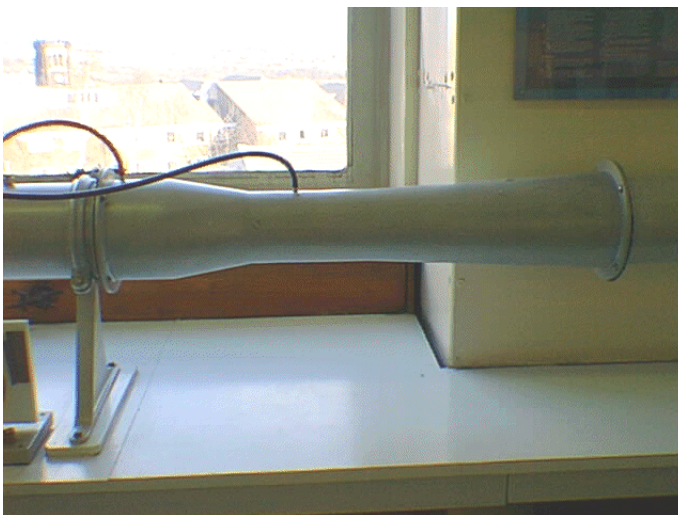

A Venturi meter in laboratory.

The working formulae are similar for the three devices. Let us for illustration show the one for the Venturi meter. Applying the Bernoulli equation along the streamline from point 1 to point 2 in the narrow *throat* of the Venturi meter, we have

$$\frac{p_1}{\rho g} + z_1 + \frac{V_1^2}{2g} = \frac{p_2}{\rho g} + z_2 + \frac{V_2^2}{2g}$$

By using the continuity equation we can eliminate the velocity V_2 , $Q = A_1V_1 = A_2V_2$ or $V_2 = A_1V_1 / A_2$.

Substituting this into and rearranging the Bernoulli equation we get

$$V_1 = \sqrt{\frac{2g \left[\frac{p_1 - p_2}{\rho g} + z_1 - z_2 \right]}{(A_1 / A_2)^2 - 1}}$$

To get the theoretical discharge this is multiplied by the area. To get the actual discharge taking in to account the losses due to friction, we include a coefficient of discharge

$$Q_{\text{ideal}} = A_1V_1; \quad Q_{\text{actual}} = C_d Q_{\text{ideal}} = C_d A_1V_1 = C_d A_1 \sqrt{\frac{2g \left[\frac{p_1 - p_2}{\rho g} + z_1 - z_2 \right]}{(A_1 / A_2)^2 - 1}}$$

Suppose a differential manometer is connected between (1) and (2). Then the terms inside the square brackets can be related to the manometer reading h as given by

$$p_1 + \rho g z_1 = p_2 + \rho_{\text{man}} g h + \rho g (z_2 - h) \Rightarrow \frac{p_1 - p_2}{\rho g} + z_1 - z_2 = h \left(\frac{\rho_{\text{man}}}{\rho} - 1 \right)$$

Thus the discharge can be expressed in terms of the manometer reading:

$$Q_{\text{actual}} = C_d A_1 \sqrt{\frac{2gh \left[\frac{\rho_{\text{man}}}{\rho} - 1 \right]}{(A_1 / A_2)^2 - 1}}$$

Notice how this expression does not include any terms for the elevation or orientation (z_1 or z_2) of the Venturi meter. This means that the meter can be at any convenient angle to function.

The purpose of the diffuser in a Venturi meter is to assure gradual and steady deceleration after the throat. This is designed to ensure that the pressure rises again to something near to the original value before the Venturi meter. The angle of the diffuser is usually between 6 and 8 degrees. Wider than this and the flow might separate from the walls resulting in increased friction and energy and pressure loss. If the angle is less than this the meter becomes very long and pressure losses again become significant. The efficiency of the diffuser of increasing pressure back to the original is rarely greater than 80%.

It should be noted that in deriving a formula for a discharge measuring device (Venturi, nozzle, orifice meters, etc), assumptions are taken to simplify the situations so that the Bernoulli equation can be applied. For example, there is no energy loss and the flow is steady. In this way, exact analytical solutions can be obtained, but as the assumptions are not exactly true, these solutions fail to account for the real situations. Empirical coefficients such as C_v , C_d are therefore introduced to allow for these errors. The final formula will be an analytical solution modified by an empirical coefficient. On the other hand, the value of the empirical coefficient can also reflect the justification of using the ideal approach. C_d for orifice meter is far below unity (0.6-0.65), while C_d for nozzles and venturi meters are close to one (approximately 0.98). It shows that energy loss is rather substantial in an orifice meter, as is expected from its abrupt configuration.

5) Force on a pipe nozzle

Let us from here on consider several applications of the momentum equations. A simple application is to find the force on the nozzle at the outlet of a pipe. Because the fluid is contracted at the nozzle forces are induced in the nozzle. Anything holding the nozzle (e.g. a fireman) must be strong enough to withstand these forces.

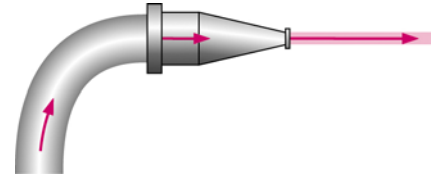

Steps in analysis:

1. Draw a control volume
2. Decide on a coordinate-axis system
3. Calculate the total force, given by the rate of change of momentum across the control volume
4. Calculate the pressure force F_p
5. Calculate the body force F_B
6. Calculate the resultant reaction force F_R

1 & 2. Control volume and co-ordinate axis are shown in the figure below.

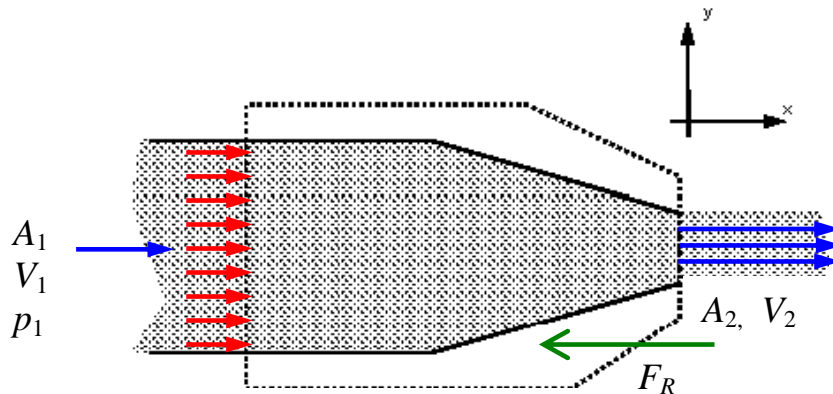

Notice how this is a one-dimensional system which greatly simplifies matters.

3. Calculate the total force

$$\sum F = \rho Q(V_2 - V_1)$$

By continuity, $Q = A_1V_1 = A_2V_2$, so

$$\sum F = \rho Q^2 \left(\frac{1}{A_2} - \frac{1}{A_1} \right)$$

4. Calculate the pressure force (red arrows)

$$F_p = \text{pressure force at 1} - \text{pressure force at 2} = p_1A_1 - p_2A_2$$

We use the Bernoulli equation to calculate the pressure

$$\frac{p_1}{\rho g} + z_1 + \frac{V_1^2}{2g} = \frac{p_2}{\rho g} + z_2 + \frac{V_2^2}{2g}$$

Since the nozzle is horizontal, $z_1 = z_2$, and the pressure outside is atmospheric, $p_2 = 0$, and with continuity the Bernoulli equation gives

$$p_1 = \frac{\rho Q^2}{2} \left(\frac{1}{A_2^2} - \frac{1}{A_1^2} \right)$$

$$\Rightarrow F_p = \frac{\rho Q^2 A_1}{2} \left(\frac{1}{A_2^2} - \frac{1}{A_1^2} \right)$$

5. Calculate the **body** force

The only body force is the weight due to gravity in the y -direction - but we need not consider this as the only forces we are considering are in the x -direction.

6. Calculate the **reaction** force that the nozzle acts on the fluid (green arrow)

Since the indicated direction of the reaction force is opposite to x -axis, a negative sign is included

$$\sum F = -F_R + F_p + \cancel{F_B} = \rho Q^2 \left(\frac{1}{A_2} - \frac{1}{A_1} \right)$$

$$\Rightarrow F_R = \frac{\rho Q^2 A_1}{2} \left(\frac{1}{A_2^2} - \frac{1}{A_1^2} \right) - \rho Q^2 \left(\frac{1}{A_2} - \frac{1}{A_1} \right) = \frac{\rho Q^2}{2A_1} \left(\frac{A_1}{A_2} - 1 \right)^2$$

So the fireman must be able to resist the force of F_R .

6) Force due to a two-dimensional jet hitting an inclined plane

Consider a two-dimensional (i.e., very wide in the spanwise direction) jet hitting a flat plate at an angle θ . For simplicity gravity and friction are neglected from this analysis.

We want to find the reaction force normal to the plate so we choose the axis system such that it is normal to the plate.

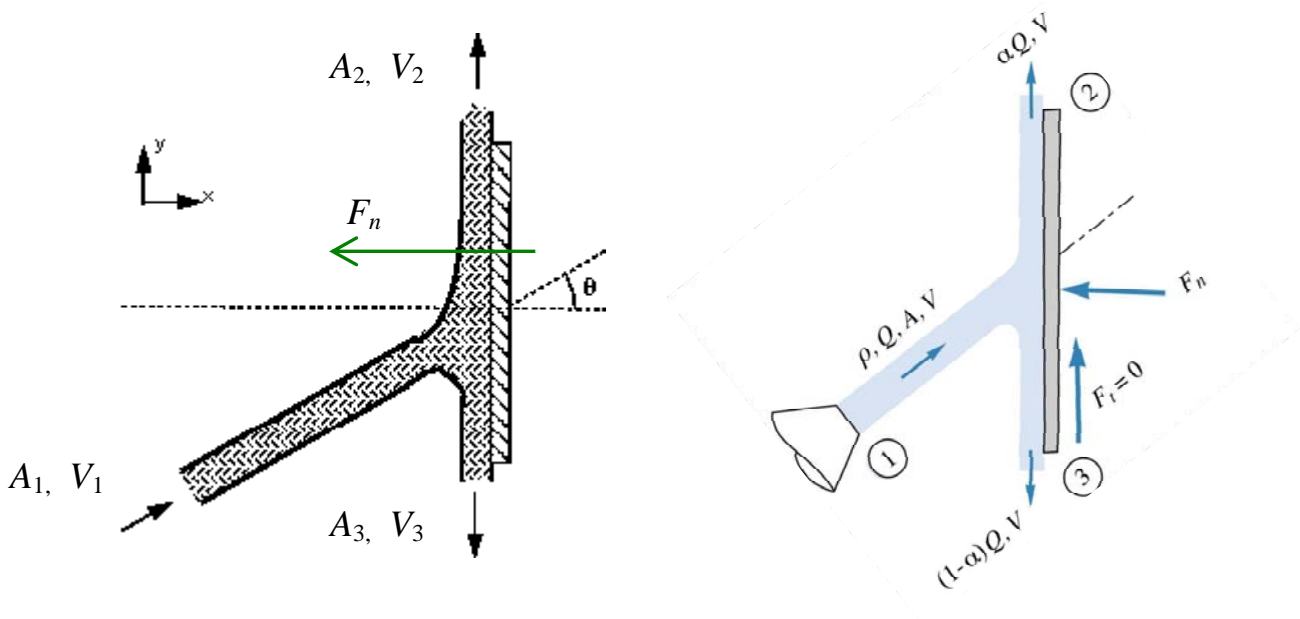

A two-dimensional jet hitting an inclined plate.

We do not know the velocities of flow in each direction. To find these we can apply the Bernoulli equation

$$\frac{p_1}{\rho g} + z_1 + \frac{V_1^2}{2g} = \frac{p_2}{\rho g} + z_2 + \frac{V_2^2}{2g} = \frac{p_3}{\rho g} + z_3 + \frac{V_3^2}{2g}$$

The height differences are negligible i.e., $z_1 = z_2 = z_3$, and the pressures are all atmospheric = 0. So

$$V_1 = V_2 = V_3 = V$$

By continuity

$$\begin{aligned} Q_1 = Q_2 + Q_3 &\Rightarrow V_1 A_1 = V_2 A_2 + V_3 A_3 \\ &\Rightarrow A_1 = A_2 + A_3 \end{aligned}$$

Using this we can calculate the forces in the same way as before.

1. Calculate the total force in the x-direction.

Remember that the co-ordinate system is normal to the plate.

$$\sum F_x = \rho [(Q_2 V_{2x} + Q_3 V_{3x}) - Q_1 V_{1x}]$$

but $V_{2x} = V_{3x} = 0$ as the jets are parallel to the plate with no component in the x-direction, and $V_{1x} = V \cos \theta$, so

$$\sum F_x = -\rho Q_1 V \cos \theta$$

2. Calculate the pressure force

All zero as the pressure is everywhere atmospheric.

3. Calculate the body force

As the control volume is small, hence the weight of fluid is small, we can ignore the body forces.

4. Calculate the resultant reaction force

$$\sum F_x = -F_n + \cancel{F_p} + \cancel{F_B} = -\rho Q_1 V \cos \theta \quad \Rightarrow \quad F_n = \rho Q_1 V \cos \theta$$

which is the force exerted **on the fluid by the plate**.

We can further find out how much discharge goes along in each direction on the plate. Along the plate, in the y-direction, the total force must be zero, $\sum F_y = 0$, since friction is ignored.

Also in the y-direction: $V_{1y} = V \sin \theta$, $V_{2y} = V$, $V_{3y} = -V$, so

$$\sum F_y = \rho [(Q_2 V_{2y} + Q_3 V_{3y}) - Q_1 V_{1y}] = \rho V [Q_2 - Q_3 - Q_1 \sin \theta] = \rho V^2 [A_2 - A_3 - A_1 \sin \theta]$$

Setting this to zero, we get

$$0 = A_2 - A_3 - A_1 \sin \theta$$

and as found earlier we have $A_1 = A_2 + A_3$, so on solving

$$A_2 = A_3 \left(\frac{1 + \sin \theta}{1 - \sin \theta} \right)$$

by which we readily obtain that $\frac{Q_2}{Q_1} = \alpha = \frac{1}{2}(1 + \sin \theta)$, $\frac{Q_3}{Q_1} = 1 - \alpha = \frac{1}{2}(1 - \sin \theta)$

So we know how the discharge is divided between the two jets leaving the plate.

7) Flow past a pipe bend

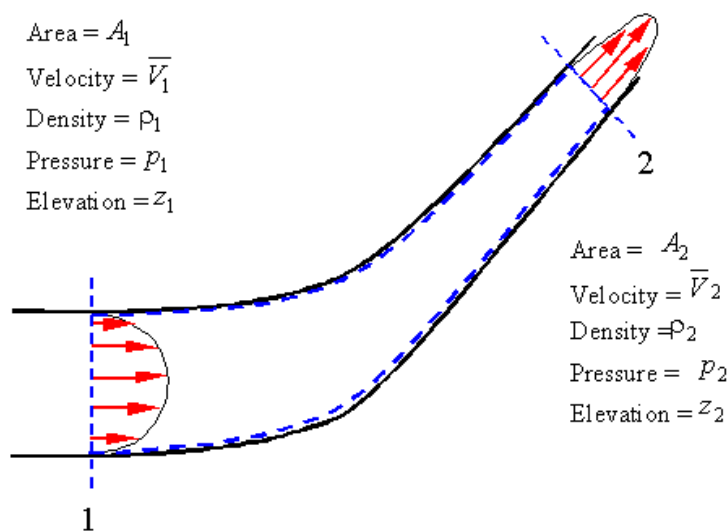
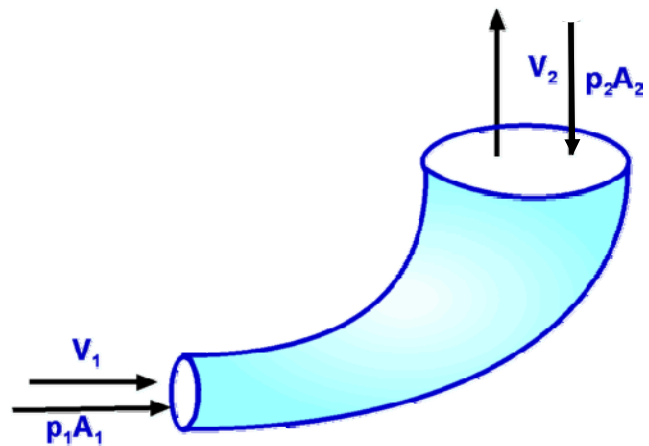

Consider the pipe bend shown above. We may first draw a free body diagram for the control volume with the forces:

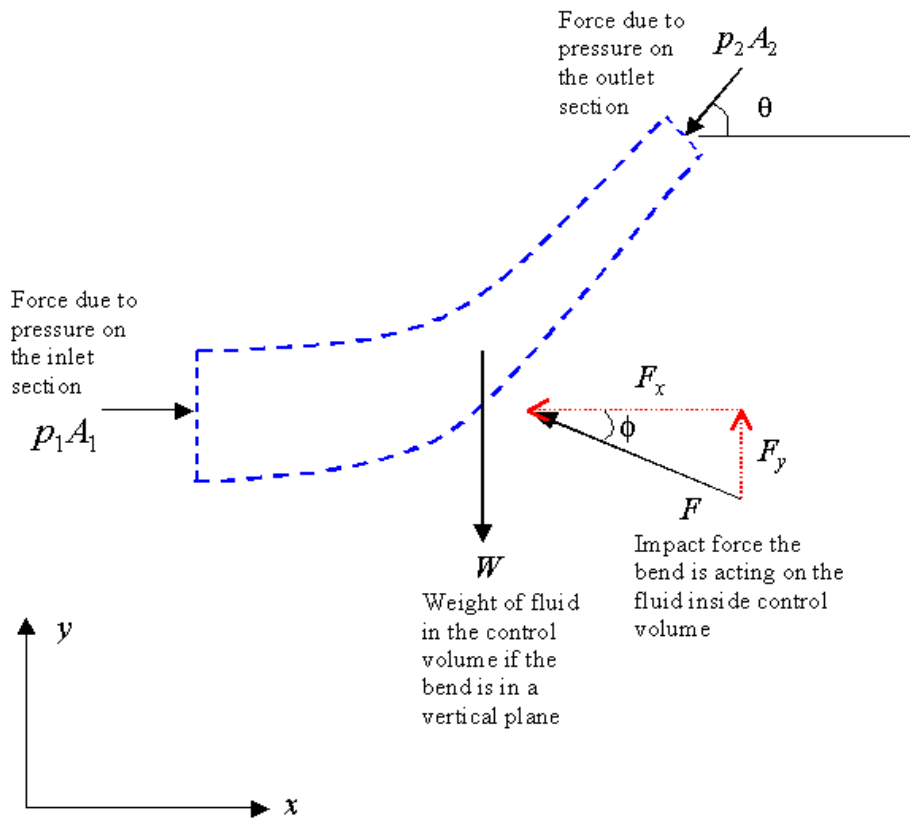

Paying due regard to the positive x and y directions, we may write the summation of forces in these two directions:

$$\sum F_x = p_1 A_1 - p_2 A_2 \cos \theta - F_x$$

$$\sum F_y = F_y - p_2 A_2 \sin \theta - W$$

Relating these components to the net change of momentum flux through the inlet and exit surfaces

x -Direction

$$p_1 A_1 - p_2 A_2 \cos \theta - F_x = \rho Q (\bar{V}_2 \cos \theta - \bar{V}_1)$$

y -Direction

$$F_y - p_2 A_2 \sin \theta - W = \rho Q (\bar{V}_2 \sin \theta - 0)$$

From these two equations and using the continuity equation and the Bernoulli equation, we may calculate the two force components. The magnitude and direction of the resultant force from the bend on the fluid are

$$F = \sqrt{F_x^2 + F_y^2}$$

$$\phi = \tan^{-1} (F_y / F_x)$$

As a reaction, the impact force on the pipe bend is equal in magnitude, but opposite in direction to the one on the fluid.

E. Solution of Problems Selected from the Textbook

3.7R

Water flows into a large tank at a rate of $0.011 \text{ m}^3/\text{s}$ as shown in Fig. P3.7R. The water leaves the tank through 20 holes in the bottom of the tank, each of which produces a stream of 10-mm diameter. Determine the equilibrium height, h , for steady state operation.

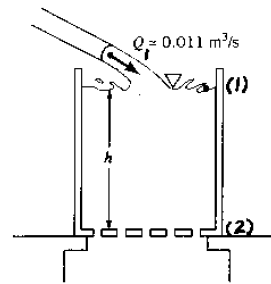

$$Q_1 = Q_2 \quad \text{where } Q_1 = 0.011 \frac{\text{m}^3}{\text{s}}$$

and

$$Q_2 = 20 A_2 V_2 = 20 \frac{\pi}{4} D_2^2 V_2$$

but

$$\frac{p_1}{\rho} + \frac{V_1^2}{2g} + z_1 = \frac{p_2}{\rho} + \frac{V_2^2}{2g} + z_2 \quad \text{where } p_1 = p_2 = 0, V_1 = 0,$$

and $z_1 - z_2 = h$

Thus,

$$V_2 = \sqrt{2gh}$$

so that

$$0.011 \frac{\text{m}^3}{\text{s}} = 20 \frac{\pi}{4} (0.01 \text{ m})^2 \sqrt{2(9.81 \frac{\text{m}}{\text{s}^2})h}$$

or

$$h = \underline{\underline{2.50 \text{ m}}}$$

3-6R

3.14R

3.14R (Flowrate) Water flows through the pipe contraction shown in Fig. P3.14R. For the given 0.2-m difference in manometer level, determine the flowrate as a function of the diameter of the small pipe, D .

ANS. $0.0156D^3/s$

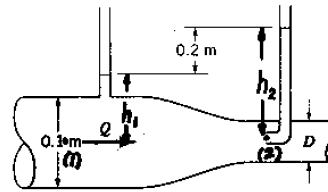

FIGURE P3.14R

$$\frac{p_1}{\rho} + \frac{V_1^2}{2g} + z_1 = \frac{p_2}{\rho} + \frac{V_2^2}{2g} + z_2, \text{ where } z_1 = z_2 \text{ and } V_2 = 0$$

Thus,

$$V_1 = \sqrt{2g \frac{(p_2 - p_1)}{\rho}}$$

But

$$p_1 = \rho h_1, \text{ and } p_2 = \rho h_2, \text{ so that } p_2 - p_1 = \rho(h_2 - h_1) = 0.2\rho$$

Thus,

$$V_1 = \sqrt{2g \frac{0.2\rho}{\rho}} = \sqrt{2g(0.2)}$$

or

$$Q = A_1 V_1 = \frac{\pi}{4} (0.1 \text{ m})^2 \sqrt{2(9.81 \frac{\text{m}}{\text{s}^2})(0.2 \text{ m})} = \underline{\underline{0.0156 \frac{\text{m}^3}{\text{s}}}}$$

3-12R

3.26

3.26 Small-diameter, high-pressure liquid jets can be used to cut various materials as shown in Fig. P3.26. If viscous effects are negligible, estimate the pressure needed to produce a 0.10-mm-diameter water jet with a speed of 700 m/s. Determine the flowrate.

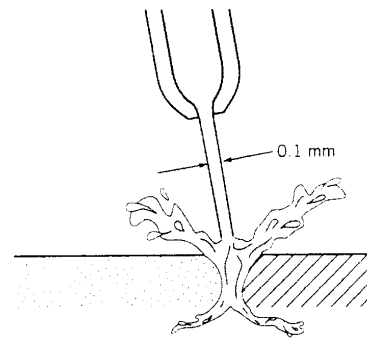
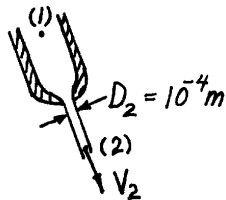

■ FIGURE P3.26

$$\frac{p_1}{\rho} + \frac{V_1^2}{2g} + z_1 = \frac{p_2}{\rho} + \frac{V_2^2}{2g} + z_2 \quad \text{where } V_1 \approx 0, z_1 \approx z_2, \text{ and } p_2 = 0$$

$$\text{Thus } p_1 = \frac{1}{2} \rho V_2^2 = \frac{1}{2} (999 \frac{\text{kg}}{\text{m}^3}) (700 \frac{\text{m}}{\text{s}})^2 = \underline{\underline{2.45 \times 10^5 \frac{\text{kN}}{\text{m}^2}}}$$

Also,

$$Q = V_2 A_2 = 700 \frac{\text{m}}{\text{s}} \left[\frac{\pi}{4} (10^{-4} \text{ m})^2 \right] = \underline{\underline{5.50 \times 10^{-6} \frac{\text{m}^3}{\text{s}}}}$$

3.27

3.27 Air is drawn into a wind tunnel used for testing automobiles as shown in Fig. P3.27. (a) Determine the manometer reading, h , when the velocity in the test section is 60 mph. Note that there is a 1-in. column of oil on the water in the manometer. (b) Determine the difference between the stagnation pressure on the front of the automobile and the pressure in the test section.

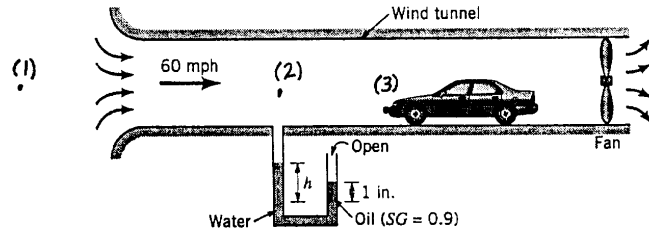

■ FIGURE P3.27

$$(a) \frac{p_1}{\rho} + z_1 + \frac{V_1^2}{2g} = \frac{p_2}{\rho} + \frac{V_2^2}{2g} + z_2$$

where

$$z_1 = z_2, \quad p_1 = 0, \quad \text{and} \quad V_1 = 0$$

$$\text{Thus, with } V_2 = 60 \text{ mph} = 88 \frac{\text{ft}}{\text{s}},$$

$$\frac{p_2}{\rho} = -\frac{V_2^2}{2g} \quad \text{or}$$

$$p_2 = -\frac{1}{2} \rho V_2^2 = -\frac{1}{2} (0.00238 \frac{\text{slugs}}{\text{ft}^3}) (88 \frac{\text{ft}}{\text{s}})^2 = -9.22 \frac{\text{lb}}{\text{ft}^2}$$

$$\text{But } p_2 + \gamma_{H_2O} h - \gamma_{oil} (\frac{1}{12} \text{ft}) = 0 \quad \text{where } \gamma_{oil} = 0.9 \gamma_{H_2O} = 0.9 (62.4 \frac{\text{lb}}{\text{ft}^3}) = 56.2 \frac{\text{lb}}{\text{ft}^3}$$

Thus,

$$-9.22 \frac{\text{lb}}{\text{ft}^2} + 62.4 \frac{\text{lb}}{\text{ft}^3} (h \text{ft}) - 56.2 \frac{\text{lb}}{\text{ft}^3} (\frac{1}{12} \text{ft}) = 0, \quad \text{or } h = \underline{\underline{0.223 \text{ft}}}$$

$$(b) \frac{p_2}{\rho} + z_2 + \frac{V_2^2}{2g} = \frac{p_3}{\rho} + z_3 + \frac{V_3^2}{2g}$$

where

$$z_2 = z_3 \quad \text{and} \quad V_3 = 0$$

Thus,

$$\frac{p_2}{\rho} + \frac{V_2^2}{2g} = \frac{p_3}{\rho} \quad \text{or}$$

$$p_3 - p_2 = \frac{1}{2} \rho V_2^2 = \frac{1}{2} (0.00238 \frac{\text{slugs}}{\text{ft}^3}) (88 \frac{\text{ft}}{\text{s}})^2 = \underline{\underline{9.22 \frac{\text{lb}}{\text{ft}^2}}}$$

3.29

3.29 A large open tank contains a layer of oil floating on water as shown in Fig. P3.29. The flow is steady and inviscid. (a) Determine the height, h , to which the water will rise. (b) Determine the water velocity in the pipe. (c) Determine the pressure in the horizontal pipe.

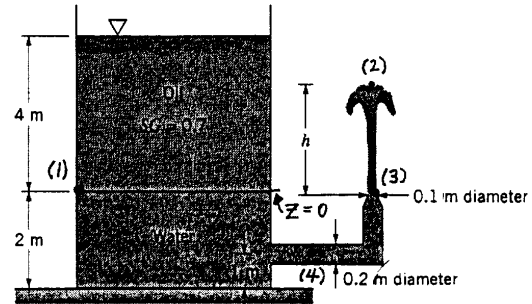

FIGURE P3.29

$$(a) \frac{p_1}{\gamma} + z_1 + \frac{V_1^2}{2g} = \frac{p_2}{\gamma} + z_2 + \frac{V_2^2}{2g} \quad (1)$$

where

$$z_1 = 0, p_2 = 0, V_1 = V_2 = 0, z_2 = h, \text{ and } \rho_1 = 4m (\gamma_{oil})$$

$$\text{Thus, with } \gamma_{oil} = SG \gamma_{H_2O} = 0.7 (9.80 \frac{kN}{m^3}) = 6.86 \frac{kN}{m^3}$$

and from Eq. (1)

$$\frac{p_1}{\gamma} = z_2 \quad \text{or} \quad p_1 = \gamma h \quad \text{so that}$$

$$h = \frac{4m \gamma_{oil}}{\gamma} = 4m \frac{6.86 \frac{kN}{m^3}}{9.80 \frac{kN}{m^3}} = \underline{\underline{2.80m}}$$

$$(b) V_4 A_4 = V_3 A_3 \quad \text{or} \quad V_4 = \frac{A_3}{A_4} V_3 = \frac{\frac{\pi}{4} (0.1m)^2}{\frac{\pi}{4} (0.2m)^2} V_3 = \frac{1}{4} V_3$$

But from the Bernoulli equation,

$$V_3 = \sqrt{2gh} = \sqrt{2(9.81 m/s^2)(2.80m)} = 7.41 \frac{m}{s}$$

Thus,

$$V_4 = \frac{1}{4} (7.41 \frac{m}{s}) = \underline{\underline{1.85 \frac{m}{s}}}$$

$$(c) \frac{p_4}{\gamma} + z_4 + \frac{V_4^2}{2g} = \frac{p_2}{\gamma} + z_2 + \frac{V_2^2}{2g}$$

where

$$z_4 = -1m, V_4 = 1.85 \frac{m}{s}, p_2 = 0, z_2 = 2.8m, V_2 = 0$$

Thus,

$$\frac{p_4}{\gamma} - 1m + \frac{(1.85 \frac{m}{s})^2}{2(9.81 \frac{m}{s^2})} = 2.8m \quad \text{or} \quad \frac{p_4}{\gamma} = 3.63m$$

Thus,

$$p_4 = 3.63m (9.80 \frac{kN}{m^3}) = \underline{\underline{35.5 kPa}}$$

3.32

3.32 Water flows through the pipe contraction shown in Fig. P3.32. For the given 0.2-m difference in the manometer level, determine the flowrate as a function of the diameter of the small pipe, D .

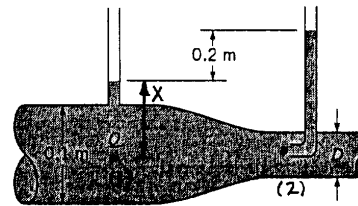

■ FIGURE P3.32

$$\frac{P_1}{\rho} + \frac{V_1^2}{2g} + Z_1 = \frac{P_2}{\rho} + \frac{V_2^2}{2g} + Z_2$$

where $Z_1 = Z_2$ and $V_2 = 0$.

Thus,

$$\frac{P_1}{\rho} + \frac{V_1^2}{2g} = \frac{P_2}{\rho}$$

But

$$\frac{P_1}{\rho} = X \text{ and } \frac{P_2}{\rho} = 0.2m + X \text{ so that}$$

$$X + \frac{V_1^2}{2g} = 0.2m + X \text{ or}$$

$$V_1 = \sqrt{2g(0.2m)} = (2(9.81 \frac{m}{s^2})(0.2m))^{\frac{1}{2}} = 1.98 \frac{m}{s}$$

Thus,

$$Q = A_1 V_1 = \frac{\pi}{4} (0.1m)^2 (1.98 \frac{m}{s}) = \underline{\underline{0.0156 \frac{m^3}{s} \text{ for any } D}}$$

3.47

3.47 Determine the flowrate through the pipe in Fig. P3.47.

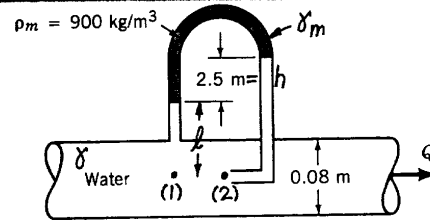

FIGURE P3.47

$$\frac{\rho_1}{\rho} + \frac{V_1^2}{2g} + z_1 = \frac{\rho_2}{\rho} + \frac{V_2^2}{2g} + z_2 \quad \text{where } z_1 = z_2 \text{ and } V_2 = 0$$

Thus,

$$\frac{\rho_1}{\rho} + \frac{V_1^2}{2g} = \frac{\rho_2}{\rho} \quad \text{or } V_1 = \sqrt{2g \frac{(\rho_2 - \rho_1)}{\rho}}$$

but,

$$\rho_1 - \rho l - \rho_m h + \rho(l+h) = \rho_2 \quad \text{or } \rho_2 - \rho_1 = (\rho - \rho_m)h$$

so that

$$V_1 = \sqrt{2g \left(1 - \frac{\rho_m}{\rho}\right) h} = \left[2 \left(9.81 \frac{\text{m}}{\text{s}^2}\right) \left(1 - \frac{900 \frac{\text{kg}}{\text{m}^3}}{999 \frac{\text{kg}}{\text{m}^3}}\right) (2.5 \text{ m}) \right]^{1/2}$$

$$= 2.20 \frac{\text{m}}{\text{s}}$$

Thus,

$$Q = A_1 V_1 = \frac{\pi}{4} (0.08 \text{ m})^2 (2.20 \frac{\text{m}}{\text{s}}) = \underline{\underline{0.0111 \frac{\text{m}^3}{\text{s}}}}$$

3.85

3.85 Water flows from the pipe shown in Fig. P3.85 as a free jet and strikes a circular flat plate. The flow geometry shown is axisymmetrical. Determine the flowrate and the manometer reading, H .

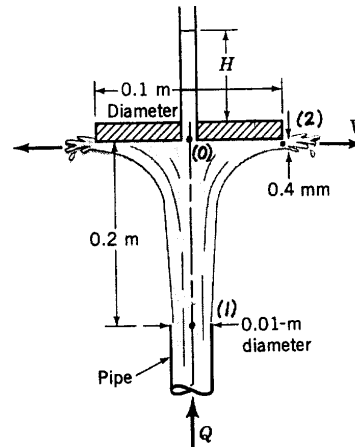

FIGURE P3.85

$$\frac{p_1}{\rho} + \frac{V_1^2}{2g} + z_1 = \frac{p_2}{\rho} + \frac{V_2^2}{2g} + z_2, \text{ where } p_1 = 0, p_2 = 0, z_1 = 0, \text{ and } z_2 = 0.2 \text{ m}$$

Thus,

$$\frac{V_1^2}{2g} = \frac{V_2^2}{2g} + z_2 \text{ where } A_1 V_1 = A_2 V_2 = Q \quad (1)$$

$$\text{or } V_1 = \frac{A_2}{A_1} V_2 = \frac{\pi D_2 h}{\pi D_1^2} V_2 = \frac{4 D_2 h}{D_1^2} V_2 = \frac{4(0.1 \text{ m})(4 \times 10^{-4} \text{ m})}{(0.01 \text{ m})^2} V_2 = 1.6 V_2$$

Hence, Eq. (1) gives

$$(1.60 V_2)^2 = V_2^2 + 2(9.81 \frac{\text{m}}{\text{s}^2})(0.2 \text{ m}) \text{ or } V_2 = 1.59 \frac{\text{m}}{\text{s}}$$

so that

$$Q = A_2 V_2 = \pi(0.1 \text{ m})(4 \times 10^{-4} \text{ m})(1.59 \frac{\text{m}}{\text{s}}) = \underline{\underline{2.00 \times 10^{-4} \frac{\text{m}^3}{\text{s}}}}$$

Also,

$$\frac{p_1}{\rho} + \frac{V_1^2}{2g} + z_1 = \frac{p_0}{\rho} + \frac{V_0^2}{2g} + z_0, \text{ where } V_0 = 0, z_0 = 0.2 \text{ m}, V_1 = 1.60 V_2$$

$$\text{or } V_1 = 1.60(1.59 \frac{\text{m}}{\text{s}}) = 2.54 \frac{\text{m}}{\text{s}}, \text{ and } p_1 = 0$$

Thus,

$$H = \frac{p_0}{\rho} = \frac{V_1^2}{2g} - z_0 = \frac{(2.54 \frac{\text{m}}{\text{s}})^2}{2(9.81 \frac{\text{m}}{\text{s}^2})} - 0.2 \text{ m} = \underline{\underline{0.129 \text{ m}}}$$

3.87

3.87 A conical plug is used to regulate the air flow from the pipe shown in Fig. P3.87. The air leaves the edge of the cone with a uniform thickness of 0.02 m. If viscous effects are negligible and the flowrate is $0.50 \text{ m}^3/\text{s}$, determine the pressure within the pipe.

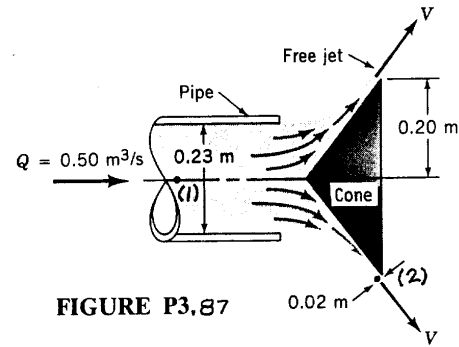

FIGURE P3.87

$$\frac{p_1}{\gamma} + \frac{V_1^2}{2g} + z_1 = \frac{p_2}{\gamma} + \frac{V_2^2}{2g} + z_2 \quad \text{where } z_1 = z_2 \text{ and } p_2 = 0$$

Also,

$$V_1 = \frac{Q}{A_1} = \frac{0.5 \frac{\text{m}^3}{\text{s}}}{\frac{\pi}{4} (0.23 \text{ m})^2} = 12.0 \frac{\text{m}}{\text{s}}$$

and

$$V_2 = \frac{Q}{A_2} = \frac{Q}{2\pi R h} = \frac{0.5 \frac{\text{m}^3}{\text{s}}}{2\pi (0.2 \text{ m})(0.02 \text{ m})} = 19.9 \frac{\text{m}}{\text{s}}$$

Thus,

$$p_1 = \frac{1}{2} \rho (V_2^2 - V_1^2) = \frac{1}{2} (1.23 \frac{\text{kg}}{\text{m}^3}) (19.9^2 - 12.0^2) \frac{\text{m}^2}{\text{s}^2} = \underline{\underline{155 \frac{\text{N}}{\text{m}^2}}}$$

5.31

5.31 A nozzle is attached to a vertical pipe and discharges water into the atmosphere as shown in Fig. P5.31. When the discharge is $0.1 \text{ m}^3/\text{s}$, the gage pressure at the flange is 40 kPa . Determine the vertical component of the anchoring force required to hold the nozzle in place. The nozzle has a weight of 200 N , and the volume of water in the nozzle is 0.012 m^3 . Is the anchoring force directed upward or downward?

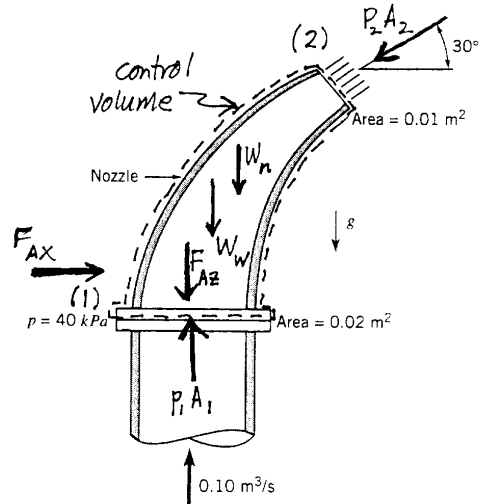

FIGURE P5.31

The analysis leading to the solution of this problem is similar to the one outlined in Example 5.10. Included in the control volume are the nozzle and the water in the nozzle at an instant. Application of the vertical or z -direction component of the linear momentum equation (Eq. 5.22) to the flow through this control volume leads to

$$\dot{m}(V_2 \sin 30^\circ - V_1) = p_1 A_1 - F_{Az} - W_n - W_w - p_2 A_2 \sin 30^\circ \quad (1)$$

Solving Eq. 1 for F_{Az} yields

$$F_{Az} = p_1 A_1 - W_n - W_w - \dot{m}(V_2 \sin 30^\circ - V_1) \quad (2)$$

For \dot{m} we use $\dot{m} = \rho Q$

For W_w we use $W_w = \gamma V_w$

From conservation of mass we obtain

$$Q_2 = Q_1$$

$$\text{or } V_2 = \frac{Q_1}{A_2}$$

(cont)

5.31 (con't)

Also, we note that $V_1 = \frac{Q_1}{A_1}$

Thus, Eq. 2 becomes

$$F_{Az} = P_1 A_1 - W_n - \frac{\rho Q}{w} \left(\frac{Q}{A_2} \sin 30^\circ - \frac{Q}{A_1} \right)$$

or

$$\begin{aligned} F_{Az} &= (40 \text{ kPa}) \left(1 \frac{\text{N}}{\text{m}^2 \cdot \text{Pa}} \right) \left(1000 \frac{\text{Pa}}{\text{kPa}} \right) (0.02 \text{ m}^2) - 200 \text{ N} \\ &\quad - (0.012 \text{ m}^3) \left(9.8 \frac{\text{kN}}{\text{m}^3} \right) \left(1000 \frac{\text{N}}{\text{kN}} \right) \\ &\quad - \left(999 \frac{\text{kg}}{\text{m}^3} \right) \left(0.01 \frac{\text{m}^3}{\text{s}} \right) \left(1 \frac{\text{N} \cdot \text{s}^2}{\text{kg} \cdot \text{m}} \right) \left[\left(\frac{0.01 \frac{\text{m}^3}{\text{s}}}{0.01 \text{ m}^2} \right) \sin 30^\circ - \left(\frac{0.01 \frac{\text{m}^3}{\text{s}}}{0.02 \text{ m}^2} \right) \right] \end{aligned}$$

and

$$F_{Az} = 800 \text{ N} - 200 \text{ N} - 117.6 \text{ N} - 0 \text{ N} = \underline{\underline{482 \text{ N}}} \text{ downward}$$

5-30

5.33

Water flows as two free jets from the tee attached to the pipe shown in Fig. P5.33. The exit speed is 15 m/s. If viscous effects and gravity are negligible, determine the x and y components of the force that the pipe exerts on the tee.

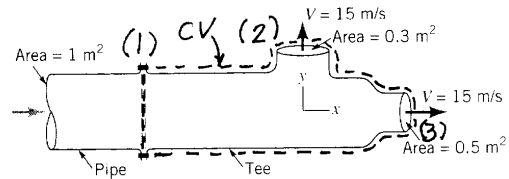

Use the control volume shown.

For the x -component of the force exerted by the pipe on the tee we use the x -component of the linear momentum equation.

$$\begin{aligned} -V_1 \rho V_1 A_1 + V_3 \rho V_3 A_3 &= P_1 A_1 - P_3 A_3 - P_{atm} (A_1 - A_3) + F_x \\ &= (P_{gage} + P_{atm}) A_1 - (P_{gage} + P_{atm}) A_3 - P_{atm} (A_1 - A_3) + F_x \\ &= P_{gage} A_1 + F_x \end{aligned} \quad (1)$$

To get V_1 , we use conservation of mass

$$Q_1 = Q_2 + Q_3$$

$$\text{or } A_1 V_1 = A_2 V_2 + A_3 V_3$$

$$\text{so } V_1 = \frac{A_2 V_2 + A_3 V_3}{A_1} = \frac{(0.3 \text{ m}^2)(15 \text{ m/s}) + (0.5 \text{ m}^2)(15 \text{ m/s})}{1 \text{ m}^2} = 12 \text{ m/s}$$

To estimate P_{gage} we use Bernoulli's equation for flow between (1) and (2)

$$\frac{P_{gage}}{\rho} + \frac{V_1^2}{2} = \frac{P_{gage}}{\rho} + \frac{V_2^2}{2}$$

$$P_{gage} = \rho \left(\frac{V_2^2 - V_1^2}{2} \right) = \left(999 \frac{\text{kg}}{\text{m}^3} \right) \left[\frac{(15 \frac{\text{m}}{\text{s}})^2 - (12 \frac{\text{m}}{\text{s}})^2}{2} \right] \left(\frac{1 \text{ N} \cdot \text{s}^2}{\text{kg} \cdot \text{m}} \right)$$

$$P_{gage} = 40,500 \frac{\text{N}}{\text{m}^2}$$

Now using Eq. (1) we get:

$$\left[-\left(12 \frac{\text{m}}{\text{s}} \right) \left(999 \frac{\text{kg}}{\text{m}^3} \right) \left(12 \frac{\text{m}}{\text{s}} \right) (1 \text{ m}^2) + \left(15 \frac{\text{m}}{\text{s}} \right) \left(999 \frac{\text{kg}}{\text{m}^3} \right) \left(15 \frac{\text{m}}{\text{s}} \right) (0.5 \text{ m}^2) \right] \left(\frac{1 \text{ N} \cdot \text{s}^2}{\text{kg} \cdot \text{m}} \right) = (40,500 \frac{\text{N}}{\text{m}^2}) (1 \text{ m}^2) + F_x$$

$$\text{or } -72,000 \text{ N} = F_x$$

$$\text{so } F_x = \underline{72,000 \text{ N}} \leftarrow$$

For the y component of the force exerted by the pipe on the tee we use the y component of the linear momentum equation to get

$$V_2 \rho V_2 A_2 = F_y$$

$$\left(15 \frac{\text{m}}{\text{s}} \right) \left(999 \frac{\text{kg}}{\text{m}^3} \right) \left(15 \frac{\text{m}}{\text{s}} \right) (0.3 \text{ m}^2) = \underline{67,400 \text{ N}} \uparrow = F_y$$

5-33

5.38

5.38 A circular plate having a diameter of 300 mm is held perpendicular to an axisymmetric horizontal jet of air having a velocity of 40 m/s and a diameter of 80 mm as shown in Fig. P5.38. A hole at the center of the plate results in a discharge jet of air having a velocity of 40 m/s and a diameter of 20 mm. Determine the horizontal component of force required to hold the plate stationary.

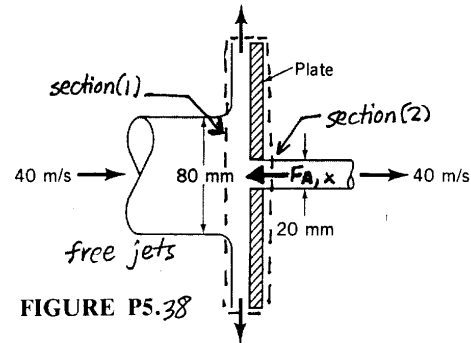

FIGURE P5.38

The control volume contains the plate and flowing air as indicated in the sketch above. Application of the horizontal or x direction component of the linear momentum equation yields

$$-u_1 \rho u_1 A_1 + u_2 \rho u_2 A_2 = -F_{A,x}$$

or

$$F_{A,x} = u_1^2 \rho \frac{\pi D_1^2}{4} - u_2^2 \rho \frac{\pi D_2^2}{4} = u_1^2 \rho \frac{\pi}{4} (D_1^2 - D_2^2)$$

Thus

$$F_{A,x} = \left(40 \frac{\text{m}}{\text{s}}\right)^2 \left(1.23 \frac{\text{kg}}{\text{m}^3}\right) \frac{\pi}{4} \left[\frac{(80 \text{ mm})^2 - (20 \text{ mm})^2}{(1000 \frac{\text{mm}}{\text{m}})^2} \right] \left(1 \frac{\text{N}}{\text{kg} \cdot \frac{\text{m}}{\text{s}^2}}\right)$$

and

$$F_{A,x} = \underline{\underline{9.27 \text{ N}}}$$

5.47

A free jet of fluid strikes a wedge as shown in Fig. P5.47. Of the total flow, a portion is deflected 30° ; the remainder is not deflected. The horizontal and vertical components of force needed to hold the wedge stationary are F_H and F_V , respectively. Gravity is negligible, and the fluid speed remains constant. Determine the force ratio, F_H/F_V .

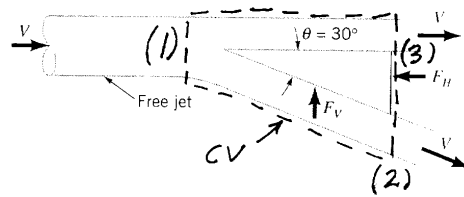

The horizontal and vertical components of the linear momentum equation are applied to the contents of the control volume shown to get

$$-V_1 \rho V_1 A_1 + V_2 \rho V_2 A_2 + V_3 \cos 30^\circ \rho V_3 A_3 = -F_H \quad (1)$$

$$-V_3 \sin 30^\circ \rho V_3 A_3 = F_V \quad (2)$$

However $V_1 = V_2 = V_3 = V$ so eqs. (1) and (2) become

$$V^2 \rho (A_2 + A_3 \cos 30^\circ - A_1) = -F_H$$

$$V^2 \rho A_3 \sin 30^\circ = -F_V$$

and

$$\frac{F_H}{F_V} = \frac{A_2 + A_3 \cos 30^\circ - A_1}{A_3 \sin 30^\circ} \quad (3)$$

From conservation of mass we get

$$Q_1 = Q_2 + Q_3$$

or

$$A_1 V = A_2 V + A_3 V$$

and

$$A_1 = A_2 + A_3 \quad (4)$$

Combining Eqs. (3) and (4) we get

$$\frac{F_H}{F_V} = \frac{A_2 + A_3 \cos 30^\circ - A_2 - A_3}{A_3 \sin 30^\circ} = \frac{A_3 (\cos 30^\circ - 1)}{A_3 \sin 30^\circ} = -0.27$$

The negative sign indicates that F_V is down rather than up as shown in the sketch.

5.55

5.55 Assuming frictionless, incompressible, one-dimensional flow of water through the horizontal tee connection sketched in Fig. P5.55, estimate values of the x and y components of the force exerted by the tee on the water. Each pipe has an inside diameter of 1 m.

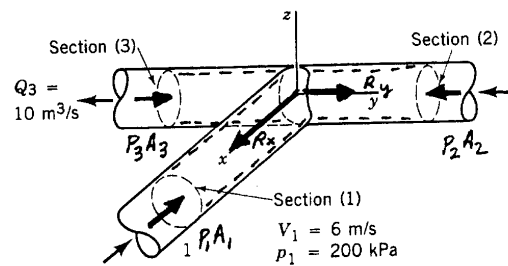

FIGURE P5.55

We can use the x and y components of the linear momentum equation (Eq. 5.22) to determine the x and y components of the reaction force exerted by the water on the tee. For the control volume containing water in the tee, Eq. 5.22 leads to

$$R_x = p_1 A_1 + V_1 \rho Q_1 = p_1 \frac{\pi D_1^2}{4} + V_1 \rho Q_1 \quad (1)$$

and

$$R_y = p_2 \frac{\pi D_2^2}{4} - p_3 \frac{\pi D_3^2}{4} + V_2 \rho Q_2 - V_3 \rho Q_3 \quad (2)$$

The reaction forces in Eqs. 1 and 2 are actually exerted by the tee on the water in the control volume. The reaction of the water on the tee is equal in magnitude but opposite in direction.

Conservation of mass (Eq. 5.4) leads to

$$Q_2 = Q_3 - Q_1 = Q_3 - V_1 \frac{\pi D_1^2}{4} = 10 \frac{\text{m}^3}{\text{s}} - \left(6 \frac{\text{m}}{\text{s}}\right) \frac{\pi (1\text{m})^2}{4} = 5.288 \frac{\text{m}^3}{\text{s}}$$

Also

$$Q_1 = V_1 \frac{\pi D_1^2}{4} = \left(6 \frac{\text{m}}{\text{s}}\right) \frac{\pi (1\text{m})^2}{4} = 4.712 \frac{\text{m}^3}{\text{s}}$$

Further

$$V_2 = \frac{Q_2}{\frac{\pi D_2^2}{4}} = \frac{\left(5.288 \frac{\text{m}^3}{\text{s}}\right)}{\frac{\pi (1\text{m})^2}{4}} = 6.733 \frac{\text{m}}{\text{s}}$$

and

$$V_3 = \frac{Q_3}{\frac{\pi D_3^2}{4}} = \frac{\left(10 \frac{\text{m}^3}{\text{s}}\right)}{\frac{\pi (1\text{m})^2}{4}} = 12.73 \frac{\text{m}}{\text{s}}$$

(con't)

5-57

5.55 (con't)

Because the flow is incompressible and frictionless we assume that Bernoulli's equation (Eq. 5.74) is valid throughout the control volume. Thus

$$P_3 = P_1 + \frac{\rho}{2}(V_1^2 - V_3^2) = 200 \text{ kPa} + \frac{(999 \frac{\text{kg}}{\text{m}^3})}{2} \left[\left(6 \frac{\text{m}}{\text{s}}\right)^2 - \left(12.73 \frac{\text{m}}{\text{s}}\right)^2 \right] \left(\frac{1 \text{ N}}{\text{kg} \cdot \frac{\text{m}}{\text{s}^2}} \right) \left(10^{-3} \frac{\text{kPa}}{\frac{\text{N}}{\text{m}^2}} \right)$$

or

$$P_3 = 137 \text{ kPa}$$

Also

$$P_2 = P_1 + \frac{\rho}{2}(V_1^2 - V_2^2) = 200 \text{ kPa} + \frac{(999 \frac{\text{kg}}{\text{m}^3})}{2} \left[\left(6 \frac{\text{m}}{\text{s}}\right)^2 - \left(6.733 \frac{\text{m}}{\text{s}}\right)^2 \right] \left(\frac{1 \text{ N}}{\text{kg} \cdot \frac{\text{m}}{\text{s}^2}} \right) \left(10^{-3} \frac{\text{kPa}}{\frac{\text{N}}{\text{m}^2}} \right)$$

or

$$P_2 = 195.3 \text{ kPa}$$

With Eq. 1

$$R_x = \left(200,000 \frac{\text{N}}{\text{m}^2} \right) \frac{\pi}{4} (1\text{m})^2 + \left(6 \frac{\text{m}}{\text{s}} \right) \left(999 \frac{\text{kg}}{\text{m}^3} \right) \left(4.712 \frac{\text{m}^3}{\text{s}} \right) \left(\frac{1 \text{ N}}{\text{kg} \cdot \frac{\text{m}}{\text{s}^2}} \right) = 185,000 \text{ N} = 185 \text{ kN}$$

and the x-direction component of force exerted by the water on the tee is -185 kN.

With Eq. 2

$$R_y = \left(195,300 \frac{\text{N}}{\text{m}^2} \right) \frac{\pi}{4} (1\text{m})^2 - \left(137,000 \frac{\text{N}}{\text{m}^2} \right) \frac{\pi}{4} (1\text{m})^2 + \left(6.733 \frac{\text{m}}{\text{s}} \right) \left(999 \frac{\text{kg}}{\text{m}^3} \right) \left(5.2 \right) + \left(6.733 \frac{\text{m}}{\text{s}} \right) \left(999 \frac{\text{kg}}{\text{m}^3} \right) \left(5.288 \frac{\text{m}^3}{\text{s}} \right) \left(\frac{1 \text{ N}}{\text{kg} \cdot \frac{\text{m}}{\text{s}^2}} \right)$$

or

$$R_y = -45,800 \text{ N} = -45.8 \text{ kN}$$

and the y-direction component of force exerted by the water on the tee is +45.8 kN.

5-58

5.57

Water flows steadily into and out of a tank that sits on frictionless wheels as shown in Fig. P5.57. Determine the diameter D so that the tank remains motionless if $F = 0$.

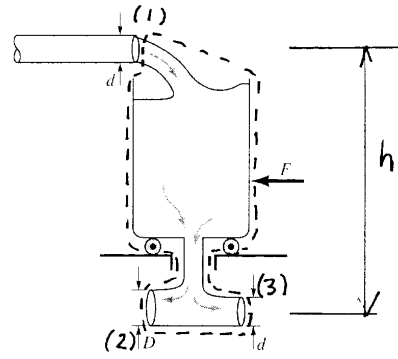

Applying the horizontal component of the linear momentum equation to the contents of the control

Volume shown in the sketch we get:

$$\int_{cs} \vec{V} \rho \vec{V} \cdot \hat{n} dA = \Sigma \vec{F}$$

$$\text{or } -V_1 \rho V_1 A_1 - V_2 \rho V_2 A_2 + V_3 \rho V_3 A_3 = 0$$

$$\text{and } -V_1^2 \rho \frac{\pi d^2}{4} - V_2^2 \rho \frac{\pi D^2}{4} + V_3^2 \rho \frac{\pi d^2}{4} = 0$$

Since $V_2 = V_3 = \sqrt{2gh}$ we obtain

$$V_1^2 d^2 = V_3^2 d^2 - V_3^2 D^2 \quad (1)$$

From the conservation of mass equation we get

$$Q_1 = Q_2 + Q_3$$

$$\text{or } V_1 d^2 = V_2 D^2 + V_3 d^2$$

Again, since $V_2 = V_3 = \sqrt{2gh}$ we get

$$V_1 d^2 = V_3 D^2 + V_3 d^2 \quad (2)$$

Looking at Eqs. (1) and (2) together we conclude

If $V_3 < V_1$, eq. (1) cannot be satisfied
eq. (2) can be satisfied

If $V_3 > V_1$, eq. (1) can be satisfied
eq. (2) cannot be satisfied

If $V_3 = V_1$, eq. (1) can be satisfied with $D = 0$
eq. (2) can be satisfied with $D = 0$

So $V_3 = V_1$ and $D = 0$

For $V_3 = V_1$, h must be set so that

$$V_3 = \sqrt{2gh} = V_1$$

5.60

5.60 A vertical jet of water leaves a nozzle at a speed of 10 m/s and a diameter of 20 mm. It suspends a plate having a mass of 1.5 kg as indicated in Fig. P5.60. What is the vertical distance h ?

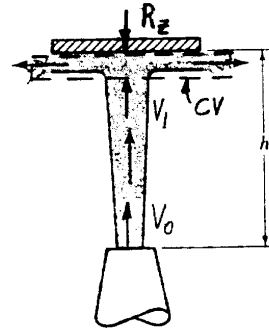

FIGURE P5.60

To determine the vertical distance h we apply the vertical direction component of the linear momentum equation (Eq. 5.22) to the water in the control volume shown in the sketch above. Thus,

$$-R_z - \rho g \nabla_{\text{water}} = -V_1 \rho A_1 V_1 = -\rho V_1^2 \frac{\pi D_1^2}{4} \quad (1)$$

The vertical reaction force of the plate on the water is equal in magnitude to the weight of the plate, or

$$R_z = g m_{\text{plate}} = (9.81 \frac{\text{m}}{\text{s}^2})(1.5 \text{ kg}) = 14.7 \text{ N}$$

Also, the weight of the water within the control volume, $\rho g \nabla_{\text{water}}$, is negligible, and the mass flow rate is

$$\dot{m} = \rho A_0 V_0 = \rho A_0 V_0 = (999 \frac{\text{kg}}{\text{m}^3}) \frac{\pi}{4} (0.02 \text{ m})^2 (10 \frac{\text{m}}{\text{s}}) = 3.13 \frac{\text{kg}}{\text{s}}$$

Thus, Eq. 1 becomes

$$-14.7 \text{ N} = -V_1 \dot{m} \quad \text{or} \quad V_1 = \frac{14.7 \text{ N}}{3.13 \text{ kg/s}} = 4.70 \frac{\text{m}}{\text{s}}$$

From the Bernoulli Equation (Eq. 3.7) we have

$$p_0 + \frac{1}{2} \rho V_0^2 + \gamma z_0 = p_1 + \frac{1}{2} \rho V_1^2 + \gamma z_1, \quad \text{where } p_0 = p_1 = 0 \\ z_0 = 0, \quad z_1 = h$$

Thus,

$$\frac{1}{2} \rho V_0^2 = \frac{1}{2} \rho V_1^2 + \gamma h \\ \text{or since } \gamma = \rho g$$

$$h = \frac{1}{2g} (V_0^2 - V_1^2) = \frac{1}{2(9.81 \frac{\text{m}}{\text{s}^2})} (10^2 - 4.70^2) \frac{\text{m}^2}{\text{s}^2} = \underline{\underline{3.97 \text{ m}}}$$

5-63