

IBM System Storage TS3310 Tape Library



Setup and Operator Guide

Machine Type 3576

IBM System Storage TS3310 Tape Library



Setup and Operator Guide

Machine Type 3576

Note!

Before using this information and the product it supports, be sure to read the general information under “Notices” on page E-1.

To ensure that you have the latest publications, visit the web at <http://www.ibm.com/storage/lto>.

Second Edition (May 2006)

This edition applies to the *IBM System Storage TS3310 Tape Library Setup and Operator Guide*, GA32-0477-01, and to the subsequent releases and modifications until otherwise indicated in new editions.

© Copyright International Business Machines Corporation 2005, 2006. All rights reserved.

US Government Users Restricted Rights – Use, duplication or disclosure restricted by GSA ADP Schedule Contract with IBM Corp.

Read this First

Accessing Online Technical Support

For online Technical Support for your Library, visit:
<http://www.ibm.com/storage/ito>

Registering for My Support

My Support registration provides email notification when new firmware levels have been updated and are available for download and installation. To register for My Support, visit the web at <http://www.ibm.com/support/mySupport>.

Sending Us Your Comments

Your feedback is important in helping IBM provide accurate and useful information. If you have comments or suggestions for improving this publication, send your comments by:

- E-mailing IBM:
 - Internet or IBMLink™ from US: *starpubs@us.ibm.com*
 - IBMLink from Canada: *STARPUBS at TORIBM*

Include the following information in your e-mail:

- Exact publication title
- Form number (for example, GA32-1234-02) or part number (located on the back cover of the publication)
- Page number to which you are referring
- Using the Readers' Comments form at the back of this publication
- Mailing your comments to:

International Business Machines Corporation
Information Development
Department GZW
9000 South Rita Road
Tucson, AZ 85744-0001 USA

Contacting IBM Technical Support

In the USA: Call 1-800-IBM_SERV (1-800-426-7378).

All other Countries/Regions: Visit <http://www.ibm.com>.

To open a Service Request online: Under **Get Support**, click on **Open a Service Request**.

Summary of Changes

- Incorporated 23U specifications
- Added email notifications
- Modified Web User Interface menus
- Added instructions for updating firmware using the Web User Interface

- |
- |
- |
- |
- Re-ordered the installation instructions to better distinguish between desktop and rack-mount installations
- Added new Service Action Tickets and Diagnostic Resolutions
- Updated the Parts List

Contents

Read this First. iii

Accessing Online Technical Support	iii
Registering for My Support	iii
Sending Us Your Comments	iii
Contacting IBM Technical Support	iii
Summary of Changes	iii

Figures xi

Tables xiii

Safety and Environmental Notices . . . xv

Danger Notice	xv
Caution Notice	xv
Possible Safety Hazards	xv
Laser Safety and Compliance	xvi
Class I Laser Product	xvi
Protective Devices	xvi
Monitored Access to the Library	xvi
Main Power Switch	xvi
Rack Safety	xvii
Power Cords.	xix
Disposal of Library Components Containing Mercury	xx
European Directive About Product Recycling and Disposal	xx
Battery Return Program	xxi
Cable Warning	xxi

Preface xxiii

Intended Audience	xxiii
Related Publications	xxiii

Chapter 1. Product Description 1-1

Front Panel Components.	1-2
Control Module (3576 Model L5B)	1-2
Expansion Module (3576 Model L5B)	1-3
I/O Station	1-3
Access Door	1-3
Operator Panel	1-4
Power Button	1-4
Front Panel LEDs	1-4
Rear Panel Components	1-5
Library Control Blade (LCB)	1-5
Tape Drives	1-5
Power Supply	1-6
Interior Components	1-6
Storage Columns	1-7
Robotic System	1-7
Optional Features	1-8
Ultrium 3 Tape Drives	1-8
Redundant Power Supply (Feature Code 1900)	1-9
Feature Licenses	1-9

Library & Drive Code Update (Feature Code 0500)	1-11
Location Coordinates	1-11
Modules.	1-12
Columns.	1-12
Slots	1-13
Drives	1-13
Power Supplies	1-13
Media	1-14
Environmental and Shipping Specifications for Tape Cartridges	1-14
Multi-Path Architecture.	1-15
Specifications	1-15
Product Environment	1-16
Supported Servers, Operating Systems, and Software.	1-17
Supported Device Drivers	1-17

Chapter 2. Installation Planning 2-1

Determining the Number of Logical Libraries (Partitions)	2-1
Basic Guidelines	2-1
Library Sharing.	2-1
Using Multiple Logical Libraries for Library Sharing	2-2
Using Multiple Control Paths	2-2
Using Multiple Control Paths for System i, iSeries, and AS/400 Attachment	2-3
Using Multiple Control Paths for Control Path Failover	2-3
Using Multiple Data Paths for Data Path Failover	2-3
Determining SCSI and Fibre Channel IDs	2-4
SCSI Drive IDs	2-4
Fibre Channel Drive IDs	2-5
Server Attachment	2-8
SCSI Interface	2-8
Fibre Channel Interface	2-10

Chapter 3. Installing the Library. . . . 3-1

Step 1: Unpacking and Verifying Shipment Contents	3-1
Step 2: Installing Your Library	3-4
Reducing Library Weight	3-4
Preparing the Library Module(s) for Installation	3-6
Transferring the Bottom Cover from the 5U CM to the 9U EM	3-6
Installing Your Library on a Desktop	3-10
Installing Your Library in a Rack.	3-11
Enabling the Picker Assembly	3-27
Installing Library Components Removed for Weight Reduction.	3-28
Step 3: Cabling the Library	3-30
Cabling a 5U Library	3-30
Cabling a 14U Library	3-31
Cabling a 23U Library	3-33

Step 4: Powering ON the Library	3-34
Step 5: Configuring the Library	3-34

Chapter 4. Configuration Planning 4-1

Understanding Cartridge Assignment in the Library	4-1
Modifying Network Settings	4-1
Applying a License Key	4-2
Cleaning Slots Configuration	4-2
Host-based Cleaning of a Drive	4-3
Configuring I/O Stations	4-3
Selecting Drive IDs and Drive Types	4-3
Working with Logical Libraries	4-4
Automatically Creating Logical Libraries	4-4
Manually Creating Logical Libraries	4-5
Deleting Logical Libraries	4-5
Changing Logical Library Access	4-5
Changing Logical Library Modes	4-5
Working with User Accounts	4-6
Creating User Accounts	4-6
Modifying User Accounts	4-7
Deleting User Accounts	4-7

Chapter 5. User Interfaces 5-1

Operator Panel	5-1
Common Operator Panel Elements	5-2
Keyboards	5-3
Login Screen	5-3
Home Page	5-3
Menus Available from the Operator Panel	5-4
Web User Interface (UI)	5-7
Logging in to the Web User Interface	5-7
Common Header Elements	5-7
Menus Available from the Web User Interface	5-7
User Privileges	5-8

Chapter 6. Configuring the Library 6-1

Step 1: Log in to the Operator Panel	6-2
Step 2: Access the Setup Wizard	6-3
Step 3: Ensure that all Hardware is Installed	6-3
Step 4: Set up the Library Network Configuration	6-3
Step 5: Enter License Keys	6-4
Step 6: Assign Cleaning Cartridge Slots	6-4
Step 7: Assign I/O Station Slots	6-5
Step 8: Assign Logical Libraries	6-5
Step 9: Set the Date and Time	6-5
Step 10: Insert Cleaning Cartridge(s)	6-6
Step 11: Populate your Library with Data Cartridges	6-6
Step 12: Register for My Support	6-7

Chapter 7. Operating Procedures 7-1

Library and Logical Libraries	7-2
Viewing System Information	7-2
Accessing the Setup Wizard	7-2
Library Verify Diagnostic Tests	7-2
Creating Logical Libraries	7-3
Deleting/Modifying a Logical Library	7-3
Assigning Cleaning Slots	7-3
Assigning I/O Station Slots	7-4
Entering License Keys	7-4

Creating Users Accounts	7-4
Modifying/Deleting User Accounts	7-4
Setting the Date and Time	7-5
Setting Up Email Notifications	7-5
Resetting the Library Control Blade IP Address	7-5
Managing the Network (SSL, Trap Registration, and SNMP Version)	7-6
Configuring the Library for Remote Access	7-7
Taking a Logical Library Offline/Online	7-7
Shutting Down/Restarting the Library	7-8
Viewing Error Messages	7-9
Capturing a Library Snapshot	7-9
Viewing Library Information	7-9
Locking/Unlocking the I/O Station	7-10
Firmware Upgrades	7-10
Updating Library Firmware	7-10
Updating Drive Firmware	7-11
Drives	7-13
Viewing Drive Information	7-13
Loading a Drive	7-14
Unloading a Drive	7-14
Taking a Drive Offline/Online	7-14
Adding a Control Path Drive to a Logical Library	7-14
Assigning Drive IDs	7-14
Modifying a Fibre Channel Drive Port Setting	7-15
Capturing a Drive Dump	7-15
Cartridges	7-15
Inserting Data Cartridges	7-15
Removing a Data Cartridge	7-16
Moving Data Cartridges	7-16
Inserting a Cleaning Cartridge	7-16
Removing a Cleaning Cartridge	7-17

Chapter 8. Using Ultrium Media 8-1

Cartridge Compatibility	8-2
Data Cartridge	8-2
Capacity Scaling	8-3
WORM (Write Once, Read Many)	8-3
WORM Media	8-3
Data Security on WORM Media	8-3
WORM Media Errors	8-4
Cleaning Cartridge	8-4
Cartridge Memory Chip (LTO-CM)	8-4
Bar Code Label	8-4
Guidelines for Using Bar Code Labels	8-6
Write-Protect Switch	8-7
Handling the Cartridges	8-7
Provide Training	8-8
Ensure Proper Packaging	8-8
Provide Proper Acclimation and Environmental Conditions	8-9
Perform a Thorough Inspection	8-9
Examples of Cartridge Problems	8-10
Repositioning or Reattaching a Leader Pin	8-10
Repositioning a Leader Pin	8-11
Reattaching a Leader Pin	8-13
Environmental and Shipping Specifications for Tape Cartridges	8-17
Disposing of Tape Cartridges	8-17
Ordering Media Supplies	8-18

Ordering Bar Code Labels 8-19

Chapter 9. Troubleshooting 9-1

How the Library Reports Problems 9-1

Operator Intervention Messages 9-2

Diagnosing a Problem 9-2

Interpreting LEDs 9-6

Power Button LEDs 9-7

Library Control Blade LEDs. 9-7

Tape Drive LEDs 9-9

Power Supply LEDs 9-11

Picker LED 9-12

| Checking / Reseating Cables 9-13

| External Cables 9-13

E-mailing Logs 9-16

| Manually Recovering Tape from Picker 9-16

Pre-Call Checklist. 9-17

Contacting IBM Technical Support 9-17

Chapter 10. Service Action Tickets (Txxx) and Diagnostic Resolutions (DRxxx) 10-1

Service Action Tickets 10-1

T001: Manually remove cartridge from Picker, motion OK 10-1

T002: PUT operation failed, cartridge final position unknown, motion OK 10-2

T003: GET operation failed, cartridge final position unknown, motion OK 10-3

T004: PUT operation failed, cartridge back in source location, motion OK 10-4

T005: X, Y, θ motion profile failure, cartridge in Picker, motion NOT OK 10-5

T006: X, Y, θ motion profile failure, no cartridge in Picker, motion NOT OK. 10-6

T007: X, Y, θ motion obstruction, motion OK 10-7

T008: Cannot home, motion OK 10-7

T009: Drive load unsuccessful, motion OK 10-8

T010: Drive unload failed 10-9

T013: Invalid or damaged library serial number label 10-9

| T014: I/O Station Magazine Missing 10-10

T015: Cannot read sled bar code label 10-10

| T017: Invalid storage or I/O position 10-11

T018: Invalid Drive Position 10-11

T019: Cannot calibrate drive, motion OK 10-11

T020: Cannot calibrate storage, motion OK 10-12

T021: Lost electrical connection/communications with drive sled 10-13

T022: Lost electrical connection/communication with drive brick 10-13

T023: Drive sled fan spinning too slow or not at all. 10-14

T024: AC power loss 10-14

T025: Lost electrical connection with single power supply 10-14

T031: Cannot unlock I/O Station 10-15

T032: Cannot lock I/O Station 10-15

T033: Drive TapeAlert Flag 3 - Hard read or write error. 10-16

T034: Drive TapeAlert Flag 4 - Media. 10-16

T035: Drive TapeAlert Flag 5 - Read Failure 10-17

T036: Drive TapeAlert Flag 6 - Write Failure 10-17

T037: Drive TapeAlert Flag 8 - Not Data Grade 10-17

T038: Drive TapeAlert Flag 9 - Write Protected 10-17

T039: Drive TapeAlert Flag 12 - Unsupported Format 10-18

T040: Drive TapeAlert Flag 15 - MIC Chip Failure 10-18

T041: Drive TapeAlert Flag 16 - Forced Eject 10-18

T045: Drive TapeAlert Flag 20 - Clean Now 10-19

T046: Drive TapeAlert Flag 21 - Clean Periodic 10-19

T047: Drive TapeAlert Flag 22 - Expired Cleaning Media 10-19

T048: Drive TapeAlert Flag 23 - Invalid Cleaning Tape 10-20

T049: Drive TapeAlert Flag 30 - Hardware A 10-20

T050: Drive TapeAlert Flag 31 - Hardware B 10-21

T051: Drive TapeAlert Flag 32 - Interface 10-21

T052: Drive TapeAlert Flag 33 - Eject media error recovery 10-21

T060: Door Open 10-22

T062: Frame Configuration Problem 10-22

T063: Cannot Read or Mismatch WWN Label 10-23

T064: Library Control Blade hardware failure 10-24

T065: Library Control Blade robot power fuse (F3) blown (42 volt bus) 10-24

T066: Drive power fuse (F1) blown 10-25

T067: Display Assembly hardware failure 10-25

T068: Destination element for a move media is full 10-26

T069: Source element for a move media is empty 10-26

T070: Logical library control path failed 10-26

T071: Power Supply not present 10-27

T072: The system has reported an unmanaged fault. 10-27

T073: I/O Storage Door Open 10-28

T074: Sled Auto-Leveling Failure 10-28

T075: Unsupported Module Configuration 10-29

T076: Robot Initialization Failure 10-29

T077: I/O Station Partially Open or Unplugged 10-30

T080: Control module serial number changed or chassis removed 10-30

T082: Bar Code Scanner not operating 10-31

T083: Robot Assembly not level. 10-31

T084: Library managed cleaning cartridge is missing. 10-32

T085: Cleaning slot occupied by non imported cartridge 10-33

T086: Inaccessible tape cartridge 10-34

Diagnostic Resolutions 10-34

DR001: Manually Recover Tape from Picker 10-34

DR002: Manually Recover Tape from Source or Destination Slot 10-35

DR003: Drive Unload Diagnostic 10-35

DR004: Manually Inspect Destination Element 10-35

DR005: Motion Failure Diagnostic (a Library Verify Test) 10-35

DR006: Drive Diagnostic (a Library Verify Test)	10-36
DR007: Bar Code Scanner Diagnostic (a Library Verify Test)	10-36
DR009: AC Failure Diagnostic	10-37
DR010: Expansion Module Connectivity Diagnostic	10-37
DR011: I/E (I/O Station) Lock Diagnostic (a Library Verify Test)	10-38
DR012: Host Cabling Diagnostic	10-38
DR014: Write Protect or WORM Diagnostic	10-39
DR015: Unsupported Format Diagnostic	10-39
DR018: Manually Clean Drive	10-40
DR019: Door Open Diagnostic	10-40
DR020: Re-inventory the Library	10-40
DR021: Contact Service	10-41
DR022: Power Supply Not Present.	10-41
DR023: I/O Station Magazine Missing	10-41
DR024: Close IO Door	10-41
DR026: Unsupported Module Configuration	10-42
DR027: Replace Library SN Label	10-42
DR028: Motion Obstruction Diagnostic	10-42
DR029: Drive Communication Loss Resolution	10-43
DR030: Drive Load Failure Resolution	10-43
DR031: Robot Initialization Resolution	10-43
DR032: Control Path Failure Resolution	10-44
DR033: Drive Sled Auto Level Resolution	10-44
DR034: IO Storage Door Open Resolution	10-44
DR035: Robot Fuse Blown Resolution.	10-45
DR036: I/O Station Partially Open or Unplugged	10-45
DR039: Logical Library Deletion Required	10-45
DR041: Check Robot Installation	10-46
DR042: Import a Library Cleaning Cartridge	10-46
DR043: Invalid Cartridge in Cleaning Slot	10-46
DR044: Tape Alert 4 Media Error	10-47
DR045: Tape Alert 5, 6 – Read/Write Failure	10-47
DR046: Tape Alert 8 – Suspect Data Grade Tape.	10-47
DR047: Tape Alert 15 – Cartridge Memory Failure	10-48
DR048: Tape Alert 16 – Forced Reject	10-48
DR049 Tape Alert 30, 31 – Drive Hardware Error	10-48
DR050 Remove Cartridge from Invalid Location	10-49

Chapter 11. Add, Remove, Replace Procedures 11-1

Required Library State	11-1
Preparing a Library or Library Module for Repairs	11-2
Returning a Library or Library Module to Normal Operations after Repairs	11-2
Removing/Replacing a Power Supply (Primary and Redundant)	11-2
Removing a Primary Power Supply.	11-4
Replacing a Primary Power Supply	11-4
Adding a Redundant Power Supply	11-4
Removing a Redundant Power Supply.	11-5
Adding/Removing/Replacing a Drive Sled	11-5
Adding a New Drive	11-5

Removing a Drive Sled	11-8
Replacing a Drive Sled	11-9
Removing/Replacing the Library Control Blade and Compact Flash Card	11-11
Removing the Library Control Blade (LCB)	11-11
Replacing the Library Control Blade (LCB)	11-13
Removing/Replacing the Compact Flash Card	11-14
Removing the Compact Flash Card	11-16
Replacing the Compact Flash Card	11-18
Upgrading the Compact Flash Card Firmware	11-18
Library Conversions	11-19
Desktop to Rack Mounted Library Conversion	11-19
Rack Mounted to Desktop Library Conversion	11-19
Removing/Installing Library Foot Pads	11-21
Removing Library Foot Pads	11-21
Installing Library Foot Pads	11-21
Verifying Front and Rear Gear Racks Alignment	11-22

Chapter 12. Parts List 12-1

Appendix A. Message Retrieval at the Host A-1

Obtaining Error Information From an RS/6000	A-1
Library Error Log Example.	A-2
Drive Error Log Example	A-3
SCSI Bus Error Example 1	A-4
SCSI Bus Error Example 2	A-5
Summary Report	A-5
Retrieving from an AS/400 System with RISC Processor.	A-6
AS/400 Product Activity Log	A-8
Retrieving from a Sun System.	A-9
Retrieving from an HP-UX System	A-9

Appendix B. TapeAlert Flags B-1

TapeAlert Flags Supported by the Drive	B-1
--	-----

Appendix C. Sense Data. C-1

Library Sense Data	C-1
Drive Sense Data	C-8

Appendix D. Library Configuration Form D-1

Library Information	D-1
Drive Information.	D-1
SCSI Drives	D-1
Fibre Channel Drives.	D-1
Firmware Information	D-2
Users Account Information.	D-2
My Support.	D-3

Notices E-1

Trademarks	E-2
Electronic Emission Notices.	E-2
Federal Communications Commission (FCC) Class A Statement	E-2
European Union (EU) Electromagnetic Compatibility Directive	E-3

People’s Republic of China Class A Electronic Emission Statement	E-3
Taiwan Class A Electronic Emission Statement	E-3
Japan VCCI Class A ITE Electronic Emission Statement.	E-3
Industry Canada Class A Emission Compliance Statement.	E-3
Avis de conformité à la réglementation d’Industrie Canada	E-4

Germany Electromagnetic Compatibility Directive	E-4
Korean Class A Electronic Emission Statement	E-4

Glossary	F-1
---------------------------	------------

Index	X-1
------------------------	------------

Figures

1-1.	Front panel of a 14U library	1-2	5-6.	Tools menu screen	5-6
1-2.	Rear panel of a 14U library	1-5	5-7.	3576 Tape Library menu tree	5-6
1-3.	Storage columns	1-7	6-1.	Operator Panel Log in screen.	6-2
1-4.	Robotic System of the library.	1-7	8-1.	The IBM TotalStorage LTO Ultrium 400 GB Data Cartridge	8-2
1-5.	SCSI Ultrium 3 Tape Drives in the library control module	1-8	8-2.	Ultrium 3 WORM Tape Cartridge	8-3
1-6.	Library Location Coordinates	1-12	8-3.	Sample bar code label on the LTO Ultrium 3 Tape Cartridge	8-6
1-7.	Drive location coordinates	1-13	8-4.	Setting the write-protect switch	8-7
1-8.	Power supply location coordinates	1-14	8-5.	Tape cartridges in a Turtlecase	8-8
3-1.	Library with internal packaging material	3-2	8-6.	Double-boxing tape cartridges for shipping	8-9
3-2.	Yellow ribbon-like packing pieces	3-3	8-7.	Checking for gaps in the seams of a cartridge	8-10
3-3.	Library packaging material pieces	3-4	8-8.	Leader pin in the incorrect and correct positions	8-11
3-4.	Power Supply	3-5	8-9.	Placing the dislodged leader pin into the correct position	8-12
3-5.	SCSI Drive Sled (detail)	3-6	8-10.	Rewinding the tape into the cartridge	8-12
3-6.	Picker locking mechanism.	3-7	8-11.	Leader Pin Reattachment Kit	8-13
3-7.	Bottom cover of the 5U Control Module	3-8	8-12.	Attaching the leader pin attach tool to the cartridge	8-14
3-8.	Home sensor on inner side of bottom cover	3-9	8-13.	Winding the tape out of the cartridge	8-15
3-9.	Bottom view of picker assembly lock mechanism	3-9	8-14.	Removing the C-clip from the leader pin	8-15
3-10.	Foot pad Locations.	3-11	8-15.	Attaching the leader pin to the tape	8-16
3-11.	Rack Mount Kit hardware (parts not sized proportionately in figure)	3-12	9-1.	Power button LEDs	9-7
3-12.	Library configurations.	3-14	9-2.	Library Control Blade LEDs	9-8
3-13.	EIA identification and rail stud locations for FRONT vertical rack rails	3-15	9-3.	Tape drive LEDs	9-10
3-14.	EIA identification and rail stud locations for REAR vertical rack rails	3-15	9-4.	Power supply LEDs	9-11
3-15.	Rails installed in rack (front view)	3-17	9-5.	Picker LED	9-13
3-16.	Rails installed in rack (rear view)	3-18	9-6.	Cabling of a 5U Library with SCSI Drives	9-13
3-17.	Gear racks positions (rear gear racks shown).	3-19	9-7.	Cabling of a 14U Library with Fibre Drives	9-14
3-18.	Sling handles folded properly	3-20	9-8.	Cabling of a 23U Library with SCSI and Fibre Drives	9-15
3-19.	Rear flange and thumb screw on rack rail	3-21	9-9.	Drive gears	9-16
3-20.	Picker assembly lock mechanism	3-22	11-1.	Power supplies in a control module	11-2
3-21.	Module-to-Module alignment pin and front thumb screw	3-23	11-2.	Power Supply	11-3
3-22.	Sling	3-24	11-3.	Control module with one SCSI drive and one cover plate	11-5
3-23.	Rear thumb screws.	3-25	11-4.	Control module with one SCSI drive installed and one open drive slot with cover plate removed	11-6
3-24.	Installing the rack ears on a Control Module	3-26	11-5.	Control Module with two Drive Sleds	11-7
3-25.	Releasing the picker assembly lock mechanism	3-27	11-6.	Drive sled (detail)	11-9
3-26.	Control Module Drive Sled	3-28	11-7.	Control Module Drive Sled.	11-10
3-27.	Guide rails and guide slots inside a drive slot	3-28	11-8.	Drive sled slot	11-10
3-28.	Tape Drive (detail)	3-29	11-9.	Library Control Blade (LCB)	11-12
3-29.	Control Module Power Supply	3-30	11-10.	Library Control Blade (LCB)	11-13
3-30.	Cabling of a 5U library with fibre drives	3-31	11-11.	Library Control Blade (LCB)	11-14
3-31.	Cabling of a 14U library containing multiple SCSI drives	3-32	11-12.	LCB with compact flash card	11-15
5-1.	Operator Panel common header elements and subsystem status buttons	5-2	11-13.	Removing the Compact Flash Card from the Library Control Blade	11-17
5-2.	Operator Panel Login screen	5-3	11-14.	Removing the rack ears on a Control Module	11-20
5-3.	Home Screen Capacity View	5-4	11-15.	Foot pad Locations	11-22
5-4.	Setup menu screen	5-5	11-16.	Gear rack	11-23
5-5.	Operations menu screen	5-5	11-17.	Picker assembly locking mechanism	11-24

12-1.	Types of Power Cord Receptacles	12-3	A-4.	SCSI Problem Points to Library Control
A-1.	AIX ERRPT Library Error Log Example	A-2		Path as Possible Cause. A-5
A-2.	AIX ERRPT Drive Error Log Example	A-3	A-5.	AIX ERRPT Commands Error Log Example A-5
A-3.	Example of Error Suggesting SCSI Bus Problem, Which Takes Down Entire Bus . . .	A-4		

Tables

1-1.	Library I/O Station configurations	1-3	5-2.	Administrative User and User Command and Access	5-9
1-2.	Optional features	1-8	5-3.	Web User Interface Menu Commands and Access	5-10
1-3.	Licensable cartridge slots (storage and I/O) per model	1-10	8-1.	Ultrium data cartridge compatibility with Ultrium 3 tape drive	8-2
1-4.	Environment for operating, storing, and shipping the IBM LTO Ultrium Tape Cartridge	1-15	8-2.	Bar code label requirements for Ultrium tape drives and libraries	8-5
1-5.	Physical specifications for the library	1-15	8-3.	Cartridges and VOLSERS compatible with the Ultrium 3 Tape Drive	8-5
1-6.	Library component weight	1-15	8-4.	Environment for operating, storing, and shipping the LTO Ultrium Tape Cartridge	8-17
1-7.	Power specifications for a maximum configuration of the library	1-16	8-5.	Media supplies	8-18
1-8.	Other specifications for the library	1-16	8-6.	Authorized suppliers of custom bar code labels	8-19
1-9.	Environmental specifications for the library	1-16	9-1.	LCB LEDs	9-8
2-1.	Default SCSI ID for each SCSI drive in a 14U library	2-4	9-2.	Amber LED on an LCB	9-9
2-2.	Default Loop IDs and their associated AL_PAs for Ultrium Tape Drives in a 14U library	2-5	9-3.	Tape Drive Activity	9-10
2-3.	Valid Loop IDs and their associated AL_PAs for Ultrium Tape Drives in the library	2-5	9-4.	Fibre Port Link LED on Tape Drive	9-11
2-4.	Choosing the port for your topology and Fibre Channel connection	2-7	9-5.	Power Supply LEDs	9-12
2-5.	Maximum bus length between terminators	2-8	11-1.	Library state required when servicing library components	11-1
2-6.	Recommended maximum quantity of drives per SCSI bus	2-9	12-1.	Power Cords	12-3
3-1.	Shipment contents	3-1	A-1.	AIX ERRPT Library Sense Data	A-2
3-2.	Rack Mount Kit contents	3-12	A-2.	AIX ERRPT Drive Sense Data	A-3
3-3.	Additional Rack Hardware Kit contents (included with each expansion module)	3-13	B-1.	TapeAlert Flags Supported by the Ultrium Tape Drive	B-1
5-1.	Menus available from the Web User Interface	5-7	C-1.	Library Sense Data and associated ASC/ASCQs	C-1
			C-2.	LTO Tape Drive Sense Data	C-8

Safety and Environmental Notices

When using this product, observe the danger, caution, and attention notices that are contained in this guide. The notices are accompanied by symbols that represent the severity of the safety condition.

The sections that follow define each type of safety notice and give examples.





Danger Notice



A danger notice calls attention to a situation that is potentially lethal or extremely hazardous to people. A lightning bolt symbol always accompanies a danger notice to represent a dangerous electrical condition

Caution Notice

A caution notice calls attention to a situation that is potentially hazardous to people because of some existing condition. A caution notice can be accompanied by one of several symbols:

If the symbol is...	It means....
	A hazardous electrical condition with less severity than electrical danger.
	A generally hazardous condition not represented by other safety symbols.
	A hazardous condition due to the use of a laser in the product. Laser symbols are always accompanied by the classification of the laser as defined by the U. S. Department of Health and Human Services (for example, Class I, Class II, and so forth).
	A hazardous condition due to mechanical movement in or around the product.
 32-55 kg (70.5-121.2 lbs)	A hazardous condition due to the weight of the unit. Weight symbols are accompanied by an approximation of the product's weight.

Possible Safety Hazards

Possible safety hazards to the operation of this product are:

Electrical An electrically charged frame can cause serious electrical shock.

Mechanical Hazards, such as a safety cover missing, are potentially harmful to people.

Chemical Do not use solvents, cleaners, or other chemicals not approved for use on this product.

Repair any of the preceding problems before you use the library.

Laser Safety and Compliance

Before using the library, review the following laser safety information.

Class I Laser Product

The library may contain a laser assembly that complies with the performance standards set by the U.S. Food and Drug Administration for a Class I laser product. Class I laser products do not emit hazardous laser radiation. The library has the necessary protective housing and scanning safeguards to ensure that laser radiation is inaccessible during operation or is within Class I limits. External safety agencies have reviewed the library and have obtained approvals to the latest standards as they apply.

Protective Devices

The library has the following protective devices:

- Monitored access to the library
- Main power switch

The sections that follow describe each type of protection.

Monitored Access to the Library

The library is completely surrounded by an enclosure. The library can be accessed only through monitored access areas.

The enclosure around the library separates the danger area of the library from the normal working area. The danger area is the area in which personnel can be injured by component movements.



CAUTION:

Movements of mechanical components in the library can cause serious injury. Access to the library should be restricted to authorized personnel only.

Main Power Switch

To turn ON the power to the library, press 1 on each power switch installed in the library. To turn OFF the power, press 0 on the switch. In case of danger to personnel or property, immediately turn OFF the main power switch.



CAUTION:

To completely remove all power, disconnect the line cord from the electrical outlet.

Attention: Except in emergencies, stop the library with the normal shutdown procedure before you switch OFF the main power switch. IBM is not responsible for damage caused by improper use of the main power switch. Such risk lies entirely with the user.



CAUTION:

Movements of mechanical components in the tape library can cause serious injury. Before turning the main power switch ON and restarting the tape library, confirm that no danger exists to personnel or property.

Rack Safety

The following general safety information should be used for all rack mounted devices.

DANGER

- Always lower the leveling pads on the rack cabinet.
- Always install stabilizer brackets on the rack cabinet.
- To avoid hazardous conditions due to uneven mechanical loading, always install the heaviest devices in the bottom of the rack cabinet. Always install servers and optional devices starting from the bottom of the rack cabinet.
- Rack mounted devices are not to be used as a shelf or work space. Do not place any object on top of rack mounted devices.
- Each rack cabinet might have more than one power cord. Be sure to disconnect all power cords in the rack cabinet before servicing any device in the rack cabinet.
- Connect all devices installed in a rack cabinet to power devices installed in the same rack cabinet. Do not plug a power cord from a device installed in one rack cabinet into a power device installed in a different rack cabinet.
- An electrical outlet that is not correctly wired could place hazardous voltage on the metal parts of the system or the devices that attach to the system. It is the responsibility of the customer to ensure that the outlet is correctly wired and grounded to prevent an electrical shock.

CAUTION:

- **Do not install a unit in a rack where the internal rack ambient temperatures will exceed the manufacturer's recommended ambient temperature for all your rack mounted devices.**
- **Do not install a unit in a rack where the air flow is compromised. Ensure that air flow is not blocked or reduced on any side, front, or back of a unit used for air flow through the unit.**
- **Consideration should be given to the connection of the equipment to the supply circuit so that overloading of the circuits does not compromise the supply wiring or overcurrent protection. To provide the correct power connection to a rack, refer to the rating labels located on the equipment in the rack to determine the total power requirement of the supply circuit.**
- *(For sliding drawers)* **Do not pull out or install any drawer or feature if the rack stabilizer brackets are not attached to the rack. Do not pull out more than one drawer at a time. The rack may become unstable if you pull out more than one drawer at a time.**
- *(For fixed drawers)* **This drawer is a fixed drawer and should not be moved for servicing unless specified by the manufacturer. Attempting to move the drawer partially or completely out of the rack may cause the rack to become unstable or cause the drawer to fall out of the rack.**

(R001)

CAUTION:

Removing components from the upper positions in the rack cabinet improves rack stability during relocation. Follow these general guidelines whenever you relocate a populated rack cabinet within a room or building:

- Reduce the weight of the rack cabinet by removing equipment starting at the top of the rack cabinet. When possible, restore the rack cabinet to the configuration of the rack cabinet as you received it. If this configuration is not known, you must do the following:
 - Remove all devices in the 32U position and above.
 - Ensure that the heaviest devices are installed in the bottom of the rack cabinet.
 - Ensure that there are no empty U-levels between devices installed in the rack cabinet below the 32U level.
- If the rack cabinet you are relocating is part of a suite of rack cabinets, detach the rack cabinet from the suite.
- Inspect the route that you plan to take to eliminate potential hazards.
- Verify that the route that you choose can support the weight of the loaded rack cabinet. Refer to the documentation that comes with your rack cabinet for the weight of a loaded rack cabinet.
- Verify that all door openings are at least 760 x 230 mm (30 x 80 in.).
- Ensure that all devices, shelves, drawers, doors, and cables are secure.
- Ensure that the four leveling pads are raised to their highest position.
- Ensure that there is no stabilizer bracket installed on the rack cabinet during movement.
- Do not use a ramp inclined at more than ten degrees.
- Once the rack cabinet is in the new location, do the following:
 - Lower the four leveling pads.
 - Install stabilizer brackets on the rack cabinet.
 - If you removed any devices from the rack cabinet, repopulate the rack cabinet from the lowest position to the highest position.
- If a long distance relocation is required, restore the rack cabinet to the configuration of the rack cabinet as you received it. Pack the rack cabinet in the original packaging material, or equivalent. Also lower the leveling pads to raise the casters off of the pallet and bolt the rack cabinet to the pallet.

(R002)

Power Cords



To avoid electrical shock, a power cord with a grounded attachment plug has been provided. Use only properly grounded outlets.

All power cords use an appliance coupler that complies with the International Electrotechnical Commission (IEC) Standard 320, Sheet C13.

If the power cord that you receive does not match your receptacle, contact your local dealer.

Power cords used in the United States and Canada are listed by Underwriter's Laboratories (UL), are certified by the Canadian Standards Association (CSA), and comply with the plug standards of the National Electrical Manufacturers Association (NEMA).

Disposal of Library Components Containing Mercury

The fluorescent lamp in the liquid crystal display contains mercury. Dispose of it as required by local ordinances and regulations.

European Directive About Product Recycling and Disposal

This unit must be recycled or discarded according to applicable local and national regulations. IBM encourages owners of information technology (IT) equipment to responsibly recycle their equipment when it is no longer needed. IBM offers a variety of product return programs and services in several countries to assist equipment owners in recycling their IT products. Information on IBM product recycling offerings can be found on IBM's Internet site at <http://www.ibm.com/ibm/environment/products/prp.shtml>.

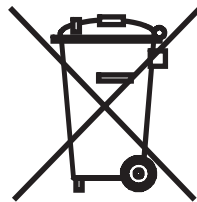

Notice: This mark applies only to countries within the European Union (EU) and Norway.

This appliance is labelled in accordance with European Directive 2002/96/EC concerning waste electrical and electronic equipment (WEEE). The Directive determines the framework for the return and recycling of used appliances as applicable throughout the European Union. This label is applied to various products to indicate that the product is not to be thrown away, but rather reclaimed upon end of life per this Directive.

In accordance with the European WEEE Directive, electrical and electronic equipment (EEE) is to be collected separately and to be reused, recycled, or recovered at end of life. Users of EEE with the WEEE marking per Annex IV of the WEEE Directive, as shown above, must not dispose of end of life EEE as unsorted municipal waste, but use the collection framework available to customers for the return, recycling and recovery of WEEE. Customer participation is important to minimize any potential effects of EEE on the environment and human health due to the potential presence of hazardous substances in EEE. For proper collection and treatment, contact your local IBM representative.

注意：このマークは EU 諸国およびノルウェーにおいてのみ適用されます。

この機器には、EU 諸国に対する廃電気電子機器指令 2002/96/EC(WEEE) のラベルが貼られています。この指令は、EU 諸国に適用する使用済み機器の回収とリサイクルの骨子を定めています。このラベルは、使用済みになった時に指令に従って適正な処理をする必要があることを知らせるために種々の製品に貼られています。

Remarque : Cette marque s'applique uniquement aux pays de l'Union Européenne et à la Norvège.

L'étiquette du système respecte la Directive européenne 2002/96/EC en matière de Déchets des Equipements Electriques et Electroniques (DEEE), qui détermine les dispositions de retour et de recyclage applicables aux systèmes utilisés à travers l'Union européenne. Conformément à la directive, ladite étiquette précise que le produit sur lequel elle est apposée ne doit pas être jeté mais être récupéré en fin de vie.

Battery Return Program

This product may contain sealed lead acid, nickel cadmium, nickel metal hydride, lithium, or lithium ion battery. Consult your user manual or service manual for specific battery information. The battery must be recycled or disposed of properly. Recycling facilities may not be available in your area. For information on disposal of batteries outside the United States, go to <http://www.ibm.com/ibm/environment/products/batteryrecycle.shtml> or contact your local waste disposal facility.

In the United States, IBM has established a return process for reuse, recycling, or proper disposal of used IBM sealed lead acid, nickel cadmium, nickel metal hydride, and other battery packs from IBM Equipment. For information on proper disposal of these batteries, contact IBM at 1-800-426-4333. Please have the IBM part number listed on the battery available prior to your call.

In Taiwan, the following applies:



Please recycle batteries.

廢電池請回收

Cable Warning

WARNING: Handling the cord on this product or cords associated with accessories sold with this product, will expose you to lead, a chemical known to the State of California to cause cancer, and birth defects or other reproductive harm. **Wash hands after handling.**

Preface

This manual contains information and instructions necessary for the installation, operation, and service of the IBM® System Storage™ TS3310 Tape Library.

Intended Audience

The information in this manual is intended for use by end users.

Related Publications

Refer to the following publications for additional information. To ensure that you have the latest publications, visit the web at <http://www.ibm.com/storage/lto>.

- *IBM System Storage TS3310 Tape Library SCSI Reference* (GA32-0476) provides supported SCSI commands and protocol governing the behavior of SCSI interface.
- *IBM System Storage TS3310 Tape Library Maintenance Information* (GA32-0478) provides information for installation, operation, and maintenance.
- *IBM Ultrium Device Driver Installation and User's Guide* (GA32-0430) provides instructions for attaching IBM-supported hardware to open-systems operating systems. It indicates what devices and levels of operating systems are supported. It also gives requirements for adapter cards, and tells how to configure hosts to use the device driver. All of the above are with the Ultrium family of devices.
- *IBM Ultrium Device Driver Programming Reference* (GC35-0483) supplies information to application owners who want to integrate their open-systems applications with IBM-supported Ultrium hardware. The reference contains information about the application programming interfaces (APIs) for each of the various supported operating-system environments.

Chapter 1. Product Description

“Front Panel Components” on page 1-2

“Rear Panel Components” on page 1-5

“Interior Components” on page 1-6

“Optional Features” on page 1-8

“Location Coordinates” on page 1-11

“Media” on page 1-14

“Multi-Path Architecture” on page 1-15

“Specifications” on page 1-15

“Product Environment” on page 1-16

“Supported Servers, Operating Systems, and Software” on page 1-17

“Supported Device Drivers” on page 1-17

The IBM System Storage™ TS3310 Tape Library offers high performance, capacity, and technology designed for reliability and the heavy demands of tape storage. This library is highly modular with scalability varying from the base library 5U control module to additional expansion units of 9U height each. This automated tape library incorporates high-performance IBM LTO Ultrium 3 Tape Drives for the midrange to enterprise open systems environment. Tape cartridge physical capacity has doubled to 400 GB native capacity (800 GB with 2:1 compression) with the IBM TotalStorage® LTO Ultrium 400 GB Data Cartridge (for use only with Ultrium 3 format tape drives), and drive performance has more than doubled to 80 MB/second native data transfer rate with the IBM TotalStorage LTO Ultrium 3 Tape Drives compared to IBM LTO Ultrium 2 Tape Drives. IBM LTO Ultrium 3 tape drives can read and write original LTO Ultrium 2 data cartridges and read LTO Ultrium 1 data cartridges.

The TS3310 library contains the library control module, fixed tape cartridge storage of 30 slots, I/O station of 6 slots, a touch screen display, cartridge handling robotics, and up to two LTO Ultrium 3 tape drives.

The 14U library contains the 5U library plus a optional expansion modules. Each 9U expansion module can accommodate up to 4 LTO Ultrium 3 Tape Drives and up to 80 tape cartridge slots, and 12 configurable I/O station slots.

This library supports LTO Ultrium 3 Tape Drives with either LVD Ultra160 SCSI or native switched fabric Fibre Channel attachment for connection to a wide spectrum of open system servers.

Front Panel Components

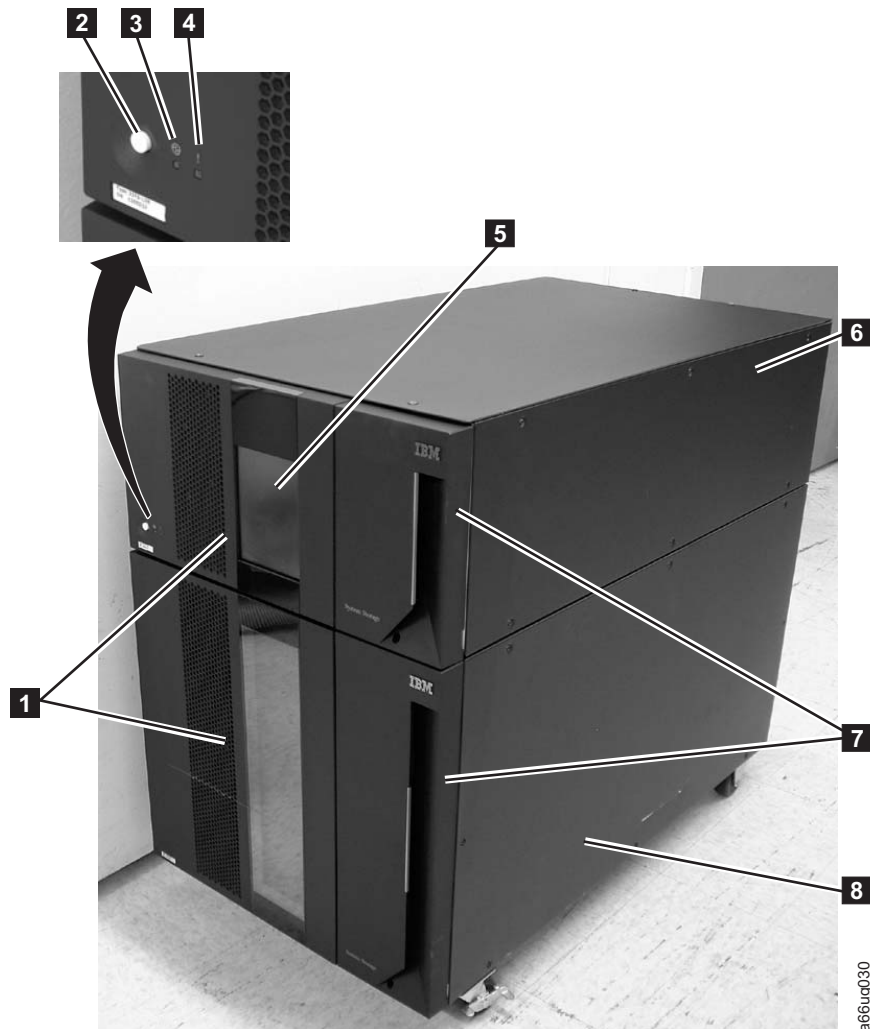

Figure 1-1. Front panel of a 14U library

1	Access doors	5	Operator Panel
2	Power button	6	5U control module
3	Green power ON LED	7	I/O Stations
4	Amber Operator Intervention Alert LED	8	9U expansion module

Control Module (3576 Model L5B)

All library configurations include the control module (**6** in Figure 1-1). The control module contains the robotics, library control blade (LCB), and touch screen display. The control module also contains an I/O station, fixed storage slots, tape drives, and at least one power supply.

The control module can contain one or two tape drives and one or two power supplies. At least one power supply is always required.

Expansion Module (3576 Model L5B)

Each 9U expansion module (**8** in Figure 1-1 on page 1-2) is a supplementary module that is attached to the 5U Control Module. Like the control module, the expansion modules provide fixed storage slots, tape drive slots, and power supply slots. The I/O station in an expansion module can be configured as storage.

If an expansion module contains only cartridges, all power is derived from the control module.

I/O Station

I/O Stations (7 in Figure 1-1 on page 1-2) are located on the front panel of the library and enable the importing and exporting of cartridges without interrupting normal library operations. A control module I/O Station has a capacity of six cartridges. A 9U expansion module I/O Station has a capacity of 12 cartridges.

When an I/O Station slot is assigned to a logical library, only that logical library can access that slot. The I/O Station is shared among all logical libraries, but the I/O Station slots are owned by one logical library at a time.

In a 5U library, the six I/O Station slots cannot be configured as storage. In a library that has expansion modules, the I/O Stations can be configured as follows:

Table 1-1. Library I/O Station configurations

No. of I/O Station Slots	Location of I/O Station Slots
6	All six I/O Station slots are in the control module.
12	All twelve I/O Station slots are in the 9U expansion module.
18	Six of the I/O Station slots are in the control module. The remaining twelve I/O Station slots are in the 9U expansion module.
24	All twenty-four I/O Station slots are in the 9U expansion modules.
30	Six of the I/O Station slots are in the control module. The remaining twenty-four I/O Station slots are in the 9U expansion modules.

Note: I/O slots can be reassigned each time the I/O Station is opened by rearranging the order of the cartridges in the I/O Station.

Access Door

Each control module and expansion module has a door on the front panel that allows access to the internal components of the library.

This door is locked by the I/O Station. To open the Access Door (**1** in Figure 1-1 on page 1-2), you must first open the I/O Station.

If you want to restrict access to the library, lock the I/O Station door. To do this:

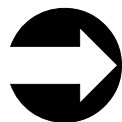

From the Operator Panel: **Operations** → **I/O Station Lock/Unlock**

Attention: When any Access Door is opened, all in-progress motion commands stop, the Picker lowers to the bottom of the library, and the library is taken offline (the library must be put back online manually). When the Access Door is closed, the library returns any media in the Picker to its original storage slot.

Operator Panel

The Operator Panel (**5** in Figure 1-1 on page 1-2) is the touchscreen display device located on the Access Door of the control module. Library operations and service functions are performed from this screen.

The Web User Interface offers some of the same functionality as the Operator Panel via a web browser which enables remote access to the library. For more information on the Operator Panel and the Web User Interface, see Chapter 5, "User Interfaces," on page 5-1.

Power Button

Pressing the Power Button (**2** in Figure 1-1 on page 1-2) on the front panel of a control module turns the Picker and Operator Panel ON or OFF; however, power is still applied to the power supplies. The Power Button is used during library shutdown and to manually reboot the library.

Front Panel LEDs

Two LEDs are located on the front of the library to the right of the Power Button.

- Green power ON LED (**3** in Figure 1-1 on page 1-2): When lit, this LED indicates that the library power is ON.
- Amber Operator Intervention Alert LED (**4** in Figure 1-1 on page 1-2): When lit, this LED indicates that there is a Library, Drives, or Media Operator Intervention available. To access the Operator Intervention, select **Tools** → **Operator Intervention** from the Operator Panel.

Rear Panel Components

The following components are located on the rear panel of the library:

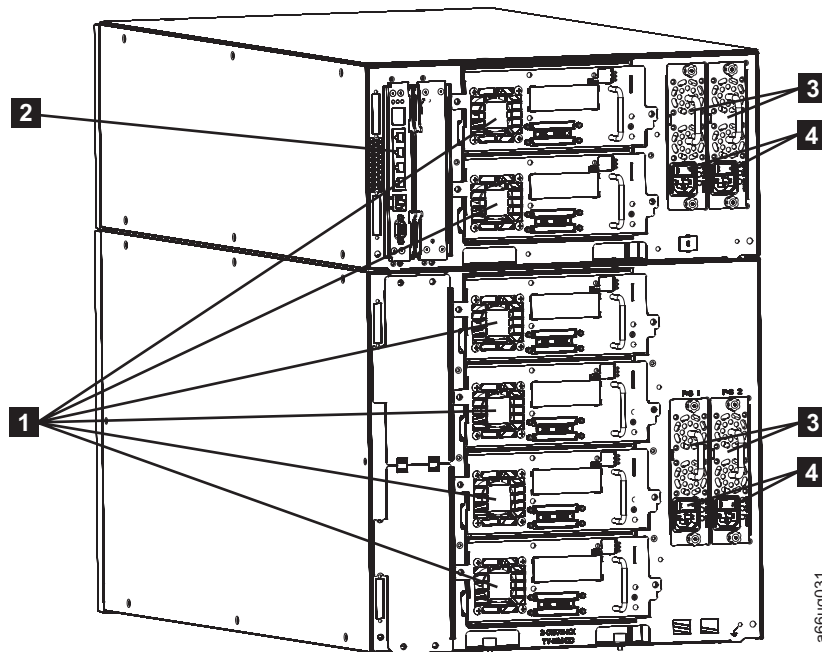

Figure 1-2. Rear panel of a 14U library

- | | | | |
|----------|---------------------------------|----------|---|
| 1 | Tape drives (SCSI drives shown) | 3 | Power supplies (2 in control module; 2 in expansion module) |
| 2 | Library Control Blade | 4 | Power supply switches |

Library Control Blade (LCB)

The Library Control Blade (**2** in Figure 1-2) manages the entire library, including the Operator Panel and Picker, and is responsible for running system tests to ensure that the library is functioning properly.

The LCB houses the Compact Flash Card which stores vital product data (VPD) such as library settings, serial number, etc.

The LCB indicates status with three light emitting diodes (LEDs). These LEDs, located near the top of the LCB, are green, amber, and blue in color.

- Green indicates a good status.
- Amber indicates a degraded status.
- Blue indicates a potential fault. See “Interpreting LEDs” on page 9-6.

Tape Drives

The library supports Ultrium 3 SCSI and Fibre Channel tape drives.

Tape drives (**1** in Figure 1-2) are hot addable (library power remains ON and operations of the installed tape drives are still active). Drives can be removed and installed without tools.

SCSI tape drives are attached directly to a host. Fibre Channel tape drives can be directly attached to a host or a Storage Area Network (SAN).

Drives mounted in sleds are installed into tape drive slots in the rear of the library. If a tape drive slot is empty, a metal plate covers the empty drive slots to prevent debris from entering the library.

Power Supply

The library supports single and redundant power configurations. Each module must have at least one power supply. A single power configuration will have a power supply installed in the left slot of each library module. A redundant power configuration will have power supplies installed in both slots of each library module.

The single configuration has a single AC line input and a single DC power supply. The optional redundant configuration has dual AC line input and dual DC power supplies. A power supply (**3** in Figure 1-2 on page 1-5) can be hot swapped if the library has a redundant power supply. A redundant power supply can be hot added.

A power switch (**4** in Figure 1-2 on page 1-5) is located on every power supply on a control module and expansion module. This switch is used to remove all power from the library for emergency and service situations. Except in emergency situations, use the shutdown procedure before switching off the power switch. For more information, see “Shutting Down the Library” on page 7-8.

The power system of the library contains the following components:

- Power supply
- AC power cord

The power supply has three light emitting diodes (LEDs) that provide status information. These LEDs, located to the right of the power switch, are green, amber, and blue in color.

- Green indicates a good AC or DC status.
- Amber indicates a degraded status.
- Blue indicates a potential fault. See “Interpreting LEDs” on page 9-6

Interior Components

The following components are located inside the library:

- “Storage Columns” on page 1-7
- “Robotic System” on page 1-7

Storage Columns

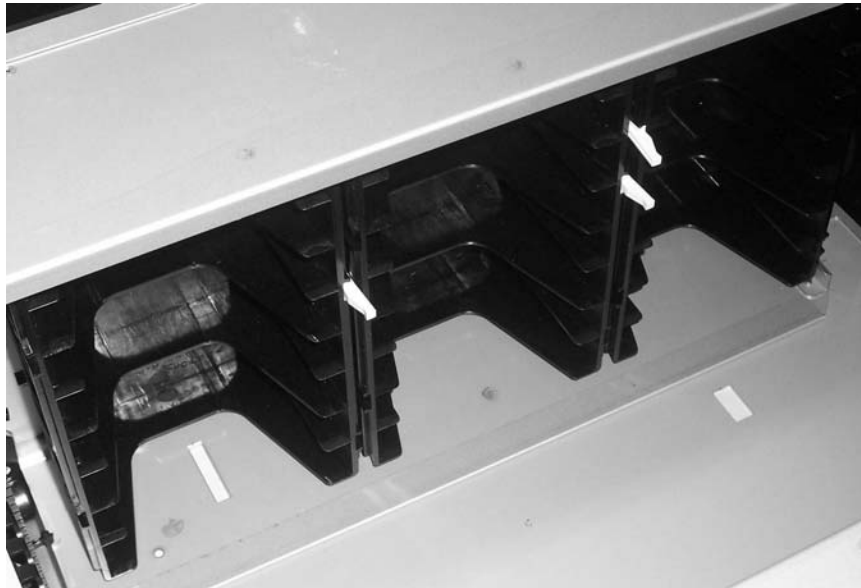

Figure 1-3. Storage columns

Storage columns within the library store cartridges while they are not being utilized by a drive. The library contains six storage columns. One of those six columns is the I/O Station.

Robotic System

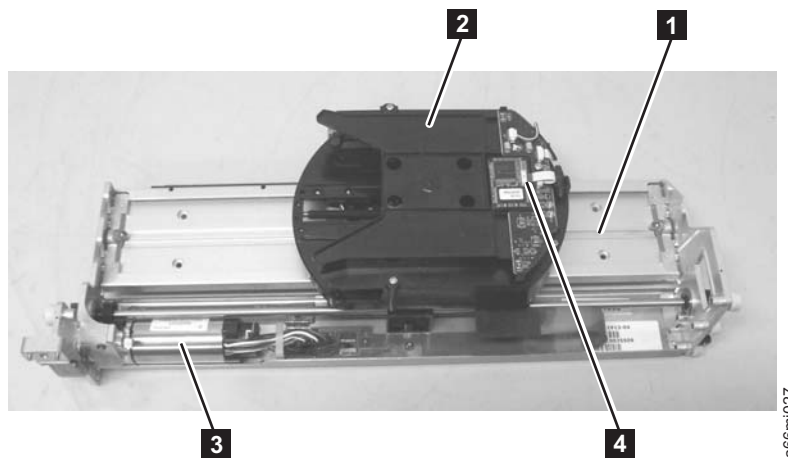

Figure 1-4. Robotic System of the library

The Robotic System includes the Y-axis Assembly which houses the Y Motor (**3** in Figure 1-4), the Picker (**2** in Figure 1-4) which is attached to the Carrier (**1** in Figure 1-4), and the Bar Code Scanner (**4** in Figure 1-4). The Climber moves the Robotic System within the library.

The Picker (robotic arm) has fingers that enable it to grab tape cartridges and move them to and from the I/O Station, storage slots, and drives. The Bar Code Scanner

reads each cartridge bar code label and the fiducial labels that identify the types of cartridge magazines and tape drives installed in the library.

Optional Features

The table below lists additional features that can be added to the library to enhance performance.

Table 1-2. Optional features

Type of Feature	Description	Feature Code
Ultrium 3 Tape Drives	SCSI	8037
	4 Gb Fibre Channel	8042
Power Supply	Redundant	1900
Feature Licenses	Capacity Expansion	1640
	Path Failover	1682
Library and Drive Code Update	Library and drive code update by an IBM Service Representative	0500
Rack Mount Kit	Hardware required to mount your library in a rack	7003
Rack PDU Line Cord		9848

For information on ordering additional features or replacement parts for your library, see Chapter 12, “Parts List,” on page 12-1.

Ultrium 3 Tape Drives

This library supports the Ultrium 3 Tape Drive. Each tape drive in the library is packaged in a container called a drive sled. The drive is a customer replaceable unit (CRU), and is designed for quick removal and replacement in the library.

The IBM Ultrium 3 Tape Drive supports LVD Ultra160 or Fibre Channel interfaces. It features two HD68 connectors or one LC Fibre Channel connector.

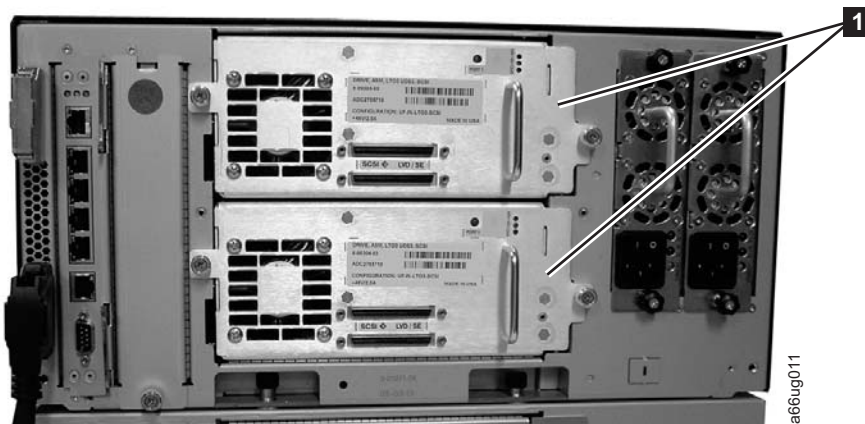

Figure 1-5. SCSI Ultrium 3 Tape Drives in the library control module

Note: LTO-3 SCSI and Fibre Channel drives are not allowed in the same logical library.

Speed Matching

To improve system performance, the Ultrium 3 Tape Drive uses a technique called *speed matching* to dynamically adjust its native (uncompressed) data rate to the slower data rate of the attached server.

Channel Calibration

The channel calibration feature of the Ultrium 3 Tape Drive customizes each read/write data channel for optimum performance. The customization enables compensation for variations in the recording channel transfer function, media characteristics, and read/write head characteristics.

Power Management

The Ultrium 3 Tape Drive's power management function controls the drive's electronics so that part of the electronics completely turn OFF when circuit functions are not needed for the drive's operation.

Redundant Power Supply (Feature Code 1900)

The optional redundant configuration power supplies may be hot swapped without interrupting library operation. Each supply in a control module and expansion module includes its own input AC line cord. During redundant operation, each supply carries one-half the power load. If a line cord or power supply fails, the second supply sources the complete power load. Optionally, a single power supply and line cord may be installed if redundant power is not required. The second power supply slot is physically covered in this configuration. The library may be upgraded to redundant power at a later time.

Feature Licenses

A feature license controls the setting of feature-enabled flags that are based on a user input key and the library serial number that is stored in the library vital product data (VPD). A unique key exists for each library based on an encryption of the chassis serial number and a feature code.

After a feature is enabled, it cannot be disabled. The library's serial number can only be assigned at the factory.

The library uses feature licenses to enable the Capacity Expansion feature and the Path Failover feature.

Capacity Expansion (Feature Code 1640)

At any time, the Capacity Expansion feature (Feature Code 1640) allows you to enable the unused storage slots within a library via a firmware license key.

The TS3310 Tape Library Model L5B control module includes license key enablement for 82 total cartridges, thus enabling all cartridge slots in the L5B and approximately one half the capacity of an added TS3310 Tape Library Model E9U expansion module. Enabling the remaining cartridge storage slots in the E9U expansion module requires the purchase of the Capacity Expansion feature #1640. One Capacity Expansion feature #1640 would be required to totally access and enable all available cartridge slots in a 14U configured library (one L5B and one E9U). Two Capacity Expansion features #1640 would be required to totally access and enable all available cartridge slots in a 23U configured library (one L5B and two E9Us).

To see your library's current configuration:



- From the Operator Panel: view the **Capacity View** home screen.
- From the Web User Interface: **Monitor System** → **System Summary**

To enter a Capacity Expansion license key:



From the Operator Panel: **Setup** → **License**

When the license key is entered, the total number of available slots in the library increases. To verify that the number of slots did increase:



- From the Operator Panel, view the Capacity View home screen.
- From the Web User Interface: **Monitor System** → **System Summary**

Table 1-3. Licensable cartridge slots (storage and I/O) per model

Library Configuration	Number of Available I/O Station Slots*	Number of Accessible Storage Slots	Total Slots**	Capacity Expansion License Keys required for...
5U library (control module)	6	30	36	no license key required
14U library (control module + 9U expansion module)	6/12/18	76/70/ 64	82	no license key required
	6/12/18	122/116/110	128	1 license key required (to enable the full capacity of a 14U library)
23U library (control module + 2 9U expansion modules)	6/12/18/ 24/30	168/162/156// 150/144	174	first license key enables additional 46 slots of second 9U expansion module
	6/12/18/ 24/30	212/206/200/ 194/188	218	2 license keys required to enable the full capacity of a 23U library

*The I/O station, in the 9U expansion module, contains 12 slots which can be configured as either I/O or storage slots. If the 9U expansion module I/O slots are configured as I/O, the control module slots can be configured as storage slots.

**The number of available I/O and storage slots listed in the table above are adjusted for the unusable slots in each configuration that are not accessible due to space restrictions which limit the movement of the Picker.

Path Failover (Feature Code 1682)

The Path Failover feature includes license keys for activating control path failover and data path failover.

Control Path Failover

A control path is a logical path into the library through which a server sends standard SCSI Medium Changer commands to control the logical library. Additional control paths reduce the possibility that failure in one control path will cause the entire library to be unavailable. Use of the control path failover feature further reduces that possibility. For more information, see “Using Multiple Control Paths” on page 2-2).

Data Path Failover

Data Path Failover is designed to provide a failover mechanism in the IBM device driver, which enables you to configure multiple redundant paths in a SAN environment. In the event of a path or component failure, the failover mechanism is designed to automatically provide error recovery to retry the current operation using an alternate, pre-configured path without aborting the current job in progress. This allows you flexibility in SAN configuration, availability, and management. For more information, see “Using Multiple Data Paths for Data Path Failover” on page 2-3.

Library & Drive Code Update (Feature Code 0500)

Order feature code 0500, Library and Drive Code Update, if you would like an IBM Service Representative dispatched to your location to update your library and drive firmware.

Location Coordinates

A numbering system is used to identify components of the library. The library location coordinates contain the following digits: [Module],[Column],[Slot]. The figure below illustrates how a library with a control module and an expansion module are numbered.

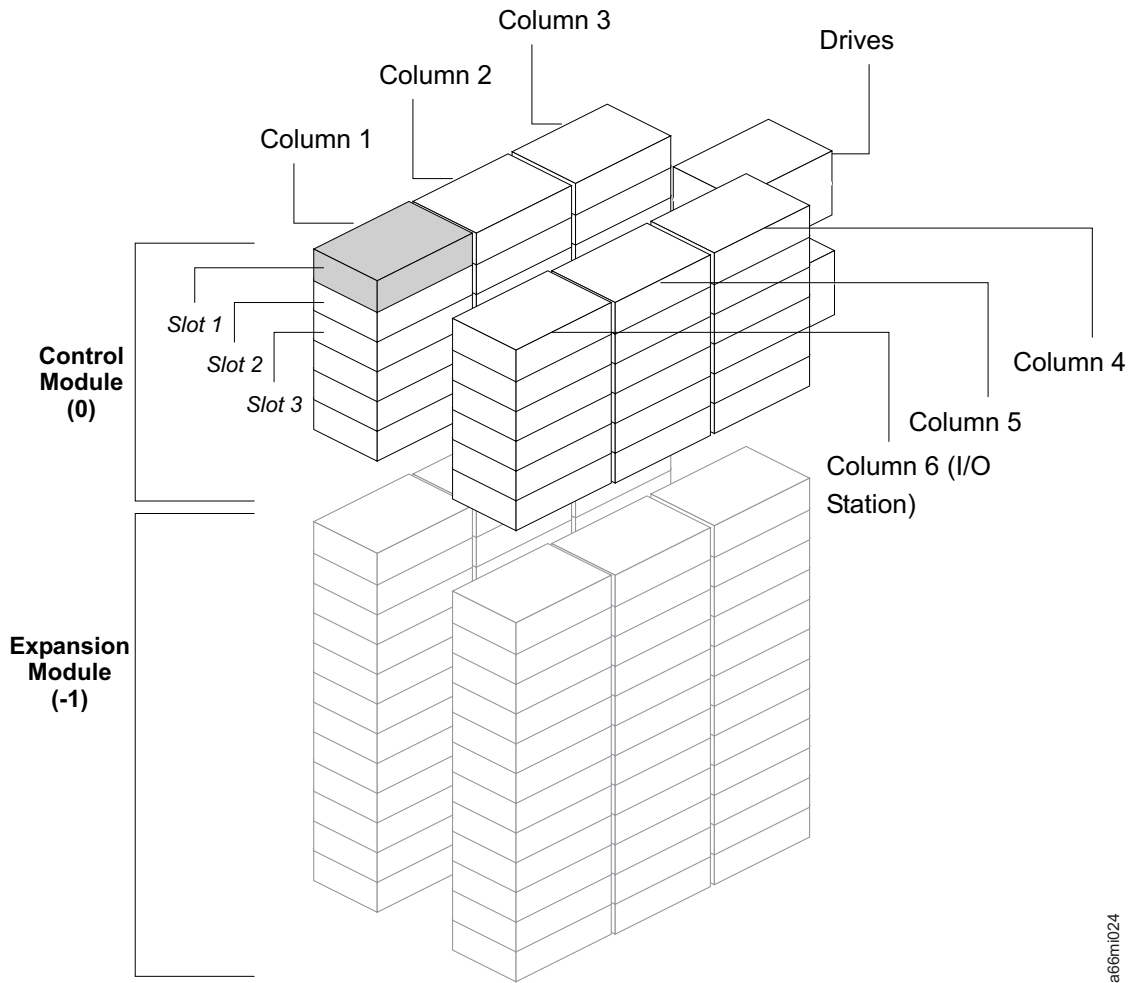

Figure 1-6. Library Location Coordinates

The module digit uses a zero-based numbering system. The control module is labeled as 0 (zero). The front, left-most column in the module is labeled 1. The top slot in each column is labeled 1. For more information, refer to the sections that follow.

Modules

Library modules are represented by the first digit of a library coordinate. Modules are identified relative to the control module (CM). The CM is number 0. The module stacked below the CM is numbered with a negative integer depending on its relative position to the CM. The expansion module directly below the CM is number -1. If there is an expansion module installed about the CM, it will be numbered +1.

Columns

A storage column is a group of slots arranged vertically in the library. Columns are represented by the second digit of a library coordinate. Columns are identified relative to the front left of the library. The column in the front left of the library is number 1. The column numbering continues around the library in a clockwise direction. The I/O Station column is always number 6.

Slots

Fixed storage slots are represented by the third digit of the library location coordinate. Slots are numbered from top to bottom within each column starting with 1 at the top of the column.

Drives

Drives are addressed by module and drive bay within a module. The drive bays within a module are numbered from top to bottom. A one-based numbering system is used. The top drive bay is drive bay 1. A full address of a drive is of the form [Module, Drive Bay], examples: [0,1], [-1,2].

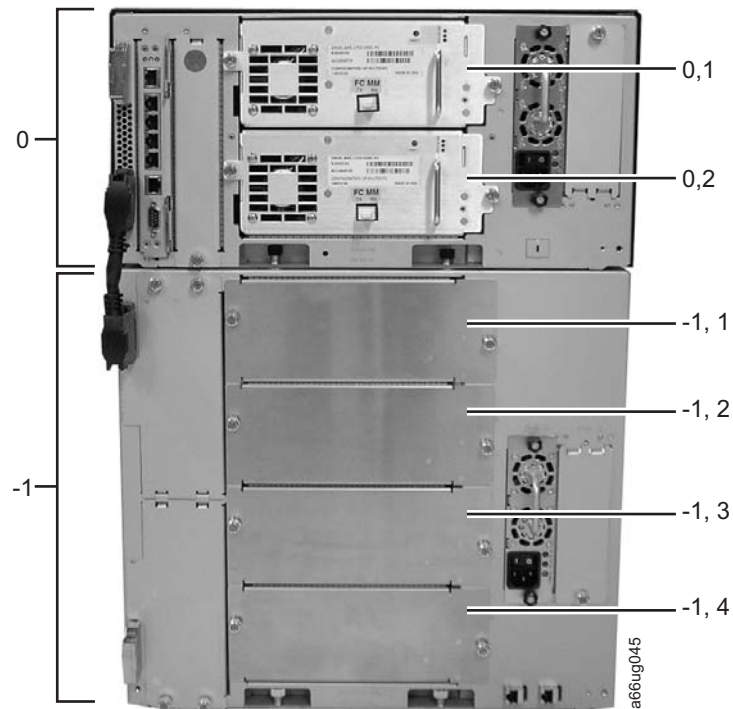

Figure 1-7. Drive location coordinates

Power Supplies

Power supplies are addressed as [Module, PS#], where PS# is 1 for the left supply and 2 for the right.



Figure 1-8. Power supply location coordinates

- | | | | |
|----------|---|----------|---|
| 1 | 0, PS1 (primary power supply in a control module) | 2 | 0, PS2 (redundant power supply in a control module) |
|----------|---|----------|---|

Media

The library uses Ultrium Tape Cartridges that provide up to 400 GB native capacity (up to 800 GB with 2:1 hardware data compression).

Supported cartridges include:

- IBM TotalStorage LTO Ultrium 400 GB Data Cartridge (Ultrium 3)
- IBM TotalStorage Write-Once-Read-Many Data Cartridge (WORM; Ultrium 3 only)
- IBM TotalStorage LTO Ultrium 200 GB Data Cartridge (Ultrium 2)
- IBM LTO Ultrium 100 GB Data Cartridge (Ultrium 1; read only)
- IBM TotalStorage LTO Ultrium Cleaning Cartridge

For additional information, see Chapter 8, “Using Ultrium Media,” on page 8-1.

Environmental and Shipping Specifications for Tape Cartridges

Before using a tape cartridge, acclimate it to the operating environment for 24 hours or the time necessary to prevent condensation in the drive (the time will vary, depending on the environmental extremes to which the media was exposed).

The best storage container for the cartridges (until opened) is the original shipping container. The plastic wrapping prevents dirt from accumulating on the cartridges and partially protects them from humidity changes.

When shipping a cartridge, place it in a jewel case or in a sealed, moisture-proof bag to protect it from moisture, contaminants, and physical damage. Ship the cartridge in a container that has enough packing material to cushion the cartridge and prevent it from moving within the container.

Table 1-4 gives the environment for operating, storing, and shipping IBM LTO Ultrium Tape Cartridges.

Table 1-4. Environment for operating, storing, and shipping the IBM LTO Ultrium Tape Cartridge

Environmental Specifications				
Environmental Factor	Operating	Operational Storage	Archival Storage	Shipping
Temperature	10°C to 45°C (50°F to 113°F)	16°C to 32°C (61°F to 90°F)	16°C to 25°C (61°F to 77°F)	-23°C to 49°C (-9°F to 120°F)
Relative humidity (noncondensing)	10% to 80%	20% to 80%	20% to 50%	5% to 80%
Wet bulb temperature	26°C (79°F)	26°C (79°F)	26°C (79°F)	26°C (79°F)
Note:				
1. Operational storage is considered to be less than 1 year.				
2. Archival storage is considered to be 1 to 10 years.				

Multi-Path Architecture

Storage Area Network (SAN)-ready Multi-Path Architecture allows homogeneous or heterogeneous open systems applications to share the library's robotics without middleware or a dedicated server (host) acting as a library manager. The Multi-Path Architecture is compliant with the following attachment interfaces:

- SCSI
- Fibre Channel

The library is certified for SAN solutions (such as LAN-free backup).

Multi-Path Architecture allows additional control paths and data paths to be configured for any one logical library. For more information, see "Using Multiple Control Paths" on page 2-2 and "Using Multiple Data Paths for Data Path Failover" on page 2-3.

Specifications

Table 1-5. Physical specifications for the library

Physical Specification	Measurement	
	5U control module	9U expansion module
Width	44.45 cm (17.5 in.)	44.45 cm (17.5 in.)
Depth	76.83 cm (30.25 in.)	76.83 cm (30.25 in.)
Height	21.87 cm (8.61 in.)	40.0 cm (15.75 in.)

Table 1-6. Library component weight

Component	Weight
Drive	4.082 kg (9.0 lbs.)
Power supply	1.814 kg (4.0 lbs.)
Robotics	2.041 kg (4.5 lbs.)
5U control module chassis (empty)	21.55 kg (47.5 lbs.)
9U expansion module chassis (empty)	29.48 kg (65.0 lbs.)

Table 1-7. Power specifications for a maximum configuration of the library

Power Specification	Measurement			
	5U control module		9U expansion module	
Voltage	100 to 127 Vac.	200-240 Vac.	100 to 127 Vac.	200-240 Vac.
Frequency	50 to 60 Hz	50 to 60 Hz	50 to 60 Hz	50 to 60 Hz
Current	2.0 A	1.0 A	2.0 A	1.0 A
Inrush current	50 A	100 A	50 A	100 A
Power	200 W	200 W	200 W	200 W
kVA	0.2	0.2	0.2	0.2
kBtu/hr	0.68	0.68	0.68	0.68

Table 1-8. Other specifications for the library

Specification	Measurement
Maximum altitude	2500 m (8202 ft) for operating and storage

Table 1-9. Environmental specifications for the library

Environmental Factor	Operating (see Note)	Storage	Shipping
Drive temperature	10 to 38°C (50 to 100°F)	10 to 43°C (50 to 109.4°F)	-40 to 60°C (-40 to 140°F)
Heat output	542 W (483 Cal/Hr)	Not applicable	Not applicable
Relative humidity	20 to 80%	10 to 90%	10 to 90%
Maximum wet bulb temperature	26°C (79°F) max.	27°C (80.6°F) max.	29°C (84.2°F) max.
<p>Note: The operating environment of the library must not conflict with the media storage requirements (see “Environmental and Shipping Specifications for Tape Cartridges” on page 1-14 and the section about media storage requirements in the Setup and Operator Guide. The library may be capable of operating at elevated temperatures for an extended period of time, the temperature could shorten the useful life of media that is stored in the library. If media is stored in the library for more than 10 hours, the storage temperature requirements for media should be met. It should be assumed that media stored in the library will be 2 degrees above ambient temperature when the library is powered ON.</p>			

Product Environment

The library is designed to operate in a general business environment.

The library meets the acoustical requirements for general business area category 2D. Category 2D states that the library should be installed a minimum of 4 m (13 ft.) from a permanent work station.

To allow for service access, install the library a minimum of 0.9 m (3 ft.) from all obstacles.

The library is a precision computer peripheral. To ensure maximum longevity of your library, locate the library away from dust, dirt, and airborne particulates:

- Keep the library away from high-traffic areas, especially if the floor is carpeted. Carpeting harbors dust and people walking on the carpet can cause the carpet fibers and the dust to become airborne.
- Keep the library out of printer/copier rooms because of toner and paper dust. Additionally, do not store paper supplies next to the library.
- Keep the library away from moving air caused by doorways, open windows, fans, and air conditioners.

Ensure that the machine covers are always kept closed to minimize any contamination from airborne particles.

Supported Servers, Operating Systems, and Software

The library is supported by a wide variety of servers (hosts), operating systems, and adapters. These attachments can change throughout the life cycle of the product.

To determine the latest supported attachments, visit the web at <http://www.ibm.com/storage/lto>, and look at the **Interoperability Matrix**.

Supported Device Drivers

Device drivers are included on a CD-ROM in the ship group for the library. IBM maintains the latest levels of device drivers and driver documentation for the library on the Internet. You can use one of the following procedures to access this material. **(Note: If you do not have Internet access and you need information about device drivers, contact your Marketing Representative.)**

- Using a browser, type one of the following:
 - <http://www.ibm.com/storage/lto>
 - <ftp://ftp.software.ibm.com/storage/devdrv>
- Using File Transfer Protocol (FTP), enter the following specifications:
 - FTP site: `ftp.software.ibm.com`
 - IP Addr: `207.25.253.26`
 - Userid: `anonymous`
 - Password: (use your current e-mail address)
 - Directory: `/storage/devdrv`

IBM provides Portable Document Format (.pdf) and Postscript (.ps) versions of its device driver documentation in the `/storage/devdrv/Doc` directory:

- `IBM_ultrium_tape_IUG.pdf` and `IBM_ultrium_tape_IUG.ps` contain the current version of the *IBM Ultrium Device Drivers Installation and User's Guide*.
- `IBM_ultrium_tape_PROGREF.pdf` and `IBM_ultrium_tape_PROGREF.ps` contain the current version of the *IBM Ultrium Device Drivers Programming Reference*.

A list of device drivers for each supported server appears at `/storage/devdrv/` in the following directories:

- | • AIX
- | • HP-UX
- | • LINUX
- | • Solaris
- | • Windows

Note: The device driver for the AS/400[®] server and System i[™] server is included in the OS/400[®] operating system.

| For more information about device drivers, refer to any of the preceding
| directories.

Chapter 2. Installation Planning

“Determining the Number of Logical Libraries (Partitions)”

“Using Multiple Control Paths” on page 2-2

“Using Multiple Data Paths for Data Path Failover” on page 2-3

“Determining SCSI and Fibre Channel IDs” on page 2-4

“Server Attachment” on page 2-8

Installation planning is an important first step in the installation process. By planning the installation, all decisions about system layout will be made prior to actually handling the hardware. This should simplify the installation process.

Important: Make a copy of the Appendix D, “Library Configuration Form,” on page D-1. Using this form, make a record of your library’s configuration. Store this form in a safe location and update it any time hardware is added or settings are modified.

Determining the Number of Logical Libraries (Partitions)

You can partition the library into as many logical libraries as there are drives in the library. LTO-3 SCSI and Fibre Channel drives are allowed in the same library; however, they are not allowed in the same logical library.

Basic Guidelines

- Each logical library must contain at least one drive.
- A library configuration of exactly one partition equals the entire physical library.
- The library prevents requests from the server to move media across the boundaries of logical libraries.

Library Sharing

The library’s default configuration allows a single application to operate the library through a single control path. Often, however, it is advantageous to be able to share a single library between heterogeneous (dissimilar) or homogeneous (similar) applications. Some applications (and some servers) do not allow for sharing a library between systems. Configurations can be created that enable the library to process commands from multiple heterogeneous applications (such as an IBM eServer System P™ application and a Windows® application) and multiple homogeneous applications (for example, the same application run by several pSeries servers).

From the library’s Web User Interface or Operator Panel, the following actions can be performed:

- Configure the library so that it is partitioned into separate logical libraries that independently communicate with separate applications through separate control paths. This configuration requires no special capabilities from the server or application. (For more information, see “Using Multiple Logical Libraries for Library Sharing” on page 2-2.)

- Configure any single logical library (including the entire physical library) so that it is shared by two or more servers that are running the same application. Depending on the capabilities of the server and application, there are several ways to set up this type of configuration. Three typical ways include:
 - Configuring one server (host) to communicate with the library through a single control path; all other servers send requests to that server through a network. This configuration is used by Tivoli® Storage Manager (TSM).
 - Configuring all of the servers to communicate with the library through a single, common control path. This configuration is used in high-availability environments such as IBM’s High Availability Clustered Microprocessing (HACMP) and Microsoft’s Systems Management Server (SMS) and Clustered Server Environments. Multi-initiator configurations are only supported by certain adapters and independent software vendors (ISVs). Check with your ISV.
 - Configuring a single logical library to communicate with multiple servers through multiple control paths. This configuration requires that control paths be added (see “Using Multiple Control Paths”). It is used by Backup Recovery and Media Services (BRMS).

Library configuration is not limited to the examples given above. Many configurations are possible, and can be designed according to your business needs. For additional information, refer to your host application documentation.

Using Multiple Logical Libraries for Library Sharing

Multiple logical libraries are an effective way for the library to simultaneously back up and restore data from heterogeneous applications. For example, the library can be partitioned so that it processes:

- Commands from Application 1 (about Department X) in Logical Library A
- Commands from Application 2 (about Department Y) in Logical Library B
- Commands from Application 3 (about Department Z) in Logical Library C

In this configuration, the storage slots and drives in each logical library are dedicated to that library and are not shared among other libraries. Commands issued by the applications travel to the library through three unique control paths. Thus, the data processing for:

- Department X is confined to the storage slots and drives in Logical Library A
- Department Y is confined to the storage slots and drives in Logical Library B
- Department Z is confined to the storage slots and drives in Logical Library C

Using Multiple Control Paths

In addition to creating multiple logical libraries, any logical library can be configured to have more than one control path. When configuring additional control paths, additional library sharing configurations and availability options are made possible. Access to the logical library is on a first-come, first-served basis and each control path for a logical library can accept commands while the library is in use by another control path. By default, a logical library can communicate with the server only through the first LUN-1-enabled drive that is installed in the partition.

Note: Microsoft Windows® 2000 and Microsoft Windows 2003 Removable Storage Manager (RSM) does not support multiple control paths within a logical library. IBM recommends that RSM be disabled to use this feature.

To add or remove additional control paths, refer to “Adding a Control Path Drive to a Logical Library” on page 7-14. For a particular logical library, you can enable as many control paths as there are drives in that logical library.

Using Multiple Control Paths for System i, iSeries, and AS/400 Attachment

The use of control paths for the System i, iSeries, and AS/400 servers is unique. In general, every iSeries adapter must recognize the control path that is associated with the drives to which it is connected. For the iSeries and AS/400 servers, one to six drives are supported by LVD and Fibre Channel adapters and the OS/400 5.1, OS/400 5.2, or i5/OS 5.3 operating system.

Using Multiple Control Paths for Control Path Failover

Command failures and timeouts are costly. You want your library to run smoothly and efficiently. To ensure continued processing, the library offers an optional control path failover feature that enables the host device driver to resend the command to an alternate control path for the same logical library. With control path failover installed, the alternate control path can include another HBA, SAN, or library control path drive. The device driver initiates error recovery and continues the operation on the alternate control path without interrupting the application. AIX, Linux, Solaris, HP-UX, and Windows hosts are currently supported for this feature.

The Control Path Failover feature can be installed by the customer. For ordering information, see Chapter 12, “Parts List,” on page 12-1.

Note: The Control Path Failover feature is activated by a license key.

For more information about using the control path failover feature, see the *IBM Ultrium Device Drivers Installation and User's Guide*.

Note: LTO-3 SCSI and Fibre Channel drives are not allowed in the same logical library.

Using Multiple Data Paths for Data Path Failover

Data Path Failover and Load Balancing exclusively supports native Fibre Channel Ultrium 3 Tape Drives in the library using the IBM device driver for AIX and Linux. Data Path Failover is designed to provide a failover mechanism in the IBM device driver, which enable multiple redundant paths to be configured in a SAN environment. In the event of a path or component failure, the failover mechanism is designed to automatically provide error recovery to retry the current operation using an alternate, pre-configured path without aborting the current job in progress. This allows flexibility in SAN configuration, availability, and management.

When accessing a tape drive device that has been configured with alternate paths across multiple host ports, the IBM device driver automatically selects a path through the host bus adapter (HBA) that has the fewest open tape devices and assigns that path to the application. This autonomic self-optimizing capability is called Load Balancing. The dynamic load balancing support is designed to optimize resources for devices that have physical connections to multiple HBAs in the same machine. The device driver is designed to dynamically track the usage on each HBA as applications open and close devices, and balance the number of applications using each HBA in the machine. This may help optimize HBA

resources and improve overall performance. Further, Data Path Failover provides autonomic self-healing capabilities similar to Control Path Failover, with transparent failover to an alternate data path in the event of a failure in the primary host-side path. Data Path Failover and Load Balancing for Ultrium 3 Tape Drives requires an optional feature.

Currently Data Path Failover is not available on Windows with Ultrium 3 tape drives. Data Path Failover is also not available on HP-UX at this time.

The Data Path Failover feature is activated by a license key. For ordering information, see Chapter 12, “Parts List,” on page 12-1.

For additional information, refer to your device driver documentation.

Determining SCSI and Fibre Channel IDs

SCSI IDs are required for SCSI drives. Loop IDs are required for Fibre Channel drives.

SCSI Drive IDs

Based on its physical position in the library, each SCSI tape drive is assigned a default SCSI ID (from 0 to 15). The table below lists the default SCSI IDs for a 14U library.

Table 2-1. Default SCSI ID for each SCSI drive in a 14U library

Module	Position	Drive Location Coordinate	Default SCSI IDs
Control Module	Drive 1	0, 1	2
	Drive 2	0, 2	1
9U Expansion Module	Drive 3	-1, 1	6
	Drive 4	-1, 2	5
	Drive 5	-1, 3	4
	Drive 6	-1, 4	3

Note: You can change a SCSI ID by using the Web User Interface or the Operator Panel.

LUN Assignments for Ultrium Tape Drives

The logical unit number (LUN) for the Sequential Access device is always LUN 0 of the drive, and the LUN for the Medium Changer device is always LUN 1 (all other LUNs are invalid addresses). These devices are compatible with the SCSI-3 standard. For information about the SCSI commands for the tape drive and the library, see the *IBM TotalStorage LTO Ultrium Tape Drive SCSI Reference* and the *IBM System Storage TS3310 Tape Library SCSI Reference*.

Note: The Medium Changer SCSI ID is the same as the SCSI ID for the control path drive. You can enable additional drives to optionally provide Medium Changer (LUN 1) addressing by configuring more than one logical library or by enabling additional control paths (see “Determining the Number of Logical Libraries (Partitions)” on page 2-1).

Fibre Channel Drive IDs

Each Fibre Channel Ultrium Tape Drive in the library must have a Loop ID and corresponding Arbitrated Loop Physical Address (AL_PA) to communicate in a Fibre Channel topology. The table below lists the default Loop IDs and AL_PAs for each drive in a 14U library.

Table 2-2. Default Loop IDs and their associated AL_PAs for Ultrium Tape Drives in a 14U library

Module	Drive Position	Drive Location Coordinate	Default Loop ID	Default AL_PA
Control Module	1	0, 1	0	X'EF'
	2	0, 2	1	X'E8'
9U Expansion Module	3	-1, 1	2	X'E4'
	4	-1, 2	3	X'E2'
	5	-1, 3	4	X'E1'
	6	-1, 4	5	X'E0'

Note: Loop IDs are given in decimal format and AL_PA values are given in hexadecimal format.

You can change a Loop ID by using the library's operator panel or Web User Interface. Using a method called hard addressing, the drive then automatically selects the corresponding AL_PA, which is the identifier that devices use to communicate. Valid Loop ID values range between 0 and 125. The higher the number of the Loop ID (and AL_PA), the lower the priority of the device in the loop.

You can also specify Loop IDs that allow the drive to dynamically arbitrate the AL_PA with other Fibre Channel devices on the loop. This method avoids conflicts over the address and is called soft addressing. To dynamically arbitrate the AL_PA, specify a Loop ID of 126 or 127.

For a complete list of Loop IDs and their corresponding AL_PAs, see the table below.

Table 2-3. Valid Loop IDs and their associated AL_PAs for Ultrium Tape Drives in the library

7-bit Loop ID (decimal)	8-bit AL_PA (hexadecimal)	7-bit Loop ID (decimal)	8-bit AL_PA (hexadecimal)	7-bit Loop ID (decimal)	8-bit AL_PA (hexadecimal)
0	X'EF'	43	X'A3'	86	X'4D'
1	X'E8'	44	X'9F'	87	X'4C'
2	X'E4'	45	X'9E'	88	X'4B'
3	X'E2'	46	X'9D'	89	X'4A'
4	X'E1'	47	X'9B'	90	X'49'
5	X'E0'	48	X'98'	91	X'47'
6	X'DC'	49	X'97'	92	X'46'
7	X'DA'	50	X'90'	93	X'45'
8	X'D9'	51	X'8F'	94	X'43'
9	X'D6'	52	X'88'	95	X'3C'
10	X'D5'	53	X'84'	96	X'3A'

Table 2-3. Valid Loop IDs and their associated AL_PAs for Ultrium Tape Drives in the library (continued)

7-bit Loop ID (decimal)	8-bit AL_PA (hexadecimal)	7-bit Loop ID (decimal)	8-bit AL_PA (hexadecimal)	7-bit Loop ID (decimal)	8-bit AL_PA (hexadecimal)
11	X'D4'	54	X'82'	97	X'39'
12	X'D3'	55	X'81'	98	X'36'
13	X'D2'	56	X'80'	99	X'35'
14	X'D1'	57	X'7C'	100	X'34'
15	X'CE'	58	X'7A'	101	X'33'
16	X'CD'	59	X'79'	102	X'32'
17	X'CC'	60	X'76'	103	X'31'
18	X'CB'	61	X'75'	104	X'2E'
19	X'CA'	62	X'74'	105	X'2D'
20	X'C9'	63	X'73'	106	X'2C'
21	X'C7'	64	X'72'	107	X'2B'
22	X'C6'	65	X'71'	108	X'2A'
23	X'C5'	66	X'6E'	109	X'29'
24	X'C3'	67	X'6D'	110	X'27'
25	X'BC'	68	X'6C'	111	X'26'
26	X'BA'	69	X'6B'	112	X'25'
27	X'B9'	70	X'6A'	113	X'23'
28	X'B6'	71	X'69'	114	X'1F'
29	X'B5'	72	X'67'	115	X'1E'
30	X'B4'	73	X'66'	116	X'1D'
31	X'B3'	74	X'65'	117	X'1B'
32	X'B2'	75	X'63'	118	X'18'
33	X'B1'	76	X'5C'	119	X'17'
34	X'AE'	77	X'5A'	120	X'10'
35	X'AD'	78	X'59'	121	X'0F'
36	X'AC'	79	X'56'	122	X'08'
37	X'AB'	80	X'55'	123	X'04'
38	X'AA'	81	X'54'	124	X'02'
39	X'A9'	82	X'53'	125	X'01'
40	X'A7'	83	X'52'	126	X'00'
41	X'A6'	84	X'51'	127	
42	X'A5'	85	X'4E'		

Supported Topologies

The Ultrium 3 Tape Drive can be attached in a two-node configuration, either directly to a switch as a public device (switched fabric) or directly to a host bus adapter (HBA) as a private device. It can connect as a public device in a switched fabric topology (through an F_port) or connect using Arbitrated Loop topology (through an L_port or FL_port).

The Ultrium 3 tape drive automatically configures to an L_port or an N_port when it boots. The type of port to which it configures depends on whether the drive recognizes the connection as a loop or a point-to-point connection:

- An L_Port supports a Fibre Channel Arbitrated Loop connection to an NL_port or an FL_port.
- An N_Port supports a point-to-point connection to an F_port (for example, a director-class switch) in a switched fabric topology.

Regardless of the port to which you connect the drive, it automatically configures to a public device (through an F_port or FL_port to a switch) or to a private device (through an L_port by using direct attachment to a server).

The table below lists the topologies in which the Ultrium Tape Drive can operate, the Fibre Channel server connections that are available, and the port through which communication must occur.

Table 2-4. Choosing the port for your topology and Fibre Channel connection

Type of Topology	Type of Fibre Channel Connection to Server	
	Direct Connection(Private)	Switched Fabric(Public)
Fibre Channel Aribtrated Loop(can be Two-Node Arbitrated Loop or Two-Node Switched Fabric Loop; is limited to two nodes)	L_Port	FL_Port
Switched fabric (two nodes)	N/A	F_Port

LUN Assignments

The logical unit number (LUN) for the Sequential Access device is always LUN 0 of the drive, and the LUN for the Medium Changer device is always LUN 1 (all other LUNs are invalid addresses). These devices are compatible with the SCSI-3 standard. For information about the SCSI commands for the tape drive and the library, see the *IBM TotalStorage LTO Ultrium Tape Drive SCSI Reference* and the *IBM System Storage TS3310 Tape Library SCSI Reference*.

Note: The Medium Changer SCSI ID is the same as the SCSI ID for the control path drive. You can enable additional drives to optionally provide Medium Changer (LUN 1) addressing by configuring more than one logical library or by enabling additional control paths (see “Determining the Number of Logical Libraries (Partitions)” on page 2-1).

Using World Wide Names

Normally, blocks of World Wide Name (WWN) addresses are assigned to manufacturers by the IEEE Standards Committee, and are built into devices during manufacture. In the case of the library, however, it assigns World Wide Node Names and World Wide Port Names to the drives. This technique is referred to as persistent world wide names. Potential drive slots are each assigned a WWN which does not change when a drive is swapped or replaced.

The WWN of the drive is location-dependent and not device-dependent. That is, each time that the drive is reset or powered on, the library reestablishes the WWN so that a drive in Slot x always keeps the same WWN, even if the drive is replaced. The design of a WWN is such that if a drive needs service or

replacement, host parameters do not need to be changed or reconfigured. The library's configuration can also easily survive a reboot.

Server Attachment

The library can be attached to servers by using:

- "SCSI Interface"
- "Fibre Channel Interface" on page 2-10

SCSI Interface

Note: Although the LVD hardware in the library is capable of operating in single-ended (SE) mode, SE operation is not recommended or supported.

The library supports SCSI LVD attachments by using SCSI cables with 68-pin, D-connectors. SCSI adapters must be properly terminated.

Before installing the SCSI cables, inspect all cables for damage. Do not install a cable if it is damaged. Report the damage immediately by contacting your place of purchase.

The maximum allowable length of your bus cabling depends on the type of SCSI bus that you use (LVD).

- For a server with an LVD SCSI bus:
 - Use a maximum system-to-device cable length of 10 m (33 ft) when attaching to the host interface board (SCSI) and one or two daisy-chained drives.
 - Use a maximum system-to-device cable length of 5 m (17 ft) when attaching to the host interface board (SCSI) and three to six daisy-chained drives.

Note: For maximum performance, it is recommended to have a maximum of one drive per SCSI bus.

- Only use the maximum system-to-device cable length of 25 m (82 ft) when attaching directly to one device (a point to point interconnection).

Physical Characteristics of the SCSI Interface

The library operates as a set of SCSI-3 devices. The Ultrium Tape Drives attach to servers using an LVD Ultra160 SCSI interface. Each SCSI drive sled uses shielded, HD68-pin connectors, and can attach directly to a 2-byte-wide SCSI cable.

Any combination of up to two initiators (servers) and up to four targets (devices) is allowed on a single SCSI bus if the following conditions are met:

- The SCSI bus is terminated properly at each end
- Cable restrictions are followed according to the SCSI-3 specification

Under the SCSI-3 protocol, this type of attachment allows cable lengths of up to 25 m (81 ft) with the appropriate cable and terminator. The table below gives the maximum bus length between terminators for the LVD interface. For information about cable connectors, see "SCSI Connectors and Adapters" on page 2-9.

Table 2-5. Maximum bus length between terminators

Type of Interconnection	Maximum Bus Length Between Terminators (in meters)
Point-to-point (1 server and 1 drive)	25

Table 2-5. Maximum bus length between terminators (continued)

Type of Interconnection	Maximum Bus Length Between Terminators (in meters)
Multi-drop/daisy-chain (1 server and multiple drives)	12 (LVD)

For maximum performance, multiple SCSI buses may be required (see “Using Multiple SCSI Buses”), and IBM Ultrium Tape Drives must be the only target devices that are active on the bus.

Note: For maximum performance, the quantity of tape drives that you can attach to one SCSI bus is limited, and is based on the type of bus that you have and the amount of data compression achieved. Ultra160 SCSI buses have a bandwidth of 160 MB per second; Ultra320 SCSI buses have a bandwidth of 320 MB per second. The table below lists the types of SCSI buses and gives the recommended maximum quantity of drives that you can attach.

Table 2-6. Recommended maximum quantity of drives per SCSI bus

Type of Drive	Type of SCSI Bus	
	Ultra160	Ultra320
LVD Ultrium 3	2 (1 drive at 2:1 compression)	2 (1 drive at 2:1 compression)

Using Multiple SCSI Buses

The library has two SCSI connectors for each tape drive in the library. Each drive can be daisy-chained using a SCSI bus jumper that is included with each tape drive.

Removal of any jumpers will create a SCSI bus for each drive installed in your library for attachment to multiple servers or to multiple SCSI adapter cards on one server. Multiple SCSI buses may be required for maximum performance, depending on the application and data compression ratio. Note, however, that library (Medium Changer) control is required on at least one SCSI bus.

The Medium Changer device is required to be addressed via LUN 1 of the lowest-numbered drive position of each logical library. The Medium Changer device may additionally be addressed via LUN 1 of other drives in any logical library.

Any bus containing a Medium Changer device via LUN 1 of a drive is referred to as a control and data path. Any other bus is referred to as a data path. For information about control paths, see “Using Multiple Control Paths” on page 2-2.

Terminating the Bus

The SCSI bus and all of the wires in the SCSI cable must be properly terminated according to the SCSI standard.

You can plug an external terminator into one of the SCSI connectors. A terminator must be installed on the last device on each end of a string of multiple devices. A terminator is included with each Ultrium Tape Drive.

SCSI Connectors and Adapters

The library is supported by a wide variety of servers (hosts), operating systems, and adapters. These attachments can change throughout the product’s life cycle. To

determine the latest supported attachments, visit the web at <http://www.ibm.com/storage/1to>. Or, contact your IBM Sales Representative.

Fibre Channel Interface

Cables and Speeds

Ultrium 3 Fibre Channel tape drives use LC duplex fiber optics cables.

The maximum distances that the library supports on a Fibre Channel link is determined by the link speed, the type of fiber (50-micron or 62.5-micron), and the device to which the library is attached.

If the library attaches to an HBA, refer to the distances that are supported by the HBA. If the library attaches to a switch, the supported distances are:

- For a 50-micron cable:
 - 1-Gbit link speed = up to 500 m (1640 ft)
 - 2-Gbit link speed = up to 300 m (984 ft)
- For a 62.5-micron cable:
 - 1-Gbit link speed = up to 175 m (574 ft)
 - 2-Gbit link speed = up to 150 m (492 ft)

The library uses 50-micron cables internally. Therefore, you must use a 50-micron cable to attach to the library's port. To attach to a 62.5-micron SAN, you must attach the 50-micron cable to an active port, such as a port on a switch.

Using Zoning to Isolate Devices and Enhance Security

For security reasons, it is important to limit the devices that a server or servers can recognize or access. Also, some performance configurations and SAN configurations can result in a device being seen multiple times from the same server. For example, if you have two HBAs from the same server connected to an Ultrium Tape Drive in the library, the drive will be detected and appear as two logical devices. That is, there will be two special files for one physical device. Zoning can address these issues.

Zoning allows you to partition your SAN into logical groupings of devices so that each group is isolated from the other and can only access the devices in its own group. Two types of zoning exist: hardware zoning and software zoning. Hardware zoning is based on physical fabric port number. Software zoning is defined with WWNN or WWPN. While zoning can be reconfigured without causing an outage, some zoning configurations can become complicated. The advantage of the library's WWNN implementation is that you can avoid the exposure of introducing zoning errors because you do not have to change the zoning configuration if a drive needs service or replacement.

Attention: It is recommended that tape storage devices be connected on a separate HBA from disk storage devices to avoid potential configuration incompatibilities.

Using Persistent Binding to Ensure SCSI ID Assignment

When a server is booted, devices are discovered and assigned SCSI target and LUN IDs. It is possible for these SCSI assignments to change between boots. Some operating systems do not guarantee that devices will always be allocated the same

SCSI target ID after rebooting. Also, some software depends on this association, so you do not want it to change. The issue of SCSI ID assignment is addressed by persistent binding.

Persistent binding is an HBA function that allows a subset of discovered targets to be bound between a server and device. Implemented by a WWNN or WWPNN, persistent binding causes a tape drive's WWNN to be bound to a specific SCSI target ID. After a configuration has been set, it survives reboots and any hardware configuration changes because the information is preserved. If a drive needs to be replaced, the new drive assumes the WWNN of the old drive because the WWNN for the drive is location-dependent within the library. Because the WWNN does not change, persistent binding does not need to be changed which would cause an outage.

Fibre Channel Connectors and Adapters

The library is supported by a wide variety of servers (hosts), operating systems, and adapters. These attachments can change throughout the product's life cycle. To determine the latest supported attachments, visit the web at <http://www.ibm.com/storage/1to>.

Sharing on a Storage Area Network

With Storage Area Network (SAN) components, the possibilities for connecting multiple systems and multiple drives have increased. Not all software and systems are designed to share drives. Before you install a drive that would allow two systems to share it, check that the systems and their software support sharing. If your software does not support sharing, note that Fibre Channel switches have a zoning capability to form a SAN partition. For systems that do not cooperate, use zoning to prevent the systems from sharing the same drive. You can remove zoned partitions as you upgrade software and system levels.

Chapter 3. Installing the Library

“Step 1: Unpacking and Verifying Shipment Contents”

“Installing Your Library in a Rack” on page 3-11

“Step 3: Cabling the Library” on page 3-30

“Step 4: Powering ON the Library” on page 3-34

“Step 5: Configuring the Library” on page 3-34

Step 1: Unpacking and Verifying Shipment Contents

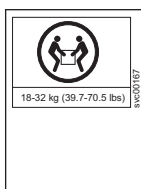

Important: Because of the weight of a multi-module library, it is strongly recommended that you install it in the lowest position in a rack. Without drive sleds and power supplies, a 5U library (control module) weighs approximately 50 lbs. Without drive sleds and power supplies, a 14U library (control module + 9U expansion module) weighs approximately 65 lbs.

1. Open and unpack all the boxes in your shipment.
2. Remove all external packaging materials from around the library module.

Note: Leave the library module on the lifting sling until it is ready to be installed.

3. Verify the contents of your shipment.

Table 3-1. Shipment contents

No. of Items	Description
1	Library
2	Module communication terminators (2 per library)
1	Module-to-Module communication cable (1 for each expansion module ordered)
1	Power cord for each power supply (If you are installing your library in a rack, you will need Feature Code 9848, Rack Power Distribution Unit (PDU) power cord.)
2	Wrap Plugs (1 for SCSI drives; 1 for Fibre drives)
1	SCSI or Fibre cable for each tape drive (if ordered)
1	SCSI drive-to-drive cable with each SCSI drive ordered
1	SCSI terminator for each SCSI tape drive
1	Data cartridge
1	Cleaning cartridge
1	Ethernet crossover cable (for service use only)
1	Ethernet customer network cable (if ordered)
1	Setup and Operator Guide (this book)
1	Maintenance Information manual

Table 3-1. Shipment contents (continued)

No. of Items	Description
1	Device driver CD-ROM
1	Rack Mount Kit (if ordered) (1 for each library)
1	Additional Rack Hardware Kit (1 for each expansion module ordered)
1	Deskside Kit (library feet and screws)
1	Sling (for lifting and installing library modules)
Important: <ul style="list-style-type: none"> If any of these items are missing, please call the appropriate number listed on the Hotline Card included in your shipment. 	

- Remove all internal packaging materials that are securing the Picker assembly.



Figure 3-1. Library with internal packaging material

Note: Failure to remove all internal packaging material before powering ON the library will result in damage to your library.

- Cut the plastic tie (**1** in Figure 3-1) across the top of the picker packaging material. **DO NOT REMOVE THE TIE, YET.**

Note: A hook and loop fastening strap may be used in place of the plastic tie on some libraries.

Important: Be careful not to damage the picker assembly when removing the following packing materials. DO NOT USE EXCESSIVE FORCE.

- b. Remove the cardboard packaging material (**2** in Figure 3-1 on page 3-2), the foam packaging material (**3** in Figure 3-1 on page 3-2), and the small cardboard packaging material (not shown in picture).

Important: There are library signal cables very near the raised metal loop on the right hand side of the control module floor. Be careful not to cut or damage these cables when removing the plastic tie pieces in the next step.

- c. Remove the plastic tie pieces. The tie should be threaded under a raised metal loop on each side of the library floor. It may be necessary to cut the tie in more than one place to remove it from the metal loops.
5. Remove the yellow ribbon-like packing pieces (**1** in Figure 3-2) from around the I/O Station magazines.

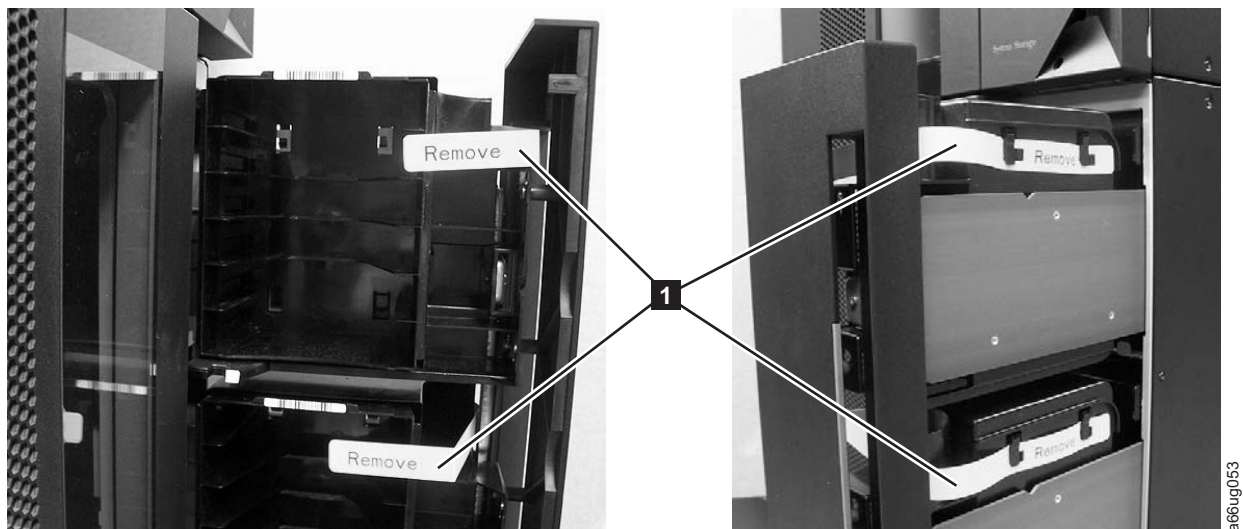

Figure 3-2. Yellow ribbon-like packing pieces

6. Refer to Figure 3-3 on page 3-4 and ensure that you have removed all of the packaging material.

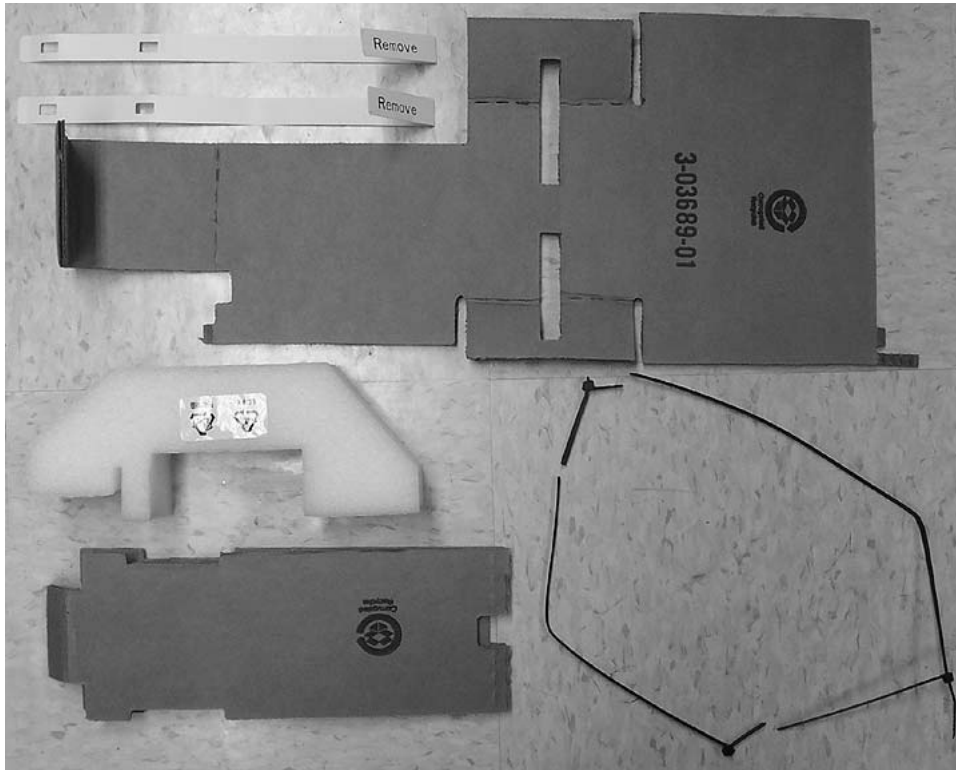

Figure 3-3. Library packaging material pieces

If any items are missing from your shipment, call the appropriate number listed on the Quality Hotline card included in your shipment.

Step 2: Installing Your Library

You can install your library in a rack or on a desktop. In either case, you'll need to perform the following:

- "Reducing Library Weight"
- "Preparing the Library Module(s) for Installation" on page 3-6
- "Transferring the Bottom Cover from the 5U CM to the 9U EM" on page 3-6

If you are installing your library in a rack, continue with the instructions in "Installing Your Library in a Rack" on page 3-11.

If you are installing your library on a desktop, continue with the instructions in "Installing Your Library on a Desktop" on page 3-10.

Once you have completed the rack or desktop installation steps, continue installing the library beginning with "Installing Library Components Removed for Weight Reduction" on page 3-28.

Reducing Library Weight

For weight reduction, remove the following components from each unit in the library:

- Power supplies
- Drives sleds

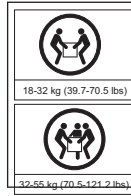

Important: Because of the weight of a multi-module library, it is strongly recommended that you install it in the lowest position in a rack. Without drive sleds and power supplies, a 5U library (control module) weighs approximately 50 lbs. Without drive sleds and power supplies, a 14U library (control module + 9U expansion module) weighs approximately 110 lbs.

Removing a Power Supply

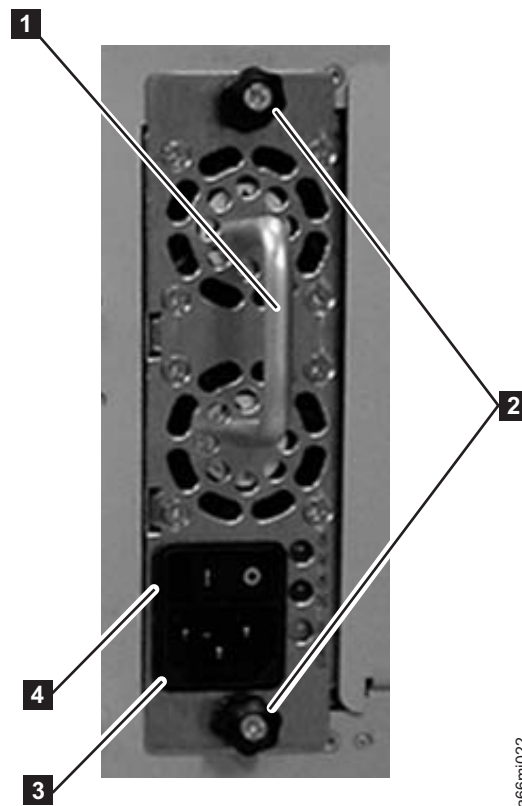

Figure 3-4. Power Supply

For each power supply installed in the library:

1. Loosen the two thumb screws (**2** in Figure 3-4) on the power supply by turning them counterclockwise.
2. To remove the power supply, grasp the handle (**1** in Figure 3-4) and slowly pull it toward you, while supporting it from underneath.

Removing a Drive Sled

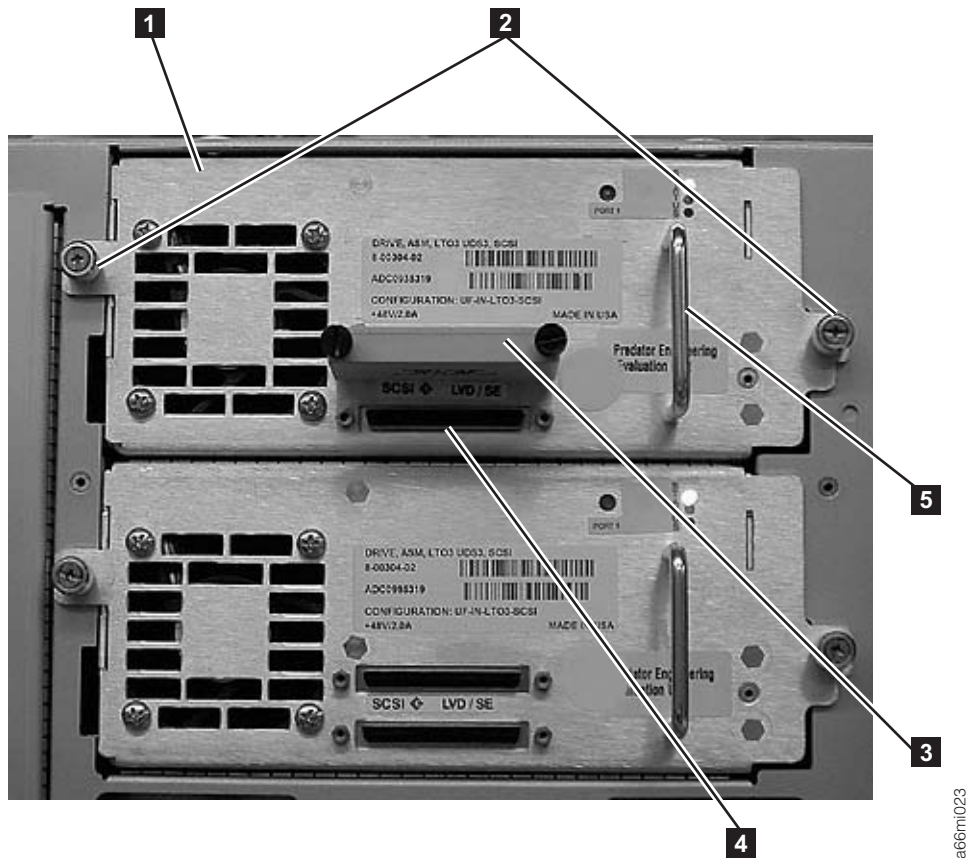

Figure 3-5. SCSI Drive Sled (detail)

For each drive installed in the library:

1. Loosen the two thumb screws (2 in Figure 3-5) that hold the drive sled in place by turning them counterclockwise.
2. To remove the drive sled, grasp the handle (5 in Figure 3-5) and slowly pull it toward you, while supporting the drive sled from underneath.

Preparing the Library Module(s) for Installation

1. Ensure that the drive sleds and power supplies have been removed from the modules to be installed. See “Reducing Library Weight” on page 3-4.
2. Refer to Figure 3-12 on page 3-14 and determine which library module will be installed first (on the bottom).
3. If you choose a configuration that has a 9U EM on the bottom it will be necessary to transfer the bottom cover from the 5U control module to the 9U module that will be on the bottom. Refer to “Transferring the Bottom Cover from the 5U CM to the 9U EM.”

If you choose a configuration that has a 5U CM on the bottom, continue to “Installing Your Library on a Desktop” on page 3-10 or “Installing Your Library in a Rack” on page 3-11.

Transferring the Bottom Cover from the 5U CM to the 9U EM

1. Engage the picker assembly lock mechanism (1 in Figure 3-6 on page 3-7).



a66m1053

1

Figure 3-6. Picker locking mechanism

2. Turn the 5U Control Module on it's side and remove the 5 - T10 Torx bottom cover screws (1 in Figure 3-7 on page 3-8).

Important: DO NOT loosen or remove the screw holding the home sensor (2 in Figure 3-7 on page 3-8). This screw has the same T10 Torx head as the cover screws, but it is longer and has a coarse thread for screwing into the plastic home sensor.

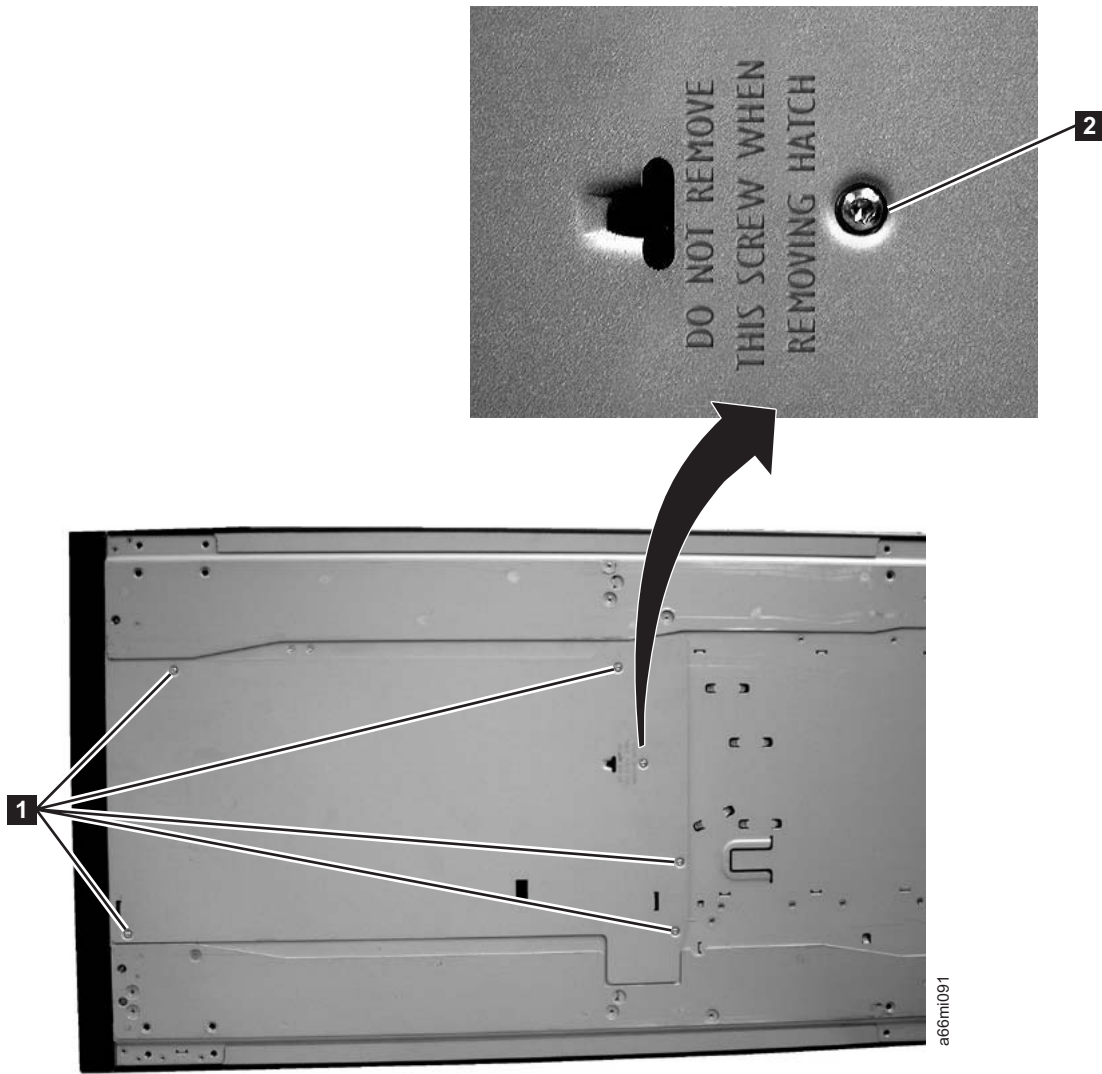

Figure 3-7. Bottom cover of the 5U Control Module

3. Remove the bottom cover from the 5U CM.

Note: Ensure that the home sensor plastic piece is mounted on the inner side of the bottom cover (**1** in Figure 3-8 on page 3-9).

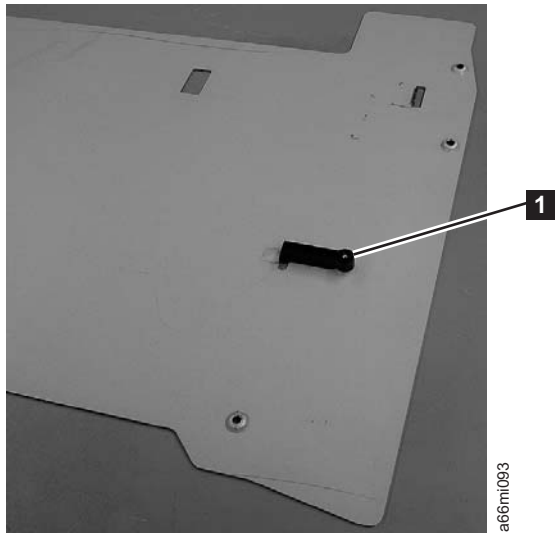

Figure 3-8. Home sensor on inner side of bottom cover

Important: Ensure that the picker lock mechanism (**1** in Figure 3-9) is engaged as shown. This will prevent the picker mechanism from falling out of the bottom of the 5U CM when it is returned to the upright position without a bottom cover installed.



Figure 3-9. Bottom view of picker assembly lock mechanism

4. Return the 5U CM to the upright position.
5. Remove the top cover from the 5U CM (4 - #2 Phillips screws).
6. Ensure that the front and rear gear racks of both the 5U CM and 9U EM are locked in the upper position (see **2** in Figure 3-17 on page 3-19).
7. Turn the 9U EM on it's side and install the bottom cover, using the 5 - T10 Torx screws.
8. Return the 9U EM to the upright position.

9. If you are installing your library in a rack, continue with the instructions in “Installing Your Library in a Rack” on page 3-11.
10. If you are installing your library on a desktop, continue with the instructions in “Installing Your Library on a Desktop.”

Installing Your Library on a Desktop

If you are installing your library on a desktop, follow the instructions in the following sections.

- “Installing Library Foot Pads”
- “Installing Library Components Removed for Weight Reduction” on page 3-28

If you are installing a 14U library, you’ll also need to follow the instructions in “Installing a 5U CM or 9U EM in the Middle (or Top) of Your Library Configuration” on page 3-21.

Installing Library Foot Pads

To install the library foot pads:

1. Place the sling that was shipped with your library underneath the library halfway between the front and back feet. Ensure that both sling handles are an equal distance from the sides of the library. Use of the sling is strongly recommended for a 9U module. A 5U module is much lighter in weight, and it may not be necessary to use the sling.
2. Being very careful, lay the library on its side.
3. Using a #2 Phillips screwdriver, install the foot pads on the bottom of the library chassis. See Figure 3-10 on page 3-11 for foot pad locations.

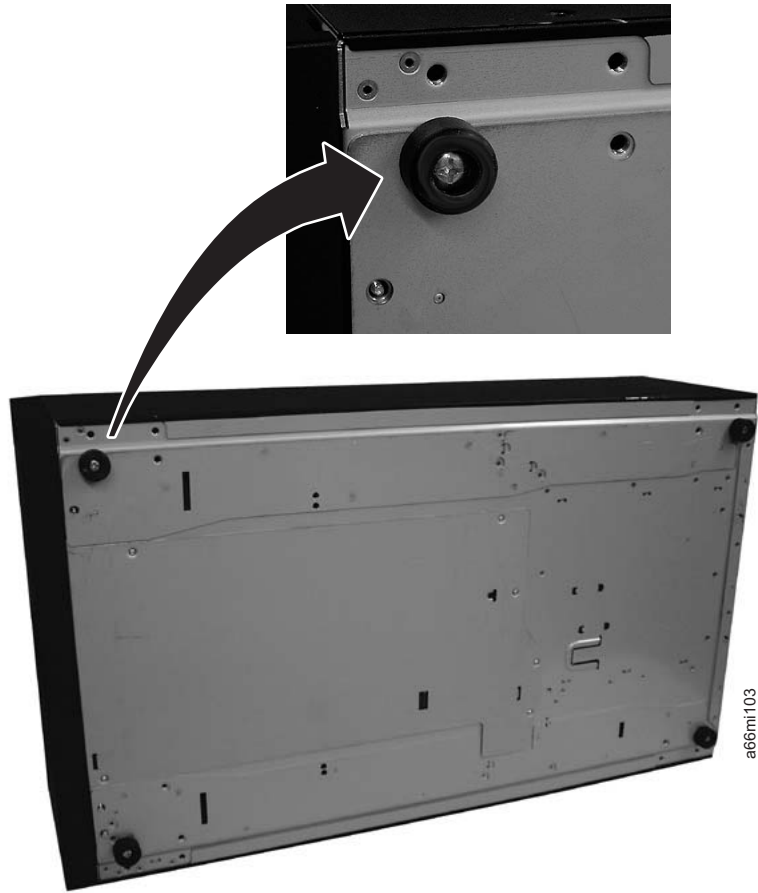

Figure 3-10. Foot pad Locations

4. Carefully return the library to an upright position.
5. Use the lifting sling to place the library module in the desktop location.
6. When you finish these desktop installation steps, store the installation sling in a secure location for possible future use. Then continue the library installation with the instructions on “Enabling the Picker Assembly” on page 3-27.

Installing Your Library in a Rack

The following sections give instructions on installing your library in a rack.

- “Verifying Rack Mount Kit Contents” on page 3-12
- “Identifying the Location in the Rack” on page 3-13
- “Installing the Rails” on page 3-16
- “Installing Bottom Library Module (5U or 9U)” on page 3-19
- “Installing a 5U CM or 9U EM in the Middle (or Top) of Your Library Configuration” on page 3-21
- “Placing the Library in the Rack” on page 3-25
- “Installing the Rack Ears” on page 3-26

When you complete these rack installation steps, continue installing your library by “Enabling the Picker Assembly” on page 3-27.

Verifying Rack Mount Kit Contents

The Rack Mount Kit will include rails and hardware to install one library module in a rack. An Additional Rack Hardware Kit with the necessary parts to install an additional module will be included with each additional module ordered.

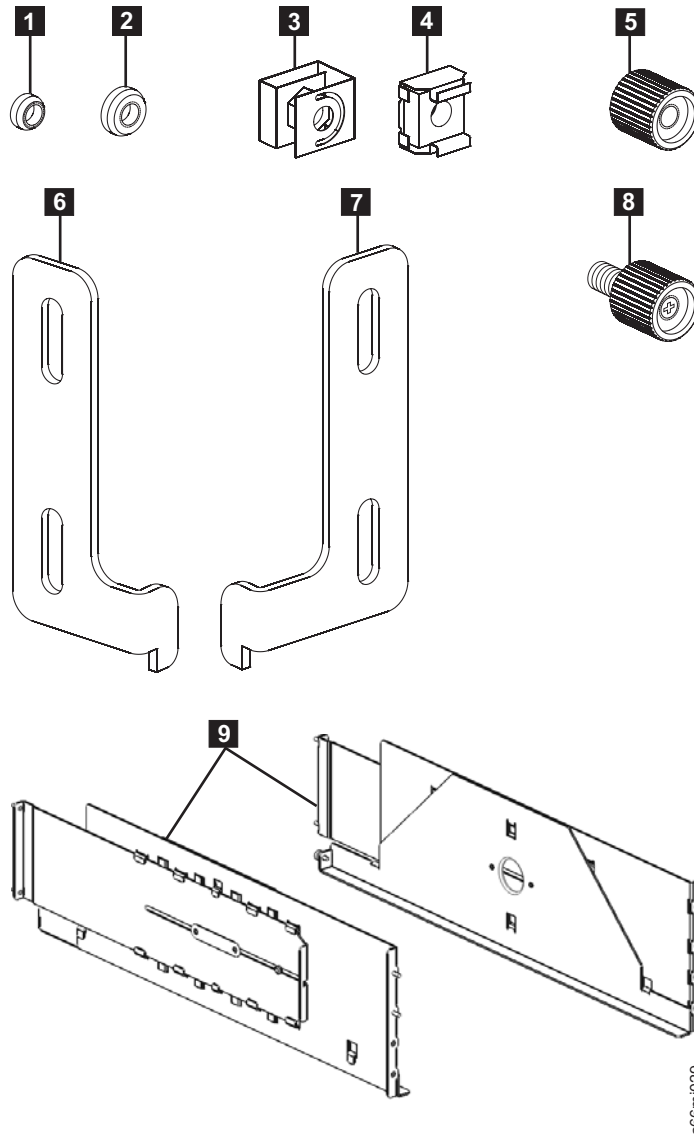

Figure 3-11. Rack Mount Kit hardware (parts not sized proportionately in figure)

Table 3-2. Rack Mount Kit contents

Quantity*	Description
16	Centering nuts: <ul style="list-style-type: none"> • 8 for racks with round holes (1 in Figure 3-11) • 8 for racks with square holes (2 in Figure 3-11)
8	Black thumb nuts (5 in Figure 3-11)
2	Rack ears (6 and 7 in Figure 3-11):
4	Rack ear screws (8 in Figure 3-11):

Table 3-2. Rack Mount Kit contents (continued)

Quantity*	Description
2	Rails (9 in Figure 3-11 on page 3-12)
<p>Important: If any of these items are missing, please call the appropriate number listed on the Quality Hotline Card included in your shipment.</p> <p>* Extra pieces of the small parts may be included.</p>	

Table 3-3. Additional Rack Hardware Kit contents (included with each expansion module)

Quantity	Description
8	Clip/Cage nuts: <ul style="list-style-type: none"> • 4 clip nuts for racks with round holes (3 in Figure 3-11 on page 3-12) • 4 cage nuts for racks with square holes (4 in Figure 3-11 on page 3-12)
2	Rack ears (6 and 7 in Figure 3-11 on page 3-12):
4	Rack ear screws (8 in Figure 3-11 on page 3-12):
<p>Important:</p> <ul style="list-style-type: none"> • This additional Rack Hardware Kit will be included with all expansion modules. If you are not rack mounting your library at this time, store this kit for future use. • If any of these items are missing, please call the appropriate number listed on the Hotline Card included in your shipment. 	

Identifying the Location in the Rack

Refer to Figure 3-12 on page 3-14 and select one of the possible configurations for your library installation.

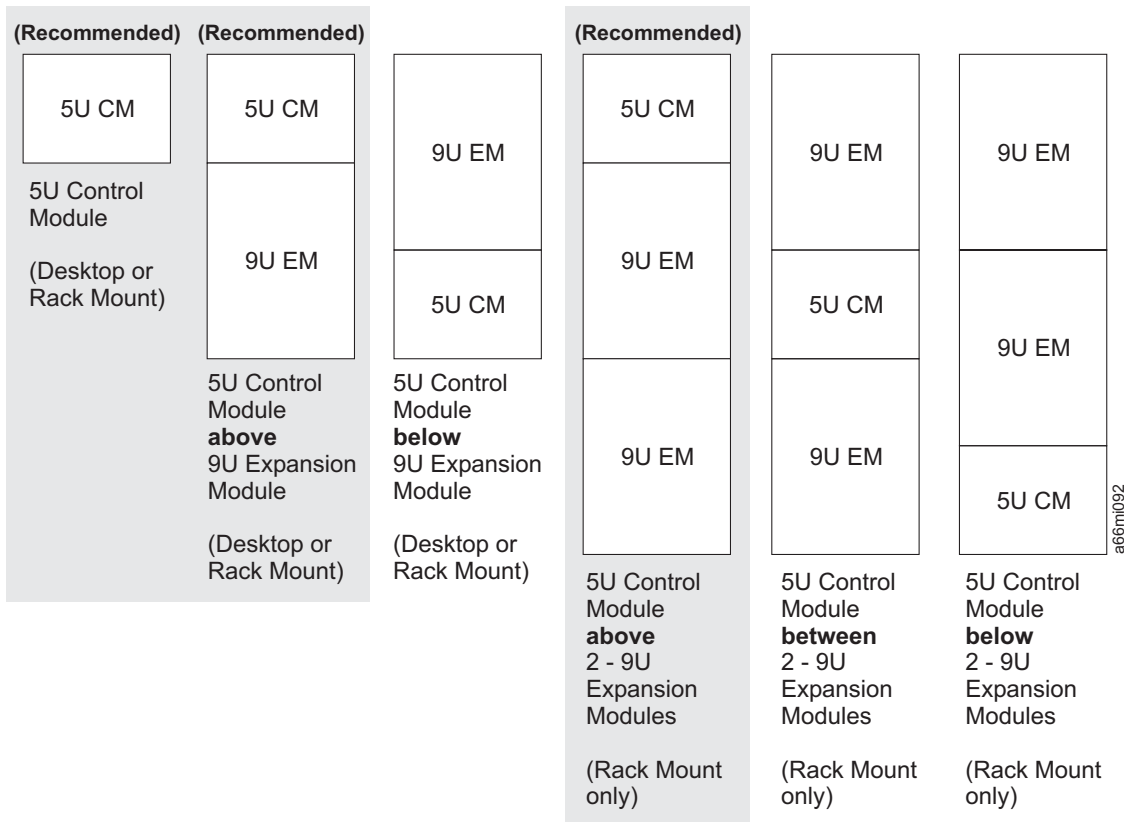



Figure 3-12. Library configurations

When deciding on a location in your rack for the library, remember that the Operator Panel is a touchscreen and should be positioned to allow easy access, and the rear of the library should be free from any obstructions to allow easy access to rear panel components. Also, if you think there is a possibility of adding another expansion module to your library in the future, you may want to allow for this when deciding where to locate the library in your rack.

Note: Before beginning the rack installation of your library, read the information on Rack Safety in the *Safety and Environmental Notices* chapter. Also, verify that no foot pads are installed on the bottom of your library. If foot pads are installed, perform “Removing Library Foot Pads” on page 11-21, then return here.

	<p>Important: Because of the weight of a multi-module library, it is strongly recommended that you install it in the lowest position in a rack. Without drive sleds and power supplies, a 5U library (control module) weighs approximately 50 lbs. Without drive sleds and power supplies, a 9U expansion module weighs approximately 65 lbs.</p>
---	--

The following table gives the amount of rack space required for each library. One unit of vertical rack space is designated as an EIA. One EIA is equal to 4.45 cm (1.75 in.).

Library	Required Rack Space
5U control module	5 EIAs (5U)
9U expansion module	9 EIAs (9U)

The rails (**9** in Figure 3-11 on page 3-12) in the Rack Mount Kit require five EIAs of vertical rack space and are installed in the lowest five EIAs of the selected rack location for the library.

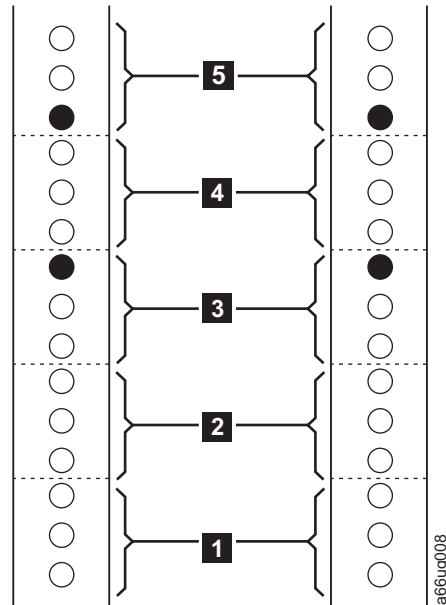

Figure 3-13. EIA identification and rail stud locations for FRONT vertical rack rails

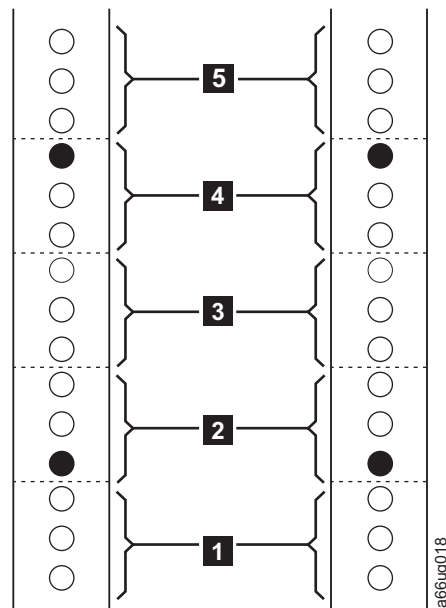

Figure 3-14. EIA identification and rail stud locations for REAR vertical rack rails

1. Using a pencil, make a mark below the first EIA (**1** in Figure 3-13 and **1** in Figure 3-14) in the five EIAs selected in each vertical rail in your rack. The bottom of the rail shelf must align with the bottom hole of the first EIA in the front vertical rails in your rack.
2. The rail studs are located on the front and back of each rail included in the Rack Mount Kit. The rail studs will be positioned as indicated by the black filled circles in Figure 3-13 and Figure 3-14:

- a. In the front vertical rack rails, rail studs will be positioned as follows:
 - Top hole of the third EIA (**3** in Figure 3-13 on page 3-15).
 - Bottom hole of the fifth EIA (**5** in Figure 3-13 on page 3-15).
 - b. In the rear vertical rack rails, rail studs will be positioned as follows:
 - Bottom hole of the second EIA (**2** in Figure 3-14 on page 3-15).
 - Top hole of the fourth EIA (**4** in Figure 3-14 on page 3-15).
3. For a 14U library, install clip nuts (**3** in Figure 3-11 on page 3-12) for vertical rack rails with round holes or cage nuts (**4** in Figure 3-11 on page 3-12) for vertical rack rails with square holes in the front rack rails in the following positions:
 - Top hole of the tenth EIA
 - Top hole of the eleventh EIA

These clip/cage nuts will be positioned to secure the rack ear screws for the upper unit of a 14U library.

Installing the Rails

Follow these steps to install the Rack Mount Kit rails.



Important: Because of the weight of a multi-module library, it is strongly recommended that you install it in the lowest position in a rack. Without drive sleds and power supplies, a 5U library (control module) weighs approximately 50 lbs. Without drive sleds and power supplies, a 9U expansion module weighs approximately 65 lbs.

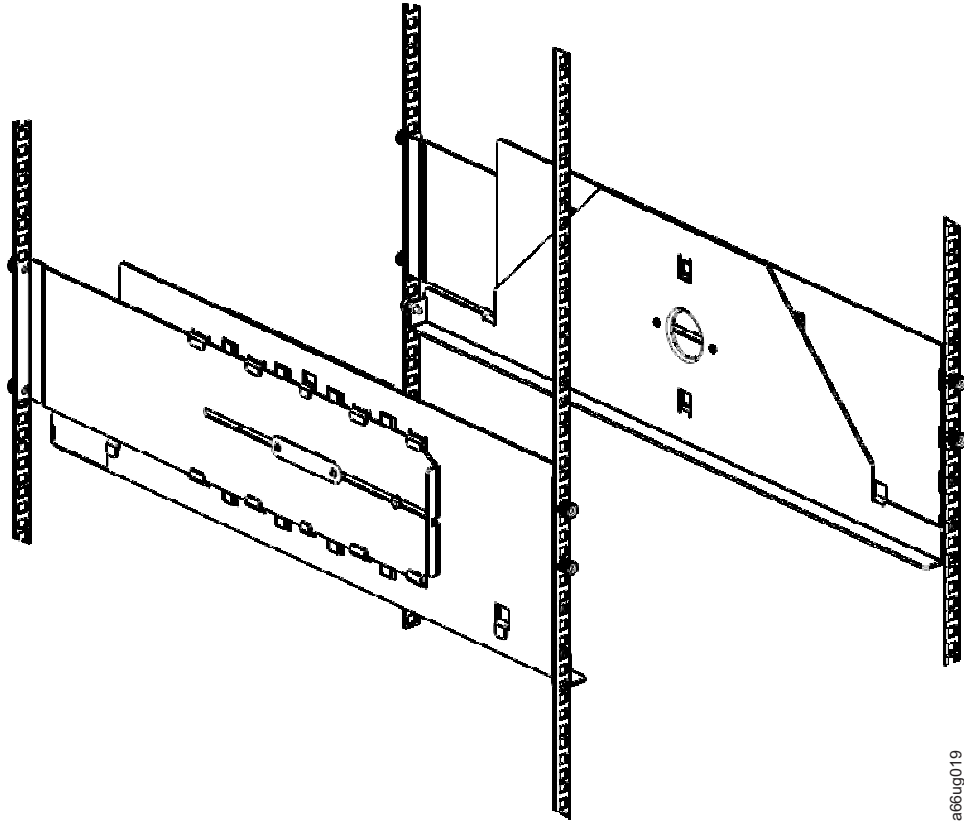

a66ug019

Figure 3-15. Rails installed in rack (front view)

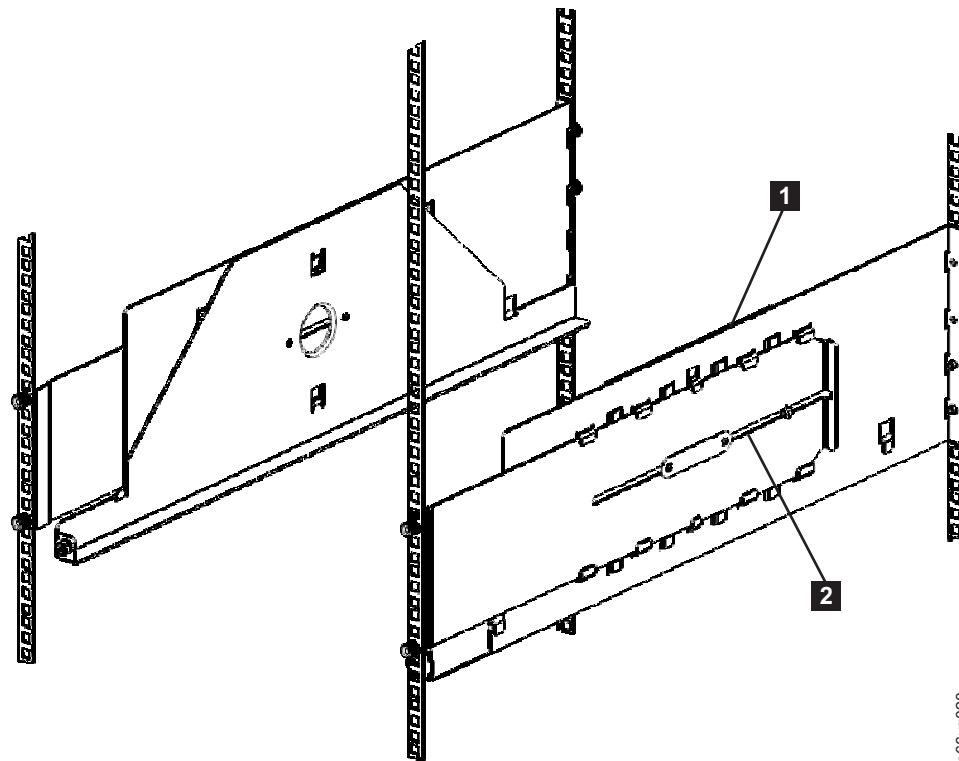

a66ug020

Figure 3-16. Rails installed in rack (rear view)

1. Collapse the rail (**1** in Figure 3-16). Loosen the nut (**2** in Figure 3-16), if necessary. The nut should be finger tight.
2. Put a centering nut on each rail stud (two studs on the front edge of each rail; two studs on the back edge of each rail) and finger-tighten (The flat side of the centering nut should be against the flange of the rail when properly installed.).
 - Use the round hole centering nuts (**1** in Figure 3-11 on page 3-12) for vertical rack rails with round holes.
 - Use the square hole centering nuts (**2** in Figure 3-11 on page 3-12) for vertical rack rails with square holes.
3. From the front of the rack:
 - a. Position the rail to the applicable side (right or left) and insert the rail studs through the marked holes in the vertical rack rail.

Note: The small shelf portion of the left rail should be positioned to the right side of the rail. The small shelf portion of the right rail should be positioned to the left side of the rail. Positioning the rails in this way will form the shelf on which the library will be installed.

- b. Place a thumb nut (**5** in Figure 3-11 on page 3-12) on each stud and tighten.
4. From the back of the rack:
 - a. Extend the rail and insert the rail studs through the marked holes in the vertical rack rail.
 - b. Place a thumb nut (**5** in Figure 3-11 on page 3-12) on each stud and tighten.

5. From the front of the rack, visually verify that the rail is aligned properly with the rack. You should see thumb screw holes (for mounting the rack ears) in the following locations:
 - Top hole of the first EIA (see Figure 3-13 on page 3-15)
 - Top hole of the second EIA in the vertical rack rails (see Figure 3-13 on page 3-15)
6. Repeat this procedure for the other rail.

Installing Bottom Library Module (5U or 9U)

Note: The bottom module in the library is the only module that has a bottom cover installed.

1. If you are installing a 5U Control Module as the bottom module, remove the top cover. (4 - #2 Phillips screws).
2. For all configurations, ensure that the front and rear gear racks are locked in the upper position. See **2** in Figure 3-17.

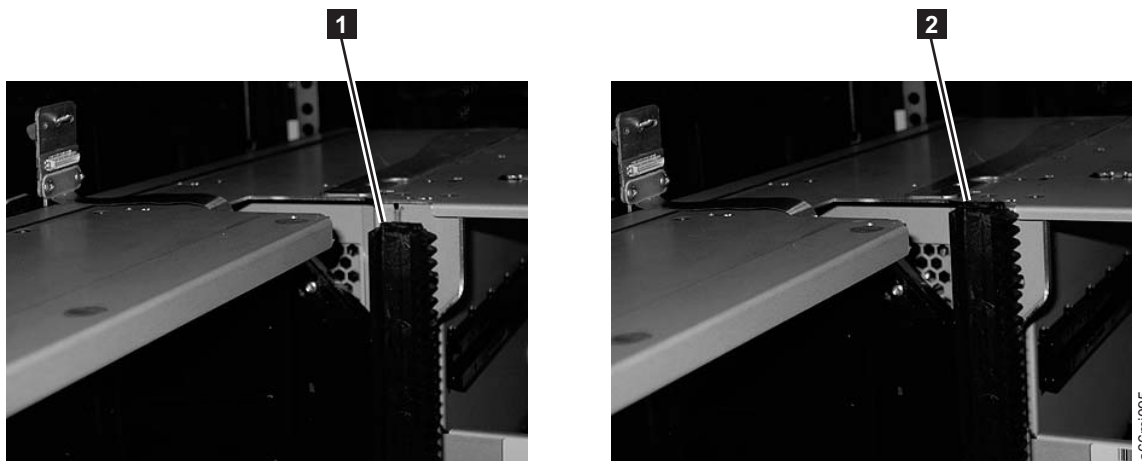

Figure 3-17. Gear racks positions (rear gear racks shown)

- | | | | |
|----------|--------------------------------|----------|------------------------------|
| 1 | Gear rack in the down position | 2 | Gear rack in the up position |
|----------|--------------------------------|----------|------------------------------|

3. With a person on each side of the module, lift the module with the sling provided (see Figure 3-18 on page 3-20).

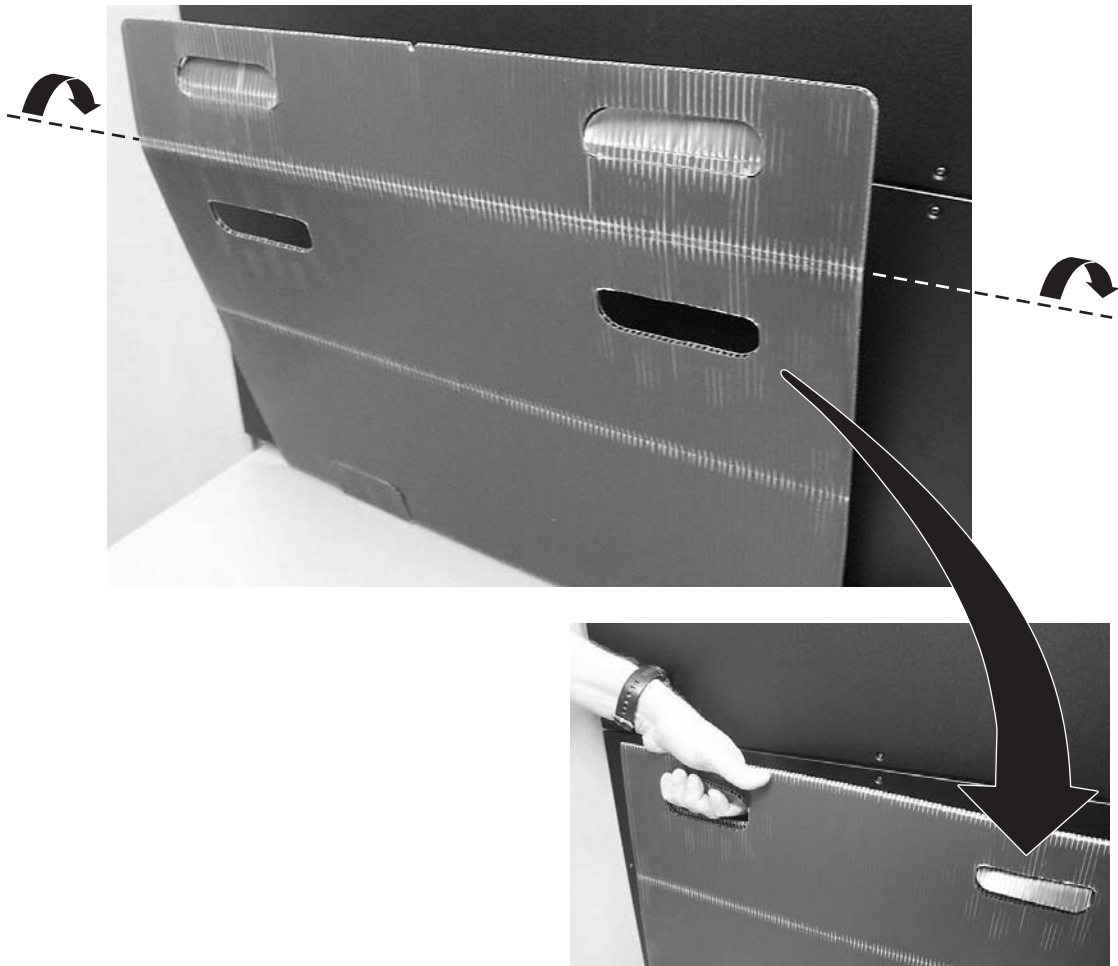

Figure 3-18. Sling handles folded properly

4. Slide the module partially onto the rail shelves in the rack.
5. Continue to support the library module from the front while you remove the sling.
6. Push the module into the rack until it contacts the flange on the rear of each rack mount rail.
7. Install and tighten the rear thumb screws (**1** in Figure 3-19 on page 3-21) located on the flange on the rear of each rack mount rail.



Figure 3-19. Rear flange and thumb screw on rack rail

Installing a 5U CM or 9U EM in the Middle (or Top) of Your Library Configuration

1. If you are installing a 5U control module, ensure that the picker assembly lock mechanism (**1** in Figure 3-20 on page 3-22) is engaged as shown.



1

Figure 3-20. Picker assembly lock mechanism

2. **IMPORTANT:** Ensure that the front and rear gear racks are locked in the upper position. See **2** in Figure 3-17 on page 3-19.
3. Ensure that the module-to-module alignment pin (**1** in Figure 3-21 on page 3-23) is in the raised position. If necessary, raise the pin and rotate it half a turn to lock it in the raised position.

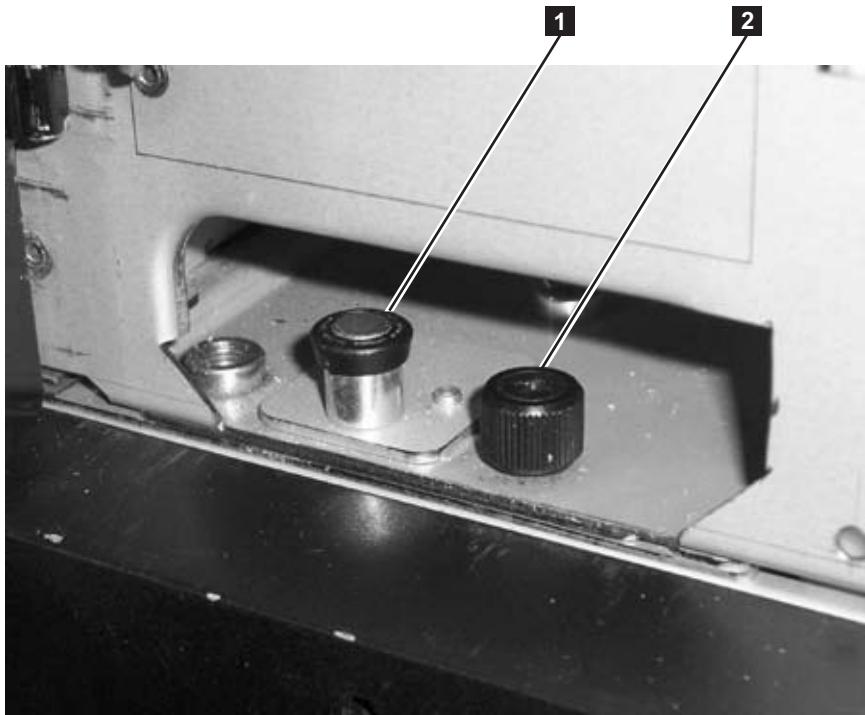

Figure 3-21. Module-to-Module alignment pin and front thumb screw

4. With a person on each side of the module, lift the module with the sling provided. See Figure 3-22 on page 3-24 to see how the sling handles should be folded.

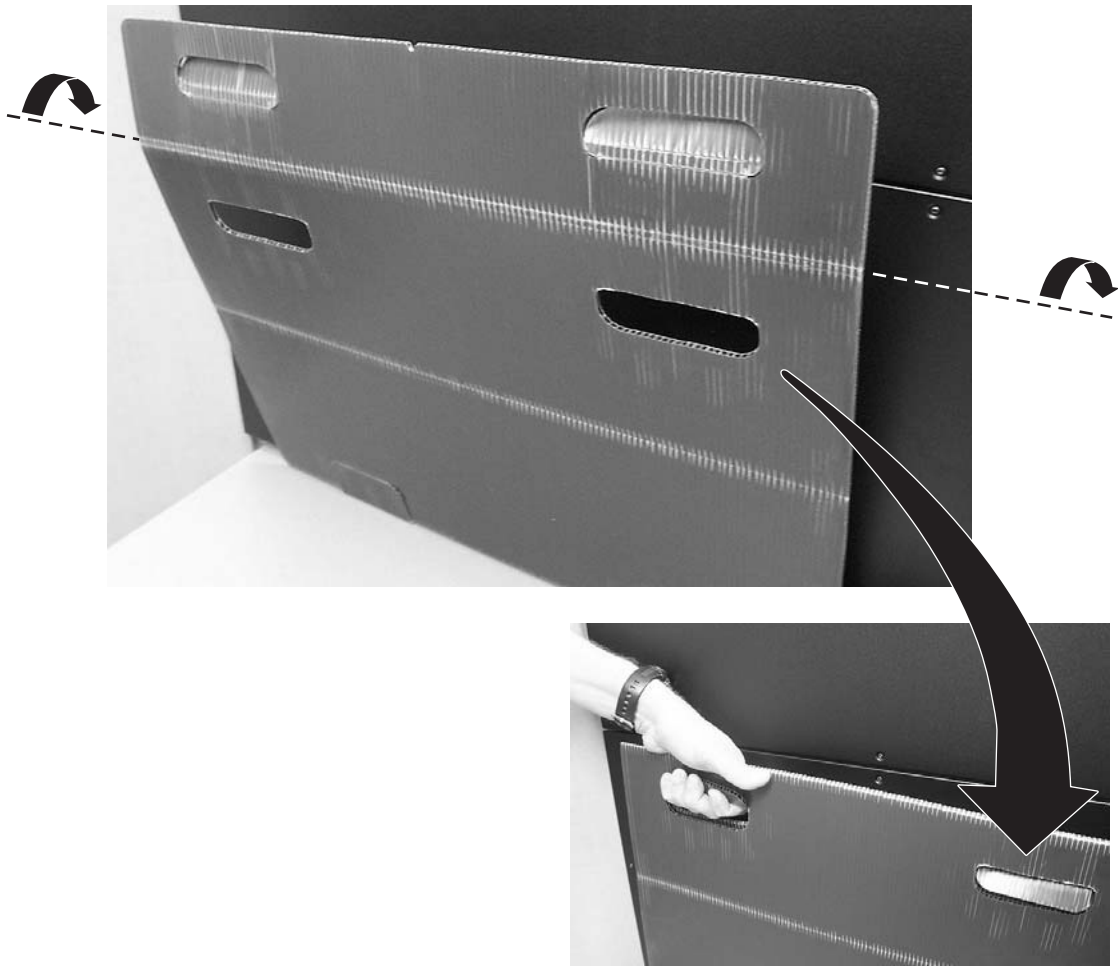

Figure 3-22. Sling

5. Slide the module partially on top of the already installed module(s).
6. Continue to support the library module from the front while you remove the sling.
7. Open the I/O Station door then the Access Door of the upper module to expose the alignment pin behind the Access Door.
8. Push the upper module onto the lower module.
9. Twist the upper module alignment pin (**1** in Figure 3-21 on page 3-23) to unlock it from the up position.
10. Adjust the upper module's position on top of the lower module until the upper module alignment pin drops into the alignment pin receptacle in the lower module.
11. Tighten the front thumb screw (**2** in Figure 3-21 on page 3-23) and the thumb screw behind the I/O Station door to secure the front of the upper module to the lower module.
12. Tighten the rear thumb screws (**1** in Figure 3-23 on page 3-25) that secure the upper module to the lower module.



Figure 3-23. Rear thumb screws

13. **IMPORTANT:** Lower the gear racks into the down (operating) position. See **1** in Figure 3-17 on page 3-19.
14. If this is a desktop installation, return to “Installing Library Foot Pads” on page 3-10.
15. If this is not the top module in the library, repeat this procedure for the top module.
16. If your library is installed in a rack, install the rack ears on the front of all modules to secure the library to the rack (see “Installing the Rack Ears” on page 3-26).
17. Store the installation lifting sling and the desktop kit (library feet and screws) in a secure location for possible future use.

Placing the Library in the Rack:

- **To place a 5U library (control module) in a rack:**

1. With a person on each side, lift the library and slide it onto the rail shelves in the rack until the library is flush with the flange on the rear of each Rack Mount Kit rail.
2. Install and tighten rear thumb screws located on the flange on the rear of each Rack Mount Kit rail.

- **To place a 14U library (control module + 9U expansion module) in a rack:**

1. With a person on each side lifting the library using the sling and one person holding the front of the library, slide it partially onto the rail shelves in the rack.
2. Continuing to support the library from the front, remove the sling and continue pushing the library into the rack until it is flush with the flange on the rear of each Rack Mount Kit rail.
3. Install and tighten rear thumb screws located on the flange on the rear of each Rack Mount Kit rail.

Installing the Rack Ears:

Rack ears are installed on the front of each module of a library to retain the module on the rack shelves.

1. Install the right rack ear (**2** in Figure 3-24).

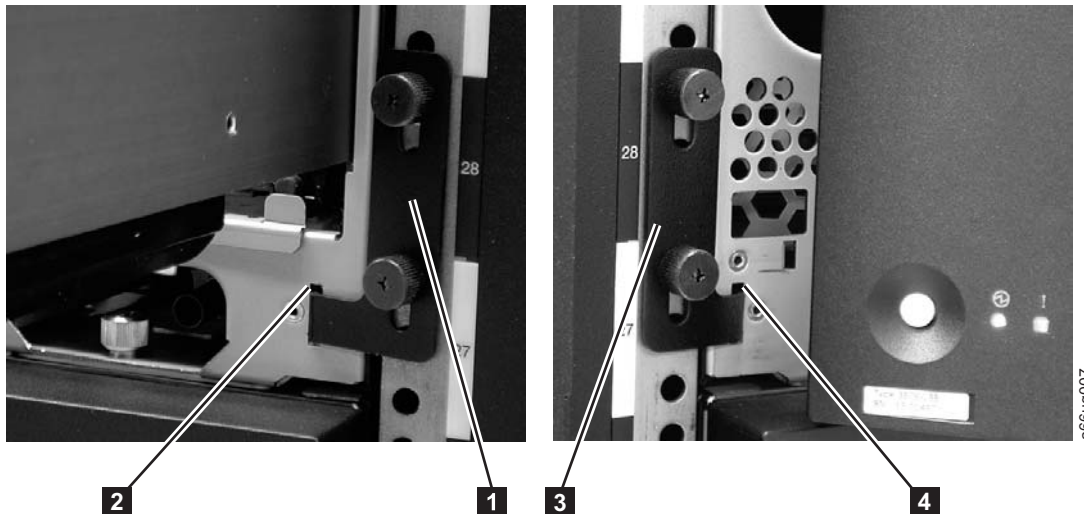

Figure 3-24. Installing the rack ears on a Control Module

- a. At the bottom right of the I/O Station position on each library module, there is a slot (**2** in Figure 3-24). Insert the right rack ear (**1** in Figure 3-24 and **7** in Figure 3-11 on page 3-12) into the slot.
 - b. Position the right rack ear flush with the rack. The slots in the rack ear should be positioned as follows:
 - In the bottom library module, over the holes in the rack that align with the holes in the rack kit rails.
 - In the middle or top library module, over the holes in the rack that have clip/cage nuts installed.
 - c. Place the screws (**8** in Figure 3-11 on page 3-12) in the slots on the right rack ear and tighten.
2. Install the left rack ear (**3** in Figure 3-24 and **6** in Figure 3-11 on page 3-12).
 - a. Open the left door of the library module slightly.
 - b. Grasp the hinged side of the door and, while pulling on the door, push to the right to expose the slot (**4** in Figure 3-24) for the left rack ear .
 - c. Insert the left rack ear (**3** in Figure 3-24) into the slot.
 - d. Position the left rack ear flush with the rack. The slots in the rack ear should be positioned as follows:
 - In the bottom library module, over the holes in the rack that align with the threaded holes in the rack kit rails
 - In the middle or top library module, over the holes in the rack that have clip/cage nuts installed
 - e. Place the screws (**8** in Figure 3-11 on page 3-12) in the slots on the left rack ear and tighten.
 3. Close the I/O Station and Access doors.
 4. Repeat this procedure for all modules in the library.

Enabling the Picker Assembly

Important: Picker assembly damage or library accessor errors can occur if the front or rear gear racks are not engaged properly.

1. **IMPORTANT:** Ensure that the front and rear gear racks are in the down (operating) position. See **1** in Figure 3-17 on page 3-19.
2. Feel the junction of the gear racks between each library module, front and rear. Ensure that there are no gaps between the gear racks before you release the picker assembly lock mechanism.
3. Manually raise the picker assembly while you release the lock mechanism (**1** in Figure 3-25).

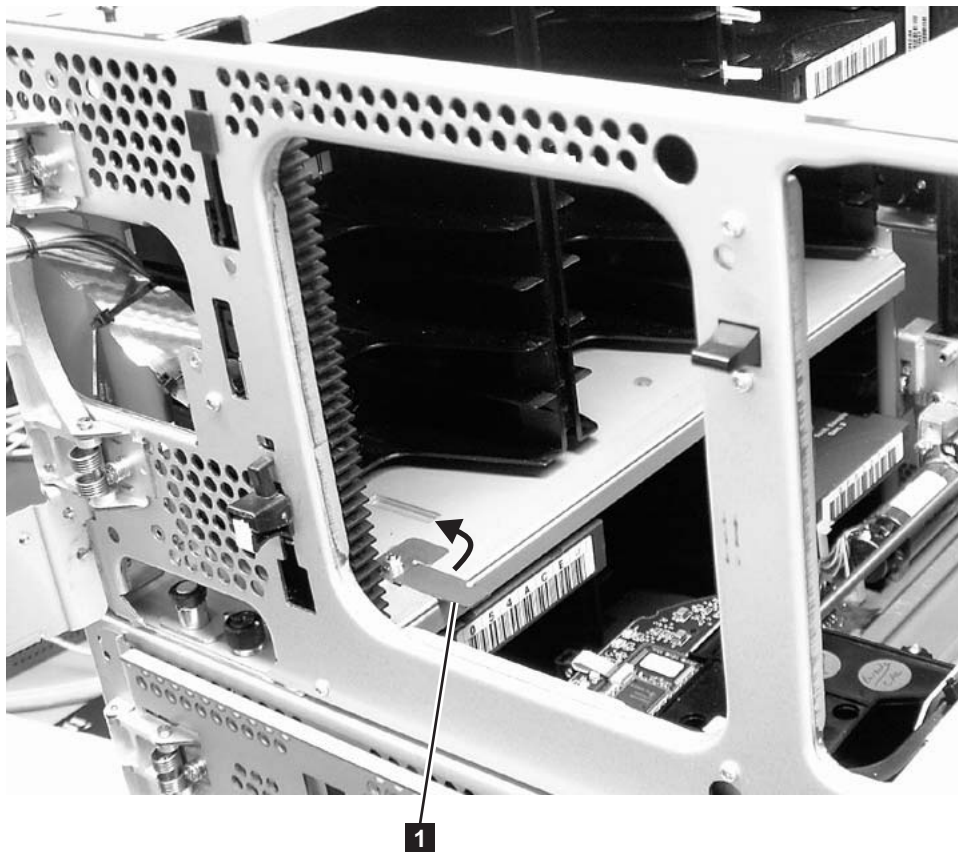

Figure 3-25. Releasing the picker assembly lock mechanism

4. Release the picker assembly and observe it as it slowly drops to the bottom of the library. It should move smoothly as it travels from one module into the other.

Note: If the picker jumps or bumps noticeably as it travels from one module into the other, an error is likely to occur when the library is powered on. Follow the instructions in “T083: Robot Assembly not level” on page 10-31 to correct the problem.

5. Reinstall the top cover on the top module of the library (4 - #2 Phillips screws).

Installing Library Components Removed for Weight Reduction

At this point in the installation procedure, you reinstall the drive sleds and power supplies that were removed for weight reduction.

Replacing a Drive Sled

Attention: NEVER install a drive sled when a cartridge is in the drive in the eject position. Remove the cartridge first.

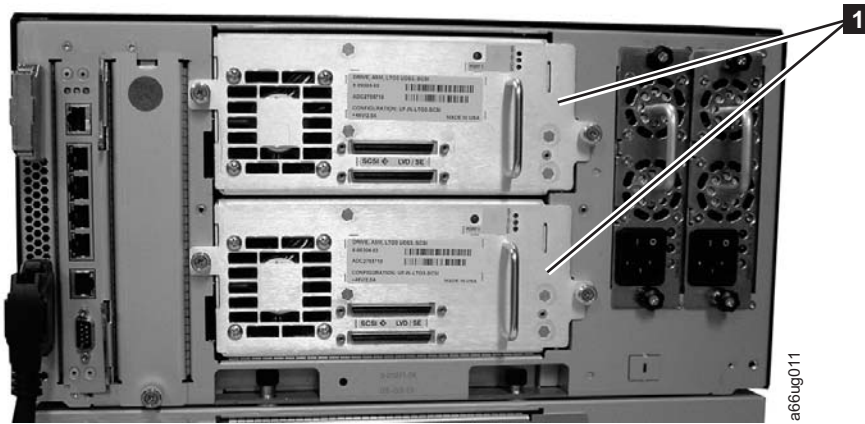

Figure 3-26. Control Module Drive Sled

1. Align the drive sled with the guide rails and guide slots along the tracks (3 in Figure 3-27).

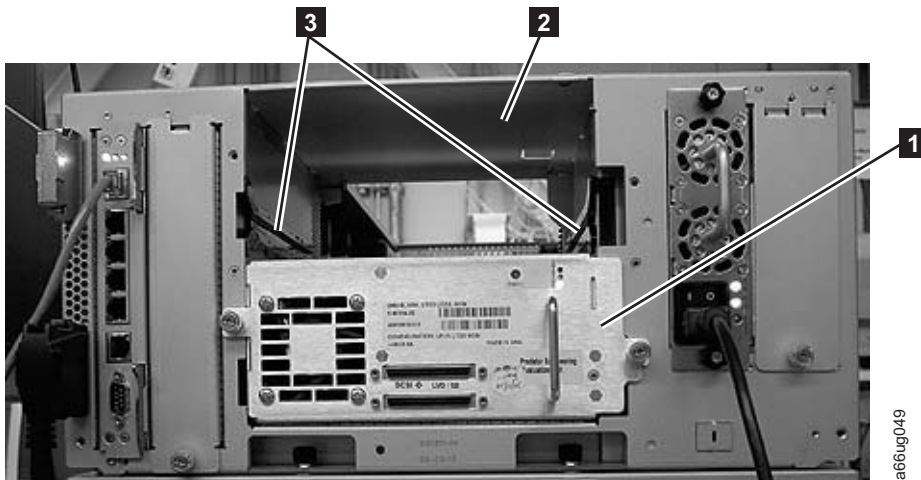

Figure 3-27. Guide rails and guide slots inside a drive slot

2. Grasp the handle (5 in Figure 3-28 on page 3-29) and slowly slide the drive sled into the drive slot, while supporting the drive sled from underneath.

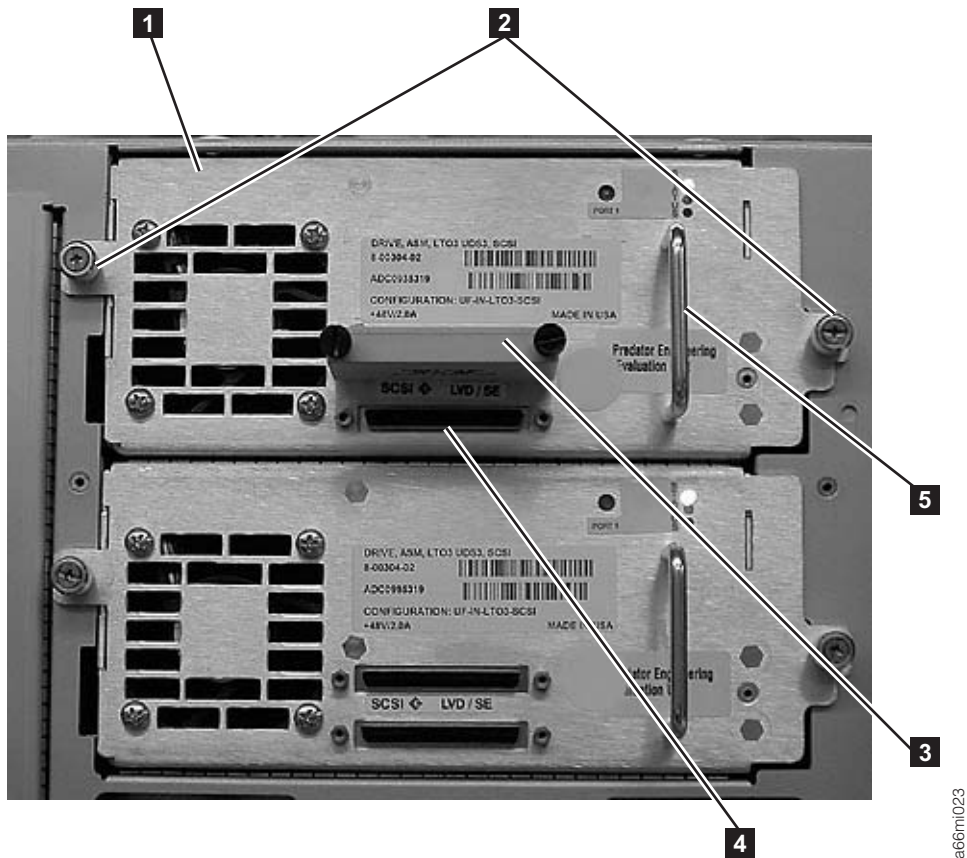

Figure 3-28. Tape Drive (detail)

3. Tighten the two thumb screws (2 in Figure 3-28) that hold the drive sled in place by turning them clockwise.
4. Repeat this procedure for all drives to be re-installed in the library.

Replacing a Power Supply

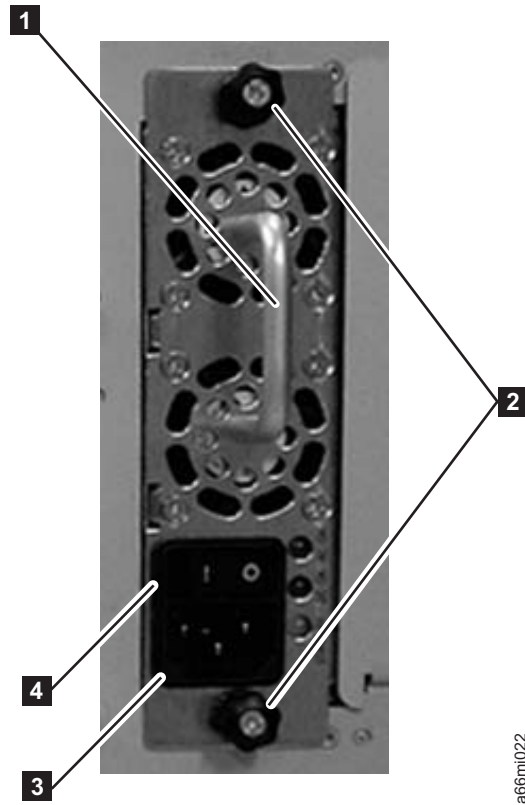

Figure 3-29. Control Module Power Supply

1. Replace the power supply component by sliding it into the power supply slot. First, grasp the handle (**1** in Figure 3-29) while supporting the power supply component from underneath. Then, line up the power supply component with the guides in the power supply slot, and carefully push it into the library.
2. Tighten the two thumb screws (**2** in Figure 3-29) on the power supply component by turning them clockwise.
3. Repeat this procedure for each library power supply.

Step 3: Cabling the Library

At this point in the installation procedure, you install the module-to-module communication cable, the module communication terminators, the customer-supplied Ethernet cable, the drive sled cables, and the power supply cabling. Select and perform one of the following cabling procedures, depending upon your library configuration:

- “Cabling a 5U Library”
- “Cabling a 14U Library” on page 3-31
- “Cabling a 23U Library” on page 3-33

Cabling a 5U Library

To cable a 5U library (control module), complete the following steps:

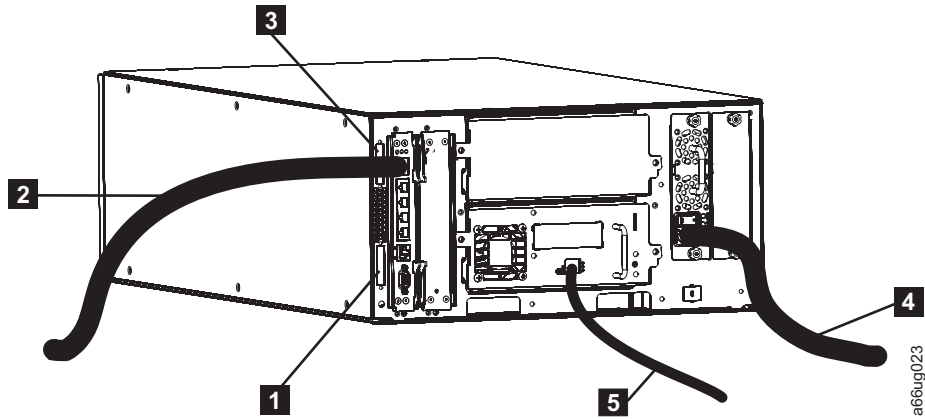

Figure 3-30. Cabling of a 5U library with fibre drives

- | | | | |
|----------|------------------------------------|----------|-------------------|
| 1 | Module communication terminator | 4 | Power cord |
| 2 | Ethernet cable (customer supplied) | 5 | Fibre drive cable |
| 3 | Module communication terminator | | |

1. Install the upper module communication terminator (**3** in Figure 3-30).
2. Install the lower module communication terminator (**1** in Figure 3-30)).
3. Connect one end of the customer-supplied Ethernet cable (**2** in Figure 3-30) in the Library Control Blade Ethernet port, then connect the other end of the cable to your network.
4. Connect one end of the drive cable (**5** in Figure 3-30) to the library, then connect the other end of the cable to your network. Repeat this for every drive in your library.
5. Connect one end of the power cord (**4** in Figure 3-30) in the receptacle in a power supply in your library, then connect the other end of the cord to your power source. Repeat this for every power supply in your library.
6. Continue with “Step 4: Powering ON the Library” on page 3-34.

Cabling a 14U Library

To cable a 14U library (control module + 9U expansion module), complete the following steps:

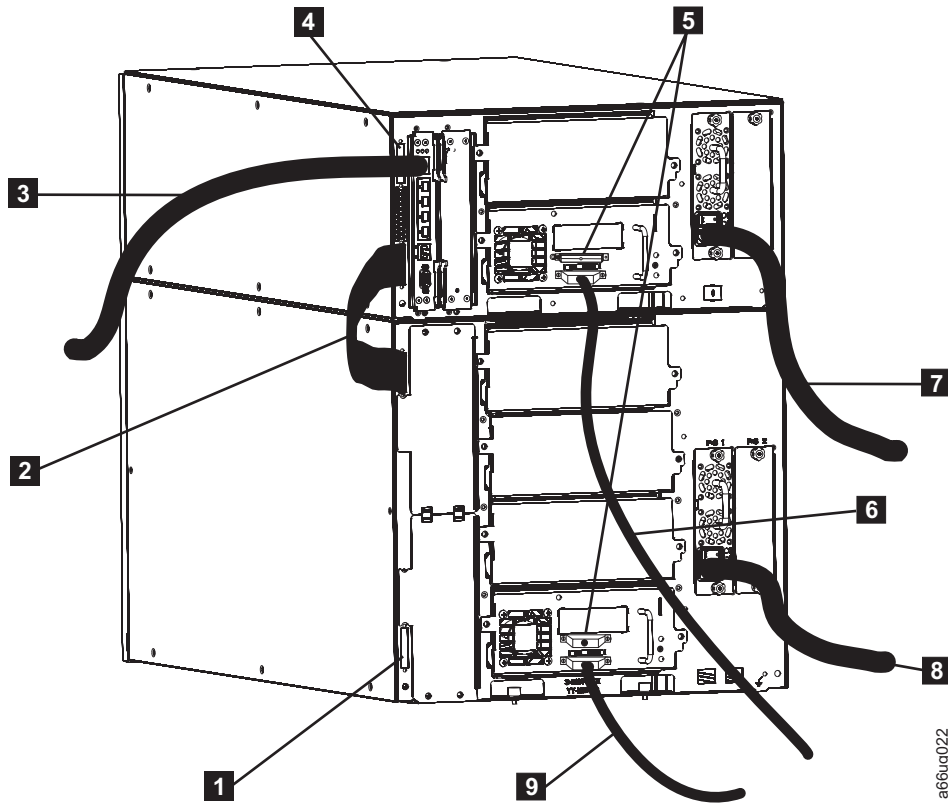

a66ug022

Figure 3-31. Cabling of a 14U library containing multiple SCSI drives

1	Module communication terminator	6	SCSI drive-to-host cable
2	Module-to-module communication cable	7	Power cord (upper module)
3	Ethernet cable (customer supplied)	8	Power cord (lower module)
4	Module communication terminator	9	SCSI drive-to-host cable
5	SCSI terminators		

1. Install a module communication terminator in the upper receptacle of the upper module of your library (**4** in Figure 3-31).
2. Install one end of the module-to-module communication cable (**2** in Figure 3-31) in the lower receptacle of the upper module of your library, then install the other end in the upper receptacle of the lower module of your library.
3. Install a module communication terminator in the lower receptacle of the lower module of your library (**1** in Figure 3-31).
4. Install one end of the customer-supplied Ethernet cable (**3** in Figure 3-31) in the Library Control Blade Ethernet port, then connect the other end of the cable to your network.
5. Installation of the SCSI cable(s) and terminator(s) depends upon how many drives are in your library. For maximum SCSI drive performance:
 - For each SCSI drive, install a SCSI terminator (**5** in Figure 3-31) in the upper receptacle of each SCSI drive in your library.

- For each SCSI drive, connect one end of a SCSI cable to the lower receptacle of each SCSI drive (**6** in Figure 3-31 on page 3-32), then connect the other end of the cable to the host.
- If you prefer to daisy-chain your SCSI drives:
 - a. Install a SCSI terminator in the upper receptacle of the top SCSI drive in the daisy-chain.
 - b. Connect one end of a shorter drive-to-drive SCSI cable included in your shipment to the lower receptacle of the top SCSI drive in the daisy-chain, then connect the other end of the cable to the upper receptacle of the next drive in the daisy-chain. Repeat this for every SCSI drive in your library.
 - c. On the last drive in the daisy-chain, connect one end of the longer drive-to-host SCSI cable included in your shipment to the lower receptacle of the last drive in the daisy-chain, then connect the other end of the cable to the host.

Note: Maximum performance of the SCSI drives in your library will not be achieved if the drives are daisy-chained.

6. Connect one end of the power cord (**7** and **8** in Figure 3-31 on page 3-32) in the receptacle of a power supply in your library, then connect the other end of the cord to your power source. Repeat this for every power supply in your library.
7. Continue with “Step 4: Powering ON the Library” on page 3-34.

Cabling a 23U Library

To cable a 23U library (control module) with SCSI and Fibre Channel drives, complete the following steps:

SCSI and Fibre Channel drives can reside in the same library; however, they can not reside in the same logical library.

1. Install a module communication terminator in the upper receptacle of the upper module of your library.
2. Install one end of one of the module-to-module communication cable in the lower receptacle of the upper module of your library, then install the other end in the upper receptacle of the middle module of your library.
3. Install one end of the other module-to-module communication cable in the lower receptacle of the middle module of your library, then install the other end in the upper receptacle of the bottom module of your library.
4. Install a module communication terminator in the lower receptacle of the bottom module of your library.
5. Install one end of the customer-supplied Ethernet cable in the Library Control Blade Ethernet port, then connect the other end of the cable to your network.
6. For SCSI drives, installation of the SCSI cable(s) and terminator(s) depends upon how many drives are in your library.

For maximum drive performance:

- Install a SCSI terminator in the upper receptacle of each SCSI drive in your library.
- Connect one end of a SCSI cable to the lower receptacle of each SCSI drive, then connect the other end of the cable to the host.
- If you prefer to daisy-chain your SCSI drives:
 - a. Install a SCSI terminator in the upper receptacle of the top SCSI drive in the daisy-chain.

- b. Connect one end of a shorter drive-to-drive SCSI cable included in your shipment to the lower receptacle of the top SCSI drive in the daisy-chain, then connect the other end of the cable to the upper receptacle of the next drive in the daisy-chain. Repeat this for every SCSI drive in your library.
- c. On the last drive in the daisy-chain, connect one end of the longer drive-to-host SCSI cable included in your shipment to the lower receptacle of the last drive in the daisy-chain, then connect the other end of the cable to the host.

Note: Maximum performance of the SCSI drives in your library will not be achieved if the drives are daisy-chained.

7. For Fibre drives:
 - Install one end of the drive fibre cable in a fibre drive in the library, then connect the other end of the cable to your network. Repeat this for every fibre drive in your library.
8. Connect one end of the power cord in the receptacle of a power supply in your library, then connect the other end of the cord to your power source. Repeat this for every power supply in your library.
9. Continue with "Step 4: Powering ON the Library."

Step 4: Powering ON the Library

1. Turn the switch on each power supply (4 in Figure 3-29 on page 3-30) to the ON (I) position.
2. Push the power button on the front panel of the library. A green LED to the left of the power button indicates that the power is ON.
3. Wait for the library to initialize. This will take approximately 10 minutes.

Note: If the operator panel does not initialize, check all cable connections, and ensure that all doors are tightly closed and all power supply switches are in the ON position. Then, repeat steps 1 and 2.

4. When initialization is complete, configure the library.

Step 5: Configuring the Library

Now it is time to configure the library using the Setup Wizard. Read the information in Chapter 4, "Configuration Planning," on page 4-1 and Chapter 5, "User Interfaces," on page 5-1 before proceeding to Chapter 6, "Configuring the Library," on page 6-1.

Chapter 4. Configuration Planning

"Understanding Cartridge Assignment in the Library"

"Modifying Network Settings"

"Applying a License Key" on page 4-2

"Cleaning Slots Configuration" on page 4-2

"Configuring I/O Stations" on page 4-3

"Selecting Drive IDs and Drive Types" on page 4-3

"Working with Logical Libraries" on page 4-4

"Working with User Accounts" on page 4-6

Understanding Cartridge Assignment in the Library

When a cleaning or data cartridge is placed in the I/O Station, the library scans the I/O Station, then a screen is displayed asking you to assign the cartridge to "System" or to a logical library. Cleaning cartridges are assigned to "System" which makes them available to all drives regardless of the logical library to which the drive is assigned. Data cartridges are assigned to a logical library which restricts them from being accessed by another logical library. A drive Firmware (FMR) cartridge placed in the I/O Station for drive firmware update must also be assigned as a SYSTEM cartridge when the assignment screen is presented after the I/O Station door is closed. Selecting CANCEL or allowing the assignment screen to time out will default all newly discovered cartridges in the I/O Station as SYSTEM cartridges.

Once a cartridge is assigned to "System" or to a logical library, the cartridge must be physically exported from the library to the I/O Station, then moved to a different slot in the I/O Station before it can be reassigned to a new destination within the library. If the cartridge is left in the same I/O Station slot, the library will retain the same assignment, even if the I/O Station door is opened and closed.

Cartridges that are placed in the I/O Station **before** the library is powered ON will not have an initial assignment. To "force" an assignment screen for newly discovered cartridges, the I/O Station must be opened and then closed. Shuffling of the cartridges to different I/O Station slots is not necessary. Previously assigned cartridges prior to power OFF and remaining in the same I/O Station slots will retain their original assignment.

Modifying Network Settings

The network settings set the connectivity of the library to the network. The connection allows the administrative user to transfer information while managing the library on the network.

Administrative users can modify the network settings from the Operator Panel only.

Note: Make sure that the library is connected to the network before modifying network settings.

To modify network settings, you need to provide the data for the following fields:

- **Library Name** is the network name you want to assign to the library. The library name can be up to a maximum of twelve characters long.
- **Dynamic Host Configuration Protocol (DHCP)** setting defaults to enabled. Setting the library to enable triggers via DHCP to automatically configure the library network settings. "Enable" makes the **IP Address**, **Subnet Mask**, and **Default Gateway** text boxes unavailable. "Disable" makes the **IP Address**, **Subnet Mask**, and **Default Gateway** text boxes available for you to manually set the library network settings.
- **IP Address** is the IP Address of the library. This text box is available only if DHCP is disabled.
- **Default Gateway** is the IP Address of the default gateway for your portion of the Ethernet network. This text box is available only if DHCP is disabled.
- **Subnet Mask** text box is available only if DHCP is disabled.

Applying a License Key

License keys can be purchased for expanding library capacity, control path failover, and data path failover.

License keys are absolute values that can only increase a licensed feature. For example, if a license key specified a slot count of 92 slots and later a different license key was installed that specified 46 slots, the total licensed slot count would still be 92 slots. It is possible to license more slots than are physically available in the library at the time. If an Expansion Module (EM) is added, the extra licensed slots become available.

A Capacity Expansion license key (Feature Code 1640) can be applied to the library during the initial configuration or at any time in the future. If additional features are purchased (Control Path Failover and/or Data Path Failover), the new license key replaces the current license key. The new license key includes all previously licensed features along with the newly licensed features.

A Path Failover license key (Feature Code 1682) supplies one or both licenses for Control Path Failover and/or Data Path Failover. For more information, refer to "Using Multiple Control Paths for Control Path Failover" on page 2-3 and "Using Multiple Data Paths for Data Path Failover" on page 2-3.

Note: The license key is made up of 5 alphanumeric characters.

Cleaning Slots Configuration

Zero to four (0 to 4) cleaning slots can be configured in your library. These slots are taken from the unassigned available storage slots. Cleaning cartridges in these slots are used by the library's Auto Clean function when the drives request cleaning.

Host-based cleaning will not use these slots. Host-based cleaning will import cleaning cartridges (CLNxxx) as data cartridges and assign them to a particular logical library.

Host-based Cleaning of a Drive

Backup applications or archive firmware applications use different techniques to automate the process of cleaning drives. These tools specify cleaning cycles based on cycle counts of the drive, drive requests, or regularly scheduled intervals.

The cleaning process itself requires certain considerations:

- Cleaning cartridges must be labeled with a volume serial number. In some cases, specific labels have been established as industry standard. For instance, the prefix “CLN” might be used to identify a cleaning cartridge. The library does not require a specific content to the label and accepts conventional cartridge labels.
- Insert a cleaning cartridge just as you do any other data cartridge. For example, the most common method is by means of the I/O station using host application control.
- Cleaning cartridges often have limited lives that can last only as long as 20 cycles. The controlling host application manages the number of uses of a cleaning cartridge. Errors can occur if a cartridge is inserted into a drive when the cartridge has already been used the maximum number of times.
- Export a cleaning cartridge just as you would export any other data cartridge.
- The concepts of physical libraries and logical libraries must be considered when setting up cleaning procedures and methods.

Configuring I/O Stations

I/O Station slots are used to import and export cartridges into and out of the library without disrupting normal library operations. I/O Stations in Expansion Modules (EMs) can be configured as either I/O Station slots or storage slots.

Depending on the configuration, the library contains at least one I/O Station, which can contain one or two magazines. Each magazine contains six slots.

- A control module contains six I/O Station slots, and one magazine.
- A 9U expansion module contains twelve I/O Station slots, and two magazines. Both magazines in a 9U expansion module must be configured the same way.

Note: If the library consists of a control module only, the I/O Station must be configured as I/O Station slots.

Storage slots in an I/O Station configured as storage are normally assigned across multiple logical libraries. In order to increase or decrease the number of I/O Station slots in the library. If it is desired to keep all the cartridges in a particular logical library together,

- Export the cartridges by logical library and keep them grouped together.
- Delete all logical libraries from the I/O station.
- Import as a group back to that particular logical library after the I/O Station slots have been reconfigured.

Selecting Drive IDs and Drive Types

You can change the SCSI ID for a SCSI-attached tape drive or the Loop ID for a Fibre-attached tape drive. This is necessary, for example, when the default ID for a tape drive that you are installing conflicts with the assigned SCSI ID of an existing tape drive. In addition, you might be using a host application that expects to

communicate with a tape drive at a specific SCSI ID, but that SCSI ID might already have been configured for use in another logical library.

Note: SCSI tape drives use SCSI IDs that are limited to a numerical value between 0-15. Fibre Channel tape drives use Loop IDs that are limited to a numerical value between 0-125.

For more information on drive IDs, refer to “Determining SCSI and Fibre Channel IDs” on page 2-4

Working with Logical Libraries

Logical libraries are virtual sections within a library that present the appearance of multiple, separate libraries for purposes of file management, access by multiple users, or dedication to one or more host applications. By default, the library has one logical library, which includes all of the library’s resources.

There are two ways to create logical libraries:

- **Automatically** - where the library divides the available resources equally among the number of logical libraries chosen.
- **Manually** - where an administrative user assigns the number of slots per logical library. (This is only done through the Web User Interface.)

Note: When changing the logical library mode from online to offline, all host application commands in progress at the start of the mode change are completed.

Administrative users can create, modify, delete, and control access to all logical libraries. Users can be given access to only certain logical libraries and denied access to others.

At a minimum, a logical library consists of one tape drive and one slot. The tape drive or slot cannot be shared with another logical library (an exception to the sharing restrictions are cleaning cartridges, which can be shared among all logical libraries). I/O Station slots and cleaning slots are shared between all logical libraries.

Each logical library is specific to a tape drive interface (for example, SCSI or Fibre Channel). Mixed media is allowed within logical libraries. For example, a logical library can contain LTO 2 and LTO 3 tape cartridges.

Automatically Creating Logical Libraries

When the library automatically creates logical libraries, the available resources are divided equally among the number of logical libraries created. Prior to creating logical libraries, it is important to first designate the desired number of cleaning slots and I/O slots (if an expansion module is present). This is necessary because the Automatic Create Logical Library function will divide all available storage slots among the chosen number of logical libraries.

From the Operator Panel, all remaining available resources are divided among the number of automatically created logical libraries. Use the Web User Interface (UI) to manually create logical libraries.

Note: On the Web User Interface, all logical libraries must be deleted for the **Automatic** button to appear. If the **Automatic** button does not appear, delete all existing logical libraries.

Manually Creating Logical Libraries

Every logical library must have at least one drive and one storage slot assigned to it. For example, if the library has two tape drives and 12 slots available, the maximum number of logical libraries that can be created is two. Up to 12 slots can be allocated between the two logical libraries in any configuration.

If the library has only one logical library with all resources assigned to it, that logical library must be deleted before reallocating resources to a new logical library.

You may need to provide information for the following fields:

- **Emulation Type** emulates the logical library.
- **Logical Library Name** can be up to a maximum of 12 alphanumeric characters.
- **Media Barcode Format** defaults to the last 8 characters.
- **Automatic Drive Cleaning** is enabled by default and requires at least one cleaning cartridge and a communication interface to the tape drive with the ability of the tape drive to indicate that cleaning is needed.
- **Number of Slots** is the number of tape cartridge slots that are to be allocated to the new logical library.

Deleting Logical Libraries

A logical library can be deleted when it is no longer needed. After a logical library is deleted, its resources become unassigned and can be used to create additional logical libraries or added to existing logical libraries.

Changing Logical Library Access

An administrative user can control what logical libraries a specified user can access. This is done by modifying a user's account.

To change logical library access, you must provide the following information:

- **Password** - a unique string of alphanumeric characters that can be viewed and modified by the Administrator.
- **Privilege level** - the library functions a user is assigned access. Refer to "User Privileges" on page 5-8 for more information on user privilege levels.

Changing Logical Library Modes

By default, the library has one logical library enabled. The logical library mode must be changed in order to modify the logical library or library. There are two logical library modes: online and offline.

- **Online** - the normal operating condition for a logical library. In this mode, the robotics are enabled and all host application commands are processed.
- **Offline** - the logical library does not process any host application commands. If a logical library is taken offline, the physical library and other logical libraries are not affected.

You can take the physical library or any of its logical libraries online or offline. Some operations require that the logical library be offline. Administrative users can take a logical library offline rather than the entire library so as to minimize

disruption of library operations. Administrative users must manually change the logical library mode to online or offline from the Operator Panel or the Web User Interface (UI).

Details on changing logical library modes include:

- The default logical library mode is online.
- When you access these screens, only logical libraries accessible by the user appear.

When you are changing logical library mode, be aware of the following information:

- The **Online/Offline** button toggles between states.
- If a logical library is in use, the **Online/Offline** button is grayed out.
- Set the button to read **Online** to take either the physical library or a logical library, depending on the current view, to an online state, which is the normal operating condition. In this mode, the robotics are enabled and all host commands are processed.
- Set the button to read **Offline** to take either the physical library or a logical library, depending on the current view, to an offline state. If only the physical library is taken offline, logical libraries will not process robotics commands, even though they are online. If only a logical library is taken offline, neither the physical library nor the other logical libraries are affected.

Working with User Accounts

There are two types of user accounts: user and administrative user.

- **User** - has access to one or more assigned logical libraries and can perform functions within a logical library, such as performing media and drive functions. A user cannot perform actions that affect the physical library, such as creating, modifying, or deleting a logical library.
- **Administrative user** - has access to the entire physical library and all of its logical libraries.

One administrative user account, Admin, is configured by default and can be modified at any time, but not deleted. An administrative user can perform all user account functions; a user cannot perform any administrative account functions. Refer to “User Privileges” on page 5-8 for more information on library permission levels.

Creating User Accounts

Administrative users can create user accounts any time after the initial configuration. Users cannot create user accounts. A maximum of 300 user accounts can be created in the physical library.

Note: User account user names are limited to 1-12 alphanumeric characters, and passwords are limited to 6-12 alphanumeric characters.

To create user accounts, you need to provide information for the following fields:

- **User Name** is the login name of the user account you are creating.
- **Password** is a unique string of alphanumeric characters for the user account you are creating.
- **Privilege** level is set to either User or Admin. Refer to “User Privileges” on page 5-8 for more information on user privilege levels.

Modifying User Accounts

After a user account has been initially created, the account settings, such as the password, privilege level, and logical library access, can be modified at any time by an administrative user.

Note: User account passwords are limited to 6-12 alphanumeric characters.

To modify user accounts, you need to provide information for the following fields:

- **User Name** is the login name of the user account you are creating.
- **Password** is a unique string of alphanumeric characters for the user account you are creating.
- **Privilege** level is set to either User or admin. Refer to “User Privileges” on page 5-8 for more information on user privilege levels.

Deleting User Accounts

When a user account is no longer needed, it can be deleted at any time.

Chapter 5. User Interfaces

“Operator Panel”

“Web User Interface (UI)” on page 5-7

“User Privileges” on page 5-8

The library has a local interface, the Operator Panel, and a remote Web User Interface (UI).

The Operator Panel is located on the front door of the control module (CM) and allows users to work locally on the library via the user interface. The Web UI allows users to view and perform some library functions from remote sites and is best viewed using Internet Explorer 4.0 or higher.

Operator Panel

The Operator Panel is physically attached to the front door of the control module (CM). The user interface appears on the touchscreen LCD display of the Operator Panel for executing basic library management functions. Audible feedback, such as “key click” sounds, are generated when a user touches a button on the touchscreen.

Common Operator Panel Elements

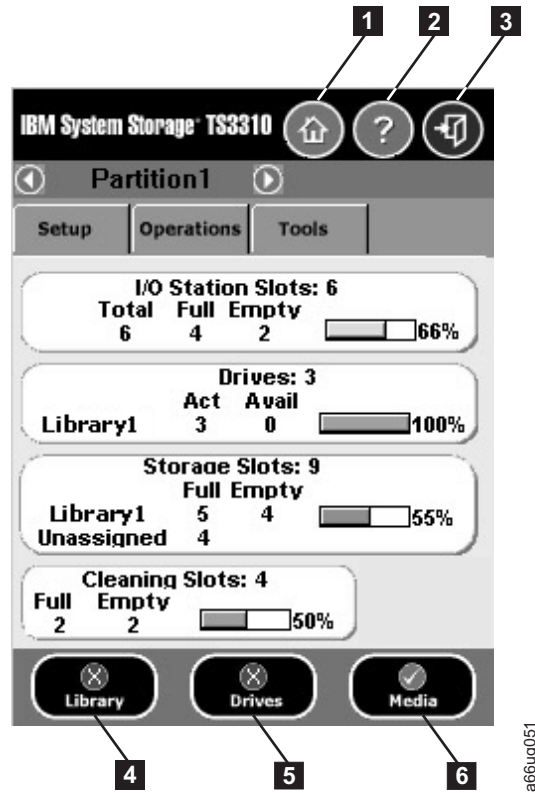

Figure 5-1. Operator Panel common header elements and subsystem status buttons

Common Header Elements

All Operator Panel screens (except for the Login screen) contain the following common elements in the header:

- **Home** (1 in Figure 5-1) - displays the default **Capacity View** screen.
- **Help** (2 in Figure 5-1) - context-sensitive help for the associated page
- **Logout** (3 in Figure 5-1) - ability to log out

System Summary and Subsystem Status

The health of the library can be gauged by three subsystem status buttons located at the bottom of the home page. These buttons provide easy access to the health of the library for faster recovery if problems occur. You can select the buttons to view detailed information about the library and gain access to library subsystems. The three subsystems are:

- **Library** (4 in Figure 5-1)- opens a library menu selection screen and then the operator interventions for the library.
- **Drives** (5 in Figure 5-1)- opens the operator intervention screen for drives.
- **Media** (6 in Figure 5-1)- opens the operator intervention screen for media.

Each button has three states indicated by color. The three states are:

- Good - green
- Degraded - yellow (An operator intervention has been created.)
- Investigate - red (An operator intervention has been created; however, the library may still be operational.)

Keyboards

When a user touches a text box requiring data entry, a keyboard screen appears. Either the alphabetic or numeric keyboard appears, depending on the type of input field. All alphabetic character entries are lower case. The text box appears at the top of the screen and the number/characters appear as they are entered. The **123** button opens the numeric keyboard from alphabetic keyboard, The **abc** button opens the alphabetic keyboard from the numeric keyboard. The back arrow erases one character at a time.

Attention: To use the touchscreen effectively, tap lightly to make your selections.

Login Screen

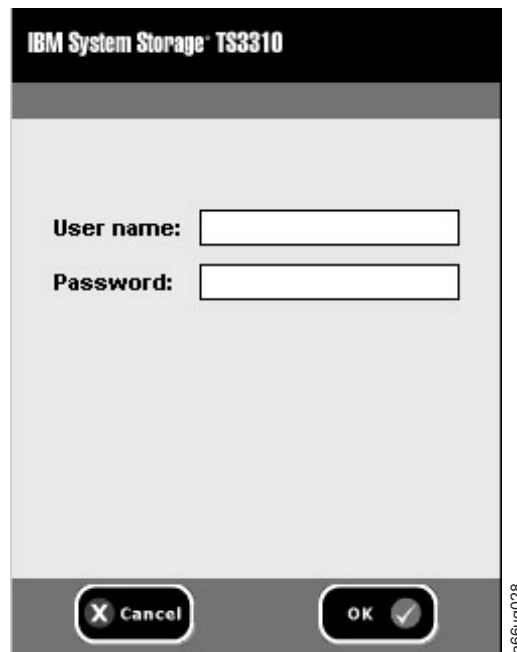

Figure 5-2. Operator Panel Login screen

To fill in the **User name**, lightly touch the blank field to display the alphabetic and numeric touch pads then, use the touch keys to spell out the user ID and touch **OK**. Similarly, enter the **Password** and touch **OK**.

For initial login, the administrator should use the following:

- User name: **admin**
- Password: **secure**

Home Page

The **Home Page** screen provides tabular data on the capacity of the various areas of the library. Use this screen to see a quick summary of the capacity of the selected logical library based on a user login.

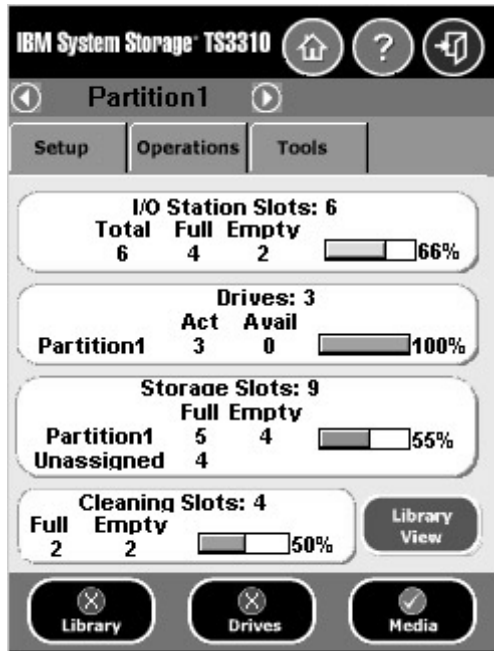

Figure 5-3. Home Screen Capacity View

If users have access to more than one logical library, they can navigate to other logical libraries using arrows next to the logical library name at the top of the screen.

If an administrative user is logged in, a view of the physical library appears.

If a user is logged in, the first logical library that they have access to, in alphabetical order, appears.

Menus Available from the Operator Panel

The following four menus organize commands into logical groups:

- The **Setup** menu consists of commands that you can use to set up and configure various aspects of the library, including logical libraries connectivity, network, physical library, users, date and time, licenses, and SNMP trap registration.



Figure 5-4. Setup menu screen

- The **Operations** menu consists of commands that enable you to change the library's mode of operations, import and export cartridges, load and unload drives, move media, and shutdown/restart the library.

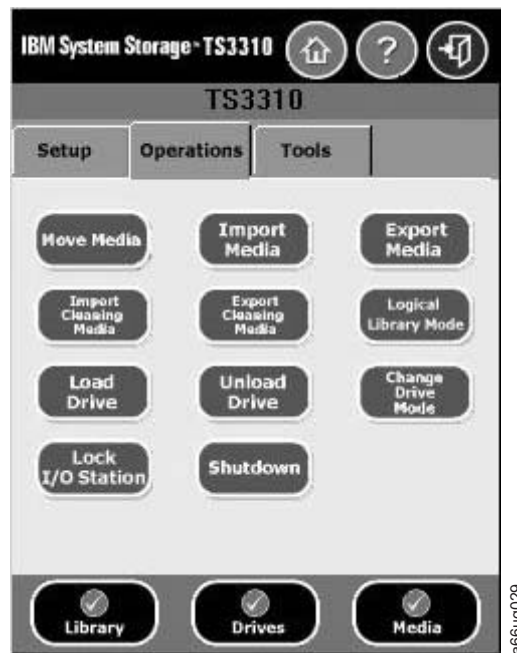

Figure 5-5. Operations menu screen

- The **Tools** menu consists of commands that you can use to maintain your library such as viewing operator interventions, capturing the library snapshot, identifying ports, and updating firmware using an FMR (Firmware) cartridge.

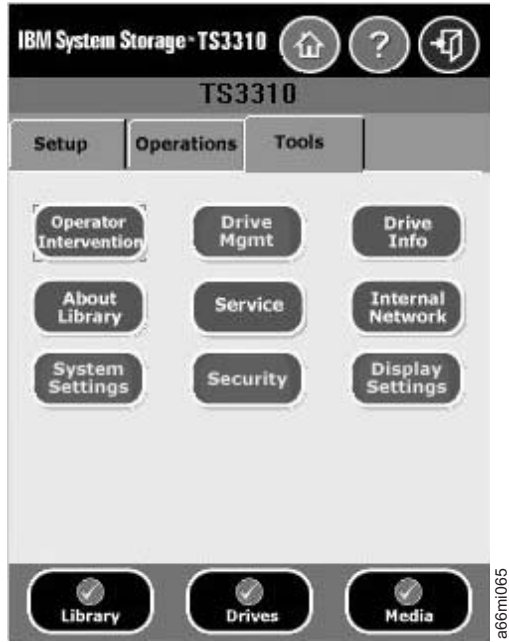

Figure 5-6. Tools menu screen

The following figure is a menu tree showing all functions available from the Operator panel interface.

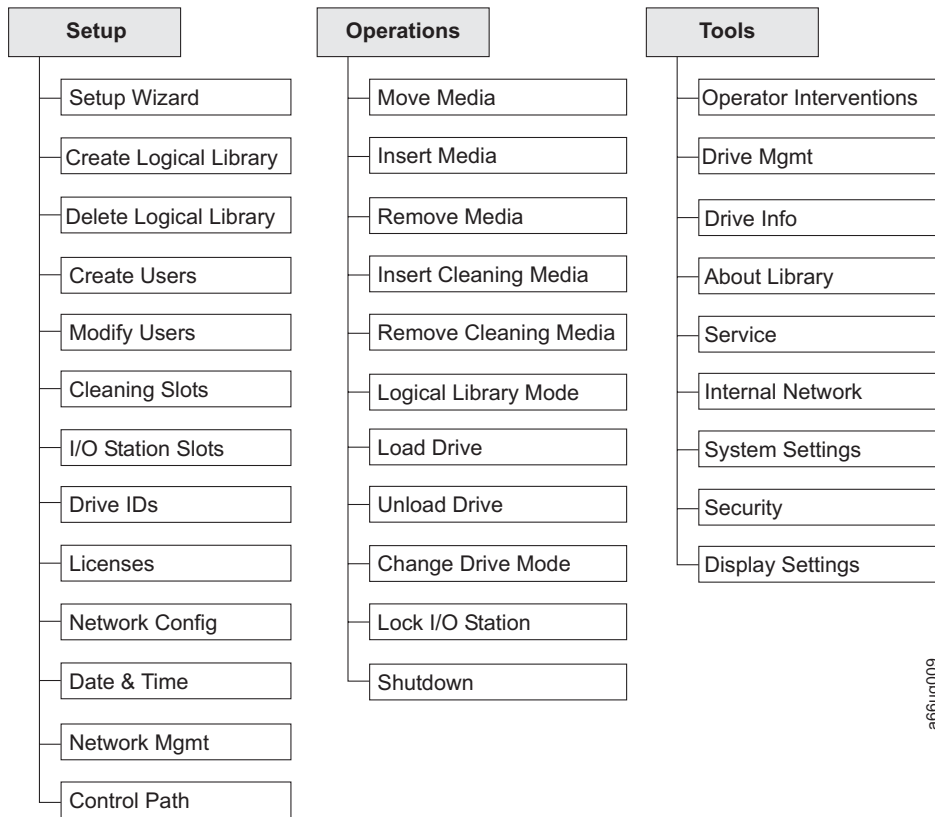

Figure 5-7. 3576 Tape Library menu tree

Web User Interface (UI)

The Web UI is accessible from a web browser and is best viewed using Internet Explorer 4.0 or higher.

To manage the library using the Web UI, you must set up the initial network configuration of the library from the Operator Panel touchscreen. For more information, see “Modifying Network Settings” on page 4-1 and “Step 4: Set up the Library Network Configuration” on page 6-3.

Logging in to the Web User Interface

Initial login information is as follows:

- User: **admin**
- Password: **secure**

For more information on user privileges, see “User Privileges” on page 5-8.

Common Header Elements

All Operator Panel screens (except for the Login screen) contain the following common elements in the header:

- **Help** - context-sensitive help for the associated page
- **Logout** - ability to log out

Menus Available from the Web User Interface

Table 5-1. Menus available from the Web User Interface

■	Welcome Page
■	Monitor System
	System Summary
	Library Map
	Logged in Users
	Network Settings
■	Manage Cartridges
	Data Cartridges
	Cleaning Cartridges
	I/O Station
	Lock/Unlock I/O Station Doors
■	Manage Drives
	Load
	Unload
	Clean
	State (Online/Offline)
	Control Paths
	Drive IDs
	Fibre Channel Ports
■	Manage Library
	Setup Wizard

Table 5-1. Menus available from the Web User Interface (continued)

Logical Libraries

Cleaning Slots

I/O Station Slots

■ **Settings**

Feature Licenses

Date & Time

Email Notifications

Outgoing Server (SMTP) Configuration

Contact Information

Save/Restore Configuration

■ **Manage Access**

Users

Set Session Timeout

■ **Service Library**

Operator Interventions

Capture Library Log

Capture Drive Log

Update Library Firmware

Update Drive Firmware

Drive Firmware Levels

Shutdown/Restart Library

User Privileges

User privilege levels are manually assigned to user accounts created within the library. Controlling access to screens and operations within the library preserves the integrity of the library and the data that is stored within the library.

There are two types of user privileges in the library.

- **Administrative users** are allowed access to the entire physical library and all of its logical libraries. One and only one administrator user must be assigned the login name **admin**.
- **Users** are allowed to operate a logical library, but not perform actions that affect the physical library.

User privileges include:

- A screen saver is invoked after 10 minutes of inactivity on the Operator Panel. The Web User Interface (UI) does not use a screen saver. The User, Administrative user, or Service user who is inactive between 10 and 30 minutes returns to the last accessed screen when activating the screen again.
- Any logged in User, Administrative user, or Service user who is inactive for more than 30 minutes is logged out.
- Up to 10 Users and/or one Administrative user can be logged in at one time on the Web UI. Only one user (Administrative or Service) can be logged in at one time on the Operator Panel. One Administrative user can disconnect another Administrative user.

- Any user can be logged in to only one interface at a time.
- When a Service user logs in, all other Users and Administrative users are logged out and notified that they cannot perform actions on the library. A message is posted that Service is logged in and no other users can access the library until after Service has logged out.

Table 5-2. Administrative User and User Command and Access. ("X" if access allowed; "-" if access not allowed)

Menu Command	Administrative User	User
Setup		
Setup Wizard	X	—
Logical Libraries->Create	X	—
Logical Libraries->Delete	X	—
Users->Create	X	—
Users->Modify	X	—
Cleaning Slots	X	—
I/O Station Slots	X	—
Drive IDs	X	—
Licenses	X	—
Network Config	X	—
Date and Time	X	—
Network Management->SSL, Trap Registration, SNMP Version	X	—
Control Path	X	—
Operations		
Media->Move	X	X
Media->Insert	X	X
Media->Remove	X	X
Cleaning Media->Insert	X	X
Cleaning Media->Remove	X	X
Logical Libraries->Change Mode	X	X
Drive->Load	X	X
Drive->Unload	X	X
Drive->Change Mode	X	X
I/O Station Lock/Unlock	X	—
System Shutdown	X	—
Tools		
Operator Interventions	X	—
Drive Management	X	—
Drive Info	X	X
About Library	X	X
Service	X	—
Internal Network	X	—

Table 5-2. Administrative User and User Command and Access (continued). ("X" if access allowed; "-" if access not allowed)

Menu Command	Administrative User	User
System Settings	X	—
Security	X	—
Display Settings	X	—

Table 5-3. Web User Interface Menu Commands and Access. ("X" if access allowed; "-" if access not allowed)

Menu Command	Administrative User	User
Monitor System		
System Summary	X	X
Library Map	X	—
Logged In Users	X	—
Network Settings	X	—
Manage Cartridges		
Data Cartridges	X	X
Cleaning Cartridges	X	X
I/O Station	X	X
Lock/Unlock I/O Station Doors	X	—
Manage Drives		
Load	X	X
Unload	X	X
Clean	X	X
State (Online/Offline)	X	X
Control Paths	X	—
Drive IDs	X	X
Fibre Channel Ports	X	X
Manage Library		
Setup Wizard	X	—
Logical Libraries	X	X
Cleaning Slots	X	—
I/O Station Slots	X	—
Settings		
Feature Licenses	X	—
Date & Time	X	X
Email Notifications	X	X
Outgoing Server (SMTP) Configuration	X	—
Contact Information	X	X
Save/Restore Configuration	X	X
Manage Access		

Table 5-3. Web User Interface Menu Commands and Access (continued). ("X" if access allowed; "-" if access not allowed)

Menu Command	Administrative User	User
Users	X	—
Set Session Timeout	X	—
Service Library		
Operator Interventions	X	X
Capture Library Log	X	X
Capture Drive Log	X	X
Update Library Firmware	X	—
Update Drive Firmware	X	—
Drive Firmware Levels	X	X
Shutdown/Restart Library	X	X

Chapter 6. Configuring the Library

“Step 1: Log in to the Operator Panel” on page 6-2

“Step 2: Access the Setup Wizard” on page 6-3

“Step 3: Ensure that all Hardware is Installed” on page 6-3

“Step 4: Set up the Library Network Configuration” on page 6-3

“Step 5: Enter License Keys” on page 6-4

“Step 6: Assign Cleaning Cartridge Slots” on page 6-4

“Step 7: Assign I/O Station Slots” on page 6-5

“Step 8: Assign Logical Libraries” on page 6-5

“Step 9: Set the Date and Time” on page 6-5

“Step 10: Insert Cleaning Cartridge(s)” on page 6-6

“Step 11: Populate your Library with Data Cartridges” on page 6-6

“Step 12: Register for My Support” on page 6-7

Initial configuration customizes the library for your specific needs and environment. Use the Operator Panel Setup Wizard to configure your library.

Details on using the Setup Wizard include:

- The only time that you do not need to log in to the library is when the Setup Wizard appears on the Operator Panel the first time the library is turned on.
- After a timeout period of one hour, the Setup Wizard will close, and you will be logged out of the library. Use the default Admin account to log in on the Operator Panel.
- If you timeout of the Setup Wizard or do not complete all the Setup Wizard screens, the library will apply the default configuration settings plus whatever modifications (if any) you made. The default settings are as follows:
 - Network settings: DHCP enabled (IP addresses are dynamically assigned to network devices in your network.)
 - I/O Station slots: 6 (in the control module)
 - Cleaning cartridge slots: 1
 - Logical libraries: 1
- You can only configure network settings on the Operator Panel, and you cannot log in to the library from the web interface until you have configured network settings.
- You can always return to the Setup Wizard whenever you are logged in to the Operator Panel.
- Any administrative users you create will also be able to use the Setup Wizard as well as Setup and Operations menu commands to reconfigure the library.
- If necessary, you can cancel out of the Setup Wizard on the Operator Panel and begin using the library locally with the default settings in place. If you accept the default network configuration settings, you will not be able to access the

library remotely from the Web User Interface. You can, however, return to the Setup Wizard at any time and modify network and other settings.

Important: Use the Appendix D, “Library Configuration Form,” on page D-1 to record all library settings. At this time, there is no way to electronically save and restore library settings.

Step 1: Log in to the Operator Panel

If necessary, log in to the Operator Panel. If the **Setup Wizard: Welcome** screen appears, skip this step.

On the Operator Panel Log in screen:

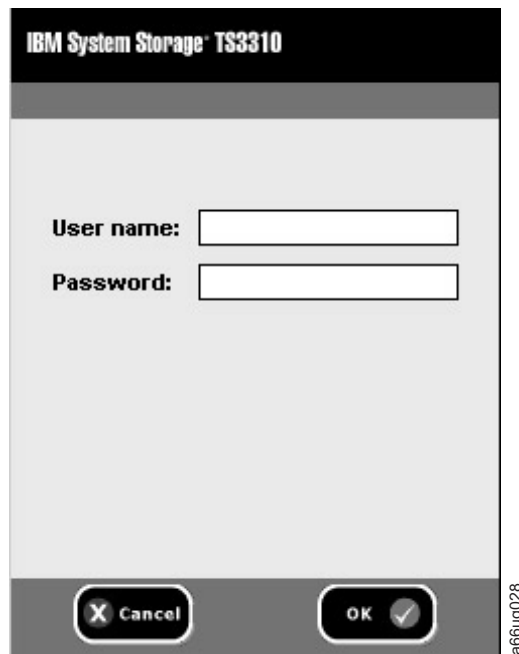

Figure 6-1. Operator Panel Log in screen

1. Touch the **User name** text field to access the alphanumeric keyboards.
2. Use the alphabetic keyboard to enter **admin**, then touch **OK**.
3. Touch the **Password** text field to access the alphanumeric keyboards.
4. Use the alphabetic keyboard to enter **secure**, then touch **OK**.
5. Touch **OK** again to access the **Home Page** screen which displays the default configuration of the library.
6. Delete the library's default logical library setting.
 - a. Select **Setup** → **Delete Logical Libraries**. and follow the on-screen prompts.

Now you are ready to configure your library using the Setup Wizard.

Step 2: Access the Setup Wizard

Important: If at any point you touch **Cancel** while in the Setup Wizard, the **Setup Wizard: Cancel** screen appears. The screen is dynamically updated to indicate what the current configuration of the library is, including any settings that have been applied thus far in the Wizard. Touching **Cancel** on the Cancel screen navigates you back to the last accessed screen in the Setup Wizard. Touching **OK** applies the current settings and returns you to the **Home Page** screen.

1. If the **Setup Wizard: Welcome** screen does not display automatically, select **Setup** → **Setup Wizard** to display the Welcome screen.
2. After reading the information on the screen, touch **Begin**.

Step 3: Ensure that all Hardware is Installed

1. Read the **Hardware Installation** screen.
2. Ensure that all tape drives and the customer-supplied Ethernet cable are installed.
3. If the drives and Ethernet cable are installed, touch **Next** to continue.

Step 4: Set up the Library Network Configuration

Read “Modifying Network Settings” on page 4-1 before beginning this step.

Important: You will not be able to access the library remotely until the network settings are applied. Library firmware can only be updated using the remote Web User Interface.

Touch **No** if you do not know your network settings and to continue configuring your library.

To set up the network configuration:

1. Determine your network settings (IP Address, Default Gateway, and Subnet Mask) and record this information on the Appendix D, “Library Configuration Form,” on page D-1.
2. Touch **Yes** to begin configuring the library network.
3. Choose a name for your library.
4. Touch the **Library Name** text box to access the alphanumeric keyboards.
5. Using the alphanumeric keyboards, enter the name into the **Library Name** field.

Note: The library name can be a maximum of 12 alphanumeric characters. Any letters used in the library name must be lowercase.

6. Select **Dynamic Host Configuration Protocol (DHCP)** to have the library network setting automatically configured. To configure your network manually, enter the following network settings:
 - **IP Address** - the Internet protocol (IP) address of the library
 - **Default Gateway** - the IP address of the default gateway for your portion of the Ethernet network

Note: Each IP address consists of four sets of numbers ("octets") separated by periods. Do not use "0" in the last octet of the address because it will reset the Gateway to the original address set at the factory.

- **Subnet Mask** - the IP address of the subnetwork
7. Touch **Apply** to save the network settings.
 8. After a successful save, touch **Close**.
 9. Touch **Local** to complete configuring your library using the Operator Panel.

Note: The **Setup Wizard** is not available from the Web User Interface.

Step 5: Enter License Keys

Read "Applying a License Key" on page 4-2 before beginning this step.

If you purchased a Control Path Failover License Key (Feature Code 1682 which includes Control Path Failover and Data Path Failover) with your library or a Capacity Expansion License Key (Feature Code 1640) with your 14U or larger library, enter those license keys now.

Note: A Data Path Failover license key (Feature Code 1682) is entered at the host. Refer to the device driver documentation shipped with your library and the installation instructions shipped with your license keys for more information.

Touch **No** if you would like to continue configuring your library without entering a license key.

To enter a license key:

1. Locate the license key labels.
2. Touch **Yes**.
3. Touch the **License Key** text field to access the alphanumeric keyboards.
4. Use the alphanumeric keyboards to enter the key.
5. Touch **Apply**.
6. Touch **Close** to continue.
7. Verify that your library has the correct number of licensed slots by selecting the **Home** icon (**1** in Figure 5-1 on page 5-2) to view the **Home Page** screen.
8. Place a license key label on the cover plate located on the rear of the library to the right of the Library Control Blade.
9. Place another license key label on the Appendix D, "Library Configuration Form," on page D-1 for safe keeping.
10. Repeat this procedure for each license key.

Step 6: Assign Cleaning Cartridge Slots

Read "Cleaning Slots Configuration" on page 4-2 before beginning this step.

One cleaning cartridge slot is assigned as a default in the library. A maximum of four cleaning cartridge slots are allowed in the library. If you do not wish to assign additional cleaning cartridge slots, touch **No** to continue configuring your library.

To assign additional cleaning cartridge slots:

1. Touch **Yes**.
2. Using the up and down arrows, choose the number of cleaning slots you would like to assign in your library.
3. Touch **Next** to continue.

Step 7: Assign I/O Station Slots

Read “Configuring I/O Stations” on page 4-3 before beginning this step.

The library has six I/O Station slots assigned as a default. If you purchased a E9U expansion module and a Capacity Expansion license key (Feature Code 1640), you can assign additional I/O Station slots. Up to 12 I/O Station slots can be assigned in each E9U expansion module. If you do not wish to assign additional I/O Station slots, touch **No** to continue configuring your library.

To assign additional I/O Station slots:

1. Touch **Yes**.
2. Using the up and down arrows, choose the number of I/O Station slots you would like to assign in your library.
3. Touch **Next** to continue.

Step 8: Assign Logical Libraries

Read “Working with Logical Libraries” on page 4-4 before beginning this step.

The library has one logical library configured as a default. The maximum number of logical libraries that can be configured is equal to the number of drives installed in the library.

If you do not wish to create additional libraries, touch **No** to continue configuring your library.

To create additional logical libraries:

1. Touch **Yes** to change the number of logical libraries in your library.
2. Using the up and down arrows, choose the number of logical libraries you wish to set up in your library.
3. Touch **Next** to continue.
4. Modify the library names that appear by touching the text box, and using the alphanumeric keyboards to type in a name.
5. Touch **Next** to continue.
6. Verify that the number of cleaning slots, I/O Station slots, and logical libraries created is correct.
7. Touch **Apply** to save the settings and exit the Setup Wizard.

Step 9: Set the Date and Time

1. Enter the current date and time by touching each square and entering the current value.

Note: The library clock is on a 24-hour cycle. For example, 4:00 pm would be entered as 16 (HH) and 00 (MM). Clock management may require you to reset the time.

2. Touch **Apply** to save the date and time settings and to continue.
3. Touch **Close** to continue.

Step 10: Insert Cleaning Cartridge(s)

Read “Understanding Cartridge Assignment in the Library” on page 4-1 before beginning this step.

1. Place a cleaning cartridge in the I/O Station.
2. Touch **System** to assign the cleaning cartridge to the entire library system and not to a specific logical library.
3. Select **Operations** → **Inserting Cleaning Media**.
4. Select the designed destination slot for the cleaning cartridge.
5. Touch **OK**.
6. Repeat this procedure for each cleaning cartridge.

Step 11: Populate your Library with Data Cartridges

Read “Understanding Cartridge Assignment in the Library” on page 4-1 before beginning this step.

Two methods are available for populating your library with data cartridges:

- Bulk loading
- Importing via the I/O Station

Only bulk load cartridges into your library if the following criteria is met:

- if your logical library is licensed for full capacity
- if you are loading blank cartridges
- if cleaning slots have been assigned and hold cleaning cartridges

Note: Do not bulk load cartridges into the bottom two rows of the library. Also, if your library is 23U or larger, do not bulk load cartridges into the top slot of column 4 or column 5. These storage slots are not accessible by the robot due to mechanical limitations.

Storage slots are not assigned consecutively in a logical library. To ensure that your cartridges get placed in the correct logical library, import your data cartridges via the I/O Station following the procedure below.

1. Determine the number of available storage slots in each logical library by referring to the Library Map on the Web User Interface (**Monitor System** → **Library Map**).
2. Using the right and left arrows near the top of the screen, scroll between logical libraries and make note of the number of storage slots assigned to each logical library.
3. Load the I/O Station with data cartridges.
4. Choose the logical library to which these cartridges are to be assigned.
5. Select **Operations** → **Insert Media**.
6. Repeat this procedure until all data cartridges have been imported into the library.

Step 12: Register for My Support

My Support registration provides email notification from IBM when new firmware levels have been updated and are available for download and installation as well as other information about your library.

To register for My Support:

- Visit the web at <https://www-1.ibm.com/support/mysupport/us/en/>.
- Enter your user name and password on the Appendix D, “Library Configuration Form,” on page D-1.

IBM recommends that you update library and drive firmware when new levels become available.

- For instruction on updating library and drive firmware, see “Updating Library Firmware” on page 7-10 and “Updating Drive Firmware” on page 7-11.

Now you are ready to use your library.

Chapter 7. Operating Procedures

Library / Logical Libraries	"Viewing System Information" on page 7-2
	"Accessing the Setup Wizard" on page 7-2
	"Creating Logical Libraries" on page 7-3
	"Deleting/Modifying a Logical Library" on page 7-3
	"Assigning Cleaning Slots" on page 7-3
	"Assigning I/O Station Slots" on page 7-4
	"Entering License Keys" on page 7-4
	"Creating Users Accounts" on page 7-4
	"Setting the Date and Time" on page 7-5
	"Setting Up Email Notifications" on page 7-5
	"Managing the Network (SSL, Trap Registration, and SNMP Version)" on page 7-6
	"Resetting the Library Control Blade IP Address" on page 7-5
	"Configuring the Library for Remote Access" on page 7-7
	"Managing the Network (SSL, Trap Registration, and SNMP Version)" on page 7-6
	"Taking a Logical Library Offline/Online" on page 7-7
	"Shutting Down/Restarting the Library" on page 7-8
	"Viewing Error Messages" on page 7-9
	"Capturing a Library Snapshot" on page 7-9
	"Viewing Library Information" on page 7-9
	"Locking/Unlocking the I/O Station" on page 7-10
Firmware Upgrades	"Updating Library Firmware" on page 7-10
	"Updating Drive Firmware" on page 7-11
	"Using the ITDT SCSI Firmware Update, Dump Retrieval and Drive Test Tool" on page 7-11
Drives	"Viewing Drive Information" on page 7-13
	"Loading a Drive" on page 7-14
	"Unloading a Drive" on page 7-14
	"Taking a Drive Offline/Online" on page 7-14
	"Adding a Control Path Drive to a Logical Library" on page 7-14
	"Assigning Drive IDs" on page 7-14
	"Modifying a Fibre Channel Drive Port Setting" on page 7-15
Cartridges	"Inserting Data Cartridges" on page 7-15
	"Removing a Data Cartridge" on page 7-16
	"Moving Data Cartridges" on page 7-16
	"Inserting a Cleaning Cartridge" on page 7-16
	"Removing a Cleaning Cartridge" on page 7-17

Library and Logical Libraries

The following sections give information on operating procedures related to the library or logical libraries within your library.

Viewing System Information

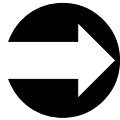

From the Web User Interface: **Monitor System** → **System Summary**

This menu item gives information on the overall health of the library, as well as, the current assignment of I/O slots, drives, cleaning cartridge slots, and storage slots.

Accessing the Setup Wizard

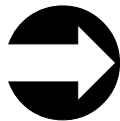

From the Operator Panel: **Setup** → **Setup Wizard**

For information on using the Setup Wizard, refer to Chapter 6, “Configuring the Library,” on page 6-1.

Library Verify Diagnostic Tests

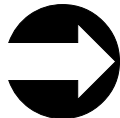

From the Operator Panel: **Tools** → **Service** → **SystemService** → **System**

1. Follow the menu path shown above.
2. Touch **Yes** to take all logical libraries OFFLINE.
3. Select **Library**, then choose one of the following diagnostic tests and follow the on-screen instructions:
 - Robotics - tests the library robotics (see “DR005: Motion Failure Diagnostic (a Library Verify Test)” on page 10-35)
 - I/O - tests the open/close and lock/unlock sensors of the I/O Station doors (see “DR011: I/E (I/O Station) Lock Diagnostic (a Library Verify Test)” on page 10-38)
 - Bar code - tests the ability of the bar code scanner to read an internal library bar code (see “DR007: Bar Code Scanner Diagnostic (a Library Verify Test)” on page 10-36)
 - Drive - tests the read/write function of a selected drive; a scratch (blank) cartridge is required for this test (see “DR006: Drive Diagnostic (a Library Verify Test)” on page 10-36)
 - Door - tests the open/close sensors of the Access Doors (Each Access Door in your library must be tested individually. After closing the Access Door just tested, wait until the library inventory is complete before running the next test or resuming normal library operations.)
4. Touch **Back** to return to the **System Diagnostics** screen.
5. Touch **Back** to return to the **Library Offline** screen.

6. Touch **No** to exit the **Bringing logical libraries OFFLINE** screen.
7. Touch **Back** to return to the **Service** menu screen.
8. Touch **Exit** to return to the **Tools** menu.
9. Touch the **Operations** tab, then touch **Logical Library Mode** to bring your logical libraries back ONLINE.

Creating Logical Libraries

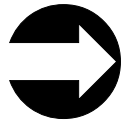

From the Operator Panel: **Setup** → **Create Logical Libraries**

From the Web User Interface: **Manage Library** → **Logical Libraries**

Use this menu to create logical libraries within your library. The maximum number of logical libraries allowed in the library is equal to the number of drives installed in the library. For more information, see “Determining the Number of Logical Libraries (Partitions)” on page 2-1 and “Working with Logical Libraries” on page 4-4.

Deleting/Modifying a Logical Library



From the Operator Panel: **Setup** → **Delete Logical Libraries**

From the Web User Interface: **Manage Library** → **Logical Libraries**

Use this menu to delete or modify logical libraries within your library. The modify function is only available from the Web User Interface. When all library resources are assigned to logical libraries, at least one logical library must be deleted to make library resources available before a new logical library can be created or an existing logical library can be modified.

The maximum number of logical libraries allowed in the library is equal to the number of drives installed in the library. For more information, see “Working with Logical Libraries” on page 4-4.

Assigning Cleaning Slots

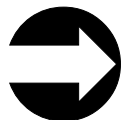

From the Operator Panel: **Setup** → **Cleaning Slots**

From the Web User Interface: **Manage Library** → **Cleaning Slots**

Use this menu item to designate slots for cleaning cartridges in your library and automatically enable the AutoClean function. All cleaning cartridges must have “CLNxxx” as part of its bar code in order for the library’s bar code scanner to recognize it as a cleaning cartridge.

For information, see “Cleaning Slots Configuration” on page 4-2.

Assigning I/O Station Slots



From the Operator Panel: **Setup** → **I/O Station Slots**

From the Web User Interface: **Manage Library** → **I/O Station Slots**

A 5U library has six I/O Station slots. A14U library can have six (in the control module), twelve (in the expansion module), or all eighteen (six in the control module plus 12 in the expansion module) I/O Station slots. For more information, see “Configuring I/O Stations” on page 4-3.

Entering License Keys

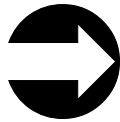

From the Operator Panel: **Setup** → **License**

License keys can be purchased for Capacity Expansion (Feature Code 1640) and Path Failover (Feature Code 1682). The Capacity Expansion license key will expand the capacity of your 14U library in increments of 46 slots. The Path Failover feature supplies two license keys: one for Control Path Failover and one for Data Path Failover. For more information, see “Feature Licenses” on page 1-9.

After entering a license key, place one of the extra license key labels on the Appendix D, “Library Configuration Form,” on page D-1.

Creating Users Accounts



From the Operator Panel: **Setup** → **Create Users**

From the Web User Interface: **Manage Access** → **Users**

An administrator can create additional administrator and user accounts. User accounts can be restricted to specific areas of the library. For more information, see “User Privileges” on page 5-8.

Enter all user IDs and passwords on the Appendix D, “Library Configuration Form,” on page D-1.

Modifying/Deleting User Accounts



From the Operator Panel: **Setup** → **Modify Users**

From the Web User Interface: **Manage Access** → **Users**

An administrative user can use this menu item to modify or delete any user account.

Setting the Date and Time



From the Operator Panel: **Setup** → **Date and Time**

The date and time on your library will need to be changed at the initial installation of your library, after a power outage, and when daylight savings time comes and goes. For more information on changing the date and time on your library, see “Step 4: Set up the Library Network Configuration” on page 6-3.

Setting Up Email Notifications

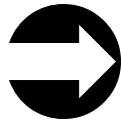

From the Web User Interface: **Manage Library** → **Settings** → **Email Notifications** → **Add**

When enabled, this feature will automatically send an email containing a library log (snapshot) or drive dump, along with the library serial number, the RAS ticket number, and the DR code to an email address that you specify whenever an Operator Intervention occurs.

1. Follow the menu path shown above.
2. Type the email address to which the library should send notifications.
3. Select the Alert level of the notification filter. It is recommended that you select “Low” if you need to be notified of all RAS Operator’s Interventions.
4. Click OK.
5. Check to make sure that the email address you provided is enabled for notification.
6. Select the Outgoing Server (SMTP) from **Library Task** → **Settings**.
7. Key in the Network Server IP address.
8. Create a name to distinguish between libraries in the sender address box.
9. Select Submit Change.

Resetting the Library Control Blade IP Address



From the Operator Panel: **Tools** → **Internal Network**

The architecture of the library has two ethernet networks in it. The Library Control Blade (LCB) can be connected to your network for remote management via the web interface. There is also an “internal network” that the LCB communicates on. The internal network includes the Service Ethernet Port (which happens to be physically located on the outside of the LCB).

The LCB has two networks with associated IP addresses. You cannot have two devices with the same IP trying to communicate with the LCB. The internal network is set by default to a 10.10.10.X set of IP’s.

To prevent conflict with the other devices on the network that may have the same IP, the library internal network can be reconfigured to addresses that range from 10.10.20.x to 10.10.90.x.

Managing the Network (SSL, Trap Registration, and SNMP Version)

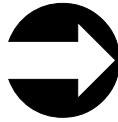

From the Operator Panel: **Setup** → **Network Management**

The network management screens contain these tabs:

- **SSL** (Secure Sockets Layer)
Secure Socket Layer (SSL) is a protocol used for transmitting data securely over the Internet. Browsers, such as Netscape and MS Internet Explorer, use a private key that encrypts the data before it is transferred. The recipient of this secured data can then use that key to decode the information.
- **Trap Registration**
Registration Traps are alerts or status messages that can be collected, monitored, and used to proactively manage attached libraries using SNMP protocol with the host server(s).
- **SNMP** (Simple Network Management Protocol) **Version**
Version Simple Network Management Protocol (SNMP) is a set of protocols for managing complex networks. SNMP works by sending messages, called protocol data units (PDUs), to different parts of a network. Agents, which are SNMP-compliant devices, store data about themselves in Management Information Bases (MIBs) and return this data to the SNMP requesters, such as the host's monitoring application.

Touching **Apply** on any one of the three tabs applies the settings on all tabs. HTTP Service is restarted as a response to selecting **Apply** after modifying the **SSL**, **Trap Registration**, and/or **SNMP Version** settings. All logged in users will have to reconnect after HTTP services have been restarted.

The administrative user can modify the settings at any time on the Operator Panel. The network management settings can only be modified on the Operator Panel.

Enabling SSL

Administrative users can enable or disable SSL settings. The default setting is disable.

Selecting **Apply** applies the modified settings to all tabs: **SSL**, **Trap Registration**, and **SNMP Version**.

Setting Trap Registration

The library ignores all SNMP SET operations, so external management applications cannot register themselves to receive SNMP traps from the library. The **Trap Registration** tab lets you manually register external applications.

The trap registration can only be set by administrative users from the Operator Panel.

Note: The screen lists existing IP Addresses and the corresponding port numbers.

Selecting **Apply** applies the modified settings to all tabs: **SSL**, **Trap Registration**, and **SNMP Version**.

The following options are available on the screen:

- **Create IP address**
 - An empty IP Address field appears at the top of the list.
 - Default Port number is 162.
 - If no IP Address is selected, the **Modify** and **Delete** buttons are dimmed.
- **Modify IP address**
 - If an IP Address is selected, the **Create** button is dimmed.
- **Delete IP address**
 - If an IP Address is selected, the **Create** button is dimmed.

Enabling SNMP Version

The SNMP versions available on the library can be enabled or disabled at any time. It is recommended that SNMP v3 be enabled.

- SNMP v1 and SNMP v2c
- SNMP v3 - enabled by default

The authentication algorithm is set to MD5 and the encryption is disabled system-wide.

Selecting **Apply** applies the modified settings to all three tabs: **SSL**, **Trap Registration**, and **SNMP Version**.

Configuring the Library for Remote Access

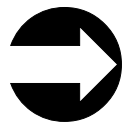

From the Operator Panel: **Setup** → **Network Config**

You must configure your library's network before you can use the remote Web User Interface. For more information, see "Modifying Network Settings" on page 4-1 and "Step 4: Set up the Library Network Configuration" on page 6-3.

Taking a Logical Library Offline/Online



From the Operator Panel: **Operations** → **Logical Library Mode**

From the Web User Interface: **Manage Library** → **Logical Libraries**

It is sometimes necessary to take a logical library offline before adding or replacing certain parts in the library. After those parts are added or replaced, it is necessary to bring the logical library back online. These menu items allow you to take logical libraries offline and online.

Shutting Down/Restarting the Library



From the Operator Panel: **Operations** → **Shut down/Restart**

When powering down the library under normal circumstances (e.g. the library is in an idle state - no movement, backup operations, accessing of log files, etc), it is acceptable to power down the library via the power switch. However, when there is an operation in process, the library needs to be shutdown using this menu item.

Shutdown shuts down the library's operating system and firmware. This prepares the library to physically turn off power. When performing a shutdown, the library finishes all active commands received from the host application and does not process any new commands. It also shuts down all logical libraries. Always perform a shutdown from the Operator Panel before removing power from the library.

To completely remove power from the library, including the power supplies, press the front power switch once. To turn the library back on, press the front power switch again and then follow the login procedure.

Important: If you do not perform library shutdown before you power off the library, loss of data could occur.

Restart shuts down and restarts the library's operating system and firmware. When performing a restart, the library finishes all active commands received from the host application and does not process any new commands. The library shuts down all logical libraries and restarts them during the reboot. In addition, the library performs an inventory of cartridges, tape drives, and slots during a reboot.

Shutting Down the Library

Servicing some components requires only that you take the library offline, while servicing other components requires that you power OFF the entire library. For details, see "Required Library State" on page 11-1. When library power is switched OFF, the Picker assembly slowly falls to rest at the bottom of the library.

Important: To completely remove all power before servicing or in an emergency, push the front power button, toggle the power switch on each power supply to the OFF (O) position, and disconnect all power cords from their electrical source.

1. Using the library's Operator Panel, ensure that no applications are accessing the library. If a **Progress Screen** is open, wait until the operation completes.
2. Take the entire library (including all drives and logical libraries) offline.
 - To take each logical library offline using the Operator Panel, select **Operations** → **Change Logical Library Mode**.
 - To take each drive offline using the Operator Panel, select **Operations** → **Change Drive Mode**.
3. Shut down the library from the Operator Panel by selecting **Operations** → **Shutdown**. The **System Shutdown** window appears.
4. In the **System Shutdown** window, select **Shutdown** and click **Apply**.
5. In the **System Shutdown Confirmation** window, click **Yes**.

6. Press the power button located on the front of the control module.
7. Toggle the power switch on each power supply to the OFF (O) position.
8. Disconnect the library's power cords from their electrical source.

Restarting the Library

1. Using the library's Operator Panel, ensure that no applications are accessing the library. If a **Progress Screen** is open, wait until it closes before attempting to restart the library.
2. Take the entire library (including all drives and logical libraries) offline.
 - To take each logical library offline using the Operator Panel, select **Operations** → **Change Logical Library Mode**.
 - To take each drive offline using the Operator Panel, select **Operations** → **Change Drive Mode**.
3. From the **Operations** menu, click **Restart**. The **System Shutdown** window appears.
4. In the **System Shutdown** window, select **Restart** and click **Apply**.
5. In the **System Restart Confirmation** window, click **Yes**.
6. Bring the entire library (including all drives and logical libraries) online.
 - Bring the desired logical libraries back online using the Operator Panel by selecting **Operations** → **Logical Library Mode**.
 - Bring each drive online using the Operator Panel by selecting **Operations** → **Change Drive Mode**.

Viewing Error Messages

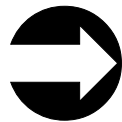

From the Operator Panel: **Tools** → **Operator Interventions**

This menu item provides a method for managing any logged service action tickets.

If no logged service action tickets are on file, the following message is displayed: "No operator interventions were found."

Capturing a Library Snapshot

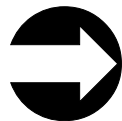

From the Web User Interface: **Service Library** → **Capture Log**

This menu item allows the capturing of a library log. Wait for the **Save** window to appear, then click on **Save**. The log can be saved to the host and emailed to a remote site for diagnosis.

Viewing Library Information

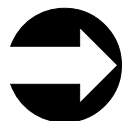

From the Operator Panel: **Tools** → **About Library**

The **About Library** command gives status information about the host, including the following:

- Host name
- AIN number (part number)
- Serial number
- Firmware level
- Current date and time

Touch the **Logical Library Info** button to display the information about each logical library, including the following:

- Control path
- Serial number
- Status
- Slots
- Media
- Drives

Touch the **View Drive Info** button to display the information described in “Viewing Drive Information” on page 7-13.

Locking/Unlocking the I/O Station

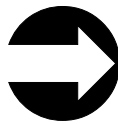

From the Operator Panel: **Operations** → **Lock/Unlock I/O Station**

This menu item enables you to set the I/O Station Door to either a locked or an unlocked state. This command applies to the I/O Station slots in all modules of the library.

Firmware Upgrades

The following sections give information on upgrading library and drive firmware.

Any time you upgrade library and/or drive firmware, record the firmware level on the Appendix D, “Library Configuration Form,” on page D-1.

Important: When updating firmware:

- Ensure all host applications are varied offline.
- Do not power-off the drive until the update is complete, or the firmware may be lost.

Updating Library Firmware



From the Web User Interface: **Service Library** → **Update Library Firmware**

Administrative users can use the **Update Library Firmware** command to download firmware to the library. Updating library firmware can be performed only from the Web User Interface.

To update library firmware:

1. Download the latest level of library firmware to your host computer by visiting <http://www-1.ibm.com/servers/storage/tape/lto/>.
2. From the Web User Interface, select **Service Library** → **Update Library Firmware**.
3. Browse to the file on your computer, select the ".tgz" file that was downloaded from the IBM web site, then click **Update Library Firmware**. The Web User Interface will indicate that the operation has completed. This means that the firmware file has been successfully moved from the host computer to the library.
4. Wait for the library to reboot before resuming normal library operations. It will be several minutes before the library reboots.

Important: After the update process starts, you must wait until the library reboots. Do not attempt to interrupt the process in any way, or the upgrade will not be successful.

Updating Drive Firmware

Drive firmware is best updated using the drive's application interface, SCSI or fibre.

There are tools readily available to facilitate this process. The recommended tool, ITDT, is available on the IBM web site and requires no special device drivers. ITDT is available for multiple platforms. Other tools, such as NTUTIL and TapeUTIL can also be used for drive firmware updates.

The library also supports drive firmware update by creating and using an FMR cartridge. However, to create an FMR cartridge with the latest drive firmware, one of the methods described above must be used to first download the firmware to one of the drives. An FMR cartridge can then be created and used to update the remaining drives for that drive type, SCSI or fibre. For more information on FMR cartridges, refer to "Updating Drive Firmware Using a Firmware (FMR) Cartridge" on page 7-12.

A third option is to update your drive firmware through the Web User Interface. For more details, see "Updating Drive Firmware Using the Web User Interface" on page 7-12.

The **recommended** method to update drive firmware:

1. Download the latest drive firmware to your host computer by visiting <http://www-1.ibm.com/servers/storage/tape/lto/>.
2. Update all SCSI and/or fibre drives in the library by using the ITDT tool. Refer to "Using the ITDT SCSI Firmware Update, Dump Retrieval and Drive Test Tool."

Using the ITDT SCSI Firmware Update, Dump Retrieval and Drive Test Tool

A newly designed tool, ITDT, is a tool with multiple functional capability and is a very quick, convenient and efficient method for drive firmware updates. As a note, drive dump retrievals can be performed by the tool as well.

Below are some of the capabilities of this tool:

- Firmware update capability via SCSI to all IBM LTO Tape Drive products.
- The tool does not require any special device drivers.
- The tool is available for most major platforms (Windows, AIX®, SUN, Linux™, NetWare).
- The tool is capable of uploading drive dump files.
- The tool's primary function is thoroughly testing a drive. However, if the library is online to the server/host where the tool resides, ITDT will communicate with the drive through the library to load and unload a test cartridge thereby exercising some library functions.
- The tool scans the SCSI bus and will find and display for selection all IBM LTO devices. The tool will not display and allow for selection any non-IBM device.
- Each function has a "Help" selection which explains the required syntax as well as a brief explanation of the particular function.
- A Readme text file will be posted with the .exe for a thorough explanation of initial tool download information from the web as well as explanation of tool capabilities.
- The tool is currently a "command line" tool with a simple entry by keying in the executable name, **itdt**, from the directory where the tool is located.

To download the ITDT tool and instructions for using the tool, visit <http://www-03.ibm.com/servers/storage/support/>.

Updating Drive Firmware Using the Web User Interface



From the Web User Interface: **Service Library** → **Update Drive Firmware**

Administrative users can use the **Update Drive Firmware** command to download firmware to the drive.

To update drive firmware:

1. Download the latest level of drive firmware to your host computer by visiting <http://www-1.ibm.com/servers/storage/tape/lto/>.
2. From the Web User Interface, select **Service Library** → **Update Drive Firmware**.
3. Select a drive media and interface type.
4. Select the drive(s) to be updated.
5. Browse to the file on your computer, select the ".tgz" file that was downloaded from the IBM web site, then click **Yes** to begin.

Updating Drive Firmware Using a Firmware (FMR) Cartridge

A firmware (FMR) cartridge is a blank tape cartridge that is used to transfer updated drive firmware code to the library. The drive code image is copied onto the FMR cartridge, which can then be used to update the drive firmware on all of the specified drives within the library. See "Creating a Drive FMR (Firmware) Cartridge" on page 7-13 for more information.

Important: Before you update drive firmware during this procedure, make sure that tapes are not mounted in any of the drives. If the cartridges are

mounted in drives during the update process, the library loses track of the cartridge home cell in storage, resulting in library and host inventory issues.

Creating a Drive FMR (Firmware) Cartridge:

You must create an FMR cartridge, if you do not already have one, to update drive firmware with this method. FMR cartridges are created using a blank (scratch) data cartridge. To create an FMR cartridge of a drive firmware version already in use in your library, follow the steps below:

1. Select **Tools** → **Update Drive Firmware** → **Create Firmware Cartridge**.
2. When the Operator Panel displays the request, place a blank, scratch cartridge into the top slot of the empty I/O station. If other cartridges reside in the I/O Station, remove them before inserting the FMR cartridge.

After the I/O Station door is closed, select **System** on the **I/O Assignment** screen. The library moves the media from the I/O station to the source drive and instructs the source drive to create an FMR cartridge from its current code version.

Other Methods for Updating Drive Firmware through the SCSI or Fibre Channel

Attention: SCSI drives and Fibre Channel drives require different firmware images.

When updating drive firmware by using the SCSI or Fibre Channel interface, the procedure varies, depending on whether your server uses an IBM tape device driver or a non-IBM tape device driver (such as a driver from Sun, Hewlett-Packard, or Microsoft®).

For instructions about updating firmware from a server that uses an IBM tape device driver, refer to the *IBM Ultrium Device Drivers Installation and User's Guide*.

To update firmware from a server that uses a non-IBM tape device driver, refer to the documentation for that device.

Drives

The following sections contain information on operating the drives installed in your library.

Viewing Drive Information

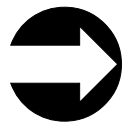

From the Operator Panel: **Tools** → **Drive Info**

This menu item provides the following information for each drive:

- Drive location
- Control path (Yes or No)
- Vendor ID
- Model number
- Type
- Serial number

- Firmware level

Loading a Drive



From the Operator Panel: **Operations** → **Load Drive**

From the Web User Interface: **Manage Drives** → **Load Drive**

This menu item takes a cartridge from a cleaning slot or storage slot and loads it into the selected drive.

Unloading a Drive

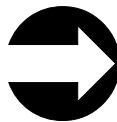

From the Operator Panel: **Operations** → **Unload Drive**

From the Web User Interface: **Manage Drives** → **Unload Drive**

This menu item enables you to choose the drive to unload from a list of loaded drives. The cartridge being unloaded from the drive will be returned to its designated storage slot.

Taking a Drive Offline/Online



From the Operator Panel: **Operations** → **Change Drive Mode**

From the Web User Interface: **Manage Drives** → **Change State of Drives**

Before replacing a drive in the library, the installed drive that is to be replaced must be taken offline. After the new drive is installed, it must be taken online. Use these menu items to take drives offline/online.

Adding a Control Path Drive to a Logical Library



From the Operator Panel: **Setup** → **Control Path**

The lowest drive physically in a logical library is automatically set as the control path drive for that logical library. Each drive in a logical library can be a control path drive. Use this menu item to assign an additional control path drive in a logical library.

For more information, see “Using Multiple Control Paths” on page 2-2.

Assigning Drive IDs

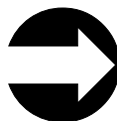

From the Operator Panel: **Setup** → **Drive IDs**

From the Web User Interface: **Manage Drives** → **Drive IDs**

The library automatically sets SCSI and Fibre Channel drive IDs. Use this menu item if your host system requires different IDs than those chosen by the library.

For more information, see “Determining SCSI and Fibre Channel IDs” on page 2-4 and “Selecting Drive IDs and Drive Types” on page 4-3.

Record all drive IDs on the Appendix D, “Library Configuration Form,” on page D-1.

Modifying a Fibre Channel Drive Port Setting

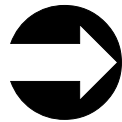

From the Web User Interface: **Manage Drives** → **Drive Fibre Port Channels**

Use this menu item to modify the port setting of Fibre Channel drives installed in your library. For more information, see “Supported Topologies” on page 2-6.

Capturing a Drive Dump

To capture a drive dump, use the ITDT tool or the Web User Interface . For more information, see “Using the ITDT SCSI Firmware Update, Dump Retrieval and Drive Test Tool” on page 7-11 or “Capturing Drive Dumps.”

Capturing Drive Dumps

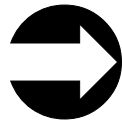

From the Web User Interface: **Service Library** → **Capture Drive Logs**

Administrative users can use the **Capture Drive Logs** command to capture information about the status of the drive at the time of an error.

Cartridges

The following sections contain information on working with cartridges.

Inserting Data Cartridges

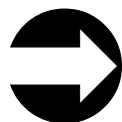

From the Operator Panel: **Operations** → **Insert Media**

From the Web User Interface: **Manage Cartridges** → **I/O Station**

After a data cartridge is loaded in the I/O Station, assign the data cartridge to a logical library. (For more information on cartridge assignment, see “Understanding Cartridge Assignment in the Library” on page 4-1.)

After the cartridge has been assigned to a logical library, choose where in the logical library that the cartridge will reside.

Note: Cartridges can be damaged during shipping or from being mishandled. Before inserting a cartridge in your library, check that the leader pin is

properly seated by sliding open the cartridge door and visually inspecting the leader pin. For more information, see “Repositioning or Reattaching a Leader Pin” on page 8-10.

Removing a Data Cartridge



From the Operator Panel: **Operations** → **Remove Media**

From the Web User Interface: **Manage Cartridges** → **Data Cartridges**

A data cartridge is removed from a storage slot to the I/O Station. Before the same data cartridge can be inserted into another logical library, it must be moved from one I/O Station slot to another and then assigned to a different logical library.

For information on inserting a data cartridge, see “Inserting Data Cartridges” on page 7-15.

Moving Data Cartridges



From the Operator Panel: **Operations** → **Move Media**

From the Web User Interface: **Manage Cartridges** → **Data Cartridges**

This menu item is used to move data cartridges between the I/O Station, storage slots, and drives. You can view information about a specific cartridge if its volume serial number is known. Otherwise, if the volume serial number is unknown, you can filter media by one of the following locations:

- I/O station
- Storage
- Drives

Inserting a Cleaning Cartridge

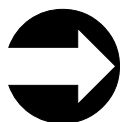

From the Operator Panel: **Operations** → **Insert Cleaning Media**

From the Web User Interface: **Manage Cartridges** → **Cleaning Cartridges**

Before a cleaning cartridge can be inserted, a cleaning slot must be designated in the library for the cartridge. For information on assigning a cleaning slot, see “Assigning Cleaning Slots” on page 7-3.

All cleaning cartridges must have “CLNxxx” as part of its bar code in order for the library’s bar code scanner to recognize it as a cleaning cartridge.

Note: Cartridges can be damaged during shipping or from being mishandled. Before inserting a cartridge in your library, check that the leader pin is properly seated by sliding open the cartridge door and visually inspecting the leader pin. For more information, see “Repositioning or Reattaching a Leader Pin” on page 8-10.

Removing a Cleaning Cartridge



From the Operator Panel: **Operations** → **Remove Cleaning Media**

From the Web User Interface: **Manage Cartridges** → **Cleaning Cartridges**

These menu items will remove a cleaning cartridge from its assigned cleaning slot to the I/O Station for removal from the library. This will be necessary when a cleaning cartridge expires and needs to be replaced.

To replace an expired cleaning cartridge, refer to “Inserting a Cleaning Cartridge” on page 7-16.

All cleaning cartridges must have “CLNxxx” as part of its bar code in order for the library’s bar code scanner to recognize it as a cleaning cartridge.

Chapter 8. Using Ultrium Media

“Cartridge Compatibility” on page 8-2

“Data Cartridge” on page 8-2

“WORM (Write Once, Read Many)” on page 8-3

“Cleaning Cartridge” on page 8-4

“Cartridge Memory Chip (LTO-CM)” on page 8-4

“Bar Code Label” on page 8-4

“Write-Protect Switch” on page 8-7

“Handling the Cartridges” on page 8-7

“Repositioning or Reattaching a Leader Pin” on page 8-10

“Environmental and Shipping Specifications for Tape Cartridges” on page 8-17

“Disposing of Tape Cartridges” on page 8-17

“Ordering Media Supplies” on page 8-18

To ensure that your IBM Ultrium Tape Drive conforms to IBM’s specifications for reliability, use only IBM LTO Ultrium tape cartridges. The IBM TotalStorage LTO Ultrium 400 GB Data Cartridge cannot be interchanged with the media used in other IBM non-LTO Ultrium tape products.

The different generations of IBM TotalStorageUltrium data cartridges can be identified by color:

Data Cartridge	Case Color
Ultrium 3 WORM	Slate blue top; platinum (silvery gray) bottom
Ultrium 3	Slate blue
Ultrium 2	Purple
Ultrium 1	Black

All three generations contain 1/2-inch, dual-coat, metal-particle tape. The native data capacity of Ultrium data cartridges is as follows:

Data Cartridge	Native Data Capacity
Ultrium 3 WORM	400 GB (800 GB at 2:1 compression)
Ultrium 3	400 GB (800 GB at 2:1 compression)
Ultrium 2	200 GB (400 GB at 2:1 compression)
Ultrium 1	100 GB (200 GB at 2:1 compression)

You can order tape cartridges with the bar code labels included, or you can order custom labels. To obtain tape cartridges and bar code labels, see “Ordering Media Supplies” on page 8-18.

Cartridge Compatibility

Table 8-1. Ultrium data cartridge compatibility with Ultrium 3 tape drive

IBM Ultrium Tape Drive	IBM TotalStorage LTO Ultrium Data Cartridges		
	400 GB (Ultrium 3) 400 GB WORM	200 GB (Ultrium 2)	100 GB (Ultrium 1)
Ultrium 3	Read/Write	Read/Write	Read only

Data Cartridge

When processing tape in the cartridges, Ultrium Tape Drives use a linear, serpentine recording format. The Ultrium 3 drive reads and writes data on 704 tracks, sixteen tracks at a time. The first set of tracks is written from near the beginning of the tape to near the end of the tape. The head then repositions to the next set of tracks for the return pass. This process continues until all tracks are written and the cartridge is full, or until all data is written.

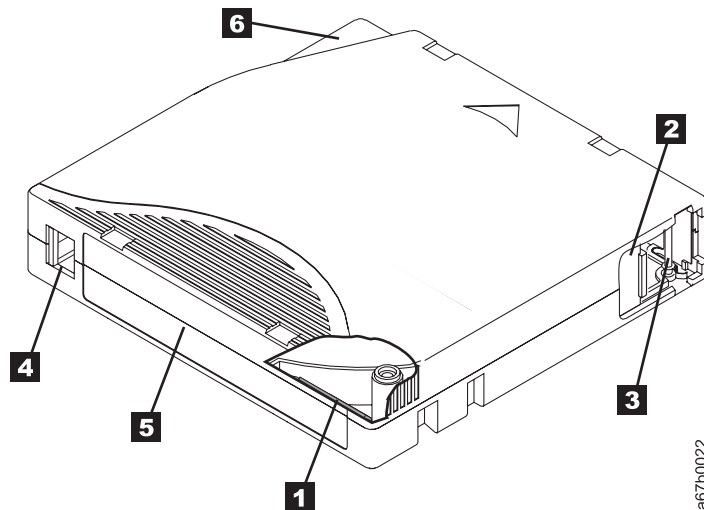

Figure 8-1. The IBM TotalStorage LTO Ultrium 400 GB Data Cartridge

- | | | | |
|----------|--------------------------------------|----------|----------------------|
| 1 | LTO cartridge memory (cut-away view) | 4 | Write-protect Switch |
| 2 | Cartridge door | 5 | Label area |
| 3 | Leader Pin | 6 | Insertion guide |

The cartridge door (**2** in Figure 8-1) protects the tape from contamination when the cartridge is out of the drive. Behind the door, the tape is attached to a leader pin (**3** in Figure 8-1). When the cartridge is inserted into the drive, a threading mechanism pulls the pin (and tape) out of the cartridge, across the drive head, and onto a non-removable take-up reel. The head can then read or write data from or to the tape.

The write-protect switch (**4** in Figure 8-1) prevents data from being written to the tape cartridge. For more information, see “Write-Protect Switch” on page 8-7.

The label area (5 in Figure 8-1 on page 8-2) provides a location to place a label. For more information, see “Bar Code Label” on page 8-4.

The insertion guide (6 in Figure 8-1 on page 8-2) is a large, notched area that prevents the cartridge from being inserted incorrectly.

All generations of the LTO Ultrium Data Cartridge have a nominal cartridge life of 5000 load and unload cycles.

Capacity Scaling

To control the capacity of the cartridge (for example, to obtain a faster seek time) issue the SCSI command SET CAPACITY. For information about this command, refer to the *IBM TotalStorage Ultrium Tape Drive SCSI Reference*.

WORM (Write Once, Read Many)

Certain records retention and data security applications require a Write Once, Read Many (WORM) method for storing data on tape. To meet this data storage requirement, a new WORM feature has been made available on IBM LTO Ultrium generation 3 drives. The WORM feature can be enabled by upgrading to WORM-capable drive firmware and using a special WORM tape cartridge.

No physical hardware changes are required to make Ultrium 3 drives compatible with the WORM feature; however, appropriate WORM-capable drive firmware must be installed.

WORM Media

Because standard read/write media are incompatible with the WORM feature, a specially formatted WORM tape cartridge is required. Each WORM cartridge has a unique, worldwide cartridge identifier (WWCID), which comprises the unique CM chip serial number and the unique tape media serial number. “Ordering Media Supplies” on page 8-18 provides information on how to choose and purchase the appropriate WORM tape cartridges for your library.

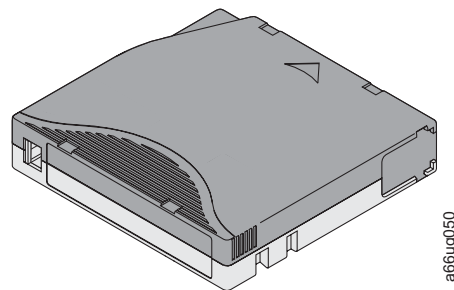

Figure 8-2. Ultrium 3 WORM Tape Cartridge

Data Security on WORM Media

Certain built-in security measures help ensure that the data written on a WORM cartridge does not become compromised, for example:

- The format of an IBM Ultrium 3 400 GB WORM Tape Cartridge is unlike that of standard read/write media. This unique format prevents a drive that lacks WORM-capable firmware from writing on a WORM tape cartridge.

- When the drive senses a WORM cartridge, the firmware prohibits the changing or altering of user data already written on the tape. The firmware keeps track of the last appendable point on the tape.

WORM Media Errors

The following conditions cause WORM media errors to occur:

- Information in the servo manufacturer's word (SMW) on the tape must match information from the cartridge memory (CM) module in the cartridge. If it does not match, a media operator intervention will be posted. Error Code 7 will post on the drive's single-character display (SCD).
- Inserting a WORM tape cartridge into a drive that is not compatible with WORM causes the cartridge to be treated as an unsupported medium. The library will report a media operator intervention.

Cleaning Cartridge

A specially labeled IBM LTO Ultrium Cleaning Cartridge is supplied in your shipment to clean the drives in your library. The drive itself determines when a head needs to be cleaned and communicates this to the library.

When the cleaning is finished, the drive ejects the cartridge and the Picker takes the cartridge and places it back in its designated cleaning slot.

To remove a cleaning cartridge from its designated cleaning slot, export it from the library.

The IBM Cleaning Cartridges are valid for 50 uses. The cartridge's LTO-CM chip tracks the number of times that the cartridge is used.

Cartridge Memory Chip (LTO-CM)

All generations of the IBM LTO Ultrium Data Cartridges include a Linear Tape-Open Cartridge Memory (LTO-CM) chip (1 in Chapter 8, "Using Ultrium Media," on page 8-1), that contains information about the cartridge and the tape (such as the name of the manufacturer that created the tape), as well as statistical information about the cartridge's use. The LTO-CM enhances the efficiency of the cartridge. For example, the LTO-CM stores the end-of-data location which, when the next time this cartridge is inserted and the Write command is issued, enables the drive to quickly locate the next available recording area and begin recording. The LTO-CM also aids in determining the reliability of the cartridge by storing data about its age, how many times it has been loaded, and how many errors it has accumulated. Whenever a tape cartridge is unloaded, the tape drive writes any pertinent information to the cartridge memory. The storage capacity of the LTO-CM is 4096 bytes.

Bar Code Label

A bar code label contains:

- A volume serial number (VOLSER) that is human-readable
- A bar code that the library can read

Table 8-2. Bar code label requirements for Ultrium tape drives and libraries

Ultrium Tape Drive/Library	Bar Code Label Requirements
3580	Not required
3581	Required with optional Bar Code Reader
3582	Required
3583	Required
TS3310 (3576)	Required
TS3500 (3584)	Required
TS3100 (3573)	Required

When read by a library's bar code reader, the bar code identifies the cartridge's VOLSER to the library. The bar code also tells the library whether the cartridge is a data cartridge or cleaning cartridge. In addition, the bar code includes the two-character media-type identifier Lx, where x equals 1, 2, or 3. L identifies the cartridge as an LTO cartridge. 1 indicates that the cartridge is the first generation of its type; 2 indicates that the cartridge is the second generation of its type; 3 indicates that the cartridge is the third generation of its type. Figure 8-3 on page 8-6 shows a sample bar code label for the LTO Ultrium Tape Cartridge.

Tape cartridges can be ordered with the labels included or with custom labels. To order tape cartridges and bar code labels, see "Ordering Media Supplies" on page 8-18. The bar code for usage in IBM tape libraries must meet predefined specifications. They include (but are not limited to):

- Eight uppercase alphanumeric characters, where the last two characters must be L3, L2, or L1
- Label and printing to be non-glossy
- Nominal narrow line or space width of 0.423 mm (0.017 in.)
- Wide to narrow ratio of 2.75:1
- Minimum bar length of 11.1 mm (0.44 in.)

Table 8-3. Cartridges and VOLSERs compatible with the Ultrium 3 Tape Drive

Cartridges	VOLSER
Ultrium 3 Data Cartridge	xxxxxxL3
Ultrium 3 WORM Cartridge*	xxxxxxLT
Ultrium 2 Data Cartridge	xxxxxxL2
Ultrium 1 Data Cartridge (READ ONLY)	xxxxxxL1
IBM TotalStorage LTO Ultrium Cleaning Cartridge (universal)	CLNUxxL1
*An Ultrium 3 Tape Drive must have a minimum firmware level of 54xx for it to be compatible with the WORM cartridge.	

The LTO cartridge label uses the bar code symbology of USS-39. A description and definition is available from the Automatic Identification Manufacturers (AIM) specification Uniform Symbol Specification (USS-39) and the ANSI MH10.8M-1993 ANSI Bar code specification.

To determine the complete specifications of the bar code and the bar code label, visit the web at <http://www.ibm.com/storage/lto> (search for "IBM LTO Ultrium Cartridge Label Specification"), or contact your IBM Sales Representative.

When attaching a bar code label to a tape cartridge, place the label only in the recessed label area (see 4 in Chapter 8, "Using Ultrium Media," on page 8-1). A label that extends outside of the recessed area can cause loading problems in the drive.

Attention: Do not place any type of mark on the white space at either end of the bar code. A mark in this area may prevent the library from reading the label.

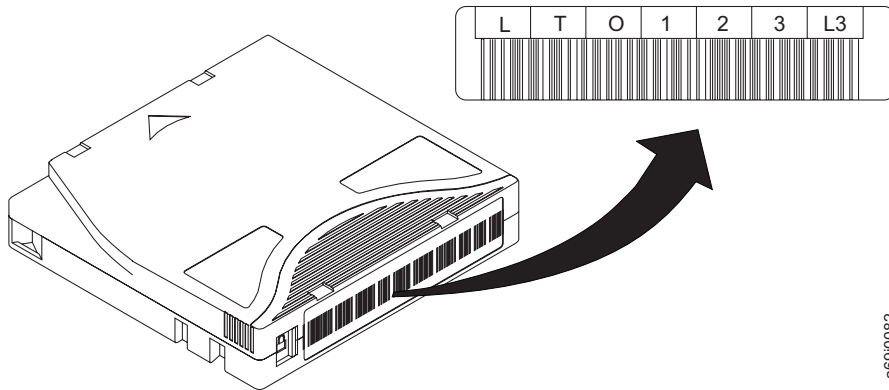

Figure 8-3. Sample bar code label on the LTO Ultrium 3 Tape Cartridge. The volume serial number (LTO123) and bar code are printed on the label.

Guidelines for Using Bar Code Labels

Apply the following guidelines whenever using bar code labels:

- Use only IBM-approved bar code labels on cartridges to be used in an IBM tape library.
- Do not reuse a label or reapply a used label over an existing label.
- Before you apply a new label, remove the old label by slowly pulling it at a right angle to the cartridge case.
- Use peel-clean labels that do not leave a residue after being removed. If there is glue residue on the cartridge, remove it by gently rubbing it with your finger. Do not use a sharp object, water, or a chemical to clean the label area.
- Examine the label before applying it to the cartridge. Do not use the label if it has voids or smears in the printed characters or bar code (a library's inventory operation will take much longer if the bar code label is not readable).
- Remove the label from the label sheet carefully. Do not stretch the label or cause the edges to curl.
- Position the label within the recessed label area (see 5 in Chapter 8, "Using Ultrium Media," on page 8-1).
- With light finger pressure, smooth the label so that no wrinkles or bubbles exist on its surface.
- Verify that the label is smooth and parallel, and has no roll-up or roll-over. The label must be flat to within 0.5 mm (0.02 in.) over the length of the label and have no folds, missing pieces, or smudges.
- Do not place other machine-readable labels on other surfaces of the cartridge. They may interfere with the ability of the drive to load the cartridge.

Write-Protect Switch

The position of the write-protect switch on the tape cartridge (see 1 in Figure 8-4) determines whether you can write to the tape. If the switch is set to the:

- The locked position  (solid red), data cannot be written to the tape.
- The unlocked position (black void), data can be written to the tape.

If possible, use your server's application software to write-protect your cartridges (rather than manually setting the write-protect switch). This allows the server's software to identify a cartridge that no longer contains current data and is eligible to become a scratch (blank) data cartridge. Do not write-protect scratch (blank) cartridges; the tape drive will not be able to write new data to them.

If you must manually set the write-protect switch, slide it left or right to the desired position.

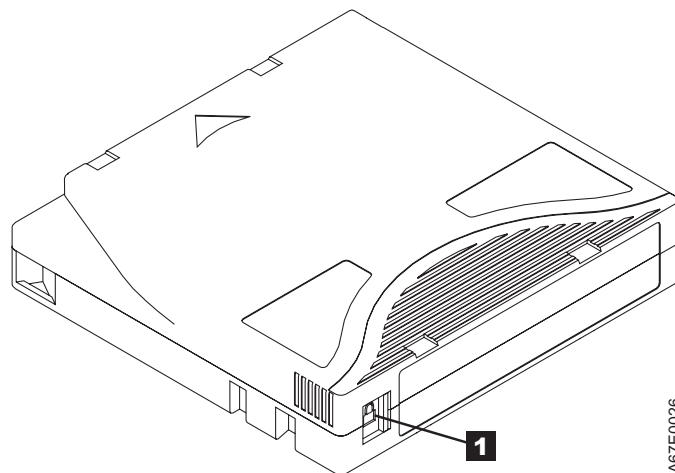

Figure 8-4. Setting the write-protect switch

Handling the Cartridges

Attention: Do not insert a damaged tape cartridge into the drive. A damaged cartridge can interfere with the reliability of a drive and may void the warranties of the drive and the cartridge. Before inserting a tape cartridge, inspect the cartridge case, cartridge door, and write-protect switch for breaks.

Incorrect handling or an incorrect environment can damage cartridges or their magnetic tape. To avoid damage to your tape cartridges and to ensure the continued high reliability of your IBM LTO Ultrium Tape Drives, use the following guidelines:

- Do not drop the cartridge. If the cartridge drops, slide the cartridge door back and ensure that the leader pin is properly seated in the pin-retaining spring clips (**2** in Figure 8-8 on page 8-11). If the leader pin has become dislodged, go to "Repositioning or Reattaching a Leader Pin" on page 8-10.
- Do not handle tape that is outside the cartridge. Handling the tape can damage the tape's surface or edges, which may interfere with read or write reliability. Pulling on tape that is outside the cartridge can damage the tape and the brake mechanism in the cartridge.

- Do not stack more than six cartridges.
- Do not degauss a cartridge that you intend to reuse. Degaussing makes the tape unusable.

Provide Training

- Post procedures that describe proper media handling in places where people gather.
- Ensure that anyone who handles tape has been properly trained in handling and shipping procedures. This includes operators, users, programmers, archival services, and shipping personnel.
- Ensure that any service or contract personnel who perform archiving are properly trained in media-handling procedures.
- Include media-handling procedures as part of any services contract.
- Define and make personnel aware of data recovery procedures.

Ensure Proper Packaging

- When shipping a cartridge, use the original or better packaging.
- Always ship or store a cartridge in a jewel case.
- Use only a recommended shipping container that securely holds the cartridge in its jewel case during transportation. Ultrium Turtlecases (by Perm-A-Store) have been tested and found to be satisfactory (see Figure 8-5). They are available at <http://www.turtlecase.com/>.



Figure 8-5. Tape cartridges in a Turtlecase

- Never ship a cartridge in a commercial shipping envelope. Always place it in a box or package.
- If you ship the cartridge in a cardboard box or a box of a sturdy material, ensure the following:
 - Place the cartridge in a polyethylene plastic wrap or bag to protect it from dust, moisture, and other contaminants.
 - Pack the cartridge snugly; do not allow it to move around.

- Double-box the cartridge (place it inside a box, then place that box inside the shipping box) and add padding between the two boxes (see Figure 8-6).



Figure 8-6. Double-boxing tape cartridges for shipping

Provide Proper Acclimation and Environmental Conditions

- Before using a cartridge, let it acclimate to the normal operating environment for 1 hour. If condensation is visible on the cartridge, wait an additional hour.
- Ensure that all surfaces of a cartridge are dry before making it available for use.
- Do not expose the cartridge to moisture or direct sunlight.
- Do not expose recorded or blank cartridges to stray magnetic fields of greater than 100 oersteds (for example, terminals, motors, video equipment, X-ray equipment, or fields that exist near high-current cables or power supplies). Such exposure can cause the loss of recorded data or make the blank cartridge unusable.
- Maintain the conditions that are described in “Environmental and Shipping Specifications for Tape Cartridges” on page 8-17.

Perform a Thorough Inspection

After purchasing a cartridge and before using it, perform the following steps:

- Inspect the cartridge’s packaging to determine potential rough handling.
- When inspecting a cartridge, open only the cartridge door. Do not open any other part of the cartridge case. The upper and lower parts of the case are held together with screws; separating them destroys the usefulness of the cartridge.
- Inspect the cartridge for damage before using or storing it.
- Inspect the rear of the cartridge (the part that loads first into the tape load compartment) and ensure that there are no gaps in the seam of the cartridge case (**1** in Figure 8-7 on page 8-10 and **4** in Figure 8-9 on page 8-12). If there are gaps in the seam (see Figure 8-7 on page 8-10), the leader pin may be dislodged. Go to “Repositioning or Reattaching a Leader Pin” on page 8-10.

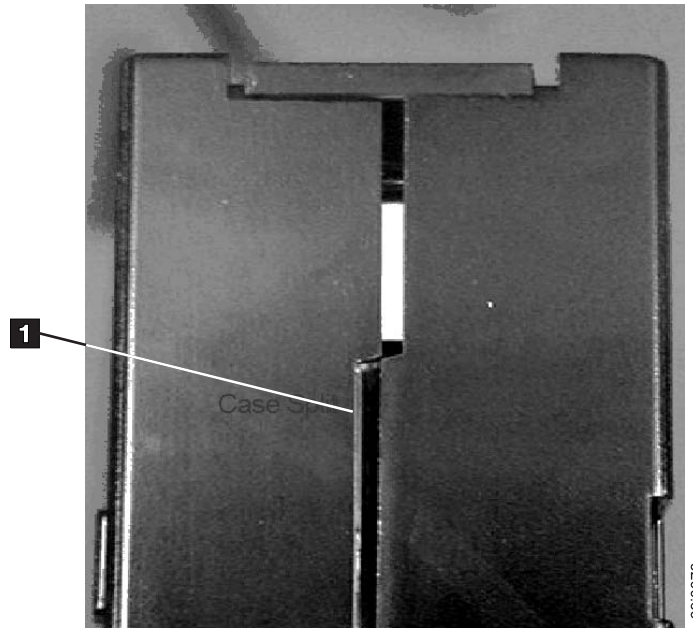

Figure 8-7. Checking for gaps in the seams of a cartridge

- Check that the leader pin is properly seated (see 2 in Figure 8-8 on page 8-11).
- If you suspect that the cartridge has been mishandled but it appears usable, discard the mishandled cartridge.

Examples of Cartridge Problems

Example: Split Cartridge Case (see “Perform a Thorough Inspection” on page 8-9)

The cartridge’s case is damaged. There is a high possibility of media damage and potential loss. Perform the following steps:

1. Look for cartridge mishandling.
2. Use the IBM Leader Pin Reattachment Kit (part number 08L9129) to correctly seat the pin (see “Repositioning a Leader Pin” on page 8-11). Then, immediately use data recovery procedures to minimize chances of data loss.
3. Review media-handling procedures.

Example: Improper Placement of Leader Pin (see Figure 8-8 on page 8-11)

The leader pin is misaligned. Perform the following steps:

1. Look for cartridge damage.
2. Use the IBM Leader Pin Reattachment Kit (part number 08L9129) to correctly seat the pin. Then, immediately use data recovery procedures to minimize chances of data loss.

Repositioning or Reattaching a Leader Pin

Attention: Use a repaired tape cartridge only to recover and move data to another cartridge. Continued use of a repaired cartridge may void the warranties of the drive and the cartridge.

If the leader pin in your cartridge becomes dislodged from its pin-retaining spring clips or detaches from the tape, you must use the IBM Leader Pin Reattachment Kit (part number 08L9129) to reposition or reattach it. (Do not reattach the pin if you must remove more than seven meters (23 feet) of leader tape.) The sections that follow describe each procedure.

Attention: Use a repaired tape cartridge only to recover and move data to another cartridge. Continued use of a repaired cartridge may void the warranties of the drive and the cartridge.

Repositioning a Leader Pin

A leader pin that is improperly seated inside a cartridge can interfere with the operation of the drive. Figure 8-8 shows a leader pin in the incorrect (**1**) and correct (**2**) positions.

To place the leader pin in its proper position, you will need the following tools:

- Plastic or blunt-end tweezers
- Cartridge manual rewind tool (from Leader Pin Reattachment Kit, part number 08L9129)

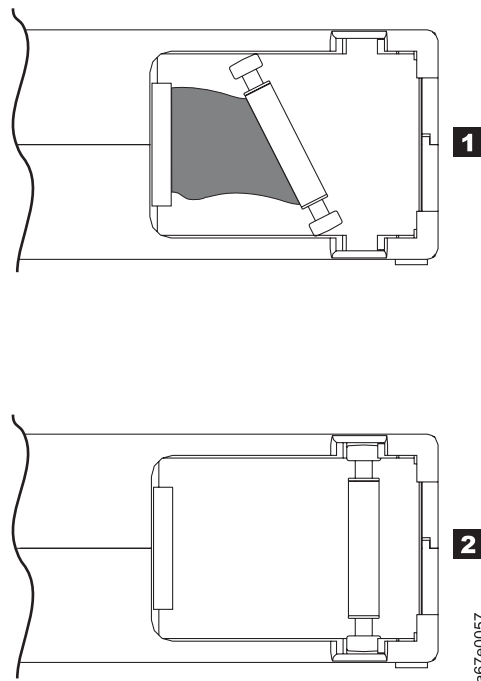

Figure 8-8. Leader pin in the incorrect and correct positions. The cartridge door is open and the leader pin is visible inside the cartridge.

To reposition the leader pin, perform the following steps.

1. Slide open the cartridge door (**1** in Figure 8-9 on page 8-12) and locate the leader pin (**2** in Figure 8-9 on page 8-12) You may need to shake the cartridge gently to roll the pin toward the door.

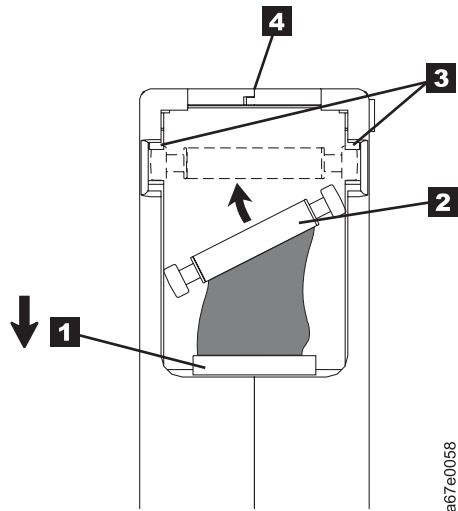

Figure 8-9. Placing the dislodged leader pin into the correct position. The cartridge door is open to show the leader pin.

2. With plastic or blunt-end tweezers, grasp the leader pin and position it in the pin-retaining spring clips (**3** in Figure 8-9). **Be careful not to touch the tape.**
3. Press the leader pin gently into the clips until it snaps into place and is firmly seated.
4. Close the cartridge door.
5. To rewind the tape, insert the cartridge manual rewind tool (**1** in Figure 8-10) into the cartridge's hub (**2** in Figure 8-10) and turn it clockwise until the tape becomes taut.

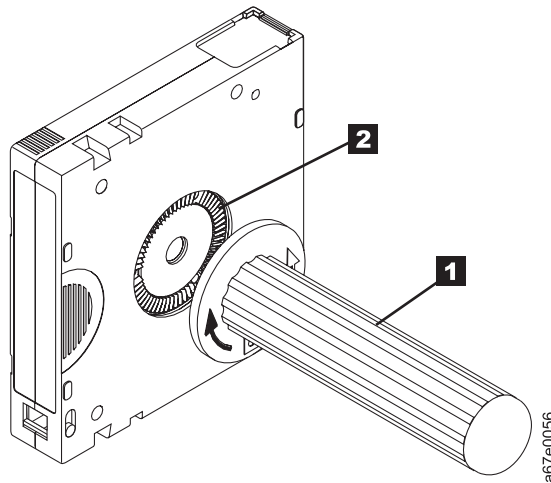

Figure 8-10. Rewinding the tape into the cartridge

6. Remove the rewind tool by pulling it away from the cartridge.
7. If you suspect that the cartridge has been mishandled but it appears useable, copy any data onto a good cartridge immediately for possible data recovery. Discard the mishandled cartridge.

Reattaching a Leader Pin

The first meter of tape in a cartridge is leader tape. Once the leader tape has been removed there is a possibility of tape breakage. After reattaching the leader pin, transfer data from the defective tape cartridge. **Do not reuse the defective tape cartridge.**

The Leader Pin Reattachment Kit contains three parts:

- **Leader pin attach tool (1)** in Figure 8-11). A plastic brace that holds the cartridge door open.
- **Cartridge manual rewind tool (2)** in Figure 8-11). A device that fits into the cartridge's hub and lets you wind the tape into and out of the cartridge.
- **Pin supplies (3)** in Figure 8-11). Leader pins and C-clips.

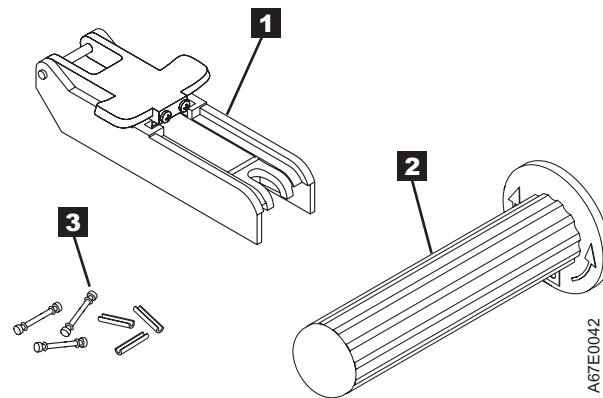

Figure 8-11. Leader Pin Reattachment Kit

Attention:

- Use only the IBM Leader Pin Reattachment Kit to reattach the leader pin to the tape. Other methods of reattaching the pin will damage the tape, the drive, or both.
- Use this procedure on your tape cartridge only when the leader pin detaches from the magnetic tape and you must copy the cartridge's data onto another cartridge. Destroy the damaged cartridge after you copy the data. This procedure may affect the performance of the leader pin during threading and unloading operations.
- Touch only the end of the tape. Touching the tape in an area other than the end can damage the tape's surface or edges, which may interfere with read reliability.

The following procedure describes how to reattach a leader pin.

To reattach a leader pin by using the IBM Leader Pin Reattachment Kit:

1. Attach the leader pin attach tool (1) in Figure 8-12 on page 8-14) to the cartridge (2) in Figure 8-12 on page 8-14) so that the tool's hook (3) in Figure 8-12 on page 8-14) latches into the cartridge's door (4). Pull the tool back to hold the door open, then slide the tool onto the cartridge. Open the tool's pivot arm (5).

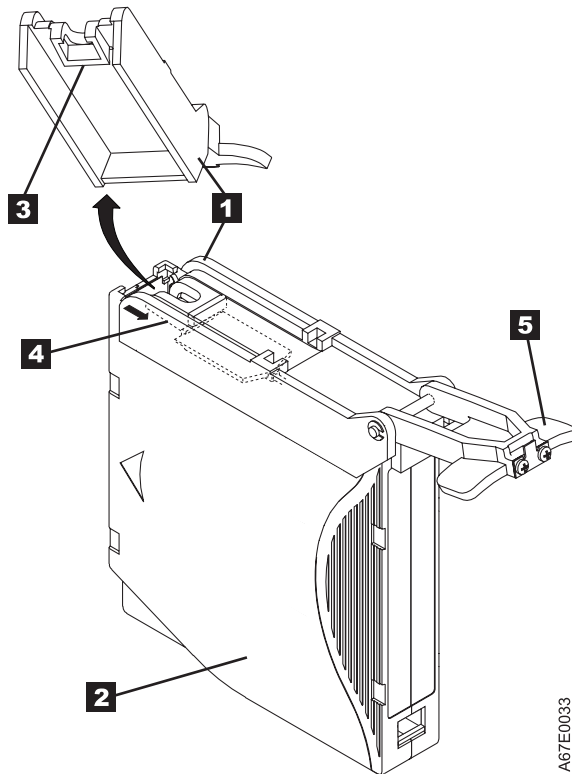

A67E0033

Figure 8-12. Attaching the leader pin attach tool to the cartridge. To hold the cartridge door open, hook the tool into the door and pull the tool back.

2. To find the end of the tape inside the cartridge, attach the cartridge manual rewind tool (**1** in Figure 8-13 on page 8-15) to the cartridge's hub 2 by fitting the tool's teeth between the teeth of the hub. Turn the tool clockwise until you see the end of the tape inside the cartridge. Then, slowly turn the rewind tool counterclockwise to bring the tape edge toward the cartridge door (**3** in Figure 8-13 on page 8-15).
3. Continue to turn the rewind tool counterclockwise until approximately 13 cm (5 in.) of tape hangs from the cartridge door. If necessary, grasp the tape and pull gently to unwind it from the cartridge.
4. Remove the rewind tool by pulling it away from the cartridge. Set the tool and the cartridge aside.

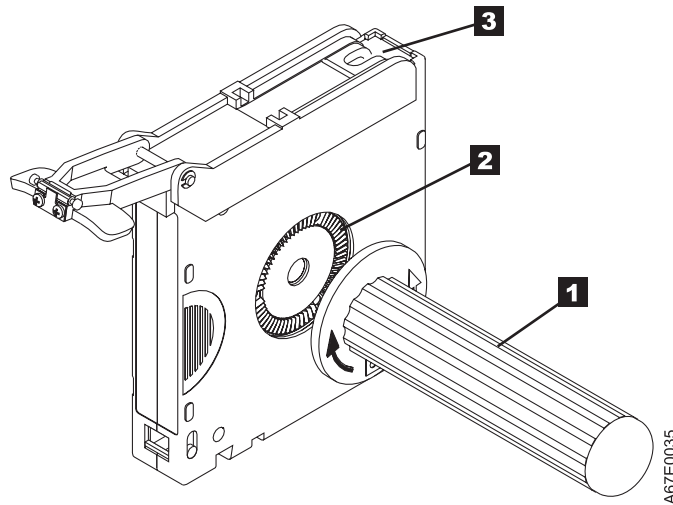

Figure 8-13. Winding the tape out of the cartridge. Turn the cartridge manual rewind tool clockwise to see the end of the tape, then turn it counterclockwise to bring the tape to the cartridge door.

5. On the leader pin (1 in Figure 8-14), locate the open side of the C-clip (2 in Figure 8-14). The C-clip is a small black part that secures the tape (3 in Figure 8-14) to the pin.
6. Remove the C-clip from the leader pin by using your fingers to push the clip away from the pin. Set the pin aside and discard the clip.

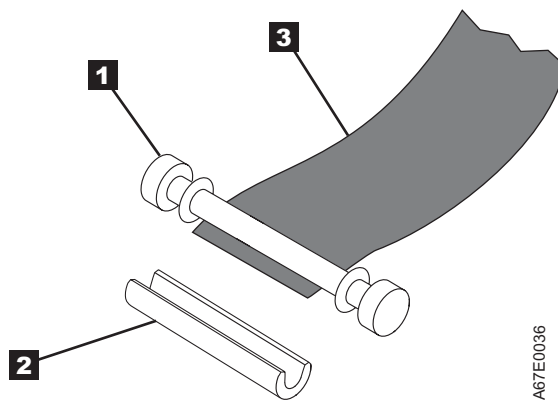

Figure 8-14. Removing the C-clip from the leader pin. Use your fingers to push the C-clip from the leader pin.

7. Position the tape in the alignment groove of the leader pin attach tool (1 in Figure 8-15 on page 8-16).
8. Place a new C-clip into the retention groove (2 in Figure 8-15 on page 8-16) on the leader pin attachment tool and make sure that the clip's open side faces up.
9. Place the leader pin into the cavity (3 in Figure 8-15 on page 8-16) of the leader pin attach tool.

Note: To prevent the leader pin from rolling into the cartridge, in the following step use care when folding the tape over the pin.

10. Fold the tape over the leader pin and hold it with your fingers (see Figure 8-15 on page 8-16).

Note: Use care to ensure that the tape is centered over the leader pin. Failure to properly center the tape on the pin will cause the repaired cartridge to fail. When the tape is properly centered, a 0.25-mm (0.01-in.) gap exists on both sides of the pin.

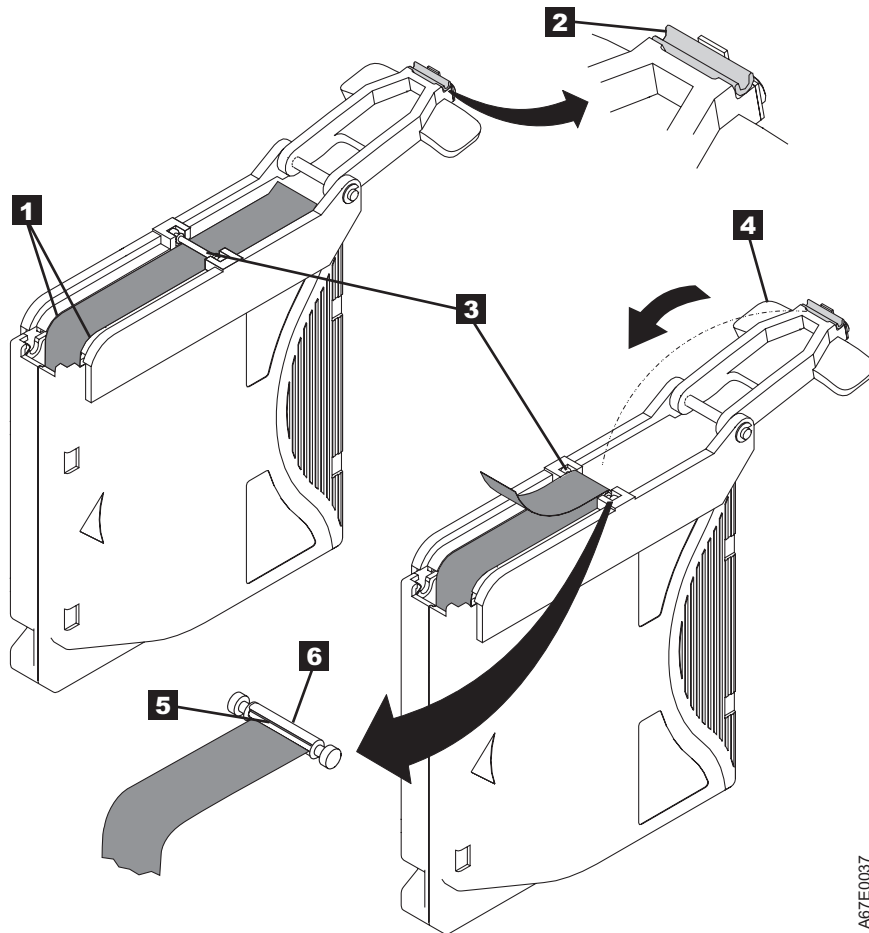

Figure 8-15. Attaching the leader pin to the tape

11. Close the pivot arm (**4** in Figure 8-15) of the leader pin attach tool by swinging it over the leader pin so that the C-clip snaps onto the pin and the tape.
12. Swing the pivot arm open and trim the excess tape (**5** in Figure 8-15) so that it is flush with the reattached leader pin (**6** in Figure 8-15).
13. Use your fingers to remove the leader pin from the cavity (**3** in Figure 8-15) in the leader pin attach tool.
14. Use the cartridge manual rewind tool to wind the tape back into the cartridge (wind the tape clockwise). Ensure that the leader pin is latched by the pin-retaining spring clips on each end of the leader pin.
15. Remove the rewind tool.
16. Remove the leader pin attach tool by lifting its end up and away from the cartridge.

Environmental and Shipping Specifications for Tape Cartridges

Before you use a tape cartridge, acclimate it to the operating environment for a minimum of 24 hours or the time necessary to prevent condensation in the drive (the time will vary, depending on the environmental extremes to which the cartridge was exposed).

The best storage container for the cartridges (until they are opened) is the original shipping container. The plastic wrapping prevents dirt from accumulating on the cartridges and partially protects them from humidity changes.

When you ship a cartridge, place it in its jewel case or in a sealed, moisture-proof bag to protect it from moisture, contaminants, and physical damage. Ship the cartridge in a shipping container that has enough packing material to cushion the cartridge and prevent it from moving within the container.

Table 8-4 gives the environment for operating, storing, and shipping LTO Ultrium Tape Cartridges.

Table 8-4. Environment for operating, storing, and shipping the LTO Ultrium Tape Cartridge

Environmental Factor	Environmental Specifications			
	Operating	Operational Storage ¹	Archival Storage ²	Shipping
Temperature	10 to 45°C(50 to 113°F)	16 to 32°C(61 to 90°F)	16 to 25°C(61 to 77°F)	-23 to 49°C(-9 to 120°F)
Relative humidity (non-condensing)	10 to 80%	20 to 80%	20 to 50%	5 to 80%
Maximum wet bulb temperature	26°C(79°F)	26°C(79°F)	26°C(79°F)	26°C(79°F)
Note:				
1. Operational storage equals less than one year.				
2. Archival storage equals one to ten years.				

Disposing of Tape Cartridges

Under the current rules of the U.S. Environmental Protection Agency (EPA), regulation 40CFR261, the LTO Ultrium Tape Cartridge is classified as non-hazardous waste. As such, it may be disposed of in the same way as normal office trash. These regulations are amended from time to time, and you should review them at the time of disposal.

If your local, state, country (non-U.S.A.), or regional regulations are more restrictive than EPA 40CFR261, you must review them before you dispose of a cartridge. Contact your account representative for information about the materials that are in the cartridge.

If a tape cartridge must be disposed of in a secure manner, you can erase the data on the cartridge by using a high-energy ac degausser (use a minimum of 1200 oersted peak field over the entire space that the cartridge occupies). Degaussing makes the cartridge unusable.

If you burn the cartridge and tape, ensure that the incineration complies with all applicable regulations.

Ordering Media Supplies

Table 8-5 lists the cartridges and media supplies that you can order for the drive.

Table 8-5. Media supplies

Supply Item	Methods of Ordering
<p>IBM TotalStorage LTO Ultrium 400 GB Data Cartridge</p> <p>Bar code labels are pre-applied to cartridges.</p> <p>This media can be used with LTO 3 drives (read/write).</p>	<ul style="list-style-type: none"> • Order the cartridge from your IBM Sales Representative or any authorized IBM Business Partner by specifying Machine Type 3589 Model 009. Specify the VOLSER characters that you want. • Order as part number 96P1470 (color label) or 96P1471 (black and white label) through an IBM-authorized distributor (for the closest distributor, visit the web at http://www.ibm.com/storage/media). Or, call 1-888-IBM-MEDIA. Specify the VOLSER characters that you want.
<p>IBM TotalStorage LTO Ultrium 400 GB Data Cartridge</p> <p>Order VOLSER labels separately.</p> <p>This media can be used with LTO 3 drives (read/write).</p>	<ul style="list-style-type: none"> • Order the cartridge from your IBM Sales Representative or any authorized IBM Business Partner by specifying Machine Type 3589 Model 008. • Order as part number 24R1922 through an IBM-authorized distributor (for the closest distributor, visit the web at http://www.ibm.com/storage/media). Or, call 1-888-IBM-MEDIA. Specify the VOLSER characters that you want.
<p>IBM Ultrium 3 400 GB WORM Tape Cartridge (with attached labels)</p> <p>(IBM TotalStorage 3589 Model 028/Feature Code 2820 is a 20-pack of WORM cartridges labeled with starting volume serial information and, optionally, packed in individual jewel cases. Attached labels have been preprinted with a Bar Code that ends with LT, where L stands for LTO, and T identifies the cartridge as a WORM cartridge.)</p> <p>This media can be used with LTO 3 drives (read/write).</p>	<ul style="list-style-type: none"> • Order by Machine Type/Model and Feature Code through an IBM-authorized distributor (for the closest distributor, visit the web at http://www.ibm.com/storage/media). • If you do not have Internet access, order the cartridge from any authorized IBM Business Partner or your IBM Sales Representative. • Call 1-888-IBM-MEDIA.
<p>IBM Ultrium 3 400 GB WORM Tape Cartridge (without attached labels)</p> <p>(IBM TotalStorage 3589 Model 029/Feature Code 2920 is a 20-pack of WORM cartridges packed in individual jewel cases with unattached blank labels.)</p> <p>This media can be used with LTO 3 drives (read/write).</p>	<ul style="list-style-type: none"> • Order by Machine Type/Model and Feature Code through an IBM-authorized distributor (for the closest distributor, visit the web at http://www.ibm.com/storage/media). • If you do not have Internet access, order the cartridge from any authorized IBM Business Partner or your IBM Sales Representative. • Call 1-888-IBM-MEDIA.
<p>IBM TotalStorage LTO Ultrium 200 GB Data Cartridge</p> <p>Bar code labels are pre-applied to cartridges.</p> <p>This media can be used with LTO 2 drives (read/write) and LTO 3 drives (read/write).</p>	<ul style="list-style-type: none"> • Order the cartridge from your IBM Sales Representative or any authorized IBM Business Partner by specifying Machine Type 3589 Model 006. Specify VOLSER characters you want. • call 1-888-IBM-MEDIA.

Table 8-5. Media supplies (continued)

Supply Item	Methods of Ordering
<p>IBM TotalStorage LTO Ultrium 200 GB Data Cartridge</p> <p>Order VOLSER labels separately (see "Ordering Bar Code Labels").</p> <p>This media can be used with LTO 2 drives (read/write) and LTO 3 drives (read/write).</p>	<ul style="list-style-type: none"> • Order the cartridge from your IBM Sales Representative or any authorized IBM Business Partner by specifying Machine Type 3589 Model 007. • call 1-888-IBM-MEDIA.
<p>IBM LTO Ultrium 100 GB Data Cartridge</p> <p>Order VOLSER labels separately (see "Ordering Bar Code Labels").</p> <p>This media can be used with LTO 1 drives (read/write), LTO 2 drives (read/write), and LTO 3 drives (read only).</p>	<ul style="list-style-type: none"> • Order as part number 08L9120 through an IBM-authorized distributor (for the closest distributor, visit the web at http://www.ibm.com/storage/media), or • if you do not have Internet access, order the cartridge from any authorized IBM Business Partner or your IBM Sales Representative, or • call 1-888-IBM-MEDIA.
<p>IBM TotalStorage LTO Ultrium Cleaning Cartridge (universal cleaning cartridge for use with Ultrium 1, Ultrium 2, and Ultrium 3 drives)</p> <p>VOLSER labels are included.</p>	<ul style="list-style-type: none"> • Order as part number 35L2086 through an IBM-authorized distributor (for the closest distributor, visit the web at http://www.ibm.com/storage/media), or • if you do not have Internet access, order the cartridge from any authorized IBM Business Partner or your IBM Sales Representative, or • call 1-888-IBM-MEDIA.
Leader Pin Reattachment Kit	Order as part number 08L9129 through an IBM-authorized distributor (for the closest distributor, visit the web at http://www.ibm.com/storage/media).
Manual Rewind Tool	Order as part number 08L9130 through an IBM-authorized distributor (for the closest distributor, visit the web at http://www.ibm.com/storage/media).

Ordering Bar Code Labels

The IBM TotalStorage Tape Drive does not require cartridge bar code labels. If you use your data cartridges or cleaning cartridges in an IBM tape library product, you may need cartridge bar code labels if your tape library product requires them. You can order these labels separately from the IBM Data Cartridges and Cleaning Cartridges.

You can order bar code labels directly from the authorized label suppliers in Table 8-6.

Table 8-6. Authorized suppliers of custom bar code labels

In America	In Europe and Asia
<p>EDP/Colorflex 2550 W. Midway Blvd. Broomfield, CO 80020 U. S. A. Telephone: 800-522-3528 http://www.colorflex.com/</p>	<p>EDP Europe, Ltd. 43 Redhills Road South Woodham Ferrers Chelmsford, Essex CM3 5UL U. K. Telephone: 44 (0) 1245-322380 http://www.edpeurope.com/media_labelling.htm</p>

Table 8-6. Authorized suppliers of custom bar code labels (continued)

In America	In Europe and Asia
Dataware P.O. Box 740947 Houston, TX 77274 U. S. A. Telephone: 800-426-4844 http://www.datawarelabels.com/	Dataware Labels Europe Heubergstrasse 9 D-83052 Bruckmuhl-Gotting Germany Telephone: 49 8062-9455 http://www.datawarelabels.com/
NetC P. O. Box 1067 Fairfield, CT 06825 U. S. A. Telephone: 203-372-6382 http://www.netc11c.com/	NetC Europe Ltd Town Farm Bungalow The Pavement North Curry TA3 6LX Somerset U. K. Telephone: 44 (0) 1823 49 1439 http://www.netclabels.co.uk
	NetC Asia Pacific Pty Ltd Locked Bag 1 Kenthurst NSW 2156 Australia Telephone: 61 (0) 2 4573 6556 http://www.netclabels.com.uk

Chapter 9. Troubleshooting

“Diagnosing a Problem” on page 9-2
“How the Library Reports Problems”
“Operator Intervention Messages” on page 9-2
“Interpreting LEDs” on page 9-6
“Checking / Reseating Cables” on page 9-13
“E-mailing Logs” on page 9-16
“Pre-Call Checklist” on page 9-17
“Contacting IBM Technical Support” on page 9-17

Before ordering a CRU replacement part, observe the LEDs on all library components to determine exactly which part is failing. See “Interpreting LEDs” on page 9-6 for more information. If the LEDs on all components are functioning properly, see “Contacting IBM Technical Support” on page 9-17.

Important: This library has mandatory CRUs (customer replaceable units). These CRUs are parts of the library that must be added, removed, and replaced by the customer. If a customer chooses to have the CRU added or removed/replaced by an IBM Service Representative, there will be a charge for the service.

Before ordering a replacement CRU, ensure that the following criteria is met:

- The failure is repeatable.
- A dump is captured for emailing to IBM Service.
 - Use the ITDT tool for drive dumps.
 - Use the Web User Interface (**Service Library** → **Capture Log**) for library dumps.

How the Library Reports Problems

This library uses advanced problem detection, reporting, and notification technology to alert customers of problems as soon as they occur. It performs numerous self-tests to monitor the library’s temperature, voltage and currents, and standard library operations. These self-tests are performed each time the library is powered ON, and during normal operation when the library is idle.

If the self-test detects a problem, the library generates a service report, or Operator Intervention, that identifies which component is likely causing the problem. The library’s LEDs may also turn ON, OFF, or blink to indicate an abnormal state. If the problem is not severe, the library continues to provide full functionality to all unaffected logical libraries.

When possible, the library provides instructions for resolving problems. These instructions appear on the library’s Operator Panel.

Note: If resolution of the problems includes instructions to open an Access Door, an Access Door must be opened and closed to clear the error and to enable the robotics to function properly.

Customers can frequently resolve a simple problem themselves by using the information found in “Diagnosing a Problem.” If the problem involves a field replaceable unit (FRU), the customer must contact IBM Technical Support(see “Contacting IBM Technical Support” on page 9-17). Only qualified service technicians can service FRUs.

Operator Intervention Messages

From the **Tools** menu on the Operator Panel, you can view all of the library operator interventions. This view lists all of the library operator interventions in the order in which they were created starting with the most recent. Each message contains a Service Action Ticket (SAT) code (see “Service Action Tickets” on page 10-1) and an explanation of what error the library encountered. You can navigate resolution details from this screen as well (see “**Diagnostic Resolutions**” on page 10-34). Before replacing a library component, closing a ticket, or contacting IBM Technical Support, refer to “Diagnosing a Problem” for additional help on resolving the problem.

Before ordering a CRU replacement part, observe the LEDs on all library components to determine exactly which part is failing. See “Interpreting LEDs” on page 9-6 for more information.If the LEDs on all components are functioning properly, see “Contacting IBM Technical Support” on page 9-17.

Diagnosing a Problem

Problem Area	If...	Then...
Error Message	<p>Your library issues an Operator Intervention...</p> <p>You will know when an Operator Intervention has been issued when the Library, Drives, or Media button at the bottom of the Operator Panel screen turns yellow or red. Operator Interventions are also indicated by the amber Operator Intervention Alert LED on the front panel of the library to the right of the power button, or by e-mail notifications, if this feature is enabled.</p>	<ul style="list-style-type: none"> • Touch the Library, Drives, or Media button at the bottom of the Operator Panel screen, then touch Operator Interventions to view the error message(s). • After reading an error message, touch the Resolve button to display the suggested resolution for the problem. • Refer to Chapter 10, “Service Action Tickets (Txxx) and Diagnostic Resolutions (DRxxx),” on page 10-1 for more information about the Service Action Ticket number (Txxx).

Problem Area	If...	Then...
	<p>The resolution for an Operator Intervention suggests a CRU or FRU replacement...</p>	<p>Before calling IBM to order a replacement CRU or to request FRU replacement:</p> <ul style="list-style-type: none"> • Refer to Chapter 10, "Service Action Tickets (Txxx) and Diagnostic Resolutions (DRxxx)," on page 10-1 for additional information on resolving the problem. • Observe the LEDs on all components (For more information, see "Interpreting LEDs" on page 9-6.). If the LEDs on a component indicate that there is a problem, reseal the component. • Visually check, and reseal if necessary, all of the cables that are connected to the failing FRU or CRU. For more information, see "Checking / Reseating Cables" on page 9-13. • If possible, power cycle the library. • If the error occurs again: <ul style="list-style-type: none"> - If the suspect component is a CRU, refer to Chapter 11, "Add, Remove, Replace Procedures," on page 11-1 for detailed instructions. - OR - - If the suspect component is a FRU, see "Pre-Call Checklist" on page 9-17 and "Contacting IBM Technical Support" on page 9-17 to request FRU replacement service.
	<p>A TapeAlert message was received...</p>	<p>Refer to Appendix B, "TapeAlert Flags," on page B-1.</p>
	<p>You are experiencing a problem with your library and no Operator Intervention was created...</p>	<p>If after trying all diagnostic procedures you are unable to resolve the problem, refer to "Contacting IBM Technical Support" on page 9-17.</p>
	<p>The Operator Panel displays, "Error - cannot Determine Personality"...</p>	<ol style="list-style-type: none"> 1. Power cycle the library. 2. If the same message appears, replace the Compact Flash Card (see "Removing/Replacing the Library Control Blade and Compact Flash Card" on page 11-11).
	<p>You get repeated errors, multiple functions surface failure messages, or Txxx codes...</p>	<p>Open and close an Access Door to ensure that all previous error handling is completed and to enable normal library robotic function.</p>
	<p>HTML error 404 appear on computer screen when trying to launch the Web User Interface...</p>	<ol style="list-style-type: none"> 1. Verify that the Ethernet cable is properly connected at both ends. 2. Ping the library address to verify communication. 3. Verify network settings at host and library. 4. If the cable is properly connected, refer to "Removing/Replacing the Library Control Blade and Compact Flash Card" on page 11-11.

Problem Area	If...	Then...
Operator Panel	The Operator Panel display is blank, hung, frozen, or a visual problem occurs (incorrect characters, missing characters, and so forth), dim display, or non-responsive touchscreen...	<ol style="list-style-type: none"> 1. Verify that power is being applied to the library. 2. Gather failure information by logging in to the Web User Interface and selecting Service Library → Capture Log. 3. Cycle library power. 4. Verify that you are running the latest levels of library and drive firmware, then upgrade if necessary (see “Firmware Upgrades” on page 7-10). 5. If the Operator Panel display is still failing, refer to “Contacting IBM Technical Support” on page 9-17.
Media	A cartridge leader pin has detached from the cartridge...	Reposition the leader pin (see “Repositioning or Reattaching a Leader Pin” on page 8-10).
	A cartridge is not ejecting from a drive...	<ol style="list-style-type: none"> 1. Take the logical library to which the drive is assigned offline (refer to “Taking a Logical Library Offline/Online” on page 7-7). 2. Open the I/O Station door(s), then open the Access Door(s). 3. Locate the drive that will not eject the cartridge, then locate the blue Unload Button on the drive. 4. Press the blue Unload Button once. The Status Light located to the left of the Unload Button will flash green while the drive is rewinding and unload the cartridge. 5. If the cartridge does not eject from the drive, refer to “Contacting IBM Technical Support” on page 9-17.
	Tape is broken, stretched, folded over, or wrinkled inside the cartridge...	<ol style="list-style-type: none"> 1. Replace the tape cartridge. 2. Ensure that the latest available drive code is installed (refer to “Updating Drive Firmware” on page 7-11). <p>If the problem continues, replace the drive (refer to “Adding/Removing/Replacing a Drive Sled” on page 11-5).</p>
Firmware	A firmware problem is suspected...	Verify that you are running the latest levels of library and drive firmware, then upgrade if necessary (see “Firmware Upgrades” on page 7-10). If new firmware does not resolve the problem, refer to “Contacting IBM Technical Support” on page 9-17.
	The Library firmware does not complete the boot-up process and appears hung... Failure of the Working screen to appear on the Operator Panel in 15 minutes indicates that the boot-up process is not completing.	<ol style="list-style-type: none"> 1. Power OFF the library and wait at least one minute before powering ON to recover the problem. 2. If a library firmware update was just performed, try to repeat the update procedure.
	Library firmware is being updated...	Additional time is required by the library, including a blank screen then a backlit screen, before the Working screen appears.
	All firmware (library and drive) is not at the latest level...	Refer to “Firmware Upgrades” on page 7-10 for instructions on updating all of the components which are not at the latest level. The procedure will direct you to the IBM web site to check for latest firmware levels.

Problem Area	If...	Then...
Logs	You are required to capture a library snapshot or a drive dump...	<ul style="list-style-type: none"> For information on capturing a library snapshot, refer to "Capturing a Library Snapshot" on page 7-9. For information on capturing a drive dump, refer to "Using the ITDT SCSI Firmware Update, Dump Retrieval and Drive Test Tool" on page 7-11.
	You need to acquire library or drive information at the host...	Refer to Appendix A, "Message Retrieval at the Host," on page A-1.
Diagnostics	You need to run library diagnostic tests...	Refer to "Library Verify Diagnostic Tests" on page 7-2.
Configuration	Configuring the library resulted in less storage slots than are actually present.	Verify that the a Capacity Expansion license key has been applied.
Configuration	You are reinstalling a feature requiring a License Key code.	<ol style="list-style-type: none"> From the Operator Panel, select Setup → License. Re-enter the license key code. If the license key code can not be located, contact your IBM Sales Representative.
Power	If the power supply power switch is ON and power indicator is OFF..	<ol style="list-style-type: none"> Verify that the power switch is ON. Verify that the power cable is properly seated on the Power Supply. Analyze the problem by observing the Power Supply LEDs (see "Power Supply LEDs" on page 9-11). If necessary, replace the failing power supply (refer to "Removing/Replacing a Power Supply (Primary and Redundant)" on page 11-2).
	If the blue LED on the power supply is ON, the power ON/OFF button on the front of the library is ON (button pushed IN), but the power indicator on the front of the library is OFF..	<ol style="list-style-type: none"> Suspect a failing power ON/OFF push button on the front of the library, or a loose or broken cable. See "Contacting IBM Technical Support" on page 9-17.

Problem Area	If...	Then...
Picker	The Picker is stuck in one position and is making a clicking sound...	<ol style="list-style-type: none"> 1. Visually verify that all gear racks (front and rear) are properly aligned. If they are not aligned, refer to "Verifying Front and Rear Gear Racks Alignment" on page 11-22. 2. Verify that the Picker assembly is level. If it is not level, see "Contacting IBM Technical Support" on page 9-17. 3. Check for broken gear teeth on the Y motor. If there are broken teeth, see "Contacting IBM Technical Support" on page 9-17.
	The Picker Assembly does not move within five minutes after Power ON...	<ol style="list-style-type: none"> 1. Check cable connections from the Cable Spool to the Y-axis Assembly and from the Y-axis Assembly to the Picker. 2. With Access Doors closed, note if the green LED on top of the Picker is ON. <ul style="list-style-type: none"> • For a 5U library, open the I/O Station door to view. • For a 14U library or larger, look through the expansion module window. 3. If the green LED is OFF, suspect the Picker Assembly, the Y-axis Assembly, the module communication terminator, or an open door. 4. If the Picker Assembly is still not working, refer to "Contacting IBM Technical Support" on page 9-17.
Web User Interface	A Web User Interface Help page is not opening...	Verify that other help pages are not currently open. If other pages are currently open, close them and try again.
Library Not Booting	<ul style="list-style-type: none"> • There is a blank operator panel/display • Picker doesn't move • Display is stuck on IBM or initialization for more than 20 minutes • Lights are not correct on back of library... 	Suspect the LCB compact flash or the power supply.

Interpreting LEDs

Light emitting diodes (LEDs) provide a visual indication about the status of certain library components. LEDs can sometimes communicate that a problem exists when operator interventions cannot. For example, an LED can indicate a firmware problem that prohibits the library from generating operator interventions.

The following components of the library have LEDs:

- "Power Button LEDs" on page 9-7
- "Library Control Blade LEDs" on page 9-7
- "Tape Drive LEDs" on page 9-9
- "Power Supply LEDs" on page 9-11
- "Picker LED" on page 9-12

Some of these components may also include a fibre port link LED.

Power Button LEDs

Two LEDs are located to the right of the library's power button (1) on the front panel of the control module.



Figure 9-1. Power button LEDs

- Green power ON LED (2) - When lit, this LED indicates that the library power is ON.
- Amber Operator Intervention Alert LED (3) - When lit, this LED indicates that there is a Library, Drives, or Media Operator Intervention available. To view the Operator Intervention, select **Tools** → **Operator Intervention** from the Operator Panel.

Library Control Blade LEDs

The library contains a Library Control Blade (LCB). LEDs are used to indicate the status of the LCB.

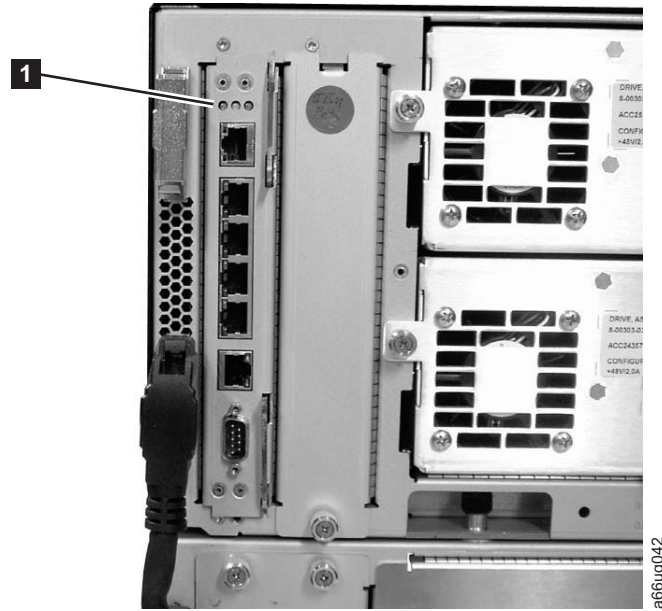

Figure 9-2. Library Control Blade LEDs

LCB LEDs (1) indicate status by the rate at which they blink. The color of the LED identifies the area of the component being reported.

Use the following table to interpret the current status of LCB LEDs:

Table 9-1. LCB LEDs

LED Color	Represents	Blade Status
Green	Processor status	<ul style="list-style-type: none"> • Solid ON - Processor not operating • Solid ON for 3 seconds, then blinks twice - LCB firmware is downloading • 1 blink per second - Normal: Processor operating • 10 blinks per second - Identify mode • Solid OFF - Processor not operating
Amber	Health status	<ul style="list-style-type: none"> • 1 blink per second - Main processor not operating • Solid OFF - Normal: Blade operational
Blue	Power control status	<ul style="list-style-type: none"> • Solid ON - Swap mode: LCB is powered down and can be removed • 1 blink per 10 seconds - Normal: LCB on • Solid OFF - LCB not receiving power

Amber LED on Library Control Blade

Under normal operating conditions, the amber LED on a Library Control Blade (LCB) is not lit. If you see that the amber LED on an LCB is either blinking continuously or solidly lit for at least 20 minutes, service the LCB as soon as possible. The library may or may not generate an operator intervention, depending on the source of the problem.

Attention: Never remove an LCB when its amber LED is solidly lit, unless it has been solidly lit for at least 20 minutes.

The following table indicates the actions you can take, based on the condition of the LED.

Table 9-2. Amber LED on an LCB

State of Amber LED	Suggested Service Action
Solid ON for 10+ minutes	Replace the LCB.
1 blink per second	Check the firmware for the LCB and make sure that you have the most current firmware available (visit http://www.ibm.com/storage/lto). Do not replace the LCB. It is unlikely that the LCB hardware is the source of the problem. Observe LEDs on other components before referring to "Contacting IBM Technical Support" on page 9-17.

Servicing a Library Control Blade Based on LED Status

When servicing a blade based on the status of an LED:

1. Observe the blinking patterns of the LEDs for at least 30 seconds, and log your observations in both the operator intervention and the equipment failure report that you must return with the defective part. Accurate reporting of all LED states for the entire green, amber, and blue set of LEDs is critical for diagnosing the cause of the problem.
2. Generate a current log of the library, and send it to technical support for analysis.

Tape Drive LEDs

Operator interventions typically report all problems related to tape drives, including error codes and tape alerts. By observing the blinking pattern of LEDs on tape drives, however, you can discern which operation the tape drive is currently performing.

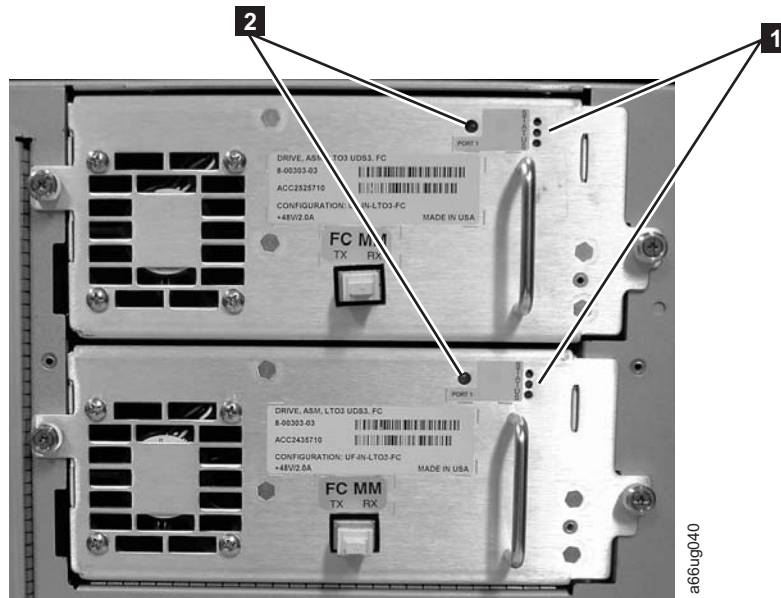

Figure 9-3. Tape drive LEDs

Use the following table to interpret tape drive activity by observing tape drive LEDs (**1** in Figure 9-3).

Table 9-3. Tape Drive Activity

LED Color	Represents	Drive Status
Green	Processor activity	<ul style="list-style-type: none"> • Solid ON - Drive's main processor is not operating • Solid ON for 3 seconds, then blinks twice - Drive firmware is downloading • 1 blink per second - Normal: Drive operational • Blinks 3 times in 3 seconds, then pauses (solid OFF), and then repeats - Drive is activating (varying online) • 10 blinks per second - Identify mode • Solid OFF - Drive's main processor is not operating
Amber	Health of the drive	<ul style="list-style-type: none"> • Solid ON - Drive has failed • Solid OFF - Normal: drive operational
Blue	Power control	<ul style="list-style-type: none"> • Solid ON - Drive is powered down and ready to be replaced or varied online • 1 blink per 10 seconds - Normal: Drive operational • Solid OFF - Drive is not receiving power

Fibre Port Link LED

The fibre port link LED (**2** in Figure 9-3) shows the current state of the fibre channel link and indicates whether or not the link is ready to transmit commands.

Use the following table to interpret fibre channel link activity.

Table 9-4. Fibre Port Link LED on Tape Drive

LED Color	Represents	Fibre Port Link Status
Green	LIP and activity	<ul style="list-style-type: none">• Solid ON - Loop Initialization Protocol (LIP) has occurred.• Blinks at regular intervals - Host command/data activity is occurring.
Amber	Online and light detected	<ul style="list-style-type: none">• Solid ON - The library has enabled the drive data bus, and it can detect light through a fiber optic cable.
No color	No activity or no light detected	<ul style="list-style-type: none">• Solid OFF - Either the drive is off or the drive cannot detect light through a fiber optic cable (which is equivalent to a missing fibre cable). If the drive is varied OFF, the blue status LED will be solidly lit.

Power Supply LEDs

Operator interventions typically report all problems related to power supplies. You can also observe the blinking pattern of LEDs on power supplies to see if they are functioning appropriately.

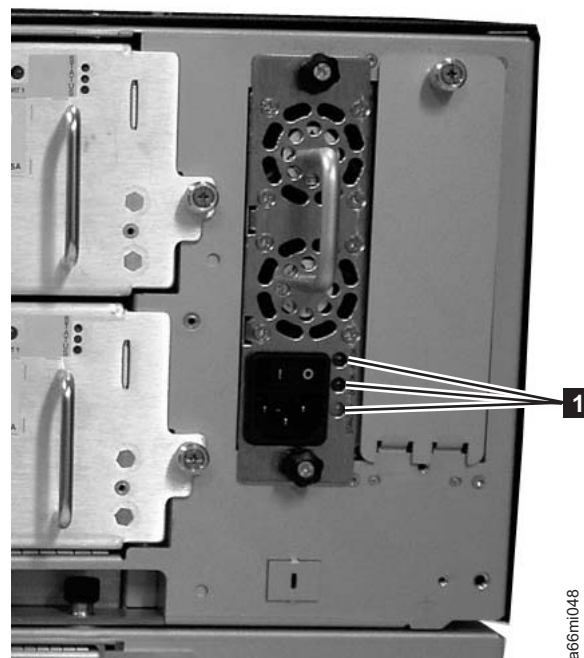

Figure 9-4. Power supply LEDs

Power supply LEDs indicate status by the rate at which they blink. The color of the LED identifies the area of the component being reported.

Table 9-5. Power Supply LEDs

LED Color	Represents	Power Supply Status
Green	AC OK (top)	<ul style="list-style-type: none"> • Solid ON - The power supply's AC input is above the minimum requirements to operate. • Solid OFF - The power supply's AC input is below the minimum requirements to operate.
Green	DC OK (middle)	<ul style="list-style-type: none"> • Solid ON - The power supply's output voltage is within regulation. • Solid OFF - The power supply's output voltage is not within regulation.
Blue	Fault (bottom)	<ul style="list-style-type: none"> • Solid ON - Indicates that one of the following faults has been detected: <ul style="list-style-type: none"> - Power supply is outside of specifications - Current limit has been exceeded - Temperature limit has been exceeded - Fan failed while AC input is present and above the minimum operating voltage - AC input is below the minimum operating voltage - The power supply is ON, the Power button ON, but the library's indicator panel is OFF • Solid OFF - Normal: No faults detected

In the operator intervention associated with the defective power supply, record both the number of the module and the number of the power supply connected to that module.

Each module can have up to two power supplies. The power supply on the right is considered to be #1, while the power supply on the left is #2.

Modules are numbered according to their position in relation to the control module (CM).

Picker LED

The Picker has one green LED (1 in Figure 9-5 on page 9-13) that must be ON for the Picker to function properly. If the LED is not lit, the Picker assembly should be investigated for problems (module-to-module communication terminator is not in place, an Access Door is open).

To observe the status of the Picker LED:

1. Look through the viewing window on the front of an expansion module and determine whether or not the Picker LED is ON.
2. If you cannot see the Picker LED, power OFF the library. The Picker will move to the bottom of the library.
3. Power ON the library.
4. Open the lowest I/O Station door in your library and, looking through the opening to the left of the flap inside the I/O Station, observe the Picker LED.

Note: Do not open the Access Door to observe the Picker LED. If the Access Door is opened, the Picker LED is turned OFF.

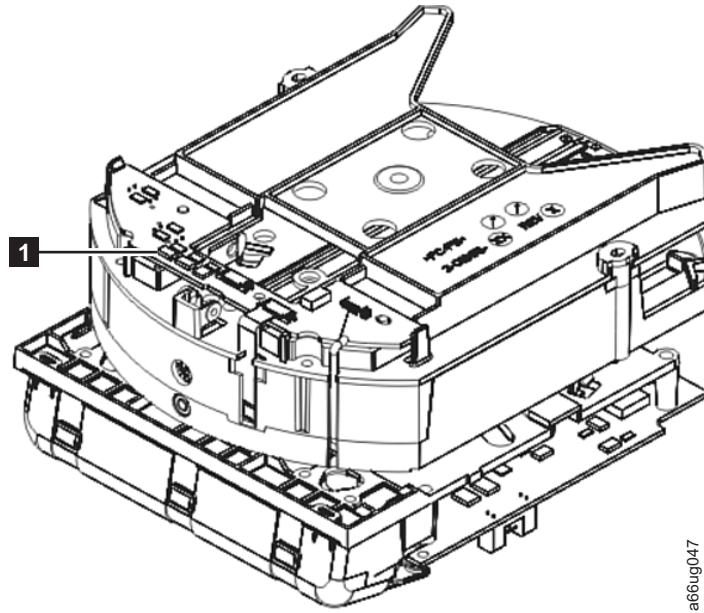

a66ug047

Figure 9-5. Picker LED

Checking / Reseating Cables

External Cables

To check or reseat external library cables and terminators, perform the following steps:

1. Locate the cables and terminators by referring to the example figures below.

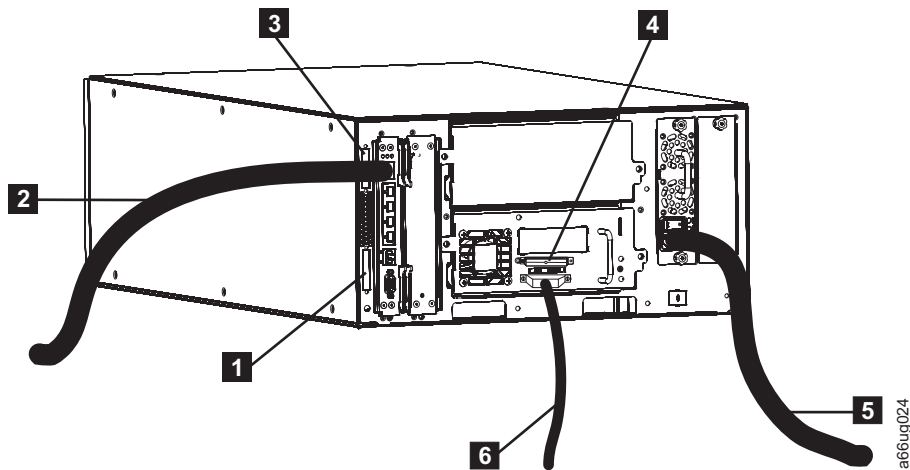

a66ug024

Figure 9-6. Cabling of a 5U Library with SCSI Drives

- | | | | | | |
|----------|------------------------------------|----------|---------------------------------|----------|------------------|
| 1 | Module communication terminator | 3 | Module communication terminator | 5 | Power cord |
| 2 | Ethernet cable (customer supplied) | 4 | SCSI terminator | 6 | SCSI drive cable |

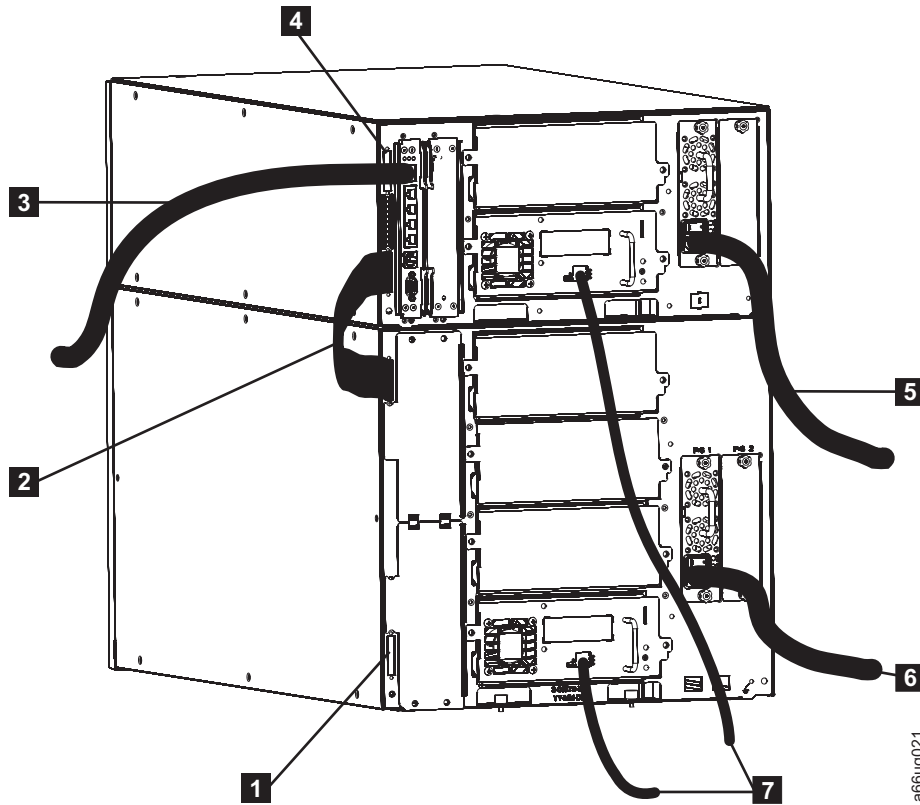

a66ug021

Figure 9-7. Cabling of a 14U Library with Fibre Drives

- | | | | | | |
|----------|--------------------------------------|----------|---------------------------------|----------|-------------------------------|
| 1 | Module communication terminator | 4 | Module communication terminator | 7 | Fibre drive-to-network cables |
| 2 | Module-to-module communication cable | 5 | Power cord (upper module) | | |
| 3 | Ethernet cable (customer supplied) | 6 | Power cord (lower module) | | |

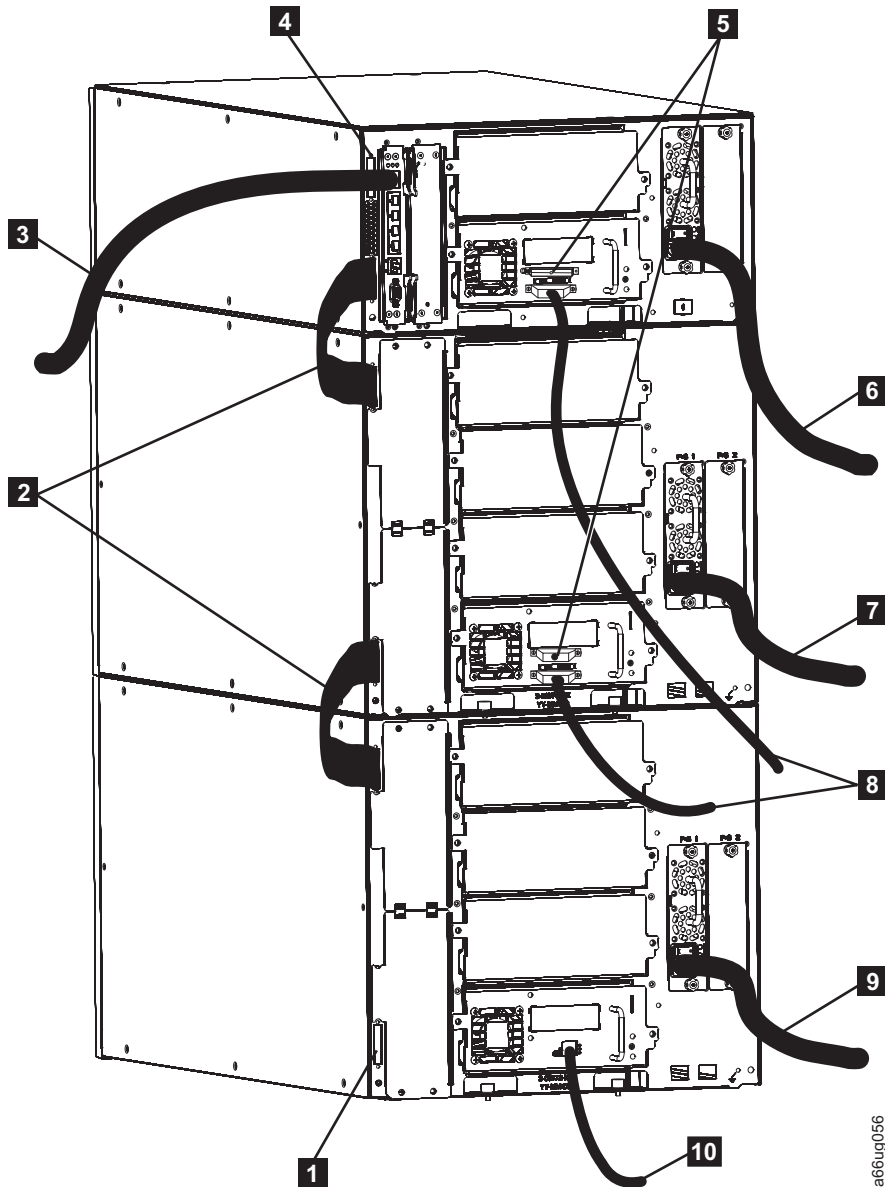

Figure 9-8. Cabling of a 23U Library with SCSI and Fibre Drives

- | | | |
|---|--|--|
| 1 Module communication terminator | 5 SCSI terminators | 8 SCSI drive cables |
| 2 Module-to-module communication cable | 6 Power cord (Control Module) | 9 Power cord (Expansion Module) |
| 3 Ethernet cable (customer supplied) | 7 Power cord (Expansion Module) | 10 Fibre drive-to-network cable |
| 4 Module communication terminator | | |

2. Check and reset, if necessary, all of the cables and terminators connected to your library.
3. Verify that there is no damage to any connector pins.

E-mailing Logs

Logs provide a summary of the current status of the library, and include configuration settings and information provided in Operator Interventions.

Capture current logs of the library both before and after you perform service. To e-mail current logs:

1. Ensure that no applications are accessing the library. If a **Progress Screen** is open, wait until it closes before attempting to generate the logs.
2. Capture a current library log. To capture a library log from the Web User Interface, select **Service Library** → **Capture Log**.
3. When requested by IBM, attach the log to an email message and send it to IBM Technical Support for further diagnosis.

Manually Recovering Tape from Picker

1. Manually rotate the picker so you can access the 3 drive gears, as shown in Figure 9-9



Figure 9-9. Drive gears

2. Rotate the large gear (**1**) in Figure 9-9 with your thumb or finger, in the direction shown by the arrow. Continue rotating the gear until the cartridge is ejected from the picker.

Pre-Call Checklist

If you have questions or problems concerning the library, perform the following steps before placing a call to IBM Technical Support.

Note: Where instructions refer you to the web, visit <http://www.ibm.com/storage/support/ito>.

1. Verify that you have exhausted all troubleshooting options (refer to “Diagnosing a Problem” on page 9-2).
2. Verify that the drive’s firmware is at the most recent level (see “Viewing Drive Information” on page 7-13). To determine the latest release of firmware, visit the web.
3. Verify that your device drivers are at the most recent level (see your server (host) manual for instructions).
 - For the latest release of IBM device drivers, visit the web.
 - For the latest release of device drivers by Independent Software Vendors (ISVs), visit the appropriate third-party web site.
4. Verify whether your hardware and software configuration is supported. To determine the latest supported attachments, visit the web.
5. Perform a general checkup of the hardware and connections:
 - Ensure that you are using the correct SCSI terminator and that you are not mistakenly using a SCSI wrap plug.
 - Ensure that the SCSI cable connector does not contain bent or recessed pins.
 - Ensure that all retention screws for the SCSI cable and terminator are securely tightened.
6. If you still have a problem after completing the above steps, see “Contacting IBM Technical Support.”

Contacting IBM Technical Support

- Perform the steps in “Pre-Call Checklist” before placing a call to IBM Technical Support.
- Prior to calling IBM Technical Support, the customer is responsible for following IBM’s published LTO diagnostic procedures including any needed update to the latest level of firmware. For details, visit <http://www.ibm.com/storage/support/ito>.
- The IBM Support Center will assist with problem determination and initiate shipment of a replacement part, if needed, to the customer’s location. Transportation costs, both ways, are paid by IBM. The replacement part becomes the property of the customer in exchange for the failed part, which becomes the property of IBM. The customer is responsible for packing the failed part into the shipping carton that contained the replacement part. Failure to return the failed part to IBM within 30 days will result in the customer being billed for the new list price. The customer is responsible for installing and setting up the CRU replacement part. All FRU replacement parts will be installed by an authorized IBM Service Representative.
- Failure to use the carton in which the replacement part was received, or failure to otherwise properly pack the returned part, could result in charges being incurred by the customer for damage to the failed part during shipment.
- Before calling support, follow these steps which will help you take full advantage of your call:
 1. Be prepared to provide library and drive firmware levels currently installed.

2. Review all documentation carefully. (Experience has demonstrated that most questions are answered in your documentation.)
3. Be prepared to explain whether the software or hardware has worked properly at anytime in the past. Have you changed anything recently?
4. Pinpoint the exact location of your problem, if possible. Note the steps that led to the problem. Can you duplicate the problem or is it a one-time occurrence?
5. Note any error messages displayed on your PC monitor or file server. Write down the exact error message.
6. If at all possible, call while at your computer, with the library installed and turned on.
7. If running on a network, have all relevant information available (that is, type, version number, network hardware, and so on).
8. Be prepared to provide:
 - Machine type and Model name(s)
 - Serial number of the library (front of the control module on the label underneath the power button)
 - Software version numbers
 - Device driver information
 - Host application name and version
 - Hardware configuration, including firmware versions, date, and number
 - Type of host, operating system version, clock speed, RAM, network type, network version, and any special boards installed
 - A brief description of the problem, including Service Action Ticket number (Txxx).

Having this information available when you call for customer assistance will enable support personnel to resolve your problem in the most efficient manner possible.

- To contact IBM Technical Support:
 - In the USA: 1-800-IBM_SERV (1-800-426-7378)
 - All other Countries/Regions: <http://www.ibm.com/planetwide/>
 - To open a Service Request online: Under **Get Support**, click **Open a Service Request**.

Chapter 10. Service Action Tickets (Txxx) and Diagnostic Resolutions (DRxxx)

“Service Action Tickets”

“Diagnostic Resolutions” on page 10-34

Before ordering a CRU replacement part, observe the LEDs on all library components to determine exactly which part is failing. See “Interpreting LEDs” on page 9-6 for more information. If the LEDs on all components are functioning properly, see “Contacting IBM Technical Support” on page 9-17.

Service Action Tickets

When the library detects a problem, it generates an error code and displays it in the Operator Intervention report, along with a full description of the problem and suggestions for resolving it.

The sections below offer more information than will be displayed in an Operator Intervention on the Operator Panel. Refer to this information for additional help in resolving problems.

Check your host for Sense Data and refer to Appendix C, “Sense Data,” on page C-1.

T001: Manually remove cartridge from Picker, motion OK

Description	The Picker is logically not expecting to see a cartridge in the Picker but the cartridge present sensor indicates otherwise. The cartridge cannot legitimately be returned to a home slot nor can it be placed in a destination slot. The VOLSER (Volume Serial Number) may be unknown, the library may be full, or changing the host(s) inventory is disruptive.
Detection Scenarios	<ol style="list-style-type: none">1. The Picker becomes enabled after a door is opened or the library system boots up and discovers that the cartridge present sensor detects a cartridge.2. The system has tried to recover from a PUT failure and wants to return the cartridge to a home slot; however, the home slot recovery logic completes without recovery (home slot is a drive or the I/O Station is open or the I/O Station is full).3. The cartridge present sensor and sensing circuit is falsely representing the presence of a cartridge.

Root Causes	<ol style="list-style-type: none"> 1. Operator did not recover cartridge. 2. Operator put a cartridge in the Picker. 3. Power loss during a move with media and the library logic cannot legitimately return it to the proper cell. 4. Physical contamination such as dust and debris on the sensor gives a "false full state". 5. Various electrical failures.
Possible CRU Replacements	<ul style="list-style-type: none"> • Tape Cartridge • Library Control Blade
Possible FRU Replacements	<ul style="list-style-type: none"> • Picker Assembly • Y-axis Cable Spool • Internal Cables and Boards Kit
Resolution	Perform "DR001: Manually Recover Tape from Picker" on page 10-34.

T002: PUT operation failed, cartridge final position unknown, motion OK

Description	The library cannot successfully put a cartridge into a drive, storage or I/O location and the final "resting place" of the cartridge is unknown. There are no additional recovery logic paths to be exercised. Fundamental servo control seems OK. If the operation was initiated by a host MOVE MEDIA, the MOVE MEDIA command has failed with a SK/ASC/ASCQ 4h/15h/01h (hardware mechanical positioning error).
Detection Scenarios	PUT is not successful, PUT recovery is not successful, and a cartridge is not known to be properly seated in the Picker or a storage slot.
Root Causes	<ol style="list-style-type: none"> 1. Magazine is damaged. 2. Magazine is the wrong type for the cartridge. 3. A storage cell is blocked by foreign material or not clipped in and seated correctly. 4. Calibration problem resulted in improper Picker position. 5. Picker offset problem. 6. Cartridge is damaged. 7. Unlabeled cartridge or intermittently readable cartridge label in destination slot. 8. Drive load mechanism is not working. 9. A variety of Picker problems such as slipping gears, encoder issues, etc.
Possible CRU Replacements	<ul style="list-style-type: none"> • Tape Cartridge • Library Control Blade
Possible FRU Replacements	<ul style="list-style-type: none"> • Picker Assembly • Y-axis Cable Spool • Internal Cables and Boards Kit

Resolution	<p>Perform “DR002: Manually Recover Tape from Source or Destination Slot” on page 10-35.</p> <p>Before closing the ticket:</p> <ul style="list-style-type: none"> • If a storage cell is blocked by foreign material, remove the foreign material. • If the Picker is improperly positioned, power cycle the library. • If the suspect cartridge is damaged, copy the data onto a new cartridge then destroy the suspect cartridge. If the data cannot be copied, replace the suspect cartridge. • If the suspect cartridge does not have a bar code label, apply a label. • If the suspect cartridge has a damaged bar code label, remove the damaged label and apply a new label. • If the problem persists, refer to “Diagnosing a Problem” on page 9-2 for additional diagnostic procedures.
-------------------	--

T003: GET operation failed, cartridge final position unknown, motion OK

Description	The library cannot successfully get a cartridge from a drive, storage or I/O location. The final “resting place” of the cartridge is unknown. There are no additional recovery logic paths. Fundamental servo control appears to be OK. If the operation was initiated by a host MOVE MEDIA, the MOVE MEDIA command has failed with an ASC/ASCQ of 4h/15h/01h (hardware mechanical positioning error).
Detection Scenarios	GET is not successful, GET recovery is not successful, and the cartridge is not known to be properly seated in the Picker or a storage slot.
Root Causes	<ol style="list-style-type: none"> 1. Magazine is damaged. 2. Magazine is the wrong type for the cartridge. 3. A storage cell is blocked by foreign material or not clipped in and seated correctly. 4. Calibration problem resulted in improper Picker position. 5. Picker offset problem. 6. Cartridge is damaged. 7. Unlabeled cartridge or intermittently readable cartridge label in destination slot. 8. Drive load mechanism is not working. 9. A variety of Picker problems such as slipping gears, encoder issues, etc.
Possible CRU Replacements	<ul style="list-style-type: none"> • Tape Cartridge • Library Control Blade
Possible FRU Replacements	<ul style="list-style-type: none"> • Picker Assembly • Y-axis Cable Spool • Internal Cables and Boards Kit

Resolution	<p>Perform “DR002: Manually Recover Tape from Source or Destination Slot” on page 10-35.</p> <p>Before closing the ticket:</p> <ul style="list-style-type: none"> • If a storage cell is blocked by foreign material, remove the foreign material. • If the Picker is improperly positioned, power cycle the library. • If the suspect cartridge is damaged, copy the data onto a new cartridge then destroy the suspect cartridge. Otherwise, replace the cartridge. • If the suspect cartridge does not have a bar code label, apply a label. • If the suspect cartridge has a damaged bar code label, remove the damaged label and apply a new label. • If the problem persists, refer to “Diagnosing a Problem” on page 9-2 for additional diagnostic procedures.
-------------------	---

T004: PUT operation failed, cartridge back in source location, motion OK

Description	The library cannot successfully put a cartridge into the intended target drive, storage or I/O location. The library has successfully returned the cartridge to the source location. Fundamental servo control appears to be OK.
Detection Scenarios	PUT is not successful and PUT recovery is not successful at the destination element. Recovery logic has allowed the cartridge to be returned to the initial source location. If the operation was initiated by a host MOVE MEDIA, the MOVE MEDIA command has failed with a Sense Key/ASC/ASCQ of 4h/15h/01h.
Root Causes	<ol style="list-style-type: none"> 1. Magazine is damaged, wrong type, cell is blocked by foreign material, or not clipped in and seated correctly. 2. Calibration problem. 3. Picker offset problem. 4. Destination cell full with labeled cartridge (invalid inventory). 5. Destination cell is full with cartridge that has damaged label or is unlabeled or has an intermittently readable label. 6. A variety of Picker problems such as slipping gears, encoder issues, etc.
Possible CRU Replacements	<ul style="list-style-type: none"> • Tape Cartridge • Library Control Blade
Possible FRU Replacements	<ul style="list-style-type: none"> • Picker Assembly • Y-axis Cable Spool • Internal Cables and Boards Kit

Resolution	<p>Perform “DR004: Manually Inspect Destination Element” on page 10-35.</p> <p>Before closing the ticket, perform the following:</p> <ol style="list-style-type: none"> 1. If a magazine cell is blocked by foreign material, remove the foreign material. 2. If a magazine is not clipped in and seated correctly, reseal the magazine. 3. If your library is reporting an invalid inventory, verify that you have purchased and entered your Capacity Expansion key. To determine the number of available slots in your library: <ul style="list-style-type: none"> • From the Operator Panel, view the Capacity View home screen. • From the Web User Interface, select Monitor System → System Summary. <p>If the number of available slots is incorrect, re-enter your Capacity Expansion license key by selecting Setup → License from the Operator Panel.</p> 4. If the destination cell contains a cartridge that has a damaged label or is unlabeled, remove the damaged label, if necessary, then apply a new label to the cartridge. 5. Power cycle the library. 6. If the problem persists, refer to “Diagnosing a Problem” on page 9-2 for additional diagnostic procedures.
-------------------	---

T005: X, Y, θ motion profile failure, cartridge in Picker, motion NOT OK

Description	<p>An unrecoverable motion failure occurs during a move with a cartridge in the Picker. This problem only occurs during a move and NOT a get or put. Because the cartridge is in the Picker, cartridge recovery must be a part of the resolution strategy. This ticket cause specifically excludes any Z-axis motion failures that are typically associated with GET or PUT actions. Specifically included are motion failures that occur while pivoting, moving on the X-axis, or moving on the Y-axis.</p>
Detection Scenarios	<ol style="list-style-type: none"> 1. A specified move in the X-axis cannot complete. 2. A specified move in the Y-axis cannot complete. 3. A specified movement in the θ-axis cannot complete.
Root Causes	<ol style="list-style-type: none"> 1. A large number of electrical hardware failures. Code or hardware detects that motion control is not occurring properly (encoder issues, motor driving circuit issues, motor winding issues, cable connection issues, etc.). 2. A relatively small number of mechanical hardware errors that do not result in the detection of a complete obstruction but where motion control does not appear to be normal (contamination or damage to encoder wheel, high friction, etc).

Possible CRU Replacements	<ul style="list-style-type: none"> • Tape Cartridge • Library Control Blade
Possible FRU Replacements	<ul style="list-style-type: none"> • Picker Assembly • Y Motor • Y-axis Assembly • Y-axis Cable Spool • Internal Cables and Boards Kit
Resolution	<ul style="list-style-type: none"> • Perform “DR001: Manually Recover Tape from Picker” on page 10-34 • Perform “DR005: Motion Failure Diagnostic (a Library Verify Test)” on page 10-35. <p>If the problem persists, refer to “Diagnosing a Problem” on page 9-2 for additional diagnostic procedures.</p>

T006: X, Y, θ motion profile failure, no cartridge in Picker, motion NOT OK

Description	An unrecoverable motion failure occurs at an operational point where a cartridge is not in the Picker. Because the cartridge is not in the Picker, cartridge recovery is not necessary as part of the resolution to this issue. This cause specifically excludes any Z-axis motion failures. Specifically included are motion failures that occur while pivoting, moving on the X-axis or moving on the Y-axis.
Detection Scenarios	<ol style="list-style-type: none"> 1. A specified move in the X-axis cannot complete. 2. A specified move in the Y-axis cannot complete. 3. A specified movement in the θ-axis cannot complete.
Root Causes	<ol style="list-style-type: none"> 1. A large number of electrical hardware failures. Code or hardware detects that motion control is not occurring properly (encoder issues, motor driving circuit issues, motor winding issues, cable connection issues, etc.). 2. A relatively small number of hardware errors that do not result in complete obstruction but where servo control does not appear to be normal.
Possible CRU Replacements	<ul style="list-style-type: none"> • Tape Cartridge • Library Control Blade
Possible FRU Replacements	<ul style="list-style-type: none"> • Picker Assembly • Y Motor • Y-axis Assembly • Y-axis Cable Spool • Internal Cables and Boards Kit
Resolution	<p>Perform “DR005: Motion Failure Diagnostic (a Library Verify Test)” on page 10-35.</p> <p>If the problem persists, refer to “Diagnosing a Problem” on page 9-2 for additional diagnostic procedures.</p>

T007: X, Y, θ motion obstruction, motion OK

Description	A complete physical obstruction exists in a motion path that precludes repeated attempts to move beyond a certain point in the range of motion. Servo control appears normal but a move profile cannot be completed. Cartridge may have been returned to a home slot.
Detection Scenarios	<ol style="list-style-type: none"> 1. A specified move in the X-axis cannot complete but motion control appears normal. 2. A specified move in the Y-axis cannot complete but motion control appears normal. 3. A specified move in the θ-axis cannot complete but motion control appears normal.
Root Causes	<ol style="list-style-type: none"> 1. Operator Intervention that results in foreign material or an obstructing object in a library motion path. 2. Picker locking mechanism left engaged in the library motion path. 3. Certain damaged hardware conditions that obstruct motion at a particular point along an axis.
Possible CRU Replacements	Tape Cartridge
Possible FRU Replacements	<ul style="list-style-type: none"> • Picker Assembly • Y-axis Assembly • Internal Cables and Boards Kit
Resolution	<ul style="list-style-type: none"> • Verify that no obstructions are present in the path of the Picker. • Perform “DR028: Motion Obstruction Diagnostic” on page 10-42. • If the problem persists, refer to “Diagnosing a Problem” on page 9-2 for additional diagnostic procedures.

T008: Cannot home, motion OK

Description	Robot motion and servo control appear normal but home sensors do not transition when the robot is moved through prescribed search distances and times.
Detection Scenarios	<ol style="list-style-type: none"> 1. X home sensor does not transition while homing. 2. Y home sensor does not transition while homing. 3. θ home sensor does not transition while homing. 4. Z home sensor does not transition while homing.

Root Causes	<ol style="list-style-type: none"> 1. Malfunctioning home sensors. 2. Missing or damaged mechanical flags that trigger home sensors. 3. Hardware failures that result in apparent normal motion according to encoders, but no actual motion (ex. slipping gears). 4. Picker path obstruction. 5. Picker locking mechanism left engaged in the library motion path (see Figure 3-6 on page 3-7).
Possible CRU Replacements	<ul style="list-style-type: none"> • Library Control Blade
Possible FRU Replacements	<ul style="list-style-type: none"> • Picker Assembly • Y Motor • Y-axis Assembly • Internal Cables and Boards Kit
Resolution	<ul style="list-style-type: none"> • Verify that no obstructions are present in the path of the Picker. • Perform “DR028: Motion Obstruction Diagnostic” on page 10-42. • If the problem persists, refer to “Diagnosing a Problem” on page 9-2 for additional diagnostic procedures.

T009: Drive load unsuccessful, motion OK

Description	The robot has successfully completed all motion profiles associated with putting to a drive but the drive reports that the tape cartridge did not load.
Detection Scenarios	While checking the status of a drive after a PUT motion profile to the drive is completed, the drive does not report back a loaded state.
Root Causes	<ol style="list-style-type: none"> 1. Defective drive. 2. Defective tape cartridge. 3. Motion profile was successful as detected at motor encoders but cartridge did not get placed far enough. 4. Picker dragged cartridge back out of drive but not far enough to trigger Picker cartridge present sensor.
Possible CRU Replacements	<ul style="list-style-type: none"> • Tape Cartridge • Drive Sled
Possible FRU Replacements	<ul style="list-style-type: none"> • Picker Assembly
Resolution	<p>Perform “DR030: Drive Load Failure Resolution” on page 10-43.</p> <p>Before closing the ticket, perform the following:</p> <ul style="list-style-type: none"> • Inspect the suspect cartridge for damage. Copy data onto a new cartridge if the suspect cartridge is damaged, then destroy the suspect cartridge. If data cannot be copied onto a new cartridge, replace the suspect cartridge. • Before replacing a drive, refer to “Diagnosing a Problem” on page 9-2 for additional diagnostic procedures.

T010: Drive unload failed

Description	The library is expecting the drive to achieve an unloaded state, but the drive does not.
Detection Scenarios	<ol style="list-style-type: none"> 1. After being issued a move media from a host that requires a GET from a drive, the drive never achieves the unloaded state. 2. When GUI commands are issued that require a drive unload (manual drive unload, move media, etc.) and the drive never achieves the unloaded state. <p>Note: Since the library will always issue an unload command, it will not be possible to determine if a host unload command failed first, followed by a subsequent failure of a library issued unload command.</p>
Root Causes	Drive fails to unload after the library issues an unload command.
Possible CRU Replacements	<ul style="list-style-type: none"> • Tape Cartridge • Drive Sled
Resolution	<p>Perform "DR003: Drive Unload Diagnostic" on page 10-35.</p> <p>Before replacing a drive, refer to "Diagnosing a Problem" on page 9-2 for additional diagnostic procedures.</p>

T013: Invalid or damaged library serial number label

Description	The library will report a problem when it cannot read a serial number or detects an invalid serial number.
Detection Scenarios	<ol style="list-style-type: none"> 1. At first power ON during installation, the library must establish the serial number for the first time. There may be no serial number in system memory at this point. 2. At any power up, system memory already has a serial number established for the Library Control Blade. 3. A Library Control Blade is improperly swapped into a different physical library and the system reads the physical library label.
Root Causes	<ol style="list-style-type: none"> 1. Library Control Blades swapped between libraries. 2. Label is damaged. 3. Bar code scanner not working properly. 4. Entire communication path to bar code scanner is not working properly.
Possible CRU Replacements	Library Control Blade
Possible FRU Replacements	<ul style="list-style-type: none"> • Picker Assembly • Y Motor • Y-axis Assembly • Y-axis Cable Spool • Internal Cables and Boards Kit <p>Note: The system serial number label is part of the enclosure FRU.</p>

Resolution	<p>Perform “DR007: Bar Code Scanner Diagnostic (a Library Verify Test)” on page 10-36.</p> <p>Before replacing a library component, refer to “Diagnosing a Problem” on page 9-2 for additional diagnostic procedures.</p>
-------------------	---

T014: I/O Station Magazine Missing

Description	There is a fixed bar code label location on the I/O Station structure behind the removable magazines. It decodes as %XXX. The purpose of the label is to allow the library to detect that an I/O Station magazine is not installed. This is important on I/O Station magazines, because they are user removable. While performing an inventory of the I/O Station magazines, the library ends up verifying the presence of the magazine by NOT detecting this special fixed label.
Detection Scenarios	Any time the library attempts to inventory an I/O Station magazine, it will read the fixed label if a magazine is missing. I/O Station magazines are always expected to be present.
Root Causes	<ol style="list-style-type: none"> 1. Missing I/O Station magazine 2. A cartridge in an I/O Station just happens to have a label that decodes as “%XXX”. <p>Note: The inability to communicate between the Library Control Blade and the bar code scanner should result in a different ticket cause.</p>
Resolution	Perform “DR023: I/O Station Magazine Missing” on page 10-41.

T015: Cannot read sled bar code label

Description	When the library is attempting to determine the type of a drive and verify its physical presence in the library, it cannot do so because it cannot read a label where it expects to find one.
Detection Scenarios	<ol style="list-style-type: none"> 1. Installation of a drive into a library drive slot triggers the library to discover it. 2. Boot up causes the library to physically discover any drive that is electrically connected in the system.
Root Causes	<ol style="list-style-type: none"> 1. Damaged label or marginal label that cannot be read 2. Drive with invalid label is present (earlier generation of plug compatible drive sled)
Possible CRU Replacements	Drive sled
Resolution	Perform “DR007: Bar Code Scanner Diagnostic (a Library Verify Test)” on page 10-36.

T017: Invalid storage or I/O position

Description	Calibration completes and the coordinates of each storage and I/O element are calculated. The calculated values are determined to be outside travel limits that have been established for the robot.
Detection Scenarios	Calculated element positions fail validity check against travel limits.
Root Causes	<ol style="list-style-type: none"> 1. Calibration targets not in position. 2. Calibration sensor detects edges but is not correctly finding calibration target edges.
Possible FRU Replacements	<ul style="list-style-type: none"> • Fiducial targets • Storage Column • Y Motor • Y-axis Assembly • Y-axis Cable Spool • Picker Assembly • Internal Cables and Boards Kit
Resolution	Before contact IBM Technical Support, refer to “Diagnosing a Problem” on page 9-2 for additional diagnostic procedures.

T018: Invalid Drive Position

Description	Calibration completes and the coordinates of each drive are calculated. The calculated values are determined to be outside travel limits that have been established for the robot.
Detection Scenarios	Calculated element positions fail validity check against travel limits.
Root Causes	<ol style="list-style-type: none"> 1. Drive calibration target is not in position. 2. Calibration sensor detects edges but is not correctly finding calibration target edges.
Possible CRU Replacements	Drive Sled
Possible FRU Replacements	<ul style="list-style-type: none"> • Y Motor • Y-axis Assembly • Picker Assembly • Y-axis Cable Spool • Internal Cables and Boards Kit
Resolution	Before replacing a library component or contact IBM Technical Support, refer to “Diagnosing a Problem” on page 9-2 for additional diagnostic procedures.

T019: Cannot calibrate drive, motion OK

Description	System electrically detects a drive and is able to scan the bar code label but cannot successfully calibrate the position of the drive. The calibration search pattern completes successfully.
--------------------	--

Detection Scenarios	Calibration motion completes but edge finding of one or more edges does not occur.
Root Causes	<ol style="list-style-type: none"> 1. Calibration sensor not functioning properly. 2. Calibration target not functioning properly. 3. Drive or Picker position is so far off nominal that search pattern cannot locate target.
Possible CRU Replacements	Drive Sled
Possible FRU Replacements	<ul style="list-style-type: none"> • Y Motor • Y-axis Assembly • Y-axis Cable Spool • Picker Assembly • Internal Cables and Boards Kit
Resolution	<p>Before replacing a library component, refer to “Diagnosing a Problem” on page 9-2 for additional diagnostic procedures.</p> <p>If the problem can not be resolved using the information in this document, perform “DR021: Contact Service” on page 10-41</p>

T020: Cannot calibrate storage, motion OK

Description	System cannot successfully calibrate the position of a storage magazine but the calibration search pattern completes successfully.
Detection Scenarios	Calibration motion completes but edge finding of one or more edges does not occur.
Root Causes	<ol style="list-style-type: none"> 1. Calibration sensor not functioning properly. 2. Calibration target not functioning properly. 3. Drive or Picker position is so far off nominal that search pattern cannot locate target. This can also generate a T083: Picker Assembly not level.
Possible FRU Replacements	<ul style="list-style-type: none"> • Fiducial Targets • Y Motor • Y-axis Assembly • Y-axis Cable Spool • Picker Assembly • Internal Cables and Boards Kit
Resolution	<p>Before replacing a library component or contacting IBM Technical Support, refer to “Diagnosing a Problem” on page 9-2 for additional diagnostic procedures.</p> <p>If the problem can not be resolved using the information in this document, perform “DR021: Contact Service” on page 10-41.</p>

T021: Lost electrical connection/communications with drive sled

Description	The library had been communicating with a drive sled and had considered it to be assigned to a logical library. Two way communications no longer occur. This ticket is specifically NOT caused by physical removal of a drive if the drive is not assigned to a logical library.
Detection Scenarios	<ol style="list-style-type: none"> 1. Routine polling of the sled can no longer occur. 2. Specific library to drive sled commands are not responded to.
Root Causes	<ol style="list-style-type: none"> 1. Drive is physically remove/unplugged (intentional or never installed correctly). 2. Various hardware failures on the drive sled. 3. Various hardware failures in the library.
Possible CRU Replacements	<ul style="list-style-type: none"> • Library Control Blade • Drive Sled
Possible FRU Replacements	Internal Cables and Boards Kit
Resolution	<p>Perform "DR029: Drive Communication Loss Resolution" on page 10-43.</p> <p>Before closing the ticket, perform the following:</p> <ol style="list-style-type: none"> 1. If a drive is physically removed from the library, reinstall the drive (refer to "Adding/Removing/Replacing a Drive Sled" on page 11-5). 2. If a drive is unplugged, reconnect the drive. 3. Before replacing a library component or contacting IBM Technical Support, refer to "Diagnosing a Problem" on page 9-2 for additional diagnostic procedures.

T022: Lost electrical connection/communication with drive brick

Description	Internal to the drive, the sled control board can no longer communicate with the drive brick.
Detection Scenarios	<ol style="list-style-type: none"> 1. Routine Polling between sled control board and drive brick can no longer occur. 2. Specific commands such as unload, reset, etc. are not responded to.
Root Causes	<ol style="list-style-type: none"> 1. Cable broken, unplugged, damaged, etc. 2. Drive brick failure.
Possible CRU Replacements	Drive Sled
Resolution	<p>Before performing the following:</p> <ol style="list-style-type: none"> 1. "Removing a Drive Sled" on page 11-8 2. "Replacing a Drive Sled" on page 11-9 <p>refer to "Diagnosing a Problem" on page 9-2 for additional diagnostic procedures.</p>

T023: Drive sled fan spinning too slow or not at all

Description	A drive sled fan is spinning too slow or not at all.
Detection Scenarios	Regular polling/monitoring of the fan indicates a problem.
Root Causes	<ol style="list-style-type: none"> 1. Hardware failure of fan. 2. Wiring or PCBA failure. 3. Blocked air paths. 4. Physical obstruction.
Possible CRU Replacements	Drive Sled
Resolution	<p>Before performing the following:</p> <ol style="list-style-type: none"> 1. "Removing a Drive Sled" on page 11-8 2. "Replacing a Drive Sled" on page 11-9 <p>refer to "Diagnosing a Problem" on page 9-2 for additional diagnostic procedures.</p>

T024: AC power loss

Description	A power supply has detected loss of AC power. AC power loss to a single power supply control module is unlikely to be able to post this ticket due to the speed at which system shut down occurs after an AC loss. This Ticket is most likely to occur when there is AC loss to a redundant power supply in a control module or any supply in any expansion module.
Detection Scenarios	AC power status from the supply creates an interrupt that is managed by software.
Root Causes	<ol style="list-style-type: none"> 1. AC supply is gone (cord removed, customer side AC failure, etc.). 2. Individual on/off switch for the supply has been set to off. 3. Hardware failure inside supply.
Possible CRU Replacements	Power Supply
Resolution	<p>Perform the following:</p> <ul style="list-style-type: none"> • "DR009: AC Failure Diagnostic" on page 10-37 <p>Before performing the following:</p> <ul style="list-style-type: none"> • "Removing a Primary Power Supply" on page 11-4 • "Replacing a Primary Power Supply" on page 11-4 <p>refer to "Diagnosing a Problem" on page 9-2 for additional diagnostic procedures.</p>

T025: Lost electrical connection with single power supply

Description	Power supplies report four failure conditions that are considered to be a hardware failure within the supply: Fan Fail, Over Temp, DC Fail and Over Current. These failures can occur in both single and redundant power supply control modules and any expansion module with a power supply.
--------------------	---

Detection Scenarios	Regular polling between Library Control Blade and power supply is not successful.
Root Causes	<ol style="list-style-type: none"> 1. Detected fan failure in the supply. 2. Detected over temp condition in the supply. 3. Detected DC failure in the supply. 4. Detected over current failure in the supply.
Possible CRU Replacements	<ul style="list-style-type: none"> • Power Supply • Library Control Blade
Possible FRU Replacements	Internal Cables and Boards Kit
Resolution	Before performing any remove/replace procedures, refer to "Diagnosing a Problem" on page 9-2 for additional diagnostic procedures.

T031: Cannot unlock I/O Station

Description	System logic or external command is requiring I/O station lock to unlock but it will not.
Detection Scenarios	When unlock action is attempted, lock/unlock position sensor does not detect the proper state.
Root Causes	<ol style="list-style-type: none"> 1. Lock mechanism not working properly. 2. Lock position sensor not working properly. 3. Mechanical binding or obstruction prevents proper motion and detection. 4. Mechanical failure of sensor flag.
Possible CRU Replacements	Library Control Blade
Possible FRU Replacements	<ul style="list-style-type: none"> • I/O Station Lock Assembly • Operator Panel • Internal Cables and Boards Kit
Resolution	<p>Perform the following:</p> <ul style="list-style-type: none"> • "DR011: I/E (I/O Station) Lock Diagnostic (a Library Verify Test)" on page 10-38 • Before replacing a library component or contacting IBM Technical Support, refer to "Diagnosing a Problem" on page 9-2 for additional diagnostic procedures.

T032: Cannot lock I/O Station

Description	System logic or external command is requiring I/O station lock to lock but it will not.
Detection Scenarios	When a lock action is attempted, the lock/unlock position sensor does not detect the proper state.
Root Causes	<ol style="list-style-type: none"> 1. Lock mechanism not working properly. 2. Lock position sensor not working properly. 3. Mechanical binding or obstruction prevents proper motion and detection. 4. Mechanical failure of sensor flag.
Possible CRU Replacements	Library Control Blade

Possible FRU Replacements	<ul style="list-style-type: none"> • I/O Station Lock Assembly • Operator Panel • Internal Cables and Boards Kit
Resolution	<p>Perform the following:</p> <ul style="list-style-type: none"> • “DR011: I/E (I/O Station) Lock Diagnostic (a Library Verify Test)” on page 10-38 • Before replacing a library component or contacting IBM Technical Support, refer to “Diagnosing a Problem” on page 9-2 for additional diagnostic procedures.

T033: Drive TapeAlert Flag 3 - Hard read or write error

Description	System determines that the drive has issued a TapeAlert 3 indicating an unrecoverable read, write or positioning error.
Detection Scenarios	Tape drive issues a Tape Alert 3 which is recognized by the library during the continuous 4 second polling cycle of drive status.
Root Causes	Drive has determined that there is a problem per its internal algorithms.
Possible CRU Replacements	<ul style="list-style-type: none"> • Cartridge • Tape Drive
Resolution	<p>If the cartridge is managed by a host application, export the cartridge via the host application.</p> <p>If the cartridge is managed by the library, perform the following:</p> <ul style="list-style-type: none"> • Remove the suspect cartridge(see “Removing a Data Cartridge” on page 7-16 or “Removing a Cleaning Cartridge” on page 7-17). • Import a new cartridge(see “Inserting Data Cartridges” on page 7-15 or “Inserting a Cleaning Cartridge” on page 7-16).

T034: Drive TapeAlert Flag 4 - Media

Description	System determines that the drive has issued a TapeAlert 4 indicating an unrecoverable read, write or positioning error that the drive specifically isolates to a the media.
Detection Scenarios	Tape drive issues a TapeAlert 4 which is recognized by the library during the continuous four second polling cycle of drive status.
Root Causes	Drive has determined that there is a problem per its internal algorithms.
Possible CRU Replacements	Tape Cartridge
Resolution	Perform “DR044: Tape Alert 4 Media Error” on page 10-47

T035: Drive TapeAlert Flag 5 - Read Failure

Description	System determines that the drive has issued a TapeAlert 5 indicating an unrecoverable read error where isolation is uncertain between drive and media.
Detection Scenarios	Tape drive issues a TapeAlert 5 which is recognized by the library during the continuous 4 second polling cycle of drive status.
Root Causes	Drive has determined that there is a problem per its internal algorithms.
Possible CRU Replacements	Tape Cartridge
Resolution	Perform "DR045: Tape Alert 5, 6 – Read/Write Failure" on page 10-47.

T036: Drive TapeAlert Flag 6 - Write Failure

Description	System determines that the drive has issued a TapeAlert 6 indicating an unrecoverable write error where isolation is uncertain between drive and media.
Detection Scenarios	Tape drive issues a TapeAlert 6 which is recognized by the library during the continuous four second polling cycle of drive status.
Root Causes	Drive has determined that there is a problem per its internal algorithms.
Possible CRU Replacements	Tape Cartridge
Resolution	Perform "DR045: Tape Alert 5, 6 – Read/Write Failure" on page 10-47.

T037: Drive TapeAlert Flag 8 - Not Data Grade

Description	System determines that the drive has issued a TapeAlert 8 indicating that the tape cartridge in the drive is not a data grade tape.
Detection Scenarios	Tape drive issues a TapeAlert 8 which is recognized by the library during the continuous four second polling cycle of drive status.
Root Causes	Drive has determined that there is a problem per its internal algorithms.
Possible CRU Replacements	Tape Cartridge
Resolution	Perform "DR046: Tape Alert 8 – Suspect Data Grade Tape" on page 10-47.

T038: Drive TapeAlert Flag 9 - Write Protected

Description	System determines that a write was attempted on a write protected tape.
Detection Scenarios	Tape drive issues a TapeAlert 9
Root Causes	Write protect feature on tape is protecting the tape but the user is trying to write to it.

Possible CRU Replacements	Tape Cartridge
Resolution	Perform "DR014: Write Protect or WORM Diagnostic" on page 10-39. To remove the write protection feature from the cartridge, refer to "Write-Protect Switch" on page 8-7.

T039: Drive TapeAlert Flag 12 - Unsupported Format

Description	System determines that the drive has issued a TapeAlert 12 indicating that the media loaded is an unsupported format. In the case of the IBM LTO family of drives, full backward read and write compatibility stopped when LTO 3 was introduced. LTO 3 cannot write in LTO 1 format. Therefore an LTO 1 tape is an unsupported format when trying to write to it with an LTO 3 drive.
Detection Scenarios	Tape drive issues a TapeAlert 12 which is recognized by the library during the continuous four second polling cycle of drive status.
Root Causes	Drive has determined that there is a problem per its internal algorithms.
Possible CRU Replacements	Tape Cartridge
Resolution	Perform "DR015: Unsupported Format Diagnostic" on page 10-39.

T040: Drive TapeAlert Flag 15 - MIC Chip Failure

Description	System determines that the drive has issued a TapeAlert 15 indicating that MIC (memory in cassette) of the media loaded is not working properly. The MIC is the memory that is part of the cartridge, also called LTO CM.
Detection Scenarios	Tape drive issues a TapeAlert 15 which is recognized by the library during the continuous four second polling cycle of drive status.
Root Causes	Drive has determined that there is a problem per its internal algorithms.
Possible CRU Replacements	Tape Cartridge
Resolution	Perform "DR047: Tape Alert 15 – Cartridge Memory Failure" on page 10-48

T041: Drive TapeAlert Flag 16 - Forced Eject

Description	System determines that the drive has issued a TapeAlert 16 indicating that an unload of a drive was triggered while the drive was actively reading or writing. The source of the unload can be either an operator initiated manual push button on the drive itself or a GUI initiated command.
Detection Scenarios	Tape drive issues a TapeAlert 16 which is recognized by the library during the continuous four second polling cycle of drive status.

Root Causes	Drive has determined that there is a problem per its internal algorithms.
Possible CRU Replacements	Tape Cartridge
Resolution	Perform "DR048: Tape Alert 16 – Forced Reject" on page 10-48.

T045: Drive TapeAlert Flag 20 - Clean Now

Description	System determines that the drive has issued a TapeAlert 20 indicating that the drive requires cleaning. This should be coincident with a "C" on the drive seven segment display.
Detection Scenarios	Tape drive issues a TapeAlert 20 which is recognized by the library during the continuous four second polling cycle of drive status.
Root Causes	Drive has determined that there is a problem per its internal algorithms.
Possible CRU Replacements	<ul style="list-style-type: none"> • Tape Drive • Tape Cartridge
Resolution	Perform "DR018: Manually Clean Drive" on page 10-40.

T046: Drive TapeAlert Flag 21 - Clean Periodic

Description	System determines that the drive has issued a TapeAlert 21 indicating that the drive requires cleaning. This should be coincident with a "C" on the drive seven segment display.
Detection Scenarios	Tape drive issues a TapeAlert 21 which is recognized by the library during the continuous four second polling cycle of drive status.
Root Causes	Drive has determined that there is a problem per its internal algorithms.
Possible CRU Replacements	<ul style="list-style-type: none"> • Tape Drive • Tape Cartridge
Resolution	Perform "DR018: Manually Clean Drive" on page 10-40.

T047: Drive TapeAlert Flag 22 - Expired Cleaning Media

Description	System determines that a cleaning media is expired.
Detection Scenarios	<ul style="list-style-type: none"> • Tape drive issues a TapeAlert 22 • Code that manages library based cleaning determines that a cartridge is consumed based on actively managing the use count.
Root Causes	Cleaning tape is used up.
Possible CRU Replacements	<ul style="list-style-type: none"> • Tape Cartridge

Resolution	<p>If the cartridge is managed by a host application, export the cartridge via the host application.</p> <p>If the cartridge is managed by the library, perform the following:</p> <ul style="list-style-type: none"> • Remove the suspect cartridge (see “Removing a Cleaning Cartridge” on page 7-17). • Import a new cartridge(see “Inserting a Cleaning Cartridge” on page 7-16).
-------------------	---

T048: Drive TapeAlert Flag 23 - Invalid Cleaning Tape

Description	System determines that the drive has issued a TapeAlert 23 indicating that the drive was expecting a cleaning tape but the loaded cartridge is not a cleaning tape.
Detection Scenario	Tape drive issues a TapeAlert 23 which is recognized by the library during the continuous four second polling cycle of drive status.
Root Causes	<ul style="list-style-type: none"> • User or library attempts to mount a cleaning tape but the tape is not actually a cleaning tape. • User mistakenly loads a data tape as a cleaning tape • Inventory or application issue results in data tape being loaded when drive expects cleaning tape
Possible CRU Replacements	<ul style="list-style-type: none"> • Tape Cartridge
Resolution	<p>If the cartridge is managed by a host application, export the cartridge via the host application.</p> <p>If the cartridge is managed by the library, perform the following:</p> <ul style="list-style-type: none"> • Remove the suspect cartridge(see “Removing a Cleaning Cartridge” on page 7-17). • Import a new cartridge(see “Inserting a Cleaning Cartridge” on page 7-16).

T049: Drive TapeAlert Flag 30 - Hardware A

Description	System determines that the drive has issued a TapeAlert 30 indicating a hardware error that requires a drive power cycle before the drive might recover to a usable state.
Detection Scenario	Tape drive issues a TapeAlert 30 which is recognized by the library during the continuous four second polling cycle of drive status.
Root Causes	Drive has determined that there is a problem per its internal algorithms.
Possible CRU Replacements	Drive Sled

Resolution	<p>Before performing the following:</p> <ul style="list-style-type: none"> • “Removing a Drive Sled” on page 11-8 • “Replacing a Drive Sled” on page 11-9 <p>refer to “Diagnosing a Problem” on page 9-2 for additional diagnostic procedures.</p> <ul style="list-style-type: none"> • Perform “DR049 Tape Alert 30, 31 – Drive Hardware Error” on page 10-48. • From the Operator Panel, select Tools → Service → Drive to run the drive diagnostic. A blank, scratch cartridge is required for this test.
-------------------	---

T050: Drive TapeAlert Flag 31 - Hardware B

Description	System determines that the drive has issued a TapeAlert 31 indicating a hardware error that requires a drive power cycle before the drive might recover to a usable state.
Detection Scenario	Tape drive issues a TapeAlert 31 which is recognized by the library during the continuous four second polling cycle of drive status.
Root Causes	Drive has determined that there is a problem per its internal algorithms.
Possible CRU Replacements	Drive Sled
Resolution	<p>Before performing the following:</p> <ul style="list-style-type: none"> • “Removing a Drive Sled” on page 11-8 • “Replacing a Drive Sled” on page 11-9 <p>refer to “Diagnosing a Problem” on page 9-2 for additional diagnostic procedures.</p>

T051: Drive TapeAlert Flag 32 - Interface

Description	System determines that the drive has issued a TapeAlert 32 indicating a tape drive has detected a problem with the application client interface.
Detection Scenarios	Tape drive issues a TapeAlert 32 which is recognized by the library during the continuous four second polling cycle of drive status.
Root Causes	Drive has determined that there is a problem per its internal algorithms.
Possible CRU Replacements	Tape Drive
Resolution	Perform “DR012: Host Cabling Diagnostic” on page 10-38.

T052: Drive TapeAlert Flag 33 - Eject media error recovery

Description	System determines that the drive has issued a TapeAlert 33 indicating that the drive requires a cartridge to be ejected in order to resolve a problem.
Detection Scenarios	Tape drive issues a TapeAlert 33 which is recognized by the library during the continuous four second polling cycle of drive status.

Root Causes	Drive has determined that there is a problem per its internal algorithms.
Possible CRU Replacements	Tape Drive
Resolution	From the Operator Panel, select Tools → Service → Drive to run the drive diagnostic. A blank, scratch cartridge is required for this test. Before performing the following: <ul style="list-style-type: none"> • “Removing a Drive Sled” on page 11-8 • “Replacing a Drive Sled” on page 11-9 refer to “Diagnosing a Problem” on page 9-2 for additional diagnostic procedures.

T060: Door Open

Description	At boot time or run time the library detects that at least one main door is open. The main access door switches are physically wired in series and the system firmware can not distinguish which switch/door is open. In addition, the health of the module-to-module connection and termination affects the series wiring of the switches. Firmware logic will not report this ticket if the module-to-module termination is totally missing or not proper.
Detection Scenario	Constant monitoring of the switch electrical circuit (hardware interrupt) detects a door open. This is true at run time or boot up.
Root Causes	<ol style="list-style-type: none"> 1. Any main access door is actually open. 2. A number of electrical hardware failures in the door switch circuit (this includes intermittent issues). 3. Mechanical issues where door switch is not being made even though door is closed (this includes intermittent issues).
Possible CRU Replacements	<ul style="list-style-type: none"> • Module-to-Module communication cable • Module communication terminator • Library Control Blade
Possible FRU Replacements	Door Interlock Switch
Resolution	Perform “DR019: Door Open Diagnostic” on page 10-40.

T062: Frame Configuration Problem

Description	At boot time or run time the library physical frame configuration is not valid.
--------------------	---

Detection Scenarios	<ol style="list-style-type: none"> 1. Code determines that there is greater than one control module based on geographic address bits. 2. Code detects five frames or greater above the control module per the geographic address bits. 3. Code detects five frames or greater below the control module per the geographic address bits. 4. Code detects that one or more geographic address bit patterns do not match a valid configuration. 5. The code detects/communicates with a device (I/O Stations, power supplies, drives, blades, fan blades) that should not exist per the detected frame count and frame configuration. 6. Code determined frame configuration based on frame count and geographic address bit pattern does not match hard stops found by Y motion tests.
Root Causes	<ol style="list-style-type: none"> 1. Greater than one control module exists in a stack of frames wired together. 2. Five frames or greater are actually above the control module. 3. Five frames or greater are actually below the control module. 4. Hardware failure results in one or more invalid geo bit patterns. 5. Hardware failure results in one or more valid but incorrect geo bit patterns when compared to frame count (more frames detected than actual or less frames detected than actual).
Possible CRU Replacements	<ul style="list-style-type: none"> • Module-to-Module communication cable • Module communication terminator • Library Control Blade
Possible FRU Replacements	Internal Cables and Boards Kit
Resolution	Perform "DR010: Expansion Module Connectivity Diagnostic" on page 10-37.

T063: Cannot Read or Mismatch WWN Label

Description	<p>The library logic learns the library worldwide name (WWN) of the system by reading an internal WWN bar code label. This is done at first boot up from a "cleared to ship" condition in order to establish the WWN. It is also done on subsequent boot ups to verify that the persisted information on the library compact flash file system matches the physical library chassis. The library will report a problem when it cannot read the WWN or if it reads a WWN value that does not match the persisted library configuration. A different motion related problem will be reported if motion is preventing the proper reading of the WWN.</p>
--------------------	---

Detection Scenarios	<ol style="list-style-type: none"> 1. At first boot up from clear to ship, the library must establish the WWN for the first time. There may be no WWN in system memory at this point. 2. Any power up. System memory already has a WWN established for the Library Control Blade. 3. The Library Control Blade is improperly swapped into a different physical chassis and the system reads the physical chassis WWN label.
Root Causes	<ol style="list-style-type: none"> 1. The Library Control Blade has been swapped between libraries. 2. WWN label is damaged. 3. Bar code scanner is not working properly. 4. Entire communication path to bar code scanner is not working properly.
Possible CRU Replacements	Library Control Blade
Possible FRU Replacements	<ul style="list-style-type: none"> • Picker • Internal Cables and Boards Kit
Resolution	<p>Perform “DR007: Bar Code Scanner Diagnostic (a Library Verify Test)” on page 10-36.</p> <p>Before you replace a library component, refer to “Diagnosing a Problem” on page 9-2 for additional diagnostic procedures.</p>

T064: Library Control Blade hardware failure

Description	The library encounters an error which appears to be isolated to hardware on the Library Control Blade itself.
Detection Scenarios:	Code detects a board level voltage problem.
Root Causes:	Board level voltage problems.
Possible CRU Replacements:	Library Control Blade
Resolution	<ul style="list-style-type: none"> • Observe library component LEDs (refer to “Interpreting LEDs” on page 9-6. • Refer to instructions to remove and replace the Library Control Blade (see “Removing/Replacing the Library Control Blade and Compact Flash Card” on page 11-11).

T065: Library Control Blade robot power fuse (F3) blown (42 volt bus)

Description	The library detects that the 42V, F3 picker power fuse located on the LCB has blown.
Detection Scenarios	Monitoring of voltage divider indicates partial or complete voltage drop
Root Causes	<ol style="list-style-type: none"> 1. Board level hardware failures 2. Permanent or temporary short in cables, connectors, Picker 3. Various hardware failures in Picker that cause too much current to be drawn

Possible CRU Replacements	• Library Control Board
Possible FRU Replacements	Picker
Resolution	Perform "DR035: Robot Fuse Blown Resolution" on page 10-45

T066: Drive power fuse (F1) blown

Description	The library detects that an F1 drive fuse located on a Drive Sled Interface Board (DSIB) has failed. Each module has a DSIB card to provide an electrical connection point for the drive sleds. Each DSIB has a replaceable fuse for the overall drive power bus. This protects the core library hardware components from some type of short or over current problem in one or more drives.
Detection Scenarios	• Monitoring of voltage divider indicates partial or complete voltage drop
Root Causes:	1. Board level hardware failure 2. Permanent or temporary short circuit conditions in drives, drive sleds, docking connectors, etc.
Possible CRU Replacements	Tape Drive
Possible FRU Replacements	• DSIB fuse • Internal Cables and Boards Kit
Resolution	See "Contacting IBM Technical Support" on page 9-17.

T067: Display Assembly hardware failure

Description	The library encounters an error which appears to be isolated to Operator Panel hardware. This includes the Operator Panel board.
Detection Scenarios	No communication with operator panel board.
Root Causes	1. Board level hardware failures 2. Display not plugged in 3. Cable failure or not plugged in
Possible FRU Replacements	• Operator Panel • Internal Cables and Boards Kit
Resolution	Remove and replace the Operator Panel (see "Contacting IBM Technical Support" on page 9-17).

T068: Destination element for a move media is full

Description	The robot has attempted to put to a drive, I/O, or storage element and has determined that the element is full. This is distinctly NOT a SCSI illegal request situation. At the beginning of the move media, the library inventory has indicated that the destination element was in an empty state to allow it to be a valid destination. During recovery operations, the library has concluded that the cell is obstructed by a piece of media. Any failure that is not thought to be a piece of media in the destination should not be mapped to this ticket.
Detection Scenarios	The destination element for a move media is full with a LABELED cartridge. Library inventory does not know that the cell is full.
Root Causes	Inventory has not occurred since cartridge was placed in element by some manual operator intervention.
Possible CRU Replacements	Tape Cartridge
Resolution	Perform "DR020: Re-inventory the Library" on page 10-40.

T069: Source element for a move media is empty

Description	The robot has attempted to get from a drive, I/O, or storage element and has determined that the element is empty. This is distinctly NOT a SCSI illegal request situation. At the beginning of the move media, the library inventory has indicated that the source element was not in an empty state and it was a valid source for a move media command. During recovery operations, the library has concluded that the cell is genuinely empty. Empty is defined as NOT containing a cartridge with a readable volume serial number.
Detection Scenarios	The library fails to successfully get a cartridge during a move media. The cartridge present sensor in the Picker indicates no cartridge at the conclusion of a GET and a subsequent inventory scan of the cell indicates that no cartridge is present.
Root Causes	Inventory has been manually changed since last robotic inventory. Cartridge was removed from or moved within the system.
Possible CRU Replacements	Tape Cartridge
Resolution	Perform "DR020: Re-inventory the Library" on page 10-40.

T070: Logical library control path failed

Description	The library media changer control path through a drive has failed. The host that owns and runs the logical library can no longer be expected to be able to control the library. The control path must be fixed or a user could choose to switch the control path to a different drive within the same logical library.
--------------------	--

Detection Scenarios	<ol style="list-style-type: none"> 1. The loss of communications between the library and the drive sled 2. The loss of communications between the drive sled controller board and the drive brick.
Root Causes	<ol style="list-style-type: none"> 1. Various hardware problems inside the drive sled. 2. Drive firmware problem 3. Drive sled firmware problem 4. Library communication firmware problem 5. Drive Sled Interface Board (DSIB) hardware problem 6. Loss of power to sled (DSIB 48 V fuse)
Possible CRU Replacements	Tape Drive
Resolution	<ul style="list-style-type: none"> • Update drive firmware (see “Updating Drive Firmware” on page 7-11). • Update library firmware (see “Updating Library Firmware” on page 7-10). • If the problem still exists, replace the drive sled (see “Adding/Removing/Replacing a Drive Sled” on page 11-5).

T071: Power Supply not present

Description	The library can no longer detect the presence of a power supply that was previously physically installed and logically added to the system.
Detection Scenarios	Regular polling between LCB and power supply checks for presence of the power supply.
Root Causes	<ol style="list-style-type: none"> 1. Power Supply has been physically removed after being added to a powered ON system. 2. Hardware failure inside supply 3. Hardware failure in library side connector of other electronics.
Possible CRU Replacements	Power Supply
Resolution	Perform “DR022: Power Supply Not Present” on page 10-41.

T072: The system has reported an unmanaged fault

Description	Library firmware has reported a problem that is not associated with a specific ticket and corresponding diagnostic resolution. This problem cannot be resolved without escalation to tech support and engineering.
Resolution	Perform “DR021: Contact Service” on page 10-41.

T073: I/O Storage Door Open

Description	Certain IO doors can be designated as storage slots. When one of these doors is open, the system should not become operational because these storage slots would not be available to the robot. The ticket is posted as a means of informing the user that the library cannot become operational and that they should close the door so the system can lock it and start using it.
Detection Scenario	<ol style="list-style-type: none"> 1. When the main doors are closed and the robot attempts to initialize, the state of "I/O Storage Doors" will be checked. 2. When the library powers up and the robot attempts to initialize, the state of the "I/O Storage Doors" will be checked.
Root Causes	<ol style="list-style-type: none"> 1. I/O Storage door is left open by user. 2. Hardware failure in the I/O door open/closed sensing.
Possible FRU Replacements	<ul style="list-style-type: none"> • I/O Lock Assembly • I/O mechanism
Resolution	Perform "DR034: IO Storage Door Open Resolution" on page 10-44.

T074: Sled Auto-Leveling Failure

Description	The normal auto level process for a sled did not work. When a drive sled is inserted into a powered ON library or when a library powers ON, the firmware level of the drive sled is checked to be consistent with the level required by the main library firmware. If the level is not correct, the sled will be up-leveled or down-leveled accordingly. Failure in this process to set the correct firmware level in the sled results in this ticket.
Root Causes	<ol style="list-style-type: none"> 1. Physical interruption of the firmware down load process. 2. Firmware problems. 3. Hardware failures that result in intermittent or failed communication between library and drive sled.
Possible CRU Replacements	<ul style="list-style-type: none"> • Firmware • Drive sled
Possible FRU Replacements	Internal Cables and Boards Kit
Resolution	Perform "DR033: Drive Sled Auto Level Resolution" on page 10-44.

T075: Unsupported Module Configuration

Description	The current level of library firmware does not support the module configuration as detected by scanned module serial number labels. The causes for this ticket will likely change over time as new valid configurations are added to the system. At GA time, the firmware will allow 5U, 14U, and 23U configurations. It will specifically not run with anything greater than 23U or with a 10U configuration.
Detection Scenario	During initialization, the robot reads serial numbers on the chassis modules that are present that indicate a configuration other than a 5U, 14U, or 23U.
Root Causes	<ol style="list-style-type: none"> 1. The system really is an invalid configuration and all modules are labeled correctly. 2. A chassis module is not labeled correctly. 3. The firmware level loaded on the library does not support a valid configuration.
Possible CRU Replacements	Firmware
Possible FRU Replacements	Internal Cables and Boards Kit
Resolution	Perform "DR026: Unsupported Module Configuration" on page 10-42.

T076: Robot Initialization Failure

Description	This ticket is designed to notify the user if the robot cannot initialize at all.
Detection Scenario	<ol style="list-style-type: none"> 1. Any time the main door(s) closes and the robot goes through an initialization sequence. 2. At power up of the library if the main door(s) is closed.
Root Causes	<ol style="list-style-type: none"> 1. Complete loss of connection to robot (i.e. unplugged cable spool or equivalent). 2. Broken connection to y-motor 3. Numerous hardware failures on the picker assembly
Possible CRU Replacements	Library Control Blade
Possible FRU Replacements	<ul style="list-style-type: none"> • Picker assembly • Y-axis Assembly • Y-axis Cable Spool • Internal Cables and Boards Kit
Resolution	Perform "DR031: Robot Initialization Resolution" on page 10-43.

T077: I/O Station Partially Open or Unplugged

Description	This ticket is specifically designed to report the problem that would occur if the cable connecting any of the I/O stations is unplugged. Hardware limitations make it such that an unplugged I/O and a partially open I/O cannot be distinguished from one another. The default state of the open and closed door sensors is such that only the partially open state looks like the unplugged state (door not open + door not closed). The detection logic will check for this condition only at boot up to avoid triggering the ticket during any operational door open / close sequence.
Detection Scenario	Any time the library boots up it checks for the state of the I/O open and close sensors to see if there is a not open and not closed condition.
Root Causes	<ol style="list-style-type: none"> 1. I/O station is unplugged at boot up 2. I/O station is left in a not open and not closed state at boot up
Possible FRU Replacements	<ul style="list-style-type: none"> • I/O Station Lock assembly • Internal Cables and Boards Kit
Resolution	Perform "DR036: I/O Station Partially Open or Unplugged" on page 10-45.

T080: Control module serial number changed or chassis removed

Description	When the library powers ON and the robot initializes, the bar code serial number (SN) labels in each module are scanned by the robot beginning at the bottom of the library (closest to the y-axis home) and then working up. The library uses the control module (CM) SN and any expansion module SN to establish key operational properties and characteristics of library storage slots and partitions. A change in the CM SN or the removal of an EM (even if it is replaced with another EM) will "break" any already established partition in such a way that it must be deleted. This ticket was designed to notify the user that a condition exists that requires the deletion of a partition(s) and allow the user to assess whether perhaps human error is involved such as mixing the Library Control Blade's compact flash memory between libraries
Detection Scenario	At library power ON, the robot attempts to scan all module SN's. When SN's are discovered, they are compared to persistent data on the Library Control Blade's compact flash.

Root Causes	<ol style="list-style-type: none"> 1. A Library Control Blade is improperly swapped into a different physical chassis and the system reads the physical chassis label. 2. A CM chassis FRU is replaced in an already configured system 3. A previously detected and configured EM is removed completely from a vertical stack of modules. 4. A previously detected and configured EM is removed completely from a vertical stack of modules and replaced with another EM of similar OR different size and location.
Resolution	Perform "DR039: Logical Library Deletion Required" on page 10-45.

T082: Bar Code Scanner not operating

Description	The bar code scanner is detected to be in a state where the library control logic cannot use it. Library robot power is known to be applied (door is closed and robot is detected to be functioning enough to confirm power is applied) and yet scanner communication cannot be established at all or appears to be not healthy.
Detection Scenario	<ol style="list-style-type: none"> 1. During any library power ON or door close operation, Picker power is applied and bar code scanner communication is established. 2. During run time operations such as inventory where the bar code scanner is used.
Root Causes	<ol style="list-style-type: none"> 1. Scanner is physically disconnected 2. Various electrical hardware failures that prevent proper communication between the Library Control Blade and bar code scanner.
Possible CRU Replacements	Library Control Blade
Possible FRU Replacements	<ul style="list-style-type: none"> • Picker assembly • Y-axis assembly • Y-axis Cable Spool
Resolution	Refer to "DR021: Contact Service" on page 10-41.

T083: Robot Assembly not level

Description	The firmware has detected a condition that indicates the Robot Assembly (Y carriage + Picker) is not installed level within the system. The robot assembly has drive gears that mate with rack gears inside the library modules. There are field assembly problems and hardware failure problems that can cause the robot assembly to not be level and therefore not function properly.
--------------------	---

Detection Scenario	<ol style="list-style-type: none"> 1. The robot cannot move to its Y-axis parking position after homing in Y because the front of the Y Carriage hits the floor. Parking position is below homing position. 2. Front and back magazine fiducial positions on the left side are not at the same Y level. This test algorithm can detect non-level conditions in both directions (front high or back high). <p>Note: There are a few known false detection scenarios: Certain specific size obstructions sitting on the floor of the library. Magazines not seated correctly. Damaged fiducials that can be detected but are detected as mispositioned because they are damaged.</p>
Root Causes	<ol style="list-style-type: none"> 1. Robot drive gears not installed in Y racks at the same time. This can result in the two ends of the Y Carriage being 1 to 2 teeth out of synchronization. 2. Y racks not seated properly/evenly. Both the front and rear Y rack are intended to be released from their shipping latches and lowered such that the racks in the very bottom module rest on the floor of the unit. 3. There are hardware failure and assembly failure modes that can result in the front and rear drive gears on the Y Carriage being excessively out of phase with each other.
Possible FRU Replacements	<ul style="list-style-type: none"> • Y-axis Assembly • Internal Cables and Boards Kit
Resolution	Perform "DR041: Check Robot Installation" on page 10-46.

T084: Library managed cleaning cartridge is missing

Description	<p>When using the library to manage drive cleaning, the cleaning cartridges that are imported into the library are not visible to any host and are not part of any partition. Rather, they are in the "system" partition. Under all circumstances, the user should use the import and export cleaning cartridge functions to move cleaning cartridges into and out of the cleaning slots in this "system" partition. If the library becomes aware during inventory that a system cleaning cartridge has been removed manually (through an open door and/or with the power OFF) this ticket will be used to notify the user that this cleaning resource is now missing. Because the cartridge has gone missing, the library cleaning functionality is no longer in tact. It is either degraded (less cleaning cartridges available) or totally absent (no cleaning cartridge in the library).</p>
Detection Scenario	<ol style="list-style-type: none"> 1. When library inventory occurs during robot initialization from a power ON. 2. When library inventory occurs during robot initialization from a door close.

Root Causes	<ol style="list-style-type: none"> 1. User removes cartridge manually instead of via export cleaning media GUI functionality. 2. Bar code label on a system cleaning cartridge is not read during inventory. 3. Any scenario where a properly imported system cleaning cartridge which has not yet been properly exported is detected to be missing based on library inventory operations.
Possible CRU Replacements	Cleaning cartridge
Resolution	Perform "DR042: Import a Library Cleaning Cartridge" on page 10-46.

T085: Cleaning slot occupied by non imported cartridge

Description	When using the library to manage drive cleaning, the cleaning cartridges that are imported into the library are not visible to any host and are not part of any partition. Rather, they are in the "system" partition. Under all circumstances, the user should use the import and export cleaning cartridge functions to move cleaning cartridge into and out of the cleaning slots in this "system" partition. If the library becomes aware during inventory that an unexpected (non-imported) cartridge has been inserted into a cleaning slot manually (through an open door and/or with the power OFF) this ticket will be used to notify the user that this slot contains cartridge that cannot be used for cleaning. Because the cartridge was not imported as a cleaning cartridge, the library cleaning functionality is no longer in tact. It is either degraded (less valid cleaning cartridges available) or totally absent (no valid cleaning cartridge in the library).
Detection Scenario	<ol style="list-style-type: none"> 1. When library inventory occurs during robot initialization from a power ON. 2. When library inventory occurs during robot initialization from a door close.
Root Causes	<ol style="list-style-type: none"> 1. User adds a cartridge manually instead of via the import cleaning media GUI functionality. 2. Any time a cleaning slot is defined via the GUI functionality and there is a rogue, labeled cartridge in the slot. This can occur under door open conditions or covers off. 3. Any scenario where a bar code labeled cartridge ends up in a cleaning slot by means other than via the proper import GUI functionality.
Possible CRU Replacements	Cleaning cartridge
Resolution	Perform "DR042: Import a Library Cleaning Cartridge" on page 10-46.

T086: Inaccessible tape cartridge

Description	In library configurations of 23U or more, the two storage slots in the top row of the right side of the library (columns 4 and 5) become inaccessible to the library robot. When the vertical stack of library modules becomes 23U or higher, the robot is no longer adequately supported by the y-racks to get and put tape cartridges from these two specific storage slots. All other storage slots in the library remain accessible. This ticket is produced when a user manually inserts a cartridge into one of these slots and the library detects the cartridge during inventory. The library itself will not load a tape into one of these slots via host or operator panel commands. The slots themselves will not be presented as usable in library partitions. Although the library can not reliably get and put tapes from these storage locations, the library can still discover bar code labeled cartridges in these slots during normal inventory operations.
Detection Scenario	In libraries of 23U or greater, the library discovers a bar code labeled cartridge in one of the two top slots in column 4 or 5 during inventory.
Root Causes	A user manually places a cartridge in one of the top two slots of column 4 or 5 in a library that is at least 23U or greater.
Possible CRU Replacements	Cartridge
Resolution	Perform "DR050 Remove Cartridge from Invalid Location" on page 10-49.

Diagnostic Resolutions

Diagnostic Resolutions are accessed via wizard screens on the Operator Panel. When an Operator Intervention occurs, a diagnostic resolution wizard is available to help you resolve the problem.

DR001: Manually Recover Tape from Picker

<p>Problem:</p> <p>The library has a cartridge in the Picker but cannot recover without user intervention to remove the cartridge.</p>
<p>Troubleshooting Steps:</p> <ol style="list-style-type: none"> 1. Open the library main Access Doors. 2. Rotate the Picker by hand so that the opening faces the drives. 3. Use the gear thumb wheel on the right side of the Picker base closest to you to manually drive the cartridge out of the Picker towards the tape drives. 4. Close the library main Access Doors once the cartridge has been removed. Wait for the library to initialize. 5. Import the cartridge to the appropriate logical library via the host application. 6. Continue operations. <p>If there is no cartridge in the Picker when you investigate, it is likely that the cartridge present sensor in the Picker is malfunctioning.</p> <p>Before contacting IBM Technical Support, refer to "Diagnosing a Problem" on page 9-2 for additional diagnostic procedures.</p>

DR002: Manually Recover Tape from Source or Destination Slot

Problem

The library robot (Picker assembly) has failed during a move media. The cartridge must be manually recovered before operations should be continued.

Troubleshooting Step:

1. Open the main Access Door(s) and find the cartridge. It may be stranded between the Picker and the source or destination of the move.
2. Recover the cartridge.
3. Close the doors and wait for the system to complete initialization.
4. Use the **Tools** → **Service** → **Library** → **Robot** test to verify if the robot is operational.
 - If the test fails, refer to “Diagnosing a Problem” on page 9-2.
 - If the test passes, Close the Operator Intervention and continue operations and monitor for reoccurrence.

DR003: Drive Unload Diagnostic

Problem:

A tape drive did not unload a cartridge when it should have. Automatic recovery has failed. User intervention required.

Troubleshooting Steps:

1. Retry drive unload from host backup application.
2. Open the library Access Doors.
3. Push the blue unload button on the front of the drive. Remove the cartridge if it is ejected by the drive.
4. Import the drive into the appropriate logical library.

DR004: Manually Inspect Destination Element

Problem:

The library attempted to put a cartridge in a drive, storage, or the I/O Station. The destination location appears to be blocked or partially blocked. The library has successfully returned the cartridge to the source location.

Troubleshooting Steps:

1. Identify the coordinate provided in the Details of the ticket.
2. Open the library bulk load doors (*Access Doors*) and locate the problem location.
3. Inspect it for the presence of unlabeled media, or other contamination or damage that prevented the library robot from placing the cartridge.

DR005: Motion Failure Diagnostic (a Library Verify Test)

Problem:

The Picker has failed to perform a motion. The detected failure is likely to be a genuine hardware failure.

Troubleshooting Step:

1. Open the I/O Station door then the Access Door and look for any obvious problems such as unplugged cables or damage to the Picker.
2. Remove any tapes from the Picker or from the path of the Picker.
3. Close the doors and wait for the system to complete initialization.
4. Select **Tools** → **Service** → **Library** → **Robotics** to determine if the failure is permanent.
 - If the test fails, contact IBM Technical Support (see "Contacting IBM Technical Support" on page 9-17).
 - If the test passes, monitor for reoccurrence.

DR006: Drive Diagnostic (a Library Verify Test)

This tape drive diagnostic requires a blank, scratch cartridge.

Problem:

A drive is suspected of having a problem.

Troubleshooting Steps:

1. From the Operator Panel, select **Tools** → **Service** → **System**.
2. Touch **Yes** to take all logical libraries OFFLINE.
3. Select **Library**.
4. Select **Drive**.
5. Select the drive to be tested.
6. Place a scratch cartridge in the top slot of the top I/O Station, then close the I/O door.
7. When the **Assign I/O** screen is displayed, touch **System**, then **Next** to continue.
8. Touch **Next** to begin the test.
9. The scratch cartridge will be returned to the top slot of the top I/O Station and the results of the test will be displayed.
10. Touch **Exit** to return to the **Library Verify** screen.
11. Touch **Back** to return to the **System Diagnostics** screen.
12. Touch **Back** to return to the **Library Offline** screen.
13. Touch **No** to exit the "bring all logical libraries OFFLINE" screen.
14. Touch **Back** to return to the **Service Menu** screen.
15. Touch **Exit** to return to the **Tools** menu.
16. Touch the **Operations** tab, then touch the **Logical Library Mode** button to bring the logical libraries back ONLINE.

DR007: Bar Code Scanner Diagnostic (a Library Verify Test)

Problem:

The library has failed to scan one of the following system bar code labels:

- system serial number
- world wide name
- drive identification label
- module serial number

This problem IS NOT associated with failure to read a tape cartridge bar code label.

Troubleshooting Steps:

1. Select **Tools** → **Service** → **Library** → **Barcode** to help isolate the problem and determine if it is intermittent.
2. Run the test several times and note the results.
 - If the test passes, the failure is most likely with a particular bar code label.
 - If the test fails, the failure is most likely with the Picker Assembly that contains the bar code scanner. Contact IBM Technical Support (see “Contacting IBM Technical Support” on page 9-17).

DR009: AC Failure Diagnostic

Problem:

The facility AC power appears to be failed on a power supply. This can be the result of the facility power actually being OFF, the power switch on the power supply being turned OFF, or an actual failure in the power supply.

Troubleshooting Steps:

1. Check the facility AC power and the power supply power switch.
2. Correct them if necessary and Close the Operator Intervention.
3. If the facility AC power and the power supply power switch are OK, contact IBM Technical Support (see “Contacting IBM Technical Support” on page 9-17).

DR010: Expansion Module Connectivity Diagnostic

Problem:

The library requires two connectors to be plugged into two specific ports on the rear of the library in order to automatically detect its configuration. In a multi-module system, these plugs are placed in the expansion modules at the very top and bottom of the vertical stacking. In addition, cables must connect modules together.

Troubleshooting Steps:

Are the terminators and all module to module cables plugged in properly?

- **No** - You reported that the cables and terminators were not plugged in correctly. Power down the library, plug the cables in and power the library back on. When the library powers up, it should detect the presence of the cables and terminators and properly configure itself.
- **Yes** - Place both terminators on the CM to begin isolating the problem. You may back up or proceed with the Self Test.

– **Self Test Failed** - Self Test failed. Contact IBM Service to order replacement terminators. See product documentation to determine how to order parts.

– **Self Test Passed** - Self Test passed. Both terminators and the control module are working properly. Continue to isolate the failure by plugging the terminator into the first upper module and installing the module-to-module communication cable. Once the terminator and cables are installed, perform the Self Test again.

If there is no upper expansion module, select the **Next** button.

- **Self Test Failed** - Self Test failed. Contact IBM Service to order replacement cable or upper expansion module. See product documentation to determine how to order parts.

- **Self Test Passed** - Upper expansion module Self Test passed or there was no upper expansion module. Continue to isolate the failure by plugging the terminator into the first lower module and installing the module-to-module communication cable. Once the terminator and cables are installed, perform the Self Test again.

If there is no lower module, select the **Next** button.

• **Self Test Failed** - Self Test failed. Contact IBM Service to order replacement cable or lower expansion module. See product documentation to determine how to order parts.

• **Self Test Passed** - All self testing has passed. Problem is no longer detected.

The library must be power cycled for the module configuration to be fully invoked as the intended operating configuration.

DR011: I/E (I/O Station) Lock Diagnostic (a Library Verify Test)

Problem:

The library cannot lock or unlock the I/O Station in module *n*.

Troubleshooting Steps:

To proceed with troubleshooting the library should be taken out of service.

- All host operations should be quiesced by the user.
- All logical libraries should be taken offline.

It may take several minutes to achieve offline state for all partitions depending on host commands in progress.

Do you want to set all logical libraries to offline at this time?

- **No** - You have elected to troubleshoot at a later time. Ticket will remain open.
- **Yes** - Open all I/O Station doors. Select Self Test to trigger the library to verify all doors are open.
 - **Self Test Failed** - Test failed. Door *X* is not detected open. Replace I/O Station lock assembly.
 - **Self Test Passed** - Door open test passed.

Close all I/O Station doors. Select Self Test to trigger the library to verify all I/O Station doors are closed.

- **Self Test Failed** - Test failed. Door *X* is not detected closed. Replace I/O Station lock assembly.
- **Self Test Passed** - Door closed test passed.

Select Self Test to trigger the library to verify that all I/O station locks can be locked and opened.

- **Self Test Failed** - Test failed. Lock *X* is not opening and closing properly. Replace I/O Station lock assembly.
- **Self Test Passed** - Lock test passed.

Attempt to open all I/O Station doors to confirm that doors are locked.

Did any of the doors open?

- **Yes** - I/O Station door *X* opened when the lock should have prevented it. Replace I/O Station lock assembly.
- **No** - Doors locked shut test passed.

The system will now attempt to locate the I/O Station magazines with the robotics.

- **Self Test Failed** - I/O Station magazine *X* in I/O Station *Y* cannot be properly calibrated. Replace I/O Station lock assembly and magazine.
- **Self Test Passed** - All self tests have passed. The original problem has been resolved.

Ticket has been closed.

Monitor for reoccurrence.

DR012: Host Cabling Diagnostic

Problem:

A tape drive has detected a hardware type problem on the host interface. This can be caused by bad termination, loose cabling, improper connections, or other FC (Fibre Channel) or SCSI communication issues.

Troubleshooting Step:

1. If the drive is SCSI:
 - check for proper termination
 - check cable length meets SCSI limits
 - check host and drive connectors for bent or broken pins
 - secure host and drive connectors
2. If the drive is Fibre Channel:
 - check cable connections are secure
 - check for broken or pinched cables
 - check for cable bend radius too sharp
 - check cable connections are clean
3. Check all hardware components between host and drive are communicating correctly.
4. Check host HBA and components are communicating correctly.
5. If problem remains unresolved, before contacting IBM Technical Support, refer to “Diagnosing a Problem” on page 9-2 for additional diagnostic procedures.

DR014: Write Protect or WORM Diagnostic

Problem:

A back up application attempted to write data to a write protected or WORM cartridge.

Troubleshooting Step:

Determine whether the cartridge should be write protected or not.

If not, export the cartridge via your back up application and correct the problem by manually changing the write protect switch on the cartridge.

If the cartridge is correctly set as a “read only” tape, investigate your host application to determine why a write was attempted.

DR015: Unsupported Format Diagnostic

Problem:

A cartridge that is not a correct format has been loaded into a drive. There are several common scenarios:

1. FMR update cartridge loaded as a data cartridge
2. Cleaning cartridge loaded as a data cartridge
3. Data cartridge loaded as a FMR cartridge
4. Data cartridge loaded as a cleaning cartridge

Troubleshooting Step:

If the cartridge was loaded to the drive via the Library GUI, export the cartridge via the library **Operations** → **Media** → **Export** function. Import the proper type of cartridge for the desired operation and continue.

If the cartridge was loaded to the drive via a host application, export the cartridge via the host application. Import the proper type of cartridge for the desired operation and continue.

DR018: Manually Clean Drive

Problem:

A drive has reported that it requires cleaning. This problem should be addressed differently based on your system setup.

Troubleshooting Steps:

There are two cases to consider:

1. Library controlled or host controlled cleaning is enabled. When this problem is reported, the cleaning process should have already been triggered if there was a valid, not expired cleaning cartridge available. Normally you can close this problem and consider it as notification that a cleaning cycle of a cartridge has been consumed. Cleaning cartridges have a limited number of useful cycles. Consult the user information you received with your cleaning cartridge for specific cycle life information.
2. No automatic cleaning is enabled. The drive is in a state where it requires cleaning and can not be used for normal operations again until it is cleaned. The library provides a user prompted cleaning function where a cleaning cartridge can be imported into the library to perform a one-time clean operation. Consult your user documentation for instructions on how to perform a one-time clean operation or how to enable automatic cleaning on the library.

DR019: Door Open Diagnostic

Problem:

One of the library's main Access Doors has been opened.

There are two basic scenarios to recover from:

1. Door open DID NOT interrupt a library MOVE MEDIA.
2. Door open DID interrupt a library MOVE MEDIA.

Resolutions:

1. Door open DID NOT interrupt a library MOVE MEDIA.
If the door opening was planned and performed when the Picker was idle, recovery consists of simply closing the door. The library will re-inventory and trigger back up applications to resynchronize inventory.
2. Door open DID interrupt a library MOVE MEDIA.
If the door opening was not planned, MOVE MEDIA operations may have been interrupted. Check back up applications to make sure that no jobs have been interrupted. Follow the **Resolve** instructions for any other problems.

DR020: Re-inventory the Library

Problem:

The library has encountered a problem that indicates a mismatch between library inventory and host application inventory. A re-inventory of the library is required.

Troubleshooting Step:

Check for unlabeled media or media with a damaged label.

To trigger an inventory of the library, open and close one of the bulk load doors (*Access Doors*). The library will automatically notify host applications that the inventory status of the library has changed and host applications should synchronize to the new library inventory.

DR021: Contact Service

This Operator Intervention requires technical assistance from IBM. Please contact an IBM Service Representative by phone or web to open a Service Request.

In the USA: 800-IBM-SERV (1-800-426-7378)

All other countries/regions: <http://www.ibm.com>

To open a Service Request online: <http://www.ibm.com>

At the direction of IBM Technical Support, you may be asked to perform the following functions:

- Capture Snapshot (From the Web User Interface, select **Service Library** → **Capture Library Log**)
- Close Operator Intervention.

DR022: Power Supply Not Present

Problem:

A power supply is detected to be missing in the system. This is most likely caused by an actual removal of a power supply.

Troubleshooting Step:

If you have recently removed a power supply from the library, replace it and **Close** this Operator Intervention.

If all power supplies appear to be present, see “Contacting IBM Technical Support” on page 9-17 for possible power supply hardware replacement.

DR023: I/O Station Magazine Missing

Problem:

An I/O Station has been closed with a cartridge magazine missing. The library can still perform most operations; however, any attempt to export a cartridge to this I/O Station location will fail.

Troubleshooting Step:

1. If the magazine was intentionally removed, the only action required is to close this operator intervention.
2. If the magazine was removed by mistake, open the I/O Station and reinstall the magazine. Close the operator intervention.
3. If the magazine was installed when this problem was detected, refer to “DR021: Contact Service.”

DR024: Close IO Door

Problem:

An I/O Station door is open but the library requires it to be closed to continue operation.

Troubleshooting Step:

Close the I/O Station door and close the Operator Intervention.

DR026: Unsupported Module Configuration

Problem:

The library has detected a configuration of expansion module frames that is not supported by the current firmware. There are two possible scenarios:

- The configuration is valid and your system requires newer firmware to support the configuration.
- The configuration of EM's is not a valid configuration.

Troubleshooting Steps:

Contact IBM Technical Support (see "Contacting IBM Technical Support" on page 9-17) to determine why your module configuration is not supported.

DR027: Replace Library SN Label

Problem:

The library can not read one of the module serial number labels but has already validated that the bar code scanning system is working properly. There are two likely scenarios:

1. Line of sight from the scanner to the module serial number bar code label is blocked by foreign material such as a media bar code label.
2. The module serial number bar code label is damaged and the bar code scanner can not read it reliably.

Troubleshooting Steps:

1. Open the main library doors.
2. Look for and remove any obstructions in front of the module serial number bar code labels.
3. If no obvious foreign material is found, the module SN is damaged and the EM or CM will need to be replaced. The library is not operational until it can successfully read the bar code label. Contact Service for possible CM or EM replacement.

DR028: Motion Obstruction Diagnostic

Problem:

The library robot has failed to perform a motion. It appears that the motion has been obstructed by a foreign object or a misplaced cartridge.

Troubleshooting Steps:

1. Open the main Access Door(s) and look for any obvious foreign objects or tapes obstructing motion.
2. Look under the robot to make sure that there is no tape or other hidden obstruction on the floor of the library.
3. Close the doors and wait for the System to complete initialization.
4. Use the **Tools** → **Service** → **Library** → **Robot Test** to exercise the robot and verify that the obstruction is cleared.
 - If the test fails, contact IBM Technical Support for further troubleshooting. Refer to "Contacting IBM Technical Support" on page 9-17.
 - If the test passes, the obstruction is cleared. Monitor for reoccurrence.

DR029: Drive Communication Loss Resolution

Problem:

The system can no longer communicate with a drive sled.

There are a few scenarios that can create this problem.

1. A user removed a drive sled
2. A hardware failure that results in the drive appearing to be disconnected.

Troubleshooting Steps:

1. If the drive was intentionally removed, close this problem.
2. If the problem occurred during operation, make sure the sled was properly installed. Check the thumb screws on the drive to make sure they are tight and the drive is mounted flush to the library chassis.
3. Check for other problems. There are other problems such as T066-Drive Power Fuse Blown, that can cause drive communication loss.
4. If the steps above do not resolve the problem, replace the drive. Refer to “Adding/Removing/Replacing a Drive Sled” on page 11-5.

DR030: Drive Load Failure Resolution

Problem:

The robot was unable to load a tape drive. The robot motion completed normally but the drive did not report that it successfully loaded the tape.

There are two possible scenarios that can lead to this problem:

1. The drive hardware is not functioning properly.
2. The robot hardware is not functioning properly.

Troubleshooting:

1. The problem is most likely isolated to the specific drive referenced under the Details button. However, check for the same problem being reported for other drives in the system.
2. If this same problem is reported on multiple drives, contact IBM Technical Support.
3. If this problem is isolated to an individual drive, replace the drive. Refer to “Adding/Removing/Replacing a Drive Sled” on page 11-5.

DR031: Robot Initialization Resolution

Problem:

During a power ON or after closing library main access doors, the robot did not initialize properly.

A common cause for this problem is an unplugged cable that leads to the robot. Other permanent hardware failures that result in loss of connection to the robot can also be a root cause.

Troubleshooting Steps:

1. Open the library main access doors. This will allow access to the robot and remove power from the robot. Check for any obvious disconnected cables leading to the robot.
2. If any disconnected cables are discovered, plug them in and close all main access doors. The robot automatically attempt to initialize.
3. If no problem is found or the robot still fails, contact IBM Technical Support.

DR032: Control Path Failure Resolution

Problem:

A control path to a library has failed. It is likely that a drive sled failure is being reported as a separate problem.

In libraries with more than one drive you have the option to use an alternate drive as the control path if your host connection architecture permits it.

Changing the control path can be a temporary work around until the original drive problem is corrected OR a permanent change in your setup.

Procedure:

1. Use the functions under the **Setup> Control Path** menu to switch the control path.
2. Whether you change the control path or not, you may Close this problem.
3. Any associated drive problem must be resolved separately.

DR033: Drive Sled Auto Level Resolution

Problem:

The library has attempted to change the firmware level in a drive sled but the process failed.

Troubleshooting Steps:

1. Using the drive coordinate from the problem Details, identify the drive sled that failed.
2. After you have located the drive on the rear of the library, unscrew the thumbscrews and pull the drive out of the library completely for at least 30 seconds. Re-insert the drive and tighten the thumbscrews.
3. The library should now attempt to discover and initialize the drive again.
4. If this second attempt to establish the drive firmware level fails, contact IBM Technical Support (see "Contacting IBM Technical Support" on page 9-17).

DR034: IO Storage Door Open Resolution

Problem:

This library has an I/O station door that is configured to function as tape storage. This door was detected to be open at a time when the library needed it to be closed. The library cannot access these tape storage locations until this I/O door is closed and locked by the library.

Troubleshooting Steps:

There are two scenarios:

1. An I/O station door is genuinely open. If any I/O station doors are open, close them. Once the I/O station doors are closed, the library will automatically lock doors that are designated as storage. Close this operator intervention and monitor for reoccurrence.
2. There is a hardware failure that make it appear that an I/O station door is open. If all doors already appear to be closed, use the I/O station test under **Tools → Service → Library** to test the function of the I/O station.

DR035: Robot Fuse Blown Resolution

Problem:

The robot has momentarily pulled too much current. Circuit protection has occurred and a fuse may have blown or an internal power supply may have temporarily shut off.

Troubleshooting Steps:

1. In all cases, the picker should be replaced as the likely root cause of the over current condition. See “Contacting IBM Technical Support” on page 9-17.
2. In addition, if the fuse is blown on the LCB, the LCB will need to be replaced. See “Removing/Replacing the Library Control Blade and Compact Flash Card” on page 11-11.
3. Picker replacement occurs with the library power OFF. Prior to powering down the library, open a main Access Door and then Close this problem.
4. If this problem is reported again with the new picker installed and the library powered back up, then the LCB must be replaced.

DR036: I/O Station Partially Open or Unplugged

Problem:

The I/O station appears to have failed.

Possible Causes:

1. The I/O Station door may be partially open. If so, please close it.
2. The control cable to the I/O Station is unplugged.
3. There is a hardware failure that makes it appear that an I/O Station door is partially open.

Troubleshooting Steps:

1. If any of the I/O Station doors are partially open, close them.
2. If none of the doors is partially open, open the access door and look for the unplugged cable on the back of the lock assembly.
3. If none of the doors appear partially open and cables are connected, use the I/O Station test under the **Tools** → **Service** → **Library** menu to test the function of the I/O Station.
4. If problem persists, refer to “Contacting IBM Technical Support” on page 9-17.

DR039: Logical Library Deletion Required

Problem:

The system has detected a change in module configuration such as a new control module serial number or a removed expansion module that will invalidate any existing logical library(s). Although a logical library may be visible on the user interface, the assignment of storage slots and drives is broken due to the new module configuration.

Troubleshooting Steps:

1. Using the Operator Panel, navigate to **Setup** → **Logical Library** and delete any existing logical libraries.
2. Refer to “Creating Logical Libraries” on page 7-3 for more information.

DR041: Check Robot Installation

Problem:

The library has detected a condition that indicates the Robot Assembly has been installed incorrectly. The Robot travels on rack gears located at the front and rear of the library. If the Robot is installed into the rack gears with one end higher or lower than the other, the Robot may not function properly.

Troubleshooting Steps:

1. The installation of the Robot should be performed again to correct the problem. See the Library Maintenance Guide procedure for removing and replacing the Y-Axis assembly.
2. Prior to powering OFF the library to perform the procedure, close this operator intervention. When powering ON the library, monitor for reoccurrence.
 - If the operator intervention DOES NOT appear again, the problem has been corrected.
 - If the operator intervention DOES appear again, contact Service for further troubleshooting.

DR042: Import a Library Cleaning Cartridge

Problem:

While performing inventory, the library determined that a cleaning cartridge is missing.

This cleaning cartridge was originally imported via the library operator interface specifically for the library to use for cleaning tape drives. This cartridge is not managed by any host applications.

It is likely that this cartridge was manually removed while the library was powered OFF or when the main access door was opened.

Troubleshooting Steps:

1. You can determine the bar code label of the missing cleaning cartridge and the coordinate where it is used to be stored by selecting the **Details** button.
2. A valid cleaning cartridge should be imported into the library to allow cleaning operations to function properly.
3. If inspection of the cartridge slot shows the cartridge to be present, the bar code label is not being read reliably by the library. Replace the bar code label or the cartridge.

DR043: Invalid Cartridge in Cleaning Slot

Problem:

While performing inventory, the library determined that an invalid cartridge is occupying a cleaning slot.

In order for a cartridge to be a valid cleaning cartridge, it must be imported as a cleaning cartridge via the library operator interface.

It is likely that this invalid cartridge was manually inserted while the library was powered OFF or when the main access door was opened.

Troubleshooting Steps:

1. You can determine the bar code label of the invalid cleaning cartridge and the coordinate where it is located by selecting the **Details** button.
2. Open the library main access door(s) and remove this cartridge.
3. A valid cleaning cartridge should be imported into the library to allow cleaning operations to function properly.

DR044: Tape Alert 4 Media Error

Problem:

The tape cartridge is suspected due to failing tape operations. Data may be at risk based on the condition of the tape.

This problem may be caused by:

- the specific tape
- the specific drive
- the interaction of the tape and drive

Troubleshooting Steps:

1. You can determine the specific cartridge and drive involved in the problem by selecting the **Details** button.
2. Retry the operation with the same cartridge in the same drive.
3. If the retry attempt fails, copy data to a new cartridge.
4. Restart the current operation using a different cartridge.
5. If the problem remains unresolved, contact Service.

DR045: Tape Alert 5, 6 – Read/Write Failure

Problem:

A drive has detected a problem reading from or writing to a tape.

This problem may be caused by:

- the specific tape
- the specific drive
- the interaction of the tape and drive

Troubleshooting Steps:

1. You can determine the specific cartridge and drive involved in the problem by selecting the **Details** button.
2. Retry the operation with the same cartridge in the same drive.
3. If the retry attempt fails, try the operation to the same cartridge in a different drive.
4. If the cartridge fails in more than one drive, retire the cartridge.
5. If the cartridge tests OK, use a known good cartridge to test the drive by performing read/write operations from a host, or by using a drive-specific utility. Contact Service for information on a drive utility for your specific drive type.
6. If the problem persists, gather a drive log after the next occurrence of a Table Alert 5 or 6. Drive logs are pulled by using the Tools>Drive Operations>Retrieve Drive Log menu selection from the local operator interface. Contact Service and provide the drive log.

DR046: Tape Alert 8 – Suspect Data Grade Tape

Problem:

A drive has determined that a tape is not data grade and therefore data should not be written to it.

There can be several possible causes of this problem. Not all of the causes are genuine bad tapes, but in some cases a cartridge should be retired.

Troubleshooting Steps:

1. Attempting invalid operations with a cleaning cartridge may cause this problem. If the cartridge is a cleaning cartridge, remove it from the host application inventory of valid data cartridges.
2. If the cartridge is new, the tape may not have been formatted by the cartridge manufacturer. The drive will automatically attempt to format the tape. If successful, all other operations to the tape will continue without incident and this problem can be closed.
3. On LTO cartridges, the cartridge memory chip may be corrupted. Using host application utilities, force a read of the entire tape. When the tape is unloaded, the drive should repair the memory chip corruption. Monitor this cartridge for reoccurrence of a Tape Alert 8. Retire this cartridge if the problem occurs again.

DR047: Tape Alert 15 – Cartridge Memory Failure

Problem:

A drive has determined that a memory in cassette (MIC) has failed. This will reduce performance. The cartridge memory may be repairable.

Troubleshooting Steps:

1. Attempt to repair the cartridge memory by using host backup application utilities to read the entire tape. When the tape is unloaded, the cartridge may be able to repair the cartridge memory.
2. To verify that the cartridge memory is repaired, attempt to use the cartridge again for normal read/write operations. If this cartridge fails again, retire the cartridge.

DR048: Tape Alert 16 – Forced Reject

Problem:

A cartridge was manually ejected from a drive while it was actively reading or writing. This typically occurs when a user is servicing the drive and has not stopped all host operations to the drive.

Troubleshooting Steps:

1. Establish the cartridge back into the library inventory and host backup installation inventory.
2. Restart the operation.

DR049 Tape Alert 30, 31 – Drive Hardware Error

Problem:

The tape drive has detected an internal hardware error that requires a power cycle of the drive to recover.

Troubleshooting Steps:

1. Stop all additional host operations to this drive.
2. If a cartridge is still mounted in the drive, unload it using the host application or library operator interface.
3. Using the local library operator interface, take the drive offline with the **Operations → Drive → Change Mode** command.
4. Once the drive is offline, the blue LED on the rear of the drive should be turned on solid blue. At this point, remove the drive completely from the library for at least 1 minute.
5. Re-install the drive and wait for the normal drive LED states to be established:
 - green blink once per second
 - amber off
 - blue on solid (drive is offline)
6. Using the local library operator interface, take the drive online with the **Operations → Drive → Change Mode** command.
7. Attempt host operations again. If the drive fails immediately or the problem becomes chronic, contact Service.

DR050 Remove Cartridge from Invalid Location

Problem:

While performing inventory, the library determined that a cartridge is located in an invalid location. In any library 23U or taller, the two top slots in storage columns 4 and 5 can not be accessed by the robot and therefore can not be used for cartridge storage. It is likely that this cartridge was placed into the slot manually by a user. The library will not place cartridges into these slots based on host or user commands.

Troubleshooting Steps:

1. Select the Details button to determine the barcode label of the cartridge and the coordinate where it is located.
2. Open the main access door(s) and remove this cartridge. Columns 4 and 5 are on the right side of the library as you face it.
3. Close the door(s) and resume operations.

Chapter 11. Add, Remove, Replace Procedures

“Required Library State”

“Preparing a Library or Library Module for Repairs” on page 11-2

“Returning a Library or Library Module to Normal Operations after Repairs” on page 11-2

“Removing/Replacing a Power Supply (Primary and Redundant)” on page 11-2

“Adding/Removing/Replacing a Drive Sled” on page 11-5

“Removing/Replacing the Library Control Blade and Compact Flash Card” on page 11-11

“Removing/Replacing the Compact Flash Card” on page 11-14

“Library Conversions” on page 11-19

“Removing/Installing Library Foot Pads” on page 11-21

“Verifying Front and Rear Gear Racks Alignment” on page 11-22

Important: This library has mandatory CRUs (customer replaceable units). These CRUs are parts of the library that must be added, removed, and replaced by the customer. If a customer chooses to have the CRU added or removed/replaced by an IBM Service Representative, there will be a charge for the service.

Before ordering a replacement CRU, ensure that the following criteria is met:

- The failure is repeatable.
- A dump is captured for emailing to IBM Service.
 - Use the ITDT tool for drive dumps.
 - Use the Web User Interface (**Service Library** → **Capture Log**) for library dumps.

Before beginning a procedure, read and understand all related instructions.

Required Library State

Adding, removing, and replacing library components usually requires you to power OFF the entire library. There are a few components, however, that you can service without powering OFF the library. Instead, you may need only to take a certain logical library offline or you may not need to impact the status of the library at all.

Use the following table to determine the state that the library must be in before you begin servicing it.

Table 11-1. Library state required when servicing library components

Library Component	Required Library State
Library Control Blade	Power OFF
Power Supply	ON/Normal

Table 11-1. Library state required when servicing library components (continued)

Library Component	Required Library State
Storage Column	Power OFF
Drive	Power ON

Preparing a Library or Library Module for Repairs

1. If necessary, vary drives and logical libraries offline.
2. Power OFF the library.
 - If the library is idle:
 - a. Press the power button on the front panel of the control module.
 - b. Toggle each power supply switch to the OFF (O) position.
 - If the library is processing:
 - a. From the Operator Panel, select **Operations** → **Shutdown** to end the current library task and shut down the library's operating system.
 - b. When the library becomes idle, press the power button on the front panel of the control module.
 - c. Toggle each power supply switch to the OFF (O) position.

Returning a Library or Library Module to Normal Operations after Repairs

1. Power ON the library.
 - a. Toggle each power supply switch to the ON (I) position.
 - b. Press the power button on the front of the library.
2. If necessary, replace all tape cartridges in library or library module.
3. If necessary, vary drives and logical libraries online.

Removing/Replacing a Power Supply (Primary and Redundant)



Figure 11-1. Power supplies in a control module

- 1** Primary power supply **2** Redundant power supply

Library power is controlled at the individual power supplies and at the front panel of the library. The switch on the rear of each power supply controls power for the library (Note: Power supplies remained powered ON.). The button on the front of the control module controls power for all control module and expansion module power supplies.

A second (redundant) power supply helps ensure that your library does not lose power (and become inaccessible) if the primary power supply should happen to fail. The library automatically switches to the redundant power supply if the primary power supply fails for any reason.

A redundant power supply should be connected to a different AC circuit from the primary power supply. Even better, the redundant power supply should be connected to a separate power distribution source. In the event that the primary power supply fails or becomes unstable, the redundant power supply will automatically power the library as long as it is turned ON.

If your library has a redundant power supply, you can replace the primary power supply without powering OFF the library. If your library does not have a redundant power supply installed, the empty slot will be covered by a metal plate.

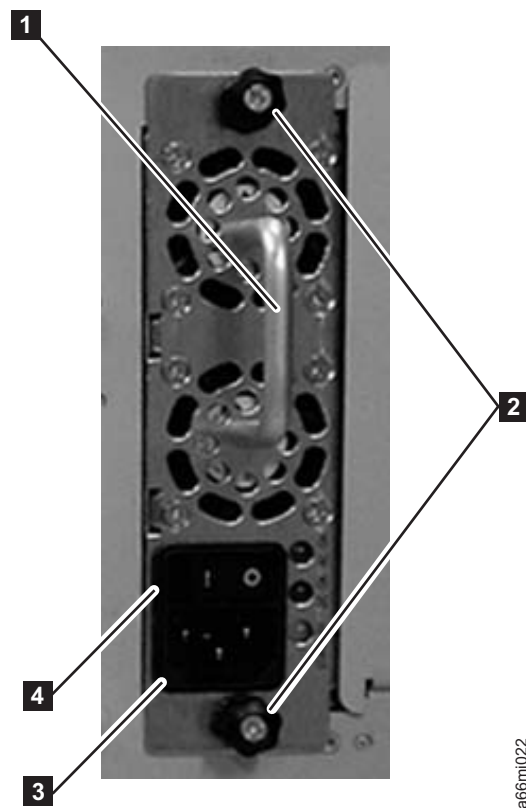

Figure 11-2. Power Supply

- | | | | |
|----------|--------------|----------|-----------------------|
| 1 | Handle | 3 | Power cord receptacle |
| 2 | Thumb screws | 4 | Power switch |

Removing a Primary Power Supply

1. Perform “Preparing a Library or Library Module for Repairs” on page 11-2.
2. Unplug each end of the power cord in the proper sequence.
Attention: First, disconnect the power cord from the power source. Then, disconnect the power cord from the power supply receptacle (**3** in Figure 11-2 on page 11-3).
3. Loosen the two thumb screws (**2** in Figure 11-2 on page 11-3) by turning them counterclockwise.
4. Grasp the handle (**1** in Figure 11-2 on page 11-3) and slowly pull the power supply toward you, while supporting it from underneath.
5. Install a metal cover plate over the vacant power supply slot if you are not immediately installing a replacement.

Replacing a Primary Power Supply

1. Grasp the handle (**1** in Figure 11-2 on page 11-3) while supporting the power supply from underneath. Then, line up the power supply with the guides in the slot, and carefully push the power supply into the library.
2. Tighten the two thumb screws (**2** in Figure 11-2 on page 11-3) by turning them clockwise.
3. Connect the power supply by plugging in each end of the power cord in the proper sequence.
Attention: First, connect the power cord to the power supply receptacle (**3** in Figure 11-2 on page 11-3). Then, connect the power cord to the power source.
4. Perform “Returning a Library or Library Module to Normal Operations after Repairs” on page 11-2.

Adding a Redundant Power Supply

1. Locate the vacant power supply slot and remove the metal plate by loosening the thumb screws.
2. Grasp the handle (**1** in Figure 11-2 on page 11-3) while supporting the power supply from underneath. Then, line up the power supply with the guides in the slot, and carefully push the power supply into the library.
Note: Make sure you insert the redundant power supply in the correct position, with its on/off switch located at the bottom, below the handle. The redundant power supply must be level to slide into the control module smoothly.
3. Tighten the thumb screws (**2** in Figure 11-2 on page 11-3) by turning them clockwise.
4. Plug in the power cord to the redundant power supply receptacle (**3** in Figure 11-2 on page 11-3).
5. Toggle the power switch (**4** in Figure 11-2 on page 11-3) to the | (ON) position.
6. Check the status of the redundant power supply’s LEDs. The top green LED and the blue LED should remain solidly lit until the library is powered on.
7. Power on the library using the power button on the front of the machine.
8. Check that status of the redundant power supply’s LEDs, and verify that the two green LEDs are solidly lit and that the blue LED is not lit.

Removing a Redundant Power Supply

1. Locate the slot for the redundant power supply to be removed on the back of the library.
2. Toggle the redundant power supply power switch (**4** in Figure 11-2 on page 11-3) to the **O** (OFF) position.
3. Unplug the power cord from the redundant power supply receptacle (**3** in Figure 11-2 on page 11-3).
4. Loosen the two thumb screws (**2** in Figure 11-2 on page 11-3) by turning them counterclockwise.
5. Grasp the handle (**1** in Figure 11-2 on page 11-3) and pull the power supply toward you. Support the component from underneath with your other hand.
6. Install a metal cover plate over the vacant redundant power supply slot if you are not immediately installing a replacement.

Adding/Removing/Replacing a Drive Sled

Tape drives mounted in sleds are installed into tape drive slots in the rear of the library.

Adding a New Drive

You might need to add a drive if you are adding a new logical library or a new host to your library.

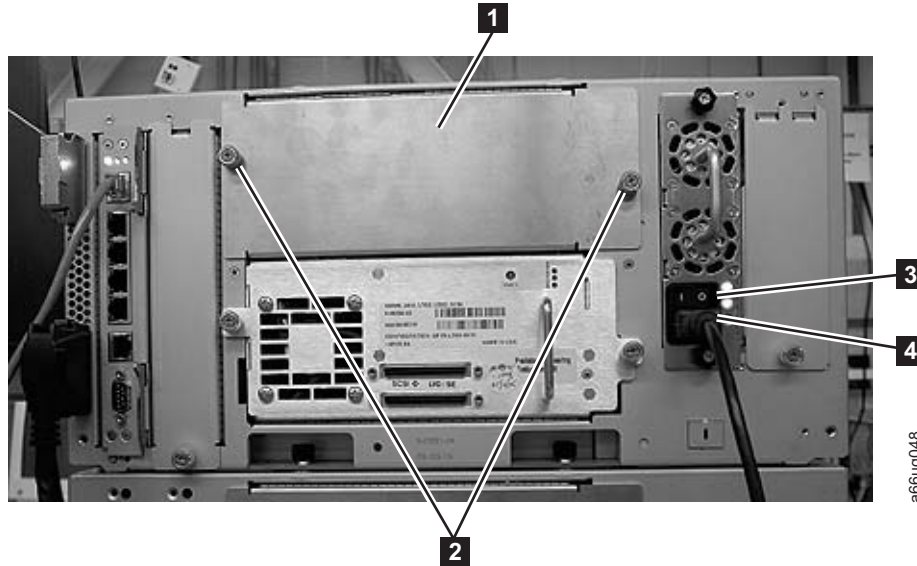

Figure 11-3. Control module with one SCSI drive and one cover plate

- | | | | |
|----------|--------------------------|----------|---------------------------|
| 1 | Drive slot cover plate | 3 | Power supply power switch |
| 2 | Cover plate thumb screws | 4 | Power supply power cord |

1. Perform “Preparing a Library or Library Module for Repairs” on page 11-2.
2. Disconnect the power supply by unplugging each end of the power cord in the proper sequence.

Attention: First, disconnect the power cord from the power source. Then, disconnect the power cord from the power supply receptacle (**4** in Figure 11-3 on page 11-5).

3. Remove the drive slot cover plate.
 - a. Locate the module's vacant drive slot. Detach the cover plate over the drive slot by turning the two thumbscrews (**2** in Figure 11-3 on page 11-5) counterclockwise to loosen them and then removing the cover plate (**1**).
Figure 11-4 shows a control module with one SCSI drive sled installed (**1**) and the empty drive slot exposed (**2**), after the cover plate has been removed.
 - b. Store the cover plate in a secure location. If you later decide to remove this drive, you will need to reinstall the cover plate.
4. Add the drive.

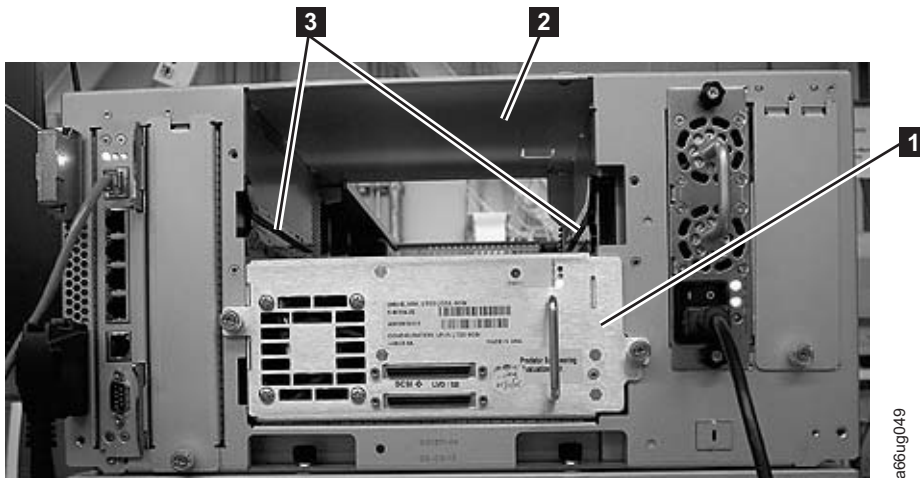

Figure 11-4. Control module with one SCSI drive installed and one open drive slot with cover plate removed

- 1** Installed drive **2** Available drive slot **3** Drive slot guide rails

- a. Insert the new drive sled into the empty drive slot. Use the guide rails on both the drive sled and in the drive slot (**3** in Figure 11-4), slowly slide the drive sled into the slot. The drive sled must be level to slide in smoothly.
 - b. When the drive sled is in place (**1** in Figure 11-5 on page 11-7), tighten the thumb screws (**2** in Figure 11-5 on page 11-7) by turning them clockwise to secure the drive to the module.
5. Put the library back online.

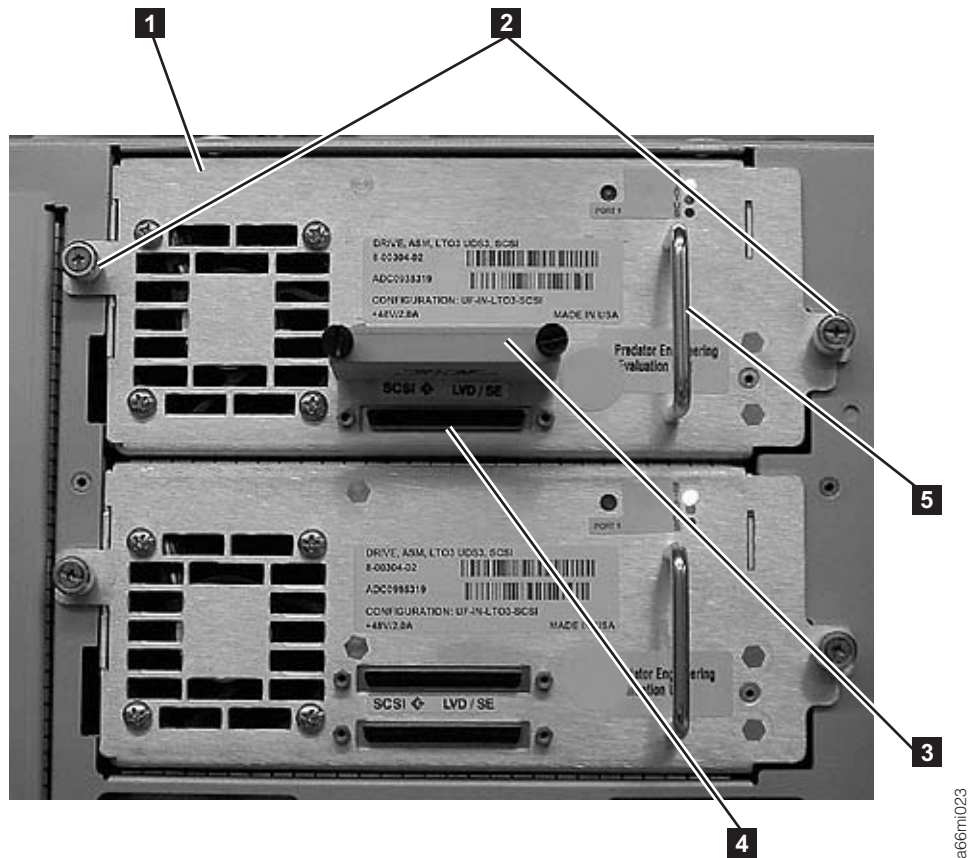

Figure 11-5. Control Module with two Drive Sleds

- | | | | |
|----------|--------------------|----------|-----------------|
| 1 | Tape drive | 4 | SCSI receptacle |
| 2 | Drive thumb screws | 5 | Drive handle |
| 3 | SCSI terminator | | |

Note: The thumb screws must be aligned with the screw holes in the module. If they are not aligned, the drive sled was not inserted correctly.

- a. Perform “Returning a Library or Library Module to Normal Operations after Repairs” on page 11-2
- b. Check the new drive’s LED to ensure that it functions correctly.

Note: Moments after you power on the library, when the library and drives are booting up, the green LED blinks once per second. When the drive is downloading library application code to the drive sled, the amber LED is solidly lit and both the blue and green LEDs flash once per second. Firmware begins to download as soon as the library detects a new drive. A firmware download typically take up to 25 minutes.

- c. Connect the host interface cables to the drive. In the example configuration shown in Figure 11-5, the bottommost SCSI connector (**4** in Figure 11-5) is being used to link the module to the host and the SCSI bus terminator is plugged in to the topmost connector (**3** in Figure 11-5).
- d. Vary the drive online.

- From the Operator Panel, select **Operations** → **Change Drive Mode**
- From the Web User Interface, select **Manage Drives** → **Change State of Drives**

Note: The library can use the drive immediately after the library application code has been downloaded.

- e. Verify the drive's firmware level by selecting **Tools** → **Drive Info** from the Operator Panel. If the drive does not have the appropriate firmware level, update it (see "Updating Drive Firmware" on page 7-11).

6. Add the new drive to a logical library. See "Deleting/Modifying a Logical Library" on page 7-3 and "Creating Logical Libraries" on page 7-3.

Note: The modify function is only available from the Web User Interface. If you are using the Operator Panel, you must delete the existing logical libraries and then create new logical libraries to utilize the new drives.

Removing a Drive Sled

Important: If removing more than one drive sled at a time, record the locations of each drive before they are removed. Ensure that the drives are reinstalled in the correct location.

1. Vary all drives offline from the host.
 - From the Operator Panel, select **Operations** → **Change Drive Mode**.
 - From the Web User Interface, select **Manage Drives** → **Change State of Drives**.

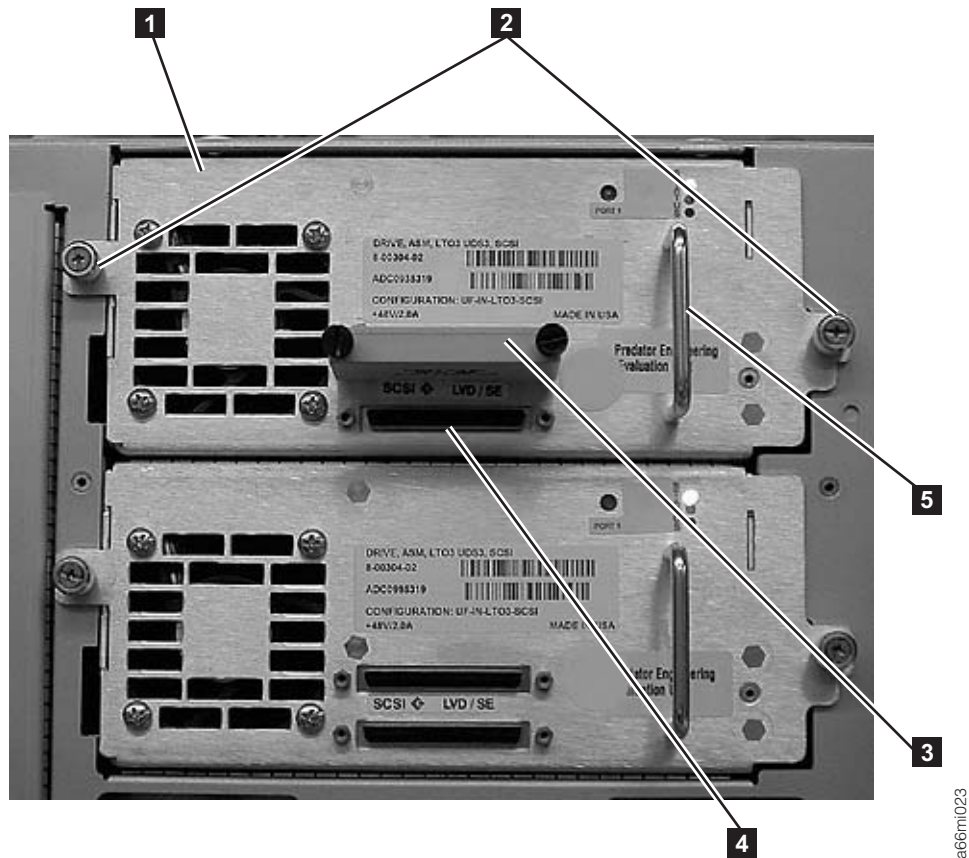

Figure 11-6. Drive sled (detail)

2. Disconnect the drive cable and place it on a flat surface in a secure location to avoid damaging the cable.
 - a. For a SCSI drive, loosen the two thumb screws that hold the SCSI cable and terminator in place by turning them counterclockwise. Disconnect the cable and terminator from the drive being removed.
 - b. For a Fibre Channel drive, unplug the fibre cable.
3. Loosen the two thumb screws (2 in Figure 11-6) that hold the drive in place by turning them counterclockwise.
4. Slide the drive out of the library module. Grasp the handle (5 in Figure 11-6) and slowly pull the drive toward you, while supporting the drive sled from underneath.

Replacing a Drive Sled

Attention: NEVER install a drive sled when a cartridge is in the drive in the eject position. Remove the cartridge first.

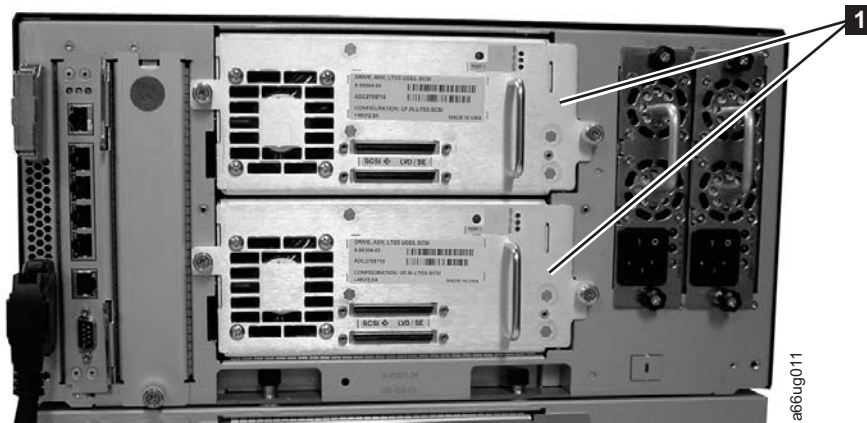

Figure 11-7. Control Module Drive Sled

1. Align the drive sled with the guide rails and guide slots along the tracks (**3** in Figure 11-8) in the open drive sled slot (**2** in Figure 11-8). Grasp the handle (**5** in Figure 11-6 on page 11-9) and slowly slide the drive sled into the CM, while supporting the drive sled from underneath.

Note: The thumb screws must be aligned with the screw holes in the module. If they are not aligned, the drive sled was not inserted correctly.

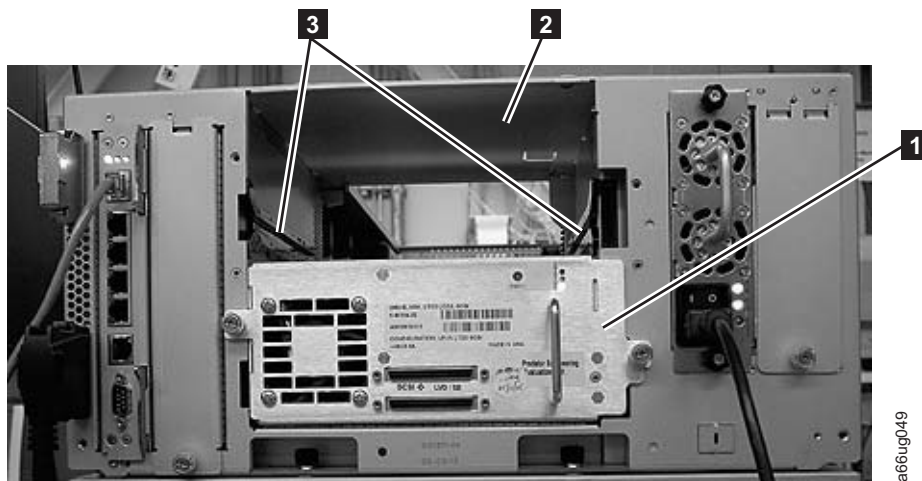

Figure 11-8. Drive sled slot

2. Tighten the two thumb screws (**2** in Figure 11-6 on page 11-9) that hold the drive sled in place by turning them clockwise.
3. Reconnect the drive sled cable.
 - a. For a SCSI drive sled, plug the cable and terminator into the drive sled. Tighten the thumb screws that hold the SCSI cable (**4** in Figure 11-6 on page 11-9 shows the SCSI receptacle) and terminator (**3** in Figure 11-6 on page 11-9) in place by turning them clockwise.
 - b. For a Fibre Channel drive sled, connect the fibre cable.
4. Repeat this procedure for all drives to be reinstalled in the library.
5. Vary all drives online from the host.

Removing/Replacing the Library Control Blade and Compact Flash Card

The Library Control Blade (LCB) manages the entire library, including the Operator Panel and picker assembly. It also runs system tests to ensure that the library is functioning properly.

The Compact Flash Card is housed on the LCB and contains the library vital product data (VPD) such as configuration settings. For information on removing and replacing this card, see “Removing the Compact Flash Card” on page 11-16 and “Replacing the Compact Flash Card” on page 11-18.

Removing the Library Control Blade (LCB)

Important: When handling the LCB, you must wear an ESD anti-static wrist strap, or touch the library frame to discharge any static electricity in your body. Do not handle the LCB without taking appropriate ESD precautions.

1. Perform “Preparing a Library or Library Module for Repairs” on page 11-2.
2. On the LCB (Figure 11-9 on page 11-12), disconnect the Ethernet cable (**2** in Figure 11-9 on page 11-12) by pinching the tab to disengage the cable, and then pull the connector out of the LCB.

Note: Six slots reside below the Ethernet cable. The four topmost slots are reserved for future use. The two bottommost slots are designated as Ethernet (**5** in Figure 11-9 on page 11-12) and serial (**6** in Figure 11-9 on page 11-12) ports, and are reserved for use by IBM Service Personnel.

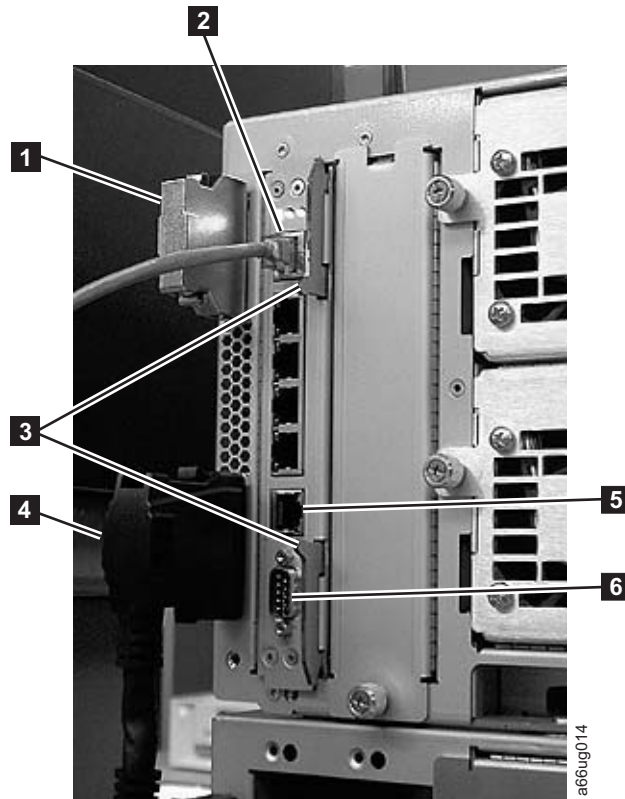

Figure 11-9. Library Control Blade (LCB)

- | | | | |
|----------|------------------------------------|----------|---|
| 1 | Module communication terminator | 4 | Module-to-module communication cable |
| 2 | Ethernet cable (customer supplied) | 5 | Ethernet port (for IBM service personnel use) |
| 3 | Latches | 6 | Serial port (for IBM service personnel use) |

3. Grasp the pair of latches (**3** in Figure 11-9) near the top and bottom of the LCB. Simultaneously push the latches to the left, and then pull them out and away from the LCB.
4. Simultaneously grasp the same pair of latches again, and slowly pull them toward you. As the LCB begins to slide out of the control module, be sure to support the LCB from underneath, being careful to touch only the metal cover and the ground plane.

Important: DO NOT touch any components on the LCB firmware board. Hold it by the metal cover and support it by the metal ground plane along the bottom edge.

5. Once the LCB has been removed from the control module, carefully lay it (Figure 11-10 on page 11-13) on a clean, flat surface.

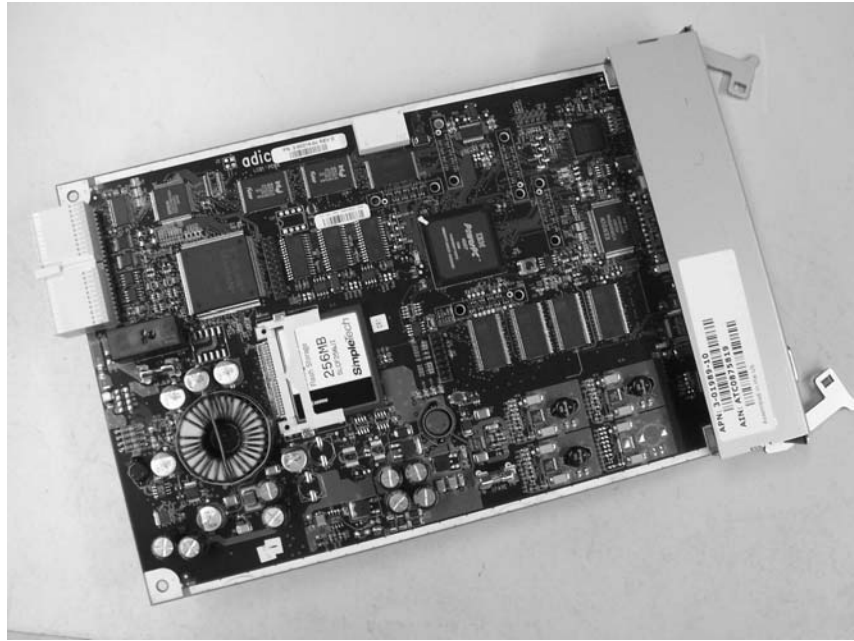

a66ug012

Figure 11-10. Library Control Blade (LCB)

Replacing the Library Control Blade (LCB)

Important: When handling the LCB, you must wear an ESD anti-static wrist strap, or touch the library frame to discharge any static electricity in your body. Do not handle the LCB without taking appropriate ESD precautions.

1. Unpack the new LCB and carefully lay it on a clean, flat surface.

Important: DO NOT touch any components on the LCB firmware board (see Figure 11-10). Hold it by the metal cover and support it by the metal ground plane only.

2. Locate the empty LCB slot on the rear panel of the control module (CM). Then, carefully line up the new LCB board along the guide slots, and gently slide it into the control module until the connector seats.

Important: As the LCB begins to slide into the control module, be sure to support the firmware board from underneath, being careful to touch only the metal cover and the ground plane along the bottom edge.

3. Grasp the pair of latches near the top and bottom of the LCB (**3** in Figure 11-11 on page 11-14) by pushing them in until they click into place.

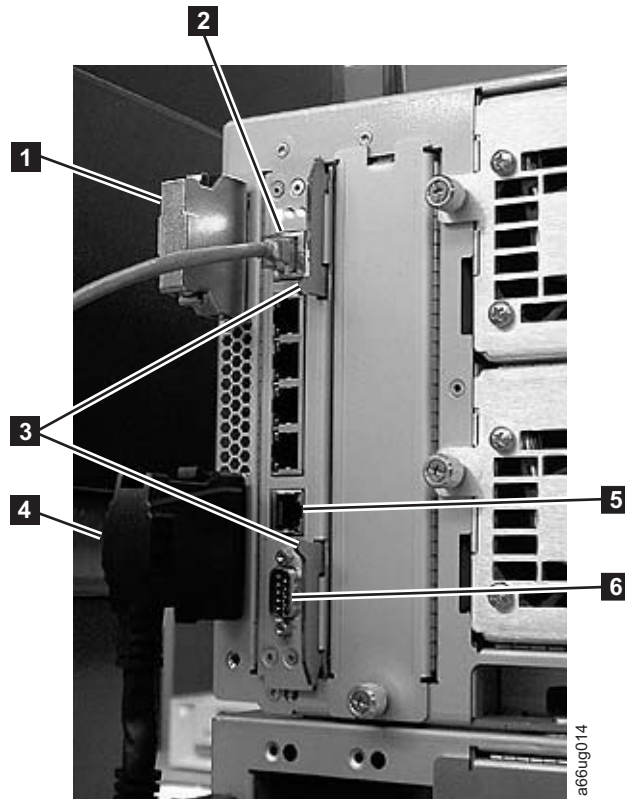

Figure 11-11. Library Control Blade (LCB)

- | | | | |
|----------|------------------------------------|----------|---|
| 1 | Module communication terminator | 4 | Module-to-module communication cable |
| 2 | Ethernet cable (customer supplied) | 5 | Ethernet port (for IBM service personnel use) |
| 3 | Latches | 6 | Serial port (for IBM service personnel use) |

- Reconnect the Ethernet cable (**2** in Figure 11-11) by pinching the tab and pushing the connector into the LCB.

Note: Six slots reside below the Ethernet cable. The four topmost slots are reserved for future use. The two bottommost slots are designated as Ethernet (**5** in Figure 11-11) and serial (**6** in Figure 11-11) ports, and are reserved for use by IBM Service Personnel.

- Perform “Returning a Library or Library Module to Normal Operations after Repairs” on page 11-2.

Removing/Replacing the Compact Flash Card

The compact flash card stores firmware and other important data that pertains to the drive and the library. The compact flash card is a component of a control module and resides on the Library Control Blade (LCB).

In Figure 11-12 on page 11-15, the area inside the white circle shows the location of compact flash card on the LCB. A close-up of the compact flash card (see **1** in Figure 11-12 on page 11-15) is shown in the detailed view of the same illustration.

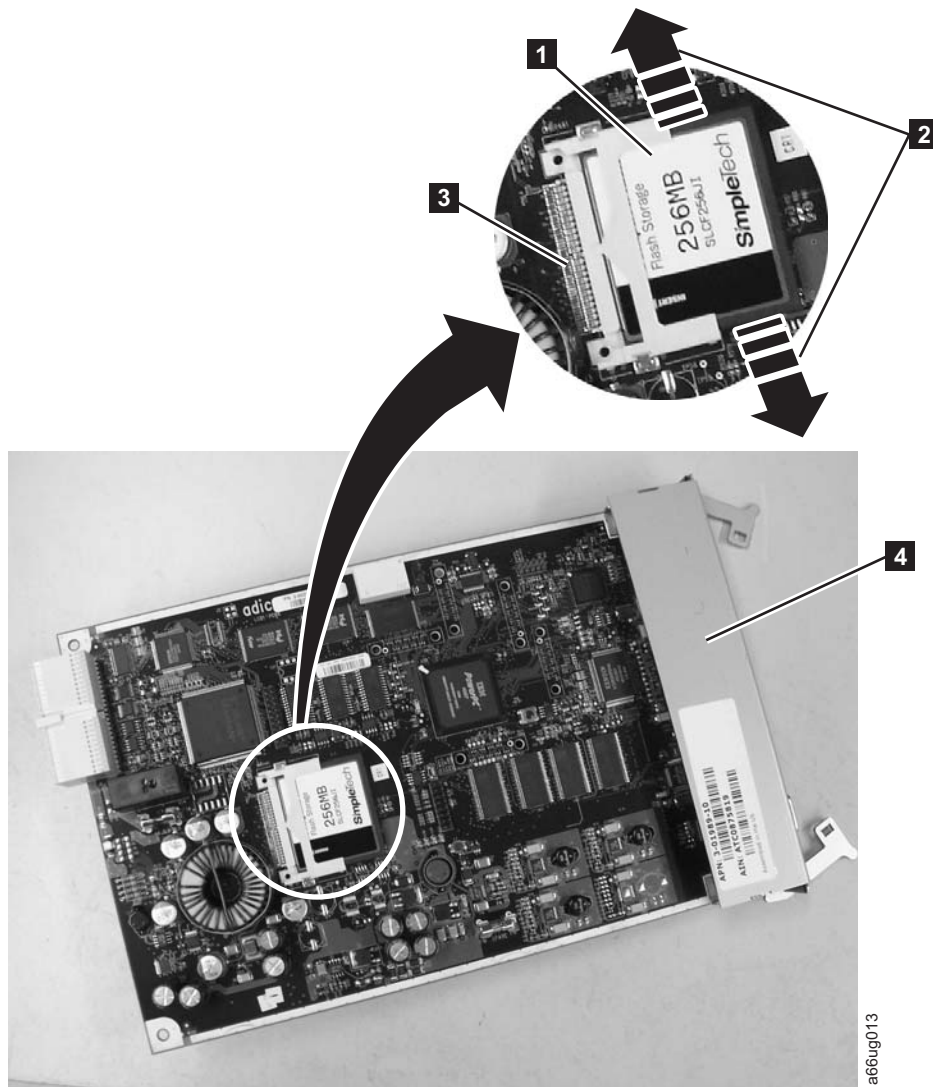

Figure 11-12. LCB with compact flash card

- | | | |
|---|---|--|
| <p>1</p> <p>Compact flash card</p> | <p>2</p> <p>Side-to-side motion required to remove card from Library Control Blade</p> | <p>3</p> <p>Card connector pins</p> |
|---|---|--|

The following information is stored on the compact flash card:

- the most current version of the library firmware
- the most current version of the drive firmware
- Vital Product Data (VPD)
- error log data
- a machine state "snapshot" the library saves when an error occurs

The drive firmware is retained on an EPROM on the drive. If a new drive with downlevel drive firmware is installed, the library automatically updates the new drive with the latest version of drive firmware, which is stored on the compact

flash card. The library boot code loads the library application firmware from the compact flash card to active RAM memory on power up.

In the event that the LCB malfunctions and needs to be replaced, the compact flash card must be removed from the old LCB and mounted on the replacement LCB.

Removing the Compact Flash Card

Important: When handling the Compact Flash Card, you must wear an ESD anti-static wrist strap, or touch the library frame to discharge any static electricity in your body. Do not handle the Compact Flash Card without taking appropriate ESD precautions.

Selections made during library configuration reside on the Compact Flash Card. Using the Appendix D, "Library Configuration Form," on page D-1, record all current library settings before removing the card. You will need this information to re-configure your library after replacing the card. Use the Operator Panel to re-configure your library.

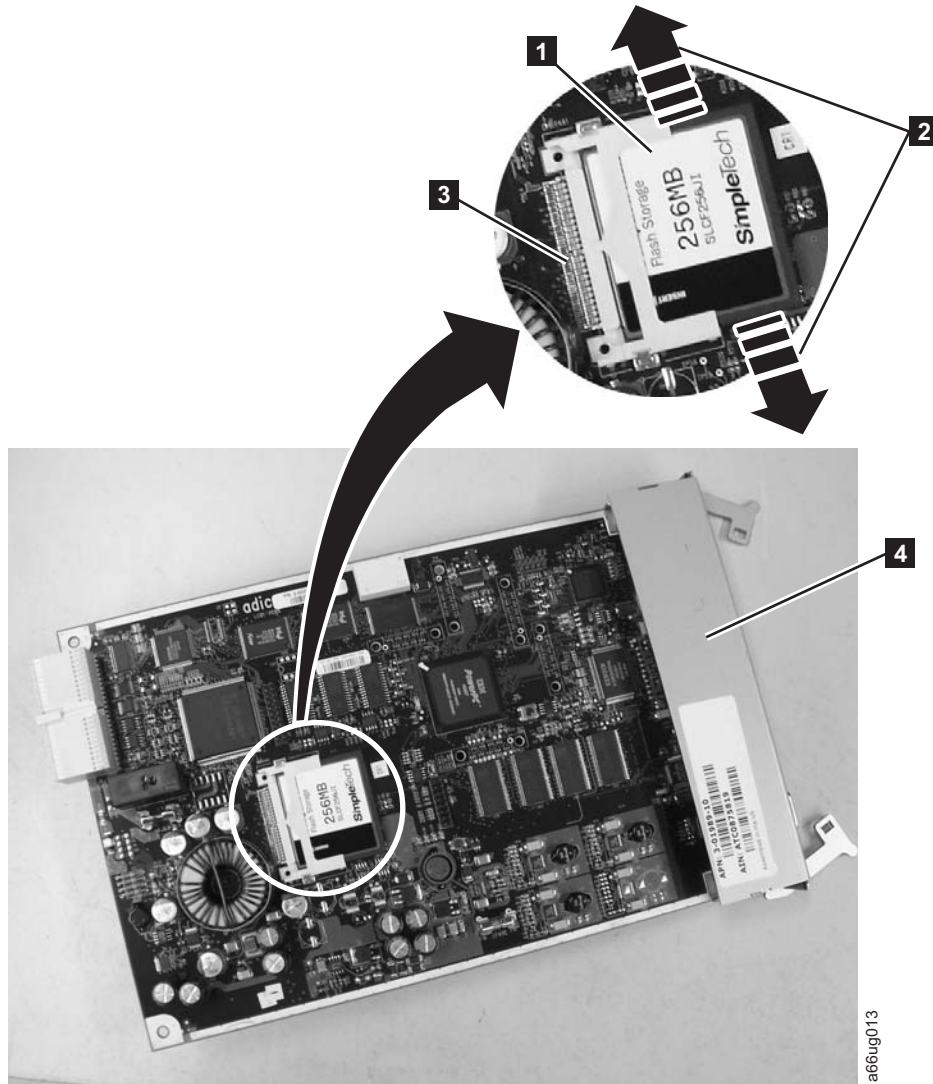

a66ug013

Figure 11-13. Removing the Compact Flash Card from the Library Control Blade

1. Ensure the library power is OFF. See “Preparing a Library or Library Module for Repairs” on page 11-2.
2. Remove the Library Control Blade (LCB). See “Removing the Library Control Blade (LCB)” on page 11-11) for detailed instructions.
3. Locate the compact flash card component on the LCB board (**1** in Figure 11-13).
4. Without touching any other components on the LCB firmware board, carefully grasp the compact flash card and wiggle it using a gentle, side-to-side motion (**2** in Figure 11-13) until the pins on the compact flash card become disconnected from the pins on the LCB board (**3** in Figure 11-13). Then, slowly slide the compact flash card out of the guide slots.
5. Carefully lift the compact flash card out of the LCB board and place it on a clean, flat surface.

Replacing the Compact Flash Card

Important: When handling the compact flash card, you must wear an ESD anti-static wrist strap or touch the library frame to discharge any static electricity in your body. Do not handle the compact flash card without taking appropriate ESD precautions.

Selections made during library configuration reside on the Compact Flash Card. Using the Configuration Form in the Setup and Operator Guide, record all current library settings before removing the card. You will need this information to re-configure your library after replacing the card. Use the Operator Panel to re-configure your library.

1. Locate the vacant slot for the compact flash card position on the Library Control Blade (LCB).
(See the area enclosed in the white circle in Figure 11-13 on page 11-17 for location).
2. Transfer the compact flash card to the new LCB board with the label up, and pins aligned. Without touching any other components on the LCB board, carefully grasp the compact flash card, and slowly slide it into the guide slots. Continue to push the compact flash card into the guide slots until the pins start to connect. Then hold the LCB board metal connector shield (4 in Figure 11-13 on page 11-17) with one hand and push the compact flash card into the connector with your other hand. The compact flash card should be firmly seated against the connector (3 in Figure 11-13 on page 11-17).

Note: The card is properly connected when no gold pins are visible.

3. Install the LCB board into the Control Module as directed in “Replacing the Library Control Blade (LCB)” on page 11-13.
4. Power ON the library and wait for it to initialize. This may take from 2 to 10 minutes, depending on the level of firmware on the Library. If the Compact Flash Card is new and has never been initialized, it contains a minimal level of library firmware which allows the library to boot up and display an Upgrade Notification message. In order to use the library, you must upgrade to the latest level of library firmware. See “Upgrading the Compact Flash Card Firmware.”

Upgrading the Compact Flash Card Firmware

If the Compact Flash Card is new and has never been initialized, it contains a minimal level of library firmware which allows the library to boot up and display an Upgrade Notification message. In order to use the library, you must upgrade to the latest level of library firmware. Use the following steps to upgrade firmware the first time you use a new Compact Flash Card.

1. Log on to the local operator panel as ADMIN. The “Network Configuration” screen will appear.
2. Turn OFF the DHCP selection.
3. Enter the IP Address, Subnet Mask, and Default Gateway selections.
4. Verify the Library Name selection.
5. Select Apply.
6. When the SUCCESS message appears, select CANCEL. This will log OFF from the local operator panel.
7. Log ON to the remote web browser as ADMIN. The Upgrade Notification message should display on the web console.

8. Click on the upgrade firmware link provided, then browse to locate the firmware file. See “Updating Library Firmware” on page 7-10 for detailed instructions.

Library Conversions

Refer to the following sections for library conversion instructions:

- “Desktop to Rack Mounted Library Conversion”
- “Rack Mounted to Desktop Library Conversion”

Desktop to Rack Mounted Library Conversion

Complete the following to convert your library from a desktop unit to a rack mounted unit.

1. Perform “Preparing a Library or Library Module for Repairs” on page 11-2.
2. Disconnect library cables.
 - a. Disconnect all power cords from the power source and the library.
 - b. Disconnect all drive cables.
 - c. Disconnect the Ethernet cable from the Library Control Blade.
3. Remove the library foot pads. For instructions, refer to “Removing/Installing Library Foot Pads” on page 11-21.
4. Install the library in the rack. For instructions, refer to “Installing Your Library in a Rack” on page 3-11.
5. Cable the library. For instructions, refer to “Step 3: Cabling the Library” on page 3-30.
6. Perform “Returning a Library or Library Module to Normal Operations after Repairs” on page 11-2.

Rack Mounted to Desktop Library Conversion

Complete the following to convert your library from a rack mounted unit to a desktop unit.

1. Perform “Preparing a Library or Library Module for Repairs” on page 11-2.
2. Disconnect library cables.
 - a. Disconnect all power cords from the power source and the library.
 - b. Disconnect all drive cables.
 - c. Disconnect the Ethernet cable from the Library Control Blade.
3. Reduce library weight. For instructions, refer to “Reducing Library Weight” on page 3-4.
4. Remove rack ears from all library modules.
 - a. Grasp the I/O Station handle and pull it toward you until it locks in the open position.
 - b. Remove the right rack ear (**2** in Figure 11-14 on page 11-20).

|

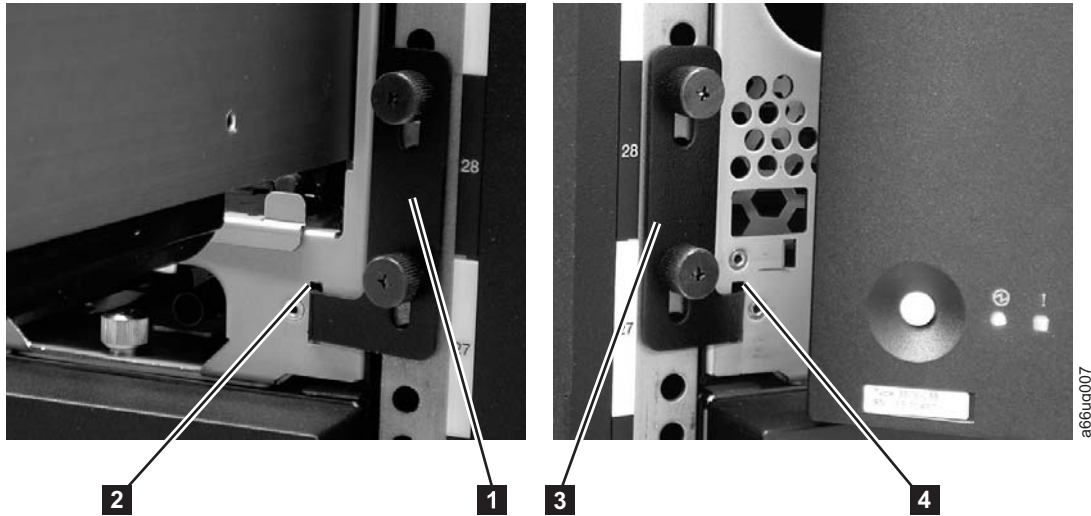

Figure 11-14. Removing the rack ears on a Control Module

- 1) Loosen the right rack ear thumb screws.
- 2) Remove the right rack ear.
- c. Remove the left rack ear (**3** in Figure 11-14).
 - 1) Open the left door of the library unit slightly.
 - 2) Grasp the hinged side of the door and, while pulling on the door, push right to expose the left rack ear.
 - 3) Loosen the left rack ear thumb screws.
 - 4) Remove the left rack ear.
- d. Repeat this process for all modules in the library.
5. Remove the library from the rack.

Note: Without drive sleds and power supplies, a 5U library (control module) weighs approximately 50 lbs., and a 14U library (control module + 9U expansion module) weighs approximately 110 lbs.

- a. With a person on each side of the library, slide it out of the rack. You may prefer to slide each unit of a multi-unit library out of the rack separately.
- b. Place the unit on a sturdy work surface to repair.
6. Install library foot pads. For instructions, refer to “Removing/Installing Library Foot Pads” on page 11-21.
7. Install the library components removed for weight reduction. For instructions, refer to “Installing Library Components Removed for Weight Reduction” on page 3-28.
8. Cable the library. For instructions, refer to “Step 3: Cabling the Library” on page 3-30.
9. Perform “Returning a Library or Library Module to Normal Operations after Repairs” on page 11-2.

Removing/Installing Library Foot Pads

If your library is currently rack mounted, foot pads must be installed on the bottom of the library chassis before the library can be used as a desktop unit. If your library is currently being used as a desktop unit, foot pads will be installed on the bottom of the library. Foot pads must be removed before the library can be installed in a rack.

- “Removing Library Foot Pads”
- “Installing Library Foot Pads” on page 3-10

Removing Library Foot Pads

To remove the library foot pads:

1. Place the sling that was shipped with your library underneath the library halfway between the front and back feet. Ensure that both sling handles are an equal distance from the sides of the library. Use of the sling is strongly recommended for a 9U module. A 5U module is much lighter in weight, and it may not be necessary to use the sling.
2. Being very careful, lay the library on its side.
3. Using a #2 Phillips screwdriver, remove the foot pads attached to the bottom of the library. Store these parts for future use.
4. Carefully return the library to an upright position on top of the sling.

Installing Library Foot Pads

To install the library foot pads:

1. Place the sling that was shipped with your library underneath the library halfway between the front and back feet. Ensure that both sling handles are an equal distance from the sides of the library. Use of the sling is strongly recommended for a 9U module. A 5U module is much lighter in weight, and it may not be necessary to use the sling.
2. Being very careful, lay the library on its side.
3. Using a #2 Phillips screwdriver, install the foot pads on the bottom of the library chassis. See Figure 3-10 on page 3-11 for foot pad locations.

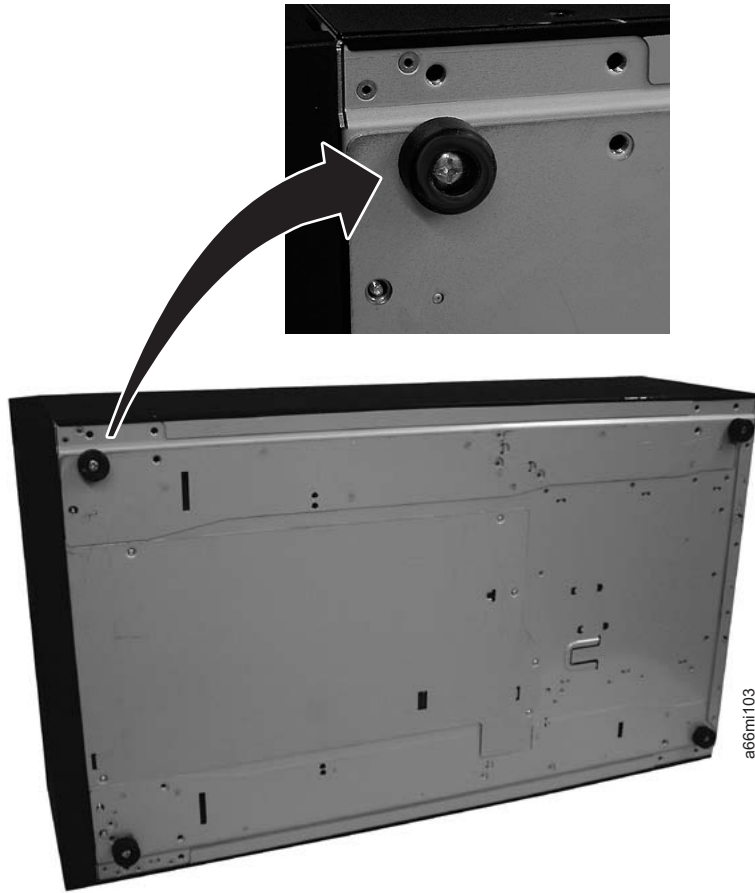

Figure 11-15. Foot pad Locations

4. Carefully return the library to an upright position.
5. Use the lifting sling to place the library module in the desktop location.
6. When you finish these desktop installation steps, store the installation sling in a secure location for possible future use. Then continue the library installation with the instructions on “Enabling the Picker Assembly” on page 3-27.

Verifying Front and Rear Gear Racks Alignment

In order for the picker to move from one unit to the next in a multi-module library, the front (**3** in Figure 11-16 on page 11-23) and rear (**1** in Figure 11-16 on page 11-23) gear racks in the control module must be properly aligned with the gear racks in the expansion module.

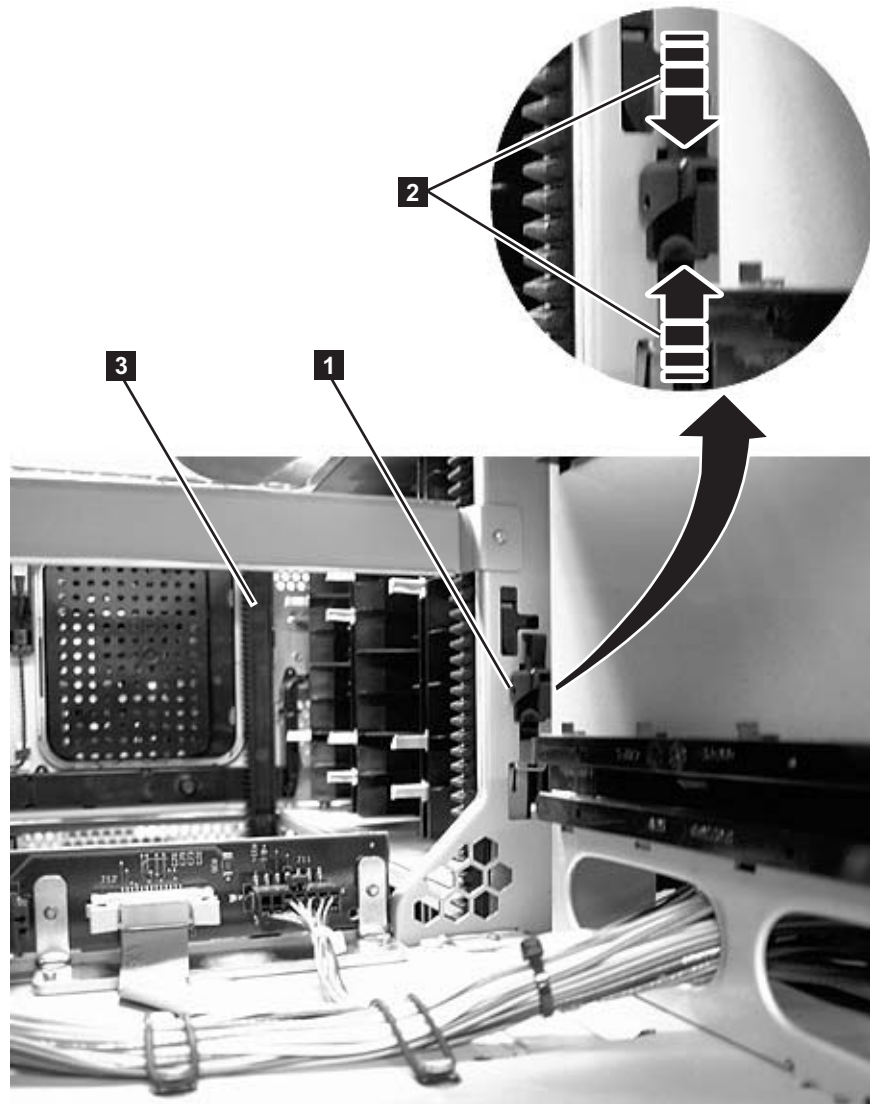

Figure 11-16. Gear rack

- | | | |
|--|---|---------------------------------|
| <p>1 Rear gear rack locking mechanism</p> | <p>2 Magnification of rear gear rack locking mechanism</p> | <p>3 Front gear rack</p> |
|--|---|---------------------------------|

Verify that the front (**3** in Figure 11-16) and rear (**1** in Figure 11-16) gear racks are properly aligned and positioned.

- In a control module, verify that the gear racks are in the down position. Pinch the gear rack locking mechanism (**2** in Figure 11-16) and push the gear rack down. Ensure that the lock is not engaged in the hole in the frame.
- In an expansion module:
 - Verify that the gear racks are in the down position. Pinch the gear rack locking mechanism (**2** in Figure 11-16) and push the gear rack down. Ensure that the lock is not engaged in the hole in the frame.
 - Verify that there are no gaps in the gear racks between library units.

To align the gear racks in a multi-module library:

1. Slightly push up and pinch the gear rack locking mechanism (**1** in Figure 11-16 on page 11-23) to unlock the gear rack in the control module.
2. While pinching the gear rack locking mechanism (**2** in Figure 11-16 on page 11-23), push the gear rack down until it aligns with the gear rack in the expansion module, then release your hold on the locking mechanism.
3. Manually inspect the track to ensure there are no gaps.
4. Repeat Steps 1 through 3 for the other gear rack.
5. Manually raise the picker and disengage the picker locking mechanism (**1** in Figure 11-17) if necessary. If the gear racks are properly aligned, the picker will slowly move to the bottom of the library.



Figure 11-17. Picker assembly locking mechanism

Chapter 12. Parts List

Customer Replaceable Unit (CRU) parts list

To order CRU parts, contact your IBM Sales Representative.

For information on ordering media, refer to “Ordering Media Supplies” on page 8-18.

Important: This library has mandatory CRUs (customer replaceable units). These CRUs are parts of the library that must be added, removed, and replaced by the customer. If a customer chooses to have the CRU added or removed/replaced by an IBM Service Representative, there will be a charge for the service.

Before ordering a replacement CRU, ensure that the following criteria is met:

- The failure is repeatable.
- A dump is captured for emailing to IBM Service.
 - Use the ITDT tool for drive dumps.
 - Use the Web User Interface (**Service Library** → **Capture Log**) for library dumps.

CRU Type	Description	Feature Code	CRU Part Number
Assemblies	LTO Ultrium Gen 3 LVD Ultra160 drive sled	8037	23R6182
	LTO Ultrium Gen 3 2 Gb Fibre drive sled	8038	23R2601
	LTO Ultrium Gen 3 4Gb Fibre drive sled	8042	23R6450
	Power Supply	1900	23R2582
	Library Control Blade	—	23R6165
	Library Control Blade Compact Flash Memory Card	—	23R7301
	Rack Mount Kit	7003	—
License Keys	Capacity Expansion	1640	—
	Path Failover	1682	—
Terminators & Wrap Plugs	Terminator, LVD multi-mode	—	19P0874
	Terminator, Module Communication	—	23R2603
	LVD SCSI Wrap Tool	—	19P0481
	Fibre Wrap Tool	—	11P3847
Interposers	Interposer, LC-SC fibre cable	—	18P8689
	Interposer, VHDCI/HD68 SCSI cable	—	19P0482

CRU Type	Description	Feature Code	CRU Part Number
Miscellaneous	Cable, Module-to-Module Communication	—	23R2602
	Cable, RJ45 Ethernet Crossover	—	23R3663
	Cover, top for control module and expansion module	—	23R2594
	Cover, side for 5U control module	—	23R2595
	Covers, side for 9U expansion module	—	23R2596
	Cover plate for fan slot	—	23R2604
	Cover plate for empty Power Supply slot	—	23R2606
	Cover plate for empty drive slot	—	23R2605
	Library and Drive Firmware Update (by an IBM Service Representative)	0500	—
	Rack ears	—	23R3349
	Rack Power Distribution Unit (PDU) power cord	9848	35M5378
	Foot pads	—	23R2599
SCSI Cables, HD68/HD68	0.4 m	—	23R6408
SCSI Cables, VHDCI/HD68	2.5 m	—	19P3841
	4.5 m	—	19P3594
	10 m	—	19P3593
Fibre Cables, LC-LC	5 m	—	12R9914
	13 m	—	12R9559
	25 m	—	12R9915

Power Cords and Receptacles

Figure 12-1 on page 12-3 shows the plugs that are used by the power cords in Table 12-1 on page 12-3. Match the index number that is beside each plug to the index number in the table.

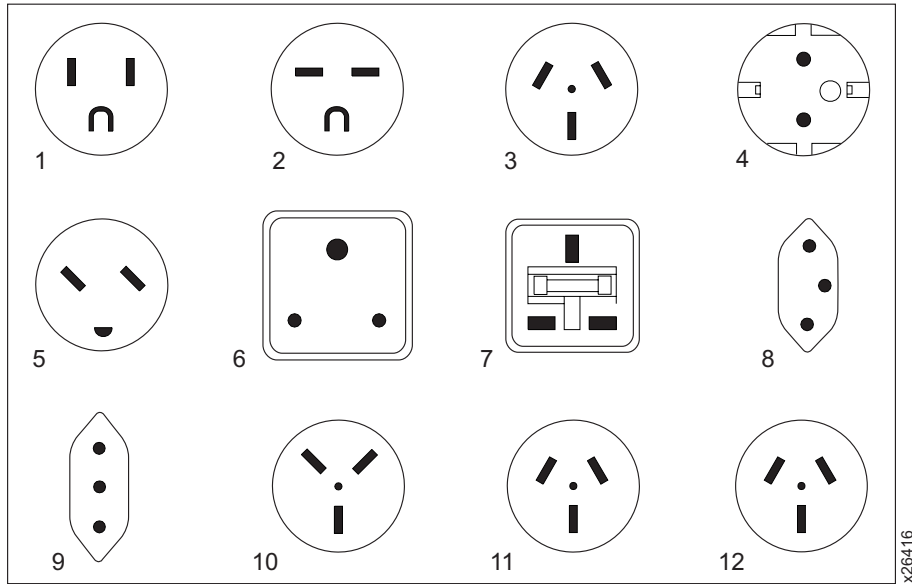

Figure 12-1. Types of Power Cord Receptacles

Table 12-1. Power Cords

Description, Feature Code (FC), and Part Number (PN)	Plug Standard Reference	Country or Region	Index Number in Figure 12-1
US/Canada <ul style="list-style-type: none"> • 2.8 m, 125V • FC 9800 • PN 39M5081 • (See Note) 	NEMA 5-15P	Aruba, Bahamas, Barbados, Bermuda, Bolivia, Brazil, Canada, Cayman Islands, Colombia, Costa Rica, Curacao, Dominican Republic, Ecuador, El Salvador, Guatemala, Guyana, Haiti, Honduras, Jamaica, Japan, Liberia, Mexico, Netherlands Antilles, Nicaragua, Panama, Peru, Philippines, Saudi Arabia, South Korea, Suriname, Taiwan, Trinidad Tobago, Venezuela, US	1
Chicago <ul style="list-style-type: none"> • 1.8 m, 125 V • FC 9986 • PN 39M5080 	NEMA 5-15P	Chicago, U.S.A.	1

Table 12-1. Power Cords (continued)

Description, Feature Code (FC), and Part Number (PN)	Plug Standard Reference	Country or Region	Index Number in Figure 12-1 on page 12-3
US/Canada <ul style="list-style-type: none"> • 2.8 m, 250 V • FC 9833 • PN 39M5095 	NEMA 6-15P	Aruba, Bahamas, Barbados, Bermuda, Bolivia, Brazil, Canada, Cayman Islands, Costa Rica, Curacao, Dominican Republic, Ecuador, El Salvador, Guatemala, Guyana, Haiti, Honduras, Jamaica, Japan, Liberia, Netherlands Antilles, Nicaragua, Panama, Peru, Philippines, Suriname, Taiwan, Thailand, Trinidad Tobago, Venezuela, US	2
Australia <ul style="list-style-type: none"> • 2.8 m, 250V • FC 9831 • PN 39M5102 	AS 3112 NZS 198	Argentina, Australia, China, Colombia, New Zealand, Papua New Guinea, Paraguay, Uruguay, Western Samoa	3
France, Germany <ul style="list-style-type: none"> • 2.8 m, 250V • FC 9820 • PN 39M5123 	CEE 7 - VII	Afghanistan, Algeria, Andorra, Angola, Aruba, Austria, Belgium, Benin, Brazil, Bulgaria, Burkina Faso, Burundi, Cameroon, Central African Republic, Chad, Congo-Brazzaville, Curacao, Czech Republic, Democratic Republic of Congo, Denmark, Egypt, Finland, France, French Guiana, Germany, Greece, Guinea, Hungary, Iceland, Indonesia, Iran, Ivory Coast, Jordan, Kenya, Korea, Lebanon, Luxembourg, Macau, Malagasy, Mali, Martinique, Mauritania, Mauritius, Monaco, Morocco, Mozambique, Netherlands, Netherlands Antilles, New Caledonia, Niger, Norway, Poland, Portugal, Romania, Russia, Saudi Arabia, Senegal, Spain, Sweden, Sudan, Syria, Togo, Tunisia, Turkey, Yugoslavia, Zaire, Zimbabwe, Vietnam	4
Denmark <ul style="list-style-type: none"> • 2.8 m, 250V • FC 9821 • PN 39M5130 	DK2-5A	Denmark	5

Table 12-1. Power Cords (continued)

Description, Feature Code (FC), and Part Number (PN)	Plug Standard Reference	Country or Region	Index Number in Figure 12-1 on page 12-3
South Africa <ul style="list-style-type: none"> • 2.8 m, 250V • FC 9829 • PN 39M5144 	SABS 164	Bangladesh, Burma, Pakistan, South Africa, Sri Lanka	6
United Kingdom <ul style="list-style-type: none"> • 2.8 m, 250V • FC 9825 • PN 39M5151 	BS 1363	Antigua, Bahrain, Bermuda, Brunei, Channel Islands, China (Hong Kong S.A.R.), Cyprus, Fiji, Ghana, Guyana, India, Iraq, Ireland, Jordan, Kenya, Kuwait, Malaysia, Malawi, Malta, Nepal, Nigeria, Oman, Polynesia, Qatar, Sierra Leone, Singapore, Tanzania, Uganda, UK, United Arab Emirate (Dubai), Yemen, Zambia	7
Switzerland <ul style="list-style-type: none"> • 2.8 m, 250V • FC 9828 • PN 39M5158 	SEV SN 416534	Liechtenstein, Switzerland	8
Italy <ul style="list-style-type: none"> • 2.8 m, 250V • FC 9830 • PN 39M5165 	CEI 23- 16	Chile, Ethiopia, Italy, Libya, Somalia	9
Israel <ul style="list-style-type: none"> • 2.8 m, 250V • FC 9827 • PN 39M5172 	S11-32-1971	Israel	10
Argentina <ul style="list-style-type: none"> • 2.8 m, 250V • FC 9834 • PN 39M5068 	IEC 83-A5	Argentina, Brazil, Colombia, Paraguay, Trinidad Tobago, Uruguay	11
China <ul style="list-style-type: none"> • 2.8 m, 250V • FC 9840 • PN 39M5206 	CCEE	People's Republic of China	12
Taiwan LV* <ul style="list-style-type: none"> • 2.8 m, 125V • FC 9835 • PN 39M5247 	CNS 10917-3	Taiwan	13
Taiwan HV** <ul style="list-style-type: none"> • 2.8 m, 250V • FC 9841 • PN 39M5254 	CNS 10917-3	Taiwan	14

Table 12-1. Power Cords (continued)

Description, Feature Code (FC), and Part Number (PN)	Plug Standard Reference	Country or Region	Index Number in Figure 12-1 on page 12-3
Japan LV* <ul style="list-style-type: none"> • 2.8 m, 125V • FC 9842 • PN 39M5199 	JIS C8303, C8306	Japan	15
Japan HV** <ul style="list-style-type: none"> • 2.8 m, 250V • FC 9843 • PN 39M5186 	JIS C8303, C8306	Japan	16
Korea HV** <ul style="list-style-type: none"> • 2.8 m, 250V • FC 9844 • PN 39M5219 	KS C8305, K60884-1	Korea	17
India HV** <ul style="list-style-type: none"> • 2.8 m, 250V • FC 9845 • PN 39M5226 	IS 6538	India	18
Brazil LV* <ul style="list-style-type: none"> • 2.8 m, 125V • FC 9846 • PN 39M5233 	InMetro NBR 6147	Brazil	19
Brazil HV** <ul style="list-style-type: none"> • 2.8 m, 250V • FC 9847 • PN 39M5240 	InMetro NBR 14136	Brazil	20
* Low Voltage ** High Voltage			

Appendix A. Message Retrieval at the Host

Retrieving message from different hosts are discussed in this appendix.

“Obtaining Error Information From an RS/6000”

“Retrieving from an AS/400 System with RISC Processor” on page A-6

“Retrieving from a Sun System” on page A-9

“Retrieving from an HP-UX System” on page A-9

Obtaining Error Information From an RS/6000

IBM device drivers for the RS/6000 system logs error information when an error occurs on a tape drive or library.

The error information includes the following:

1. Device VPD
2. SCSI command parameters
3. SCSI sense data (if available)

The AIX Tape and Media Changer Device Driver for the RS/6000 provides logging to the system error log for a variety of errors. You can view the error log by following this procedure.

1. At the AIX command line, type **errpt |pg** to display a summary report, or type **errpt -a |pg** to display a detailed report. Press **[Enter]**.

Note: In most cases you will use the summary report to find the date and time of any errors related to library devices, then use the detail report to obtain the sense data needed to identify the cause of the error.

2. Press **[Enter]** to scroll through the error log.
3. Type **q** and press **[Enter]**, to quit the error log at any time.

To correct a problem you noticed in the **errpt** report, determine the type of error by using the examples that follow:

- For library errors [Resource Name = **smcn** (for example, smc0) and Resource Type = 3576]), refer to “Library Error Log Example” on page A-2 and locate the SCSI sense data.
- For drive errors [Resource Name = **rmtn** (for example, rmt0) and Resource Type = LTO], refer to “Drive Error Log Example” on page A-3 and locate the SCSI sense data.
- For SCSI bus errors (not SCSI adapter errors), refer to “SCSI Bus Error Example 1” on page A-4 and “SCSI Bus Error Example 2” on page A-5 to determine which host adapter, SCSI bus, and device or devices are affected.
- For Fibre Channel errors (not Fibre Channel adapter errors), determine which host adapter and device are affected.
- For SCSI adapter errors (not SCSI bus errors), use the maintenance package for the host.

Note: See Appendix C, "Sense Data," on page C-1 for further details on sense data.

Library Error Log Example

```

LABEL: TAPE_ERR2
IDENTIFIER: 476B351D
Date/Time: Wed Oct 11 11:42:17
Sequence Number: 25265
Machine ID: 000D090D4C00
Node ID: tsm
Error Class: H
Error Type: PERM
Resource Name: smc0
Resource Class: tape
Resource Type: 3576
Location: 40-60-00-6,0
VPD:
Manufacturer.....IBM
Machine Type and Model.....ULT3576-TL
Serial Number.....IBM7810698
Device Specific . (FW) .....x.xx (Firmware Level)
Description
TAPE DRIVE FAILURE
Probable Causes
TAPE DRIVE
Failure Causes
TAPE
TAPE DRIVE
Recommended Actions
PERFORM PROBLEM DETERMINATION PROCEDURES
Detail Data
SENSE DATA
0C00 0000 A500 0001 1009 0101 0000 0000 0000 0000 7000 0400 0000 0046 0000 0000
4400 8100 0000 0000 0000 0000 0000 0200 4801 E300 0000 0000 0000 0000 0000
0000 0000 0000 0000 0000 0000 0000 0000 0000 0000 0000 0000 0000 0000
0000 0000 0000 0000 0000 0000 0000 0000 0000 0000 0000 0000 0000 0000
0000 0000 0000 0000 0000 0000 0000 0000 0000 0000 0000 0000 0000

```

Figure A-1. AIX ERRPT Library Error Log Example

Table A-1. AIX ERRPT Library Sense Data

Hex	Description
A5	SCSI Command
0001, 1009, 0101	Command Parameters
70	Byte 0 of Library Sense Data
04	Sense Key
4400	ASC/ASCQ (Additional Sense Code/Additional Sense Code Qualifier)
81	Library SAT (Service Action Ticket) Code

Drive Error Log Example

```

LABEL: TAPE_ERR1
IDENTIFIER: 4865FA9B
Date/Time: Wed Oct 10 11:39:43
Sequence Number: 25264
Machine ID: 000D090D4C00
Node ID: tsm
Class: H
Type: PERM
Resource Name: rmt2
Resource Class: tape
Resource Type: LTO
Location: 40-60-00-2,0
VPD:
Manufacturer.....IBM
Machine Type and Model.....ULT3576-TD3
Serial Number.....1300015078
Device Specific.(FW).....xxxx (Firmware Level)
Description
TAPE OPERATION ERROR
Probable Causes
TAPE
User Causes
MEDIA DEFECTIVE
DIRTY READ/WRITE HEAD
Recommended Actions
FOR REMOVABLE MEDIA, CHANGE MEDIA AND RETRY
PERFORM PROBLEM DETERMINATION PROCEDURES
Detail Data
SENSE DATA
0602 0000 0100 0000 0200 0000 0000 0000 0000 0000 0000 7000 0300 0000 001C 0000 0000
5200 0700 20B0 0000 0000 0000 0000 0000 0000 0000 0000 058A 0212 0000 0000 0000 0000
0000 0000 0000 0000 0000 0000 0000 0000 0000 0000 0000 0000 0000 0000 0000 0000
0000 0000 0000 0000 0000 0000 0000 0000 0000 0000 0000 0000 0000 0000 0000 0000
0000 0000 0000 0000 0000 0000 0000 0000 0000 0000 0000 0000 0000 0000 0000 0000
    
```

Figure A-2. AIX ERRPT Drive Error Log Example

Table A-2. AIX ERRPT Drive Sense Data

Hex	Description
01	SCSI Command
0000, 0200, 0000	Command Parameters
70	Byte 0 of Tape Drive Sense Data
03	Sense key (Hardware error in this example)
5200	ASC/ASCQ (Additional Sense Code/Additional Sense Code Qualifier)
20B0	FSC (Fault Symptom Code)
058A	Relative LPOS
02	SCSI ID

SCSI Bus Error Example 1

```
LABEL: SCSI_ERR10
IDENTIFIER: 0BA49C99
Date/Time: Wed Oct 17 09:55:32
Sequence Number: 16140
Machine Id: 00003ABF4C00
Node Id: ofgtsm
Class: H
Type: TEMP
Resource Name: scsi3
Resource Class: adapter
Resource Type: sym896
Location: 40-59
VPD:
Product Specific.( ).....DUAL CHANNEL PCI TO ULTRA2 SCSI
ADAPTER
Part Number.....03N3606
EC Level.....F71335
Manufacture ID.....A16592
Serial Number.....0749
Description
SCSI BUS ERROR
Probable Causes
CABLE
CABLE TERMINATOR
DEVICE
ADAPTER
Failure Causes
CABLE LOOSE OR DEFECTIVE
DEVICE
ADAPTER
Recommended Actions
PERFORM PROBLEM DETERMINATION PROCEDURES
CHECK CABLE AND ITS CONNECTIONS
Detail Data
SENSE DATA
0001 0017 0000 0000 0000 0091 0000 0000 0000 0000 0000 0000 0000 0000 0000 0000
0000 0000 0000 4304 0000 0000 0000 0000 2000 0003 0203 6760 9808 0000 F7FB E1B8
0000 0015 000B 0210 0678 C800 0000 8200 8277 1B20 00A2 ED00 0000 0002 FFFF FFFF
00FF 0000 111F F000 F3DF F110
```

Figure A-3. Example of Error Suggesting SCSI Bus Problem, Which Takes Down Entire Bus

SCSI Bus Error Example 2

```
LABEL: TAPE_ERR4
IDENTIFIER: 5537AC5F
Date/Time: Wed Oct 17 09:00:41
Sequence Number: 16101
Machine Id: 00003ABF4C00
Node Id: ofgtsm
Class: H
Type: PERM
Resource Name: smc0
Resource Class: tape
Resource Type: 3576
Location: 40-58-00-0,1
VPD:
Manufacturer.....IBM
Machine Type and Model.....ULT3576-TL
Serial Number.....IBM7810698
Device Specific.(FW).....x.xx
Description
TAPE DRIVE FAILURE
Probable Causes
ADAPTER
TAPE DRIVE
Failure Causes
ADAPTER
TAPE DRIVE
Recommended Actions
PERFORM PROBLEM DETERMINATION PROCEDURES
Detail Data
SENSE DATA
0600 0000 1200 0000 FF00 0000 0000 0000 0200 0800 0000 0000 0000 0000 0000 0000
0000 0000 0000 0000 0000 0000 0000 0000 0000 0000 0000 0000 0000 0000 0000 0000
0000 0000 0000 0000 0000 0000 0000 0000 0000 0000 0000 0000 0000 0000 0000 0000
0000 0000 0000 0000 0000 0000 0000 0000 0000 0000 0000 0000 0000 0000 0000 0000
0000 0000 0000 0000 0000 0000 0000 0000 0000 0000 0000 0000 0000 0000 0000 0000
```

Figure A-4. SCSI Problem Points to Library Control Path as Possible Cause

Summary Report

```
1 2 34 5 6
FFE2F73A 1012150900 U H rmt5 UNDETERMINED ERROR
0BA49C99 1012150800 T H scsi8 SCSI BUS ERROR 7
C60BB505 1012141500 P S SOFTWARE PROGRAM ABNORM TERMINATED
C42F11D4 1012105200 U S VSC:DE SOFTWARE ERROR
C42F11D4 1012105000 U S VSC:DE SOFTWARE ERROR
FFFA352B 1012104900 U S MS:CS SOFTWARE ERROR
FFFA352B 1012104900 U S MS:CS SOFTWARE ERROR
5537AC5F 1012091700 P H rmt9 TAPE DRIVE FAILURE
5537AC5F 1012091700 P H rmt9 TAPE DRIVE FAILURE
5537AC5F 1012091700 P H rmt9 TAPE DRIVE FAILURE
5537AC5F 1012091600 P H rmt8 TAPE DRIVE FAILURE
5537AC5F 1012091600 P H rmt8 TAPE DRIVE FAILURE
5537AC5F 1012091600 P H rmt8 TAPE DRIVE FAILURE
C60BB505 1012082000 P S SOFTWARE PROGRAM ABNORM TERMINATED
C42F11D4 1011183600 U S VSC:DE SOFTWARE ERROR
C42F11D4 1011183300 U S VSC:DE SOFTWARE ERROR
C42F11D4 1011181800 U S VSC:DE SOFTWARE ERROR
C42F11D4 1011174700 U S VSC:DE SOFTWARE ERROR
FFFA352B 1011172900 U S MS:CS SOFTWARE ERROR
FFFA352B 1011172900 U S MS:CS SOFTWARE ERROR
C42F11D4 1011155300 U S VSC:DE SOFTWARE ERROR
C42F11D4 1011153900 U S VSC:DE SOFTWARE ERROR
C42F11D4 1011153800 U S VSC:DE SOFTWARE ERROR
C42F11D4 1011150900 U S VSC:DE SOFTWARE ERROR
```

Figure A-5. AIX ERRPT Commands Error Log Example

NUMBER	DESCRIPTION
1	Error ID
2	Timestamp
3	Error Type
4	Error Class
5	Resource Name
6	Error Description
7	How SCSI Bus Error will Display in Log

ERROR CLASS	DESCRIPTION
H	Hardware
S	Software
O	Informational

ERROR TYPE	DESCRIPTION
PEND	The availability loss of a device or component is imminent.
PERF	The performance of a device or component has degraded to an unacceptable level.
PERM	A hardware or software condition that could not be recovered from.
TEMP	A hardware condition that was recovered from after several unsuccessful attempts.
UNKN	The severity of the condition could not be determined.

A69M0170

Retrieving from an AS/400 System with RISC Processor

IBM device drivers for the AS/400 system logs error information when an error occurs on a tape drive or library.

The error information includes the following:

1. Device VPD
2. SCSI command parameters
3. SCSI sense data (if available)

To gain access to the AS/400 problem logs and error logs, sign on at any available workstation using the QSRV logon and its security password (QSRV). After signing on, the proper access authorizations will be granted and the AS/400 MAIN MENU displays.

1. Type STRSST (Start System Service Tools) command on the command entry line on the AS/400 Main Menu, and press **[Enter]**.
2. On the "System Service Tool (SST)" screen, select **Start a service tool**, and press **[Enter]**.
3. On the "Start a Service Tool" screen, select **Product activity log**, and press **[Enter]**.
4. On the "Product activity log" screen, select **Analyze log**, and press **[Enter]**.
5. On the "Select Subsystem Data" screen, select **Magnetic media**, enter the From and To time period for searching the error log, and press **[Enter]**.
6. On the "Select Analysis Report Options" screen, select the following, and press **[Enter]**.
 - a. Report type. 1
 - b. Optional entries to include

- 1) Informational YES
- 2) Statistic NO
- c. Reference code selection
 - 1) Option 1
 - 2) Reference codes. *ALL
- d. Device selection
 - 1) Option 1
 - 2) Device type or resource names . . *ALL
- 7. On the "Log Analysis Report" screen, enter a 5 on an error line that has a resource type of 3583 (library) or 3580 (drive), and press [Enter].
- 8. On the "Display Detail Report for Resource" screen, press:
 - F4=Additional Information.
Pressing F4 will display the machine type and serial number of the device. It also will display SCSI sense data, if available.
 - F6=Hexadecimal report.
Pressing F6 will display the device hexadecimal data (for support use).
 - F9=Address Information.
Pressing F9 will display the SCSI address information.

AS/400 Product Activity Log

Product Activity Log Page . . . : 1

ROMLPAR1 08/26/05 10:28:40

Invocation : Product Activity Log

Title : Log ID Report

System type : 9406

System model : 825

System release : V5R3M0

System name : ROMLPAR1

System serial

number : 10-F321B

Log ID : 09020145

Include hexadecimal

data : Y Y=YES

N=NO

Product Activity Log Page . . . : 2

ROMLPAR1 08/26/05 10:28:40

Detail Report for Resource

Serial Resource

Name Type Model Number Name

TAPMLB19 3580 001 00-1004538

Log ID : 09020145 Sequence : 211510

Date : 04/21/05 Time : 10:40:11

Reference code : 9350 Secondary code . . . : 00000000

Table ID : 63A00001 IPL source/state . . : B / 3

Class : Permanent

System ref code : 63A09350

Tape unit detected a read or write error on tape medium

Physical location:

Frame ID :

Card position :

Device position :

Logical address:

PCI bus: Library:

System bus : 36 I/O adapter : 2

System board : 0 I/O bus : 1

System card : 32 Library: 20

Controller : 4

Device : 0

SENSE DATA FOLLOWS. :

DATA OFFSET 0 1 2 3 4 5 6 7 8 9 A B C D E F

00000000 71000300 0000001C 00000000 53000600

00000010 31190601 00020000 00000000 00000000

00000020 00000301

00000000 0000 C5D3F0F5 00000188 00E00180 8983EBC2 4B9D8001 00033A36 20E00902 01450000 *EL05...h...ic.B.....*

00000000 0040 F3F8F2F8 F4F4F6F3 C1F00002 00240000 00200000 00050001 00140004 00000002 *3B284463A0.....*

00000000 0060 00000000 00000000 00000000 40404040 40404040 40400000 00000000 00000000 *.....*

00000000 0080 00000000 00000000 00000000 00000000 00000000 00000000 00000000 0000E3C1 *.....TA*

00000000 00A0 D704D3C2 F1F94040 00000000 00000000 00000000 00000000 40404040 40404040 *PMLB19*

00000000 00C0 40404040 40404040 40404040 40404040 40404040 40404040 40404040 40404040 * * * * *

00000000 00E0 F6F3C1F0 F0F0F0F1 0000E2D3 C9C3C9D6 4040E5F5 D9F3D4F0 40400000 00000000 *63A00001..SLICIO V5R3M0

00000000 0100 01030000 00000000 00000141 00000000 00000000 01950000 00000000 00000197 *.....n.....p*

00000000 0120 00000000 00000000 00000000 00000000 00000000 00000000 00000000 00000000 *.....*

00000000 0140 E3C1D7F2 F7404040 40404040 40404040 40404040 40404040 00070001 *TAP27

00000000 0160 00000000 10200003 00000000 00000000 00000000 00000000 0009001E 0000018B *.....h*

00000000 0180 F8807800 28440001 00002600 21410400 63A00001 93500100 45381202 05D80000 *8.....1&.....Q..*

00000000 01A0 00000000 00004624 00000000 00000000 00040000 00003580 0001A170 02903435 *.....*

Product Activity Log Page . . . : 3

ROMLPAR1 08/26/05 10:28:40

00000000 01C0 36310040 00007100 03000000 001C0000 00005300 06003119 06010002 00000000 *.....*

00000000 01E0 00000000 00000000 03010000 00000000 00000000 00000000 00000000 00000000 *.....*

00000000 0200 00000000 0000D9C5 D8400000 D9E2000C 02000000 0000E2C3 E2C91202 00180000 *.....REQ ..RS.....SCSI.....*

00000000 0220 00000000 0000C5D9 D940C3C8 C3D20444 8502D9E2 0000E2C3 E2C91202 00180300 *.....ERR CHCK..e.RS..SCSI.....*

00000000 0240 00008000 0000E2D5 E2C47100 03000000 001C0000 0000C5D9 D7C11202 05D80000 *.....SNSD.....ERPA...Q..*

00000000 0260 00171202 05D8D9C5 E2D70000 00171202 05D8D9E2 00000000 D4C5C4C9 C10000C3 *.....QRESP.....QRS....MEDIA..C*

00000000 0280 D7D7F1F2 F5C500D4 E3C1D7C3 D3D500C3 D7D7F6F4 F0F000E4 C6C9F0F0 F8F7F1C3 *PP125E.MTAPCLN.CPP6400.UFI00871C*

00000000 02A0 D7D7F1F8 F5C600D5 00000000 00000000 00000000 00000000 00000000 00000000 *PP185F.N.....*

00000000 02C0 00000000 00000000 00000000 00000000 00000000 00000000 C3D7D7F6 F3F0C3D5 *.....CPP630CN*

00000000 02E0 F6F3C1F0 F9F3F5F0 F0F0F0F0 F0F0F0F0 F0F1F9F7 F8F0F0F7 0000E8D5 *63A093500000000000001978007..YN*

00000000 0300 00000000 00000000 40404040 40404040 40404040 40404040 40404040 40404040 *.....*

* * * * * E N D O F C O M P U T E R P R I N T O U T * * * * *

Retrieving from a Sun System

The Sun System provides information when an error occurs on a tape drive or library in `system-errlog /var/adm/messages`. When you have located the error information, go to Chapter 9, "Troubleshooting," on page 9-1.

The two following service aid programs are provided with the IBM SCSI Tape Device Driver for SunOS:

- Tape service program

A tape service program called **tapesrv.c** is provided and contains the following service aids:

- Query device serial number
- Format tape cartridge
- Force device error dump
- Save device error dump
- Download device code

The tape service program is invoked by using the `/opt/stdutil/tapesrv` command.

Note: You must have root authority to run the tape service program.

The program is menu driven. Use discretion when running this program because it opens the device in diagnostic mode.

- Sample program

A sample program called **tapetest.c** is provided, which gives a demonstration of the device driver interface usage.

The sample program is invoked by using the `/opt/stdutil/tapetest` command. The program is useful for verifying that the device driver and the device are functional. The program is menu driven.

Retrieving from an HP-UX System

The HP-UX system provides information when an error occurs on a tape drive or library in `syslog /var/adm/syslog.log`. When you have located the error information, go to Chapter 9, "Troubleshooting," on page 9-1.

Appendix B. TapeAlert Flags

This appendix is intended to provide additional information to the reader about the tape drive. All error code and diagnostic information contained in this chapter can be accessed from the Operator Panel of the Library. The drive portion of the Operator Panel Display will contain any drive error codes. Therefore there is no need to open the Library to access the buttons on the drive as described in this chapter. See the Setup and Operator Guide for a complete description of the Operator Panel functions and Displays.

TapeAlert is a standard that defines status conditions and problems experienced by devices such as tape drives, autoloaders, and libraries. The standard enables a server to read TapeAlert messages (called *flags*) from a tape drive via the SCSI bus. The server reads the flags from Log Sense Page 0x2E.

This library is compatible with TapeAlert technology, which provides error and diagnostic information about the drives and the library to the server. Because library and drive firmware may change periodically, the SNMP interface in the library does not require code changes if devices add additional TapeAlerts that are not supported today. However, should this occur the MIB is written to minimize impact to the SNMP monitoring station. At the time of this writing, the TapeAlert flags in this appendix correctly represent TapeAlerts that will be sent. The MIB file should not be taken to mean that all traps that are defined in the MIB will be sent by the library or that they will be sent in the future.

This appendix lists TapeAlert flags that are supported by the Ultrium 3 Tape Drives.

TapeAlert Flags Supported by the Drive

Table B-1. TapeAlert Flags Supported by the Ultrium Tape Drive

Flag Number	Flag	Description	Action Required
3	Hard error	Set for any unrecoverable read, write, or positioning error. (This flag is set in conjunction with flags 4, 5, or 6.)	See the Action Required column for Flag Number 4, 5, or 6 in this table.
4	Media	Set for any unrecoverable read, write, or positioning error that is due to a faulty tape cartridge.	Replace the tape cartridge.
5	Read failure	Set for any unrecoverable read error where isolation is uncertain and failure could be due to a faulty tape cartridge or to faulty drive hardware.	If Flag 4 is also set, the cartridge is defective. Replace the tape cartridge. If Flag Number 4 is not set, see "Contacting IBM Technical Support" on page 9-17.

Table B-1. TapeAlert Flags Supported by the Ultrium Tape Drive (continued)

Flag Number	Flag	Description	Action Required
6	Write failure	Set for any unrecoverable write or positioning error where isolation is uncertain and failure could be due to a faulty tape cartridge or to faulty drive hardware.	If Flag Number 9 is also set, make sure that the write-protect switch is set so that data can be written to the tape (see "Write-Protect Switch" on page 8-7). If Flag Number 4 is also set, the cartridge is defective. Replace the tape cartridge. If Flag Number 4 is not set, see "Contacting IBM Technical Support" on page 9-17.
8	Not data grade	Set when the cartridge is not data-grade. Any data that you write to the tape is at risk.	Replace the tape with a data-grade tape.
9	Write protect	Set when the tape drive detects that the tape cartridge is write-protected.	Make sure that the cartridge's write-protect switch is set so that the tape drive can write data to the tape (see "Write-Protect Switch" on page 8-7).
10	No removal	Set when the tape drive receives an UNLOAD command after the server prevented the tape cartridge from being removed.	Refer to the documentation for your server's operating system.
11	Cleaning media	Set when you load a cleaning cartridge into the drive.	No action required.
12	Unsupported format	Set when you load an unsupported cartridge type into the drive or when the cartridge format has been corrupted.	Use a supported tape cartridge.
14	Unrecoverable snapped tape	Set when the operation failed because the tape in the drive snapped.	Do not attempt to extract the old tape cartridge. Call the tape drive supplier's help line.
15	Cartridge memory chip failure	Set when a cartridge memory (CM) failure is detected on the loaded tape cartridge.	Replace the tape cartridge. If this error occurs on multiple cartridges, see "Contacting IBM Technical Support" on page 9-17.
16	Forced eject	Set when you manually unload the tape cartridge while the drive was reading or writing.	No action required.
18	Tape directory corrupted in the cartridge memory	Set when the drive detects that the tape directory in the cartridge memory has been corrupted.	Re-read all data from the tape to rebuild the tape directory.
20	Clean now	Set when the tape drive detects that it needs cleaning.	Clean the tape drive the section about cleaning drives in the <i>IBM TotalStorage 3576 Modular Tape Library Setup and Operator Guide</i> .
21	Clean periodic	Set when the drive detects that it needs routine cleaning.	Clean the tape drive as soon as possible. The drive can continue to operate, but you should clean the drive soon. See the section about cleaning drives in the <i>IBM TotalStorage 3576 Modular Tape Library Setup and Operator Guide</i> .

Table B-1. TapeAlert Flags Supported by the Ultrium Tape Drive (continued)

Flag Number	Flag	Description	Action Required
22	Expired clean	Set when the tape drive detects a cleaning cartridge that has expired.	Replace the cleaning cartridge.
23	Invalid cleaning tape	Set when the drive expects a cleaning cartridge and the loaded cartridge is not a cleaning cartridge.	Use a valid cleaning cartridge.
30	Hardware A	Set when a hardware failure occurs that requires that you reset the tape drive to recover.	If resetting the drive does not recover the error, note the error code on the single-character display and see "Contacting IBM Technical Support" on page 9-17 for the appropriate instructions.
31	Hardware B	Set when the tape drive fails its internal Power-On Self Tests.	Note the error code on the single-character display and see "Contacting IBM Technical Support" on page 9-17 for the appropriate instructions.
32	Interface	Set when the tape drive detects a problem with the SCSI, Fibre Channel, or RS-422 interface.	See "Contacting IBM Technical Support" on page 9-17
33	Eject media	Set when a failure occurs that requires you to unload the cartridge from the drive.	Unload the tape cartridge, then reinsert it and restart the operation.
34	Download fail	Set when an FMR image is unsuccessfully downloaded to the tape drive through the SCSI or Fibre Channel interface.	Ensure that it is the correct FMR image. Download the FMR image again.
36	Drive temperature	Set when the drive's temperature sensor indicates that the drive's temperature is exceeding the recommended temperature of the library.	See "Contacting IBM Technical Support" on page 9-17
37	Drive voltage	Set when the drive detects that the externally supplied voltages are either approaching the specified voltage limits or are outside the voltage limits (see "Specifications" on page 1-15).	See "Contacting IBM Technical Support" on page 9-17
39	Diagnostics required	Set when the drive detects a failure that requires diagnostics for isolation.	See "Contacting IBM Technical Support" on page 9-17
51	Tape directory invalid at unload	Set when the tape directory on the tape cartridge that was previously unloaded is corrupted. The file-search performance is degraded.	Use your backup software to rebuild the tape directory by reading all the data.
52	Tape system area write failure	Set when the tape cartridge that was previously unloaded could not write its system area successfully.	Copy the data to another tape cartridge, then discard the old cartridge.
53	Tape system area read failure	Set when the tape system area could not be read successfully at load time.	Copy the data to another tape cartridge, then discard the old cartridge.

Appendix C. Sense Data

“Library Sense Data”

“Drive Sense Data” on page C-8

When a drive encounters an error, it makes sense data available. You can use IBM device drivers to examine the sense data and determine errors. Instructions for downloading, installing, and properly configuring the IBM device drivers are available in the *IBM Ultrium Device Drivers Installation and User's Guide*. The IBM device drivers may conflict with some commercial software applications unless properly configured. To avoid conflicts on Windows operating systems, refer to your device driver's procedures for setting the driver to manual startup mode. For applications that use Open Systems device drivers that are provided by IBM (for example, AIX, Linux, Sun Solaris, HP-UX, Windows 2003, and Windows 2000), the *IBM Ultrium Device Drivers Installation and User's Guide* contains information about how to obtain sense data after an error has occurred.

If your application uses other device drivers, see the appropriate documentation for those drivers to obtain the sense data.

Raw sense data (as returned from the drive) is documented in the *IBM TotalStorage LTO Ultrium Tape Drive SCSI Reference*.

In addition to device drivers, other methods exist for obtaining sense data and error information. The sections that follow describe alternatives for gathering such information from the IBM AS/400, eServer iSeries, RS/6000®, and eServer pSeries servers.

Library Sense Data

The following table lists the Additional Sense Codes (ASC) and Additional Sense Code Qualifiers (ASCQ) associated with the reported Sense Keys.

A sense key of 00h (no sense) has no ASC/ASCQ associated with it. A few ASC/ASCQs can be associated with more than one sense key. The sense keys that can give a particular ASC/ASCQ are indicated within the Sense Key column. ASC/ASCQs that can indicate an abnormal element state as part of element descriptor.

Table C-1. Library Sense Data and associated ASC/ASCQs

Sense Key	ASC	ASCQ	Description	Required Action
2	04h	00h	The library is not ready due to an unknown cause.	Not Ready - Cause Not Reportable. A cartridge is present in the drive, but it is in the process of unloading. Failure Isolation Procedure No repair action required.

Table C-1. Library Sense Data and associated ASC/ASCQs (continued)

Sense Key	ASC	ASCQ	Description	Required Action
2	04h	01h	The library is becoming ready.	Not Ready - Becoming Ready. The drive has not finished the load and thread operation yet. <u>Failure Isolation Procedure</u> No repair action required.
2	04h	03h	The library is not ready and a manual intervention is required.	**Not Ready - Manual Intervention Required. <u>Failure Isolation Procedure</u> Check the library Operator Panel to ensure that the library is not in offline, setup, or maintenance mode. Check front doors to ensure that they are all closed. Ensure that power is on each of the installed drives. Possible failure of a door switch. <u>FRU/CRU List</u> See "Contacting IBM Technical Support" on page 9-17.
2	04h	83h	The library is not ready due to aisle power being disabled.	**Not Ready - Library Has Not Been Set Up. Library needs configuration and/or calibration. Check the Spooler Cable connection. <u>Failure Isolation Procedure</u> Have your customer run Library Configuration (select Reports->Library Configuration) <u>FRU/CRU List</u> See "Contacting IBM Technical Support" on page 9-17.
2	04h	8Dh	The library is not ready, because it is offline.	**Library is Offline. <u>Failure Isolation Procedure</u> Check the library Operator Panel to ensure that the library is not in offline, setup, or maintenance mode.
B	08h	80h	LU Communication - SCSI Failure	
B	08h	82h	LU Communication - SCSI Command Execution or Queuing Failure	
B	08h	83h	LU - SCSI Command Failed	
B	08h	84h	LU Communication - SCSI Time-Out	
B	08h	85h	LU Communication - SCSI Autosense Failed	

Table C-1. Library Sense Data and associated ASC/ASCQs (continued)

Sense Key	ASC	ASCQ	Description	Required Action
B	08h	86h	LU Communication - SCSI Aborted	
B	08h	87h	LU Communication - SCSI Abort Failed	
B	08h	88h	LU Communication - SCSI Status Failed	
B	08h	B0h	LU Communication - FC Data Underrun	
B	08h	B1h	LU Communication - FC DMA Error	
B	08h	B2h	LU Communication - FC Reset	
B	08h	B3h	LU Communication - FC Data Overrun	
B	08h	B4h	LU Communication - FC Queue Full	
B	08h	B5h	LU Communication - Port Unavailable	
B	08h	B6h	LU Communication - Port Logged Out	
B	08h	B7h	LU Communication - Port Configuration Changed	
4	15h	01h	A mechanical positioning error occurred.	<p>**Ask the customer to try the job using a different tape cartridge. If the problem persists, see if updated drive code is available. If newer code is available, install it.</p> <p>Failure Isolation Procedure</p> <p>CRU/FRU List</p> <ol style="list-style-type: none"> 1. If the problem persists, select Tools → Service and run the Robotics Test. 2. If the problem persists, contact your next level of support.
5	1Ah	00h	Parameter list length error.	<p>Wrong or invalid firmware values.</p> <p>Failure Isolation Procedure</p> <p>See "Contacting IBM Technical Support" on page 9-17.</p>
B	1Bh	00h	Synchronous data transfer error	<p>Failure Isolation Procedure</p> <p>Review host error data to determine which control path drive reported the error, then isolate and repair the failing SCSI or Fibre Channel component.</p>
5	20h	00h	Illegal opcode in CDB	<p>Invalid Command Operation Code in CDB. The Operation Code specified in the Command Descriptor Block was not valid.</p> <p>Failure Isolation Procedure</p> <p>See "Contacting IBM Technical Support" on page 9-17.</p>
5	21h	01h	Invalid element address in CDB	<p>Wrong or invalid firmware values.</p> <p>Failure Isolation Procedure</p> <p>See "Contacting IBM Technical Support" on page 9-17.</p>

Table C-1. Library Sense Data and associated ASC/ASCQs (continued)

Sense Key	ASC	ASCQ	Description	Required Action
5	24h	00h	Invalid field in CDB	An invalid value was detected in the Command Descriptor Block. Failure Isolation Procedure See "Contacting IBM Technical Support" on page 9-17.
5	25h	00h	Illegal LUN	The command was addressed to a non-existent Logical Unit Number. Failure Isolation Procedure See "Contacting IBM Technical Support" on page 9-17.
5	26h	00h	Invalid field in Parameter List	An invalid value was detected in the data sent during the data phase. Failure Isolation Procedure See "Contacting IBM Technical Support" on page 9-17.
5	26h	04h	Invalid release of persistent reservation	
6	28h	00h	Door(s) opened and closed	A cartridge has been loaded successfully into the drive and is now ready to be accessed.
6	28h	01h	I/O station opened and closed	**The I/O Station was opened and closed since the last time the initiator last accessed it.
6	29h	00h	Power on or reset occurred	Reset. The drive has powered on or received a reset since the initiator last accessed it. Failure Isolation Procedure No action is necessary. these are only status messages.
6	29h	01h	Power on occurred	Reset. The drive has powered on or received a reset since the initiator last accessed it. Failure Isolation Procedure No action is necessary. these are only status messages.
6	29h	04h	Internal reset occurred	Status changed. Failure Isolation Procedure No action is necessary. These are only status messages.

Table C-1. Library Sense Data and associated ASC/ASCQs (continued)

Sense Key	ASC	ASCQ	Description	Required Action
6	2Ah	01h	Mode parameters have been changed.	<p>**The Mode parameters for the drive have been changed by an initiator other than the one issuing the command. Mode Select parameters were changed by another host, or commands were cleared by another host.</p> <p><u>Failure Isolation Procedure</u></p> <p>No action is necessary. These are only status messages.</p>
6	2Ah	03h	Reservations preempted.	
6	2Ah	04h	Reservations released.	
6	2Ah	05h	Registrations preempted.	
5	2Ch	00h	Command sequence error	<p>Command sequence error.</p> <p><u>Failure Isolation Procedure</u></p> <p>See “Contacting IBM Technical Support” on page 9-17.</p>
5	*30h	*00h	Incompatible medium installed	<p>Incompatible Media. A Write operation was requested on a cartridge which is not writable.</p> <p><u>Failure Isolation Procedure</u></p> <p>No action is necessary. This is only a status message.</p>
5	39h	00h	Saving parameters not supported	<p>Saving Parameters is not supported.</p> <p><u>Failure Isolation Procedure</u></p> <p>No action is necessary. These messages indicate that a host application sent an invalid/unsupported command or multiple hosts attempted to use a drive at the same time.</p>
4-5	3Bh	0Dh	The destination element is full.	<p>The host is attempting to move a cartridge, but the attempt was rejected as invalid.</p> <p><u>Failure Isolation Procedure</u></p> <p>See “Contacting IBM Technical Support” on page 9-17.</p>
4-5	3Bh	0Eh	The source element is empty.	<p>The host is attempting to move a cartridge, but the attempt was rejected as invalid.</p> <p><u>Failure Isolation Procedure</u></p> <p>See “Contacting IBM Technical Support” on page 9-17.</p>

Table C-1. Library Sense Data and associated ASC/ASCQs (continued)

Sense Key	ASC	ASCQ	Description	Required Action
5	*3Bh	*12h	Media magazine not installed.	**Library detected a missing magazine during inventory. <u>Failure Isolation Procedure</u> No action is necessary. This is only a status message.
5	*3Bh	*A0h	Media type does not match destination media type.	
6	3Fh	01h	New firmware loaded	Status changed. <u>Failure Isolation Procedure</u> No action is necessary. These are only status messages.
4	3Fh	0Fh	Echo buffer overwritten	
4	40h	80h	Component failure	
B	43H	00H	Message error	A message could not be sent or received due to excessive transmission errors. <u>Failure Isolation Procedure</u> If the problem persists, go to "Contacting IBM Technical Support" on page 9-17.
4-B	44h	00h	Firmware detected an internal logic failure.	**
B	45h	00h	Select or reselect failure	Select or reselect failure <u>Failure Isolation Procedure</u> Review host error data to determine which control path drive reported the error, then isolate and repair the failing SCSI or Fibre Channel component (go to "Contacting IBM Technical Support" on page 9-17).
B	47h	00h	SCSI parity error	SCSI Parity error. <u>Failure Isolation Procedure</u> Review host error data to determine which control path drive reported the error, then isolate and repair the failing SCSI or Fibre Channel component (go to "Contacting IBM Technical Support" on page 9-17).
B	48h	00h	Initiator detected error message received.	Initiator Detected Error message. a command failed because the Initiator Detected Error message was received by the drive. <u>Failure Isolation Procedure</u> If the problem persists, go to "Contacting IBM Technical Support" on page 9-17.

Table C-1. Library Sense Data and associated ASC/ASCQs (continued)

Sense Key	ASC	ASCQ	Description	Required Action
B	49h	00h	Invalid message error	A command failed because an invalid message was received by the drive. <u>Failure Isolation Procedure</u> If the problem persists, go to “Contacting IBM Technical Support” on page 9-17.
B	4Ah	00h	Command phase error	A command could not be executed because too many parity errors occurred during the Command phase. <u>Failure Isolation Procedure</u> If the problem persists, go to “Contacting IBM Technical Support” on page 9-17.
B	4Bh	00h	Data phase error	A command could not be executed because too many parity errors occurred during the Data phase. <u>Failure Isolation Procedure</u> If the problem persists, go to “Contacting IBM Technical Support” on page 9-17.
B	4Eh	00h	Overlapped commands attempted	An initiator attempted to send a command to the drive even though it already had another command being processed in the drive. <u>Failure Isolation Procedure</u> If the problem persists, go to “Contacting IBM Technical Support” on page 9-17.
4	53h	00h	A drive did not load or unload a tape.	An attempt to load or eject the cartridge failed. <u>Failure Isolation Procedure</u> See “Contacting IBM Technical Support” on page 9-17.
4-5	*53h	*01h	A drive did not unload a cartridge.	
5	*53h	*02h	Medium removal prevented.	
5	53h	81h	I/O Station door is open.	
4	53h	82h	Cannot lock the I/O Station.	
4	53h	83h	Cannot unlock the I/O Station	
4	*83h	*00h	Label too short or too long	
5	*83h	*02h	Barcode label questionable	
5	*83h	*03h	Cell status and barcode label questionable	
5	*83h	*04h	Data transfer element not installed.	
5	*83h	*05h	Data transfer element is varied off and not accessible for library operations.	

Table C-1. Library Sense Data and associated ASC/ASCQs (continued)

Sense Key	ASC	ASCQ	Description	Required Action
5	*83h	*06h	Element is contained within an offline tower or I/O Station and is not accessible for library operations.	

Drive Sense Data

Table C-2. LTO Tape Drive Sense Data

Byte	Bit Address or Name							
	7	6	5	4	3	2	1	0
0	Address valid When set to 1, the info byte field contains a valid logical block address.	Error Code						
1	Segment Number (0)							
2	Filemark	EOM (end of medium)	ILI (Incorrect length indicator)	Reserved	Sense Key Description 0 --- No sense 1 --- Recovered error 2 --- Not ready 3 --- Media error 4 --- Hardware error 5 --- Illegal request 6 --- Unit attention 7 --- Data protect 8 --- Blank Check 9 --- Reserved A --- Reserved B --- Aborted command C --- Reserved D --- Volume overflow E --- Reserved F --- Reserved			
3	Information byte (most significant byte)							
4	Information byte							
5	Information byte							
6	Information byte (least significant byte)							
7	Additional Sense Length							
8-11	Command specific information							

Table C-2. LTO Tape Drive Sense Data (continued)

Byte	Bit Address or Name							
	7	6	5	4	3	2	1	0
12-13	<p>Additional Sense Code (ASC) Additional Sense Code Qualifier (ASCQ) Byte 12 Byte 13 ASC ASCQ 00 00 - No additional sense — The flags in the sense data indicate the reason for the command failure 00 01 - Filemark detected — A Read or Space command terminated early due to an FM The FM flag is set. 00 02 - EOM — A Write or Write File Marks command failed because the physical end of tape was encountered, or a Read or Space command encountered EOM The EOM flag is set 00 04 - BOM — A space command ended at Beginning of Tape The EOM bit is also set 00 05 - EOD — Read or Space command terminated early because End of Data was encountered 00 16 - Operation in progress 04 00 - Cause not reportable — A cartridge is present in the drive, but it is in the process of being unloaded 04 01 - Becoming Ready — A media access command was received during a front panel initiated load or an immediate reported load command 04 02 - Initializing Command Required — A cartridge is present in the drive, but is not logically loaded. A Load command is required 04 03 - Manual Intervention Required — A cartridge is present in the drive but could not be loaded or unloaded without manual intervention 04 12 - Logical Unit Not Ready, Offline 08 01 - Logical Unit Communication Failure 09 00 - Track Following Error (Servo) 0C 00 - Write Error — A Write operation has failed. This is probably due to bad media, but may be hardware related 11 00 - Unrecovered Read Error — A Read operation failed. This is probably due to bad media, but may be hardware related 14 00 - Recorded Entity Not Found — A space or Locate command failed because a format violation prevented the target from being found. 14 03 - End Of Data not found — A Read type operation failed because a format violation related to a missing EOD data set 17 01 - Recovered Data with Retries 1A 00 - Parameter list length error — The amount of parameter data sent is incorrect 20 00 - Invalid Command Operation Code — The Operation Code in the command was not a valid Operation Code 24 00 - Invalid field in CDB — An invalid field has been detected in a Command Descriptor Block 25 00 - LUN not supported — The command was addressed to a non-existent logical unit number 26 00 - Invalid Field in Parameter List — An invalid field has been detected in the data sent during the data phase 27 00 - Write Protect — A Write type operation has been requested on a cartridge which has been write protected 28 00 - Not Ready to Ready Transition — A cartridge has been loaded successfully into the drive and is now ready to be accessed 28 01 - Import or Export Element Accessed 29 00 - Reset — The drive has powered on, received a reset signal or a bus device reset signal since the initiator last accessed it 29 04 - Device Internal Reset (Continued on next page)</p>							

Table C-2. LTO Tape Drive Sense Data (continued)

Byte	Bit Address or Name							
	7	6	5	4	3	2	1	0
12-13	<p>Additional Sense Code (ASC) — Additional Sense Code Qualifier (ASCQ) (Continued) Byte 12 Byte 13 ASC ASCQ 2A 01 - Mode Parameters Changed — The Mode parameters for the drive have been changed by an initiator other than the one issuing the command 2C 00 - Command Sequence Error 2F 00 - Commands Cleared by Another Initiator 30 00 - Incompatible Media Installed — A write type operation could not be executed because it is not supported on the cartridge type that is loaded. 30 01 - Unknown Format — An operation could not be carried out because the cartridge in the drive is of a format not supported by the drive 30 02 - Incompatible Format — An operation could not be completed because the Logical Format is not correct 30 03 - Cleaning Cartridge Installed — An operation could not be carried out because the cartridge in the drive is a cleaning cartridge 30 05 - Cannot Write Medium, Incompatible Format 30 07 - Cleaning Failure — A cleaning operation was attempted, but could not be completed for some reason 31 00 - Media format corrupted — Data could not be read because the format on tape is not valid, but is a known format. A failure occurred attempting to write the FID 37 00 - Rounded parameter — A Mode Select command parameter has been rounded because the drive can not store it with the accuracy of the command. 3A 00 - Media Not Present — A media access command has been received when there is no cartridge loaded 3B 00 - Sequential Positioning Error — A command has failed and left the logical position at an unexpected location 3B 0C - Position Past Beginning of Medium — A command that required the medium to be at BOP was attempted when the medium was not at BOP (e.g., Set Capacity) 3D 00 - Invalid bits in identify Message — An illegal Identify Message has been received at the drive at the start of a command 3E 00 - Logical Unit has not Self-Configured — The drive has just powered on and has not completed its self test sequence and can not process commands 3F 01 - Code Download — The firmware in the drive has just been changed by a Write Buffer command 3F 03 - Inquiry Data has Changed 3F 0E - Reported LUNs Data has Changed 3F 0F - Echo Buffer Overwritten 40 xx - Diagnostic failure — A diagnostic test has failed. The xx (ASCQ) is a vendor specific code indicating the failing component. 41 00 - Data Path Failure 43 00 - Message Error — A message could not be sent or received due to excessive transmission errors 44 00 - Internal target failure — A hardware failure has been detected in the drive that has caused the command to fail 45 00 - Select/Reset Failure — An attempt to reselect an initiator in order to complete the command has failed 48 00 - Initiator Detected Error Message Received 49 00 - Invalid Message Error 4A 00 - Command Phase Error 4B 00 - Data Phase Error — A command could not be completed because too many parity errors occurred during the Data phase 4E 00 - Overlapped Commands — An initiator selected the drive even though it already had a command outstanding in the drive (Continued on next page)</p>							

Table C-2. LTO Tape Drive Sense Data (continued)

Byte	Bit Address or Name							
	7	6	5	4	3	2	1	0
12-13	Additional Sense Code (ASC) — Additional Sense Code Qualifier (ASCQ) (Continued) Byte 12 Byte 13 ASC ASCQ 50 00 - Write Append Error — A write type command failed because the point at which to append data was unreadable 51 00 - Erase failure — An Erase command failed to erase the required area on the media 52 00 - Cartridge fault — A command could not be completed due to a fault in the tape cartridge 53 00 - Media Load/Eject Failed — (Sense Key 03) An attempt to load or eject the cartridge failed due to a problem with the cartridge. 53 00 - Media Load/Eject Failed — (Sense Key 04) An attempt to load or eject the cartridge failed due to a problem with the drive 53 02 - Media Removal Prevented — An Unload command has failed to eject the cartridge because media removal has been prevented 5A 01 - Operator Medium Removal Request 5D 00 - Failure Prediction Threshold — Failure Prediction thresholds have been exceeded indicating that a failure may occur soon 5D FF - Failure Prediction False — A Mode Select command has been used to test for Failure Prediction system. 82 82 - Drive requires cleaning — The drive has detected that a cleaning operation is required to maintain good operation 82 83 - Bad Code Detected — The data transferred to the drive during a firmware upgrade is corrupt or incompatible with drive hardware A3 01 - OEM Vendor-Specific							
14	FRU code							
15	SKSV	C/D	Reserved		BPV	Bit pointer		
					When set to 1, the bit pointer is valid.			
16-17	SKSV = 0: First Error Fault Symptom Code (FSC). SKSV = 1: Field Pointer							
18-19	First Error Flag Data							
20	Reserved (0)							
21					CLN	Reserved	Reserved	VolValid
22-28	Volume Label							
29	Current Wrap							
30-33	Relative LPOS							
34	SCSI Address							
35	Reserved				Reserved			

The descriptions below serve only as an overview of sense reporting in the tape drive. This tape drive conforms to all sense field reporting as specified in the SCSI standards.

Note:

1. The Error Code field (Byte 0) is set to 70h to indicate a current error, that is one associated with the most recently received command. It is set to 71h to indicate a deferred error which is not associated with the current command.
2. The segment number (Byte 1) is zero since the Copy, Compare, and Copy and Verify commands are not supported.
3. The File Mark flag (Byte 2, bit 7) is set if a Space, Read, or Verify command did not complete because a file mark was read.
4. The End of Media (EOM) flag (Byte 2, bit 6) is set if a Write or Write File Marks command completed in the early warning area. Spacing into BOM also causes this flag to be set. It is also set on an attempt to read or space past EOD, or if an attempt is made to space into Beginning of Media.
5. The Illegal Length Indicator (ILI) flag (Byte 2, bit 5) is set if a Read or Verify ended because a block was read from tape that did not have the block length requested in the command.
6. The Information Bytes (Bytes 3–5) are only valid if the Valid flag is set. This occurs only for current errors and not for deferred errors.
7. The Field Replaceable Unit field (Byte 14) is set to either zero or to a non-zero, vendor-specific code indicating which part of the drive is suspected of causing the failure.
8. The Clean (CLN) flag (Byte 21, bit 3) is set if the drive needs cleaning and clear otherwise.
9. The Volume Label Fields Valid (VolValid) bit (Byte 21, bit 0) is set if the Volume Label being reported is valid.
10. The Volume Label field (Bytes 22–28) reports the volume label if a cartridge is loaded in the drive and Volume Label Fields Valid is set.
11. The Current Wrap field (Byte 29) reports the physical wrap of the tape. The least significant bit reflects the current physical direction. A 0 means that the current direction is away from the physical beginning of the tape. A 1 means that the current direction is towards the physical beginning of the tape.
12. Relative LPOS fields (Bytes 30–33) reports the current physical position on the tape.
13. SCSI Address field (Byte 34) reports the SCSI Bus Address for the drive. Values returned range from 00h to 0Fh.

Drive Address	Serial No.	Loop ID	AL-PA	Worldwide Node Name	Location Coordinate	Control Path Drive	Host

Firmware Information

Type of Firmware	Current Firmware Level				
Library					
Drive ___					
Drive ___					
Drive ___					
Drive ___					
Drive ___					
Drive ___					
Drive ___					
Drive ___					
Drive ___					
Drive ___					
Drive ___					

Users Account Information

The Administrator password is listed in the table below. Add additional Administrator and User names and passwords that are created.

User name	Password
Administrator	secure

User name	Password

My Support

Username	
Password	

Notices

This information was developed for products and services offered in the U.S.A. IBM may not offer the products, services, or features discussed in this document in other countries (or regions). Consult your local IBM representative for information on the products and services currently available in your area. Any reference to an IBM product, program, or service is not intended to state or imply that only that IBM product, program, or service may be used. Any functionally equivalent product, program, or service that does not infringe any IBM intellectual property right may be used instead. However, it is the user's responsibility to evaluate and verify the operation of any non-IBM product, program, or service.

IBM may have patents or pending patent applications covering subject matter described in this document. The furnishing of this document does not give you any license to these patents. You can send license inquiries, in writing, to:

IBM Director of Licensing
IBM Corporation
North Castle Drive
Armonk, NY 10504-1785
U.S.A.

The following paragraph does not apply to the United Kingdom or any other country (or region) where such provisions are inconsistent with local law: INTERNATIONAL BUSINESS MACHINES CORPORATION PROVIDES THIS PUBLICATION "AS IS" WITHOUT WARRANTY OF ANY KIND, EITHER EXPRESS OR IMPLIED, INCLUDING, BUT NOT LIMITED TO, THE IMPLIED WARRANTIES OF NON-INFRINGEMENT, MERCHANTABILITY OR FITNESS FOR A PARTICULAR PURPOSE. Some states (or regions) do not allow disclaimer of express or implied warranties in certain transactions, therefore, this statement may not apply to you.

This information could include technical inaccuracies or typographical errors. Changes are periodically made to the information herein; these changes will be incorporated in new editions of the publication. IBM may make improvements and/or changes in the product(s) and/or the program(s) described in this publication at any time without notice.

Any references in this information to non-IBM web sites are provided for convenience only and do not in any manner serve as an endorsement of those web sites. The materials at those web sites are not part of the materials for this IBM product and use of those web sites is at your own risk.

IBM may use or distribute any of the information you supply in any way it believes appropriate without incurring any obligation to you.

Information concerning non-IBM products was obtained from the suppliers of those products, their published announcements or other publicly available sources. IBM has not tested those products and cannot confirm the accuracy of performance, compatibility or any other claims related to non-IBM products. Questions on the capabilities of non-IBM products should be addressed to the suppliers of those products.

Trademarks

The following are trademarks of International Business Machines Corporation in the United States, or other countries (or regions), or both:

AIX	RS/6000
AS/400	xSeries
IBM	Tivoli
iSeries	TotalStorage
OS/400	xSeries
pSeries	System Storage

The following are U.S. trademarks of Hewlett-Packard Company, International Business Machines Corporation, and Certance.

Linear Tape-Open
LTO
Ultrium

Intel is a registered trademark of Intel Corporation in the United States, or other countries (or regions), or both.

Microsoft, Windows, Windows NT, Windows 2000, and the Windows logo are registered trademarks of Microsoft Corporation in the United States, or other countries (or regions), or both.

Solaris and Sun are registered trademarks of Sun Microsystems Incorporated.

Unix is a trademark of The Open Group in the United States, or other countries or regions, or both.

Other company, product, or service names may be the trademarks or service marks of others.

Electronic Emission Notices

Federal Communications Commission (FCC) Class A Statement

Note: This equipment has been tested and found to comply with the limits for a Class A digital device, pursuant to Part 15 of the FCC Rules. These limits are designed to provide reasonable protection against harmful interference when the equipment is operated in a commercial environment. This equipment generates, uses, and can radiate radio frequency energy and, if not installed and used in accordance with the instruction manual, may cause harmful interference to radio communications. Operation of this equipment in a residential area is likely to cause harmful interference, in which case the user will be required to correct the interference at his own expense.

IBM is not responsible for any radio or television interference caused by unauthorized changes or modifications to this equipment. Unauthorized changes or modifications could void the user's authority to operate the equipment.

This device complies with Part 15 of the FCC Rules. Operation is subject to the following two conditions: (1) this device may not cause harmful interference, and (2) this device must accept any interference received, including interference that may cause undesired operation.

European Union (EU) Electromagnetic Compatibility Directive

This product is in conformity with the protection requirements of EU Council Directive 89/336/EEC on the approximation of the laws of the Member States relating to electromagnetic compatibility. IBM cannot accept responsibility for any failure to satisfy the protection requirements resulting from a non-recommended modification of the product, including the fitting of non-IBM option cards.

This product has been tested and found to comply with the limits for Class A Information Technology Equipment according to European Standard EN 55022. The limits for Class A equipment were derived for commercial and industrial environments to provide reasonable protection against interference with licensed communication equipment.

Attention: This is a Class A product. In a domestic environment this product may cause radio interference in which case the user may be required to take adequate measures.

People's Republic of China Class A Electronic Emission Statement

中华人民共和国“A类”警告声明

声明

此为A级产品，在生活环境中，该产品可能会造成无线电干扰。在这种情况下，可能需要用户对其干扰采取切实可行的措施。

Taiwan Class A Electronic Emission Statement

警告使用者：
這是甲類的資訊產品，在居住的環境中使用時，可能會造成射頻干擾，在這種情況下，使用者會被要求採取某些適當的對策。

taitemi

Japan VCCI Class A ITE Electronic Emission Statement

この装置は、情報処理装置等電波障害自主規制協議会（VCCI）の基準に基づくクラスA情報技術装置です。この装置を家庭環境で使用すると電波妨害を引き起こすことがあります。この場合には使用者が適切な対策を講ずるよう要求されることがあります。

vcci

Industry Canada Class A Emission Compliance Statement

This Class A digital apparatus complies with Canadian ICES-003.

Avis de conformité à la réglementation d'Industrie Canada

Cet appareil numérique de la classe A est conforme à la norme NMB-003 du Canada.

Germany Electromagnetic Compatibility Directive

Zulassungsbescheinigung laut dem Deutschen Gesetz über die elektromagnetische Verträglichkeit von Geräten (EMVG) vom 18. September 1998 (bzw. der EMC EG Richtlinie 89/336)

Dieses Gerät ist berechtigt, in Übereinstimmung mit dem Deutschen EMVG das EG-Konformitätszeichen - CE - zu führen.

Verantwortlich für die Konformitätserklärung nach Paragraph 5 des EMVG ist die: IBM Deutschland Informationssysteme GmbH 70548 Stuttgart.

Informationen in Hinsicht EMVG Paragraph 4 Abs. (1) 4:

Das Gerät erfüllt die Schutzerfordernungen nach EN 55024 und EN 55022 Klasse A.

EN 55022 Klasse A Geräte müssen mit folgendem Warnhinweis versehen werden: "Warnung: dies ist eine Einrichtung der Klasse A. Diese Einrichtung kann im Wohnbereich Funkstörungen verursachen; in diesem Fall kann vom Betreiber verlangt werden, angemessene Maßnahmen durchzuführen und dafür aufzukommen."

Anmerkung: Um die Einhaltung des EMVG sicherzustellen, sind die Geräte wie in den IBM Handbüchern angegeben zu installieren und zu betreiben.

Korean Class A Electronic Emission Statement

이 기기는 업무용으로 전자파 적합등록을 받은 기기 이오니, 판매자 또는 사용자는 이점을 주의하시기 바라며, 만약 잘못 구입하셨을 때에는 구입한 곳에서 비업무용으로 교환하시기 바랍니다.

Glossary

This glossary defines the special terms, abbreviations, and acronyms that are used in this publication. If you do not find the term you are looking for, refer to the index or to the *Dictionary of Computing*, 1994.

Numbers

2:1 compression. The relationship between the quantity of data that can be stored with compression as compared to the quantity of data that can be stored without compression. In 2:1 compression, twice as much data can be stored with compression as can be stored without compression.

A

A. Ampere.

ac. Alternating current.

access method. A technique for moving data between main storage and input or output devices.

adapter card. A circuit board that adds function to a computer.

adj. Adjustment.

AIX. Advanced Interactive Executive. IBM's implementation of the UNIX[®] operating system. The RS/6000 system, among others, uses AIX as its operating system.

alphanumeric. Pertaining to a character set that contains letters, numerals, and usually other characters, such as punctuation marks.

alter. To change.

ambient temperature. The temperature of air or other media in a designated area, particularly the area surrounding equipment.

ampere (A). A unit of measure for electric current that is equivalent to a flow of one coulomb per second, or to the current produced by one volt applied across a resistance of one ohm.

ANSI. American National Standards Institute.

archive. To collect and store files in a designated place.

ASCII. American National Standard Code for Information Interchange. A 7 bit coded character set (8

bits including parity check) that consists of control characters and graphic characters.

assigning a device . The establishing of the relationship of a device to a running task, process, job, or program.

assignment. The naming of a specific device to perform a function.

asynchronous. Pertaining to two or more processes that do not depend upon the occurrence of specific events such as common timing signals.

attention (notice). A word for calling attention to the possibility of danger to a program, device, or system, or to data. Contrast with *caution* and *danger*.

ATTN. Attention.

B

backup. To make additional copies of documents or software for safekeeping.

bar code. A code representing characters by sets of parallel bars of varying thickness and separation which are read optically by transverse scanning.

bar code label. Paper bearing a bar code and having an adhesive backing. The bar code label must be affixed to a tape cartridge to enable the library to identify the cartridge and its volume serial number.

bar code reader. A laser device specialized for scanning and reading bar codes and converting them into either the ASCII or EBCDIC digital character code.

bezel. Decorative and safety cover.

bicolored. Having two colors.

bit. Either of the digits 0 or 1 when used in the binary numbering system.

BM or bill of materials. A list of specific types and amounts of direct materials expected to be used to produce a given job or quantity of output.

browser. A client program that initiates requests to a Web server and displays the information that the server returns.

buffer . A routine or storage used to compensate for a difference in rate of flow of data or time of occurrence of events, when transferring data from one device to another.

bus. A facility for transferring data between several devices located between two end points, only one device being able to transmit at a given moment.

byte. A string consisting of a certain number of bits (usually 8) that are treated as a unit and represent a character. A fundamental data unit.

C

capacity. The amount of data that can be contained on storage media and expressed in bytes of data.

cartridge manual rewind tool. A device that can be fitted into the reel of a cartridge and used to rewind tape into or out of the cartridge.

cartridge storage slot. Individual slot located within a magazine that is used to house tape cartridges.

caution (notice) . A word to call attention to possible personal harm to people. Contrast with *attention* and *danger*.

CE. Customer engineer; field engineer; service representative.

centimeter (cm). One one-hundredth of a meter (0.01 m). Approximately 0.39 inch.

channel command . An instruction that directs a data channel, control unit, or device to perform an operation or set of operations.

char. Character.

CHK. Check.

cleaning cartridge. A tape cartridge that is used to clean the heads of a tape drive. Contrast with *data cartridge*.

command. A control signal that initiates an action or the start of a sequence of actions.

compact disc (CD). A disc, usually 4.75 inches in diameter, from which data is read optically by means of a laser.

compression. The process of eliminating gaps, empty fields, redundancies, and unnecessary data to shorten the length of records or blocks.

concurrent. Refers to diagnostic procedures that can be run on one control unit while the rest of the subsystem remains available for customer applications.

contingent connection. A connection between a channel path and a drive caused when a unit check occurs during an I/O operation.

controller. A device that provides the interface between a system and one or more tape drives.

CP. Circuit protector.

ctrl. Control.

CU. Control unit.

D

danger (notice). A word to call attention to possible lethal harm to people. Contrast with *attention* and *caution*.

data. Any representations such as characters or analog quantities to which meaning is or might be assigned.

data buffer. The storage buffer in the control unit. This buffer is used to increase the data transfer rate between the control unit and the channel.

data cartridge. A tape cartridge dedicated to storing data. Contrast with *cleaning cartridge*.

data check. A synchronous or asynchronous indication of a condition caused by invalid data or incorrect positioning of data.

dc. Direct current.

degauss. To make a magnetic tape nonmagnetic by means of electrical coils carrying currents that neutralize the magnetism of the tape.

degausser. A device that makes magnetic tape nonmagnetic.

degradation . A decrease in quality of output or throughput or an increase in machine error rate.

degraded. Decreased in quality of output or throughput or increased machine error rate.

deserialize. To change from serial-by-bit to parallel-by-byte.

detented. A part being held in position with a catch or lever.

device. Any hardware component or peripheral, such as a tape drive or tape library, that can receive and send data.

device driver. A file that contains the code needed to use an attached device.

DIAG . Diagnostic section of maintenance information manual.

differential. See *High Voltage Differential (HVD)*.

direct access storage. A storage device in which the access time is independent of the location of the data.

download. (1) To transfer programs or data from a computer to a connected device, typically a personal

computer. (2) To transfer data from a computer to a connected device, such as a workstation or microcomputer.

DRAM. Dynamic random-access memory.

drive, magnetic tape . A mechanism for moving magnetic tape and controlling its movement.

DRV. Drive.

DSE. Data security erase.

DSP. Digital signal processor.

E

EBCDIC. Extended binary-coded decimal interchange code.

EC. Edge connector. Engineering change.

ECC. Error correction code.

EEPROM. Electrically erasable programmable read-only memory.

EIA. Electronics Industries Association.

EIA unit. A unit of measure, established by the Electronic Industries Association, equal to 44.45 millimeters (1.75 inches).

eject. To remove or force out from within.

electronic mail. Correspondence in the form of messages transmitted between user terminals over a computer network.

e-mail. See *electronic mail*.

EPO. Emergency power off.

EPROM. Erasable programmable read only memory.

EQC . Equipment check.

equipment check. An asynchronous indication of a malfunction.

Error log. A dataset or file in a product or system where error information is stored for later access.

ESD. Electrostatic discharge.

F

fault symptom code (FSC). A hexadecimal code generated by the drive or the control unit microcode in response to a detected subsystem error.

FC. Feature code.

FCC. Federal communications commission.

FE. Field engineer, customer engineer, or service representative.

fiducial. A target used for teaching a physical location to a robot.

field replaceable unit (FRU). An assembly that is replaced in its entirety when any one of its components fails.

file. A named set of records stored or processed as a unit. Also referred to as a dataset.

file protection. The processes and procedures established in an information system that are designed to inhibit unauthorized access to, contamination of, or deletion of a file.

file transfer protocol (FTP). In the Internet suite of protocols, an application layer protocol that uses TCP and Telnet services to transfer bulk-data files between machines or hosts.

firmware. Proprietary code that is usually delivered as microcode as part of an operating system. Firmware is more efficient than software loaded from an alterable medium and more adaptable to change than pure hardware circuitry. An example of firmware is the Basic Input/Output System (BIOS) in read-only memory (ROM) on a PC motherboard.

FLASH EEPROM. An electrically erasable programmable read-only memory (EEPROM) that can be updated.

FMR. Field microcode replacement.

format. The arrangement or layout of data on a data medium.

formatter. Part of a magnetic tape subsystem that performs data conversion, speed matching, encoding, first level error recovery, and interfaces to one or more tape drives.

FP. File protect.

frayed. Damaged as if by an abrasive substance.

FRU. Field replaceable unit.

FSC. Fault symptom code.

FSI. Fault symptom index.

functional microcode . Microcode that is resident in the machine during normal customer operation.

G

g. Gram.

GB. gigabyte.

GBIC. Gigabit Interface Converter.

Gbi. gigabit

gigabit (Gbit). 1 000 000 000 bits.

gigabyte (GB). 1 000 000 000 bytes.

Gigabit Interface Converter (GBIC). Converts copper interface to optic interface.

gnd. Ground.

H

hertz (Hz). Unit of frequency. One hertz equals one cycle per second.

hex. Hexadecimal.

High Voltage Differential (HVD). A logic signaling system that enables data communication between a supported host and the library. HVD signaling uses a paired plus and minus signal level to reduce the effects of noise on the SCSI bus. Any noise injected into the signal is present in both a plus and minus state, and is thereby canceled. Synonymous with *differential*.

HVD. SCSI Bus High Voltage Differential

Hz . Hertz (cycles per second).

I

IBM Ultrium Tape Drive. Located within the library, a data-storage device that controls the movement of the magnetic tape in an IBM LTO Ultrium Tape Cartridge. The drive houses the mechanism (drive head) that reads and writes data to the tape.

ID. Identifier.

identifier (ID). (1) In programming languages, a lexical unit that names a language object; for example, the names of variables, arrays, records, labels, or procedures. An identifier usually consists of a letter optionally followed by letters, digits, or other characters. (2) One or more characters used to identify or name data element and possibly to indicate certain properties of that data element. (3) A sequence of bits or characters that identifies a program, device, or system to another program, device, or system.

IML. Initial microprogram load.

initial microprogram load (IML) . The action of loading a microprogram from an external storage to writable control storage.

initiator. The component that executes a command. The initiator can be the host system or the tape control unit.

INST. Installation.

interface. A shared boundary. An interface might be a hardware component to link two devices or it might be a portion of storage or registers accessed by two or more computer programs.

interposer. The part used to convert a 68-pin connector to a 50-pin D-shell connector.

intervention required. Manual action is needed.

INTRO. Introduction.

I/O. Input/output.

IOP. Input/output processor.

IPL. Initial program load.

ITST. Idle-time self-test.

K

kilogram (kg). One thousand grams (approximately 2.2 pounds).

km. kilometer. 1000 Meters, Approximately 5/8 mile.

L

LAN . Local area network. A computer network within a limited area.

LCD. See *liquid crystal display*.

LED. Light-emitting diode.

Linear Tape-Open (LTO). A type of tape storage technology developed by the IBM Corporation, Hewlett-Packard, and Certance. LTO technology is an "open format" technology, which means that its users will have multiple sources of product and media. The "open" nature of LTO technology enables compatibility between different vendors' offerings by ensuring that vendors comply with verification standards. The LTO technology is implemented in two formats: the Accelis format focuses on fast access; the Ultrium format focuses on high capacity. The Ultrium format is the preferred format when capacity (rather than fast access) is the key storage consideration. An Ultrium cartridge has a compressed data capacity of up to 800 GB (2:1 compression) and a native data capacity of up to 400 GB.

liquid crystal display (LCD). A low-power display technology used in computers and other I/O devices.

loadable. Having the ability to be loaded.

LTO cartridge memory (LTO-CM). Within each LTO Ultrium data cartridge, an embedded electronics and

interface module that can store and retrieve a cartridge's historical usage and other information.

LVD. SCSI Bus Low Voltage Differential

M

magnetic tape. A tape with a magnetical surface layer on which data can be stored by magnetic recording.

MAP. Maintenance analysis procedure.

mask. A pattern of characters that controls the retention or elimination of portions of another pattern of characters. To use a pattern of characters to control the retention or elimination of portions of another pattern of characters.

master file. A file used as an authority in a given job and that is relatively permanent, even though its contents may change. Synonymous with main file.

MB. Mega Byte (usually expressed as data rate in MB/s or MB/second).

media capacity. The amount of data that can be contained on a storage medium, expressed in bytes of data.

media-type identifier. Pertaining to the bar code on the bar code label of the IBM Ultrium Tape Cartridge, a 2-character code, L1, that represents information about the cartridge. L identifies the cartridge as one that can be read by devices which incorporate LTO technology; 1 indicates that it is the first generation of its type.

mega. One million of.

meter. In the Metric System, the basic unit of length; equal to approximately 39.37 inches.

micro. One millionth of.

microcode. (1) One or more micro instructions. (2) A code, representing the instructions of an instruction set, implemented in a part of storage that is not program-addressable. (3) To design, write, and test one or more micro instructions. (4) See also *microprogram*.

microdiagnostic routine. A program that runs under the control of a supervisor, usually to identify field replaceable units.

microdiagnostic utility. A program that is run by the customer engineer to test the machine.

microinstruction. A basic or elementary machine instruction.

microprogram. A group of microinstructions that when executed performs a preplanned function.

The term microprogram represents a dynamic arrangement or selection of one or more groups of

microinstructions for execution to perform a particular function. The term microcode represents microinstructions used in a product as an alternative to hard-wired circuitry to implement certain functions of a processor or other system component.

MIM. Media information message.

mm. Millimeter.

modifier. That which changes the meaning.

mount a device. To assign an I/O device with a request to the operator.

MP. Microprocessor.

ms. Millisecond.

MSG. Message.

multipath. Pertaining to using more than one path.

N

N/A. Not applicable.

node. In a network, a point at which one or more functional units connect channels or data circuits.

NVS. Nonvolatile storage. A storage device whose contents are not lost when power is cut off.

O

oersted. The unit of magnetic field strength in the unrationalized centimeter-gram-second (cgs) electromagnetic system. The oersted is the magnetic field strength in the interior of an elongated, uniformly wound solenoid that is excited with a linear current density in its winding of one abampere per 4π centimeters of axial length.

offline. Pertaining to the operation of a functional unit without the continual control of a computer. Contrast with *online*.

online. Pertaining to the operation of a functional unit that is under the continual control of a computer. Contrast with *offline*.

OPER. Operation.

ov. Over voltage.

overrun. Loss of data because a receiving device is unable to accept data at the rate it is transmitted.

overtightening. To tighten too much.

P

parameter. A variable that is given a constant value for a specified application and that may denote the application.

p bit. Parity bit.

PC. Parity check.

PCC. Power control compartment.

PDF. Portable Document Format.

PE. Parity error. Product engineer.

pick. Pertaining to the library, to remove, by means of a robotic device, a tape cartridge from a storage slot or drive.

picker. A robotic mechanism located inside the library that moves cartridges between the cartridge storage slots and the drive.

PM . Preventive maintenance.

POR. Power-on reset.

port. A physical connection for communication between the 3590 and the host processor. The 3590 has two SCSI ports.

Portable Document Format (PDF). A standard specified by Adobe Systems, Incorporated, for the electronic distribution of documents. PDF files are compact, can be distributed globally (via e-mail, the Web, intranets, or CD-ROM), and can be viewed with the Acrobat Reader, which is software from Adobe Systems that can be downloaded at no cost from the Adobe Systems home page.

PROM. Programmable read only memory.

PS. Power supply.

PWR. Power.

R

rack. A unit that houses the components of a storage subsystem, such as the library.

rackmount kit. A packaged collection of articles used to install the rack mounted version of the library.

RAM. Random access memory.

Random access memory. A storage device into which data is entered and from which data is retrieved in a nonsequential manner.

RAS. Reliability, availability, and serviceability.

record. A collection of related data or words, treated as a unit.

recording density. The number of bits in a single linear track measured per unit of length of the recording medium.

recoverable error. An error condition that allows continued execution of a program.

ref. Reference.

reg. Register.

reinventor. To inventory again.

retension. The process or function of tightening the tape onto the cartridge, if it is sensed that the tape has a loose wrap on the cartridge.

robot. Picker.

robotics. Picker assembly.

RPQ. Request for price quotation.

R/W. Read/write.

S

s. Seconds of time.

SAC. Service Action Code. Code developed to indicate possible FRU or FRU's to replace to repair the hardware.

scratch cartridge. A data cartridge that contains no useful data, but can be written to with new data.

SCSI. Small computer system interface.

segment. A part.

sel. Select.

serialize. To change from parallel-by-byte to serial-by-bit.

serializer. A device that converts a space distribution of simultaneous states representing data into a corresponding time sequence of states.

servo, servos. An adjective for use in qualifying some part or aspect of a servomechanism.

servomechanism. A feedback control system in which at least one of the system signals represents mechanical motion.

Small Computer Systems Interface (SCSI). A standard used by computer manufacturers for attaching peripheral devices (such as tape drives, hard disks, CD-ROM players, printers, and scanners) to computers (servers). Pronounced "scuzzy". Variations of the SCSI

interface provide for faster data transmission rates than standard serial and parallel ports (up to 160 megabytes per second). The variations include:

- **Fast/Wide SCSI:** Uses a 16-bit bus, and supports data rates of up to 20 MBps.
- **SCSI-1:** Uses an 8-bit bus, and supports data rates of 4 MBps.
- **SCSI-2:** Same as SCSI-1, but uses a 50-pin connector instead of a 25-pin connector, and supports multiple devices.
- **Ultra SCSI:** Uses an 8- or 16-bit bus, and supports data rates of 20 or 40 MBps.
- **Ultra2 SCSI:** Uses an 8- or 16-bit bus and supports data rates of 40 or 80 MBps.
- **Ultra3 SCSI:** Uses a 16-bit bus and supports data rates of 80 or 160 MBps.
- **Ultra160 SCSI:** Uses a 16-bit bus and supports data rates of 80 or 160 MBps.

SNS. Sense.

special feature. A feature that can be ordered to enhance the capability, storage capacity, or performance of a product, but is not essential for its basic work.

SR. Service representative, see also *CE*.

SRAM. Static random access memory.

SS. Status store.

ST. Store.

standard feature . The significant design elements of a product that are included as part of the fundamental product.

START. Start maintenance.

subsystem. A secondary or subordinate system, usually capable of operating independently of, or asynchronously with, a controlling system.

SUPP. Support.

sync. Synchronous, synchronize. Occurring with a regular or predictable time relationship.

T

tachometer, tach. A device that emits pulses that are used to measure/check speed or distance.

tape cartridge. A container holding magnetic tape that can be processed without separating it from the container.

tape void. An area in the tape in which no signal can be detected.

TCP/IP. Transmission Control Protocol/Internet Protocol.

TCU. Tape control unit.

TH. Thermal.

thread/load operation. A procedure that places tape along the tape path.

TM. Tapemark.

U

UART. Universal asynchronous receiver/transmitter.

unload. Prepare the tape cartridge for removal from the drive.

utilities. Utility programs.

utility programs. A computer program in general support of the processes of a computer; for instance, a diagnostic program.

uv . Under voltage.

V

VOLSER. Volume serial number.

volume. A certain portion of data, together with its data carrier, that can be handled conveniently as a unit.

VPD. Vital product data. The information contained within the tape drive that requires nonvolatile storage used by functional areas of the drive, and information required for manufacturing, RAS, and engineering.

W

word. A character string that is convenient for some purpose to consider as an entity.

Write. Write command.

WT. world trade.

X

XR. External register.

XRA. External register address register.

Index

A

- Access Door 1-3
- add 11-1, 11-5

B

- Bar Code Labels 8-4
 - guidelines for using 8-6
 - ordering 8-19
- Bar Code Scanner
 - diagnostic 10-36

C

- Cables
 - host cabling diagnostic 10-38
 - reseating 9-13
- capacity expansion feature license 1-9
- capacity view 5-4
- cartridge
 - assignment 4-1
- Cartridge 1-14, 8-1
 - capacity scaling 8-2, 8-3
 - cleaning 8-4
 - compatibility 8-2
 - data 8-2
 - disposal of 8-17
 - environmental specifications 1-14
 - export 1-3
 - import 1-3
 - leader pin 8-10
 - manually inspect destination element 10-35
 - manually recover from Picker 10-34
 - manually recovering from source or destination slot 10-35
 - memory chip 8-4
 - ordering 8-18
 - proper handling 8-7
 - shipping specifications 1-14
 - specifications 8-17
 - write-protect switch 8-7
- cartridge assignment 4-1
- cartridges 7-15
 - cleaning
 - importing 6-6
 - data
 - bulk loading 6-6
 - importing 6-6
 - exporting 7-16
 - exporting cleaning 7-17
 - importing 7-15
 - importing cleaning 7-16
 - moving 7-16
- channel calibration 1-9
- cleaning cartridges
 - exporting 7-17
 - importing 6-6, 7-16
- cleaning slots
 - assign 7-3

- cleaning slots (*continued*)
 - assigning 6-4
- code update
 - library and code feature 1-11
- column coordinates 1-13
- compact flash card
 - remove 11-14
 - replace 11-14
- Compact Flash Card
 - remove/replace 11-11
- components 11-1
 - front panel 1-2
 - access door 1-3
 - control module 1-2
 - expansion module 1-3
 - I/O Station 1-3
 - Operator Panel 1-4
 - power button 1-4
 - interior 1-6
 - picker assembly 1-7
 - robotic system 1-7
 - Storage column 1-7
 - rear panel 1-5
 - drives 1-5
 - Library Control Blade 1-5
 - power supply 1-6
- configuration 6-1
 - access the Setup Wizard 6-3
 - applying a license key 4-2
 - assigning cleaning slots 6-4
 - assigning I/O slots 6-5
 - assigning logical libraries 6-5
 - cleaning slots 4-2
 - creating user accounts 4-6
 - deleting user accounts 5-1
 - drive IDs 4-4
 - drive types 4-4
 - ensure hardware is installed 6-3
 - entering license keys 6-4
 - host-based drive cleaning 4-3
 - I/O stations 4-3
 - importing cleaning cartridges 6-6
 - importing data cartridges 6-6
 - log in 6-2
 - logical libraries 4-4
 - changing access 4-5
 - changing modes 4-5
 - create automatically 4-4
 - delete 4-5
 - modifying network settings 4-1
 - modifying user accounts 4-7
 - planning 4-1
 - registering for My Support 6-7
 - setting the date and time 6-5
 - setting up library network 6-3
 - user accounts 4-6
- control module 1-2
- control path drive 7-14
- control path failover 1-11, 2-3
- control path failover feature license 1-9

- control paths
 - additional, role in reducing library failure 1-15
 - multiple 2-2
 - multiple paths for iSeries and as/400 2-3
 - using multiple for control path failover 2-3

D

- data cartridges
 - bulk loading 6-6
 - exporting 7-16
 - importing 6-6, 7-15
 - moving 7-16
- data path failover 1-11
- data path failover feature license 1-9
- Data paths
 - multiple 2-3
- date 7-5
 - setting 6-5
- depth of tape library 1-15
- description of library 1-1
- Device drivers supported 1-17
- Diagnostic Resolution
 - DR001 10-34
 - DR002 10-35
 - DR003 10-35
 - DR004 10-35
 - DR005 10-35
 - DR006 10-36
 - DR007 10-36
 - DR009 10-37
 - DR010 10-37
 - DR011 10-38
 - DR012 10-38
 - DR014 10-39
 - DR015 10-39
 - DR018 10-40
 - DR019 10-40
 - DR020 10-40
 - DR021 10-41
 - DR022 10-41
 - DR024 10-41
 - DR026 10-42
 - DR028 10-42
 - DR029 10-43
 - DR030 10-43
 - DR031 10-43
 - DR032 10-44
 - DR033 10-44
 - DR034 10-44
 - DR035 10-45
 - DR036 10-45
- Diagnostic Resolutions 10-1, 10-34
- dimensions of tape library 1-15
- Doors
 - Access 1-3
 - DR001 10-34
 - DR002 10-35

- DR003 10-35
- DR004 10-35
- DR005 10-35
- DR006 10-36
- DR007 10-36
- DR009 10-37
- DR010 10-37
- DR011 10-38
- DR012 10-38
- DR014 10-39
- DR015 10-39
- DR018 10-40
- DR019 10-40
- DR020 10-40
- DR021 10-41
- DR022 10-41
- DR024 10-41
- DR026 10-42
- DR028 10-42
- DR029 10-43
- DR030 10-43
- DR031 10-43
- DR032 10-44
- DR033 10-44
- DR034 10-44
- DR035 10-45
- DR036 10-45

- drive
 - add new 11-5
- Drive 1-5
 - channel calibration 1-9
 - control path failure 10-44
 - coordinates 1-13
 - determining SCSI and Fibre Channel IDs 2-4
 - general diagnostic 10-36
 - LEDs 9-10
 - load failure 10-43
 - loss of communication 10-43
 - manually clean 10-40
 - power management 1-9
 - remove 11-8
 - sled not auto leveling 10-44
 - speed matching 1-9
 - unload diagnostic 10-35
- drive dump 7-15
- drive sled
 - description 1-8
 - remove/replace 11-5
- drives 7-13
 - adding control path 7-14
 - capturing a dump 7-15
 - dumps 7-15
 - fibre channel IDs 2-5
 - IDs 7-14
 - loading 7-14
 - modifying fibre settings 7-15
 - online/offline 7-14
 - SCSI IDs 2-4
 - unloading 7-14
 - viewing information 7-13

E

- email 7-5
- environment 1-16
 - operating 1-16

- environment (*continued*)
 - particulates 1-16
- Error codes
 - Service Action Tickets 10-1
- error messages
 - viewing 7-9
- Error messages
 - operator intervention 9-2
- errors
 - obtaining from library and drives A-1
 - RS/6000 A-1
- errpt command, using A-1
- expansion module 1-3
 - connectivity diagnostic 10-37

F

- feature licenses
 - capacity expansion 1-9
 - control path failover 1-9, 1-11
 - data path failover 1-9, 1-11
 - path failover 1-9, 1-11
- features
 - optional 1-8
 - capacity expansion 1-9
 - drives 1-8
 - firmware update by IBM service personnel 1-11
 - license keys 1-9
 - path failover 1-11
 - redundant power supply 1-9
- Fibre Channel
 - drive IDs 2-5
 - supported topologies 2-6
- Fibre Channel drive
 - compatibility with Multi-Path Architecture 1-15
- Fibre Channel interface 2-10
 - cables and speeds 2-10
 - connectors and adapters 2-11
 - LUN assignments 2-7
 - persistent binding 2-10
 - sharing on a SAN 2-11
 - World Wide names 2-7
 - zoning 2-10
- firmware
 - upgrades 7-10
- Firmware
 - drive 7-11, 7-12
 - FMR tape 7-12
 - creating 7-13
 - library 7-10
 - updating
 - using Fibre Channel interface 7-13
 - using ITDT Tool 7-11
 - using SCSI interface 7-13
- foot pads
 - remove 11-21
 - replace 11-21
- front panel
 - access door 1-3
 - control module 1-2
 - expansion module 1-3
 - I/O Station 1-3
 - Operator Panel 1-4

- front panel (*continued*)
 - power button 1-4

G

- gear rack alignment 11-22
- glossary F-1

H

- height of tape library 1-15
- host
 - sharing library 1-15
- hp-ux system error information A-9

I

- I/O slots
 - assign 7-4
 - assigning 6-5
- I/O Station 1-3
 - close door 10-41
 - lock diagnostic 10-38
 - locking/unlocking 7-10
- IBM Ultrium Tape Drive 1-8
- install planning 2-1
- installation 3-1
 - cabling a 14U library with SCSI drives 3-31
 - cabling a 5U library 3-30
 - cabling the library 3-30
 - configuring the library 3-34
 - desktop 3-10
 - identifying location 3-13
 - installing a drive 3-28
 - installing a power supply 3-29
 - installing components removed for weight reduction 3-28
 - placing the library 3-25
 - planning 2-1
 - powering on the library 3-34
 - rack 3-4, 3-5, 3-11, 3-12, 3-13, 3-16, 3-25, 3-26, 3-28, 3-29
 - rack ears 3-26
 - rails 3-16
 - reducing library weight 3-4
 - removing drive 3-5
 - removing power supply 3-5
 - unpacking shipment 3-1
 - verifying kit contents 3-12
 - verifying shipment 3-1
- interfaces, supported 1-8
- interior components 1-6
 - picker assembly 1-7
 - robotic system 1-7
 - Storage column 1-7
- inventory library 10-40

K

- Keyboards 5-3

L

- Labels
 - bar code 8-4
 - guidelines for using 8-6
 - ordering 8-19
- LEDs
 - drive 9-10
 - fibre port link 9-10
 - interpreting 9-6
 - library control blade 9-8, 9-9
 - picker 9-12
 - power supply 9-11
- library and drive code update 1-11
- library configuration form D-1
- library control blade
 - resetting the IP address 7-5
- Library Control Blade 1-5
 - remove/replace 11-11
- library conversions
 - desktop to rack mount 11-19
 - rack mount to desktop 11-19
- library information 7-9
- library log
 - capturing 7-9
- library snapshot
 - capturing 7-9
- library state required 11-1
- Library Verify Test 7-2, 10-38
 - bar code scanner diagnostic 10-36
 - general drive diagnostic 10-36
 - motion failure diagnostic 10-35
- license keys 7-4
 - entering 6-4
- location coordinates 1-11
 - columns 1-13
 - drives 1-13
 - modules 1-12
 - power supplies 1-13
 - slots 1-13
- logical libraries
 - assigning 6-5
 - create manually 4-5
 - creating 7-3
 - delete 7-3
 - determining number 2-1
 - basic guidelines 2-1
 - modify 7-3
 - offline 7-7
 - online 7-7
 - sharing 1-15
 - using multiple for sharing 2-2
- logs
 - capturing 7-15
 - e-mailing 9-16
- low voltage differential (LVD) SCSI
 - interface 1-8
- low-power mode 1-9
- LVD SCSI interface 1-8

M

- media 1-14
- Media 8-1
 - cartridge
 - environmental specifications 1-14
 - shipping specifications 1-14

- Media (*continued*)
 - unsupported format diagnostic 10-39
 - Write Protect or WORM Diagnostic 10-39
- Menus
 - Operator Panel 5-4
- mixed drive types, protection against
 - non-support 1-15
- module coordinates 1-12
- motion obstructed 10-42
- Multi-Path Architecture 1-15
- Multiple control paths 2-2
- My Support
 - registering 6-7

N

- network managing 7-6
 - SNMP Version 7-7
 - SSL 7-6
 - trap registration 7-6
- notifications 7-5

O

- operating procedures 7-1
 - library 7-2
 - logical libraries 7-2
 - viewing system information 7-2
- operating systems supported 1-17
- operator interventions 9-2
- operator panel
 - login 5-3
- Operator Panel 1-4, 5-1, 5-2
 - capacity view 5-4
 - common elements 5-2
 - header elements 5-2
 - keyboards 5-3
 - menus 5-4
 - subsystem status 5-2
 - system summary 5-2

P

- partitioning capability of SAN-ready
 - Multi-Path Architecture 1-15
- parts list 12-1
- path failover 1-11
- path failover feature license 1-9
- Picker
 - blown fuse 10-45
 - LEDs 9-12
 - manually recover cartridge 10-34
 - motion failure 10-35
 - not initializing 10-43
- picker assembly 1-7
- power
 - AC failure 10-37
 - specifications 1-15
- power button 1-4
- power cords 12-1
- power management 1-9
- power plugs 12-1
- power supply 1-6
 - adding redundant 11-4
 - coordinates 1-13

- power supply (*continued*)
 - LEDs 9-11
 - missing 10-41
 - redundant 1-9
 - remove/replace 11-2
 - removing primary 11-4
 - removing redundant 11-5
 - replacing primary 11-4
- powering on the library 3-34
- Pre-call checklist 9-17
- problem reporting 9-1
- problem solving 9-2

R

- rear panel 1-5
 - drives 1-5
 - Library Control Blade 1-5
 - power supply 1-6
- redundant power supply 1-9
- remote access 7-7
- remove 11-1
- repair preparation 11-2
- repairs 11-2
- replace 11-1
- restarting the library 7-8, 7-9
- returning library to normal
 - operations 11-2
- robotic system 1-7
- RS/6000
 - error information A-1

S

- SCSI
 - drive IDs 2-4
- SCSI IDs 2-4
- SCSI interface 2-8
 - bus termination 2-9
 - connectors and adapters 2-9
 - description 1-8
 - multiple buses 2-9
 - physical characteristics 2-8
- Sense data
 - using C-1
- server attachment 2-8
 - SCSI interface 2-8
- servers supported 1-17
- Service
 - contact information 10-41
- Service Action Ticket
 - T001 10-1
 - T002 10-2
 - T003 10-3
 - T004 10-4
 - T005 10-5
 - T006 10-6
 - T007 10-7
 - T008 10-7
 - T009 10-8
 - T010 10-9
 - T013 10-9
 - T017 10-11
 - T018 10-11
 - T019 10-11
 - T020 10-12

Service Action Ticket (continued)

T021 10-13
T022 10-13
T023 10-14
T024 10-14
T025 10-14
T031 10-15
T032 10-15
T033 10-16
T034 10-16
T035 10-17
T036 10-17
T037 10-17
T038 10-17
T039 10-18
T040 10-18
T041 10-18
T045 10-19
T046 10-19
T047 10-19
T048 10-20
T049 10-20
T050 10-21
T051 10-21
T052 10-21
T060 10-22
T062 10-22
T063 10-23
T064 10-24
T065 10-24
T066 10-25
T067 10-25
T068 10-26
T069 10-26
T070 10-26
T071 10-27
T072 10-27
T073 10-28
T074 10-28
T075 10-29
T076 10-29
T077 10-30

Service Action Tickets 10-1

Setup Wizard

accessing 6-3, 7-2

Sharing the library 2-1

shutting down the library 7-8

sled, description of tape drive 1-8

slot coordinates 1-13

SNMP Version 7-7

software supported 1-17

Specifications

cartridges 8-17

library 1-15

speed matching 1-9

SSL 7-6

Storage column 1-7

subsystem status 5-2

system information 7-2

system summary 5-2

T

T001 10-1
T002 10-2
T003 10-3
T004 10-4

T005 10-5
T006 10-6
T007 10-7
T008 10-7
T009 10-8
T010 10-9
T013 10-9
T017 10-11
T018 10-11
T019 10-11
T020 10-12
T021 10-13
T022 10-13
T023 10-14
T024 10-14
T025 10-14
T031 10-15
T032 10-15
T033 10-16
T034 10-16
T035 10-17
T036 10-17
T037 10-17
T038 10-17
T039 10-18
T040 10-18
T041 10-18
T045 10-19
T046 10-19
T047 10-19
T048 10-20
T049 10-20
T050 10-21
T051 10-21
T052 10-21
T060 10-22
T062 10-22
T063 10-23
T064 10-24
T065 10-24
T066 10-25
T067 10-25
T068 10-26
T069 10-26
T070 10-26
T071 10-27
T072 10-27
T073 10-28
T074 10-28
T075 10-29
T076 10-29
T077 10-30
tape cartridge 1-14
Tape drive
LUN assignments 2-4
Tape drives
channel calibration 1-9
power management 1-9
quantity in library 1-8
speed matching 1-9
TapeAlert Flags
for drives B-1
technical support 9-17
time 7-5
setting 6-5
trap registration 7-6
troubleshooting 9-1

U

Ultrium Tape Drives 1-8
unsupported configuration 10-42
Updating firmware
using Fibre Channel interface 7-13
using ITDT Tool 7-11
using SCSI interface 7-13
user accounts
creating 7-4
user interfaces 5-1
Operator Panel 5-2
user privileges 5-8
web user interface 5-7
user privileges 5-8

V

voltage 1-15

W

Web User Interface 5-1, 5-7
logging in 5-7
menus 5-7
screen elements 5-7
weight of library components 1-15
width of tape library 1-15
write-protect switch
setting 8-7
Write Protect Switch Setting B-2

Readers' Comments — We'd Like to Hear from You

IBM System Storage TS3310 Tape Library
Setup and Operator Guide
Machine Type 3576

Publication No. GA32-0477-01

Overall, how satisfied are you with the information in this book?

	Very Satisfied	Satisfied	Neutral	Dissatisfied	Very Dissatisfied
Overall satisfaction	<input type="checkbox"/>	<input type="checkbox"/>	<input type="checkbox"/>	<input type="checkbox"/>	<input type="checkbox"/>

How satisfied are you that the information in this book is:

	Very Satisfied	Satisfied	Neutral	Dissatisfied	Very Dissatisfied
Accurate	<input type="checkbox"/>	<input type="checkbox"/>	<input type="checkbox"/>	<input type="checkbox"/>	<input type="checkbox"/>
Complete	<input type="checkbox"/>	<input type="checkbox"/>	<input type="checkbox"/>	<input type="checkbox"/>	<input type="checkbox"/>
Easy to find	<input type="checkbox"/>	<input type="checkbox"/>	<input type="checkbox"/>	<input type="checkbox"/>	<input type="checkbox"/>
Easy to understand	<input type="checkbox"/>	<input type="checkbox"/>	<input type="checkbox"/>	<input type="checkbox"/>	<input type="checkbox"/>
Well organized	<input type="checkbox"/>	<input type="checkbox"/>	<input type="checkbox"/>	<input type="checkbox"/>	<input type="checkbox"/>
Applicable to your tasks	<input type="checkbox"/>	<input type="checkbox"/>	<input type="checkbox"/>	<input type="checkbox"/>	<input type="checkbox"/>

Please tell us how we can improve this book:

Thank you for your responses. May we contact you? Yes No

When you send comments to IBM, you grant IBM a nonexclusive right to use or distribute your comments in any way it believes appropriate without incurring any obligation to you.

Name

Address

Company or Organization

Phone No.



Fold and Tape

Please do not staple

Fold and Tape



NO POSTAGE
NECESSARY
IF MAILED IN THE
UNITED STATES

BUSINESS REPLY MAIL

FIRST-CLASS MAIL PERMIT NO. 40 ARMONK, NEW YORK

POSTAGE WILL BE PAID BY ADDRESSEE

International Business Machines Corporation
Information Development
Department GZW
9000 South Rita Road
Tucson, Arizona U.S.A. 85775-4401



Fold and Tape

Please do not staple

Fold and Tape



Part Number: 23R7499

Printed in USA

GA32-0477-01



(1P) P/N: 23R7499

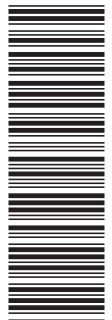

Spine information:



IBM System Storage TS3310 Tape
Library

TS3310 Tape Library Setup and Operator Guide

Machine Type 3576