A photograph of two men in business suits running on a track. One man is in the foreground, leaning forward, holding a briefcase. The other man is behind him, also running. The background is a blurred track with white lane markings. The image is overlaid with large, semi-transparent circles in shades of blue and red.

The next step in
IT optimization
begins here

IT Service Management

Alan Ganek

CTO, Tivoli Software

VP, Autonomic Computing

A horizontal bar with several colored segments: green, yellow, red, purple, cyan, and grey.A row of small icons: a server rack, a circular arrow, a woman's face, a hand holding a pen, and a hand holding a device.

Tivoli software

ON DEMAND BUSINESS™

Agenda

- IT challenges and trends
- IBM's management vision and approach
- IT Service Management solutions for System z
- Next steps to realizing the value of ITSM



“What matters is how satisfied customers are, how costs are being saved on the supplier side, and how to allow for more creativity and added value at all levels of the organization.” --Erik Brynjolfsson, Director of the Center for eBusiness at MIT

The Challenge: IT Organizations Are Under Tremendous Pressure



- **Change:** Market demands, workloads, service levels
- **Compliance:** Regulations, security, audit capabilities
- **Complexity:** Heterogeneous resources, silos, composite applications
- **Cost:** Management and administration



“We’re trying to resolve a huge morass of IT complexity, while demand for our services keeps going up. We’re getting hit from both sides. So what are we doing about it? We’re delivering an adaptive IT organization that provides services on demand to support the needs of the business.”

George Surdu, Director, Global Information Technology Infrastructure, Ford Motor Company, September 2005

IT Infrastructure Trends – Increasing Complexity

Complexity of today's composite applications...



"... most **Global 2000 companies support 500-1000 applications**, and the majority of these are not of the shrink-wrapped variety."

"Application Management Poll Reveals New Trends"
Cameron Haight
Gartner April 2004

...make managing IT infrastructure
a different challenge every day.

"**Composite applications** have contributed to increased management complexity. Organizations need to be able to maximize the potential for these types of applications by **ensuring that robust management processes are in place – across the application lifecycle.**"

Cameron Haight
Gartner February 2005

IT Infrastructure Trends – Compliance

The changing global regulatory and business environment requires security, privacy, and ongoing audit capabilities.



"On a typical day, the security team logs 38,000 attempts – by unauthorized individuals or automated probes – to access the state's networks. **That's about one every 2.3 seconds.**"

"Defending Data: a Never-Ending Vigil"

*Todd Spangler quoting Dan Lohrman, Chief Security Officer for the State of Michigan
Baseline, 2004*

IT Infrastructure Trends – Speed of Change

Rising workloads in a volatile business climate, make meeting service level expectations a daunting challenge.



“... the largest z/OS installations **have more than doubled their ‘MIPS to head count’ ratio.**”

“Find the Right Staffing Level for Your z/OS Data Center”
L. Mieritz, M. Willis-Fleming
Gartner, February 2004

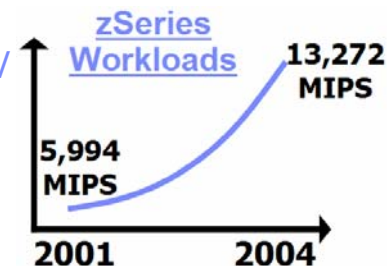

“Business activity across our applications is in constant flux. The correct settings for performance yesterday will be different from what it needs to be today, and different from what it will need to be tomorrow.”

Ken Van Kley, Blue Cross Blue Shield Illinois

Distributed Server spending vs management costs

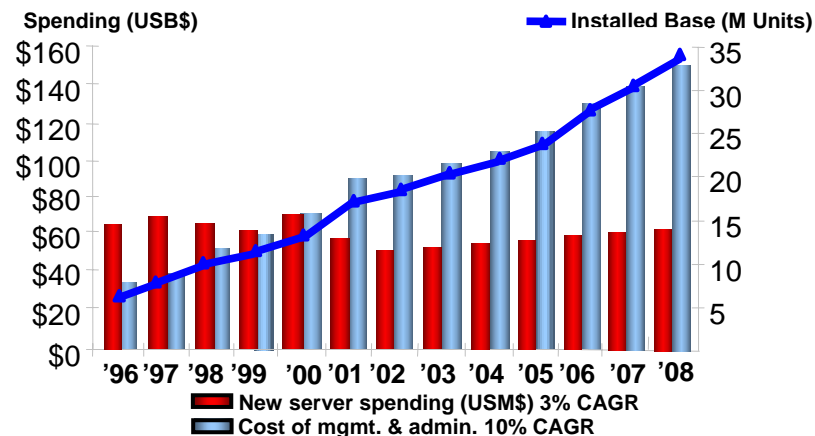

IT Infrastructure Trends – Cost

Decrease in Efficiency as IT Spending Shifts to Operations Labor

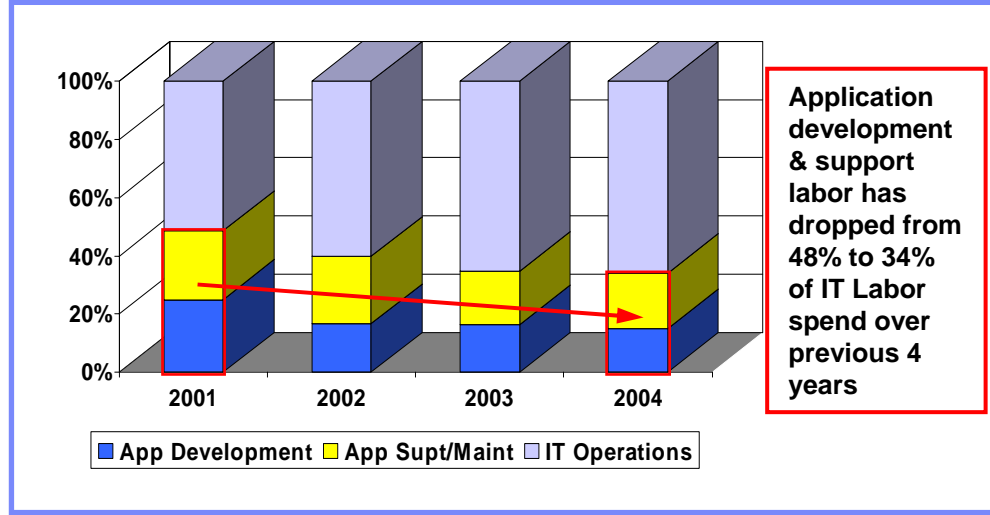
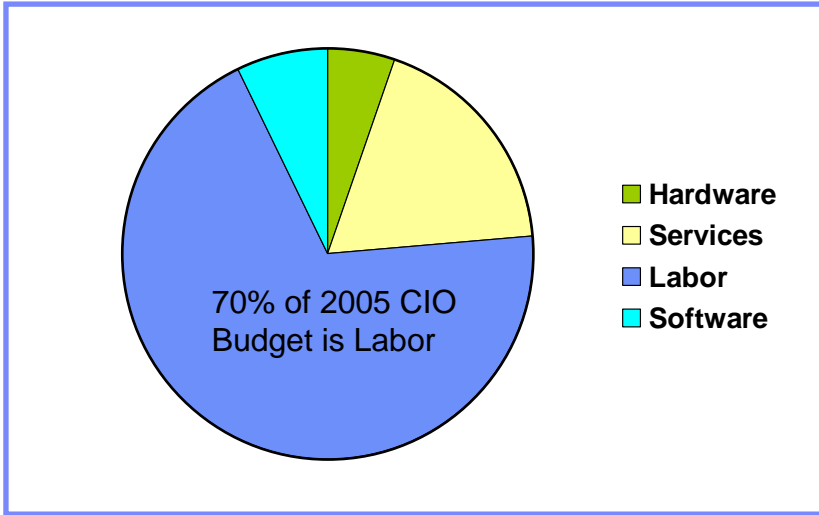

- 70% of CIO budget is labor
- Operations labor will be 73% of CIO labor budgets by 2008
- Application development will decline at -10% CGR to 2008
- \$325B in operations labor by 2008

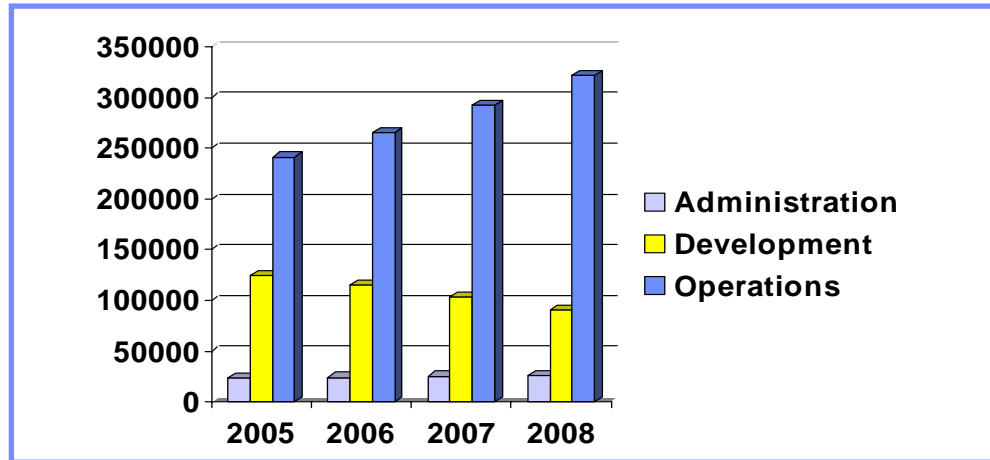

Source: Tivoli Commissioned IDC Study 1Q05

Source: Gartner Group, IT spending and staffing surveys

Architectural Complexity Exposes Organizational Complexity

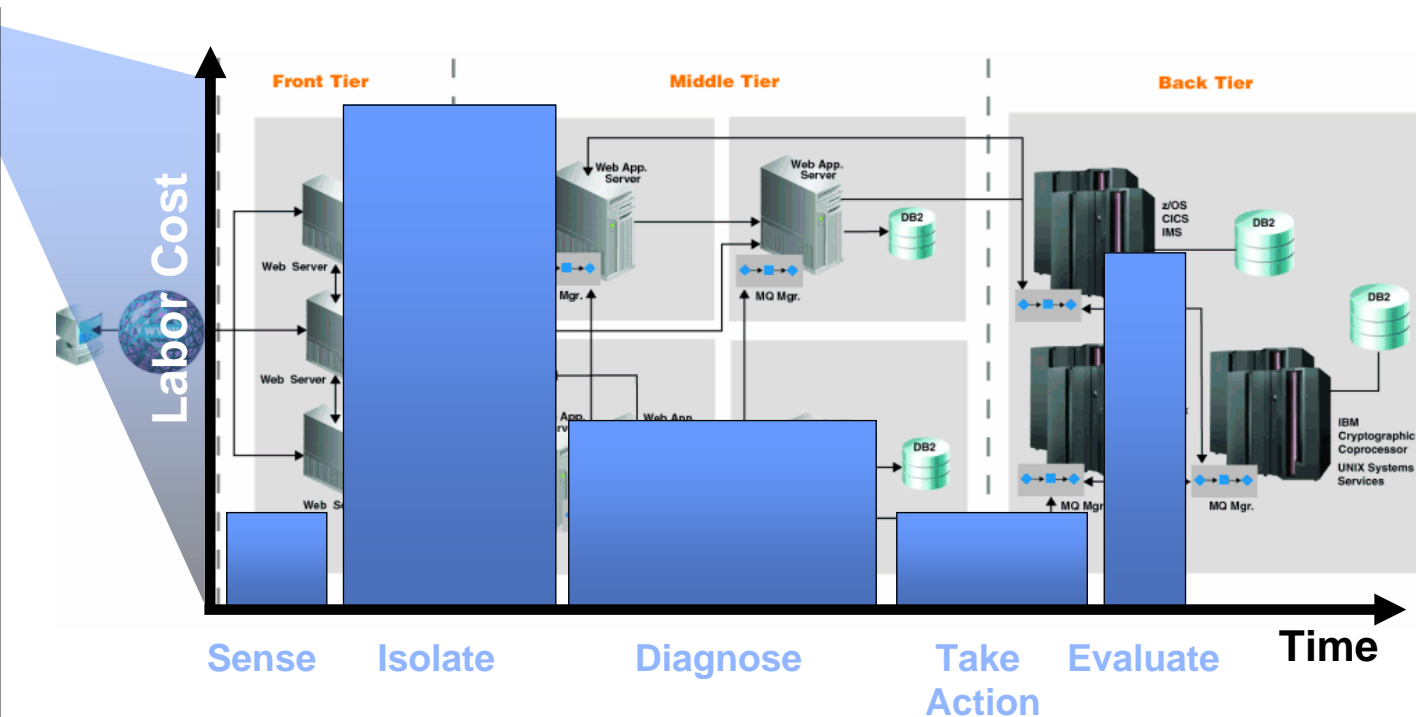
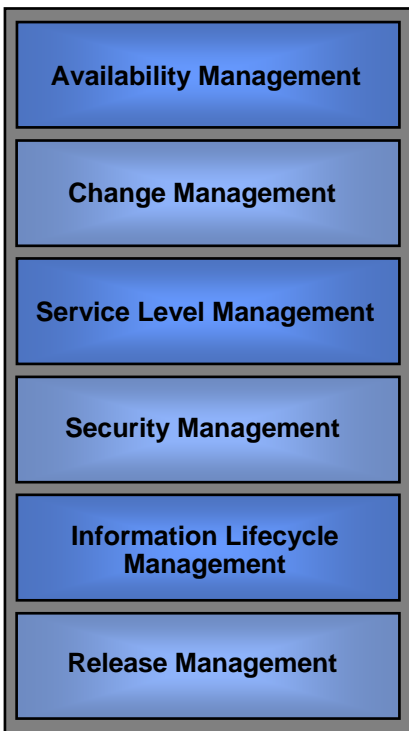
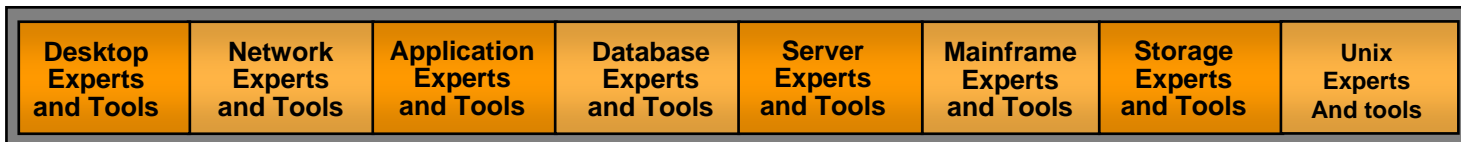

IT Vision: Managing IT Like a Business

Effective and efficient delivery of IT services in support of business goals

Desktop Experts and Tools	Network Experts and Tools	Application Experts and Tools	Database Experts and Tools	Server Experts and Tools	Mainframe Experts and Tools	Storage Experts and Tools	Unix Experts And tools
---------------------------	---------------------------	-------------------------------	----------------------------	--------------------------	-----------------------------	---------------------------	------------------------

Availability Management
Change Management
Service Level Management
Security Management
Information Lifecycle Management
Release Management

Technology

- Infrastructure Management technologies and products for resilient services
- Integrates self-managing autonomic technologies

Information

- Information for the technologies that act on it
- Standardized and centralized view of information

People

- Governance establishes the decision framework
- Organization functions in clearly understood roles

Processes

- Integrated to enable increased value add from IT Services
- Automation of process and service workflows to reduce costs

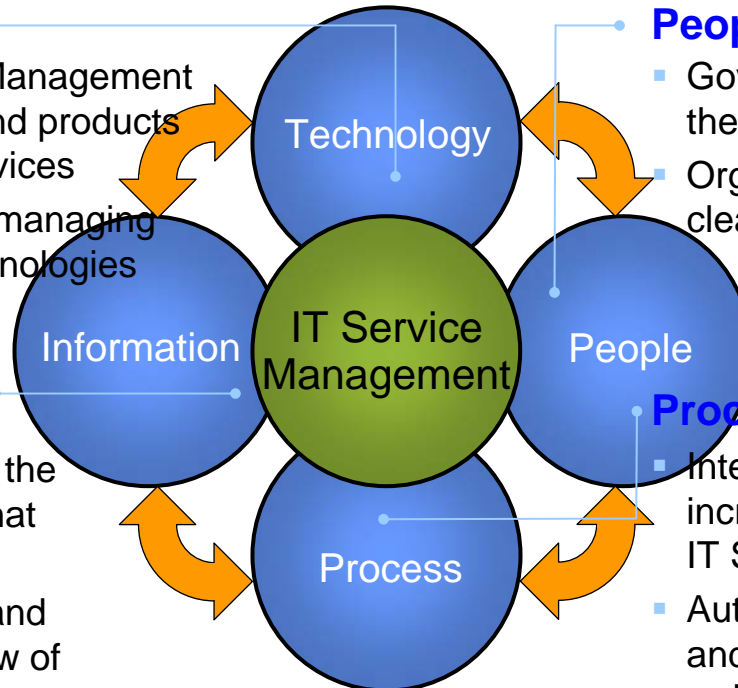

Putting IT Service Management into Action

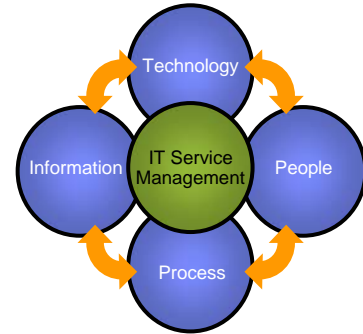

IBM IT Service Management

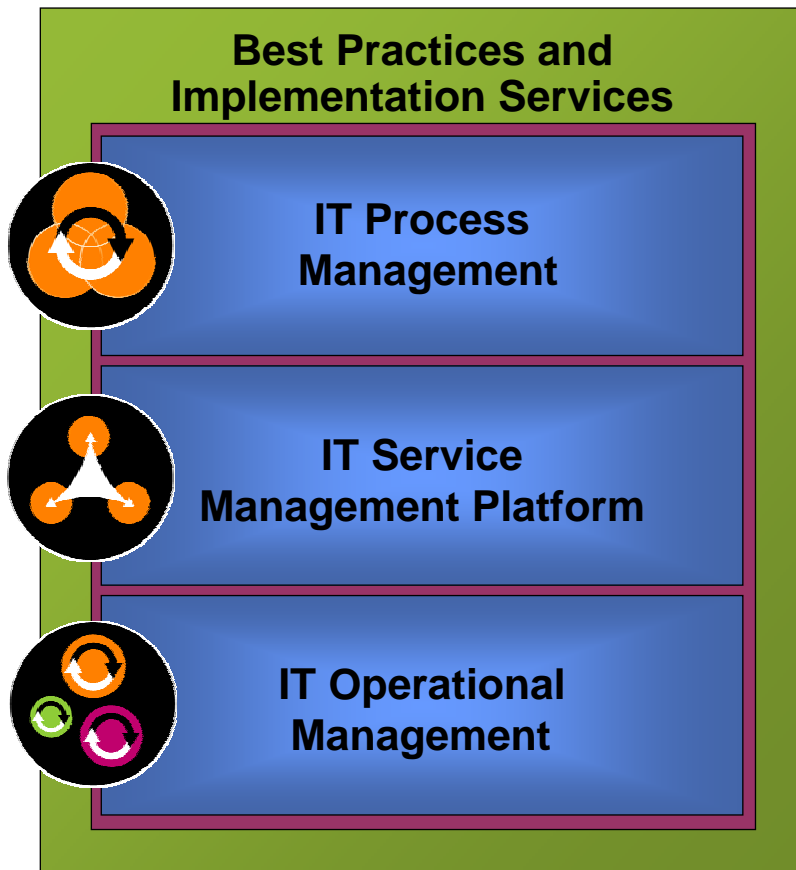

- Automated ITIL-aligned workflows
- Open, standards-based CMDB and workflow engine
- Automated infrastructure-aligned tasks
- Best Practices and Implementation Support
- Built on SOA and Autonomic Computing Technologies

IBM IT Service Management

A Differentiated, Flexible Approach

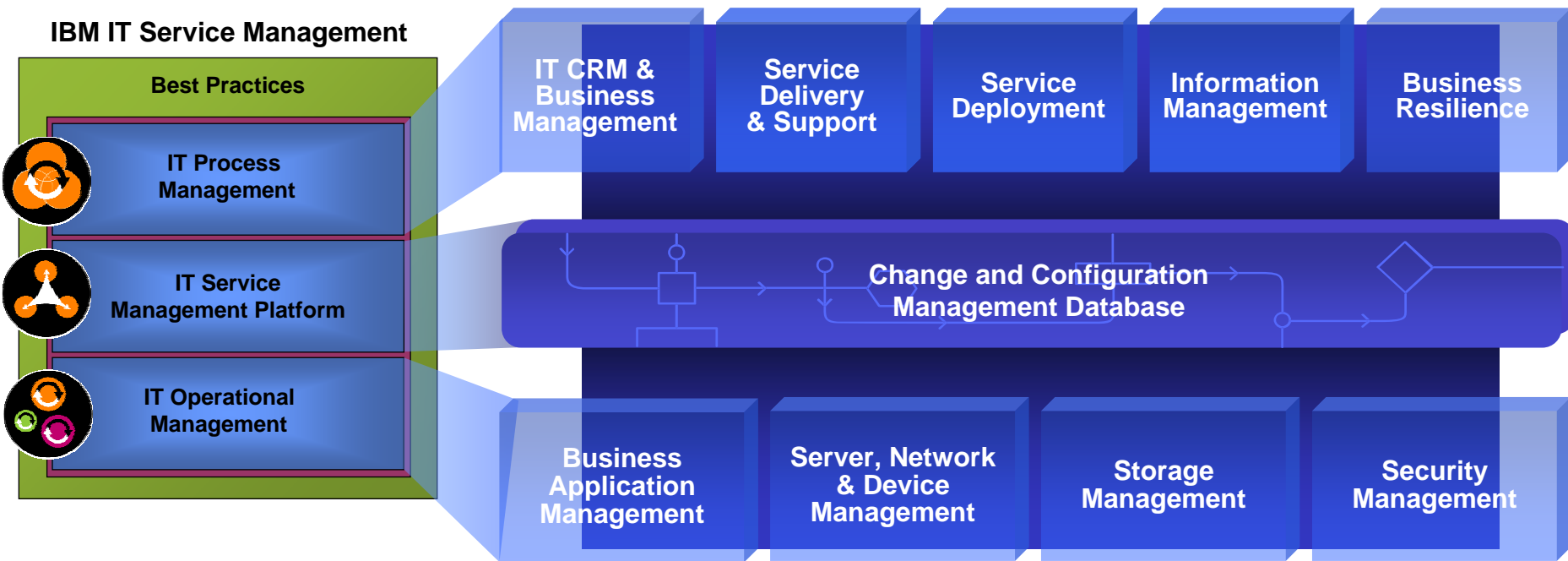

ITSM Process Managers: Automated Management of Your Key Business Processes Right Out of the Box

- Packaged solutions with predefined processes
- Improves customer focus and satisfaction
- Integrates with Tivoli and non-Tivoli products
- Assists in regulatory compliance

IBM IT Service Management

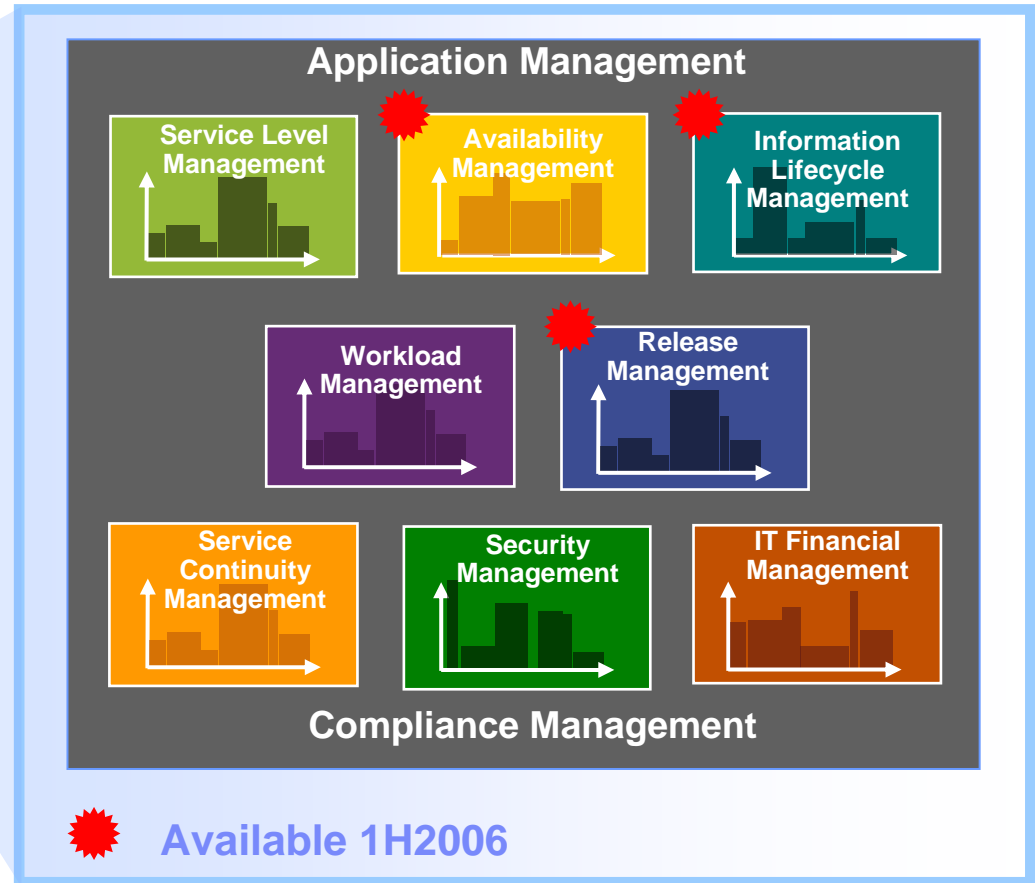
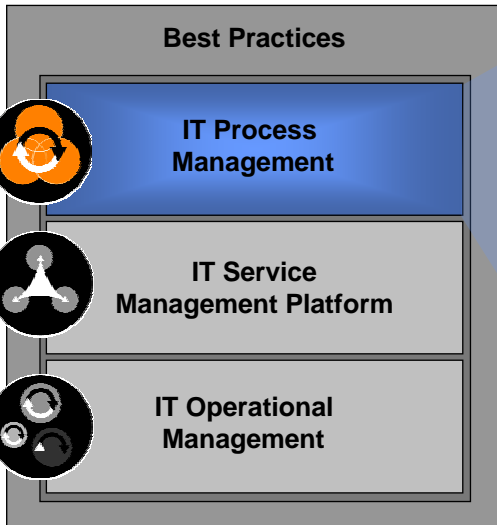

Tivoli Change and Configuration Management Database – A Platform for IT Service Management

Based on proven IBM technology:



IBM IT Service Management

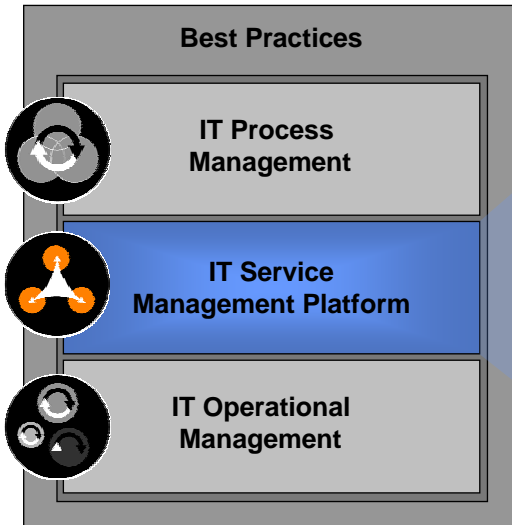

- **Configuration Management Database**
 - Open, federated model
 - API and GUI reporting access
- **Workflow Engine**
 - Based on WebSphere technology
 - Process modeling and simulation
 - Automated process execution
 - Real-time monitoring and reporting
- **Automated Process Workflows**
 - Change & configuration management

Limited availability now

Tivoli IT Service Management Technology & Products

– Leverage Current Technology and Products

IBM IT Service Management

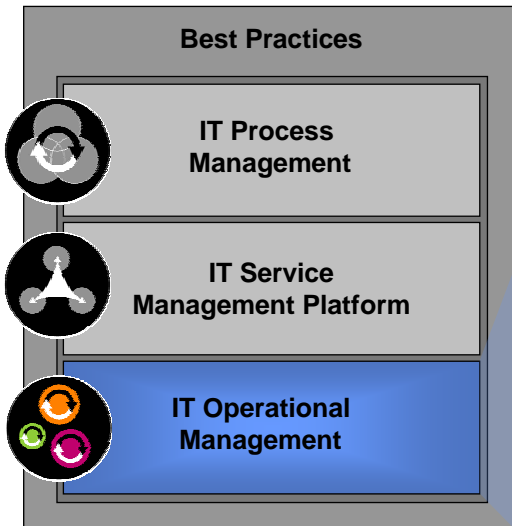

Automation



- Tivoli Business Systems Manager
- Tivoli Enterprise Console
- Tivoli Monitoring
- Tivoli NetView
- Tivoli OMEGAMON XE
- Tivoli Systems Automation
- Tivoli Workload Scheduler
- Tivoli License Management

Security



- Tivoli Access Manager
- Tivoli Identity Manager
- Tivoli Federated Identity Manager

Storage



- Tivoli Storage Manager
- Tivoli Continuous Data Protection
- Total Storage Productivity Center

Leverage Best Practices and Implementation Support from IBM

Open Process Automation Library (OPAL)

IBM Global Services

- Innovation Workshops
- Infrastructure Services Readiness Engagement
- IT Service Management Design
- Implementation Services

Ecosystem of System Integrators and Business Partners

- Vision Creation Workshops
- Readiness Assessments
- ITIL Process Design
- Consulting and outsourcing services
- Implementation and deployment services

IBM Tivoli Unified Process

- IBM Process Reference Model for IT incorporates ITIL, COBIT, and IBM best practice processes in a complete, cohesive model
- Tools Mentor - make ITIL actionable!

IBM IT Service Management

Best Practices



IT Process Management



IT Service Management Platform



IT Operational Management

What Our Customers Are Saying...

“ The IBM approach to IT Service Management is taking Enterprise Systems Management at Ford to a new level. Optimization of both the IT infrastructure and IT processes will help to make ITIL best practices a reality and Ford a more flexible, dynamic organization.”



- George Surdu, Director Information Technology Infrastructure, Ford Motor Company

“ With their new IT Service Management strategy, IBM Tivoli is now really focused on the big picture – not only delivering tools, but an integrated combination of tools, sharing their data through a central database and supporting ITIL processes.”



- Andres Golombek, IT Production, Commerzbank

“ IT Service Management is a never ending story, and while implementing ITIL best practices has value, they are only part of the story. The IBM IT Service Management strategy promises to provide greater value through enhanced process integration and visualization.”



- Yves Vlamijnck - Team manager Network & IT Monitoring, Belgacom



DMdata Improves Problem Determination with Autonomic Computing Technology

The Challenge

Problem determination and resolution across a large scale heterogeneous complex infrastructure must be efficient and fast to maintain a high level of service for customers

The Solution

Autonomic Computing Technology from IBM to import and convert multiple log files in different formats using the *Generic Log Adapter* to a standardized structure enabling cross-domain, chronological correlation with the *Log and Trace Analyzer*



Technology Benefits:

- z/OS and TBSM log conversion to industry standard WSDM Event Format (WEF), for a consistent view across multiple components
- Use of the Log Analyzer for a consistent log view and time-based correlation of log data across the infrastructure

On demand Business Benefits

- Improved availability and resilience for DMdata's customers
- Improved problem determination process

'It is not just about the fact that use of Common Base Events and the Log Analyzer reduces the time required for causal analysis of problems by at least 50% - but that it removes the need for Swat Teams searching across multiple logs for hours. Problem Determination is more or less impossible for some outages – this approach makes it possible!' – Kurt Kristiansen, General Manager, DMdata

ITSM Maximizes The Value of IBM Mainframes for Your On Demand Business

- ▶ **IT Service Management: The future of systems management**
- ▶ **No better foundation for ITSM than the mainframe and System z**
- ▶ **In an industry bombarded by constant change, mainframe remains a dependable platform**
- ▶ **Many reasons behind mainframe's enduring success:**
 - Low cost of ownership
 - High availability ...reliability ... scalability ... and security
 - The benchmark in Autonomic Computing capability
- ▶ **We're committed to bringing mainframe solutions that:**
 - Expand mainframe capabilities while enhancing its proven strengths
 - Reduce the costs associated with operations and systems management



Most Extensive Portfolio for Mainframe Management

BUSINESS SERVICE MANAGEMENT

- IBM Tivoli Business Systems Manager
- IBM Tivoli Service Level Advisor

INFRASTRUCTURE MANAGEMENT

- IBM Tivoli Information Management for z/OS
- IBM Tivoli Performance Modeler for z/OS
- IBM Tivoli Decision Support for z/OS
- IBM Tivoli Decision Support Accounting Workstation

AVAILABILITY PERFORMANCE MANAGEMENT

- IBM Tivoli OMEGAMON XE on z/OS
- IBM Tivoli OMEGAMON XE for CICS on z/OS
- IBM Tivoli OMEGAMON XE for IMS on z/OS
- IBM Tivoli OMEGAMON XE for DB2 on z/OS
- IBM Tivoli OMEGAMON XE for Databases
- IBM Tivoli OMEGAMON XE for Mainframe Networks
- IBM Tivoli OMEGAMON XE for Storage on z/OS
- IBM Tivoli OMEGAMON XE for USS
- IBM Tivoli OMEGAMON XE for Linux on zSeries
- IBM Tivoli OMEGAMON for z/VM
- IBM Tivoli Monitoring for Web Infrastructure for z/OS

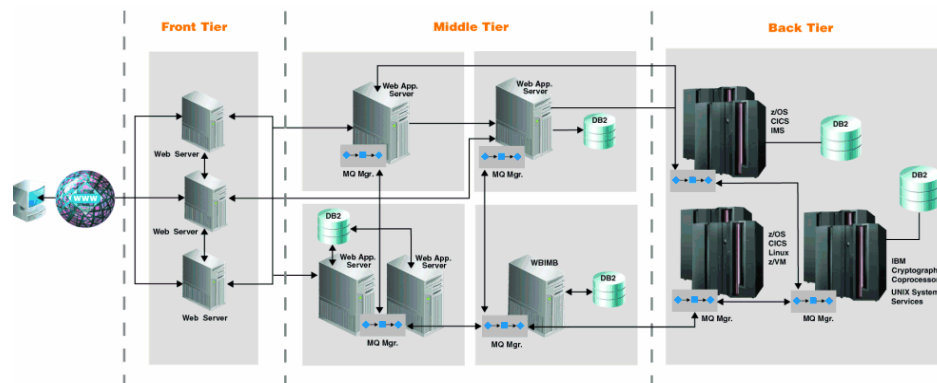

COMPOSITE APPLICATION MANAGEMENT

- IBM Tivoli Composite Application Manager for SOA on z/OS
- IBM Tivoli OMEGAMON XE for WebSphere Application Server on z/OS
- IBM WebSphere Studio Application Manager
- IBM Tivoli Monitoring for Transaction Performance for z/OS

OPERATIONS MANAGEMENT

- IBM Tivoli NetView for z/OS
- IBM Tivoli System Automation for z/OS
- IBM NetView Access Services for MVS
- IBM Tivoli AF/Operator
- IBM Tivoli AF/Remote

Continued Commitment to Our Mainframe Customers

SECURITY MANAGEMENT

- IBM Tivoli Access Manager for Business Integration
- IBM Tivoli Access Manager for e-Business
- IBM Tivoli Security Administrator for RACF
- Vanguard Security Center
- Vanguard Administrator
- Vanguard Analyzer
- Vanguard Enforcer
- Vanguard Advisor

OPTIMIZATION PRODUCTION CONTROL

- IBM Tivoli Workload Scheduler for Host Edition
- IBM Tivoli Output Manager for z/OS
- IBM Tivoli Automated Tape Allocation Manager for z/OS
- IBM Tivoli Allocation Optimizer for z/OS
- Diversified Software Systems (DSSI)
- Job/SCAN
- Docu/TEXT



COMPLIANCE

- IBM Tivoli License Compliance Manager for z/OS
- IBM Tivoli Contract Compliance Manager

STORAGE MANAGEMENT

- IBM Tivoli Storage Manager for z/OS
- IBM Tivoli Storage Optimizer for z/OS



Simplify z/OS Operations with Tivoli Enterprise Portal

-- New management console integrates tools, data and processes

Business Services **Distributed Resources** **J2EE Transactions** **Mainframe Resources**

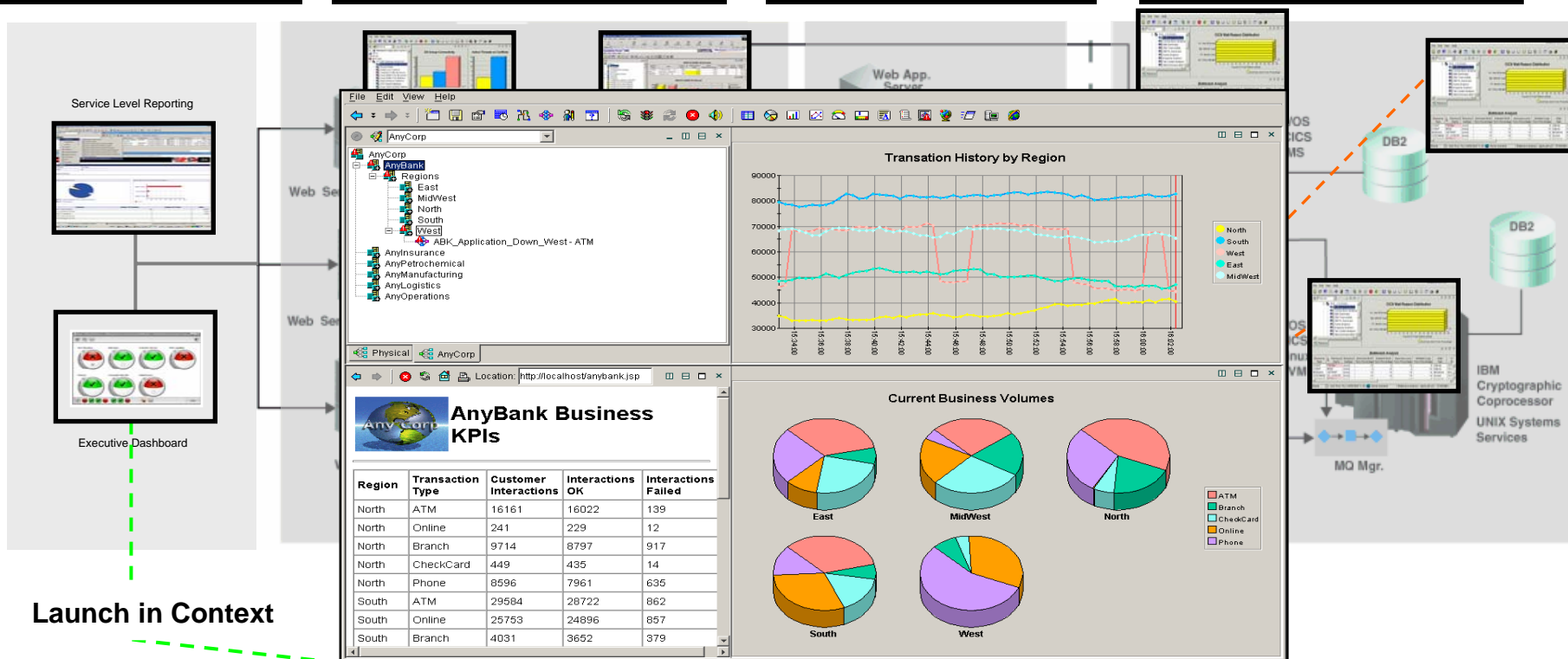

Launch in Context

Everything at your Fingertips

← **End-to-End Management** →

Advanced Monitoring and Managing of Mainframe Performance

Enhanced! **IBM Tivoli OMEGAMON XE for IBM System z9 and eServer zSeries**

- Proactively manage your mainframe infrastructure
- Quickly identify and solve system delays by analyzing bottlenecks and building a detailed picture of resource usage
- Integrates with Tivoli Enterprise Portal

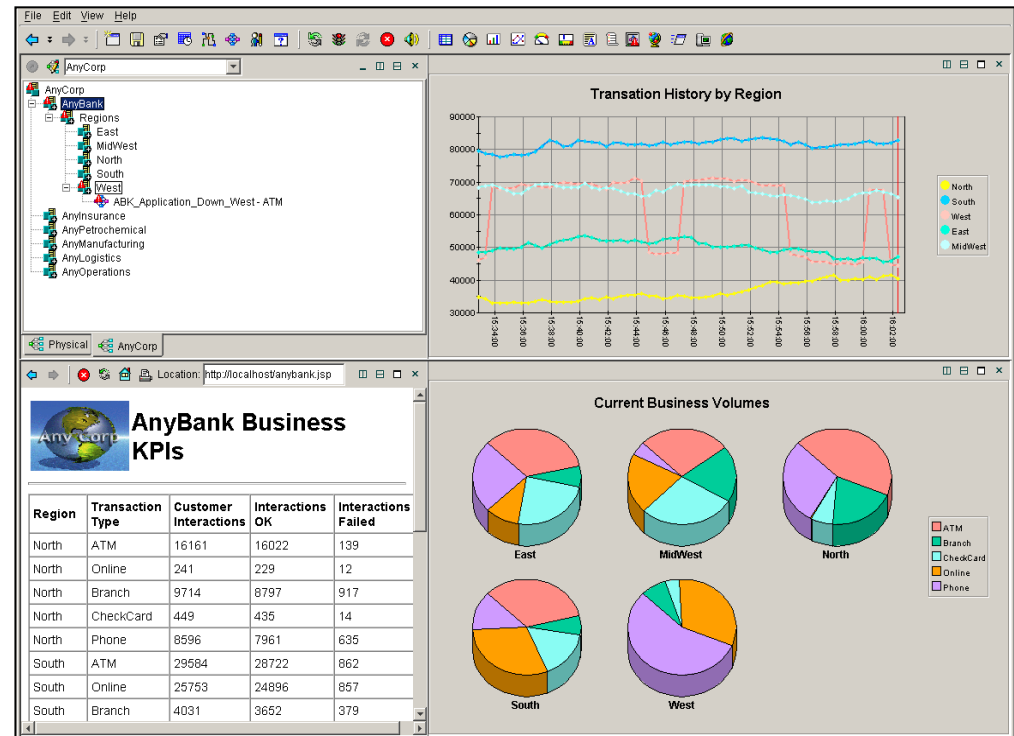

Exceptional Availability Management of Mainframe Networks

Enhanced!

IBM Tivoli NetView for z/OS

- Improve network and system availability by managing both mainframe TCP/IP and SNA networks
- Manage larger networks, more resources and more systems with fewer resources and personnel
- Integrates with Tivoli solutions to provide comprehensive, seamless availability management across your IT environment

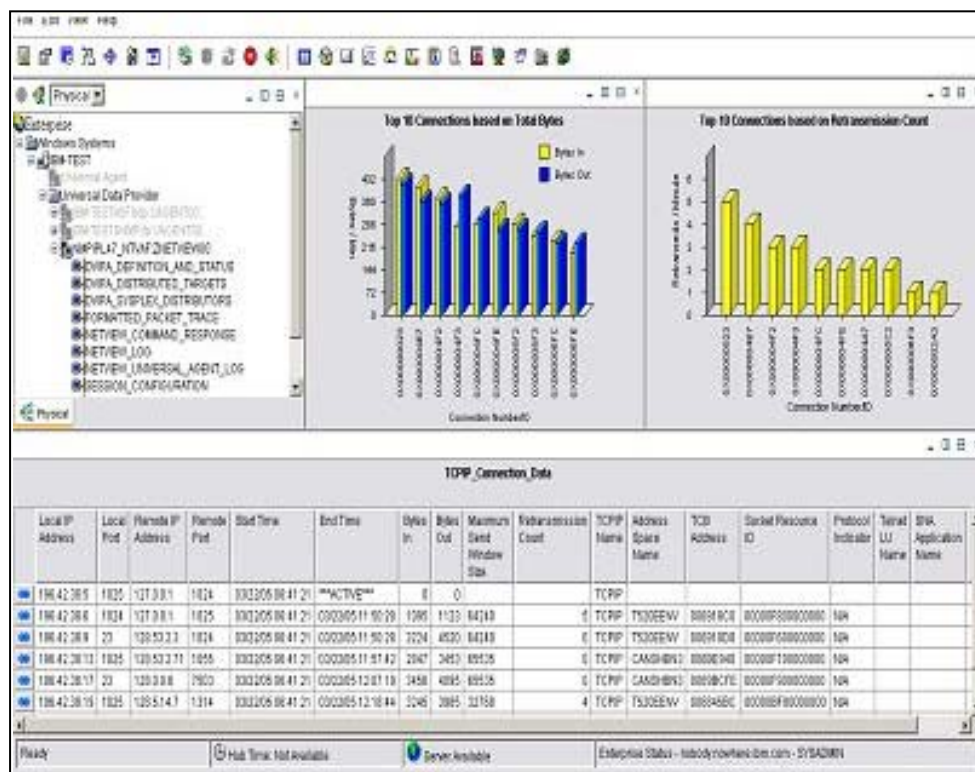

Automated Management for z/OS and Multiplatform Environments

Enhanced!

IBM Tivoli System Automation z/OS & Multiplatform

- High availability for critical business applications through policy-based self-healing
- Automate the process of bringing up and down composite applications and supporting resources
- Pre-packaged best practices for SAP, Siebel, WebSphere and more

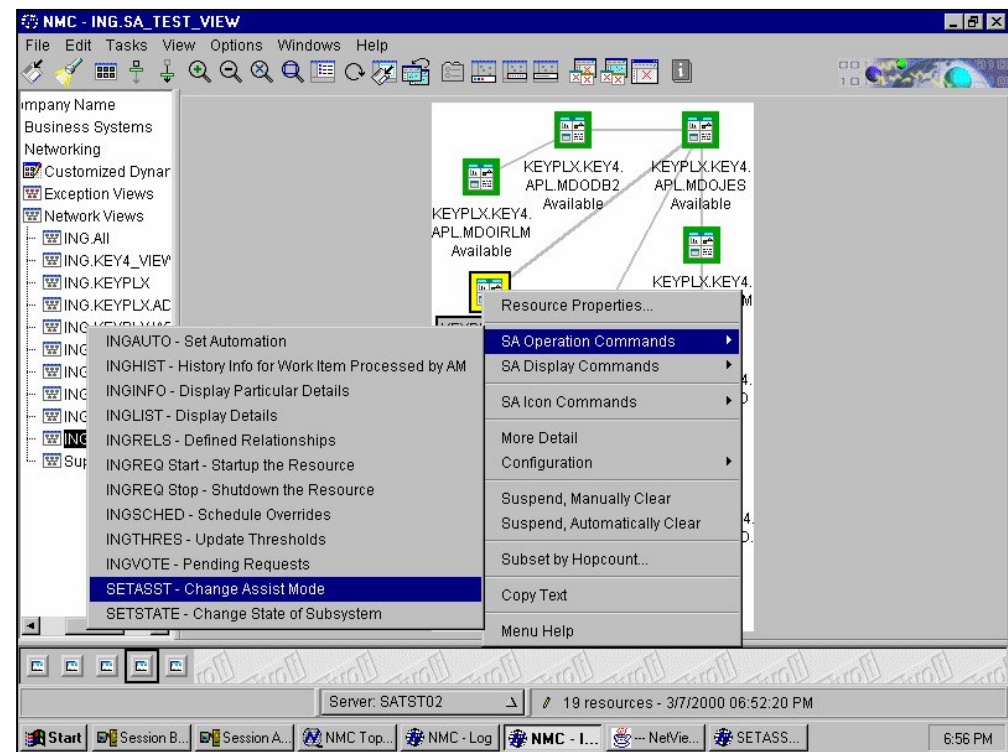

System Automation for z/OS in the TEP (4Q06)

```

INGKYSTO
Domain ID = IPUNG
Operator ID = WAS
CMD: A Update B Start C Stop D INGRELS E INGVOTE F INGINFO
      G Members H DISPTRG I INGSCHED J INGGROUP M DISPMTR / scroll
CMD Name
ALWA
AMSI
AMSI
AMSI
AOC1
AOC1
APLM
APLM
ASSI
ASSI
BZOE
CAPM
CAPM
CAPM
CHIL
CHIL
CHIL
CHIL
CHIL
CHIL
EICI
EICI
EIDB
EIDB
Command
PF1=Hel
        
```

SA z/OS - Command Dialogs Line 1 of 125

Date = 05/28/05
Time = 13:46:24

Sysplex = AOC1PLEX

File Edit View Help

Physical

- Enterprise
- Sysplex1
- Sysplex2
 - Coupling Facility Systems Data
 - Coupling Facility Structures Data
 - Coupling Facility Paths Data
 - XCF Systems Data
 - XCF Path Data
 - Automation Data
 - System Images
 - LPAR1 (z/OS image)
 - LPAR2 (z/OS image)
 - LPAR3 (z/OS image)
 - Address Space Data
 - Operations Stats
 - Paging Data

INGLIST Compound Status

Take Action

Action Name: <Select Action>

Command:

Arguments...

Destination System(s):

Run

INGLIST													
Name	Type	System	Compound	Desired	Observed	Nature	Automation	Startable	Health	Auto	Hold	Description	
ALWAYSUP	APL	AOC1	SATISFACTORY	AVAILABLE	AVAILABLE		IDLE	YES	N/A	YES	NO	Appl linked to always UP high pri SVP	
AMSINGLE	APG	AOC1	SATISFACTORY	AVAILABLE	AVAILABLE	BASIC	INTERNAL	YES	N/A	YES	NO	Automation managers for single systems	
AMSINGLE	APL	AOC1	SATISFACTORY	AVAILABLE	AVAILABLE		IDLE	YES	N/A	YES	NO	Real appl : Prim. AM for single systems	
AMINGL2	APL	AOC1	SATISFACTORY	AVAILABLE	AVAILABLE		IDLE	YES	N/A	YES	NO	Real appl : Secnd. AM for single systems	
AOC1	SYG	AOC1	PROBLEM	AVAILABLE	PROBLEM	BASIC	INTERNAL	YES	NORMAL	YES	NO		
AOC1	SYS	AOC1	SATISFACTORY	AVAILABLE	AVAILABLE		IDLE	YES	N/A	YES	NO		
APLMTRA	APL	AOC1	SATISFACTORY	AVAILABLE	AVAILABLE		IDLE	YES	NORMAL	YES	NO	API with monitor routine MTRA	
APLMTRB	APL	AOC1	SATISFACTORY	AVAILABLE	AVAILABLE		IDLE	YES	NORMAL	YES	NO	APL with monitor MTRB1, MTRB2, MTRB3	
ASSISTD	APL	AOC1	SATISFACTORY	AVAILABLE	AVAILABLE		IDLE	YES	N/A	YES	NO	Application with assist mode (Display)	
ASSISTL	APL	AOC1	SATISFACTORY	AVAILABLE	AVAILABLE		IDLE	YES	N/A	YES	NO	Application with assist mode (Log)	
BZOENEW	APL	AOC1	SATISFACTORY	AVAILABLE	AVAILABLE		IDLE	YES	N/A	YES	NO	Class for emulation appls	
CAPMSBLA	APL	AOC1	SATISFACTORY	AVAILABLE	AVAILABLE		IDLE	YES	N/A	YES	NO	APL with Captured Messages Limit = 0	
CAPMSBLB	APL	AOC1	SATISFACTORY	AVAILABLE	AVAILABLE		IDLE	YES	N/A	YES	NO	APL with Captured Messages Limit = 10	
CAPMSBLC	APL	AOC1	SATISFACTORY	AVAILABLE	AVAILABLE		IDLE	YES	N/A	YES	NO	APL with Captured Messages Limit = 999	
CAPMSBLD	APL	AOC1	SATISFACTORY	AVAILABLE	AVAILABLE		IDLE	YES	N/A	YES	NO	APL with default Cap. Messages Limit	
CHILDLST	APL	AOC1	SATISFACTORY	UNAVAILABLE	SOFTDOWN		IDLE	YES	N/A	YES	NO	Parent/Child scenario - last child	

Ready Hub Time: Not Available Server Available Enterprise Status - nobody.nowhere.ibm.com - SYSADMIN

The ITCAM Solution Portfolio

Managing high-performance composite applications.

Analyze and Measure Transactions & Services

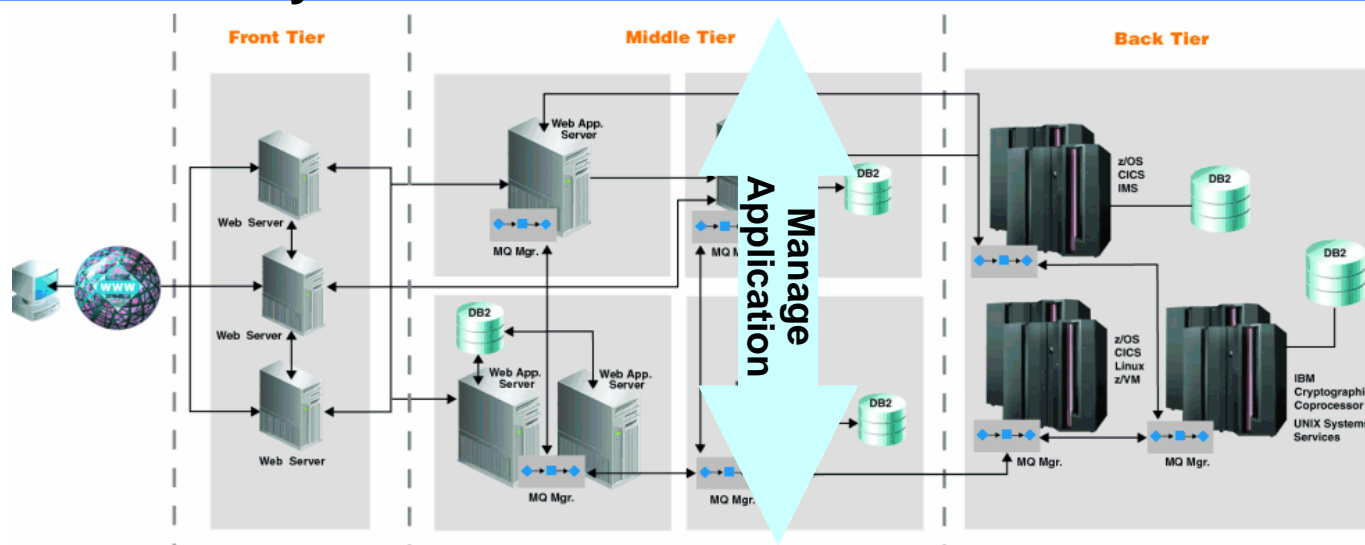

Monitor Infrastructure

ITCAM for RTT

ITCAM for WebSphere

ITCAM for SOA

ITM, OMEGAMON XE

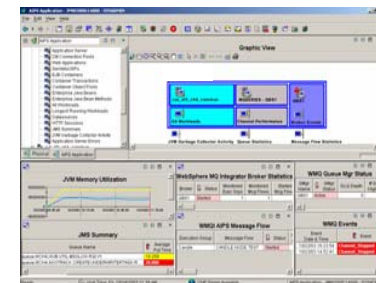
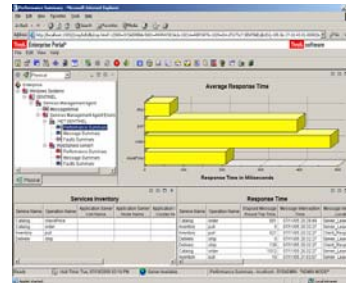
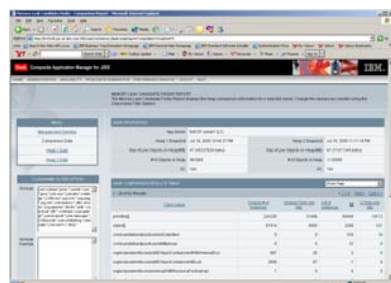
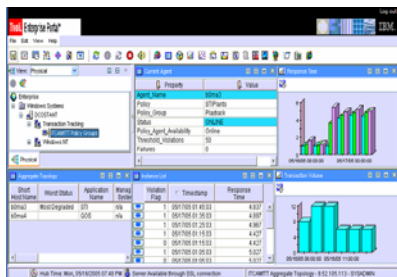

Expanded Software Asset Management Solutions

Help Control Costs, Meet Compliance Challenges

IBM Tivoli License Compliance Manager for z/OS

(formerly Isogon SoftAudit)

- Auto-discovery, centralized, accurate software inventory and usage information

IBM Tivoli Contract Compliance Manager (formerly Isogon Vista)

- Manage contractual and financial details of IT software and hardware agreements

The screenshot displays the 'Views - Software Inventory and Usage by Hardware' window. The left pane shows a tree view of hardware assets, including 'Partition (LPAR) Prod Sys D' and 'Server Data Center'. The main pane shows a table of installed software products with columns for 'Installed Software Product' and 'Total activity'. The right pane shows 'Properties - SAS/Base' with various details like 'Name', 'Type', 'Date installed', and 'Usage'.

Installed Software Product	Total activity
FileAID	
GA GADYTRIEVE PLUS	
DF3DRT	
FileAID/aaaAger	
DB2	3
DB2 Catalog Manager	8
DASD Manager Plus	8
DB2 CHECK PLUS	8
Unload Plus for DB2	11
RACF MVS	42
Planning Plan for DB2	62
Hyndler	55
AlteraAID	69
SAS/Share	129
Load Plus for DB2	131
SAS/Connect	143
SAS/Graph	158
Language Environment for MVS	152
SAS/Access Interface to DB2	214
TSD/AE	225
SAS/Base	303
FileAID for DB2	311
ISPF for MVS	1785
DB2 UDB for OS/390	1821
DB2 Server for OS/390	3057
CA-MICS	3366
Zelle	3468
Cobol for MVS 1 VM	4457
OS/390	8039
ISPF PDFE	9969
Synconet	300116
CA-ACF2	3023049

Manage software inventory, usage and licenses

- Complete, accurate reporting on software assets and usage
- Manage software costs by learning which software justifies more investment ...or less
- Demonstrate adherence to stringent accounting standards
- Better planning, budgeting and control of enterprise software costs based on business needs

The only vendor with solutions spanning mainframe and distributed platforms

Tougher Security Solutions Strengthen Protection from Intrusion and Help Manage Compliance Requirements

Reseller Agreement with Vanguard Beefs Up Security Management Solution

- ▶ Security administration, integrity auditing, and intrusion detection and management
- ▶ Helps address the most stringent security rules and regulations
- ▶ Reduce complexities of RACF security administration and enforce best practices

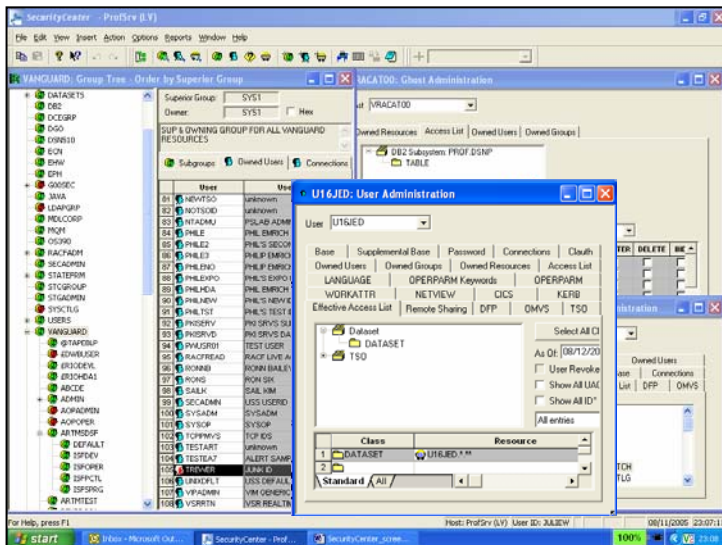

IBM and Vanguard Security Solutions

- ▶ **Vanguard Security Center** offers an easy-to-use graphical user interface for RACF and DB2 security administration on z/OS
- ▶ **Vanguard Administrator** provides advanced security server management and analysis with automation and power utilities
- ▶ **Vanguard Analyzer** assists with security system snapshots or full-scale System z9 security audits
- ▶ **Vanguard Enforcer** manages and enforces security policy on z/OS and RACF
- ▶ **Vanguard Advisor** provides event detection, analysis and reporting capabilities for z/OS and RACF
- ▶ **IBM Tivoli Security Administrator for RACF** is designed to provide a low-cost RACF management solution

Centralized End-to-End Job Scheduling Management

IBM Tivoli Workload Scheduler

- *Single solution to integrate workloads from multiple applications, across multiple platforms.*
- *Integrates with systems management solutions*
 IBM LoadLeveler, Tivoli System Automation, Tivoli Business Systems Manager, Tivoli Intelligent Orchestrator, etc.
- *Improves availability and integrity of production systems with market leading High Availability and Fault Tolerant architecture*
- *Dynamic real-time workload automation enabling SOA driven workload management solutions*

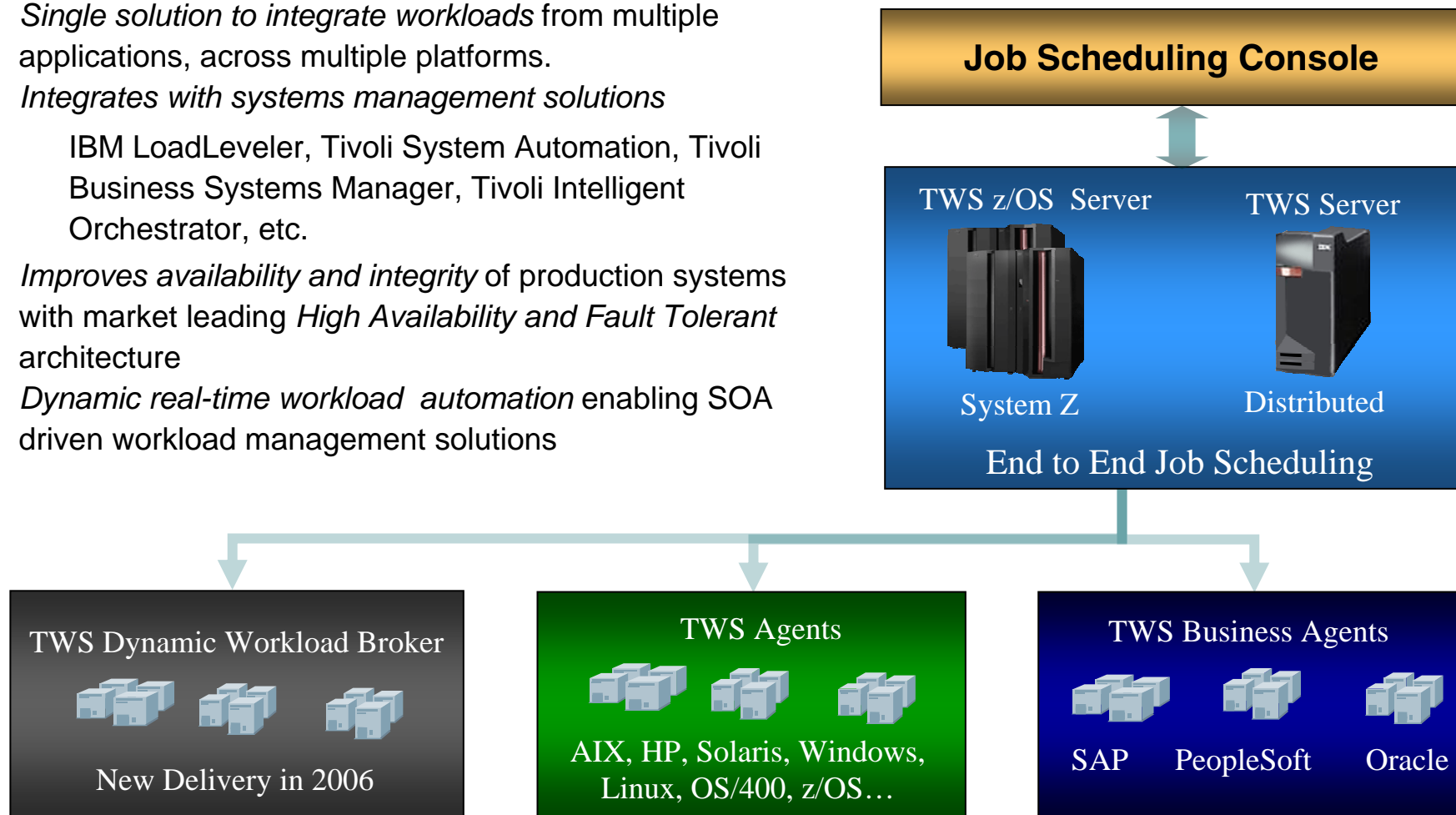

Making End-to-End Management a Reality

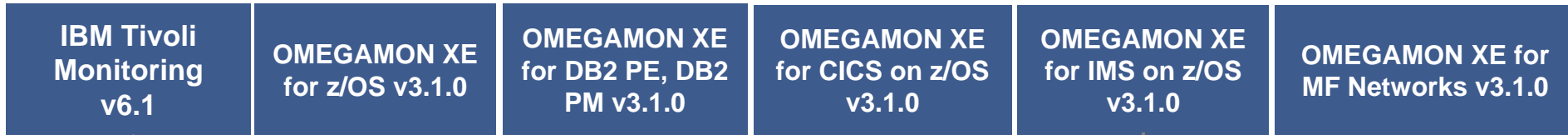

Customers

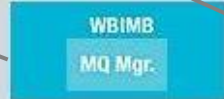

Tivoli. software



UNIX

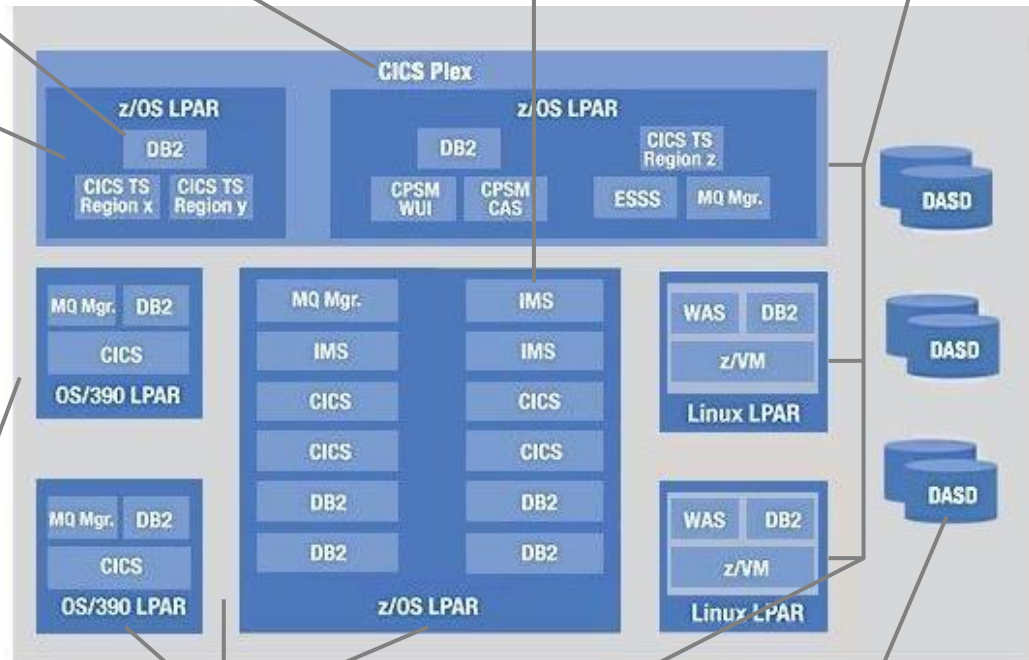

IBM Tivoli Unified Process (ITUP) Knowledgebase

IBM Tivoli Unified Process

[Feedback](#)
[About](#)

Getting Started

ITUP Method Content

- [IT Processes](#)
- [Roles](#)
- [Work Products](#)
- [Scenarios](#)
- [Tools](#)

Process Mappings

- [ITIL® Process Mapping](#)
- [CobiT Process Mapping](#)
- [RUP® Process Mapping](#)
- [Six Sigma Alignment](#)

FAQs

[ITUP Site/ Updates](#)

ITUP Method Content

The IBM Tivoli Unified Process (ITUP) describes a comprehensive set of processes within an IT organization. Each process is defined by:

- an overall **introduction** (describing goals, mission, scope, and KPIs)
- a **workflow**
- **roles**
- **work products**
- **tools** that help implement aspects of the process

In addition, **scenarios** describe how processes work together to solve important IT issues.

To explore ITUP content starting from a specific perspective, **click the appropriate area of the graphic below.**

[IT Processes](#) |
 [Products \(Tools\)](#) |
 [People \(Roles\)](#) |
 [Information \(Work Products\)](#) |
 [Problem Scenarios](#)

Four Points to Take Away

- **End-to-End Management Solutions**

Providing System Z and distributed management to find and fix problems quickly

- **IBM Mainframe Leadership**

Continued investment in hardware and software to integrate and interoperate with new platforms and applications

- **Delivering on ITIL Best Practices with ITSM**

Improving service delivery with solutions that manage IT processes, based on ITIL best practices

- **Cost Effective IT Service Management**

Effective and efficient delivery of IT services in support of business goals

