



IBM @server Cluster 1350
Preinstallation Planning Guide





@server

IBM @server Cluster 1350
Preinstallation Planning Guide

Note!

Before using this information and the product it supports, review the safety information in “Safety and environmental notices” on page v.

Fourth edition, February 2004

© Copyright International Business Machines Corporation 2004. All rights reserved.

US Government Users Restricted Rights – Use, duplication or disclosure restricted by GSA ADP Schedule Contract with IBM Corp.

Contents

Safety and environmental notices	v
Safety notices	v
Danger notices	vi
Laser safety information and compliance	x
Environmental and product recycling and disposal notice	x
Notices and statements used in this document	xi
Chapter 1. System overview	1
Chapter 2. Related publications	3
Chapter 3. Environmental requirements	5
Chapter 4. Preinstallation planning checklist	13
Chapter 5. Physical requirements	15
Stability kit	19
Floor loading.	20
Chapter 6. Electrical requirements	23
AC mains supply quality	23
Low nominal line voltages	23
Brownouts and line sags	23
Power-line impulses	23
Frequency stability	24
Earthing/grounding requirements	24
AC power requirements.	25
Receptacle styles and pin-outs	31
Communication-port protection	33
PDU requirements	33
Chapter 7. Cabinet placement and intercabinet cabling	35
Minimum service clearances	35
Types of intercabinet cabling	36
Appendix A. Declaration of IBM product noise emission values	39
Appendix B. Notices	41
Edition notice	41
Trademarks	42
Important notes.	42
Product recycling and disposal	43
Battery return program	43
Electronic emission notices	44
Federal Communications Commission (FCC) statement	44
Industry Canada Class A emission compliance statement	44
Australia and New Zealand Class A statement	44
United Kingdom telecommunications safety requirement.	44
European Union EMC Directive conformance statement.	45
Taiwanese Class A warning statement	45
Chinese Class A warning statement	45
Japanese Voluntary Control Council for Interference (VCCI) statement	45
Power cords	46

Index 49

Safety and environmental notices

For general information concerning safety, see *Electrical Safety for IBM Customer Engineers*, S229-8124. For a copy of the publication, contact your IBM® account representative or the IBM branch office serving your locality.

Enterprise Rack Safety Information: Read the safety notices in the manual provided with the Enterprise Rack before beginning work. Keep the Enterprise Rack Manual near the rack for fast reference.

Safety notices

The procedures described in this document must be performed by qualified service personnel. Safety warnings are contained within these procedures. If you cannot read the language of this document, do not perform any procedures until you receive a translated copy. IBM does not accept responsibility or liability for failure to follow these procedures correctly.

قبل تركيب هذا المنتج، يجب قراءة الملاحظات الأمنية

Antes de instalar este produto, leia as Informações de Segurança.

在安装本产品之前，请仔细阅读 **Safety Information** (安全信息)。

安裝本產品之前，請先閱讀「安全資訊」。

Prije instalacije ovog produkta obavezno pročitajte Sigurnosne Upute.

Před instalací tohoto produktu si přečtěte příručku bezpečnostních instrukcí.

Læs sikkerhedsforskrifterne, før du installerer dette produkt.

Lees voordat u dit product installeert eerst de veiligheidsvoorschriften.

Ennen kuin asennat tämän tuotteen, lue turvaohjeet kohdasta Safety Information.

Avant d'installer ce produit, lisez les consignes de sécurité.

Vor der Installation dieses Produkts die Sicherheitshinweise lesen.

Πριν εγκαταστήσετε το προϊόν αυτό, διαβάστε τις πληροφορίες ασφάλειας (safety information).

לפני שתתקינו מוצר זה, קראו את הוראות הבטיחות.

A termék telepítése előtt olvassa el a Biztonsági előírásokat!

Prima di installare questo prodotto, leggere le Informazioni sulla Sicurezza.

製品の設置の前に、安全情報をお読みください。

본 제품을 설치하기 전에 안전 정보를 읽으십시오.

Пред да се инсталира овој продукт, прочитајте информацијата за безбедност.

Les sikkerhetsinformasjonen (Safety Information) før du installerer dette produktet.

Przed zainstalowaniem tego produktu, należy zapoznać się z książką "Informacje dotyczące bezpieczeństwa" (Safety Information).

Antes de instalar este produto, leia as Informações sobre Segurança.

Перед установкой продукта прочтите инструкции по технике безопасности.

Pred inštaláciou tohto zariadenia si pečítajte Bezpečnostné predpisy.

Pred namestitvijo tega proizvoda preberite Varnostne informacije.

Antes de instalar este producto, lea la información de seguridad.

Läs säkerhetsinformationen innan du installerar den här produkten.

Danger notices

Important:

All caution and danger statements in this documentation begin with a number. This number is used to cross reference an English caution or danger statement with translated versions of the caution or danger statement in the *IBM NetBAY Rack Safety Information* book.

For example, if a caution statement begins with a number 1, translations for that caution statement appear in the *IBM NetBAY Rack Safety Information* book under statement 1.

Be sure to read all caution and danger statements in this documentation before performing the instructions. Read any additional safety information that comes with your server or optional device before you install the device.

Statement 1:



CAUTION:

To ensure safety, all configurations of the rack cabinet must be certified by a nationally recognized testing laboratory in order to verify compliance with country-specific safety regulations. This process ensures that the end product remains safe for the operator and service personnel under normal and foreseeable misuse conditions.

Statement 2:



DANGER

- Always lower the leveling pads on the rack cabinet.
- Always install stabilizer brackets on the rack cabinet.
- Always install servers and optional devices starting from the bottom of the rack cabinet.
- Always install the heaviest devices in the bottom of the rack cabinet.

Statement 3:



DANGER

- Do not extend more than one sliding device at a time.
- The maximum allowable weight for devices on slide rails is 80 kg (176 lb). Do not install sliding devices that exceed this weight.

DANGER

To avoid a shock hazard

Do not connect or disconnect any cables or perform installation, maintenance, or reconfiguration of this product during an electrical storm.

Connect all power cords to a properly wired and grounded electrical outlet.

When touching two surfaces with different electrical grounds, use one hand, when possible, to connect or disconnect signal cables.

This product has high leakage current. Earth connection is essential before connection to supply.



Class 1 Laser Product
Laser Klasse 1
Laser Klass 1
Luokan 1 Laserlaite
Appareil À Laser de Classe 1

Statement 4:



DANGER

Electrical current from power, telephone, and communication cables is hazardous.

To avoid a shock hazard:

- **Do not connect or disconnect any cables or perform installation, maintenance, or reconfiguration of this product during an electrical storm.**
- **Connect all power cords to a properly wired and grounded electrical outlet.**
- **Connect to properly wired outlets any equipment that will be attached to this product.**
- **When possible, use one hand only to connect or disconnect signal cables.**
- **Never turn on any equipment when there is evidence of fire, water, or structural damage.**
- **Disconnect the attached power cords, telecommunications systems, networks, and modems before you open the device covers, unless instructed otherwise in the installation and configuration procedures.**
- **Connect and disconnect cables as described in the following table when installing, moving, or opening covers on this product or attached devices.**

To Connect:	To Disconnect:
<ol style="list-style-type: none">1. Turn everything OFF.2. First, attach all cables to devices.3. Attach signal cables to connectors.4. Attach power cords to outlet.5. Turn device ON.	<ol style="list-style-type: none">1. Turn everything OFF.2. First, remove power cords from outlet.3. Remove signal cables from connectors.4. Remove all cables from devices.

Statement 7:



CAUTION:

The power control button on the device and the power switch on the power supply do not turn off the electrical current supplied to the device. The device also might have more than one power cord. To remove all electrical current from the device, ensure that all power cords are disconnected from the power source.

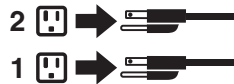

Statement 8:



DANGER

- Plug power cords from devices in the rack cabinet into electrical outlets that are located near the rack cabinet and are easily accessible.
- Each rack cabinet might have more than one power cord. Be sure to disconnect all power cords in the rack cabinet before servicing any device in the rack cabinet.
- Install an emergency-power-off switch if more than one power device (power distribution unit or uninterruptible power supply) is installed in the same rack cabinet.
- Connect all devices installed in a rack cabinet to power devices installed in the same rack cabinet. Do not plug a power cord from a device installed in one rack cabinet into a power device installed in a different rack cabinet.

Statement 10:



CAUTION:

Removing components from the upper positions in the Enterprise Rack cabinet improves rack stability during relocation. Follow these general guidelines whenever you relocate a populated rack cabinet within a room or building:

- Reduce the weight of the rack cabinet by removing equipment starting at the top of the rack cabinet. When possible, restore the rack cabinet to the configuration of the rack cabinet as you received it. If this configuration is not known, you must do the following:
 - Remove all devices in the 32 U position and above.
 - Ensure that the heaviest devices are installed in the bottom of the rack cabinet.
 - Ensure that there are no empty U-levels between devices installed in the rack cabinet below the 32 U level.
- If the rack cabinet you are relocating is part of a suite of rack cabinets, detach the rack cabinet from the suite.
- Inspect the route that you plan to take to eliminate potential hazards.
- Verify that the route that you choose can support the weight of the loaded rack cabinet. Refer to the documentation that comes with your rack cabinet for the weight of a loaded rack cabinet.
- Verify that all door openings are at least 760 x 2030 MM. (30 x 80 in.)
- Ensure that all devices, shelves, drawers, doors, and cables are secure.
- Ensure that the four leveling pads are raised to their highest position.
- Ensure that there is no stabilizer bracket installed on the rack cabinet.
- Do not use a ramp inclined at more than ten degrees.
- Once the rack cabinet is in the new location, do the following:
 - Lower the four leveling pads.
 - Install stabilizer brackets on the rack cabinet.
 - If you removed any devices from the rack cabinet, repopulate the rack cabinet from the lowest position to the highest position.

If a long distance relocation is required, restore the rack cabinet to the configuration of the rack cabinet as you received it. Pack the rack cabinet in the original packaging material, or equivalent. Also, lower the leveling pads to raise the casters off of the pallet and bolt the rack cabinet to the pallet.

Laser safety information and compliance

The IBM eserver xSeries Cluster 1350 hardware components might contain communication adapters that are fiber-optic based and use lasers.

All lasers are certified in the U.S. to conform to the requirements of DHHS 21 CFR Subchapter J for class 1 laser products. Outside the U.S., they are certified to be in compliance with the IEC 825 (first edition 1984) as a class 1 laser product. See the label on each part for laser certification numbers and approval information.

Environmental and product recycling and disposal notice

This product contains materials such as circuit boards, cables, electromagnetic compatibility gaskets, and connectors that might contain lead and copper/beryllium alloys that require special handling and disposal at end of life. Before this unit is disposed of, these materials must be removed and recycled or discarded according

to applicable regulations. IBM offers product return programs in several countries. You can find country-specific instructions at www.ibm.com/ibm/environment/products/prp.phtml.

This product might contain nickel-cadmium or lithium batteries in communication adapters. The batteries must be recycled or disposed of properly. Recycling facilities might not be available in your area. In the United States, IBM has established a collection process for reuse, recycling, or proper disposal of used sealed lead-acid, nickel-cadmium and nickel metal hydride batteries and battery packs from IBM equipment. For information on proper disposal of batteries in this product, please contact IBM at 1-800-426-4333. For information on disposal of batteries outside the United States, contact your local waste disposal or recycling facility.

Notices and statements used in this document

The caution and danger statements that appear in this document are also in the multilingual *IBM NetBAY Rack Safety Information* document, which is on the IBM Documentation CD. Each caution and danger statement is numbered for reference to the corresponding statements in the *Safety Information* document.

The following types of notices and statements are used in this document:

- **Note:** These notices provide important tips, guidance, or advice.
- **Important:** These notices provide information or advice that might help you avoid inconvenient or problem situations.
- **Attention:** These notices indicate possible damage to programs, devices, or data. An attention notice is placed just before the instruction or situation in which damage could occur.
- **Caution:** These statements indicate situations that can be potentially hazardous to you. A caution statement is placed just before the description of a potentially hazardous procedure step or situation.
- **Danger:** These statements indicate situations that can be potentially lethal or extremely hazardous to you. A danger statement is placed just before the description of a potentially lethal or extremely hazardous procedure step or situation.

Chapter 1. System overview

The IBM@server[®] Cluster 1350 provides an array of computational and storage devices connected through high-speed networks. The Cluster 1350 is an engineered system and therefore provides the following advantages:

Interoperability

A clustered system contains many diverse parts, not all of which are designed to work together. If you assemble a system without anticipating mismatches, there is great risk of system failures, performance degradation, technical incompatibilities, lengthy installation times, and frequent service calls. The Cluster 1350 system has been designed and tested to prevent operational mismatches.

Increased reliability

Guaranteed interoperability provides greater reliability. For example, a common mismatch in nonengineered systems is thermal stability. Each module in a cluster provides airflow for cooling of internal parts, but if the outflow from one module is placed next to the intake for another module, the second module will always be at risk of overheating and eventual failure. In the most severe case, a thermal loop might cause total system failure. As another example, power connections might not be distributed equitably, overloading power distribution units and causing repeated failures within the system. System-wide testing ensures that the Cluster 1350 system reliability cannot be undermined.

Ease of installation and service

The Cluster 1350 establishes rules for system configurations, placement of modules, and lengths of cables. For these reasons, installation and service can be accomplished more smoothly. Standardized placement of modules allows for use of manufactured cable harnesses, reducing installation time and minimizing the chance of incorrect cable placement. Systems arrive well-packaged with minimal waste material. Service can be accomplished from the front or rear of the cabinet without having to move cabinets.

Electromagnetic interference (EMI) compliance

EMI radiation is an important consideration. The Cluster 1350 system is engineered to provide the shielding and cable routing necessary to comply with national and international certifications for radiated energy. Nonengineered systems have not been tested against these requirements.

Safety Weight distribution within a cabinet is important. The standardized placement of modules in a Cluster 1350 minimizes the danger of tipping.

Ease of expansion

Because the Cluster 1350 is built upon standardized increments of modules, you can start with a minimal system and easily expand the system over time, knowing that interoperability considerations have been accounted for. The typical Cluster 1350 configuration has 512 nodes in addition to the one required management node. However, with ease of expansion, the possibilities are unrestricted. All nodes run one of the supported Linux distributions.

The Cluster 1350 identifies two types of cabinet: primary and expansion. A cabinet is called primary if it contains the management node and console monitor. An expansion cabinet can contain storage nodes or mass-storage devices as well as computing nodes, called cluster nodes; it does not contain a management node or a console.

Chapter 2. Related publications

This guide provides general information about your cluster, including information about features, prerequisites, planning, and installation. For more information about the cluster, see the following documents:

- *Using the IBM @server Cluster 1350 Linux Cluster Installation Tool version 3.1*
This document contains instructions on installing and using the Linux Cluster Installation Tool to set up your cluster environment.
- *IBM @server Cluster 1350 Installation and Service Guide*
This document contains information about hardware and software specifications, electrical and environmental considerations, and troubleshooting.

Your cluster might have features that are not described in the documentation that you received with the products. The documentation might be updated occasionally to include information about those features, or technical updates might be available to provide additional information that is not included in your documentation. These updates are available from the IBM Web site. Complete the following steps to check for updated documentation and technical updates:

1. Go to <http://www.ibm.com/pc/support/>.
2. In the **Learn** section, click **Online publications**.
3. On the "Online publications" page, in the **Brand** field, select **Servers**.
4. In the **Family** field, select **Clustering**.
5. Click **Continue**.

Chapter 3. Environmental requirements

The temperature and humidity data shown in Table 1 are from the individual specifications of the equipment (by IBM and other manufactures) contained in the rack. The table shows the ranges of temperature and humidity that are acceptable to the products when operating, when not operating, and when being shipped or stored.

Generally, the air-conditioning system must be designed for 22°C (72°F) and 45% relative humidity for maximum availability and reliability.

Table 1. Environmental characteristics for IBM @server Cluster 1350

System Components	Environmental Characteristics
@server 325 server	<p>Temperature:</p> <ul style="list-style-type: none"> Operating at altitude of 0 to 914 m (3000 ft): 10° to 35°C (50.0° to 95.0°F) Operating at altitude of 914 m (3000 ft) to 2133 m (7000 ft): 10° to 35°C (50° to 95.0°F) Non-operating: 10° to 43°C (50° to 109.4°F) <p>Humidity:</p> <ul style="list-style-type: none"> Operating: 8% to 80% Non-operating: 8% to 80% <p>Altitude:</p> <ul style="list-style-type: none"> Maximum: 2133 m (7000 ft) Minimum: 914 m (3000 ft) <p>Heat output (approximate)</p> <ul style="list-style-type: none"> Maximum: 1366 British thermal units per hour (Btu per hour) (400 watts) Minimum: 409 Btu per hour (120 watts)
xSeries® 335 server	<p>Temperature:</p> <ul style="list-style-type: none"> Operating at altitude of 0 to 914 m (3000 ft): 10° to 35°C (50° to 95°F) Operating at altitude of 914 m (3000 ft) to 2133 m (7000 ft): 10° to 32°C (50° to 89.6°F) Non-operating: 10° to 43°C (50° to 109.4°F) <p>Humidity:</p> <ul style="list-style-type: none"> Operating: 8% to 80% Non-operating: 8% to 80% <p>Altitude:</p> <ul style="list-style-type: none"> Maximum: 2133 m (7000 ft) Minimum: 914 m (3000 ft) <p>Heat output (approximate)</p> <ul style="list-style-type: none"> Maximum: 1195 British thermal units per hour (Btu per hour) (350 watts) or 1366 Btu per hour (400 watts) Minimum: 375 Btu per hour (110 watts) or 409 Btu per hour (120 watts)

Table 1. Environmental characteristics for IBM @server Cluster 1350 (continued)

System Components	Environmental Characteristics
xSeries 345 server	<p>Temperature:</p> <ul style="list-style-type: none"> • Operating at altitude of 0 to 914 m (3000 ft): 0° to 35°C (50° to 95°F) • Operating at altitude of 914 m (3000 ft) to 2133 m (7000 ft): 10° to 35°C (50° to 95°F) • Non-operating: -40° to 60°C (-40° to 140°F) <p>Humidity:</p> <ul style="list-style-type: none"> • Operating: 8% to 80% • Non-operating: 8% to 80% <p>Altitude:</p> <ul style="list-style-type: none"> • Maximum: 2133 m (7000 ft) • Minimum: 914 m (3000 ft) <p>Heat output (approximate)</p> <ul style="list-style-type: none"> • Maximum: 2200 British thermal units per hour (Btu per hour) (645.2 watts) • Minimum: 341 Btu per hour (100 watts)
xSeries 360 server	<p>Temperature:</p> <ul style="list-style-type: none"> • Operating at altitude of 0 to 914 m (3000 ft): 10° to 35°C (50° to 95°F) • Operating at altitude of 914 m (3000 ft) to 2133 m (7000 ft): 10° to 32°C (50° to 89.6°F) • Non-operating: 10° to 43°C (50° to 109.4°F) <p>Humidity:</p> <ul style="list-style-type: none"> • Operating: 8% to 80% • Non-operating: 8% to 80% <p>Altitude:</p> <ul style="list-style-type: none"> • Maximum: 2133 m (7000 ft) • Minimum: 914 m (3000 ft) <p>Heat output (approximate)</p> <ul style="list-style-type: none"> • Maximum: 3566 British thermal units per hour (Btu per hour) (1045 watts) • Minimum: 1232 Btu per hour (360 watts)

Table 1. Environmental characteristics for IBM @server Cluster 1350 (continued)

System Components	Environmental Characteristics
<p>@server BladeCenter™ HS20 blade server</p>	<p>Temperature:</p> <ul style="list-style-type: none"> • Operating at altitude of 0 to 914 m (3000 ft): 10° to 32°C (50.0° to 89.6°F) • Storage: -40° to 60°C (-40° to 140°F) • Transit: -40° to 60°C (-40° to 140°F) <p>Humidity:</p> <ul style="list-style-type: none"> • Operating: 8% to 80% • Storage: 5% to 95% • Non-operating humidity: 8% to 80% <p>Altitude:</p> <ul style="list-style-type: none"> • Maximum: 2134 m (7000.0 ft) • Minimum: 0 to 914 m (3000 ft) <p>Heat output (approximate)</p> <ul style="list-style-type: none"> • Maximum: 9622 British thermal units per hour (Btu per hour) (2820 watts) • Minimum: 1365 Btu per hour (400 watts)
<p>TotalStorage® FAST600 Fibre Channel storage server</p>	<p>Temperature:</p> <ul style="list-style-type: none"> • Operating at altitude of 0 to 914 m (3000 ft): 10° to 35°C (50° to 95°F) • Storage: -10° to 50°C (14° to 122°F) • Transit: -40° to 60°C (-40° to 140°F) <p>Humidity:</p> <ul style="list-style-type: none"> • Operating: 8% to 80% • Storage: 5% to 95% • Non-operating humidity: 8% to 80% <p>Altitude:</p> <ul style="list-style-type: none"> • Maximum: 2134 m (7000.0 ft) • Minimum: 0 to 914 m (3000 ft)
<p>TotalStorage FAST700 Fibre Channel storage server</p>	<p>Temperature:</p> <ul style="list-style-type: none"> • Operating at altitude of 0 to 914 m (3000 ft): 10° to 35°C (50° to 95°F) • Storage: 10° to 43°C (50° to 109.4°F) • Transit: -40° to 60°C (-40° to 140°F) <p>Humidity:</p> <ul style="list-style-type: none"> • Operating: 8% to 80% • Storage: 5% to 95% • Non-operating humidity: 8% to 80% <p>Altitude:</p> <ul style="list-style-type: none"> • Maximum: 2134 m (7000.0 ft) • Minimum: 0 to 914 m (3000 ft)

Table 1. Environmental characteristics for IBM @server Cluster 1350 (continued)

System Components	Environmental Characteristics
TotalStorage FAST900 Fibre Channel storage server	<p>Temperature</p> <ul style="list-style-type: none"> • Operating: 10° to 35°C (50° to 95°F) • Storage: -10° to 50°C (14° to 122°F) • Transit: -40° to 60°C (-40° to 140°F) <p>Humidity:</p> <ul style="list-style-type: none"> • Operating: 8 to 80% • Storage: 5% to 95%
EXP400 storage expansion unit	<p>Temperature:</p> <ul style="list-style-type: none"> • Operating: 10° to 35°C (50° to 95°F) • Storage: 10° to 50°C (50.0° to 1.4°F) <p>Humidity:</p> <ul style="list-style-type: none"> • Operating: 8% to 80% • Storage: 10% to 90%
EXP700 storage expansion unit	<p>Temperature:</p> <ul style="list-style-type: none"> • Operating: 10° to 35°C (50° to 95°F) • Storage: 10° to 43°C (50° to 109°F) • Transit: -40° to 60°C (-40° to 140°F) <p>Humidity:</p> <ul style="list-style-type: none"> • Operating: 8% to 80% • Storage: 5% to 95%
1 U monitor	<p>Temperature:</p> <ul style="list-style-type: none"> • Operating: 10°C to 40°C (50°F to 104°F) • Storage: -25°C to 45°C (13°F to 113°F) • Transit: -40° to 60°C (-40° to 140°F) <p>Humidity:</p> <ul style="list-style-type: none"> • Operating: 10% to 80% • Storage: 5% to 95%
NetBAY Remote Console Manager switch (KVM)	<p>Temperature:</p> <ul style="list-style-type: none"> • Operating: 10° to 50°C (50° to 122°F) • Storage: -20° to 60°C (-4° to 140°F) • Transit: -40° to 60°C (-40° to 140°F) <p>Humidity:</p> <ul style="list-style-type: none"> • Operating: 20% to 80% • Storage: 5% to 95%
NetBAY 2x8 console switch (KVM)	<p>Temperature:</p> <ul style="list-style-type: none"> • Operating: 0° to 40°C (32° to 104°F) • Storage: -20° to 70°C (-40° to 167°F) • Transit: -40° to 60°C (-40° to 140°F) <p>Humidity:</p> <ul style="list-style-type: none"> • Operating: 10% to 95% • Storage: 5% to 95%

Table 1. Environmental characteristics for IBM @server Cluster 1350 (continued)

System Components	Environmental Characteristics
Cisco 4003 switch	<p>Temperature:</p> <ul style="list-style-type: none"> • Operating: 0° to 40°C (32° to 104°F) • Storage: -40° to 75°C (-40° to 158°F) • Transit: -40° to 60°C (-40° to 140°F) <p>Humidity:</p> <ul style="list-style-type: none"> • Operating: 10–95% • Storage: 5% to 95% <p>Altitude:</p> <ul style="list-style-type: none"> • Operating: 500 to 6500 ft (-150 to 2000 m) • Storage: 1000 to 30 000 ft (-300 to 1950 m)
Cisco 4006 switch	<p>Temperature:</p> <ul style="list-style-type: none"> • Operating: 0° to 40°C (32° to 104°F) • Storage: -40° to 75°C (-40° to 167°F) • Transit: -40° to 60°C (-40° to 140°F) <p>Humidity:</p> <ul style="list-style-type: none"> • Operating: 10% to 90% • Storage: 5% to 95% <p>Altitude:</p> <ul style="list-style-type: none"> • Operating: 500 to 6500 ft (-150 to 2000 m) • Storage: 1000 to 30 000 ft (-300 to 1950 m)
Cisco Catalyst 3550–24 XL (24-port) switch	<p>Temperature:</p> <ul style="list-style-type: none"> • Operating: 0° to 45°C (32° to 113°F) • Storage: -25° to 70°C (13° to 158°F) • Transit: -40° to 60°C (-40° to 140°F) <p>Humidity:</p> <ul style="list-style-type: none"> • Operating: 10–85% • Storage: 5% to 95% <p>Altitude:</p> <ul style="list-style-type: none"> • Operating: Up to 10 000 ft (3000 m) • Storage: 15 000 ft (4570 m) <p>Heat Output (approximate): 222 British thermal units per hour (Btu per hour)</p>

Table 1. Environmental characteristics for IBM @server Cluster 1350 (continued)

System Components	Environmental Characteristics
Cisco Catalyst 3550-48 XL (48-port) switch	<p>Temperature:</p> <ul style="list-style-type: none"> • Operating: 0° to 45°C (32° to 113°F) • Storage: -25° to 70°C (13° to 158°F) • Transit: -40° to 60°C (-40° to 140°F) <p>Humidity:</p> <ul style="list-style-type: none"> • Operating: 10% to 85% • Storage: 5% to 95% <p>Altitude:</p> <ul style="list-style-type: none"> • Operating: Up to 10 000 ft (3000 m) • Storage: 15 000 ft (4570 m) <p>Heat Output (approximate): 375 British thermal units per hour (Btu per hour)</p>
Cisco Catalyst 3508G (8-port) switch	<p>Temperature:</p> <ul style="list-style-type: none"> • Operating: 0° to 45°C (32° to 113°F) • Storage: -10° to 65°C (-4° to 149°F) • Transit: -40° to 60°C (-40° to 140°F) <p>Humidity:</p> <ul style="list-style-type: none"> • Operating: 10% to 85% • Storage: 5% to 95% <p>Altitude:</p> <ul style="list-style-type: none"> • Operating: Up to 10 000 ft (3000 m) • Storage: 15 000 ft (4570 m) <p>Heat Output (approximate): 280 British thermal units per hour (Btu per hour)</p>
In-Reach LX 4000 (32-port) terminal server	<p>Temperature:</p> <ul style="list-style-type: none"> • Operating: 0° to 45°C (32° to 113°F) • Storage: -20° to 60°C (-4° to 140°F) <p>Operating humidity: 10% to 90% (noncondensing)</p>
In-Reach LX 4000 (48-port) terminal server	<p>Temperature:</p> <ul style="list-style-type: none"> • Operating: 0° to 45°C (32° to 113°F) • Storage: -20° to 60°C (-4° to 140°F) <p>Operating humidity: 10% to 90% (noncondensing)</p>
Myrinet model M3-E32 (5-slot) switch	<ul style="list-style-type: none"> • Operating temperature: 5° to 40°C • Relative humidity 15% to 80% and 40°C (noncondensing) • Storage temperature: -40° to 70°C • Relative humidity: 90% and 65°C • Shock and vibration: conforms to EN 60068 (IEC 68) • Fans on fan tray: three 92 mm • Total airflow: 60 cfm • Maximum British thermal units per hour (Btu per hour) with line cards in all slots: 840 Btu per hour

Table 1. Environmental characteristics for IBM @server Cluster 1350 (continued)

System Components	Environmental Characteristics
Myrinet model M3-E64 (9-slot) switch	<ul style="list-style-type: none"> • Operating temperature: 5° to 40°C • Storage temperature: -40° to 70°C • Relative humidity: 90% at 65°C • Relative humidity: 15% to 80% and 40°C (noncondensing) • Shock and vibration: conforms to EN 60068 (IEC 68) • Fans on fan tray: four 92 mm • Total airflow: 120 cfm • Maximum British thermal units per hour (Btu per hour) with line cards in all slots: 1680 Btu per hour
Myrinet model M3-E128 (17-slot) switch	<ul style="list-style-type: none"> • Operating temperature: 5° to 40°C • Storage temperature: -40° to 70°C • Relative humidity: 90% at 65°C • Relative humidity: 15% to 80% and 40°C (noncondensing) • Shock and vibration: conforms to EN 60068 (IEC 68) • Fans on fan tray: eight 92 mm • Total airflow: 240 cfm • Maximum British thermal units per hour (Btu per hour) with line cards in all slots: 3360 Btu per hour
Myrinet model M3F-PC164C-2 (PCI card) switch	<ul style="list-style-type: none"> • Operating temperature: 0° to 50°C • Storage temperature: -40° to 70°C • Relative humidity: 90% at 65°C • Relative humidity: 15% to 80% at 50°C (noncondensing) • Shock and vibration: conforms to EN 60068 (IEC 68) • Fans on fan tray: eight 92 mm • Total airflow: 240 CFM • Maximum British thermal units per hour (Btu per hour) with line cards in all slots: 3360 Btu per hour
Myrinet model M3F-PCIXD-2 (PCI card) switch	<ul style="list-style-type: none"> • Operating temperature: 0° to 50°C • Storage temperature: -40° to 70°C • Relative humidity: 90% at 65°C • Relative humidity: 15% to 80% at 50°C (noncondensing) • Shock and vibration: conforms to EN 60068 (IEC 68) • Fans on fan tray: eight 92 mm • Total airflow: 240 cfm • Maximum British thermal units per hour (Btu per hour) with line cards in all slots: 3360 Btu per hour
Myrinet cluster expansion card	<ul style="list-style-type: none"> • Operating temperature: 0° to 50°C • Storage temperature: -40° to 70°C • Relative humidity: 90% at 65°C • Relative humidity: 15% to 80% at 50°C (noncondensing) • Maximum British thermal units per hour (Btu per hour) with line cards in all slots: 3360 Btu per hour

Table 1. Environmental characteristics for IBM @server Cluster 1350 (continued)

System Components	Environmental Characteristics
SMC8624T (24-port) switch	<ul style="list-style-type: none"> • Operating temperature: 0° to 660°C • Storage temperature: -40° to 1580°C • Relative humidity: 5% to 95% (noncondensing) • Shock and vibration: conforms to EN 550222 (IEC 1000-4 2/3/4/6) • Maximum British thermal units per hour (Btu per hour) with line cards in all slots: 239 Btu per hour
SMCBGSLCX1 mini-GBIC expansion module	<ul style="list-style-type: none"> • Operating temperature: 0° to 60°C • Storage temperature: -10° to 85°C
APC MasterSwitch model AP9212	<p>Temperature</p> <ul style="list-style-type: none"> • Operating: 0° to - 45 °C (32° to 113°F) • Storage: -15° to 65°C (5° to 149°F) <p>Humidity: 0% to 95%</p> <p>Altitude:</p> <ul style="list-style-type: none"> • Operating: 0 ft to 10 000 ft (0 m to 3000 m) • Storage: 0 ft to 50 000 ft (0 m to 15000 m)
NetBAY Rack power-distribution unit	<ul style="list-style-type: none"> • Operating temperature: 10° to 32°C (50° to 90°F) • Humidity: 0% to 95%
NetBAY front end power-distribution unit	<ul style="list-style-type: none"> • Operating temperature: 10° to 32°C (50° to 90°F) • Humidity: 0% to 95%
@server xSeries Distributed Power Interconnect rack power-distribution unit	<ul style="list-style-type: none"> • Operating temperature: 10° to 35°C (50° to 95°F) • Humidity: 8% to 80% (noncondensing)
@server xSeries Distributed Power Interconnect front end power-distribution unit	<ul style="list-style-type: none"> • Operating temperature: 10° to 35°C (50° to 95°F) • Humidity: 8% to 80% (noncondensing)
IBM Distributed Power Interconnect high density power-distribution unit	<ul style="list-style-type: none"> • Operating temperature: 10° to 35°C (50° to 95°F) • Humidity: 8% to 80% (noncondensing)

Chapter 4. Preinstallation planning checklist

Use the following preinstallation checklist prior to the initial set up of an IBM @server Cluster 1350.

Important:

The IBM @server Cluster 1350 must be maintained only by system administrators experienced with Linux, DHCP, NFS, and Linux networking and administration.

To prepare for the delivery and installation of the Cluster 1350 you must complete the following actions before the installer arrives on site to install the hardware.

Completing these steps early in the process of planning for your cluster will help the installation proceed smoothly:

- 1. Review the safety information.
- 2. Review the physical, environmental, and electrical requirements for the Cluster 1350.
Make sure that the installation site meets all the requirements described in this document. If there is a problem with the installation site, work with your IBM marketing representative to define an acceptable alternate approach.
- 3. Review the proposed configuration from the IBM marketing representative.
The IBM marketing representative will provide you with a suggested configuration for your cluster. The configuration will show the optimal racking scenario for your Cluster 1350.
- 4. Complete the Cluster 1350 preinstallation planning checklist and submit the results to your IBM Sales Support Representative.
Consider the physical, environmental, and electrical requirements, along with the proposed configuration of the cluster, when gauging the readiness of your installation site.
- 5. Plan the rack layout and floorplan.
Use the information in Chapters 3 and 4, along with the proposed configuration to sketch the rack layout. Consider the number of racks, rack dimensions, required clearances, floor loading restrictions, and heating and cooling concerns.
- 6. Assess the quality of the ac mains power supply.
Arrange for a qualified electrician to assess your current power supply and to verify your power and electrical plans.
- 7. Determine the grounding requirements and power consumption of your Cluster 1350.
The proposed configuration that an IBM marketing representative provides shows the number and type of power distribution units (PDUs) included in each rack.
- 8. Determine the ac power sources required to support your configuration.
Each PDU has its own ac power cord that requires an external power connection outside of the cabinet.
- 9. Unpack the cabinets only.
The other boxes include instructions for the installer and miscellaneous components that might have been removed to satisfy shipping requirements.

Caution:

Make sure that all rack-mounted units are fastened in the rack frame. Do not extend or exchange any rack-mounted units when the stabilizer is not installed.

The power-supply cords provide the main disconnect for this product. If the rear door is locked, thus preventing access to the PDU disconnect, the power-socket outlet must be installed near the product and must be readily accessible.

This product has more than one power-supply cord. Disconnect all power-supply cords before servicing.

This product might contain a lithium battery. To avoid possible explosion, do not burn, exchange, or charge the battery. Discard the battery as instructed by local regulations for lithium batteries.

This product might contain a Class 1 laser device.

- ___ 10. Dispose of all packing material.
- ___ 11. Refer to Chapter 7, "Cabinet placement and intercabinet cabling," on page 35 to ensure proper placement of the cabinets by following the parameters listed.
- ___ 12. Arrange for a phone line near the cabinet.
- ___ 13. Schedule the installation with the IBM installer.

Make sure that the installation area meets the physical, environmental, and electrical requirements for the Cluster 1350. The IBM installer performs the final cabling and hardware installation steps. If the installation site is not ready when the installer arrives, the installer will not be able to complete the installation. A return visit might result in an additional charge.

After the IBM installer completes the system hardware installation, you can install your software and connect your network cables.

Chapter 5. Physical requirements

Table 2 shows the physical requirements of all IBM @server™ Cluster 1350 components.

Table 2. Physical characteristics for @server Cluster 1350

System components	Physical characteristics
@server 325 server	Width: 440 mm (17.32 in.) Depth: 660 mm (25.98 in.) Height: 440 mm (17.32 in.) Weight: approximately 12.7 kg (28 lb) fully configured
@server 325 server for 64-bit operating systems	Width: 440 mm (17.32 in.) Depth: 660 mm (25.98 in.) Height: 440 mm (17.32 in.) Weight: approximately 12.7 kg (28 lb) fully configured
xSeries 335 server	Width: 440 mm (17.32 in.) Depth: 660 mm (25.98 in.) Height: 43 mm (1.69 in.) Weight: approximately 12.7 kg (28 lb) fully configured
xSeries 345 server	Width: 440 mm (17.32 in.) Depth: 660 mm (25.98 in.) Height: 43 mm (1.69 in.) Weight: approximately 12.7 kg (28 lb) fully configured
xSeries 360 server	Width: 441.9 mm (17.4 in.) Depth: 701 mm (27.6 in.) Height: 133.35 mm (5.25 in.) Weight: 31.7 kg (70 lb)
@server BladeCenter unit	Width: 444.5 mm (17.50 in.) Depth: 711.2 mm (28 in.) Height: 311.15 mm (12.25 in.) Weight: approximately 122.47 kg (270 lb) fully configured
@server BladeCenter HS20 blade server	Width: 29 mm (1.14 in.) Depth: 446 mm (17.6 in.) Height: 245 mm (9.7 in.) Weight: 5.4 kg (12 lb), fully configured

Table 2. Physical characteristics for @server Cluster 1350 (continued)

System components	Physical characteristics
TotalStorage FASiT600 fibre channel storage server	Width: 4.82 mm (18.97 in.) Depth: 597 mm (23.6 in.) Height: 132 mm (5.2 in.) Weight: 39.10 kg (86.2 lb), fully configured
TotalStorage FASiT700 Fibre Channel storage server	Width: 4.82 mm (18.97 in.) Depth: 635 mm (25 in.) Height: 174.5 mm (6.87 in.) Weight: 37.65 kg (83 lb), fully configured
TotalStorage FASiT900 Fibre Channel storage server	Width: 4.82 mm (18.97 in.) Depth: 635 mm (25 in.) Height: 174.5 mm (6.87 in.) Weight: 37.65 kg (83 lb), fully configured
TotalStorage FASiT EXP400 storage expansion unit	Width: Front ears: 48.3 cm (19 in.), chassis: 44.7 cm (17.6 in.) Depth: 57.5 cm (22.6 in.) Height: Front ears: 13.2 cm (5.2 in.), chassis: 12.9 cm (5.1 in.) Weight: 37.65 kg (83 lb), fully configured
TotalStorage FASiT EXP700 storage expansion unit	Width: 445 mm (17.52 in.) Depth: 563 mm (22.17 in.) Height: 128 mm (5.03 in.) Weight: 30.1 kg (66.4 lb), fully configured
1-U flat panel monitor (32P1031)	Width: 482.6 mm (19 in.) Depth: 751.84 mm (29.6 in.) Height: 44.4 mm (1.75 in.) Weight: 17.0 kg (37 lb)
NetBAY Remote Console Manager KVM switch	Width: 432 mm (17.0 in.) Depth: 279.4 mm (11.0 in.) Height: 45 mm (1.75 in.) Weight: 3.6 kg (8 lb)
NetBAY 2x8 console switch	Width: 432 mm (17.0 in.) Depth: 203 mm (8.0 in.) Height: 45 mm (1.75 in.) Weight: 2.38 kg (5.3 lb)

Table 2. Physical characteristics for @server Cluster 1350 (continued)

System components	Physical characteristics
Cisco Catalyst 3550–24 XL (24-port) 10/100-Mb Ethernet switch	Width: 44.45 cm (17.5 in.) Depth: 30.02 cm (11.82 in.) Height: 4.45 cm (1.75 in.) Weight: 5.45 kg (12 lb)
Cisco Catalyst 3550–48 XL (48-port) 10/100-Mb Ethernet switch	Width: 44.45 cm (17.5 in.) Depth: 39.0 cm (15.34 in.) Height: 4.39 cm (1.73 in.) Weight: 5.45 kg (12 lb)
Cisco Catalyst 3508G (8-port) 1 Gb Ethernet switch	Width: 40.46 cm (16.0 in.) Depth: 44.4 cm (17.5 in.) Height: 4.45 cm (1.75 in.) Weight: 5.45 kg (12 lb)
SMC8624T (24-port) 1 Gb Ethernet switch	Width: 35.3 cm (13.9 in.) Depth: 4.3 cm (1.7 in.) Height: 44.1cm (17.37 in.) Weight: 4.3 kg (9.46 lb)
SMCBGSLCX1 mini-GBIC expansion module	Width: 13.9 in. (35.3 cm) Depth: 1.7 in. (4.3 cm) Height: 17.37 in. (44.1cm) Weight: 9.46 lb (4.3 kg)
In-Reach LX 4000 (32-port) terminal server	Width: 482.6 mm (19 in.) Depth: 297.1 mm (11.7 in.) Height: 44.5 mm (1.75 in.) Weight: 11 lb (5.0 kg)
In-Reach LX 4000 (48-port) terminal server	Width: 482.6 mm (19 in.) Depth: 297.1 mm (11.7 in.) Height: 44.5 mm (1.75 in.) Weight: 12 lb (5.4 kg)
Myrinet model M3-E32 (5-slot) high-speed switch (optical)	Width: enclosure 43.64 cm (17.18 in.), to rack-mount ears 48.26 cm (19.0 in.) Depth: 44.45 cm (17.5 in.) Height: 3 U, 13.3 cm (5.25 in.) Weight: without line cards: 12.1 lb (5.5 kg), with line cards in all slots: 18.3 lb (8.3 kg)

Table 2. Physical characteristics for @server Cluster 1350 (continued)

System components	Physical characteristics
Myrinet model M3-E64 (9-slot) high-speed switch (optical)	Width: enclosure 43.64 cm (17.18 in.), to rack-mount ears 48.26 cm (19.0 in.) Depth: 44.45 cm (17.5 in.) Height: 5 U, 22.2 cm (8.75 in.) Weight: without line cards: 10 kg (22 lb), with line cards in all slots: 15 kg (33 lb)
Myrinet model M3-E128 (17-slot) high-speed switch (optical)	Width: enclosure 43.64 cm (17.18 in.), to rack-mount ears 48.26 cm (19.0 in.) Depth: 44.45 cm (17.5 in.) Height: 9 U, 40.0 cm (15.75 in.) Weight: without line cards: 21 kg (46.2 lb), with line cards in all slots: 31 kg (68.2 lb)
Myrinet model M3F-PC164C-2 (PCI card) high-speed switch (optical)	Depth: 44.45 cm (17.5 in.) Height: 6.4 cm (2.5 in.) Weight: 82 grams
Myrinet model M3F-PCIXD-2 (PCI card) high-speed switch (optical)	Depth: 44.45 cm (17.5 in.) Height: 6.4 cm (2.5 in.) Weight: 82 grams
Myrinet cluster expansion card for blade servers	Width: 12.65 cm (4.98 in.) Depth: 0.304 cm (0.12 in.) Height: 9.86 cm (3.88 in.)
Cisco Catalyst 4003 high-speed switch	Width: 437 mm (17.25 in.) Depth: 300 mm (11.81 in.) Height: 266 mm (10.5 in.) Weight: 18 kg (40 lb)
Cisco Catalyst 4006 high-speed switch	Width: 437 mm (17.25 in.) Depth: 300 mm (11.81 in.) Height: 400 mm (15.75 in.) Weight: 27.7 kg (61 lb)
APC MasterSwitch model AP9212 power management module	Width: 431.8 mm (17.00 in.) Depth: 165.1 mm (6.50 in.) Height: 47.6 mm (1.88 in.) Weight: 2.95 kg (6.50 lb)

Table 2. Physical characteristics for @server Cluster 1350 (continued)

System components	Physical characteristics
NetBAY rack power distribution unit	Width: 192 mm (7.5 in.) Depth: 221 mm (8.7 in.) Height: 43 mm (1.7 in.) Weight: 1.6 kg (3.5 lb)
NetBAY front end power distribution unit	Width: 192 mm (7.5 in.) Depth: 221 mm (8.7 in.) Height: 43 mm (1.7 in.) Weight: 1.6 kg (3.5 lb)
IBM Distributed Power Interconnect rack power distribution unit	Width: 222.5 mm (8.76 in.) Depth: 114.5 mm (4.51 in.) Height: 41.5 mm (1.7 in.) Weight: 1.7 kg (3.7 lb)
IBM Distributed Power Interconnect rack high density power distribution unit	Width: 448 mm (17.6 in.) Depth: 213 mm (8.4 in.) Height: 43.9 mm (1.73 in.) Weight: 11.3 kg (25 lb)
IBM 1410–42L system cabinet ^{1,2}	Width: 647.7 mm (25.5 in.) with side panels Depth: 1099.8 mm (43.3 in.) with front and rear doors Height: 2019.2 mm (79.5 in.) Empty Weight: 333.8 kg (736 lb) Maximum Weight: 1003 kg (2211 lb)
Total square footage with minimum serviceability space	
6.50 m ² (70 ft ²) (65032.13 cm ²)	
Notes:	
<ol style="list-style-type: none"> 1. The front and back doors have latches but do not lock. 2. IBM does not support installation of Cluster 1350 components in racks by other manufacturers. Service and warranty for each Cluster 1350 is by rack serial number. 	

Stability kit

A stability kit (IBM part number 31L8305), containing one tilt foot, is included with the 1410 rack. Install the tilt foot when the rack is at the final installation location. Figure 1 on page 20 shows the attachment of the tilt foot.

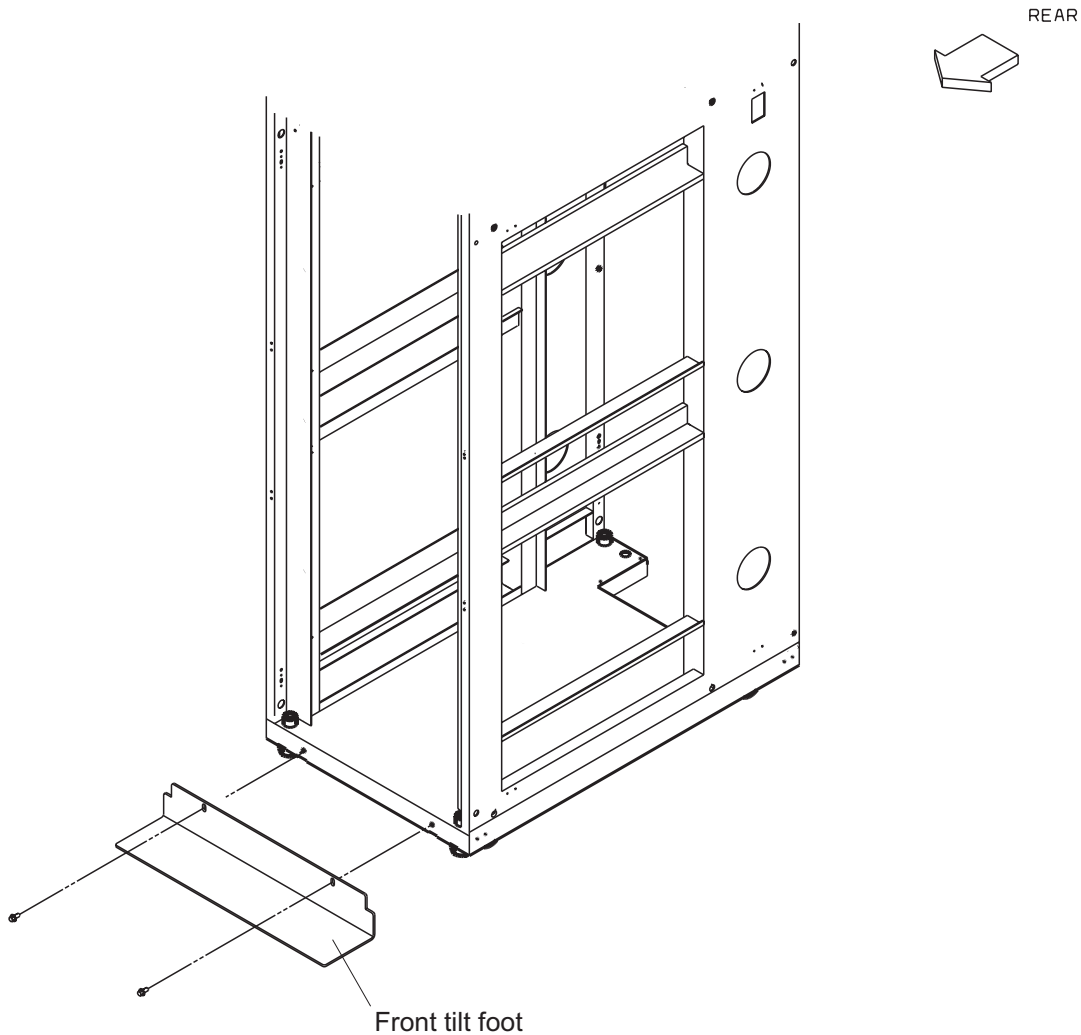

Figure 1. Cluster 1350 stability kit

Floor loading

To determine the clearances required for each rack, you must know the maximum floor load rating in pounds per square foot or kilograms per square meter at your installation site. Table 3 on page 21 shows the necessary clearances or weight-distribution distances for a fully configured rack. The weight-distribution distances in all four directions indicate the area around the rack (minus covers) necessary to distribute the weight beyond the perimeter of the rack. Weight-distribution areas must not overlap with adjacent computer equipment weight-distribution areas.

For example, if the raised floor at your site could safely support 351.5 kg/m^2 (72.0 lb/ft^2) then the correct distance between the sides of each cabinet would be 1524 mm (40 inches). You would also maintain front and back clearances of 762 mm (30 inches), making sure that no other equipment was placed within the area.

The Cluster 1350 cabinet footprint without covers is 622 mm (24.5 inches) by 1021 mm (40.2 inches). The values shown in the Table 3 assume a maximum rack weight

of 1003 kilograms (2211 pounds). Floor loading will vary by configuration. Contact your IBM representative if you need to know floor loading for a specific configuration.

If you need to know the approximate point load that each caster exerts on a raised floor panel, divide the weight of the rack by three.

Table 3. Floor loading

lb/ft²	kg/m²	Side clearances	Front and back clearances
72.0	351.5	508 mm (20 in.)	762 mm (30 in.)
78.4	382.8	508 mm (20 in.)	610 mm (24 in.)
86.8	423.8	508 mm (20 in.)	457 mm (18 in.)
93.1	454.6	254 mm (10 in.)	762 mm (30 in.)
102.4	500.0	254 mm (10 in.)	610 mm (24 in.)
114.5	559.1	254 mm (10 in.)	457 mm (18 in.)
112.8	550.8	127 mm (5 in.)	762 mm (30 in.)
124.8	609.3	127 mm (5 in.)	610 mm (24 in.)
140.5	686.0	127 mm (5 in.)	457 mm (18 in.)
139.3	680.1	25 mm (1 in.)	762 mm (30 in.)
154.9	756.3	25 mm (1 in.)	610 mm (24 in.)
175.4	856.4	25 mm (1 in.)	457 mm (18 in.)

Chapter 6. Electrical requirements

Before delivery, you must arrange for an electrician to verify or install the necessary ac power sources and grounding system.

To provide for future expansion, size your ac power sources to support the maximum configuration for each rack. Additionally, to provide a level of redundancy, arrange for each connection coming out of a rack to have its own branch circuit.

If you are planning to use existing ac power sources, see Table 4 on page 26 and add up the total power requirements of your racks to ensure that existing ac power sources are able to support your planned installation.

This checklist can help you prepare your site electrically for your IBM Cluster 1350:

- 1. Assess existing ac mains supply quality.
- 2. Determine earthing/grounding requirements for your system.
- 3. Determine ac power requirements of your system configuration.
- 4. Determine ac power sources needed to meet these power requirements.

AC mains supply quality

The amount of power your system requires cannot be your sole consideration; power quality is also a concern. If ac power is not consistent and of sufficient quality, the performance and life expectancy of your system will suffer. If the installation site has a history of ac power-line disturbances, you must consider whether corrective measures, such as power-line conditioning or an uninterruptible power supply (UPS), might be necessary.

Low nominal line voltages

Each system is designed to operate within the specified voltage ranges. A main supply that is consistently close to the bottom of the voltage range makes the system more susceptible to momentary line disturbances, which can result from problems with the power utility company, wiring deficiencies (in the building), or an overloaded local transformer.

If consistently low line voltages are a problem at your site, make sure that a qualified electrician investigates and corrects the problem. If a nominal voltage cannot be maintained, a regulated and shielded power conditioner or UPS should be used.

Brownouts and line sags

Brownouts and line sags often result from power-company load switching or load switching within buildings. In addition, power companies might deliberately reduce the line voltage during general overload or high demand, producing short-term brownout.

Power-line impulses

Power-line transient impulses can result when other equipment shares the power source within the system. Electromagnetic interference (EMI) can pass from the power line to the system chassis ground. These transient impulses can then flow into connecting cables, causing errors or the loss or damage of data.

Proper grounding and bonding procedures protect against most power-line impulses. A shielded isolation transformer with single-point grounding at the secondary provides added protection.

Frequency stability

Generally, large power-distribution networks maintain a stable frequency, but smaller and isolated power-distribution systems (motor or diesel generators) might not. The power-line frequency of the system must be stable within the specified limits.

Earthing/grounding requirements

Earthing/grounding requirements for safe operation of equipment are documented in international standards, national standards, and local electrical codes. The local authority having jurisdiction over enforcement of electrical requirements at your location or a local electrician qualified to do commercial electrical work can tell you which standards and codes apply to your installation location. These recommendations are industry-proven practices that help to minimize the effects of external electrical disturbances by providing a common ground potential for interconnected equipment, even when equipment is separated by long distances.

The intent of the standards and codes is to provide a safe environment for personnel and property in the event of a power fault, equipment wiring fault, or lightning event. However, there are earthing/grounding recommendations or requirements that are important for proper operation, reliability, and performance of sensitive electronic equipment. These recommendations or requirements exceed what is documented in the standards and codes but do not compromise the baseline provisions that are considered necessary for safety.

To ensure proper operation of your Cluster 1350 you must provide a common ground potential for interconnected equipment, even when equipment is separated by long distances. The Cluster 1350 line cords contain an insulated equipment grounding wire that connects the rack frame to the ground terminal on the receptacle. The receptacle for IBM equipment should be connected by an insulated equipment grounding conductor to the grounding bus bar in the branch-circuit distribution panel. The grounding bus bar should be connected by an insulated equipment grounding wire back to the service entrance or suitable building ground.

The earthing/grounding conductor must be continuous from the receptacle where the Cluster 1350 is installed to the service entrance or suitable building earth/ground. The earthing/grounding conductor must be in the same conduit as the associated feed wires. For example, in the United States, the grounding conductor from the circuit-breaker panel to the receptacle where the Cluster 1350 is installed must be in the same conduit as the two line conductors that supply 200 - 240 V ac to the Cluster 1350. The earthing/grounding conductor must have sufficiently low impedance to facilitate the operation of over-current protective devices. Figure 2 on page 25 shows one way to properly ground sensitive electrical equipment.

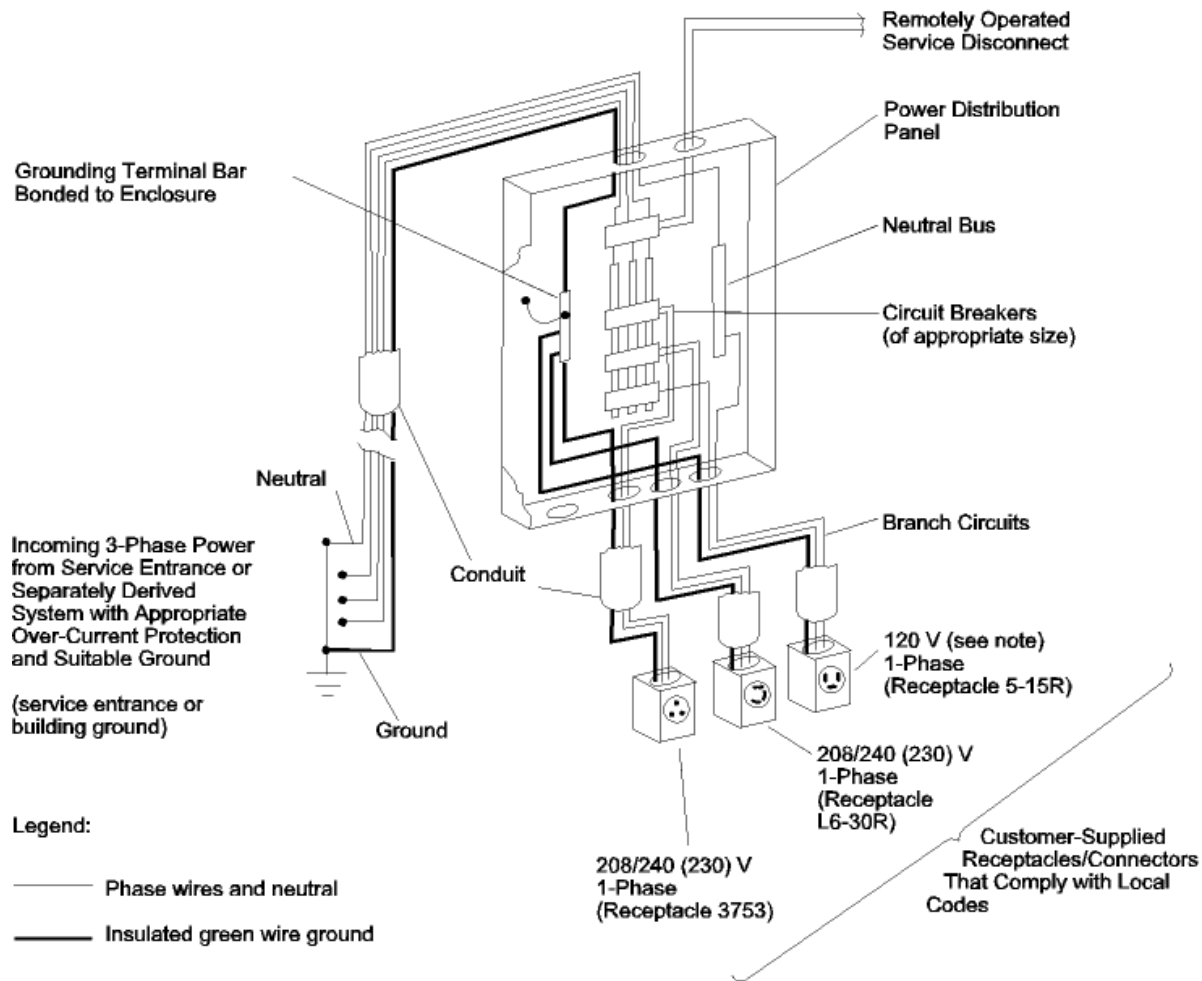

RV20031-1

Figure 2. Properly grounding sensitive electrical equipment

AC power requirements

Each rack contains one or more IBM NetBAY rack power-distribution units (PDUs) or IBM distributed power interconnect PDUs. The PDUs are mounted sideways in the rack space. The types of PDUs used:

- NetBay Rack PDU
- NetBay Front-End PDU
- Distributed Power Interconnect (DPI) Rack PDU
- Distributed Power Interconnect (DPI) Front-End PDU
- Distributed Power Interconnect (DPI) High-Density PDU

Rack PDUs provide power to components within a cabinet, and front-end PDUs provide the connection to the external power source and distribute the power among the rack PDUs. A rack PDU can also be directly connected to the external power source to eliminate the need for the front end PDU. Up to four front-end PDUs or up to 12 rack PDUs can be placed in each cabinet.

Regardless of the PDU configuration used in the rack, each connector coming out of the rack must be attached to an ac mains power source that provides 30 amps of single phase 200 - 240 V ac, 50/60 Hz power.

Table 4 lists the power requirements for each IBM Cluster 1350 system component. The power usages are summarized to aid in sizing total power requirements and backup power systems.

Table 4. Electrical specifications of individual components

System Components	Electrical requirements
@server 325 server	<p>Power supply: One 411 watt (115 - 230 V ac)</p> <p>Electrical input:</p> <ul style="list-style-type: none"> • Sine-wave input (50-60 Hz) required • Input voltage low range: <ul style="list-style-type: none"> – Minimum: 100 V ac – Maximum: 127 V ac ac • Input voltage high range: <ul style="list-style-type: none"> – Minimum: 200 V ac – Maximum: 240 V ac ac • Input kilovolt-amperes (kVA) approximately: <ul style="list-style-type: none"> – Minimum: 0.120 kVA – Maximum: 0.400 kVA
xSeries 335 server	<p>Power supply: One 320 watt (115 - 230 V ac)</p> <p>Electrical input:</p> <ul style="list-style-type: none"> • Sine-wave input (50-60 Hz) required • Input voltage low range: <ul style="list-style-type: none"> – Minimum: 100 V ac – Maximum: 127 V ac ac • Input voltage high range: <ul style="list-style-type: none"> – Minimum: 200 V ac – Maximum: 240 V ac ac • Input kilovolt-amperes (kVA) approximately: <ul style="list-style-type: none"> – Maximum: 0.323 kVA
xSeries 345 server	<p>Hot-swap power supplies: 350 watt (115 - 230 V ac)</p> <ul style="list-style-type: none"> • Minimum: One • Maximum: Two - the second power supply provides redundant power <p>Electrical input:</p> <ul style="list-style-type: none"> • Sine-wave input (50-60 Hz) required • Input voltage low range: <ul style="list-style-type: none"> – Minimum: 100 V ac – Maximum: 127 V ac ac • Input voltage high range: <ul style="list-style-type: none"> – Minimum: 200 V ac – Maximum: 240 V ac ac • Input kilovolt-amperes (kVA) approximately: 0.354 kVA

Table 4. Electrical specifications of individual components (continued)

System Components	Electrical requirements
xSeries 360 server	<p>Hot-swap power supplies: 370 watt (115 - 230 V ac)</p> <ul style="list-style-type: none"> • Minimum: One or two power supplies come with the server, depending on model • Maximum: Three - the third power supply provides redundant power <p>Electrical input:</p> <ul style="list-style-type: none"> • Sine-wave input (50-60 Hz) required • Input voltage low range: <ul style="list-style-type: none"> – Minimum: 100 V ac – Maximum: 127 V ac ac • Input voltage high range: <ul style="list-style-type: none"> – Minimum: 200 V ac – Maximum: 240 V ac ac • Input kilovolt-amperes (kVA) approximately: <ul style="list-style-type: none"> – Minimum: 0.08 kVA (ac power connected, server off) – Minimum: 0.38 kVA (dc power on, server idle) – Maximum: 1.1 kVA
@server BladeCenter unit and HS20 blade server	<p>Power supply: Two 1200 watt (200 - 240 V ac)</p> <p>Electrical input:</p> <ul style="list-style-type: none"> • Sine-wave input (50-60 Hz single-phase) required • Input voltage low range: <ul style="list-style-type: none"> – 200 V ac • Input voltage high range: <ul style="list-style-type: none"> – 240 V ac ac
IBM TotalStorage FAStT600 storage server	<ul style="list-style-type: none"> • Sine-wave input (50-60 Hz) required • Input voltage low range: <ul style="list-style-type: none"> – Minimum: 100 V ac – Maximum: 127 V ac ac • Input voltage high range: <ul style="list-style-type: none"> – Minimum: 200 V ac – Maximum: 240 V ac ac • Input kilovolt-amperes (kVA) approximately: <ul style="list-style-type: none"> – Maximum configuration: 0.37 kVA – Minimum configuration: 0.06 kVA
IBM TotalStorage FAStT700 storage server	<ul style="list-style-type: none"> • Sine-wave input (50-60 Hz) required • Input voltage low range: <ul style="list-style-type: none"> – Minimum: 100 V ac – Maximum: 127 V ac ac • Input voltage high range: <ul style="list-style-type: none"> – Minimum: 200 V ac – Maximum: 240 V ac ac • Input kilovolt-amperes (kVA) approximately: <ul style="list-style-type: none"> – Maximum configuration: 0.155 kVA

Table 4. Electrical specifications of individual components (continued)

System Components	Electrical requirements
IBM TotalStorage FAStT900 storage server	<ul style="list-style-type: none"> • Sine-wave input (50-60 Hz) required • Input voltage low range: <ul style="list-style-type: none"> – Minimum: 100 V ac – Maximum: 127 V ac ac • Input voltage high range: <ul style="list-style-type: none"> – Minimum: 200 V ac – Maximum: 240 V ac ac • Input kilovolt-amperes (kVA) approximately: <ul style="list-style-type: none"> – Maximum configuration: 0.155 kVA
IBM EXP400 storage expansion unit	<ul style="list-style-type: none"> • Sine-wave input (50-60 Hz) required • Input voltage low range: <ul style="list-style-type: none"> – Minimum: 90 V ac – Maximum: 136 V ac ac • Input voltage high range: <ul style="list-style-type: none"> – Minimum: 198 V ac – Maximum: 264 V ac ac • Input kilovolt-amperes (kVA) approximately: <ul style="list-style-type: none"> – Minimum configuration: 0.06 kVA – Maximum configuration: 0.45 kVA
IBM EXP700 storage expansion unit	<ul style="list-style-type: none"> • Sine-wave input (50-60 Hz) required • Input voltage low range: <ul style="list-style-type: none"> – Minimum: 100 V ac – Maximum: 127 V ac ac • Input voltage high range: <ul style="list-style-type: none"> – Minimum: 200 V ac – Maximum: 240 V ac ac • Input kilovolt-amperes (kVA) approximately: <ul style="list-style-type: none"> – Maximum configuration: 0.390 kVA
1 U flat monitor	<p>Supply voltage: 90 - 264 V ac, 50/60</p> <p>Power consumption:</p> <ul style="list-style-type: none"> • Normal operation: 26 W • Standby: 3 W
NetBAY 2x8 console switch	<p>In/out voltage - low range</p> <ul style="list-style-type: none"> • Minimum: 90 V ac • Maximum: 136 V ac <p>In/out voltage - high range</p> <ul style="list-style-type: none"> • Minimum: 198 V ac • Maximum: 264 V ac
NetBAY Remote Console Manager	<ul style="list-style-type: none"> • ac input power: 40 W maximum • ac input voltage: 100 - 240 V ac (autosensing) • ac current rating: 1 A • ac frequency: 50/60 Hz • Power consumption: 25 W
Cisco Catalyst 3550 - 24 XL (24-port) Ethernet switch	<ul style="list-style-type: none"> • ac input voltage: 100 -127/200 -240 V ac (autoranging), 50 - 60 Hz • Power consumption: 65 W
Cisco Catalyst 3550 - 48 XL (48-port) Ethernet switch	<ul style="list-style-type: none"> • ac input voltage: 100 -127/200 - 240 V ac (autoranging) 50 - 60 Hz • Power consumption: 110 W

Table 4. Electrical specifications of individual components (continued)

System Components	Electrical requirements
Cisco Catalyst 3508G (8-port) Ethernet switch	<ul style="list-style-type: none"> ac input voltage: 100 - 127/200 - 240 V ac (autoranging) 50 - 60 Hz dc input voltages: +3.3 V at 14 A, +12 V @ 3 A Power consumption: 82.2 W
SMC8624T (24-port) (1RU) Ethernet switch	<ul style="list-style-type: none"> ac input voltage: 100 - 240 V ac (autoranging) 50 - 60 Hz Power consumption: 70 W
SMCBGSLCX1 mini-GBIC expansion module	<ul style="list-style-type: none"> ac input voltage: 100 - 240 V ac (autoranging) 50 - 60 Hz Power consumption: 70 W
In-Reach LX 4000 (32-port) terminal server	<ul style="list-style-type: none"> Power external supply: 100 - 240 V ac Power consumption: 32 W
In-Reach LX 4000 (48-port) terminal server	<ul style="list-style-type: none"> Power external supply: 100 - 240 V ac Power consumption: 32 W
Myrinet model M3-E32 (5-slot) high-speed switch	<ul style="list-style-type: none"> Power input: 100 - 127/200 - 240 V ac, 50 Hz/60 Hz Maximum total power with line cards in all slots: 240 W Maximum input current at 100 - 127 V ac: 2.4 A Maximum input current at 200 - 240 V ac: 1.2 A
Myrinet model M3-E64 (9-slot) high-speed switch	<p>Power input: 100 - 127/200 - 240 V ac, 50 Hz/60 Hz</p> <p>Maximum total power with line cards in all slots: 480 W</p> <p>Maximum input current at 100 - 127 V ac: 4.8 A</p> <p>Maximum input current at 200 - 240 V ac: 2.4 A</p>
Myrinet model M3-E128 (17-slot) high-speed switch	<p>Power input: 100 - 127/200 - 240 V ac, 50 Hz/60 Hz</p> <p>Maximum total power with line cards in all slots: 960 W</p> <p>Maximum input current at 100 - 127 V ac: 9.6 A</p> <p>Maximum input current at 200 - 240 V ac: 4.8 A</p>
Myrinet model M3F-PC164C-2 (PCI card) high-speed switch	<ul style="list-style-type: none"> Power input: 3.3 V ac from PCI bus, 50 Hz/60 Hz Maximum input current: 1.8 A Maximum total power: 6 W
Myrinet model M3F-PCIXD-2 (PCI card) high-speed switch	<ul style="list-style-type: none"> Power input: 3.3 V ac from PCI bus, 50 Hz/60 Hz Maximum input current: 1.8 A Maximum total power: 6 W

Table 4. Electrical specifications of individual components (continued)

System Components	Electrical requirements
Myrinet cluster expansion card	<p>Power supply: 200 - 240 V ac</p> <p>Electrical input:</p> <ul style="list-style-type: none"> • Sine-wave input (50-60 Hz single-phase) required • Input voltage low range: <ul style="list-style-type: none"> – 200 V ac • Input voltage high range: <ul style="list-style-type: none"> – 240 V ac
Catalyst 4003 switch	<ul style="list-style-type: none"> • Power input: 100 - 240 V ac, 50 Hz/60 Hz • Maximum total power: 530 W
Catalyst 4006 switch	<ul style="list-style-type: none"> • Power input: 100 - 240 V ac, 50 Hz/60 Hz • Maximum total power: 725 W
APC MasterSwitch model AP9212 power management module	<ul style="list-style-type: none"> • Nominal input voltage: 208, 230 V ac • Input frequency (Hz): 50/60 Hz \pm 5 Hz (manual switch) • Input connection type: IEC-320 C14 • Acceptable input voltage: 253 V ac • Maximum line current: 10 A • Maximum input current: 10 A
NetBay rack power distribution unit	<p>Output power: 16 A, 180 - 240 V ac, 50 - 60 Hz</p> <p>Receptacles:</p> <ul style="list-style-type: none"> • Input - IEC 60320 C20 outlet • Output - (7) IEC 60320 C13 outlets <p>Maximum current draw for each outlet is 10 A. Maximum for all 7 outlets is 13 A</p>
NetBAY front end power distribution unit	<p>Output power: 16 A, 100 - 240 V ac, 50 - 60 Hz</p> <p>Receptacles:</p> <ul style="list-style-type: none"> • Input - IEC 60320 C20 outlet • Output - (3) IEC 60320 C13 outlets
IBM Distributed Power Interconnect rack power-distribution unit	<p>Output power: 16 A, 100 - 240 V ac, 50 - 60 Hz</p> <p>Receptacles:</p> <ul style="list-style-type: none"> • Input - IEC 60320 C20 outlet • Output - (7) IEC 60320 C13 outlets
IBM Distributed Power Interconnect front-end power-distribution unit	<p>Output power: 16 A, 120 - 240 V ac, 50 - 60 Hz</p> <p>Receptacles:</p> <ul style="list-style-type: none"> • Input - IEC 60320 C20 outlet • Output - (7) IEC 60320 C13 outlets
IBM Distributed Power Interconnect high-density power-distribution unit	<p>Output power: 32-63 A, 200 - 240 V ac, 50 - 60 Hz</p> <p>Receptacles:</p> <ul style="list-style-type: none"> • Input - IEC 320 C19 outlet • Output - (12) IEC 320 C19 outlet

Receptacle styles and pin-outs

Power is supplied to the Cluster 1350 system through power-distribution units (PDUs) and power cords. Table 5 describes the possible power cords and shows the pin patterns and nominal voltages for the various receptacles.

Table 5. AC receptacle patterns with voltage pin-outs

International or country type (IBM type number)	Receptacle pattern	Cluster 1350 part number	Supported countries and regions
NEMA L6-30 (IBM connector type 12)		37L6884	Afghanistan, Anguilla, Antigua, Argentina, Aruba, Bahamas, Bangladesh, Barbados, Belize, Bermuda, Bolivia, Bonaire, Brunei, Caicos Islands, Canada, Cape Verde Islands, Cayman Islands, Chile, China (Hong Kong S.A.R.) Colombia, Costa Rica, Curacao, Dominican Republic, Ecuador, El Salvador, Guam, Guatemala, Haiti, Honduras, Indonesia, Jamaica, Japan, Malaysia, Mexico, Montserrat, Myanmar, Netherlands Antilles, Nicaragua, Panama, Paraguay, People's Republic of China, Peru, Philippines, Puerto Rico, Sri Lanka, St. Kitts, St. Martin, Suriname, Taiwan, Thailand, Tobago, Tortola (BVI), Trinidad, Turks Island, United States, Uruguay, Venezuela, Virgin Islands

Table 5. AC receptacle patterns with voltage pin-outs (continued)

International or country type (IBM type number)	Receptacle pattern	Cluster 1350 part number	Supported countries and regions
IEC 309, 32A, P+N+G (IBM connector type 46)		37L6885	Albania, Algeria, Andorra, Angola, Armenia, Azores, Belarus, Belgium, Benin, Bosnia, Bulgaria, Burkina Faso, Burundi, Cambodia, Cameroon, Central African Republic, Chad, China (Macau S.A.R), Congo, Croatia, Dahomey, Djibouti, Egypt, Equatorial Guinea, Faero Islands, France, French Guiana, French Polynesia, Gabon, Georgia, Germany, Greece, Greenland, Guadeloupe, Guinea, Guinea-Bissau, Hungary, Iceland, Iran, Ivory Coast, Kazakhstan, Kirghizia, Laos, Lebanon, Liberia, Luxembourg, Macedonia, Malagasy Republic, Mali, Martinique, Mauritania, Moldavia, Monaco, Mongolia, Morocco, Mozambique, Netherlands, New Caledonia, Niger, Norway, Poland, Principe, Reunion, Romania, Rwanda, Sao Tome Island, Saudi Arabia, Senegal, Serbia, Slovakia, Slovenia, Spain, Sudan, Swaziland, Syria, Tahiti, Togo, Tunisia, Ukraine, Uzbekistan, Vietnam, Zaire, Zimbabwe
CEE 7 VII (IBM connector type 18)		37L6868	Czech Republic, Estonia, Finland, Latvia, Lithuania, Russia, Sweden, Turkey, Korea
IEC 309, 16A, 3P+N+G (IBM connector type 46)		37L6870	Denmark, Liechtenstein, Switzerland
SII 32-1971 (IBM connector type 32)		37L6872	Israel

Table 5. AC receptacle patterns with voltage pin-outs (continued)

International or country type (IBM type number)	Receptacle pattern	Cluster 1350 part number	Supported countries and regions
SABS 164 BS 546 (IBM connector type 22)		37L6876	South Africa
SAA®-AS 3112 (IBM connector type 54)		24P7884	Australia, Fiji, New Zealand, Papua New Guinea, Western Samoa

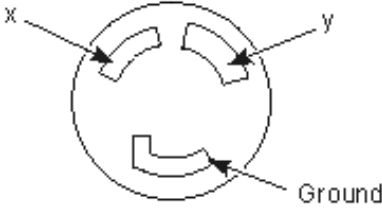
Communication-port protection

IBM Cluster 1350 products are designed to meet all industry-standard requirements for data communication interfaces, but the necessary external cables make the interfaces vulnerable to damage from sources such as electrical-storm lightning or power-line surges.

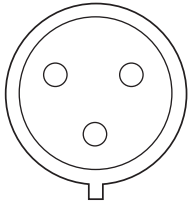
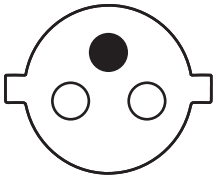
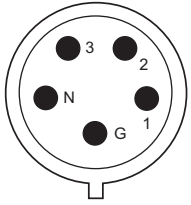
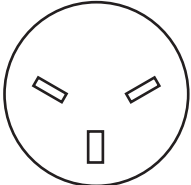
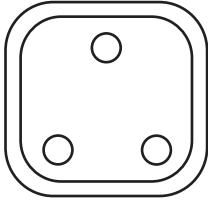
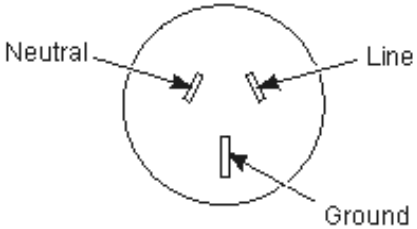
Protect your system's data communications interfaces by implementing procedures described in one or more of the following standards:

- ANSI TI.313, *Electrical Protection For Telecommunications Central Offices and Similar Type Facilities*
- CCITT K.15, *Protection of Remote-Feeding Systems and Line Repeaters Against Lightning and Interference From Neighboring Electricity Lines*
- ECMA 200, *Immunity of Information Technology Equipment to Lightning Surges*
- MIL-HDBK-1004/6, *Lightning Protection*
- NFPA 70, *National Electrical Code*
- TR-NWT-001089, *Electromagnetic Compatibility and Electrical Safety Generic Criteria For Network Telecommunication Equipment (Bellcore)*
- VDE 0845 (PTI), *Protection of Telecommunication Systems Against Lightning, Electrostatic Discharges, and Overvoltages From Electric Power Installations*

PDU requirements

The power-distribution units (PDUs) that are installed in an IBM Clusters 1350 cabinet are not powered through a cabinet ac breaker. Each front end PDU has its own ac power cord that requires an external power connection outside of the cabinet. Rack PDUs can be attached either to the front-end PDUs or directly to an external power connection outside of the cabinet. Safe power-down of a cabinet with PDUs installed requires that each PDU power cord must be disconnected from its ac power source or the PDU. Prepare the cluster site so that PDU power cords are visible and identifiable. Their external ac-power source receptacles must be readily accessible for fast disconnection.

DANGER

The breaker switch on the PDU is not accessible. To turn off power to the cabinet, you must disconnect all the power cords from the power receptacles or all the connectors from individual PDUs.

Chapter 7. Cabinet placement and intercabinet cabling

CAUTION:

Make sure that all rack-mounted units are fastened in the rack frame. Do not extend or exchange any rack-mounted units when the stabilizer is not installed.

Minimum service clearances

Several factors influence final cabinet placement. In addition to adequate cable length and staying within safe floor loading limits for your installation site, observe the minimum clearances required for service of the racks in the Cluster 1350. You might want to plan for extra space around the racks to allow movement of racks for service.

Figure 3 shows the clearances needed for servicing a rack in the Cluster 1350. Note that the service clearances for the sides of the rack are not required for operation, but only for servicing the PDUs.

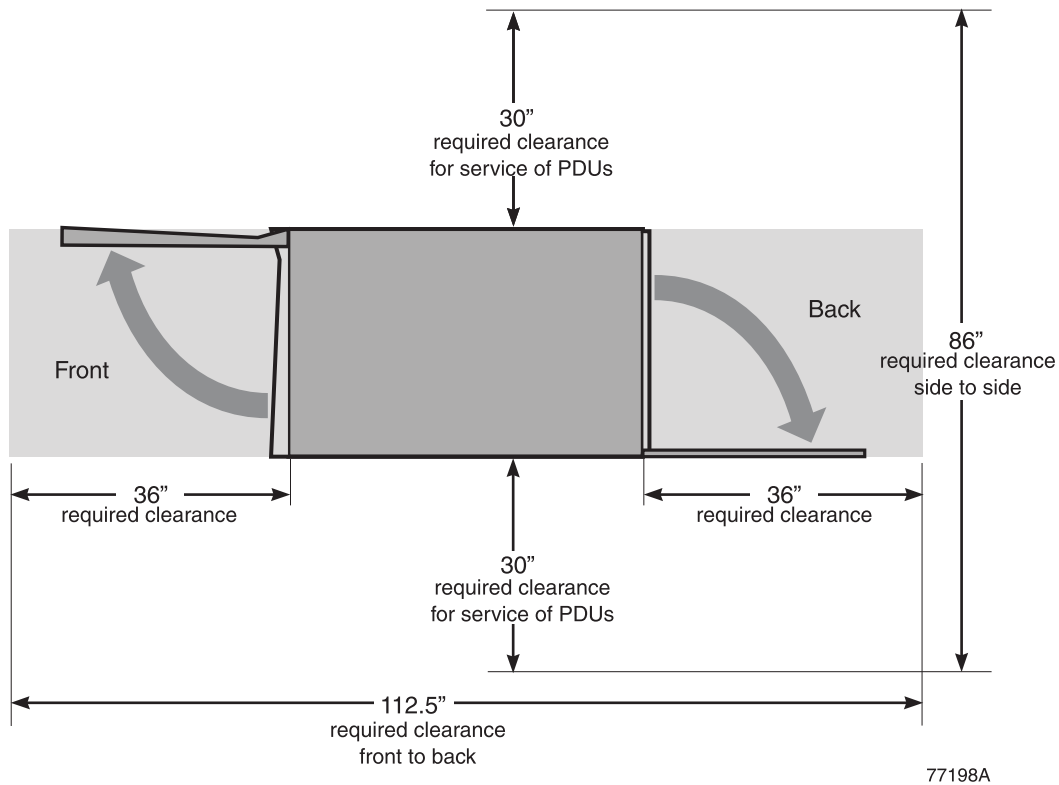
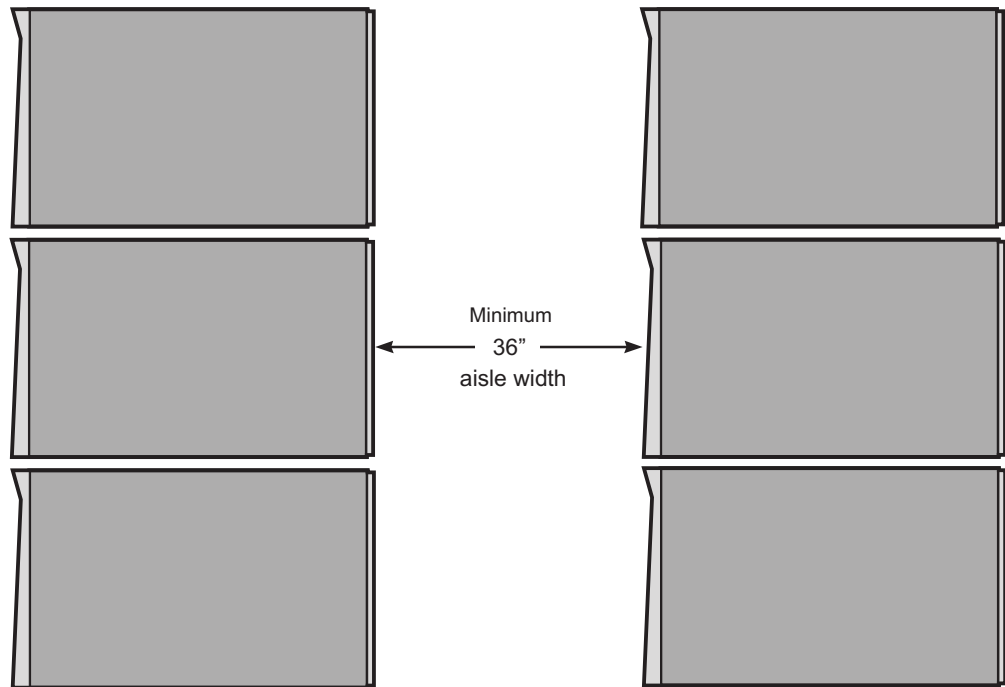

Figure 3. Cabinet clearances required for service

If you are planning the installation of a large cluster and you want to arrange the racks in several rows, you must maintain a minimum aisle width of 36 inches as shown in Figure 4 on page 36. This will allow enough space for the front and back covers of the racks to open. An aisle width of 48 inches might be more appropriate if you want to make sure that you have enough room to move the rack to gain access to the sides for servicing the PDUs.

Figure 4. Minimum aisle width for Cluster 1350 installations



Final cabinet placement will determine what will qualify as adequate cable lengths. This chapter gives guidelines for intercabinet (rack-to-rack) cabling. Use these guidelines to determine the best cable lengths for your installation.

Remember to install the stability kit when the cabinets are placed in their final location. See “Stability kit” on page 19 for information about installing the stability kit that comes with each cabinet.

Types of intercabinet cabling

Cabinet placement is partly determined by the cables that run between cabinets. Both optical and copper cables are involved.

All intercabinet (rack-to-rack) cables and cable harnesses come in varying lengths up to 25 meters. There are no layout restrictions.

Color-coded CAT5E intercabinet Ethernet cables are available for intercabinet cabling of the cluster components. The color-coded cables operate exactly as the existing cluster intercabinet Ethernet cables with the added advantage of being able to group like-devices by a specific color. The cable colors and lengths include:

- Blue - 0.6 m, 1m, 1.5 m, 2 m, 2.5 m, 3 m, 10 m, 25 m

- Green - 0.6 m, 1 m, 1.5 m, 2 m, 2.5 m, 3 m, 10 m, 25 m
- Yellow - 0.6 m, 1 m, 1.5 m, 2 m, 2.5 m, 3 m, 10 m, 25 m

Note: In some clusters, the FRU intercabinet cables can also be white or gray.

Table 6 shows the available lengths for the different cables and cable harnesses.

Table 6. Available lengths for fibre-based Ethernet and Fibre Channel cables

Length	Part number	Note
1 m	36L9973	Fibre cable, SC to SC
5 m	03K9306	Fibre cable, SC to SC
25 m	03K9305	Fibre cable, SC to SC
1 m	19K1247	Fibre cable, LC to LC
3 m	31P6327	Fibre cable, LC to LC
5 m	19K1248	Fibre cable, LC to LC
10 m	31P6326	Fibre cable, LC to LC
25 m	19K1249	Fibre cable, LC to LC
0.208 m	19K1250	Fibre cable, SC to LC

Appendix A. Declaration of IBM product noise emission values

General noise emission values for the Cluster 1350 are shown in Table 7.

Table 7. General noise emission values for the Cluster 1350

Declaration of IBM product noise emission values				
Product configuration	Declared A-weighted sound power levels L_{wAd} (B)		Declared A-weighted sound pressure level L_{pAm} (db) at 1 meter bBystander position	
	Cluster 1350 (fully configured racks)	8.0 (bels) operating	8.0 (bels) idling	62 (db) operating
Note: L_{wAd} is the declared (upper limit) sound power level for a random sample of machines. L_{pAm} is the mean value of the A-weighted sound pressure levels at the bystander (1 - meter) positions for a random sample of machines. All measurements are made in accordance with ISO 7779 and declared in conformance with ISO 9296.				

Noise emission values are different for racks that contain BladeCenters. Each BladeCenter unit has two blowers for cooling. An optional acoustics module is available that dampens the noise generated by the blowers. Table 8 shows the maximum sound levels emitted by BladeCenter units without the acoustics module and with the acoustics module. This represents the minimum and maximum number of BladeCenter units that can be installed in a 42-U rack.

Table 8. Noise emission values for racks containing BladeCenters

	Number of BladeCenter units per rack	Maximum sound power idle	Maximum sound power operating
Without acoustics module	1	7.4 bels	7.4 bels
With acoustics module	1	6.9 bels	6.9 bels
Without acoustics module	4	8 bels	8 bels
With acoustics module	4	7.5 bels	7.5 bels
Without acoustics module	6	8.2 bels	8.2 bels
With acoustics module	6	7.7 bels	7.7 bels

Appendix B. Notices

This information was developed for products and services offered in the U.S.A.

IBM may not offer the products, services, or features discussed in this document in other countries. Consult your local IBM representative for information on the products and services currently available in your area. Any reference to an IBM product, program, or service is not intended to state or imply that only that IBM product, program, or service may be used. Any functionally equivalent product, program, or service that does not infringe any IBM intellectual property right may be used instead. However, it is the user's responsibility to evaluate and verify the operation of any non-IBM product, program, or service.

IBM may have patents or pending patent applications covering subject matter described in this document. The furnishing of this document does not give you any license to these patents. You can send license inquiries, in writing, to:

*IBM Director of Licensing
IBM Corporation
North Castle Drive
Armonk, NY 10504-1785
U.S.A.*

INTERNATIONAL BUSINESS MACHINES CORPORATION PROVIDES THIS PUBLICATION "AS IS" WITHOUT WARRANTY OF ANY KIND, EITHER EXPRESS OR IMPLIED, INCLUDING, BUT NOT LIMITED TO, THE IMPLIED WARRANTIES OF NON-INFRINGEMENT, MERCHANTABILITY OR FITNESS FOR A PARTICULAR PURPOSE. Some states do not allow disclaimer of express or implied warranties in certain transactions, therefore, this statement may not apply to you.

This information could include technical inaccuracies or typographical errors. Changes are periodically made to the information herein; these changes will be incorporated in new editions of the publication. IBM may make improvements and/or changes in the product(s) and/or the program(s) described in this publication at any time without notice.

Any references in this information to non-IBM Web sites are provided for convenience only and do not in any manner serve as an endorsement of those Web sites. The materials at those Web sites are not part of the materials for this IBM product, and use of those Web sites is at your own risk.

IBM may use or distribute any of the information you supply in any way it believes appropriate without incurring any obligation to you.

Edition notice

© Copyright International Business Machines Corporation 2003. All rights reserved.

U.S. Government Users Restricted Rights — Use, duplication, or disclosure restricted by GSA ADP Schedule Contract with IBM Corp.

Trademarks

The following terms are trademarks of International Business Machines Corporation in the United States, other countries, or both:

Active Memory	Predictive Failure Analysis
Active PCI	PS/2
Active PCI-X	ServeRAID
Alert on LAN	ServerGuide
BladeCenter	ServerProven
C2T Interconnect	TechConnect
Chipkill	ThinkPad
EtherJet	Tivoli
e-business logo	Tivoli Enterprise
@server	TotalStorage
FlashCopy	Update Connector
IBM	Wake on LAN
IBM (logo)	XA-32
IntelliStation	XA-64
NetBAY	X-Architecture
Netfinity	Xcel4
NetView	XpandOnDemand
	xSeries

Lotus, Lotus Notes, SmartSuite, and Domino are trademarks of Lotus Development Corporation and/or IBM Corporation in the United States, other countries, or both.

Intel, MMX, and Pentium are trademarks of Intel Corporation in the United States, other countries, or both.

Microsoft, Windows, and Windows NT are trademarks of Microsoft Corporation in the United States, other countries, or both.

UNIX is a registered trademark of The Open Group in the United States and other countries.

Java and all Java-based trademarks and logos are trademarks or registered trademarks of Sun Microsystems, Inc. in the United States, other countries, or both.

Other company, product, or service names may be trademarks or service marks of others.

Important notes

Processor speeds indicate the internal clock speed of the microprocessor; other factors also affect application performance.

CD-ROM drive speeds list the variable read rate. Actual speeds vary and are often less than the maximum possible.

When referring to processor storage, real and virtual storage, or channel volume, KB stands for approximately 1000 bytes, MB stands for approximately 1 000 000 bytes, and GB stands for approximately 1 000 000 000 bytes.

When referring to hard disk drive capacity or communications volume, MB stands for 1 000 000 bytes, and GB stands for 1 000 000 000 bytes. Total user-accessible capacity may vary depending on operating environments.

Maximum internal hard disk drive capacities assume the replacement of any standard hard disk drives and population of all hard disk drive bays with the largest currently supported drives available from IBM.

Maximum memory may require replacement of the standard memory with an optional memory module.

IBM makes no representation or warranties regarding non-IBM products and services that are ServerProven[®], including but not limited to the implied warranties of merchantability and fitness for a particular purpose. These products are offered and warranted solely by third parties.

IBM makes no representations or warranties with respect to non-IBM products. Support (if any) for the non-IBM products is provided by the third party, not IBM.

Some software may differ from its retail version (if available), and may not include user manuals or all program functionality.

Product recycling and disposal

This unit contains materials such as circuit boards, cables, electromagnetic compatibility gaskets, and connectors which may contain lead and copper/beryllium alloys that require special handling and disposal at end of life. Before this unit is disposed of, these materials must be removed and recycled or discarded according to applicable regulations. IBM offers product-return programs in several countries. Information on product recycling offerings can be found on IBM's Internet site at <http://www.ibm.com/ibm/environment/products/prp.shtml>.

Battery return program

This product may contain a sealed lead acid, nickel cadmium, nickel metal hydride, lithium, or lithium ion battery. Consult your user manual or service manual for specific battery information. The battery must be recycled or disposed of properly. Recycling facilities may not be available in your area. For information on disposal of batteries outside the United States, go to <http://www.ibm.com/ibm/environment/products/batteryrecycle.shtml> or contact your local waste disposal facility.

In the United States, IBM has established a collection process for reuse, recycling, or proper disposal of used IBM sealed lead acid, nickel cadmium, nickel metal hydride, and battery packs from IBM equipment. For information on proper disposal of these batteries, contact IBM at 1-800-426-4333. Have the IBM part number listed on the battery available prior to your call.

In the Netherlands, the following applies.

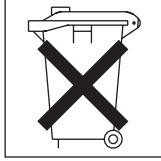

Electronic emission notices

Federal Communications Commission (FCC) statement

Note: This equipment has been tested and found to comply with the limits for a Class A digital device, pursuant to Part 15 of the FCC Rules. These limits are designed to provide reasonable protection against harmful interference when the equipment is operated in a commercial environment. This equipment generates, uses, and can radiate radio frequency energy and, if not installed and used in accordance with the instruction manual, may cause harmful interference to radio communications. Operation of this equipment in a residential area is likely to cause harmful interference, in which case the user will be required to correct the interference at his own expense.

Properly shielded and grounded cables and connectors must be used in order to meet FCC emission limits. IBM is not responsible for any radio or television interference caused by using other than recommended cables and connectors or by unauthorized changes or modifications to this equipment. Unauthorized changes or modifications could void the user's authority to operate the equipment.

This device complies with Part 15 of the FCC Rules. Operation is subject to the following two conditions: (1) this device may not cause harmful interference, and (2) this device must accept any interference received, including interference that may cause undesired operation.

Industry Canada Class A emission compliance statement

This Class A digital apparatus complies with Canadian ICES-003.

Avis de conformité à la réglementation d'Industrie Canada

Cet appareil numérique de la classe A est conforme à la norme NMB-003 du Canada.

Australia and New Zealand Class A statement

Attention: This is a Class A product. In a domestic environment this product may cause radio interference in which case the user may be required to take adequate measures.

United Kingdom telecommunications safety requirement

Notice to Customers

This apparatus is approved under approval number NS/G/1234/J/100003 for indirect connection to public telecommunication systems in the United Kingdom.

European Union EMC Directive conformance statement

This product is in conformity with the protection requirements of EU Council Directive 89/336/EEC on the approximation of the laws of the Member States relating to electromagnetic compatibility. IBM cannot accept responsibility for any failure to satisfy the protection requirements resulting from a nonrecommended modification of the product, including the fitting of non-IBM option cards.

This product has been tested and found to comply with the limits for Class A Information Technology Equipment according to CISPR 22/European Standard EN 55022. The limits for Class A equipment were derived for commercial and industrial environments to provide reasonable protection against interference with licensed communication equipment.

Attention: This is a Class A product. In a domestic environment this product may cause radio interference in which case the user may be required to take adequate measures.

Taiwanese Class A warning statement

警告使用者：
這是甲類的資訊產品，在居住的環境中使用時，可能會造成射頻干擾，在這種情況下，使用者會被要求採取某些適當的對策。

Chinese Class A warning statement

聲 明
此為 A 級產品。在生活環境中，該產品可能會造成無線電干擾。在這種情況下，可能需要用戶對其干擾採取切实可行的措施。

Japanese Voluntary Control Council for Interference (VCCI) statement

この装置は、情報処理装置等電波障害自主規制協議会（VCCI）の基準に基づくクラスA情報技術装置です。この装置を家庭環境で使用すると電波妨害を引き起こすことがあります。この場合には使用者が適切な対策を講ずるよう要求されることがあります。

Power cords

For your safety, IBM provides a power cord with a grounded attachment plug to use with this IBM product. To avoid electrical shock, always use the power cord and plug with a properly grounded outlet.

IBM power cords used in the United States and Canada are listed by Underwriter's Laboratories (UL) and certified by the Canadian Standards Association (CSA).

For units intended to be operated at 115 volts: Use a UL-listed and CSA-certified cord set consisting of a minimum 18 AWG, Type SVT or SJT, three-conductor cord, a maximum of 15 feet in length and a parallel blade, grounding-type attachment plug rated 15 amperes, 125 volts.

For units intended to be operated at 230 volts (U.S. use): Use a UL-listed and CSA-certified cord set consisting of a minimum 18 AWG, Type SVT or SJT, three-conductor cord, a maximum of 15 feet in length and a tandem blade, grounding-type attachment plug rated 15 amperes, 250 volts.

For units intended to be operated at 230 volts (outside the U.S.): Use a cord set with a grounding-type attachment plug. The cord set should have the appropriate safety approvals for the country in which the equipment will be installed.

IBM power cords for a specific country or region are usually available only in that country or region.

IBM power cord part number	Used in these countries and regions
02K0546	China
13F9940	Australia, Fiji, Kiribati, Nauru, New Zealand, Papua New Guinea
13F9979	Afghanistan, Albania, Algeria, Andorra, Angola, Armenia, Austria, Azerbaijan, Belarus, Belgium, Benin, Bosnia and Herzegovina, Bulgaria, Burkina Faso, Burundi, Cambodia, Cameroon, Cape Verde, Central African Republic, Chad, Comoros, Congo (Democratic Republic of), Congo (Republic of), Cote D'Ivoire (Ivory Coast), Croatia (Republic of), Czech Republic, Dahomey, Djibouti, Egypt, Equatorial Guinea, Eritrea, Estonia, Ethiopia, Finland, France, French Guyana, French Polynesia, Germany, Greece, Guadeloupe, Guinea, Guinea Bissau, Hungary, Iceland, Indonesia, Iran, Kazakhstan, Kyrgyzstan, Laos (People's Democratic Republic of), Latvia, Lebanon, Lithuania, Luxembourg, Macedonia (former Yugoslav Republic of), Madagascar, Mali, Martinique, Mauritania, Mauritius, Mayotte, Moldova (Republic of), Monaco, Mongolia, Morocco, Mozambique, Netherlands, New Caledonia, Niger, Norway, Poland, Portugal, Reunion, Romania, Russian Federation, Rwanda, Sao Tome and Principe, Saudi Arabia, Senegal, Serbia, Slovakia, Slovenia (Republic of), Somalia, Spain, Suriname, Sweden, Syrian Arab Republic, Tajikistan, Tahiti, Togo, Tunisia, Turkey, Turkmenistan, Ukraine, Upper Volta, Uzbekistan, Vanuatu, Vietnam, Wallis and Futuna, Yugoslavia (Federal Republic of), Zaire
13F9997	Denmark
14F0015	Bangladesh, Lesotho, Macao, Maldives, Namibia, Nepal, Pakistan, Samoa, South Africa, Sri Lanka, Swaziland, Uganda

IBM power cord part number	Used in these countries and regions
14F0033	Abu Dhabi, Bahrain, Botswana, Brunei Darussalam, Channel Islands, China (Hong Kong S.A.R.), Cyprus, Dominica, Gambia, Ghana, Grenada, Iraq, Ireland, Jordan, Kenya, Kuwait, Liberia, Malawi, Malaysia, Malta, Myanmar (Burma), Nigeria, Oman, Polynesia, Qatar, Saint Kitts and Nevis, Saint Lucia, Saint Vincent and the Grenadines, Seychelles, Sierra Leone, Singapore, Sudan, Tanzania (United Republic of), Trinidad and Tobago, United Arab Emirates (Dubai), United Kingdom, Yemen, Zambia, Zimbabwe
14F0051	Liechtenstein, Switzerland
14F0069	Chile, Italy, Libyan Arab Jamahiriya
14F0087	Israel
1838574	Antigua and Barbuda, Aruba, Bahamas, Barbados, Belize, Bermuda, Bolivia, Brazil, Caicos Islands, Canada, Cayman Islands, Costa Rica, Colombia, Cuba, Dominican Republic, Ecuador, El Salvador, Guam, Guatemala, Haiti, Honduras, Jamaica, Japan, Mexico, Micronesia (Federal States of), Netherlands Antilles, Nicaragua, Panama, Peru, Philippines, Taiwan, United States of America, Venezuela
24P6858	Korea (Democratic People's Republic of), Korea (Republic of)
34G0232	Japan
36L8880	Argentina, Paraguay, Uruguay
49P2078	India
49P2110	Brazil
6952300	Antigua and Barbuda, Aruba, Bahamas, Barbados, Belize, Bermuda, Bolivia, Caicos Islands, Canada, Cayman Islands, Colombia, Costa Rica, Cuba, Dominican Republic, Ecuador, El Salvador, Guam, Guatemala, Haiti, Honduras, Jamaica, Mexico, Micronesia (Federal States of), Netherlands Antilles, Nicaragua, Panama, Peru, Philippines, Saudi Arabia, Thailand, Taiwan, United States of America, Venezuela

Index

Numerics

- 1 U flat monitor
 - electrical requirements 28
- 1 U flat panel monitor
 - physical characteristics 16
- 1 U monitor
 - environmental characteristics 8
- 2x8 console switch
 - physical characteristics 16

A

- AC mains
 - supply quality 23
- AC power requirements 25
- APC MasterSwitch AP9212
 - physical characteristics 18
- APC MasterSwitch model AP9212
 - environmental characteristics 12
- APC MasterSwitch model AP9212 power management module
 - electrical requirements 30

B

- BladeCenter unit
 - electrical requirements 27
 - physical characteristics 15
- blue CAT5E Ethernet cables
 - part number 37
- brownouts 23

C

- cabinet placement
 - general information 35
 - service clearances 35
- cables
 - color-coded Ethernet cables 37
- cabling
 - intercabinet, general information 35
 - types of intercabinet 36
- CAT5E cables
 - color-coded Ethernet cables 37
 - part numbers 37
- checklist
 - preinstallation 13
- Cisco 4003 switch
 - electrical requirements 30
- Cisco 4006 switch
 - electrical requirements 30
- Cisco Catalyst 3508G Ethernet switch
 - electrical requirements 29
- Cisco Catalyst 3508G switch
 - environmental characteristics 10
 - physical characteristics 17

- Cisco Catalyst 3550-24 XL Ethernet switch
 - electrical requirements 28
- Cisco Catalyst 3550-24 XL switch
 - environmental characteristics 9
 - physical characteristics 17
- Cisco Catalyst 3550-48 XL Ethernet switch
 - electrical requirements 28
- Cisco Catalyst 3550-48 XL switch
 - environmental characteristics 10
 - physical characteristics 17
- Cisco Catalyst 4003 switch
 - environmental characteristics 9
 - physical characteristics 18
- Cisco Catalyst 4006 switch
 - environmental characteristics 9
 - physical characteristics 18
- Class A electronic emission notice 44
- clearances
 - floor loading 20
- cluster
 - PDU requirements 33
- color-coded Ethernet cables
 - CAT5E cables 37
 - part numbers 37
- communication port protection 33

E

- electrical requirements 23
 - 1 U flat monitor 28
 - APC MasterSwitch model AP9212 power management module 30
 - BladeCenter unit 27
 - Cisco 4003 switch 30
 - Cisco 4006 switch 30
 - Cisco Catalyst 3508G Ethernet switch 29
 - Cisco Catalyst 3550-24 XL Ethernet switch 28
 - Cisco Catalyst 3550-48 XL Ethernet switch 28
 - eserver 325 26
 - HS20 blade server 27
 - IBM Distributed Power Interconnect front end power distribution unit 30
 - IBM Distributed Power Interconnect high density power distribution unit 30
 - IBM Distributed Power Interconnect rack power distribution unit 30
 - In-Reach LX 4000 (32-port) terminal server 29
 - In-Reach LX 4000 (48-port) terminal server 29
 - Myrinet cluster expansion card 30
 - Myrinet model M3-E128 high-speed switch 29
 - Myrinet model M3-E32 high-speed switch 29
 - Myrinet model M3-E64 high-speed switch 29
 - Myrinet model M3F-PC164C-2 high-speed switch 29
 - Myrinet model M3F-PC1XD-2 high-speed switch 29
 - NetBay 2x8 console switch 28
 - NetBay front end power distribution unit 30
 - NetBay rack power distribution unit 30

electrical requirements (<i>continued</i>)	
NetBay remote console manager	28
SMC8624T Ethernet switch	29
SMCBGSLCX1 mini-GBIC expansion module	29
TotalStorage EXP400 storage expansion unit	28
TotalStorage EXP700 storage expansion unit	28
TotalStorage FAStT600 storage server	27
TotalStorage FAStT700 storage server	27
TotalStorage FAStT900 storage server	28
xSeries 335	26
xSeries 345	26
xSeries 360	27
electronic emission Class A notice	44
emission values, product noise	39
environmental characteristics	
1 U monitor	8
APC MasterSwitch model AP9212	12
Cisco Catalyst 3508G switch	10
Cisco Catalyst 3550-24 XL switch	9
Cisco Catalyst 3550-48 XL switch	10
Cisco Catalyst 4003 switch	9
Cisco Catalyst 4006 switch	9
eserver 325	5
eserver xSeries DPI front end power distribution unit	12
eserver xSeries DPI rack power distribution unit	12
EXP400 storage expansion unit	8
EXP700 storage expansion unit	8
HS20 blade server	7
IBM DPI high density power distribution unit	12
In-Reach LX 4000 (32-port) terminal server	10
In-Reach LX 4000 (48-port) terminal server	10
Myrinet cluster expansion card	11
Myrinet model M3-E128 switch	11
Myrinet model M3-E32 switch	10
Myrinet model M3-E64 switch	11
Myrinet model M3F-PC164C-2 switch	11
Myrinet model M3F-PCIXD-2 switch	11
NetBay 2x8 console switch	8
NetBay front end power distribution unit	12
NetBay rack power distribution unit	12
NetBay remote console manager switch	8
TotalStorage FAStT600 fibre channel storage server	7
TotalStorage FAStT700 fibre channel storage server	7
TotalStorage FAStT900 fibre channel storage server	8
xSeries 335	5
xSeries 345	6
xSeries 360	6
environmental requirements	5
eserver 325	
electrical requirements	26
environmental characteristics	5
physical characteristics	15
eserver xSeries DPI front end power distribution unit	
environmental characteristics	12
eserver xSeries DPI rack power distribution unit	
environmental characteristics	12
EXP400 storage expansion unit	
environmental characteristics	8
EXP700 storage expansion unit	
environmental characteristics	8
F	
FAStT EXP400	
physical characteristics	16
FAStT EXP700	
physical characteristics	16
FAStT600	
physical characteristics	16
FAStT700	
physical characteristics	16
FAStT900	
physical characteristics	16
FCC Class A notice	44
floor loading	
clearances	20
frequency stability	24
G	
green CAT5E Ethernet cables	
part number	37
H	
HS20 blade server	
environmental characteristics	7
physical characteristics	15
I	
IBM 1410-42L	
physical characteristics	19
IBM Distributed Power Interconnect front end power distribution unit	
electrical requirements	30
IBM Distributed Power Interconnect high density power distribution unit	
electrical requirements	30
IBM distributed power interconnect power distribution unit	
physical characteristics	19
IBM distributed power interconnect rack high density power distribution unit	
physical characteristics	19
IBM Distributed Power Interconnect rack power distribution unit	
electrical requirements	30
IBM DPI high density power distribution unit	
environmental characteristics	12
impulses, power-line	23
In-Reach LX 4000 (32-port) terminal server	
electrical requirements	29
environmental characteristics	10
physical characteristics	17

- In-Reach LX 4000 (48-port) terminal server
 - electrical requirements 29
 - environmental characteristics 10
 - physical characteristics 17
- information
 - cabinet placement 35
 - intercabinet cabling 35
- installing
 - rack stability kit 19
- intercabinet cabling
 - general information 35
 - types 36

L

- line sags 23
- line voltages
 - low nominal 23
- low line voltages 23

M

- Myrinet cluster expansion card
 - electrical requirements 30
 - environmental characteristics 11
 - physical characteristics 18
- Myrinet model M3-E128
 - physical characteristics 18
- Myrinet model M3-E128 high-speed switch
 - electrical requirements 29
- Myrinet model M3-E128 switch
 - environmental characteristics 11
- Myrinet model M3-E32
 - physical characteristics 17
- Myrinet model M3-E32 high-speed switch
 - electrical requirements 29
- Myrinet model M3-E32 switch
 - environmental characteristics 10
- Myrinet model M3-E64
 - physical characteristics 18
- Myrinet model M3-E64 high-speed switch
 - electrical requirements 29
- Myrinet model M3-E64 switch
 - environmental characteristics 11
- Myrinet model M3F-PC164C-2
 - physical characteristics 18
- Myrinet model M3F-PC164C-2 high-speed switch
 - electrical requirements 29
- Myrinet model M3F-PC164C-2 switch
 - environmental characteristics 11
- Myrinet model M3F-PC1XD-2
 - physical characteristics 18
- Myrinet model M3F-PC1XD-2 high-speed switch
 - electrical requirements 29
- Myrinet model M3F-PCIXD-2 switch
 - environmental characteristics 11

N

- NetBay 2x8 console switch
 - electrical requirements 28

- NetBay 2x8 console switch (*continued*)
 - environmental characteristics 8
- NetBay front end power distribution unit
 - electrical requirements 30
 - environmental characteristics 12
- NetBAY front end power distribution unit
 - physical characteristics 19
- NetBay rack power distribution unit
 - electrical requirements 30
 - environmental characteristics 12
- NetBAY rack power distribution unit
 - physical characteristics 19
- NetBay remote console manager
 - electrical requirements 28
- NetBay remote console manager switch
 - environmental characteristics 8
- nominal line voltages, low 23
- notes, important 42
- notices
 - electronic emission 44
 - FCC, Class A 44
 - used in this book xi

O

- online publications 3
- overview, system 1

P

- part number
 - blue CAT5E Ethernet cables 37
 - green CAT5E Ethernet cables 37
 - grey CAT5E Ethernet cables 37
 - yellow CAT5E Ethernet cables 37
- PDU requirements 33
- physical characteristics
 - 1 U flat panel monitor 16
 - 2x8 console switch 16
 - APC MasterSwitch AP9212 18
 - BladeCenter unit 15
 - Cisco Catalyst 3508G switch 17
 - Cisco Catalyst 3550-24 XL switch 17
 - Cisco Catalyst 3550-48 XL switch 17
 - Cisco Catalyst 4003 switch 18
 - Cisco Catalyst 4006 switch 18
 - eserver 325 15
 - FAST EXP400 16
 - FAST EXP700 16
 - FAST600 16
 - FAST700 16
 - FAST900 16
 - HS20 blade server 15
 - IBM 1410-42L 19
 - IBM distributed power interconnect rack high density power distribution unit 19
 - IBM rack distributed power interconnect power distribution unit 19
 - In-Reach LX 4000 (32-port) terminal server 17
 - In-Reach LX 4000 (48-port) terminal server 17
 - Myrinet cluster expansion card 18

- physical characteristics *(continued)*
 - Myrinet model M3-E128 18
 - Myrinet model M3-E32 17
 - Myrinet model M3-E64 18
 - Myrinet model M3F-PC164C-2 18
 - Myrinet model M3F-PC1XD-2 18
 - NetBAY front end power distribution unit 19
 - NetBAY rack power distribution unit 19
 - remote console manager 16
 - SMC8624T gigabit switch 12, 17
 - SMCBGSLCX1 gigabit switch expansion module 17
 - xSeries 335 15
 - xSeries 345 15
 - xSeries 360 15
- physical requirements 15
- pin-outs 31
- port protection, communication 33
- power cords 46
- power distribution units
 - supported 25
- power requirements
 - AC 25
- power-line impulses 23
- preinstallation
 - requirements 13
- preinstallation customer checklist 13
- product noise emission values 39
- product recycling and disposal x
- protection, communication port 33

R

- receptacle styles 31
- remote console manager
 - physical characteristics 16
- requirements
 - AC power 25
 - electrical 23
 - environmental 5
 - PDU 33
 - physical 15
 - preinstallation planning 13

S

- safety
 - environmental v
 - notices v
- service clearances
 - cabinet placement 35
- SMC8624T Ethernet switch
 - electrical requirements 29
- SMC8624T gigabit switch
 - physical characteristics 12, 17
- SMCBGSLCX1 gigabit switch expansion module
 - physical characteristics 17
- SMCBGSLCX1 mini-GBIC expansion module
 - electrical requirements 29
- stability kit
 - installation 19
- stability, frequency 24

- styles, receptacle 31
- supply quality, AC 23
- supported components
 - color-coded Ethernet cables 37
 - grey Ethernet cables 37
 - power distribution units 25
- system overview 1

T

- TotalStorage EXP400 storage expansion unit
 - electrical requirements 28
- TotalStorage EXP700 storage expansion unit
 - electrical requirements 28
- TotalStorage FASt600 fibre channel storage server
 - environmental characteristics 7
- TotalStorage FASt600 storage server
 - electrical requirements 27
- TotalStorage FASt700 fibre channel storage server
 - environmental characteristics 7
- TotalStorage FASt700 storage server
 - electrical requirements 27
- TotalStorage FASt900 fibre channel storage server
 - environmental characteristics 8
- TotalStorage FASt900 storage server
 - electrical requirements 28
- trademarks 42

U

- United States electronic emission Class A notice 44
- United States FCC Class A notice 44

V

- voltages
 - low nominal line 23

X

- xSeries 335
 - electrical requirements 26
 - environmental characteristics 5
 - physical characteristics 15
- xSeries 345
 - electrical requirements 26
 - environmental characteristics 6
 - physical characteristics 15
- xSeries 360
 - electrical requirements 27
 - environmental characteristics 6
 - physical characteristics 15

Y

- yellow CAT5E Ethernet cables
 - part number 37



Part Number: 25K8406

Printed in USA

(1P) P/N: 25K8406

