

PUBLICATIONS REVISION

System 80 Models 10/20

Capabilities Overview

UP-12443 Rev. 1

This Library Memo announces the release and availability of *System 80 Models 10/20 Capabilities Overview*, UP-12443 Rev. 1.

This overview describes the hardware and software of the System 80 Models 10/20 data processing systems. System 80 Models 10/20 feature high-quality, compact, integrated hardware, complemented by advanced, easy-to-use, interactive software. They use Operating System /3 (OS/3).

This revision documents the new 8494 disk subsystem and incorporates editorial changes.

Destruction Notice: This revision supersedes and replaces Operating System/3 (OS/3) *System 80 Models 10/20 Capabilities Overview*, UP-12443, released on Library Memo dated April 1987. Please destroy all copies of UP-12443, and its Library Memo.

Additional copies may be ordered through you local Unisys representative.

LIBRARY MEMO ONLY

Mailing Lists
MBZ, MCZ, MMZ, MDE,
MGZ, and MHA

LIBRARY MEMO AND ATTACHMENTS

Mailing Lists
MBA8, MBW, MBVO, MB00, MB01,
and AF01
(156 pages plus Memo)

THIS SHEET IS

Library Memo for
UP-12443 Rev. 1

RELEASE DATE:

December 1987



UNISYS

**System 80
Models 10/20**

**Capabilities
Overview**

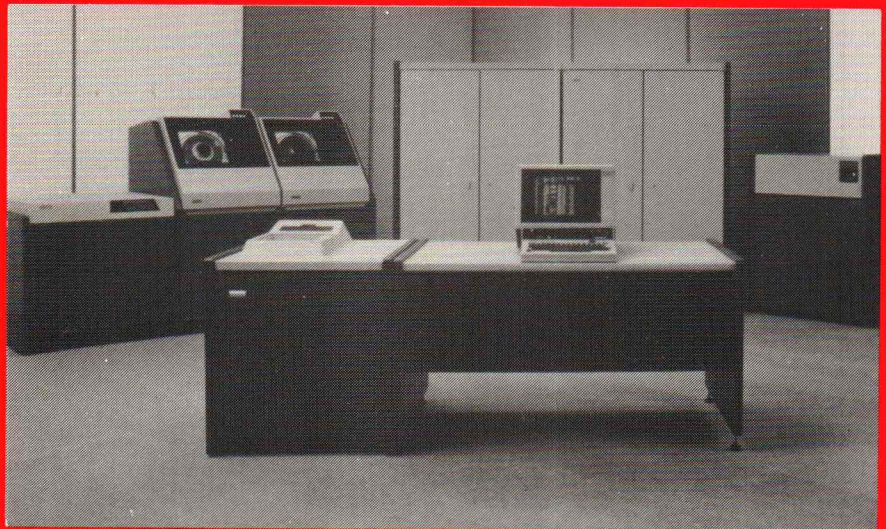

Relative to OS/3 Release
Level 11.0

Priced Item

December 1987

Printed in U S America
UP-12443 Rev. 1



UNISYS

System 80 Models 10/20

Capabilities Overview

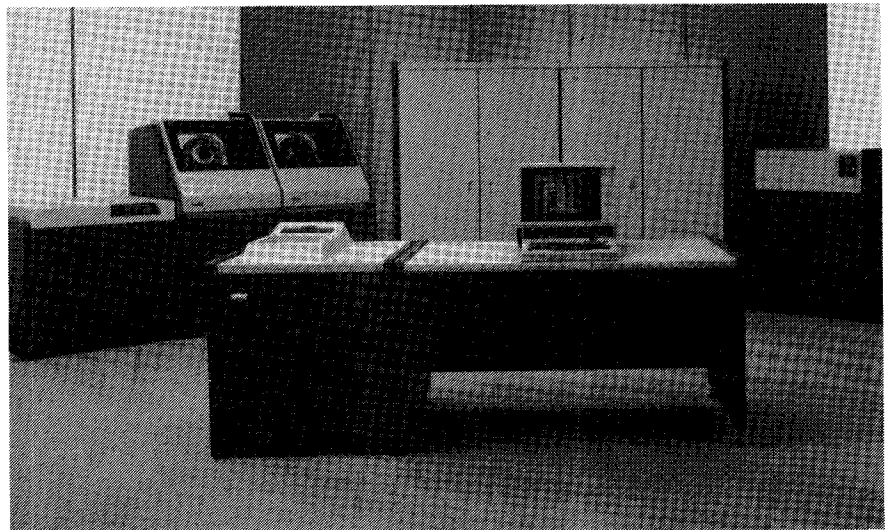

Copyright © 1987 Unisys Corporation.
All rights reserved.

Unisys is a trademark of Unisys Corporation.

Relative to OS/3 Release
Level 11.0

Priced Item

December 1987

Printed in U S America
UP-12443 Rev. 1

The names, places, and/or events used in this publication are not intended to correspond to any individual, group, or association existing, living, or otherwise. Any similarity or likeness of the names, places, and/or events with the names of any individual living or otherwise, or that of any group or association is purely coincidental and unintentional.

NO WARRANTIES OF ANY NATURE ARE EXTENDED BY THE DOCUMENT. Any product and related material disclosed herein are only furnished pursuant and subject to the terms and conditions of a duly executed Program Product License or Agreement to purchase or lease equipment. The only warranties made by Unisys, if any, with respect to the products described in this document are set forth in such License or Agreement. Unisys cannot accept any financial or other responsibility that may be the result of your use of the information in this document or software material, including direct, indirect, special or consequential damages.

You should be very careful to ensure that the use of this information and/or software material complies with the laws, rules, and regulations of the jurisdictions with respect to which it is used.

The information contained herein is subject to change without notice. Revisions may be issued to advise of such changes and/or additions.

Contents

1. INTRODUCTION / 1

- 1.1. SYSTEM 80, MODELS 10/20 / 1
 - 1.1.1. Advanced Hardware Technology / 2
 - 1.1.2. Peripheral Compatibility / 3
 - 1.1.3. System Flexibility / 3

2. ADVANCED CAPABILITIES OF SYSTEM 80, MODELS 10/20 / 4

- 2.1. ADVANCED CAPABILITIES OVERVIEW / 4
- 2.2. INTERACTIVE SERVICES / 4
 - 2.2.1. Workstations / 5
 - 2.2.2. Editors / 6
 - 2.2.3. Screen Format Services / 7
 - Screen Format Generator / 8
 - Screen Format Coordinator / 9
 - 2.2.4. Dialog Processing Services / 10
 - The Dialog Processor / 11
 - Job Control Dialog / 11
 - System Generation Dialog / 12
 - Data Utilities Dialog / 13
 - User-Written Dialogs / 13
- 2.3. ENHANCED PROGRAMMING LANGUAGES / 13
 - 2.3.1. ESCORT / 14
 - 2.3.2. RPG II / 14
 - 2.3.3. COBOL / 14
 - 2.3.4. FORTRAN IV / 14
 - 2.3.5. BASIC / 14
 - 2.3.6. Basic Assembly Language (BAL) / 14
- 2.4. INFORMATION MANAGEMENT SYSTEM / 14
 - 2.4.1. IMS Features / 15
 - Inquiry/Update Language / 15
 - Interfaces / 16
 - Data File Types / 16

2.5.	DATA BASE MANAGEMENT SYSTEM / 16
2.5.1.	DMS Features / 16
	Physical Data Base Characteristics / 16
	Logical Data Base Characteristics / 17
	Storage Structures / 17
	Manipulation of Data / 17
	System Support Functions / 17
	IMS/DMS Interface / 17
	Recovery / 17
2.6.	MULTI-JOB PROCESSING / 18
2.6.1.	Batch Job Processing / 18
2.6.2.	Interactive Job Processing / 18
2.7.	DYNAMIC RESOURCE MANAGEMENT / 19
2.7.1.	Resource Management Product / 20
2.8.	DATA COMMUNICATIONS / 20
2.9.	DISTRIBUTED DATA PROCESSING / 22
2.9.1.	DDP Software Packages / 23
	DDP Transfer Facility / 24
	DDP File Access / 24
	IMS-DDP Transaction Facility / 25
2.10.	APPLICATIONS PROGRAMS / 25
3.	SYSTEM SOFTWARE / 26
3.1.	SOFTWARE DESIGN CONCEPTS AND CAPABILITIES / 26
3.2.	SYSTEM CONTROL SOFTWARE / 27
3.2.1.	Supervisor / 27
	Supervisor Interrupt Requests / 29
	Task Switcher / 30
	Physical Input/Output Control System (PIOCS) / 30
	Disk Cache Facility (DCF) / 31
	Transient Management / 32
	Timer Service Management / 33
	System Console Management / 33
	Workstation Management / 33
	Error Recovery / 33
	Error Logging / 34
	Multitasking / 34
	Diagnostic Services / 34
	Main Storage Management / 35
	Security Maintenance Utility / 36
	Installation Verification Programs / 36

- 3.2.2. Job Control / 37
 - Job Coordination / 38
 - Device Assignment / 39
 - Job Step Operation / 39
 - Regulation of Job Environment / 40
 - Dialog for Job Control Stream and Jproc Preparation / 41
 - File Cataloging / 41
- 3.2.3. Interactive Processors / 42
 - Workstation Command Processors / 42
 - Dialog Processor / 42
 - Screen Format Coordinator / 43
- 3.2.4. Consolidated Data Management / 43
 - Logical Input/Output Control System / 45
 - Disk Access Method / 45
 - Diskette Access Method / 45
 - Workstation Access Method / 45
 - Magnetic Tape and Unit Record Device Access Methods / 46
 - Device Independence / 46
- 3.2.5. System Service Programs / 46
 - System Librarians / 46
 - Linkage Editor / 48
 - Disk, Diskette, and Tape Initialization Routines / 50
 - Dump Routines / 50
 - System Maintenance Packages and Changes / 51
 - Catalog Manipulation Utility / 51
 - Disk Dump/Restore / 52
 - Disk Copy / 52
 - Disk Prep / 53
- 3.2.6. System Installation Facilities / 53
 - Software Installation Facilities / 53
 - System Generation Facilities / 53
- 3.3. EXTENDED SUPPORT SOFTWARE / 54
 - 3.3.1. Screen Format Generator / 54
 - 3.3.2. Dialog Specification Language Translator / 55
 - 3.3.3. Data Utilities / 55
 - 3.3.4. SORT/MERGE / 56
 - 3.3.5. IBM Compatible Sort / 57
 - 3.3.6. Spooling and Job Accounting/Reporting / 59
- 3.4. ADDITIONAL SOFTWARE / 61
 - 3.4.1. Menu Services / 61
 - Menu Generator / 61
 - Menu Processor / 61
 - Using Menu Services / 61
 - 3.4.2. Language Processors / 62
 - ESCORT / 62
 - RPG II / 64
 - COBOL / 66
 - COBOL Divisions / 66
 - ANSI '74 COBOL Editor / 66
 - BASIC / 67
 - FORTTRAN IV / 67
 - Basic Assembly Language (BAL) / 67

- 3.4.3. Interactive Services / 68
- 3.4.4. The General Editor / 69
- 3.4.5. Integrated Communications Access Method (ICAM) / 70
 - ICAM Features / 70
 - ICAM Components / 73
 - ICAM Interfaces / 76
 - NTR System Utility / 78
- 3.4.6. Information Management System / 78
 - Action Definition / 78
 - IMS File Processing Package - UNIQUE / 79
 - User-Written Action Programs / 79
 - Configuring an IMS System / 79
 - IMS Advanced Interface Capabilities / 79
 - Advanced IMS Capabilities / 80
- 3.4.7. Data Base Management System / 80
 - DMS Components / 81
 - Data Base Languages / 81
 - Run-Time Software / 82
 - System Support Functions / 82
 - DMS System Limits / 83
 - Advanced DMS Capabilities / 83
- 3.4.8. Distributed Data Processing / 84
 - DDP Transfer Facility / 84
 - Job Transfer Manager / 85
 - File Transfer Manager / 85
 - Files Transmitted Between Systems / 86
 - DDP File Access / 86
 - IMS-DDP Transaction Facility / 86
- 3.4.9. MAPPER Software / 87
 - MAPPER 5 to OS/3 Connectivity / 87
 - MAPPER 80 System / 88
- 3.4.10. PC Connectivity To OS/3 / 88
 - File Transfer Utility (PCTTRAN) / 88
 - PC On-Line Transfer (OLTRAN) / 89
 - PC On-Line Extract / 89
 - PC On-Line Disk / 89

- 3.4.11. Applications Programs / 89
 - Universal Industrial System 80 (UNIS 80) / 90
 - Production Engineering Data Control / 90
 - Product Costing / 91
 - Customer Order Processing / 91
 - Inventory Status and Control / 91
 - Forecasting and Analysis / 92
 - Master Scheduling / 92
 - Material Requirements Management / 92
 - Production Planning / 92
 - Work Order Control / 93
 - Universal Industrial System 80-Extended (UNIS 80-E) / 93
 - Accounting Management System 80 (AMS 80) / 93
 - AMS Functions / 93
 - Universal Financial Accounting System 80 (UNIFACS 80) / 94
 - UNIFACS 80 Functions / 94
 - SUFICS 80 / 95
 - Financial Accounting Control System (FACS) / 96
 - Information Collection System 80 (ICS 80) / 97
 - ICS 80 Capabilities / 97
 - Universal Distribution Information System - Wholesale (UNIDIS) / 97
 - Order Entry / 98
 - Stock Control / 98
 - Inventory Management / 99
 - Wholesale Applications Management System 80 (WAMS 80) / 99
- 3.4.12. SUBAS 80 / 100
 - General Ledger / 100
 - Sales Ledger / 101
 - Purchase Ledger / 101
- 3.4.13. Maintenance and Diagnostic Software / 101
 - Hardware Diagnostics / 101
 - Resident Diagnostics / 101
 - Offline Diagnostics / 101
 - Online Diagnostics / 102
- 3.4.14. The System Activity Monitor (SAM) / 102
 - System Activity Functions / 103
 - Monitor Class Mode / 103
 - Event Trace Mode / 103
 - File Placement Analyzer (FIPLAN) / 104
- 3.4.15. UTS 400/4000 Support / 104
 - UTS 400 COBOL / 104
 - UTS 400 Edit Processor / 104
 - UTS 400 Load/Dump Facility / 105

4. HARDWARE

- 4.1. SYSTEM 80, MODELS 10/20 COMPONENTS / 106
 - 4.1.1. Central Processor / 106
 - Basic Processing Unit / 106
 - System Control Processor / 107
 - Mainframe Interface Adapter / 107
 - Main Storage Unit / 107
 - Operand and Instruction Caches / 107
 - Floating Point Processor / 107
 - 4.1.2. I/O Facilities / 107
 - Input/Output Processor / 107
 - Selector Channel / 108
 - 4.1.3. Instruction Set / 108
 - Nonprivileged Instruction Set / 108
 - Privileged Instruction Set / 108
- 4.2. HARDWARE CONFIGURATIONS / 109
 - 4.2.1. Basic System / 110
 - 4.2.2. System Growth / 110
 - 4.2.3. Migration from Other Systems / 111
- 4.3. PERIPHERAL SUBSYSTEMS / 111
 - 4.3.1. Disk Subsystems / 111
 - 8416/8418 Disk Subsystems / 112
 - 8430/8433 Disk Subsystems / 113
 - 8470/8480 Disk Subsystems / 114
 - 8417 Nonremovable Disk Drive / 115
 - 8419 Removable Disk Drive / 116
 - 8494 Disk Subsystem / 117
 - 4.3.2. Workstation Subsystem / 118
 - Workstation Capabilities / 118
 - Local Workstations / 118
 - Model 1 Workstation / 118
 - Model 2 Workstation / 120
 - Workstation Printers / 120
 - Remote Workstations / 122
 - 4.3.3. System Console / 122
 - 4.3.4. Printer Subsystems / 122
 - 0789 Line Printer / 123
 - 0776 High-Performance Line Printer / 124
 - 0770 Line Printer / 125
 - 0770 II Line Printer / 126
 - 0798 Character Printer / 127
 - 4.3.5. Magnetic Tape Subsystems / 128
 - UNISERVO 10 (Type 0871) Magnetic Tape Subsystem / 128
 - UNISERVO 10/14 Magnetic Tape Subsystem / 129
 - UNISERVO 12/16 Magnetic Tape Subsystem / 130
 - UNISERVO 20 Magnetic Tape Subsystem / 131
 - UNISERVO 22/24 Magnetic Tape Subsystem / 132
 - UNISERVO 26/28 Magnetic Tape Subsystem / 133
 - Streaming Magnetic Tape Subsystem / 134

- 4.3.6. Diskette Subsystem / 135
 - T8420/8422 Diskette Drives / 135
- 4.3.7. Punched Card Subsystems / 136
 - 0716 Card Reader Subsystem / 136
 - 0719 Card Reader Subsystem / 137
 - 0608 Card Punch/Reader Subsystem / 138
- 4.3.8. Communications Subsystems / 139
 - Universal Terminal System 20 / 140
 - Universal Terminal System 30 / 140
 - Universal Terminal System 40 / 140
 - Universal Terminal System 4000 / 141
 - Universal Terminal System 400 / 142
 - SVT 1120 Terminal / 142
 - SVT 1123 Remote Workstation / 143
 - SVT 1124 Remote Workstation / 143
 - Additional Communications Devices / 143
- 4.4. HARDWARE SUMMARY / 144

FIGURES

- 1-1. System 80, Models 10/20 Installation / 1
- 3-1. Menu Screen / 61
- 3-2. HELP Screen / 62
- 4-1. System 80, Models 10/20 Minimum Configuration / 109

TABLES

- 4-1. Local Workstation Characteristics / 119
- 4-2. Communications Functions / 139
- 4-3. System Characteristics / 144



1. Introduction

1.1. SYSTEM 80, MODELS 10/20

System 80, models 10/20 feature high-quality, integrated hardware, complemented by an advanced, yet easy-to-use interactive software package: the Unisys Operating System/3 (OS/3). Together, they comprise a resource widely useful to any business. Figure 1-1 shows an installation of System 80, models 10/20, with the central processing complex, the system console, and a variety of devices, including manual and autoloader diskettes, a high-speed printer, and magnetic tape drives.



Figure 1-1. System 80, Models 10/20 Installation

A prime consideration when purchasing a new computer system is the amount of productive computing time the user can expect from the system. To ensure continuing reliability and maintainability of its computer systems, Unisys has included extensive automatic recovery and maintenance features in the hardware and software design for System 80, models 10/20.

The hardware represents the state of the art in both technology and reliability. Extensive testing before shipment ensures that any installed hardware is in perfect operating condition.

The OS/3 software has proven itself through years of reliable service. However, even the most reliable system can suffer an occasional failure. To address this possibility, Unisys provides the following:

- A large array of diagnostic facilities that can detect any possible software and hardware failure
- Self-monitoring by the system to help predict the possibility of a failure
- Extensive backup and recovery features
- Substantial reduction in the number and duration of service calls through direct remote maintenance assistance from the Customer Support Center.

1.1.1. Advanced Hardware Technology

System 80, models 10/20 incorporate a number of advanced hardware features that increase system efficiency and enhance user productivity:

- Large-scale integrated circuits increase system speed and processing power.
- A four-stage pipeline instruction processor with a multi-instruction buffer decreases execution time by reading multiple instructions simultaneously.
- A floating point processor, operand cache, and instruction cache on model 20 improve throughput processing.
- High-density, high capacity, removable and nonremovable disk devices offer the user expandable mass storage facilities.
- Autoload diskette drives can cycle up to 20 diskettes without user intervention.
- High-speed printers offer flexibility in character sets and line length selections, to provide maximum printing capacity.
- High-density, extremely reliable tape drives, including streaming tape drives, make Unisys tape systems valuable mass storage devices for all users.

1.1.2. Peripheral Compatibility

Users of Series 90/25, 90/30, 90/40 systems, System 80, models 3-6, and System 80, model 8 data processing systems, that upgrade to System 80, models 10/20, can connect many of their present peripheral devices to models 10/20. These peripherals include disk devices, tape drives, card readers, and printers. For further information on which peripherals can be connected to System 80, models 10/20, refer to 4.3.

1.1.3. System Flexibility

System 80, models 10/20 can grow with an expanding business; they are designed to make expansion as easy as possible by adding peripheral devices and increasing main storage capacity. Additionally, the OS/3 operating system is now enhanced by the inclusion of integrated, interactive software.

The system offers the following:

- A variety of programming languages
- Interactive programming aids
- Integrated communications
- Information and data base facilities
- Interactive communications with the system

Section 2 presents an overview of the significant software features of System 80, models 10/20. Section 3 provides more comprehensive information regarding these and other software facilities. Section 4 describes the hardware components of System 80, models 10/20.

2. Advanced Capabilities of System 80, Models 10/20

2.1. ADVANCED CAPABILITIES OVERVIEW

This section introduces some of the significant features of System 80, models 10/20 that uniquely qualify it as a powerful, flexible and total business data processing system. These features include the following:

- A full range of interactive services
- Enhanced programming languages
- Information management system (IMS)
- Data base management system (DMS)
- Multi-job processing
- Dynamic resource management
- Data communications (integrated communications access method (ICAM))
- Distributed data processing (DDP)
- Applications programs

Section 3 explains many of these features, and other components of System 80, models 10/20, in greater detail.

2.2. INTERACTIVE SERVICES

System 80, models 10/20 offer an array of interactive programming features that greatly enhance programmer and operator efficiency and also make the system accessible and understandable to non-programming users. Multiple users simultaneously can access and operate the system with the following results:

- Increased productivity through faster response time
- Authorized user access to the system while maintaining security precautions
- Simplified programming for the novice and enhanced efficiency for the experienced programmer
- Improved data entry and retrieval methods for the non-programming user

Using the workstation as the primary means of communicating with the system, the user can employ any of the following interactive services:

- General and language editors
- Screen format services
- Dialog processing services

2.2.1. Workstations

In the OS/3 programming environment, a set of interactive commands can be issued directly from the workstation to accomplish the following:

- Direct the operation of the system or a system component
- Query the system for specific information
- Direct the execution of a job
- Create and modify source programs, data files, job control streams

The workstation can be used as an input/output device dedicated to a job or system component or as a program development tool using various interactive facilities, such as Editor, RPG II editor, COBOL editor, ESCORT™, and BASIC. These interactive facilities interface with the following:

- Information management system (IMS)
- Data base management system (DMS)
- Integrated communications access method (ICAM)
- Distributed data processing (DDP)

Unisys offers a wide range of workstations with System 80, models 10/20. A typical workstation consists of a keyboard to input entries and a video screen to display the input entries and system responses.

ESCORT is a trademark of Unisys Corporation.

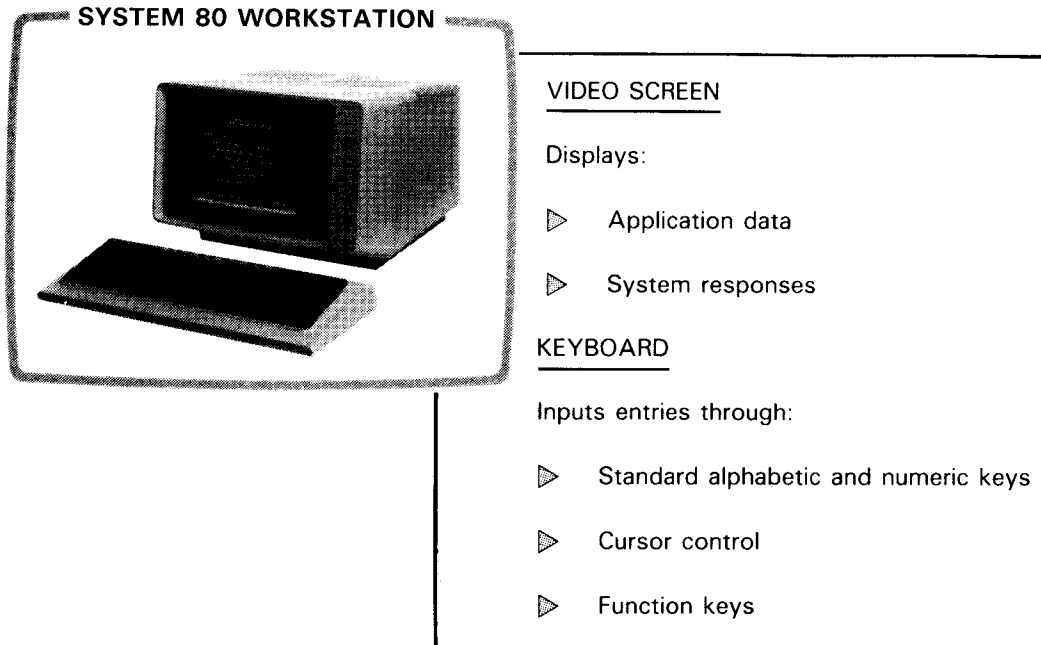

2.2.2. Editors

The OS/3 editors help the user to enter data, set up program files, and create and edit job control streams. Each type of editor is activated by a simple command from the workstation. OS/3 provides the following types of editors:

- General editor - features a comprehensive command set to create and maintain files on disk or diskette.
- Error file processor (EFP) - is a general editor subsystem that lets the programmer write, compile, and debug programs without having to wait for printouts or leave the workstation.
- Language editors - help the user create and update source language programs. There are language editors for COBOL and RPG II.

The general editor and the language editors are shown here to illustrate how they are used in System 80, models 10/20.

**GENERAL EDITOR
IS USED TO CREATE AND EDIT DATA AND PROGRAM FILES**

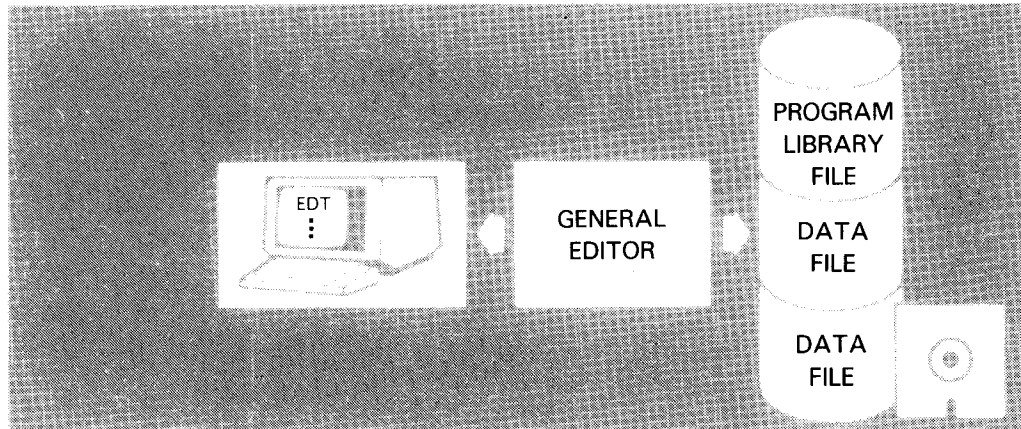

**LANGUAGE EDITORS
ARE SPECIALIZED SUBSYSTEMS OF THE GENERAL EDITOR DESIGNED TO HELP
CREATE AND EDIT SOURCE LANGUAGE PROGRAMS**

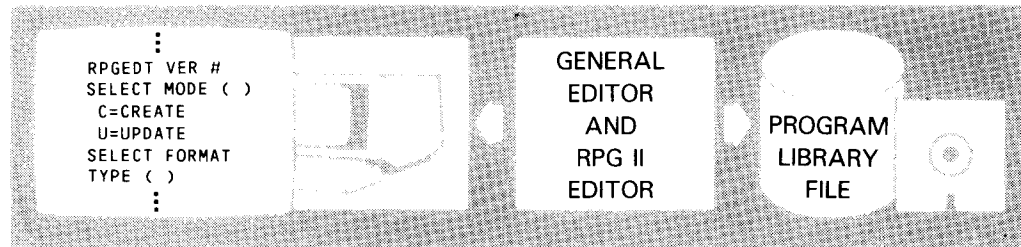

2.2.3. Screen Format Services

OS/3 screen format services simplifies the entering of variable data into the system through the use of standardized data input formats.

SCREEN FORMAT SERVICES LET THE USER:

- Design personalized fill-in-the-blank forms (screen formats)
- Route data entered in response to a screen format back to the application program that requested it
- Display *filled in* screen formats to a workstation for informational purposes

Screen format services comprise two software components - the screen format generator, which helps the user create screen formats, and the screen format coordinator, which manages screen formats once they are created.

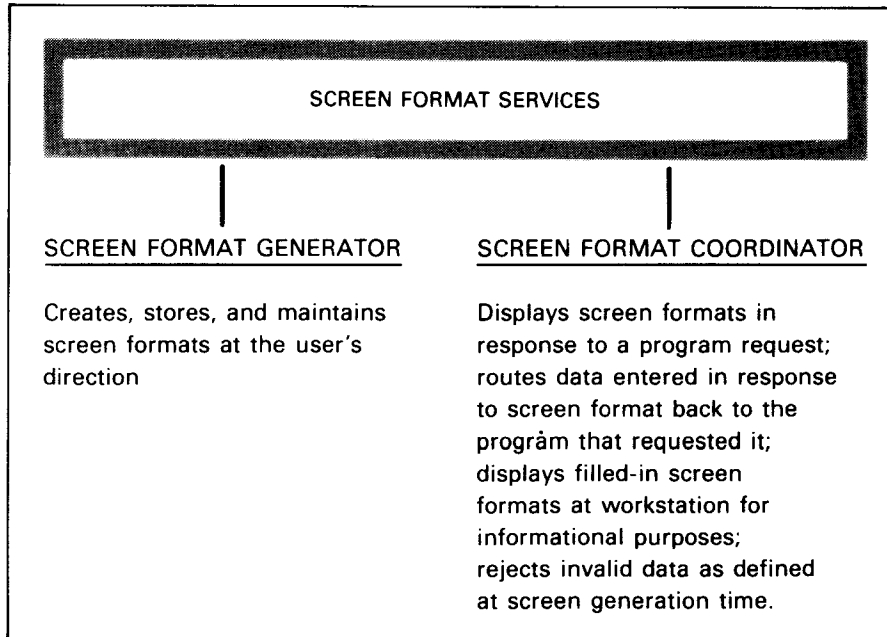

Screen Format Generator

A simple workstation command activates the screen format generator. HELP screens assist the user to create a new screen, or model a new screen after an existing one. The screen format generator asks the user about the variable data fields of the screen format. It automatically stores the screen format in a permanent library file once it is created or modified.

Screen Format Coordinator

The screen format coordinator is activated in response to a program request. It retrieves the appropriate screen formats from the permanent file and displays them - with either blank input fields or with fields filled in with variable data. The variable data is stored with the program. If a program calls a screen format that was created as both an input and output screen format, the screen format coordinator handles the display of the screen format and variable data, accepts new variable data from the workstation user, and routes that data back to the application program that called the screen format coordinator.

SCREEN FORMAT COORDINATOR DISPLAYS INPUT SCREEN FORMATS AND THE WORKSTATION USER SUPPLIES THE VARIABLE DATA

INVNTY	
ITEM	----
PRICE	----
QTY	----
REORDER	----

Variable data fields are underscored.

INVNTY	
ITEM	1234
PRICE	0035
QTY	0010
REORDER	10/15

Workstation user supplies variable data that is routed by the screen format coordinator to an application program.

SCREEN FORMAT COORDINATOR DISPLAYS OUTPUT SCREEN FORMATS FOR INFORMATION PURPOSES

INVNTY	
ITEM	1234
PRICE	0035
QTY	0010
REORDER	10/15

The screen format coordinator retrieves the screen format from the permanent file and adds the variable data from the application program.

SCREEN FORMAT COORDINATOR DISPLAYS INPUT/OUTPUT SCREEN FORMATS

INVNTY	
ITEM	1234
PRICE	0035
QTY	0010
REORDER	10/15

The screen format coordinator displays an output screen format and...

INVNTY	
ITEM	1234
PRICE	0035
QTY	1000
REORDER	12/15

...the workstation user supplies new variable data.

2.2.4. Dialog Processing Services

OS/3 dialog processing services lets programmers and operators communicate easily with the programs and procedures in operation by providing interactive, conversational dialogs. Novice operators and non-programming users are primary beneficiaries of the dialog services. HELP screens provide tutorial assistance to explain concepts and dialog choices. Responses to the dialogs are routed to the appropriate processor and then stored in a permanent library file.

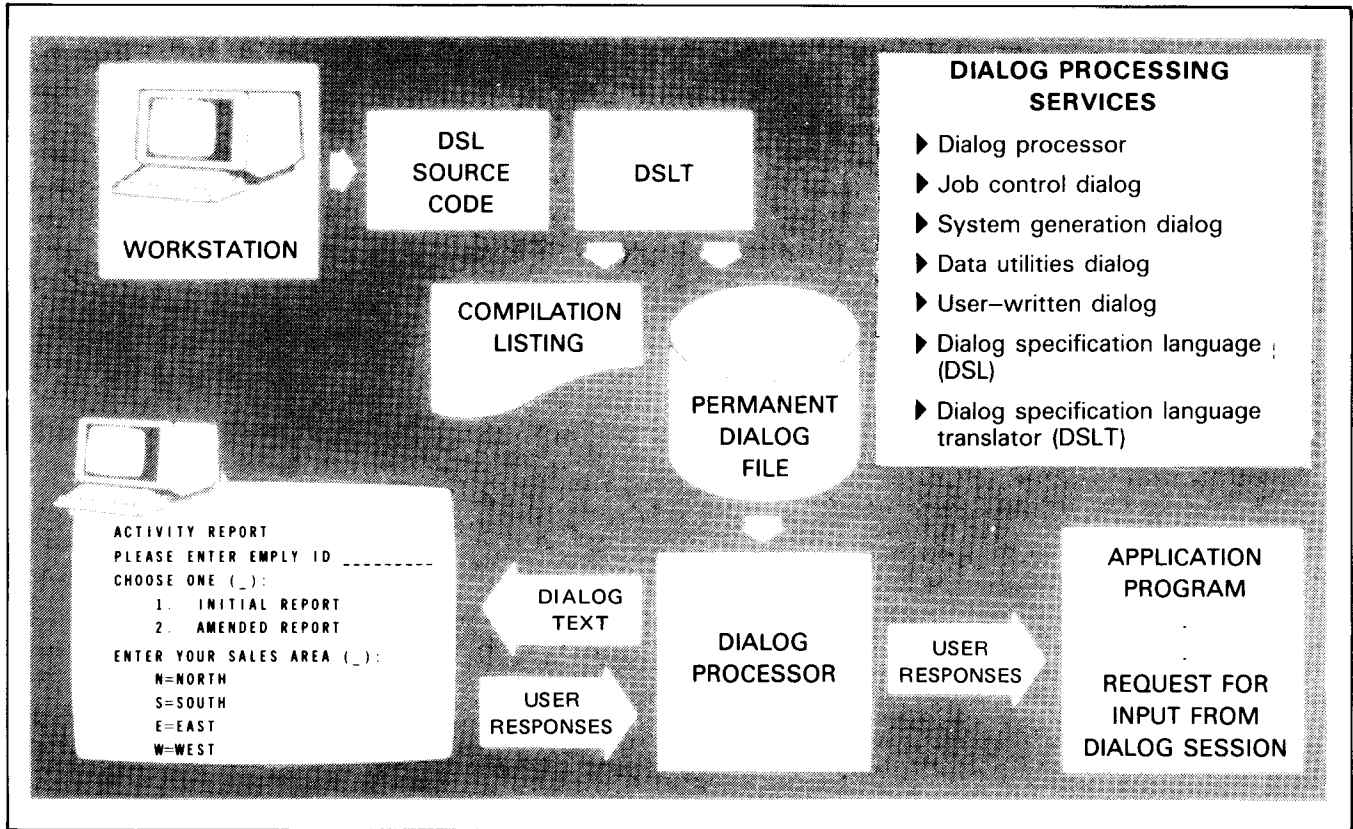

The Dialog Processor

The dialog processor produces a printed summary and an audit file of each dialog session. These are used as guides to change responses in a subsequent session.

The application programs that solicit input from a dialog session are written in all OS/3 programming languages.

Job Control Dialog

The job control dialog guides the user step by step through the building of a valid job control stream. The job control statements and system job control procedures (jprocs) that make up a job control stream are presented in the form of menu items.

An experienced programmer can use this dialog to build a syntactically correct control stream quickly. A novice can use the HELP screens to learn about job control while building a valid job control stream.

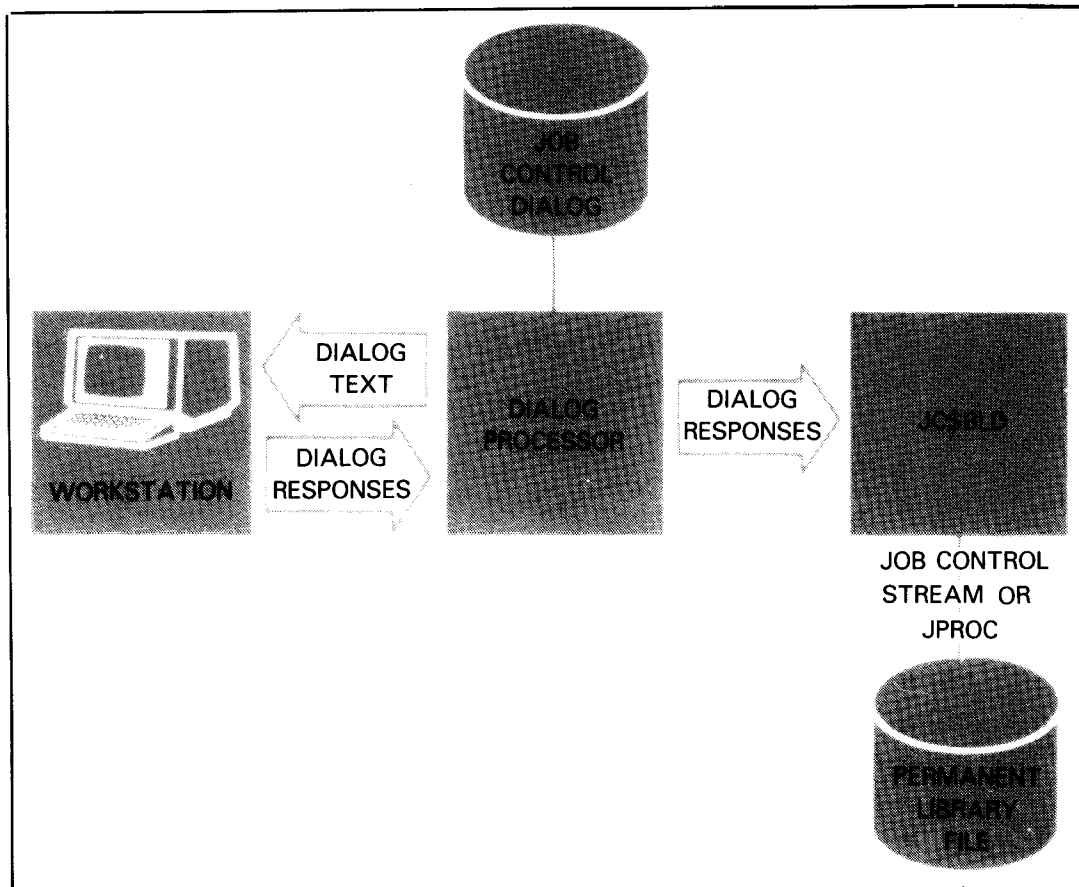

System Generation Dialog

The system generation (SYSGEN) dialog guides the user step by step through the building of valid SYSGEN streams. The operator is prompted to enter SYSGEN parameters to configure the operating system to suit the user's processing needs.

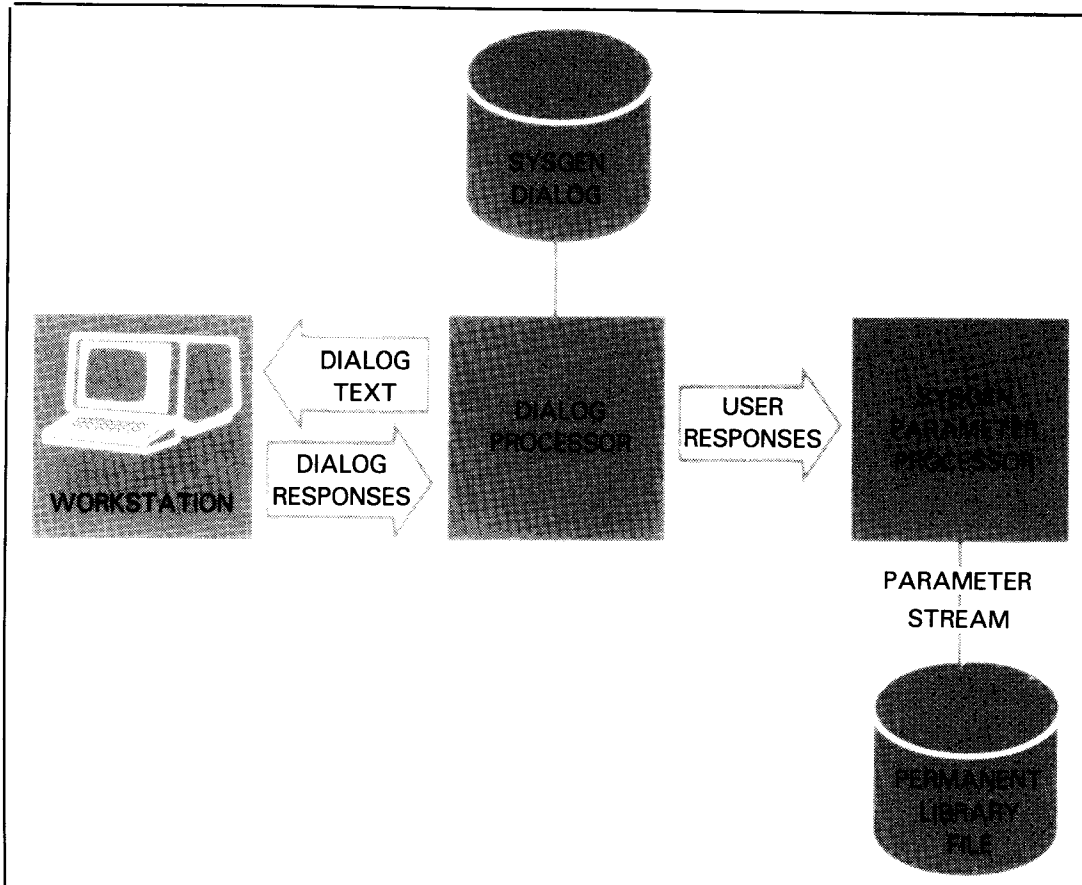

Data Utilities Dialog

The data utilities dialog asks the user which system functions to use. This dialog is similar to the job control and SYSGEN dialogs. It is activated through a simple workstation command, and HELP screens are available. The completed dialog automatically initializes the functions requested.

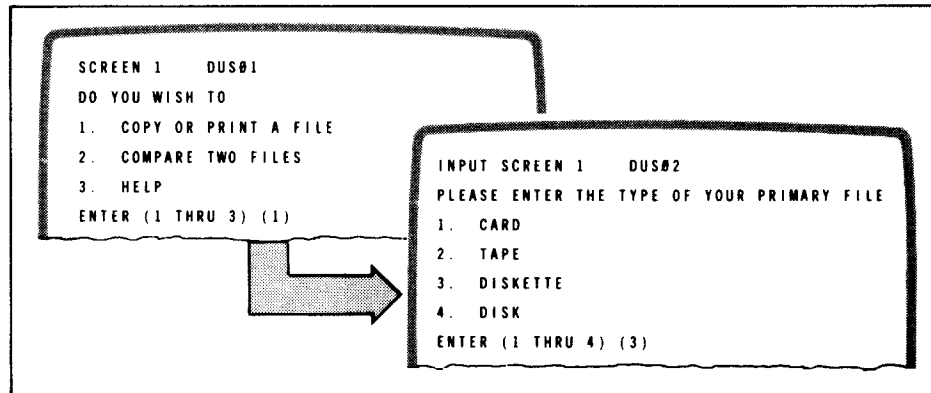

User-Written Dialogs

The programmer or user can write interactive dialog text that is later displayed in order to accept varied user responses. This input is routed back to the application program that the dialog complements.

For example, a dialog is written to ask the user the type of report desired. The responses cause the program to produce the requested report.

User-written dialogs are written in dialog specification language (DSL). DSL source code is submitted to the dialog specification language translator (DSLTL), which compiles the source code to produce the desired dialog, store the dialog in a permanent file, and produce a compilation listing.

2.3. ENHANCED PROGRAMMING LANGUAGES

System 80, models 10/20 feature a full range of standard, versatile, programming languages. Of the languages supported, BASIC, COBOL, RPG II, and ESCORT are fully interactive. Source statements for these languages are entered directly through the workstation.

Language editors and error file processors support the interactive development of programs at the workstation. The languages allow programs to access workstations for dynamic data entry and display during execution. Error messages are provided for the easy identification of syntax errors.

2.3.1. ESCORT

ESCORT is especially suited for developing file processing programs and reports. This language is among the easiest to learn and use. Even the most inexperienced programmers can quickly and easily generate useful and productive programs. ESCORT offers extensive prompting and help at the workstation.

2.3.2. RPG II

RPG II is a high-level language designed to produce reports and maintain files in a business environment. The RPG II cycle provides the basic logical flow of a program. The user specifies the details of processing by using the input format, output format, calculations, and other specifications. Source program statements are entered using formatted displays. Auto Report, which accepts simplified RPG II source statements and creates a complete RPG II program, is also available.

2.3.3. COBOL

COBOL is a general purpose, yet powerful language designed for business applications, such as payroll, accounting, inventory, and personnel management. The COBOL supplied by Unisys also offers a powerful sorting facility that lets users sort data files on multiple keys. In addition, COBOL users can readily interface with the IMS and the DMS.

2.3.4. FORTRAN IV

FORTRAN IV is a powerful, mathematically oriented programming language geared primarily towards scientific and business applications that require extensive mathematical computing.

2.3.5. BASIC

BASIC combines ease-of-use with extensive interactive programming features geared to the novice programmer. BASIC has many business and scientific applications.

2.3.6. Basic Assembly Language (BAL)

BAL is a flexible, machine-level language that offers a variety of features that let the user specify the most complex algorithms as a series of mnemonic symbols and command directives. Each mnemonic represents a single machine action. BAL can be of great value to the user with particular programming requirements.

2.4. INFORMATION MANAGEMENT SYSTEM

The information management system (IMS) is an interactive, transaction processing system. It allows data processing personnel and other users to instantly access and manipulate large-scale data files to obtain and update current information. All IMS activities are initiated by an inquiry; each inquiry results in a system response. IMS can be configured to fit any installation's requirements.

2.4.1. IMS Features

A few of the many features and capabilities provided by IMS are discussed. See Section 3 for more information.

Inquiry/Update Language

The uniform inquiry update element (UNIQUE) is a general purpose language that enables extensive file processing capabilities. Users initiate file activity through UNIQUE commands. In addition to UNIQUE, the user can write IMS action programs in BAL, COBOL, or RPG II. This gives the programmer more flexibility in designing IMS programs. See 3.4.6.

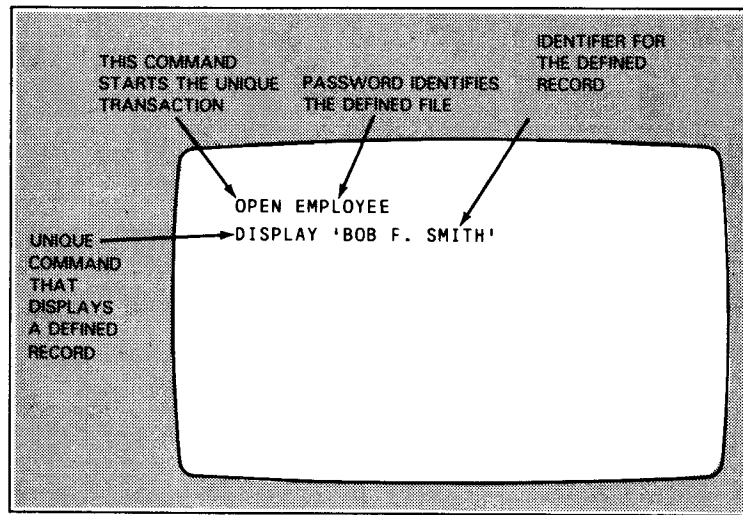

An Input Screen to be Processed by UNIQUE

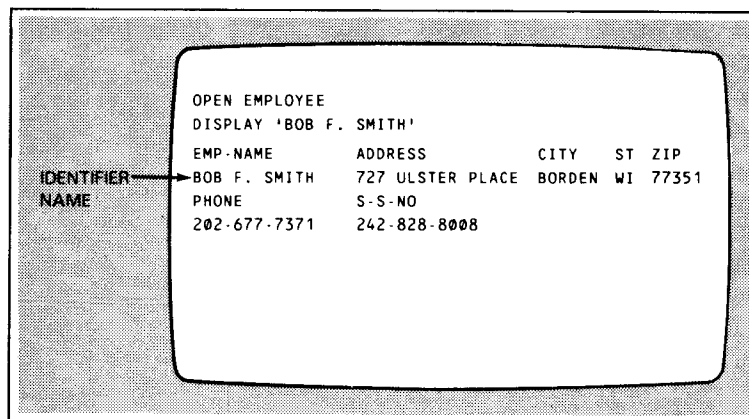

Output Screen Generated by UNIQUE

Interfaces ---

IMS interfaces with the following:

- Integrated communications access method - ICAM is the communications software that handles all input and output between your terminals and IMS.
- Data base management system - The IMS/DMS interface lets IMS users access OS/3 data bases through UNIQUE and user-written action programs. This provides IMS users with the structural flexibility and powerful access mechanisms available to data base management systems.
- Distributed data processing - Two independent computer systems can communicate with each other through DDP. Each can use the other's capabilities and data. By interfacing IMS with DDP, you can process IMS transactions within a network of remotely located data processing systems.
- Screen format services - SFS lets users create and maintain their own screens. See 2.2.3. for more information.

Data File Types ---

IMS can access any type of user disk data file, including the following:

- Files generated by DMS - These can also interface with COBOL action programs.
- User-written data definition files - These let the user logically redefine a file without actually altering the physical file structure. Redefined files can then be used by IMS action programs.
- MIRAM files - These are used for sequential, direct or indexed file processing. IMS supports multi-key, duplicate key, and key change features to MIRAM files while in CDM mode.

2.5. DATA BASE MANAGEMENT SYSTEM

The data base management system (DMS) is a collection of system programs that support the development of integrated data bases. These programs handle the description, initialization, creation, accessing, maintenance, backup, and recovery of data bases. The languages used in the description and manipulation of DMS data bases are derived from the CODASYL data base specifications. A data base can be accessed with DMS application programs, IMS action programs, and the IMS inquiry and update language, UNIQUE.

2.5.1. DMS Features

Physical Data Base Characteristics ---

The device media control language (DMCL) defines physical characteristics of a user data base and the data dictionary.

Logical Data Base Characteristics _____

The description of data in a DMS data base is entirely separate from the manipulation of that data in application programs. This results in a higher level of data independence for application programs. All descriptions are done in a high-level language (data description language) which is comparable to the data declaration language of COBOL.

Storage Structures _____

Data is organized into three storage structures: sequential, tree, and network. The same record belongs to several different structures simultaneously. The record is stored directly by data base key, sequentially within area, by calculated key value, or according to its set relationship to other records in the storage structure. This reduces data redundancy and promotes processing efficiency.

Manipulation of Data _____

Two languages are used to access the data base: data manipulation language (DML) or conversation data base manipulation language (CDML). The applications programmer can include DML statements within conventional COBOL statements. The program then proceeds through the normal preprocessing, compiling, and linking steps. CDML lets the user interactively access and manipulate a data base. It eliminates the need for subsequent processing steps.

System Support Functions _____

DMS supplies processors to generate and maintain a data base, process reports, and collect statistics. Utilities are available to initialize the data base, perform dump, restore and recovery services, and other functions.

IMS/DMS Interface _____

IMS user-written action programs or UNIQUE action programs can access DMS data bases separately or concurrently. DMS also supports IMS in a consolidated data management (CDM) environment.

Recovery _____

Offline recovery utilities use a journal file generated by the data base management system for forward and backward data base recovery. Online recovery automatically restores a data base after a system crash or an abnormal program termination.

2.6. MULTI-JOB PROCESSING

OS/3 can concurrently process from 1 to 48 jobs, in both batch and interactive processing environments. Each job consists of one or more job steps, such as a program compilation or the execution of a system-supplied program. The interactive facilities provide maximum response time to each individual workstation. The allocation of processor time is based on a system switch list that contains information regarding program priorities, task synchronization, and input/output utilization. While one task is awaiting the completion of an external event (such as completion of an I/O request), OS/3 activates another task that is ready to execute. This ensures optimum use of the processor's capabilities and maximizes system productivity.

2.6.1. Batch Job Processing

In batch processing, the user builds a control stream for a job by coding and keypunching the stream on cards or entering the data on a diskette and submitting the job to the system operator to run. The user communicates with the system operator through job control statements in the control stream.

The user controls the way the job is processed through job control specifications. Jobs can also initiate from the control stream of another job through a special job control statement. Job control streams and programs are stored through system console commands. The results of the batch jobs are seen after the run, sometimes hours or days later.

2.6.2. Interactive Job Processing

In interactive processing, the user communicates directly with the system from a workstation, and controls all processing activities from program source code creation through the execution of the job. The user can request the status of a job, terminate a job, or create, modify, and store programs and control streams in permanent files using the general editor and job control dialog.

Interactive job control facilities let the user perform dynamic skip functions to actually change the way a job executes and to submit variable values for a job at run time.

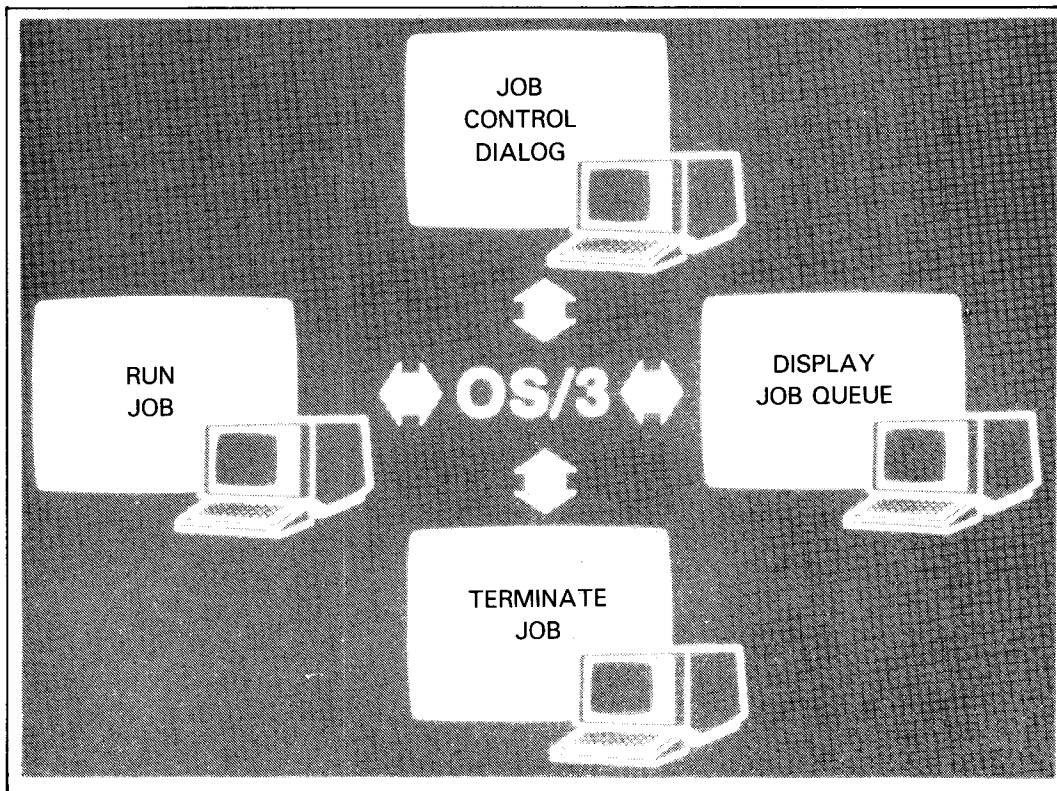

2.7. DYNAMIC RESOURCE MANAGEMENT

OS/3 provides dynamic resource management for both batch and interactive programming activities. This frees the programmer from the need to predict the extent of the resources required for a job and the constraints of the physical devices and software components.

The system can dynamically manage the following:

- Main storage assigned to a job
- Unassigned main storage
- Workstations
- Allocation of peripheral devices, such as disk, diskette, and tape drives

2.7.1. Resource Management Product

In addition to the dynamic resource management OS/3 software routinely provides, Unisys markets the resource management product. This software lets the operator balance job turnaround time and workstation response time by setting the limits for main storage and job initiation without system regeneration. Resource management allows the console operator to:

- Control the percentage of main storage for:
 - Symbionts
 - Interactive jobs
 - Batch jobs
- Control the maximum number of:
 - Total jobs
 - Jobs initiated from workstations
 - Jobs initiated from any single workstation
 - Logged-on interactive users
 - Concurrently executing batch tasks initiated by the ENTER command
 - Concurrently executing run symbionts

The console operator can issue these commands at any time during a session.

2.8. DATA COMMUNICATIONS

OS/3 provides an integrated, modular communications package that is flexible and has a broad range of capabilities. The integrated communications access method (ICAM) terminal support facility offers:

- Levels of support - Several levels of support automatically balance the services with the quantity of system resources required.
- Flexibility - ICAM is a modular software package that provides configuration flexibility to meet the needs of users with simple, moderate, or complex communication needs.
- Device independence - Total device independence is provided to the user programs that interface with the system, and to the system programs that interface with ICAM.

- Network configuration - A single ICAM configuration provides concurrent support for multiple user programs that handle a variety of terminals and line types. The user can configure a variety of terminal device types and communications lines into a single network that is accessible to a number of user and system programs concurrently.
- Resource assignment - ICAM is responsible for preventing conflicting resource assignment and releasing facilities when jobs terminate.

ICAM supports numerous other Unisys components, such as the following:

ICAM COMMUNICATIONS SUPPORT	
Information Management System (IMS)	COBOL Communications
Distributed Data Processing (DDP)	Remote Batch Processing (RBP)
RPG II Telecommunications	Nine Thousand Remote (NTR) Processing
Local Workstations	Interactive Services (IS)
UNIX [®] O/S	MAPPER [®] 5
PC Online Transfer (OLTRAN)	PC On-line Extract

ICAM supports the following types of communication:

- Narrowband transmissions - Permit voice-grade communication (dial-up), switched direct distance dialing (DDD) and privately leased lines.
- Wideband transmissions - Permit data transmission over high-speed privately leased lines.
- Full-duplex and half-duplex interfaces for Unisys terminals and commercially available data sets

UNIX is a registered trademark of AT&T.

MAPPER is a registered trademark and service mark of Unisys Corporation.

ICAM PROVIDES

- Message queueing in main storage or disk (a user option) while waiting for servicing
- Specifying multiple destinations for a single message
- Scheduling activities and supporting user-defined priority levels
- Message and queue reconstruction from user-specified points in the event of system failures
- Accumulation of relevant statistical information

An ICAM configuration includes the following:

- Software modules included in the system during system generation
- Communications lines
- Terminal devices
- System utilities that the ICAM network requires
- Programs that interface with the network

2.9. DISTRIBUTED DATA PROCESSING

The Unisys distributed data processing (DDP) system lets users tie separate systems together in a network; each sharing the data files and processing load of an entire organization. The DDP facility offers the following:

- Lower costs - DDP lets an organization share resources rather than duplicate the facilities at each site. This tremendous savings on hardware also reduces the number of personnel required to support the hardware.
- Efficiency - DDP decreases the load on the central system and increases throughput. The computer spends less time switching among competing jobs and can devote more resources to accomplishing tasks.

- **Reduced storage** - The distribution of data files throughout an organization's data processing network can reduce mass storage at each processing location tied to the network. This lets users retain current systems, rather than purchase a larger one.
- **Improved operation** - Distributing the processing work among systems in a DDP network can provide improved business operations and management control. Managers get their data faster and more easily.
- **Security** - There is added security because a disaster at any one location does not destroy all the data used within the processing network. Also, DDP can make copies of your files on a remote host. You can access or recopy these in an emergency.
- **Decentralization** - Jobs are decentralized and given to the location responsible for gathering and using the data. DDP supports a distributed management system where local managers control local data, but central managers can quickly access it.
- **Recovery** - DDP automatically recovers all work orders in progress at the time of a system crash or communications line failure.
- **Program control** - DDP lets programs automatically control the execution of other programs at remote sites. In addition, each part of an application job is executed at the site where it is done most efficiently.
- **Greater control** - DDP also provides greater control over work priority, improved response times, and more efficient use of all the data processing systems within the network.

2.9.1. DDP Software Packages

Distributed data processing functions in OS/3 are divided into three software packages, each offering the user different elements. Thus, users can tailor distributed processing software to include only the particular features their installation requires.

The three software packages follow:

- **DDP transfer facility**
- **DDP file access**
- **IMS-DDP transaction facility**

DDP Transfer Facility

The DDP transfer facility provides these capabilities:

- Site-to-site data file and program library transfers
- Remote job initiation and control
- Operator console control over remote site and routing of messages to remote consoles
- Routing print and punch spooled output files to different host computer systems
- Routing print output files to remote auxiliary printers

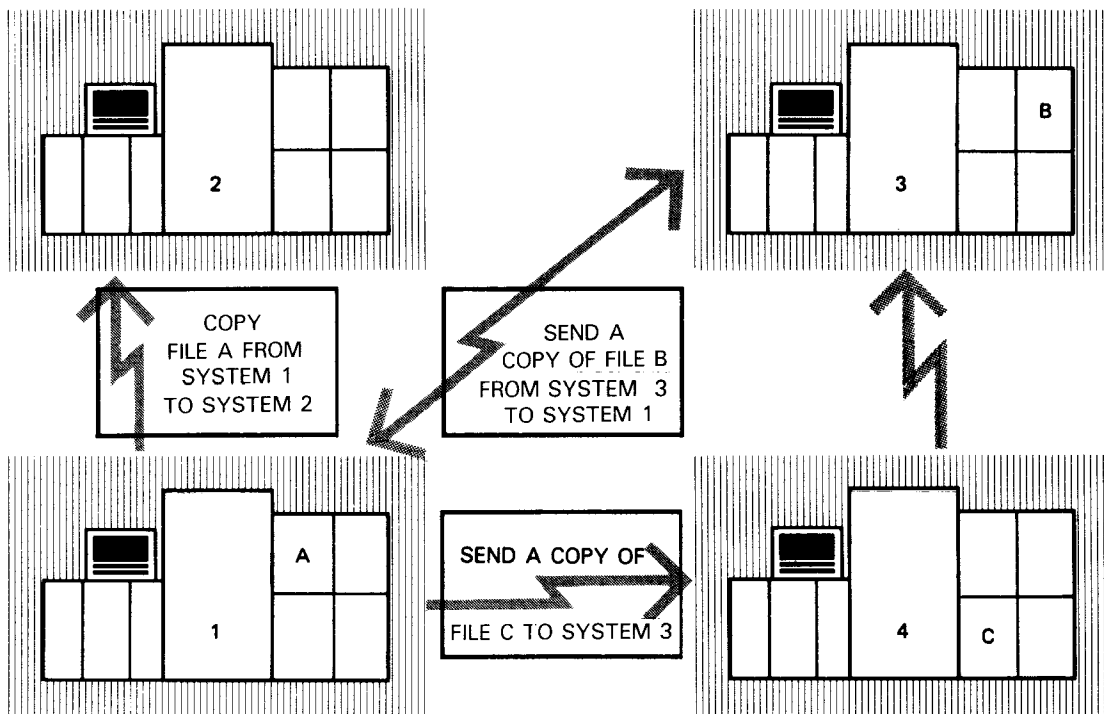

DDP File Access

The DDP file access provides these capabilities:

- A program can access, through job control statements, a MIRAM disk data file residing on a remote system and use it as if it resided on the local system.
- A program can access another program, in a multi-host environment, as if it were a disk file.

IMS-DDP Transaction Facility

The IMS-DDP transaction facility lets users perform transaction processing on any local or remote files within a DDP network. The transactions are processed by IMS user action programs written in BAL, COBOL, and RPG II, or by the UNIQUE inquiry language.

2.10. APPLICATIONS PROGRAMS

OS/3 supports the diverse needs of an organization. In addition to major stand-alone applications systems, such as the Universal Industrial System (UNIS), the OS/3 applications programs library contains many programs and subroutines that can solve a wide variety of business and technical problems. The interactive nature of OS/3 makes it especially suitable for the support of these operations without any unusual scheduling or data entry impact on the primary system users.

The list of available applications programs constantly changes as Unisys adds new programs and modifies existing software to meet the ever-changing needs of today's business community. Users interested in applications programs tailored to their needs should contact a local Unisys representative.

3. System Software

3.1. SOFTWARE DESIGN CONCEPTS AND CAPABILITIES

OS/3 directs the efficient and flexible centralized control of all System 80, models 10/20 activities. OS/3 software gives the user a multijobbing environment that uses the full capabilities of System 80, models 10/20. This environment allows concurrent operation of programs with immediate response to user inquiries and requests at local and remote workstations.

OS/3 is designed to take advantage of the increased speed and capacity of System 80, models 10/20 to dramatically improve job throughput. The software makes optimum use of all available hardware facilities resulting in efficient job turnaround time. OS/3 also supports a wide range of peripheral hardware.

OS/3 is a comprehensive library of software that supports System 80, models 10/20 at three levels:

1. System control software (SCS)
2. Extended support software
3. Additional software

System control software consists of the software facilities necessary to load, operate and maintain the minimum System 80, models 10/20 operating environment. SCS is mandatory software for operation of any of the other proprietary system software products.

Extended support software is built on the basis of SCS. It includes the wide range of Unisys proprietary software programs that extend the usability of System 80, models 10/20. Extended support software includes language translators, utility programs and general application programs.

The OS/3 additional software supports special purpose services such as hardware diagnostics, performance evaluation, and migration/conversion programs.

3.2. SYSTEM CONTROL SOFTWARE

System control software consists of the supervisor, job control and other programs that form the basis of OS/3 operations. System control software also makes the following functions possible:

- Interactive processing
- Communications
- Batch processing
- User program development
- Disk processing
- Resource management

3.2.1. Supervisor

The supervisor is a collection of sophisticated routines that provide the central control needed to make the system's hardware, software, user programs, and interactive facilities work together efficiently. The supervisor services make many features possible. Among them are the following:

- Multiple program processing
- Simultaneous interactive access
- Error control and recovery
- Automatic resource management

The supervisor manages and coordinates all system activities, handles randomly occurring events, initiates and coordinates the execution of batch and interactive programs, and provides advanced programming facilities. The supervisor is one of the most complex components in the system, but it makes the System 80, models 10/20 an easy-to-use and efficient data processing system.

The supervisor is built around executable modules, or routines, each of which has a specialized function. Resident routines are commonly used by the supervisor and always reside in main storage. Other less often used routines, called transients, are stored on the system resident volume and are loaded in main storage only when the supervisor needs them. This arrangement minimizes the amount of main storage the supervisor uses by overlaying unneeded transients with newly loaded transients, and it eliminates the input/output time needed to load the most commonly used routines by keeping them resident.

SUPERVISOR FUNCTIONS AND SERVICES

Supervisor interrupt requests	- Service the various interrupts generated by the system.
Task switcher	- Determines the order in which the various tasks are given CPU time.
Physical input/output control	- Controls the dispatching, queueing, and interrupt processing for all I/O devices directly connected to the system.
Disk cache facility	- Stores data in a reserved cache to improve I/O performance.
Transient management	- Schedules, locates, and loads transient (nonresident) supervisor routines.
Timer and day clock services	- Provide a system clock for timed, batch, or interactive activities.
System console and workstation management	- Controls information to and from the system console and various workstations configured.
Error recovery and logging	- Handles any program or machine error that causes an interrupt.
Multitasking	- Concurrently processes more than one task from one or more jobs.
Diagnostic services	- Support a variety of diagnostic services to isolate and correct diverse error conditions.
Main storage management	- Allocates and deallocates main storage as required by other system control software.
Security	- Controls access to the subsystem environment.
Installation verification	- Tests functional capability of system components.

The supervisor is configured during the system generation procedure (SYSGEN). During SYSGEN, users enter parameters to indicate the supervisor routines they want to include as resident or transient. Additional features increase the main storage requirements of the supervisor.

A number of supervisor generation parameters provide default values the supervisor uses to handle certain conditions. You can fast-load the supervisor and generate a number of separate supervisors during system generation, but you can only operate one supervisor at a time.

Supervisor Interrupt Requests

A supervisor interrupt is a request made to the supervisor to perform a function. Requests are generated by the various hardware and software components. Interrupts stop the normal processor flow and must be completed in some way before processing can continue. OS/3 recognizes eight types of interrupts:

SUPERVISOR INTERRUPTS	
Supervisor call	- Occurs in response to the SUPERVISOR CALL (SVC) machine instruction. Although it is handled as an interrupt, programs routinely use the supervisor call to request supervisor services.
Input/output	- Occurs in response to signals from I/O channels.
Exigent machine check	- Indicates a malfunction in or around the processor from which the supervisor cannot recover.
Repressible machine check	- Indicates a malfunction in or around the processor from which supervisor recovery is possible.
External interrupt	- Generated either by the processor interval time or the system console interrupt key.
Program check	- Occurs when the processor attempts to execute a nonexistent instruction or to execute an existing instruction in an illegal manner.
Program event recording (PER)	- Provides dynamic monitoring of executing programs by storing information about the current instruction when a specified event occurs.
Restart	- Occurs when the restart key on the system console is pressed and can be used to put a stopped processor in the operating state.

Some interrupts, like supervisor call or input/output, are routine; others, like program or exigent machine checks, represent errors that the supervisor must handle with minimal system interruption.

Task Switcher

A task is the smallest entity to compete for central processing unit (CPU) time. The system, as well as users, can initiate tasks. Tasks initiated by users are interactive activities or functions requested through job control. The system initiates tasks to support user requests or as a part of normal system operation. The task switcher coordinates the processing of all current tasks and decides, based on established priority, which task should be processed next.

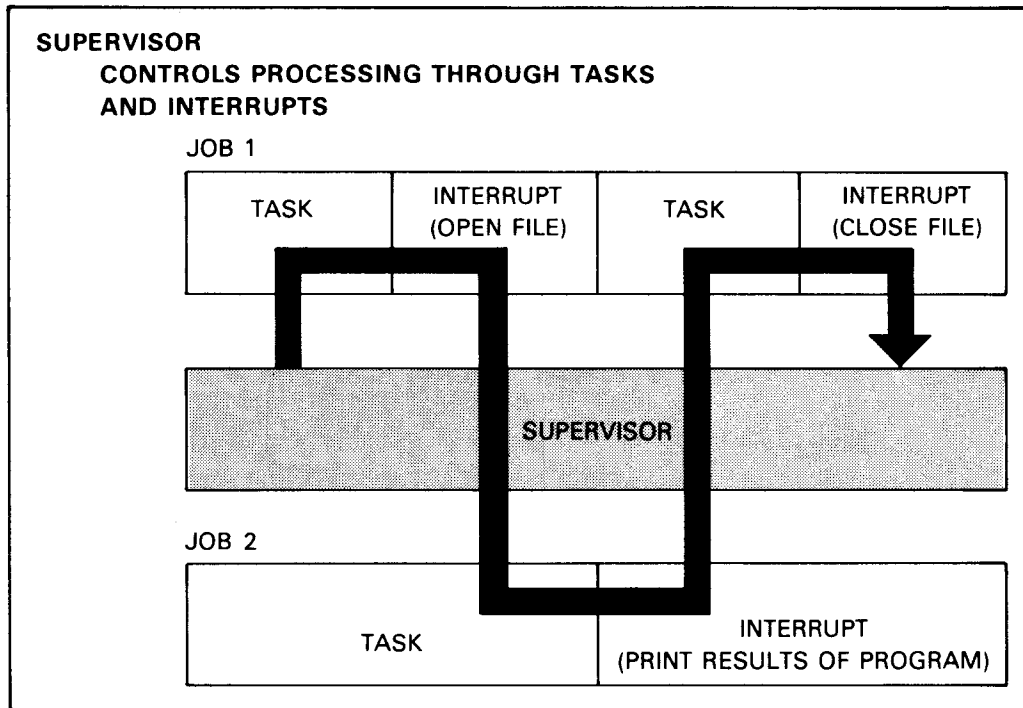

Physical Input/Output Control System (PIOCS)

OS/3 performs all input/output (I/O) operations with peripheral devices through the physical input/output control system (PIOCS). OS/3 PIOCS is composed of general purpose software routines that provide maximum throughput on all peripheral devices and allow expansion to support new devices.

PIOCS handles the queuing and initiation of all I/O commands, and the processing of I/O interrupts in the following ways:

- Control - PIOCS receives control when a request is issued for an I/O operation. Control is not returned until the I/O request is completed. However, other tasks in the system can be activated if status indicates a ready-to-run condition.
- Queuing - Requests for I/O operations are initially queued, by priority, in device and channel queues.

- Dispatching - Dispatching follows the queuing of an I/O order when the device and channel are free. When the device and channel are not free, dual co-channeling provides nonsimultaneous access to control units of two selector channels.
- Dispatch routines - The I/O dispatch routines perform needed service functions such as disk address verification and parameter checking. Interrupts from I/O channels are serviced as a high priority function of the supervisor to free the channel for dispatching other I/O orders that were queued.
- Completion of I/O request - Upon completion of an I/O order, a general I/O status analysis is performed to determine whether an abnormal condition occurred.

Normal I/O terminations occur:

- When additional requests are queued and control returns to the I/O dispatcher.
- When no additional requests are queued and control passes to the task switcher which returns control to another task.

Abnormal I/O terminations occur:

- When the appropriate device is flagged as unavailable for all tasks.
- For errors on the system resident device. The resident error recovery routine receives control.
- For other error conditions where a more detailed analysis is required. A device error recovery overlay routine is called in to complete processing of the error condition.

PIOCS only requires operator responses when unavoidable. However, if specified at SYSGEN, the operating system can respond internally to the system messages for the operator.

Disk Cache Facility (DCF) _____

The OS/3 disk cache facility increases system performance by reducing the I/O bottleneck to disk devices. I/Os are slow relative to processor speed. The I/O bottleneck is reduced by reducing the number of physical I/Os.

When a particular area on a disk is read, the disk cache facility writes to a reserved cache storage area all or a portion of the track being read (depending on the size of the cache entered when DCF was initialized). A physical I/O is unnecessary in subsequent reads of that same disk area since that data is already present in storage.

Reducing the number of I/Os required results in the following reductions:

- Queuing delays - I/O requests must wait to be issued in turn.
- Disk seek time - The disk accessor moves to the proper cylinder.
- Latency - The disk rotates so that the disk read/write heads reach the proper record.
- Data transfer time (from disk to storage)
- Process time overall

Main storage disk cache is supported by software included in the system microcode file. It is called, through the system definition file, to maintain consistency among all System 80 models.

DCF is normally initialized during IPL. Commands also let the operator:

- Initialize DCF
- Override defaults
- Activate and deactivate drives to DCF
- Change the cache segment and buffer sizes
- Remove and reactivate DCF from the system
- Monitor DCF activity

Transient Management

The supervisor takes full advantage of auxiliary storage to provide maximum services while keeping main storage requirements at a minimum. The supervisor uses two types of routines, resident and transient.

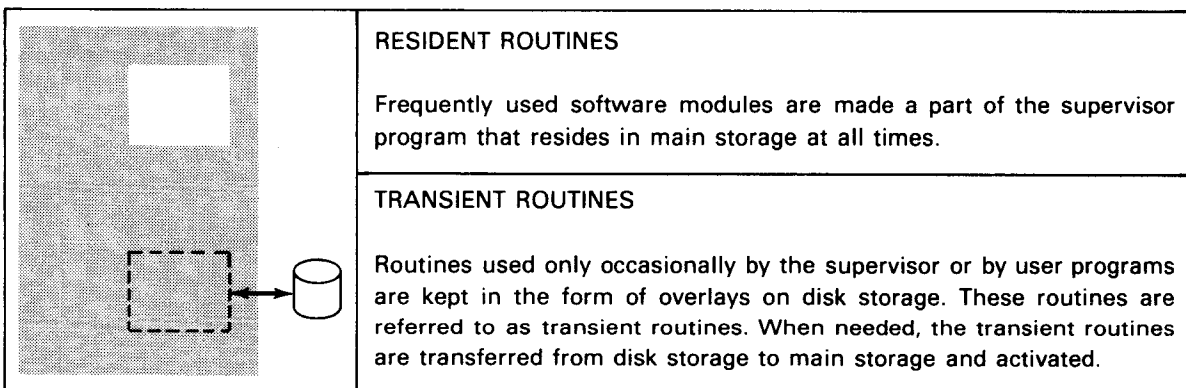

Each user specifies the number of areas in main storage set aside to contain transient routines. The supervisor manages these transient areas by monitoring their use, controlling the loading of a requested transient routine into a selected area, and transferring control to the transient routine. Only one disk access is required to load a transient routine. Opening and closing files, and terminating jobs are examples of transient routines. The user can make resident some frequently used transient routines. This reduces load time for the transient routines and the number of I/O operations performed by the system.

Timer Service Management _____

The central processor complex contains a high-resolution timer that can provide an interrupt after any time period greater than 1 millisecond. The calling task can specify a wait interval in milliseconds or seconds, or can specify a time of day when an interrupt is to occur.

The supervisor uses a simulated day clock to provide the time of day to tasks upon request and to time stamp messages and job accounting entries.

System Console Management _____

System console management controls message displays on the system console, with responses and commands coming from the operator. The screen images scroll upward, with new display lines or operator input appearing on the bottom of the screen. Console management routines selectively delete messages from the top of the screen that do not require responses.

Workstation Management _____

Workstation management provides physical level support for the interactive services and data transfers for workstations dedicated to a job. Workstation management coordinates all the activities of the workstation with those of the requested functions to ensure efficient operation.

Error Recovery _____

The supervisor examines any error that causes a program interrupt to determine the type of error, such as program check or protection violation, and the type of job involved.

Optional, user-supplied subroutines process error information. Standard error control actions are initiated in the absence of user code. If the supervisor detects an error, it halts the system and attempts a restart from that point. If recovery fails, the supervisor collects information for an orderly abnormal termination.

Invalid or inconsistent requests for supervisor functions are reported to the requesting program.

The supervisor examines machine check interrupts to determine if the error is recoverable. If the error is not recoverable or recovery fails, the supervisor abnormally terminates the system. The supervisor collects and logs all information pertinent to the abnormal termination.

Error Logging

The error logging facility records hardware and software errors in the system error log file. The records placed in this file can be retrieved and used to prepare statistical reports.

The error logging facility is loaded at system generation time. The supervisor then determines the type of errors to be recorded and the devices to be monitored. Error logs are collected for every device configured into the system. Error log records are collected for four types of errors:

- Peripheral device
- Communications
- Machine check
- User specified

During the initial program load (IPL) of a new session, the operator can retain the error log file from the previous session or reset the file with either the same set of collection parameters or a new set. During the operation of the system, the operator can alter the collection of record types.

Multitasking

Multitasking is a programming technique that significantly reduces the time required to process a job. Each job entered into the system consists of one or more functions, or tasks, for the system to perform. Normally, each job step has only one task actively using the CPU. Through multitasking, the user establishes a hierarchy of independent tasks such that several tasks from a single job step are active at the same time. CPU control passes from one task that is awaiting completion of an external event to another task. If that second task is from the same job, that job gets processed faster. The separate tasks defined for each job step are called subtasks. They vie for CPU time as independent tasks with tasks from other jobs.

Diagnostic Services

Diagnostic services provided by the supervisor include the following:

- Monitor routine - A hardware monitor interrupt lets the monitor routine trace the execution of a program to locate and correct errors. The routine interrupts each instruction before it executes and tests for conditions specified in the monitor input. When a specified condition is satisfied (a specified storage location, instruction, or instruction sequence is reached), the monitor can print out current program information, a program status word (PSW), register contents, next instruction to execute, etc., and can suspend program execution or continue with or without monitor intervention.

Trace conditions and information to print is specified through the job control stream or entered at the system console. An entire program or a portion of a program can be monitored.

- Snapshot display of main storage - A partial main storage printout aids in solving main storage problems. The area of main storage displayed and the time the display is to occur are identified by parameters at run time, or specified in the body of the program.
- Main storage dumps - A main storage dump can provide diagnostics under the following conditions:
 - Abnormal termination dump for user program - Provides a main storage dump of a program region in hexadecimal, alphanumeric, or both, plus a formatted display of error codes, job-oriented tables, and supervisor information to assist the user in debugging.
 - Program or operator request dump - Lets the operator or any program request a main storage dump in the same format as the abnormal termination dump.
 - System failure dump - This routine is used when an abnormal condition occurs and other dump programs cannot be used.
- Standard system error message interface - An error message service routine provides complete and specific error messages. This routine locates the message in a disk file and transfers control to the system console handler for message display.
- Error response to user jobs - Error codes returned by the supervisor to the calling program are standardized to provide a uniform interface for all system services. If a user requires the return of control after the detection of a hardware failure or software exception, a user-supplied subroutine is provided; otherwise, an orderly abnormal termination, which can optionally include a main storage dump, is called for the user job.

Main Storage Management _____

The supervisor ensures the efficient operation and proper use of the system's main storage. Primarily, the supervisor reserves the main storage space required by jobs, programs, and system routines and loads them into their reserved areas. The supervisor makes certain that they are loaded into the proper areas and at the proper time. In addition, the supervisor can:

- Dynamically expand the main storage regions of certain programs, jobs, and routines when necessary
- Rearrange and consolidate job regions to provide as much contiguous free space as possible
- Temporarily suspend and remove jobs from main storage to make room for preemptive priority jobs

The supervisor performs main storage management functions to promote system efficiency and ease of use by streamlining main storage operations and providing as much automatic storage management as possible.

Security Maintenance Utility

The security maintenance utility (SMU) controls access to the interactive facilities of the system through security information located in the system security file. The system administrator determines who is able to access the system and assigns identification to each system user. The security maintenance utility also accounts for computer time used by interactive system users and automatically executes predefined sets of interactive commands when users log on.

The security maintenance utility performs its tasks by creating three types of profiles:

- A user profile contains security and accounting information, as well as execution and command profile names.
- An execution profile contains the commands for automatic execution at logon, as well as the execution profile name.
- A command profile lets the system administrator specify the system commands a user can enter from a workstation.

The system administrator decides what to include in each of these profiles and can display or modify them.

In addition, the security maintenance utility restricts access to the system by use of the logon procedure which:

- Requires the user to enter a password
- Requires a user profile definition for each individual
- Can allow access only during a specific time or date range
- Prevents a user from logging on after a specified date

Installation Verification Programs

Unisys supplies a set of installation verification programs that should be run after SYSGEN is complete to test the functional capability and operation of the various components included on the resident disk unit.

The VTOC verification routine performs a thorough analysis of a volume table of contents (VTOC), looking for any inconsistencies between the labels. When the routine detects an inconsistency, it displays a message providing the details on the error. When no inconsistencies are found, the routine informs the user that the volume is free of problems. VTOC verification can be performed at automatic volume recognition (AVR) time or through a console command.

3.2.2. Job Control

Job control manages the system resources and prepares jobs submitted for execution. A job represents a unit of work to be performed by OS/3. Each job consists of one or more job steps, each requesting the execution of a system or user program.

OS/3 performs job control services:

- Prior to the execution of the initial job step
- During the transition between job steps
- At the conclusion of the job

The services of job control are directed by the user through statements provided by the job control language (JCL). These control statements define the system resources required for proper execution of a job and facilitate the efficient management of these resources.

OS/3 JCL is a flexible language that lets the user specify the requirements for a variety of essential resources and affords a high degree of independence from limitations imposed by system configurations. Through the use of cataloged procedures, OS/3 effectively reduces the usual effort required when running frequently executed jobs.

JOB CONTROL SERVICES
Automatic job scheduling and initiation
Automatic main storage allocation
Device assignment
Initiation of interactive services for user input from a dedicated workstation
Volume and file label processing
Retrieval of cataloged control streams for subsequent modification and execution
File cataloging
Program restart from a checkpoint
Query of dedicated workstation for run-time variables
Scheduling of additional jobs from within a job
Control stream and data storage

A control stream is a group of sequenced statements, written in the OS/3 job control language, that define a job and direct its execution. These statements are divided into these functional groups:

- Job Coordination
- Job Step Operation
- Device Assignment
- Regulation of Job Environment

Job Coordination

This group of control statements provides an interface that coordinates overall job execution. Statements for job coordination specify information on the following:

- Job identification and delimitation - Uniquely identifies the job and indicates its starting and ending points.
- Scheduling Priority - One of the following priorities is used to schedule a job:
 - Normal priority - for regular scheduling considerations within the system
 - High priority - for rush scheduling
 - Preemptive priority - for urgent jobs that require immediate scheduling and execution

Within priorities, all jobs are scheduled for execution on a first-in, first-fit basis. Main storage is allocated for preemptive jobs through the rollout/rollin capability.

- Main storage requirements - OS/3 calculates the main storage requirements for a job if all programs to be executed by the job either currently reside in a load library or are specified by the user through the job control language. The user can specify a minimum and maximum value.

The minimum value is the basic storage requirement needed to properly execute all programs within the job. The maximum value specifies an additional storage requirement that, if available, could be dynamically used by the programs within the job to improve and speed up job execution.

The resource management capability lets the user balance job turnaround time and workstation response time by setting the limits for main storage usage and job initiation. As processing needs change, the user can adjust the percentage of main storage used for symbionts, interactive jobs and batch jobs. The user also controls the number of jobs initiated and executing.

- Scheduling a job from within a job - OS/3 JCL lets the user serially execute jobs by allowing a currently active job to request another job.
- Restart of an interrupted job - Specify job restart from a program checkpoint through JCL by giving the required checkpoint information and resource requirements for the recurring portions of the job. The user must establish checkpoint data prior to requesting job control to restart a job.

Device Assignment ---

This group of control statements identifies the devices required for the proper execution of a job. Statements for device assignment specify information on the following:

- Device assignment sets - OS/3 JCL offers a set of control statements that provide the information required to assign devices and establish the relationship between files or volumes and devices, such as the number of files per volume and the number of volumes that contain a file. The peripheral devices assigned to satisfy the requirements of a job include card punches, card readers, printers, disk, diskette, tape drives, and workstations.
- Logical device assignment - This function temporarily changes the logical unit number associated with a given device type from that specified at system generation time to one that will be used for a specific job. This permits the user to run existing control streams among different supervisors.
- Release of peripheral devices - This function releases peripheral devices that are presently assigned to a job and not required in subsequent job steps. Upon release, they are no longer available to the original job, but are made available for subsequent assignment to other jobs queued for initiation.
- Deletion of files - This function deletes specified files from the system prior to the execution of a job step.

Job Step Operation ---

This group of control statements specifies job step operation. A job consists of one or more job steps. One job step could compile a source program, another job step could link the object program, followed by a job step to execute it. Statements for job step operation specify information on:

- Program execution - OS/3 JCL specifies that a system or user program must be loaded for execution from a system library or an alternate user library. A job step priority is also indicated, with the lowest value indicating the highest priority.
- Altering programs - This feature of job control alters programs at execution time. Modules are altered according to specified changes after being loaded into main storage. However, a copy of the named module in the load library on disk remains intact.
- Data and parameter specification - OS/3 JCL lets the user include information in the control stream as embedded data or program parameters. This information is stored in the temporary control stream library for subsequent retrieval by a system or user program.

Regulation of Job Environment

This group of control statements regulates the environment of the job by (1) making designated job steps conditional on the outcome of a previous job step or on any errors that previously occurred during execution, or (2) modifying the environment of the job. Statements regulating job environment specify information on:

- Job step options - OS/3 JCL lets the user specify certain optional software functions to be performed in a job step. The specified functions are effective only in the job step in which they are included. The user can request any of the following options:
 - Alter - Indicates that a loaded program alters prior to getting control for execution.
 - Binary overflow - Indicates that the loaded user program gets control for execution with binary overflow enabled.
 - Decimal overflow - Indicates that the loaded user program gets control for execution with decimal overflow enabled.
 - Load module construction - Indicates that the compiled source program is linked and executed using default linker parameters.
 - No abnormal dump - Indicates that a dump is not desired in the event of abnormal job step termination.
 - System dump - Indicates that a system dump is desired in place of a job dump in the event of abnormal job termination.
 - No volume label check - Indicates that header labels are not read and verified on disk, diskette, or tape volumes.
- Skip control statements - This feature lets the user bypass any number of control statements, including all statements in an executing control stream. The user can indicate a forward skip from any control statement to any other control statement in the stream.
- Job-to-workstation communications - During execution, job control can communicate with the workstation by including statements that instruct the job to display queries on the workstation screen during the running of the job. The user has the option of altering the processing of the job at the point where the message was displayed. The user can use the MAS job control option to transfer program control to another workstation on either a local or remote host.
- Job-to-operator communications - This feature lets the user communicate with the operator. The user can place a message of up to 60 characters anywhere in the control stream. The message displays on the screen of the system console during control stream processing.
- Program-to-DDP communications - Job control statements let one program initiate a connection to, or receive a connection from a local or remote program.

- Date change - This lets the user alter or modify the calendar date for a specific job by submitting a 6-character date consisting of the month, day, and year in any order, or a 5-character date consisting of two characters for the year and three characters for the day.
- Trace mode - OS/3 JCL provides a trace option for use in program debugging. When the trace mode is requested, every instruction in the job step is examined before execution without interfering with the normal operation of the program. The system prints pertinent operational information for every traced instruction.
- Magnetic tape positioning - This feature positions tape volumes prior to the execution of a job step. It positions a data file or pre-positions a multifile tape volume. It spaces the tape volume forward or backward a specified number of tape marks or blocks, rewinds the tape volume, or writes a tape mark.

Dialog for Job Control Stream and Jproc Preparation _____

The job control dialog, supplied by Unisys, is a product that leads the user step by step through the process of building a job control stream or a jproc from a workstation. It lets the user choose the statements and system jprocs required from lists of menu items and requests parametric values where necessary. It also provides HELP screens, when requested by the user, to explain the choices available. The dialog can guide inexperienced personnel in building valid job control streams. The job control dialog automatically stores the control streams and jprocs in either the system job control library file (\$Y\$JCS) or an alternate library file identified by the user.

File Cataloging _____

The file cataloging facility provides a method to control file usage and to restrict the use of selected files to only authorized individuals. File cataloging also builds and maintains generation files. In addition, file cataloging is used as a convenience facility because it reduces the job control required to access a file.

To use the cataloging facility, the device assignment sets of the files cataloged are placed in the system catalog file. A device assignment set consists of the job control statements that define a file and its location. To place a device assignment set into the catalog, include a cataloging statement in the device assignment set.

If the use of a cataloged file is restricted, protective read and write passwords are assigned to the file. A read password assigned to a file restricts access to the file. A write password assigned to a file restricts those who can change the file.

The file cataloging facility provides the capability to alter a file and at the same time retain a copy of the file as it was before alteration. The files created are called generation files. For example, three generations of a payroll file could be kept: present payroll, week-old payroll, and 2-week-old payroll.

A catalog manipulation utility is provided for the system administrator to perform certain maintenance functions on the catalog. This utility can:

- Assign a protective password to the entire catalog file to prevent unauthorized access
- Make a backup copy of the file and restore the copy as necessary
- Obtain a listing of the contents of the file

3.2.3. Interactive Processors

Three interactive processors support the workstation-to-job command interface:

- Workstation command processors
- Dialog processor
- Screen format coordinator

Workstation Command Processors _____

The workstation command processors provide the interface between the workstation and the various functional components of the OS/3 software. The command processors handle the following:

- Commands requesting control system functions, such as logging on and job execution
- Commands issued to control the processing of jobs
- Commands issued to the various interactive facilities

Dialog Processor _____

Dialogs are used to simplify the process of entering variable data from a workstation directly to a program. The dialog processor:

- Coordinates the display of prefiled dialogs
- Extracts the data entered in response to the dialog
- Routes the data to the appropriate user program for processing

When a program contains dialog specification language (DSL) commands, the DSL translator prompts the dialog processing services to locate and display the specified dialog. The processor maintains an audit file to store entries made to the dialog for future retrieval. The user can add to, or amend the dialog information. An audit file summary is printed each time a dialog is created or altered.

Screen Format Coordinator

Screen formats are forms displayed on the workstation screen. The formats are designed by the user and used by a program to input data from or output data to a workstation user. A screen format can be requested through the following:

- A workstation command
- An IMS action program
- An application program
- UNIQUE commands

3.2.4. Consolidated Data Management

The consolidated data management system is an intermediary between user programs and the input/output facilities of the supervisor and helps the user to access data files on peripheral devices. The user does not need to code routines for block/deblocking, buffering, and communicating with the PIOCS. The following features are offered:

- A single access method for disk files
- Shared data management modules
- Device independence
- Support of the interactive features and workstation data transfers

**DATA MANAGEMENT HANDLES
THE MOVEMENT OF DATA BETWEEN DEVICES**

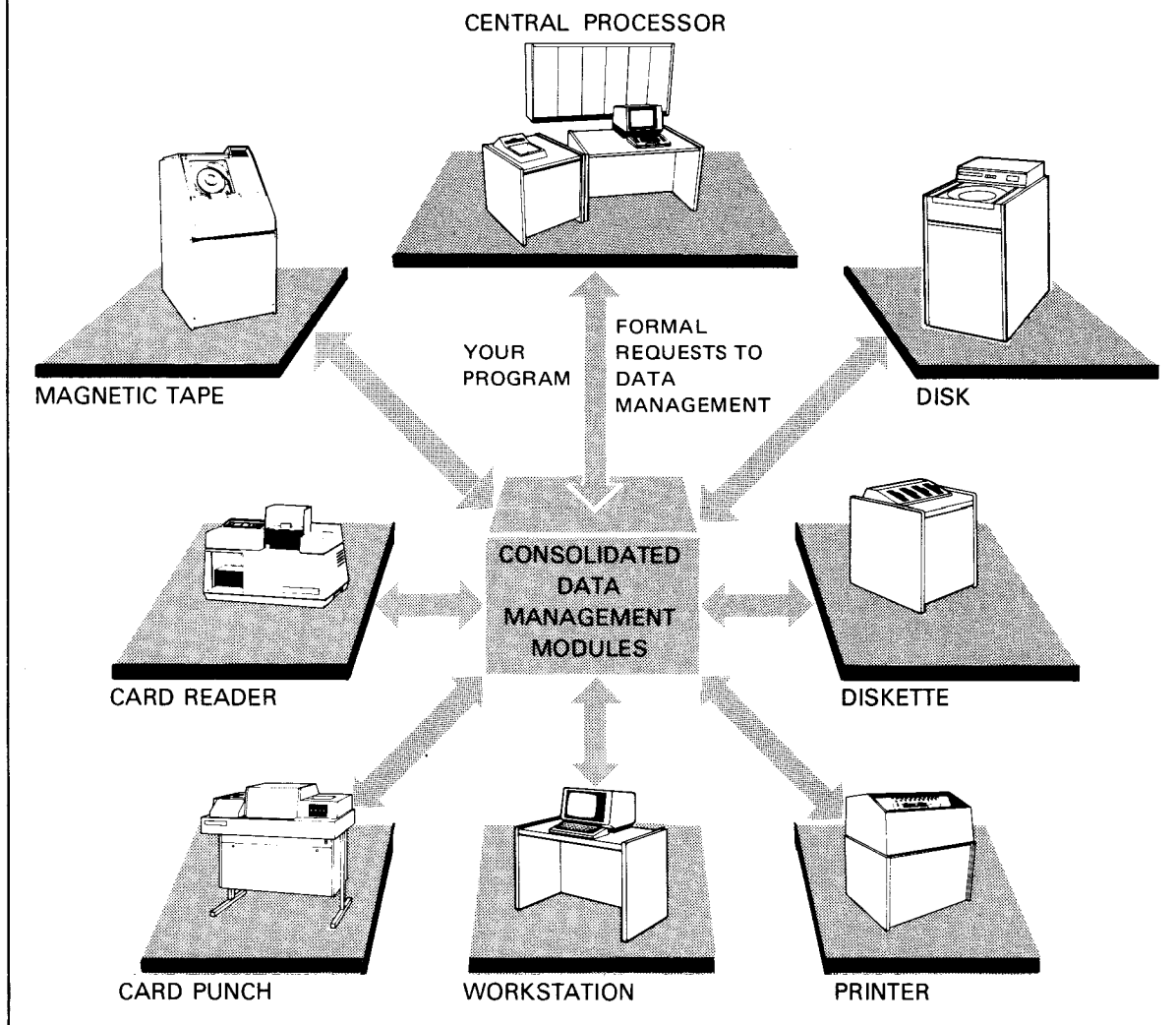

Logical Input/Output Control System ---

The logical input/output control system (IOCS) modules that control each access method are sharable subroutines. When referenced within a user program, these subroutines are dynamically loaded into main storage and available to many user programs.

Disk Access Method ---

The OS/3 consolidated data management access method for disk files is the multiple indexed random access method (MIRAM). MIRAM simplifies the data management requirements for disk files by offering a single access method that provides several ways to access a disk file. The records of a MIRAM file can be accessed as follows:

- Sequentially in order of placement
- Sequentially by ascending key
- Randomly by multiple keys
- Randomly by relative record number

Using MIRAM conserves main storage space by providing a single data management module for disk access shared by every user program, rather than having several data management modules for each access method. A fast loader utility allows CDM users to efficiently load keyed MIRAM files. CDM supports the accessing of remote data (but not library) disk files. The processors must be running under the same operating system.

Diskette Access Method ---

Consolidated data management allows accessing records of a diskette file:

- Sequentially in order of placement
- Randomly by relative record number
- By data set labels

Workstation Access Method ---

The workstation access method provides the logical level interface between the workstation, the system, and user software. The workstation access method ensures the following:

- Automatic support for the workstation as an interactive programming device, including the support of the interactive features that cause screen displays and the management of the screen displays
- The transfer of application data and application messages between the workstation and user job

- Console-like capability between the user program, system console operator, and the workstation operators
- Support of workstation function key capabilities
- Device independence

The workstation access method is automatically enabled. It can also be controlled through a set of declarative and imperative macroinstructions that connect workstations at a logical level through the common data interface.

Magnetic Tape and Unit Record Device Access Methods _____

I/O operations are performed in sequential order on magnetic tape subsystems, card readers, card punches, and printers. Records are handled from the first to last according to physical placement. The OS/3 consolidated data management provides sequential access method (SAM) modules to handle the access requests of user programs for these four device types.

Device Independence _____

Device independence allows logical data transfers among devices having dissimilar physical characteristics. A single system control table format that controls and defines all file types (including disk, diskette, and printer) results in a significant level of device independence. The files in a program can change from one type to another (e.g. disk to diskette) without requiring the user to alter the source code of the program that accesses that file. Job control statement changes that associate the file with a device, are required. Device-unique commands such as tape position commands, occurring in source programs, should be removed or altered accordingly.

3.2.5. System Service Programs

System Librarians _____

System and user program libraries generate either system access technique (SAT) files or multiple indexed random access (MIRAM) files. OS/3 includes two program librarians: the SAT librarian, and the MIRAM librarian, to help the user maintain program libraries.

The OS/3 SAT librarian is a set of integrated subroutines that maintains the system and user libraries generated as SAT files. Programs and elements such as language processor source modules, language processor output (relocatable object modules), or system-executable load modules, reside within a library (which is either a system or private file in the OS/3 environment).

The SAT librarian performs these functions:

- Maintenance - The primary task of the librarian is to perform maintenance functions on library modules. These modules consist of entire program libraries, groups of program elements within a specified library, or individual program elements.

Library functions include storing, correcting, adding, duplicating and transposing library modules. The librarian can modify existing libraries, create new libraries, and duplicate or purge libraries in their entirety. The librarian also ensures that a given library does not contain any modules with identical names and types.

- **Transferring** - The librarian also transfers program library modules from one medium to another. While library modules reside primarily within disk files, the librarian transposes program libraries to or from a card, diskette, or tape medium.

Control statements which perform operations and correct/verify SAT library modules are supplied to the librarian through a control stream. A user can print or card punch the contents of an individual program module or groups of program modules or get a table-of-contents-type listing of all the program modules in a file. Source modules can be corrected or updated, as well as sequenced. When any program module is processed by the librarian, its format is verified.

The librarian provides a map of the functions requested and the results of the action taken, with diagnostic error indications and warnings. The extent of information provided on the coded librarian control statements depends on the options specified by the user. The user can include the control statements as part of the library map.

The MIRAM librarian is used to perform maintenance functions on program libraries generated as MIRAM files. System libraries generated as MIRAM files include the system screen format library and the saved, expanded run library. The MIRAM librarian:

- Copies all or selected modules from one library to another
- Deletes selected modules from a library
- Prints all or selected modules in a library
- Prints a library directory consisting of all active header records
- Inserts comments into a module header record
- Changes the name or type of a module

The MIRAM librarian responds to a set of user control statements inserted into the control stream that executed the librarian. The librarian produces a printed listing of all operations performed during a given librarian session. This listing is called a librarian map.

The system librarian also:

- Produces a listing of all modules in a library without the need to copy them into another file.
- Uses a blocking factor of up to 15 kilobytes to access all library files, including disk, diskette, and tape files when extra main storage is available.
- Displays the actual disk volume, library, and logical file name on the LIB printout.
- Creates multiple library files on a single tape volume.

Linkage Editor

Compilers produce object modules as output. The user can tailor these modules into an executable program using the OS/3 linkage editor. The linkage editor can structure object modules from various language processor compilations into a single loadable program. Additionally, the object modules can contain cross-references to each other for specific purposes of program execution and communication. The linkage editor resolves such cross-references between separately compiled modules when these elements are collected and a loadable program is constructed.

The loadable program consists of program segments split into multiple regions. Each of these regions is structured as a hierarchical tree with specific boundaries defined as branches of a root segment. This structure lets a user produce a program that is larger than the main storage area assigned for its execution. The various segments of a multiphase load module are loaded and executed as required by the logic of the program.

Cross-references, made by the user (within compiled object modules) and resolved by the linkage editor in forming the loadable program, exist within or across segments. Segments are composed of one or more object modules, and the loadable program is composed of one or more segments; the initial segment is always designated as the root phase segment. To establish cross-references between processor object modules, the user needs the following:

- Language processor external reference declarations (EXTRN) that create indirect references in requesting object modules
- External definition declarations (ENTRY) that create indirect definitions in satisfying object modules

The linkage editor uses these declarations to resolve cross-references between two or more object modules that are linked together at link-edit time. Executable program generation is essentially a two-fold process:

1. The source program code is compiled by the various language processors to produce one or more object modules.
2. The various object modules are combined by the linkage editor to create a single, executable load module.

At link-edit time, the linkage editor assigns a new relative address to the object modules included in the load module, based upon their new relative position within the load module. Any cross-references that exist between object modules are satisfied by replacing them with the relative address of their respective definitions or references. The output of the linkage editor is, therefore, a loadable executable program acceptable to the OS/3 loader.

The role of the linkage editor in program preparation is shown in this diagram:

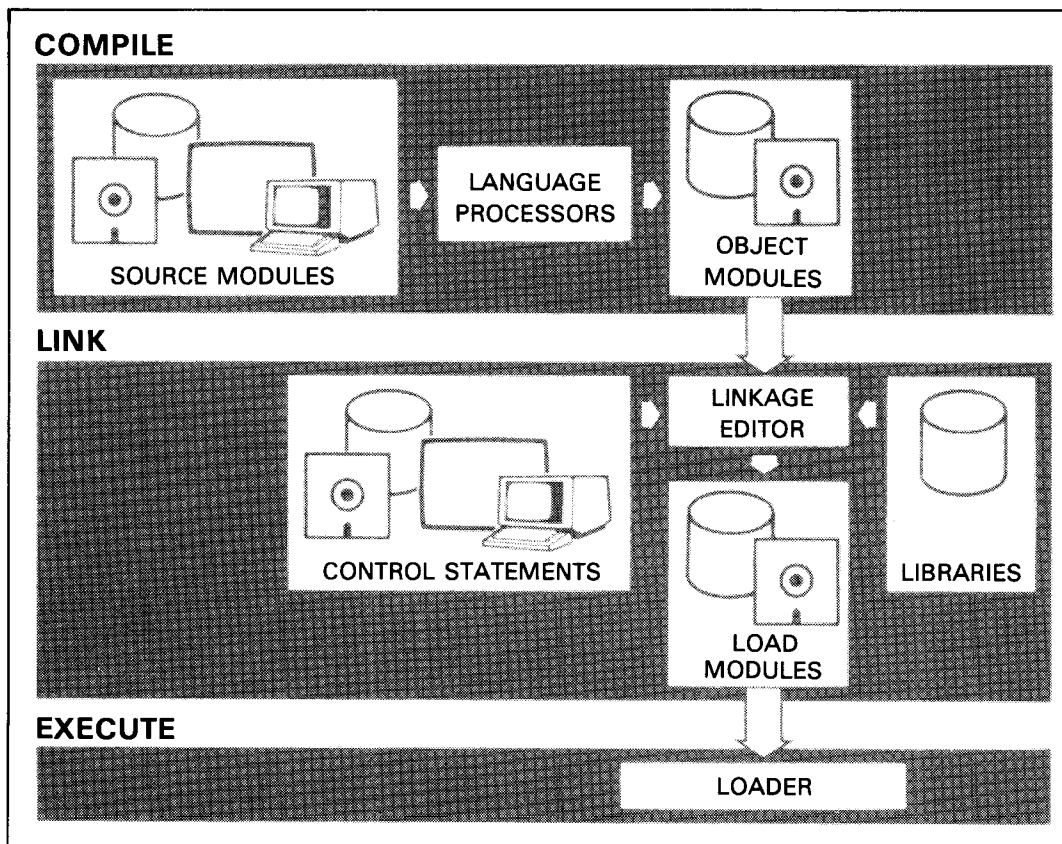

There are several advantages when the linkage editor constructs a single executable load module from several object modules:

- If a change is required in one of the included object modules, only that object module is compiled or assembled again.
- The various source modules are written in the appropriate language and combined into a single executable program.
- Routines common to two or more object modules only need to be assembled or compiled once and the resulting object code linked as required. The result is a reduction in the total time required to generate an executable program.

In addition to the basic linking function, the linkage editor:

- Searches an appropriate library and, either on request or automatically, incorporates object elements other than those in its primary input
- Performs program modification by deleting and rearranging control sections of an object module as directed
- Produces an optional overlay structure to be used by the supervisor during loading
- Reserves space automatically for common storage requests generated by the language processor

Disk, Diskette, and Tape Initialization Routines _____

The various tape, disk, and diskette initialization, or prep, routines check the condition of the magnetic storage media and prepare them for use by the system. The disk and diskette prep routines respond to a set of keyword parameters inserted into the job control stream. These parameters handle expiration date validation, data file allocation, and diskette fast prep. They also assign alternate track, defect skipping, and surface analysis functions.

Dump Routines _____

The system has a variety of dump routines to aid in the diagnosis of subtle hardware and software errors. These routines include a system dump routine, and user dump routines.

- System dump routine - The system dump routine provides a printout of all, or selected portions, of the contents of main storage. The user can initiate the routine unconditionally or preset the routine to automatically begin if a system failure occurs. The dump obtained is the same in either case. The system dump routines comprise:
 - JOBDUMP - creates a dump file that is proportional to the size of the job being dumped, reducing the amount of space required for the dump file.
 - SYSDUMP - reinitiates the same job while the dump is in progress, rather than waiting until the dump is completed.
 - SYSDUMPO - prints the hardware error log along with the normal SYSDUMP data.
 - MINIDUMP - prints a dump of only the actual main storage regions involved in the system error or HPR.

The system dump listing is divided into several parts, each part corresponding to a system component. The sections are clearly labeled with the appropriate heading. A typical system dump listing contains the following:

- Contents of low order storage
- Translated job region
- Physical unit, system information, and channel control blocks
- Supervisor
- Hexadecimal job region
- System switch list
- Free region

The dump listing is in hexadecimal or EBCDIC format.

- User dump routines - It is possible for a job to terminate abnormally with no apparent reason. The only way to determine the cause of termination is to list and review all information in the system relating to the job. This is called a job dump. Two routines are used to obtain a job dump: the job dump routine, and the user end-of-job (EOJ) dump routine. Both routines produce a listing containing the same type of information, but the formats are different.

System Maintenance Packages and Changes _____

The system is maintained and enhanced by installing system maintenance packages (SMPs). SMPs contain a collection of software changes called system maintenance changes (SMCs) that are issued to maintain the system's effectiveness.

SMPs are distributed on diskette on a regular basis. They contain installation routines that simplify installation of the SMP and protect system integrity during the SMP application. For example, if an SMP affects installed modules, the system is automatically regenerated to ensure proper operation.

Catalog Manipulation Utility _____

The catalog manipulation utility maintains the system catalog file that holds the device assignment sets for often-used user files. If a file device assignment set is placed in the system catalog file, it is accessed thereafter through one job control statement. The catalog manipulation utility lets the system administrator assign a protective password to the catalog file, make backup copies of the catalog file, and restore these copies to disk when required. The utility operates in response to a set of command statements embedded in the job control stream that executes the utility.

Disk Dump/Restore

The disk dump/restore utility lets the user make backup copies of the contents of a disk volume. The dump/restore utility can copy the following:

- All or part of a disk to a magnetic tape or diskette
- A magnetic tape or diskette to a disk
- All or part of a disk to another disk
- A tape created by a previous dump/restore operation to another tape
- A diskette created by a previous dump/restore operation to another diskette

The disk dump/restore utility executes as an interactive program or runs as a batch job. If executed as an interactive program, the user initiates the disk dump/restore utility through a simple keyin command. Control specifications for the program are entered in response to a dialog displayed on the workstation screen. Once the user provides all appropriate information through the dialog, the program executes and performs the specified operation.

If the disk dump/restore utility executes as a batch job, through job control, the user must prepare a job control stream. The appropriate program control statements are included in the job control stream.

The dump/restore utility supports the following:

- File expiration date validation
- Execution from a workstation
- File processing by prefix
- Streaming tape support for input and output, providing a fast method of backing up disk information
- Restart function
- File locking

The stand-alone dump/restore program is used during system installation to read diskettes created in file mode by the standard dump/restore program and write tracks of data to disks. The program can also copy the volume table of contents (VTOC) when requested by the user.

Disk Copy

The disk copy utility (SU\$CSL) copies from one to six volumes with the option to verify the data copied. It supports 8430/8433 disks.

The disk copy utility (SU\$C16) supports 8416/8418 disks.

The disk copy utility (SU\$C19) supports 8419 disks.

Disk Prep

The stand-alone disk prep program, used during system installation, formats disks and performs defect skipping and surface analysis. The program creates a volume label for the prepped disk. This utility supports 8470/8417 disks.

The standard disk prep program performs disk formatting, surface analysis, IMP/IPL processing, and assigns alternate track functions. This program also preps a single-sided, single-density diskette and writes the System 80, models 10/20 processor microcode onto it. This utility supports 8416/8418 and 8430/8433 disks.

3.2.6. System Installation Facilities

System installation is the process of installing the Unisys System 80 models 10/20 hardware. Once hardware installation is complete, the user installs and generates the Unisys Operating System/3 (OS/3) software.

Software Installation Facilities

Unisys delivers OS/3 software on a set of release diskettes, tapes, or disk. Software installation involves the transfer of this delivered software to a system disk pack. Once the delivered software has been copied onto the disk, the disk is referred to as the system resident volume, or SYSRES. The SYSRES disk holds all system software and must remain on line when the system is in operation.

To accomplish software installation, Unisys provides installation routines as part of the standard OS/3 release. These routines help the user to install the following:

- The initial release of OS/3 software
- Any new software received between releases
- Updated software as new releases of OS/3 become available
- Software maintenance packages and changes

System Generation Facilities

System generation, or SYSGEN, is the process whereby the user defines the system's hardware configuration to OS/3 and generates, or creates, the control elements required to meet particular processing requirements.

To simplify the procedure, Unisys provides these SYSGEN facilities:

- Dialog
- Parameter processor
- Job control streams

The SYSGEN dialog is an easy-to-use facility to prepare and process required SYSGEN parameters directly through the workstation. The user selects SYSGEN parameters in response to queries displayed on the workstation screen. OS/3 provides default values for omitted or incorrectly specified parameters to ensure that a usable system is generated.

The dialog accepts user choices and passes them to the SYSGEN parameter processor which, in turn, validates the submitted parameter selections and generates a series of job control streams.

The user then executes the actual system generation by interactively running the generated job control streams through simple workstation keyins.

3.3. EXTENDED SUPPORT SOFTWARE

The extended system software provides a number of optional features and improves the utilization and operation of the system. The extended system software is available as a package, and includes these components:

- Screen format generator
- Dialog specification language translator
- Data utilities
- SORT/MERGE*
- SORT3*
- Spooling and job accounting/reporting facility

** Available as separate items*

3.3.1. Screen Format Generator

The screen format generator lets the user interactively create template-like formats on workstation screens. These formats simplify the process of entering variable data and parameters, and they present output data on the screen in a formatted manner.

The screen format generator prompts the user for information and provides HELP screens to simplify the generation and modification of screen formats. The generator lets the user specify the following:

- A maximum of 255 fields displayed on the screen
- The characteristics of each field such as numeric, alphanumeric, and field length
- The editing attributes of each field
- Whether the field is input, output or both
- Whether the field is displayed conditionally, such as an error message
- Range checks for verification. A field that fails the range check can be blinked on the screen.
- The disposition of the screen after use
- A full 24 lines used to format the screen

Once the screen format is created, the generator automatically stores it in a permanent screen format library file. It can be accessed later by the programs that need it or by workstation users for further modification. An existing screen format can be modified to create a new format. Error and help detection capabilities are provided during the creation and modification process.

3.3.2. Dialog Specification Language Translator

The dialog specification language translator lets the user create job-oriented dialogs. It accepts dialog specification language source code as input and uses that input to generate a dialog display on a workstation screen. Dialogs consist of a series of queries to which the user responds with appropriate information. The user assigns a name to each generated dialog. This name is used to access the dialog which is displayed on a specified workstation screen. Information entered in response to the dialog is passed to the requesting program for processing.

3.3.3. Data Utilities

The data utilities program (DATA) performs a number of essential data file maintenance and manipulation functions. Through the data utilities program, the user:

- Makes a copy of a data file on the same or different type of storage device
- Reformats the records of a data file
- Selects or deletes specific areas of a file
- Produces a printed listing of a file in a variety of formats
- Compares duplicated files to their originals to check for discrepancies

The DATA program processes files stored on any of the supported storage media: disk, diskette, tape, or cards. Files can be transferred from one medium to any other medium, and printed listings can be made from files on any medium. Users can also perform such device-related functions as label checking, tape rewinds, sequence checking, and write protected files.

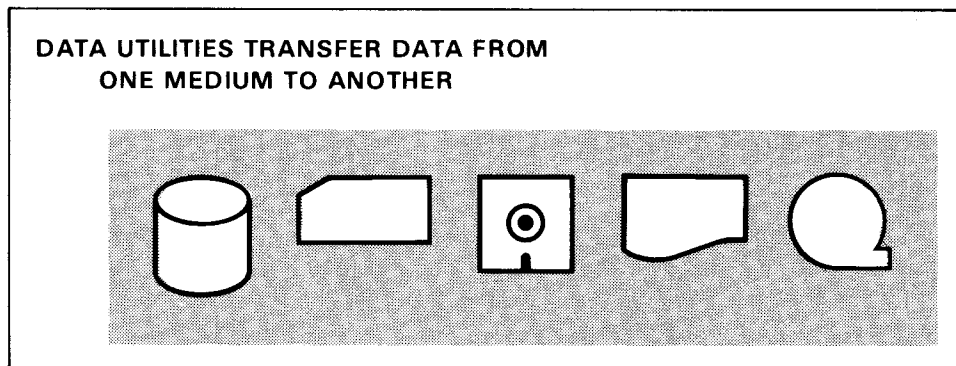

The DATA program executes as an interactive program or runs as a batch job. If executed as an interactive program, the user initiates the DATA program through a simple keyin command. Control specifications for the program are entered in response to a dialog displayed on the workstation screen. Once the user has provided all appropriate information to the dialog, the DATA program executes and performs the specified function.

If the DATA program executes as a batch job, the user must prepare a job control stream. The appropriate DATA program control statements are included in the control stream. The DATA program has the same capabilities regardless of how it executes.

3.3.4. SORT/MERGE

OS/3 SORT/MERGE operates as an independent sort/merge program or as a modular subroutine. As an independent sort/merge program, defined and initiated by job control, SORT/MERGE is constructed as a processor with interrelated modules operating within the framework of a system-driver program. Each module performs a specific function. As SORT/MERGE executes, the modules required are called by the driver program, loaded into main storage, and executed.

As a modular subroutine integrated into a user program, SORT/MERGE gives the user flexibility and freedom. SORT/MERGE can be called from a language processor program that includes the verb specifying this operation. The modular structure gives the user efficient operation despite variations in hardware configurations and data requirements. The modular structure allows a module to be changed, replaced, deleted, or added.

SORT/MERGE CAPABILITIES	
An interface that permits disk or magnetic tape to be used as work area	Input and output that can be associated independently with disk, diskette, or magnetic tape
Sorting of blocked or unblocked records	Sorting of fixed-length or variable-length records
Handling of seven types of key field formats: <ul style="list-style-type: none"> ▪ Character ▪ Binary (signed or unsigned) ▪ EBCDIC data in ASCII collating sequence ▪ Decimal (signed zoned and unsigned zoned) ▪ Leading and trailing sign numeric ▪ Overpunched leading and trailing sign numeric ▪ Floating point (single/double precision) 	Specification of up to 255 key fields
Execution of input and output code	Sorting of noncontiguous key fields in ascending or descending sequence
Shared input and reserved output devices	User specification of alternate collation sequence
A merge-only capability	Sorting of two or more different characters with the same collating value (multiple character sort)
Convenient restart procedure	Performing of data validity and data integrity checks during sorting
Printing of VOL and LBL information	Automatic extended SORT output file
	Optimized IRAM/MIRAM file handling

3.3.5. IBM Compatible Sort

Unisys also supplies an IBM[®] compatible sort (SORT3). SORT3 is compatible with sort programs provided by IBM for its System/3, System/32, and System/34 data processing systems. SORT3 is an OS/3 program initiated through job control. This sort can process disk, diskette, or tape files, card input, and:

- Rearrange the records in a file
- Reformat the records in a file

IBM is a registered trademark of International Business Machines Corporation.

- Summarize fields in the records
- Select specific records from a file

SORT3 provides the following features:

- Displays messages both at workstations and on the printer
- Prints LBL information
- Provides keyword specifications for month, day and year
- Optimizes IRAM/MIRAM file handling
- Provides a maximum overflow field length of 256 bytes
- Supports 8470 disks

SORT3 performs three different types of sorts: full record sort, tag sort, and summary sort.

The output from the full record sort is a 10-byte (binary) relative record number of the records in the input file. The tag sort output is a file of sorted records that contains control fields and data, control fields only, or data only. The output of the summary sort can be any of the following:

- Control fields only
- Data fields only
- Summary data fields only
- Data fields and summary data fields
- Control fields and summary data fields
- Control fields, data fields, and summary data fields

3.3.6. Spooling and Job Accounting/Reporting

Spooling (simultaneous peripheral operations on line) is a technique that increases the throughput of System 80, models 10/20. Data from low-speed peripheral devices is transferred to disk storage independently of the program that uses the data. When a user program logically retrieves data from a low-speed peripheral, it physically retrieves the data from a higher speed device. On output, the user program logically specifies a low-speed device, but the images are physically recorded on disk storage, and are later transferred to a low-speed device under system control. Spooling of output allows concurrent use of a specified device by multiple programs. OS/3 spooling consists of these routines:

- Input readers - Input readers accept data files from local or remote subsystems. When these data files are used, the method of submission is not considered.
- Spooler cooperative - The spooler routine stores card data in the spool file until the data is required by a user program. Data output from a user program is stored by the spooler in the spool file until a printer or punch is available.
- Output writers - Output writers provide local or remote users with output from user programs that receive identical service regardless of final destination. In addition, the operator of the printer controls the following:
 - Forms recovery at page increments
 - The printed or punched order of the spool files
 - The number of copies
 - Rerouting of output to other devices
 - Retention of print or punch output in the spool file or on disk or diskette after processing
 - Starting and stopping

Spooling is supported for a printerless System 80, models 10/20. It generates printer files for subsequent printing on an OS/3 system that has a physical printer configured. Spool print files can be routed to auxiliary printers. These printers can be connected to a SVT1122 or a UTS 40D local workstation or to a UTS 400 terminal/workstation or SVT.

In a normal spooling operation, job accounting information is generated for each job run on the system. This information is included in the normal message output log, but the information is not saved. However, the user can save all the accounting data generated for each job in a spooling LOG file.

Here is how several active jobs use the concurrent spooling capability of OS/3:

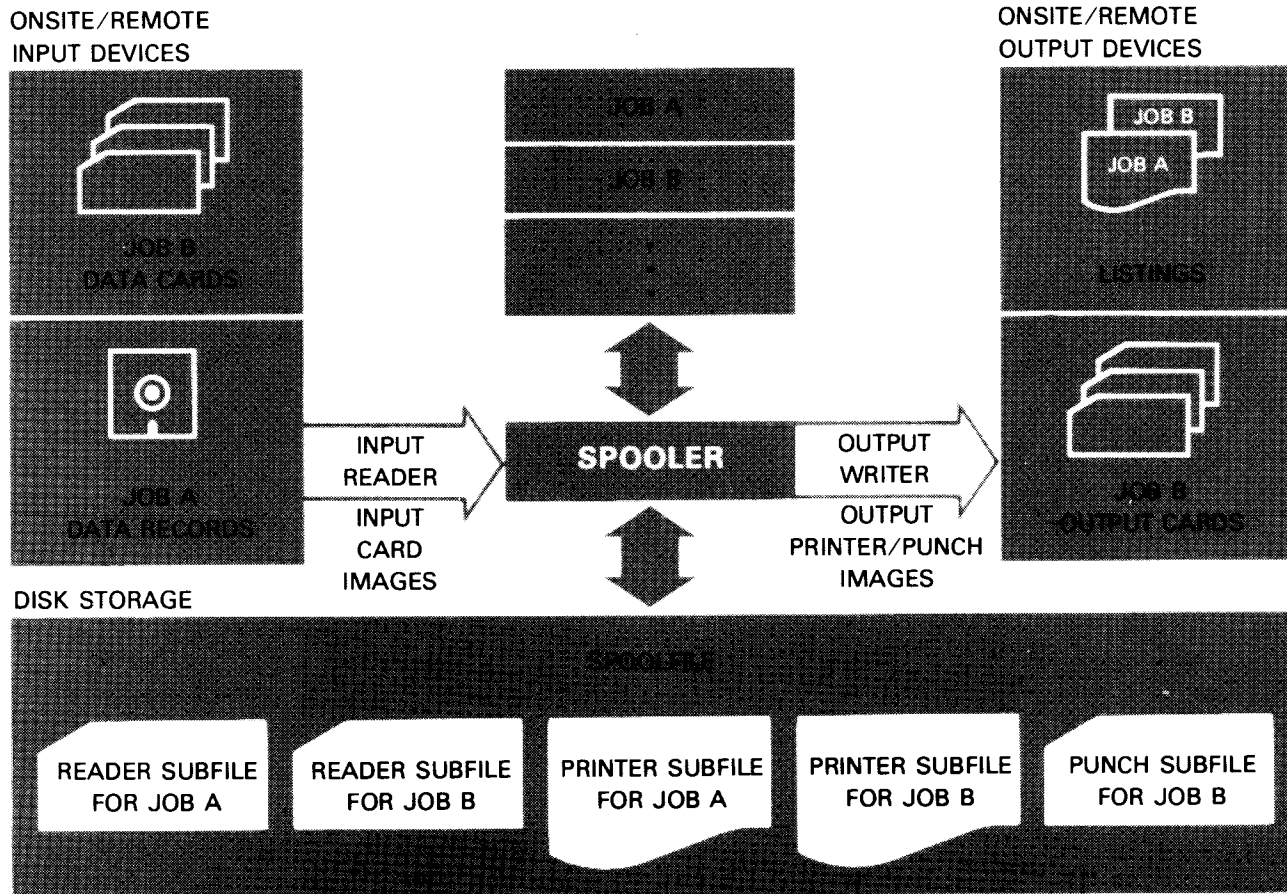

The system console and job log accounting utilities gather selected information from the system spool LOG file, sort the information according to user specifications, and produce a printed report. The system console and job log accounting utilities are:

- System log accumulation utility
- Joblog report program

The system log accumulation utility transfers all, or selected portions, of the spooling LOG file onto a disk or tape file for use as input to the system job log program or the user accounting routines. The system log accumulation routine is initiated by running a canned job control stream.

Once created, the file can be used by the joblog report program to create a printed report containing selected job accounting information. This program gathers information and sorts it according to user specifications. The joblog report program is also initiated by running a canned job control stream. The user selects the type of accounting records to include in the report and the manner in which they are sorted.

3.4. ADDITIONAL SOFTWARE

3.4.1 Menu Services

The menu services software supports menus to aid the user in data processing activities. Menus are screen displays that list, by number, the options available to the user, such as system programs, interactive commands, and other system activities.

OS/3 menu services consists of two components, the menu generator and the menu processor.

Menu Generator

The menu generator lets the user create, modify, and display menus. The user engages in a dialog to create the menu and the HELP screens for all or some of the items offered by the menu. The menus the user creates can execute programs and interactive services commands, can call other menus, and return constant data to a program.

Menu Processor

The menu processor retrieves and displays menus on workstation or terminal screens, handles user input from the menu, and arranges for program or command execution. The menu processor also keeps track of multiple menu sequences. The processor displays the menus in the order specified and responds to user commands to display other menus. Menu processing is available to user jobs through job control language or interactive services.

Using Menu Services

A Unisys system menu is shown in Figure 3-1. These menus give users lists of easily executed system programs and interactive services commands.

Enter the appropriate selection number to execute the corresponding option.

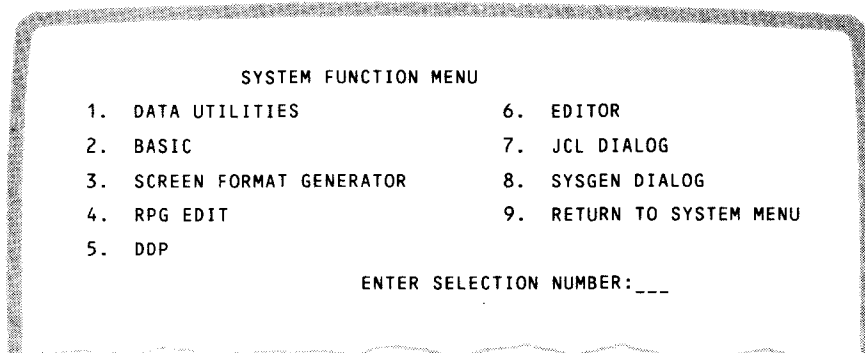

Figure 3-1. Menu Screen

Menus also provide on-line HELP screens that provide supplemental information regarding a menu option. Figure 3-2 shows a HELP screen explaining the programming language BASIC, one of the choices on the menu shown in Figure 3-1.

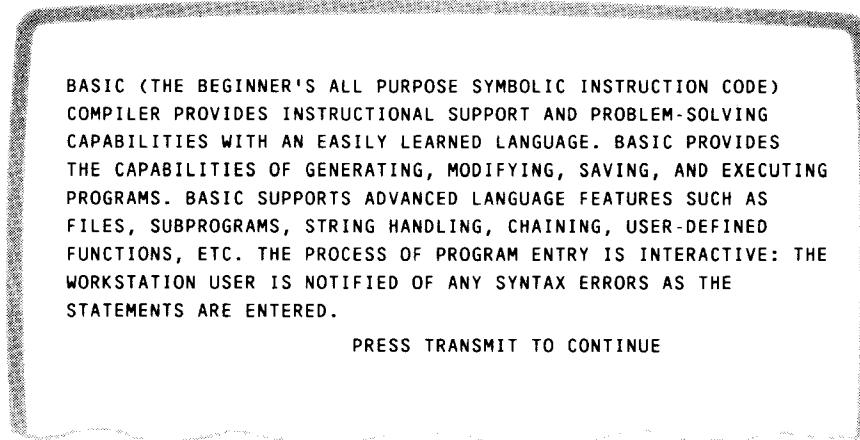
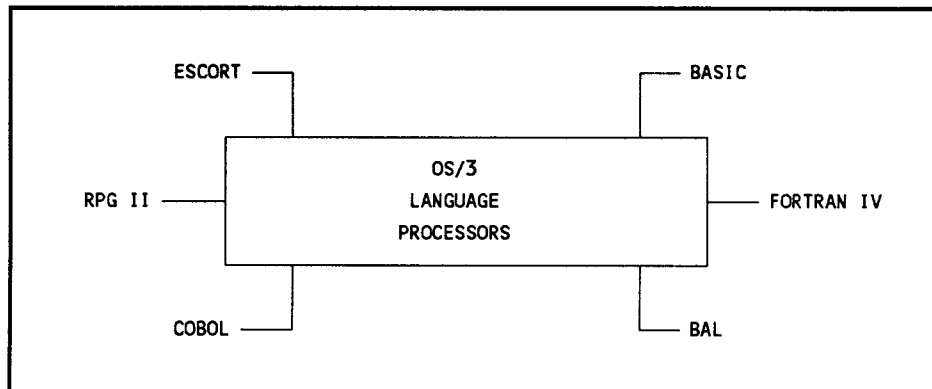

Figure 3-2. HELP Screen

3.4.2. Language Processors

Six language processors provide flexibility in preparing programs for use with OS/3:



ESCORT

ESCORT is a high-level, interactive programming language used to generate file processing, data handling programs, and report generation. It is easy to use, requires minimal training, yet has the power of more complex data handling languages. The ESCORT language uses English verbs and clauses to express programming operations. Thus, even a programming novice can quickly begin producing useful programs.

Here is a typical ESCORT screen display:

```
CHANGE DATA STATEMENT
CHANGE DATA OF file-m (structure-m) (FROM {file-i (structure-i)
                                           {WS (structure-i)
                                           WS (structure-i,formname)}})
FROM clause, structure-names and formname ARE OPTIONAL PARAMETERS
file-m IS NAME OF DATA FILE BEING CHANGED
file-i IS NAME OF FILE CONTAINING CHANGE CRITERIA
IF WORKSTATION IS USED AS CHANGE CRITERIA DEVICE, THEN
KEYIN WS FOR file-i parameter
KEYIN PARAMETERS
file-m----- structure-m-----
file-i----- structure-i----- formname-----
```

An ESCORT program creates, sorts, or merges files; adds, deletes, sorts, or replaces records within a file; updates selected records from a workstation; issues prompting messages to a workstation for input data; and validates the input data. Computational operations available include addition, subtraction, multiplication, division, and modulo, a division operation in which the result is the remainder only.

ESCORT programming sessions are conducted directly at the workstation. Jobs and programs are initiated from the ESCORT call. The ESCORT compiler uses prompting messages for data entry. The amount of prompting used depends on the programming expertise of the user.

The novice can conduct a session in interactive tutorial mode that creates an ESCORT program using a question-and-answer technique. HELP displays explain various choices offered by the question-and-answer display screens. In tutorial mode, the full ESCORT set of string relational operators is enabled. Each menu has a default option and programs can be saved without exiting the session.

The experienced user can use the interactive program mode to create ESCORT programs faster, with less prompting. Program mode is used in two ways.

- To create programs by filling in the blanks on menu screens displayed by ESCORT
- To enter ESCORT statements directly onto a blank screen

Direct entry is the quickest way to create an ESCORT program. The compiler offers immediate syntax checking of ESCORT statements and sends messages when it detects errors. These errors can be corrected immediately through the workstation.

ESCORT uses the common data interface for data transfers. All data files are MIRAM files. In addition, field names and attributes for the records within a file are contained in control data for the file. The programmer does not need to know detailed data descriptions for existing files and can concentrate more fully on how to solve the problem. ESCORT data files can be protected by requiring read and write passwords specified by the users.

The ESCORT report system lets the user create, modify, display, and print reports. The functions of the ESCORT report system are as follows:

- Multiple formats for displaying data records
- Searching and updating data
- Entering and saving data
- User-defined headers and titles
- Totaling, subtotaling, and averaging of data
- Arithmetic computations on each line of data

RPG II

The OS/3 report program generator (RPG II) is a processing language that generates an object program from a series of interrelated specifications. RPG II provides the basic logic of the program with the RPG II cycle. Through the various RPG II specifications forms, the user can define records and indicate the operations to be performed on these records.

To define a report program for generation, the requirements are listed by the programmer on specifications forms. The information coded on these forms becomes the input to the RPG II compiler. The compiler generates an object module for input into the linkage editor. The subsequent output is a loadable program module. The user can display the RPG II formats on the workstation screen and complete the proper entries. Users can also enter unformatted RPG II source statements.

Enhancements let the user develop more sophisticated report programs within the existing framework of the language. These enhancements are as follows:

- Telecommunications interfaces, supplied through an RPG II specifications form, that offer extensive communication capabilities to the RPG II user
- Eight control-stream user switches (indicators) that condition calculations, input files, output files, or specific output records
- IMS action programs written in RPG II
- Workstations that are accessible through programmed operations

- MIRAM file support for single key and multikey files
- Error diagnostic messages that can optionally be written by the RPG II compiler to a module accessed by the Editor's error file processor
- Specification of the currency sign (Japanese or other type) used in place of the dollar sign in edit words on the Control Specification
- Testing the processing of screen formats through the RPG II indicator table. Also, indicators, set on when the workstation function keys are pressed, are added to the RPG II language.
- Data structures that allow multiple definitions of internal data, subdivision of data files, and grouping of fields
- The handling of multiple workstations and workstation error processing

Unisys offers two facilities to simplify RPG II source program entry:

- RPG II editor
- Auto report facility

The RPG II editor is an extension of the general editor and is used specifically to create and maintain RPG II source programs. The RPG II editor is initiated at the workstation and provides a number of ways for the user to enter and update the source programs. The experienced RPG II user can enter the source statements in a free-form format. The less experienced programmer can use the positional format which numbers the columns to be completed. The novice can use the simplified specification format, which is the standard RPG II specifications format displayed with detailed explanations of all possible entries and their uses. The source generated programs can be stored in a program library chosen by the user and redisplayed in any format for updating.

The RPG II editor accepts and processes the following types of source statements:

- Standard RPG II source statements
- Auto report statements
- Multikey file description specification statements
- Currency sign on control specification statements
- Data structure statements
- /EJECT, /SPACE, and /TITLE statements
- SHTDN (shutdown) and NEXT operation codes.

The RPG II auto report facility accepts simplified specifications and standard RPG II source statements and generates a complete RPG II source program. Auto Report supports the ERRFIL parameter to create an error file module during its process. This module is then accessible to the interactive workstation through the editor's error file processor.

COBOL

COBOL is a programming language oriented toward problems in business applications. The language is similar to the English language, rather than a form of notation that considers the technical aspects of a particular data processing system. The source programs are easily transferable among systems that accept *American National Standard COBOL, X3.23-1974*. These systems have a COBOL compiler that translates the COBOL source program into a machine-oriented object program. The ability to advance from one generation of equipment to another in a logical, orderly, and rapid manner is assured through this limited machine dependence. ANSI-1974 COBOL supports workstation files, function keys, indicator bytes and error status checking. System 80, models 10/20 hardware also supports *American National Standard-1968 COBOL (BASIC AND EXTENDED)*. However, CDM, MIRAM files and workstations are not supported under ANSI-1968 COBOL.

COBOL Divisions

Source programs written in COBOL consist of four major divisions:

- Identification division - contains information identifying the source program and the output of a compilation; the author and installation can also be identified.
- Environment division - specifies the physical characteristics of a system, the compiling system hardware characteristics, and input/output control techniques.
- Data division - describes the data that the object program:
 - Accepts as input
 - Manipulates
 - Creates
 - Produces as output

The data division is further divided into sections that describe data contained in input or output files or data developed during the program, or present as constant information to be used in the object program.

- Procedure division - describes the logical steps that must be taken in the solution of the data processing problem.

ANSI '74 COBOL Editor

The ANSI '74 COBOL Editor helps the programmer create and maintain ANSI '74 COBOL source statements through the following:

- Providing COBOL statement prompt screens at the workstations for the novice programmer
- Creating COBOL source statements and transmitting them to the general purpose editor (EDT) to add to the source file in the EDT work space

- Providing procedure verb syntax
- Allowing full access to the general purpose editor and its commands
- Displaying messages that describe errors found in user-entered data and indicating the erroneous data by blinking the field on the screen

BASIC _____

BASIC language is an interactive programming language that meets the requirements of both business and scientific programming. The BASIC language available on the OS/3 operating system complies with the *American National Standard Minimal BASIC, X3.60-1978* and includes Dartmouth features and compatibility. It has a powerful set of commands that allow the novice to learn the language quickly, yet gives the experienced programmer an extensive list of features for various applications.

BASIC source statements entered directly at the screen are checked for syntax errors as they are entered. A message appears on the screen if a line is in error. Also, BASIC source programs can be compiled directly at the workstation and errors corrected immediately. During an interactive BASIC session, users can input, modify, execute, and save programs.

The OS/3 BASIC compiler can perform arithmetic operations, data file processing, matrix generation and processing, and logical operations. Subroutines and string operations can be used in a BASIC program.

FORTRAN IV _____

FORTRAN IV is a programming language designed to perform mathematical computations required to solve engineering and scientific problems. FORTRAN IV is also useful for many nonscientific data processing applications.

FORTRAN IV can express an algorithm in a natural way. The user requires minimal understanding of the system in which the program is executed. FORTRAN IV can reference procedures written in another language by name and make them an explicit part of the program.

FORTRAN IV is a proper superset of the *American National Standard FORTRAN, X3.10-1966*. It is also a compatible superset of the IBM/DOS 360 FORTRAN IV. This system features code optimization, high-performance I/O, and extended functional capability.

FORTRAN IV generates a formatted error file module for the interactive error file processor. The user can specify the library file and element name where the error file is written.

Basic Assembly Language (BAL) _____

BAL is a versatile and detailed symbolic language combining a macro facility with the ability to handle procedural directives. Each instruction within the language is assigned a mnemonic to denote the particular hardware function performed.

The assembler recognizes a set of directives used to direct operations. These directives control program sectioning, base register assignment, the format of the output listing, sequence checking, and other auxiliary functions.

The assembler includes a macro facility that reduces the effort required to write patterns of coding, either repeated in one program or common among several programs. The macro facility allows a macro to be written so that the pattern of coding generated can vary widely, depending upon the parameters supplied with the call. Macro definitions are specified in two formats: macro and proc. The elements of each format type can not be mixed within a definition; however, definitions of both types are permitted within a program.

Output from the assembler run consists of a complete listing of symbolic coding, generated object coding, diagnostic messages, and a cross-reference listing. A relocatable object module is produced that can link to other modules before it is loaded for subsequent execution.

3.4.3. Interactive Services

Interactive services (IS) offers a number of interactive programming features, all initiated and controlled through the workstation. They allow for decentralization of system operation, interactive program development and execution, and the initiation of system utilities. IS offers these features and benefits:

- Enhanced productivity - More extensive system usage through faster response time and simplified data entry and retrieval methods.
- Easy access - Allows every authorized member of an organization to access the system through easy-to-use facilities.
- Security - Maintains a high degree of security through protective passwords and user identification features.
- Simplified programming - Simplifies the entire programming effort by providing interactive communication to the system control software.
- Interactive access - Allows entry of variable data into jobs currently running in the system.
- Help for novice programmers - Assists novice programmers in building a valid job control stream through a job control dialog.
- Help for operators - Assists operators in system generation by soliciting SYSGEN parameters through a SYSGEN dialog. A data utilities dialog similarly prompts the operator or programmer to perform system utilities.
- Screen formats - Lets programmers and other personnel create fill-in-the blank screens to input, maintain, and display data.
- Multijobbing - Supports 48 jobs slots, of which 47 are available for user jobs and 1 for IS.

3.4.4. The General Editor

The Unisys OS/3 General Editor, commonly known as EDT, is a user-oriented interactive program that lets the user:

- Create and update library modules, data, and text files from a workstation
- Interactively create and update source programs, job control streams, and data files
- Copy, delete, and concatenate files
- Create and call procedures

The general editor offers the following versatile features:

- Command language - EDT provides an easy-to-learn interactive command language.
- Procedure files - EDT lets you divide the EDT work-space file into a maximum of ten subfiles (procedure files) consisting of a main work file and nine other procedure files. EDT procedure files are basically like the main work file; they consist of data and/or EDT commands. However, unlike the main work file, EDT procedure files can be executed. The commands or data entered in them can be executed against the main work file or any of the other defined procedure files.
- Subeditors - Two subeditors, the RPG editor and the COBOL editor, provide syntax checking on source entry for the RPG and COBOL languages. Source entry is through the general editor. Source entry without syntax checking is available directly through EDT screen mode.

Screen commands let the user perform the following functions:

- Enter multiple commands and data
- Request help with EDT error messages
- View and update the EDT environment parameters
- Display the EDT commands and their HELP screens
- Return to the EDT session from a screen command
- View and update lines

The editor has file protection facilities that prevent a file from being inadvertently destroyed or incorrectly altered, either by direct action of the user or through some system failure.

The general editor operates in two modes: line mode and screen mode. Each mode offers the user full editorial functions.

- Line mode - the user creates or edits material one line at a time. After each line is created or edited, the user transmits the line of information to the editor, which places that line in a work file created for that session of editorial use. Lines of material, displayed to the user one at a time, roll up the screen as more lines are created or edited.
- Screen mode - the user can enter from 1 to 14 lines at a time while using special formatted screen displays to enter source programs in the COBOL, FORTRAN, and RPG II programming languages. The user can also use a free-form screen display. The free-form display provides tabs, set for uniform entry of data or used to code assembly language programs. The free-form display also lets the user create data files without running a user or system program, simplifying the process of bulk data entry.

The general editor offers another aid to creating programs, the error file processor (EFP). The EFP lets the user display source program errors on the workstation screen immediately after compiling a program. The errors can be corrected using the general editor without waiting for a printout of the compiler error listing.

The EFP reads an error file during program compilation. It also reads the file where the user's source program is stored. It then displays each error message with the line or lines of source code where the error was found. The user can see the mistakes and quickly correct them by using the general editor.

3.4.5. Integrated Communications Access Method (ICAM)

The integrated communications access method (ICAM) is designed for the casual as well as the professional real-time communications user. A wide range of system options provides support for users committed to a real-time multijobbing environment without penalizing those whose needs are more modest. ICAM is available for workstation support as well as for terminals supported over a communication line through the ICAM Terminal Support Facility.

ICAM Features

ICAM offers the communications user these features:

- Message queueing - Message queueing stacks complete messages in main or disk storage while they wait to be serviced by a remote device handler or a message processing program. A single message queue consists of one or more messages with their header segments linked together. The message text that overflows the header segments is contained in additional segments that have secondary links out of the header segment. A network contains one or more message queues associated with lines, terminals, process files, or program-related queues called local application files (LOCAPs).

A user can select line or terminal message queueing to define the network configuration. Terminal queueing results in defining a single queue for each terminal on a communications line. Line queueing results in defining a single queue for all terminals associated with a line.

- Multiple destination routing - ICAM supports multiple routing of messages. A single message can be routed to up to 255 destinations. The message is released from its queue only when all deliveries have been made. The user must ensure that the message text sent to each device is appropriate to the particular device.
- Activity scheduling and priority control - The ICAM activity scheduling routine gives the user optional priority suspension and scheduling services. Small systems that do not require suspension capability can have only a single level of scheduling. Large systems with critical timing requirements are provided with multiple-priority-level scheduling and suspension capability.
- Timer service - ICAM provides a centralized timing service to control active data buffers and to schedule activities used by all ICAM software elements. The timer service also lets the user specify the time interval for polling communication devices.
- Checkpoint/restart - Restart procedures can reconstruct message queues to their status at the point of system hardware or software failure. The reconstruction involves only complete messages; incomplete messages must be reprocessed after the recovery operation. Status messages are transmitted to remote terminals to effect an orderly restart and provide assurance that messages are not lost in the system. Restart is supported only in conjunction with a checkpoint and journaling feature. Checkpoint results in the complete network definition being written on a tape or disk file.
- Journal control - Journal files are required when an ICAM user needs recovery/restart capability, or when a statistical accounting of the network operation is required. The journal control routine records message processing events and message data on a disk or magnetic tape file. To reduce the number of I/O accesses required, each journal entry is transferred into a larger buffer area for staging prior to being written on the output device.
- Statistics accumulation - ICAM maintains statistics that reflect the operating status of the communications environment. These statistics are maintained by line and by terminal and are available to a user program upon request. The accumulation contains totals for types of information, such as the number of:
 - Messages received
 - Output transmission requests
 - Input retransmission requests
 - Poll messages
 - Messages transmitted
 - No-traffic responses

These statistics are maintained in the network definition and provide the user with information not generally available from journal files.

- Public Data Network Support - ICAM supports the following public data networks:

SWITCHING	NETWORK NAME	LOCATION
Packet	DATEX-P	W. Germany
Packet	DATAPAC	Canada
Packet	TRANSPAC	France
Packet	PSS	Great Britain
Packet	IBERPAC	Spain
Circuit	NORDIC	Sweden, Denmark, Finland, and Norway
Circuit	DATEX-L	W. Germany

- Trace facility - The user initiates the ICAM trace facility through the console, defines the items to be traced, and specifies the number of events to be traced. The trace facility:
 - Gives the user run-time control over the ICAM event recording mechanism
 - Reduces the amount of main storage permanently dedicated to tracing
 - Increases the number of events being traced
 - Provides a single-trace recording for ICAM

In addition, the trace facility:

- Writes trace entries to disk and spools them automatically
- Prints snapshots of trace buffers
- Inhibits overwriting of trace area in main storage
- Pauses and resumes trace
- Traces individual lines

- Dynamic buffer expansion - ICAM automatically acquires additional network buffers as the need for more buffers increases. The user is not required to respecify the amount of buffer space needed.

At system generation time, the user can choose the level of support needed to meet the site requirements. Levels of support are arranged by combining the appropriate ICAM library elements. The levels are named for the interface between the user's message processing program and the ICAM modules combined into a loadable software module. Each interface contains its own unique set of macroinstructions.

- Autodialing - ICAM supports autodialing through a single line communications adapter (SLCA). One SLCA AUTODIALER can serve three ACUs and three associated data lines. Circuit switching also supports the autodialing capability of the SLCA.

ICAM Components

- Channel control routine (CCR) - CCR provides the physical input/output interface to single line communications adapters (SLCA) and the specific type of communications subsystems.
- Remote device handlers (RDH) - Remote device handlers provide the software logic and control required to interface the unique characteristics of specific remote devices to the other ICAM components.

RDHs are available to accommodate a wide range of terminal equipment, including the following Unisys equipment:

- Local (for IMS) and remote System 80, models 10/20 workstations
- UNISCOPE[®] 100 and 200 Display Terminals
- UTS 400 Universal Terminal System
- UTS 20, UTS 30, and UTS 40 Universal Terminal System
- SVT 1123/1124
- Unisys PCs
- UNIX (5000) UNISCOPE emulator
- MAPPER 5
- IBM 3270

UNISCOPE is a registered trademark of Unisys Corporation.

- TELETYPE[®] teletypewriter models 33, 35, 37 and 38
- Binary synchronous communications procedures are also supported.

Remote device handlers provide all device-dependent functions that are required to permit other ICAM components to function independently of the terminal device. These device-dependent functions include the following:

- Station and device polling where applicable
 - Error detection and correction
 - Code translation
 - Accumulation of operation statistics
 - Compression and decompression of data where necessary
- Communications network controller (CNC) - CNC coordinates message flow between the remote device handlers and either main storage or a disk-based message queue. CNC is the ICAM component that places incoming messages on the appropriate processing queues or submits them to special system functions for disposal. CNC also detects a message on an outgoing (destination) queue and provides the orderly transmission of that message.

The following additional functions are performed, directly or indirectly, by the CNC:

- Ability to dynamically modify a network in a changing operating environment
 - Monitoring the orderly shutdown of ICAM during end-of-job processing (this service is extended to both ICAM and user programs)
 - Scheduling the message user service transcriber (MUST) routines when new activity is detected and there is an outstanding request waiting
- Distributed communications architecture termination system (DCA TS) - DCA TS coordinates the flow of messages between local and remote message queues. DCA TS places incoming messages in appropriate message queues or submits them to special system functions for processing. It manages outgoing message queues. The DCA TS also protects messages from being lost when communications links break down, and provides data throttling and recovery services.

TELETYPE is a registered trademark of the Teletype Corporation.

ICAM DCA TS supports these remote workstations:

- UTS 20, UTS 30, and UTS 40 terminals operating as local workstations
- SVT 1123/1124 terminals
- Unisys PCs

The remote workstation can be used as a workstation connected to OS/3, or as a workstation or terminal connected to an ICAM end user.

ICAM also supports the DCP 10A, DCP 20, and DCP 40 running TELCON as remote DCA termination systems, allowing the user to function in several modes.

- Communications control area (CCA) - A CCA contains all the tables required to define and control a specific network configuration. CCAs can be tailored to specific needs.

ICAM controls a network by setting indicators and flags in the line, terminal, and queue tables within the CCA. These flags control polling, indicate the operational status of communications hardware, and reflect the current disposition of message queues.

Each CCA contains a pool of network buffers that are under the control of ICAM. Incoming and outgoing messages are temporarily staged in these network buffers during their active transition through the system. Buffers from this pool provide the base when main storage queueing is specified. When disk storage queueing is specified, these network buffers provide intermediate storage during the active input or transmit phase of a message.

- Message user service task (MUST) - The MUST routine provides a message staging service that isolates a message processing program from device dependence. MUST copies input message data from the network buffer pool into designated work areas. It also copies output message data into the network buffers.

Variations of a MUST routine provide support for specific user program interfaces, such as remote batch processor (RBP), RPG II, and IMS. The MUST routine isolates these functions from the CNC and device handlers, obtaining the maximum commonality of ICAM components.

- Deferred user service task (DUST) - The deferred user service task component is a series of ICAM overlays performing functions that are neither time-dependent nor used frequently.

DUST performs the following functions:

- | | |
|-------------------------------|-------------------------------------|
| - ICAM initialization | - Line connect and autodialing |
| - Network initialization | - Program termination |
| - Subsystem parameter loading | - System console message processing |

- Global user service task (GUST) - GUST allows the formation of a global, or nondedicated, communications network which permits several user programs to be accessed concurrently. The GUST routine controls network and line requests, and releases, in a global environment.

ICAM Interfaces

In addition to providing a communications interface between a terminal network and System 80, models 10/20, ICAM also supports the following interfaces:

- Standard message control program interface (STDMCP) - The standard message control program interface is a conventional GET/PUT interface for communications that queues input and output messages in network buffers automatically. In this interface, the processing program requests data from a process file or input queue and not directly from the line. Conversely, output is placed in a destination queue or output queue for transmission by ICAM. An extended set of macroinstructions, known as message processing procedure specifications (MPPS), are optionally available to this interface for additional processing of messages.
- Transaction control interface (TCI) - The transaction control interface provides the communications facilities needed by the information management system (IMS). TCI is available only to IMS. After defining the communications network, TCI's operation is completely transparent to the IMS user.
- RPG II telecommunications - RPG II users are provided with a simplified remote I/O capability through RPG II telecommunications and the ICAM direct data interface. Support for RPG II telecommunications is extended to all the devices already listed under remote device handlers, as well as the IBM System/3, the IBM System 360/20 (BSCA equipped), and the IBM System 360 (with OS or DOS BTAM binary synchronous communications support).
- COBOL message control system (CMCS) - Users can write COBOL programs that access and use the resources of their ICAM system. COBOL programs interface with ICAM through the COBOL message control system (CMCS) which handles the flow of control information and data between COBOL programs and ICAM. CMCS translates the COBOL communications verbs into ICAM instructions and translates ICAM error and status conditions into COBOL format. CMCS accesses ICAM through the standard interface. Message processing procedure specification features are included in COBOL communications programs.
- Remote batch processing (RBP) - ICAM provides an RBP capability that permits entry of jobs into the computer system from a variety of remote terminal devices. The software components that perform the RBP functions operate as system tasks and are referred to as symbionts.

These symbionts can be configured as input only, output only, or input and output. Remote symbionts can be loaded and initialized manually through the system console, or they can be processed automatically in response to a call from a remote station. An instruction set is available to send job requests, activate workstations, defer processing, obtain status, and deactivate workstations.

- **UNIX remote job entry** - The UNIX operating system can initiate an OS/3 jobstream through the 2780/3780 emulator and send output to a connected printer.
- **OS/3 to UNIX pass thru mode support** - Permits a local workstation or terminal user connected to the System 80, models 10/20 to run UNIX commands or application programs as if the terminal were connected directly to a UNIX system.
- **IBM 3270 emulator** - The IBM 3270 emulator lets the user connect the System 80, models 10/20 to an IBM host system. System 80, models 10/20 workstation users can access IBM applications and program products running on an IBM host by emulating a 3270 information display system. The 3270 emulator:
 - Acts as an IBM 3271 control unit, providing communication between System 80, models 10/20 and the IBM host system
 - Supports both user programs and System 80, models 10/20 local workstations
- **Remote terminal processor (RTP)** - The remote terminal processor permits a System 80, models 10/20 to act as a remote job entry terminal to one or more IBM host processors. RTP lets System 80, models 10/20 send jobs to an IBM host, send and receive files on tape, diskette, or punched cards, and communicate with the host processor by using binary synchronous communications (BSC) lines.

RTP simulates an IBM multileaving workstation by using the Houston automatic spooling program (HASP) protocol through BSC facilities. RTP functions include the following:

- Communication data compression/expansion
- Multileaving of job streams
- Interleaving of data and acknowledgment messages
- EBCDIC transparent and ASCII modes
- Use of OS/3 spooling facilities
- Individual activation/deactivation
- Control of the BSC communications links

RTP interfaces with the following IBM software systems:

- Job Entry System 2 (JES2)
- Job Entry System 3 (JES3)
- Asymmetric multiprocessing system (ASP)
- Houston automatic spooling program (HASP)

- Demand mode interface (DMI) - DMI provides improved network status reporting, completion threshold processing, and the capability to stage both input and output messages in more than one buffer (data chaining). This is a system interface for interactive services and DDP, and is transparent to the user.

NTR System Utility

The nine thousand remote (NTR) system utility makes System 80, models 10/20 act as a remote terminal to a Unisys Series 1100 system. The NTR is a combination system utility and job task that can run concurrently with other job tasks. It uses a modified version of the direct data interface. NTR provides data transmission control, operator-to-operator communications, and control features for status and command functions between both systems. The NTR utility controls local input and output tasks through a combination of data management macroinstructions and a set of special NTR macroinstructions for user code control of device buffers.

3.4.6. Information Management System

Unisys information management system is a transaction-oriented processing system. Each time the user enters an input message, such as a transaction code, applications programs (called action programs) process the input message, access data files, and provide an output message response to the terminal. IMS operates in a multithread environment where IMS actions from several terminals are processed concurrently. The action program that processes the input message can be written by the user or provided by IMS.

Action Definition

The entire process, from entering an input message to the completion of the programming function, is called an action. An action is the basic unit of work in IMS. One or more actions comprise a transaction. When one action accomplishes a task, it is called a simple transaction. A sequence of two or more actions that are needed to complete a task is called a dialog transaction. In a dialog transaction, the first action program tells IMS the name of the action program that processes the second message.

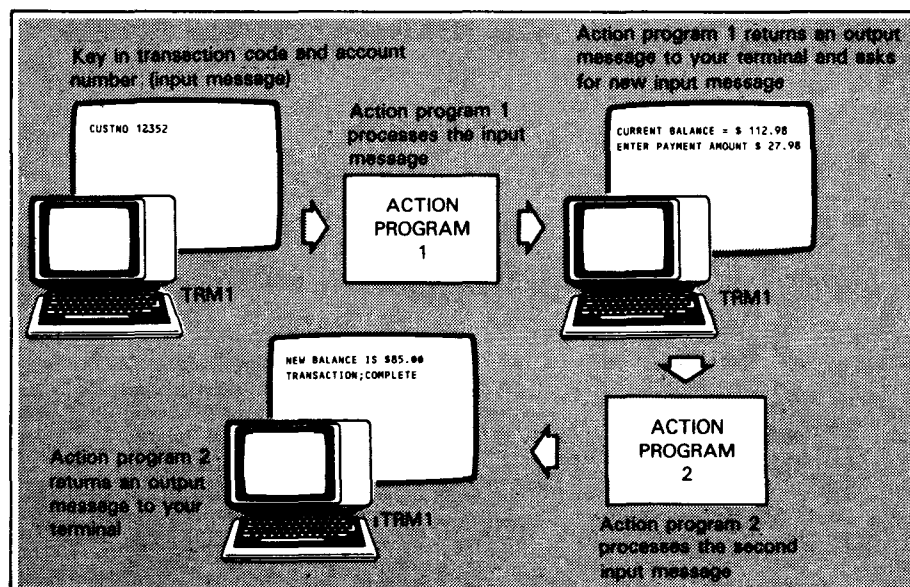

IMS File Processing Package - UNIQUE

IMS supplies a set of action programs called the uniform inquiry update element, (UNIQUE) that lets the user access, retrieve and update his files. UNIQUE also lets the user calculate statistics on those files.

To use UNIQUE, the user first creates defined files from elements of existing files using an IMS utility called the data definition processor. A password is defined in the data definition that lets the user access a defined file. The password is the same as the defined file name, and all configured terminals can use it.

User-Written Action Programs

IMS also supports user-written action programs in BAL, COBOL, and RPG II. Action programs operate under the control of IMS and access files through IMS. Programming is simplified because IMS handles all communications and file I/O functions. IMS software allocates resources, and schedules action programs to process each transaction.

Both UNIQUE and user-written action programs can access defined files that derive from DMS data base records.

Configuring an IMS system

To create an IMS system in a configuration process, you must define the communications network, user files, action programs, and optional IMS features. Any number of different IMS load modules can be configured. This lets the user tailor each on-line IMS system to a specific application and conserve main storage. The configuration process is simplified by an IMS configuration job control procedure and by the use of default parameters.

IMS Advanced Interface Capabilities

- **IMS/CDM** - IMS, in consolidated data management (CDM) mode, lets action programs access records in a DMS data base. IMS loads fixed and variable MIRAM files into a common storage area during start-up. This eliminates disk reads and writes whenever action programs access records in these files.

IMS multithread can be configured to support CDM or data transfer facility.

- **IMS/ICAM** - ICAM presentation services is a group of modules that build a chain of linked buffers for holding messages at the ICAM remote workstation. This enables ICAM to use its resources more efficiently. Use this facility when you have a remote workstation with a data mode session to IMS.
- **IMS/DMS** - IMS action programs can concurrently access DMS data bases through data manipulation statements embedded in COBOL action programs. DMS modules support 48 jobs slots.
- **IMS/DDP** - In a multithread environment, IMS/DDP gives the user flexibility in the design of transaction routing to the directory, to action programs, and to the operator.

Advanced IMS Capabilities

- **Interactive commands** - Assist with the administrative and operational aspects of IMS. A user can control processing by designating a master terminal to control the processing activity of the entire network through a master terminal command set.
- **Language section** - Allows the user to define a command set for use with UNIQUE. Non-English commands, abbreviated commands, or business-oriented terms are examples of the types of command sets that can be defined.
- **Multi-key support** - IMS supports multi-key, duplicate key, and key change features to MIRAM files during operation in the CDM environment. This lets the user retrieve records from an indexed MIRAM file by using any key of reference. Deletion of records through CDM is also provided for MIRAM files containing single or multi-key records.
- **Statistical reporting** - Statistics such as the total number of file accesses on a transaction basis, terminal statistics on an IMS session basis, and the number of input and output messages per transaction are available.
- **Multijobbing** - IMS can run in a multijobbing environment because IMS executes as a program under control of OS/3.
- **Dynamic storage allocation** - For both single-thread and multithread versions, IMS online provides dynamic main storage allocation at action scheduling time. This lets the user modify the size of an action program without reconfiguring it.
- **Reliability** - IMS provides extensive features to prevent accidental alteration or destruction of data files. Record locking and recovery facilities are also provided.

3.4.7. Data Base Management System

The data base management system (DMS) accesses and controls data bases stored on direct access devices. There are two main areas of responsibility in DMS:

- **Data base administration (DBA)** - The DBA is responsible for the following:
 - Defining data structures (logical and physical) and choosing access methods
 - Monitoring system performance
 - Reorganizing the data base as needed to improve system performance
 - Operating DMS utilities to maintain a stable data base
 - Start-up/shutdown of the DMS job
- **Data base application** - The applications programmer is responsible for writing COBOL/data manipulation language (DML) programs using a defined data base structure to interface with the data base.

DMS Components

DMS consists of the following components:

- Four language processors:
 - Device media control language processor (DMCLP)
 - Schema processor (SCHMAP)
 - Subschema processor (SUBSP)
 - Data manipulation language preprocessor (DMLP)
- The data base management system (DBMS) run-time software component
- System support modules that include utility processors, library files, and procedure files

Data Base Languages

- Device media control language (DMCL) - Defines physical characteristics of a user data base and data dictionary. DMCL is the source input for the DMCLP.
- Data description language (DDL) - Develops a schema to describe the logical structure of the data base, and subschemas to describe data base subsets that relate to specific applications. A DMS data dictionary can contain more than one schema and its related network. DDL is the source input for the SCHMAP and SUBSP.

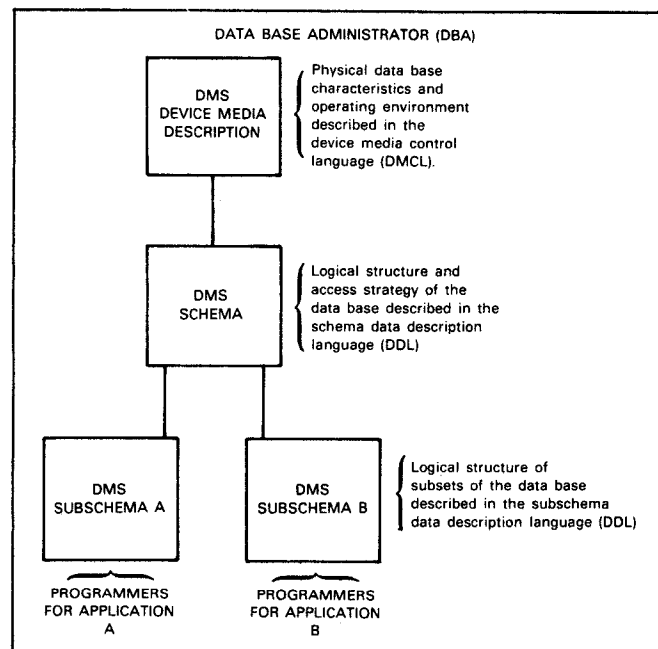

User's View of a DMS Data Base

The data dictionary is the data base used by DMS language processors. Two languages are available to access the data base:

- Data manipulation language (DML) - Statements are included within conventional COBOL Procedure Division statements for batch processing.
- Conversational data base manipulation language (CDML) - Assists the DMS user in accessing a data base. The programmer does not need to prepare, preprocess, compile, or link programs; it is all done by CDML.

Run-Time Software

The DMS data base management system (DBMS) is the main set of routines that actually performs the functions requested by a run unit (either a DMS processor or a user application program). It retrieves and updates data base records conforming to the user-defined data bases and creates a journal file for use in offline manual recovery.

The DBMS is a single reentrant run-time component running as a privileged job under OS/3.

System Support Functions

The system support functions create, establish, and maintain a data base. There are three categories of system support functions:

- Configuration function - Creates an installation version of DMS that fulfills specific processing requirements.
- System generation function - Creates and initializes a data dictionary and a data base description.
- System maintenance function - Is a recovery-related utility processor. The DMS Utility Processor Language (DUPL) lets the user specify the utility functions to be performed, and the portion of the data base they operate upon. DMS recovery utility functions include the following:
 - Journaling, which saves images of a data base for recovery
 - Security dumping, which reconstructs a data base in case of damage or corruption
 - Automatic and manual recovery methods
 - DBA processors that print reports and statistics. They help you to monitor and maintain a stable data base. A DBA processor comprises include a data base page dump (DBPAG), a journal file audit utility (JFAUD), and numeric field parameters.

DMS System Limits

The following table lists the minimum and maximum limits that apply to a DMS independent system:

DMS System Limits

Function	Minimum	Maximum
Number of files	1	35
Number of areas	1	246
Number of data base buffers	3	255
Number of space inventory buffers	1	255
Number of pages per data base	1	8,388,607
Number of pages per file	1	8,388,607
Number of pages per area	1	8,388,607
Number of sets per record	0	999
Number of record types	1	9900
Number of records per data page	0	255
Page size	2,048	32,768
Logical key size	1	256

Advanced DMS Capabilities

- A programmer can exclusively lock a record as soon as it is retrieved to prevent record update conflicts.
- The action program can test the availability of a data base record before retrieving it. If the record is not available, a minor end is returned rather than a fatal thread cancellation.
- The user can sequentially process the same data base using two or more DMCLs.
- DBPAG prints a compromised data base page instead of terminating with an error message. This allows analysis of hardware or software problems suspected of causing the compromises.
- 32 index keys per record are allowed.

- The user can specify a unique journal file for each data base. This allows concurrent operation of journaling and use of multiple data bases that have different page sizes.
- Disk journal files can be extended over more than one DBMS session.
- DMS can restore a MIRAM file that is accidentally initialized.
- The user can obtain a system dump when an unexpected data management error occurs.
- The DBMS log records the activity of the DBMS.
- DBMON provides a *window* into the DBMS run time component during execution through 12 monitor screens. Data on the monitor screens allow the user to analyze and improve DBMS performance.

3.4.8. Distributed Data Processing

OS/3 distributed data processing lets the user:

- Distribute files between remote data processing systems
- Engage those systems to cooperatively process jobs
- Access files and other programs on remote systems
- Perform transaction processing between remote systems

These functions are accomplished through three software packages:

- DDP transfer facility
- DDP file access
- IMS-DDP transaction facility

DDP Transfer Facility

The DDP transfer facility lets the user view each system in the DDP network as an available resource for scheduling and executing his work. Using simple commands, the user can initiate job distribution and file transfer within the system without concern for the requirements of the hardware and software of each system, and without concern for the communications protocols needed to initiate and monitor the distribution of a job. The DDP transfer facility consists of two pieces of software, the job transfer manager and the file transfer manager.

Job Transfer Manager _____

The job transfer manager lets the user initiate execution of a job on any system within the DDP network and monitor the execution from the initiating site. Any printed or punched output generated by the job is normally routed to the initiating system. However, the initiator can request routing of this output to any available system in the network.

The job transfer manager also lets the user reroute print or punch output files to different host computer systems. Print output files can be routed to remote auxiliary printers connected to remote workstations as well.

File Transfer Manager _____

The file transfer manager transfers sequential files from one system to another or duplicates file structures between systems.

Files can be transferred between systems that contain the same file handling facilities, in which case no data transformation is required. Files with serially-accessible records can be transferred between systems of dissimilar architecture with or without character conversion. That is, a file can be transferred as a bit stream to be reformatted by the user, or it can be converted (character translation only) during the transfer process to the internal code recognized by the receiving system.

When transfer is between systems of dissimilar architectures, the file transfer manager does not support automatic reformatting of records within a file, or the converting of records to their equivalent form in the destination system. In this case, the contents of the file are treated as all character data or bit string data. Neither record sensitivity, record sequence, nor numeric field characteristics are recognized or adjusted during the transfer operation.

File transfer can be directed into the file area of the destination system or, if the destination file area is in use, to a temporary file area in the destination system. Transfer from the temporary file to the destination file is made when the destination file becomes available.

JOB TRANSFER MANAGER	FILE TRANSFER MANAGER
<p>Provides commands to:</p> <ul style="list-style-type: none"> - Submit jobs to the DDP network - Monitor execution of submitted jobs - Cancel a submitted job - Communicate with a remote operator's console - Issue instructions to a remote operating system - Respond to messages issued by a job executing on a remote system 	<p>Permits the user to:</p> <ul style="list-style-type: none"> - Generate a file directory to catalog the characteristics of files - Transfer copies of data files and program libraries - Delete a file from the file directory - Obtain a listing of a file's characteristics from the file directory

Files Transmitted Between Systems

- Data files - Are formatted in the OS/3 MIRAM format. Files transmitted from OS/3 are MIRAM files. Files transmitted to OS/3 will be created in MIRAM format.
- Program libraries - Any directly-accessible module in a program library can be transferred between systems, or an entire library can be transferred.

DDP File Access

The DDP file access lets a user program, through OS/3 job control language, access files residing on remote OS/3 systems within a DDP network. DDP file access also lets user programs exchange data and control information. The user can transfer program control between systems and reroute spooled output.

The DDP file access permits the following:

- User programs to access disk files residing on a remote OS/3 host through the // DVC job control statement
- Programs running on remote hosts to access each other as files

IMS-DDP Transaction Facility

The IMS-DDP transaction facility lets users perform inquiries and updates on files residing at remote workstations anywhere within the DDP network.

IMS-DDP software requires a configured communications network to physically link the DDP processors at each included site. The processors interpret all DDP related commands and perform the requested functions. The processors are designed to operate in an interactive environment and respond to commands issued from a workstation.

There are three ways in which IMS can route a transaction to a remote system:

1. **Directory routing** - A terminal operator at the primary IMS enters a transaction code that identifies a transaction at a particular remote system. The primary IMS routes the message to the secondary IMS, where action programs or UNIQUE process the transaction. Once the transaction begins, a communications link is established between the terminal operator and the remote system. This allows a dialog transaction consisting of multiple input and output messages.
2. **Operator routing** - Operator routing is similar to directory routing. In this case, a special character, rather than a transaction code, is associated with the remote system. When the terminal operator enters a transaction code prefixed by the special character, IMS routes the message to the secondary IMS, where the transaction is processed in the same manner as in directory routing.
3. **Action program routing** - The terminal operator enters a transaction code that initiates a transaction at the primary IMS. A COBOL or BAL action program at the primary IMS issues an ACTIVATE function call to IMS, identifies the remote system in its output message header, and generates a message containing a transaction code. IMS routes this message to the remote IMS, where action programs process the transaction and return a message to the originating action program or its successor. The action program at the primary IMS can then return a message to the terminal operator or can issue another ACTIVATE call to initiate another remote transaction.

3.4.9. MAPPER Software

The MAPPER system is a general online report processing system that uses a report-structured data base. Programming knowledge is not required to use MAPPER software. OS/3 supports two MAPPER products, MAPPER 5 and MAPPER 80.

Each product enables you to define and maintain your data in report form without requiring the services of an experienced programmer. Most data access is interactive from a workstation. Many easy-to-use functions allow you to select and sort your report data in a variety of ways. Common sequences of MAPPER functions can be stored as a run and invoked with a single command.

Printed output can be directed to a local workstation printer, the main system printer, or an auxiliary printer.

MAPPER 5 to OS/3 Connectivity

A terminal or local workstation user who is signed on to the OS/3 operating system can access MAPPER 5 data in the same manner as a terminal user who is directly connected to the MAPPER 5 processor.

MAPPER 80 System

The MAPPER 80 system generates reports from a DMS data base. Data on the DMS can only be accessed by MAPPER 80 software. However, MAPPER 80 utilities can capture MAPPER 80 data from external files (spool or other OS/3 data files) and transfer report data to DMS files.

The MAPPER 80 system also uses screen format services. Some available screen characteristics are:

- Lowercase translation
- Original and overlay formats
- Special editing characters
- Nondisplayed fields

The MAPPER 80 system has an internal system of locks to prevent data inconsistencies from occurring when more than one user tries to update the same report at the same time. Two or more users can look at the same report simultaneously, but it can be updated by only one user at a time.

3.4.10. PC Connectivity To OS/3

The Unisys Personal Computer (PC) user has an increasing need to access System 80, models 10/20 data bases and software applications for daily business use. Unisys provides four utilities to facilitate the task of connecting PCs to the System 80, models 10/20:

- File Transfer
- On-Line Transfer
- PC On-Line Extract
- PC On-Line Disk

File Transfer Utility (PCTRAN)

The file transfer utility (PCTRAN) permits transfer of data files, library modules, and source program files between a diskette on a PC and a disk, diskette, or tape on the Unisys System 80, models 10/20. Three input screens are used to specify the desired file transfer mode and the file names and media location to be used by both the host computer and the PC.

PCTRAN supports character and PC hex mode data transmission. These modes are selected by the user. When using hex mode, the PC terminal emulation software and PCTRAN translate the data during file transfer. This option allows PC object code and binary data to be transferred to and from the OS/3 host system.

When transferring OS/3 object or load modules to the PC, the data is translated by PCTRAN and maintained on the PC as character data. When the module is transmitted back to the host system, it is translated by PCTRAN to OS/3 object code format.

PC On-Line Transfer (OLTRAN)

OLTRAN is an OS/3 program product that offers users an easy way to transfer files between a PC and a System 80, models 10/20 mainframe. Users can transfer OS/3 MIRAM files and SAT file elements to and from PC ASCII data files.

ASCII files can be transferred from a PC to the OS/3 mainframe with or without translation to EBCDIC code. A complete error-checking protocol is provided to ensure error-free data transfer.

PC On-Line Extract

On-line extract provides a bridge between MAPPER software on the host system and applications on the PC. On-Line Extract allows the user, with a simple MAPPER system report-style or spreadsheet-style interface, to specify the extraction of data from Series 1100, System 11, MAPPER 10 or MAPPER 5 system reports. A PC configured as a System 80, models 10/20 workstation can extract data from MAPPER 5 system reports in OS/3 pass-through mode. The user can transfer extracted data to a PC for use in PC spreadsheets, data management, word processing, or other applications.

PC On-Line Disk

The PC on-line disk allows the user to allocate and format OS/3 files as Unisys PC diskettes or hard disks. Multiple PCs can use the same disk files allowing users to share data, keep backup copies of data diskettes on an OS/3 host, and assign an area of random access memory (RAM) for use as a diskette.

This utility supports most MS-DOS™ PC operating commands and MS-DOS compatible software.

3.4.11. Applications Programs

Unisys offers a wide variety of applications programs with the System 80, models 10/20 data processing system. The list of available packages varies as Unisys institutes changes to meet the needs of its customers.

MS-DOS is a trademark of Microsoft Corporation.

Unisys APPLICATIONS PROGRAMS	
- Universal Industrial System 80 (UNIS™ 80)	- Universal Industrial System 80-Extended (UNIS 80-E)
- Accounting Management System 80 (AMS 80)	- Universal Financial Accounting System 80 (UNIFAC 80)
- Unisys Universal Financial Integrated Control System 80 (SUFICS 80)	- Financial Accounting Control System (FACS)
- Information Collection System 80 (ICS 80)	- Universal Distribution Information System - Wholesale (UNIDIS 80)
- Wholesale Applications Management System 80 (WAMS 80)	- Unisys Business Application System (SUBAS 80)

Universal Industrial System 80 (UNIS 80)

The Universal Industrial System 80 (UNIS 80) offers comprehensive production and inventory planning control systems. UNIS 80 provides the facilities to meet the requirements of a total manufacturing control system, including production scheduling, inventory control, and material handling. Terminal screen displays, called menus, lead the user through the system. UNIS 80 interfaces with an integrated data base and permits multiple interactive users to access the system simultaneously. It also provides noninteractive, or batch, support. UNIS 80 is modular and consists of the following application modules:

Production Engineering Data Control

This feature collects, maintains, and retrieves all basic engineering and production data used as primary information and as a basis for other applications in manufacturing. It handles bills of material, parts data, manufacturing routings, and work center data. The user is provided with the following:

- Part engineering data
- Single-level where-used
- Single-level bills of material
- Indented where-used

UNIS is a trademark of Unisys Corporation.

- Indented bills of material
- Summarized bills of material
- Manufacturing routings
- Tool data
- Work center data
- Summarized where-used
- Highest-level where-used
- Work center where-used
- Tool where-used

Product Costing _____

This feature uses data to accumulate standard costs for materials, labor, and overhead. The following areas are covered by this application:

- Cost data entry
- Part cost
- Cost buildup (roll-up or fold-in)
- Costed bill of material

Customer Order Processing _____

This feature utilizes customer, vendor, and part or end-item information to process customer orders from receipt to shipment. This application includes the following:

- Customer search
- Customer shipping, billing, and part information
- Entry and control of customer orders
- Inventory checking and availability
- Returned goods processing
- Order status
- Packing slips and confirmation
- Shipping documents
- Invoicing
- Profitability control

Inventory Status and Control _____

This function provides stock and replenishment order transactions and current inventory status. Typical applications include:

- Stock receipts, issues, transfers, and adjustments
- Stock status reporting
- Cycle count
- Order status
- Stock location control

Forecasting and Analysis

This feature statistically forecasts requirements and analyzes usage. The following features are available:

- ABC analysis
- Requirements and scrap factor forecasting - linear, trend, and seasonal models
- Model analysis

Master Scheduling

The manufacturing user constructs a master schedule. The system provides the following:

- Master schedule report
- Lead-time picture
- Master schedule load analysis
- Two-level master scheduling
- Master schedule list

Material Requirements Management

This feature provides both statistical order control and material requirements planning (MRP) processing. The following facilities are available:

- MRP (regenerative and net change)
- Order action recommendations
- Requirements by part and order
- Stock and order status reporting
- Order point control (optional)
- Lot sizing

Production Planning

This feature schedules work and determines capacity requirements, such as the following:

- Work order scheduling
- Capacity requirements planning (infinite)
- Capacity requirements planning (finite)
- Lead-time reduction factors

Work Order Control _____

This feature determines work-in-progress status on the following:

- Work order release
- Material availability checking
- Shop floor reporting
- Scrap reporting
- Work order status
- Dispatch reporting

Universal Industrial System 80-Extended (UNIS 80-E) _____

The Universal Industrial System 80-Extended (UNIS 80-E) is a version of the UNIS 80 system offering all of the features of that system. In addition, UNIS 80-E allows the user to modify the system to meet particular needs. Included in the system are the following UNIS 80 modules:

- Production engineering data management
- Inventory status and control
- Master scheduling
- Material requirements management
- Product costing
- Customer order processing
- Forecasting and analysis
- Production planning and work order control

Accounting Management System 80 (AMS 80) _____

The accounting management system (AMS) includes a series of packaged financial applications, written in RPG II, that provide standard business accounting functions. AMS consists of four subsystems: accounts payable, accounts receivable, payroll, and general ledger.

AMS Functions _____

- **Accounts payable** - The AMS accounts payable subsystem includes all functions needed to build and maintain the accounts payable files, select the invoices to be paid, issue the appropriate checks, and print reports reflecting the system operations. These files contain all the needed vendor information.
- **Accounts receivable** - The AMS accounts receivable subsystem includes all functions needed to build and maintain accounts receivable files. These files contain all required information on customers, including, year-to-date sales figures, and credit limits. Daily accounts receivable transactions are summarized by the system to generate appropriate entries for the AMS general ledger subsystem.
- **Payroll** - The AMS multi-state payroll subsystem is designed after the manual methods familiar to accountants and bookkeepers.

The payroll subsystem is ready to use and provides all accounting records required by the Internal Revenue Service. It can accommodate multicompany and multidivisional payrolls. The AMS multi-state payroll subsystem can pay an employee out of multiple taxing jurisdictions and multibank checking. Personnel working with the payroll subsystem need no data processing training or experience.

- General Ledger - The AMS general ledger subsystem provides control of accounting records, including an audit trail of entries, and the balancing and validation of all bookkeeping entries. Balance sheets and income statements are produced.

The general ledger subsystem accepts input from the accounts payable, accounts receivable, and payroll subsystems.

Universal Financial Accounting System 80 (UNIFACS 80) _____

The Universal Financial Accounting System 80 (UNIFACS 80) is a series of packaged applications, written in ANS'74 COBOL, that provide the user with all the standard features and functions of a business accounting package and give the user added capabilities in the areas of personnel record-keeping and budgeting.

UNIFACS 80 Functions _____

- Accounts payable - The UNIFACS 80 accounts payable subsystem provides all functions needed to maintain accounts payable records, select invoices for payment, issue appropriate checks, and produce reports needed for control and future planning.

The accounts payable package performs such functions as invoice entry and validation, duplicate invoice monitoring, recurring payment processing, cash requirements forecasting, check printing, invoice aging, Federal Form 1099 reporting, and use tax reporting.

- Accounts receivable - The UNIFACS 80 accounts receivable subsystem provides all functions needed to maintain accounts receivable records. The subsystem is designed to allow maximum control and flexibility in processing cash payments and in controlling outstanding receivables.

General ledger transactions created by the accounts receivable subsystem are accepted directly by the UNIFACS 80 general ledger subsystem. The accounts receivable subsystem also creates the sales history necessary for sales analysis functions.

- Payroll/personnel - The UNIFACS 80 payroll/personnel subsystem provides a comprehensive, easy-to use payroll processing system, with additional features for personnel record-keeping. Payroll/personnel supports a variety of pay categories and all federal and state tax calculations. It can process up to 20 regular deductions per employee and process hand-written and voided checks.

The payroll/personnel subsystem also provides for labor distribution, payroll distribution, EEO reporting, and personnel history maintenance.

- **General ledger/budgeting** - The UNIFACS 80 general ledger/budgeting subsystem maintains all necessary general ledger and budgeting information for many types of users, including those with multicompany requirements. The subsystem can process different companies, divisions, departments, etc, as well as any combination of accounting periods in the same run.

General ledger/budgeting can handle current period transactions for financial systems ranging from 4 quarterly periods per fiscal year up to 13 four-week periods, including the standard 12 monthly periods. The general ledger/budgeting subsystem accepts automated input from the UNIFACS 80 accounts payable, accounts receivable, and payroll/personnel subsystems.

In addition to the general ledger functions, the subsystem provides the user with budgeting functions. Multiple budgets can be created and maintained. Customized budget reports and actual-versus-budget comparisons are available through the use of the Financial Reporter budgeting subsystem.

SUFICS 80

SUFICS 80 offers the user an advanced, interactive financial modeling and planning system. SUFICS 80 uses English-language-based statements, allowing the user to easily construct and change models of all or part of a company. The easy-to-use SUFICS 80 statements also allow users to produce a wide variety of reports to fill analytical and forecasting needs.

SUFICS 80 is a powerful analytical tool that enables the user to perform "what-if", statistical, and risk analyses. SUFICS 80 also offers hierarchical consolidation, providing 3-dimensional modeling and consolidation - all through the use of English-like SUFICS statements.

The analytical capabilities of SUFICS 80 can be applied to such diverse areas as:

- | | |
|---|--|
| ▪ Budgeting | ▪ Inflation evaluation |
| ▪ Cash flow forecasting | ▪ Merger and acquisition evaluation |
| ▪ Capital investment analysis | ▪ Cost estimating |
| ▪ Long-term and strategic planning | ▪ Product profitability analysis |
| ▪ Market planning; product launching and planning | ▪ Consolidations |
| ▪ Corporate modeling | ▪ Statistical analysis and forecasting |
| ▪ Corporate financing | |

Financial Accounting Control System (FACS)

The OS/3 financial accounting control system (FACS), is an integrated system designed to provide cost-effective financial controls for businesses and non-profit organizations. The system offers ease of installation and use, and contains many comprehensive features to help managers establish better accounting controls.

FACS consists of five individual modules:

- **General Ledger:**
 - Accommodates up to 18 digit account codes
 - Conforms to generally accepted accounting principles
 - Tailors chart of accounts to user needs
 - Provides complete audit trail reporting and online viewing capabilities
- **Accounts Receivable:**
 - Automatically distributes all transactions
 - Provides current status of outstanding balances, payments, and items
 - Applies cash under multiple options, eliminates delays and accelerates cash flow
- **Accounts Payable provides:**
 - Interactive, one-time data entry at detail levels
 - Use of cash or accrual basis of accounting
 - Multiple accounting distribution
 - Cash requirements planning reports
 - Check reconciliation and preparation capability
 - Automatic discounts, and payment "HOLD" features.
- **Fixed Assets provides:**
 - Tax and book depreciation provisions
 - Accomodates acquisition, sale and retirement of assets
 - Identifies key information including serial number and location of assets

▪ Purchase Order Processing provides:

- Online inquiry of purchase orders, vendor receipts, invoices and file information
- Matching of purchase orders, receipts and vendor invoices on a line item basis
- Override standard terms and/or discounts

Information Collection System 80 (ICS 80) _____

The information collection System 80 (ICS 80) is a highly efficient online information collection system implemented as action programs to IMS. It offers a practical and economical solution to information and data collection problems. The system helps to make the best use of computer resources, aids in the introduction of online information processing, and provides the following important capabilities:

ICS 80 Capabilities _____

- Online collection of data and information. The same workstation used for the collection of data and information can also be used for file inquiry and updating.
- A full range of data validation and checking routines. These can be application-dependent checks specified by the user.
- Information and data collection handled simultaneously with other processing in a multiprogramming environment.
- A simple implementation language for specifying the formats to be used to enter data.

Universal Distribution Information System - Wholesale (UNIDIS) _____

The universal distribution information system - wholesale (UNIDIS) offers a complete distribution control system designed to optimize cash flow, increase profits, streamline operations, and improve customer service.

UNIDIS - wholesale ordering maximize inventory and offer the user positive control over all goods flowing into and out of the user organization. It is a real-time system allowing the user to respond immediately to customer orders and retrieve billing information quickly and easily.

UNIDIS functions can be broken down into order entry, stock control, and inventory management.

Order Entry

UNIDIS offers real-time, online order entry with immediate response capability. In addition, order entry offers:

- Online availability determination/reservation
- Specialized delivery instructions and comments, including item substitution
- Automatic pick list generation and route optimization
- Standard ship-to and bill-to address
- Inventory and demand history updating
- Automatic discount and pricing capabilities
- Pre- and post-billing accounting procedures
- Profitability control
- Blanket order, back order, and drop shipment processing
- Customer credit limit control
- Automatic assignment of customer order identifiers
- Invoice Transactions

Stock Control

Stock control provides for the control of goods from their receipt on the shipping dock, through count verification, inspection, repair, and rework until the goods reach stock or scrap. Stock control offers:

- | | |
|--|--|
| ▪ Online processing | ▪ Inventory updating |
| ▪ Receipt verification against purchase orders | ▪ Generation of financial transactions |
| ▪ Quantity tolerance verification | ▪ Location control of all goods, stock, and nonstock |
| ▪ System control of goods movement | |

Inventory Management

Inventory management provides a sophisticated set of statistical features to analyze demand patterns and suggest replenishment strategies. The system provides the following features:

- Demand models with automatic model analysis
- Service level specification
- Product group or warehouse processing
- EOQ calculation
- Alarm reports
- Graphic representation of demand patterns and forecast model
- Tracking signal/demand filters

Wholesale Applications Management System 80 (WAMS 80)

The wholesale applications management System 80 (WAMS 80) is an online, interactive system that provides the basic wholesale distribution management functions required by today's business environment.

WAMS 80 consists of four subsystems: inventory/sales analysis, order entry/billing, credit return, and expanded sales analysis.

- **Inventory/sales analysis** - The WAMS 80 inventory/sales analysis subsystem includes the functions necessary to create and maintain the inventory file. The inventory file includes required information on a product, such as pricing levels, stock levels, reorder levels, sales data, vendor number, and substitute product designation.
- **Order entry/billing** - The WAMS order entry/billing subsystem is an online interactive system. It achieves the classic ordering goals of having inventory and customer information instantly available for the user, while accurately performing all of the required order processing operations. This includes identifying products, determining stock availability and pricing, identifying the shipping customer, discounts applicable, commission allocations, applicable taxes, producing invoices and pick slips, producing billing records for accounts receivable, maintaining all sales records, and producing management reports.
- **Credit return** - The WAMS 80 credit return subsystem is an online interactive system. It achieves the goals of having inventory and customer information instantly available, while accurately performing all of the required returned merchandise operations. This includes identifying products, discerning pricing and customer discounts, identifying the shipping customer, determining commission allocations and tax liabilities, producing credit invoices, producing credit records for accounts receivable, maintaining credit records and information, and producing various management reports.

- Expanded sales analysis - The WAMS 80 expanded sales analysis subsystem provides expanded sales reports to the user. The reports produced by this subsystem are detailed and tailored to the needs of each user. This subsystem is used in conjunction with the WAMS 80 Order Entry/Billing and Credit Return subsystems to extract input data. The extracted data is then reformatted, stored, and utilized in the various reports. Files from the WAMS 80 Accounts Receivable subsystem and Inventory/Sales Analysis subsystem are accessed to obtain supporting data for these reports.

This subsystem provides monthly reports on product analysis, customer analysis, territory analysis, and monthly and year-to-date sales reports by customer/product class, as well as by salesman/customer/product class. Comparative analysis by customer/product class and salesman/customer/product class is also provided.

3.4.12. SUBAS 80

SUBAS 80 covers a complete integrated Financial Accounting solution. It is a MIRAM, IMS, ICAM based system using COBOL and Assembler programming languages. SUBAS 80 contains the following modules:

- General ledger
- Sales ledger
- Purchase ledger

The key features and functions of SUBAS 80 are:

- Online interactive, real-time
- Integration of all modules
- Multi-language
- Multi-currency
- Validation of user input transactions
- Automatic transaction generation

General Ledger _____

Postings to the general ledger system can be done in real-time or in batch mode. Powerful inquiry capabilities exist with the SUBAS general ledger including:

- Current balance display
- Batch data entered by input date or batch number
- Detailed posting displays

The user can post to the general ledger in 14 user-specified accounting periods. In a multi-company environment you can freely mix companies that use different numbers of accounting periods and varying fiscal years. Up to two financial years can be open per user company at any time. An additional two periods are provided for year-end closing purposes. This enables you to perform year-end closing in a number of stages and process concurrent data for the new year. Each time a closing is made, SUBAS 80 will automatically generate adjustments to forward balance postings and turnover totals.

Sales Ledger _____

This module lets the user enter and process all sales ledger transactions such as invoices, credit notes, and payments interactively. The sales ledger module also integrates with the general ledger. Multiple payment allocations including direct online payment entry with automatic allocation, is available.

Purchase Ledger _____

This module allows interactive entry and processing of all purchase ledger transactions such as supplier invoices, debit notes and payments. Payment processing, from payment proposal to the printing of payment documents, is fully automated.

3.4.13. Maintenance and Diagnostic Software

Hardware Diagnostics _____

The System 80, models 10/20 hardware diagnostics are used to isolate and identify system hardware faults. The hardware diagnostic routines to operate in an interactive programming environment and make use of displayed dialogs and messages for initiation and entry of control information. The hardware diagnostic system consists of the following:

Resident Diagnostics _____

The resident diagnostic routines are an integral part of the system and perform basic error checking on the central processor complex. The central processor complex includes the central processor, control storage, and the resident disk control hardware. Resident diagnostics also check the paper peripheral, diskette, and workstation controllers along with the single line communications adapter. These checks are performed automatically whenever the system is powered on or reset.

Offline Diagnostics _____

The offline diagnostics consist of microdiagnostic and macrodiagnostic routines. The microdiagnostic routines isolate detected hardware faults to the particular component responsible. Initiated at the console, these routines diagnose problems in the basic processing unit, main storage, and channels. The macrodiagnostics check the operability of all system instructions and verify the OS/3 operating system load paths.

Online Diagnostics

The online diagnostic routines check all peripheral and communications devices to ensure proper functioning and operation. These routines are under the control of the operating system and run concurrent with user jobs. During normal system operation, errors are logged to allow interrogation and analysis by these routines. Error log edit and analysis programs display individual error events and summary information.

Some hardware online diagnostic programs provided or enhanced follow:

- The online utility error reporting log program (ONELAN) has been enhanced to provide summary error log data in graph form. Plotting equipment performance, trends, and deviations are some of the diagnostics performed.
- The error log edit diagnostic program (ONUERL) has been enhanced to display disk and tape device errors, and various device summary data.
- ON5055 supports the testing of UNISERVO 22, 24, 26, and 28 tape subsystems that are attached to a T5055 tape control unit.
- ONSRVO supports the T5017, T5034 and T5045 tape control units and their corresponding tape drives (UNISERVO 12/16, UNISERVO 12/16/20 and UNISERVO 10/14).
- ONDCU now tests and verifies 8470, 8416/8418 and 8417/8419 disk subsystem functions in conjunction with OS/3.
- ONRPNT provides support for testing the 0789 and 0798 remote printer subsystems.
- ONCOM2 provides functional testing of the models 1 and 2 remote workstations, and the high-speed SLCA-5.
- ONSTPE incorporates diagnostic tests to support 7-track UNISERVO 10 Tape Subsystems.
- ON5039 tests and verifies 8430/8433 disk subsystem functions in conjunction with OS/3.
- ONREAD tests and verifies 0716 card reader subsystem functions in conjunction with OS/3.

The OS/3 online maintenance routine executes functional and verification tests, and error log edits. ON3774 tests the electrical and mechanical operation of the Streaming Tape Subsystem attached to the Integrated Tape Control Unit (F3774). The program is divided into functional tests and verification tests.

3.4.14. The System Activity Monitor (SAM)

The system activity monitor (SAM) is used to measure system efficiency by monitoring and recording various system activities. It is an optional software feature configured during system generation.

System Activity Functions ---

The monitor measures the following functions:

- Central processor and main storage usage
- Disk usage
- Input/output operations
- Supervisor interrupts
- Various communications activities

The information gathered by the monitor allows you to:

- Detect possible production bottlenecks
- Develop an optimum job mix
- Change system variables to enhance system performance
- Determine the optimum use of the system's peripheral devices

SAM operates in two modes: monitor class mode, and event trace mode.

Monitor Class Mode ---

- SAM groups data it collects into classes of system activity.
- Data can be output to the system console, or written to a disk data file.
- It measures such data as input/output activity, disk storage activity, and communications activity.

Event Trace Mode ---

- Data is collected for each occurrence of a specific event.
- Keeps track of two types of events:
 - I/O requests by device, command code, and requesting job
 - Disk cylinder address reference patterns

Data collected in either mode can be used to generate reports. A report program called SAMRPT can generate either tabular statistical reports or histogram reports. SAM supports models 10/20 hardware, including CPU time measurement, and I/O and trace monitoring. Co-channel statistics by channel or device are not supported.

File Placement Analyzer (FIPLAN)

The file placement analyzer can improve system performance by projecting optimum file allocation. The projections are based on the contents of the volume's VTOC when SAM is initialized.

FIPLAN can analyze and project allocations for up to 500 files at a time. The allocation of files, recommended by FIPLAN, can result in the relocation of user files across volume boundaries to achieve optimum load balancing. FIPLAN does not analyze dynamic file extensions and new files created during the monitor session.

3.4.15. UTS 400/4000 Support

OS/3 offers the following software components to support the Unisys Universal Terminal System 400 (UTS 400) and Universal Terminal System 4000 (UTS 4000):

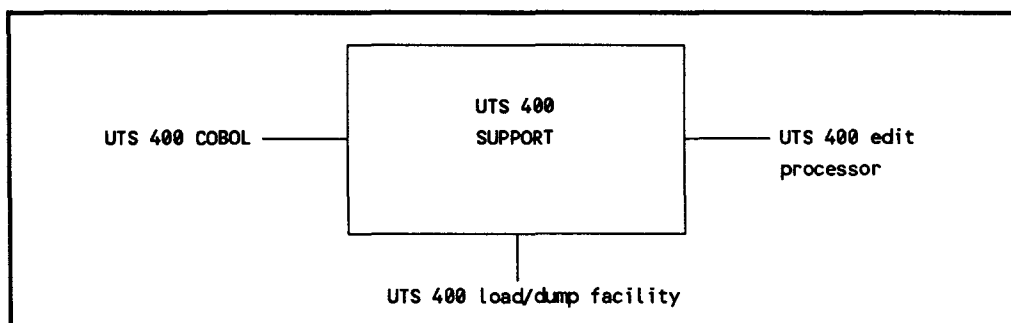

UTS 400 COBOL

UTS 400 COBOL is a high-level, business-oriented international language with features to complement the capabilities of the UTS 400 and UTS 4000 terminals. The UTS 400 COBOL compiler meets the ANSI X3.23-1974 standards and the ISO recommendations on COBOL. The compiler also contains extensions to provide for interactive data entry, program control, and screen management. The UTS 400 COBOL compiler executes under control of OS/3 and produces a compiled program that can be downline loaded to the terminal or placed on a diskette.

UTS 400 Edit Processor

The UTS 400 edit processor lets the user create and manipulate text data on a diskette file. It provides an easy and efficient way to create and update line-oriented files of data. Lines can be inserted, replaced, deleted, or changed in any order. Error messages advise the user of mistakes made in entering data. Lines up to 118 characters in length can be inserted in an edit processor file.

UTS 400 Load/Dump Facility

The UTS 400 load/dump facility provides the following facilities for the use of the UTS 400 COBOL and edit processor:

- A communications program to extract a load module from an OS/3 library and transmit this module (downline load) to a remote UTS terminal.
- A communications program to accept UTS 400 dump information and store it on an OS/3 dump file.

4. Hardware

4.1. SYSTEM 80, MODELS 10/20 COMPONENTS

The System 80, models 10/20 architecture provides processing power and main memory storage to meet expanding business needs. System 80, model 10 has more than 2.5 times the processing power of System 80, model 6 and twice the storage capacity. Similarly, System 80, model 20 offers almost three times the processing power and twice the storage capacity of System 80, model 8.

The System 80, models 10/20 processor complex, in either its minimum configuration or with maximum expansion, comprises field-installable modules, including basic processing and input/output control components. High-speed technology is used throughout the system based upon VSLI circuitry. The result is faster processing of larger amounts of data in a more stable computing environment.

4.1.1. Central Processor

The central processor (CP) is the controlling center that provides the data path and control logic for instruction execution, system control, and I/O support. The CP provides a generalized microprogrammed architecture implemented in modular system components. The components used in System 80, models 10/20 follow:

- Basic processing unit (BPU) with control storage (CS)
- System control processor (SCP)
- Mainframe interface adapter (MIA)
- Main storage unit (MSU)
- Operand cache (OC) and instruction cache (IC), model 20 only
- Floating point processor (FPP), model 20 only

Basic Processing Unit

The basic processing unit (BPU) provides the data path, registers and associated control logic required for instruction execution and system control. The BPU interfaces to a common bus which provides the common path for all channels and the BPU to access main storage. The basic BPU contains a four-stage pipeline with a multi-instruction buffer. The BPU for the model 20 is enhanced with an instruction cache, an operand cache, and a floating point processor.

System Control Processor _____

The system control processor (SCP) provides a system function and a service function. The primary system function is system clock generation. The service function is provided by a service processor which supports diagnostics, maintenance, service frames, console support, IPL and IMPL for the system.

Mainframe Interface Adapter _____

The mainframe interface adapter (MIA) is the interface between the IOP channel(s) and the main system bus. The MIA also includes a separate bus that is used to load IOP microcode and perform IOP maintenance operations.

Main Storage Unit _____

The main storage unit (MSU) stores data in a 4-byte word format. Address and data are checked for correct parity. Double and single-bit error correction, as well as data alignment and error correction code (ECC) are provided by the MSU. Storage protection assures data and program integrity in the system. Main storage ranges from 2 to 8MB in the model 10, and 4 to 16MB in model 20. Main storage expansion from 2 to 16MB is accomplished in 2- and 4-MB increments by basic memory unit (BMU) feature selection. Additional bits are also provided for error detection and correction.

Operand and Instruction Caches _____

The model 20 is accelerated through separate operand and instruction caches for use by the basic processing unit. Each cache contains 16K bytes. The operand cache uses a *store through* method for main storage. Cache bypass is provided for selected instructions.

Floating Point Processor _____

The model 20 also receives processing acceleration through the use of a separate floating point processor. Floating point and multiply instructions are accelerated.

4.1.2. I/O Facilities

The system provides a complete range of input/output facilities. One input/output processor (IOP) and one selector channel (SEL) are an integral part of each system. Five additional SELs and one additional IOP can be used in System 80, models 10/20.

Input/Output Processor _____

The IOP supports low-speed peripheral subsystems through the shared direct memory access (SMDA) function. Paper peripherals, local workstations, diskettes, disks and tapes can be attached through the IOP. The multiple line communication multiplexer (MLCM) and associated single line communications adapters (SLCAs) are used to connect a comprehensive complex of communications devices and provide interconnection capability to other systems.

Selector Channel _____

The selector channel (SEL) is used to control high speed I/O devices including disks, magnetic tape, high speed printers, and card readers. Each SEL can interface up to 8 freestanding controllers, or 4 freestanding controllers plus integrated disk control units (IDCUs) in any combination with no more than 3 IDCUs. The SEL operates at 2.2 MB per second.

4.1.3. Instruction Set

The instruction set for System 80, models 10/20 consists of general, floating point, decimal, and system control instructions. Compatibility with the Series 90/30 system and other System 80 systems is maintained on nonprivileged instructions except where restrictions are noted for 90/30.

The instruction repertoire of System 80, models 10/20 includes six instruction types:

- Register-to-register (RR) instructions
- Register-to-indexed-storage (RX) instructions
- Register-to-storage (RS) instructions
- Storage (S) instructions
- Storage-and-immediate-operand (SI) instructions
- Storage-to-storage (SS) instructions

Nonprivileged Instruction Set _____

Nonprivileged instructions process fixed-length binary numbers, floating-point numbers, packed and unpacked decimal numbers, and EBCDIC or ASCII characters. Data can be transferred between main storage and the user program set of general registers, as well as from one location in main storage to another. The operations of shifting, branching, and logical functions are also included.

Privileged Instruction Set _____

Privileged instructions are used by the operating system software when operating in the supervisory state. In this state, all installed instructions are valid and can be executed. This set of instructions includes facilities to load and store the contents of low-order main storage and to load the writable section of the microprogram control storage. Privileged instructions cannot be included in a user program.

4.2. HARDWARE CONFIGURATIONS

The extensive capabilities of System 80, models 10/20 permit you an almost unlimited variety of system configurations. The system is configured from the basic processor complex to maximum expansion with two expansion cabinets. Figure 4-1 illustrates the System 80, models 10/20 minimum configuration.

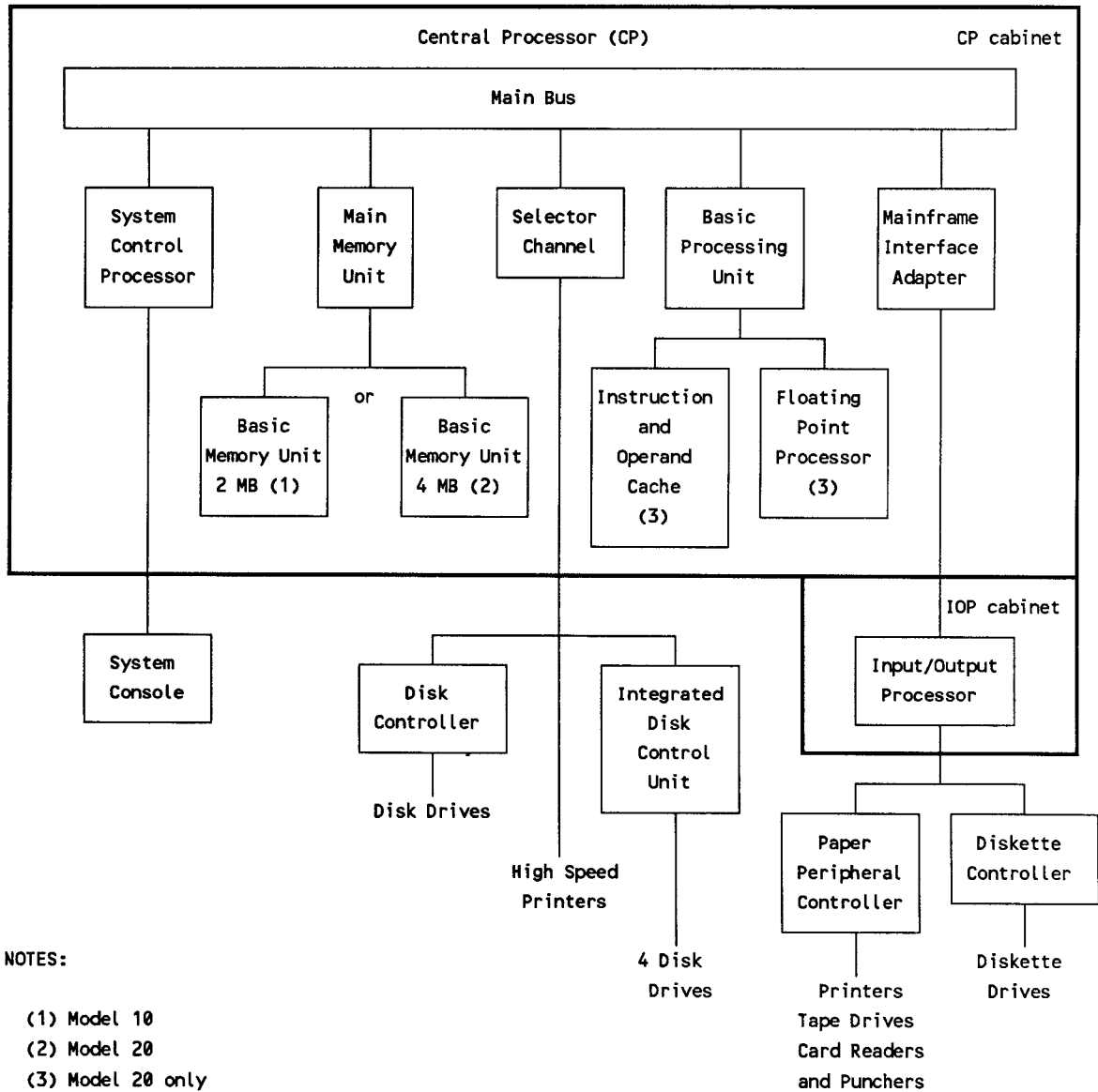

Figure 4-1. System 80, Models 10/20 Minimum Configuration

4.2.1. Basic System

The basic System 80, models 10/20 system includes the central processor components and a minimum set of I/O subsystems as follows:

- Processor cabinet and I/O cabinet with power
- Central processor, four-stage pipeline with 16K bytes instruction buffer
- Main storage processor and main storage unit with 2MB of main storage for model 10 and 4MB of main storage for model 20
- One selector channel
- Floating point processor (model 20 only)
- Operand cache (model 20 only), 16K bytes capacity, 200 ns access
- Instruction cache (model 20 only), 16K bytes capacity, 200 ns access
- Input/output processor (IOP) with a diskette controller and diskette drive
- One disk control unit
- Either one large capacity disk drive, or two medium capacity disk drives
- System console with system control panel
- Paper peripheral controller and line printer, or a line printer attached to the selector channel

The console can be located up to 30 feet (9 meters) from the processor cabinet. The diskette subsystem can be located up to 50 feet (15 meters) from the processor or I/O cabinet.

4.2.2. System Growth

System 80, models 10/20 can expand from its minimum configuration to meet the increasing data processing demands of a growing business. Following are some capsule descriptions of the expansion capabilities of System 80, models 10/20:

- Main storage expansion from 2 to 8MB (model 10) and from 4 to 16MB (model 20)
- Up to 48 removable and nonremovable-media disk drives; up to 11 billion bytes of online disk storage
- Up to 120 locally connected workstations

- High-speed magnetic tape subsystems
- Magnetic tape subsystems for backing up nonremovable-media disk storage
- Additional paper peripherals, including printers, card readers, and punches
- Communications control units, capable of interfacing with System 80, models 4, 6, and 10/20 and Series 90 systems running under OS/3

4.2.3. Migration from Other Systems

The System 80, models 10/20 offer growth capability as upgrade and replacement systems for System 80, models 3-6, and System 80, model 8. They also provide upgrades for Series 90/25, 30, and 40 systems. Software compatibility with these models complements Unisys base retention support.

Additionally, a System 80, model 10 system can be easily expanded to a model 20 system at your location without replacing the basic hardware and with no software changes.

4.3. PERIPHERAL SUBSYSTEMS

System 80, models 10/20 can operate with a wide variety of peripheral subsystems. They are illustrated and briefly described in sections 4.3.1 through 4.3.8.

4.3.1. Disk Subsystems

Various configurations can operate in the System 80, models 10/20 system. A minimum system requires at least one nonremovable, high capacity disk drive or two removable, medium capacity disk drives.

The following pages provide detailed descriptions of these disk subsystems:

- 8416/8418
- 8430/8433
- 8470/8480
- 8417
- 8419
- 8494

8416/8418 Disk Subsystems

An integrated controller located inside the System 80, models 10/20 processor cabinet controls up to eight 8416 or 8418 disk drives. The drives operate through the integrated disk channel.

DISK SUBSYSTEM

8416

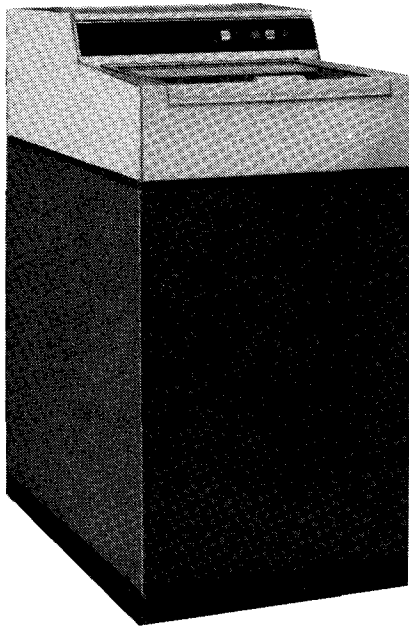

8418

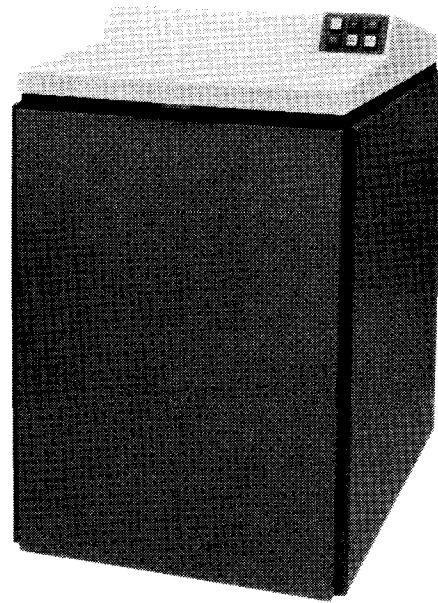

	8416	8418
Record format (bytes)	256	256
Tracks per cylinder	7	7
Number of cylinders	404 + alternates	808 + 7 alternates
Data rate	625 KB/s	625 KB/s
Average access time	27 milliseconds	33 milliseconds
Data capacity	29 MB	58 MB
Disk media	Removable	Removable
Rotational speed	2800 rpm	2800 rpm

8430/8433 Disk Subsystems

The 8430 and 8433 disk subsystems use their own type 5039 control unit in a freestanding cabinet. The disk subsystem is connected to the system through the selector channel. A single control unit supports up to 16 disk drives in any intermix of types 8430 and 8433. Multiple disk subsystems can be configured up to the system maximum of 24 disk drives and dual channel operating capability is available.

DISK SUBSYSTEM

8430

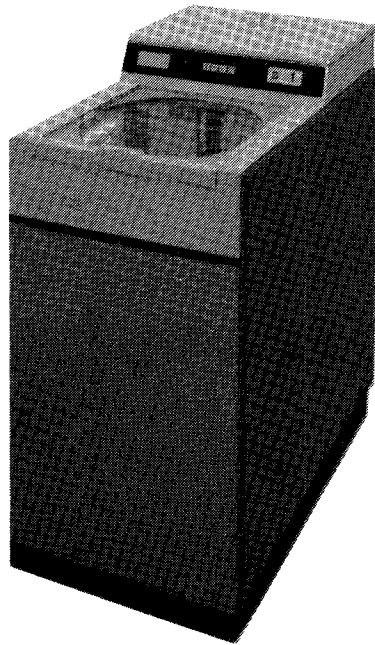

8433

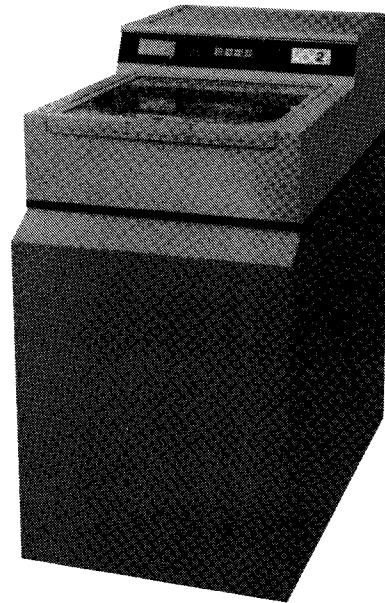

	8430	8433
Record Format (bytes)	Variable	Variable
Tracks per cylinder	19	19
Number of cylinders	411	815
Data rate	806 KB/s	806 KB/s
Average access time	27 milliseconds	30 milliseconds
Data capacity	100 MB	200 MB
Disk media	Removable	Removable
Rotational speed	3600 rpm	3600 rpm

8470/8480 Disk Subsystems

The 8470 disk subsystem uses fixed media disk drives and is controlled by a disk controller located inside the models 10/20 processor cabinet. The 8470 disk subsystem has as an optional feature dual access capability (by two controllers). Up to eight drives may be connected to one controller. The 8480 disk subsystem (not shown) has the same operating characteristics as the 8470 model. The 8480 contains four fixed media drives in a single cabinet that requires less floor space than four 8470s. One 8470 subsystem counts as 4 devices toward the maximum permitted on the IDCU.

DISK SUBSYSTEM

8470

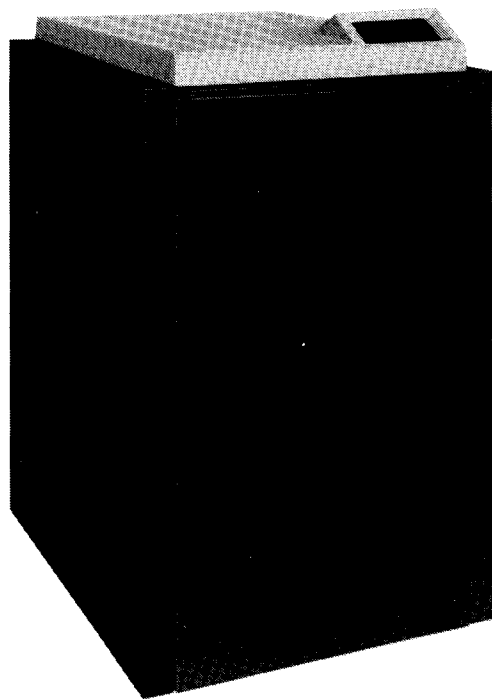

Record Format (bytes)	1024 (physical); 256 (logical)
Tracks per cylinder	32
Number of cylinders	625 + 5 alternates
Data rate	2.1 MB/s
Average access time	23 milliseconds
Data capacity	491 + 4 MB alternate
Disk media	Fixed
Rotational speed	3600 rpm

8417 Nonremovable Disk Drive

The 8417 nonremovable disk drive is a freestanding disk storage device. It is capable of storing up to 118.2MB of information. Up to three 8417 disk drives can be housed in a single cabinet.

DISK SUBSYSTEM

8417

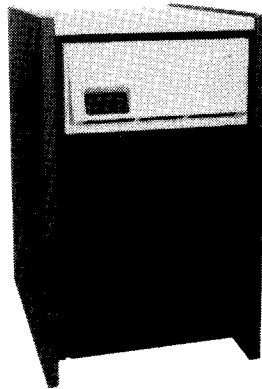

Record format (bytes)	256
Tracks per cylinder	14
Number of cylinders	550 + 10 alternates
Bytes per disk (MB)	118.2
Optional fixed-head capacity (MB)	0.86
Data rate (MB/s)	1.1
Head positioning time (ms)	
Minimum	7
Average	35
Maximum	70
Rotational latency (ms)	
Average	8.8
Maximum	17.6

8419 Removable Disk Drive

The 8419 removable disk drive is a freestanding disk storage device that includes its own power supply and operator control panel. It is capable of storing up to 72.3MB of information.

DISK SUBSYSTEM

8419

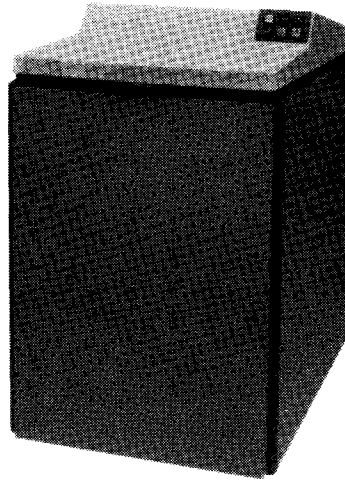

Record format (bytes)	256
Tracks per cylinder	7
Number of cylinders	808 + 7 alternates
Bytes per disk (MB)	72.3
Optional fixed-head capacity (MB)	NA
Data rate (MB/s)	0.78
Head positioning time (ms)	
Minimum	10
Average	33
Maximum	60
Rotational latency (ms)	
Average	10.7
Maximum	21.4

8494 Disk Subsystem

The 8494 disk subsystem uses fixed media disk drives. It can be used both as a SYSRES or a data device. The minimum system consists of one control unit and two 300MB devices. A complete subsystem of eight disks and two controllers can be housed in a single cabinet. Disk drives may be added in increments of two.

DISK SUBSYSTEM

8494

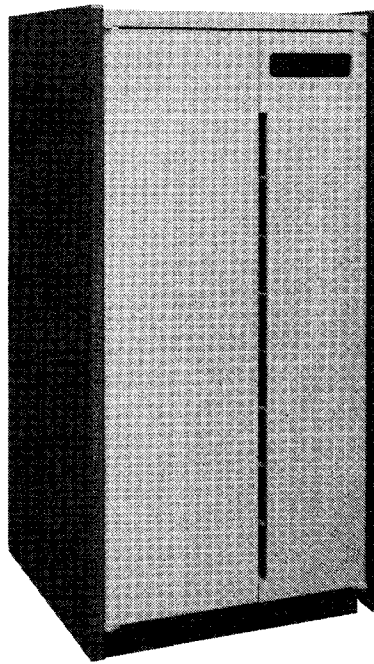

Record format (bytes)	512 (physical); 256 (logical)
Tracks per cylinder	20
Number of cylinders	626 + 6 alternates
Data rate	2.2 MB/s
Average access time	18 milliseconds
Data capacity	307 + 3 MB (alternate)
Disk media	Fixed
Rotational speed	3600 rpm

4.3.2. Workstation Subsystem

A workstation subsystem consists of a microprocessor controller and up to eight workstations. Additional workstation controllers can be attached, expanding the number of workstations in the system to 120 maximum.

Workstation Capabilities ---

The workstations are designed for ease of operation. Many operating capabilities are included for maximum versatility and access to the system. Indicators inform the operator of the workstation mode of operation (system or workstation) when power is on. They also inform the operator when there are messages waiting to be transferred from the system to the workstation.

Local Workstations ---

There are three types of local workstations available with the System 80 models 10/20: the model 1, model 2, and the SVT 1122. Each of these workstations can be intermixed on the same workstation controller. The model 1 and model 2 workstations are compared here since the model 2 and the SVT 1122 workstations are similar. The SVT 1122 features a 14-inch diagonal screen with 24 lines by 80 or 132 characters and two set-up menus that provide a page to select operator-convenient parameters and a communications page to select terminal configuration.

Each local workstation can be located up to 5000 cable feet (1500 meters) from the processor cabinet. The controller uses dedicated buffers to allow data transfers at a rate of 19,200 bits per second. The model 2 workstation offers an increased functionality over the model 1 workstation through its capability to be programmed by the user and its expanded selection of peripheral devices.

Model 1 Workstation ---

The model 1 workstation features are:

- Protected characters - Characters displayed on the screen can be protected so that the operator cannot position the cursor on protected characters. If all character locations are protected, the cursor moves to the home position. Characters to be protected are selected by programming commands. Protected characters are identified on the display by a different intensity or reverse video.
- Cursor scan - The operator can scan the cursor backward, forward, up, or down by pressing appropriate keys on the keyboard. Rapid corrections or changes can be made by entering the desired character location through the shortest path.
- Operating modes - The workstation operator maintains complete control of his operating environment by allowing use of console commands to the operating system without restricting use of the display screen. The operating modes are:

- Workstation mode - In normal operation, the workstation mode provides communications to applications programs.
- System mode - In system mode, the workstation is directly connected to OS/3. Workstation mode is suspended, and the top two lines of the display indicate system information. The first line is used by the operator to enter inputs to the system, the second line displays the system response messages. Lines 3 through 24 continue to display workstation mode information.
- Blink marker characters - Special characters can be selected for blink (delta) display fields. This helps the operator change the contents of unprotected locations within blink fields. The delta symbols indicate the beginning and end of these fields.
- Reverse video display - Programmers can designate areas of the terminal screen for reverse video display. This highlights a particular point on the screen. Reverse video does not affect other operations of the workstation in either mode.
- Magnetic stripe reader - A magnetic stripe reader that reads data in either the American Banking Association or International Air Transport Association format can be connected to the workstations. Data from the magnetic stripe reader is treated as if it were entered from the keyboard. The magnetic stripe can be on a bank card or similar media.

Table 4-1 lists the local workstation characteristics.

Table 4-1. Local Workstation Characteristics

Type of display	Cathode ray tube (CRT), green phosphor display 12 inch screen model 1/2, 14 inch screen SVT 1122
Number of display lines	24 data plus 1 status line
Characters per line	80 for model 1 and 2, 132 for SVT 1122
Keyboard arrangements	Three for model 1 and model 2 Typewriter layout Typewriter layout with numeric and function pads UTS 400 layout SVT 1122 has UTS 30 layout (94 Keys)
Direct connect communications interface characteristics	- Serial - Asynchronous, full-duplex connection - 19,200 bps - Optically isolated
Languages supported	Eight, as follows: Domestic, United Kingdom, Germany, France, Spain, Denmark/Norway, Sweden/Finland, and Italy

Model 2 Workstation

The model 2 workstation provides all the features of the model 1 workstation and offers three important additional features:

- **Additional peripheral support** - model 2 supports a diskette drive and correspondence-quality printer. The diskette drive provides the model 2 with offline file accessibility and file-building capability. The 132-column correspondence-quality printer produces clean, clear-cut characters on business letter head paper or continuously-fed, sprocketed, multi-part forms. The printer operates at a speed of 45 characters per second. When horizontal spacing is set at 12 characters per inch, the printer can print up to 158 characters per line.
- **Screen bypass** - The screen bypass feature permits the user, when using certain components of the system control software, to specify a model 2 workstation with a printer as two separate devices. This allows data to be output to a printer connected to the workstation at the same time the workstation is engaged by other system functions or user programs.
- **User programmability** - A most important feature of the model 2 workstation is that it can be programmed by the user in COBOL. Model 2 can be programmed for such functions as data creation, formatting and validation, and various arithmetic operations.

Programs for model 2 are coded in a special subset of *American National Standard COBOL X3.23-1974*. The programs are compiled and linked on the System 80, models 10/20 to which the workstation is connected. The resulting load module is downline loaded into the peripheral diskette or directly into the workstation memory. The model 2 can be configured with up to 64K bytes of storage. Storage is added to the model 2 in increments of 32K bytes.

Workstation Printers

The following is a sample of the printers supported by the model 2 Workstation.

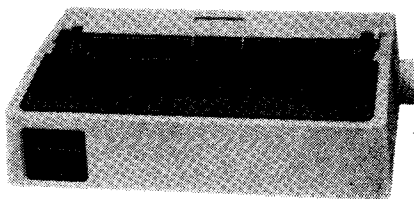

80-Column Printer

The 80-column printer is an inexpensive printer, lightweight and compact. A tension-loaded printhead forms 7- by 9-dot matrix characters. The printer prints at speeds up to 80 characters per second. The printer is available with a friction-feed platen to print cut sheets or with a pin-feed platen for printing on continuous-feed forms. (Not available on the SVT 1122.)

132-Column Printer

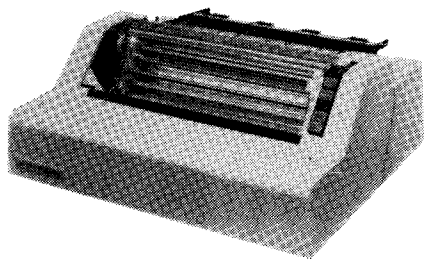

The 132-column printer maintains the economy of character-by-character serial printing while offering high-speed printing rates of up to 200 characters per second. The same character sets available for the workstation are offered for the 132-character printer. The USA character set is available as a standard 64-character set, a standard 96-character set, and a 96-character set with descenders. The latter includes certain letters (i.e., j, p, and q) formatted so that the tail of the letter descends below the normal print line. (Not available on the SVT 1122.)

0425 Printer

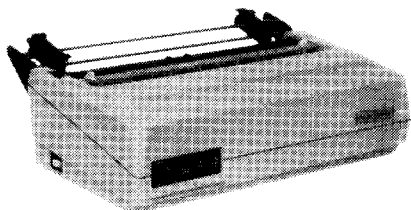

The Unisys 0425 printer uses a dot matrix printing system to print at speeds of up to 160 characters per second. Two different dot matrices are available with the printer. The standard is a 9 x 7 dot matrix, with lower case descenders, for draft-quality printing. Available as a special feature is an 18 x 40 dot matrix producing high-resolution characters at speeds of up to 40 characters per second. The printer prints up to 132 columns. Paper can be fed either with a friction platen, capable of producing an original and up to three copies, or the printer can use sprocketed forms with a forms tractor, capable of producing an original and up to five copies. Variable spacing is selectable at either 6 or 8 lines per inch. Horizontal spacing can be set at 10, 12.5, or 16.6 characters per inch. (For the SVT 1122, the model 25 printer is the same as the 0425 printer.)

Other printers supported by the model 2 and the SVT 1122 workstation are:

Model 2 Printers

model 445
model 789
model 791

SVT 1122 Printers

model 15 (445)
model 21 (471)
model 115 (472)

See your local Unisys representative for a detailed description of printers best suited to your workstation requirements.

Remote Workstations

There are 5 remote workstations used on the System 80, models 10/20:

- The model 1 remote workstation (UTS 20) is similar to the model 1 local workstation (UTS 20D).
- The model 2 remote workstation (UTS 40) is similar to the model 2 local workstation (UTS 40D).
- The SVT 1123 remote workstation is a modification of the SVT 1120 terminal. The SVT 1123 provides System 80, models 10/20 style *System Response Mode* and restricts operator set-up languages to English, German, French, and Italian.
- The SVT 1124 remote workstation is also a modification of the SVT 1120 terminal providing System 80, models 10/20 style *System Response Mode* but restricts operator set-up languages to English, German, Spanish, and Dutch.
- The Unisys family of PCs can also be used as remote workstations.

4.3.3. System Console

The system console permits the system operator to power up the system, control its operation, and power it down at the close of business. In addition, it serves as the interface between the system operator and system software, and provides diagnostic information for the operator and maintenance personnel. The system console operates in the following three modes:

- System console mode - Provides communications between operator and system software for system console functions.
- System control mode - Provides communications between operator and system control functions, such as initial microprogram load (IMPL) or initial program load (IPL).
- Maintenance mode - Provides communications between the Unisys customer engineer and system hardware for maintenance-panel functions.

The system operator also has the ability to define a specific local workstation as an alternate console by setting the ALTCON parameter to YES during system installation. Only one alternate console can be generated per supervisor. See the I/OGEN section of the *System 80 System Installation Guide*, UP-8839.

4.3.4. Printer Subsystems

Printer subsystems are connected to the System 80, models 10/20 through the paper peripheral controller and selector channel. Character printers can also be attached to each workstation. The 0789 printer, 0776 high-performance line printer, and 0798 character printer are connected through the paper peripheral controller. The selector channel supports the 0776 and 0770 printers. They are both high-speed printers. A remote printer attachment permits the connection of a remote printer, either the 0789 or 0798 line printers, or the 200 cps character printer. There is no degradation in print speed when printers are connected as remote printers.

0789 Line Printer

The 0789 printer is a freestanding impact line printer. It uses a horizontal moving band in a print cartridge assembly that makes it easy to change print cartridges.

Three printer speeds are available with the 0789 line printer: 180, 300, and 640 lines per minute (lpm). The exact print speed is determined by the print band speed, paper advance time, data transfer rate, the number of times an individual character appears on a print band, and the character density (characters/inch).

LINE PRINTER

0789

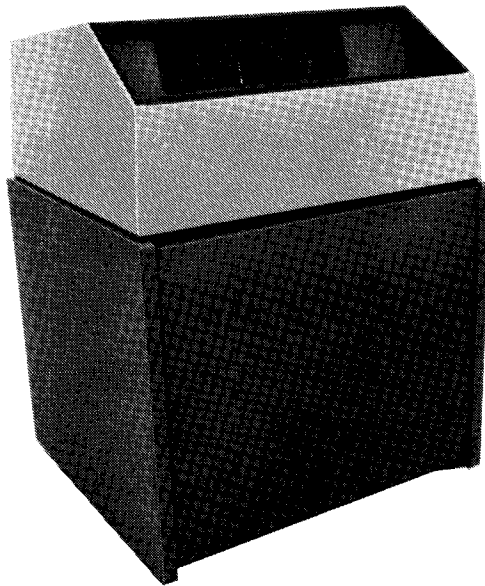

Print speed	180, 300, 640 lpm for 48-character set
Print line	132 columns wide
Printing density	10 columns per inch
Line spacing	6 or 8 lines per inch (operator selectable)
Line advance	30 ms at 6 lines per inch
Forms slew rate	15 inches per second (38 cm/s)
Forms width	16 inches (40.6 cm)
Forms length	22 inches (56 cm)
Number of copies	1 original plus five carbons

0776 High-Performance Line Printer

The 0776 high-performance line printer is a freestanding impact line printer capable of print speeds up to 1200 lines per minute. It uses a horizontal-moving print band in a print cartridge assembly that makes it easy to change print cartridges.

The print rate of the 0776 printer is dependent upon the model printer and character set used for printing. For example, the print speed of model 0776-00 for a character set containing 48 characters is 760 lines per minute, while the print speed of model 0776-06 for a character set containing 48 characters is 1200 lines per minute.

LINE PRINTER

0776

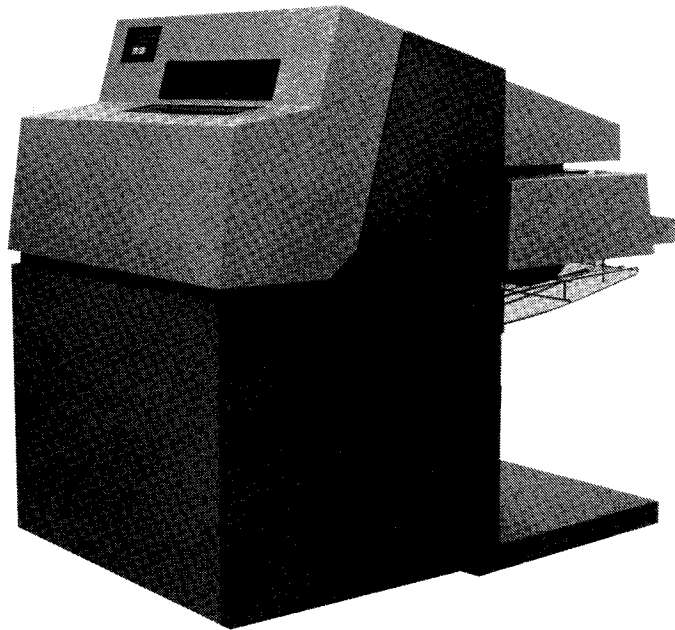

Print speeds	760, 900,, or 1200 lines per minute
Print line	120 columns or 136 columns by feature
Print density	10 columns per inch
Line spacing	6 or 8 lines per inch (operator selectable)
Line advance	16 ms at 6 lines per inch (single line)
Forms slew rate	22 to 50 inches per second (127 cm/s)
Forms width	18.75 inches (47.6 cm)
Forms length	18 inches (45.7 cm)
Number of copies	1 original plus 5 carbons

0770 Line Printer

The 0770 printer is a freestanding impact line printer. It can print at speeds of up to 2000 lines per minute. The 0770 printer contains its own controller and is connected to the system through the byte multiplexer.

LINE PRINTER

0770

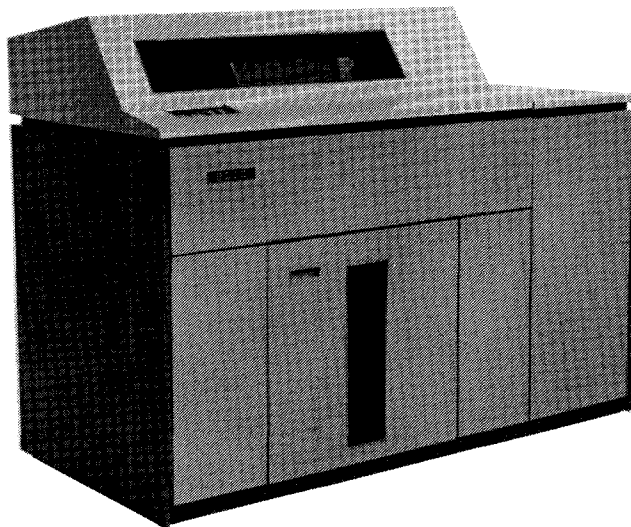

Print speeds	800 lpm, 1400 lpm, or 2000 lpm, depending on model
Print line	132 columns or 160 columns by feature
Print density	10 columns per inch
Line spacing	6 or 8 lines per inch (program selectable)
Forms advance rate	50, 75, and 100 inches per second depending on the model
Data codes	EBCDIC, ASCII, or any code of 6, 7, or 8 bits
Character set	48 standard, up to 384 by feature
Vertical format	Program control
Forms width	3.5 to 18.75 inches (8.89 to 47.6 cm)
Forms length	7 to 24 inches (17.8 to 61 cm)
Number of copies	1 original plus 5 carbons

0770 II Line Printer

The 0770 II printer (model T0770-06/07) is a freestanding impact line printer. It can print at speeds of up to 2000 lines per minute. The 0770 II printer has several advantages over the earlier 0770-04/05 line printer. Equal throughput is maintained with a smaller footprint, higher reliability, less weight, and lower cost.

LINE PRINTER

0770 II

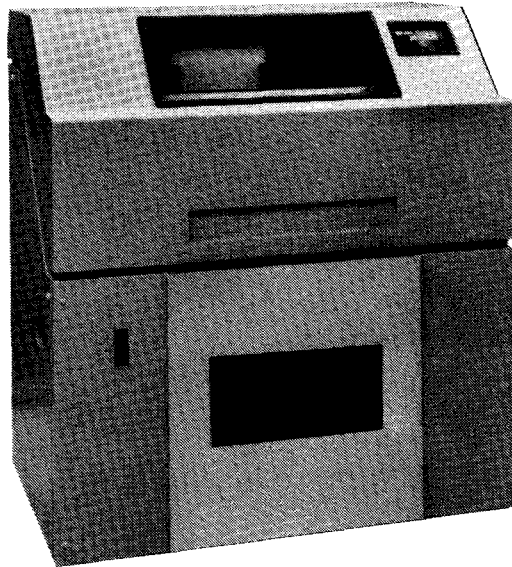

Print speeds	950 lpm, 1200 lpm, 1640 lpm, or 2000 lpm depending on character set size
Print line	136 columns
Print density	10 columns per inch
Line spacing	6 or 8 lines per inch (program selectable)
Forms advance rate	Up to 100 inches per second
Data codes	EBCDIC, ASCII, or any code of 6, 7, or 8 bits
Character set	48 standard, up to 384 by feature
Character fonts	OCR-A, OCR-B, H-14, and IBM 407
Forms width	4 to 17 inches (101.6 to 431.8 mm)
Forms length	8 to 22 inches (203.2 to 558.8 mm)
Number of copies	1 original plus 5 carbons

0798 Character Printer

The 0798 printer is a 132-column matrix character printer that can be connected to the paper peripheral controller, a remote printer controller, or to a workstation. The printer is available with a standard 64-character print set, a standard 96-character set, and a 96-character set with lowercase descenders.

CHARACTER PRINTER

0798

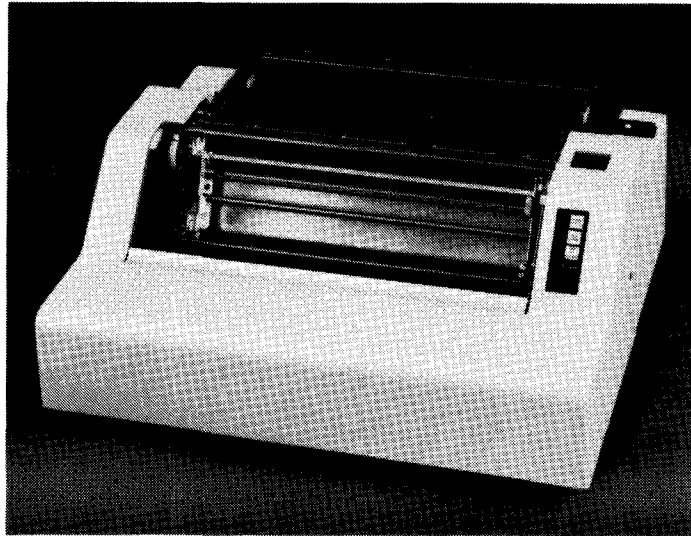

Print speed	37.5 lines per minute, equivalent to 75 lines per minute when printing is bidirectional (200 characters per second)
Print line	132 columns
Print density	10 columns per inch
Line spacing	6 or 8 lines per inch (operator selectable)
Print matrix size	7 x 7 or 7 x 9 by feature
Forms slew rate	6.7 inches per second (17 cm/s)
Forms width	15 inches (38 cm)
Number of copies	1 original plus 5 carbons
Paper feed	tractor control

4.3.5 Magnetic Tape Subsystems

A variety of magnetic tape subsystems can be connected to System 80, models 10/20. The Series 90 UNISERVO® 10/14, 12/16, 20 and 22/24 magnetic tape subsystems are connected to System 80, models 10/20 through the selector channel. The UNISERVO 22 and streaming magnetic tape subsystems are connected to models 10/20 through the integrated tape controller. The System 80, UNISERVO 10 (Type 0871) magnetic tape subsystem is connected by a dedicated controller through the IOP. A maximum of eight UNISERVO 10 tape drives can be connected in this way.

UNISERVO 10 (Type 0871) Magnetic Tape Subsystem

The System 80, UNISERVO 10 magnetic tape subsystem is a low-cost unit using magnetic tape conforming to standards specified by the American National Standards Institute (ANSI). The UNISERVO 10 has features such as automatic tape loading, and uses the ANSI-standard, industry-compatible, wraparound tape cartridge.

UNISERVO 10 MAGNETIC TAPE SUBSYSTEM

0871

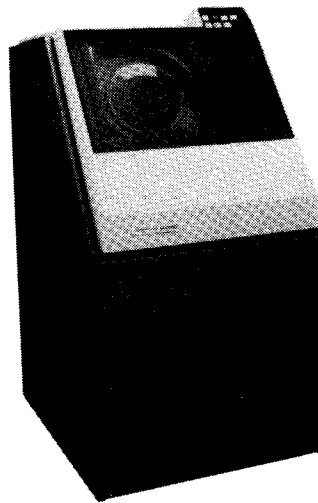

Tape speed	25 inches per second (63.5 cm/s)
Read access time	17 milliseconds
Start/Stop time	17 milliseconds
Reversal time	16 milliseconds
Rewind time	180 seconds for 2400 feet (731.5 meters) of tape
Data rate	40 KB/s
Recording density	800 and 1600 bits per inch in NRZI or PE mode recording 9 tracks; 200, 556, and 800 bits per inch in NRZI recording 7 tracks

UNISERVO is a registered trademark of Unisys Corporation.

UNISERVO 10/14 Magnetic Tape Subsystem

The UNISERVO 10/14 magnetic tape subsystem offers data transfer rates of up to 96 KB per second. A basic UNISERVO 10/14 subsystem contains two tape drives and a controller in one tape drive cabinet. Up to eight tape drives are supported by one controller and can be included in one subsystem.

MAGNETIC TAPE SUBSYSTEM

UNISERVO 10/14

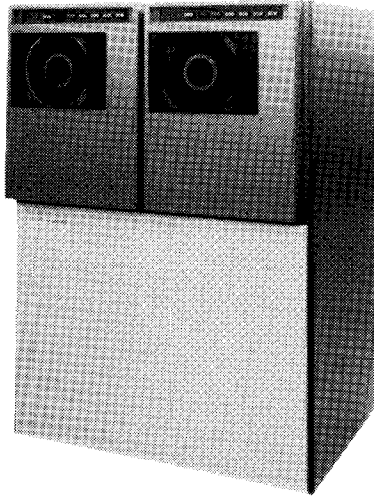

	UNISERVO 10	UNISERVO 14
Tape speed	25 ips (63.5 cm/s)	60 ips (152.4 cm/s)
Read access time	17 milliseconds	7 milliseconds
Reversal time	17 milliseconds	6.3 milliseconds
Rewind time	170 seconds	170 seconds
Data transfer rates:		
9 track	40 KB/s	96 KB/s
9 track NRZI	20 KB/s	48 KB/s
7 track NRZI at:		
200 bpi	15 KB/s	12 KB/s
556 bpi	13.9 KB/s	33.4 KB/s
800 bpi	20 KB/s	48 KB/s
Bit density	800 and 1600 bpi in NRZI or PE 9 track; 200, 556, 800 in NRZI 7 track	

UNISERVO 12/16 Magnetic Tape Subsystem

The UNISERVO 12/16 magnetic tape subsystem consists of a controller and up to 16 tape drives. The drives can be all UNISERVO 12 or UNISERVO 16 drives, or any combination of the two.

MAGNETIC TAPE SUBSYSTEM

UNISERVO 12

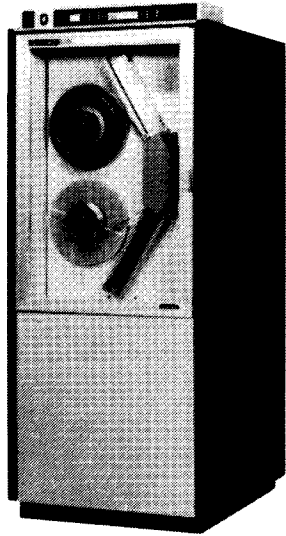

UNISERVO 16

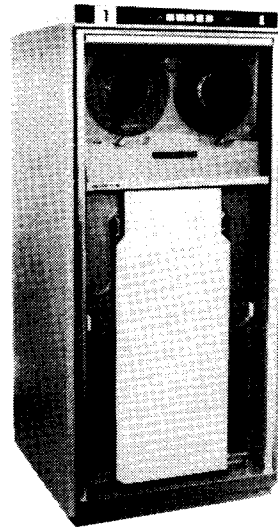

	UNISERVO 12	UNISERVO 16
Tape speed	42.7 ips	120 ips
Reversal time	25 milliseconds	10 milliseconds
Rewind time	180 seconds	120 seconds
Data transfer rates:		
9-track PE	68 KB/s	192 KB/s
9-track NRZI	34 KB/s	96 KB/s
7-track NRZI at:		
200 bpi	6.4 KB/s	18 KB/s
556 bpi	17.8 KB/s	50 KB/s
800 bpi	25.6 KB/s	72 KB/s

UNISERVO 20 Magnetic Tape Subsystem

The UNISERVO 20 magnetic tape subsystem is a high-performance tape handling subsystem, consisting of a control unit and from 1 to 16 magnetic tape units. The UNISERVO 20 control unit can be configured with a mixture of UNISERVO 12, 16, and 20 tape units.

MAGNETIC TAPE SUBSYSTEM

UNISERVO 20

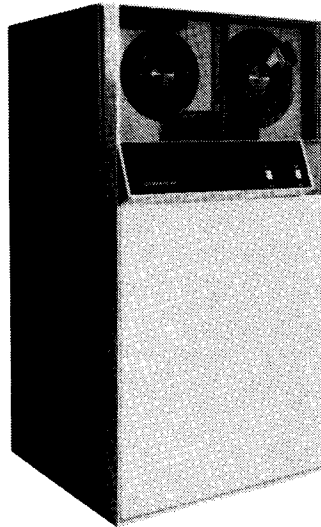

Tape speed	200 ips
Data transfer rate	320 KB/s
Recording density	1600 bpi
Reversal time	16 ms
Rewind time	1 minute
Recording mode	9-track PE

UNISERVO 22/24 Magnetic Tape Subsystem

The UNISERVO 22/24 magnetic tape subsystem offers the user a high-speed magnetic tape subsystem in a compact cabinet. The UNISERVO 22/24 subsystem connects to the selector channel through an SU00039 interface. Each UNISERVO 22/24 subsystem consists of a controller and one to eight tape drives. UNISERVO 22 and 24 drives can be intermixed in a subsystem. The UNISERVO 22 tape drive can also be connected through the integrated tape controller.

MAGNETIC TAPE SUBSYSTEM

UNISERVO 22/24

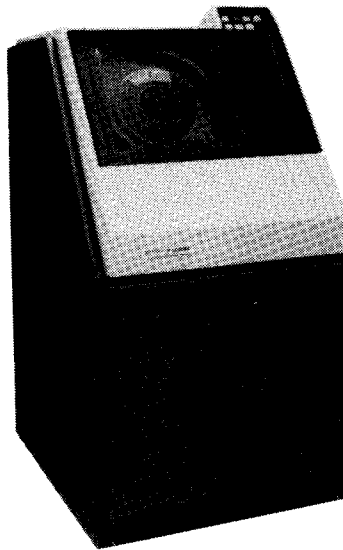

	UNISERVO 22	UNISERVO 24
Tape speed	75 ips	125 ips
Recording density	800 bpi NRZI 1600 bpi PE	800 bpi PE 1600 bpi NRZI
Reversal time	10 ms	10 ms
Rewind time	120 seconds	120 seconds
Transfer rate	NRZI 60 KB/s PE 120 KB/s	NRZI 100 KB/s PE 200 KB/s

UNISERVO 26/28 Magnetic Tape Subsystem

The UNISERVO 26/28 magnetic tape subsystem is a low cost, high-performance, magnetic tape unit that connects to the selector channel through a SU00039 interface. Each UNISERVO 26/28 subsystem consists of a controller and one to eight tape drives that can be intermixed in a subsystem.

UNISERVO 26/28 Magnetic Tape Subsystem

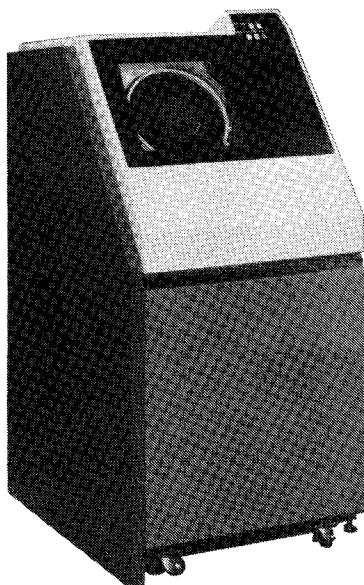

	UNISERVO 26	UNISERVO 28
Tape speed	75 ips	125 ips
Recording density	1600 bpi PE 6250 bpi GCR	1600 bpi PE 6250 bpi GCR
Reversal time	10 ms	10 ms
Rewind time	120 seconds	120 seconds
Transfer rate	PE 120 KB/s GCR 469 KB/s	PE 200 KB/s GCR 781 KB/s

Streaming Magnetic Tape Subsystem

The streaming magnetic tape subsystem is primarily used as a tape backup for high-capacity disk drives. It is connected to System 80, models 10/20 through the integrated tape controller. Up to four streaming tape drives can be configured on System 80, models 10/20. A total of eight drives can be attached to the integrated tape controller: any combination of streaming tape drives and UNISERVO 22 tape drives, with a maximum of four streaming tape drives.

STREAMING MAGNETIC TAPE SUBSYSTEM

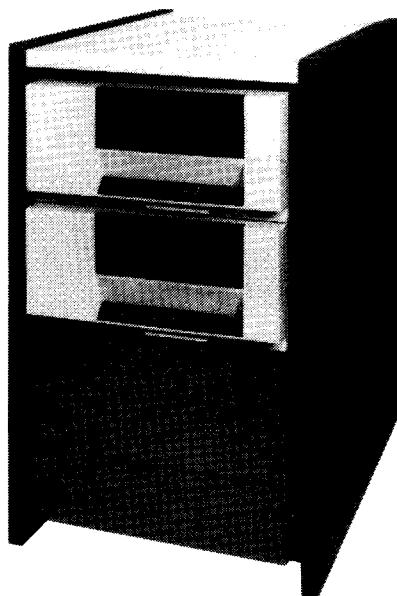

	High Speed	Low Speed
Tape speed	100 ips	25 ips
Interblock gap passing time	6 ms	24 ms
Rewind time	190 seconds	190 seconds
Data rates:	160 KB/s	40 KB/s
Data density	1600 cpi	1600 cpi
Recording format	9-track PE	9-track PE

4.3.6. Diskette Subsystem

The diskette subsystem supports up to two auto-load drives and two manual drives or four manual drives. At least one diskette drive is required in the minimum models 10/20 configuration. The diskette controller is buffered and performs label checking in data-set mode. The controller uses microprocessors and interfaces the IOP through shared direct memory access.

T8420/8422 Diskette Drives

Both the manual and auto-load drives read 1- and 2-sided diskettes recorded in either single or double density. Diskettes can be recorded in IBM-compatible basic data exchange (BDE) format for data interchange between IBM and Unisys systems. A diskette drive cabinet holds up to one auto-load and one manual drive, or four manual drives.

DISKETTE SUBSYSTEM

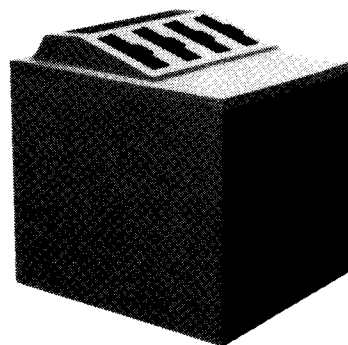
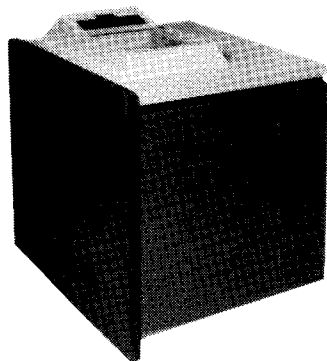

Auto-load hopper/stacker capacity	20 diskettes
Load/unload time per diskette	5 seconds maximum (60 Hz model) 6 seconds maximum (50 Hz model)
Data read/write heads	2/drive
Access time	3 milliseconds track-to-track
Tracks per diskette	77 tracks/side
Tracks per inch	48
Sector size	128, 256, 512, dependent on density method
Data transfer rate	31 KB/s at 256 bytes/sector 62 KB/s at 512 bytes/sector based on sector sequence setup
Bit density	3400 or 6800 bpi (8704 or 17,408 bpcm)

4.3.7. Punched Card Subsystems

System 80, models 10/20 offer several punched card peripheral devices. Two card readers and one card punch are available. One card reader and card punch are integrated with the system and controlled by the paper peripheral controller. The other card reader is freestanding and contains its own controller.

0716 Card Reader Subsystem

The 0716 card reader subsystem contains its own controller and synchronizer. The synchronizer regulates the flow of data and control signals to and from the reader mechanism. The controller connects to the byte multiplexer.

CARD READER SUBSYSTEM

0716

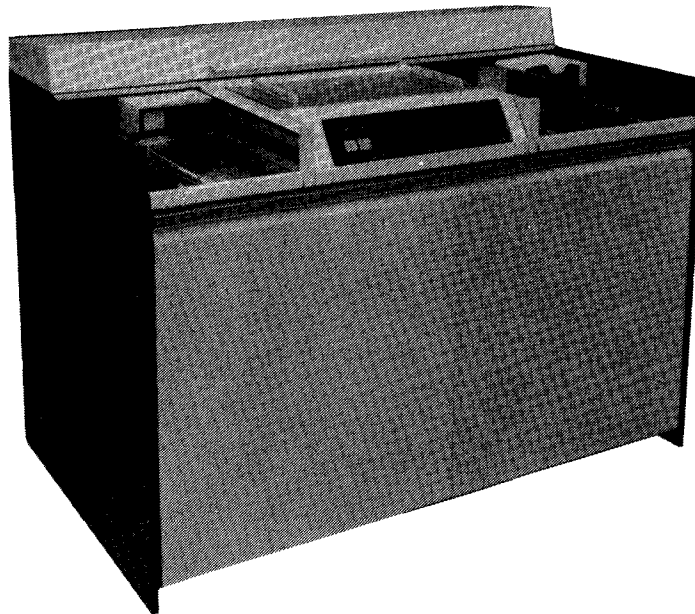

Reading speed	600 or 1000 cards per minute
Hopper capacity	2400 cards
Stacker capacity	2000 cards each (two stackers)
Read modes	Image mode at 160 characters per card Translate mode at 80 characters per card for EBCDIC, ASCII, and compressed codes
Card sizes	51-column and 66-column short cards, 80-column standard cards
Verification	Multiread validity checking

0719 Card Reader Subsystem

The 0719 card reader subsystem is a table-top reader that connects to the system through the paper peripheral controller and then to the IOP through the shared direct memory access. No other controller is required in the reader cabinet.

CARD READER SUBSYSTEM

0719

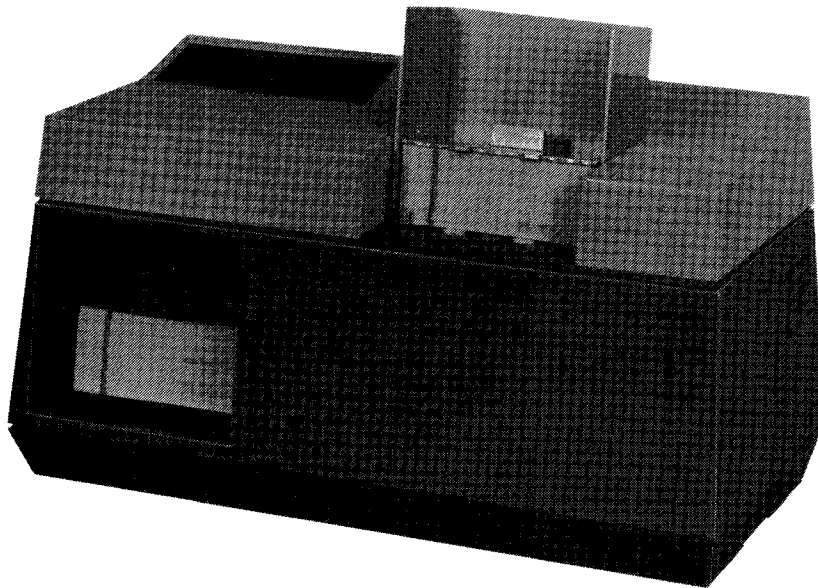

Reading speed	300 cards per minute
Hopper capacity	1000 cards
Stacker capacity	1000 cards
Read modes	Image mode at 160 characters per card Translate mode at 80 characters per card
Card size	80-column standard
Read technique	2-column sensors, dual redundant column checking
Read-stating sensing	Column by column

0608 Card Punch/Reader Subsystem

The 0608 card punch/reader subsystem is connected through the paper peripheral controller and then to the IOP through the shared direct memory access. The card punch contains an auxiliary error stacker that holds 100 cards.

CARD PUNCH/READER SUBSYSTEM

0608



Punch speed	75 cards per minute with 80 columns punched or 160 cards per minute with first 28 columns punched; 120 columns per second advance speed
Punch code	Image or compressed
Card size	80-column standard
Checking method	Punch motion check
Feeding method	Column serial, on demand
Hopper capacity	700 cards
Stacker capacity	Primary stacker: 700 cards Auxiliary stacker: 100 cards
Read/validity check	Reads prepunched cards at 160 cards per minute

4.3.8 Communications Subsystems

The single line communications adapters (SLCAs) provide system communications capability. The multiple line communications multiplexer (MLCM) component of the IOP supports up to 14 half-duplex SLCAs operating at medium or low speeds, or up to 7 full- or 12 half-duplex SLCAs operating at high speed.

Remote workstations, terminals, and other communications devices are supported through the SLCAs. Various communications lines can be used with the SLCAs:

- Digital data network for distributed data processing
- Public data networks
- Private leased lines
- Automatic answering/autodial capability
- Telegraph
- Military communications networks

The SLCA controls communications line characteristics and the communications device attached to the line. Each line can accept devices operating at speeds of up to 56K bits per second. SLCAs also perform special character recognition, integrity checks, data transfer control between main storage and devices, and other required control functions.

Table 4-2 lists the basic protocols used with the SLCA.

Table 4-2. Communications Functions

Protocol/Function	Line Speed	Mode	Interface
UTS 20, UTS 30, UTS 40, UTS 400, SVT 1122	2400 - 19.2K bps	Half duplex, synchronous	RS-232-C or MIL-STD-188
BSC	2000 - 9600 bps	Half duplex, synchronous	RS-232-C or MIL-STD-188
UTS 10/TTY (or equivalent)	50 - 9600 bps	Half duplex, asynchronous	RS-232-C or MIL-STD-188
Universal Data Link Control (UDLC)	9600 - 56K bps	Full duplex, synchronous	RS-232-C/X.21, BIS or CCITT V.35
NTR	4800 - 56K bps	Full duplex, synchronous	RS-232-C or MIL-STD-188 or CCITT V.35
SVT 1120, SVT 1123, SVT 1124, UTS 4020/4040	2400 - 19.2K bps	Half duplex, synchronous	RS-232-C or CCITT V.24

The following subsections describe, in more detail, some of the communications devices shown in Table 4-2 that can be attached to the system communications lines.

Universal Terminal System 20

The Universal Terminal System 20 (UTS 20) is a versatile, single station, display terminal used to send, receive, display, and manipulate data. As an efficient input/output and display device interfaced with your host system, this terminal provides the basic capabilities required at remote locations - online interactive data transfers and a hard-copy printer.

The functions of this nonprogrammable terminal are stored in an electronic program cartridge, which can be easily installed in the back of the terminal.

Universal Terminal System 30

The Universal Terminal System 30 (UTS 30) single station is a low-cost intelligent display terminal specially tailored in three different versions for sending, receiving, manipulating, and displaying data.

The following describes the three versions:

- **Basic UTS 30** - The powerful UTS 30 capabilities are loaded from diskette by a Unisys 8439 double-sided diskette subsystem or provided by a program cartridge that is easily installed. This version can be used in a communications network with other Unisys terminals.
- **Programmable UTS 30** - This efficient display terminal provides versatile capabilities for use at remote locations. The operating modes give the user the advantages of hard-copy printers, peripheral data storage, online interactive data transfers, offline data-handling potential, user programmability, and host-processor-initiated retrieval of data in peripheral storage.
- **Twisted pair interface** - The UTS 30T version can be downloaded without a program cartridge or system diskette.

Universal Terminal System 40

The Universal Terminal System 40 (UTS 40) single station is an intelligent, programmable display terminal used to send, receive and display data. The UTS 40 is a very efficient and versatile display terminal that can be interfaced with the host system. The UTS 40 offers many useful capabilities for remote locations: hard-copy printers, peripheral data storage, online interactive data transfers, offline data handling potential, programmability for user-selected functions, and host-processor-initiated retrieval of data in peripheral storage.

Universal Terminal System 4000

The UTS 4000 is a comprehensive family of communications devices that has a wide range of interactive communications capabilities. The UTS 4000 can be used for a variety of applications, from simple data entry and retrieval to sophisticated distributed data processing. Through use of interchangeable components, the system can be configured to meet the needs of any communications user.

The UTS 4000 uses a terminal cluster architecture with a programmable controller unit attached to the host processor. Terminals and other peripheral devices are connected through the controller. Available terminal types are video display devices and include editing and programmable terminals. Peripheral devices include a desk-top diskette unit supporting 1MB diskettes and a variety of terminal printers.

The UTS 4000 control unit (the UTS 4020) is a programmable, microprocessor-based unit capable of acting as a stand-alone processor, as well as a communications controller. Provided with an integrated diskette unit, random access storage, and a complement of software elements, it is one of the most advanced communications devices available. The stand-alone processing capabilities of the UTS 4020, coupled with its advanced communications features, make the UTS 4000 ideally suited for inclusion in a distributed data processing network.

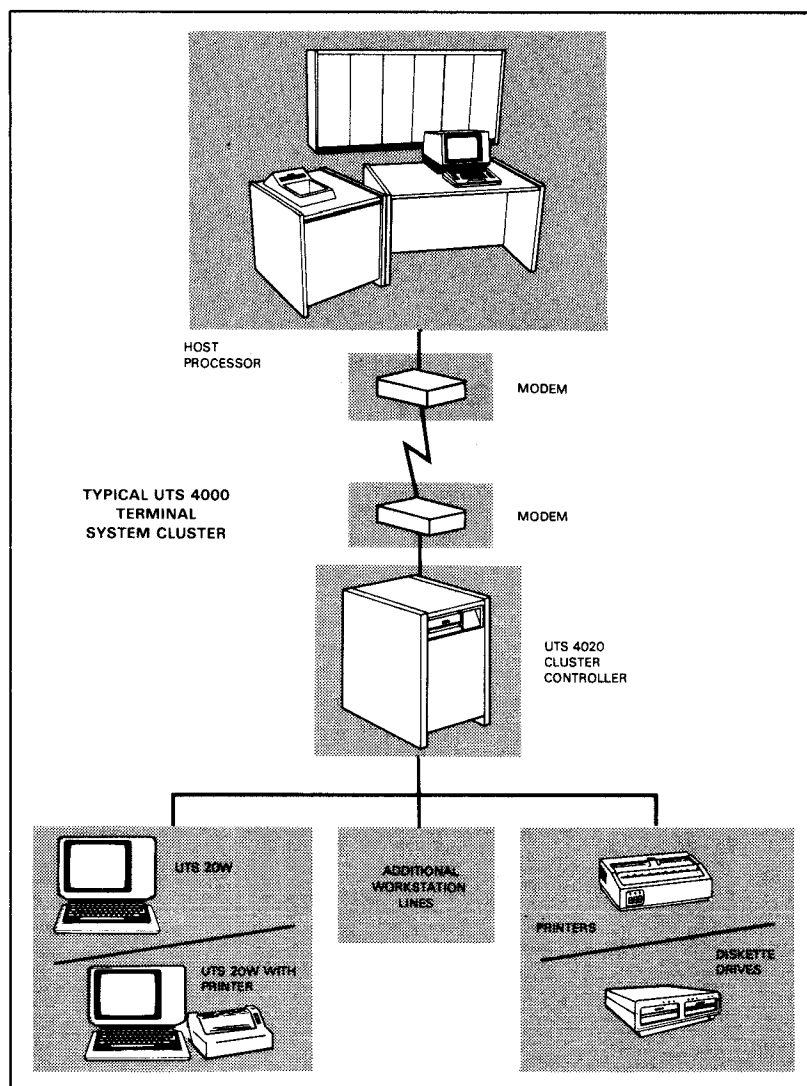

Universal Terminal System 400

The UTS 400 is a powerful, programmable terminal display device. A variety of presentation formats provide a total display capacity of 960, 1024, 1536, or 1920 characters. The UTS 400 can operate as a data entry device or as a display device conveniently located at the central computer site or at a remote location.

The UTS 400 can be configured as a master terminal with up to two slave terminals, or as a controller with up to six slave terminals. It also can be used with the UNISCOPE 100 or UNISCOPE 200 display terminals in multidrop or multiplexer configurations.

UTS 400 UNIVERSAL TERMINAL SYSTEM

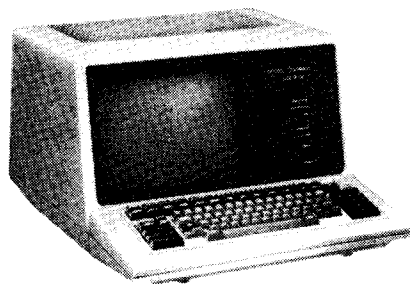

SVT 1120 Terminal

The SVT 1120 terminal is UNISCOPE control code compatible and functions similar to the UTS 20 terminal but with several significant enhancements.

The monitor is a 14-inch CRT with P31 green phosphor. The operator can select 80 or 132 columns by 25 lines. The display features a CRT saver for time delay display shut-off and a display intensity control.

Keyboard selectable languages supported include: English, British, French, German, Italian, Spanish, Danish/Norwegian, and Swedish/Finnish.

Two menu-driven, set-up control pages are provided. One establishes operator convenient parameters, and the other establishes communications configuration parameters.

SVT 1123 Remote Workstation ---

The SVT 1123 remote workstation has the System 80 style *System Response Mode* and therefore has the characteristics associated with a System 80 remote workstation (UTS 20).

The terminal setup menus include four languages: English, German, French, and Italian.

SVT 1124 Remote Workstation ---

The SVT 1124 remote workstation is the same as the SVT 1123 except that the four terminal setup languages are: English, German, Spanish, and Dutch.

Additional Communications Devices ---

In addition to the Unisys devices listed, the following devices can also be attached as communications terminals:

- Unisys PCs
- MAPPER 5
- UNIX OS systems
- Distributed Communications Processor (DCP)
- IBM 3270 terminal system
- TELETYPE Models 33, 35, 37, and 38

While these devices can be attached as communications terminals, all services available to the normal communications user can not be available to users of these devices.

4.4. HARDWARE SUMMARY

Table 4-3 summarizes the system hardware characteristics of the System 80, models 10/20.

Table 4-3. System Characteristics (Part 1 of 2)

Characteristics	
System orientation	Disk, with concurrent interactive and batch processing
Central processing unit	Two sets of 16 general-purpose registers Four floating-point registers Priority controller for access to any two units on a priority basis Four-stage pipeline with 16K bytes instruction buffer Maximum system bus transfer rate of 16 MB/s
Main storage processor	64 relocation registers for address conversion (48 for user programs, 16 for operating system use) 48 protection keys, error correction, storage protection
Main storage unit	2 MB expandable to 8 MB (model 10), 4MB expandable to 16 MB (model 20). Expansion in 2MB to 4MB increments
Operand & instruction caches	16 KB capacity each, 200 ns access (model 20 only)
Floating point processor	Floating point and multiply accelerator (model 20 only)
Selector channel	Maximum of six selector channels supporting the following: <ul style="list-style-type: none"> ▪ Up to three integrated disk control units, and one freestanding control unit or eight freestanding control units. ▪ Supports removable disk drives with capacities of 29, 58, 72, 100, and 200 MB. Fixed media disk units with capacities of 118.2, 491, 1964, and 2464 MB. ▪ Additional peripheral controllers, supporting the following peripherals: <ul style="list-style-type: none"> - UNISERVO 10/14, 12/16, 20, 22/24 and 26/28 tape drives - 0770 freestanding line printer (2000 lpm)

Table 4-3. System Characteristics (Part 2 of 2)

Characteristics	
Input/output processor	<p>Maximum of two IOPs per system, each supporting up to eight device controllers consisting of:</p> <ul style="list-style-type: none"> ▪ Diskette controller with up to four manual drives, or two autoloader plus two manual load drives. No more than a total of four diskette drives per system. ▪ Workstation controller supports eight workstations with a maximum of 120 workstations per system. ▪ Paper peripheral controller supporting: <ul style="list-style-type: none"> - Two type 0719 card readers, or one card reader and one type 0608 card punch - Two local printers, from 200 characters per second to 1200 lines per minute not to exceed 1500 lpm. ▪ Maximum of 12 paper peripheral controllers per system ▪ Remote printer controllers, each supporting one type 0789 or 0798 printer ▪ Integrated tape controller capable of supporting a total of eight magnetic tape drives in the following combinations: <ul style="list-style-type: none"> - Up to four streaming tape drives - Up to eight UNISERVO 22 tape drives - Any combination of the two not exceeding four streaming tape drives or eight tape drives total. ▪ Dedicated tape controller channel, supporting up to eight UNISERVO 10 (Type 0871) tape drives. ▪ Multiple line communications multiplexer (MLCM) interfaces up to 14 low or medium speed SLCAs or up to 7 full- or 12 half-duplex high speed SLCAs.





