

**TYPE 1840 MODIFIED
MAGNETIC TAPE
TRANSPORT
AND
POWER SUPPLY**

**TECHNICAL
MANUAL**

TECHNICAL MANUAL

for

TYPE 1840 MODIFIED

MAGNETIC TAPE TRANSPORT

AND

POWER SUPPLY

OCTOBER 1973

PX 7984-0-3

SPERRY  **UNIVAC**
DEFENSE SYSTEMS

LIST OF EFFECTIVE PAGES

PAGE NUMBER	CHANGE IN EFFECT
Title Page	Original
ii thru ix	Original
1-0 thru 1-6	Original
2-1 thru 2-10	Original
3-1 thru 3-4	Original
4-1 thru 4-28	Original
5-1 thru 5-74	Original
6-1 thru 6-64	Original
7-1 thru 7-2	Original
Figure 7-1	Original
thru 7-20	Original

TABLE OF CONTENTS

SECTION 1 - GENERAL INFORMATION

Paragraph		Page
1-1.	Scope	1-1
1-2.	Description	1-1
	a. MTT	1-1
	b. 400-Hz Power Supply	1-2
1-3.	Equipment Options	1-2
1-4.	Equipment Similarities	1-2
1-5.	Equipment Lists	1-4
	a. Equipment and Publications Supplied	1-4
	b. Equipment Required But Not Supplied	1-4
1-6.	Terms, Symbols, and Abbreviations	1-4

SECTION 2 - INSTALLATION

2-1.	Unpacking and Handling	2-1
2-2.	Outline and Dimensional Data	2-1
2-3.	Cables and Connectors	2-1

SECTION 3 - OPERATION

3-1.	General	3-1
3-2.	Controls and Indicators	3-1
3-3.	Preliminary Checks	3-1
3-4.	Write Enable Ring	3-1
3-5.	Tape Load Procedure	3-1
3-6.	Tape Unload Procedure	3-2
3-7.	Power Supply Turn On	3-3

SECTION 4 - PRINCIPLES OF OPERATION

4-1.	General	4-1
4-2.	Simplified Block Diagram Analysis	4-1
	a. General	4-1
	b. Control Section	4-1
	c. Autoload Function Generator	4-1
	d. Autoload Interface	4-1
	e. Autoload Servo Control	4-5
	f. Reel Servo	4-5
	g. Capstan Servo	4-5
	h. Dc-to-Dc Converter	4-5
	(1) +75 Vdc	4-5
	(2) +30/-30 Vdc	4-5
	(3) -15 Vdc	4-5
	(4) +15 Vdc	4-5
	(5) +5 Vdc	4-5
	i. Buffer Column Sensors	4-5
	j. AIR 1 and AIR 2 Solenoids	4-6
	k. Reel Servo System	4-6

TABLE OF CONTENTS (CONT)

Paragraph	Page
4-3. MTT/Controller Interface	4-6
a. Input Control Signals	4-6
(1) ERASE	4-6
(2) REV	4-10
(3) FWD	4-10
(4) FAST	4-10
(5) WRITE	4-10
(6) AUTO	4-10
b. Output Control Signals	4-10
(1) BOT	4-10
(2) EOT	4-10
(3) READY	4-10
(4) HIGH TAPE	4-10
(5) LOW TAPE	4-10
(6) SET AUTO	4-10
(7) CAPSTAN ZERO	4-10
(8) WRITE ENABLE	4-10
c. Data Signals	4-11
(1) READ	4-11
(2) WRITE	4-11
d. Miscellaneous Signals	4-11
(1) LOAD REMOTE INDICATOR	4-11
(2) READY REMOTE INDICATOR	4-11
(3) UNLOAD REMOTE INDICATOR	4-11
(4) LOAD REMOTE SWITCH	4-11
(5) UNLOAD REMOTE SWITCH	4-11
e. Prime Power	4-11
(1) 400-Hz, 3 ϕ , 208 Vac	4-11
(2) +75 Vdc	4-11
(3) 400-Hz Relay Control	4-11
(4) 4-KHz Inverter Drive	4-11
4-4. Automatic Load Operation	4-11
a. General	4-11
b. Function 0F	4-12
c. Function 1F	4-12
d. Function 2F	4-21
(1) Jump to 6F	4-21
(2) Return to 0F	4-21
(3) Advance to 3F	4-21
e. Function 3F	4-21
f. Function 4F	4-22
g. Function 5F	4-22
h. Function 6F	4-22
i. Function 7F	4-22
j. Function 8F	4-23
k. Function 9F	4-23
(1) Unload	4-23
(a) Unload·Hi Tape·BOT	4-23
(b) Unload·Hi Tape	4-24
(c) Unload·BOT	4-24

TABLE OF CONTENTS (CONT)

Paragraph	Page
(2) Fault	4-24
(3) Stop	4-24
l. Function 10F	4-24
m. Function 11F	4-24
n. Function 12F	4-24
4-5. 400-Hz Power Supply	4-25

SECTION 5 - MAINTENANCE AND REPAIR

5-1. General	5-1
5-2. Preventive Maintenance	5-1
a. Daily Preventive Maintenance	5-1
b. Weekly Preventive Maintenance	5-2
c. Operating Time Preventive Maintenance	5-3
5-3. Removal and Replacement Procedures	5-3
a. General	5-3
b. Removal of the MTT From the Cabinet	5-3
c. Printed Circuit Card Removal	5-4
d. Vacuum Blower Removal	5-4
e. Front Cover Removal	5-4
f. Takeup Drive Motor Removal	5-4
g. Power Supply Removal and Replacement	5-5
(1) Removal	5-5
(2) Replacement	5-5
h. Head Basket Assembly Removal and Replacement	5-5
(1) Removal	5-5
(2) Replacement	5-13
5-4. General Adjustment Information	5-13
a. SRS Ramp	5-13
b. TRS Ramp	5-13
c. SRS Slo Speed Open Loop	5-13
d. SRS Frequency Adjust	5-13
e. SRS Balance Adjust	5-13
f. SRS Speed Adjust	5-15
g. TRS Controls	5-15
h. Clock Rate Adjust	5-15
i. EOT	5-15
j. BOT	5-15
k. Lo Tape	5-15
l. Hi Tape	5-15
m. Rewind Speed	5-15
n. Speed Balance	5-15
o. Capstan Speed	5-15
p. Capstan Ramp	5-15
5-5. Adjustment Procedures	5-16
a. Clock Rate Adjust	5-16
b. Autoload Fault Cycle Test	5-17
c. Autoload with Work Tape	5-17
d. Reload Function Test	5-18

TABLE OF CONTENTS (CONT)

Paragraph	Page
e. Unload Function Test	5-19
f. BOT/EOT Sensor Alignment	5-19
g. BOT Sensor Sensitivity	5-19
h. High Tape Sensor Adjustment	5-20
i. Low Tape Sensor Adjustment	5-20
j. EOT Adjustment	5-20
k. Capstan Ramp Adjustment	5-21
l. File Protect Adjustment	5-22
m. Capstan Speed and Balance Adjust	5-23
n. Reel Speed and Reel Ramp Adjustments	5-23
o. Rewind Speed Adjust	5-25
p. Reel Drive Balance Adjust	5-25
q. Power Supply Adjustments	5-26
5-6. Printed Circuit Cards	5-26
5-7. Digital Integrated Circuits	5-26

SECTION 6 - PARTS LIST

6-1. Introduction	6-1
6-2. Group Assembly Parts List	6-1
a. Figure and Index Number Column	6-1
b. Reference Designation Column	6-1
c. Indenture Column	6-1
d. Description	6-1
e. Manufacturers Code	6-1
f. Part Number Column	6-1
g. Units Per Assembly	6-1
h. Used On Code Column	6-2
6-3. Numerical Index	6-2

SECTION 7 - FUNCTIONAL SCHEMATICS

7-1. General	7-1
7-2. Components	7-1

LIST OF ILLUSTRATIONS

SECTION 1 - GENERAL INFORMATION

Figure		Page
1-1.	UNIVAC Type 1840 Modified Magnetic Tape Transport and 400-Hz Power Supply	1-0

SECTION 2 - INSTALLATION

2-1.	Outline and Dimensional Data	2-1
2-2.	Cable and Connector Location/Reference Designators	2-2
2-3.	Read Amplifier Cable Destinations	2-7

SECTION 4 - PRINCIPLES OF OPERATION

4-1.	MTT Simplified Block Diagram	4-2
4-2.	Autoload Function Generator, Simplified Schematic, F = 10	4-3
4-3.	Buffer Column Sensors	4-6
4-4.	Reel Drive Control, Simplified Block Diagram	4-8
4-5.	MTT Interface Signals	4-9
4-6.	Function Generator Control Signals Flow Chart	4-13
4-7.	208 Vac Power Supply and Control, Simplified Schematic	4-27

SECTION 5 - MAINTENANCE AND REPAIR

5-1.	MTT, Front View	5-6
5-2.	MTT, Rear View	5-7
5-3.	MTT, Front View, Cover Removed	5-9
5-4.	MTT, Rear View, Cover Removed	5-11
5-5.	Head Basket Assembly	5-12
5-6.	Card Rack Adjustment Identification	5-13
5-7.	Reel Servo Input Circuit Card Assembly (7600627)	5-27
5-8.	Reel Servo Input Schematic Diagram (7600627)	5-29
5-9.	Reel Servo Output Circuit Card Assembly (7600629)	5-31
5-10.	Reel Servo Output Schematic Diagram (7600629)	5-33
5-11.	Capstan Servo Input Circuit Card Assembly (7600635)	5-35
5-12.	Capstan Servo Input Schematic Diagram (7600635)	5-37
5-13.	Capstan Servo Logic Circuit Card Assembly (7600643)	5-39
5-14.	Capstan Servo Logic Schematic Diagram (7600643)	5-41
5-15.	Autoload Function Generator Circuit Card Assembly (7600669)	5-43
5-16.	Autoload Function Generator Schematic Diagram (7600669)	5-45
5-17.	Autoload Servo Control Circuit Card Assembly (7600671)	5-47
5-18.	Autoload Servo Control Schematic Diagram - Part 1 (7600671)	5-49
5-19.	Autoload Servo Control Schematic Diagram - Part 2 (7600671)	5-51
5-20.	Autoload Interface Circuit Card Assembly (7600673)	5-53
5-21.	Autoload Interface Schematic Diagram (7600673)	5-55
5-22.	Capstan Drive Assembly (7600868)	5-57
5-23.	Capstan Drive Assembly Schematic Diagram (7601896)	5-59
5-24.	Reel Drive Assembly (7600869)	5-61
5-25.	Reel Drive Assembly Schematic Diagram (7601896)	5-63
5-26.	Read Amplifier Circuit Card Assembly (7091825)	5-65
5-27.	Read Amplifier Schematic Diagram - Part 1 (7091825)	5-67

LIST OF ILLUSTRATIONS

Figure	Page
5-28. Read Amplifier Schematic Diagram - Part 2 (7091825)	5-69
5-29. DC-To-DC Converter Assembly (7600870)	5-71
5-30. TTL/MSI 9301 One-of-Ten Decoder	5-72
5-31. TTL/MSI 9316 4-Bit Binary Counter	5-73

SECTION 6 - PARTS LIST

6-1. 400 Hz to 75 Vdc Power Supply	6-5
6-2. Regulator Subassembly	6-9
6-3. Capacitor Assembly	6-13
6-4. Front End Subassembly	6-16
6-5. Relay Subassembly	6-19
6-6. 400 Hz Front End Circuit Card Assembly	6-21
6-7. 75 Vdc Regulator Circuit Card Assembly	6-24
6-8. 1840 (Mod) Magnetic Tape Transport	6-28
6-9. Vacuum/Pressure Assembly	6-35
6-10. DC-DC Converter Assembly	6-37
6-11. DC-DC Converter Circuit Card Assembly	6-40
6-12. Reel Drive Assembly	6-43
6-13. Reel Drive Circuit Card Assembly	6-46
6-14. .320 Protrusion File Protect Assembly	6-49
6-15. Capstan Drive Assembly	6-51
6-16. Capstan Drive Circuit Card Assembly	6-54
6-17. Power Harness	6-57

SECTION 7 - FUNCTIONAL SCHEMATICS

Figure	Sheet No.
7-1. Logic Symbology	-
7-2. Control Signals	2
7-3. Reel Servo Input	3
7-4. Autoload Function Generator	4
7-5. Autoload Function Generator	5
7-6. Autoload Interface	6
7-7. Autoload Servo Control	7
7-8. Autoload Servo Control	8
7-9. Reel Servo Output	9
7-10. Reel Servo Output	10
7-11. Reel Drivers	11
7-12. Capstan Servo Logic	12
7-13. Capstan Servo Input	13
7-14. Power Distribution/Capstan Drive	14
7-15. DC-DC Converter	17
7-16. 400-Hz to 75 Vdc Power Supply Schematic	1
7-17. 400-Hz to 75 Vdc Power Supply Schematic	2
7-18. 400 Hz to 75 Vdc Power Supply Schematic	3
7-19. Power Distribution	-
7-20. Signal Distribution	-

LIST OF TABLES

SECTION 1 - GENERAL INFORMATION

Table		Page
1-1.	MTT Quick Reference Data	1-3
1-2.	Equipment Options	1-4
1-3.	Equipment and Publications Supplied	1-4
1-4.	Equipment Required But Not Supplied	1-4
1-5.	Nonstandard Terms, Symbols, and Abbreviations	1-5

SECTION 2 - INSTALLATION

2-1.	Input Power Connector J1 Pin Assignments	2-3
2-2.	Input Signal Connector J2 Wire Assignments	2-4
2-3.	Connector Pin Assignments, J3 to E Terminals	2-5
2-4.	Read Amplifier Cable Pin Assignments	2-7
2-5.	Power Supply Jack Pin Assignments	2-9

SECTION 3 - OPERATION

3-1.	MTT Controls and Indicators	3-2
------	---------------------------------------	-----

SECTION 4 - PRINCIPLES OF OPERATION

4-1.	Function Generator Control Signals	4-18
4-2.	Power Supply Assembly Identification	4-25

SECTION 5 - MAINTENANCE AND REPAIR

5-1.	Test Equipment and Special Tools	5-2
5-2.	Legend for Figure 5-3	5-8
5-3.	Legend for Figure 5-4	5-10
5-4.	Initial Control Setting.	5-16

SECTION 6 - PARTS LIST

6-1.	List of Manufacturers	6-3
------	---------------------------------	-----

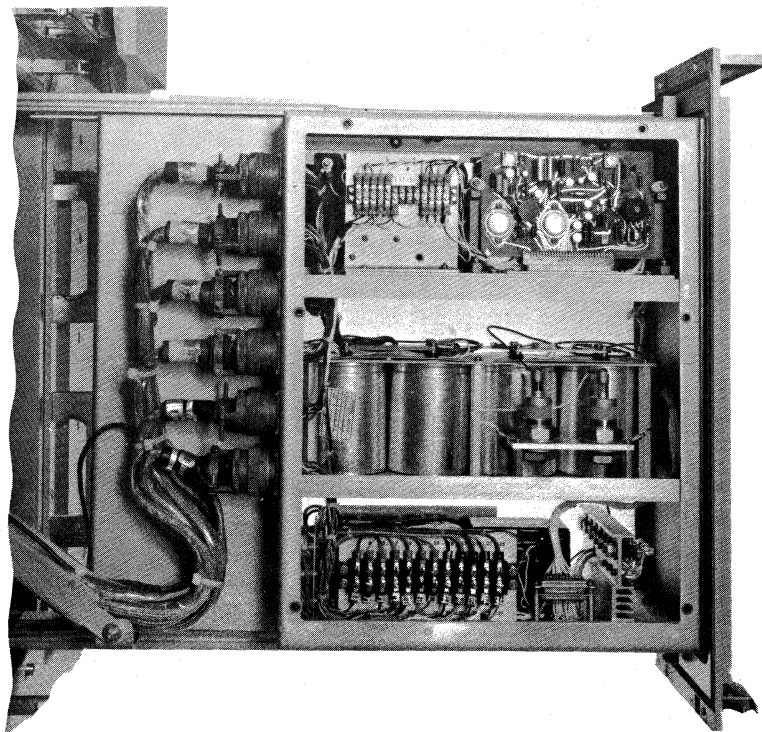
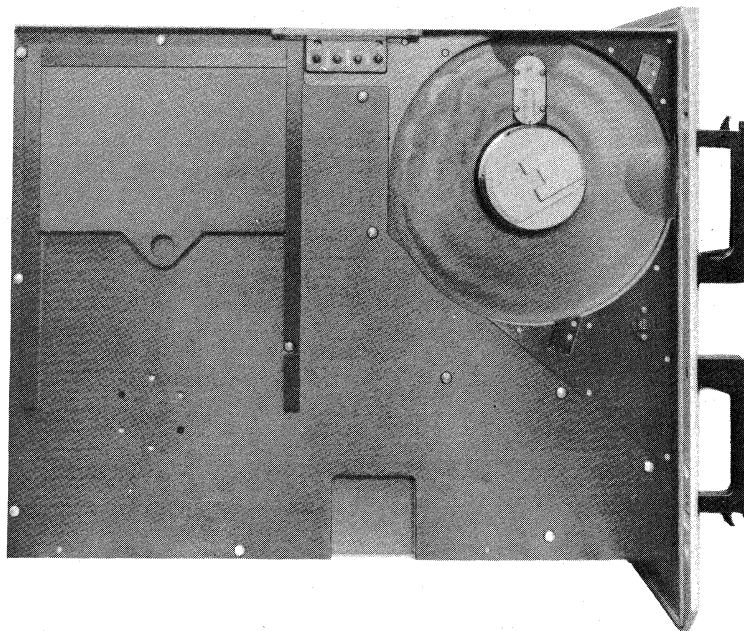

Figure 1-1. UNIVAC Type 1840 Modified Magnetic Tape Transport and 400-Hz Power Supply

SECTION 1

GENERAL INFORMATION

1-1. SCOPE.

This manual provides information and instructions to install, operate, troubleshoot, and maintain the UNIVAC Type 1840 Modified Magnetic Tape Transport and the 400-Hz Power Supply, hereinafter referred to as the MTT and power supply, respectively. The MTT and power supply described in this technical manual are components of the UNIVAC Type 1840 Modified Magnetic Tape Subsystem (MTS) which also contains a Control Unit (CU), Maintenance Console (MC), and a system control panel. For detailed operating procedures of the MTS, CU, MC, and system control panel, refer to the UNIVAC Type 1840 Modified MTS Technical Manual, PX 7985.

Section 1 contains a general description of the MTT and is intended as an introduction to MTT fundamentals for personnel requiring only a general knowledge of the equipment.

Section 2 contains the information required to install the MTT and power supply into the MTS. It also contains a tabular listing of the plugs, jacks, and terminal boards, and the signal source and signal destination of each item listed.

Section 3 contains operating procedures for the MTT including initial turn-on, normal operation, manual operation, and emergency shutdown.

Section 4 contains a detailed functional description of the MTT with references to the functional schematics contained in Section 7. Included are functional block diagrams, simplified functional schematics, and logical descriptions of the MTT.

Section 5 contains maintenance procedures for preventive maintenance and emergency maintenance in the event of a malfunction. Included are general removal and replacement procedures and operational adjustments.

Section 6 contains the MTT and power supply parts list.

Section 7 contains the functional logic schematics, power control and distribution drawings, and power supply functional schematics.

1-2. DESCRIPTION.

a. MTT. - The MTT (figure 1-1) is designed to meet the electrical and environmental requirements of MIL-E-16400; the functional requirements of the industry-standard, 7-track and 9-track recording formats; and the mechanical requirements of a reliable, vacuum-buffered, tape moving mechanism. Long-life, read/write heads and pluggable assemblies minimize maintenance requirements. The tape transport characteristics allow its utilization as new equipment design, or for upgrading or replacing existing units. Although designed primarily as a functional unit of the UNIVAC Type 1840 Modified Magnetic Tape Subsystem, the 7-track version of the MTT is functionally, electrically, and mechanically compatible with the UNIVAC Type 1240 and UNIVAC Type 1540 Magnetic Tape Units and, through the use of retrofit kits, may be used to upgrade these systems.

Features of the MTT include automatic tape loading, read, write, and erase electronics operated under MTS control, supply and takeup reel drive motors, motor servos, speed control, and an internal power supply. A single-capstan, vacuum-column drive and controlled start-stop technique provide for gentle handling of the tape, enabling more than 100,000 passes over the read/write head with no permanent tape damage. Other features include a quick-release hub which will accept industry-standard, 8.0- or 10.5-inch reels, subminiature parts, multilayer component boards, linear and digital integrated circuits, and unique design and packaging of servo and power supply circuits.

The MTT is slide-mounted in either a two- or four-handler cabinet and contains four controls/indicators for manual control during test and maintenance procedures. For additional information on these controls, refer to paragraph 3-2.

The MTT is compatible with standard, industry-accepted tape systems. It utilizes 0.5-inch, A-wound (oxide coating on the underside), polyester-based tape. It performs either standard 7-track or optional 9-track forward recording and forward/reverse reading at computer-controlled densities of 200, 556, 800 or 1600 (9-track only) bits per inch at a tape speed of either 112.5 or 120 inches per second. It has a fast forward or reverse speed of approximately 200 inches per second with an automatic stop at either the beginning-of-tape (BOT) marker or end-of-tape (EOT) marker as appropriate.

For larger system operation, up to eight MTT's can be controlled by the CU under computer direction. Selection of a specific MTT for operation is a function of the computer and an MTT will not operate until selected. The MTT can be operated in either simplex or duplex modes provided the computers and CU's have the necessary control electronics. The actual operation is a function of the computer program.

For detailed physical and functional characteristics of the MTT, refer to table 1-1.

b. 400-HZ POWER SUPPLY. - The 400-Hz power supply, located in the lower left bay of the 1840 Modified Magnetic Tape Subsystem cabinet, provides the operating voltages for the entire MTS. These voltages, controlled primarily from the System Control Panel (control panel), are distributed to the two or four MTT units through an individual circuit breaker for each unit.

The power supply supplies the 4-KHz signal to each MTT to enable the dc-to-dc converter inverter drive. In addition, if the voltage output of the power supply varies out of the allowable tolerance, a signal is sent to the control unit to disable operation.

1-3. EQUIPMENT OPTIONS.

The MTT is available in several optional configurations providing flexibility in operation. Refer to table 1-2 for a listing of the available options.

1-4. EQUIPMENT SIMILARITIES.

The 1840 Modified Magnetic Tape Transport is similar to the UNIVAC Type 1240, the UNIVAC Type 1540, and the UNIVAC Type 1840 Magnetic Tape Transports and, with the use of an available retrofit kit, may be used as a direct replacement for the 1240 and 1540 units.

TABLE 1-1. MTT QUICK REFERENCE DATA

PHYSICAL CHARACTERISTICS	
Height (Overall)	22.32 inches
Width (Overall)	13.60 inches
Depth (Overall)	25.50 inches
Weight	135 pounds
Reel Size	8.0 or 10.5 inches
Head Life	Long-Life (10,000 hours)
FUNCTIONAL CHARACTERISTICS	
Read/Write Speed	120 ips
Rewind Speed	120 ips
Fast Forward/Rewind Speed	200 ips
Channels	7 (9 by option)
Density	Computer Controlled 200, 556, 800, or 1600 bpi (9-channel only)
Interrecord Gap	
Normal	7-track 0.75 inches 9-track 0.60 inches
Extended	3.5 inches (7- and 9-track)
Power Requirements	
Input AC Power to Power Supply	208 Vac $\pm 10\%$, 400 Hz $\pm 5\%$, 3 Phase, 4 wire, 250 Watts
*Input DC Power to MTT	75 Vdc $\pm 2\%$, 3 Amperes
Internal Operating Power (MTT)	+30 Vdc -30 Vdc +15 Vdc -15 Vdc +5 Vdc
*A 4-KHz square-wave signal is required for operation of the dc-dc converter.	

1-5. EQUIPMENT LISTS.

a. EQUIPMENT AND PUBLICATIONS SUPPLIED. - Table 1-3 lists the equipment and publications supplied with the MTT.

b. EQUIPMENT REQUIRED BUT NOT SUPPLIED. - Table 1-4 lists the equipment which is required, but not supplied with the MTT.

1-6. TERMS, SYMBOLS, AND ABBREVIATIONS.

Table 1-5 lists the nonstandard terms, symbols, and abbreviations and their definitions used in this manual.

TABLE 1-2. EQUIPMENT OPTIONS

OPTION	FUNCTION
9-Track Read/Write Head	For use with 32-bit Central Processors
1240 Option	Update UNIVAC Type 1240 Magnetic Tape Unit
1540 Option	Update UNIVAC Type 1540 Magnetic Tape Unit

TABLE 1-3. EQUIPMENT AND PUBLICATIONS SUPPLIED

QUANTITY	ITEM	DESIGNATION
1	Magnetic Tape Transport	7601767 (Univac)
1	400-Hz Power Supply	7601768 (Univac)
1 Set per MTS	Technical Manual for Type 1840 Modified Magnetic Tape Transport and Power Supply	PX 7984-0-2

TABLE 1-4. EQUIPMENT REQUIRED BUT NOT SUPPLIED

QUANTITY	ITEM	FUNCTION	SOURCE AND DESIGNATION
1	IBM Master Skew Tape TS 800	To check basic functions of MTT, including read deskew	IBM No. 432641
As required (AR)	IBM Mag- netic Tape Markers (250)	To fabricate test tapes and to repair tapes	IBM No. 352407

TABLE 1-5. NONSTANDARD TERMS, SYMBOLS, AND ABBREVIATIONS

TERM, SYMBOL, OR ABBREVIATION	DEFINITION
CAP	Capstan
CAP TACH	Capstan Tachometer
CLOSED LOOP	Takeup reel servo and/or supply reel servo operating under control of the capstan tachometer.
OPEN LOOP	Takeup reel servo or supply reel servo operating under control of MTT-generated signals, independent from the capstan.
SOL	Solenoid
SRS	Supply Reel Servo
TACH	Tachometer
TC	Time Count
TRS	Takeup Reel Servo

SECTION 2
INSTALLATION

2-1. UNPACKING AND HANDLING.

The MTT and power supply are normally shipped completely installed in the MTS. In the event of other methods of shipment, information regarding unpacking will be included.

2-2. OUTLINE AND DIMENSIONAL DATA.

Figure 2-1 contains MTT outline and dimensional data. When mounted in the cabinet the unit can be extended approximately 28 inches. Adequate clearance must be provided to fully extend the unit to facilitate maintenance and removal.

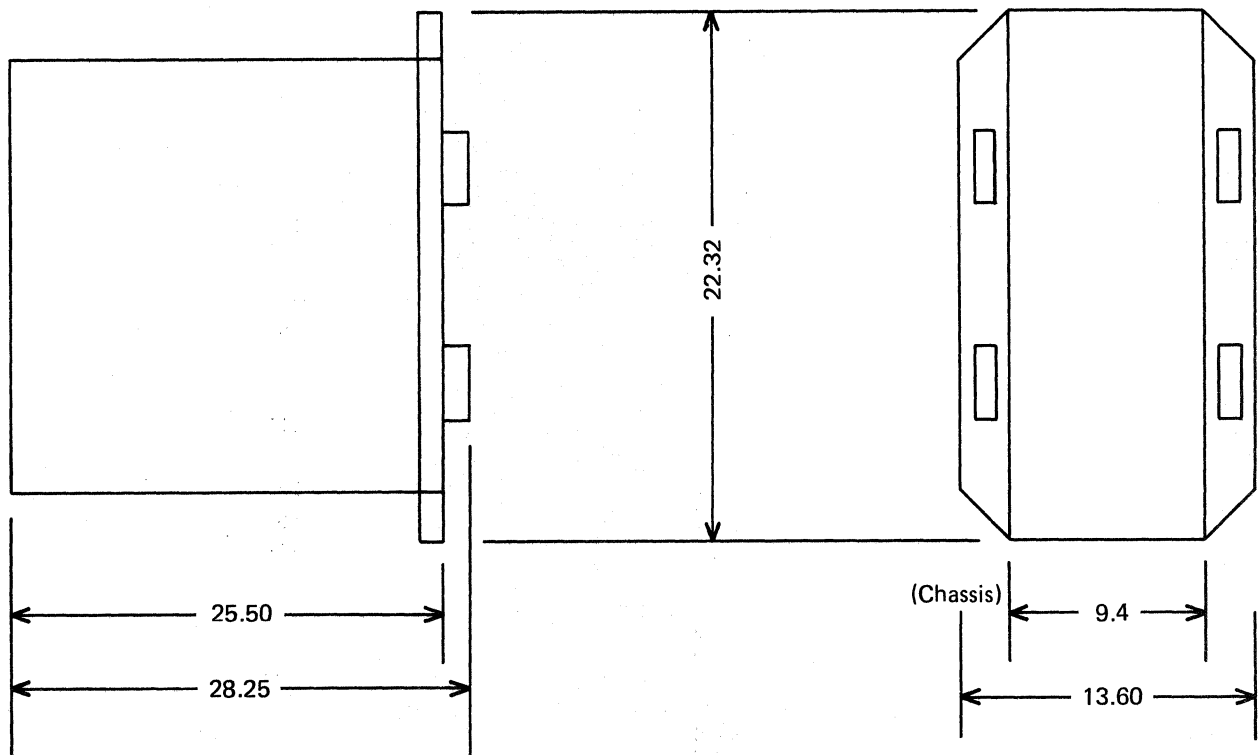

Figure 2-1. Outline and Dimensional Data

2-3. CABLES AND CONNECTORS.

Cables and connectors for operation of the MTT are integral parts of the MTS. Only those cables and connectors inside the cabinet bay and connected to the retractable "grasshopper" arm are required. Tables 2-1 through 2-3 list the connectors and the signal name and destination on all used pins. The 400-Hz power supply jack pin assignments are listed in table 2-5. Figure 2-2 identifies the location of each jack and plug listed in the following tables.

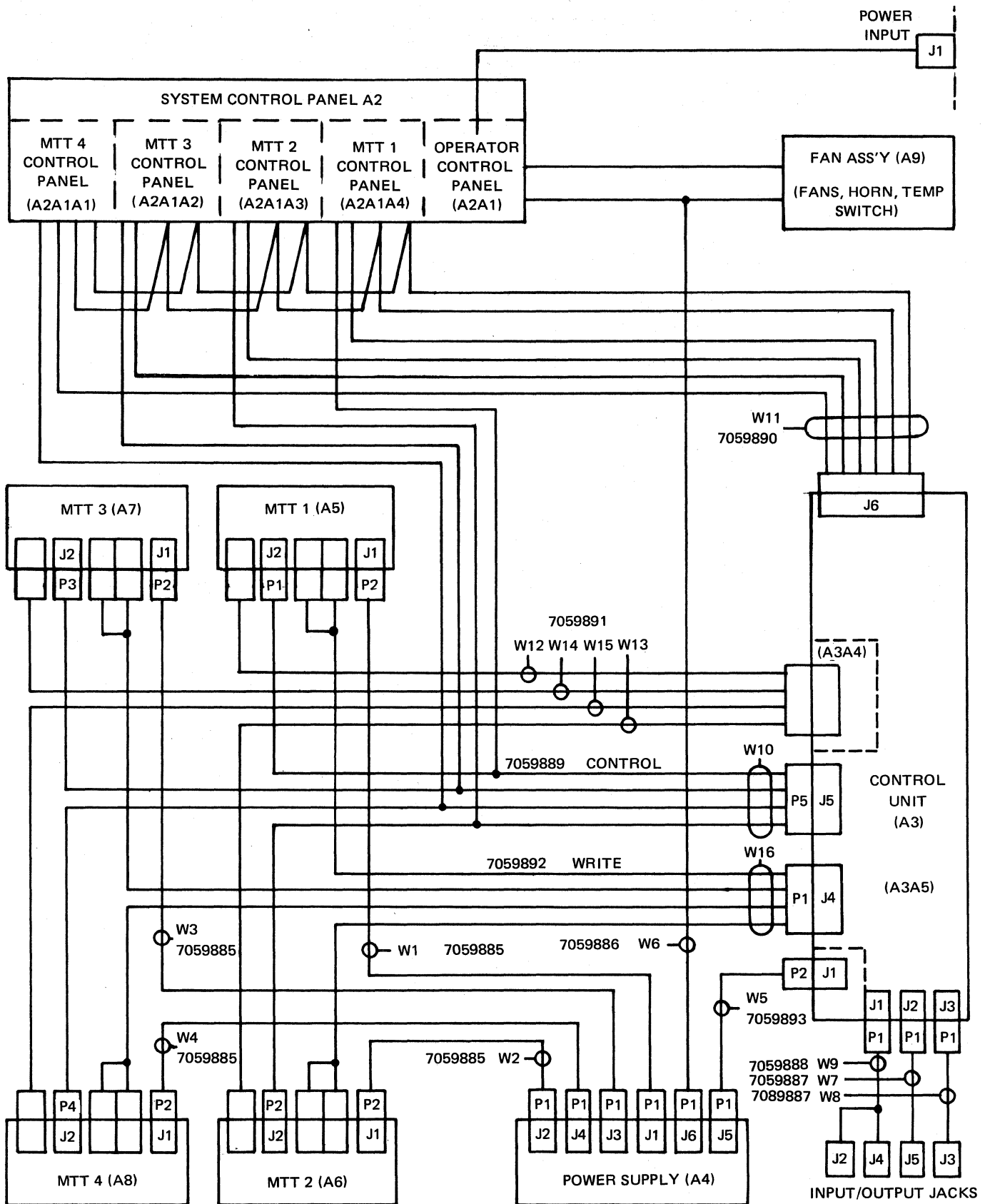

Figure 2-2. Cable and Connector Location/Reference Designators

TABLE 2-1. INPUT POWER CONNECTOR J1 PIN ASSIGNMENTS

PIN	DESTINATION	SIGNAL
A	A1TB1-1	208 Vac OA
B	A1TB1-2	208 Vac OB
C	A1TB1-3, M1-1	208 Vac OC
D	M1-2	208 Vac Neutral
E	P4-1	+75 Vdc
F	P4-2	+75 Vdc
G	A4TB1-1	+75 Vdc
H	P4-3	75V Return
J	P4-4	75V Return
K	A4TB1-2	75V Return
L	P5-37	In. Drive 2 In.
M	P5-40	In. Drive 1 In.
P	P5-2	Auto Gnd
R	P3-15	Blower Relay HI
S	P3-20	Blower Relay LO
T	E1	Chassis Ground

TABLE 2-2. INPUT SIGNAL CONNECTOR J2 WIRE ASSIGNMENTS

FROM CU	TO MTT	VIA	SIGNAL
J2-A	J01A-46	P01-46	Reverse
J2B	J01A-10	P01-10	Forward
J2C	J01A-8	P01-8A	Reverse Return
J2D	J01A-8	P01-8B	Forward Return
J2E	J01A-11	P01-11	Fast
J2F	J01A-13	P01-13	BOT
J2H	J01A-8	P01-8C	Fast Return
J2-J	J01A-8	P01-8D	BOT Return
J2-K	J01A-14	P01-14	EOT
J2-L	J01A-33	P01-33	Ready
J2-M	J01A-8	P01-8E	EOT Return
J2-N	J01A-22	P01-22A	Ready Return
J2-P	J01A-16	P01-16	Low Tape
J2-R	J01A-27	P01-27	Write Enable
J2-S	J01A-22	P01-22B	Low Tape Return
J2-T	J01A-22	P01-22D	Write Enable Return
J2-U	J01A-23	P01-23	Capstan Zero
J2-V	J01A-20	P01-20	Write
J2-W	J01A-50	P01-50D	Capstan Zero Return
J2-X	J01A-22	P01-22E	Write Return
J2-d	J01A-37	P01-37	Stop Switch
J2-f	J01A-36	P01-36A	Stop Switch Return
J2-h	J01A-48	P01-48	Load Switch
J2-k	J01A-36	P01-36C	Load Switch Return
J2-j	J01A-19	P01-19	Load Indicator

TABLE 2-2. INPUT SIGNAL CONNECTOR J2 WIRE ASSIGNMENTS (CONT)

FROM CU	TO MTT	VIA	SIGNAL
J2-m	J01A-50	P01-50A	Load Indicator Return
J2-n	J01A-52	P01-52	Unload Switch
J2-p	J01A-7	P01-7	Unload Indicator
J2-r	J01A-36	P01-36E	Unload Switch Return
J2-s	J01A-50	P01-50C	Unload Indicator Return
J2-u	J01A-2	P01-2	Ready Indicator
J2-w	J01A-50	P01-50B	Ready Indicator Return
J2-y	J01A-55	P01-55A	+5 Vdc

TABLE 2-3. CONNECTOR PIN ASSIGNMENTS, J3 to E TERMINALS

FROM	TO	VIA	SIGNAL
J3-A	E-29	P2-A	Read Data 0
J3-B	E-30	P2-B	Read Data 0 Return
J3-C	E-28	P2-C	Signal Ground
J3-D	E-32	P2-D	Read Data 1
J3-E	E-33	P2-E	Read Data 1 Return
J3-F	E-31	P2-F	Signal Ground
J3-G	E-35	P2-G	Read Data 2
J3-H	E-36	P2-H	Read Data 2 Return
J3-J	E-34	P2-J	Signal Ground
J3-K	E-38	P2-K	Read Data 3
J3-L	E-39	P2-L	Read Data 3 Return
J3-M	E-37	P2-M	Signal Ground
J3-N	E-41	P2-N	Read Data 4
J3-P	E-42	P2-P	Read Data 4 Return
J3-R	E-40	P2-R	Signal Ground

TABLE 2-3. CONNECTOR PIN ASSIGNMENTS, J3 to E TERMINALS (CONT)

FROM	TO	VIA	SIGNAL
J3-S	E-44	P2-S	Read Data 5
J3-T	E-45	P2-T	Read Data 5 Return
J3-U	E-43	P2-U	Signal Ground
J3-V	E-47	P2-V	Read Data 6
J3-W	E-48	P2-W	Read Data 6 Return
J3-X	E-46	P2-X	Signal Ground
J3-Y	E-50	P2-Y	Read Data 7
J3-Z	E-51	P2-Z	Read Data 7 Return
J3-a	E-49	P2-a	Signal Ground
J3-b	E-53	P2-b	Read Data 8
J3-c	E-54	P2-c	Read Data 8 Return
J3-d	E-52	P2-d	Signal Ground
J3-k	E-55	P2-k	+6 Vdc
J3-m	E-56	P2-m	Analog Ground
J3-q	E-57	P2-q	-6 Vdc
J2-r	E-59	P2-r	Outer Shield

NOTE

The terminals designated E-XX in column 2 (TO) above are located on the read amplifier assembly located physically in card jack location J09A. These are the output signals to the controller. See figure 2-3 for the origin and destination of the signal lines and table 2-4 for the read amplifier cable pin assignments.

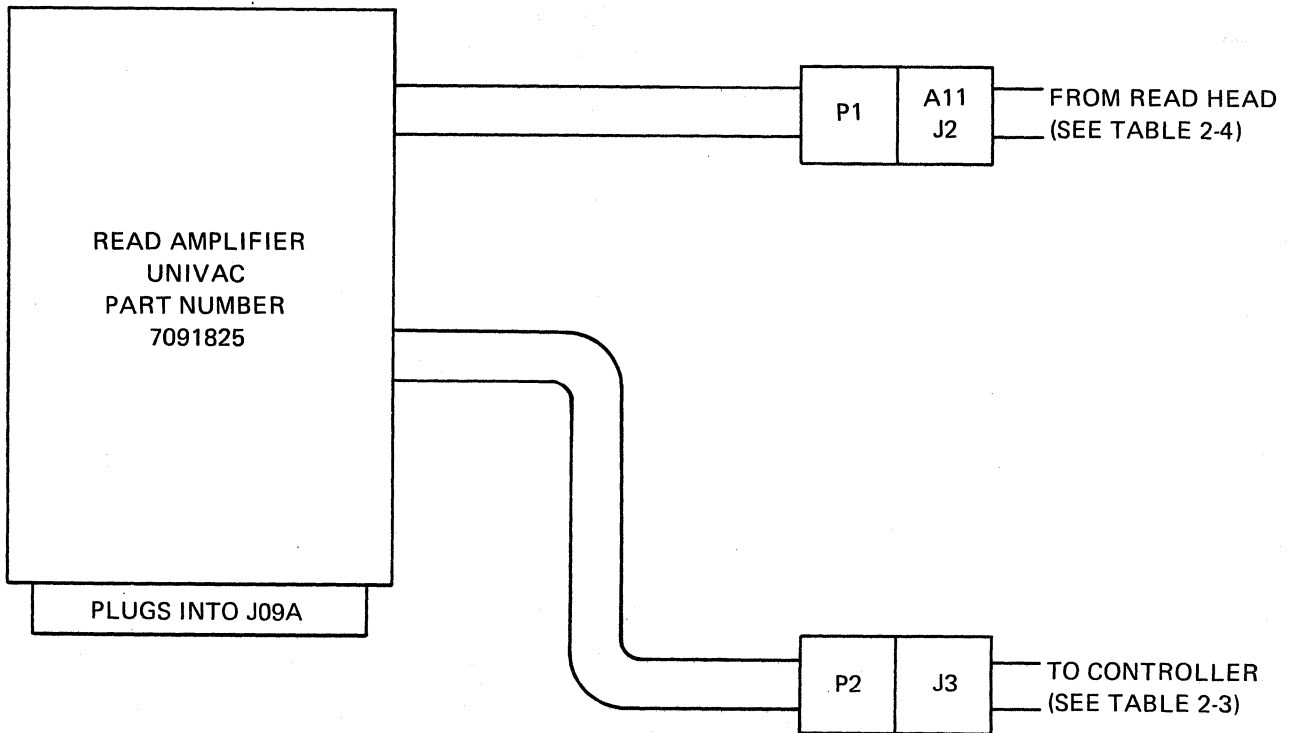

Figure 2-3. Read Amplifier Cable Destinations

TABLE 2-4. READ AMPLIFIER CABLE PIN ASSIGNMENTS

FROM (Read Head)	TO (7091825)	SIGNAL
P1-	E-1	*
P1-A	E-2	Data Bit 0
P1-C	E-3	Data Bit 0
P1-	E-4	*
P1-D	E-5	Data Bit 1
P1-F	E-6	Data Bit 1
P1-	E-7	*
P1-H	E-8	Data Bit 2
P1-K	E-9	Data Bit 2
P1-	E-10	*
* No Connection at P1.		

TABLE 2-4. READ AMPLIFIER CABLE PIN ASSIGNMENTS (CONT)

FROM (Read Head)	TO (7091825)	SIGNAL
P1-L	E-11	Data Bit 3
P1-N	E-12	Data Bit 3
P1-	E-13	*
P1-P	E-14	Data Bit 4
P1-S	E-15	Data Bit 4
P1-	E-16	*
P1-T	E-17	Data Bit 5
P1-V	E-18	Data Bit 5
P1-	E-19	*
P1-W	E-20	Data Bit 6
P1-Y	E-21	Data Bit 6
P1-	E-22	*
P1-Z	E-23	Data Bit 7
P1-b	E-24	Data Bit 7
P1-	E-25	*
P1-c	E-26	Data Bit 8
P1-e	E-27	Data Bit 8
P1-	E-58	*

* No Connection at P1.

TABLE 2-5. POWER SUPPLY JACK PIN ASSIGNMENTS

PIN NO.	SIGNAL
J1, J2, J3, J4	POWER TO MTTs
<p>A</p> <p>B</p> <p>C</p> <p>D</p> <p>E</p> <p>F</p> <p>G</p> <p>H</p> <p>J</p> <p>K</p> <p>L</p> <p>M</p> <p>N</p> <p>R</p> <p>S</p> <p>T</p>	<p>208 Vac, 400 Hz, Phase A</p> <p>208 Vac, 400 Hz, Phase B</p> <p>208 Vac, 400 Hz, Phase C</p> <p>208 Vac, 400 Hz, Neutral</p> <p>75 Vdc Positive</p> <p>75 Vdc Positive</p> <p>75 Vdc Positive</p> <p>75 Vdc Return</p> <p>75 Vdc Return</p> <p>75 Vdc Return</p> <p>4 KHz, Phase A</p> <p>4 KHz, Phase B</p> <p>4 KHz Return</p> <p>Relay Line 1</p> <p>Relay Line 2</p> <p>Shield Ground</p>
J5	POWER TO CU
<p>A</p> <p>B</p> <p>E</p> <p>J</p> <p>T</p> <p>U</p> <p>V</p> <p>W</p>	<p>115 Vac, 400 Hz</p> <p>115 Vac, 400 Hz Return</p> <p>75 Vdc Positive</p> <p>75 Vdc Return</p> <p>Chassis Ground</p> <p>Out-of-Tolerance High</p> <p>Out-of-Tolerance Return</p> <p>Shield Ground</p>

TABLE 2-5. POWER SUPPLY JACK PIN ASSIGNMENTS (CONT)

PIN NO.	SIGNAL
J6	INPUT POWER TO POWER SUPPLY
A	208 Vac, 400 Hz, Phase A
B	208 Vac, 400 Hz, Phase B
C	208 Vac, 400 Hz, Phase C
D	208 Vac, 400 Hz, Neutral
E	Transformer Shield
G	115V Auxiliary Hot
H	115V Auxiliary Switch
J	115V Auxiliary Return
L	115 Vac 400 Hz, Phase A
M	115 Vac 400 Hz, Phase B
N	115 Vac 400 Hz, Phase C
P	208 Vac 400 Hz, Phase A
R	High Overtemperature
S	High Overtemperature Return
T	Shield and Chassis Ground
W	208 Vac, 400 Hz, Phase B
X	208 Vac, 400 Hz, Phase C

SECTION 3

OPERATION

3-1. GENERAL.

This section contains the information and instructions for operation of the MTT. Normally, operation of the MTT is automatic and performed under control of the MTS through command signals. The command signals are FWD, REV, REWIND, FAST, STOP, AUTOLOAD, and UNLOAD. For a description of these signals and their functions, refer to the technical manual for Type 1840 Modified MTS, PX 7985.

As an optional feature, the MTT may be adapted to operate as a replacement tape transport in either a UNIVAC Type 1240 or UNIVAC Type 1540 Magnetic Tape System to either upgrade or enhance the system.

3-2. CONTROLS AND INDICATORS.

The MTT contains two pushbutton switch-indicators, one indicator, and one push-button switch. These controls are located on the front panel of the transport deck and are shown in figure 1-1. Table 3-1 contains a listing of these controls and their functions. All other controls and indicators used for MTT operation are located on the system control panel (control panel) and on the controller.

3-3. PRELIMINARY CHECKS.

Before applying power to the MTT, check all cables and connectors to and from the MTT to ensure the connections are secure.

3-4. WRITE ENABLE RING.

If a write operation is to be performed, a write enable ring must be installed on the tape supply reel. A write operation cannot be performed unless this ring is installed. Read and other nonwrite operations can be performed with the write enable ring either installed or removed, but the ring should be removed for such operations to prevent accidental erasing and writing on the tape. The write enable ring is an industry-standard item and is usually included with each tape reel purchased.

3-5. TAPE LOAD PROCEDURE.

The controls and indicators required for tape loading are contained on the front panel of the transport deck. To load the MTT, perform the following steps.

STEP 1. Ensure that power has been removed from transport to be loaded.

STEP 2. Extend transport from cabinet.

STEP 3. Release supply hub latch.

CAUTION

Avoid touching the tape at any point beyond the beginning-of-tape (BOT) marker. If the tape must be handled, grasp it along the outside edges.

TABLE 3-1. MTT CONTROLS AND INDICATORS

NAME	TYPE	FUNCTION
LOAD W2S1	Pushbutton Switch- Indicator	Pressing the LOAD switch initiates the load sequence which terminates with the tape loaded in the buffer columns and, for the initial load of a new reel of tape, at the load point. The LOAD indicator is illuminated during the load sequence. Upon completion of the load sequence, the load indicator is extinguished and the READY signal is supplied to the Controller to illuminate the READY indicator.
READY W2S2	Indicator	The READY indicator is illuminated when the MTT is loaded and ready to accept an operational command.
UNLOAD W2S3	Pushbutton Switch- Indicator	Press the UNLOAD switch initiates the unload sequence during which all tape is run on the supply reel and the vacuum blower is turned off. The UNLOAD indicator is illuminated during the unload sequence.
STOP W2S4	Pushbutton Switch	Press the STOP switch terminates all MTT operation and turns off the vacuum blowers. Tape is wound out of columns onto supply reel. To resume operation, press the LOAD switch.

- STEP 4. If operation to be performed includes a write mode, ensure that write enable ring is installed on tape reel.
- STEP 5. Install reel on reel hub so that tape is fed in a clockwise direction.
- STEP 6. Lock supply hub latch.
- STEP 7. Apply power to transport.

NOTE

The following step may be performed either from the control panel or the MTT switch panel. Where a difference in switch nomenclature exists, the control panel nomenclature is in parentheses.

- STEP 8. Press LOAD switch.

The tape will now automatically load to the BOT and the BOT indicator and READY indicator will be lighted. Operation under computer control may now be performed.

-6. TAPE UNLOAD PROCEDURE.

To unload the tape and reel from the MTT, perform the following steps.

- STEP 1. Apply power to MTT.

STEP 2. Press UNLOAD switch. Tape will rewind on supply reel.

STEP 3. After tape has been rewound onto supply reel, remove reel from transport.

3-7. POWER SUPPLY TURN ON.

To initiate operation of the power supply, place the main power switch on the control panel in the ON position. Extend the power supply and place the appropriate circuit breakers, CB1 through CB5, in the ON position. CB1 controls power to MTT1, CB2 controls power to MTT2, etc. CB5 controls power to the control unit.

SECTION 4

PRINCIPLES OF OPERATION

4-1. GENERAL.

This section describes the operating principles of the MTT. Included in this section are block diagram analysis, functional analysis, and a description of the interface between the MTT and the controller. The magnetic tape format is included in the technical manual for Type 1840 Modified MTS, PX 7985.

The information presented in this section is a simplified description of the functions of the MTT and power supply and references the logic diagrams in Section 7. For detailed functional diagrams of the printed circuit cards and subassemblies, refer to Section 5. For detailed information describing the role of the MTT in the Magnetic Tape Subsystem, refer to PX 7985.

4-2. SIMPLIFIED BLOCK DIAGRAM ANALYSIS.

a. GENERAL. - The MTT consists of six major sections (figure 4-1) as follows: Control Section, Autoload Function Generator, Autoload Interface, Autoload Servo Control, Reel Servo, and Capstan Servo. The MTT also contains a power supply which converts input power to the required operating voltages.

For all operation, automatic or manual, the MTT must be connected to the MTS controller and power supply for the necessary commands and power. The control panel on the MTS contains the POWER on-off switch which controls the application of power to the MTT during any operation. To operate a magnetic tape subsystem under computer control, the MTT must be interfaced with the controller to complete a minimum configuration.

b. CONTROL SECTION. - The control section (figure 7-2) provides the control signals for manual operation of the MTT and supplies the indicator enables to notify the operator of MTT operational status. The MTT must be connected to the controller for any read or write operation. However, commands to load, unload, and stop may be manually generated on the MTT switch panel.

c. AUTOLOAD FUNCTION GENERATOR. - The autoload function generator (figures 7-4 and 7-5) provides the function signals to identify the sequential operations during an automatic load procedure. Each function, identified by a OF through 12F signal from the decoder, performs specific transport load procedures, normally within a definite time period established through an internal counter or clock. As the operation advances to the next function, the clock is reset to reestablish the time base.

The autoload function generator consists of a series of AND gates which, with given input signals, produces a resultant output. Figure 4-2 shows a simplified functional schematic of the autoload function generator. In this schematic, a low signal from any one output will indicate the active function and can be traced back to a unique combination of inputs. In the example, the 10F output is the result of the indicated input signal levels and all other outputs would be high.

d. AUTOLOAD INTERFACE. - The autoload interface circuits (figure 7-6) provide the necessary interface between the automatic loading circuits and both the MTT

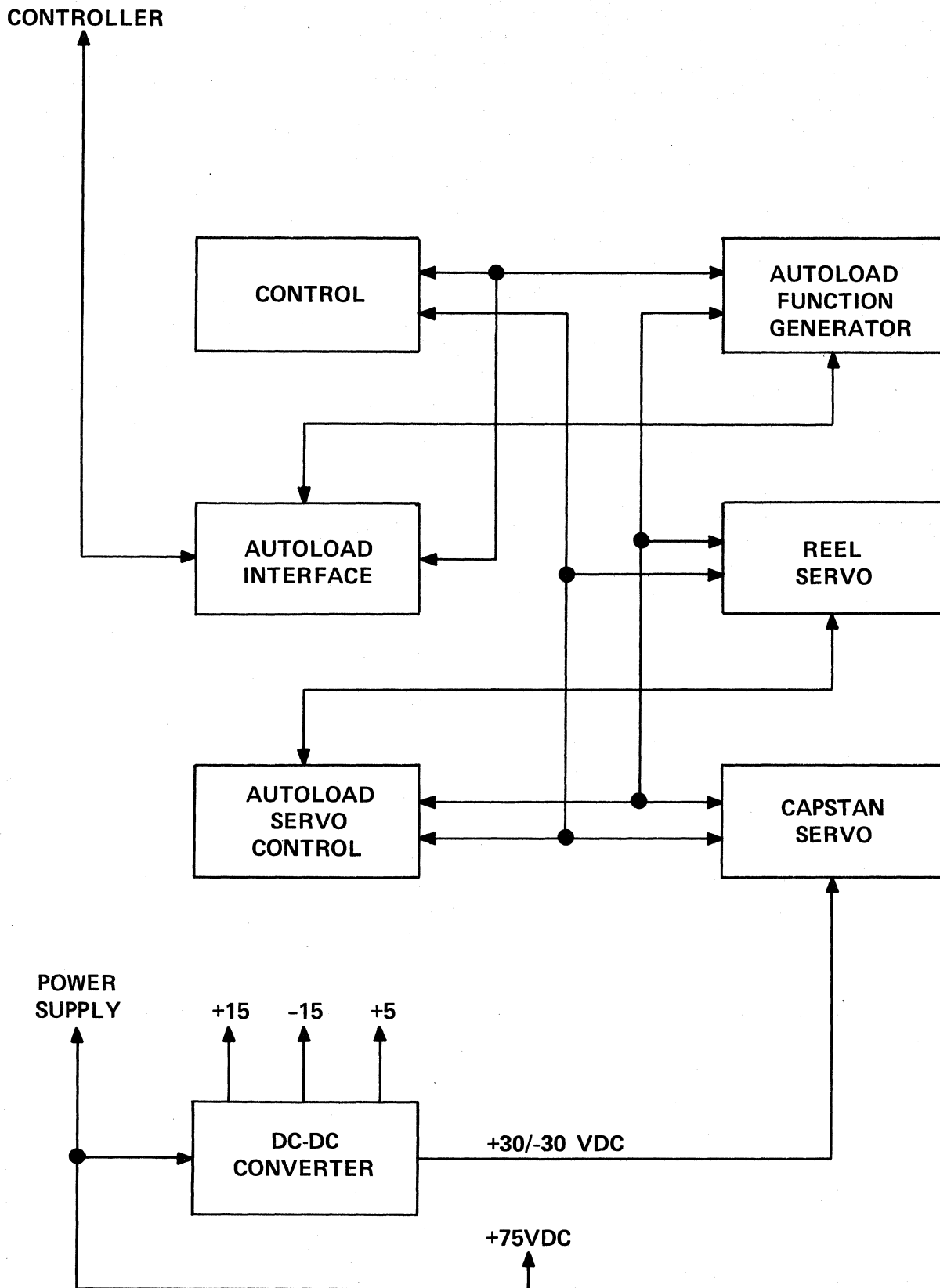

Figure 4-1. MTT Simplified Block Diagram

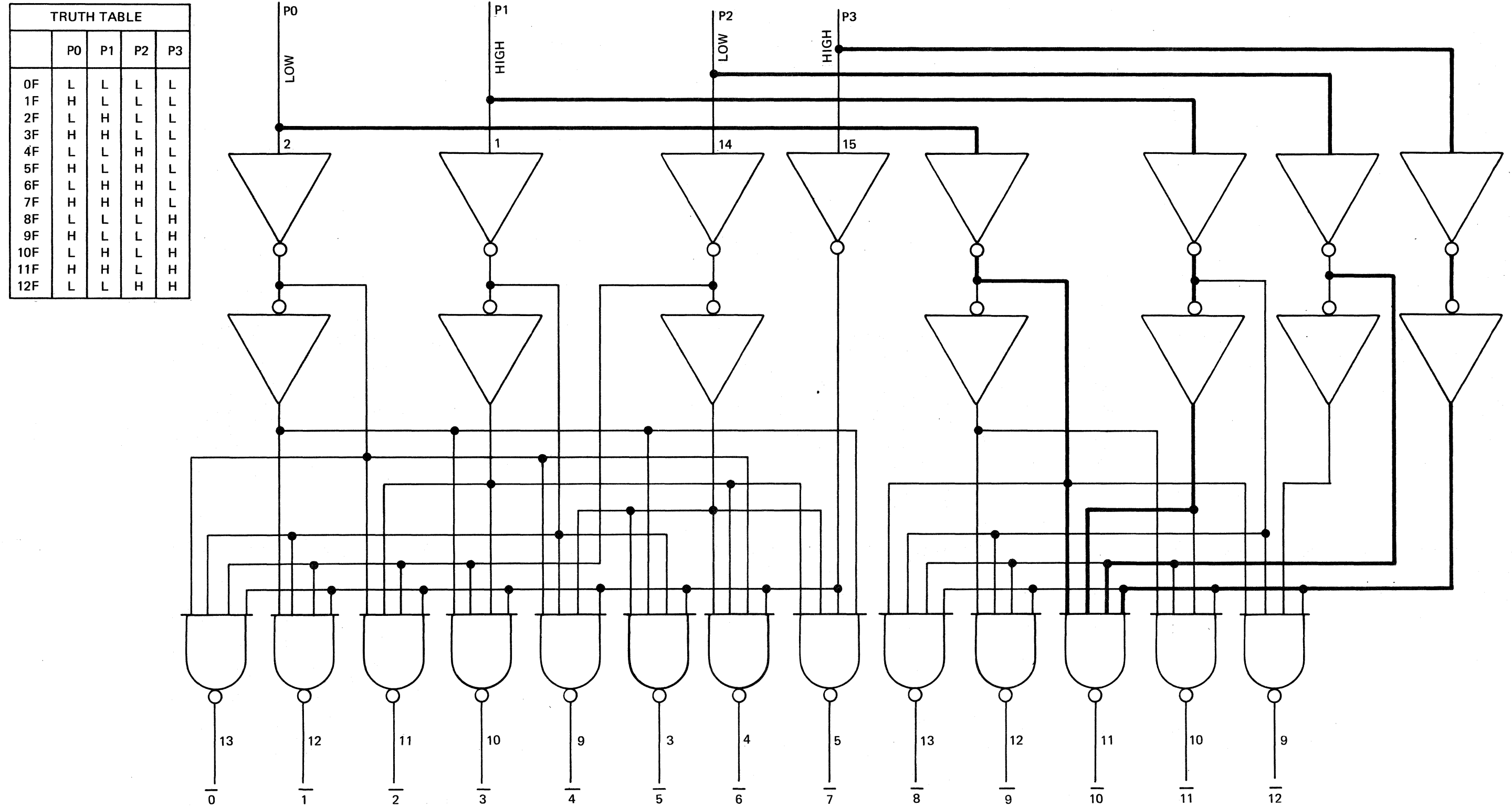

Figure 4-2. Autoload Function Generator, Simplified Schematic, F = 10

switch panel and controller. These signals notify the operator or controller circuitry of the operation being performed and the status of the transport.

e. AUTOLOAD SERVO CONTROL. - The autoloader servo control circuits (figures 7-7 and 7-8) provide the timing signals in the form of timed clock (TC) pulses from a decade counter and generate the signals to the servo circuits for movement during the automatic load procedures. These signals are generated primarily during the open-loop condition during which the controller is not in control of MTT operation.

f. REEL SERVO. - The reel servo circuits (figure 7-3, and figures 7-9 through 7-11) control the operation of both the takeup (TRS) and supply (SRS) reel servo systems. As commands are received from the autoloader servo control, each reel servo, operating basically independent from each other, performs the operation dictated by the command. These commands are forward and reverse at slow or fast speeds, depending upon the function being performed. The reel servo motors are pulse driven, i.e., the applied voltage is a series of drive pulses rather than a steady dc voltage, from pulses generated by an oscillator in the reel servo circuits. The speed of the motor is determined primarily by the duration (pulse width) of the applied pulses. The direction of rotation is controlled by two of four switching transistors which are turned on or off by the signals representing the desired direction. For forward operation, drive A and C are used; for reverse operation, drive B and D are used.

g. CAPSTAN SERVO. - The capstan servo circuits (figures 7-12 and 7-13) control the operation of the capstan motor by supplying drive commands generated from input signals from the controller. Capstan direction and speed are controlled by these commands.

h. DC-TO-DC CONVERTER. - The dc-to-dc converter (figure 7-15) is basically a dc power supply which converts the +75 Vdc input to +30/-30 Vdc, -15 Vdc, +15 Vdc, and a +5 Vdc for the operating voltages within the MTT.

(1) +75 VDC. - The +75 Vdc output is used to supply drive voltages to the reel servo motors in the form of dc pulses at a 1.1-KHz rate. These pulses are developed by pulse-modulating the +75 Vdc in the reel drive circuits. The pulse width determines the speed of the servo motor.

(2) +30/-30 VDC. - The +30/-30 Vdc output is used to provide drive voltage for the capstan motor. An electronic switch will apply either a positive or a negative 30 Vdc to the capstan motor for either forward or reverse drive.

(3) -15 VDC. - Two separate -15 Vdc outputs are provided to supply (a) logic voltage to the MTT, and (b) logic voltage to the write circuits only. These two voltages are isolated to prevent transient signals from being written as false data on the tape when in a write mode.

(4) +15 VDC. - The +15 Vdc output, as with the +5 Vdc output, is used as a logic voltage for circuit operation throughout the MTT.

(5) +5 VDC. - The +5 Vdc output supplies logic voltages throughout the MTT.

i. BUFFER COLUMN SENSORS. - Each buffer column contains four vacuum/pressure sensors which are used to notify the logic circuitry of tape location within the column. The sensors are designated A, B, C, and D (figure 4-3). During normal

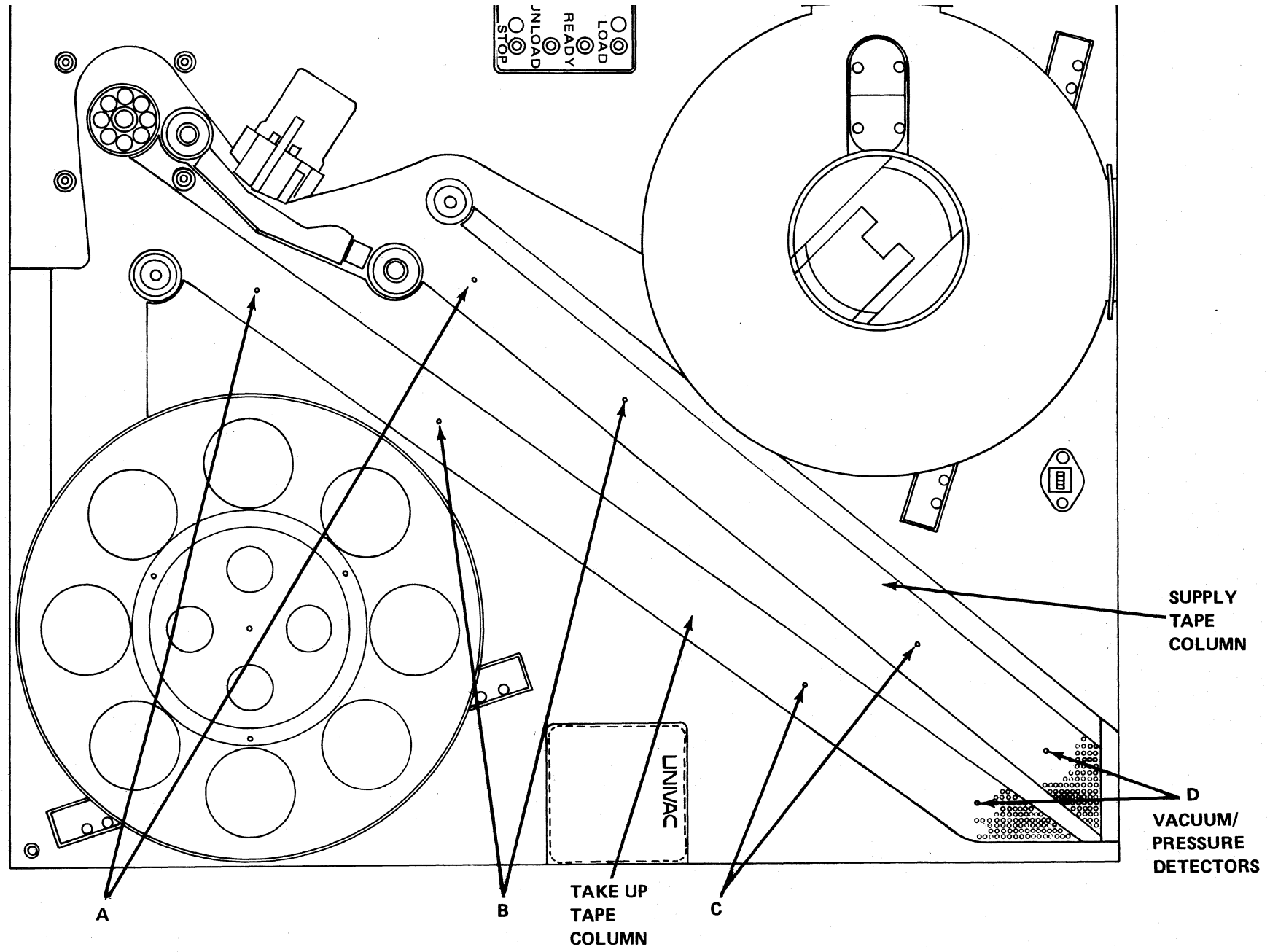

Figure 4-3. Buffer Column Sensors

operation, the tape location is between sensors B and C which are called control sensors. If the tape loop should reach sensors A or D, normally called fault sensors A or D, normally called fault sensors, a fault condition will be indicated. Sensors A and B should normally sense atmospheric pressure while sensors C and D should sense a vacuum. The sensors may be further identified by the column location designator such as TRS-A, SRS-C, etc.

j. AIR 1 AND AIR 2 SOLENOIDS. - The MTT contains two air control solenoids which control the application of vacuum and pressure during both the load sequence and normal operation. During the first phase of the load operation, the AIR 1 solenoid is energized to apply pressure to the buffer columns to prevent the tape from following the buffer column path and direct the tape to the takeup reel. The AIR 2 solenoid is energized to supply a vacuum to the takeup reel hub to ensure that the tape adheres to the reel hub during the load procedure. After the tape has been wound around the takeup reel hub, both solenoids are deenergized to apply a vacuum to the buffer columns and thus pull the tape into the columns.

k. REEL SERVO SYSTEM. - The MTT contains two identical but functionally independent reel servo systems (figure 4-4), one for each of the two reel drive motors. Input signals to the reel control logic are received primarily from the reel tachometers which detect tape speed, from the capstan logic, and from the vacuum/pressure sensors in the tape buffer columns. The resulting drive signals are applied to the reel motors to drive in either direction, accelerate, operate at rewind speed, slow down, brake, stop, or hold after stop.

The output from the 1.1-KHz oscillator (logic element 003 on figure 7-9) is applied to three logic gates, only one of which is enabled at any time. If the SRS LOOP SPEED 2 signal is present, the output from the single-shot 010 is used. This pulse output is approximately 30% of the duty cycle of the input 1-KHz sine wave and will produce the SRS fast speed signal during open-loop operation. If the SRS LOOP SPEED 1 signal is present, the output from the 012 single-shot is used to generate the SRS slow speed signal during open-loop operation. This output is adjustable and is normally set at approximately 5% of the duty cycle. (See Section 5 for the adjustment procedures). In closed-loop operation, the error voltage; i.e., the difference between the output of the capstan tachometer and the reel tachometer, is enabled to produce a resulting pulse width from the pulse-width modulator which will determine the percentage of the duty cycle that is generated to control the effective speed of the reel motor. The above explanation also applies to the TRS reel motor (figure 7-10).

4-3. MTT/CONTROLLER INTERFACE.

The logic and electronic circuits within the MTT receive, interpret, and respond to control signals; transmit and receive data signals; and develop power voltage levels from input power. Interface voltages can be classed as input control signals, output control signals, data, and prime power. In general, the control signals represent the control function if they are at a +5 Vdc level, indicating a logical 1. Figure 4-5 shows the MTT interface signals described in the following paragraphs.

a. INPUT CONTROL SIGNALS. -

(1) ERASE. - The erase control signal is supplied directly from the controller to the erase head on the MTT. It performs no logic or physical function within the MTT other than to erase data from the tape. Refer to system manual, PX 7985, for the characteristics and function of the erase signal.

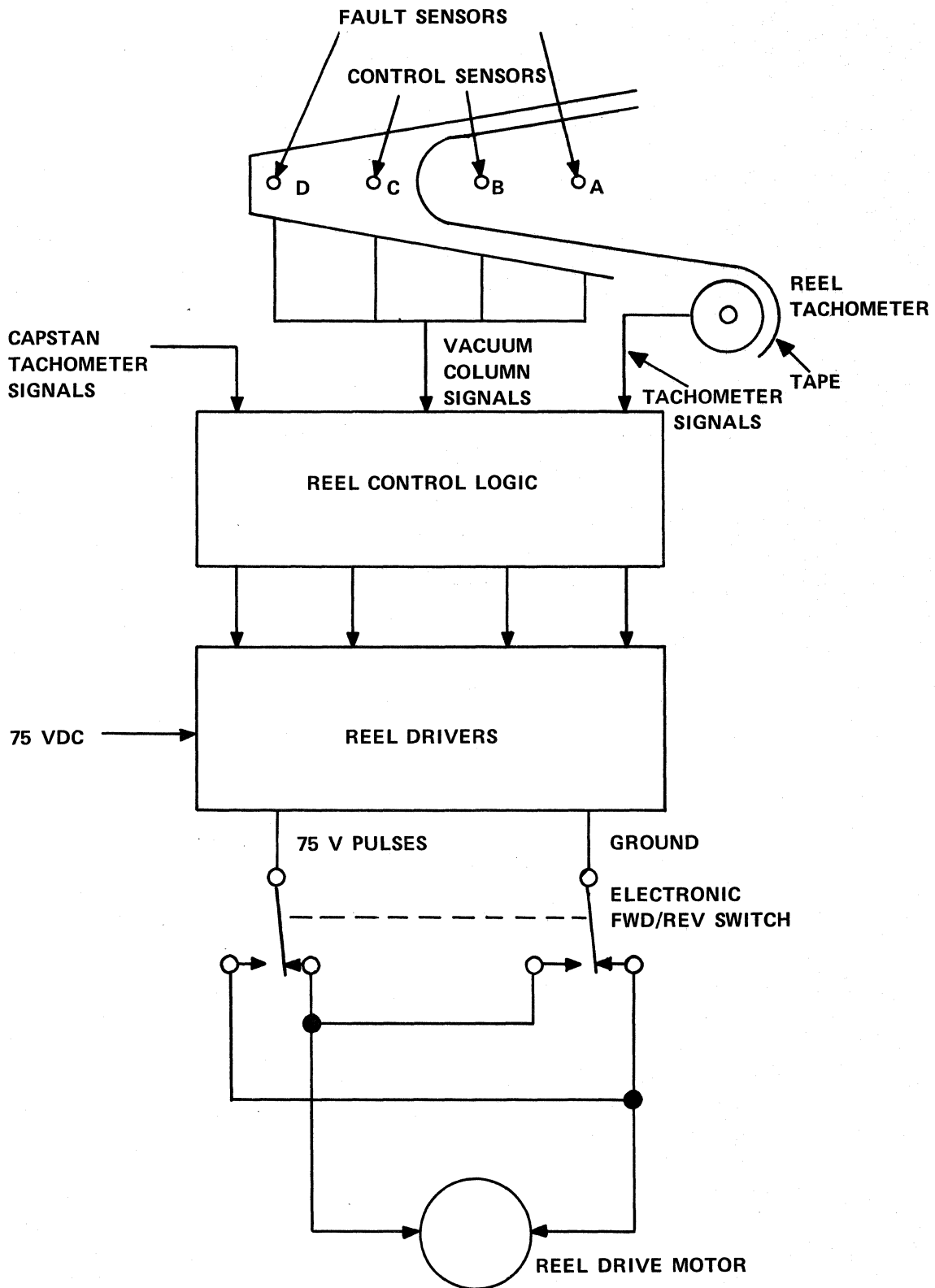

Figure 4-4. Reel Drive Control, Simplified Block Diagram

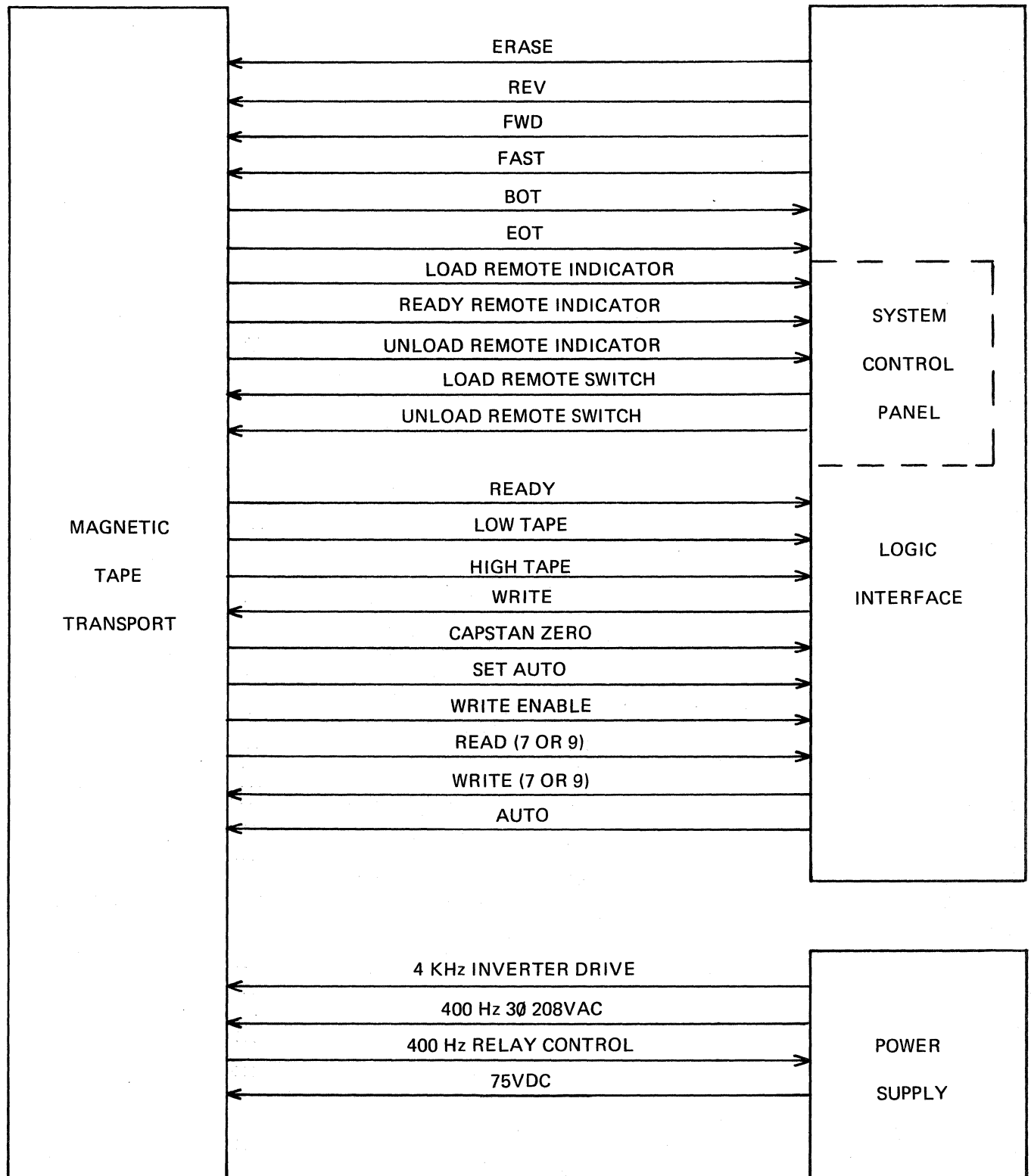

Figure 4-5. MTT Interface Signals

(2) REV. - When the REV signal (+5v identifying a reverse operation) is received from the controller, tape motion is from the takeup reel to the supply reel. When the BOT is detected, tape motion will stop and the MTT will await further commands.

(3) FWD. - When the FWD signal (+5v identifying a forward operation) is received from the controller, tape motion is from the supply reel to the takeup reel. When the EOT is detected, tape motion will stop and the MTT will await further commands. However, in manual, tape motion will not stop at EOT.

(4) FAST. - If the FAST signal (+5v) is received at the same time as a FWD or REV signal, tape motion will be at 200 inches per second.

(5) WRITE. - When the WRITE signal is received, the write start time will be decreased and the write stop time will be increased, both by approximately 10%, to insure complete erasure of the tape and to prevent intergap noise.

(6) AUTO. - The AUTO signal (0v) is applied to enable the MTT for initiating autoloading and unload operations. When this signal is absent, these operations are inhibited.

b. OUTPUT CONTROL SIGNALS. -

(1) BOT. - The BOT signal (+5v) is sent to the controller to indicate that the beginning-of-tape marker has been detected by the EOT/BOT sensor.

(2) EOT. - The EOT signal (+5v) is sent to the controller to indicate that the end-of-tape marker has been detected by the EOT/BOT sensor.

(3) READY. - The READY signal (0v) is generated and sent to the controller after power has been applied to the MTT. The vacuum blower is operating, and the tape is threaded and properly positioned in the buffer columns.

(4) HIGH TAPE. - The HIGH TAPE signal (+5v) is developed when the high tape sensor detects that less than 100 feet of tape remains on the takeup reel.

(5) LOW TAPE. - The LOW TAPE signal (+5v) is developed when the low tape sensor detects that less than 100 feet of tape remains on the supply reel.

(6) SET AUTO. - The SET AUTO signal is generated to inform the controller that the autoloading sequence has been successfully completed and the MTT is available for automatic operation.

(7) CAPSTAN ZERO. - The signal on the CAPSTAN ZERO output line is a logic high (+5 Vdc) when the capstan is moving and a logic low (0 Vdc) when the capstan is stopped to inform the controller of the capstan status.

(8) WRITE ENABLE. - The WRITE ENABLE signal is used to inform the controller that a write enable ring has been installed on the supply reel and that writing on the tape may commence. When this signal is present, the write enable output line is an open circuit. When the signal is not present, this signal will be a logic low (0 Vdc).

c. DATA SIGNALS. -

(1) READ. - The MTT, through optional selection, contains the logic to read up to nine tracks of data written on the tape. This data is amplified prior to being transferred to the controller. A read-data operation is under complete control of the controller.

(2) WRITE. - Up to nine tracks of data may be written on the tape for storage and later retrieval. A write-data operation is under complete control of the controller.

d. MISCELLANEOUS SIGNALS. -

(1) LOAD REMOTE INDICATOR. - The LOAD REMOTE INDICATOR signal (+5v) is transmitted to the controller during the time the autoloading procedure is being performed.

(2) READY REMOTE INDICATOR. - The READY REMOTE INDICATOR signal (0v) is transmitted to the controller after the tape has been successfully loaded and the MTT is awaiting further commands.

(3) UNLOAD REMOTE INDICATOR. - The UNLOAD REMOTE INDICATOR signal (0v) is transmitted to the controller during the time that an unload function is being performed.

(4) LOAD REMOTE SWITCH. - The LOAD REMOTE SWITCH signal (+5v) is sent to the MTT to remotely control an automatic loading function from the control panel.

(5) UNLOAD REMOTE SWITCH. - The UNLOAD REMOTE SWITCH signal is applied to the MTT to allow remote control of an unload function from the control panel.

e. PRIME POWER. -

(1) 400-HZ, 3Ø, 208 VAC. - Prime input power to the MTT is 400-Hertz, 3-Phase, 208 Vac supplied through cabinet wiring.

(2) +75 VDC. - Supplemental power, +75 Vdc, is supplied through the cabinet wiring for operation of the drive motors and, through the dc-dc converter, supply the logic and operating voltages of the remaining MTT circuitry. A 4-KHz square wave is applied to the MTT to operate the dc-dc converter.

(3) 400-HZ RELAY CONTROL. - A 400-Hz relay control voltage shall be applied to the power supply for relay operation.

(4) 4-KHZ INVERTER DRIVE. - A 4-KHz square wave is used to enable dc-dc converter operation.

4-4. AUTOMATIC LOAD OPERATION

a. GENERAL. - During the automatic load operation (autoloading), several processes are executed. These processes are referred to as functions and are identified on the functional schematics in Section 7 as: OF which identifies an off condition,

1F which identifies the first function, continuing to 12F which identifies function 12. Depending upon conditions which exist, some functions may be skipped by the logic sequence. The flow chart in figure 4-6 presents a diagram of this sequence.

Operating in conjunction with the function generator (figure 7-4) are timed counts developed by the decode counter (figure 7-7). This counter produces timed counts or clock pulses identified as 1TC, 2TC, etc., of approximately 1.9-second duration. As the counter advances, the clock pulses ensure that a given function is performed within a predetermined time period before advancing to the next succeeding function.

During the following explanation of the autoloading operation, reference is made to the functional schematics contained in Section 7. Before proceeding to the explanation, it is necessary to become familiar with the nomenclature as defined in figure 7-1. Table 4-1 contains a tabular listing of the function progression and the resultant operations performed.

b. FUNCTION OF. - When initial power is applied to the MTT, the logic circuitry conditions itself to accept an operational command such as load or unload. This conditioning is referred to as the OF function or simply OF (Zero of F). The initial application of power causes the PWR ON SS, (logic element O10, figure 7-7) to initialize the system by generating the PWR ON RESET signal to both the decade counter (clock) in figure 7-7 and to the logic in figure 7-5 where it clears the UNLOAD and TACH flip-flops and becomes the DECODER MC signal to figure 7-4. The DECODER MC master clears the BCD to 1 of 12 DECODE, hereinafter referred to as the function generator, which supplies the OF and $\overline{\text{OF}}$ signals.

On figure 7-5, the OF signal enables gate O35 to receive either a UL SW or an AL SW signal which will establish a 1F function. The $\overline{\text{OF}}$ signal ensures that the TACH flip-flop is cleared and enables the setting of the UNLOAD flip-flop if a UL SW signal is received.

On figure 7-6, the $\overline{\text{OF}}$ signal inhibits the lighting of the AL indicator and the remote AL indicator on the control panel.

On figure 7-7, the $\overline{\text{OF}}$ signal inhibits presetting the 1OF fault function as no fault exists. It also maintains a low signal on the master reset of the counter to disable the clock pulses.

On figure 7-8, the $\overline{\text{OF}}$ signal inhibits turning on the blower through logic element O39. The circuitry is now conditioned to accept an autoloading signal from the LOAD switch on the control or switch panel once the tape has been loaded on the supply reel hub.

c. FUNCTION 1F. - To initiate function 1F, press the AL switch to produce the AL SW signal (figure 7-5) to logic element O26. The output is AND'ed with the OF signal which results in the DELTA RTC signal to the function generator (figure 7-4) to advance its output to 1F and to reset the clock to zero (figure 7-7). Also produced by the DELTA RTC is the DECODER CLK (figure 7-4) which functions as a locking pulse to prevent possible spikes from generating a second spurious pulse to further advance the function generator.

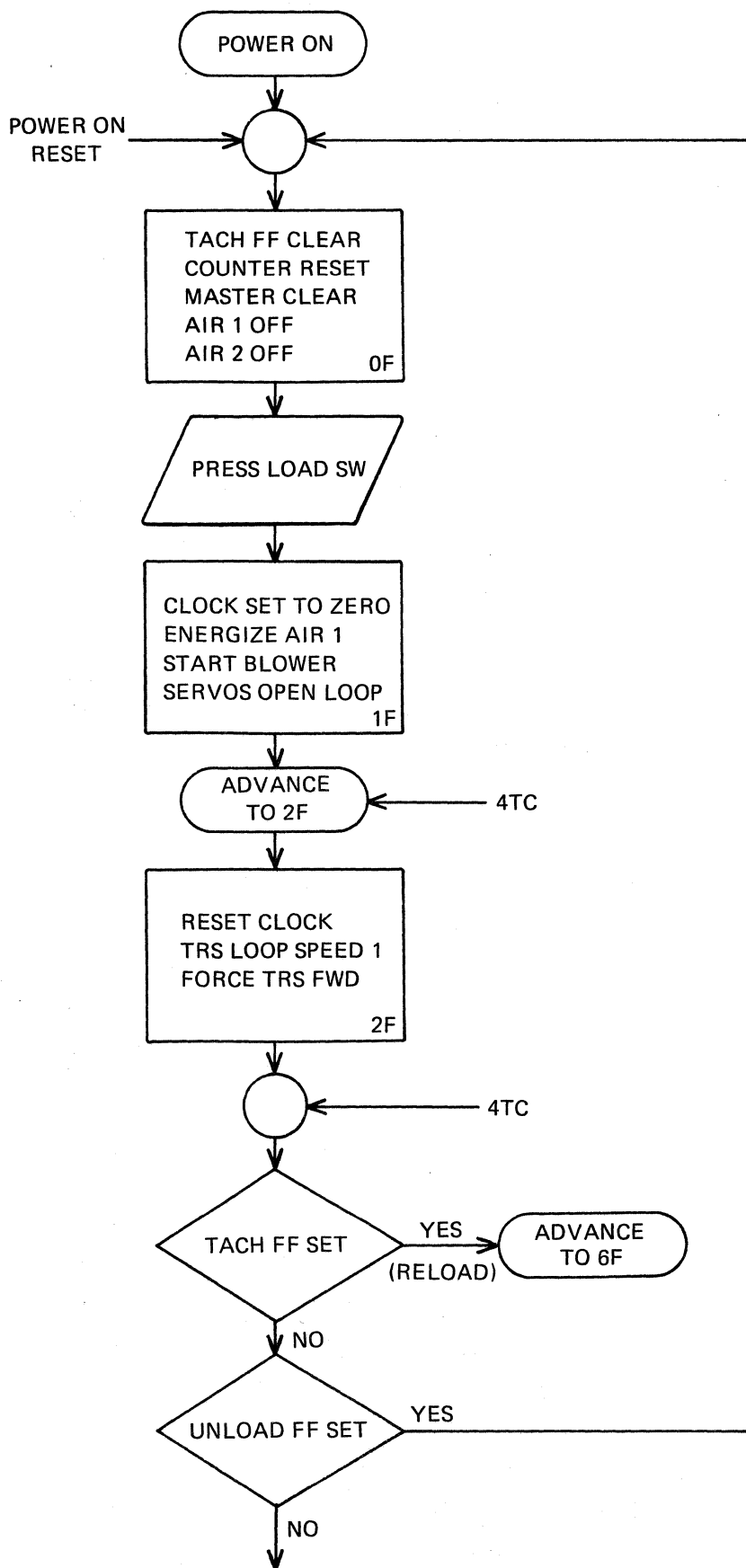

Figure 4-6. Function Generator Control Signals Flow Chart (Sheet 1 of 5)

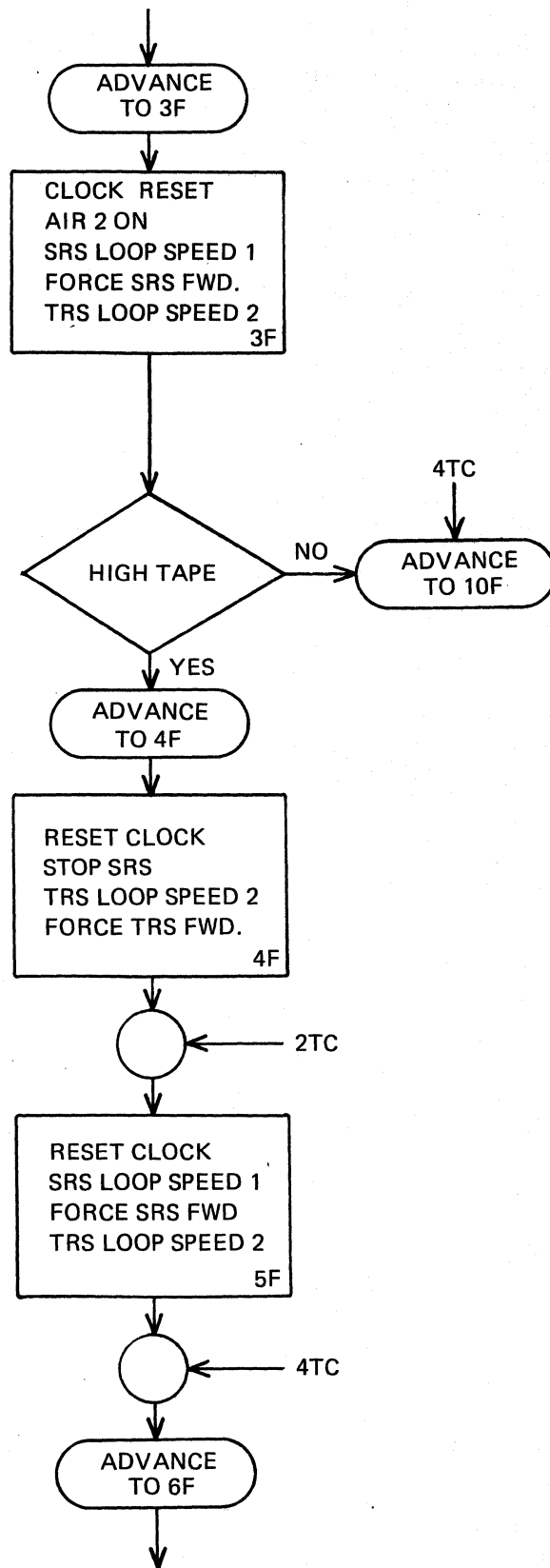

Figure 4-6. Function Generator Control Signals Flow Chart (Sheet 2 of 5)

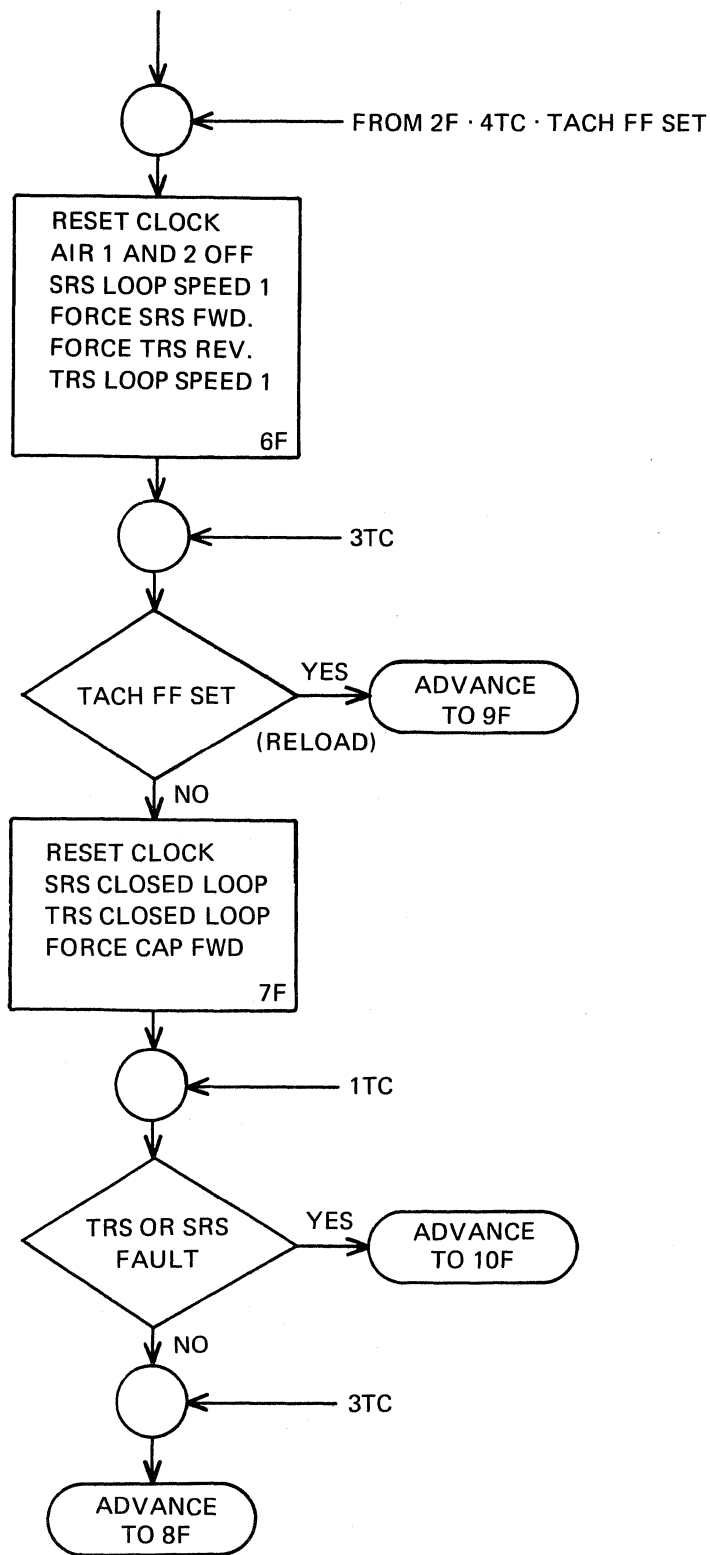

Figure 4-6. Function Generator Control Signals Flow Chart (Sheet 3 of 5)

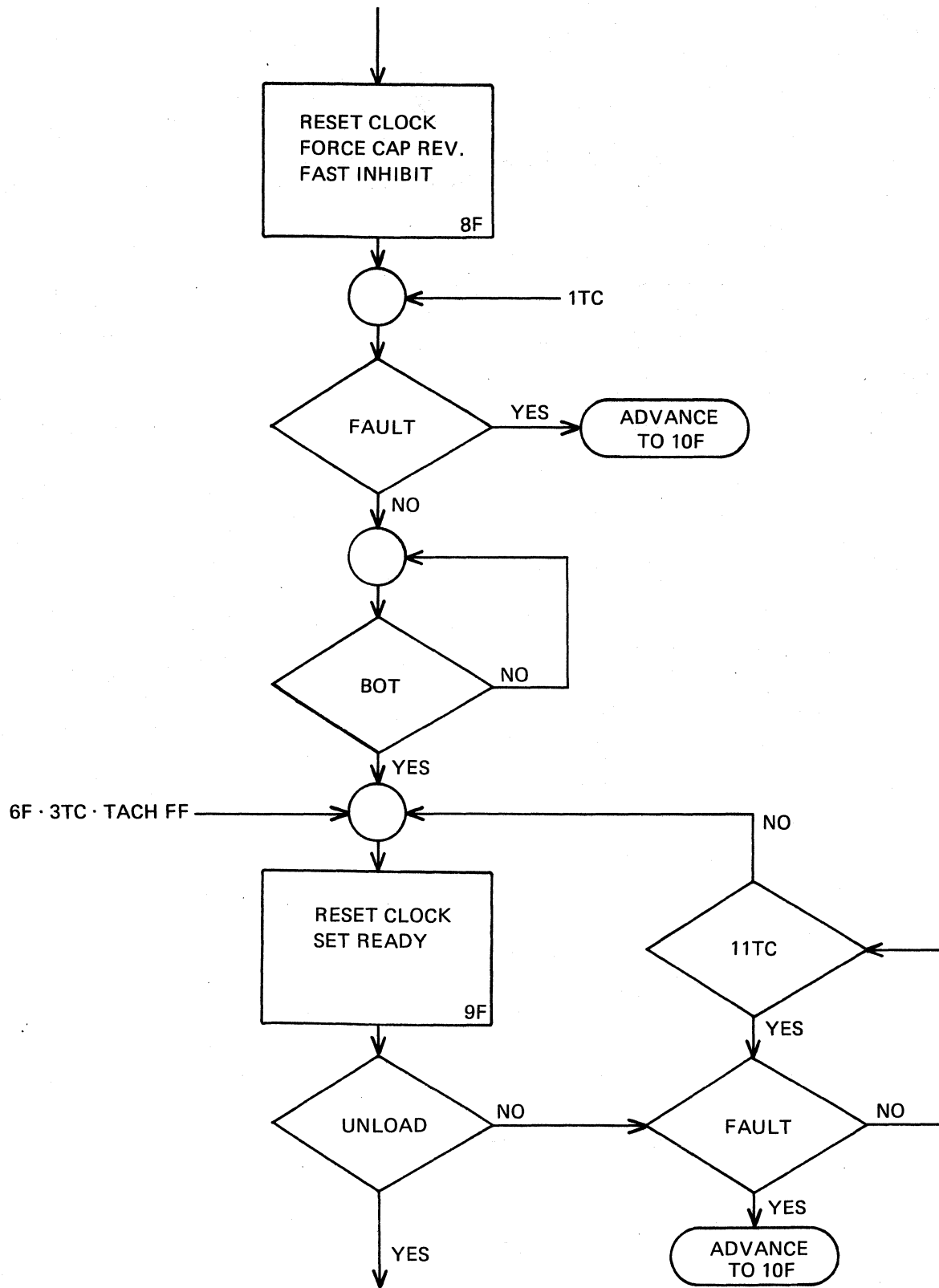

Figure 4-6. Function Generator Control Signals Flow Chart (Sheet 4 of 5)

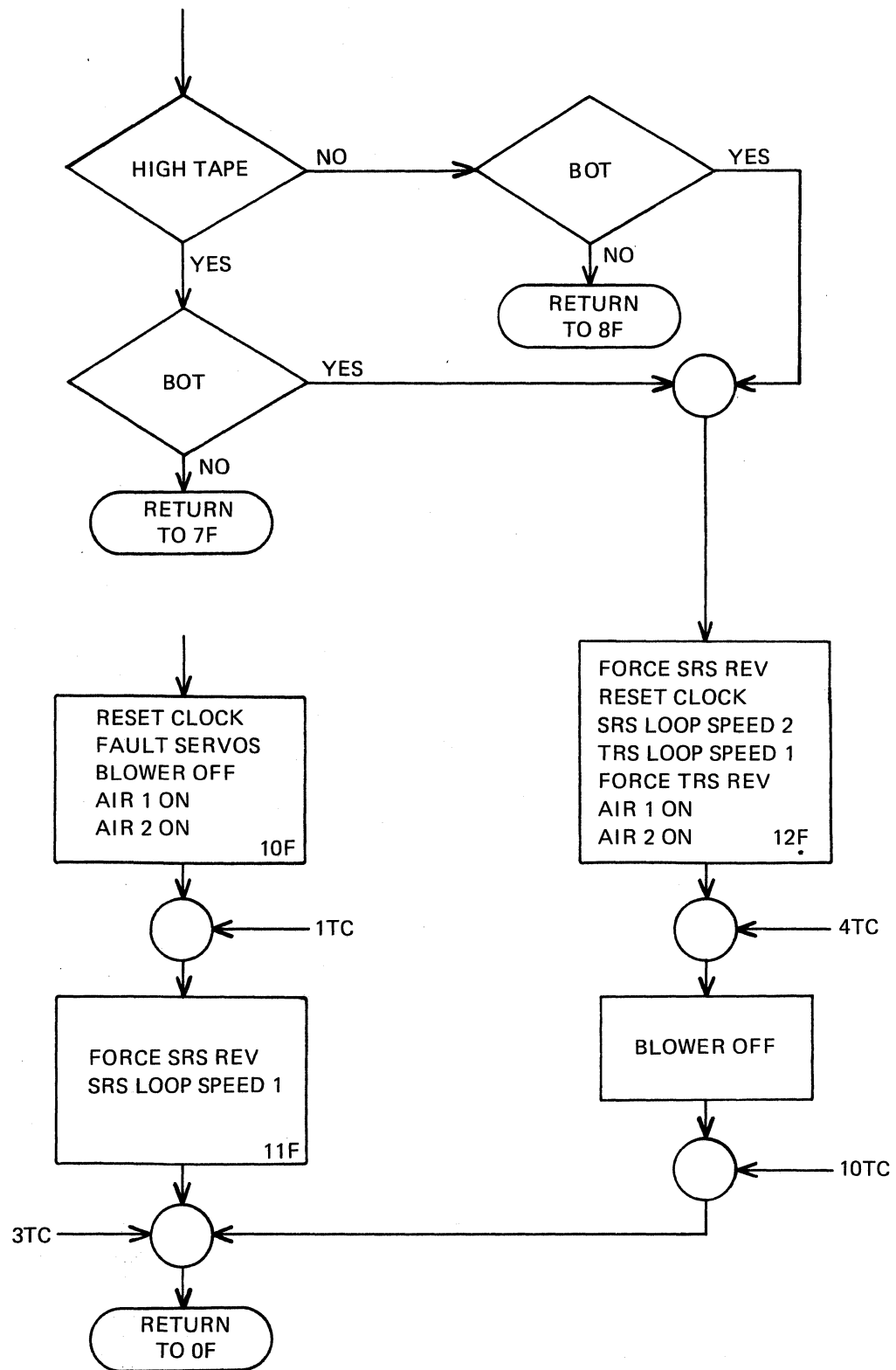

Figure 4-6. Function Generator Control Signals Flow Chart (Sheet 5 of 5)

TABLE 4-1. FUNCTION GENERATOR CONTROL SIGNALS

NOTE	
<p>The numbers enclosed in parentheses in the CONDITION/ACTION column are references to the functional schematics in Section 7 of this manual. For example: (5) implies refer to figure 7-5 for location of signal.</p>	
FUNCTION	CONDITION/ACTION
OF	Enables input from AL or UL switch (5)
$\overline{\text{OF}}$	Clears TACH flip-flop (5) AL indicator off (6) Master reset of counter (7) Disables preset 1OF (7) Inhibits blower on (8) Inhibits AIR 1 (8)
<p>Press AL switch to generate $\overline{\text{AL SW}}$ (5) ANDED with OF to produce DELTA RTC which updates function generator to 1F.</p>	
1F	DELTA RTC is gated with $\overline{\text{OF}}$ (7), now a high, to generate pulse from single-shot 07-024 to reset decade counter (clock) to zero. Energizes AIR 1 solenoid by removing $\overline{\text{OF}}$ inhibit (8) Starts blower by removing OF inhibit (8) SRS and TRS now in open loop (8)
1F·4TC	Advances function generator to 2F by producing a DELTA RTC (5), reset clock.
2F	If TACH flip-flop is set, advance to 6F (4).
$\overline{\text{2F}}$	Generates TRS LOOP SPEED 1 which is the slow speed determined by the setting of SLOW SPEED OPEN LOOP control. This generates FORCE TRS FWD (8) to drive TRS forward at slow speed. This is done by producing forward drive voltage and forward drive pulses at a rate determined by the oscillator output.
$\overline{\text{2F}} \cdot \overline{\text{UNLOAD}} \cdot \text{TACH} \cdot 4\text{TC}$	Return to OF by DECODER MC (5)
$\overline{\text{2F}} \cdot \overline{\text{UNLOAD}} \cdot \text{TACH} \cdot 4\text{TC}$	Advance function generator to 3F by producing DELTA RTC (5), reset clock (7).
$\overline{\text{3F}}$	Generate TRS LOOP SPEED 2 (8) to TRS reel servo output (10) Generate AIR 2 (8) to energize AIR 2 solenoid (11) Maintain FORCE TRS FWD (8) (SRS SLOW FWD) Generate SRS LOOP SPEED 1 (8)
3F·H TAPE	Inhibit DELTA RTC (5)

TABLE 4-1. FUNCTION GENERATOR CONTROL SIGNALS (CONT)

FUNCTION	CONDITION/ACTION
3F·H TAPE· 4TC	Generate PRESET 10F, (7), Advance to 10F (4), signify FAULT condition.
3F·H TAPE	Generate DELTA RTC (5), Advance to 4F (4), Reset clock (7).
4F	Maintains AIR 2 Solenoid (8) Maintains <u>TRS LOOP SPEED 2</u> (8) (TRS FAST FWD) Maintains <u>FORCE TRS FWD</u> (8) Removes <u>FORCE SRS FWD</u> (8) Removes SRS LOOP SPEED 1 (8) to stop supply reel motor.
4F·2TC	Generate DELTA RTC (5), Advance to 5F (4), reset clock (7).
5F	Clear TACH flip-flop (5)
5F	Maintain AIR 2 Solenoid (8) Maintain <u>TRS LOOP SPEED 2</u> (8) (TRS FAST FWD) Maintain <u>FORCE TRS FWD</u> (8) Generates <u>SRS LOOP SPEED 1</u> (8) (SRS SLOW FWD) Generates <u>FORCE SRS FWD</u> (8)
5F·4TC	Generate DELTA RTC (5), advance to 6F (4), reset clock (7)
6F	Remove AIR 1 (8), remove AIR 2 (8), remove <u>FORCE TRS FWD</u> (8), remove TRS LOOP SPEED 2 (8), receive SRS FAULT 1 (8) from (3) <u>because air not energized, generates SRS LOOP SPEED 1 and FORCE SRS FWD (8).</u> TRS FAULT 1 generated to produce FORCE TRS REV and TRS LOOP SPEED 1. TRS now in slow reverse; SRS in slow forward.
<p>NOTE</p> <p>When air solenoids are deenergized, the tape is pulled into the vacuum columns. If tape movement is detected by the capstan tachometer, the TACH flip-flop is set to produce the TACH flip-flop signal. As soon as the tape is in the columns and in the proper position, the FAULT signals are removed and the reel servos stop.</p>	
6F·3TC·TACH FF not set	Generate DELTA RTC (5), advance to 7F (4), reset clock (7).
6F·3TC·TACH FF set	Advance to 9F through inputs to function decoder.
7F	Generate SRS CLOSED LOOP (8), generate <u>FORCE CAP FWD</u> (7). Generate TRS CLOSED LOOP (8). TRS and SRS now under control of the capstan and capstan tachometer.

TABLE 4-1. FUNCTION GENERATOR CONTROL SIGNALS (CONT)

FUNCTION	CONDITION/ACTION
$\overline{7F \cdot 1TC \cdot SRS}$ $\overline{FAULT 1 \cdot TRS}$ $\overline{FAULT 1}$	Preset 10F, fault function. Advance to 10F (7).
$\overline{7F \cdot 3TC}$	Generate DELTA RTC (5), advance to 8F (4), reset clock (7).
8F	Generate $\overline{FORCE CAP REV}$ (8) which, in turn, produces a $\overline{FAST INH}$ (12) to force the capstan to run at slow speed.
8F·BOT	Generate DELTA RTC (5), advance to 9F (4), reset clock (7).
8F·1TC· FAULT	Preset 10F, fault function. Advance to 10F.
9F·UNLOAD· H1 TAPE	Return to 8F.
9F·UNLOAD· BOT	Jump to 12F.
9F·FAULT	Advance to 10F.
9F·STOP	Preset 10F. Advance to 10F.
10F	SRS and TRS open loop.
10F·1TC	Reset function generator. Advance to 11F.
11F	SRS slow reverse, remove tape from columns.
11F·3TC	Generate DECODER MC. Clear function generator. Advance to 0F.
12F	Force SRS Rev, SRS Loop Speed 2.
12F·SRS FAULT 1	Generate $\overline{TRS LOOP SPEED 1}$ and $\overline{FORCE TRS REV}$.
12F·4TC	$\overline{BLO ON}$ generated to turn blowers off.
12F·10TC	DECODER MC, advance to 0F.

Removing the \overline{OF} disable to logic element 039 (figure 7-8) provides the $\overline{BLO ON}$ signal to start the blower motor. This same signal, \overline{OF} , is also removed from logic element 026 (figure 7-8) to generate the AIR 1 signal which activates the AIR 1 solenoid to provide pressure in the buffer columns and in the forward path to prevent tape from being fed down the columns during the initial phases of the autoloading sequence. The 1F function must also establish an open-loop condition. This condition exists to prevent the tape reel motors from performing under the control of the

tachometers, and thus operate with the tachometer circuits open. Consequently, the term "open loop" is applied. To accomplish this, the output from logic elements 025 and 027 (figure 7-8) must be high which will also inhibit any fault conditions during the open-loop sequence.

Because the $\overline{6F}$ signal is not yet developed, this input will be a high to both logic elements 014 and 016 with resulting lows being applied to logic elements 025 and 027. The $\overline{7F}$, $\overline{8F}$, and $\overline{9F}$ signals are not yet available which results in the output of logic element 015 being high to logic elements 025 and 027. The third input to logic element 027 is dependent upon the $\overline{12F}$ signal, which at this time is high, to produce the third high to logic element 027. Thus, both the $\overline{\text{TRS FAULT 2}}$ and $\overline{\text{SRS FAULT 2}}$ signals are inhibited and the TRS CLOSED LOOP and SRS CLOSED LOOP signals are low to produce the open-loop condition in figures 7-9 and 7-10.

After the clock has reached a 4TC count, approximately 4 seconds, the $\overline{4TC}$ and 1F signals are combined element 017, (figure 7-5) to generate a DELTA RTC to update the function generator to 2F and reset the clock to zero.

d. FUNCTION 2F. - The 2F function has three possible terminating results which are dependent upon existing logic conditions. These are to jump to 6F, return to 0F, or advance to 3F.

(1) JUMP TO 6F. - If the capstan tachometer detects tape movement, indicating that tape is already loaded, the TACH flip-flop, (figure 7-5) will be set to produce the TACH flip-flop signal which is gated with the 2F signal (figure 7-4) to advance the function generator to function 6F (See paragraph 4-2c, Autoload Function Generator). Reload.

(2) RETURN TO 0F. - At 2F and 4TC, the output from logic element 023 (figure 7-5) is gated with the output of the UNLOAD flip-flop. If the UNLOAD flip-flop is set, indicating that an unload operation has been selected, the two high inputs to logic element 028 will generate the DECODER MC signal to master clear the logic circuitry, including the function generator, and return to function 0F.

(3) ADVANCE TO 3F. - Assuming that neither of the previous situations exist, the 2F signal to logic element 034 (figure 7-8) will produce the TRS LOOP SPEED 1 signal which is the slow speed for the takeup reel servo. This is directed to enable the oscillator output (figure 7-10) to produce the drive pulses for the TRS. The pulse width out of the single-shot 012 is preset by the slow-speed, open-loop potentiometer (R13). The takeup reel should start by the $\overline{\text{FORCE TRS FWD}}$ output from logic element 042 (figure 7-8), a product of the $\overline{2F}$ signal. Forward movement of the takeup reel is at slow speed until the 4TC signal is ANDED with the 2F signal in logic element 016 (figure 7-5). At this time, a DELTA RTC signal is generated to advance to function 3F. If tape is already present on the takeup reel, forward movement of takeup reel produces tach movement for a jump to 6F.

e. FUNCTION 3F. - When the DELTA RTC advances the function generator output to 3F, the signal to logic element 023 (figure 7-8) will produce SRS LOOP SPEED 1 and $\overline{\text{FORCE SRS FWD}}$ to rotate the supply reel forward at slow speed. The $\overline{3F}$ signal is also routed to logic element 009 (figure 7-8) to produce TRS LOOP SPEED 2 (fast), AIR 2, and to maintain the $\overline{\text{FORCE TRS FWD}}$. The takeup reel servo will rotate at fast speed. The AIR 2 signal energizes the AIR 2 solenoid and applies a vacuum to the takeup reel hub. AIR 1 and AIR 2 must both be energized to provide pressure in the buffer columns at this time. As tape is unwound from the supply reel, pressure in

the buffer columns prevents it from being directed down the columns and it will feed smoothly past the capstan to the takeup reel where the vacuum will cause the tape to adhere to the hub. Prior to adhering to the hub, the tape motion will cause the high tape sensor to detect tape because of the tape movement, and through logic element 033 (figure 7-5), generates a DELTA RTC signal to advance to function 4F.

If tape motion is not detected within approximately 4 seconds to advance to function 4F, as indicated by the 4TC output from the clock, the 3F and 4TC are gated together in logic element 004 (figure 7-7) to produce the PRESET 10F and jump to function 10F, the fault indicating function.

f. FUNCTION 4F. - Updating the function generator to function 4F also resets the clock. The 4F signal is used to maintain the TRS LOOP SPEED 2, AIR 2, and FORCE TRS FWD signals through logic element 009 (figure 7-8). It is also used to remove the FORCE SRS FWD and SRS LOOP SPEED 1 signals by removing the 3F signal to logic element 023 (figure 7-8) and, at 2TC, to generate the DELTA RTC signal through logic element 016 (figure 7-5).

In effect, the takeup reel continues to rotate at fast speed, the supply reel stops to create a drag by the tape on the capstan roller, and after approximately 2 seconds, the function generator advances to function 5F and resets the clock.

g. FUNCTION 5F. - Advancing the function generator to function 5F produces a 5F signal which will clear the TACH flip-flop (figure 7-5). The 5F signal will maintain the energized condition of the AIR 2 solenoid (figure 7-8), TRS LOOP SPEED 2, and the FORCE TRS FWD signals. It will also generate the SRS LOOP SPEED 1 and the FORCE SRS FWD signals. The result is that vacuum is still applied to the takeup reel hub, the takeup reel will rotate fast-forward and the supply reel will rotate slow-forward, winding tape onto the takeup reel.

When the 4TC clock pulse is generated, it is gated with the 5F signal in logic element 015 (figure 7-5) to produce the DELTA RTC and advance to function 6F.

h. FUNCTION 6F. - When function 6F occurs, the signals which had previously maintained the AIR 1, AIR 2, FORCE TRS FWD, and TRS LOOP SPEED 2 signal (figure 7-8) are removed to deenergize the air solenoids and stop the takeup reel. TRS and SRS faults are generated to produce SRS LOOP SPEED 1 and FORCE SRS FWD, and TRS LOOP SPEED 1 and FORCE TRS REV signals. The takeup reel is now rotating slow-reverse and the supply reel is rotating slow-forward. Deenergizing the solenoids applies a vacuum to the buffer columns to pull tape into the columns. As soon as the vacuum/pressure sensors detect proper tape position, the fault conditions are removed and the reel servos stop.

If the TACH flip-flop is set, indicating that the function jumped from 2F to 6F, at 3TC the routine jumps to function 9F of the function generator.

If the TACH flip-flop is not set, indicating that the function advanced from 5F to 6F, at 3TC the next DELTA RTC is generated to advance to 7F and reset the clock.

i. FUNCTION 7F. - Initiating function 7F produces the TRS CLOSED LOOP signal through logic elements 004, 015, and 027 (figure 7-8). The SRS CLOSED LOOP signal is produced through logic elements 004, 015 and 025. These signals place both the takeup and supply reel servos under the tachometer control to rotate at a speed determined by the error voltage between the capstan tachometer and the associated

reel tachometer. This error voltage, referred to as SRS IN 1 and TRS IN 1 in (figure 7-3) and sent to figures 7-9 and 7-10 respectively, creates a resulting voltage to the TACH ERROR AMPLIFIER, a comparison of the voltage and the output of the individual reel tachometer. The presence of this error voltage indicates the need for either forward or reverse drive. If the error voltage is negative, forward drive is required; a positive error voltage indicates reverse drive.

The 7F signal also generates the FORCE CAP FWD signal from logic element 034 (figure 7-7) which is applied to figure 7-12 and produces the CAP FWD signal. This signal forces the capstan to drive forward for approximately 3 seconds (3TC).

At ITC, if either a TRS or SRS fault exists as indicated by the vacuum/pressure sensors detecting an erroneous tape position, the routine jumps to 10F, the fault indicating function. This is accomplished through logic elements 007 and 014 (figure 7-7) to generate a PRESET 10F signal. If no fault exists, the DELTA RTC will be generated at 3TC to advance to 8F and reset the clock.

j. FUNCTION 8F. - Function 8F, applied to the logic element 008 (figure 7-8) produces the FORCE CAP REV signal through logic element 029 which, when applied to figure 7-12, is gated with the output of the high tape sensor (a low indicating no high tape) to produce the FAST INH signal. As a result, the capstan will run in reverse at a slow rate of speed. The FORCE CAP REV signal will also clear the CAPSTAN flip-flop, logic element 038, and produce the CAP REV signal through logic elements 037, 041, and 059. The CAP REV signal is applied to logic element 001 (figure 7-13) which produces a negative voltage to the dual-rate ramp generator, which generates a negative ramp voltage. The negative ramp voltage will be the SLOW output signal limited by the CAP FAST signal being a high. The resulting CAP REV DRIVE is applied to the bidirectional power drive (figure 7-14) which acts as an electronic switch to apply a negative 30 volts to the capstan for reverse-direction rotation. If a BOT is detected, it is gated with the 8F signal in logic element 033 (figure 7-5) to produce the DELTA RTC which advances the function generator to 9F and resets the clock to zero.

If a fault exists, the fault signal, the 8F signal, and ITC are gated together in logic element 014 (figure 7-7) to produce the PRESET 10F and cause the routine to jump to 10F, the fault indicating function.

k. FUNCTION 9F. - Upon reaching 9F, the automatic load procedure is complete in that the ready command is issued to the control unit, unless an unload command has been received or a fault condition has been detected. The control unit may now issue the operational commands for reading or writing on the tape. The outputs from the UNLOAD flip-flop, the BOT/EOT sensor, the HI TAPE sensor, and the vacuum/pressure sensors are constantly monitored to determine if normal operations is to be terminated and, if so, the functions to be performed for that termination.

(1) UNLOAD. - If the terminating function is an unload, the UNLOAD flip-flop will be set to produce the UNLOAD·9F signal to the function generator. The input logic of the function generator will compare this signal with the output from the high/low tape sensors and the BOT sensor.

(a) UNLOAD·HI TAPE·BOT. - If the output from the high tape sensor indicates a high tape condition, this output is applied to logic element 015 (figure 7-12) to produce the H TAPE output to logic element 034 (figure 7-5). The output then becomes L TAPE applied to the function generator (figure 7-4). The resulting decoding

causes the routine to revert to the 7F function by applying the appropriate code to the function generator. (See figure 4-2, Function Generator, Simplified Schematic.) The tape will run forward for three time counts, advance to 8F, and run in reverse until the BOT marker is detected.

(b) UNLOAD·HI TAPE. - If in the unload procedure a high tape is not detected, the resulting inputs to the function generator will cause the routine to revert to the 8F function where the tape will run in reverse until the BOT marker is detected.

(c) UNLOAD·BOT. - Once the BOT has been detected, the inputs to the function generator cause the routine to advance to the 12F function. The 12F function is presented in paragraph 4-7n.

(2) FAULT. - If a fault condition develops during normal operation, the MTT logic allows a maximum of 1TC (approximately 1 second) for the fault condition to be rectified or removed, or, after the 1TC, jump to the 10F function. This is accomplished by gating the 9F, 1TC, and fault signals together in logic element 014 (figure 7-7). The resulting output, PRESET 10F, will condition the function generator to advance to 10F, the fault indicating function.

If a fault condition develops during the automatic loading sequence (refer to the flow charts in figure 4-6) and the fault requires returning to function 0F, the function generator advances to 10F and performs the procedures so listed for that function. However, several fault conditions are ignored through function 6F as explained in previous paragraphs and the load sequence advances sequentially. If the fault conditions are detected after 6F and 1TC has elapsed, the sequence jumps to 10F.

(3) STOP. - Pressing the STOP switch produces a PRESET 10F signal to terminate a load or ready operation.

1. FUNCTION 10F. - When the operating sequence is advanced to the 10F function due to a fault condition, the reel servos are placed in an open-loop condition, power is removed from the blower, and the AIR 1 solenoid is energized. The open-loop condition is a result of removing the 9F signal from logic element 002, (figure 7-8) and thus inhibiting the SRS and TRS CLOSED LOOP signals which place the reel servos under logic control. Power is removed from the blower by routing the 10F signal through logic element 019 to inhibit the BLO ON signal output from logic element 039. The AIR 1 signal is also a result of removing the 9F signal input to logic element 002.

After 1TC, the DELTA RTC is generated through logic element 014 (figure 7-5) to advance the function generator to 11F and reset the clock.

m. FUNCTION 11F. - Function 11F forces the supply reel to run in slow-reverse to remove tape from the buffer columns through logic element 020 (figure 7-8). After 3TC, the DECODER MC signal is generated to clear the function generator (figure 7-5) and return the system to the 0F condition to await further commands.

n. FUNCTION 12F. - The 12F function is a terminate function which results in the tape being wound on the supply reel and the function generator set to 0F. Produced from the 9F function, the 12F function is generated where an unload operation is required and the BOT marker is detected.

The 12F signal (figure 7-8) produces the FORCE SRS REV and SRS LOOP SPEED 2 signals to force the supply reel to run in fast-reverse. When the SRS FAULT 1 is detected, indicating that tape has been removed from the supply column, the TRS LOOP SPEED 1 and FORCE TRS REV are generated to remove the tape from the takeup reel onto the supply reel. The 12F is gated with either the 4TC or 8TC signal to generate the BLO ON. At 12F and 10TC (figure 7-5) the DECODER MC is generated to reset the function generator to OF.

4-5. 400-HZ POWER SUPPLY.

The 400-Hz power supply, located in the lower left bay of the MTS cabinet, produces the operating voltages for the control unit and the magnetic tape transports in the subsystem. Components in the power supply are identified by the physical location in which they are mounted, A1A1, A1A2, A2, etc. Table 4-2 contains a listing of these assemblies and their identification.

TABLE 4-2. POWER SUPPLY ASSEMBLY IDENTIFICATION

ASSEMBLY	UNIVAC PART NO.	NOMENCLATURE
A1	7601770	Regulator Subassembly
A1*	7600665	Circuit Card Assembly
A2*	7600667	Circuit Card Assembly
A2	7600863	Capacitor Assembly
A3	7601769	Front-End Subassembly
A4	7601784	Wiring Harness
A5	7601771	Relay Subassembly

*A1 on the logic diagrams is identified as A6 in Section 6, Parts List;
A2 is identified as A7.

Operation of the power supply is controlled from the System Control Panel at the top front of the cabinet. Input power may be either 115 VAC, 3 wire or 208 VAC, 4 wire and will determine the position of the bus strips on terminal strip A3TB1. Power is applied from the control panel through jack J6, pins A, B, C, and D to the contacts of relay A3K1 (figure 7-16). Operation of the relay is controlled by the POWER ON/OFF switch on the control panel through pin H of J6. Input power is applied to transformer A3T1 to develop the resulting 62 Vdc to T1-5 and the 26 Vdc bias voltage to the Regulator Assembly boards.

The A1 circuit card contains the rectifiers and components to produce the 62 Vdc and 26 Vdc for the A2 circuit card operation.

The output from the A1 card is applied to the A2 card where overload and over-voltage control is maintained. Overload control is adjusted via A1A2R23. Over-voltage control is adjusted via A1A1R48. If an overvoltage condition exists, the Enable signal from the photo-coupled transistor to the control panel is removed to indicate the fault condition. Relay A1K1, energized during normal operation, is used to drain the 75-volt charge on A2C2 through A1R7 when power is removed. The 75-volt output is adjusted via A1A2R3. The Enable signal is removed any time the 75-volt output is out of tolerance.

A 4-KHz oscillator, consisting of A1A2Q6, A1A2Q7 and associated components, produces the 4-KHz signal to operate the inverter in the power supply and the dc-dc converters in the tape transports and control unit.

Figure 4-7 contains a simplified diagram of the power control and distribution. Figures 7-16, 7-17, and 7-18 contain the schematic diagrams for the power supply.

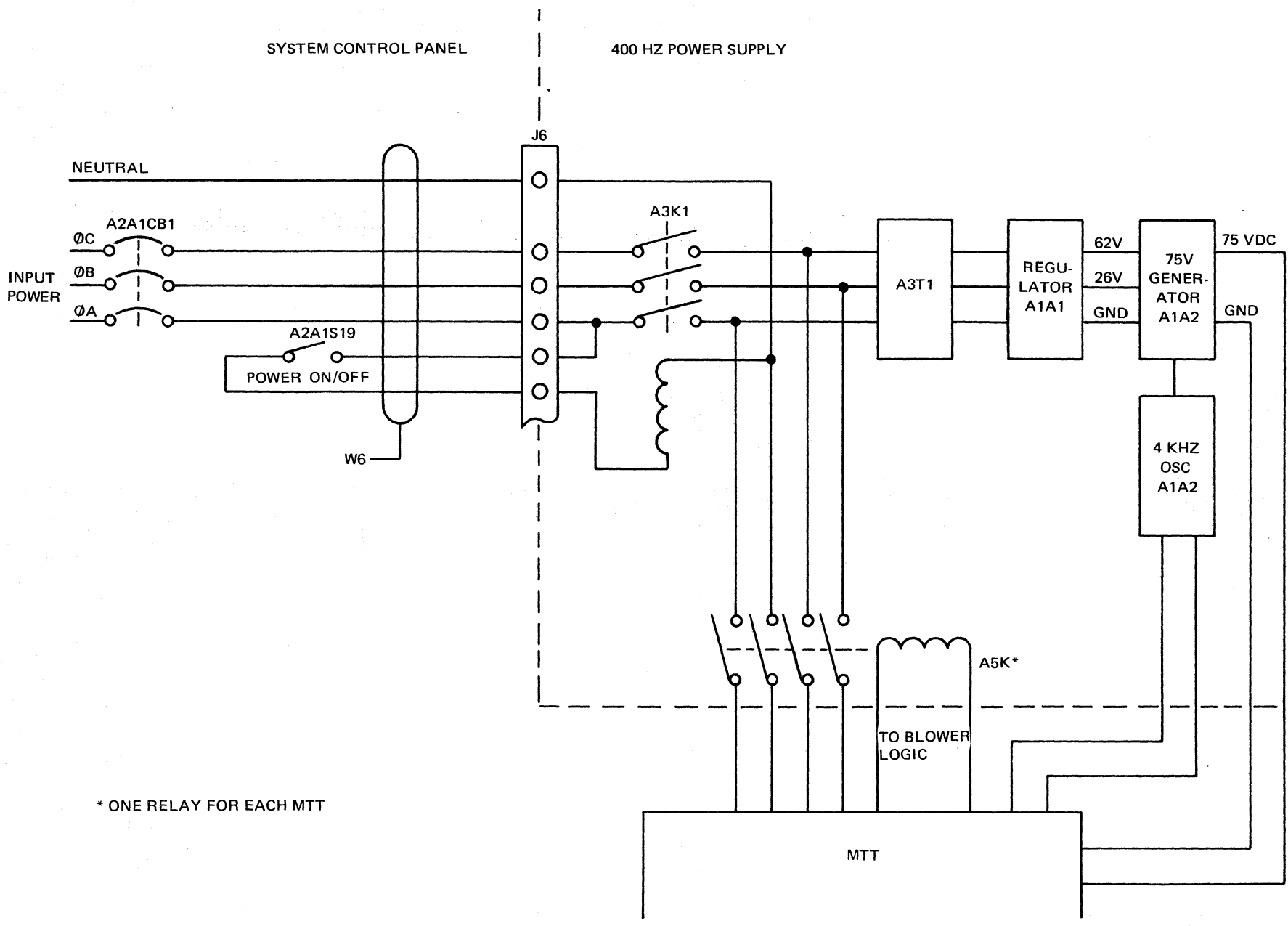

Figure 4-7. 208 VAC Power Supply and Control, Simplified Schematic

SECTION 5

MAINTENANCE AND REPAIR

5-1. GENERAL.

This section contains the recommended maintenance and repair procedures to minimize system malfunctions through scheduled maintenance and to isolate and correct system malfunctions. The test equipment and special tools required for maintenance and repair are listed in table 5-1 and support the maintenance concept which enables field replacement of all switches, relays, fan motors, drive motors, power supplies, lamps, sensors, rollers, guides, and printed circuit logic cards as well as the capstan and reel drive assemblies. Although this section provides instructions for this depth of repair, the actual maintenance concept in use should be determined by the local directive based on skill level, parts availability, and available maintenance time.

5-2. PREVENTIVE MAINTENANCE

Preventive maintenance is performed to extend the operational life of the equipment and to reduce unscheduled maintenance. Many common failures which cause unscheduled interruptions can be eliminated by strict adherence to the preventive maintenance schedule and the instructions in this section.

The preventive maintenance procedures are divided into daily, monthly, and operating-time categories. Operating time is determined from the time-totalizing meter located on the front panel of the MTT.

a. DAILY PREVENTIVE MAINTENANCE. - Each day or every eight hours of operating time, perform the following steps.

STEP 1. Extend MTT from cabinet.

STEP 2. Remove tape reel from supply reel hub.

STEP 3. Open head access cover and vacuum clean or use a soft brush to clean heads, guides, and rollers.

STEP 4. Ensure that tach rollers spin freely.

STEP 5. Use a small amount of Freon on a cleaning tissue and clean magnetic heads and capstan.

CAUTION

Do not use Freon on the tape guides above and below the read/write head because Freon makes the lower washer expand and could cause the tape to bind. If the guides are dirty, clean with isopropyl alcohol. Do not use alcohol on the tape heads.

STEP 6. Vacuum supply reel hub and hub area.

TABLE 5-1. TEST EQUIPMENT AND SPECIAL TOOLS

ITEM	FUNCTION	REQUIREMENTS
Oscilloscope with Dual-Trace Capability (Tektronix Model 454 or equivalent)	Display MTT waveforms during checkout and troubleshooting.	Bandwidth of 60 MHz Sweep rate of 100 nsec/div.
Pulse Counter	Measure and align oscillator outputs.	Speed of 100 KHz Sensitivity of 400 mv
Multimeter	General voltage, current, and resistance measurements.	DC Range 0-300 Volts AC Range 0-200 Volts DC Current 0-12 Amps Resistance 0-100 Megohms
Tool Kit, 1840 (Mod) Consisting of:	Maintenance and Repair of MTT.	Univac Type 7602202-00
Extender Card	To provide test points for troubleshooting.	Univac Type 7074100 (7602202-02)
Card Extractor	To remove printed circuit cards.	Univac Type 7215010 (7602202-01)
Card Extender	To extend PC cards and provide test points during troubleshooting.	Univac Type 7600575-01 (7602202-03)
Set Block	To adjust height of capstan.	Univac Type 7602199 (7602202-05)
Hub Height Gage	To align supply reel motor hub after repair or replacement.	Univac Type 7602200 (7602202-06)
Hub Height Gage	To align take-up reel motor after repair or replacement.	Univac Type 7602201 (7602202-04)
Connector Pin Extraction Tool	To extract pins from connector pins.	Univac Type 7904604 (7602202-07)

b. WEEKLY PREVENTIVE MAINTENANCE. - Each week or approximately every 48 hours of operating time, perform the following maintenance steps.

STEP 1. Vacuum entire exterior of MTT.

STEP 2. Remove rear cover and vacuum interior of MTT including wiring harnesses, motors, card rack, etc. The MTT does not contain air filters and therefore dirt and dust will accumulate and exist as a potential malfunction source.

STEP 3. Remove the front panel to expose the buffer columns (see paragraph 5-3e for removal procedures). Use a small amount of Freon and clean the columns of dust, dirt, and oxides. Clean the takeup reel recess and vacuum the entire MTT.

c. OPERATING TIME PREVENTIVE MAINTENANCE. - Operating time preventive maintenance requirements are based on hours of MTT and power supply operation rather than calendar days. After each 500 hours of operation, perform adjustments as contained in paragraph 5-5.

5-3. REMOVAL AND REPLACEMENT PROCEDURES.

a. GENERAL. - This information consists of procedures for the replacement and repair of items where the procedure is not obvious or where special tools and/or test equipment is required.

WARNING

Prior to performing removal and replacement procedures, insure that power has been removed from the system to prevent electrical shock.

b. REMOVAL OF THE MTT FROM THE CABINET. - To remove the MTT from the cabinet, perform the following steps.

STEP 1. Fully extend MTT to be removed.

STEP 2. Turn seven captive screws on rear cover (figure 5-2) one-quarter turn and remove cover.

STEP 3. Disconnect plugs from jacks J1 (item 1, figure 5-4) J2 (item 2, figure 5-4), and J3 (item 3, figure 5-4). Refer to table 5-3.

STEP 4. Disconnect wire from ground lug E1 (item 4, figure 5-4).

STEP 5. Open head access cover (figure 5-1) and remove plastic protective cover.

STEP 6. Using a rocking motion, gently remove plug connected to write head (item 1, figure 5-3, table 5-2).

NOTE

All cables which are associated with the retractable grasshopper arm (item 5, figure 5-4) should now be disconnected.

STEP 7. Remove retaining screw which secures retractable grasshopper arm to chassis and carefully retract arm and associated cables into cabinet.

WARNING

The MTT must be supported during the remaining procedures to prevent possible serious injury to personnel and damage to the equipment. Upon removing the screws from the slide, the MTT is basically free from cabinet support.

STEP 8. Remove four retaining screws from top slide (item 6, figure 5-4).

STEP 9. Draw MTT forward, supporting both ends, and release quick-disconnect bottom slide. MTT may now be bench-mounted for maintenance.

c. PRINTED CIRCUIT CARD REMOVAL. - To remove the printed circuit cards from the MTT, perform the following steps.

STEP 1. Fully extend MTT from cabinet.

STEP 2. Turn seven captive screws on rear cover (figure 5-2) and remove cover.

STEP 3. Remove eight screws from card rack assembly cover (item 7, figure 5-4) and remove cover.

The printed circuit cards are now exposed and may be removed by using the card extractor (see table 5-1).

d. VACUUM BLOWER REMOVAL. - To remove the vacuum blower, perform the following steps.

STEP 1. Fully extend MTT from cabinet.

STEP 2. Remove rear cover.

STEP 3. Remove front panel (figure 5-2) by removing eleven screws securing panel to transport frame.

STEP 4. Remove and tag wires connected from wiring harness to A1TB1 and A1TB2.

STEP 5. Remove three hex-head retaining screws which secure blower to transport frame.

STEP 6. Carefully withdraw blower from MTT.

e. FRONT COVER REMOVAL. - It is necessary to remove the front cover to gain access to the vacuum columns, high and low tape sensors, and the takeup reel and hub. To remove the front cover, perform the following steps.

STEP 1. Fully extend the MTT from the cabinet.

STEP 2. Open head access cover (figure 5-1) and turn to release the 1/4-turn fastener.

STEP 3. Turn to release the eleven 1/4-turn fasteners around the perimeter of the cover.

STEP 4. Carefully remove the cover from the MTT.

f. TAKEUP DRIVE MOTOR REMOVAL. - To remove the takeup drive motor it is necessary to first remove the front cover as directed in paragraph 5-3e. After front cover is removed, proceed with the following steps.

STEP 1. Remove and tag wires from terminal board associated with drive motor to be removed.

- STEP 2. Measure and record height of hub from tape deck. Release setscrews and remove reel hub.
- STEP 3. Remove four screws which secure motor to transport frame and carefully remove motor.

g. POWER SUPPLY REMOVAL AND REPLACEMENT.

(1) REMOVAL. - To remove the power supply from the cabinet, perform the following steps.

- STEP 1. Extend power supply from cabinet.
- STEP 2. Disconnect cables connected to J1 through J6.
- STEP 3. Remove two Phillips head screws which connect grasshopper arm to power supply at bottom rear of chassis.
- STEP 4. Press quick-disconnect latch on both top and bottom slides and withdraw chassis from cabinet.

(2) REPLACEMENT. - To replace the power supply in the cabinet, perform the following steps.

- STEP 1. Align slides on cabinet to guides on power supply chassis and slide chassis inward to engage slide catches.
- STEP 2. Fasten grasshopper arm to chassis with two Phillips head screws.
- STEP 3. Connect cables to J1 through J6.

h. HEAD BASKET ASSEMBLY REMOVAL AND REPLACEMENT.

(1) REMOVAL. - To remove the read/write head assembly, perform the following steps.

WARNING

Always insure that power has been removed from the MTS prior to any removal or replacement procedures.

- STEP 1. Extend the MTT from the cabinet and lower the head access cover to expose the head assembly.
- STEP 2. Remove the rear cover from the MTT.

CAUTION

Do not loosen or remove any screws other than those specifically called out in this procedure. Alignment of the head basket assembly is critical and must be done at the factory. Use the same hardware to reinstall the assembly.

- STEP 3. Use a Phillips screwdriver and remove the two screws (item 1, figure 5-5) and the connector stop (2) from the head area.

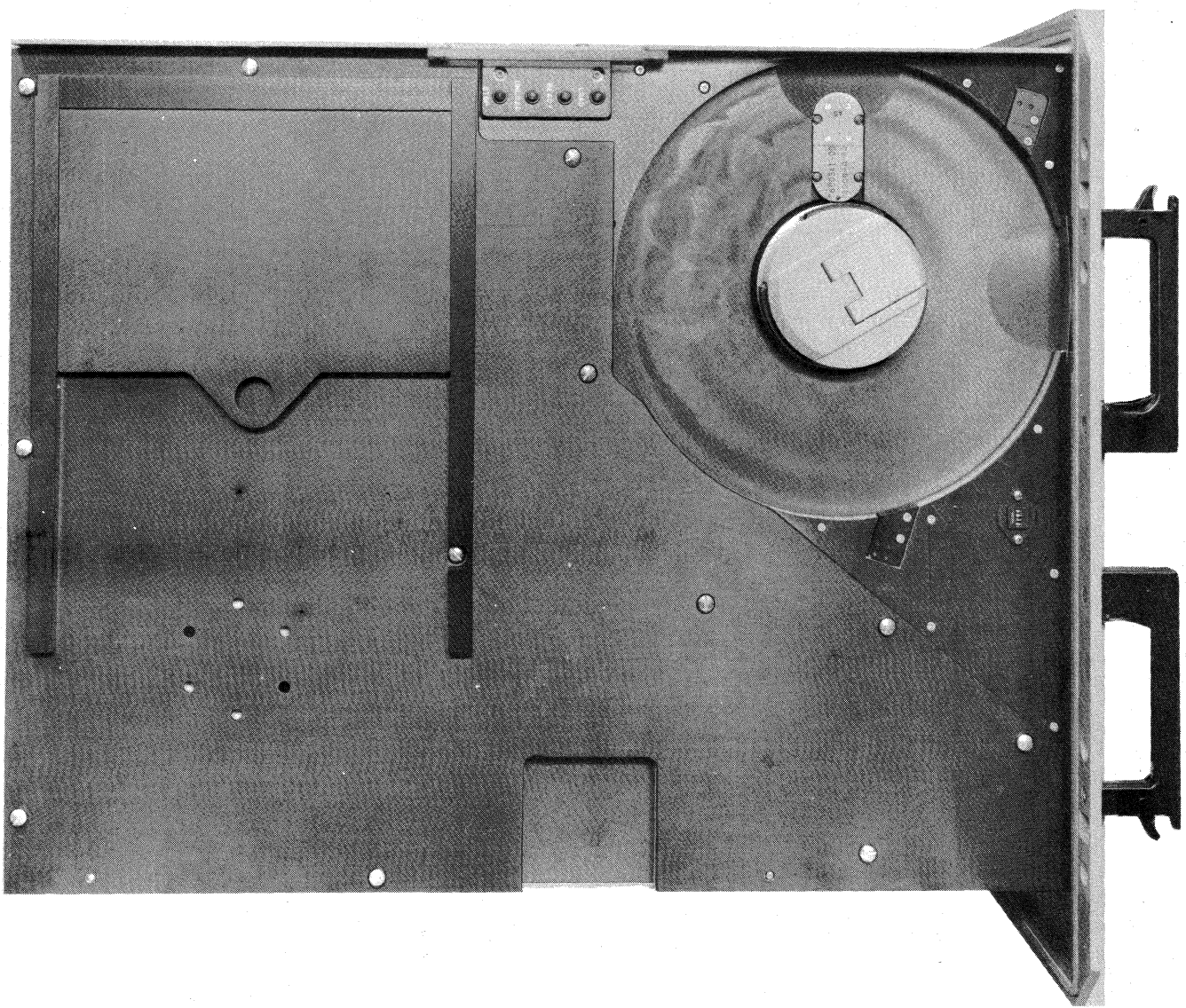

Figure 5-1. MTT, Front View

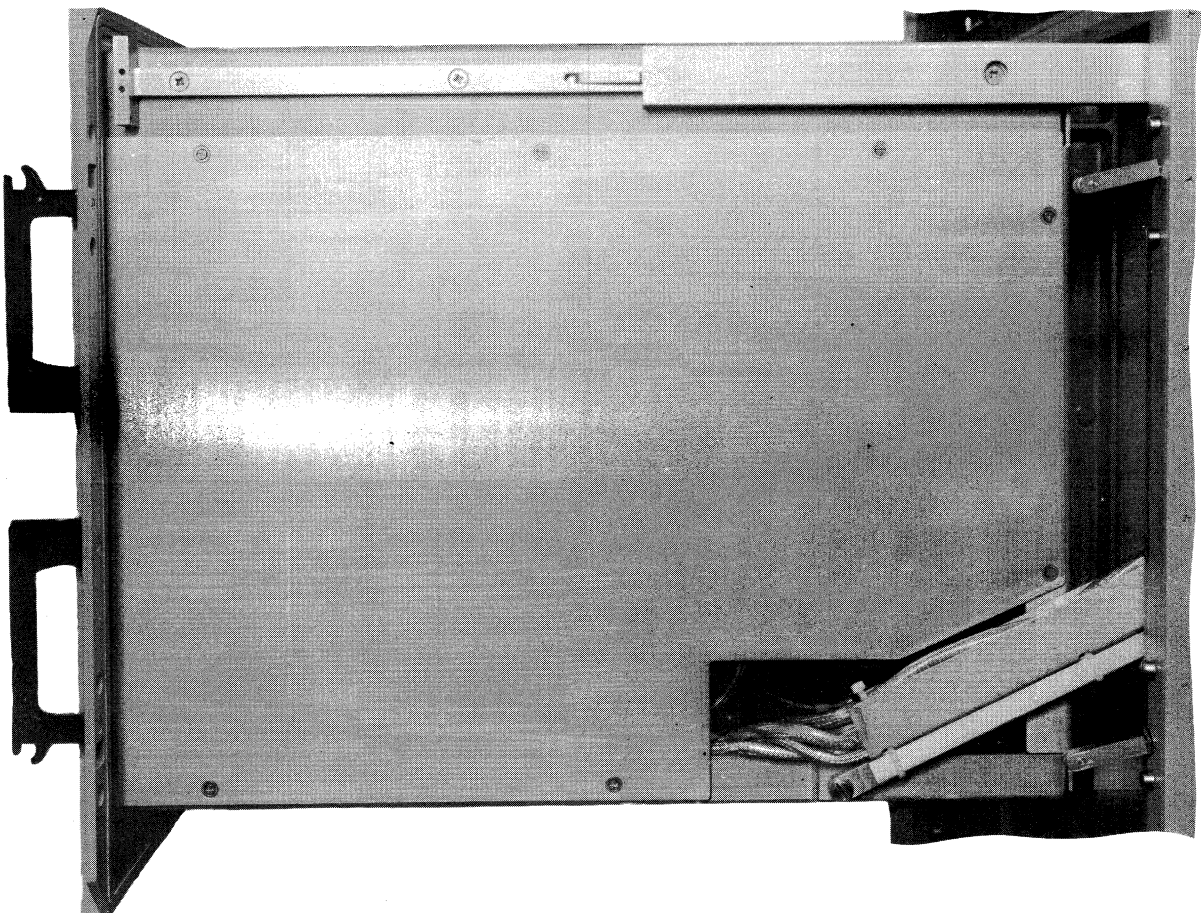

Figure 5-2. MTT, Rear View

TABLE 5-2. LEGEND FOR FIGURE 5-3

ITEM NO.	DESCRIPTION
1	Takeup Reel Tachometer
2	Capstan
3	Read Head
4	Write Head
5	Erase Head
6	EOT/BOT Sensor
7	Supply Reel Tachometer
8	Low Tape Sensor Emitter
9	Supply Reel Hub
10	Time-Totalizing Meter
11	Low Tape Sensor Receiver
12	High Tape Sensor Emitter
13	High Tape Sensor Receiver
14	Takeup Reel

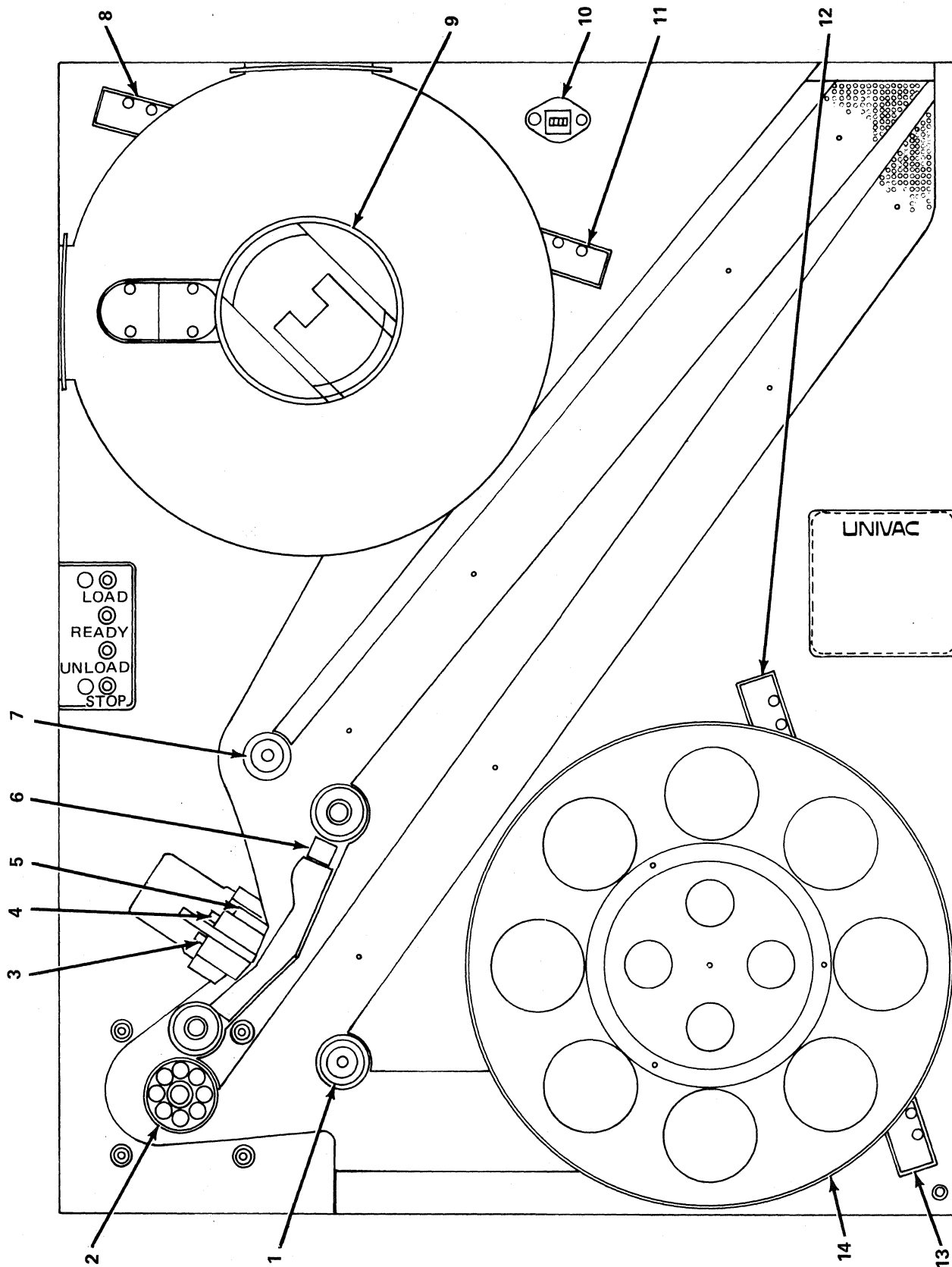

Figure 5-3. MTT, Front View, Cover Removed

TABLE 5-3. LEGEND FOR FIGURE 5-4

ITEM NO.	DESCRIPTION
1	Vacuum/Pressure Assembly A1
2	DC-DC Converter Assembly A2
3	Supply Reel Drive Assembly A4
4	Supply Reel Drive Motor B1
5	Slide Retaining Screws (2 hidden)
6	Card Rack Assembly A7
7	Convactor J1 (hidden)
8	Read/Write/Erase Head Assembly
9	Capstan Drive Motor MG1
10	Capstan Tachometer
11	Connector J3
12	Connector J2
13	Takeup Reel Drive Motor B2
14	Takeup Reel Drive Assembly A9
15	Retractable Grasshopper Arm
16	Retaining Screw
17	Vacuum/Pressure Switches S1 through S8 (hidden)
18	Terminal Board TB4
19	Capstan Drive Assembly A10 (hidden)

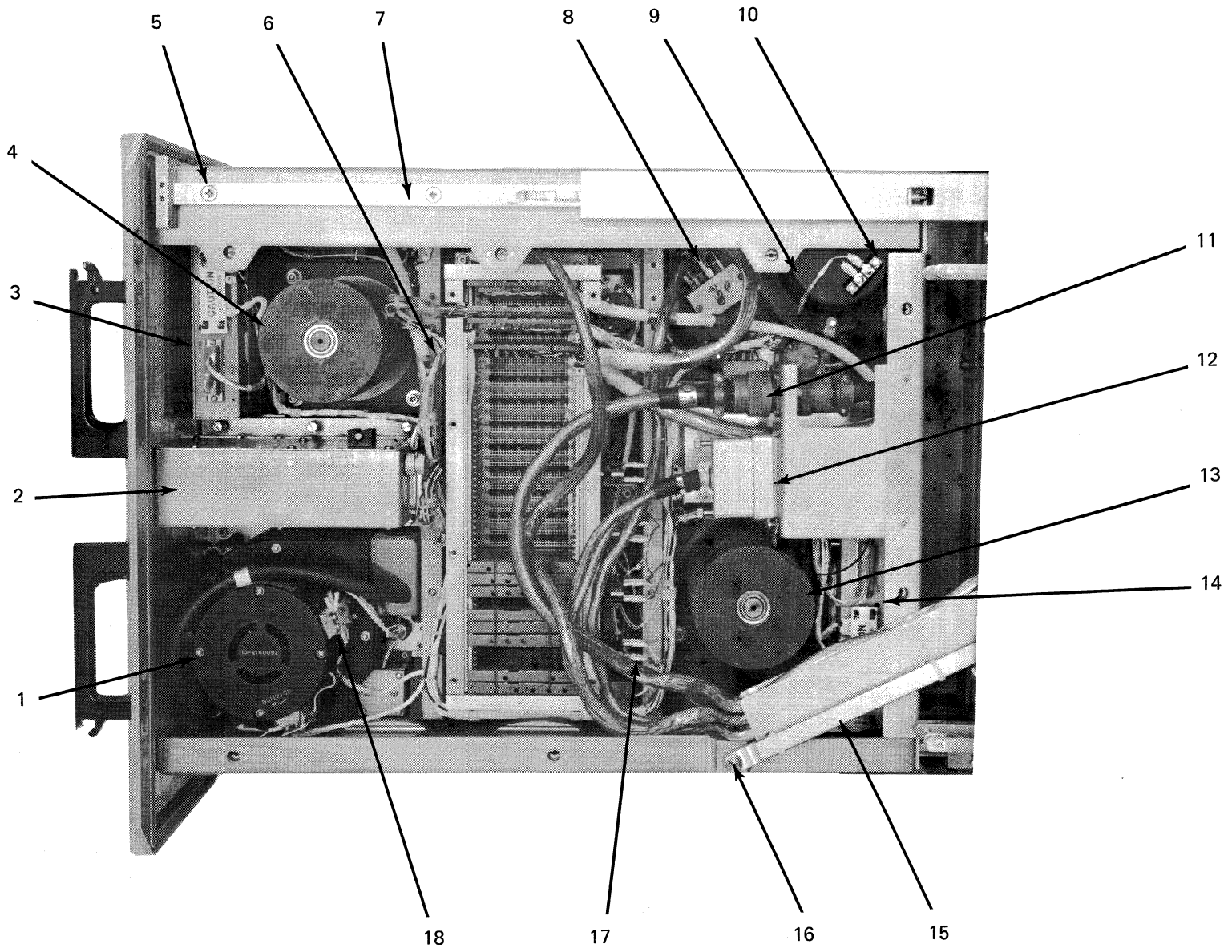
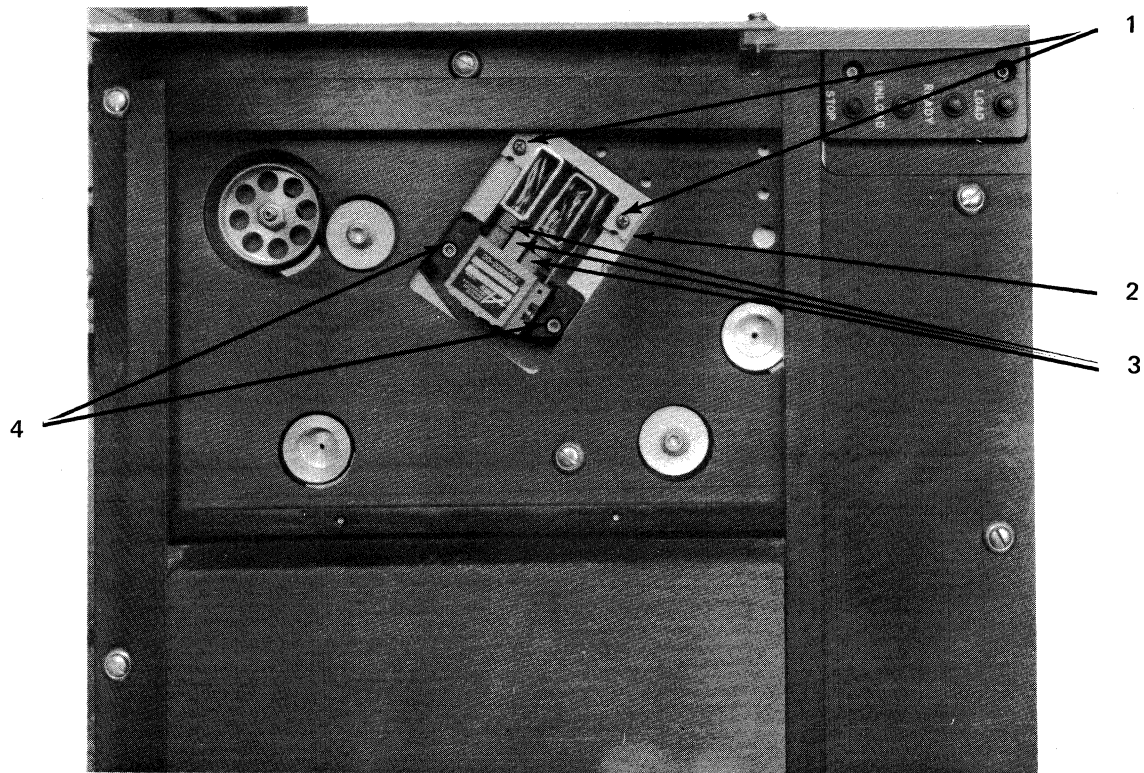
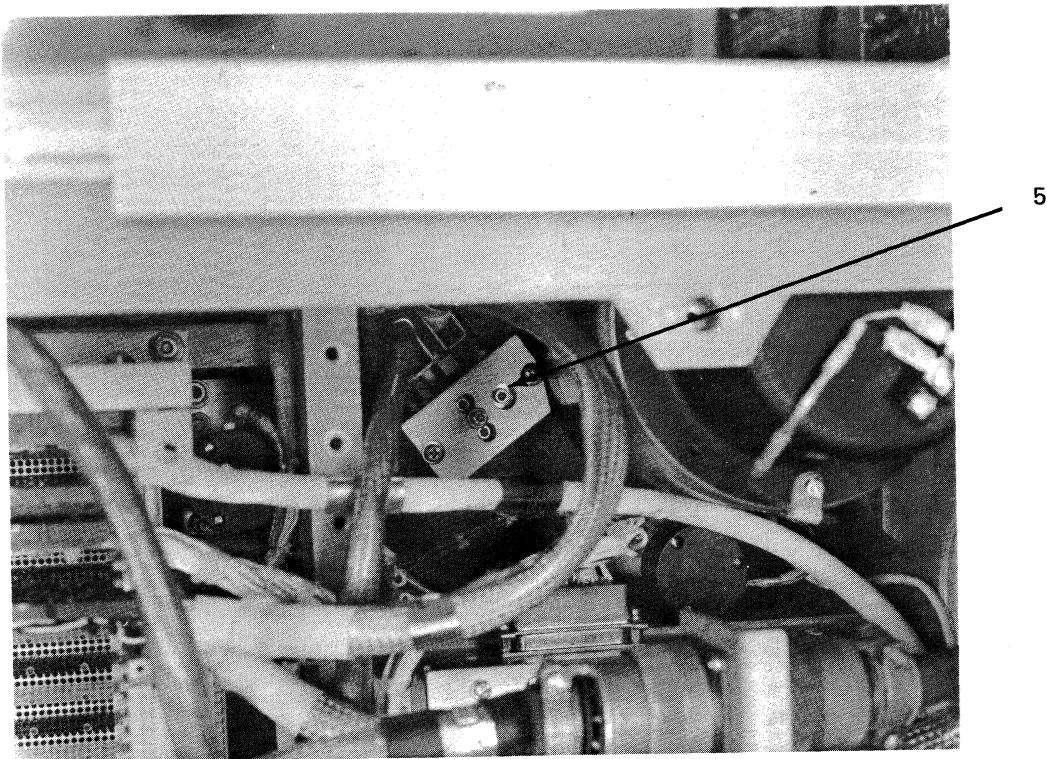

Figure 5-4. MTT. Rear View Cover Removed



FRONT VIEW



REAR VIEW

Figure 5-5. Head Basket Assembly

- STEP 4. Disconnect the cables and plugs to jacks J1, J2, and J3 (3).
- STEP 5. Remove the two screws (4) which secure the front of the head basket assembly.
- STEP 6. From the rear, remove the allen-head screw (5) which secures the rear of the head basket assembly.
- STEP 7. Carefully slip the head basket assembly from the unit.

(2) REPLACEMENT. - To replace the head basket assembly, perform the following steps:

- STEP 1. Place the assembly firmly in position by aligning the two positioning pins in the associated holes.
- STEP 2. Fasten the assembly in place with the two front screws (4) and one rear screw (5).
- STEP 3. Connect the plugs to the three jacks (3).
- STEP 4. Fasten the connector stop (2) in place with the two screws (1).
- STEP 5. Perform the read and write deskew procedures as listed in the MTS manual, PX 7985, Section 5.

5-4. GENERAL ADJUSTMENT INFORMATION.

The MTT contains several adjustments, located on printed circuit cards, which may require readjustment during or after repair or replacement procedures. Figure 5-6 identifies these adjustments and their physical location. The following paragraphs briefly describe the function of each adjustment.

a. SRS RAMP. - The SRS RAMP control R3, located on the 7600627 card in J47, adjusts the ramp rate for the supply reel servo. Adjusting the control in the clockwise direction decreases the speed at which the ramp increases. The control is normally adjusted to produce a ramp speed of approximately 100 milliseconds.

b. TRS RAMP. - The TRS RAMP control R27, located on the 7600627 card in J47, performs a similar function for the takeup reel servo as does the SRS RAMP control for the supply reel servo.

c. SRS SLO SPEED OPEN LOOP. - The SRS SLO SPEED O.L. control R13, located on the 7600629 card in J49, is used to set the speed of the supply reel to between one-half and one revolution per second when given an autoloading command. Turning the control clockwise causes the reel speed to decrease.

d. SRS FREQUENCY ADJUST. - The SRS FREQ ADJ control R31, located on the 7600629 card in J49, is adjusted to produce a drive pulse rate of 1000 Hz. Turning the control clockwise causes the drive rate to increase.

e. SRS BALANCE ADJUST. - The SRS BAL ADJ control R34, located on the 7600629 card in J49, is used to eliminate reel drift while the reels are stopped under closed-loop control. Turning the control clockwise causes the reel to drive forward.

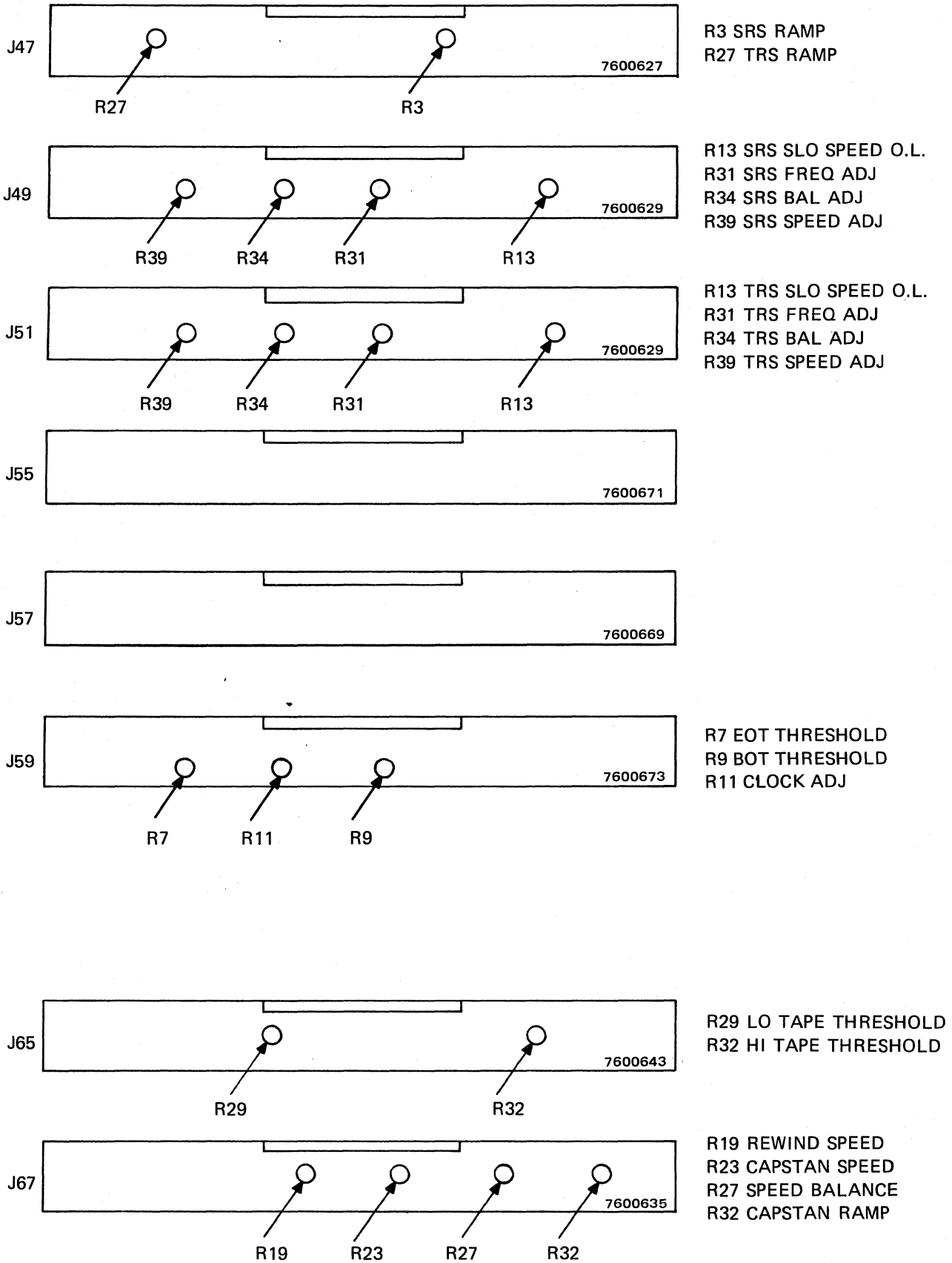

Figure 5-6. Card Rack Adjustment Identification

- f. SRS SPEED ADJUST. - The SRS SPEED ADJ control R39, located on the 7600629 card in J49, is used to adjust the reel speed while the reels are moving under closed-loop control. Turning the control clockwise causes the reel speed to increase.
- g. TRS CONTROLS. - The TRS controls R13, R31, R34, and R39, located on the 7600629 card in J51, are identical to those on the SRS card in J49. The output from the TRS card is used to control the takeup reel servo and performs the same functions as in paragraphs 5-3c, d, e, and f.
- h. CLOCK RATE ADJUST. - The CLOCK ADJ control R11, located on the Autoload Interface card 7600673 in J59, is adjusted to produce a one-second count signal. Adjusting the control in the clockwise direction causes signal duration to increase.
- i. EOT. - The EOT control R7, located on the 7600673 card in J59, is used to either increase or decrease the sensitivity of the EOT sensor. Turning the control clockwise decreases the sensitivity and consequently the voltage level at which the signal voltage switches.
- j. BOT. - The BOT control R9, located on the 7600673 card in J59, performs the same function for the BOT sensor as the EOT adjust does for the EOT sensor.
- k. LO TAPE. - The LO TAPE control R29, located on the 7600643 card in J65, is adjusted to produce the LO TAPE signal when approximately 100 feet (approximately 5.5 inches measured across the center of the reel hub) of tape remains on the supply reel. This adjustment should produce approximately 5.0 Vdc on the wiper arm of the control.
- l. HI TAPE. - The HI TAPE control R32, located on the 7600643 card in J65, performs the same function for the takeup reel as the LO TAPE adjust does for the supply reel and is adjusted in a like manner.
- m. REWIND SPEED. - The REWIND SPEED control R19, located on the 7600635 card in J67, adjusts the capstan drive speed in a rewind mode of operation. Turning the control in a clockwise direction will cause the capstan drive speed to decrease. This speed should be 200 inches per second.
- n. SPEED BALANCE. - The SPEED BALANCE control R27, located on the 7600635 card in J67, adjusts the balance between the capstan speeds in both the forward and reverse direction. The control should be used in conjunction with the CAPSTAN SPEED control R23 to adjust the forward speed. Turning the control in a clockwise direction decreases the forward speed of the capstan.
- o. CAPSTAN SPEED. - The CAPSTAN SPEED control R23, located on the 7600635 card in J67, adjusts the forward speed of the capstan during normal operation.
- p. CAPSTAN RAMP. - The CAPSTAN RAMP control R32, located on the 7600635 card in J67, the rate at which the capstan will start or stop by controlling the rate at which the drive voltage reaches its maximum levels.

See table 5-4 for detailed information on performing any of the above adjustments.

TABLE 5-4. INITIAL CONTROL SETTING

POTENTIOMETER	CARD AND LOCATION	SIGNAL	SETTING
R13	7600629(J49)	SRS SLO SPEED OPEN LOOP	8 turns CCW from fully CW
R39	7600629(J49)	SRS SPEED ADJ	Fully CCW
R13	7600629(J51A)	TRS SLO SPEED OPEN LOOP	8 turns CCW from fully CW
R39	7600629(J51A)	TRS SPEED ADJ	Fully CCW
R7	7600673(J59A)	EOT THRESHOLD	Fully CW
R9	7600673(J59A)	BOT THRESHOLD	10 turns CW from fully CCW
R29	7600643(J65A)	LO TAPE THRESHOLD	3 turns CW from fully CCW
R32	7600643(65A)	HI TAPE THRESHOLD	3 turns CW from fully CCW

NOTE

The setting of unlisted controls is relatively unimportant until alignment procedures are actually performed.

5-5. ADJUSTMENT PROCEDURES.

If it is necessary to replace parts or assemblies to rectify malfunctions, it may be necessary to adjust circuit components for proper operation. For most adjustments, measurements and scope connections are made on the test card, installed in card jack J53A and/or J63A. Table 5-4 lists the initial setting for controls; however, it is not necessary that all controls be in the initialized position, only those controls on the replacement component.

a. CLOCK RATE ADJUST. - To adjust the clock rate, perform the following steps.

STEP 1. Install test card in J63A. Connect the oscilloscope to J63A-35.

STEP 2. Press the LOAD switch on the MTT and observe a waveform familiar to that shown below.

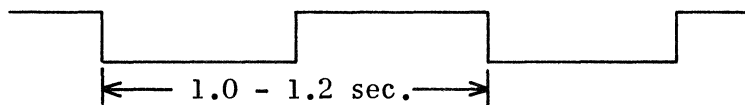

STEP 3. If necessary, adjust potentiometer R11 on the 7600673 in J59A for proper pulse width.

STEP 4. Connect the oscilloscope to J53A-37 and adjust R31 on the 7600629 card in J49A for a pulse width similar to that shown above.

? STEP 5. Connect the oscilloscope to J53-38 and observe a waveform similar to that shown above. If necessary, adjust R31 on the 7600629 card in J51A to obtain proper pulse width.

b. AUTOLOAD FAULT CYCLE TEST. - The autoloading fault cycle test is detailed here and referenced in preceding tests to indicate initial operation is successful. To initiate the test, perform the following steps.

STEP 1. On control panel, set MTT AUTO-MAN switch corresponding to MTT under test to MAN. Set POWER switches to ON.

STEP 2. Extend MTT to be tested.

STEP 3. Press MTT LOAD switch and observe the following operation. Time measurements listed are approximate.

At T - Blower starts operating. AIR 1 solenoid is energized as indicated by no vacuum in the buffer columns and forced air is flowing from the thread guidance relief holes. The small fan on the blower exhausts air from its casting.

At T + 4 sec. - The takeup reel turns counterclockwise.

At T + 8 sec. - The AIR 2 solenoid is energized as indicated by vacuum present in the takeup reel hub. The supply reel turns slowly clockwise. The takeup reel changes from slow to fast counterclockwise.

At T + 12 sec. - Both reels stop, the blower shuts down, and the AIR 2 solenoid is deactivated.

At T + 13 sec. - The supply reel turns slowly counterclockwise.

At T + 16 sec. - The supply reel stops and the AIR solenoid is deactivated.

If necessary, adjust R13 on the 7600629 card in J49A so the supply reel completes between 4 and 4.5 revolutions clockwise after T + 8 seconds before reversing to counterclockwise.

STEP 4. Set the AUTO-MAN switch to AUTO.

STEP 5. Press the LOAD switch and observe that no action results.

STEP 6. Set the AUTO-MAN switch to MAN.

c. AUTOLOAD WITH WORK TAPE. - To perform automatic load with a work tape, install the work tape, without a write enable ring, on the supply reel hub seated firmly on the hub. Ensure that the work tape has a BOT marker between 9 and 16 feet from the beginning of the tape. Press MTT LOAD switch and observe the following.

At T - The blower starts operating. The AIR 1 solenoid is activated as indicated by a lack of vacuum in the buffer columns and forced air is flowing from the thread guidance relief holes.

At T + 4 sec. - The takeup reel rotates counterclockwise.

At T + 8 sec. - The AIR 2 solenoid is activated as indicated by a vacuum in the takeup reel hub. The supply reel rotates clockwise. The leading edge of the tape is peeled from the supply reel and flows smoothly along the threaded path, past the read/write head and the capstan, and enters the takeup reel cavity. After the tape wraps approximately 3/4 turn around takeup reel, the supply reel stops temporarily to allow tape to tighten around takeup reel and capstan. It may be necessary to adjust R13 on the 7600629 card in J49A for a worst-case condition.

NOTE

Worst-case condition exists when the supply reel must rotate one full revolution before feeding tape down the threading path. R13 adjusts the time the supply reel remains stopped while the takeup reel tightens slack tape. The supply reel rotates clockwise and tape winds smoothly on the takeup reel.

At T + 12 sec. - Both AIR 1 and AIR 2 solenoids are deactivated indicated by the vacuum being removed from the takeup reel hub and being applied to the buffer columns. Air pressure is removed from the buffer columns and threading path and is exhausted from the rear of the blower. The supply reel continues forward rotation; the takeup reel rotates in reverse. As loops are formed between sensors B and C, both the supply and takeup reels stop momentarily as operation is now closed-loop with the tachometers providing the drive signals for the reel motors.

At T + 15 sec. - The capstan rotates forward with both reels in a closed loop condition.

At T + 18 sec. - The capstan rotates in reverse with both reels in a closed loop condition. Tape stops at the BOT marker and the READY indicator is lighted.

NOTE

If any faults occur during tape loading, the reel speed potentiometer may have to be coarsely adjusted to complete the Auto Load cycle.

d. RELOAD FUNCTION TEST. - The reload function test is used to check the ability of the MTT to automatically reload tape after power has been removed with tape still in the buffer columns. To perform the reload function test, perform the following steps.

STEP 1. After tape is loaded and the READY indicator is lighted, press STOP switch on MTT. Observe that the blower motor stops. Allow approximately 30 seconds for the vacuum to be released from the buffer columns and tape in the columns to relax.

STEP 2. Press the LOAD switch on the MTT and observe that the blower starts to operate. The takeup reel rotates counterclockwise to pull tape from the buffer columns, first from the takeup column and then the supply column.

After tape tightens on the capstan forcing the capstan to move, the take-up reel reverses direction and the supply reel drives forward loading tape in the buffer columns. After tape is reloaded, both reels stop and the READY indicator is lighted. The time required for the reload operation should be between 5 and 7 seconds.

NOTE

If the vacuum blower does not build vacuum fast enough to complete the reload function, readjust the clock rate adjustment for a longer clock pulse.

e. UNLOAD FUNCTION TEST. - The unload function test is performed to demonstrate the capability of the MTT to unload the tape from the takeup reel to the supply reel. To check the unload function, perform the following steps.

- STEP 1. Press the UNLOAD switch on the MTT and observe that the reels drive fast forward in a closed loop condition, until the high tape indication occurs. Both reels then drive fast reverse until the BOT is detected. At the BOT, both reels return to a slow speed open loop condition. The supply reel continues in reverse to pull the tape from the buffer columns and start the takeup reel rotating clockwise and all tape is rewound on the supply reel.
- STEP 2. If the takeup reel does not rotate fast enough to allow all tape to be removed from the reel, adjust R13 on the 7600629 card in J51A to increase the reel speed.
- STEP 3. Reload the tape and repeat the unload function test to assure proper adjustment.
- STEP 4. Remove the tape from the MTT.

f. BOT/EOT SENSOR ALIGNMENT. - If the BOT/EOT sensor is replaced, it is necessary to mechanically align the sensor so that both sides of the sensor have the same distance from the tape ($x_1=x_2$) as shown below.

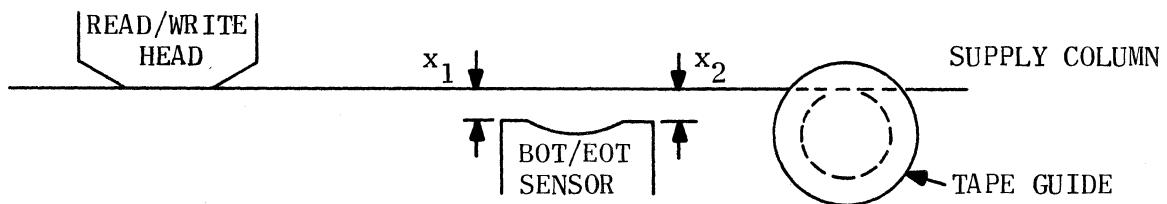

g. BOT SENSOR SENSITIVITY. - To adjust the sensitivity of the BOT, perform the following steps.

- STEP 1. Use oscilloscope to monitor J63A-37.
- STEP 2. With tape loaded, turn R9 on 7600763 card in J59A fully clockwise.
- STEP 3. Turn capstan until BOT marker is not in front of sensor. Turn R9 counterclockwise and count the number of turns until oscilloscope indicates 0 ± 0.5 Vdc. Turn R9 counterclockwise and count the numbers of turns

until oscilloscope indicates 5 ± 1 Vdc. Turn R9 counterclockwise one-half the number of counted turns.

h. HIGH TAPE SENSOR ADJUSTMENT. - The high tape sensor informs the transport logic that the tape on the takeup reel is within 100 feet of the end and causes the rewind speed to decrease. Actually located adjacent to the takeup reel, the high tape sensor detects when tape is less than 5.5 inches across the center of the reel hub. To adjust the high tape sensor, perform the following steps.

STEP 1. Use an oscilloscope to monitor J53A-12.

STEP 2. With tape loaded at BOT, adjust R32 on 7600643 card in J65A clockwise until oscilloscope indicates 0 Vdc. Turn R32 three turns from this point counterclockwise.

STEP 3. Press FWD switch on control panel. After approximately 15 seconds, momentarily press STOP and then REWIND switches. The reels should rewind at fast speed.

STEP 4. When high tape function is detected, as indicated by the reels changing from fast to slow speed, use a timer and check the time until the reels stop, indicating BOT. This time should be between 9 and 15 seconds. If this time is too short, turn R32 counterclockwise to increase the time. If this time exceeds 15 seconds, turn R32 clockwise to come within specified tolerance.

i. LOW TAPE SENSOR ADJUSTMENT. - To adjust the sensitivity of the low tape sensor, to indicate that less than 100 feet of tape remain on the supply reel, perform the following steps.

STEP 1. On the control panel, press the FWD switch and allow tape to run to EOT and stop.

STEP 2. Press the REV switch and allow tape to run reverse for 15 seconds. Press STOP switch.

STEP 3. Connect oscilloscope to J63-31 and observe 0 volt indication.

STEP 4. Press the FWD switch and allow tape to run forward. Check the time from when scope indication changes to +5 volts until reel stops. Time should exceed 9 seconds. If time is greater than 9 seconds, omit steps 5 and 6.

STEP 5. Turn R29 on the 7600643 card in J65A fully counterclockwise. Oscilloscope should indicate 5 volts. Turn R29 clockwise and count the turns until the oscilloscope indicates 0 volts.

STEP 6. Turn R29 counterclockwise one-half the counted turns. Run tape reverse for approximately 15 seconds. Repeat step 4.

STEP 7. Run tape to BOT.

j. EOT ADJUSTMENT. - If it becomes necessary to adjust the EOT sensitivity, perform the following steps.

STEP 1. Use an oscilloscope and monitor the signal at pin J63A-39.

- STEP 2. Load tape on MIT. Press FWD switch on control panel and allow tape to run until EOT indicator on control panel is lit.
- STEP 3. Manually rotate supply reel counterclockwise until oscilloscope indicates 0 Vdc.
- STEP 4. Count the number of turns and adjust R7 on 7600673 card in J59A counterclockwise until oscilloscope indicates 0 Vdc.
- STEP 5. Turn R7 clockwise one-half the number of turns counted.

If the previous steps do not produce the required oscilloscope indication, perform the following steps.

- STEP 1. Manually rotate capstan counterclockwise until EOT market is not in front of sensor.
- STEP 2. Turn R7 fully clockwise.
- STEP 3. Turn R7 counterclockwise, counting the number of turns, until oscilloscope indicates 0 Vdc.
- STEP 4. Turn R7 clockwise one-half the number of turns counted.
- STEP 5. If oscilloscope will not indicate 5 Vdc, turn R7 ten turns clockwise from fully counterclockwise position.

k. CAPSTAN RAMP ADJUST. - The capstan ramp adjust is performed to insure capstan start and stop times are within specified tolerances. To adjust the capstan ramp, perform the following steps.

- STEP 1. On the control panel, place the AUTO/MAN switch for the transport under test in the MAN position.
- STEP 2. Load tape to BOT. If tape has already been loaded, insure it is at BOT.
- STEP 3. On the maintenance panel, place the TT START/STOP switch corresponding to the transport under test in the up position.
- STEP 4. Use the RUN and STOP controls to adjust the duration and frequency of capstan movement.

NOTE

If a 7092440-01 printed circuit card is used in J04B of the control unit, do not allow tape to run to EOT. The transport will not detect the EOT in the manual mode and entire tape will wind on takeup reel.

- STEP 5. Install the test card in J63A and connect the oscilloscope sync to J63A-25. Sync positive.
- STEP 6. Use the oscilloscope and monitor J63A-26.

- STEP 7. On the control panel, press the FWD switch for the transport under test. Use the CAPSTAN RAMP control R32 on the 7600635 card in J67A and adjust the length of the capstan ramp as shown below.

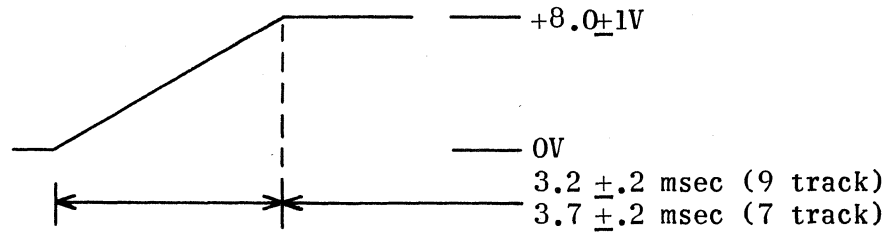

- STEP 8. Use the RUN and STOP controls and vary the speed of the capstan movement. Observe that the waveform remains constant.
- STEP 9. Sync negative and observe the waveform shown below. Vary the speed of capstan movement and observe that the waveform remains constant.

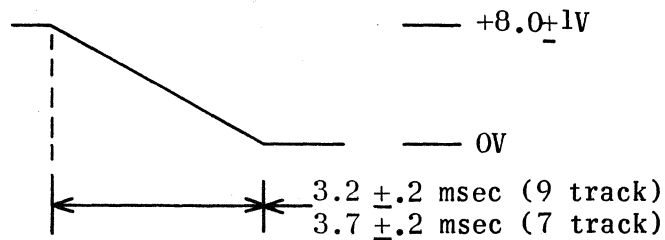

- STEP 10. Readjust the CAPSTAN RAMP control if necessary to obtain the proper waveform. Recheck the waveform as in steps 7 through 9.
- STEP 11. On the control panel, press the associated STOP switch. Return the TT START/STOP switch to the down position.
- STEP 12. Unload the work tape from the MTT.
1. FILE PROTECT ADJUSTMENT. - If it is necessary to replace the file protect assembly, it is necessary to insure that the file protect switch is operating correctly. To check the switch, perform the following steps.
- STEP 1. Remove supply reel from supply reel hub.
- STEP 2. Use a 6-inch straight edge and press the file protect pin to the rear hub flange. Listen and insure that the micro switch closes before the pin is within $3/16$ inch from the surface of the file protect assembly.
- STEP 3. Hold the pin in and press the load switch. Observe that the solenoid holds the pin in.
- STEP 4. Press the STOP switch and observe that the pin is released and returns to the extended position.
- STEP 5. Press the LOAD switch and observe that the pin is not pulled in. Press the STOP switch.

m. CAPSTAN SPEED AND BALANCE ADJUST. - To adjust capstan speed and balance, perform the following steps.

STEP 1. Load deskew reference tape.

CAUTION

While running the deskew reference tape, do not stop at any point between BOT and EOT. Allow tape to run to either BOT or EOT without stopping.

STEP 2. Run tape forward to EOT.

STEP 3. Connect counter to TP6 on card in A25 of the Control Unit (see MTS system manual, PX 7985).

STEP 4. Run tape in reverse. While tape is running in reverse, adjust CAPSTAN SPEED control R23 on 7600635 card in J67A to obtain a reading of less than 45 KHz. Readjust R23 to obtain a reading of 48 ± 0.1 KHz on counter. Allow tape to run to BOT.

STEP 5. Run tape forward. While tape is running forward, adjust SPEED BALANCE control R27 on 7600635 card in J67A to obtain a reading of 48 ± 0.1 KHz on counter. Allow tape to run to EOT.

NOTE

Adjusting R27 will cause either the forward frequency to increase and reverse speed to decrease, or cause the forward speed to decrease and reverse speed to increase.

STEP 6. Repeat steps 4 and 5 adjusting R23 and R27 until counter number reads within tolerance in both directions.

STEP 7. After adjustments have been made, unload deskew reference tape.

n. REEL SPEED AND REEL RAMP ADJUSTMENTS. - To adjust the reel speed and reel ramp, perform the following steps.

STEP 1. Load a work tape on MTT. Install test card in J53A.

STEP 2. Connect oscilloscope to test point J53A-6. Connect oscilloscope trigger to J53A-25.

STEP 3. Run tape forward and adjust RAMP ADJUST control R3, on 7600627 card in J47A, for supply reel, to obtain pulse widths as shown in waveform on following page.

STEP 4. Adjust SR SPEED ADJUST control R39, on 7600629 card in J49A, for the pulse repetition rate as shown in waveform on following page.

NOTE

The two adjustments in steps 3 and 4 interact when adjusted. These two steps should be repeated until the readings are within tolerance.

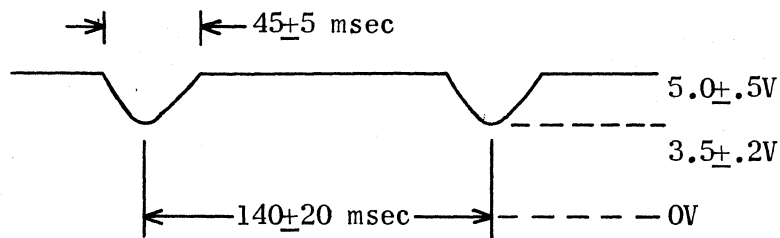

STEP 5. Allow tape to run to EOT, and then run tape in reverse. Observe following waveform and repeat adjustments in steps 3 and 4, if necessary.

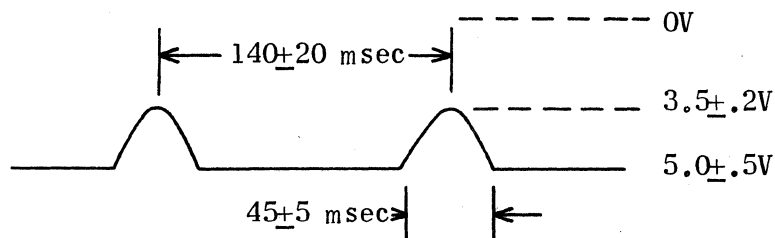

STEP 6. If necessary repeat steps 3, 4, and 5 until waveforms are within tolerance. These waveform adjustments are nominal and may have to be readjusted in later steps.

STEP 7. Connect oscilloscope to J53A-5 and oscilloscope trigger to J53A-34. Run tape forward.

STEP 8. Adjust RAMP ADJUST control R27, 7600627 card in J47A, for the takeup reel, to obtain pulse widths as shown in waveform below.

STEP 9. Adjust TR SPEED ADJUST control R39, on 7600629 card in J51A, for repetition rate shown below.

STEP 10. Because adjustments are interacting, repeat steps 8 and 9 until waveforms are within tolerance. Allow tape to run to EOT.

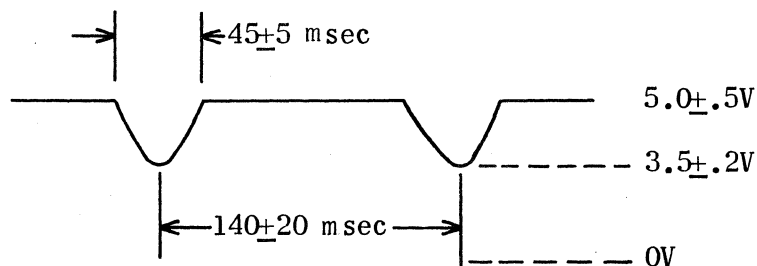

STEP 11. Run tape in reverse and observe following waveforms. If necessary, repeat steps 8, 9, and 10 to obtain optimum results. These waveform adjustments are nominal and may have to be readjusted in later steps.

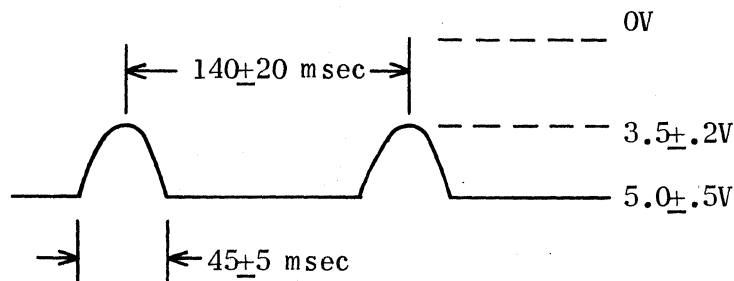

STEP 12. Repeat steps 3 through 10 to obtain optimum results.

o. REWIND SPEED ADJUST. - To adjust the rewind speed, perform the following steps.

STEP 1. Load the deskew reference tape.

CAUTION

While running the deskew reference tape, do not stop at any point between BOT and EOT. Allow tape to run to either BOT or EOT without stopping.

STEP 2. Run tape forward to EOT.

STEP 3. Connect counter to TP6 on the card in A25 of the Control Unit.

STEP 4. Press the REWIND switch and, while tape is rewinding, adjust REWIND SPEED control R19 on the 7600635 card in J67A to obtain a reading of 80 ± 1.5 KHz on the counter.

NOTE

The SRS FREQ ADJUST control R31 on the 7600629 card in J49A may require readjustment to prevent a fault condition occurring across the D sensor in the supply column. Adjust clock rate upward in 50 Hz steps and repeat Rewind Speed test to verify correction of fault condition (see paragraph 5-5a).

p. REEL DRIVE BALANCE ADJUST. - To adjust the reel drive balance, perform the following steps.

STEP 1. Install and load a work tape on the tape transport. Observe that the BOT indicator on the control panel is lighted.

STEP 2. Run tape forward for approximately 15-20 seconds. Press the STOP switch.

STEP 3. Observe the supply reel and insure that there is no rotational movement of the reel. If movement is observed, adjust the SRS REEL BAL control R34 on the 7600629 card in J49A to eliminate movement.

STEP 4. Observe the lub of the takeup reel and insure there is no rotational movement of the lub. If movement is observed, adjust the TRS REEL BAL control R34 on the 7600629 card in J51A to eliminate the movement.

STEP 5. Repeat steps 2, 3, and 4 to insure adjustment is correct.

STEP 6. Unload tape.

q. POWER SUPPLY ADJUSTMENTS. - The power supply contains three potentiometers which are located on the printed circuit cards in the A1 Regulator Subassembly and shown in Figures 7-16 and 7-18. The 26v bias voltage can be measured across the A1A1C52 or A1A1C48 capacitor. The overload adjust A1A2R23 is adjusted to shut down the regulator during an overload condition when output current exceeds 15 amperes. A1A2R3 is adjusted to produce an output voltage of $+75 \pm 0.1$ Vdc. A1A1R48 is adjusted to cause the output voltage to drop to zero volts if this voltage is not within 10% of the specified value.

NOTE

To prevent possible damage to the power supply components, set each potentiometer on the printed circuit cards (R3 and R23 on the 7600667 card and R48 on the 7600665 card) midrange before interchanging cards in the power supply.

5-6. PRINTED CIRCUIT CARDS.

Figures 5-7 through 5-29 contain the parts layout and schematic diagrams of the printed circuit cards used in the MTT. These are provided for reference only and are not intended to provide information for piece-part repair.

5-7. DIGITAL INTEGRATED CIRCUITS.

The MTT uses two unique digital integrated circuits (IC's). The logic diagrams, truth tables, and pin assignments are provided in figures 5-30 and 5-31 as an aid in malfunction isolation and not as replacement data. Because the maintenance philosophy is for card replacement rather than circuit component replacement, no procedures are provided to repair circuit cards. The data presented on the IC's is informational only. Component replacement may be performed for emergency operation following normal shop procedures.

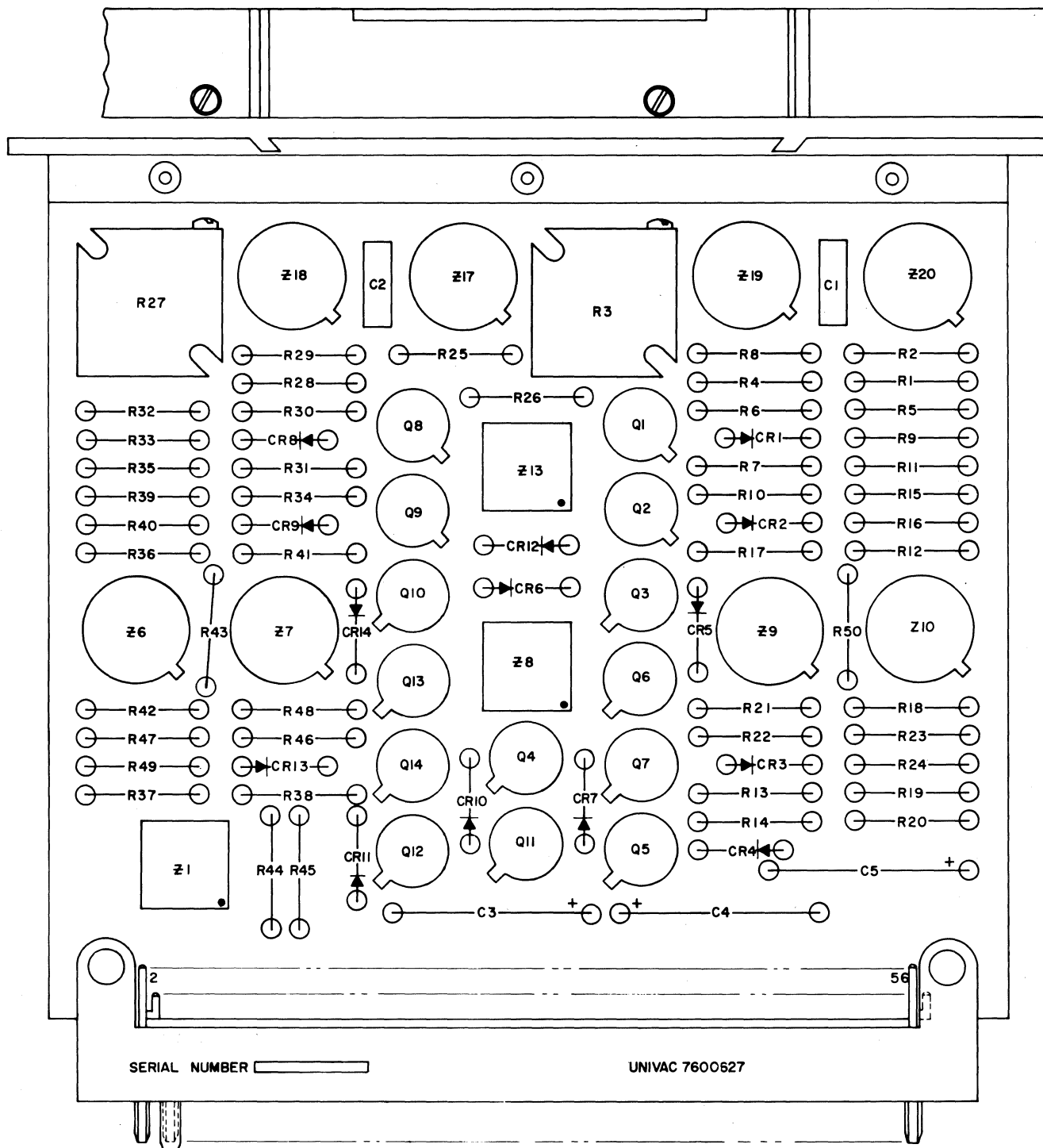

Figure 5-7. Reel Servo Input Circuit Card Assembly (7600627)

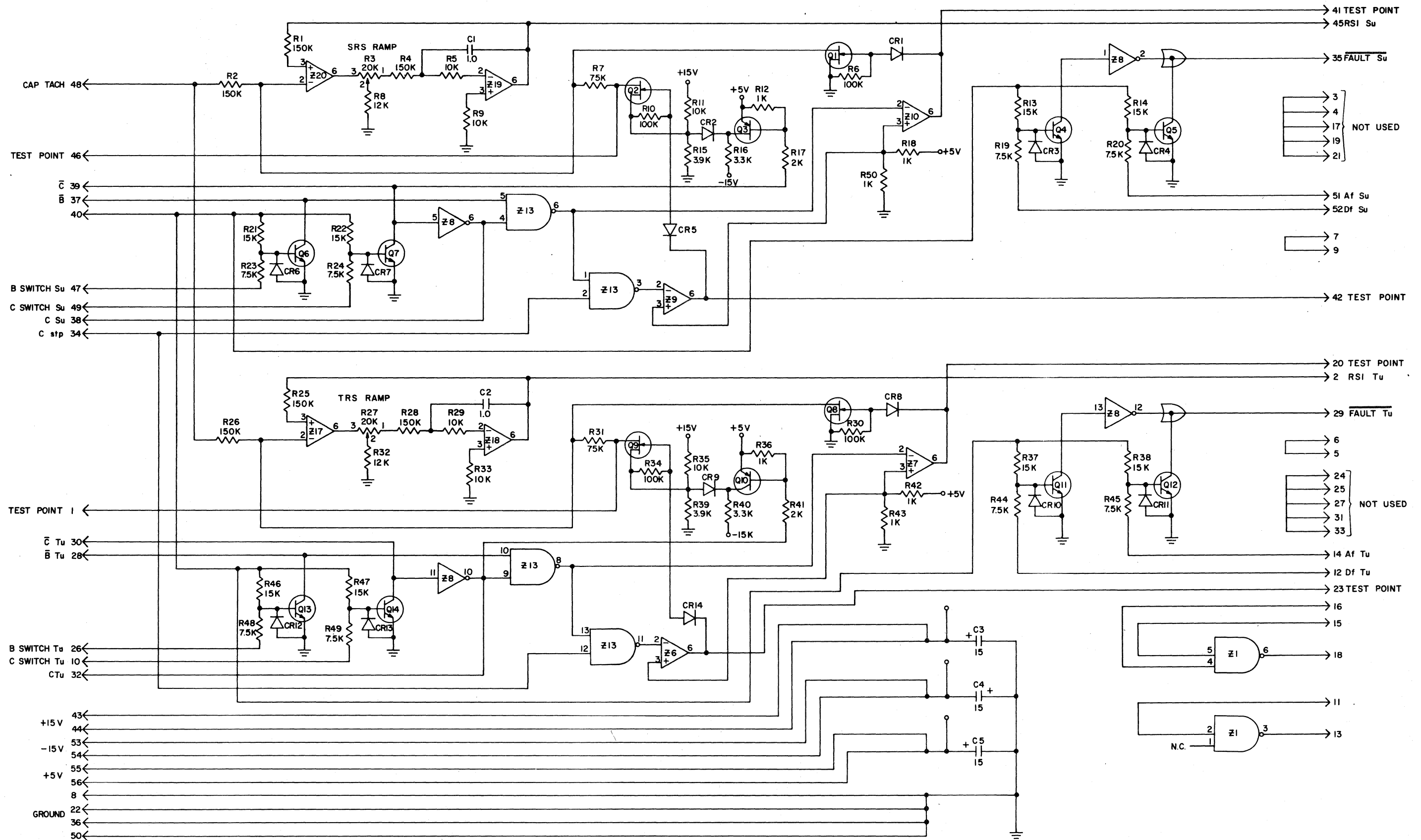

Figure 5-8. Reel Servo Input Schematic Diagram (7600627)

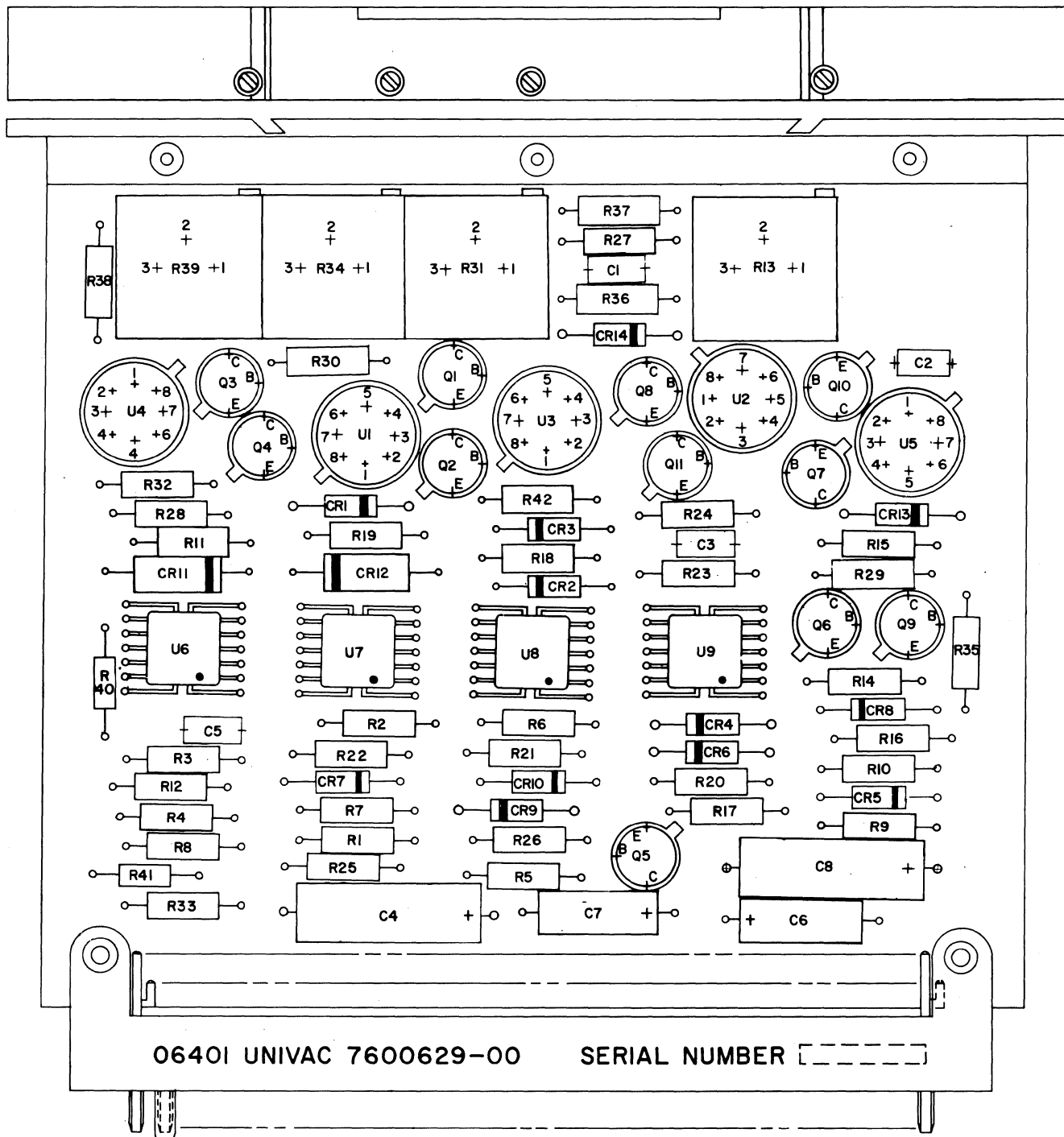

Figure 5-9. Reel Servo Output Circuit Card Assembly (7600629)

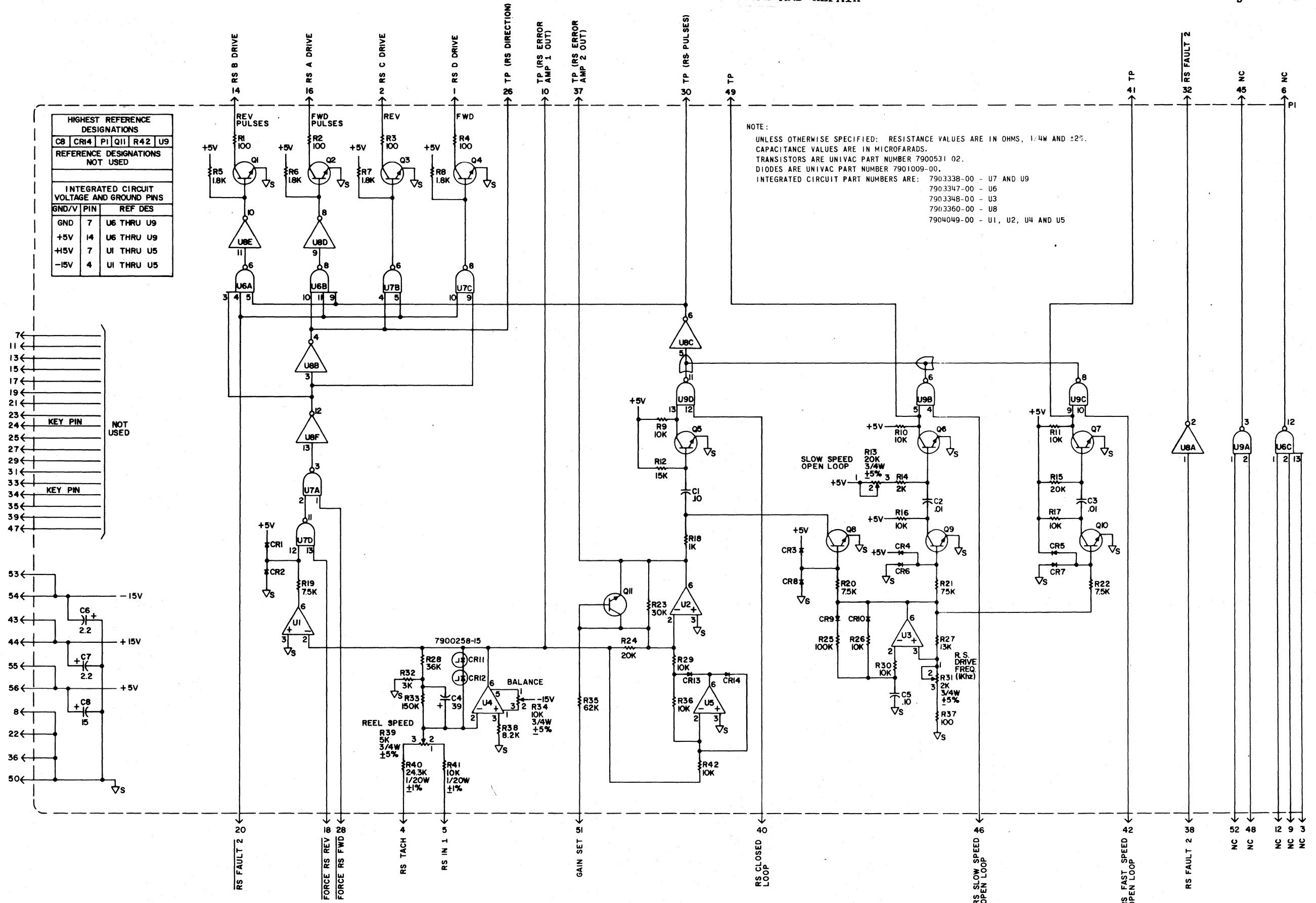

Figure 5-10. Reel Servo Output Schematic Diagram (7600629)

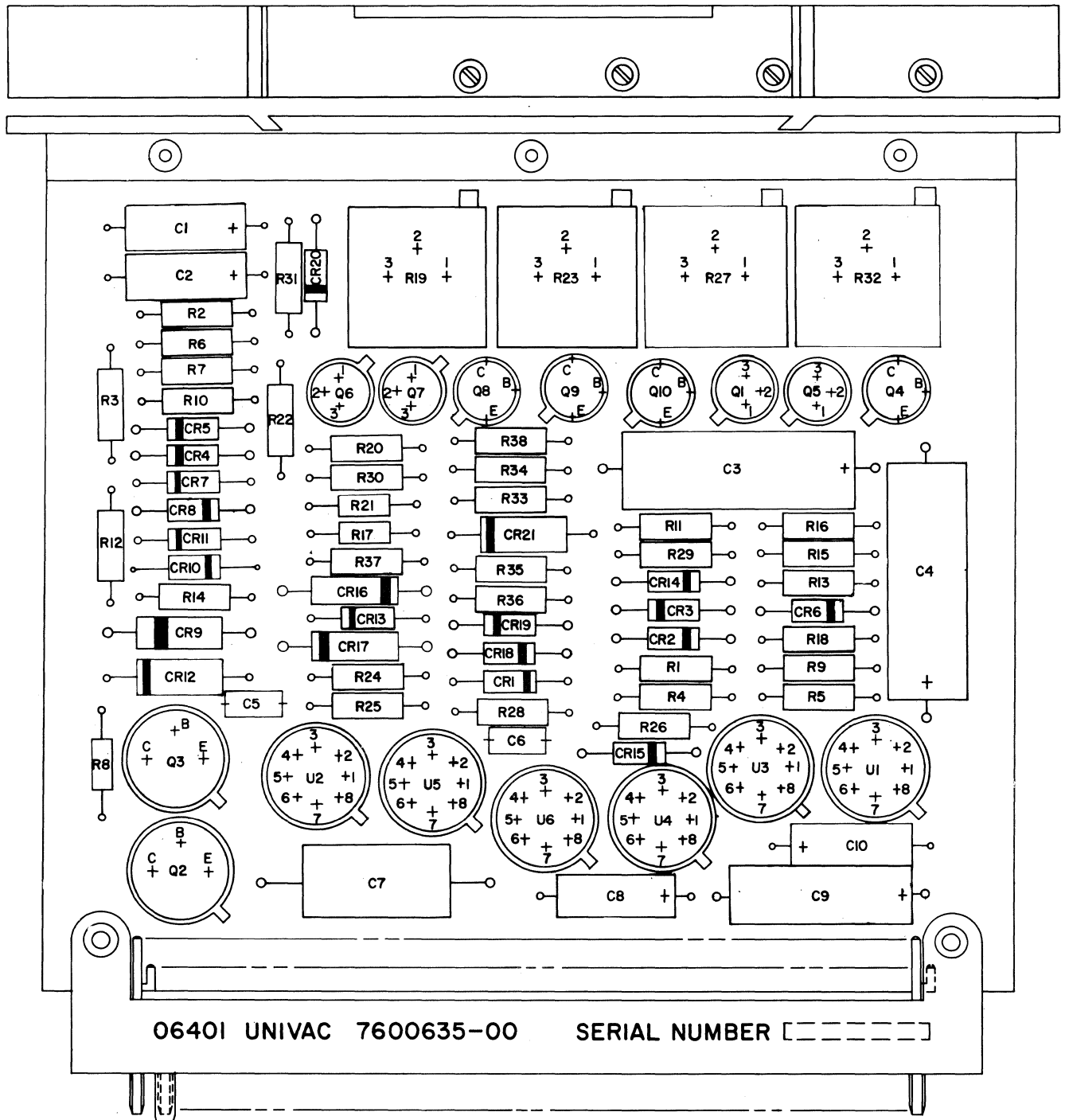

Figure 5-11. Capstan Servo Input Circuit Card Assembly (7600635)

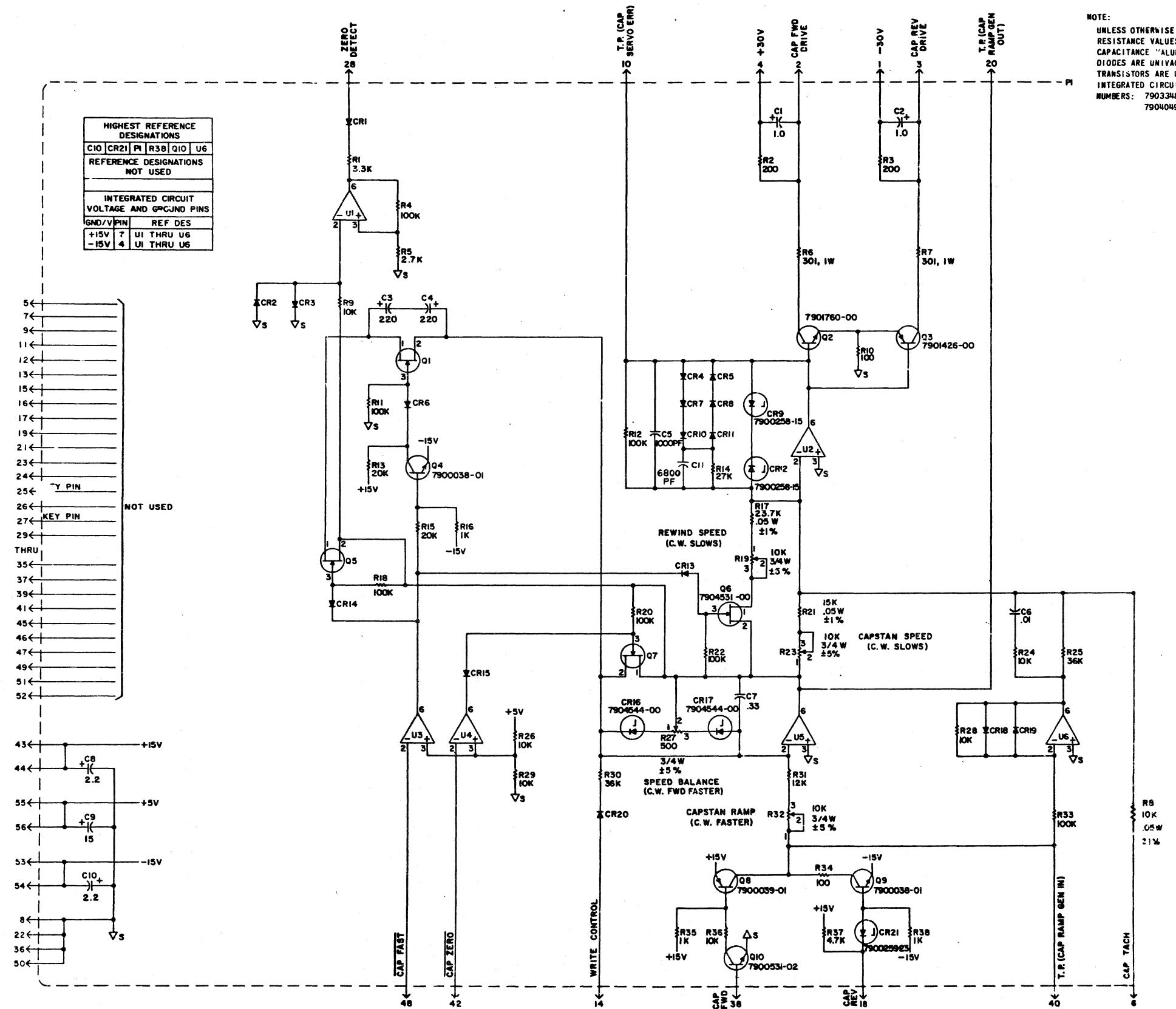

Figure 5-12. Capstan Servo Input Schematic Diagram (7600635)

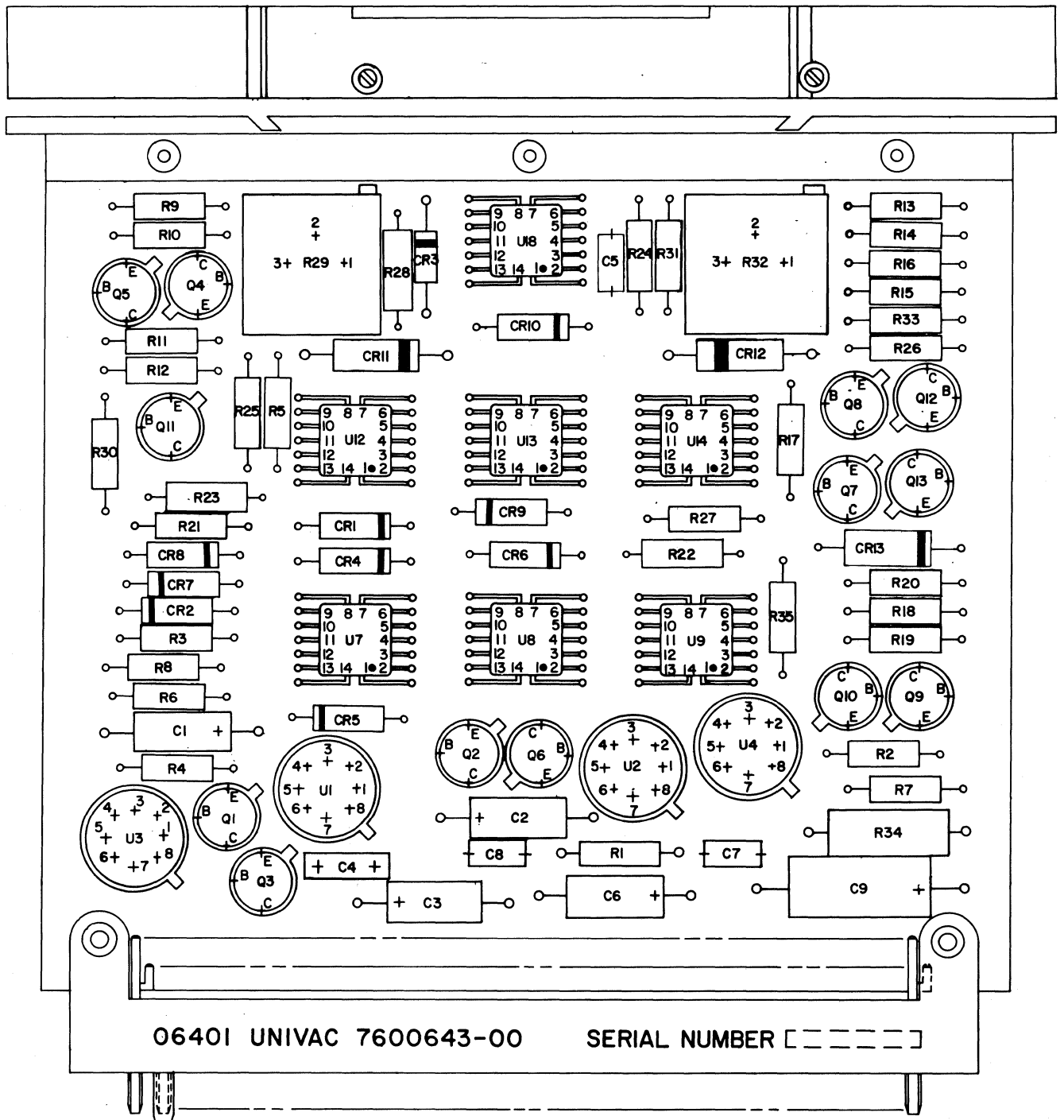

Figure 5-13. Capstan Servo Logic Circuit Card Assembly (7600643)

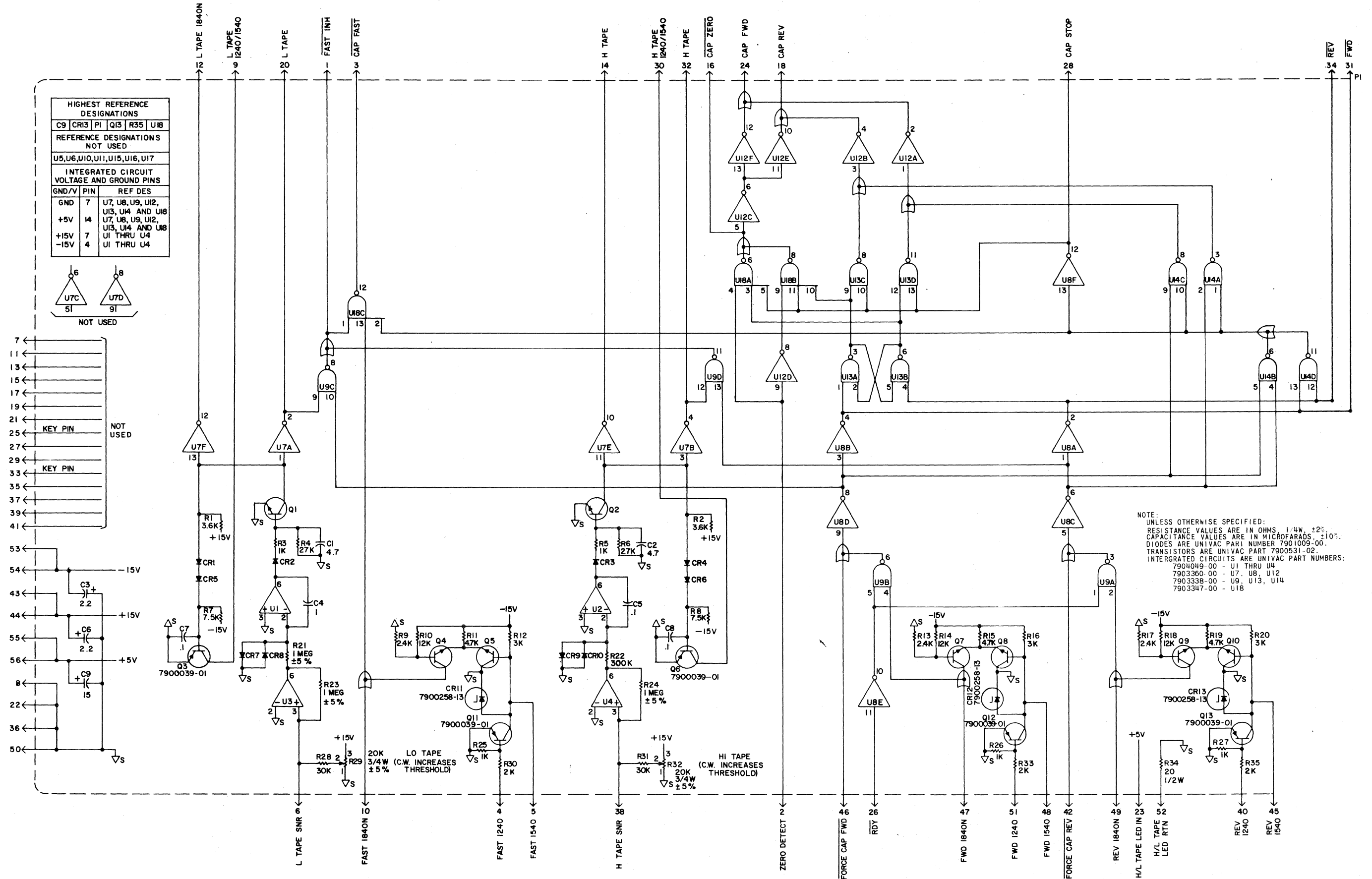

Figure 5-14. Capstan Servo Logic Schematic Diagram (7600643)

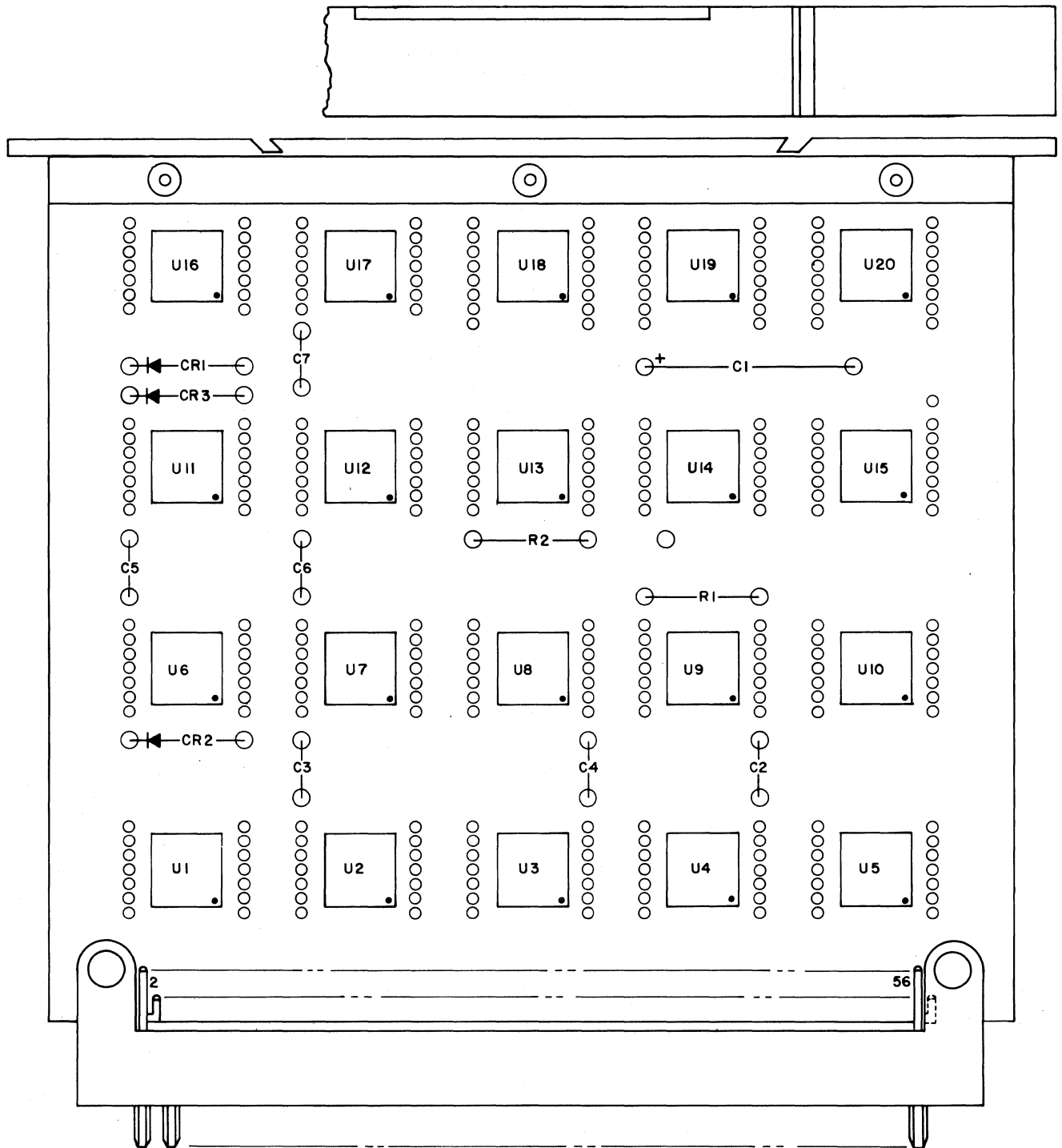

Figure 5-15. Autoload Function Generator Circuit Card Assembly (7600669)

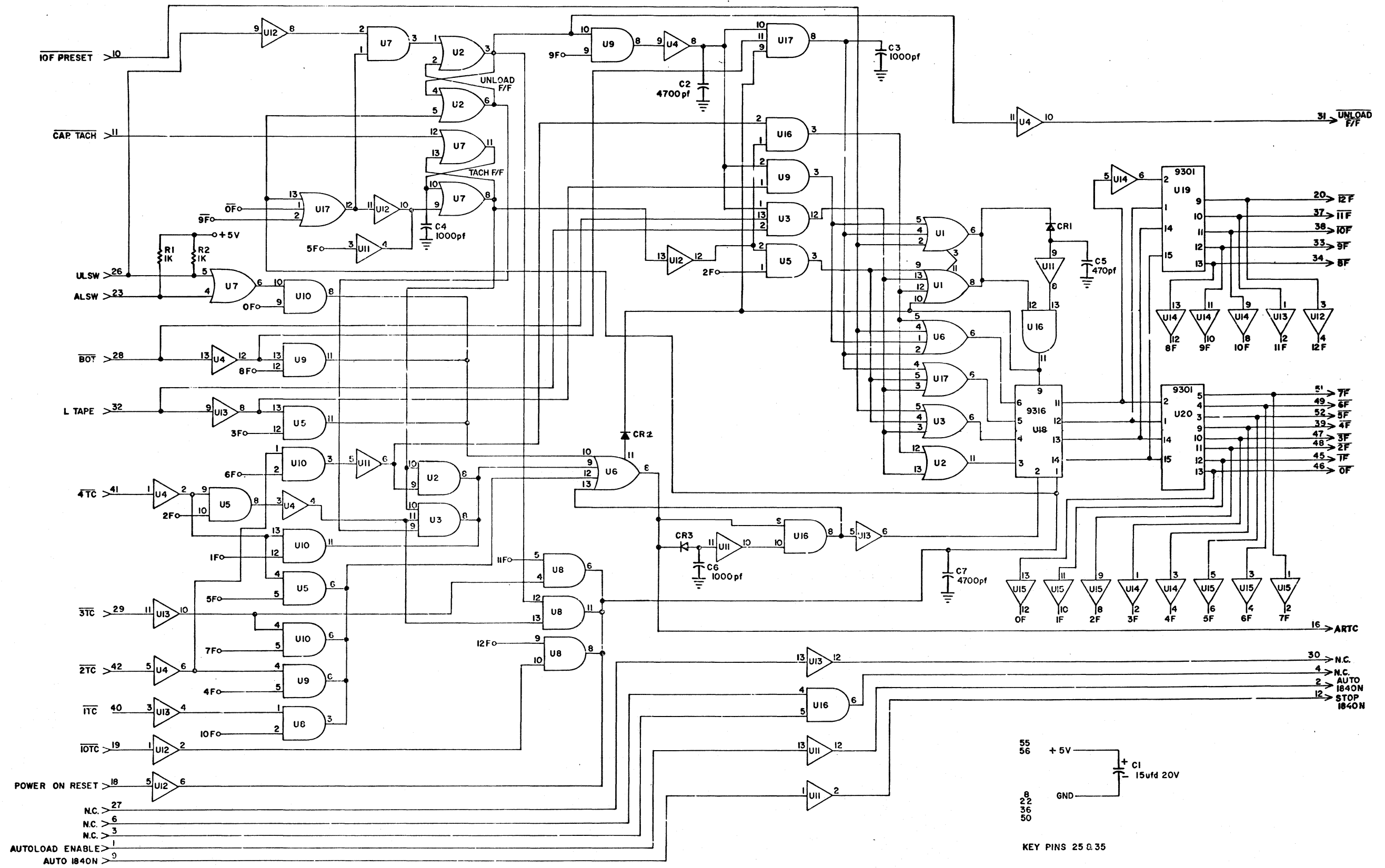

Figure 5-16. Autoload Function Generator Schematic Diagram (7600669)

ORIGINAL

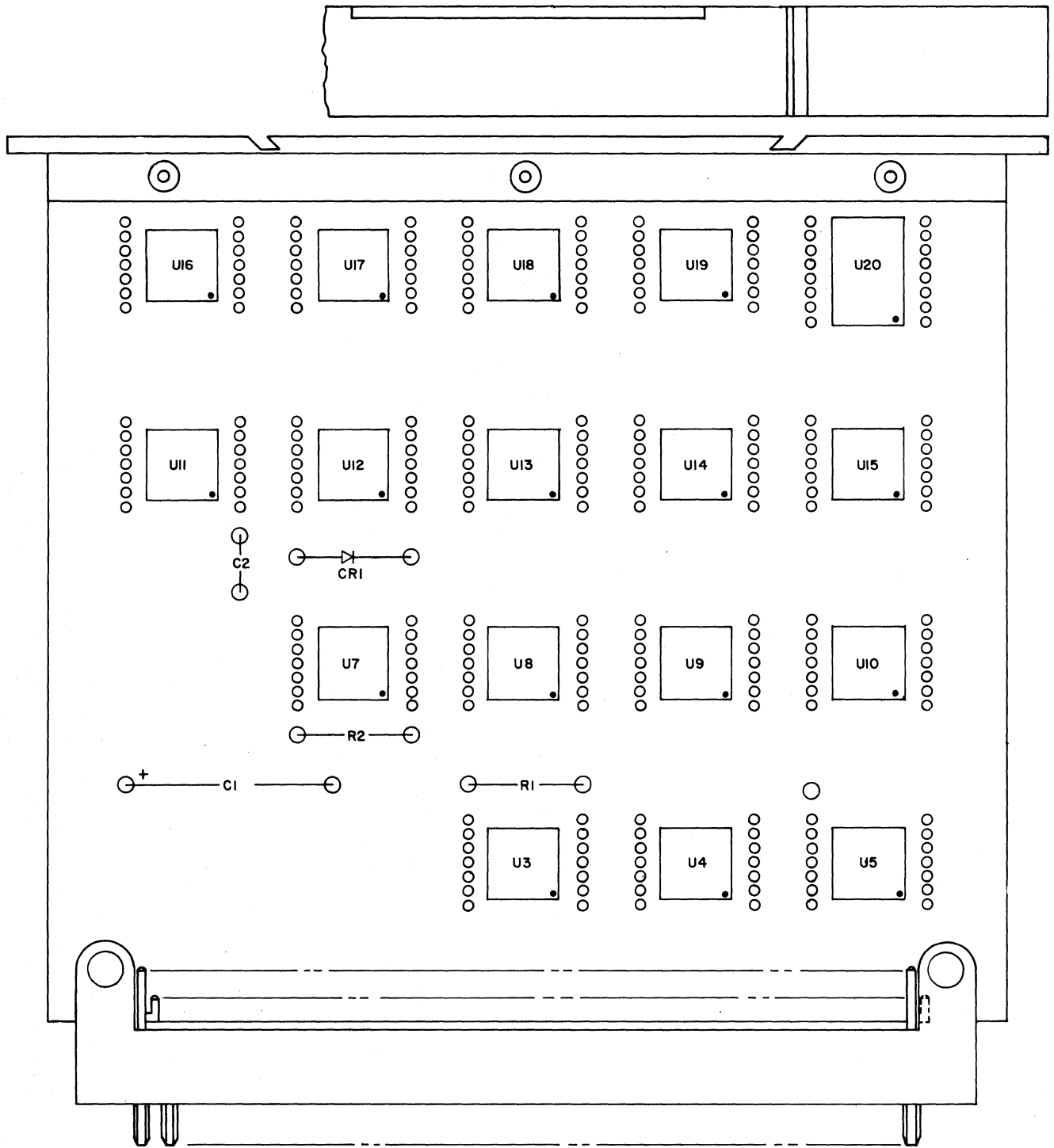

Figure 5-17. Autoload Servo Control Circuit Card Assembly (7600671)

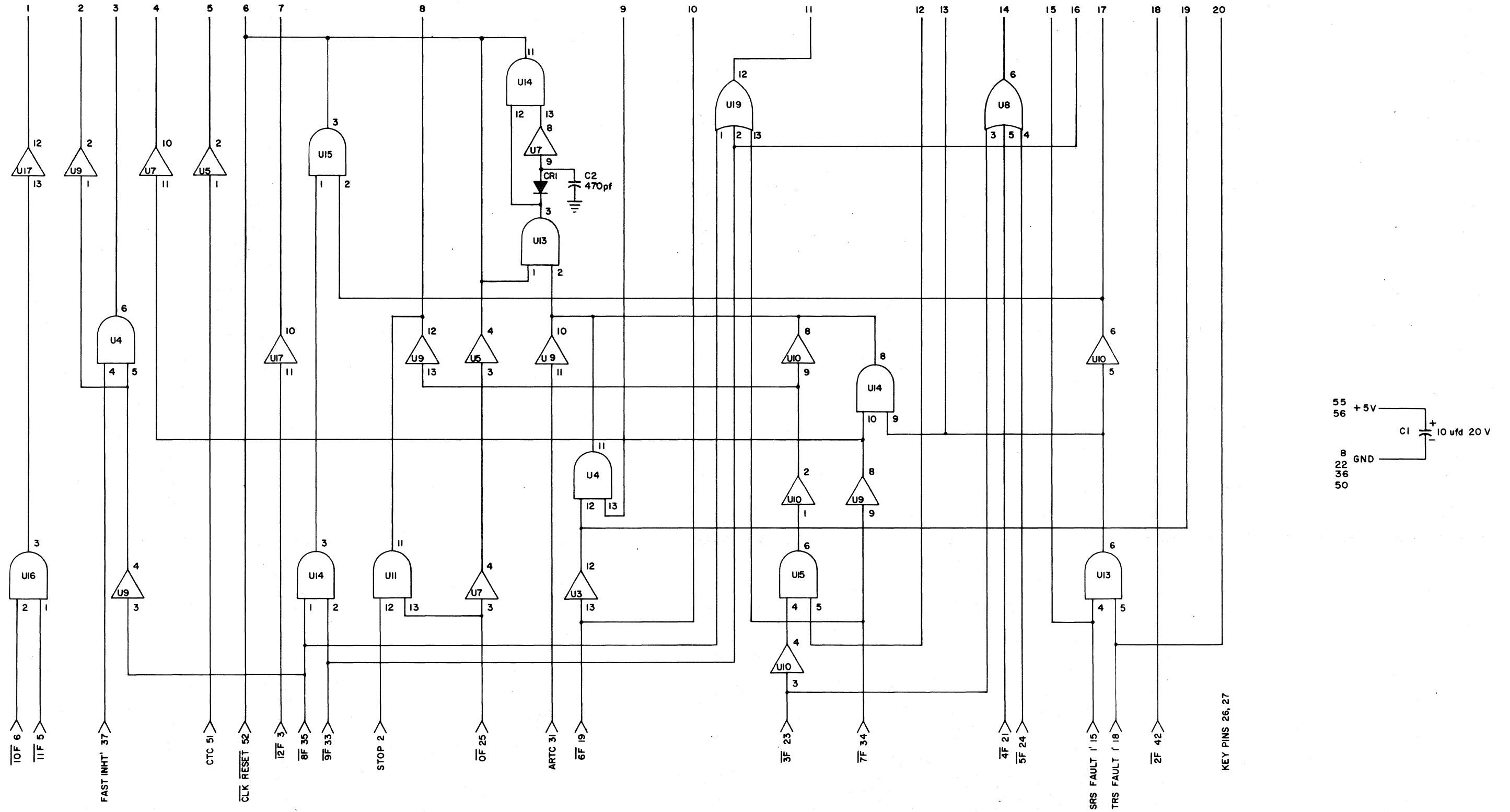
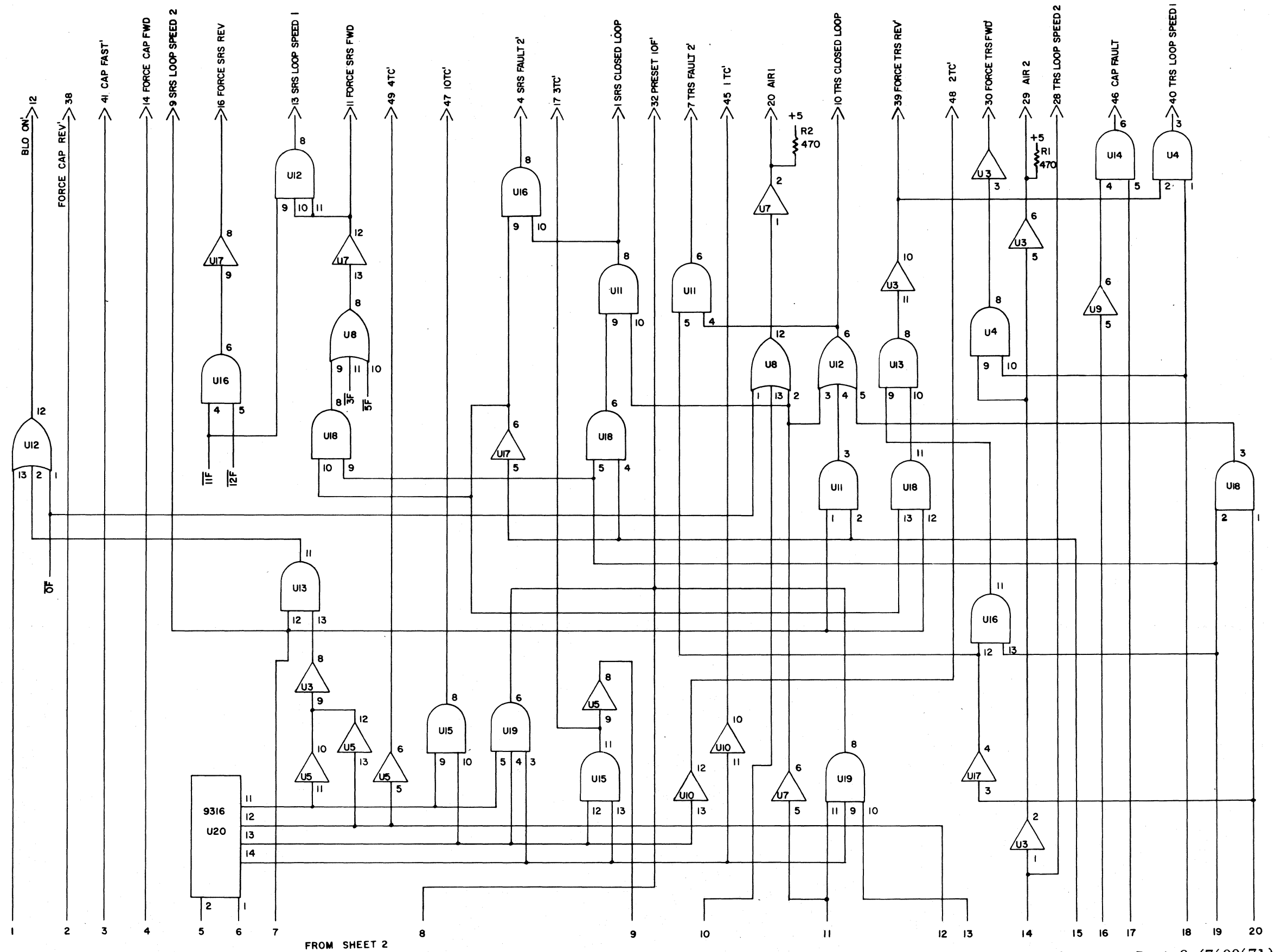

Figure 5-18. Autoload Servo Control Schematic Diagram - Part 1 (7600671)

ORIGINAL



FROM SHEET 2

Figure 5-19. Autoload Servo Control Schematic Diagram - Part 2 (7600671)

ORIGINAL

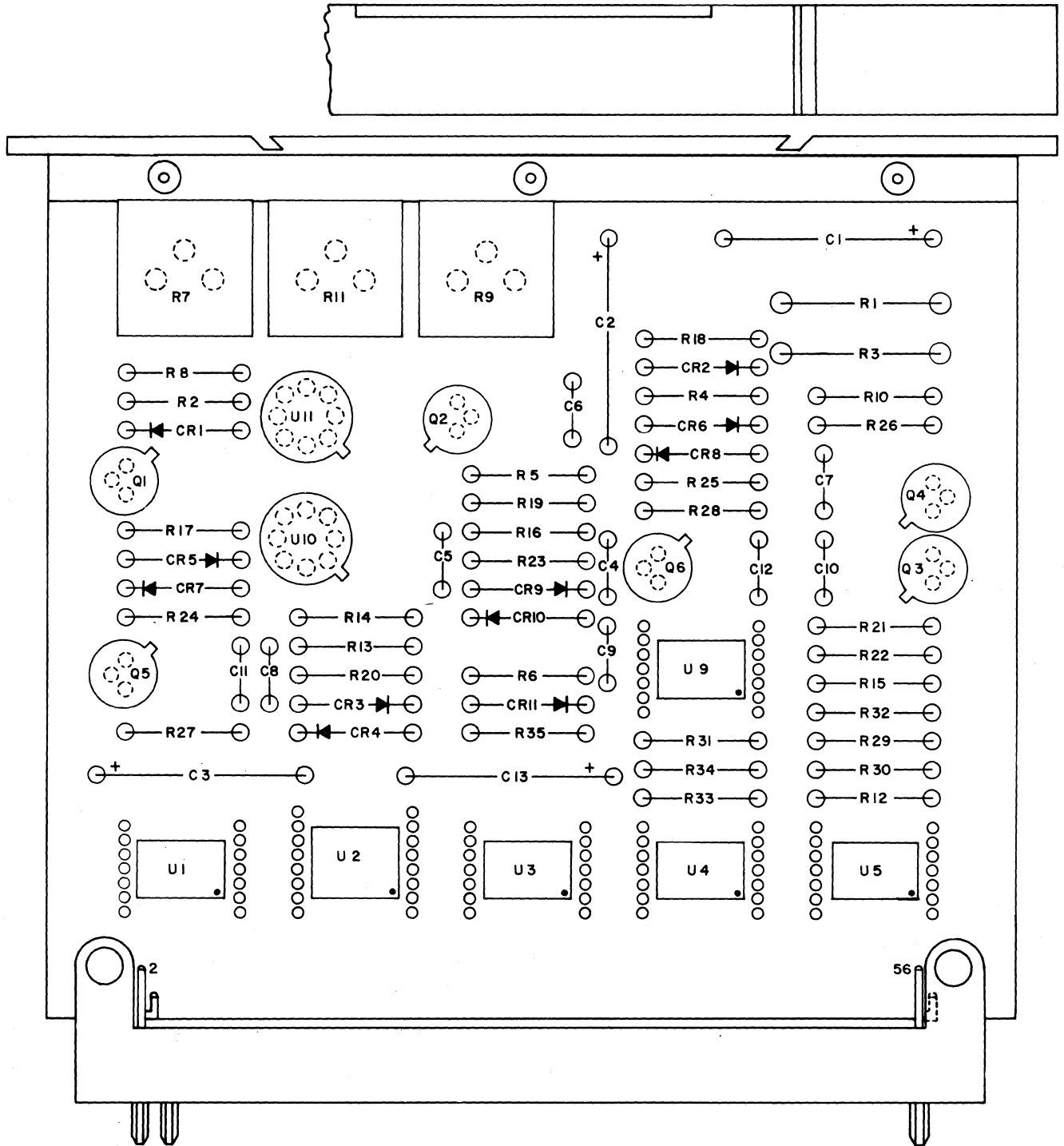

Figure 5-20. Autoload Interface Circuit Card Assembly (7600673)

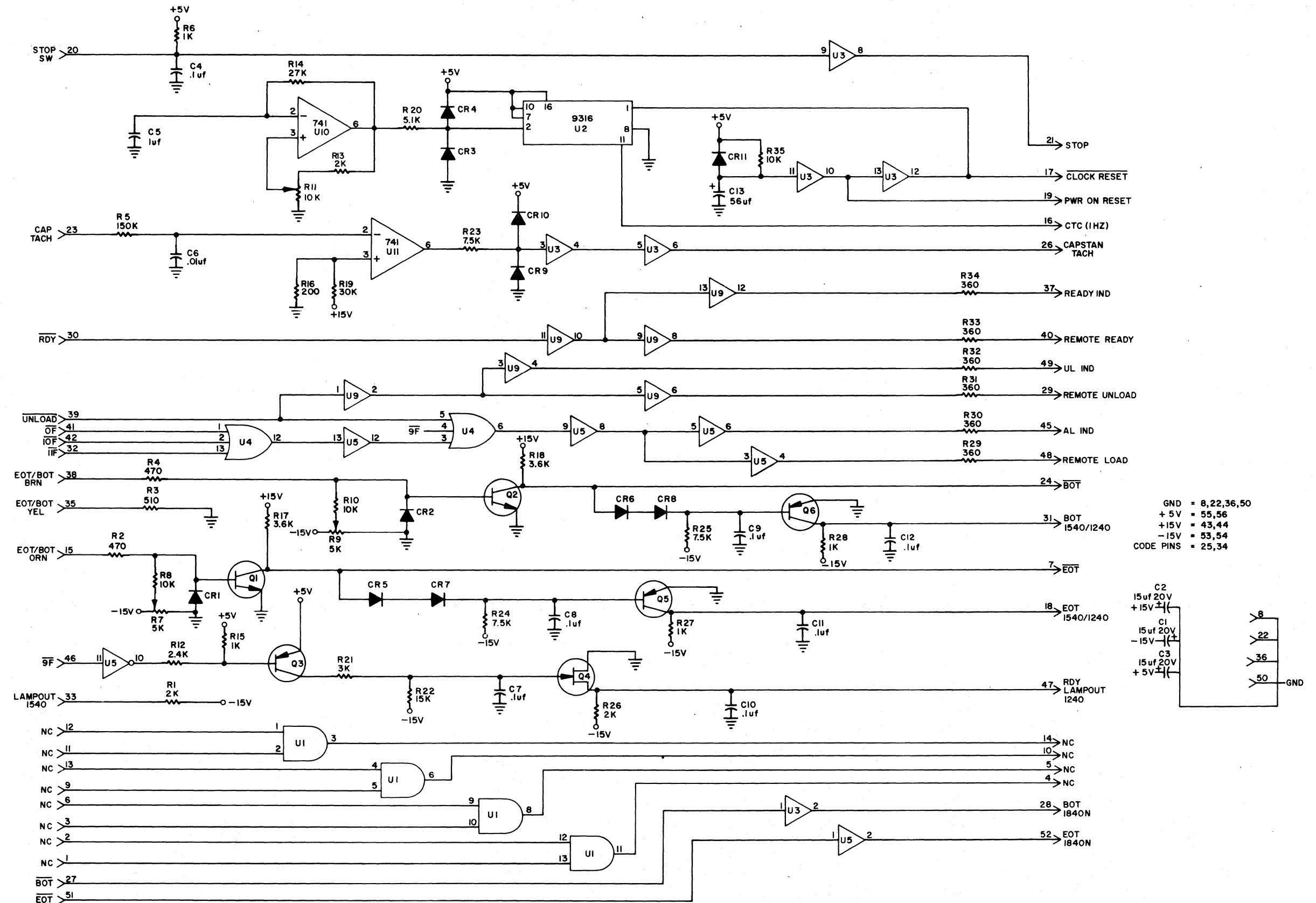

Figure 5-21. Autoload Interface Schematic Diagram (7600673)

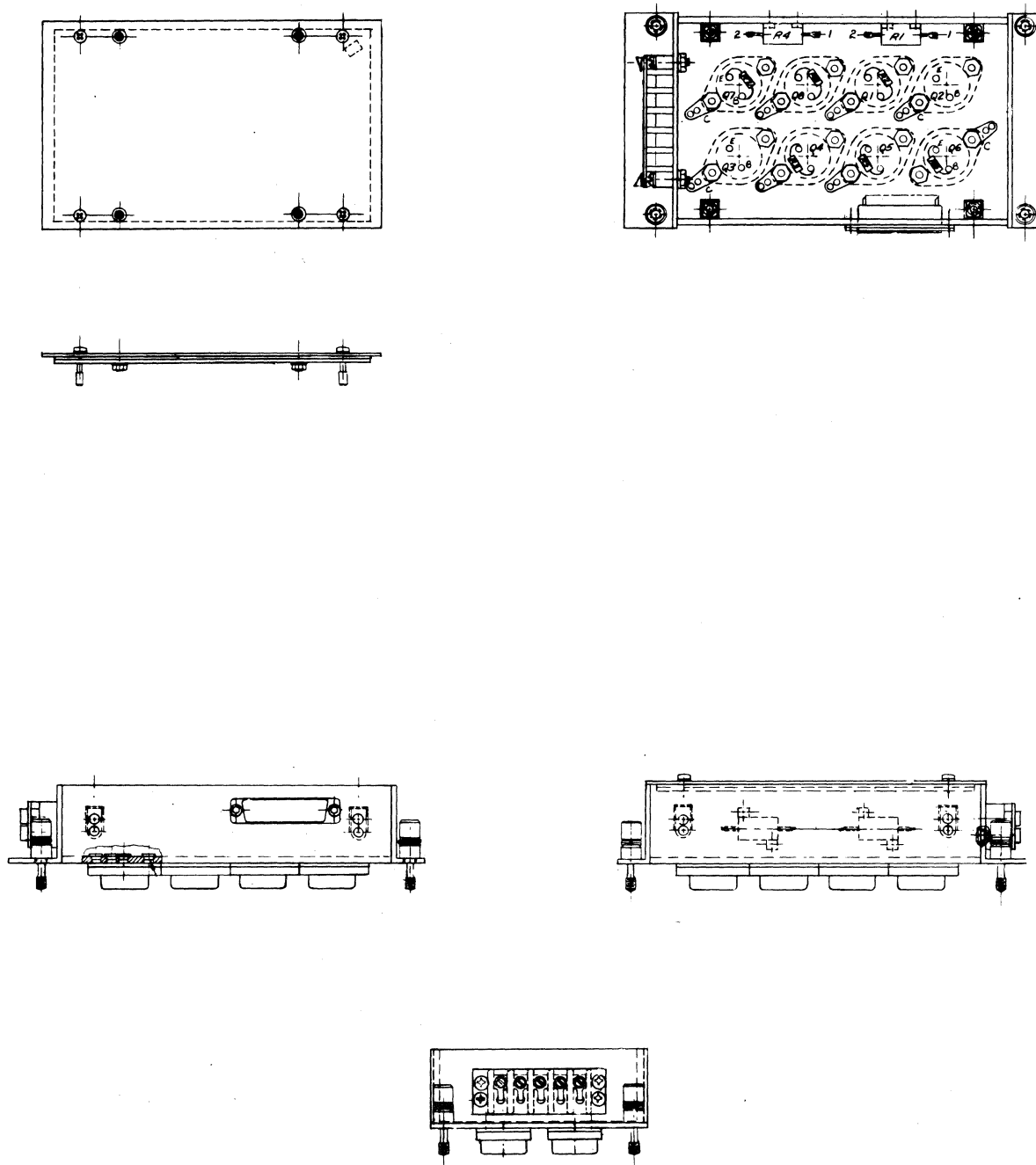

Figure 5-22. Capstan Drive Assembly (7600868)

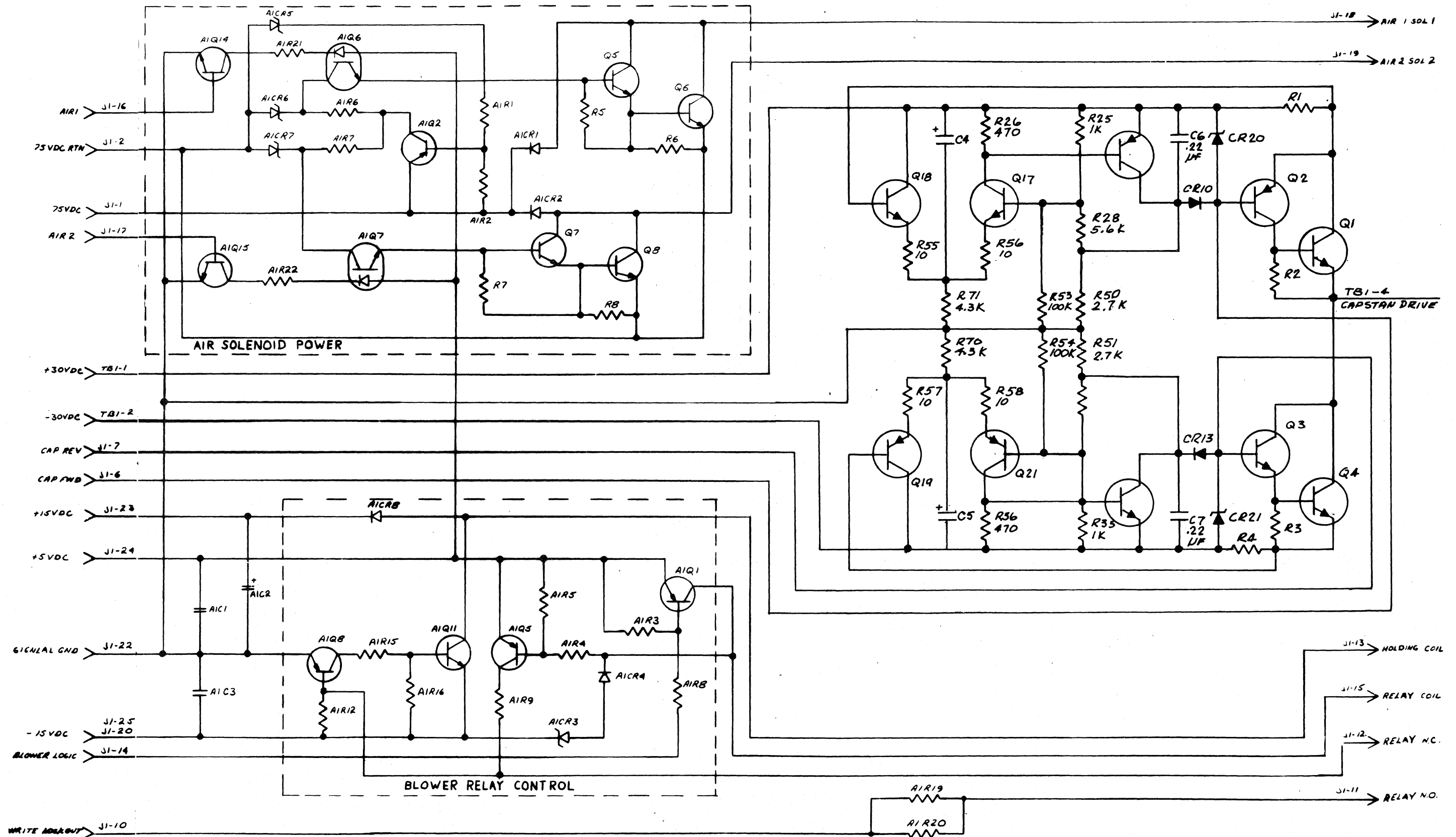

Figure 5-23. Capstan Drive Assembly Schematic Diagram (7601896)

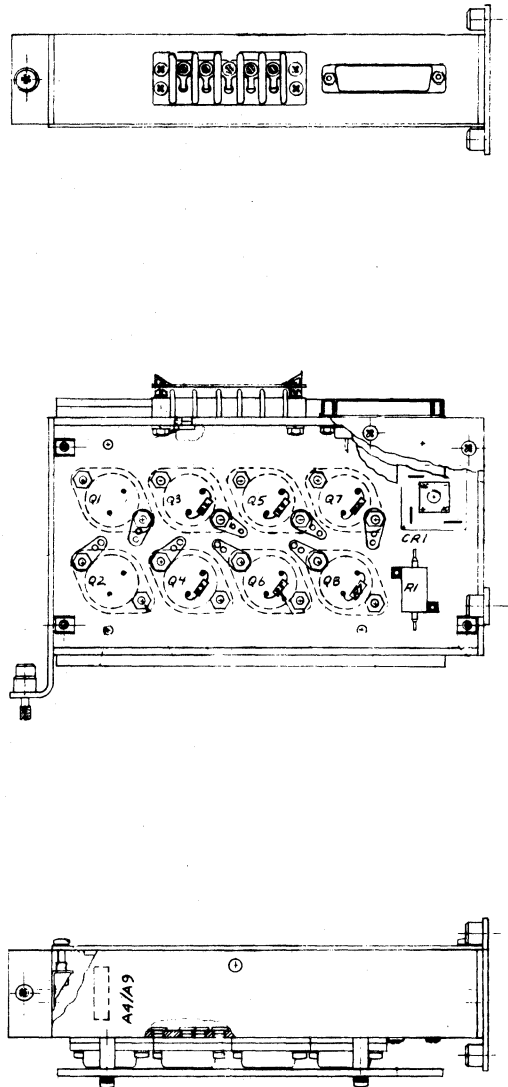

Figure 5-24. Reel Drive Assembly (7600869)

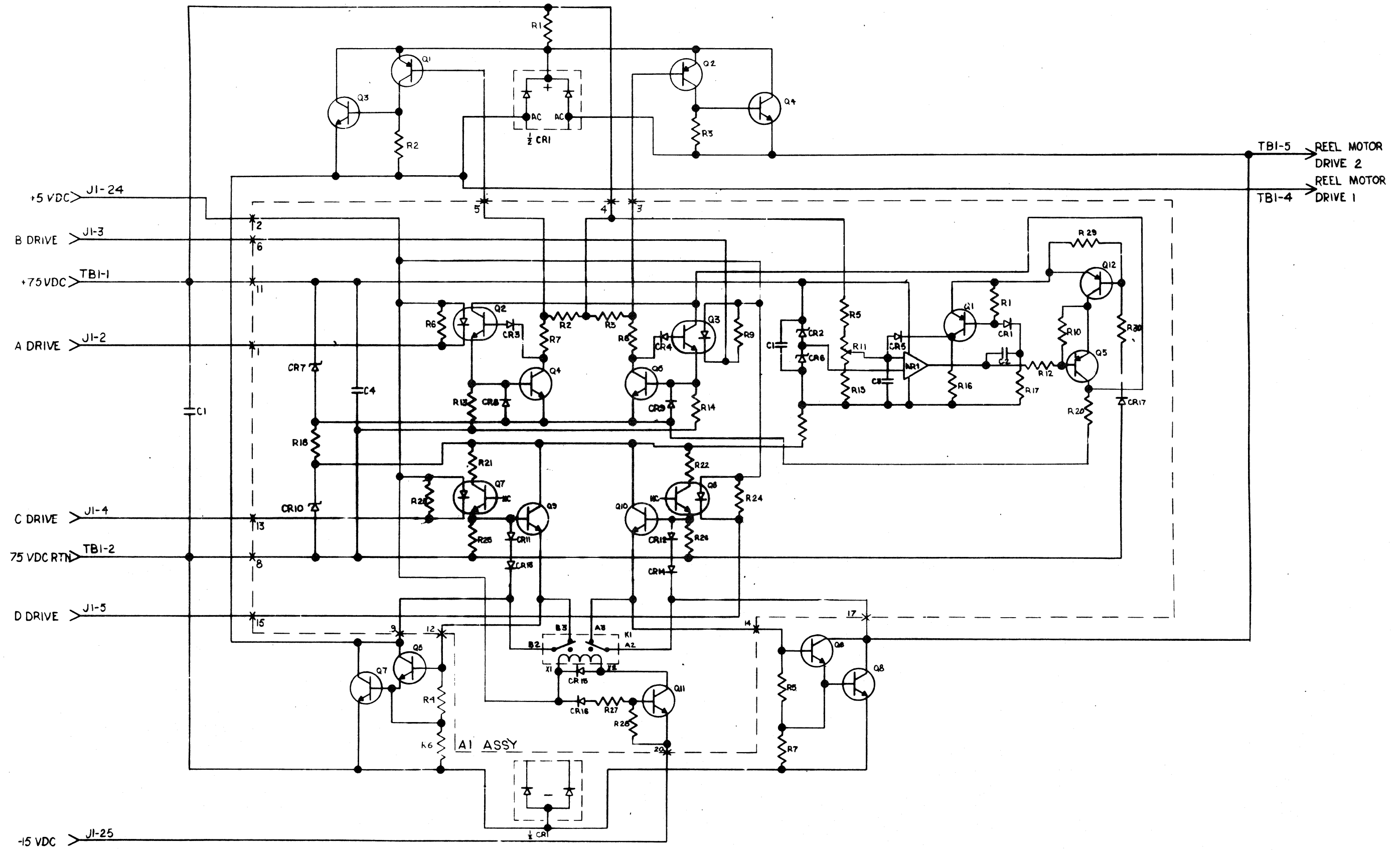

Figure 5-25. Reel Drive Assembly Schematic Diagram (7601896)

ORIGINAL

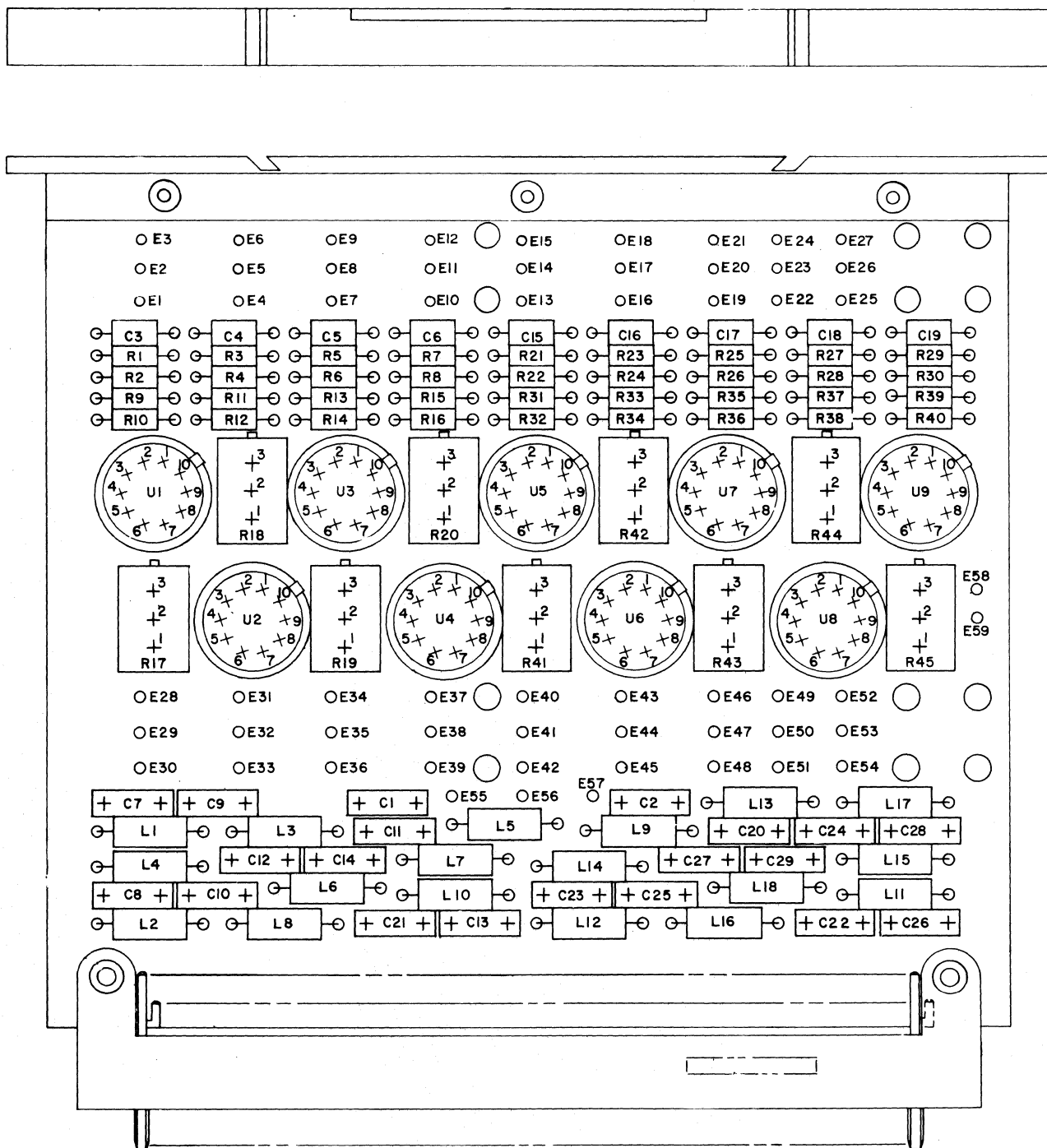

Figure 5-26. Read Amplifier Circuit Card Assembly (7691825)

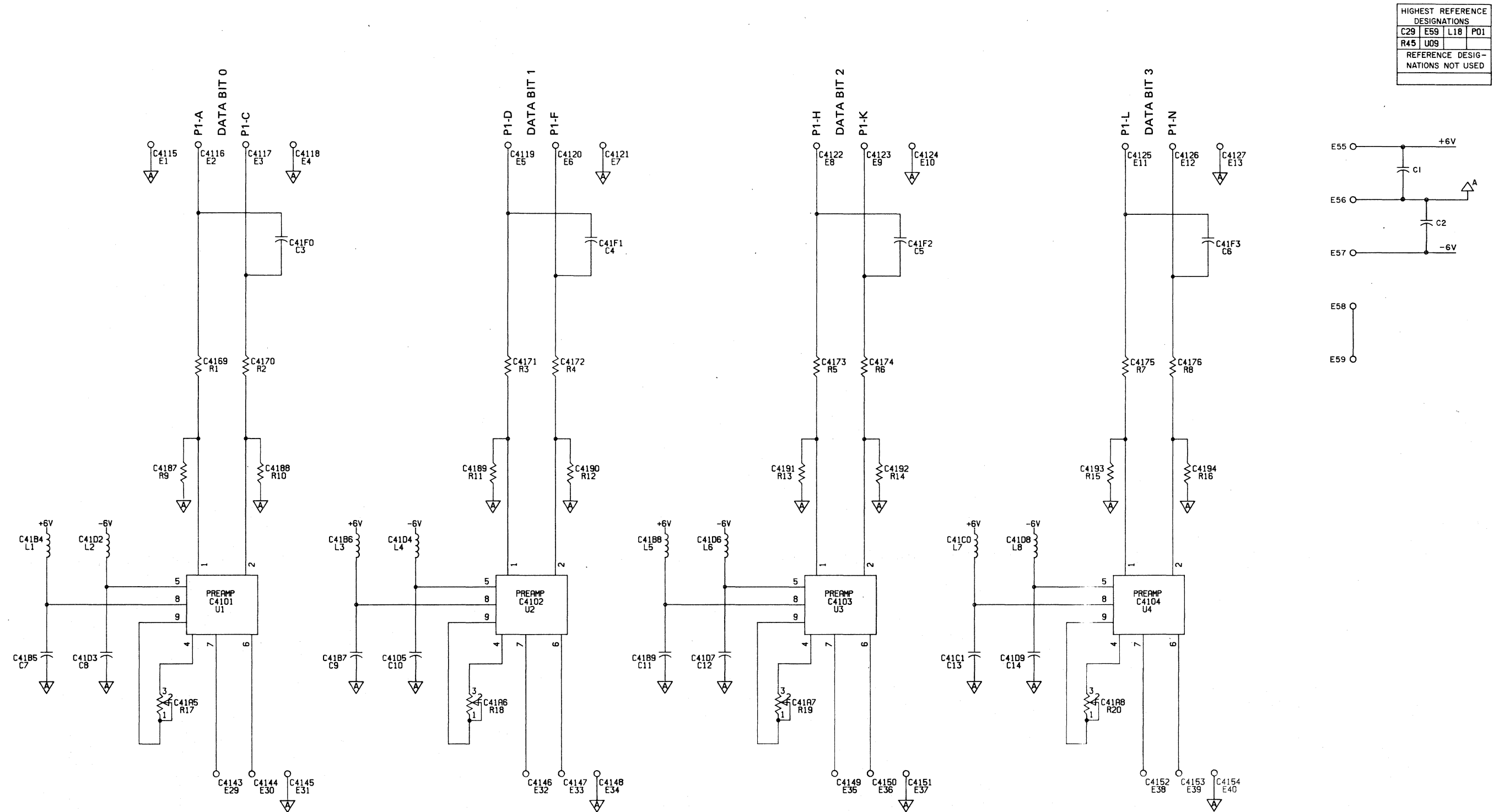
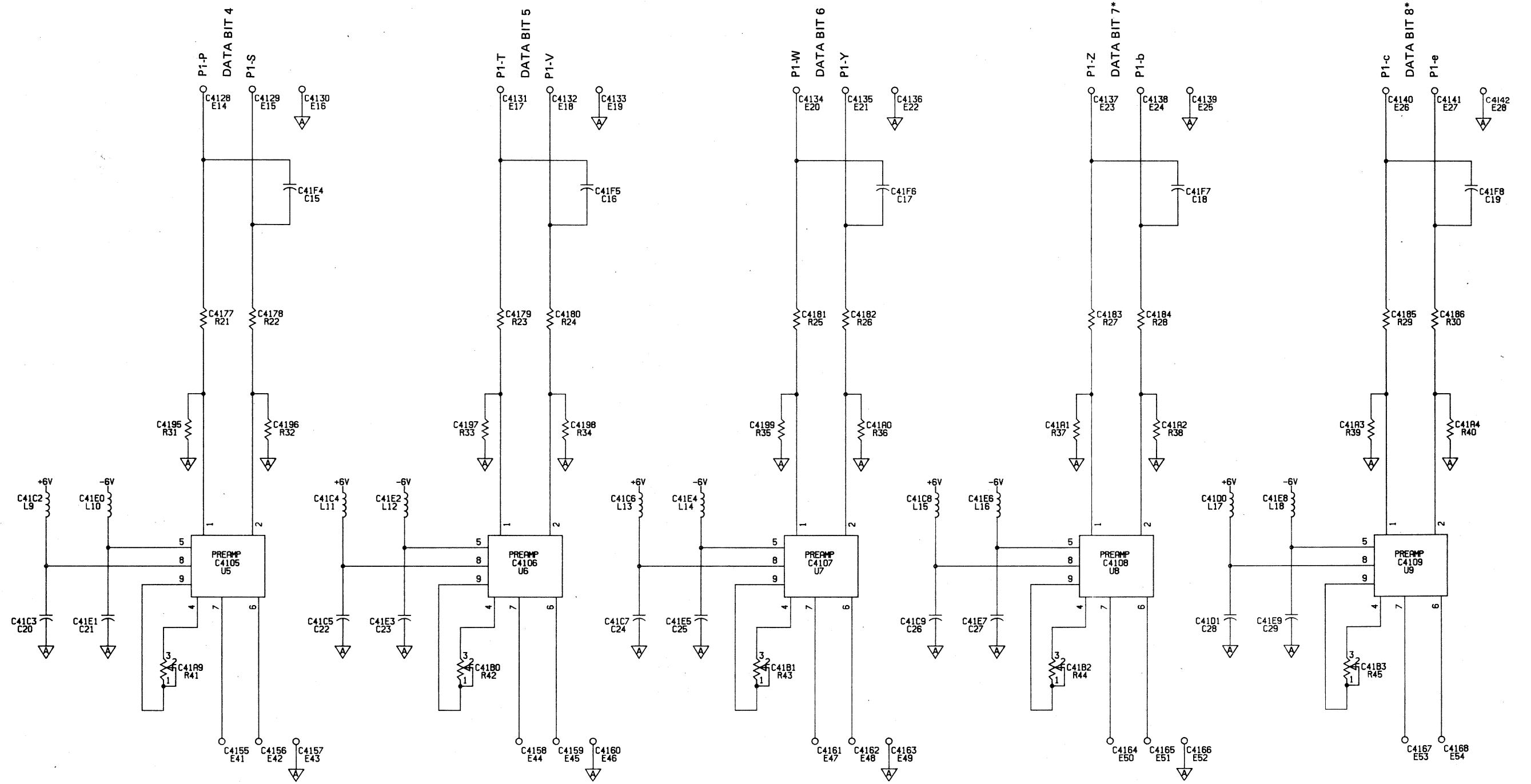

Figure 5-27. Read Amplifier Schematic Diagram - Part 1 (7091825)

ORIGINAL



*WHEN US :

Figure 5-28. Read Amplifier Schematic Diagram - Part 2 (7091825)

ORIGINAL

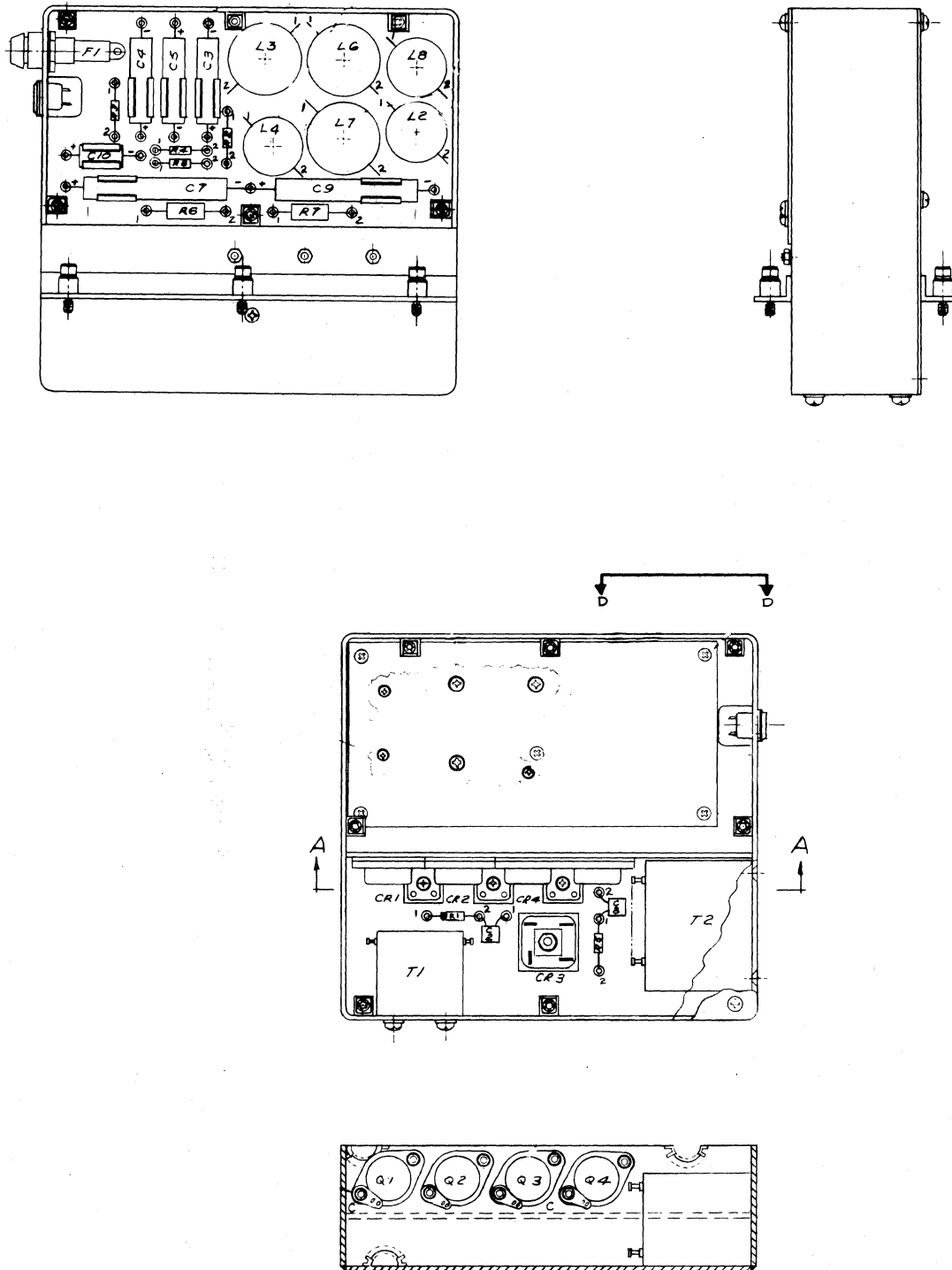
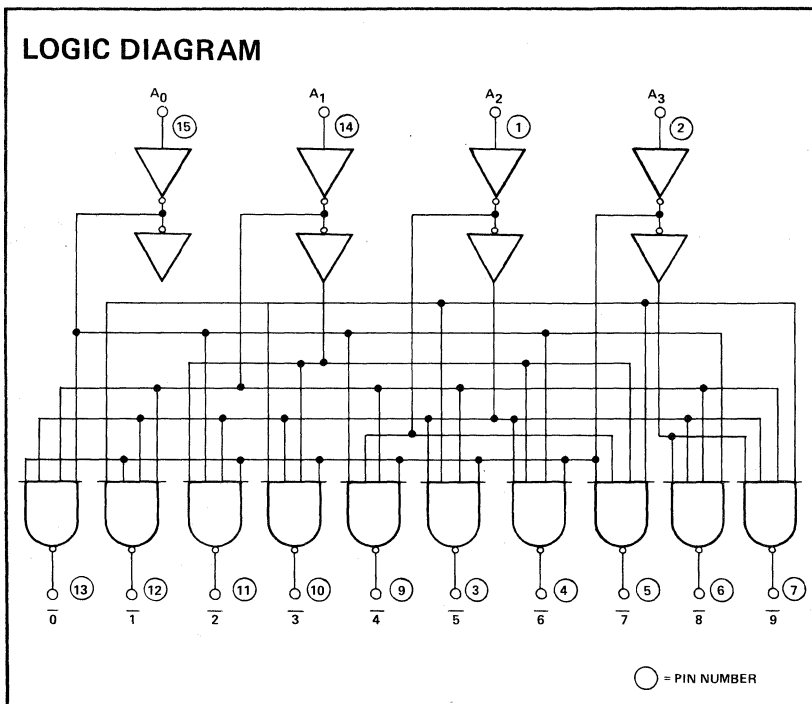
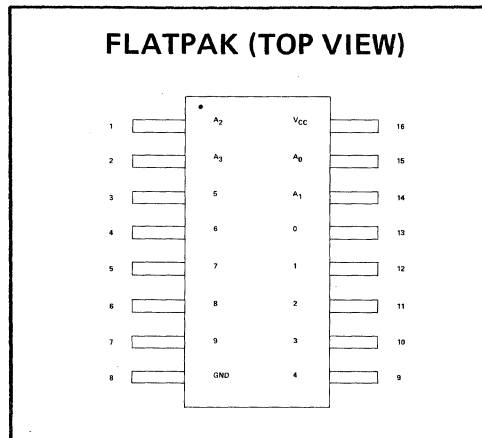

Figure 5-29. DC-to-DC Converter Assembly (7600870)

DESCRIPTION – The 9301 is a Multipurpose Decoder designed to accept four inputs and provide 10 mutually exclusive outputs. The circuit uses TTL for high speed and high fan out capability, and is compatible with all members of the Fairchild TTL family.

- **MULTI-FUNCTION CAPABILITY**
- **MUTUALLY EXCLUSIVE OUTPUTS**
- **GUARANTEED FANOUT OF 10 TTL LOADS OVER THE FULL TEMPERATURE RANGE AND SUPPLY VOLTAGE RANGES**
- **HIGH CAPACITIVE DRIVE CAPABILITY**
- **DEMULPLEXING CAPABILITY**
- **TYPICAL POWER DISSIPATION OF 145 mW**
- **THE INPUT/OUTPUT CHARACTERISTICS PROVIDE EASY INTERFACING WITH FAIRCHILD DTL, LPDTL AND TTL FAMILIES**
- **ALL CERAMIC "HERMETIC" 16 LEAD DUAL IN-LINE PACKAGE**
- **INPUT CLAMP DIODES LIMIT HIGH SPEED LINE TERMINATION EFFECTS**



A ₀	A ₁	A ₂	A ₃	0	1	2	3	4	5	6	7	8	9
L	L	L	L	L	H	H	H	H	H	H	H	H	H
H	L	L	L	H	L	H	H	H	H	H	H	H	H
L	H	L	L	H	H	L	H	H	H	H	H	H	H
H	H	L	L	H	H	H	L	H	H	H	H	H	H
L	L	H	L	H	H	H	H	L	H	H	H	H	H
H	L	H	L	H	H	H	H	H	L	H	H	H	H
L	H	H	L	H	H	H	H	H	H	L	H	H	H
H	H	H	L	H	H	H	H	H	H	H	L	H	H
L	L	L	H	H	H	H	H	H	H	H	H	L	H
H	L	L	H	H	H	H	H	H	H	H	H	H	L
L	H	L	H	H	H	H	H	H	H	H	H	H	H
H	H	L	H	H	H	H	H	H	H	H	H	H	H
L	L	H	H	H	H	H	H	H	H	H	H	H	H
H	L	H	H	H	H	H	H	H	H	H	H	H	H
L	H	H	H	H	H	H	H	H	H	H	H	H	H
H	H	H	H	H	H	H	H	H	H	H	H	H	H

Figure 5-30. TTL/MSI 9301 One-of-Ten Decoder

DESCRIPTION - The 9316 is a High Speed Synchronous 4-Bit Binary Counter. They are synchronously presettable, multifunctional MSI building blocks useful in a large number of counting, digital integration and conversion applications. Several stages of synchronous operation are obtainable with no external gating packages required through an internal carry lookahead counting technique.

- SYNCHRONOUS COUNTING AND PARALLEL ENTRY
- DECODED TERMINAL COUNT
- BUILT-IN CARRY CIRCUITRY
- TYPICAL COUNTING FREQUENCY OF 45 MHz
- TYPICAL POWER DISSIPATION OF 325 mW
- THE INPUT/OUTPUT CHARACTERISTICS PROVIDE EASY INTERFACING WITH FAIRCHILD DTL, LPDTL, AND TTL FAMILIES
- INPUT DIODE CLAMPING
- TTL COMPATIBLE

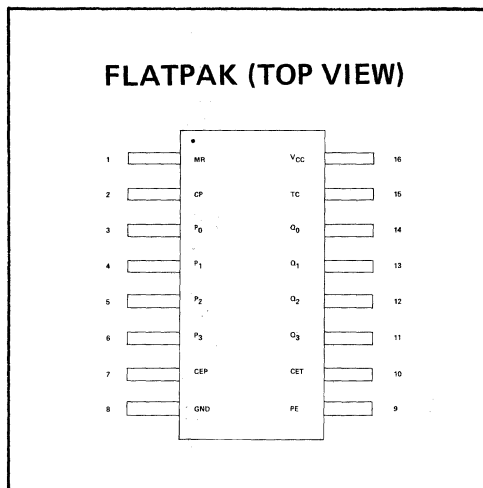

**9316
MODE SELECTION**

PE	CEP	CET	MODE
L	L	L	Preset
L	L	H	Preset
L	H	L	Preset
L	H	H	Preset
H	L	L	No Change
H	L	H	No Change
H	H	L	No Change
H	H	H	Count

(MR = HIGH)

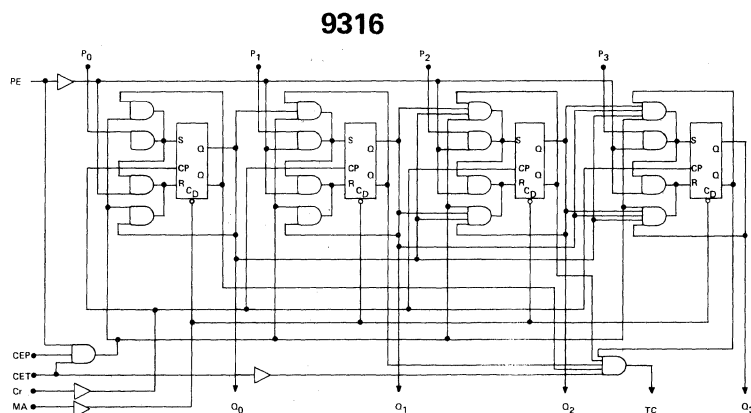

**9316
TERMINAL COUNT GENERATION**

CET	9316 (Q ₀ • Q ₁ • Q ₂ • Q ₃)	TC
L	L	L
L	H	L
H	L	L
H	H	H

TC = CET • Q₀ • Q₁ • Q₂ • Q₃ (9316)

POSITIVE LOGIC = H = HIGH Voltage Level
L = LOW Voltage Level

Figure 5-31. TTL/MSI 9316 4-Bit Binary Counter

SECTION 6

PARTS LIST

6-1. INTRODUCTION.

THIS ILLUSTRATED PARTS BREAKDOWN (IPB) LISTS AND ILLUSTRATES THE FIELD-REPLACEABLE PARTS FOR THE POWER SUPPLY, FIGURE 6-1 THROUGH 6-7, AND THE 1840 (MOD) MAGNETIC TAPE TRANSPORT, FIGURE 6-8 THROUGH 6-17.

THIS IPB SHOULD NOT BE USED FOR DISASSEMBLY OR ASSEMBLY PROCEDURES.

6-2. GROUP ASSEMBLY PARTS LIST.

THE GROUP ASSEMBLY PARTS LIST CONSISTS OF ILLUSTRATIONS AND LISTINGS OF ASSEMBLIES AND DETAIL PARTS. THE ACCOMPANYING ILLUSTRATION PRECEDES THE PARTS BREAKDOWN LISTING FOR EACH ASSEMBLY. EACH ASSEMBLY IS FOLLOWED BY A LISTING OF ITS COMPONENT PARTS.

A. FIGURE AND INDEX NUMBER COLUMN. - THIS COLUMN SHOWS THE FIGURE NUMBER OF THE ASSEMBLY AND ALL COMPONENT PART INDEX NUMBERS. EACH NEW ASSEMBLY SECTION AND FIGURE NUMBER IS CARRIED FORWARD AS THE FIRST ENTRY OF EACH SUCCEEDING PAGE.

B. REFERENCE DESIGNATION COLUMN. - THIS COLUMN LISTS THE REFERENCE DESIGNATOR ASSIGNED TO THE ASSEMBLY OR DETAIL PART. THESE DESIGNATORS COINCIDE WITH THE DESIGNATIONS MARKED ON THE EQUIPMENT, DRAWINGS, AND DIAGRAMS.

C. INDENTURE COLUMN. - THIS COLUMN IS CODED NUMERICALLY TO SHOW RELATIONSHIP TO THE NEXT HIGHER ASSEMBLY.

D. DESCRIPTION. - THIS COLUMN LISTS THE ITEM NAME OF A PART OR ASSEMBLY FOLLOWED BY AN IDENTIFYING DESCRIPTION. ATTACHING PARTS ARE LISTED IMMEDIATELY FOLLOWING THE ASSEMBLY OR PART WHICH THEY SECURE.

THE ABBREVIATIONS NHA, NLA, U/W AND AP APPEARING IN THE DESCRIPTION COLUMN HAVE THE FOLLOWING MEANINGS- NHA INDICATES NEXT HIGHER ASSEMBLY, NLA INDICATES NEXT LOWER ASSEMBLY, U/W INDICATES USED WITH, AND AP INDICATES ATTACHING PARTS.

E. MANUFACTURERS CODE. - THE FEDERAL SUPPLY CODE FOR MANUFACTURERS (FSCM) IS A CODING SYSTEM OF FIVE-DIGIT NUMBERS ASSIGNED TO MANUFACTURERS HAVING DESIGN CONTROL OF ITEMS OF SUPPLY PROCURED BY AGENCIES OF THE FEDERAL GOVERNMENT. THE CODES USED IN THIS SECTION ARE LISTED IN NUMERICAL SEQUENCE IN TABLE 6-1.

F. PART NUMBER COLUMN. - THE FIRST ENTRY IN THIS COLUMN IS THE UNIVAC PART NUMBER, OR UNIVAC SPECIFICATION DRAWING NUMBER, WITH THE CORRESPONDING GOVERNMENT PART NUMBER OR VENDOR PART NUMBER AS THE NEXT ENTRY.

A COML ENTRY INDICATES THAT THE PART MAY BE PURCHASED COMMERCIALY.

G. UNITS PER ASSEMBLY. - THIS COLUMN LISTS THE QUANTITY OF PARTS PER ASSEMBLY. WHEN EQUIPMENT CONTAINS TWO OR MORE IDENTICAL ASSEMBLIES, OR IF SIMILAR ASSEMBLIES HAVE BEEN COMBINED IN ONE ILLUSTRATION, THIS COLUMN WILL INDICATE THE

QUANTITY OF PARTS FOR ONE ASSEMBLY ONLY.

TWO ABBREVIATIONS ARE USED IN THIS COLUMN; REF AND AR. THE REF INDICATES THE QUANTITY USED ON AN ASSEMBLY PREVIOUSLY CONSIDERED. THE AR INDICATES A QUANTITY AS REQUIRED.

H. USED ON CODE COLUMN. - LETTER CODES IN THIS COLUMN INDICATE VARIATIONS OF PARTS AND ASSEMBLIES WHICH BECAUSE OF THEIR PHYSICAL SIMILARITY HAVE BEEN COMBINED ON ONE ILLUSTRATION. NO CODE SIGNIFIES THE PART IS USED ON ALL ASSEMBLIES.

6-3. NUMERICAL INDEX.

THE NUMERICAL INDEX PROVIDES ALL THE PART NUMBERS IN ALPHANUMERIC ORDER. THE FIGURE AND INDEX NUMBERS ARE GIVEN FOR EACH PART TO AID IN LOCATING THE PART IN THE GROUP ASSEMBLY PARTS LIST. THIS INDEX IS LOCATED AT THE END OF THE SECTION.

TABLE 6-1. LIST OF MANUFACTURERS

CODE	NAME	ADDRESS
00141	PIC DESIGN DIVISION BENRUS CORP	PO BOX 335 RENRUS CENTER RIDGEFIELD CT 06877
00287	CEM CO INC	24 SCHOOL DANIELSON CT 06239
00779	AMP INC	PO BOX 3608 HARRISBURG PA 17105
01295	TEXAS INSTRUMENTS INC COMPONENTS GROUP	BOX 5012 13500 N CENTRAL EXPRESS DALLAS TX 75222
03508	GENERAL ELECTRIC CO SEMI-CONDUCTOR PRODUCTS DEPT	ELECTRONICS PARK SYRACUSE NY 13201
03877	TRANSISTRON ELECTRONIC CORP	168-186 ALBION ST WAKEFIELD MA 01880
04264	CIRCON COMPONENT CORP	SANTA BARB MUNICIPAL AIRPORT GOLETA CA 93017
04713	MOTOROLA INC SEMICONDUCTOR PRODUCTS DIVISION	5005 EAST MCDOWELL ROAD PHOENIX AZ 85008
04810	ASHLUND ELECTRIC PRODUCTS INC	32-02 QUEENS BLVD LONG ISLAND CITY NY 11101
05277	WESTINGHOUSE ELECTRIC CORP SEMICONDUCTOR PRODUCTS DEPT	YOUNGWOOD PA 15697
06540	AMATOM ELECTRONIC HARDWARE DIVISION OF MITE CORP	446 BLAKE STREET NEW HAVEN CT 06515
07797	ROCKER SOLENOID CO DBA ROCKER INDUSTRIES	1500 W 240TH ST HARBOR CITY CA 90710
09023	CORNELL-DUBILIER ELECTRONICS DIV FEDERAL PACIFIC ELECTRIC CO	2562 DALRYMPLE STREET SANFORD NC 27330
09922	BURNDY CORP	RICHARDS AVE NORWALK CT 06852
12969	UNITRODE CORP	580 PLEASANT STREET WATERTOWN MA 02172
13103	THERMALLOY CO	BOX 34829 2021 W VALLEY VIEW LANE DALLAS TX 75234
16512	FABRI-TEK INC NATIONAL CONNECTOR DIVISION	9210 SCIENCE CENTER DRIVE NEW HOPE MN 55428
16636	INDIANA GENERAL ELECTRO MECH PROD A DIV OF ELECTRONIC MEMORIES	517 W WALNUT STREET OGLESBY ILL 61348
16759	LABORATORY DIAGNOSTICS CO INC	1116 WALNUT STREET ROSELLE NJ 07203

TABLE 6-1. LIST OF MANUFACTURERS

CODE	NAME	ADDRESS
32388	SPECTRONICS INC	541 STERLING DRIVE RICHARDSON TX 75080
56289	SPRAGUE ELECTRIC CO	NORTH ADAMS MA 01247
70674	ADC PRODUCTS DIVISION OF MAGNETIC CONTROLS CO	4900 WEST 78TH STREET MINNEAPOLIS MN 55435
71286	REXNORD INC SPECIALTY FASTENER DIV	22 SPRING VALLEY ROAD PARAMUS NJ 07652
71468	ITT CANNON ELECTRIC	666 EAST DYER ROAD SANTA ANA CA 92702
71785	TRW ELECTRONIC COMPONENTS CINCH DIVISION	1501 MORSE AVE ELK GROVE VILLAGE IL 60007
72962	ELASTIC STOP NUT DIVISION OF AMERACE ESNA CORP	2330 VAUXHALL ROAD UNION NJ 07083
74193	HEINEMANN ELECTRIC CO	2600 BRUNSWICK PIKE TRENTON NJ 08602
75382	KULKA ELECTRIC CORP	633-643 SOUTH FULTON AVE MOUNT VERNON NY 10550
78189	ILLINOIS TOOL WORKS INC SHAKEPROOF DIVISION	ST CHARLES ROAD ELGIN IL 60126
78553	TINNERMAN PRODUCTS INC	8700 BROOKPARK ROAD CLEVELAND OH 44129
81135	ELLIOT-LEWIS CORP	120 SOUTH 30TH STREET PHILADELPHIA PA 19010
81312	WINCHESTER ELECTRONICS DIVISION OF LITTON INDUSTRIES INC	MAIN STREET AND HILLSIDE AVE OAKVILLE CT 06779
81349	MILITARY SPECIFICATION PROMULGATED BY MILITARY DEPARTMENTS/AGENCIES	UNDER AUTHORITY OF DEFENSE STANDARDIZATION MANUAL 4120 3-M
83058	CARR FASTENER CO A UNITED-CARR DIV OF TRW INC	31 AMES STREET CAMBRIDGE MA 02142
90536	SPERRY UNIVAC DEFENSE SYSTEMS	UNIVAC PARK PO BOX 3525 ST PAUL MN 55165
91929	HONEYWELL INC MICRO SWITCH DIVISION	CHICAGO AND SPRING STREETS FREEPORT IL 61032
96906	MILITARY STANDARDS PROMULGATED BY MILITARY DEPARTMENTS UNDER	AUTHORITY OF DEFENSE STANDARDIZATION MANUAL 4120 3-M

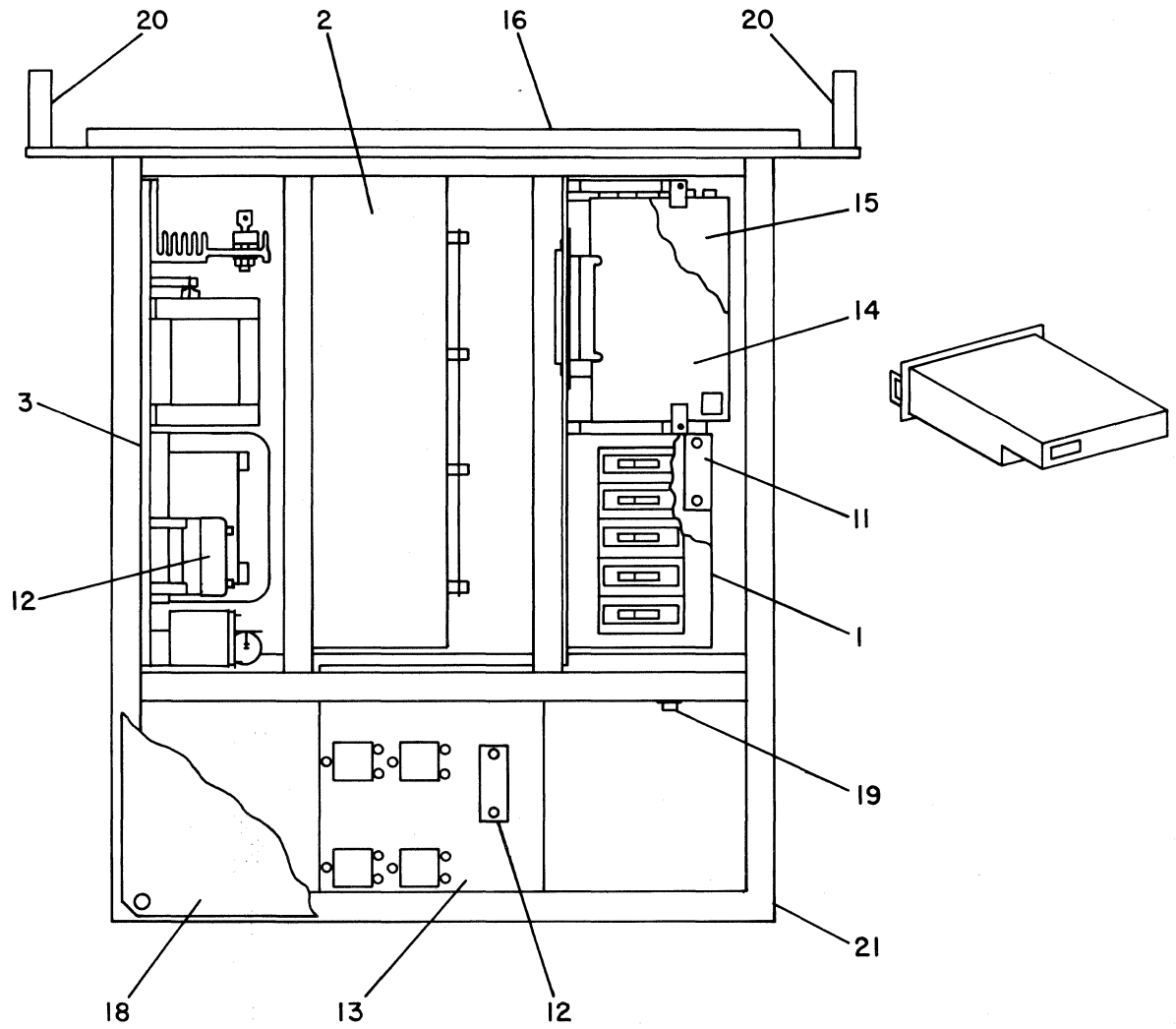

TOP VIEW

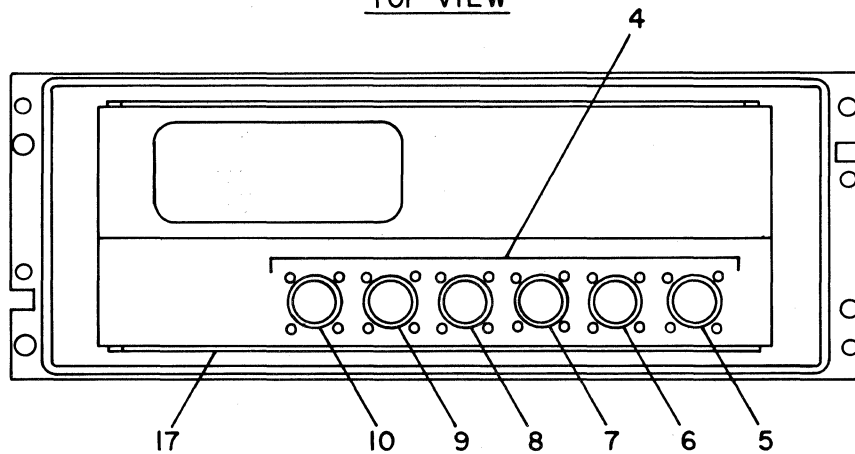

REAR VIEW

FIGURE 6-1. 400HZ TO 75VDC POWER SUPPLY

GROUP ASSEMBLY PARTS LIST

PARTS LIST

FIG & INDEX NO	REF DESIG	I N D	DESCRIPTION	MFR CODE	UNIVAC PART NO MFR PART NO	QTY PER ASSY	USED ON
6-1		1	POWER SUPPLY, 400HZ TO 75VDC PP-7067/UYK	90536	7601768-01	1	A
			POWER SUPPLY, 400HZ TO 75VDC	90536	7601768-02	1	B
1-1	A1	2	REGULATOR SUBASSEMBLY (FOR NLA SEE FIG 6-2)	90536	7601770-00	1	
1		2	SCREW, MACH, PAN HD, 10-32UNF-2A 5/8 L (AP)	96906	4912534-01 MS51958-64	5	
			WASHER, FLAT, NO 10 (AP)	96906	4912548-03 MS15795-808	5	
			SCREW, MACH, PAN HD, 6-32UNC-2A 1/2 L (AP)	96906	4912531-04 MS51957-30	AR	
			WASHER, FLAT, NO 6 (AP)	96906	4912548-01 MS15795-805	AR	
1-2	A2	2	CAPACITOR ASSEMBLY (FOR NLA SEE FIG 6-3)	90536	7600863-00	1	
1		2	SCREW, MACH, FLH, 100 CSK 6-32UNC-2A, 0.625 L (AP)	96906	7903133-19 MS24693-C29	2	
			SCREW, MACH, FLH, 100 CSK 8-32UNC-2A, 0.250 LG (AP)	96906	7903133-29 MS24693-C46	3	
1-3	A3 A3	2	FRONT END SUBASSEMBLY FRONT END SUBASSEMBLY (FOR NLA SEE FIG 6-4)	90536 90536	7601769-00 7601769-01	1 1	A B
1		2	SCREW, MACH, PAN HD, 10-32UNF-2A 5/8 L (AP)	96906	4912534-01 MS51958-64	4	
			WASHER, FLAT, NO 10 (AP)	96906	4912548-03 MS15795-808	6	
			SCREW, MACH, PAN HD, 10-32UNF-2A 3/4 L (AP)	96906	4912534-02 MS51958-65	2	
1-4	A4	2	WIRING HARNESS, POWER SUPPLY	90536	7601784-00	1	
1		2	SCREW, MACH, PAN HD, CRES 4-40UNC-2A, 1/2 L (AP)	96906	908552-07 MS51957-17	24	
			WASHER, PL, FLT NO 4 (AP)	96906	7903354-02 NAS620C4	48	
			WASHER, LOCK, SPRING HELICAL (AP)	96906	4912550-00 MS35338-135	24	
			NUT, PLAIN, HEX, MACH, CRES 4-40UNC-2B (AP)	96906	4912540-00 MS35649-244	24	
1-5	A4J1	3	CONN, RCPT, ELEC, FEMALE, 21 CONTACT	96906	7900589-01 MS3120E22-21SW	1	
1-6	A4J2	3	CONN, RCPT, ELEC, FEMALE, 21 CONTACT	96906	7900589-02 MS3120E22-21SX	1	
1-7	A4J3	3	CONN, RCPT, ELEC, FEMALE, 21 CONTACT	96906	7900589-03 MS3120E22-21SY	1	
1-8	A4J4	3	CONN, RCPT, ELEC, FEMALE, 21 CONTACT	96906	7900589-04 MS3120E22-21SZ	1	

PARTS LIST

GROUP ASSEMBLY PARTS LIST

FIG & INDEX NO	REF DESIG	I N D	DESCRIPTION	MFR CODE	UNIVAC PART NO MFR PART NO	QTY PER ASSY	USED ON
6- 1			POWER SUPPLY, 400HZ TO 75VDC		CONTINUED		
1-9	A4J5	3	CONN, RCPT, ELEC, FEMALE, 21 CONTACT	96906	7900589-00 MS3120E22-21S	1	
1-10	A4J6	3	CONN, RCPT, ELEC, MALE, 21 CONTACT	96906	7900588-00 MS3120E22-21P	1	
1		3	CONTACT, ELEC, CONN, MALE, SIZE 0.062 (U/W A4J1 THRU A4J6)	96906	7903062-01 MS17803-16-16	11	
1-11	A4P2	3	CONN, ELEC, RECT, MALE, 34 CONTACT LOCATIONS	81312	7901314-01 MRAC34P-NSS436	1	
1		3	CONTACT, ELEC, CONN, MALE SIZE 0.062 (U/W A4P2)	96906	7903062-00 MS17803-16-20	13	
1-12	A4P1 A4P3	3	CONN, ELEC, FEMALE, RECT, 34 CONTACT	81312	4913630-01 MRAC34SNS	2	
1		3	CONTACT, ELEC, CONN, FEMALE SIZE 0.062 (U/W A4P1 AND A4P3)	96906	7903061-00 MS17804-16-20	27	
		3	CONTACT, ELEC, CONN, FEMALE SIZE 0.062 (U/W A4P1)	96906	7903061-01 MS17804-16-16	18	
1-13	A5	2	RELAY SUBASSEMBLY (FOR NLA SEE FIG 6-5)	90536	7601771-00	1	
1		2	SCREW, MACH, PAN HD, 6-32UNC-2A 1/2 L (AP)	96906	4912531-04 MS51957-30	4	
			WASHER, FLAT NO 6 (AP)	96906	4912548-01 MS15795-805	4	
1-14	A1A1	2	CIRCUIT CARD ASSEMBLY, 400HZ FRONT END (FOR NLA SEE FIG 6-6)	90536	7600665-00	1	
1-15	A1A2	2	CIRCUIT CARD ASSEMBLY, 75VDC REGULATOR (FOR NLA SEE FIG 6-7)	90536	7600667-00	1	
1-16		2	PANEL, FRONT (POWER SUPPLY)	90536	7600935-00	1	
1		2	SCREW, CAP, SOCKET HD 10-32UNF-3A, 1-3/8 L (AP)		911606-13 COML	7	
			WASHER, FLAT, NO 10 (AP)	96906	4912548-03 MS15795-808	7	
1-17		2	ACCESS PANEL, L/H	90536	7600757-01	1	
1-18		2	ACCESS PANEL, R/H	90536	7600758-01	1	
1		2	SCREW, MACH, FL HD, 10-32UNF-2A 0.500 L (AP)	96906	7903133-49 MS24693-C272	8	
			SCREW, MACH, FL HD, 10-32UNF-2A 0.625 L (AP)	96906	7903133-50 MS24693-C273	5	
1-19	E1	2	SCREW, CAP, HEX HD, 1/4-20UNC-2A 1 L		903072-12 COML	1	

FIG & INDEX NO	REF DESIG	I N D	DESCRIPTION	MFR CODE	UNIVAC PART NO MFR PART NO	QTY USED PER ON ASSY
6- 1			POWER SUPPLY, 400HZ TO 75VDC		CONTINUED	
1		2	WASHER, FLAT NO 1/4 (AP)		4912548-04	2
			WASHER, LOCK E/T SIZE 1/4 (AP)	96906	MS15795-810	
			NUT, PLAIN, HEX, 1/4-20UNC-2B (AP)		4912551-04 COML	4
					4912545-00 COML	2
1-20		2	LATCH SET, RIM, CHASSIS HANDLE BLACK	71286	7901084-01 72L2-1-1AB	2
1		2	SKEW, MACH, FL HD, 10-32UNF-2A 0.500 L (AP)	96906	7903133-49 MS24693-C272	4
1-21		2	CHASSIS, POWER SUPPLY (WELDMENT)	90536	7600867-01	1

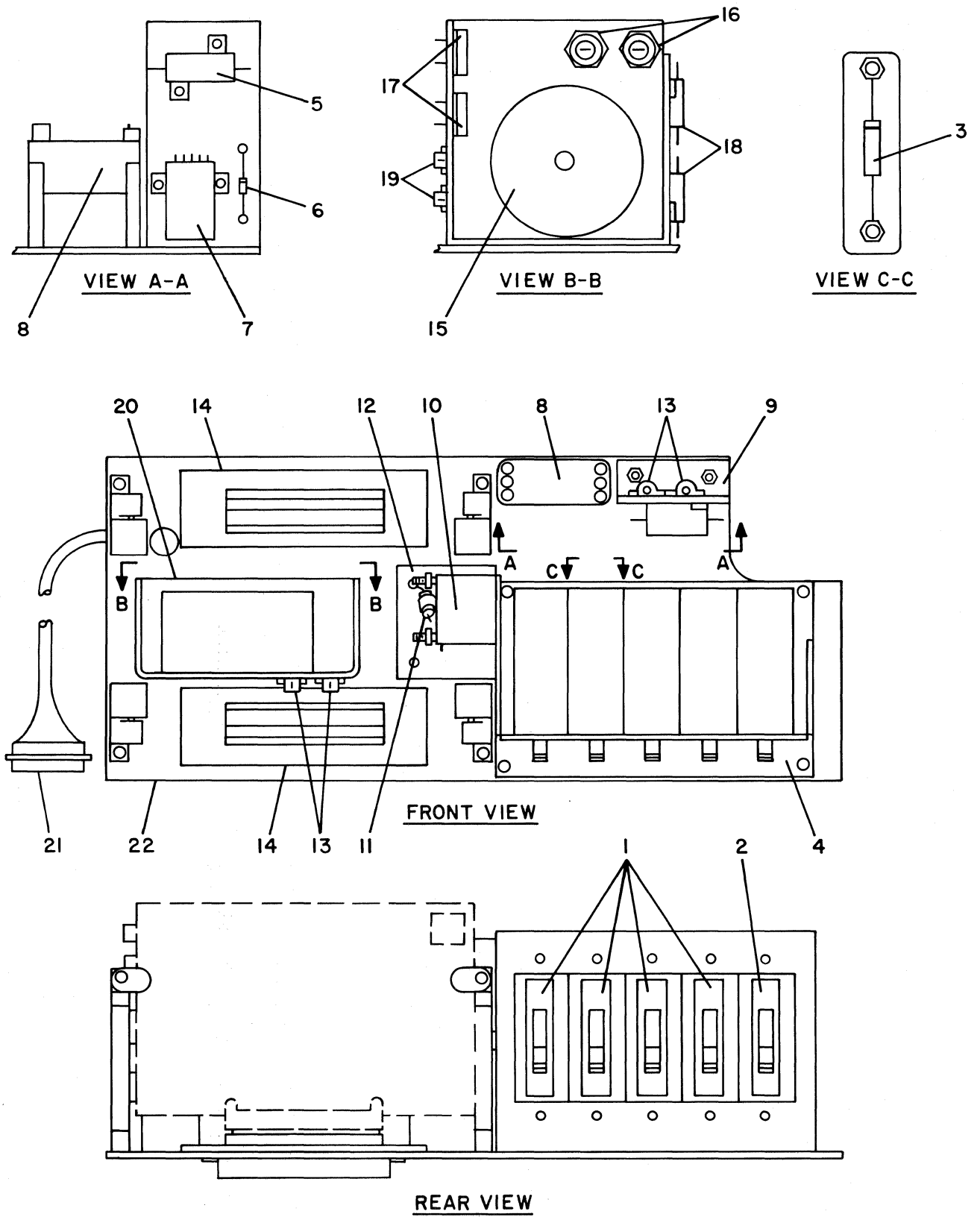

FIGURE 6-2. REGULATOR SUBASSEMBLY A1

GROUP ASSEMBLY PARTS LIST

PARTS LIST

FIG & INDEX NO	REF DESIG	I N D	DESCRIPTION	MFR CODE	UNIVAC PART NO MFR PART NO	QTY USED PER ON ASSY
6-2	A1	2	REGULATOR SUBASSEMBLY (FOR NHA SEE FIG 6-1)	90536	7601770-00	REF
2-1	CB1 THRU CB4	3	CIRCUIT BREAKER, MAG, LOW-POWER SINGLE POLE	74193	7904525-01 AM1510-MG3-5-125 DC-3	4
2-2	CB5	3	CIRCUIT BREAKER, MAG, LOW-POWER SINGLE POW	74193	7904525-00 AM1510-MG3-57.5- 25DC-3	1
2-3	CR35 THRU CR38 CR40	3	SEMICONDUCTOR DEVICE, DIODE 300MW, 1A, 200V	81349	7902067-00 1N3611	5
2-4		3	BRACKET ASSEMBLY, CIRCUIT BREAKERS	90536	7600999-00	1
2-5	R7	3	RESISTOR, FXD, WW, 20W, 51.5 OHM +-1PCT	81349	7902491-260 RE70G51R5	1
2		3	SCREW, MACH, FL HD, 4-40UNC-2A 0.437 L (AP) WASHER, PLAIN, FL NO 4 (AP) NUT, SELF-LOCKING, HEX (AP)	96906 81349 72962	7903133-04 MS24693-C5 7903354-02 NAS620C4 903790-03 F92-1660-440	2 2 2
2-6	CR7	3	SEMICONDUCTOR DEVICE, DIODE, VR 47V, 100MA	81349	7903093-20 1N4974	1
2-7	K1	3	RELAY, ARMATURE, 2 SPDT CONTACTS	81349	7904570-00 M5757-13-038	1
2-8	J3	3	CONN, ELEC, FEMALE, RECT, 34 CONTACT LOCATIONS	81312	4913630-01 MRAC34S-NSS	1
2		3	SCREW, MACH, 4-40UNC-2A, 1/2 L (AP) SCREW, MACH, FLT HD, 4-40UNC-2A 1/2 L (AP) SPACER, SLEEVE, TAPPED 4-40UNC-2B, 1-1/2 L (AP)	96906 96906 06540	4913387-06 MS35275-217 7903133-05 MS24693-C6 7900581-02 8169-A-0440-16	4 4 4
2		3	CONTACT, ELEC, CONN, FEMALE SIZE 0.062, 24AWG (U/W J3) CONTACT, ELEC, CONN, FEMALE SIZE 0.062, 22AWG (U/W J3) CONTACT, ELEC, CONN, FEMALE SIZE 0.062, 20AWG (U/W J3) CONTACT, ELEC, CONN, FEMALE SIZE 0.062, 18AWG (U/W J3) CONTACT, ELEC, CONN, FEMALE SIZE 0.062, 16AWG (U/W J3)	81312 81312 81312 81312 81312 81312	910879-00 100-1024S55 910879-01 100-1022S55 910879-02 100-1020S55 910879-03 100-1018S55 910879-04 100-1016S55	6 5 1 2 2
2-9		3	BRACKET, COMPONENT	90536	7601776-00	1

PARTS LIST

GROUP ASSEMBLY PARTS LIST

FIG & INDEX NO	REF DESIG NO	I N D	DESCRIPTION	MFR CODE	UNIVAC PART NO MFR PART NO	QTY PER ASSY	USED ON
6- 2			REGULATOR SUBASSEMBLY		CONTINUED		
2-10	T2	3	TRANSFORMER, STEP-DOWN NON-SATURATING INVERTER	70674	7904518-00 3-19620	1	
2		3	NUT, PLAIN, HEX, MACH 8-32UNC-2B (AP)	96906	4912540-02 MS35649-284	2	
			WASHER, FLAT, NO 8 (AP)		4912548-02	2	
			WASHER, LOCK, HEL, NO 8 (AP)	96906	MS15795-807 4912550-02	2	
			SCREW, MACH, FL HD, 8-32UNC-2A 1.750 L (AP)	96906	MS35338-137 7903133-41	1	
			SCREW, MACH, FL HD, 8-32UNC-2A 2.000 L (AP)	96906	MS24693-C60 7903133-42	1	
				96906	MS24693-C62		
2-11	C3	3	CAPACITOR, FXD, ELCT, 150V 8.2UF, +30PCT, -10PCT	81349	7902616-55 M39018-01-0223	1	
2		3	CLAMP, LOOP, P-STYLE (AP)	09922	900129-05 HP-6N	1	
2-12	L1	3	REACTOR, FILTER 350UH, 15A	70674	7904514-00 3-19614	1	
2		3	SCREW, MACH, PAN HD, 6-32UNC-2A 1/2 L (AP)	96906	4912531-04 MS51957-30	4	
			WASHER, FLAT, NO 6 (AP)	96906	4912548-01	4	
			WASHER, LOCK, NO 6 (AP)	96906	MS15795-805 4912550-01	4	
				96906	MS35338-136		
2-13	R1A R1B R2 R3	3	RESISTOR, FXD, WW, 5W, 0.100 OHM +-1PCT	81349	7901859-00 RE606R100	4	
2		3	SCREW, MACH, FL HD, 2-56UNC-2A 0.38 L (AP)	96906	906009-04 MS51959-5	8	
			WASHER, PLAIN, FLAT, NO 2 (AP)	81349	7903354-01 NAS620C2	8	
			NUT, SELF-LOCKING, HEX (AP)	72962	903790-01 F92-1660-26	8	
2-14	J1A J2A	3	CONN, PLATE, RCPT	90536	7601781-00	2	
2		3	SCREW, MACH, PAN HD, 6-32UNC-2A 3/8 L (AP)	96906	4912531-02 MS51957-28	4	
			WASHER, LOCK, NO 6 (AP)	96906	4912550-01 MS35338-136	4	
2-15	T1	3	TRANSFORMER, NON-SATURATING INVERTER, STEPDOWN	70674	7904517-00 3-19619	1	
2		3	SCREW, MACH, PAN HD, 8-32UNC-2A 2.000 L (AP)	96906	7903132-37 MS51957-53	1	

FIG & INDEX NO	REF DESIG	I N D	DESCRIPTION	MFR CODE	UNIVAC PART NO MFR PART NO	QTY PER ASSY	USED ON
6- 2			REGULATOR SUBASSEMBLY		CONTINUED		
			WASHER, FLAT, NO 8 (AP)		4912548-02	1	
			NUT, PLAIN, HEX, 8-32UNC-2B (AP)	96906	MS15795-807 4912540-02	1	
				96906	MS35649-284		
2-16	CR1 CR2	3	SEMICONDUCTOR DEVICE, DIODE MEDIUM POWR, 30A, 50V	03877	7901637-00 SR-1590	2	
2-17	Q1 Q2	3	TRANSISTOR, NPN, HIGH-POWER	05277	7904528-00 1843-2010	2	
2-18	R45 R67	3	RESISTOR, FXD, WW, 20W, 51.5 OHM +-1PCT	81349	7902491-260 RE70651R1	2	
2-19	R5 R6	3	RESISTOR, FXD, WW, 5W, 2.49 OHM +-1PCT	81349	7901859-07 RE6062R49	2	
2		3	SCREW, MACH, PAN HD, 2-56UNC-2 0.312 L (AP FOR IDX 18 AND 19)	96906	7903132-03 MS51957-4	8	
			WASHER, FLAT, NO 2 (AP FOR IDX 18 AND 19)	96906	4912548-09 MS15795-802	8	
			WASHER, LOCK, HEL, NO 2 (AP FOR IDX 18 AND 19)	96906	4912550-09 MS35338-134	8	
			NUT, PLAIN, HEX, 2-56UNC-2B (AP FOR IDX 18 AND 19)	96096	4912540-04 MS35649-224	8	
2-20		3	BRACKET, TRANSFORMER	90536	7600997-00	1	
2		3	SCREW, MACH, PAN HD, 6-32UNC-2A 7/16 L (AP)	96906	4912531-03 MS51957-29	2	
			WASHER, LOCK, HEL, NO 6 (AP)	96906	4912550-01 MS35338-136	2	
2-21	P1	3	CONN, RCPT, ELEC, MALE 25 CONTACT	71468	903800-00 DBM-25P	1	
2-22		3	BASE PLATE, REGULATOR	90536	7601775-00	1	

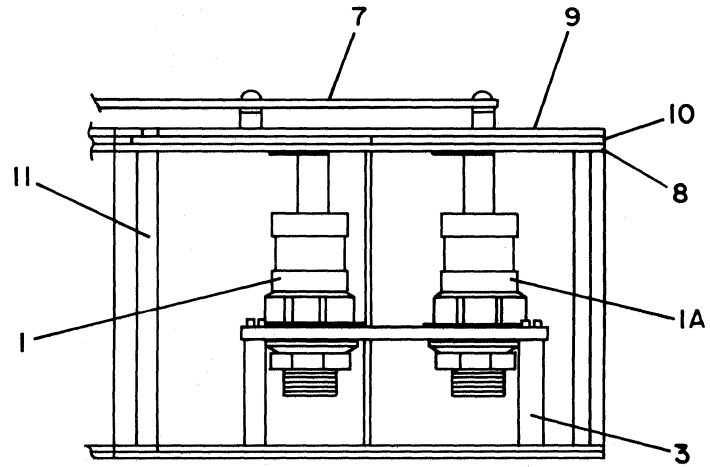

VIEW A-A
(ROTATED 180°)

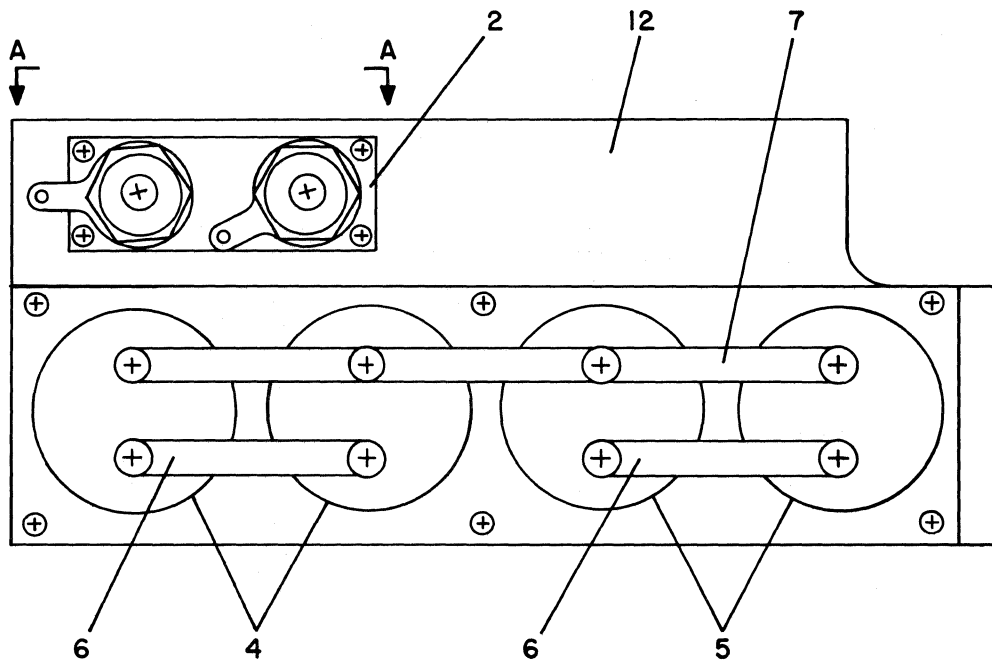

FIGURE 6-3. CAPACITOR ASSEMBLY A2

FIG & INDEX NO	REF DESIG	I N D	DESCRIPTION	MFR CODE	UNIVAC PART NO MFR PART NO	QTY PER ASSY	USED ON ASSY
6-3	A2	2	CAPACITOR ASSEMBLY (FOR NHA SEE FIG 6-1)	90536	7600863-00	REF	
3-1	CR3	3	SEMICONDUCTOR DEVICE, DIODE 47 VOLTS	16759	7904546-06 DPZ30-47R	1	
3-1A	CR4	3	SEMICONDUCTOR DEVICE, DIODE 30 VOLTS	16759	7904546-00 DPZ30-30R	1	
3		3	SCREW, MACH, PAN HD, 10-32UNF-2A 3/8 L (AP)	96906	908555-02 MS51958-61	2	
			WASHER, LOCK, I/T, NO 10 (AP)		4912552-03 COML	2	
			WASHER, FLAT, NO 10 (AP)		4912549-03 COML	2	
			TERMINAL, CRIMPING, 12-10 AWG (AP)	96906	7900810-25 MS25036-112	2	
3-2		3	PLATE, MOUNTING	90536	7600896-00	1	
3		3	SCREW, MACH, FL HD, 6-32UNC-2A 0.437 L (AP)	96906	7903133-17 MS24693-C27	4	
			SCREW, MACH, PAN HD, 6-32UNC-2A 5/8 L (AP)	96906	4912531-05 MS51957-31	4	
			WASHER, FLAT, NO 6 (AP)	96906	4912548-01 MS15795-805	4	
			WASHER, LOCK, HEL, NO 6 (AP)	96906	4912550-01 MS35338-136	4	
3-3		3	STANDOFF	90536	7600897-00	4	
3-4	C1A C1B	3	CAPACITOR, FXD, ELCT, 16000UF +75 -10PCT	09023	7904524-00 FAH163-75	2	
3-5	C2A C2B	3	CAPACITOR, FXD, ELCT, 100V 4700UF, -10 +75PCT	81349	7900219-23 M62-12-036	2	
3-6		3	BUS BAR	90536	7600991-00	2	
3-7		3	BUS BAR	90536	7600991-01	1	
3		3	SCREW, MACH, PAN HD, 10-32UNC-2A 9/16 L (AP)	96906	908555-05 MS51958-62	8	
			WASHER, LOCK, HEL, NO 10 (AP)	96906	4912550-03 MS35338-138	8	
			WASHER, FLAT, NO 10 (AP)	96906	4912548-03 MS15795-808	8	
3-8		3	BRACKET, CAPACITOR HOLDER	90536	7600943-00	1	
3-9		3	PLATE, CAPACITOR HOLD-DOWN	90536	7600959-00	1	
3-10		3	SHIM, CAPACITOR	90536	7600962-00	1	
3		3	SCREW, MACH, PAN HD, 6-32UNC-2A 7/16 L (AP)	96906	4912531-03 MS51957-29	6	

PARTS LIST

GROUP ASSEMBLY PARTS LIST

FIG & INDEX NO	REF DESIG	I N D	DESCRIPTION	MFR CODE	UNIVAC PART NO MFR PART NO	QTY PER ASSY	USED ON
6- 3			CAPACITOR ASSEMBLY		CONTINUED		
			WASHER, FLAT, NO 6 (AP)		4912548-01	6	
			SCREW, MACH, FL HD, 6-32UNC-2A 0.437 L (AP)	96906	MS15795-805 7903133-17	6	
				96906	MS24693-C27		
3-11		3	STANDOFF	90536	7600748-00	3	
3-12		3	BASE PLATE, CAPACITOR	90536	7600961-00	1	

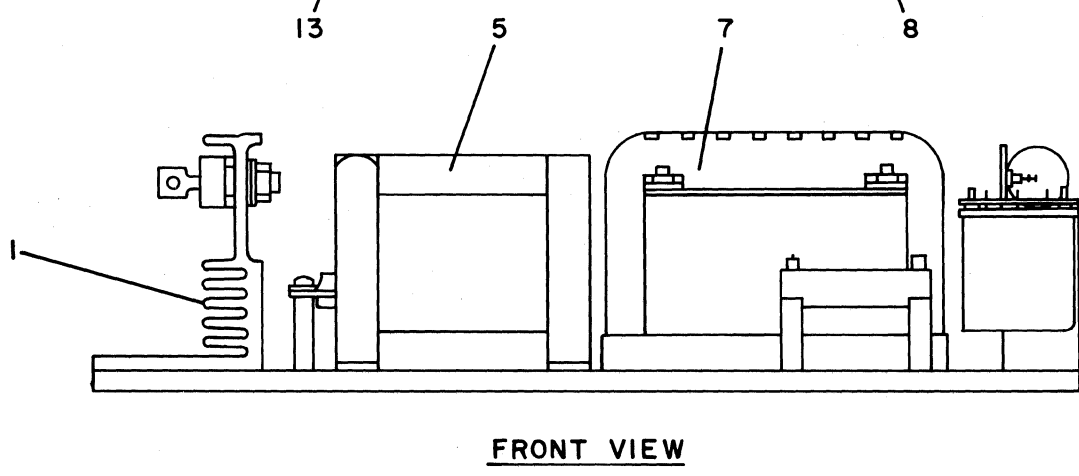
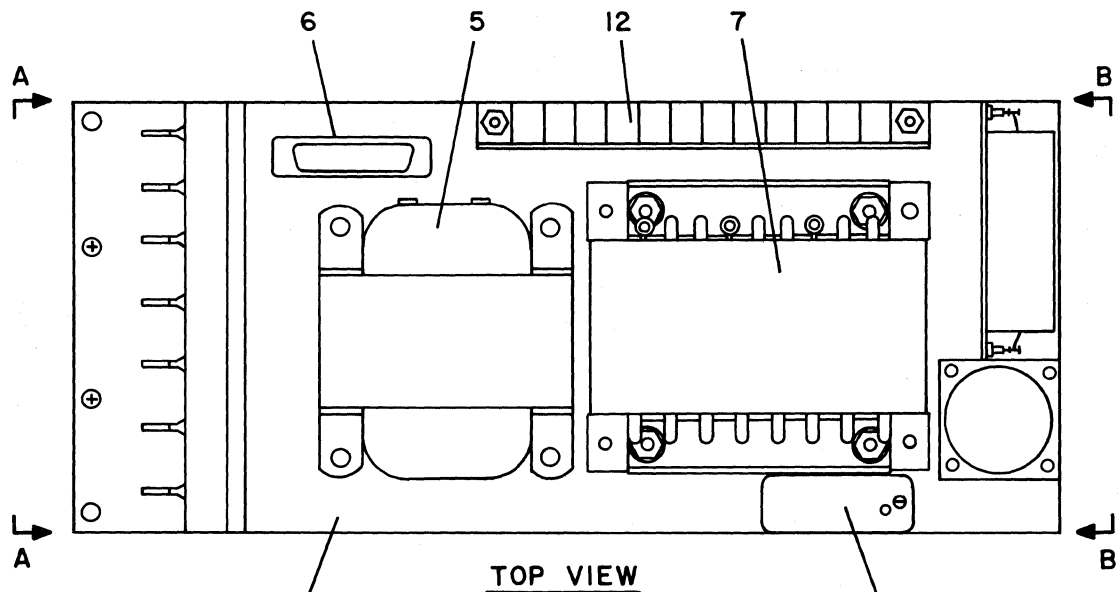
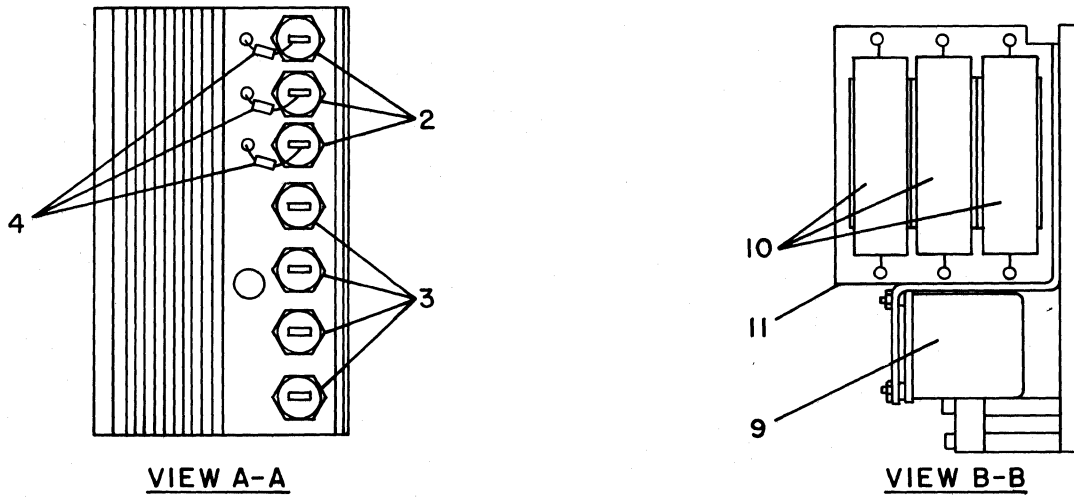

FIGURE 6-4. FRONT END SUBASSEMBLY A3

PARTS LIST

GROUP ASSEMBLY PARTS LIST

FIG & INDEX NO	REF DESIG	I N D	DESCRIPTION	MFR CODE	UNIVAC PART NO MFR PART NO	QTY PER ASSY	USED ON
6-4	A3	2	FRONT END SUBASSEMBLY	90536	7601769-00		REF
	A3		FRONT END SUBASSEMBLY (FOR NHA SEE FIG 6-1)	90536	7601769-01		REF
4-1		3	HEAT SINK, FRONT END	90536	7600996-00		1
4		3	SCREW, MACH, PAN HD, 6-32UNC-2A 7/8 L (AP)	96906	908553-10 MS51957-33		2
			WASHER, LOCK, HEL, NO 6 (AP)	96906	4912550-01 MS35338-136		2
			WASHER, FLAT, NO 6 (AP)	96906	4912548-01		2
			NUT, PLAIN, HEX, 6-32UNC-2B (AP)	96906	MS15795-805 4912540-01		2
				96906	MS35649-264		
4-2	Q31 Q32 Q33	3	SEMICONDUCTOR DEVICE, TRIODE SWITCH, 200V, 22A	81349	7904633-00 2N897		3
4-3	CR31 THRU CR33 CR51	3	SEMICONDUCTOR DEVICE, DIODE 35A, 200V	81349	7900134-00 1N1186		4
4-4	R64 R65 R66	3	RESISTOR, FXD, FILM, 1/4W, 1.0K OHM, +-2PCT	81349	7902753-31 RLR07C102GM		3
4-5	L34	3	REACTOR, FILTER, DUAL, SERIES 4.8MH, 12A, PAR 1.2MH, 24A	70674	7904516-00 3-19624		1
4		3	SCREW, MACH, FL HD, 10-32UNF-2A 0.875 L (AP)	96906	7903133-52 MS24693-C275		4
			WASHER, LOCK, HEL NO, 10 (AP)	96906	4912550-03 MS35338-138		4
			WASHER, FLAT, NO 10 (AP)	96906	4912548-03		4
			NUT, PLAIN, HEX, MACH 10-32UNF-2B (AP)	96906	MS15795-808 4912542-00		4
				96906	MS35650-304		
4-6	J1	3	CONN, SUBMINIATURE, ELECT FEMALE, RECT, 25 CONTACT	71468	903801-00 DBM-25S		1
4		3	SCREW, MACH, PAN HD, 4-40UNC-2A 1/2 L (AP)	96906	908552-07 MS51957-17		2
			WASHER, LOCK, HEL, NO 4 (AP)	96906	4912550-00 MS35338-135		2
			WASHER, FLAT, NO 4 (AP)	96906	7903354-02		2
			SPACER, SLEEVE, TAPPED 4-40UNC-2B, 1 L (AP)	81349 06540	NAS620C4 7900581-01 8161-A-0440-16		2
4-7	T1	3	TRANSFORMER, POWER, STEP-DOWN	70674	7904523-00 3-19627		1
4		3	SCREW, MACH, PAN HD, 8-32UNC-2A 1 L (AP)	96906	4912532-04 MS51957-49		4

FIG & INDEX NO	REF DESIG	1 N D	DESCRIPTION	MFR CODE	UNIVAC PART NO MFR PART NO	QTY USED PER ON ASSY
6- 4			FRONT END SUBASSEMBLY		CONTINUED	
			WASHER, LOCK, HEL, NO 8 (AP)		4912550-02	4
			WASHER, FLAT, NO 8 (AP)	96906	MS35338-137 4912548-02	4
			NUT, PLAIN, HEX, MACH 8-32UNC-2B (AP)	96906	MS15795-807 4912540-02 MS35649-284	4
4-8	J2	3	CONN, ELEC, MALE, RECT, 34 CONTACT, GUIDE PIN LOCKING	81349	7901314-01 MRAC34P-NSS436	1
4		3	SCREW, MACH, FL HD, 4-40UNC-2A 0.500 L (AP)	96906	7903133-05 MS24693-C6	2
			SPACER, SLEEVE, TAPPED 4-40UNC-2B, 1 L (AP)	06540	7900581-01 8161-A-0440-16	2
			SCREW, MACH, FILLISTER HD 4-40UNC-2A, 1/2 L (AP)	96906	4913387-06 MS35275-217	2
4		3	CONTACT, ELEC, CONN, SIZE 0.62 20AWG (U/W J2)	96906	7903062-00 MS17803-16-20	1
			CONTACT ELEC, CONN, MALE SIZE 0.62, 16AWG (U/W J2)	96906	7903062-01 MS17803-13-13	17
4-9	K1	3	RELAY, ARMATURE, 115VAC, 400HZ 3 SPST CONTACT	96906	7902350-00 MS27418-1A	1
4		3	WASHER, FLAT, NO 6 (AP)	96906	4912548-01 MS15795-805	4
			WASHER, LOCK, HEL, NO 6 (AP)	96906	4912550-01 MS35338-136	4
			NUT, PLAIN, HEX, MACH 6-32UNC-2B (AP)	96906	4912540-01 MS35649-264	4
4-10	C1 C2 C3	3	CAPACITOR, FXD, PLASTIC, 2.5UF 300V	56289	7904549-01 260P25553S4	3
4-11		3	GUARD, TERMINAL BOARD	90536	7600922-00	1
4		3	SCREW, MACH, PAN HD, 4-40UNC-2A 1/2 L (AP)	96906	908552-07 MS51957-17	3
			WASHER, FLAT, NO 4 (AP)	96906	4912548-00 MS15795-803	3
			WASHER, LOCK, HEL, NO 4 (AP)	96906	4912550-00 MS35338-135	3
			NUT, PLAIN, HEX, MACH 4-40UNC-2B (AP)	96906	4912540-00 MS35649-244	3
4-12	TB1	3	TERMINAL BOARD, BARRIER TYPE	75382	900125-05 601C12	1
4-13		3	BASE PLATE, FRONT END	90536	7601774-00	1

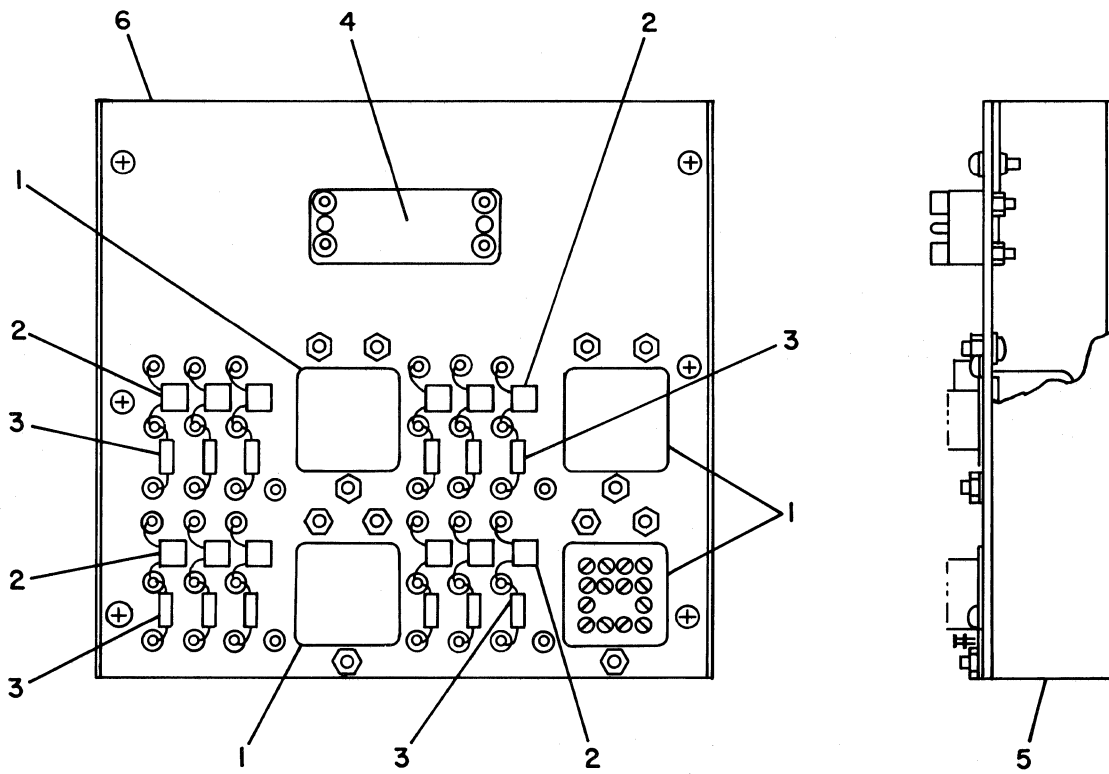

FIGURE 6-5. RELAY SUBASSEMBLY A5

GROUP ASSEMBLY PARTS LIST

PARTS LIST

FIG & INDEX NO	REF DESIG	I N D	DESCRIPTION	MFR CODE	UNIVAC PART NO MFR PART NO	QTY PER ASSY	USED ON
6-5	A5	2	RELAY SUBASSEMBLY (FOR NHA SEE FIG 6-1)	90536	7601771-00	REF	
5-1	K1 THRU K4	3	RELAY, ARMATURE, 28VDC, 4 SPDT CONTACT	96906	7904533-00 MS27400-1	4	
5		3	SCREW, MACH, PAN HD, 6-32UNC-2A 7/16 L (AP)	96906	4912531-03 MS51957-29	12	
			WASHER, PLAIN, FLAT, NO 6 (AP)	81349	7903354-03 NAS620C6	24	
			WASHER, LOCK, HEL, NO 6 (AP)	96906	4912550-01	12	
			NUT, PLAIN, HEX, MACH 6-32UNC-2B (AP)	96906	MS35338-136 4912540-01	12	
5-2		3	CAPACITOR, FXD, CER, DIELECTRIC 200V, 0.01UF	81349	7901102-36 CK06BX103K	12	
5-3		3	RESISTOR, FXD, COMP, 1/4W 20 OHM, +-5PCT	81349	7902751-21 RCR07G200JM	12	
5-4	J1	3	CONN, ELEC, MALE, RECT, 34 CONT GUIDE PIN LOCKING	81312	7901314-01 MRAC34P-NSS436	1	
5		3	SCREW, MACH, FILLISTER HD 4-40UNC-2A, 5/8 L (AP)	96906	4913387-07 MS35275-218	4	
			WASHER, FLAT, NO 4 (AP)	96906	4912548-00 MS15795-803	4	
			NUT, SELF-LOCKING, HEX 4-40NC-3B (AP)	72962	903790-03 F92-1660-40	4	
5		3	CONTACT, ELEC, CONN, MALE SIZE 0.62, 16AWG (U/W J1)	96906	7903062-01 MS17803-16-16	26	
5-5		3	BRACKET, RELAY HOLD-DOWN	90536	7601773-00	1	
5-6		3	PLATE, RELAY	90536	7601772-00	1	
5		3	SCREW, MACH, PAN HD, 6-32UNC-2A 5/8 L (AP)	96906	4912531-03 MS51957-29	6	
			WASHER, FLAT, NO 6 (AP)	96906	4912548-01 MS15795-805	6	

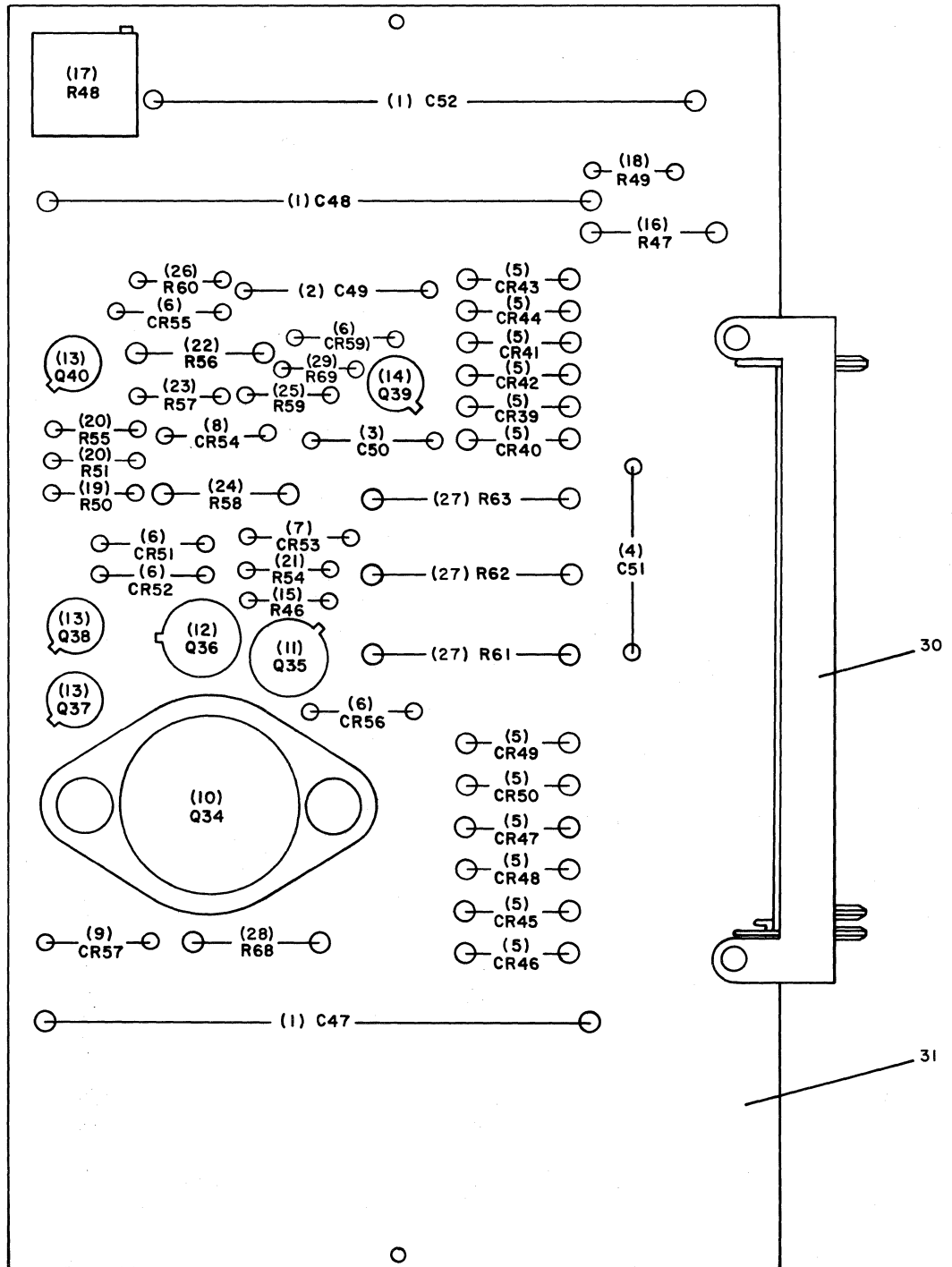

FIGURE 6-6. 400HZ FRONT END CIRCUIT CARD ASSEMBLY A1A1

FIG & INDEX NO	REF DESIG	I N D	DESCRIPTION	MFR CODE	UNIVAC PART NO MFR PART NO	QTY PER ASSY	USED ON ASSY
6-6	A1A1	2	CIRCUIT CARD ASSEMBLY, 400HZ FRONT END (FOR NHA SEE FIG 6-1)	90536	7600665-00	1	
6-1	C47 C48 C52	3	CAPACITOR, FXD, ELCT, 50V, 150UF +30 -10PCT	81349	7902616-37 M39018-01-0151	3	
6-2	C49	3	CAPACITOR, FXD, CER, 50V, 3.3UF +-20PCT	81349	7903309-42 CK16BR335M	1	
6-3	C50	3	CAPACITOR, FXD, ELCT, 20V, 2.2UF +-10PCT	81349	7902696-29 M39003-01-2283	1	
6-4	C51	3	CAPACITOR, FXD, CER, 100V 0.15UF, +-20PCT	81349	7903309-26 CK15BR154M	1	
6-5	CR39 THRU CR50	3	SEMICONDUCTOR DEVICE, DIODE SILICON, F/R	81349	7903079-00 1N4942	12	
6-6	CR51 CR52 CR55 CR56 CR59	3	SEMICONDUCTOR DEVICE, DIODE SILICON, 500MW, 75V	03508	7901009-00 DJXR499	5	
6-7	CR53	3	SEMICONDUCTOR DEVICE, DIODE, VR 500MW, 9.0V	81349	7901094-00 1N935B	1	
6-8	CR54	3	SEMICONDUCTOR DEVICE, DIODE, VR 3.3V	81349	7900258-03 1N746A	1	
6-9	CR57	3	SEMICONDUCTOR DEVICE, DIODE, VR 6.2V	81349	7900258-10 1N753A	1	
6-10	Q34	3	TRANSISTOR, PNP, SILICON HIGH-POWER	81349	7904548-00 2N3792	1	
6-11	Q35	3	SEMICONDUCTOR DEVICE, TRIODE SWITCH, SILICON	81349	7904573-00 2N2324	1	
6-12	Q36	3	TRANSISTOR, DUAL, NPN, 0.5W 60V, 0.5A	81349	7902441-00 2N2060	1	
6-13	Q37 Q38 Q40	3	TRANSISTOR, PNP, SILICON, SW 400MW, 45V	04713	7901556-00 SS1308	3	
6-14	Q39	3	TRANSISTOR, SILICON, UNIJUNCTION	81349	7904529-00 2N5431	1	
6-15	R46	3	RESISTOR, FXD, FILM, 1/4W, 1.0K OHM, +-2PCT	81349	7902753-31 RLR07C1026M	1	
6-16	R47	3	RESISTOR, FXD, FILM, 1/2W 3000 OHM, +-2PCT	81349	7902750-58 RLR20C3026M	1	

PARTS LIST

GROUP ASSEMBLY PARTS LIST

FIG & INDEX NO	REF DESIG	I N D	DESCRIPTION	MFR CODE	UNIVAC PART NO MFR PART NO	QTY PER ASSY	USED ON ASSY
6- 6			CIRCUIT CARD ASSEMBLY, 400HZ		CONTINUED		
6-17	R48	3	RESISTOR, VARIABLE, WW, 3/4W 200 OHM, +-5PCT	81349	7901477-02 RT22C2P201	1	
6-18	R49	3	RESISTOR, FXD, FILM, 1/4W 1.1K OHM, +-2PCT	81349	7902753-32 RLR07C112GM	1	
6-19	R50	3	RESISTOR, FXD, FILM, 1/4W 3.3K OHM, +-2PCT	81349	7902753-43 RLR07C332GM	1	
6-20	R51 R55	3	RESISTOR, FXD, FILM, 1/4W 1.3K OHM, +-2PCT	81349	7902753-34 RLR07C132GM	2	
6-21	R54	3	RESISTOR, FXD, FILM, 1/4W 820 OHM, +-2PCT	81349	7902753-29 RLR07C821GM	1	
6-22	R56	3	RESISTOR, FXD, FILM, 1/2W 2000 OHM, +-2PCT	81349	7902750-54 RLR20C202GM	1	
6-23	R57	3	RESISTOR, FXD, COMP, 1/4W 620K OHM, +-5PCT	81349	7902751-129 RCR07G624JM	1	
6-24	R58	3	RESISTOR, FXD, FILM, 1/2W 2400 OHM, +-2PCT	81349	7902750-56 RLR20C242GM	1	
6-25	R59	3	RESISTOR, FXD, FILM, 1/4W 2.2K OHM, +-2PCT	81349	7902753-39 RLR07C222GM	1	
6-26	R60	3	RESISTOR, FXD, COMP, 1/4W 20 OHM, +-5PCT	81349	7902751-21 RCR07G200JM	1	
6-27	R61 THRU R63	3	RESISTOR, FXD, FILM, 2W, 300 OHM +-2PCT	81349	7900182-35 RL42S301G	3	
6-28	R68	3	RESISTOR, FXD, FILM, 1/2W 1600 OHM, +-2PCT	81349	7902750-52 RLR20C162GM	1	
6-29	R69	3	RESISTOR, FXD, FILM, 1/4W 100K OHM, +-2PCT	81349	7902753-79 RLR07C104GM	1	
6-30	P1	3	CONN, PLUG, ELEC, MALE, 56 CONT	16512	7901665-00 200125-01	1	
6-31		3	PRINTED WIRING BOARD, 400HZ FRONT END	90536	7600664-00	1	

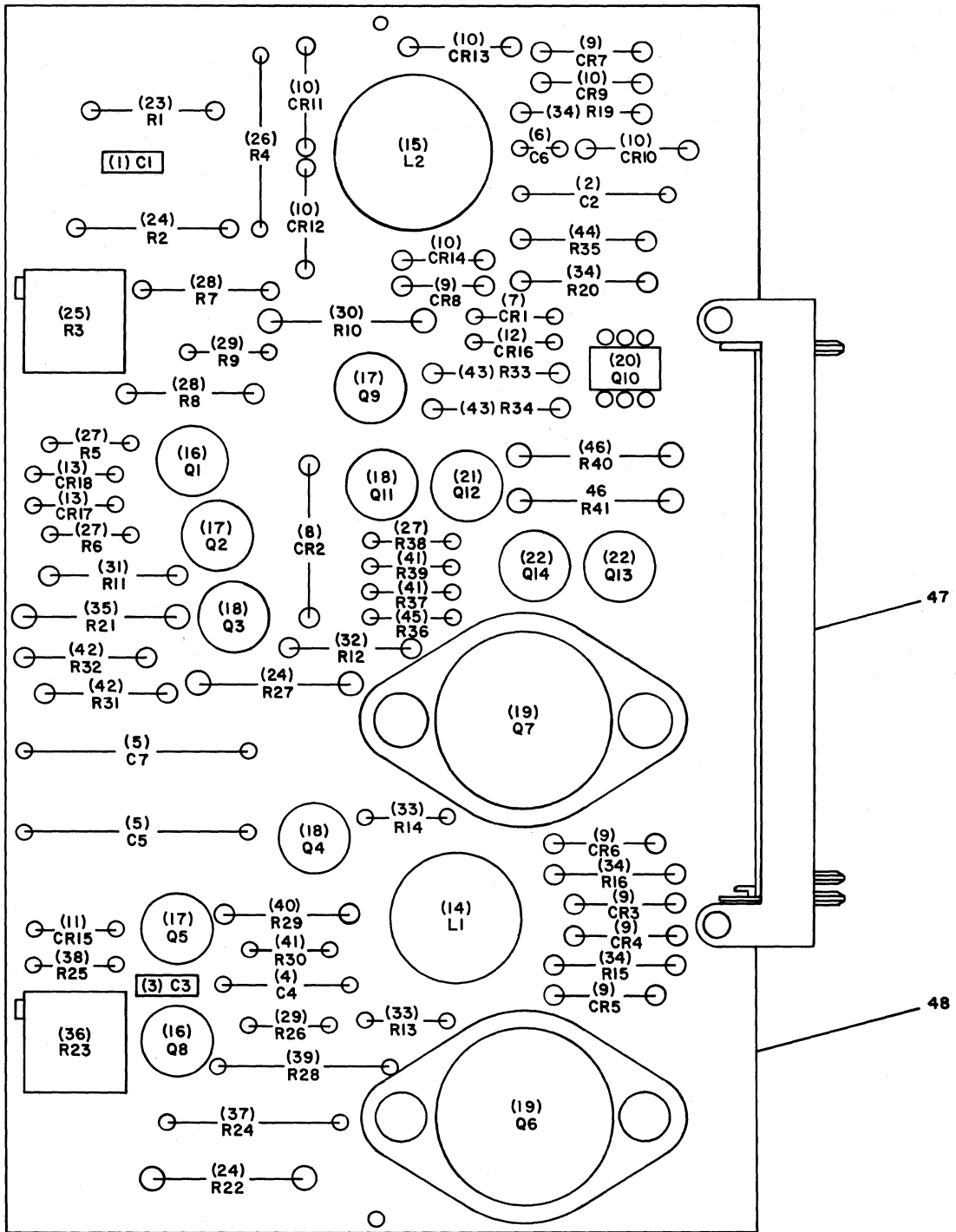

FIGURE 6-7. 75VDC REGULATOR CIRCUIT CARD ASSEMBLY A1A2

PARTS LIST

GROUP ASSEMBLY PARTS LIST

FIG & INDEX NO	REF DESIG NO	I N D	DESCRIPTION	MFR CODE	UNIVAC PART NO MFR PART NO	QTY PER ASSY	USED ON ASSY
6-7	A1A2	2	CIRCUIT CARD ASSEMBLY, 75VDC REGULATOR (FOR NHA SEE FIG 6-1)	90536	7600667-00		REF
7-1	C1	3	CAPACITOR, FXD, DIELECTRIC 100V, 4700PF, +-10PCT	81349	7901102-44 CK05BX472K	1	
7-2	C2	3	CAPACITOR, FXD, ELECT, 10V 33UF, +-10PCT	81349	7902696-11 M39003-01-2257	1	
7-3	C3	3	CAPACITOR, FXD, CER, DIELECTRIC 50V, .22UF, +-10PCT	81349	7901102-101 CK06BX224K	1	
7-4	C4	3	CAPACITOR, FXD, ELECT, 50V 1.0UF, +-10PCT	81349	7902696-77 M39003-01-2356	1	
7-5	C5 C7	3	CAPACITOR, FXD, ELECT, 10V 220UF, +-10PCT	81349	7902696-17 M39003-01-2265	2	
7-6	C6	3	CAPACITOR, FXD, CER, DIELECTRIC 50V, 0.10UF, +-10PCT	81349	7901102-60 CK05BX104K	1	
7-7	CR1	3	SEMICONDUCTOR DEVICE, DIODE, VR 500MW, 9.0V	81349	7901094-01 1N937R	1	
7-8	CR2	3	SEMICONDUCTOR DEVICE, DIODE, 1W 8.2V, +-5PCT	81349	7900063-13 1N3018B	1	
7-9	CR3 THRU CR8	3	SEMICONDUCTOR DEVICE, DIODE 300MW, 1A, 200V	81349	7902067-00 1N3611	6	
7-10	CR9 THRU CR14	3	SEMICONDUCTOR DEVICE, DIODE, SI FAST RECOVERY	81349	7903079-00 1N4942	6	
7-11	CR15	3	SEMICONDUCTOR DEVICE, DIODE, SI VR, 6.2V	81349	7900258-10 1N753A	1	
7-12	CR16	3	SEMICONDUCTOR DEVICE, DIODE, SI VR, 3.3V	81349	7900258-03 1N746A	1	
7-13	CR17 CR18	3	SEMICONDUCTOR DEVICE, DIODE, SI SWITCH, 500MW, 75V	03508	7901009-00 DJXR499	2	
7-14	L1	3	REACTOR, SATURATING, DUAL UNIT	70674	7904513-00 3-19613	1	
7-15	L2	3	REACTOR, SATURATING	70674	7904515-00 3-19615	1	
7-16	Q1 Q8	3	TRANSISTOR, DUAL, NPN, 0.5W 60V, 0.5A	81349	7902441-00 2N2060	2	
7-17	Q2 Q5 Q9	3	TRANSISTOR, PNP, SI, SWITCH 400MW, 45V	04713	7901556-01 SS1309	3	

FIG & INDEX NO	REF DESIG	I N D	DESCRIPTION	MFR CODE	UNIVAC PART NO MFR PART NO	QTY USED PER ON ASSY
6- 7			CIRCUIT CARD ASSEMBLY, 75VDC		CONTINUED	
7-18	Q3 Q4 Q11	3	TRANSISTOR, NPN, SI, SWITCH 3.5W, 80V, 1.0A	04713	7901760-00 SS1530	3
7-19	Q6 Q7	3	TRANSISTOR, NPN, HIGH VOLTAGE PWR, 75W, 2A, 325V	04713	7902308-00 SJ1240	2
7-20	Q10	3	SEMICONDUCTOR DEVICE, PHOTO COUPLER	04713	7904551-00 MRD300	1
7-21	Q12	3	TRANSISTOR, PNP, SI, SWITCH 5.0W, 1A, 40V	01295	7901426-00 SG2460	1
7-22	Q13 Q14	3	TRANSISTOR, NPN, SI, PWR	81349	7904571-00 2N3418	2
7-23	R1	3	RESISTOR, FXD, FILM, 1/2W 4700 OHM, +-2PCT	81349	7902750-63 RLR20C472GM	1
7-24	R2 R22 R27	3	RESISTOR, FXD, WW, 3W 8250 OHM, +-1PCT	81349	7904552-00 RW79U8251F	3
7-25	R3	3	RESISTOR, VARIABLE, WW, 3/4W 200 OHM, +-5PCT	81349	7901477-02 RT22C2P201	1
7-26	R4	3	RESISTOR, FXD, FILM, 1/4W 1000 OHM, +-1PCT	81349	7901573-32 RN65E1001F	1
7-27	R5 R6 R38	3	RESISTOR, FXD, FILM, 1/4W 3.3K OHM, +-2PCT	81349	7902753-43 RLR07C332GM	3
7-28	R7 R8	3	RESISTOR, FXD, FILM, 1/2W 27 OHM, +-2PCT	81349	7902750-09 RLR20C270GM	2
7-29	R9 R26	3	RESISTOR, FXD, FILM, 1/4W 2.0K OHM, +-2PCT	81349	7902753-38 RLR07C202GM	2
7-30	R10	3	RESISTOR, FXD, FILM, 1W 9.1K OHM, +-2PCT	81349	7900185-54 RL32S912G	1
7-31	R11	3	RESISTOR, FXD, FILM, 1/2W 680 OHM, +-2PCT	81349	7902750-43 RLR20C681GM	1
7-32	R12	3	RESISTOR, FXD, FILM, 1/2W 750 OHM, +-2PCT	81349	7902750-44 RLR20C751GM	1
7-33	R13 R14	3	RESISTOR, FXD, FILM, 1/4W 6.2K OHM, +-2PCT	81349	7902753-50 RLR07C622GM	2
7-34	R15 R16	3	RESISTOR, FXD, FILM, 1/2W 51 OHM, +-2PCT	81349	7902750-16 RLR20C510GM	4

PARTS LIST

GROUP ASSEMBLY PARTS LIST

FIG & INDEX NO	REF DESIG	I N D	DESCRIPTION	MFR CODE	UNIVAC PART NO MFR PART NO	QTY PER ASSY	USED ON
6-7			CIRCUIT CARD ASSEMBLY, 75VDC		CONTINUED		
	R19						
	R20						
7-35	R21	3	RESISTOR, FXD, WW, 3W, 300 OHM +-5PCT	81349	910509-42 RW69V301	1	
7-36	R23	3	RESISTOR, VARIABLE, WW, 3/4W 100 OHM, +-5PCT	81349	7901477-01 RT22C2P101	1	
7-37	R24	3	RESISTOR, FXD, FILM, 1/4W 1270 OHM, +-1PCT	81349	7901573-42 RN65E1271F	1	
7-38	R25	3	RESISTOR, FXD, FILM, 1/4W 3.0K OHM, +-2PCT	81349	7902753-42 RLR07C302GM	1	
7-39	R28	3	RESISTOR, FXD, FILM, 1/4W 1330 OHM, +-1PCT	81349	7901573-44 RN65E1331F	1	
7-40	R29	3	RESISTOR, FXD, FILM, 1/2W 1500 OHM, +-2PCT	81349	7902750-51 RLR20C152GM	1	
7-41	R30 R37 R39	3	RESISTOR, FXD, FILM, 1/4W 10K OHM, +-2PCT	81349	7902753-55 RLR07C103GM	3	
7-42	R31 R32	3	RESISTOR, FXD, FILM, 1/2W 10 OHM, +-2PCT	81349	7902750-00 RLR20C100GM	2	
7-43	R33 R34	3	RESISTOR, FXD, FILM, 1/2W 2400 OHM, +-2PCT	81349	7902750-56 RLR20C242GM	2	
7-44	R35	3	RESISTOR, FXD, FILM, 1/2W 240K OHM, +-2PCT	81349	7902750-104 RLR20C244GM	1	
7-45	R36	3	RESISTOR, FXD, FILM, 1/4W 6.8K OHM, +-2PCT	81349	7902753-51 RLR07C682GM	1	
7-46	R40 R41	3	RESISTOR, FXD, FILM, 1W, 240 OHM +-2PCT	81349	7900185-16 RL32S241G	2	
7-47	P1	3	CONN, PLUG, ELEC, MALE, 56 CONT	16512	7901665-00 200125-01	1	
7-48		3	PRINTED WIRING BOARD, 75VDC REGULATOR	90536	7600666-00	1	

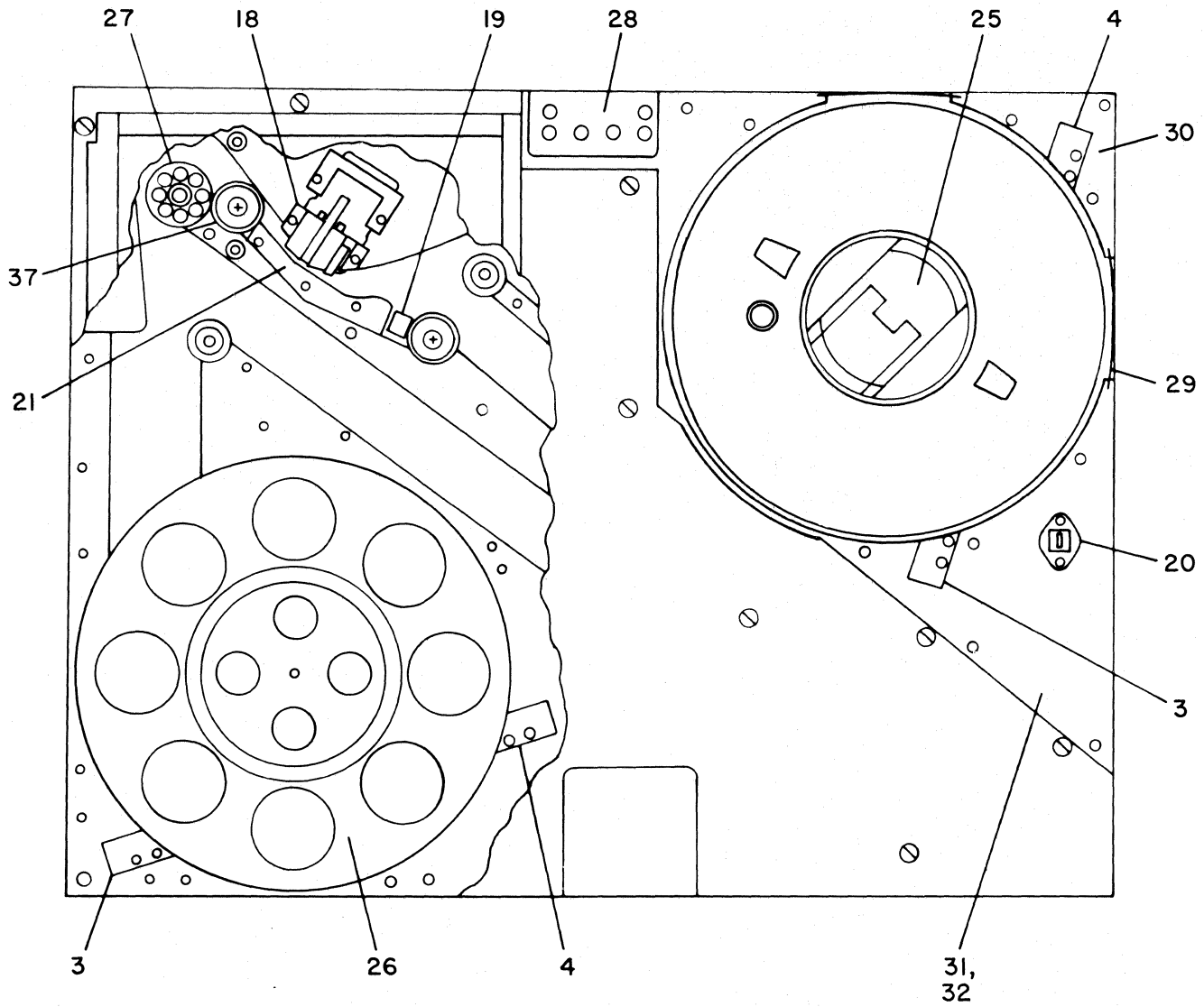

FIGURE 6-8. 1840 (MOD) MAGNETIC TAPE TRANSPORT (SHEET 1 OF 2)

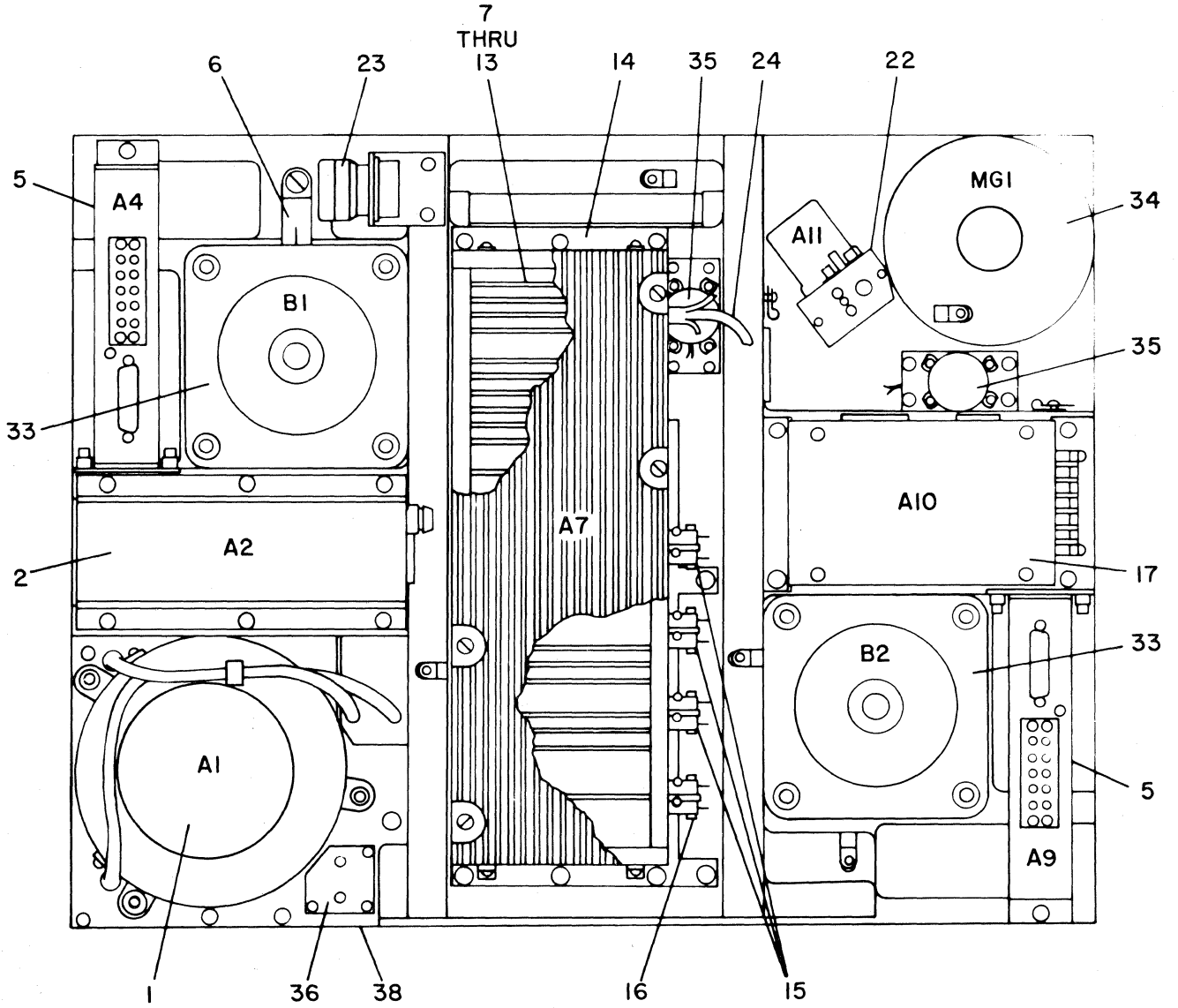

FIGURE 6-8. 1840 (MOD) MAGNETIC TAPE TRANSPORT (SHEET 2 OF 2)

FIG & INDEX NO	REF DESIG	I N D	DESCRIPTION	MFR CODE	UNIVAC PART NO MFR PART NO	QTY PER ASSY	USED ON
6-8		1	TRANSPORT, MAG TAPE, 1840 (MOD)	90536	7601767-01	1	A
			TRANSPORT, MAG TAPE, 1840 (MOD)	90536	7601767-02	1	B
8-1	A1	2	VACUUM/PRESSURE ASSEMBLY (FOR NLA SEE FIG 6-9)	90536	7600913-01	1	
8		2	GASKET, BLOWER HOUSING (U/W A1)	90536	7600974-00	1	
			SCREW, CAP, SOCKET HEAD 1/4-28UNF-3A, 1 L (AP)	96906	911607-04 MS16996-24	3	
			WASHER, PLAIN, FLAT, NO 1/4 (AP)	96906	4912548-04 MS15795-810	3	
			WASHER, LOCK, HEL, NO 1/4 (AP)	96906	4912550-04 MS35338-139	3	
8-2	A2	2	DC-DC CONVERTER ASSEMBLY (FOR NLA SEE FIG 6-10)	90536	7600870-01	1	
8-3	A3 A12	2	SENSOR ASSEMBLY, LOW TAPE RECEIVER	90536	7600850-00	2	
8-4	A6 A8	2	SENSOR ASSEMBLY, LOW TAPE EMITTER	90536	7600849-00	2	
8		2	SCREW, MACH, PAN HD, 4-40UNC-2A 11/16 L (AP FOR IDX 3 & 4)	96906	908552-10 MS51957-18	8	
			WASHER, LOCK, HEL, NO 4 (AP FOR IDX 3 & 4)	96906	4912550-00 MS35338-135	8	
			WASHER, PLAIN, FLAT, NO 4 (AP FOR IDX 3 & 4)	81349	7903354-02 NAS620C4	8	
8-5	A4 A9	2	REEL DRIVE ASSEMBLY (FOR NLA SEE FIG 6-12)	90536	7600869-00	2	
8-6	A5	2	FILE PROTECT ASSEMBLY, .320 PROTRUSION (FOR NLA SEE FIG 6-14)	90536	7600840-00	1	
8		2	SCREW, MACH, PAN HD, 4-40UNC-2A 5/16 L (AP)	96906	908552-04 MS51957-14	4	
			WASHER, PLAIN, FLAT, NO 4 (AP)	81349	7903354-02 NAS620C4	4	
			WASHER, LOCK, HEL, NO 4 (AP)	96906	4912550-00 MS35338-135	4	
8-7	A39A	2	CIRCUIT CARD ASSY, REEL SERVO INPUT	90536	7600627-00	1	
8-8	A41A A42A	2	CIRCUIT CARD ASSY, REEL SERVO OUTPUT	90536	7600629-00	2	
8-9	A43A	2	CIRCUIT CARD ASSY, AUTOLOAD SERVO CONTROL, 1840 (MOD)	90536	7600671-00	1	
8-10	A44A	2	CIRCUIT CARD ASSY, AUTOLOAD FUNCTION GENERATOR, 1840 (MOD)	90536	7600669-00	1	
8-11	A45A	2	CIRCUIT CARD ASSY, AUTOLOAD INTERFACE, 1840 (MOD)	90536	7600673-00	1	

PARTS LIST

GROUP ASSEMBLY PARTS LIST

FIG & INDEX NO	REF DESIG	I N D	DESCRIPTION	MFR CODE	UNIVAC PART NO MFR PART NO	QTY PER ASSY	USED ON ASSY
6- 8			TRANSPORT, MAG TAPE, 1840 (MOD)		CONTINUED		
8-12	A48A	2	CIRCUIT CARD ASSY, CAPSTAN SERVO LOGIC	90536	7600643-00	1	
8-13	A49A	2	CIRCUIT CARD ASSY, CAPSTAN SERVO INPUT	90536	7600635-00	1	
8-14	A7	2	CARD RACK ASSEMBLY, TRANSPORT	90536	7600873-01	1	
8		2	SCREW, CAP, SOCKET HD 10-32UNF-3A, 5/8 L (AP)	96906	911606-06 MS16996-11	8	
			WASHER, LOCK, HEL, NO 10 (AP)	96906	4912550-03	8	
			WASHER, FLAT, NO 10 (AP)	96906	MS35338-138 4912548-03	8	
			WASHER, SHOULDER, FIBRE FOR NO 10 SCREW (AP)	96906	MS15795-808 7903387-05	8	
				06540	2642-24850-F194-30		
8-15	A7S1 THRU A7S6	3	PRESSURE SENSOR ASSEMBLY	90536	7600848-00	3	
8-16	A7S7 A7S8	3	PRESSURE SENSOR ASSEMBLY	90536	7600848-01	2	
8		3	SCREW, MACH, PAN HD, 4-40UNC-2A 5/16 L (AP)	96906	908552-04 MS51957-14	8	
			WASHER, LOCK, HEL, NO 4 (AP)	96906	4912550-00	8	
			WASHER, PLAIN, FLAT, NO 4 (AP)	96906	MS35338-135 4912548-00	8	
				96906	MS15795-803		
8-17	A10	2	CAPSTAN DRIVE ASSEMBLY (FOR NLA SEE FIG 6-15)	90536	7600868-01	1	
8-18	A11	2	HEAD, RECORDER-REPRODUCER 9 TRACK, PL-1365/UYK	90536	7601884-00	1	A
	A11	2	HEAD, RECORDER-REPRODUCER 7 TRACK, PL-1364/UYK	90536	7601884-01	1	B
8-19	A13	2	SEMICONDUCTOR DEVICE, PHOTO BOT-EOT SENSOR	32388	7904541-00 SCA1343	1	
8		2	SCREW, MACH, PAN HD, 4-40UNC-2A 5/8 L (AP)	96906	908552-09 MS51957-18	1	
8-20	M1	2	METER, TIME TOTALIZING, 115V 400HZ	96906	7902614-01 MS17322-6	1	
8		2	SCREW, MACH, PAN HD, 4-40UNC-2A 1/2 L (AP)	96906	908552-07 MS51957-17	2	
			WASHER, PLAIN, FLAT, NO 4 (AP)	81349	7903354-02 NAS620C4	2	

FIG & INDEX NO	REF DESIG	I N D	DESCRIPTION	MFR CODE	UNIVAC PART NO MFR PART NO	QTY PER ASSY	USED ON ASSY
6- 8			TRANSPORT, MAG TAPE, 1840 (MOD)		CONTINUED		
			WASHER, LOCK, HEL, NO 4 (AP)	96906	4912550-00 MS35338-135	2	
8-21		2	GUIDE, HEAD AREA	90536	7601793-00	1	
8		2	GUIDE/DUCT, HEAD AREA (AP)	90536	7601794-00	1	
			SCREW, MACH, FLAT HD, 4-40UNC-2A 0.625 L (AP)	96906	7903133-06 MS24693-C7	3	
8-22		2	PRESSURE BRACKET	90536	7601792-00	1	
8		2	SCREW, MACH, PAN HD, 6-32UNC-2A 7/8 L (AP)	96906	908553-10 MS51957-33	2	
			WASHER, PLAIN, FLAT, NO 4 (AP)	96906	4912548-01 MS15795-805	2	
			WASHER, LOCK, HEL, NO 6 (AP)	96906	4912550-01 MS35338-136	2	
8-23	W1	2	HARNESS, POWER (FOR NLA SEE FIG 6-17)	90536	7600917-00	1	
8		2	SCREW, MACH, PAN HD, 4-40UNC-2A 7/8 L (AP)	96906	908552-12 MS51957-20	4	
			WASHER, PLAIN, FLAT, NO 4 (AP)	81349	7903354-02 NAS620C4	4	
			WASHER, LOCK, HEL, NO 4 (AP)	96906	4912550-00 MS35338-135	4	
			NUT, PLAIN, HEX, 4-40UNC-2B (AP)	96906	4912540-00 MS35649-244	4	
8-24	W2	2	HARNESS, SIGNAL	90536	7600916-00	1	
8	W2P1	3	CIRCUIT CARD ASSEMBLY	90536	7600661-00	1	
8		2	TRANSPORT SERVO	90536	7600918-01	1	
8-25		3	HUB, QUICK RELEASE	90536	7600736-00	1	
8-26		3	HUB ASSEMBLY, TAKE-UP	90536	7600914-00	1	
8-27		3	CAPSTAN	90536	7600809-00	1	
8		3	WASHER, FLAT, NO 10 (AP)	96906	4912548-03 MS15795-808	1	
			WASHER, LOCK, HEL, NO 10 (AP)	96906	4912550-03 MS35338-138	1	
			NUT, PLAIN, HEX, MACH 10-32UNF-2B (AP)	96906	4912542-00 MS35650-304	1	
			SHIM, CAPSTAN (AP)	90536	7600910-00	1	
8-28		3	BRACKET, READY	90536	7600808-01	1	
8		3	SCREW, CAP, SOCKET HD 4-40UNC-3A, 5/8 L (AP)	96906	911603-08 MS16995-10	2	

PARTS LIST

GROUP ASSEMBLY PARTS LIST

FIG & INDEX NO	REF DESIG	I N D	DESCRIPTION	MFR CODE	UNIVAC PART NO MFR PART NO	QTY PER ASSY	USED ON
6-8			TRANSPORT, MAG TAPE, 1840 (MOD)		CONTINUED		
			WASHER, LOCK, HEL, NO 4 (AP)		4912550-00	2	
			WASHER, FLAT, NO 4 (AP)	96906	MS35338-135 4912548-00	2	
				96906	MS15795-803		
8-29		3	GUIDE, TAPE	90536	7600908-00	2	
8-30		3	TAPE GUIDE, UPPER A	90536	7600813-01	1	
8-31		3	TAPE GUIDE, UPPER B	90536	7600815-00	1	
8-32		3	TAPE GUIDE, LOWER B	90536	7600816-00	1	
8		3	SCREW, MACH, FLAT HD, 4-40UNC-2A 0.625 L (AP)	96906	7903133-06 MS24693-C7	9	
8-33	B1 B2	3	MOTOR, DC		7904504-00	2	
				16636	4030-30		
8		3	SCREW, CAP, SOCKET HD 1/4-28UNF-3A, 1 L (AP)	96906	911607-04 MS16996-24	8	
			WASHER, FLAT, NO 1/4 (AP)	96906	4912548-04 MS15795-810	8	
			WASHER, LOCK, HEL, NO 1/4 (AP)	96906	4912550-04 MS35338-139	8	
8-34	MG1	3	GENERATOR, MOTOR TACHOMETER		7904507-00	1	
				13094	01438-00-000		
8-35	G1 G3	3	TACHOMETER ASSEMBLY	90536	7600911-00	2	
8		3	SCREW, CAP, SOCKET HD 10-32UNF-3A, 11/16 L (AP)	96906	911606-07 MS16996-10	8	
			WASHER, FLAT, NO 10 (AP)	96906	4912548-03 MS15795-808	8	
			WASHER, LOCK, HEL, NO 10 (AP)	96906	4912550-03 MS35338-138	8	
8		3	BASEPLATE/GUIDE AND VACUUM ASSEMBLY	90536	7600920-01	1	
8-36		4	VALVE ASSEMBLY, VACUUM	90536	7601974-00	1	
8		4	SCREW, CAP, SOCKET HD 6-32UNC-2A, 1/2 L (AP)	96906	911604-05 MS16995-18	3	
			WASHER, LOCK, HEL, NO 6 (AP)	96906	4912550-01 MS35338-136	3	
			WASHER, FLAT, NO 6 (AP)	96906	4912548-01 MS15795-805	3	
8-37		4	SLEEVE, TAPE GUIDE	90536	7600800-00	2	
			SPRING, COMPRESSION	90536	7600067-00	2	
			GUIDE, REAR	90536	7600066-00	2	

FIG & INDEX NO	REF DESIG	I N D	DESCRIPTION	MFR CODE	UNIVAC PART NO MFR PART NO	QTY PER ASSY	USED ON
6- 8			TRANSPORT, MAG TAPE, 1840 (MOD)		CONTINUED		
			GUIDE, REAR	90536	7600065-00	2	
			GUIDE, FRONT	90536	7600063-00	2	
8		2	SCREW, CAP, SOCKET HD 10-32UNF-3A, 1 L (AP)	96906	911606-10 MS16996-14	2	
			WASHER, LOCK, HEL, NO 10 (AP)	96906	4912550-03 MS35338-138	2	
			WASHER, FLAT, NO 10 (AP)	96906	4912548-03 MS15795-808	2	
8-38		4	COVER, PLENUM	90536	7600855-00	1	
8		4	SCREW, CAP, SOCKET HD 10-32UNF-3A, 5/8 L (AP)	96906	911606-06 MS16996-11	5	
			WASHER, LOCK, HEL, NO 10 (AP)	96906	4912550-03 MS35338-138	5	
			WASHER, FLAT, NO 10 (AP)	96906	4912548-03 MS15795-808	5	

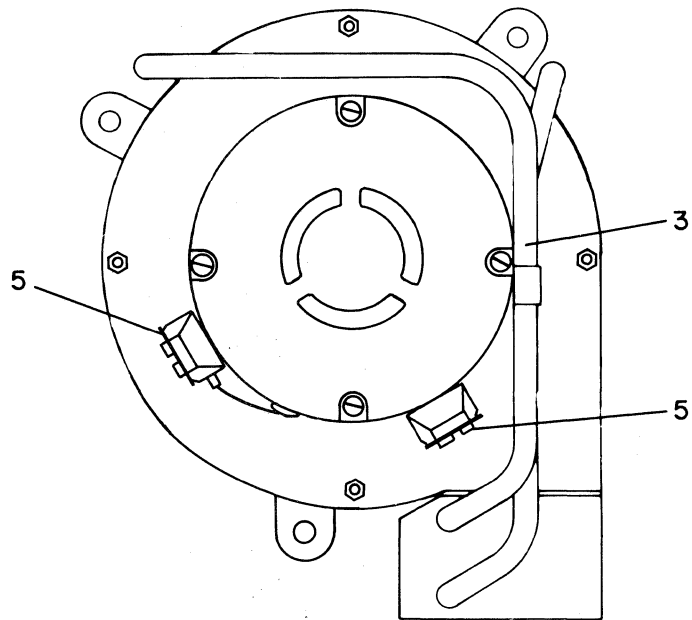

TOP VIEW

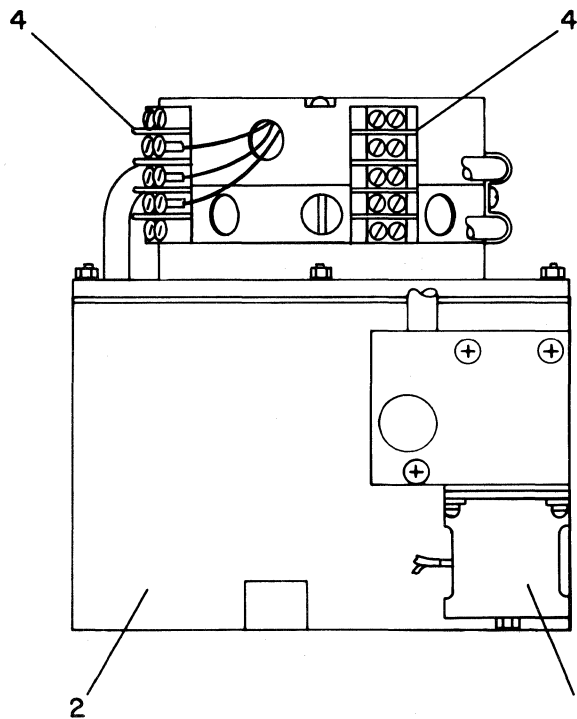

SIDE VIEW

FIGURE 6-9. VACUUM/PRESSURE ASSEMBLY A1

GROUP ASSEMBLY PARTS LIST

PARTS LIST

FIG & INDEX NO	REF DESIG	I N D	DESCRIPTION	MFR CODE	UNIVAC PART NO MFR PART NO	QTY USED PER ON ASSY
6-9	A1	2	VACUUM/PRESSURE ASSEMBLY (FOR NHA SEE FIG 6-8)	90536	7600913-01	REF
9	A1	3	VALVE, ASSEMBLY PRESSURE	90536	7601967-00	1
9		3	SCREW, MACH, FLAT HD, 8-32UNC-2A 2.000 L (AP)	96906	7903133-42 MS24693-C62	3
9-1	A1L1	4	SOLENOID, ELEC, ROTARY, 0.585 STUD LENGTH		7904505-00 R14S222	1
9-2		3	FAN, CENTRIFUGAL, 4 STAGE	04810	7904506-00 SC11Y169J-1	1
9-3		3	TUBE, PLATIC, FLUORO-ELASTOMER 5/16 ID, 7/16 OD, RED	34384	7904566-02 7904566-02	AR
9		3	JOINT, TUBE (AP)	90536	7600943-00	4
			CLAMP, TUBING (AP)	90536	7600947-00	1
			SCREW, MACH, PAN HD, 4-40UNC-2A 5/16 L (AP)	96906	908552-04 MS51957-14	1
			WASHER, LOCK, HEL, NO 4 (AP)	96906	4912550-00	1
			WASHER, PLAIN, FLAT, NO 4 (AP)	96906	MS35338-135 7903354-02	1
				81349	NAS620C4	
9-4	TB1 TB2	3	TERMINAL BOARD, BARRIER TYPE	81349	4912675-03 37TB4	2
9		3	SCREW, MACH, PAN HD, 6-32UNC-2A 3/4 L (AP)	96906	4912531-06 MS51957-32	8
			WASHER, LOCK, HEL, NO 6 (AP)	96906	4912550-01	8
			WASHER, PLAIN, FLAT, NO 6 (AP)	96906	MS35338-136 7903354-03	8
				81349	NAS620C6	
9-5		3	COVER, TERMINAL BOARD	90536	7600260-04	2

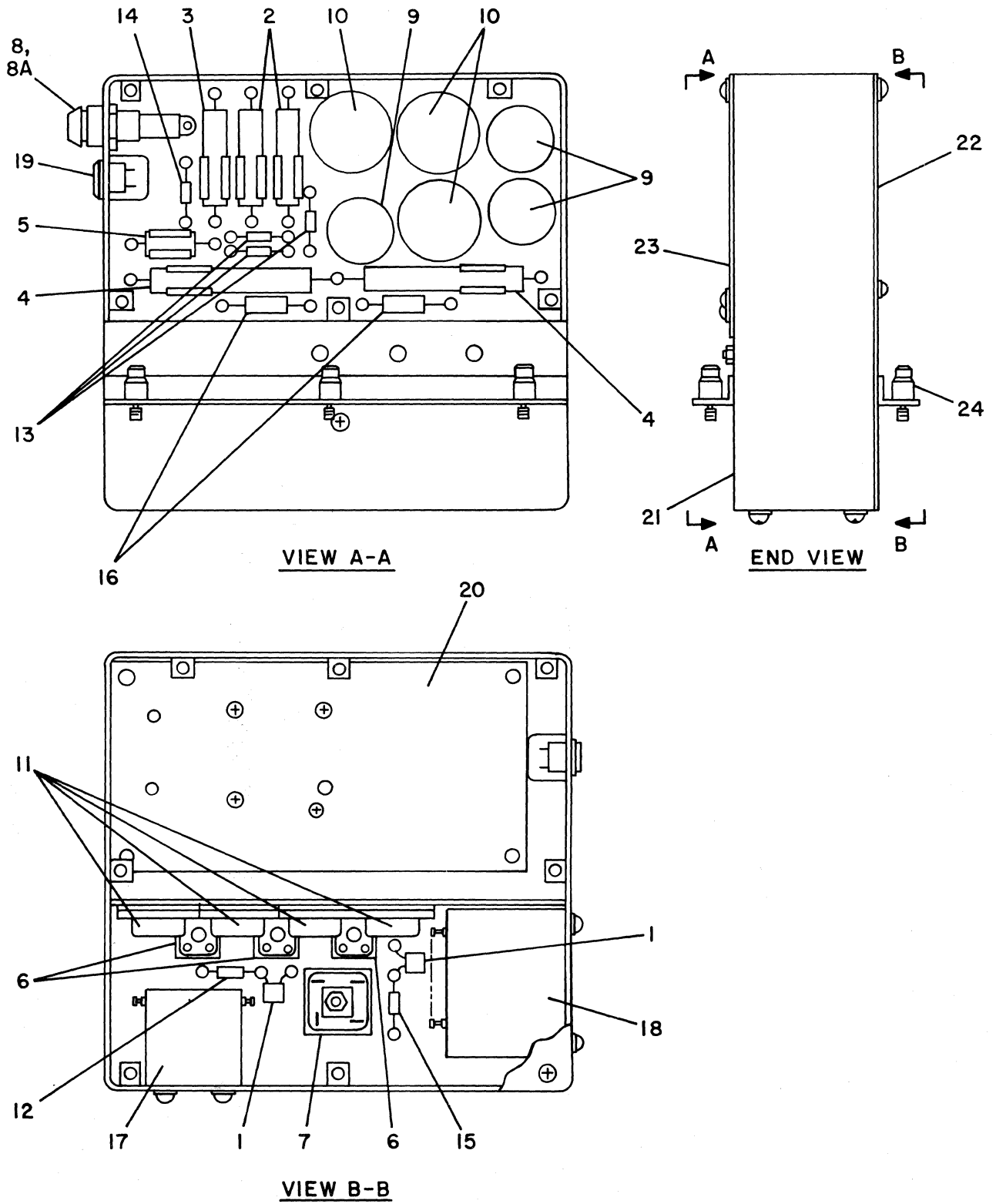

FIGURE 6-10. DC-DC CONVERTER ASSEMBLY A2

GROUP ASSEMBLY PARTS LIST

PARTS LIST

FIG & INDEX NO	REF DESIG	I N D	DESCRIPTION	MFR CODE	UNIVAC PART NO MFR PART NO	QTY USED PER ON ASSY
6-10	A2	2	DC-DC CONVERTER ASSEMBLY (FOR NHA SEE FIG 6-8)	90536	7600870-01	REF
10-1	C2 C8	3	CAPACITOR, FXD, CER, DIELECTRIC 100V, .047UF, +-10PCT	81349	7901102-93 CK06BX473K	2
10-2	C3 C5	3	CAPACITOR, FXD, ELCT, 30V 220UF, +30PCT -10PCT	81349	7902616-28 M39018-01-0115	2
10-3	C4	3	CAPACITOR, FXD, ELCT, 10V 470UF, +30PCT -10PCT	81349	7902616-11 M39018-01-0047	1
10-4	C7 C9	3	CAPACITOR, FXD, ELCT, 75V 120UF, +30PCT -10PCT	81349	7902616-45 M39018-01-0183	2
10-5	C10	3	CAPACITOR, FXD, ELCT, 20V 100UF, +-10PCT	81349	7902696-41 M39003-01-2301	1
10-6	CR1 CR2 CR4	3	RECTIFIER, SEMICONDUCTOR, BV 50	12969	7904542-00 684-1	3
10-7	CR3	3	RECTIFIER, SEMICONDUCTOR, BV 100	12969	7904543-00 683-1	1
10-8	F1	3	FUSE, CARTRIDGE, N/B, 1/4 BY 1-1/4	81349	907783-12 F02A250V3AS	2
10-8A	XF1	3	FUSEHOLDER, NON-INDICATING 30AMP, 250VOLT	81349	7901127-00 FHN26G1	1
10-9	L2 L4 L8	3	REACTOR, INDUCTIVE, 0.40MHZ	70674	7904510-00 3-19610	3
10-10	L3 L6 L7	3	REACTOR, INDUCTIVE, 0.25MHZ 3.8A	70674	7904511-00 3-19612	3
10-11	Q1 THRU Q4	3	TRANSISTOR, NPN, HIGH VOLTAGE PWR, 75W, 2A, 325V	04713	7902308-00 SJ1240	4
10-12	R1	3	RESISTOR, FXD, FILM, 1/2W 10 OHM, +-2PCT	81349	7902750-00 RLR20C100GM	1
10-13	R2 R4 R8	3	RESISTOR, FXD, FILM, 1/2W 910 OHM, +-2PCT	81349	7902750-46 RLR20C911GM	3
10-14	R3	3	RESISTOR, FXD, FILM, 1/2W 100 OHM, +-2PCT	81349	7902750-23 RLR20C101GM	1
10-15	R5	3	RESISTOR, FXD, FILM, 1/2W 51 OHM, +-2PCT	81349	7900185-00 RL32S510G	1
10-16	R6 R7	3	RESISTOR, FXD, FILM, 2W 910 OHM, +-2PCT	81349	7900182-47 RL42S911G	2

PARTS LIST

GROUP ASSEMBLY PARTS LIST

FIG & INDEX NO	REF DESIG	I N D	DESCRIPTION	MFR CODE	UNIVAC PART NO MFR PART NO	QTY PER ASSY	USED ON
6-10			DC-DC CONVERTER ASSEMBLY		CONTINUED		
10-17	T1	3	TRANSFORMER, PWR, STEP/DOWN NON-SATURATING, INVERTER	70674	7904519-00 3-19621	1	
10-18	T2	3	TRANSFORMER, PWR, STEP/DOWN NON-SATURATING, INVERTER	70674	7904520-00 3-19622	1	
10-19	J1	3	CONN, RECP, ELEC, MALE, 25 CONT	71468	903800-00 DBM-25P	1	
10-20	A1	3	CIRCUIT CARD ASSY, DC-DC CONV (FOR NLA SEE FIG 6-11)	90536	7600657-00	1	
10		3	SCREW, MACH, PAN HD, 4-40UNC-2A 9/16 L (AP)	96906	908552-08 MS51957-17	4	
			WASHER, PLAIN, FLAT, NO 4 (AP)	96906	4912548-00	4	
			WASHER, LOCK, HEL, NO 4 (AP)	96906	MS15795-803 4912550-00	4	
			NUT, PLAIN, HEX, MACH 4-40UNC-2b (AP)	96906	MS35338-135 4912540-00	4	
			STANDOFF, HEX (AP)	90536	MS35649-244 7600897-03	4	
10-21		3	CHASSIS, DC-DC CONVERTER	90536	7600883-01	1	
10-22		3	COVER, DC-DC CONVERTER	90536	7600858-00	1	
10-23		3	COVER, DC-DC CONVERTER	90536	7600859-00	1	
10		3	SCREW, MACH, PAN HD, 6-32UNC-2A 1/2 L (AP)	96906	4912531-04 MS51957-30	11	
			WASHER, PLAIN, FLAT, NO 6 (AP)	96906	4912548-01	11	
			NUT, PLAIN, PUSH-ON TYPE, NO 6 (AP)	96906	MS15795-805 7903072-00	11	
10-24		3	SCREW, CAP, SKT HD, RELIEVED BODY, 10-32, 0.75 L	90536	78553 C103755-012-103	6	
10		3	WASHER, LOCK, HEL, NO 10 (AP)	96906	4912550-03	6	
			WASHER, PLAIN, FLAT, NO 10 (AP)	81349	MS35338-138 7903354-05 NAS620C10	6	

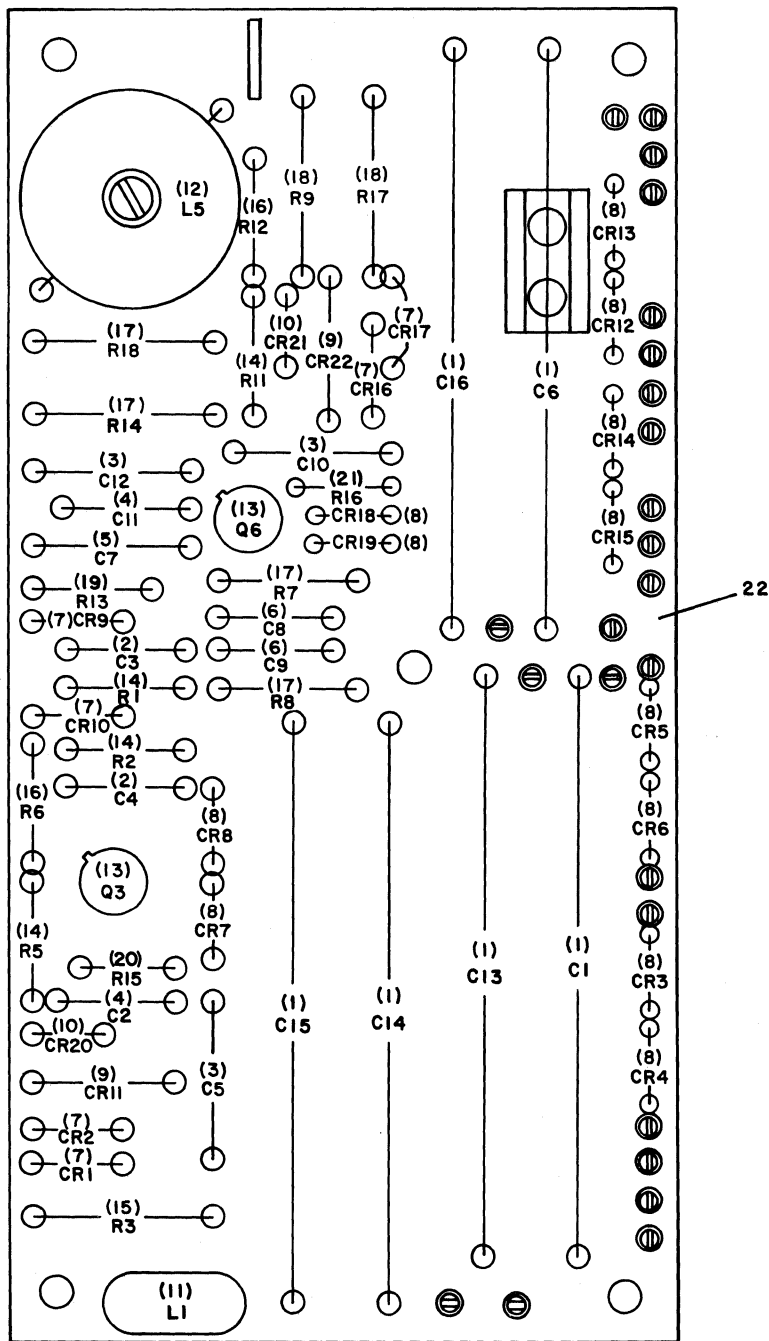

FIGURE 6-11. DC-DC CONVERTER CIRCUIT CARD ASSEMBLY A2A1

PARTS LIST

GROUP ASSEMBLY PARTS LIST

FIG & INDEX NO	REF DESIG	I N D	DESCRIPTION	MFR CODE	UNIVAC PART NO MFR PART NO	QTY PER ASSY	USED ON ASSY
6-11	A2A1	3	CIRCUIT CARD ASSY DC-DC CONVERTER (FOR NHA SEE FIG 6-10)	90536	7600657-00	REF	
11-1	C1 C6 C13 THRU C16	4	CAPACITOR, FXD, ELCT, 100V 68UF, +30 -10PCT	81349	7902616-52 M39018-01-0211	6	
11-2	C3 C4	4	CAPACITOR, FXD, ELCT, 50V 0.10UF, +-10PCT	81349	7902696-65 M39003-01-2338	2	
11-3	C5 C10 C12	4	CAPACITOR, FXD, ELCT, 100V 1.0UF, +-10PCT	81349	7902696-149 M39003-01-2465	3	
11-4	C2 C11	4	CAPACITOR, FXD, ELCT, 75V 0.15UF, +-10PCT	81349	7902696-96 M39003-01-2385	2	
11-5	C7	4	CAPACITOR, FXD, ELCT, 15V, 22UF +-10PCT	81349	7902696-21 M39003-01-2271	1	
11-6	C8 C9	4	CAPACITOR, FXD, ELCT, 50V 0.56UF, +-10PCT	81349	7902696-74 M39003-01-2352	2	
11-7	CR1 CR2 CR9 CR10 CR16 CR17	4	SEMICONDUCTOR DEVICE, DIODE SI, FAST RECOVERY	81349	7903079-00 1N4942	6	
11-8	CR3 THRU CR8 CR12 THRU CR15 CR18 CR19	4	SEMICONDUCTOR DEVICE, DIODE 300MW, 1A, 200V	81349	7902067-00 1N3611	12	
11-9	CR11 CR22	4	SEMICONDUCTOR DEVICE, DIODE, 1W 24V, +-5PCT	81349	7900063-24 1N3029B	2	
11-10	CR20 CR21	4	SEMICONDUCTOR DEVICE, DIODE, SI SWITCHING, 500MW, 75V	03508	7901009-00 DJXR499	2	
11-11	L1	4	REACTOR, INDUCTIVE, 0.7MHY 0.63ADC	70674	7904565-00 3-19616	1	
11-12	L5	4	REACTOR, INDUCTIVE, 0.40MHY	70674	7904510-00 3-19610	1	
11-13	Q3 Q6	4	TRANSISTOR, NPN, SI, SWITCHING 3.5W, 80V, 1.0A	04713	7901760-00 SS1530	2	

GROUP ASSEMBLY PARTS LIST

PARTS LIST

FIG & INDEX NO	REF DESIG	I N D	DESCRIPTION	MFR CODE	UNIVAC PART NO MFR PART NO	QTY USED PER ON ASSY
6-11			CIRCUIT CARD ASSY DC-DC		CONTINUED	
11-14	R1 R2 R5 R11	4	RESISTOR, FXD, FILM, 1/2W 100 OHM, +-2PCT	81349	7902750-23 RLR20C101GM	4
11-15	R3	4	RESISTOR, FXD, FILM, 2W 6800 OHM, +-2PCT	81349	7900182-68 RL42S682G	1
11-16	R6 R12	4	RESISTOR, FXD, FILM, 1/2W 3900 OHM, +-2PCT	81349	7902750-61 RLR20C392GM	2
11-17	R7 R8 R14 R18	4	RESISTOR, FXD, WW, 3W, 7.5 OHM +-5PCT	81349	910509-06 RW69V7R5	4
11-18	R9 R17	4	RESISTOR, FXD, FILM, 2W 3900 OHM, +-2PCT	81349	7900182-62 RL42S392G	2
11-19	R13	4	RESISTOR, FXD, FILM, 1/2W 200 OHM, +-2PCT	81349	7902750-30 RLR20C201GM	1
11-20	R15	4	RESISTOR, FXD, FILM, 1/2W 24K OHM, +-2PCT	81349	7902750-80 RLR20C243GM	1
11-21	R16	4	RESISTOR, FXD, FILM, 1/2W 7500 OHM, +-2PCT	81349	7902750-68 RLR20C752GM	1
11-22		4	PRINTED WIRING BOARD, DC-DC CONVERTER	90536	7600656-00	1

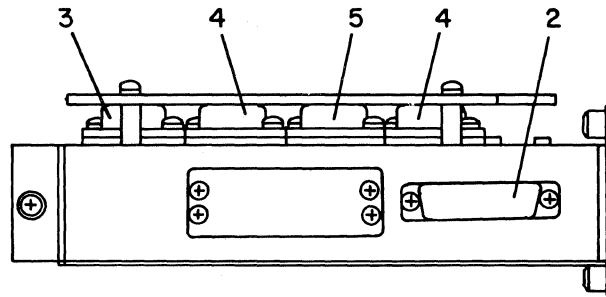

SIDE VIEW

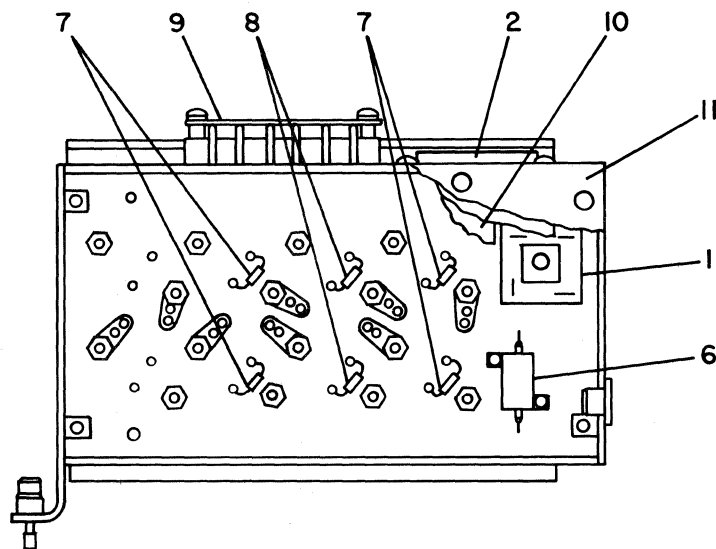

TOP VIEW

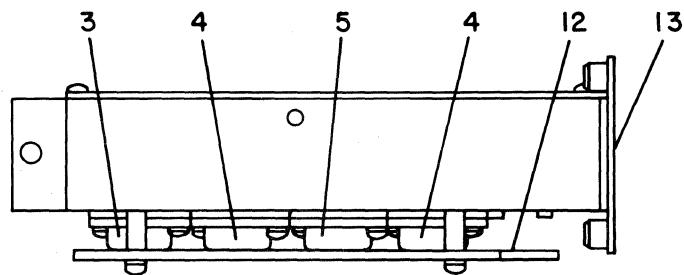

SIDE VIEW

FIGURE 6-12. REEL DRIVE ASSEMBLY A4, A9

GROUP ASSEMBLY PARTS LIST

PARTS LIST

FIG & INDEX NO	REF DESIG	I N D	DESCRIPTION	MFR CODE	UNIVAC PART NO MFR PART NO	QTY USED PER ON ASSY
6-12	A4 A9	2	REEL DRIVE ASSEMBLY (FOR NHA SEE FIG 6-8)	90536	7600869-00	REF
12-1	CR1	3	RECTIFIER, SEMICONDUCTOR DEVICE RV 100	12969	7904543-00 683-1	1
12-2	J1	3	CONN, RCPT, ELEC, MALE, 25 CONT	71785	903800-00 DBM-25P	1
12		3	HARDWARE SET, ELECTRICAL CONNECTOR (AP)	71468	904656-00 20418-2	2
12-3	Q1 Q2	3	TRANSISTOR, PNP, SI, HIGH PWR	81349	7904548-00 2N3792	2
12-4	Q3 Q4 Q7 Q8	3	TRANSISTOR, NPN, SI, HIGH PWR	04713	7904527-00 SJ2953 OR SJ2953H	4
12-5	Q5 Q6	3	TRANSISTOR, NPN, SI, PWR	81349	7902257-00 2N3716	2
12		3	INSULATOR, PLATE, TRANSISTOR (U/W IDX 3, 4 & 5)	13103	7902640-00 4003	8
			TERMINAL, LUG-SOLDER, LOCKING NO 4 (U/W IDX 3, 4 & 5)	78189	900805-00 2102-04-00	8
			SCREW, MACH, PAN HD, 4-40UNC-2A 9/16 L (AP FOR IDX 3, 4 & 5)	96906	908552-08 MS51957-17	16
			WASHER, SHOULDER, FIBRE FOR NO 4 SCREW SIZE (AP FOR IDX 3, 4 & 5)	06540	7903387-02 2630-18550-F116-30	32
			WASHER, LOCK, HEL, NO 4 (AP FOR IDX 3, 4 & 5)	96906	4912550-00 MS35338-135	8
			WASHER, PLAIN, FLAT, NO 4 (AP FOR IDX 3, 4 & 5)	81349	7903354-02 NAS620C4	16
			NUT, PLAIN, HEX, MACH 4-40UNC-2B (AP FOR IDX 3, 4 & 5)	96906	4912540-00 MS35649-244	16
12-6	R1	3	RESISTOR, FXD, Ww, 10W, 0.75 OHM, +-1PCT	81349	7902323-180 RE65GR750	1
12		3	SCREW, MACH, PAN HD, 2-56UNC-2A 0.375 L (AP)	96906	7903132-04 MS51957-5	2
			WASHER, LOCK, HEL, NO 2 (AP)	96906	4912550-09 MS35338-134	2
			WASHER, FLAT, PLAIN, NO 2 (AP)	81349	7903354-01 NAS620C2	4
			NUT, PLAIN, HEX, MACH 2-56UNC-2B (AP)	96906	4912540-04 MS35649-224	2
12-7	R2, R3 R6, R7	3	RESISTOR, FXD, FILM, 1/4W 51 OHM, +-2PCT	81349	7902753-00 RLR07C5106M	4
12-8	R4 R5	3	RESISTOR, FXD, FILM, 1/4W 100 OHM, +-2PCT	81349	7902753-07 RLR07C1016M	2

PARTS LIST

GROUP ASSEMBLY PARTS LIST

FIG & INDEX NO	REF DESIG	I N D	DESCRIPTION	MFR CODE	UNIVAC PART NO MFR PART NO	QTY PER ASSY	USED ON
6-12			REEL DRIVE ASSEMBLY		CONTINUED		
12-9	TB1	3	TERMINAL BOARD, BARRIER TYPE 7.5A	81349	7904526-03 40TB5	1	
12		3	COVER, TERMINAL BOARD (U/W TB1)	90536	7600260-05	1	
			CLIP, TERM BU COVER (U/W TB1)	90536	7600261-01	2	
			SCREW, MACH, FLT HD, 6-32UNC-2A 3/4 L (AP)	96906	4912531-06 MS51957-32	4	
			WASHER, PLAIN, FLAT, NO 6 (AP)	96906	7903354-03	8	
			NUT, SELF-LOCKING, HEX, 250 DEG 6-32UNC-3B, NO 6 (AP)	81349	NAS620C6 4912796-01	4	
				96906	MS21044-C06		
12-10		3	CIRCUIT CARD ASSEMBLY, REEL DRIVE (FOR NLA SEE FIG 6-13)	90536	7600655-00	1	
12		3	INSULATOR BOARD (U/W IDX 10)	90536	7600861-00	1	
			SCREW, MACH, FLT HD, 4-40UNC-2A 0.375 L (AP)	96906	7903133-03 MS24693-C4	4	
			WASHER, PLAIN, FLAT, NO 4 (AP)	96906	7903354-02	4	
			WASHER, LOCK, HEL, NO 4 (AP)	81349	NAS620C4 4912550-00	4	
			NUT, PLAIN, HEX, 4-40UNC-3B (AP)	96906	MS35338-135 4912540-00	4	
				96906	MS35649-244		
12-11		3	COVER, REEL DRIVE	90536	7600857-00	1	
12		3	SCREW, EXTERNALLY RELIEVED BODY 6-32UNC-2A, 0.687 L (AP)	06540	7902788-05 6237-SS-0632	4	
			WASHER, PLAIN, FLAT, NO 6 (AP)	81349	7903354-03 NAS620C6	4	
12-12		3	GUARD, REEL DRIVE	90536	7600971-00	1	
12		3	SCREW, MACH, PAN HD, 6-32UNC-2A 11/16 L (AP)	96906	908553-08 COML 4912548-01	4	
			WASHER, PLAIN, FLAT, NO 6 (AP)	96906	MS15795-805 905989-03	4	
			SPACER, SLEEVE, ZINC PLATED STEEL, 1/4 OD, 3/8 L (AP)	83058	SS-52176-K2915	4	
12-13		3	CHASSIS, REEL DRIVE	90536	7600882-00	1	
12		3	SCREW, CAP, SKT HD, RELIEVED BODY, 10-32, 0.75 L (AP)	90536	7601950-21	3	
			WASHER, PLAIN, FLAT, NO 10 (AP)	81349	7903354-05 NAS620C10	3	
			WASHER, LOCK, HEL, NO 10 (AP)	96906	4912550-03 MS35338-138	3	

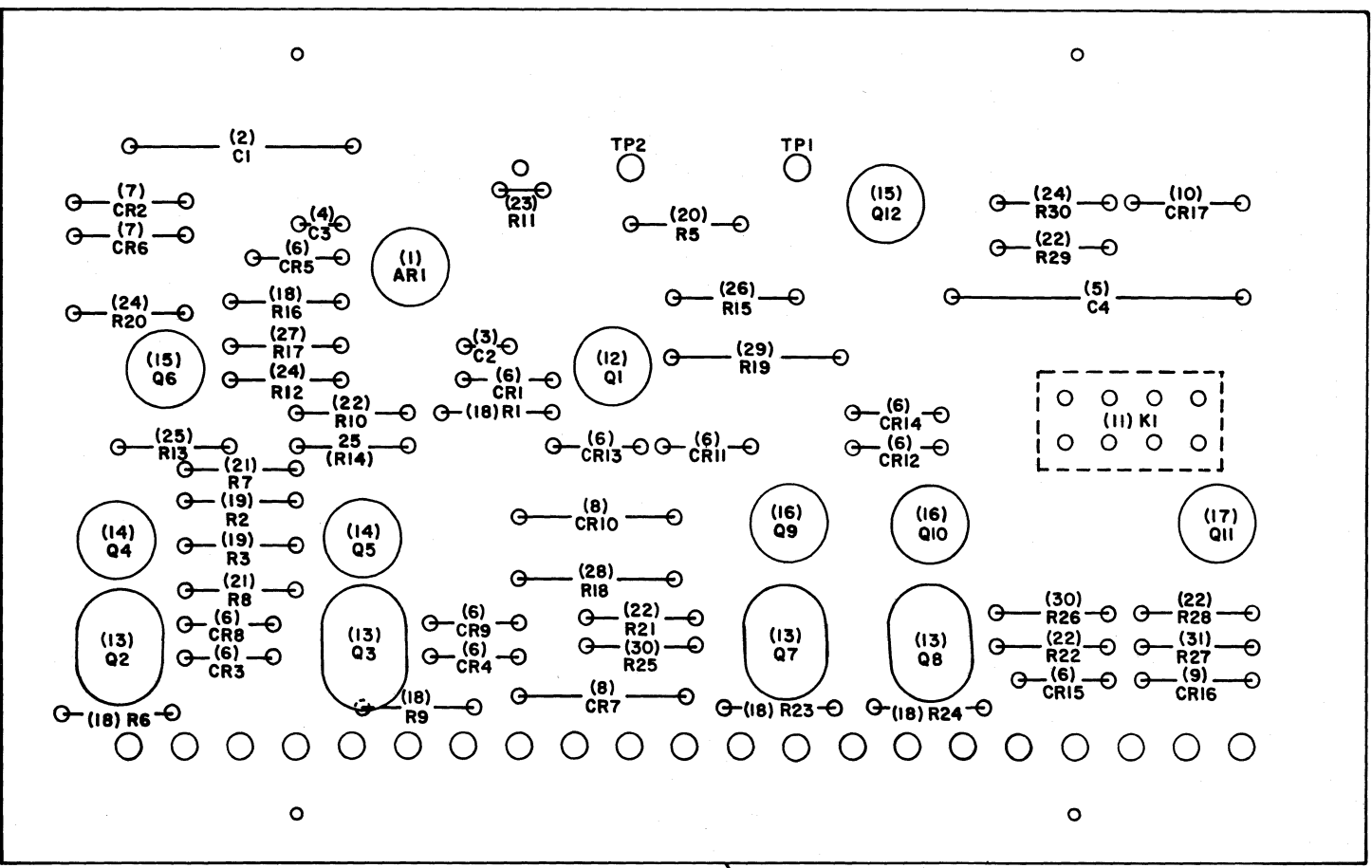

32

FIGURE 6-13. REEL DRIVE CIRCUIT CARD ASSEMBLY

PARTS LIST

GROUP ASSEMBLY PARTS LIST

FIG & INDEX NO	REF DESIG	I N D	DESCRIPTION	MFR CODE	UNIVAC PART NO MFR PART NO	QTY PER ASSY	USED ON ASSY
6-13		3	CIRCUIT CARD ASSEMBLY, REEL DRIVE (FOR NHA SEE FIG 6-12)	90536	7600655-00		REF
13-1	AR1	4	INTEGRATED CIRCUIT, LIN OPNL AMPL, SI ML, QA TEST METHOD 1	04713	7903348-00 SC65786H	1	
13-2	C1	4	CAPACITOR, FXD, ELCT, 50V, 18UF +-10PCT	81349	7902696-92 M39003-01-2379	1	
13-3	C2	4	CAPACITOR, FXD, CER, DIELECTRIC 200V, 0.01UF, +-10PCT	81349	7901102-36 CK06BX103K	1	
13-4	C3	4	CAPACITOR, FXD, CER, DIELECTRIC 200V, 1000PF, +-10PCT	81349	7901102-73 CK05BX102M	1	
13-5	C4	4	CAPACITOR, FXD, ELCT, 150V 8.2UF, +30 -10PCT	81349	7902616-55 M39018-01-0223	1	
13-6	CR1 CR3 CR4 CR5 CR8 CR9 CR11 THRU CR15	4	SEMICONDUCTOR DEVICE, DIODE, SI SWITCHING, 500MW, 75V	03508	7901009-00 DJXR499	11	
13-7	CR2 CR6	4	SEMICONDUCTOR DEVICE, DIODE, SI VR, 15V	81349	7900259-20 1N9658	2	
13-8	CR7 CR10	4	SEMICONDUCTOR DEVICE, DIODE, 1W 10V, +-5PCT	81349	7900063-15 1N3020B	2	
13-9	CR16	4	SEMICONDUCTOR DEVICE, DIODE, SI VR, 12V	81349	7900259-17 1N963B	1	
13-10	CR17	4	SEMICONDUCTOR DEVICE, DIODE, SI VR, 51V	81349	7900259-36 1N978B	1	
13-11	K1	4	RELAY, ARMATURE, 26.5VDC, 2 SPDT CONTACTS	81349	7904532-00 M5757-9-003	1	
13-12	Q1	4	TRANSISTOR, PNP, SI, SWITCHING 400MW, 45V	04713	7901556-01 SS1309	1	
13-13	Q2, Q3 Q7, Q8	4	SEMICONDUCTOR DEVICE, PHOTO COUPLER	32388	7904551-00 SCA1343	4	
13-14	Q4 Q5	4	TRANSISTOR, NPN, SI, SWITCHING 360MW, 40V	04713	7900531-02 SF2544	2	
13-15	Q6 Q12	4	TRANSISTOR, PNP, SI, SWITCHING	04713	7900039-01 SM1573	2	
13-16	Q9 Q10	4	TRANSISTOR, NPN, SI, SWITCHING 3.5W, 80V, 1.0A	04713	7901760-00 SS1530	2	

FIG & INDEX NO	REF DESIG	I N D	DESCRIPTION	MFR CODE	UNIVAC PART NO MFR PART NO	QTY USED PER ON ASSY
6-13			CIRCUIT CARD ASSEMBLY, REEL		CONTINUED	
13-17	Q11	4	TRANSISTOR, NPN, SI, SWITCHING	04713	7900038-01 SM7154	1
13-18	R1, R6 R9 R16 R23 R24	4	RESISTOR, FXD, FILM, 1/4W, 10K OHM, +-2PCT	81349	7902753-55 RLR07C103GM	6
13-19	R2 R3	4	RESISTOR, FXD, FILM, 1/4W, 100 OHM, +-2PCT	81349	7902753-07 RLR07C101GM	2
13-20	R5	4	RESISTOR, FXD, FILM, 1/4W, 3.0K OHM, +-2PCT	81349	7902753-42 RLR07C302GM	1
13-21	R7 R8	4	RESISTOR, FXD, FILM, 1/4W, 150 OHM, +-2PCT	81349	7902753-11 RLR07C151GM	2
13-22	R10 R21 R22 R28 R29	4	RESISTOR, FXD, FILM, 1/4W, 1.0K OHM, +-2PCT	81349	7902753-31 RLR07C102GM	5
13-23	R11	4	RESISTOR, VARIABLE, WW, 3/4W 10K OHM, +-5PCT	81349	7901477-07 RT22C2P103	1
13-24	R12 R20 R30	4	RESISTOR, FXD, FILM, 1/4W, 15K OHM, +-2PCT	81349	7902753-59 RLR07C153GM	3
13-25	R13 R14	4	RESISTOR, FXD, FILM, 1/4W, 30K OHM, +-2PCT	81349	7902753-66 RLR07C303GM	2
13-26	R15	4	RESISTOR, FXD, FILM, 1/4W, 5.1K OHM, +-2PCT	81349	7902753-48 RLR07C512GM	1
13-27	R17	4	RESISTOR, FXD, FILM, 1/4W, 100K OHM, +-2PCT	81349	7902753-79 RLR07C104GM	1
13-28	R18	4	RESISTOR, FXD, WW, 3W, 2000 OHM +-5PCT	81349	910509-62 RW69V202	1
13-29	R19	4	RESISTOR, FXD, FILM, 1W, 2.4K OHM, +-2PCT	81349	7900185-40 RL32S242G	1
13-30	R25 R26	4	RESISTOR, FXD, FILM, 1/4W, 2.0K OHM, +-2PCT	81349	7902753-38 RLR07C202GM	2
13-31	R27	4	RESISTOR, FXD, FILM, 1/4W, 1.2K OHM, +-2PCT	81349	7902753-33 RLR07C122GM	1
13-32		4	PRINTED CIRCUIT CARD, REEL DRIVE	90536	7600654-00	1

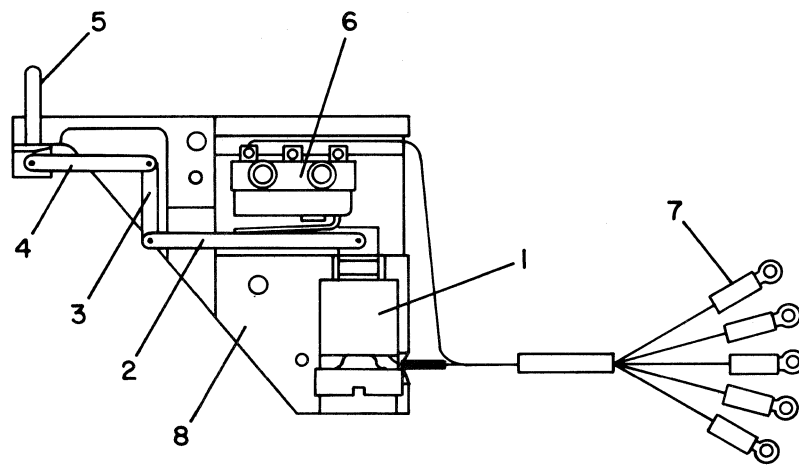

FIGURE 6-14. .320 PROTRUSION FILE PROTECT ASSEMBLY A5

GROUP ASSEMBLY PARTS LIST

PARTS LIST

FIG & INDEX NO	REF DESIG	I N D	DESCRIPTION	MFR CODE	UNIVAC PART NO MFR PART NO	QTY USED PER ON ASSY
6-14	A5	2	FILE PROTECT ASSEMBLY, .320 PROTRUSION (FOR NHA SEE FIG 6-8)	90536	7600840-00	REF
14-1	L1	3	SOLINOID, ELECTRICAL, 24VDC	07797	7903320-00 5979	1
14		3	PLUG, SOLENOID (AP)	90536	7600169-00	1
			CLEVIS, SOLENOID (AP)	90536	7600118-01	1
14-2		3	LINKAGE ARM	90536	7600812-01	1
14-3		3	LINKAGE ARM	90536	7600812-02	1
14-4		3	LINKAGE ARM	90536	7600812-00	1
14-5		3	PROBE	90536	7600114-01	1
14		3	PIN, STRAIGHT, HEADLESS		7904556-05	2
			0.25 L (AP FOR IDX 2 THRU 5)	00141	D2-250	
			PIN SPRING, SPIRAL, 1/32 OD		907449-07	2
			1/2 L (AP FOR IDX 2 THRU 5)	00287	031-0500-MDP	
			EYELET, METALLIC, FLAT, GOLD PLATED, 0.031 OD, 0.125 L (AP FOR IDX 2 THRU 5)	04264	7902166-13 CME-28	2
14-6	S1	3	SWITCH, SENSITIVE, SPDT, LEAF 4 AMP	91929	7904539-00 111SM1-T	1
14		3	SCREW, MACH, FILLISTER HD		904631-05	2
			2-56NC-2A, 7/16 L (AP)	81349	AN500C2-7	
			WASHER, PLAIN, FLAT, NO 2 (AP)	81349	7903354-01 NAS620C2	2
14-7		3	TERMINAL LUG, CRIMP TYPE, INSL 26-24AWG, NO 2 STUD	00779	7901480-00 320733	5
14-8		3	BRACKET ASSEMBLY	90536	7600841-00	1

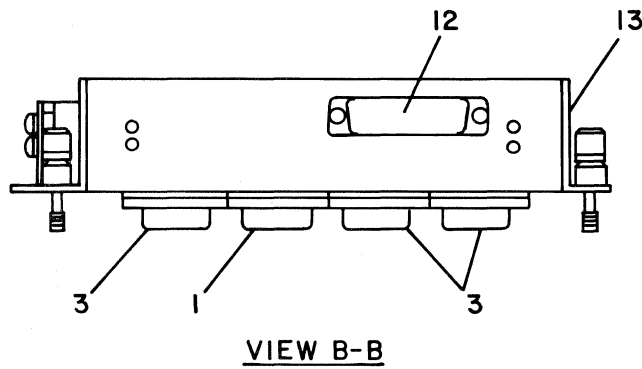
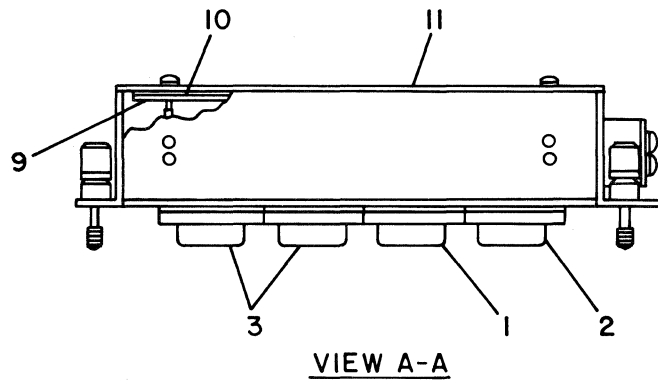
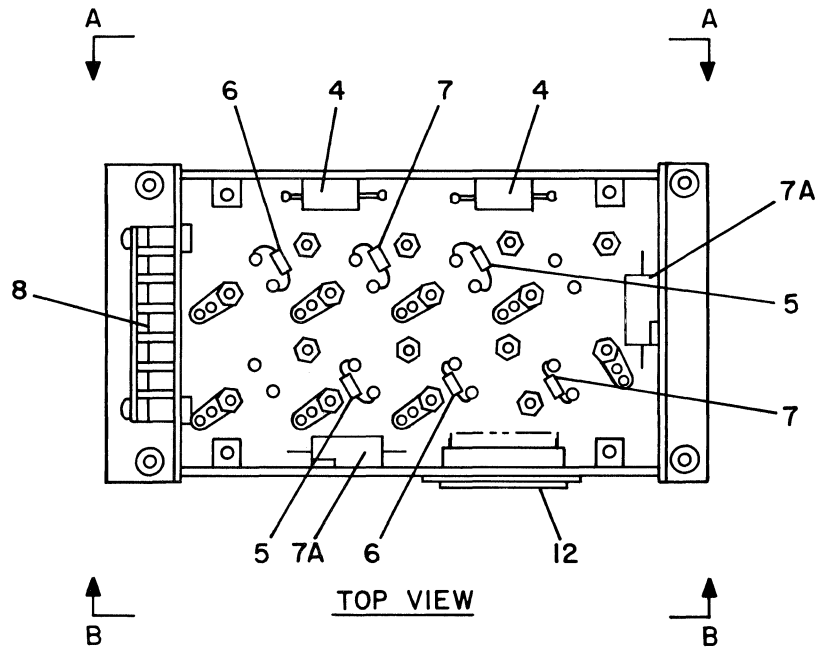

FIGURE 6-15. CAPSTAN DRIVE ASSEMBLY A10

GROUP ASSEMBLY PARTS LIST

PARTS LIST

FIG & INDEX NO	REF DESIG	I N D	DESCRIPTION	MFR CODE	UNIVAC PART NO MFR PART NO	QTY USED PER ON ASSY
6-15	A10	2	CAPSTAN DRIVE ASSEMBLY (FOR NHA SEE FIG 6-8)	90536	7600868-01	REF
15-1	Q1 Q4	3	TRANSISTOR, NPN, SI, HIGH PWR	04713	7904527-00 SJ2953 OR SJ2953H	2
15-2	Q2	3	TRANSISTOR, PNP, SI, HIGH PWR	81349	7904548-00 2N3792	1
15-3	Q3 Q5 THRU Q8	3	TRANSISTOR, NPN, SI, PWR	81349	7902257-00 2N3716	5
15		3	TERMINAL, LUG-SOLDER, LOCKING NO 4 (U/W IDX 1, 2 & 3)	78189	900805-00 2102-04-00	8
			INSULATOR PLATE, TRANSISTOR (U/W IDX 1, 2 & 3)	13103	7902640-00 4003	8
			SCREW, MACH, PAN HD, 4-40UNC-2A 9/16 L (AP FOR IDX 1, 2 & 3)	96906	908552-08 MS51957-17	16
			WASHER, LOCK, HEL, NO 4 (AP FOR IDX 1, 2 & 3)	96906	4912550-00 MS35338-135	16
			WASHER, PLAIN, FLAT, NO 4 (AP FOR IDX 1, 2 & 3)	81349	7903354-02 NAS620C4	16
			WASHER, SHOULDER, FIBRE FOR NO 4 SCREW SIZE (AP FOR IDX 1, 2 & 3)	06540	7903387-02 2630-18550-F116-30	32
			NUT, PLAIN, HEX, MACH 4-40UNC-2B (AP FOR IDX 1, 2 & 3)	96906	4912540-00 MS35649-244	16
15-4	R1 R4	3	RESISTOR, FXD, WW, 10W, 0.393 OHM, +-1PCT	81349	7902323-153 RE65GR392	2
15		3	SCREW, MACH, PAN HD, 2-56UNC-2A 0.375 L (AP)	96906	7903132-04 MS51957-5	4
			WASHER, LOCK, HEL, NO 2 (AP)	96906	4912550-09 MS35338-134	4
			WASHER, PLAIN, FLAT, NO 2 (AP)	96906	4912548-09 MS15795-802	4
			NUT, PLAIN, HEX, MACH 2-56UNC-2B (AP)	96906	4912540-04 MS35649-224	4
15-5	R2 R3	3	RESISTOR, FXD, FILM, 1W, 100 OHM, +-2PCT	81349	7902753-07 RLR07C1016M	2
15-6	R5 R7	3	RESISTOR, FXD, FILM, 1/4W, 200 OHM, +-2PCT	81349	7902753-14 RLR07C2016M	2
15-7	R6 R8	3	RESISTOR, FXD, FILM, 1W, 100 OHM, +-2PCT	81349	7900185-07 RL32S101G	2
15-7A	R9 R10	3	RESISTOR, FXD, WW, 20W 49.9 OHM, +-1PCT	81349	7902491-259 RE70G49R9	2
15		3	SCREW, MACH, PAN HD, 4-40UNC-2A 7/16 L (AP)	96906	908552-06 MS51957-16	4

PARTS LIST

GROUP ASSEMBLY PARTS LIST

FIG & INDEX NO	REF DESIG NO	I N D	DESCRIPTION	MFR CODE	UNIVAC PART NO MFR PART NO	QTY PER ASSY	USED ON
6-15			CAPSTAN DRIVE ASSEMBLY		CONTINUED		
			WASHER, PLAIN, FLAT, NO 4 (AP)		7903354-02	4	
			WASHER, LOCK, HEL, NO 4 (AP)	81349	NAS620C4	4	
			NUT, PLAIN, HEX, MACH 4-40UNC-2B (AP)	96906	4912550-00 MS35338-135	4	
				96906	4912540-00 MS35649-244	4	
15-8	TB1	3	TERMINAL BOARD, BARRIER TYPE 7.5A	81349	7904526-00 40TB5	1	
15		3	COVER, TERMINAL BOARD (U/W TB1)	90536	7600260-05	1	
			CLIP, TERM BD COVER (U/W TB1)	90536	7900261-01	2	
			SCREW, MACH, FLT HD, 6-32UNC-2A 3/4 L (AP)	96906	4912531-06 MS51957-32	4	
			WASHER, PLAIN, FLAT, NO 6 (AP)		7903354-03	4	
			NUT, SELF LOCKING, HEX, 250 DEG 6-32UNC-3B (AP)	81349	NAS620C6	4	
				96906	4912796-01 MS21044-C06	4	
15-9		3	CIRCUIT CARD ASSY, CAPSTAN DRIVE (FOR NLA SEE FIG 6-16)	90536	7602225-00	1	
15-10		3	INSULATOR BOARD, CAPSTAN DRIVE	90536	7600860-00	1	
15		3	SCREW, MACH, FLAT HD, 4-40UNC-2A 0.375 L (AP FOR IDX 9 & 10)	96906	7903133-03 MS24693-C4	4	
			WASHER, PLAIN, FLAT, NO 4 (AP FOR IDX 9 & 10)	81349	7903354-02 NAS620C4	4	
			NUT, SELF LOCKING, HEX, 250 DEG 4-40UNC-3B (AP FOR IDX 9 & 10)	96906	4912796-00 MS21044-C04	4	
15-11		3	COVER, CAPSTAN DRIVE	90536	7600856-00	1	
15		3	SCREW, EXTERNALLY RELIEVED BODY 6-32UNC-2A, 0.687 L (AP)	06540	7902788-05 6237-SS-0632	4	
			WASHER, PLAIN, FLAT, NO 6 (AP)	81349	7903354-03 NAS620C6	4	
15-12	J1	3	CONN, RCPT, ELEC, MALE, 25 CONT	71468	903800-00 DBM-25P	1	
15		3	HARDWARE SET, ELEC, CONN	71468	904656-00 20418-2	2	
15-13		3	CHASSIS, CAPSTAN DRIVE	90536	7600881-00	1	
15		3	SCREW, CAP, SOCKET HD 0.75 L (AP)	90536	7601950-21	4	
			WASHER, PLAIN, FLAT, NO 10 (AP)	81349	7903354-05 NAS620C10	4	
			WASHER, LOCK, HEL, NO 10 (AP)	96906	4912550-03 MS35338-138	4	

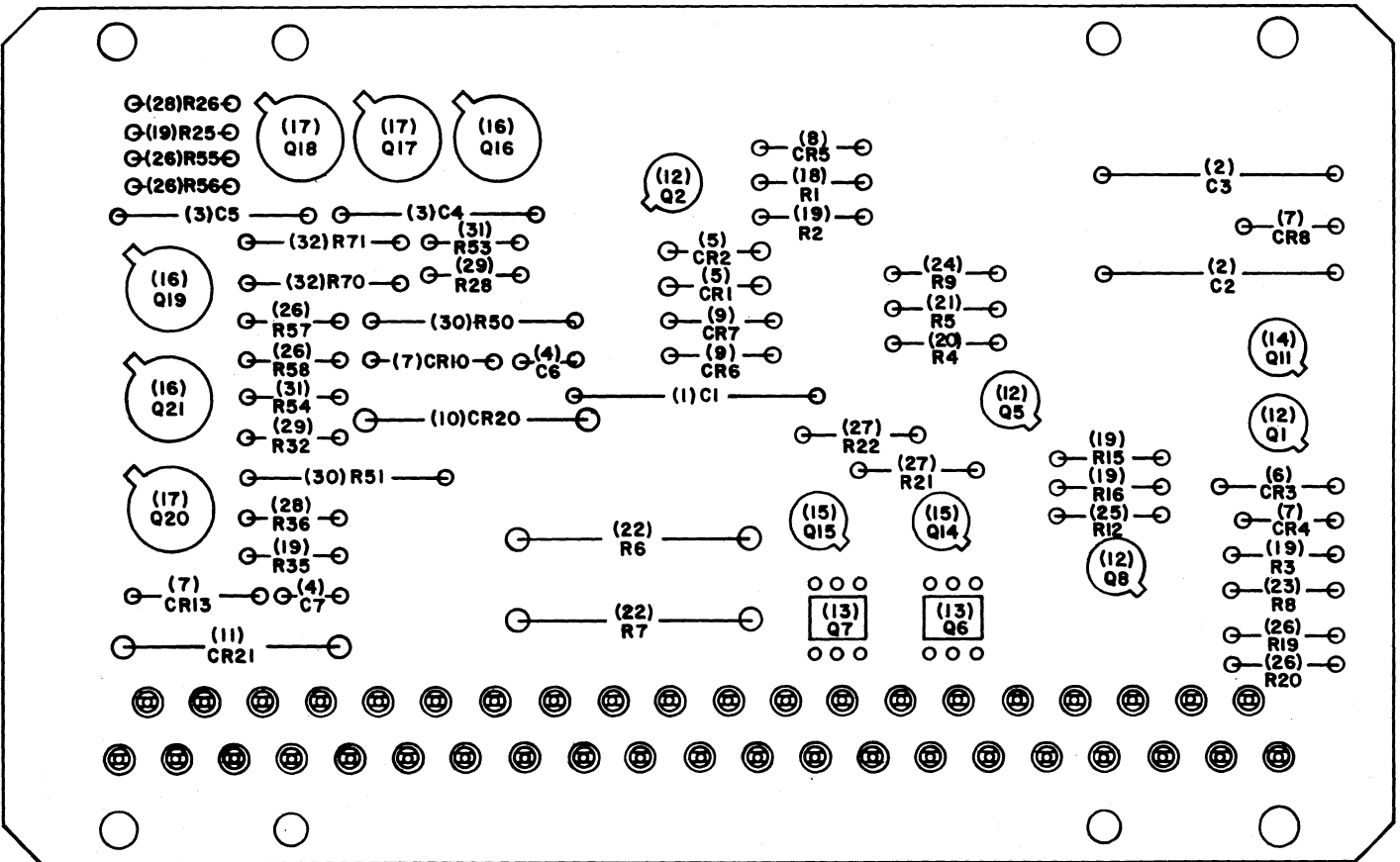

FIGURE 6-16. CAPSTAN DRIVE CIRCUIT CARD ASSEMBLY

PARTS LIST

GROUP ASSEMBLY PARTS LIST

FIG & INDEX NO	REF DESIG NO	I N D	DESCRIPTION	MFR CODE	UNIVAC PART NO MFR PART NO	QTY PER ASSY	USED ON ASSY
6-16		3	CIRCUIT CARD ASSEMBLY, CAPSTAN DRIVE (FOR NHA SEE FIG 6-15)	90536	7602225-00	REF	
16-1	C1	4	CAPACITOR, FXD, ELCT, 10V 220 UF, +-10PCT	81349	7902696-17 M39003-01-2265	1	
16-2	C2 C3	4	CAPACITOR, FXD, ELCT, 20V 47UF, +-10PCT	81349	7902696-37 M39003-01-2295	2	
16-3	C4 C5	4	CAPACITOR, FXD, ELCT, 50V 4.7UF, +-10PCT	81349	7902696-85 M39003-01-2368	1	
16-4	C6 C7	4	CAPACITOR, FXD, CER DIELECTRIC 50V, 0.22UF, +-10PCT	81349	7901102-101 CK05BX224K	2	
16-5	CR1 CR2	4	SEMICONDUCTOR DEVICE, DIODE 300MW, 1A, 200V	81349	7902067-00 1N3611	2	
16-6	CR3	4	SEMICONDUCTOR DEVICE, DIODE SI, VR, 20V	81349	7900259-25 1N968B	1	
16-7	CR4 CR8 CR10 CR13	4	SEMICONDUCTOR DEVICE, DIODE SI, SWITCHING, 500MW, 75V	03508	7901009-00 DJXR499	4	
16-8	CR5	4	SEMICONDUCTOR DEVICE, DIODE SI, VR, 51V	81349	7900259-36 1N978B	1	
16-9	CR6 CR7	4	SEMICONDUCTOR DEVICE, DIODE SI, VR, 10.0V	81349	7900258-15 1N758A	2	
16-10	CR20	4	SEMICONDUCTOR DEVICE, DIODE 1W, 5.6V	81349	7900063-09 1N3827A	1	
16-11	CR21	4	SEMICONDUCTOR DEVICE, DIODE 1W, 6.2V	81349	7900063-10 1N3828A	1	
16-12	Q1, Q2 Q5, Q8	4	TRANSISTOR, PNP, SI, SWITCHING	04713	7900039-01 SM1573	4	
16-13	Q6 Q7	4	SEMICONDUCTOR DEVICE, PHOTO COUPLER	04713	7904551-00 MDC1000	2	
16-14	Q11	4	TRANSISTOR, NPN, SI, SWITCHING	04713	7900038-01 SM7154	1	
16-15	Q14 Q15	4	TRANSISTOR, NPN, SI, SWITCHING 360MW, 40V	04713	7900531-02 SM7169	2	
16-16	Q16 Q19 Q21	4	TRANSISTOR, PNP, SI, SWITCHING 5.0W, 1A, 40V	01295	7901426-00 SG2460	3	
16-17	Q17 Q18	4	TRANSISTOR, NPN, SI, SWITCHING 3.5W, 80V, 1.0A	01295	7901760-00 SW7748	3	

FIG & INDEX NO	REF DESIG	I N D	DESCRIPTION	MFR CODE	UNIVAC PART NO MFR PART NO	QTY USED PER ON ASSY
6-16			CIRCUIT CARD ASSEMBLY, CAPSTAN		CONTINUED	
	Q20					
16-18	R1	4	RESISTOR, FXD, FILM, 1/4W, 15K OHM, +-2PCT	81349	7902753-59 RLR07C153GM	1
16-19	R2, R3 R15 R16 R25 R35	4	RESISTOR, FXD, FILM, 1/4W, 1.0K OHM, +-2PCT	81349	7902753-31 RLR07C102GM	6
16-20	R4	4	RESISTOR, FXD, FILM, 1/4W, 30K OHM, +-2PCT	81349	7902753-66 RLR07C303GM	1
16-21	R5	4	RESISTOR, FXD, FILM, 1/4W, 3.0K OHM, +-2PCT	81349	7902753-42 RLR07C302GM	1
16-22	R6 R7	4	RESISTOR, FXD, FILM, 2W, 10000 OHM, +-2PCT	81349	7900182-72 RL42S103G	2
16-23	R8	4	RESISTOR, FXD, FILM, 1/4W, 620 OHM, +-2PCT	81349	7902753-26 RLR07C621GM	1
16-24	R9	4	RESISTOR, FXD, FILM, 1/4W, 1.5K OHM, +-2PCT	81349	7902753-35 RLR07C152GM	1
16-25	R12	4	RESISTOR, FXD, FILM, 1/4W, 10K OHM, +-2PCT	81349	7902753-55 RLR07C103GM	1
16-26	R19 R20 R55 THRU R58	4	RESISTOR, FXD, COMP, 1/4W, 10 OHM, +-5PCT	81349	7902751-14 RCR07G100JM	2
16-27	R21 R22	4	RESISTOR, FXD, FILM, 1/4W, 100 OHM, +-2PCT	81349	7902753-07 RLR07C101GM	2
16-28	R26 R36	4	RESISTOR, FXD, FILM, 1/4W 470 OHM, +-2PCT	81349	7902753-23 RLR07C471GM	2
16-29	R28 R32	4	RESISTOR, FXD, FILM, 1/4W, 5.6K OHM, +-2PCT	81349	7902753-49 RLR07C562GM	2
16-30	R50 R51	4	RESISTOR, FXD, FILM, 1W, 2700 OHM, +-2PCT	81349	7903596-57 RLR32C272GM	2
16-31	R53 R54	4	RESISTOR, FXD, FILM, 1/4W, 100K OHM, +-2PCT	81349	7902753-79 RLR07C104GM	2
16-32	R70 R71	4	RESISTOR, FXD, FILM, 1/2W, 4300 OHM, +-2PCT	81349	7902750-62 RLR20C432GM	2
16-33		4	PRINTED WIRING BOARD, CAPSTAN DRIVE	90536	7602224-00	1

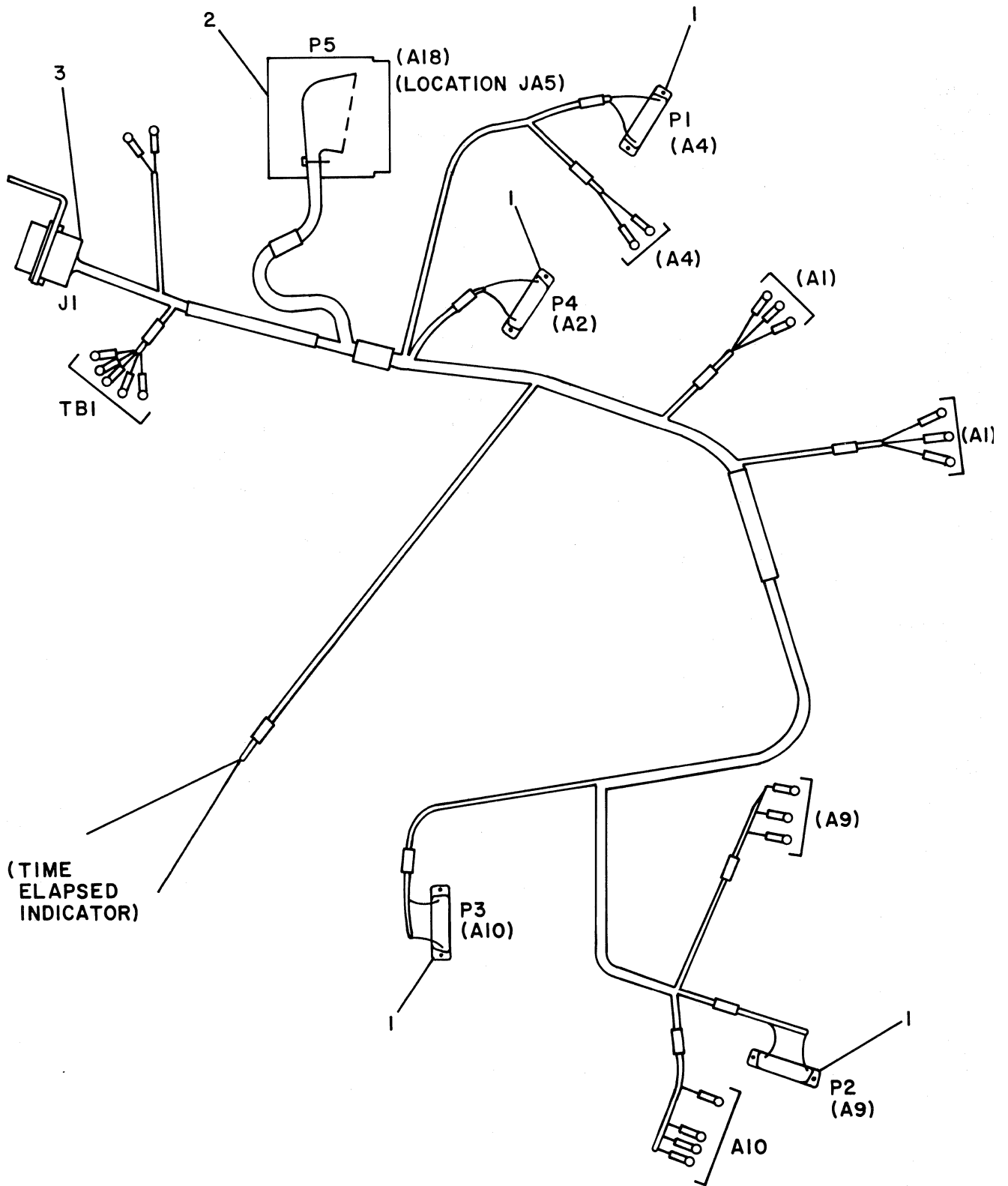

FIGURE 6-17. POWER HARNESS W1

GROUP ASSEMBLY PARTS LIST

PARTS LIST

FIG & INDEX NO	REF DESIG	I N D	DESCRIPTION	MFR CODE	UNIVAC PART NO MFR PART NO	QTY PER ASSY	USED ON
6-17	W1	3	HARNESS, POWER (FOR NHA SEE FIG 6-8)	90536	7600917-00	REF	
17-1	P1 THRU P4	4	CONN, SUBMINITURE, ELEC, FEMALE RECTANGULAR, 25 CONT	71468	903801-00 DBM-25S	4	
17-2	P5	4	CIRCUIT CARD ASSY, INTERFACE	90536	7600661-00	1	
17-3	J1	4	CONN, RCPT, ELEC, MALE, 21 CONT	96906	7900588-00 MS3120E22-21P	1	
17		4	BRACKET, POWER CONN (U/W J1)		7601788-00	1	
			SCREW, MACH, PAN HD, 4-40UNC-2A 5/8 L (AP)	96906	908552-09 MS51957-18	4	
			WASHER, FLAT, NO 4 (AP)	96906	4912548-00	8	
			WASHER, LOCK, HEL, NO 4 (AP)	96906	MS15795-803 4912550-00	4	
			NUT, PLAIN, HEX, MACH 4-40UNC-2B (AP)	96906	MS35338-135 4912540-00	4	
				96906	MS35649-244		

PART NUMBER	FIG & INDEX	PART NUMBER	FIG & INDEX	PART NUMBER	FIG & INDEX
AM1510-MG3-5-125	6- 2-1	MS15795-805	6- 8	MS35338-134	6-12
LC-3		MS15795-805	6-10	MS35338-134	6-15
AM1510-MG3-57.5-	6- 2-2	MS15795-805	6-12	MS35338-135	6- 1
25DC-3		MS15795-807	6- 2	MS35338-135	6- 4
AN500C2-7	6-14	MS15795-807	6- 4	MS35338-135	6- 8
CK05BX102M	6-13-4	MS15795-808	6- 1	MS35338-135	6- 9
CK05BX104K	6- 7-6	MS15795-808	6- 3	MS35338-135	6-10
CK05BX224K	6-16-4	MS15795-808	6- 4	MS35338-135	6-12
CK05BX472K	6- 7-1	MS15795-808	6- 8	MS35338-135	6-15
CK06BX103K	6- 5-2	MS15795-810	6- 1	MS35338-135	6-17
CK06BX103K	6-13-3	MS15795-810	6- 8	MS35338-136	6- 2
CK06BX224K	6- 7-3	MS16995-10	6- 8	MS35338-136	6- 3
CK06BX473K	6-10-1	MS16995-18	6- 8	MS35338-136	6- 4
CK15BR154M	6- 6-4	MS16996-10	6- 8	MS35338-136	6- 5
CK16BR335M	6- 6-2	MS16996-11	6- 8	MS35338-136	6- 8
CME-28	6-14	MS16996-14	6- 8	MS35338-136	6- 9
C1037SS-012-103	6-10	MS16996-24	6- 8	MS35338-137	6- 2
DBM-25P	6- 2-21	MS17322-6	6- 8-20	MS35338-137	6- 4
DBM-25P	6-10-19	MS17803-13-13	6- 4	MS35338-138	6- 3
DBM-25P	6-12-2	MS17803-16-16	6- 1	MS35338-138	6- 4
DBM-25P	6-15-12	MS17803-16-16	6- 5	MS35338-138	6- 8
DBM-25S	6- 4-6	MS17803-16-20	6- 1	MS35338-138	6-10
DBM-25S	6-17-1	MS17803-16-20	6- 4	MS35338-138	6-12
DJXR499	6- 6-6	MS17804-16-16	6- 1	MS35338-138	6-15
DJXR499	6- 7-13	MS17804-16-20	6- 1	MS35338-139	6- 8
DJXR499	6-11-10	MS21044-C04	6-15	MS35649-224	6- 2
DJXR499	6-13-6	MS21044-C06	6-12	MS35649-224	6-12
DJXR499	6-16-7	MS21044-C06	6-15	MS35649-224	6-15
DP230-30R	6- 3-1A	MS24693-C27	6- 3	MS35649-244	6- 1
DP230-47R	6- 3-1	MS24693-C272	6- 1	MS35649-244	6- 4
D2-250	6-14	MS24693-C273	6- 1	MS35649-244	6- 8
FAH163-75	6- 3-4	MS24693-C275	6- 4	MS35649-244	6-10
FHN2661	6-10-8A	MS24693-C29	6- 1	MS35649-244	6-12
F02A250V3AS	6-10-8	MS24693-C4	6-12	MS35649-244	6-15
F92-1660-26	6- 2	MS24693-C4	6-15	MS35649-244	6-17
F92-1660-40	6- 5	MS24693-C46	6- 1	MS35649-264	6- 4
F92-1660-440	6- 2	MS24693-C5	6- 2	MS35649-264	6- 5
HP-6N	6- 2	MS24693-C6	6- 2	MS35649-284	6- 2
MDC1000	6-16-13	MS24693-C6	6- 4	MS35649-284	6- 4
MRAC34P-NSS436	6- 1-11	MS24693-C60	6- 2	MS35650-304	6- 4
MRAC34P-NSS436	6- 4-8	MS24693-C62	6- 2	MS35650-304	6- 8
MRAC34P-NSS436	6- 5-4	MS24693-C62	6- 9	MS51957-14	6- 8
MRAC34SNSS	6- 1-12	MS24693-C7	6- 8	MS51957-14	6- 9
MRAC34S-NSS	6- 2-8	MS25036-112	6- 3	MS51957-16	6-15
MRD300	6- 7	MS27400-1	6- 5-1	MS51957-17	6- 1
MS15795-802	6- 2	MS27418-1A	6- 4-9	MS51957-17	6- 4
MS15795-802	6-15	MS3120E22-21P	6- 1-10	MS51957-17	6- 8
MS15795-803	6- 4	MS3120E22-21P	6-17-3	MS51957-17	6-10
MS15795-803	6- 5	MS3120E22-21S	6- 1-9	MS51957-17	6-12
MS15795-803	6- 8	MS3120E22-21SW	6- 1-5	MS51957-17	6-15
MS15795-803	6-10	MS3120E22-21SX	6- 1-6	MS51957-18	6- 8
MS15795-803	6-17	MS3120E22-21SY	6- 1-7	MS51957-18	6-17
MS15795-805	6- 1	MS3120E22-21SZ	6- 1-8	MS51957-20	6- 8
MS15795-805	6- 2	MS35275-217	6- 2	MS51957-28	6- 2
MS15795-805	6- 3	MS35275-217	6- 4	MS51957-29	6- 2
MS15795-805	6- 4	MS35275-218	6- 5	MS51957-29	6- 3
MS15795-805	6- 5	MS35338-134	6- 2	MS51957-29	6- 5

PART NUMBER	FIG & INDEX	PART NUMBER	FIG & INDEX	PART NUMBER	FIG & INDEX
MS51957-30	6- 1	NAS620C6	6- 9	RLR20C101GM	6-11-14
MS51957-30	6- 2	NAS620C6	6-12	RLR20C152GM	6- 7-40
MS51957-30	6-10	NAS620C6	6-15	RLR20C162GM	6- 0-28
MS51957-31	6- 3	RCR07G100JM	6-16-26	RLR20C201GM	6-11-19
MS51957-32	6- 9	RCR07G200JM	6- 5-3	RLR20C202GM	6- 6-22
MS51957-32	6-12	RCR07G200JM	6- 6-26	RLR20C242GM	6- 6-24
MS51957-32	6-15	RCR07G624JM	6- 6-23	RLR20C242GM	6- 7-43
MS51957-33	6- 4	RE60GK100	6- 2-13	RLR20C243GM	6-11-20
MS51957-33	6- 8	RE60G2R49	6- 2-19	RLR20C244GM	6- 7-44
MS51957-4	6- 2	RE65GR392	6-15-4	RLR20C270GM	6- 7-28
MS51957-49	6- 4	RE65GR750	6-12-6	RLR20C302GM	6- 6-16
MS51957-5	6-12	RE70G49R9	6-15-7A	RLR20C392GM	6-11-16
MS51957-5	6-15	RE70G51R1	6- 2-18	RLR20C432GM	6-16-32
MS51957-53	6- 2	RE70G51R5	6- 2-5	RLR20C472GM	6- 7-23
MS51958-61	6- 3	RLR07C101GM	6-12-8	RLR20C510GM	6- 7-34
MS51958-62	6- 3	RLR07C101GM	6-13-19	RLR20C681GM	6- 7-31
MS51958-64	6- 1	RLR07C101GM	6-15-5	RLR20C751GM	6- 7-32
MS51958-65	6- 1	RLR07C101GM	6-16-27	RLR20C752GM	6-11-21
MS51959-5	6- 2	RLR07C102GM	6- 4-4	RLR20C911GM	6-10-13
M39003-01-2257	6- 7-2	RLR07C102GM	6- 6-15	RLR32C272GM	6-16-30
M39003-01-2265	6- 7-5	RLR07C102GM	6-13-22	RL32S101G	6-15-7
M39003-01-2265	6-16-1	RLR07C102GM	6-16-19	RL32S241G	6- 7-46
M39003-01-2271	6-11-5	RLR07C103GM	6- 7-41	RL32S242G	6-13-29
M39003-01-2283	6- 6-3	RLR07C103GM	6-13-18	RL32S510G	6-10-15
M39003-01-2295	6-16-2	RLR07C103GM	6-16-25	RL32S912G	6- 7-30
M39003-01-2301	6-10-5	RLR07C104GM	6- 6-29	RL42S103G	6-16-22
M39003-01-2338	6-11-2	RLR07C104GM	6-13-27	RL42S301G	6- 6-27
M39003-01-2352	6-11-6	RLR07C104GM	6-16-31	RL42S392G	6-11
M39003-01-2356	6- 7-4	RLR07C112GM	6- 6-18	RL42S682G	6-11-15
M39003-01-2368	6-16-3	RLR07C122GM	6-13-31	RL42S911G	6-10-16
M39003-01-2379	6-13-2	RLR07C132GM	6- 6-20	RN65E1001F	6- 7-26
M39003-01-2385	6-11-4	RLR07C151GM	6-13-21	RN65E1271F	6- 7-37
M39003-01-2465	6-11-3	RLR07C152GM	6-16-24	RN65E1331F	6- 7-39
I39018-01-0047	6-10-3	RLR07C153GM	6-13-24	RT22C2P101	6- 7-36
I39018-01-0115	6-10-2	RLR07C153GM	6-16-18	RT22C2P103	6-13-23
I39018-01-0151	6- 6-1	RLR07C201GM	6-15-6	RT22C2P201	6- 6-17
I39018-01-0183	6-10-4	RLR07C202GM	6- 7-29	RT22C2P201	6- 7-25
I39018-01-0211	6-11-1	RLR07C202GM	6-13-30	RW69V202	6-13-28
I39018-01-0223	6- 2-11	RLR07C222GM	6- 6-25	RW69V301	6- 7-35
I39018-01-0223	6-13-5	RLR07C302GM	6- 7-38	RW69V7R5	6-11-17
5757-13-038	6- 2-7	RLR07C302GM	6-13-20	RW79U8251F	6- 7-24
5757-9-003	6-13-11	RLR07C302GM	6-16-21	R14S222	6- 9-1
62-12-036	6- 3-5	RLR07C303GM	6-13-25	SCA1343	6- 8-19
AS620C10	6-10	RLR07C303GM	6-16-20	SCA1343	6-13-13
AS620C10	6-12	RLR07C332GM	6- 6-19	SC11Y169J-1	6- 9-2
AS620C10	6-15	RLR07C332GM	6- 7-27	SC6578GH	6-13-1
AS620C2	6- 2	RLR07C471GM	6-16-28	SF2544	6-13-14
AS620C2	6-12	RLR07C510GM	6-12-7	SG2460	6- 7-21
AS620C2	6-14	RLR07C512GM	6-13-26	SG2460	6-16-16
AS620C4	6- 1	RLR07C562GM	6-16-29	SJ1240	6- 7-19
AS620C4	6- 2	RLR07C621GM	6-16-23	SJ1240	6-10-11
AS620C4	6- 4	RLR07C622GM	6- 7-33	SJ2953	6-12-4
AS620C4	6- 8	RLR07C682GM	6- 7-45	SJ2953	6-15-1
AS620C4	6- 9	RLR07C821GM	6- 6-21	SJ2953H	6-12-4
AS620C4	6-12	RLR20C100GM	6- 7-42	SJ2953H	6-15-1
AS620C4	6-15	RLR20C100GM	6-10-12	SM1573	6-13-15
AS620C6	6- 5	RLR20C101GM	6-10-14	SM1573	6-16-12

PARTS LIST

NUMERICAL INDEX

PART NUMBER	FIG & INDEX	PART NUMBER	FIG & INDEX	PART NUMBER	FIG & INDEX
SM7154	6-13-17	2N897	6- 4-2	4912540-02	6- 2
SM7154	6-16-14	200125-01	6- 6-30	4912540-02	6- 4
SM7169	6-16-15	200125-01	6- 7-47	4912540-04	6- 2
SK-1590	6- 2-16	20418-2	6-12	4912540-04	6-12
SS-52176-K2915	6-12	20418-2	6-15	4912540-04	6-15
SS1308	6- 6-13	2102-04-00	6-12	4912542-00	6- 4
SS1309	6- 7-17	2102-04-00	6-15	4912542-00	6- 8
SS1309	6-13-12	260P25553S4	6- 4-10	4912545-00	6- 1
SS1530	6- 7-18	2630-18550-F116-	6-12	4912548-00	6- 4
SS1530	6-11-13	30		4912548-00	6- 5
SS1530	6-13-16	2630-18550-F116-	6-15	4912548-00	6- 8
Sw7748	6-16-17	30		4912548-00	6-10
01438-00-000	6- 8-34	2642-24850-F194-	6- 8	4912548-00	6-17
031-0500-MDP	6-14	30		4912548-01	6- 1
1N1186	6- 4-3	3-19610	6-10-9	4912548-01	6- 2
1N3018B	6- 7-8	3-19610	6-11-12	4912548-01	6- 3
1N3020B	6-13-8	3-19612	6-10-10	4912548-01	6- 4
1N3029B	6-11-9	3-19613	6- 7-14	4912548-01	6- 5
1N3611	6- 2-3	3-19614	6- 2-12	4912548-01	6- 8
1N3611	6- 7-9	3-19615	6- 7-15	4912548-01	6-10
1N3611	6-11-8	3-19616	6-11-11	4912548-01	6-12
1N3611	6-16-5	3-19619	6- 2-15	4912548-02	6- 2
1N3827A	6-16-10	3-19620	6- 2-10	4912548-02	6- 4
1N3828A	6-16-11	3-19621	6-10-17	4912548-03	6- 1
1N4942	6- 6-5	3-19622	6-10-18	4912548-03	6- 3
1N4942	6- 7-10	3-19624	6- 4-5	4912548-03	6- 4
1N4942	6-11-7	3-19627	6- 4-7	4912548-03	6- 8
1N4974	6- 2-6	320733	6-14-7	4912548-04	6- 1
1N746A	6- 6-8	37TB4	6- 9-4	4912548-04	6- 8
1N746A	6- 7-12	40TB5	6-12-9	4912548-09	6- 2
1N753A	6- 6-9	40TB5	6-15-8	4912548-09	6-15
1N753A	6- 7-11	4003	6-12	4912549-03	6- 3
1N758A	6-16-9	4003	6-15	4912550-00	6- 1
1N935B	6- 6-7	4030-30	6- 8-33	4912550-00	6- 4
1N937B	6- 7-7	4912531-02	6- 2	4912550-00	6- 8
1N963B	6-13-9	4912531-03	6- 2	4912550-00	6- 9
1N9658	6-13-7	4912531-03	6- 3	4912550-00	6-10
1N968B	6-16-6	4912531-03	6- 5	4912550-00	6-12
1N978B	6-13-10	4912531-04	6- 1	4912550-00	6-15
1N978B	6-16-8	4912531-04	6- 2	4912550-00	6-17
100-1016S55	6- 2	4912531-04	6-10	4912550-01	6- 2
100-1018S55	6- 2	4912531-05	6- 3	4912550-01	6- 3
100-1020S55	6- 2	4912531-06	6- 9	4912550-01	6- 4
100-1022S55	6- 2	4912531-06	6-12	4912550-01	6- 5
100-1024S55	6- 2	4912531-06	6-15	4912550-01	6- 8
111SM1-T	6-14-6	4912532-04	6- 4	4912550-01	6- 9
1843-2010	6- 2-17	4912534-01	6- 1	4912550-02	6- 2
2N2060	6- 6-12	4912534-02	6- 1	4912550-02	6- 4
2N2060	6- 7-16	4912540-00	6- 1	4912550-03	6- 3
2N2324	6- 6-11	4912540-00	6- 4	4912550-03	6- 4
2N3418	6- 7-22	4912540-00	6- 8	4912550-03	6- 8
2N3716	6-12-5	4912540-00	6-10	4912550-03	6-10
2N3716	6-15-3	4912540-00	6-12	4912550-03	6-12
2N3792	6- 6-10	4912540-00	6-15	4912550-03	6-15
2N3792	6-12-3	4912540-00	6-17	4912550-04	6- 8
2N3792	6-15-2	4912540-01	6- 4	4912550-09	6- 2
2N5431	6- 6-14	4912540-01	6- 5	4912550-09	6-12

PART NUMBER	FIG & INDEX	PART NUMBER	FIG & INDEX	PART NUMBER	FIG & INDEX
4912550-09	6-15	7600812-02	6-14-3	7601769-00	6- 1-3
4912551-04	6- 1	7600813-01	6- 8-30	7601769-01	6- 1-3
4912552-03	6- 3	7600815-00	6- 8-31	7601770-00	6- 1-1
4912675-03	6- 9-4	7600816-00	6- 8-32	7601771-00	6- 1-13
4912796-00	6-15	7600840-00	6- 8-6	7601772-00	6- 5-6
4912796-01	6-12	7600841-00	6-14-8	7601773-00	6- 5-5
4912796-01	6-15	7600848-00	6- 8-15	7601774-00	6- 4-13
4913387-06	6- 2	7600848-01	6- 8-16	7601775-00	6- 2-22
4913387-06	6- 4	7600849-00	6- 8-4	7601776-00	6- 2-9
4913387-07	6- 5	7600850-00	6- 8-3	7601781-00	6- 2-14
4913630-01	6- 1-12	7600855-00	6- 8-38	7601784-00	6- 1-4
4913630-01	6- 2-8	7600856-00	6-15-11	7601788-00	6-17
5979	6-14-1	7600857-00	6-12-11	7601792-00	6- 8-22
601C12	6- 4-12	7600858-00	6-10-22	7601793-00	6- 8-21
6237-SS-0632	6-12	7600859-00	6-10-23	7601794-00	6- 8
6237-SS-0632	6-15	7600860-00	6-15-10	7601884-00	6- 8-18
683-1	6-10-7	7600861-00	6-12	7601884-01	6- 8-18
683-1	6-12-1	7600863-00	6- 1-2	7601950-21	6-10-24
684-1	6-10-6	7600867-01	6- 1-21	7601950-21	6-12
72L2-1-1A8	6- 1-20	7600868-01	6- 8-17	7601950-21	6-15
7600063-00	6- 8	7600869-00	6- 8-5	7601967-00	6- 9
7600065-00	6- 8	7600870-01	6- 8-2	7601974-00	6- 8-36
7600066-00	6- 8	7600873-01	6- 8-14	7602224-00	6-16-33
7600067-00	6- 8	7600881-00	6-15-13	7602225-00	6-15-9
7600114-01	6-14-5	7600882-00	6-12-13	7900038-01	6-13-17
7600118-01	6-14	7600883-01	6-10-21	7900038-01	6-16-14
7600169-00	6-14	7600896-00	6- 3-2	7900039-01	6-13-15
7600260-04	6- 9-5	7600897-00	6- 3-3	7900039-01	6-16-12
7600260-05	6-12	7600897-03	6-10	7900063-09	6-16-10
7600260-05	6-15	7600908-00	6- 8-29	7900063-10	6-16-11
7600261-01	6-12	7600910-00	6- 8	7900063-13	6- 7-8
7600627-00	6- 8-7	7600911-00	6- 8-35	7900063-15	6-13-8
7600629-00	6- 8-8	7600913-01	6- 8-1	7900063-24	6-11-9
7600635-00	6- 8-13	7600914-00	6- 8-26	7900134-00	6- 4-3
7600643-00	6- 8-12	7600916-00	6- 8-24	7900182-35	6- 6-27
7600654-00	6-13-32	7600917-00	6- 8-23	7900182-47	6-10-16
7600655-00	6-12-10	7600918-01	6- 8	7900182-62	6-11-18
7600656-00	6-11-22	7600920-01	6- 8	7900182-68	6-11-15
7600657-00	6-10-20	7600922-00	6- 4-11	7900182-72	6-16-22
7600661-00	6- 8	7600935-00	6- 1-16	7900185-00	6-10-15
7600661-00	6-17-2	7600943-00	6- 3-8	7900185-07	6-15-7
7600664-00	6- 6-31	7600943-00	6- 9	7900185-16	6- 7-46
7600665-00	6- 1-14	7600947-00	6- 9	7900185-40	6-13-29
7600666-00	6- 7-48	7600959-00	6- 3-9	7900185-54	6- 7-30
7600667-00	6- 1-15	7600961-00	6- 3-12	7900219-23	6- 3-5
7600669-00	6- 8-10	7600962-00	6- 3-10	7900258-03	6- 6-8
7600671-00	6- 8-9	7600971-00	6-12-12	7900258-03	6- 7-12
7600673-00	6- 8-11	7600974-00	6- 8	7900258-10	6- 6-9
7600736-00	6- 8-25	7600991-00	6- 3-6	7900258-10	6- 7-11
7600748-00	6- 3-11	7600991-01	6- 3-7	7900258-15	6-16-9
7600757-01	6- 1-17	7600996-00	6- 4-1	7900259-17	6-13-9
7600758-01	6- 1-18	7600997-00	6- 2-20	7900259-20	6-13-7
7600800-00	6- 8-37	7600999-00	6- 2-4	7900259-25	6-16-6
7600808-01	6- 8-28	7601767-01	6- 8	7900259-36	6-13-10
7600809-00	6- 8-27	7601767-02	6- 8	7900259-36	6-16-8
7600812-00	6-14-4	7601768-01	6- 1	7900261-01	6-15
7600812-01	6-14-2	7601768-02	6- 1	7900531-02	6-13-14

PART NUMBER	FIG & INDEX	PART NUMBER	FIG & INDEX	PART NUMBER	FIG & INDEX
7900531-02	6-16-15	7902067-00	6-16-5	7902750-63	6- 7-23
7900581-01	6- 4	7902166-13	6-14	7902750-68	6-11-21
7900581-01	6- 4	7902257-00	6-12-5	7902750-80	6-11-20
7900581-02	6- 2	7902257-00	6-15-3	7902751-129	6- 6-23
7900588-00	6- 1-10	7902308-00	6- 7-19	7902751-14	6-16-26
7900588-00	6-17-3	7902308-00	6-10-11	7902751-21	6- 5-3
7900589-00	6- 1-9	7902323-153	6-15-4	7902751-21	6- 6-26
7900589-01	6- 1-5	7902323-180	6-12-6	7902753-00	6-12-7
7900589-02	6- 1-6	7902350-00	6- 4-9	7902753-07	6-12-8
7900589-03	6- 1-7	7902441-00	6- 6-12	7902753-07	6-13-19
7900589-04	6- 1-8	7902441-00	6- 7-16	7902753-07	6-15-5
7900810-25	6- 3	7902491-259	6-15-7A	7902753-07	6-16-27
7901009-00	6- 6-6	7902491-260	6- 2-5	7902753-11	6-13-21
7901009-00	6- 7-13	7902491-260	6- 2-18	7902753-14	6-15-6
7901009-00	6-11-10	7902614-01	6- 8-20	7902753-23	6-16-28
7901009-00	6-13-6	7902616-11	6-10-3	7902753-26	6-16-23
7901009-00	6-16-7	7902616-28	6-10-2	7902753-29	6- 6-21
7901084-01	6- 1-20	7902616-37	6- 6-1	7902753-31	6- 4-4
7901094-00	6- 6-7	7902616-45	6-10-4	7902753-31	6- 6-15
7901094-01	6- 7-7	7902616-52	6-11-1	7902753-31	6-13-22
7901102-101	6- 7-3	7902616-55	6- 2-11	7902753-31	6-16-19
7901102-101	6-16-4	7902616-55	6-13-5	7902753-32	6- 6-18
7901102-36	6- 5-2	7902640-00	6-12	7902753-33	6-13-31
7901102-36	6-13-3	7902640-00	6-15	7902753-34	6- 6-20
7901102-44	6- 7-1	7902696-11	6- 7-2	7902753-35	6-16-24
7901102-60	6- 7-6	7902696-149	6-11-3	7902753-38	6- 7-29
7901102-73	6-13-4	7902696-17	6- 7-5	7902753-38	6-13-30
7901102-93	6-10-1	7902696-17	6-16-1	7902753-39	6- 6-25
7901127-00	6-10-8A	7902696-21	6-11-5	7902753-42	6- 7-38
7901314-01	6- 1-11	7902696-29	6- 6-3	7902753-42	6-13-20
7901314-01	6- 4-8	7902696-37	6-16-2	7902753-42	6-16-21
7901314-01	6- 5-4	7902696-41	6-10-5	7902753-43	6- 6-19
7901426-00	6- 7-21	7902696-65	6-11-2	7902753-43	6- 7-27
7901426-00	6-16-16	7902696-74	6-11-6	7902753-48	6-13-26
7901477-01	6- 7-36	7902696-77	6- 7-4	7902753-49	6-16-29
7901477-02	6- 6-17	7902696-85	6-16-3	7902753-50	6- 7-33
7901477-02	6- 7-25	7902696-92	6-13-2	7902753-51	6- 7-45
7901477-07	6-13-23	7902696-96	6-11-4	7902753-55	6- 7-41
7901480-00	6-14-7	7902750-00	6- 7-42	7902753-55	6-13-18
7901556-00	6- 6-13	7902750-00	6-10-12	7902753-55	6-16-25
7901556-01	6- 7-17	7902750-09	6- 7-28	7902753-59	6-13-24
7901556-01	6-13-12	7902750-104	6- 7-44	7902753-59	6-16-18
7901573-32	6- 7-26	7902750-16	6- 7-34	7902753-66	6-13-25
7901573-42	6- 7-37	7902750-23	6-10-14	7902753-66	6-16-20
7901573-44	6- 7-39	7902750-23	6-11-14	7902753-79	6- 6-29
7901637-00	6- 2-16	7902750-30	6-11-19	7902753-79	6-13-27
7901665-00	6- 6-30	7902750-43	6- 7-31	7902753-79	6-16-31
7901665-00	6- 7-47	7902750-44	6- 7-32	7902788-05	6-12
7901760-00	6- 7-18	7902750-46	6-10-13	7902788-05	6-15
7901760-00	6-11-13	7902750-51	6- 7-40	7903061-00	6- 1
7901760-00	6-13-16	7902750-52	6- 6-28	7903061-01	6- 1
7901760-00	6-16-17	7902750-54	6- 6-22	7903062-00	6- 1
7901859-00	6- 2-13	7902750-56	6- 6-24	7903062-00	6- 4
7901859-07	6- 2-19	7902750-56	6- 7-43	7903062-01	6- 1
7902067-00	6- 2-3	7902750-58	6- 6-16	7903062-01	6- 4
7902067-00	6- 7-9	7902750-61	6-11-16	7903062-01	6- 5
7902067-00	6-11-8	7902750-62	6-16-32	7903072-00	6-10

PART NUMBER	FIG & INDEX	PART NUMBER	FIG & INDEX	PART NUMBER	FIG & INDEX
7903079-00	6- 6-5	7904515-00	6- 7-15	904656-00	6-12
7903079-00	6- 7-10	7904516-00	6- 4-5	904656-00	6-15
7903079-00	6-11-7	7904517-00	6- 2-15	905989-03	6-12
7903093-20	6- 2-6	7904518-00	6- 2-10	906009-04	6- 2
7903132-03	6- 2	7904519-00	6-10-17	907449-07	6-14
7903132-04	6-12	7904520-00	6-10-18	907783-12	6-10-8
7903132-04	6-15	7904523-00	6- 4-7	908552-04	6- 8
7903132-37	6- 2	7904524-00	6- 3-4	908552-04	6- 9
7903133-03	6-12	7904525-00	6- 2-2	908552-06	6-15
7903133-03	6-15	7904525-01	6- 2-1	908552-07	6- 1
7903133-04	6- 2	7904526-00	6-15-8	908552-07	6- 4
7903133-05	6- 2	7904526-03	6-12-9	908552-07	6- 8
7903133-05	6- 4	7904527-00	6-12-4	908552-08	6-10
7903133-06	6- 8	7904527-00	6-15-1	908552-08	6-12
7903133-17	6- 3	7904528-00	6- 2-17	908552-08	6-15
7903133-19	6- 1	7904529-00	6- 6-14	908552-09	6- 8
7903133-29	6- 1	7904532-00	6-13-11	908552-09	6-17
7903133-41	6- 2	7904533-00	6- 5-1	908552-10	6- 8
7903133-42	6- 2	7904539-00	6-14-6	908552-12	6- 8
7903133-42	6- 9	7904541-00	6- 8-19	908553-08	6-12
7903133-49	6- 1	7904542-00	6-10-6	908553-10	6- 4
7903133-50	6- 1	7904543-00	6-10-7	908553-10	6- 8
7903133-52	6- 4	7904543-00	6-12-1	908555-02	6- 3
7903309-26	6- 6-4	7904546-00	6- 3-1A	908555-05	6- 3
7903309-42	6- 6-2	7904546-06	6- 3-1	910509-06	6-11-17
7903320-00	6-14-1	7904548-00	6- 6-10	910509-42	6- 7-35
7903348-00	6-13-1	7904548-00	6-12-3	910509-62	6-13-28
7903354-01	6- 2	7904548-00	6-15-2	910879-00	6- 2
7903354-01	6-12	7904549-01	6- 4-10	910879-01	6- 2
7903354-01	6-14	7904551-00	6- 7-20	910879-02	6- 2
7903354-02	6- 1	7904551-00	6-13-13	910879-03	6- 2
7903354-02	6- 2	7904551-00	6-16-13	910879-04	6- 2
7903354-02	6- 4	7904552-00	6- 7-24	911603-08	6- 8
7903354-02	6- 8	7904556-05	6-14	911604-05	6- 8
7903354-02	6- 9	7904565-00	6-11-11	911606-06	6- 8
7903354-02	6-12	7904566-02	6- 9-3	911606-07	6- 8
7903354-02	6-15	7904570-00	6- 2-7	911606-10	6- 8
7903354-03	6- 5	7904571-00	6- 7-22	911606-13	6- 1
7903354-03	6- 9	7904573-00	6- 6-11	911607-04	6- 8
7903354-03	6-12	7904633-00	6- 4-2	911607-04	6- 8
7903354-03	6-15	8161-A-0440-16	6- 4		
7903354-05	6-10	8169-A-0440-16	6- 2		
7903354-05	6-12	900125-05	6- 4-12		
7903354-05	6-15	900129-05	6- 2		
7903387-02	6-12	900805-00	6-12		
7903387-02	6-15	900805-00	6-15		
7903387-05	6- 8	903072-12	6- 1-19		
7903596-57	6-16-30	903790-01	6- 2		
7904504-00	6- 8-33	903790-03	6- 2		
7904505-00	6- 9-1	903790-03	6- 5		
7904506-00	6- 9-2	903800-00	6- 2-21		
7904507-00	6- 8-34	903800-00	6-10-19		
7904510-00	6-10-9	903800-00	6-12-2		
7904510-00	6-11-12	903800-00	6-15-12		
7904511-00	6-10-10	903801-00	6- 4-6		
7904513-00	6- 7-14	903801-00	6-17-1		
7904514-00	6- 2-12	904631-05	6-14		

SECTION 7

FUNCTIONAL SCHEMATICS

7-1. GENERAL.

Section 7 contains the functional schematics, power control and distribution diagrams, and 400-Hz power supply schematics for the MTT. References are made to the figures in Section 7 from Sections 4 and 5. These figures are included to provide assistance in malfunction isolation. Figure 7-1 illustrates the drawing concept (logic symbology) applied to figures 7-2 through 7-14. Figure 7-15 contains the electrical schematic of the dc-to-dc converter which converts the input 75 Vdc to those voltages required for logic operation. Figures 7-16 through 7-18 are 400-Hz power supply schematics. Figure 7-19 shows the MTT power distribution, and figure 7-20 shows the signal distribution.

7-2. COMPONENTS.

Individual components represented by the logic symbology in the figures of Section 7 may be identified by the drawings in Section 5. However, those drawings are informational in nature and not intended for piece-part replacement on the printed circuit cards except in an emergency situation.

SHEET INDEX	
FIG. NO.	FUNCTIONAL DESCRIPTION
1	LOGIC SYMBOLOGY
2	CONTROL SIGNALS
3	REEL SERVO INPUT
4	AL FUNCTION GENERATOR
5	AL FUNCTION GENERATOR
6	AL INTERFACE
7	AL SERVO CONTROL
8	AL SERVO CONTROL
9	SR SERVO OUTPUT
10	TR SERVO OUTPUT
11	REEL DRIVERS
12	CAPSTAN SERVO LOGIC
13	CAPSTAN SERVO INPUT
14	CAPSTAN DRIVE
15	DC-DC CONVERTER ASSEMBLY
16	POWER SUPPLY SCHEMATIC Sheet 1
17	POWER SUPPLY SCHEMATIC Sheet 2
18	POWER SUPPLY SCHEMATIC Sheet 3
19	POWER DISTRIBUTION
20	SIGNAL DISTRIBUTION

NOTES:

- LOGIC ELEMENT IDENTIFICATION AND INTER-SHEET COMMUNICATION CONSISTS OF A TWO DIGIT FIGURE NUMBER PLUS A THREE DIGIT ELEMENT UNIQUE NUMBER (NUMBERING STARTS WITH 001 ON EACH SHEET).

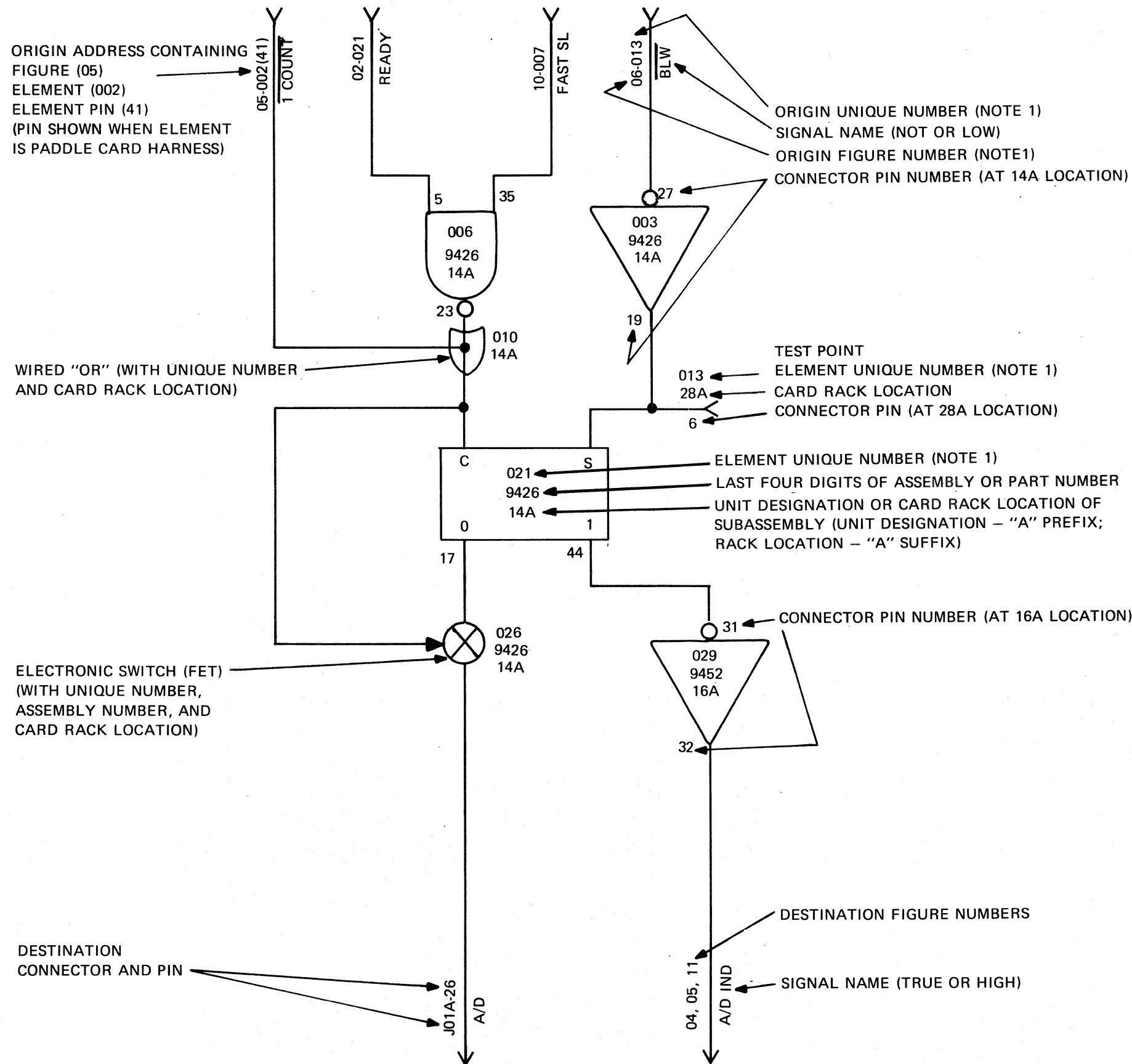
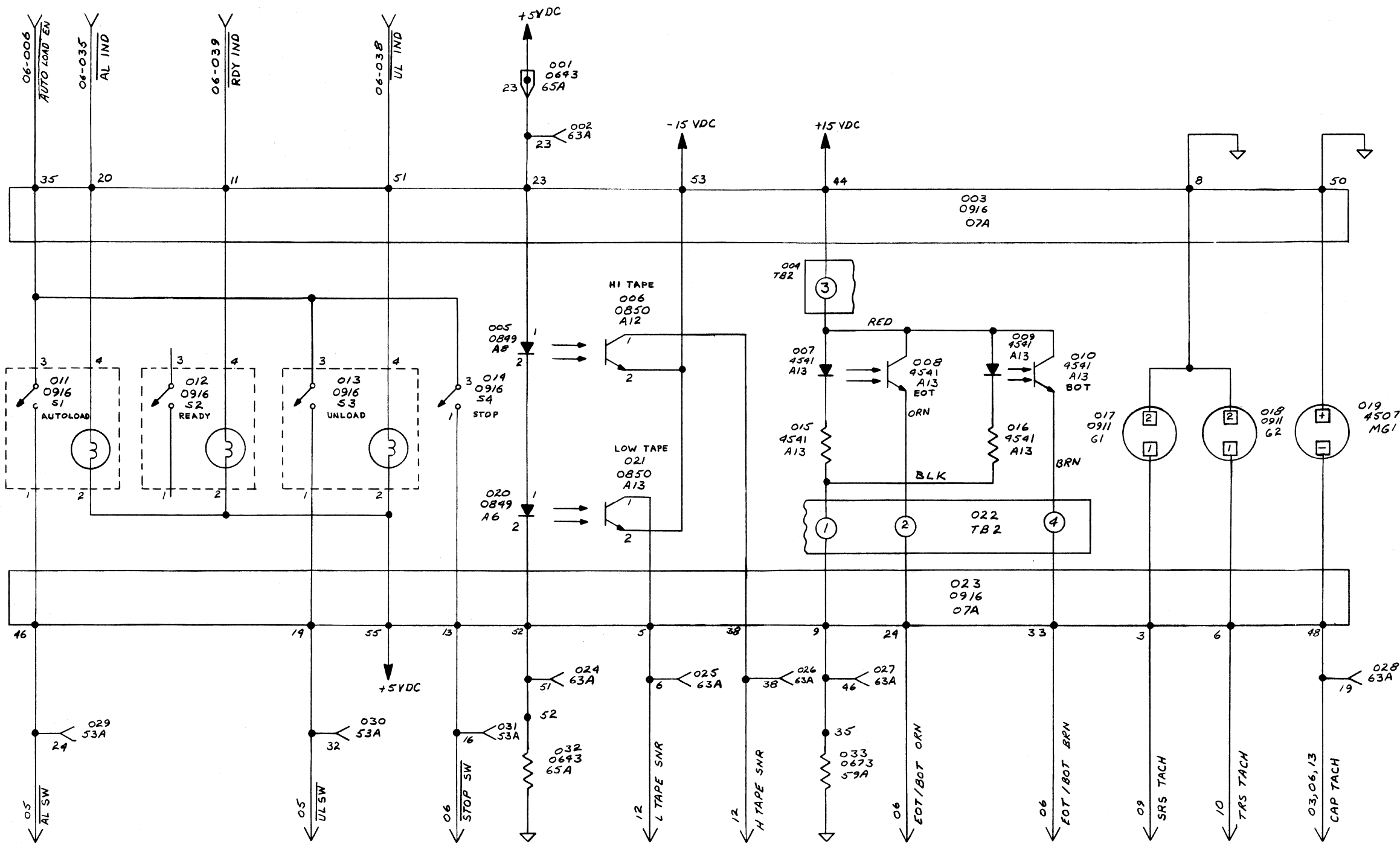

Figure 7-1. Logic Symbology

NOTES—When Government drawings, specifications, or other data are used for any purpose other than in connection with a definitely related Government procurement operation, the United States Government hereby incurs no responsibility for any alterations, modifications, or other changes that may be made, and the fact that the Government may have furnished, furnished, or in any way supplied the said drawings, specifications or other data is not to be regarded by implication or otherwise as in any manner limiting the liability of any other person or organization or waiving any rights or privileges in connection therewith, or as in any way patented invention that may in any way be related thereto.

REVISIONS				
ZONE	LTR.	DESCRIPTION	DATE	APPD.



CONTROL SIGNALS

02

SIZE	CODE IDENT NO.	DWG NO.
D	06401	7601896
SCALE	CLASS 3	SHEET 2

DWG NO. 7601896

NOTICE—When Government drawings, specifications, or other data are used for any purpose other than in connection with a definitely related Government procurement operation, the United States Government thereby incurs no responsibility for any obligation whatsoever, and the fact that the Government may have formulated, furnished, or in any way supplied the said drawings, specifications or other data is not to be regarded by implication or otherwise as in any manner licensing the holder or any other person or corporation or conveying any rights or permission to manufacture, use, or sell any patented invention that may in any way be related thereto.

REVISIONS				
ZONE	LTR.	DESCRIPTION	DATE	APPROVED

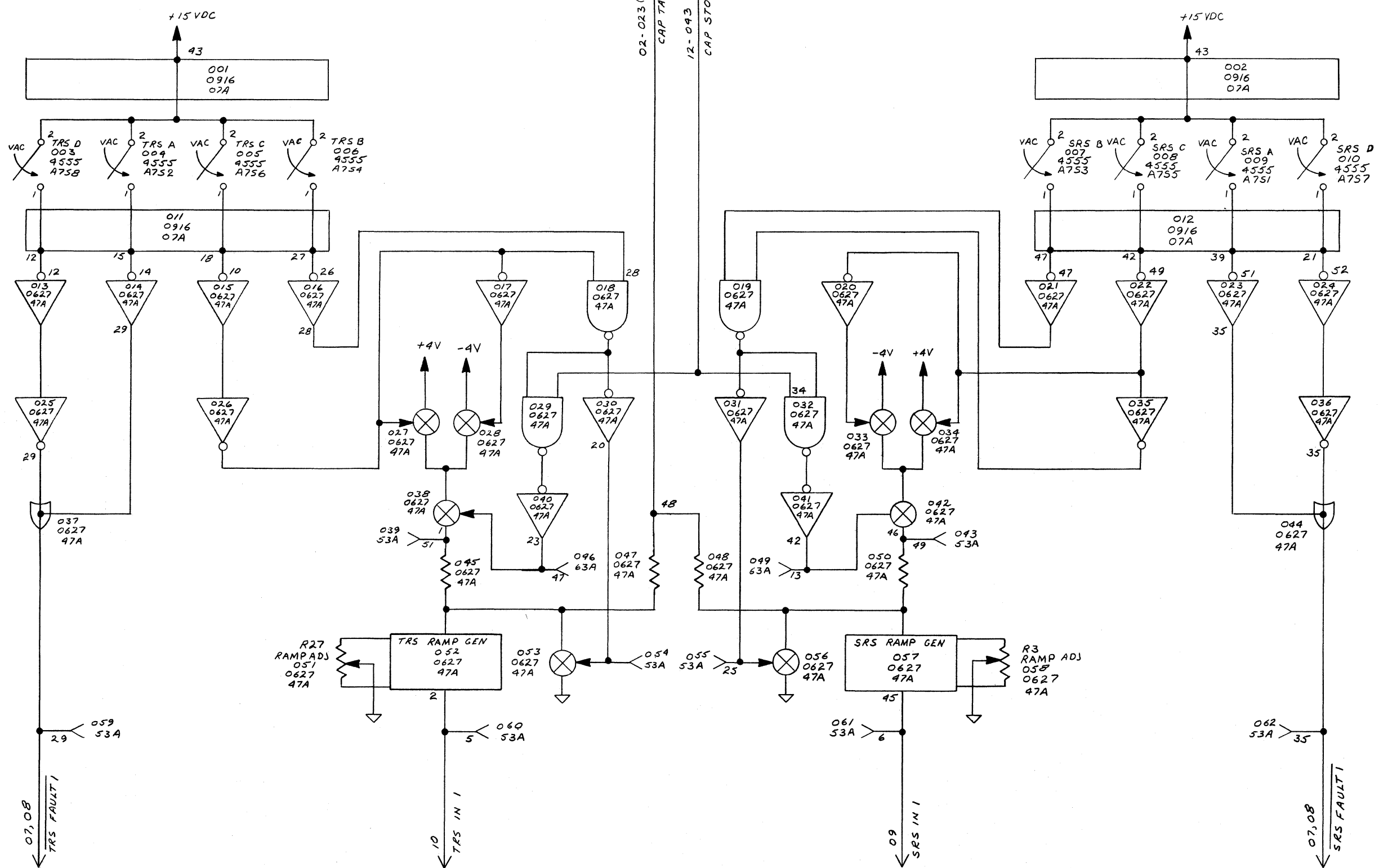

REEL SERVO INPUT 03

SIZE	CODE IDENT NO.	DWG NO.
D	06401	7601896
SCALE	FORM	SHEET 3

DWG. NO. 7601896

NOTICE—When Government drawings, specifications, or other data are used for any purpose other than in connection with a definitely related Government procurement operation, the United States Government thereby incurs no responsibility nor any obligation whatsoever and the fact that the Government may have furnished, furnished, or in any way supplied the said drawings, specifications or other data is not to be regarded by implication or otherwise as in any manner constituting the holder or any other person or corporation or conveying any rights or permission in manufacture, use, or sale any patented invention that may in any way be related thereto.

REVISIONS				
ZONE	LTR.	DESCRIPTION	DATE	APPROVED

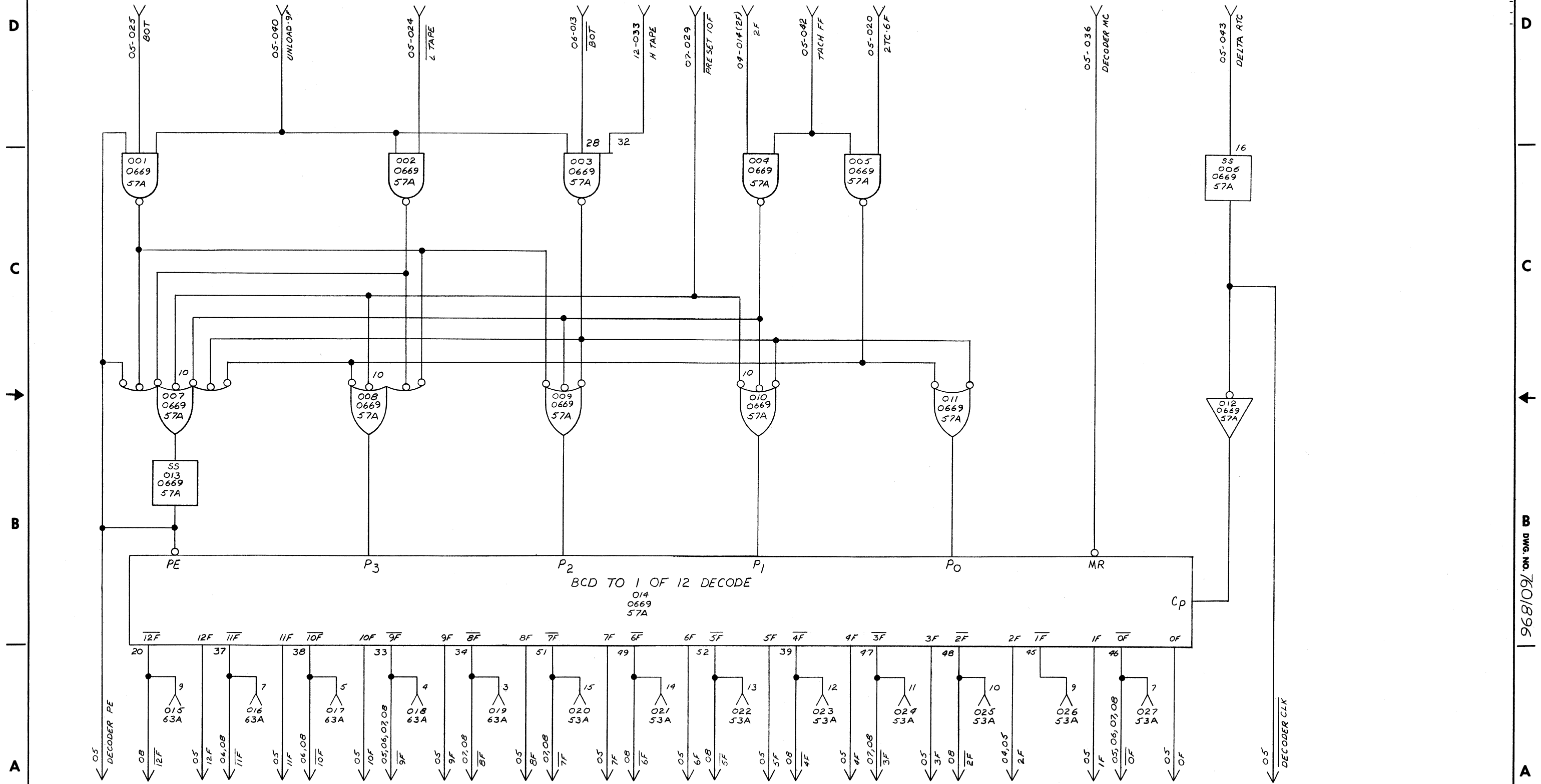

04

AUTO LOAD
FUNCTION GENERATOR

SIZE	CODE IDENT NO.	DWG NO.
D	06401	7601896
SCALE	FORM 3	SHEET 4

NOTICE—When Government drawings, specifications, or other data are used for any purpose other than in connection with a definitely related Government procurement operation, the United States Government thereby incurs no responsibility for any obligation whatsoever and the fact that the Government may have furnished, furnished, or in any way supplied the said drawings, specifications or other data is not to be regarded by implication or otherwise as in any manner licensing the holder or any other person or corporation or conveying any rights of permission to manufacture, use, or sell any patented invention that may in any way be related thereto.

REVISIONS				
ZONE	LTR.	DESCRIPTION	DATE	APPD.

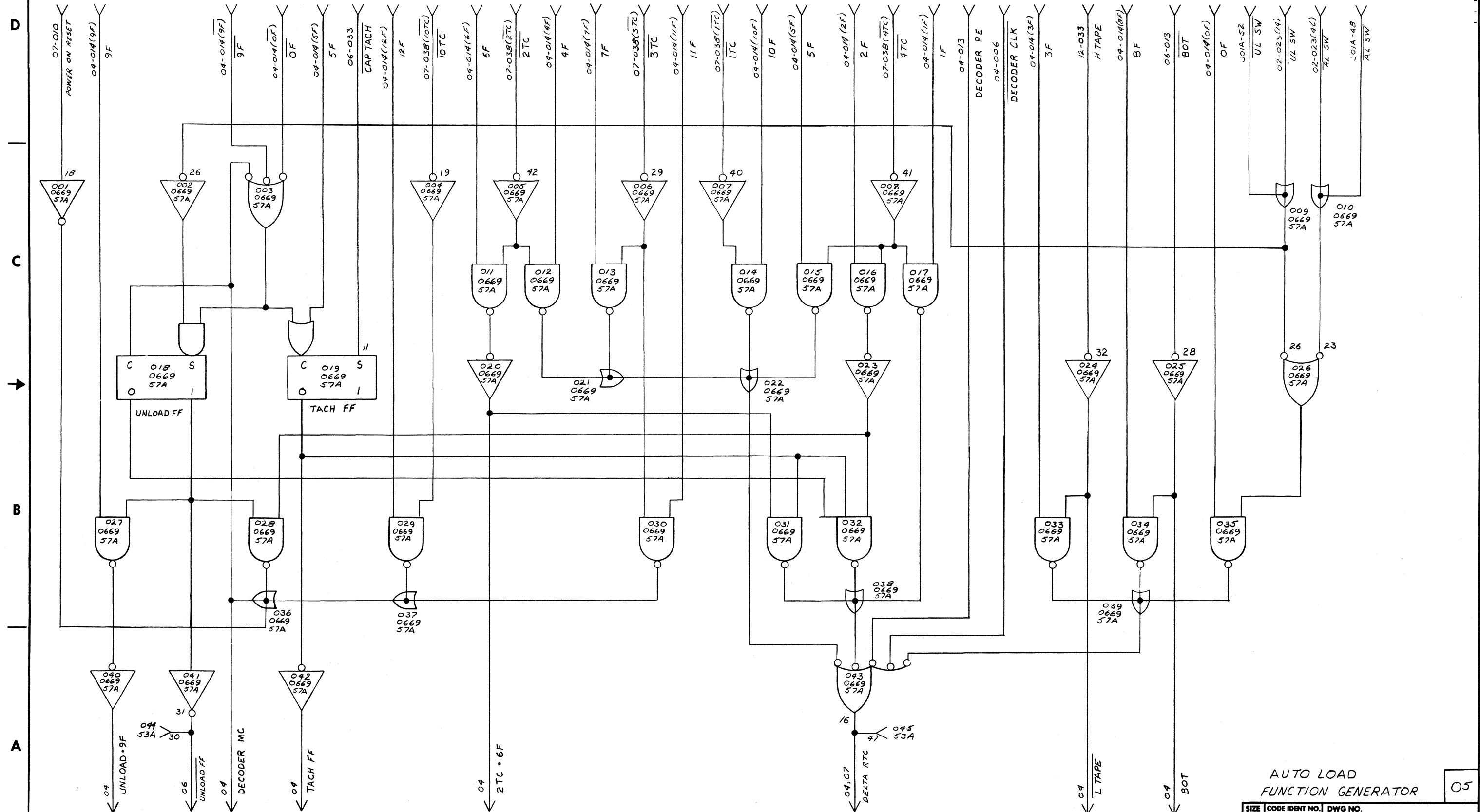

AUTO LOAD
FUNCTION GENERATOR

05

SIZE	CODE IDENT NO.	DWG NO.
D	06401	7601896
SCALE	CLASS	SHEET 5

NOTICE—When Government drawings, specifications, or other data are used for any purpose other than in connection with a definitely related Government procurement operation, the United States Government thereby incurs no responsibility for any obligation whatsoever; and the fact that the Government may have furnished, furnished, or in any way supplied the said drawings, specifications or other data is not to be regarded by implication or otherwise as in any manner licensing the holder or any other person or corporation or conveying any rights or permission to manufacture, use, or sell any patented invention that may in any way be related thereto.

REVISIONS				
ZONE	LTR.	DESCRIPTION	DATE	APPD.

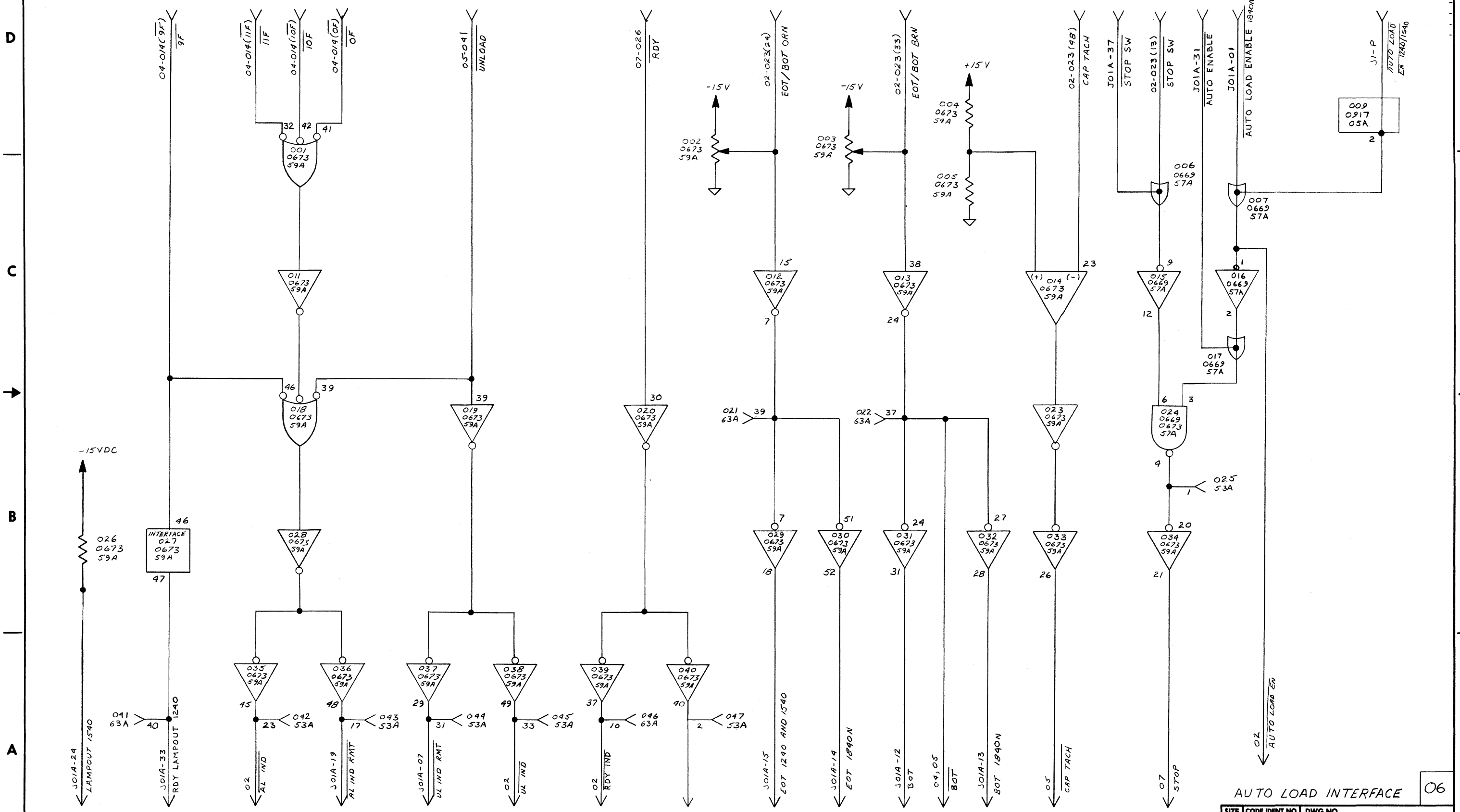

06

AUTO LOAD INTERFACE

SIZE	CODE IDENT NO.	DWG NO.
D	06401	7601896
SCALE	CLASS	SHEET 6

NOTICE—When Government drawings, specifications, or other data are used for any purpose other than in connection with a definitely related Government procurement operation, the United States Government thereby incurs no responsibility nor any obligation whatsoever; and the fact that the Government may have furnished, furnished, or in any way supplied the said drawings, specifications or other data is not to be regarded by implication or otherwise as in any manner licensing the holder or any other person or corporation or conveying any rights or permission to manufacture, use, or sell any patented invention that may in any way be related thereto.

REVISIONS				
ZONE	LTR.	DESCRIPTION	DATE	APPD.

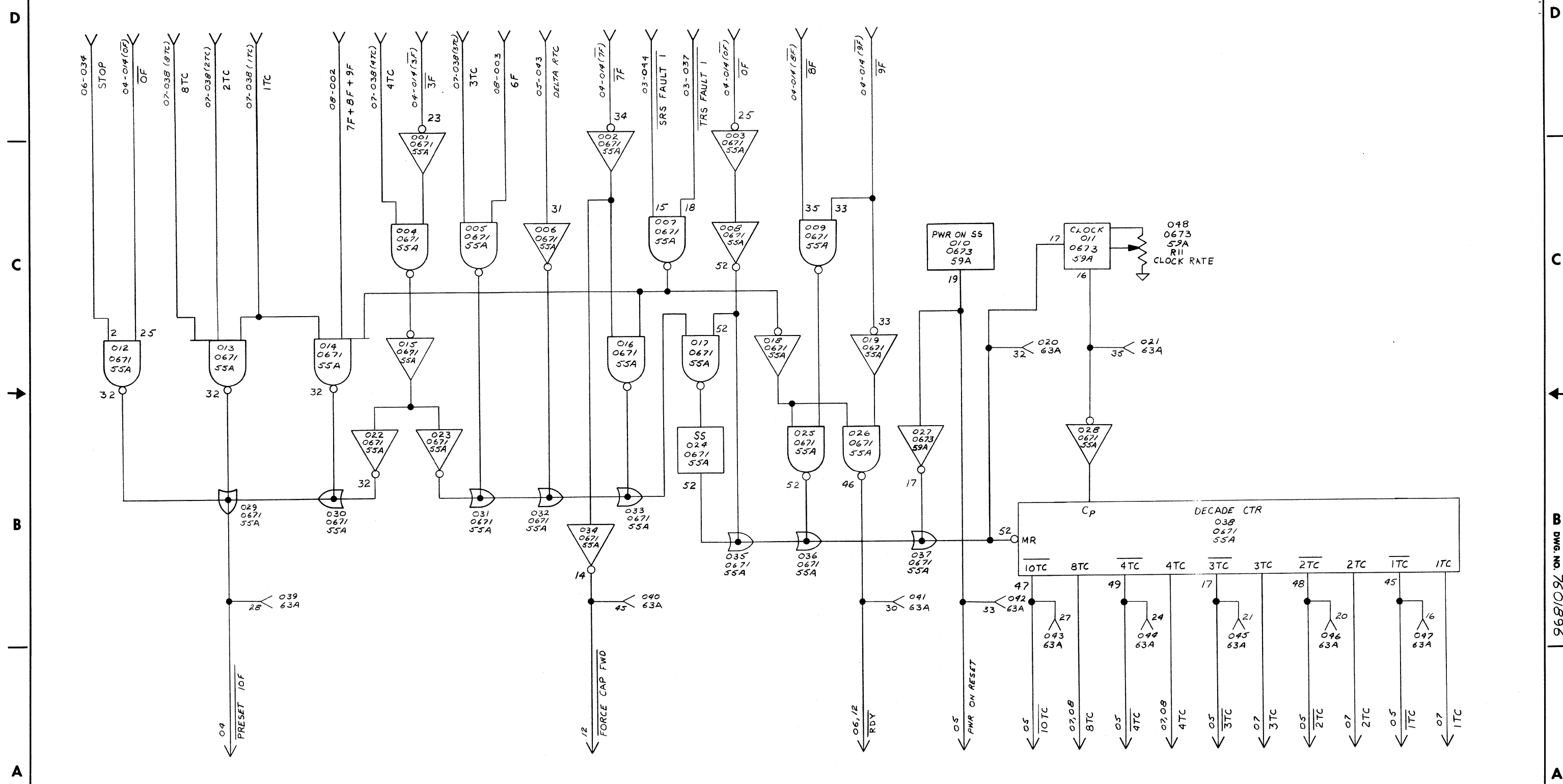

LAST UNIQUE NO. = 48

AUTO LOAD SERVO CONTROL 07

SIZE	CODE IDENT NO.	DWG NO.
D	06401	7601896
SCALE	CLASS	SHEET 7

NOTICE—When Government drawings, specifications, or other data are used for any purpose other than in connection with a definitely related Government procurement operation, the United States Government thereby incurs no responsibility for any obligation whatsoever; and the fact that the Government may have furnished, furnished, or in any way supplied the said drawings, specifications or other data is not to be regarded by implication or otherwise as in any manner licensing the holder or any other person or corporation or conveying any rights or permission to manufacture, use, or sell any patented invention that may in any way be related thereto.

REVISIONS				
ZONE	LTR.	DESCRIPTION	DATE	APPD.

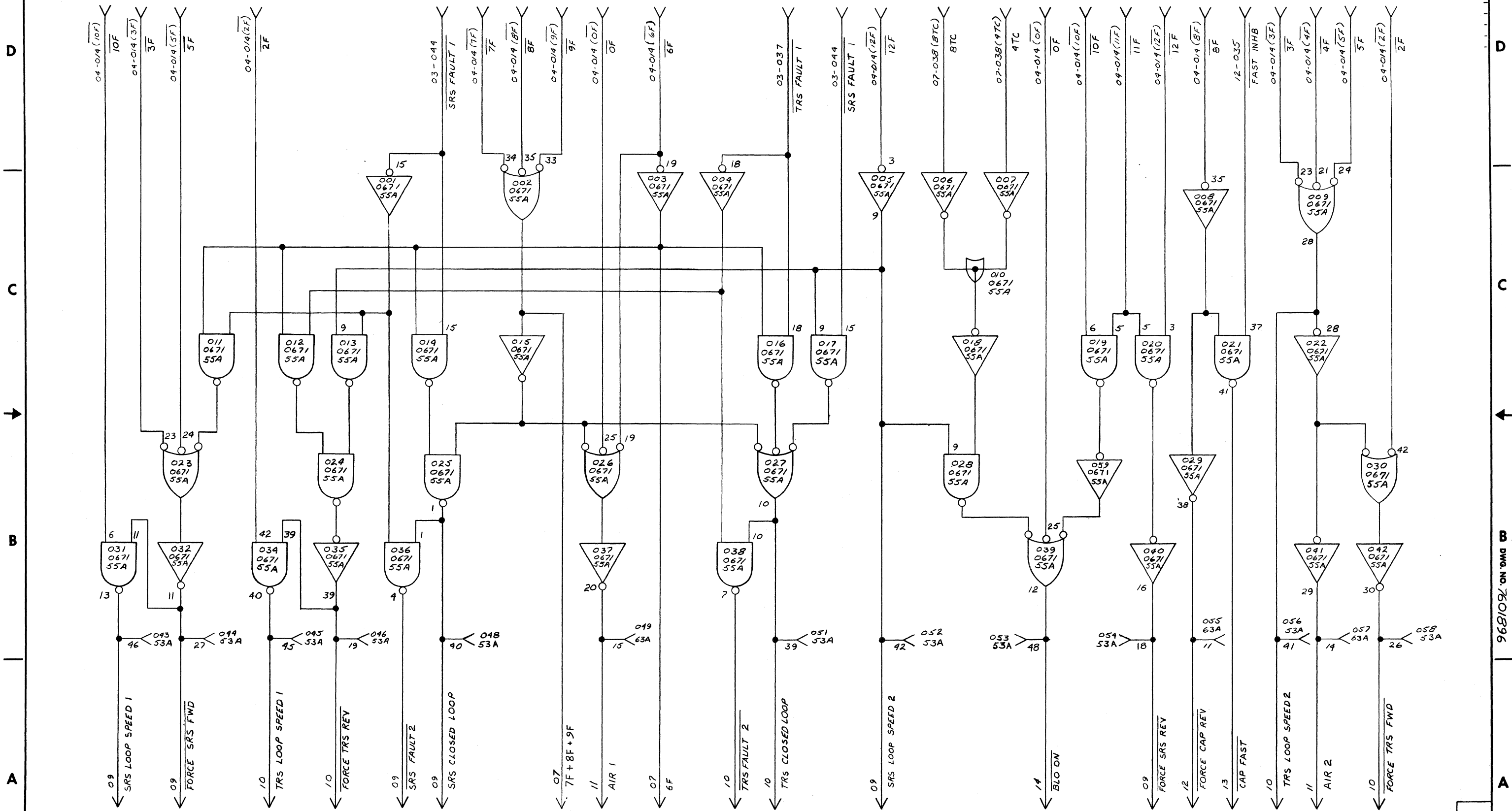

LAST UNIQUE NO. = 059

AUTO LOAD SERVO CONTROL 08

SIZE	CODE IDENT NO.	DWG NO.
D	06401	7601896
SCALE	CLASS	SHEET 8

968106 DWG NO. 7601896

NOTICE—When Government drawings, specifications, or other data are used for any purpose other than in connection with a definitely related Government procurement operation, the United States Government incurs no responsibility for any obligation whatsoever; and the fact that the Government may have furnished, furnished, or in any way supplied the said drawings, specifications or other data is not to be regarded by implication or otherwise as in any manner favoring the holder or any other person or corporation or conveying any rights or permission to manufacture, use, or sell any patented invention that may in any way be related thereto.

REVISIONS				
ZONE	LTR.	DESCRIPTION	DATE	APPD.

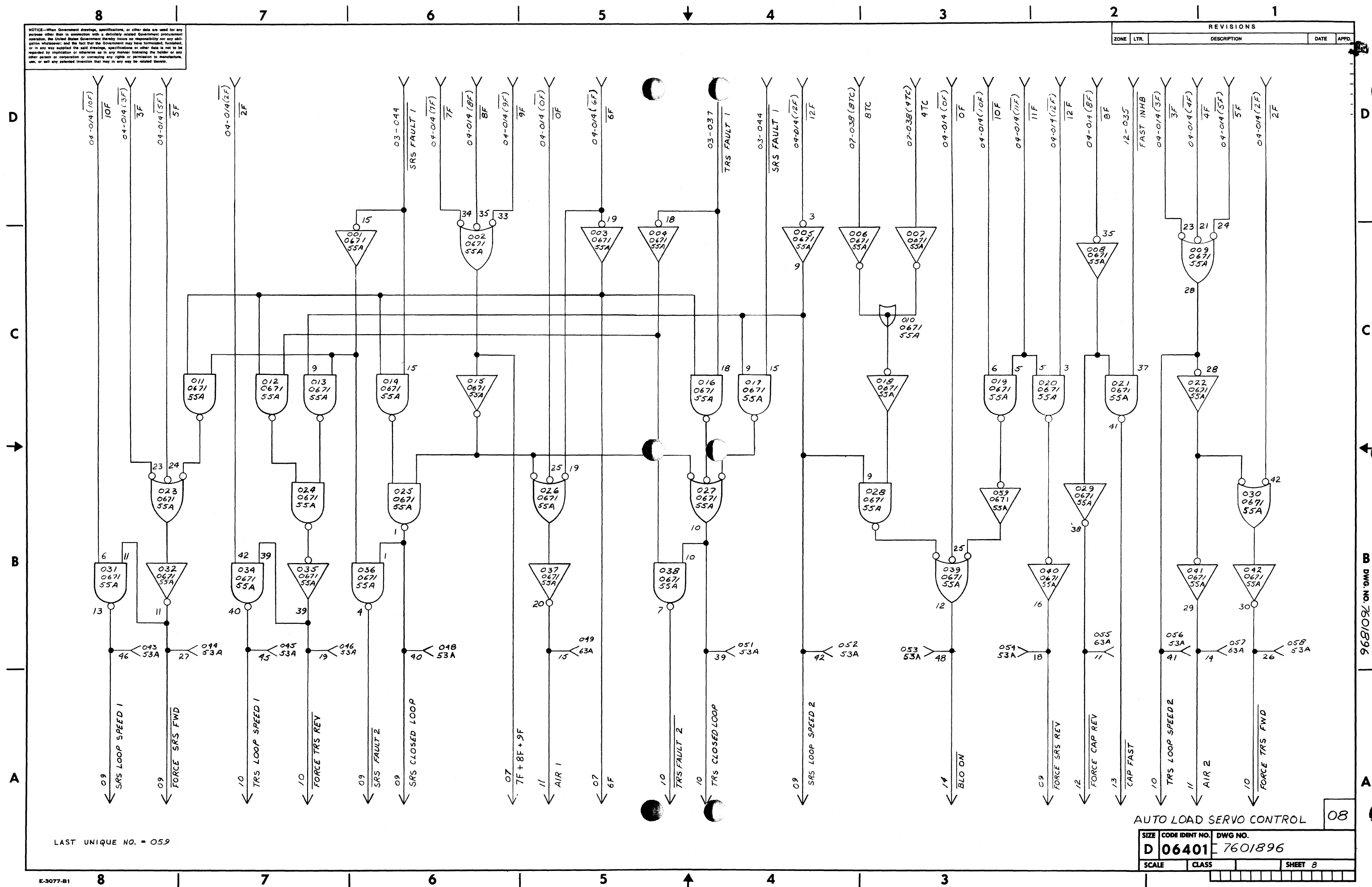

LAST UNIQUE NO. = 059

AUTO LOAD SERVO CONTROL 08

SIZE	CODE IDENT NO.	DWG NO.
D	06401	7601896
SCALE	CLASS	SHEET 8

NOTICE—When Government drawings, specifications, or other data are used for any purpose other than in connection with a definitely related Government procurement operation, the United States Government thereby incurs no responsibility nor any obligation whatsoever; and the fact that the Government may have furnished, furnished, or in any way supplied the said drawings, specifications or other data is not to be regarded by implication or otherwise as in any manner licensing the holder or any other person in or to the use, manufacture, sale, or in any way the disclosure, reproduction, use, or all any patented invention that may in any way be related thereto.

REVISIONS				
ZONE	LTR.	DESCRIPTION	DATE	APPD.

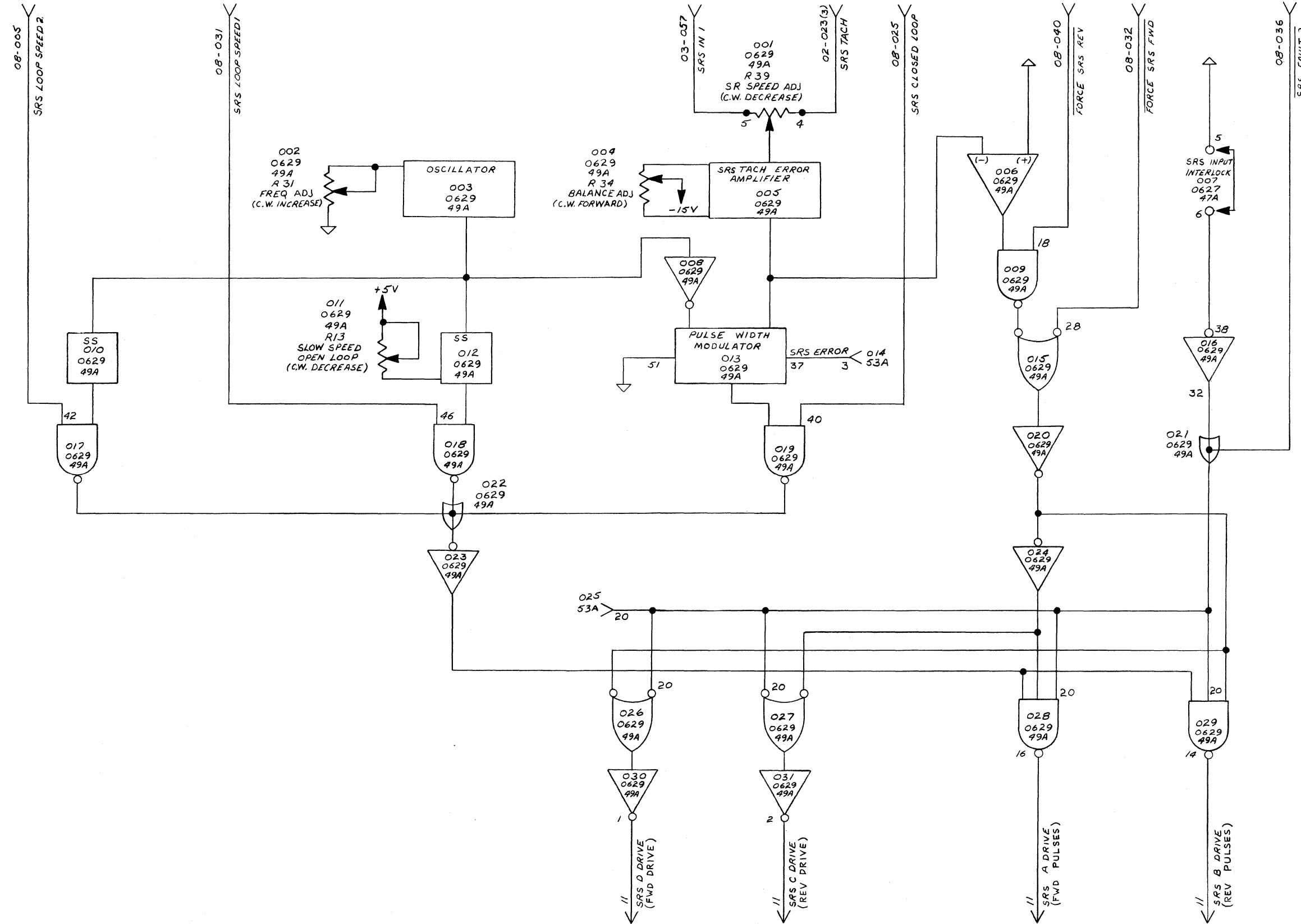

REEL SERVO OUTPUT 09

SIZE	CODE IDENT NO.	DWG NO.
D	06401	7601896
SCALE	CLASS	SHEET 9

NOTICE—When Government drawings, specifications, or other data are used for any purpose other than in connection with a definitely related Government procurement operation, the United States Government thereby incurs no responsibility for any obligation whatsoever; and the fact that the Government may have formulated, furnished, or in any way supplied the said drawings, specifications or other data is not to be regarded by implication or otherwise as in any manner licensing the holder or any other person or corporation or conveying any rights or permission to manufacture, use, or sell any patented invention that may in any way be related thereto.

REVISIONS				
ZONE	LTR.	DESCRIPTION	DATE	APPROVED

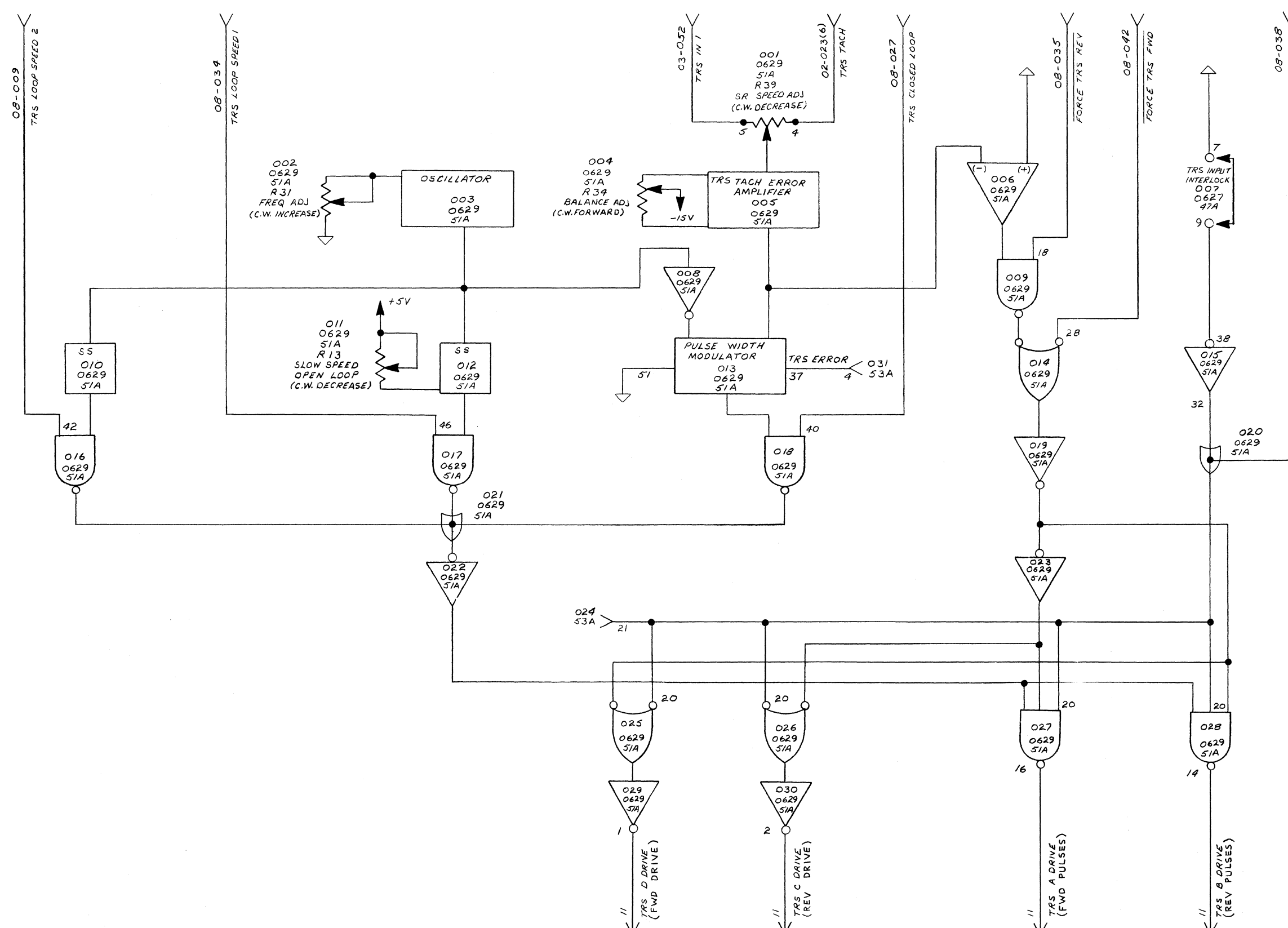

REEL SERVO OUTPUT

10

SIZE	CODE IDENT NO.	DWG NO.
D	06401	7601896
SCALE	FORM	SHEET 10

8

7

6

5

4

3

2

1

NOTICE: When Government drawings, specifications, or other data are used for any purpose other than in connection with a definitely related Government procurement operation, the United States Government thereby incurs no responsibility for any obligation whatsoever; and the fact that the Government may have furnished, furnished, or in any way supplied the said drawings, specifications or other data is not to be regarded by implication or otherwise as in any manner licensing the holder or any other person or corporation or conveying any rights or permission to manufacture, use, or sell any patented invention that may in any way be related thereto.

REVISIONS				
ZONE	LTR.	DESCRIPTION	DATE	APPD.

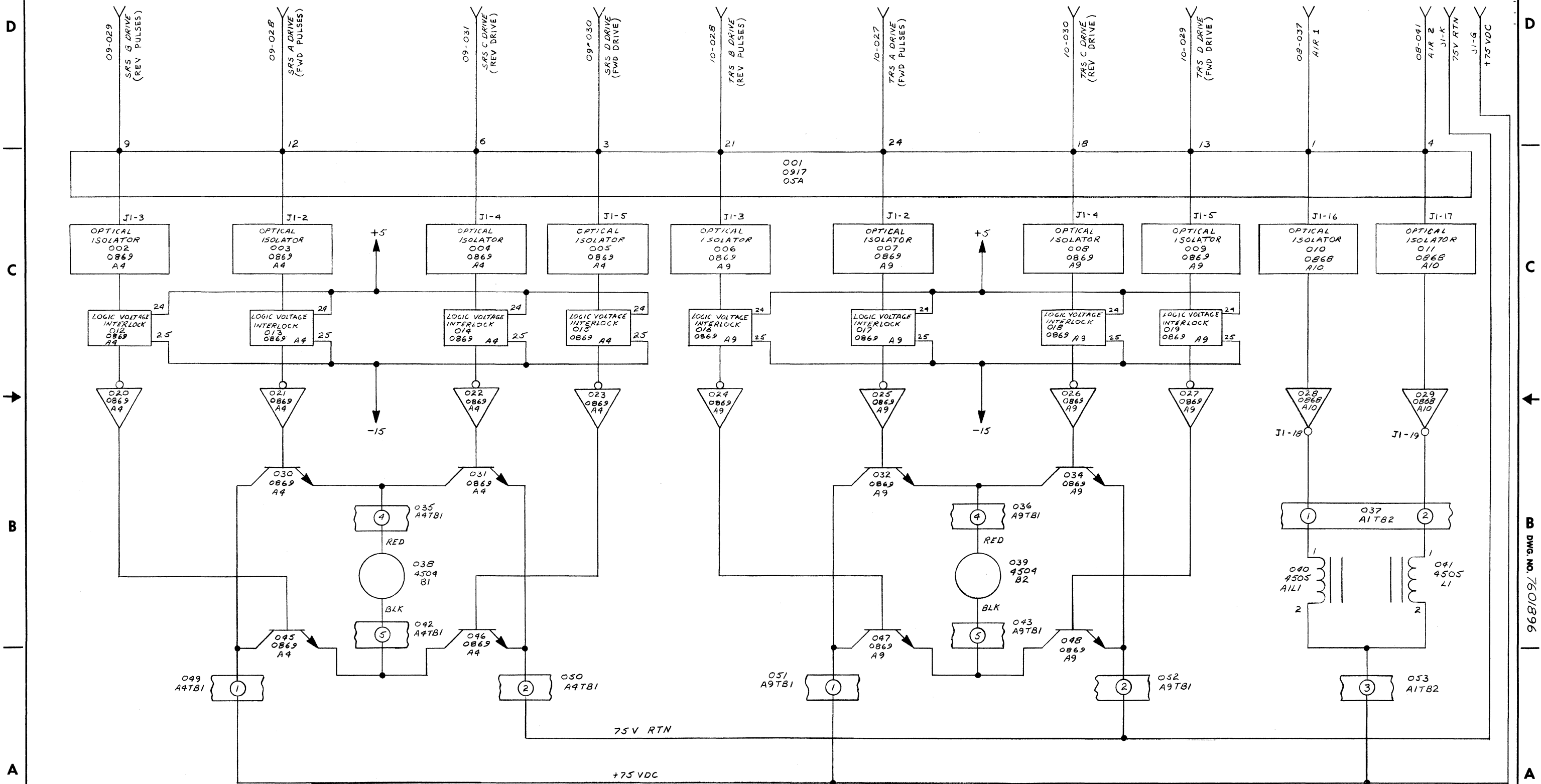

REEL DRIVERS

11

SIZE	CODE IDENT NO.	DWG NO.
D	06401	7601896
SCALE	CLASS	SHEET 11

8

7

6

5

4

3

NOTICE—When Government drawings, specifications, or other data are used for any purpose other than in connection with a definitely related Government procurement operation, the United States Government thereby incurs no responsibility for any obligation whatsoever; and the fact that the Government may have furnished, furnished, or in any way supplied the said drawings, specifications or other data is not to be regarded by implication or otherwise as in any manner licensing the holder or any other person or corporation or conveying any rights or permission to manufacture, use, or sell any patented invention that may in any way be related thereto.

REVISIONS			
ZONE	LTR.	DESCRIPTION	DATE

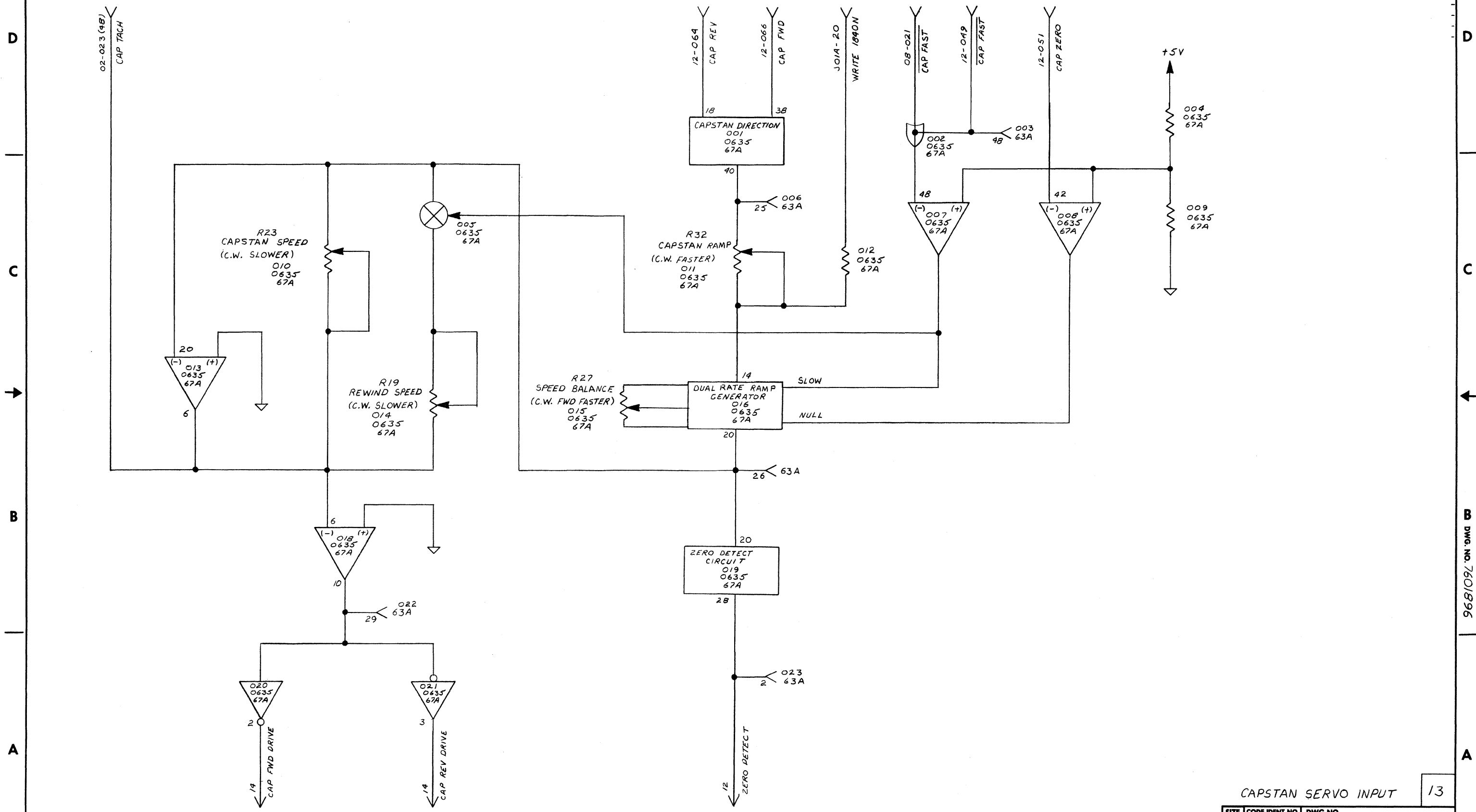

CAPSTAN SERVO INPUT		13
SIZE	CODE IDENT NO.	DWG NO.
D	06401	7601896
SCALE	CLASS 3	SHEET 13

NOTICE—When Government drawings, specifications, or other data are used for any purpose other than in connection with a definitely related Government procurement operation, the United States Government hereby incurs no responsibility for any obligation whatsoever; and the fact that the Government may have furnished, furnished, or in any way supplied the said drawings, specifications or other data is not to be regarded by implication or otherwise as in any manner licensing the holder or any other person or corporation or conveying any rights or permission to manufacture, use, or sell any patented invention that may in any way be related thereto.

REVISIONS				
ZONE	LTR.	DESCRIPTION	DATE	APPD.

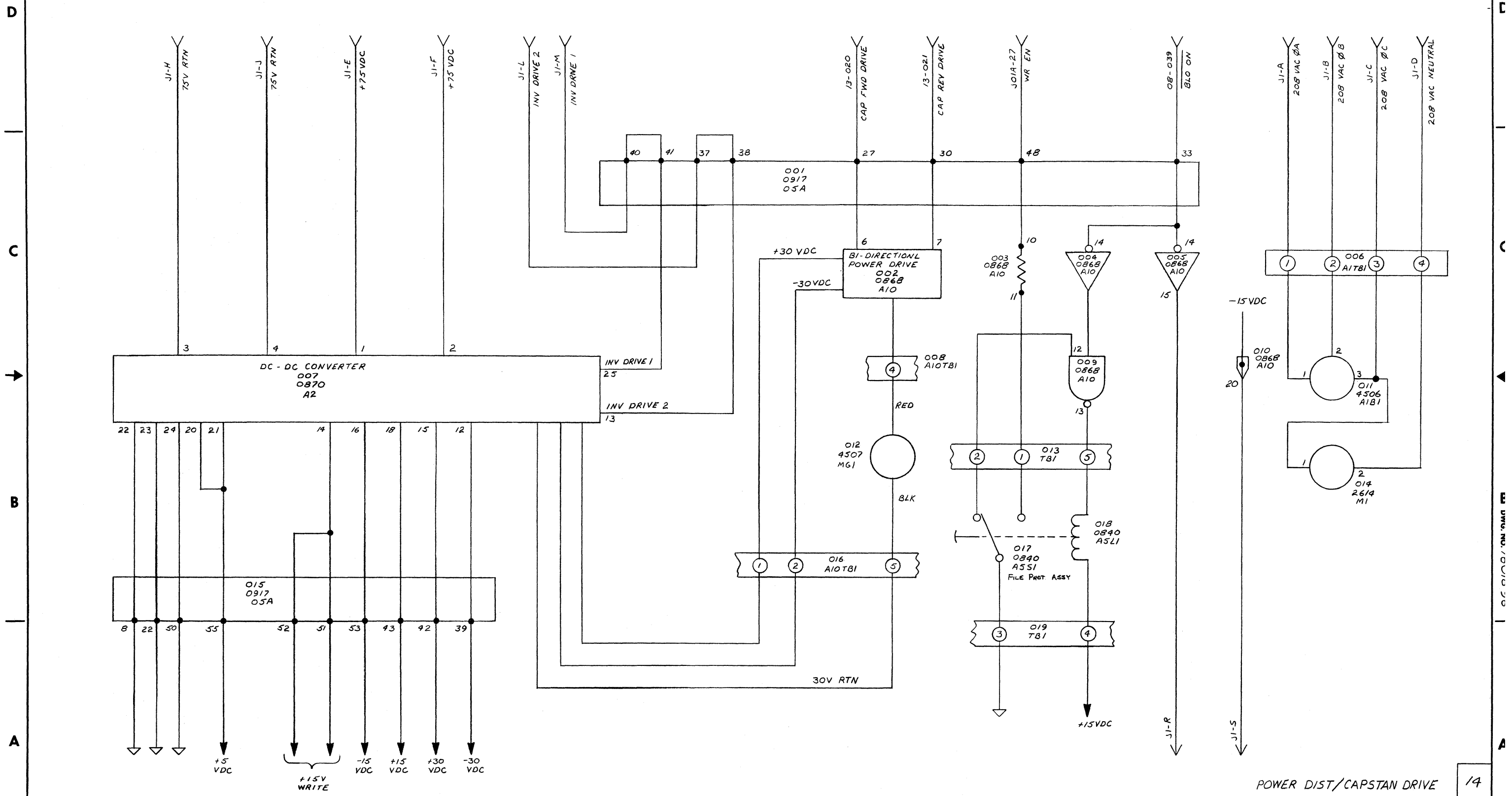

POWER DIST/CAPSTAN DRIVE 14

SIZE	CODE IDENT NO.	DWG NO.
D	06401	7601896
SCALE	CLASS	SHEET 14

8

7

6

5

4

3

2

1

NOTICE—When Government drawings, specifications, or other data are used for any purpose other than in connection with a definitely related Government procurement operation, the United States Government thereby incurs no responsibility or any obligation whatsoever; and the fact that the Government may have furnished, furnished, or in any way supplied the said drawings, specifications or other data is not to be regarded by implication or otherwise as in any manner licensing the holder or any other person or corporation or conveying any rights or permission to manufacture, use, or sell any patented invention that may in any way be related thereto.

REVISIONS				
ZONE	LTR.	DESCRIPTION	DATE	APPD.

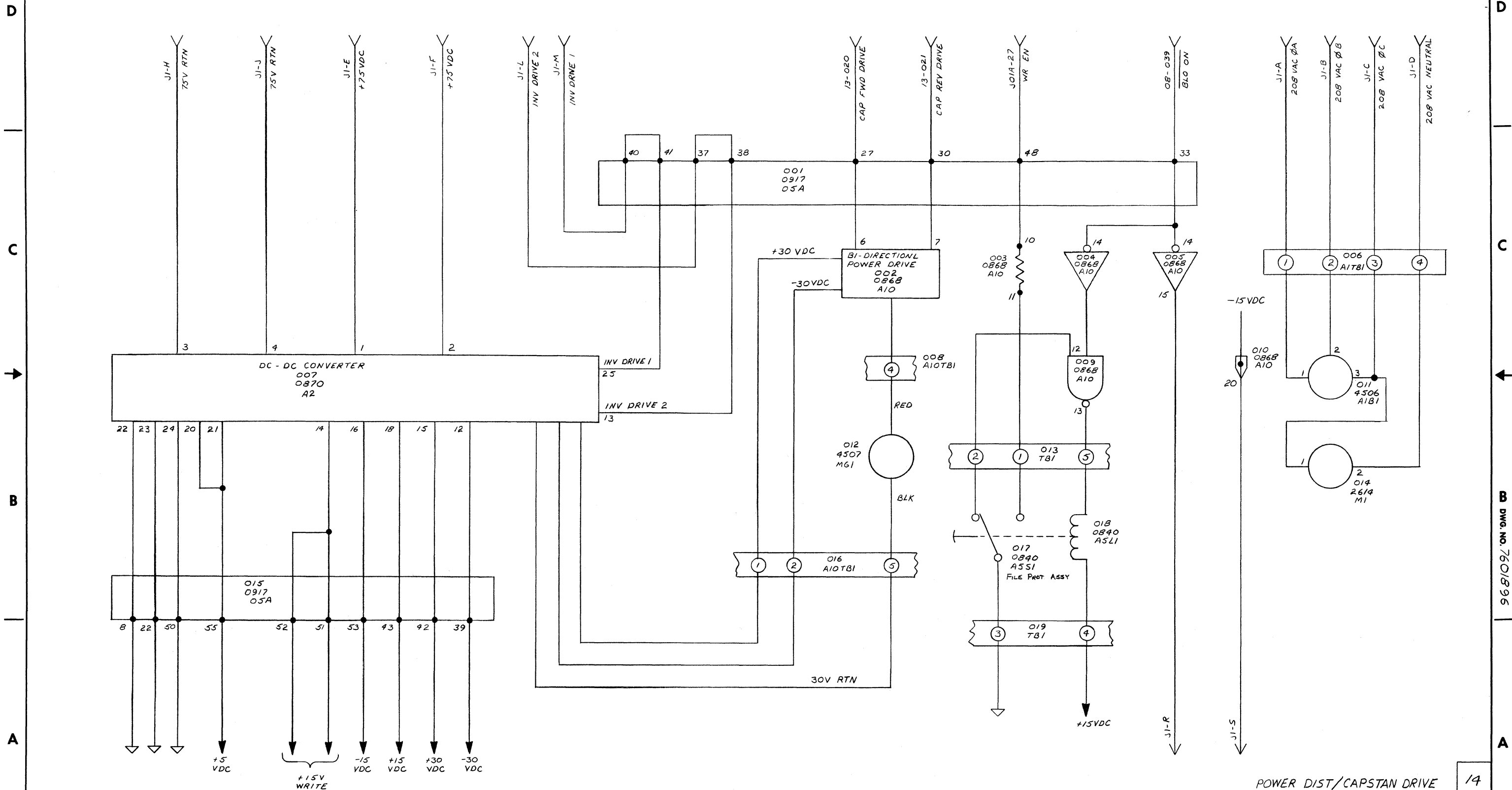

POWER DIST/CAPSTAN DRIVE 14

SIZE	CODE IDENT NO.	DWG NO.
D	06401	7601896
SCALE	CLASS	SHEET 14

NOTICE—When Government drawings, specifications, or other data are used for any purpose other than in connection with a definitely related Government procurement operation, the United States Government hereby disclaims any responsibility for any obligation whatsoever; and the fact that the Government may have furnished, furnished, or in any way supplied the said drawings, specifications or other data is not to be regarded by implication or otherwise as in any manner indicating the holder or any other person in connection or conveying any rights or privileges in manufacture, use, or sale of patented inventions that may in any way be related thereto.

REVISIONS				
ZONE	LTR.	DESCRIPTION	DATE	APPD.

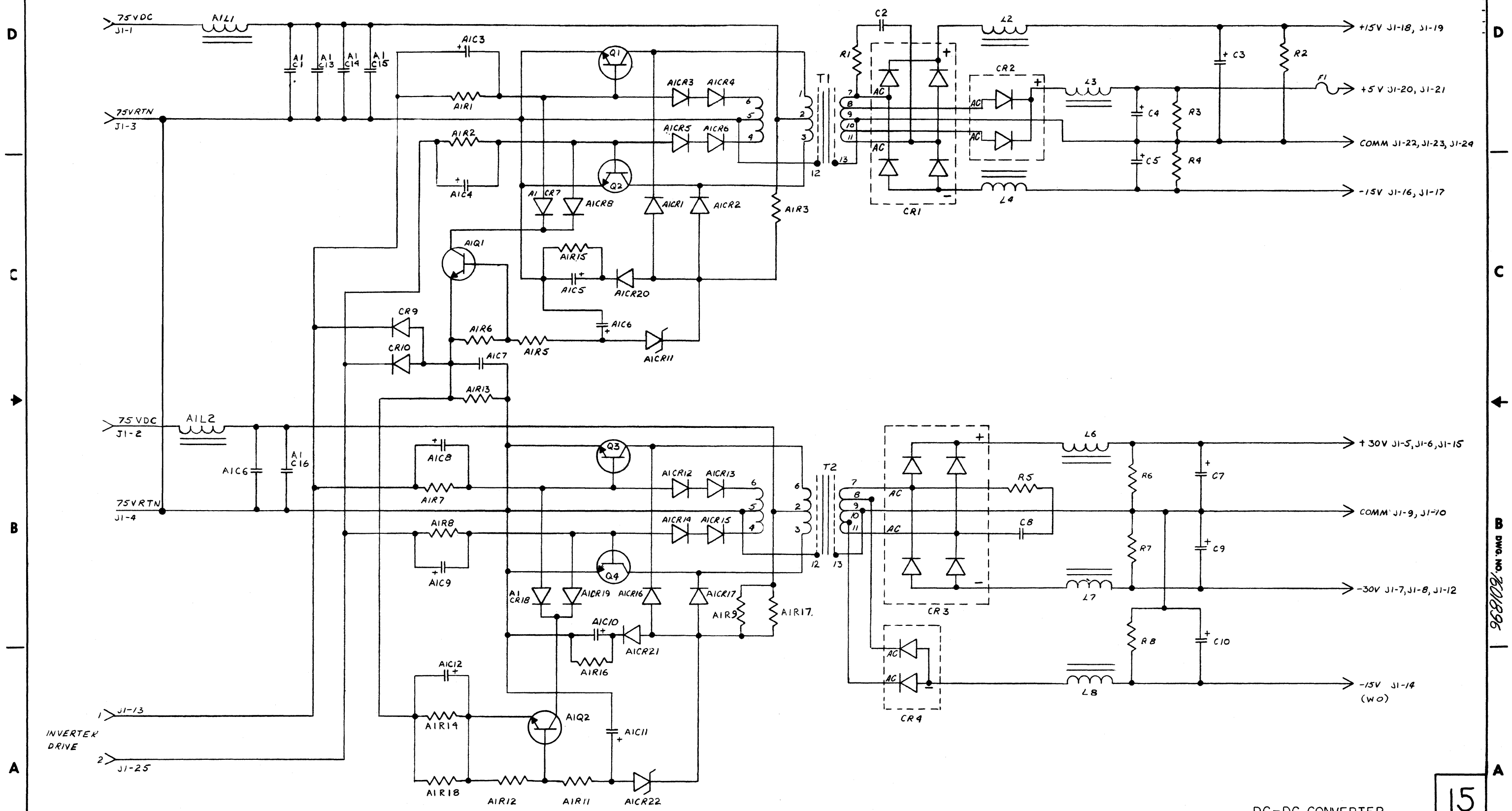

DC-DC CONVERTER

15

SIZE	CODE IDENT NO.	DWG NO.
D	06401	7601896
SCALE	CLASS	SHEET 17

NOTICE - When Government drawings, specifications, or other data are used for any purpose other than in connection with a definitely related Government procurement operation, the United States Government hereby incurs no responsibility for any dissemination whatsoever, and the fact that the Government may have furnished, furnished, or in any way supplied the said drawings, specifications or other data is not to be regarded as an endorsement or approval as in any manner indicating the holder or any other person or corporation or conveying any right or permission to manufacture, use, or sell any patented invention that may in any way be related thereto.

REVISIONS				
ZONE	LTR.	DESCRIPTION	DATE	APPD.
A		SEE EIR E-6885	6-21-73	CMV

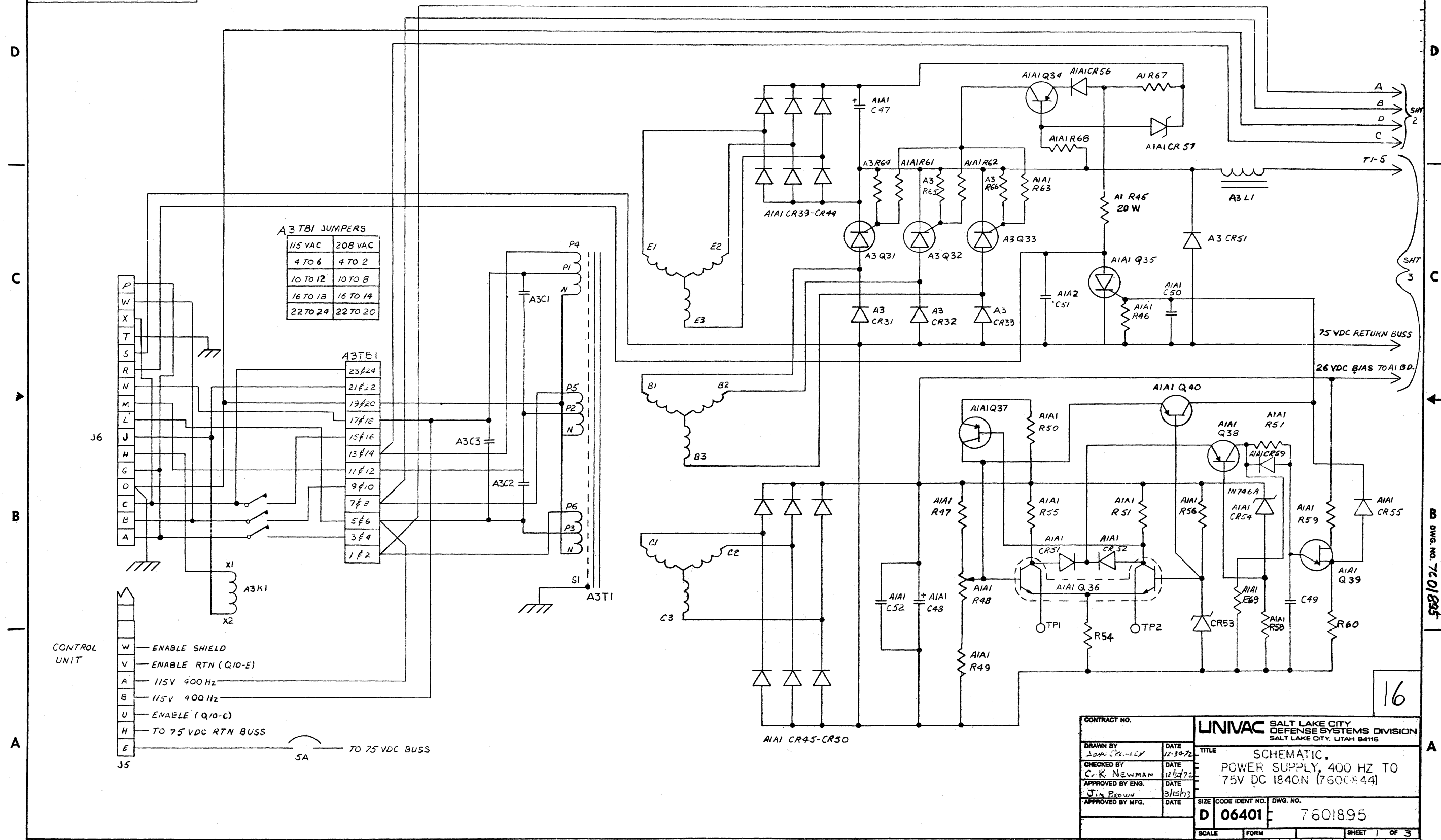

A3 TBI JUMPERS

115 VAC	208 VAC
4 TO 6	4 TO 2
10 TO 12	10 TO 6
16 TO 18	16 TO 14
22 TO 24	22 TO 20

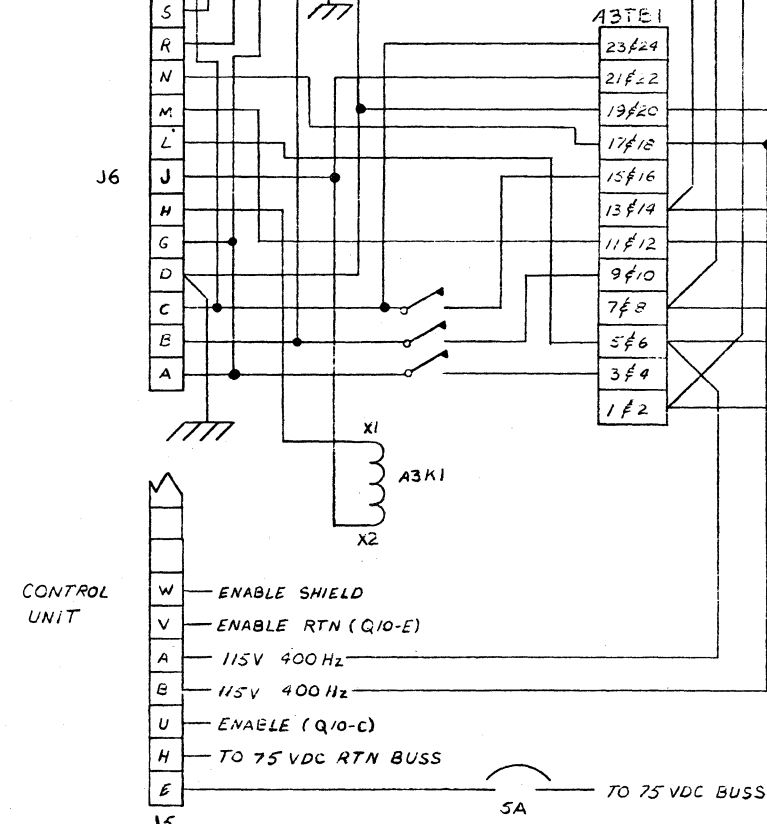

CONTRACT NO.		UNIVAC SALT LAKE CITY DEFENSE SYSTEMS DIVISION SALT LAKE CITY, UTAH 84116	
DRAWN BY L. M. CRAWLEY	DATE 12-30-72	TITLE SCHEMATIC, POWER SUPPLY, 400 HZ TO 75V DC 1840N (7600844)	
CHECKED BY C. K. NEWMAN	DATE 12-29-72	APPROVED BY ENG. DATE 3/15/73	
APPROVED BY MFG.	DATE	APPROVED BY MFG.	
D 06401		DWG. NO. 7601895	
SCALE	FORM	SHEET	OF 3

NOTICE—When Government drawings, specifications, or other data are used for any purpose other than in connection with a definitely related Government procurement operation, the United States Government thereby incurs no responsibility for any application whatsoever; and the fact that the Government may have formulated, furnished, or in any way supplied the said drawings, specifications or other data is not to be regarded by implication or otherwise as in any manner favoring the holder or any other person or corporation or conveying any rights or permission to manufacture, use, or sell any patented invention that may in any way be related thereto.

REVISIONS				
ZONE	LTR.	DESCRIPTION	DATE	APPD.

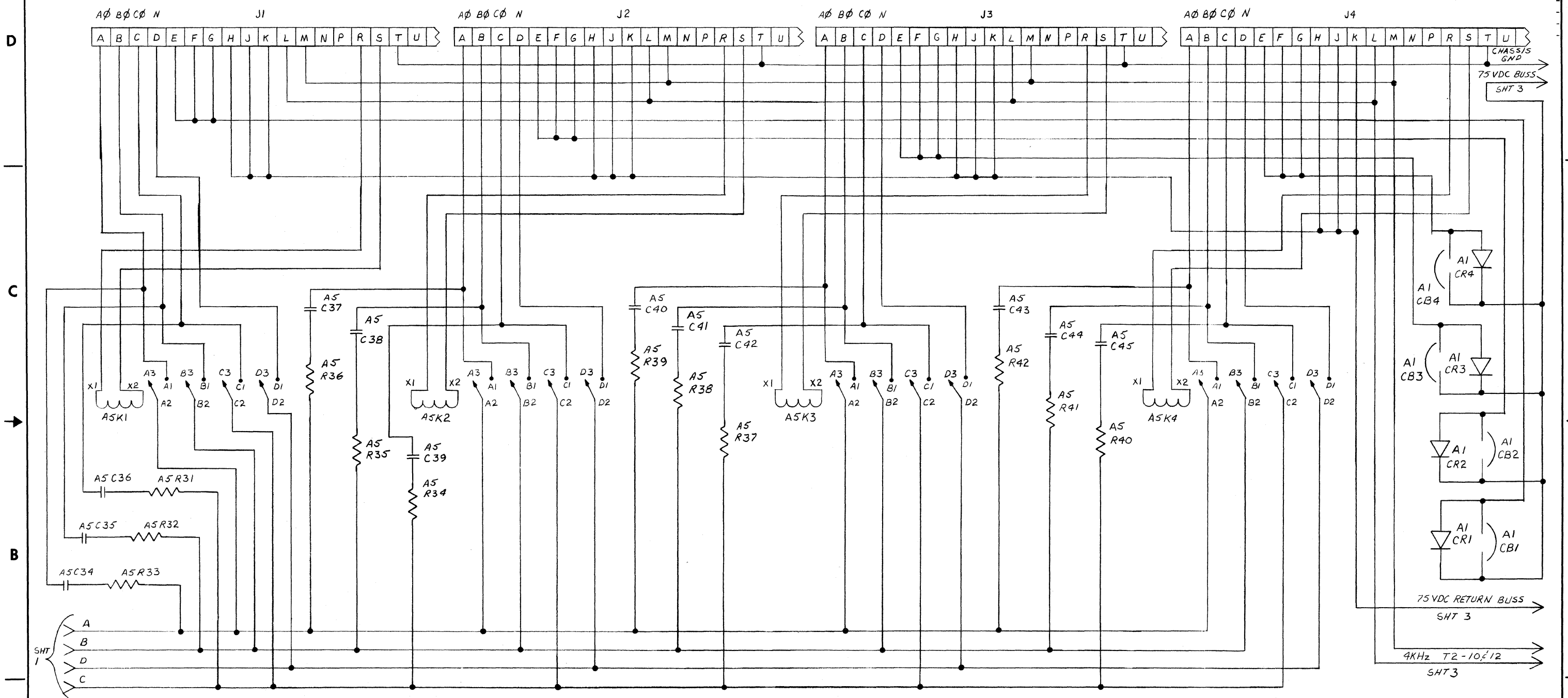

17

SIZE	CODE IDENT NO.	DWG NO.
D	06401	7601895
SCALE	CLASS	SHEET 2

8

7

6

5

4

3

2

1

NOTICE—When Government drawings, specifications, or other data are used for any purpose other than in connection with a definite related Government procurement transaction, the United States Government hereby incurs no responsibility for any distribution whatsoever; and the fact that the Government may have furnished, furnished, or in any way supplied the said drawings, specifications or other data is not to be regarded as an endorsement or approval in any manner of the holder or any other person or corporation or conveying any rights or permission to manufacture, use, or sell any patented invention that may in any way be related thereto.

REVISIONS				
ZONE	LTR.	DESCRIPTION	DATE	APPD.

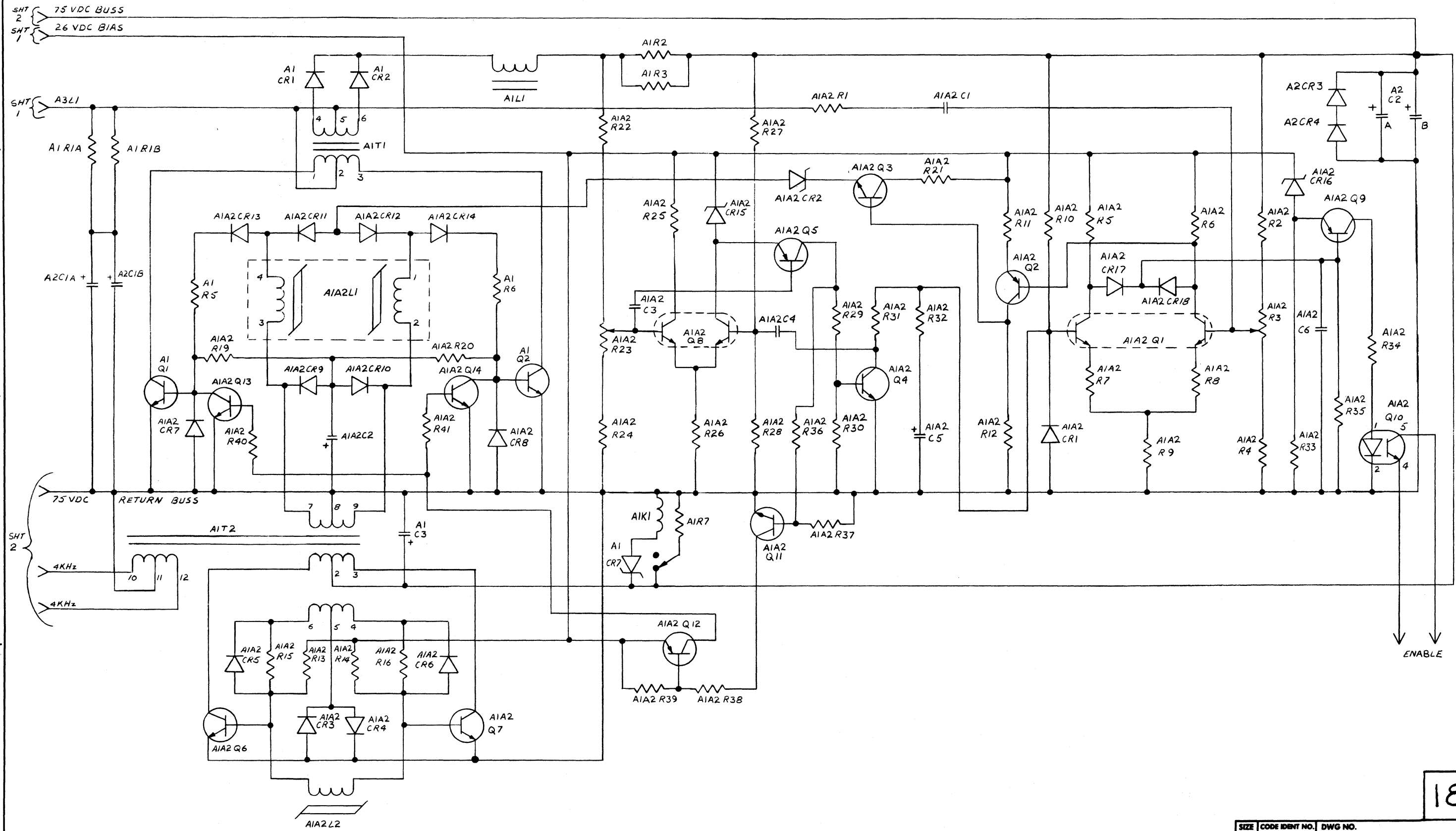

B Dwg. No. 7601895

18

SIZE	CODE IDENT NO.	DWG NO.
D	06401	7601895
SCALE	CLASS	SHEET 3

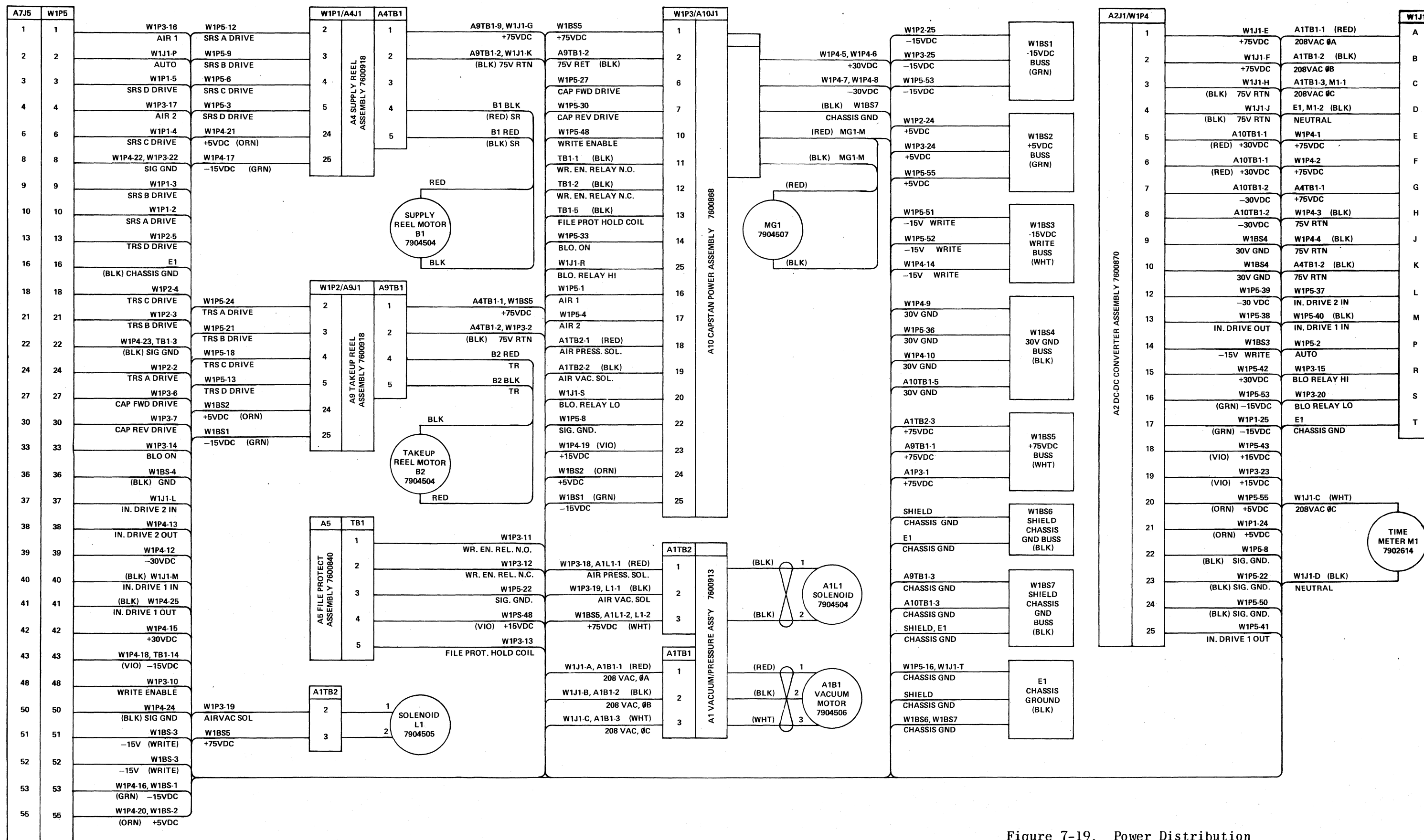

Figure 7-19. Power Distribution

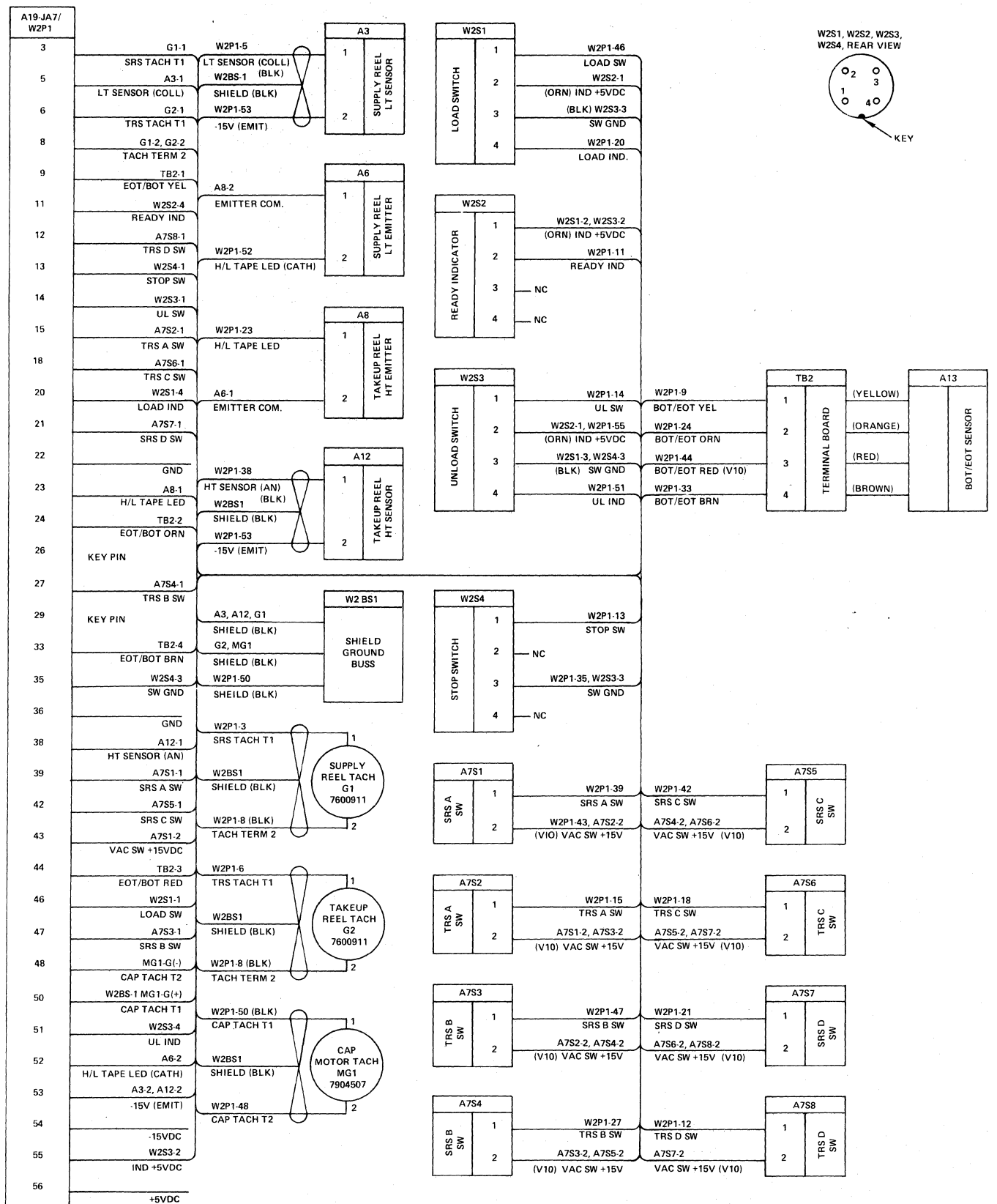

Figure 7-20. Signal Distribution