

3-209. KEYBOARD OPERATION, GENERAL.

For off-line operations, the keyboard operation is initiated by depressing KEYBOARD and PUNCH indicator switches on the I/O Console control panel. When these indicator switches are depressed, power is applied to the keyboard/printer and punch motors.

3-210. When a key is depressed at the keyboard, the serializer is initiated, SERIALIZER READY F/F cleared, and KEYBOARD INPUT READY F/F set. After 81.81 msec, the data has been gated serially to the input register and to the printer. At this time SERIALIZER READY F/F is set, then the KEYBOARD REQUEST ENABLE F/F and OFF-LINE READ ONE F/F are set. With OFF-LINE READ ONE F/F set, an output acknowledge occurs to allow the input register to be gated to the output register and to set the TAPE FEED F/F. When the punch sync pulse occurs, data is gated to the punch. Four msec after the start of the sync pulse, the TAPE FEED F/F is cleared to generate a simulated input acknowledge. Then the output register, input register, KEYBOARD INPUT READY F/F, KEYBOARD REQUEST ENABLE F/F, and INTERRUPT F/F are cleared. When the next key is depressed at the keyboard, the same action takes place.

3-211. KEYBOARD OPERATION, DETAILED.

Refer to operational flow diagram (figure 3-55) and referenced functional schematic diagrams for the following discussion of off-line operations.

3-212. Light KEYBOARD Indicator and Start Printer Motor. Depressing the KEYBOARD indicator switch (DS 23, figure 5-6) disables one side of 27D00 (5-6, 3D). The other side is disabled by the high from 21D00 (5-6, 6B), which is present during all off-line operations. With 27D00 (5-6, 3D) completely disabled, its low output partially enables the interlocking side of KB gate 28D00 (5-6, 4B). Gate 28D00 (5-6, 4B) is fully enabled by the low from READ gate 29D00 (5-6, 5B), which is present at all times except during reader operations.

Gate 28D00 (5-6, 4B) remains enabled and holds READ gate disabled by interlocking action between the two gates. The high from 28D00 (5-6, 4B) lights DS 23 and is inverted to a low by 33D00 (5-6, 4B). This low is inverted by 34D00 (5-6, 4C) which is inverted by 50D01 (5-6, 8B). The low from 50D01 (5-6, 8B) energizes PRINTER relay (K2, figure 5-13). When K2 is energized, it completes a 115-VAC, 60-Hz path to keyboard/printer input A7P1-Z and starts the keyboard/printer motor.

3-213. Clear Output Register. Refer to paragraph 3-205.

3-214. Set PUNCH F/F and Start Punch Motor. Refer to paragraph 3-187.

3-215. Set PUNCH READY F/F. Refer to paragraphs 3-188 and 3-190.

3-216. Keyboard Coding. When a key is depressed, a train of 11 pulses arrive serially from the keyboard. These pulses are referred to as spaces or marks. To further understand the composition of these pulse trains, see figure 3-52. The first pulse, or start pulse is a space, which is followed by seven consecutive data pulses. These seven data pulses are a combination of spaces and marks, depending upon the ASCII code combination for the key depressed. Following these seven data pulses is parity and two stop pulses. The parity pulse and stop pulses are always marking. Since each pulse is 9.09 msec in length, each complete character received from the keyboard has a coded length of 99.99 msec.

3-217. Clear KEYBOARD DATA F/F and Initiate Serializer. The low when KB signal from 33D00 (5-6, 4B) partially enables gate 30H01 (5-7, 8B). When a key is depressed at the keyboard, the first pulse, or start pulse, is received by the I/O Console control circuits as a low when KB DATA, SPACE signal which fully enables 30H01 (5-7, 8B) to clear KEYBOARD DATA F/F OXH01 (5-7, 8B).

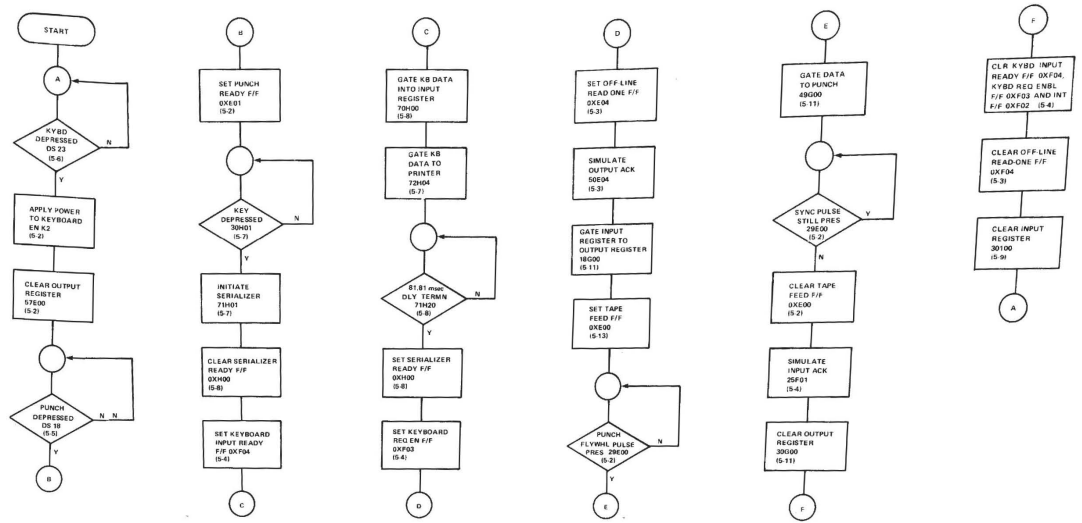

Figure 3-55. Off-Line Keyboard/Printer-Punch, Operational Flow Sequence Diagram.

3-218. Enable Serializer. The high from KEYBOARD DATA F/F OXH01 (5-7, 8B) is inverted by 71H00 (5-7, 7C) to partially enable 71H01 (5-7, 7C).

3-219. Initiate Serializer and Clear SERIALIZER READY F/F. Gate 71H01 (5-7, 7C) is fully enabled by the low when SERIAL CONVERTER READY line. A low is present on this line at all times except when SERIALIZER READY F/F OXH00 (5-8, 3C) is cleared. When 71H01 (5-7, 7C) is enabled, its low output is delayed 2 μ sec by circuits 74H61 (5-7, 7C) and 74H62 (5-7, 7C) and routed to figure 5-8 to clear OXH00 (5-8, 3C). With OXH00 (5-8, 3C) cleared, the high on the low when SERIAL CONVERTER READY output disables 71H01 (5-7, 7C). Gate 71H01 therefore produces a 2 μ sec low output whenever it is enabled. This 2 μ sec negative pulse from 71H01 (5-7, 7C) initiates the serializer action necessary for keyboard/prINTER operation.

3-220. Set KEYBOARD INPUT READY F/F and Remove Clear Input Register Signal. Gate 20F04 (5-4, 8C) is partially enabled by the low when EN GATE INPUT DATA signal from READ gate 29D00 (5-6, 5B). The high from KEYBOARD gate 28D00 (5-6, 4B) is inverted to a low by 18F04 (5-4, 7B). As described in paragraph 3-204, SERIALIZER READY F/F OXH00 (5-8, 3C) is cleared 2 μ sec after a key is depressed. The low when KB stroke from its clear side output is inverted by 20F03 (5-4, 7B) and reinverted to a low by 19F04 (5-4, 7B). When 18F04 (5-4, 8B) and 19F04 (5-4, 7B) are both producing lows, their combined outputs further enable 20F04 (5-4, 8C). Gate 20F04 (5-4, 8C) is fully enabled by the low from the clear side of KEYBOARD REQ ENABLE F/F OXF03 (5-4, 7C) (which is cleared at this time). The low output from 20F04 (5-4, 8C) sets KEYBOARD INPUT READY F/F OXF04 (5-4, 8C) and is also routed to figure 5-8 as the low when GATE INPUT DATA signal where it is used to partially enable gate 70H00 (5-8, 4C).

The high from the clear side of OXF04 (5-8, 8C) disables 50F04 (5-4, 7D), removing the low when CLR INPUT REG signal output, thereby making it possible to set information into the input register flip-flops (figures 5-9 and 5-10).

3-221. Basic Serializer Operations. Refer to paragraph 3-203.

3-222. Keyboard Gating and Serial Transfer of ASCII Code to Input Register. Refer to paragraphs 3-114 and 3-115.

3-223. Serial Data Transmission to Printer. Refer to paragraph 3-125.

3-224. DATA to PRINTER Signal Generation. Refer to paragraph 3-126.

3-225. Set KEYBOARD DATA F/F and SERIALIZER READY F/F. Refer to paragraphs 3-116 and 3-117.

3-226. Set KEYBOARD REQ ENABLE F/F. Refer to paragraph 3-117.

3-227. Set OFF-LINE READ ONE F/F and Simulate Output Acknowledge. With KEYBOARD REQ ENABLE F/F OXF03 (5-4, 7C) set, the low when SET OFF-LINE READ ONE F/F signal from its set side OFF-LINE READ ONE F/F signal from its set side of OFF-LINE READ ONE F/F OXE04 (5-3, 6B), providing a low to 50E04 (5-3, 5C) which has been partially enabled. Gate 50E04 (5-3, 5C) is fully enabled at this time by lows from S3-2 and S4-2, which are present during all off-line operations when READ ONE switch (S3) is not being depressed. With 50E04 (5-3, 5C) enabled, its high output simulates an output acknowledge signal.

3-228. Set TAPE FEED F/F and Remove Clear from Output Register. The high from 50E04 (5-3, 5C) is inverted by 51E04 (5-3, 3C) to partially enable 53E04 (5-3, 3D). The low from 51E04 (5-3, 3C) is also routed through 52E04 (5-3, 3C), which allows 53E04 (5-3, 3D)

to be fully enabled for 2 μ sec. The 53E04 (5-3, 3D) output is a 2 μ sec low when GATE OUTPUT DATA signal which is used to partially enable setting TAPE FEED F/F 01E00 (5-2, 4C). F/F 01E00 (5-2, 4C) is fully enabled at this time due to the low from PUNCH READY F/F OXE01 (5-2, 4B), which was previously set (refer to paragraph 3-170). The high output from TAPE FEED F/F OXE00 (5-2, 4C) lights TAPE FEED indicator switch (DS 20) and disables 53E00 (5-2, 6C). The low from 53E00 (5-2, 6C) is inverted by 57E00 (5-2, 8C), removing the low when CLR OUTPUT REG signal from its output line.

3-229. Gate Input Register to Output Register. Refer to paragraph 3-197.

3-230. Gate Data to Punch and Clear TAPE FEED F/F. Refer to paragraphs 3-199 through 3-201.

3-231. Clear Output Register. Refer to paragraph 3-190.

3-232. Simulate Input Acknowledge. Refer to paragraph 3-207.

3-233. Clear KEYBOARD INPUT READY F/F, KEYBOARD REQ ENABLE F/F, and INTERRUPT F/F. The 2 μ sec high simulated input acknowledge from 28F01 (5-4, 5B) is inverted by 29F01 (5-4, 5C) and used to clear KEYBOARD INPUT READY F/F OXF04 (5-4, 8C), KEYBOARD REQ ENABLE F/F OXF03 (5-4, 7C), and INTERRUPT F/F OXF02 (5-4, 6C).

3-234. Clear OFF-LINE READ ONE F/F. The 2 μ sec high from 28F01 (5-4, 5B) is also inverted by 30E04 (5-3, 6B) to clear OFF-LINE READ ONE F/F OXE04 (5-3, 6B), disabling generation of a simulated output at this time.

3-235. Clear Input Register. Refer to paragraphs 3-185 and 3-187.

3-236. Repetitive Keyboard Operations. When another key is depressed at the keyboard, the cycle repeats from paragraph 3-215 until the keyboard operation is terminated.

3-237. Termination of Keyboard Operations. Keyboard operations may be terminated by not pressing another key at the keyboard or by the following methods.

a. Depressing KEYBOARD CLEAR switch (S6, 5-6, 3D), PRINT CLEAR switch (S10, 5-6, 7C), and PUNCH CLEAR switch (S7, 5-5, 5D).

b. Depressing the MASTER CLEAR switch (S1, 5-3, 7B).

3-238. KEYBOARD/PRINTER.

3-239. KEYBOARD. The keyboard provides a means for converting a manually initiated mechanical action into an electrical signal. Depressing a key lever begins a series of mechanical movements that: (1) position the code bars into a unique arrangement for the particular character or function selected, and (2) engage the signal generator clutch causing the signal generator cam to open and close a set of contacts producing a string of electrical pulses peculiar to the code bar arrangement. These electrical pulses (comprised of marks and spaces) are transmitted to the logic circuitry in I/O Console and ultimately turn transistor Q10 (figure 5-13) on and off (space pulse indicates OFF, marking pulse indicates ON). Transistor Q10 controls operation of the selector magnet in the printing unit, i.e., the selector magnet is energized when Q10 is ON and deenergized when Q10 is OFF. The ON/OFF operations of the selector magnet mechanically align a second set of code bars (located in the printing unit), and eventually result in a character being printed or a function (such as Line Feed) being executed.

3-240. CODE BAR MECHANISM AND SIGNAL GENERATOR. As the code key lever (figure 3-56) is depressed, the corresponding code lever rotates about its pivot point. The rear end of the code lever comes up and rotates the code lever universal bail. This movement causes the code lever universal bail extension to

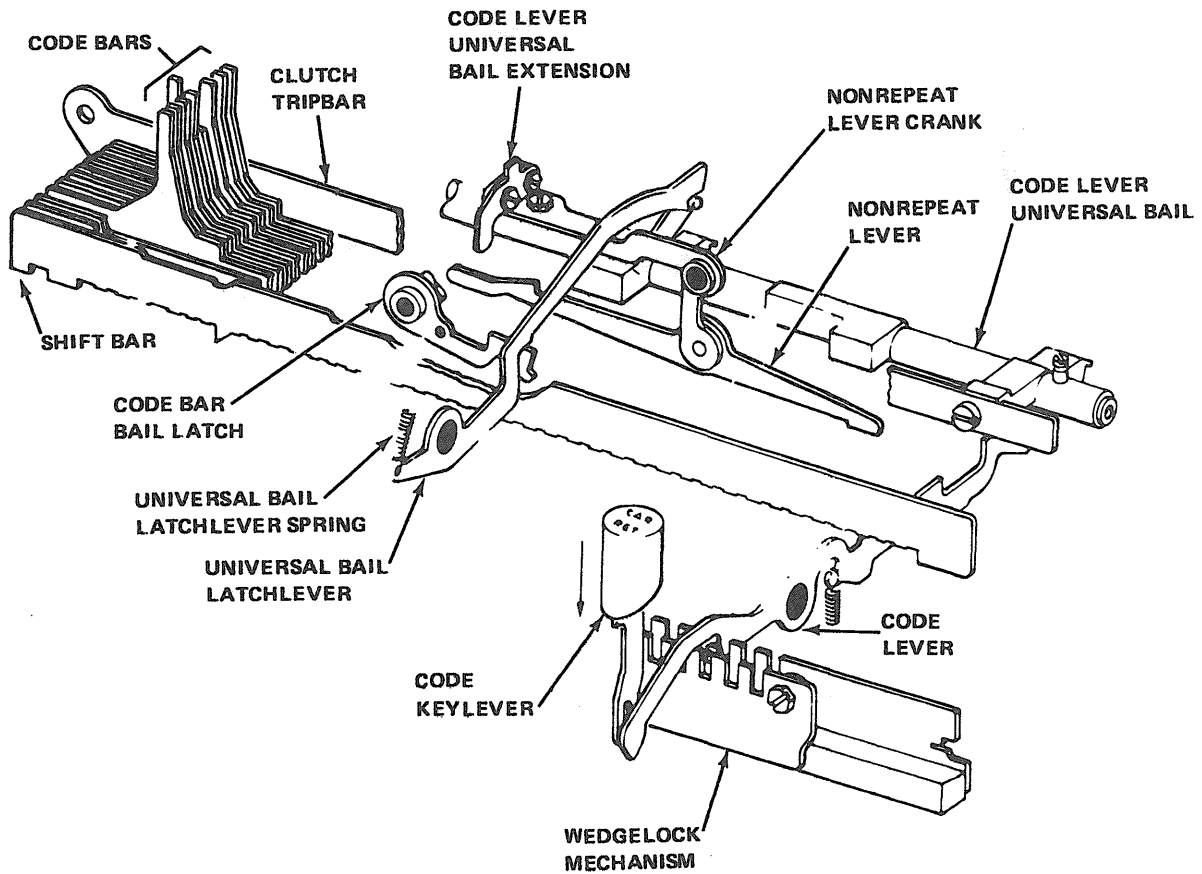

Figure 3-56. Code Bar and Code Lever Universal Bail Mechanism.

disengage with the step at the rear end of the universal bail latchlever. (This occurs when the code key lever and code lever are about two-thirds of the way toward full stroke.) The universal bail latchlever then moves downward under spring force developed by the universal bail latchlever spring. As the universal bail latchlever comes down, it strikes the code bar reset bail latchlever and carries it downward. When the corner of the code bar reset bail latchlever descends beyond the center line of the needle bearing (figure 3-57) that is mounted on the code bar reset bail, the various spring forces action on the code bar reset bail cause it to swing to the right, leaving the code bars free to move to the right if their movement has not been blocked by the code lever.

3-241. The bottom of each code bar consists of a unique series of notches and projections. Code bars whose projections strike the side of the code lever are prevented by moving to the right and are termed unselected (figure 3-58). Code bars whose notches allow them to move to the right are termed selected. The various combinations of selected and unselected code bars are what determine the graphic or function which will be generated.

3-242. Code bars have vertical extensions near their left ends that engage a curved part of the signal generator transfer levers (figure 3-59). Code bars that are permitted to move to the extreme right also move the corresponding transfer lever to the right; how-

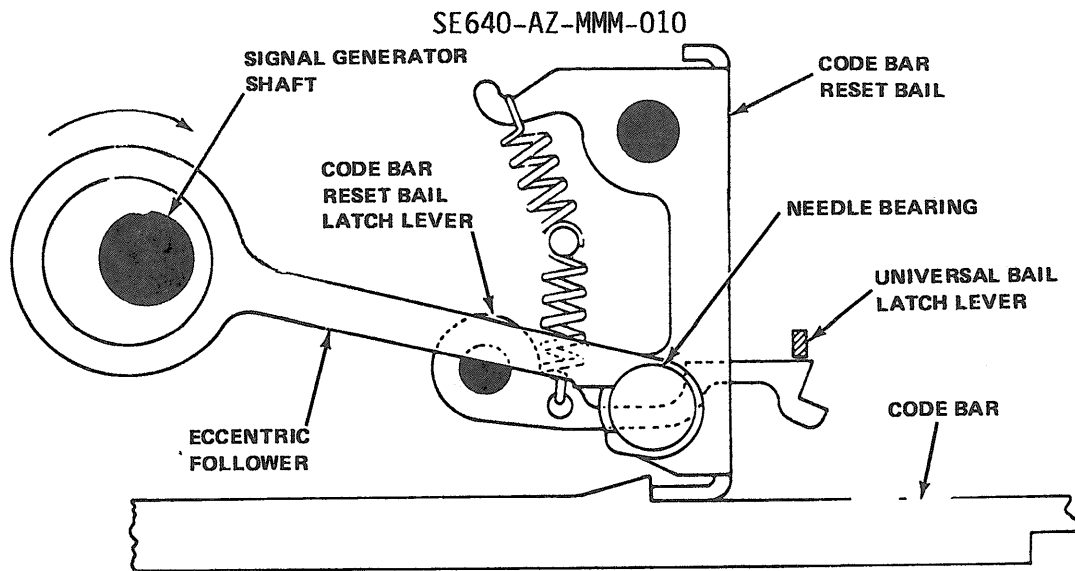

Figure 3-57. Code Bar Bail Mechanism.

ever, those code bars that are stopped because their projections engage the activated code lever, do not quite touch or move their corresponding transfer levers. Hence, those transfer levers remain in their normal left-hand position. Simultaneously with the release of the code bar reset bail and the movement of the code bars to the right, the clutch tripbar (figure 3-56), which is located in the rear slots of the code bar guides, moves to the right. This clutch tripbar engages the clutch stop lever and moves it out of latch with the clutch stop lug.

NOTE

To this point, all action has been initiated by manual operation of the keytop and its associated code lever.

3-243. Engagement of the clutch allows the signal generator drive shaft to rotate the cam assembly. The cam assembly is mounted within the transfer lever mechanism (figure 3-59), and the lobe on each cam operates its associated transfer lever.

NOTE

When viewed from the front, the cam assembly rotates in a clockwise direction.

3-244. The arrangement of the cam assembly is such that when it begins to rotate, the fourth cam from the rear begins to push downward on its corresponding transfer lever (figure 3-59). At almost the same time, the first cam from the front, whose lobe normally holds the locking bail down, rotates slightly and allows the locking bail spring to begin pulling the locking bail upward. Full lock position occurs at approximately the halfway point of the start pulse (48.5° of rotation).

3-245. The blade portion of the locking bail goes up beside a downward projection on each transfer lever. The locking projection is to the right of the locking bail on selected transfer levers, and to the left of the locking bail on those not selected. Thus, during the first few degrees of cam rotation, the transfer levers are locked into position, and the code bars and clutch tripbar are free to be reset to their normal latched position.

3-246. The cams and their corresponding transfer levers are numbered from rear to front. The number 4 cam engages its transfer lever first, and forces it down. Since the start pulse is always spacing, no code bar is required to engage this lever. Hence, it is always held to the left by its spring. As the fourth cam moves the lever down, the

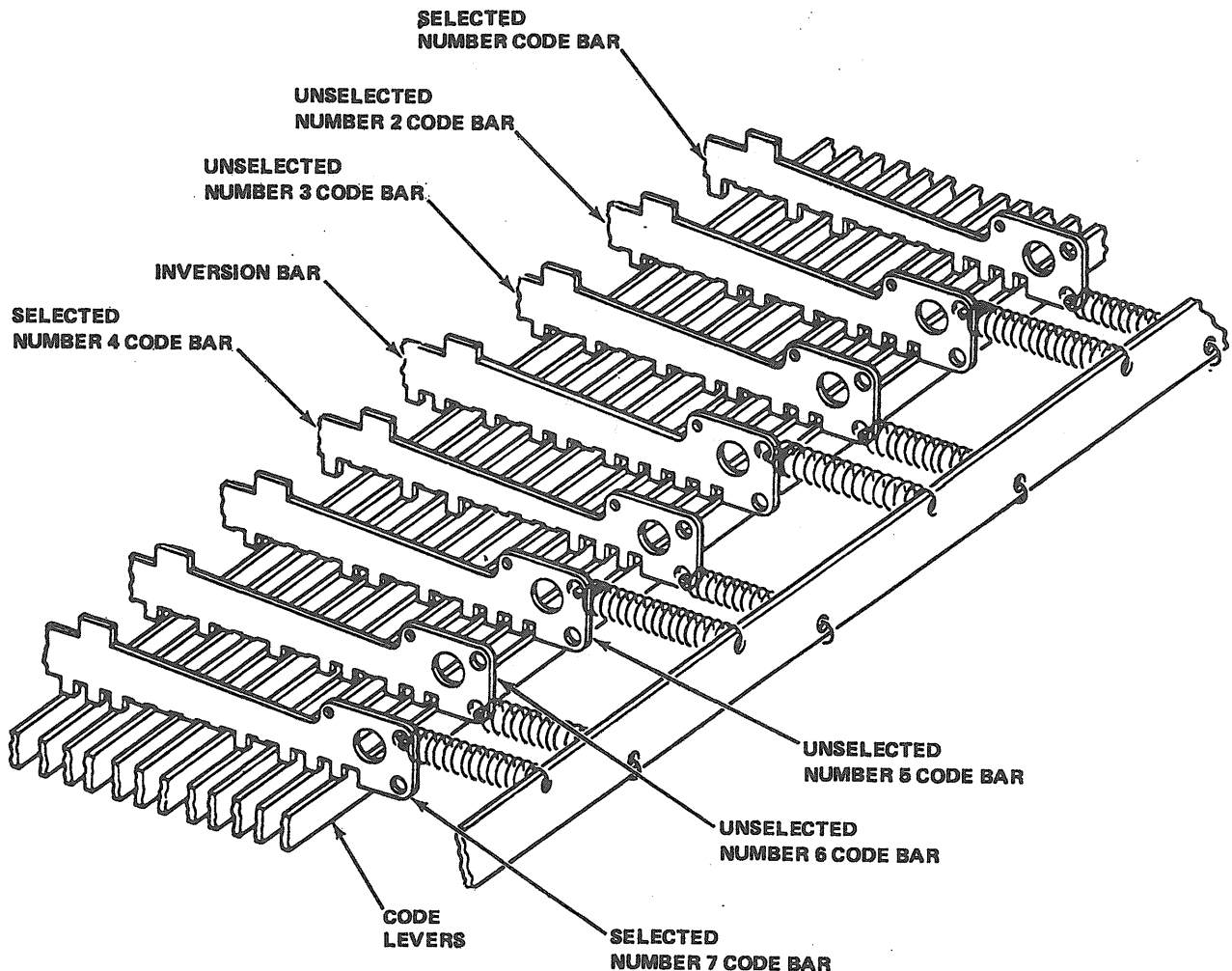

Figure 3-58. Code Bar Selection.

hook at the upper right side of the transfer lever engages the right side of the transfer (rocker) bail. This tips the transfer bail to the right and pulls the contact drive link to the right. The resulting action of the contact toggle is such that the left set of the contacts acts as a pivot and the right hand contacts begin to open. When these contacts are open, no current is present in the signal circuit. Therefore, the first pulse (start pulse) of any character code is a spacing (no current) pulse.

3-247. Next, the number 1 cam and the transfer lever move downward. In turn, the upper left hook of the associated transfer lever pulls down on the rocker bail (holding it to the right or tilting it back to the left). This pushes the drive link to the left (or right), closing the right (or left) contacts and allowing a marking (spacing) pulse to be transmitted. Similarly, the remaining transfer levers are pulled downward by their respective cams. The resulting pulse is marking if the transfer lever is to the right, or spacing if it is to

SE640-AZ-MMM-010

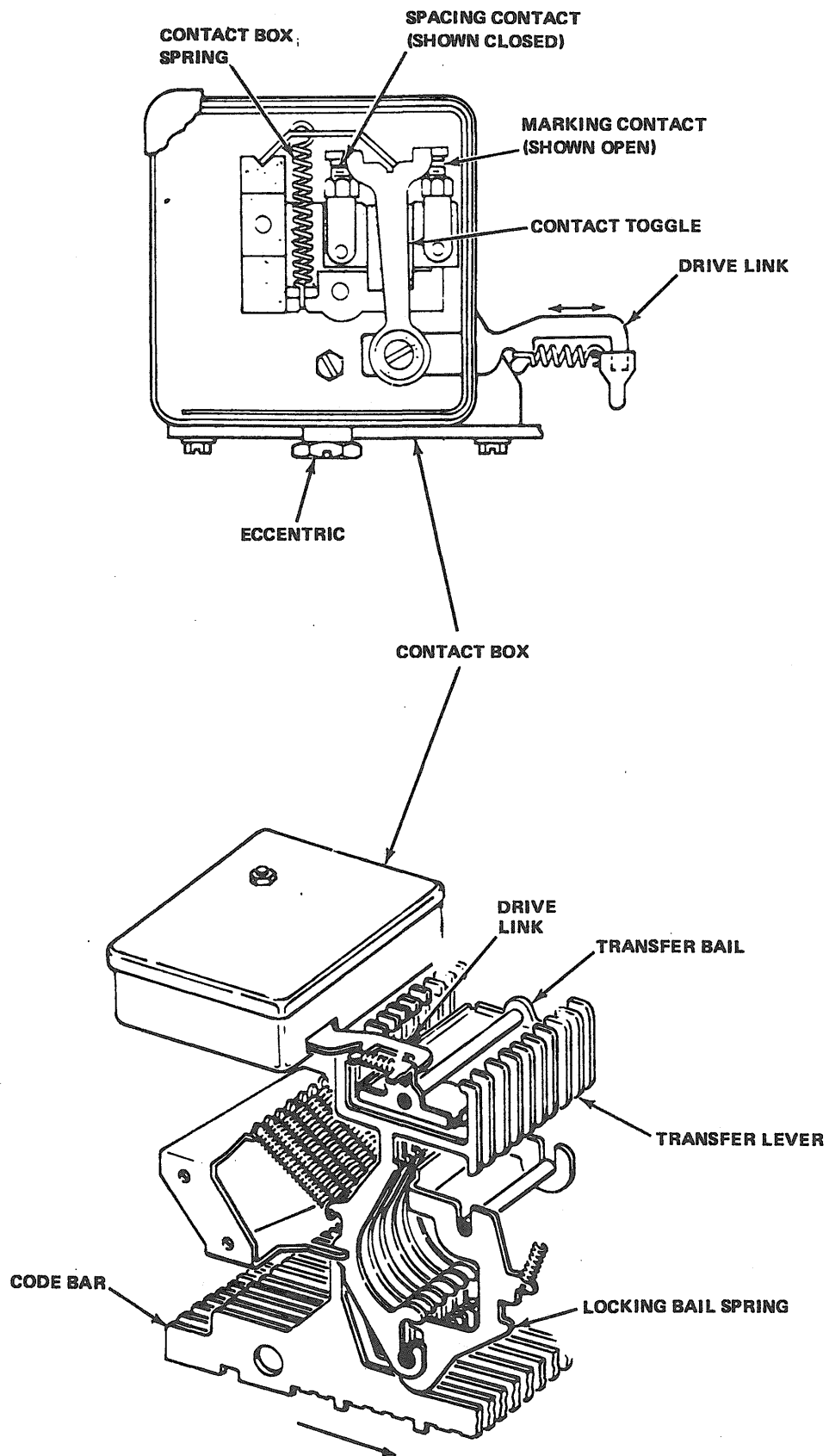

Figure 3-59. Signal Generator Transfer Lever Mechanism and Contact Box Mechanism.

the left. The last transfer lever is held to the right by a stop pin. Therefore, the last pulse (stop pulse) is always marking (current on). Shortly after the start of the last pulse, the lobe on the first cam from the front begins forcing the locking bail downward. At a point about halfway through the stop pulse, all transfer levers become unlocked and may return to their normal inoperative positions.

3-248. Code bars are reset by means of an eccentric lobe on the front of the cam assembly, which drives an eccentric follower arm (figure 3-57). This arm engages a stud on the side of the code bar reset bail and pulls the reset bail to the left as the cam rotates. At the peak position of the reset eccentric, the code bar reset bail latch is clear of the needle bearing stud. This permits the latch spring to pull the latch into locking position while the code bar reset bail is latched, as the eccentric drives the follower arm back to its initial position. As the code bar reset bail is moved to the left (into reset), it engages projections on the permuted code bars, clutch tripbar, and a step on the nonrepeat lever. Thus, all of these components are moved to the left into latched reset position.

3-249. The reset eccentric is positioned in an angular relationship to the remainder of the cam so that pick-up of the code bars and the nonrepeat lever begins at 92.5° . At 145° , the code bars have been moved to the left sufficiently to permit the code lever which determined the permutation to drop out of the universal bail. This permits the universal bail to rotate forward and kick the nonrepeat lever down and off the reset bail. At the same time, the extension of the universal bail moves beneath its latchlever and holds it up, almost in the same position that the pawl on the nonrepeat lever had held it

in the early reset movement. With the universal bail latch supported, the reset bail continues to move forward, a second keytop can be depressed. However, from this point, a full cam rotation must expire before a third or any successive keytops can be operated. The wedgelock mechanism depicted in figure 3-60 prevents the actuation of more than one key at a time.

3-250. LOCAL CARRIAGE RETURN MECHANISM. Operation of the local carriage return keylever causes its function lever to raise the forward end of the local carriage return bail (figure 3-61). The bail rotates about its pivot point until the upper end engages the carriage return lever on the typing unit.

3-251. LOCAL LINE FEED MECHANISM. Operation of the local line feed keylever causes its function lever to raise the forward end of the local line feed bail (figure 3-62). The bail rotates about its pivot point and the upper end pushes the trip link until the link engages the line feed clutch trip lever on the typing unit.

3-252. REPEAT MECHANISM. Simultaneous operation of the repeat keylever with another keylever or with the space bar, disables the nonrepeat mechanism and causes the character or function selected to be repeated for as long as the repeat keylever is activated. The activated repeat keylever causes its function lever to raise the right end of the nonrepeat lever (figure 3-63), and rotate it about its pivot point. In this position, the nonrepeat keylever cannot be engaged and operated by the code bar bail. Therefore, the nonrepeat bell crank will not reset the operated code lever bail latchlever, which then maintains both the code lever bail and the code bar bail latchlever in their operated positions until the repeat keylever is released.

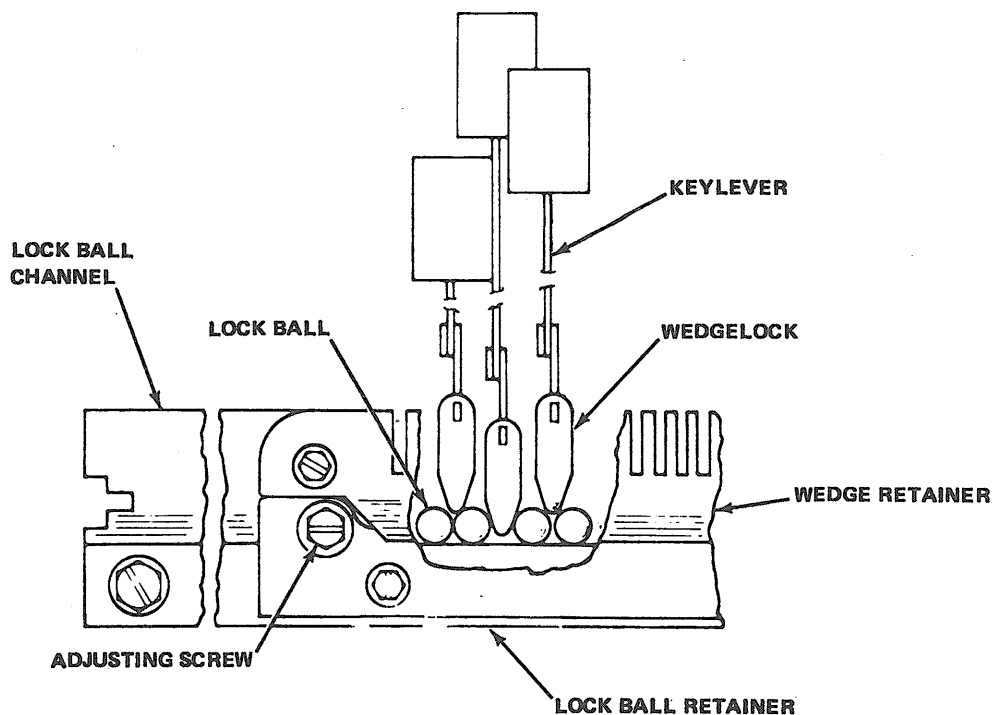

Figure 3-60. Wedglock Mechanism.

3-253. MARGIN INDICATOR MECHANISM. The margin indicator cam disk on the printing unit spring drum rotates with the drum as printing or spacing occurs. As the end of each line is approached, the cam surface of the disk makes contact with the margin indicator contact lever and rotates it clockwise about its pivot point (figure 3-64). When the contact lever leaves the switch plunger, the margin indicator switch operates and closes the circuit to a margin indicator light. A carriage return cycle returns the cam disk to its starting position and the margin indicator switch opens.

3-254. CONTROL KEY MECHANISM. Depression of the control key introduces the upper case of a specific key by the deletion of the number 7 pulse. This is accomplished by the control code lever blocking the number 7 code bar from moving to the right.

3-255. SHIFT KEY MECHANISM. To obtain a shift bit inversion case character, the enlarged shift key (at either side of the keyboard) is held down while depressing a complementary key. This shift key preconditions the keyboard for the function of adding or deleting (as the case may be) the number 5 code bit to obtain its complementary key code. This is accomplished by means of a shift code lever engaging a diagonal camming surface, on the under side of the shift lockbar (outside slot of the code bar guide), and directing its motion to the left. As this motion develops, the bail riding the upper diagonal camming surface is raised. This permits the inversion code bar (feed hole slot) to fall only when the complementary key is depressed. This inversion bar, upon moving to the right, operates a transfer lever number 5 pulse by a mechanical connection. The code transmitted is

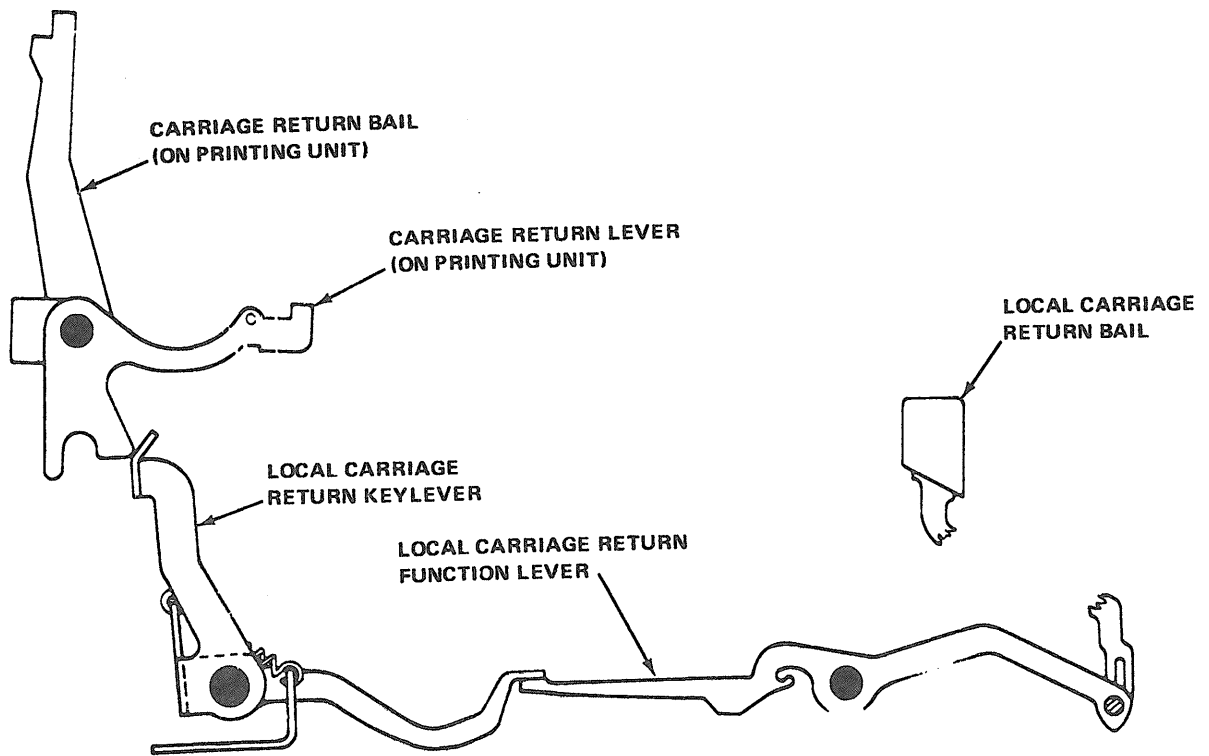

Figure 3-61. Local Carriage Return Mechanism.

then the addition or omission of the number 5 pulse combined with the transfer levers selected by the complementary key.

3-256. FRICTION FEED PRINTING UNIT. This section includes a complete description and basic principles of operation of the Model 35 Friction Feed Printing Unit. The term Friction Feed denotes the method used to advance the paper through the rollers.

3-257. Unless stated to the contrary, references in the text to left or right indicate the operator's left or right, facing the front of the unit, the selector mechanism at the right, and the print box at the front. In illustrations, unless specifically labeled otherwise, it is assumed that the equipment is being viewed from the front. Pivot points are shown in the drawings

by circles or ellipses which are solid black to indicate fixed pivot points and crosshatched to indicate floating points.

3-258. With the main shaft under power (associated equipment main power supply on), the printing unit is described as running closed when a steady current (marking) condition is maintained in the signal line and no signal intelligence is received. It is described as running open when a no current (spacing) condition is maintained through an interruption in signal line current.

3-259. The printing unit is an electro-mechanical device which translates eight level signal code combinations, sequentially received as an eleven unit transmission pattern, into mechanical actions which print the message and perform incidental functions. The friction-feed printing unit (figure 3-65) prints the

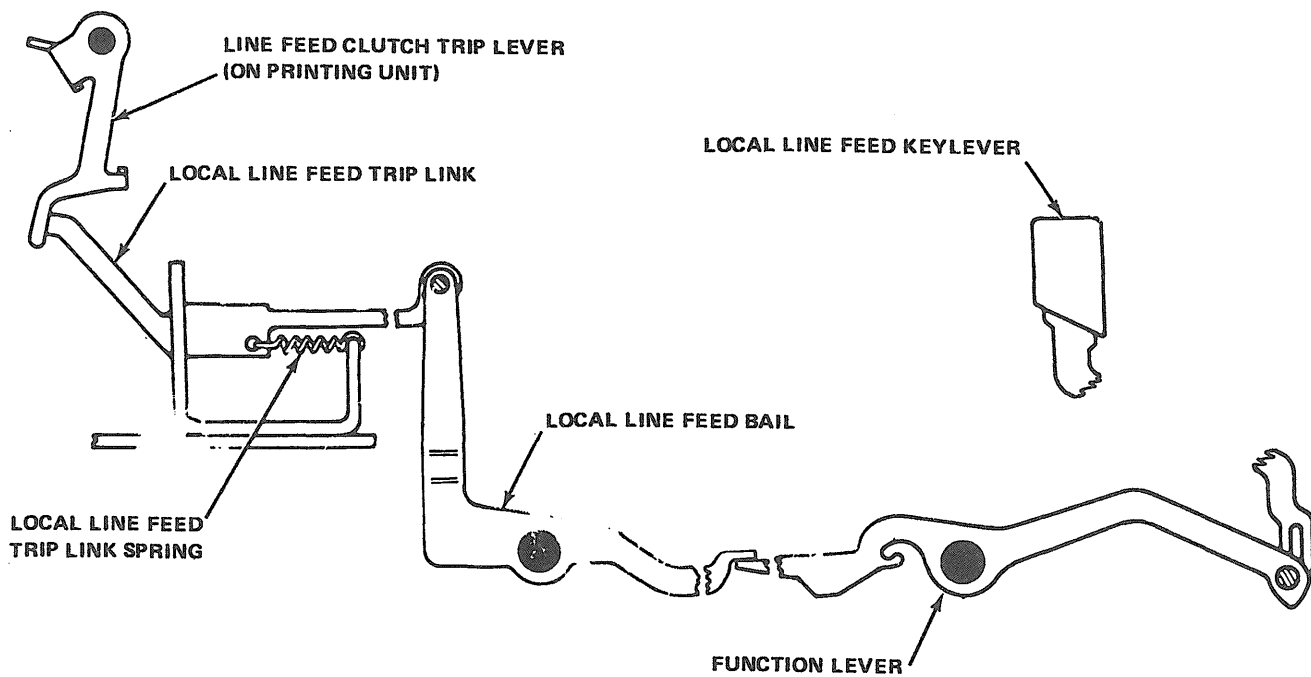

Figure 3-62. Local Line Feed Mechanism.

message upon single or multiple copy paper supplied from a 5-inch roll.

3-260. Motive power for operation of the printing unit is received through the intermediate gear mechanism of the keyboard base on which the unit is mounted. Power is applied to the driven gear which is centrally located on the main shaft at the rear of the printing unit. The main shaft rotates at a constant speed, and equipment is capable of operating at speeds of zero to 100 words per minute.

3-261. Six all-steel internal expansion clutches convert the rotary motion of the main shaft to the linear mechanical requirements for operation of the printer. The clutches rotate with the main shaft when engaged and do not rotate when disengaged (latched). From left to right in their installed position on the main shaft, the clutches control the print box, line feed, spacing, function, code bar and selecting mechanisms respectively.

3-262. The line feed and spacing clutches are provided with three sets of stop lugs permitting operation of associated mechanisms through a one-third revolution of the main shaft each time they are engaged. All other clutches are one stop clutches, permitting operation of associated mechanisms through a full revolution of the main shaft each time they are engaged.

3-263. Clutch engagement usually is initiated by an incoming electrical signal code which is sensed by the selecting mechanism. The selector, code bar, and function clutches operate on each incoming signal. The spacing and printing clutches normally operate on each incoming signal, but these operations may be suppressed if the code combination received represents a function for which there is no graphic (printed) equivalent. The line feed clutch normally does not operate except in response to a code for the line feed

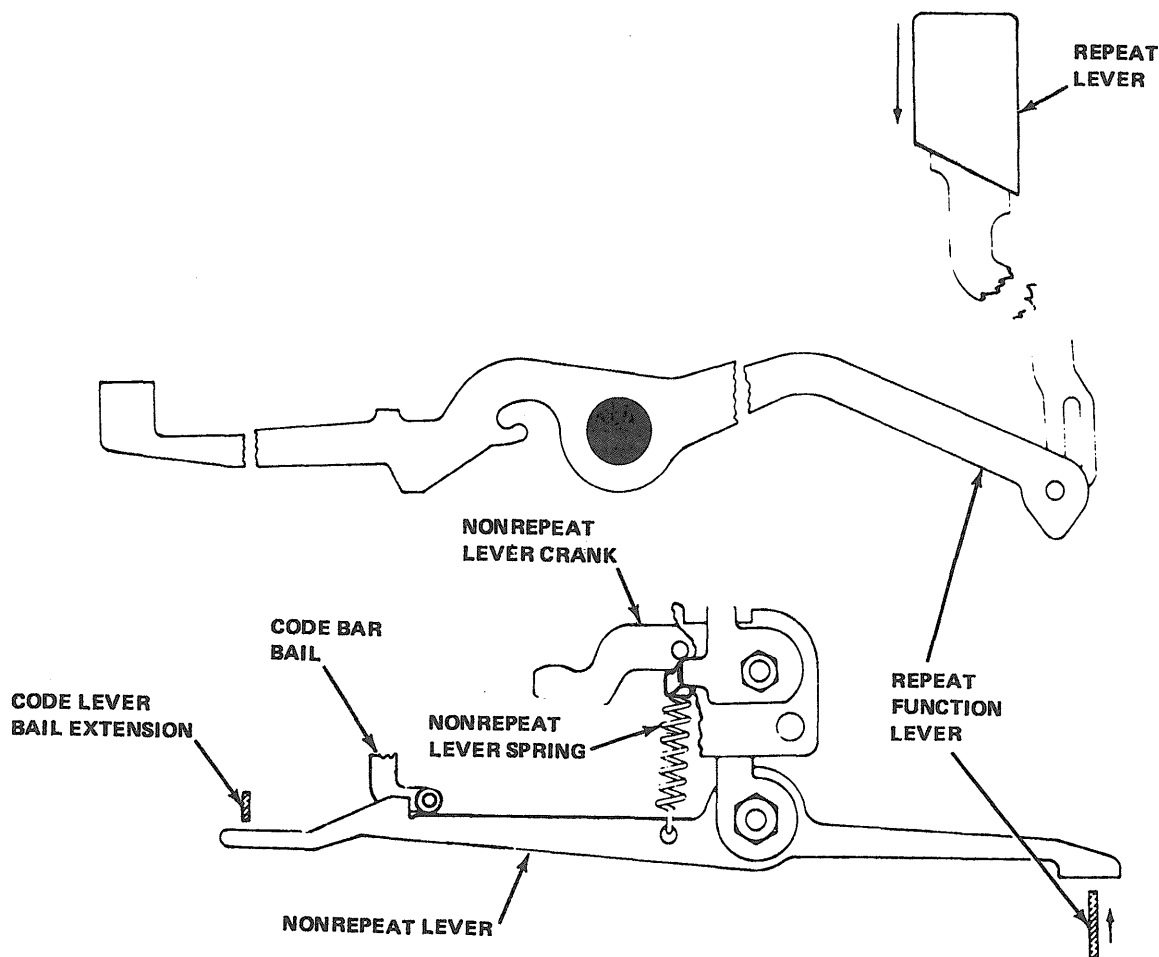

Figure 3-63. Repeat Mechanism.

function. Both the line feed and spacing clutches, however, may be operated independently of all other mechanisms by a direct mechanical linkage to the associated keyboard for local line feeding, spacing, or carriage return functions.

3-264. The selecting mechanism, in addition to the clutch, includes a two-coil magnet in series with the external signal line. The magnets are operated on a 0.5 ampere current provided by the logic circuitry in the I/O Console. A rangefinder is used to refine the mechanical orientation of the selector to the signaling code.

3-265. The code bar mechanism, when positioned by the selecting mechanism to correspond to the input code intelligence, sets up mechanical requirements for print box positioning, printing and stunt box operation.

3-266. The print box is capable of vertical and horizontal positioning in response to the permutations set up by the code bar mechanism. When positioned to correspond to the input code, the print box presents a single type pallet with the embossed graphic equivalent of the selected code for printing. Printing is accomplished when the pallet is struck

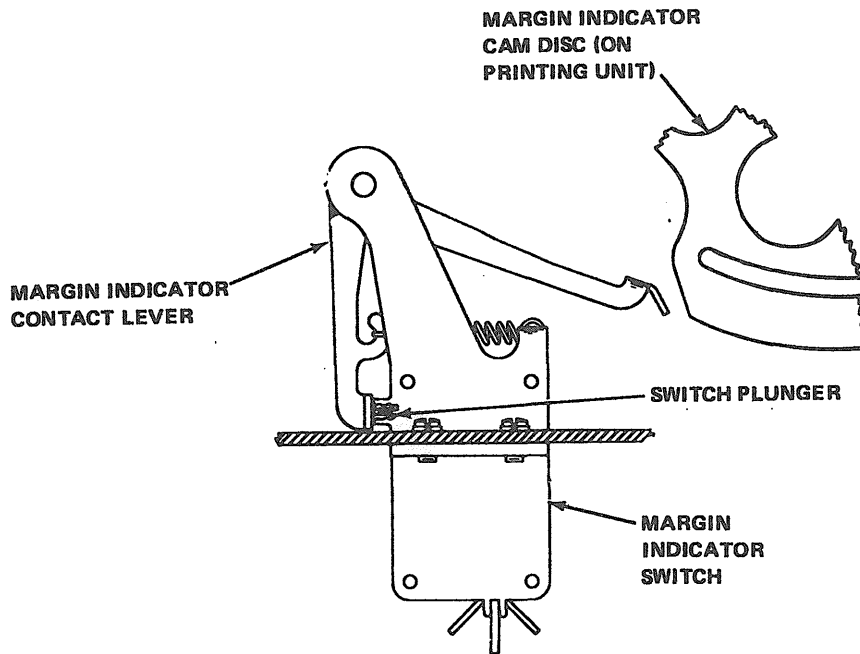

Figure 3-64. Margin Indicator Mechanism.

by the print hammer which presses an inked ribbon against the paper supported by the printing unit platen.

3-267. The spacing mechanism moves the print box and printing mechanism one character to the right each time a graphic character is received and imprinted. A suppression mechanism prevents spacing upon receipt of certain nonprinting functions.

3-268. The line feed mechanism permits a single line advance of paper in the platen mechanism when the code combination for this function is received. The function may also be initiated locally through mechanical linkage with the keyboard base.

3-269. The stunt box operates in response to permutations equivalent to nonprinting function code combinations set up in the code bar mechanism. The stunt box mechanisms initiate either mechanical or electrical switching sequences for operating the associated function or for the control of external equipment.

3-270. PRINCIPLES OF OPERATION. The basic function of the Model 35 Printing Unit is to record, in page printed form, information received in the form of a signaling code combination which represents characters or functions. The printing unit translates these electrical code combinations into mechanical motions which imprint the message or initiate the indicated function, such as line feed, carriage return, or signal bell. Printing is accomplished through an inked ribbon upon paper rolled around a horizontally stationary platen while the printing mechanism moves from left to right across the page. All operations of the printing unit are performed automatically in response to input signal code combinations. A few local off-line functions such as line feed or carriage return may be initiated independently of the signal line from the keyboard.

3-271. Character representations, or graphics, are the alphabetic, numeric symbolic intelligence equivalents of the input code combinations. Function representations are the coded equivalent of

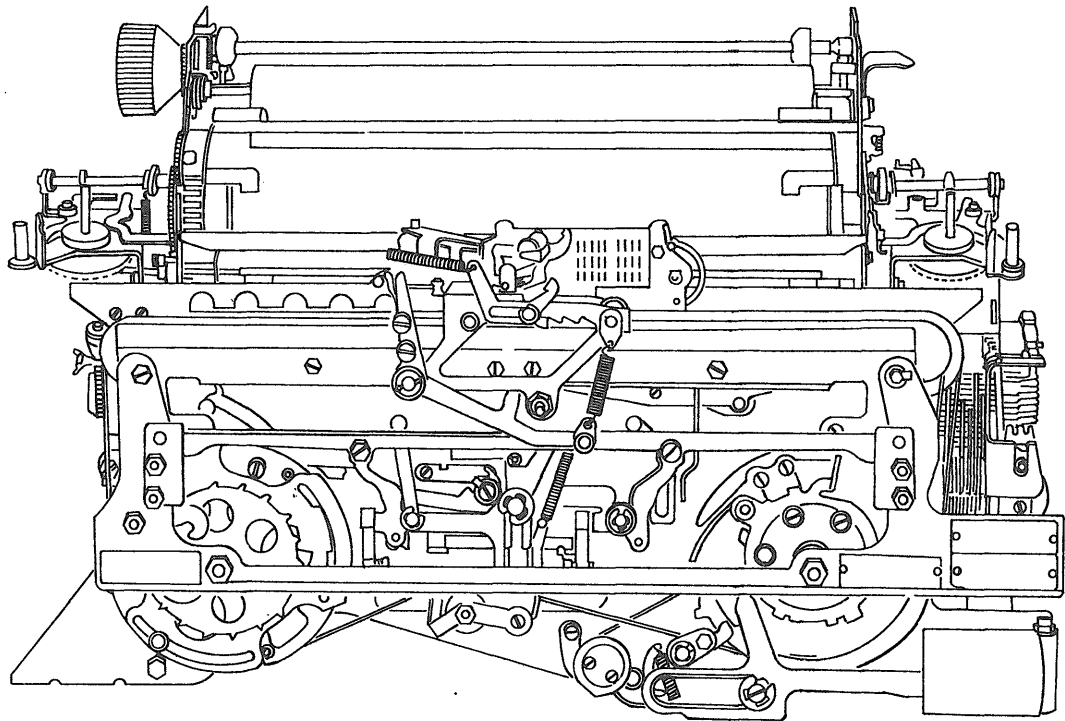

Figure 3-65. Friction Feed Printing Unit.

nonprinting operations auxiliary to the reception of the graphics, such as line feed, carriage return, or signal bell. The speed of operation of the equipment is usually given in the operations per minute. Speed in words per minute is roughly one-sixth of the operations per minute. The printing unit is designed to operate at 100 words per minute.

3-272. Information is received by the printing unit in the eight level American Standard Code for Information Interchange (ASCII). Each character is represented by a sequential combination of current and no-current time intervals. Intervals during which current flows in the signal circuit are referred to as marking, and those during which no current flows are referred to as spacing. Each combination includes eight bits that carry the intelligence, each of which may be either marking or spacing. Bits 1 through 7 provide the ASCII code for the particular character or function desired. The eighth bit is not

used in this application and is always marking.

NOTE

In other applications, the eighth bit is used as a parity bit and may be either marking or spacing in order to always provide an even number of marking pulses for each combination.

3-273. The intelligence bits are preceded by a start bit (always spacing) and are followed by two stop bits (always marking). A typical waveform is shown in figure 3-66. The start and stop bits ensure synchronization between the transmitting and receiving equipment by bringing the receiving equipment to a complete halt at the end of each combination. The stop pulse is of double length in order to ensure the receiving unit has time to completely detect the last information pulse before the transmitter begins the next character. Thus, the combination consists of 11 equal units of time and is referred to as an 11 unit transmission pattern.

3-274. The gearing arrangement within the keyboard/printer allows it to operate at any rate from zero to 100 words per minute. Assuming the average word contains five characters and a space, the maximum number of characters that can be generated in one second is as follows:

$$\frac{100 \text{ words}}{\text{minutes}} \times \frac{1 \text{ minute}}{60 \text{ seconds}} \times \frac{6 \text{ characters}}{1 \text{ word}} = \frac{10 \text{ characters}}{\text{sec}}$$

The time required to generate one character is one-tenth of a second (100 milliseconds). The time length of each pulse (or unit) in the waveform shown in figure 3-66 is equal to:

$$\frac{100 \text{ msec}}{11 \text{ units}} = 9.08 \text{ msec}$$

3-275. The code representations for the graphics U and * are illustrated in figure 3-67. In these combinations, alternate markings and spacing conditions for the intelligence bits are required.

3-276. The total number of permutations of an eight level, 11 unit code (with the eighth level always marking) is 2^7 , or 128. Function representations (figures 3-66 and 3-67) which are blank are unassigned in the current application, but the equipment can be readily adapted to their recognition and execution. For a more complete discussion of the signaling code, refer to the applicable section.

3-277. The relationship of the operating mechanisms of the printing unit are illustrated in block diagram figure 3-68 (FO). Rotary motion from the intermediate gear mechanism of the keyboard base is applied to the main shaft, which turns constantly as long as the associated unit is under power. A 0.5 ampere signal to the selector magnets initiates operating sequences. The application of 115-VAC circuits to the stunt box and to various switches and controls is depen-

dent upon external circuitry and associated equipment.

3-278. The signaling code combinations are applied to the selecting mechanism through pins 1 and 2 of the cable connector located just above the selector magnets. The start pulse (spacing) of each code combination permits the start lever to fall to the rear behind the magnet armature and rotate to trip the selector cam clutch. The rangefinder mechanism permits adjustment of the angular relationship of the trip-off point to the optimum quality incoming line signal.

3-279. The selector cam clutch is driven by the main shaft like the other clutches. When it is engaged by the main shaft, however, it effectively converts the incoming electrical signal into mechanical marking or spacing operations which are equivalent to corresponding bits in the signal code.

3-280. The code bar clutch initiates mechanical actions which position the code bars in patterns determined by the selecting mechanism (marking-left, spacing-right), and condition the printer for print box positioning, function selection, and printing. A cam operated by the code bar clutch operates the function clutch and print box clutch trip mechanisms.

3-281. The function clutch controls the function bail and the stripper bail. The function bail permits transfer of intelligence from the code bars to the function mechanism and, upon receipt of a function code, operates the function switch, or the contact corresponding to the input signal code. The stripper bail resets selected function mechanisms. When the input signal calls for carriage return function, direct mechanical linkage between the stunt box and the spacing mechanism initiates this function. When the input signal calls for line feed, the function mechanism trips to line feed mechanism, engaging the line feed clutch.

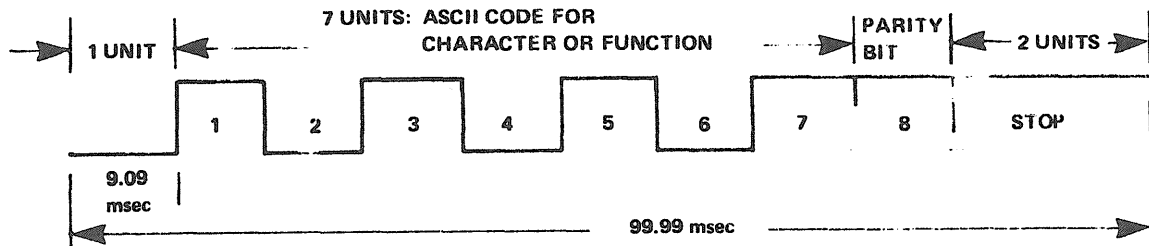

Figure 3-66. Eleven Unit Transmission Pattern.

3-282. The line feed clutch operates mechanical linkages which advance the paper one line space by rotating the platen.

3-283. The code bar mechanism (paragraph 3-298) and the code bar clutch operate in combination either to trip or to block the tripping of the print box clutch. In the latter case, all printing mechanisms are idle as print suppression permits performance of a function without interference with the page printed message. When the print box clutch is tripped, it initiates mechanisms involved in vertical positioning of the print box, shift, horizontal type box positioning, ribbon feed, and printing. The main rocker bail provides power from the print box clutch (and main shaft), and the code bars determine the specific application of that power required for each input signal code combination representing a graphic. A cam plate on the main rocker bail trips the spacing clutch stop mechanism to engage the spacing clutch, except when spacing is suppressed.

3-284. The spacing clutch, when tripped by the cam plate on the printing mechanism main rocker bail, advances the print box and printing hammer one character space to the right across the paper. Spacing suppression may be initiated by the function mechanism, to permit execution of a nonprinting function without interference with the page printed message by the carriage return mechanism, or by the printing mechanism when the print box reaches the end of a printed line.

3-285. The print box, positioned by the printing and spacing mechanisms in accordance with intelligence set up in the code bars, presents a single graphic in printing position for each unsuppressed operating cycle. At the proper moment, with the print box locked in printing position, a spring loaded print hammer is released to tap the selected print pallet sharply against the inked ribbon and the paper or form. A cleanly imprinted graphic character corresponding to the input signal code combination results, and the printing mechanism trips the spacing clutch to move both the print box and the print hammer to the next horizontal printing position to the right.

3-286. MAIN SHAFT. The main shaft (figure 3-69) is located in the lower rear portion of the printing unit, supported in the two side frames in ball bearings. It extends the full width of the printer.

3-287. Centrally located on the shaft are two driving gears. The larger gear meshes with the intermediate gear mechanism of the keyboard base to transmit power from the motor to the printing unit. The smaller gear drives the signal generator mechanism of an associated keyboard base.

3-288. Power takeoff from the constantly rotating main shaft is controlled by six clutches, each of which when engaged or unlatched, drives its associated mechanism. From the right end of the shaft, these clutches may be identified as the selector clutch (with cam

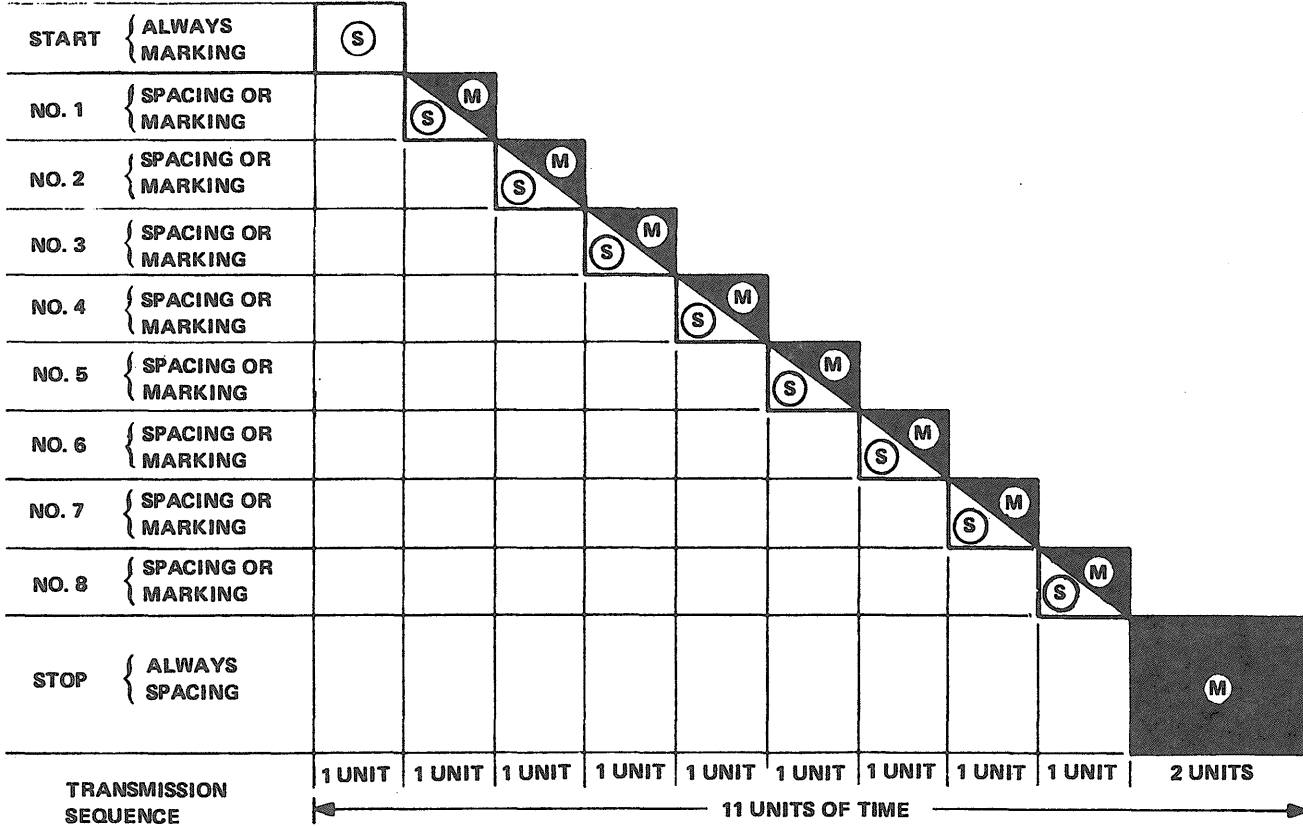
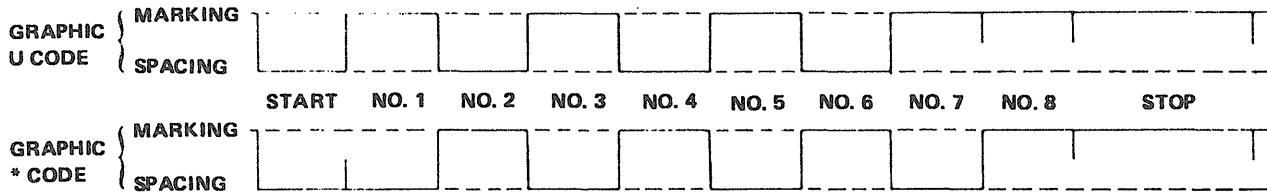

Figure 3-67. Eleven Unit Transmission Pattern Signaling Code.

sleeve), the code bar clutch, the function clutch, the spacing clutch, the line feed clutch and the print box clutch. The engagement sequence for the clutches is selector, code bar, function, print box, spacing and line feed. However, the print box and spacing clutch engagement may be suppressed under certain operating conditions, and the line feed clutch is operative only upon a specific set of input signal code combinations.

3-289. The spacing and line feed clutches are three-stop clutches (figure 3-70), each permitting their associated

mechanism to operate through one-third of a revolution of the main shaft. All other clutches are one-stop clutches (figures 3-71 and 3-72), operating through an entire revolution of the main shaft.

3-290. ONE-STOP CLUTCHES. The clutch drums are attached to and rotate with the main shaft (figure 3-69). In the disengaged position, as shown in figure 3-71, the clutch shoes do not contact the drum, and the shoes and cam disk are held stationary. Engagement is accomplished by moving the stop arm toward the rear of the printing unit, away from

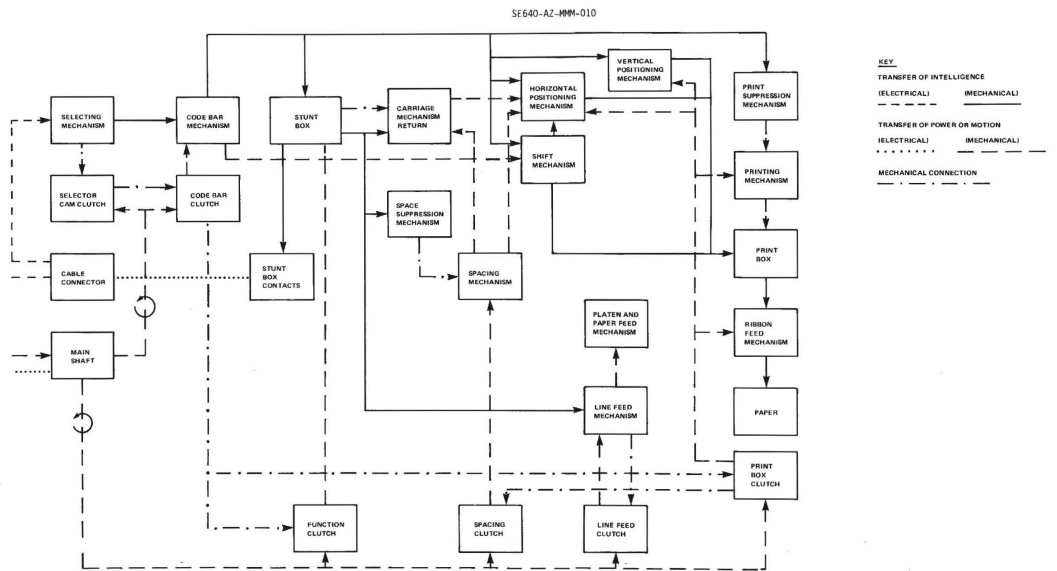

Figure 3-68. Printing Unit Block Diagram.

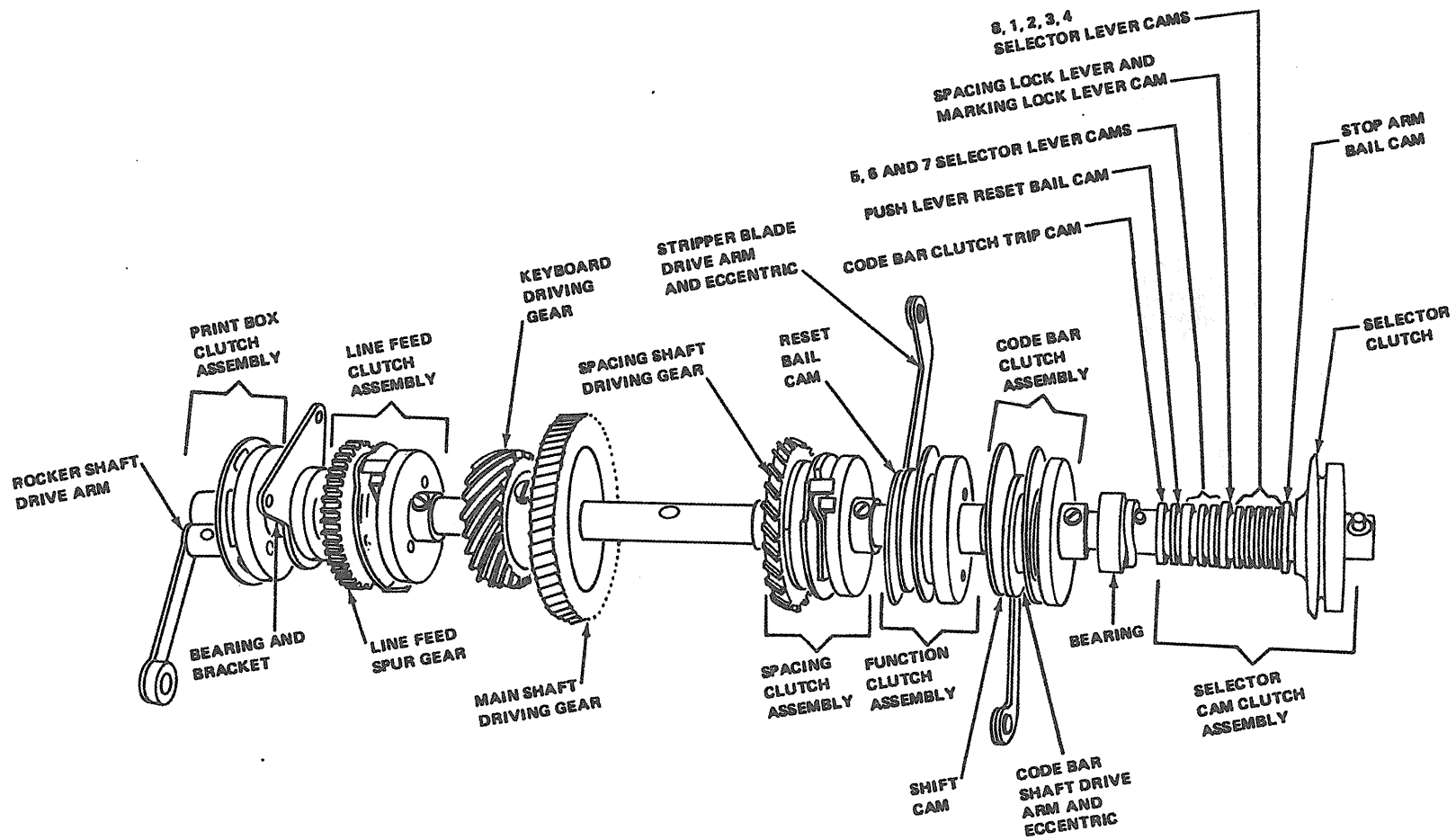

Figure 3-69. Main Shaft.

SE640-AZ-NMM-010

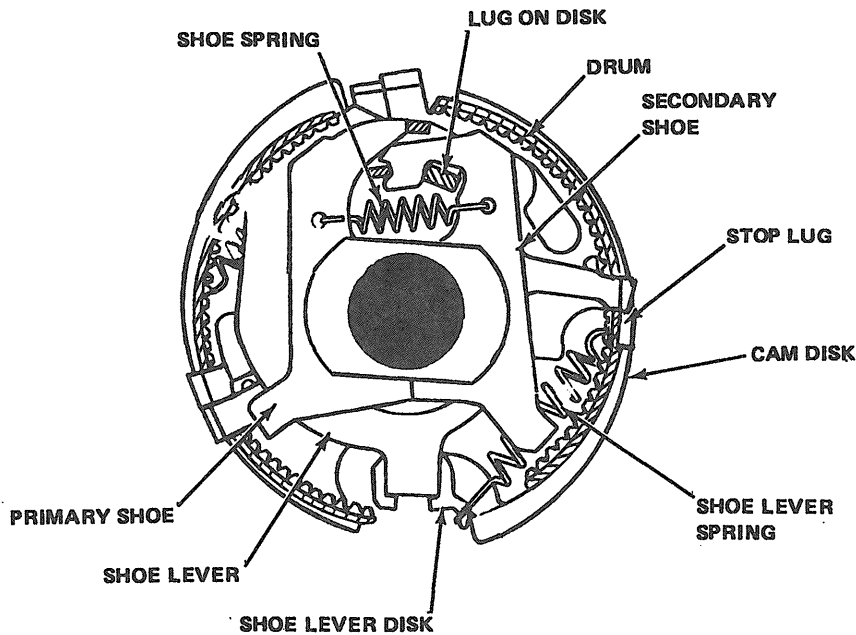

Figure 3-70. Three-Stop Clutch.

the clutch, thus releasing stop lug A and the lower end of shoe lever B (figure 3-72). The upper end of lever B pivots about its ear C, which bears against the upper end of the secondary shoe and moves its ear D and the upper end of the primary shoe to the left until the shoe makes contact with the notched inner surface of the rotating drum at point E. As the drum turns counterclockwise, it drives the primary shoe downward so that it again makes contact with the drum at point F. There, the combined forces acting on the primary shoe cause it to push against the secondary shoe at point G. The lower end of the secondary shoe then bears against the drum at point I. The forces involved are multiplied at each of the preceding steps. The aggregate force is applied through the shoes to the lug J on the clutch cam disk, and the disk and attached cam turn in unison with the drum.

3-291. Disengagement is effected when the lower end of shoe lever B strikes the stop arm. Lug A and the lower end

of the shoe lever are brought together, and the upper end of lever B pivots about its ear C and allows its other ear D to move toward the right. The upper spring then pulls the two shoes together and away from the drum. The latch lever seats in the indent in the cam disk, and the cam is held in its stop position until the clutch is again engaged.

3-292. THREE-STOP CLUTCHES. The spacing and line feed clutches have three sets of lugs equally spaced about their periphery (figure 3-70). The action is as described in paragraphs 3-290 and 3-291, but the clutch is permitted to rotate through only one-third revolution before the stop lever and latch lever halt its motion.

3-293. SELECTION. The selecting mechanism consists of two magnet coils, an armature with an antibounce stop, a selector cam clutch and the associated levers, arms, bails and slides necessary to convert the electrical bits of the start-stop code to the mechanical arrangements which govern the character to

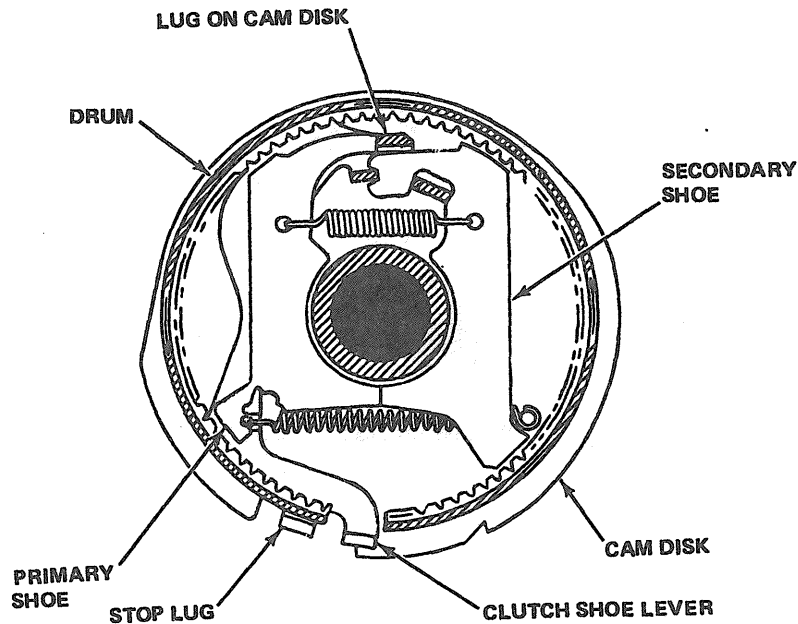

Figure 3-71. One-Stop Clutch (Disengaged).

be printed and the function to be performed. The selector cam clutch assembly comprises, from right to left (figure 3-73), the clutch; the stop arm bail cam; the eighth, first, second, third and fourth selector lever cams; the cam for spacing and marking lock levers; the fifth, sixth and seventh selector lever cams; the push lever reset bail cam; and the code bar clutch trip cam.

3-294. During the time in which a closed line circuit (marking) condition exists, the selector magnet coils are energized and hold the selector armature against the selector magnet pole pieces. In this stop position, the selector armature blocks the start lever (figure 3-73). While the signal for any character or function is being received, the start (spacing) bit releases the selector armature which, under the tension of its spring, moves away from the magnet cores, and thus unlatches the start lever. The start lever rotates clockwise (as viewed from the right) under tension of its spring, moving the stop arm bail into the indent of the first cam.

As the stop arm bail rotates about its pivot point, the attached stop arm is moved out of engagement with the clutch shoe lever. The selector cam clutch engages and begins to rotate. The stop arm bail immediately rides to the high part of its cam, where it remains to hold the start lever away from the selector armature during the reception of the signal code combination. When the stop bit at the end of the signal code combination is received, the selector armature is pulled up to block the start lever. Thus, the stop arm bail is prevented from dropping into the indent of its cam, and the attached stop arm is held so as to stop the clutch shoe lever. The clutch cam disk upon which the latch lever rides has an indent as its stop position. When the clutch shoe lever strikes the stop arm, the inertia of the cam disk assembly causes it to continue to turn until its lug makes contact with the lug on the clutch shoe lever. At this point, the latch lever drops into the indent in the cam disk, and the clutch is held disengaged until the next start bit is received.

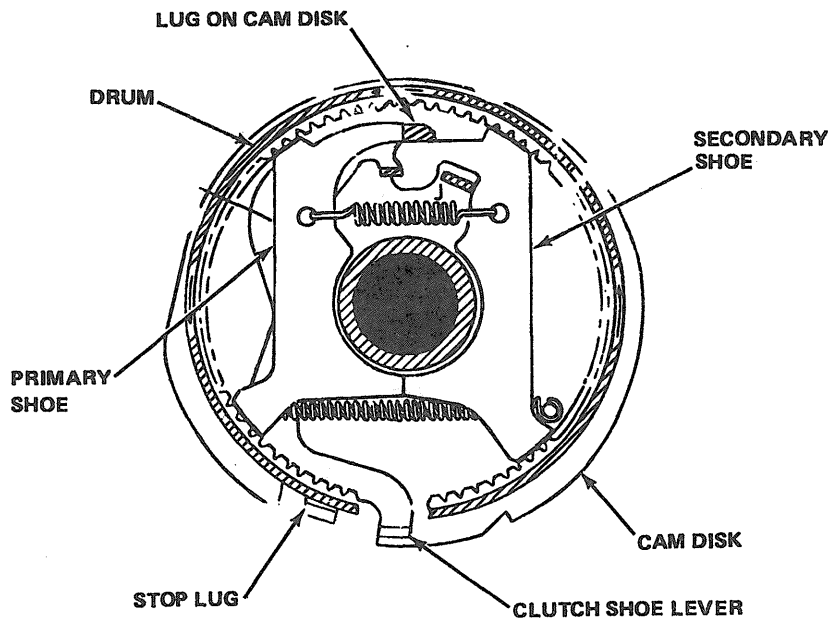

Figure 3-72. One-Stop Clutch (Engaged).

3-295. The series of seven selecting levers (the eighth position, always marking, is not equipped with a selecting lever) and a marking lock lever ride their respective cams on the selector cam clutch. As the marking or spacing signal bits are applied to the selector magnets, the selector cam clutch rotates and actuates the selector levers. When a spacing bit is received, the marking lock lever is blocked by the end of the armature, and the spacing lock lever swings toward the rear, above the armature and locks it in the spacing position until the next signal bit is received. Extensions on the marking lock lever present the selector levers from following their cams (figure 3-74). When a marking bit is received, the spacing lock lever is blocked by the end of the armature, and the marking lock lever swings to the rear, to lock below the armature in the marking position until the next signal bit is received. During this marking condition, the selector levers are not blocked by the marking lock lever and are permitted to move against their respective cams.

The selecting lever that is opposite the indent in its cam while the armature is locked in marking condition swings momentarily to the rear (selected) position.

3-296. Each selecting lever has an associated push lever which drops into a notch on the top of the selecting lever when the selecting lever engages the indent in its cam. As the selector cam clutch rotates, each selecting lever is moved forward as it rides to the high part of its cam. Selected (dropped) push bars are also moved forward. Unselected push bars remain in the rear position, on top of the notch of the selecting lever. When all seven code bits have been received, push levers are held in their selected or unselected position until the next start bit is received. When the subsequent start bit is received the cam clutch is again engaged. The push lever reset bail, following its cam, unlatches the selected push levers. The push levers then retract under spring tension to their unselected (rear) position.

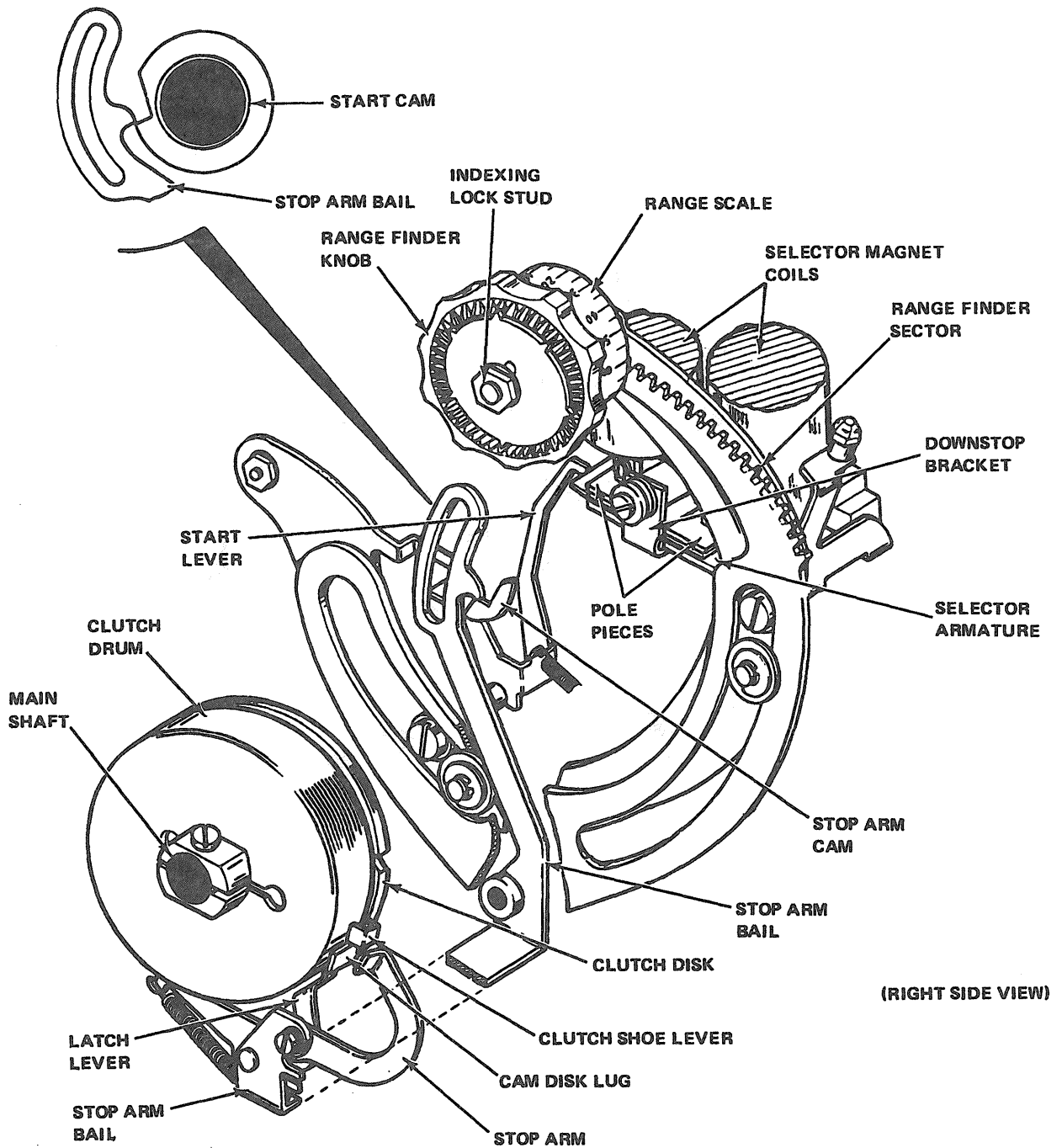

Figure 3-73. Selector Clutch and Rangefinder.

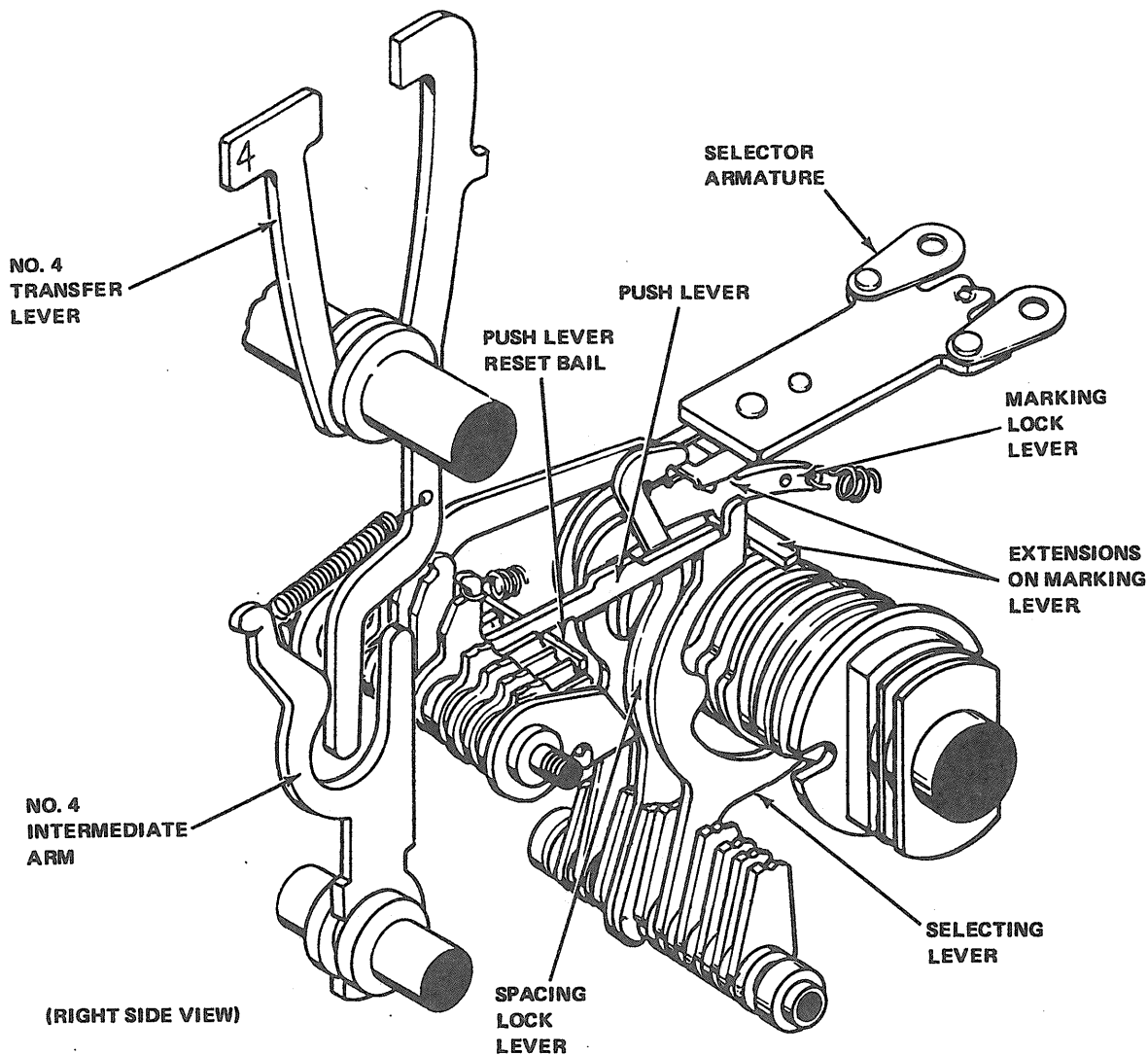

Figure 3-74. Selecting Mechanism and Transfer Mechanism.

3-297. ORIENTATION. The selecting mechanism (figures 3-73 and 3-74) utilizes only approximately 20 percent of an intelligence pulse to initiate the appropriate mechanical actions. As the rising and trailing edges of each pulse are somewhat distorted, it becomes necessary to adjust the selecting mechanism so that it samples a pulse somewhere near its center. The rangefinder mechanism (figure 3-73) is used for this purpose. When the rangefinder knob (figure 3-73) is pushed inward and rotated, the attached gear moves the rangefinder sector (which mounts the

stop arm bail, stop counterclockwise about the selector cam clutch. This changes the angular position at which the selector cam clutch stops with respect to the selecting levers. The method for determining the proper setting of the rangefinder is as follows:

a. While the printing unit is rapidly printing out a known character (or message), the rangefinder knob is rotated clockwise until printing errors are observed. The value of the range scale opposite the fixed index mark is recorded.

b. Repeat step a. while rotating the rangefinder knob in the opposite (counterclockwise) direction.

c. The optimum setting of the rangefinder knob is determined by adding both range scale readings together and dividing by two. After an optimum setting is obtained, the rangefinder knob is released. Its inner teeth engage the teeth of the indexing lock stud to lock the rangefinder mechanism in position.

3-298. CODE BAR MECHANISM. The character printed or the function executed by the printing unit is basically determined by the code bar mechanism (figure 3-75) to which the input signal intelligence, translated into mechanical form, is transmitted from the selecting mechanism push bars. The code bars are positioned by code bar shift bars which move to the left for marking and the right for spacing. The shift bars, positioned to the rear for marking and forward for spacing, are pushed into marking position by selected push bars through a mechanical linkage of intermediate arms and transfer levers.

3-299. Power to position the selected code bar levers is supplied through the code bar clutch. The code bar clutch is engaged by its cam on the selector cam clutch (paragraph 3-293). The code bar clutch also drives a cam which activates the shift mechanism as well as the function and print box clutches.

3-300. At the left end of the code bar mechanism, a printing suppression mechanism is operated by the code bars. The blocking levers are rotated by the code bars to prevent release of the print box clutch trip lever through a blocking bail.

3-301. CODE BAR POSITIONING. Each selector push lever (paragraph 3-295) has an associated intermediate arm, transfer lever, and code bar shift bar (figure 3-75). In addition, there is a common transfer lever with its code bar shift

bar (figure 3-76). When a push lever is toward the rear (spacing), its associated intermediate arm and transfer lever are pulled toward each other by a spring. The upper end of the transfer lever is held forward (spacing), holding the code bar shift bar in spacing position. When a push lever is moved forward (marking), it rotates the intermediate arm counterclockwise, positioning the transfer lever to the rear (marking) and holding the code bar shift in marking position. The common transfer lever (fourth from left, operating the common code bar, third from bottom) has two extensions which pass behind transfer levers 4 (to the right) and 5 (to the left). There is no connection between the common transfer lever and the selecting mechanism, but when the number 4 of number 5 push bar is selected, the associated transfer levers position the common code bar shift bar to the rear (marking). The right ends of these code bars determine vertical positioning of the print box (figure 3-77).

3-302. As the selector cam clutch completes its revolution, the trip shaft operating lever rides to the peak of the code bar clutch trip cam (figure 3-71). This causes the shaft to turn slightly counterclockwise, to move the code bar clutch-trip lever away from the clutch-stop lug and engage the clutch. Rotation of the clutch operates an eccentric and the shift lever drive shaft, shift lever drive arm, and shift lever drive link. The drive link moves two code bar shift levers in a scissors like action, the front lever moving to the left, the rear moving to the right. Any code bar shift bar that is marking position (left) during the previous operating cycle is moved to spacing position (right) by the forward shift lever, unless the transfer lever is once again holding that bar to the rear (marking). The rear shift bar, as it moves to the left (figure 3-76) carries with it any code bar shift bar held in the marking position, completing the transfer of intelligence from the selecting mechanism to the code bars.

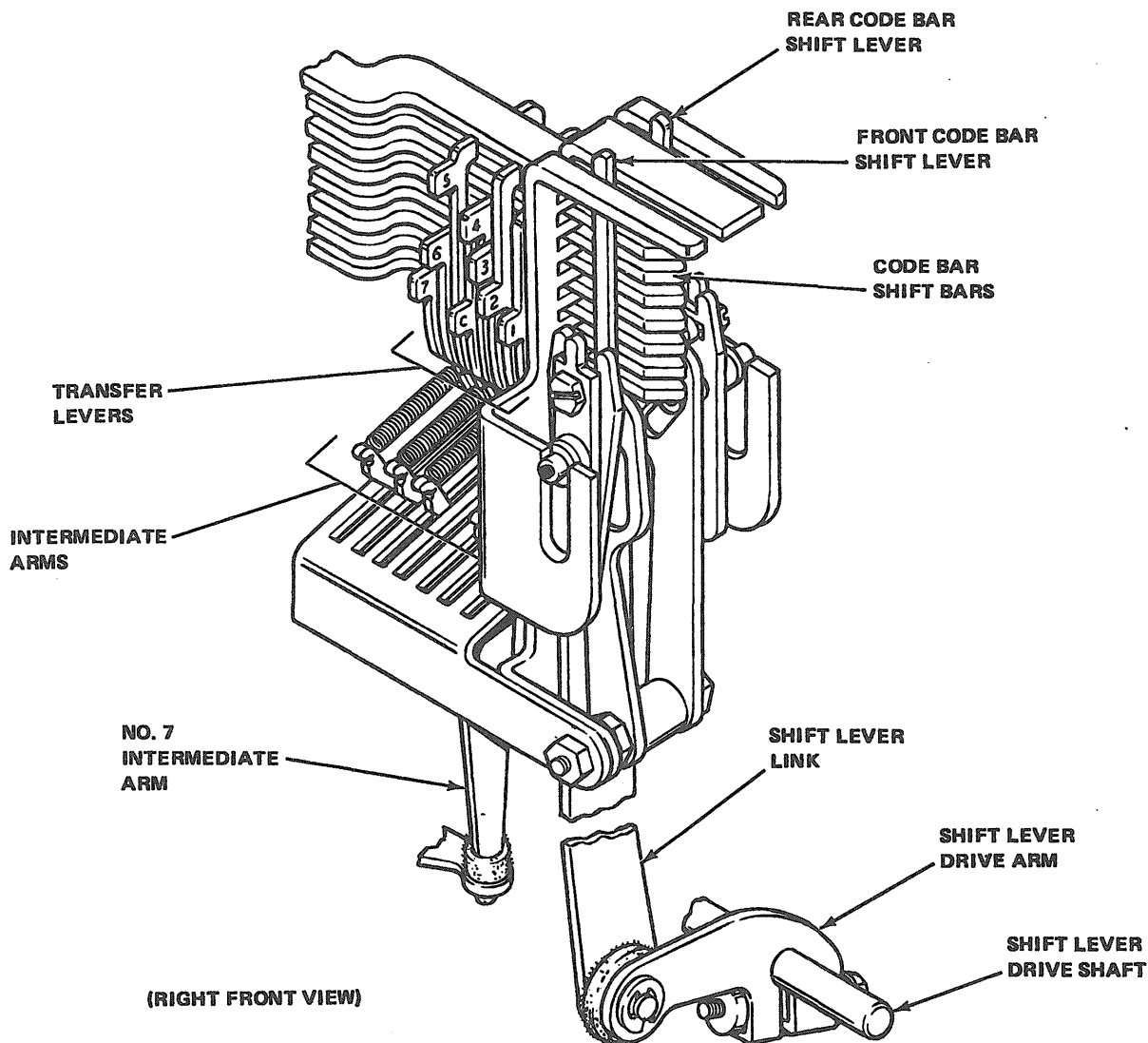

Figure 3-75. Code Bar Mechanism.

3-303. At the end of one revolution, the code bar clutch trip lever strikes the clutch shoe lever. Inertia of the cam disk assembly causes it to continue to turn to permit the latch lever to drop into the indent in the cam disk, and the clutch is held disengaged. The code bars, code bar shift bars and shift levers are held in the selected position, but the transfer levers and intermediate arms are free to position the shift bars forward or rearward, in response to new input signals from the selector.

3-304. ARRANGEMENT OF CODE BARS. A total of nine code bars in marking (left) or spacing (right) position convey mechanically translated signal intelligence to the printing and function mechanisms. The code bars are arranged from top to bottom as follows: suppression; number 2, 5, 1, 4, 3, and common; and numbers 7 and 6 (figure 3-77). In the printing units as furnished, the disabling clip engages a notch at the left end of the upper (suppression) code bar. This code bar, when used, is operated by the function box for print

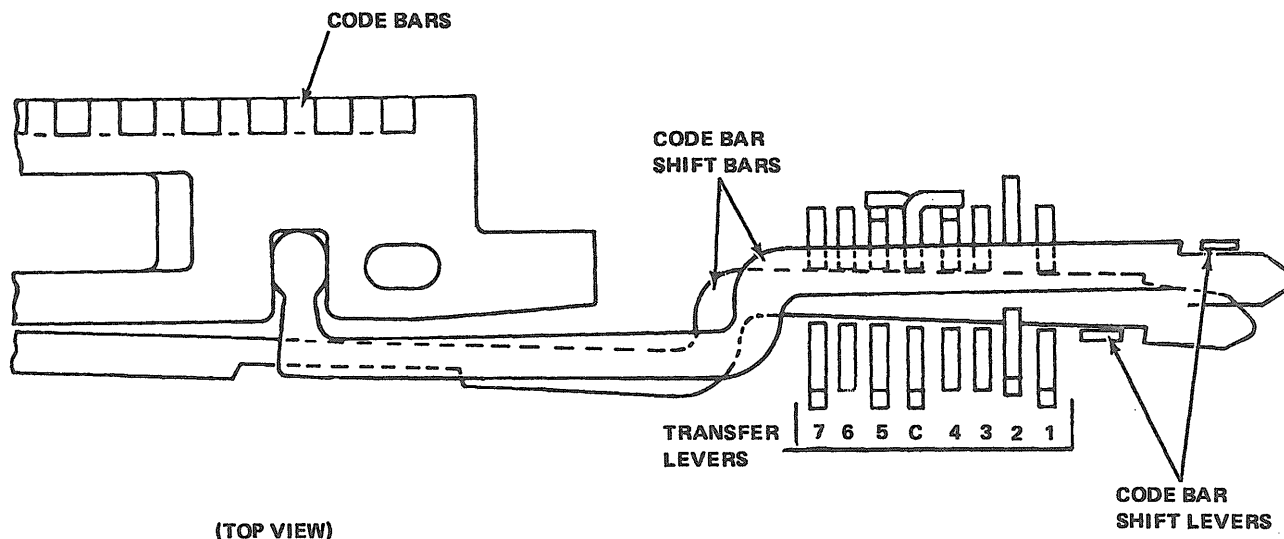

Figure 3-76. Code Bar Shift Bar Positioning.

suppression through the print suppression mechanism (paragraphs 3-323 through 3-326). There is no shift bar and transfer mechanism linkage for the suppression code bar.

3-305. PRINT BOX AND PRINT BOX CARRIAGE. All characters (graphics) printed by the printing unit are formed by print pallets which are arranged in a print box. The print box is mounted in a carriage from which it may be removed for cleaning or replacement. In order to print any selected character, the print box carriage is positioned so that the character on the pallet is directly over the desired location on the paper. Since the pallets are arranged in four horizontal rows and sixteen vertical rows, it is necessary to position the print box carriage both horizontally and vertically. See figure 3-78 for arrangement of graphics which are represented on the print box pallets. See figure 3-65 for input signal code permutations equivalent to each graphic representation.

3-306. The print box carriage rides on rollers over a track which is moved vertically for positioning in that particular plane. The carriage is positioned horizontally on its track by the oscillating rail slide and print box carriage link. The slide rides the oscillating rail and is clamped to the rear section of the upper draw wire rope. The link provides a flexible connection to permit the print box carriage to follow both the vertical movement of the print box carriage track and the horizontal movement of the oscillating rail slide.

3-307. The lower right rear end of the upper draw wire rope is fastened to the spacing drum. From this point, it passes part way around the spacing drum, upward and around the right rail pulley and downward to the spring drum. After passing part way around the spring drum, the upper draw wire rope is doubled backward around it and passes upward to the left printing carriage rail pulley over to the right printing carriage rail pulley, and downward to the spacing drum

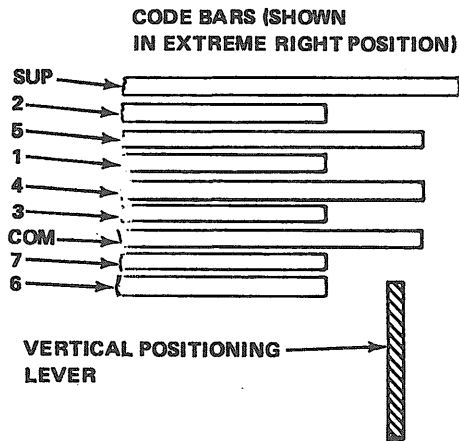

Figure 3-77. Vertical Arrangement of Code Bars.

to which it is again fastened. The left end of the lower draw wire rope is fastened to the spring drum and, the right end fastened to the spacing drum. It acts in opposition to the upper draw wire rope and holds the two drums in phase (figure 3-79). A tensioning pulley rides the under side of the lower draw wire rope, to take up any slack which may occur due to stretching of the upper and lower draw wire ropes.

3-308. The oscillating rail is supported by pivoted arms at each end. These arms, which extend downward, are pivoted on the printing frame at their lower ends. Thus, the oscillating rail and draw wire rope that it carries may be shifted to the left or right with no change in relative position. The oscillating rail shift slide and two oscillating rail shift links are used to accomplish the horizontal positioning of the oscillating rail, and also to connect it with the oscillating rail shift slide. The links are pivoted and are of such a length that only one at a time may be fully extended.

3-309. **SHIFT MECHANISM.** Mechanical limitations of the equipment restrict selection from the print box pallets to four horizontal and eight vertical rows. Since there are sixteen vertical rows in the print box, a means is provided

for determining which of two fields, figures (left half of the print box), or letters (right half of the print box) will be presented for positioning. This is accomplished by the shift mechanism which is activated by the code bar mechanism. The seventh bit in the input signal code determines the field selection as figures (number 7 spacing) or letters (number 7 marking).

3-310. Two pawls on the shift selector arm (figure 3-80) are positioned left (spacing) or right (marking) by a tail descending from the seventh code bar mechanism intermediate arm. The selector arm and its pawls are mounted to the lower front corner of the right side plate and extend through slots in two shift pawls on the rear of the front plate mechanism. When moved (simultaneously) to the left (spacing) position, the shift pawls are positioned so that the shift drive pawl, driven upward by the code bar clutch shift lever cam shaft, would strike the right pawl, driving it upward. When moved to the right (marking), the shift drive pawl lifts the left pawl. If the right shift pawl is already raised, a spacing signal on the seventh intelligence bit would not affect the shift mechanism. A marking signal would not affect the mechanism when the left pawl is raised in the preceding operating cycle.

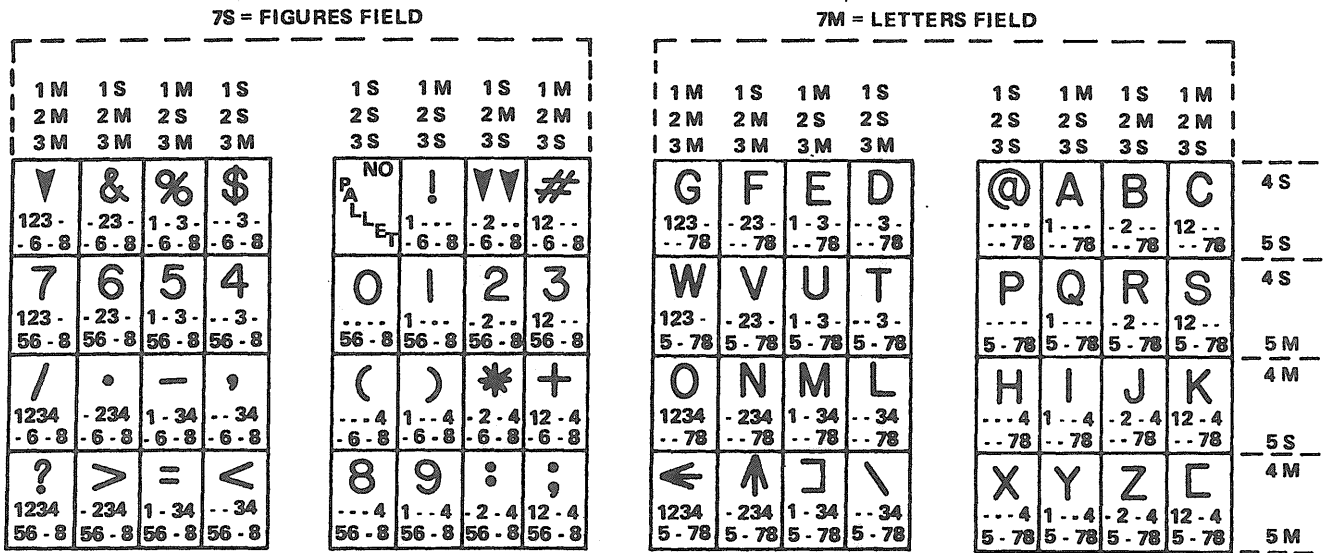

Figure 3-78. Print Box Pallet Arrangement.

3-311. The left and right shift pawls operate a toggle on the rear of the front plate mechanism, rotating the toggle clockwise for marking, counterclockwise for spacing. The toggle is linked to the shift rocker lever (figure 3-81). When rotated clockwise, the shift rocker lever initiates a figures (number 7 code bar spacing) shift. When rotated counterclockwise, the shift rocker lever initiates a shift to the letters field. The rocker bail raises the left or right shift breaker slide, breaking the oscillating rail shift links above the raised slide. This permits the oscillating rail to shift to the opposite end of its travel limits, setting up the figures field for printing when moved to the right and the letters field when moved to the left.

3-312. PRINT BOX POSITIONING. The selection of the various characters from the four horizontal rows and eight vertical rows in either field (figures or letters) and the printing of those characters takes place as described in paragraphs 3-313 through 3-318.

3-313. The number 4 and number 5 code bars determine the selection of the horizontal row. The number 3 code bar determines whether the selection is to be

made from the left four vertical rows (in either the figures or the letters field, as determined by the shift mechanism, paragraph 3-309) or the right four vertical rows. The number 1 and number 2 code bars determine the selection of one row from the four vertical rows predetermined by the number 3 code bar.

3-314. Four code bars which are longer than the others extend through the right code bar bracket and serve as stops for the right vertical positioning levers (figure 3-82). They are (from top to bottom) the suppression, number 5 and number 4, and common code bars. Notches are arranged in the left ends of these code bars so that the left side vertical positioning levers are stopped, in each case, by the same bar that blocks the right side levers. After all code bars have been positioned by the code bar positioning mechanism, the code bar clutch cam follower arm and its roller, in traversing the sloping indent on the code bar clutch cam, rotates the clutch trip lever shaft. As the shaft turns, it first causes the function clutch lever to release the function clutch (figure 3-83) and then causes the print box clutch trip arm to engage its trip lever and release the type box clutch.

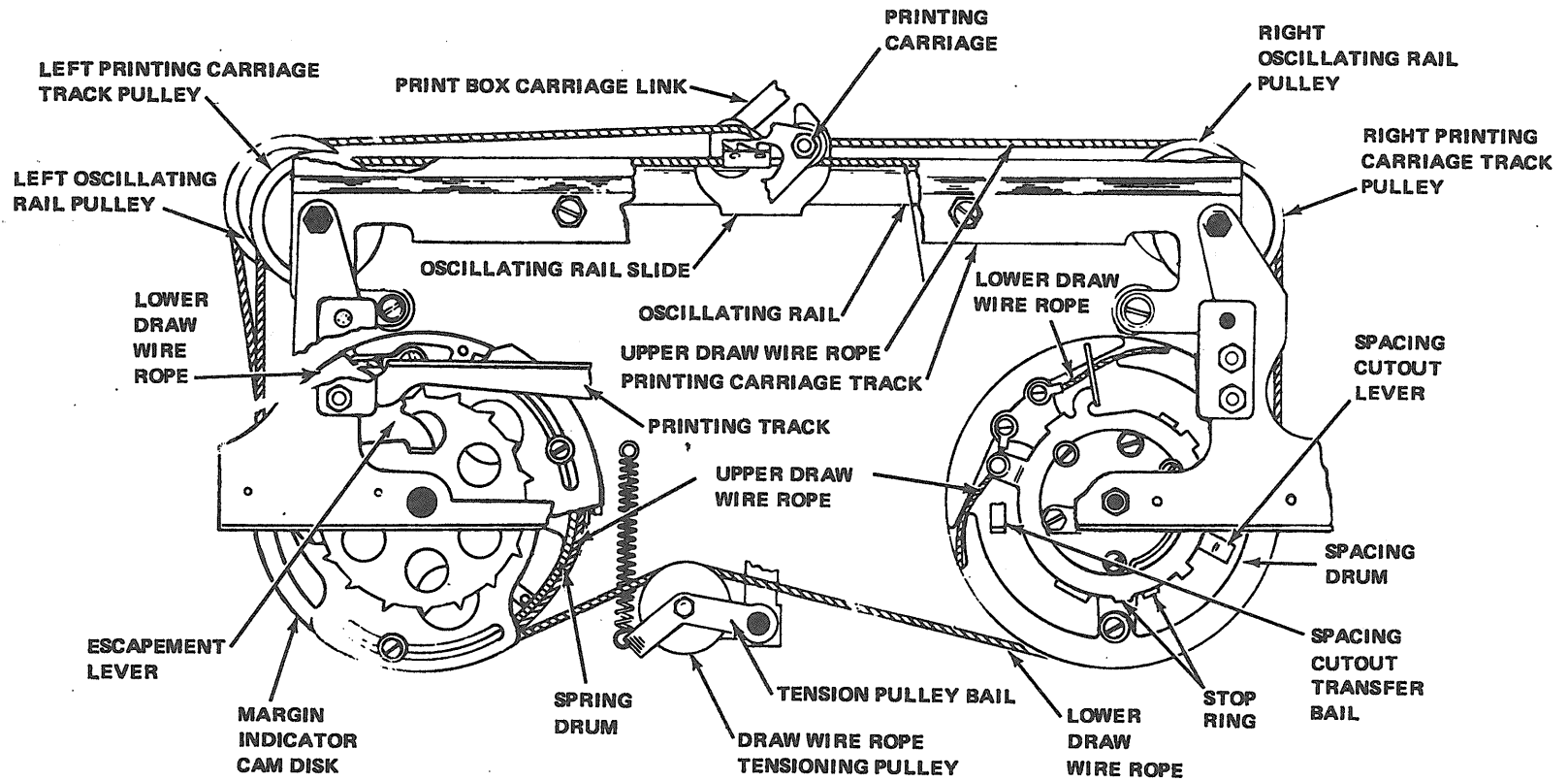

Figure 3-79. Draw Wire Rope Drums.

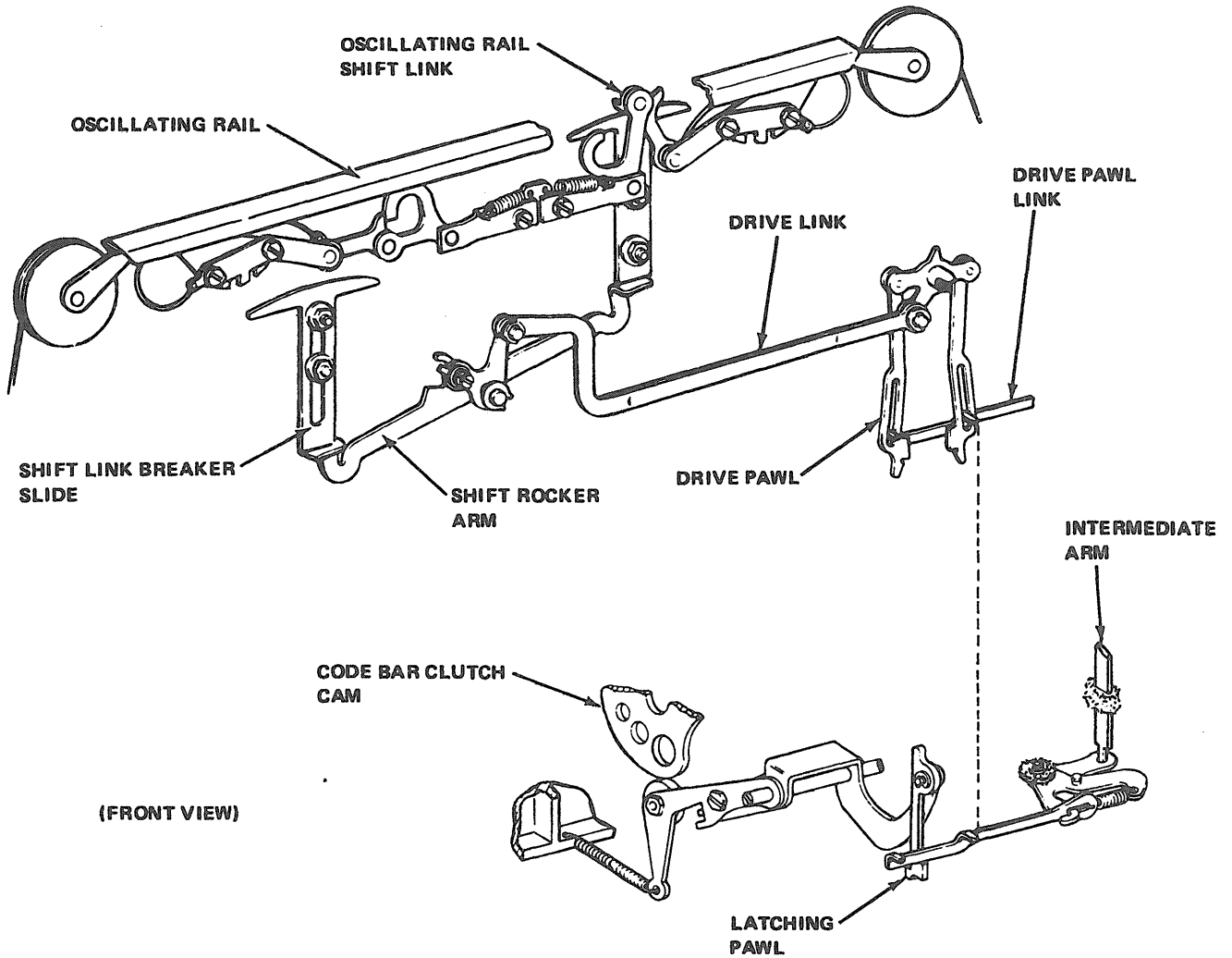

Figure 3-80. Shift Mechanism.

When the print box clutch completes its revolution, it is disengaged by its trip lever and latch lever in the same manner as was the code bar clutch (paragraph 3-303). During rotation, the print box clutch operates a drive link and a bracket causing the main rocker shaft to oscillate. This in turn, through its left and right brackets and the main side drive links, extends the motion of the vertical positioning levers (figure 3-82). These levers are driven upward until they strike a projecting code bar, which causes them to buckle. The print box carriage track is mounted between vertical positioning levers which control its vertical motion.

3-315. When the number 4 and number 5 code bars are toward the right (spacing), the common code bar is also toward the right, where it blocks the vertical positioning levers. The top row of pallets in the print box are in line for printing. When the number 5 code bar is toward the left (marking), the common code bar is toward the left. If the number 4 code bar is toward the right (spacing), it blocks the vertical positioning levers, and the second row of pallets (from the top) are then in line for printing. When the number 4 code bar is toward the left (marking), the common code bar is toward the left. If the number 5 code bar is toward the

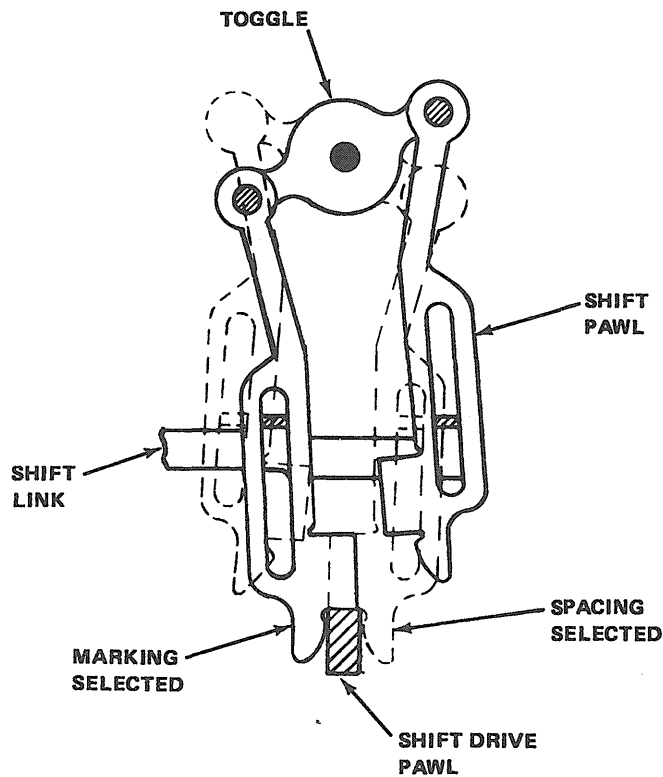

Figure 3-81. Shift Mechanism Positioning.

right (spacing), it blocks the vertical positioning levers, and the third row of pallets is in line for printing. When both the number 4 and number 5 code bars are to the left (marking), the common code bar is also to the left. The print suppression code bar blocks the vertical positioning levers, and the fourth (bottom) row of pallets in the print box are then in line for printing. At each of the four levels where the vertical positioning levers may be stopped, they are momentarily locked by lock levers controlled by the main side lever follower arms.

3-316. A bracket attached to the main rocker shaft applies vertical motion to the main bail by means of two main bail links (figure 3-84). Attached to each end of the oscillating rail shift slide are pivoted buckling type drive links which extend downward to each end of the main bail. As the main bail moves downward driven by the print box clutch, the left shift slide links, if not buckled,

will try to shift the oscillating rail slide drive links toward the right, while the right shift slide drive links, if not buckled, will try to shift the oscillating rail shift slide links to the left. When the number 3 code bar is shifted toward the left (marking), the horizontal motion reversing slide is shifted toward the left by the reversing slide shift lever and is held there by detent levers. A bracket near the right end of the reversing slide will then make contact with the right shift slide drive linkage and cause them to buckle. As the main bail is driven downward, the unbuckled left shift slide drive link will start to shift the oscillating rail shift slide toward the right. This positions the print box so that the characters to be printed will be located at the left half of the figures or the letters field. In a similar manner, when the number 3 code bar is shifted toward the right (spacing), the horizontal motion reversing slide is also shifted toward the right by the shift lever and

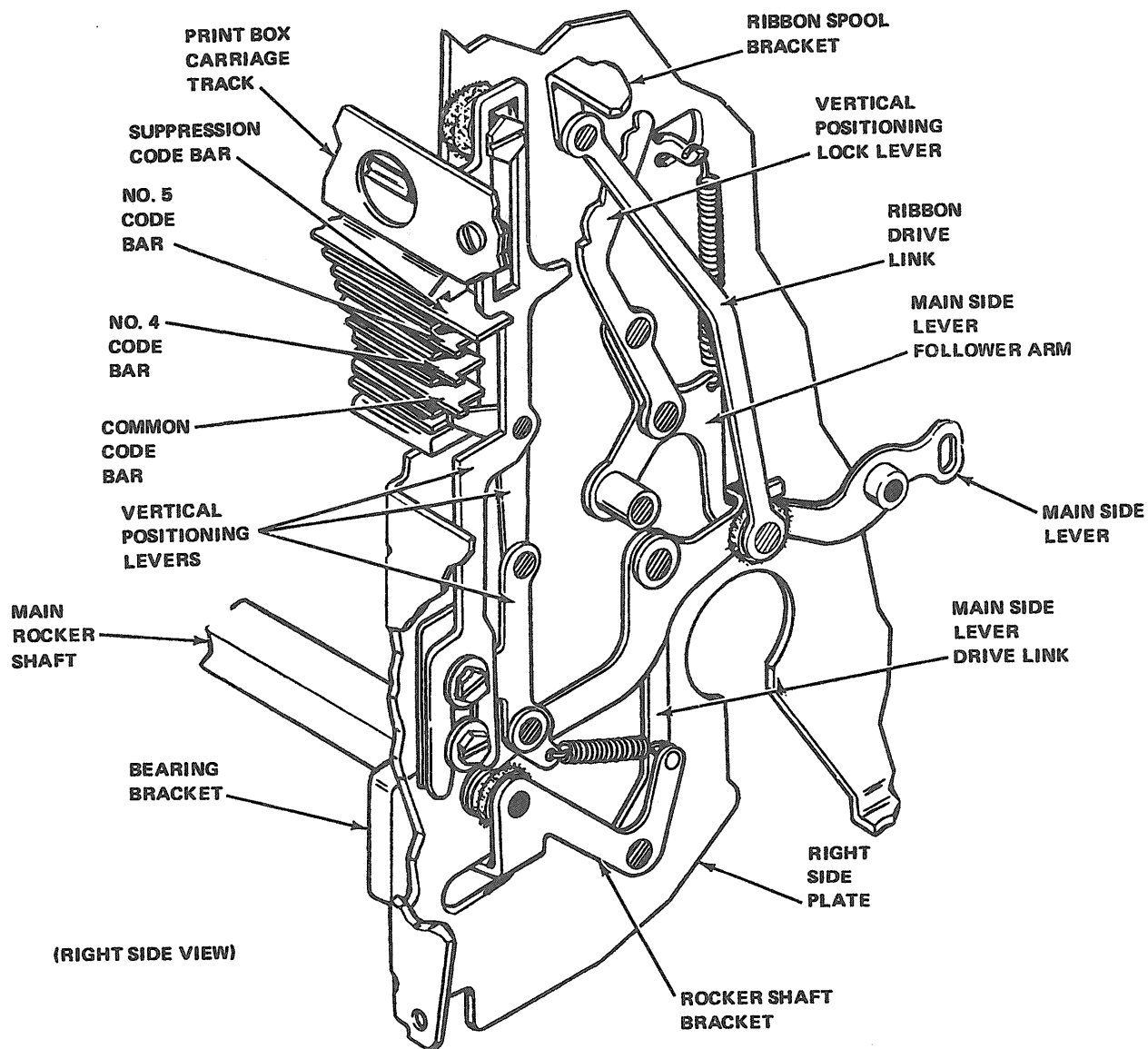

Figure 3-82. Right Side Plate Mechanisms.

is held there by the detent levers. A bracket near the left end of the horizontal motion reversing slide then makes contact with the left shift drive links and causes them to buckle. As the main bail is driven downward, the unbuckled right shift slide drive links will start to shift the oscillating rail shift slide toward the left. This positions the print box so that the characters to be printed will be located in the right half of the figures or the letters field.

3-317. After determination of the field (figures or letters) and the group of vertical rows in which the character to be printed is located, the number 1 and number 2 code bars operate three horizontal motion stop slides to determine the row in that group where the character is to be found (figure 3-84). A wedge shaped horizontal positioning lock lever, which is pulled downward by the main bail through a yield spring, bears against the horizontal positioning lock lever arm. This arm drives the oscillating

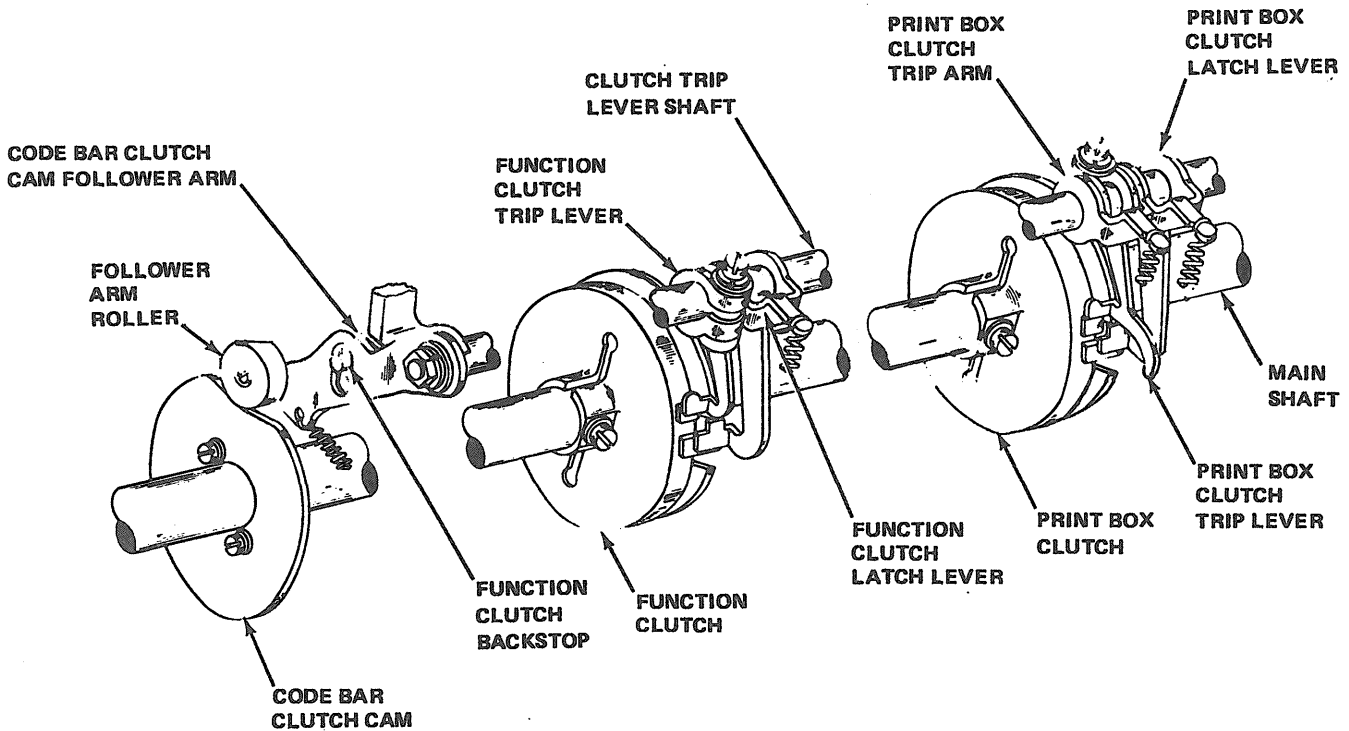
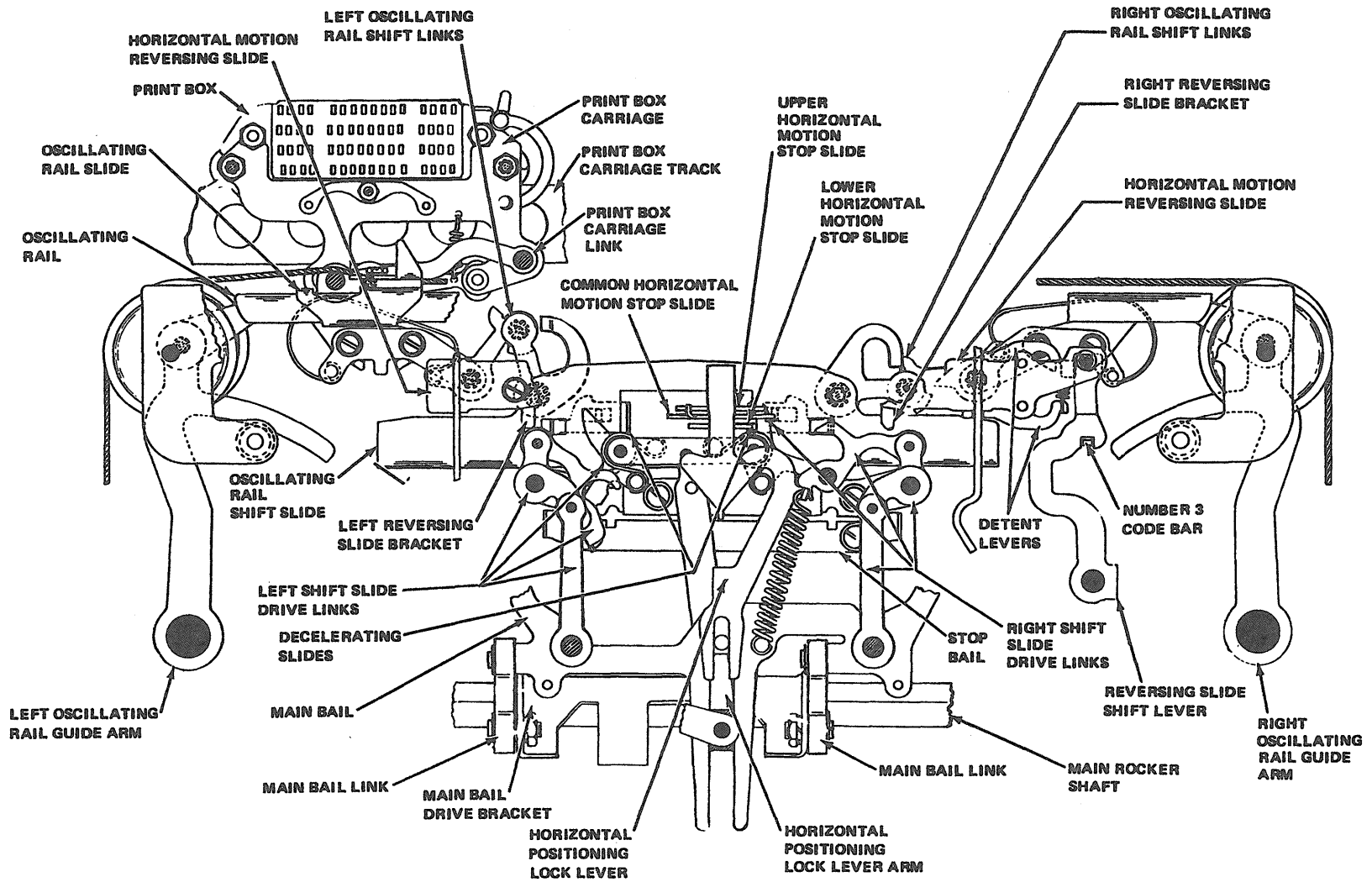

Figure 3-83. Clutch Trip Mechanisms.

rail shift slide in the direction in which it was started (by the number 3 code bar selection) until one or two decelerating slides, which are mounted on the oscillating rail shift slide, strikes an unselected horizontal motion stop slide. A camming surface on the unbuckled shift slide drives the decelerating slide and causes the drive links to buckle. The oscillating rail shift slide finally comes to rest when it strikes the blocked decelerating slide. This, in turn, ends the downward excursion of the lock lever, and the yield spring extends until the main bail reaches the lowest point of its oscillation. As the main bail returns upward, it centers the oscillation rail shift slide. It is during this time that the horizontal motion stop slides are positioned for the selection of the next character. The number 1 and number 2 code bars each operate a code bar bail bell crank. Each, in turn, moves a horizontal motion stop slide toward the front (marking) or toward the rear

(spacing) (figure 3-85). A third (common) stop slide (spring tensioned toward the rear) is located between the upper and lower stop slides and has projections which pass across the front edges of these slides (figure 3-84). Each stop slide is of a different length. The common stop slide, which is the longest stop, has an additional stop on its shank, so that it serves as the shortest stop when all the slides are moved forward. The upper slide (operated from the number 2 code bar) is the second longest stop, and the lower slide (operated from the number 1 code bar) is the third longest stop.

3-318. When both the number 1 and number 2 code bars are moved toward the right (spacing), their respective horizontal motion stop slides are toward the rear. The oscillating rail shift slide is moved to the right or left of its central position (determined by the number 3 code bar) until it is stopped by one end of the common horizontal motion



SE640-AZ-MMM-010

Figure 3-84. Horizontal Positioning Mechanisms.

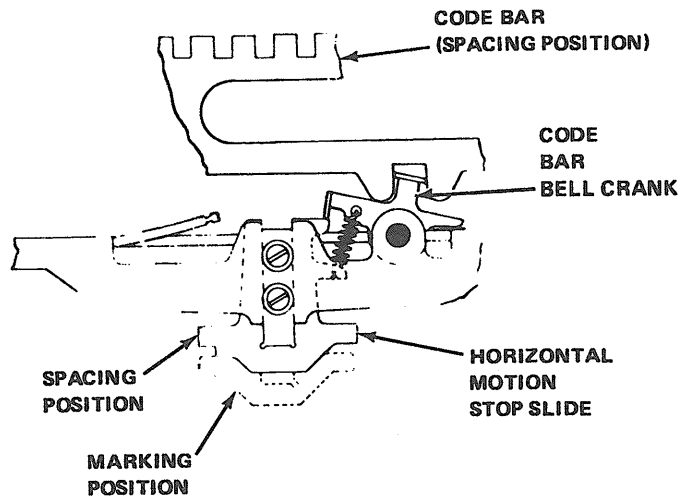

Figure 3-85. Stop Slide Positioning.

stop slide. This positions the first vertical row (right or left of the center of the figures field or the letters field) in line for printing. When the number 2 code bar is toward the right (spacing), and the number 1 code bar is toward the left (marking), the lower and the common stop slides are toward the front, and the upper stop slide is toward the rear. The oscillating rail shift slide is moved to the right or left of its central position until it is stopped by one end of the upper stop slide. This positions the second vertical row (right or left of the center of the figures field or the letters field) in line for printing. When the number 2 code bar is toward the left (marking) and the number 1 code bar is toward the right (spacing), the upper and the common stop slide is toward the rear. The oscillating rail shift slide is moved toward the right or left of its central position until it is stopped by one end of the lower stop slide. This positions the third vertical row (right or left of the center figures field or the letters field) in line for printing. When both the number 1 and the number 2 code bars are toward the left (marking), their respective horizontal motion stop slides

and the common stop slide are toward the front. The oscillating rail shift slide is moved toward the right or left of its central position until it is stopped by one side of the shank of the common stop slide. This positions the fourth vertical row (right or left of the center of the figures field or the letters field) in line for printing.

3-319. PRINT HAMMER AND PRINTING CARRIAGE. After the print box has been moved so that the selected print pallet is in its proper position, it must be struck by a print hammer in order to print (figure 3-86). This is accomplished by the action of the printing carriage located on the printing carriage track at the top of the front plate mechanism.

3-320. The printing carriage rides on rollers on the printing carriage track, which is rigidly attached to the printing unit front plate. The carriage is clamped to the forward section of the upper draw wire rope. This moves the carriage along its track in such a manner that the hammer advances to the next printing position after each character (graphic) is imprinted.

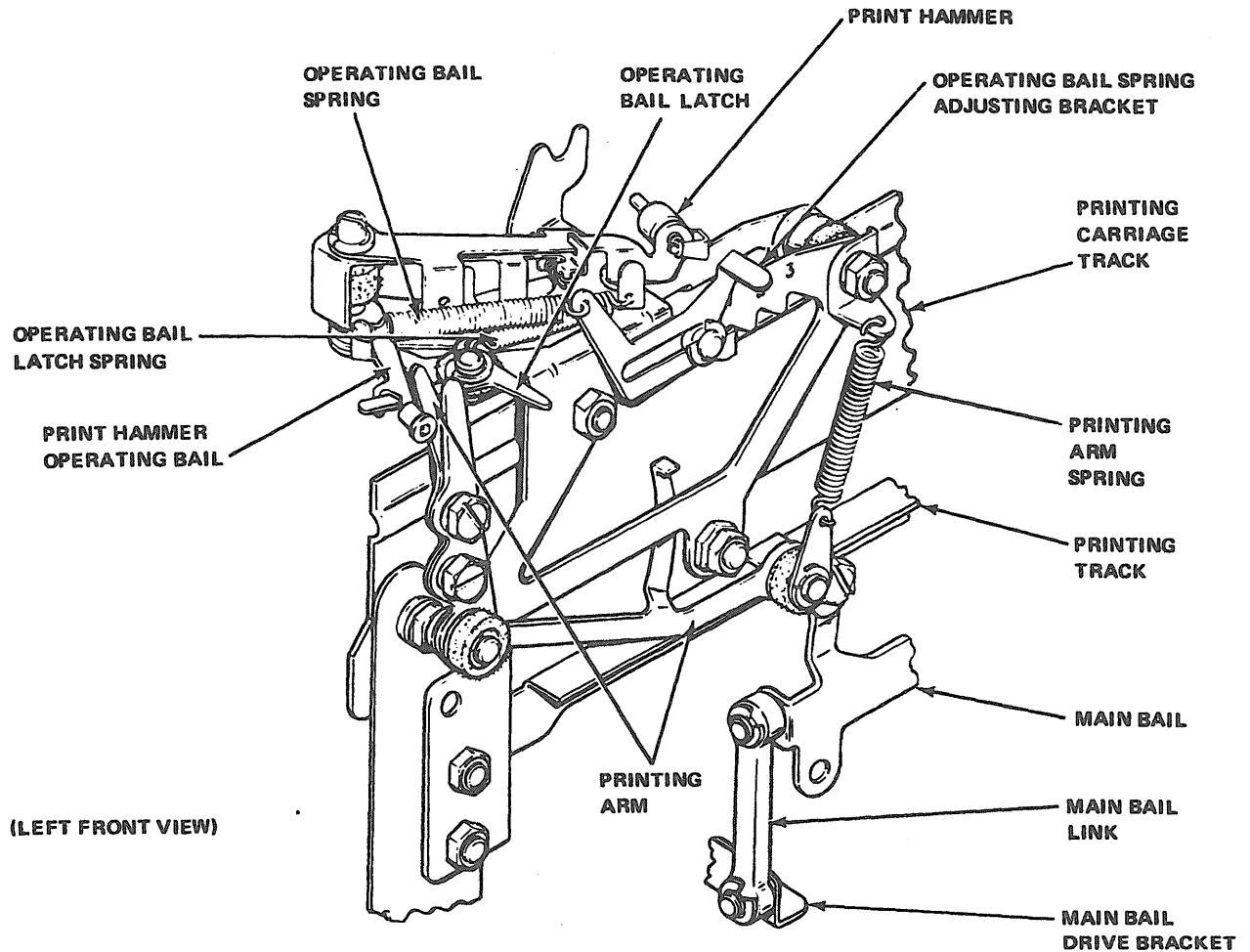

Figure 3-86. Print Hammer and Carriage.

3-321. The printing track which is located on the front of the printing unit (figure 3-86) is fastened to an extension at each end of the main bail. As the main bail reciprocates vertically, it extends the motion through the printing track, which travels in guides located at each end of the track. The printing arm, which extends downward from the printing carriage, rides the printing track. As the arm follows the reciprocating motion of the track, its upper end moves first toward the left and then toward the right. When the upper end of the arm moves toward the left, it rotates the print hammer operating bail clockwise against its spring tension until it becomes latched by the operating bail latch.

3-322. The print hammer operating bail draws the print hammer away from the print box by means of the print hammer bail spring. When the upper end of the printing arm moves to its extreme right position, it makes contact with the latch and causes it to release the print hammer operating bail. The operating bail is swung in a counterclockwise direction by the operating bail spring until it strikes its stop. The print hammer bail, in being driven by the operating bail, is swung toward the print box. When the operating bail is stopped, momentum causes the print hammer bail to continue its travel against the tension of the print hammer bail spring until the printing hammer strikes the selected print pallet. The force with

which the hammer strikes is adjustable to three positions marked on the carriage.

3-323. PRINT SUPPRESSION. A print suppression mechanism (figure 3-87) designed to prevent printing and spacing on nonprinting function code combination signal input, is located on the left end of the code bar mechanism and operated by the code bars. Three blocking levers are pivoted by the code bars either to pass or block the blocking bail, which in turn permits operation of the print box clutch trip lever or blocks its operation through a clutch suppression arm. The effect is to block the trip lever and suppress printing, when the sixth and seventh code bits are simultaneously spacing, or when the third, fourth, fifth, sixth and seventh code bits are simultaneously marking.

3-324. The front end of the lower blocking lever (figure 3-87) rotates counterclockwise (top view) when the number 5 and number 7 code bars are in spacing position (right). The blocking bail is then blocked by the rear of the blocking lever. When either of these code bars is marking position (left), the lever is rotated clockwise to free the blocking bail, permitting the clutch suppression arm to rotate when the clutch trip lever is rotated by the trip shaft.

3-325. The front end of the center blocking lever is engaged by notches in the numbers 3, 4, 5, 6, and 7 code bars in such a way that when any are in the spacing position, the lever is rotated counterclockwise to permit free movement of the blocking bail, thus permitting engagement of the print box clutch. When all of these code bars are marking, the blocking lever is rotated clockwise to suppress print through the blocking bail.

3-326. The upper blocking lever is controlled by the suppression code bar.

Since the suppression code bar is retained in spacing position by a disabling clip, the blocking lever is held in counterclockwise position, permitting printing at all times. The suppression code bar, if operated, would be operated from the stunt box.

3-327. SPACING MECHANISM. To space the printed character properly, the print box and printing carriages must be advanced with each character printed. The spacing must also be accomplished when the input signal code combination represents a letter space. As was shown in paragraph 3-310 and figure 3-79, the carriages are connected to a draw wire rope which, in turn, is fastened to the spring drum and the spacing drum. The purpose of the spring drum, which contains a torsion spring, is to tension the draw wire rope, and thus the carriages, to the left. The spacing drum has ratchet teeth about its perimeter which are engaged by the eccentrically driven spacing drum feed pawls (figure 3-88). The spacing shaft which mounts the spacing eccentrics is driven through a helical gear attached to the three stop spacing clutch on the main shaft. The gear ratio (1-1/2:1) causes the spacing shaft to turn one-half revolution each time the spacing clutch is tripped. This allows the feed pawls to advance the spacing drum by one ratchet tooth.

3-328. The same trip shaft which, through a cam on the code bar clutch (paragraph 3-278), trips the function clutch also rotates the print box clutch trip lever counterclockwise (viewed from the left). Unless movement of this lever is blocked by the print suppression mechanism, the print box clutch is engaged, oscillating the main rocker shaft, which drives the printing mechanism (paragraph 3-314). A cam plate (figure 3-88) fastened to the bottom of the rocker shaft is moved upward as the shaft begins to move. The cam plate operates the spacing trip lever bail.

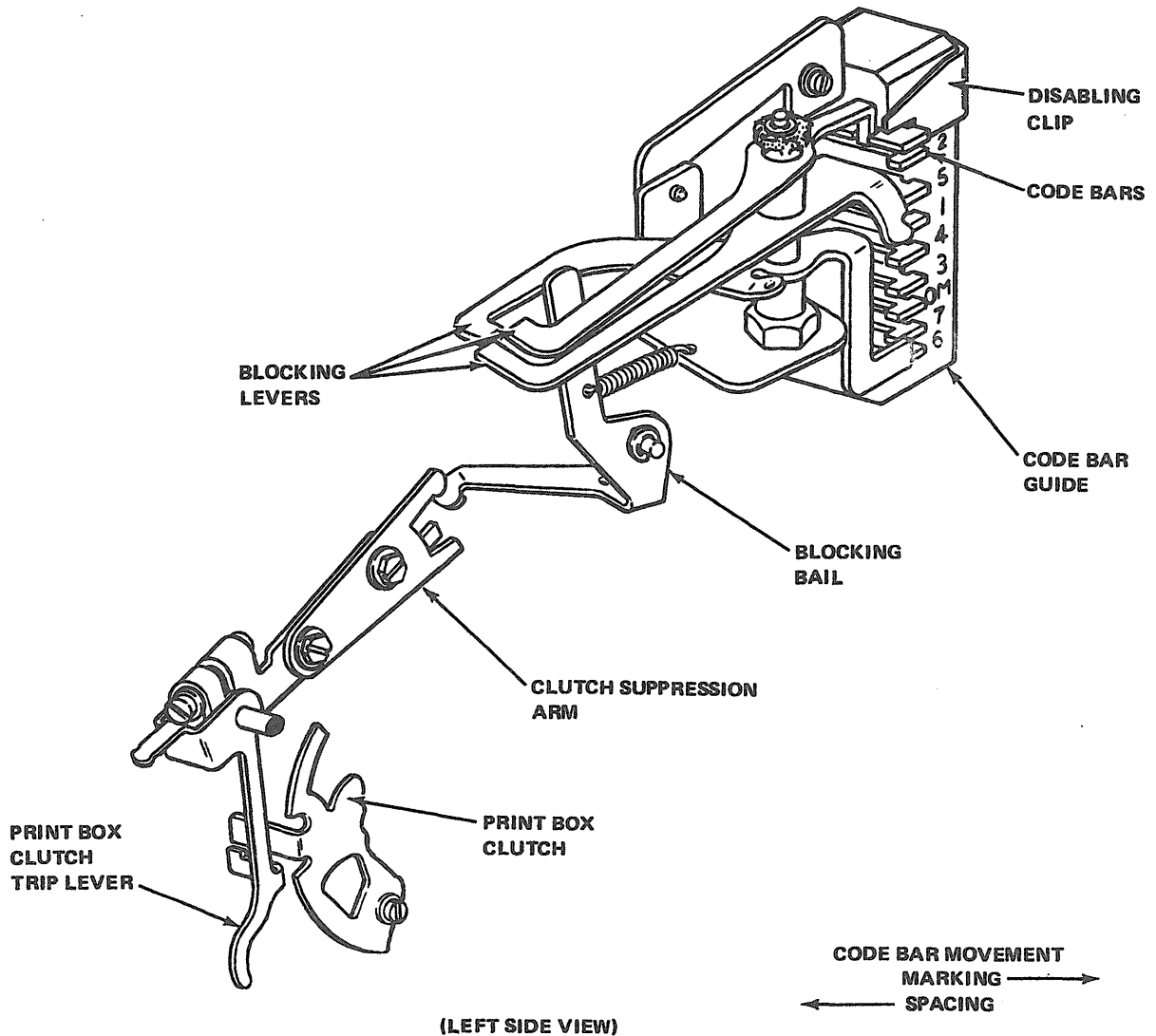

Figure 3-87. Print Suppression Mechanism.

The bail is rotated, raising the spacing trip lever until it latches onto the spacing clutch trip lever arm. As the rocker shaft reverses its direction of rotation, the spacing trip lever bail and the trip lever move downward under spring tension, causing the latched spacing clutch trip lever arm to operate the spacing clutch trip lever and engage the spacing clutch.

3-329. Before the spacing clutch completes one-third revolution, its restoring cam moves the spacing trip lever about its pivot point, releasing the

spacing clutch trip lever, which returns to its normal position in time to stop the spacing clutch after one-third revolution. The spacing clutch three-stop cam disk upon which the latch lever rides has an indent at each stop position. When one of the three lugs on the clutch shoe lever disk strikes the spacing clutch trip lever, the inertia of the cam disk assembly causes it to turn until its lug makes contact with the lugs on the clutch shoe lever disk. The latch lever drops into an indent in the cam disk, and the clutch is held disengaged until the trip lever is again operated.

3-330. **SPACING FUNCTION.** The nonprinting function by which spacing between words is accomplished or any spacing other than that which accompanies printing is initiated when the code bars are set in a combination equivalent to the spacing code combination (all spacing except the sixth bit marking). The function is executed through the code bar clutch, tripping of the printing clutch, and activation of the spacing clutch as described in paragraphs 3-327 through 3-329. For this function, the print box is positioned so that a vacant pallet (top horizontal row, first right row in the figures field) is presented beneath the print hammer. No printing occurs when the print hammer is tripped in its normal fashion. The stunt box is not involved in the execution of this function.

3-331. **SPACING SUPPRESSION.** When certain nonprinting functions are selected or when the carriages reach their extreme right position, it is necessary to suppress spacing to avoid interference with the page printed message or damage to the equipment. This is accomplished by moving the spacing suppression slide (figure 3-88) forward to a point at which it will hold the upper end of the spacing trip lever forward and prevent it from engaging the spacing clutch trip lever.

3-332. In the case of spacing suppression on selection of a function code combination, the spacing suppression slide is shifted forward by the spacing suppression bail, which is mounted beneath the function box. When space suppressing function levers are selected, the levers engage the bail and, when the function mechanism is operated, move the bail forward. The suppression slide which is moved forward with the bail, prevents engagement of the spacing clutch.

3-333. When the carriages are near their extreme right position, a cutout ring on the spacing drum engages the

spacing cutout transfer bail (figure 3-88), which in turn operates the spacing cutout bail. The ring and the end of the spacing cutout transfer bail are shown in figure 3-79. The spacing cutout bail shifts the spacing suppression slide forward and prevents engagement of the spacing clutch until the carriages are returned. The maximum number of characters which the printing unit may print in a line is 85, including spaces. In order to prevent spacing beyond this point with subsequent damage to the equipment, several teeth are omitted from the spacing drum ratchet wheel.

3-334. **MARGIN INDICATOR.** When used in conjunction with a keyboard base, the printing unit actuates a base mounted margin indicator switch (figure 3-79). Before the print box carriage reaches the end of its travel, an actuator mounted on the face of the spring drum operates the switch contact. The angular position of the cam disk with respect to the spring drum may be altered to change the point at which the indicator contact will be closed.

3-335. **RIBBON FEED MECHANISM.** The left and right ribbon feed mechanisms (figure 3-89) oscillate in a vertical plane with each revolution of the print box clutch. They are driven by ribbon drive links attached to the main side levers (figure 3-82). At their uppermost positions, the ribbon mechanisms position the ribbon relative to the horizontal print box row being printed. After each character is printed, the ribbon mechanisms drop together with, and behind, the print box in order that the last character printed may be viewed. The ribbon is held in place by a ribbon guide fastened to the rear of the print box carriage.

3-336. Each of the ribbon mechanisms consists of a bracket which is hinged at its rear end and upon which is mounted a ribbon spool shaft (figure 3-89). A ribbon tension bracket is keyed to the lower end of the ribbon spool shaft. A ribbon ratchet wheel is mounted freely

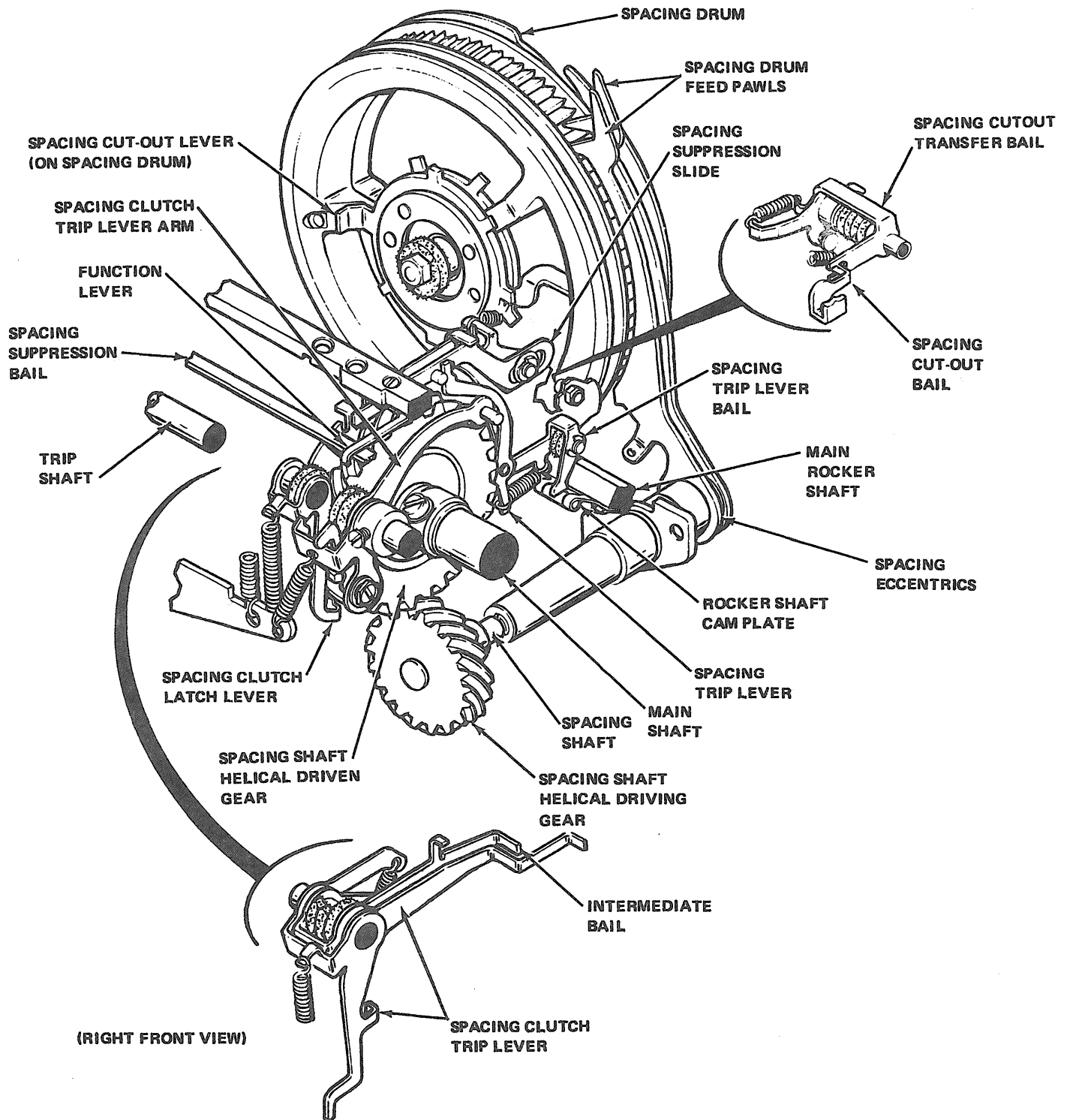

Figure 3-88. Spacing Mechanism.

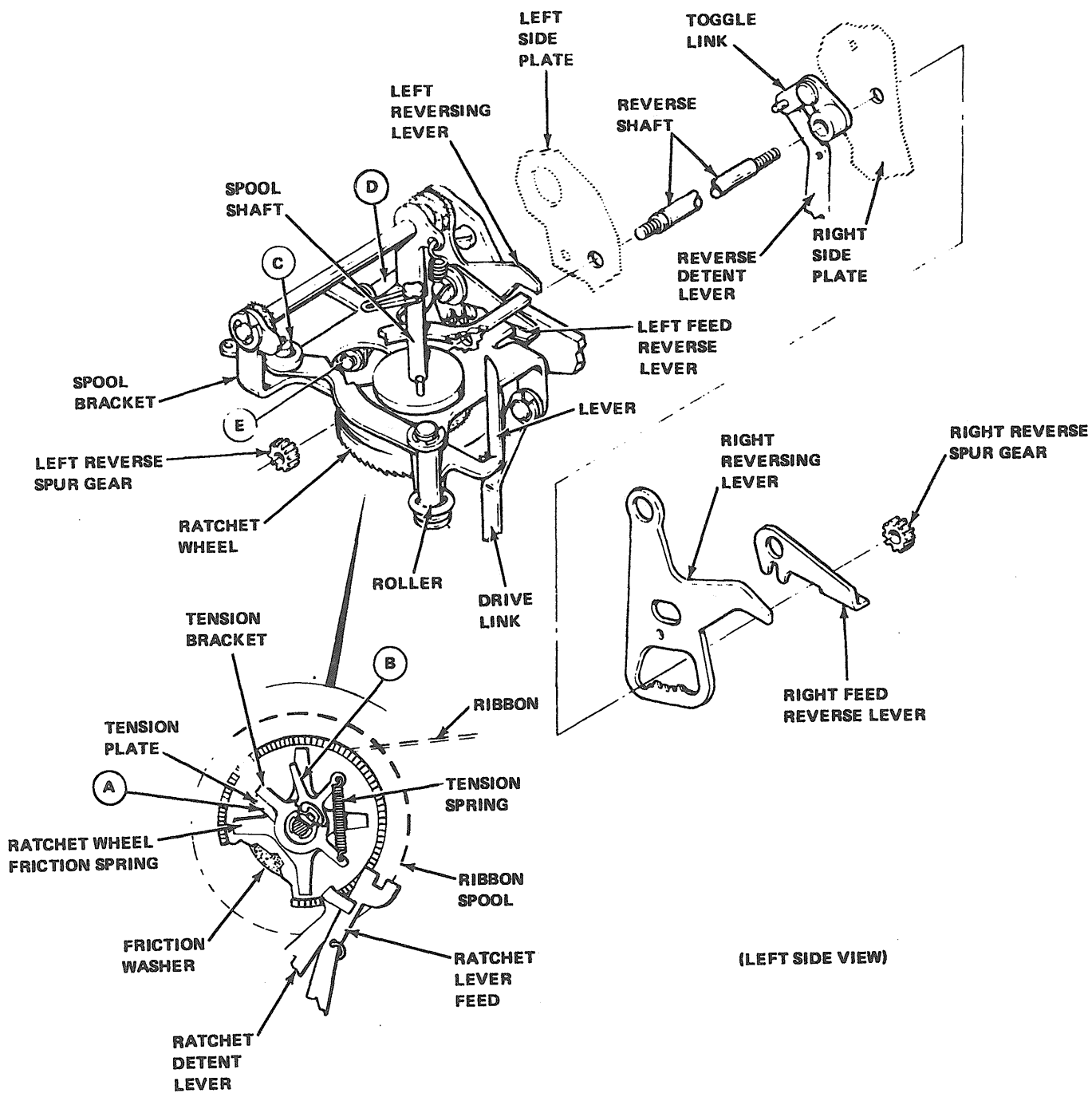

Figure 3-89. Ribbon Feed and Reverse Mechanisms.

on the ribbon spool shaft just below the ribbon spool bracket, from which it is separated by a friction washer. This applies a constant drag to the ratchet wheel.

3-337. A ribbon tension plate which is keyed to the hub of the ribbon ratchet wheel has two projecting lugs (A and B, figure 3-89) that straddle the lug on the ribbon tension bracket. A ribbon

tension spring maintains the ribbon tension bracket against lug A of the ribbon tension plate. In operation, the ribbon spool bracket, driven by the ribbon drive link, pivots about point C. The ratchet feed and ratchet detent levers pivot about points D and E respectively, and are held against the teeth on the ribbon ratchet wheel by their springs. As the ribbon spool bracket is moved upward, the ratchet wheel feed lever skips over one tooth, while the ratchet detent lever holds the ribbon ratchet wheel from turning backward. When the ribbon spool bracket is moved downward, the ratchet feed lever engages a ratchet tooth and pushes the ratchet wheel. A tooth on the ribbon ratchet wheel then skips over the ratchet detent lever. The teeth on the left and right ribbon ratchet wheels face in opposite directions so that when their feed levers are engaged, the left ribbon ratchet wheel turns counterclockwise (viewed from the top). In order for the ribbon to be pulled from one ribbon spool to the other, only one of the ribbon mechanisms at a time can have its ratchet feed and ratchet detent levers engaged with the ribbon ratchet wheel. As the ribbon ratchet wheel turns, the ribbon tension plate also turns, and extends the ribbon tension spring. When lug B of the ribbon tension plate makes contact with the ribbon tension bracket, the ribbon spool shaft is activated and the ribbon is wound on the ribbon spool.

3-338. When the ribbon has been completely unwound from one spool, it is necessary to reverse its direction so it can rewind. This is accomplished automatically by disengaging one set of ratchet feed and ratchet detent levers and engaging the other set. While the ribbon is passing from the left spool to the right spool, the right set of levers is engaged. The left set is held disengaged against the tension of the springs by the left ribbon feed reverse

lever, which is in its downward position (figure 3-89). The lever is held in this position by means of the ribbon reverse detent lever through the intervening ribbon reverse detent cam, ribbon reverse shaft and ribbon reverse spur gear. As the ribbon unwinds from the ribbon spool, it passes around the ribbon roller and through the slot in the end of the ribbon lever. When the ribbon nears its end, an eyelet which is fastened to the ribbon catches in the ribbon lever slot and pulls the lever toward the right. The next time the ribbon mechanism is moved upward, the displaced ribbon lever engages the end of the left ribbon reversing lever causing it to move. As the lever moves, its teeth rotate the left spur gear which, through the ribbon reverse shaft, turns the detent cam and the right spur gear. As the right spur gear moves the right ribbon reversing lever downward, a pin on the lever drives the right ribbon feed lever downward to disengage the ratchet feed and wheel. At the same time, a pin on the left ribbon reversing lever upward to permit the left ratchet feed and detent levers to engage the left ribbon ratchet wheel. Thus, the ribbon mechanisms are positioned to rewind the ribbon on the left ribbon spool. When it nears its end on the right ribbon spool, the ribbon is again reversed in a manner similar to that just described. During the reversing cycle, the ribbon is kept taut by the previously extended ribbon tension spring.

3-339. FUNCTIONS. There are two types of operation which can be performed by the printing unit. The first embodies those mechanical actions which are directly necessary to the actual printing of a character (or space function). The second embodies mechanical action which alters the positions of the various mechanisms or activates external devices or circuits through switching contacts. The latter are known as functions.

NOTE

Spacing may technically be considered a function, but it is mechanically associated with the printing operation, except when suppressed by function mechanisms.

3-340. As in printing, the reception of function codes results in the positioning of the code bars (paragraph 3-240). The back edges of the code bars are notched (figure 3-90). Positioned directly behind the code bars is a stunt box, which contains the function bars for the various functions (figure 3-91 and 3-92). Each function bar has a series of tines on its end, offset to one side or the other to correspond with the marking and spacing elements of the particular input signal code combination to which it responds. Tines positioned to the right are spacing; those to the left are marking.

3-341. When the function clutch is engaged (figure 3-90), it actuates the function bar reset bail (through the intervening cam and follower arm and the function rocker shaft causing the function bar reset bail, with its attached reset bail blade, to momentarily release the function bars (figure 3-93). As the spring tension function bars are released, they move forward to bear against the code bars. If the code bars are positioned for a function, each tine on the function bar for that function will be opposite a notch in the code bar. This will permit the selected function bar to continue to move forward into the code bars, while the other function bars are blocked by one or more code bars (figure 3-94).

3-342. Associated with each function bar in the stunt box is a function pawl and a function lever. In the unselected position, the function bar is disengaged from its function pawl (figure 3-95). When the function bar reset bail blade

releases the function bars, any selected bar will move sufficiently forward (to the left, in figure 3-95) to permit it to engage its function pawl. Then, as the reset bail blade returns the function bar to its initial position, the function bar carries the function pawl to the rear (to the right, figure 3-96). The function pawl, in turn moves the function lever clockwise about its pivot point. A projection at the lower end of the function levers operates the spacing suppression bail (paragraph 3-332) selected levers moving the bail forward. Either the upper or the lower end operates the indicated function.

3-343. Near the end of the function cycle, a stripper blade (figure 3-97) operated by a cam on the function clutch assembly rises to engage any selected function pawl and strip it from its function bar. Springs return the released function pawl and the function lever to their original position. The function clutch is disengaged upon completion of one revolution when its latch lever falls into the indent of the clutch cam, in the same manner as described in connection with the code bar clutch (paragraph 3-303).

3-344. CARRIAGE RETURN FUNCTION. The carriage return function mechanism is located in the right end of the printing unit. Receipt of the input signal code combination for the function causes the function bar, pawl, and lever to operate (figure 3-98). The lower end of the function lever engages the carriage return slide arm and pushes it forward. The slide arm, in turn, moves the carriage return bail and its lever about their pivot point. As the front portion of the lever moves downward, it takes with it the lower section of the spacing drum feed pawl release link. This causes the upper portion of the link to turn and disengage the spacing drum feed pawls from the spacing drum (figure 3-99).

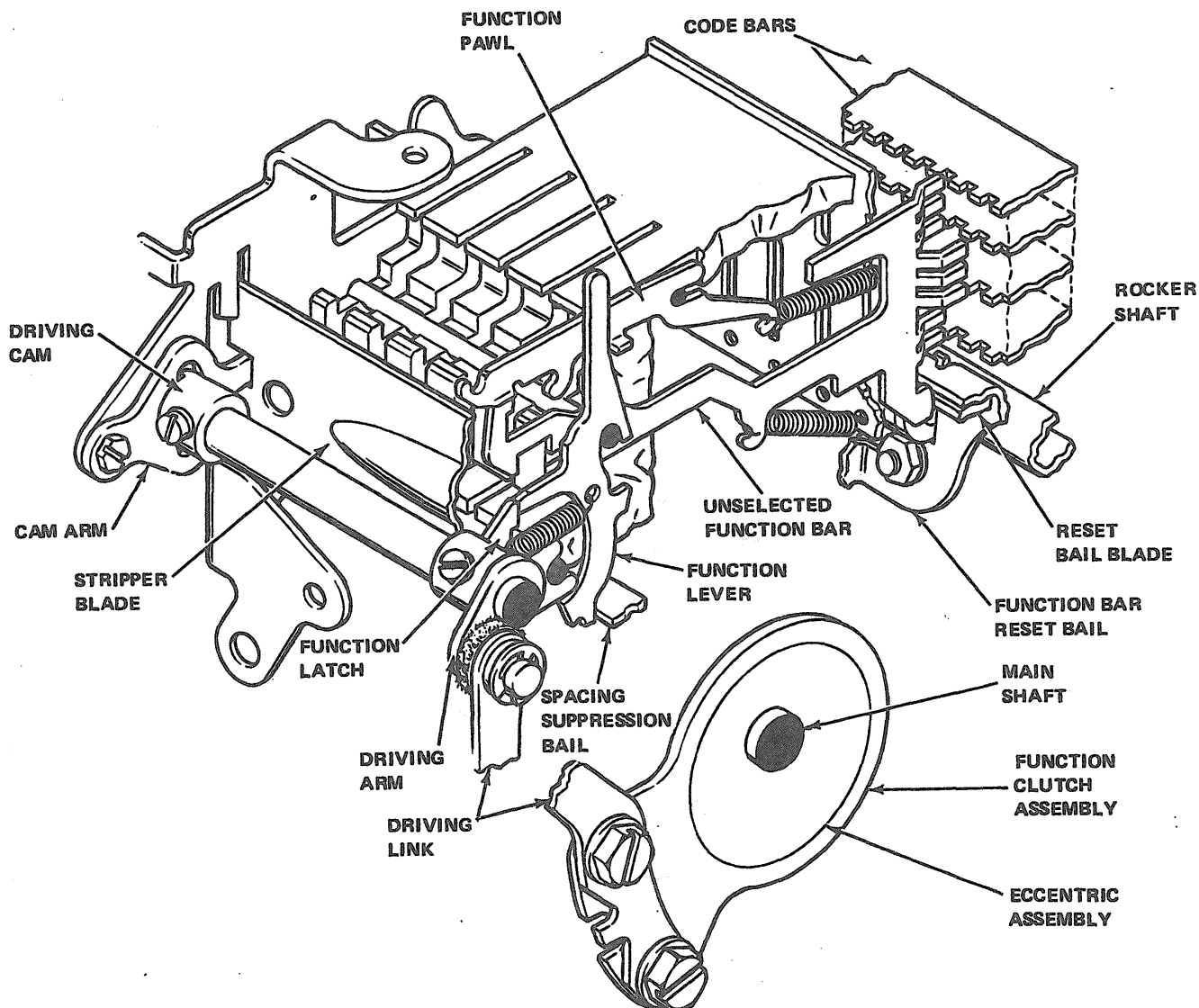

Figure 3-90. Stunt Box (Function Linkage Unselected).

3-345. When the carriage return lever reaches the lowest point, the carriage return latch bail locks it there. The disengagement of the spacing drum feed pawls from the spacing drum permits the spring drum to return the printing and print box carriages to the left side of the printing unit. As the spacing drum nears the end of its counterclockwise rotation, the roller on the stop arm contacts the transfer slide, which in turn, drives the dashpot piston into the dashpot cylinder. A small passage-way with an inlet from the inside of

the cylinder and three outlets to the outside is incorporated in the end of the cylinder. Two of the openings to the outside are closed by a steel ball, which is held in its seat by means of a compression spring. A locking setscrew is used to regulate the spring pressure on the ball. The rate of deceleration provided by the cushioning effect of the trapped air is automatically regulated for various line lengths by means of a ball valve. This, together with the direct opening to the outside, determines the rate at which air may escape

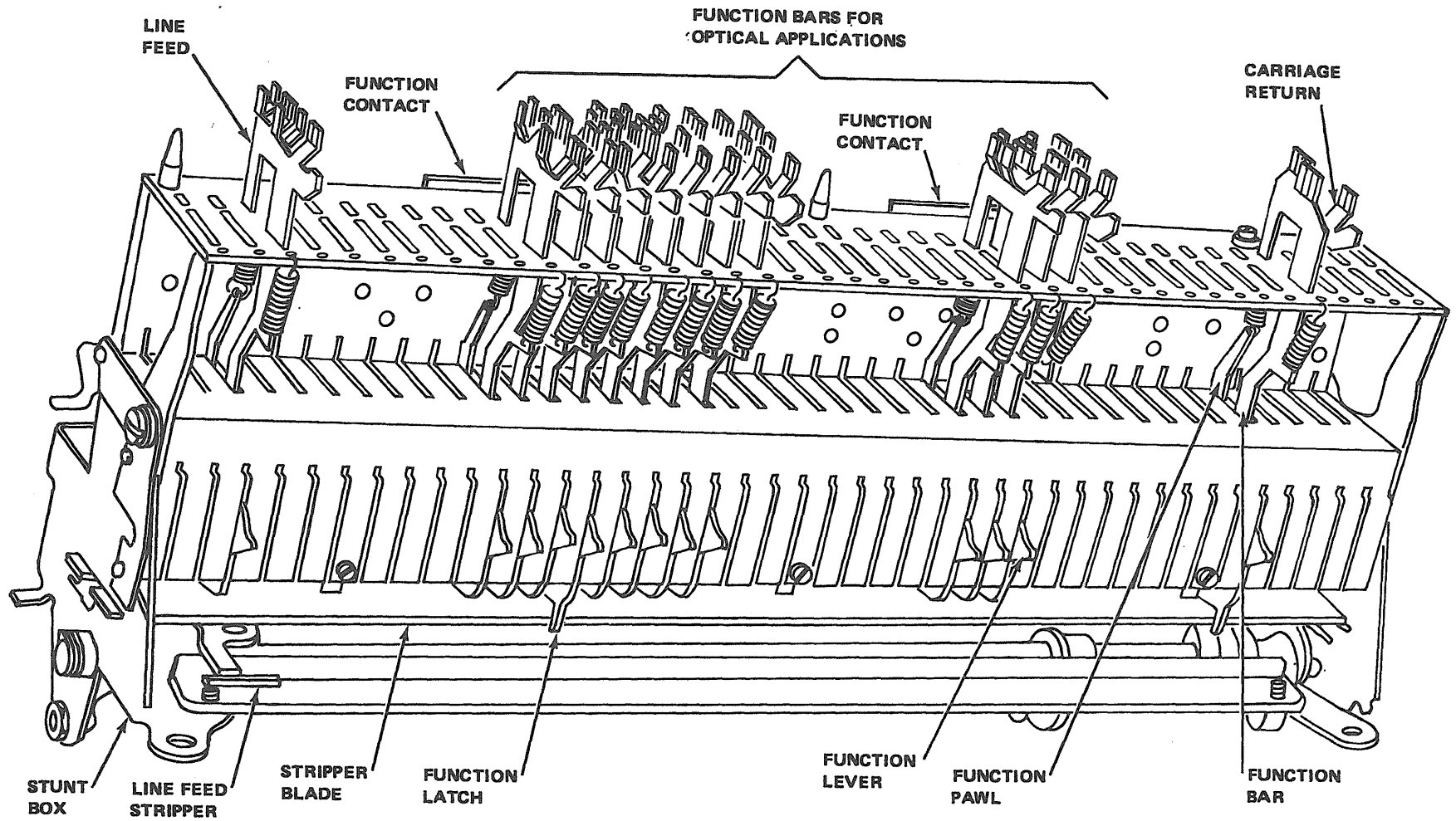
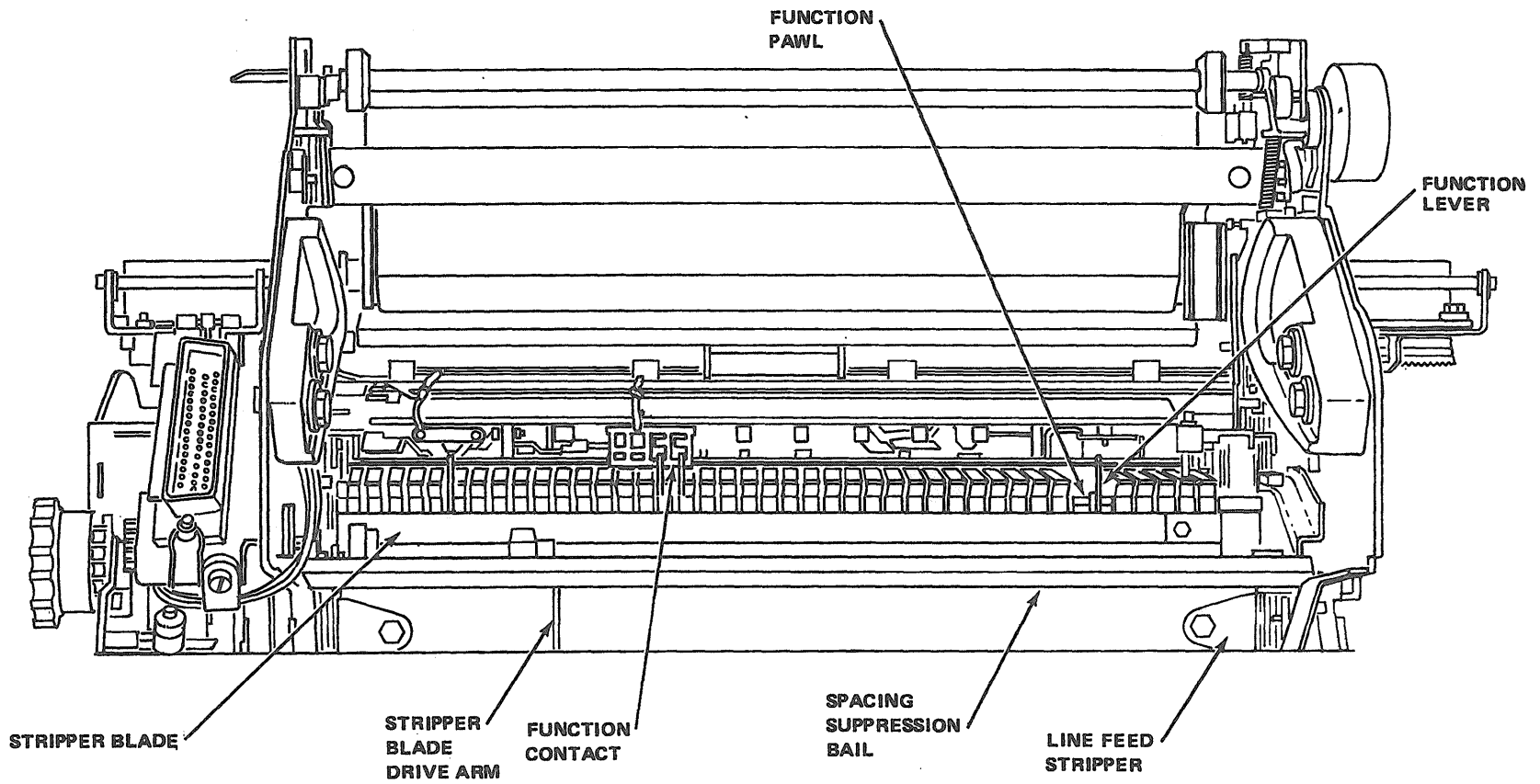

Figure 3-91. Typical Stunt Box (Bottom View).



SE640-AZ-MMM-010

Figure 3-92. Stunt Box (Rear View).

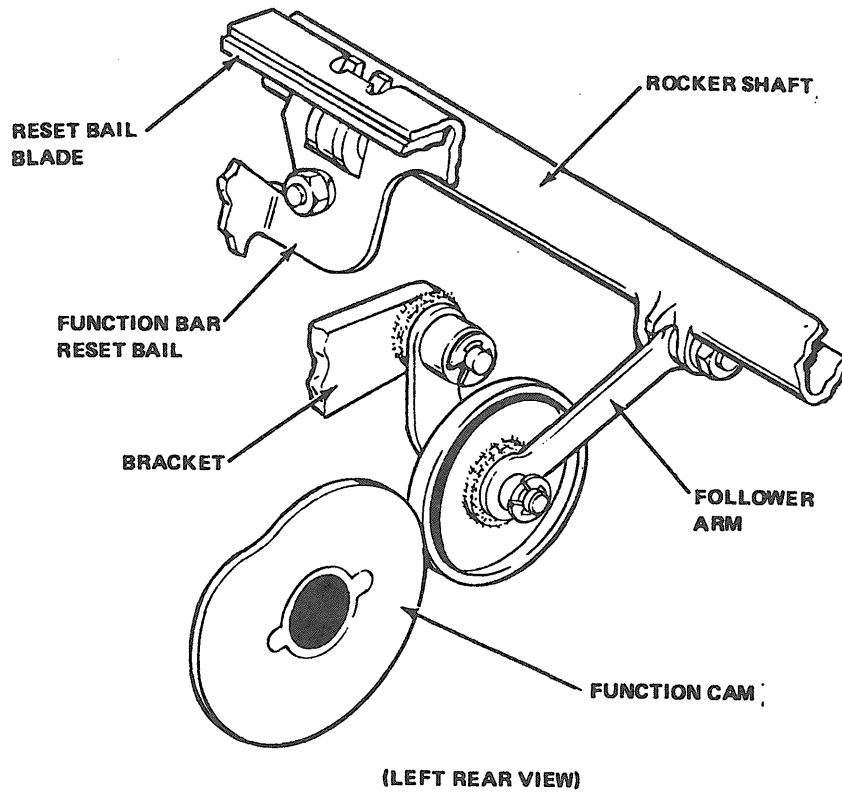

Figure 3-93. Reset Bail Mechanism.

from the cylinder. When the spacing drum reaches its extreme counterclockwise position, an extension on the stop arm trips the carriage return latch bail plate, which is fastened to the carriage return latch bail. The latch bail disengages the carriage return lever, and the feed pawls are again permitted to engage the spacing drum.

3-346. Local (off-line) operation of the carriage return mechanism may be obtained from the keyboard base or base on which the printing unit is mounted. A projection beneath the carriage return lever (figure 3-99), when rotated to the rear (counterclockwise, viewed from the right), operates the carriage return mechanism in the same way as when this lever is operated by the stunt box.

3-347. LINE FEED FUNCTION. The line feed function mechanism is located in the left end of the printing unit. The code bar mechanism set to correspond to an input signal code combination for spacing permits two line feed function bars, pawls and levers to operate. The function linkage at the far left of the stunt box operates the line feed mechanism (figure 3-100). The function bar positioned in slot 29 of the stunt box is used, in connection with line feed, only for space suppression. The lower end of the line feed function lever engages the line feed slide arm and pushes it forward. The slide arm, in turn, moves the line feed clutch trip arm and the trip lever above their pivot point until the trip lever releases the three-stop line feed clutch. The line feed

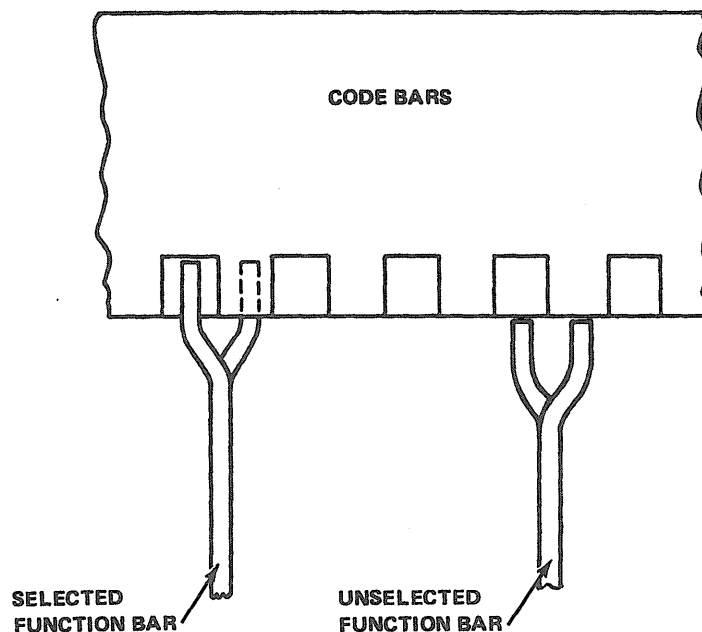

Figure 3-94. Function Bar Selection.

gearing is such that each one-third revolution of the clutch will advance the platen by one line. Therefore, the length of time that the line feed clutch trip lever is held away from the clutch will determine the number of line feeds that occur.

3-348. The timing relationship between the stripper blade cycle and the main shaft rotation is such that the function pawl is not stripped from a function bar until after more than one-third revolution of the clutch has occurred. Thus, the line feed clutch trip lever will stop the clutch after a two-thirds revolution, or double line feed has occurred. When single line feed is desired, it is necessary to strip the function pawl from the line feed function bar before the line feed clutch completes one-third revolution. This is accomplished by use of an auxiliary function pawl stripper which is attached to the left end of the stripper bail. The cam disk on the three-stop line feed clutch provides the motive force to operate the stripper bail once each one-third revolution of the line feed clutch.

3-349. The stripper bail on which the slotted line feed function pawl stripper rides may be shifted toward the right (double) or to the left (single) by action of the single or double line feed lever (figure 3-101). The upper end of the pivoted single or double line feed lever protrudes from the upper left of the left side plate of the printing unit, where it rides in the two position side frame detent extension. When the lever is in position 1, the stripper bail engages the line feed function stripper to raise it into contact with the function pawl before the stripper blade would strike it. When the lever is moved to the rear (position 2), the bail is disengaged from the blade, and the stripper blade strikes the function pawl in the normal cycling of the function box stripper blade.

3-350. When single line feed is being used, the line feed function lever is released too soon (by the line feed function pawl stripper) to prevent spacing. Therefore, an additional line feed function bar, pawl and lever are installed in slot 29 of the stunt box for the

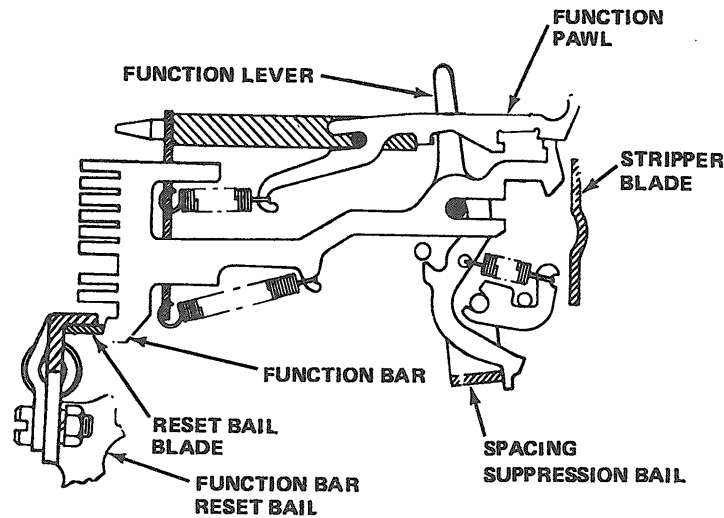

Figure 3-95. Typical Function Linkage (Unselected).

purpose of suppressing spacing on single line feed function. This mechanism, which always operates on the line feed function code bar arrangement, is released only by the stunt box stripper blade and, therefore, holds the spacing suppression bail forward until the spacing cycle is completed. After the line feed clutch is stopped by its trip lever, it disengages as the latch lever drops into the indent in the clutch cam in the same manner as described for the code bar clutch (paragraph 3-303).

3-351. Each one-third revolution of the line feed clutch causes its attached spur gear (figure 3-101) to rotate the line feed eccentric spur gear and its attached eccentrics one-half revolution. The eccentrics, which are offset in opposite directions, each carry a line feed bar. These bars are guided by the line feed bar bell crank and alternately engage the line feed spur gear on the platen advancing the platen one line for each one-half turn. A platen detent bail engages the line feed spur gear to retain the platen at each setting.

3-352. The platen may be manually positioned, by rotating the platen handwheel at the top of the right side plate.

This causes the platen handwheel spur gear to engage the platen idler gear, which in turn is engaged with the platen spur gear on the platen shaft. At the same time, the line feed bar release lever (figure 3-101) engages the line feed bar bell crank and causes it to disengage the line feed bars from the line feed spur gear.

3-353. Local (off-line) operation of the line feed mechanism may be obtained from the keyboard base or base on which the printing unit is mounted. A projection beneath the line feed clutch trip lever (figure 3-100), when rotated to the rear (counterclockwise, viewed from the right), operates the line feed mechanisms in the same way as when this lever is operated by the function box. Since the clutch is manually engaged, line feed is continuous until released at the keyboard or base.

3-354. STUNT BOX CONTACTS. For external circuit control and switching functions, function levers may be positioned to operate normally open, normally closed, or by single pole double throw (SPDT) switches mounted on the top of the stunt box (figures 3-102 and 3-103). In general, the function contacts are

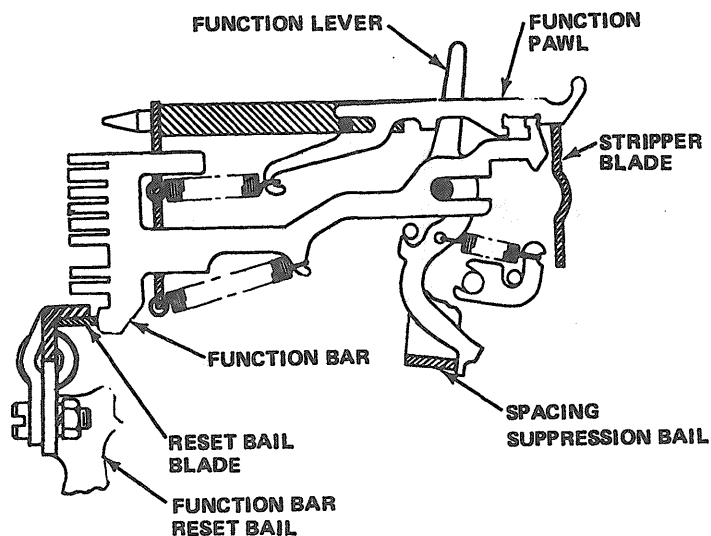

Figure 3-96. Typical Function Linkage (Selected).

similar except for electrical connections, which are determined by external requirements. The contact arm configuration is changed as required to either make or break the contact when the associated function lever is in selected (rear) position. All contacts are wired through the cable connector located on the right side plate. A typical contact (NO) is illustrated in unselected (figure 3-102) and selected (figure 3-103) condition.

3-355. The contact operated by the function linkage in slot 14 of the stunt box operates in response to an input signal code combination representing R1 OFF (Receiver Off). This is a normally closed contact. The contacts operated by the function linkages in slots 15, 16, 27, 28, 30, and 32 of the stunt box are normally open contacts. They operate in response to the following input signal code combinations (from right to left on the stunt box) in sets operating in switched network service:

1. 15 R1 ON - Receiver On
2. 16 BELL - Signal Bell

3. 27 EOT - End of Transmission
4. 28 X-ON - Transmitter On
5. 30 ACK - Acknowledge
6. RU - Are You?

3-356. The contacts operated by the function linkages in slots 25 and 26 (in sets operating in switched network service) both respond to an input signal code combination representing WRU (Who Are You?). The contact operated by the function linkage in slot 31 responds to X-OFF (Transmitter Off) code. These switches are all SPDT contacts.

3-357. When the ACK code is received (by sets operating in switched network service) the function linkage in slot 30 of the stunt box is operated. This linkage also engages the adjoining line feed function bar linkage in slot 29 as it pushes rearward on an ear of the line feed function lever. The line feed function lever ear latches the ACK function bar, and the contact operated is held closed until released by receipt of a line feed input signal code combination.

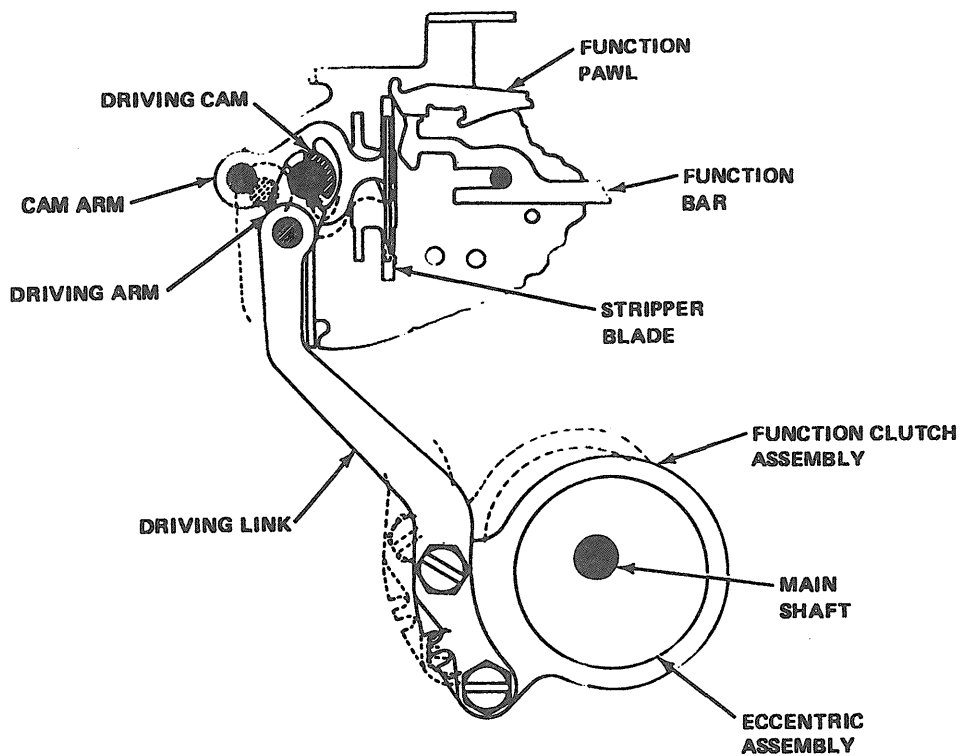

Figure 3-97. Stripper Blade Mechanism.

3-358. PLATEN MECHANISM. Paper for the page printed message is stored on an 8-1/2 inch roll, mounted on a spindle suspended between the two side plates at the rear of the printing unit. From the roll, the paper passes over a paper straightener shaft, downward behind the platen (figure 3-104) and between the platen and three pressure rollers. A paper pressure bail at the front of the platen equalizes pressure applied by the pressure rollers. When it is necessary to straighten the paper or remove it from the platen, the pressure bail may be released by rotating to the rear (clockwise, viewed from the right) the paper release lever located at the top of the right side platen. Two fingers operated on a spring tensioned shaft across the front of the platen hold copy paper firmly against the platen in position for printing.

3-359. SYNCHRONOUS MOTOR UNIT. The stator of the synchronous motor has two

windings (figure 3-105) a starting winding and an operating (or run) winding. The starting winding, starting capacitor, and the normally open contacts of the starting relay are connected in series. The coil of the current-operated starting relay is connected in series with the operating winding. When power is applied, the initial current through the operating winding (and also the starting relay coil) energizes the relay, and its contacts close the circuit to the starting winding. As the speed of the rotor increases, the current in the operating winding decreases, and when the current has decreased to the predetermined magnitude, the starting relay deenergizes. Its contacts open and remove the starting winding from the operating circuit. The rotor continues to accelerate until it reaches the synchronous operating speed. Rotation is counterclockwise, as viewed from the fan or short-shaft end of the motor.

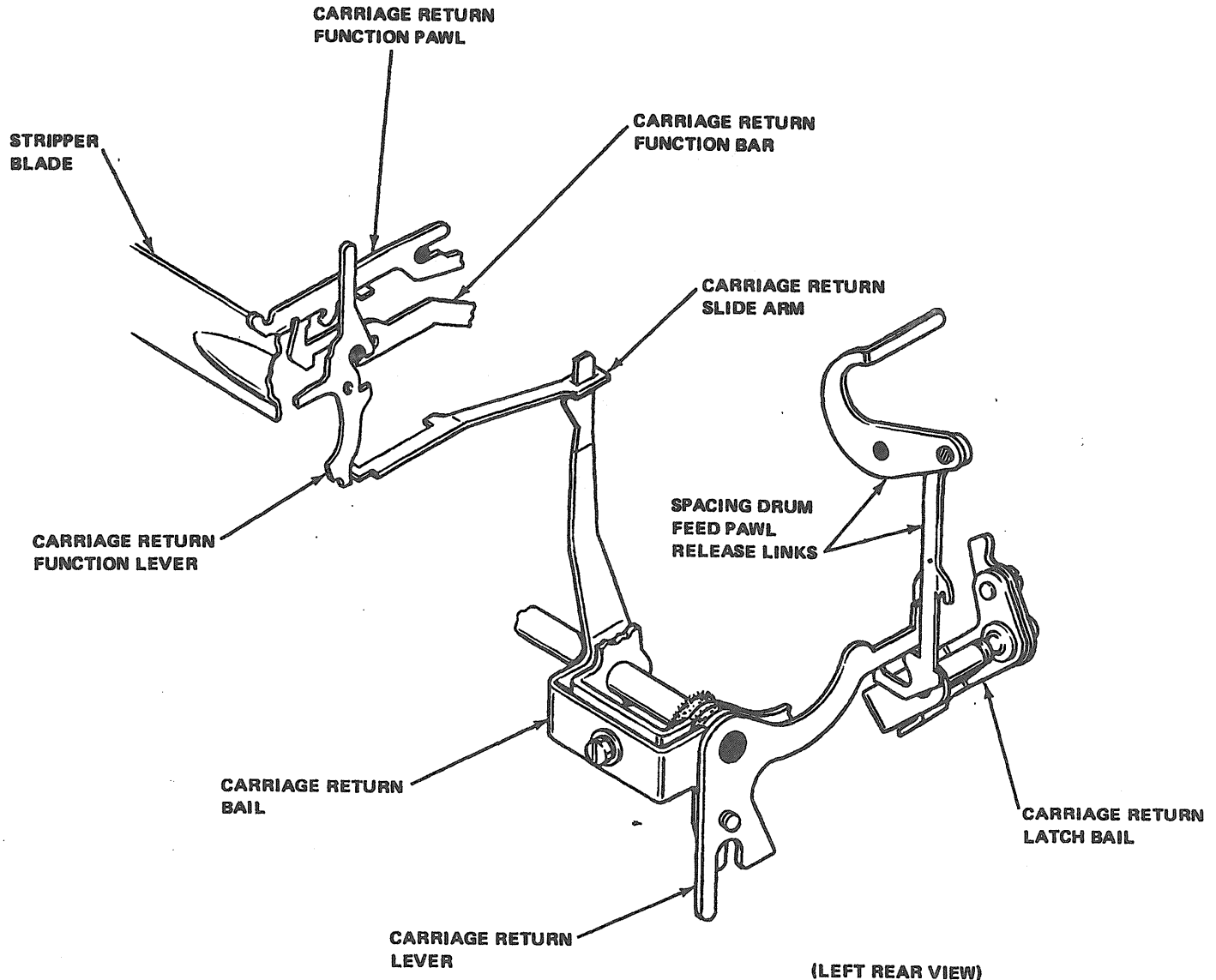

Figure 3-98. Carriage Return Function Mechanism.

3-360. The thermostatic cutout switch is connected in series with both stator windings. This temperature-operated device opens the circuit to these windings whenever excessive current is drawn (such as may occur if the motor is stalled), and prevents overheating and damage to the motor and control parts. The switch may be reset after the unit has cooled by depressing a pushbutton.

3-361. TAPE PUNCH.

3-362. OPERATION. Figure 3-106 is a schematic diagram of the operation of the tape punch. It illustrates the reception of a six-level electrical code combination 1-3-5, and its corresponding tape perforation. It also illustrates the relative timing of the process. The operation represented by the figure is described in the following paragraphs.

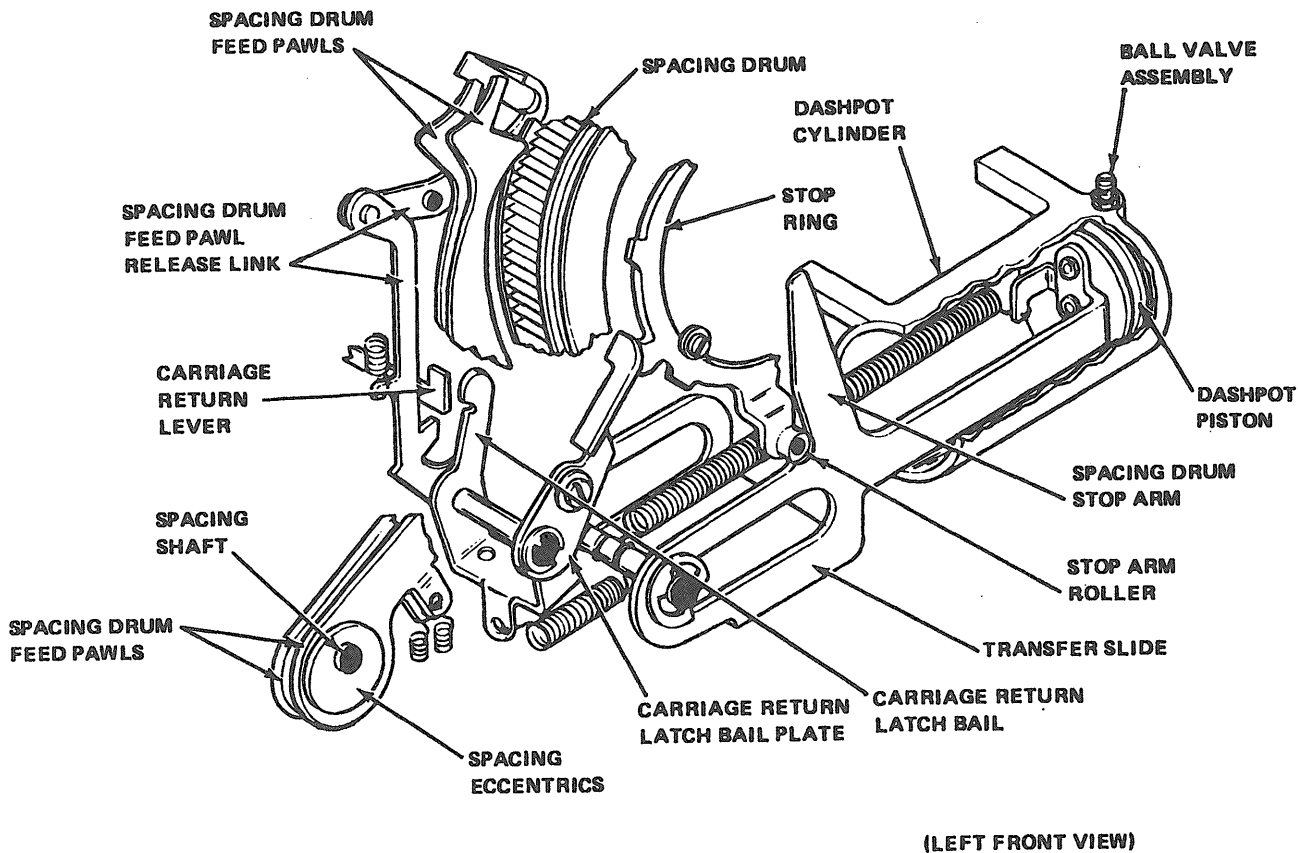

Figure 3-99. Carriage Mechanism.

3-363. AC power is applied to the motor unit through the MOTOR switch. When the switch is ON, the motor converts the electrical power into rotary mechanical motion which is delivered to the drive mechanism on the punch unit. The drive mechanism translates the motion from rotary to oscillating and distributes it to the perforating and feed mechanisms.

3-364. The basic motion of the punch is oscillating, or simple harmonic. There are actually two sets of motions involved; perforating and feeding. In figure 3-107, the vertical motions of key parts of these mechanisms are plotted against the rotation of the main shaft in degrees. Top Dead Center (TDC) of the perforating mechanism has been designated as 0° . The drive mechanism is so designed that the feed mechanism reaches TDC 45° after the perforating mechanism.

3-365. An operation of the punch may be thought of as measured from TDC of the perforating mechanism to TDC of the feed mechanism, a period of 405° (figure 3-106). This is the period required by the equipment to perforate a character and advance the tape upon receipt of an electrical code combination. As shown in the figure 3-106, the operations overlap each other by 45° .

3-366. For each operation, the magnetic pickup, actuated by an iron insert in the flywheel, sends out a synchronizing pulse whose function is to actuate the external control circuits. The timing of this pulse is adjustable to a number of factors explained in paragraph 3-373. If no intelligence is ready in the control circuits, no feed or code pulses are sent to the magnets, and the punch undergoes an operation without perforating or feeding the tape.

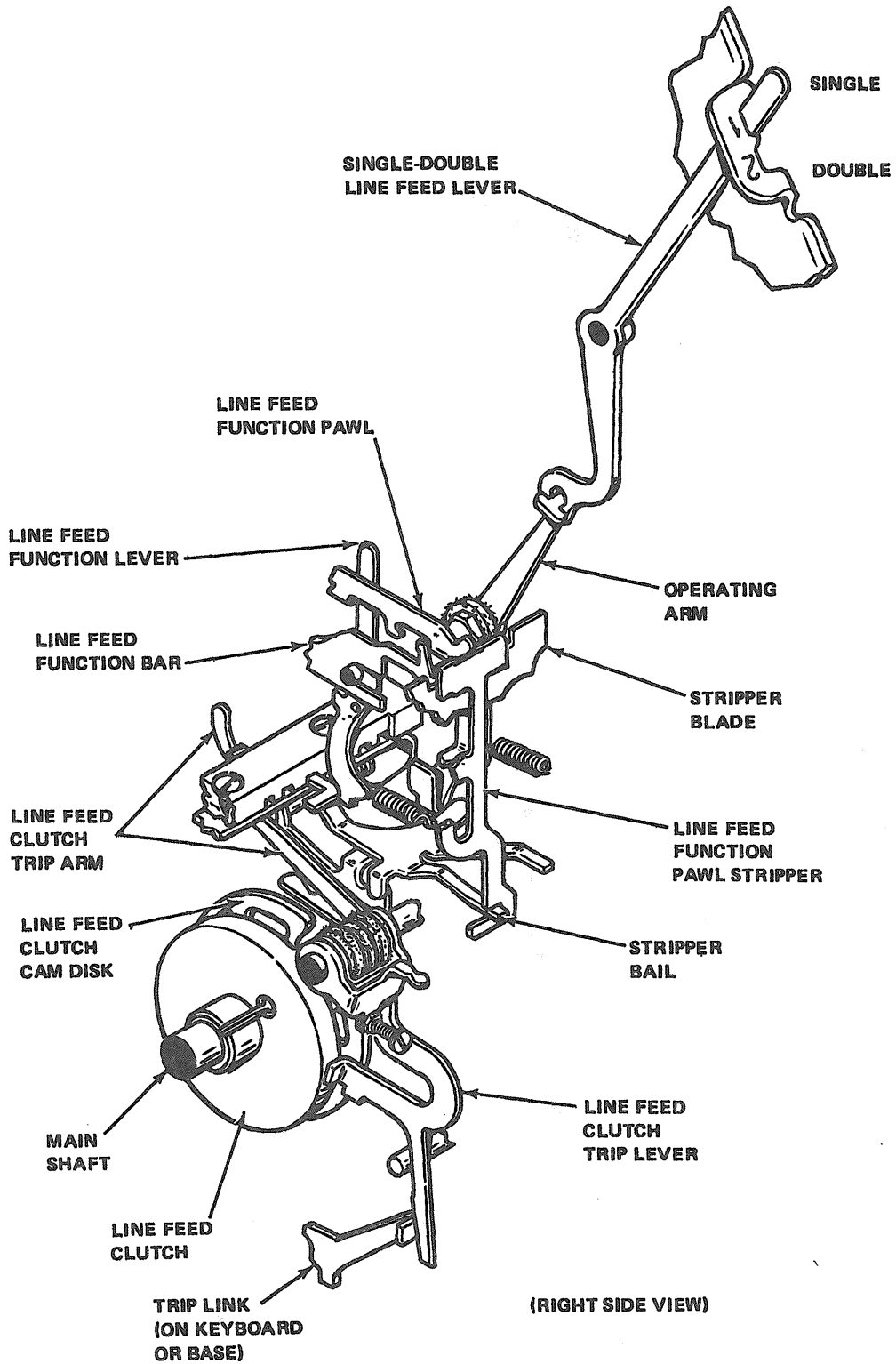

Figure 3-100. Line Feed Mechanism.

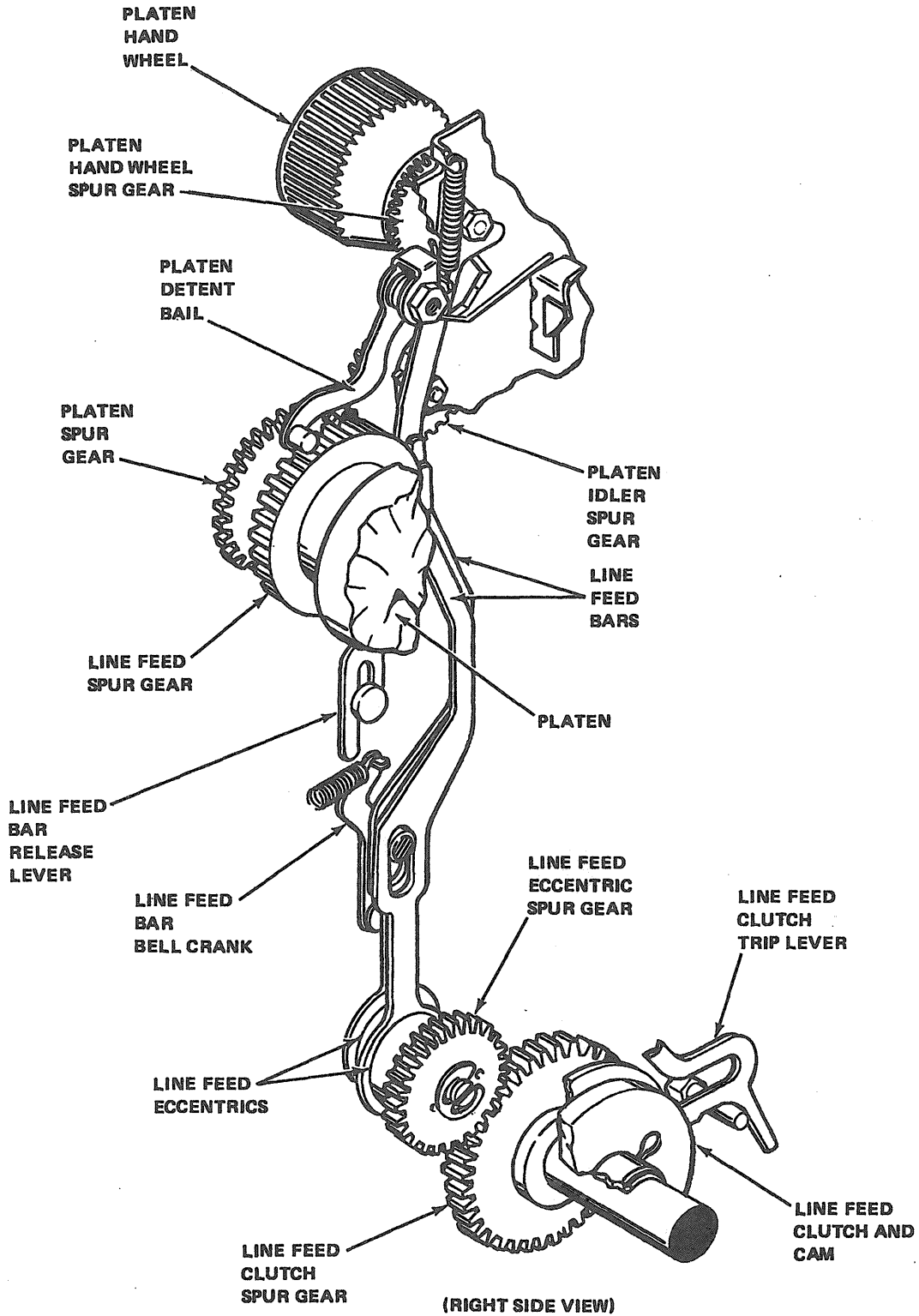

Figure 3-101. Single And Double Line Feed Lever.

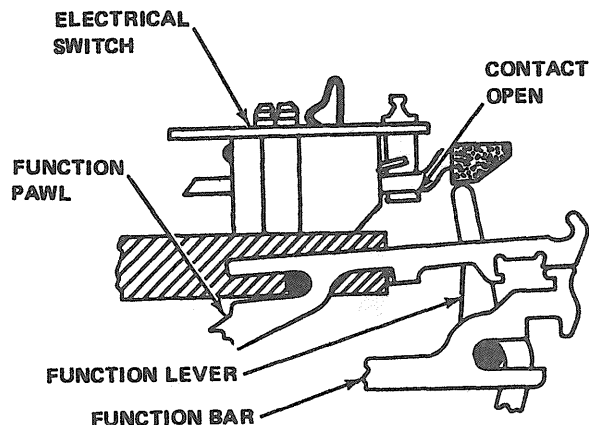

Figure 3-102. Typical Box Contact (Unselected).

3-367. On the other hand, if there is intelligence ready in the control circuits, a combination of code pulses and a feed pulse are applied to the code magnets and feed magnet respectively. Under the control of the code magnets, the perforating mechanism punches code holes in the tape corresponding to the marking pulses received. In addition, the perforating mechanism automatically punches a feed hole with each code combination. As indicated in figures 3-106 and 3-107 perforating occurs about midway through the operation following reception of the pulses.

3-368. The feed magnet, energized by the feed pulse, causes the feed mechanism to advance the tape late in the operation after perforation has been completed. As the punch continues to cycle, it perforates a character for each operation that the control circuit has ready.

3-369. MOTOR UNIT (LMU-6). Mechanical motion to operate the tape punch set is supplied by a series wound (governed) motor unit (figure 3-108). See figure 3-109 for the following description of the operation of the motor unit.

3-370. The series wound motor utilizes an electromechanical governor for speed regulation. The governor regulates the

speed at 3,600 rpm \pm 1 percent, by alternately increasing and decreasing the current in the series connected field windings and armature, which are also in series with the governor contact. A 250 ohm resistor and a 0.5 μ F capacitor are connected in parallel with the governor contact. The contact is held closed by spring tension, which is adjustable. With the contact closed, the resistor is shorted out. When the speed of the motor exceeds the predetermined rate, centrifugal force acting upon the contact momentarily overcomes the spring tension and the contact is opened. This removes the short from the resistor putting it in series with the field windings and armature, reducing their current, and consequently reducing the motor speed.

3-371. The tension on the contact spring is adjustable by a contact screw to maintain motor speed at 3,600 rpm. To make this adjustment, a target is provided to compare motor speed with a standard. The outside surface of the governor cover is finished in white with three rows of black spots equally spaced about its periphery. The outer, center, and inner rows contain 4, 6, and 35 spots, respectively. The four spot row is a target which should remain essentially stable at 3,600 rpm when viewed through the moving shutter of a 120 vibrations-per-second tuning fork. The

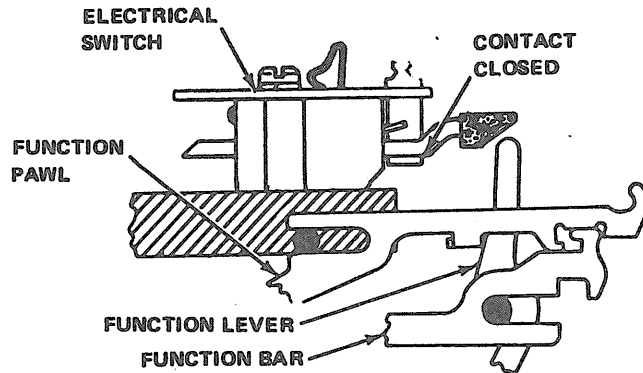

Figure 3-103. Typical Box Contact (Selected).

6 spot and 35 spot rows serve as targets when using an 87.6 vibrations-per-second tuning fork. The 6 spot row is used to approach an on-speed setting and the 35 spot row is used to arrive at an accurate setting of 3,600 rpm.

3-372. Speed of the motor units rotary motion is geared up and transferred to the main shaft of the punch unit via the timing belt (figure 3-110). The drive mechanism translates rotary motion of the drive parts to oscillating motion, and distributes it to perforating and feed mechanisms. Two portions of the main shaft are formed into cams. Through bearings and drive links, the forward cam causes the punch bail of the perforating mechanism to oscillate in simple harmonic motion as represented by the heavy solid line in figure 3-107. The other cam causes a feed drive lever of the feed mechanism to oscillate as represented by the light solid line in figure 3-107. The throws of the two cams are so related that the feed drive link reaches top dead center 45° after the punch bail does. The drive mechanism cycles and transfers motion to the feed and perforating mechanisms as long as the MOTOR switch is ON.

3-373. SYNCHRONIZATION. Since the punch cycles continuously, the feed and code pulses must be introduced at a specific time (within certain limits) to be properly processed by the punch. To achieve synchronization between code pulse delivery and mechanical timing of the punch, a flywheel and magnetic pick-up system is utilized. Timing requirements are discussed in paragraph 3-368 and 3-368, and illustrated in figure 3-107.

3-374. The magnetic pick-up (figures 3-110 and 3-111) consists of a permanent magnetic coil (with an iron core) which is arranged to create a permanent magnetic field around the pickup. With each rotation of the main shaft, the iron insert on the periphery of the flywheel passes through and disturbs the field, inducing a voltage in the coil. The flywheel may be oriented in 60° steps with respect to the main shaft. This provides an option of six initial positions from which various combinations of operating speed, magnets, and control-circuit delays may be accommodated. Fine adjustment of the pickup is made by means of the timing scale, which is adjustable 60° .

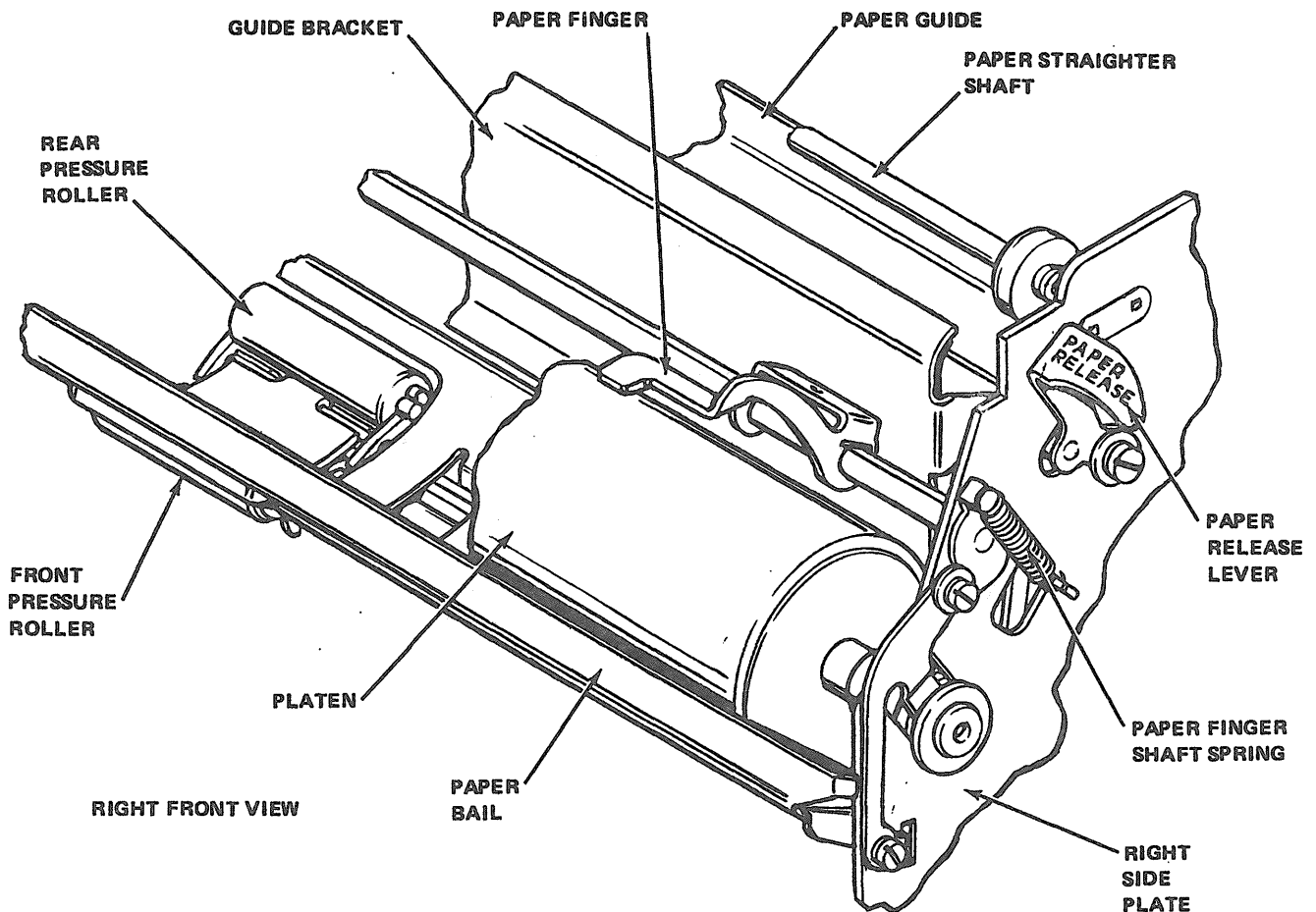

Figure 3-104. Friction Feed Platen Mechanism.

3-375. The voltage induced in the coil, due to the rapidly rotating insert, produces a pulse which is applied to the control circuits. The control circuits are designed so that the pulse will cause them to release any code combination they have ready in storage.

3-376. TAPE PERFORATION. The perforating mechanism is shown in figure 3-112. For each level of the code there is a code magnet, armature, blocking pawl, toggle linkage, drive link and punch pin. In the idling condition, with motor running and no intelligence being received, the armatures are held by springs away from the magnetic pole faces. This is referred to as their released (or spacing) position, and they, in turn, hold associated blocking pawls in their spacing position. As the drive mechanism cycles, it causes

the punch bail and toggle linkages to oscillate as represented in figure 3-107.

3-377. When the toggle linkages move down at the beginning of each idling operation, toggle extensions encounter the blocking pawls and cause the linkages to buckle at 51° of shaft rotation. Motion is imparted to the punch pins through the drag links, but not enough to drive them through the tape. Thus no code holes are perforated. The travel of the pins for spacing is represented by the heavy dotted line in figure 3-107. Each operation of the drive mechanism causes a feed hole toggle arm and drive link (having no associated magnet or buckling knee) to drive a feed hole punch pin through the tape. In the idling condition, this pin moves up and down in the same hole.

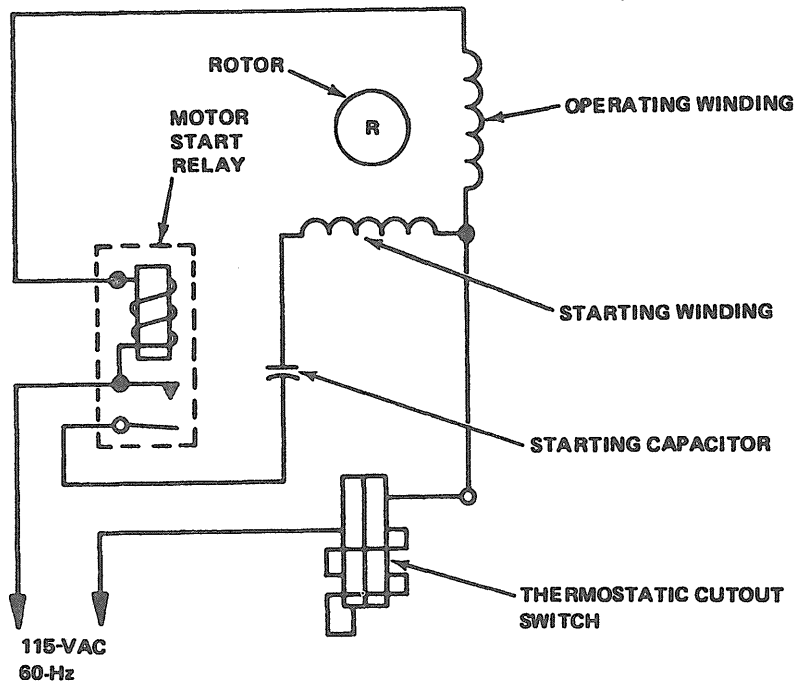

Figure 3-105. Schematic Diagram, Motor Unit (LMU-3).

3-378. When a code combination is received, the magnets and associated parts corresponding to the spacing levels of the code operate the same as described in the two previous paragraphs. For the marking levels of the combination, the magnets are energized and pull their armatures to their attracted (or marking) position. The armatures, in turn, hold the blocking pawls in their marking position. The timing is such that the armatures reach their marking position before the end of the selection interval (320° to 40° of shaft rotation) illustrated in figure 3-107.

3-379. As the toggle linkages move down at the beginning of the operation, the toggle extensions associated with the marking levels clear their blocking pawls, and the unbuckled linkages drive their pins through the tape and punch code holes. The motion of the pins for marking is represented by the solid heavy line in figure 3-107. Perforation occurs about midway through the operation, or between 140° and 220° of shaft rotation. Each time the tape is ad-

vanced (described in paragraph 3-389) the feed hole punch pin perforates a feed hole with the combination of code holes.

3-380. TAPE FEEDING. The tape feed mechanism is shown in figure 3-113. It includes a magnet and toggle linkage similar to those of the perforating mechanism. In idling condition the magnet is deenergized, and the armature and blocking pawl are held under spring tension in their spacing position. The drive mechanism, through the feed drive lever, causes the toggle linkage to oscillate. As the linkage moves down during the early part of each idling operation, it is buckled by the blocking pawl at 90° of shaft rotation (figure 3-107). The linkage rotates a pivot arm which, in turn, lifts the feed pawl, but not enough to raise it above the next tooth on the feed wheel ratchet. The motion of the feed pawl for idling (or spacing) is represented by the light dotted line in figure 3-107. In this condition, the feed wheel is not rotated and the tape is not advanced.

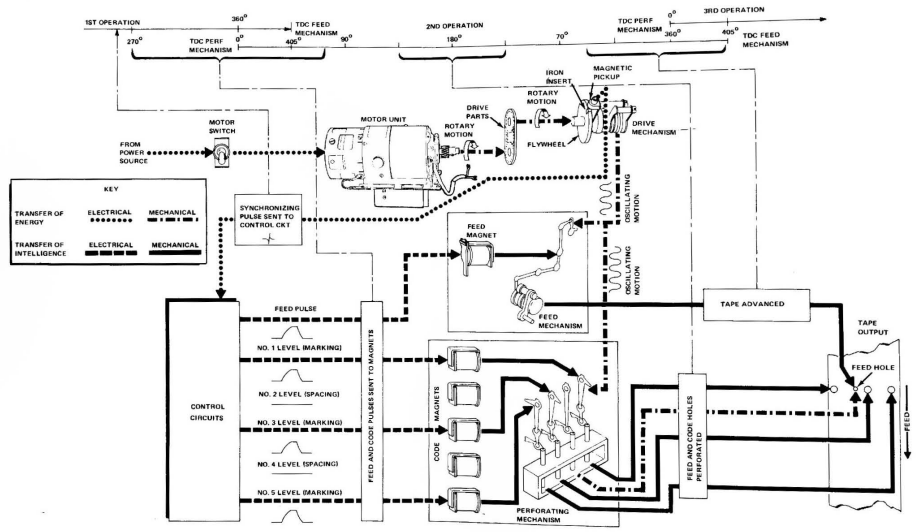

Figure 3-106. Schematic Diagram of Punch Operation.

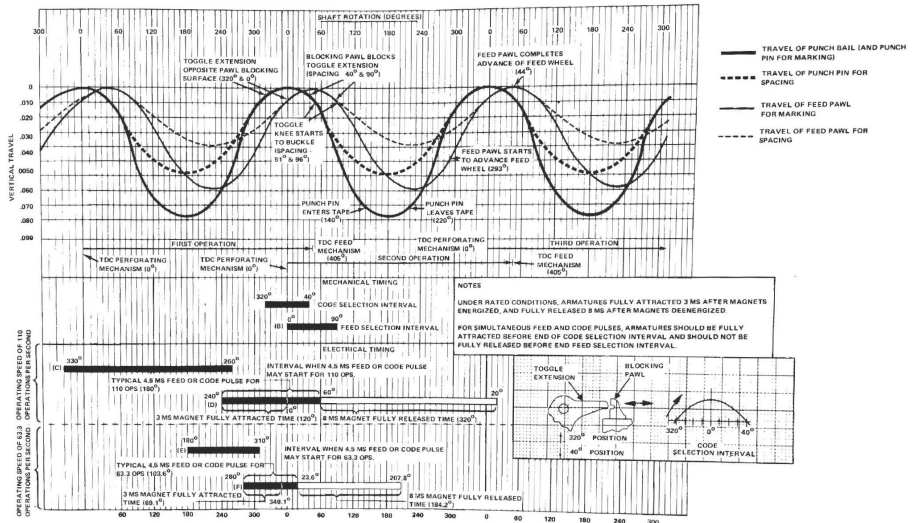

Figure 3-107. Paper Tape Punch Timing Diagram.

3-381. When a code combination is received, a feed pulse is applied to the feed magnet which pulls the armature and blocking pawl into their marking position. The timing is such that the armature does not reach its fully released position before the end of the feed selection interval. As the toggle linkage moves down during the early part of the operation, the toggle extension clears the blocking pawl, the linkage remains in its unbuckled condition, and the feed pawl is lifted above the next tooth on the ratchet. When the linkage moves up during the latter part of the operation, it causes the pawl to act on the ratchet and rotate the feed wheel one tooth. Pins on the periphery of the wheel engage the feed holes and advance the tape one character. As shown in figure 3-107, feeding occurs between 293° and 44° of shaft rotation.

3-382. Near the end of its downward travel, the pawl is engaged by a wedge block which prevents overtravel. Constant spacing of code perforations is ensured by a detent with a roller that is held under spring pressure against the ratchet and secures the feed wheel and tape in position between feeding operations. Constant spacing of perforations in relation to the edge of the tape is maintained by a biasing spring which holds the tape back against a reference surface on the block (figure 3-114). Tape is fed into the punch block through a tape guide (figure 3-115), and is held on the feed wheel by a spring biased tape lid which may be raised to initially insert tape.

3-383. MANUAL FEED OUT. When the feed-out lever is manually depressed, it moves the feed-magnet armature and its blocking pawl to their marking position (see figure 3-116). As the punch cycles, the feed mechanism operates as if the feed magnet were energized and tape is fed out continuously until the lever is released. The code magnets are de-energized and thus no code holes are

perforated. Since the feed hole punch pin is driven through the tape during every operation, a feed hole is perforated each time the tape is advanced.

3-384. TAPE REEL AND BRAKE MECHANISM. The tape reel and brake mechanism (figure 3-117) on the base provides a rotating reel for the tape roll and controls its rapid acceleration and deceleration during starting and stopping. When feeding starts, the abrupt pull of the tape on the tape guide pivots a brake and moves its friction surface away from the periphery of the reel. The giving action of the tape guide serves to dissipate the inertia of the stationary tape roll. During feeding, the tape guide and brake keep the tape taut by alternately braking and releasing the reel. When feeding stops, the tape's pressure on the tape guide is released, and the reel is quickly braked to a stop to prevent excess tape from unwinding.

3-385. LOW-TAPE MECHANISM. The low-tape mechanism (figure 3-117) may be connected so as to actuate an external audible or visual alarm when the tape roll is near depletion. A low-tape lever under spring tension rides on the tape roll. When the roll reaches a predetermined diameter, the lever closes the low-tape contacts which will complete an alarm circuit. The lever serves a secondary purpose by holding any loose loops on the roll until they are taken up by the feeding operation.

3-386. TIMING. The timing of the punch is based on the top dead center position (TDC) of the perforating mechanism (or the punch bail) which is designated as 0° of shaft rotation and 0 time in milliseconds (see figure 3-107).

3-387. Mechanical. The feed and code selection intervals are represented by bars (a) and (b) in figure 3-107. As illustrated by the insert in figure 3-107 the selection interval is that period during any operation when the

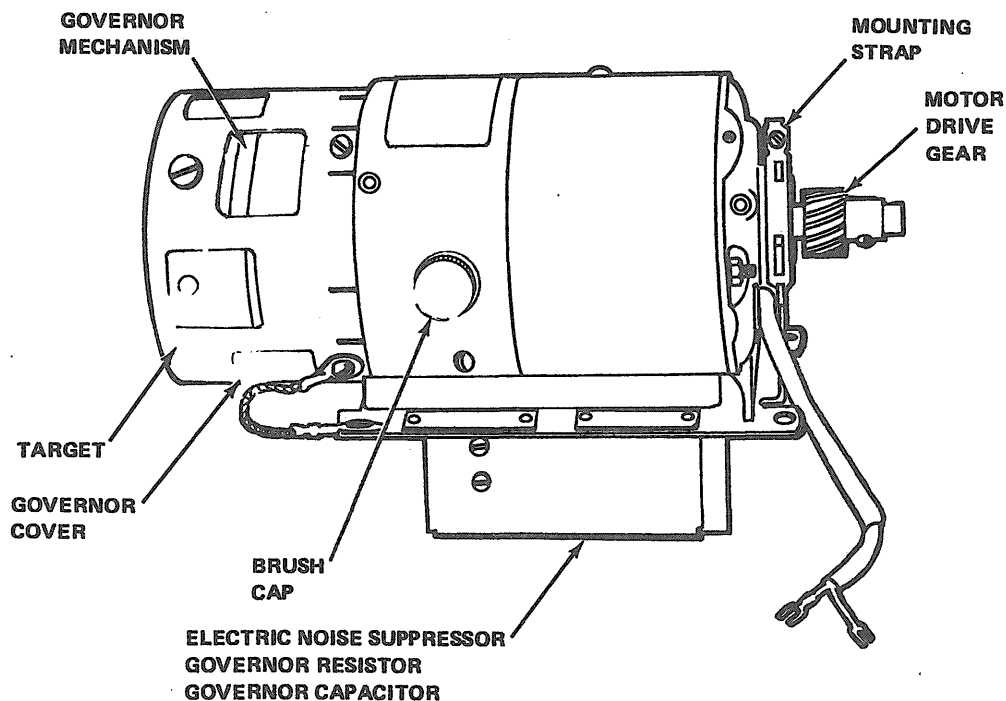

Figure 3-108. Typical Series (Governed) Motor Unit.

feed or code toggle extension is above the blocking surface of the blocking pawl. When a feed or code pulse is applied to a magnet, the associated blocking pawl (operated by the armature) must be in its marking position, out of the way of the toggle extension, at the end of the selection interval for the tape to be advanced or perforated. The feed mechanism operates 45° after the perforating mechanism to allow perforation to be completed before the tape is advanced.

3-388. The code selection interval for any given operation (shown as the second operation in figure 3-107) extends from 40° before to 40° after TDC of the punching mechanism [bar (a) of figure 3-107]. The feed selection interval extends from 0° to 90° after TDC of the perforating mechanism [bar (b)]. For simultaneous feed the code pulses (feed and all code pulses starting and ending at the same time), feed and code magnet

armatures should reach their fully attracted position before the end of the code selection interval, and should not reach their fully-released position until after the end of the feed selection interval.

3-389. Electrical. To meet the mechanical requirements for 110 punch operations per second (ops), $4.5\mu\text{sec}$ feed and code pulses should begin between 390° ($9.75\mu\text{sec}$) and 100° ($2.5\mu\text{sec}$) before TDC of the perforating mechanism [bar (c)]. A typical $4.5\mu\text{sec}$ feed or code pulse for 110 ops is represented by the shaded portion of bar (d). It begins at 120° ($3\mu\text{sec}$) before and ends at 60° ($1.5\mu\text{sec}$) after TDC of the perforating mechanism. Since the armature fully attracted time is 3 ms (120°) the armature is fully attracted at 0.0° (0.00 ms) TDC. The armature fully released time 8 ms (320°) and is fully released at 380° (9.50 ms) after TDC of the perforating mechanism.

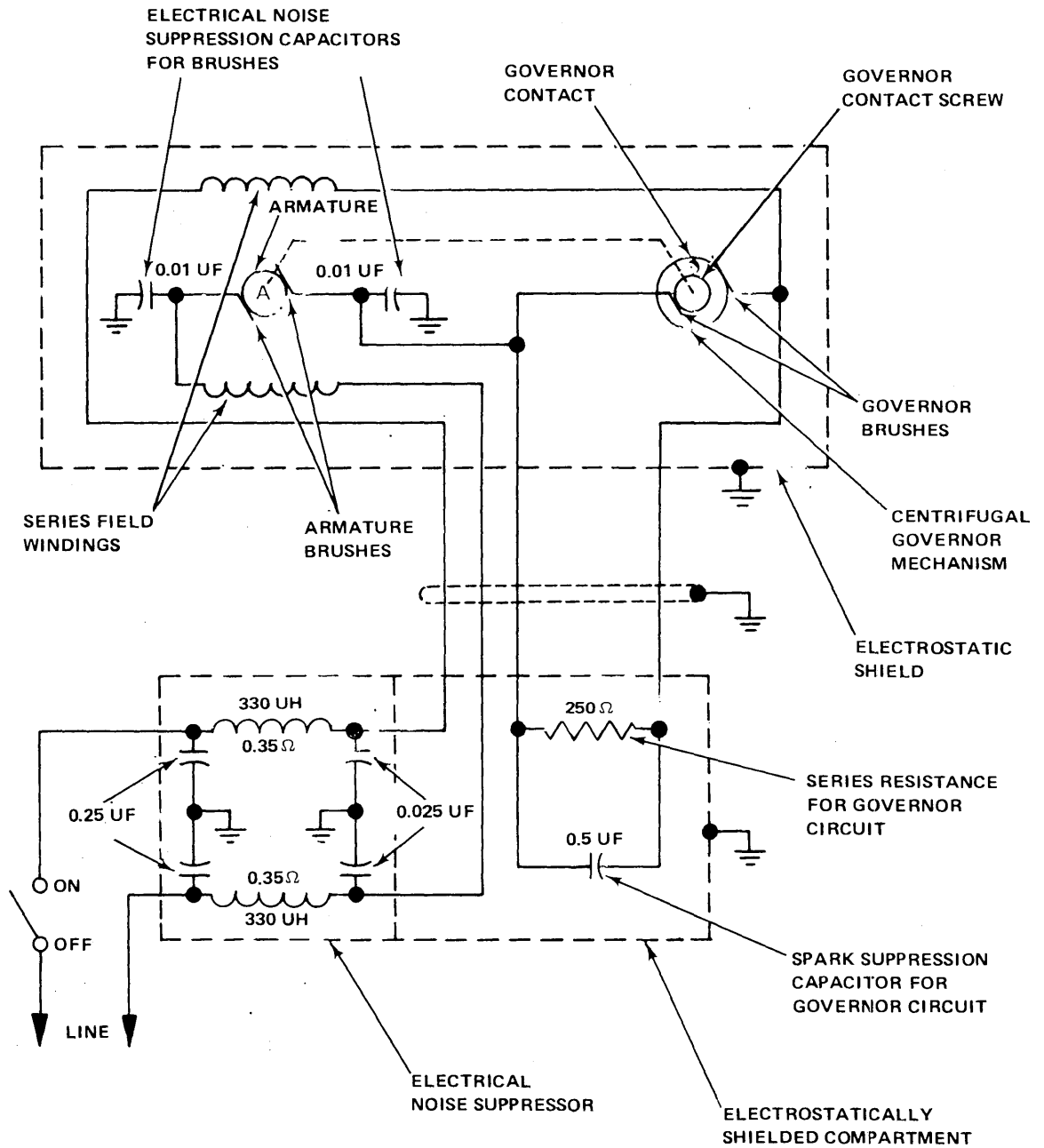

Figure 3-109. Schematic Diagram, Typical Series (Governed) Motor Unit (LMU-6).

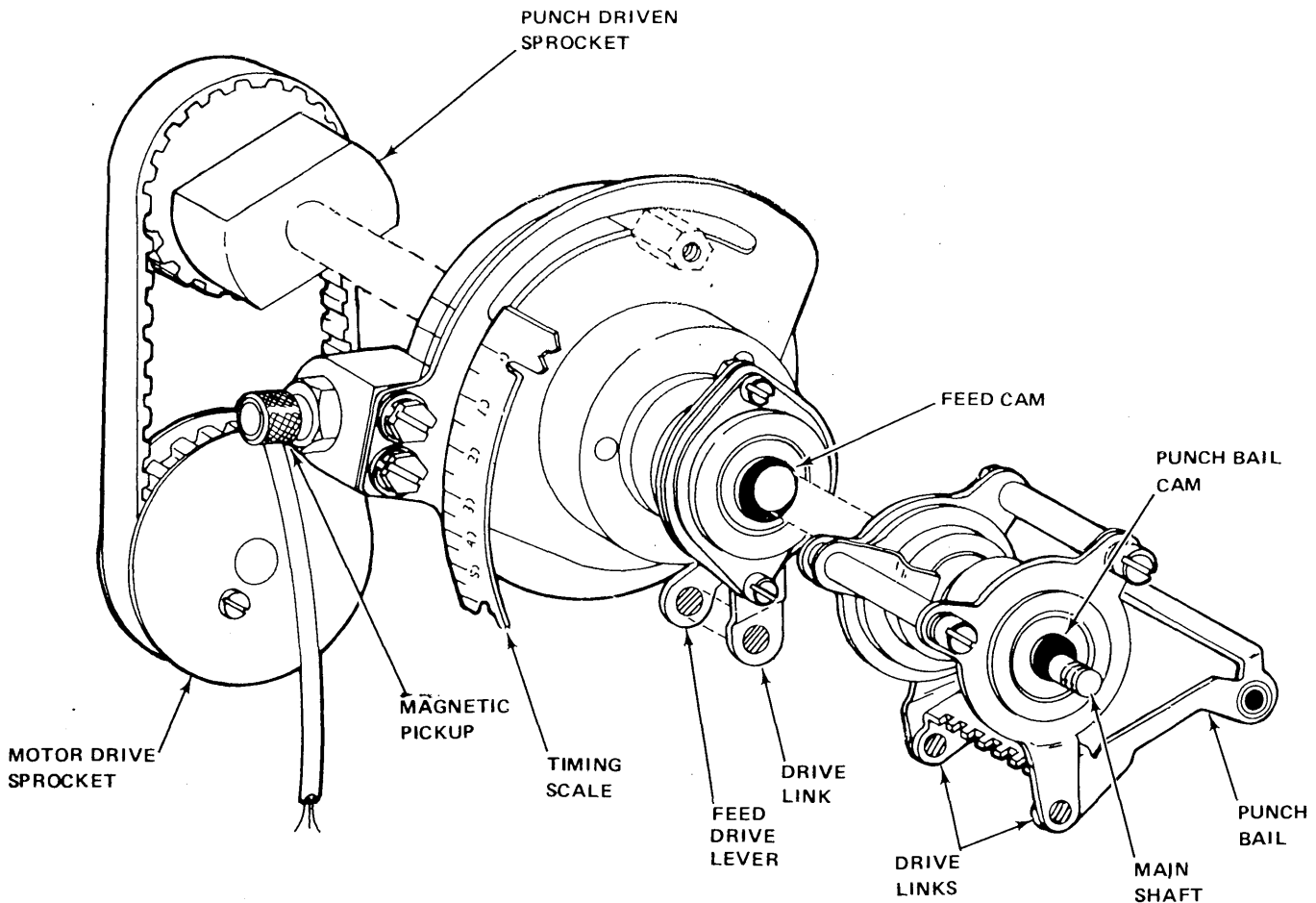

Figure 3-110. Drive Mechanism.

3-390. Flywheel Orientation. Refer to figures 3-118 and 3-119 for instructions for orienting the flywheel of the punch.

3-391. TAPE READER.

3-392. POWER SUPPLY. The power supply operates on 115 ± 10 VAC 60-Hz single-phase and draws 125 watts of power. The power supply provides 15 and -15 VDC for the tape drive and tape read systems, and 8.6-VDC for the exciter lamp [see figure 5-23 (F0)].

3-393. AC power is applied through the 1.5 ampere slo-blo fuse F1 and power switch S1, to the capstan drive motor M1 through terminal board TB1-1 to fan motor B1, and the primary transformer

T1. The secondary of T1 applies 35-VAC to the full-wave diode rectifier bridge CR3. The outputs of CR3 are 15 and -15 VDC filtered by $10,000\mu\text{F}$, 25-VDC capacitors, C2 and C3. These outputs are applied to the tape drive and tape read circuitry. The 15-VDC is also applied through a 5 ohm, 10 watt resistor R21 to adjustable power resistor R22 where it is reduced to 8.6-VDC and applied to the exciter lamp.

3-394. The -15 VDC is also applied to the READY/LOAD switch S2, and the output (referred to as -15L) is applied to pin AA of the input/output connector J2. The -15L signal is returned to the reader at pin Z of connector J2 and is called -15S. The -15S signal is applied

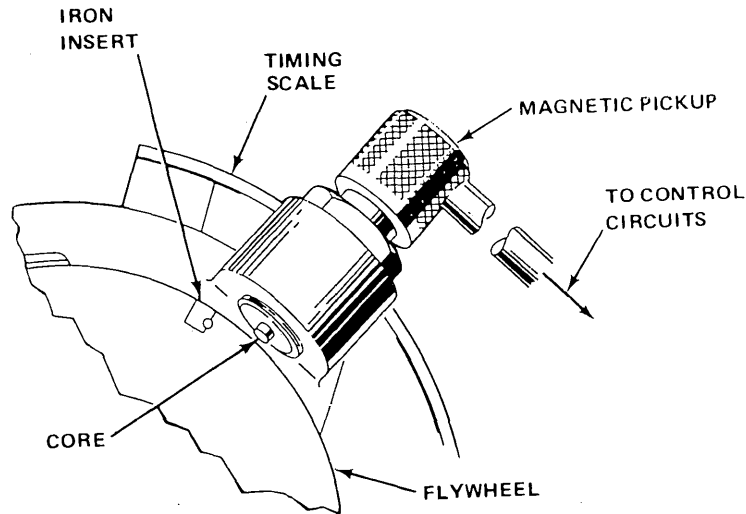

Figure 3-111. Magnetic Pickup.

through a 25 ohm, 25 watt resistor R1, and a 20 ohm, 25 watt resistor R2 and becomes signals PR2R and B2R. Signals PR2R and B2R are applied to one side of the pinch roller solenoid and one side of the brake solenoid respectively. These two signal voltages are filtered by four, 47 μ F 20-VDC capacitors C4, C5, C6, and C7.

3-395. The purpose of the READY/LOAD switch, and signals -15 and 15S (available at connector J2) is to enable the pinch roller and brake solenoids to be deenergized without removing AC power from the unit.

3-396. Transformer T1 also contains a filter winding, which in conjunction with a 2.0 μ F, 440-V resonating capacitor (C1), is used to suppress fluctuations in the AC line voltage.

3-397. TAPE DRIVE SYSTEM. Electrically, the switch time from a stop condition to a run condition is approximately 2 μ sec; however, the mechanical switching time is much slower. From a complete stop, full energizing of the pinch roller takes approximately 3 μ sec. This time must be added to the time required to read one character at the slew

speed, and then multiplied by the appropriate friction factor in table 3-4 to determine the start time. When slewing tape at 300 characters per second, the time it takes the tape to come to a complete stop will be approximately 1 μ sec. It is because of this mechanical switching time that the maximum stepping rate with open-loop operation is 60 characters per second.

3-398. The reader will stop in the stop character; however, it may or may not stop in the sprocket hole of the stop character. The design of the console logic circuitry allows the reader to stop anywhere from the data and sprocket holes of the stop character to the space preceding the following character (see figure 3-120).

3-399. CONTROL CIRCUITRY. When a -6 VDC run signal is applied to the run/stop input (pin Y of the connector J2), it is applied through diode CR5 of the input buffer to inverter Q1. Q1 inverts the -6 VDC input to 0 volts and applies it to the pinch roller circuit where it energizes the pinch roller. The 0 volt output of Q1 is also applied through diode CR6 of a second buffer to inverter Q2, where it is inverted to a negative

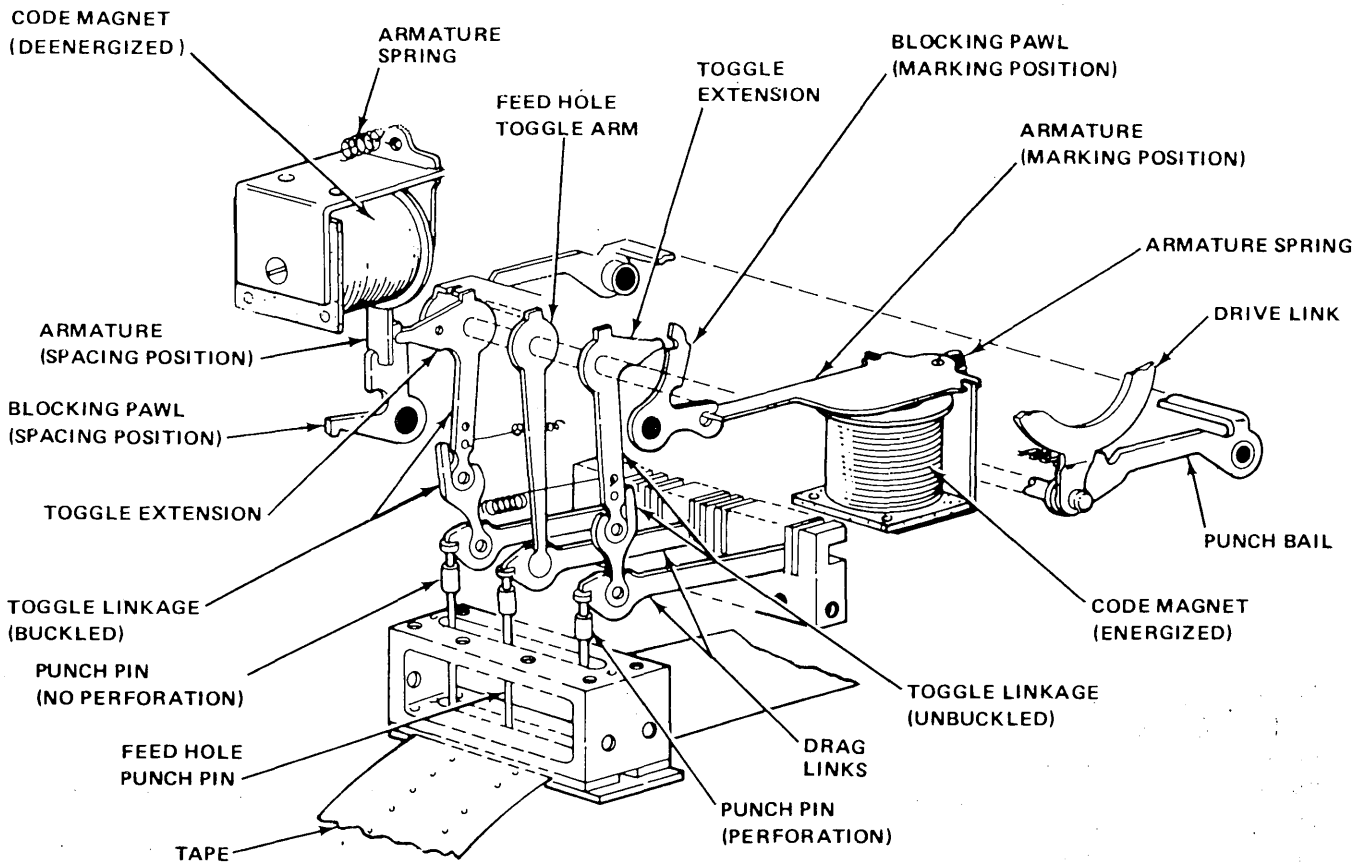

Figure 3-112. Perforating Mechanism.

level and applied to the brake circuit, deenergizing the brake. With the pinch roller energized and the brake deenergized, the tape will continue to run until a stop signal is applied to the run/stop input.

3-400. When a 0 volt stop signal is applied to the run/stop input, it is passed through CR5 of the input buffer to Q1, where it is inverted to a negative level and applied to the pinch roller circuit deenergizing the pinch roller. The negative output of Q1 is also applied through CR6 of the second buffer to Q2 where it is inverted to 0 volts and applied to the brake circuit, energizing the brake. With the pinch roller deenergized and the brake energized, the tape will be stopped.

3-401. The control circuit has -15 VDC applied to a 10 μ F, 25V capacitor (C8), which prevents unwanted tape run until the capstan reaches normal operating speed after power is initially turned on. Due to the instantaneous current flow through C8 when power is initially turned on, the negative voltage is applied through CR7 to inverter Q2 which inverts it to 0 volts and applies it to the brake circuit, causing the brake to be energized. The brake will remain energized until the output of Q2 returns to a negative level as a result of reduced current flow through C8 as the capacitor becomes charged.

3-402. PINCH ROLLER AND BRAKE CIRCUITS. The pinch roller and brake circuits (figure 5-23) are identical; each having

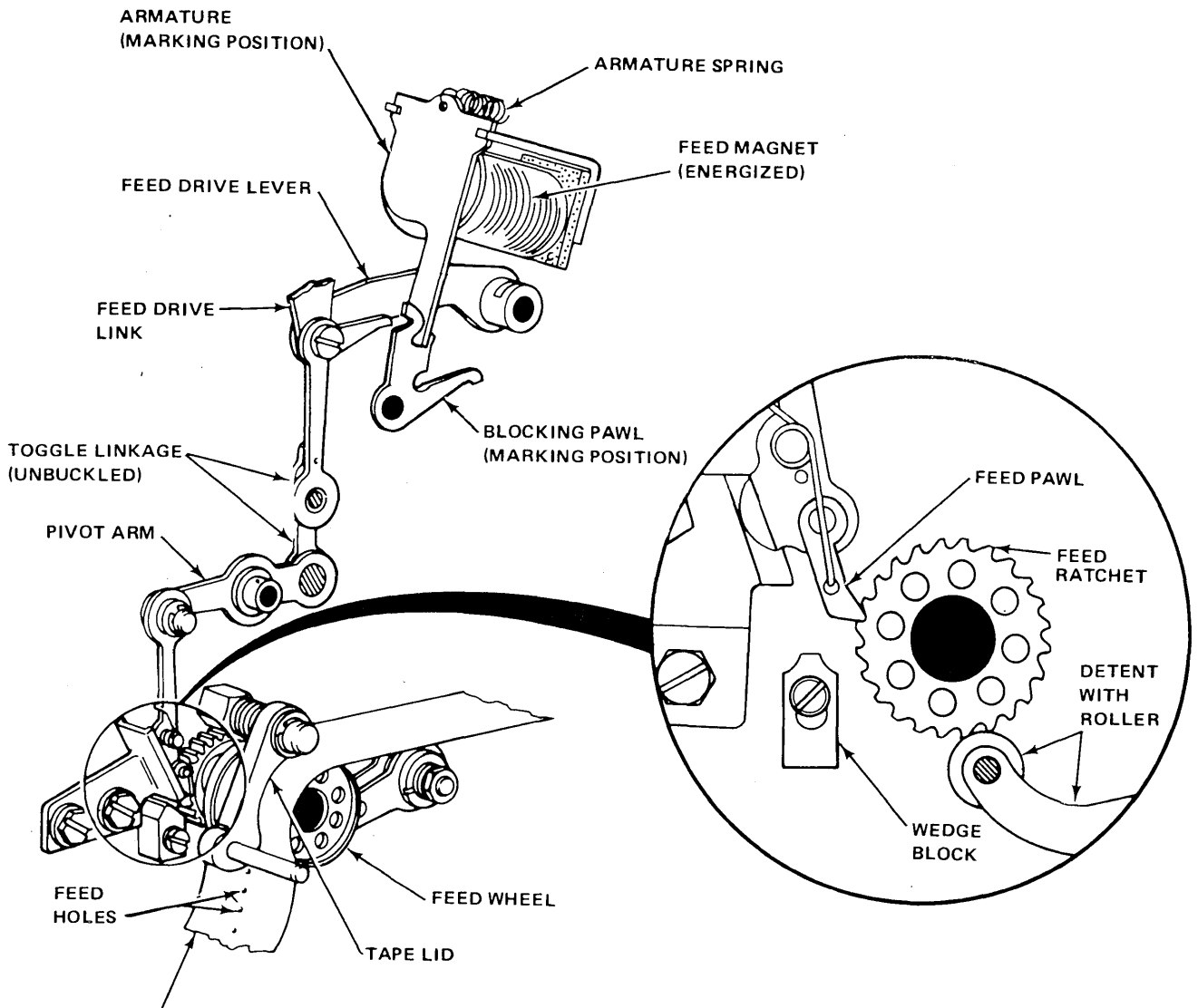

Figure 3-113. Tape Feeding Mechanism.

two inverting amplifiers, with the output of the second inverter being applied to one side of the solenoid (PR1C side of the pinch roller solenoid and the B1C side of the brake solenoid). The -15 VDC for the reader pinch roller and brake solenoids is applied to pin AA of the input/output connector, and pin Z is wired to the solenoids. This permits applying the -15 VDC through the tape handler so that the tape handler can be used to interrupt the -15 VDC to the reader solenoids during tape rewind, thereby deenergizing the solenoids.

3-403. The first inverter (Q3 or Q4) is a power driver which supplies increased current to the base of the second inverter (Q5 or Q6). The second inverter is a power amplifier whose output swings from -15 VDC when it is off, to 0 volts when it is turned on, and is capable of handling the 1.5 ampere current surge requirements of the solenoid.

3-404. The pinch roller and brake are operated inversely by the control circuit; that is, when the pinch roller is energized, the brake is deenergized and

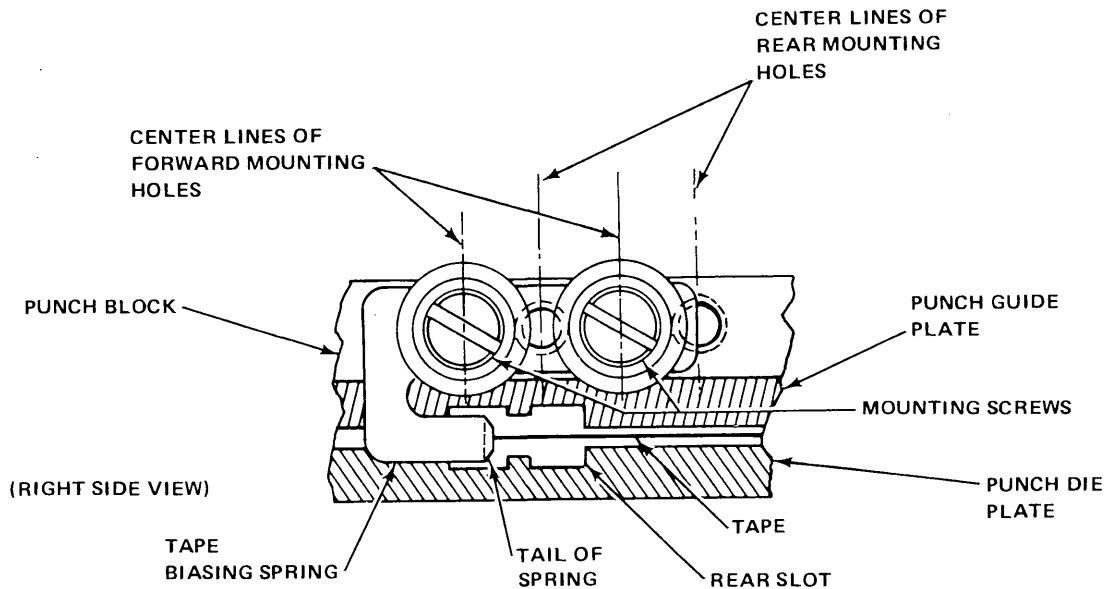

Figure 3-114. Punch Block Assembly.

vice versa. When a run signal is applied to the run/stop input, the control circuit applies a 0 volt input to the pinch roller circuit and a negative input to the brake circuit. When a 0 volt stop signal is applied to the run/stop input, the control circuit applies a negative input to the pinch roller circuit and a 0 volt input to the brake circuit.

3-405. When a 0 volt input is applied to the pinch roller circuit (or brake circuit), the 0 volt signal is inverted to a negative level by Q4 (or Q3). The negative output of Q4 (or Q3) is inverted again to 0 volts by Q6 (or Q5) and applied to the solenoid. With 0 volts applied to PR1C (or B1C) side of the solenoid, the pinch roller (or brake) will be energized.

3-406. When a negative input is applied to the pinch roller circuit (or brake circuit), the negative voltage is inverted to 0 volts by Q4 (or Q3). The 0 volt output of Q4 (or Q3) is inverted again to a negative level (-15 VDC) by Q6 (or Q5) and applied to the solenoid.

With -15 VDC applied to the PR1C (B1C) side of the solenoid, the pinch roller (or brake) will be deenergized.

3-407. The collectors of Q4 and Q6 are protected by clamping diodes CR1 and CR2 respectively, which prevent the collector voltage from exceeding -15 VDC.

3-408. TAPE READ SYSTEM. The positive side of the sprocket channel (figure 5-23) photodiode is biased by 4-VDC which is derived from the voltage dividing network of resistors R18, R19, and R22 (figure 5-23). During a hole condition, the photodiode output will go positive to 3.6-VDC, and negative to -6 VDC during a no-hole condition.

3-409. As a hole passes over the sprocket photodiode, the positive output of the photodiode is applied to the base of emitter follower Q1-9. This positive signal is coupled to the base of inverting amplifier Q2-9, turning it off and resulting in the collector going negative. This signal is applied to the Schmitt trigger circuit of Q3 and Q4. The negative-going input at the base of Q3 results in the collector going posi-

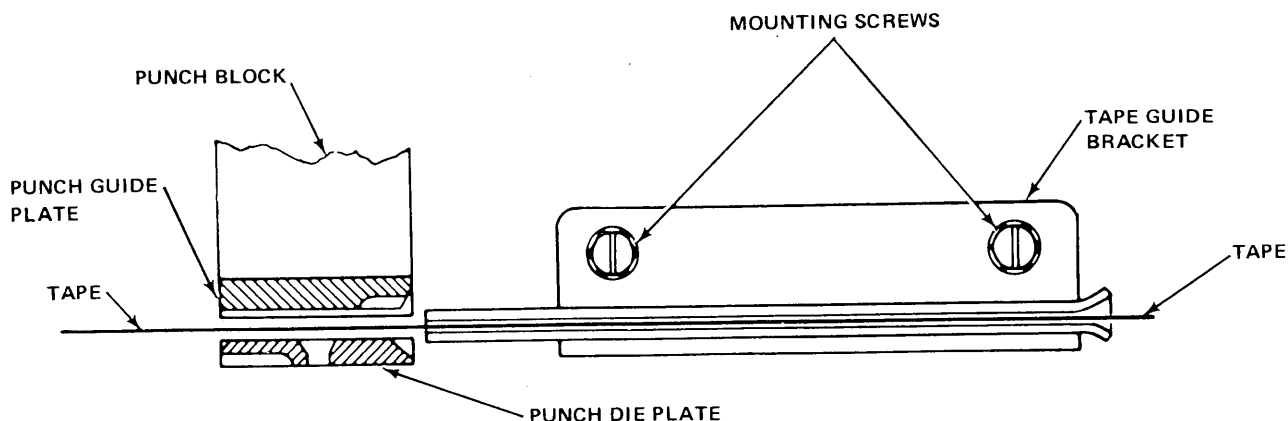

Figure 3-115. Tape Guide Unit.

tive. The positive-going voltage is coupled through C3 to the base emitter follower Q4. Conduction in Q4 decreases with the collector current being drawn through emitter resistor R10, which is common to both Q3 and Q4. The decreased current through R10 results in a positive-going change in the emitter potential of Q3. The cumulative effect of an increasingly negative base potential and increasingly positive emitter potential accelerates the increase in the collector current of Q3. The collector potential is thereby driven more positive, and is coupled through R7 and R8 to the base of Q4, with the result that conduction through Q4 is further decreased. This positive feedback effect thus produces a rapid turn on (saturation) of the first stage (Q3), while driving the second stage (Q4) into cutoff. The effect of the Schmitt trigger circuit on the input signal is to produce a rapid rise-time on the leading edge and fall-time on the trailing edge, thereby shaping the signal into a clean square wave.

3-410. The output of Q4 is positive (2-VDC) during a hole condition, and negative (-6 VDC) during a no-hole condition, and is applied to pin S (G1) of connector J2, and the base of inverter Q5. The output of Q5 is

-15.0 VDC (no-during a hole condition, and 0.0-VDC during a no-hole condition, and is applied to pin V (PSP) of J2.

3-411. DATA CHANNEL SECTION. The negative side of the data photodiodes is biased by a regulated -3.6 VDC supplied by Zener diode CR4. During a hole condition, the output of a data photodiode will be at a negative level (-3 VDC), and at a positive level during a no-hole condition (figure 5-23). As a hole passes over a photodiode, the negative output is applied to the base of emitter follower Q1-1. The negative output of Q1-1 is gated with signal PSPG, with the output of the gate being applied to the base of amplifier Q2-1.

3-412. Because the data signals occur before the sprocket signal, when the data outputs are gated by the sprocket signal output, the gate will be blocked by PSPG being 4-VDC until the sprocket signal occurs. When the sprocket signal occurs, PSPG will go to -4 VDC allowing the gate and applying a negative signal to the base of Q2-1. When the data outputs are not gated by the sprocket output, PSPG will always be -4 VDC. In this case, when the output of Q1-1 goes negative the gate will be enabled and the negative signal will be applied to the base of Q2-1.

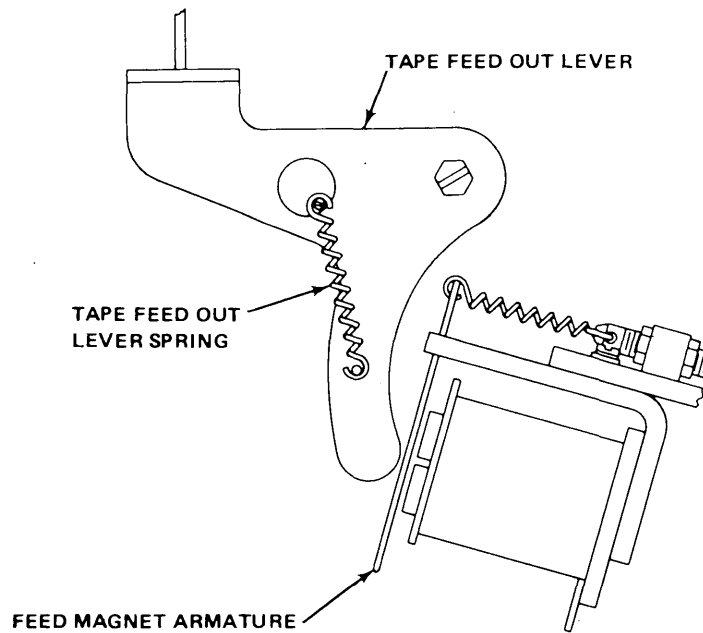

Figure 3-116. Tape Feed-Out Lever and Armature.

3-413. When a negative signal is applied to the base of Q2-1, the output of Q2-1 will go positive and be applied to the base of Q3-1. This will turn off Q3-1 and the collector will go to -15 VDC (no-load). The Q3-1 outputs of the data channels (signals PD-1 to PD-8) are applied to pins A through J of connector J2. During a hole condition, Q3-1 is capable of supplying -10 VDC at 5 milliamperes into a 2K Ω external load.

3-414. During a no-hole condition, the positive output of the photodiode is applied to Q1-1. This is coupled by Q1-1 to the base of Q2-1 driving the collector of Q2-1 negative. This negative signal is applied to the base of Q3-1 turning it on and driving the collector to 0 volts. During a no-hole condition, the maximum current through Q3-1 from the external equipment must not exceed 8 milliamperes.

3-415. POWER DISTRIBUTION.

3-416. GENERAL. The power supply provides all of the operating voltages used by the I/O Console. The power supply receives external power from two sources:

Motor-Generator Set provides 115-VAC 3-phase 400-Hz power, and the conventional power source of the operating area provides 115-VAC 60-Hz. The 400-Hz power is processed by transformer/rectifier circuits to produce -28 VDC for the keyboard/printer and tape punch, and -4.5 VDC, -15 VDC, and 15-VDC for the I/O Console logic. The 60-Hz power is used to energize the motors of the fan assembly, printer, tape punch, and tape reader.

3-417. POWER CONTROL CIRCUIT. Input power is applied through line filters A5FL1, A5FL2, A5FL3, A5FL4, and A5FL5, as shown in figure 5-13. Power is applied from these filters via F1, F2, F5, F6, and F7 to the normally open contacts of K4. The power ON/OFF switch A1S1 (figure 5-15) located on the power panel controls the closure of K4. The switch is a two-position momentary-contact toggle switch. Setting the switch to the ON position momentarily provides a current path from the phase 2 line through contacts 3, 4, and 5 of the switch, through the coil of K4 (figure 5-13), and to the phase 3 line. K4 closes, applying the operating voltages to the

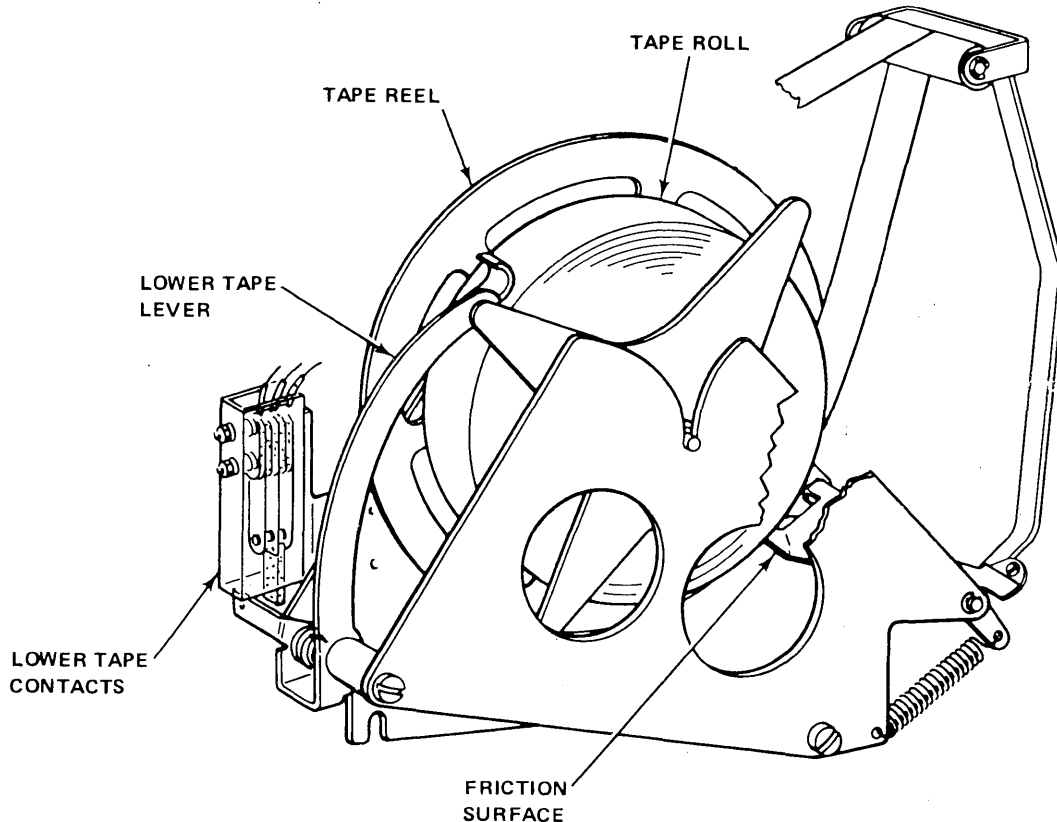

Figure 3-117. Tape Reel and Brake Assembly.

power supply circuits. Contacts F1 and F2 of K4 provide the holding current path when the switch is released. Setting the switch to the OFF position breaks the holding current path and K4 opens, removing power from the power supply circuits. Filters A1FL1, A1FL2, A1FL3, and A2FL10 in the switch circuit (figure 5-15) are LC networks for the reduction of radio frequency interference (RFI).

3-418. AC POWER OUTPUT. The AC power output from the power supply is the same 115-VAC 60-Hz power that is supplied from the external source. This power is filtered to remove RFI by the LC networks of A5FL1 and A5FL2 (figure 5-13) in conjunction with resistors A4R12 and A4R13 (figure 5-16). When K4 closes, power is immediately applied to the fan

motors A4B1 and A4B2 in fan assembly A4 (figure 5-14), and to the BLOWER POWER indicator on the power control panel (figure 5-15). The 115-VAC 60-Hz power is also applied to the normally open contacts of K1, K2, and K3 in the power supply (figure 5-13). When these relays are energized upon command from the I/O Console logic, 115-VAC 60-Hz power is applied through the relay contacts to the motors of the tape punch, printer, and tape reader.

3-419. DC POWER OUTPUT. The source of the DC outputs of the power supply is the externally supplied 115-VAC 400-Hz 3-phase input power. This input power is RFI filtered by the LC networks of filters A5FL3, A5FL4, and A5FL5 in conjunction with resistors A4R9, A4R10, and A4R11 (figure 5-16). When K4 closes,

FOLLOWING ADJUSTMENT PROCEDURE, FIGURES (3-118 AND 3-119), PERTAINS TO PUNCH UNITS WITH A 60 POINT TIMING SCALE. ADJUSTMENTS MUST BE MADE IN INDICATED ORDER.

FLYWHEEL ORIENTATION

(1) GENERAL:

THE FLYWHEEL MAY BE ORIENTED IN 60° STEPS WITH RESPECT TO MAIN SHAFT. THIS PROVIDES AN OPTION OF SIX INITIAL POSITIONS FROM WHICH VARIOUS COMBINATIONS OF OPERATING SPEEDS, MAGNETS, AND CONTROL-CIRCUIT DELAYS MAY BE ACCOMMODATED.

(2) DETERMINE 0'CLOCK POSITION:

COMBINE ATTRACT TIME OF MAGNETS (3 TO 4 msec) AND DELAY TIME OF CONTROL CIRCUITS TO OBTAIN TIME (T) IN MILLISECONDS (MS) AT WHICH ARMATURES ARE FULLY ATTRACTED AFTER PICKUP FIRES. LOCATE T ON TIME SCALE AT LOWER LEFT OF FIGURE 3-119. EXTEND A LINE HORIZONTALLY TO RIGHT UNTIL IT INTERSECTS LINE REPRESENTING OPERATING SPEED OF PUNCH UNIT IN OPERATIONS PER SECOND (OPS). EXTEND A LINE VERTICALLY UPWARD FROM THIS POINT UNTIL IT INTERSECTS ONE OF THE 0'CLOCK LINES. EXTEND A LINE FROM THIS POINT HORIZONTALLY TO LEFT UNTIL IT INTERSECTS SCALE AT UPPER LEFT. THIS POINT REPRESENTS POSITION TO TOGGLE LINKAGES IN DEGREES (AS ILLUSTRATED IN FIGURE 3-118) WHEN ARMATURES REACH FULLY ATTRACTED POSITION. IT SHOULD FALL WITHIN SELECTION INTERVAL. USE 0'CLOCK POSITION REPRESENTED BY INTERSECTED LINE IN POSITIONING FLYWHEEL AS INSTRUCTED BELOW.

(3) EXAMPLE:

ASSUME THAT PUNCH UNIT IS TO OPERATE AT SPEED OF 110 OPS, THAT ATTRACT TIME OF MAGNETS IS 2 MS AND DELAY OF CONTROL CIRCUITS IS 1 MS. COMBINED TIME (T) IS THUS 3 MS. LOCATE 3 ON TIME SCALE IN FIGURE 3-119. EXTEND A LINE FROM 3 TO RIGHT UNTIL IT INTERSECTS 110 OPS LINE. EXTEND A LINE VERTICALLY UPWARD FROM THIS POINT. AS CAN BE SEEN IN FIGURE 3-119, LINE INTERSECTS 9 0'CLOCK LINE. WHEN A LINE IS EXTENDED TO LEFT FROM THIS POINT, IT INTERSECTS SCALE AT 339° . THUS TOGGLE LINKAGES ARE IN SELECTION INTERVAL WHEN MAGNETS REACH FULLY ATTRACTED POSITION. POSITION FLYWHEEL AT 9 0'CLOCK AS INSTRUCTED BELOW.

(4) POSITION FLYWHEEL:

VIEW UNIT FROM FRONT. ROTATE FLYWHEEL UNTIL SETSCREW IS IN 12 0'CLOCK POSITION. IF IRON INSERT IS AT 0'CLOCK POSITION DETERMINED ABOVE, LOOSEN FLYWHEEL NUT AND REMOVE SETSCREW. POSITION SHAFT SO THAT KEYWAY IS IN 12 0'CLOCK POSITION. HOLD SHAFT IN THIS POSITION AND ROTATE FLYWHEEL SO THAT IRON INSERT IS AT 0'CLOCK POSITION DETERMINED ABOVE. INSERT SETSCREW IN HOLE IN HUB AT 12 0'CLOCK POSITION AND TIGHTEN JUST ENOUGH TO HOLD FLYWHEEL IN POSITION. TIGHTEN NUT. TIGHTEN SETSCREW SECURELY.

NOTE

SETSCREW MUST LINE UP WITH KEYWAY ON MAINSHAFT.

Figure 3-118. Flywheel Orientation.

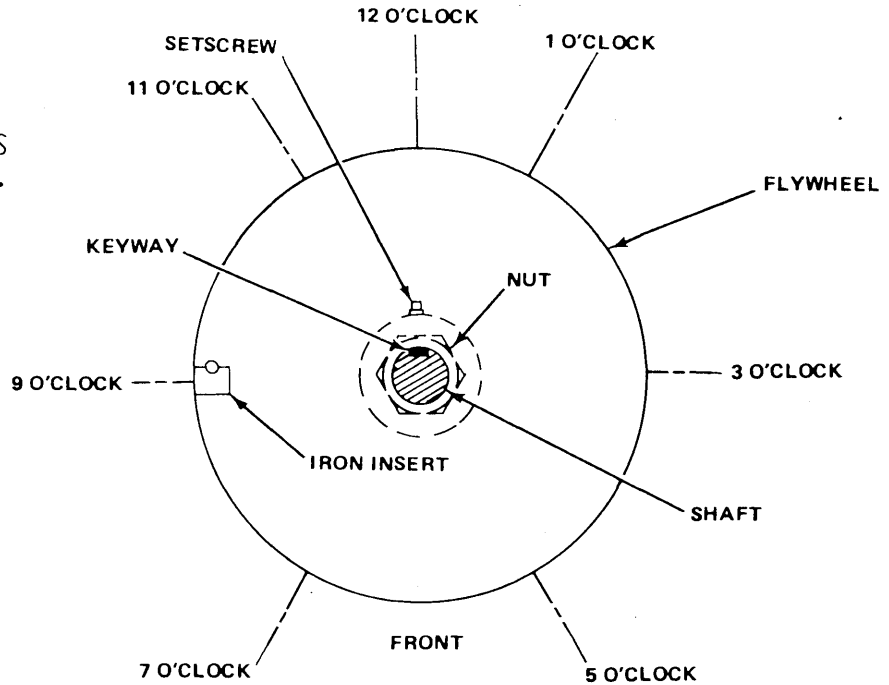

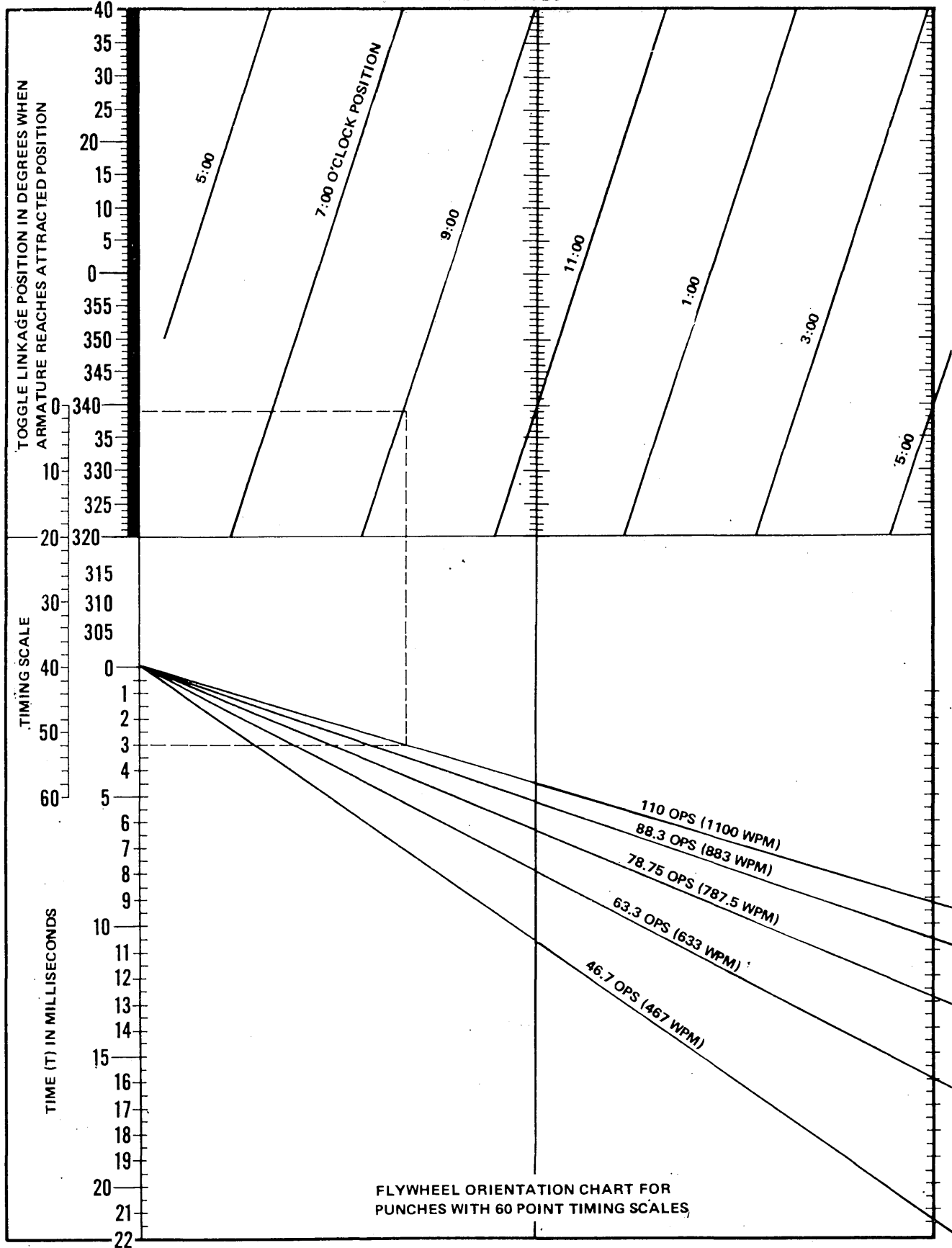

Figure 3-119. Flywheel Orientation Chart for Punches with 60 Point Timing Scales.

Table 3-4. Coefficient of Friction for Perforated Tape

Type of Tape	Friction Factor ¹
Dry Paper	1.1 through 1.3
Oiled Paper	1.3 through 1.5
Mylar (aluminized or solid)	1.5 through 4.0
Paper Mylar Laminate	1.1 through 1.3

Note:

¹These friction factors are approximate since the coefficient of friction varies from sample to sample.

the 3-phase power is applied to transformer A6T1 and the internal power supply, PS1T1 (figure 5-13). Transformer A6T1 operates in conjunction with diode rectifiers A6CR1 through A6CR6 to transform the input power to -28 VDC unregulated. The output voltage, filtered by an inductor within the transformer and by capacitor A6C9, goes to the keyboard/printer and tape punch (figure 5-13).

3-420. Power supply PS1 contains transformer PS1T1 and diodes PS1CR1 through PS1CR18 (figure 5-13). The power supply provides output voltages of -4.5 VDC, -15 VDC, and 15-VDC unregulated. The output voltage, filtered by an inductor within the transformer and by capacitor A6C9, goes to the keyboard/printer and tape punch (figure 5-13).

3-421. Power supply PS1 contains transformer PS1T1 and diodes PS1CR1 through PS1CR18 (figure 5-13). The power supply provides output voltages of -4.5 VDC, -15 VDC, and 15-VDC unregulated. The -4.5 VDC is taken across the center windings of the transformer secondaries, and is provided by full-wave rectifier diodes PS1CR13 through PS1CR18. This voltage is applied to terminal 4 of all printed circuit card modules in the logic chassis assembly. The -15 VDC and 15-VDC are taken across the full secondary windings of transformer PS1T1. The -15 VDC is provided by diodes PS1CR1

through PS1CR6, and applied to terminal 3 of all printed circuit card modules in the logic chassis assembly. This voltage is applied to one end of the coils of relays K1, K2, and K3. The associated relay contacts close when the I/O Console logic applies a ground to complete the current path through the coils. At this time, 115-VAC 60-Hz power is applied through the relay contacts to the motors on the tape punch, printer, and tape reader. The 15-VDC from the secondary of transformer PS1T1 is provided by diodes PS1CR7 through PS1CR12. This voltage is applied to terminal 2 of all printed circuit card modules, and to the indicator switches in the logic chassis assembly. The voltage is also available for operation of the overtemperature alarm.

3-422. OVERTEMPERATURE PROTECTION CIRCUITS. The I/O Console contains two overtemperature protection circuits. One circuit activates visual and audible alarms when the temperature within the I/O Console exceeds 46°C (115°F); the other circuit removes all operating power when the internal temperature exceeds 60°C (140°F). The warning circuit is controlled by thermal switch S1 (figure 5-18). When the power supply is ON, one side of S1 is connected to 15-VDC. The other side of S1 is connected to horn A4LS1 and OVERTEMP indicator A1DS3 (figure 5-18). Under normal temperature

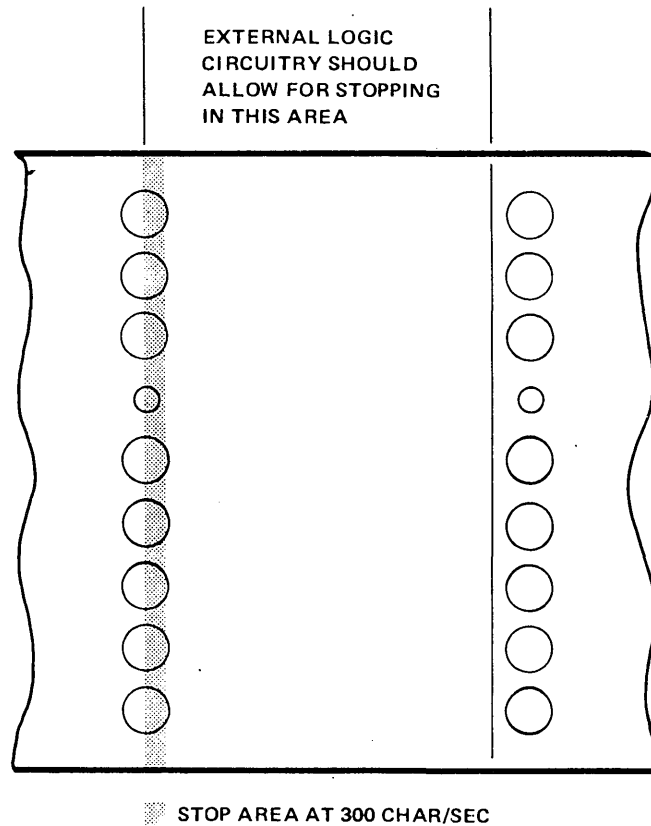

Figure 3-120. Reader Stop Distance.

conditions, S1 is open and the alarms are deenergized. If the temperature rises to 46°C (115°F), S1 closes and the alarms energize. The horn can be shut off by setting the NORMAL/ALARM BYPASS switch on the power panel to the ALARM BYPASS position, but the indicator will remain lighted. The power disabling circuit is controlled by thermal switch

S2 (figure 5-15). This switch is in series with the holding current path for K4 (figure 5-13). Under normal temperature conditions S2 is closed, and the holding current path is completed. If the temperature rises above 60°C (140°F), S2 opens and the relay deactuates, removing all AC and DC power from the I/O Console.