Storage Technology Corporation

**2920
Tape
Subsystem**

Maintenance Manual

PN 95521

Information contained in this publication is subject to change. In the event of changes, the publication will be revised. Comments concerning the contents of this manual should be directed to Tape/Disk Technical Publications at the address below. A prepaid Reader's Comment Form is provided at the back of the manual.

This publication was prepared by Storage Technology Corporation, Tape/Disk Technical Publications, MD 97, 2270 South 88th Street, Louisville, Colorado 80028.

Warning: For the purpose of designing a system that complies with FCC Rules and Regulations, Volume II, Part 15, Subpart J, this product is considered to be a component within the total system configuration. It is the customer's responsibility to take such action as necessary (shielded cabling, cabinet considerations, etc.) while integrating this product into his system so as to comply with the above rules. Contact Storage Technology Corporation for technical assistance in this matter.

Copyright © 1984
by
Storage Technology Corporation
All Rights Reserved

LIST OF EFFECTIVE PAGES

Publication PN 95521

Issue Date: August 1983 EC 49546

Reissue Date: October 1984 EC 49717 KIT PN 97772

Total number of pages in this document is 260, consisting of the following pages:

Page	EC No.	Kit PN	Disposition
Title	49717	97772	Replace all pages in this manual
Copyright	49717	97772	
iii thru XX	49717	97772	
1-1 thru 1-12	49717	97772	
2-1 thru 2-22	49717	97772	
3-1 thru 3-20	49717	97772	
4-1 thru 4-38	49717	97772	
5-1 thru 5-30	49717	97772	
6-1 thru 6-16	49717	97772	
7-1 thru 7-12	49717	97772	
8-1 thru 8-30	49717	97772	
9-1 thru 9-20	49717	97772	
A-1 thru A-2	49717	97772	
B-1 thru B-8	49717	97772	
C-1 thru C-6	49717	97772	
D-1 thru D-6	49717	97772	
E-1 thru E-6	49717	97772	
Index 1 thru 8	49717	97772	
Reader's Comment Form	None	None	
Business Reply Mailer	None	None	

(INTENTIONALLY LEFT BLANK)

TABLE OF CONTENTS

Paragraph	Title	Page
CHAPTER 1 GENERAL INFORMATION		
1.1	Introduction	1-1
1.2	General Description	1-1
1.2.1	Power Features	1-7
1.2.2	Interface Features	1-7
1.2.3	Mounting Options	1-7
1.2.4	Diagnostic Features	1-7
1.2.5	Electronics	1-7
1.3	Specifications	1-10
1.3.1	Physical Dimensions	1-10
1.3.2	Environmental Requirements	1-10
1.3.3	Power Requirements	1-11
CHAPTER 2 OPERATION		
2.1	Introduction	2-1
2.2	Power On/Off Switch	2-1
2.3	Display	2-1
2.4	Operator Functions Area	2-2
2.4.1	Ready Indicator (Green)	2-2
2.4.2	Select Indicator (Yellow)	2-2
2.4.3	EOT/BOT Indicator (Green)	2-2
2.4.4	On Line Indicator (Green)	2-2
2.4.5	Machine Check Indicator (Red)	2-2
2.4.6	File Protect Indicator (Red)	2-2
2.4.7	System Select/1600/6250 Indicators (Yellow)	2-4
2.4.8	Density Select Key	2-5
2.4.9	Rewind/Unload Key	2-5
2.4.10	Reset Key	2-5
2.4.11	Load/Rewind Key	2-5
2.4.12	On Line Key	2-5
2.5	Diagnostic Keypad	2-6
2.5.1	Enter Address Key	2-6
2.5.2	Display Address Key	2-7
2.5.3	Modify Memory Key	2-7
2.5.4	Enter Probe Key	2-8
2.5.5	Enter Diagnostic Key	2-8
2.5.6	Enter Key	2-8
2.5.7	Clear Key	2-9
2.6	Tape Threading Operations	2-9
2.6.1	Automatic Thread/Load--Vertical Mount	2-9

TABLE OF CONTENTS CONT

Paragraph	Title	Page
2.6.2	SemiAutomatic Thread/Load-Vertical Mount	2-10
2.6.3	SemiAutomatic Thread/Load--Center of Gravity Mount	2-10
2.6.4	Manual Thread/Load--Vertical or Center of Gravity Mount	2-11
2.6.5	Midtape Load, EOT Area	2-11
2.6.6	Rewind	2-11
2.6.7	Unload	2-13
2.7	Operator Maintenance	2-13
2.7.1	Read/Write Head and Tape Cleaner Block	2-13
2.7.2	EOT/BOT and Leader Sensors	2-13
2.7.3	Tape Guides, Rollers, and Swing Arms	2-15
2.7.4	Capstan	2-15
2.7.5	File Reel Hub	2-15
2.8	Tape Motion Characteristics	2-15
2.8.1	Start/Stop Mode	2-15
2.8.2	Streaming Mode	2-17
2.9	Interblock Gap (IBG) Generation	2-18
2.10	Reposition Timing	2-19
2.11	Reinstruct Times	2-19
2.12	50/100 ips Speed Change	2-19
2.13	Turnaround Delays	2-20
2.14	Duty Cycle	2-21

CHAPTER 3 INSTALLATION

3.1	Introduction	3-1
3.2	Inspection	3-1
3.3	Power Connection	3-2
3.4	Preliminary Checkout	3-4
3.5	Vertical Cabinet Mounting	3-8
3.6	Center of Gravity (Horizontal) Cabinet Mount	3-12
3.7	Storagetek Standard Interface Cabling	3-12
3.8	Industry Standard Interface Cabling	3-17
3.9	Address Selection	3-17
3.10	Reshipping	3-17

CHAPTER 4 STORAGE TECHNOLOGY STANDARD INTERFACE

4.1	Introduction	4-1
4.2	Input Line Definitions	4-1
4.2.1	MTS Address (AD0, AD1)	4-1

TABLE OF CONTENTS CONT

Paragraph	Title	Page
4.2.2	Initiate Command (START)	4-5
4.2.3	Command Select (CMD0, CMD1, CMD2, CMD3)	4-5
4.2.4	Density Select (DS0, DS1)	4-6
4.2.5	Transfer Acknowledge (TRAK)	4-6
4.2.6	Terminate Command (STOP)	4-7
4.2.7	System Reset (RESET)	4-7
4.2.8	Select Multiplex (SLX0, SLX1, SLX2)	4-7
4.2.9	Bi-Directional Data (DATA 0-7,P)	4-8
4.3	Output Line Definitions	4-8
4.3.1	Transfer Request (TREQ)	4-8
4.3.2	Expecting Data (RECV)	4-9
4.3.3	Block Sensed (BLOCK)	4-9
4.3.4	Oscillator (OSC)	4-9
4.3.5	End of Data Pulse (ENDATP)	4-9
4.3.6	Busy (BUSY)	4-9
4.3.7	Identification Burst (ID BRST)	4-9
4.3.8	Tape Mark Status (TMS)	4-10
4.3.9	Command REJECT (REJECT)	4-10
4.3.10	Operation Incomplete (OP INC)	4-10
4.3.11	Overrun Status (OVRNS)	4-10
4.3.12	EPROM Error (ROMPS)	4-11
4.3.13	Slave Status Change (SSC)	4-11
4.3.14	Data Check (DATA CHK)	4-11
4.3.15	Error Multiplex (ERRMX 0-7,P)	4-11
4.3.15.1	Mux Byte 0	4-11
4.3.15.2	Mux Byte 1	4-13
4.3.15.3	Mux Byte 2	4-14
4.3.15.4	MUX Byte 3	4-14
4.3.16	Corrected Error (CRERR)	4-17
4.3.17	Data Bus Parity Error (BUPER)	4-17
4.3.18	Online Status (ONLS)	4-17
4.3.19	Ready Status (RDYS)	4-17
4.3.20	Beginning of Tape Status (BOTS)	4-17
4.3.21	End of Tape Status (EOTS)	4-17
4.3.22	File Protect Status (FPTS)	4-18
4.3.23	Write Status (WRTS)	4-18
4.3.24	High Density Status (HDNS)	4-18
4.3.25	Rewinding Status (REWS)	4-18
4.4	Functional Mode Command Descriptions	4-18
4.4.1	General Information	4-18
4.4.1.1	Command Initiation	4-19
4.4.1.2	REJECT Conditions	4-19
4.4.1.3	Operation Completed	4-20
4.4.1.4	Ending Status Validity	4-20
4.4.1.5	End of Tape Status (EOTS)	4-20

TABLE OF CONTENTS CONT

Paragraph	Title	Page
4.4.1.6	Commands with MTS in Write Status . . .	4-20
4.4.1.7	Improper Command Sequences	4-20
4.4.2	No Operation (NOP) Command (0000)	4-21
4.4.3	Drive Clear (CLR) Command (0001)	4-21
4.4.4	Diagnostic Mode Set (DMS) Command (0010)	4-21
4.4.4.1	DMS/NOP (Status Lines Test Command)	4-22
4.4.4.2	DMS/WRT (SLX 2,1,0 = 000) (Write In Place Command)	4-24
4.4.4.3	DMS/WRT (SLX 2,1,0 = 001) (Write No Motion Command)	4-24
4.4.4.4	DMS/RDF (SLX 2,1,0 = 000) (Read No Motion Command)	4-24
4.4.4.5	DMS/WRT (SLX 2,1,0 = 111) (Functional Speed/Gap Select)	4-25
4.4.4.6	DMS/FSF (SLX 2,1,0 = 000) (Perform Loaded Diagnostics)	4-25
4.4.4.7	DMS/FSB (SLX 2,1,0 = 000) (Perform All Diagnostics)	4-25
4.4.4.7.1	DSB5 and DSB6 Description	4-26
4.4.4.7.2	DSB8 Through DSB55 Description	4-26
4.4.5	Read Forward a Block (RDF) Command (0100)	4-27
4.4.5.1	Signal Sequence	4-27
4.4.5.2	RDF/BOT	4-29
4.4.5.3	RDF/Tape Mark Blocks	4-29
4.4.6	Read Backward a Block (RDB) Command (0101)	4-29
4.4.6.1	RDB/BOT	4-29
4.4.6.2	RDB/Tape Mark Blocks	4-30
4.4.7	Write a Data Block (WRT) Command (0110)	4-30
4.4.7.1	Signal Sequence	4-30
4.4.7.2	WRT/BOT	4-32
4.4.8	Loop Write-to-Read (LWR) Command (0111)	4-32
4.4.9	Backspace a File (BSF) Command (1000)	4-32
4.4.9.1	BSF/BOT	4-32
4.4.10	Backspace a Block (BSB) Command (1001)	4-33
4.4.10.1	Signal Sequence	4-33
4.4.10.2	BSB/BOT	4-33
4.4.10.3	BSB/Tape Mark	4-33
4.4.11	Forward Space a File (FSF) Command (1010)	4-33
4.4.11.1	FSF/BOT	4-34
4.4.12	Forward Space a Block (FSB) Command (1011)	4-34
4.4.12.1	Signal Sequence	4-34

TABLE OF CONTENTS CONT

Paragraph	Title	Page
4.4.12.2	FSB/BOT	4-34
4.4.12.3	FSB/Tape Mark	4-34
4.4.13	Write Tape Mark (WTM) Command (1100)	4-34
4.4.13.1	WTM/BOT	4-35
4.4.14	Erase Gap (ERG) Command (1101)	4-35
4.4.14.1	ERG/BOT	4-35
4.4.15	Rewind (REW) Command (1110)	4-35
4.4.15.1	REW/BOT	4-35
4.4.16	Rewind and Unload (RUN) Command (1111)	4-36
4.4.16.1	RUN/BOT	4-36
4.4.17	Sense Drive Status (SNS) Command (0011)	4-36
4.4.17.1	Signal Sequence	4-36
4.4.17.2	Sense Bytes Description	4-36

CHAPTER 5 INDUSTRY STANDARD INTERFACE

5.1	Introduction	5-1
5.2	Input Line Definitions	5-1
5.2.1	MTS Address (FFAD, FTAD0, FTAD1)	5-6
5.2.2	Initiate Command (FGO)	5-7
5.2.3	Rewind To BOT (FREW)	5-7
5.2.4	Command Offline (FOFL)	5-7
5.2.5	Formatter Enable (FFEN)	5-8
5.2.6	Last Word (FLWD)	5-8
5.2.7	Write Data Lines (FWD0-7,p)	5-8
5.2.8	High Speed Select (FHISP) (2922 devices only)	5-8
5.2.9	Long Gap Select (FLGAP) (2922 devices only)	5-8
5.2.10	Command Select Lines (CMD0, 1, 2, 3, and 4)	5-9
5.3	Output Signal Definitions	5-10
5.3.1	Formatter Busy (FFBY)	5-10
5.3.2	Data Busy (FDBY)	5-10
5.3.3	Identification Burst (FID)	5-11
5.3.4	Hard Error (FHER)	5-11
5.3.5	File Mark Detected (FFMK)	5-11
5.3.6	Corrected Error (FCER)	5-11
5.3.7	Ready (FRDY)	5-12
5.3.8	Online (FONL)	5-12
5.3.9	Rewind (FRWD)	5-12
5.3.10	End Of Tape (FEOT)	5-12
5.3.11	File Protect (FFPT)	5-12
5.3.12	Load Point (FLDP)	5-12

TABLE OF CONTENTS CONT

Paragraph	Title	Page
5.3.13	High Speed Streaming (FHSPD)	5-12
5.3.14	High Density Status (GCR)	5-13
5.3.15	Demand Write Data Strobe (FDWDS)	5-13
5.3.15.1	FDWDS Timing, 50 IPS Operations	5-13
5.3.15.2	FDWDS Timing, 100 IPS Operations	5-14
5.3.16	Read Data Strobe (FRSTR)	5-14
5.3.16.1	FRSTR Timing, 50 IPS Operation	5-15
5.3.16.2	FRSTR Timing, 100 IPS Operation	5-15
5.3.17	Read Data Lines 0-7,p (FRD0-7, p)	5-15
5.4	Command Lines Decodes - Functional Commands Description	5-15
5.4.1	Read Forward Command (00000)	5-15
5.4.2	Read Reverse Command (01000)	5-15
5.4.3	Write Command (00100)	5-16
5.4.4	Write File Mark Command (00110)	5-17
5.4.5	Write Extended Command (01110)	5-17
5.4.6	Fixed Erase Command (00111)	5-17
5.4.7	Controlled Erase Command (00101)	5-17
5.4.8	Data Security Erase Command (10111)	5-18
5.4.9	Space Forward Command (00001)	5-18
5.4.10	Space Reverse Command (01001)	5-18
5.4.11	File Search Forward Command (Ignore Data) (00011)	5-18
5.4.12	File Search Reverse Command (Ignore Data) (01011)	5-18
5.4.13	Select PE Command (10011)	5-19
5.4.14	Select GCR Command (11011)	5-19
5.4.15	Read Sense Command (11001)	5-19
5.5	Detailed Functional Sense Bytes Description	5-19
5.5.1	Sense Byte 0 (Faults, Mode And Not Ready)	5-19
5.5.2	Sense Byte 1 (Last Command Issued)	5-20
5.5.3	Sense Byte 2 (Tape Status)	5-20
5.5.4	Sense Bytes 3 And 4 (Hard Errors)	5-20
5.5.4.1	Sense Byte 3	5-20
5.5.4.2	Sense Byte 4	5-21
5.5.5	Sense Byte 5 (Reject Status)	5-21
5.5.6	Sense Byte 6 (Corrected Error And Dead Track P)	5-21
5.5.7	Sense Byte 7 (Dead Track register)	5-22
5.6	Command Lines Decodes - Diagnostic Commands Description	5-22
5.6.1	Invoke Diagnostics (01100)	5-22
5.6.1.1	Run Diagnostic Package (Byte 1 = 01)	5-22
5.6.1.2	Run Loaded Diagnostics (Byte 1 = 02)	5-25

TABLE OF CONTENTS CONT

Paragraph	Title	Page
5.6.2	Loop Write to Read (01111)	5-25
5.6.3	Initiate Status Sequencer (10000)	5-25
5.6.4	Command to Status Wrap (10001)	5-26
5.6.5	Data Loopback (1111)	5-27
5.6.6	Read Extended Sense (11101)	5-27
5.7	Detailed Diagnostic Sense Bytes Description	5-28
5.7.1	DSB0 and DSB1 Description	5-28
5.7.2	DSB2 and DSB3 Description	5-28
5.7.3	DSB8 Through DSB55 Description	5-28

CHAPTER 6 FUNCTIONAL DESCRIPTION

6.1	Introduction	6-1
6.2	Interface/Microprocessor (IF Card)	6-1
6.3	Write Data Path (DP Card)	6-4
6.4	Write Drivers (WR Card)	6-6
6.5	Read (RD Card)	6-6
6.6	Read Data Path (DP Card)	6-9
6.6.1	PE Operation	6-9
6.6.2	GCR Operation	6-11
6.7	Servo System (SV Card)	6-12
6.8	Power System	6-15

CHAPTER 7 MAINTENANCE

7.1	Introduction	7-1
7.2	Quarterly Preventive Maintenance Checklist	7-1
7.3	Quarterly Power Supply Check	7-2
7.4	Tape Tracking and Skew Adjustment after parts replacement	7-2
7.4.1	Capstan Alignment (Tape Tracking)	7-3
7.4.2	Head Skew Adjustment	7-5
7.5	Quarterly Tape Skew Checks	7-9
7.6	Bit Position Check After Part Replacement	7-10
7.7	Quarterly Read Amplitude Checks	7-11

CHAPTER 8 REMOVAL AND REPLACEMENT

8.1	Introduction	8-1
8.1.1	Fuses	8-1
8.1.2	Torx Screws	8-3
8.2	Tape Path	8-3

TABLE OF CONTENTS CONT

Paragraph	Title	Page
8.2.1	EOT/BOT Sensor Replacement	8-3
8.2.2	Leader Sensor Replacement	8-4
8.2.3	Tape Cleaner Block Replacement	8-4
8.2.4	File Protect Sensor Replacement	8-5
8.2.5	Read/Write Head Replacement	8-5
8.3	Swing Arms	8-7
8.3.1	Lower Swing Arm Assembly Replacement	8-7
8.3.2	Lower Swing Arm Tach Assembly Replacement	8-10
8.3.3	Upper Swing Arm Assembly Replacement	8-11
8.3.4	Upper Swing Arm Tach Assembly Replacement	8-14
8.3.5	Retractor Assembly Replacement	8-15
8.4	Capstan, Reels, and Blower	8-18
8.4.1	Capstan Motor Replacement	8-18
8.4.2	File Reel Hub Replacement	8-20
8.4.3	File Reel Motor Replacement	8-20
8.4.4	Machine Reel Motor Replacement	8-21
8.4.5	Vacuum Blower Replacement	8-22
8.5	Circuit Cards	8-22
8.5.1	Card Cage Circuit Cards Replacement	8-22
8.5.2	Front Operator Panel Replacement	8-23
8.5.3	AK Card Replacement	8-23
8.5.4	PK Card Replacement	8-24
8.5.5	Motherboard Replacement	8-25
8.6	Power Supply and Fans	8-25
8.6.1	Regulator Assembly Replacement	8-25
8.6.2	Transformer Replacement	8-26
8.6.3	Main Circuit Breaker Replacement	8-27
8.6.4	Cooling Fan Replacement	8-27
8.7	Cable Harness Replacement	8-27
8.7.1	Cable Harness, Power	8-28
8.7.2	Cable Harness, AC	8-28
8.7.3	Cable Harness, Motor	8-28
8.7.4	Cable Harness, Sensor	8-28

CHAPTER 9 DIAGNOSTIC/MAINTENANCE PROGRAMS

9.1	Introduction	9-1
9.1.1	Test Initiation	9-1
9.1.2	Status Buffers	9-2
9.2	Section 0 - Maintenance Routines	9-2
9.2.1	Forward Motion (00)	9-2
9.2.2	Backward Motion (01)	9-3

TABLE OF CONTENTS CONT

Paragraph	Title	Page
9.2.3	Shoeshine Motion (02)	9-3
9.2.4	Start/Stop Motion (03)	9-4
9.2.5	Speed Select Option (04)	9-4
9.2.6	Continue Option (05)	9-4
9.2.7	Loop Option (06)	9-5
9.2.8	Bypass Error Option (07)	9-5
9.2.9	Keyboard/LED Driver (08)	9-5
9.2.10	Reel/Capstan Driver (09)	9-5
9.2.11	Status A Display (0A)	9-6
9.2.12	Status B Display (0B)	9-6
9.2.13	Status C Display (0C)	9-6
9.2.14	Maintenance Write (0E)	9-6
9.2.15	Maintenance Write (0F)	9-7
9.3	Internal Diagnostics	9-7
9.3.1	Section 1 - Power-Up Tests	9-7
9.3.1.1	Test Package Initiator (10)	9-9
9.3.1.2	Memory/PROM Checksum (12)	9-9
9.3.1.3	IF Test 1 (13)	9-9
9.3.1.3.1	Routine 13 for Storagetek Interface Card	9-9
9.3.1.3.2	Routine 13 for Industry Standard Interface Card	9-10
9.3.1.4	IF Test 2 (14)	9-10
9.3.1.4.1	Routine 14 for Storagetek Interface Card	9-10
9.3.1.4.2	Routine 14 for Industry Standard Interface Card	9-10
9.3.1.5	Keyboard Status (15)	9-10
9.3.1.6	Servo-LSI Register Loop (18)	9-10
9.3.1.7	Data Path Status (1B)	9-11
9.3.1.8	Write Card Status (1D)	9-11
9.3.1.9	Release/Retract Swing Arms (1F)	9-11
9.3.2	Section 2 - Formatter Tests	9-11
9.3.2.1	PE Basic Loop Write-to-Read, 50 IPS (22)	9-12
9.3.2.2	PE LWR Velocity (23)	9-12
9.3.2.3	GCR Basic Loop Write-to-Read, 50 IPS (24)	9-12
9.3.2.4	GCR LWR Velocity (25)	9-13
9.3.2.5	PE LWR, One Track Dead (26)	9-13
9.3.2.6	GCR LWR, One Track Dead (27)	9-14
9.3.2.7	PE LWR, Two Tracks Dead (28)	9-14
9.3.2.8	GCR, LWR, Two Tracks Dead (29)	9-14
9.3.2.9	PE Basic LWR, 100 IPS (2C)	9-15
9.3.2.10	GCR Basic LWR, 100 IPS (2E)	9-15

TABLE OF CONTENTS CONT

Paragraph	Title	Page
9.3.3	Section 3 - Transport Tests	9-15
9.3.3.1	Unload/Load (32)	9-15
9.3.3.2	Drive Basic Motion, 50 IPS(34)	9-15
9.3.3.3	Drive Basic Motion, 100 IPS (35)	9-16
9.3.3.4	Drive Rewind (36)	9-16
9.3.4	Section 4 (50 IPS) and Section 5 (100 IPS) - R/W Tests	9-16
9.3.4.1	PE Amplitude Sensor (42=50 IPS, 52=100 IPS)	9-16
9.3.4.2	GCR Amplitude Sensor (43=50 IPS, 53=100 IPS)	9-17
9.3.4.3	PE Write Records (48=50 IPS, 58=100 IPS)	9-17
9.3.4.4	PE Read Forward (49=50 IPS, 59=100 IPS)	9-17
9.3.4.5	PE Read Backward (4A=50 IPS, 5A=100 IPS)	9-17
9.3.4.6	PE Positioning (4B=50 IPS, 5B=100 IPS)	9-17
9.3.4.7	GCR Write Records (4C=50 IPS, 5B=100 IPS)	9-18
9.3.4.8	GCR Read Forward (4D=50 IPS, 5D=100 IPS)	9-18
9.3.4.9	GCR Read Backward (4E=50 IPS, 5E=100 IPS)	9-18
9.3.4.10	GCR Positioning (4F=50 IPS, 5F=100 IPS)	9-18
9.4	External Diagnostics	9-18

APPENDIX A SPECIAL TEST EQUIPMENT, TOOLS, AND SUPPLIES

APPENDIX B DATA FORMATS

APPENDIX C MEMORY ALLOCATION, STK STANDARD INTERFACE - 2921

APPENDIX D MEMORY ALLOCATION, STK STANDARD INTERFACE - 2922

APPENDIX E MEMORY ALLOCATION, INDUSTRY STD INTERFACE - 292X

TABLE OF CONTENTS CONT

Paragraph
INDEX

Title

Page

(INTENTIONALLY LEFT BLANK)

LIST OF ILLUSTRATIONS

Figure	Title	Page
1-1	Model 292X MTS Front View (Vertical Mount) . . .	1-2
1-2	Model 292X MTS Front View (Center of Gravity Mount)	1-3
1-3	Model 292X MTS Rear View (Vertical Mount)	1-4
1-4	Model 292X MTS Rear View (Center of Gravity Mount)	1-5
1-5	Model 292X MTS STORAGETEK Standard Card Cage . . .	1-8
1-6	Model 292X MTS Industry Standard Card Cage . . .	1-9
2-1	Operator Panel, Vertical Mount	2-3
2-2	Operator Panel, Center of Gravity Mount	2-4
2-3	Tape Thread Path	2-12
2-4	Tape Path Components--Tape Not Loaded	2-14
2-5	Start/Stop Mode Velocity Profile	2-16
2-6	Capstan Velocity Profile	2-17
3-1	Cables and Connectors	3-3
3-2	Interface Card Address,	3-6
3-3	IF Card Terminator and Address Switch Locations	3-7
3-4	Vertical Mounting Installation	3-9
3-5	Vertical Mounting Dimensions	3-10
3-6	Suggested Lifting Methods	3-11
3-7	Center of Gravity Mounting Dimensions	3-13
3-8	Storagetek Standard Interface Cabling	3-14
3-9	Storagetek Standard Interface Cable Configuration	3-16
3-10	Industry Standard Interface Cabling	3-18
4-1	MTS-User Interface Circuits	4-2
4-2	Command Initiation, Operation, and Completion	4-19
4-3	RDF or RDB Command TREQ, TRAK, and DATA Timing	4-28
4-4	Write Commands Initiating TREQ/TRAK/DATA Timing (Applies to First Byte of Data)	4-31
4-5	WRT Command TREQ, TRAK and DATA Timing (Applies to All Subsequent Bytes of Data)	4-31
5-1	Standard Industry Interface Circuits	5-2
5-2	Interface Timing For 50 IPS Start Stop, Worst Case	5-13
5-3	Interface Timing For 100 IPS Streaming, Worst Case	5-14
6-1	MTS Block Diagram	6-2

LIST OF ILLUSTRATIONS CONT

Figure	Title	Page
6-2	Interface/Microprocessor Block Diagram (IF Card)	6-3
6-3	Write Path Block Diagram (DP Card)	6-5
6-4	Write Driver Block Diagram (WR Card)	6-7
6-5	Read Block Diagram (RD Card)	6-8
6-6	Read Path Block Diagram (DP Card)	6-10
6-7	Capstan Servo System Block Diagram	6-13
6-8	Reel Servo System Block Diagram	6-14
6-9	Power System Block Diagram	6-16
7-1	Static and Dynamic Skew and Turnaround Jump	7-3
7-2	Capstan and Read/Write Head Alignment	7-4
7-3	+Dif Analog Test Points	7-7
7-4	Bit Position Check	7-11
8-1	2920 MTS Deck (Front)	8-2
8-2	Read/Write Head	8-6
8-3	Swing Arm Assemblies	8-8
8-4	Retractor Assembly	8-17
B-1	PE Tape Format	B-2
B-2	GCR Tape Format	B-4
B-3	GCR Data Block Format (Sheet 1 of 3)	B-5

LIST OF TABLES

Table	Title	Page
1-1	Performance Specifications	1-6
1-2	Nominal Access Time From Stop (milliseconds)	1-6
1-3	Power Requirements	1-11
2-1	Generated Interblock Gap Lengths	2-18
2-2	Selectable Interblock Gaps	2-19
2-3	Reposition Times	2-19
2-4	Nominal Reinstruct Times (Maximum Gap)	2-20
2-5	Nominal Reinstruct Times (Minimum Gap)	2-20
3-1	PK Board Wiring for Input Power	3-4
4-1	STK Standard Interface Output Lines	4-3
4-2	STK Standard Interface Input Lines	4-4
4-3	MTS Address Line Decode	4-4
4-4	Command Select Decode	4-5
4-5	Density Select Line Decode	4-6
4-6	Select Multiplex Decode	4-8
4-7	Error Conditions Setting DATA CHK	4-12
4-8	Error Multiplex Bus Decode for Functional Mode	4-12
4-9	Status Lines Asserted with WTM CHK	4-13
4-10	REJECT Codes (Sheet 1 of 2)	4-15
4-11	Status Line Assertion For DMS/NOP Command Sheet 1 of 2	4-22
4-12	Status Line Assertion For Diagnostic Wrap Mode	4-24
4-13	Speed And Gap Selection Decodes	4-25
4-14	Diagnostics Extended Sense Bytes Summary	4-26
4-15	A-0 Through C-F Sense Bytes Cross Reference	4-27
4-16	Operational Sense Bytes Summary	4-37
5-1	Industry Standard Interface Input Lines	5-3
5-2	Industry Standard Interface Output Lines	5-4
5-3	Interface Connector J6 Pin Functions	5-5
5-4	Interface Connector J7 Pin Functions	5-6
5-5	MTS Address Line Decodes	5-7
5-6	Functional Command Lines Decodes	5-9
5-7	Diagnostic Command Lines Decodes	5-10
5-8	Reject Codes (Sheet 1 of 2)	5-23
5-9	Status Line Assertion for ISS Command	5-26
5-10	Status Line Assertion For Diagnostic Wrap Mode	5-26
5-11	Diagnostic Sense Bytes Summary	5-27
5-12	A-0 Through C-F Sense Bytes Cross Reference	5-29
7-1	Capstan Alignment Instructions	7-4

LIST OF TABLES CONT

Table	Title	Page
9-1	Maintenance Routines	9-3
9-2	Internal Diagnostics (Sheet 1 of 2)	9-8

CHAPTER 1

GENERAL INFORMATION

1.1 INTRODUCTION

This chapter is an introduction to the Storage Technology Corporation Model 292X Magnetic Tape Subsystem (MTS). This chapter includes a general description of the physical and functional layout of the MTS and includes the MTS specifications.

Two model types are available, the 2921 and the 2922. The 2921 has a tape speed of 50 inches per second (ips) (127 cm/s), start/stop. The 2922 has a tape speed of 50 ips (127 cm/s) start/stop and 100 ips (254 cm/s) streaming.

1.2 GENERAL DESCRIPTION

The MTS (Figures 1-1 through 1-4) is an integrated tape formatter/controller and half-inch (12.7 cm) tape drive packaged as a single self-contained unit (1x1). The MTS is a dual-density device capable of recording and reading ANSI compatible tapes in phase-encoded (PE) format at 1600 bits per inch (bpi) (63 bpmm) and group-coded recording (GCR) format at 6250 bpi (246 bpmm) at a tape speed of 50 (127 cm/s) or 50/100 ips (127 cm/s/254 cm/s), depending on the model.

The MTS is a low-cost, medium performance device intended for use in normal tape processing and/or disk off-loading. The device features automatic or semiautomatic tape threading/loading of open reel sizes 7, 8.5, and 10.5 inches; tension arm tape buffering; microprocessor capstan servo and microprocessor reel servo; and on-board diagnostics for functional verification and fault detection.

Data can be read when tape is moving either forward or backward but recording can be performed during forward tape motion only. Performance specifications are shown in Table 1-1.

Nominal access time from stop is shown in Table 1-2. Access time is defined as the time from assertion of Busy on receipt of a read or write command at the interface to the time the beginning of the record is read from or written to tape. This is assuming tape starts from a stopped position, no turn-around condition is required, and tape is not positioned at BOT. See Chapter 2 for a detailed description of the access time and interblock gap generation.

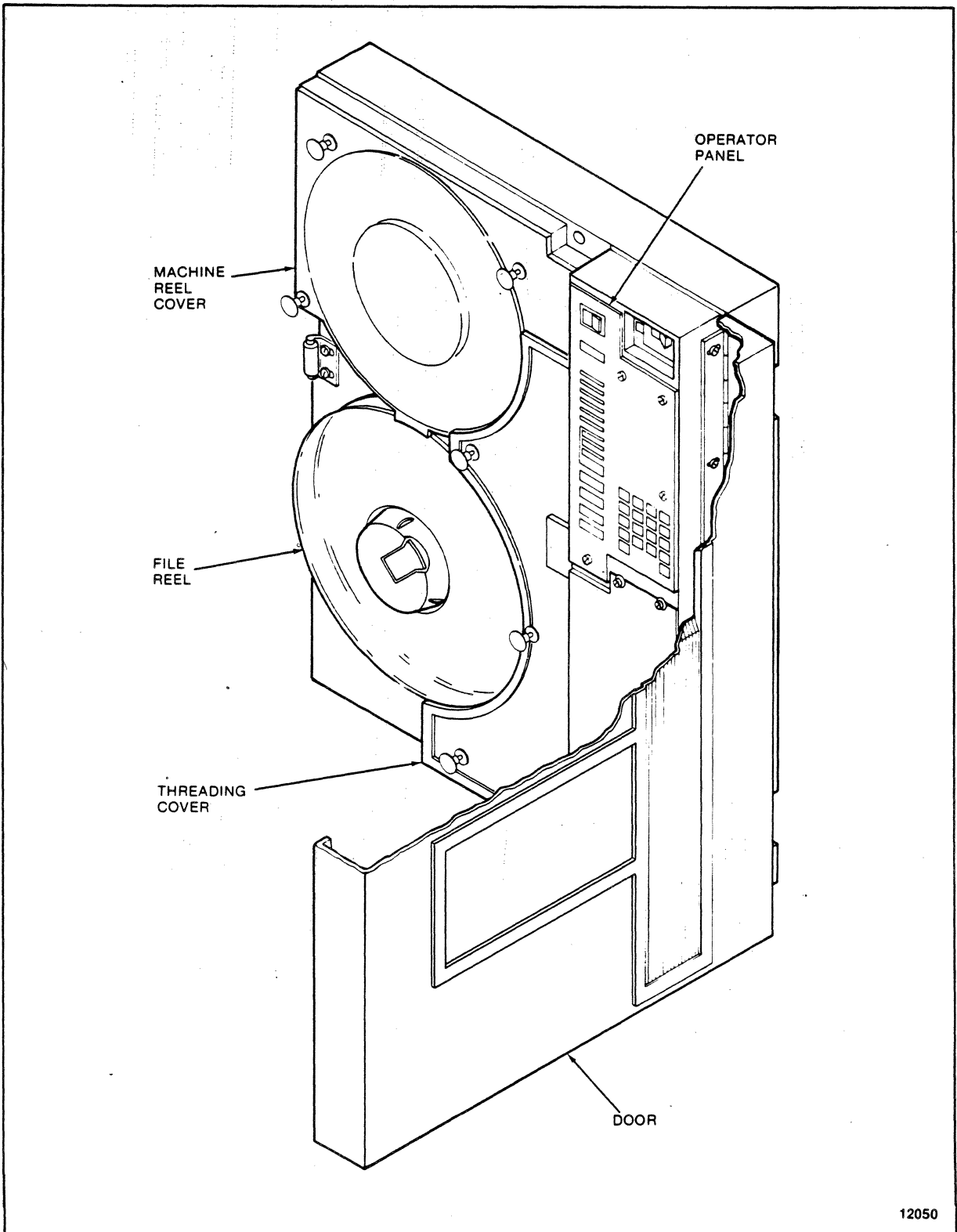

Figure 1-1. Model 292X MTS Front View (Vertical Mount)

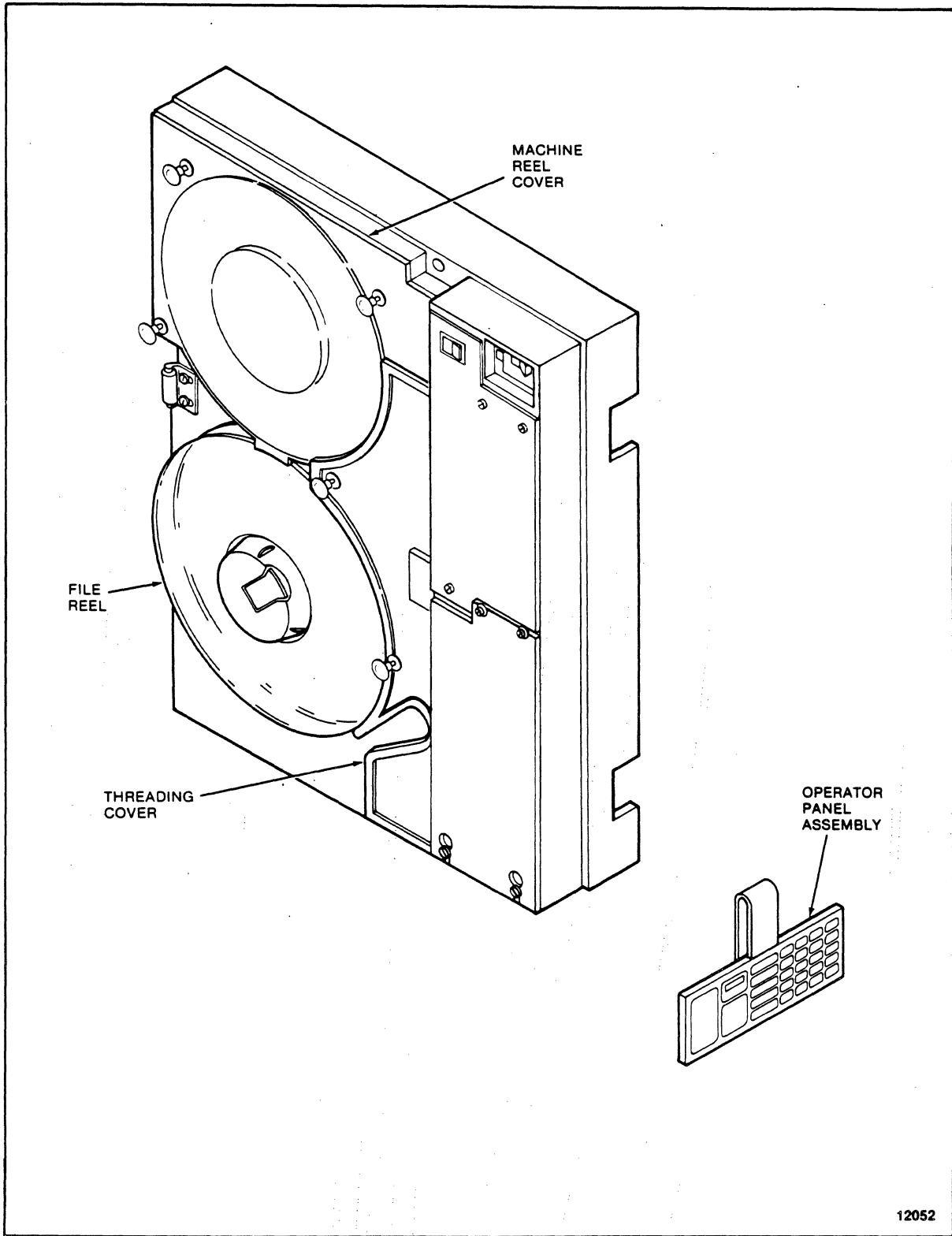

Figure 1-2. Model 292X MTS Front View (Center of Gravity Mount)

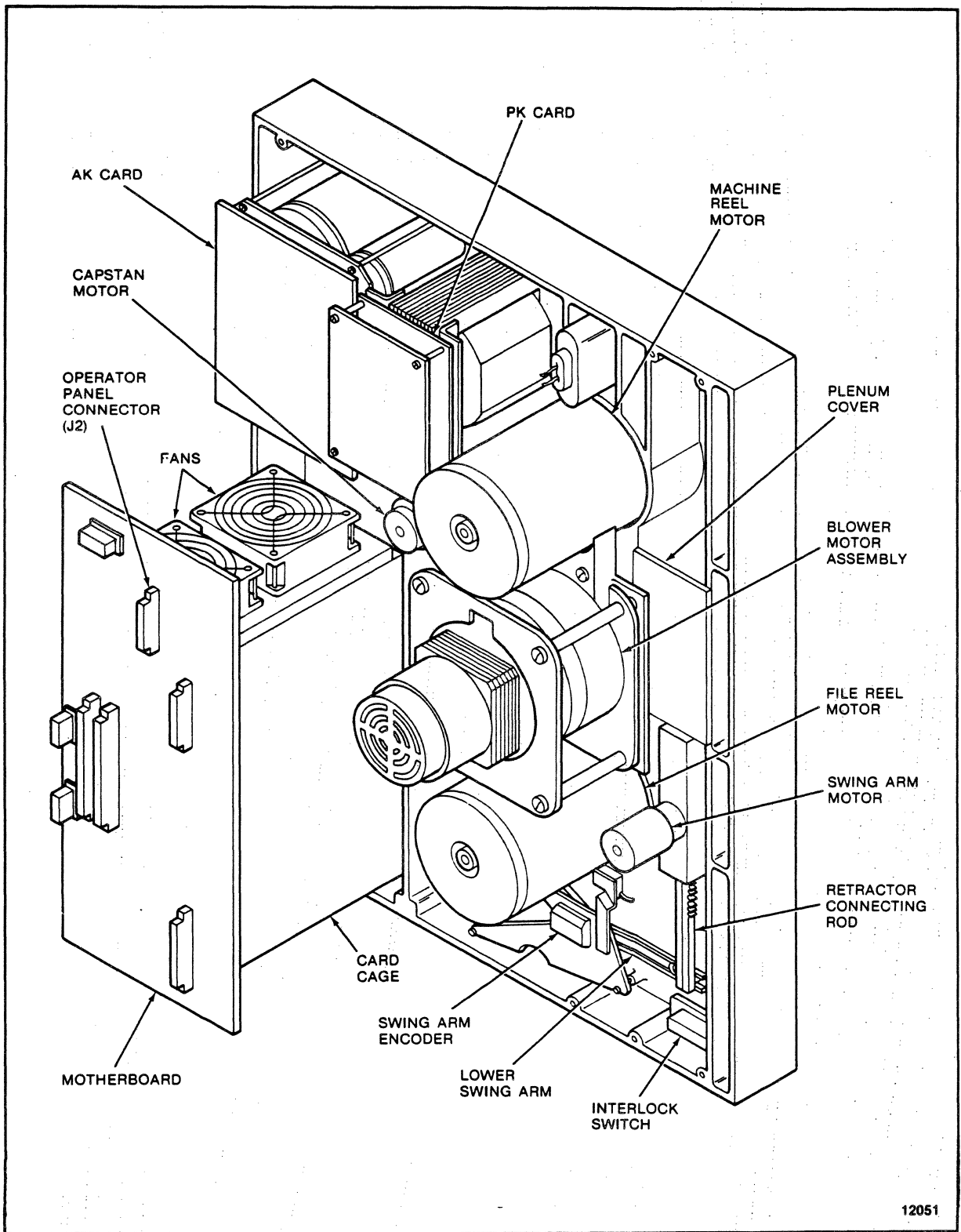

Figure 1-3. Model 292X MTS Rear View (Vertical Mount)

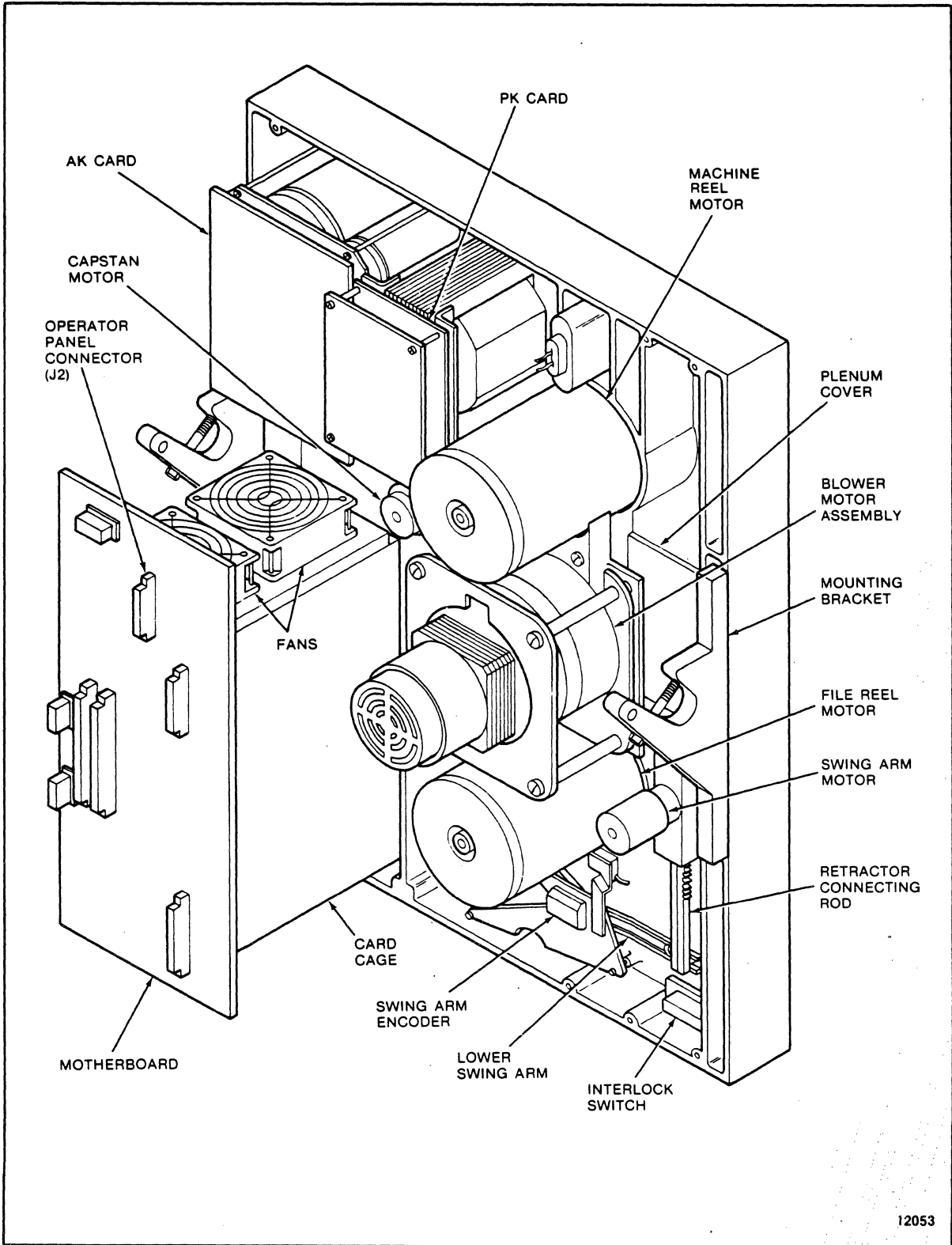

Figure 1-4. Model 292X MTS Rear View (Center of Gravity Mount)

Table 1-1. Performance Specifications

Tape Speed	50 ips/127 cm/s	100 ips/254 cm/s
Data Density GCR PE	6250 bpi (246 bpmm) 1600 bpi (63 bpmm)	6250 bpi (246 bpmm) 1600 bpi (63 bpmm)
Data Transfer Rate GCR PE	313 kB/s 80 kB/s	625 KB/s 160 KB/s
Access Time (nominal)	5.0 ms	See Table 1-2
Write Interblock Gap (nominal) GCR PE	0.45 in. (1.14 cm) 0.60 in. (1.52 cm)	See Chapter 2
Rewind Time (nominal) (2400-foot reel) (731.52 meter reel)	2.5 minutes	2.5 minutes

Table 1-2. Nominal Access Time From Stop (milliseconds)

MODE	IBG	READ	WRITE
Start/Stop 6250 bpi 246 bpmm	0.28 in./0.71 cm	5.6 ms	--
	0.30 in./0.76 cm	6.0 ms	--
	0.45 in./1.14 cm	9.0 ms	6.0 ms
Start/Stop 1600 bpi 63 bpmm	0.50 in./1.27 cm	5.6 ms	--
	0.60 in./1.52 cm	7.6 ms	6.0 ms
Streaming 6250 bpi 246 bpmm	0.28 - 1.2 in./ 0.71 - 3.05 cm	12.0 ms	--
	0.30 in./0.76 cm	--	12.5 ms
Streaming 1600 bpi 63 bpmm	0.5 - 1.2 in./ 1.27 - 3.05 cm	12.0 ms	--
	0.60 in./1.52 cm	--	12.5 ms

1.2.1 Power Features

Models 2921 and 2922 operate from either a 120 Vac, 60 Hz power source or a 220 Vac, 50 Hz power source. Chapter 6 provides a description of the power supply.

1.2.2 Interface Features

Both models can be provided with either the StorageTek Standard Interface or the Industry Standard Interface (Perfec). The STK Standard Interface is described in Chapter 4 and the Industry Standard Interface is described in Chapter 5.

1.2.3 Mounting Options

Both models are available with either vertical or center of gravity (horizontal) mounting options. Chapter 3 describes each installation.

1.2.4 Diagnostic Features

The internal diagnostics programs are capable of detecting fault conditions in the tape subsystem and isolating failures within a specific number of field replaceable units (FRUs). A unique package is required for machines using the Industry Standard Interface. Optional programs are available on floppy diskettes to provide 292X interface verification and limited online exercising. See Chapter 9 for details.

1.2.5 Electronics

The electronics of the MTS are located on five plug-in printed circuit cards located in a card cage below the operator panel. The Industry Standard Interface requires two additional cards: PA and PB adaptor cards. These cards are identified in Figures 1-5 and 1-6. In addition, there is an operator panel circuit card (KK) and three power supply circuit cards: the AK and NK regulator cards and the PK power circuit damage protection card. Chapter 6 describes the functions of each card.

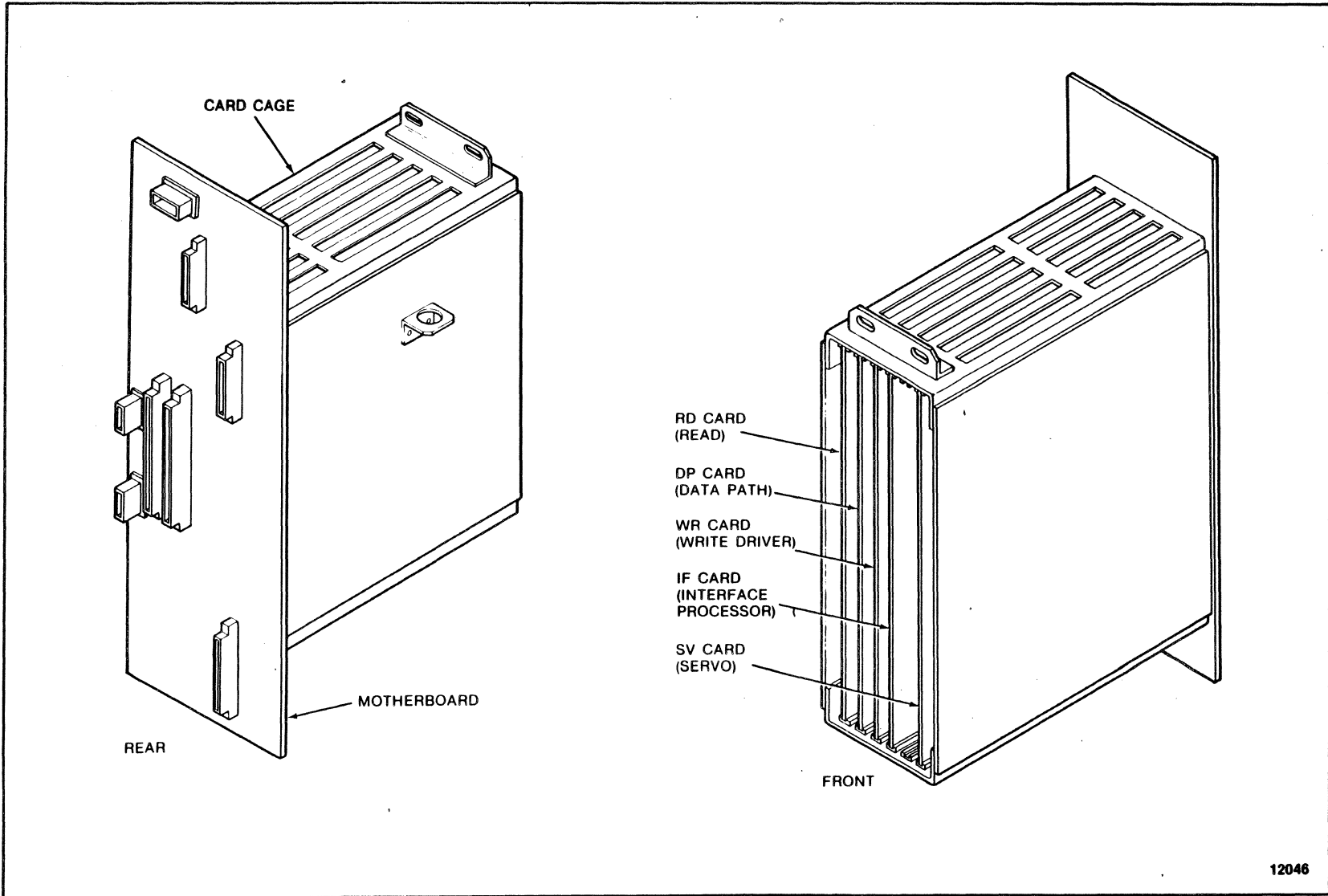

Figure 1-5. Mode1 292X MTS STORAGETEK Standard Card Cage

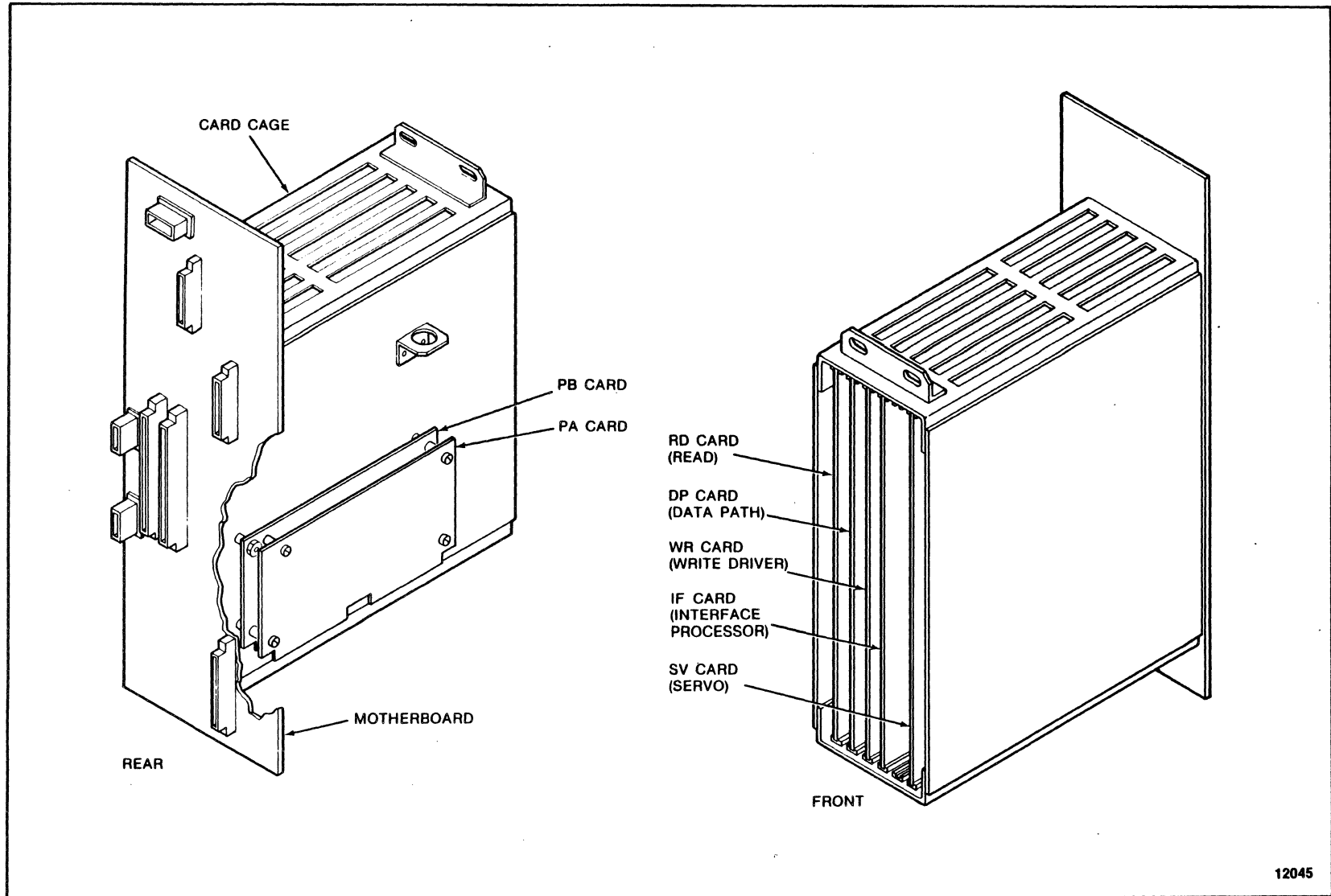

Figure 1-6. Model 292X MTS Industry Standard Card Cage

1.3 SPECIFICATIONS

Physical, environmental and power requirements for the MTS are as follows:

1.3.1 Physical Dimensions

The nominal outside dimensions of the MTS are:

Height	24.5 inches (62.2 cm)	
Width	19.0 inches (48.3 cm)	
Depth	16.0 inches (40.6 cm)	
Projection	4.8 inches (12.2 cm)	from RETMA mounting surface
Weight	125 pounds (57 kg)	

1.3.2 Environmental Requirements

Temperature (Ambient Room Air):

Optimum	+16°C to +22°C (+60°F to +72°F)
Operating	+16°C to +31°C (+60°F to +90°F)
Non-Operating	-40°C to +70°C (-40°F to +158°F)

Relative Humidity:

Optimum	37% to 42%, noncondensing
Operating	20% to 80%, noncondensing
Storage	10% to 90%, noncondensing
Shipping	Any, noncondensing

The storage environment must not exist outside the limits of the operating environment for a period longer than six months.

The MTS must not be subjected to a temperature change greater than 8°C (15°F) per hour.

Altitude:

Operating	Up to 1830 meters (6,000 feet) standard Up to 3050 meters (10,000 feet) with manual-assisted thread
Non-Operating	Up to 15,240 meters (50,000 feet)

1.3.3 Power Requirements

The MTS is designed to operate on any one of the following single-phase power sources (refer to Table 1-3) :

Table 1-3. Power Requirements

Nominal Voltage	Voltage Range	Frequency	Maximum Current
100 Vac	85-110	60 (± 1) Hz	4 amps
120 Vac	102-132	60 (± 1) Hz	4 amps
100 Vac	85-110	50 (± 1) Hz	4 amps
200 Vac	170-220	50 (± 1) Hz	2 amps
220 Vac	187-242	50 (± 1) Hz	2 amps
240 Vac	204-264	50 (± 1) Hz	2 amps

The MTS is assembled and shipped to operate from either a 120 Vac, 60 Hz power source or a 220 Vac, 50 Hz power source. Conversion to other power sources requires changes to the primary side wiring of the MTS input power transformer (refer to chapter 3).

(INTENTIONALLY LEFT BLANK)

CHAPTER 2

OPERATION

2.1 INTRODUCTION

This chapter describes the operator panel functions and status indicators, the common MTS operating procedures, and the required operator maintenance.

2.2 POWER ON/OFF SWITCH

The Power On/Off switch is used to power up or power down the MTS. When powered up, the MTS initializes and invokes a series of power-up diagnostics.

2.3 DISPLAY

The operator panel contains a four-character display. When the MTS is in Online Status, the display is blank. During machine check conditions, the display contains a three-digit fault code. When the MTS is offline and at idle, the display contains four dashes indicating that the MTS is ready to accept diagnostic commands. When a key is depressed, all segments of the display are lit to indicate that the key has been recognized and accepted. When pressure is removed from the key, the display returns to its previous state.

Throughout this manual, display conditions are shown enclosed within parentheses. To summarize the display conditions and their meanings:

()	Online
(----)	Offline, panel idle, test successfully completed
(@n)	Executing test
(@nn)	Executing test
(nn)	Displaying data (flashing if from probe)
(nnnn)	Displaying address
(??)	Request for data or test ID input
(????)	Request for address input
(nnn)	Fault code (refer to Fault Code Dictionary PN 97712 or 87004)

2.4 OPERATOR FUNCTIONS AREA

The operator functions area of the operator panel (Figures 2-1 and 2-2) provides status indicators and a keypad for operator control of the normal functions of the MTS.

2.4.1 Ready Indicator (Green)

The Ready indicator is illuminated when the MTS is fully loaded and not performing a rewind operation. The indicator is active whether or not the MTS is in Online Status.

2.4.2 Select Indicator (Yellow)

The Select indicator is illuminated when the MTS is in Online Status and has been selected for use by the USER (that is, the MTS Address lines match the address of the MTS).

2.4.3 EOT/BOT Indicator (Green)

The EOT/BOT indicator is illuminated when EOT or BOT Status is set in the MTS; that is, when the BOT marker is detected by the BOT sensor or when the EOT marker has been detected by or is past the EOT sensor. When the indicator is lit at EOT, it remains illuminated until a rewind or backward read operation moves the EOT marker back past the EOT sensor.

2.4.4 On Line Indicator (Green)

The On Line indicator is illuminated when Online Status is set in the MTS; that is, when the MTS is available to the USER.

2.4.5 Machine Check Indicator (Red)

The Machine Check (MACH CHK) indicator flashes to signal either a load check, which may be operator correctable, or to signal a malfunction of the MTS that requires service. A fault code of three characters will be posted in the display.

2.4.6 File Protect Indicator (Red)

The File Protect (FILE PROT) indicator is illuminated when tape is loaded and a write enable ring is not in place on the file reel. Write operations can not be performed when this indicator is illuminated.

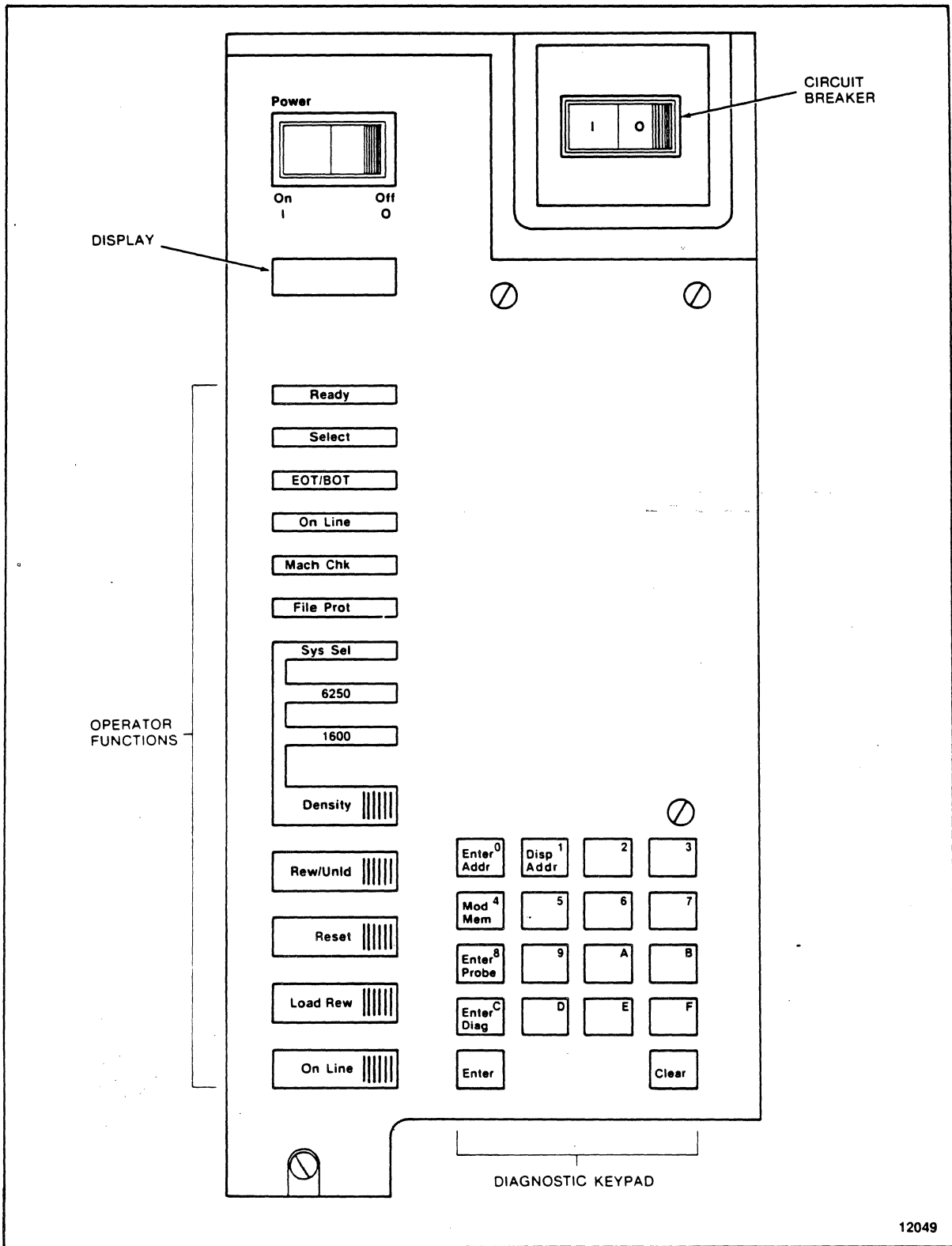

Figure 2-1. Operator Panel, Vertical Mount

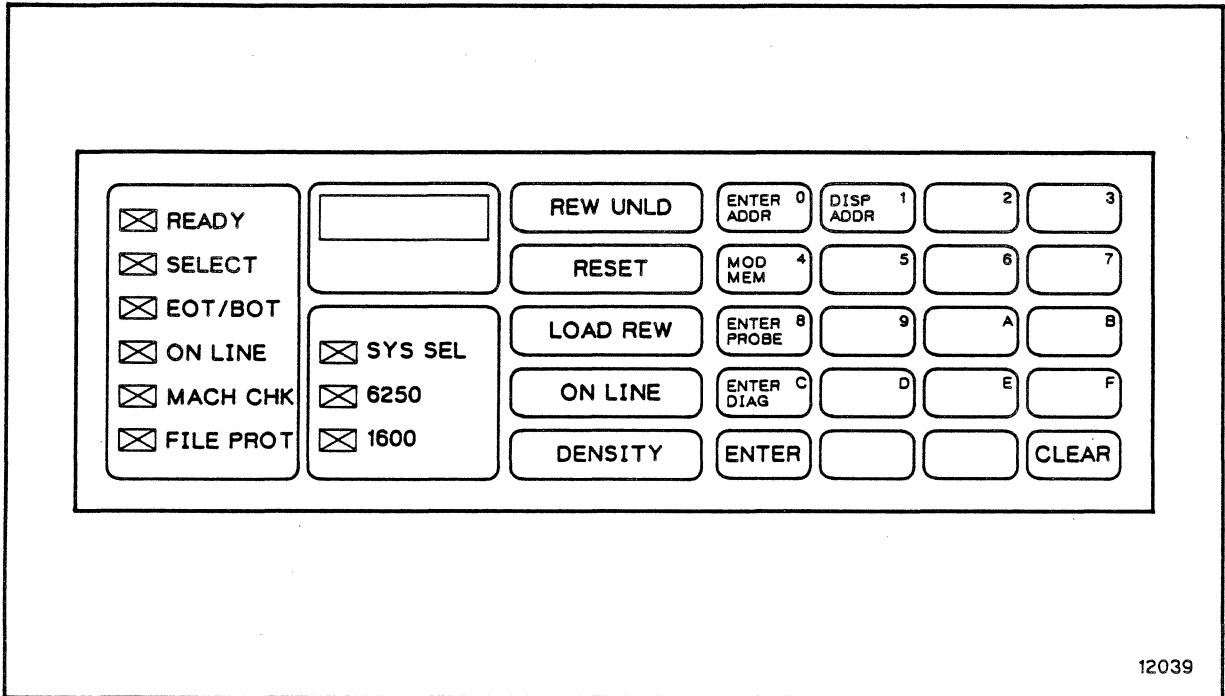

Figure 2-2. Operator Panel, Center of Gravity Mount

2.4.7 System Select/1600/6250 Indicators (Yellow)

The System Select (SYS SEL), 1600, and 6250 indicators are used to show the current operating density of the MTS. The operator may select a density mode using the Density Select key when the MTS is either not loaded or loaded and positioned at BOT. The selected mode determines the density in which a tape is to be written.

Illumination of the 1600 indicator alone indicates that the tape will be written in 1600 bpi density (PE format). Illumination of the 6250 indicator alone indicates that the tape will be written in 6250 bpi density (GCR format). Illumination of the System Select indicator in combination with illumination of the 1600 indicator indicates that the recording density is to be selected by the CPU. On power up, the MTS will indicate System Select and 1600.

A read operation will be in the correct density regardless of the initial setting of the indicators. When the density of the tape being read has been determined, the corresponding indicator (1600 or 6250) is illuminated.

2.4.8 Density Select Key

The Density Select (DENSITY) key is used to select a recording density when the drive is unloaded or tape is loaded and at BOT. Successive actuations of the key causes the MTS to cycle through the possible density modes. Upon power up, the MTS will be set to SYS SEL/1600 mode. Pressing DENSITY causes the MTS to go to 1600 bpi density. A second press causes the MTS to go to 6250 bpi density. Entering DENSITY a third time returns the MTS to SYS SEL/1600 mode.

Execution of a diagnostic routine may cause the density status of the MTS to change. A tape load operation will reinitialize the MTS to SYS SEL/1600 mode.

2.4.9 Rewind/Unload Key

The Rewind/Unload (REW/UNLD) key is used to unload tape. If tape is not at BOT when the key is pressed, a high speed rewind to BOT is initiated, the swing arms are retracted, and tape is unloaded from the tape path. Select and Ready Status are reset by this key. This key is not accepted if the MTS is in Online Status.

2.4.10 Reset Key

The Reset key is used to generate a subsystem reset. Pressing this key resets Select, puts the MTS in Offline Status, terminates any operation and tape motion that is in progress, clears any machine check condition, and returns the display to idle (----).

2.4.11 Load/Rewind Key

The Load/Rewind (LOAD/REW) key serves a dual purpose. If tape is not loaded, this key is used to load tape and position tape at BOT. If tape is loaded, this key causes tape to be rewound and positioned at BOT. This key is disabled if the MTS is in Online Status.

2.4.12 On Line Key

The On Line key is used to set the MTS to Online Status. Setting the MTS to online status will cause all presently on-going MTS operations to cease. Online status disables the Rewind/Unload and Load/Rewind keys. The online condition is reset by the reset key.

2.5 DIAGNOSTIC KEYPAD

Commands entered on the diagnostic keypad (Figures 2-1 and 2-2) allow access to various functions. These include maintenance programs execution, internal diagnostics execution, memory examination and modification, and a continuous readout of a memory space location (probe). The operations available are dependent upon the status of the MTS and the current display contents. The keypad will not respond when the MTS is in Online Status or if a machine check is present (nnn). While idle (----) or error (nnn) is present, all panel functions are available. During the execution of a maintenance program or diagnostic routine (@n) or (@nn), only memory read functions are available (Enter Address, Enter Probe, and Display Address). The Reset key serves to return the panel to an idle condition (----).

The main function of each key on the keypad is marked on the key. Some keys have alternate control functions. The protocol for using the diagnostic keypad consists of entering a control function and then entering data characters as required. The display contains input and output symbols appropriate to the function in process.

The diagnostic keypad is also used to enter data characters. The data character associated with a given key appears in its upper right corner.

2.5.1 Enter Address Key

The Enter Address key is used to select an address from which data display is desired. Pressing the Enter Address <ENTER ADDR> key allows the entry of a hexadecimal number representing a location within the memory of the MTS controller. The display prompts for the entry with four question marks (????) until the first entry is made. The first entry then appears right-justified in the display with subsequent entries producing a shift left on the display. Any number of entries may be made. If the target address desired is the same as that most recently referenced, a press of the Enter key directly following the prompt display is sufficient.

When the desired address appears on the display, the Enter key terminates address entry and causes the byte at that address to be displayed as two hexadecimal digits, right-justified. At this time each actuation of the Enter key displays the contents of the next memory location.

2.5.2 Display Address Key

When using the Enter key to display a long series of memory locations, it may be necessary to determine the location currently being displayed. The Display Address Key is used to display the MTS current address. Pressing the Display Address <DISP ADDR> key causes the current address to be displayed as four hexadecimal digits. Press the Enter key to display the contents of this address as in a normal enter address sequence.

The address last displayed is stored so that normal machine operation will not destroy it. The Display Address Key may then be used at any time (for instance, following a diagnostic routine) and the Enter key may be pressed to recall a frequent memory location.

If the Display Address key is pressed following subsystem power up and before the Enter Address function is used, memory location 0000 is displayed.

2.5.3 Modify Memory Key

The Modify Memory <MOD MEM> key is used to modify a writeable memory location within the MTS controller. This key is recognized only while data from the target location (from an <ENTER ADDR> or <DISP ADDR> key sequence) is being displayed. No memory modification is allowed while a diagnostic routine is executing. If this key is pressed at any other time, there will be no response.

CAUTION

If the memory is modified, MTS operation is not guaranteed.

Following the actuation of the Modify Memory key, the display prompts for a byte value input (two hexadecimal entries) by displaying two question marks (??). The operator may now use as many keystrokes as necessary to produce the required data in the display. Each entry results in a shift left of the two digits on the right (the two digits on the left remain blank).

When the data desired to be written is being displayed, pressing the Enter key causes the data to be stored in the current memory location. (If the location being written is a read-only address, there will be no effect on that location.)

2.5.4 Enter Probe Key

The Enter Probe <ENTER PROBE> key is used to cause a constantly updated display of a particular controller memory space location. The updating is indicated by a rapidly flashing byte on the display.

Following the actuation of the Enter Probe key, the display prompts for address input by displaying four question marks (????). Input of the address is as described in Section 2.5.1. Following the delimiting Enter Key actuation, the contents of that address is displayed in the two digits on the right. The display flashes the byte continuously at about ten times per second. The system may be brought back to idle by using either the Clear or Reset Key.

2.5.5 Enter Diagnostic Key

The Enter Diagnostic <ENTER DIAG> key is used to initiate the entry of subsystem self-contained diagnostic routine numbers. After pressing the Enter Diagnostic Key, the display prompts for the entry of a two-digit hexadecimal routine identification by displaying two question marks (??). The operator may now use as many keystrokes as necessary to produce the required ID in the display. Each entry results in a shift left of the two digits on the right (the two digits on the left remain blank).

When the desired routine number appears in the display, pressing the Enter Key results in the attempted execution of that routine. The ID is displayed while the routine is being executed. If the routine is not successful, fault codes are displayed as three hexadecimal digits. If the routine is successful, completion is indicated by the idle display (----).

A routine in progress may be terminated by pressing the Reset key.

2.5.6 Enter Key

The Enter <ENTER> key is specific in nature and is described in the sections above for all sequences. For most cases this key serves to delimit address and data entries and initiates the performance of a requested function.

2.5.7 Clear Key

The Clear <CLEAR> key is used to clear the last data and/or address entry in the display and return to the prompt mode (question marks in the display) of the last function attempted. If the MTS is currently in a prompt mode (no entry has been made), the MTS returns to an idle state and awaits a function request. If a diagnostic routine is being executed, its ID is again displayed.

2.6 TAPE THREADING OPERATIONS

MTS operations are provided by the operator functions keypad on the operator panel. Machines with vertical mount can have tape loaded automatically, semiautomatically, or manually. Machines with center of gravity mount can have tape loaded semiautomatically or manually. Procedures are described below.

2.6.1 Automatic Thread/Load--Vertical Mount

The automatic thread/load is the normal procedure for vertically mounted machines.

1. Power up the MTS, if necessary; the swing arms automatically extend and then retract. Ensure the machine reel cover and the thread cover are closed.
2. Unlatch the file hub locking lever. Place the reel of tape on the file reel hub, then relatch the lever. Make certain that the reel is secure.
3. Press LOAD/REWIND. The vacuum blower motor turns on, the sensors are enabled, and power for the reel motors is turned on.

The MTS initially assumes that the tape leader is positioned at the entrance of the tape threading path and rotates clockwise to slip the tape leader into the path. If tape is not sensed at the EOT/BOT sensor within a given amount of time, the file reel reverses and attempts to position the tape leader using the leader sensor. If the leader cannot be sensed, it is assumed that the leader is stuck to the tape reel with static and the file reel is rotated rapidly to try to break the static. When the leader is sensed, it is positioned at the entrance of the tape threading path.

Vacuum created by the blower motor pulls the tape up the tape threading path. The tape is sensed at the EOT/BOT sensor as

Tape Present. When the tape has wrapped the machine reel hub, it is sensed as Tape Attached and the blower motor turns off. If any of these steps fails to occur in the prescribed time, a mark is counted against the load. If three marks are counted, the load has been unsuccessful and a fault code is posted in the display.

When Tape Attached is sensed, the tape is moved forward until the beginning-of-tape (BOT) marker is found. Tape continues to move forward a few feet and stops. The swing arms are lowered into their normal operating area.

Tape is rewound to BOT. When BOT is sensed and tape is stopped, the file reel is moved such that the MTS logic can determine file reel size. Tape then moves forward past BOT and a series of start/stop operations is run forward and then repeated backward. These start/stops allow the adaptive features of the capstan control algorithms to initialize for the current tape.

Tape is then brought back to BOT and stopped. The Ready indicator is illuminated and the MTS is ready for operation.

4. Pressing ON LINE after the Ready indicator is lit enables the MTS to accept commands from the user.

2.6.2 Semiautomatic Thread/Load--Vertical Mount

If the tape does not load successfully during automatic thread/load, the semiautomatic thread/load procedure can be used.

1. Power up the MTS and load the file reel onto the hub.
2. Press the Load/Rewind button twice, with a four second interval between presses.
3. Manually and slowly rotate the file reel clockwise to allow the tape leader to drop into the tape path until the file motor moves on its own.

2.6.3 Semiautomatic Thread/Load--Center of Gravity Mount

The semiautomatic thread/load is the normal procedure for center of gravity mounted machines.

1. Power up the MTS and load the file reel onto the hub.
2. Press the Load/Rewind button once.

3. Manually and slowly rotate the file reel clockwise and pull the tape leader into the tape path cavity.
4. Continue to rotate the file reel until enough tape leader is released into the tape path for the file motor to move on its own.

2.6.4 Manual Thread/Load--Vertical or Center of Gravity Mount

If the blower motor is not operating, tape must be loaded manually. Refer to 2-3

1. Power up the MTS and load the file reel onto the hub.
2. Open the thread cover and remove the machine reel cover.
3. Pull the tape leader under the lower swing arm roller, through the tape path, over the capstan wheel, under the upper swing arm roller and over the machine reel.
4. Manually wind the upper reel clockwise, using a finger to hold the tape leader against the machine reel hub, until the tape is secured to the reel.
5. Press the Load/Rewind button.

2.6.5 Midtape Load, EOT Area

If a load is required when the tape is in the EOT area (after POWER DOWN or LOOP OUT), a load problem may occur. A forward search for BOT will be initiated and may cause tape to be pulled off the file reel. To avoid this, use the following procedure:

1. Power up the machine if necessary (allow diagnostics to complete).
2. Press 'UNLOAD'.
3. Allow the tape to rewind onto the file reel for about 10 seconds.
4. Press 'RESET' to halt the unload.
5. Press 'LOAD' for a midtape load.

2.6.6 Rewind

1. If the MTS is in Online Status, press RESET.

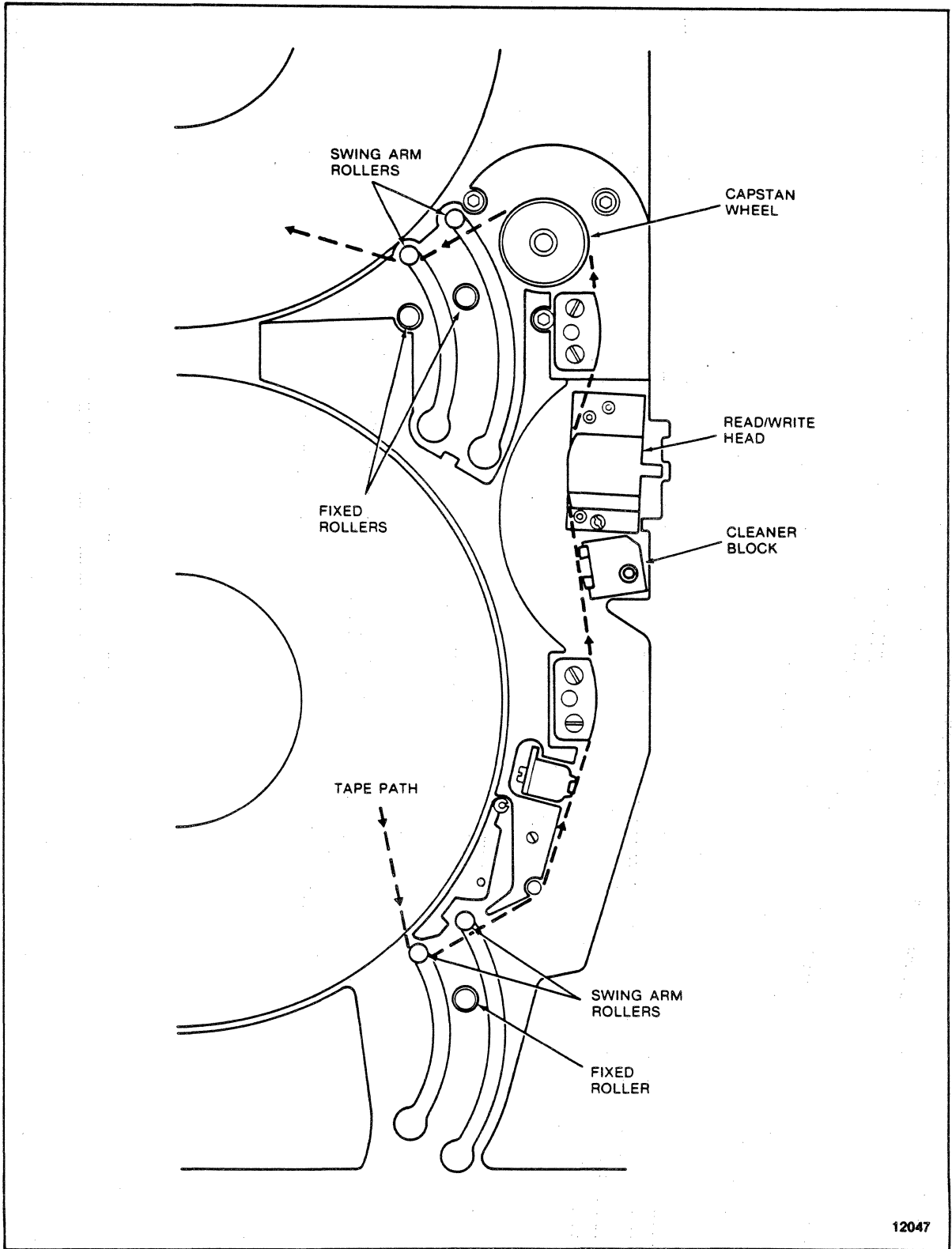

Figure 2-3. Tape Thread Path

2. Press LOAD/REWIND. Tape rewinds at high speed, passes BOT, stops, moves forward to the BOT marker, and stops in Ready Status.

2.6.7 Unload

1. If the MTS is in Online Status, press RESET.
2. Press REWIND/UNLOAD. If tape is positioned off BOT, it will rewind at high speed, pass BOT, stop, and move forward to the BOT marker. With tape at BOT, the swing arms retract, tape is unloaded onto the file reel, and power for the reel motors is turned off.

2.7 OPERATOR MAINTENANCE

Because cleanliness is crucial to successful magnetic tape operations, there are several operator cleaning procedures which should be performed daily or after each eight-hour shift under normal operating conditions.

These procedures are for cleaning components of the tape path (Figure 2-4). Cleaning should be done using only Storage Technology Hub and Transport Cleaner Fluid to moisten a lint-free cloth or foam-tipped swab. Refer to Appendix B for the part number of the cleaning supplies. After applying cleaner, allow a few minutes for excess fluid to evaporate before mounting a tape.

2.7.1 Read/Write Head and Tape Cleaner Block

WARNING

The tape cleaner blade is sharp. Use extreme care when handling the tape cleaner block.

Clean the read/write head and the tape cleaner block using a lint-free cloth moistened with Hub and Transport Cleaner Fluid. Make certain the head and cleaner block are free of oxide deposits. Use foam-tipped swabs to clean the cleaner block.

2.7.2 EOT/BOT and Leader Sensors

Clean the EOT/BOT and leader sensor windows using a foam-tipped swab moistened with Hub and Transport Cleaner Fluid. Allow time for complete drying and remove any residue with a dry swab.

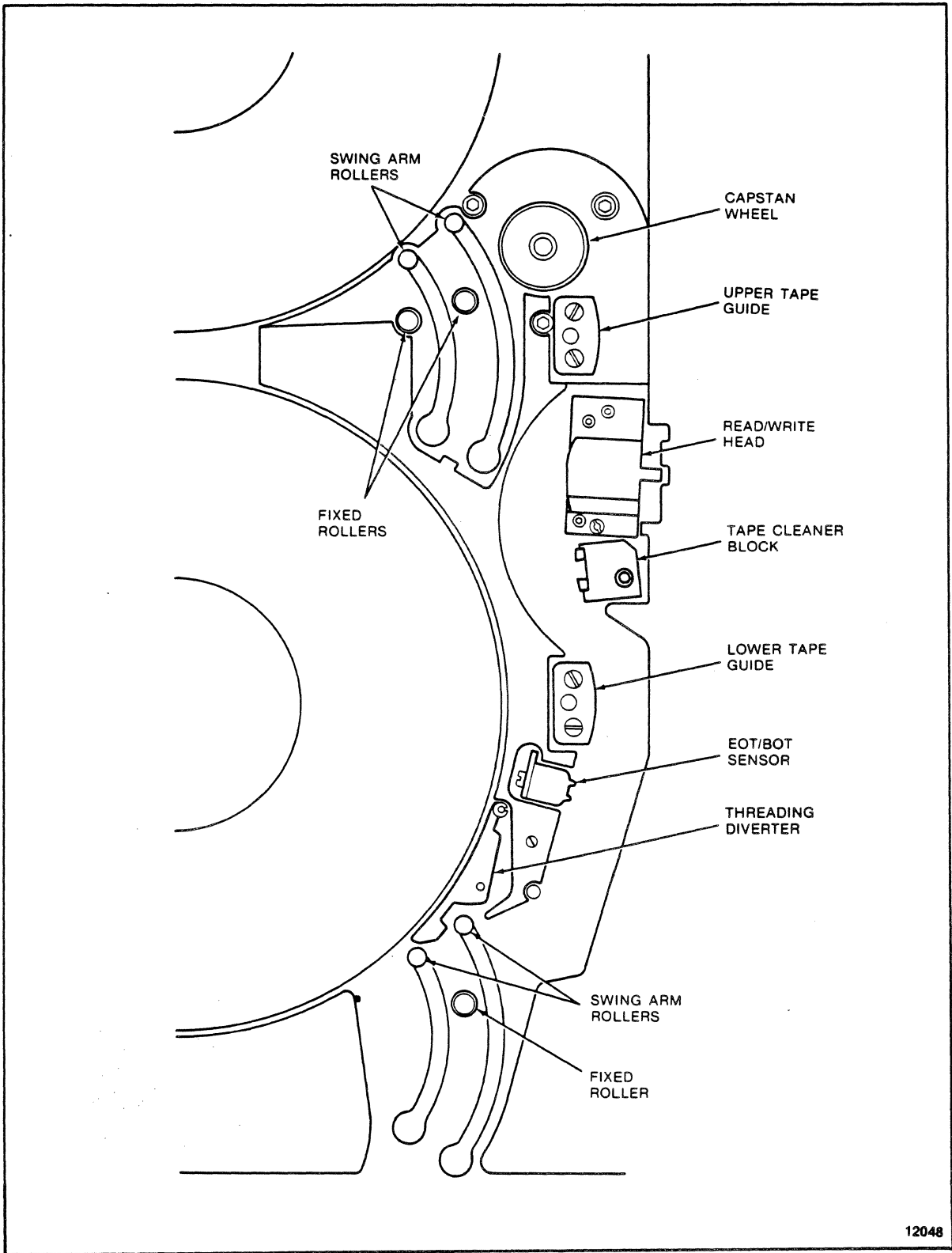

Figure 2-4. Tape Path Components--Tape Not Loaded

2.7.3 Tape Guides, Rollers, and Swing Arms

Clean the two tape guides, the three fixed rollers, and the four swing arm rollers using a lint-free cloth moistened with Hub and Transport Cleaner Fluid. To reach otherwise inaccessible areas, foam-tipped swabs may be used. If necessary, the edge of a data processing card may be used to clean the flange corners of the guides.

2.7.4 Capstan

Clean the capstan using a lint-free cloth wrapped around the index finger and moistened with Hub and Transport Cleaner Fluid.

CAUTION

Do not touch the outer, tape-contacting surface of the capstan with the bare hand as the surface is sensitive to contamination. Always use a cloth when handling the capstan and grip only the hub of the capstan.

With the free hand, slowly rotate the capstan hub while wiping the capstan surface with the moistened cloth. Two or three revolutions is sufficient. Wipe the capstan with a dry, lint-free cloth to remove excess cleaner fluid.

2.7.5 File Reel Hub

Clean the expansion surface of the file reel hub using a lint-free cloth moistened with Hub and Transport Cleaner Fluid.

2.8 TAPE MOTION CHARACTERISTICS

The MTS will operate at a nominal tape velocity of 50 ips in start/stop mode or 100 ips in streaming mode.

NOTE

The MTS will default to 50 ips mode at power on.

2.8.1 Start/Stop Mode

In start/stop mode the tape will travel a certain distance after the read head reaches the end of the record before the tape begins to decelerate. This can be useful at 1600 bpi density. This holdover travel gives the maximum reconstruct window

during which the MTS can be given a new command and remain traveling at full speed. The nominal holdover distances at 1600 bpi are 0.25 inches (0.64 cm) for a read and 0.19 inches (0.48 cm) for a write, which translates into reinstruct windows of 4.0 milliseconds and 2.8 milliseconds, respectively.

If the MTS is reinstructed during the deceleration ramp in either density, tape will not come to a full stop. Refer to Figure 2-5.

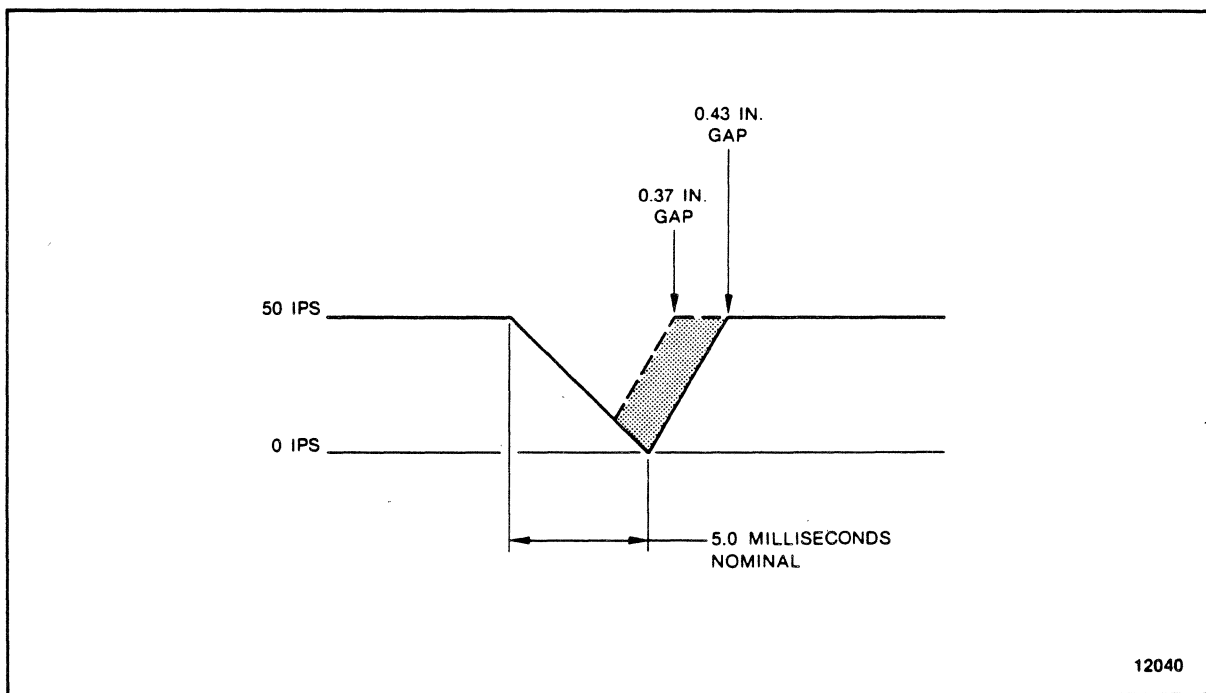

Figure 2-5. Start/Stop Mode Velocity Profile

In GCR, if a write reinstruct is issued within the first half of the deceleration period (within 2.5 milliseconds) a 0.37 in. (0.94 cm) gap will result. The gap after a full stop will be 0.43 in. (1.09 cm). See Figure 2-5.

The nominal start or stop time at 50 ips in 5.0 milliseconds. The dotted area in Figure 2-5, however, shows that tape need not come to a full stop if reinstructed early enough. The start and stop times are then less than 5.0 milliseconds. If tape does come to a full stop, it may be started again without any further delays.

2.8.2 Streaming Mode

In the 100 ips streaming mode, tape should not stop at all if reinstructed promptly enough. However, if the end of the Interblock Gap is reached and a new command has not been received, then a repositioning cycle is performed. Repositioning is accomplished relatively quickly by using the capstan to stop tape and back it up to the point where it is ready for the next instruction. Meanwhile, the machine and file reels are decelerated more slowly, with the difference in tape being taken up by the tension arm buffer. The reels need not come to a full stop before the next command is executed. If the time between commands is long enough, the reels will stop, but will not back up. See Figure 2-6.

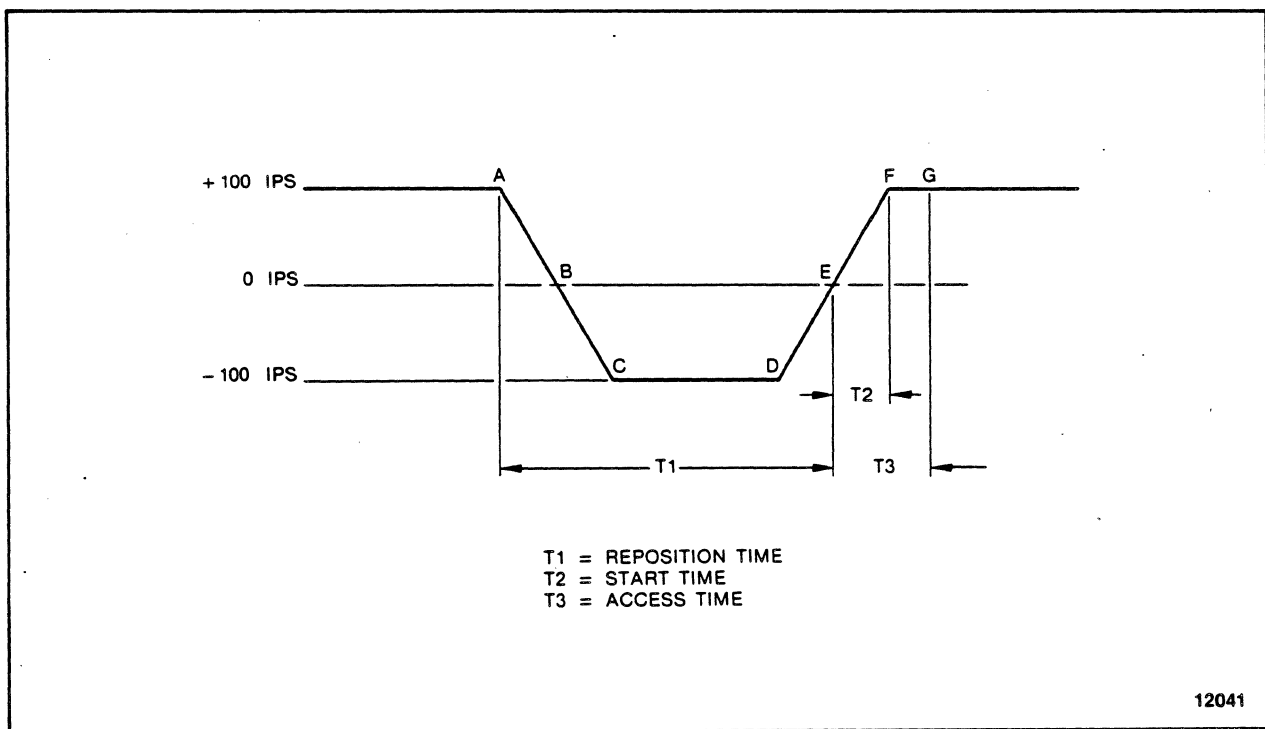

Figure 2-6. Capstan Velocity Profile

At point A, tape has traversed the gap without a reinstruct. The capstan decelerates to a stop at B, then ramps up to backward velocity at C. The amount of time that tape moves at full backward velocity between C and D is a function of interlock gap length. The longer the gap selected, the longer it takes to back up. Tape then decelerates and stops at point E. If a reinstruct has been received before this time, forward acceleration will begin immediately. If not, tape will remain at E until a new

command is received. The nominal streaming mode start time between E and F is 10.0 milliseconds. Point G denotes the beginning of the next record on tape.

2.9 INTERBLOCK GAP (IBG) GENERATION

Interblock gaps will be generated by the MTS as shown in Table 2-1. In the 50 ips start/stop mode, the nominal GCR IBGs will vary as a function of reconstruct time. In this mode, tape will decelerate but need not stop if reconstructed early enough, causing the shorter 0.37 in. (0.94 cm) nominal gap to be written. When in the 100 ips streaming mode, variable gaps may be selected. The gap size is then a function of how quickly the MTS is reconstructed, up to the maximum length selected. For example, if 0.9 (2.29 cm) inch maximum gap length is selected and the MTS is reconstructed before tape moves that far, then a shorter gap (between 0.3 and 0.9 inch (0.76 and 2.29 cm) for 6250 bpi) will be generated. If not reconstructed in time, then a repositioning cycle is necessary and the next gap generated is the short gap length listed under fixed. For example, after repositioning in 6250 bpi, a 0.30 in. (0.76 cm) gap will be generated. The maximum gap lengths which may be selected are shown in Table 2-2.

Table 2-1. Generated Interblock Gap Lengths

DENSITY	50 IPS START/STOP			100 IPS STREAMING	
	MIN (ANSI)	NOMINAL	MAX	FIXED	VARIABLE
6250 BPI	0.28 0.71cm	0.37 - 0.43 0.94 - 1.09cm	0.50 1.27cm	0.30 0.76cm	0.30 - SELECT 0.76cm - SELECT
1600 BPI	0.50 1.27cm	0.60 1.52cm	0.65 1.65cm	0.60 1.52cm	0.60 - SELECT 1.52cm - SELECT

When reading either 6250 bpi or 1600 bpi in the 100 ips streaming mode, a reposition cycle will occur if a gap of 1.2 in. (3.05 cm) is traversed or no reconstruct is received before the next block is encountered. This is independent of the gap size selected. The minimum read gap which is supported is 0.28 in. (0.71 cm) in 6250 bpi and 0.50 in. (1.27 cm) in 1600 bpi. If the next block is encountered before being reconstructed, tape will be repositioned relative to the start of this next block, rather than to the beginning of the IBG, so that minimum access time can be achieved.

Table 2-2. Selectable Interblock Gaps

DENSITY	GAP SIZE
6250 BPI	0.3, 0.6, or 0.9 in. 0.76, 1.52, or 2.29 cm
1600 BPI	0.6, 0.9, or 1.2 inches 1.52, 2.29, or 3.05 cm

2.10 REPOSITION TIMING

Reposition time is the time to get from Point A to Point E in Figure 2-6. It is a function of the maximum interblock gap length selected. For the gap lengths shown in Table 2-2, the corresponding reposition times are shown in Table 2-3.

Table 2-3. Reposition Times

DENSITY	INTERBLOCK GAP			
	0.3 in. 0.76 cm	0.6 in. 1.52 cm	0.9 in. 2.29 cm	1.2 in. 3.05 cm
6250 BPI	50 ms	53 ms	56 ms	-
1600 BPI	-	50 ms	53 ms	56 ms

2.11 REINSTRUCT TIMES

Reinstruct time is defined for streaming mode as the amount of time from the completion of a command when the interface output signal busy is reset to the time when tape moves to the latest point in the interblock gap beyond which a reposition cycle is required. These times are a function of gap size, density, and read- or write-type operation. Table 2-4 shows the times for the longest gaps and Table 2-5 for the shortest gaps.

2.12 50/100 IPS SPEED CHANGE

Changing speeds between 50 ips and 100 ips is accomplished by an interface command sequence. The MTS can change speed at various times, for example, at beginning of tape or after reading some data, provided execution of the previous command is complete.

Table 2-4. Nominal Reconstruct Times (Maximum Gap)

DENSITY (BPI)	INTERBLOCK GAP (INCHES)	READ (MILLISECONDS)	WRITE (MILLISECONDS)
6250 BPI	0.9 in. 2.29 cm	8.0 ms	6.5 ms
1600 BPI	1.2 in. 3.05 cm	11.0 ms	9.5 ms

Table 2-5. Nominal Reconstruct Times (Minimum Gap)

DENSITY (BPI)	INTERBLOCK GAP (INCHES)	READ (MILLISECONDS)	WRITE (MILLISECONDS)
6250 BPI	0.3 in. 0.76 cm	2.0 ms	0.5 ms
1600 BPI	0.6 in. 1.52 cm	5.0 ms	3.5 ms

This will cause tape, if loaded, to be repositioned and the tension arms to move to a new position. The amount of time to accomplish this change is:

- 100 ips to 50 ips: approximately 400 milliseconds,
- 50 ips to 100 ips: approximately 700 milliseconds.

2.13 TURNAROUND DELAYS

Turnaround delays are encountered between certain command sequences. For example, when a Write command follows a Read Forward or Read Backward command, the erase head must be properly repositioned within the Interblock Gap. When a Read Backward (Reverse) follows a Write, a gap is erased in the forward direction before the backward (reverse) command is executed.

Turnaround delays include not only any time necessary for tape repositioning but also time for the swing arms to approach their normal stopped positions. At 50 ips the arms may take as long as 100.0 milliseconds to stabilize. However, if sufficient time has elapsed since the previous command ended, then the arms may have already stopped so that no extra time for arm motion is required.

In the 100 ips mode a change in direction will necessitate a delay even if the swing arms are stable. Since the stop position forward is different from the stop position backward, a change in direction means the swing arms must first move toward their new stop position before any motion can take place. This change of stop positions takes about 160 milliseconds.

2.14 DUTY CYCLE

There is no duty cycle limit for 50 ips start/stop or 100 ips streaming mode. If the tape speed is operated in 100 ips start/stop operation and the number of starts exceeds approximately 6,000 in 10 minutes, a delay is introduced to lower the duty cycle. Note that 100 ips start/stop operation is not the same as 50 ips start/stop mode. The former refers to rapid, short command sequences performed in 100 ips streaming mode.

(INTENTIONALLY LEFT BLANK)

CHAPTER 3

INSTALLATION

3.1 INTRODUCTION

This chapter provides instructions for inspection, power set up, preliminary checkout, and cabinet mounting of the MTS.

Each MTS is shipped on a foam cushion shipping pallet assembly with a corrugated overcarton. The container provides stability and protection for the MTS and should not be removed until the unit is ready to be mounted into an equipment rack. Provision has been made for an operational checkout of the MTS while on the shipping pallet.

3.2 INSPECTION

1. Position the packaged MTS upright at the operational checkout station.

WARNING

The MTS and its shipping carton weigh approximately 150 pounds (68 kg). Use appropriate mechanical aids and sufficient personnel when moving the unit to prevent personnel injury or equipment damage.

2. Remove the unpacking instructions and any other documents from the exterior of the shipping carton.
3. Visually inspect the exterior of the shipping carton for evidence of physical damage that may have occurred in transit. Verify that a shock watch is located on the carton and inspect the bubble. A red bubble indicates that damage has occurred. If any damage is found or if no shock watch is located on the carton, promptly report the condition to a company representative.
4. Remove only the top of the shipping container (corrugated carton, corrugated inner tray, and top foam cushion). The MTS should be sitting upright, supported by the bottom of the cushion pallet assembly. Do not lay the MTS on its side.

5. Remove the front cushion foam from the lower front area of the cushion pallet. This permits access to the front of the MTS.
6. Open the taped end of the antistatic polybag. Pull the bag completely down around the sides of the MTS. Cut the polybag as necessary to permit free opening of the front door of the MTS. Do not attempt to remove the polybag from under the MTS until ready to mount the unit in a rack.
7. Check all items against the shipping list to verify container contents. Verify that the serial number of the unit corresponds to that on the shipping invoice. Contact a company representative in case of a packing shortage or incorrect serial number.
8. Visually inspect the MTS for evidence of physical damage that may have occurred during handling or in transit. If any damage is found, promptly report the condition to a company representative.
9. Open the front door of the MTS and remove any cellophane and tape.
10. Remove all packing materials from cables and connectors. Check for bent or misaligned pins and straighten as necessary.
11. Verify that all cable connections are tight. (Refer to Figure 3-1.)
12. Check for loose hardware throughout the MTS and tighten as necessary. Ensure that all DIP packages on the circuit cards in the card cage are secure in their sockets.

3.3 POWER CONNECTION

The input frequency rating for the unit is determined by the frequency option installed at the time of manufacture.

Verify that the facility AC power frequency and voltage matches that indicated on the CAUTION - HIGH VOLTAGE label on the MTS before connecting the unit to the facility power.

If the facility AC power does not match the machine configuration, move the X or PKX wire to the appropriate terminal on top of the PK board as shown in Table 3-1.

If this wire is moved in order to change the input voltage rating of the unit, ensure that the indication on the CAUTION - HIGH VOLTAGE label accurately reflects the new configuration.

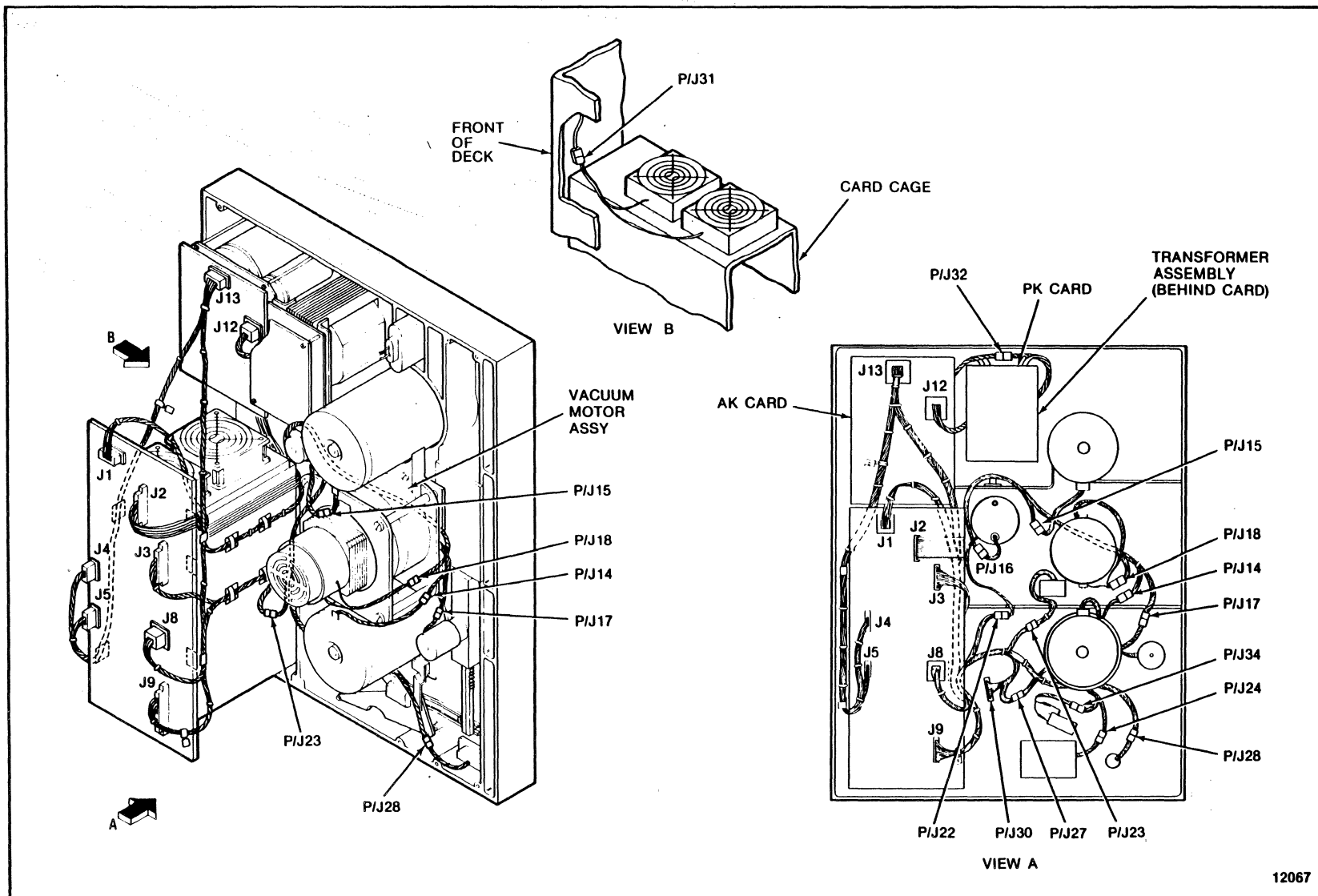

12067

Figure 3-1. Cables and Connectors

Table 3-1. PK Board Wiring for Input Power

Input VAC	Input Freq.	Connect X or PKX Wire
100	60 Hz	To PK Board Terminal 6
120	60 Hz	To PK Board Terminal 4
200	50 Hz	To PK Board Terminal 6
220	50 Hz	To PK Board Terminal 4
240	50 Hz	To PK Board Terminal 2

The MTS is equipped with a three-conductor power cable. The card cage and the deck casting are connected to the safety ground of the power cord. The center pin of the power plug is the ground connection.

3.4 PRELIMINARY CHECKOUT

The preliminary checkout tests the major electrical functions of the MTS offline before it is installed in an equipment rack. Test the MTS on the cushion pallet assembly and without connections to the CPU.

1. Ensure the Power On/Off switch is off, then plug the power cord into the facility power.

WARNING

Do not touch any part inside the MTS when the MTS is powered up to prevent electrical shock or damage to the machine.

2. Set the circuit breaker to ON.
3. Press on the operator panel Power On/Off switch. The cooling fans in the top of the electronics cage should turn on and MTS power-on diagnostics will be initiated.
4. Without a tape on the file reel hub, press LOAD/REWIND. The threading vacuum blower will come on and the machine reel

will rotate as if in a tape threading sequence. Since the presence of tape will not be detected, the operation will halt and the Machine Check indicator will flash, indicating a load failure. Press RESET to enable the MTS again.

NOTE

Center of gravity (horizontal) mounting requires the semiautomatic thread procedure on every tape load. Enabling the Center of Gravity Option causes the load sequence to automatically pause for manual positioning of the tape leader. To enable this option, set the appropriate DIP switch on the IF card to the OFF position. Refer to Figures 3-2 and 3-3.

5. Mount a write enable ring onto a reel of scratch tape.
6. For vertically mounted units, use the following procedure:
 - a) Mount the reel of scratch tape onto the file hub with the tape leader end positioned at the threading channel.
 - b) Ensure that the threading door is closed with all catches firmly engaged.
 - c) Press the Load/Rewind button; tape will load automatically.
7. For center of gravity (horizontally) mounted units, use the following procedure:
 - a) Mount the reel of scratch tape onto the file hub.
 - b) Press the Load/Rewind button.
 - c) Manually and slowly rotate the file reel clockwise and pull the tape leader into the tape path cavity.
 - d) Continue to rotate the file reel until enough tape leader is released into the tape path for the file motor to move on its own.
8. Successful tape thread and load causes the EOT/BOT indicator to be illuminated and the File Protect indicator to be off.
9. Remove the write enable ring from the scratch tape, mount the reel of scratch tape onto the file hub, and load the tape as in step 6 or 7 above. Both the EOT/BOT indicator and the File Protect indicator should be illuminated.

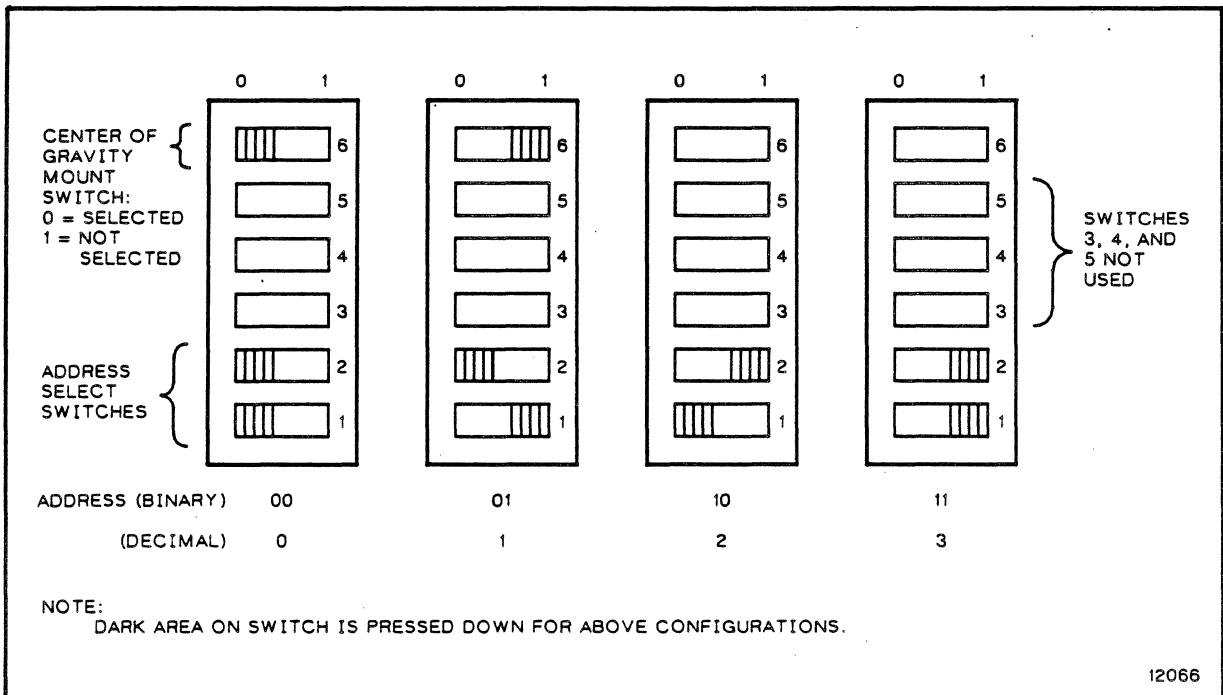

Figure 3-2. Interface Card Address, Center of Gravity Configuration

10. Check reel motion by completing the following steps. Terminate each step by pressing RESET.
 - a) Initiate steady state forward motion by entering the following at the diagnostic keypad: <ENTER DIAG>, <0>, <ENTER>.
 - b) Initiate steady state backward motion by entering: <ENTER DIAG>, <1>, <ENTER>.
 - c) Initiate shoeshine motion by entering: <ENTER DIAG>, <2>, <ENTER>. Change shoeshine motion speed by continuing to press <ENTER>.
 - d) Initiate start/stop motion (backward and forward) by entering: <ENTER DIAG>, <3>, <ENTER>. Change speed and direction by continuing to press <ENTER>.
11. Press REWIND/UNLOAD and ensure that the MTS rewinds to BOT and successfully unloads the reel of tape. Remove the reel of tape.
12. If the MTS is not to be rack mounted at this time, reinstall all packaging material previously removed to assure safe storage.

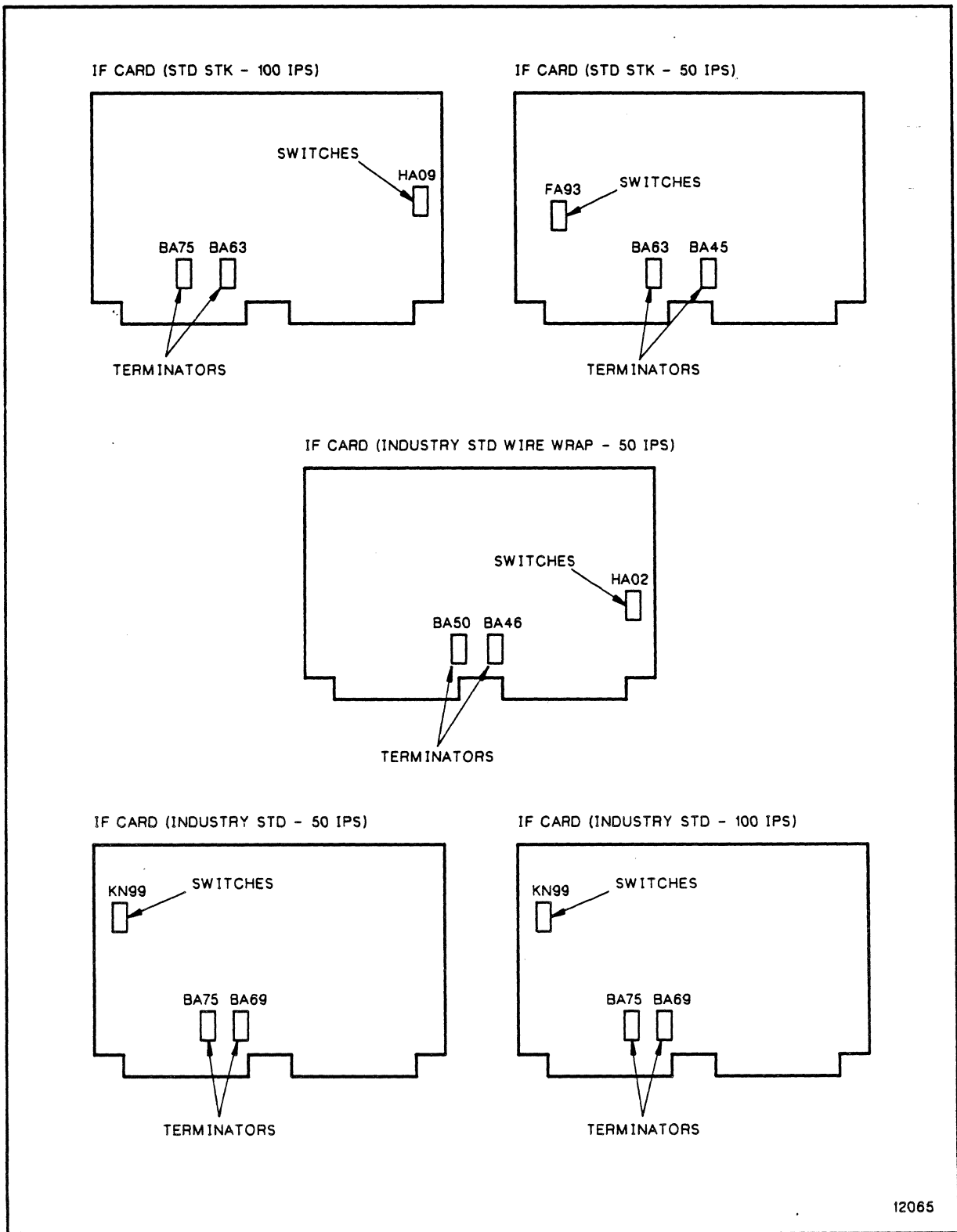

Figure 3-3. IF Card Terminator and Address Switch Locations

3.5 VERTICAL CABINET MOUNTING

The MTS is designed to be mounted in a standard 19-inch RETMA rack or universal cabinet with a minimum panel space of 29.8 inches (75.8 cm). Refer to Figure 3-5 for other installation dimensions.

NOTE

The hinges, screws, and keeper required for mounting the MTS onto a vertical rack are supplied in a package shipped with the MTS.

CAUTION

Instability of the vertical rack may occur when the deck casting is open. To prevent tipping, a 90 pound (40 kg) ballast (refer to Figure 3-4) may be secured to the bottom of the rack at the back. Any suitable alternative may be used if the possibility of the rack tipping is precluded.

1. Install the two half hinges on the mounting rails of the rack as shown in Figure 3-5 using two 10-32 x 0.750-inch screws with flat and lockwashers (supplied). Note that the half hinge with the longer hinge pin is the bottom hinge.

WARNING

The MTS weighs approximately 125 pounds (57 kg). Use appropriate mechanical aids and sufficient personnel when moving the unit to avoid personnel injury or equipment damage. A suggested lifting method is shown in Figure 3-6.

2. Lift the MTS from the cushion pallet assembly. Ensure that the antistatic polybag does not hang or pull on the MTS components causing damage.
3. Position the MTS near the hinges and start the unit onto the lower hinge pin, then onto the upper hinge pin (refer to Figure 3-5).
4. Loosen the bottom screw of the upper half hinge on the MTS casting, slide the keeper into place, then refasten the screw. Refer to Figure 3-5.

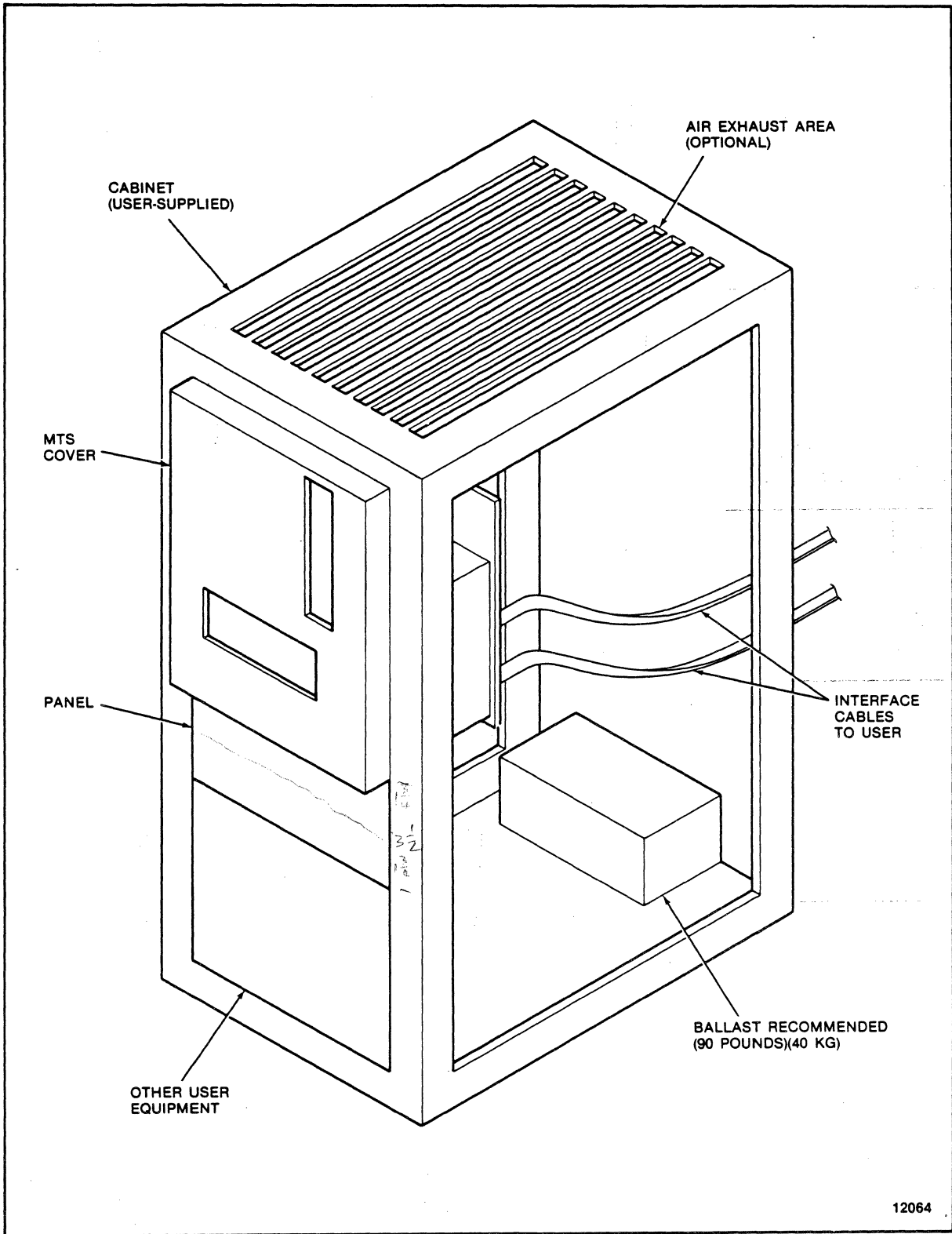

Figure 3-4. Vertical Mounting Installation

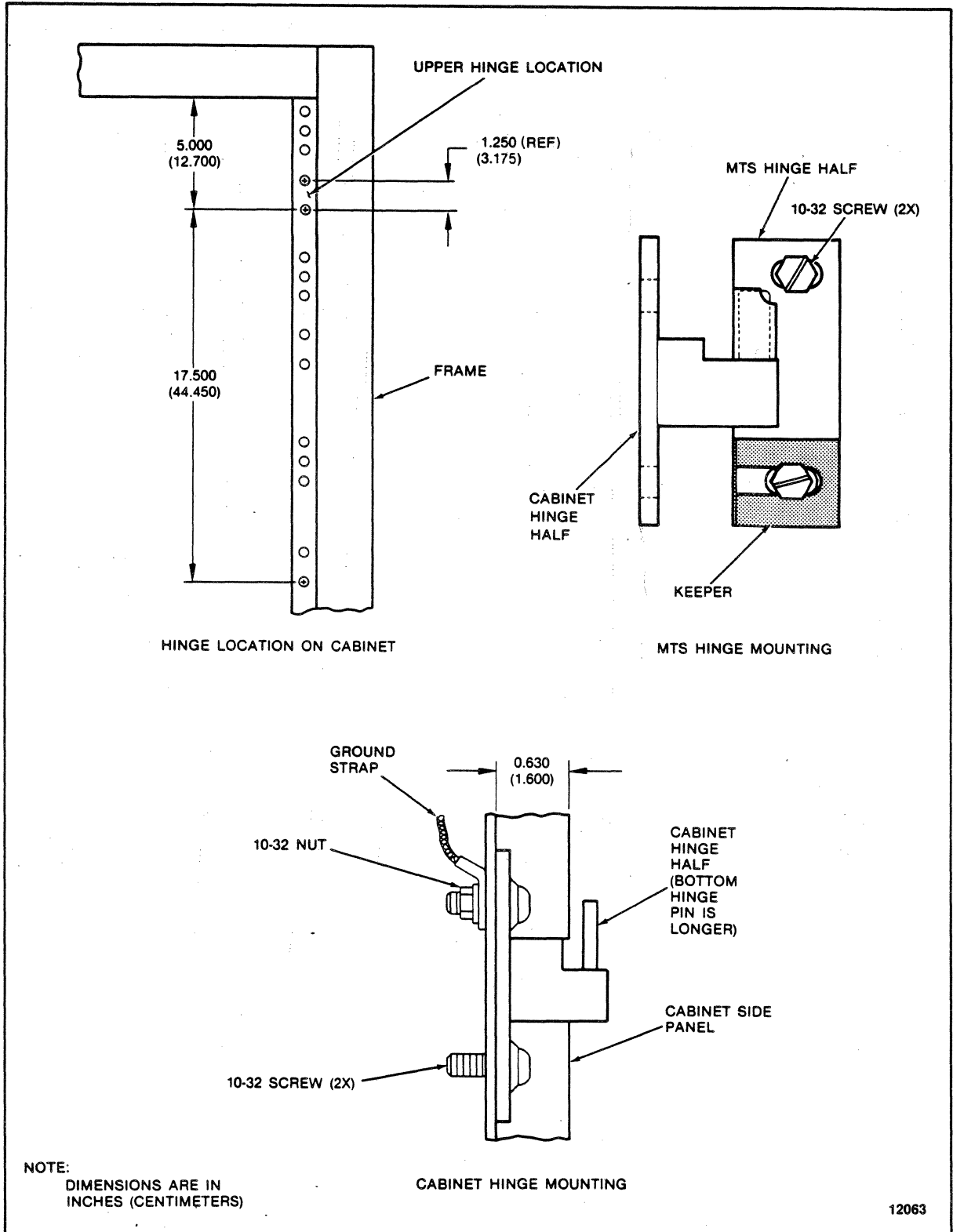

Figure 3-5. Vertical Mounting Dimensions

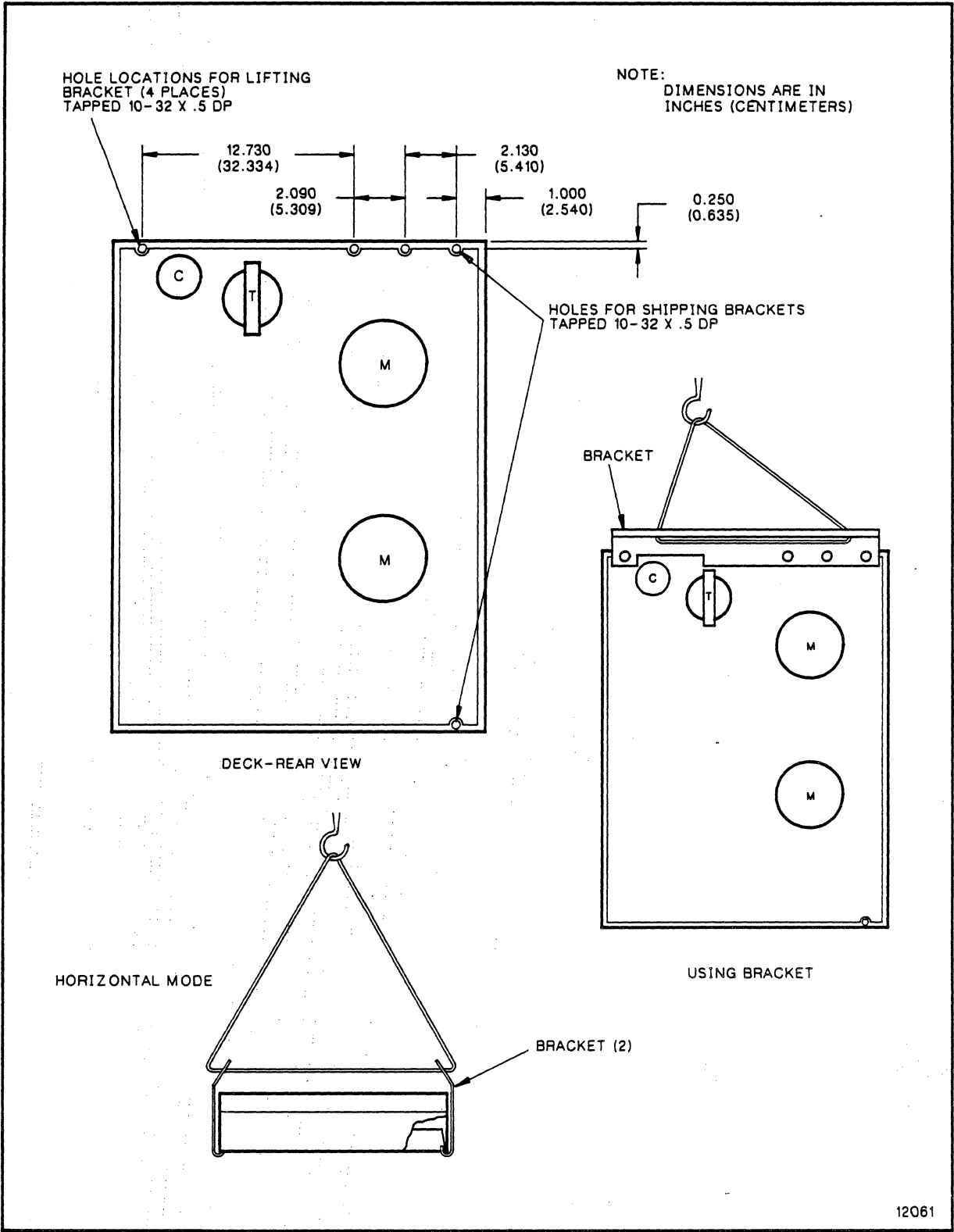

Figure 3-6. Suggested Lifting Methods

5. Connect the MTS chassis ground strap by placing the ground strap lug over the top screw of the top hinge on the back side of the mounting rail and securing with a 10-32 nut and lockwasher.

3.6 CENTER OF GRAVITY (HORIZONTAL) CABINET MOUNT

NOTE

A mounting kit is shipped with each center of gravity mount MTS. Detailed instructions are included in the kit. Follow these instructions when mounting the MTS.

WARNING

The MTS weighs approximately 125 pounds (57 kg). Use appropriate mechanical aids and sufficient personnel when moving the unit to avoid personnel injury or equipment damage. A suggested lifting method is shown in Figure 3-6.

Cabinet Dimension requirements and casting pivot locations and dimensions are shown in Figure 3-7.

3.7 STORAGETEK STANDARD INTERFACE CABLING

Interface cables are not supplied with the MTS. For electromagnetic compatibility (EMC) purposes, shielded I/O cables are recommended (Spectra-Strip 152-2831-060 or equivalent, plus Spectra-Strip 802-060 60-pin connectors). Two cables are required. The maximum cable length from the USER CPU to the last MTS in the string is 40 feet (12.19 meters). Refer to Figures 3-8 and 3-9. Terminators are required only on the IF card (slot A3) of the last MTS in the string and must be removed from any other MTS units in the string. Refer to Figure 3-3 for the locations of the terminators.

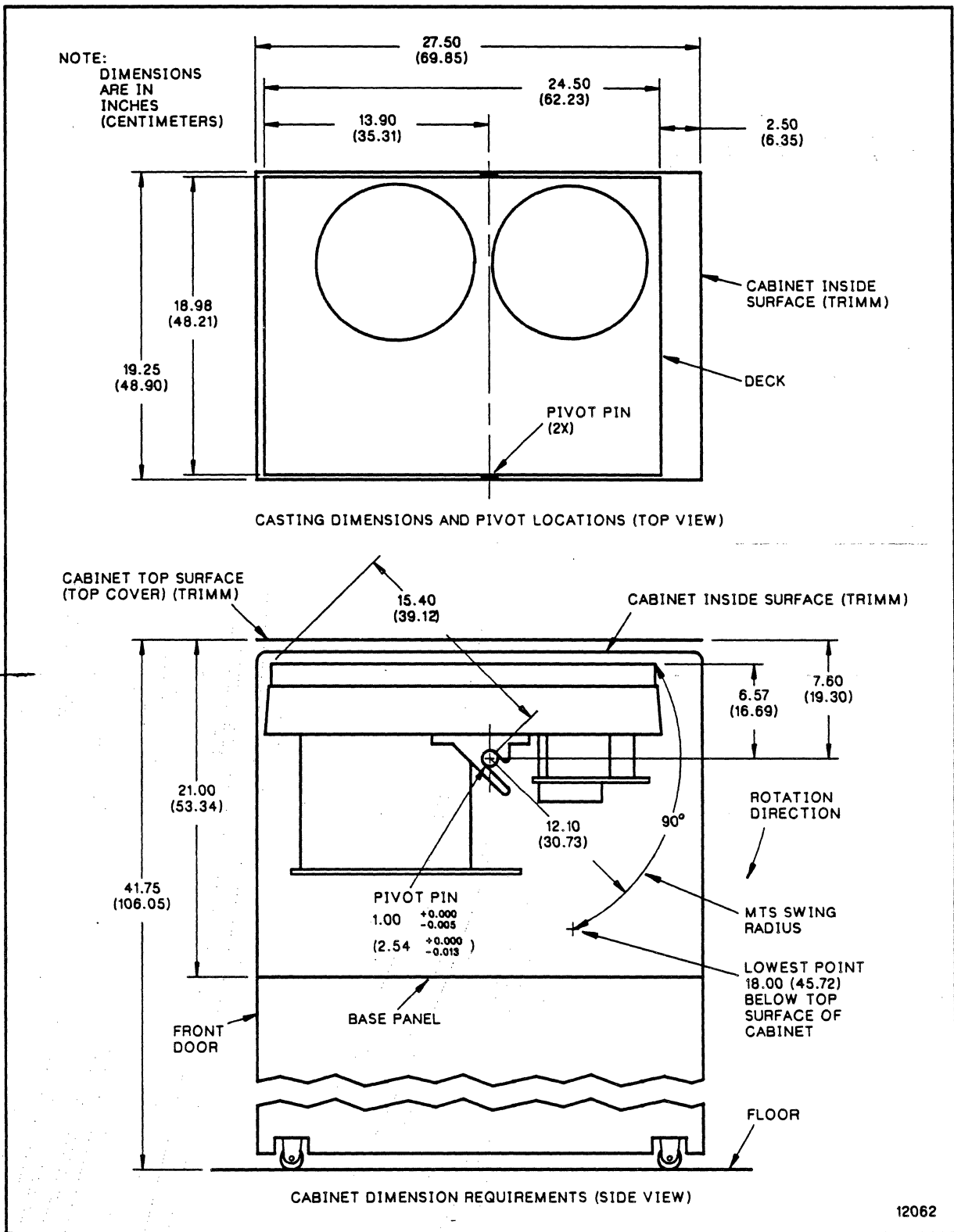

Figure 3-7. Center of Gravity Mounting Dimensions

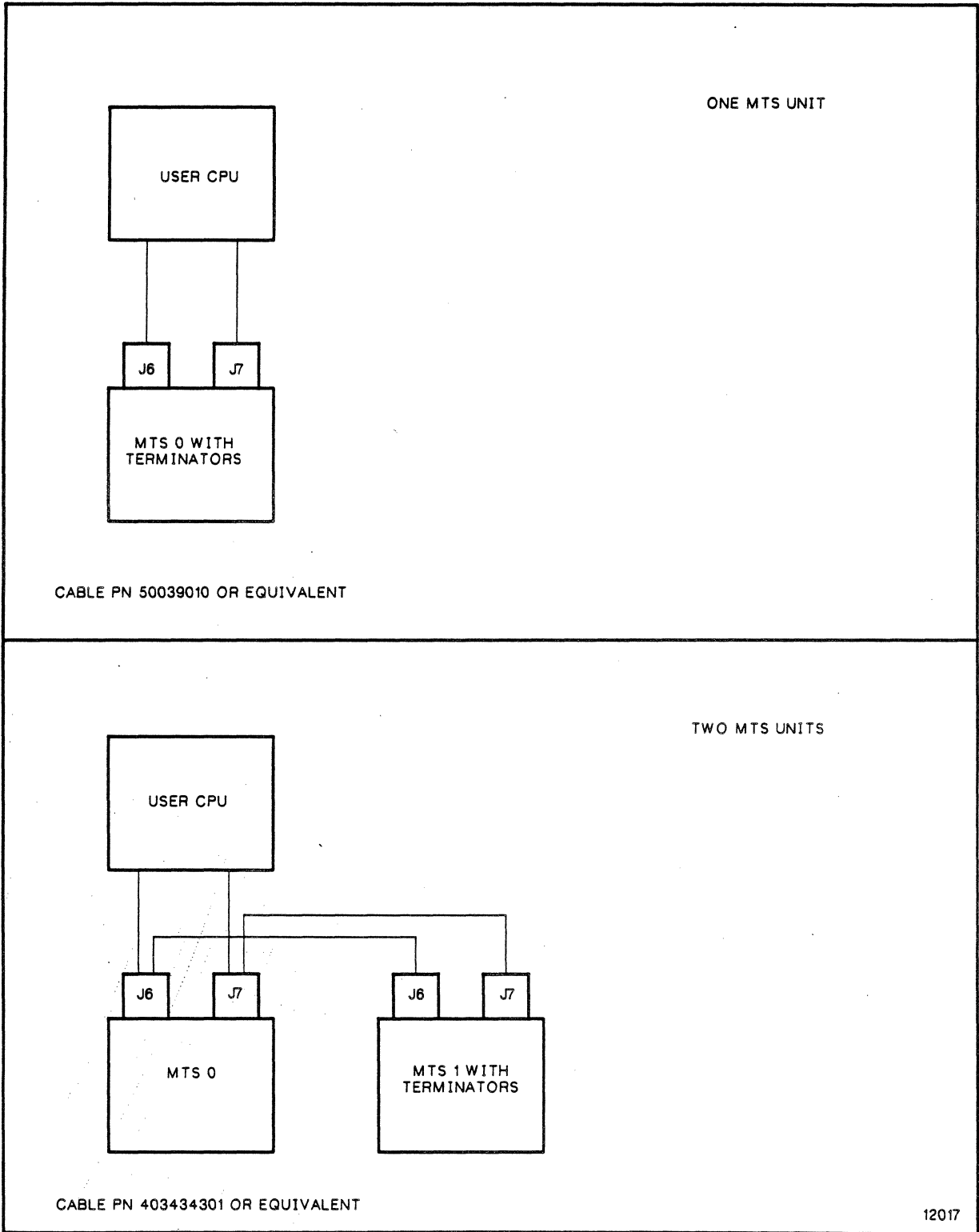
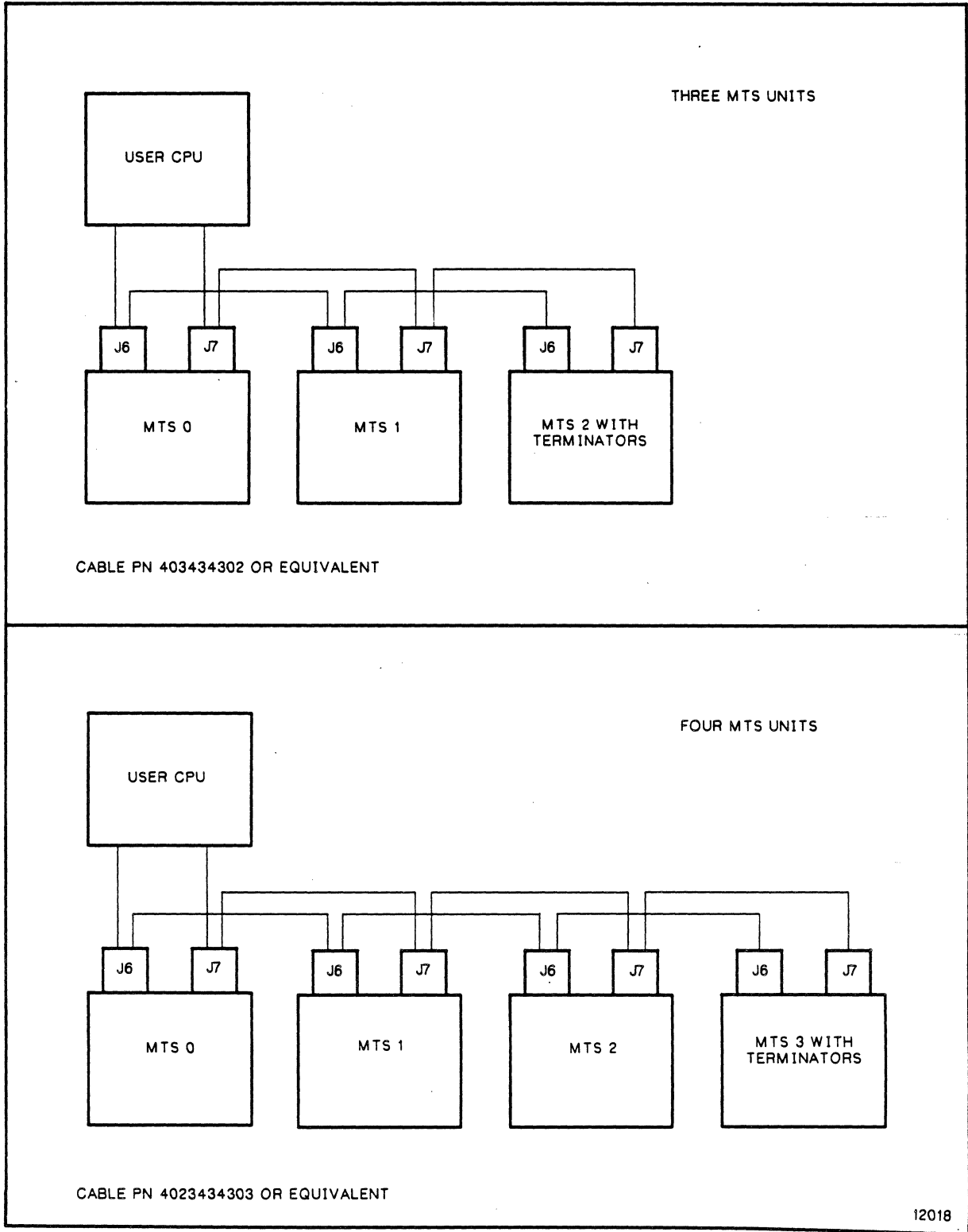
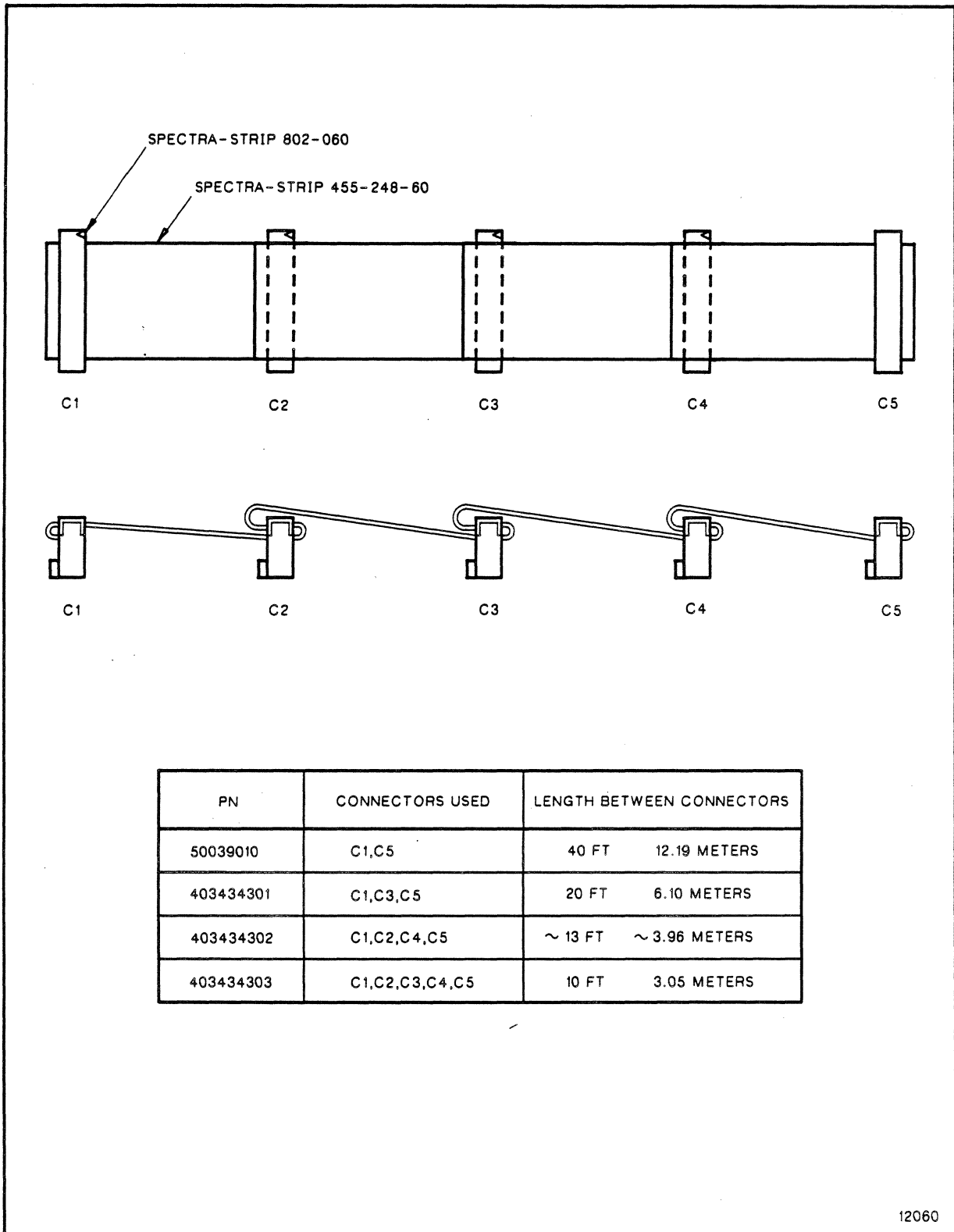

Figure 3-8. Storagetek Standard Interface Cabling Block Diagram (Sheet 1 of 2)



**Figure 3-8. Storagetek Standard Interface Cabling
Block Diagram (Sheet 2 of 2)**



12060

Figure 3-9. Storagetek Standard Interface Cable Configuration

3.8 INDUSTRY STANDARD INTERFACE CABLING

Interface cables are not supplied with the MTS. Two 50-conductor twisted-pair cables are required, with card edge connector AMP 88373-1 or equivalent and keying plug AMP 88113-1 or equivalent. For electromagnetic compatibility (EMC) purposes, shielded I/O cables are recommended (Spectra-Strip 152-2831-050 or equivalent, plus Spectra-Strip 802-050 50-pin connectors).

The keys between tabs are located as follows:

Connectors:	J6A	J6B	J7A	J7B
Key Between Tabs:	5, 7	5, 7	11, 13	11, 13

The maximum cable length from the USER CPU to the last MTS in the string is 40 feet (12.19 meters). Refer to Figure 3-10.

Terminators are required only on the IF card of the last MTS in the string and must be removed from any other MTS units in the string. Refer to Figure 3-3 for the locations of the terminators.

NOTE

For I/O cables exiting the cabinet, clamps (3M 3504-2 or equivalent) should be mounted at the point of exit and adequate ground contact made to the cable shield.

3.9 ADDRESS SELECTION

The address of the MTS is selected by setting the appropriate DIP switches on the IF card. Refer to Figures 3-2 and 3-3.

3.10 RESHIPPING

If the MTS requires reshipping, Field Bill 68370 supplies the necessary parts and Field Instruction 68369 contains detailed instructions to ensure that the MTS is shipped without damage.

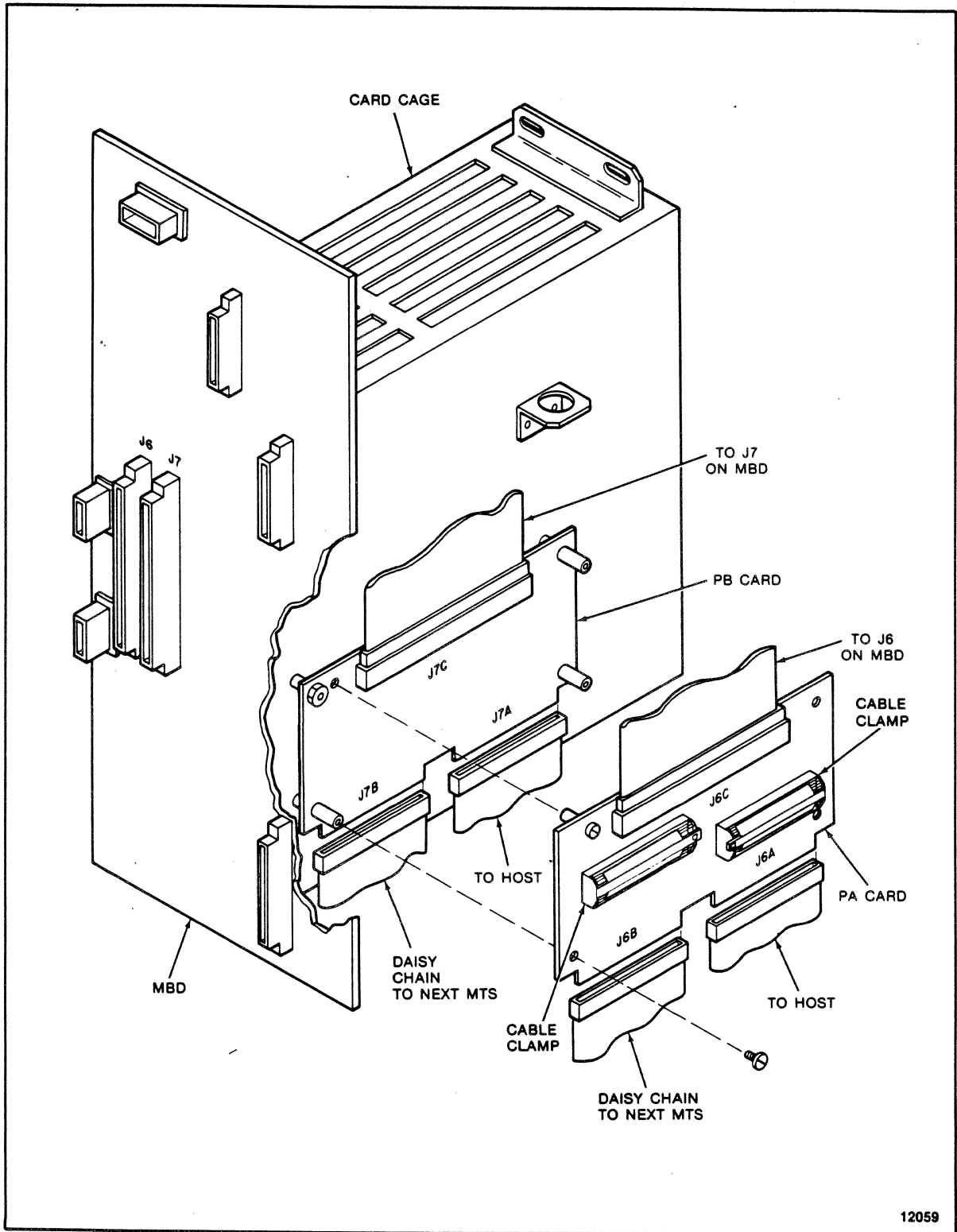

12059

Figure 3-10. Industry Standard Interface Cabling
(Sheet 1 of 3)

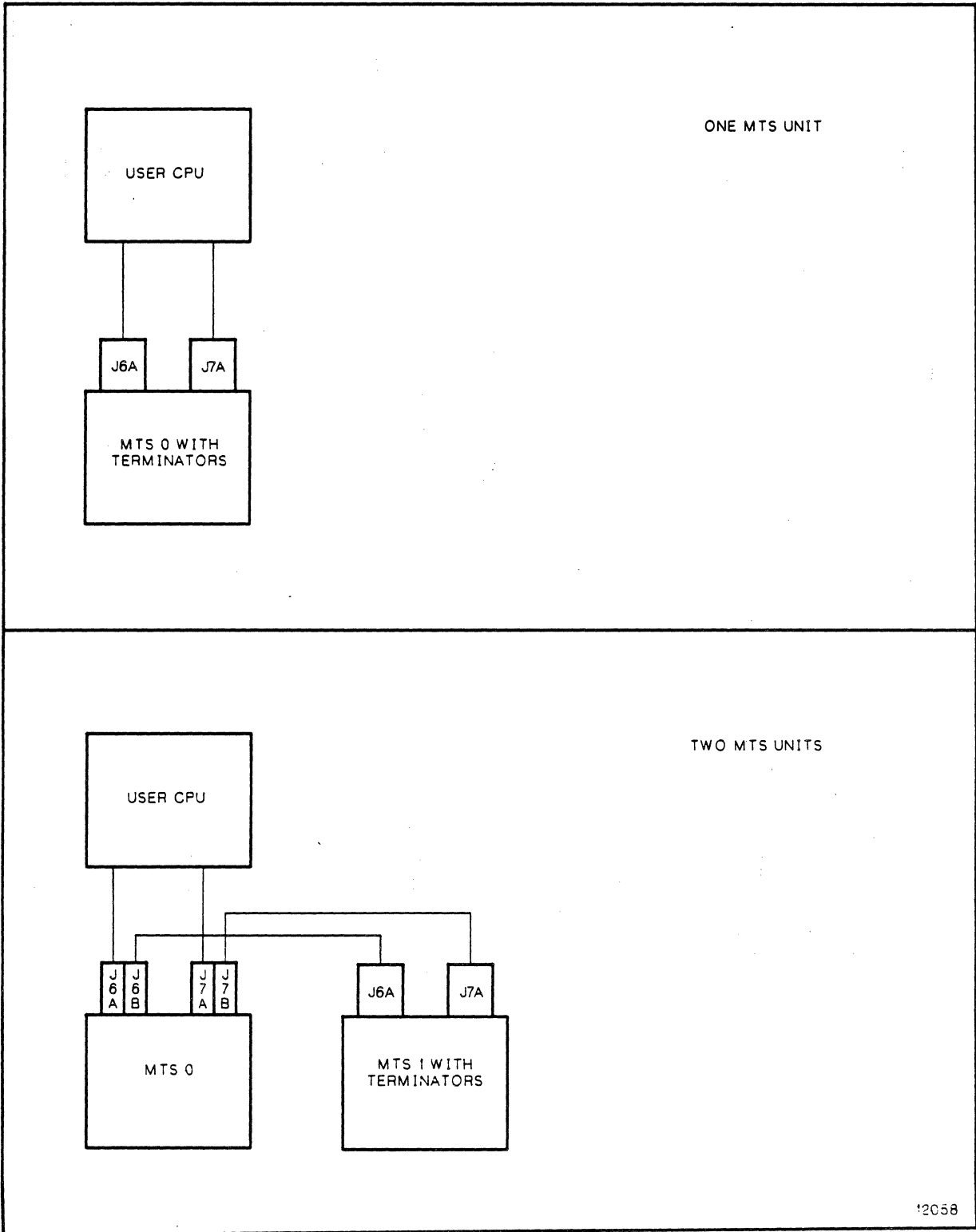

Figure 3-10. Industry Standard Interface Cabling Block Diagram (Sheet 2 of 3)

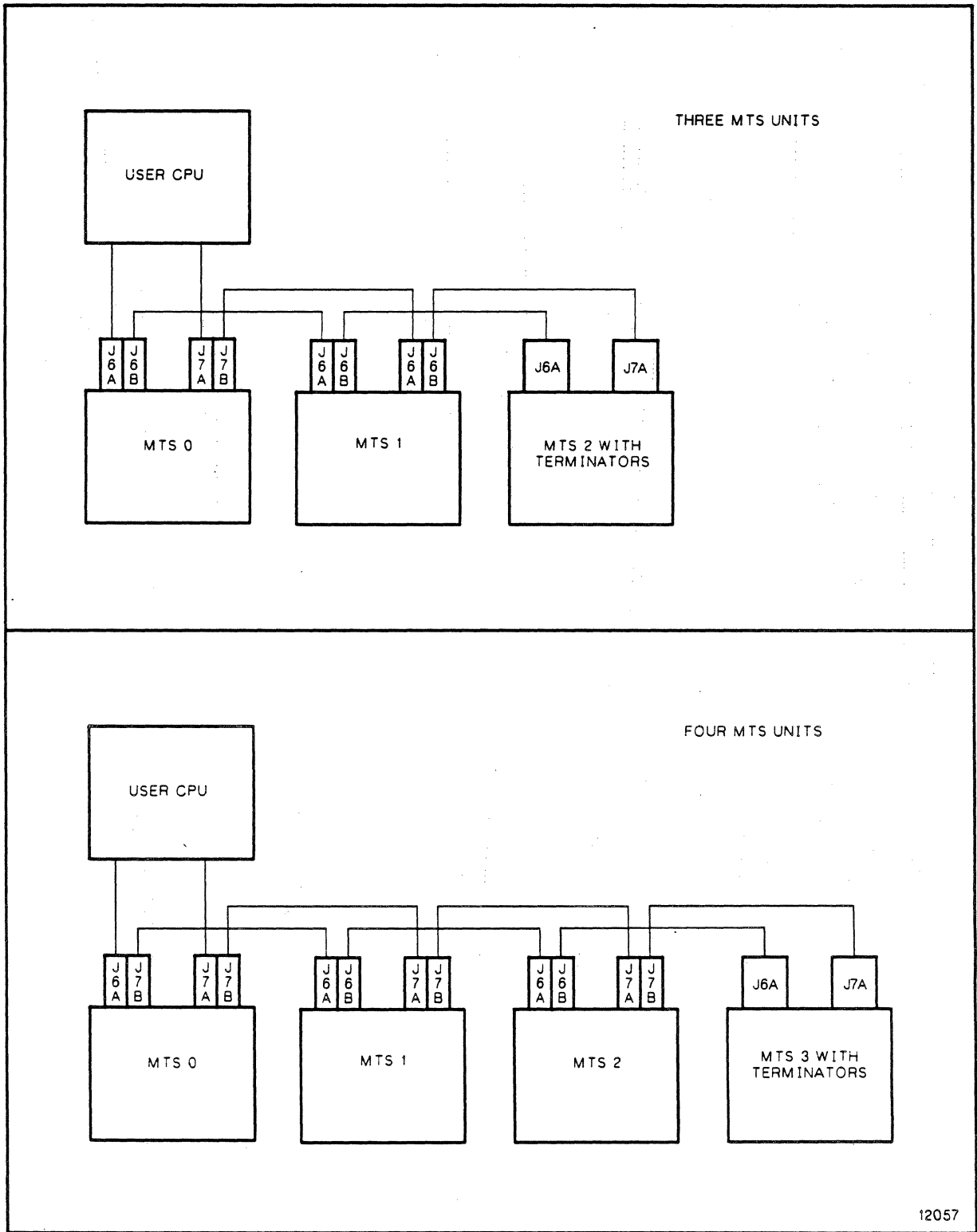

Figure 3-10. Industry Standard Interface Cabling Block Diagram
(Sheet 3 of 3)

CHAPTER 4

STORAGE TECHNOLOGY STANDARD INTERFACE

4.1 INTRODUCTION

This chapter provides a description of the MTS-user interface circuits, defines the MTS-user interface signals, and describes the user commands to the MTS for the Storage Technology Standard Interface.

The MTS and user interface connections are shown in Tables 4-1 and 4-2. The MTS and user interface circuits are shown in Figure 4-1. The maximum allowable cable length from the user system to the last MTS in a chain is 40 feet (12.19 meters).

The interface signal levels are:

Unasserted (Reset) = +3.4 (± 0.3) Vdc = nonselected line
Asserted (Set) = 0 (<0.7) Vdc = selected line

The interface resistive termination for each signal is 390 ohms to ground and 180 ohms to +5 Vdc. The termination for each signal line is provided in the MTS or required of the user interface or both. The termination includes a ground wire, connected in both the MTS and the user interfaces. Only the last MTS in a chain contains terminators.

4.2 INPUT LINE DEFINITIONS

The following input line definitions are for functional mode only. The timing specifications given refer to measurements made at the standard interface connector.

4.2.1 MTS Address (AD0, AD1)

The two MTS Address lines are decoded to select one of the four possible MTSS (Table 4-3).

If the MTS is not busy (the Busy line is not asserted), the address lines may be changed at will to select a different MTS and thus view a different set of MTS status lines. The delay time between the selection of a new MTS and stabilization of the MTS status lines is 150 nanoseconds maximum.

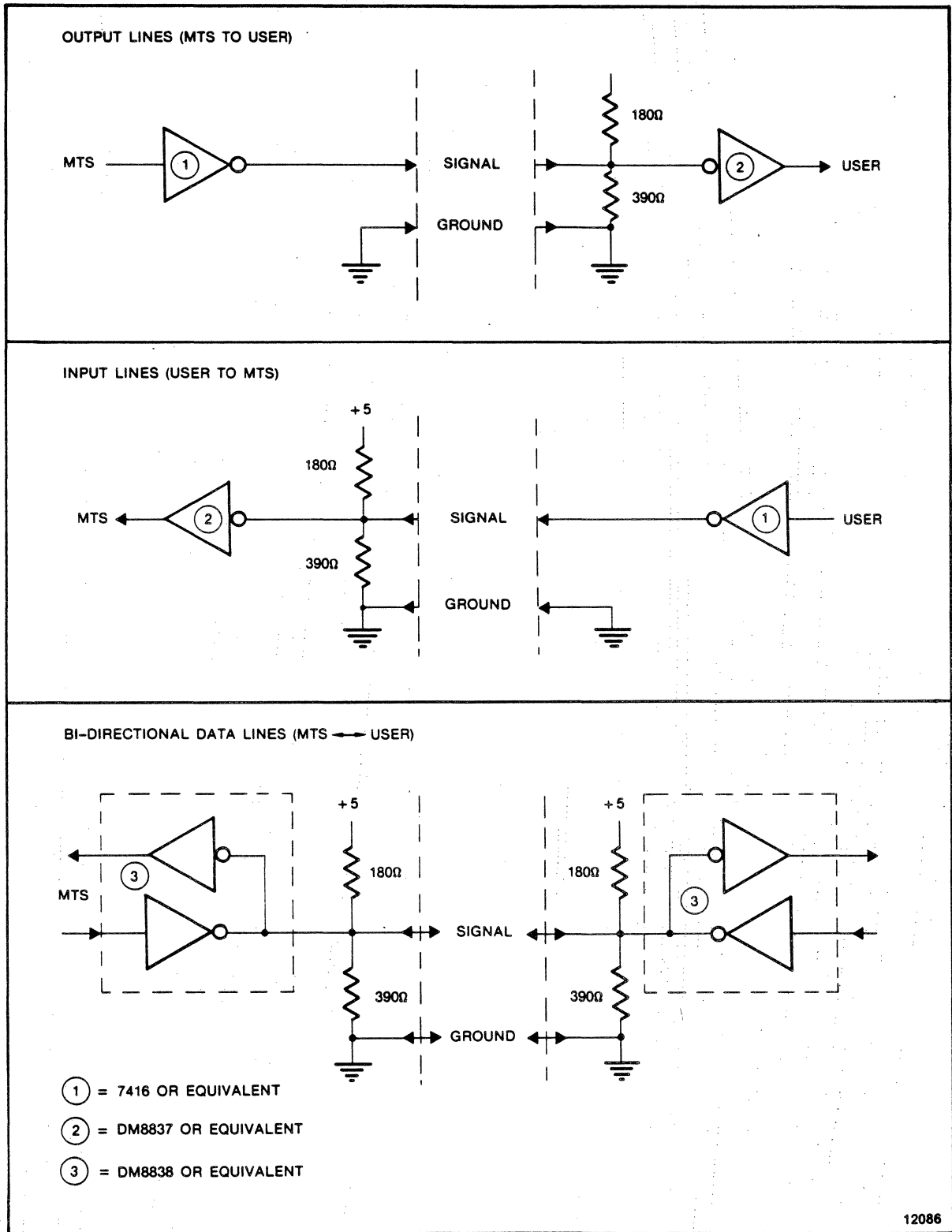

Figure 4-1. MTS-User Interface Circuits

Table 4-1. STK Standard Interface Output Lines

DESCRIPTION	MNEMONIC	MTS CONNECTOR			TERMINATION RESISTANCE LOCATION
		NO.	SIGNAL PIN	GROUND PIN	
Slave Status Change	SSC	J7	A25	B25	user
Oscillator	OSC	J7	A26	B26	user
End of Tape Status	EOTS	J7	A27	B27	user
Begin. of Tape Status	BOTS	J7	A28	B28	user
File Protect Status	FPTS	J7	A29	B29	user
Rewinding Status	REWS	J7	A30	B30	user
Error Multiplex P	ERRMX-P	J6	A1	B1	user
Error Multiplex 0	ERRMX-0	J6	A2	B2	user
Error Multiplex 1	ERRMX-1	J6	A3	B3	user
Error Multiplex 2	ERRMX-2	J6	A4	B4	user
Error Multiplex 3	ERRMX-3	J6	A5	B5	user
Error Multiplex 4	ERRMX-4	J6	A6	B6	user
Error Multiplex 5	ERRMX-5	J6	A7	B7	user
Error Multiplex 6	ERRMX-6	J6	A8	B8	user
Error Multiplex 7	ERRMX-7	J6	A9	B9	user
Busy	BUSY	J6	A10	B10	user
Transfer Request	TREQ	J6	A11	B11	user
Expecting Data	RECV	J6	A12	B12	user
Identification Burst	ID BRST	J6	A13	B13	user
Operation Incomplete	OP INC	J6	A14	B14	user
End of Data Pulse	ENDATP	J6	A15	B15	user
Tape Mark Status	TMS	J6	A16	B16	user
Command REJECT	REJECT	J6	A17	B17	user
Overrun Status	OVRNS	J6	A18	B18	user
Data Check	DATA CHK	J6	A19	B19	user
EPROM Error	ROMPS	J6	A20	B20	user
Corrected Error	CRERR	J6	A21	B21	user
Block Sensed	BLOCK	J6	A22	B22	user
Reserved		J6	A23	B23	user
Data Bus Parity Error	BUPER	J6	A24	B24	user
Online Status	ONLS	J6	A25	B25	user
High Density Status	HDNS	J6	A26	B26	user
Ready Status	RDYS	J6	A27	B27	user
Write Status	WRTS	J6	A28	B28	user
Reserved		J6	A29	B29	
Reserved		J6	A30	B30	

Table 4-2. STK Standard Interface Input Lines

DESCRIPTION	MNEMONIC	MTS CONNECTOR			TERMINATION RESISTANCE LOCATION
		NO.	SIGNAL PIN	GROUND PIN	
MTS Address 0	AD0	J7	A01	B01	MTS
MTS Address 1	AD1	J7	A02	B02	MTS
Command Select 0	CMD0	J7	A03	B03	MTS
Command Select 1	CMD1	J7	A04	B04	MTS
Command Select 2	CMD2	J7	A05	B05	MTS
Command Select 3	CMD3	J7	A06	B06	MTS
Density Select 0	DS0	J7	A07	B07	MTS
Initiate Command	START	J7	A08	B08	MTS
Terminate Command	STOP	J7	A09	B09	MTS
Transfer Acknowledge	TRAK	J7	A10	B10	MTS
Bi-Directional Data P	DATA-P	J7	A11	B11	Both
Bi-Directional Data 0	DATA-0	J7	A12	B12	Both
Bi-Directional Data 1	DATA-1	J7	A13	B13	Both
Bi-Directional Data 2	DATA-2	J7	A14	B14	Both
Bi-Directional Data 3	DATA-3	J7	A15	B15	Both
Bi-Directional Data 4	DATA-4	J7	A16	B16	Both
Bi-Directional Data 5	DATA-5	J7	A17	B17	Both
Bi-Directional Data 6	DATA-6	J7	A18	B18	Both
Bi-Directional Data 7	DATA-7	J7	A19	B19	Both
System Reset	RESET	J7	A20	B20	MTS
Select Multiplex 1	SLX1	J7	A21	B21	MTS
Select Multiplex 0	SLX0	J7	A22	B22	MTS
Density Select 1	DS1	J7	A23	B23	MTS
Select Multiplex 2	SLX2	J7	A24	B24	MTS

Table 4-3. MTS Address Line Decode

AD1	AD0	MTS No.
0	0	0
0	1	1
1	0	2
1	1	3

For command operations, the MTS Address lines must be stable 90 nanoseconds prior to the assertion of Start, remain stable until the selected MTS responds by asserting Busy, and not change while Busy is asserted.

4.2.2 Initiate Command (START)

The assertion of the Initiate Command line causes the user Command Select and Density Select lines to be captured and the command operation to begin. Start must remain asserted until the MTS responds by asserting Busy, after which time Start may be reset. Start assertions while Busy is asserted have no effect. Start must be asserted before the MTS Address lines change.

4.2.3 Command Select (CMD0, CMD1, CMD2, CMD3)

The four Command Select lines are decoded in the MTS and cause one of 16 command operations. These lines must be stable 90 nanoseconds prior to the assertion of Start and must remain stable until the MTS responds by asserting Busy. Command Select decoding is shown in Table 4-4. The detailed description and timing of each command operation are specified in Section 4-4.

Table 4-4. Command Select Decode

CMD0	CMD1	CMD2	CMD3	MNEMONIC	DESCRIPTION
0	0	0	0	NOP	No Operation
0	0	0	1	CLR	Drive Clear
0	0	1	0	DMS	Diagnostic Mode Set
0	0	1	1	SNS	Sense Drive Status
0	1	0	0	RDF	Read Forward a Block
0	1	0	1	RDB	Read Backward a Block
0	1	1	0	WRT	Write a Data Block
0	1	1	1	LWR	Loop Write-to-Read
1	0	0	0	BSF	Backspace a File
1	0	0	1	BSB	Backspace a Block
1	0	1	0	FSF	Forward Space a File
1	0	1	1	FSB	Forward Space a Block
1	1	0	0	WTM	Write Tape Mark
1	1	0	1	ERG	Erase Gap
1	1	1	0	REW	Rewind
1	1	1	1	RUN	Rewind and Unload

4.2.4 Density Select (DS0, DS1)

A switch on the MTS operator panel is used to select 1600 bpi (PE), 6250 bpi (GCR), or System Select recording density. With 1600 or 6250 bpi selected and tape positioned at BOT, the MTS generates tapes written in the selected density. With System Select and tape positioned at BOT, the MTS generates tapes written in the density selected by the Density Select lines. The Density Select lines must be stable 90 nanoseconds prior to the assertion of Start and remain stable until the MTS responds by asserting Busy. The decode of the Density Select lines is shown in Table 4-5.

Table 4-5. Density Select Line Decode

DENSITY SELECT LINES		SELECTED DENSITY
DS1	DS0	
0	0	1600 (PE)
0	1	6250 (GCR)

The MTS recording density can be altered only at the time of a write command issued with tape positioned at BOT. At all other times, the MTS reads and writes the density indicated by the ID burst of the tape in use.

4.2.5 Transfer Acknowledge (TRAK)

The assertion of the Transfer Acknowledge line by the user is in response to the assertion of TREQ by the MTS. The assertion of TREQ by the MTS on a WRT operation indicates that the MTS is requesting data character transfer on the Bi-Directional Data bus and the responding assertion of TRAK (or Stop) by the user indicates that the Bi-Directional Data bus contains the valid data character to be accepted.

The assertion of TREQ by the MTS on a RDF or RDB operation indicates that a data character is valid on the Bi-Directional Data bus and the responding assertion of TRAK (or Stop) by the user indicates that the data character has been transferred. The signal protocol for TREQ and TRAK is similar for either a write or a read operation, that is, once TREQ is asserted it remains asserted until TRAK or Stop is asserted. TRAK must remain asserted until TREQ is reset at which time TRAK must be reset.

4.2.6 Terminate Command (STOP)

The Terminate Command line is asserted by the user in response to TREQ or Block to indicate one of the following situations:

1. During a WRT or LWR command in response to TREQ, that the last data character to be written in the data block has been placed on the Bi-Directional Data bus.
2. On a RDF or RDB command in response to TREQ, that the MTS is to terminate the transfer of data characters on the Bi-Directional Data bus.
3. On a BSB or FSB operation in response to Block, that the MTS is to terminate spacing over blocks.

For the first two situations, Stop replaces TRAK (see Section 4.2.5) as the user response to TREQ. In response to Stop, the MTS terminates the command in progress and resets Busy, but only after the MTS has completed the necessary tape formatting, deformatting, and positioning according to the nature of the command in progress.

4.2.7 System Reset (RESET)

The assertion of System Reset by the user causes the MTS to immediately terminate any command in progress. Busy is asserted until the completion of the reset procedure. No command is accepted while Busy is asserted. Between the assertion of Reset and the clearing of Busy, status output lines are reset. The density selected remains unchanged.

During termination, the MTS discontinues formatting and deformatting, and causes tape motion to halt without regard to IBG positioning. (Note: Partially written or erased blocks during write commands may occur when a Reset is given.) If the system is in diagnostic mode, it is set to functional mode.

The Reset pulse from the user interface must be 1 microsecond minimum.

4.2.8 Select Multiplex (SLX0, SLX1, SLX2)

The three Select Multiplex lines are decoded in the MTS and determine which of four 9-bit registers is multiplexed to the Error Multiplex (ERRMX) output lines. The ERRMX lines are valid only as a part of the ending status (that is, after Busy has been reset). The delay time between the selection of a Select

Multiplex code and the stabilization of the selected mux byte is 150 nanoseconds maximum. Table 4-6 shows the Select Multiplex decode. More complete descriptions of each byte are given in Section 4.3.15.

Table 4-6. Select Multiplex Decode

SLX2	SLX1	SLX0	MUX BYTE	DESCRIPTION
0	0	0	0	Dead Tracks
0	0	1	1	Read/Write Errors
0	1	0	2	Diagnostic Aids
0	1	1	3	Drive Sense Byte

4.2.9 Bi-Directional Data (DATA 0-7,P)

The nine Bi-Directional Data lines are used to transfer the data characters between the interfaces in conjunction with the TRAK (or Stop) responses to TREQ. When a line is asserted, a ONE bit is transferred between the interfaces and when a line is reset, a ZERO bit is transferred. Odd parity must be maintained on these lines for all functional mode data transfer operations. Data bit 7 is the least significant bit; data bit 0 is the most significant. The data lines must be stable 90 nanoseconds prior to the assertion of TRAK (or Stop) during a write operation or TREQ during a read operation.

4.3 OUTPUT LINE DEFINITIONS

The following output line definitions are for functional mode only.

4.3.1 Transfer Request (TREQ)

The Transfer Request line is asserted by the MTS to request data character transfer on the Bi-Directional Data bus. The signal protocol for TREQ and TRAK (or Stop) is specified in Sections 4.2.5 and 4.2.6.

4.3.2 Expecting Data (RECV)

The Expecting Data line is asserted by the MTS to indicate that the Bi-Directional Data bus is under control of the user interface and that the MTS will receive data character transfers. This line is asserted on WRT or LWR command operations only. It remains asserted until a new command is initiated.

4.3.3 Block Sensed (BLOCK)

The Block Sensed line is asserted by the MTS to indicate that a data block or a tape mark block has been detected. This line asserted during BSB and FSB commands or during any read type command detecting a tape mark block. Block is a pulse of 400 nanoseconds nominal duration.

4.3.4 Oscillator (OSC)

The Oscillator line is derived from the internal MTS crystal oscillator. The frequency is 2.5 MHz (400 nanosecond period). The frequency is stable within 0.01% and the half-cycle periods are symmetrical within 5%.

4.3.5 End of Data Pulse (ENDATP)

The End of Data Pulse line is asserted by the MTS to indicate that the last data character has been read from tape and transferred to the user. ENDATP is asserted on read command operations (RDF or RDB) only. The ENDATP pulse is 800 nanoseconds in duration.

4.3.6 Busy (BUSY)

The Busy line is asserted by the MTS following the acceptance of the command initiated by Start. This line remains asserted until completion of the command operation or until conditions arise which cause a REJECT. A command operation maybe initiated only when Busy is reset.

4.3.7 Identification Burst (ID BRST)

The Identification Burst line is asserted by the MTS to indicate that an identification burst procedure is being performed by the MTS. It is asserted on read or write commands from BOT. ID BRST is asserted only while the identification burst procedure is being performed.

On a read command, the procedure includes the determination of the format (PE or GCR) of the burst.

If the ID burst procedure is performed satisfactorily, the MTS proceeds with the command initiated. If the procedure is not performed satisfactorily, REJECT and a reject code (Section 4.3.15) are asserted. ID BRST remains asserted. ID BRST is also asserted if a backward operation is initiated with tape positioned off BOT and tape reaches either BOT or an ARA ID burst before the end of the operation. (Under this condition, DATA CHK is also set).

4.3.8 Tape Mark Status (TMS)

The Tape Mark Status line is asserted by the MTS to indicate that a tape mark block has been detected. This line is asserted following a Write Tape Mark command and following any read or space command when a tape mark block is detected. TMS is reset by the next command issued unless that command is a CLR, SNS, or NOP.

4.3.9 Command REJECT (REJECT)

The Command REJECT line is asserted by the MTS whenever conditions within the MTS are inappropriate to the command operation. The conditions which cause REJECT are given in Section 4.3.15 under the Error Multiplex bus definitions. After the assertion of REJECT and the reset of Busy, reject codes for the conditions causing the reject are the contents of the diagnostic aids register, addressable on the Error Multiplex bus as MUX Byte 2. Read or write commands given after REJECT is received may result in mispositioning and/or creation of an unreadable portion of tape.

4.3.10 Operation Incomplete (OP INC)

The Operation Incomplete line is asserted by the MTS in conjunction with the reject codes in MUX Byte 2 (Section 4.3.15.3). OP INC indicates that the given command was initiated but was not completed. REJECT includes those commands that were not able to be initiated as well as those not completed.

4.3.11 Overrun Status (OVRNS)

During a write operation, the Overrun Status line is asserted by the MTS when the write buffer of the MTS is not being supplied

data characters by the user as fast as the MTS requires them. This may occur when previous TREQ/TRAK responses were not within the timing requirements or when Stop was not asserted. The data block written will be incorrectly encoded. If OVRNS is asserted, DATA CHK is also asserted following the read validity checking.

During a read operation, OVRNS is asserted by the MTS when data characters have backed up in and overflowed the MTS buffer due to the user not accepting data at a high enough rate.

4.3.12 EPROM Error (ROMPS)

The EPROM Error line is asserted by the MTS to indicate that an error in the microprogram code was detected after a diagnostic check sum was performed.

4.3.13 Slave Status Change (SSC)

The Slave Status Change line is asserted by the MTS to indicate that it has gone online, gone offline, or gone from not ready to ready. SSC is reset after issuing any command (other than a NOP or SNS) to the MTS that had one of these three status changes.

4.3.14 Data Check (DATA CHK)

The Data Check line is asserted by the MTS to indicate that one or more of the error conditions of Table 4-7 has occurred. References to more detailed descriptions of each error are included in the table.

4.3.15 Error Multiplex (ERRMX 0-7,P)

The nine Error Multiplex lines are asserted by the MTS to allow transfer of additional error and reject status information. The lines are valid only as a part of the ending status of the most recently completed command (that is, after Busy is reset). One of four registers is multiplexed to the ERRMX bus as selected by SLX0, SLX1, and SLX2 (Section 4.2.8). Table 4-8 gives the ERRMX decode for functional mode operation.

4.3.15.1 MUX BYTE 0

ERRMX bits P through 0 are asserted upon detecting a dead track during a read or a write operation. A dead track is caused by the inability to detect correct data on a specific track on tape. These bits are reset at the start of each new command.

Table 4-7. Error Conditions Setting DATA CHK

ERROR CONDITION	REFERENCE SECTION
CRC Error	4.3.15.2, item 1
Write Tape Mark Check	4.3.15.2, item 2
Uncorrectable Error	4.3.15.2, item 3
Partial Record	4.3.15.2, item 4
Multiple Track Error	4.3.15.2, item 5
End of Data Check	4.3.15.2, item 6
Velocity Error	4.3.15.2, item 7
Overrun	4.3.11
BOT Reached	Note 1
PE Postamble Error	Note 2
Single Track Error	Note 3

<p>1 This error indicates that a backward command was initiated tape positioned off BOT and BOT was reached before the command was completed. ID BRST and BOTS are also set.</p> <p>2 During a PE read or write operation, the length of the postamble was not correct.</p> <p>3 During a PE write operation, an error detected in any track will set DATA CHK.</p>

Table 4-8. Error Multiplex Bus Decode for Functional Mode

MUX BYTE	ERROR MULTIPLEX BIT										DESCRIPTION
	P	7	6	5	4	3	2	1	0		
0	DTP	DT7	DT6	DT5	DT4	DT3	DT2	DT1	DT0		Dead Track
1	CRC ERR	WTM CHK	UCE	PART REC	MTE	NOT USED	END DATA CHK	VEL ERR	DIAG MODE LTCH		Read/Write Errors
2	TACH	DA7	DA6	DA5	DA4	DA3	DA2	DA1	DA0		Diagnostic Aid Bits
3	WRTS	EOTS	BOTS	NOT USED	FPTS	BWDS	HDNS	RDYS	ONLS		Status

4.3.15.2 MUX BYTE 1

The following bits of Mux Byte 1 are asserted when the conditions defining the bit occur:

1. Cyclic Redundancy Character Error (CRC ERR)

The internal checks of data character CRC registers indicate a loss of data integrity. This error may occur during read or write operations in GCR or during write operations in PE. DATA CHK is also asserted.

2. Write Tape Mark Check (WTM CHK)

The MTS has been unable to write a tape mark correctly (see Section 4.4.13). DATA CHK and REJECT may also be asserted, depending on the severity of the problem (Table 4-9).

Table 4-9. Status Lines Asserted with WTM CHK

ASSERTED LINES			COMMENTS
WTM CHK	DATA CHK	REJECT	
X	X		The tape mark written does not meet ANSI specifications but is readable as a TM.
X		X	The tape mark written is probably not readable as a TM. Noise may be left on tape and may not be detected by any read or space command.

3. Uncorrectable Error (UCE)

An uncorrectable error has been detected. This error may occur during PE or GCR read or write commands. DATA CHK is also asserted.

4. Partial Record (PART REC)

An IBG is detected before detecting end-of-data characters. This error may occur during PE or GCR read or write commands. DATA CHK is also asserted.

5. Multiple Track Error (MTE)

Two or more tracks are detected in error. This error may occur during PE or GCR read or write commands. DATA CHK is also asserted.

6. End of Data Check (END DATA CHK)

The end-of-data characters are not detected, or the preambles and postambles do not meet format requirements. This error may occur during PE or GCR read or write commands. DATA CHK is also asserted.

7. Velocity Error (VEL ERR)

The MTS speed indication was outside acceptable limits. This error may occur during PE or GCR write commands. DATA CHK is also asserted.

8. Diagnostic Mode Latch (DIAG MODE LTCH)

The diagnostic mode of operation has been set in the MTS.

4.3.15.3 MUX BYTE 2

ERRMX bit P is the digital tachometer (TACH) from the MTS and contains information concerning tape speed and distance. This line is used in certain diagnostic routines and is valid during commands as well as after the command is completed.

ERRMX bits 7 and 6 (DA7 and DA6) are used during diagnostic mode operation only.

Various reject codes are asserted on bits 5 through 0 under their defining conditions. The reject code is the octal equivalent of bits DA5 through DA0 with bit DA5 being most significant and bit DA0 being least significant. Table 4-10 defines REJECT Codes 1 through 37, and indicates those that set OP INC.

4.3.15.4 MUX BYTE 3

Mux Byte 3 contains MTS status bits. These bits, with the exception of Backward Status (BWDS), are duplicated as separate interface output lines (Sections 4.3.18 through 4.3.24). Mux Byte 3 also acts as Status Byte 0 as defined at the end of this chapter for the Sense command.

The Backward Status bit is asserted when the command in progress or just completed is a backward tape motion command. If the current or previous command is a forward tape motion command, this bit is unasserted.

Table 4-10. REJECT Codes (Sheet 1 of 2)

REJECT CODE (HEX)	DESCRIPTION
1	The MTS is not in Ready Status.
2	Reserved
3*	The TRAK response to the initiating TREQ was not received within 75 milliseconds on a write-type command.
4	Reserved
5	The MTS is in File Protect Status when a write-type command is attempted.
6*	The MTS did not go to Erase Status only.
7	Command cannot be executed as given.
8*	The MTS did not go to Read Status.
9*	The MTS is unable to read a PE or GCR ID burst either during a read operation or during a read check while writing the ID burst.
A	Reserved
B	Reserved
C*	The MTS did not go to Write Status.
D	Reserved
E	Reserved
F*	Noise (possibly data) was detected during an Erase Gap command or during a Write command following a read-type command.
10*	The MTS is in Write Overrun Status at EOT.
11*	The MTS reset Ready Status.
12	Reserved
* OP INC is also set	

Table 4-10. REJECT Codes (Sheet 2 of 2)

REJECT CODE (HEX)	DESCRIPTION
13	A backward-type command (except a rewind or a rewind/unload command) was given, but tape was already positioned at BOT.
14*	The ARA BURST portion of the GCR ID-burst just written did not have all nine tracks active.
15*	An IBG longer than 25 feet in PE mode or longer than 15 feet in GCR mode was detected on a read or space-type command.
16	Reserved
17	Reserved
18*	The MTS is not in the recording density selected.
19	LWR attempted when tape loaded and positioned off BOT
1A*	No tape motion.
1B*	During a readback check of a write operation, data was detected in an IBG area.
1C	Reserved
1D*	The MTS attempted to backspace over a bad record just written but was unable to detect the record.
1E*	The ARA ID burst was unreadable during a GCR write command.
1F*	During the readback check of a write or write tape mark command, no data was detected.
* OP INC is also set.	

4.3.16 Corrected Error (CRERR)

The Corrected Error line is asserted by the MTS to indicate:

1. A single-track error has been corrected during a PE read or a PE readback check during a write.
2. A single- or double-track error has been corrected during a GCR read or a GCR readback check during a write.

4.3.17 Data Bus Parity Error (BUPER)

The Data Bus Parity Error line is asserted by the MTS to indicate that the Bi-Directional Data Bus detected an even parity data character during a TREQ/TRAK data transfer. On WRT operations, assertion of this line indicates that the data written on tape is incorrect. On RDF or RDB operations, assertion of this line indicates either an uncorrectable read error or an internal malfunction of the MTS read data processing system. Data transmission is not halted in either write or read operations until the normal ending point is reached.

4.3.18 Online Status (ONLS)

This line is asserted by the MTS when in Online Status. (The MTS may be in Online Status when it is not in Ready Status.) If the MTS is not in Online Status, all other status is invalid. The Online key is used to set the MTS to Online Status; the Reset key is used to reset Online Status.

4.3.19 Ready Status (RDYS)

This line is asserted by the MTS when in Ready Status. (The MTS is in Ready Status when it has tape loaded, is not rewinding, and is not in Machine Check Status.)

4.3.20 Beginning of Tape Status (BOTS)

The Beginning of Tape Status line is asserted by the MTS when tape is positioned at the BOT marker.

4.3.21 End of Tape Status (EOTS)

The End of Tape Status line is asserted by the MTS when the tape is positioned on or past the EOT marker, indicating that tape is within the end of recording area.

4.3.22 File Protect Status (FPTS)

The File Protect Status line is asserted by the MTS when tape is loaded and the file reel does not contain a write enable ring.

4.3.23 Write Status (WRTS)

This line is asserted by the MTS when in Write Status.

4.3.24 High Density Status (HDNS)

The High Density Status line indicates the recording format (density) in which the MTS is operating. HDNS set indicates GCR format; HDNS reset indicates PE format.

On read or space commands from BOT, the MTS first sets to PE mode, reads the ID burst, and then sets to the format indicated. Once positioned away from BOT, the MTS reads in the density previously determined by reading the ID burst of the tape in use.

On write operations from BOT, the MTS sets to the density selected by the user (Section 4.2.5).

The MTS defaults to PE mode whenever it has just been loaded, unloaded, or powered up.

4.3.25 Rewinding Status (REWS)

The Rewinding Status line is asserted by the MTS when in the process of rewinding tape to BOT (that is, the MTS is loaded and in Online Status but not in Ready Status).

4.4 FUNCTIONAL MODE COMMAND DESCRIPTIONS

The following commands are decoded from the four Command Select lines (CMD0, 1, 2 and 3) as described in Section 4.2.3 and Table 4-4.

4.4.1 General Information

The paragraphs immediately following provide general information regarding command execution in functional mode only. Specific command descriptions start with Paragraph 4.4.2.

4.4.1.1 COMMAND INITIATION

All commands are initiated by asserting the appropriate address, density, and command lines and then asserting Start. The MTS Address, Density Select, and Command Select lines must be valid and stable for 90 nanoseconds minimum prior to the assertion of Start. Start must have had a reset duration of 90 nanoseconds minimum prior to assertion. Upon the assertion of Start, the addressed MTS stores the density and command, asserts Busy, and resets ending status from the previous operation. Start must remain asserted until Busy is asserted. Once Busy is asserted, the Density Select, Command Select, and Start lines may change state. Start must be unasserted when the MTS Address lines are changed. Refer to Figure 4-2 for command initiation timing.

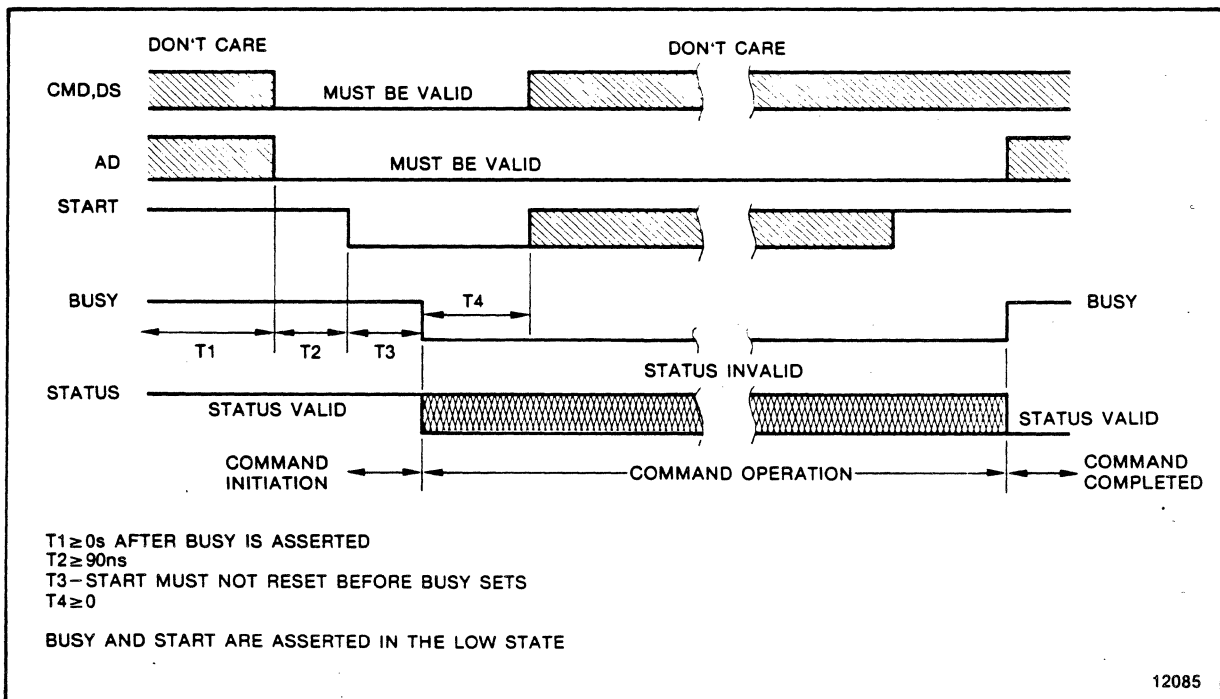

Figure 4-2. Command Initiation, Operation, and Completion

4.4.1.2 REJECT CONDITIONS

During the command operation, when reject conditions occur as specified in Section 4.3.15.3 and Table 4-10, REJECT is asserted, Busy resets, and the operation terminates.

4.4.1.3 OPERATION COMPLETED

The command operation can only be considered as completed or terminated after Busy is reset. A new command can be initiated only when Busy is reset.

4.4.1.4 ENDING STATUS VALIDITY

All MTS status (and error) lines may change during an operation; however, all lines must be considered invalid while Busy is asserted and valid only after completion of the operation when Busy is reset (Figure 4-2).

4.4.1.5 END OF TAPE STATUS (EOTS)

EOTS (Read/Write head positioned in the end of recording area) does not affect, inhibit, or control command operations within the MTS. If forward-type commands are repeated (such as WRT) or allowed to continue (such as FSB) when EOTS is asserted and the physical end of tape is reached, the MTS goes not ready, the operation terminates, and REJECT is asserted. The tape will be completely removed from the file reel and require manual loading before a rewind can be performed.

4.4.1.6 COMMANDS WITH MTS IN WRITE STATUS

When a backward command (BSB, BSF, REW, RDB, RUN) is initiated and the addressed MTS is in Write Status, the MTS automatically causes an erasure of tape in the forward direction of 1.5 inches (nominal) before commencing the command operation.

Forward read commands (FSB, RDF, FSF) with the addressed MTS in Write Status are considered improper command sequences. (See Section 4.4.1.7.)

4.4.1.7 IMPROPER COMMAND SEQUENCES

The tape area forward of a just completed write-type command (WRT, WTM, ERG) is erased for a short distance. When this erasure impinges into another block, this block is partially erased. Write-type commands followed by forward read commands are not prohibited but should be avoided or the user tape operating system should maintain knowledge of the condition.

4.4.2 No Operation (NOP) Command (0000)

NOP command operations perform essentially no function. The MTS error status outputs do not change. Busy is asserted only for the short time necessary to accept and process the command.

Other than command initiation, no signal responses are required of the user interface.

4.4.3 Drive Clear (CLR) Command (0001)

CLR resets the OVRNS, DATA CHK, ID BRST, CRERR, BUPER, and ERRMX status outputs if they are asserted from the previous operation. CLR also resets SSC. The MTS remains in Online Status if previously in that state.

The functions of a Drive Clear command are always performed automatically by the MTS as the initial part of all commands except a NOP, SNS, or DMS command.

Other than command initiation, no signal responses are required of the user interface.

4.4.4 Diagnostic Mode Set (DMS) Command (0010)

The DMS command causes the MTS to accept certain commands, most of which are used for diagnostic purposes, but some of which are tailored for functional operation use.

Other than command initiation, no signal responses are required from the user interface.

Diagnostic mode to functional mode change is accomplished when the user asserts the Reset line or when the MTS automatically transfers mode after certain diagnostic mode command sequences.

The Diagnostic Mode Set command must be followed by the specific command desired. This second command consists of a functional type command AND an identifying code on SLX 2,1 and 0 lines in the following format:

DMS/CCC s1x

Where CCC is the command following DMS, and s1x is the code on the SLX lines.

In most cases (except some parts of the DMS/NOP command), the command following the DMS command is not valid unless it comes

with the proper SLX lines code. The available DMS commands are described in the following paragraphs.

4.4.4.1 DMS/NOP (STATUS LINES TEST COMMAND)

This command initiates and sequences the status line test portion of the interface test. Following the initial NOP command [which reset all status except the Online Status (ONLS) line], each subsequent NOP command results in the assertion of an individual status line (in addition to ONLS) in the order shown in Table 4-11.

Following the 52nd assertion of NOP, the subsystem enters a Command Wrap Mode. In this mode the host may issue any command (with START assertions) with SLX Lines 2,1,and 0 = x00. For each subsequent START assertion, Busy is set and the individual incoming command lines are mapped to the outgoing status lines shown in Table 4-12. This mode of operation is maintained until a Reset command is issued. Only after a Reset is issued can functional operations proceed.

Table 4-11. Status Line Assertion For DMS/NOP Command
Sheet 1 of 2

NOP NO.	S L X 2 1 0	ASSERTED STATUS
1	x x x	Initial NOP, all status except ONLS is reset
2	x x x	Identification Burst Status (ID BRST)
3	x x x	File Protect Status (FPTS)
4	x x x	Rewinding Status (REWS)
5	x x x	Expecting Data Status (RECV)
6	x x x	Operation Complete Status (OP INC)
7	x x x	None, except ONLS
8	x x x	Tape Mark Status (TMS)
9	x x x	Overrun Status (OVRNS)
10	x x x	Data Check Status (DATA CHK)
11	x x x	EPROM Error Status (ROMPS)
12	x x x	Corrected Error Status (CRERR)
13	x x x	None, except ONLS
14	x x x	High Density Status (HDNS)
15	x x x	Ready Status (RDYS)
16	x x x	Write Status (WRTS)

x = do not care

Table 4-11. Status Line Assertion For DMS/NOP Command
Sheet 2 of 2

NOP NO.	S 2	L 1	X 0	ASSERTED STATUS
17	x	0	0	MUX Byte 0 Bit 0 (ERRMX 0)
18	x	0	0	MUX Byte 0 Bit 1 (ERRMX 1)
19	x	0	0	MUX Byte 0 Bit 2 (ERRMX 2)
20	x	0	0	MUX Byte 0 Bit 3 (ERRMX 3)
21	x	0	0	MUX Byte 0 Bit 4 (ERRMX 4)
22	x	0	0	MUX Byte 0 Bit 5 (ERRMX 5)
23	x	0	0	MUX Byte 0 Bit 6 (ERRMX 6)
24	x	0	0	MUX Byte 0 Bit 7 (ERRMX 7)
25	x	0	0	MUX Byte 0 Bit P (ERRMX P)
26	x	0	1	MUX Byte 1 Bit 0 (ERRMX 0)
27	x	0	1	MUX Byte 1 Bit 1 (ERRMX 1)
28	x	0	1	MUX Byte 1 Bit 2 (ERRMX 2)
29	x	0	1	MUX Byte 1 Bit 3 (ERRMX 3)
30	x	0	1	MUX Byte 1 Bit 4 (ERRMX 4)
31	x	0	1	MUX Byte 1 Bit 5 (ERRMX 5)
32	x	0	1	MUX Byte 1 Bit 6 (ERRMX 6)
33	x	0	1	MUX Byte 1 Bit 7 (ERRMX 7)
34	x	0	1	MUX Byte 1 Bit P (ERRMX P)
35	x	1	0	MUX Byte 2 Bit 0 (ERRMX 0)
36	x	1	0	MUX Byte 2 Bit 1 (ERRMX 1)
37	x	1	0	MUX Byte 2 Bit 2 (ERRMX 2)
38	x	1	0	MUX Byte 2 Bit 3 (ERRMX 3)
39	x	1	0	MUX Byte 2 Bit 4 (ERRMX 4)
40	x	1	0	MUX Byte 2 Bit 5 (ERRMX 5)
41	x	1	0	MUX Byte 2 Bit 6 (ERRMX 6)
42	x	1	0	MUX Byte 2 Bit 7 (ERRMX 7)
43	x	1	0	MUX Byte 2 Bit P (ERRMX P)
44	x	1	1	MUX Byte 3 Bit 0 (ERRMX 0)
45	x	1	1	MUX Byte 3 Bit 1 (ERRMX 1)
46	x	1	1	MUX Byte 3 Bit 2 (ERRMX 2)
47	x	1	1	MUX Byte 3 Bit 3 (ERRMX 3)
48	x	1	1	MUX Byte 3 Bit 4 (ERRMX 4)
49	x	1	1	MUX Byte 3 Bit 5 (ERRMX 5)
50	x	1	1	MUX Byte 3 Bit 6 (ERRMX 6)
51	x	1	1	MUX Byte 3 Bit 7 (ERRMX 7)
52	x	1	1	MUX Byte 3 Bit P (ERRMX P)

x = do not care

Table 4-12. Status Line Assertion For Diagnostic Wrap Mode

INCOMING COMMAND LINES	MAPPED TO ERRMX LINES
CMD0	7
CMD1	6
CMD2	5
CMD3	4
DS0	3
DS1	2
SLX0	1
SLX1	0
SLX2	P

4.4.4.2 DMS/WRT (SLX 2,1,0 = 000) (WRITE IN PLACE COMMAND)

This command results in a functional write but with tape positioning such that the rewrite occurs at the same place. This command is used in a diagnostic write error recovery sequence which attempts to isolate media as the cause of temporary errors. This command is intended to follow a failing WRT, BSB command sequence.

4.4.4.3 DMS/WRT (SLX 2,1,0 = 001) (WRITE NO MOTION COMMAND)

This command initiates data transfer to the subsystem without tape motion, and is part of the interface bust test. TREQ and TRAK are used to sequence data across the data bus at a slower than normal, processor-controlled rate. The last two bytes transferred are stored in the subsystem for later retrieval by the DMS/RDF command. This command terminates in diagnostic mode so that the DMS/RDF command may immediately follow.

4.4.4.4 DMS/RDF (SLX 2,1,0 = 000) (READ NO MOTION COMMAND)

This command results in a diagnostic data transfer to the host system. The transfer rate is processor controlled, and is therefore slower than the TREQ/TRAK specifications for functional data transfers. Only the first two bytes transferred are significant, but transfer continues until the user asserts STOP in response to TREQ. These two bytes are the last bytes sent for the Write No Motion command described above.

4.4.4.5 DMS/WRT (SLX 2,1,0 = 111) (FUNCTIONAL SPEED/GAP SELECT)

This command initiates the transfer of data as in the previous DMS/WRT commands. In this case, however, the last byte sent is interpreted as the gap/speed select control as defined in Table 4-13. Receipt of a value not defined in the table results in REJECT Code 7, illegal command. This command is used in functional mode operations.

Table 4-13. Speed And Gap Selection Decodes

BITS OF LAST DATA BYTE								SPEED SELECT	PE GAP IN./CM.	GCR GAP IN./CM.
0	1	2	3	4	5	6	7			
0	0	0	0	0	0	0	1	50 IPS	0.6/1.52	0.43/1.09
0	0	0	0	1	0	0	0	100 IPS	0.6/1.52	0.30/0.76
0	0	0	0	1	0	0	1	100 IPS	0.9/2.29	0.60/1.52
0	0	0	0	1	0	1	0	100 IPS	1.2/3.05	0.90/2.29

4.4.4.6 DMS/FSF (SLX 2,1,0, = 000) (PERFORM LOADED DIAGNOSTICS)

This command initiates the Loaded subset of internal diagnostics and bypasses all test that require the MTS to be unloaded. This eliminates all Section 1 routines (power up), and Test 32 (unload/load). Note that this limited set of internal diagnostics results in a lesser detection and isolation of problems than optimum.

The sense bytes resulting from this command are described under the next heading - DMS/FSB command.

4.4.4.7 DMS/FSB (SLX 2,1,0 = 000) (PERFORM ALL DIAGNOSTICS)

This command initiates the entire package of internal diagnostics. Busy is set until successful completion or an error is detected. At this time the user may interrogate termination status by means of the Sense (SNS) command.

In addition to the operational sense bytes (DSB0-4) as described at the end of this chapter, an extended set of status bytes (DSB5-55) is available for diagnostic purposes. A definition of the extended sense bytes is given in Table 4-14 and in the following paragraphs.

Table 4-14. Diagnostics Extended Sense Bytes Summary

SENSE BYTES	SENSE BYTE DEFINITION
DSB5	Last Test Identifier
DSB6	Last Test Return Code
DSB7	Reserved
DSB8-23	Status A-0 through A-F (16 bytes)
DSB24-39	Status B-0 through B-F (16 bytes)
DSB40-55	Status C-0 through C-F (16 bytes)

4.4.4.7.1 DSB5 and DSB6 Description

These two sense bytes together may be used to reconstruct the Fault Code Dictionary specific fault code by the following formula:

$$\text{3-digit fault code} = (\text{DSB5} \times 10 \text{ hex}) + \text{DSB6}$$

For example, when DSB5 = 32, and DSB6 = 11, the specific fault code is calculated as follows:

$$\begin{array}{r} 32 \text{ hex} \times 10 \text{ hex} = 320 \text{ hex} \\ \text{PLUS} \qquad \qquad \qquad 11 \text{ hex} \\ \hline \text{results in a} \qquad \qquad 331 \text{ hex specific fault code} \end{array}$$

This fault code is the same as appears on the operator panel during machine operation.

4.4.4.7.2 DSB8 Through DSB55 Description

These sense bytes hold status information bytes identified in the Fault Code Dictionary as A-0 through C-F. Each information byte (A-0, A-1, etc.) is located in a specific sense byte identified in Table 4-15.

For example, if there is a reference in the Fault Code Dictionary to 'Status A-8: Data Checks' this refers (according to Table 4-15) to Sense Byte 16, where additional data pertinent to this error condition is stored. The type of additional information stored in A-0 through C-F depends on the type of error encountered.

Table 4-15. A-0 Through C-F Sense Bytes Cross Reference

STATUS CODE	SENSE BYTE	STATUS CODE	SENSE BYTE	STATUS CODE	SENSE BYTE
A-0	8	B-0	24	C-0	40
A-1	9	B-1	25	C-1	41
A-2	10	B-2	26	C-2	42
A-3	11	B-3	27	C-3	43
A-4	12	B-4	28	C-4	44
A-5	13	B-5	29	C-5	45
A-6	14	B-6	30	C-6	46
A-7	15	B-7	31	C-7	47
A-8	16	B-8	32	C-8	48
A-9	17	B-9	33	C-9	49
A-A	18	B-A	34	C-A	50
A-B	19	B-B	35	C-B	51
A-C	20	B-C	36	C-C	52
A-D	21	B-D	37	C-D	53
A-E	22	B-E	38	C-E	54
A-F	23	B-F	39	C-F	55

4.4.5 Read Forward a Block (RDF) Command (0100)

The RDF command causes tape to be moved in the forward direction and the next block (only) to be read. Non-data characters of the block are detected, decoded, checked for validity, and used for their specific purposes, but not transferred across the interface. Data characters of the block are detected, decoded, checked for validity, corrected if appropriate, and transferred across the interface. Data is transferred until end-of-data is detected or until Stop is asserted by the user interface. All characters within the block are checked for validity even if they are not all transferred. Tape motion is then halted with the read head positioned in the following interblock gap (IBG). Ending status signals reflect the validity check for the entire block.

4.4.5.1 SIGNAL SEQUENCE

After command initiation, the MTS moves tape in the forward direction. When a data block is detected and sufficient data characters have been decoded and deformatted, the MTS asserts a data character on the Bi-Directional Data bus (DATA), delays approximately 90 nanoseconds, and then asserts TREQ.

The user interface must then signal transfer of the data character by asserting TRAK or Stop. Upon sensing the TRAK or Stop assertion, the MTS resets TREQ. The user interface must then reset TRAK or Stop. Responses must meet the timing requirements of Figure 4-3.

If TRAK or Stop does not respond according to the timing requirements, an MTS internal read buffer may be overloaded. If the MTS buffer does become overloaded, data characters may be lost. Although data transfer could resume by asserting TRAK, lost data characters cannot be recovered during the in-process command operation. When data characters are lost in this type of signal sequence, CRC ERR, OVRNS, and DATA CHK are in the ending status.

Normal TREQ/TRAK responses and data character transfer continue until the user interface signals Stop, until the MTS transfers the last byte of data, or until the MTS sets REJECT and terminates the command. When end-of-data is decoded, the MTS asserts the End of Data Pulse (ENDATP). Unless the user TRAK timing is greater than the specified maximum, all data will have been transferred before ENDATP is asserted. Any data not transferred by the time ENDATP is asserted is unrecoverable.

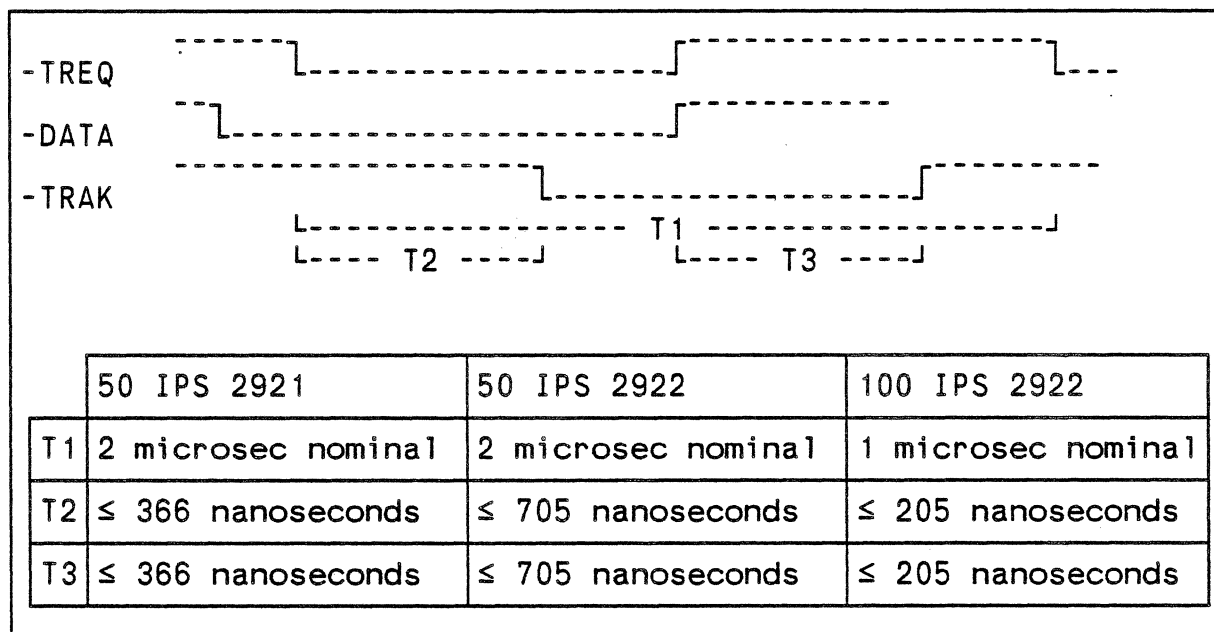

Figure 4-3. RDF or RDB Command TREQ, TRAK, and DATA Timing

The MTS then halts tape motion in the following IBG. The MTS waits for the drive to reach the IBG, asserts ending status, resets Busy, and the command operation is completed.

4.4.5.2 RDF/BOT

When a RDF command is initiated with tape positioned at BOT, the MTS first processes the identification area (ID area) before proceeding to process the first block. The processing of the ID area is automatic within the operation, requiring no signal responses from the user interface. In the processing, the ID area is detected and interpreted and the MTS is set to the appropriate density. The MTS asserts ID BRST during the process. The processing of the following block then occurs. If the ID area is uninterpretable, the MTS asserts the interface signals as defined in Section 4.3.7 and terminates the operation.

4.4.5.3 RDF/TAPE MARK BLOCKS

When a RDF operation is initiated, but the next block is tape mark block, the MTS positions the read head in the following IBG, asserts Tape Mark Status (TMS), asserts Block, and resets Busy. A data block will not have been processed and no data characters will have been transferred across the interface. No signal responses will have been requested from the user interface.

4.4.6 Read Backward a Block (RDB) Command (0101)

This operation proceeds as in Section 4.4.5 for RDF except that tape motion is backward and when the operation is completed the read head will be positioned in the IBG preceding (on the BOT side of) the data block.

The signal sequence is the same as described in Section 4.4.5.1 for RDF except that data is transferred in the opposite order of the RDF command.

4.4.6.1 RDB/BOT

RDB commands initiated with tape positioned at BOT are invalid commands. REJECT is asserted and the operation is terminated.

RDB commands initiated in which tape reaches the ID area without a data or tape mark block having been detected, set DATA CHK and the operation is terminated. Upon completion of this command, the tape will be positioned at BOT.

For both of the above conditions, no signal responses will have been requested from the user interface.

4.4.6.2 RDB/TAPE MARK BLOCKS

This situation is the same as that described in Section 4.4.5.3 except that tape motion is backward and, when the command is completed, the read head will be positioned in the IBG preceding the tape mark block.

4.4.7 Write a Data Block (WRT) Command (O110)

The WRT command causes tape to be moved in the forward direction, the ending portion of the preceding IBG to be generated, the data block to be written, the data block to be read and checked for validity, and the beginning portion of the next IBG to be generated. The data block is written in the format as determined by the Density Status lines and the Density Select switch (Section 4.2.4 and Chapter 2)

Non-data characters of the data block are automatically generated, encoded, formatted, and written. Data characters to be written are transferred serially across the interface, automatically encoded, formatted, and written.

4.4.7.1 SIGNAL SEQUENCE

After the command initiation, the MTS first asserts RECV, signifying that the Bi-Directional Data bus (DATA) is under control of the user interface and that the MTS will receive data transfer on DATA.

The MTS next asserts one initiating TREQ signal sequence. The user interface must respond with assertions of data characters on DATA and by assertion of TRAK within the timing limitations of Figure 4-4. If the user interface does not respond accordingly, the MTS resets TREQ, asserts REJECT, and terminates the command. The MTS starts tape motion. When the ending portion of the IBG has been created, the preamble is written; the user interface must respond to TREQ by placing a data character on DATA and then asserting TRAK. The MTS acknowledges transfer of the data character by resetting TREQ. At this time the user interface may change DATA and must reset TRAK.

Normal TREQ/TRAK/DATA response will continue until the user interface signals STOP, signifying that the last character to be written is being transferred. The MTS then formats and writes the remainder of the block. The read-after-write checks are performed and the beginning portion of the next IBG generated. Ending status is asserted, Busy is reset, and the operation is completed. RECV remains asserted until a command other than a WRT or LWR command is initiated.

These user interface responses must meet the timing limitations in Figure 4-5. The time between consecutive TREQ signals may not

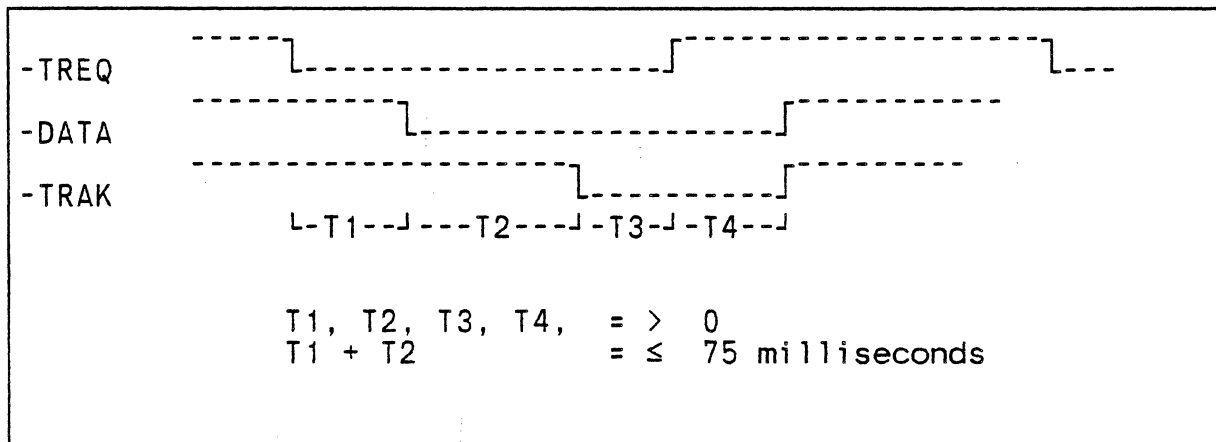

Figure 4-4. Write Commands Initiating TREQ/TRAK/DATA Timing
(Applies to First Byte of Data)

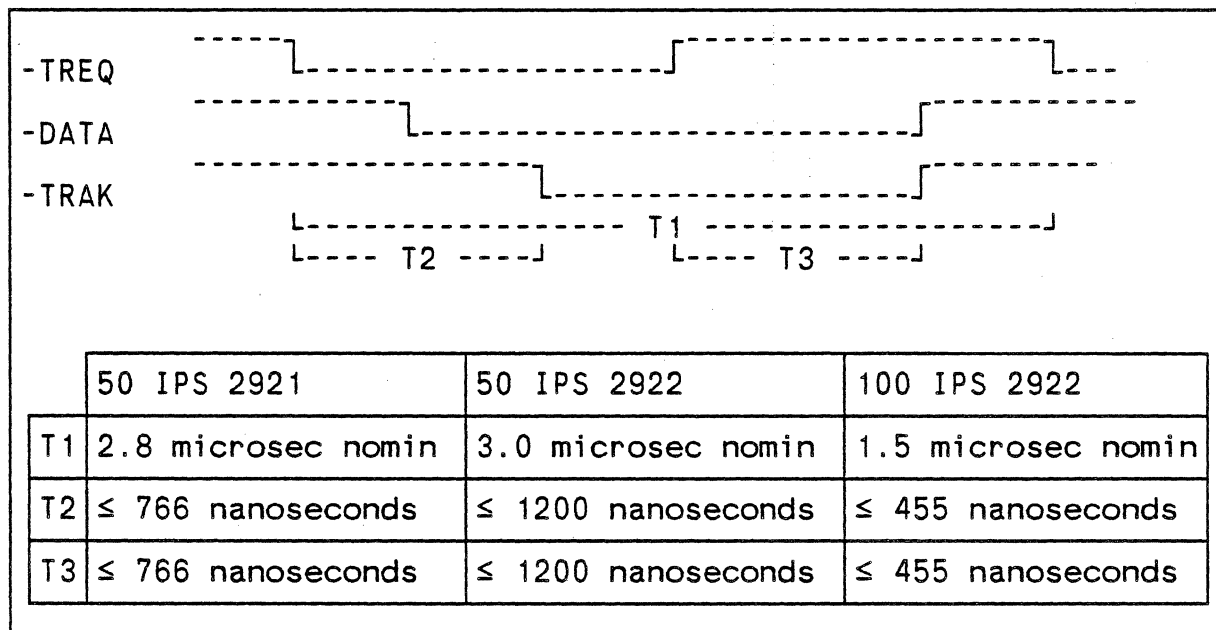

Figure 4-5. WRT Command TREQ, TRAK and DATA Timing
(Applies to All Subsequent Bytes of Data)

be uniform. If TRAK or Stop does not respond according to the timing limitations, an internal MTS write data character buffer may be overrun. When this occurs, incorrect data encoding has occurred; the MTS discontinues requesting data, finishes formatting the block, sets Overrun Status (OVRNS), and tape motion halts.

4.4.7.2 WRT/BOT

When a WRT command is initiated with tape positioned at BOT, the MTS writes and checks the ID area before proceeding to the WRT command. The ID area is written and checked automatically within the MTS, requiring no signal responses from the user interface.

If the ID area cannot be written and read with validity, the operation is terminated; a data block will not have been written and the WRT command will not have been performed. Appropriate ID BRST, REJECT, and DATA CHK signals are included in the ending status.

4.4.8 Loop Write-to-Read (LWR) Command (0111)

The LWR command operations provide a means of testing the read and write data circuit paths within the MTS. Read signals are derived (looped) within the MTS from the write circuits. There is no tape motion.

The Loop Write to Read operation may be performed only if the MTS is unloaded or loaded and at BOT. If the command is issued with the tape loaded and not at BOT, a REJECT will result.

The signal sequence is the same as that described in Section 4.4.7.1 for a WRT command operation.

4.4.9 Backspace a File (BSF) Command (1000)

The BSF command causes tape to move backward, passing over data blocks encountered until a tape mark block is detected. Tape motion is halted with the read head positioned in the IBG preceding (on the BOT side of) the tape mark. Tape Mark Status is included in the ending status and the operation is completed. No data characters are checked for validity or transferred across the interface. Block is not asserted for any data blocks passed over; Block is asserted only at the tape mark.

Other than command initiation, no signal responses are required of the user interface.

4.4.9.1 BSF/BOT

If the ID area is reached before finding a tape mark block, the operation is terminated. Tape will be positioned at BOT. DATA CHK and BOTs are asserted in the ending status. If BSF is initiated with tape positioned at BOT, the command is invalid, REJECT is asserted, and the operation is terminated.

4.4.10 Backspace a Block (BSB) Command (1001)

The BSB command operation causes tape to be moved backward, passing over data blocks until signaled to Stop by the user interface. When signaled to stop, the read head will be positioned in the IBG preceding the last data block passed over. No data characters are checked for validity or transferred across the interface.

4.4.10.1 SIGNAL SEQUENCE

After the command initiation, the MTS begins backward tape motion. If a data block is detected, the MTS asserts Block. If data block spacing is to be terminated, the user interface must assert Stop. This assertion must occur within 2 microseconds of the assertion of Block and must have a 1 microsecond minimum duration. If data block spacing is not to be terminated, Stop must not be asserted, tape motion continues, and Block is reset and then reasserted when and if the next block detected is a data block. When Stop is asserted, tape motion is halted with the read head positioned in the preceding IBG, Busy is reset, and the operation is completed.

4.4.10.2 BSB/BOT

If BOT is reached before Stop is asserted or before a data block is detected, the operation is terminated. Tape is positioned at BOT. DATA CHK and BOTS are asserted in the ending status. If BSB is initiated with tape positioned at BOT, the command is invalid; REJECT is asserted and the operation is terminated.

4.4.10.3 BSB/TAPE MARK

When a tape mark block is encountered during the operation, tape motion is halted with tape positioned in the IBG preceding the tape mark block. TMS is included in the ending status.

4.4.11 Forward Space a File (FSF) Command (1010)

This operation is the same as that described in Section 4.4.9 for BSF except that tape motion is forward and, at the completion of the command, the read head is positioned in the IBG following the tape mark block.

Other than initiating the command, no signal responses are required of the user interface.

4.4.11.1 FSF/BOT

When an FSF command is initiated with tape positioned at BOT, the MTS first processes the ID area as described in Section 4.4.5.2 for RDF/BOT before proceeding to space to the next tape mark block.

4.4.12 Forward Space a Block (FSB) Command (1011)

This operation is the same as that described in Section 4.4.10 for BSB except that tape motion is forward and, at the completion of the command, the read head is positioned in the IBG following the data block.

4.4.12.1 SIGNAL SEQUENCE

The signal sequence is the same as that described in Section 4.4.10.1 for BSB.

4.4.12.2 FSB/BOT

When a FSB command is initiated with tape positioned at BOT, the MTS first processes the ID AREA as described in Section 4.4.5.2 for RDF/BOT before commencing the FSB operation.

4.4.12.3 FSB/TAPE MARK

When a tape mark block is encountered during the operation, tape motion halts with the read head positioned in the IBG following the tape mark block. TMS is included in the ending status.

4.4.13 Write Tape Mark (WTM) Command (1100)

The WTM command causes tape to be moved forward and a tape mark block to be written and checked for validity.

If the validity check indicates that the tape mark does not meet ANSI specifications, the MTS automatically backspaces and erases forward over the written tape mark and rewrites the tape mark block. Two rewrites may be automatically attempted. If the tape mark does not meet ANSI specifications after the rewrite attempts, WTM CHK is asserted.

Other than initiating the command, no signal responses are required of the user interface.

4.4.13.1 WTM/BOT

When a WTM command is initiated with tape positioned at BOT, the MTS first writes and checks the ID area as described in Section 4.4.7.2 for WRT/BOT before commencing the WTM operation.

4.4.14 Erase Gap (ERG) Command (1101)

The ERG command causes tape to be moved in the forward direction and a 3.6 inch (9.14 cm) nominal PE or 3.4 inch (8.64 cm) nominal GCR section of tape to be erased. During the ERG operation, read checks are performed to verify that erasure has occurred. If read signals are detected, REJECT is asserted in ending status.

Other than initiating the command, no signal responses are required of the user interface.

4.4.14.1 ERG/BOT

When an ERG command is initiated with tape positioned at BOT, the MTS first automatically causes the generation and checking of the ID area as described in Section 4.4.7.2 for WRT/BOT before commencing the ERG operation.

4.4.15 Rewind (REW) Command (1110)

The REW command causes tape to move in the backward direction at rewind speed. Tape motion halts with tape positioned at BOT, Busy is asserted only until the MTS accepts the REW command. The MTS will reset Ready Status and assert Rewinding Status while performing a rewind operation and will reassert Ready Status and reset Rewinding Status when BOT is reached.

Other than initiating the command, no signal responses are required of the user interface.

4.4.15.1 REW/BOT

No tape motion occurs and tape remains positioned at BOT. Busy is asserted only for the short time required to check that tape was positioned at BOT.

4.4.16 Rewind and Unload (RUN) Command (1111)

The RUN command causes tape to move in the backward direction at rewind speed. When BOT is reached, tape motion slows and tape is wound onto the file reel. Busy is asserted only until the MTS accepts the RUN command. The MTS resets Online Status and Ready status upon accepting the command.

Other than initiating the command, no signal responses are required of the user interface.

4.4.16.1 RUN/BOT

Tape is wound completely onto the file reel. The MTS resets Online Status upon accepting the command.

4.4.17 Sense Drive Status (SNS) Command (0011)

This command initiates the transfer of the various drive status bytes (DSBs) across the Error Multiplex Bus to the user. Upon receiving a SNS command, the MTS places the next DSB on the interface. This DSB remains valid until the MTS is issued a NOP command. At this point the MTS may be issued a CLR command to place DSB0 on the Error Multiplex Bus and return the MTS to the idle mode or the MTS may be issued a SNS command to request the next sequential DSB.

4.4.17.1 SIGNAL SEQUENCE

Each SNS must be followed by a NOP command which in turn must be followed by SNS or a CLR command. The assertion of the Reset line at any time during this sequence will place DSB0 on the Error Multiplex Bus and return the MTS to the idle mode.

4.4.17.2 SENSE BYTES DESCRIPTION

Table 4-16 summarizes the function of sense bytes bits. A detailed description of each sense byte follows. Note that only sense bytes 0-4 are used during functional mode operation. Sense bytes 5 and up are used for diagnostic purposes only.

Sense Byte 0

This sense byte is the same as the multiplex error byte 3. For a full description refer to Section 4.3.15.

Table 4-16. Operational Sense Bytes Summary

SENSE BYTES	SENSE BYTES BITS								
	P	7	6	5	4	3	2	1	0
DSB0	WRTS	EOTS	BOTS	0	FPTS	BWDS	HDNS	RDYS	ONLS
DSB1	X	1	1	1	D0	1*	0	0	M0
DSB2	X	0	0	S1	S0	G3	G2	G1	G0
DSB3	X	T3	T2	T1	T0	L11	L10	L9	L8
DSB4	X	L7	L6	L5	L4	L3	L2	L1	L0

X = not defined * = always on, indicates a 29XX subsystem

Sense Byte 1

Bits 1-2 and 5-7,P are not used. They maintain the constant state shown in Table 4-16.

Bit 0, M0; when reset, indicates that MTS is in 50 IPS PE or GCR mode. When set, indicates that MTS is in 100 IPS PE or GCR streaming mode.

Bit 3; Always set. This bit is used to distinguish the 29XX family from the 19XX family of products.

Bit 4, D0; When reset, indicates that the MTS is in 1600 bpi PE mode, When set, indicates that the MTS is in 6250 bpi GCR mode.

Sense Byte 2

Bits 6-7,P are not used. They maintain the constant state shown in Table 4-16.

Bits 0-3, G0-G3; These bits indicate MTS gap and speed selection as follows:

G3	G2	G1	G0		G3	G2	G1	G0	
0	0	0	0	not used	1	0	0	0	100 IPS; PE 0.6 gap
0	0	0	1	50 IPS					GCR 0.3 gap
				start/stop	1	0	0	1	100 IPS; PE 0.9 gap
0	0	1	0	spare					GCR 0.6 gap
0	0	1	1	spare	1	0	1	0	100 IPS; PE 1.2 gap
0	1	0	0	spare					GCR 0.9 gap
0	1	0	1	spare	1	0	1	1	spare
0	1	1	0	spare	1	1	0	0	spare
0	1	1	1	spare	1	1	0	1	spare
					1	1	1	0	spare
					1	1	1	1	spare

Bits 4-5, S0 and S1; These bits indicate the S0 and S1 front panel bit positions and reflect the following machine status:

S1	S0	FRONT PANEL SWITCH POSITIONS
0	0	software select
0	1	not used
1	0	1600 PE mode
1	1	6250 GCR mode

Sense Byte 3

Bits 0-3, L8-L11; These are the high order bits of the operational and diagnostic code level of the MTS. The low order bits are in sense byte 4.

Bits 4-7, T0-T3; These bits indicate the machine type as follows;

T3	T2	T1	T0	MACHINE TYPE
1	0	1	0	2921 (50 IPS start/stop)
1	0	1	1	2922 (50 IPS start/stop and, 100 IPS streaming)

Sense Byte 4

Bits 0-6, L0-L7; These are the low order bits of the operational and diagnostic code level of the MTS. The high order bits are in sense byte 3.

CHAPTER 5

INDUSTRY STANDARD INTERFACE

5.1 INTRODUCTION

This chapter provides a description of the Industry Standard Interface circuits, defines the interface signals, and describes the user commands to the MTS.

The MTS and user interface connections are shown in Tables 5-1 and 5-2. The MTS and USER interface circuits are shown in Figure 5-1. The maximum allowable cable length from the user system to the last MTS in a chain is 40 feet (12.19 meters).

The interface signal levels are:

	<u>TRANSMITTED</u>	<u>RECEIVED</u>
True = 0	0.0V - 0.4V	0.0V - 0.8V
False = 1	2.4V - 5.0V	2.0V - 5.0V

The interface resistive termination for each signal is 330 ohms to ground and 220 ohms to +5 Vdc. The termination for each signal line is provided in the MTS or the user interface at each signal destination point. The termination includes a ground wire, connected in both the MTS and the user interfaces. Only the last MTS in a chain contains terminators.

5.2 INPUT LINE DEFINITIONS

The following input line definitions are for functional mode only. The timing specifications given refer to measurements made at the interface connectors.

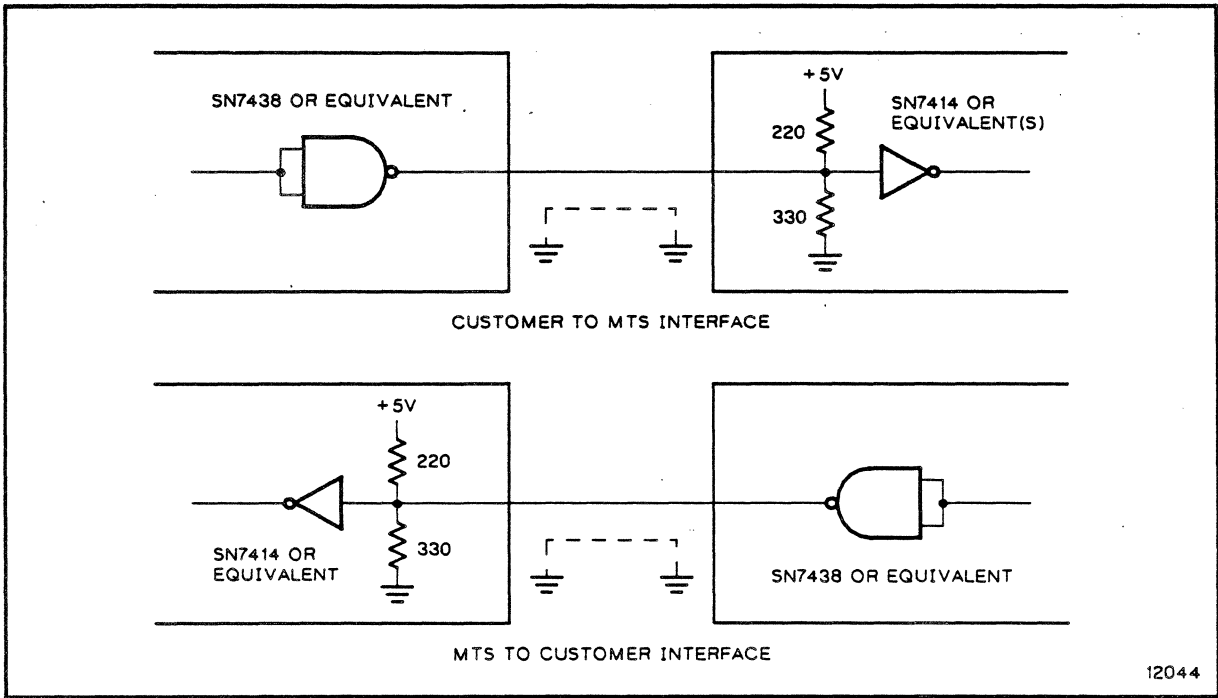

Figure 5-1. Standard Industry Interface Circuits

Table 5-1. Industry Standard Interface Input Lines

DESCRIPTION (NEG.TRUE)	MNEMONIC	MTS CONNECTOR		
		NO.	SIGNAL PIN	GROUND PIN*
Formatter Enable	FFEN	J6	18	17
Command Offline	FOFL	J6	24	23
Address Bit 1	FTAD1	J6	46	45
Formatter Address	FFAD	J6	48	47
High Speed Select	FHISP	J6	50	49
Last Word	FLWD	J7	04	03
Write Bit 4	FWD4	J7	06	05
Start Command	FGO	J7	08	07
Write Bit 0	FWD0	J7	10	09
Write Bit 1	FWD1	J7	12	11
Spare 3	----	J7	14	13
Spare 2	----	J7	16	15
Command Bit 3	FREV	J7	18	17
Rewind To BOT	FREW	J7	20	19
Write Bit P	FWDP	J7	22	21
Write Bit 7	FWD7	J7	24	23
Write Bit 3	FWD3	J7	26	25
Write Bit 6	FWD6	J7	28	27
Write Bit 2	FWD2	J7	30	29
Write Bit 5	FWD5	J7	32	31
Command Bit 2	FWRT	J7	34	33
Long Gap	FLGAP	J7	36	35
Command Bit 4	FEDIT	J7	38	37
Command Bit 0	FERASE	J7	40	39
Command Bit 1	FWFM	J7	42	41
Spare 1	----	J7	44	43
Address Bit 0	FTAD0	J7	46	45

* All gnd pins are connected to a single gnd bus.

Table 5-2. Industry Standard Interface Output Lines

DESCRIPTION (NEG TRUE)	MNEMONIC	MTS CONNECTOR		
		NO.	SIGNAL PIN	GROUND PIN*
Read Bit P	FRDP	J6	01	
Read Bit 0	FRD0	J6	02	
Read Bit 1	FRD1	J6	03	
Load Point (BOT)	FLDP	J6	04	
Read Bit 4	FRD4	J6	06	05
Read Bit 7	FRD7	J6	08	07
Read Bit 6	FRD6	J6	10	09
Hard Error	FHER	J6	12	11
File Mark	FFMK	J6	14	13
ID Burst	FID	J6	16	15
Read Bit 5	FRD5	J6	20	19
End Of Tape	FEOT	J6	22	21
Density Status	FGCR	J6	26	25
Drive Ready	FRDY	J6	28	27
Rewinding	FRWD	J6	30	29
File Protected	FFPT	J6	32	31
Data Read Strobe	FRSTR	J6	34	33
Data Write Strobe	FDWDS	J6	36	35
Data Busy	FDBY	J6	38	37
High Speed Status	FHSPD	J6	40	39
Corrected Error	FCER	J6	42	41
Online Status	FONL	J6	44	43
Formatter Busy	FFBY	J7	02	01
Read Bit 2	FRD2	J7	48	47
Read Bit 3	FRD3	J7	50	49

* All gnd pins are connected to a single gnd bus.

Table 5-3. Interface Connector J6 Pin Functions

PIN	MNEMONIC	DESCRIPTION
01	FRDP	Read Bit P
02	FRD0	Read Bit 0
03	FRD1	Read Bit 1
04	FLDP	Load Point (BOT)
06	FRD4	Read Bit 4
08	FRD7	Read Bit 7
10	FRD6	Read Bit 6
12	FHER	Hard Error
14	FFMK	File Mark
16	FID	ID Burst
18	FFEN	Formatter Enable
20	FRD5	Read Bit 5
22	FEOT	End of Tape
24	FOFL	Command Offline
26	GCR	Density Status
28	FRDY	Drive Ready
30	FRWD	Rewinding
32	FFPT	File Protect
34	FRSTR	Data Read Strobe
36	FDWDS	Data Write Strobe
38	FDBY	Data Busy
40	FHSPD	High Speed Status
42	FCER	Corrected Error
44	FONL	Online Status
46	FTAD1	Address Bit 1
48	FFAD	Formatter Address
50	FHISP	High Speed Select

Table 5-4. Interface Connector J7 Pin Functions

PIN	Mnemonic	Description
02	FFBY	Formatter Busy
04	FLWD	Last Word
06	FWD4	Write Bit 4
08	FGO	Start Command
10	FWD0	Write Bit 0
12	FWD1	Write Bit 1
14	----	Spare 3
16	----	Spare 2
18	FREV	Command Bit 3
20	FREW	Rewind to BOT
22	FWDP	Write Bit P
24	FWD7	Write Bit 7
26	FWD3	Write Bit 3
28	FWD6	Write Bit 6
30	FWD2	Write Bit 2
32	FWD5	Write Bit 5
34	FWRT	Command Bit 2
36	FLGAP	Long Gap
38	FEDIT	Command Bit 4
40	FERASE	Command Bit 0
42	FWFM	Command Bit 1
44	----	Spare 1
46	FTAD0	Address Bit 0
48	FRD2	Read Bit 2
50	FRD3	Read Bit 3

5.2.1 MTS Address (FFAD, FTAD0, FTAD1)

The MTS Address lines are decoded to select one of the four possible MTSSs. (Table 5-5). Controller board switches, corresponding to the address lines, must be set to indicate MTS Address 0,1,2, or 3 to match the address lines coming from the host cpu or controller. The address lines from the host may be switched as long as the Formatter Busy (FFBY) and Data Busy (FDBY) lines are not set. The address must be stable one microsecond before any of the following command lines are activated:

FGO (Start Command)
 FOFL (Command Offline)
 FREW (Rewind To BOT)
 FFEN (Formatter Enable)

These lines must not be activated when switching machine address.

Table 5-5. MTS Address Line Decodes

MTS ADDRESS LINES			SELECTED MTS
FFAD	FTAD1	FTAD0	
0	0	0	0
0	0	1	1
0	1	0	2
0	1	1	3

5.2.2 Initiate Command (FGO)

The assertion of the Initiate Command line causes five user Command lines to be captured and the command operation to begin. All the command lines must be stable at the start of the FGO pulse and are clocked in on the trailing edge of the pulse. The FGO pulse from the host must have a minimum one microsecond width. A commands decode table is given in the next paragraph. The commands themselves are described further down in this chapter.

If the FGO signal comes up while the the Formatter Address.(FFAD) or Data Busy (FDBY) signal is still up, The new command is ignored and Command Overrun is set. The FGO signal is also ignored if the MTS is offline.

5.2.3 Rewind To BOT (FREW)

A pulse on this line causes the selected MTS to rewind to BOT. The drive drops the Ready (FRDY) signal and asserts the Rewind (FRWD) signal one microsecond after the leading edge of the FREW signal. The FREW signal must be held true for at least one microsecond. This signal is ignored if the MTS is offline and if the formatter is busy.

5.2.4 Command Offline (FOFL)

A pulse on this line causes the MTS to go offline and rewind. The drive drops the Ready (FRDY) signal one microsecond after the leading edge of the FOFL signal. The processor then drops Online Status (FONL) and starts to rewind. After the rewind is complete, the tape is unloaded. The FOFL line must be held true for at least one microsecond. This signal is ignored if the MTS is offline and if the formatter is busy.

5.2.5 Formatter Enable (FFEN)

This signal enables MTS operations and is usually held true. If the line goes false, drive motion stops and the current command is terminated.

Subsystem programmers should use this line only to terminate a run-away condition. There is no need to use this line as a 'reset' to clear status lines, since all status lines are reset on the acceptance of a new command. Using this line as a 'reset' between commands also forces repositioning between each command, thus causing slower subsystem performance. For system IPL, the drive only needs to be set online and rewound to BOT.

This line is ignored if the MTS is offline.

5.2.6 Last Word (FLWD)

During a write command, this line is asserted with Write Bits 0-7,P (FWD 0-7,p) to indicate that the character strobed with Write Strobe (FWDWS) is the last byte of the record.

5.2.7 Write Data Lines (FWDO-7,p)

These nine lines transmit data to the MTS. FWDO is the most significant bit.

5.2.8 High Speed Select (FHISP) (2922 devices only)

This line selects 100 IPS operation if true, and 50 IPS operation if not true. This line is asserted when a read or write command is issued. If the MTS is in the opposite speed when the command is issued, the unit will first change speed and then execute the command.

5.2.9 Long Gap Select (FLGAP) (2922 devices only)

When this line is asserted, an interblock gap of nominal plus +0.3 in. (+0.76 cm) is generated. When this line is not asserted, the gap is nominal. This line has effect in data streaming mode (100 IPS mode) only.

5.2.10 Command Select Lines (CMD0, 1, 2, 3, and 4)

The five Command Select lines are decoded in the MTS and cause one of 21 command operations, 15 functional commands and 6 diagnostic commands. These lines must be stable when the FGO line is asserted. Command line decodes are given in Tables 5-6 and 5-7. Detailed description of the commands are given further down in this chapter.

Table 5-6. Functional Command Lines Decodes

CMD4 FEDIT	CMD3 FREV	CMD2 FWRT	CMD1 FWFM	CMD0 FERASE	MNE- MONIC	COMMAND
0	0	0	0	0	RDF	Read Forward
0	1	0	0	0	RDR	Read Reverse
1	1	0	0	1	RDS	Read Sense
0	0	1	0	0	WRT	Write
0	0	1	1	0	WFM	Write File Mark
0	1	1	1	0	WRE	Write Extended
0	0	1	0	1	ERV	Controlled Erase
0	0	1	1	1	ERF	Fixed Erase
1	0	1	1	1	ERT	Data Security Erase
0	0	0	0	1	SPF	Space Forward
0	1	0	0	1	SPR	Space Reverse
0	0	0	1	1	FSF	File Search Forward (ignore data)
0	1	0	1	1	FSR	File Search Reverse (ignore data)
1	0	0	1	1	SPE	Select PE
1	1	0	1	1	GCR	Select GCR

Table 5-7. Diagnostic Command Lines Decodes

CMD4 FEDIT	CMD3 FREV	CMD2 FWRT	CMD1 FWFM	CMD0 FERASE	MNE- MONIC	COMMAND
0	1	1	0	0	INV	Invoke Diagnostics
0	1	1	1	1	LWR	Loop Write To Read
1	0	0	0	0	INS	Initiate Status Sequencer
1	0	0	0	1	WRAP	Command To Status Wrap
1	1	1	0	1	EXS	Read Extended Sense
1	1	1	1	1	LOOP	Data Loopback

5.3 OUTPUT SIGNAL DEFINITIONS

The following output line definitions are for functional mode only. The timing specifications given refer to measurements made at the interface connectors.

5.3.1 Formatter Busy (FFBY)

This line is used to indicate that a command is being processed. It goes true within one microsecond after the leading edge of the FGO line. The FFBY line remains true until the full completion of the present command.

5.3.2 Data Busy (FDBY)

When this line goes true, it indicates that the data transfer part of a command takes place, and data is exchanged. This line goes false upon the completion of data transfer. When the line goes false, tape motion has not stopped yet, but a new command can be received; the new command, if received, is processed after completion of the last command.

When this line goes false and before a new command is asserted, the host must examine for the presence of the Hard Error (FHER) line in order to determine whether to retry the last command or send a new one.

The FDBY line is MTS microprocessor controlled. While this line is asserted, no new command may be issued.

5.3.3 Identification Burst (FID)

This line is asserted by the MTS to indicate to the host that an identification burst (ID Burst) procedure is being performed by the MTS. The FID line is asserted from Beginning Of Tape (BOT) marker during read or write operations.

During write operations, the ID Burst procedure writes a PE or GCR tape identification burst at BOT, depending on what mode the MTS is instructed to be in, before writing starts.

During read operations, the ID Burst procedure identifies the type of data on tape (PE or GCR) from the ID Burst written on tape, then sets the MTS to the proper mode before reading of data starts.

The FID and GCR (later described) lines together indicate to the host the mode the MTS is in, PE or GCR.

5.3.4 Hard Error (FHER)

If an error is detected while the MTS is busy, this line is pulsed low. When the MTS becomes not busy, this line remains a solid low. See the description of sense bytes in this chapter.

5.3.5 File Mark Detected (FFMK)

This line is pulsed while Data Busy (FDBY) is asserted in a read/write operation, when a tape mark pattern is being detected.

5.3.6 Corrected Error (FCER)

When correcting an error, A series of pulses are asserted on this line. When Data Busy (FDBY) becomes unasserted, FCER stays a solid low, but is reset prior to the next record.

The type of read error corrections indicated by this line are as follows;

- A single track error correction during PE Read,
- A single track PE error correction after read back check during write,
- A single or double track error correction during GCR Read,

- A single or double track GCR error correction after read back check during write.

5.3.7 Ready (FRDY)

This line when asserted indicates that the MTS is ready to accept a read or write type command. This is the case when the tape is loaded, is not rewinding and is not in Machine Check status.

5.3.8 Online (FONL)

This line is asserted when the MTS is online and is able to communicate back to the host. If the MTS is offline, all other status back to the host is unasserted.

5.3.9 Rewind (FRWD)

When this line is asserted, it indicates to the host that the MTS is rewinding to BOT.

5.3.10 End Of Tape (FEOT)

This line is asserted when the EOT marker is detected, and stays asserted past the EOT marker, indicating that the tape is within the end of the recording area. EOT status is reset when the EOT marker is detected in backward or rewind mode.

5.3.11 File Protect (FFPT)

When this line is asserted, it indicates that the mounted file reel does not contain a write enable ring, and that no write operation can take place.

5.3.12 Load Point (FLDP)

When this line is asserted, it indicates that the tape is loaded and positioned at BOT.

5.3.13 High Speed Streaming (FHSPD)

When this line is asserted, it indicates that the selected MTS is in the streaming, 100 IPS mode. When this line is not asserted, the drive is in the Start/Stop, 50 IPS mode. (2922 Model Drives only)

5.3.14 High Density Status (GCR)

When this line is asserted, it indicates that the selected drive is in the GCR, 6250 BPI mode. When this line is not asserted, the drive is in the PE, 1600 BPI mode.

5.3.15 Demand Write Data Strobe (FDWDS)

A pulse is asserted on this line for each character to be written on tape. It functions somewhat differently for 50 IPS and 100 IPS operations, as described below.

5.3.15.1 FDWDS TIMING, 50 IPS OPERATIONS

The first data character must be available on the data input lines no later than ten microseconds after the Data Busy (FDBY) signal has been asserted. The succeeding characters must be placed on the data input lines within 0.7 microseconds of the trailing edge of FDWDS. The FDWDS signal has a pulse width of 1.0 to 1.2 microseconds and a minimum period of two microseconds. (Figure 5-2).

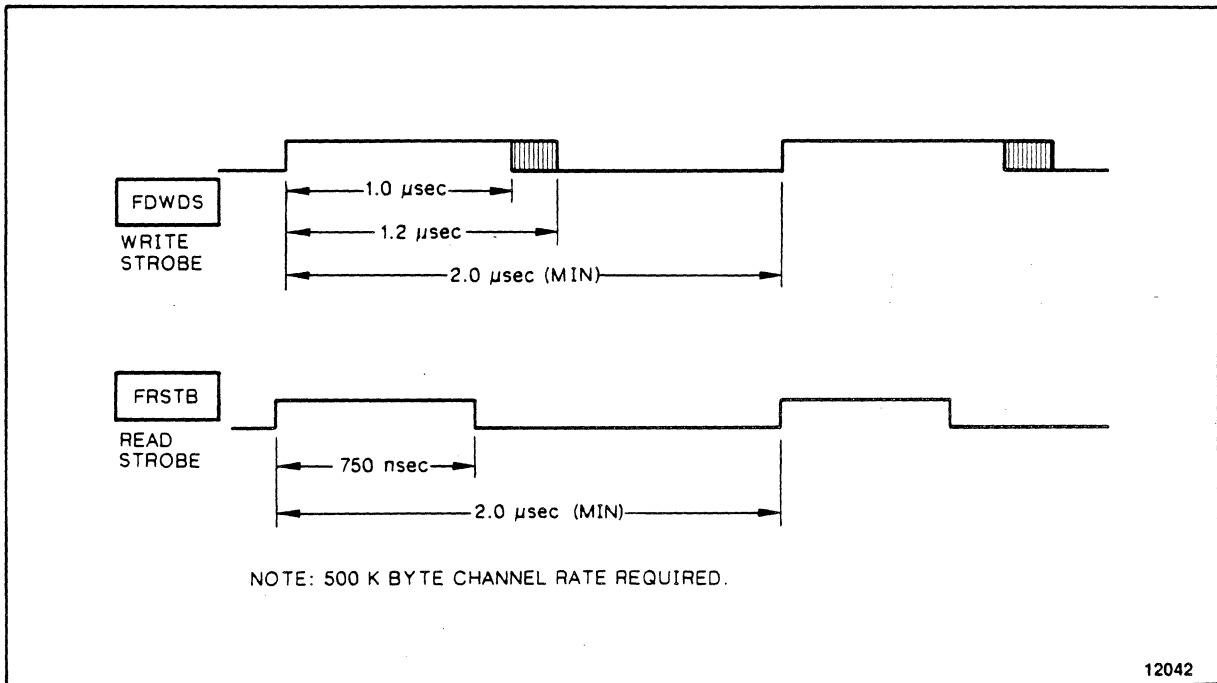

Figure 5-2. Interface Timing For 50 IPS Start Stop, Worst Case

5.3.15.2 FDWDS TIMING, 100 IPS OPERATIONS

The first data character must be available on the data input lines no later than ten microseconds after the Data Busy (FDBY) signal has been asserted. The succeeding characters must be placed on the data input lines within 0.3 microseconds of the trailing edge of FDWDS. The FDWDS signal has a width of 0.4 to 0.6 microseconds and a minimum period of one microsecond. (Figure 5-3).

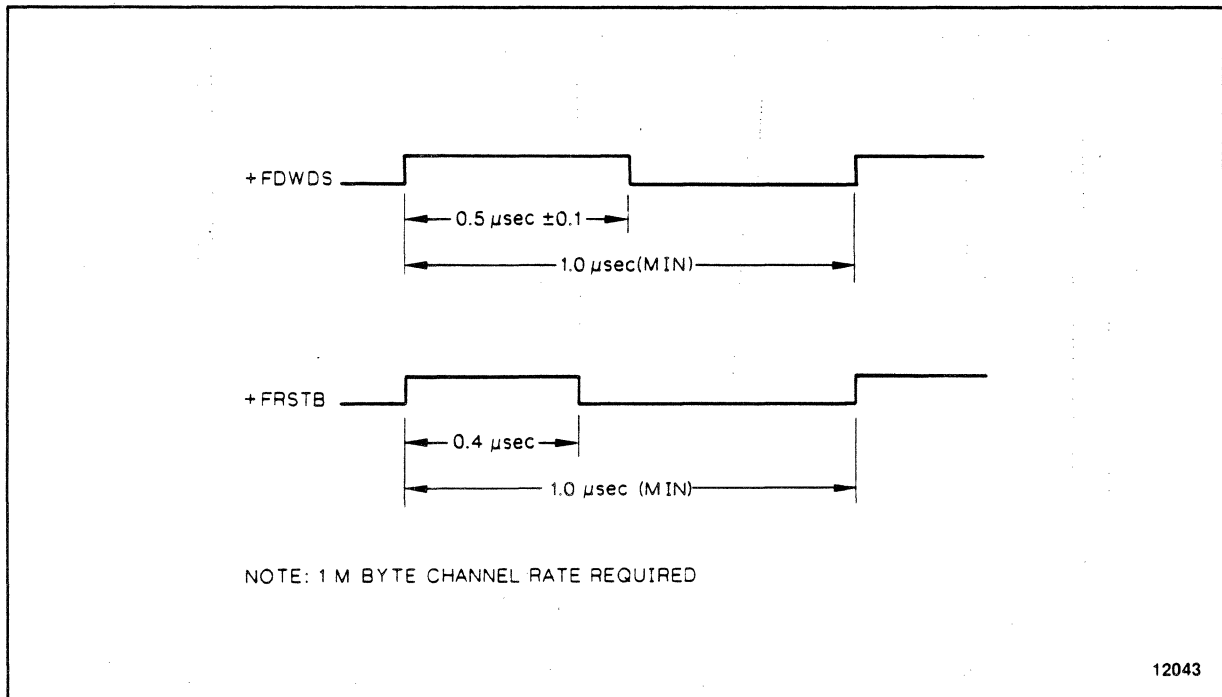

Figure 5-3. Interface Timing For 100 IPS Streaming, Worst Case

5.3.16 Read Data Strobe (FRSTR)

A pulse is asserted on this line for each character of read information to be transmitted to the host controller interface and is used to sample the read data lines. This line acts somewhat differently for 50 IPS and 100 IPS operations as described below.

Note that the strobe is switched from hardware to software control during a Read Sense command.

5.3.16.1 FRSTR TIMING, 50 IPS OPERATION

In 50 IPS operations the FRSTR signal has a pulse width of 0.75 microseconds and a minimum period of two microseconds. Data is valid 0.3 microseconds before the read strobe (Figure 5-2).

5.3.16.2 FRSTR TIMING, 100 IPS OPERATION

In 50 IPS operations the FRSTR signal has a pulse width of 0.40 microseconds and a minimum period of one microseconds. Data is valid 0.3 microseconds before the read strobe (Figure 5-3).

5.3.17 Read Data Lines 0-7,p (FRD0-7, p)

These nine lines transmit data from the MTS to the customer controller. Each character read from tape is available by sampling these lines in parallel with the read data strobe (FRSTR). FRD0 is the most significant bit of data.

The read data lines FRD0-7,P are also used to transmit the eight bytes of sense information when the Read Sense command is issued.

5.4 COMMAND LINES DECODES - FUNCTIONAL COMMANDS DESCRIPTION

The function of the five command lines (CMD0-4) has been previously described (Table 5-6). A detailed description of the decoded functional commands follows.

5.4.1 Read Forward Command (00000)

The Read Forward command causes tape to be moved in the forward direction to read a block of data. Non-data characters are detected, decoded, checked for validity, and used for their specific purposes, but are not transferred across the interface. Data is transferred until End Of Data is detected. The Last Word (FLWD) line is ignored if issued during a read operation.

5.4.2 Read Reverse Command (01000)

The Read Reverse command causes tape to be moved in the reverse direction to read a block of data. Non-data characters are detected, decoded, checked for validity, and used for their specific purposes, but are not transferred across the interface. Data is transferred until End Of Data is detected. The Last Word (FLWD) line is ignored if issued during a read operation.

When the 50 IPS Read Reverse operation is completed the read head is positioned in the Inter Block Gap (IBG) preceding the data block.

When the 100 IPS, streaming mode, Read Reverse operation is completed, positioning of the read head in the IBG is not guaranteed.

5.4.3 Write Command (00100)

The Write command causes tape to be moved in the forward direction and the following to take place;

1. The ending portion of the preceding IBG is written,
2. The data block is written and simultaneously read and checked for validity,
3. The beginning portion of the next IBG is generated

Non-data characters of the data block are automatically generated, encoded, formatted and written. Data characters to be written arrive from the interface, are automatically encoded, formatted, and written.

The overall write command execution sequence is as follows;

1. User asserts the Write command and the FGO line,
2. MTS acknowledges FGO by asserting Formatter Busy (FFBY),
3. MTS acknowledges Write by asserting Data Busy (FDBY) and starts motion,
4. MTS asserts Data Write Strobe (FDWDS) pulses until user asserts Last Word (FLWD); the host does not respond - data is assumed to be correct and on time,
5. MTS continues to move tape to perform read back check. When data transmission and status accumulation are completed, the MTS drops FDBY to enable user to read the status and issue the next command,
6. If the user does not issue a new command, the drive stops and FFBY is dropped.

5.4.4 Write File Mark Command (00110)

This command causes tape to move forward and a tape mark block to be written and checked for validity. Two retries are automatically done.

5.4.5 Write Extended Command (01110)

This command allows the host to change the Inter Block Gap (IBG) length for streaming mode operations (100 IPS). The command requires a one byte write transfer to completely define the operation. Formatter Busy (FFBY) and Data Busy (FDBY) remain asserted throughout the transfer. The byte sent defines the gap size selection as follows;

00 hex = nominal IBG
01 hex = nominal IBG + 0.3 in. (0.76 cm)
02 hex = nominal IBG + 0.6 in. (1.52 cm)

When a gap length has been selected by the Write Extended command, Long Gap (FLGAP) is ignored until the gap has been set back to nominal by another Write Extended command.

5.4.6 Fixed Erase Command (00111)

This command causes tape to move forward and the following lengths of tape to be erased;

PE = 3.6 in. (9.14 cm) nominal
GCR = 3.4 in. (8.64 cm) nominal

During the erase operation, read checks are performed to verify that erasure took place. If read signals are detected, Data Check is asserted in Status Byte 0.

5.4.7 Controlled Erase Command (00101)

This command causes the MTS to move and erase tape continuously until the Last Word signal from the user is asserted. This terminates the erase operation.

When the erase command is given from BOT, an ID Burst is written before erasing starts.

5.4.8 Data Security Erase Command (10111)

This command causes the MTS to erase tape from its present position to a position approximately ten feet (3.05 meters) past the End Of Tape (EOT) marker.

When the erase command is given from BOT, an ID Burst is written before erasing starts.

5.4.9 Space Forward Command (00001)

This command causes tape to move forward and pass over one block of data. If no new command is given while Formatter Busy (FFBY) is still asserted Data Busy (FDBY) is false, the read head is positioned in the IBG following the data block. No data characters are checked for validity or transferred across the interface.

5.4.10 Space Reverse Command (01001)

This command causes tape to move backward and pass over one block of data. If no new command is given while Formatter Busy (FFBY) is still asserted Data Busy (FDBY) is false, the read head is positioned in the IBG preceding the data block. No data characters are checked for validity or transferred across the interface.

5.4.11 File Search Forward Command (Ignore Data) (00011)

This command causes tape to move forward, passing over each data block encountered until a Tape Mark block is detected. Tape motion is halted with the read head positioned in the IBG following the tape mark. No data characters are checked for validity or transferred across the interface.

5.4.12 File Search Reverse Command (Ignore Data) (01011)

This command causes tape to move backward, passing over each data block encountered until a Tape Mark block is detected. Tape motion is halted with the read head positioned in the IBG preceding the tape mark. No data characters are checked for validity or transferred across the interface.

5.4.13 Select PE Command (10011)

This command is issued by the host to put the MTS in PE mode. The dropping of Formatter Busy (FFBY) indicates completion of the command. This command is only accepted when the drive is unloaded or loaded and at BOT.

5.4.14 Select GCR Command (11011)

This command is issued by the host to put the MTS in GCR mode. The dropping of Formatter Busy (FFBY) indicates completion of the command. This command is only accepted when the drive is unloaded or loaded and at BOT.

5.4.15 Read Sense Command (11001)

This command is issued by the host in order to retrieve the sense information accumulated in the MTS registers. Eight sense bytes are issued. See next heading for sense bytes descriptions.

5.5 DETAILED FUNCTIONAL SENSE BYTES DESCRIPTION

Eight sense bytes are retrieved from the MTS in response to the Read Sense (11001) command from the host. The processor puts the first byte of data on the read bus, not including the parity bit, then pulses the Read Strobe ((FRSTR) line. The next byte is then put on the read bus and the FRSTR is pulsed again. This sequence is repeated until all eight bytes have been transferred to the host or controller. The status bytes defined below are listed in bit order 0 to 7. The 0 bit represents the most significant bit of data and is transferred on FRD0. Odd parity is sent with each sense byte to ensure data integrity. A description of all the sense bytes bits follows.

5.5.1 Sense Byte 0 (Faults, Mode And Not Ready)

BIT	MEANING	DESCRIPTION
0	Command Illegal	Set when the MTS receives an illegal command
1	Not Ready	Set when the MTS is not ready
2	Drive Type	Set when the MTS has the 100 IPS data streaming feature, reset when the MTS is 50 IPS Start/Stop
3	Equipment Check	Set when the MTS has a fault code on the operator display panel.

- | | | |
|---|-----------------|---|
| 4 | Data Check | Set when the MTS has detected one or more of the error conditions in Sense Byte 3 and Bits 0,1 or 2 of Sense Byte 4 |
| 5 | Command Overrun | Set if a command was received while Data Busy (FDBY) is true. Also sets Sense Byte 0, Bit 0 |
| 6 | Unit Check | Set when Bit 0,1,3,4 or 5 of Sense Byte 0 is set |
| 7 | Unit Exception | Set when error correction is performed during a read operation (Bits 0, 1 or 2 in Sense Byte 4) |

5.5.2 Sense Byte 1 (Last Command Issued)

BIT	MEANING	DESCRIPTION
0	Command Bit 7	Spare 1
1	Command Bit 6	High Speed Select
2	Command Bit 5	Long Gap
3	Command Bit 4	Edit
4	Command Bit 3	Reverse
5	Command Bit 2	Write
6	Command Bit 1	Write File Mark
7	Command Bit 0	Erase

5.5.3 Sense Byte 2 (Tape Status)

BIT	MEANING
0	Backward Status
1	On Line
2	Rewinding
3	File Protected
4	GCR Density
5	100 IPS Streaming mode
6	Beginning Of Tape (BOT)
7	End Of Tape (EOT)

5.5.4 Sense Bytes 3 And 4 (Hard Errors)

5.5.4.1 SENSE BYTE 3

BIT MEANING

- 0 Write Tape Mark Check
- 1 Uncorrectable Error
- 2 Partial Record
- 3 Multiple Track Error
- 4 Spare (always zero)
- 5 End Of Data Check
- 6 Velocity Error
- 7 CRC Error

5.5.4.2 SENSE BYTE 4

BIT MEANING

- 0 BOT Reached
- 1 PE Postamble Error
- 2 Single Track Error in PE Write
- 3 Spare (always zero)
- 4 Command Reject; command could not be completed - see reject codes in Sense Byte 5
- 5 Bus Parity Error
- 6 Operation Incomplete
- 7 Overrun Error

5.5.5 Sense Byte 5 (Reject Status)

BIT MEANING

- 0 Diagnostic Mode Set (MSB)
- 1 Spare (always zero)
- 2 Reject Code Bit 5
- 3 Reject Code Bit 4
- 4 Reject Code Bit 3
- 5 Reject Code Bit 2
- 6 Reject Code Bit 1
- 7 Reject Code Bit 0 (LSB)

Table 5-8 shows the decodes for Reject Code Bits 0-5.

5.5.6 Sense Byte 6 (Corrected Error And Dead Track P)

Sense Byte 6 contains the corrected error status information. If the Corrected Error Status line (FCER) is set, either Bit 0, 1, or 2 in Sense Byte 6 is also set.

BIT MEANING

- 0 Single track in PE Read corrected
- 1 Single Track in GCR Read corrected
- 2 Double track in GCR Read corrected
- 3 Nominal gap +0.3 in. (0.76 cm) selected by last Write Extended (WRE) command
- 4 Nominal gap +0.6 in. (1.52 cm) selected by last Write Extended (WRE) command
- 5 Spare (always zero)
- 6 Spare (always zero)
- 7 Dead Track P (also see Sense Byte 7)

5.5.7 Sense Byte 7 (Dead Track register)

BIT MEANING

- 0 Dead Track 0
- 1 Dead Track 1
- 2 Dead Track 2
- 3 Dead Track 3
- 4 Dead Track 4
- 5 Dead Track 5
- 6 Dead Track 6
- 7 Dead Track 7

5.6 COMMAND LINES DECODES - DIAGNOSTIC COMMANDS DESCRIPTION

The function of the five command lines (CMD0-4) is described previously in this chapter under input signal definitions (Table 5-7). Detailed descriptions of the decoded commands follows.

5.6.1 Invoke Diagnostics (01100)

This command allows the host to invoke the resident diagnostics and specify run-time options. It requires a 2-byte write transfer to completely define the operation. Formatter Busy (FFBY) and Data Busy (FDBY) remain asserted throughout the 2-byte transfer and the subsequent diagnostic execution. The two bytes transferred define the operation (first byte and options (second byte) as follows:

- 1st byte = 01: run complete diagnostic package
(unloads drive)
- 02: run loaded diagnostic subpackage
- 2nd byte = 00: no option
(all other values reserved)

Table 5-8. Reject Codes (Sheet 1 of 2)

REJECT CODE (HEX)	DESCRIPTION
1	The MTS is not in Ready Status.
2	Reserved
3*	Reserved
4	Reserved
5	The MTS is in File Protect Status when a write-type command is attempted.
6*	The MTS did not go to Erase Status only.
7	Illegal Command Sequence
8*	The MTS did not go to Read Status.
9*	The MTS is unable to read a PE or GCR ID burst either during a read operation or during a read check while writing the ID burst.
A	Reserved
B	Reserved
C*	The MTS did not go to Write Status.
D	Reserved
E	Reserved
F*	Noise (possibly data) was detected during an Erase Gap command or during a Write command following a read-type command.
10*	The MTS is in Write Overrun Status at EOT.
11*	The MTS reset Ready Status.
12	Reserved
* OP INC is also set	

Table 5-8. Reject Codes (Sheet 2 of 2)

REJECT CODE (HEX)	DESCRIPTION
13	A backward-type command (except a rewind or a rewind/unload command) was given, but tape was already positioned at BOT.
14*	The ARA BURST portion of the GCR ID-burst just written did not have all nine tracks active.
15*	An IBG longer than 25 feet in PE mode or longer than 15 feet in GCR mode was detected on a read or space-type command.
16	More than one speed change requested without an intervening motion command.
17	Reserved
18*	The MTS is not in the recording density selected.
19	LWR attempted when tape loaded and positioned off BOT
1A*	No tape motion.
1B*	During a readback check of a write operation, data was detected in an IBG area.
1C	Reserved
1D*	The MTS attempted to backspace over a bad record just written but was unable to detect the record.
1E*	The ARA ID burst was unreadable during a GCR write command.
1F*	During the readback check of a write or write tape mark command, no data was detected.
* OP INC is also set.	

5.6.1.1 RUN DIAGNOSTIC PACKAGE (BYTE 1 = 01)

This operation invokes the execution of all internal diagnostics. This includes power up (not including memory test), Loop Write to Read, Transport, and Read/Write diagnostics. Formatter Busy (FFBY) is reset when tests are completed or an error is detected. At this time status may be retrieved (see Read Extended command) to determine completion status.

5.6.1.2 RUN LOADED DIAGNOSTICS (BYTE 1 = 02)

This operation invokes the execution of all diagnostics executable on a loaded transport, and which do not require unloading of the MTS. These include Loop Write to Read, Transport, and Read/Write diagnostics. Formatter Busy (FFBY) is reset when test are completed or an error is detected. At this time status may be retrieved (see Read Extended command) to determine completion status.

5.6.2 Loop Write to Read (01111)

This command provides a means of testing the read and write data circuit paths within the MTS. Read signals are looped within the MTS from the write circuits to the read circuits. No tape motion takes place during the execution of this command. This command is not allowed if tape is loaded and positioned away from Beginning Of Tape (BOT). Errors, if any, are reported the same as if a normal write command took place. If the command is issued with the tape loaded and not at BOT, a REJECT will result.

5.6.3 Initiate Status Sequencer (10000)

This operation initiates and sequences the status line test portion of the interface test. Following the initial Initiate Status Sequencer (ISS) command (at which time FGO is also asserted), all status except Online Status (FONL) is reset. Each subsequent assertion of FGO results in the setting of a single status line in addition to FONL, and the resetting of Formatter Busy (FFBY). The order of status assertion is shown in Table 5-9.

To complete this test, the user may issue the 14th FGO (the command sent with FGO will not be performed), or reset the subsystem by dropping Formatter Enable (FFEN). Note that the subsystem must be reset should the testing stop in mid-sequence.

Table 5-9. Status Line Assertion for ISS Command

FGO NO.	ASSERTED STATUS
1	initial FGO, all status except FONL is reset
2	ID Burst (FID)
3	Data Busy (FDBY)
4	Hard Error (FHER)
5	File Mark (FFMK)
6	Corrected Error (FCER)
7	End Of Tape (FEOT)
8	Load Point (FLDP)
9	File Protected (FFPT)
10	High Speed (FHSPD)
11	Density Status (FGCR)
12	Formatter Ready (FRDY)
13	Rewinding (FRWD)
14	normal (no action on command)

5.6.4 Command to Status Wrap (10001)

This operation initiates a continuous wrapping of incoming command lines to outgoing status lines. This allows the host to verify functionality of command lines via the status lines. The transfer of command to status lines occurs following each FGO and is completed with the reset of Formatter Busy (FFBY). The command to status lines mapping is shown in Table 5-10.

Table 5-10. Status Line Assertion For Diagnostic Wrap Mode

INCOMING COMMAND LINES	MAPPED TO STATUS LINES
Command 0 (FERASE)	ID Burst (FID)
Command 1 (FWFM)	Data Busy (FDBY)
Command 2 (FWRT)	Hard Error (FHER)
Command 3 (FREV)	File Mark (FFMK)
Command 4 (FEDIT)	Corrected Error (FCER)
Long Gap (FLGAP)	Load Point (FLDP)
High Speed Select (FHISP)	File Protected (FFPT)
Spare 1	High Speed (FHSPD)
Spare 2	Density Status (FGCR)
Command Offline (FOFL)	Drive Ready (FRDY)
Rewind To BOT (FREW)	Rewinding (FRWD)

Since Command 0 (FERASE) and Command 4 (FEDIT) are active to initiate this operation, the ID Burst (FID) and Corrected Error (FCER) lines are initially asserted. In subsequent commands, however, any combination of command lines may be activated with each assertion of FGO, with resulting output on the status lines. The subsystem remains in this diagnostic mode until Formatter Enable (FFEN) is dropped (subsystem reset).

5.6.5 Data Loopback (1111)

This operation wraps diagnostic write data back to the read bus with no tape motion. Data is transferred (via the Data Write Strobe -FDWDS- request) until Last Word (FLWD) is asserted. Following each FDWDS, a Data Read Strobe (FRSTR) transfers an identical data byte back to the coupler on the read data lines. If even parity is detected on the write data lines, it is regenerated on the Read Bit P (FRDP) line, allowing host verification of the parity checking circuits.

5.6.6 Read Extended Sense (11101)

This command allows the reading of status specifically for use by an external diagnostic package. This command is normally issued following the invocation and completion of internal diagnostics via the Invoke Diagnostics command. This command transfers 56 status bytes with normal Read Sense command protocol. The sense bytes are summarized in Table 5-11 and explained below.

Table 5-11. Diagnostic Sense Bytes Summary

SENSE BYTES	SENSE BYTE DEFINITION
DSB0	Microcode revision (MSBs)
DSB1	Microcode revision (LSBs)
DSB2	Last internal diagnostic executed
DSB3	Return code from last diagnostic
DSB4-7	Reserved
DSB8-23	Status A-0 through A-F (16 bytes)
DSB24-39	Status B-0 through B-F (16 bytes)
DSB40-55	Status C-0 through C-F (16 bytes)

5.7 DETAILED DIAGNOSTIC SENSE BYTES DESCRIPTION

The Read Extended Sense command can retrieve the 56 sense bytes summarized in Table 5-11 above, and explained in the following paragraphs.

5.7.1 DSB0 and DSB1 Description

These two sense bytes together indicate the operational and diagnostic code level installed in the MTS. DSB0 holds the Most Significant Bits (MSBs) and DSB1 holds the Least Significant Bits (LSBs).

5.7.2 DSB2 and DSB3 Description

These two sense bytes together may be used to reconstruct the Fault Code Dictionary specific fault code by the following formula:

$$\text{3-digit fault code} = (\text{DSB2} \times 10 \text{ hex}) + \text{DSB3}$$

For example, when DSB2 = 32 and DSB3 = 11, the specific fault code is calculated as follows:

$$\begin{array}{r} 32 \text{ hex} \times 10 \text{ hex} = 320 \text{ hex} \\ \text{PLUS} \quad \quad \quad \underline{11 \text{ hex}} \\ \text{results in a} \quad \quad \underline{331 \text{ hex}} \text{ specific fault code} \end{array}$$

This fault code is the same as appears on the operator panel during machine operation.

5.7.3 DSB8 Through DSB55 Description

These sense bytes hold status information bytes identified in the Fault Code Dictionary as A-0 through C-F. Each information byte (A-0, A-1, etc.) is located in a specific sense byte identified in Table 5-12.

For example, if there is a reference in the Fault Code Dictionary to 'Status A-8: Data Checks' this refers (according to Table 5-12) to Sense Byte 16, where additional data pertinent to this error condition is stored. The type of additional information stored in A-0 through C-F depends on the type of error encountered.

Table 5-12. A-0 Through C-F Sense Bytes Cross Reference

STATUS CODE	SENSE BYTE	STATUS CODE	SENSE BYTE	STATUS CODE	SENSE BYTE
A-0	8	B-0	24	C-0	40
A-1	9	B-1	25	C-1	41
A-2	10	B-2	26	C-2	42
A-3	11	B-3	27	C-3	43
A-4	12	B-4	28	C-4	44
A-5	13	B-5	29	C-5	45
A-6	14	B-6	30	C-6	46
A-7	15	B-7	31	C-7	47
A-8	16	B-8	32	C-8	48
A-9	17	B-9	33	C-9	49
A-A	18	B-A	34	C-A	50
A-B	19	B-B	35	C-B	51
A-C	20	B-C	36	C-C	52
A-D	21	B-D	37	C-D	53
A-E	22	B-E	38	C-E	54
A-F	23	B-F	39	C-F	55

(INTENTIONALLY LEFT BLANK)

CHAPTER 6

FUNCTIONAL DESCRIPTION

6.1 INTRODUCTION

This chapter provides brief functional descriptions of the circuit cards of the MTS. Although the circuit cards are not repairable in the field, a basic knowledge of the functions of each card may be useful for troubleshooting and repair of the MTS. Refer to Figure 6-1 for a general block diagram of the MTS circuit cards.

6.2 INTERFACE/MICROPROCESSOR (IF CARD)

All functions of the MTS are controlled by the IF interface/microprocessor card (Figure 6-2). The microprocessor responds to commands from the operator panel and the USER, generates control signals for the capstan and reel servo systems, monitors the interlock and fault detection circuits, and provides status information to the operator panel and to the USER.

The 2921 memory is comprised of four EPROMs and the 2922 memory is comprised of five EPROMs, all plugged into sockets. One static RAM chip with 2K of RAM is available for functional and diagnostic storage. Two hundred fifty-six bytes of RAM is used for diagnostic storage and internal loop write to read. The 256 bytes of RAM can be shut off from the Z80 and used as a source and receiver of Simulated Data to provide the ability to run diagnostics in a standalone mode. All Z80 controls and status are sent to and from other circuit cards (DP, WR, SV, and KK) through the Z80 bus.

Functional Code		Diagnostics Code	
50 ips	100 ips	50 ips	100 ips
16K	24K	16K	16K

The oscillator provides a 20.48 MHz reference frequency which is then divided by four to provide the Z80 microprocessor with a 5 MHz input clock. The frequency is divided by eight to provide a 2.5 MHz clock with a 25% duty cycle as master and slave clocks for the LSI chips. Power Up Reset clears all TTL status and starts the Z80 at instruction 0000. A Watchdog Timer is generated

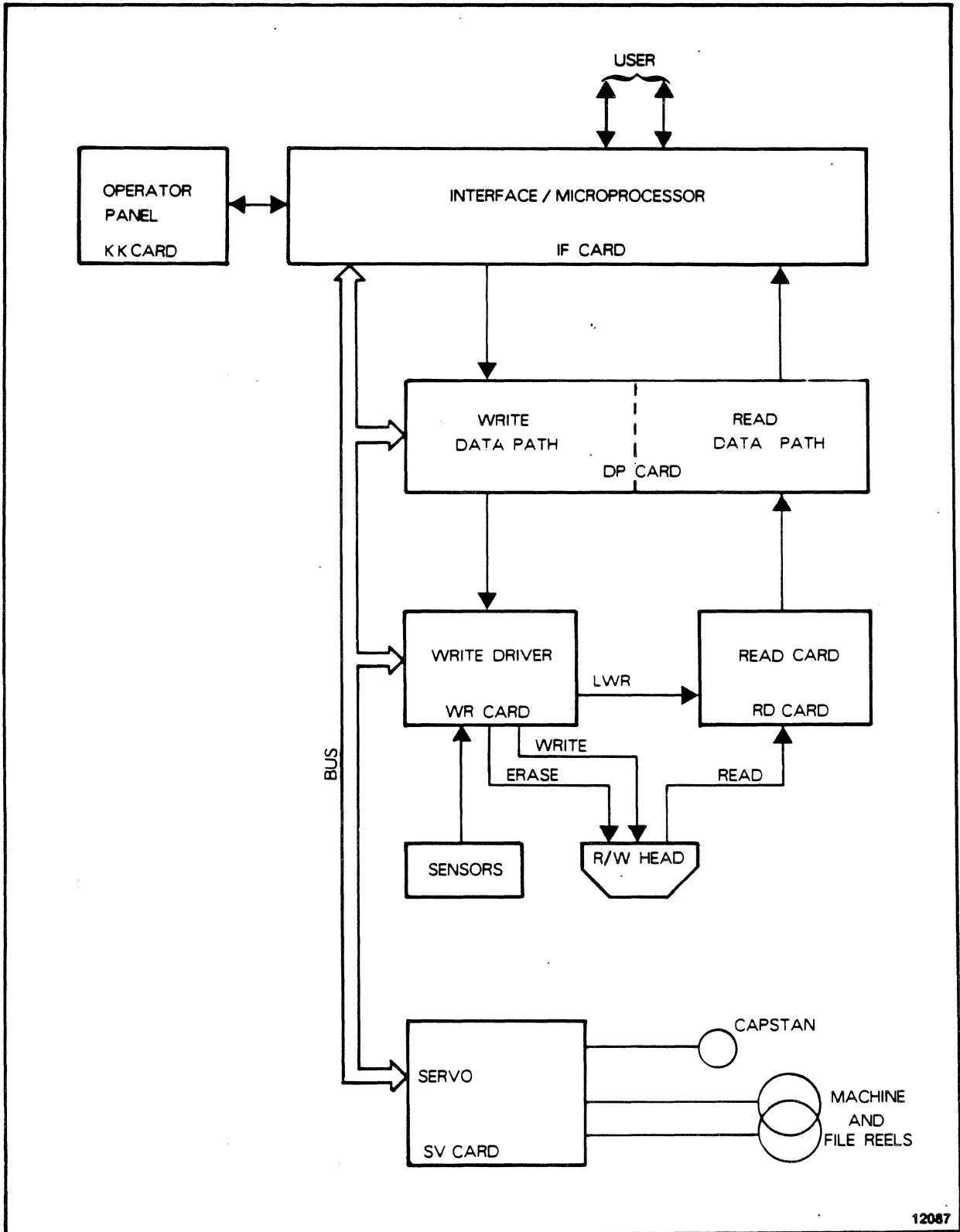

12087

Figure 6-1. MTS Block Diagram

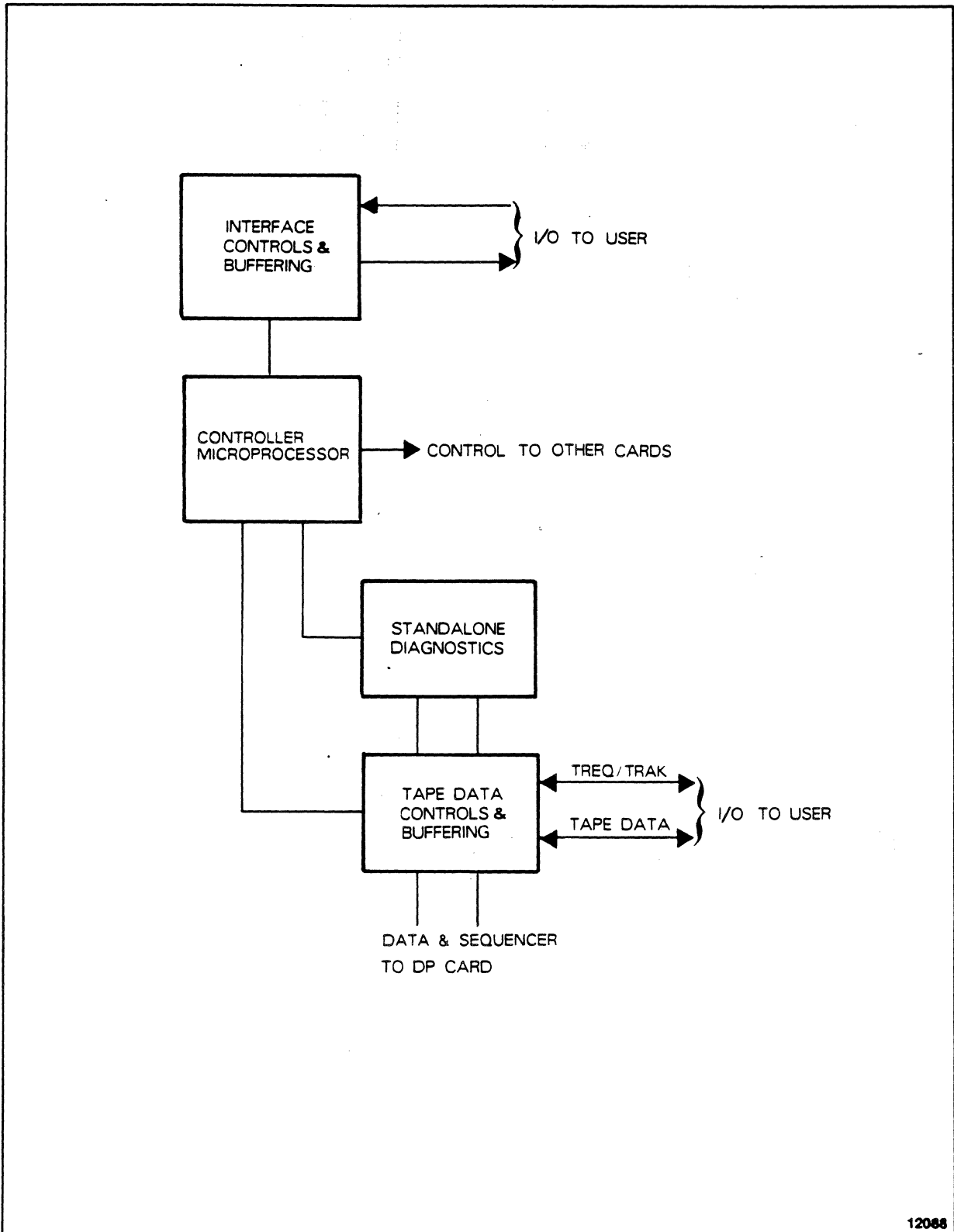

Figure 6-2. Interface/Microprocessor Block Diagram (IF Card)

as a check on the code for the Z80. The Z80 retriggers the Watchdog Timer once every 10 milliseconds; otherwise, a non-maskable interrupt occurs which causes the Z80 to EPO, turning off all servo controls and reinitializing the MTS.

6.3 WRITE DATA PATH (DP CARD)

The write data path of the DP data path card (Figure 6-3) is comprised of two CMOS LSI chips (XWC and XWD) and receives its data from a third dual-purpose LSI chip (XBR). XBR is used in both read and write modes and is used during write operation as a 7-byte FIFO to interface between the IF card and XWC.

Data is input to XBR via TREQ/TRAK handshaking sequences. Once XBR has data ready to be written, it signals XWC by raising Data Available. XWC accepts the data when needed and, upon taking the data, sends XBR a Write Strobe to indicate that the data byte has been accepted. This process continues until the interface raises STOP and XBR signals XWC that the last byte has been taken. Once the data has entered into XWC, check characters are generated for the data and it is clocked into XWD. The data is clocked out of XWD as write triggers.

XWC controls the overall format of data records which are to be written to tape. These records may be written in either PE format (1600 bpi density) or GCR format (6250 bpi density). XWC takes data from an interface data buffer, generates check characters for the data, and strobes the data into XWD.

When writing GCR format records, data bytes are processed in groups of four with the four data bytes being input, strobed into the check character generators, and output to the XWD. When writing PE format records, data bytes are processed one at a time with a data byte being loaded from the interface and then output to XWD.

Four Command lines and one Density Select line are used to control the operation of XWC:

C3	C2	C1	C0	
1	0	0	1	Write Data Record
1	0	1	0	Write ID
1	0	1	1	Write ARA Burst
1	1	0	0	Write ARA ID
1	1	1	1	Write Tape Mark

XWD inputs data from XWC and, in the case of GCR format, performs a 4-to-5 conversion on the data and outputs the data in the form of write triggers. In PE format, data is input from XWC and transformed into two write triggers (Data and Phase).

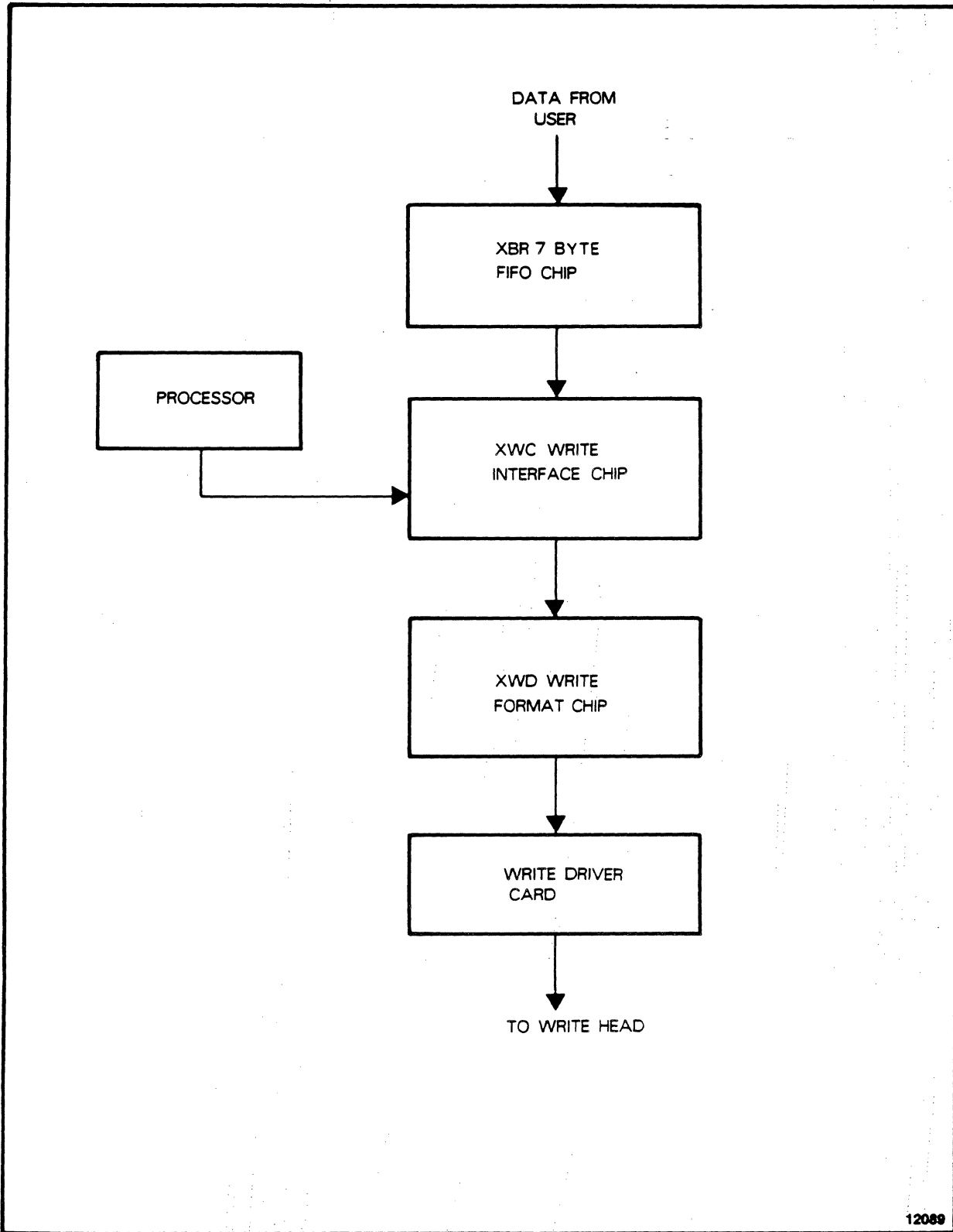

Figure 6-3. Write Path Block Diagram (DP Card)

6.4 WRITE DRIVERS (WR CARD)

The basic write circuits are located on the WR write driver card (Figure 6-4). Erase and write functions are controlled by enables from the IF card. The logic establishes the proper head current for the specific density to be recorded and current sensing on each of the nine tracks is used to verify that write currents are of proper magnitude for the density. Hardware failures resulting in incorrect write or erase current produce a hardware interrupt which immediately stops the tape drive.

The WR card is also used for machine sensor circuits. The sensor circuits are used to detect tape present, BOT, EOT, the tape leader as it passes the entrance to the thread path, and the write enable ring (file protect). The machine reel and file reel index channels and the swing arms extended switch sensors are included on the card.

6.5 READ (RD CARD)

Each of the nine differential analog signals from the read head is amplified, filtered, and differentiated by the analog signal processing circuits on the RD read card (Figure 6-5). The resulting nine analog read signals at the bandpass filter output (+Dif Analog) are available at test points on the card before they are converted to digital read data by the limiter. The nominal single-ended analog signal amplitude, measured peak-to-valley at the test point, is 1.2 volts.

The analog signal at the bandpass filter output is monitored for amplitude integrity by the amp sensor. The analog signal zero-to-peak amplitude is compared to a threshold voltage level: either a fixed DC level, which represents the minimum acceptable worst-case analog amplitude; or an adaptive DC level, which represents a fixed percentage of the zero-to-peak analog amplitude. Whichever threshold voltage is higher at any instant in time will be the amp sensor threshold level. The threshold level is controlled by -Record Latch (-RL), +Write Mode (+WR), and +Write Triggers Active (+WTA). When the analog signal zero-to-peak amplitude is above the threshold level, the amp sense output switches to a high TTL level; when the analog signal level drops below the threshold level, the amp sense output switches to a low TTL level.

The loop write-to-read (LWR) multiplexer selects either Read Data from the limiter in normal operation or Write Triggers from the DP card in test mode.

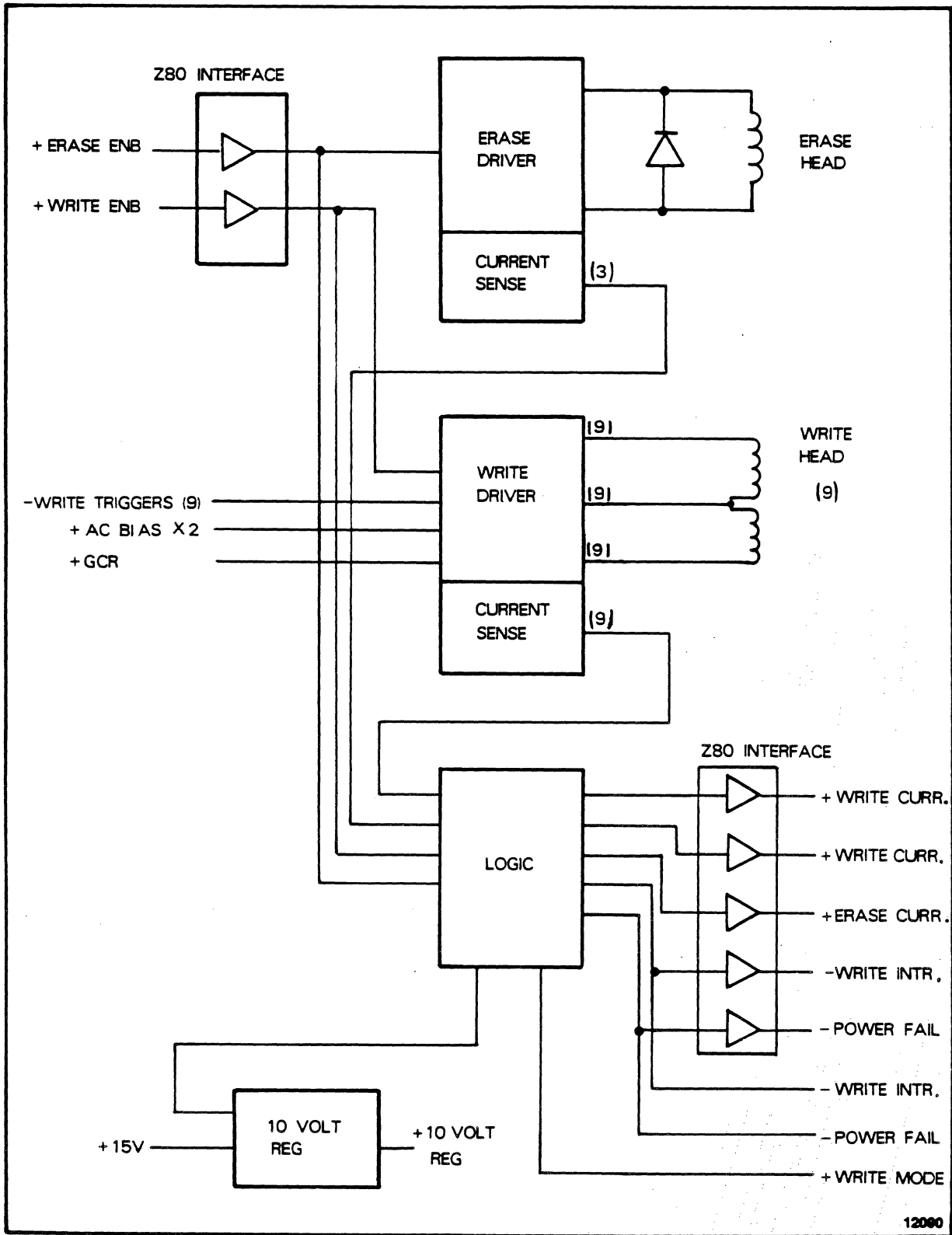

Figure 6-4. Write Driver Block Diagram (WR Card)

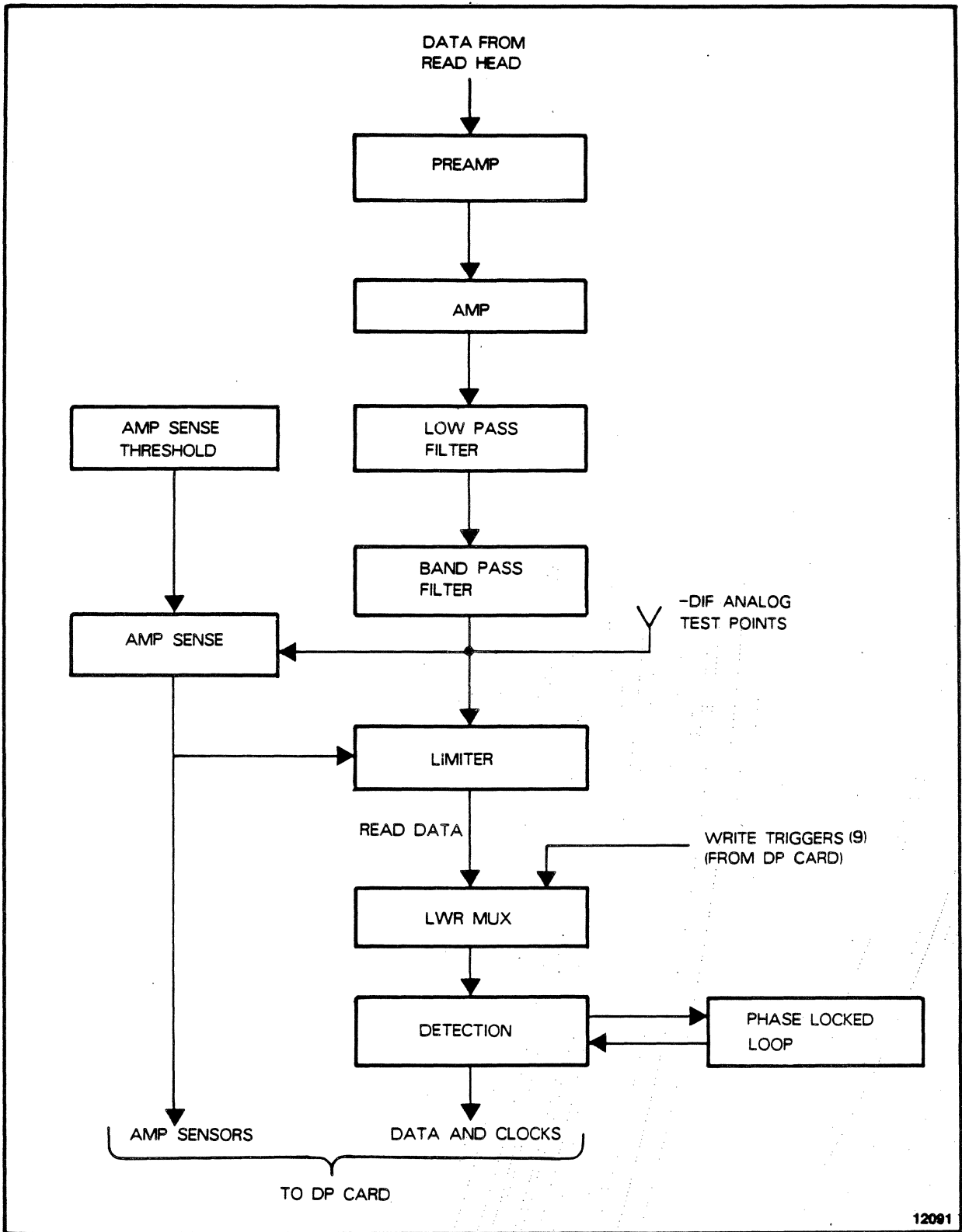

Figure 6-5. Read Block Diagram (RD Card)

Three CMOS LSI chips, each containing three tracks of logic, detect the phase of the data passed through the LWR multiplexer. This phase information is used in the phase-locked loop (PLL) to correct the frequency of the voltage-controlled oscillator (VCO). The VCO output, in turn, clocks the LSI chips at the proper rate in order to track tape velocity. The chips also convert the data from GCR format (6250 bpi density) or PE format (1600 bpi density) to NRZ (non-return-to-zero) format. NRZ data and clocks for each track are output to the DP card.

6.6 READ DATA PATH (DP CARD)

The read data path of the DP card (Figure 6-6) receives its data input from the RD read card. The data is processed on the DP card and output via TREQ/TRAK handshaking sequences to the interface.

6.6.1 PE Operation

PE (1600 bpi density) is handled in 5-byte groups. Data is fed into the XRB skew buffer from the digital detection circuit on the RD read card. Each track sets Track Ready when it has these five bytes available. All Track Ready signals feed XCR. With all tracks ready, a Load Group Buffer pulse occurs followed by four Shift Group Buffer pulses. These five pulses transfer the five bytes from XRB to XEC and XBE. The data is actually stored only in XBE while XEC inputs each byte into the error correction system. After the fourth Shift Group Buffer, XEC sets ECC Full, preventing more transfers from XRB.

No correction cycle is required as correction is done on-the-fly; therefore, a Shift Out Mode is immediately initiated. During Shift Out Mode, data in XBE is transferred into the XBR data buffer with XEC supplying the proper correction. After the Shift Out Mode, ECC Full is reset and XRB can supply another 5-byte group to the XEC and XBE.

XBR now contains five bytes of corrected data, ready to be transferred to the interface; however, because of the method of PE end-of-data detection, XBR inhibits data transfer until it sees that ECC Full is set again. This is done so that a look-ahead function can be performed for determining PE end-of-data. This function checks the next group (the one in the XBE buffer) for four bytes of all-ZEROs. If the ending all-ONES byte of PE data is present on the output of XBR and the following four bytes are all-ZEROs, PE end-of-data is declared and the read process is stopped.

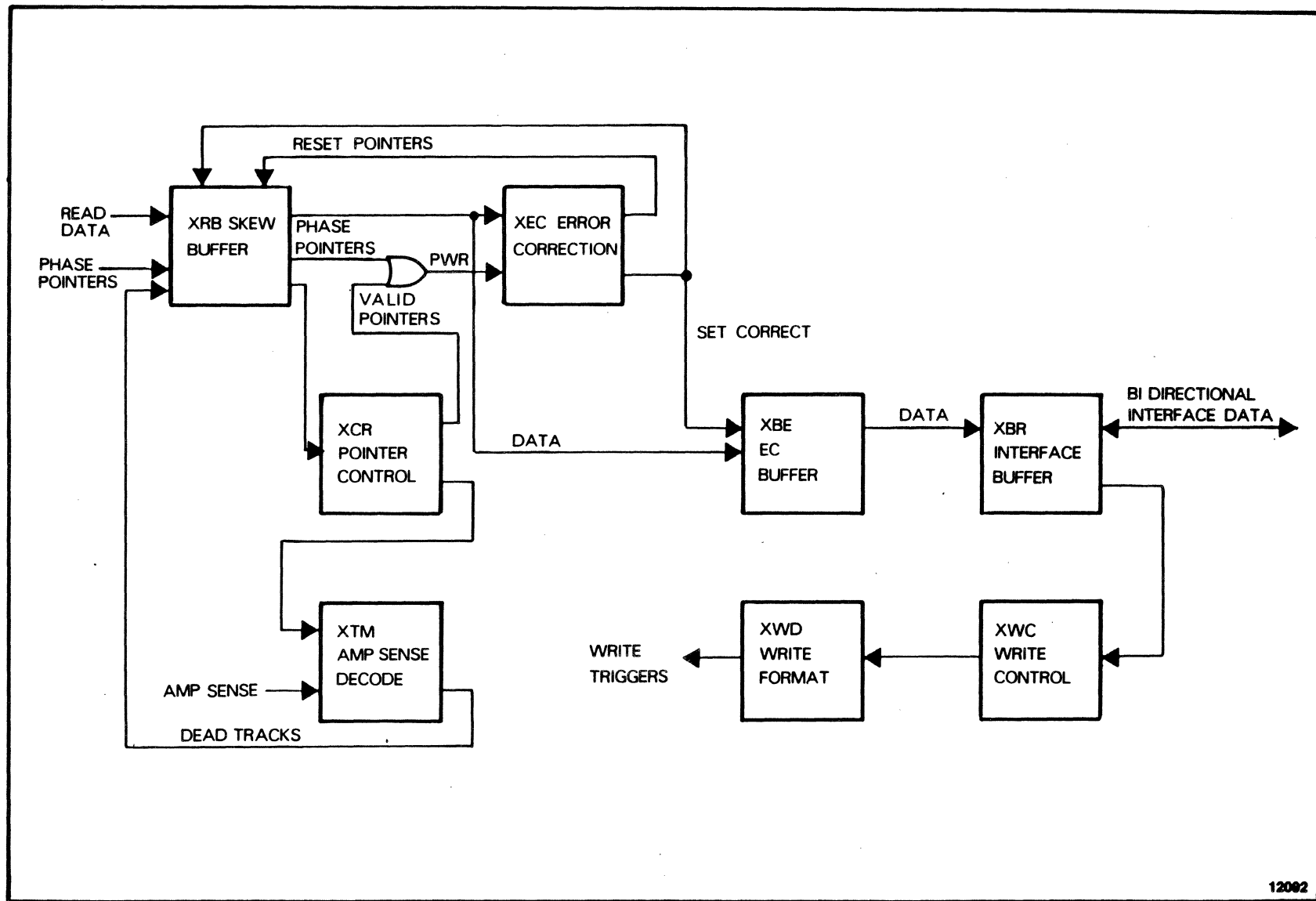

Figure 6-6. Read Path Block Diagram (DP Card)

With XBR Buffer Full and ECC Full set, the interface data transfer is started via TREQ/TRAK handshake sequences. The XBR buffer will now be empty, allowing XEC to transfer another group out of the XBE buffer and into the XBR buffer. End of Data is set by XBR immediately after the last byte of data has been transferred to the interface.

6.6.2 GCR Operation

Handling of GCR (6250 bpi density) data differs slightly from that of PE. The major difference is that GCR data is handled in 8-byte groups. XRB assembles a 4-byte subgroup and sets Track Ready. These four bytes are then transferred to XEC and XBE with the four Shift Group Buffer pulses. The Load Group Buffer signal does occur but data is not transferred with it; it is used by XEC to initialize registers between groups and by XBE to count groups. The next 4-byte subgroup is transferred from XRB and then ECC Full is set. XEC handles inputting of data to XBE by propagating Shift Group Buffer pulses. The ECC byte present in each 8-byte group is stripped from the group by XEC by blocking the last Shift Group Buffer (first Shift Group Buffer when reading backward) to XBE.

XEC now determines if a correction cycle is necessary and, if not, Shift Out Mode begins immediately. If correction is required, Shift Out Mode will be delayed by as much as 2.8 microseconds for 50 ips and 1.75 microseconds for 100 ips, the maximum duration of a correction cycle. Shift Out Mode is set for seven cycles (2.8 microseconds for 50 ips and 1.75 microseconds for 100 ips), during which time the seven bytes in XBE are transferred to the XBR data buffer while being corrected. XBR does not need to wait for another ECC Full to transfer data, so it will do seven transfers to the interface. The Shift Out Mode which filled the XBR buffer causes XBR Buffer Full to set and also causes ECC Full to reset. While XBR is transferring data to the interface, XRB may start filling XEC and XBE again. XEC may not do another Shift Out Mode until XBR has completed the seven transfers at which time it will reset XBR Buffer Full.

XBE determines the presence of the GCR format groups based on information supplied by XRB and XCR. XCR determines when End Mark is in XRB by looking at Sync Mark and Format signals from XRB. When End Mark is in XRB, XCR issues a Load Group Buffer pulse without any Shift Group Buffer pulses. End Mark is not loaded into XEC and XBE. In read forward, the next group is the Residual Group which is transferred from XBE to XBR while the Residual Group signal is on. This causes XBR to hold the Residual Group until the following CRC Group can be received and the residual byte of the CRC Group can be determined. The residual byte

informs XBR how many bytes in the residual group are data and which are pads. At this time the last data transfers of the record occur and End of Data is set.

In GCR backward operations, the CRC and residual groups must be handled first and then operate as in forward read operations. The CRC Group comes into the XBR buffer first. The residual character is saved and the buffer waits for the residual group to be loaded. When it is in XBR, it determines the number of valid data bytes in the group and transfers them to the interface. The rest of the record is then processed normally. XBR does not do End of Data detection in GCR for read backward; XBE performs this function by sensing that the Mark 1 character has been detected and the appropriate number of ONEs in the preamble have been checked. End of Data is set after the last data byte has transferred.

6.7 SERVO SYSTEM (SV CARD)

The SV servo card contains the analog and digital circuits which comprise the capstan servo system, the two reel servo systems, the swing-arm retraction motor control, the emergency power-off (EPO) logic and relay control, and the servo power failure detector.

The SV card interfaces to the system microprocessor (which resides on the IF card); to the optical encoders, which are the servo transducers for the capstan motor and the swing-arms; to the capstan, reel, and arm retraction motors; to the EPO relay; and to the power supply. All of the interfaces are via connectors on the motherboard.

The capstan servo system (Figure 6-7) consists of a CMOS LSI controller which operates in conjunction with the system microprocessor. This LSI circuit generates digital commands which are converted to an analog voltage via a digital-to-analog converter (DAC). A linear power amplifier converts this voltage to motor drive current.

The reel servo system (Figure 6-8) consists of a CMOS LSI controller which operates in conjunction with the microprocessor. Digital commands to a set of twin DACs and pulse-width modulated power amplifiers generate the currents for the two reel motors.

The swing-arm retraction motor control is a bipolar power switch which operates under logical control of the microprocessor together with the reel servo controller chip.

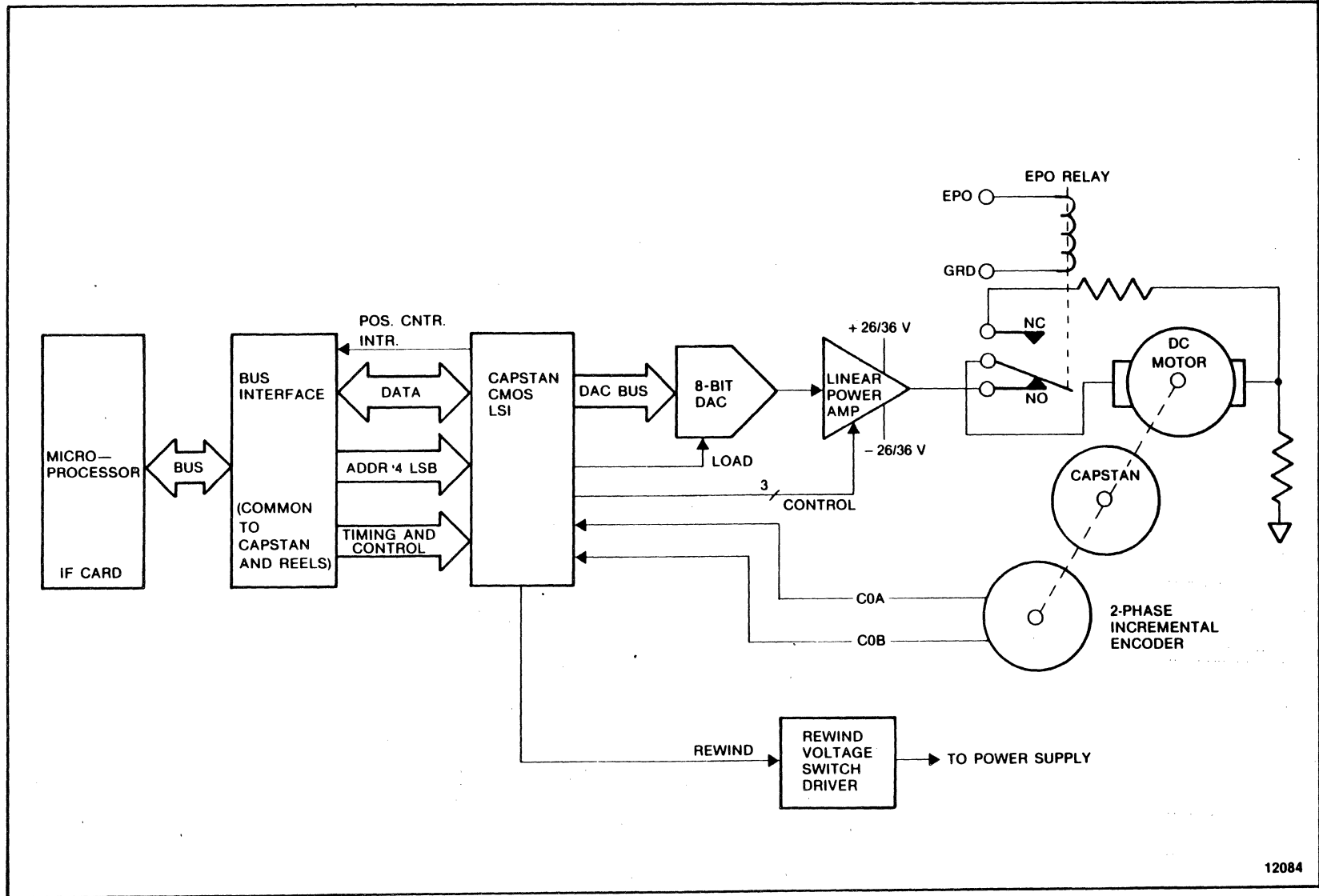

12084

Figure 6-7. Capstan Servo System Block Diagram

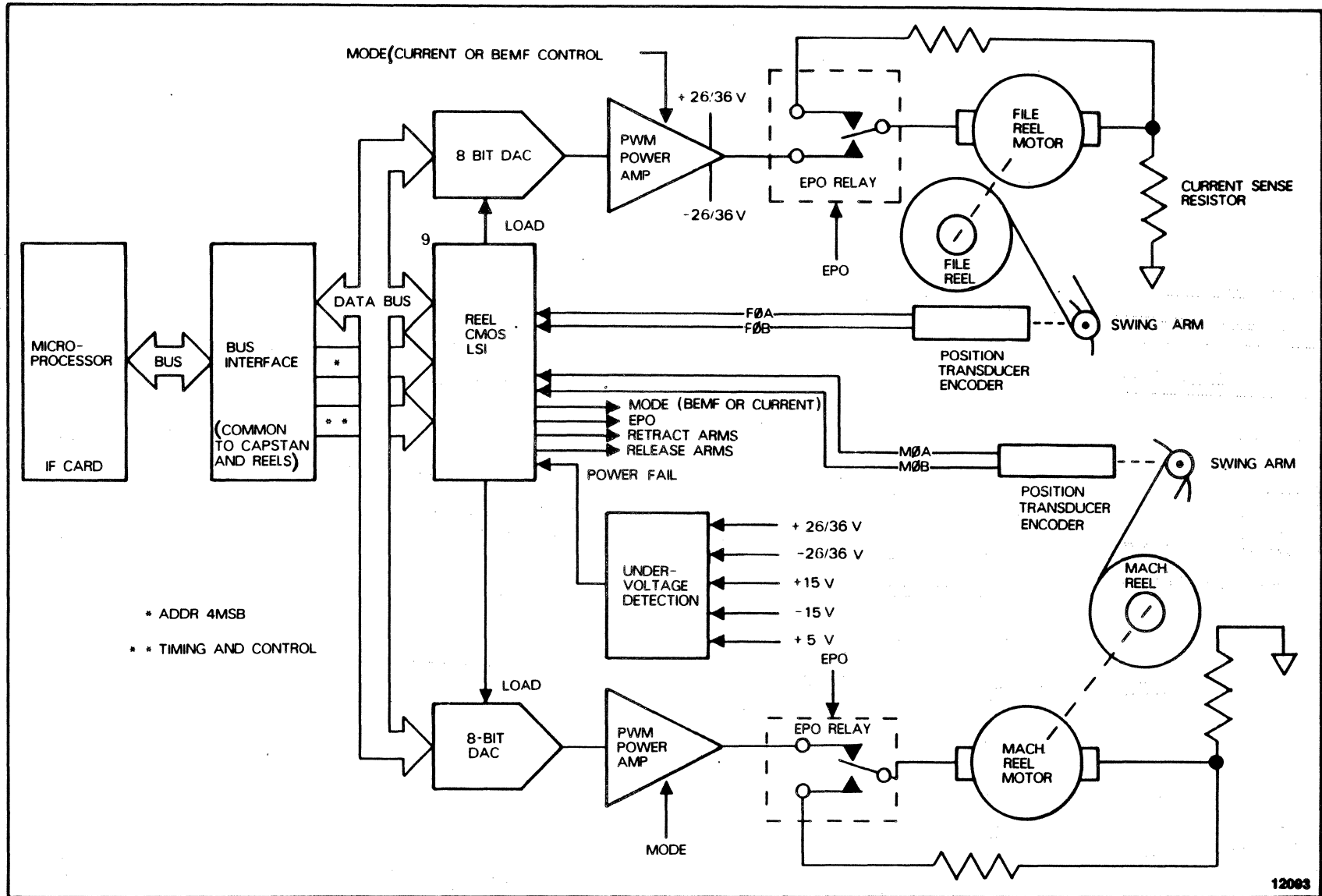

Figure 6-8. Reel Servo System Block Diagram

The EPO relay control consists of logic in the reel servo controller chip which generates the logical function that controls a regulated relay driver.

The power failure detector is a set of voltage comparator circuits which monitor the $\pm 26/36$ volt and ± 15 volt power supplies for undervoltage. This circuit generates a logic signal which is one of the elements of the EPO control.

6.8 POWER SYSTEM

The power system is comprised of the main circuit breaker, the Power On/Off switch on the operator panel, a line filter, transformer, AK regulator card, PK protection card, and NK regulator card. Refer to Figure 6-9 for a simplified block diagram of the power system.

The power system provides logic voltages for the electronics and power voltages for the capstan and reel motor drives as well as the vacuum blower motor. In addition, 120 Vac is provided for the the cooling fan.

Overcurrent protection is provided by the PK protection card which will trip the main circuit breaker remotely if any power system output is shorted. A short on the primary will also trip the main circuit breaker. If an overvoltage of 5.7 volts (or higher) occurs on the +5 Vdc output, fuse F2 on the AK regulator card will open.

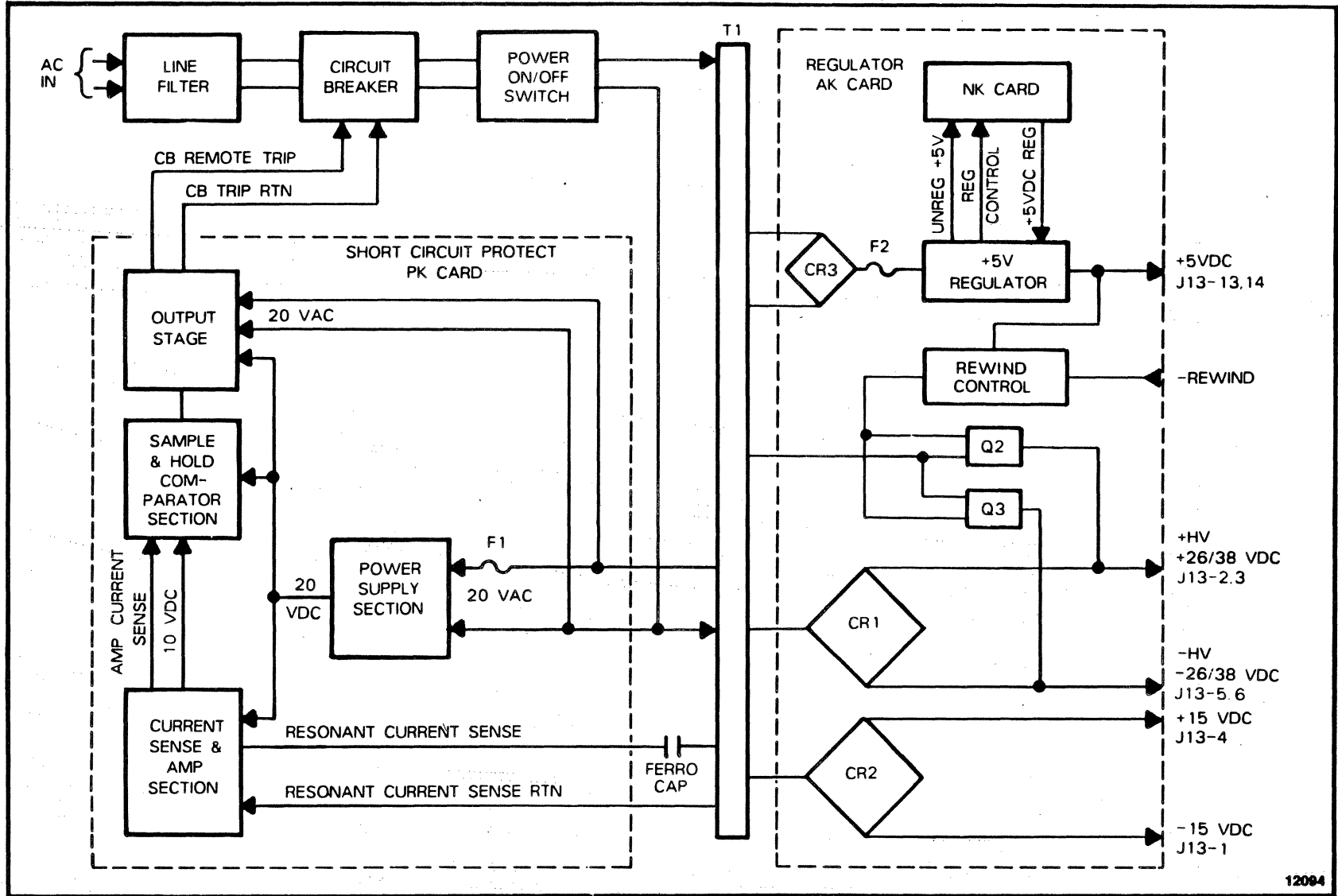

12094

Figure 6-9. Power System Block Diagram

CHAPTER 7

MAINTENANCE

7.1 INTRODUCTION

This chapter provides instructions for the performance of maintenance procedures. Some of these procedures must be performed quarterly to ensure proper operation and at such times the MTS does not perform according to specifications. Other procedures should be performed only after parts replacements, or if the scheduled maintenance so indicates, as explained in the text. Should there be a defective part, Chapter 8 provides instructions for changing field replaceable parts. Operating procedures for maintenance programs are described in Chapter 9.

7.2 QUARTERLY PREVENTIVE MAINTENANCE CHECKLIST

The following is a checklist of the routine preventive maintenance to be performed quarterly by trained personnel.

1. With power off, check the file reel hub for free operation. Thoroughly clean as necessary with Hub and Transport Cleaner Fluid.
2. Remove the tape cleaner block. (Refer to Chapter 8 for removal procedures.) Thoroughly clean the block with Hub and Transport Cleaner Fluid. Inspect the cleaner block blade for damage in the form of scratches or nicks and replace the block if it is damaged.
3. With power on, ensure that the cooling fans are operating.
4. Check the power supply output levels. (Refer to Section 7.3.)
5. Check the file protect mechanism for proper operation using a work tape, both with and without a write enable ring installed. The Write Protect indicator light should be on with ring removed, and off with ring installed.
6. Check rewind for proper operation. Rewind time is about 2.5 minutes for 2400 feet of tape.
7. Check the read/write head for proper skew alignment, and adjust skew as necessary. (Refer to Section 7.5)
8. Check the read output amplitudes. (Refer to Section 7.7)

7.3 QUARTERLY POWER SUPPLY CHECK

The power supply output voltage levels are not adjustable. A failing voltage may be due to power supply or voltage regulator failure, or a defective circuit board. The tape may be loaded but should not be in motion except for checking the ± 38 Volts, when tape must be in rewind mode.

Voltage test points are on motherboard slot A1. Use pin B01 at slot A3 for ground.

Test Point	Voltage
A01	+5.1 (± 0.25) Maximum ripple: 100 mV P-P
C03	+15 (+1.0, -1.5)
C01	-15 (+1.0, -1.5)
C05	+26 (± 4.0)
C17	-26 (± 4.0)
C05	+38 (32-42) In rewind only
C17	-38 (32-42) In rewind only

7.4 TAPE TRACKING AND SKEW ADJUSTMENT AFTER PARTS REPLACEMENT

Tape tracking and skew checks should be performed when any of the following components are replaced:

- Upper Swing Arm
- Lower Swing Arm
- Capstan
- Capstan Motor
- Read/Write Head
- Upper Tape Guide

An understanding of tape tracking and skew requirements is helpful in the performance of the capstan alignment (tape tracking) and read/write head alignment (skew) procedures: alignment of the capstan to the tape path assures that the tape does not take an angular path across the read/write head; alignment of the read/write head assures that the head is properly aligned with the tape. All tape tracking and skew alignment adjustments must be done with the MTS in 50 IPS mode.

Initial tape tracking adjustments are made visually to set coarse alignment and then a skew tape and oscilloscope are used for the final alignment to detect static and dynamic skew variations. Static skew, as shown in Figure 7-1, is the time from the peak of the bit used for the scope sync to the peak of any other bit. Dynamic skew, also shown in Figure 7-1, is the width of the variation or flutter of the bit not used as the scope sync. The two outside tracks (4 and 5) are used to check final alignment.

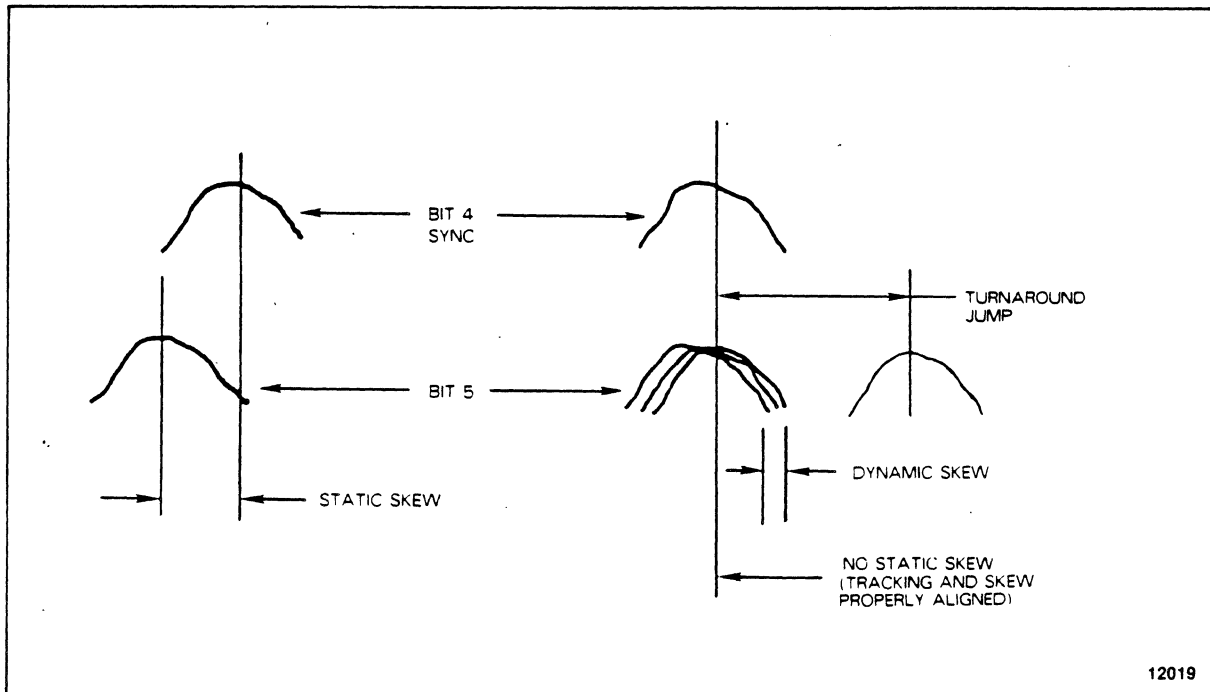

Figure 7-1. Static and Dynamic Skew and Turnaround Jump

7.4.1 Capstan Alignment (Tape Tracking)

The capstan motor is mounted with three spring-loaded screws. Adjusting the screws will influence the lateral position of the capstan wheel. The capstan wheel must be positioned so that the tape travels properly in the tape guide, as in the following procedure:

1. Open the threading cover and remove the outer flange from the upper tape guide.
2. Close the threading cover, mount and load a known good scratch tape, then open the threading cover to provide access for checks and adjustments.
3. Enter maintenance program 00 to move tape forward. Ensure that tape is flush with but not forced against the rear flange of the upper guide and is not riding over the front of the upper guide. If necessary, adjust capstan motor mounting screw 3. Refer to Table 7-1 and Figure 7-2.

4. Enter maintenance program 02 to perform the shoeshine routine (forward/backward tape motion). Ensure that tape is not pushed against the back flange or hanging over the front of the tape guide in either forward or backward motion.

Table 7-1. Capstan Alignment Instructions

CONDITION	ADJUSTMENT
Tape tracks to front edge in both forward and backward	Turn screw 3 CW
Tape tracks to back edge in both forward and backward	Turn screw 3 CCW
Tape tracks to back in forward and tracks to front in backward	Turn screw 1 CW or turn screw 2 CCW
Tape tracks to front in forward and tracks to back in backward	Turn screw 1 CCW or turn screw 2 CW

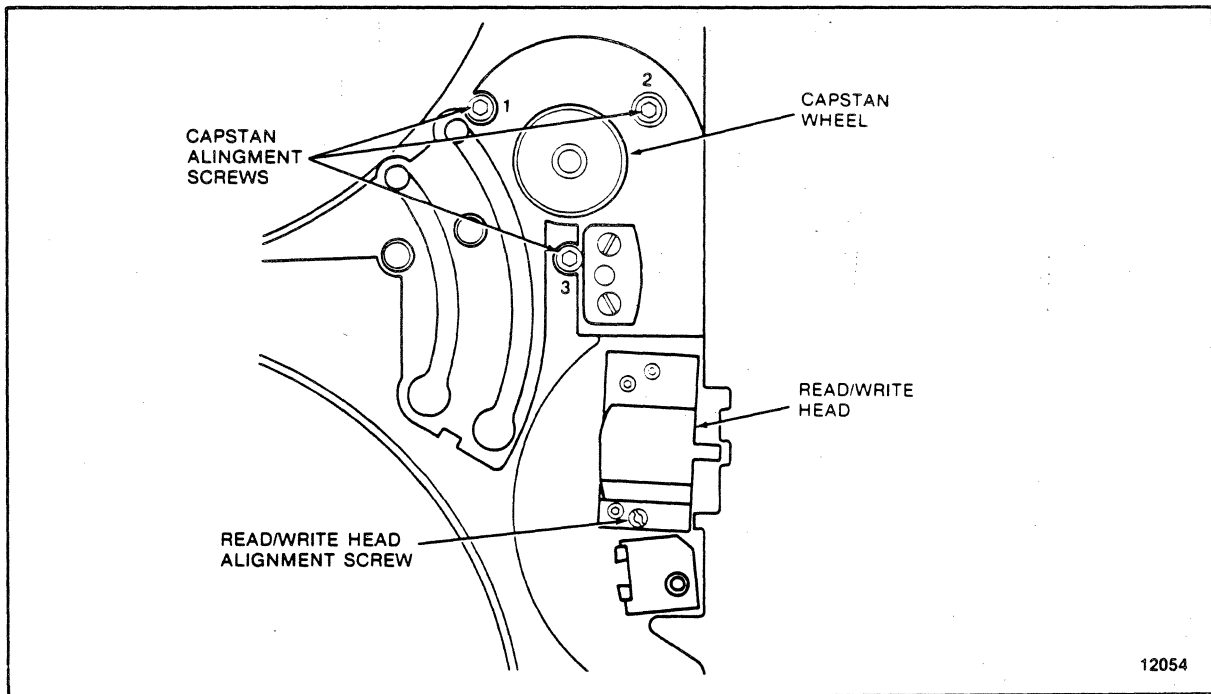

Figure 7-2. Capstan and Read/Write Head Alignment

If necessary, use instructions in Table 7-1 and Figure 7-2 to adjust tracking so that the tape travels in the same position on the guide in both forward and backward directions.

Ignore at this time any tape jump which may be present just as the capstan changes direction; do not attempt to adjust out the jump.

5. Check tape position on the capstan wheel. Ensure that tape tracks towards center of the capstan wheel and does not overhang the wheel on either side. If necessary, adjust motor mounting screw 3 as in step 3 above. If an adjustment was necessary, repeat step 4 above.
6. Unload and remove the scratch tape and reinstall the outer flange of the upper tape guide.

7.4.2 Head Skew Adjustment

The head skew must be adjusted so that all bits of a data byte will come under the R/W head within a specified time window. The adjustment also ensures that the head is not so skewed that it reads bits from more than one data byte at a time.

1. With power off, remove the card cage cover and disconnect the write head cable from the front of the WR card (slot A4).
2. With power on, mount and load a master alignment tape without a write enable ring. Tape must meet the requirements of Storage Technology specifications. Ensure the File Protect indicator is illuminated at the completion of the load.

CAUTION

Never do a high speed rewind on a master alignment tape.

3. Connect a dual-trace oscilloscope channel 1 to bit 4 (TP 4) on the RD card (slot A6) and channel 2 to bit 5 (TP 5). (Refer to Figure 7-3) The scope settings should be as follows:

Sweep	5 microseconds/division
Trigger	Negative Slope
	Channel 1 Only
	Internal
	HF Reject
	Normal
Mode	Chopped
Channel 1	50 millivolts/division
Channel 2	50 millivolts/division

4. Enter maintenance program 00 to move tape forward. Adjust the read/write head alignment screw (Figure 7-2) until forward skew is less than 1 microsecond and as close as possible to 0.
5. Ensure that the the R/W head skew is not out of alignment by one or more bytes. Do this by monitoring all bits with scope channel 2 (see Figure 7-3 for test points). The head is out of alignment when any bit shows a phase loss or a phase shift on the scope.
6. If the head is out of alignment, do Steps 7 and 8. If the head is properly aligned, go to step 9.
7. Move scope channel 2 up to bit 6 (TP 6) (refer to Figure 7-3). Adjust the head alignment screw to align bits 4 and 6. Move channel 2 to the next bits in the following order:

0, 1, 2, p, 3, 7

If any bit is not aligned, again adjust the alignment screw. Continue until all bits have been checked and aligned.

8. Repeat Step 4
9. Move scope channel 2 to all other bits (7,3,p,2,1,0,6 - refer to Figure 7-3) and verify that none of the bits has a skew greater than ± 2.5 microseconds. If any bit exceeds this allowance, the head should be replaced and the entire tape tracking and skew adjustment must be repeated.
10. Enter maintenance program 01 to move tape backward. With scope channel 1 still on bit 4 (TP 4) and channel 2 on bit 5 (TP 5), adjust capstan motor mounting screw 1 or 2 very slightly until backward static skew is less than 1 microsecond and as close as possible to 0.
11. Enter maintenance program 00 to move tape forward. Ensure that forward static skew is still less than 1 and close to 0 microseconds. If necessary, readjust the read/write head

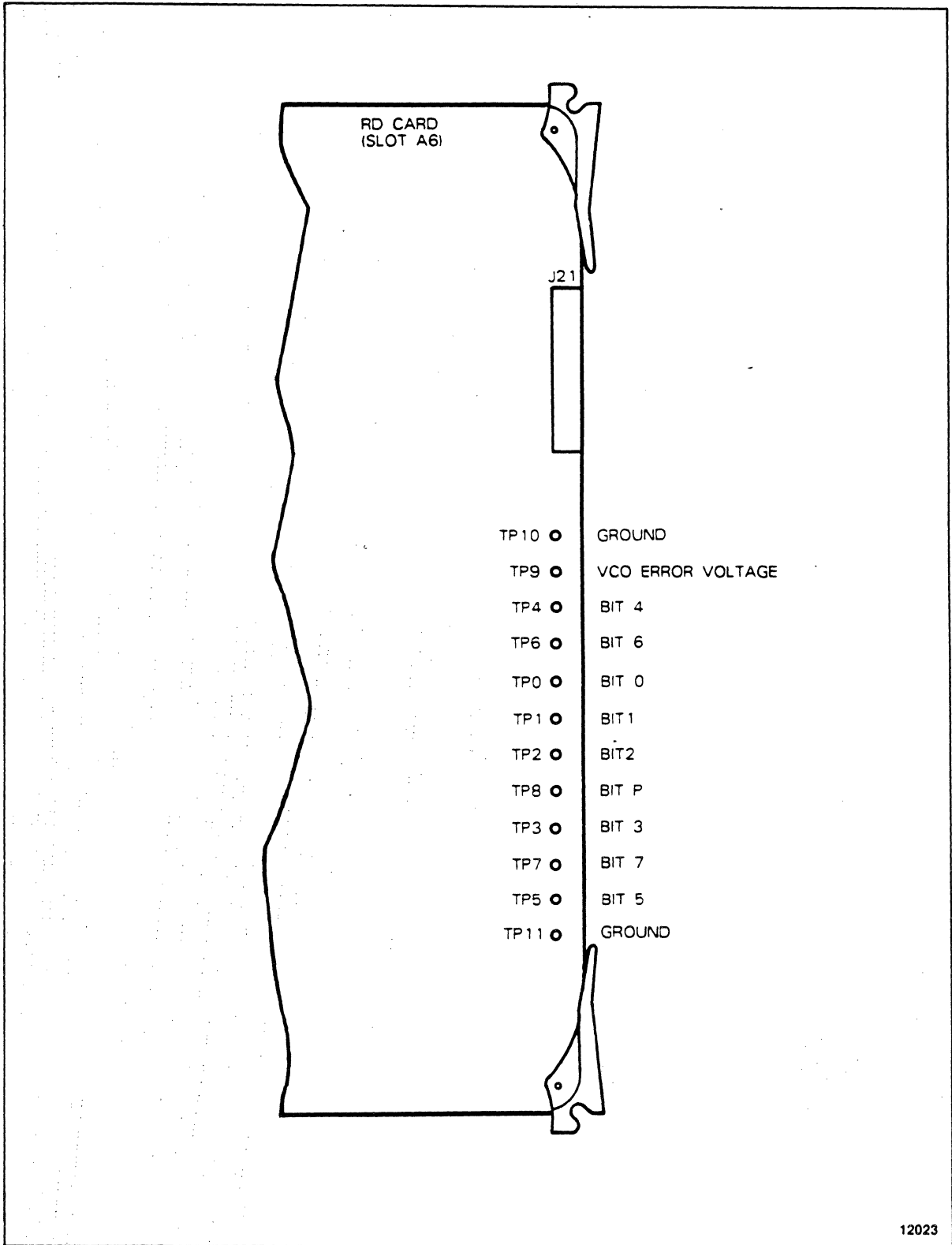

Figure 7-3. +Dif Analog Test Points

alignment screw. (It may be necessary to perform steps 10 and 11 three or four times to ensure that forward and backward skew are negligible.)

12. Enter maintenance program 02 to perform the shoeshine routine. Examine closely the upper tape guide and ensure that tape is not forced to the guide flanges. This can be best accomplished by removing the outer flange of the upper guide and ensuring that tape does not overhang the guide. Reinstall the flange when the check is completed.
13. If necessary, very slightly adjust capstan motor mounting screw 3. If this adjustment is made, return to step 10

Failure to achieve proper alignment may require reperforming this procedure or may indicate a defective component in the tape path, such as bent swing arm, a defective capstan, or a burred or nicked tape guide or flange. A bent swing arm is often characterized by excessive tape jump on the capstan as tape direction changes.

14. Measure the dynamic skew (timing jitter) using the following measurement technique:
 - a) Enter maintenance program 00 to move tape forward.
 - b) Sync scope on Bit 5 and measure the timing width of the scope trace at 0 Vac point (50% point of peak-to-peak transition),
 - c) sync scope on Bit 4 and measure the total time width (jitter) of Bit 5 scope trace at 0 Vac point,
 - d) The dynamic skew is equal to the measurement of Step c minus the measurement of Step b. It must be equal to or less than 7.0 microseconds.
 - e) Enter maintenance program 01 to move tape backward and repeat Steps b through d to measure backward dynamic skew. It must be equal to or less than 7.0 microseconds.
15. If dynamic skew is not within specifications, check for defective tape path parts. If any parts must be replaced, repeat entire tape tracking and skew adjustment procedure.
16. When the tracking and skew requirements are met, unload and remove the master alignment tape. With power off, reconnect the cable to the WR card and reinstall the card cage cover.
17. Run all internal diagnostics.

7.5 QUARTERLY TAPE SKEW CHECKS

This procedure checks whether tape skew has remained within an allowable range. A greater skew tolerance than in the previous calibration procedure (Section 6.4.2) is allowed. If any of the measurements below do not fall within specifications, the entire tape tracking and skew adjustment procedure (Section 6.4) must be performed.

1. With power off, remove the card cage cover and disconnect the write head cable from the front of the WR card (slot A4).
2. With power on, mount and load a master alignment tape without a write enable ring. Tape must meet the requirements of Storage Technology specifications. Ensure the File Protect indicator is illuminated at the completion of the load.

CAUTION

Never do a high speed rewind on a master alignment tape.

3. Connect a dual-trace oscilloscope channel 1 to bit 4 (TP 4) on the RD card (slot A6) and channel 2 to bit 5 (TP 5). The scope settings should be as follows:

Sweep	5 microseconds/division
Trigger	Negative Slope
	Channel 1 Only
	Internal
	HF Reject
	Normal
Mode	Chopped
Channel 1	50 millivolts/division
Channel 2	50 millivolts/division

4. Enter maintenance program 00 to move tape forward. Ensure forward skew is equal to or less than 4 microseconds.
5. Enter maintenance program 01 to move tape backward. With scope channel 1 still on bit 4 (TP 4) and channel 2 on bit 5 (TP 5), ensure that backward static skew is equal to or less than 4 microseconds.
6. Measure the dynamic skew (timing jitter) using the following measurement technique:
 - a) Enter maintenance program 00 to move tape forward.

- b) Sync scope on Bit 5 and measure the timing width of the scope trace at 0 Vac point (50% point of peak-to-peak transition),
- c) sync scope on Bit 4 and measure the total time width (jitter) of Bit 5 scope trace at 0 Vac point,
- d) The dynamic skew is equal to the measurement of Step c minus the measurement of Step b. It must be equal or less than 7.0 microseconds.
- e) Enter maintenance program 01 to move tape backward and repeat Steps b through d to measure backward dynamic skew. It must be equal to or less than 7.0 microseconds.

7.6 BIT POSITION CHECK AFTER PART REPLACEMENT

This check is required only if a component in the tape path was replaced, including the R/W head, and the subsequent tape tracking and skew adjustment performed. This procedure is not required for scheduled maintenance.

In the rare occasions when the shimmed skew block is replaced, it is the most likely reason for bit position problems.

1. Load a reel of blank tape with a write enable ring installed.
2. Enter maintenance program 0F, select 1600 bpi density at BOT, and write all ONEs on all tracks for about 10 seconds.
3. Use tape developer to develop two feet of the recorded tape.
4. Use a magnifier (jeweler's loupe) with a reticle scale to inspect the developed tape. The distance from the edge of tape to the edge of the outside track (physical track 1, bit 5) should be 0.007 ± 0.003 inch (0.178 ± 0.076 mm) (Refer to Figure 7-4).
5. If the outside track does not meet this specification, recheck the capstan alignment.

CAUTION

Cut the developed tape from the reel and place a new BOT marker on the tape. Do not reuse the developed part of the tape as damage to the read/write head could result.

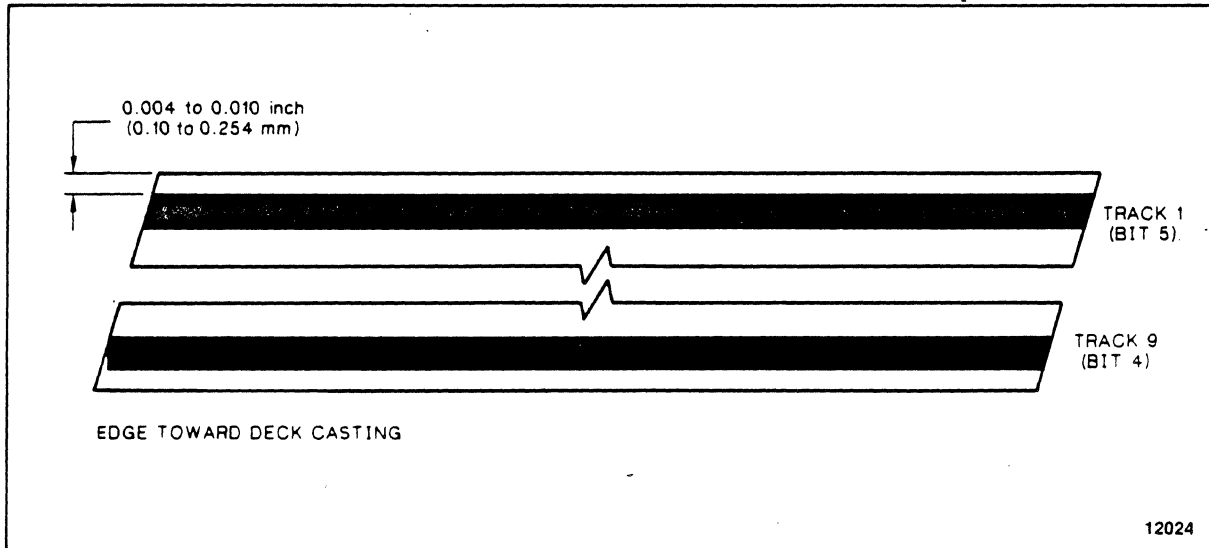

Figure 7-4. Bit Position Check

7.7 QUARTERLY READ AMPLITUDE CHECKS

All amplitude checks must be performed at both 50 IPS and 100 IPS modes. The procedure below gives values for 50 IPS mode checks. Amplitude values at 100 IPS mode must be within 20% of amplitudes at 50 IPS mode.

The read amplitude measurements should be made only after all other measurements, alignments, and checks have been performed.

The amplitude measurements are made on the RD card at the +Dif Analog test points (Figure 7-3). Use an oscilloscope to measure each bit from peak to valley. Ground the scope at one of the two ground test points available on the card.

1. Load a master output tape with a write enable ring installed.
2. While positioned at BOT, select 1600 bpi density with the operator panel Density Select switch. Enter maintenance program 0F to write all-ONES on all tracks. (There should be an X in the display.) The signal amplitude of each bit while writing should be 0.7 to 3.0 volts.
3. Enter maintenance program 00 to perform a read forward operation. The signal amplitude of each bit should be within 10% of the signal amplitude measured in step 2.

4. Enter maintenance program 01 to perform a read backward operation. The signal amplitude of each bit should be within 15% of the signal amplitude measured in step 2.
5. After repositioning tape to BOT, select 6250 bpi density. Enter maintenance program 0F and write a high/low frequency pattern on all tracks. The signal amplitude of each bit while writing should be 0.6 to 3.0 volts.

In 6250 bpi (GCR), Program 0F writes a pattern of all ONEs and then 1/3 all ONEs. The amplitude must be checked on the the all ONEs pattern.

6. Alternately enter maintenance programs 00 and 01 to perform three read passes. On the third read pass (forward), the signal amplitude of each bit should be 90% or greater of the signal amplitude measured in step 5.
7. Enter maintenance program 01 to perform a read backward operation. The signal amplitude of each bit should be within 20% of the signal amplitudes measured in step 6.

CHAPTER 8

REMOVAL AND REPLACEMENT

8.1 INTRODUCTION

This chapter provides removal and replacement procedures. The procedures are arranged by location and/or function under the following major headings:

1. Tape Path
2. Swing Arms
3. Capstan, Reels, and Blower
4. Circuit Cards
5. Power Supply and Fans

To prevent safety hazards and damage to the Magnetic Tape Subsystem (MTS), turn off the main circuit breaker located behind the right front cover before performing any replacement procedure. Certain procedures specify disconnecting the main power cord as well.

Removal of components may require access to rear of MTS casting. To access vertical models, release deck lock shown in Figure 8-1.

NOTE

The cables and connectors mentioned in this chapter are depicted in Chapter 3, Figure 3-1.

8.1.1 Fuses

Four fuses are used in the MTS; their locations and sizes are:

PK Card	1 amp slow blow
AK Card	20 amp fast blow
Retractor Motor (inline)	3/4 amp slow blow
Vacuum Blower (inline)	4 amp slow blow

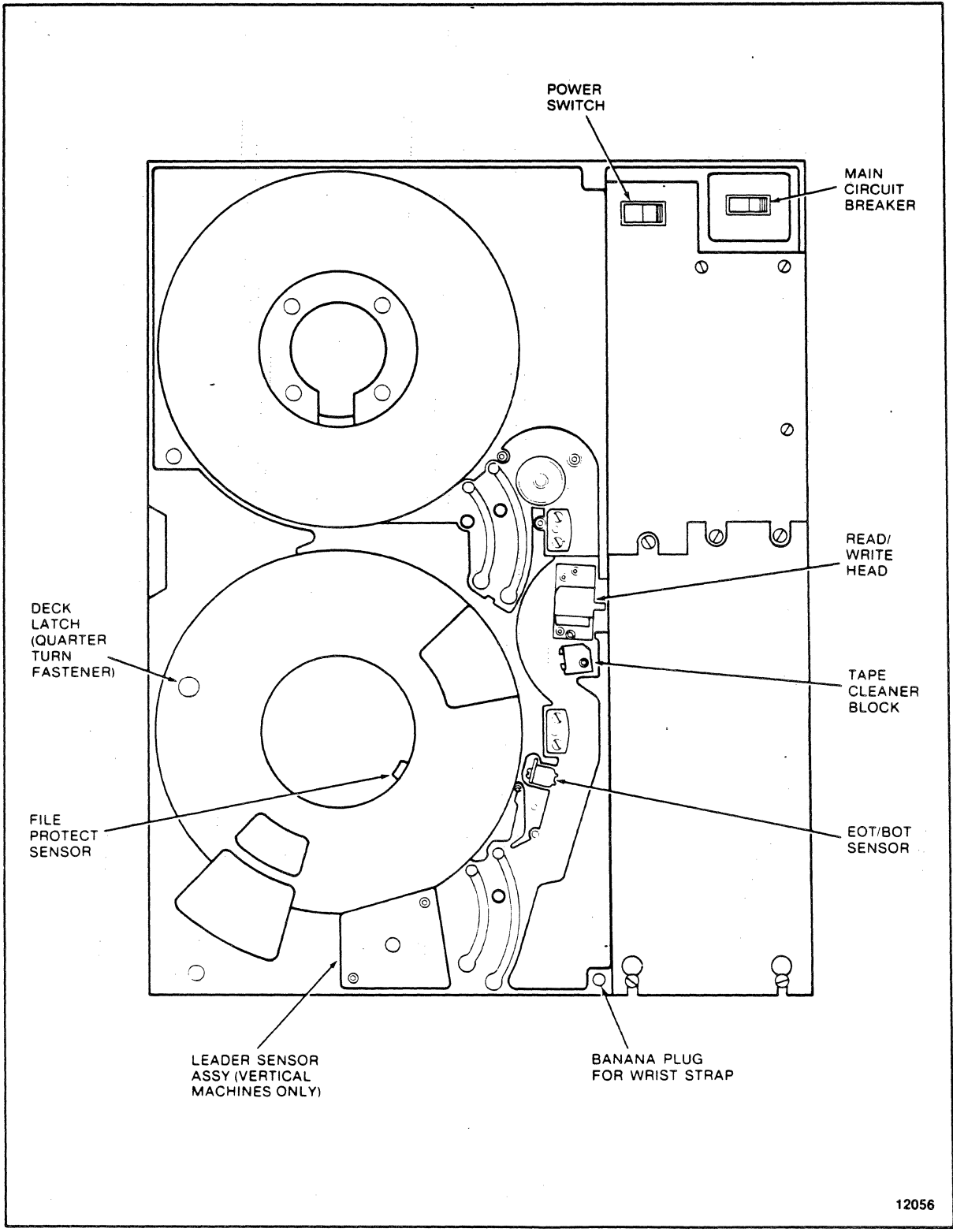

Figure 8-1. 2920 MTS Deck (Front)

8.1.2 Torx Screws

The majority of the screws used in the assembly of the MTS are #6 and #10 Torx¹ thread-forming screws. Remove and reinstall these screws by using a standard flat-blade screwdriver or Torx driver (refer to Appendix A; Special Test Equipment, Tools, And Supplies).

CAUTION

The screw threads must be clean when Torx screws are reinstalled in the aluminum deck casting. Start the screw by hand; do not overtighten.

8.2 TAPE PATH

The locations of the FRUs detailed in this section are shown in Figure 8-1.

CAUTION

When working on the tape path, always assure that the machine reel cover is in place before closing the tape path door.

8.2.1 EOT/BOT Sensor Replacement

1. Switch off the main circuit breaker.
2. Remove the EOT/BOT sensor mounting screw and pull the EOT/BOT assembly from the front of the deck casting. It may be necessary to use a pair of longnose pliers to remove the assembly.
3. Use the original mounting hardware to install the replacement EOT/BOT assembly. Tighten the mounting screw firmly, but do not overtighten.
4. Power up the MTS, load a work tape, and check that BOT is properly detected.

1 ¹Trademark of the Camcar Division of Textron Inc.

5. Enter maintenance program 00 to run the tape forward. Check that EOT is properly detected. If a machine check occurs, refer to Fault Code Dictionary PN 97712 or 87004.

8.2.2 Leader Sensor Replacement

1. Switch off the main circuit breaker.
2. Remove the tie-wrap that secures the leader sensor cable.
3. Disconnect J28 from the leader sensor.
4. Remove the two leader sensor housing mounting screws. Remove the sensor housing by pulling J28 through the front of the deck. Be careful not to break the connector.
5. Remove the plastic sensor from housing. Install new sensor with manufacturer's decal visible. Do not overtighten.
6. Reinstall the leader sensor housing using the original mounting hardware. Reconnect J28.
7. Power up the MTS and run all internal diagnostics (refer to Chapter 9).

8.2.3 Tape Cleaner Block Replacement

1. Switch off the main circuit breaker.

WARNING

Take care when handling the tape cleaner block because the blade is sharp.

2. Remove the cleaner block mounting screw. Remove the block from the deck casting.
3. When replacing the tape cleaner block, make sure that the alignment pin in the deck is aligned with the hole in the cleaner block and that the cleaner block is seated against the casting before tightening the mounting screw. Tighten the screw firmly, but do not overtighten.
4. Power up the MTS and load a work tape.

5. Enter maintenance program 00 to run the tape forward. Check to see that the tape very slightly contacts the blade and screen of the cleaner block.

8.2.4 File Protect Sensor Replacement

1. Switch off the main circuit breaker.

CAUTION

There may be shims between the file protect sensor and the deck casting that may drop out as the following step is performed.

2. Disconnect J27 from the file protect sensor. Remove the screw that secures the file protect assembly to the back of the deck casting.
3. Install the replacement file protect sensor over the locating pin and install the sensor mounting screw. Reinstall the shims, if any, over the screw. Secure the mounting screw, do not overtighten. Reconnect J27.
4. Power up the MTS and load a work tape with a write enable ring installed. Check that the file protect indicator turns off.
5. Unload the tape, remove the ring, and reload the tape. Check that the file protect indicator is illuminated.

8.2.5 Read/Write Head Replacement

1. Switch off the main circuit breaker.
2. Remove the three screws that secure the thread door, taking care not to lose the springs.
3. Remove the filler block over the read/write head cables (refer to Figure 8-2).
4. Loosen the three screws that secure the card cage cover to the card cage; remove the cover.
5. Disconnect the read cable from the RD card and the write cable from the WR card.

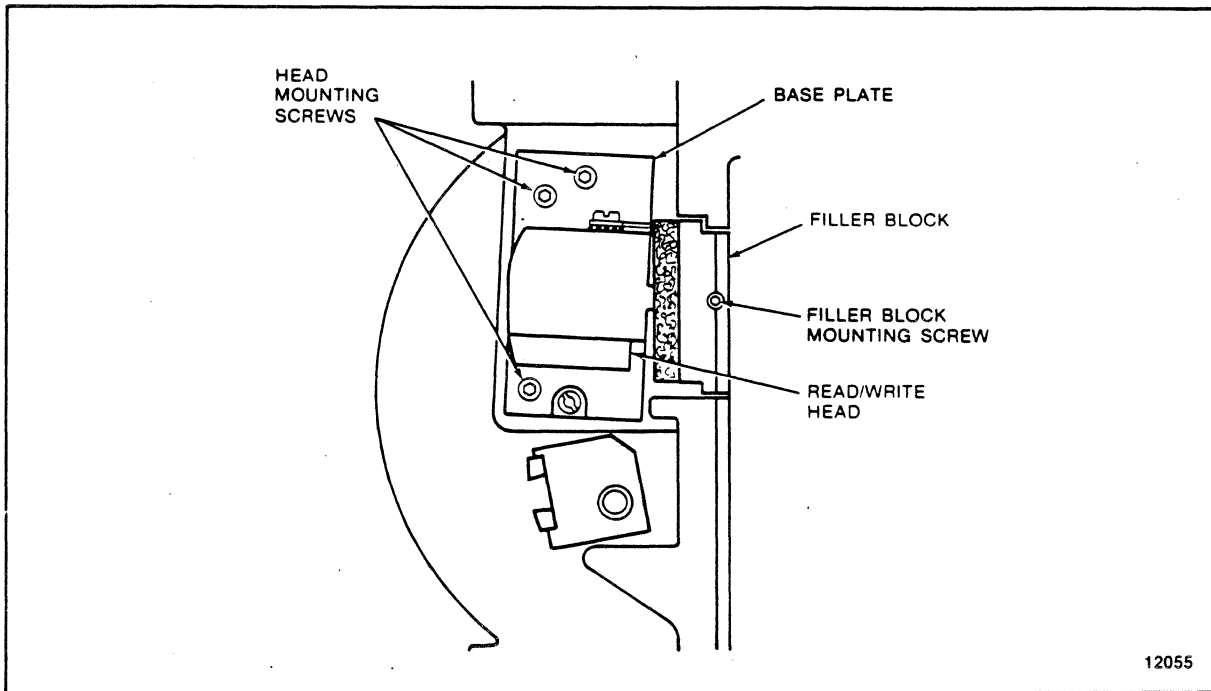

12055

Figure 8-2. Read/Write Head

6. Remove the three socket head screws that secure the read/write head assembly to the skew block. Remove the head assembly. Do not remove the baseplate from the read/write head.
7. Mount the replacement read/write head on the skew block. Make sure that the pins are aligned. Firmly seat the read/write head against the skew block before inserting the retaining screws.

CAUTION

Do not tap or pound on the read/write head assembly: permanent damage can occur.

8. Reconnect the read and write cables.
9. Reinstall the filler block. Make sure that the filler block is clamped over the read/write head cable insulation and does not pinch any wires that may be unsheathed in this area.

10. Remove the protective covering from the replacement read/write head. (Use this covering to protect the tape-contacting area of the original read/write head.) Clean the replacement head with approved Hub and Transport Cleaner.
11. Reinstall the thread door. Operate the door to be sure that it does not bind when it is opened and closed. Binds can cause the door to be improperly seated, resulting in vacuum leaks that could affect tape threading.
12. Perform the tape tracking and skew procedure and the read amplitude checks (refer to Chapter 7).

8.3 SWING ARMS

The procedures for replacing the swing arm assemblies are given in the following sections.

8.3.1 Lower Swing Arm Assembly Replacement

1. Switch off the main circuit breaker.
2. Disconnect J24 from the lower swing arm tach assembly, J34 from the retractor switch assembly, and J17 from the retractor gear motor.
3. Push up on the bottom of the retractor connecting rod until the swing arms are in the extended position (refer to Figure 8-3).
4. If the retractor arm has a loop end, remove the connecting rod end. If the retractor arm has a slot end, loosen the attachment screw (refer to Figure 8-3, detail A.).
5. Unhook the lower swing arm tension spring from the spring post on the deck casting.
6. Remove the three screws that secure the swing arm pivot plate to the deck casting. Remove the lower swing arm assembly, guiding the rollers through the holes in the deck.
7. Remove the tension spring from the removed swing arm and install the tension spring on the replacement swing arm, making certain that the open side of the hook faces out from the swing arm.
8. Mount the replacement swing arm assembly in position and secure it with the original hardware.

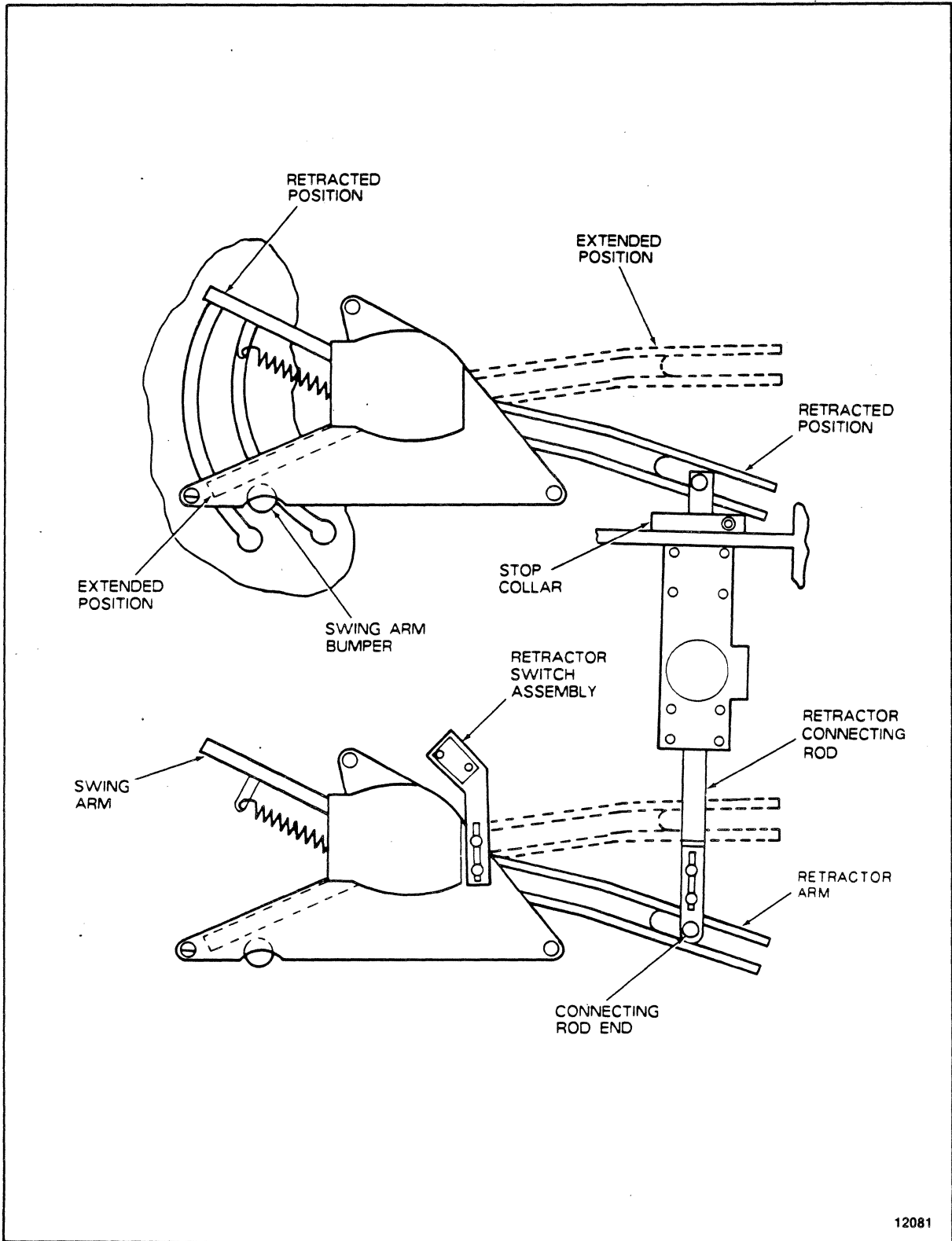

Figure 8-3. Swing Arm Assemblies

9. Reinstall the connecting rod end if it was removed earlier, but do not tighten the attachment screw at this time.
10. Check the retractor switch bracket to see if it has two holes or a slot where it attaches to the pivot plate. If it has the holes, no adjustment is necessary. If there is a slot, then push the connecting rod up approximately 1/4-in. (0.64 cm) beyond the point where the swing arms contact the swing arm bumpers. Loosen the two screws that hold the retractor switch bracket to the swing arm pivot plate. Move the switch assembly until the retractor activates the switch. Tighten the two screws.
11. Pull the connecting rod down until the stop collar under the rear cover is in contact with the deck casting. Push down on the connecting rod end until the lower swing arm pins are very lightly contacting the end of the slots in the deck. Tighten the screw that secures the connecting rod end.
12. Push up on the connecting rod until the swing arms are in the extended position. Reconnect the tension spring to the spring post.
13. Reconnect J24 to the tach assembly and J34 to the retractor switch assembly.
14. Power up the MTS. There will be a machine check indication because the retractor motor is still unplugged (at J17). Press RESET on the operator panel.
15. On the diagnostic keypad, press <ENTER PROBE> <6061> <ENTER>. The display should show a two-digit hex character. Move the swing arms gently through their arc. Check to see that the display value changes as:
 - a) the arms move out of their bottom position;
 - b) the arms are just below the fixed roller;
 - c) the arms are near the top of their arc.

Now pull the connecting rod down until the stop collar contacts the deck. Check to see that there is a gap between the swing arm pins and the end of the slot that should have been created by the tension spring pulling down on the swing arm. As a check, this gap should measure between 0.03 in. (0.08 cm) and 0.08 in. (0.20 cm) at the outside pin. This can be measured on the front of the deck by placing a steel rule by the roller pin and moving the pin until it contacts. If the gap is incorrect, go back to step 11. Check the

display panel and see if the display changes as you move the arm through the distance of the gap. If the display changes, follow the procedure in the following paragraph. Otherwise, go to step 16.

If the display changes within the range of the gap described above, loosen the three screws holding the pivot plate to the deck. From the back of the deck, rotate the plate counterclockwise as far as it will go, then tighten the screws. Check the display again as described above.

CAUTION

To prevent damage to the retractor motor, do not proceed if this test fails.

16. Switch off the main circuit breaker.
17. Reconnect J17 to the retractor gear motor.
18. Power up the MTS. The power-up diagnostics will cycle the swing arms. Enter diagnostic routine 1F to ensure proper operation of the retractors and swing arms.
19. Perform the tape tracking and skew procedure (refer to Chapter 7).
20. Run all internal diagnostics (refer to Chapter 9).

8.3.2 Lower Swing Arm Tach Assembly Replacement

1. Switch off the main circuit breaker.
2. Disconnect J24 from the sensor assembly.
3. Remove the plastic snap-off cover over the sensor assembly.
4. The tach disc is secured to the swing arm shaft by a screw and two washers. The larger washer has a small hole that keys onto the dowel pin in the shaft. Remove the screw and washers. (On a few older machines, the tach disc is secured to the shaft by two retaining rings, a spring washer, and a flat washer.)
5. Remove the four socket-head screws that secure the sensor assembly to the swing arm pivot plate. Remove the tach assembly.

6. Install the replacement tach assembly with the hardware removed in step 5. The two ICs on the tach card should be located on the left. Align the small hole in the tach disc with the dowel pin on the swing arm shaft. Install the large washer, aligning the small hole in the washer with the dowel pin of the shaft. Install the small washer and secure it with the screw.

CAUTION

Make sure that the hole in the tach disc is properly aligned before tightening the screw. Permanent damage to the disc will occur if it is not properly aligned before tightening.

7. Reinstall the plastic cover over the sensor assembly.
8. Reconnect J24 to the sensor assembly.
9. Power up the MTS. If there is a failure of the tach assembly, the power-up diagnostics should display a fault code in the LED display (refer to Fault Code Dictionary PN 97712 or 87004). Run all internal diagnostics (refer to Chapter 9).
10. An additional check of the swing arm tach assembly can be made using the LED display. To perform this check, move the swing arms to their fully extended (downward) position. To do this, enter maintenance program 1F. When the swing arms reach the bottom of their travel, press RESET. You may have to do this several times to stop the arms in the proper position. On the diagnostic keypad, press <ENTER PROBE> <6061> <ENTER>. The LED display should display a two-digit hex character. The movement of the swing arms gently through their swing arc should cause a change in the units position of the display when each arm is at the top, at the bottom, and just below the fixed roller post position of the arc. Do not allow the arms to slip free and drop to the bottom under spring tension; this can damage the arms by changing the alignment.

8.3.3 Upper Swing Arm Assembly Replacement

1. Switch off the main circuit breaker.
2. Disconnect J14 from the file reel motor, J17 from the retractor motor, J18 from the vacuum blower motor, and J23 from the upper swing arm tach.

3. Remove the four screws that secure the vacuum blower and adapter assembly to the deck casting. Remove the blower and adapter assembly.
4. Remove the seal around the capstan motor. Remove all of the screws that secure the rear plenum cover to the deck casting. Remove the plenum cover.
5. Push up on the bottom of the connecting rod in order to place the swing arms in the extended position (refer to Figure 8-3).
6. Unhook the upper and lower swing arm tension springs from their spring posts on the deck.
7. Remove the three screws that secure the swing arm pivot plate to the deck casting. Remove the upper swing arm assembly, guiding the rollers through the holes in the deck.
8. Remove the tension spring from the removed swing arm and install the tension spring on the replacement swing arm, making certain that the open side of the hook faces out from the swing arm.
9. Mount the new swing arm assembly in position and secure it with the hardware removed in step 7.
10. Push down on the connecting rod end until the rollers of both swing arms lightly contact the end of the slots in the deck casting. If the rollers of both arms reach this position, go to Step 15. If one of the arms does not reach the proper position, do the following steps.
11. Loosen the stop collar clamping screw.
12. Loosen the connecting rod end screw.
13. Push down on the top of the connecting rod until the upper swing arm rollers are very lightly contacting the end of the slots in the deck casting. Position the stop collar flat against the deck and firmly tighten the screw.
14. Push down on the connecting rod end until the lower swing arm rollers are very lightly contacting the end of the slots in the deck casting. Tighten the connecting rod end.
15. Push up on the connecting rod until the swing arms are in the extended position. Reconnect the tension springs to the spring posts.
16. Reconnect J23 to the upper swing arm tach assembly.

17. Power up the MTS. There will be a machine check indication because the retractor motor is still unplugged (J17). Press RESET on the operator panel.
18. On the diagnostic keypad, press <ENTER PROBE> <6061> <ENTER>. The display should show a two-digit hex character. Move the swing arms gently through their arc. Check to see that the display value changes as:
 - a) the arms move out of their bottom position;
 - b) the arms are just below the fixed roller;
 - c) the arms are near the top of their arc.

Now pull the connecting rod down until the stop collar contacts the deck. Check to see that there is a gap between the swing arm pins and the end of the slots that should have been created by the tension springs pulling down on the swing arms. As a check, this gap should measure between 0.03 in. (0.08 cm) and 0.08 in. (0.20 cm) at the outside pin. This can be measured on the front of the deck by placing a steel rule by the roller pin and moving the pin until it contacts. If the gap is incorrect, go back to step 11. Check the display panel and see if the display changes as you move the arms through the distance of the gap. If the display changes, follow the procedure in the following paragraph. Otherwise, go to step 16.

If the display changes within the range of the gap described above, loosen the three screws holding the pivot plate to the deck of the assembly that causes the display to change. From the back of the deck, rotate the plate counterclockwise as far as it will go, then tighten the screws. Check the display again as described above.

CAUTION

To prevent damage to the retractor motor, do not proceed if this test fails.

19. Switch off the main circuit breaker.
20. Reconnect J17 to the retractor gear motor.
21. Power up the MTS. The power-up diagnostics will cycle the swing arms. Enter diagnostic routine 1F to ensure proper operation of the retractors and swing arms.

22. Power down the MTS. Clean and install the vacuum plenum cover and capstan seal, ensuring that the seal is properly pressed against the plenum cover. Check the alignment of all cables emerging from the vacuum plenum in their respective slots before tightening the plenum cover screws.
23. Reinstall the vacuum blower and adapter assembly using the hardware removed in step 5.
24. Reconnect J18 and J14 to the vacuum blower and file motor.
25. Power up the MTS and perform the tape tracking and skew procedure (refer to Chapter 7).
26. Run all internal diagnostics (refer to Chapter 9).

8.3.4 Upper Swing Arm Tach Assembly Replacement

1. Switch off the main circuit breaker.
2. Disconnect J14 from the file reel motor, J17 from the retractor motor, J18 from the vacuum blower motor, and J23 from the upper swing arm tach.
3. Remove the four screws that secure the vacuum blower and adapter assembly to the deck casting. Remove the blower and adapter assembly.
4. Remove the seal around the capstan motor. Remove all the screws that secure the vacuum plenum cover to the deck casting. Remove the plenum cover.
5. Remove the plastic snap-off cover over the sensor assembly.
6. The tach disc is secured to the swing arm shaft by a screw and two washers. The larger washer has a small hole that keys onto the dowel pin in the shaft. Remove the screw and washers. (On a few older units, the tach disc is secured to the shaft by two retaining rings, a spring washer, and a flat washer.)
7. Remove the four socket-head screws that secure the tach assembly to the swing arm pivot plate.
8. Install the replacement tach assembly with the hardware removed in step 8. The two ICs on the tach card should be located on the left. Align the small hole in the tach disc with the dowel pin on the shaft. Install the large washer, aligning the small hole in the washer with the dowel pin of

the shaft. Install the small washer and secure it with the screw.

CAUTION

Make sure that the hole in the tach disc is properly aligned before tightening the screw. Permanent damage to the disc will occur if it is not properly aligned before tightening.

9. Reinstall the plastic cover over the sensor assembly.
10. Reconnect J23 to the tachometer.
11. Power up the MTS. If there is a failure of the tach assembly, the power-on diagnostics should display a fault code (refer to Fault Code Dictionary PN 97712 or 87004). For a further check of the tach assembly, refer to step 10 of the lower swing arm tach assembly replacement procedure (refer to Chapter 7).
12. Power down the MTS. Disconnect J23 from the tach. Clean and install the vacuum plenum cover and capstan seal, ensuring that the seal is properly pressed against the plenum cover. Check the alignment of all cables emerging from the vacuum plenum in their respective slots before tightening the plenum cover screws.
13. Install the vacuum blower and adapter assembly using the hardware removed in step 3.
14. Reconnect J14 to the file reel motor, J17 to the retractor motor, J18 to the vacuum blower motor, and J23 to the upper swing arm tach.
15. Power up the MTS and run all internal diagnostics (refer to Chapter 9).

8.3.5 Retractor Assembly Replacement

1. Switch off the main circuit breaker.
2. Disconnect J17 from the retractor motor.
3. Push upward on the bottom of the connecting rod to position the swing arms in the extended position (refer to Figure 8-3).

4. Remove the four socket-head screws (located at B in Figure 8-4) that secure the retractor assembly to the casting.
5. Remove stop collar clamp from top of connecting rod (Figure 8-4), and slide the entire assembly out of the hole in the casting.
6. On new retractor assembly, gently push the connecting rod all the way up.
7. Mount the new retractor assembly in reverse order of removal and remount the stop collar clamp but do not tighten.
8. Loosen the connecting rod end screw.
9. Push down on the top of the connecting rod until the upper swing arm rollers are very lightly contacting the end of the slots in the deck casting. Position the stop collar flat against the deck and firmly tighten the screw.
10. Push down on the connecting rod end until the lower swing arm rollers are very lightly contacting the end of the slots in the deck casting. Tighten the connecting rod end.
11. Power up the MTS. There will be a machine check indication because the retractor motor is still unplugged (J17). Press RESET on the operator panel.
12. On the diagnostic keypad, press <ENTER PROBE> <6061> <ENTER>. The display should show a two-digit hex character. Move the swing arms gently through their arc. Check to see that the display value changes as:
 - a) the arms move out of their bottom position;
 - b) the arms are just below the fixed roller;
 - c) the arms are near the top of their arc.

Now pull the connecting rod down until the stop collar contacts the deck. Check to see that there is a gap between the swing arm pins and the end of the slots that should have been created by the tension springs pulling down on the swing arms. As a check, this gap should measure between 0.03 in. (0.08 cm) and 0.08 in. (0.20 cm) at the outside pin. This can be measured on the front of the deck by placing a steel rule by the roller pin and moving the pin until it contacts. If the gap is incorrect, go back to step 11. Check the display panel and see if the display changes as you move the arms through the distance of the gap. If the display

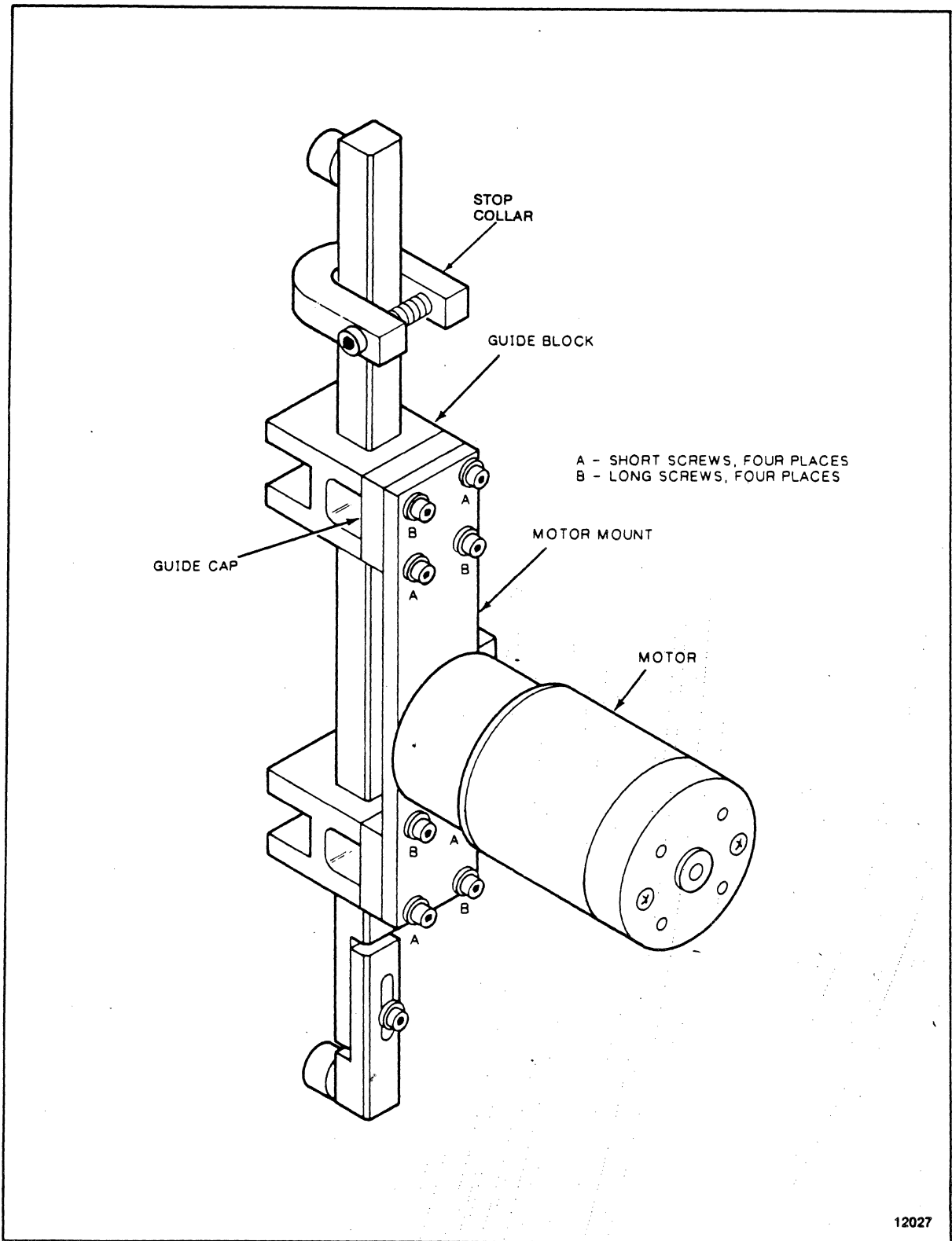

Figure 8-4. Retractor Assembly

changes, follow the procedure in the following paragraph. Otherwise, go to step 16.

If the display changes within the range of the gap described above, loosen the three screws holding the pivot plate to the deck of the assembly that causes the display to change. From the back of the deck, rotate the plate counterclockwise as far as it will go, then tighten the screws. Check the display again as described above.

CAUTION

To prevent damage to the retractor motor, do not proceed if this test fails.

13. Switch off the main circuit breaker.
14. Reconnect J17 to the retractor motor.
15. Power up the MTS. The power-on diagnostics will cycle the arms and check for proper operation of the arms during this procedure. You can cause additional cycling of the arms by entering diagnostic routine 1F. The LED display should indicate four dashes for proper operation. A fault code indicates failure and should be investigated before proceeding (refer to Fault Code Dictionary PN 97712 or 87004).
16. Run all internal diagnostics (refer to Chapter 9).

8.4 CAPSTAN, REELS, AND BLOWER

Procedures for replacing the capstan motor, file reel hub, file and machine reel motors, and vacuum blower are given in the following sections.

8.4.1 Capstan Motor Replacement

1. Switch off the main circuit breaker.
2. Disconnect J14 from the file reel motor, J17 from the retractor motor, J18 from the vacuum blower motor, and J23 from the upper swing arm tach.
3. Disconnect J16 from the capstan motor.

4. Remove the four screws that secure the vacuum blower adapter to the deck casting. Remove the blower and adapter assembly.
5. Remove the seal from around the capstan motor. Remove all the screws that secure the vacuum plenum cover to the deck casting. Remove the plenum cover.
6. At the front of the deck casting, remove the screw that secures the capstan wheel to the motor shaft. Remove the capstan wheel.
7. Each of the three capstan motor mounting screws retains a spring between the capstan motor and the deck casting. These springs are required during reassembly and are critical to proper operation.

Equally loosen the three screws that secure the capstan motor to the deck casting while supporting the capstan motor from the rear, but do not pull the screws from the casting until you can remove the springs from the rear. Remove the springs and store them safely for reassembly.

8. Reassemble all components in reverse order of disassembly. Position the capstan motor with the tach cable to the left (as viewed from the rear) and route the cable through the groove in the casting directly below the motor.

Insert the three capstan motor mounting screws through the front of the casting and slide the springs on the exposed threaded portions of the screws from the rear.

9. With the springs properly placed on the screws, install the motor and moderately tighten the screws. Tighten screws alternately and equally to prevent stripping.
10. Back off each mounting screw by one complete turn.
11. Clean and replace the plenum cover. Ensure that all cables emerging from the vacuum plenum are located properly in their respective slots in the deck casting before tightening the plenum cover retaining screws. Replace the seal around the capstan motor, ensuring that the wide flange is pressed against the plenum cover.
12. Reinstall the vacuum blower and adapter assembly.
13. Reconnect J14 to the file reel motor, J16 to the capstan motor, J17 to the retractor motor, J18 to the vacuum blower motor, and J23 to the upper swing arm tach.

14. Perform the tape tracking and skew procedure (refer to Chapter 7).

8.4.2 File Reel Hub Replacement

1. Remove the three socket-head screws that secure the hub cover to the hub assembly. Remove the hub cover.
2. Remove the three socket-head screws that secure the hub assembly to the clamp collar. Slide the hub off the reel motor shaft.
3. Slide the replacement file reel hub assembly onto the reel motor shaft. Align the screw holes in the hub with the holes in the clamp collar. Insert the mounting screws and tighten securely.
4. Reinstall the hub cover. Do not overtighten the screws. Overtightening can damage the hub cover.
5. Power up the MTS and load a scratch tape. Enter maintenance program 00 to run the tape forward. Check that the tape does not contact either flange of the reel. Perform the same check using maintenance program 01 to run the tape backward.

If necessary, use the clamp collar to reposition the hub until the tape wraps on the reel without contacting the reel flanges.

6. Check the alignment and operation of the file protect sensor. To check for proper operation of file protect, load a scratch tape with a write enable ring installed and check that the file protect indicator turns off. Unload the tape, remove the ring, reload the tape, and check that the file protect indicator is illuminated.

8.4.3 File Reel Motor Replacement

1. Switch off the main circuit breaker.
2. Disconnect J14 from the file reel motor.
3. Remove the three socket-head screws in the hub cover. Remove the hub cover by opening the hub latch and pulling off the cover with a slight counterclockwise twist to clear the hub latch.

4. Remove the three screws that secure the hub assembly to the clamp collar and remove the hub assembly.
5. Remove wire tie from rear of motor
6. Remove the four screws that secure the reel motor to the deck casting and remove the motor.
7. Reassemble in reverse order. The outer edge of the clamp collar should be positioned $0.816 \text{ in.} \pm 0.002 \text{ in.}$ ($2.07 \pm 0.005 \text{ cm}$) from the front of the reel motor.
8. To check for proper alignment of the reel to the tape path, power up the MTS, mount and load a scratch tape, enter maintenance program 00, and run tape forward to EOT. Rewind while observing the tape as it wraps back on the file reel: the tape should not contact either flange of the reel. If necessary, use the clamp collar to reposition the hub until the tape wraps on the reel without contacting the reel flanges.
9. Check the alignment and operation of the file protect sensor. To check for proper operation of file protect, load a scratch tape with a write enable ring installed and check that the file protect indicator turns off. Unload the tape, remove the ring, reload the tape, and check that the file protect indicator is illuminated.

8.4.4 Machine Reel Motor Replacement

1. Switch off the main circuit breaker.
2. Disconnect J15 from the reel motor.
3. Remove the machine reel cover.
4. Remove the three screws that secure the machine reel hub cap to the hub and remove the cap and outer flange.
5. Remove the three screws that secure the hub assembly to the clamp collar and remove the hub assembly.
6. From the front of the deck casting, remove the four screws that secure the machine reel motor to the deck casting. Remove the motor.
7. Install the replacement reel motor. The outer edge of the clamp collar should be positioned $0.642 \pm 0.005 \text{ in.}$ ($1.63 \pm 0.013 \text{ cm}$) from the front of the reel motor.

8. Reassemble all components in reverse order. Ensure that the rim of the outer flange is positioned outwards.
9. Power up the MTS and load a scratch tape. Enter maintenance program 00 to run the tape forward. Check for proper alignment of the reel to the tape path. The tape should not contact either flange of the reel as it wraps on the machine reel. You may remove the column door and the machine reel cover once the tape has been loaded to observe the machine reel area.

If necessary, use the clamp collar to reposition the hub on the motor shaft until the tape wraps on the reel without contacting the reel flanges.

8.4.5 Vacuum Blower Replacement

1. Switch off the main circuit breaker.
2. Disconnect J18 from the vacuum blower.
3. Remove the four screws that secure the vacuum blower to the vacuum blower adapter. Remove the blower.
4. Remove the blower mounting plate from the blower and install the plate on the replacement blower.
5. Reassemble in reverse order. When installing the four screws, make sure that the threads of all the screws are caught before completely tightening any one screw. Reconnect J18 and check the subsystem by performing at least 10 tape load operations.

8.5 CIRCUIT CARDS

The procedures for replacing circuit cards are given in the following sections.

8.5.1 Card Cage Circuit Cards Replacement

1. Switch off the main circuit breaker.
2. Loosen the four screws that secure the card cage cover and remove the cover.
3. Put on a wrist strap and plug its banana clip into the receptacle on the deck casting (refer to Figure 8-1).

4. If you are removing the WR card, disconnect the card's front edge connector. If you are removing the RD card, disconnect front edge connectors from both the WR and RD cards. Remove the circuit card by pulling on the ends of the tabs at the top and bottom of the card.

CAUTION

When replacing the RD card, ensure components on the card do not rub against inside of the card cage, as this may damage the card.

5. Insert the replacement card. Make sure that the tab ends are locked in the mating slots of the card cage.
6. Power on the MTS and run all internal diagnostics to ensure proper operation (refer to Chapter 9).

8.5.2 Front Operator Panel Replacement

1. Switch off the main circuit breaker and disconnect the main power cord.
2. Remove the four screws that secure the front panel assembly to the deck casting.
3. Remove the electrical connectors from the back of the card, and remove the ground cable from the lug on the deck casting. Note the orientation of the connectors for proper reassembly.
4. Reassemble in reverse order.
5. Power up the MTS and run maintenance program 08, the Keyboard/LED Test. Each depressed key displays its ASCII code. The RESET key terminates the test.

8.5.3 AK Card Replacement

1. Switch off the main circuit breaker and disconnect the main power cord.
2. Remove J11, J12, and J13 from the AK card. The connectors are keyed and labeled.
3. Remove the seven screws that secure the AK card to the capacitor bank. Do not drop the screws into the fans or card

cage. You may have to hold the standoffs behind the AK card with a 5/16-in. open-end wrench when loosening the screws. Remove the card.

4. When reassembling the AK card to the capacitor bank, start all screws before completely tightening any one screw. As the screws make electrical contact, make sure they are tightened securely.
5. Reconnect all three electrical connectors (J11, J12, and J13).
6. Power up the MTS and check all power supply output voltages (refer to Chapter 7).
7. Run all internal diagnostics to ensure proper operation (refer to Chapter 9).

8.5.4 PK Card Replacement

1. Switch off the main circuit breaker and disconnect the main power cord.
2. Remove the clear plastic safety cover from the PK card standoffs.
3. Remove the insulator boot and the wire from the ferro capacitor.
4. Remove the wires connected to the top edge of the PK card. Note the wire numbers are relative to the terminal post positions.
5. Pull the card away from the transformer. Pull the wire that was attached to the ferro cap through the sense coil on the PK card.
6. Reassemble in reverse order.
7. Power up the MTS and check all power supply output voltages (refer to Chapter 7).
8. Run all internal diagnostics to ensure proper operation (refer to Chapter 9).

8.5.5 Motherboard Replacement

1. Switch off the main circuit breaker and disconnect the main power cord.
2. Loosen the four screws that secure the card cage cover and remove the cover.
3. Unlatch all circuit cards in the card cage and slide the cards forward. It is not necessary to slide the cards completely out of the cage.
4. Remove all electrical connectors from the motherboard.
5. Disconnect the four wires from the solid state relay. The wires are marked to show the relay connections.
6. Release motherboard harness from the two plastic cable clamps.
7. Remove the eight nuts and washers that secure the motherboard to the card cage.
8. Reassemble in reverse order. Insert the circuit cards in the motherboard connectors before tightening the eight motherboard mounting screws to ensure proper alignment of the motherboard.
9. Power up the MTS and run all internal diagnostics to ensure proper operation (refer to Chapter 9).

8.6 POWER SUPPLY AND FANS

The procedures for replacing the power supply components and cooling fan are given in the following sections.

8.6.1 Regulator Assembly Replacement

1. Switch off the main circuit breaker and disconnect the main power cord.
2. Disconnect the ground strap located on the left side (as viewed from rear) of the rectifier assembly.
3. Remove the AK card from the regulator assembly. (See Step 8.5.3-AK card replacement.)

4. Loosen the three remaining screws that secure the rectifier assembly to the deck casting. Slide the rectifier assembly to the right to clear the screw heads and pull it to the rear of the MTS.
5. Reassemble in reverse order.
6. Power up the MTS and check all power supply output voltages (refer to Chapter 7).
7. Run all internal diagnostics to ensure proper operation (refer to Chapter 9).

8.6.2 Transformer Replacement

1. Switch off the main circuit breaker and disconnect the main power cord.
2. Remove the PK card. Refer to Section 8.5.4 for the procedure.
3. Remove and mark the remaining wire from the ferro capacitor.
4. Disconnect J12 from the AK card.
5. Disconnect J31 located beneath the power transformer.
6. Loosen all four screws that secure the transformer brackets to the deck casting. Remove the two screws on the right side. (on older machines, it may be necessary to remove all four screws).
7. Slide the transformer to the right and off the two remaining screws. Use caution: the transformer weighs 25 pounds (11.4 kg).
8. Transfer the insulated stand-offs from the removed transformer to the replacement transformer.
9. Reassemble in reverse order.
10. Power up the MTS and check all power supply output voltages (refer to Chapter 7).
11. Run all internal diagnostics to ensure proper operation (refer to Chapter 9).

8.6.3 Main Circuit Breaker Replacement

1. Switch off the main circuit breaker and disconnect the main power cord.
2. The circuit breaker is snapped into its receptacle from the front of the deck. Recessed areas are formed on either side of the breaker to allow removal with a screwdriver blade.
3. Note the locations of the electrical connections before disconnecting them. Prevent wires from falling into the deck casting recess. Disconnect the wires and remove the circuit breaker.
4. Reassemble in reverse order.

8.6.4 Cooling Fan Replacement

1. Switch off the main circuit breaker and disconnect the main power cord.
2. Disconnect J31 located near the card cage.
3. Remove the ground wire from the fan assembly.
4. Remove the screw that secures the fan assembly to the card cage.
5. Slide the fan assembly back to free the locking tabs at the forward end of the fan assembly; then slide the assembly forward and out from under the securing screw. Finally, pivot the assembly to the left to clear the card cage and the motherboard.
6. An individual fan may be replaced by removing it from the mounting plate. Check the airflow direction as indicated on the side of the fan before installation. Air flow should be upward. Remove the fan guard and attach it to the replacement fan.
7. Reassemble in reverse order.
8. Power up the MTS and check the fans for proper operation.

8.7 CABLE HARNESS REPLACEMENT

The procedures for replacing the power cable harness, the AC cable harness, the motor cable harness, and the sensor cable harness are given in the following sections.

NOTE

Unit must be unplugged from the voltage source when removing or replacing cable harnesses.

8.7.1 Cable Harness, Power

1. Disconnect J13, J8, J4, and J5 connectors.
2. Remove the cable from the clamps at the side of the card cage and motherboard.
3. Reinstall the cable assembly in reverse order.

8.7.2 Cable Harness, AC

1. Remove the regulator assembly per paragraph 8.6.1. Document the wire connections from the AC cable harness as assemblies are disconnected. Observe the wire routing.
2. Remove the operator panel from the front of the deck and disconnect the wires from the power switch, main circuit breaker, and line filter.
3. Disconnect the AC harness where it attaches to the PK card.
4. Reinstall the harness in reverse order.

8.7.3 Cable Harness, Motor

1. Unplug connectors J17, J18, J14, J15, J16, and J1. Remove the harness clamps, if any.
2. Remove the blower assembly to gain access to and to remove the harness. Observe how the harness is routed to assure connectors terminate at the proper places.
3. Reverse the procedure to reinstall the replacement harness. Reattach the cable ties in the proper locations.

8.7.4 Cable Harness, Sensor

1. Unplug connectors J22, J23, J24, J27, J28, J34, J3, J9, and single fast-on lugs to the door interlock switch. Remove the two screws from J30 connector (EOT/BOT assembly). Notice that pin 1 of J30 is toward the top.

NOTE

J28 is not connected if the MTS is used in the horizontal mount configuration.

2. Cut the appropriate cable ties to free up the harness. Observe the harness routing to assure the replacement harness does not interfere with moving parts.
3. Replace the harness in reverse order. Replace the cable ties previously removed.

(INTENTIONALLY LEFT BLANK)

CHAPTER 9

DIAGNOSTIC/MAINTENANCE PROGRAMS

9.1 INTRODUCTION

The 2920 Magnetic Tape Subsystem (MTS) diagnostic programs are capable of detecting fault conditions in the tape subsystem and isolating failures within a specific number of field replaceable units (FRUs). The programs, which consist of internal diagnostic programs and maintenance programs, reside in the Diagnostic PROM.

An optional set of diagnostics, external programs, are released on floppy diskettes and run from a Storage Technology Corporation Model 3910 Detached Diagnostic Device via the standard 1900 interface. The external routine library provides complete 2920 interface verification and limited online exercising. The 1900 Diagnostic Monitor, under which the external diagnostic routines are run, also provides a high-level, interpretive language with which to create online command sequences quickly. (Refer to the 3910 User's Guide For 1900 Diagnostics Manual, PN 9613.) An ANSI Fortran (X3.9-1966) source code equivalent of the 1900 Diagnostic Monitor and routine library is also available for installation. This option allows testing of the entire interface from the host system to the 2920 MTS. (Refer to the 1900 Fortran Monitor Manual, PN 9646.)

Some of the information in the rest of this chapter is unique to 50 IPS, 100 IPS, Storagetek Standard Interface, or Industry Standard Interface. This is indicated in the text or tables where applicable.

9.1.1 Test Initiation

The internal diagnostic package provides several options in the execution of diagnostic library routines. The following panel key sequences are used to implement these options:

Complete internal package:	<ENTER DIAG>,10,<ENTER>
Individual test:	<ENTER DIAG>,id,<ENTER>
Test run modification:	<ENTER DIAG>, n,<ENTER>
Continue:	n = 5
Loop:	6
Bypass Error:	7

Note that the test run modification entry is to be followed by the individual test entry to which that option is applied.

Options can be combined but cannot be applied to any other Section 0 routine (maintenance routines).

9.1.2 Status Buffers

In many cases the fault code dictionary refers to the status buffers A, B, or C. Access to any of the 16 bytes contained in each buffer is obtained via the maintenance routine of matching ID (e.g., <ENTER DIAG>,B,<ENTER>). Once entered, the 16 buffer bytes can be scrolled by repeatedly pressing <ENTER>. Pressing <ENTER> displays the buffer ID and index (B1,B2...); releasing <ENTER> displays the contents. The index is presented in hexadecimal notation (as is all data displayed) and wraps around upon reaching the last entry (...BE,BF,B0,B1...).

9.2 SECTION 0 - MAINTENANCE ROUTINES

The maintenance routines have several functions. They are not in themselves intended to isolate hardware malfunctions, but they permit the operator do any of the following:

- exercise the machine in basic motion operating modes,
- select operating options for diagnostic routines,
- manually do some independent tests from the operator panel,
- retrieve status from memory registers for display on panel.

These functions are tabulated in Table 9-1.

The maintenance routines are initiated by entering the routine ID number at the diagnostic keypad. Refer to Chapter 2 for descriptions of the diagnostic keypad. The routines are individually described below in the order of their routine number.

9.2.1 Forward Motion (00)

The Forward Motion routine initiates forward tape motion in read mode. If subsystem density is to be selected, it must be done while the tape is positioned at BOT and prior to the initiation of this routine. Tape motion halts when EOT is detected or when the Reset key is pressed.

Table 9-1. Maintenance Routines

ROUTINE TYPE	ROUTINE NAME	ROUTINE ID
Motion Routines	Forward Motion	00
	Backward Motion	01
	Shoeshine Motion	02
	Start/Stop Motion	03
	Maintenance Write	0E
	Maintenance Write	0F
Diagnostics Runtime Options	Speed Select Option	04
	Continue Option	05
	Loop Option	06
	Bypass Error Option	07
Manual Operating Tests	Keyboard/LED Driver	08
	Reel/Capstan Driver	09
Status Display	Status A Display	0A
	Status B Display	0B
	Status C Display	0C

9.2.2 Backward Motion (01)

The Backward Motion routine initiates backward tape motion in read mode. Subsystem density remains as indicated on the front panel. Tape motion halts when BOT is detected or when the Reset key is pressed.

9.2.3 Shoeshine Motion (02)

The Shoeshine Motion routine performs a continuously alternating forward/backward motion with the motion duration selectable at the front panel. This routine halts when EOT is detected in the forward direction, BOT is detected in the backward direction, or when the Reset key is pressed. The least significant display digit indicates the operating rate and direction as follows (pressing <ENTER> selects the next rate):

Forward motion time	Display Contents
2 sec	(@2 1)
1 sec	(@2 2)
500 ms	(@2 3)
250 ms	(@2 4)

9.2.4 Start/Stop Motion (03)

The Start/Stop Motion routine performs a start/stop-type motion with the start/stop rate and direction selectable at the front panel. This routine halts when EOT is detected in the forward direction, BOT is detected in the backward direction, or when the Reset key is pressed. The least significant display digit indicates the operating rate and direction as follows (pressing <ENTER> selects the next rate):

Motion/Stop Time (each)	Least Sig Digit of Display	
	Forward	Backward
500 ms	(1)	(5)
250 ms	(2)	(6)
125 ms	(3)	(7)
63 ms	(4)	(8)

9.2.5 Speed Select Option (04)

This routine toggles the internal speed selection circuitry. If the subsystem was in the 50 IPS mode before the command was issued, the display will indicate the new mode of 100 IPS (@4 H) for approximately one half second before the display returns to idle (----). If the subsystem was in the 100 IPS mode before the command was issued, the display will indicate the new mode of 50 IPS (@4 L).

Speed mode change will occur whether or not tape is loaded. If the tape is loaded, the arm positions will change to the reference position appropriate to the newly selected mode.

9.2.6 Continue Option (05)

The Continue Option routine sets the Continue option for a subsequent diagnostic run request. This modifies the monitor's handling of diagnostic termination, allowing execution to continue with the next entry in the internal test library rather than to the normal return-to-idle response (----). Execution terminates for any one of the following conditions:

1. An error is detected (unless the Bypass Error option is set).
2. The end of the internal test library is detected (unless the Loop option is set).
3. The Reset Key is pressed.

9.2.7 Loop Option (06)

The Loop Option routine sets the Loop option for a subsequent diagnostic run request (see Test 05 if used with the Continue option). If the Continue option is not set, the Loop option will result in the repeated execution of the subsequently requested diagnostic routine. Execution terminates for any one of the following conditions:

1. An error is detected (unless the Bypass Error option is set).
2. The Reset key is pressed.

9.2.8 Bypass Error Option (07)

The Bypass Error Option routine sets the Bypass Error option for a subsequent test run request. This option is only valid if issued with a Continue or Loop Option (Tests 05 and 06).

9.2.9 Keyboard/LED Driver (08)

The Keyboard/LED Driver routine samples the keyboard input (ASCII data) and copies the data to all four digits of the display. Pressing the Reset key terminates the routine; holding the key down causes every other LED on the front panel to illuminate. When the key is released, these LEDs extinguish and the remaining LEDs illuminate. This permits the operator to verify independent functioning of all panel indicators.

9.2.10 Reel/Capstan Driver (09)

The Reel/Capstan Driver routine drives the reels and capstan in various modes selectable at the front panel. The mode number is displayed as the least significant digit on the panel display. Initially, Mode 0, all servos are nulled. Each time <ENTER> is pressed, the mode number seen in the display is bumped and the appropriate motion occurs as defined below:

Mode 0: Servo drivers nulled

- 1: Capstan forward, uP control (approx 25 ips), low gain
- 2: Capstan forward, uP control (approx 25 ips), high gain
- 3: Capstan forward, velocity control (50 ips), high gain
- 4: Capstan backward, uP control (approx 25 ips), low gain
- 5: Capstan backward, uP control (approx 25 ips), high gain
- 6: Capstan backward, velocity control (50 ips), high gain

- 7: Machine reel forward, thread mode
- 8: Machine reel backward, thread mode
- 9: Machine reel forward, current mode
- A: Machine reel backward, current mode

- B: File reel forward, thread mode
- C: File reel backward, thread mode
- D: File reel forward, current mode
- E: File reel backward, current mode

The routine repeats this sequence upon reaching the last entry. Pressing the Reset key terminates the routine.

9.2.11 Status A Display (0A)

The Status A Display routine allows the display of the 16 bytes in status area A. While <ENTER> is pressed, the index to the status bytes (A0,A1,...) is displayed in the first two display digits; when released, the content of that location is displayed in the last two digits. Upon reaching the last byte, the sequence is repeated (...AE,AF,A0,A1,...). The panel is returned to idle by pressing the Reset key or <CLEAR>.

The last location examined is remembered, and can be accessed using <DISP ADDR> or <ENTER PROBE> without an address entry.

9.2.12 Status B Display (0B)

The Status B Display routine displays the contents of the status area B (see Test 0A).

9.2.13 Status C Display (0C)

The Status C Display routine displays the contents of status area C (see Test 0A).

9.2.14 Maintenance Write (0E)

This Maintenance Write routine erases all tracks and writes one track as selected at the front panel. Initially all tracks are erased by setting all diagnostic dead track bits, thereby disallowing write trigger transitions (an X is displayed in the least significant display digit). <ENTER> may then be used to select the writing of one track only and the track number (0-7,P) is displayed. The track selections repeat upon reaching track P. Pressing the Reset key terminates the routine.

Note that the density in which the tape is to be written must be selected at BOT (use the Density Key) prior to initiating this routine. If PE density is selected, the track written will contain the all-ONES frequency appropriate for PE density. If GCR is selected, two frequencies will be written: the higher frequency representing the all-ONES data rate, and the lower representing the minimum frequency allowed in GCR recording (one-third the all-ONES rate). This feature is provided for dynamic range measurement of the read channel.

9.2.15 Maintenance Write (OF)

This Maintenance Write routine writes in all tracks or allows the selection of one track to be erased. Initially all tracks are written by resetting all diagnostic dead track bits, thereby allowing write trigger transitions (an X is displayed in the least significant display digit). <ENTER> may then be used to select the erasure of one track only and the track number (0-7,P) is displayed. The track selections repeat upon reaching track P. Pressing the Reset Key terminates the routine.

9.3 INTERNAL DIAGNOSTICS

The internal diagnostics are a set of routines (Table 9-2), each executable by specifying a program ID at the diagnostic keypad. The internal diagnostics are arranged numerically so that if they are run in sequence, they will test the subsystem from the microprocessor and RAM outward to the drive. These routines are divided into four sections: power-up, formatter, transport, and read/write tests.

9.3.1 Section 1 - Power-Up Tests

The power-up tests are automatically executed whenever power is applied to the subsystem or they can be run individually from the diagnostic keypad by entering the test ID number when the panel is idle. These routines ensure basic operation of the microprocessor and control logic of the subsystem which includes the testing of memory (RAM and PROM checksum), counter/timers, interrupt hardware, stuck keyboard conditions, servo control register loop back, status from the data path and write cards, and swing-arm motions. Errors that occur during power-up will display a three-digit hexadecimal fault code and flash a machine check indication. This condition will prevent further subsystem operation until the Reset key is pressed. Errors that occur following the manual initiation of an internal diagnostic test will also display a fault code but will not flash a machine check indication or prevent placing the subsystem online.

Table 9-2. Internal Diagnostics (Sheet 1 of 2)

TEST TYPE	TEST NAME	TEST ID
Section 1 - Power-up	Test Package Initiator	10
	Memory/PROM Checksum	12
	IF Test 1	13
	IF Test 2	14
	Keyboard Status	15
	Servo-LSI Register Loop	18
	Data Path Status	1B
	Write Card Status	1D
	Release/Retract Swing Arms	1F
	Section 2 - Formatter	PE Basic LWR
PE LWR Velocity		23
GCR Basic LWR		24
GCR LWR Velocity		25
PE LWR, One Track Dead		26
GCR LWR, One Track Dead		27
PE LWR, Two Tracks Dead		28
GCR LWR, Two Tracks Dead		29
PE Basic LWR, 100 IPS		2C
GCR Basic LWR, 100 IPS		2E
Section 3 - Transport	Unload/Load	32
	Drive Basic Motion, 50 IPS	34
	Drive Basic Motion, 100 IPS	35
	Drive Rewind	36
Section 4 - Read/Write, 50 IPS	PE Amplitude Sensor	42
	GCR Amplitude Sensor	43
	PE Write Records	48
	PE Read Forward	49
	PE Read Backward	4A
	PE Positioning	4B
	GCR Write Records	4C
	GCR Read Forward	4D
	GCR Read Backward	4E
	GCR Positioning	4F

Table 9-2. Internal Diagnostics (Sheet 2 of 2)

TEST TYPE	TEST NAME	TEST ID
Section 5 - Read/Write, 100 IPS	PE Amplitude Sensor	52
	GCR Amplitude Sensor	53
	PE Write Records	58
	PE Read Forward	59
	PE Read Backward	5A
	PE Positioning	5B
	GCR Write Records	5C
	GCR Read Forward	5D
	GCR Read Backward	5E
	GCR Positioning	5F

9.3.1.1 TEST PACKAGE INITIATOR (10)

The Test Package Initiator routine sets the Continue option and returns the subsystem to the monitor. Testing begins with Test 12 and continues until its completion or an error is detected.

9.3.1.2 MEMORY/PROM CHECKSUM (12)

The Memory/PROM Checksum test checks all of memory (RAM and PROM). RAM is tested (both the diagnostic loop write-to-read buffer and functional memory) for its ability to write, read, write complement, and read with a demanding Z80 instruction sequence. The PROMs are read and the checksums verified.

9.3.1.3 IF TEST 1 (13)

The testing performed by this routine depends in the type of interface card installed; Storagetek or Industry Standards. The tests are described in the following paragraphs.

9.3.1.3.1 Routine 13 for Storagetek Interface Card

This routine checks all three counters (8253) for their down-count ability through the entire 16-bit count range. A terminal count pulse is expected at the interrupt controller (8259) for each counter in a fixed sequence following a fixed delay.

9.3.1.3.2 Routine 13 for Industry Standard Interface Card

This routine checks counter functions and interrupt generation of the MK3801 by preloading the three counters with independent values and ensuring a similar sequence of interrupts.

9.3.1.4 IF TEST 2 (14)

The testing performed by this routine depends in the type of interface card installed; Storagetek or Industry Standards. The tests are described in the following paragraphs.

9.3.1.4.1 Routine 14 for Storagetek Interface Card

This routine checks that all counter-related interrupts are functional. Counters 0, 1, and 2 are set for delays of 200, 400, and 600 microseconds, respectively. When the interrupts are received by the handler, a bit corresponding to the one received is set in a processor register, allowing verification of the sequence of interrupts received.

9.3.1.4.2 Routine 14 for Industry Standard Interface Card

This routine checks the read/write memory registers for independent functions. These registers are located in memory addresses INSTATA, INSTATB, INSTATC, INTCLR and DIAGSTAT.

9.3.1.5 KEYBOARD STATUS (15)

This Keyboard Status test ensures that there are no stuck-active conditions in the keyboard control and status registers. All row selects (0 through 4) are individually activated and status KBDATA is read to check the column-depressed response. An error will be displayed if more than one key is indicated as being active.

9.3.1.6 SERVO-LSI REGISTER LOOP (18)

The Servo-LSI Register Loop routine tests the loopable paths through the XRS and XCS chips including the capstan position counter PCREAD, capstan velocity register VR, and both swing arm position counters READMPOS, READFPOS. All registers are loaded with walking ONEs and ZEROS such that independent functioning of these addresses can be verified.

9.3.1.7 DATA PATH STATUS (1B)

The Data Path Status routine checks that proper status is seen from the data path card following resets in both PE and GCR modes. Status is examined in DP card Registers DTREG through AMPSREG.

9.3.1.8 WRITE CARD STATUS (1D)

The Write Card Status routine enables each sensor individually and when the associated control lines are disabled, the following conditions are expected in the sensor status register (SENSORS):

1. EOT, BOT, and Leader Status must be off
2. File Protect must be asserted
3. Tape Present is a don't care (due to the possibility of tape in the thread path)

Also, Sensor Error must never be asserted as this indicates detection of an impossible combination by the WR write card (e.g., LED off but detector active).

This routine also ensures resetting write/erase currents. Write Current Active is tested by the first write test (42) in the diagnostic package.

9.3.1.9 RELEASE/RETRACT SWING ARMS (1F)

The Release/Retract Swing Arms routine drives the swing arms to the extent of their travel. The swing arms are first driven to their extended position and then returned to retracted position. During the retract motion, proper phasing of the motion tachs is checked. A software count representing the distance travelled is expected to match that detected by the position counters of the SV servo card XRS chip. (If tape is detected in the thread path, all count compares are bypassed.)

9.3.2 Section 2 - Formatter Tests

The formatter tests ensure proper data path operation by simulating record writing in a loop write-to-read mode. No tape motion takes place in these tests; they may be executed in a tape loaded or unloaded state.

9.3.2.1 PE BASIC LOOP WRITE-TO-READ, 50 IPS (22)

The PE Basic Loop Write-to-Read (LWR) routine is the initial test of the subsystem's PE loop write-to-read capability. This routine sets the subsystem to the PE mode and simulates records of selected data and byte counts.

The first six patterns (all-ONES, all-ZEROs, AA-55, 55-AA, walking ZERO bit, and walking ONE bit) are written as short records (five to eight bytes). In each of these cases, data is retained in the read path for subsequent data comparison. These pattern and length combinations result in the transfer of 1128 bytes in 144 records.

The next eight records are written as long records (one to eight kilobytes). For these records, a 32-byte data pattern is repeated up to the desired length (based on time) and then STOP is asserted to the DP data path card. When the data path indicates completion, status is used to indicate data integrity. Approximately 36 kilobytes are transferred in the eight records.

These transfers involve the IF processor card, DP data path card, and RD read card. No errors are forced by this test so that the occurrence of an error will result in a fault code.

9.3.2.2 PE LWR VELOCITY (23)

The PE LWR Velocity routine verifies the velocity error detection thresholds normally enabled during PE writes. A capstan tach will be approximately 20 tach periods in length. The velocity check circuitry counts the number of VCO pulses received from the RD card for each tach period. Four records will be used to simulate 50 IPS velocity errors of +12.5%, +5.6%, -8.2%, and -11.7%. Of these, the first and last records will exceed the 10% threshold and a Velocity Check is expected.

9.3.2.3 GCR BASIC LOOP WRITE-TO-READ, 50 IPS (24)

The GCR Basic Loop Write-to-Read (LWR) routine is the initial test of the subsystem's GCR loop write-to-read ability. This routine sets the subsystem to GCR mode and simulates records of selected data and byte counts.

The first six patterns (all ONES, all ZEROs, AA-55, 55-AA, walking ZERO bit, and walking ONE bit) are written as short records (one to six bytes). In each of these cases, data is retained in the read path for subsequent data comparison. These pattern and length combinations result in the transfer of 660 bytes in 120 records.

The next eight records are written as long records (one to eight bytes). For these records, a 32-byte data pattern is repeated up to the desired length (based on time) and then STOP is asserted to the data path card. When the data path indicates completion, status is used to indicate data integrity. Approximately 36 kilobytes are transferred in the eight records.

These transfers involve the IF processor card, DP data path card, and RD read card. No errors are forced by this by this test so that the occurrence of an error will result in a fault code.

9.3.2.4 GCR LWR VELOCITY (25)

The GCR LWR Velocity routine verifies the velocity error detection thresholds normally enabled during GCR write operations. A capstan tach is diagnostically simulated during the writing of records approximately 20 tach periods in length. The velocity check circuitry counts the number of VCO pulses received from the RD card for each tach period. Four records will be used to simulate 50 IPS velocity errors of +12.5%, +5.6%, -8.2%, and -11.7%. Of these records, the first and last records will exceed the 10% threshold and a Velocity Check is expected.

9.3.2.5 PE LWR, ONE TRACK DEAD (26)

The PE LWR, One Track Dead routine tests the error detection and correction ability of the PE loop write-to-read function. Sixty-four short records and eight long records are written with a test track forced inactive. Track 0 is the initial test track, shifting up to track P with each successful completion of the 72 records.

The short records use the walking ZERO bit pattern with a length of six bytes. Corrected data is compared to the write buffer upon readback. For the short records, dead tracking is performed throughout from preamble through postamble. This procedure tests the hardware's ability to recognize a late ready track.

The long records are identical to those used in Test 22 with lengths from one to eight kilobytes. Dead tracking starts approximately halfway through the preamble ensuring record latch and testing early track ready indications.

Only correction status is expected for these single track-in-error situations.

9.3.2.6 GCR LWR, ONE TRACK DEAD (27)

The GCR LWR, One Track Dead routine tests the error detection and correction ability of the GCR loop write-to-read function. Forty-eight short records and eight long records are written with a test track forced inactive. Track 0 is the initial test track, shifting up to track P with each successful completion of the 56 records.

The short records use the walking ZERO bit pattern with a length of eight bytes. Corrected data is compared to the write buffer upon readback. For the short records, dead tracking is performed throughout from preamble through postamble. This procedure tests the hardware's ability to recognize a late ready track.

The long records are identical to those used in Test 22 with lengths from one to eight kilobytes. Dead tracking starts approximately halfway through the preamble ensuring record latch and testing early track ready indications.

Only correction status is expected from the data path card (DP) for these single track-in-error situations.

9.3.2.7 PE LWR, TWO TRACKS DEAD (28)

The PE LWR, Two Tracks Dead routine checks that two tracks in error are identified and that an uncorrectable record is flagged. The test procedure is as described for Test 26 except that the dead tracking is performed on all 36 permutations of two tracks from 0 and 1 to 7 and P. This procedure results in the transfer of 18,432 bytes in 2,403 short records and 1296 kilobytes in 288 long records.

This test expects the following status from the data path card: Uncorrectable, Partial Record, Multi-track Error, and End Data Check.

9.3.2.8 GCR, LWR, TWO TRACKS DEAD (29)

This routine checks that two GCR tracks in error are identified and that data correction is performed. The test procedure is as described for test 27 except that the dead-tracking is performed on all 36 permutations of two tracks from 0 and 1 to 7 and p. This results in the transfer of 10,368 bytes in 1728 short records and 1296K bytes in 288 long records. This test expects Multi Track error status from the data path (DP) card.

9.3.2.9 PE BASIC LWR, 100 IPS (2C)

This routine switches the subsystem to 100 IPS mode, then performs tests as in Routine 22.

9.3.2.10 GCR BASIC LWR, 100 IPS (2E)

This routine switches the subsystem to 100 IPS mode, then performs tests as in Routine 24.

9.3.3 Section 3 - Transport Tests

Once the formatter has been checked, the diagnostic routines test the tape transport. The transport tests ensure proper servo operation, tape handling during a load operation, motion control, and high-speed rewind functions.

9.3.3.1 UNLOAD/LOAD (32)

The Unload/Load routine tests the reel and capstan servos by cycling through an unload/load sequence. Testing takes place primarily during the load sequence as the unload phase is not guaranteed to occur. The capstan is cycled through a forward and backward ramp and the tach examined for phasing through a complete revolution. The reel servos are driven in both current and voltage feedback modes and the proper response is expected of the pump up/down drive signals. The drive will complete the thread sequence and stop just after the swing arms are in servoing position.

Note that this routine interrupts the normal rewind-to-BOT procedure so that Test 34 can diagnose any ramp problems. This means that the sizing of the file reel and the initialization of the adaptive motion variables are not yet complete. These will occur upon completion of the next rewind, whether it be commanded offline from the panel, online from the interface, or a result of the continuation of this test package (Test 36).

9.3.3.2 DRIVE BASIC MOTION, 50 IPS(34)

The Drive Basic Motion routine performs the first test of loaded drive motion in the diagnostic package. The drive's start/stop characteristics are analyzed by allowing the functional code to control motions with the normal interrupts (250 us capstan acceleration/deceleration; 1 ms capstan at velocity; 10 ms reel control). This routine monitors the result of the functional

code control: that capstan position error limits are not exceeded during the ramps, that swing arm position feedback for the reel servo is within a certain range (isolating tape slip problems), and that capstan velocity is correct during sustained motion.

9.3.3.3 DRIVE BASIC MOTION, 100 IPS (35)

This routine test for 100 IPS start/stop characteristics, analyzes characteristics of ramp error, instantaneous velocity error, and stop lock positioning.

9.3.3.4 DRIVE REWIND (36)

The Drive Rewind routine tests the performance of the functional rewind task. Following a 125-foot forward motion (providing that EOT is not detected), a rewind is initiated. A ramp up to a minimum of 175 ips is expected. This only verifies that initial ramp up can be completed without excessive reel error but not that the nominal rewind speed of 220 ips can be attained.

9.3.4 Section 4 (50 IPS) and Section 5 (100 IPS) - R/W Tests

The Read/Write Tests check the subsystem read/write electronics. Data transfer from the data path card, read backward/forward operations, and tape positioning (PE and GCR) are verified by these tests.

9.3.4.1 PE AMPLITUDE SENSOR (42=50 IPS, 52=100 IPS)

The PE Amplitude Sensor routine is the first test of the subsystem read/write electronics. Write Current Status is verified before any motion occurs (the drive must be write enabled). This routine checks amplitude sensor response by writing (in PE density) an all-ONES pattern on all tracks (using the Write ARA command). Verification of over 30 feet of tape will isolate bad tape as a failure mechanism. The individual functioning of all amp sensors is then tested by using the diagnostic dead-track control to write one-track-at-a-time and all-but-one-track combinations (nine times each). Finally, gross write-to-read feedthrough problems are detected by toggling write triggers with tape motion halted.

9.3.4.2 GCR AMPLITUDE SENSOR (43=50 IPS, 53=100 IPS)

The GCR Amplitude Sensor routine is identical to that of Test 42 except that the subsystem is placed in GCR mode. This requires the generation of the proper write current levels by the WR write card and amp sensor threshold selection by the RD read card.

9.3.4.3 PE WRITE RECORDS (48=50 IPS, 58=100 IPS)

The PE Write Records routine performs the first formatted PE write test of the test package. As the DP data path card has been verified by the loop write-to-read tests, this routine detects and isolates faults in the WR write card, RD read card, and read/write head. If any velocity errors occur, both the DP data path card and the SV servo card will be indicated.

256 records are written (16 groups separated by tape marks). Each record contains data representing its tape position. Any reject or machine check that occurs during the writing of a record will be displayed.

9.3.4.4 PE READ FORWARD (49=50 IPS, 59=100 IPS)

The PE Read Forward routine isolates read failures associated with the RD read card and the read/write head since data transfer from the data path card has been tested with the loop write-to-read tests. Following a rewind, the records written by Test 48 are read forward and the data verified. Any reject or machine check that occurs during the writing of a record will be displayed.

9.3.4.5 PE READ BACKWARD (4A=50 IPS, 5A=100 IPS)

The PE Read Backward routine verifies read backward operations using the tape formatted by Test 48. After positioning on the BOT side of the logical end-of-tape (two tape marks), the 256 records are read backward and the data verified. Any reject or machine check that occurs during the reading of a record will be displayed.

9.3.4.6 PE POSITIONING (4B=50 IPS, 5B=100 IPS)

The PE Positioning routine tests the positioning commands (Forward Space File, Backward Space File, Backspace A Block, and Forward Space A Block). Various combinations of these commands are issued expecting the tape formatted by Test 48. Tape position is verified by the data read from the records.

9.3.4.7 GCR WRITE RECORDS (4C=50 IPS, 5B=100 IPS)

The GCR Write Records routine performs the first formatted GCR write of the test package. Failures detected by this test are now limited to the WR write card, RD read card, and the read/write head.

256 records are written (16 groups separated by tape marks). Each record contains data representing its tape position. Any reject or machine check that occurs during the writing of a record will be displayed.

9.3.4.8 GCR READ FORWARD (4D=50 IPS, 5D=100 IPS)

The GCR Read Forward routine isolates read failures associated with the RD read card and the read/write head since the data transfer from the data path has been tested by the loop write-to-read tests. Following a rewind, the records written by Test 4C are read forward and the data verified. Any reject or machine check that occurs during the writing of a record will be displayed at operator panel.

9.3.4.9 GCR READ BACKWARD (4E=50 IPS, 5E=100 IPS)

The GCR Read Backward routine verifies read backward operations using the tape formatted by Test 4C. After positioning on the BOT side of the logical end-of-tape (two tape marks), the 256 records are read backward and the data verified. Any reject or machine check that occurs during the reading of a record will be displayed.

9.3.4.10 GCR POSITIONING (4F=50 IPS, 5F=100 IPS)

The GCR Positioning routine tests the positioning commands (Forward Space File, Backward Space File, Backspace A Block, and Forward Space A Block). Various combinations of these commands are issued expecting the tape formatted by Test 4C. Tape position is verified by the data read from the records.

9.4 EXTERNAL DIAGNOSTICS

The External Diagnostics are supplied on a floppy diskette with the standard 1900 diagnostic control monitor. The routine library consists of an interface verification test, an internal diagnostic initiator, and several online exerciser routines (PE and GCR).

Interface verification is performed by the internal manipulation of all status lines following invocation by the 3910 Detached Diagnostic Device. The interface test sets the subsystem in a diagnostic mode which allows the independent activation of each standard interface line. The 3910 verifies that all status line transitions occur. With satisfactory communication ensured, internal diagnostics can be initiated and the test results obtained. All subsystem fault isolation is performed by the internal diagnostics. The remaining online 3910 routines are not intended to isolate any fault conditions within the subsystem, but only to provide a figure of merit for subsystem performance.

(INTENTIONALLY LEFT BLANK)

APPENDIX A

SPECIAL TEST EQUIPMENT, TOOLS, AND SUPPLIES

This appendix lists the special test equipment, special tools, and supplies required to maintain the MTS. The part numbers provided are Storage Technology part numbers unless otherwise specified.

ITEM	PART NUMBER	FUNCTION
Cleaning Kit includes:	6164	Tape path cleaning
Hub/Transport Cleaner Fluid	402626502	
Lint-free Cloth	6168	
Foam-Tipped Swabs	11698	
Wrist Strap	24000027	Circuit card handling
Master Alignment Tape	4611	Read/write head alignment
Master Output Tape	401202102	Read amplitude check
Tape Developer (Magna-See)	4583	Bit position check
Jeweler's Loupe (optional)	Bauch&Lomb 81-34-35	Bit position check
Torque Screwdriver		Screw removal
Torx T15 for #6 screws	403443401	
Torx T25 for #10 screws	403443501	
Torx T30 for 1/4 screws	403443601	
Torx key for #6 screws	403443701	

(INTENTIONALLY LEFT BLANK)

APPENDIX B

DATA FORMATS

3.1 INTRODUCTION

The MTS is capable of formatting and deformatting data in both PE and GCR recording modes. This appendix describes how each recording mode is formatted.

B.2 PHASE ENCODED (PE) OPERATION (1600 BPI)

ANSI Compatibility. The MTS writes and reads half-inch magnetic tapes in phase-encoded recording mode as specified by ANSI x3.39-1973.

Recorded Format. The PE recorded format is as shown in Figure B-1. Recording density is 1600 bits per inch (nominal).

Block Length. The MTS does not control or limit the number of data characters within a block or record except to disallow the writing of data blocks containing no data characters. The USER has control over block size and may exceed the ANSI-specified maximum and minimum values. Minimum block size is one byte.

Maximum Interblock Gap (IBG). The USER may generate extended length IBGs by issuing multiple Erase Gap (ERG) commands. The USER should avoid generating gaps in excess of the ANSI-specified maximum of 25 feet (7.62 meters). When reading, detection of an erase section in excess of 25 feet causes Empty Tape Error to be set.

End of Recording Area. The USER must control or limit operations beyond the EOT marker (end of recording area).

Tape Mark Block. A tape mark will be read if sufficient characters in zone 2 with at least one track of zone 1 together with the erasure of zone 3 can be detected or zone 1 and erasure of zone 3.

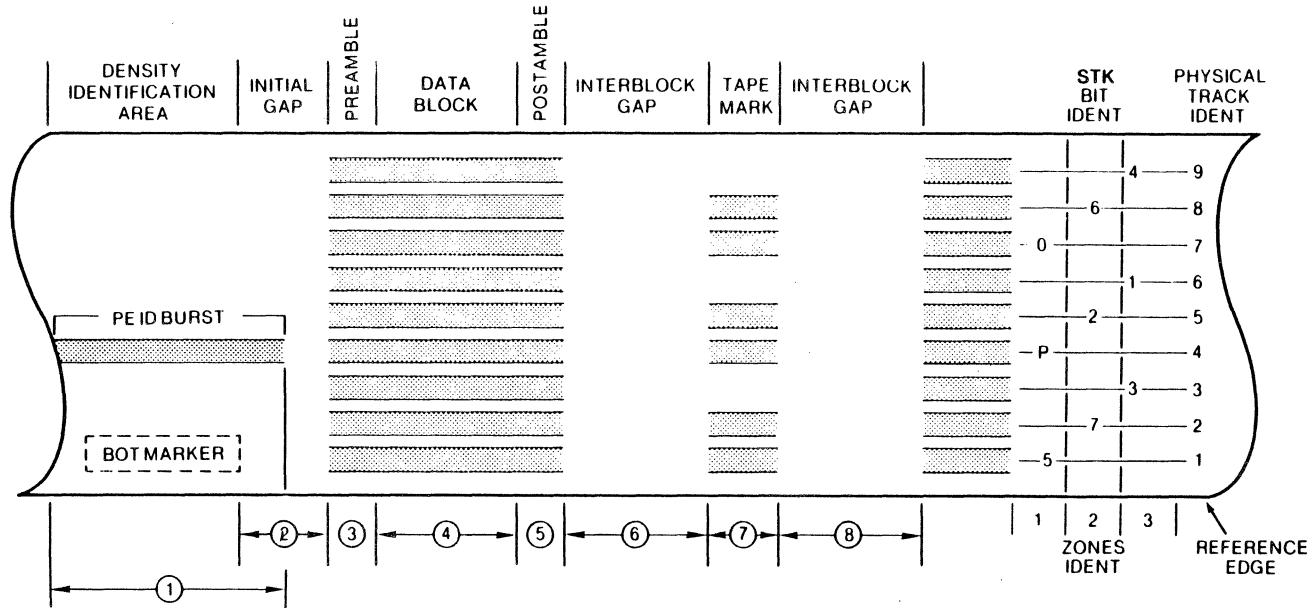

- A. Tape is shown oxide side up.
- B. Areas shown without recording, including IBGs, are magnitized so that the rim end of the tape is a north-seeking pole.
- Density Identification Area - PE recording is identified by an ID burst of recording at the BOT marker consisting of 1600 FCI on track 4 and erasure on all other tracks. This burst begins 1.7 inches minimum before the trailing edge of the BOT marker, continues past the trailing edge, ending at least 0.5 inch before the first block.
 - Initial Gap - The gap between the trailing edge of the BOT marker and the first recorded character is 3 inches minimum and 25 feet maximum.
 - Preamble - Preceding data in each block, a preamble is written consisting of 41 characters, of which the first 40 characters contain ZERO bits followed by a single character containing ONES in all tracks.
 - Data Block - ANSI specifies this shall contain a minimum of 18 or a maximum of 2048 characters. Actual block length is under USER control.
 - Postamble - Following data in each block, a postamble is written consisting of 41 characters of which the first character contains ONES in all tracks followed by 40 characters containing ZEROS in all tracks.
 - Tape Mark/Interblock Gap - The IBG immediately preceding a tape mark is 3.6 inches long nominal.
 - Tape Mark - The PE mark is written as 64 to 256 flux reversals at 3200 FCI in zone 2 (physical tracks 2,5,8) and zone 1 (physical tracks 1,4,7). Zone 3 (physical tracks 3,6,9) is DC erased.
 - Interblock Gaps - IBGs are 0.6 inch nominal, 0.5 inch minimum. Extended length IBGs may be generated by the USER.
 - End of Recording Area - The recording area starts at the leading edge of the EOT marker

Figure B-1. PE Tape Format

3.3 GROUP-CODED RECORDING (GCR) OPERATION (6250 BPI)

ANSI Compatibility. The MTS writes and reads half-inch magnetic tapes in group-coded recording mode as specified by ANSI X3.54-1976.

Recorded Format. The GCR recorded format is as shown in Figures B-2 and B-3. Recording density is 6250 bits per inch (nominal).

Block Length. The MTS does not control or limit the number of data characters within a block or record except to disallow the writing of data blocks containing no data characters. The USER has control over block size and may exceed the ANSI-specified maximum and minimum values. Minimum block size is one byte.

Maximum Interblock Gap (IBG). The USER may generate extended length IBGs by issuing multiple Erase Gap (ERG) commands. The USER should avoid generating gaps in excess of the ANSI-specified maximum of 15 feet. When reading, detection of an erase section in excess of 15 feet (4.572 meters) causes Empty Tape Error to be set.

End of Recording Area. The USER must control or limit operations beyond the EOT marker (end of recording area).

Tape Mark Block. A tape mark will be read if sufficient characters in zone 2 with at least one track of zone 1 together with the erasure of zone 3 can be detected or zone 1 and erasure of zone 3.

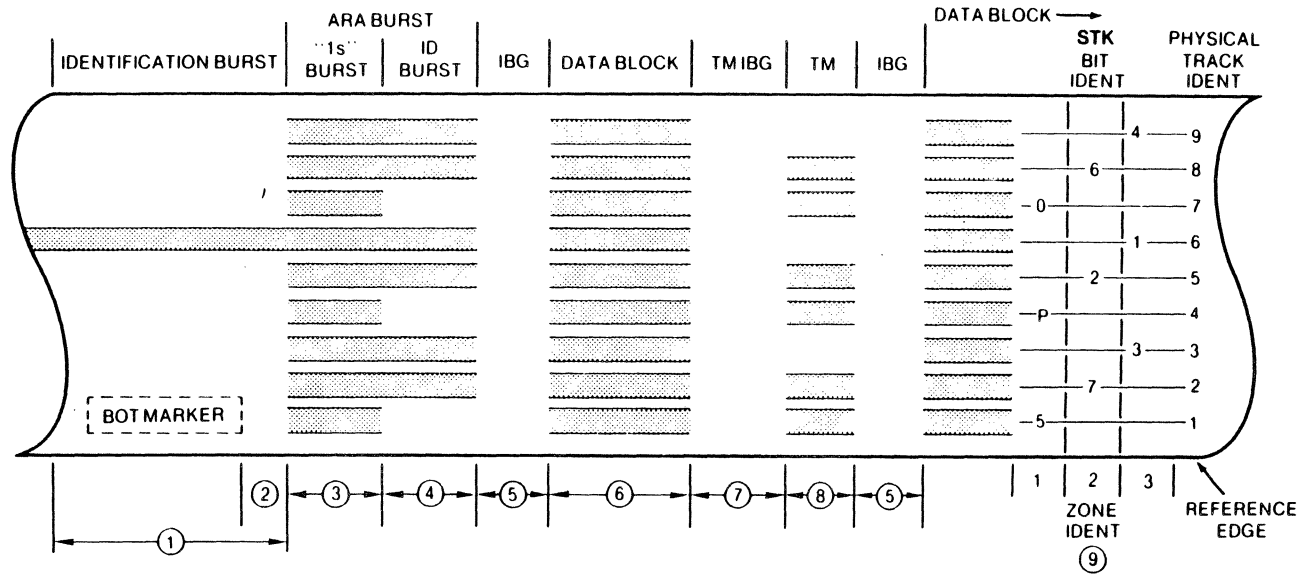

- A. Tape is shown oxide side up.
- B. Areas shown without recording, including IBG's are magnitized so that the rim end at the tape is a north-seeking pole.
1. Identification Burst - The GCR method is identified by a burst of a recording at the BOT marker. The burst is in the PE frequency range (1600 BPI) on track 6 and erasure on all other tracks. The ID burst begins 1.7 inches minimum before the trailing edge of BOT and continues past the trailing edge of the BOT marker.
 2. ARA Burst - The ARA burst enables the capability of writing all tracks to be verified. It begins no sooner than 1.5 inches and no later than 4.3 inches as measured from the leading edge of the BOT marker.
 3. ARA '1s' Burst - Immediately following the ID burst there is an ARA Burst (all ONES in all tracks) which is separated from the ID Burst by an undefined gap. It ends sooner than 9.5 inches and no later than 11.5 inches as measured from the leading edge of the BOT marker.
 4. ARA ID Burst - Appended to the end of the ARA '1s' Burst is an ID character consisting of ONES in tracks 2,3,5,6,8, and 9 and erasure in tracks 1,4, and 7. This ID character is approximately 2 inches long. (At least a contiguous 1/4-inch section of this 2-inch long burst must be error-free in all tracks simultaneously). There is a normal IBG between the ARA ID character and the first data block.
 5. Interblock Gaps - IBGs are 0.285 inch minimum and 0.3 inch nominal. Extended length IBGs may be generated by the USER.
 6. Data Block - See GCR Data Block Format Illustration.
 7. Tape Mark Interblock Gap - The IBG immediately preceding a tape mark is 3.3 inches nominal.
 8. Tape Mark - The GCR tape mark is written as 250 to 400 flux reversals at 9042 FCI in zone 2 (physical tracks 2,5,8) and zone 1 (physical tracks 1,4,7). Zone 3 (physical tracks 3,6,9) is DC erased.
 9. End of Recording Area - The end of the recording area starts at the leading edge of the BOT marker.

12096

Figure B-2. GCR Tape Format

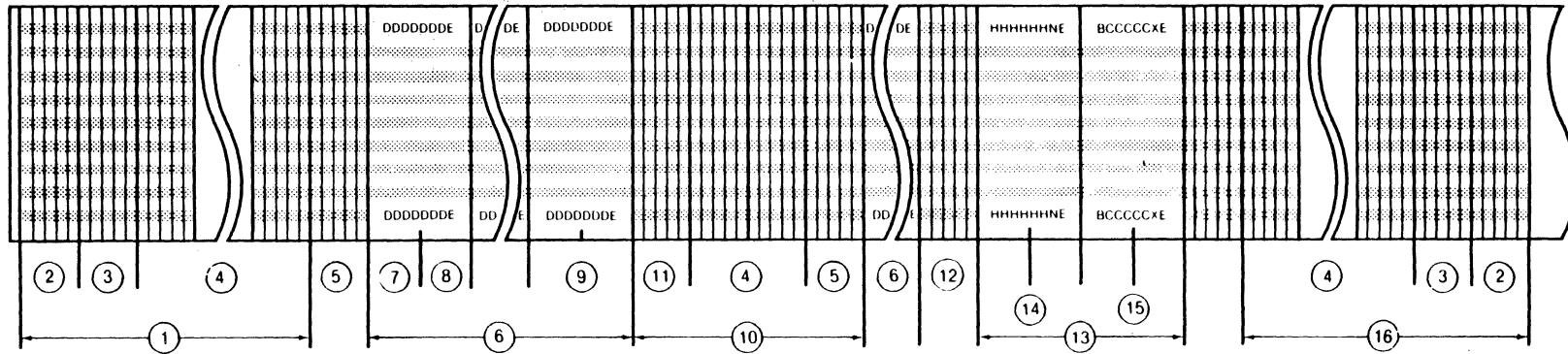

NOTE DATA GROUPS ARE SHOWN PRIOR TO ENCODING AND RECORDING.

- B CRC OR PAD CHARACTER
- C CYCLIC REDUNDANCY CHARACTER (CRC)
- D DATA CHARACTERS
- E ERROR CORRECTION CHARACTER ECC
- H PAD OR DATA CHARACTER
- L LAST CHARACTER
- N AUXILIARY CRC
- X RESIDUAL CHARACTER

DATA VALUES	RECORD VALUES
0 0 0 0	1 1 0 0 1
0 0 0 1	1 1 0 1 1
0 0 1 0	1 0 0 1 0
0 0 1 1	1 0 0 1 1
0 1 0 0	1 1 1 0 1
0 1 0 1	1 0 1 0 1
0 1 1 0	1 0 1 1 0
0 1 1 1	1 0 1 1 1
1 0 0 0	1 1 0 1 1
1 0 0 1	0 1 0 0 1
1 0 1 0	0 1 0 1 0
1 0 1 1	0 1 0 1 1
1 1 0 0	1 1 1 1 0
1 1 0 1	0 1 1 0 1
1 1 1 0	0 1 1 1 0
1 1 1 1	0 1 1 1 1

Figure B-3. GCR Data Block Format (Sheet 1 of 3).

The following are notes that explain sheet 1 of the figure. These notes are numbered to correspond with the numbers on the illustration.

- ① Preamble - Sixteen subgroups of five bytes each. The subgroups initiate the read circuits and synchronize them.
- ② Terminator Control Subgroup - The data in this subgroup provides for a long wave length input to the read detection circuits, thus ensuring high level inputs into the circuits at the beginning of a read operation. These inputs in turn ensure that the Read Detectors are turned ON before they are synchronized.

The Terminator Control Subgroup is one set of nine parallel 5-bit serial values of 10101 in all tracks located at the BOT end of each block and 1010L at the EOT end of each block, where L represents the resetting of the last character (which restores the Write Triggers to the erase state).

- ③ The Second Control Subgroup - This is a part of sync, explained below. The second Control Subgroup consists of 5-bit serial values of 01111 in all tracks for the BOT end of the block and 11110 for the EOT end of the block.

- ④ Sync Control Subgroup - These are fourteen 5-byte subgroups which synchronize the Read Reference Oscillator. Each subgroup consists of 5-bit serial values of all '1s' in all tracks.

- ⑤ Mark 1 Control Subgroup - This subgroup marks the coming of data. It ensures that the buffer counters are properly initiated so the data being read is formatted into the correct 5-byte groups. This is necessary for correct decoding (retranslation from five to four bit codes) of the data which is being read. The Mark 1 Control Subgroup is one set of 5-bit serial values of 00111 on all tracks. On backward operations, the Mark 1 becomes the Mark 2 Subgroup.

- ⑥ Data - Any recorded section of the tape which has only data and the ECC recorded on it (no Control Subgroups). The data is formatted into groups and the groups are divided into subgroups. These data subgroups are identified as data subgroup A and data subgroup B. Data subgroup A consists of four data bytes before translation (the storage group). The same is true for data subgroup B except that it is made up of three bytes and one ECC (Error Correction Character) before translation. The ECC is used for data correction. All data correction in GCR is done on the 8-byte data groups (byte 8 is the ECC).

Data Values/Record Values - During GCR recording, four bits from each track are translated into the 5-bit code. After translation, the 5-bit code is moved serially to the TU for recording. The data values and record values show the bit patterns before and after translation. During read operations, the 5-bit code is reconverted to the original four bits. Thus, the data sent to CPU is in its original form.

- ⑦ Data Subgroup A consists of four data bytes before translation (the storage group).
- ⑧ The same is true for Data Subgroup B except that it is made up of three data bytes and one ECC (Error Correction Character) before translation. The ECC is used for data correction. All data correction in GCR is done on the 8-byte data groups (byte 8 is the ECC).
- ⑨ There may be no more than 158 contiguous data groups in a recorded data block. If there are more than 1112 data bytes (before translation) in an incoming record, resynchronization is necessary before the recording can be continued.
- ⑩ Resync Burst - This burst is used to resynchronize the data of failing tracks when a data record is longer than 1112 data bytes (before translation). See notes 6 through 9.
- ⑪ Mark 2 Control Subgroup - This subgroup marks the ending of data and the coming of nondata information. The Mark 2 Control Subgroup consists of one set of 5-bit serial values of 11100 on all tracks. On backward operations, the Mark 2 becomes the Mark 1 Subgroup.
- ⑫ End Mark Control Subgroup - This subgroup warns of the approach of the Residual Data Group, which is defined in note 14. The End Mark Control Subgroup consists of one set of 5-bit serial values of 11111 on all tracks.
- ⑬ RES/CRC Data - This data includes both the Residual Data Group and the CRC Data Group (these group are described in notes 14 and 15). These two groups are written at the end of a data record.
- ⑭ Residual Data Group - This group is formed when there are six or less data bytes remaining in a data record. If six data bytes remain, the seventh byte of the Residual Data Group is the Auxillary CRC Character (a data validity check character) and byte eight is the normal ECC. If there are less than six residual data bytes, pad characters of all ZEROS with correct parity are added to the data group to pad it to six bytes. Thus, the Residual Data Group consists of the remaining bytes, the pad characters, the Auxillary CRC, Character (N), and the ECC (E). (All data groups must have eight bytes total in GCR mode).
- ⑮ Before this data group is written, the CRC character normally has odd parity if there was an odd number of data groups, and even parity if there was an even number of data groups. If the record has an odd number of data groups, the CRC character is even. Since an even parity byte is not allowed in a GCR Data Group, the CRC character must be made odd. To accomplish this an additional pad byte consisting of all ZEROS and a parity bit (B) is added to the record. The addition of this byte changes the number of bytes in the CRC generation and provides an odd parity CRC character.

12098

Figure B-3. GCR Data Block Format (Sheet 2 of 3)

The next five bytes of the CRC Data Group are identical CRC characters. The additional CRC characters serve to fill the CRC Data Group, since there is no more data to be read.

Next in the CRC Data Group is the Residual Character (X). By definition this character is used as a record data counter. Bits 3-7 are the module 32 counter. These bits are used by StorageTek in a proprietary manner. Bits 0-2 are used as a module 7 count of the Residual Data Group bytes are data. The module 7 count of the Residual character indicates how many data bytes are to be retrieved from the Residual Data Group.

The ECC in this data group, as in all other groups, is used to verify the correctness of data in the group and to isolate the error, if any, during read operations for data correction.

- ⑩ Postamble - The Postamble is the mirror image of the Preamble except for the terminator control subgroup. In read backward operations, the Postamble is used the same way the Preamble is used in read forward operations. See the description of Preamble in notes 1 through 4.

Check Characters - Three Check Characters are used in the GCR tape format: CRC (B), Auxillary CRC (N), and ECC (E).

The CRC characters are used to verify data validity during write and read back check operations. The ECC is used to verify data and validity, and for error identification and correction during read operations.

Figure B-3. GCR Data Block Format (Sheet 3 of 3)

(INTENTIONALLY LEFT BLANK)

APPENDIX C

MEMORY ALLOCATION, STK STANDARD INTERFACE - 2921

C.1 MEMORY MAP

0000 1FFF	PROM 1 (Functional)	(0000-1FFF)	8k
2000 3FFF	PROM 2 (Functional)	(2000-3FFF)	8k
4000 5FFF	PROM 3 (Diagnostics)	(4000-5FFF)	8k
6000 7FFF	Memory-Mapped I/O	(6000-7FFF)	8k
8000 8FFF	Diagnostic RAM (8000-87FF) 2k The first 64 bytes (8000-803F) constitute the internal LWR buffer.		
9000 9FFF	Not Used		
A000 AFFF	Functional Ram	(A000-A7FF)	2K
B000	Not Used		
FFFF	Not Used		

C.2 KEYBOARD/OP PANEL REGISTER ALLOCATION

Read Keyboard (0 = key depressed)

KBDATA

6010 R/O				Co14	Co13	Co12	Co11	Co10
-------------	--	--	--	------	------	------	------	------

C.3 DIAGNOSTIC REGISTER ALLOCATION

Diagnostic Status (IDG)

DIAGSTAT

6014 R/O						Diag Read Done RDFIN	Diag Write Done WTFIN	Diag Prty Error PRITY
-------------	--	--	--	--	--	-------------------------------	--------------------------------	--------------------------------

Read Diagnostic Download Byte

DIAGDWNL

6017 R/O	msb	lsb
-------------	-----	-----	-----	-----	-----	-----	-----	-----

Servo Diagnostic Status

DIAGSERV

6050 R/O	Tach Phase A TACHA	Tach Phase B TACHB			Mach Pump Down MPD	Mach Pump Up MPU	File Pump Down FPD	File Pump Up FPU
-------------	-----------------------------	-----------------------------	--	--	-----------------------------	---------------------------	-----------------------------	---------------------------

Diagnostic Sense (ISN)

DIAGSENS

6078 R/O	Diag Switch 1	Diag Switch 0	Buper	Stop	Trak	Diag Sel 2	Diag Sel 1	Diag Sel 0
-------------	---------------------	---------------------	-------	------	------	------------------	------------------	------------------

C.4 CAPSTAN CONTROL REGISTER ALLOCATION

Read Position Count							PCREAD
6025 R/O	msb	1sb

Read Capstan Velocity							VR
6027 R/O	msb	1sb

C.5 REEL CONTROL REGISTER ALLOCATION

Read Machine Position Count							READMPOS
6034 R/O	msb	1sb

Read File Position Count							READFPOS
6035 R/O	msb	1sb

Reel Status (RSS)						SRVOSENS		
6036 R/O	Mach Phase B MPHSB	Mach Phase A MPHSA	File Phase B FPHSB	File Phase A FPHSA	Watch Dog EPO WDERR		Loop Out EPO LOOPF	Power Fail EPO PWRP

Read Thread Counter							THRDREAD
603B R/O	msb	1sb

C.6 DATA PATH CARD REGISTER ALLOCATION

Dead Track Register (-)

DTREG

6040 R/O	(-) Dead TRK 7	(-) Dead Trk 0
-------------	----------------------	-----	-----	-----	-----	-----	-----	----------------------

Data Path Status A (DSA)

DPSTATA

6041 R/O	Write TM Check WTMCK	Uncor Error UNCOR	Part Rec PRTRC	Mult Track Error MTE	Read Corr RDCOR	End Data Check ENDCK	Vlcty Check VELCK	
-------------	-------------------------------	-------------------------	----------------------	-------------------------------	-----------------------	-------------------------------	-------------------------	--

Data Path Status B (DSB)

DPSTATB

6042 R/O	Cmd Rej REJ	ID Check IDCHK	Read Ovrfl ROVR	Write Ovrfl WOVR	CRC C CRCC	CRC A CRCA	CRC CRC	Buper BUPER
-------------	-------------------	----------------------	-----------------------	------------------------	------------------	------------------	------------	----------------

Data Path Status C (DSC)

DPSTATC

6043 R/O	Over Block BLOCK	Data Avail DAVAIL	PE ID PEID	GCR ID GCRID	TM Stat TMS	-DT P NDTP	AS P ASP	PH P PHASP
-------------	------------------------	-------------------------	------------------	--------------------	-------------------	---------------	-------------	---------------

Phase Pointers

PHASREG

6044 R/O	Phase Pntr Trk 7	Phase Pntr Trk 0
-------------	------------------------	-----	-----	-----	-----	-----	-----	------------------------

Amp Sensors

AMPSREG

6045 R/O	Amp Sense Trk 7	Amp Sense Trk 0
-------------	-----------------------	-----	-----	-----	-----	-----	-----	-----------------------

C.7 WRITE DRIVER AND SENSOR REGISTER ALLOCATION

		Sensors (SS1)					SENSORS	
6060	R/O	EOT	BOT	Tape Prsnt TAPE	Leadr Seen LEADR	File Prot FILEP		Sensr Error ERROR

		Current Monitor (WMN)					CURRNTM	
6061	R/O	All Trks Wrt WRTAL	Erase Curr On ERS	All Trks Off WROFF	(-) Wrt F Itrpt CUROK	Arms Extnd XTEND	File Arm Index FINDX	Mach Arm Index MINDX

C.8 INTERFACE REGISTER ALLOCATION

		Interface Command (ICM)				INTFCMD			
6077	R/O	Sys Reset Latch SYSRS	Addr Match SELCT	Dens Sel 1 NRZI	Dens Sel 0 GCR	Cmd Bit 3	Cmd Bit 2	Cmd Bit 1	Cmd Bit 0

(INTENTIONALLY LEFT BLANK)

APPENDIX D

MEMORY ALLOCATION, STK STANDARD INTERFACE - 2922

D.1 MEMORY MAP

0000 1FFF	PROM 1 (Functional)	(0000-1FFF)	8k
2000 3FFF	PROM 2 (Functional)	(2000-3FFF)	8k
4000 5FFF	PROM 3 (Functional)	(4000-5FFF)	8k
6000 7FFF	Memory-Mapped I/O	(6000-7FFF)	8k
8000 8FFF	Diagnostic RAM (8000-87FF) The first 64 bytes (8000-803F) constitute the internal LWR buffer.		2k
9000 9FFF	Not Used		
A000 AFFF	Functional RAM	(A000-A7FF)	2k
B000 BFFF	Not Used		
C000 DFFF	PROM 4 (Diagnostic)	(C000-DFFF)	8k
E000 FFFF	PROM 5 (Diagnostic)	(E000-FFFF)	8k

D.2 KEYBOARD/OP PANEL REGISTER ALLOCATION

Read Keyboard (0 = key depressed)

KBDATA

6010 R/O				Co14	Co13	Co12	Co11	Co10
-------------	--	--	--	------	------	------	------	------

D.3 DIAGNOSTIC REGISTER ALLOCATION

Diagnostic Status (IDG)

DIAGSTAT

6014 R/O						Diag Read Done RDFIN	Diag Write Done WTFIN	Diag Prty Error PRITY
-------------	--	--	--	--	--	-------------------------------	--------------------------------	--------------------------------

Read Diagnostic Download Byte

DIAGDWNL

6017 R/O	msb	lsb
-------------	-----	-----	-----	-----	-----	-----	-----	-----

Servo Diagnostic Status

DIAGSERV

6050 R/O	Tach Phase A TACHA	Tach Phase B TACHB			Mach Pump Down MPD	Mach Pump Up MPU	File Pump Down FPD	File Pump Up FPU
-------------	-----------------------------	-----------------------------	--	--	-----------------------------	---------------------------	-----------------------------	---------------------------

Diagnostic Sense (ISN)

DIAGSENS

6078 R/O	Diag Switch 1	Diag Switch 0	Buper	Stop	Trak	Diag Sel 2	Diag Sel 1	Diag Sel 0
-------------	---------------------	---------------------	-------	------	------	------------------	------------------	------------------

D.4 CAPSTAN CONTROL REGISTER ALLOCATION

		Read Position Count						PCREAD
6025	R/O	msb	1sb

		Read Capstan Velocity						VR
6027	R/O	msb	1sb

D.5 REEL CONTROL REGISTER ALLOCATION

		Read Machine Position Count						READMPOS
6034	R/O	msb	1sb

		Read File Position Count						READFPOS
6035	R/O	msb	1sb

		Reel Status (RSS)					SRVOSENS	
6036	R/O	Mach Phase B MPHSB	Mach Phase A MPHSA	File Phase B FPHSB	File Phase A FPHSA	Watch Dog EPO WDERR	Loop Out EPO LOOPF	Power Fail EPO PWRF

		Read Thread Counter						THRDREAD
603B	R/O	msb	1sb

D.6 DATA PATH CARD REGISTER ALLOCATION

Dead Track Register (-)

DTREG

6040
R/O

(-) Dead TRK 7	(-) Dead Trk 0
----------------------	-----	-----	-----	-----	-----	-----	----------------------

Data Path Status A (DSA)

DPSTATA

6041
R/O

Write TM Check WTMCK	Uncor Error UNCOR	Part Rec PRTRC	Mult Track Error MTE	Read Corr RDCOR	End Data Check ENDCK	Vlcty Check VELCK	
-------------------------------	-------------------------	----------------------	-------------------------------	-----------------------	-------------------------------	-------------------------	--

Data Path Status B (DSB)

DPSTATB

6042
R/O

Cmd Rej REJ	ID Check IDCHK	Read Ovrfl ROVR	Write Ovrfl WOVR	CRC C CRCC	CRC A CRCA	CRC CRC	Buper BUPER
-------------------	----------------------	-----------------------	------------------------	------------------	------------------	------------	----------------

Data Path Status C (DSC)

DPSTATC

6043
R/O

Over Block BLOCK	Data Avail DAVAIL	PE ID PEID	GCR ID GCRID	TM Stat TMS	-DT P NDTP	AS P ASP	PH P PHASP
------------------------	-------------------------	------------------	--------------------	-------------------	---------------	-------------	---------------

Phase Pointers

PHASREG

6044
R/O

Phase Pntr Trk 7	Phase Pntr Trk 0
------------------------	-----	-----	-----	-----	-----	-----	------------------------

Amp Sensors

AMPSREG

6045
R/O

Amp Sense Trk 7	Amp Sense Trk 0
-----------------------	-----	-----	-----	-----	-----	-----	-----------------------

D.7 WRITE DRIVER AND SENSOR REGISTER ALLOCATION

Sensors (SS1)							SENSORS
6060 R/O	EOT	BOT	Tape Prsnt TAPE	Leadr Seen LEADR	File Prot FILEP		Sensr Error ERROR

Current Monitor (WMN)						CURRNTM	
6061 R/O	All Trks Wrt WRTAL	Erase Curr On ERS	All Trks Off WROFF	(-) Wrt F Itrpt CUROK	Arms Extnd XTEND	File Arm Index FINDX	Mach Arm Index MINDX

D.8 INTERFACE REGISTER ALLOCATION

Interface Command (ICM)					INTFCMD			
6077 R/O	Sys Reset Latch SYSRS	Addr Match SELCT	Dens Sel 1 NRZI	Dens Sel 0 GCR	Cmd Bit 3	Cmd Bit 2	Cmd Bit 1	Cmd Bit 0

(INTENTIONALLY LEFT BLANK)

APPENDIX E

MEMORY ALLOCATION, INDUSTRY STD INTERFACE - 292X

E.1 MEMORY MAP

0000 1FFF	PROM 1 (Functional)	(0000-1FFF)	8k
2000 3FFF	PROM 2 (Functional)	(2000-3FFF)	8k
4000 5FFF	PROM 3 (Functional)	(4000-5FFF)	8k
6000 7FFF	PROM 4 (Diagnostic)	(6000-7FFF)	8k
8000 9FFF	PROM 5 (Diagnostic)	(8000-9FFF)	8k
A000 AFFF	Diagnostic RAM	(A000-A0FF)	256 bytes
B000 BFFF	Not Used		
C000 CFFF	RAM (Functional)	(C000-C7FF)	2k
D000 DFFF	Not Used		
E000 EFFF	Memory-Mapped I/O	(E000-E0FF)	256 bytes
F000 FFFF	Not Used		

E.2 KEYBOARD/OP PANEL REGISTER ALLOCATION

Read Keyboard (0 = Key depressed)

KBDATA

E008 R/O				Co14	Co13	Co12	Co11	Co10

E.3 DIAGNOSTIC REGISTER ALLOCATION

Diagnostic Status (IDG)

DIAGSTAT

E028 R/O	Ready	Rewnd	Formt Busy		100 ips		Diag W/R Done WTFIN	Diag Prty Error PRITY

Read Diagnostic Download Byte

DIAGDWNL

E038 R/O	msb	lsb

Servo Diagnostic Status

DIAGSERV

E0D0 R/O	Tach Phase A TACHA	Tach Phase B TACHB			Mach Pump Down MPD	Mach Pump Up MPU	File Pump Down FPD	File Pump Up FPU

Diagnostic Sense (ISN)

DIAGSENS

E030 R/O		Diag Switch 0	Buper	Stop	Trak	Diag Sel 2	Diag Sel 1	Diag Sel 0

E.4 CAPSTAN CONTROL REGISTER ALLOCATION

Read Position Count PCREAD

EOA5 R/O	msb	1sb

Read Capstan Velocity VR

EOA7 R/O	msb	1sb

E.5 REEL CONTROL REGISTER ALLOCATION

Read Machine Position Count READMPOS

EOB4 R/O	msb	1sb

Read File Position Count READFPOS

EOB5 R/O	msb	1sb

Reel Status (RSS) SRVOSENS

EOB6 R/O	Mach Phase B MPHSB	Mach Phase A MPHSA	File Phase B FPHSB	File Phase A FPHSA	Watch Dog EPO WDERR		Loop Out EPO LOOPF	Power Fail EPO PWRF

Read Thread Counter THRDREAD

EOBB R/O	msb	1sb

E.6 DATA PATH CARD REGISTER ALLOCATION

Dead Track Register (-)

DTREG

EOC0
R/O

(-) Dead TRK 7	(-) Dead Trk 0
----------------------	-----	-----	-----	-----	-----	-----	----------------------

Data Path Status A (DSA)

DPSTATA

EOC1
R/O

Write TM Check WTMCK	Uncor Error UNCOR	Part Rec PRTRC	Mult Track Error MTE	Read Corr RDCOR	End Data Check ENDCK	Vlcty Check VELCK	
-------------------------------	-------------------------	----------------------	-------------------------------	-----------------------	-------------------------------	-------------------------	--

Data Path Status B (DSB)

DPSTATB

EOC2
R/O

Cmd Rej REJ	ID Check IDCHK	Read Ovrfl ROVR	Write Ovrfl WOVR	CRC C CRCC	CRC A CRCA	CRC CRC	Buper BUPER
-------------------	----------------------	-----------------------	------------------------	------------------	------------------	------------	----------------

Data Path Status C (DSC)

DPSTATC

EOC3
R/O

Over Block BLOCK	Data Avail DAVAIL	PE ID PEID	GCR ID GCRID	TM Stat TMS	-DT P NDTP	AS P ASP	PH P PHASP
------------------------	-------------------------	------------------	--------------------	-------------------	---------------	-------------	---------------

Phase Pointers

PHASREG

EOC4
R/O

Phase Pntr Trk 7	Phase Pntr Trk 0
------------------------	-----	-----	-----	-----	-----	-----	------------------------

Amp Sensors

AMPSREG

EOC5
R/O

Amp Sense Trk 7	Amp Sense Trk 0
-----------------------	-----	-----	-----	-----	-----	-----	-----------------------

E.7 WRITE DRIVER AND SENSOR REGISTER ALLOCATION

Sensors (SS1)							SENSORS
E0E0 R/O	EOT	BOT	Tape Prsnt TAPE	Leadr Seen LEADR	File Prot FILEP		Sensr Error ERROR

Current Monitor (WMN)							CURRNTM
E0E1 R/O	All Trks Wrt WRTAL	Erase Curr On ERS	All Trks Off WROFF	(-) Wrt F Itrpt CUROK		Arms Extnd XTEND	File Arm Index FINDX Mach Arm Index MINDX

E.8 INTERFACE REGISTER ALLOCATION

Interface Command (ICM)							INTFCMD
E020 R/O	Cmd Bit 7	Cmd Bit 6	Cmd Bit 5	Cmd Bit 4	Cmd Bit 3	Cmd Bit 2	Cmd Bit 1 0

Read Switches and Stop							INTSTATD
E030 R/O		Erase Stop	Stop Wrt	Swch 6	Swch 5	Swch 4	Swch 3 Match

R/W Port A of 8155							INTSTATA
E001 R/W	Load Point	File Prot	+Runn 100ips	Lwr	Wide Point	Back Wards	GCR Mach R/W 100ips

R/W Port B of 8155							INTSTATB
E002 R/W	Wrt Stat	EOT	Corr Error	File Mark	Hard Error	Data Busy	ID Burst Enble Stop

R/W Port C of 8155

INTSTATC

E003
R/W

		Z80 to Host (Read)	Z80 fr Host (Wrt)	Fake WRSTB	Fake RDSTB	-Enb1 WRSTB	-Enb1 RDSTB
--	--	--------------------------	-------------------------	---------------	---------------	----------------	----------------

Interface Registers

INTCLR

E019
W/O

Ready	Rewnd	Formt Busy					
-------	-------	---------------	--	--	--	--	--

INDEX

Address Selection.	3-17	Command Initiation	4-19
AK Card Replacement.	8-23	Command Lines Decodes -	
Automatic		Diagnostic Commands	
Thread/Load--Vertical		Description.	5-22
Mount.	2-9	Command Lines Decodes -	
		Functional Commands	
		Description.	5-15
Backspace a Block (BSB)		Command Offline (FOFL)	5-7
Command (1001)	4-33	Command REJECT (REJECT).	4-10
Backspace a File (BSF)		Command Select (CMD0,	
Command (1000)	4-32	CMD1, CMD2, CMD3).	4-5
Backward Motion (01)	9-3	Command Select Lines	
Beginning of Tape Status		(CMD0, 1, 2, 3, and 4)	5-9
(BOTS)	4-17	Command to Status Wrap	
Bi-Directional Data (DATA		(10001).	5-26
0-7,P)	4-8	Commands with MTS in Write	
Bit Position Check After		Status	4-20
Part Replacement	7-10	Continue Option (05)	9-4
Block Sensed (BLOCK)	4-9	Controlled Erase Command	
BSB/BOT.	4-33	(00101).	5-17
BSB/Tape Mark.	4-33	Cooling Fan Replacement.	8-27
BSF/BOT.	4-32	Corrected Error (CRERR).	4-17
Busy (BUSY).	4-9	Corrected Error (FCER)	5-11
Bypass Error Option (07)	9-5		
		Data Bus Parity Error	
		(BUPER).	4-17
Cable Harness Replacement.	8-27	Data Busy (FDBY)	5-10
Cable Harness, AC.	8-28	Data Check (DATA CHK).	4-11
Cable Harness, Motor	8-28	Data Formats	B-1
Cable Harness, Power	8-28	Data Loopback (1111)	5-27
Cable Harness, Sensor.	8-28	Data Path Card Register	
Capstan.	2-15	Allocation	C-4, D-4, E-4
Capstan Alignment (Tape		Data Path Status (1B).	9-11
Tracking).	7-3	Data Security Erase	
Capstan Control Register		Command (10111).	5-18
Allocation	C-3, D-3, E-3	Demand Write Data Strobe	
Capstan Motor Replacement.	8-18	(FDWDS).	5-13
Capstan, Reels, and		Density Select (DS0, DS1).	4-6
Blower	8-18	Density Select Key	2-5
Card Cage Circuit Cards		Detailed Diagnostic Sense	
Replacement.	8-22	Bytes Description.	5-28
Center of Gravity		Detailed Functional Sense	
(Horizontal) Cabinet		Bytes Description.	5-19
Mount.	3-12	Diagnostic Features.	1-7
Circuit Cards.	8-22	Diagnostic Keypad.	2-6
Clear Key.	2-9		

INDEX CONT

Diagnostic Mode Set (DMS)		Ending Status Validity . . .	4-20
Command (0010)	4-21	Enter Address Key.	2-6
Diagnostic Register		Enter Diagnostic Key	2-8
Allocation	C-2, D-2, E-2	Enter Key.	2-8
Diagnostic/Maintenance		Enter Probe Key.	2-8
Programs	9-1	Environmental	
Display.	2-1	Requirements	1-10
Display Address Key.	2-7	EOT/BOT and Leader	
DMS/FSB (SLX 2,1,0 = 000)		Sensors.	2-13
(Perform All		EOT/BOT Indicator (Green).	2-2
Diagnostics)	4-25	EOT/BOT Sensor Replacement	8-3
DMS/FSF (SLX 2,1,0, = 000)		EPROM Error (ROMPS).	4-11
(Perform Loaded		Erase Gap (ERG) Command	
Diagnostics)	4-25	(1101)	4-35
DMS/NOP (Status Lines Test		ERG/BOT.	4-35
Command)	4-22	Error Multiplex (ERRMX	
DMS/RDF (SLX 2,1,0 = 000)		0-7,P)	4-11
(Read No Motion		Expecting Data (RECV).	4-9
Command)	4-24	External Diagnostics	9-18
DMS/WRT (SLX 2,1,0 = 000)			
(Write In Place		FDWDS Timing, 100 IPS	
Command)	4-24	Operations	5-14
DMS/WRT (SLX 2,1,0 = 001)		FDWDS Timing, 50 IPS	
(Write No Motion		Operations	5-13
Command)	4-24	File Mark Detected (FFMK).	5-11
DMS/WRT (SLX 2,1,0 = 111)		File Protect (FFPT).	5-12
(Functional Speed/Gap		File Protect Indicator	
Select).	4-25	(Red).	2-2
Drive Basic Motion, 100		File Protect Sensor	
IPS (35)	9-16	Replacement.	8-5
Drive Basic Motion, 50		File Protect Status	
IPS(34).	9-15	(FPTS)	4-18
Drive Clear (CLR) Command		File Reel Hub.	2-15
(0001)	4-21	File Reel Hub Replacement.	8-20
Drive Rewind (36).	9-16	File Reel Motor	
DSB0 and DSB1 Description.	5-28	Replacement.	8-20
DSB2 and DSB3 Description.	5-28	File Search Forward	
DSB5 and DSB6 Description.	4-26	Command (Ignore Data)	
DSB8 Through DSB55		(00011).	5-18
Description.	4-26, 5-28	File Search Reverse	
Duty Cycle	2-21	Command (Ignore Data)	
		(01011).	5-18
Electronics.	1-7	Fixed Erase Command	
End of Data Pulse (ENDATP)	4-9	(00111).	5-17
End Of Tape (FEOT)	5-12	Formatter Busy (FFBY).	5-10
End of Tape Status		Formatter Enable (FFEN).	5-8
(EOTS)	4-17, 4-20	Forward Motion (00).	9-2

INDEX CONT

Forward Space a Block (FSB) Command (1011)	4-34	Head Skew Adjustment	7-5
Forward Space a File (FSF) Command (1010)	4-33	High Density Status (GCR).	5-13
Front Operator Panel Replacement.	8-23	High Density Status (HDNS)	4-18
FRSTR Timing, 100 IPS Operation.	5-15	High Speed Select (FHISP) (2922 devices only).	5-8
FRSTR Timing, 50 IPS Operation.	5-15	High Speed Streaming (FHSPD).	5-12
FSB/BOT.	4-34	Identification Burst (FID).	5-11
FSB/Tape Mark.	4-34	Identification Burst (ID BRST).	4-9
FSF/BOT.	4-34	IF Test 1 (13)	9-9
Functional Description	6-1	IF Test 2 (14)	9-10
Functional Mode Command Descriptions	4-18	Improper Command Sequences.	4-20
Fuses.	8-1	Industry Standard Interface.	5-1
GCR Amplitude Sensor (43=50 IPS, 53=100 IPS).	9-17	Industry Standard Interface Cabling.	3-17
GCR Basic Loop Write-to-Read, 50 IPS (24)	9-12	Initiate Command (FGO)	5-7
GCR Basic LWR, 100 IPS (2E)	9-15	Initiate Command (START)	4-5
GCR LWR Velocity (25).	9-13	Initiate Status Sequencer (10000).	5-25
GCR LWR, One Track Dead (27)	9-14	Input Line Definitions.	4-1, 5-1
GCR Operation.	6-11	Inspection	3-1
GCR Positioning (4F=50 IPS, 5F=100 IPS)	9-18	Installation	3-1
GCR Read Backward (4E=50 IPS, 5E=100 IPS)	9-18	Interblock Gap (IBG) Generation	2-18
GCR Read Forward (4D=50 IPS, 5D=100 IPS)	9-18	Interface Features	1-7
GCR Write Records (4C=50 IPS, 5B=100 IPS)	9-18	Interface Register Allocation	C-5, D-5, E-5
GCR, LWR, Two Tracks Dead (29)	9-14	Interface/Microprocessor (IF Card).	6-1
General Description.	1-1	Internal Diagnostics	9-7
General Information.	1-1, 4-18	Introduction 1-1, 2-1, 3-1, 4-1, 5-1, 6-1, 7-1, 8-1, 9-1, B-1	
Group-Coded Recording (GCR) Operation (6250 BPI)	B-3	Invoke Diagnostics (01100).	5-22
Hard Error (FHER).	5-11	Keyboard Status (15)	9-10
		Keyboard/LED Driver (08)	9-5

INDEX CONT

Keyboard/Op Panel Register Allocation . . . C-2, D-2, E-2	MTS Address (AD0, AD1) . . . 4-1
Last Word (FLWD) 5-8	MTS Address (FFAD, FTAD0, FTAD1) 5-6
Leader Sensor Replacement. 8-4	Mux Byte 0 4-11
Load Point (FLDP). 5-12	Mux Byte 1 4-13
Load/Rewind Key. 2-5	Mux Byte 2 4-14
Long Gap Select (FLGAP) (2922 devices only). . . 5-8	MUX Byte 3 4-14
Loop Option (06) 9-5	No Operation (NOP) Command (0000) 4-21
Loop Write to Read (01111). 5-25	On Line Indicator (Green). 2-2
Loop Write-to-Read (LWR) Command (0111) 4-32	On Line Key. 2-5
Lower Swing Arm Assembly Replacement. 8-7	Online (FONL). 5-12
Lower Swing Arm Tach Assembly Replacement . . 8-10	Online Status (ONLS) . . . 4-17
Machine Check Indicator (Red). 2-2	Operation. 2-1
Machine Reel Motor Replacement. 8-21	Operation Completed. . . . 4-20
Main Circuit Breaker Replacement. 8-27	Operation Incomplete (OP INC) 4-10
Maintenance. 7-1	Operator Functions Area. . 2-2
Maintenance Write (OE) . . . 9-6	Operator Maintenance . . . 2-13
Maintenance Write (OF) . . . 9-7	Oscillator (OSC) 4-9
Manual	Output Line Definitions. . 4-8
Thread/Load--Vertical or Center of Gravity Mount. 2-11	Output Signal Definitions. 5-10
Memory Allocation, Industry STD Interface - 292X E-1	Overrun Status (OVRNS) . . 4-10
Memory Allocation, STK Standard Interface - 2921 C-1	PE Amplitude Sensor (42=50 IPS, 52=100 IPS) 9-16
Memory Allocation, STK Standard Interface - 2922 D-1	PE Basic Loop Write-to-Read, 50 IPS (22) 9-12
Memory Map C-1, D-1, E-1	PE Basic LWR, 100 IPS (2C) 9-15
Memory/PROM Checksum (12). 9-9	PE LWR Velocity (23) . . . 9-12
Midtape Load, EOT Area . . 2-11	PE LWR, One Track Dead (26) 9-13
Modify Memory Key. 2-7	PE LWR, Two Tracks Dead (28) 9-14
Motherboard Replacement. . 8-25	PE Operation 6-9
Mounting Options 1-7	PE Positioning (4B=50 IPS, 5B=100 IPS). 9-17
	PE Read Backward (4A=50 IPS, 5A=100 IPS) 9-17
	PE Read Forward (49=50 IPS, 59=100 IPS) 9-17

INDEX CONT

PE Write Records (48=50 IPS, 58=100 IPS)	9-17	Read/Write Head Replacement	8-5
Phase encoded (pe) operation (1600 BPI)	B-1	Ready (FRDY)	5-12
Physical Dimensions	1-10	Ready Indicator (Green)	2-2
PK Card Replacement	8-24	Ready Status (RDYS)	4-17
Power Connection	3-2	Reel Control Register Allocation	C-3, D-3, E-3
Power Features	1-6	Reel/Capstan Driver (09)	9-5
Power On/Off Switch	2-1	Regulator Assembly Replacement	8-25
Power Requirements	1-11	Reinstruct Times	2-19
Power Supply and Fans	8-25	REJECT Conditions	4-19
Power System	6-15	Release/Retract Swing Arms (1F)	9-11
Preliminary Checkout	3-4	Removal and Replacement	8-1
Quarterly Power Supply Check	7-2	Reposition Timing	2-19
Quarterly Preventive Maintenance Checklist	7-1	Reset Key	2-5
Quarterly Read Amplitude Checks	7-11	Reshipping	3-17
Quarterly Tape Skew Checks	7-9	Retractor Assembly Replacement	8-15
RDB/BOT	4-29	REW/BOT	4-35
RDB/Tape Mark Blocks	4-30	Rewind	2-11
RDF/BOT	4-29	Rewind (FRWD)	5-12
RDF/Tape Mark Blocks	4-29	Rewind (REW) Command (1110)	4-35
Read (RD Card)	6-6	Rewind and Unload (RUN) Command (1111)	4-36
Read Backward a Block (RDB) Command (0101)	4-29	Rewind To BOT (FREW)	5-7
Read Data Lines 0-7,p (FRD0-7, p)	5-15	Rewind/Unload Key	2-5
Read Data Path (DP Card)	6-9	Rewinding Status (REWS)	4-18
Read Data Strobe (FRSTR)	5-14	Routine 13 for Industry Standard Interface Card	9-10
Read Extended Sense (11101)	5-27	Routine 13 for Storagetek Interface Card	9-9
Read Forward a Block (RDF) Command (0100)	4-27	Routine 14 for Industry Standard Interface Card	9-10
Read Forward Command (00000)	5-15	Routine 14 for Storagetek Interface Card	9-10
Read Reverse Command (01000)	5-15	Run Diagnostic Package (Byte 1 = 01)	5-25
Read Sense Command (11001)	5-19	Run Loaded Diagnostics (Byte 1 = 02)	5-25
Read/Write Head and Tape Cleaner Block	2-13	RUN/BOT	4-36
		Section 0 - Maintenance Routines	9-2
		Section 1 - Power-Up Tests	9-7

INDEX CONT

Section 2 - Formatter		Space Reverse Command	
Tests	9-11	(01001)	5-18
Section 3 - Transport		Special Test Equipment,	
Tests	9-15	Tools, and Supplies . . .	A-1
Section 4 (50 IPS) and		Specifications	1-10
Section 5 (100 IPS) -		Speed Select Option (04) . .	9-4
R/W Tests	9-16	Start/Stop Mode	2-15
Select GCR Command		Start/Stop Motion (03) . . .	9-4
(11011)	5-19	Status A Display (0A)	9-6
Select Indicator (Yellow) .	2-2	Status B Display (0B)	9-6
Select Multiplex (SLX0,		Status Buffers	9-2
SLX1, SLX2)	4-7	Status C Display (0C)	9-6
Select PE Command (10011) .	5-19	Storage Technology	
SemiAutomatic		Standard Interface	4-1
Thread/Load--Center of		Storagetek Standard	
Gravity Mount	2-10	Interface Cabling	3-12
SemiAutomatic		Streaming Mode	2-17
Thread/Load-Vertical		Swing Arms	8-7
Mount	2-10	System Reset (RESET)	4-7
Sense Byte 0 (Faults, Mode		System Select/1600/6250	
And Not Ready)	5-19	Indicators (Yellow)	2-4
Sense Byte 1 (Last Command			
Issued)	5-20	Tape Cleaner Block	
Sense Byte 2 (Tape		Replacement	8-4
Status)	5-20	Tape Guides, Rollers, and	
Sense Byte 3	5-21	Swing Arms	2-15
Sense Byte 4	5-21	Tape Mark Status (TMS) . . .	4-10
Sense Byte 5 (Reject		Tape Motion	
Status)	5-21	Characteristics	2-15
Sense Byte 6 (Corrected		Tape Path	8-3
Error And Dead Track P) .	5-21	Tape Threading Operations . .	2-9
Sense Byte 7 (Dead Track		Tape Tracking and Skew	
register)	5-22	Adjustment after parts	
Sense Bytes Description . .	4-36	replacement	7-2
Sense Bytes 3 And 4 (Hard		Terminate Command (STOP) . .	4-7
Errors)	5-21	Test Initiation	9-1
Sense Drive Status (SNS)		Test Package Initiator	
Command (0011)	4-36	(10)	9-9
Servo System (SV Card) . . .	6-12	Torx Screws	8-3
Servo-LSI Register Loop		Transfer Acknowledge	
(18)	9-10	(TRAK)	4-6
Shoeshine Motion (02) . . .	9-3	Transfer Request (TREQ) . . .	4-8
Signal		Transformer Replacement . . .	8-26
Sequence	4-27,	Turnaround Delays	2-20
4-30, 4-33, 4-34, 4-36			
Slave Status Change (SSC) .	4-11		
Space Forward Command			
(00001)	5-18	Unload	2-13

INDEX CONT

Unload/Load (32)	9-15	Write Data Path (DP Card).	6-4
Upper Swing Arm Assembly Replacement.	8-11	Write Driver And Sensor Register Allocation	C-5, D-5, E-5
Upper Swing Arm Tach Assembly Replacement	8-14	Write Drivers (WR Card).	6-6
Vacuum Blower Replacement.	8-22	Write Extended Command (01110).	5-17
Vertical Cabinet Mounting.	3-8	Write File Mark Command (00110).	5-17
Write a Data Block (WRT) Command (0110)	4-30	Write Status (WRTS).	4-18
Write Card Status (1D)	9-11	Write Tape Mark (WTM) Command (1100)	4-34
Write Command (00100).	5-16	WRT/BOT.	4-32
Write Data Lines (FWD0-7,p)	5-8	WTM/BOT.	4-35
		50/100 ips Speed Change.	2-19

(INTENTIONALLY LEFT BLANK)

READER'S COMMENT FORM

Please check or fill in the items; adding explanations/comments in the space provided.

Which of the following terms best describes your job?

- | | | | |
|---|--|---|--|
| <input type="checkbox"/> Field Engineer | <input type="checkbox"/> Manager | <input type="checkbox"/> Programmer | <input type="checkbox"/> Systems Analyst |
| <input type="checkbox"/> Engineer | <input type="checkbox"/> Mathematician | <input type="checkbox"/> Sales Representative | <input type="checkbox"/> Systems Engineer |
| <input type="checkbox"/> Instructor | <input type="checkbox"/> Operator | <input type="checkbox"/> Student/Trainee | <input type="checkbox"/> Other (explain below) |

How did you use this publication?

- | | | | |
|--|---|-----------------------------------|--|
| <input type="checkbox"/> Introductory text | <input type="checkbox"/> Reference manual | <input type="checkbox"/> Student/ | <input type="checkbox"/> Instructor text |
| <input type="checkbox"/> Other (explain) _____ | | | |

Did you find the material easy to read and understand? Yes No (explain below)

Did you find the material organized for convenient use? Yes No (explain below)

Specific criticisms (explain below):

Clarifications on pages _____

Additions on pages _____

Deletions of pages _____

Errors on pages _____

Explanations and other comments:

Note: Staples can cause problems with automated mail sorting equipment. Please use pressure sensitive or other gummed tape to seal this form. If you would like a reply, please supply your name and address on the reverse side of this form.

Thank you for your cooperation. No postage stamp necessary if mailed in the U.S.A.

FOLD AND TAPE

DO NOT STAPLE

FOLD AND TAPE



NO POSTAGE
NECESSARY
IF MAILED
IN THE
UNITED STATES

BUSINESS REPLY MAIL
FIRST CLASS PERMIT NO. 2 LOUISVILLE, CO U.S.A.

POSTAGE WILL BE PAID BY ADDRESSEE

Storage Technology Corporation
2270 South 88th Street
Louisville, Colorado 80028

Attn: Technical Publications MD 97

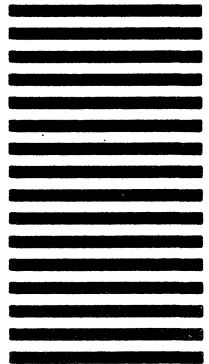

FOLD

DO NOT STAPLE

FOLD AND TAPE

If you would like a reply, please print:

Your Name: _____

Company Name: _____ Department: _____

Street Address: _____

City: _____

State: _____ Zip Code: _____

STORAGE TECHNOLOGY CORPORATION
2270 South 88th Street
Louisville, Colorado 80028