

Xerox Removable Disk Storage System

Models 7240/7242/7246

Reference Manual

BOOK # 20



DISK PACK ORDER CODES

<u>Hexadecimal Code</u>	<u>Function</u>
01	Write
02	Read 2
03	Seek
04	Sense
05	Check-Write
09	Header Write
0A	Header Read
12	Read 1
13	Select Test Mode
23	Release
33	Restore Carriage

Xerox Data Systems

XEROX

701 South Aviation Boulevard
El Segundo, California 90245
213 679-4511

Xerox Removable Disk Storage System

Models 7240/7242/7246

Reference Manual

90 16 71B

August 1971

Price: \$1.75

REVISION

This publication is a revision of the Xerox Sigma Removable Disk Storage System/Reference Manual, Publication Number 90 16 71A (dated April 1970). The significant addition to the manual is the new section "I/O Faults and Recovery Procedures". A change in text from that of the previous manual is indicated by a vertical line in the margin of the page.

RELATED PUBLICATIONS

<u>Title</u>	<u>Publication No.</u>
Xerox Sigma 3 Computer/Reference Manual	90 15 92
Xerox Sigma 5 Computer/Reference Manual	90 09 59
Xerox Sigma 6 Computer/Reference Manual	90 17 13
Xerox Sigma 7 Computer/Reference Manual	90 09 50
Xerox Sigma 8 Computer/Reference Manual	90 17 49
Xerox Sigma 9 Computer/Reference Manual	90 17 33
Xerox Meta-Symbol/LN, OPS Reference Manual	90 09 52
Xerox Macro-Symbol/LN, OPS Reference Manual	90 15 78
Xerox Symbol/LN, OPS Reference Manual (Sigma 2/3)	90 10 51
Xerox Symbol/LN, OPS Reference Manual (Sigma 5-9)	90 17 90
Xerox Extended Symbol/LN, OPS Reference Manual	90 10 52

Manual Content Codes: BP – batch processing, LN – language, OPS – operations, RBP – remote batch processing, RT – real-time, SM – system management, TS – time-sharing, UT – utilities.

CONTENTS

<p>1. GENERAL DESCRIPTION 1</p> <p style="padding-left: 20px;">Introduction _____ 1</p> <p style="padding-left: 40px;">System Components _____ 1</p> <p>2. FUNCTIONAL DESCRIPTION 3</p> <p style="padding-left: 20px;">Data Presentation _____ 3</p> <p style="padding-left: 20px;">System States _____ 3</p> <p style="padding-left: 40px;">Operational States _____ 3</p> <p style="padding-left: 40px;">Unavailable Condition _____ 3</p> <p style="padding-left: 40px;">Ready Condition _____ 3</p> <p style="padding-left: 40px;">Busy Condition _____ 3</p> <p style="padding-left: 40px;">Mode _____ 3</p> <p style="padding-left: 40px;">Transitions Between States _____ 3</p> <p style="padding-left: 20px;">Data Transfer _____ 3</p> <p>3. PROGRAM INTERFACE 4</p> <p style="padding-left: 20px;">Disk Pack Organization _____ 4</p> <p style="padding-left: 20px;">Data Organization _____ 4</p> <p style="padding-left: 20px;">Data Access _____ 4</p> <p style="padding-left: 20px;">Error Detection _____ 4</p> <p style="padding-left: 20px;">Headers _____ 4</p> <p style="padding-left: 20px;">Device Orders _____ 4</p> <p style="padding-left: 40px;">Seek _____ 6</p> <p style="padding-left: 40px;">Sense _____ 6</p> <p style="padding-left: 40px;">Write _____ 7</p> <p style="padding-left: 40px;">Header Write _____ 7</p> <p style="padding-left: 40px;">Check-Write _____ 7</p> <p style="padding-left: 40px;">Read 1 _____ 8</p> <p style="padding-left: 40px;">Read 2 _____ 8</p> <p style="padding-left: 40px;">Header Read _____ 8</p> <p style="padding-left: 40px;">Restore Carriage _____ 8</p> <p style="padding-left: 40px;">Release _____ 8</p> <p style="padding-left: 40px;">Select Test Mode _____ 9</p> <p style="padding-left: 20px;">Key Events _____ 9</p> <p style="padding-left: 40px;">Start Input/Output _____ 9</p> <p style="padding-left: 40px;">Unusual End Conditions _____ 9</p> <p style="padding-left: 40px;">Channel End Conditions _____ 9</p> <p style="padding-left: 40px;">Transmission Error Conditions _____ 10</p> <p style="padding-left: 40px;">Incorrect Length Conditions _____ 10</p> <p style="padding-left: 20px;">Status Response _____ 10</p> <p style="padding-left: 40px;">I/O Instruction Status Bits _____ 10</p> <p style="padding-left: 40px;">Device Status Byte _____ 10</p> <p style="padding-left: 20px;">Programming Considerations _____ 10</p> <p style="padding-left: 40px;">Command Chaining _____ 10</p> <p style="padding-left: 40px;">Interrupts _____ 10</p> <p style="padding-left: 40px;">Sequence of Activity _____ 10</p> <p style="padding-left: 20px;">I/O Faults and Recovery Procedures _____ 24</p> <p style="padding-left: 40px;">I/O Interrupt Environment _____ 24</p> <p style="padding-left: 40px;">Software Timeout Values _____ 24</p> <p style="padding-left: 40px;">IOCD Flags _____ 24</p> <p style="padding-left: 40px;">Additional Programming Considerations _____ 24</p> <p style="padding-left: 40px;">I/O Operation Evaluation _____ 25</p> <p style="padding-left: 40px;">I/O Fault Evaluation and Recovery Procedures _____ 25</p> <p style="padding-left: 40px;">Irrecoverable Errors _____ 29</p>	<p>4. OPERATIONS 30</p> <p style="padding-left: 20px;">Controls and Indicators _____ 30</p> <p style="padding-left: 20px;">Operating Instructions _____ 30</p> <p style="padding-left: 40px;">System Power Turn-On Procedure _____ 30</p> <p style="padding-left: 40px;">Deck or Spindle Power Turn-On Procedure _____ 32</p> <p style="padding-left: 40px;">Power Turn-Off Procedure _____ 34</p> <p style="padding-left: 40px;">Disk Pack Installation _____ 34</p> <p style="padding-left: 40px;">Disk Pack Removal _____ 35</p> <p style="padding-left: 40px;">Disk Drive/Pack Inspection for Damage _____ 35</p> <p style="padding-left: 40px;">Disk Pack Cleaning _____ 36</p> <p style="padding-left: 40px;">Disk Pack Filter Replacement _____ 37</p> <p style="padding-left: 40px;">Disk Pack Usage Log _____ 38</p> <p style="padding-left: 20px;">Recommended Do's and Don'ts for Disk Packs _____ 38</p>
--	--

FIGURES

<p>Model 7242 Disk Storage Unit _____ v</p> <p>1. Disk Pack Organization _____ 5</p> <p>2. Controlling/Disk Storage System Actions _____ 14</p> <p>3. Data In/Data Out Operations _____ 15</p> <p>4. Release Order _____ 15</p> <p>5. Restore Carriage Order _____ 15</p> <p>6. Select Test Mode Order _____ 15</p> <p>7. Seek Order _____ 16</p> <p>8. Sense Order _____ 17</p> <p>9. Header Write Order _____ 18</p> <p>10. Header Read Order _____ 19</p> <p>11. Position Verification _____ 20</p> <p>12. Write Order _____ 21</p> <p>13. Check-Write Order _____ 22</p> <p>14. Read Orders _____ 23</p> <p>15. Location of Disk Storage Unit Controls and Indicators _____ 30</p> <p>16. Operator Panel Controls and Indicators _____ 31</p> <p>17. Filter Box Panel _____ 33</p> <p>18. Controller Power Distribution Panel _____ 33</p> <p>19. Controller Power Supply Panel _____ 33</p> <p>20. Logic Chassis Maintenance Panel _____ 33</p> <p>21. Power Supply Panel _____ 34</p> <p>22. Disk Pack Installation/Removal _____ 34</p> <p>23. Disk Pack Load/Unload Mechanism _____ 35</p> <p>24. Disk Pack Filter _____ 37</p> <p>25. Disk Pack Filter Location _____ 38</p>	
---	--

TABLES

1. Characteristics _____	1	6. Status Response to TDV _____	12
2. State Transitions _____	3	7. Status Response to AIO _____	13
3. Sense Status Bytes 8 and 9 _____	6	8. Operational Status Byte _____	13
4. I/O Instruction Execution Response _____	11	9. Removable Disk Storage System Testing Sequence _____	26
5. Status Response to SIO, TIO, and HIO _____	11	10. Recommended Recovery Procedures _____	29
		11. Operator Panel Controls and Indicators _____	31



Model 7242 Removable Disk Storage Unit



1. GENERAL DESCRIPTION

INTRODUCTION

XDS Model 7240/7242/7246 Removable Disk Storage System provides high-volume, random-access storage. It is a moving-arm, removable-medium, rotating magnetic disk system used as secondary storage for Sigma computers.

Model 7240 Controller controls up to four Model 7242/7246 storage units and permits execution of the orders required to use this system. Optional Model 7243/7247 Device Pooling Feature permits two computers or one computer with two Model 7240 controllers to have simultaneous access to any two spindles out of a maximum of eight independent spindles. Optional Model 7241 Extended Width Interface allows the system to operate in a 4-byte parallel format in conjunction with the appropriate Input/Output Processor (IOP).

To use this manual effectively, the reader should be familiar with the Sigma Computer Reference Manual applicable to his installation, particularly the discussion of input/output instructions and operations.

SYSTEM COMPONENTS

A system consists of some combination of the following components:

<u>Model No.</u>	<u>Component</u>
7240	Disk Storage Controller
7241	Extended Width Interface (optional)
7242	Disk Storage Unit (dual spindle)
7243	Device Pooling Feature (dual spindle) (optional)
7244	Removable Disk Pack
7246	Disk Storage Unit (single spindle)
7247	Device Pooling Feature (single spindle) (optional)

Model 7240 Controller serves one to eight spindles composed of Model 7242 and 7246 storage units (maximum of four units) and is attached to one channel on an IOP. Model 7241 permits data transfers with an IOP on a 32-bit basis. Model 7243/7247 Device Pooling Feature may be added to Model 7242/7246 to provide dual access by two controllers. This allows simultaneous read/read, write/write, or read/write on any two spindles. Model 7244 Disk Pack is the removable storage medium, consisting of 11 disks with 20 usable recording surfaces. The disk pack has a special indexing ring to provide reference points for the 6-sector recording format.

A minimum configuration consists of one Model 7240 Controller and one Model 7242 or 7246 storage unit.

Table 1. Characteristics

Operating Characteristics	
Recording format	1024 bytes/sector 6 sectors/track 203 tracks/surface 1 head/surface 20 recording surfaces/pack
Recording method	Track serial
Mode	Double frequency NRZ
Recording Frequency	2.50 Mhz
Rotational speed	2400 rpm
Model 7246 (single spindle)	24,576,000 bytes
Model 7242 (dual spindle)	49,152,000 bytes
Maximum system (4 units, i. e., 8 spindles/controller)	196,608,000 bytes
Access (positioning) time	
Maximum	135 ms
Maximum access time between adjacent tracks	24.5 ms
Average	75 ms
Transfer rate	
Single sector	312,500 bytes/second
Multiple sectors (average)	250,800 bytes/second
Physical Characteristics	
Model 7240 (space provided for 7241)	
Height	63.5 in.
Width	32 in.
Depth	35 in.
Weight (approx.)	500 lb

Table 1. Characteristics (cont.)

Physical Characteristics (cont.)	
Model 7242 or 7246 (space provided for 7243/7247)	
Height	67 in.
Width	33 in.
Depth	41 in.
Weight (approx.)	
Model 7242	1200 lb
Model 7246	800 lb
Environmental Characteristics	
Power Requirements	
Model 7240	120 vac ± 10%, 49-61 Hz, single-phase, input power 1.0 kw, power factor 0.8
Model 7242	208 vac ± 10%, 60 ± 0.5 Hz, three-phase, input power 1.8 kw, power factor 0.7
Model 7246	208 vac ± 10%, 60 ± 0.5 Hz, three-phase, input power 1.3 kw, power factor 0.7
Operating temperature	60° to 90° F

Table 1. Characteristics (cont.)

Environmental Characteristics (cont.)	
Operating humidity	10% to 80%
Thermal dissipation	
Model 7240	3435 btu/hr
Model 7242	6180 btu/hr
Model 7246	4460 btu/hr
Cable length	
IOP to Model 7240	40 ft maximum
7240 to first 7242/7246	50 ft maximum
7240 to last 7242/7246	70 ft maximum
Operating and Physical Characteristics	
Model 7244 Disk Pack	
Disks/pack	11
Usable recording surfaces/pack	20
Disk surface coating	Magnetic oxide
Disk surface diameter	14 in.
Disk pack canister diameter	15 in.
Disk pack canister height	5.75 in.
Weight	14.5 lb

2. FUNCTIONAL DESCRIPTION

DATA PRESENTATION

Data is transferred from the I/O system to the controller on a one-, two-, or four-byte interface (depending on options installed) and is transferred between the controller and disk pack unit serially, bit by bit.

SYSTEM STATES

The initial state of the device depends on its power status. Complete absence of power removes the device from the controlling system (i. e. , no address recognition). If power is applied to the controller, address recognition occurs when an I/O instruction is issued.

OPERATIONAL STATES

The disk pack system reports the "operational" state if the I/O address is recognized and the device is "operational" as defined below:

1. Disk speed is within operating limits.
2. Temperature is within operating limits.
3. All interlocks are closed.
4. All power is normal in the controller and disk storage units.
5. No "fault" condition exists within a disk storage unit.

When "operational", an SIO instruction will be accepted if

1. The addressed controller/device is "ready".
2. The device is available, that is, not reserved by another controller.
3. No channel interrupts are pending.

The condition of the disk pack system at any given time is returned to the central processor in response to the I/O instructions, SIO, HIO, and TIO. Other I/O instructions, TDV and AIO, obtain other specific indications of device status (see "Status Response").

UNAVAILABLE CONDITION

In the "unavailable" condition, the device is reserved by another controller; therefore, it cannot accept an SIO instruction.

READY CONDITION

In the "ready" condition, the controller can accept an SIO instruction, provided that the addressed device is available and no channel interrupt is pending. To be "ready" the device must be "operational" and execution of an order must not be in progress or pending.

BUSY CONDITION

In the "busy" condition, the controller has accepted an SIO instruction. It will not accept a new order until the current order (or orders) is completed.

MODE

The disk pack system is always in the "automatic" mode, as long as it is in the "operational" state.

TRANSITIONS BETWEEN STATES

Table 2 summarizes the state transitions and conditions required to cause them.

Table 2. State Transitions

Present State	Next State	Conditions
Ready Automatic	Busy Automatic	Acceptance of SIO instruction.
Busy Automatic	Ready Automatic	HIO instruction received, I/O reset signal received, or operation associated with last order completed.

DATA TRANSFER

An operation is initiated from the controlling system by an SIO instruction if the following conditions are satisfied:

1. I/O address recognition exists.
2. Device and controller are in "ready" condition (and no channel interrupt is pending).
3. Device is available.

If these conditions are satisfied, the controller enters the "busy" condition. The controller initiates the transfer of data to or from the disk pack unit, as specified by the order, until the required number of bytes have been transferred. The operation then terminates, and the device returns to the "ready automatic" state.

3. PROGRAM INTERFACE

DISK PACK ORGANIZATION

Each disk pack (see Figure 1) contains 11 disks with 20 usable recording surfaces. (The outside surfaces of the top and bottom disks are not usable.) Each surface has its own movable read/write head but the 20 heads are all aligned in the same vertical plane and move as a unit through the stack, though only one head is reading or writing at any one time. Head numbers range from 0 through 19. Each recording surface is logically divided into six sectors numbered from 0 through 5 and into 203 concentric rings or tracks on which data is recorded. The tracks begin at the periphery of a disk and progress inward toward the center. Each set of 20 tracks aligned vertically in the stack is referred to as a cylinder. Thus, there are 203 cylinders in a disk pack, numbered from 000 through 202. Cylinder 000, for example, consists of track 000 on surface 0, track 000 on surface 1, and so on through track 000 on surface 19.

The addressing is summarized, as follows:

<u>Field</u>	<u>Range</u>
Sector	0-5 ₁₀
Head	0-19 ₁₀
Cylinder	0-202 ₁₀

DATA ORGANIZATION

Data is stored in groups of 1024 bytes. Each data group has a unique address composed of its device, cylinder, head, and sector number. Each data group is preceded by a header containing the cylinder, head, and sector number for the group. The header is used for address identification and verification.

DATA ACCESS

To select a disk pack unit, the I/O instruction must contain an address specifying both the device controller and the device. Since Model 7240 is a multiunit device controller, its addresses range from 8 through F. The device addresses range from 0 through 7.

To address a particular data group for reading or writing, a Seek order must be given to the device to select the desired cylinder (move the heads into place), head, and sector. While reading or writing the sector (in a Read, Write, Check-Write or Header Read/Write operation), the controller automatically increments the sector number to the next one in sequence. Upon completing the last sector of a track, the controller sets the sector number to zero and increments the head number to the next one in sequence. Thus a single order may cause a number of sequential sectors and then tracks of a cylinder to be read or written. On

reaching the end of a cylinder, a new Seek order must be issued to the controller to select the next cylinder, since it does not automatically increment to the next one.

ERROR DETECTION

A two-byte check character is written at the end of each header and at the end of each sector data field. The check characters are computed and inserted by the controller. When reading a header, the check characters are again computed and compared with those read. Any difference causes an "unusual end" termination. Upon reading data, the check characters are also recomputed and compared with those read. In this case, if there is a difference, the controller signals transmission error but not "unusual end".

HEADERS

Prior to writing data on the disk, headers must be written identifying the addresses of all data groups (sectors). The headers are used for locating the desired data group and for address verification when successive data groups are written or read. Failure to acquire a given address within one revolution results in a verification error. When the program detects a defective track, it should write flaw marks in all sector headers of the track. A defective track is one in which an error has been detected on each of three successive "write and then read" operations. An alternate head and cylinder number is then obtained from the "flawed" header. The program will normally use the alternate head and cylinder number as the new Seek address.

DEVICE ORDERS

After completing a SIO instruction, or during command chaining, the controller makes a 1-byte service call to the IOP to obtain the order for the next operation. In all data transmission operations, the data address is incremented to the next sector even if it is a nonexistent address, e.g., head 20.

The following list shows order decoding. The reactions to these orders are described in subsequent paragraphs.

<u>Order</u>	Binary Representation							<u>Hexadecimal Code</u>	
	Bit Positions								
	<u>0</u>	<u>1</u>	<u>2</u>	<u>3</u>	<u>4</u>	<u>5</u>	<u>6</u>	<u>7</u>	
Seek	M	0	0	0	0	0	1	1	X'03'
Sense	0	0	0	0	0	1	0	0	X'04'
Write	0	0	0	0	0	0	0	1	X'01'
Header Write	0	0	0	0	1	0	0	1	X'09'
Check-Write	0	0	0	0	0	1	0	1	X'05'
Read 1	0	0	0	1	0	0	1	0	X'12'
Read 2	0	0	0	0	0	0	1	0	X'02'
Header Read	0	0	0	0	1	0	1	0	X'0A'

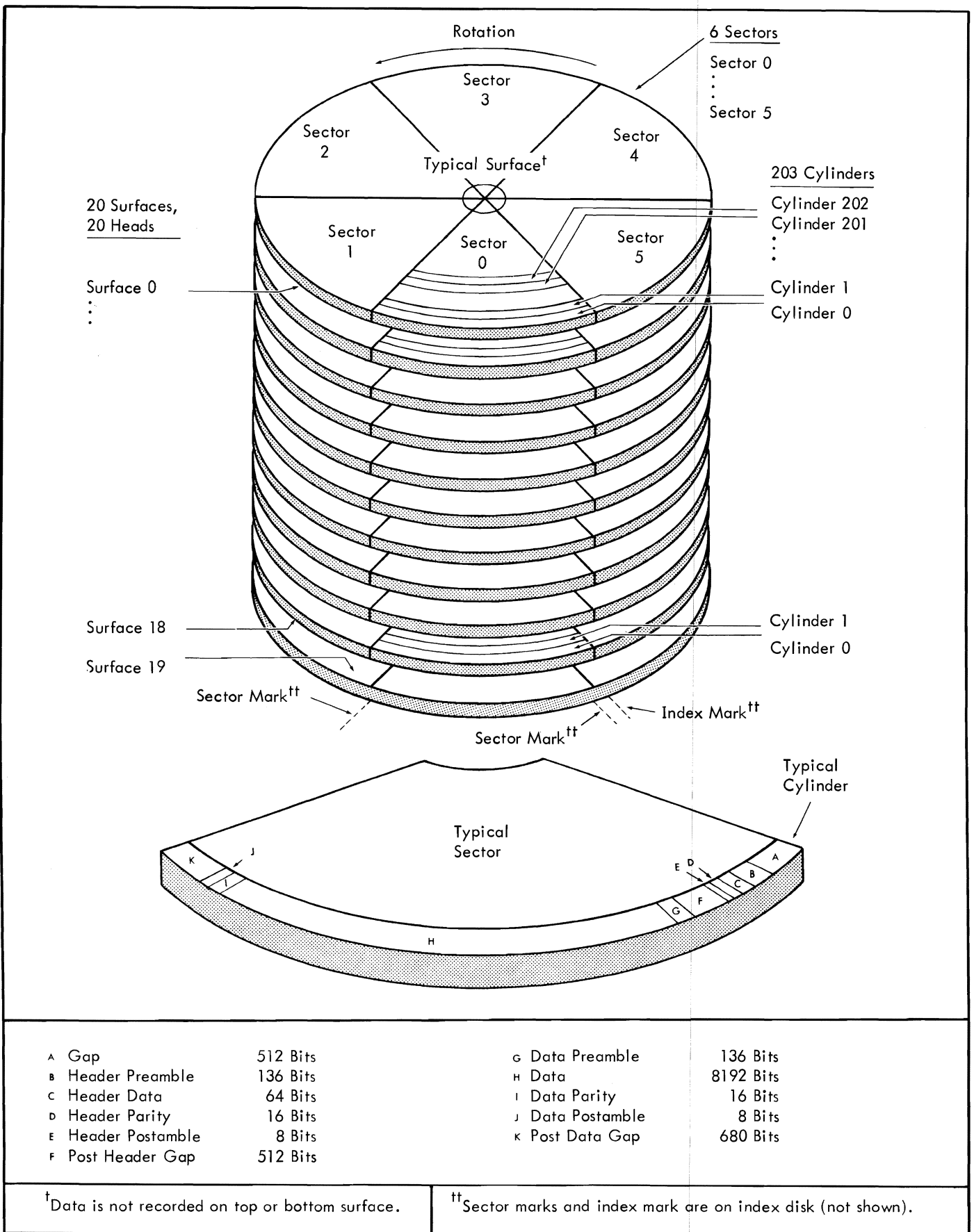

Figure 1. Disk Pack Organization

Order	Binary Representation							Hexadecimal Code	
	0	1	2	3	4	5	6		7
Restore Carriage	0	0	1	1	0	0	1	1	X'33'
Release	0	0	1	0	0	0	1	1	X'23'
Select Test Mode	0	0	0	1	0	0	1	1	X'13'
Invalid order	0	0	0	0	0	0	0	0	--

where M signifies Modifier bit (explained under "Seek" order).

SEEK (X'03')

The Seek order alerts the controller to request a 4-byte address from the IOP, as indicated below. The controller then directs any subsequent data transmission operation to begin at this address.

Byte 0		Byte 1		Byte 2		Byte 3	
0	Cylinder	0	Head	0	S		

where S signifies sector number.

A byte count of less than four causes the controller to signal incorrect length without completing the Seek operation. If the byte count is greater than four, the Seek operation is performed using the first four bytes transferred, but incorrect length will still be signaled. An "unusual end" termination will occur in either case.

An order Modifier bit (bit 0), when set, causes a device interrupt to be initiated when the positioning system indicates that positioning is complete or a Seek timeout error (i.e., exceeding maximum time allowed for arm movement) has occurred. The interrupt call is always made at the beginning of the sector prior to the one specified by the Seek operation. However, if the controller is "busy" with another device when the device signal is received, the interrupt call to the IOP will be postponed until the controller is "not busy". If the interrupt call is not serviced before the beginning of the next sector, it will be postponed. Seek orders may be issued successively to several devices and each device will interrupt as it completes its operation.

A device interrupt may be cleared by an AIO or HIO instruction, or by an I/O Reset (from the computer control panel). The AIO or HIO clears only a single device interrupt, whereas the I/O Reset simultaneously clears all pending device interrupts.

If a Seek operation indicates a nonexistent cylinder (≥ 203), head (≥ 20), or sector (≥ 6), the controller will proceed to an "unusual end" termination without signaling the device to seek. The Sector Unavailable status bit for TDV will be set (see Table 6). An "unusual end" termination will also occur if the arm is currently in motion when the Seek order is received for the same device. (See Restore Carriage order.)

SENSE (X'04')

The Sense order causes the controller to transmit up to 10 bytes of information to the IOP, as follows:

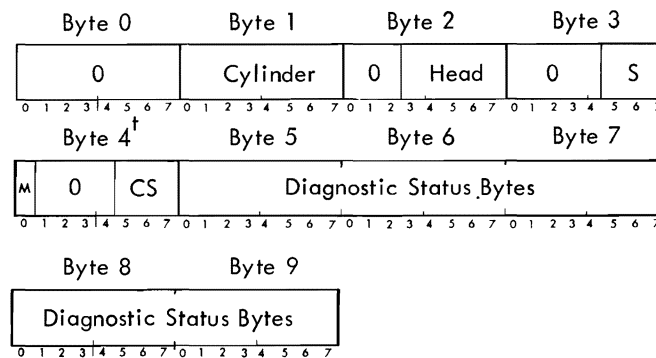

where

S signifies sector number.

M signifies Modifier bit.

CS signifies current sector number.

Note: Bytes 5-9 are used for diagnostic purposes. See Table 3 for the function of the diagnostic status bits in bytes 8 and 9.

Table 3. Sense Status Bytes 8 and 9

Byte No.	Bit No.	Function
8	0	Data parity error
	1	Check-Write error
	2	Sector verification error
	3	Head verification error
	4	Cylinder verification error
	5	Sector address not zero at start of header write operation
	6	Difference select sent to device
9	7	Sector select sent to device
	0	Control select sent to device
	1	Head select sent to device
	2	Cylinder select sent to device
	3	Seek forward set
	4	Read gate sent to device
	5	Write and erase gate sent to device
6	Read cylinder select sent to device	
7	Not used	

Note: Bytes 8 and 9 are used by diagnostic programs.

[†]Three bits of byte 4 indicate current sector number, but if the most significant bit (M) is a 1, the arm was in motion at time of sense and current sector number is meaningless. If the head number is nonexistent, (M) will also be a 1.

If the byte count is ten or less, only the requested number of bytes, beginning with byte 0, are transmitted to the IOP. If the byte count is greater than ten, only ten bytes are transmitted. Incorrect length is not signaled, in any case, for the Sense order.

When reading the header during a Sense operation, detection of a flaw mark, verification error, or header parity error causes the pertinent TDV status bits to be set. It also causes "unusual end" termination after the requested bytes have been transferred to the IOP.

During the Sense operation, the cylinder number is obtained from a device register. The head and sector numbers are obtained from controller registers. The current sector number is read from the first header to pass the read head when the Sense order is executed.

The five diagnostic status bytes (for diagnostic programs) contain the two parity bytes read from the current header, a test output from the "differencing logic" normally used during a Seek operation to compute the number of cylinders that the arm must move, and two bytes of status that are shown in Table 3.

WRITE (X'01')

The Write order causes the controller to begin writing bytes at the current address. The current address is the address that was stored in the device and controller registers by a previous Seek order (head and sector portions being subject to updating by intervening "reads" or "writes").

Prior to signaling the device to write and sending data to it, the controller reads headers until the one with the requested sector number is found. If a flaw mark is detected in any header, or if the header of the requested sector does not have correct parity, or if the cylinder or head numbers do not compare with those stored in the registers, then the controller proceeds to an "unusual end" termination without writing. The pertinent TDV status bits are set to indicate flaw mark, incorrect header parity, or verification error.

Writing, once started, continues until any of the following occur:

1. Count done signal is received coincident with the end of a sector (i.e., after writing 1024 data bytes on the sector).
2. Count done signal is received before end of sector, remainder of the sector is written with zeros, and the check character is written. Incorrect length is indicated if the byte count is not a multiple of 1024.
3. The disk pack system becomes "not operational". Writing terminates with an "unusual end".
4. The controller head number increments past the end of the cylinder. Writing terminates with an "unusual end" and the Sector Unavailable status bit is set to 1.

5. A rate error (data overrun) is detected. Writing terminates with transmission error.
6. I/O Reset or HIO occurs. Writing terminates and the controller immediately proceeds to the "ready" condition without further communication with the IOP.
7. An IOP halt is indicated to the controller. The controller indicates "unusual end" and proceeds to the "ready" condition.
8. A flaw mark in a header, incorrect header parity, or verification error is encountered. The Write order terminates with an "unusual end". The current address is not incremented.

HEADER WRITE (X'09')

The Header Write order causes the controller to consider all subsequent data bytes as header information. Each header requires the following bytes:

Byte 0								Byte 1								Byte 2								Byte 3																							
Flaw Mark								0								Cylinder								0								Head															
0	1	2	3	4	5	6	7	0	1	2	3	4	5	6	7	0	1	2	3	4	5	6	7	0	1	2	3	4	5	6	7																
Byte 4								Byte 5								Byte 6								Byte 7																							
0								S								Alt. Cylinder								0								Alt. Head								0							
0	1	2	3	4	5	6	7	0	1	2	3	4	5	6	7	0	1	2	3	4	5	6	7	0	1	2	3	4	5	6	7																

After writing the bytes listed, the controller inserts two check bytes that are verified whenever the header is read. The Header Write order must always be accompanied by a byte count specifying a multiple of eight bytes. The controller always begins writing headers on sector zero. If the program specifies starting at other than sector zero, an "unusual end" results. A maximum of 120 headers (1 cylinder) or a minimum of six headers may be written with a single Header Write order.

When a track is found to be defective, Header Write is used to rewrite all six headers of the track, inserting a flaw mark at the beginning of each header. Upon subsequently detecting a flaw mark in any header, the controller assumes the entire track to be faulty and makes no attempt to read additional sectors (except for the Header Read order).

CHECK-WRITE (X'05')

The Check-Write order causes the controller to compare bytes read from the disk storage unit (current address) with bytes received from the IOP. Check-Write errors terminate the operation following the sector in which they occurred. Incorrect length is specified if the byte count is not a multiple of 1024.

The order requires that headers be read so that address acquisition and verification are performed. If a flaw mark is detected, or if the header does not have correct parity, or if the cylinder and head numbers do not compare with those stored in the registers, then an "unusual end" results.

Check-writing continues until any of the following occur:

1. Count done signal is received.
2. The disk pack system becomes "not operational". Check-writing terminates with an "unusual end".
3. The controller head number increments past the end of cylinder. Check-writing terminates with an "unusual end" and the Sector Unavailable status bit is set to 1.
4. A flaw mark, incorrect header parity, or verification error is encountered. The Check-Write order terminates with an "unusual end". The current address is not incremented.
5. A rate error (data overrun) is detected. Check-writing terminates with transmission error.
6. A noncomparison of data bytes or an error in the data check character occurs. Transmission error is indicated.
7. I/O Reset or HIO occurs. Check-writing terminates and the controller proceeds to the "ready" condition without further communication with the IOP.
8. IOP halt is indicated to the controller. The controller indicates "unusual end" and proceeds to the "ready" condition.

READ 1 (X'12')

The Read 1 order causes the controller to begin reading bytes from the file storage at the current address in the controller and transmits the bytes to the IOP. Sector data parity errors are reported following the sector in which they occurred. Such errors will be reported as transmission errors. Sector parity is determined from the check bytes written at the end of each sector. Incorrect length is specified if the byte count is not a multiple of 1024.

Prior to reading data from the sector, and sending it to the IOP, the controller reads headers until the one with the requested sector number is found. If a flaw mark is detected in any header, or if the addressed header does not have correct parity, or if cylinder or head numbers do not compare with those stored in registers, then an "unusual end" occurs without reading data. The pertinent TDV status bits are set to indicate a flaw mark, incorrect header parity, or verification error.

Reading continues until any of the following occur:

1. Count done signal is received coincident with the end of the sector and the check character has been read and compared.
2. Count done signal is received prior to the end of the sector. The remaining bytes are read by the controller (but not transmitted to the IOP) and the check character is read and compared.
3. The disk pack system becomes "not operational". Reading terminates with an "unusual end".

4. The controller head number increments past the end of cylinder. Reading terminates with an "unusual end" and the Sector Unavailable status bit is set to 1.
5. A rate error (data overrun) is detected. Reading terminates with transmission error.
6. A check character is encountered that does not successfully compare. Termination occurs at the end of the sector in error (for the Read 1 order described in this section) or is deferred until the count done signal, as described below for Read 2. Transmission error is indicated.
7. I/O Reset or HIO occurs. Reading terminates and the controller proceeds to "ready" immediately without further communication with the IOP.
8. IOP halt is indicated to the controller. The controller indicates "unusual end" and proceeds to "ready".
9. A flaw mark, incorrect header parity, or verification error is encountered. The Read order terminates with "unusual end". The current address is not incremented.

READ 2 (X'02')

The Read 2 order causes the controller to read and transmit bytes to the IOP from the file storage at the current Seek address in the controller. Sector data parity error is reported following the sector in which count done occurred. Otherwise, operation is as stated in the previous section.

HEADER READ (X'0A')

The Header Read order permits reading headers and transmitting them (excluding the parity check bytes) to the IOP. The byte count must specify that a multiple of eight bytes is to be read. A maximum of 120 headers (1 cylinder) may be read with a single Header Read order.

Detection of the flaw mark causes TDV status bit 1 to be set, but does not have any other effect. An error in the header parity check characters causes TDV status bit 7 to be set and reading to stop with an "unusual end". A verification error also causes reading to stop with an "unusual end". For either type of error, the current address is not incremented.

RESTORE CARRIAGE (X'33')

The Restore Carriage order causes the controller to issue a return-to-zero control signal to the device. Internal registers are cleared, the heads are returned to cylinder 0, and no data bytes are transferred for this order. "Channel end" occurs after order is sent to the device. (Carriage motion is not necessarily completed.)

This order must follow an HIO instruction, Seek timeout error, or Seek "unusual end".

RELEASE (X'23')

The Release order causes the controller to issue a release control signal to the addressed device, thereby releasing

that device for use by the other channel if the device is a dual-channel unit. Execution of this order has no effect if the device is a single-channel unit.

A device is reserved (i.e., it can be used only by the channels reserving it) whenever an SIO instruction is addressed to that device. Releasing the device from the reserved status may be accomplished either by an HIO, a Release order, or by an I/O Reset. The I/O Reset releases all devices on the controller, whereas the Release order or HIO releases only the addressed device. A device may only be released by the reserving controller.

No data bytes are transferred for the Release order.

SELECT TEST MODE (X'13')

The Select Test Mode order causes the controller to make a service call request for one byte of data. Three bits of that byte are used to select a test mode in which all subsequent operations will be performed. This order is used by XDS diagnostic programs.

Bits	Function
0 1 2 3 4 5 6 7	
0 0 0 0 0 0 0 0	Exit test mode
0 0 0 0 0 0 0 1	Enter test mode 1
0 0 0 0 0 0 1 0	Enter test mode 2
0 0 0 0 0 1 1 0	Enter test mode 2 – set test parity error

TEST MODE 1

Test mode 1 allows the controller buffer to be filled by a Write order and subsequently read back by a Read order. Most of the controller's data path is checked without using the devices.

TEST MODE 2

Test mode 2 allows the controller's data path and control logic to be tested without using the devices. This mode tests approximately 90 percent of the controller logic. All orders may be executed in this mode and device responses will be simulated internally. In a Read or Check-Write order, the data read from the device is simulated by an incrementing data pattern of 1024 bytes (the first byte containing the value 224).

TEST PARITY ERROR

While operating in test mode 2, this condition forces a data check byte error by changing the first data byte from 224 to 240.

KEY EVENTS

The key events that occur during an I/O operation are described in the following paragraphs. No chronological

order of occurrence should be assumed from the order of presentation.

START INPUT/OUTPUT

An I/O operation begins with the execution of an SIO instruction by the controlling system. If I/O address recognition exists and the device is in the "ready" condition and available, the controlling system sets its "I/O address recognition" and "SIO accepted" indicators. The device advances from the "ready" to the "busy" condition. It then requests an order byte from the controlling system and proceeds with the operation defined by the order byte.

UNUSAL END CONDITIONS

After an order is received, the detection of any of the following conditions causes the device to return an "unusual end" indication to the controlling system:

1. Illegal Seek address.
2. Incrementing of storage address past end-of-cylinder number before count done signal received.
3. Out-of-range storage address when Read, Write, Check-Write, Header Read, or Header Write order received by controller.
4. Invalid order code.
5. Loss of read clock from device while reading headers or data.
6. Flaw mark while Read, Write, Check-Write, or Sense order is executed. (The current address is not incremented.)
7. Device leaving "operational" state while controller "busy".
8. IOP halt signaled during data transmission.
9. Incorrect header parity check or verification error while Read, Write, Check-Write, Header Read, or Sense order being executed. (The current address is not incremented.)
10. Receipt of Seek order when arm in motion.
11. Occurrence of Seek timeout error when Seek, Read, Write, Check-Write, Header Read, or Header Write order received.
12. Attempt to start Header Write operation at sector other than zero.
13. Incorrect length on Seek order.

CHANNEL END CONDITIONS

"Channel end" is reported to the controlling system when any of the following conditions are detected.

1. Transmission of 4-byte address to device during Seek order. Arm position (carriage motion) is not necessarily completed.

2. After writing of check bytes in last sector of a Write or Header Write order following count done signal.
3. After reading of check bytes in last sector of a Read, Header Read, or Check-Write order following count done signal.
4. Following the execution of Release or Select Test Mode order.
5. Following count done signal during Sense order.
6. After reading of check bytes during a Read 1 or Check-Write order with a transmission error.
7. Data overrun (rate error).
8. "Unusual end" condition.
9. Following issuance of Restore Carriage order to the device. Arm position (carriage motion) is not necessarily completed.

TRANSMISSION ERROR CONDITIONS

Transmission errors are detected and reported to the controlling system. Conditions causing this error are

1. Failure of the end of sector parity check during a Read or Check-Write operation.
2. Failure of a data byte comparison during a Check-Write operation.
3. Data overrun (rate error).

INCORRECT LENGTH CONDITIONS

Incorrect length errors are detected and reported to the controlling system. Conditions causing this error are

1. A byte count other than four was specified for a Seek order.
2. A byte count that is not a multiple of 1024 for Read, Write, and Check-Write orders.
3. A byte count that is not a multiple of eight (one header) for a Header Read or Header Write order.

STATUS RESPONSE

The device can return status information in response to computer-executed I/O instructions. Detailed explanations of the I/O instructions are in the Sigma computer reference manuals.

I/O INSTRUCTION STATUS BITS

Execution of an I/O instruction provides two bits of information pertaining to the general status of the addressed I/O device and its controller. Table 4 lists the I/O instructions, status bit settings, and the significance of each setting.

DEVICE STATUS BYTE

Eight bits of information are made available to the controlling system in the Device Status Byte in response to the execution of an I/O instruction, as shown in Tables 5, 6, and 7.

OPERATIONAL STATUS BYTE

In addition to the information contained in the Device Status Byte, the Operational Status Byte generated at the end of each I/O operation also provides indicators to the controlling system, as shown in Table 8.

PROGRAMMING CONSIDERATIONS

COMMAND CHAINING

The command chaining feature permits changing tracks or orders. Adequate time is provided to allow command chaining during the intersector gap to change the order from one type to another, or to another order of the same type, as long as no head motion is required. Seek times must be considered when selecting a new cylinder number. Chaining from a Read or Write to another Read or Write is not allowed if the end of the cylinder has been reached. At the end of a cylinder, a Seek or Restore Carriage order must be given before additional data may be transferred.

INTERRUPTS

Two types of interrupts are generated by the controller, those resulting from "channel end" (including "unusual end" or zero byte count) and those resulting from a Seek operation. The former has priority over the latter when both are present at the same time. An interrupt may occur for either a Seek timeout error or to indicate "on-sector" (Seek complete). An "on-sector" interrupt occurs at the beginning of the sector prior to the one specified by the Seek.

Interrupts are cleared by AIO or HIO instructions or by an I/O Reset (from the computer control panel). The AIO or HIO instruction clears only a single interrupt. The I/O Reset signal clears all interrupts. A device interrupt is also cleared if it is not serviced before the next sector is reached. It will be raised to the waiting state again, however, on the following revolution of the disk pack.

If a Seek order is given to a device and is subsequently followed by an HIO to that device (before the Seek operation is completed), then that device will not interrupt upon completing the Seek operation.

SEQUENCE OF ACTIVITY

Figures 2 through 14 illustrate the sequential relationship of the key events that occur during disk pack system operations.

Table 4. I/O Instruction Execution Response

Instruction	Status Bits [†]		Significance
	CC1 or O	CC2 or C	
SIO	0	0	I/O address recognized and SIO accepted.
	0	1	I/O address recognized, but SIO not accepted.
	1	0	Controller "busy" with device other than one addressed and unable to send status.
	1	1	I/O address not recognized.
HIO	0	0	I/O address recognized and device "not busy" when halt occurred.
	0	1	I/O address recognized and device "busy" when halt occurred.
	1	0	HIO not accepted. Controller "busy" with device other than one addressed and unable to send status.
	1	1	I/O address not recognized.
TIO	0	0	I/O address recognized and SIO can currently be accepted.
	0	1	I/O address recognized, but SIO can not currently be accepted.
	1	0	Controller "busy" with device other than one addressed and unable to send status.
	1	1	I/O address not recognized.
TDV	0	0	I/O address recognized.
	0	1	I/O address recognized and controller is switched to a test mode.
	1	0	Controller "busy" with device other than one addressed, or device "not operational" and unable to send status.
	1	1	Controller address not recognized.
AIO	0	0	Normal interrupt condition present (no "unusual end").
	0	1	Unusual end or transmission error condition present.
	1	0	Invalid code.
	1	1	No interrupt condition present.

[†]The symbols "CC1" and "CC2" refer to condition code indicators in Sigma 5/7 computers. The symbols "O" and "C" refer, respectively, to overflow and carry indicators in Sigma 3 computers.

Table 5. Status Response to SIO, TIO, and HIO

Bit Position	Function	State	Meaning
0	Interrupt Pending	1	Interrupt is pending (issued, but not yet acknowledged by an AIO instruction).
1,2	Device Condition	0 0 0 1 1 0 1 1	A combination of these two bits indicates the current device condition: Device "ready". Device "not operational". Device unavailable (reserved by other channel). Device busy.
3	Mode-Automatic or Manual	1	Always in the "automatic" mode.

Table 5. Status Response to SIO, TIO, and HIO (cont.)

Bit Position	Function	State	Meaning
4	Unusual End	1	Previous controller operation terminated due to one of the conditions listed under "Unusual End Conditions".
5,6	Controller Condition	0 0 0 1 1 0 1 1	A combination of these two bits indicates the current controller condition: Controller "ready". Not applicable. Not applicable. Controller "busy".
7	Unassigned	0	Currently unassigned and always zero.

Table 6. Status Response to TDV

Bit Position	Function	State	Meaning
0	Data Overrun [†]	1	Data overrun (rate error) has occurred during execution of the previous order.
1	Flaw Mark [†]	1	A flaw mark has been detected while reading header.
2	Sector Unavailable [†]	1	A nonexistent data address was used in the previous Seek order, or the data address was incremented to a nonexistent value and a Read, Write, Header Read, or Header Write was attempted.
3	Unassigned	0	Currently unassigned and always zero.
4	Header Verification Error [†]	1	Header verification error (noncomparison) was detected.
5	On Cylinder ^{††}	1	Positioning is completed (head is on cylinder).
6	Seek Timeout Error ^{††}	1	Seek timeout error was detected.
7	Header Parity Error [†]	1	Header parity error was detected.

[†]Pertains to current or most recent controller operation.

^{††}Related specifically to that device addressed by TDV instruction.

Table 7. Status Response to AIO

Bit Position	Function	State	Meaning
0	Data Overrun	1	Data overrun (rate error) has occurred during execution of the previous order.
1-3	Unassigned	0	Currently unassigned and always zero.
4	On-Sector Interrupt [†]	1	On-sector interrupt received from device.
5	On Cylinder	1	Positioning is completed (head is on cylinder).
6	Seek Timeout Error	1	Seek timeout error was detected.
7	Unassigned	0	Currently unassigned and always zero.

[†] On-sector interrupt indicates completion of Seek operation or occurrence of Seek timeout error (bit position 6 is a 1); for Seek timeout errors, On Cylinder (bit position 5) is a 0. This bit is reset if an AIO instruction is not received before start of next sector.

Table 8. Operational Status Byte[†]

Function	State	Meaning
Transmission Data Error	1	One of the conditions listed under "Transmission Data Error Conditions" has occurred since the previous order was received.
Incorrect Length	1	One of the conditions listed under "Incorrect Length Conditions" has occurred since the previous order was received.
Chaining Modifier	0	Not used and always zero.
Channel End	1	A "channel end" is reported with every order-in to the IOP. The device has terminated its operation for any reason listed under "Channel End Conditions".
Unusual End	1	The device has terminated its operation for any reason listed under "Unusual End Conditions".
Unassigned	0	Currently unassigned and always zero.

[†] For the bit positions of these functions in the Operational Status Byte, see the applicable Sigma Computer Reference Manual.

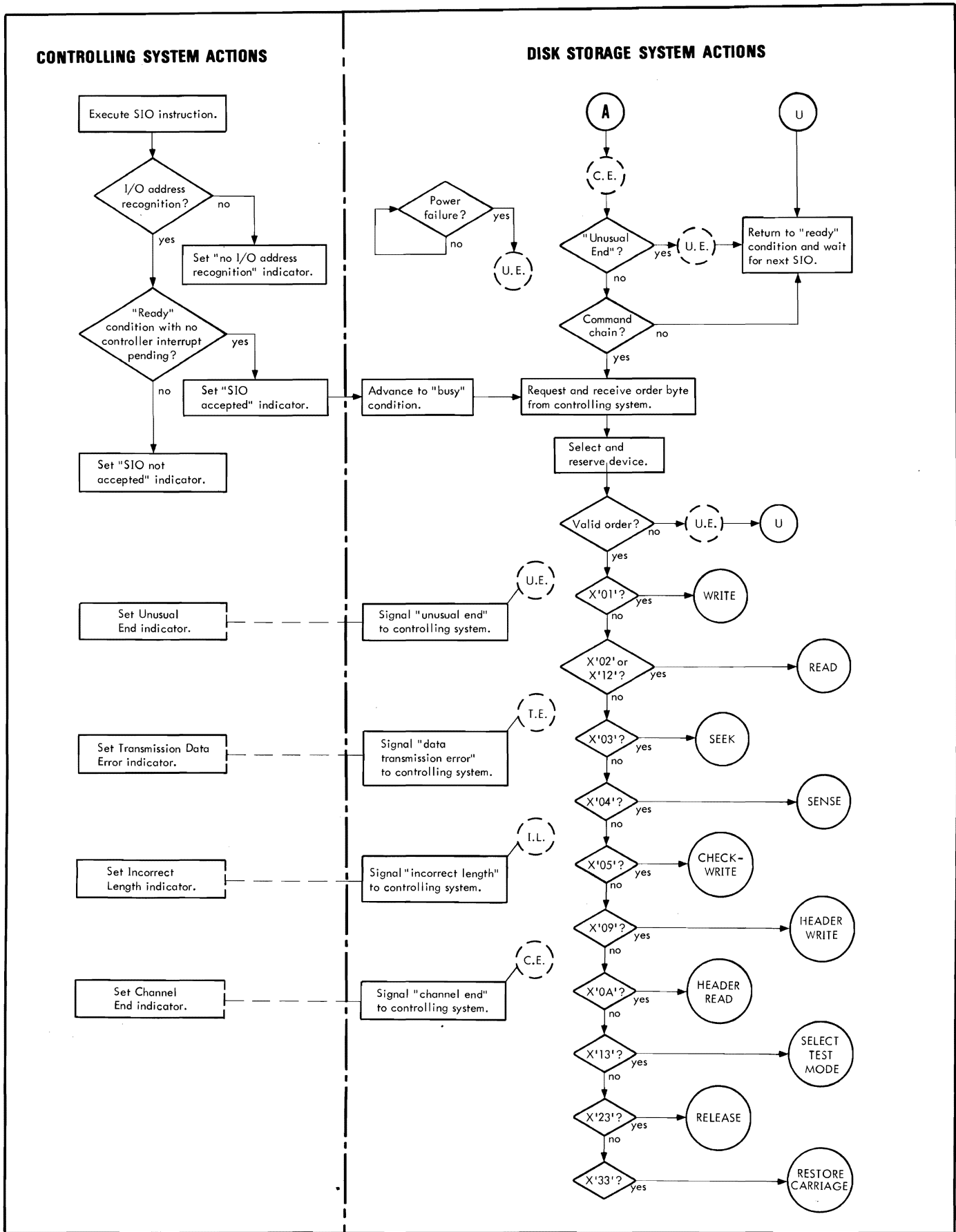

Figure 2. Controlling/Disk Storage System Actions

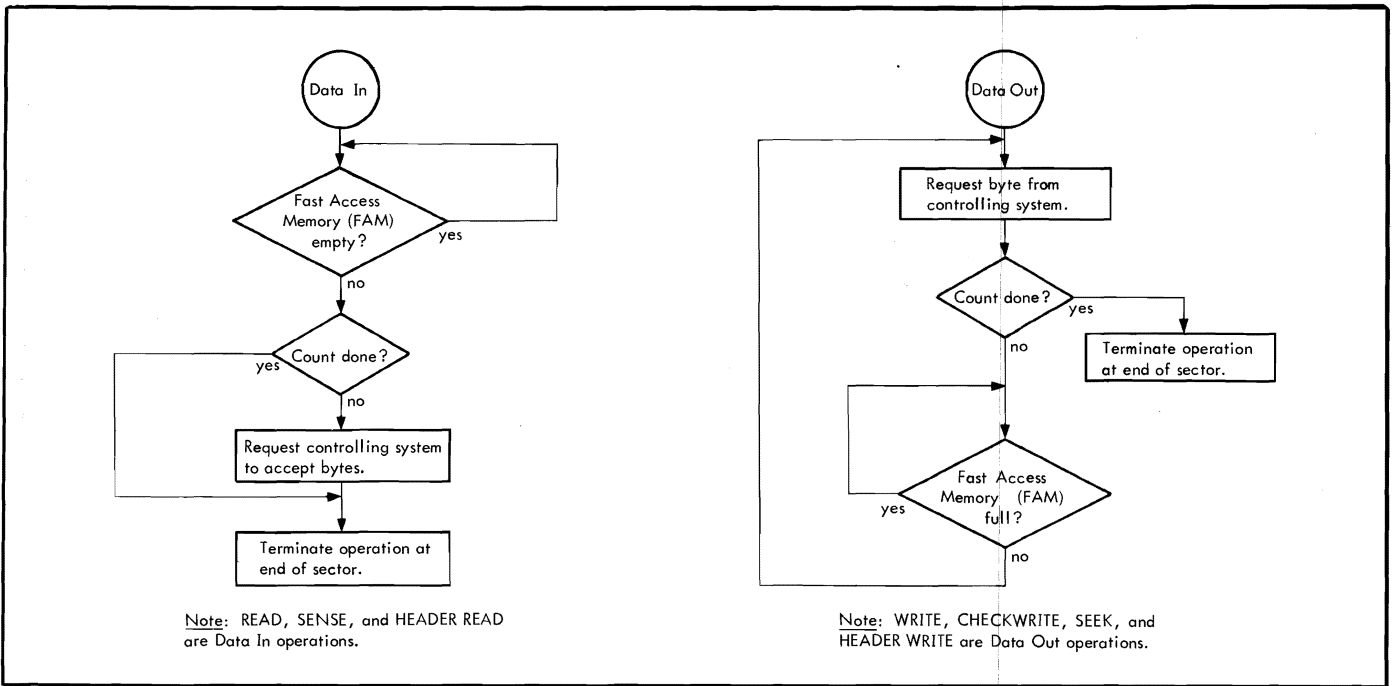

Figure 3. Data In/Data Out Operations

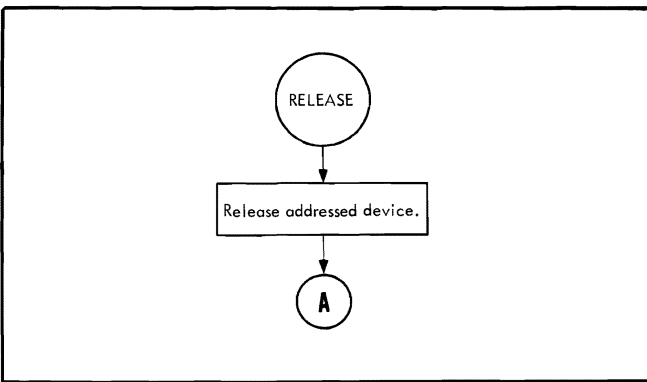

Figure 4. Release Order

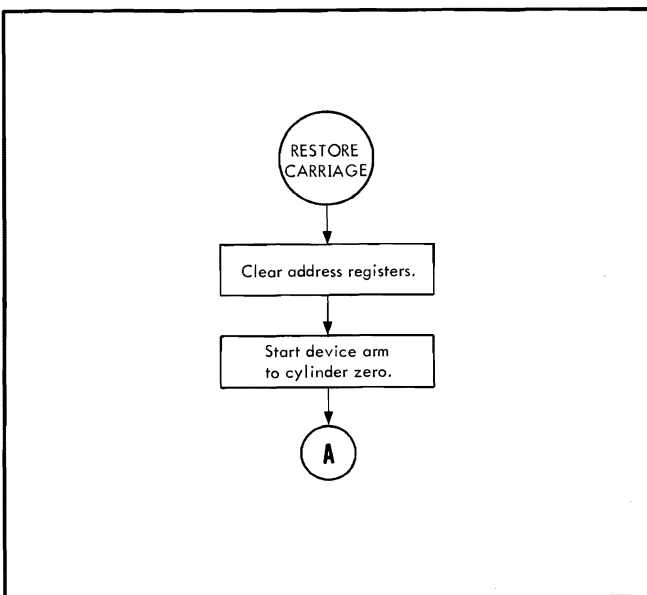

Figure 5. Restore Carriage Order

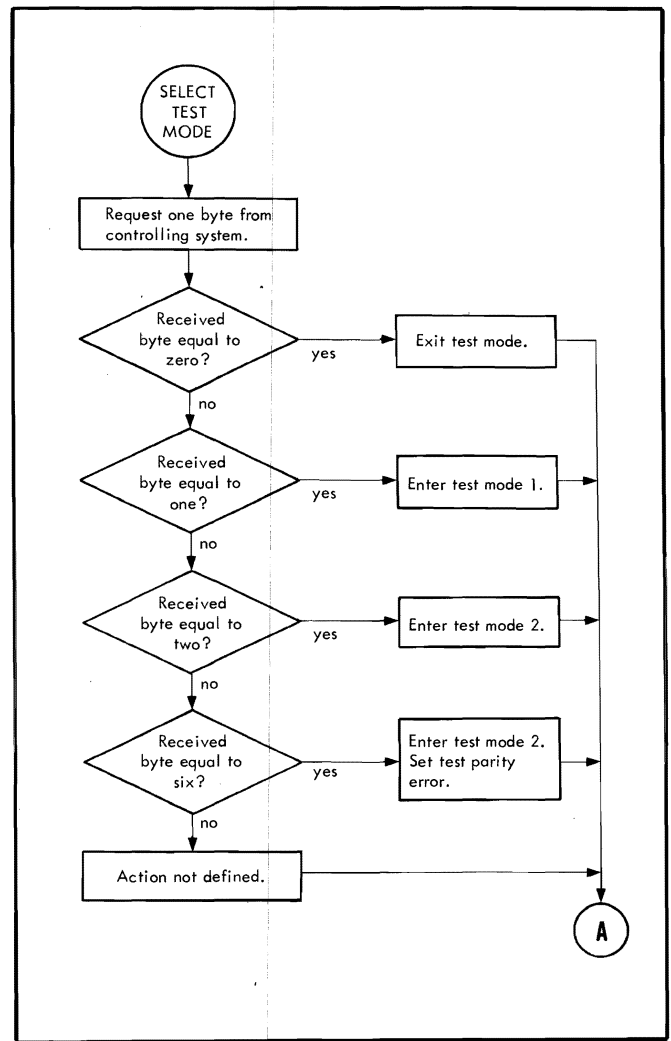

Figure 6. Select Test Mode Order

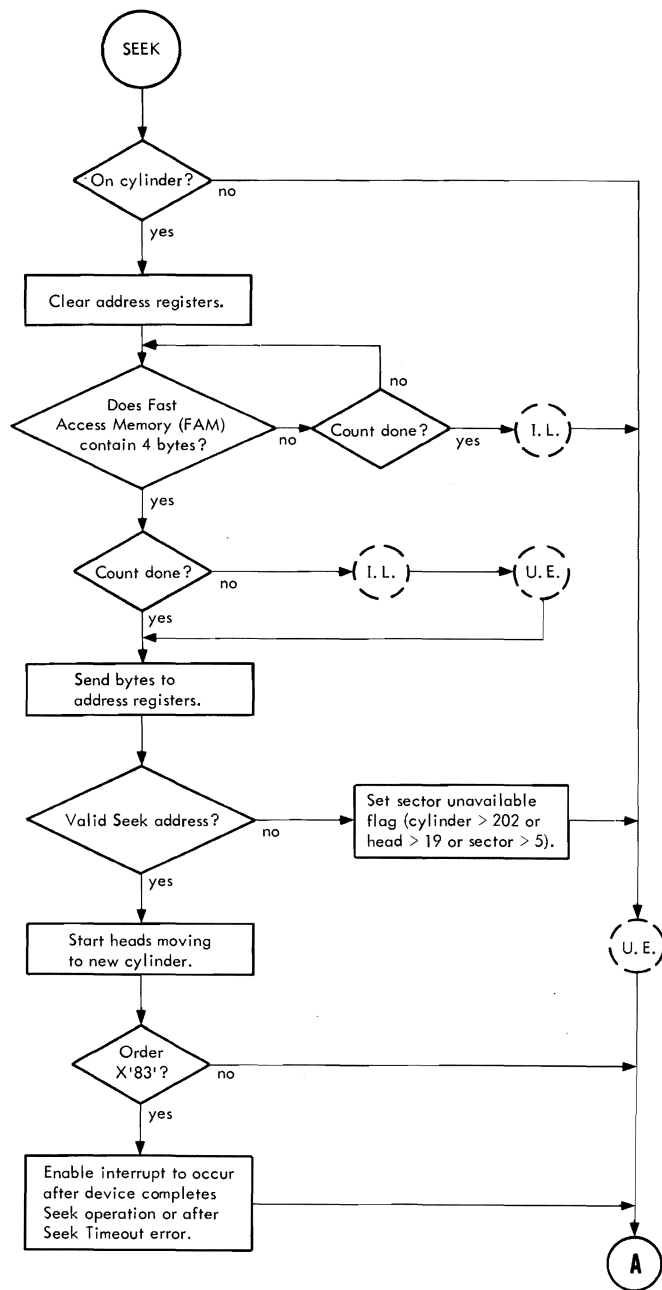

Figure 7. Seek Order

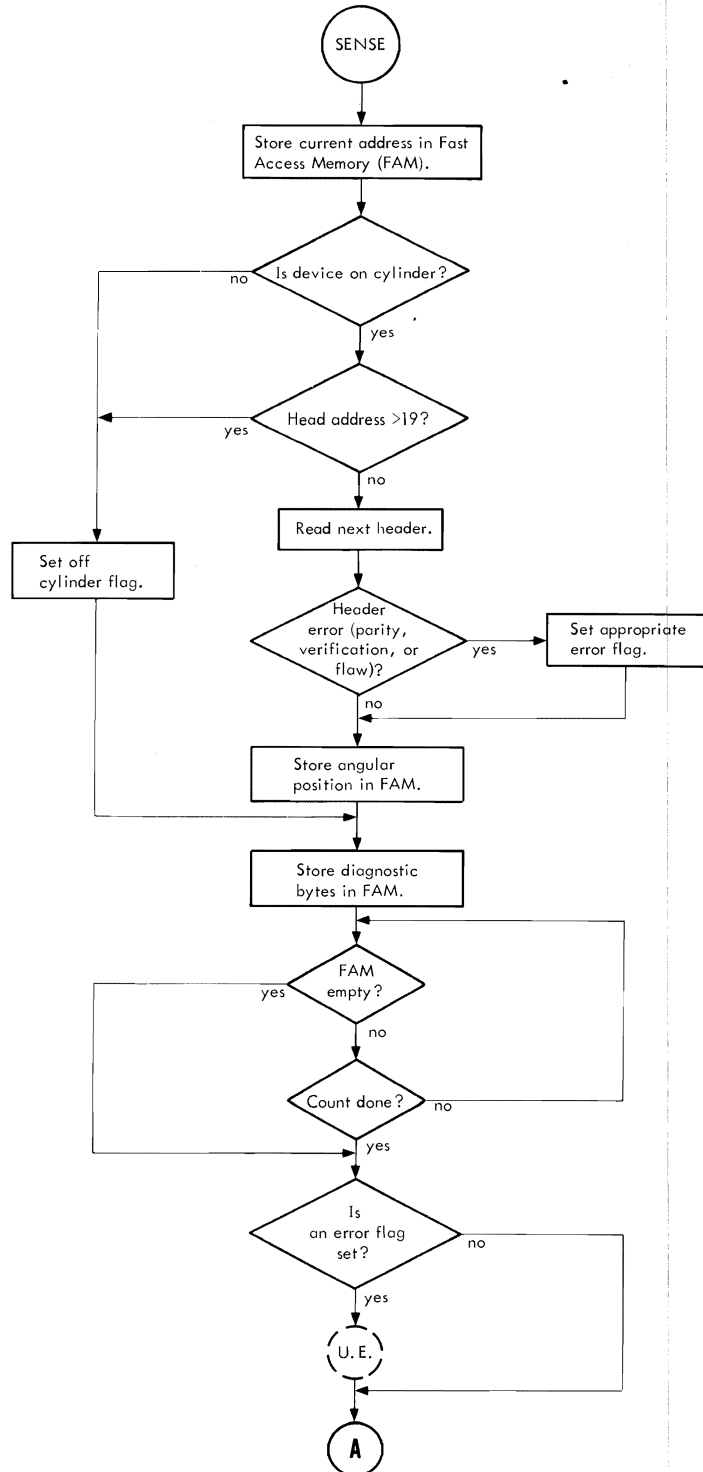

Figure 8. Sense Order

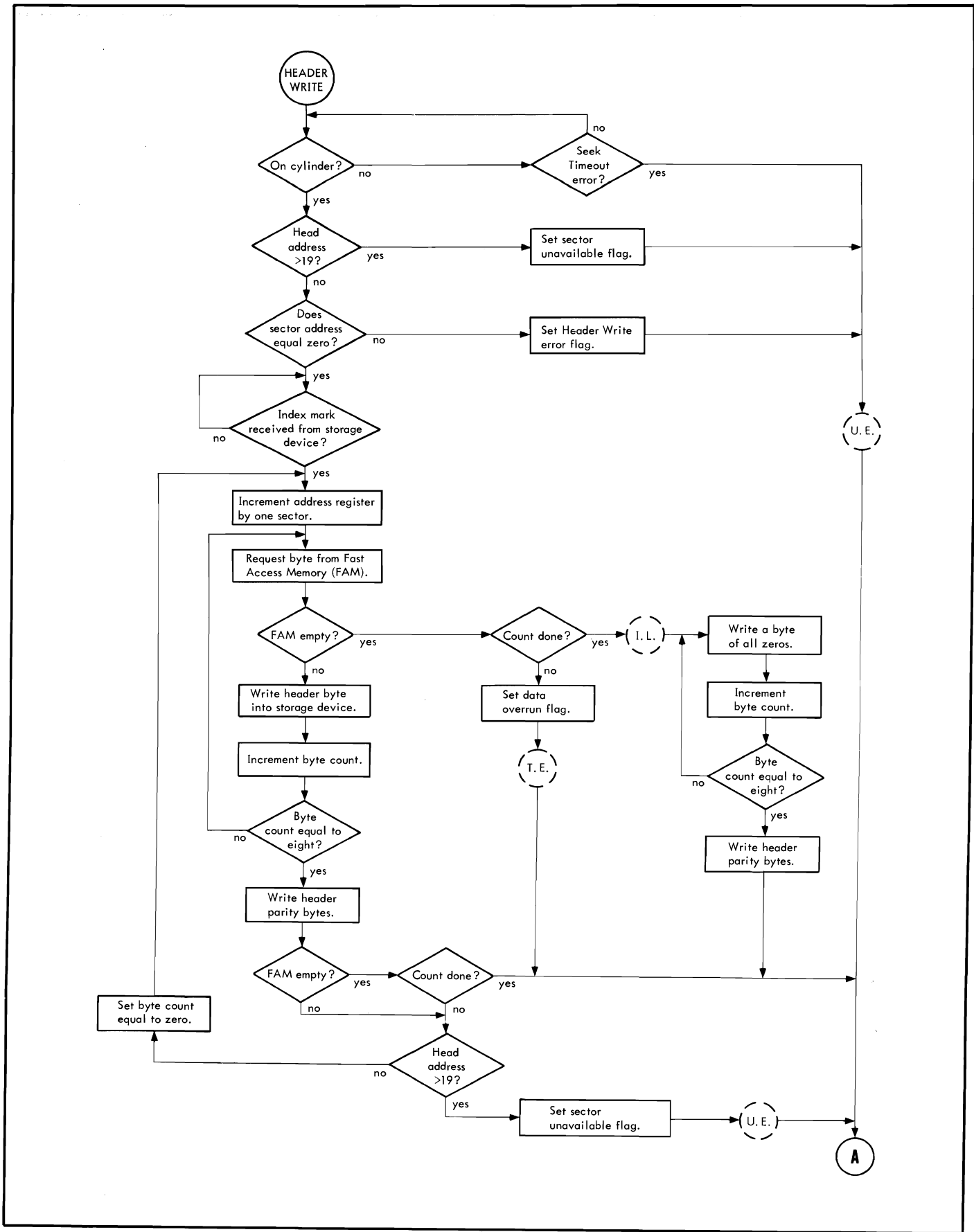

Figure 9. Header Write Order

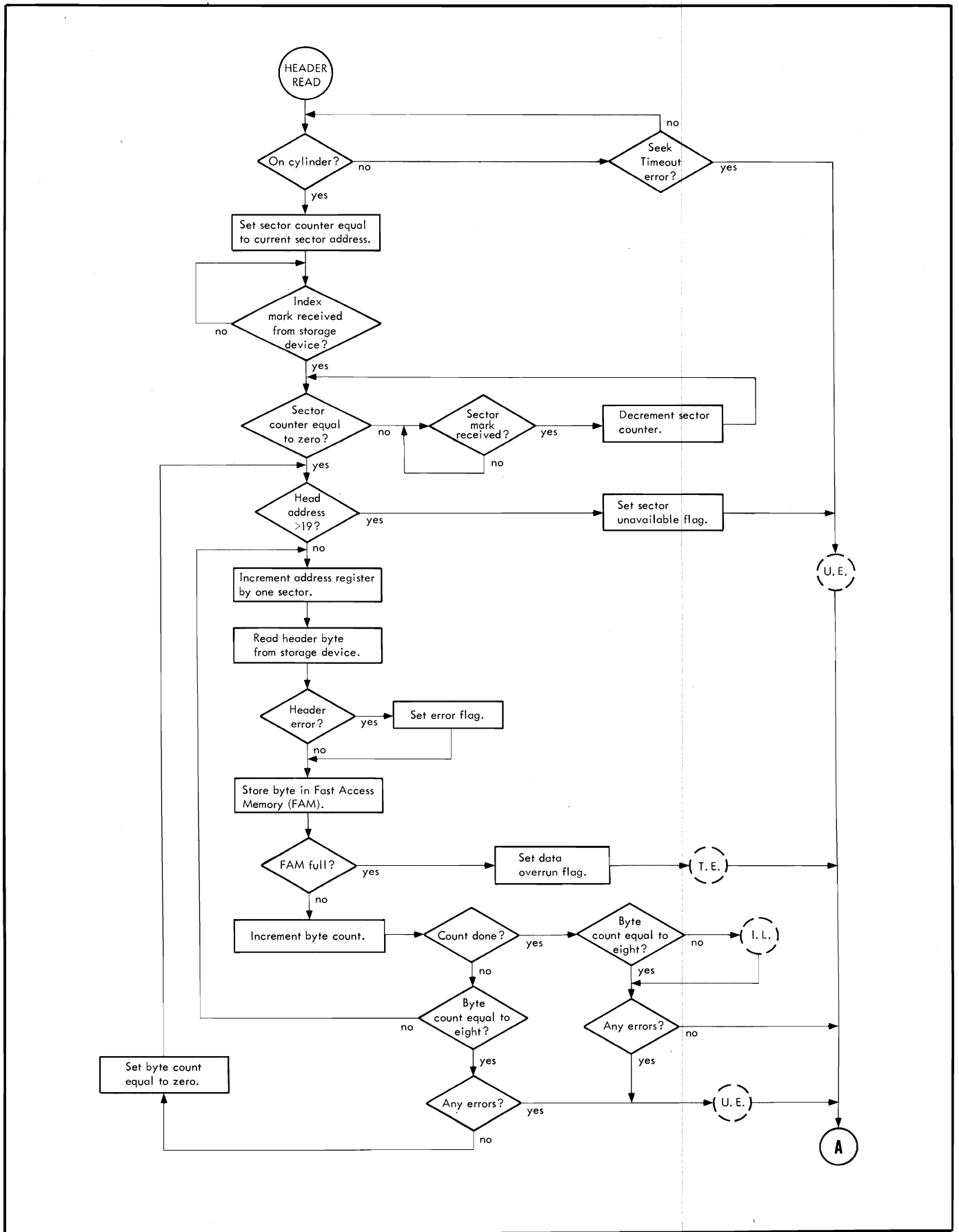

Figure 10. Header Read Order

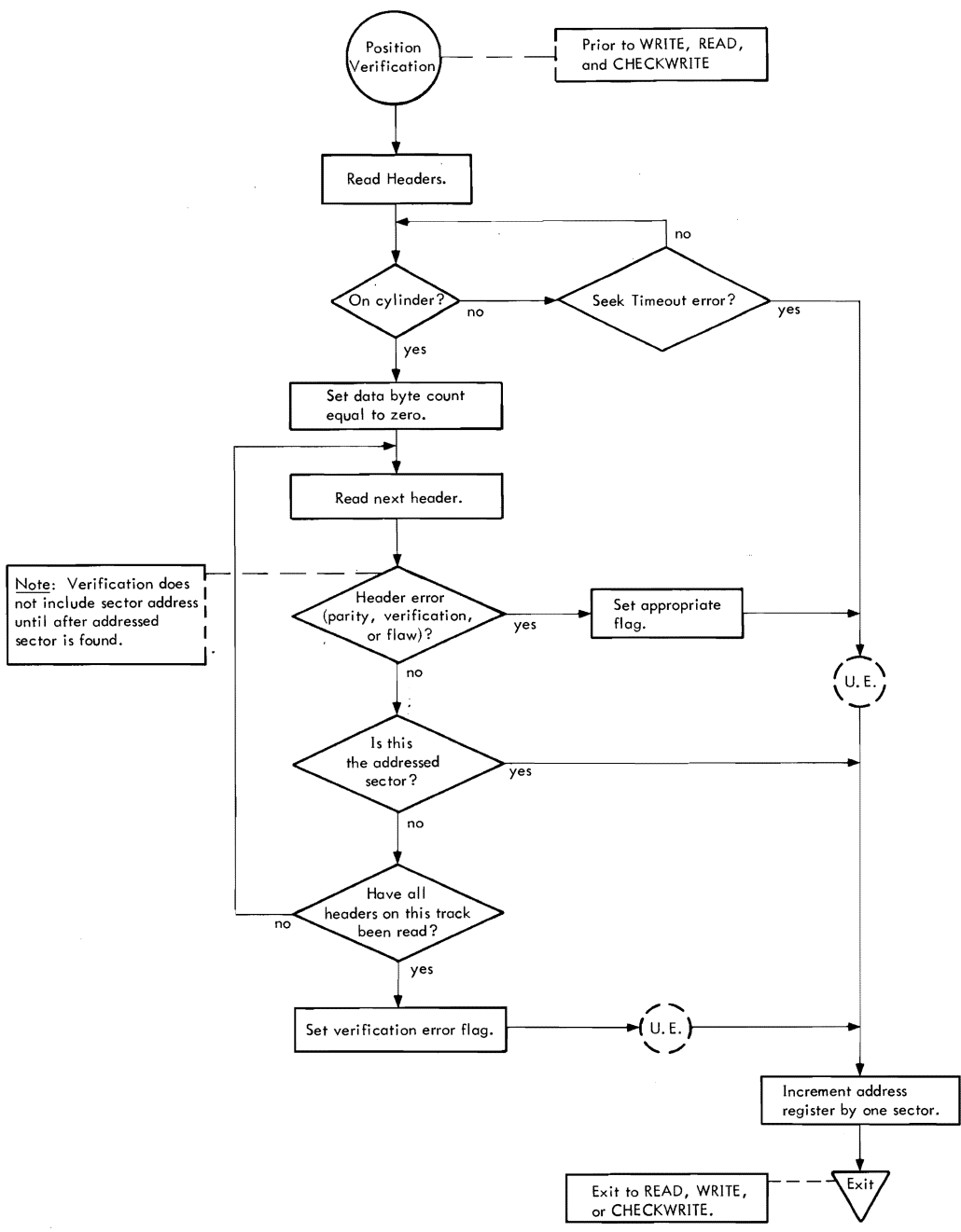

Figure 11. Position Verification

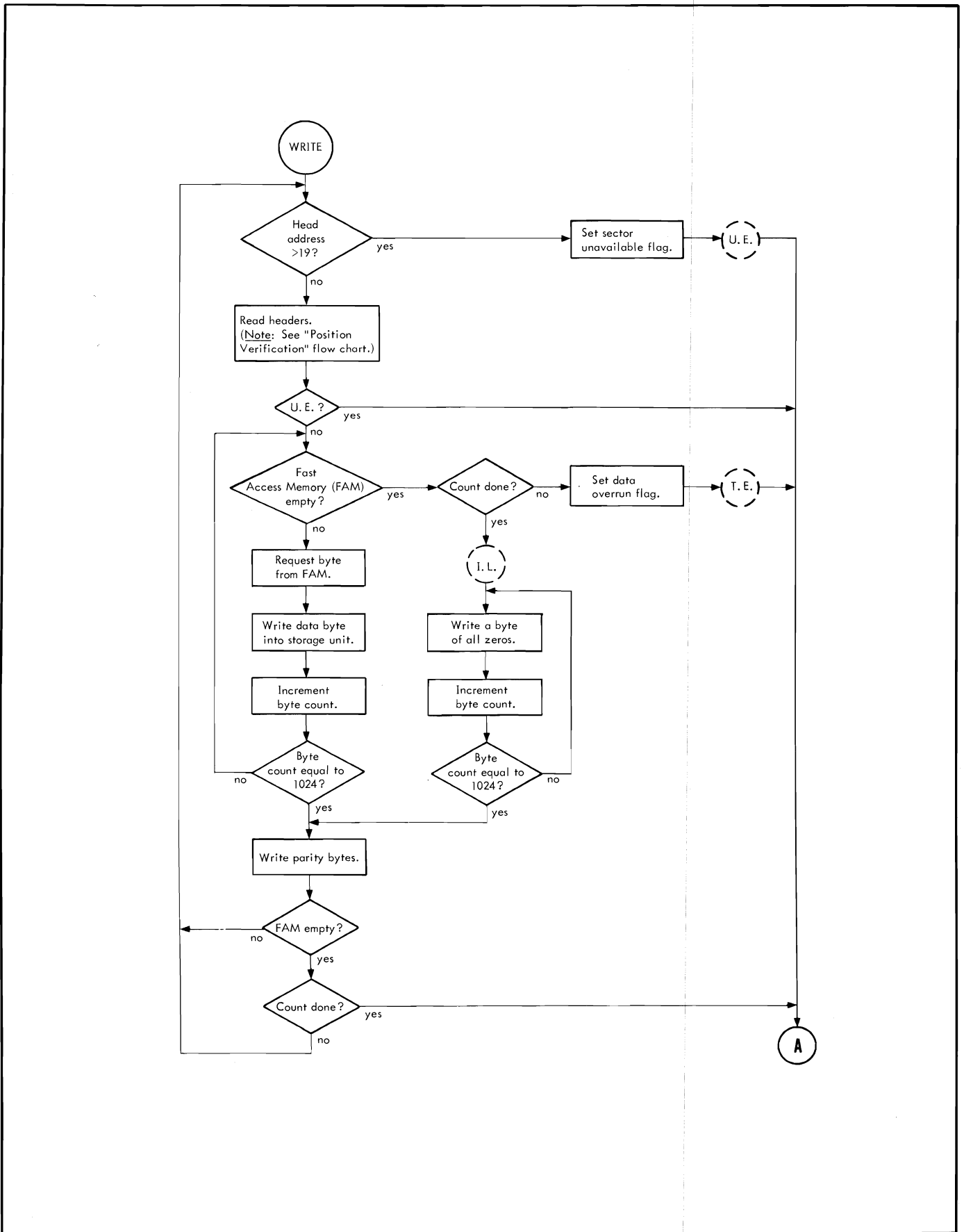

Figure 12. Write Order

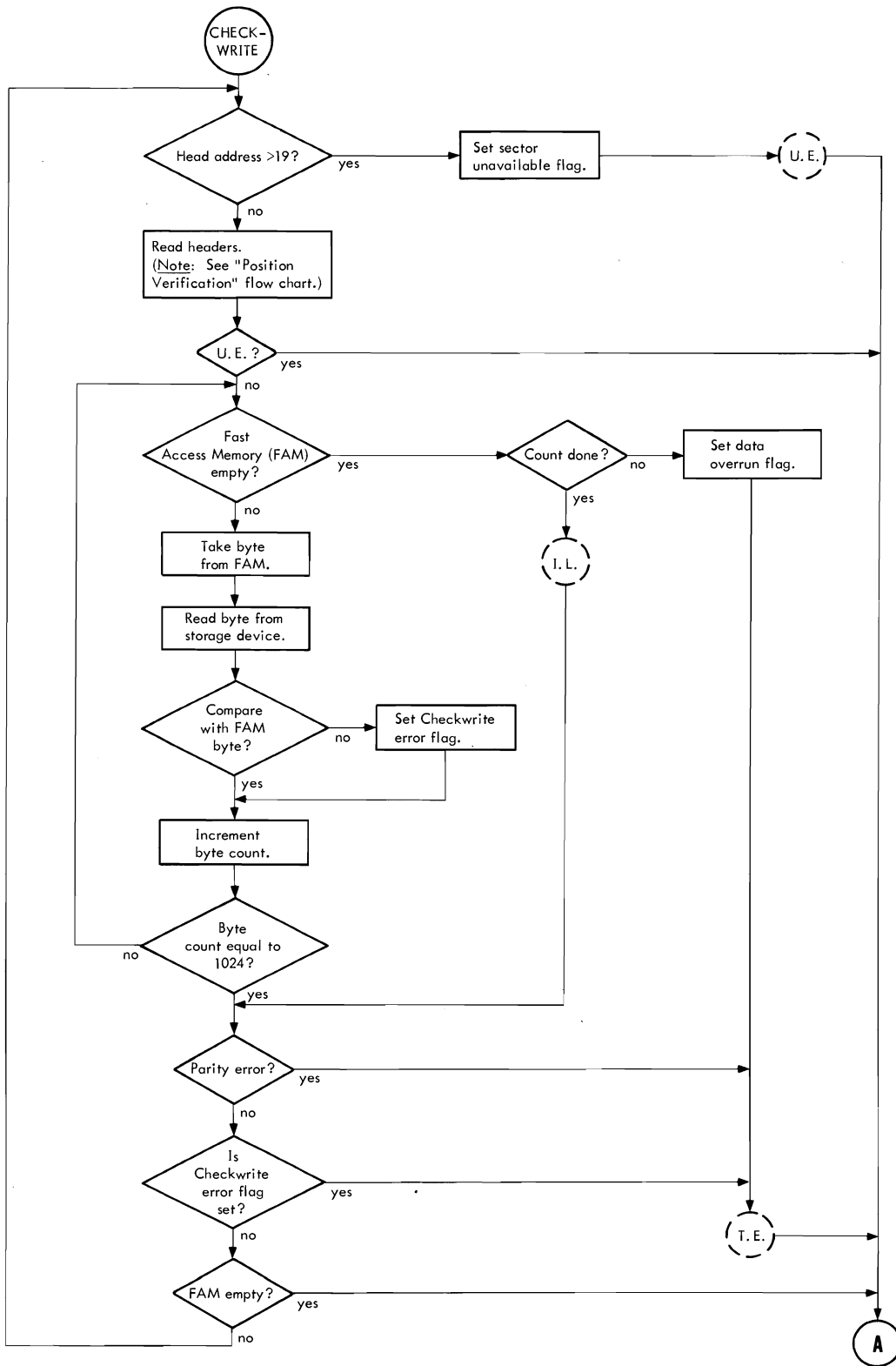

Figure 13. Check-Write Order

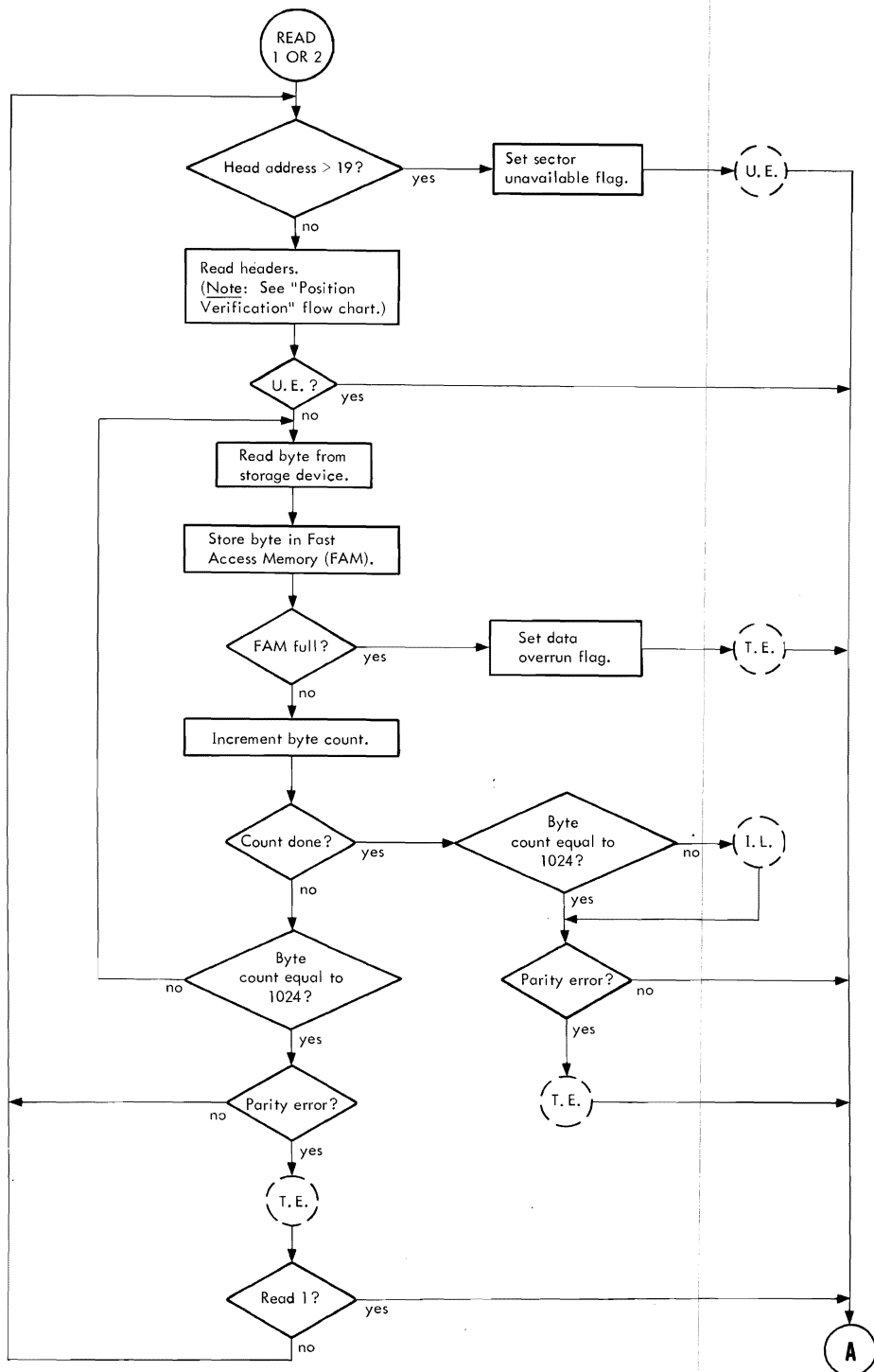

Figure 14. Read Orders

I/O FAULTS AND RECOVERY PROCEDURES

The faults and recovery procedures apply to removable disk storage systems operating with Xerox Sigma 3, 5, 6, 7, 8, or 9 computers.

This section outlines how the status response and condition code bits associated with specific I/O instructions may be evaluated to determine whether a disk I/O operation has been completed successfully or terminated due to a fault condition. Detailed information is also provided for evaluating failing I/O operations in a prescribed sequence and taking appropriate corrective action.

It is assumed that I/O operations are performed in an I/O interrupt environment and that the status response and condition code bits of an AIO and TDV instruction after an I/O interrupt provide sufficient information to determine if the I/O operation was successful. For failing I/O operations, additional information should be obtained from the status response and condition code bits of a TIO instruction. Note that before the status of any I/O instruction may be used for testing purposes, the condition codes returned with the I/O instruction must be tested to verify that the I/O instruction has been successfully executed and that the status information is available in the register.

Additional assumptions are that (1) a fault can be attributed to a specific disk order, i.e., Seek, Sense, etc., and (2) for multisector operations, the failing sector can be determined. In the case of command lists, a sequence of operations are performed before the I/O interrupt occurs and status is available. When an error occurs, the command list sequence is terminated and the failing order (operation) can be determined from the TIO current command address. The programming system then has its choice of repeating the entire command list or rebuilding the command list (bypassing all nonfailing surface operations) to repeat the operation that failed.

I/O INTERRUPT ENVIRONMENT

The I/O interrupt environment is established by setting flags within the Input/Output Command Doubleword (IOCD) of the command lists and by using specified timeout delays within software timeout routines.

SOFTWARE TIMEOUT VALUES

Recommended software timeout delay for disk operations is a minimum of one second.

IOCD FLAGS

IOCD flag settings depend on the type of computer system.

SIGMA 3 IOCD FLAG

The Interrupt flag (I) is set to a 1 in every IOCD. This will cause an I/O interrupt to be requested whenever a "channel end" or "unusual end" condition occurs. If data chaining is specified, the Interrupt flag should be set to a 1 only in the last IOCD of the command list.

SIGMA 5-9 IOCD FLAGS

When the disk is operating with a Sigma 5, 6, 7, 8, or 9 computer, the following flags must be set:

- | | |
|-----|---|
| ICE | Interrupt at Channel End. This flag is set to a 1 only in the last IOCD of a command list. |
| IUE | Interrupt at Unusual End. This flag is set to a 1 in all IOCDs. |
| HTE | Halt on Transmission Error. This flag is set to a 1 in all IOCDs. |
| SIL | Suppress Incorrect Length. This flag is set to a 1 whenever an incorrect length indication is to be inhibited from causing an IOP Halt and a subsequent "unusual end" I/O interrupt. An incorrect length indication is generated whenever any of the following conditions occur: <ol style="list-style-type: none">1. During a Read, Write, or Check-Write operation when the number of data bytes is not an integral multiple of 1024 bytes.2. During a Seek operation when a byte count other than four is specified.3. During a Header Write or Header Read operation when a byte count other than a multiple of eight bytes is specified. |

ADDITIONAL PROGRAMMING CONSIDERATIONS

The following information must also be considered when programming a removable disk storage system.

SURFACE FLAWING

When it has been determined that a sector's data field is unusable due to a defective surface area, all six sectors of the associated cylinder and head should be written with headers containing flaw marks. The use of the alternate cylinder and head assignment fields of these headers is optional.

SURFACE ORDERS

Automatic surface incrementing of sector and head addresses occurs after a surface operation (Read, Write, etc.);

however, automatic cylinder incrementing does not occur. A seek operation must be issued to cross cylinder boundaries to prevent an "unusual end" condition.

When the controller detects a flaw mark during a surface operation, automatic surface address incrementing is inhibited to allow for an immediate Header Read operation to obtain the alternate address.

TIO AND TDV INSTRUCTIONS

Frequent TIO and TDV instructions during surface operations may cause data overrun conditions.

SEEK AND RESTORE ORDERS

The Seek operation may be performed only when the disk is on cylinder. A modifier bit in the Seek order causes an on-cylinder interrupt to occur when the on-cylinder condition has been reached. The interrupt should be used to maximize controller availability.

The on-cylinder interrupt has a window that is one sector ahead of the addressed sector. Thus, it is possible for the condition code bits, CC1 and CC2, of an AIO instruction to be set to a 11 binary configuration (indicating that no interrupt was recognized). This "no interrupt recognized" condition should not be considered as a spurious interrupt.

When the seek modifier is used during Seek operations that are command chained to surface, header, or Sense operations, the on-cylinder interrupt does not occur.

When the Restore operation is performed, the on-cylinder indication must be present before a following Seek operation can be performed. In order to command chain a Restore and Seek order, a Header Read order should be used between the Restore and the Seek orders.

I/O OPERATION EVALUATION

By evaluating the status response and condition code bits obtained by executing AIO and TDV instructions after an I/O interrupt, a decision may be made as to whether the I/O operation was completed successfully or terminated due to a fault condition.

For Sigma 3 Computer Systems Only. A disk I/O operation may be considered successful if Overflow, Carry, and all the status response bits are as follows:

1. After an AIO instruction, the Overflow and Carry indicators are both 0.
2. After a TDV instruction, the Overflow and Carry indicators are both 0.
3. The Error flag in the odd I/O channel register (assigned to disk) is 0.

4. Bits 0, 1, and 4 (Operational Status Byte) in the even I/O channel register (assigned to disk) are all 0.

For Sigma 5-9 Computer Systems Only. A disk I/O operation may be considered successful if all the status response and condition code bits are as follows:

1. After an AIO instruction, condition code bits 1 and 2 are both 0.
2. After an AIO instruction, Operational Status Byte bits 8, 9, and 12 are all 0. Note that bit 8 may be a 1 if the SIL (Suppress Incorrect Length) flag is set.
3. After a TDV instruction, condition code bits 1 and 2 are both 0.
4. After a TDV instruction, Operational Status Byte bits 8-15 are all 0.

In either system (Sigma 3 or Sigma 5-9), if one or more of the specified bits are not 0, a TIO instruction must be issued to obtain the state of the device. Also, a Sense order must be executed to obtain 10 additional bytes of status and fault information.

It is recommended that an error log be maintained in which appropriate status and fault information (i.e., bytes 8 and 9 of Sense order, etc.) be recorded that will aid in hardware maintenance and repair.

I/O FAULT EVALUATION AND RECOVERY PROCEDURES

Status information that is obtained by executing an AIO, TDV, and TIO instruction after an I/O interrupt is evaluated in a prescribed manner as listed in Table 9. The first column provides a summary description of the fault when the specified bits are not 0 (indicating generally that a fault condition has occurred). Column 2 shows a specific bit configuration only if two or more bits are used to differentiate the fault indication and detailed description of the fault condition. Thus, the first two columns of Table 9 permit a fault condition to be defined as a function of the status response and condition code bits.

The Recommended Corrective Action (column 9) for a specific fault depends on the failing order (columns 3-8). Generally, for a failing Seek order, a reference is made to Recovery Procedure 3, Table 10; for failing Restore, Release, and Sense orders, a reference is made to Recovery Procedure 2; and for failing Read, Write, Check-Write, or Header Read/Write orders, a reference is made to Recovery Procedure 4.

If the device is not operational, program recovery is not possible but operator intervention may be required (see Chapter 4, "Operator Panel Controls and Indicators"). If the FAULT light on the operator control panel is on, press the FAULT switch to attempt recovery. If the light goes off, repeat the previous operation. If the light remains on, call the customer service engineer.

Table 9. Removable Disk Storage System Testing Sequence

Sequence and Summary Description	Condition Code, Status Response Bits and Detailed Description	Seek	Restore or Release	Read 1,2, Write, or Checkwrite	Header Read	Header Write	Sense	Recommended Corrective Action		
<p>Step 1.</p> <p>Performed only if TIO 5,6 ≠ 00, indicating that controller is not ready.</p>	TIO 5,6 = 01 or 10.	X						Use Recovery Procedure 3.		
	<p><u>Not Defined.</u> The controller is not ready immediately after an I/O interrupt.</p>		X				X	Use Recovery Procedure 2.		
					X	X	X		Use Recovery Procedure 4.	
	<p>TIO 5,6 = 11.</p> <p><u>Controller Busy.</u> The controller has failed to return to the ready state immediately after an I/O interrupt due to a hardware malfunction or the command list is coded with multiple interrupts.</p>		X					Use Recovery Procedure 3.		
				X				X	Use Recovery Procedure 2.	
					X	X	X		Use Recovery Procedure 4.	
<p>Step 2.</p> <p>Performed only if TIO 1,2 ≠ 00, indicating that device is not ready.</p>	TIO 1,2 = 01.	X	X	X	X	X	X	Use Recovery Procedure 1.		
	<p>TIO 1,2 = 10.</p> <p><u>Not Available.</u> The device is not available for usage through the addressed controller for the dual access hardware configuration.</p>	X	X	X	X	X	X	Use Recovery Procedure 1.		
	<p>TIO 1,2 = 11.</p> <p><u>Device Busy.</u> The device did not return to the ready state. Normally, the device is not busy when the controller is not busy. Even if the heads are moving, the device is ready when the controller is ready.</p>		X						Use Recovery Procedure 3.	
				X				X	Use Recovery Procedure 2.	
					X	X	X		Use Recovery Procedure 4.	
<p>Step 3.</p> <p>Performed only if TDV CC1,CC2 = 01.</p>	<p>TDV CC1,CC2 = 01.</p> <p><u>Test Mode.</u> The controller has been placed in the test mode either due to a hardware failure or a programming error.</p>	X	X	X	X	X	X	Use Recovery Procedure 1.		
<p>Step 4A.</p> <p>Applicable for Sigma 3 computer systems only.</p> <p>Performed only if the Error flag ≠ 0, indicating an IOP parity error.</p>	<p><u>I/O Parity Error.</u> The Error flag in the odd channel register indicates that a parity error has been detected on bytes received during an input operation, or a memory parity error was detected on an output operation. The following errors generate an IOP Halt to the device controller:</p> <p>a. A memory parity error detected while fetching an order code from memory on order-out.</p> <p>b. A memory parity error detected while fetching a new IOCD from memory during a data chaining operation.</p>	X						Use Recovery Procedure 3.		
			X					X	Use Recovery Procedure 2.	
					X	X	X			Use Recovery Procedure 4.
<p>Step 4B.</p> <p>Applicable for Sigma 5-9 computer systems only.</p> <p>Performed only if TDV 10, 11, 12, and 13 ≠ 0000, indicating an IOP operational error.</p>	<p>TDV 11 = 1.</p> <p><u>Memory Address Error.</u> This error may be due to a hardware malfunction or to a programming error.</p>	X						Use Recovery Procedure 3.		
	<p>TDV 12 = 1.</p> <p><u>IOP Memory Error.</u> This error is due to a hardware malfunction.</p>		X				X	Use Recovery Procedure 2.		
					X	X	X		Use Recovery Procedure 4.	
				X				X	Use Recovery Procedure 2.	
	<p>TDV 13 = 1.</p> <p><u>IOP Control Error.</u> This error is due to a hardware malfunction or to a programming error.</p>			X	X	X			Use Recovery Procedure 4.	
			X						Use Recovery Procedure 3.	
				X				X	Use Recovery Procedure 2.	
	<p>TDV 10 = 1.</p> <p><u>Transmission Memory Error.</u> This error is due to a hardware malfunction.</p>			X	X	X			Use Recovery Procedure 4.	
			X						Use Recovery Procedure 3.	
				X				X	Use Recovery Procedure 2.	
					X	X	X		Use Recovery Procedure 4.	
	<p>Step 5.</p> <p>Performed only if TDV 2 ≠ 0.</p>	<p><u>Sector Unavailable.</u> The surface address of the Seek operation is outside the range of available sectors, or the current surface operation has been aborted because the previous surface operation has incremented the surface address across a cylinder boundary. Both conditions are programming errors.</p>	X						Use Recovery Procedure 3.	
					X	X	X		Use Recovery Procedure 4.	

Table 9. Removable Disk Storage System Testing Sequence (cont.)

Sequence and Summary Description	Condition Code, Status Response Bits and Detailed Description	Seek	Restore or Release	Read 1, 2, Write, or Checkwrite	Header Read	Header Write	Sense	Recommended Corrective Action	
Step 6. Performed only if TDV 6 ≠ 0, indicating a Seek Timeout.	<u>Seek Timeout.</u> A hardware seek timeout has been detected because the on-cylinder device state has failed to occur after head motion has started. This is a hardware malfunction.	X	X	X	X	X		Use Recovery Procedure 3.	
							X	Use Recovery Procedure 2.	
Step 7. Performed only if TDV 7 ≠ 0, indicating a header parity error.	<u>Header Parity Error.</u> A parity error in the header has been detected, indicating that the header portion of the sector cannot be read correctly.						X	Use Recovery Procedure 2.	
				X	X			Use Recovery Procedure 3.	
Step 8. Performed only if TDV 4 ≠ 0. Sense Byte 8, bits 2, 3, and 4 indicate, respectively, the error as sector head, or cylinder (see Table 3).	<u>Header Verification Error.</u> This error may occur during a surface, Header Read, or Sense operation. In all cases, the current surface address is not incremented. <u>Surface Operations.</u> For the first surface operation after a Seek operation, the header verification error indicates a sector header corresponding to the addressed surface could not be found in any of the six sectors of the addressed cylinder and head. After the first surface operation, the header verification error indicates the header of the currently addressed sector's header is incorrect. In either case, the surface operation has not been performed. <u>Header Read Operations.</u> The header verification error during the Header Read operation indicates that the currently addressed sector's header is incorrect. <u>Sense Operations.</u> The header verification error during the Sense operation indicates that a header has been read whose cylinder and head field does not compare with the current cylinder and head address. This header may be any of the six headers of the cylinder and head.						X	Use Recovery Procedure 2.	
				X	X				Use Recovery Procedure 3.
Step 9. Performed only if TDV 1 ≠ 0, indicating a flaw mark.	<u>Flaw Mark.</u> A flaw mark has been detected during a surface, Header Read or Sense operation. In all cases, the current surface address is not incremented. <u>Surface Operations.</u> For the first surface operation after a Seek operation, the flaw mark indicates a flaw has been detected in a sector's header of the addressed cylinder and head while the sector headers were being scanned to obtain the addressed sector. On subsequent operations, the flaw mark indicates the currently addressed sector's header contains a flaw. This condition will be present when the surface address has been incremented from an unflawed cylinder and head to a flawed cylinder and head surface. In either case, the surface operation is not performed. <u>Header Read Operations.</u> Flaw mark has been detected in the currently addressed sector. This indicator should not be considered an error. <u>Sense Operations.</u> Flaw mark during a Sense operation indicates that a header has been read containing a flaw. This header may be any of the six headers of the currently addressed cylinder and head. The flaw mark indication should not be considered an error.				X		X	Use Recovery Procedure 6.	
				X					Use Recovery Procedure 5.
Step 10. Performed only if OSB ≠ 0 (Sigma 3) or TDV 9 ≠ 0 (Sigma 5-9), indicating a Transmission Data error. <u>Note:</u> OSB = Operational Status Byte	<u>Transmission Data Error.</u> This error may be caused by any of the following: a. <u>Data Over-Run.</u> When the system fails to maintain data transfer rate required during Read, Write, Checkwrite, Header Read, or Header Write operation. (TDV0 will also be set to a 1.) b. <u>Data Parity Error.</u> The sector data parity has failed to compare to the expected parity during a Read, Checkwrite, or Header Read operation. (Bit 0 of Sense Byte 8 is also set to a 1.) c. <u>Checkwrite Error.</u> When a data comparison error occurs during a Checkwrite operation. (Bit 1 of Sense Byte 8 is also set to a 1.)					X	X	Use Recovery Procedure 4.	
				X					Use Recovery Procedure 4.
				X					Use Recovery Procedure 4.

Table 9. Removable Disk Storage System Testing Sequence (cont.)

Sequence and Summary Description	Condition Code, Status Response Bits and Detailed Description	Seek	Restore or Release	Read 1, 2, Write, or Checkwrite	Header Read	Header Write	Sense	Recommended Corrective Action
Step 11. Performed only if TIO4 ≠ 0, indicating an "unusual end".	<u>Unusual End.</u> If none of the above error indications (as described in Steps 1-10) are present, then the current operation was terminated with an "unusual end" due to any of the following errors:	X						Use Recovery Procedure 3.
			X				X	Use Recovery Procedure 2.
	a. Invalid order code issued. b. The device's read clock was lost during header or data reading. c. Receiving a Seek order while the arm is in motion or an incorrect length was used with the Seek order. d. Attempting to start the Header Write operation at a sector other than zero.			X	X	X		Use Recovery Procedure 4.
Step 12. Performed only if TDV 8 ≠ 0 (Sigma 5-9) or if OSB 1 ≠ 0 (Sigma 3), indicating an incorrect length error.	<u>Incorrect Length.</u> An incorrect length has been detected. Except for the Header and Seek operations, this indication should not be considered an error (see SIL flag).			X	X			Use Recovery Procedure 4.
			X				X	Use Recovery Procedure 6.
Step 13.	<u>Inconsistent Status Error.</u> Whenever the device-dependent status has failed to indicate the specific failure for which the device-dependent status checking was invoked, it is considered a hardware malfunction.	X	X	X	X	X	X	Use Recovery Procedure 3.

Table 10. Recommended Recovery Procedures

Recovery Procedure Number	Description
1	<p><u>Abort – Operator Intervention.</u></p> <p>All operations on the device must be aborted and operator notification given that the device is either not operational or unavailable or the controller is in the test mode. The operator must then perform action to return the device to the operational state.</p>
2	<p><u>Order Retry – Program Recovery.</u></p> <p>An HIO instruction should be issued (in the case of controller and/or device not ready) and the operation retried. This sequence should be retried ten times before considering the operation irrecoverable.</p>
3	<p><u>Order Retry After Restore – Program Recovery.</u></p> <p>An HIO instruction must be issued (in the case of controller and/or device busy) followed by a Restore operation to reestablish head positional reference. A Seek operation should then be issued followed by the operation previously in error (if not a Seek operation). This sequence should be retried ten times before considering the failure irrecoverable.</p>
4	<p><u>Order Retry After Seek – Program Recovery.</u></p> <p>An HIO instruction should be issued (in the case of controller and/or device not ready) followed by a Seek operation to reestablish the surface address and head position. The operation in error is then retried. This sequence should be retried ten times before considering the failure irrecoverable.</p>
5	<p><u>Alternate Surface Selection – Program Recovery.</u></p> <p>A Header Read operation is performed to determine the assigned alternate surface address. This recovery is appropriate only when the header area is used for alternate assignment. Whenever a flaw mark is detected, a Header Read operation must be performed to differentiate between flawed sectors (only flaw mark set) and hardware problems (other fault indicators set).</p>
6	<p><u>Program Notification – No Recovery Required.</u></p> <p>The program is notified of the following conditions for which recovery is not necessarily required:</p> <ol style="list-style-type: none"> 1. A header flaw marker has been detected during a Header Read or Sense operation. 2. An incorrect length indication appears following an operation for which partial information transfer is acceptable.

IRRECOVERABLE ERRORS

If a particular fault condition persists after performing the recommended recovery procedure, the fault is irrecoverable. Specific action to be taken after an irrecoverable fault will vary with the order and with the user's

application. For example, in the case of sense failures, the system may tolerate such errors, whereas read failures may require a range of action such as job abortion to shutting down the system. On the other hand, irrecoverable write operations may require the choosing of another surface area and the flawing of the failing surface.

4. OPERATIONS

CONTROLS AND INDICATORS

The location of disk storage unit operator and maintenance panel controls and indicators is shown in Figure 15.

The Operator Panel controls and indicators are described in Table 11 and shown in Figure 16.

OPERATING INSTRUCTIONS

SYSTEM POWER TURN-ON PROCEDURE

If power is to be applied to a single deck or spindle and a part of the system is already operating on-line, refer to

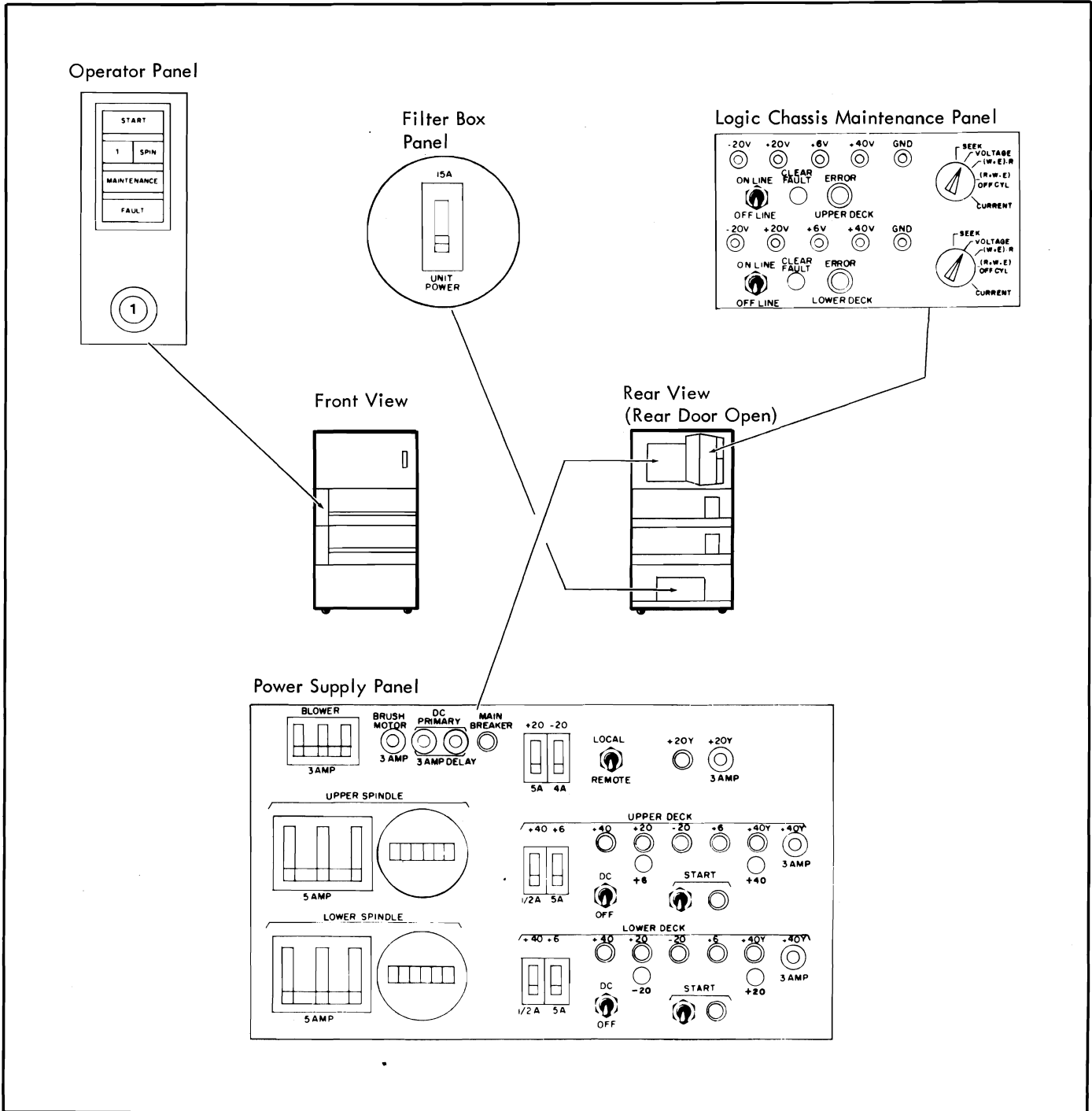

Figure 15. Location of Disk Storage Unit Controls and Indicators

Table 11. Operator Panel Controls and Indicators

Control or Indicator	Function
START switch/ indicator	<p>When pressed with indicator not lighted, starts spindle drive motor and lights indicator. The first Seek sequence begins provided that the following conditions are met:</p> <ol style="list-style-type: none"> 1. Disk pack in place. 2. Deck assembly drawer closed. 3. Circuit breakers on. 4. Sequence power available from controller (if Power Supply Panel LOCAL/REMOTE switch (see Figures 15 and 21) is set to REMOTE), or from power supply (if switch is set to LOCAL). <p>When pressed with indicator lighted, initiates power-off sequence.</p>
Unit Number/ SPIN indicator	<p>SPIN indicator lights when disk pack velocity exceeds 50 rpm. Unit Number lights when Logic Chassis Maintenance Panel ON LINE/OFF LINE switch (see Figures 15 and 20) is set to ON LINE position and read/write heads are "loaded" (positioned).</p> <p>Significance of Unit Number (0 through 7) is limited to indicating physical location of a spindle within the system. The number is unchangeable.</p>
MAINTENANCE indicator	<p>Lights when related module is not on-line as a result of one of the following conditions:</p> <ol style="list-style-type: none"> 1. LOCAL/REMOTE switch on Power Supply Panel set to LOCAL. 2. DC/OFF switch on Power Supply Panel set to OFF. 3. ON LINE/OFF LINE switch one Logic Chassis Maintenance Panel set to OFF LINE.

Table 11. Operator Panel Controls and Indicators (cont.)

Control or Indicator	Function
FAULT switch/ indicator	<p>Indicator lights when an invalid operation is attempted on the device or a failure has occurred.</p> <p>Pressing this switch clears a fault condition and turns the indicator off.</p>
Logic Number plug/indicator	<p>Indicator lights when related deck selected by controller. Removable plug that indicates device address (logic number); device address can be changed by interchanging logic number plugs.</p>

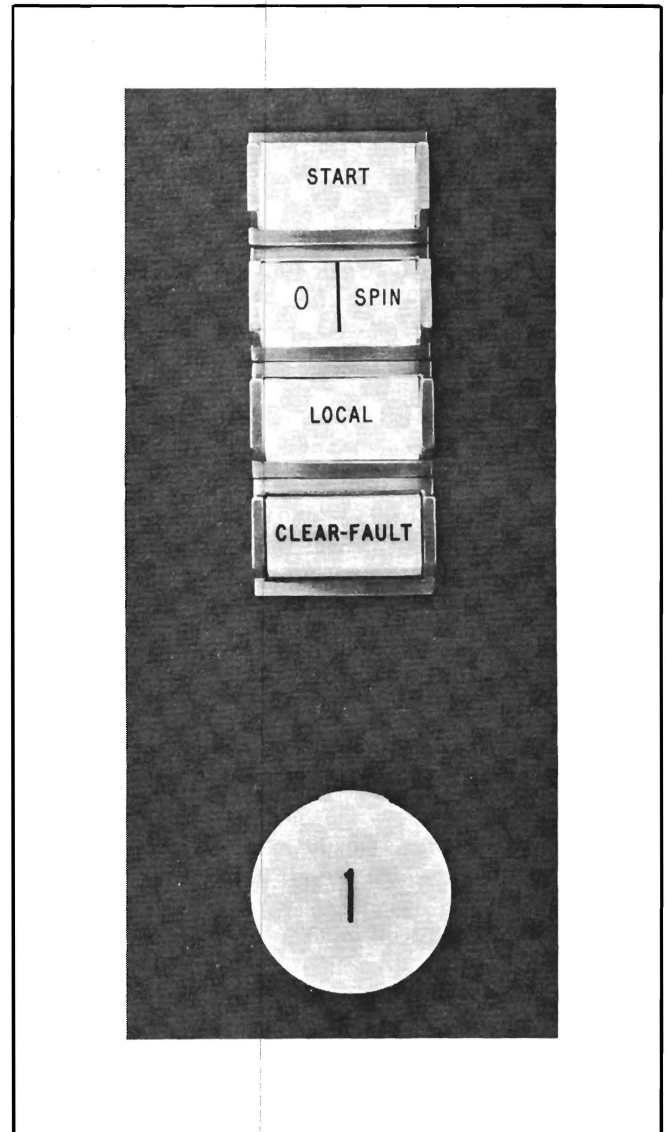

Figure 16. Operator Panel Controls and Indicators

"Deck or Spindle Power Turn-On Procedure". The following procedure prepares the system to go on-line.

1. Set the Filter Box Panel UNIT POWER circuit breaker to ON in each storage unit cabinet (see Figures 15 and 17).
2. Observe each operator panel. Only the spindles to be operating should have their START indicators lighted. Press any START switches on or off as required.
3. Apply sequence power at the controller by setting the S1 switch to REM (see Figure 18). Set the MARGIN dial to N (see Figure 19).

When a spindle completes its power-up sequence, the related Unit Number indicator will light.

Note: The controller is in a separate cabinet. The S1 switch is on the Controller Power Distribution Panel, which is at the top of the cabinet. The MARGIN dial is on the Controller Power Supply Panel, which is at the bottom of the cabinet.

4. When the required Unit Number indicators are lighted, the system is on-line and the unit is ready to receive an order.

DECK OR SPINDLE POWER TURN-ON PROCEDURE

The following procedure applies power to a deck or spindle, thereby joining other on-line units in the system.

1. Open the rear panel of the cabinet housing the spindle that is to be placed on-line.
2. Set the Logic Chassis Maintenance Panel ON LINE/OFF LINE switch (for applicable deck) to ON LINE (see Figures 15 and 20).
3. Swing out logic chassis for access to Power Supply Panel (see Figures 15 and 21).
4. If one spindle in this cabinet is already on-line, proceed to step 5; otherwise, proceed to step 8.
5. Position the Power Supply Panel switches (related to the spindle to receive power) as follows:

SPINDLE circuit breaker to ON

+40 circuit breaker to ON

+6 circuit breaker to ON

DC/OFF switch to DC

START switch to down position

6. The following Power Supply Panel indicators will light:

+20

-20

+6

7. Proceed to step 10.

8. Position the Power Supply Panel switches, as follows:

BLOWER circuit breaker to ON

+20 circuit breaker to ON

-20 circuit breaker to ON

LOCAL/REMOTE switch to REMOTE

SPINDLE (as applicable) circuit breaker to ON

+40 (as applicable) circuit breaker to ON

+6 (as applicable) circuit breaker to ON

DC/OFF (as applicable) switch to DC

START (as applicable) switch to down position

9. Set the Filter Box Panel UNIT POWER circuit breaker to ON. If Power Supply Panel START indicator lights, set related START switch to up position. The blower motor, the logic chassis fans, and the power supply fans will begin to operate and the following Power Supply Panel indicators will light:

MAIN BREAKER

+20Y

+20

-20

+6

} for the spindle to receive power

10. Swing the logic chassis into the cabinet and close the cabinet rear panel.
11. Release the front latch on the desired spindle drawer and pull the drawer out to the stop. Install a disk pack (see "Disk Pack Installation" later in this chapter).
12. Press the Operator Panel START switch. The indicator will light.
13. When the controller sequence power becomes available, the first Seek operation begins as indicated by the following Operator Panel events:

SPIN indicator lights (disk pack speed is greater than 50 rpm).

Unit Number indicator lights (heads have been positioned or "loaded").

14. The first Seek operation is completed when the heads are returned to track 0. The unit is now ready to receive an order from the controller.

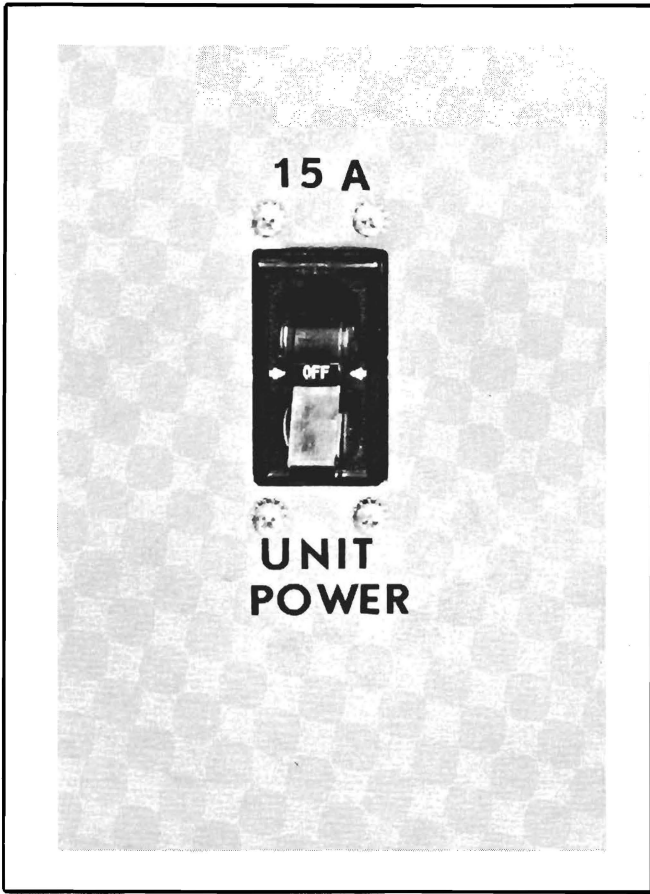

Figure 17. Filter Box Panel

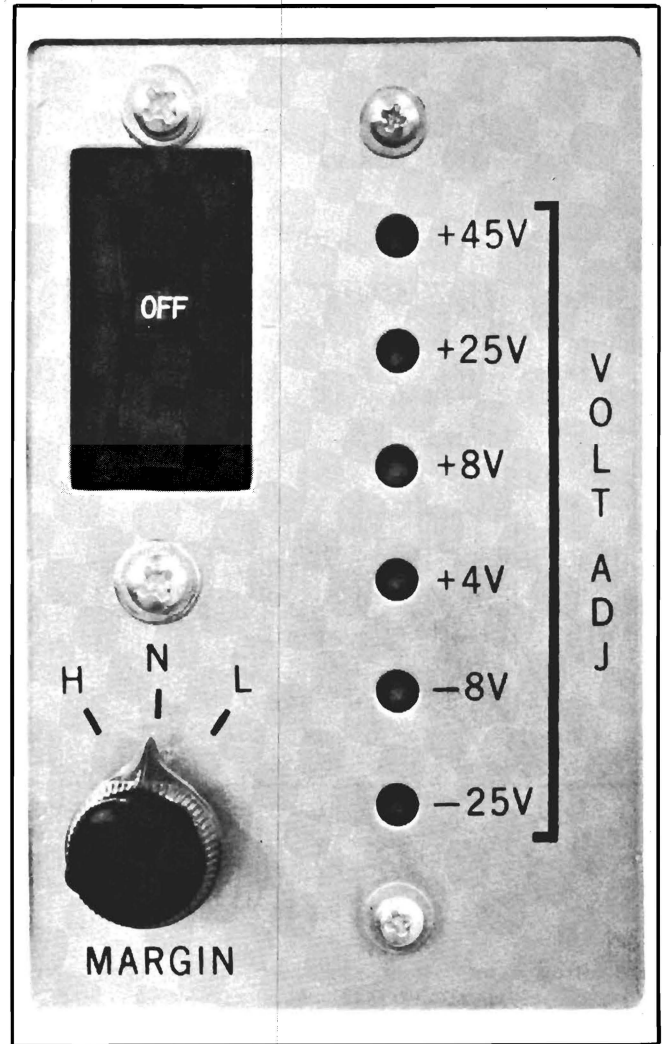

Figure 19. Controller Power Supply Panel
(in separate cabinet)

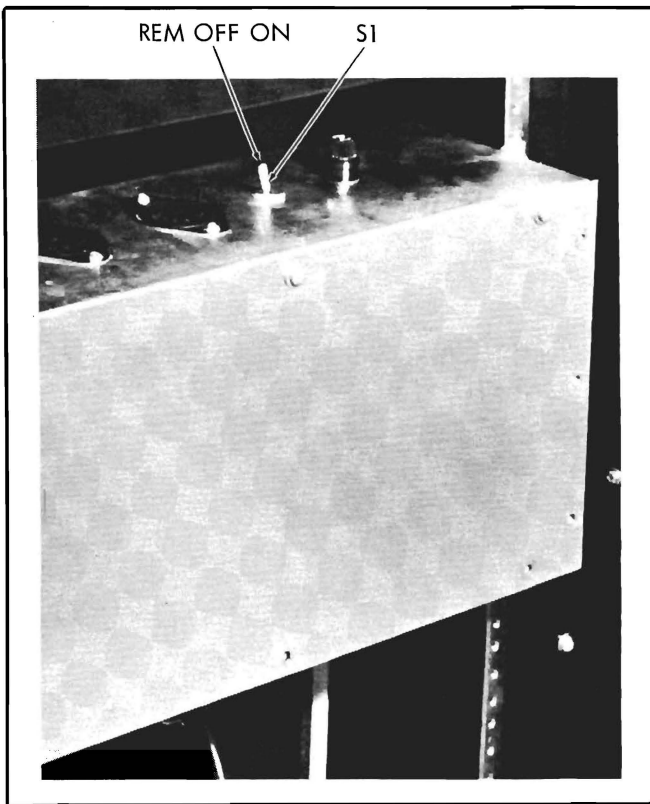

Figure 18. Controller Power Distribution Panel
(in separate cabinet)

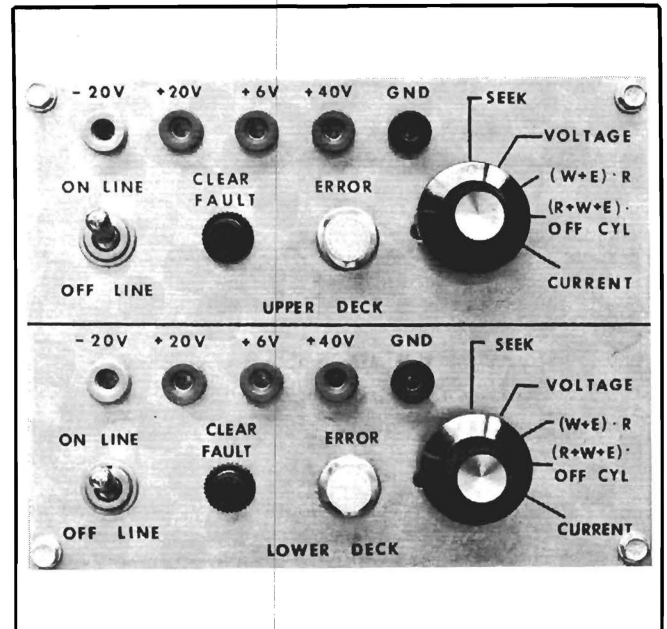

Figure 20. Logic Chassis Maintenance Panel

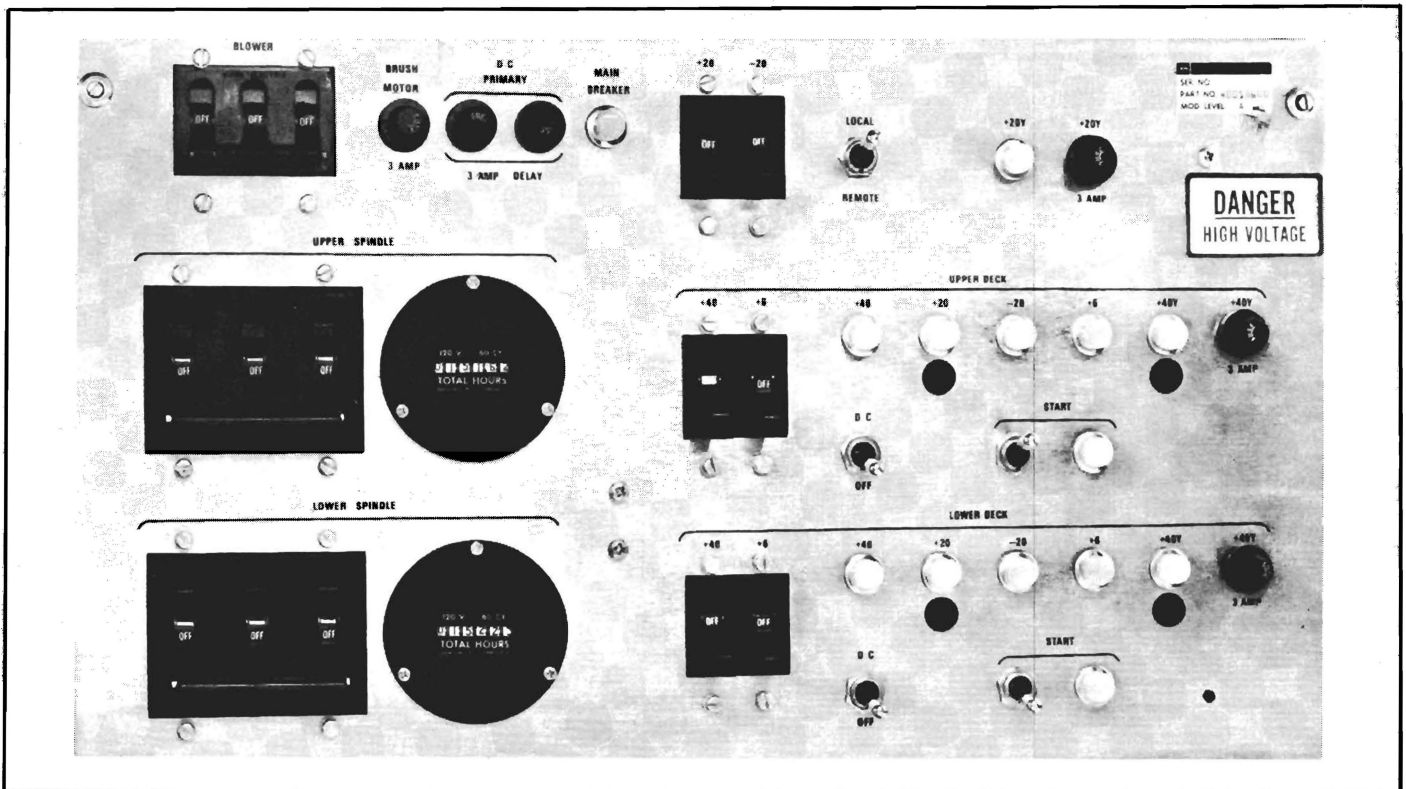

Figure 21. Power Supply Panel

POWER TURN-OFF PROCEDURE

The following procedure removes power from the entire system.

1. Turn off sequence power at the controller by setting S1 switch to OFF (see Figure 18).

Note: The controller is in a separate cabinet. The S1 switch is on the Controller Power Distribution Panel, which is at the top of the cabinet.

2. Set Filter Box Panel UNIT POWER circuit breaker to OFF in each storage unit cabinet (see Figures 15 and 17).

DISK PACK INSTALLATION (See Figure 22)

Note: The disk pack to be installed must be clean (see "Disk Pack Cleaning"). Before loading it, be sure the disk drive is completely stopped (after the SPIN light goes off).

1. Release the front latch (see Figure 23) on the desired spindle drawer and pull the drawer out to the stop.

Note: A spindle lock mechanism is actuated when the spindle drawer is opened. While a disk pack is being loaded, the mechanism holds the spindle stationary until the pack loading force exceeds the torque of the slipping clutch.

2. Lift the disk pack by the plastic canister handle.

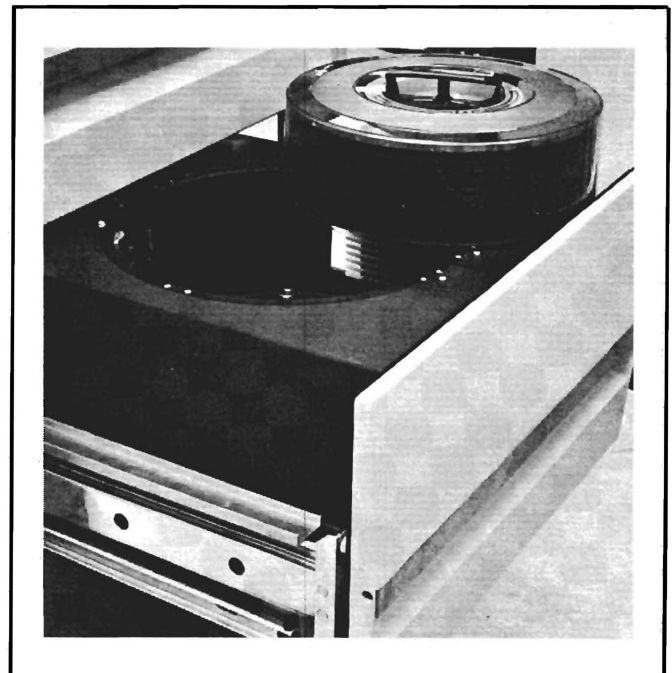

Figure 22. Disk Pack Installation/Removal

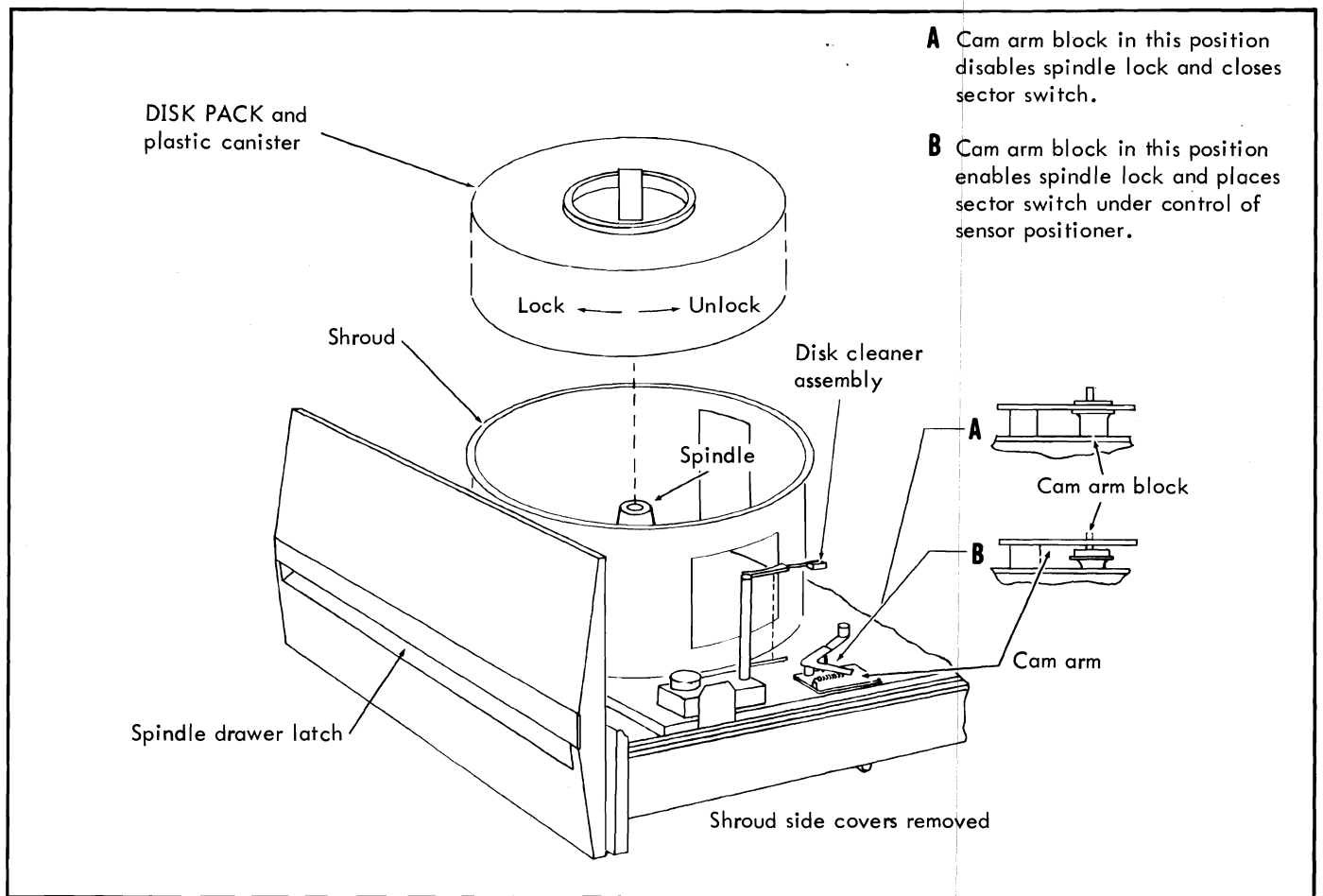

Figure 23. Disk Pack Load/Unload Mechanism

5. Twist the canister handle clockwise until the pack rotates, indicating that the clutch is slipping.
 6. Carefully lift the canister clear of the disk pack and reassemble with the bottom cover, so that the interior will remain dust free.
- Note:** If a maintenance situation requires the spindle drawer to be open (in either direction) while the spindle rotates, disable the spindle lock by positioning the cam arm block as shown in "A" of Figure 23.
7. Close the spindle drawer.
 3. Release the front latch on the desired spindle drawer and pull the drawer out to the stop.
 4. Place the canister carefully over the mounted disk pack so that the post protruding from the center of the disk pack is received into the canister handle.
 5. Twist the canister handle counterclockwise until it clicks two or three times, securing the cover to the disk pack, and freeing it from the spindle.
 6. Carefully lift the canister and the disk pack clear of the spindle.

DISK PACK REMOVAL (See Figure 22)

1. Press Operator Panel START switch if indicator is lighted. The indicator will be turned off.

Caution: A spindle lock mechanism is actuated when the spindle drawer is opened. A loud ratcheting noise occurs when the drawer of a spinning disk pack is opened. While this action is not recommended, it will not damage the unit.

2. Check that the Operator Panel SPIN indicator is not lighted.

7. Install protective cover on spindle and close the spindle drawer.
8. Place the bottom dust cover in position on the disk pack and tighten it.

DISK DRIVE/PACK INSPECTION FOR DAMAGE

When a disk pack is received, it should be carefully examined for possible damage. A distorted disk pack can cause head to disk interference that can result in a "crash". Since a number of packs are used on more than one drive unit, a

single defective pack or drive unit can spread a malfunction to all the units. If packs are subsequently installed on a damaged disk drive unit, they will also be damaged. When these defective packs are used with other drive units, these units will also be damaged. A damaged head or dirty drive unit will initiate this same damage cycle.

The following procedure is recommended to check disk packs prior to installation on a disk drive unit:

1. Visually inspect pack for damage such as covers not locking onto pack, bent or warped disks, or gross misalignment within the covers.
2. Remove bottom cover.
3. Turn pack upside down and level it so that the pack can be spun inside the top cover freely. Apply spinning force to the center, not the disk.
4. Visually inspect pack for excessive up and down motion (runout) of any of the recording disks, especially the gold-colored sector disk. If runout exceeds 1/8 inch when tested in this manner, reject the pack. Also, a 1/16 inch or more separation between the sector disk and the adjacent recording disk is cause for rejection.
5. Load the seemingly good pack on a disk drive unit and remove the top cover.
6. Turn drive unit power on and allow disk pack cleaning brushes to start cleaning cycle. As the brushes move in and out of the pack, listen for any noise that may be caused by the brush arms making contact with a disk surface, or the sector disk making contact with the drive sector block. If such noise is heard, turn off unit power. Reject defective pack. Bring to immediate attention of Customer Service Engineer.
Caution: Do not allow read/write heads to load, since extensive damage to the heads could result from a defective pack.
7. If no noise was detected, replace top cover and remove pack from drive unit spindle. Inspect sector disk on pack and sector block on drive unit for possible damage from the two making contact. (Sector disk to sector block contact is most often caused by a bent sector disk or improper alignment of the machine sector sensing block.)
8. As a final test, while a program is being run, listen closely (near the drive unit top cover) for any head to disk contact that causes a rasping sound. If such noise is heard, turn drive unit power off and remove pack. The pack has sustained mechanical damage. The drive unit has also been damaged and should not be run with any other packs, since it may damage them with the heads damaged by the first failure.

DISK PACK CLEANING

Disk pack surfaces should be cleaned monthly. The top and bottom covers of the disk pack should be kept clean and free of fingerprints, label adhesives, etc. To clean

covers, use a lint-free cloth (or Kimwipe) moistened with pure 91 percent isopropyl alcohol (from a chemical supply house — not a drug store; drug store alcohols often contain harmful oils, medicinals, and perfumes).

To clean disk pack surfaces, proceed as follows:

1. Stop spindle motor.
2. Release front latch, pull the deck drawer out to the stop, and install disk pack to be cleaned on spindle.
3. Release four half-turn fasteners securing right-hand (as viewed from front of unit) shroud side cover.
Caution: The spindle lock mechanism must be enabled before the disk pack is removed (see Figure 23).
4. Disable spindle lock mechanism (see Figure 23).
5. Wrap a piece of lint-free gauze (or Kimwipe) around a plastic spatula (or tongue depressor) and dampen (do not soak) with 91 percent isopropyl alcohol.
6. Insert the spatula through pack cleaning brushes port in side of shroud until tip contacts hub of disk pack.
7. Slowly rotate disk pack while very slowly withdrawing tip of spatula. (Apply moderate and constant pressure to disk surface with spatula during this step.) Continue withdrawing spatula until tip is clear of disk pack circumference.
8. Repeat steps 5, 6, and 7 for a disk surface until gauze comes away clean from disk surface.
9. Wrap a clean, dry piece of gauze on spatula and repeat steps 6 and 7 to remove residue released by alcohol.
10. Repeat steps 5 through 9 for each remaining recording surface of disk pack.
11. Dampen a piece of gauze with alcohol and wipe clean the exposed top surface of disk pack. Dry the surface.
12. Use alcohol-dampened gauze to clean both pieces of disk pack container. Dry the container.
13. Enable spindle lock mechanism.
14. Remove disk pack from spindle, install bottom of disk pack container, and set pack and container aside.
15. Clean spindle cone of disk drive unit thoroughly with alcohol-dampened gauze.

To clean shroud and spindle, proceed as follows:

1. Stop spindle motor.
2. Release front latch and pull the deck drawer out to the stop.

3. Remove disk pack.
4. Clean shroud with lint-free gauze (or Kimwipe) that is slightly dampened with alcohol. Wipe shroud to remove all dirt and smudges. Thoroughly wipe spindle surface.
5. After cleaning shroud, use a pad of adhesive-type tape and pick up any particles that were not picked up with gauze. Make certain that all particles are removed from interior of shroud.

When a disk surface is improperly cleaned, the alcohol may dry leaving a splotchy residue. These splotches are concentrated areas of contaminants cleared from the disk, and may be more harmful than if the pack was not cleaned at all. The packs should be inspected immediately after being cleaned. Packs with splotches must be recleaned immediately.

DISK PACK FILTER REPLACEMENT

Disk packs are fitted with an air filter made of mesh nylon in a plastic frame (see Figure 24). The filter is located in

the base of the hub and is secured in place by an "O" ring (see Figure 25). In normal use, a filter must be replaced monthly to maintain a clean disk pack. More frequent replacement may be necessary, since it depends upon the number of operating hours and environment.

FILTER REMOVAL

To remove a filter from a disk pack for inspection or replacement, the procedure is:

1. Remove disk pack bottom cover. For location of filter, see Figure 25.
2. With thumb and index finger, squeeze the "O" ring, which secures the filter in place, with a sliding motion so that the ring stretches in one direction. A gap will be formed between the ring and the hub, permitting the ring to be removed from the hub.

Caution: Do not use a sharp instrument to remove the "O" ring, since sharp objects may puncture the filter or generate contamination by abrading the hub.

3. Remove filter from hub.

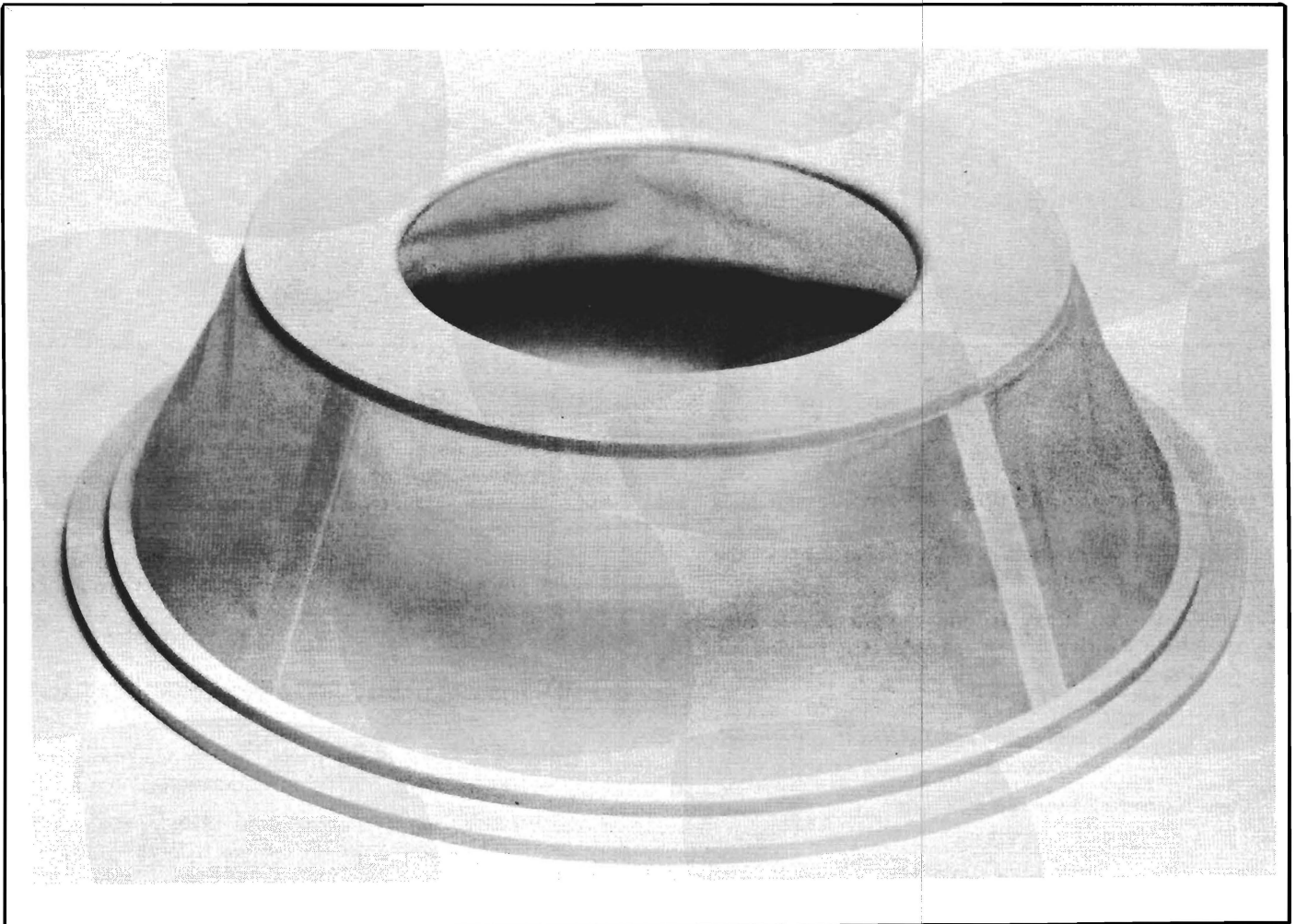

Figure 24. Disk Pack Filter

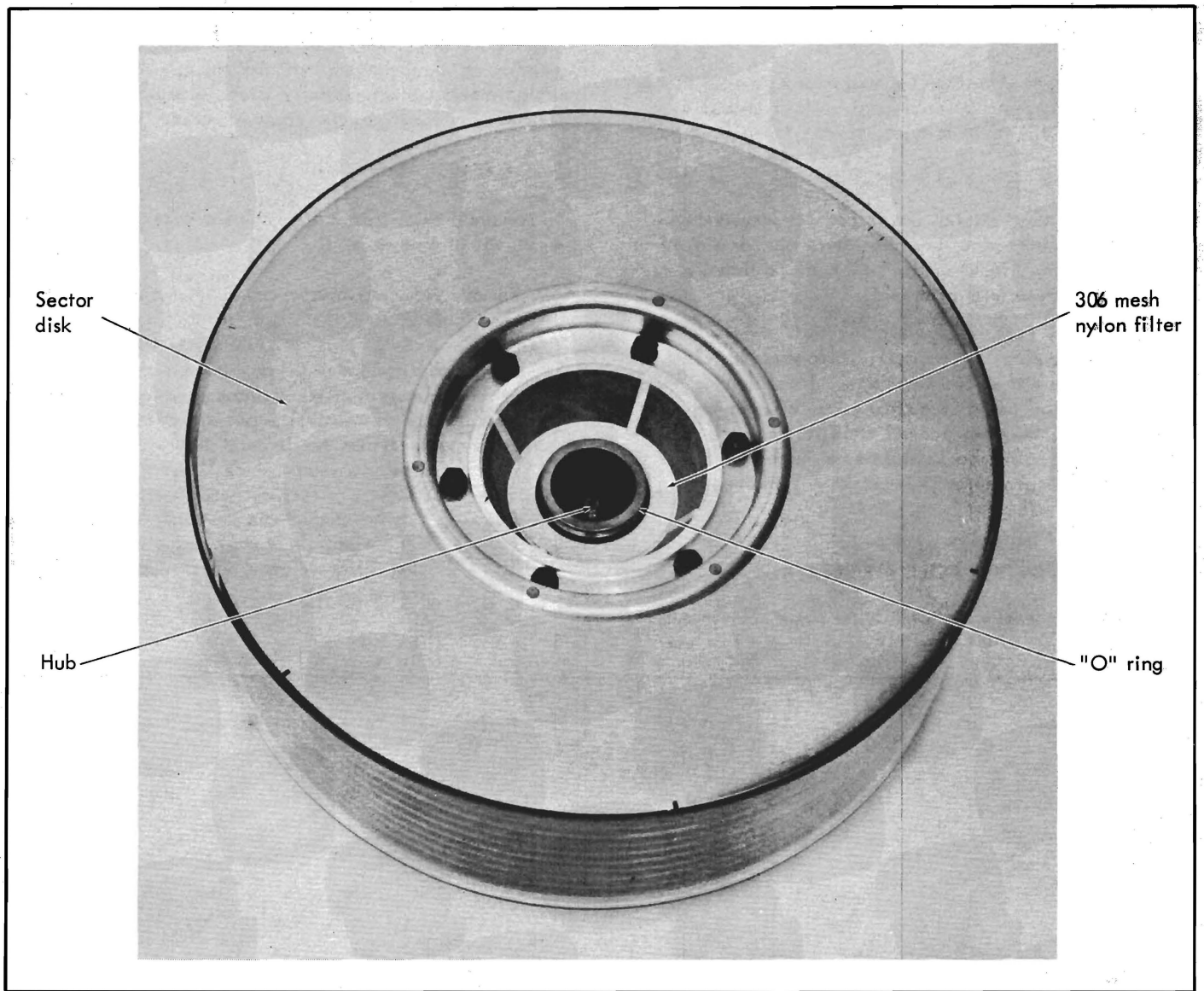

Figure 25. Disk Pack Filter Location

FILTER INSTALLATION

To replace or install a new filter, the procedure is:

1. Slide filter over bottom of hub and seat it below the "O" ring groove (see Figure 25).
2. Hook a portion of the ring into the groove. By slightly stretching the ring around the hub, seat the ring into the ring groove.

Caution: Do not roll the "O" ring into its groove as this may result in a twisted ring that can come loose during machine operation.

3. Replace bottom cover on disk pack.

DISK PACK USAGE LOG

A log must be attached to each disk drive unit for identifying all packs that have been used on that unit. Since

one defective pack or drive unit can spread damage to other units in an installation, it is important to check which packs have been used when a malfunctioning unit or defective pack has been discovered.

The log entry should consist of pack identification and date and time of insertion.

RECOMMENDED DO'S AND DON'TS FOR DISK PACK

- Handle a disk pack only with the top and bottom covers on, except when loading or unloading it.
- After installing a disk pack on a drive, reassemble the top with the bottom cover, so that it remains dust free.
- Replace cracked, distorted, or damaged covers.
- Clean disk pack covers with a lint-free soft cloth to prevent dust build up.

- Use only a lint-free cloth moistened with pure isopropyl alcohol (from a chemical supply house) to remove label adhesive, fingerprints, etc.

Caution: Do not use medicinal isopropyl alcohol from a drug store, since it often contains harmful additives.

- Do not touch the surfaces of the disks with finger, pencil, clothing, or other objects.
- Use only the center trim shield of the disk pack for labeling.
- Do not put notes, markers, identification cards, etc., inside the pack.
- Do not stop a disk drive by pressing on the top disk. Wait until it stops by itself.

- Only store disk packs flat, resting on the bottom cover, unless they are in their shipping containers.
- Do not store disk packs in direct sunlight and do not expose them to magnetic fields from high current electric cables, transformers, or similar equipment. An ideal environment is the computer room.
- Keep storage area free of dust and contaminants.
- Do not drop the disk pack. This could change the disk contour and cause misalignment of the disk surfaces with the heads. If it is dropped, inspect for damage (see "Disk Drive/Pack Inspection for Damage").
- Before using a disk pack, condition it to machine room temperature for a minimum of two hours.

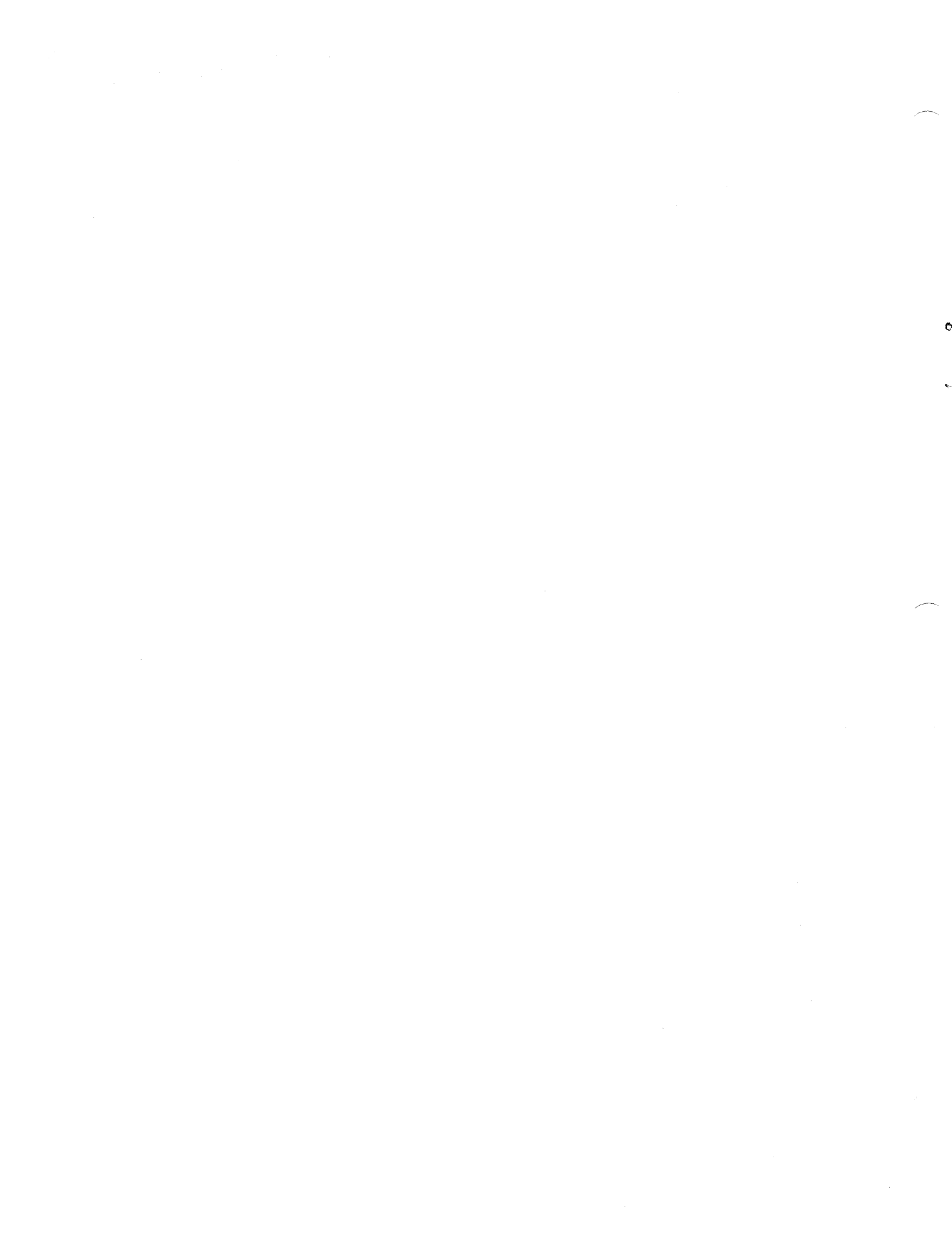

STAPLE

STAPLE

FOLD

FIRST CLASS
PERMIT NO. 229
EL SEGUNDO, CALIF.

BUSINESS REPLY MAIL
NO POSTAGE STAMP NECESSARY IF MAILED IN THE UNITED STATES

POSTAGE WILL BE PAID BY

XEROX®

701 South Aviation Boulevard
El Segundo, California 90245

ATTN: PROGRAMMING PUBLICATIONS

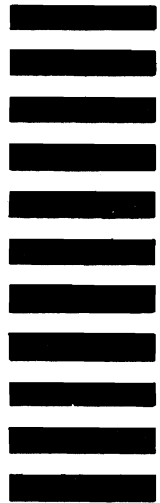

CUT ALONG LINE

FOLD