

PROJECT WHIRLWIND

Contract N5ori60

SUMMARY REPORT NO. 2

VOLUME 11

INPUT AND OUTPUT
(PART I)

SERVOMECHANISMS LABORATORY
MASSACHUSETTS INSTITUTE OF TECHNOLOGY

Copy 30



SPECIAL DEVICES CENTER

M-145

Page 1 of 3

PROJECT WHIRLWIND
Summary Report No. 2
November, 1947

INPUT AND OUTPUT, PART I

Volume 11 of 22 Volumes

Servomechanisms Laboratory
Massachusetts Institute of Technology
Cambridge, Massachusetts

M-145

- 3 -

CONTENTS

- M-145, Summary Report No. 2, Introduction to
Volume 11
- Eastman Kodak Progress Report No. 1, October 1,
1947, Film Reader-Recorder for Use with
Computer
- Reversible Binary Counter and Shaft Position
Indicator, by H. P. Stabler
- M-89, Mechanical to Binary Converter, by H. P.
Stabler, July 22, 1947
- M-101, Notes on Visit to Moore School, University of
Pennsylvania on September 3, 1947, by
Edwin S. Rich, September 9, 1947
- R-124, Magnetic Recording-Its Use for Storage of
Information in Electronic Computers, by
Edwin S. Rich, July 29, 1947
- M-106, Proposed Program for Investigation of Magnetic
Recording, by Edwin S. Rich, September 26, 1947
- M-157, Typewriter-Printer, by Robert R. Everett,
November 10, 1947

M-145

- 3 -

INTRODUCTION

There are three general types of input and output equipment required for Whirlwind I. These are:

a) Numerical

35mm film will be used for inserting and extracting numerical information from the Whirlwind computer. The general outline of the proposed system is given in M-73, Vol. 11. The Eastman Kodak Progress Report in Vol. 11 describes the actual film reader-recorder in more detail. Some project work has been done on automatic conversion on a decimal keyboard to binary numbers on the film. This work is described in a thesis by David J. Crawford in Vol. 12. M-157 describes briefly some of the requirements for an output printer.

b) Mechanical and Electrical

The first work on the conversion from mechanical and electrical information to numerical information for the computer to use in simulation problems was done by H. P. Stabler. His report in Vol. 11, entitled Reversible Binary Counter and Shaft Position Indicator, describes this work. M-89 in Vol. 11 describes a simple mechanical to binary converter. The report R-129 in Vol. 12 is a survey by H. P. Stabler of the whole conversion problem from shaft position to binary numbers. Some of these methods are actually conversion from electrical quantities to binary numbers and many of them can be reversed for converting computer output data to physical quantities. The project is continuing work on these problems.

c) Graphical

No reports are given on graphical recorders. It should be possible to use one of the graphical recorders already developed by the Eastman Kodak Company for other purposes.

Page 1 of 3

REFERENCE INDEX

K Series Memorandum

<u>REF.</u>	<u>VOL.</u>	<u>REF.</u>	<u>VOL.</u>	<u>REF.</u>	<u>VOL.</u>
M-32	8	M-95	8	M-133	18
M-46	9	M-96	9	M-134	7
M-55	9	M-99	15	M-135	7
M-58	15	M-100	8	M-136	7
M-61	8	M-101	11	M-137	7
M-62	4	M-103	16	M-138	15
M-63	4	M-105	19	M-140	4
M-64	4	M-106	11	M-141	7
M-65	14	M-107	19	M-142	8
M-66	4	M-109	16	M-144	9
M-68	15	M-110	15	M-145	10
M-69	4	M-111	7	M-146	11
M-71	8	M-112	9	M-148	12
M-72	16	M-113	7	M-147	13
M-74	14	M-114	12	M-148	14
M-76	4	M-116	16	M-149	15
M-77	15	M-117	7	M-150	16
M-78	8	M-118	16	M-152	17
M-80	16	M-119	16	M-152	18
M-81	16	M-121	7	M-153	19
M-82	16	M-122	7	M-154	20
M-83	16	M-124	8	M-155	21
M-85	14	M-127	7	M-156	22
M-86	11	M-128	16	M-157	11
M-91	15	M-129	7	M-158	7
M-92	15	M-130	9	M-159	9
M-94	8	M-131	16	M-160	8
		M-132	16	M-161	7

REFERENCE INDEX

E Series Memorandums

C Series Memorandum

<u>REF.</u>	<u>VOL.</u>	<u>REF.</u>	<u>VOL.</u>
E-7	14	E-52	19
E-24	7	E-53	13
E-31	10	E-54	19
E-32	10	E-55	19
E-33	19	E-56	15
E-37	15	E-57	15
E-38	19	E-58	19
E-39	15	E-59	19
E-41	15	E-60	19
E-42	15	E-61	16
E-44	19	E-63	19
E-45	19	E-64	15
E-47	15	E-68	13
E-48	19	E-69	15
E-49	19	E-71	19
E-50	16	E-73	16
C-15	14		

REFERENCE INDEX
R Series Memorandums

<u>REF.</u>	<u>VOL.</u>	<u>REF.</u>	<u>VOL.</u>
R-36	14	R-115	4
R-49	14	R-116	4
R-63	14	R-117	16
R-84	3	R-118	16
R-89	19	R-120	10
R-90	4	R-121	19
R-94	14	R-122	18
R-98	14	R-123	17
R-100	14	R-124	11
R-103	14	R-125	14
R-104	16	R-126	19
R-106	15	R-127	5
R-108	15	R-127	6
R-109	19	R-128	10
R-110	9	R-129	12
R-111	15	R-130	9
R-113	15	R-131	10
R-114	8	R-132	10

FILM READER-RECORDER FOR USE WITH COMPUTER

Under contract N6ori-205 The Eastman Kodak Company is developing a device both for recording digital records on photographic film and for reading these records. It is proposed that this device shall -

- (a) Record the output from a computer.
- (b) Record the output from a typewriter keyboard used in the preparation of input data for the computer.
- (c) Read film records prepared by the device in a form suitable for input to a computer.
- (d) Read the film records prepared by the device in a form suitable for input to a second device of the same type for such purposes as duplicating films, preparing new program film using parts of old program film, and correcting errors that may have been made in preparation of a film.

The film reader-recorder is being designed with a view to the widest possible application, but will be constructed specifically to meet the requirements of Project Whirlwind, Device P4-X-3. This project requires that the photographic equipment both record and read about 500 fifty digit binary words per second. Positive signals for both 0's and 1's will be provided by recording both the word and its invert. It is hoped that a speed of 1000 words per second can be attained. Considerable component research is required to determine rates such as this. This research will lead to the establishing of practical values for such quantities as (1) spot size, (2) speed of film motion, (3) amount of light required.

The Eastman Kodak Company is also designing and will build an automatic machine for the rapid processing of the film employed for number storage. This machine will be quite simple to operate. No darkroom facilities will be necessary for its use.

By now breadboard models of all the circuits have been built and all the operations seem feasible. The mechanical and optical parts have been designed and are being constructed. A breadboard model of the recorder has been built and 8 place digital information has been recorded reliably. Much of the component research has been carried out.

We shall consider in more detail the manner in which data are stored on the film. Each digit is recorded on the film as a rectangular spot .020" wide and .010" long. If the digit is

-2-

a "1" the spot in the line or lines reserved for the work will be exposed; if a "0" the spot in the line or lines reserved for the invert will be exposed. See Fig. 1 and Fig. 2. This particular spot size was chosen as a result of experiments in which tracks of spots forming an endless loop were driven millions of times through a gate to detect whether they could be read reliably by a photocell. Reading of spots smaller than .010" x .020" was unreliable due to dust particles sticking to the film and to scratches in the film. Such a spot size permits 50 channels plus timing markers to be stored across 35 mm film. Therefore, 50 fifty digit words plus their inverts can be stored along one inch of 35 mm film. Thus 60,000 fifty digit numbers can be stored in a small 100 ft. roll of 35 mm film.

At the beginning of the project various methods for obtaining a suitable modulated light source for recording were considered. Mechanical shutters were obviously too slow. Electro-optical shutters are inadequate and much too complicated at the present state of the art. The use of an array of discharge lamps was a distinct possibility, but the control system for such an array would be complicated. Also the life of such tubes seems to be questionable. The most simple and probably the most reliable light source capable of modulation is the cathode-ray tube. It is possible in principle to write many lines of data on a C.R.T. face and record a frame at a time. Such a procedure would require a film speed of 10 to 20 frames per second. This is not excessive, but the precision control of the beam position in the vertical direction would be a difficult problem. It was felt that a simpler and more flexible procedure would be to record during the film motion, using a sweep so short that the film would move inappreciably during the recording. Preliminary experiments using a 5JP11 tube with 2000 V. post acceleration and commercially available films, Eastman Super XX, Eastman Recording Ortho, and Eastman Recording Pan, indicated that ample light output would likely be available if a 5RP11 tube were used with post acceleration of 10 to 20 KV. More recent experiments indicate this is true even though the film which will be used will be somewhat less sensitive due to the fact that it must stand the hot developer of an automatic processing machine. There is not a large margin of safety when a 50 microsecond sweep is used, but the margin seems to be sufficient for reliable results. At the present time experiments are being carried out to determine the best manner in which to operate the tubes to obtain the most light output for our particular use. The fact that the duty cycle will likely be less than 1/20 can be used to advantage in obtaining more light since the decrease in efficiency when high beam currents are used seems to be due to the average power dissipated and, therefore, to the average current instead of the peak current. Measurements are being made on a number of tubes and preliminary results indicate no serious differences.

-3-

The maximum speed of the film motion depends principally upon the sweep speed which can be used, since this together with the film speed determines the slant of a line of data across the film. Project whirlwind has requested that provision be made in the reader-recorder for film motion in either direction (however, they will furnish the two direction drive whenever it is needed.) Therefore, compensation for the motion of the film to reduce slant is not feasible. The slant encountered in the reading and recording of 500 words and their inverts per second should not be at all serious. However, the reading and recording of 1000 words per second may be unreliable in the case of one of the sweep methods to be considered. The prototype film drive is being made to provide 20 in./sec. film speed, (1000 words per second) but may be modified if necessary. Another much slower drive is being furnished for word by word reading and recording when the recorder is used in the duplication of films or in making corrections in films. With this speed 10-20 words per second can be read.

Since data will likely both be furnished to the recorder and asked for from the reader intermittently it is necessary to start and stop the film motion as rapidly as possible. A magnetic clutch will be used for this purpose. Tests already made on such clutches indicate that the stopping and starting time can probably be made less than 10 milliseconds and further tests will soon be made on an improved design. An automatic loop former will be employed to reduce the load on the clutch, especially when 1000 foot rolls of film are being used. The loop must be maintained on both sides of the drive since the film must be capable of moving in either direction. Models of two automatic loop forming devices have been built, but cannot be adequately tested until the entire film drive mechanism is completed. One method involves the use of a roller on the end of a long lever whose position is held within bounds by limit switches controlling a small servo motor. In the other method the arm position is maintained by a proportional servo built according to suggestions of the M.I.T. Servo Laboratory.

A schematic of the proposed optical system is shown in Fig. 3 and a schematic of the proposed electrical circuits is shown in Fig. 4 for the double sweep method and in Fig. 5 for the single sweep method. Let us first consider recording. The computer will have stored a number of words, perhaps 50 or a hundred, in a set of special registers reserved for this purpose. The computer will then signal the reader-recorder to start recording. The signal will energize the moving member of a magnetic clutch attracting the armature and thus turning the drum drive which is attached to it. A circular plate containing clear slits on a dark background is attached to and turns with the drum drive. Light from a lamp is focused through these slits onto a phototube, giving a signal each time the drum drive advances sufficiently

-4-

to permit the recording of another digit. This timing signal passes through a limiting amplifier and starts a sweep, if the gate between the limiting amplifier and sweep circuit is open. This gate is provided so that the film may be advanced without the recording of a series of zeros as would be the case if no gate were provided. Coincident with the starting of the sweep, the beam is unblanked and remains unblanked until the sweep has moved some distance past the end of the mask. As the sweep progresses across the tube face it passes first over the long thin slit which records a timing signal on the film. Not all of the light falls on the film, but some of it is reflected and focused onto a monitoring mask. The clear holes in the monitor mask are only half or less the width of the clear holes in the C.R.T. mask and are phased with respect to the holes in the C.R.T. mask so that light can pass through the monitor mask only when the beam is moved near to the trailing end of the corresponding hole in the C.R.T. mask. Two phototubes pick up the light passing through the monitor mask; one picking up the light through the word position, the other the light through the invert position. The signals pass through limiting amplifiers and are sent back to the computer unit so that the whole transmission and recording process can be checked. In addition these signals are combined in a mixing circuit and the resulting signal is transmitted simultaneously along two paths. Along one path the signal passes through a delay and an output buffer to the computer unit where it steps the word in the register one place thus furnishing the next digit for recording. Along the other path the signal passes through another delay and to a trigger pair which controls, through a D.C. amplifier, the vertical position of the beam. Both delays prevent any deflection of the beam until the sweep has completely traversed the spot which furnished the stepping signal. The second delay is not necessary if both zeros and ones are furnished from the computer unit. However, if only ones are furnished it is necessary to always put the trigger pair into the zero position after the sweep has traversed the spot, but before the next digit is stepped into the reader-recorder. These deflections, of course, take place behind the mask. At the end of the unblanking pulse a second trigger pair is tripped starting the second sweep. This trigger pair is connected through the D.C. amplifier to the second vertical plate and so positions the beam for the second sweep. A third trigger pair counts the two sweeps and at the end of the second sweep sends a signal to the computer unit indicating that the recording is completed and that the computer unit may check the process and prepare to furnish another word.

For reading, ¹the mask over the C.R.T. is changed so that a scanning spot (probably .005" x .012") can be projected onto the film. Also a prism is inserted to form two images of the sweep, one covering the word position, the other covering the invert position. At the same time the beam splitter is re-

¹It will be noted that this method of reading is different from that originally proposed. In the original proposal a bank of fifty phototubes, one looking at each channel was to be used and the film was to be illuminated with a steady light source.

-5-

moved to allow all the light to fall on the reader phototubes. The power will be removed from the recording circuits not in use during reading. The holes in the reader mask are made smaller than those in the recorder mask; laterally to take care of side motion of the film, and film shrinkage, and lengthwise to take care of slant of the line across the film and inaccuracies of timing the reading sweep. The sweep is started by a signal from a phototube which "looks at" the timing signal recorded along one edge of the word. This region of the film is illuminated by a steady auxiliary light source. Separate phototubes read the word and invert at the same time. The signals are amplified and pass through the same limiting amplifiers and output buffers as did the monitor signals. The stepping signal steps the part of the word already read one place to the right making room for the next digit. As in the recording process, at the end of the first unblanking pulse a signal is sent to a trigger pair starting the second sweep and also positioning it.

A simplified breadboard recorder has been built and made to record satisfactorily. A 16 mm cine kodak with a special motor drive and with a shutter arranged to open only during the pull down was used. Since no computer unit or stepping circuits similar to those which will be used by project Whirlwind were available from M.I.T., a stepping circuit was designed and an eight place stepping register built. The circuit is fairly simple requiring only 3 triodes ($1\frac{1}{2}$ 6J6's) per digit. The circuit will step up to a maximum rate of about 750 K.C. per sec.

The type of mask used for the single sweep method is shown in Fig. 2. This method involves the circuit changes that can be seen in Fig. 5. Although it is not mandatory that both 0's and 1's be furnished by the computer unit it is considerably more difficult to work with only 1's when the single sweep method is employed. The lower vertical deflection plate is now used to position every other digit instead of the second sweep. This method has the advantages of (1) resulting in less slant error, (2) simplifying the optics somewhat, but has the disadvantage of (1) requiring much faster deflection circuits, and (2) requiring much more careful timing of delays and sweep rate.

Tests on the single sweep method are now under way and will likely continue for two or three weeks until it is known whether it can be made to work well enough to be used instead of the double sweep method which is now known to work. There has as yet been no actual recording but all the equipment (control and an additional 8 place stepping register) has been built and most of it is working satisfactorily. Microphotometer traces of the recordings will be made in order to measure the density across the entire spot.

-6-

A study has been made of the various automatic processing machines already built or under design at Kodak. The first model of a machine, which very nearly satisfies the requirements of Project Whirlwind, has been built on another project and used to process 16 mm film at a rate of 8 ft./min. It is small and extremely simple to operate; however, requires hot water connections, compressed air connections, and a drain connection. A new machine is being designed based on the principal features of the 16 mm machine but capable of processing 35 mm film and requiring only a cold water connection and a drain connection. This unit as well as the reader-recorder will handle 1000 ft. reels of film. To process 1000 ft. of film will require about a gallon of developer, a gallon of fixer, and several gallons of water if the film is to have good lasting qualities.

Although some parts which could be used in the prototype reader-recorder are now being constructed, further experimentation is required before the final design can be completed. As soon as all the optical and mechanical parts are completed a breadboard model will be set up to check both the recording and reading operations. In the meantime tests on individual components will continue. For instance tests will be made on the magnetic clutch to determine its starting and stopping time. Two different materials are being considered for the iron path. Comparative tests on two types of loop forming mechanisms will be tried using 1000 ft. reels of film.

About a year ago we performed some simple experiments which showed that the troublesome drift of 931A photo-multiplier tubes could be very greatly reduced by using them under pulsed light conditions with a low duty cycle. Later R.C.A. reported the same finding. We have therefore, hoped that the 931A tubes will be stable under our method of operation. There has been no noticeable trouble from tube drift in the breadboard recorder. However, since we are operating with a somewhat higher duty cycle than that used in the earlier experiments we feel that further controlled tests should be performed on a number of tubes. At the same time we hope to check the life characteristics of a number of cathode-ray tubes since no such characteristics useful to us can be obtained from the manufacturer.

We have been using a 10 KV RF power supply, the Dumont 263A, and a 30 KV supply made by Essex Coil Co. The latter was actually operated variably between 10 KV and 20 KV. The Dumont supply is very stable, but considerable difficulty has been encountered with the Essex supply. Much of this has been due to mechanical faults. However, another model has been ordered and we hope to run exhaustive tests on it to determine if it will meet our requirements.

Project whirlwind asked if we might incorporate in addition to the above features, two other features (a) the ability to take single frame pictures of the entire face of the cathode-ray tube and (b) the ability to remove the normal cathode-ray

-7-

tube and replace it with a bank of smaller tubes for multi-channel graphical recording. The first would have required a flat gate and a considerably more complicated drive mechanism. In view of the fact that the job can probably be done with an auxiliary oscilloscope and commercially available cameras, it was jointly agreed that this feature should not be incorporated. The second feature involved sufficient changes in the power supplies, optics, and tube mount to require essentially another device. We have considered certain other possibilities. Some of the seismograph equipment might be satisfactory except that it uses 6 inch paper which, of course, could not be processed in the automatic processing machine. Perhaps the equipment most likely to satisfy the needs of Project Whirlwind is a graphical recorder being considered by the Naval Ordnance Division of Kodak. The specifications for this unit have been sent to Mr. Forrester for comments. Although no contract has yet been let for the construction of this recorder, it is expected that this will be done soon.

To summarize: much of the component research has been completed, a breadboard recorder has been built and found to work satisfactorily, all of the components required for a breadboard reader-recorder are under construction, and an automatic developing machine is being designed. Further component testing is necessary to determine (a) the merits of the single sweep relative to the double sweep method of reading and recording (b) the best way to operate the C.R.T.'s to give the most light compatible with long life, (c) Drift and life characteristics of 931A phototubes as used in the reader-recorder, (d) a satisfactory method for automatically maintaining a film loop, (e) action time of the magnetic clutch, and (f) the characteristics of the rf power supply under the worst conditions to be encountered.

RDONeal/mw
Development Department
EASTMAN KODAK COMPANY
10/7/47

A-3117

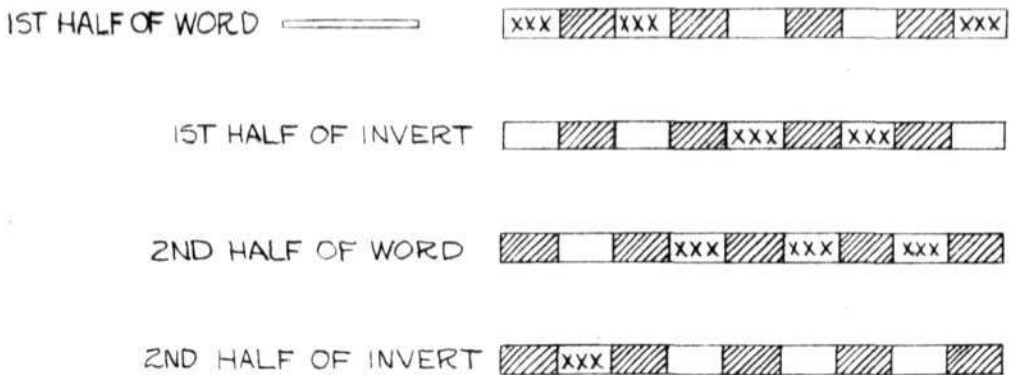

CRT MASK FOR DOUBLE-SWEEP RECORDING (9 DIGITAL PLACES).
 XXX REPRESENTS SWEEP POSITION FOR WORD 110010111.

FIG. 1

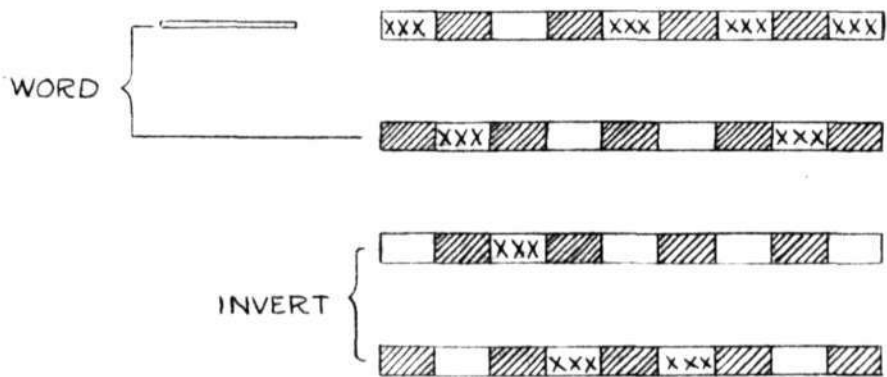

CRT MASK FOR SINGLE SWEEP RECORDING (9 DIGITAL PLACES).
 XXX REPRESENTS BEAM POSITION FOR WORD 110010111.

FIG. 2

TRACED FROM EASTMAN KODAK REPORT

USED IN EASTMAN KODAK REPORT

A-3117B

APPROVED FOR PUBLIC RELEASE. CASE 06-1104.

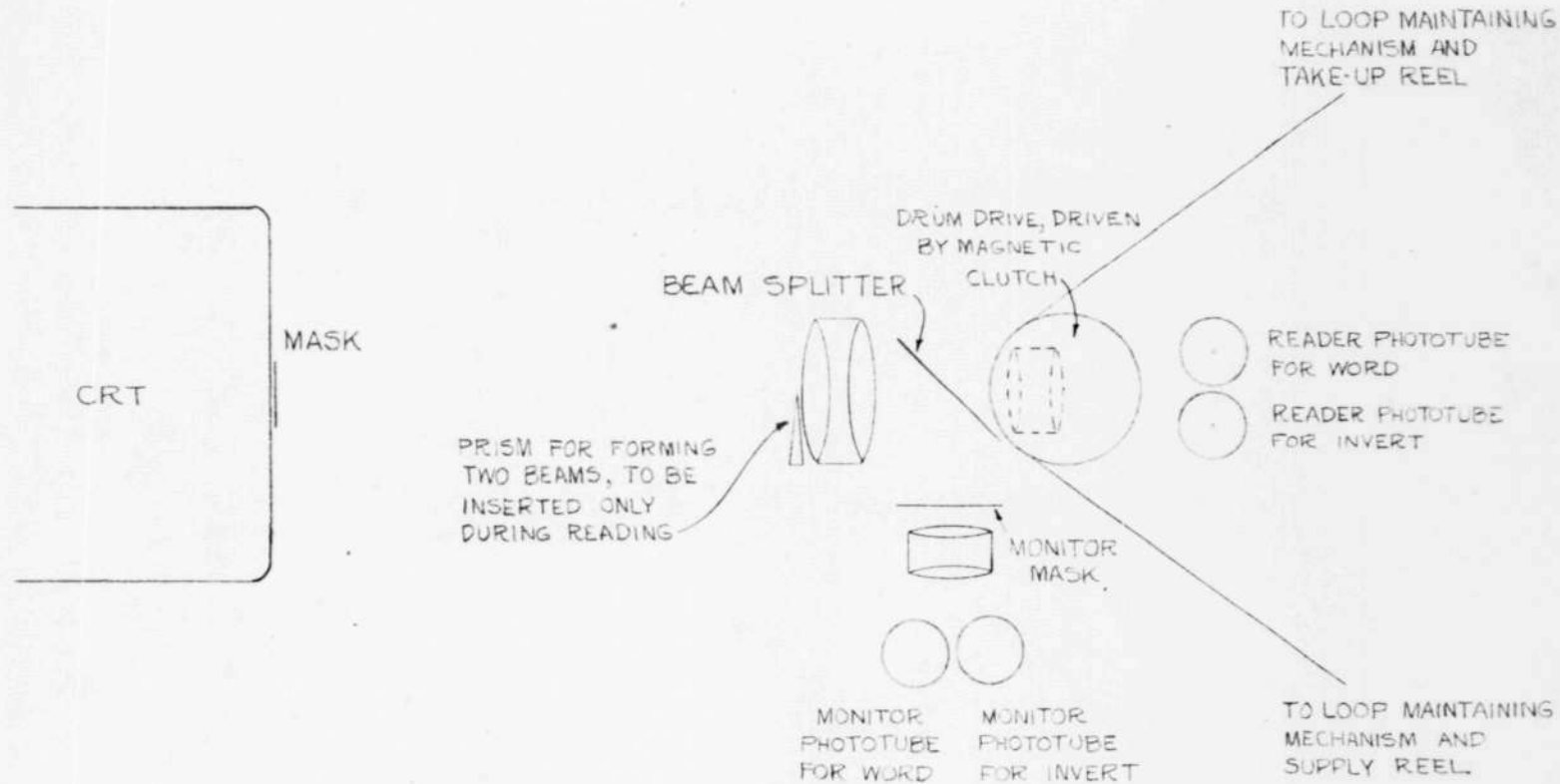

SCHEMATIC OF PRINCIPAL OPTICAL SYSTEM.

FIG. 3

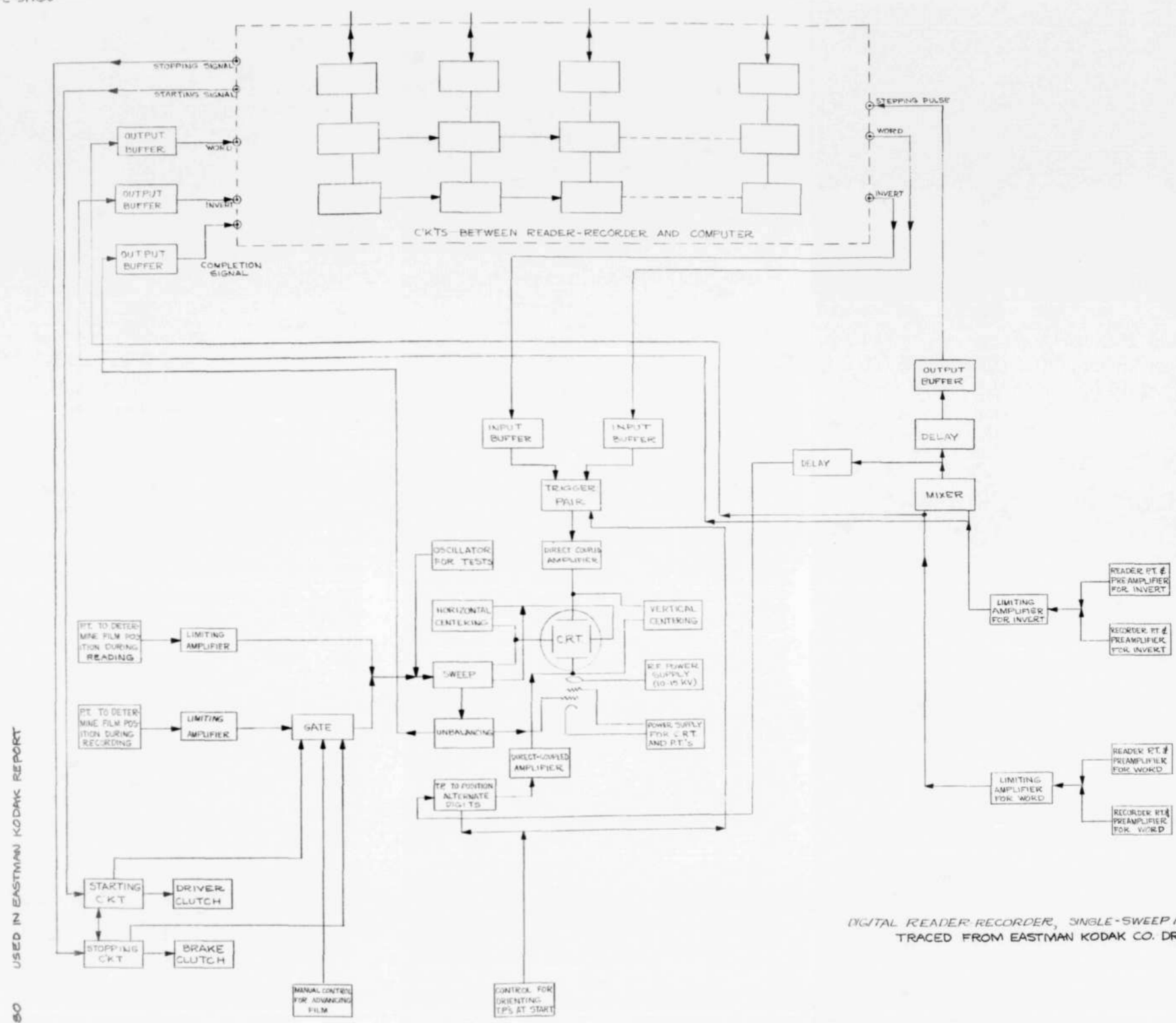

3-31180 USED IN EASTMAN KODAK REPORT

DIGITAL READER-RECORDER, SINGLE-SWEEP METHOD.
 TRACED FROM EASTMAN KODAK CO. DRAWING

C-31181

31181 USED IN EASTMAN KODAK REPORT

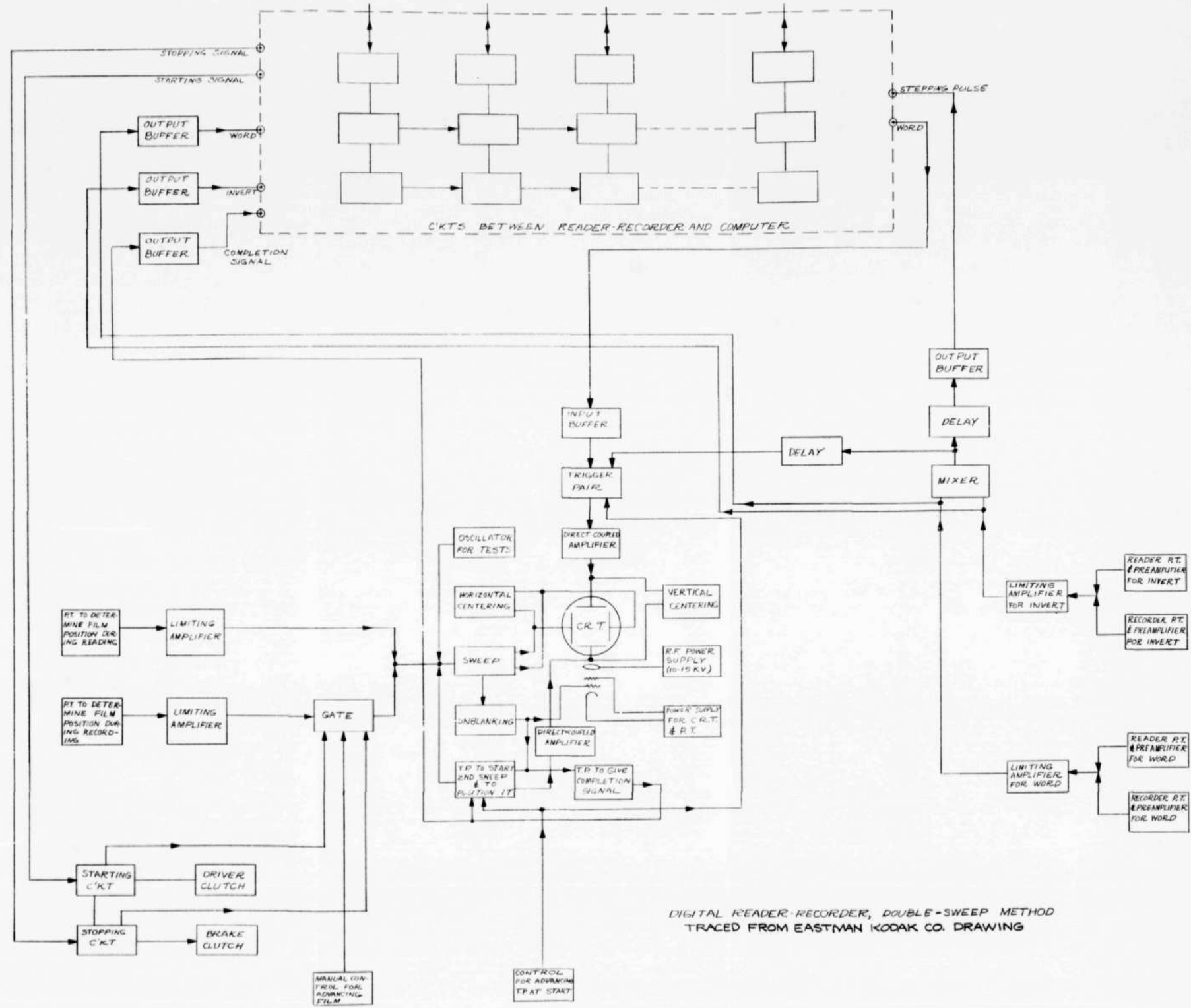

DIGITAL READER-RECORDER, DOUBLE-SWEEP METHOD
TRACED FROM EASTMAN KODAK CO. DRAWING

REVERSIBLE BINARY COUNTER AND
SHAFT POSITION INDICATOR

Abstract

A binary counter has been developed that responds to subtracting pulses as well as to adding pulses. The two types of pulses are distinguished by different input channels, by polarity, or by size, and the reversible action is accomplished by suitable carry-over provisions between the counter stages. Each stage employs four 6AK5's. Resolving times of 10^{-5} sec and less are readily obtainable. In conjunction with a photoelectric actuated pulse generator and a reading circuit, the counter has been used to indicate the angular position of a rotating shaft. The pulse generator produces adding pulses for clockwise rotation of the shaft and subtracting pulses for counterclockwise rotation. The reading circuit "scans" the several counter stages and gives the counter reading in the form of a microsecond pulse binary wave-form number. While the system has been designed to provide one of the input parameters to a digital electronic computer, the methods employed can be used for other situations involving two directional motion and differential counting.

H. P. Stabler

REVERSIBLE BINARY COUNTER AND
SHAFT POSITION INDICATOR

INTRODUCTION

The components described in this paper have been developed to serve as an input device for a digital computer. The computer itself is a component of a large control mechanism, the association being such that at least one of the input parameters must be furnished by the angular position of a shaft. The shaft is free to turn in either direction at irregular intervals and speeds. Precise information concerning the position of the shaft must be continuously available and it must be furnished to the computer in the form of a binary wave-form number.

The system which has been developed to furnish the necessary mechanical-electrical link is shown in block diagram form in Figure 1. As the shaft rotates a pulse generator produces a pulse for each minimum discrete angular increment. These pulses are counted by a reversible counter. A reading circuit then scans the counter stages and furnishes the necessary wave-form number to the computer. The pulse generator is designed to distinguish the direction of the shaft rotation and the counter responds correctly to both adding and subtracting pulses.

While the system constitutes one solution of a specialized problem, the reversible aspects of the counter and pulse generator are new, and the general method employed can be used for other situations involving two directional motion and differential counting.

-2-

PULSE GENERATOR

The shaft carries a slotted disc which serves as a light shutter for the phototubes V1 and V2. In order to distinguish the direction of rotation these tubes are placed as shown in Figure 2. Light transitions on V1 are instrumental in causing pulses, provided that these transitions occur while V2 is illuminated. The transition light to dark causes a clockwise (or adding) pulse; the transition dark to light causes a counter-clockwise (or subtracting) pulse. If phototube V2 is not illuminated, the pulses that would otherwise result from V1 transitions are blanked from the generator output. Thus, for example, continuous clockwise rotation results in a series of adding pulses, one being produced at the instant the trailing edge of each slot passes in front of the slit aperture for V1.

The essential features of the pulse generator circuit are shown in Figure 3. V5 and V6 constitute a direct coupled multivibrator that is stable only when one tube is completely cut off. The circuit constants have been chosen so that the high transition (V5 changing suddenly from non-conducting to conducting) occurs as the potential of the V5 grid increases above 60 volts, while the low transition (V5 changing suddenly from conducting to non-conducting) occurs as this potential decreases below 50 volts. The sudden rise of the plate potential of V5 at the low transition (phototube V1 light to dark) causes a positive pulse on the grid of V9, which (if V2 is light) produces a pulse in the clockwise output channel. A similar rise in the potential of the V6 plate at the high transition causes a positive pulse on the grid of V10, which (for V2 light) produces a pulse in the counter-clockwise output. Phototube V2 controls a multivibrator

V7-V8 identical to V5-V6. V9 and V10 can transmit pulses only if V7 is non-conducting. The differential of 10 volts between the high and low transition points insures that the multivibrators remain stable even if the disc jitters back and forth across a transition position.

A complete circuit diagram is shown in Figure 4 (DWG-A-36). V3 and V4 are DC amplifiers for V1 and V2. Direct coupling is required to the grids of V5 and V8 in order to take care of very slow disc motion. Their "dark" potential must be below 45 volts and their "light" potential above 65 volts. Pulses approximately 15 volts in size and of 0.7 microsecond duration are obtained in the 70 ohm outputs.

During rotation of the disc the potentials applied to the grids of V5 and V8 vary approximately sinusoidally about 55 volts with a 90° phase difference between them. The pulsing circuits have been tested by applying sinusoidal potentials from an oscillator to these grids with proper phase difference. Clockwise pulses appear when the V5 grid leads the V8 grid and counter-clockwise pulses when the V5 grid lags the V8 grid. The generator operates satisfactorily at frequencies up to 300 kc. This limit can be extended if necessary.

The photoelectric system has been operated so far only with a small disc having 150 slots. It is planned to produce "slots" and "teeth" photographically. The degree of angular subdivision possible depends on the closeness with which practical lines can be placed, the associated inertia of the disc system, and the acceleration to which it must respond. 500 lines per inch appear feasible (employing motion picture sound track techniques) corresponding to a direct resolution of about $2\frac{1}{2}$ minutes for a 6 inch diameter disc.

For such an optical arrangement type 931A multiplier phototubes are to be used, their plates being connected directly to the respective multivibrator grids and V3 and V4 omitted.

REVERSIBLE COUNTER

A conventional scaling circuit or counter consists of a series of direct coupled trigger pairs. Suppose the components of a pair are called A and B tubes, and assume that for zero indication the B component of each stage conducts, or is ON. Every other input pulse (to any stage) causes a carry-over pulse to the next stage. For binary addition a carry-over pulse must occur on the transition 1 to 0, that is, when the A component changes from ON to OFF. The direction of the counter progression will reverse, corresponding to subtraction, if carry-over takes place instead on the transition 0 to 1, or when B changes from ON to OFF.

Figure 5 shows a functional diagram of the reversible counter. Three counter pairs are indicated by the six circles, the prefixes 0, 1, 2 (and so on) denoting the power of two associated with each stage. The C and D squares represent coincidence tubes. All C tubes are associated with additive carry-over, the D tubes, with subtractive carry-over. A pulse to be added is received in the upper channel. It triggers a self-restoring multivibrator, the addition gate, and applies a positive square wave to the screens of all C tubes. This prepares the C tubes for activity. The input pulse also passes through a brief delay section to the grids of the first counter tubes. If OA is conducting, the pulse turns OA OFF and OC provides a pulse to the next stage. Similarly, a subtractive pulse

-5-

(in the lower channel) first prepares the D tubes for activity and carry-over takes place when a B tube is changed from ON to OFF.

The delays shown (of about 1 microsecond) are introduced to allow time for all C or D tubes to be properly prepared before the pulse is counted. The add and subtract gates must have a duration sufficiently long to allow all necessary carry-over to take place, even to the end of the counter. The method necessarily requires two input channels. The two types of pulses may be transmitted to the counter over a single line, however, if they are distinguished by size or by polarity. Simple discriminating circuits then trigger off either the add or subtract gates as required.

Figure 6 shows a schematic of one stage of the counter. The A and B tubes are connected in a standard Eccles-Jordan circuit with self-bias, and the tubes are triggered with negative pulses applied simultaneously to both grids. The screen potential of the C (or D) tubes changes from -8 volts to +100 volts during the add (or subtract) gate interval. During addition C transmits a carry-over pulse when its control grid receives a positive signal caused by the rise of the A plate. Using 6AK5's and the constants indicated the quiescent current per stage is about 10 ms. A single stage has a resolving time of about 2 microseconds and a carry-over time of about 0.1 microsecond.

For a 15 stage counter, the add and subtract gates can have a duration of 4 microseconds. This allows time for 15 successive carry-over pulses and for reasonable rates of rise and fall of the C and D screen voltages. The minimum resolving time between input pulses is determined by this gate length and is thus about 6 microseconds.

-6-

The counter is reset to any desired reading by momentarily interrupting the screen currents of the appropriate combination of A and B tubes.

Figure 7 is a complete schematic of input arrangements that have been used reliably with a 5 stage trial counter. In this circuit the delay for both add and subtract channels is provided by the self-restoring multivibrator V3. V1 serves to trigger the add multivibrator V4 as well as V3, and V2 acts similarly for the subtract channel. The two gate voltages are taken from the cathode followers V6 and V8.

READER

A simple reading circuit is shown in Figure 8. It consists of a series of 6AS6 coincidence tubes, V0E, V1E, V2E, ---. The suppressor grids of these tubes are connected directly to the plates of V0B, V1B, V2B, --- respectively. The cathodes of the E tubes are kept at the normal non-conducting potential of the E tube plates and their grids are biased to cut-off. The E plates are connected to a common output circuit. If a single positive reading pulse is applied to the control grid of each E tube successively at microsecond intervals, a pulse wave-form number corresponding to the counter reading will be generated in the output. The microsecond delay introduced between each E grid can be provided by delay lines with amplification as needed to balance the progressive attenuation.

The reading pulse can be initiated by the fall of the add or subtract gates of the counter, so that a new number is sent out

-7-

whenever the counter reading changes. This feature necessarily lengthens the time that must be allowed between input pulses to the counter.

An alternative method of generating a scanning pulse for each stage is shown in Figure 9. The E tubes are connected as they are in Figure 8. The FG tubes are Eccles-Jordan pairs. Each F tube receives negative "clock" pulses of 0.2 microsecond duration at microsecond intervals from the synchronizing system of the computer. These pulses normally keep all F tubes non-conducting, G tubes conducting. When the counter is to be read a single positive pulse is applied to the gr¹ of V9. This triggers the first pair, turning VOG off. The next clock pulse turns VOG on again and the fall of its plate voltage is transmitted to the grid of V1G as a negative pulse. This triggers the V1P-V1G pair. V1G remains off the the microsecond interval between clock pulses and as it returns to the on state V2F-V2G is triggered. In this way, the F tubes are successively turned on for microsecond intervals. As each F tube returns to its normal off state the rise of its plate gives the required positive scanning pulse to the corresponding E tube grid.

A 5 stage reader has been constructed and operated with the constants shown in Figure 9. The circuit is quite critical to the characteristics of the clock pulse, and difficulty is experienced with the tendency of later stages to trigger previous ones. A low impedance clock pulse source and careful shielding between stages should increase the reliability, and some modification of the constants is also probably desirable.

-5-

OTHER APPLICATIONS

The pulse generator can be operated in conjunction with a reversible decade counter and visual indicator of the type developed by Regener*. The method then constitutes a substitute for a selsyn indicating system, with the advantages of lower associated inertia and higher speed possibilities.

The method can be adapted to provide precise continuous indication of linear displacements. Either optical or supersonic interference fringes are suitable to serve as the discrete increments counted. A directional sense is obtained if a 90° phase difference is introduced between the fringe systems that produce signals on the two input grids of the pulse generator.

* V. H. Regener, Rev. Sci. Inst. 17, p375, 1946.

APPROVED FOR PUBLIC RELEASE. CASE 06-1104.

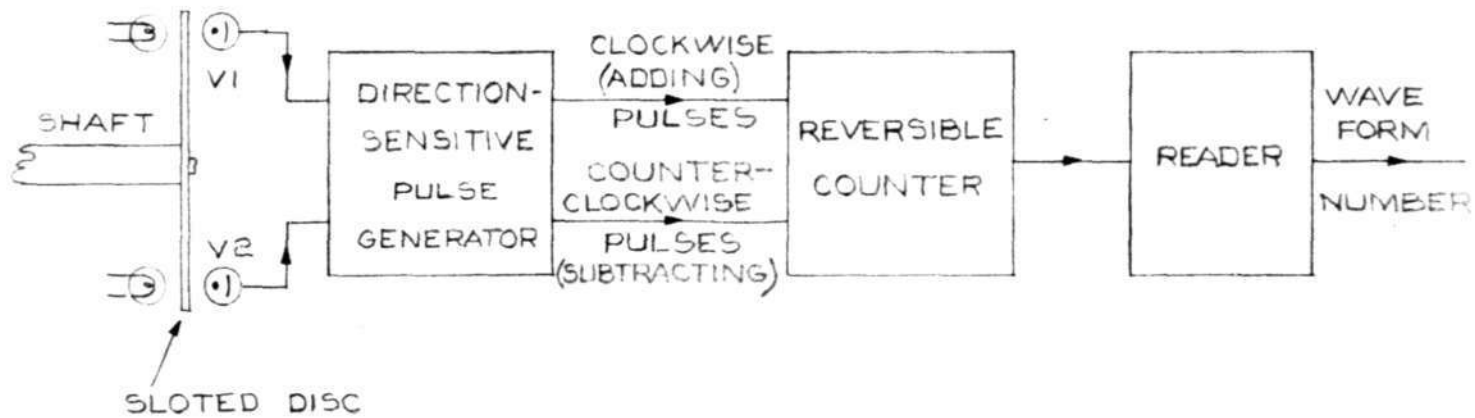

FIGURE 1.

A-31166

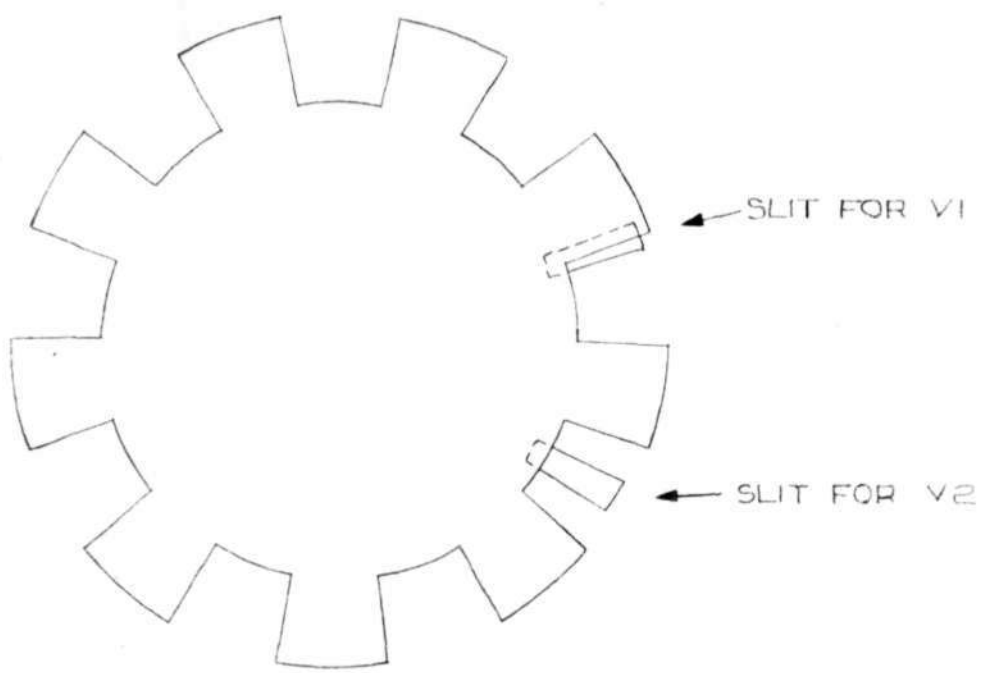

FIGURE 2

1-31166 USED IN STABLER REPORT

A-31167

USED IN STABLER REPORT

-31167

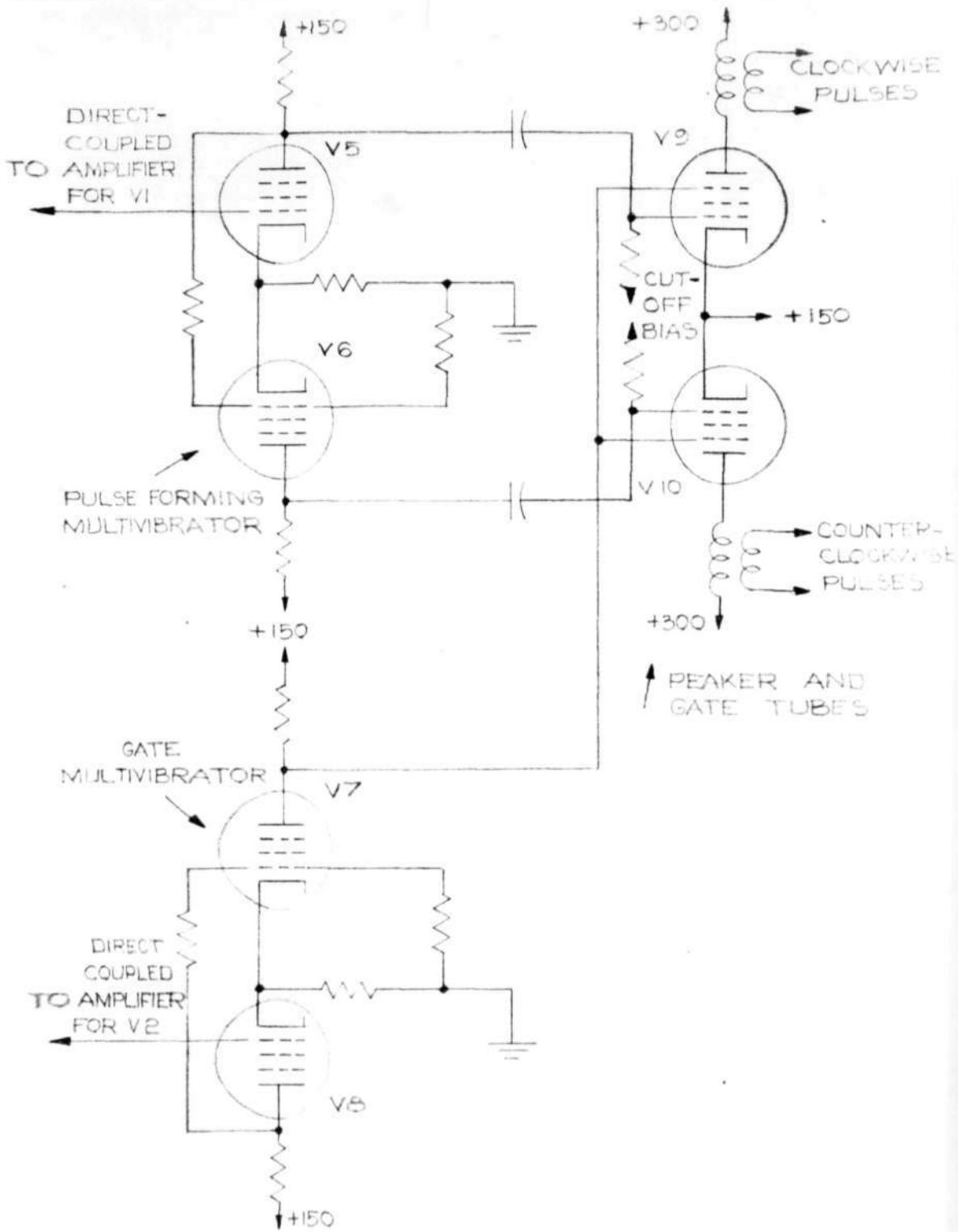
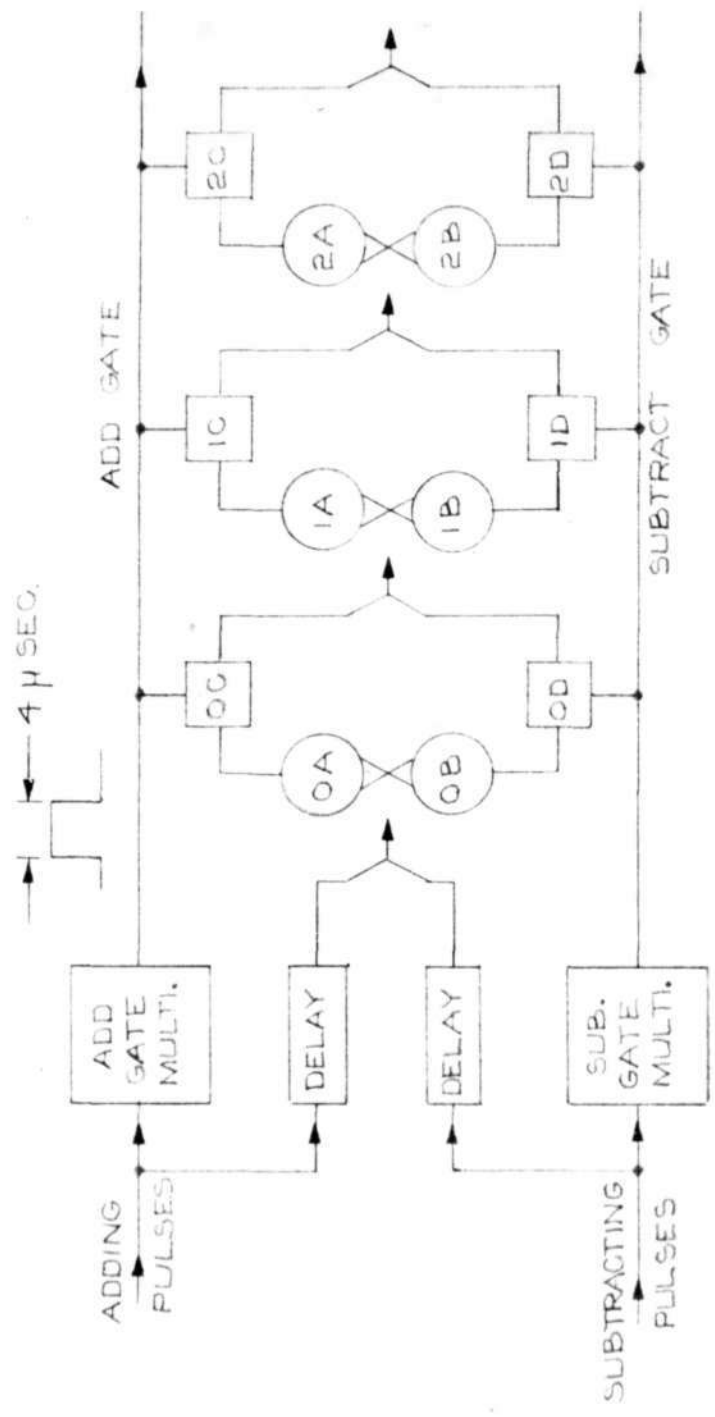

FIGURE 3

A-3116B

USED IN STABLER REPORT

-3116B



ZERO INDICATION: ALL B TUBES "ON"
 ADD CARRY-OVER: A ON → OFF (1 → 0)
 SUBTRACT CARRY-OVER: B ON → OFF (0 → 1)

FIGURE 5

APPROVED FOR PUBLIC RELEASE. CASE 06-1104.

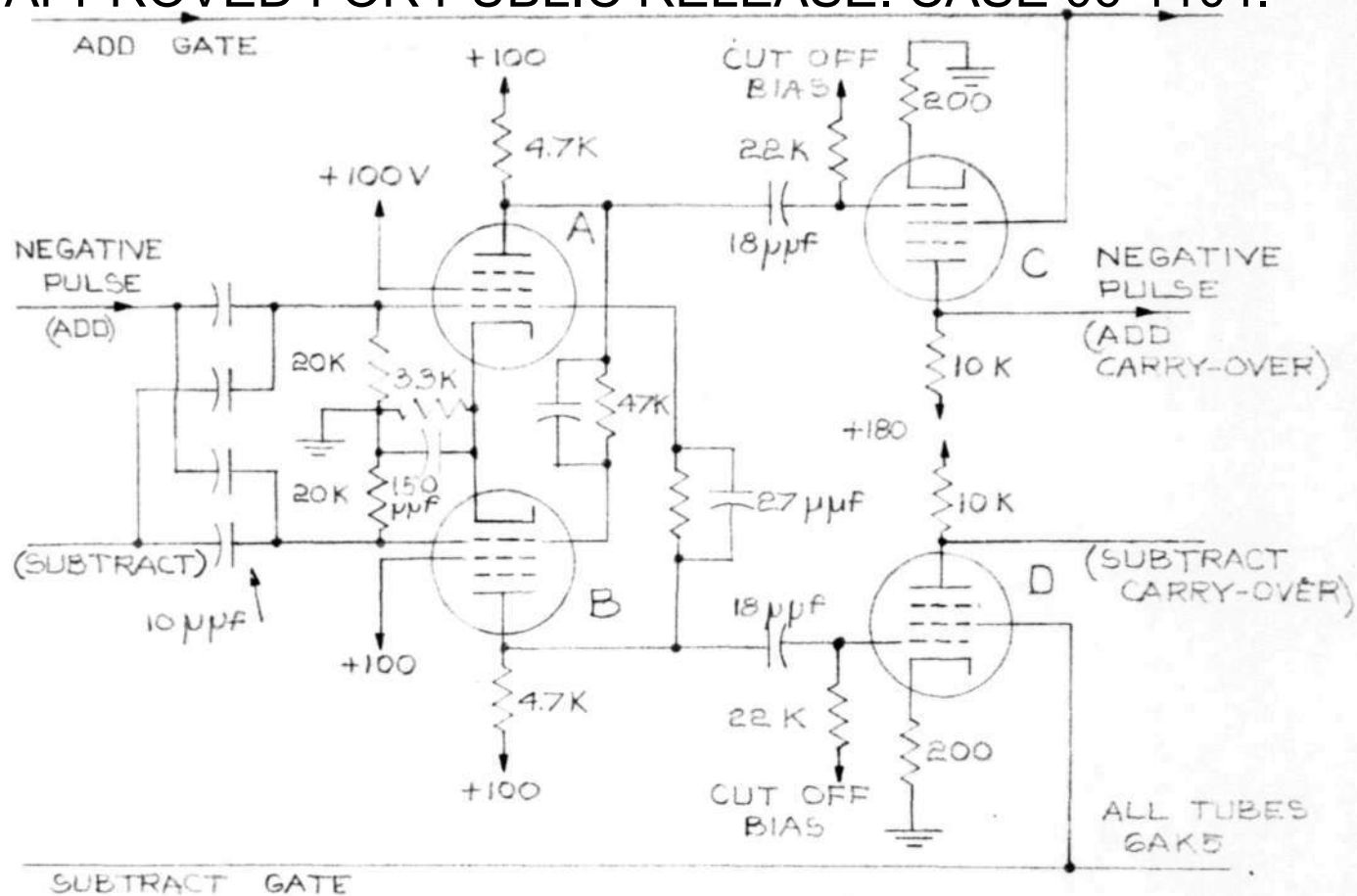

FIGURE 6

A-31171

-31171 USED IN STABLER REPORT

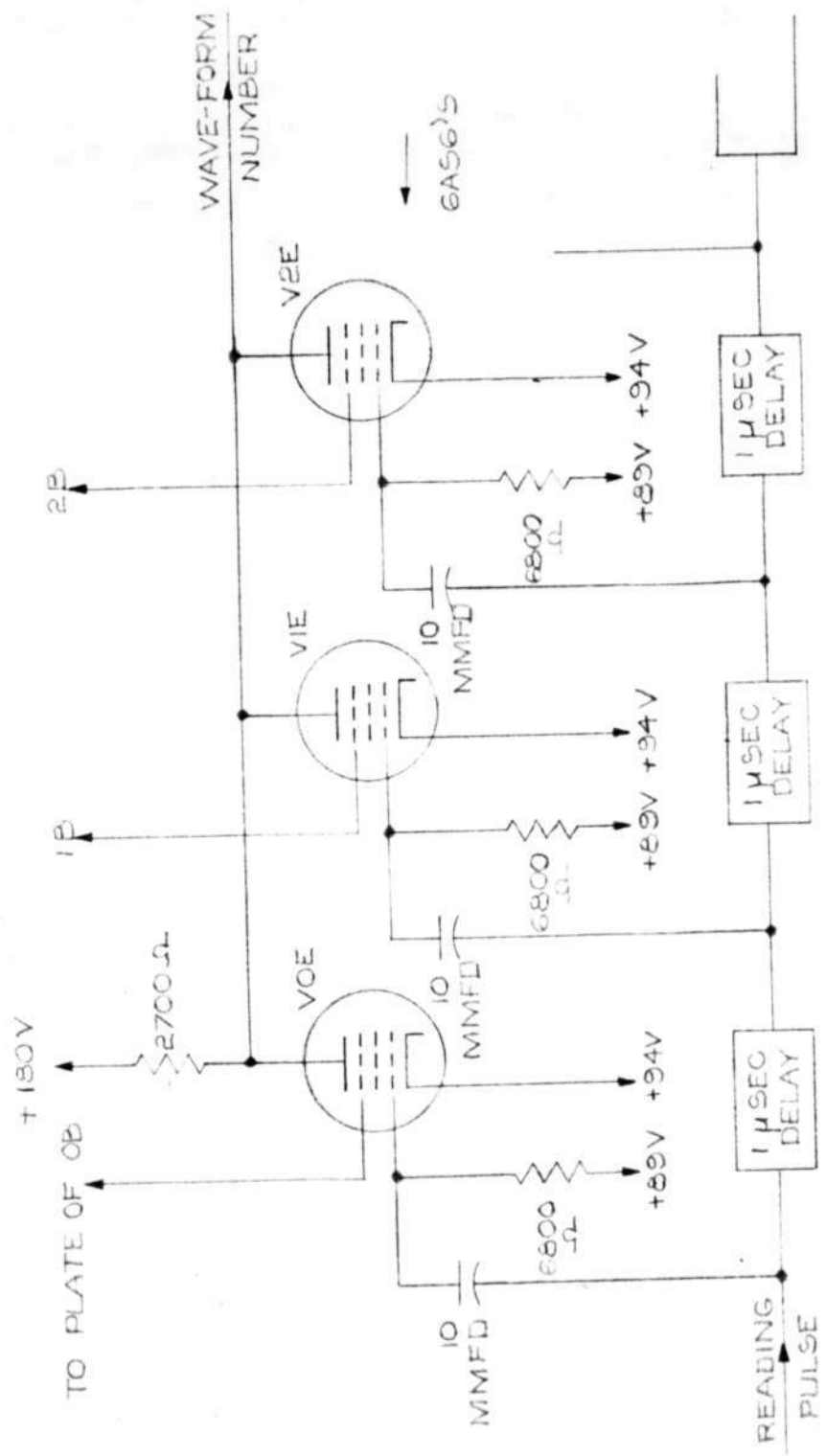

FIGURE 8

M-89

MEMORANDUM M-89

Servomechanisms Laboratory
 Massachusetts Institute of Technology
 Cambridge, Massachusetts

To: Jay W. Forrester, R. E. Everett
 From: H. P. Stabler
 Subject: Mechanical to Binary Converter
 Date: July 22, 1947

6345

Page 1 of 5 pages

Apparently some 45 of the 50 parameters need only be known to a subdivision accuracy of about 1 part in 128. Since the maximum speed and acceleration of the associated controls are small, it seems likely that brush contacts or cam operated leaf switches could be used to advantage.

One such arrangement is shown schematically in Figure 1. Eight binary figures (0 to 255) are provided by eight cam operated switches. The cam discs are mounted in sets of four on two shafts. The first shaft advances the switches 16 digits per revolution. The second shaft is coupled to the first by a mechanical carry-over pinion and advances 1/16th turn once each revolution of the first shaft. While the second shaft is in motion it moves at the same speed as the first shaft.

To avoid ambiguity at the transition edges (and therefore make possible reasonable tolerances for their alignment), the digit switches are inactivated at each transition position by means of a blanking switch. Figure 2 shows the phasing of the cams and blanking switch contacts. Blanking occurs over half the area.

The circuit schematic is shown in Figure 3. The output sides of the respective digit switches of each parameter are connected in parallel to a gate tube. The input sides of all digit switches for any one parameter are common and connected through the blanking switch to an input line. To read the numbers a gate voltage is applied successively to the input line for each parameter in turn. The numbers are placed successively in their respective storage registers.

Assuming the control knob can be turned a maximum velocity of 1 rev/sec or 32 digits/sec, the minimum time for a blanking disc segment will be 1/64 sec. Allowing 100 μ sec. to read each number, the reading repetition rate per parameter could be 1/200 sec. Thus any change in number would always be detected.

Memorandum M-89

-2-

6345

July 22, 1947

The success of the method clearly depends on the reliability, life, and speed possibilities of the switches. The unit could probably be designed as a small compact unit. Some investigation of brush contacts and cam operated switches seems warranted, after which design of the mechanical parts for a model could be undertaken.

Other methods seem likely to require calibration or adjustment and at least a one tube circuit at each parameter station.

Bob Everett points out that the blanking method described here requires too frequent admission to storage. He suggests that the blanking switch instead consist of a double throw switch which serves to select which of two sets of number switches are to be read, the two sets being slightly displaced in phase.

H. P. Stabler

H. P. Stabler

HPS:vh

cc: C. R. Wieser

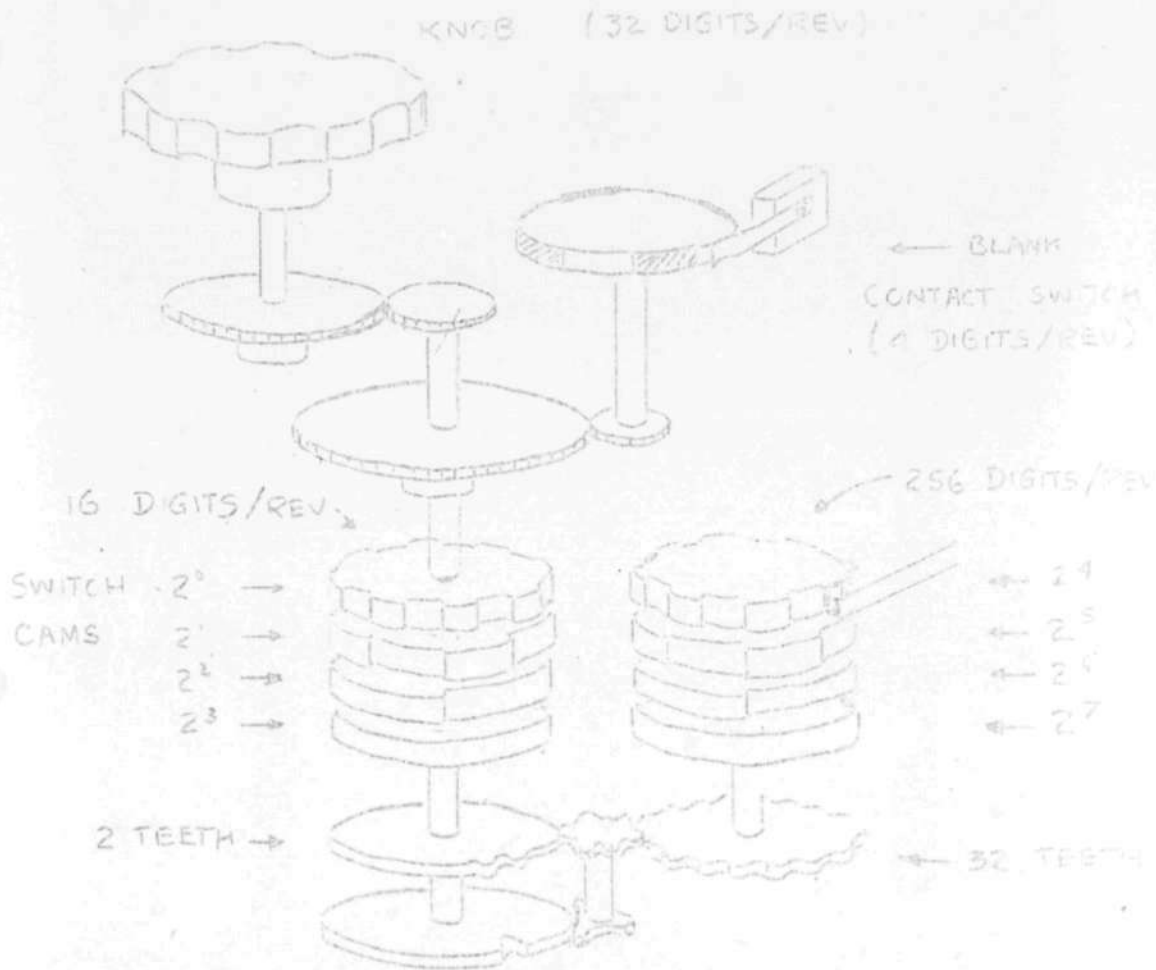

FIGURE 1

Memorandum H-89

6348
July 28, 1947

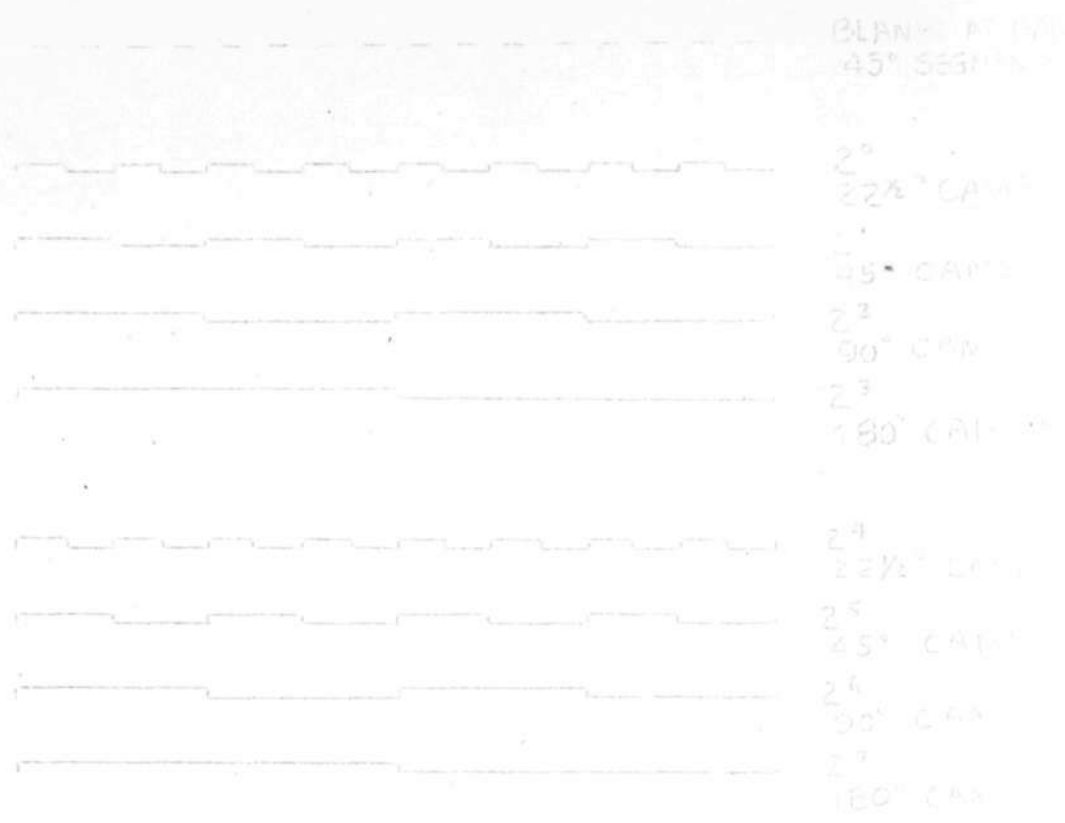

FIGURE 2

Memorandum 36-09

0210
July 23, 1947

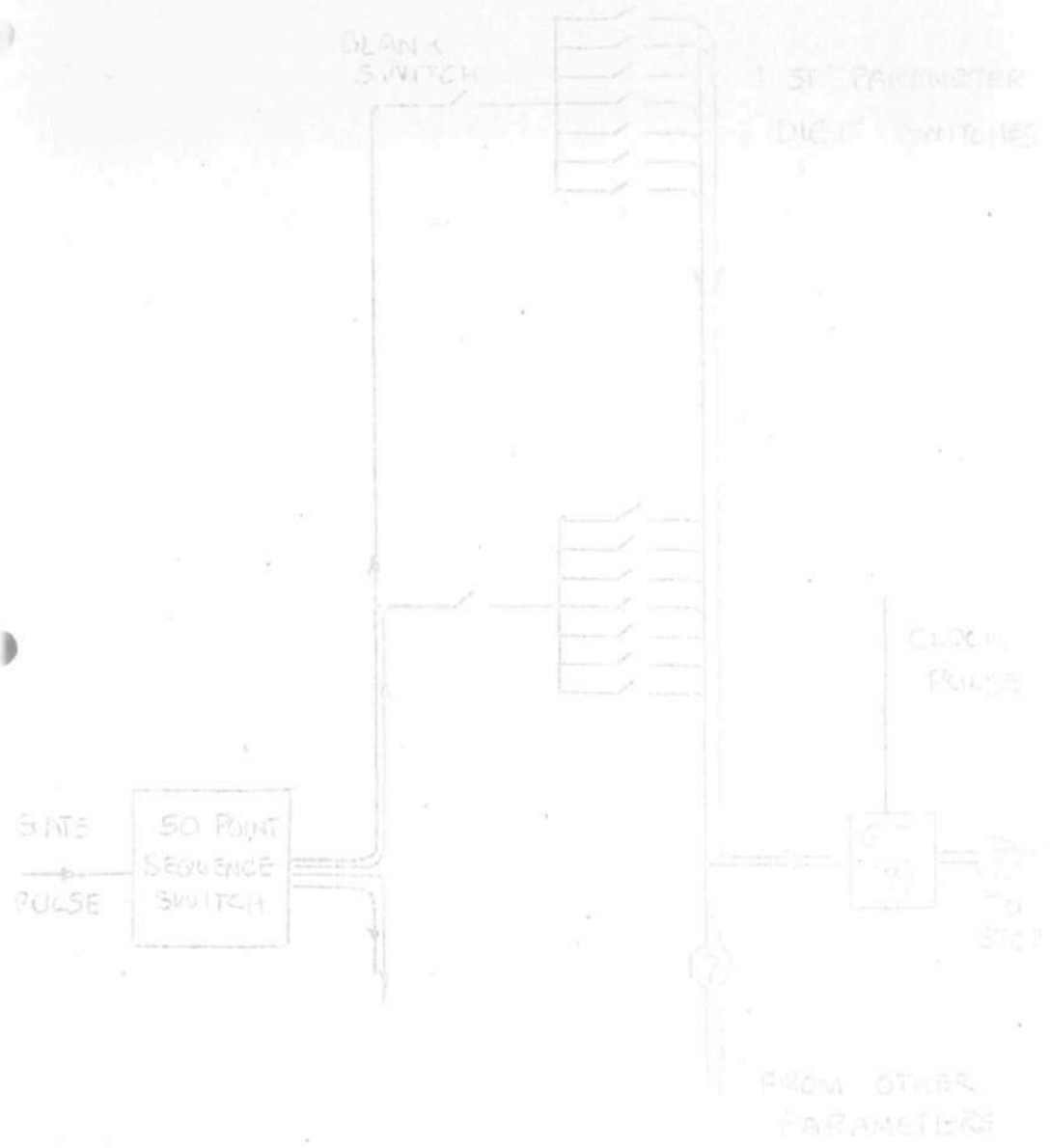

FIGURE 3

M-101

Memorandum M-101

Servomechanisms Laboratory
 Massachusetts Institute of Technology
 Cambridge, Massachusetts

To: Jay W. Forrester, R. R. Everett, H. R. Boyd, 6345
 H. Fahnestock, C. R. Wieser, S. H. Dodd, Page 1 of 6
 P. Youtz, W. J. Nolan, D. R. Brown and N. Taylor

From: E. S. Rich

Subject: Notes on Visit to Moore School, University of Pennsylvania
 on September 3, 1947

Date: September 9, 1947

1. Purpose of Visit

The purpose of the visit to the Moore School was to discuss the use of magnetic recording as a storage medium in electronic computers. The discussion on this subject took place with Dr. Chuan Chu and Mr. Sharpless. Mr. Joseph Moore also discussed some of his work on mercury delay lines used for high speed storage.

2. Magnetic Recording

a. Results of Research at the Moore School. Up to the present time, the research program on magnetic recording at the Moore School has been directed toward development of a satisfactory recording method for use with the EDVAC, so the results achieved represent a complete working system rather than the ultimate in the design of such equipment.

In the EDVAC, magnetic recording media are to be used in the input and output devices. The principle features of the magnetic recording system in these devices are as follows:

- | | | |
|------------------|---|--|
| Recording Medium | - | Plated wire manufactured by the Brush Development Company |
| Drive | - | Capstan drive coupled to an induction motor by a clutch system. Simple servos will be used to turn the feeding and take-up reels and maintain the proper amount of tension in the wire. |
| Heads | - | A single head design is used for the three functions of erasing, recording and playback. A single ring-shaped lamination of Mo-Permalloy has been selected as the best type of core for these heads. |

6345
Memorandum M-101

-2-

September 9, 1947

Recorded Signals - Pulses are recorded at the rate of 2000 pps with a spacing on the wire of 40 pulses per inch. Positive and negative pulses are used to represent the two binary digits. A marker pulse of the order of a half-inch in length is recorded at the end of each word.

Wire Speed - A wire speed of 50 inches/sec is to be used in all operations in both the input and the output devices except when reading information out into the printer. For this operation a speed sufficiently low so as to match that of the printer will be used.

The main considerations in the selection of the recording medium were the computer requirements, the recording performance of the magnetic material, and the availability of this material. Since information is to be fed into and received from the computer in serial fashion, a single channel recording such as may be obtained on a wire is sufficient. The performances of various magnetic materials were indicated by the results of tests conducted by Dr. Chu on several recording media. These results are shown in the attached table. Although the Brush Plated Wire does not give the highest resolution of pulsed signals, it was selected because it gives a relatively high output level, has very uniform magnetic properties, and is commercially available at low cost. Spools containing about 2 miles of wire are to be used.

A clutch system to control the drive capstan is to be used for rapid starting and stopping of the wire. The clutch performance is such that the wire can be stopped and then brought up to speed again within the length of the recorded marker pulse.

A single head design for erasing, recording, and playback was decided upon so that recordings may be made for either direction of wire motion. A complete system will contain two such heads, one for erasing and the other for recording or playback. To reverse the recording direction, it is necessary merely to interchange the function of the respective heads by electrical switching.

The choice of 40 pulses per inch as the pulse spacing on the wire rather than a greater number which the table shows is possible was dictated by the necessity for reading into the printer at low speeds. The longer pulse length allows a higher level signal to be recorded and hence gives a higher output in the playback process.

A marker pulse at the end of each word is to be used so that the position of recorded information with respect to the playback head is known at all times. For the most part this recorded information is to be used in sequence, but if it is necessary to return to a previous word in the sequence this word may be located by counting the marker pulses. With the clutch system used, it was found

6345
Memorandum M-101

-3-

September 9, 1947

that there was an optimum wire speed for most efficient use of the storage medium. Since the time required to stop and start the wire is a function of wire speed, the marker pulse length and hence the ratio of marker pulse length to word length is also a function of wire speed. Consideration of this factor resulted in the choice of the wire speed and the marker pulse length previously stated.

A special circuit is to be used in the EDVAC for reading information from the wire. The details of this circuit were not discussed but the principle was stated. Because of the differentiating action of the playback head, the voltage generated in this head by recorded pulse signals has the wave shapes shown below. Both positive and negative pulses are

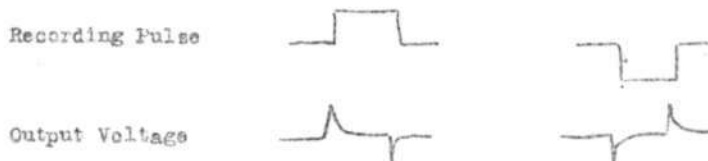

produced for a single recorded pulse. The reading circuit consists of flip-flops that are triggered by the first of the pair of output pulses but are insensitive to the second of these pulses. The use of an integrating circuit to obtain single output pulses caused too great an attenuation of the signals to be practical.

b. High-Speed Pulse Recording. Dr. Chu stated that he hoped to be able to start a program of research on high-speed pulse recording in the near future. For this work he plans to use a metal cylinder plated with a layer of magnetic material for his recording medium. It is his opinion that heads cannot be in contact with the medium for operating speeds greater than about 10 ft/sec without causing excessive wear either of the heads or of the medium itself. A greater recording gap length is necessary when heads are spaced away from the medium so poorer resolution must be expected. For heads spaced 0.005" away, the number of pulses that can be recorded per inch might be about 75% of the number that could be recorded with the heads in contact with the medium. It was his understanding that the Institute of Advanced Study in conducting its research on this subject has obtained a recording rate of 50,000 pps with an operating speed of about 50 ft/sec.

3. Mercury Delay Lines

Mr. Chedaker demonstrated his equipment for high speed storage in the EDVAC using a mercury delay line and discussed some of the features of the line and its associated circuits. The delay line consists of a column of mercury 22 inches long and 3/8 inch in diameter contained in a glass tube with a quartz

6345
Memorandum M-101

-4-

September 9, 1947

crystal mounted in each end of the tube. The "pulse packet" applied to the tube consists of two cycles of a 5 megacycle frequency generated by applying a pulse to a ringing circuit. In traversing the tube, the packet is greatly attenuated and is slightly spread out, i.e. it contains more than two cycles. The output voltage from the line has approximately the wave shape shown below.



Most of the attenuation occurs in the crystal transducers. There is a 30 db loss in each crystal and 6 db loss in the mercury column itself. The output packet is amplified, rectified, reshaped, and then fed back to the ringing circuit to cause another pulse packet to be sent down the delay line. In this way it may be retained as long as desired.

The 22-inch line produces a delay of 256 μ s so that, for the one megacycle repetition frequency used in the EDVAC, 256 pulses may be stored in such a line.

4. General

Mr. Chedaker stated that they are looking for a better method of coupling between stages in the electronic circuits. In the delay line demonstration a considerable change in pulse wave shape was evident as the spacing between pulses was varied from 1 μ s to 256 μ s.

A small model of the EDVAC had been built up in the laboratory and was used for testing the various components of the computer. However, it was not operating at the time of this visit. It was understood that the design of the EDVAC has been completed and that the computer will have been constructed by the first of 1948.

E. S. Rich

E. S. Rich

ESR:vh

APPROVED FOR PUBLIC RELEASE. CASE 06-1104.

Results of Tests on Various Magnetic Recording Materials by Dr. Chu at the Moore School,
University of Pennsylvania, (Operating speed - about 10 "/sec.)

Designation of Wire or Tape	Dimensions dia. of wires thickness of tape - mils	Weight gms/1000 ft.	Breaking Strength Pounds	Material	Magnetic Properties			
					σ_c	B_r	H_c/B_r	$\frac{B-H}{a}$
GE Stainless-A	Wire 4	19.5	4	Stainless Steel	320	1800	17.8	
GE Stainless-B	" 3.9	19.0	3.9	Stainless Steel	*1	*1	*1	
GE Stainless-C	" 4	19.0	4.	Stainless Steel	30	7000	0.43	
GE Piano E	" 4.1	20.0	4.5	Steel	60	5300	1.13	
GE Cunife I-D	" 4.1	21.0	3.	Cu-Ni-Fe Alloy	65	2100	3.09	
GE Cunife No. 331	" 4.2	20.5	3.5	Cu-Ni-Co Alloy				
GE Cunife I No. 327	" 4.2	20.5	4.	Cu-Ni-Fe Alloy				
Nat'l Stan Cunife	" 3.9	20.5	3.5	Cu-Ni-Fe Alloy				
Nat'l. Stan. H ^c =350 #350b	" 4	19.5	11	Stainless Steel				
Nat'l. Stan. H ^c =480 #3261	" 4	20.0	10.5	Stainless Steel	480	2200	21.8	
Nat'l. Stan. H ^c =240	" 4	19.5	9.	Stainless Steel	240	2200	10.9	
Nat'l. Stan. H ^c =180	" 3.9	19.0	10.	Stainless Steel	180	6300	3.6	
Swedish Tono-120-S	" 4.2	20.0	8.		700	200	350.	
Brush Plated Wire BK-913	" 4.5	27.5	4.5	Co-Ni Alloy on phosphor-bronze	220	9000	2.44	
Nat'l. Stan. Flat Stainless Wire	2x6	19.0	9.5	Stainless Steel	300	2500	12.0	
Brush Plated Tape	2.8 x 14.6	61.0	12.	Co-Ni Alloy on phosphor-bronze	220	9000	2.44	
Brush Paper Tape BK-914	2.3	149.	7.5	Synthetic Magnetite	115	400	29.	1220
Brush Paper Tape BK-29	2.2	144.	7.		115	760	15	1680
Lear Paper Tape No. 11	4.1	183	12.	Red iron oxide *				
Lear Paper Tape No. 23	3.9	181	12.	Red iron oxide	105	900	12	2000
Lear Paper Tape No. 34	3.9	182	12.	Red iron oxide				
German type L Tape	1.8	126.	6.	Synthetic Magnetite	85	100	85	
Armour Tape No. 140	2.3	142.	5.		290	410	71.	680
Ind. St. Prod. Paper Tape - Stan.	2.7	161.	12.		310	*2	---	
Ind. St. Prod. Paper Tape - Hyflux	2.3	157.	10		500	1000	50	2200

*1 - Almost non-magnetic

*2 - a few hundred gaussses

6346
Memorandum M-101

-5-

September 5, 1947

Memorandum N-101

Designation of Wire or Tape	Noise Arbitrary Units	Output at Peak same units	Sine Wave Response $\frac{\text{feet}}{\text{db down}}$	Pulses per inch	Rise Time	Pulses per inch	Sq. Wave per inch	
								*3
GE Stainless-A	0.2	0.6	600	80-2000	120	750	67	60
GE Stainless-B	0.15	---	---	---	---	---	---	---
GE Stainless-C	0.2	0.4	300(?)	100-300(?)	15	3500	14	16
GE Flano-E	0.3	5.0	500	100-1700	50	2500	20	30
GE Cunife I-D	0.25	1.4	800	50-2000	75	1250	40	40
GE Cunife No. 331	0.25	0.7	1000	150-2400	200	440	110	100
GE Cunife I No. 327	0.2	1.6	600	150-1800	---	550	90	85
Natl. Stan. Cunife	0.2	1.5	800	150-2900	160	500	100	95
Natl. Stan. Hc=350#3505	0.2	0.8	800	125-3000	160	625	74	75
Natl. Stan. Hc=480#3261	0.25	1.3	1600	350-4700	210	375	133	120
Natl. Stan. Hc=240	0.2	1.3	1200	200-4000	150	500	100	100
Natl. Stan. Hc=180	0.25	1.5	800	60-2600	90	1375	36	35
Swedish Tono-120-S	0.2	0.6	2000	600-6000	200	250	200	160
Brush Plated Wire BK-913	0.2	2.4	1200	200-4000	160	750	67	70
Natl. Stan. Flat Stainless Wire	0.2	2.0	2200	400-6000	300	251	200	210
Brush Plated Tape	0.2	1.6	1600	300-3500	280	292	170	160
Brush Paper Tape BK-914	0.2	2.6	1600	400-4000	240	250	200	160
Brush Paper Tape BX-29	0.2	5.0	1600	500-5100	230	310	160	170
Lear Paper Tape No. 11	0.2	9.0	1800	400-3400	250	310	160	180
Lear Paper Tape No. 23	0.2	14.0	1400	400-3400	230	417	120	130
Lear Paper Tape No. 34	0.2	15.0	1200	250-2600	230	520	96	120
German type L Tape	0.1	0.8	1400	350-4000	270	310	160	150
Armour Tape No. 140	0.15	6.0	2000	350-4000	280	210	240	200
Ind. St. Prod. Paper Tape - Stan.	0.3	2.4	1600	400-4000	250	250	200	170
Ind. St. Prod. Paper Tape-Ryflux	0.4	4.2	2000	500-4800	280	210	240	190

*3 - Noise figures doubtful because scope and amplifier noise is almost 0.2 units alone

*4 - Recorded 17.5 microsec. pulses in groups of 2. 2nd pulse down 10%

*5 - 100 cycle sq. wave recorded microsec.

*6 - On basis of Time Rise

*7 - Calculated from sq. wave frequency at which E₀ drops 10%

R-124

6345
Report E-124

Page 1 of 26

Project Whirlwind
Servomechanisms Laboratory
Massachusetts Institute of Technology
Cambridge, Massachusetts

SUBJECT: MAGNETIC RECORDING - ITS USE FOR STORAGE OF INFORMATION IN
ELECTRONIC COMPUTERS

Written by: E. S. Rich

Date: September 17, 1947

FOREWORD

The following report contains a survey of the field of magnetic recording, a summary of the work done in this field in the Center of Analysis at M.I.T. from September 1946 to June 1947, and recommendations for further experimental work. The purpose of the work was to investigate magnetic recording as a means for storing information for electronic computing machines.

TABLE OF CONTENTS

	Page Number
FOREWORD	1
SUMMARY	2
Work done to date	2
Recommendations for further experimental work	3
DISCUSSION	4
The nature of a magnetic recording	4
Types of magnetic recordings	4
Types of head construction	4
Comparison of types of recordings and types of heads	4
Methods of recording	5
Signal reproduction	6
Erasing	6
Frequency response of a magnetic recording system	7
Requirements in a recording system	9
Experimental magnetic recording system	11
Results of tests on Experimental System	12
RECOMMENDATIONS FOR FURTHER EXPERIMENTAL WORK	15
REFERENCES	18
APPENDIX	19
B-H curve tracer	19
Table of symbols and definitions	23
Description of magnetic materials	24
List of drawings	26

SUMMARYWork Done to Date

Up to the present time, the investigation of magnetic recording systems for storage purposes has covered only some preliminary stages of construction of test equipment, design of recording, playback, and erasing heads, and comparison of different types of recording media. This preliminary work was undertaken to determine the best recording medium and the best system design for testing various storage methods. Since a maximum number of words per unit length of the medium is desirable for efficient storage, the upper frequency limit of a recording for a given linear speed of the medium was taken as a measure of the system performance.

The recording equipment used was designed and constructed in the laboratory. It consisted of pulleys arranged on a panel to hold a short loop of a recording medium and draw it at a uniform speed over the erasing, recording, and playback heads. Suitable amplifiers connected to these heads allowed the recording and reproduction of continuous sinusoidal signals. Six different recording media were tested, three of these being paper or cellulose acetate tapes coated with a powdered magnetic material and the others being solid metal tapes. A tape speed of 3"/sec was used in all tests.

All of the heads were of ring-type core construction, since such cores permit recording of higher frequencies than is possible with other types. They were oriented so as to produce longitudinal magnetization in the tapes. Demagnetization by means of a 50-KC field accomplished the erasing process, and a high-frequency bias in the recording head provided a minimum of amplitude distortion in the recorded signal. These methods were chosen instead of erasing by saturating the medium and using a d-c bias to provide a linear characteristic because of the higher signal-to-noise ratio obtainable.

In articles in the literature it has been shown that a high residual flux density in the recording medium gives high output at low frequencies, while a high coercive force contributes to a high output at high frequencies. The ideal response of the system for a constant recording-signal current is an output voltage proportional to frequency. However, at high frequencies the output voltage decreases rapidly because of self-demagnetization in the medium, demagnetization caused by leakage flux around the working gap of the recording head, decreased flux penetration in the medium as a result of skin effect, and a decrease in flux linkages through the playback head because of its finite air-gap width. Self-demagnetization is a function of the slope of the demagnetizing portion of the B-H curve; therefore the ratio of residual flux density, B_R , to coercive force, H_C , has been described as a figure of merit for the high frequency response of a given medium. For a low B_R to H_C ratio, self-demagnetization is less and the output at high frequencies is greater.

Demagnetization caused by leakage flux at the recording head is minimized by using a core material with the highest permeability possible at the flux densities involved and recording with the minimum flux density consistent with output requirements.

Hysteresis loops and frequency response curves were plotted for the magnetic tapes previously mentioned. The best high-frequency response was obtained from one of the powder-coated tapes which had a coercive force of about 350 oersteds and the lowest B_R to H_C ratio, which was about 2.2. The difference

in response between solid metal tapes and coated ones, however, was not wholly indicated by this ratio. For example, a solid tape having an H_c of 215 oersteds and B_R to H_c ratio of 28 gave approximately the same high frequency response as a coated tape having an H_c of 130 oersteds and a B_R to H_c ratio of 5.4. In general a high coercive force is desirable in a magnetic recording medium, but this value is limited to about 400 oersteds because of the difficulty of producing sufficient MMF in the heads for erasing and recording.

Operating with optimum values of signal and bias currents for good high-frequency response, it was found that the best powder-coated tape was one obtained from Minnesota Mining and Manufacturing Company and the best solid metal tapes were Vicalloy and the Brush Development Company's plated tape, the latter two giving approximately equal results. The Vicalloy tape is a homogeneous metal, whereas the Brush plated tape has a thin magnetic plating on a brass strip. Assuming a minimum signal-to-noise ratio of 25 db as defining the upper frequency limit of recording, it was observed that the MMN powder-coated tape allowed a maximum of about 1200 cycles per inch of tape, while the Vicalloy and the Brush plated tape each allowed about 800 cycles per inch.

Recommendations for Further Experimental Work.

The best method for utilizing a magnetic recording medium for storage of information must be determined by further research. Since the speed at which the medium is driven governs the rate at which information can be recorded and removed, this speed should be as high as possible. The limit in this respect would be set by the mechanical considerations of strength of the medium, wear on the heads and on the medium, and maintenance of uniform contact between the heads and the medium. Based on reports of work at other institutions, a speed of 50 to 100 feet per second should be practicable.

Pulse signals instead of modulated sinusoidal signals should be investigated. It is reasonable to assume that a discrete pulse can be recorded on the same length of tape or wire that would be required for the minimum number of cycles of a sinusoidal signal that would excite the circuits of the reading equipment. On the basis of the response figures stated above, about 200 pulses per inch might be recorded. In addition, the use of pulse signals would greatly simplify the design of the recording and reproducing circuits.

Means for improving head design should be studied. A determination of the leakage field around the recording head would be particularly helpful in selecting the core material and method of core construction. For high-speed operation a ring-type erasing head could not be used, so an alternate type would have to be designed and tested. The windings on the recording and playback heads also would have to be designed for the high frequencies or short pulses used.

Multichannel recording on a flat tape is feasible, and possible applications of this method of recording to computer problems should be determined. By using heads with thin cores, the desired narrow recording paths may be obtained. In a commercial disk recorder manufactured by the Brush Development Company a spiral path is used, giving the equivalent of 40 channels per inch.

Means for locating a particular piece of recorded information are essential in computer applications. This probably will have to be done by recorded marking and synchronizing signals which govern the driving mechanism. The way in which this control may be obtained is a problem in electrical and mechanical design which might be solved by the application of servomechanism principles or by a suitable arrangement of clutches. Multichannel recording offers certain advantages over single-channel recording in the solution of these problems: with multichannel recording more information can be stored on a given length of the medium, so that less movement of the medium is required to locate and reproduce the information.

DISCUSSION

The Nature of a Magnetic Recording

A recording on a magnetic medium such as a wire or tape consists of variations in the intensity of magnetization along the medium. These variations in intensity of magnetization are usually produced by drawing the recording medium at a uniform speed past the pole pieces of a recording head and varying the magnetomotive force of this recording head in the desired manner. To reproduce the recording, the medium is drawn past the pole pieces of a playback head, and the change of flux linkages induces a voltage in this head corresponding to the signal impressed on the medium. A recording may be erased or removed from the medium simply by passing it either through a strong unidirectional magnetic field which saturates all portions of the medium or by passing it through a strong alternating field to demagnetize it. A comparison of these methods of erasing will be made in a following section.

Types of Magnetic Recordings

Magnetic recordings may be classified into three types depending on how the magnetizing field is applied to the medium: (1) longitudinal, (2) perpendicular, and (3) transverse, in which the magnetizing MMF gradient is respectively along the length of the medium, along the thickness dimension, or along the width dimension as shown in Fig. 1. For a round wire, perpendicular and transverse recordings are, of course, identical.

Types of Head Construction

In order to evaluate these types of recordings, some knowledge of recording and playback head construction is necessary. A few general types of core construction are shown in Fig. 2. It is seen that these may have open or closed magnetic circuits and may have pole tips on one or both sides of the medium. The designs of Figs. 2(a) and 2(b) are applicable to transverse as well as perpendicular recording merely by changing the orientation of the pole pieces so that they contact the edges of the medium rather than top and bottom. The designs of Figs. 2(a) and 2(b) may also be used for longitudinal recording by shifting one pole piece slightly along the longitudinal axis of the tape as in Fig. 3(b). The ring type core of Fig. 2(c) is used primarily for longitudinal magnetization.

Comparison of Types of Recordings and Types of Heads

Longitudinal magnetization is used almost exclusively in present-day magnetic recording equipment. The chief reason for this is that the ring-type

core with a very small air gap allows a signal of shorter wavelength to be recorded and reproduced than is possible with other types of core construction. An air-gap length of 0.0005" is easily obtained with ring-type cores. For perpendicular or transverse recording, core construction of the types of Figs. 2(a) and 2(b) is necessary and the shortest wavelength that can be recorded is, to a first approximation at least, limited by the thickness of the pole pieces. To be mechanically rigid these pole pieces must be of the order of a few thousandths of an inch thick, so the shortest recorded wavelength is several times that obtainable with the ring-type core. This comparison is evident from Figs. 3(a) and 3(c). The fact that solid metal recording materials are more easily magnetized in the direction of rolling or drawing and that the ring-type head allows easy removal of the tape or wire and does not require adjustment are further reasons for the use of longitudinal type recording. From a practical point of view, a perpendicular or transverse recording in the case of a wire recording material is ruled out by the tendency for the wire to twist as it is drawn past the heads.

Methods of Recording.

The residual flux which constitutes the recording on a magnetic material is related to the MMF of the recording head by the familiar B-H curves of that material, so this relation can be considered linear only over a restricted range. In recording systems where amplitude distortion of the reproduced signal must be kept to a minimum, it is necessary to use a "biasing" MMF in the recording process to ensure that the desired linear transfer characteristic is obtained. Prior to about 1942, the recording method in use employed a constant unidirectional biasing MMF in the recording head and a recording medium that had been saturated in the erasing process by a unidirectional magnetic field. The erasing process leaves all portions of the medium with a flux density B_p as shown in Fig. 4. The biasing MMF is of the proper magnitude and direction to reduce the flux density in the portion of the medium at the pole pieces of the recording head to the value indicated by point P of the hysteresis loop of Fig. 4. If a signal MMF, $H(t)$, is superimposed on the biasing MMF, H_b , the amount by which the flux density of a given element of the medium is reduced is determined by the total MMF in the recording head at the time that element is at the pole pieces of the head. If the minimum MMF is H_1 and the maximum is H_2 , the flux density of successive elements will be lowered to values corresponding to points between M and N on the B-H curve of Fig. 4. When the tape elements leave the recording head the applied MMF drops to zero and the residual flux density rises along minor hysteresis loops to corresponding values between M' and N'. By proper choice of biasing MMF and signal amplitude, then, an approximately linear relation between signal and recorded flux may be obtained.

About 1942 a recording method employing a high-frequency or subsonic bias was adopted. This method permits recording on a demagnetized medium, so that the noise level of the output is much less than for a saturated medium, while the maximum signal amplitudes are approximately equal in the two cases. This improvement in signal-to-noise ratio has resulted in almost universal adoption of the high-frequency bias where minimum non-linear distortion is desired. A signal-to-noise ratio of 50 db with only a few percent distortion is practicable with this method of recording. Bias frequencies used in commercial sound recording equipment are in the range from 20 KC to 60 KC.

A complete theory of recording on a magnetic medium by the high-frequency bias method has not been published. Such a theory would involve consideration of magnetic skin effect, the finite width of pole pieces or recording air gaps, demagnetization in the medium, and leakage flux about the recording head. However, a qualitative explanation of the recording process neglecting these effects is easily made. Assume a bias frequency of 30 KC, a signal frequency of 1000 cps, a tape speed of 10"/sec, and a recording air-gap width of 0.001". For this case any element of the recording medium is in the recording gap for 100 μ sec or 3 cycles of the bias MMF. The total MMF applied to an element of the recording medium is the instantaneous sum of the signal and bias MMF's as shown in Fig. 5(a). The bias MMF amplitude is approximately that required to just pass the lower knee of the magnetization curve. An element of the medium in passing the gap of the recording head, then, is subjected to an MMF which forces the flux density in the medium through a series of minor hysteresis loops as shown in Fig. 5 (c), (d), and (e). These figures are for elements of the medium that enter the gap at times t_1 , t_2 , and t_3 respectively (see Fig. 5 (b)). Upon leaving the gap these elements have residual flux densities of B_1 , B_2 , and B_3 as shown in the figures. The effect of this high frequency bias is to remove the curved portion of the magnetization curve at the origin and give a linear relation between signal MMF and residual flux density. It should be pointed out again that the preceding explanation is incomplete since an accurate plot of residual flux density against signal MMF would show a component of the bias frequency present. In practice this is not observed primarily because of the effect of demagnetization in the medium. This effect, which will be discussed later in connection with magnetic properties of recording media, causes elements of the medium having a length that is small compared with thickness to be brought to essentially the same residual flux density, so that the bias-frequency component is lost.

Signal Reproduction

The reproduction of a signal that has been recorded on a magnetic medium is essentially the same for all types and methods of recording. The types of core construction shown in Fig. 2 apply to playback as well as recording heads. For a given system the orientation of the pole pieces or the air gap should correspond to those of the recording head so that a maximum number of flux linkages through the playback head winding will be produced by the residual flux from the recording medium. It has been found that the ring-type core is superior to other types for playback heads for the same reasons as for recording heads.

Erasing

As has been previously mentioned, a recorded signal may be erased either by saturation or by demagnetization of the recording medium. Saturation is easily accomplished either with a permanent magnet or with an electromagnet of a type similar to one of those of Fig. 2. For this purpose, of course, neither narrow pole pieces nor a short air gap is necessary. An obvious method for demagnetizing a recording medium is to pass it through the center of a coil in which alternating current is flowing. This method is not generally used

however, because shielding of the recording and playback heads from the high leakage field becomes a problem. Present practice is to use a closed core as shown in Fig. 2(c) having an air gap of 0.010" to 0.020" in contact with the recording medium. A high-frequency MMF of sufficient magnitude to raise the flux density of the medium to saturation is applied to the medium while it is passing this air gap. As the tape leaves the gap, the flux density is effectively reduced to zero by the demagnetizing effect mentioned in connection with the recording process.

Frequency Response of a Magnetic Recording System.

It is very difficult, if not impossible, to compute theoretically the frequency response characteristic of a given magnetic recording system. If it could be assumed that a constant current in the recording-head winding produced a constant magnetizing MMF and hence a constant residual flux density for all frequencies, then the voltage generated in a ring-type playback head under ideal conditions would be

$$e = K_1 \frac{d}{dt} (\phi \sin \omega t)$$

$$= K_2 f \phi \cos \omega t$$

This corresponds to a straight line rising 6 db per octave when output voltage in db is plotted against the log of frequency as shown by the broken line in Fig. 6. The actual response from a typical recording system for a constant recording current falls below the ideal response both at low frequencies and at high frequencies as shown by the solid curve of Fig. 6. The drop at the low-frequency end occurs when the wavelength of the recorded signal is comparable to the physical dimensions of the playback head. By reference to Figs. 7(a) and (b), it is seen that when the recording medium is in a position to produce the maximum flux through the playback head, only a fraction of the total flux links the windings for long wavelengths while substantially all of the flux links the windings for short wavelengths. This results in a decreased output voltage for very low frequencies.

The drop in output at the high-frequency end is due to several factors, the major ones being demagnetization in the recording medium, leakage field about the recording head, and the scanning effect caused by the finite width of the air gap in the playback head. Magnetic skin effect in the recording medium and eddy currents in the core of the playback head may also contribute under certain conditions.

It is well known that as the ratio of the length of a bar magnet to its thickness decreases, the field at one end of the magnet due to the pole at the other end increases. This "self-demagnetization" reduces the total field strength. At high frequencies, then, when the half-wavelength of a recorded signal approaches the thickness of the medium a similar condition exists where

the section of the medium a half-wavelength long is considered as an individual magnet. For a magnetic tape 0.001" thick running at a speed of 10 inches per second, the frequency having a half-wavelength equal to the tape thickness is 5000 cycles per second.

A continuous recording of a sinusoidal signal may be considered as a series of magnets each a half-wavelength long with like poles placed next to each other. For this case the field at any point is a resultant of the field of all magnets in the vicinity. As the length of these magnets decreases, the influence of neighboring magnets becomes more pronounced and reduces the effective field of an individual magnet. The magnitudes of these demagnetizing factors are difficult to calculate since they depend not only on physical dimensions but also on the distribution of the magnetization and the magnetic properties of the recording medium. However, it can be shown that materials of high coercive force and low residual magnetism suffer less demagnetization than materials of low coercive force and high residual magnetism.

The flux that enters the recording medium from a ring-type recording head is that which fringes the air gap. In the ideal case this flux enters the medium only in the area that is between the gap faces as in Fig. 8(a). Actually the leakage flux around the recording gap spreads beyond the gap faces and enters the tape on either side of the gap as shown in Fig. 8(b). It is evident that if the direction of the recording MMF is reversed before a magnetized element of the medium leaves the region of this leakage field, the element will suffer some demagnetization. This situation, of course, exists when short-wavelength or high-frequency signals are being recorded. The use of a core material having a high-saturation flux density and recording with as low an MMF as possible helps to minimize demagnetization by this leakage field.

The decrease in output as frequency is increased that is caused by the finite width of the air gap in the playback head is readily computed to be the function

$$\frac{\sin \pi \frac{S}{\lambda}}{\pi \frac{S}{\lambda}}$$

where S is the gap width and λ is the wavelength of the recorded signal. The loss due to this effect, however, is a small part of the total loss. For example, a signal of 10 KC recorded at a speed of 10"/sec has a wavelength of 0.001", and assuming $S = 0.0005"$ the value of the above function is $\frac{2}{\pi}$, or about 4 db. The total loss under these conditions is normally several times this value.

The effect of eddy current set up in the magnetic medium during the recording process and in the core of the playback head during playback have not

been evaluated. If the operating speed is such that very high frequencies are recorded, it is reasonable to assume that some loss in output at high frequencies occurs as a result of these eddy currents. The cores of playback heads are usually laminated to minimize eddy current losses in the reproducing process. Of course skin effect at the bias frequency limits the penetration of flux into the recording medium, but this causes a decrease in output level for all signal frequencies and would not affect the shape of the response curve.

Requirements in a Magnetic Recording System.

The design of a complete magnetic recording system involves consideration of many factors. Certain properties in the recording medium, the head and the drive mechanism are basic requirements, while the materials used, the actual form of the equipment, and its operating speed are determined by the particular application for which the system is intended. From the information contained in the preceding discussion it is possible to enumerate some of these requirements.

High coercive force and low residual magnetism are essential properties in a recording medium where maximum high-frequency response or good resolution of pulsed signals is desired. However, in practice coercive force is limited to 350 to 400 oersteds by the difficulty of obtaining sufficiently high magnetizing fields in the recording head without excessive leakage flux. The value of residual magnetism also must be sufficient so that a usable output level is obtained from the playback head. Reducing the thickness of a tape or the diameter of a wire decreases the demagnetization of a recorded signal. The limit to reduction in size in this respect is set by considerations of mechanical strength and output level. High resistivity is another desirable property in the recording medium. Higher resistivity reduces the magnetic skin effect and allows greater penetration of flux in the recording process. The choice of solid metal or powdered materials and of tape, wire, or disc form depends on the particular application of the system. Solid metal materials are mechanically strong and experience little wear with use. Powdered materials coated on a suitable backing give better high-frequency response, but have a low output and wear out after a few thousand playings. Wire occupies less space than flat tape when wound onto a reel so is advantageous when a long recording time is desired.

It is evident that for the core of the recording head a high-permeability material should be used. In particular it should have the highest saturation flux density possible along with a negligible residual magnetism. It must also be of laminated construction to reduce eddy current effects particularly at the bias frequency. To facilitate winding of the coils on ring-type heads, the cores are usually made in two parts, and the faces on these two parts are ground to give a good fit on assembly. No spacer is used in the recording gap if maximum high-frequency response is desired. The type of winding used depends somewhat on the design of the amplifiers surrounding the bias and recording signals. Both high-impedance and low-impedance windings are found on commercial recording equipment, the former type being coupled directly to the plate of the output amplifier and the latter coupled through a suitable

transformer. Where high bias and signal frequencies are employed, transformers generally cannot be used. Furthermore, care must be taken to keep distributed capacity in the coil to a minimum to avoid resonance effects within the operating range. Separate windings for the bias and recording signals may be utilized, and have the advantage of more simple amplifier design when economy of tubes is not important.

The core of the playback head should satisfy the general requirements of low loss and negligible residual magnetism as in the case of the recording head. However, its important characteristic is initial permeability, which should be as high as possible. Although best results would be expected from a magnetic circuit having a single air gap, it is more practical to divide the core as has been described for the recording head. Symmetry in the core and in the windings placed on the two halves gives the further advantage of less pickup from extraneous magnetic fields. In any case magnetic shielding of the playback head is essential, especially with low-output-level recording media such as the powdered materials. A high-impedance winding to connect directly to the grid of the playback amplifier is usually satisfactory, although a low-impedance winding and step-up transformer may be desirable if the head is very small or if the core has been formed in one piece.

The requirements for the core material of the erasing head are identical with those of the recording head. Its features of construction are also the same except that a gap of 0.010" to 0.020" is necessary. Its winding should be designed to obtain a maximum power transfer from the erasing amplifier.

For faithful reproduction, the recording medium should pass the recording and the playback heads at as nearly a constant speed as possible, since fluctuation in speed will cause variations in both the amplitude and the frequency of the reproduced signal. For this reason some type of friction drive is used instead of gears or belts. Usually a mechanical filter arrangement such as a rubber-tired idler engaging both the motor shaft and the rim of a flywheel on the drive shaft is incorporated in the speed reducer design.

The choice of the form of the recording medium determines other requirements in mechanical construction of a recording system. For long recordings on tape, suitable reels and a rewinding mechanism are necessary. This also applies to long recordings on wire, but in this case level-winding devices to prevent bunching of the wire on the reels must be provided. For recordings of a few seconds or less a continuous loop of tape or wire may be formed and passed over a series of pulleys; a disc of magnetic material might also be used.

Since slight variations in the contact between the recording medium and the recording and playback heads will cause considerable variation in amplitude of the reproduced signal, the medium must be guided so that these do not occur. Equally important for good high-frequency response is proper alignment of the recording and playback gaps. Both gaps should make the same angle with the direction of tape motion. Since for high frequencies the wavelength on the tape approaches the order of magnitude of the gap width, a small difference in these angles will cause a substantial loss in output. The difficulty of maintaining this adjustment in commercial equipment prevents the use of wide cores to increase the signal level from the playback head.

Experimental Magnetic Recording System

The general features of the recording system designed for experimental purposes in the Center of Analysis laboratory are shown in Figs. 9 and 10. The base and front are of 1/4" aluminum and of standard panel width for mounting in a rack. The pulleys shown will accommodate loops of tape from 54" to 60" long and up to 1/4" wide. A brass idler pulley maintains tension in the tape. The mounting plates for the heads may be tilted in any direction by thumbscrew adjustment. They also may be raised and lowered and rotated about an axis perpendicular to the tape. This flexibility in the head mounting allows different sizes and types of heads to be adapted to the machine. The drive shaft is mounted on ball bearings with the drive pulley on the front and a brass flywheel behind the panel. The drive pulley is turned by friction between the flywheel rim and a rubber-tired wheel on the motor shaft. The motor is a 1/125 HP d-c motor with split field windings. To obtain an adjustable speed over a wide range by field control, the field windings are connected in parallel to a 220-volt line through suitable rheostats and the armature is supplied from a 110-volt line. There are two rubber wheels on the motor shaft so that two ranges of speed can be obtained by shifting the motor to engage one or the other wheel with the flywheel. By this arrangement the speed may be adjusted from about 3.5"/sec to 8"/sec and from 11"/sec to 5"/sec. The speed controls and an on-off switch, as well as input and output plugs, appear on the front panel.

A schematic diagram of the complete recording system is shown in Fig. 11. The amplifier circuits and head construction were changed from time to time, and space does not permit a description of all the designs tested. Those that were used to obtain the curves included in this report, however, will be described.

The erasing head has a split ring-type core of 0.003" x 1/4" Hipersil laminations stacked to a thickness of 1/8", the laminations being perpendicular to the radial direction of the core. This core was obtained from a Raytheon UX-7350 pulse transformer. The head has a single winding of 135 turns of No. 25 wire and a working air gap about 10 mils. wide. At 50 KC this head has an inductance of 3.2 mh and a Q of about 5.

The recording head is also of split ring-type construction but is made of 0.005" 4-79 Mc-Permalloy laminations. In this head the laminations are parallel to the radial direction and are stacked to a depth of 1/8", making the face of the head 1/8" wide as compared with 1/4" for the erasing head. The laminations are shaped so that the width of a lamination tapers to 1/16" at the working gap as shown in Fig. 12. Two windings are placed on each half of the core. The signal winding consists of 26 turns on each half or a total of 52 turns, and the bias winding 150 turns on each half or a total of 300 turns. Number 28 wire is used for all windings. Since the faces of the cores were ground to a close fit, it is estimated that the working gap of this head is less than 0.0005". The bias winding has an inductance of 6.3 mh and a Q of about 2 at 50 KC. The signal winding has an inductance of 410 μ ch at 1 KC.

The playback head is a Brush Development Company type BK-919 head. It has a core $1/8$ " wide of laminations approximately 0.015" thick and is mounted in a molded bakelite holder encased in a magnetic shield. The core is a split ring type with a winding on each half. The two halves with their windings are symmetrical to reduce pickup from extraneous fields. Data on the number of turns of the windings is not available, but the measured inductance is 300 mH at 1 KC.

As can be seen on the diagram of Fig. 11, four separate amplifiers are used in the complete recording system: for erasing, bias, recording, and playback respectively. Circuit diagrams for these are shown in Figs. 13, 14, 15, and 16.

The erasing amplifier, Fig. 13, and bias amplifier, Fig. 14, are similar; they consist of an inverter stage driving a push-pull power amplifier stage. The plate loads of these power stages consist of the windings of the respective heads tuned for parallel resonance at 50 KC and coupled to the plates of the tubes through suitable condensers. The small resistance in series with the bias winding provides a means of measuring bias current. Maximum values of 50 ma erasing current and 35 ma bias current were required for the heads used.

The recording amplifier, Fig. 15, also consists of an inverter and push-pull power amplifier but is coupled to the signal winding of the recording head through a transformer. It was designed to provide a constant current of 20 ma max. through the winding for constant input voltage over a frequency range of 100 to 15,000 cps. The desired constant current characteristic is obtained by providing a negative feedback voltage proportional to output current.

The playback amplifier, Fig. 16, is a two-stage R-C coupled amplifier having an essentially flat frequency response from 100 to 18,000 cps. To prevent the appearance of any 50 KC voltage from the erase or bias fields in the amplifier output, a low-pass filter with cutoff at 20 KC was added. With this filter the amplifier response at 50 KC is 50 db below that at 18 KC. Its gain at 1000 cps is 26.3 times or 28.4 db.

Results of Tests on Experimental System.

With the recording equipment described above tests were conducted with six different recording media to evaluate the performance of the equipment and determine what factors required further investigation to improve high-frequency response or resolution of discrete signals representing coded information. Up to the present time the data obtained is insufficient to allow conclusive statements to be made regarding some features of the system and recording media. Certain results however are significant.

The recording media used in the tests were all of tape form and included both powdered materials and solid metals, one of the latter being in the form of a plating on a brass tape. These tapes were the following:

	<u>DESCRIPTION</u>	<u>TYPE</u>	<u>SOURCE</u>
1.	Vicalloy	Solid metal	Bell Labs.
2.	Steel	Solid metal	Cut from a sheet found in laboratory
3.	Brush plated	Solid metal plated on brass	Brush Development Co.
4.	MMM	Powder coated on cellulose acetate film	Minn. Min'g & Mfg. Co.
5.	Brush paper	Powder coated on paper	Brush Development Co.
6.	Hyflux	Powder coated on paper	Indiana Steel Products Co.

Drawings showing cross-sectional dimensions of these tapes and the magnetic materials in them are presented in Fig. 17.

Hysteresis loops for each of the materials in tape form for a 60 cps magnetizing force were obtained by means of the B-H curve tracing equipment described in the Appendix. From these curves the following values of coercive force and residual flux density were determined.

	<u>DESCRIPTION</u>	<u>COERCIVE FORCE (H_c)</u> <u>(OERSTEDS)</u>	<u>RESIDUAL FLUX DENSITY (B_r)</u> <u>(GAUSS)</u>
1.	Vicalloy	235	8000
2.	Steel	85	6700
3.	Brush plated	215	6000
4.	MMM	345	750
5.	Brush paper	130	700
6.	Hyflux	(430)*	(1400)*

* For peak MMF of 1300 oersteds. The magnetic material in the Hyflux tape has an exceptionally high coercive force and the available magnetizing equipment would not produce sufficient MMF to saturate it. For this reason the figures given above for Hyflux are not the true values of H_c and B_r but are somewhat lower.

In Figure 18 are shown the complete hysteresis loops for these tapes all drawn to the same scale. These curves and the tabulated values of H_C and B_R obtained from them are included primarily to show the order of magnitude of the quantities being considered. Because of limitations in the test equipment, sources of error exist which have not been measured precisely. From correlation with known values, however, it is estimated that the errors do not exceed 10 percent.

All of the tests performed on the recording equipment were at a tape speed of 8"/sec, which of itself imposed an upper frequency limit of about 10,000 cps on the recording. This was done to reduce tape wear, reduce amplifier design problems, and allow use of a lower bias frequency. Neglecting second order effects, the shape of the frequency response curve is a function of tape wavelength rather than actual frequency. Therefore, tests taken at a low speed were considered to be indicative of system performance at higher speeds.

A frequency of 50 KC was used both for bias and erasing. It was observed that for ratios of bias frequency to signal frequency of less than 5, modulation effects occurred, causing distortion of the output signal.

As might be expected, the maximum level of the recording signal for distortionless recording varies with different recording media, with bias amplitude, and with recording frequency. In the tests to be described the recording signal level was kept sufficiently low to avoid serious distortion from any of these causes.

Comparative response curves for the six recording media with approximately their normal values of bias current are shown in Fig. 19. The general shape of each curve corresponds to the typical response of Fig. 6. The output levels at low frequencies to a first approximation are the comparative signal levels that can be expected from the different media. It can be seen that there is a direct relationship between these levels and the respective values of B_R previously tabulated. The curve for Brush plated tape does not show this directly since it is a narrow tape having a width roughly 1/10 that of the recording path on the other tapes. However, since the signal-to-noise level is approximately the same for all media, this difference in output level at low frequencies can be compensated for by proper amplifiers. Therefore, it is the frequency or more accurately the wavelength at which maximum response occurs and the slope of the response curve for high frequencies that indicate the merit of the recording system.

As has been pointed out previously, demagnetization in the tape and leakage flux at the recording head are principal factors causing the decrease in response at short wavelengths. Since the demagnetization factor depends on the $\frac{B_R}{H_C}$ ratio, as would be expected there is a correlation between the frequencies

at which maximum response occurs in Fig. 19 and the shape of the B-H curves of Fig. 18. The steel tape has the highest $\frac{B_r}{H_c}$ ratio and lowest maximum-response frequency, while the MMM tape has the lowest $\frac{B_r}{H_c}$ ratio and highest maximum-response frequency.

The magnitude of the drop in high-frequency response caused by leakage flux at the recording head is not evident from the response curves of Fig. 19. However, the effect of this factor is illustrated in Fig. 20 and 21, which are response curves for two recording media for different values of bias current. For the higher values of bias current, or recording MMF, the maximum-response frequency is lowered and the response curve falls more rapidly with increasing signal frequency.

Some information on the variation in frequency response with changes in bias frequency was also obtained. The tests which were made show only a comparison between bias frequencies of 50 KC and 140 KC where the magnitudes of the respective bias currents were adjusted to give equal outputs for low signal frequencies. Figure 22 shows the results for the Brush plated tape and the MMM tape which are typical of the results from all of the tapes. A slightly higher output was obtained for short wavelength signals with the higher bias frequency than with the lower bias frequency. The reason for this is not known; whether it is a function of the skin effect in the tape, the leakage flux distribution in the recording head, or the mechanism of the recording process as discussed on pages 7 and 8 must be determined by further experimentation.

Recommendations for Further Experimental Work.

The test results that have been discussed in the preceding paragraphs point out a lack of information about several factors in the recording process and suggest some changes in equipment design for studying storage methods. The most obvious fault is excessive leakage flux about the working gap of the recording head. A core material such as permendur which has a very high saturation flux density should be tried, and the tips of the core might be shaped so that they contact the tape only at the gap. This would give a somewhat longer path for the unwanted leakage flux. The effect of grinding and polishing after heat treatment on the permeability of the core tips is not known, so a means for accurate determination of flux distribution around the recording gap would be very beneficial in the design and construction of recording heads.

Since the speed at which information may be recorded on and read from a magnetic storage medium depends on the speed at which the medium is moving, tests should be conducted to determine the practical limit on operating speeds and the results of recording at such speeds. It is estimated that these speeds might be of the order of magnitude of 100 ft/sec. Such high speeds would require a redesign of the erasing head as well as the recording and playback heads. At these speeds an erasing frequency that exceeds the highest that could be recorded would not have sufficient penetration for complete erasing. For this reason, erasing or demagnetization of the medium would have to be accomplished by a low-frequency decaying field such as would be obtained by passing the wire or tape through the center of an air-cored coil. For high speed operation, of course, the recording and playback heads must be designed for the high frequencies or short pulses which would be used.

Circuits for supplying and reading the coded information to be stored should be built for use with the recording system. Although little information is available on techniques of recording pulse signals, it is reasonable to assume that the length of a recorded pulse on the medium would not exceed that required for recording the minimum number of cycles of a sinusoidal signal that would excite a tuned circuit in the reading equipment for the latter type of signal. This is assuming that sinusoidal signals of two different frequencies would be used to represent the two binary digits and that the reading equipment would contain filter circuits for separating the two frequencies. In the field of carrier telegraphy it has been found that at least 5 cycles of a sinusoidal signal are required for such selection. The use of pulse signals, therefore, should not result in a loss of recording capacity, while it allows the recording and reading circuits to be of much simpler design. The use of a high-frequency bias signal in pulse recording would be unnecessary since a linear characteristic is not required; however, the results of recording with different bias frequencies, as shown in Fig. 23, indicate that the effect on pulse amplitude of using a bias signal should be investigated.

On a flat recording medium such as a tape or disk it is possible to obtain more than one recording track. In electronic computer applications the additional tracks might be utilized for synchronizing signals or for recording additional information which is not required to be read independently of that on the parallel tracks. An estimate of the width and spacing of such tracks may be obtained from data on the Brush Development Company disk-type recorder. Using a powder-coated paper disk, it produces a sound track 0.014" wide and spacing between tracks of 0.011", or the equivalent of 40 tracks per inch. Heads with thin cores are used for obtaining these narrow tracks.

The problems of marking the location of specific information recorded on a magnetic medium and of positioning the medium for removal of that information require separate study. Multi-channel recording on a flat medium has certain advantages over single-channel recording in these respects. Some of these advantages are: (1) a separate channel might be used for synchronizing and marking signals; (2) information might be grouped on sections of the tape thus reducing the time required to position the tape for playback; (3) recording might be done in opposite directions on adjacent channels to avoid loss of time in rewinding or (4) successive signals might be recorded on separate channels to allow recording at a higher pulse repetition rate; for example, with four channels, pulses 1, 5, 9, 13 etc., would be recorded on one channel, pulses 2, 6, 10, 14, etc., would be recorded on another channel, pulses 3, 7, 11, 15 etc. would be recorded on a third, and pulses 4, 8, 12, 16 etc., would be recorded on the fourth channel. The solid metal tapes providing several channels also are stronger than wire media so would be desirable where rapid positioning of the medium places considerable stress upon it.

Report R-14

Page 17

The problem of positioning the recording medium is one of mechanical design as well as electrical control. The solution may lie in a suitable application of servomechanism principles or in the construction of a satisfactory system of clutches to engage the tape or wire system with a rotating drive shaft as desired.

Written by E. S. Rish
Approved by Jay W. Forester

- References:
- Selby, M. C., "Investigation of Magnetic Tape Recorders," Electronics, Vol. 17, No. 5, (May 1944) pp. 133-135
- Holmes, L. C., and Clark, D. L., "Supersonic Bias for Magnetic Recording," Electronics, Vol. 18, No. 7, (July 1945) pp. 126-136
- Woolbridge, D. E., "Signal and Noise Levels in Magnetic Tape Recording", AIEE Trans., Vol 65, No. 6 (June 1940) pp. 343-352
- Camras, M., "Theoretical Response from a Magnetic Wire Record." IRE Proc., Vol. 34, No. 6, (August 1946) pp. 597-602
- Begun, S. J., "Recent Developments in Field of Magnetic Recording." SMPE Journ., Vol. 48, No. 1, (January 1947) pp. 1-12
- Camras, M., "Magnetic Sound for Motion Pictures", SMPE Journ., Vol. 48, No. 1 (January 1947) pp. 14-24.
- Howell, H. A., "Magnetic Sound Recording on Coated Paper Tape". SMPE Jour., Vol. 48, No. 1 (January 1947) pp. 36-45.
- Tinkham, R. J., and Boyers, J. S., "A Magnetic Sound Recorder of Advanced Design". SMPE Journ., Vol. 48, No. 1 (January 1947) pp. 29-35
- OSRD Report No. 5325, June 30, 1945

APPENDIXB-H Curve tracer

To provide a means for comparing hysteresis loops of various magnetic recording tapes, equipment for tracing B-H curves on a cathode-ray oscilloscope was developed. It consists of a magnetizing solenoid wound on a cylindrical tube which will allow insertion of a pickup coil down the center of the tube, and suitable circuits to give the desired horizontal and vertical deflections on the cathode ray oscilloscope (CRO). A diagram of the magnetizing coil is shown in Fig. 23. The pickup coil is wound on a slotted form so that a length of the tape to be tested can easily be threaded through it. When in position for making tests, then, the pickup coil is moved to the center of the magnetizing coil and the tape passes through both coils.

The theory of the operation of the equipment is as follows. A 60-cycle sinusoidal magnetizing force is generated in the magnetizing coil by passing 60-cycle current through its winding. Since the magnetizing force is proportional to the current flowing, the voltage drop across a resistance in series with the coil is proportional to H and can be used to give the horizontal deflection on the CRO. Furthermore the voltage induced in the pickup coil is proportional to the rate of change of flux through it, so the integral of this voltage is proportional to the flux through the pickup coil. If this flux were entirely within the tape, then this integrated voltage would also be proportional to the desired value of flux density, B, and could be used to give the vertical deflection on the CRO. The pickup coil used, however, necessarily had a cross-sectional area several times that of a tape, so that the actual flux in the tape is only a fraction of the total flux through the coil. For this reason a second pickup coil similar to the first but without a slot was placed beside the slotted coil in the magnetizing field. By connecting the two pickup coils in a suitable balancing circuit, a resultant voltage proportional to the flux through the tape alone is obtained. The integral of this voltage, then, is proportional to the flux density in the tape.

Since the cross-sectional area of the magnetic material in the tape is not the same for all tapes, the circuit must be balanced for each measurement. To accomplish this a calibrating coil was also mounted with the pick-up coils. This calibrating coil was constructed to produce a voltage equal to that generated in the slotted pickup coil if it had a cross-section of $1/4" \times 0.002"$, or the dimensions of an average tape. Calibration thus consists of adjusting the output of the pickup coils to be the proper fraction of the voltage from the calibrating coil, this fraction being determined by the ratio of the tape area to the average area of 0.0005 sq. in. The construction of the complete pickup coil assembly is shown in Fig. 24.

Circuit diagrams of the amplifiers used with the B-H curve tracing equipment are shown in Figures 25 and 26. The H-amplifier (Fig. 25) consists of a single stage with a phase-shift control. It has a gain of 9. The B-amplifier (Fig. 26) contains a two-stage preamplifier, an R-C integrating

circuit, and a three-stage final amplifier. When measurements are being taken on solid metal tapes having a high flux density, the preamplifier is not required and may be switched out. The measured values of gain at 60 cps are 40 for the preamplifier, 1/165 for the integrator, and 3680 for the final amplifier, or an overall gain of 892.0. The requirements of high gain and zero phase shift over a band of frequencies necessitated careful design of the amplifiers. Compensating circuits and negative feedback were used to obtain the required phase characteristic. It was found necessary to use a d-c filament voltage because even small amounts of pickup from a 60-cycle filament current caused objectionable distortion in the curves traced on the CRO.

The procedure for making a hysteresis-loop measurement and determining the scale factors is as follows: A schematic diagram of the equipment is shown in Fig. 27. The pickup coil assembly without the tape sample is positioned at the center of the magnetizing coil and the switches are adjusted so that the output of the calibrating coil appears as the vertical deflection on the CRO. This deflection is adjusted to a convenient value by means of the gain control on the CRO. The calibrate switch is then thrown to its "test" position and the balance control adjusted until the vertical deflection is the proper fraction of that observed for the "calibrate" position this fraction being determined from the cross-sectional area of the magnetic material in the tape in the manner previously described. The phase control is now adjusted so that the trace on the CRO is a single straight line. Next the tape to be tested is inserted into the pickup coil. It should be long enough so that it extends a few inches beyond either end of the magnetizing coil. Suitable adjustment of the gain controls gives the desired B-H curve for the tape.

The horizontal scale factor for the B-H curve obtained is determined in the following manner: The output of the calibrating coil is measured with a voltmeter for the same magnetizing current as used in the test. This voltage, e_c , is

$$e_c = N_c A_c \frac{dB}{dt} \times 10^{-8} = N_c A_c \omega B_{cm} \cos \omega t \times 10^{-8} \quad (1)$$

where N_c is the number of turns on the calibrating coil, A_c is the cross-sectional area of this coil, and B_{cm} is the maximum value of flux density in it. Solving for B_{cm} and substituting constant values gives

$$B_{cm} = 3.9 \times 10^4 E_c \quad (2)$$

where E_c is the r.m.s. value of e_c .

The magnetizing force, H , is numerically equal to E , so if d_H is the peak-to-peak horizontal deflection, the desired scale factor for the abscissa,

S_H is

$$S_H = \frac{3.9 \times 10^4}{d_H/2} E_C = 7.8 \times 10^4 \frac{E_C}{d_H} \text{ oersteds per unit distance} \quad (3)$$

To determine the vertical scale factor, the peak-to-peak horizontal and vertical deflections of the B-H curve are observed. The horizontal deflection should be the same as that for which E_C was measured. Then the magnetizing force is removed and a 60 cps voltage from an oscillator or a potentiometer placed across the power line is applied to the amplifier input. The magnitude of the voltage required to produce a vertical deflection equal to the horizontal deflection observed for the B-H curve is measured with a voltmeter. Let the r.m.s. value of this voltage be V .

It is evident that if this value of V is equal to E_C then the vertical scale factor, S_V , for a tape of average cross-sectional area is the same as the horizontal scale factor or

$$S_V = 7.8 \times 10^4 \frac{E_C}{d_H} \text{ gaussses per unit distance} \quad (4)$$

For V not equal to E_C , S_V is changed in the ratio of $\frac{V}{E_C}$ so

$$S_V = 7.8 \times 10^4 \frac{E_C}{d_H} \times \frac{V}{E_C} = 7.8 \times 10^4 \frac{V}{d_H} \text{ gaussses per unit distance} \quad (5)$$

However, since E_C , and hence V , depends on the total effective flux through the pickup coils and not on the flux density alone, the factor relating the cross-sectional area of the tape, A_T , to the average area, A_A , which was used in the balancing step must be included in the expression for S_V . Therefore the complete expression for the vertical scale factor is

$$S_V = 7.8 \times 10^4 \frac{A_A}{A_T} \frac{V}{d_H} \text{ gaussses per unit distance}$$

In the operation of this equipment certain limitations were noted which might be removed by a change in design. The most objectionable defect is the tendency for the CRO trace to drift up and down on the face of the tube. When tapes requiring a low vertical gain setting are being tested, this drifting is slow and of small magnitude, but with high vertical gain settings it is rapid and of considerable amplitude. This jumping is caused by fluctuations in the supply voltage which produce spurious signals at the plate of the first tube. These signals are passed on to succeeding stages by the high-time-constant coupling networks. A regulated a-c supply and extremely stable d-c supply would be required to eliminate this drifting.

The presence of harmonics in the 60-cycle magnetizing current also is objectionable. These harmonics change the shape of the B-H curve and result in an incorrect B-H curve measurement.

Report R-124

Page 22

For tests on tapes with small cross-sectional areas, an additional calibrating coil corresponding to a smaller area than the one described would provide more accurate balance adjustments.

The use of a higher-frequency magnetizing current would be very desirable in many respects. In particular it would permit simpler amplifier design, require less amplification, and reduce the tendency for the pattern on the oscilloscope screen to drift. The 400-cycle power available in the laboratory was ruled out, however, because of its high harmonic content.

TABLE OF SYMBOLS AND DEFINITIONS

<u>SYMBOL OR TERM</u>	<u>DEFINITION</u>
MMF	Magnetonotive force.
oersted	Unit of magnetic field intensity or magnetizing force.
gauss	Unit of magnetic flux density.
H	Magnetic field intensity.
B	Magnetic flux density.
H_c - coercive force	The magnitude of the magnetizing force at which the flux density is zero when a magnetic material is being symmetrically cyclically magnetized.
B_R - residual flux density	The value of flux density for the condition of zero magnetizing force when the material is being symmetrically cyclically magnetized.
B-H curves	A plot of the flux density in a magnetic material as a function of magnetizing force.
μ - permeability	Ratio of flux density to magnetizing force.
μ_i - initial permeability	Ratio of flux density to magnetizing force for very small values of magnetizing force.
μ_m - maximum permeability	Maximum value of $\frac{B}{H}$ that occurs as the flux density in a magnetic material is increased from zero to saturation.
Saturation	Condition that exists when flux density has been increased to the point where the permeability is equal to unity.
Saturation flux density	Flux density at which the permeability drops to unity.
Flux linkages	Product of total flux passing through a coil times the number of turns in the coil.

DESCRIPTION OF MAGNETIC MATERIALS

<u>Material</u>	<u>Composition</u>	<u>Properties</u>	<u>Source</u>
Mo-Permalloy	Fe, 16.4% Ni, 79.0% Mo, 4.0% Mn, 0.6%	μ_i , 22,000 μ_m , 72,000 B_R , 5,000 gaussess H_C , 0.05 oersteds ρ , 55 μ ohm/cm Saturation flux density, 8500 gaussess Hysteresis loss at saturation 200 ergs/cc	Allegheny Ludlum Steel Corp. Brackenridge, Pa. Mr. William S. Spring Electrical Sales Eng.
Vanadium Permendur	Fe, 49.0% Co, 49.0% V, 2.0%	i , 800 m , 4500 B_R , 14,000 gaussess H_C , 2.0 oersteds ρ , 26 μ ohm/cm Saturation flux density, 24,000 gaussess Hysteresis loss at saturation, 6000 ergs/cc	(Same as for Mo-Permalloy)
Hipersil*	Fe, 96-97% Si, 3-4%	B_R , 17,400 gaussess H_C , 2 oersteds (approx) ρ , 58 μ ohm/cm Saturation flux density, 20,000 gaussess Hysteresis loss at saturation, 5000 ergs/cc	(None of this material was purchased)
Vicalloy	Va, 6-10% Co, 36-52% Fe, 30-52%	H_C , 200-400 oersteds B_R , 5000-9600 gaussess	Western Elec. Co. 195 Broadway, N.Y.C. Mr. O. Correntor Coordinator of College Relations
Brush plated Tape	Co, 80% Ni, 20% (plating)	H_C , 200 oersteds B_R , 6000-10,000 gaussess	Brush Development Co. 3405 Perkins Avenue Cleveland, Ohio
Brush Paper Tape	Powdered magnetite coating, particle diameters less than 1 micron	H_C , 100-200 oersteds B_R , 400-700 gaussess	(Same as for Brush Plated tape)

<u>Material</u>	<u>Composition</u>	<u>Properties</u>	<u>Source</u>
Hyflux Tape	Metallic powder coating, composition unknown, particle diameters less than 1 micron.	H_c , 300-550 oersteds B_R , 500-1500 gauss	Mr. John P. Manley The Indiana Steel Products Co. 58 Park Sq. Bldg. Boston, Mass.
MMM Tape	Powder coating, composition unknown.	H_c , 350 oersteds B_R , 750 gauss	Mr. McKnight Minnesota Mining & Mfg. Co. 51 Sleeper Street Boston, Mass.

- * Manufacturing process produces orientation of crystals so that there is a preferred direction of magnetization in the material. Therefore the material must be used so that the flux path is in this preferred direction.

List of Drawings

Figure number	Drawing number
1	A-30951
2	A-30952
3	A-30953
4	A-30954
5	B-30955
6	A-38293-G
7	A-30956
8	A-30957
9	A-30996
10	A-30997
11	A-30958
12	A-30959
13	A-30960
14	A-30961
15	A-30962
16	A-30963
17	A-30964
18	A-38294-G
19	A-38295-G
20	A-38296-G
21	A-38297-G
22	A-38298-G
23	A-30965
24	A-30966
25	A-30967
26	B-30968
27	A-30969

USED IN 6345 REPORT OF R-124

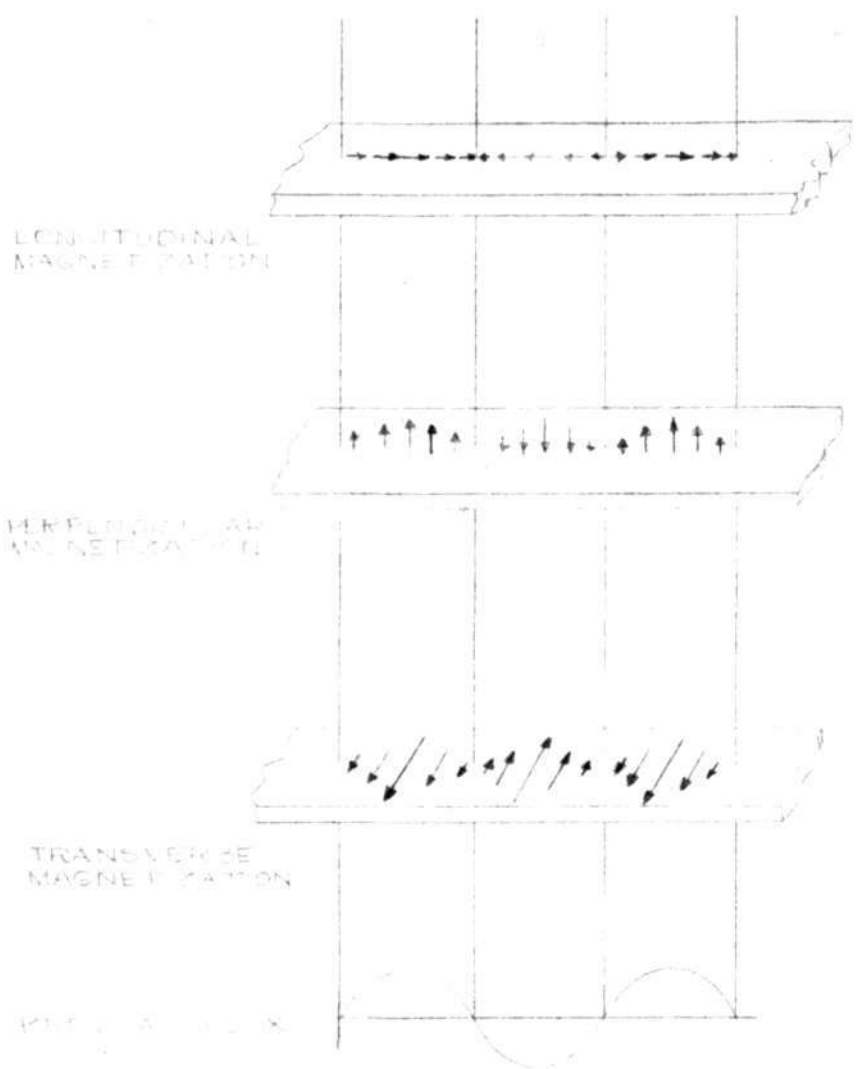
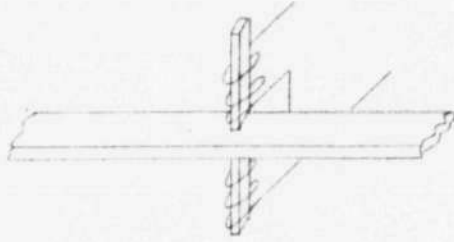
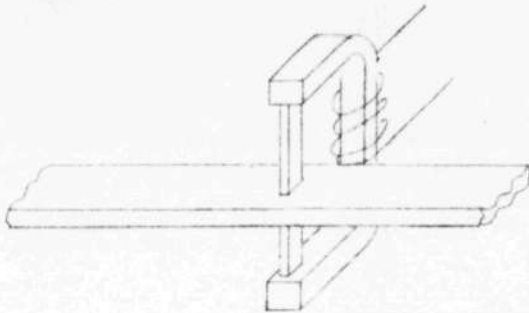

FIG. 1 TYPES OF MAGNETIC RECORDINGS. ARROWS INDICATE DIRECTION AND MAGNITUDE OF FLUX IN SECTIONS OF THE RECORDING MEDIUM.

A-30951



(a) POLE PIECES WITH OPEN MAGNETIC CIRCUIT



(b) POLE PIECES WITH CLOSED MAGNETIC CIRCUIT

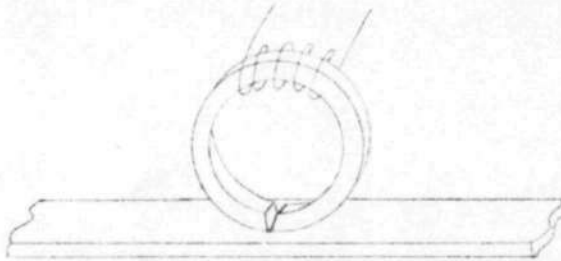

(c) RING TYPE CORE

FIG. 2. TYPES OF CORE CONSTRUCTION FOR HEADS USED IN A MAGNETIC RECORDING SYSTEM.

USED IN 6345 REPORT NO. R-124

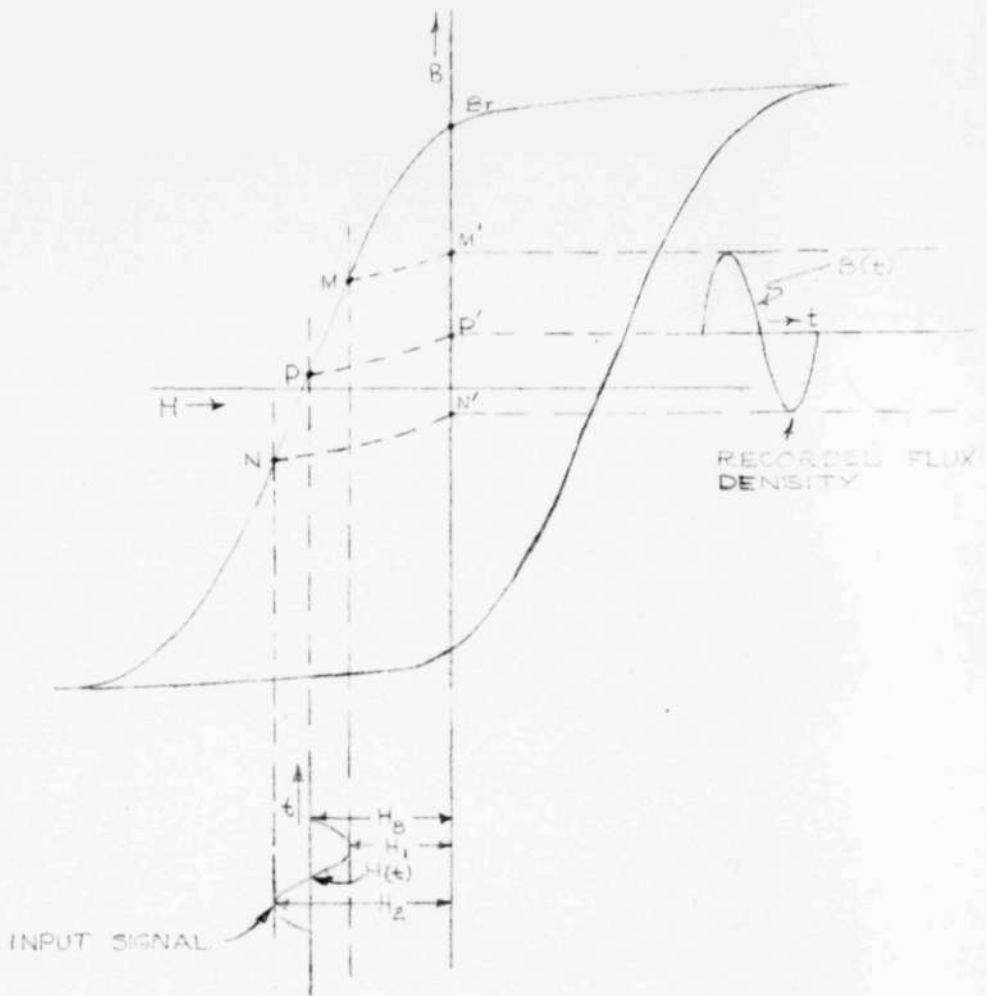

FIG. 4. RELATIONSHIP BETWEEN INPUT SIGNAL AND RECORDED FLUX DENSITY FOR THE D.C. BIAS METHOD OF RECORDING.

A-30954

USED IN 6345-REPORT NO R-124

B-300

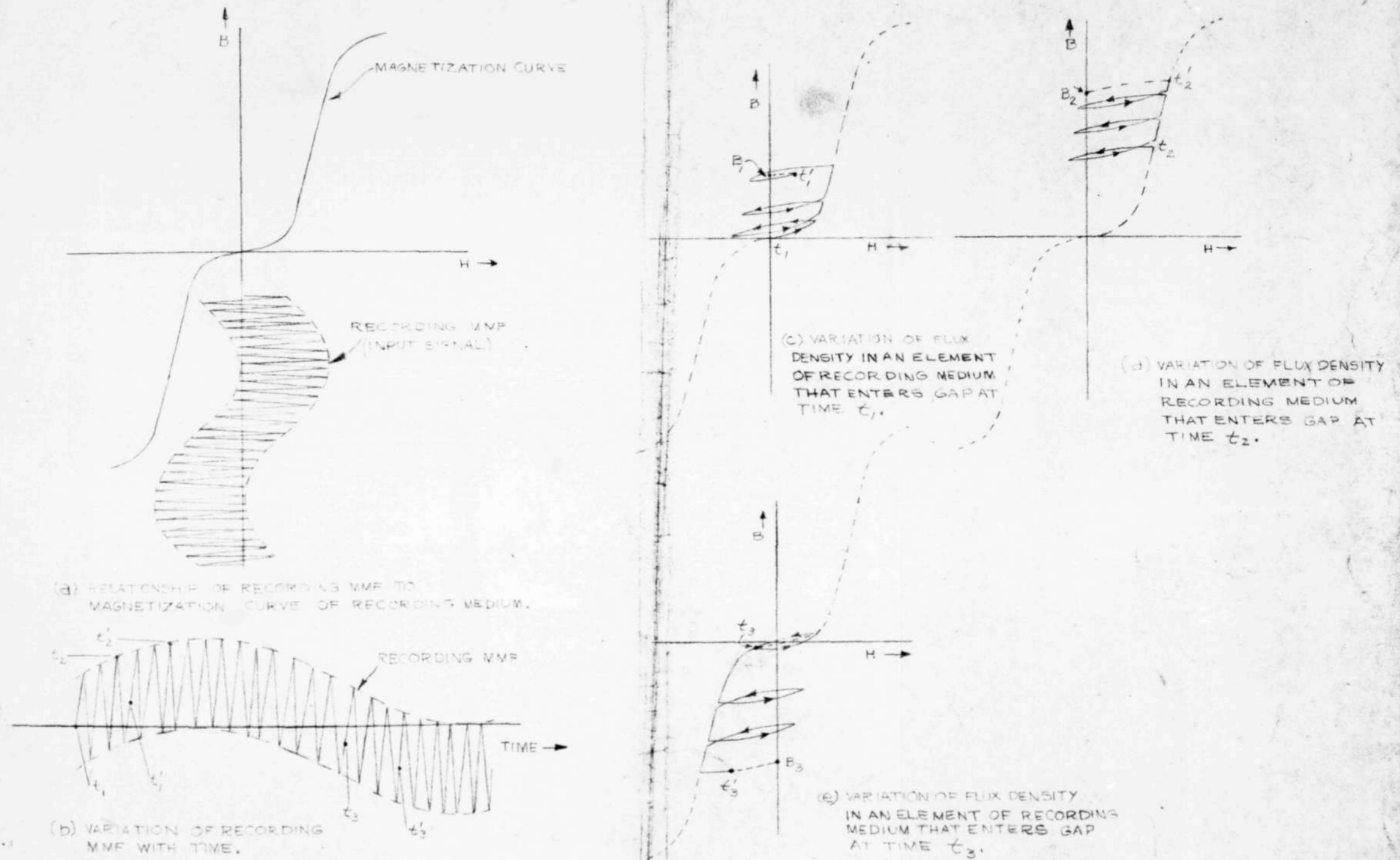
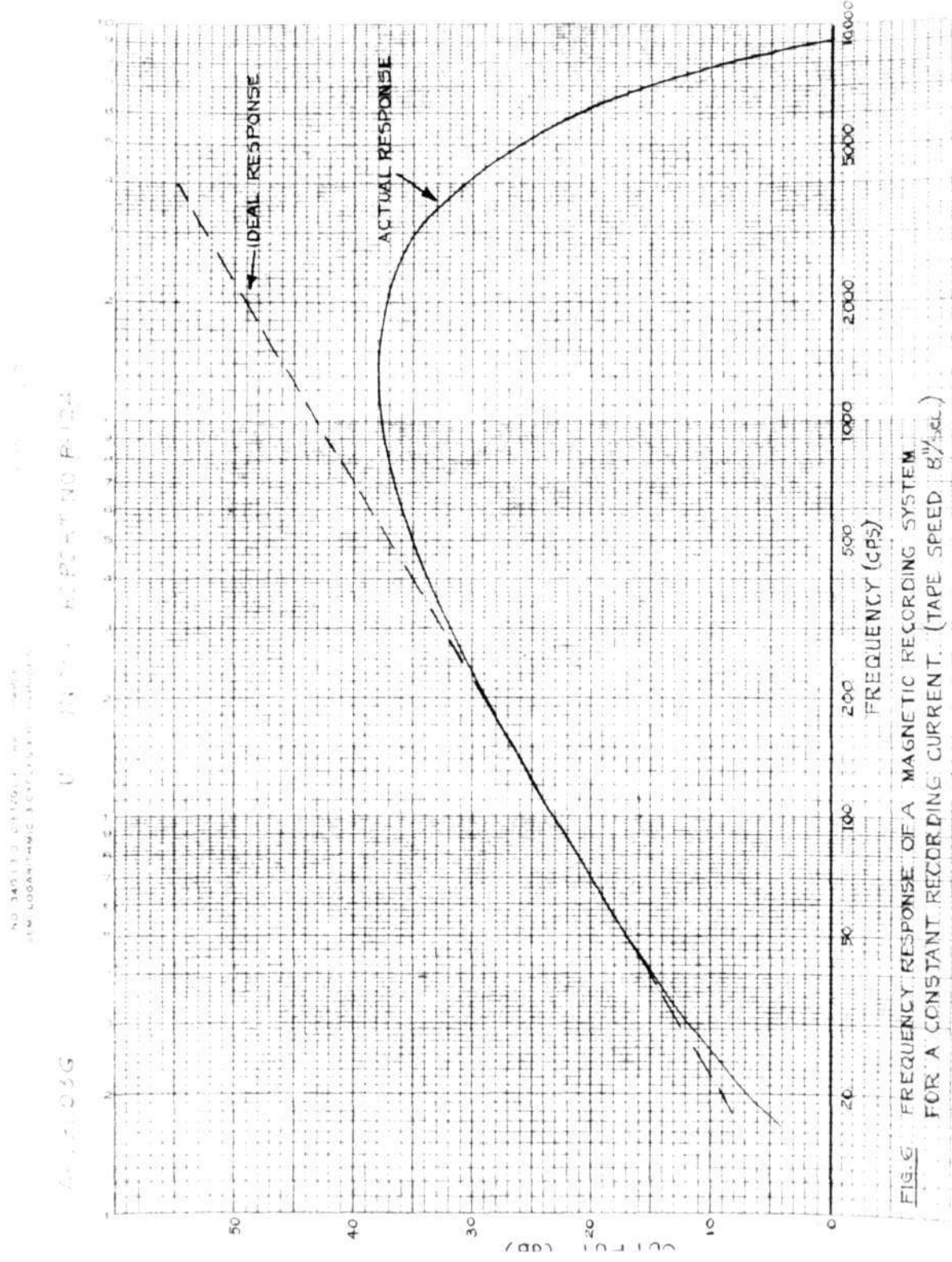
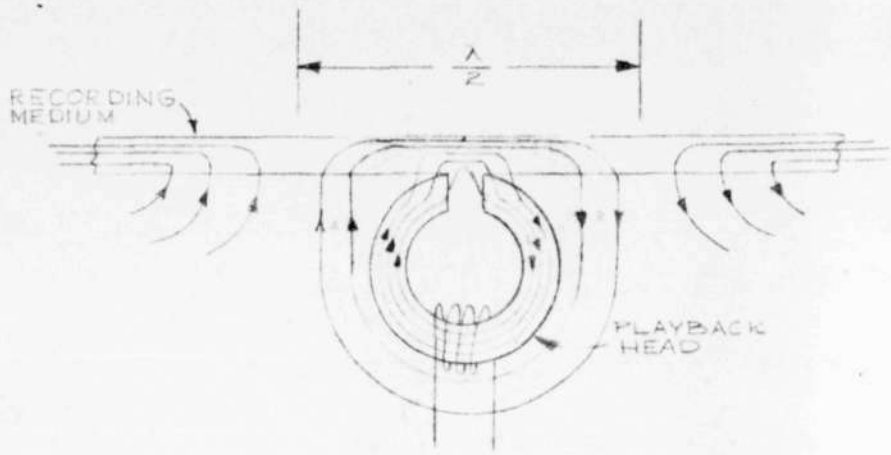
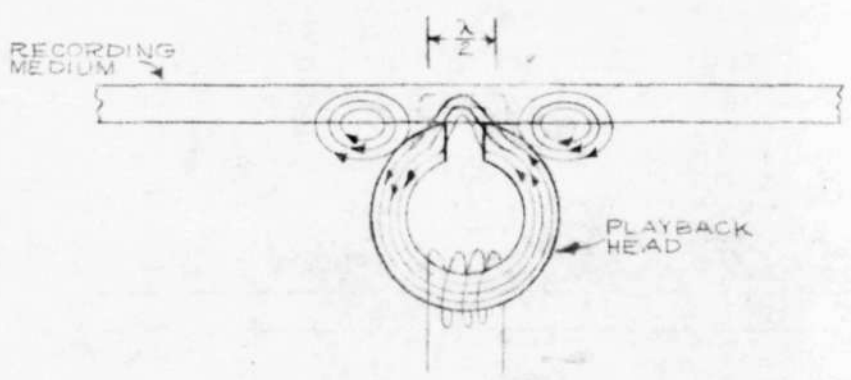

FIG. 5. RELATIONSHIP BETWEEN INPUT SIGNAL AND RECORDED FLUX DENSITY FOR THE A-C BIAS METHOD OF RECORDING.





(a) FLUX LINKAGES IN PLAYBACK HEAD FOR LONG WAVELENGTHS OF RECORDED SIGNAL.



(b) FLUX LINKAGES IN PLAYBACK HEAD FOR SHORT WAVELENGTHS OF RECORDED SIGNAL.

FIG. 7. FLUX DISTRIBUTION AROUND THE GAP OF A RING-TYPE PLAYBACK HEAD.

USED IN G345 REF. RT NO. R-124

A-309-6

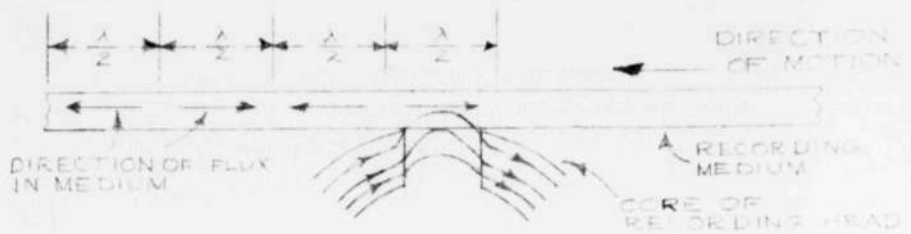

(a) FLUX CONFINED TO REGION BETWEEN GAP FACES.

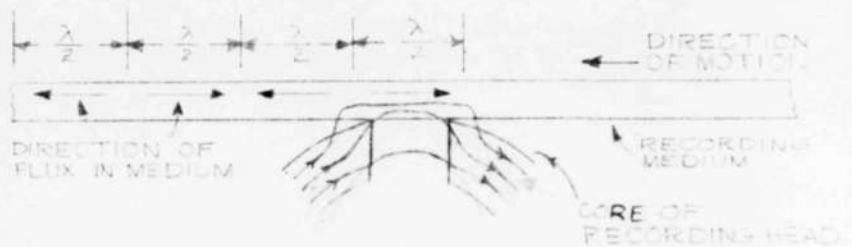

(b) LEAKAGE FLUX SPREADING BEYOND REGION BETWEEN GAP FACES.

FIG. 8. FLUX DISTRIBUTION AT GAP OF RING-TYPE RECORDING HEAD.

FIG. 4: FRONT VIEW OF EXPERIMENTAL
MAGNETIC RECORDING APPARATUS



1-30996

FIG. 10. REAR VIEW OF EXPERIMENTAL MAGNETIC RECORDING APPARATUS.



A-30997

APPROVED FOR PUBLIC RELEASE. CASE 06-1104.

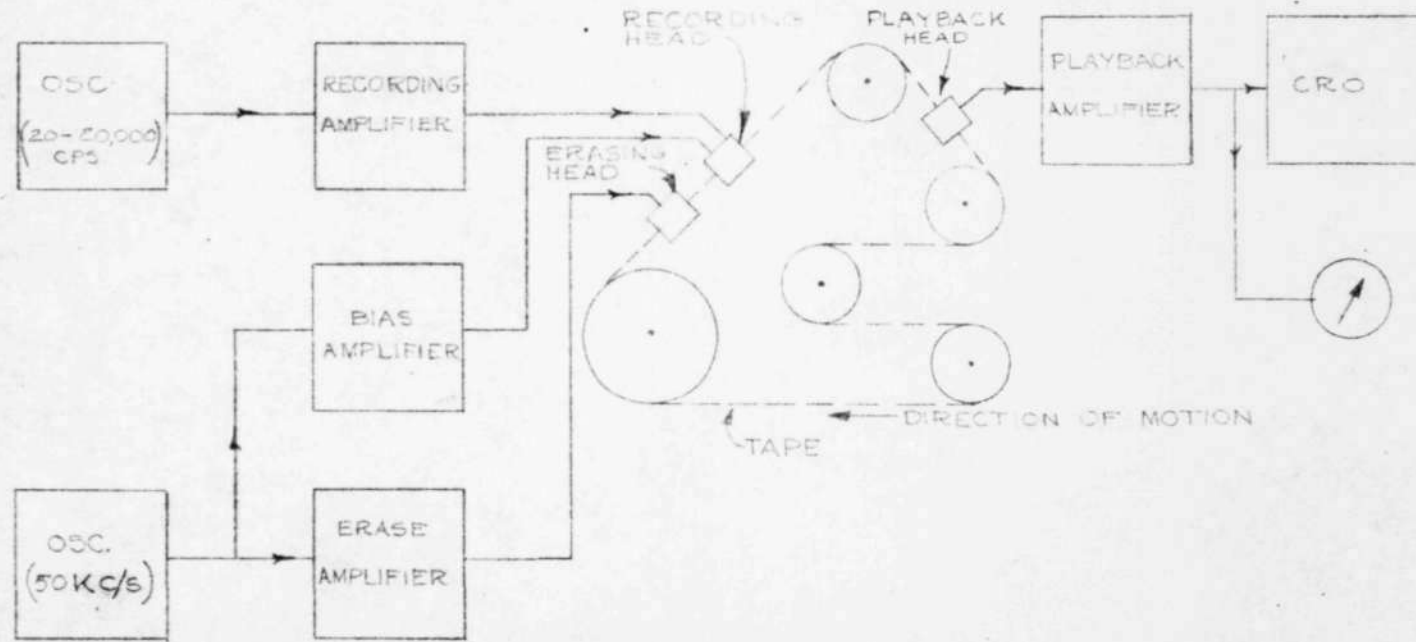

FIG. 11. SCHEMATIC DIAGRAM OF COMPLETE EXPERIMENTAL MAGNETIC RECORDING SYSTEM.

USED IN 6345 F PORT NO. R-124

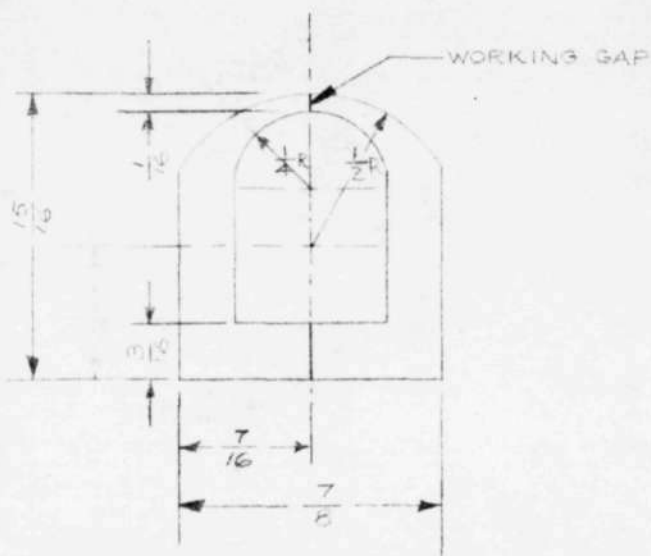

FIG. 12. SHAPE OF LAMINATIONS IN CORE OF RECORDING HEAD.

A-309 3

USED IN 6345 REPORT NO R-124

A-3096C

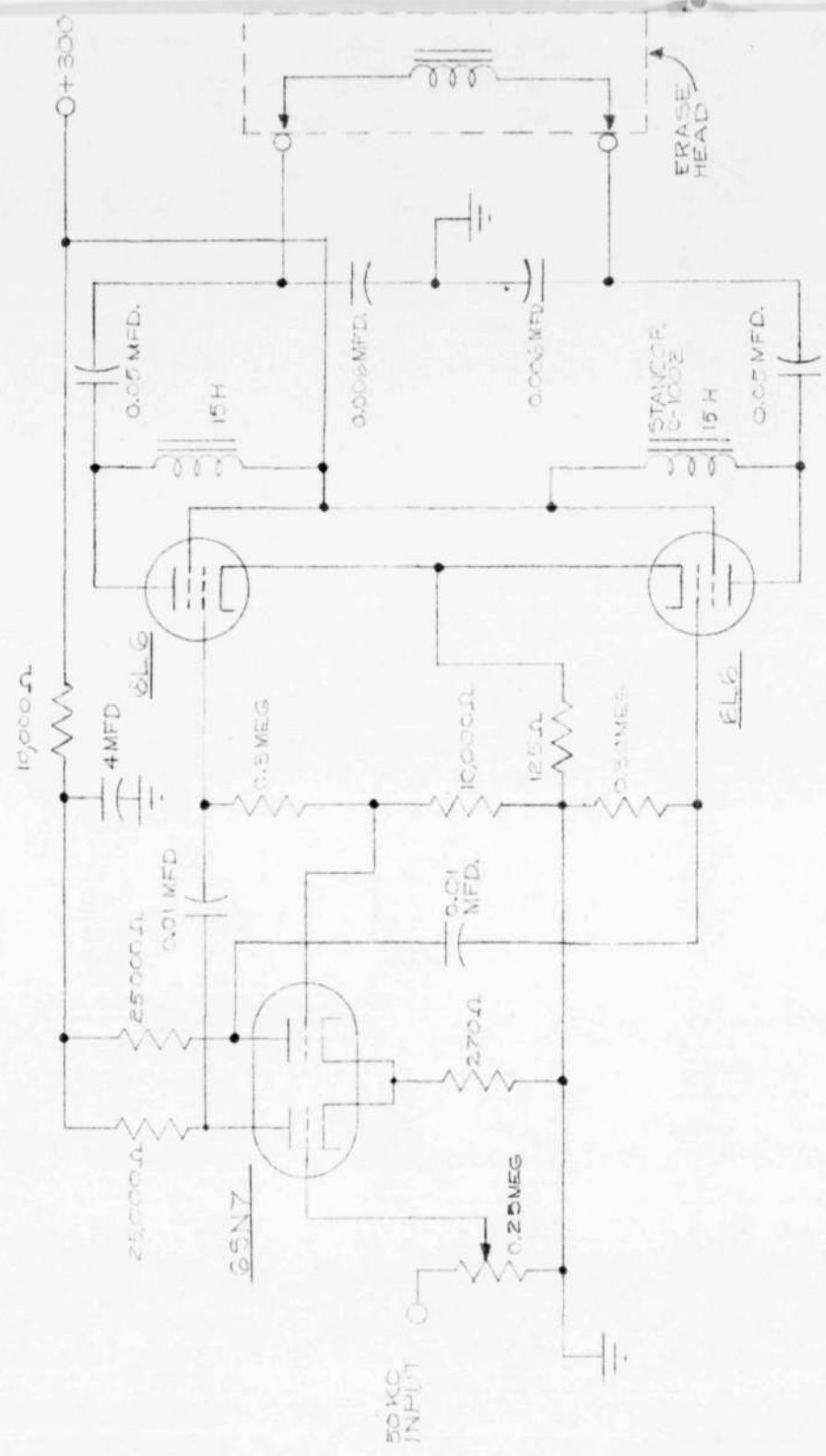

FIG. 13. CIRCUIT DIAGRAM OF ERASING AMPLIFIER.

APPROVED FOR PUBLIC RELEASE. CASE 06-1104.

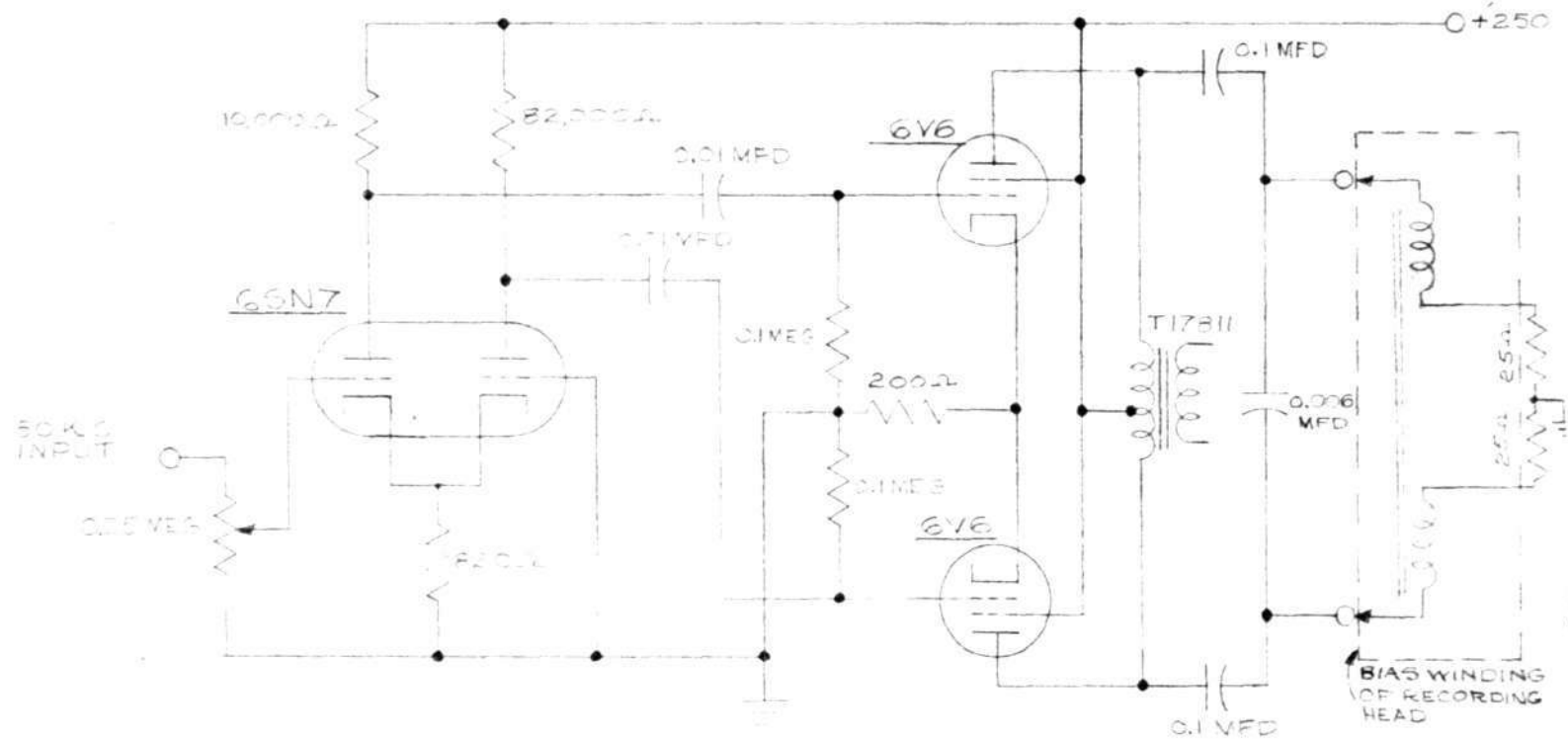

FIG. 14. CIRCUIT DIAGRAM OF BIAS AMPLIFIER.

APPROVED FOR PUBLIC RELEASE. CASE 06-1104.

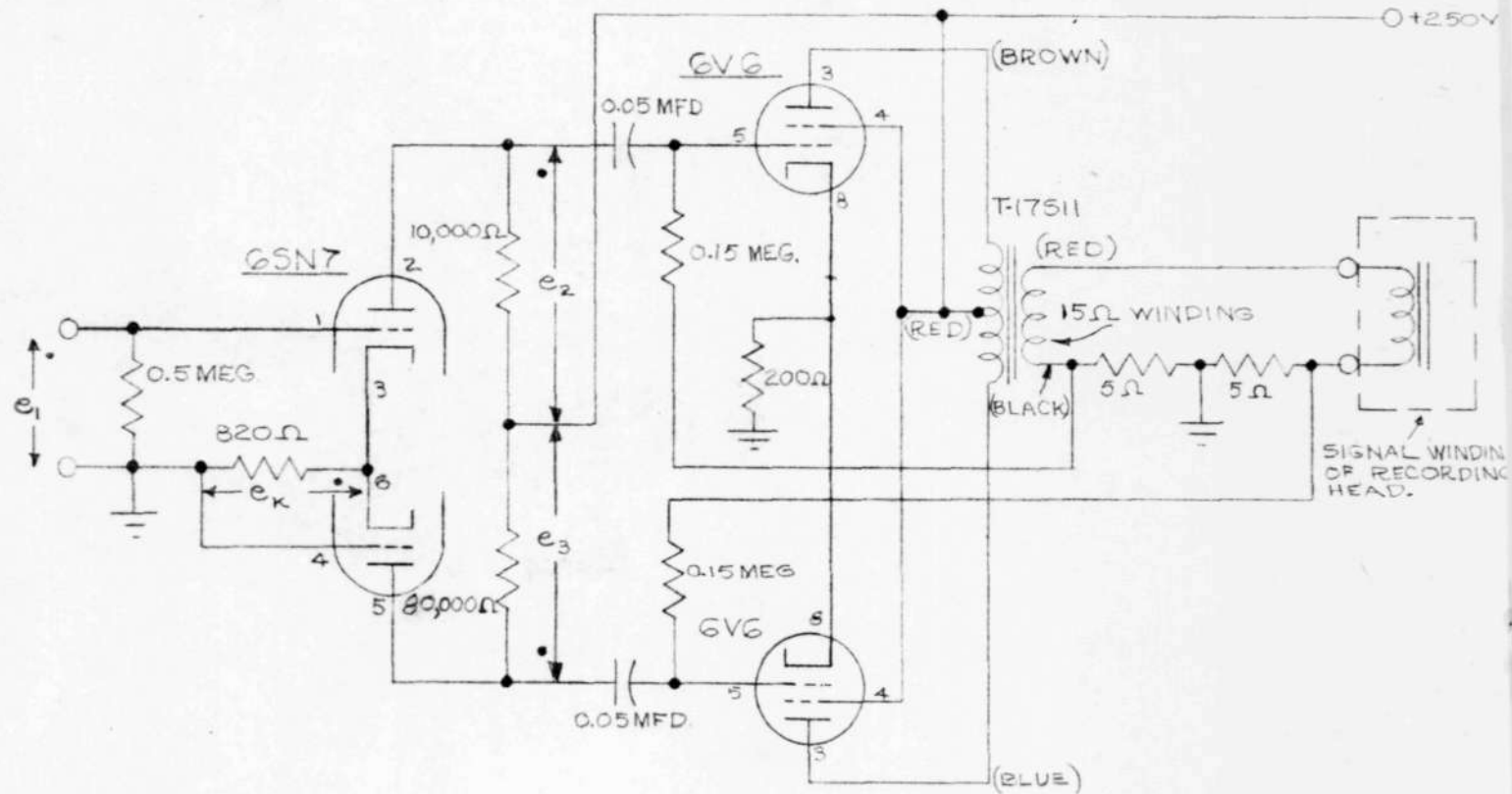

FIG. 15. CIRCUIT DIAGRAM OF RECORDING AMPLIFIER.

A-309

USED IN 6345 REPORT NO R-124

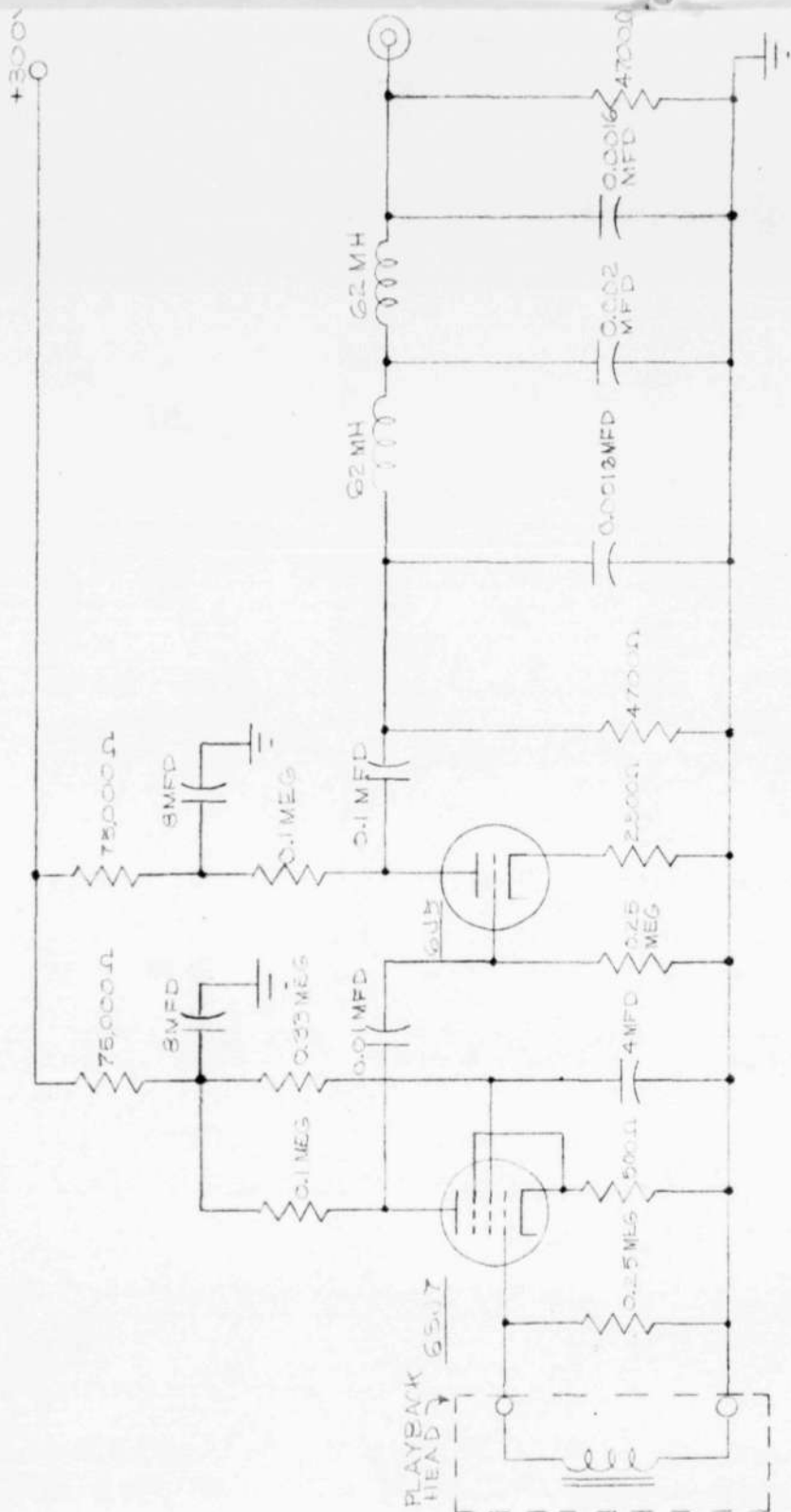
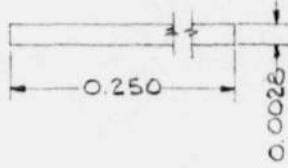
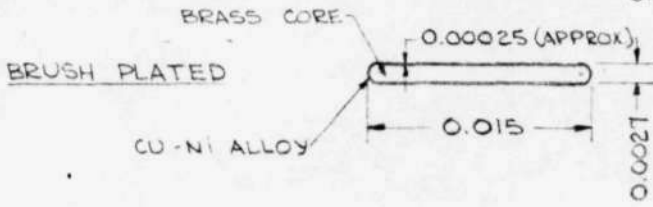
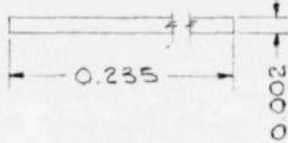

FIG. 16. CIRCUIT DIAGRAM OF PLAYBACK AMPLIFIER.

VICALLOY



STEEL



MMM

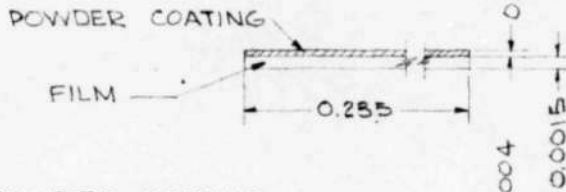

BRUSH PAPER

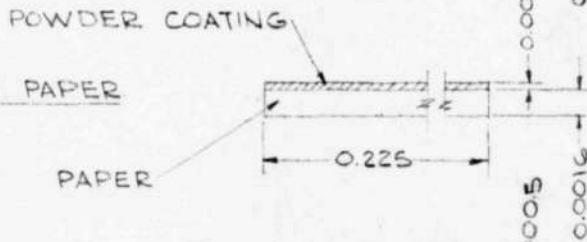

HYFLUX

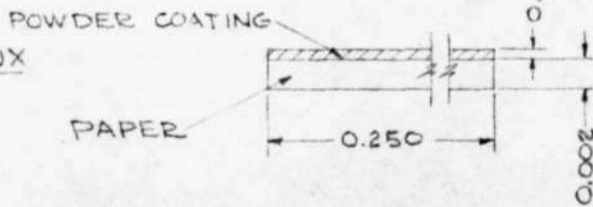

FIG. 17 CROSS-SECTIONS OF TAPES FOR MAGNETIC RECORDING

USED IN 6345 REPC T NO. R.124

A-309. 1

ADVALEX ELECTRON CO
NEW YORK, N. Y.

USED IN 6345 REPORT NO R-124

NO. 14110 DIETZEN GRAPH PAPER
10 X 12 PER. 5014

A-38294G

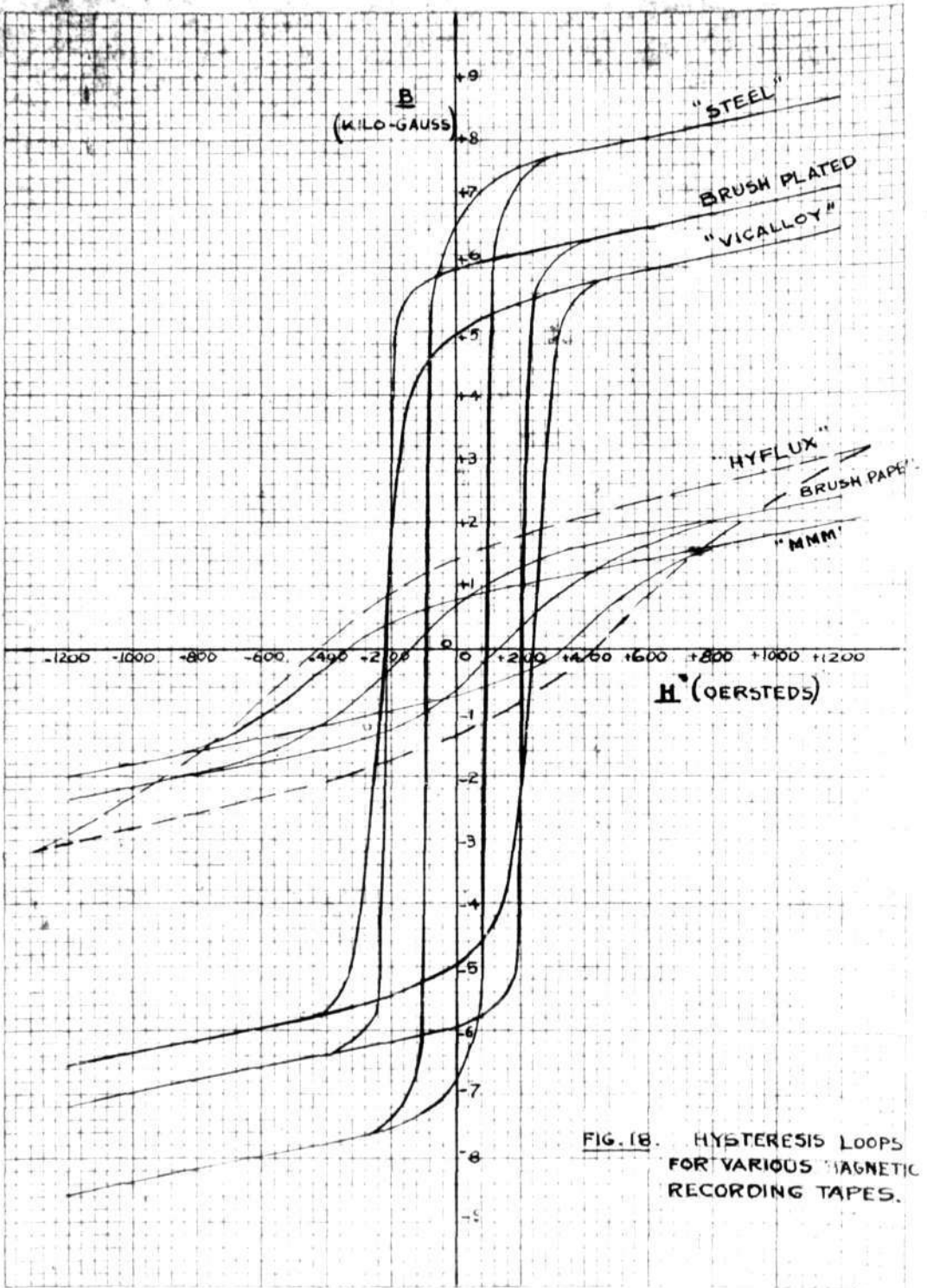

FIG. 18. HYSTERESIS LOOPS FOR VARIOUS MAGNETIC RECORDING TAPES.

NO. 340-1310 DIETZGEN GRAPH PAPER
SEMI-LOGARITHMIC, 3 CYCLES X 10 DIVISIONS
KURENE, JOHNSTON, CO.

A-38295G USED IN 6345 REPORT NO. R-124

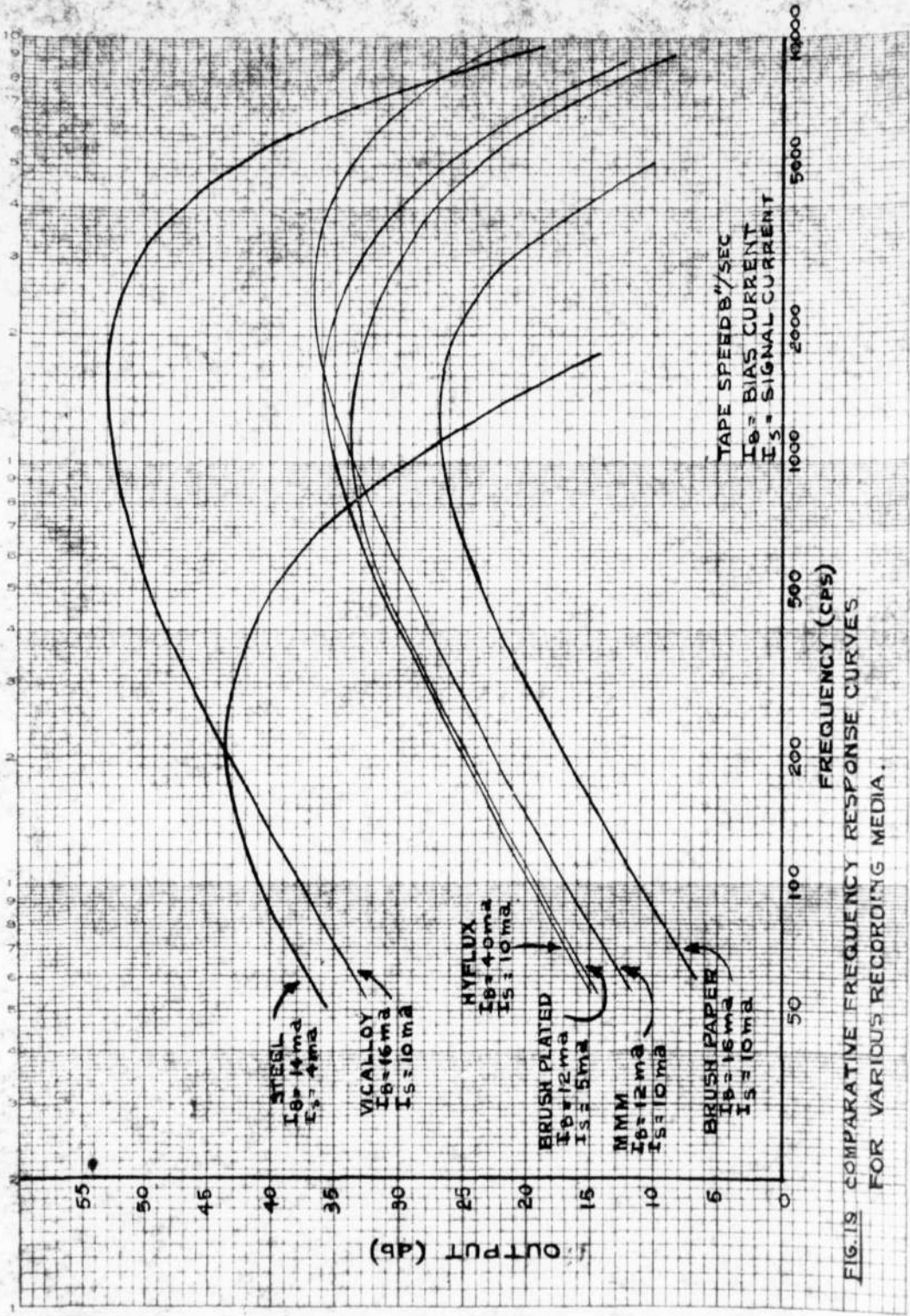

FIG. 19 COMPARATIVE FREQUENCY RESPONSE CURVES FOR VARIOUS RECORDING MEDIA.

APPROVED FOR PUBLIC RELEASE. CASE 06-1104.

A-38296G

USED IN CS45 REPORT NO. R-124

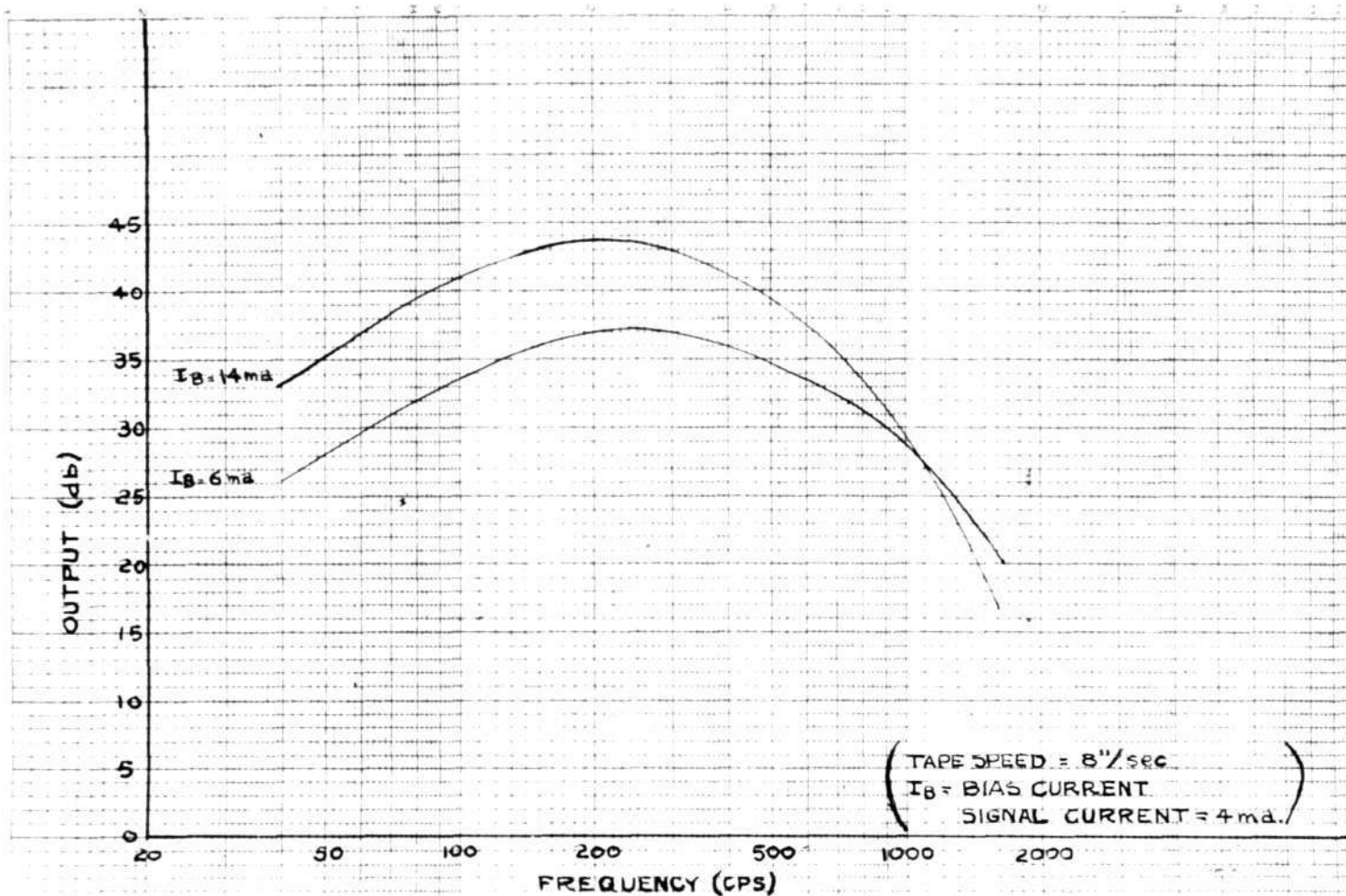

FIG.20. FREQUENCY RESPONSE OF "STEEL" TAPE FOR TWO VALUES OF BIAS CURRENT

NO. 340 L310 DIEZIGEN GRAHNS PAPER
SEMI-LOGARITHMIC CYCLES A 10 DIVISIONS

A-38297G

USED IN 6345 REPORT NO. R-124

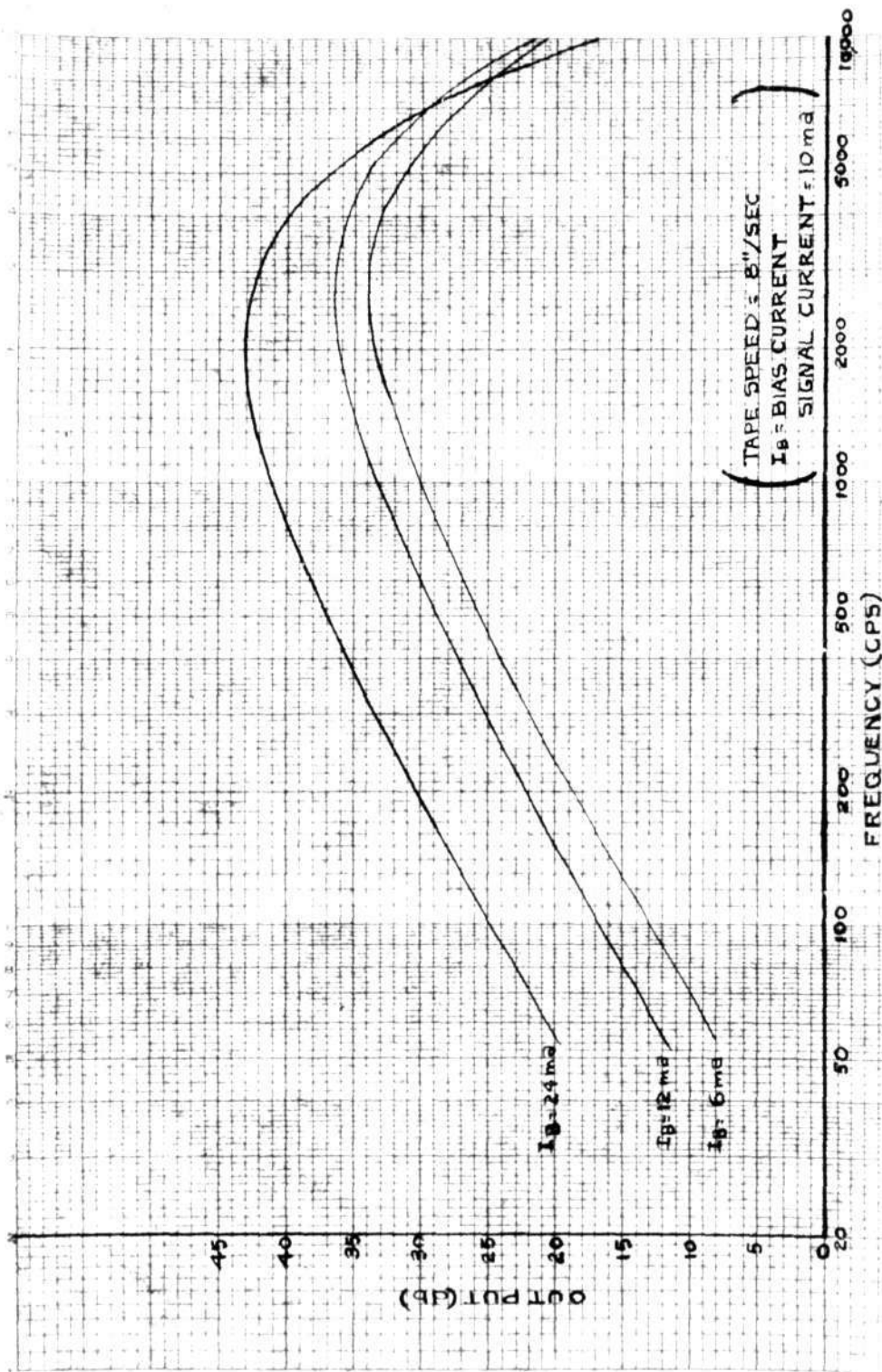

FIG. 21. FREQUENCY RESPONSE OF "MM" TAPE FOR THREE VALUES OF BIAS CURRENT.

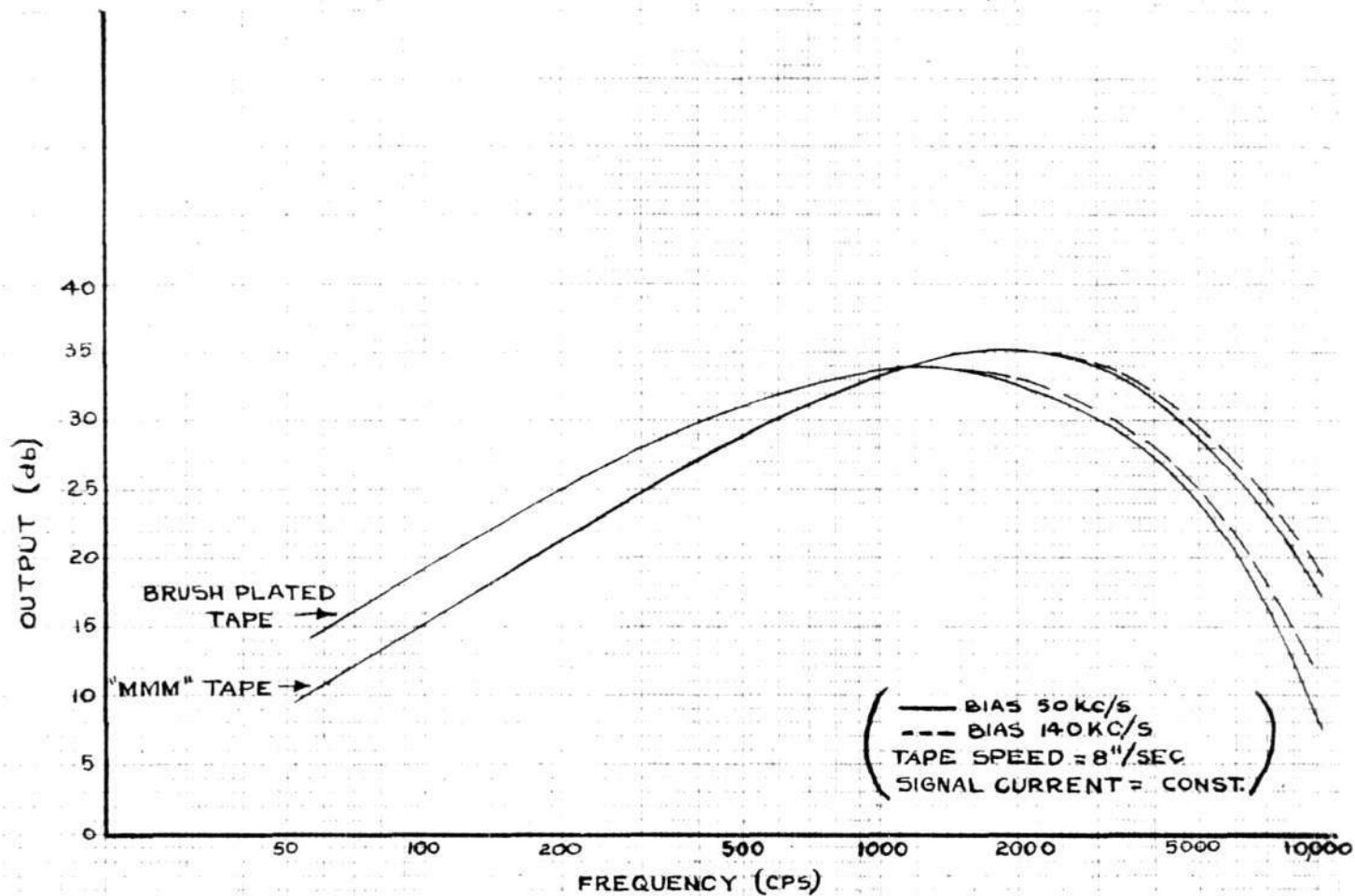

FIG. 22. VARIATION OF FREQUENCY RESPONSE OF RECORDING MEDIA WITH CHANGE IN BIAS FREQUENCY.

COIL WINDING
3385 TURNS OF #18 WIRE

BAKELITE TUBING
 $\frac{3}{8}$ " I.D. X $\frac{5}{8}$ " O.D.

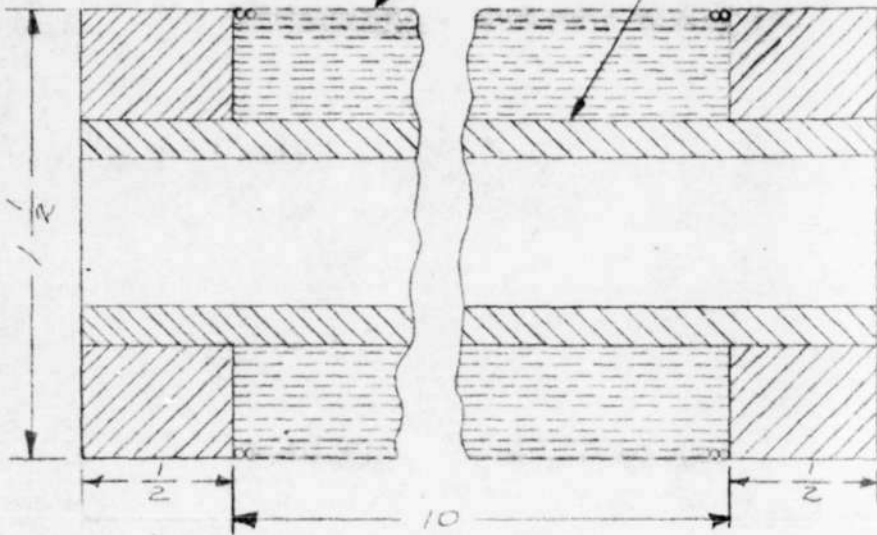

FIG. 23. MAGNETIZING COIL FOR B-H CURVE TRACER.

USED IN 6345 REF. RT. NO. R-124

A-30. 55

USED IN 6345 RE RT NO R-124

WINDINGS PICKUP COILS - 300 TURNS OF #40 ENAMELED WIRE ON EACH
CALIBRATE COIL - 52 TURNS OF #40 ENAMELED WIRE

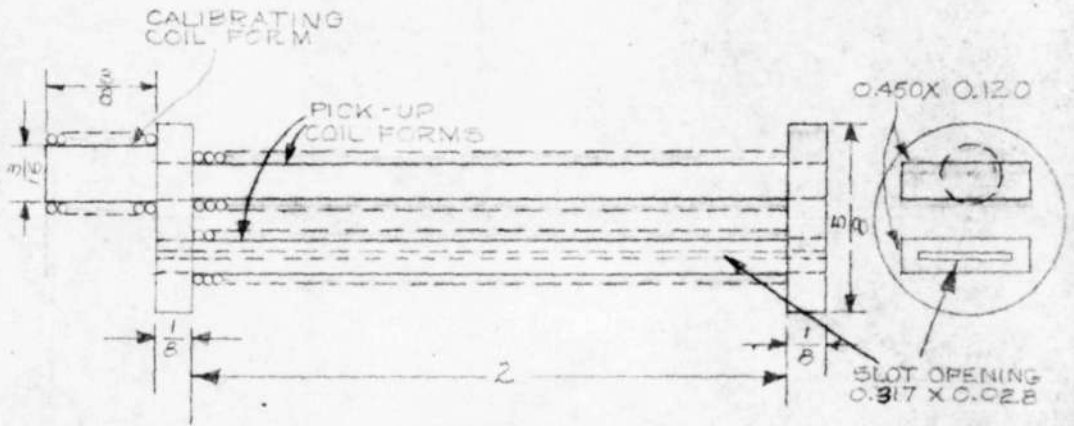

FIG. 24 PICK-UP COIL ASSEMBLY FOR B-H CURVE TRACER.

A-30 56

USED IN 6345 REPORT NO. R-124

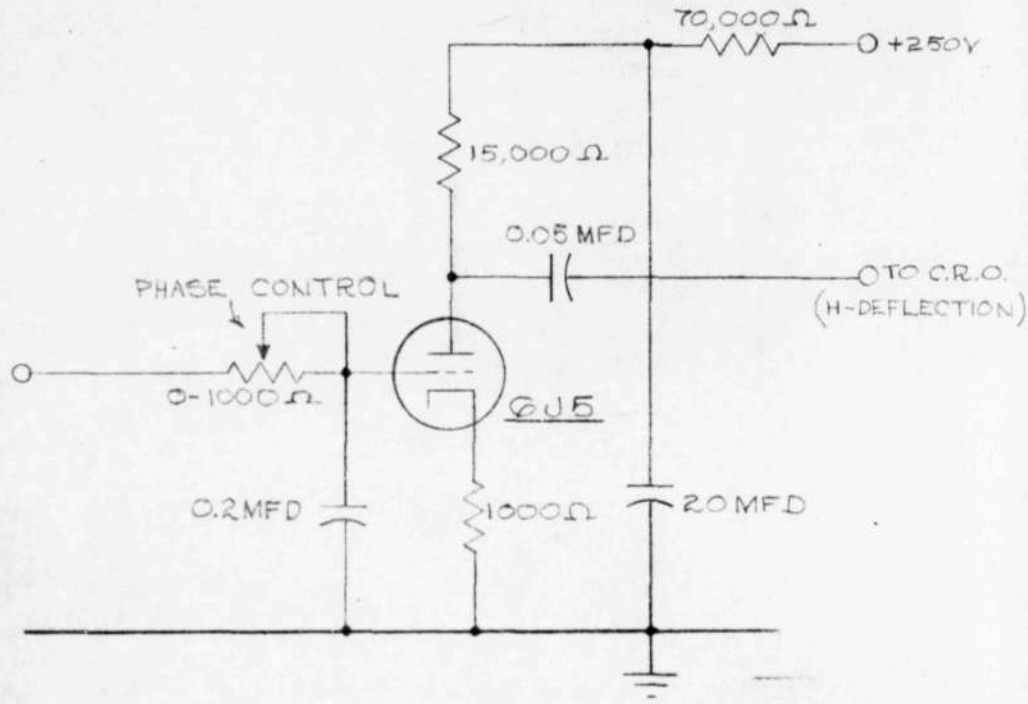

FIG. 25. H-AMPLIFIER FOR B-H CURVE TRACER

A-309

USED IN 6345 REPORT NO. R-124

E-30 68

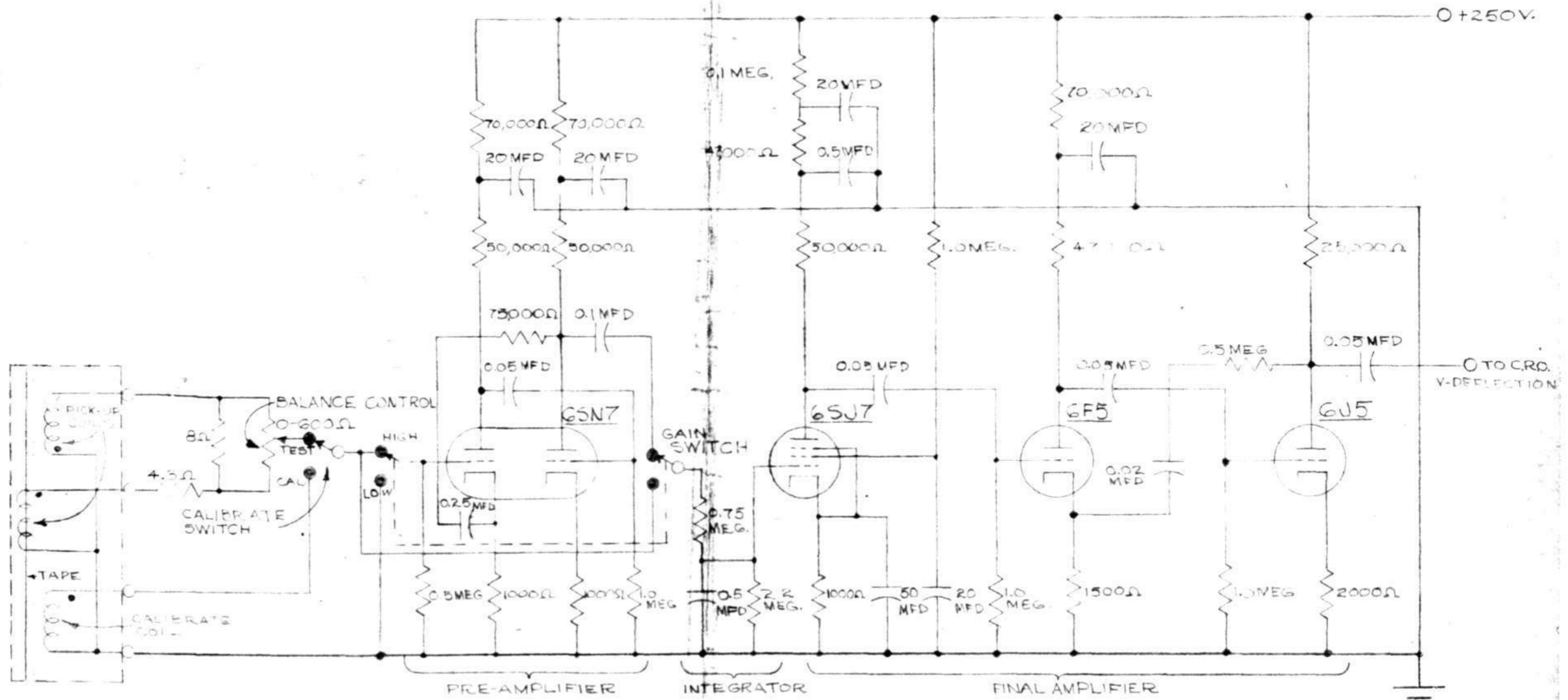

FIG. 26. B-AMPLIFIER FOR B-H CURVE TRACER

4-20-69

USED IN CAMP HEAD UNIT R-104

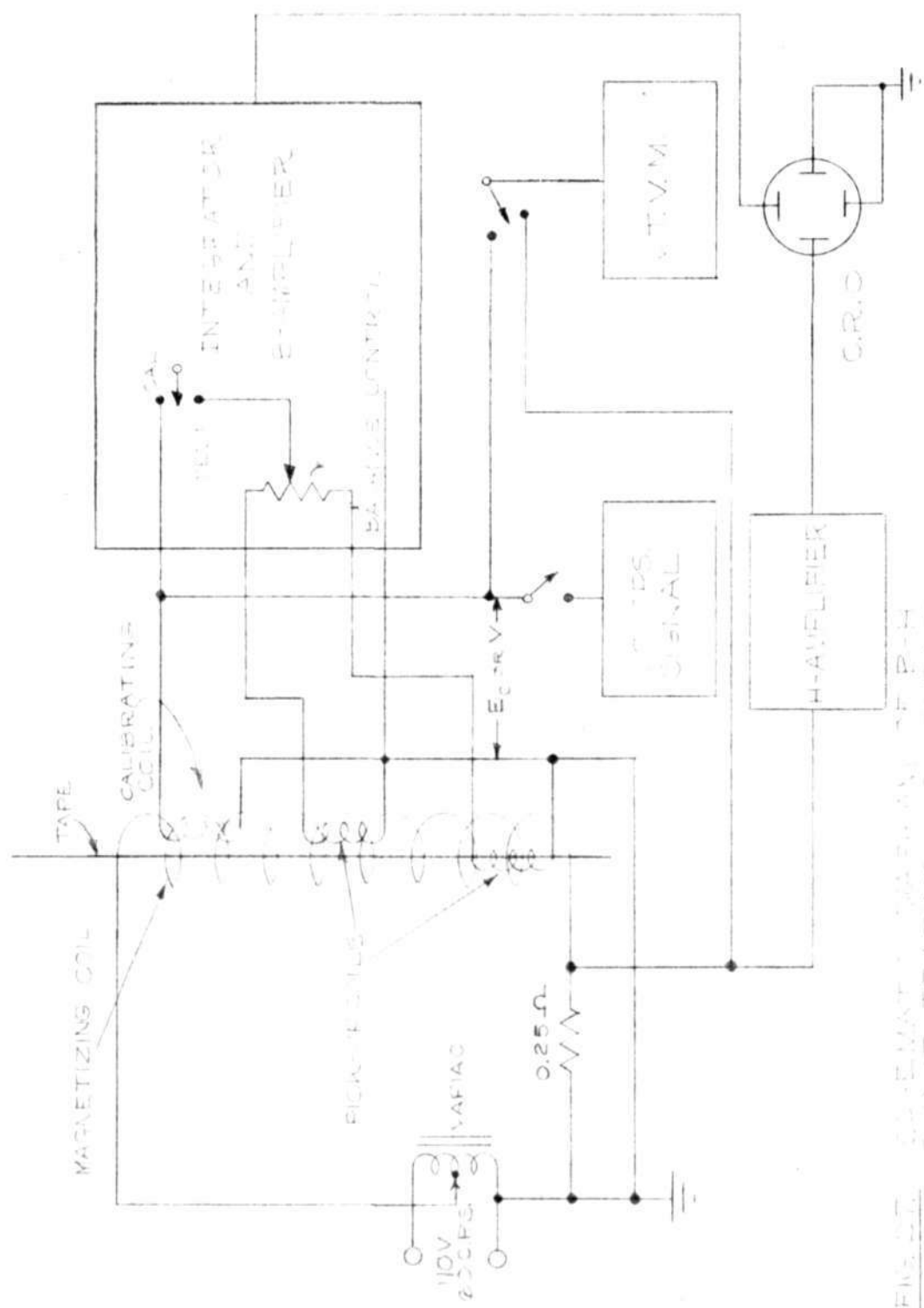

FIG. 1. SCHEMATIC DIAGRAM OF THE COMPLETE RECORDING EQUIPMENT.

M-106

6345
Memorandum M-106

Page 1 of 4

Project Whirlwind
Servomechanisms Laboratory
Massachusetts Institute of Technology
Cambridge, Massachusetts

SUBJECT: PROPOSED PROGRAM FOR INVESTIGATION OF MAGNETIC RECORDING
To: Jay W. Forrester, R. R. Everett, H. Fahnestock, and H. R. Boyd
From: E. S. Rich
Date: September 26, 1947

The following program is proposed for experimental investigation of magnetic recording for application to the Whirlwind Computers.

EXPERIMENTAL SET-UP

a. Recording Equipment. The recording equipment should consist of apparatus for driving a continuous loop of the recording medium at linear speeds up to about 10 ft/sec. A system of pulleys mounted on a panel would be adequate for this purpose. A constant speed motor could be used, and the various speeds could be obtained by changing the amount of speed reduction between the motor and the drive pulley. The pulleys would be made to accommodate either wire or flat tape up to 1/4" in width. The initial experiments would be made on a powder-coated tape since such tape is easy to handle and readily available at low cost, and since head designs and recording methods that are satisfactory for coated tape would be suitable for any other tape material. The heads would be designed so that narrow channels may be recorded, and provision would be made for mounting a maximum of three of each type of head on the panel in such a way that the spacing between channels may be adjusted.

b. Recording-Signal Generator. The recording-signal generator should be capable of producing either a series of pulses of like polarity or a series of pulses of alternating polarity. It should be possible to vary the pulse length and the spacing between pulses independently. The variation in pulse length should be approximately from 1 μ s to 50 μ s, and the variation in repetition frequency should be from about 500 pps to 200,000 pps.

c. Playback Equipment. For reproducing the recorded signals, a high-gain video amplifier for each recording channel will be necessary. These should have a band width of approximately one megacycle. An oscilloscope or a synchroscope would be used to observe the reproduced pulses.

6345
Memorandum M-106

-2-

d. Erasing Signal. Erasing will be accomplished by a high frequency signal probably in the range from 10 kc to 60 kc. A variable-frequency oscillator and power amplifiers will be required to drive the erasing heads.

PROPOSED PROCEDURE

a. Design and Testing of Heads. In general, the design of the heads would be similar to the ring-type heads used in commercial sound recording equipment. However an effort should be made to keep them as small as possible and to design the windings for satisfactory operation with short pulses. Thin cores must be used to produce narrow recording channels.

To obtain reliable information from the recording system it will be necessary to determine the characteristics of the heads. The recording head should produce changes in flux at the recording gap which will correspond to the pulses to be recorded. The waveform of this recording flux could be observed by placing a small pickup coil around the recording gap and observing the waveform of the voltage produced after it has been suitably amplified and integrated.

The playback head must satisfactorily respond to the most rapid change of flux across the pickup gap that will occur. To determine the performance of the playback head its frequency response could be measured by applying a sinusoidal signal of constant amplitude to a small coil wound over the pickup gap and measuring the output of the head as a function of frequency.

The erasing head can best be tested by observing its performance in a complete recording system. It would be desirable to measure the field strength and distribution about the working gaps of both the erasing head and the recording head but no means for doing this is evident.

b. Pulse Recording. In a discussion with Mr. Everett, it was agreed that the following questions have to be answered before further decisions on the use of magnetic recording for computers can be made.

- (1) How many pulses can be recorded per unit length of a recording channel?
- (2) How closely can channels be spaced with separate erasing of each channel?
- (3) How far does the erasing field extend along a channel, i.e., can it be localized for the erasing of a single word?

The number of pulses that can be recorded per unit length of a channel is a function of the recording pulse length and amplitude, the recording gap length, and possibly the tape speed. The influence of each of these parameters should be investigated to determine the optimum amplitude and length for the recording pulses.

6345
Memorandum M-106

-3-

The problem of obtaining satisfactory erasing of a localized portion of a recording medium is probably one of erasing head design. It would be expected that a thin core and a short air gap would confine the erasing field to a small area as in the case of the recording head, but the effect of a larger leakage field that would be caused by the higher signal level required for erasing is unknown.

PLAYBACK HEAD FOR READING AT LOW TAPE SPEEDS

Since a minimum tape speed of a few inches per second is necessary to develop a useable voltage in the playback head, some means of reading a tape independently of speed would be desirable. In particular, such a means would permit reading directly into a printer and also would make it possible to use recorded signals for servo positioning of the tape. To the knowledge of the writer such heads have not been developed but the following design might be practical. Construct a core of a single lamination in the form of a ring having a single air gap at the point of contact with the tape. File a portion of the core opposite the air gap so that it has a smaller cross-sectional area than the rest of the core. Place a winding on each side of the air gap and the filed portion, and apply a small sinusoidal signal to one winding. The second winding is connected in such a way that the output voltage to be used is the difference between the applied voltage and that induced in the second winding. The number of turns on the windings are adjusted so that this output voltage is zero when a demagnetized portion of tape is over the air gap. However, when a magnetized portion of tape is over this gap, a steady flux is set up in the core causing a change in the reluctance of the magnetic circuit, particularly of the filed portion, and hence a change in the voltage induced in the second winding. The output voltage then would be different from zero and would indicate the presence of a recorded signal at the air gap.

The success of a head design like that just described would depend on obtaining the required change of reluctance for the very small values of flux produced by the tape signals. The core material of course, should show a large change in incremental permeability for a small change in the direct component of MMF applied to it. It would be possible to add a small direct current to the a-c signal applied to the first winding and thus bias the head to a point on its B-H curve where the greatest change of reluctance will occur. This not only would increase the sensitivity but also would permit detection of positive as well as negative polarity signals. The polarity of the recorded signals would be indicated by the relative phase of the input and the output voltages of the head.

A playback head operating on the principle outlined above probably could not be used at high tape speeds when short pulses have been recorded. For such a case, a correspondingly high frequency would be required for exciting the playback head. That is, a few cycles of the exciting signal should occur during the playback pulse. Since the incremental permeability of a magnetic material

6345
Memorandum M-106

-4-

decreases with increasing frequency, it probably would be impossible to obtain the required change in reluctance in the head for exciting signals having a frequency of more than a few thousand cycles per second. However, if it is assumed that the exciting frequency is 1200 cps and that 3 cycles occur during each playback pulse, the output pulse length would be 2.5 milliseconds. This would correspond to a repetition rate of 200 pps if the spacing between pulses is made equal to the pulse length. This type of head, then, would be satisfactory for reading into a printer, while a conventional type head could be used for high speed reading into the computer.

Signed: E. S. Rich
E. S. Rich

ESK:vh

APPROVED FOR PUBLIC RELEASE. CASE 06-1104.

M-157

6345
Memorandum M-157

Page 1 of 2

Project Whirlwind
Servomechanisms Laboratory
Massachusetts Institute of Technology
Cambridge, Massachusetts

SUBJECT: OUTPUT TYPEWRITER - PRINTER UNIT FOR WHIRLWIND I

To: J. W. Forrester
From: R. R. Everett
Date: November 13, 1947

The information in this memorandum has been prepared hurriedly and is for discussion purposes only.

1. There are three kinds of output data from the computer:

A. Graphical

This is the most efficient way of presenting large quantities of data for human understanding. The results of most scientific calculations will appear in this form.

B. Physical

The use of the computer in simulation and control problems will require converting the numerical outputs of the machine to physical quantities. The graphical outputs mentioned above could be considered a form of physical output in which the motion of the physical member is recorded in some fashion.

C. Numerical

The bulk of the numerical output of the machine will be for its own use or the use of other equivalent machines at some later time. This numerical data should therefore be left in the form understandable to the machine, that is, in binary notation and on film. Some numerical outputs will be required, however, which can be understood by human beings. This information should be in decimal form and carefully arranged for easy comprehension. A printer should be available which can not only print the decimal numbers but arrange them in columns along with such punctuation and alphabetic notes as may be necessary. Reproduction can be accomplished photographically directly from the printed page. It is important that no human copying be required. The amount of such data to be printed will vary widely according to the problems being computed. It would be very small in simulation and control problems and probably in most problems of physical investigation. In

6346
Memorandum M-157

- 2 -

problems requiring the preparation of tables such as in logistics and census work, the amount of information to be printed may be very large.

2. It is possible to devise high speed automatic decimal film printers which could record very large quantities of information. These printers would become very complicated if alphabetic data were added to the requirements. In view of the type of problems proposed for Whirlwind I it does not seem worthwhile to engage in a development program for a high speed printer at this time. Instead some already available automatic typewriter or teletype printer will probably be used.

This printer will not operate directly from the machine but rather from one of the machine's output films. It seems likely at this time that the printer will operate from binary coded decimal data on the film, the conversion from binary to decimal having been accomplished in the arithmetic element of the computer itself. It may later be desirable to build automatic conversion equipment for the printer itself, so that the computer can put out binary data only. Since the printer works from film and is entirely separate from the computer, its operation rate will not slow up the main computer unless the average printing rate required is very high. It is always possible to use several printers if the printing rate becomes too high. The printer should be able to understand alphabetic, punctuation, and spacing information stored on the film. Some of the extra film channels can be used to indicate these processes. It would be very desirable if the printer could be equipped with some automatic checking procedure which could determine the actual character printed and compare it with the data on the film.

3. The complete instructions as to spacings and alphabetic notes to be printed could be put on the output film by the computer which could transfer this information from the input film. Another possibility is to provide a separate film reader or paper tape reader which would have the specific purpose of instructing the printer. Since the printing sequence is probably cyclic, this separate tape could probably be short. Paper tape might be more satisfactory if it required a simpler reader than the film and were already available. It would still be necessary to provide code marks on the film for special instructions. Printing instructions could be placed on the computer input film or the printer instruction tape at the same time that the entire problem is set up.

R. R. Everett

RRE/ss