



LAN Channel Station

SC30-3458-1

**IBM LAN Channel
Support Program
User's Guide**

Version 1.0



LAN Channel Station

SC30-3458-1

**IBM LAN Channel
Support Program
User's Guide**

Version 1.0

Note: This product is intended for use within a single establishment and within a single, homogeneous user population. For sensitive applications requiring isolation from each other, management may wish to provide isolated cabling or to encrypt the sensitive data before putting it on the network.

Second Edition (September 1988)

Changes are made periodically to the information herein; these changes will be incorporated in new editions of this publication.

Any reference to an IBM program product in this document is not intended to state or imply that only IBM's program product may be used. Any functionally equivalent program may be used instead. It is possible that this material may contain reference to, or information about, IBM products (machines and programs), programming, or services that are not announced in your country. Such references or information must not be construed to mean that IBM intends to announce such IBM products, programming, or services in your country.

Publications are not stocked at the address given below; requests for IBM publications should be made to your IBM representative or to the IBM branch office serving your locality.

A form for reader's comments is provided at the back of this publication. If the form has been removed, comments may be addressed to IBM Corporation, Communication Products Information Development, Department E02, P.O. Box 12195, Research Triangle Park, North Carolina, U.S.A. 27709. IBM may use or distribute any of the information you supply in any way it believes appropriate without incurring any obligation whatever. You may, of course, continue to use the information you supply.

Preface

This manual explains how to install and use the IBM LAN Channel Support Program on the IBM 8232 LAN Channel Station. This program enables a workstation on a local area network to communicate with a host computer when both the workstation and the host computer have the IBM Transmission Control Protocol/Internet Protocol (TCP/IP) Program, or equivalent, installed. The intended user of this manual is a member of an establishment's computer center operations staff.

Chapter 1 introduces the IBM LAN Channel Support Program.

Chapter 2 describes installing the IBM LAN Channel Support Program.

Chapter 3 explains how to use the IBM LAN Channel Support Program and describes the IBM LAN Channel Support Program user commands.

Appendix A contains a list of the IBM LAN Channel Support Program status messages.

Appendix B provides License Information for the IBM LAN Channel Support Program.

A list of abbreviations, glossary and index are provided at the back of this manual.

The IBM LAN Channel Support Program Product

The IBM LAN Channel Support Program product consists of these separate items:

- This manual
- One diskette, the IBM LAN Channel Support Program Version 1.0 diskette.

Related Publications

In addition to this manual, you may need to consult:

- *IBM 8232 LAN Channel Station Operator's Guide, GA27-3785.*
This manual tells a customer how to install LAN adapters in the IBM 8232 LAN Channel Station and how to perform basic operating procedures. The intended user of this manual is a member of an establishment's computer center operations staff. This manual is shipped with the IBM 8232.
- *IBM 8232 LAN Channel Station Installation and Testing, GA27-3796.*
This manual tells an IBM Customer Engineer (IBM CE), or an equivalent third-party service organization, how to install the IBM 8232 LAN Channel Station. Installation includes unpacking the IBM 8232, attaching it to a host system channel, and running installation diagnostics. This manual also shows the IBM CE how to use the diagnostics and online tests to repair an IBM 8232. This manual is shipped with the IBM 8232.

Reference Publications

Other publications that may be useful to you include:

- *A Building Planning Guide for Communication Wiring*, G320-8059 *
- *IBM Cabling System Planning and Installation Guide*, GA27-3361 *
- *IBM Industrial Computer Keyboard Utility Instructions* (in a kit, with Industrial Computer)
- *IBM Local Area Network Support Program User's Guide* (in a kit, with program diskette)
- *IBM PC Network Adapter II Guide to Operations* (in a kit, with adapter)
- *IBM Personal Computer Disk Operating System Reference* (in a kit, with program diskette)
- *IBM System/360 and System/370 I/O Interface Channel-to-Control Unit Original Equipment Manufacturers Information*, GA22-6974. *
- *IBM Token-Ring Network Introduction and Planning Guide*, GA27-3677 *
- *IBM Token-Ring Network PC Adapter Guide to Operations* (in a kit, with adapter and diskette)
- *IBM Transmission Control Protocol/Internet Protocol for the PC Command Reference and Installation*, GC09-1214 *
- *IBM Transmission Control Protocol/Internet Protocol for VM; Installation and Maintenance*, GC09-1203 *
- *IBM 7532 Industrial Computer Installation and Setup* (in a kit, with Industrial Computer)
- *IBM 7532 Industrial Computer Operator's Guide* (in a kit, with Industrial Computer)
- *IBM 8232 LAN Channel Station On-Line Tests*, D99-8232A *
- *Using the IBM Cabling System with Communication Products*, GA27-3620 *

The publications marked with an asterisk (*) can be obtained from your IBM representative or your local IBM branch office. Ask your IBM representative for information on purchasing the other manuals or kits.

Contents

Chapter 1. Introduction to the IBM LAN Channel Support Program	1-1
What You Need	1-2
IBM 8232 LAN Channel Station Setup and Installation Tasks	1-3
Key for Manuals Column	1-3
The IBM LAN Channel Support Program	1-4
Working Diskette	1-4
Display Requirements	1-4
Chapter 2. Installing the IBM LAN Channel Support Program	2-1
The IBM 8232 LAN Channel Station Working Diskette	2-1
Data Needed For Working Diskette	2-2
IBM 8232 Configuration Worksheet	2-3
Creating a Working Diskette	2-4
Copying IBM LAN Channel Support Program Files	2-4
Defining the IBM 8232 Configuration	2-6
Installing the IBM Local Area Network Support Program	2-6
Verifying Your Working Diskette	2-8
Creating a Second Working Diskette	2-9
Making Backup Copies of Your Diskettes	2-9
Reconfiguring Your IBM 8232 LAN Channel Station	2-9
Chapter 3. Using the IBM LAN Channel Support Program	3-1
Loading the Working Diskette	3-1
Correcting an Unsuccessful Loading Attempt	3-4
Using the IBM 8232 LAN Channel Station	3-5
Restarting the IBM LAN Channel Support Program	3-6
Changing Between Display Modes	3-6
Using the Help Facility	3-6
IBM LAN Channel Support Program Command Summary	3-7
User Command Descriptions	3-8
User Command ? (List Commands)	3-8
User Command C (Close LAN Adapter)	3-9
User Command I (LAN Adapter Performance Statistics)	3-10
User Command L (List LAN Adapters)	3-13
User Command O (Online Status)	3-14
User Command Q (Quit)	3-15
User Command R (Restart LAN Adapter)	3-16
User Command S (Channel Adapter Performance Statistics)	3-17
User Command T (Trace)	3-18
User Command Z (Memory Dump)	3-19
User Command Function Key F1 (Help)	3-20
User Command Function Key F9 (Change Screen)	3-21
Appendix A. IBM LAN Channel Support Program Status Messages	A-1
BLOKTSK Status Messages	A-1
CNTLTSK Status Messages	A-3
DBLOKTSK Status Messages	A-6
ETHTASK Status Messages	A-8
KYBDTSK Status Messages	A-13
MONTASK Status Messages	A-15
PCCATSK1 Status Messages	A-17
TOKTASK Status Messages	A-22

Appendix B. License Information	B-1
License Information	B-4
Program Specifications	B-4
Operating Environment	B-6
Machine Requirements	B-6
Program Requirements	B-6
Additional Information	B-6
Type/Duration of Program Services	B-6
Statement of Service	B-7
.....	B-8
Abbreviations	X-1
Glossary	X-3
Index	X-5



IBM 8232 Model 1

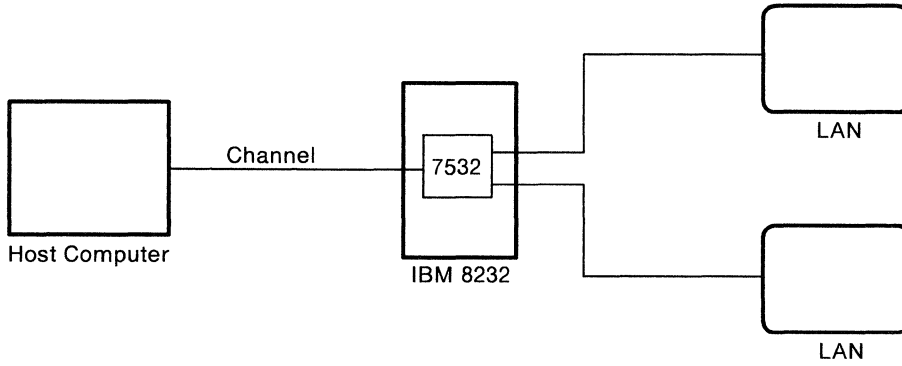

IBM 8232 Model 2

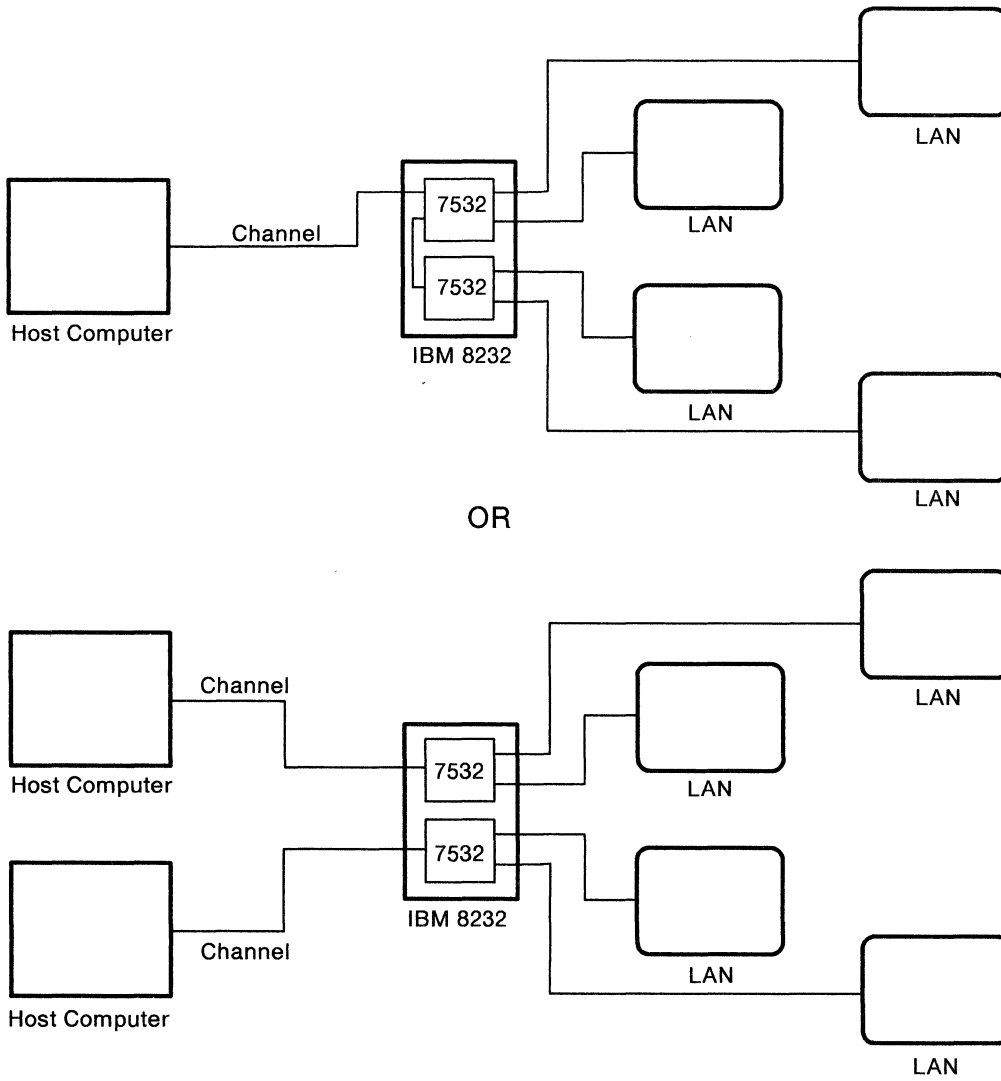

Chapter 1. Introduction to the IBM LAN Channel Support Program

This chapter introduces you to the IBM LAN Channel Support Program Version 1.0 (IBM 8232 Support Program) and describes what you will need to install it on the IBM 8232 LAN Channel Station(IBM 8232). The IBM 8232 Support Program runs in the IBM 8232, enabling it to establish communication between a host computer and any of the following local area networks:

- IBM Token-Ring Network
- IBM PC Network
- Ethernet™ Network.

The IBM 8232 LAN Channel Station is available in two models. Model 1 provides a connection between a host system and one or two local area networks through a single IBM 7532 Industrial Computer housed under the covers of the IBM 8232. Model 2 contains two IBM 7532 Industrial Computers, each connecting a host system to one or two local area networks.

When loaded in the IBM 8232, the IBM 8232 Support Program is not intended to coexist with any other Personal Computer Disk Operating System (PC DOS) applications.

™ Ethernet is a trademark of the XEROX Corporation.

What You Need

To install the IBM 8232 Support Program, you need the following:

- IBM LAN Channel Support Program Version 1.0 or later
- IBM Personal Computer Disk Operating System Version 3.3 or later
- A 5.25-inch high-capacity double-sided diskette capable of storing a total of 1.2 MB (IBM P/N 6109660 or equivalent)
- An IBM 8232 LAN Channel Station that has been installed and released for your use by the IBM CE, and has the appropriate LAN adapters installed
- An IBM 5532 Color Display (or equivalent).

If the IBM Token-Ring Network PC Adapter II or the IBM PC Network Adapter II will be used with this IBM 8232, you need:

- IBM Local Area Network Support Program Version 1.0 or later.

Note: Observe the similarity in names of two of the diskettes you may use.

- The IBM LAN Channel Support Program (the diskette with the white label included with this manual)
- The IBM Local Area Network Support Program (the diskette with the green label not included with this manual).

Do not confuse these two diskettes when asked to use one of them.

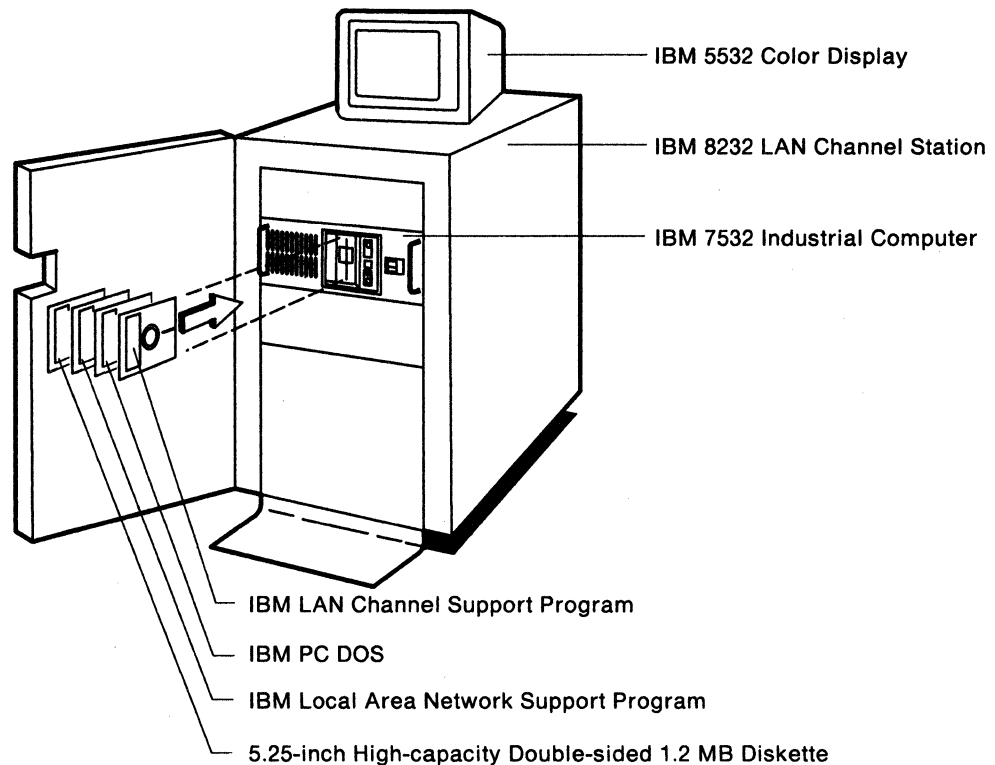

IBM 8232 LAN Channel Station Setup and Installation Tasks

Setup and installation of the IBM 8232 LAN Channel Station and installation of the IBM LAN Channel Support Program requires careful coordination between you and the IBM CE. The following table outlines the tasks in the order that they should be performed, indicates the responsible party, and lists the manuals needed to perform each task. Primary manuals are listed first, secondary manuals are shown in parenthesis. Installing the IBM LAN Channel Support Program is one of the last steps in this process. Be sure all the prerequisite tasks are complete before attempting to install it.

Note: If a customer requests an IBM CE to perform any of the customer tasks, the customer will be charged for time and materials.

Task	Performer	Manual	Complete
Place the IBM 8232 in position.	Customer	1	
Prepare host system for attaching IBM 8232.	Customer	1 (5, 11)	
Unpack and perform the physical installation.	IBM CE	2	
Run the Industrial Computer's diagnostics.	IBM CE	2 (4)	
Run the IBM 8232 diagnostics.	IBM CE	2	
Attach the IBM 8232 to the channel.	IBM CE	2	
Run the T8232A OLTs from the host.	IBM CE	5 (2)	
Turn the IBM 8232 over to customer.	IBM CE	2	
Install LAN adapters in the IBM 8232.	Customer	1 (6, 7, 8)	
Run LAN adapter diagnostics.	Customer	6, 7, 8 (1)	
Attach IBM 8232 to LANs.	Customer	1	
Install the IBM LAN Channel Support Program.	Customer	3 (1, 9, 10)	
Verify LAN-to-host communication.	Customer	11, 12 (1)	

Key for Manuals Column

1. *IBM 8232 LAN Channel Station Operator's Guide*
2. *IBM 8232 LAN Channel Station Installation and Testing*
3. *IBM 8232 LAN Channel Support Program User's Guide*
4. *IBM 7532 Industrial Computer Operator's Guide*
5. *IBM 8232 LAN Channel Station On-Line Tests*
6. *IBM Token-Ring Network PC Adapter Guide to Operations*
7. *IBM PC Network Adapter II Guide to Operations*
8. Materials provided with the Ethernet adapters
9. *IBM Personal Computer Disk Operating System Reference*
10. *IBM Local Area Network Support Program User's Guide*
11. *IBM Transmission Control Protocol/Internet Protocol for VM; Installation and Maintenance*
12. *IBM Transmission Protocol/Internet Protocol for the PC Command Reference and Installation*

The IBM LAN Channel Support Program

The IBM LAN Channel Support Program diskette packaged with this manual contains seven code modules that perform a variety of functions.

- Three of the code modules enable the IBM 8232 LAN Channel Station to communicate with any one of eight different types of host computers and with any one of three different types of local area networks.

MTCMMAIN.EXE
ETHTASK.TSK
TOKTASK.TSK

- Three modules deal with internal operations in the IBM 8232 LAN Channel Station.

MONTASK.TSK
PCCATSK1.TSK
SCRN8232.TSK

- One module provides a utility that selects the proper modules needed to interface with your particular host computer and your particular LAN(s).

MTCMCONF.EXE

Working Diskette

The IBM LAN Channel Support Program diskette is used by an establishment's computer center systems programmer to create a working diskette. When you create the IBM 8232 working diskette, you will copy portions of code from the IBM LAN Channel Support Program diskette, portions of code from the PC DOS diskette, and in some cases, portions of code from the IBM Local Area Network Support Program diskette. The IBM 8232 working diskette uses only those portions of the IBM LAN Channel Support Program code needed to support the connection of this particular IBM 8232 to its particular type of host computer and its specific type of LAN(s). Chapter 2 contains instructions for creating your working diskette.

Display Requirements

During normal operation, a display such as the IBM 5532 Color Display needs to be attached to each Industrial Computer housed in the IBM 8232 LAN Channel Station. The display is needed but is not provided with the IBM 8232 LAN Channel Station. Specifically, the display is needed when you are performing any of the following tasks:

- Creating or copying a working diskette
- Verifying a diskette
- Installing the IBM LAN Channel Support Program
- Investigating a program malfunction.

Refer to the *IBM 8232 LAN Channel Station Installation and Testing* guide to learn how to attach the display if it is not already attached.

You are now ready to create your IBM 8232 LAN Channel Station working diskette.

Chapter 2. Installing the IBM LAN Channel Support Program

Installing the IBM LAN Channel Support Program is a two-step process:

1. Creating an IBM 8232 LAN Channel Station working diskette
2. Loading the working diskette into the IBM 8232 LAN Channel Station.

This chapter shows you how to accomplish the first step. Chapter 3 describes the second step.

The IBM 8232 LAN Channel Station Working Diskette

You should protect your original IBM LAN Channel Support Program diskette provided with this manual by copying files from it to a working diskette, where they will be merged with files from several other diskettes (not provided with this package) to create an IBM 8232 working diskette for use in daily operation of the IBM 8232 LAN Channel Station.

After making your IBM 8232 working diskette, put your original diskette in a secure place. When all the proper files are copied to your working diskette and verified, and appropriate backup copies are made, leave the working diskette in the IBM 8232 LAN Channel Station diskette drive for use in daily operation.

To make your IBM 8232 LAN Channel Station working diskette, use the PC DOS procedures for copying files from one diskette to another. If you have access to an IBM Personal Computer with two 1.2-megabyte (MB) diskette drives, or a 1.2 MB diskette drive and a fixed disk drive, you might find it more convenient to create the IBM 8232 working diskette using that system. Otherwise, use the single diskette drive in the IBM 8232's Industrial Computer to make your working diskette.

Use a 5.25-inch high-capacity double-sided diskette capable of storing a total of 1.2 MB (IBM P/N 6109660 or equivalent) for your working diskette.

Note: Because of the varying recording densities of the source programs you will copy to your IBM 8232 working diskette, use the DOS command **COPY** instead of **DISKCOPY**.

The IBM LAN Channel Support Program contains a configurator module. The configurator selects the proper modules from your IBM 8232 working diskette to be used during the daily operation of the IBM 8232 LAN Channel Station. The selections made by the configurator depend on answers you give to several questions about your specific IBM 8232 LAN Channel Station configuration. Using your answers, the configurator creates a file called MTCMCONF.DAT. This file contains a list of all the modules needed for proper operation of your particular IBM 8232.

Data Needed For Working Diskette

To create an IBM 8232 working diskette, you need to answer several host system and LAN interface questions. When your IBM 8232 LAN Channel Station was installed, your establishment's computer center systems programmer should have filled out an **IBM 8232 Configuration Worksheet** containing the information you need to answer these questions.

The information from this worksheet was used on one previous occasion, when system generation [SYSGEN] was performed on the host computer. The answers you give now must match the information used on the previous occasion.

The completed **IBM 8232 Configuration Worksheet** will be found in your *IBM 8232 LAN Channel Station Operator's Guide*. If you cannot find the worksheet, consult your systems programmer for information about the host system attached to this IBM 8232, and the person who installed the LAN adapters for information about the adapters installed in this IBM 8232. A sample copy of a completed **IBM 8232 Configuration Worksheet** is shown on the next page.

As indicated in Chapter 1 of this manual, the LAN adapters should already be installed in your IBM 8232. If not, install them now according to the instructions provided with the adapter and the *IBM 8232 LAN Channel Station Operator's Guide* provided with the IBM 8232.

When you are prepared to answer the **IBM 8232 Connectivity Information, Host System Characteristics, and LAN Adapter Characteristics** questions, continue with "Creating a Working Diskette" on page 2-4.

A sample copy of a completed **IBM 8232 Configuration Worksheet** is shown on the following page.

IBM 8232 Configuration Worksheet

IBM 8232 Configuration Worksheet

Date: 7 / 6 / 88

Signature: B. C. George

IBM 8232 Connectivity Information

Is your IBM 8232 LAN Channel Station a Model 1? Yes No
 Is your IBM 8232 LAN Channel Station a Model 2? Yes No
 Is worksheet for upper or lower IBM 7532? Upper Lower
 Host Serial Number: 1347
 Host Channel Number: 05
 Local Area Network Number for network connection in slot 5: PC NET 17
 Local Area Network Number for network connection in slot 6: ~~Token-Ring~~ NET 32

Local Area Network Number for MAP 2.1 network:

Host System Characteristics

Device Address: 40
 Control Unit Blocks: 32 64
 Data Transfer Mode: DCI Streaming
 Channel Speed: 1 MBps 3 MBps

LAN Adapter Characteristics

Check One	LAN Adapter Characteristics	LAN Adapter in IBM 7532 Slot 5		LAN Adapter Characteristics	LAN Adapter in IBM 7532 Slot 6
	Adapter Type Adapter Priority Interrupt Level Memory Mapping Read Only Memory	PC Network Primary (0) 2 Standard Enabled	a n d	Adapter Type Adapter Priority Interrupt Level Memory Mapping Read Only Memory	PC Network Alternate (1) 3 Alternate Disabled
<input checked="" type="checkbox"/>	Adapter Type Adapter Priority Interrupt Level Memory Mapping Read Only Memory	PC Network Primary (0) 2 Standard Enabled	a n d	Adapter Type Adapter Priority Interrupt Level ROM Address	Token-Ring Network Alternate (1) 3 DC000
	Adapter Type Adapter Priority Interrupt Level Memory Mapping Read Only Memory	PC Network Primary (0) 2 Standard Enabled	a n d	Adapter Type Interrupt Level Memory Address	Ethernet 3 C0000
	Adapter Type Adapter Priority Interrupt Level ROM Address	Token-Ring Network Primary (0) 2 CC000	a n d	Adapter Type Adapter Priority Interrupt Level ROM Address	Token-Ring Network Alternate (1) 3 DC000
	Adapter Type Adapter Priority Interrupt Level ROM Address	Token-Ring Network Primary (0) 2 CC000	a n d	Adapter Type Adapter Priority Memory Address	Ethernet 3 C0000
	Adapter Type Adapter Priority Memory Address	Ethernet 3 C0000	a n d	Adapter Type Interrupt Level Memory Address	Ethernet 4 D0000
	Adapter Type Adapter Priority Memory Address	MAP 2.1 (1 of 2) 9 D0000	a n d	Adapter Type Interrupt Level Memory Address	MAP 2.1 (2 of 2)

Creating a Working Diskette

There are at least two series of steps involved in creating your IBM 8232 working diskette:

1. Copying the IBM LAN Channel Support Program files
2. Defining the IBM 8232 configuration

If you will be attaching your IBM 8232 to either the IBM Token-Ring Network or the IBM PC Network, a third series of steps is required:

3. Installing the IBM Local Area Network Support Program.

Note: Because of the varying recording densities of the source programs you will copy to your IBM 8232 working diskette, use the DOS command **COPY** instead of **DISKCOPY**.

Copying IBM LAN Channel Support Program Files

1. With power off, insert the PC DOS Version 3.3 or later Startup Diskette into drive A of the Industrial Computer. Insert the diskette with the label facing to the right.

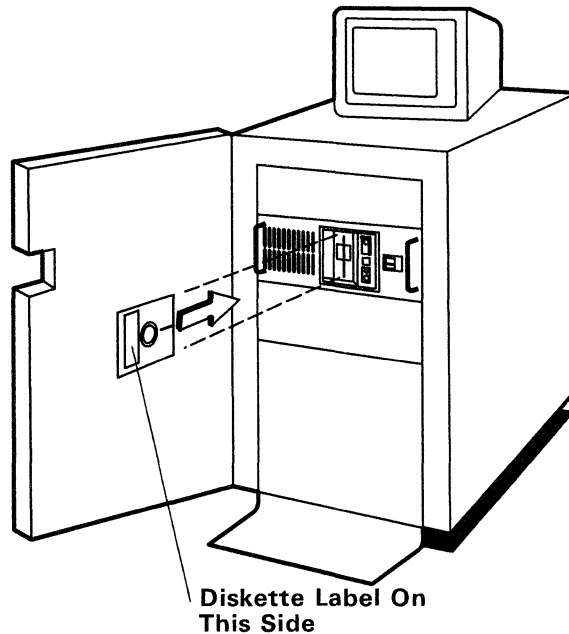

2. Turn on the power to the Industrial Computer and the display. After checking the date and time, press **Enter**. The **A >** prompt should appear.
3. Type
`FORMAT A: /S`
and press **Enter**.

4. When instructed, remove the DOS diskette.
5. Insert a blank **high-capacity diskette** and press **Enter**. Formatting takes about two minutes.
6. After formatting this diskette, you will be asked if you want to format additional diskettes. To answer No, type
N
and press **Enter**. The **A >** prompt should appear.
7. Remove the newly formatted diskette and label it, "IBM 8232 LAN Channel Station working diskette."
8. Insert your original IBM LAN Channel Support Program diskette (the one with the white label).
9. Since the Industrial Computer has only one diskette drive, DOS refers to it as both the **A** and **B** drive. Type
COPY *.* B:
and press **Enter**.
10. You will see the message:
**Insert diskette for drive B: and strike
any key when ready**

Remove your original IBM LAN Channel Support Program diskette, insert your newly formatted diskette (your working diskette), and press **Enter**.
11. After a few seconds you will see the message:
**Insert diskette for drive A: and strike
any key when ready**

Remove your working diskette, insert your original IBM LAN Channel Support Program diskette, and press **Enter**.

Note: You will repeat steps 10 and 11 about a dozen times to copy all the files from the original IBM LAN Channel Support Program diskette to your working diskette. Remember, when you see the message **Insert diskette for drive A:...**, you should insert your original IBM LAN Channel Support Program diskette. When you see the message **Insert diskette for drive B:...**, you should insert your working diskette.
12. When copying is complete you will see the message:
7 File(s) copied

Defining the IBM 8232 Configuration

13. With your IBM 8232 LAN Channel Station working diskette still in place, type
MTCMCONF
and press **Enter**.
14. This invokes the IBM LAN Channel Support Program Configuration Aid, which asks you a series of questions. Answer them by referring to your **IBM 8232 Configuration Worksheet**, a sample of which was shown on page 2-3. You will also be asked if you want your working diskette to load automatically each time the IBM 8232 LAN Channel Station is turned-on or restarted. If so, answer yes to the AUTOEXEC question.
Note: If this IBM 8232 is connected to an IBM 4361 host computer and you plan to operate it in the streaming "Data Transfer Mode", be sure your "Channel Speed" is 1 megabyte per second.
15. After you answer all the questions and press F6, the configuration aid writes a file called MTCMCONF.DAT on your IBM 8232 LAN Channel Station working diskette. If you selected the automatic loading option, a file called AUTOEXEC.BAT is also written on your working diskette. When this process is complete, remove the working diskette.

Installing the IBM Local Area Network Support Program

If the LAN side of your IBM 8232 LAN Channel Station attaches only to an Ethernet Network, you may proceed to "Verifying Your Working Diskette" on page 2-8.

If your IBM 8232 LAN Channel Station uses an IBM Token-Ring Network Adapter or an IBM PC Network Adapter, you need to install the IBM Local Area Network Support Program. You will do this in step 16 by running the IBM Local Area Network Support Program Configuration Aid. The configuration aid asks you several questions. Use the answers provided below.

- Will this copy of the program be used in THIS computer?
Answer YES.
- Will the 3270 workstation program be used?
Answer NO.
- Will programs that need the NETBIOS interface be used?
Answer NO (Do not accept the YES default).
- What drive do you want the Support Program copied onto?
Answer A or be sure you understand why a different answer is appropriate.
- Is this the LAN adapter(s) configuration you want?
Answer YES or be sure you understand why a different answer is appropriate.

To run the IBM Local Area Network Support Program Configuration Aid, follow the steps below.

16. Insert the IBM Local Area Network Support Program diskette (the one with the green label). Type

DXMAID

and press **Enter**.

17. Follow the directions in the IBM Local Area Network Support Program Configuration Aid, providing an answer to each question as indicated on page 2-6.

Note: The IBM Local Area Network Support Program lists the IBM Token-Ring Network PC adapters and the IBM PC Network adapters installed in this machine. If an Ethernet Network adapter is also installed, it will not be listed.

18. When you see the message:

**Place a formatted system diskette in
Drive A. The configuration you requested
will be created on this diskette.,**

remove the IBM Local Area Network Support Program diskette, insert your IBM 8232 working diskette and press **Enter**.

19. When you complete the configuration process, a file called CONFIG.SYS and other files are written on your working diskette. When the files have been written, you are ready to verify your working diskette as described on page 2-8.

Verifying Your Working Diskette

You have finished creating your IBM 8232 LAN Channel Station working diskette. You should verify that it is complete by comparing the files contained on it against the list below. The files on your display panel may be listed in a different order than shown below.

1. With your IBM 8232 working diskette in place, type

DIR

and press **Enter**.

2. You should see the following list of files:

```
AUTOEXEC.BAT      (if you selected this option)
COMMAND.COM
MTCMCONF.DAT
MTCMCONF.EXE
MTCMMAIN.EXE
ETHTASK.TSK
MONTASK.TSK
PCCATSK1.TSK
SCRN8232.TSK
TOKTASK.TSK
```

If you used the IBM Local Area Network Support Program configuration aid, some of the following additional files may be listed:

```
CONFIG.SYS
DXMA0MOD.SYS
DXMC0MOD.SYS      (if you are using a Token-Ring Adapter)
DXMG0MOD.SYS      (if you are using a PC Network Adapter)
```

3. If the list displayed contains the information shown above, you have successfully created one IBM 8232 working diskette. **Cover the write-protect notch on your working diskette with a write-protect tab.**
4. If your list does not contain the information shown above, return to the beginning of this chapter and carefully repeat the process of creating a working diskette. Be alert for mistakes you might have made.

Creating a Second Working Diskette

If your IBM 8232 LAN Channel Station is a Model 2 (with two Industrial Computers), repeat the process of creating an IBM 8232 LAN Channel Station working diskette for the lower Industrial Computer. Be sure that a Color Display is connected to the lower Industrial Computer before you start creating your second working diskette. Refer to the *IBM 8232 LAN Channel Station Installation and Test* guide to see how to connect a display.

Making Backup Copies of Your Diskettes

If you want to make backup copies of your IBM 8232 working diskette or your original IBM LAN Channel Support Program diskette, refer to the *IBM Personal Computer Disk Operating System* manual for PC DOS Version 3.3 or later.

Reconfiguring Your IBM 8232 LAN Channel Station

If the type or number of LAN adapters in your IBM 8232 LAN Channel Station changes after you have created your IBM 8232 working diskette, you need a new working diskette. Go to the beginning of Chapter 2 and create a new working diskette tailored to your new configuration. Be sure to use the updated version of the **IBM 8232 Configuration Worksheet** when making your new working diskette. To avoid confusing the old and new working diskettes, erase all copies of the old IBM 8232 working diskette and remove them from the area where they are normally kept.

You are now ready to load the IBM 8232 working diskette(s) and bring your IBM 8232 LAN Channel Station online.

Chapter 3. Using the IBM LAN Channel Support Program

This chapter describes how to load the files from your newly created IBM 8232 LAN Channel Station working diskette into the working memory of the IBM 8232 LAN Channel Station's Industrial Computer. It also describes the IBM LAN Channel Support Program commands and how to use them.

Note: If your IBM 8232 LAN Channel Station is a Model 2 (with two Industrial Computers), repeat the loading process for the lower Industrial Computer using your **second** IBM 8232 LAN Channel Station working diskette.

Loading the Working Diskette

To load the IBM 8232 working diskette:

1. Turn the power switch at your IBM 8232's Industrial Computer to the OFF position.
2. Locate your IBM 8232 working diskette (or diskettes if you have a Model 2). This is the diskette you created in Chapter 2.
3. Insert your IBM 8232 working diskette into the IBM 8232's Industrial Computer diskette drive.
4. Turn the power switches for your Industrial Computer and display to the ON position.
5. If you selected the AUTOEXEC.BAT option when you created your IBM 8232 working diskette, the programs on the working diskette will load automatically.
6. Otherwise, following the **A >** prompt, type
MTCMMAIN
and press **Enter**.
7. A **successful** loading of the IBM 8232 working diskette is indicated by the following two panels of information.

The first panel indicates the IBM Local Area Network Support Program loaded successfully. You will see this panel only if you copied this program onto your IBM 8232 working diskette.

IBM Local Area Network Support Program Version 1.00
(C) Copyright IBM Corporation 1987
Program Property of IBM - all rights reserved

The second panel indicates the IBM LAN Channel Support Program loaded successfully. When you see this panel, the IBM 8232 is ready for use as described on page 3-5.

```

                                Status Message Mode
-----
**>IBM LAN Channel Support Program Version 1.00
**>(C) Copyright IBM Corporation 1987
**>Program Property of IBM - All Rights Reserved

**>PCCATSK1 Version 1.00
**>TOKTASK0 Version 1.00
      (if you have one TRN or one PCN Adapter)
**>TOKTASK1 Version 1.00
      (if you have a second TRN or PCN Adapter)
**>ETHTASK0 Version 1.00
      (if you have one Ethernet Adapter)
**>ETHTASK1 Version 1.00
      (if you have a second Ethernet Adapter)
**>MONTASK Version 1.00
**>CNTLTSK Version 1.00
**>DBLOKTSK Version 1.00
**>BLOKTSK Version 1.00
-->PCCATSK1 A3: IBM 8232 is Online, Device Address: xx
-->The IBM LAN Channel Support Program Loaded Successfully
-->ETHTASK0 A0: Adapter ready
      (if you have one Ethernet Adapter)
-->ETHTASK1 A0: Adapter ready
      (if you have a second Ethernet Adapter)
-->TOKTASK0 A0: Adapter ready
      (if you have one TRN or one PCN Adapter)
-->TOKTASK1 A0: Adapter ready
      (if you have a second TRN or PCN Adapter)

                                F1=Help      F9=Change Screen Mode
STATUS: IBM 8232 Online,  ETHTASK0 Opened, TOKTASK0 Opened  0
```

8. An **unsuccessful** loading of the IBM 8232 working diskette is indicated by messages on one of the following panels.

The panel below indicates the IBM Local Area Network Support Program loading attempt was not successful. You will see this panel only if you copied this program onto your IBM 8232 working diskette. If an error message appears on this panel, refer to the *IBM Local Area Network Support Program* manual to see what the message means. Then go to "Correcting an Unsuccessful Loading Attempt" on page 3-4 in this manual.

```
IBM Local Area Network Support Program Version 1.00
(C) Copyright IBM Corporation 1987
Program Property of IBM - all rights reserved
```

(Any problem loading this program is indicated here.)

The -?> message on the following panel indicates the IBM LAN Channel Support Program loading attempt was not successful. The absence of the STATUS line normally seen at the bottom of the panel also indicates that the loading attempt was not successful. If you see this panel, go to "Correcting an Unsuccessful Loading Attempt" on page 3-4.

```
**>IBM LAN Channel Support Program Version 1.00
**>(C) Copyright IBM Corporation 1987
**>Program Property of IBM - All Rights Reserved
.
.
.
-?>MONTASK 00: Unable to attach task
```

Correcting an Unsuccessful Loading Attempt

If you see any of the unsuccessful loading indicators, do the following:

1. With the IBM 8232 working diskette still in place, load it again by turning the Industrial Computer off and then back on, or by pressing the Industrial Computer's red reset button adjacent to the diskette drive.
2. If an unsuccessful loading message reappears, check the directory on the IBM 8232 working diskette again. Following the **A >** prompt, type

DIR

and press **Enter**. Compare the directory list displayed against the list of files shown in "Verifying Your Working Diskette" on page 2-8.

3. If the directory lists are the same, check with your systems programmer to be sure the "Device Address" you used from the **IBM 8232 Configuration Worksheet** is still correct.
4. If the "Device Address" you used is correct, reload your IBM 8232 working diskette. If you still get an unsuccessful loading message, your IBM 8232 working diskette may be defective. Go back to Chapter 2, create another IBM 8232 working diskette, and load it.
5. If you have taken all the above actions and the IBM 8232 still gives you an unsuccessful loading message, have your service coordinator contact the IBM Support Center for assistance.

Using the IBM 8232 LAN Channel Station

When you have successfully loaded the IBM 8232 working diskette, you are ready to check your IBM 8232 for proper operation. Using an IBM Personal Computer connected to a local area network (LAN workstation) serviced by this IBM 8232, you may verify proper operation by sending a message to or requesting a message from the host system also serviced by this IBM 8232. Refer to the *IBM Transmission Control Protocol/Internet Protocol for the PC Command Reference and Installation* and the *IBM Transmission Control Protocol/Internet Protocol for VM; Installation and Maintenance* manuals for information about establishing communications between an IBM Personal Computer and a host system.

The LAN workstation:

- Must have a LAN adapter installed and connected to a local area network
- Must already be loaded with the program, IBM Transmission Control Protocol/Internet Protocol for the PC (TCP/IP for PC), or equivalent.

The host computer:

- Must have the channel cables connected
- Must be prepared to communicate with this IBM 8232 (host SYSGEN has been completed)
- Must already be loaded with the program, IBM Transmission Control Protocol/Internet Protocol for VM (TCP/IP for VM), or equivalent.

The IBM 8232:

- Must have the channel cables connected
- Must have the channel priority switches in its tailgate in the proper position to permit communication between the host system and the IBM 8232 (refer to the *IBM 8232 LAN Channel Station Installation and Testing* guide for instructions for setting these priority switches).

If the IBM 8232 LAN Channel Station is not passing data between the LAN and the host system, refer to the *IBM 8232 LAN Channel Station Installation and Testing* manual for help.

Once the IBM LAN Channel Support Program is installed and the IBM 8232 LAN Channel Station is operational, the display is not needed and may be turned off. However, you may want to leave it turned on to observe status messages. Status messages are listed and explained in Appendix A.

Restarting the IBM LAN Channel Support Program

Periodically, you may want to restart the program. Before restarting the program, you first need to halt it. To halt the program:

1. Press the **F9** function key to switch the IBM 8232 to “Keyboard Entry Mode” if it is not already in this mode.
2. Type **q** and press **Enter**.

Note: For more information about the **q** command, refer to Chapter 3, page 3-15 in this manual.

If you selected the AUTOEXEC.BAT option when you created your IBM 8232 working diskette, there are two ways to restart the program:

- Turn the power switch at your IBM 8232’s Industrial Computer to the off position. Wait a few seconds. Turn the power switch back on.
- Press the Industrial Computer’s red reset button. The reset button is adjacent to the diskette drive.

If you did not select the AUTOEXEC.BAT option when you created your IBM 8232 working diskette, there is only one way to restart the program:

- Following the **A >** prompt, type **MTCMMAIN** and press **Enter**.

Changing Between Display Modes

Each time the IBM LAN Channel Support Program is loaded, the display is set in the “Status Message” mode. This mode is indicated by the words “Status Message Mode” centered near the top of the display panel and a “0” in the lower right corner of the panel. In this mode, keyboard input is not accepted. For keyboard input to be recognized, you need to switch to “Keyboard Entry” mode. You may switch from either mode to the other by pressing the **F9** function key. The “Keyboard Entry” mode is indicated by the words “Keyboard Entry Mode” centered near the top of the display panel and a “1” in the lower right corner of the panel.

Using the Help Facility

The IBM LAN Channel Support Program contains an online help facility. By pressing the **F1** function key, the IBM 8232 Help Facility may be accessed any time the IBM 8232 Support Program is running. The help facility provides online information about the IBM 8232 Support Program user commands similar to the information provided on the next several pages of this manual.

IBM LAN Channel Support Program Command Summary

You can use the keyboard attached to your IBM 8232 LAN Channel Station to issue user commands. These commands are used to monitor or modify some of the operational parameters of the IBM 8232 or to request information about the LAN adapters and channel adapter installed in the IBM 8232. If your IBM 8232 is a Model 2 (with two Industrial Computers and two keyboards), be sure you are using the keyboard connected to the correct Industrial Computer. If you want to issue a command to both Industrial Computers, you need to enter the command on the keyboard for each Industrial Computer. The IBM 8232 recognizes the following commands:

?
c
i
l
o
q
r
s
t
z
F1
F9

If any other character is entered, the following error message is displayed and the input is ignored.

```
Keyboard Entry Mode
-----
Y
-?>KYBDTSK 50: Unrecognized command: Y

F1=Help      F9=Change Screen Mode
STATUS: IBM 8232 OnLine,  ETHTASK0 Opened,  TOKTASK0 Opened  1
```

User Command Descriptions

The information in this section gives a description of each user command. To enter a command, type the letter or key representing the command and then press the **Enter** key. Be sure your IBM 8232 is in the "Keyboard Entry" mode, indicated by a "1" in the lower right corner and the words "Keyboard Entry Mode" centered near the top of the display panel, before trying to enter one of these commands. If your IBM 8232 is not in the "Keyboard Entry" mode, press the **F9** function key to go to this mode.

User Command ? (List Commands)

The **?** command causes a list of the valid user commands to be shown on the display panel. You will see the following in response to the **?** command.

```
Keyboard Entry Mode
-----
?
? - Display user command list
c - Close LAN Adapter
i - Display Information for a specific LAN adapter
l - List LAN adapters in this Industrial Computer
o - Display online status and device address
q - Quit (Return to DOS)
r - Restart LAN Adapter
s - Display general statistics
t - Set trace level for a specific task

F1=Help      F9=Change Screen Mode
STATUS: IBM 8232 Online,  ETHTASK0 Opened,  TOKTASK0 Opened  1
```

Note: The **z** command is not listed in response to the **?** command. This command should be executed only under the direction of IBM service personnel.

User Command C (Close LAN Adapter)

The **c** command enables you to close any active LAN adapter in the Industrial Computer. When you issue this command, you are asked to select the LAN adapter you want to close. If you want to close both LAN adapters, you need to execute this command **twice**. The IBM 8232 discards all data from the host computer destined for a closed LAN adapter. For an IBM 8232 LAN Channel Station Model 1 with one Token-Ring adapter and one Ethernet adapter installed, you will see the following panel in response to the **c** command.

```
Keyboard Entry Mode
-----
C
-->KYBDTSK: The current LAN tasks are:
    0: ETHTASK0 (Adapter: 0 Node Address: xxxxxxxxxxxx)
    1: TOKTASK0 (Adapter: 0 Node Address: xxxxxxxxxxxx)

Enter number of target task or press ENTER to quit:_

      (If you enter a 0 you will see the following.)
-->KYBDTSK A6: Command sent to ETHTASK0

      (If you enter a 1 you will see the following.)
-->KYBDTSK A6: Command sent to TOKTASK0

                                F1=Help      F9=Change Screen Mode
STATUS: IBM 8232 Online,  ETHTASK0 Closed, TOKTASK0 Closed  1
```

User Command I (LAN Adapter Performance Statistics)

The **i** command enables you or your computer center systems programmer to collect and display performance statistics about the LAN adapters in the IBM 8232. This information can be used for workload balancing or network tuning. When you issue this command, you are asked to select the LAN adapter whose performance statistics you want to see. If you want to see performance statistics for both LAN adapters, you need to execute this command **twice**. The statistics displayed are different for each type of LAN adapter. **Holding**, **Pending**, or **Closed** is displayed for inactive LAN adapters. An inactive LAN adapter is one that is no longer operating on the local area network.

The following two sections describe the performance statistics shown when you enter the **i** command. All numerical values are reported in decimal. The words in parenthesis are the abbreviations used on the display panel to report an item.

Ethernet Adapter Performance Statistics Reported by User Command I

The performance statistics from the primary Ethernet adapter in the IBM 8232 are identified as being from ETHTASK0 and those from the alternate Ethernet adapter are identified as being from ETHTASK1. Information is reported about all the following items.

- Number of packets successfully transmitted (Xmits)
- Number of transmit packets re-transmitted (Xmit errors)
- Number of transmit packets discarded (Xmits discarded)
- Number of packets received successfully (Recvd)
- Number of receive errors that occurred (Recv errors)
- Number of receive packets discarded (Recvs discarded)
- Number of packets filtered out (Packets filtered out)
- Number of short packets received (Short)
- Number of receive alignment errors (Align)
- Number of receive CRC errors (CRC)
- Number of receive overflow errors (Overflow)
- Number of receive packets greater than 1514 bytes (Toobig)
- Number of collisions when transmitting a packet (Coll)
- Number of times 16 collisions occurred (16Coll)
- Number of times shorted network was detected (Shorted)
- Number of packets received too big for PC buffers (Buffer overflow)
- Number of times Ethernet adapter was reset (Adapter resets)

For an IBM 8232 LAN Channel Station Model 1 with one Token-Ring adapter and one Ethernet adapter installed, the display panel will look similar to the one shown below in response to the **i** command.

```
Keyboard Entry Mode
-----
I
-->KYBDTSK: The current LAN tasks are:
      0: ETHTASK0 (Adapter: 0  Node Address: xxxxxxxxxxxx)
      1: TOKTASK0 (Adapter: 0  Node Address: xxxxxxxxxxxx)

Enter number of target task or press ENTER to quit:_

      (If you enter a 0 you will see the following.)
-->ETHTASK0: Ethernet Adapter Statistics
-->ETHTASK0: X Xmits   Y Xmit errors  Z Xmits discarded
-->ETHTASK0: X Recvd   Y Recv errors  Z Recvs discarded
-->ETHTASK0: X Packets filtered out
-->ETHTASK0: W Short   X Align    Y CRC     Z Overflow
-->ETHTASK0: W Toobig  X Coll    Y 16Coll  Z Shorted
-->ETHTASK0: X Buffer overflow  Y Adapter resets

                        F1=Help      F9=Change Screen Mode
STATUS: IBM 8232 Online,  ETHTASK0 Opened,  TOKTASK0 Opened  1
```

Token-Ring and PC Network Adapter Performance Statistics Reported by User Command I

The performance statistics from the primary Token-Ring or PC Network adapter in the IBM 8232 are identified as being from TOKTASK0 and those from the alternate adapter are identified as being from TOKTASK1. Information is reported about all the following items.

- Number of packets successfully transmitted (Xmits)
- Number of errors encountered while transmitting packets (Xmit errors)
- Number of transmit packets discarded (Xmits discarded)
- Number of packets received successfully (Recvd)
- Number of receive errors that occurred (Recv errors)
- Number of receive packets discarded (Recvs discarded)
- Number of packets filtered out (Packets filtered out)
- Number of adapter errors (Adapter errors)
- Ring status (Ring status)
- Number of Industrial Computer errors (PC errors)
- Number of received packets too big for PC buffers (Buffer overflow)

Note: For the PC Network adapter, the network status is displayed as the ring status.

For an IBM 8232 LAN Channel Station Model 1 with one Token-Ring adapter and one Ethernet adapter installed, the display panel will look similar to the one shown below in response to the **i** command.

```
Keyboard Entry Mode
-----
I
-->KYBDTSK: The current LAN tasks are:
      0: ETHTASK0 (Adapter: 0  Node Address: XXXXXXXXXXXX)
      1: TOKTASK0 (Adapter: 0  Node Address: XXXXXXXXXXXX)

Enter number of target task or press ENTER to quit:_

      (If you enter a 1 you will see the following.)
-->TOKTASK0: Token-Ring/PC Network Statistics
-->TOKTASK0: X Xmits   Y Xmit errors  Z Xmits discarded
-->TOKTASK0: X Recvd   Y Recv errors  Z Recvs discarded
-->TOKTASK0: X Packets filtered out
-->TOKTASK0: X Adapter errors  Y Ring status   Z PC errors
-->TOKTASK0: X Buffer overflow

                        F1=Help      F9=Change Screen Mode
STATUS: IBM 8232 Online,  ETHTASK0 Opened,  TOKTASK0 Opened  1
```

User Command L (List LAN Adapters)

The **L** command causes the IBM LAN Channel Support Program to display information about each authorized LAN adapter installed in the IBM 8232. The information may be helpful to anyone wanting to verify the characteristics of this particular IBM 8232 LAN Channel Station. Information is reported about all the following items. The words in parenthesis are the abbreviations used on the display panel to report an item.

- Name associated with installed LAN adapter (Task Name)
 - ETHTASK0 indicates first Ethernet adapter
 - ETHTASK1 indicates second Ethernet adapter
 - TOKTASK0 indicates first Token-Ring or PC Network adapter
 - TOKTASK1 indicates second Token-Ring or PC Network adapter
- Adapter Number (Adapter)
 - 0 indicates the primary adapter
 - 1 indicates an alternate adapter
- Base subchannel address to which LAN adapter is assigned (Subchannel Address)
 - two-digit hexadecimal address
- Universally administered adapter address (Node Address)
 - twelve-digit hexadecimal address

For an IBM 8232 LAN Channel Station Model 1 with one Token-Ring adapter and one Ethernet adapter installed, the display panel will look similar to the one shown below in response to the **L** command.

```
Keyboard Entry Mode
-----
L
-->KYBDTSK: Adapter Information
-->KYBDTSK: Task Name: TOKTASK0 Adapter: 0 Subchannel Address: xx
Node Address: xxxxxxxxxxxxxx
-->KYBDTSK: Task Name: ETHTASK0 Adapter: 0 Subchannel Address: xx
Node Address: yyyyyyyyyyyy

F1=Help F9=Change Screen Mode
STATUS: IBM 8232 Online, ETHTASK0 Opened, TOKTASK0 Opened 1
```

User Command O (Online Status)

The **o** command enables you to determine if your IBM 8232 is online or offline with the channel connecting it to the host computer. It also shows you the channel device address assigned to the IBM 8232. You will see one of the following messages in response to the **o** command.

Note: If the status of a subchannel address pair is listed as "Inactive," it means that the host computer has not initiated contact with the IBM 8232.

```
Keyboard Entry Mode
-----
0
-->KYBDTSK: X subchannel address pairs are defined.
             Their individual statuses are
             XX (Active Inactive or Pending)
-->PCCATSK1 A3: IBM 8232 is Online, Device Address: xx

or

-->KYBDTSK: X subchannel address pairs are defined.
             Their individual statuses are
             XX Inactive
-->PCCATSK1 A2: IBM 8232 is Offline, Device Address: xx

F1=Help      F9=Change Screen Mode
STATUS: IBM 8232 Online,  ETHTASK0 Opened,  TOKTASK0 Opened  1
```

User Command Q (Quit)

The **q** command causes the IBM LAN Channel Support Program to halt operation. Data waiting to go to the host computer is sent. Data waiting to go to the local area network is discarded. The IBM 8232 is taken offline and control is returned to DOS. If you have an IBM 8232 Model 2, you need to execute this command **twice**, once on each IBM 7532, before the entire IBM 8232 is taken offline. For an IBM 8232 LAN Channel Station Model 1 containing one active Token-Ring adapter and one active Ethernet adapter, you will see the following panel in response to the **q** command.

```

                                     Status Message Mode
-----
Q
      (You will see a blank screen for a few seconds
      followed by an accumulated list of status
      messages followed by these quit messages.)
      .
      .
      .
-->Quit command issued by user

-->ETHTASK0 A1: Adapter closed
-->TOKTASK0 A1: Adapter closed
-->PCCATSK1 A2: IBM 8232 is Offline, Device Address: xx

-->The IBM LAN Channel Support Program has Terminated
A>_

```

User Command R (Restart LAN Adapter)

The **r** command enables you to open any authorized but inactive LAN adapter in the Industrial Computer. An inactive LAN adapter may be identified by the words **Holding**, **Pending**, or **Closed** on the STATUS line at the bottom of the panel. The adapter may be inactive due to an action on your part or an action by the local area network or the host computer. When you issue the **r** command, you are asked to select the LAN adapter you want to open. If you want to open both LAN adapters, you need to execute this command **twice**. For an IBM 8232 LAN Channel Station Model 1 with one Token-Ring adapter and one Ethernet adapter installed, you will see the following panel in response to the **r** command.

```
Keyboard Entry Mode
-----
R
-->KYBDTSK: The current LAN tasks are:
      0: ETHTASK0 (Adapter: 0 Node Address: xxxxxxxxxxxx)
      1: TOKTASK0 (Adapter: 0 Node Address: xxxxxxxxxxxx)

Enter number of target task or press ENTER to quit:_

      (If you enter a 0 you will see the following.)
-->KYBDTSK A6: Command sent to ETHTASK0

      (If you enter a 1 you will see the following.)
-->KYBDTSK A6: Command sent to TOKTASK0

      F1=Help      F9=Change Screen Mode
STATUS: IBM 8232 Online,  ETHTASK0 Opened,  TOKTASK0 Opened  1
```

User Command S (Channel Adapter Performance Statistics)

The `s` command enables you or your computer center systems programmer to collect and display performance statistics about the channel adapter in the IBM 8232. This information can be used for workload balancing or network tuning. Offline is displayed for an inactive channel adapter.

The following section describes the performance statistics shown when you enter the `s` command. All numerical values are reported in decimal. The words in parenthesis are the abbreviations used on the display panel to report an item.

Channel Adapter Performance Statistics Reported by User Command S

The performance statistics for the channel adapter in the IBM 8232 are identified as being from MONTASK. Information is reported about all the following items.

- Base subchannel address to which the statistics pertain (Subchannel Address)
- Number of data blocks received from host (Blks from host)
- Number of data blocks sent to host (Blks to host)
- Number of data packets received from host (Pkts deblocked)
- Number of data packets sent to host (Pkts blocked)
- Number of control packets received from host (Cntl rcvd)
- Number of control packets sent to host (Cntl sent)
- Number of packets received from host and discarded (Rcvd pkts dsc)
- Number of packets sent to host and discarded by host (Send pkts dsc)
- Average size of packets from host in bytes (Avg pkt from host)
- Average size of packets sent to host in bytes (Avg pkt to host)

The display panel will look similar to the one shown below in response to the `s` command.

```
Keyboard Entry Mode
-----
S

-->KYBDTSK: General Statistics
-->KTBDTSK: Subchannel Address XX
-->KYBDTSK: X Blks from host   Y Blks to host
-->KYBDTSK: X Pkts deblocked  Y Pkts blocked
-->KYBDTSK: X Cntl rcvd     Y Cntl sent
-->KYBDTSK: X Rcvd pkts dsc  Y Send pkts dsc
-->KYBDTSK: X Avg pkt from host Y Avg pkt to host
-->PCCATSK1 A3: IBM 8232 is Online, Device Address: xx
                F1=Help          F9=Change Screen Mode
STATUS: IBM 8232 Online,  ETHTASK0 Opened,  TOKTASK0 Opened  1
```

User Command T (Trace)

The **t** command enables you to set the reporting level (0 to 9) for status messages shown on the display panel. The higher the level you select, the greater the number of messages displayed. The lower the level, the more important will be the messages that are displayed. When the IBM LAN Channel Support Program is loaded, all tasks are set to report only level-0 status messages. This level should not be changed except under the direction of IBM service personnel. Setting the level higher than 0 causes more messages to be shown. When the display panel fills with messages, older messages disappear by scrolling off the panel. Processing additional messages degrades the performance of the IBM LAN Channel Support Program. You may change the reporting level for certain tasks without affecting the reporting level for other tasks. All level-0 status messages are described in Appendix A of this manual. Messages from reporting levels higher than 0 are used by IBM service personnel only.

For an IBM 8232 LAN Channel Station Model 1 with one Token-Ring adapter and one Ethernet adapter installed, you will see the following panel in response to the **t** command.

```
Keyboard Entry Mode
-----
T

-->KYBDTSK: The current tasks are:
  0: ETHTASK0 (Adapter: 0 Trace Level: 0)
  1: TOKTASK0 (Adapter: 0 Trace Level: 0)
  2: PCCATSK1 (Channel Adapter Status: Online Trace Level: 0)
  3: MONTASK/BLOKTSK/DBLOKTSK/CNTLTSK/KYBDTSK (Trace Level: 0)
  4: All tasks in the list above

Enter number of target task or press ENTER to quit:_

      (If you enter 0 to 4 you will see the following.)
Enter the desired trace level 0 to 9 or press ENTER to quit:_

      (If you enter 0 to 9 you will see one
       or more of the following messages.)
-->KYBDTSK A6: Command sent to ETHTASK0
-->KYBDTSK A6: Command sent to TOKTASK0
-->KYBDTSK A6: Command sent to PCCATSK1
-->KYBDTSK A5: Trace level set to x

      F1=Help      F9=Change Screen Mode
STATUS: IBM 8232 Online, ETHTASK0 Opened, TOKTASK0 Opened 1
```

User Command Z (Memory Dump)

The **z** command should be executed only under the direction of IBM service personnel. Executing this command causes the Industrial Computer to copy all its RAM memory onto a diskette. To execute this command, you need a blank, formatted, high-capacity 5.25-inch diskette. You will see the following panel in response to the **z** command.

```
Keyboard Entry Mode
-----
Z

You have elected to perform a memory dump. You should only
perform a memory dump under the direction of IBM service
personnel. If you proceed, you will be instructed to insert
a blank, formatted, high-capacity, 5.25-inch diskette.

If you do not wish to proceed, type N and press ENTER.
To proceed with the memory dump, type Y and press ENTER._

      (If you entered N, you will see the following.)
Memory dump cancelled.

      (If you entered Y, you will see the following.)
Insert a blank, formatted, high-capacity, 5.25-inch diskette.
Press ENTER when ready.

Memory dump in progress...

Memory dump completed.

                                F1=Help      F9=Change Screen Mode
STATUS: IBM 8232 Online,  ETHTASK0 Opened, TOKTASK0 Opened  1
```

User Command Function Key F1 (Help)

The **F1** Function Key command causes the IBM LAN Channel Support Program to invoke the online help facility. You will see the following panel in response to the **F1** command.

IBM 8232 HELP FACILITY
Help Menu

This help facility contains information on the following topics:

1. General Operations
2. Enabling/Disabling Channel Interface
3. Enabling/Disabling LAN Adapters
4. Obtaining Information and Statistics
5. Setting Trace Levels

To view information about a topic, enter the number of the topic.

F4=Return to Support Program

User Command Function Key F9 (Change Screen)

The **F9** Function Key command causes the IBM LAN Channel Support Program to switch between "Status Message" and "Keyboard Entry" modes. A mode indicator appears in the lower right corner of the display panel. A "0" indicates "Status Message" mode. A "1" indicates "Keyboard Entry" mode. The "Keyboard Entry" panel has the words "Keyboard Entry Mode" centered near the top of the panel. The "Status Message" panel has the words "Status Message Mode" centered near the top. You will see one of the following panels each time you press the **F9** key.

Status Message Panel

The "Status Message Mode" panel looks like the one below.

```

                                Status Message Mode
-----
                                (You will see an accumulated list of status
                                messages such as the ones shown below.)
                                .
                                .
                                .
-->PCCATSK1 A3: IBM 8232 is Online, Device Address: C0
-->ETHTASK0 A0: Adapter ready
-->TOKTASK0 A0: Adapter ready
-?>DBLOKTSK 23: Invalid offset in block
                                .
                                .
                                .
                                F1=Help      F9=Change Screen Mode
STATUS: IBM 8232 Online,  ETHTASK0 Opened, TOKTASK0 Opened  0
```

Keyboard Entry Panel

After starting the IBM LAN Channel Support Program, the first time you go to "Keyboard Entry" mode the "Keyboard Entry Mode" panel will look like the one below. If you enter a command, switch to "Status Message" mode, and then return to "Keyboard Entry" mode, the panel will look like it did after you entered the command.

```

                                Keyboard Entry Mode
-----
**>KYBDTSK Version 1.00

                                F1=Help      F9=Change Screen Mode
STATUS: IBM 8232 Online,  ETHTASK0 Opened, TOKTASK0 Opened  1
```

Appendix A. IBM LAN Channel Support Program Status Messages

When the IBM LAN Channel Support Program is loaded and operating, it generates status messages. These messages appear on the display attached to the IBM 8232 LAN Channel Station's Industrial Computer. The following pages list the status messages you may see, give an explanation of their meaning, and indicate the action you should take when you see a particular message. There are two types of status messages; information messages and error messages. Information messages are preceded by either **** >** or **-- >**. Error messages are preceded by **-? >**. The messages are arranged in alphabetical order beginning with BLOKTSK Status Messages and in numerical order within a group.

BLOKTSK Status Messages

**** > BLOKTSK Version 1.00**

Meaning: The BLOKTSK Version 1.00 portion of the IBM LAN Channel Support Program has been successfully loaded into the IBM 8232 LAN Channel Station's active memory.

Action: No action is required.

-? > BLOKTSK 10: Unknown msgtype X

Meaning: An undefined message was received by the IBM 8232 LAN Channel Station. *X* (0000 to FFFF) identifies the message type.

Action: Record the message exactly as it appears on the display panel. If the problem reoccurs, have your service coordinator contact the IBM Support Center for assistance.

-?> BLOKTSK 13: Xmit from unknown LAN X adapter Y

Meaning: A message has been received for the host system from an unidentified LAN. *X* identifies the LAN type (1 means the Ethernet adapter, 2 means the Token-Ring or PC Network adapter, any number higher than 2 is not defined). *Y* identifies the adapter number (0 means the primary adapter, 1 means the alternate adapter, any number higher than 1 is not defined).

Action: If this message represents an isolated incident, no action is necessary. If the message occurs again, check both the IBM 8232 LAN Channel Station and host system configurations. If both configurations are correct and the problem reoccurs, record the message exactly as it appears on the display panel, along with the number of times it occurred, then halt and restart IBM LAN Channel Support Program. To halt the program, press the **F9** function key to go to "Keyboard Entry Mode," type **q** and press **Enter**. To restart the program, press the Industrial Computer's red reset button adjacent to the diskette drive. If your IBM 8232 working diskette does not have an AUTOEXEC.BAT you also need to type **MTCMMAIN** and press **Enter**. If the problem occurs again, have your service coordinator contact the IBM Support Center for assistance.

Note: For more information about the **q** command, refer to Chapter 3, page 3-15 in this manual.

-?> BLOKTSK 26: Duplicate channel adapter buffer detected

Meaning: The IBM 8232 LAN Channel Station detected a duplicate buffer on its channel adapter.

Action: If this message represents an isolated incident, no action is necessary. If the message occurs again, record the message exactly as it appears on the display panel, along with the number of times it occurred, and report it to your establishment's computer center systems programmer. If your systems programmer cannot resolve the problem, have your service coordinator contact your provider of service for a repair action.

CNTLTSK Status Messages

** > CNTLTSK Version 1.00

Meaning: The CNTLTSK Version 1.00 portion of the IBM LAN Channel Support Program has been successfully loaded into the IBM 8232 LAN Channel Station's active memory.

Action: No action is required.

-? > CNTLTSK 01: Unable to open message queue

Meaning: The IBM 8232 LAN Channel Station was unable to establish a buffer to hold messages. The IBM LAN Channel Support Program has aborted. Control has been returned to DOS.

Action: Record the message exactly as it appears on the display panel, then restart the IBM LAN Channel Support Program. To restart the program, press the Industrial Computer's red reset button adjacent to the diskette drive. If your IBM 8232 working diskette does not have an AUTOEXEC.BAT, you also need to type MTCMMAIN and press Enter. If the problem reoccurs, have your service coordinator contact the IBM Support Center for assistance.

-? > CNTLTSK 10: Unknown msgtype X

Meaning: An undefined message was received by the IBM 8232 LAN Channel Station. X (0000 to FFFF) identifies the message type.

Action: Record the message exactly as it appears on the display panel. If the problem reoccurs, have your service coordinator contact the IBM Support Center for assistance.

-? > CNTLTSK 11: Unknown control command X

Meaning: An unknown control command was received by the IBM 8232 LAN Channel Station from the host system. X (09 to FF) is the value in the command field. This indicates a potential problem with the host system software or the channel cables. The IBM 8232 LAN Channel Station ignores the command.

Action: If this message represents an isolated incident, no action is necessary. If the message occurs again, record the message exactly as it appears on the display panel, along with the number of times it occurred, and report it to your establishment's computer center systems programmer. If your systems programmer cannot resolve the problem, have your service coordinator contact your provider of service for a repair action.

-?> **CNTLTSK 12: Unknown control message X**

Meaning: An undefined control message was received by the IBM 8232 LAN Channel Station. *X* (0000 to FFFF) identifies the message type.

Action: If this message represents an isolated incident, no action is necessary. If the message occurs again, record the message exactly as it appears on the display panel, along with the number of times it occurred, and report it to your establishment's computer center systems programmer. If your systems programmer cannot resolve the problem, have your service coordinator contact your provider of service for a repair action.

-?> **CNTLTSK 14: STRTLAN - Unknown target LAN X adapter Y**

Meaning: The IBM 8232 LAN Channel Station received a message from the host computer requesting the IBM 8232 to activate an undefined LAN adapter. *X* identifies the LAN type (1 means the Ethernet adapter, 2 means the Token-Ring or PC Network adapter, any number higher than 2 is not defined). *Y* identifies the adapter number (0 means the primary adapter, 1 means the alternate adapter, any number higher than 1 is not defined). This indicates a potential problem with the host system software or the channel cables.

Action: If this message represents an isolated incident, no action is necessary. If the message occurs again, record the message exactly as it appears on the display panel, along with the number of times it occurred, and report it to your establishment's computer center systems programmer. If your systems programmer cannot resolve the problem, have your service coordinator contact your provider of service for a repair action.

-?> **CNTLTSK 15: STOPLAN - Unknown target LAN X adapter Y**

Meaning: The IBM 8232 LAN Channel Station received a message from the host computer requesting deactivation of an undefined LAN adapter. *X* identifies the LAN type (1 means the Ethernet adapter, 2 means the Token-Ring or PC Network adapter, any number higher than 2 is not defined). *Y* identifies the adapter number (0 means the primary adapter, 1 means the alternate adapter, any number higher than 1 is not defined). This indicates a potential problem with the host system software or the channel cables.

Action: If this message represents an isolated incident, no action is necessary. If the message occurs again, record the message exactly as it appears on the display panel, along with the number of times it occurred, and report it to your establishment's computer center systems programmer. If your systems programmer cannot resolve the problem, have your service coordinator contact your provider of service for a repair action.

-?> CNTLTSK 16: LANSTAT - Unknown target LAN X adapter Y

Meaning: The IBM 8232 LAN Channel Station received a message from the host computer requesting statistics about an undefined LAN adapter. *X* identifies the LAN type (1 means the Ethernet adapter, 2 means the Token-Ring or PC Network adapter, any number higher than 2 is not defined). *Y* identifies the adapter number (0 means the primary adapter, 1 means the alternate adapter, any number higher than 1 is not defined). This indicates a potential problem with the host system software or the channel cables.

Action: If this message represents an isolated incident, no action is necessary. If the message occurs again, record the message exactly as it appears on the display panel, along with the number of times it occurred, and report it to your establishment's computer center systems programmer. If your systems programmer cannot resolve the problem, have your service coordinator contact your provider of service for a repair action.

-?> CNTLTSK 17: FILTERP - Unknown target LAN X adapter Y

Meaning: The IBM 8232 LAN Channel Station received a message from the host with packet filter information for an unknown LAN adapter. *X* identifies the LAN type (1 means the Ethernet adapter, 2 means the Token-Ring or PC Network adapter, any number higher than 2 is not defined). *Y* identifies the adapter number (0 means the primary adapter, 1 means the alternate adapter, any number higher than 1 is not defined). This indicates a potential problem with the host system software or the channel cables.

Action: If this message represents an isolated incident, no action is necessary. If the message occurs again, record the message exactly as it appears on the display panel, along with the number of times it occurred, and report it to your establishment's computer center systems programmer. If your systems programmer cannot resolve the problem, have your service coordinator contact your provider of service for a repair action.

DBLOKTSK Status Messages

** > DBLOKTSK Version 1.00

Meaning: The DBLOKTSK Version 1.00 portion of the IBM LAN Channel Support Program has been successfully loaded into the IBM 8232 LAN Channel Station's active memory.

Action: No action is required.

-? > DBLOKTSK 10: Unknown msgtype X

Meaning: An undefined message was received by the IBM 8232 LAN Channel Station. X (0000 to FFFF) identifies the message type.

Action: Record the message exactly as it appears on the display panel. If the problem reoccurs, have your service coordinator contact the IBM Support Center for assistance.

-? > DBLOKTSK 13: Unknown target LAN X adapter Y

Meaning: A message has been received from the host system for an unidentified LAN. X identifies the LAN type (1 means the Ethernet adapter, 2 means the Token-Ring or PC Network adapter, any number higher than 2 is not defined). Y identifies the adapter number (0 means the primary adapter, 1 means the alternate adapter, any number higher than 1 is not defined). This message may indicate a mismatch between configuration data in the IBM 8232 LAN Channel Station and the host system or a potential problem with the channel cables.

Action: If this message represents an isolated incident, no action is necessary. If the message occurs again, record the message exactly as it appears on the display panel, along with the number of times it occurred, and report it to your establishment's computer center systems programmer. If your systems programmer cannot resolve the problem, have your service coordinator contact your provider of service for a repair action.

-? > DBLOKTSK 22: Data runs past end of block

Meaning: The IBM 8232 LAN Channel Station received a block of data from the host computer which contains a packet that extends beyond the expected data block boundary. This indicates a potential problem with the host system software or the channel cables.

Action: If this message represents an isolated incident, no action is necessary. If the message occurs again, record the message exactly as it appears on the display panel, along with the number of times it occurred, and report it to your establishment's computer center systems programmer. If your systems programmer cannot resolve the problem, have your service coordinator contact your provider of service for a repair action.

-? > DBLOKTSK 23: Invalid offset in block

Meaning: The IBM 8232 LAN Channel Station received a block of data from the host computer containing a packet with an invalid offset value. This indicates a potential problem with the host system software or the channel cables.

Action: If this message represents an isolated incident, no action is necessary. If the message occurs again, record the message exactly as it appears on the display panel, along with the number of times it occurred, and report it to your establishment's computer center systems programmer. If your systems programmer cannot resolve the problem, have your service coordinator contact your provider of service for a repair action.

-? > DBLOKTSK 24: Packet bigger than buffer, discarded

Meaning: The IBM 8232 LAN Channel Station received a block of data (packet) from the host computer that contained more bytes than the size of the buffer permits. In trying to receive this packet, the beginning of the packet was lost. The packet has been discarded. This indicates a potential problem with the host system software or the channel cables.

Action: If this message represents an isolated incident, no action is necessary. If the message occurs again, record the message exactly as it appears on the display panel, along with the number of times it occurred, and report it to your establishment's computer center systems programmer. If your systems programmer cannot resolve the problem, have your service coordinator contact your provider of service for a repair action.

-? > DBLOKTSK 25: X identified as bad task, forced shutdown

Meaning: The IBM 8232 LAN Channel Station is not able to communicate with one of its local area networks. X (TOKTASK0, TOKTASK1, ETHTASK0, or ETHTASK1) identifies the LAN adapter attached to the problem LAN. The identified LAN adapter in the IBM 8232 has been shut down. All data from the host computer for this LAN adapter will be discarded.

Action: Record the message exactly as it appears on the display panel, then reinitialize the Primary (0) or Alternate (1) LAN adapter. To reinitialize a LAN adapter, press the **F9** function key to go to "Keyboard Entry Mode," type **r** and press **Enter**. If the problem reoccurs, it could be caused by either the LAN adapter in the IBM 8232 LAN Channel Station or the local area network attached to it. Halt the IBM LAN Channel Support Program, run the diagnostics provided with your LAN adapter and replace the adapter if indicated. To halt the program, press the **F9** function key to go to "Keyboard Entry Mode," type **q** and press **Enter**. After running the diagnostics, restart the program. To restart the program, press the Industrial Computer's red reset button adjacent to the diskette drive. If your IBM 8232 working diskette does not have an AUTOEXEC.BAT you also need to type **MTCMMAIN** and press **Enter**. If the problem still reoccurs, report it to the network administrator responsible for the local area network generating the shutdown. If the network administrator does not find a problem with the LAN, have your service coordinator contact the IBM Support Center for assistance.

Note: For more information about the **r** command, refer to Chapter 3, page 3-16 in this manual. For more information about the **q** command, refer to Chapter 3, page 3-15.

-? > DBLOKTSK 26: Duplicate channel adapter buffer detected

Meaning: The IBM 8232 LAN Channel Station detected a duplicate buffer on its channel adapter.

Action: If this message represents an isolated incident, no action is necessary. If the message occurs again, record the message exactly as it appears on the display panel, along with the number of times it occurred, and report it to your establishment's computer center systems programmer. If your systems programmer cannot resolve the problem, have your service coordinator contact your provider of service for a repair action.

ETHTASK Status Messages

All ETHTASK messages are identified as being from either ETHTASK0 or ETHTASK1. In the ETHTASK material that follows, the messages are identified as being from ETHTASK0. Identical messages could be received from ETHTASK1 if there is a second Ethernet Network adapter installed in the IBM 8232 LAN Channel Station.

** > ETHTASK0 Version 1.00

Meaning: The ETHTASK0 Version 1.00 portion of the IBM LAN Channel Support Program has been successfully loaded into the IBM 8232 LAN Channel Station's active memory.

Action: No action is required.

-- > ETHTASK0 A0: Adapter ready

Meaning: The Ethernet adapter in this IBM 8232 LAN Channel Station is open and ready to operate.

Action: No action is required.

-- > ETHTASK0 A1: Adapter closed

Meaning: The Ethernet adapter in this IBM 8232 LAN Channel Station is closed and not ready to operate.

Action: No action is required. If you want to activate the closed adapter, press the **F9** function key to go to "Keyboard Entry Mode," type **r** and press **Enter**.

Note: For more information about the **r** command, refer to Chapter 3, page 3-16 in this manual.

-- > ETHTASK0 A5: Trace level set to X

Meaning: The status message reporting level is set to X (0 to 9). When set to level-0, only the most important messages are reported. When set to level-9, all messages are reported.

Action: Unless you have specific instructions to do otherwise, set the reporting level to display only level-0 messages. To set the program to report level-0 messages, press the **F9** function key to go to "Keyboard Entry Mode," type **t** and press **Enter**. This manual documents only level-0 messages. Messages from reporting levels higher than 0 are used by IBM service personnel only.

Note: For more information about the **t** command, refer to Chapter 3, page 3-18 in this manual.

-? > ETHTASK0 01: Unable to open message queue

Meaning: The IBM LAN Channel Support Program was unable to establish a buffer to hold messages. The IBM LAN Channel Support Program has aborted. Control has been returned to DOS.

Action: Record the message exactly as it appears on the display panel, then restart the IBM LAN Channel Support Program. To restart the program, press the Industrial Computer's red reset button adjacent to the diskette drive. If your IBM 8232 working diskette does not have an AUTOEXEC.BAT you also need to type **MTCMMAIN** and press **Enter**. If the problem reoccurs, have your service coordinator contact the IBM Support Center for assistance.

-?> ETHTASK0 10: Unknown msgtype X

Meaning: An undefined message was received by the IBM 8232 LAN Channel Station. *X* (0000 to FFFF) identifies the message type.

Action: Record the message exactly as it appears on the display panel. If the problem reoccurs, have your service coordinator contact the IBM Support Center for assistance.

-?> ETHTASK0 12: Unknown control message X

Meaning: An undefined control message was received by the IBM 8232 LAN Channel Station. *X* (0000 to FFFF) identifies the message type.

Action: If this message represents an isolated incident, no action is necessary. If the message occurs again, record the message exactly as it appears on the display panel, along with the number of times it occurred, and report it to your establishment's computer center systems programmer. If your systems programmer cannot resolve the problem, have your service coordinator contact your provider of service for a repair action.

-?> ETHTASK0 17: Received command to close adapter when not open

Meaning: A control command to close the LAN adapter was received when it was already closed.

Action: No action is required.

-?> ETHTASK0 43: Unrecoverable error due to a cable problem

Meaning: The Ethernet adapter in the IBM 8232 LAN Channel Station experienced a transmission problem on the cable attaching it to the Ethernet network. The adapter was not able to recover from this condition and is now inactive.

Action: Check the cable attaching the IBM 8232 LAN Channel Station to the Ethernet network, then reinitialize the Ethernet adapter. To reinitialize the adapter, press the **F9** function key to go to "Keyboard Entry Mode," type **r** and press **Enter**. If the problem reoccurs, record the message exactly as it appears on the display panel along with any additional information shown. For assistance, contact the network administrator responsible for the local area network generating the unrecoverable error. Provide the network administrator with all the information you recorded. When the network administrator indicates the problem is fixed, check to see that this message is no longer generated.

Note: For more information about the **r** command, refer to Chapter 3, page 3-16 in this manual.

-?> ETHTASK0 4E: Received packet(s) from DBLOKTSK, adapter not ready

Meaning: The IBM 8232 LAN Channel Station received a block of data from the host computer for a LAN adapter that is not active.

Action: Related messages about the same LAN adapter may also appear indicating the reason the adapter is inactive. Record this message and any other related messages exactly as they appear on the display panel. Take the action recommended for the related message.

If no related messages appear, record this message exactly as it appears on the display panel, then reinitialize the inactive LAN adapter. To reinitialize a LAN adapter, press the **F9** function key to go to "Keyboard Entry Mode," type **r** and press **Enter**. If the problem reoccurs, contact the network administrator responsible for the local area network connected to the inactive LAN adapter. When the network administrator indicates the problem is fixed, check to see that this message is no longer generated. If the network administrator cannot resolve the problem, have your service coordinator contact the IBM Support Center for assistance.

Note: For more information about the **r** command, refer to Chapter 3, page 3-16 in this manual.

-?> ETHTASK0 60: Invalid adapter number Y

Meaning: An invalid adapter number was assigned in the MTCMCONF.DAT file. *Y* identifies the adapter number (0 means the primary adapter, 1 means the alternate adapter, any number higher than 2 is not defined).

Action: If the MTCMCONF.EXE portion of the IBM LAN Channel Support Program *was not* used to describe your LAN adapter configuration on your IBM 8232 working diskette, halt the program and make a new working diskette using the MTCMCONF.EXE configuration aid. To halt the program, press the **F9** function key to go to "Keyboard Entry Mode," type **q** and press **Enter**.

If the MTCMCONF.EXE portion of the IBM LAN Channel Support Program *was* used to describe your LAN adapter configuration, record the message exactly as it appears on the display panel, then halt and restart the IBM LAN Channel Support Program. To halt the program, press the **F9** function key to go to "Keyboard Entry Mode," type **q** and press **Enter**. To restart the program, press the Industrial Computer's red reset button adjacent to the diskette drive. If your IBM 8232 working diskette does not have an AUTOEXEC.BAT you also need to type **MTCMMAIN** and press **Enter**. If the problem reoccurs, have your service coordinator contact the IBM Support Center for assistance.

Note: For more information about the **q** command, refer to Chapter 3, page 3-15 in this manual.

-?> ETHTASK0 61: Invalid interrupt level X

Meaning: An invalid interrupt level was assigned in the MTCMCONF.DAT file. *X* (0 to 9) identifies the interrupt level.

Action: If the MTCMCONF.EXE portion of the IBM LAN Channel Support Program *was not* used to describe your LAN adapter configuration on your IBM 8232 working diskette, halt the program and make a new working diskette using the MTCMCONF.EXE configuration aid. To halt the program, press the **F9** function key to go to "Keyboard Entry Mode," type **q** and press **Enter**.

If the MTCMCONF.EXE portion of the IBM LAN Channel Support Program *was* used to describe your LAN adapter configuration, record the message exactly as it appears on the display panel, then halt and restart the IBM LAN Channel Support Program. To halt the program, press the **F9** function key to go to "Keyboard Entry Mode," type **q** and press **Enter**. To restart the program, press the Industrial Computer's red reset button adjacent to the diskette drive. If your IBM 8232 working diskette does not have an AUTOEXEC.BAT you also need to type **MTCMMAIN** and press **Enter**. If the problem reoccurs, have your service coordinator contact the IBM Support Center for assistance.

Note: For more information about the **q** command, refer to Chapter 3, page 3-15 in this manual.

-?> ETHTASK0 62: Invalid base address X

Meaning: An invalid base address was assigned in the MTCMCONF.DAT file. *X* (0000 to FFFF) identifies the base address.

Action: If the MTCMCONF.EXE portion of the IBM LAN Channel Support Program *was not* used to describe your LAN adapter configuration on your IBM 8232 working diskette, halt the program and make a new working diskette using the MTCMCONF.EXE configuration aid. To halt the program, press the **F9** function key to go to "Keyboard Entry Mode," type **q** and press **Enter**.

If the MTCMCONF.EXE portion of the IBM LAN Channel Support Program *was* used to describe your LAN adapter configuration, record the message exactly as it appears on the display panel, then halt and restart the IBM LAN Channel Support Program. To halt the program, press the **F9** function key to go to "Keyboard Entry Mode," type **q** and press **Enter**. To restart the program, press the Industrial Computer's red reset button adjacent to the diskette drive. If your IBM 8232 working diskette does not have an AUTOEXEC.BAT you also need to type **MTCMMAIN** and press **Enter**. If the problem reoccurs, have your service coordinator contact the IBM Support Center for assistance.

Note: For more information about the **q** command, refer to Chapter 3, page 3-15 in this manual.

-? > ETHTASK0 63: Invalid permanent node address detected

Meaning: The memory address on the Ethernet adapter installed in this IBM 8232 LAN Channel Station is incorrectly set.

Action: Halt the IBM LAN Channel Support Program, remove the Ethernet adapter, and check the jumpers on the adapter. To halt the program, press the **F9** function key to go to "Keyboard Entry Mode," type **q** and press **Enter**. Remove power from the IBM 8232 LAN Channel Station, then remove the Ethernet adapter and check its jumpers. To remove and check the Ethernet adapter refer to the *IBM 8232 LAN Channel Station Operator's Guide*. If the memory address jumpers are properly set reinstall the Ethernet adapter. If the problem reoccurs, have your service coordinator contact your Ethernet provider of service for a repair action.

KYBDTSK Status Messages

** > KYBDTSK Version 1.00

Meaning: The KYBDTSK Version 1.00 portion of the IBM LAN Channel Support Program has been successfully loaded into the IBM 8232 LAN Channel Station's active memory.

Action: No action is required.

-- > KYBDTSK A5: Trace level set to *X*

Meaning: The status message reporting level is set to *X* (0 to 9). When set to level-0, only the most important messages are reported. When set to level-9, all messages are reported.

Action: Unless you have specific instructions to do otherwise, set the reporting level to display only level-0 messages. To set the program to report level-0 messages, press the **F9** function key to go to "Keyboard Entry Mode," type **t** and press **Enter**. This manual documents only level-0 messages. Messages from reporting levels higher than 0 are used by IBM service personnel only.

Note: For more information about the **t** command, refer to Chapter 3, page 3-18 in this manual.

-- > KYBDTSK A6: Command sent to *TASKNAME*

Meaning: A command has been sent to the task identified by *TASKNAME*.

Action: No action is required.

-- > KYBDTSK A7: *TASKNAME* is already closed

Meaning: A command to close a task was received when it was already closed. The task is identified by *TASKNAME*.

Action: No action is required.

-- > KYBDTSK A8: *TASKNAME* is already started

Meaning: A command to activate a task was received when it was already active. The task is identified by *TASKNAME*.

Action: No action is required.

-? > KYBDTSK 03: Unable to open file for dump

Meaning: An error occurred while the IBM LAN Channel Support Program was writing header information on the memory dump diskette in response to the **z** command. The memory dump was terminated.

Action: Replace the diskette with a new blank, formatted, high-capacity, 5.25-inch diskette and repeat the command.

Note: For more information about the **z** command, refer to Chapter 3, page 3-19 in this manual.

-?> KYBDTSK 04: Error writing dump file

Meaning: An error occurred while the IBM LAN Channel Support Program was writing memory dump data on the memory dump diskette in response to the **z** command. The memory dump was terminated.

Action: Replace the diskette with a new blank, formatted, high-capacity, 5.25-inch diskette and repeat the command.

Note: For more information about the **z** command, refer to Chapter 3, page 3-19 in this manual.

-?> KYBDTSK 05: Error closing dump file

Meaning: An error occurred while the IBM LAN Channel Support Program was writing closing information on the memory dump diskette in response to the **z** command. The memory dump was terminated.

Action: Replace the diskette with a new blank, formatted, high-capacity, 5.25-inch diskette and repeat the command.

Note: For more information about the **z** command, refer to Chapter 3, page 3-19 in this manual.

-?> KYBDTSK 50: Unrecognized command: X

Meaning: An operator entered an unknown command from the IBM 8232 LAN Channel Station keyboard. The command character entered was **X**.

Action: Enter a valid command. To view a list of the valid command characters, press the **F9** function key to go to "Keyboard Entry Mode," type **?** and press **Enter**.

Note: For more information about the **?** command, refer to Chapter 3, page 3-8 in this manual.

MONTASK Status Messages

** > MONTASK Version 1.00

Meaning: The MONTASK Version 1.00 portion of the IBM LAN Channel Support Program has been successfully loaded into the IBM 8232 LAN Channel Station's active memory.

Action: No action is required.

-? > MONTASK 00: Unable to attach task

Meaning: The IBM 8232 LAN Channel Station was unable to activate one of the tasks in the IBM LAN Channel Support Program. The IBM LAN Channel Support Program has aborted. Control has been returned to DOS.

Action: Record the message exactly as it appears on the display panel, then restart the IBM LAN Channel Support Program. To restart the program, press the Industrial Computer's red reset button adjacent to the diskette drive. If your IBM 8232 working diskette does not have an AUTOEXEC.BAT you also need to type MTCMMAIN and press **Enter**. If the problem reoccurs, have your service coordinator contact the IBM Support Center for assistance.

-? > MONTASK 10: Unknown msgtype X

Meaning: An undefined message was received by the IBM 8232 LAN Channel Station. X (0000 to FFFF) identifies the message type.

Action: Record the message exactly as it appears on the display panel. If the problem reoccurs, have your service coordinator contact the IBM Support Center for assistance.

-? > MONTASK 12: Unknown control message X

Meaning: An undefined control message was received by the IBM 8232 LAN Channel Station. X (0000 to FFFF) identifies the message type.

Action: If this message represents an isolated incident, no action is necessary. If the message occurs again, record the message exactly as it appears on the display panel, along with the number of times it occurred, and report it to your establishment's computer center systems programmer. If your systems programmer cannot resolve the problem, have your service coordinator contact your provider of service for a repair action.

-? > MONTASK 40: X shutdown due to error

Meaning: The IBM 8232 LAN Channel Station is no longer communicating with a LAN because of a hard-error condition either in the LAN or the IBM 8232 LAN Channel Station. *X* (TOKTASK0, TOKTASK1, ETHTASK0, or ETHTASK1) designates the suspect LAN domain.

Action: Look for an additional displayed message either before or after this message that also identifies the same suspect LAN domain. Record the messages exactly as they appear on the display panel. For assistance, contact the network administrator responsible for the local area network generating the unrecoverable error. Provide the network administrator with all the information you recorded. When the network administrator indicates the problem is fixed, check to see that this message is no longer generated.

-? > MONTASK A2: Fast shutdown for subchannel address XX

Meaning: A HALTIO sequence has been received for the subchannel address listed. *XX* is the hexadecimal address on which the HALTIO was received. The host connection on this subchannel address pair has been made inactive.

Action: No action is required. To restart the host connection, a START sequence must be initiated by the host application.

PCCATSK1 Status Messages

** > PCCATSK1 Version 1.00

Meaning: The PCCATSK1 Version 1.00 portion of the IBM LAN Channel Support Program has been successfully loaded into the IBM 8232 LAN Channel Station's active memory.

Action: No action is required.

-- > PCCATSK1 A2: IBM 8232 is Offline, Device Address: X

Meaning: All activity has ceased on subchannel address X (00 to E0). The IBM 8232 LAN Channel Station may now be turned off without disrupting the host system.

Action: No action is required. If you want to bring the IBM 8232 LAN Channel Station back online, press the Industrial Computer's red reset button adjacent to the diskette drive. If your IBM 8232 working diskette does not have an AUTOEXEC.BAT you also need to type MTCMMAIN and press **Enter**.

-- > PCCATSK1 A3: IBM 8232 is Online, Device Address: X

Meaning: The IBM 8232 LAN Channel Station is online to the host system on subchannel address X (00 to E0).

Action: No action is required.

-? > PCCATSK1 00: REALBUF unable to attach task

Meaning: The IBM 8232 LAN Channel Station was unable to activate one of the tasks in the IBM LAN Channel Support Program. The IBM LAN Channel Support Program has aborted. Control has been returned to DOS.

Action: Record the message exactly as it appears on the display panel, then restart the IBM LAN Channel Support Program. To restart the program, press the Industrial Computer's red reset button adjacent to the diskette drive. If your IBM 8232 working diskette does not have an AUTOEXEC.BAT you also need to type MTCMMAIN and press **Enter**. If the problem reoccurs, have your service coordinator contact the IBM Support Center for assistance.

-? > PCCATSK1 01: REALBUF unable to open real buffer message queue

Meaning: The IBM 8232 LAN Channel Station has not been able to establish a buffer for the data it is ready to send to or receive from the host computer. The IBM LAN Channel Support Program has aborted. Control has been returned to DOS.

Action: Record the message exactly as it appears on the display panel, then restart the IBM LAN Channel Support Program. To restart the program, press the Industrial Computer's red reset button adjacent to the diskette drive. If your IBM 8232 working diskette does not have an AUTOEXEC.BAT you also need to type MTCMMAIN and press **Enter**. If the problem reoccurs, have your service coordinator contact the IBM Support Center for assistance.

-?> PCCATSK1 02: REALBUF unable to open virtual buffer message queue

Meaning: The IBM 8232 LAN Channel Station has not been able to establish a buffer for the data it is ready to send to or receive from the host computer. The IBM LAN Channel Support Program has aborted. Control has been returned to DOS.

Action: Record the message exactly as it appears on the display panel, then restart the IBM LAN Channel Support Program. To restart the program, press the Industrial Computer's red reset button adjacent to the diskette drive. If your IBM 8232 working diskette does not have an AUTOEXEC.BAT you also need to type MTCMMAIN and press **Enter**. If the problem reoccurs, have your service coordinator contact the IBM Support Center for assistance.

-?> PCCATSK1 03: PCCADEVI Unable to open message queue

Meaning: The IBM 8232 LAN Channel Station was unable to obtain a buffer for it to transfer messages. The IBM LAN Channel Support Program has aborted. Control has been returned to DOS.

Action: Record the message exactly as it appears on the display panel, then restart the IBM LAN Channel Support Program. To restart the program, press the Industrial Computer's red reset button adjacent to the diskette drive. If your IBM 8232 working diskette does not have an AUTOEXEC.BAT you also need to type MTCMMAIN and press **Enter**. If the problem reoccurs, have your service coordinator contact the IBM Support Center for assistance.

-?> PCCATSK1 10: PCCAWAIT Invalid message type X

Meaning: An undefined message was received by the IBM 8232 LAN Channel Station. X (0000 to FFFF) identifies the message type.

Action: Record the message exactly as it appears on the display panel. If the problem reoccurs, have your service coordinator contact the IBM Support Center for assistance.

-?> PCCATSK1 20: PCCAFREE freeing invalid buffer X

Meaning: The IBM LAN Channel Support Program attempted to free an invalid buffer on the IBM 8232's channel adapter. X (0000 to FFFF) identifies the invalid buffer.

Action: Record the message exactly as it appears on the display panel. If the problem reoccurs, have your service coordinator contact the IBM Support Center for assistance.

-?> PCCATSK1 21: PCCAGET accessed invalid buffer X, count Y

Meaning: The IBM 8232 LAN Channel Station encountered an error trying to gain access to a channel adapter buffer. X (0000 to FFFF) identifies the buffer number. Y (0000 to FFFF) identifies the number of times the IBM 8232 LAN Channel Station tried to access an invalid buffer.

Action: Record the message exactly as it appears on the display panel. If the problem reoccurs, have your service coordinator contact the IBM Support Center for assistance.

-?> **PCCATSK1 26: Duplicate channel adapter buffer detected**

Meaning: The IBM 8232 LAN Channel Station detected a duplicate buffer on its channel adapter.

Action: If this message represents an isolated incident, no action is necessary. If the message occurs again, record the message exactly as it appears on the display panel, along with the number of times it occurred, and report it to your establishment's computer center systems programmer. If your systems programmer cannot resolve the problem, have your service coordinator contact your provider of service for a repair action.

-?> **PCCATSK1 40: Unit check - parity**

Meaning: The IBM 8232 LAN Channel Station detected a parity error on the channel attaching it to the host computer. This may indicate a problem with the channel cables.

Action: Record the message exactly as it appears on the display panel and report it to the host computer console operator. If it occurs more often than once per day, have your service coordinator contact your provider of service for a repair action.

-?> **PCCATSK1 41: Unit check - Tag timeout**

Meaning: The IBM 8232 LAN Channel Station detected that the host computer has not responded to an in-tag request within the normal time allotted for a response. This may be caused if your IBM 8232 LAN Channel Station is configured to operate in data streaming mode when your channel is configured to operate in data channel interlock (DCI) mode.

Action: Record the message exactly as it appears on the display panel and report it to the host computer console operator. If the operator indicates the channel is configured for DCI, check to be sure the IBM 8232 is similarly configured. If the IBM 8232 and host computer configurations *do not* match, halt the program and make a new IBM 8232 working diskette as described in Chapter 2 of this manual. To halt the program, press the **F9** function key to go to "Keyboard Entry Mode," type **q** and press **Enter**. Be sure to update the **IBM 8232 Configuration Worksheet** before making your new working diskette. If the IBM 8232 and host computer configurations *do* match, have your service coordinator contact your provider of service for a repair action.

Note: For more information about the **q** command, refer to Chapter 3, page 3-15 in this manual.

-?> PCCATSK1 51: Channel Adapter not present

Meaning: The Channel Adapter could not be found in the IBM 7532.

Action: If the MTCMCONF.EXE portion of the IBM LAN Channel Support Program *was not* used to describe your LAN adapter configuration on your IBM 8232 working diskette, halt the program and make a new working diskette using the MTCMCONF.EXE configuration aid. To halt the program, press the **F9** function key to go to “Keyboard Entry Mode,” type **q** and press **Enter**.

If the MTCMCONF.EXE portion of the IBM LAN Channel Support Program *was* used to describe your LAN adapter configuration, record the message exactly as it appears on the display panel, then halt and restart the IBM LAN Channel Support Program. To halt the program, press the **F9** function key to go to “Keyboard Entry Mode,” type **q** and press **Enter**. To restart the program, press the Industrial Computer’s red reset button adjacent to the diskette drive. If your IBM 8232 working diskette does not have an AUTOEXEC.BAT you also need to type **MTCMMAIN** and press **Enter**.

If the problem reoccurs, have your service coordinator contact the IBM Support Center for assistance.

If the problem reoccurs, power down the IBM 8232 and remove the LAN adapter(s). Verify that the switch or jumper settings on the LAN adapter(s) reflect the information on the **IBM 8232 Configuration Worksheet**.

Note: For more information about the **q** command, refer to Chapter 3, page 3-15 in this manual.

-?> PCCATSK1 60: PCCAINIT Invalid initialization parameter X

Meaning: An invalid parameter was assigned in the MTCMCONF.DAT file. **X** identifies the parameter.

Action: If the MTCMCONF.EXE portion of the IBM LAN Channel Support Program *was not* used to describe your LAN adapter configuration on your IBM 8232 working diskette, halt the program and make a new working diskette using the MTCMCONF.EXE configuration aid. To halt the program, press the **F9** function key to go to “Keyboard Entry Mode,” type **q** and press **Enter**.

If the MTCMCONF.EXE portion of the IBM LAN Channel Support Program *was* used to describe your LAN adapter configuration, record the message exactly as it appears on the display panel, then halt and restart the IBM LAN Channel Support Program. To halt the program, press the **F9** function key to go to “Keyboard Entry Mode,” type **q** and press **Enter**. To restart the program, press the Industrial Computer’s red reset button adjacent to the diskette drive. If your IBM 8232 working diskette does not have an AUTOEXEC.BAT you also need to type **MTCMMAIN** and press **Enter**. If the problem reoccurs, have your service coordinator contact the IBM Support Center for assistance.

Note: For more information about the **q** command, refer to Chapter 3, page 3-15 in this manual.

-? > **PCCATSK1 61: Channel Adapter memory conflict**

Meaning: Another adapter has been found occupying memory that is used by the Channel Adapter.

Action: If the MTCMCONF.EXE portion of the IBM LAN Channel Support Program *was not* used to describe your LAN adapter configuration on your IBM 8232 working diskette, halt the program and make a new working diskette using the MTCMCONF.EXE configuration aid. To halt the program, press the **F9** function key to go to "Keyboard Entry Mode," type **q** and press **Enter**.

If the MTCMCONF.EXE portion of the IBM LAN Channel Support Program *was* used to describe your LAN adapter configuration, record the message exactly as it appears on the display panel, then halt and restart the IBM LAN Channel Support Program. To halt the program, press the **F9** function key to go to "Keyboard Entry Mode," type **q** and press **Enter**. To restart the program, press the Industrial Computer's red reset button adjacent to the diskette drive. If your IBM 8232 working diskette does not have an AUTOEXEC.BAT you also need to type **MTCMMAIN** and press **Enter**. If the problem reoccurs, have your service coordinator contact the IBM Support Center for assistance.

If the problem reoccurs, power down the IBM 8232 and remove the LAN adapter(s). Verify that the switch or jumper settings on the LAN adapter(s) reflect the information on the **IBM 8232 Configuration Worksheet**.

Note: For more information about the **q** command, refer to Chapter 3, page 3-15 in this manual.

TOKTASK Status Messages

All TOKTASK messages are identified as being from either TOKTASK0 or TOKTASK1. In the TOKTASK material that follows, the messages are identified as being from TOKTASK0. Identical messages could be received from TOKTASK1 if there is a second Token-Ring Network adapter or PC Network adapter installed in the IBM 8232 LAN Channel Station.

** > TOKTASK0 Version 1.00

Meaning: The TOKTASK0 Version 1.00 portion of the IBM LAN Channel Support Program has been successfully loaded into the IBM 8232 LAN Channel Station's active memory.

Action: No action is required.

-- > TOKTASK0 A0: Adapter ready

Meaning: The Token-Ring adapter or PC Network adapter in this IBM 8232 LAN Channel Station is open and ready to operate.

Action: No action is required.

-- > TOKTASK0 A1: Adapter closed

Meaning: The Token-Ring or PC Network adapter is closed and not ready to operate.

Action: No action is required. If you want to activate the closed adapter, press the **F9** function key to go to "Keyboard Entry Mode," type **r** and press **Enter**.

Note: For more information about the **r** command, refer to Chapter 3, page 3-16 in this manual.

-- > TOKTASK0 A4: Error recovery successful

Meaning: The IBM 8232 LAN Channel Station has recovered from a previously detected error condition.

Action: Notify the network administrator that the error has been corrected.

-- > TOKTASK0 A5: Trace level set to *X*

Meaning: The status message reporting level is set to *X* (0 to 9). When set to level-0, only the most important messages are reported. When set to level-9, all messages are reported.

Action: Unless you have specific instructions to do otherwise, set the reporting level to display only level-0 messages. To set the program to report level-0 messages, press the **F9** function key to go to "Keyboard Entry Mode," type **t** and press **Enter**. This manual documents only level-0 messages. Messages from reporting levels higher than 0 are used by IBM service personnel only.

Note: For more information about the **t** command, refer to Chapter 3, page 3-18 in this manual.

-?> TOKTASK0 00: Unable to attach task

Meaning: The IBM 8232 LAN Channel Station was unable to activate one of the tasks in the IBM LAN Channel Support Program. The IBM LAN Channel Support Program has aborted. Control has been returned to DOS.

Action: Record the message exactly as it appears on the display panel and restart the IBM LAN Channel Support Program. To restart the program, press the Industrial Computer's red reset button adjacent to the diskette drive. If your IBM 8232 working diskette does not have an AUTOEXEC.BAT you also need to type MTCMMAIN and press **Enter**. If the problem reoccurs, have your service coordinator contact the IBM Support Center for assistance.

-?> TOKTASK0 01: Unable to open message queue

Meaning: The IBM 8232 LAN Channel Station was unable to establish a buffer to hold messages. The IBM LAN Channel Support Program has aborted. Control has been returned to DOS.

Action: Record the message exactly as it appears on the display panel and restart the IBM LAN Channel Support Program. To restart the program, press the Industrial Computer's red reset button adjacent to the diskette drive. If your IBM 8232 working diskette does not have an AUTOEXEC.BAT you also need to type MTCMMAIN and press **Enter**. If the problem reoccurs, have your service coordinator contact the IBM Support Center for assistance.

-?> TOKTASK0 10: Unknown msgtype X

Meaning: An undefined message was received by the IBM 8232 LAN Channel Station. X (0000 to FFFF) identifies the message type.

Action: Record the message exactly as it appears on the display panel. If the problem reoccurs, have your service coordinator contact the IBM Support Center for assistance.

-?> TOKTASK0 12: Unknown control message X

Meaning: An undefined control message was received by the IBM 8232 LAN Channel Station. X (0000 to FFFF) identifies the message type.

Action: If this message represents an isolated incident, no action is necessary. If the message occurs again, record the message exactly as it appears on the display panel, along with the number of times it occurred, and report it to your establishment's computer center systems programmer. If your systems programmer cannot resolve the problem, have your service coordinator contact your provider of service for a repair action.

-?> TOKTASK0 17: Received command to close adapter when not open

Meaning: A control command to close the LAN adapter was received when it was already closed.

Action: No action is required.

-?> TOKTASK0 41: Unrecoverable initialization error, bring-up error X

Meaning: An unrecoverable error occurred when the INITIALIZE command was issued to the LAN adapter. X (20 to 48) identifies the bring-up error code.

Action: Reinitialize the Primary (0) or Alternate (1) LAN adapter. To reinitialize a LAN adapter, press the **F9** function key to go to "Keyboard Entry Mode," type **r** and press **Enter**. If the problem reoccurs, halt the IBM LAN Channel Support Program, run the diagnostics provided with your LAN adapter and replace the LAN adapter if indicated. To halt the program, type **q** and press **Enter**. After running the diagnostics, restart the program. To restart the program, press the Industrial Computer's red reset button adjacent to the diskette drive. If your IBM 8232 working diskette does not have an AUTOEXEC.BAT you also need to type **MTCMMAIN** and press **Enter**. If the problem remains, check to see if the IBM 8232 configuration was changed recently. If so and a new diskette was not created for the new configuration, halt the program and make a new IBM 8232 working diskette. Restart the program with the new working diskette. If the problem still reoccurs, have your service coordinator contact your provider of service for a repair action.

Note: For more information about the **r** command, refer to Chapter 3, page 3-16 in this manual. For more information about the **q** command, refer to Chapter 3, page 3-15.

-?> TOKTASK0 42: Error initializing adapter: X

Meaning: An error occurred when the INITIALIZE command was issued to the LAN adapter. X (00 to 1D) identifies the error code.

Action: Record the message exactly as it appears on the display panel, then reinitialize the Primary (0) or Alternate (1) LAN adapter. To reinitialize a LAN adapter, press the **F9** function key to go to "Keyboard Entry Mode," type **r** and press **Enter**. If the problem reoccurs, halt the IBM LAN Channel Support Program, run the diagnostics provided with your LAN adapter and replace the LAN adapter if indicated. To halt the program, type **q** and press **Enter**. After running the diagnostics, restart the program. To restart the program, press the Industrial Computer's red reset button adjacent to the diskette drive. If your IBM 8232 working diskette does not have an AUTOEXEC.BAT you also need to type **MTCMMAIN** and press **Enter**. If the problem remains, check to see if the IBM 8232 configuration was changed recently. If so and a new diskette was not created for the new configuration, halt the program and make a new IBM 8232 working diskette. Restart the program with the new working diskette. If the problem reoccurs, contact the network administrator responsible for the local area network connected to the inactive LAN adapter. Provide the network administrator with all the information you recorded and the actions taken. When the network administrator indicates the problem is fixed, check to see that this message is no longer generated. If the network administrator cannot resolve the problem, have your service coordinator contact your provider of service for a repair action.

Note: For more information about the **r** command, refer to Chapter 3, page 3-16 in this manual. For more information about the **q** command, refer to Chapter 3, page 3-15.

-?> TOKTASK0 43: Unrecoverable error during open, open error X

Meaning: An unrecoverable error occurred when the OPEN command was issued to the LAN adapter. X (11 to 5C) identifies the error code. Several additional lines of information are also displayed.

Action: Record the message exactly as it appears on the display panel along with any additional information shown. For assistance, contact the network administrator responsible for the local area network generating the unrecoverable open error. Provide the network administrator with all the information you recorded. When the network administrator indicates the problem is fixed, check to see that this message is no longer generated.

-?> TOKTASK0 44: Error opening adapter: X

Meaning: An error occurred when the OPEN command was issued to the LAN adapter. X (00 to 34) identifies the error code.

Action: Record the message exactly as it appears on the display panel. For assistance, contact the network administrator responsible for the local area network generating the open error. Provide the network administrator with all the information you recorded. When the network administrator indicates the problem is fixed, check to see that this message is no longer generated.

-?> TOKTASK0 45: Error canceling receive: X

Meaning: An error occurred when the command to cancel a pending receive was issued to the LAN adapter. X (00 to 40) identifies the error code.

Action: Record the message exactly as it appears on the display panel. For assistance, contact the network administrator responsible for the local area network generating the receive error. Provide the network administrator with all the information you recorded. When the network administrator indicates the problem is fixed, check to see that this message is no longer generated.

-?> TOKTASK0 46: Error closing adapter: X

Meaning: An error occurred when the CLOSE command was issued to the LAN adapter. X (00 to 1D) identifies the error code.

Action: Record the message exactly as it appears on the display panel. For assistance, contact the network administrator responsible for the local area network generating the close error. Provide the network administrator with all the information you recorded. When the network administrator indicates the problem is fixed, check to see that this message is no longer generated.

-?> TOKTASK0 47: Error return from buffer free: X

Meaning: The IBM 8232 LAN Channel Station encountered an error while trying to free a Token-Ring or PC Network buffer. X (00 to FF) identifies the error code encountered.

Action: Record the message exactly as it appears on the display panel. For assistance, contact the network administrator responsible for the local area network generating the error. Provide the network administrator with all the information you recorded. When the network administrator indicates the problem is fixed, check to see that this message is no longer generated.

-?> TOKTASK0 48: Receive completion code: X

Meaning: The IBM 8232 LAN Channel Station encountered an error while processing the receive command. *X* (00 to FF) identifies the error code encountered.

Action: Record the message exactly as it appears on the display panel. For assistance, contact the network administrator responsible for the local area network generating the error. Provide the network administrator with all the information you recorded. When the network administrator indicates the problem is fixed, check to see that this message is no longer generated.

-?> TOKTASK0 49: Adapter check: X

Meaning: The IBM 8232 LAN Channel Station detected a serious error on the Token-Ring or PC Network adapter. *X* (0000 to FFFF) identifies the error code for the adapter check.

Action: Reinitialize the LAN adapter experiencing the adapter check. To reinitialize a LAN adapter, press the **F9** function key to go to "Keyboard Entry Mode," type **r** and press **Enter**. If the problem reoccurs, halt the IBM LAN Channel Support Program, run the diagnostics provided with your LAN adapter and replace the LAN adapter if indicated. To halt the program, type **q** and press **Enter**. After running the diagnostics, restart the program. To restart the program, press the Industrial Computer's red reset button adjacent to the diskette drive. If your IBM 8232 working diskette does not have an AUTOEXEC.BAT you also need to type **MTCMMAIN** and press **Enter**. If the problem remains, check to see if the IBM 8232 configuration was changed recently. If so and a new diskette was not created for the new configuration, halt the program and make a new IBM 8232 working diskette. Restart the program with the new working diskette. If the problem still reoccurs, have your service coordinator contact your provider of service for a repair action.

Note: For more information about the **r** command, refer to Chapter 3, page 3-16 in this manual. For more information about the **q** command, refer to Chapter 3, page 3-16.

-?> TOKTASK0 4A: Ring status change: X

Meaning: The IBM 8232 LAN Channel Station detected a ring status change on either the Token-Ring or PC Network. *X* (00 to FF) identifies the ring status error code.

Action: Record the message exactly as it appears on the display panel along with any additional information shown. For assistance, contact the network administrator responsible for the local area network generating the ring status error. Provide the network administrator with all the information you recorded. When the network administrator indicates the problem is fixed, check to see that this message is no longer generated.

-?> TOKTASK0 4B: Ring status condition cleared: X

Meaning: The IBM 8232 LAN Channel Station has recovered from a ring status error. *X* (00 to FF) identifies the ring status error code.

Action: Notify the network administrator that the ring status error has been corrected.

-?> TOKTASK0 4C: PC-detected error: X

Meaning: The IBM 8232 LAN Channel Station experienced a PC-detected error. *X* (0000 to 04FF) identifies the PC-detected error code.

Action: Reinitialize the LAN adapter. To reinitialize a LAN adapter, press the **F9** function key to go to "Keyboard Entry Mode," type **r** and press **Enter**. If the problem remains, check to see if the IBM 8232 configuration was changed recently. If so and a new diskette was not created for the new configuration, halt the IBM LAN Channel Support Program and make a new IBM 8232 working diskette. To halt the program, type **q** and press **Enter**. After making a new working diskette, restart the program with the new diskette. To restart the program, press the Industrial Computer's red reset button adjacent to the diskette drive. If the problem reoccurs, record the message exactly as it appears on the display panel and have your service coordinator contact your provider of service for a repair action.

Note: For more information about the **r** command, refer to Chapter 3, page 3-16 in this manual. For more information about the **q** command, refer to Chapter 3, page 3-15.

-?> TOKTASK0 4D: Adapter support not present

Meaning: The IBM Local Area Network Support Program needed by the Token-Ring or PC Network adapters has not been loaded.

Action: If the IBM Local Area Network Support Program *was not* used when your IBM 8232 working diskette was created, halt the program and make a new working diskette using the IBM Local Area Network Support Program. To halt the program, press the **F9** function key to go to "Keyboard Entry Mode," type **q** and press **Enter**.

If the IBM Local Area Network Support Program *was* used when your IBM 8232 working diskette was created, halt and restart the IBM LAN Channel Support Program. To halt the program, press the **F9** function key to go to "Keyboard Entry Mode," type **q** and press **Enter**. To restart the program, press the Industrial Computer's red reset button adjacent to the diskette drive. If your IBM 8232 working diskette does not have an AUTOEXEC.BAT you also need to type MTCMMAIN and press **Enter**. If the problem reoccurs, halt the program and make a new IBM 8232 working diskette using the IBM Local Area Network Support Program. With this new working diskette, restart the IBM LAN Channel Support Program. If the problem still reoccurs, record the message exactly as it appears on the display panel and have your service coordinator contact the IBM Support Center for assistance.

Note: For more information about the **q** command, refer to Chapter 3, page 3-15 in this manual.

-? > TOKTASK0 4E: Received packet(s) from DBLOKTSK, adapter not ready

Meaning: The IBM 8232 LAN Channel Station received a block of data from the host computer for a LAN adapter that is not active.

Action: Related messages about the same LAN adapter may also appear, indicating the reason it is inactive. Record this message and any other related messages exactly as they appear on the display panel. Take the action recommended for the related message.

If no related messages appear, record this message exactly as it appears on the display panel, then reinitialize the inactive LAN adapter. To reinitialize a LAN adapter, press the **F9** function key to go to "Keyboard Entry Mode," type **r** and press **Enter**. If the problem reoccurs, contact the network administrator responsible for the local area network connected to the inactive LAN adapter. Provide the network administrator with all the information you recorded. When the network administrator indicates the problem is fixed, check to see that this message is no longer generated. If the network administrator cannot resolve the problem, have your service coordinator contact the IBM Support Center for assistance.

Note: For more information about the **r** command, refer to Chapter 3, page 3-16 in this manual.

-? > TOKTASK0 4F: Error during open, open error X, will retry in 30 sec

Meaning: An error occurred when the OPEN command was issued to the LAN adapter. *X* (00 to 5C) identifies the error code. The OPEN command will be retried up to three times on 30 second intervals. If the retry is successful you will see the message --> TOKTASK0 A0: Adapter ready.

Action: Record the message exactly as it appears on the display panel. Report this information to the network administrator responsible for the local area network connected to the LAN adapter causing the error. When the network administrator indicates the problem is fixed, check to see that this message is no longer generated. If the open command is not successful after three retries, a message indicating an unrecoverable open error is displayed. Take the action recommended for the unrecoverable open error.

-? > TOKTASK0 50: Error X sending packet

Meaning: The IBM 8232 LAN Channel Station detected an error while sending a packet of information to a workstation on a Token-Ring or PC Network. *X* (0000 to FFFF) identifies the error code.

Action: Record the message exactly as it appears on the display panel, along with any additional information shown. For assistance, contact the network administrator responsible for the local area network generating the error. Provide the network administrator with all the information you recorded. When the network administrator indicates the problem is fixed, check to see that this message is no longer generated.

-?> TOKTASK0 60: Invalid adapter number Y

Meaning: An invalid adapter number was assigned in the MTCMCONF.DAT file. *Y* identifies the adapter number: 0 indicates the primary adapter, 1 indicates the alternate adapter, and any number higher than 1 is not defined.

Action: If the MTCMCONF.EXE portion of the IBM LAN Channel Support Program *was not* used to describe your LAN adapter configuration on your IBM 8232 working diskette, halt the program and make a new working diskette using the MTCMCONF.EXE configuration aid. To halt the program, press the **F9** function key to go to "Keyboard Entry Mode," type **q** and press **Enter**.

If the MTCMCONF.EXE portion of the IBM LAN Channel Support Program *was* used to describe your LAN adapter configuration, record the message exactly as it appears on the display panel, then halt and restart the IBM LAN Channel Support Program. To halt the program, press the **F9** function key to go to "Keyboard Entry Mode," type **q** and press **Enter**. To restart the program, press the Industrial Computer's red reset button adjacent to the diskette drive. If your IBM 8232 working diskette does not have an AUTOEXEC.BAT you also need to type **MTCMMAIN** and press **Enter**. If the problem reoccurs, have your service coordinator contact the IBM Support Center for assistance.

Note: For more information about the **q** command, refer to Chapter 3, page 3-15 in this manual.

Appendix B. License Information

This Appendix contains the following warranty and license information:

- A Statement of Limited Warranty
- Program Specifications describing the warranted functions of the licensed program
- Operating Environment requirements
- A Statement of Service.

**STATEMENT OF LIMITED WARRANTY
(MEDIA AND PROGRAM)**

International Business Machines Corporation (IBM) grants the following limited warranty for this IBM Licensed Program (Program) if this copy of the Program is delivered by IBM, an IBM Authorized Dealer for this Program, or any other IBM approved supplier for this Program to a user. (Such a user is referred to herein as "original user.") A "user" shall mean a Customer who acquired possession of and is licensed to use this copy of the Program for its own use or for use within its own business enterprise and not for remarketing. Any unused portion of the Warranty Period may be conveyed to another user.

1. MEDIA

The Warranty Period for the media on which the Program is recorded is for three months from the date of its delivery to the original user as evidenced by a receipt.

IBM warrants that this media will be free from defects in material and workmanship under normal use during the Warranty Period. If notified during the Warranty Period that the media contains such defects, IBM will replace such media. If IBM is unable to deliver replacement media, you may terminate your license and your money will be refunded upon return of all your copies of the Program.

2. PROGRAM

The Warranty Period for this Program is for three months from the date of its delivery to the original user as evidenced by a receipt.

IBM warrants that this Program, if unaltered, will conform to its Program Specifications during the Warranty Period when such Program is properly used on a machine for which it was designed. If notified during the Warranty Period that the Program contains defects such that it does not conform to its Program Specifications, IBM will 1) attempt to make the Program operate as warranted a) if prior to the Service Expiration Date, by providing a correction, or b) if after the Service Expiration Date, by providing any existing corrections, or 2) replace the Program with a functionally equivalent Program, as determined by IBM. In the event that IBM does not provide such a remedy, you may terminate your license and your money will be refunded upon return of all your copies of the Program.

IBM does not warrant that any other defects in the Program will be corrected or that the operation of the Program will be uninterrupted.

This limited warranty will apply only if the Program is licensed and located in the United States or Puerto Rico.

THIS WARRANTY IS IN LIEU OF ALL OTHER WARRANTIES, EXPRESS OR IMPLIED, INCLUDING, BUT NOT LIMITED TO, THE IMPLIED WARRANTIES OF MERCHANTABILITY AND FITNESS FOR A PARTICULAR PURPOSE.

Some states do not allow the exclusion of implied warranties, so the above exclusion may not apply to you. This limited warranty gives you specific legal rights, and you may also have other rights which vary from state to state.

Following the end of the Warranty Period, Program Services may be available until the Service Expiration Date. The License Information contains details on such availability.

If you have a question as to where you may obtain warranty service, see the Statement of Service in the License Information for this Program.

License Information

The product to which this license information applies is the IBM LAN Channel Support Program Version 1.0. The program number for this program is 5601-232.

Program Specifications

The IBM LAN Channel Support Program, when installed on an IBM 8232 LAN Channel Station, enables a workstation on a local area network to communicate with a host computer when both the workstation and the host computer are connected to that IBM 8232 and have the IBM Transmission Control Protocol/Internet Protocol (TCP/IP) Program or the IBM Advanced Interactive Executive/370 installed.

The IBM LAN Channel Support Program functions are:

- **Multitasking.** The IBM LAN Channel Support Program multitasking facility enables data transfers to and from the host computer and the local area network to occur concurrently.
- **Online Connectivity.** This facility monitors and continuously updates a line on the display panel with Channel Adapter and LAN adapter connectivity status information.
- **Help Function.** This facility enables an operator to request information on the following topics:
 - General Operations
 - Enabling/Disabling Channel Interface
 - Enabling/Disabling LAN Adapters
 - Obtaining Information and Statistics
 - Setting Trace Levels
- **Configuration Aid.** This facility enables an operator to create a working diskette that contains information describing the specific IBM 8232 LAN Channel Station configuration in which this IBM LAN Channel Support Program will be used.
- **Automatic Program Loading.** This facility enables an operator to have the IBM LAN Channel Support Program loaded automatically each time the IBM 8232 LAN Channel Station's Industrial Computer is reset or its power is turned on.
- **Statistics.** This facility enables an operator to obtain various statistics concerning LAN adapter and channel adapter activities. This facility may be used when the IBM LAN Channel Support Program is operating in Keyboard Entry Mode.

- LAN Control. This facility provides an operator with the means to enable or disable an individual LAN adapter in the IBM 8232 LAN Channel Station.
- Display Modes. The IBM LAN Channel Support Program can be set to operate in Keyboard Entry Mode or Status Message Mode. Each mode presents a unique panel on the display. The operator, through the use of a "hot key," can easily switch from one mode to the other.
- Address Information. This facility provides an operator with the means to view the node address of LAN adapters and device address of Channel Adapters installed in the IBM 8232 LAN Channel Station.
- Message Reports. This facility provides an operator with the means to set the level of status messages reported by the IBM LAN Channel Support Program.
- Halt Operation. This facility provides an operator with the means to halt the IBM 8232 LAN Channel Station in an orderly manner. All pending data transfers on the local area network and channel are completed, the Channel Adapter is taken offline, the LAN adapters in the IBM 8232 are closed, and control is returned to DOS.

Operating Environment

The IBM LAN Channel Support Program is designed to operate with the following hardware and software.

Machine Requirements

- One Model 1 or Model 2 IBM 8232 LAN Channel Station
- One IBM Color Display for a Model 1 and two IBM Color Displays for a Model 2
- Up to two LAN adapters for an IBM 8232 Model 1 and up to four LAN adapters for an IBM 8232 Model 2.

Program Requirements

- IBM Personal Computer Disk Operating System (DOS) Version 3.3 or later
- IBM Local Area Network Support Program Version 1.1 or later.

Prerequisite Software Requirements for Host Connectivity:

- IBM Transmission Control Protocol/Internet Protocol for VM
- IBM Transmission Control Protocol/Internet Protocol for the PS/2
- IBM Advanced Interactive Executive/370.

Licensed Program Materials Availability

This licensed program is available without source licensed program materials. It is available in object code.

Additional Information

Type/Duration of Program Services

Central Service, including the IBM Support Center, will be available until discontinued by IBM with a minimum of 90 days written notice. See the Statement of Service section for details.

When Central Service is specified, one or more service locations will be designated that will accept documentation in a format described by IBM indicating that a problem is caused by a defect in the licensed program.

Statement of Service

IBM will provide service for valid program-related defects in the IBM LAN Channel Support Program to program licensees at no additional charge. Program service is available until April 30, 1990, or until after 90 days written notice by IBM that the service period has been terminated, whichever is sooner. Specify program number 5601-232 when requesting service.

The way each licensee obtains access to program service depends on the marketing channel through which the license was obtained.

In the United States and Puerto Rico, if the IBM LAN Channel Support Program was obtained through:

- The IBM North/Central or IBM South/West Marketing Divisions.

Requests for program service should be made through the service coordinator of the licensee's company.

The service coordinator is a representative of the customer who serves as the interface between end users and the IBM support location for IBM licensed program defect support. The service coordinator is registered by the IBM branch office, under the terms of the Quantity Discount Agreement. The service coordinator's responsibilities include, but are not limited to, problem determination, problem source identification, submission of problem reports, application of maintenance, and action on IBM support organization recommendations.

The service coordinator may call the IBM Support Center (1-800-237-5511) at any time, and will usually be called back within eight business hours. The IBM Support Center will contact the service coordinator Monday through Friday between 8 a.m. and 4:30 p.m., Eastern time.

Outside of the United States and Puerto Rico contact your local IBM representative or your Authorized IBM Support for information on warranty services.

If the IBM LAN Channel Support Program is obtained through transfer of license from another party under the conditions of the IBM Program License Agreement supplied with this product, the new licensee may obtain program service through the access arrangement provided for the original licensee.

When a license is transferred, if the original license was obtained through the IBM North/Central or IBM South/West Marketing Divisions, the previous licensee is responsible for contacting the IBM marketing representative to make arrangements to transfer service entitlement to the new licensee. The new licensee must also establish a qualified service coordinator to work with IBM central service.

IBM does not guarantee service results, that the program will be error-free, or that all program defects will be corrected.

When a report of a defect in an unaltered portion of a supported release of the program is submitted, IBM will respond by issuing one of the following:

- Defect correction information, such as corrected documentation, corrected code, or notice of availability of corrected code
- A restriction notice
- A bypass.

Corrected code is provided on a cumulative basis on diskettes; no source code is provided. Only one copy of the corrections with supporting documentation will be issued to the licensee, or the agent of the licensee reporting the defect. IBM will authorize various agents, such as IBM Personal Computer dealers and service coordinators of IBM North/Central and IBM South/West Marketing Division customers, to make and distribute a copy of the corrections, if needed, to each IBM LAN Channel Support Program licensee that they serve.

The total number of copies of an update distributed to IBM LAN Channel Support Program licensees within a customer's location may not exceed the number of copies of the IBM LAN Channel Support Program licensed to the customer.

IBM does not plan to release updates of the IBM LAN Channel Support Program code on a routine basis for preventive service purposes. However, should IBM determine that there is a general need for a preventive service update, it will be made available to all licensees through the same process used to distribute general IBM LAN Channel Support Program updates.

Following the discontinuance of all program services, this program will be distributed on an "as is" basis, without warranty of any kind either express or implied.

Any other documentation with respect to this licensed program, including any such documentation referenced herein, is provided for information purposes only and does not extend or modify the material contained in the License Information.

Abbreviations

CRC Cyclic Redundancy Check
DCI Data Channel Interlock
DOS Disk Operating System
IBM CE IBM Customer Engineer
LAN Local Area Network
MB Megabyte (1048576 Bytes)

OLT Online Test
PC Personal Computer
TCP/IP Transmission Control Protocol/Internet Protocol
SYSGEN System Generation
VM Virtual Machine

Glossary

A

Application Program. A program written for or by a user that applies to the user's work. Some application programs run on a special kind of application program called a *network application program*. See *network application program*.

B

Baseband Local Area Network. A local area network in which information is encoded, multiplexed, and transmitted without modulation of a carrier.

C

Channel. A functional unit, controlled by a host computer, that handles the transfer of data between processor storage and local peripheral equipment.

Channel Speed. The rate at which data is transferred between a host computer and a channel-attached device. Channel speed is dependent on the type of sub-channel defined by the channel-attached device.

Control Unit Block. The number of sub-channel addresses recognized by a host computer and a channel-attached device connected to it.

D

Data Channel Interlock (DCI). A protocol for transmitting data on a channel. In this protocol the sender raises and maintains a signal on the channel until the receiver acknowledges receipt of the signal.

Data Streaming. A protocol for transmitting data on a channel. In this protocol the sender maintains the channel in a transmit state for an abnormal length of time.

Data Transfer Mode. The method of data transfer between a host computer and a channel-attached device. Data Channel Interlock and Data Streaming are two data transfer modes.

Device Address. The first sub-channel address recognized by a channel-attached device.

E

Ethernet Network. A baseband local area network with a bus topology in which messages are broadcast on a coaxial cable using a Carrier Sense Multiple Access/Collision Detect (CSMA/CD) transmission method.

H

Host computer. The primary or controlling computer in a multiple computer installation. In this manual, the term refers to members of the System/370 class of computers including the IBM 308X series, IBM 309X series, IBM 43XX series, and IBM 937X series.

I

Industrial Computer. One of the family of IBM Industrial Computers. In this manual, the term refers to the IBM 7532 Industrial Computer.

Interrupt Level. Suspension of a process, such as execution of a computer program caused by an external event, performed in such a way that the process can be resumed.

L

LAN Adapter. The circuit card within a communicating device (such as the IBM Industrial Computer) and its associated software that enable the device to be attached to a Local Area Network. Examples are the IBM Token-Ring Network adapters, IBM PC Network adapters, and the Ethernet Adapter.

Local Area Network (LAN). A network in which communications are limited to a moderate-sized geographic area such as a single office building, warehouse, or campus and which do not generally extend across public rights-of-way.

N

Network application program. A program used to connect and communicate with adapters on a network, enabling users to perform application-oriented activities and to run other application programs.

O

Online test system (OLTS). A system that allows a user to test Input/Output (I/O) devices concurrently with execution of programs. Tests may be run to diagnose I/O errors, verify repairs and engineering changes, or to periodically check devices.

P

Packet. A sequence of binary digits, including data and control signals, that is transmitted as a composite whole.

Personal Computer Disk Operating System (PC DOS). A program that controls the operation and execution of application programs in a computer such as the IBM Industrial Computer.

PC Network. A baseband local area network with a bus topology in which messages are broadcast from PC Network adapter to PC Network adapter.

S

System generation (SYSGEN). The process of selecting optional parts of an operating system and of creating a particular operating system tailored to the requirements of a data processing installation, enabling a host computer to identify and communicate with the Input/Output (I/O) devices connected to it.

T

Tailgate. The area of a computer or control unit where Input/Output (I/O) cables are connected.

Token-Ring Network. A baseband local area network with a ring topology that passes tokens from Token-Ring adapter to Token-Ring adapter.

Transmission Control Protocol/Internet Protocol (TCP/IP). A set of protocols that allow cooperating computers to share resources across a heterogeneous network.

V

Virtual Machine (VM). A functional simulation of a computer and its associated devices. Each virtual machine is controlled by a suitable operating system, for example, conversational monitor system. VM controls concurrent execution of multiple virtual machines on a single host computer.

W

Working Diskette. A computer diskette to which files are copied from an original diskette for use in everyday operation, to protect the original diskette from damage.

Index

C

- channel offline status 3-14
- channel online status 3-14
 - user command o details 3-14
- closing LAN adapters
 - closing Ethernet adapter 3-9
 - closing PC Network adapter 3-9
 - closing Token-Ring adapter 3-9
 - user command c details 3-9

D

- data channel interlock (DCI) X-3
- diskette, high capacity 2-1
- diskette, proper insertion 2-4
- display requirements 1-4

E

- error recovery 3-4, A-1
- Ethernet Network 1-1, X-3

H

- halting the IBM 8323 Support Program 3-15
- help facility
 - defined 3-6
 - panel 3-20
 - screen 3-20
 - the F1 key 3-20
 - using 3-6
- host computer iii, 1-1, 2-2, 3-5, X-3

I

- IBM LAN Channel Support Program 1-2
 - AUTOEXEC 2-6, 3-1
 - code modules 1-4
 - coexistence 1-1
 - error messages A-1
 - BLOKTSK A-1
 - CNTLTSK A-3
 - DBLOKTSK A-6
 - ETHTASK0 A-8
 - ETHTASK1 A-8
 - KYBDTSK A-13
 - MONTASK A-15
 - PCCATSK1 A-17
 - TOKTASK0 A-22
 - TOKTASK1 A-22
 - information messages A-1
 - BLOKTSK A-1
 - CNTLTSK A-3
 - DBLOKTSK A-6
 - ETHTASK0 A-8

IBM LAN Channel Support Program (continued)

- information messages (continued)
 - ETHTASK1 A-8
 - KYBDTSK A-13
 - MONTASK A-15
 - PCCATSK1 A-17
 - TOKTASK0 A-22
 - TOKTASK1 A-22
- items needed for installation 1-2
- license information B-1
- loading working diskette 3-1
 - successful loading messages 3-1
 - unsuccessful loading messages 3-3
- MTCMCONF 2-6
- MTCMCONF.DAT 2-6
- MTCMMAIN 3-1
- operating environment B-6
- prerequisite installation tasks 1-3, 2-2, 3-5
- program number B-1, B-7
- program specifications B-4
- protecting original diskette 2-1, 2-9
- reconfiguring working diskette 2-9
- restarting the program 3-4, 3-6
- statement of service B-7
 - period of coverage B-7
- status messages A-1
 - BLOKTSK A-1
 - CNTLTSK A-3
 - DBLOKTSK A-6
 - ETHTASK A-8
 - KYBDTSK A-13
 - MONTASK A-15
 - PCCATSK1 A-17
 - TOKTASK A-22
- user command c details 3-9
- user command c panel 3-9
- user command Function Key F1 details 3-20
- user command Function Key F1 panel 3-20
- user command Function Key F9 details 3-21
- user command Function Key F9 panel 3-21
- user command i details 3-10, 3-12
- user command i panel, Ethernet adapter 3-10
- user command i panel, Token-Ring/PC Network adapter 3-12
- user command l details 3-13
- user command l panel 3-13
- user command o details 3-14
- user command o panel 3-14
- user command q details 3-15
- user command q panel 3-15
- user command r details 3-16
- user command r panel 3-16
- user command s details 3-17
- user command s panel 3-17

IBM LAN Channel Support Program (*continued*)

- user command t details 3-18
- user command t panel 3-18
- user command z details 3-19
- user command z panel 3-19
- user command ? details 3-8
- user command ? panel 3-8
- user command description 3-8
- user command list 3-7
- user commands, invalid 3-7
- user commands, valid 3-7
- using the configurator 2-6
- warranty B-2
- working diskette 2-1

IBM Local Area Network Support Program 1-2

- configurator answers 2-6
- configurator questions 2-6
- CONFIG.SYS 2-6
- DXMAID 2-6
- using the configurator 2-6

IBM Personal Computer Disk Operating System 1-2, 2-4

- DOS COPY, using 2-1, 2-5

IBM Support Center

- hours of operation B-7

IBM Transmission Control Protocol/Internet Protocol (TCP/IP) iii, 3-5

IBM 7532 Industrial Computer 1-1, X-3

IBM 8232 Configuration Worksheet 2-2, 2-3

- sample copy 2-3

IBM 8232 LAN Channel Station

- LANs supported 1-1
- loading working diskette 3-1
 - successful loading messages 3-1
 - unsuccessful loading messages 3-3
- memory dump 3-19
- Model 1 1-1
- Model 2 1-1, 2-9, 3-7
- using 3-5
- working diskette 2-1

L

LAN adapter 1-2, 1-3, 2-2, 2-6, 3-5, X-3

LAN adapter information

- Ethernet adapter information 3-13
- PC Network adapter information 3-13
- Token-Ring adapter information 3-13

- listing of user commands 3-8

M

- message trace level, setting 3-18

O

opening LAN adapters

- opening Ethernet adapter 3-16

opening LAN adapters (*continued*)

- opening PC Network adapter 3-16
- opening Token-Ring adapter 3-16
- user command r details 3-16

P

panel modes

- defined 3-6
- Keyboard Entry mode 3-6, 3-21
- Status Message mode 3-6, 3-21
- switching between modes 3-6, 3-21
- the F9 key 3-21

PC Network 1-1, 2-6, X-4

- performance statistics, channel adapter 3-17

- performance statistics, LAN adapter 3-10

- Ethernet adapter performance statistics 3-10
- PC Network adapter performance statistics 3-12
- Token-Ring adapter performance statistics 3-12

R

- reference publications iv

- related publications iii

- restarting the IBM 8323 Support Program 3-4, 3-6

S

screen modes

- defined 3-6
- Keyboard Entry mode 3-6, 3-21
- Status Message mode 3-6, 3-21
- switching between modes 3-6, 3-21
- the F9 key 3-21

- second working diskette 2-9

- streaming X-4

- system generation (SYSGEN) 3-5, X-4

T

- Token-Ring Network 1-1, 2-6, X-4

- Transmission Control Protocol/Internet Protocol (TCP/IP) X-4

U

- using this manual iii

W

- working diskette 1-4, 2-1, X-4

- backup copies 2-1, 2-9

- copying IBM LAN Channel Support Program 2-4

- creating 2-1, 2-4

- for Model 2 2-9

- list of files 2-8

- loading in Model 1 3-1

- loading in Model 2 3-1

- prerequisite information needed 2-2

working diskette (*continued*)

reconfiguring 2-9

successful loading messages 3-1

unsuccessful loading messages 3-3

verifying content 2-8

Publication No. SC30-3458-1

This manual is part of a library that serves as a reference source for systems analysts, programmers, and operators of IBM systems. You may use this form to communicate your comments about this publication, its organization, or subject matter, with the understanding that IBM may use or distribute whatever information you supply in any way it believes appropriate without incurring any obligation to you.

Note: Copies of IBM publications are not stocked at the location to which this form is addressed. Please direct any requests for copies of publications, or for assistance in using your IBM system, to your IBM representative or to the IBM branch office serving your locality.

Possible topics for comment are:

Clarity Accuracy Completeness Organization Coding Retrieval Legibility

If you wish a reply, give your name, company, mailing address, date, and location of your local IBM branch office:

What is your occupation? _____

Number of latest Newsletter associated with this publication: _____

Thank you for your cooperation. No postage stamp necessary if mailed in the U.S.A. (Elsewhere, an IBM office or representative will be happy to forward your comments or you may mail directly to the address in the Edition Notice on the back of the title page.)

Reader's Comment Form

Fold and tape

Please Do Not Staple

Fold and tape

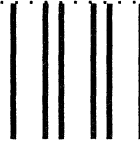

NO POSTAGE
NECESSARY
IF MAILED
IN THE
UNITED STATES

BUSINESS REPLY MAIL
FIRST CLASS PERMIT NO. 40 ARMONK, N.Y.

POSTAGE WILL BE PAID BY ADDRESSEE

International Business Machines Corporation
Dept. E02
P.O. Box 12195
Research Triangle Park, N.C. 27709-9990

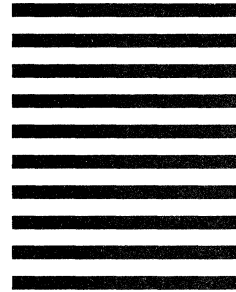

Fold and tape

Please Do Not Staple

Fold and tape





Part Number
8575291

SC30-3458-1



Printed in U.S.A.