digital

DECnet for OpenVMS Networking Manual



OpenVMS

Part Number: AA-PV60A-TK

DECnet for OpenVMS Networking Manual

Order Number: AA-PV60A-TK

May 1993

This book presents conceptual and usage information for OpenVMS users who want to manage DECnet for OpenVMS, perform operations over the network, or both.

Revision/Update Information: This manual supersedes the *VMS Networking Manual*, VMS Version 5.0

Software Version: OpenVMS AXP Version 1.5
OpenVMS VAX Version 6.0

**Digital Equipment Corporation
Maynard, Massachusetts**

May 1993

The information in this document is subject to change without notice and should not be construed as a commitment by Digital Equipment Corporation. Digital Equipment Corporation assumes no responsibility for any errors that may appear in this document.

The software described in this document is furnished under a license and may be used or copied only in accordance with the terms of such license.

No responsibility is assumed for the use or reliability of software on equipment that is not supplied by Digital Equipment Corporation or its affiliated companies.

© Digital Equipment Corporation 1993.

All Rights Reserved.

The postpaid Reader's Comments forms at the end of this document request your critical evaluation to assist in preparing future documentation.

The following are trademarks of Digital Equipment Corporation: Alpha AXP, AXP, Bookreader, CI, DDCMP, DEC, DECnet, DECnet/E, DELUA, DEQNA, DEUNA, Digital, DNA, HSC50, MicroVAX, OpenVMS, Packetnet, PDP-11, RSTS/E, RMS, RSX, RSX-11M, RSX-11S, RT-11, TOPS-10, TOPS-20, ULTRIX, VAX, VAX-11/780, VAXcluster, VAX DOCUMENT, VAXft, VMS, VMScluster, VMS RMS, VT, the AXP logo, and the Digital logo.

The following are third-party trademarks:

BASIC is a registered trademark of the Trustees of Dartmouth College, D.B.A. Dartmouth College.

IBM is a registered trademark of International Business Machines Corporation.

Intel is a trademark of Intel Corporation.

MS, Microsoft, and MS-DOS are registered trademarks of Microsoft Corporation.

Xerox is a registered trademark of Xerox Corporation.

UNIX is a registered trademark of UNIX System Laboratories, Inc.

All other trademarks and registered trademarks are the property of their respective holders.

This document was prepared using VAX DOCUMENT, Version 2.1.

Contents

Preface	xv
Part I Introduction to DECnet for OpenVMS	
1 Overview of DECnet for OpenVMS	
1.1 General Description of a DECnet Network	1-1
1.1.1 DECnet Interface with the Operating System	1-2
1.1.2 DECnet Functions	1-2
1.2 DECnet for OpenVMS Configurations	1-3
1.2.1 Ethernet Local Area Network Configuration	1-4
1.2.1.1 Ethernet Datagrams	1-4
1.2.1.2 Transmission and Reception of Ethernet Packets	1-5
1.2.2 FDDI Local Area Network Configuration	1-6
1.2.2.1 The FDDI Data Link Layer	1-6
1.2.2.2 FDDI Ring Operation	1-7
1.2.3 LAN Routers and End Nodes	1-7
1.2.4 DDCMP Network Configurations	1-7
1.2.4.1 DDCMP Point-to-Point and Multipoint Connections	1-8
1.2.4.2 Synchronous DDCMP Connections	1-8
1.2.4.3 Asynchronous DDCMP Connections	1-9
1.2.4.4 Static Asynchronous Connections	1-9
1.2.4.5 Dynamic Asynchronous Connections	1-9
1.2.5 Configurations for VMSclusters	1-10
1.2.5.1 Using the CI in a VAXcluster	1-11
1.2.5.2 Configuring an Alias Node Identifier	1-11
1.3 Managing the Network	1-11
1.3.1 Network Control Program	1-11
1.3.2 Network Management Responsibilities	1-12
1.3.3 DECnet for OpenVMS Licenses and Keys	1-12
1.3.4 DECnet for OpenVMS Network Management Software	1-12
1.3.5 Configuring a Network	1-14
1.3.5.1 Configuring a DECnet for OpenVMS Node	1-14
1.3.5.2 A Network Topology	1-14
1.4 User Interface to the Network	1-17
1.4.1 Performing Network Operations	1-17
1.4.1.1 Designing User Applications for Network Operations	1-18
1.4.1.2 Choosing a Programming Interface for a Specific Network Application	1-18
1.4.2 Accessing the Network	1-20
1.4.2.1 Using File and Task Specifications in Network Applications	1-20
1.4.2.2 Using Access Control for Network Applications	1-21
1.4.2.3 Using Logical Names in Network Applications	1-24

2 DECnet for OpenVMS Components and Concepts

2.1	Nodes	2-1
2.1.1	DECnet Node Address and Name	2-1
2.1.2	Hardware Addresses and Physical Addresses	2-2
2.1.3	LAN Multicast Addresses	2-3
2.1.4	Node Characteristics	2-4
2.1.4.1	Obtaining Remote Node Characteristics	2-5
2.1.5	Identifying a VMScluster as a Single Node	2-5
2.1.5.1	Limiting the Use of an Alias	2-5
2.1.5.2	Managing the Alias Node Identifier	2-6
2.2	Circuits	2-6
2.2.1	Classes of DECnet for OpenVMS Circuits	2-6
2.2.2	DDCMP Circuit Devices	2-7
2.2.3	CI Circuit Devices	2-10
2.2.4	Ethernet Circuit Devices	2-10
2.2.5	Ethernet Configurator Module	2-11
2.2.6	FDDI Circuit Devices	2-11
2.3	Lines	2-11
2.3.1	Classes of DECnet for OpenVMS Lines	2-11
2.3.2	DDCMP Lines	2-12
2.3.2.1	DDCMP Line Devices	2-12
2.3.2.2	Static Asynchronous Lines	2-13
2.3.2.3	Dynamic Asynchronous Lines	2-14
2.3.3	CI Line Device	2-14
2.3.4	Ethernet and FDDI Line Devices	2-14
2.4	Routing	2-15
2.4.1	Routing and Nonrouting Nodes	2-15
2.4.2	Types of DECnet Nodes	2-16
2.4.2.1	DECnet for OpenVMS Phase IV Nodes	2-17
2.4.3	Routing Features of DECnet for OpenVMS License Options	2-17
2.4.4	Area Routing	2-18
2.4.4.1	Level 1 and Level 2 Routers	2-19
2.4.5	Ethernet or FDDI Routers and End Nodes	2-19
2.4.5.1	Ethernet or FDDI Designated Routers	2-20
2.4.5.2	Ethernet or FDDI End Node Caching	2-20
2.4.5.3	Area Routing on an Ethernet Bus or FDDI Ring	2-21
2.4.6	Routers and End Nodes on CI Data Links	2-21
2.4.6.1	CI End Nodes	2-21
2.4.6.2	CI Routers	2-21
2.4.7	Routing Concepts and Terms	2-21
2.4.8	Routing Messages	2-23
2.4.8.1	Segmented Routing Messages	2-23
2.4.8.2	Timing of Routing Message Transmissions	2-24
2.5	Logical Links	2-24
2.6	Objects	2-25
2.6.1	DECnet Objects	2-25
2.6.2	Objects Using the Cluster Alias Node Identifier	2-26
2.6.3	Creating DECnet Network Server Processes	2-26
2.6.4	Potential Causes of Network Process Failures	2-27
2.7	Logging	2-28
2.8	Network Access Control	2-29
2.8.1	Routing Initialization Passwords	2-29

2.8.2	System-Level Access Control	2-30
2.8.2.1	Setting Access Control Information for Outbound Connects	2-30
2.8.2.2	Sources of Access Control Information for Logical Link Connections	2-31
2.8.2.3	Network Security and Passwords	2-33
2.8.2.4	Inbound Default Access Control for Objects	2-33
2.8.3	Access Control for Remote Command Execution	2-33
2.8.4	Node-Level Access Control	2-33
2.8.5	Proxy Login Access Control	2-34
2.8.5.1	Proxy Accounts	2-35
2.8.5.2	Controlling Proxy Login Access for Individual Accounts	2-35
2.8.5.3	Controlling Proxy Login Access for Objects	2-36
2.8.6	Security for DDCMP Point-to-Point Connections	2-36

Part II Network System Management

3 Managing and Monitoring the Network

3.1	The DECnet for OpenVMS Configuration Database	3-1
3.1.1	The Volatile Database	3-2
3.1.2	The Permanent Database	3-2
3.2	The Network Control Program	3-2
3.3	Node Commands	3-5
3.3.1	Executor Node Commands	3-5
3.3.1.1	SET EXECUTOR NODE Command	3-6
3.3.1.2	TELL Prefix	3-6
3.3.2	Node Identification	3-7
3.3.2.1	Local Node Identification Parameter	3-8
3.3.2.2	Using and Removing Node Names and Addresses	3-9
3.3.3	Identifying VMScLuster Nodes	3-9
3.3.3.1	Setting an Alias Node Identifier for the Executor	3-10
3.3.3.2	Enabling Aliases for Nodes in a VMScLuster	3-10
3.3.4	Node Parameters	3-11
3.3.4.1	Logical Link Control	3-14
3.3.4.2	Operational State of the Local Node	3-16
3.3.5	Copying Node Databases	3-17
3.3.5.1	COPY Command Parameters and Qualifiers	3-18
3.3.5.2	Clearing and Purging the Local Node Database	3-18
3.3.5.3	Copying the Node Database from a Remote Node	3-19
3.3.5.4	Example of Copying Remote Node Data	3-20
3.3.5.5	Copying the Permanent Node Database Using DCL COPY	3-21
3.3.6	Node Counters	3-21
3.4	Using the DECdns Namespace	3-22
3.4.1	Requirements	3-22
3.4.2	How DECnet for OpenVMS Nodes Use DECdns	3-22
3.4.3	Enabling and Disabling the DECdns Namespace Interface	3-23
3.5	Circuit Commands	3-24
3.5.1	Circuit Identification	3-24
3.5.1.1	DDCMP Circuit Identification	3-24
3.5.1.2	CI Circuit Identification	3-26
3.5.1.3	Ethernet and FDDI Circuit Identification	3-26
3.5.2	Circuit Parameters	3-26
3.5.2.1	Operational State of the Circuit	3-28
3.5.2.2	Circuit Timers	3-29

3.5.3	DDCMP Circuit Parameters	3-30
3.5.3.1	DDCMP Circuit Level Verification	3-30
3.5.3.2	DDCMP Tributary Control	3-31
3.5.4	Ethernet and FDDI Circuit Parameters	3-33
3.5.5	Ethernet Configurator Module Commands	3-34
3.5.5.1	Enabling Surveillance by the Ethernet Configurator	3-34
3.5.5.2	Obtaining a List of Systems on Ethernet Circuits	3-34
3.5.5.3	Disabling Surveillance by the Ethernet Configurator	3-35
3.5.6	Circuit Counters	3-35
3.6	Line Commands	3-36
3.6.1	Line Identification	3-36
3.6.1.1	Line Protocols	3-37
3.6.2	Line Parameters	3-38
3.6.2.1	Operational State of Lines	3-41
3.6.2.2	Buffer Size	3-41
3.6.3	DDCMP Line Parameters	3-42
3.6.3.1	Line Buffers	3-42
3.6.3.2	Duplex Mode	3-43
3.6.3.3	Line Timers	3-43
3.6.3.4	Satellite Transmission Control	3-44
3.6.3.5	Asynchronous DDCMP Line Parameters	3-45
3.6.4	Ethernet Line Parameters	3-46
3.6.5	FDDI Line Parameters	3-46
3.6.5.1	Displaying the Hardware Address	3-46
3.6.5.2	Displaying the Line Status	3-47
3.6.6	Line Counters	3-48
3.7	Routing Commands	3-49
3.7.1	Specifying the Node Type	3-49
3.7.2	Specifying the Area Number in a Node Address	3-50
3.7.3	Setting Routing Configuration Limits	3-50
3.7.3.1	Maximum Number of Routers and End Nodes Allowed	3-50
3.7.3.2	Maximum Number of Areas Allowed	3-51
3.7.4	Routing Control Parameters	3-51
3.7.4.1	Circuit Cost Control Parameter	3-51
3.7.4.2	Maximum Path Control Parameters	3-52
3.7.4.3	Route-Through Control Parameter	3-53
3.7.4.4	Equal Cost Path Parameters	3-53
3.7.4.5	Area Path Control Parameters	3-54
3.7.5	Routing Message Timers	3-54
3.7.6	CI End Node Circuit Failover	3-55
3.8	Logical Link Commands	3-56
3.8.1	Maximum Number of Links	3-56
3.8.2	Disconnecting Logical Links	3-56
3.8.3	Logical Link Protocol Parameters	3-56
3.8.3.1	Incoming and Outgoing Timers	3-57
3.8.3.2	Inactivity Timer	3-57
3.8.3.3	NSP Message Retransmission	3-57
3.8.3.4	Pipeline Quota	3-58
3.9	Object Commands	3-59
3.9.1	DECnet for OpenVMS Objects	3-59
3.9.1.1	DECnet for OpenVMS Object Identification	3-59
3.9.1.2	Using the Cluster Alias Node Identifier for the Object	3-60
3.9.1.3	Example of Using the Cluster Alias Node Identifier	3-60
3.9.1.4	DECnet for OpenVMS Command Procedure Identification	3-61

3.10	Logging Commands	3-62
3.10.1	Event Identification	3-63
3.10.2	Identifying the Source for Events	3-64
3.10.3	Identifying the Location for Logging Events	3-65
3.10.4	Controlling the Operational State of Logging	3-65
3.10.5	Event Logging Example	3-65
3.10.6	Using a Logging Monitor Program	3-66
3.11	Network Access Control Commands	3-67
3.11.1	Specifying Passwords for Routing Initialization	3-67
3.11.2	System-Level Access Control Commands	3-68
3.11.2.1	Establishing Default Privileged and Nonprivileged Accounts	3-68
3.11.2.2	Specifying Privileges for Objects	3-68
3.11.2.3	Specifying Privileges Required for Outgoing Connections to Objects	3-69
3.11.2.4	Setting Default Inbound Access Control Information	3-69
3.11.2.5	Indicating Access Controls for Remote Command Execution	3-69
3.11.3	Node-Level Access Control Commands	3-70
3.11.4	Proxy Login Access Control Commands	3-71
3.12	Monitoring the Network	3-72

4 DECnet for OpenVMS Host Services

4.1	Loading Unattended Systems Downline	4-1
4.1.1	Downline System Load Operation	4-2
4.1.1.1	Target-Initiated Downline Load	4-2
4.1.1.2	Operator-Initiated Downline Load	4-4
4.1.1.3	Load Requirements	4-4
4.1.2	Downline Load Parameters	4-5
4.1.2.1	TRIGGER Command	4-5
4.1.2.2	LOAD Command	4-6
4.1.2.3	Host Identification	4-9
4.1.2.4	Load File Identification	4-9
4.1.2.5	Management File Identification	4-9
4.1.2.6	Software Type	4-10
4.1.2.7	Load Assist Agent Identification	4-10
4.1.2.8	Load Assist Parameter Identification	4-10
4.1.2.9	CPU and Software Identification	4-10
4.1.2.10	Service Circuit Identification	4-10
4.1.2.11	Service Passwords	4-11
4.1.2.12	Diagnostic File	4-11
4.2	Dumping Memory Upline from an Unattended System	4-11
4.2.1	Upline Dump Procedures	4-11
4.2.2	Upline Dump Requirements	4-13
4.3	Loading RSX-11S Tasks Downline	4-14
4.3.1	Setting Up the Satellite System	4-15
4.3.2	Host Loader Mapping Table	4-16
4.3.3	HLD Operation and Error Reporting	4-17
4.3.3.1	HLD Error Messages	4-17
4.3.4	Checkpointing RSX-11S Tasks	4-18
4.3.5	Overlaying RSX-11S Tasks	4-18
4.4	Connection to Remote Console	4-18

Part III Configuring, Installing, and Testing Networks

5 Configuring a Network

5.1	Prerequisites for Establishing a Network	5-1
5.1.1	Required Privileges	5-1
5.2	Configuration Procedures	5-3
5.2.1	Default Access Options	5-3
5.2.1.1	Specific Default Accounts	5-4
5.2.2	Using NETCONFIG.COM	5-5
5.2.2.1	NETCONFIG.COM Example	5-7
5.2.2.2	NETCONFIG_UPDATE.COM for Existing Network Configurations	5-10
5.2.3	Tailoring the Configuration Database	5-11
5.2.3.1	Running DECnet over the CI	5-11
5.2.3.2	Running DECnet over Terminal Lines	5-12
5.2.3.3	Installing Static Asynchronous Lines	5-12
5.2.3.4	Installing Dynamic Asynchronous Lines	5-14
5.3	Network Configuration Examples	5-19
5.3.1	Ethernet Network Example	5-20
5.3.2	FDDI Network Example	5-21
5.3.3	Synchronous DDCMP Point-to-Point Network Example	5-23
5.3.4	DDCMP Multipoint Network Example	5-25
5.3.5	Static Asynchronous DDCMP Network Example	5-27
5.3.6	Dynamic Asynchronous DDCMP Network Examples	5-29
5.4	System Configuration Guidelines	5-31
5.4.1	Normal Memory Requirements	5-31
5.4.2	Critical Routing Node Requirements	5-32
5.4.3	CPU Time Requirements	5-32
5.4.3.1	Adjusting NETACP Quotas with the NETACP\$ Logical Names	5-33
5.4.3.2	Adjusting NETACP Node Data Block Allocations with NET\$ Logical Names	5-34
5.4.4	Permanent Database Considerations in VMSclusters	5-34

6 Installing a Network

6.1	Installing a DECnet for OpenVMS Key	6-1
6.2	Bringing Up Your Network Node Using STARTNET.COM	6-2
6.3	Testing the Installation with UETP Test Procedure	6-2
6.4	Shutting Down Your DECnet for OpenVMS Node	6-3

7 Testing the Network

7.1	Node-Level Tests	7-1
7.1.1	Remote Loopback Test	7-2
7.1.2	Local and Remote Loopback Tests Using a Loop Node Name	7-3
7.1.2.1	Local-to-Remote Loopback Testing	7-4
7.1.2.2	Local-to-Local Controller Loopback Testing	7-5
7.1.3	Local Loopback Test	7-6
7.2	Circuit-Level Tests	7-6
7.2.1	Software Loopback Test	7-7
7.2.2	Controller Loopback Test	7-8

7.2.3	Circuit-Level Loopback Testing	7-9
7.2.3.1	Testing with the PHYSICAL ADDRESS and NODE Parameters	7-9
7.2.3.2	Loopback Assistance	7-11
7.3	Using the MIRROR\$SIZE Logical	7-12

Part IV Network User Operations

8 Performing Network User Operations

8.1	Retrieving Network Status Information	8-1
8.2	Establishing Communication with a Remote Node	8-2
8.3	Accessing Files on Remote Nodes	8-3
8.3.1	Using DCL Commands and Command Procedures	8-4
8.3.2	Using Higher-Level Language Programs	8-4
8.3.3	Using OpenVMS RMS Services from Programs	8-5
8.4	Performing Task-to-Task Operations	8-7
8.4.1	Transparent and Nontransparent Task-to-Task Communication	8-7
8.4.1.1	Transparent Communication	8-7
8.4.1.2	Nontransparent Communication	8-8
8.4.2	Task Specification Strings in Task-to-Task Applications	8-9
8.4.3	Functions Required for Performing Task-to-Task Operations	8-10
8.4.3.1	Initiating a Logical Link Connection	8-11
8.4.3.2	Completing the Logical Link Connection	8-11
8.4.3.3	Exchanging Messages	8-13
8.4.3.4	Terminating a Logical Link Connection	8-14
8.5	Performing Transparent Task-to-Task Operations	8-15
8.5.1	Using DCL Commands and Command Procedures	8-15
8.5.2	Using Programming Language I/O Statements	8-16
8.5.3	Using OpenVMS RMS Service Calls in Programs	8-16
8.5.4	Using System Service Calls in Programs	8-17
8.5.4.1	Requesting a Logical Link	8-18
8.5.4.2	Completing the Logical Link Connection	8-18
8.5.4.3	Exchanging Messages	8-19
8.5.4.4	Terminating the Logical Link	8-19
8.5.4.5	Status and Error Reporting	8-19
8.5.5	Summary of System Service Calls for Transparent Operations	8-20
8.5.5.1	\$ASSIGN	8-20
8.5.5.2	\$QIO (Sending a Message to a Target Task)	8-21
8.5.5.3	\$QIO (Receiving a Message from a Target Task)	8-22
8.5.5.4	\$DASSGN (Disconnecting a Logical Link)	8-23
8.6	Performing Nontransparent Task-to-Task Operations	8-24
8.6.1	Using System Services for Nontransparent Operations	8-24
8.6.1.1	Assigning a Channel to _NET: and Creating a Mailbox	8-25
8.6.1.2	Mailbox Message Format	8-26
8.6.1.3	Requesting a Logical Link Connection	8-27
8.6.1.4	Using the Network Connect Block	8-27
8.6.1.5	Completing the Establishment of a Logical Link	8-28
8.6.1.6	Disconnecting or Aborting the Logical Link	8-30
8.6.1.7	Terminating the Logical Link	8-31

8.6.2	System Service Calls for Nontransparent Operations	8-31
8.6.2.1	\$ASSIGN (I/O Channel Assignment)	8-32
8.6.2.2	\$QIO (Requesting a Logical Link Connection)	8-32
8.6.2.3	\$QIO (Accepting Logical Link Connection Request)	8-33
8.6.2.4	\$QIO (Rejecting a Logical Link Connection Request)	8-34
8.6.2.5	\$QIO (Sending a Message to a Target Task)	8-35
8.6.2.6	\$QIO (Receiving a Message from a Target Task)	8-35
8.6.2.7	\$QIO (Sending an Interrupt Message to a Target Task)	8-35
8.6.2.8	\$QIO (Synchronously Disconnecting a Logical Link)	8-36
8.6.2.9	\$QIO (Aborting a Logical Link)	8-37
8.6.2.10	\$QIO (Declaring a Network Name or Object Number)	8-38
8.6.2.11	\$DASSGN (Terminating a Logical Link)	8-39
8.7	Designing Tasks	8-39
8.7.1	DCL Command Procedure for Task-to-Task Communication	8-39
8.7.2	FORTRAN Program for Task-to-Task Communication	8-40
8.7.3	Programs for Nontransparent Task-to-Task Communication	8-43

9 File Operations in a Multivendor Network Environment

9.1	DECnet for OpenVMS Restrictions	9-1
9.2	OpenVMS to IAS Network Operation	9-2
9.2.1	File Formats and Access Modes	9-2
9.2.2	OpenVMS RMS Interface	9-3
9.2.3	File Specifications	9-3
9.2.4	DCL Considerations	9-4
9.2.4.1	APPEND	9-4
9.2.4.2	COPY	9-4
9.3	OpenVMS to RSTS/E Network Operation	9-5
9.3.1	File Formats and Access Modes	9-5
9.3.2	OpenVMS RMS Interface	9-5
9.3.3	File Specifications	9-6
9.3.4	DCL Considerations	9-6
9.3.4.1	APPEND	9-6
9.3.4.2	COPY	9-6
9.3.4.3	DELETE	9-7
9.3.4.4	DIRECTORY	9-7
9.3.4.5	DUMP/RECORDS and TYPE Commands	9-7
9.4	OpenVMS to RSX Network Operation Using RMS-based FAL	9-7
9.4.1	File Formats and Access Modes	9-8
9.4.2	OpenVMS RMS Interface	9-8
9.4.3	File Specifications	9-8
9.4.4	DCL Considerations	9-9
9.4.4.1	COPY	9-9
9.5	OpenVMS to RSX Network Operation Using FCS-based FAL	9-9
9.5.1	File Formats and Access Modes	9-9
9.5.2	OpenVMS RMS Interface	9-10
9.5.3	File Specifications	9-10
9.5.4	DCL Considerations	9-11
9.5.4.1	APPEND	9-11
9.5.4.2	COPY	9-11
9.6	OpenVMS to RT-11 Network Operations	9-11
9.6.1	File System Constraints	9-12
9.6.1.1	File Formats and Access Modes	9-12
9.6.1.2	OpenVMS RMS Interface	9-13

9.6.2	File Specifications	9-13
9.6.3	DCL Considerations	9-14
9.6.3.1	COPY	9-14
9.6.3.2	DELETE	9-14
9.7	OpenVMS to TOPS-10 Network Operations	9-14
9.7.1	File System Constraints	9-15
9.7.1.1	File Formats and Access Modes	9-15
9.7.1.2	OpenVMS RMS Interface	9-16
9.7.1.3	File Specifications	9-16
9.7.2	DCL Considerations	9-17
9.7.2.1	COPY	9-17
9.7.2.2	DIRECTORY	9-17
9.8	OpenVMS to TOPS-20 Network Operations	9-17
9.8.1	File System Constraints	9-18
9.8.1.1	File Formats and Access Modes	9-18
9.8.1.2	OpenVMS RMS Interface	9-19
9.8.1.3	File Specifications	9-19
9.8.2	DCL Considerations	9-20
9.8.2.1	COPY	9-20
9.8.2.2	DIRECTORY	9-20
9.9	OpenVMS to MS-DOS Network Operations	9-20
9.9.1	File System Constraints	9-20
9.9.1.1	File Formats and Access Modes	9-21
9.9.1.2	OpenVMS RMS Interface	9-22
9.9.1.3	File Specifications	9-22
9.9.2	DCL Considerations	9-22
9.9.2.1	COPY	9-23
9.9.2.2	DIRECTORY	9-23
9.10	OpenVMS to ULTRIX Network Operations	9-23
9.10.1	File System Constraints	9-23
9.10.1.1	File Formats and Access Modes	9-23
9.10.1.2	OpenVMS RMS Interface	9-24
9.10.1.3	File Specifications	9-25
9.10.2	DCL Considerations	9-25
9.10.2.1	COPY	9-25
9.10.2.2	DIRECTORY	9-25
9.11	OpenVMS to IBM Network Operations	9-26
9.11.1	File System Constraints	9-26
9.11.1.1	File Formats and Access Modes	9-26
9.11.1.2	OpenVMS RMS Interface	9-27
9.11.1.3	File Specifications	9-28
9.11.2	DCL Considerations	9-28
9.12	OpenVMS to VMS Network Operations	9-28

Glossary

Index

Examples

3-1	Using the SET OBJECT OUTGOING CONNECT PRIVILEGES Command	3-69
5-1	Sample NETCONFIG.COM Dialogue for a Routing Node	5-8
8-1	FORTTRAN Task-to-Task Communication	8-41

Figures

1-1	DECnet Functions and Related DNA Layers and Protocols	1-3
1-2	Sample DECnet for OpenVMS Phase IV Configuration	1-5
1-3	DDCMP Point-to-Point and Multipoint Connections	1-8
1-4	DECnet for OpenVMS Software	1-13
1-5	Topology of a Single-Area DECnet Network	1-15
1-6	Topology of a Multiple-Area DECnet Network	1-16
1-7	DECnet for OpenVMS Programming Interfaces and Network Access Types	1-19
1-8	Remote File Access Using Access Control String Information	1-22
1-9	Remote File Access Using Default Access Control Information	1-24
2-1	Multipoint Circuits and Associated Lines	2-9
2-2	Multipoint Lines	2-13
2-3	Routing Initialization Passwords	2-30
2-4	Access Control for Inbound Connections	2-32
3-1	Remote Command Execution	3-7
3-2	Network Circuit Costs	3-52
4-1	Operator-Initiated Downline Load over Ethernet Circuit (TRIGGER Command)	4-6
4-2	Operator-Initiated Downline Load over Ethernet Circuit (LOAD Command)	4-8
4-3	Upline Dumping of RSX-11S Memory	4-13
4-4	Downline Task Loading	4-15
5-1	Dynamic Switching of Asynchronous DDCMP Lines	5-16
5-2	An Ethernet Network Configuration	5-20
5-3	An FDDI Network Configuration	5-22
5-4	A Synchronous DDCMP Point-to-Point Network Configuration	5-23
5-5	A DDCMP Multipoint Network Configuration	5-25
5-6	A Static Asynchronous DDCMP Network Configuration	5-28
5-7	A Dynamic Asynchronous DDCMP Network Configuration	5-29
7-1	Remote Loopback Test	7-3
7-2	Local-to-Remote Loopback Test Using a Loop Node Name	7-4
7-3	Local-to-Local Loopback Test Using a Loop Node Name	7-5
7-4	Local Loopback Test	7-6
7-5	Software Loopback Test	7-7
7-6	Controller Loopback Testing	7-8
8-1	Mailbox Messages	8-9
8-2	Mailbox Message Format	8-26

Tables

1-1	Programming Interfaces for Network Operations	1-18
2-1	DDCMP Circuit Devices	2-8
2-2	Ethernet Circuit Devices	2-10
2-3	FDDI Circuit and Line Devices	2-11
3-1	Node and Executor Parameters and Their Functions	3-11
3-2	Types of Circuit and Applicable Circuit Parameters	3-26
3-3	Circuit Parameters and Their Functions	3-27
3-4	Line Protocols	3-37
3-5	Line Types and Applicable Line Parameters	3-38
3-6	Line Parameters and Their Functions	3-39
3-7	FDDI Line Parameters and Their Functions	3-40
3-8	DDCMP Line Parameters and Their Functions (VAX only)	3-40
3-9	FDDI Line Status Parameters and Their Functions	3-48
3-10	Object Parameters and Their Functions	3-59
3-11	NCP Display Types	3-73
5-1	Privileges for NCP Operations	5-1
5-2	Permanent Configuration Database Files	5-34
6-1	Local Node States and Network Operations	6-4
8-1	System Service Calls for Transparent Communication	8-17
8-2	System Service Calls for Nontransparent Communication	8-24
8-3	System Mailbox Messages	8-27

Preface

Intended Audience

The *DECnet for OpenVMS Networking Manual* is for readers who perform network management functions to control, monitor or test DECnet for OpenVMS. This manual is also for users who perform remote file access or task-to-task operations using DECnet for OpenVMS. You should be familiar with the operating system but not necessarily experienced with DECnet operations.

Document Structure

The *DECnet for OpenVMS Networking Manual* is divided into four major parts:

- Part I introduces you to basic networking concepts required to understand DECnet for OpenVMS operation, and indicates how you can interact with the network.
- Part II provides usage information to those responsible for DECnet for OpenVMS system management and explains how to use the Network Control Program to manage the network and perform host services to remote systems (such as downline loading and upline dumping).
- Part III specifies the procedures for configuring, installing, and testing DECnet for OpenVMS on a operating system.
- Part IV describes the techniques for carrying out user operations over the network, including accessing remote files and performing task-to-task communications.

Associated Documents

The networking concepts and operations described in the *DECnet for OpenVMS Networking Manual* are directly related to the following three manuals:

1. *DECnet for OpenVMS Guide to Networking* — Provides a conceptual overview of networking concepts and DECnet for OpenVMS.
2. *DECnet for OpenVMS Network Management Utilities* — Provides usage information for the Network Control Program (NCP) Utility, and information for testing the network using DECnet Test Sender/Receiver commands, formerly presented in a separate manual.
3. *VMS DECnet Test Sender/DECnet Test Receiver Utility Manual* is no longer a separate manual. It has been incorporated into the *DECnet for OpenVMS Network Management Utilities*.

See also the OpenVMS Release notes for the version you are running.

The following functional specifications define Digital Network Architecture (DNA) protocols to which all implementations of DECnet Phase IV adhere:

DECnet Digital Network Architecture General Description
Digital Data Communications Message Protocol Functional Specification
Network Services Protocol Functional Specification
Maintenance Operation Protocol Functional Specification
Data Access Protocol Functional Specification
Routing Layer Functional Specification
DNA Session Control Functional Specification
DNA Phase IV Network Management Functional Specification
Ethernet Node Product Architecture Specification
Ethernet Data Link Functional Specification
Ethernet Node Product Architecture Specification

Conventions

In this manual, every use of OpenVMS AXP means the OpenVMS AXP operating system, every use of OpenVMS VAX means the OpenVMS VAX operating system, and every use of OpenVMS means both the OpenVMS AXP operating system and the OpenVMS VAX operating system.

The following conventions are used to identify information specific to OpenVMS AXP or to OpenVMS VAX:



The AXP icon denotes the beginning of information specific to OpenVMS AXP.



The VAX icon denotes the beginning of information specific to OpenVMS VAX.



The diamond symbol denotes the end of a section of information specific to OpenVMS AXP or to OpenVMS VAX.

The following conventions are also used in this manual:

Ctrl/x

A sequence such as Ctrl/x indicates that you must hold down the key labeled Ctrl while you press another key or a pointing device button.

Return

In examples, a key name enclosed in a box indicates that you press a key on the keyboard. (In text, a key name is not enclosed in a box.)

A vertical ellipsis indicates the omission of items from a code example or command format; the items are omitted because they are not important to the topic being discussed.

boldface text

Boldface text represents the introduction of a new term or the name of an argument, an attribute, or a reason.

Boldface text is also used to show user input in Bookreader versions of the manual.

<i>italic text</i>	Italic text emphasizes important information, indicates variables, and indicates complete titles of manuals. Italic text also represents information that can vary in system messages (for example, Internal error <i>number</i>), command lines (for example, /PRODUCER= <i>name</i>), and command parameters in text.
UPPERCASE TEXT	Uppercase text indicates a command, the name of a routine, the name of a file, or the abbreviation for a system privilege.
-	A hyphen in code examples indicates that additional arguments to the request are provided on the line that follows.
numbers	All numbers in text are assumed to be decimal, unless otherwise noted. Nondecimal radixes—binary, octal, or hexadecimal—are explicitly indicated.

Note

In this document, discussions that refer to VMScluster environments apply to both VAXcluster systems that include only VAX nodes and VMScluster systems that include at least one AXP node unless indicated otherwise.

In this document, discussions that refer to DECDns apply to the Distributed Name Service (DNS) V1.1.

Part I

Introduction to DECnet for OpenVMS

Overview of DECnet for OpenVMS

This chapter presents an overview of the DECnet for OpenVMS networking software which enables access to the DECnet network: what the software is, how to manage it, and how to interface with it.

The following sections introduce the network terms and concepts used throughout this manual, identify network software, describe network configurations, and provide a brief summary of network management responsibilities. The chapter also defines the application user's relationship to the network.

1.1 General Description of a DECnet Network

Computer processes communicate with one another over a data network. This network consists of two or more computer systems called **nodes** and the **logical links** between them. A logical link is a connection, at the user level, between two processes. **Adjacent nodes** are connected by physical **lines** over which **circuits** operate. A circuit is a communications data path over which all input and output (I/O) between nodes takes place. A circuit can support many concurrent logical links.

In a network of more than two nodes, the process of directing a data message from a source to a destination node through intermediate nodes is called **routing**. DECnet supports adaptive routing, which permits messages to be routed through the network over the most cost-effective path; messages are rerouted automatically if a circuit becomes disabled.

Nodes can be either **routing nodes** (called **routers**) or **nonrouting nodes** (known as **end nodes**). Both routing nodes and end nodes can send messages to and receive messages from other nodes in the network. However, routing nodes have the ability to forward or route messages from one node to another when the two nodes exchanging these messages have no direct physical link between them.

Note

Not all hardware platforms support routing. Check the DECnet for OpenVMS Software Product Description (SPD) to determine if routing is supported on your hardware platform.

End nodes can never have more than one active circuit connecting them with the network. Any node that has two or more active circuits connecting it to the network must be a router.

Phase IV DECnet supports the configuration of very large, as well as small, networks. In a network that is not divided into multiple areas, a maximum of 1023 nodes is possible. **Area routing** techniques permit configuration of very large networks, consisting of up to 63 areas, each containing a maximum of 1023 nodes. In a multiple-area network, nodes are grouped into separate **areas**,

Overview of DECnet for OpenVMS

1.1 General Description of a DECnet Network

each functioning as a subnetwork. DECnet supports routing within each area and a second, higher level of routing that links the areas. Nodes that perform routing within a single area are referred to as **level 1 routers**; those that perform routing between areas as well as within their own area are called **level 2 routers** (or **area routers**).

1.1.1 DECnet Interface with the Operating System

DECnet is the collective name for the software and hardware products that are a means for various Digital operating systems to participate in a network. DECnet for OpenVMS is the implementation of DECnet that allows an OpenVMS operating system to function as a network node. As the network interface, DECnet supports both the **protocols** necessary for communicating over the network and the functions necessary for configuring, controlling, and monitoring the network. In a network, any DECnet node can communicate with any other DECnet node, regardless of their operating systems.

A DECnet multinode network is decentralized; that is, many nodes connected to the network can communicate with each other without having to go through a central node. As a member of a multinode network, your node can communicate with any other network node, not merely the nodes that reside next to you, and gain access to software facilities that may not exist on your local node. An advantage of this type of network is that it allows different applications running on separate nodes to share the facilities of any other node.

Optionally, very large DECnet networks can be divided into multiple areas, for the purpose of hierarchical (area) routing. Area routing introduces a second, higher level of routing between areas (groups of nodes), which results in less routing traffic throughout the network. Each node in a multiple-area network can still communicate with all other nodes in the network.

1.1.2 DECnet Functions

Networking functions you can perform using DECnet for OpenVMS are as follows. (These functions are introduced in this section and described in later chapters, as indicated.)

- Network management functions
 - Controlling the network (Chapter 2 through Chapter 7)
 - Providing DECnet for OpenVMS host services to other DECnet nodes (Chapter 4)
 - Performing routing configuration and control (Chapter 2 and Chapter 3)
 - Establishing DECnet configurations (Chapter 2, Chapter 3, and Chapter 5)
- Applications user functions
 - Accessing files across the network (Chapter 8 and Chapter 9)
 - Using a heterogeneous command terminal (Chapter 8)
 - Performing task-to-task communications across the network (Chapter 8)

DECnet Phase IV products are based on the layered network design specified in the Digital Network Architecture (DNA). Figure 1-1 illustrates the DECnet functions, the various DNA layers at which they are initiated, and the DNA protocols by which these functions are implemented. Each DNA layer is a client of the next lower layer and does not function independently. For a complete

Overview of DECnet for OpenVMS

1.1 General Description of a DECnet Network

description of DNA, see the DNA specifications. The DECnet for OpenVMS configurations that use the Ethernet, Fiber Distributed Data Interface (FDDI), DDCMP and CI protocols are defined in the following section.

Figure 1-1 DECnet Functions and Related DNA Layers and Protocols

DECnet Functions	DNA Layers		DNA Protocols					
File Access Command Terminals	User		User Protocols					
Host Services Network Control	N e t w o r k	Network Application	Data Access Protocol (DAP) and Others					
		Session Control	Session Control Protocol					
Task-to-Task Communications	M a n a g e m e n t	End Communication	Network Services Protocol (NSP)					
Adaptive Routing		Routing	Routing Protocol					
Host Services		Data Link	DDCMP					
Packet Transmission/ Reception	Physical Link		S y n c	A s y n c	Ethernet	CI	X.25	FDDI

LKG-6690-92R

1.2 DECnet for OpenVMS Configurations

DECnet for OpenVMS supports network connections for Ethernet and FDDI lines in a local area network (LAN) configuration.

Overview of DECnet for OpenVMS

1.2 DECnet for OpenVMS Configurations

VAX

On VAX, DECnet for OpenVMS software also supports network connections to the following:

- A node running DECnet using the DDCMP, Digital's data communications message protocol: either a **synchronous** point-to-point or multipoint connection, or an **asynchronous** static or dynamic point-to-point connection
- Other nodes running DECnet over the computer interconnect (CI)♦

Figure 1-2 illustrates a sample DECnet Phase IV configuration showing the following ways of connecting LANs:

- An FDDI to Ethernet bridge connecting an FDDI LAN (top) to an Ethernet LAN.
- A DDCMP synchronous line connecting two LANs.♦
- A PSDN connecting two LANs via two X25routers.

VAX

DECnet for OpenVMS connections are described in the following subsections. A detailed discussion of the various types of circuits and lines used in a DECnet network is presented in Chapter 2.

1.2.1 Ethernet Local Area Network Configuration

The Ethernet is a Local Area Network (LAN) component that provides a reliable high-speed communications **channel**, optimized to connect information processing equipment in a limited geographic area, such as an office, a building, or a complex of buildings (for example, a campus).

LANs are designed to use a wide variety of technologies and arranged in many configurations. Digital Equipment Corporation, Intel Corporation, and Xerox Corporation collaborated in producing the Ethernet specification to develop a variety of LAN products. Digital's implementation of the Ethernet specification that was originated by the Xerox Corporation appears at the lowest two levels of the overall DNA specification: the Physical layer and the Data Link layer.

At the Physical layer, the Ethernet topology is a bus, in the shape of a branching tree, and the medium is a shielded coaxial cable that uses Manchester-encoded, digital baseband signaling. The maximum data rate is 10 million bits per second. Maximum use of an Ethernet's data transmission capability occurs when multiple pairs of nodes communicate simultaneously. In practice, DECnet transmission between a pair of nodes on an Ethernet occurs at a considerably lower rate. Each Ethernet can support up to 1023 nodes; the maximum possible distance between nodes on the Ethernet is 2.8 kilometers (1.74 miles).

Section 2.2.4 lists the Ethernet circuit devices supported by DECnet for OpenVMS.

1.2.1.1 Ethernet Datagrams

Message **packets** sent over Ethernet are called **datagrams**. Because there is no guarantee that a datagram will be received by the intended destination, reliable connections (in the form of virtual circuits) may be provided by a protocol being interposed between the user and the Ethernet datagram service. In DNA, this virtual circuit is provided by the Network Services Protocol (NSP) in the End Communication layer.

Overview of DECnet for OpenVMS 1.2 DECnet for OpenVMS Configurations

Figure 1-2 Sample DECnet for OpenVMS Phase IV Configuration

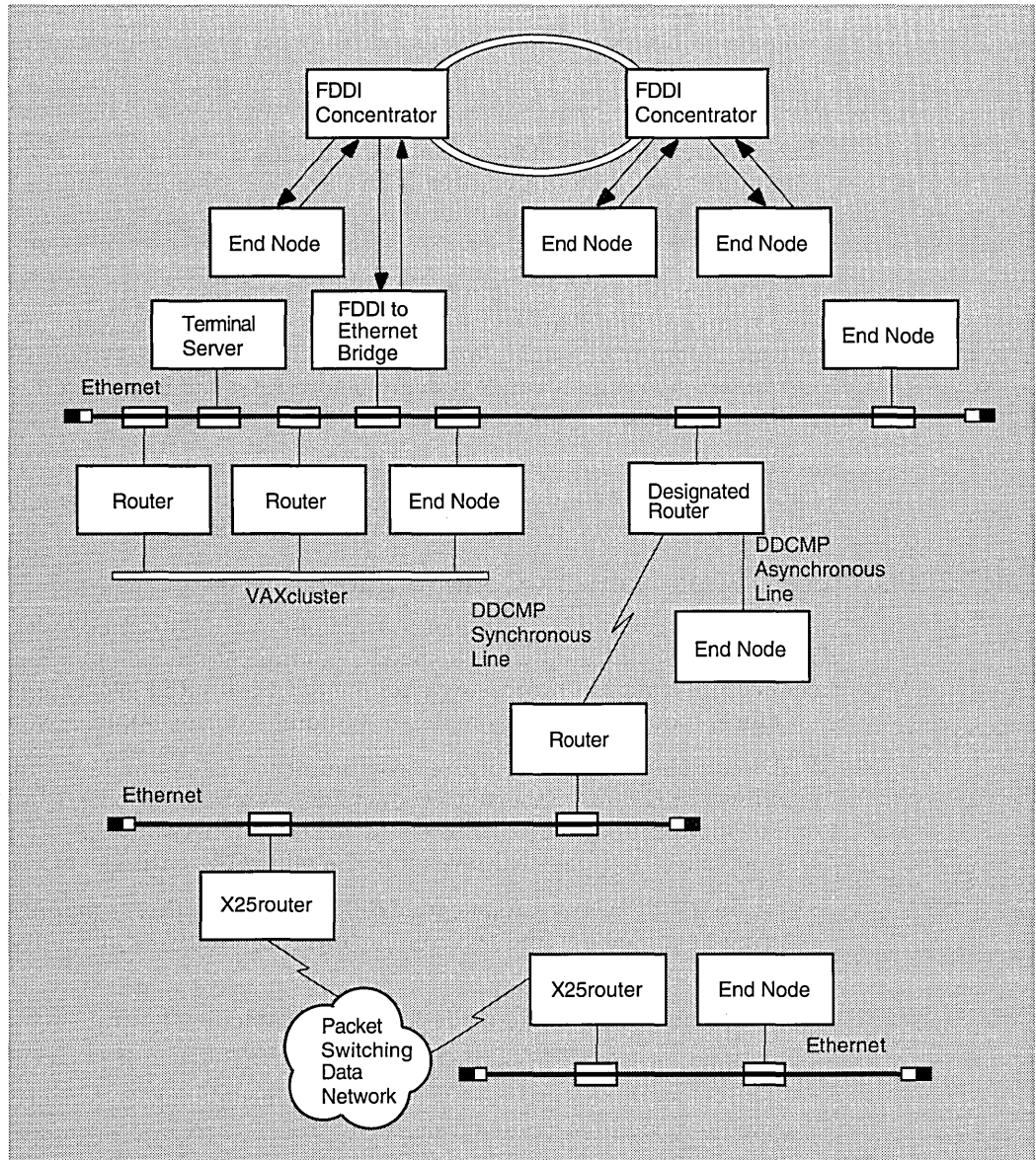

LKG-7259-92R

1.2.1.2 Transmission and Reception of Ethernet Packets

An Ethernet is a single shared network channel, with many nodes demanding equal access. The technique used to mediate these demands is **Carrier Sense, Multiple Access with Collision Detect (CSMA/CD)**. CSMA/CD performs Ethernet Data Link layer access control.

The LAN term **multiaccess** refers to the ability of any station on the LAN to use the communications medium. On Ethernet, any station may begin transmitting if it senses that no other station is transmitting.

Overview of DECnet for OpenVMS

1.2 DECnet for OpenVMS Configurations

CSMA/CD is like a social gathering in that one person speaks at a time. Before speaking, one listens to determine if another person is speaking. If two or more people, detecting silence, begin speaking at the same time, they notice this and stop speaking. After a short interval, they each try to speak again. Because the length of this interval is randomly determined, usually one person starts before the other. The second person waits for the first to conclude.

The **carrier sense** function enables Ethernet stations to determine if the communication medium is already in use. Messages are said to be *initially deferred* if they are not sent on the Ethernet because a transmission is in progress.

If two or more stations begin transmitting at the same time, they detect this and stop transmitting. This is called **collision detect**. They wait for a random period of time before trying again; on Ethernet, this situation is known as *backoff and retransmission*, and a random delay before retransmission eventually clears the collision situation.

While Ethernet stations can hear every message, some messages are intended for all stations (**broadcast address**), some are intended for a subset (**multicast address**), and some are intended for individual stations (**physical address**).

1.2.2 FDDI Local Area Network Configuration

A Fiber Distributed Data Interface LAN offers 100 Mb/s network communications. FDDI provides a reliable high-speed communications channel, optimized to connect information processing equipment in a limited geographic area, such as an office, a building, or a complex of buildings (for example, a campus).

FDDI can operate as a dedicated communications channel or interoperate with existing IEEE 802.3/Ethernet products as a high-speed backbone supporting one or more mid-speed IEEE 802.3/Ethernet subnetworks. As implemented by Digital, the FDDI physical layer has the following features:

- A dual ring of trees topology; using one ring as the primary ring, the second ring as a backup, and the tree for increased network flexibility, manageability, and availability.
- Multimode and single-mode fiber optic cable for the transmission medium.
- Reliable light emitting diodes (LEDs) as the optical transmitters, photo diodes (PINs) as the optical receivers for multimode fiber, and laser technology for single-mode fiber transmission.
- A maximum of 500 network devices, a maximum ring circumference of 100 km (62 miles), a maximum distance between multimode fiber stations of 2 km (1.2 miles) for flexible network connections and configurations, and 40 km (25 miles) distance between stations using single-mode fiber.

1.2.2.1 The FDDI Data Link Layer

The FDDI Data Link layer uses a timed token-passing protocol. The FDDI Data Link layer is divided into two sublayers: Media Access Control (MAC) and Logical Link Control (LLC).

FDDI requires LLC for proper ring operation. The LLC sublayer resides above the MAC sublayer. LLC controls the transmission of a frame of data between two nodes. LLC frames carry user information between nodes on an FDDI or other network. Each FDDI frame containing user data includes LLC information for the destination node. These frames cross bridges and can be transmitted to nodes on the extended LAN.

Overview of DECnet for OpenVMS

1.2 DECnet for OpenVMS Configurations

MAC functions include the following:

- Delivering of LLC frames
- Constructing MAC frames and tokens
- Sending, receiving, repeating, and removing MAC frames from the ring
- Fair and equal access to the ring through use of the timed token
- Communicating between attached devices using frames and tokens
- Ring initialization (claim process)
- Ring fault isolation (beacon process)

1.2.2.2 FDDI Ring Operation

To gain the right to transmit on the FDDI LAN, stations must first acquire the token, which is a unique symbol sequence that circulates around the ring following a data transmission. Once a station acquires the token, it removes the token from the ring and begins transmitting data. At the end of transmission, the station issues a new token onto the ring, providing other stations with the opportunity to transmit.

In Digital's FDDI implementation, all attached stations use asynchronous data transmission to pass data around the ring. In asynchronous transmission, all attached stations are dynamically allocated a transmission time based on the TTRT. Stations acquire the token and transmit until the token holding time expires.

1.2.3 LAN Routers and End Nodes

Local Area Networks support connections to routers and end nodes. On a LAN, a routing node selected as a **designated router** can perform routing services on behalf of end nodes. In addition, routers can route packets between LAN nodes and non-LAN nodes (such as nodes on DDCMP circuits). An end node on a LAN can communicate directly with any other node (router or end node) on the same LAN by sending a message directly to the addressed node. An end node on a non-LAN circuit can communicate only with an adjacent node on the same circuit.

Not all hardware platforms support network routing. Refer to the DECnet for OpenVMS Software Product Description (SPD) to determine if routing is supported.

1.2.4 DDCMP Network Configurations

VAX

On systems that support it, DDCMP provides a low-level communications path between systems. The DDCMP protocol performs the basic communications function of moving information blocks over an unreliable communication channel. (The protocol detects any bit errors introduced by the channel and requests retransmission of the block.) You also use DDCMP to manage the orderly transmission and reception of blocks on channels with one or more transmitters and receivers.

The DDCMP protocol is supported on some synchronous and asynchronous communications devices. DDCMP connections can be point-to-point or multipoint configurations. Point-to-point connections are either synchronous or asynchronous. The two types of asynchronous connections are static (permanent) and dynamic (switched temporary). Multipoint connections are always synchronous. These connections are described in the following section. ♦

Overview of DECnet for OpenVMS

1.2 DECnet for OpenVMS Configurations

1.2.4.1 DDCMP Point-to-Point and Multipoint Connections



A **point-to-point** configuration consists of two systems connected by a single communication channel. Figure 1-3 illustrates typical DDCMP point-to-point and multipoint configurations.

Figure 1-3 DDCMP Point-to-Point and Multipoint Connections

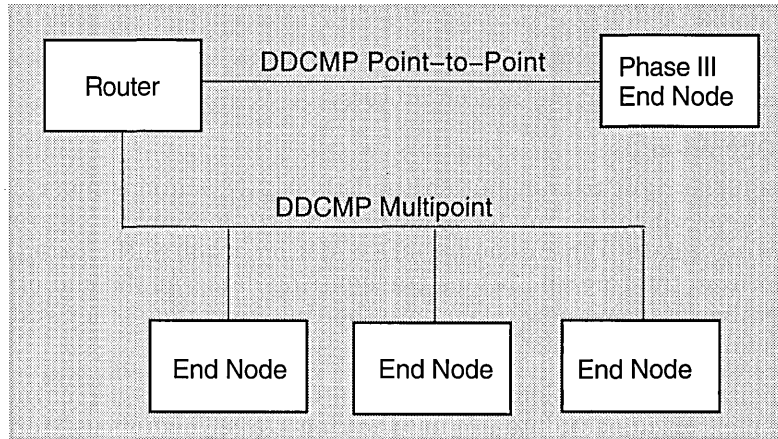

LKG-6706-92R

A **multipoint** configuration consists of two or more systems connected by a communications channel, with one of the systems (called the **control station**) controlling the channel. All other systems on the communications channel are known as **tributaries**. (Note that, if only two systems are connected in a multipoint configuration, one is the master and one is the tributary. However, this is not a very efficient use of the communication channel.) The control station is responsible for telling the tributaries, in turn, when they may use the channel; this procedure is known as **polling**. Tributaries are not allowed to use the channel until they are polled. The control station, however, may use the channel whenever it is available. Also, the tributaries on a multipoint line are not allowed to communicate directly with each other, but only through the master.

Point-to-point circuits and multipoint circuits perform as virtual circuits. Nodes on these circuits interact as though a specific circuit were dedicated to them throughout the transmission. However, the actual physical connection is allocated by the routing mechanism. Initialization of nodes on DDCMP circuits involves guaranteed delivery of routing messages. Also, individual nodes on DDCMP circuits must be addressed directly; no multicast or broadcast addressing capability is available as with an Ethernet or FDDI circuit. ♦

1.2.4.2 Synchronous DDCMP Connections



You use synchronous communications devices for high-speed point-to-point or multipoint communication (for example, connecting two VAX-11/780 systems).

The synchronous DDCMP protocol can run in full- or half-duplex operation. This allows DDCMP the flexibility of being used for local synchronous communications, or for remote synchronous communications over a telephone line using a modem. DDCMP has been implemented in microcode in such devices as the DMC11 and DMR11 to run at speeds up to one megabit per second in a point-to-point configuration. The DDCMP multipoint protocol (point-to-point also) has been

Overview of DECnet for OpenVMS

1.2 DECnet for OpenVMS Configurations

implemented in microcode in the DMP11 device to run at speeds up to 500 kilobits per second. For the DMF32, DDCMP has been implemented in the driver software for the synchronous communications port. ♦

1.2.4.3 Asynchronous DDCMP Connections

VAX

Asynchronous connections provide for low-speed, low-cost, point-to-point communication (for example, as an inexpensive way of connecting a MicroVAX system to a VAX-8000 series system). Asynchronous DDCMP is implemented in software and can be run over any directly connected terminal line that the system supports. The asynchronous DDCMP protocol provides for a full-duplex connection and can be used for remote asynchronous communications over a telephone line using a modem. Asynchronous connections are not supported for maintenance operations or for controller loopback testing.

You can make two kinds of asynchronous connections over the network:

- A static connection: the asynchronous line is permanently configured as a communications device
- A dynamic connection: a line connected to a terminal port is switched to an asynchronous communications line for the duration of a call ♦

1.2.4.4 Static Asynchronous Connections

VAX

A static asynchronous DDCMP connection is a permanent DECnet connection between two nodes physically connected by terminal lines. You convert the terminal lines to static asynchronous DDCMP lines by issuing commands to set the lines to support the DDCMP protocol. The user at each node then turns the appropriate circuits and lines on for DECnet use. After the communications link is established, it remains available until a user turns off the circuit and line and clears the entries from the DECnet database.

Static asynchronous DDCMP configurations require the asynchronous DDCMP driver to be connected. The asynchronous DDCMP protocol can run in full-duplex operation on local asynchronous communication devices. Examples of these devices are the DZ11 and the DMF32 asynchronous communications port.

You can configure a dialup line as either a static or dynamic asynchronous line, but may find the dynamic connection more secure and convenient to use. ♦

1.2.4.5 Dynamic Asynchronous Connections

VAX

A dynamic asynchronous connection is a temporary connection between two nodes, generally over a telephone line using modems. The terminal lines at both ends of the connection can be switched to asynchronous DDCMP communications lines and then switched back to terminal lines.

You can use dynamic asynchronous connections to establish a DECnet link to another computer for a limited time or to create links to different computers at different times.

For example, as a user of a personal computer (non-VMS), you can cause a dynamic asynchronous connection to be made for the length of the telephone call to a VAX 8000 series system. First establish a process on your system as a **terminal emulator** (enabling the remote connection to look like a local connection). You dial in over a telephone line to a process on the other system (which is established as a **virtual terminal**) and log in. You can then enter a command that causes the terminal lines at each end of the connection to be switched to DDCMP mode for DECnet use. When you hang up the telephone or turn off the circuit, the lines are automatically switched back to terminal lines.

Overview of DECnet for OpenVMS

1.2 DECnet for OpenVMS Configurations

Security measures provide protection against a caller at an unauthorized node forming a dynamic asynchronous connection with another node (see Section 2.8.6). Before a dialup node can establish a dynamic connection with a remote node, the remote node verifies that the dialup node is authorized to make a connection. It checks that the node is the appropriate type (router or end node), and, without revealing its own password, verifies the routing initialization password sent by the dialup node. Also, for increased security, the connection is ended automatically when the telephone is hung up, if your modem and system are set up and wired to enable this to occur.

You can establish a dynamic asynchronous connection over a hardwired terminal line. The connection is maintained for the duration of the DECnet session. The dynamic connection permits the system to be used as a terminal emulator when not switched to DECnet use. ♦

1.2.5 Configurations for VMSclusters

A VMScluster is an organization of systems that communicate over a high-speed communications path and share processor resources as well as disk storage.

DECnet connections are required for all systems in the cluster. Use of DECnet ensures that cluster system managers can access each node in the cluster from a single terminal, even if terminal-switching facilities are not available. DECnet is also required by the User Environment Test Package (UETP).

The choices for DECnet physical links for use in the cluster are as follows:

- Connecting each node in the cluster to an Ethernet or FDDI LAN.
- Using the CI that connects VAXcluster nodes as the DECnet for OpenVMS data link. The CI cables from the individual nodes in the cluster are connected to a star coupler. ♦

VAX

Connecting each cluster node to a LAN provides distinct advantages:

- Each node in the cluster can be an end node, resulting in lower overhead for these nodes, decreased routing traffic throughout the network, and simpler installation procedures. To route to systems off the LAN, there must be at least one router on the LAN to which the cluster end nodes are attached.
- A LAN provides better performance in DECnet transmissions than the CI, despite the higher data link **bandwidth** of the CI, because the LAN communications protocols allow larger buffer sizes. FDDI provides better performance in DECnet transmission than either CI or Ethernet.
- Terminal servers can be used when nodes in a cluster are connected to an Ethernet. Digital's terminal servers offer a number of benefits to the cluster user, such as load balancing and easier cluster management.

In order to use a cluster alias, at least one cluster member must be configured as a router.

A cluster node connected to a LAN may require additional DECnet lines in order to communicate with remote nodes not on the local area network. Configure a cluster node connected to more than one DECnet line as a router to pass communications between an off-LAN node and other nodes on the network.

Overview of DECnet for OpenVMS

1.2 DECnet for OpenVMS Configurations

1.2.5.1 Using the CI in a VAXcluster

VAX

If you use only one physical link to connect each VAXcluster node to the network, use the Ethernet or FDDI link instead of the CI data link, to get better performance. In this case, the CI should perform the functions of a system bus and not be enabled as a DECnet data link.

If the nodes in the cluster are not connected to a LAN, use the CI as the DECnet data link between the nodes. CI circuit devices are configured as though they were multipoint devices, but each node on the CI can talk directly to every other node and no polling is involved.

Configure at least one node as a router if more than two cluster nodes use the CI to communicate. If the VAXcluster has two nodes, both can be end nodes. For a cluster of four or more nodes, configure at least two routers to prevent the loss of communications capability between the remaining nodes if one router fails. Also, you can provide backup circuits between end nodes in case of router failure. ♦

1.2.5.2 Configuring an Alias Node Identifier

VAX

You can configure a VMScluster so that the whole cluster appears to other network nodes as though it were a single node, with an address different from that of any DECnet node within the cluster. This address usually has a node name associated with it. Thus, you can access the cluster as a whole by an **alias node identifier**, which can be either its node name or its node address.

All or some of the nodes in a cluster can elect to use this special node identifier as an alias, while retaining their unique individual node names and addresses. Each node that assumes the alias node identifier can specify whether it will accept incoming connections directed to the alias address. It can also specify the network services for which the cluster alias node identifier is to be used on outgoing connections and the network services that will accept incoming calls.

At least one of the nodes in the cluster that uses the alias node identifier must be a router. The router informs other nodes in the network of the alias node address for the cluster. When the router receives packets addressed to the alias node address, it forwards them to the appropriate nodes in the cluster. The cluster alias node identifier can be very useful in network operations involving shareable resources. Network users outside the cluster can access cluster resources without knowing which nodes are active in the cluster. For example, if a user on a cluster node sends a MAIL message, it does not matter whether that particular node is active when a reply to the message is received. ♦

1.3 Managing the Network

As system manager, you can use a network management utility program to configure the system as a DECnet for OpenVMS node in the network, and perform network management and maintenance functions for your own node and other nodes in the network. The following subsections summarize network management functions.

1.3.1 Network Control Program

Use the Network Control Program (NCP) utility to configure, control, monitor, and test the network.

The network **components** the system manager configures are listed in Section 1.3.5 and described in detail in Chapter 2. Chapter 3 discusses how to use NCP commands and parameters to perform network management. The NCP commands and parameters and guidelines for using them, including

Overview of DECnet for OpenVMS

1.3 Managing the Network

restrictions on the use of individual NCP parameters, are specified in the *DECnet for OpenVMS Network Management Utilities*.

1.3.2 Network Management Responsibilities

As system manager of a node on a DECnet network, you have a number of key responsibilities, which include the following:

- Defining network components and their parameters in a central **configuration database** at the local node and, optionally, at remote nodes. (The **local node** is the node at which you are physically located; a **remote node** is any node other than the local node in your network.)
- Coordinating with the system managers of other nodes in the network to ensure uniform assumptions about network parameter settings such as circuit cost.
- Configuring your node to ensure proper network routing operation.
- Controlling and monitoring local and remote network operation.
- Testing network hardware and software operation.
- Loading systems downline to unattended remote nodes.
- Connecting to an unattended remote node to serve as its console.

The following sections outline the network-related tasks that you perform as system manager and describes several of the facilities DECnet for OpenVMS provides to perform those tasks.

1.3.3 DECnet for OpenVMS Licenses and Keys

To enable your node to communicate with other nodes in the DECnet network, you need a DECnet for OpenVMS license and key. Purchase either a full function or an end node license, and enable the license by registering the appropriate DECnet for OpenVMS key on your system. You register DECnet for OpenVMS keys by using the License Management Facility (LMF). To register the key, you use the License Management Utility (LICENSE) to enter the information from the LMF Product Authorization Key (PAK).

The DECnet full function key allows the node on which it is enabled to be configured as either a routing node or an end node. The end node key permits the use of the DECnet end node capability only. An upgrade from end node to full function license is available, provided you have a hardware platform on which routing is supported.

1.3.4 DECnet for OpenVMS Network Management Software

Figure 1-4 displays the DECnet for OpenVMS software that the system manager uses to configure, control, and monitor the network.

Network management software components are as follows:

- Ethernet configurator module (NICONFIG), a network image that listens to system identification messages on Ethernet circuits, and maintains a user-accessible database of configuration information on all systems on the Ethernet.

Overview of DECnet for OpenVMS 1.3 Managing the Network

Figure 1-4 DECnet for OpenVMS Software

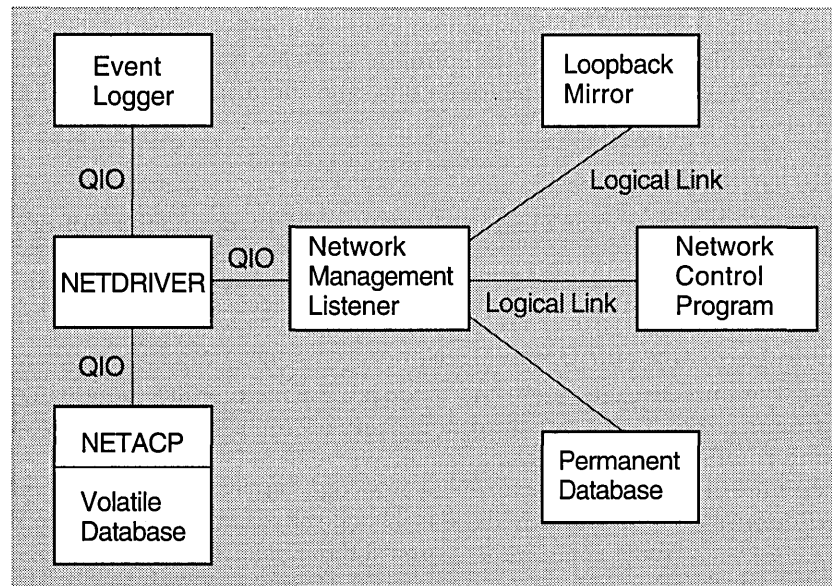

LKG-7260-92R

- Event logger (EVL), an image that logs significant **events** to provide information to the system manager for possible troubleshooting or future reference.
- File access listener (FAL), a network image that receives and processes remote file access requests for files at its node on behalf of remote users.
- Host loader (HLD), an image that communicates with the DECnet-RSX Satellite Loader (SLD) to load tasks downline to an RSX-11S node.
- Loopback mirror (MIRROR), a network image that participates in Network Service Protocol (NSP) and Routing layer loopback testing.
- Network ancillary control process (NETACP), an ancillary control process that controls all lines and circuits, maintains a picture of the network topology, and creates processes to receive inbound logical link connection requests.
- Network Control Program (NCP), an interactive utility program that permits you to control and monitor the network.
- Network driver (NETDRIVER), a pseudo-device driver that provides logical link and routing services. It implements NSP and Routing, and provides a user process with a Queue I/O (QIO) interface to a logical link service.
- Network management listener (NML), an image that receives network management commands, such as NCP commands, from the Network Management layer through the Network Information and Control Exchange (NICE) protocol. NML performs all local network management functions as well as control and information functions requested by remote nodes. NML spawns a subprocess, the maintenance operation module (MOM), for maintenance functions such as downline load, upline dump, and loopback testing.
- Permanent database, a collection of disk-resident files that define the network as known to the local node.

Overview of DECnet for OpenVMS

1.3 Managing the Network

- A volatile database, maintained by NETACP, is memory-resident and contains current network configuration parameters.

Many of these software components are user-transparent. This manual describes them only as they serve to highlight and clarify the functions and operation of NCP. The DNA specifications describe the different protocols that facilitate network communication.

1.3.5 Configuring a Network

The system manager must configure each DECnet node as part of the network.

Check the DECnet for OpenVMS Software Product Description (SPD) to determine if routing is supported on your processor.

1.3.5.1 Configuring a DECnet for OpenVMS Node

At the outset, the system manager is responsible for configuring the network from the perspective of local node network operation. This involves supplying information at the local node about various network components such as nodes, circuits, lines, and objects. This information constitutes the *configuration databases* for the local node. Each node in the network has configuration databases. You supply information for inclusion in the configuration databases through NCP.

If you are configuring a DECnet for OpenVMS node for the first time or want to completely rebuild the configuration databases for your local node, you can use the interactive NETCONFIG.COM procedure in SYS\$MANAGER to configure your node.

If supplied on your system, you can use the interactive NETCONFIG_UPDATE.COM procedure in SYS\$UPDATE to alter your system's default access options for network objects. The NETCONFIG_UPDATE.COM procedure performs no other network configuration. When you use the NETCONFIG_UPDATE.COM procedure to specify changes to default access for network objects, everything else in the configuration database remains unchanged.

To update an existing node database to contain current information about other nodes in the network, you can copy the information from the node database of another node to which you have access.

Chapter 3 discusses the function of the configuration database and the general use of NCP and most NCP commands. Chapter 5 describes how to use the NETCONFIG.COM procedure to configure your node, and presents sample configuration commands for various network configurations. The *DECnet for OpenVMS Network Management Utilities* contains a summary description of NCP operation, command prompting, and the syntax of all NCP commands.

1.3.5.2 A Network Topology

Figure 1-5 shows a hypothetical network topology in a single area. Figure 1-6 illustrates the same topology for a network that has been divided into multiple areas. These configurations are referred to as network examples throughout this manual.

**Overview of DECnet for OpenVMS
1.3 Managing the Network**

Figure 1-5 Topology of a Single-Area DECnet Network

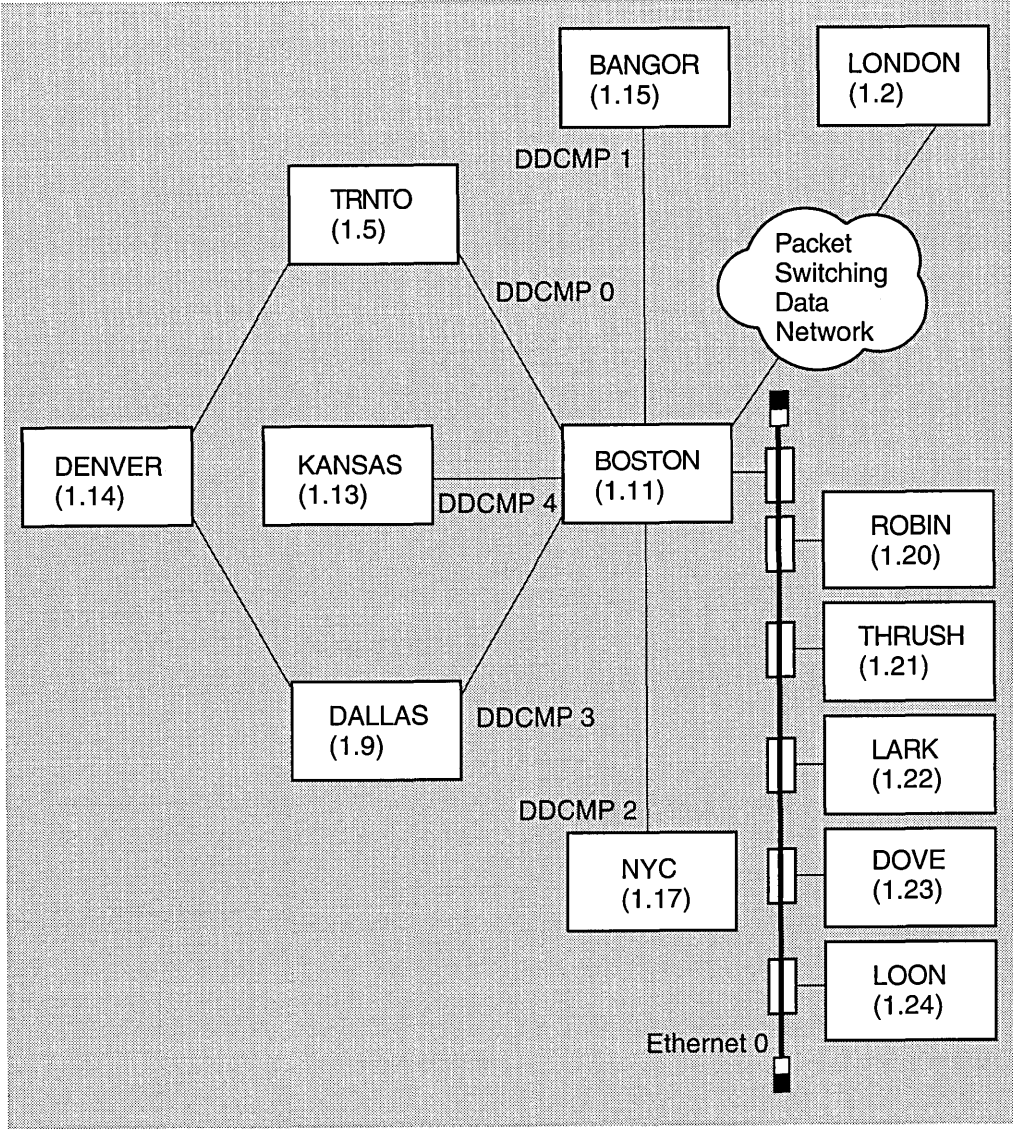

LKG-6689-92R

Overview of DECnet for OpenVMS

1.3 Managing the Network

Figure 1-6 Topology of a Multiple-Area DECnet Network

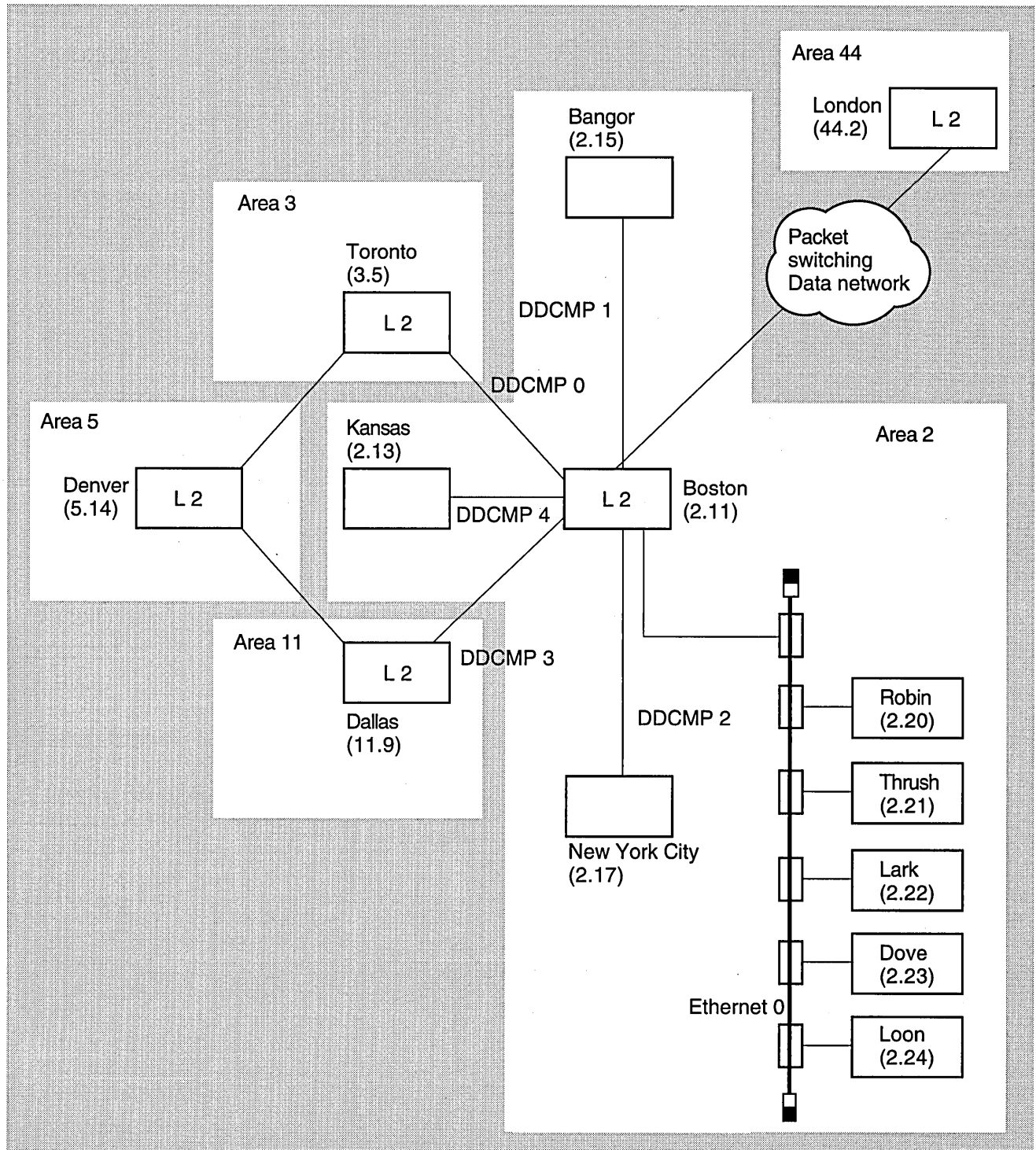

LKG-6688-92R

Figure 1-5 and Figure 1-6 show some, but not all, of the network components about which the system manager gathers and consolidates information in the configuration database.

Using NCP, you can control the following six network components:

- **Nodes.** Nodes are Digital operating systems using DECnet software to communicate with other operating systems across the network.
- **Circuits.** Circuits are virtual communications paths between nodes. Circuits operate over physical lines and are the medium on which all I/O occurs. DECnet processes “talk” over circuits by means of logical links. These links carry a single stream of full-duplex traffic between two user-level processes. There can be multiple logical links on each DECnet circuit.
- **Lines.** Lines are physical data paths between nodes.
- **Objects.** Objects are associated with processes that receive logical link requests. They perform specific network functions. An example is FAL, which is used for remote file access.
- **Logging.** Logging is a network feature that enables the automatic recording of useful network events that occur during network operation.
- **The Ethernet configurator module.** It lists all nodes on the Ethernet.

These components, the DECnet software modules and databases, and the hardware make up the network. NCP command examples in this manual relate to the components illustrated in the network example.

1.4 User Interface to the Network

This section describes the user interface to the DECnet network. It includes a general description of operations that you can perform over the network and a list of the programming languages that you can use for designing network applications. The following sections present general information that you need to know to access the DECnet network.

1.4.1 Performing Network Operations

You can use the DECnet software to perform a variety of operations over the network:

- Manipulate files on remote nodes (for example, transfer, delete, or rename files).
- Access remote files at the record level.
- Perform task-to-task communications.

DECnet for OpenVMS allows you to access files on remote nodes as though they were on your local node. It also allows you to design applications that communicate with each other over the network. For detailed information about remote file access and task-to-task communication, including examples of each type of network application, see Chapter 8.

Throughout this document, the term **task** refers to an image running in the context of a process, the term **local** refers to the node at which you are located physically, and the term **remote** refers to the node with which you establish a connection. In certain situations such as testing, you can establish a logical link between two processes on the same node.

The operating system and DECnet communications software are integrated to provide a high degree of transparency for user operations. For some applications, however, it is desirable (and sometimes necessary) to have more direct access

Overview of DECnet for OpenVMS

1.4 User Interface to the Network

to network-specific information and operations. For this purpose, DECnet for OpenVMS provides nontransparent communication.

The following sections describe some of the general transparent and nontransparent features of DECnet for OpenVMS in terms of the user interface to the network. For more detailed information, including examples of transparent and nontransparent DECnet for OpenVMS applications, see Chapter 8.

In addition to remote file access and task-to-task communication, DECnet for OpenVMS also allows you to communicate with remote nodes through the heterogeneous command terminal facility (SET HOST), described in Chapter 8.

When designing user applications to perform network operations, you can use standard DCL commands, higher-level language I/O statements, OpenVMS RMS service calls, and system service calls.

1.4.1.1 Designing User Applications for Network Operations

DECnet for OpenVMS supports network applications programming to access remote files and create tasks that exchange information across the network. You can use:

- DCL commands and command procedures
- Programs written in high-level languages with I/O statements that support RMS network access
- Programs using RMS service calls or system service calls

Table 1–1 summarizes the DECnet for OpenVMS network operations available using various programming interfaces. DCL commands, I/O statements, and RMS service calls provide transparent network access. System service calls provide transparent and nontransparent network access using QIOs.

Table 1–1 Programming Interfaces for Network Operations

Programming Interface	Network Operation
DCL commands	Network command terminals Remote file manipulation Task-to-task communication
I/O statements	Remote file access (files and records) Task-to-task communication
RMS service calls	Remote file access (files and records) Task-to-task communication
System service calls	Task-to-task communication

1.4.1.2 Choosing a Programming Interface for a Specific Network Application

The way you access the network is directly related to the programming interface you use and the network operation you perform.

For example, you may want to use standard RMS calls in a VAX MACRO program to access remote files, then use system service calls to communicate between MACRO programs in a task-to-task communication application.

Figure 1–7 shows three access types and the corresponding network operations. The various types of network access provide a convenient context in which to discuss typical user operations over the network.

Overview of DECnet for OpenVMS 1.4 User Interface to the Network

Figure 1-7 DECnet for OpenVMS Programming Interfaces and Network Access Types

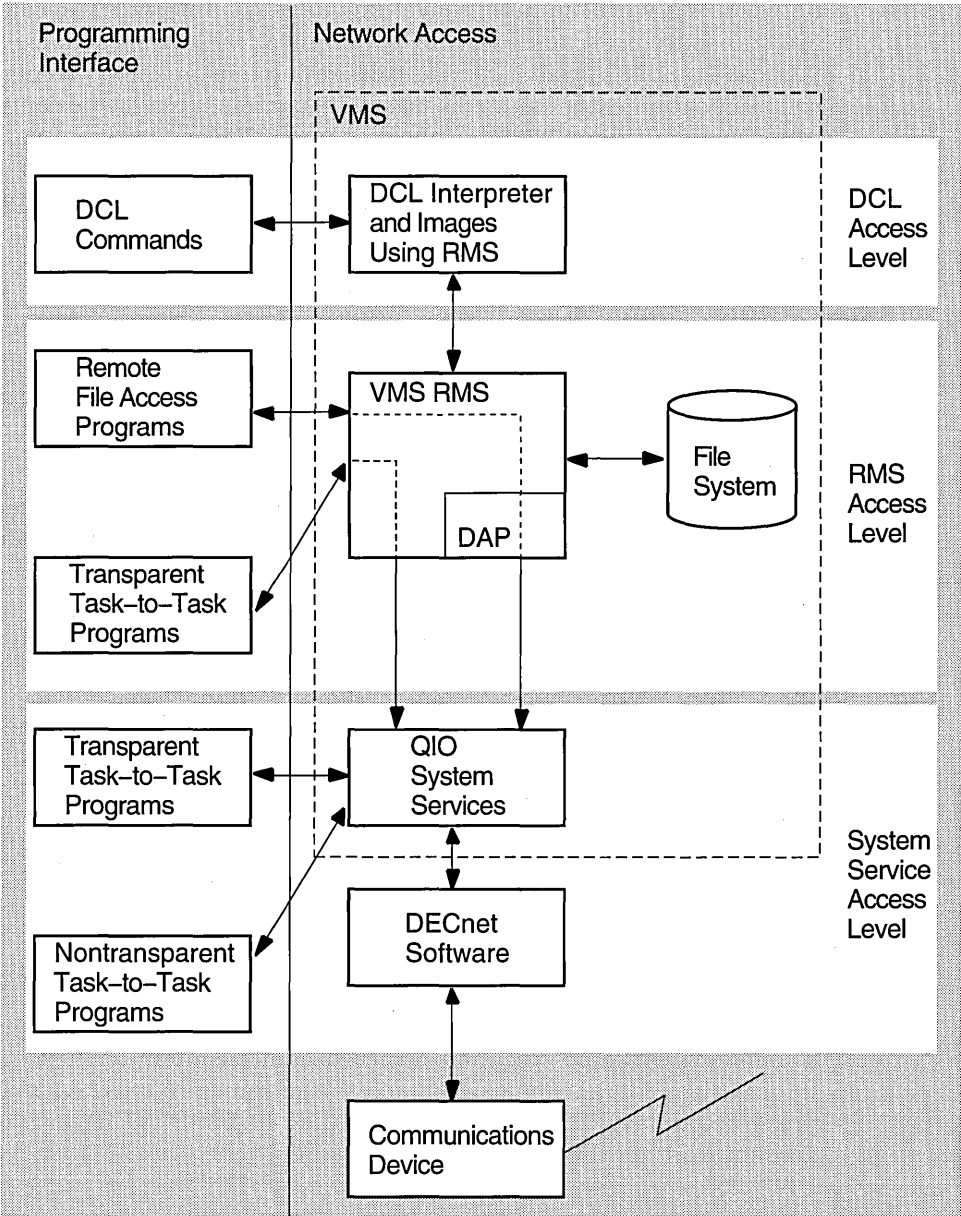

LKG-6076-92R

DCL and RMS are entirely transparent to the network user. Because you use standard DCL commands and RMS service calls to access remote files, no DECnet-specific calls are required at these levels of access. You need only specify in your file specification the remote node on which the file resides. Likewise, higher-level language tasks can use a variation of the standard OpenVMS file specification in conjunction with standard I/O statements to access remote tasks and exchange information; thus, this form of task-to-task communication is also transparent. As with device-independent I/O operations, transparent network access allows you to move data across the network with little concern for the way this operation is performed.

Overview of DECnet for OpenVMS

1.4 User Interface to the Network

System services provide both a transparent and a nontransparent user interface to the network. Transparent communication at the system-service level provides all the basic functions necessary for two tasks to exchange messages over the network. As with the higher-level language I/O interface, these operations are transparent because they do not require DECnet-specific calls. Rather, you use standard system service calls to implement them. Nontransparent communication extends this basic set of functions to allow a nontransparent task to receive multiple inbound connections and to use additional network protocol features such as optional user data and interrupt messages. As with device-dependent I/O, nontransparent communication allows you to exploit certain network-specific characteristics to coordinate a more controlled communication environment for exchanging information.

1.4.2 Accessing the Network

This section presents general information that you need to know to access the network by means of DECnet for OpenVMS software. This information covers network file and task specifications, access control parameters, and how to use logical names in network applications.

The format for file specifications is applicable to file-handling operations for both the DCL and the RMS interfaces to the network. The task specification format pertains to task-to-task communication. The information on access control is significant because it defines the way that both local and remote nodes grant access to their system resources.

1.4.2.1 Using File and Task Specifications in Network Applications

DECnet for OpenVMS uses the standard OpenVMS file specification format for remote file-handling applications. A node specification string that includes a node name must be present. You can also include an optional **access control** string in the node specification to specify explicitly the user name and password of a specific **account** to use on the remote system. For example:

```
TRNTO"SMITH JOHN"::WORK_DISK:TEST.DAT;1
```

This file specification contains explicit access control information and can be used to access the file TEST.DAT, which resides in user Smith's top-level directory on the device WORK_DISK on node TRNTO.

The following file specification, which does not contain explicit access control information, can also be used to access the remote file TEST.DAT, provided a proxy account, DECnet object account (like FAL\$SERVER), or a default DECnet account exist on the target node:

```
TRNTO::DBA1:[SMITH]TEST.DAT;1
```

For more information about file specification strings, including format examples, see the *OpenVMS User's Manual*.

Task-to-task communication requires the use of a **task specification string** enclosed in quotation marks. This string identifies the target task to which you want to connect on a remote node. For example:

```
BOSTON::"TASK=TEST2"
```

This task specification string identifies the task TEST2 by means of the TASK= form of task specification. You can also use the "0=" form to specify a task. For example:

```
BOSTON"JONES KC"::"0=TEST2"
```

Overview of DECnet for OpenVMS

1.4 User Interface to the Network

This task specification string also identifies the task TEST2. In this case, explicit access control information is also included in the node specification string. For more information about task specifications, see Chapter 8.

1.4.2.2 Using Access Control for Network Applications

Access control is the control that a node exercises over inbound logical link connections. The terms **inbound** and **outbound** refer to the direction of the logical link connection request. A node receives and processes inbound requests; it processes and sends outbound requests. This distinction is useful for discussing access control as it relates to OpenVMS nodes in a network. If the node to which you want to connect is not running the OpenVMS operating system, refer to appropriate documentation for that system.

When DECnet software sends an outbound connection request in response to either a remote file access or a task-to-task communication operation, you may need certain access control information to connect successfully to the remote node and to log in. As in logging in at your local node, you can supply specific access control information in the form of a user name and password that the remote node recognizes. The remote node processes inbound connection requests containing this information to verify that you are a valid user of the system. For more information about inbound and outbound connection requests, see Section 2.8.2.

Figure 1-8 illustrates the access control processing that takes place for a DCL command.

Overview of DECnet for OpenVMS

1.4 User Interface to the Network

Figure 1-8 Remote File Access Using Access Control String Information

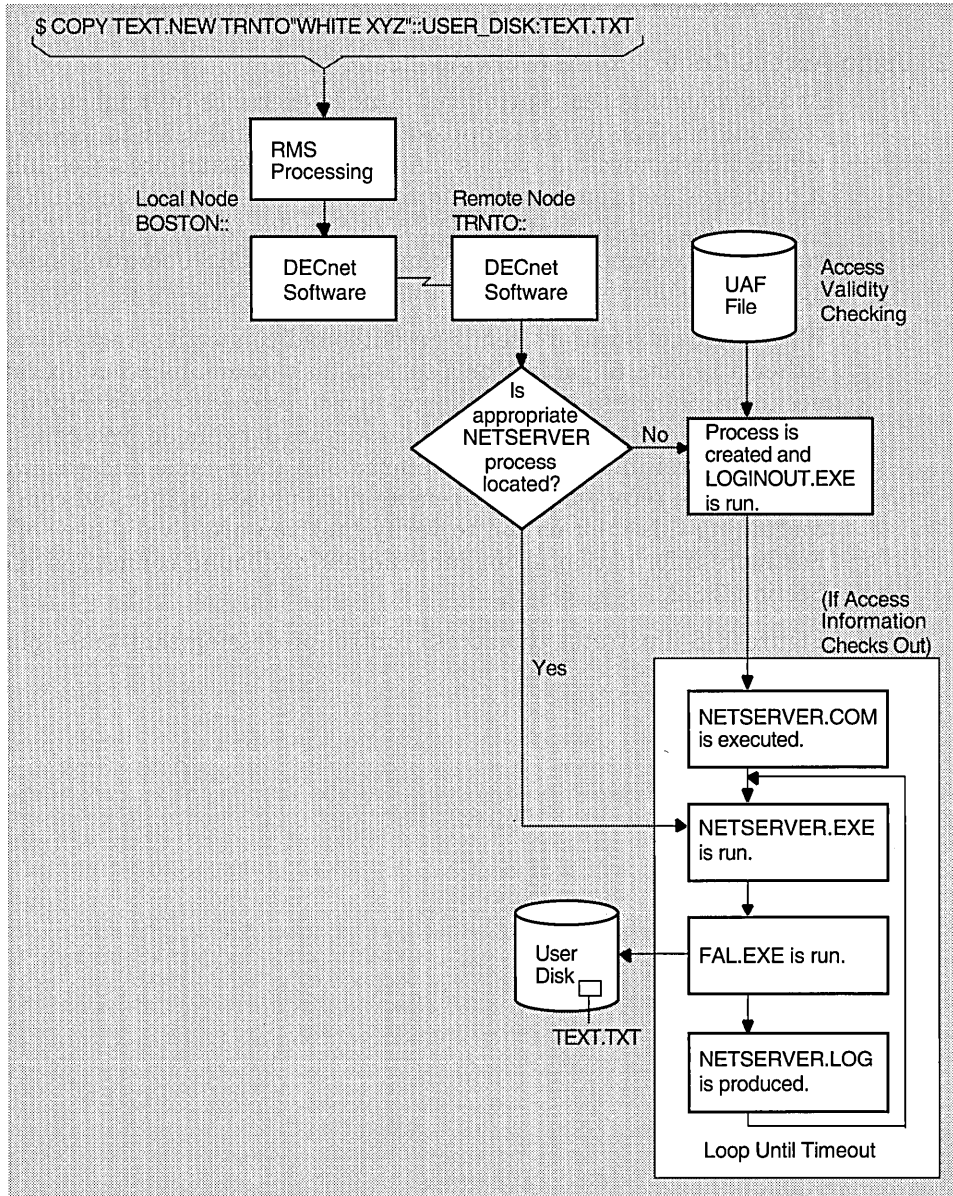

LKG-6715-92R

When you do not provide explicit access control information in the connection request, DECnet software uses the remote node name specified in the connection request as a key to locate the appropriate record in the local configuration database. This record contains default access control information applicable to the remote node. Your system manager creates this entry when establishing the configuration database. (For additional information about the configuration database, refer to Chapter 3.)

Depending on the privileges required by the object to which you want to connect and those of the user process (see Figure 1-9), one of three possible sets of default access control information is sent to the remote node: default **privileged**, default **nonprivileged**, or null.

Overview of DECnet for OpenVMS

1.4 User Interface to the Network

Because these defaults are node parameters, all privileged operations requested with default access control for a given node run under the same default account. The same is true for nonprivileged operations requested with default access control.

If the target node is running DECnet for OpenVMS, it can associate incoming connect requests with specific accounts other than a default nonprivileged DECnet account. See Section 2.6 and Section 5.2.2 for details.

Figure 1-9 illustrates the access control processing that takes place for the same DCL command as in the example in Figure 1-8, except that the DCL command does not specify an access control string.

Overview of DECnet for OpenVMS

1.4 User Interface to the Network

Figure 1-9 Remote File Access Using Default Access Control Information

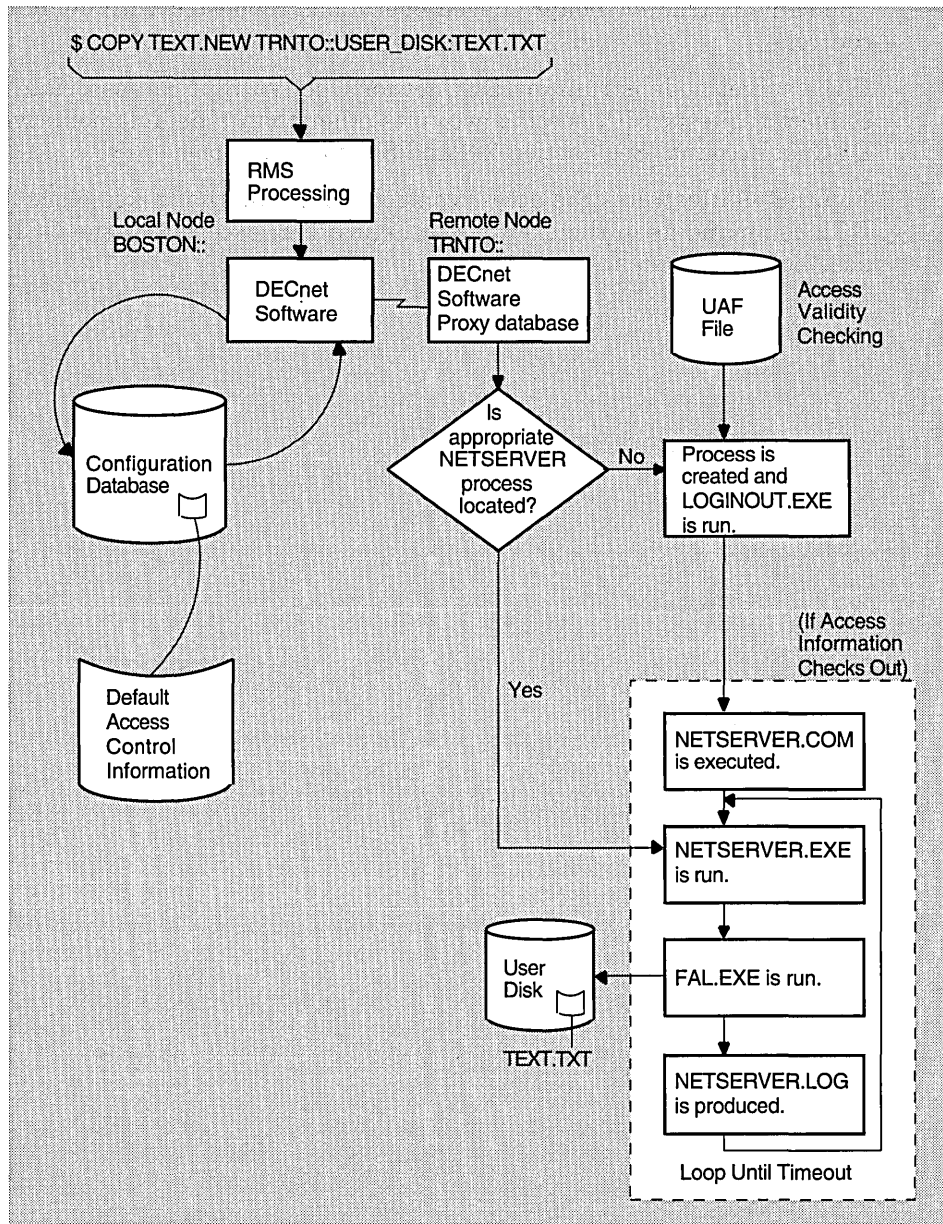

LKG-6714-92R

1.4.2.3 Using Logical Names in Network Applications

Using logical names for network operations allows you to refer to network file and task specifications without using actual names that you give these elements. Logical names serve as a kind of shorthand for specifying all or a portion of a full file specification. By using logical names, you can pass file specifications defined at the DCL level to an executing image at run time. For example, logical names allow a program to access local or remote files without changing the program. You can also use logical names to conceal access control information from other users by embedding it in a logical name defined in the process logical name table. Logical names provide convenient and powerful multilevel access control specification.

Overview of DECnet for OpenVMS

1.4 User Interface to the Network

The rules that govern the use of logical names for network operations are as follows:

- Both the device name and node name in a full file specification string can be logical names. After a node specification is encountered during file parsing, however, a device name that follows is not translated locally. Instead, it is passed unaltered to the remote node, where it is subject to logical name translation.
- A logical name appearing in the device name position in a file specification can supply any file specification string elements when translated.
- A logical name appearing in the node name position can supply only a node specification when translated. Therefore, its equivalence string must end with a double colon.
- An access control string associated with a logical node name becomes the new access control string for the node-specification of the equivalence string, even if the node specification contained an access control string. Thus, you can easily specify a default (or override any) access control string defined for the node specification resulting from logical name translation.
- After a logical node name is translated, the new node name becomes a candidate for logical node name translation.
- A maximum of ten logical device name translations and ten logical node name translations is permitted. If you exceed these limits, an error message is returned.
- While logical name translation is not done on the local node, merging the default name string (and related names) is accomplished locally.

For more information about logical names, including examples of logical names that can be used for network applications, see the *OpenVMS User's Manual*.

DECnet for OpenVMS Components and Concepts

This chapter presents networking concepts relevant to understanding the operation of the DECnet network, in terms of the DECnet for OpenVMS components.

To establish your system as part of the DECnet network, build and maintain a network configuration database, consisting of records that describe the specific network components your particular system requires. This chapter describes the DECnet for OpenVMS components and their characteristics: nodes, circuits, lines, routing, logical links, objects, logging, and network access control.

Chapter 3 discusses how you can use a DECnet for OpenVMS utility program, the Network Control Program (NCP), to enter in your configuration database specific parameters for each network component your system will use.

2.1 Nodes

A node is an operating system that uses DECnet software to communicate with other operating systems across a network. An OpenVMS node uses DECnet for OpenVMS software to communicate with other DECnet nodes.

This section describes the characteristics of nodes and the kinds of parameters you can associate with them. Chapter 3 discusses how to use NCP commands to establish node parameters.

The system at which you are physically located is called the local node. By issuing network management commands at your local node, you can perform configuration, control, and monitoring functions that affect both the local node and other nodes in the network. The node on which network management functions are actually performed is called the executor node. Usually, the executor node is the local node. You have the option, however, of entering at the local node one or more commands to be executed at a remote node. For those commands, the remote node serves as the executor node.

2.1.1 DECnet Node Address and Name

To configure an operational network at the local node, establish configuration database entries for the local node and for all adjacent nodes that are connected by circuits. Specify names and addresses for all nodes in the network. After you have done so, you can reach any other node by its name.

To satisfy routing requirements, each node in the network must have a unique address. The **node address** is a number in the format:

area-number.node-number

DECnet for OpenVMS Components and Concepts

2.1 Nodes

where:

area-number Is the number of the area in which the node resides.

node-number Is the address of the node within that area.

Each area number must be unique within the network and each node number unique within the area. If you do not specify the area number in a node address, the area number of a remote node defaults to the area number of the executor node, and the area number of the executor defaults to the number 1.

Node identification has two forms: a node address and a **node name**. A node address, a number in the format described previously, is assigned to each node in the configuration database. A node name is an optional alphanumeric string.

In the single-area network example, Figure 1-5, the node assigned node address 1.11 is also identified by the node name BOSTON. For networks not divided into areas, the default area number is 1. In the multiple-area network example, Figure 1-6, node BOSTON in area 2 has the node address 2.11.

Because it is often easier to remember a name rather than an address, you may prefer to associate a name with an address. You can do so at any time. Note, however, that node names are known only to the local node network software while node addresses are known network-wide by the routing function. To avoid potential confusion, give each node a unique name that all nodes in the network will assign to that node and use to address it.

2.1.2 Hardware Addresses and Physical Addresses

Manufacturers permanently code every Ethernet and FDDI communications device with a unique **hardware address** from a pre-assigned block of addresses.

When you power up a node, the device controller's **physical address** is initially set to the same value as its hardware address.

The node's DECnet software resets the physical address to a new six-byte value based on the DECnet node address. This allows greater flexibility; the hardware address changes any time you install a new device controller while the DECnet node address remains the same. The physical address is used for service functions such as circuit loopback tests and configurator operations.

The physical address is also used during the remote boot process. When a node emits a Maintenance Operation Protocol (MOP) request program message, it includes the physical address, which the host node uses to identify the node when responding. Because DECnet has not yet started, the physical address value and hardware address value are identical at this point.

Network devices without assigned DECnet addresses retain the hardware address in the physical address field.

If an existing network is not divided into areas, the default area number for all nodes is 1. When you divide such a network into areas, you assign some nodes a new area number. Because the area number is part of the physical address constructed when DECnet starts, any node with a new area number must be restarted to construct the new physical address.

You can construct the physical address using the following process:

1. To obtain the decimal equivalent of the DECnet node address, convert the node address in the format *area-number.node-number*, using the following algorithm:

(area-number * 1024) + node-number

2. To form the two low order bytes of the physical address, convert the decimal node address to its hexadecimal equivalent and reverses the order of the bytes.
3. To form the full physical address, append the results of step 2 to the constant AA-00-04-00. This constant is reserved by Digital.

AA-00-04-00-hexnodeaddress

For example, to determine the physical address of a node whose node address is 63.171, calculate the following:

$$(63 * 1024) + 171 = 64683 \text{ decimal} = \text{FCAB hexadecimal}$$

After reversing the order of the bytes and appending them to the constant, you have the following physical address:

AA-00-04-00-AB-FC

2.1.3 LAN Multicast Addresses

Ethernet or FDDI address types include the single-node physical address (as described in Section 2.1.2) and the **multicast address** which addresses one or more nodes on a given broadcast medium.

Physical and multicast addresses are distinguished by the least significant bit of the first byte.

	Physical Address	Multicast address
Least significant bit	0	1
Sample address	AA-00-04-00-FC-00	AB-22-22-22-22-22
First byte in hexadecimal	AA	AB
First byte in binary	1010 1010	1010 1011
Low-order bit	0	1

Multicast addresses include two subtypes:

- **Multicast group address.** An address assigned to any number of nodes; you can use this address to send a message to all nodes in the group in a single transmission. The number of different groups that you can form equals the maximum number of multicast group addresses that you can assign.
- **Broadcast address.** A single multicast address that you can use to transmit a message to all nodes on a given broadcast medium. (Use the broadcast address only for messages to be acted upon by all nodes on the Ethernet bus or FDDI ring, because all nodes must process them.)

Assigned multicast addresses include:

DECnet for OpenVMS Components and Concepts

2.1 Nodes

Value	Meaning
FF-FF-FF-FF-FF-FF	Broadcast
CF-00-00-00-00-00	Loopback assistance
AB-00-00-01-00-00	Dump/load assistance
AB-00-00-02-00-00	Remote console
AB-00-00-03-00-00	All Phase IV routers
AB-00-00-04-00-00	All Phase IV end nodes
AB-00-00-05-00-00	Reserved for future use
through	
AB-00-03-FF-FF-FF	
AB-00-04-00-00-00	For use by Digital customers for their own
through	applications
AB-00-04-FF-FF-FF	

DECnet always sets up the controller at each node to receive messages sent to any address in the preceding list of Digital multicast addresses. For information about how to send messages to Ethernet multicast addresses, refer to the *OpenVMS I/O User's Reference Manual*.

2.1.4 Node Characteristics

The configuration database for the local node must contain certain information about the local node and may contain node information for all nodes with which you want to communicate. For the local node, specify the node address, the node name and the buffer size (which determines the largest size message the node can forward). Indicate, or use the default value, for the highest address the local node will recognize.

The node type determines the routing capabilities of the local node. Some hardware platforms do not support routing type nodes; check the DECnet for OpenVMS Software Product Description (SPD) for details. See Section 2.4.2.1 for more information about node types.

You can optionally specify data link routing capabilities of the local node. For remote nodes, specify node names and addresses. You can also specify default information to be used in performing downline load or upline dump operations involving remote nodes. For any or all nodes, you can specify access control information and node counter event logging information.

The data link control information you can specify for the local node controls certain characteristics of physical line operation; including the size and number of transmit and receive buffers and the number of circuits the local node can use. Set these values to levels that ensure reasonable system operation. Set the buffers for all nodes in the network to the same size. Otherwise, packets will be dropped when routed through nodes with smaller buffer sizes. A procedure for changing the size of buffers on all nodes in the network without bringing down the whole network is given in Section 3.3.4.1.

You can control the operational **state** of the local node and thereby control its active participation in the network. This control is usually a function of whether inbound logical link connections can be established or maintained with the local node. You can use this control to restrict the operation of the node or to shut it down altogether.

2.1.4.1 Obtaining Remote Node Characteristics

To update your configuration database with current information about remote nodes in your network, you can copy the names and addresses of remote nodes from the database of another node to which you have access. Specify the node database (volatile or permanent) to be copied, and the local node database (volatile, permanent, or both) to which information is to be copied.

If you clear or purge your local node database before copying the remote node data, you can avoid possible conflicts between original and updated data. The executor node information is preserved during the clear or purge operation.

Copying a permanent node database permits you to keep your network information current even if you are part of a large network that changes frequently. Alternatively, if you configure your node without a permanent node database, you can obtain current information on other nodes in the network by copying it from another node (for example, from a node on your Ethernet that serves as a master by keeping its node database up to date).

2.1.5 Identifying a VMScluster as a Single Node

You can represent a whole VMScluster or some of the nodes in a cluster by a special identifier called the alias node identifier, which appears to other nodes in the network to identify an actual node. This mechanism allows users on DECnet nodes outside the cluster to access cluster resources without knowing what the cluster nodes are or which are active.

Any node in the cluster can elect to assume the alias node identifier while retaining its own unique node name and address. Use of the alias never precludes use of the individual node name and address. Thus, a remote node can address the cluster as a single node, and address any cluster member individually.

You can designate that your cluster node is assuming the alias node identifier by specifying in your configuration database either the alias node address or the alias node name (if you have previously associated that name with the alias address of the cluster).

2.1.5.1 Limiting the Use of an Alias

You can limit use of the alias for incoming and selected outgoing connections.

You can indicate whether your node will accept incoming connection requests directed to the alias node address. By default, a node that assumes the alias is available to receive incoming connections addressed to the alias, but a small node that uses the alias for outgoing traffic may elect not to handle the extra incoming traffic.

You can select which DECnet objects (software components that provide network services) are to use the alias by specifying in the object database that the alias address is to be used for outgoing connections originated by those objects. In addition, you can specify which objects will receive incoming connect requests directed to the alias node address.

MAIL is an example of a network object that can effectively treat the cluster as a single node. Ordinarily, replies to mail messages are directed to the node that originated the message; the reply is not delivered if that node is not available. If the node is in a cluster and uses the cluster alias, an outgoing mail message is identified by the alias node address rather than the individual address of the originating node. An incoming reply directed to the alias address is given to any active node in the cluster and is delivered to the originator's mail file.

DECnet for OpenVMS Components and Concepts

2.1 Nodes

Objects that involve multiple incoming links (such as PHONE) should not use the alias node address because each incoming link may be routed to a different node that uses the same alias. Also, do not allow objects whose resources are not accessible clusterwide to receive incoming connect requests directed to the alias node address. Section 2.6 describes network objects and discusses the type of object for which the alias node identifier is suitable.

The alias node identifier permits you to set a proxy to a remote node for the whole cluster rather than for each node in the cluster. The clusterwide proxy can be useful if the alias node address is used for outgoing connections originated by the object FAL, which accesses the file system.

Use the alias node identifier only for shareable resources accessible by all nodes in a cluster. Nodes that use the alias node identifier should use a common user authorization file (UAF).

2.1.5.2 Managing the Alias Node Identifier

At least one of the VMScluster nodes that uses the alias node identifier must be a router. It can be a level 1 router, because all cluster nodes sharing the same alias node address must be in the same area.

The cluster router informs other nodes in the network of the existence of the alias node address. Other routers in the network perceive the cluster router as the shortest path to the cluster node address and send the router packets addressed to the cluster node address. If the cluster router receives a packet addressed to the alias node address, it forwards the packet to the appropriate cluster node. If the packet is for an existing logical link, the link identifier in the packet is sufficient to select the node. If the packet is initiating a new logical link, the router selects a participating node in circular fashion.

The network manager or cluster manager should select a suitable alias node name and address for the cluster nodes. You can specify either the alias node name or address as an executor parameter in your node database. If you specify the alias node name, first associate the name with the agreed-upon alias node address. You can then assign the same parameters to this node as to other nodes, except that routing initialization passwords are not required. No point-to-point initialization can occur because a node cannot set up a circuit to an alias node address. The alias node address and name appear in the node databases of other nodes in the network.

You can optionally set a maximum value on the number of logical links that your node can initiate using the alias node identifier (see Section 2.5).

2.2 Circuits

Circuits are high-level communications data paths between nodes; communication between nodes takes place over circuits. Circuits operate over physical lines, which are low-level communications paths (see Section 3.6).

2.2.1 Classes of DECnet for OpenVMS Circuits

DECnet for OpenVMS employs four classes of circuit: DDCMP, CI, Ethernet, and FDDI.

VAX

DDCMP circuits provide the logical point-to-point or multipoint connection between two or more nodes. There are currently three types of DDCMP circuit: point-to-point, multipoint control, and multipoint tributary. A point-to-point circuit operates over a corresponding synchronous or asynchronous DDCMP point-to-point line. Asynchronous lines can be either static (permanent) or dynamic (switched).

Multipoint control circuits operate over synchronous DDCMP control lines. You can specify multiple circuits from the control (master) end of a control line, but each circuit must have a unique physical tributary address. On the tributary (slave) end, you can specify only one multipoint tributary circuit per line.

The setup of CI circuits is similar in many ways to the setup of DDCMP multipoint circuits. CI circuits, however, use their own protocol. ♦

Ethernet and FDDI LAN circuits provide for multiaccess connection between a number of nodes on the same broadcast medium. LAN circuits differ from other DECnet circuits in that there is not a single node at the other end. A LAN circuit is a path to many nodes. Each node on a single LAN circuit is considered adjacent to every other node on the circuit and equally accessible. Every node must have a unique node identification within the node's area: a physical address. (Node addressing is described in Section 2.1.2.) Ethernet circuits use the Ethernet protocol. FDDI circuits use the FDDI protocol.

Just as you specify the local node, you also specify parameters for all DECnet circuits connected to the local node.

Identify each circuit by name and specify information that directly affects the circuit's operation. You can also specify the operational state of circuits connected to your local node. Thus you can control circuit traffic and perform service functions. The state of a circuit may ultimately affect the system's ability to reach an adjacent node. The circuit state can have a similar effect on routing.

The following sections describe the circuit component. For a discussion of using NCP commands to specify circuits, see Chapter 3.

2.2.2 DDCMP Circuit Devices

VAX

On systems that support them, DDCMP circuit devices can be synchronous or asynchronous. Table 2-1 shows the devices for DDCMP circuits. These devices conform to the DDCMP Point protocol.

DECnet for OpenVMS Components and Concepts

2.2 Circuits

Table 2-1 DDCMP Circuit Devices

Mnemonic	Driver	Description
DIV	SD	DIV32 ISDN controller
DMB	SI	DMB32 synchronous line unit
DMC	XM	DMC11, DMR11 synchronous links
DMF	XG	DMF32 synchronous line unit
DMP	XD	DMP11, DMV11 synchronous point-to-point multipoint line device
DSB	SL	DSB32 synchronous line unit
DSF	SF	VAXft 3000 synchronous communications controller
DST	ZS	DST32, DSH32 synchronous circuit device
DSV	SJ	DSV11 synchronous line interface
DSW	ZT	DSW-21, DSW-41, DSW-42 synchronous communication device
TT	NO	DZ11, DZ32, DZQ11, DZV11 asynchronous circuit device
TX	NO	DMB32, DHB32, DHU11, DHV11, DHT32, DMF32 or DMZ32, DHQ11, DSH32, CXY08 asynchronous device

The asynchronous circuit devices are point-to-point circuit devices used for static or dynamic asynchronous connections.

Asynchronous DDCMP circuits need not be predefined for dynamic connections. They are established automatically during dynamic switching of terminal lines (see Section 2.3.2.3).

Other DECnet implementations may support other DDCMP circuit devices. If a node in your network uses a circuit device other than one of these, refer to the appropriate DECnet documentation for that system. This section provides a general discussion of point-to-point and multipoint circuits.

Every DDCMP circuit provides a logical point-to-point connection between two nodes. The circuit operates over the corresponding DDCMP line (for example, the DMC11 circuit operates over the DMC11 line). The DMP11, operating as a multipoint control circuit, also provides a logical, multipoint connection (over one physical line) between a control station and several tributaries (as illustrated in Figure 2-1). The DMP11 and DMV11 can also operate as multipoint tributary circuit devices that provide a logical connection between a tributary and a control station.

The following terms are used to describe the operation of multipoint circuits:

- **Control Station**—the node at the controlling end of a multipoint circuit. It controls the tributaries for that circuit.
- **Polling**—the activity that the control station performs on tributaries of a multipoint circuit. The control station regularly sends request messages to (that is, polls) each eligible tributary in the polling list. The request message asks the tributary if it has anything to send (essentially giving it permission to use the bus).
- **Tributary**—a physical termination point on a multipoint circuit that is not a control station.
- **Tributary Address**—a numeric address that identifies a tributary node on a multipoint circuit.

DECnet for OpenVMS Components and Concepts 2.2 Circuits

You can connect both a multipoint control circuit and a multipoint tributary circuit to the same node. The node could then serve as the control station for one multipoint circuit and as a tributary for another multipoint circuit.

The system manager must supply tributary addresses for a control station to use when polling each tributary in a polling list. ♦

Figure 2-1 Multipoint Circuits and Associated Lines

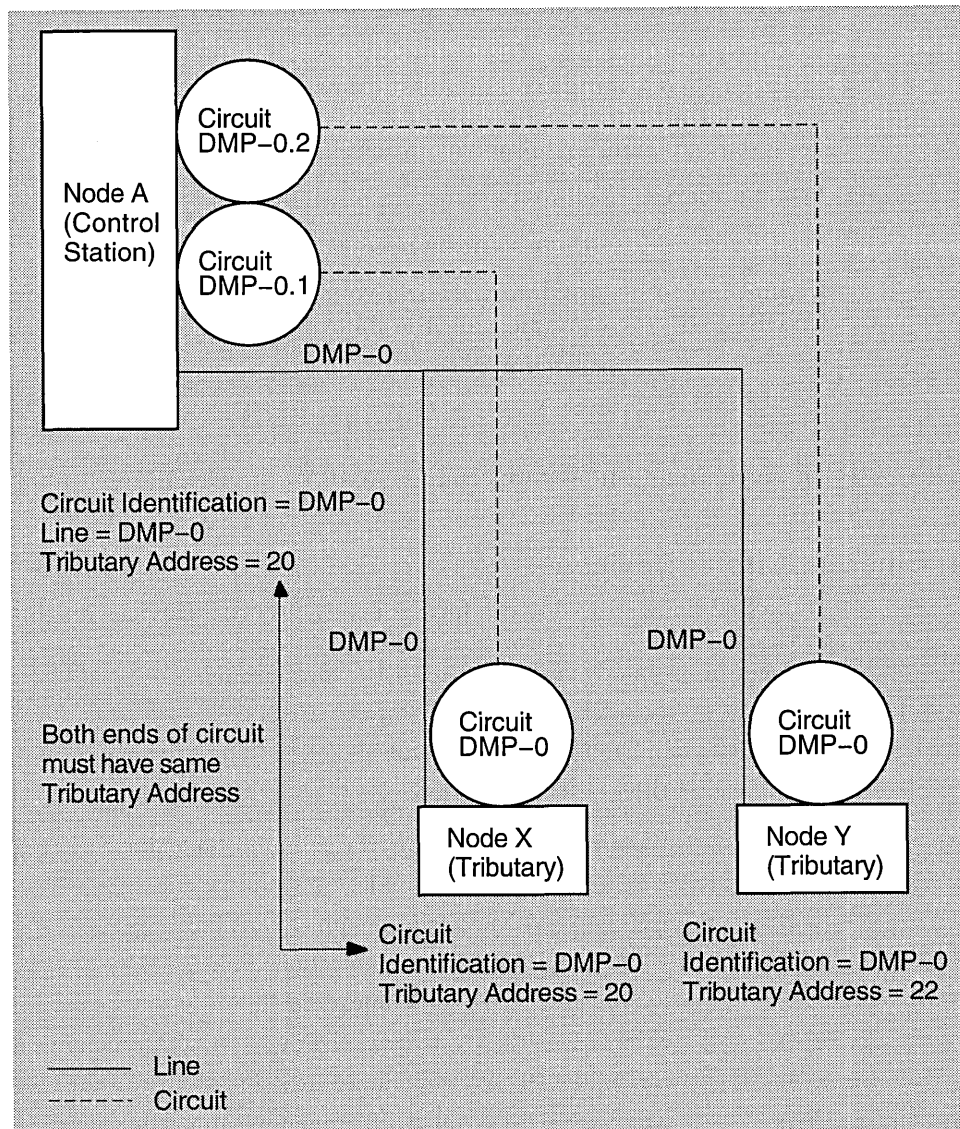

LKG-6079-92R

DECnet for OpenVMS Components and Concepts

2.2 Circuits

2.2.3 CI Circuit Devices

VAX

On systems that support the CI, DECnet can use the CI as a datalink in some configurations. All nodes connected to the same CI bus can communicate directly with each other. Only one CI controller per node is required. DECnet treats the CI controller as a multipoint data link and requires a single entry in the line database and multiple entries in the circuit database. The line database entry describes the CI controller (see Section 3.6). Each circuit database entry describes a virtual connection to a single remote node on the CI. CI multipoint circuits and DDCMP multipoint circuits differ in the following ways:

- Each station on the CI can talk directly to every other station. These stations are called tributaries and all stations are alike. There are no “control” and “tributary” stations as with DDCMP multipoint circuits. Only the setup of CI circuits is similar to multipoint circuits.
- There are no polling parameters on the CI.
- CI circuits use their own communication protocol.

If you plan to use a CI circuit, first connect the device CNA0 to the driver CNDRIVER. For example, add the following lines to the SYCONFIG.COM procedure in SYS\$MANAGER:

```
$ RUN SYS$SYSTEM:SYSGEN  
CONNECT CNA0/NOADAPTER
```

These command lines connect the CNA0 to the CNDRIVER and load the CNDRIVER.♦

2.2.4 Ethernet Circuit Devices

Table 2-2 shows the devices for Ethernet circuits. Devices on this table conform to the Ethernet/802.3 protocol. Ethernet provides multiaccess connections between many nodes on the same Ethernet circuit.

Table 2-2 Ethernet Circuit Devices

Mnemonic	Driver	Description
BNA	ET	DEBNA, DEBNI communications link
ISA	EZ	SGEC communications link
KFE	EF	VAXft 3000 communications link
MNA	EX	DEMNA communications link
MXE	EC	PMAD communications link
QNA	XQ	DEQNA, DELQA, DESQA, DEQTA communications link
SVA	ES	DESVa communications link
UNA	XE	DEUNA, DELUA communications link

Ethernet messages are sent over the Ethernet as datagrams, which means that messages can be lost because of transmission errors. DECnet provides for automatic retransmission of lost messages. The Ethernet controller and device driver can handle multiple protocol types simultaneously. Therefore, while DECnet is running, other applications can use another protocol type on the Ethernet device.

2.2.5 Ethernet Configurator Module

All nodes on an Ethernet circuit are logically adjacent. To obtain a list of all systems on an Ethernet circuit, you can use the Ethernet configurator module. The configurator module listens to system identification messages transmitted periodically by every Digital-supported node on the Ethernet circuit, and builds the configuration list from the received messages.

Approximately once every 10 minutes, each node on an Ethernet circuit that conforms to the DNA specifications transmits a system identification message (a hello message) to a multicast address that the configurator monitors. For a random distribution of nodes with possible loss of system identification datagrams, the configurator would require 40 minutes to collect all node addresses. In practice, the configurator normally requires about 12 minutes to complete a list.

The Ethernet configurator module requires a default nonprivileged DECnet account or an account associated with the \$NICONFIG object. You use NCP commands to access and control the configurator module. The configurator runs as a separate process and, once it is started, becomes available to all users on the system. The configurator module continues to execute and maintains and updates its database of information on active nodes.

When you request information about the current configuration of nodes on Ethernet circuits, the following is displayed for each system: its Ethernet physical and hardware addresses, the device connecting it to the circuit, maintenance functions it can perform, and the time of the last system identification message from the system.

2.2.6 FDDI Circuit Devices

Table 2-3 shows the devices for FDDI circuits. Devices on this table conform to the FDDI protocol.

Table 2-3 FDDI Circuit and Line Devices

Mnemonic	Driver	Description
FZA	FC	DEFZA FDDI communications link
MFA	FX	DEMFA FDDI communications link

2.3 Lines

Lines provide physical communications and are the lowest level communications path. Circuits are high-level communications paths that operate over lines.

2.3.1 Classes of DECnet for OpenVMS Lines

DECnet for OpenVMS supports four classes of line: DDCMP, CI, Ethernet, and FDDI. Some hardware platforms do not support all four classes; refer to the DECnet for OpenVMS Software Product Description (SPD) for the latest configuration-support information.

Each class of line provides a specific kind of connection. An Ethernet or FDDI line is a multiaccess connection between two or more nodes.

DECnet for OpenVMS Components and Concepts

2.3 Lines

VAX

A DDCMP line provides the physical point-to-point or multipoint connection between two or more nodes. A CI line provides a high-speed connection between two or more nodes. ♦

For DDCMP, CI, Ethernet, and FDDI configurations, each circuit is directly related to a corresponding line.

Just as you establish node and circuit parameters, you also establish parameters for all physical lines connected to the local node. Identify each line by name and specify information that directly affects the line's operation. You can control the operational state of the line, and thus control line traffic and perform service functions. The state of a line may ultimately affect the reachability of an adjacent node.

The following sections describe the line component. For a discussion of using NCP commands to specify line parameters, see Chapter 3.

2.3.2 DDCMP Lines

VAX

On systems that support them, DDCMP lines can be synchronous point-to-point or multipoint lines or asynchronous point-to-point lines. Asynchronous lines can be static (permanent) or dynamic (temporarily switched). (For a complete table of DDCMP devices and their corresponding mnemonic names, refer to Section 2.2.2.) ♦

2.3.2.1 DDCMP Line Devices

VAX

The DMC11 and the DMR11 are point-to-point line devices and are considered identical. The DMP11 can be either a point-to-point, multipoint control, or multipoint tributary line device. The DMV11 is similar to the DMP11; DECnet refers to either device as the DMP11. The DMB32 and DSB32 synchronous line units are point-to-point devices.

The asynchronous line devices are point-to-point line devices used for static or dynamic asynchronous connections.

Asynchronous DDCMP lines need not be predefined for dynamic connections. They are established automatically when a dynamic asynchronous DDCMP connection is made (see Section 2.3.2.3).

Every DDCMP line provides a point-to-point connection between two nodes. Circuits, the actual communications path, operate over the line. The DMP11 and DMV11 also provide a multipoint connection between two or more nodes. In Figure 2-2 a multipoint line controlled by the DMP11 provides the physical connection between a control node and several tributary nodes.

Figure 2-2 Multipoint Lines

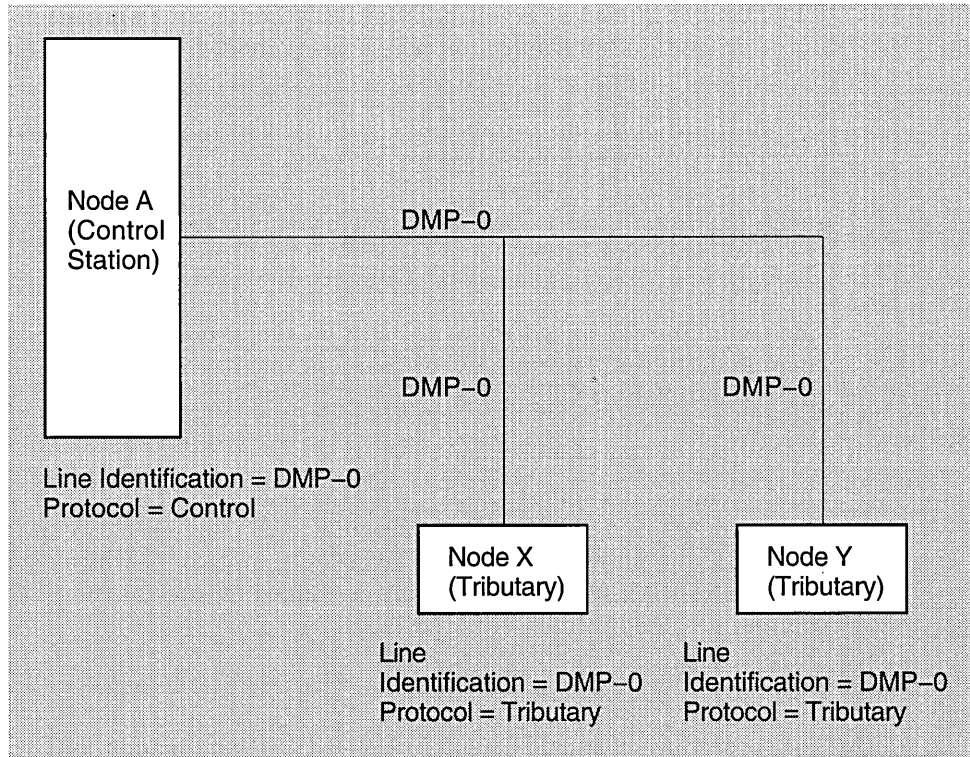

LKG-6080-92R

You can connect two multipoint lines to the same node. The node could then serve as the control station for one multipoint line and as a tributary for another multipoint line.

Because a heterogeneous network may have DDCMP line devices other than one of the preceding, become familiar with the entire range of devices and their impact on network management. If a node in your network uses a line device other than these, refer to the appropriate DECnet documentation. ♦

2.3.2.2 Static Asynchronous Lines

VAX

A static asynchronous DDCMP connection is a permanent connection established between two nodes (such as a router node and an end node). The two nodes are connected by either a modem or by a physical line attached to a terminal port at each end (for example, port TTA0 on the end node and port TXB7 on the router). A static asynchronous connection can also be made over a dialup line.

Before the DECnet connection is made, the terminal lines must be converted to static asynchronous DDCMP lines. Each terminal port must have an asynchronous DDCMP line device installed, and the system manager at each node must load the asynchronous DDCMP driver, NODRIVER.

The commands required to install static asynchronous lines and the NCP commands to configure a network using static asynchronous lines are given in Section 5.2.3.3. ♦

DECnet for OpenVMS Components and Concepts

2.3 Lines

2.3.2.3 Dynamic Asynchronous Lines

VAX

A dynamic asynchronous line differs from a static asynchronous line or other DECnet line in that it is normally switched on for network use only for the duration of a dialup connection between two nodes. When the telephone is hung up, the line reverts to being a terminal line.

Dynamic switching of terminal lines to asynchronous DDCMP lines can occur provided both nodes have DECnet installed. Assuming that both the remote node and the local node are OpenVMS operating systems, the system manager at each node must have loaded the asynchronous driver, NODRIVER, and installed the privileged shareable image DYNSWITCH. (If the local node is a personal computer, there is no need to load NODRIVER and install DYNSWITCH.)

The commands required to install static asynchronous lines and the NCP commands to configure a network using static asynchronous lines are given in Section 5.2.3.4. ♦

2.3.3 CI Line Device

VAX

On systems that support the CI, you can install CI-780, CI-750, CIBCA, and CIBCI high-speed devices. Each provides a connection between two or more nodes. If you plan to run DECnet over a CI, first connect the device CNA0 to the driver CNDRIVER. To do this, add the following lines to the SYCONFIG.COM command procedure in SYS\$MANAGER:

```
$ RUN SYS$SYSTEM:SYSGEN
CONNECT CNA0/NOADAPTER
```

This procedure connects CNA0 to CNDRIVER and loads the CNDRIVER. ♦

2.3.4 Ethernet and FDDI Line Devices

You connect a node to the local area network by an Ethernet or FDDI communications controller. The circuit operates over the line.

A particular LAN node is identified by the hardware address of its line device; this hardware address is stored in read-only memory in the controller. When DECnet starts an Ethernet or FDDI line, it constructs a physical address for the node (see Section 2.1.2). Shutting off machine power causes the controller to reset the physical address to the original hardware address.

Note

If more than one application will use a particular Ethernet or FDDI line (for example, DECnet and LAT), DECnet must be brought up first because it resets the physical address.

(For a complete table of Ethernet devices and their corresponding mnemonic names, refer to Section 2.2.4. For a complete table of FDDI devices and their corresponding mnemonic names, refer to Section 2.2.6.)

2.4 Routing

DECnet for OpenVMS supports both routing and non-routing (end) nodes.

Routing is the network function that determines the paths or routes along which packets (data) travel to reach their destinations. The Routing layer of DECnet handles routing functions. Because the need for routing pervades network operation, as much as possible is done in software to relieve you from worrying about the configuration of the network.

As system manager, however, you need to be concerned with the configuration of the network in terms of routing. You must configure each network node as either a routing or a nonrouting node, and you have the option of dividing the whole network into different areas. In addition, certain parameters in the configuration database permit a degree of indirect control over network routing, but, for most networks, the default values of these parameters are reasonable.

For very large networks, it may be helpful to have a network manager oversee the operation of the network as a whole. The network manager could ensure that all node addresses are unique and that routing control parameters provide for efficient data flow through the network.

The following sections explain the different types of routing and nonrouting nodes and configurations, describe the levels of routing, and summarize special routing techniques used with Ethernet and FDDI. They also introduce basic terms and concepts involved in routing control. Chapter 3 discusses the NCP command parameters that affect routing.

2.4.1 Routing and Nonrouting Nodes

Routing nodes (routers) are nodes that can send, receive, and route packets from one node to another. Routers have one or more active circuits. Routers regularly receive and maintain information about other nodes. They perform the routing operation by associating a circuit with the destination node for the packet and transmitting that packet over that circuit.

In a multiple-area network, all routers in a particular area can route packets within the area; some of these routers can also route packets to and from other areas. The two kinds of routers used in area routing configurations are level 1 routers and level 2 routers.

AXP

Note

On AXP systems, Digital supports level 1 routing only for nodes acting as routers for a cluster alias. Digital does not support level 2 routing or routing between multiple circuits. ♦

The level 1 router performs intra-area routing within a single area of the network. If all nodes are configured in the same area, the whole network is considered a single area (area 1), and all routers are level 1 routers. The level 2 router performs intra-area routing within its own area and interarea routing between its area and one or more other areas of the network.

On an Ethernet or FDDI LAN, if there are two or more routers, one router is elected the designated router to provide message routing services for end nodes on the LAN. If no routers are available, LAN end nodes can communicate with each other directly by sending a packet out over the LAN and then waiting until

DECnet for OpenVMS Components and Concepts

2.4 Routing

the timeout for a reply. However, routers are the only LAN nodes that can route messages to network nodes not on the LAN.

Nonrouting nodes (end nodes) contain a subset of network software that permits them to send packets or receive packets addressed to them, but not to route packets to other nodes. End nodes have a single active circuit connecting them to the rest of the network. They do not send or receive information about the network topology. If two end nodes are connected by a nonbroadcast circuit, these nodes constitute the entire network.

2.4.2 Types of DECnet Nodes

DECnet supports a variety of types of nodes developed during different phases of DNA implementation. Phase II, III, and IV nodes and DECnet/OSI nodes can all exist on a network. There are configuration restrictions in such a mixed network; one major restriction is that only nodes running adjacent phases can communicate directly, as shown in the following list:

- Phase II—Phase II
- Phase II—Phase III
- Phase III—Phase III
- Phase III—Phase IV
- Phase IV—Phase IV
- Phase IV—DECnet/OSI
- DECnet/OSI—DECnet/OSI

Phase II nodes can communicate with each other as long as there is a physical data link between them. They support only point-to-point connections. There is no Phase II support for Ethernet.

Phase III DECnet introduced adaptive routing, which allows a reasonably large number of nodes to communicate conveniently. There is no Phase III support for Ethernet or FDDI.

Phase IV DECnet permits the configuration of very large networks and expands the types of data links available for use. Phase IV supports area routing, which allows configuration of a network of up to 63 areas, each containing up to 1023 nodes.

Phase IV nodes can communicate with Phase III nodes. Certain restrictions apply, however, in a mixed Phase III/Phase IV network:

- A Phase III node should not be included in a path between Phase IV nodes.
- A Phase III node in a Phase IV multiple-area network should not be linked with nodes outside its own area.
- Routing initialization passwords (described in Section 2.8.1) are required when a Phase III node is initialized in a Phase IV network.

When DECnet/OSI nodes communicate with Phase IV nodes, they use Phase IV transport and routing protocols.

2.4.2.1 DECnet for OpenVMS Phase IV Nodes

DECnet Phase IV nodes are either of the following two types:

VAX

- Phase IV routers. These nodes deliver packets to and receive packets from other nodes, and route packets from other source nodes through to other destination nodes.
 - The level 1 router, which performs routing within a single area. The node type is ROUTING IV.
 - The level 2 router, which performs routing within its own area and to and from other areas. The node type is AREA. ♦

AXP

Note

On AXP systems, Digital supports level 1 routing only for nodes acting as routers for a cluster alias. Digital does not support level 2 routing or routing between multiple circuits. ♦

- Phase IV nonrouting nodes (end nodes). These nodes deliver packets to other nodes and receive packets from other nodes, but do not route packets. The node type is NONROUTING IV.

DECnet Phase IV nodes can also communicate with the other types of nodes supported by DECnet. Area numbers are dropped when a Phase IV node communicates with a Phase II or Phase III node. A Phase IV node adds its executor area number to the node address of a message that it receives from a Phase III node. Nodes with which Phase IV DECnet for OpenVMS nodes can communicate include the following:

- Phase III routers. These nodes deliver packets to and receive packets from other nodes, and route packets from other source nodes through to other destination nodes whose addresses are less than 256. They use DDCMP, X.25, and CI circuits, but do not support Ethernet or FDDI circuits.
- Phase III nonrouting nodes (end nodes). These nodes send packets to other nodes and receive packets from other nodes, but do not route packets. These nodes cannot support Ethernet or FDDI.
- Phase II nodes. These nodes can send packets to adjacent Phase III routers or to other adjacent Phase II nodes. However, Phase II nodes can send packets only in point-to-point configurations. In addition, a Phase III node cannot communicate with a Phase II node through another Phase III node.
- DECnet/OSI nodes.

2.4.3 Routing Features of DECnet for OpenVMS License Options

The DECnet for OpenVMS license permits you to use either of two kinds of DECnet capability:

- Full function
- End node

The full-function license permits the use of both routing and end node capabilities. The end node license permits a node to be used only as an end node. An upgrade from end node to full function capabilities is available, providing the software for your hardware platform includes routing capabilities.

DECnet for OpenVMS Components and Concepts

2.4 Routing

Both licenses permit the use of any kind of data link. Section 6.1 describes how the DECnet for OpenVMS license is enabled to turn on the appropriate capability.

A configuration consisting only of end nodes offers certain advantages:

- Less use of the central processor is required for routing.
- Data link efficiency is increased: there is no routing overhead and no route-through traffic occurs over the circuit.

End nodes also involve the following limitations:

- The user on an end node cannot directly see the status of other nodes in the network, because end nodes rely on routing nodes to maintain that information. However, an end node can communicate with other nodes in the network, including nodes outside its own area.
- Only one circuit is allowed to be active at any time. Packets are not routed between circuits on an end node. You can configure backup circuits for automatic failover should the primary circuit fail. The backup circuits are not used when the primary circuit is functioning. Set the backup circuit to have a lower cost than the primary circuit.

2.4.4 Area Routing

Phase IV DECnet permits implementation of very large networks through the use of area routing techniques, while still supporting configuration of smaller networks that are not divided into areas. The network manager has the option of partitioning a large network into areas. Each area is a group of nodes. Nodes are grouped together in areas for hierarchical routing purposes. Hierarchical routing involves the addition of a second level of routing to the network. Routing within an area is referred to as level 1 routing; routing between areas is called level 2 routing.

Level 2 routing offers the following advantages:

- Permits configuration of very large networks of more than 1023 nodes.
- Requires less routing traffic, restricting routing overhead between areas to the level 2 routers. Level 1 routers exchange routing information only about nodes in their own area.
- Makes the merging of existing networks easier.

When a level 1 router receives a packet destined for a node in another area, it uses level 1 routing to send the packet to the nearest node within its own area that can perform level 2 routing. That router forwards the packet by level 2 routing to a level 2 router in the destination area, which in turn sends the packet by level 1 routing to the destination node in its area.

If two or more level 2 routers exist in the same area, each level 1 router in that area sends packets destined for other areas to the nearest level 2 router, regardless of which level 2 router is closest to the destination area. The level 1 router has no access to level 2 routing information.

Each area in the network is assigned an area number. Every node in the area is uniquely identified by the addition of its area number as a prefix (followed by a period) to its node number. For example, node 15 in area 7 is addressed as node 7.15. The node number must be unique within the area, but may be used again within another area. Thus, node identification within an area is independent of node identification within other areas.

Phase IV DECnet permits configuration of a maximum of 63 areas (areas 1 through 63), each containing up to 1023 nodes. A Phase IV node address is a 16-bit number: the most significant six bits define the area number, and the least significant 10 bits specify the node number within the area. You can convert the Phase IV node address to its decimal equivalent for use in commands, such as COPY and MAIL, that do not recognize the area prefix (the conversion procedure is given in Section 3.7.2). You can convert to its hexadecimal equivalent for use in determining the physical address of the node (the conversion procedure is given in Section 2.1.2).

You assign the node address to your own node when you configure it. If you do not specify the area number when addressing a remote node, that node is assumed to be in the same area as your local node.

In a network not divided into multiple areas, each router performs level 1 routing throughout the network.

The characteristics of level 1 and level 2 routing nodes are described in the following section.

2.4.4.1 Level 1 and Level 2 Routers

An area can contain many level 1 routers and end nodes, and must contain at least one level 2 router to provide the connection to other areas. A level 1 router acts as a standard routing node. It keeps information on the state of nodes within its own area. Level 1 routing nodes and end nodes obtain access to nodes in other areas through a level 2 router residing in their own area.

VAX

A level 2 router keeps information on the state of nodes in its own area and also information on the **cost** and **hops** involved in reaching other areas. (The logical distance between adjacent level 2 nodes is one hop.) The level 2 router always routes packets over the least cost path to a destination area. Level 2 routers have the following characteristics:

- Level 2 routers connect areas.
- Level 2 routers also act as level 1 routers within their own area.
- A level 2 router serves as a level 1 router when it is not physically connected to another level 2 router.
- All level 2 routers must be connected in such a way that they create a network of their own.
- Level 2 routers exchange level 2 routing messages among themselves.
- In any given area, there can be more than one level 2 router.
- Each level 2 router indicates it is the nearest level 2 router to each level 1 node in its own area, but each level 1 node decides what its level 2 router is on the basis of cost. ♦

2.4.5 Ethernet or FDDI Routers and End Nodes

Two special concepts are involved in routing over an Ethernet or FDDI LAN circuit: the designated router and end node caching.

DECnet for OpenVMS Components and Concepts

2.4 Routing

2.4.5.1 Ethernet or FDDI Designated Routers

If there are two or more routers on the same LAN, one of them is elected as the designated router. By convention, the router with the highest numerical priority (the router priority parameter is set as a CIRCUIT characteristic in its database) is elected router for the circuit. In case of a tie, the node with the highest address is elected as the designated router. The function of the designated router is to route messages over the LAN on behalf of end nodes. A designated router is elected even if there are no end nodes currently on the LAN.

End nodes can also exchange messages directly without using a router. Routers are needed, however, when messages are to be routed to nodes off the LAN.

End nodes are informed of the identity of the designated router on that LAN. End nodes transmit multicast hello messages, so that routers know of their presence on the LAN. End nodes keep no information about the network configuration, except that they are permitted to keep a cache of nodes within their area that they may address directly on the LAN, rather than going through a router (see Section 2.4.5.2). Thus, an end node may send a packet directly to another end node, if the address has been cached, or it may send a packet to the designated router for forwarding.

End nodes can exist on a LAN without a router. When an end node on the LAN wants to communicate with another end node, and notes that no designated router exists, it always sends the packet directly to the addressed node using the LAN address derived from the DECnet address. If the addressed node is active, the sender receives a reply; if the addressed node is not available, a timeout occurs.

2.4.5.2 Ethernet or FDDI End Node Caching

End nodes normally send packets by means of a router. To minimize the space and time overhead involved in the routing function on Ethernet or FDDI LAN circuits, a caching mechanism is available that takes advantage of the fact that nodes on a LAN are logically one hop away from each other (one hop is the distance between two adjacent nodes).

An end node maintains a cache of limited size of the addresses of the target nodes with which it has had contact. When a designated router is present and an end node is ready to send a packet to a specific target node for the first time, the end node sends the packet to the designated router, which in turn forwards the packet to the target node. When there is no designated router on the circuit, the end node sends the packet directly, because it expects that the other node is there.

By means of the acknowledgment messages it receives, the end node builds its cache of addresses of specific nodes. If a response is received from the target node, the end node examines the received packet for the existence of specific bits (the bits are checked even if the first packet went to the designated router).

If the intra-LAN bit is set, which indicates that the target node is on the same LAN as the end node, then the next packet can be sent directly, rather than by means of the designated router. If the received packet has the intra-LAN bit clear (which indicates that the target node is not on the same LAN as the end node, but is reachable through a routing node that is on the LAN), then the next packet can be sent from the end node to the target node via a routing node, rather than by means of the designated router.

In summary, the end node uses the acknowledgment messages it receives to build a cache of addresses of target nodes that either are on the same LAN or can be reached through a node on the LAN. This mechanism is called *reverse path caching*.

2.4.5.3 Area Routing on an Ethernet Bus or FDDI Ring

All nodes on an Ethernet bus or FDDI ring need not be in the same area; you can configure more than one area on a single LAN. The areas on the same LAN are logically separate from each other.

When you configure two level 1 routing nodes on a LAN in different areas, the nodes do not communicate directly with each other. Each level 1 router communicates with a level 2 router in its own area, which sends the message to a level 2 router in the other area. The level 2 router that receives the message then transmits it to the second level 1 router.

2.4.6 Routers and End Nodes on CI Data Links



On VAX, you can configure nodes using a CI data link in a VAXcluster as routers or as end nodes.

2.4.6.1 CI End Nodes

You can configure a two-node VAXcluster that uses a CI data link using end nodes only, but at least one router is required if additional nodes are configured in the cluster. The CI protocol does not include the multiaccess capabilities of the Ethernet or FDDI protocols.

2.4.6.2 CI Routers

One or more CI routers are necessary if a VAXcluster consists of three or more nodes. CI circuit devices are treated as though they were multipoint devices (like the DMP device) rather than as multiaccess devices such as the Ethernet or FDDI circuit device. Although only one router is required in a cluster of more than two nodes, having more routers in the cluster environment increases the overall availability of the network within the cluster.

If the cluster configuration includes end nodes as well as routers, a backup, higher-cost circuit could be provided for each end node. This backup circuit could take over if the primary circuit connecting the end node to its router fails (see Section 3.7.6).

End nodes communicating through a router send all data through that router even though they are connected to the same CI. You achieve the best performance and availability by defining all cluster nodes as routers if the CI is used as the data link.♦

2.4.7 Routing Concepts and Terms

This section briefly explains routing concepts and defines those routing parameters that provide some control over network routing. Chapter 3 describes how to use NCP commands to set these routing parameters.

The following terms are used to describe DECnet routing and routing parameters:

- **Hop.** The logical distance between two nodes is measured in hops. The distance between two adjacent nodes is one hop.
- **Path.** A path is the route a packet takes from source to destination.

DECnet for OpenVMS Components and Concepts

2.4 Routing

- **Path length.** The path length is the number of hops along a path between two nodes; it is the number of circuits a packet must travel across to reach its destination. The path length never exceeds a maximum number of hops, a value that the system manager sets relative to the size and configuration of each network. For an area network, the network manager should determine the maximum number of hops permitted within an area and between areas.
- **Cost.** The cost is an integer value assigned to a circuit between two adjacent nodes. It is usually proportioned to transmission delay. Each circuit has a separate cost. In terms of the routing algorithm, packets are routed on paths with the least cost. Nodes on either end of a circuit can assign different costs to the same circuit.
- **Path cost.** The path cost is the sum of the circuit costs along a path between two nodes. The path cost never exceeds a maximum cost value the network manager specifies for the network. For an area network, the network manager sets the maximum cost for a path within an area, and for a path between areas.
- **Reachable node.** A reachable node is a destination node to which the Routing layer on the local node has a usable path; that is, the path does not exceed the values for maximum cost or hops between nodes specified in the executor database. For an area network, a reachable area is one to which the path does not exceed the values for maximum cost or hops between areas set in the executor database.
- **Maximum visits.** The maximum number of nodes through which a packet can be routed before arriving at the destination node is referred to as the maximum number of visits the packet can make. If a packet exceeds the maximum number of visits, the packet is dropped.

When configuring a network, the network manager establishes the routing parameters for circuit cost control and route-through control. These parameters allow you to control the path that data is likely to take when being transmitted through the network, and also to minimize congestion at particular nodes in the network. For most networks, the default values for these parameters are reasonable.

The network manager must assign a circuit cost to every circuit that connects the local node with adjacent remote nodes. These costs serve as values that DECnet software uses to determine the path over which data is transmitted. When the node is up and running, you can dynamically change the cost of a circuit to a higher or lower value. Altering circuit costs can change packet routing paths and thereby affect the use and availability of network circuits and resources.

Along with defining circuit costs, also consider the path lengths and total path cost for routing packets over the network. For routing purposes, DECnet software identifies the least costly path to each destination in the network. As network manager, you are responsible for defining both the maximum cost of all circuits and the maximum hops that a packet can take when routed to the destination node. If you are configuring an area network, define the maximum cost and hops for a path between nodes within your own area, and the maximum cost and hops for a path between level 2 routers in the whole network.

If multiple paths to a destination node have the same path cost, the Routing layer software can split packet loads for routing on several paths, rather than on only one. This method of **equal cost path splitting** improves network throughput.

You can define the maximum number of equal cost paths to be used for routing when a packet load is to be split.

Because equal cost path splitting implies that data packets are sent to the destination node over different paths, the packets may be received out of order by the destination node. The Network Services Protocol (NSP) maintains a cache of out-of-order packets so that they can be reassembled in order. This mechanism is called **out-of-order packet caching**. When packet loads are split and routed to a node that does not support out-of-order packet caching, the destination node is unable to reassemble any packets received out of order. Any packets received out of order by a node that does not support out-of-order packet caching need to be retransmitted. This need for retransmission hinders network performance. You can compensate for a node that does not support out-of-order packet caching by setting the appropriate value for the executor parameter PATH SPLIT POLICY for that node.

The Routing layer in each node of the network uses congestion-control algorithms to maintain an efficient level of routing throughput. In addition, as network manager, you can maintain indirect control over routing throughput by defining the maximum visits a packet can make before being received by the destination node. Packets that exceed this limit are discarded. This control prevents packets from looping endlessly through the network.

2.4.8 Routing Messages

Adjacent routing nodes exchange routing update messages. A routing update message is a packet that contains information about the cost and hops for each node in the network. In an area network, a level 1 router sends routing update messages about all nodes within its own area to adjacent routers in the area. Level 2 routers send routing update messages containing cost and hop information about all areas to adjacent level 2 routers in the network.

Whenever this routing information changes (for instance, when a circuit goes down), new routing messages are sent automatically. For example, if someone were to change the state of a circuit, rendering a remote node unreachable, this change would be reflected automatically in the routing update messages exchanged by the routing nodes.

2.4.8.1 Segmented Routing Messages

The number of nodes that Phase IV DECnet can support in a single-area network was increased to a maximum of 1023 from the limit of 256 for Phase III DECnet. This increase was due to changes in the routing update messages.

In Phase III, a legal network was restricted in size to the number of nodes for which cost and hop information could be fit into a single routing update message. Furthermore, Phase III routers had to send complete updates containing information about all nodes, whether or not their reachability had changed.

Phase IV allows partial routing messages to be sent, that is, messages that contain only the information that has been changed. Phase IV also permits segmented routing updates to be sent in multiple messages. Therefore, the size of the routing messages and the number of buffers required to receive them are reduced.

DECnet for OpenVMS Components and Concepts

2.4 Routing

2.4.8.2 Timing of Routing Message Transmissions

The network manager can set a timer for transmission of routing messages, controlling the intervals at which nonconfiguration change routing updates are transmitted. The routing timer controls the frequency of transmission of these messages on non-LAN circuits. The broadcast routing timer controls their frequency for Ethernet or FDDI broadcast circuits. Expiration of the broadcast routing timer causes the local node to send a multicast routing configuration message to all routers on the LAN.

2.5 Logical Links

DECnet uses a mechanism called a logical link to allow communication between processes running on either the same node or on separate nodes in the network. A logical link carries a stream (consisting of regular data and interrupt data) of full-duplex traffic between two user-level processes. Each logical link is a temporary data path that exists until one of the two processes terminates the connection.

The system manager can control various aspects of logical link operation on the local node. The system manager can do the following:

- Define the maximum number of logical links that can be active at the local node.
If your node can use an alias node address (which is common to some or all nodes in a VMScluster), you can specify the maximum number of logical links that can use the alias for incoming and outgoing connections. The upper limit on the number of logical links that your node can originate using the individual node address is reduced if your node also uses an alias.
- Specify the number of packets that can be transmitted on a logical link before an acknowledgment is received (the pipeline quota).
- Selectively disconnect active links on the local node while the network is running and verify that the links have been disconnected, by displaying information about the status of the links.

Logical link activity related to NSP is controlled by certain parameters that regulate the duration of NSP connect sequences and inactivity intervals, and the frequency with which NSP retransmits messages. The timers that affect this activity include the following:

- The incoming timer, which protects the local node against the overhead caused by a local process that does not respond to an inbound connection request within a specified interval
- The outgoing timer, which protects the local node against the overhead caused by a connection request to a remote node that does not complete within a specified interval
- The inactivity timer, which protects the user against a link that may be permanently unusable, by setting the frequency with which DECnet tests an inactive link

Normally use default values for the parameters that regulate the frequency of NSP message retransmission at the local node, unless you need to change the operating characteristics of a particular logical link. The retransmit time is affected by the estimated delay in round-trip transmission between the local node and the node with which it is communicating. You use the delay weight and delay factor parameters to calculate new values for this estimated delay. The

retransmit factor parameter governs the number of times NSP tries to retransmit on a logical link.

2.6 Objects

Objects provide known general-purpose network services. An object is identified by object type, which is a discrete numeric identifier for either a user task or a DECnet program such as the Network Management Listener (NML) or the File Access Listener (FAL). The DECnet network software uses object type numbers to enable logical link communication using NSP. The system manager is responsible for supplying information for those objects, both user-defined and network objects, that can be used over the network.

2.6.1 DECnet Objects

When setting up the network, supply information for two general kinds of DECnet objects:

- Objects with a 0 object type. These objects (also known as named objects) are usually user-defined images for special-purpose applications. See Section 3.9.1.4 for more information.
- Nonzero objects. Nonzero objects (also known as numbered objects) serve two purposes, as known objects that provide specific network services such as FAL (used for file access) or NML (used for network management), and as user-supplied known services for user-defined tasks. The object number serves as a standard addressing mechanism across a heterogeneous network.

The Digital-supplied objects described in the following list are defined automatically by NETACP at network startup. The NETCONFIG.COM procedure, described in Section 5.2.2, gives users a variety of access control options for these objects.

- DECnet Test Receiver (DTR)—DTR is a DECnet test program used with the DECnet Test Sender (DTS) to test logical links.
- Event logger (EVL)—EVL logs occurrences of significant events (locally or remotely) for a given network component.
- Host loader (HLD)—HLD provides downline task-loading support for RSX-11S tasks.
- File access listener (FAL)—FAL provides authorized access to the file system of a DECnet node on behalf of processes executing on any node in the network. FAL communicates with the initiating node by means of the data access protocol (DAP).
- MAIL—MAIL provides personal mail service.
- Loopback mirror (MIRROR)—MIRROR is used for loopback testing, including those run during the DECnet phase of the User Environment Test Package (UETP).
- Network management listener (NML)—NML that provides remote management of the local system, such as gathering and reporting information about network status, and modification of node and line parameters.
- PHONE—PHONE allows you to communicate with other users on your system or with any other DECnet for OpenVMS system connected to your system.

DECnet for OpenVMS Components and Concepts

2.6 Objects

- Virtual Performance Monitor (VPM) Server—VPM is used to run VMScluster monitoring features of the Monitor Utility (MONITOR).

For every object that can be started by an inbound connection request, supply a command procedure, unless either of the following conditions exist:

- The object is one of the following Digital-supplied command procedures: FAL, HLD, NML, EVL, DTR, MAIL, PHONE, MIRROR.
- The object is defined as an image, through specification of objectname.EXE as the object file name.

Chapter 3 provides rules for establishing and identifying command files for objects.

You can also specify privileges a user must have in order to connect to the object, and provide default access control information to be used for inbound connections to the object when no access control is specified by the remote node. Additionally, you can assign default proxy login access controls for the object. Refer to Section 2.8 for a discussion of access control information used for logical link connections and a description of proxy login access control.

2.6.2 Objects Using the Cluster Alias Node Identifier

If your node is in a VMScluster that is using an alias node identifier, you have the option of specifying how the cluster alias node address is to be used in relation to incoming and outgoing connections for specific network objects. By default, all objects except PHONE are able to receive connect requests directed to the alias node identifier. For outgoing connections, the default is that only the MAIL object is associated with the alias node address. If you send mail from a cluster node that uses the alias, the sender's address on the mail message is the alias node identifier.

Do not specify the alias node address for objects that require multiple incoming links, because an incoming link identified by the alias node address may be assigned to any of the nodes participating in the cluster alias node address. For example, PHONE should not use the alias node address, because it requires all incoming links to be directed to the same node in the cluster. Also, objects whose resources are not available clusterwide should not be allowed to receive incoming connect requests addressed to the alias node address.

2.6.3 Creating DECnet Network Server Processes

All DECnet objects run as processes on the OpenVMS operating system. Unless a currently running process has declared itself to be a numbered network object or a named network object (with number 0), NETACP must create a process to receive the connect request.

When the logical link request comes in, a standard procedure called NETSERVER.COM is run, which in turn causes NETSERVER.EXE to be executed. This program works in concert with NETACP to invoke the proper program for the requested object. Then, when the logical link is disconnected, the object program (such as FAL) terminates, but the process is not deleted. Instead, control returns to the NETSERVER.EXE program, which asks NETACP for another incoming logical link request to process.

This cycle continues until NETSERVER is deleted after a specified time limit. The default is 5 minutes. To use a different default time limit, specify the SYSTEM logical name NETSERVER\$TIMEOUT, using an equivalence string in the standard "delta time" format:

dddd hh:mm:ss.cc

The effect of NETSERVER is to reuse network server processes for more than one logical link request, eliminating the overhead of process creation for an often-used node. NETACP reuses a NETSERVER process only if the access control on the connect request matches that used to start the process originally.

When NETACP creates a process to receive the connect request, the process runs like a batch job. The sequence is as follows:

1. The process is logged in according to information found in the UAF. The key to this file is the user name, which is part of the access control information. The process is successfully logged in only if the password from the access control string matches the password in the UAF record. (Refer to Section 2.8 for a discussion of DECnet access control.)
2. DECnet for OpenVMS automatically creates a log file in SYS\$LOGIN:NETSERVER.LOG. Unlike the log file for a batch job, this log file is neither printed nor deleted. The log file is helpful for debugging your own network tasks. If NETSERVER.LOG cannot be created for any reason, the network job continues running but does not produce any log file.
3. The login command procedure indicated in the UAF for the process is executed.
4. The process runs a command file or image that implements the DECnet object. The rules for locating this command file differ depending on whether the object has the number 0.

Because NETSERVER.LOG files are not required for network server processes, you may explicitly inhibit all log files in your default nonprivileged DECnet account by setting the default directory for the account to a nonexistent directory. The effect of this action is to suppress all log files, while allowing network jobs to be run.

2.6.4 Potential Causes of Network Process Failures

If a logical link fails and the status information displayed is "network partner exited," this message indicates a problem in the remote network server process. To determine the details of the failure, consult the NETSERVER.LOG file at the remote node. Common reasons for failure are as follows:

- Inability to log in because of failure to access the system login procedure, or the account login procedure or any files that it accesses.
- Protection incorrectly set on network procedures and images in SYS\$SYSTEM, such as NETSERVER.COM or NETSERVER.EXE.
- Attempted execution in your LOGIN.COM file of an interactive command that does not apply to network/batch jobs (for example, a SET TERMINAL/VT100 or SET TERMINAL/INQUIRE command). Do not specify these commands in your LOGIN.COM file unless they are preceded by IF F\$MODE() .EQS. "INTERACTIVE".

For example, in your LOGIN.COM file, use the following to prevent a logical link failure:

```
$ IF F$MODE() .EQS. "INTERACTIVE" THEN -  
  SET TERMINAL/VT100
```

Any failure to create NETSERVER.LOG causes a network job to continue running, but without a log file.

2.7 Logging

The network software logs significant events that occur during network operation. An event is defined as a network or system-specific occurrence for which the logging component maintains a record. Following is a partial list of significant events:

- Circuit and node counter activity
- Changes in circuit, line, and node states
- Service requests (when a circuit or line is put in an automatic service state)
- Passive loopback (when the executor is looping back test messages)
- Routing performance and error counters (circuit, line, node, and data packet transmission)
- Data transmission performance and error counters (when errors in data transmission occur)
- Lost event reporting (when some number of events are not logged)

This information can be useful for maintaining the network because it can be recorded continuously by the event logger. The system manager is responsible for controlling certain aspects of event logging. In particular, you can control source-related parameters (actual events to be logged, the source for these events, and the location at which these events will be logged) and sink-related parameters (the name of the logging component at the local node and its operational state).

For the most part, events are logged for the various DNA layers and for system-specific resources. Events are defined by class and type, in the format class.type. The class of an event identifies the layer or resource to which the event applies, and the type is the particular form of event within the class. For example, event 4.3 indicates oversized packet loss (type 3) for the Routing layer (class 4). Event classes and types are summarized in the *DECnet for OpenVMS Network Management Utilities*. The logging component is the device or process that records logging events. There are three logging components:

- A **logging console**, which is generally a terminal or file that records events in user-readable form. If you do not specify a logging console name, the operator console (OPA0) is used.
- A **logging file**, in which events are recorded in binary format. You can obtain detailed information about the format from the *DNA Phase IV Network Management Functional Specification*. There is no default logging file name.
- A **logging monitor**, which is a program supplied by the system or user that receives and processes events. If you specify a logging monitor, events formatted in user-readable form are sent to the Operator Communication Manager (OPCOM); all network operator terminals (terminals enabled through specification of the DCL command `REPLY/ENABLE=NETWORK`) display these events. Also, if you specify a logging monitor name, events encoded in binary format are sent to the DECnet object specified by that name. You can obtain detailed information about the format from the *DNA Phase IV Network Management Functional Specification*.

You can use both the logging console and the logging monitor to display events at the operator console; however, the inherent flexibility of OPCOM and its ability to display messages at terminals being used for timesharing may make the logging monitor a more suitable choice for many sites.

The source of an event can be an area, node, module, circuit, or line component. Events can be logged at either the local node or a remote node; this node is called the **sink node**.

At the local node, you can control the operational state of the logging sink. Turn logging on before events can be logged to the sink, and off before the logging parameters for the sink can be cleared from the database. You specify the hold state to queue events for a specific logging sink.

2.8 Network Access Control

DECnet for OpenVMS regulates access to the network on various levels, including the following:

- Routing initialization passwords for links connecting the local node to remote nodes
- System-level access control for inbound logical link connections that result in a process being created
- Node-level access control for inbound and outbound logical links
- Proxy login access control for individual accounts

The following sections describe these levels of control as they relate to DECnet for OpenVMS software operation, from the perspective of the system manager's need to establish control parameters through NCP. Chapter 3 describes how to use specific NCP commands to accomplish access control.

2.8.1 Routing Initialization Passwords

Whenever you turn on a circuit, your local node attempts to initialize with the DECnet software at the remote node connection for that circuit. As part of this initialization process, the remote node may require a password to complete the operation. The system manager can specify passwords when setting up the configuration database.

In a Phase IV network, passwords are required when a Phase III node is initialized, but are optional when a Phase IV node is initialized. Generally, passwords are used in initializing Phase IV nodes only when a system has dialup telephone lines used by the network. When a dialup node seeks a dynamic connection over a terminal line, the dialup node must supply a password, but the node receiving the login request does not send a password to the dialup node.

Figure 2-3 illustrates a routing initialization sequence for the network example. When the circuit is turned on, nodes BOSTON and TRNTO initialize. On the local node, BOSTON, DECnet for OpenVMS software retrieves the transmit password for remote node TRNTO and sends it to TRNTO upon request. On node TRNTO, DECnet for OpenVMS verifies this password with the receive password specified for remote node BOSTON in its configuration database. After the passwords are verified, the link is operational; that is, the circuit state makes the transition from ON-STARTING to ON.

DECnet for OpenVMS Components and Concepts

2.8 Network Access Control

Figure 2-3 Routing Initialization Passwords

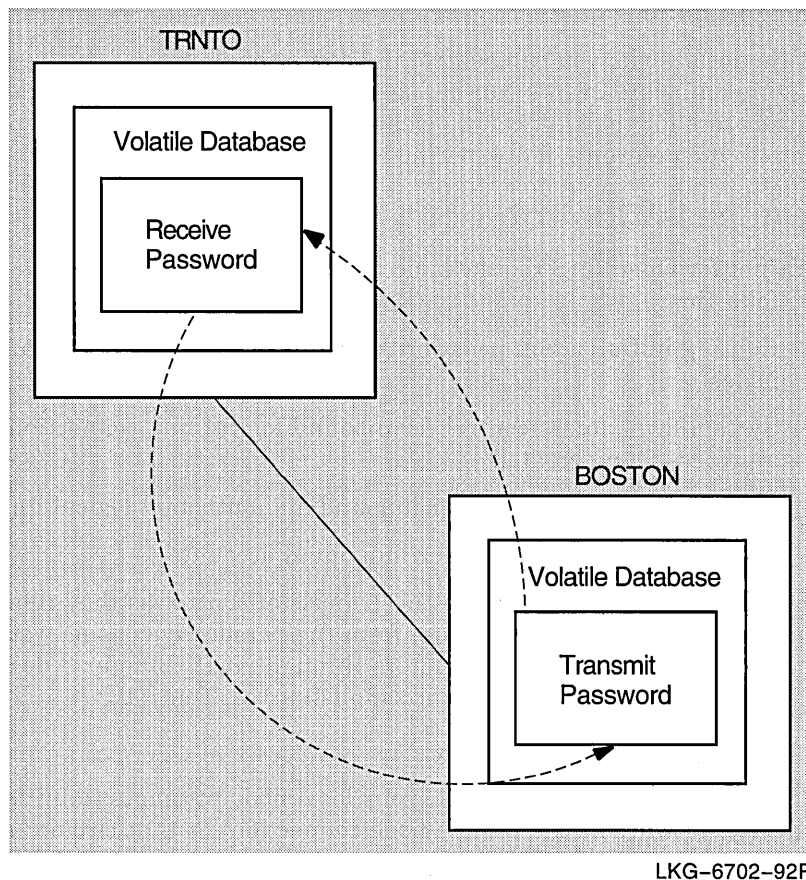

DECnet for OpenVMS always solicits a receive password. However, if verification on the circuit is disabled, or if no receive password is specified in the database for the adjacent node, DECnet for OpenVMS accepts anything the adjacent node may send. The adjacent node is still required to send the verification message.

2.8.2 System-Level Access Control

DECnet for OpenVMS provides system-level access control over logical link connections. The network user on the initiating node may explicitly supply an access control string to control which account is used on the remote node. If, however, the initiating node does not supply explicit access control information, DECnet optionally provides default access control when sending the request to the remote node. It also optionally provides default access control for incoming logical links if the initiating node has not supplied access control information.

2.8.2.1 Setting Access Control Information for Outbound Connects

The system manager can specify default access control information for outbound connections. This enables the local node to send outbound logical link requests with default access control information when that information is not explicitly provided. The remote node stores the access control information in its configuration database. The default access control information can include privileged and nonprivileged names and passwords to be used in connecting to a particular remote node.

DECnet for OpenVMS Components and Concepts

2.8 Network Access Control

The system manager at a node can specify a list of privileges required for connection to a particular object, such as NML. When the local node requests connection to an object for which privileges have been specified, it sends the default privileged access control string to the remote node. If the system manager does not specify privileges for an object, such as FAL, the object is accessible to all users. When the local node requests connection to this object, it sends the nonprivileged access control string.

2.8.2.2 Sources of Access Control Information for Logical Link Connections

Whenever a local DECnet node attempts to connect to a remote DECnet for OpenVMS node by means of a logical link, system-level access control information is sent to the LOGINOUT image running in the context of a process on the remote node. Access control information can come from a number of sources:

- The network user on the local node may explicitly supply an access control string. If this is the case, the remote node uses the access control information.
- If the access control string is not explicitly supplied, the local node checks its object database against the privileges of the initiating process. If the object does not require privileges other than TMPMBX and NETMBX, the local node sends the default nonprivileged access control string from its node database to the remote node.
- If the object requires privileges beyond TMPMBX and NETMBX, and the user process has the required privileges, the local node sends the default privileged access control string from its node database to the remote node.
- If no access control string is supplied, the local node checks to see if proxy access is enabled for the remote node. If so, LOGINOUT at the remote node checks the NETPROXY.DAT file to determine whether a user should be logged in to a designated account rather than the nonprivileged account. (Proxy login access control is described in Section 2.8.5.)
- If none of these cases are valid, the local node sends a “no” access control string.
- When the remote node sees that no access control has been specified, it checks its object database. If the object database contains a default inbound access control string, the remote node uses that string.
- If there is no default access control information in its object database, the remote node checks its executor node database for nonprivileged account information for itself. If the information is there, the remote node uses the nonprivileged access control string.

Finally, if none of these sources supply the information, the connection fails.

Note

In DECnet for OpenVMS usage, nonprivileged means NETMBX and TMPMBX privileges only. NETMBX is the minimal requirement for any network activity. Privileged means any privileges in addition to NETMBX or TMPMBX.

DECnet for OpenVMS Components and Concepts

2.8 Network Access Control

Figure 2-4 Access Control for Inbound Connections

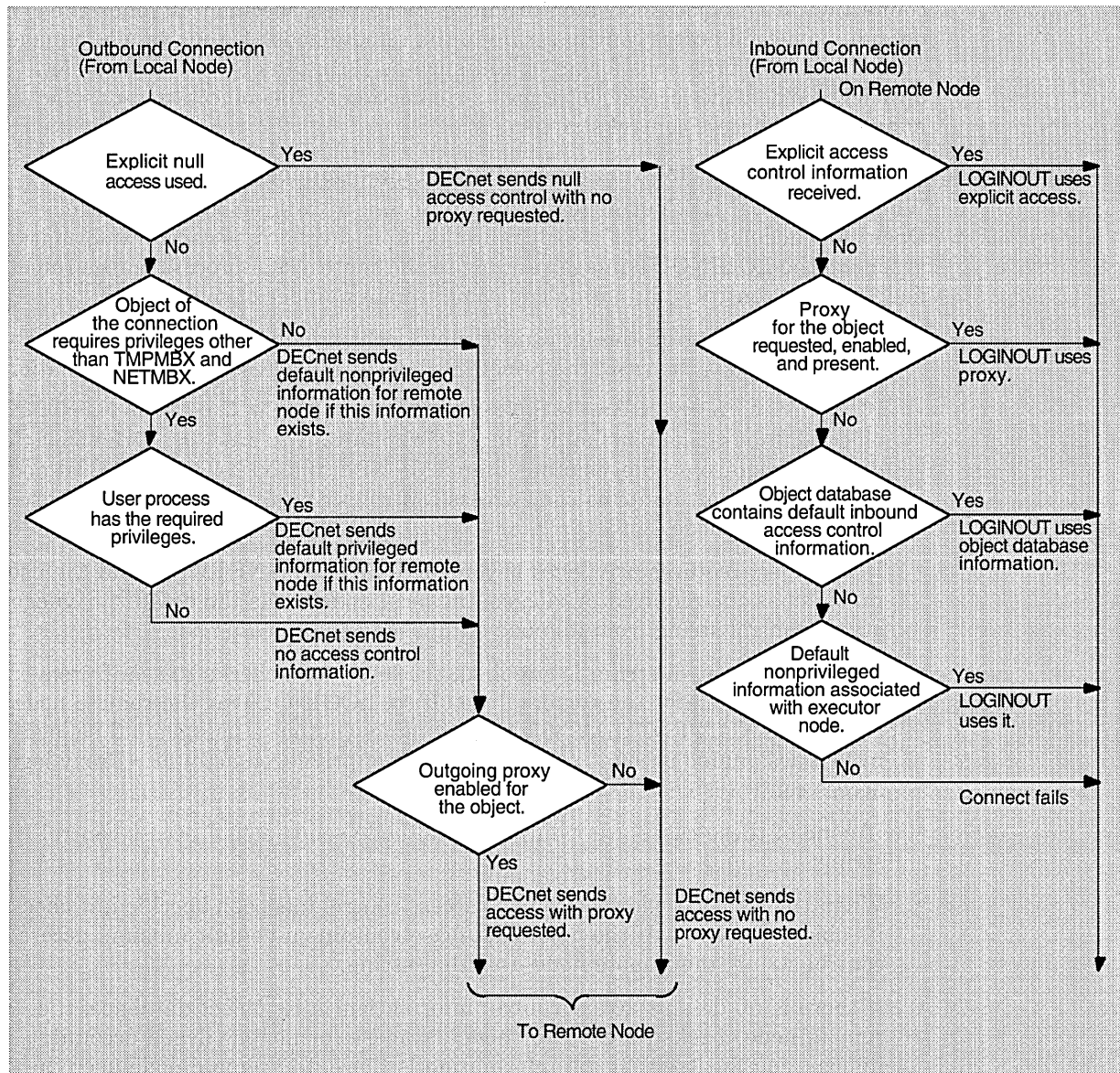

LKG-6713-92R

Figure 2-4 illustrates the local node's access control options for inbound connection requests.

Regardless of the source, the remote node uses this access control information to determine whether a logical link can be established. The way this validation process works is important for both the system manager and network users. This section discusses access control in terms of network management. Chapter 8 discusses access control as it relates to user-level operations such as remote file access and task-to-task communication.

Access control information is not used where the connection is to a program that has declared a name or object number and has started independently of DECnet.

DECnet for OpenVMS Components and Concepts

2.8 Network Access Control

Access control information allows users on remote nodes to gain access to resources on the local node. The system manager must establish access control information in both the configuration database (for objects) and the UAF (for default network accounts) on the local node. Chapter 1 briefly describes the necessity for these default accounts. Chapter 5 explains how to create a default nonprivileged DECnet account.

Whenever NETACP on the local node receives an inbound logical link connection request, it creates a process and starts the LOGINOUT image, which verifies the user's access rights by checking the UAF.

When the operating system starts a user process as a result of an inbound connection request, the privileges with which that process runs are determined by the UAF record associated with the access control information passed in the connection message. This function is almost identical to the one that occurs whenever a local user starts a batch job; the difference is that the resulting LOG file is neither printed nor deleted. Section 2.6 discusses this process in detail.

2.8.2.3 Network Security and Passwords

You can maintain password security in a network environment by protecting the network configuration files from unauthorized access. The most convenient way to do this is to require SYSPRV to access these files. NML must have access to network configuration files. NML on the remote node accesses these files when it performs the NCP commands that access the permanent database (DEFINE, PURGE, LIST, and SET "component" ALL).

Table 5-1 lists the privileges you need to perform network operations.

Avoid assigning privileges beyond those normally used. In particular, do not give the default privileged account SYSPRV. Place these default accounts in their own group to avoid extending group access to other directories on the local node. You can protect sensitive files and directories against world access by requiring explicit access control to reach them.

2.8.2.4 Inbound Default Access Control for Objects

Another form of access control specific to network objects is default account information used by inbound connects from remote nodes that send no access control information. Because no access control information is supplied, the default information you specify for the object is used to allow the logical link connection to be made.

2.8.3 Access Control for Remote Command Execution

If you request an NCP command to be executed at a remote node, you can supply an explicit access control string or default to access control information in the configuration database. To supply an explicit access control string, you use either the standard OpenVMS node specification *node"user password account"::* or specify this access control information as parameters in the NCP command to be executed at a remote node.

2.8.4 Node-Level Access Control

The system manager can regulate two forms of node-level access control for incoming and outgoing logical links. One form involves specifying the ACCESS parameter for a particular node in your volatile database, and the other involves specifying the DEFAULT ACCESS parameter in your executor database.

DECnet for OpenVMS Components and Concepts

2.8 Network Access Control

When an incoming or outgoing logical link connection is attempted, the executor node first checks its volatile database for the ACCESS entry for the target node. If the entry exists, the executor uses it.

Because it may not be feasible to include an ACCESS entry for every node in a large network, DECnet for OpenVMS provides the DEFAULT ACCESS alternative. If the logical link connection is attempted and there is no ACCESS entry for the remote node in the volatile database, the executor uses the DEFAULT ACCESS parameter value.

Both commands accept the same set of parameter values, which are as follows:

INCOMING	Allows logical link connections from the remote node, but does not allow the local node to initiate connections to the remote node.
OUTGOING	Allows the local node to initiate connections to the remote node, but does not allow connections from the remote node.
BOTH	Allows incoming and outgoing logical link connections. This is the default.
NONE	Does not allow incoming or outgoing logical link connections to this node.

If you specify no entry for the ACCESS or DEFAULT ACCESS parameter, the DEFAULT ACCESS parameter defaults to BOTH.

Only those users with OPER privilege can bypass this access protection.

For each node, you can configure the privileged and nonprivileged accounts and passwords that constitute default access control information. This default access control information should match the system-level access control information established for the node (see Section 2.8.2).

Another form of access control at the node level is the node checking that is performed before a system can dial in and form a dynamic asynchronous connection over a terminal line. For a description of security measures for dynamic asynchronous connections, see Section 2.8.6.

2.8.5 Proxy Login Access Control

Proxy login allows a user at a remote node to log in to a specific account at a local node, without having to supply any access control information. Proxy login is not the same as interactive login. Proxy login means that specific network access operations can be executed. By contrast, interactive login requires a user to supply a username and password before the user can perform any interactive operations.

In order to establish proxy login to an account on the local node (without specifying any access control information), the remote user must have a default proxy on the local node that maps to a local user account. The remote user assumes the same file access rights as the local account and also receives the default privileges of the local account.

You can use the proxy login capability to increase security, because it minimizes the need to specify explicit access control strings in node specifications passed over the network or stored in command procedures.

Network objects can also be assigned proxy login access.

The following sections summarize the procedures for establishing proxy accounts and for establishing proxy access to network objects.

DECnet for OpenVMS Components and Concepts

2.8 Network Access Control

2.8.5.1 Proxy Accounts

Proxy accounts permit users on remote nodes to obtain access rights on other nodes without having private accounts on those nodes. The remote user can enter commands to access data that is accessible by one or more local accounts to which that remote user has proxy access.

A system manager can control the use of proxy accounts at the local node, by using the Authorize Utility to create and modify the permanent proxy database, NETPROXY.DAT. In NETPROXY.DAT, each database entry maps a single remote user to one or more local accounts. The remote user is identified by either a node name and a user name, or by a node name and a remote UIC (the User Identification Code used by the Authorize Utility). The following examples show how remote users may be identified in the proxy database:

```
LARK::KELLEY  
RSTS::[23,55]
```

In the first example, the remote user is identified by the node name LARK and user name KELLEY. The second example specifies that a UIC is to be used instead of a user name to identify the user as member 55 in group 23.

In the permanent proxy database, each remote user may be mapped to one default proxy account and up to 15 additional proxy accounts on the local node. With a default proxy account, the remote user does not need to specify a user name or password when requesting proxy login. With a nondefault proxy account, the remote user must include a user name only.

For a summary description of proxy accounts and how to create them, see the *Guide to VMS System Security*.

2.8.5.2 Controlling Proxy Login Access for Individual Accounts

The permanent proxy database resides in NETPROXY.DAT. All management and maintenance of this database is handled through the Authorize Utility. NETPROXY.DAT is updated automatically any time you use the Authorize Utility to make any changes to proxy logins. When DECnet is started up, the information in NETPROXY.DAT is used to construct a volatile database in the NETACP process. NETACP consults this volatile database when incoming proxy login requests are received at the local node. When you change the proxy database, the volatile database is updated if DECnet is running.

When the local node receives a request for initiation of an inbound connection, and if no access control string is supplied and the remote node is enabled for outgoing proxy login access, the local system checks to see if the object has incoming proxy enabled. If proxy access is enabled, NETACP checks its volatile database to determine whether the user should be allowed to log into a designated account.

By default, both incoming and outgoing proxy login access are enabled at the local (executor) node. Consequently, incoming and outgoing proxy login access is permitted with all remote nodes. These default values are established by DECnet for OpenVMS to permit proxy logins to be initiated by the local node or by the remote node. These default values are the recommended settings.

However, you can restrict the use of proxy logins by specifying the NCP executor parameters INCOMING PROXY and OUTGOING PROXY in the volatile database. The possible proxy access options for the local node are as follows:

DECnet for OpenVMS Components and Concepts

2.8 Network Access Control

INCOMING PROXY enabled	Allows proxy login access from the remote node to the local node.
INCOMING PROXY disabled	Prevents proxy login access from the remote node to the local node.
OUTGOING PROXY enabled	Allows the local node to initiate proxy login access to the remote node.
OUTGOING PROXY disabled	Prevents outgoing proxy login access connections from the local node.

2.8.5.3 Controlling Proxy Login Access for Objects

Just as you can control proxy login access by individual accounts, you can control proxy login access by network objects. You control proxy login access to a specific network object by setting the value of the object parameter PROXY in the configuration database. The database contains defaults for each object.

Permitting proxy login access to an object is recommended only if the proxy access serves some useful purpose. For example, by default MAIL is set to prevent incoming proxy login, while FAL is set to allow both incoming and outgoing proxy login.

Whatever you declare for the object proxy database takes precedence over the values declared in the executor proxy database.

The following four options are available for the PROXY parameter for a network object:

INCOMING	Allows proxy login to the object.
OUTGOING	Allows the object to initiate proxy login.
BOTH	Allows both incoming and outgoing proxy login access. This is the default.
NONE	Does not allow incoming or outgoing proxy login access.

There are advantages to disallowing incoming proxy access to an object (such as MAIL) that does not require it. Whenever possible, incoming connect requests are matched with compatible existing NETSERVER processes, to avoid the overhead of unnecessary process creation. If the object disallows incoming proxy access, incoming connect requests will use default access control, with a higher probability of being matched with an existing NETSERVER process.

2.8.6 Security for DDCMP Point-to-Point Connections

VAX

On systems that support DDCMP, if a remote node requests a connection over a DDCMP point-to-point circuit, the local node can avoid revealing its routing initialization password, while requiring that the remote node supply its password. This security measure is used to protect the password of the local node when a dialup node initiates an asynchronous connection to the local node.

For example, a user at a system with an asynchronous terminal line (such as DECnet for OpenVMS software running on a MicroVAX) can dial in to another system (such as a DECnet for OpenVMS system in a VMScluster) and initiate a dynamic connection. This connection causes the terminal lines to be converted to asynchronous DDCMP communication lines for the duration of the telephone call.

To prevent attempts at access by callers at unauthorized nodes, certain checks have been included in the dynamic configuration process, as follows:

- The dialup node must be the type of node (router or end node) expected by the local node.

DECnet for OpenVMS Components and Concepts

2.8 Network Access Control

- When the dialup node attempts to initialize, it must supply a routing initialization password to the local node, although the local node does not send its password to the dialup node. The line will not be started unless the password can be verified at the local node. This convention preserves the security of the local node in case the dialup node is unauthorized.
- The line will not be started unless the transmit password sent matches the local receive password.
- Depending on how you set up the terminal line, the connection can be configured to end automatically when the telephone is hung up. ♦

Part II

Network System Management

Managing and Monitoring the Network

This chapter explains how to use network management commands and **parameters** to configure, manage, and monitor network software. The management tools and components available to DECnet for OpenVMS users include:

- Configuration database
- Network Control Program (NCP)
- Executor node and remote nodes
- Circuits
- Lines
- Links
- Objects
- Logging
- Access control
- Routing

This chapter provides enough information for you to build a network **configuration database** for your system. It also explains how to use most NCP commands at both the local node and remote nodes to modify parameters for the running network. See Chapter 5 for examples that use NCP commands to build databases for various network configurations.

Chapter 2 describes DECnet for OpenVMS network components and operating concepts. The *DECnet for OpenVMS Network Management Utilities* manual contains reference information about the operation of the Network Control Program (NCP) Utility, DTS/DTR testing, and the complete syntax of NCP commands.

3.1 The DECnet for OpenVMS Configuration Database

The DECnet for OpenVMS configuration database contains files that provide information about the local node, remote nodes, local physical lines, local circuits, local logging, and local objects. Each DECnet node in the network has a network database that supplies component and parameter information of this kind. To ensure successful node-to-node communication, each node has a configuration database that consists of the following databases:

- A node database with a record for each node, including the local node
- A circuit database with a record for each circuit known to the local node
- A line database with a record for each physical line known to the local node

Managing and Monitoring the Network

3.1 The DECnet for OpenVMS Configuration Database

- A logging database with a record for each sink (logged events are sent to the sinks)
- A default **object database** with a record for each object known to the network, including objects (for example, FAL) that are defined when you bring up the local node.

As system manager, you need to specify the nodes that can communicate with your node, the physical lines that connect the nodes, and the circuits associated with those lines. In some cases, this connection may include more than one line and circuit to the remote node. You also need to establish a variety of operational routing parameters for the local node to ensure proper network operation.

To provide network management flexibility, the DECnet for OpenVMS configuration database consists of two distinct databases, one volatile and one permanent.

3.1.1 The Volatile Database

The volatile copy of the DECnet for OpenVMS configuration database is memory resident; it allows you to control the running network without modifying the permanent database. NCP provides commands for setting, clearing, and showing network component parameters for the **volatile database**. NCP also permits you to copy current information about remote nodes from the node database of another node into your volatile database.

You can change parameters in the volatile database while the system is running; these changes, however, are in effect only until you modify them again or until the network is shut down.

3.1.2 The Permanent Database

The permanent copy of the DECnet for OpenVMS configuration database provides the initial values for the volatile database. You access the **permanent database** whenever you use the ALL parameter with the SET command, for example, when you bring up the network. In effect, the permanent database allows you to load network parameters into the volatile database when you boot the system. You can also change parameters in the permanent database.

You can use NCP commands to define, purge, and list network component parameters in the permanent database. You can also use NCP to copy current remote node entries into your permanent node database from the database of another node to which you have access.

For a new system, instead of entering the NCP commands yourself, you can use the NETCONFIG.COM procedure to configure the permanent database. See Section 5.2 for details. The NETCONFIG_UPDATE.COM procedure may be used if your system already has been configured and you want to modify default account information for Digital-supplied network objects. See Section 5.2.2.2 for information about the NETCONFIG_UPDATE.COM procedure.

3.2 The Network Control Program

The Network Control Program (NCP) is the vehicle for creating and modifying component parameters in the configuration database. In addition to the NCP command interface, DECnet for OpenVMS users can write programs that communicate with NML through the Network Information and Control Exchange (NICE) protocol. For information about this interface, refer to the *DNA Phase IV Network Management Functional Specification*.

Managing and Monitoring the Network

3.2 The Network Control Program

Most NCP commands allow you to modify either the volatile or the permanent database. NCP accesses either database, depending on which command verb you use. For example, you enter the following command to access the permanent database to create or modify the address of a remote node:

```
NCP>DEFINE NODE 14 NAME DENVER
```

To change the parameter in the volatile database, you enter the following command:

```
NCP>SET NODE 14 NAME DENVER
```

The following table distinguishes command verbs by function and the database they access.

Function	Volatile	Permanent
Creating/modifying parameters	SET	DEFINE
Clearing parameters	CLEAR	PURGE
Displaying parameters	SHOW	LIST

Because the commands to access the volatile and permanent databases are similar, this section uses volatile database commands in all examples.

When configuring your network, you can use NCP either to build upon previously specified information or to change that information. Thus you do not have to delete all existing parameters and start over. For example, assume that you have identified a remote node address. You can add node parameters for this record in the volatile database by using the SET NODE command. If you want to change the address of this node, you need to specify a new address only in the ADDRESS parameter of the SET NODE command. If you decide later that you want to remove any or all parameters for this node, then you could use the CLEAR NODE command. Commands to remove parameters exist for all network components.

NCP commands operate on network components and their parameters. When issuing an NCP command, you must provide the command verb, the component name, and one or more parameters, qualifiers, or both, as shown in the following example:

```
$ RUN SYS$SYSTEM:NCP
NCP>SET  NODE 11          NAME BOSTON COUNTER TIMER 30
NCP>SET  KNOWN LOGGING   STATE ON
      .
      .
      .
NCP>SET  EXECUTOR        STATE ON
```

Components consist of two types: singular (as with NODE BOSTON) and plural (as with KNOWN LOGGING). For example, you can display information about an individual node or all nodes (including the local node) in the network:

```
NCP>SHOW NODE BOSTON COUNTERS
      .
      .
      .
NCP>SHOW KNOWN NODES COUNTERS
```

Managing and Monitoring the Network

3.2 The Network Control Program

Most NCP commands support both singular and plural component names.

NCP accepts the asterisk (*) and the percent sign (%) as wildcard characters. You can include these wildcard characters on the NCP command line to represent a group of component names. Using a wildcard character allows you to refer to an NCP component by a general name, rather than by a specific name.

You can use wildcard characters to represent the following component names:

- Node name
- Line name
- Circuit name
- Object name
- Node address
- Events

The asterisk wildcard represents one or more characters, while the percent sign represents a single character.

The following rules define how you can use wildcard characters with component names.

- If the component name is a string, the wildcard character may occur at any location in the string. For example:

```
NCP>LIST NODE ST*R STATUS
NCP>SHOW OBJECT M* CHARACTERISTICS
```

The first command requests a list of status information for all nodes with four-letter node names beginning with "ST" and ending with "R." The second command requests a listing of characteristics for all objects with names beginning with "M."

- For node addresses, which are represented by the format *area-number.node-number*, only the *node-number* portion of the node address (the numeral on the right side of the period) can contain a wildcard. For example, the following command sets a COUNTER TIMER value of 45 seconds for all nodes in area 4:

```
NCP>SET NODE 4.* COUNTER TIMER 45
```

Specifying a node address such as *.5 is invalid because only the *node-number* can contain a wildcard.

- In a node address, a wildcard character cannot be combined with a numeral to represent a *node-number*. The node addresses 4.* and 4.% contain valid uses of the wildcard characters, but the node addresses 4.%2 and 4.1* are invalid.
- For events, which are represented by the format *class.type*, only the *type* portion of the event (the numeral on the right side of the period) can contain a wildcard. For example, the following command specifies that all class 2 events are to be logged:

```
NCP>SET KNOWN LOGGING EVENTS 2.*
```

Managing and Monitoring the Network

3.2 The Network Control Program

- Except in the case of events, only component names can contain wildcards. Parameter values cannot contain wildcards. The following command is invalid because the circuit name SVA-* is not the component name in the command. Rather, it is a parameter used to modify the component named BOSTON. Only component names can be represented by wildcard characters.

```
NCP>SET NODE BOSTON SERVICE CIRCUIT SVA-*      !INVALID COMMAND
```

The component name EVENT is used as a parameter to the LOGGING commands, and can contain wildcard characters, as long as only the *type* portion of the event number (the numeral to the right of the period) contains the wildcard. For example, the following command clears logging to the logging file for all class 2 events:

```
NCP>CLEAR LOGGING FILE EVENTS 2.*
```

- Unit numbers of circuit and line devices may contain wildcard characters, but device names of circuits and lines cannot contain wildcard characters. Circuit and line devices are typically identified by the format *dev-c*, where *dev* is a mnemonic device name, and *c* is a device unit number. In the following example, the asterisk replaces the unit number in this request for circuit information for all SVA devices:

```
NCP>SHOW CIRCUIT SVA-*
```

However, the *device-name* portion of a circuit or line name cannot contain wildcard characters. Therefore, the following commands are invalid:

```
NCP>SHOW CIRCUIT D* STATUS !INVALID COMMAND  
NCP>SHOW LINE %NA-0 SUMMARY !INVALID COMMAND
```

Substituting a wildcard character for an entire component name is equivalent to specifying the command component KNOWN. For example:

```
NCP>SHOW NODE * STATUS
```

This command is equivalent to the following command:

```
NCP>SHOW KNOWN NODES STATUS
```

For a detailed description of NCP operation, the syntax of NCP commands, and examples of NCP command prompting, refer to the *DECnet for OpenVMS Network Management Utilities*.

3.3 Node Commands

To establish your system as a node in the DECnet network, you must build the node database entries for the DECnet for OpenVMS configuration database. The following sections describe identification of the executor node and remote nodes, and the node parameters required to build an operational network node database. They also discuss how to update your node database by copying current information about remote nodes from another node to which you have access.

3.3.1 Executor Node Commands

NCP allows you to manage the operation and configuration of both your local node and remote nodes in the network. Generally, the NCP commands you enter at your local node are executed on that node. Occasionally, however, you may want to enter commands from the local node to be executed on adjacent or remote nodes. To this end, NCP incorporates the concept of an executor node. The executor node is the node on which NCP functions are actually performed, which

Managing and Monitoring the Network

3.3 Node Commands

in most cases is the local node. To perform NCP functions on remote nodes, NCP supports two commands: SET EXECUTOR NODE and TELL.

3.3.1.1 SET EXECUTOR NODE Command

The SET EXECUTOR NODE command sets the executor to the node at which you want the commands to execute. One use of this feature is to display information about the configuration database of the remote node. Figure 3-1 illustrates this use of a remote executor node.

You set the executor node by entering the following NCP command:

```
NCP>SET EXECUTOR NODE TRNTO
```

NCP executes commands that you enter at your local node, BOSTON, at the remote executor node, TRNTO. The executor node interprets each command with its own network management software, and then performs the NCP function. In this example, any information output that results from the execution of a command is displayed at node BOSTON.

To reset the executor to the local node, use the following NCP command:

```
NCP>CLEAR EXECUTOR NODE
```

The executor is always the local node when NCP is activated. Several users at one node can set their executor to different nodes.

When you issue a SET EXECUTOR NODE command, you can either include specific access control information or use the default access control information. The level of privilege allowed at the remote executor node depends on the access control information specified. (Section 3.11 describes the access control format.)

Note

When you clear the executor node, NCP communicates with NML running in the same process. Hence, clearing the executor node resets the executor's privileges to those of your current process—that is, the process running NCP.

3.3.1.2 TELL Prefix

As an alternative to using the SET EXECUTOR NODE command, you may want to execute only a single command at a remote node or you may want to temporarily override the current executor. In either case you can use the TELL prefix with an NCP command. For example, if you enter the following command at node BOSTON, NCP displays line information for all physical lines connected to node TRNTO:

```
NCP>TELL TRNTO SHOW KNOWN LINES
```

Remote execution in this case applies only to the one command entered with the TELL prefix. Again, you can specify or default the access control information.

Figure 3-1 Remote Command Execution

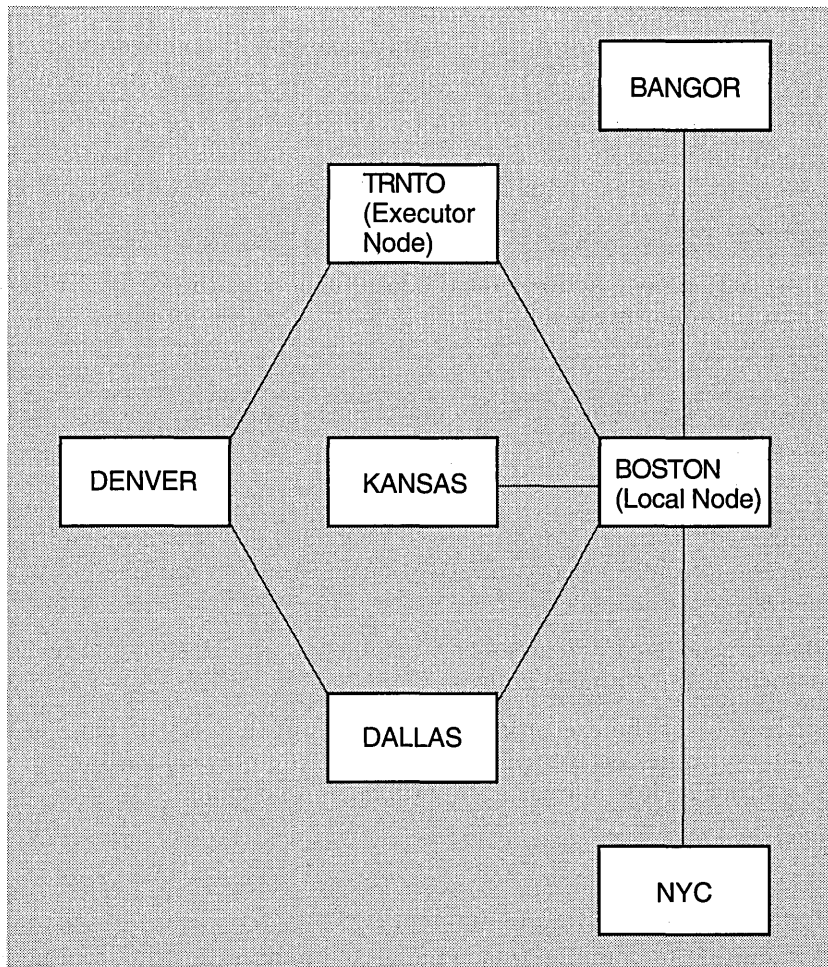

LKG-6707-92R

3.3.2 Node Identification

When configuring the network, identify the local node and all adjacent nodes connected to it by circuits in the executor configuration database. Identifying all nodes by name as well as address permits you to reach any node by its name. This section describes node identification and discusses NCP parameters relevant to identifying nodes.

Either the node address or the node name can serve as a node identifier (node-id). The node address is a decimal number assigned to the node in the configuration database. The address must be unique within the network. The node address may include as a prefix the area number, a decimal integer indicating the area in which the node is grouped. In the node address, the area number and node number are separated by a period, in the following format:

area-number.node-number

For example, if node 3 is in area 7, its node address is 7.3. The area number must be unique within the network and the node number must be unique within the area. If you do not specify an area number, the area number of the executor node is used. The default area number for the executor is area 1. In multiple-area networks, always specify the area number.

Managing and Monitoring the Network

3.3 Node Commands

A node name is an optional, unique alphanumeric string that contains up to six characters including at least one alphabetic character. You can use it interchangeably with the node address to identify a node. In single-area networks, the default area is 1. In the single-area network example, Figure 1-5, the node name BOSTON and the node address 1.11 identify the same node.

When defining remote nodes in the volatile database, use the SET NODE command to specify node names and node addresses. The following command associates the node name TRNTO with the node whose address is 1.5:

```
NCP>SET NODE 1.5 NAME TRNTO
```

To specify a node address for the local node, use the SET EXECUTOR command, as in the following example:

```
NCP>SET EXECUTOR ADDRESS 11
```

Then, use the following command to specify a node name for the local node:

```
NCP>SET NODE 11 NAME BOSTON
```

By entering these commands, you have established a remote node (TRNTO) whose address is 1.5 and the local node (BOSTON) whose address is 1.11. You can then build upon this information to establish parameters for the various nodes.

Before a node can be accessed by name, you must specify a node name to be associated with a node address.

After you set the executor node's address in the volatile database, you cannot change it unless you turn off and restart the network. However, you can change any other node's address at any time. For example:

```
NCP>SET NODE TRNTO ADDRESS 6  
NCP>SET NODE TRNTO ADDRESS 8
```

3.3.2.1 Local Node Identification Parameter

In addition to defining a node name and address for the local node, you can also specify a descriptive quoted string of alphanumeric characters. NCP displays this string whenever you enter the SHOW EXECUTOR or LIST EXECUTOR command. Use the IDENTIFICATION parameter with the SET EXECUTOR command to specify this optional information. For example:

```
NCP>SET EXECUTOR IDENTIFICATION "Accounting Department"
```

To see the current string set for the IDENTIFICATION parameter, enter the SHOW EXECUTOR CHARACTERISTICS command, as follows:

```
NCP>SHOW EXECUTOR
```

```
Node Volatile Summary as of 15-JUN-1992 11:27:07  
Executor node      = 1.11 (BOSTON)  
State              = on  
Identification     = Accounting Department
```

3.3.2.2 Using and Removing Node Names and Addresses

After you specify a node name and address, you can use them interchangeably whenever you need to specify a node-id. The local DECnet for OpenVMS software translates the node names into node addresses. In the single-area network example, the following NCP commands perform identical functions:

```
NCP>SHOW NODE 5 CHARACTERISTICS
```

```
·  
·  
·
```

```
NCP>SHOW NODE TRNTO CHARACTERISTICS
```

```
·  
·  
·
```

To remove a remote node name from the volatile database, use the **CLEAR NODE** command. The following command removes the association between TRNTO and node 5:

```
NCP>CLEAR NODE 5 NAME TRNTO
```

To remove a remote node address from the volatile database, you must remove all parameters for the node. You can also remove addresses for all known nodes other than the local node, as in the following example:

```
NCP>CLEAR NODE TRNTO ALL
```

```
·  
·  
·
```

```
NCP>CLEAR KNOWN NODES ALL
```

After all parameters for a component are removed from the volatile database, the component is no longer recognized by the network.

Note

To change the ADDRESS, BUFFER SIZE, ALIAS NODE, MAXIMUM BROADCAST ROUTERS, MAXIMUM CIRCUITS, NAME, SEGMENT BUFFER SIZE or TYPE parameters for the executor, first turn off the executor. For information about how to change the local node's operational state, refer to Section 3.3.4.2 and Chapter 6.

3.3.3 Identifying VMScLuster Nodes

For many network operations, it is convenient to be able to treat nodes within a homogeneous VMScLuster as though they were a single node in a DECnet network. You can do this by establishing an alias node identifier for the cluster. You can specify the alias node identifier as either a unique node address or a corresponding node name. Any member node can elect to use this special node identifier as an alias while retaining its own unique node identification. Use of the cluster alias node identifier is optional.

The management of a cluster alias node involves three primary decisions:

1. Will an individual node participate in the use of a cluster alias node identifier?

Managing and Monitoring the Network

3.3 Node Commands

2. If a node participates, does it want to receive inbound connect requests targeted to the cluster alias address?
3. For any object defined on a participating node, should the object's logical links appear to have originated from the cluster alias node. Should the object be able to receive incoming connect requests that are directed to the cluster alias address?

To establish an alias node identifier for a local node, use the `SET EXECUTOR` or `DEFINE EXECUTOR` command with the `ALIAS NODE` parameter, described in Section 3.3.3.1. To enable incoming requests to the cluster alias node address, use the `ALIAS INCOMING` parameter of the `SET EXECUTOR` or `DEFINE EXECUTOR` command, as described in Section 3.3.3.2.

The `SET OBJECT` command allows you to associate specific objects with the cluster alias node identifier, by means of the `ALIAS OUTGOING` parameter. You can also use the `ALIAS INCOMING` parameter to permit specific objects to receive incoming connect requests sent to the cluster alias address. Section 3.9.1 describes how to identify DECnet for OpenVMS objects.

3.3.3.1 Setting an Alias Node Identifier for the Executor

You establish an alias node identifier for the local node using the `SET EXECUTOR` command with the `ALIAS NODE` parameter. When the local node includes an alias node identifier in its database, it can be accessed by either the cluster alias or its individual node name or node address.

The alias node identifier can be either a node address or node name. Before you can establish a node name as a cluster alias, you must define the node name in the database, and associate it with a node address representing the whole cluster, by means of the `SET NODE` or `DEFINE NODE` command. For example, the following command associates the node name `CLUSTR` with the address `2.13`:

```
NCP>DEFINE NODE 2.13 NAME CLUSTR
```

You can then establish the name `CLUSTR` as the alias node identifier for the local node by using the following command:

```
NCP>DEFINE EXECUTOR ALIAS NODE CLUSTR
```

By entering these commands, you establish a node (`CLUSTR`) whose address is `2.13`. This is the cluster alias node. Its address and name appear in the database like those of all other nodes. From the viewpoint of any node in the network outside the cluster, address `2.13`, which is named `CLUSTR`, appears to be a real DECnet node that can participate in two-way communication. This cluster alias acts as a single node identifier that all participating nodes in the cluster can use to communicate with other nodes in the DECnet network.

3.3.3.2 Enabling Aliases for Nodes in a VMScluster

When you manage the VMScluster alias node, decide whether participating nodes will accept incoming connect requests directed toward the cluster alias node. You use the executor parameter `ALIAS INCOMING` to specify how incoming connect requests are to be handled. This parameter must be either enabled or disabled. To permit the node to accept incoming connect requests directed to the cluster alias node, specify the `ENABLED` option. Otherwise, specify the `DISABLED` option to avoid receiving incoming connect requests directed to the cluster alias node identifier.

The following command prevents the local node from receiving incoming connect requests directed to the alias node identifier:

```
NCP>DEFINE EXECUTOR ALIAS INCOMING DISABLED
```

By default, the ALIAS INCOMING parameter is enabled for a node if an alias node identifier has been defined for the node.

3.3.4 Node Parameters

To establish information used to control various aspects of the local node's operation within the network, you specify the SET EXECUTOR command. You can set several parameters with the SET EXECUTOR command. Specify the parameters ADDRESS and TYPE.

In addition, you may want to specify names, access control information, and node counter event logging information for any or all of the remote nodes in your network. If a remote node can be loaded downline, you can specify a number of default parameters to be used locally to perform a downline load or upline dump operation.

Executor parameters specify information used to control various operations specific to the local node. Node parameters specify information that is applicable to operations associated with both the local and remote nodes. The NCP SET EXECUTOR command is used to set executor parameters. The NCP SET NODE command is used to set node parameters for both the local and remote nodes.

When using the SET EXECUTOR command to establish or modify parameters, be sure to avoid combining in the same command, parameters that are listed under both the executor and node parameter columns in Table 3-1 with parameters that are listed under the executor parameter column only. For example, the following command is invalid and would receive the response shown:

```
NCP>DEFINE EXECUTOR ADDRESS 4.11 ALIAS NODE 4.16
%NCP-W-INVPGP, Invalid parameter grouping , Alias node
```

Table 3-1 lists node and executor parameters by function.

Table 3-1 Node and Executor Parameters and Their Functions

Parameters According to Function	Executor Parameter	Node Parameter
Access control		
ACCESS		X
INCOMING		
OUTGOING		
BOTH		
NONE		
DEFAULT ACCESS	X	
INCOMING		
OUTGOING		
BOTH		
NONE		
INCOMING PROXY	X	
ENABLED		
DISABLED		

(continued on next page)

Managing and Monitoring the Network

3.3 Node Commands

Table 3-1 (Cont.) Node and Executor Parameters and Their Functions

Parameters According to Function	Executor Parameter	Node Parameter
NONPRIVILEGED	X	X
ACCOUNT account		
PASSWORD password		
USER user-id		
OUTGOING PROXY	X	
ENABLED		
DISABLED		
PRIVILEGED	X	X
ACCOUNT account		
PASSWORD password		
USER user-id		
DDCMP circuit connection control		
†INBOUND node-type		X
ENDNODE		
ROUTER		
Declared objects		
MAXIMUM DECLARED OBJECTS number	X	
Using the DECdns namespace		
†DNS INTERFACE	X	
ENABLED		
DISABLED		
†IDP string	X	
†DNS NAMESPACE dns-namespace	X	
Downline loading		
CPU		X
DECSYSTEM1020		
PDP11		
PDP8		
VAX		
DIAGNOSTIC FILE file-spec		X
HARDWARE ADDRESS hardware-address		X
HOST node-id		X
LOAD ASSIST AGENT file-spec		X
LOAD ASSIST PARAMETER item		X
LOAD FILE file-spec		X
MANAGEMENT FILE file-spec		X
SECONDARY LOADER file-spec		X
SERVICE CIRCUIT circuit-id		X
SERVICE DEVICE device-type		X
SERVICE PASSWORD hex-password		X
SOFTWARE IDENTIFICATION software-id		X
SOFTWARE TYPE software-type		X
MANAGEMENT FILE		
SECONDARY LOADER		
SYSTEM		
TERTIARY LOADER		
TERTIARY LOADER file-spec		X
Local node state		

†VAX specific

(continued on next page)

Managing and Monitoring the Network

3.3 Node Commands

Table 3-1 (Cont.) Node and Executor Parameters and Their Functions

Parameters According to Function	Executor Parameter	Node Parameter
STATE	X	
ON		
OFF		
RESTRICTED		
SHUT		
Loop node identification		
CIRCUIT circuit-id		X
Logical link control		
ALIAS MAXIMUM LINKS number	X	
BUFFER SIZE number	X	
DELAY FACTOR number	X	
DELAY WEIGHT number	X	
INACTIVITY TIMER seconds	X	
INCOMING TIMER seconds	X	
MAXIMUM BUFFERS number	X	
MAXIMUM LINKS number	X	
OUTGOING TIMER seconds	X	
PIPELINE QUOTA quota	X	
RETRANSMIT FACTOR number	X	
SEGMENT BUFFER SIZE number	X	
Node identification		
ADDRESS node-address	X	X
ALIAS NODE node-id	X	
IDENTIFICATION id-string	X	
NAME node-name	X	X
Routing control		
ALIAS INCOMING option	X	
ENABLED		
DISABLED		
†AREA MAXIMUM COST number	X	
†AREA MAXIMUM HOPS number	X	
BROADCAST ROUTING TIMER seconds	X	
MAXIMUM ADDRESS number	X	
†MAXIMUM AREA number	X	
MAXIMUM BROADCAST NONROUTERS number	X	
MAXIMUM BROADCAST ROUTERS number	X	
MAXIMUM CIRCUITS number	X	
MAXIMUM COST number	X	
MAXIMUM HOPS number	X	
†MAXIMUM PATH SPLITS number	X	
MAXIMUM VISITS number	X	
†PATH SPLIT POLICY policy	X	
INTERIM	X	
NORMAL	X	
†ROUTING TIMER seconds	X	
TYPE node-type		
†AREA		
†ROUTING III		
ROUTING IV		
NONROUTING III		
NONROUTING IV		

†VAX specific

(continued on next page)

Managing and Monitoring the Network

3.3 Node Commands

Table 3-1 (Cont.) Node and Executor Parameters and Their Functions

Parameters According to Function	Executor Parameter	Node Parameter
Routing initialization passwords		
†RECEIVE PASSWORD password		X
†TRANSMIT PASSWORD password		X
Timer for logging node counter events		
COUNTER TIMER seconds	X	X
Upline dumping		
DUMP ADDRESS number		X
DUMP COUNT number		X
DUMP FILE filespec		X
†VAX specific		

The CLEAR NODE command clears node parameters for either the local or remote nodes. The CLEAR EXECUTOR command clears executor parameters. You cannot clear the executor parameters BUFFER SIZE and STATE from the volatile database. You can, however, purge them from the permanent database with the PURGE EXECUTOR command.

After you set the executor's state to ON, you cannot change the ADDRESS, ALIAS NODE, BUFFER SIZE, MAXIMUM CIRCUITS, MAXIMUM BROADCAST ROUTERS, NAME, SEGMENT BUFFER SIZE, or TYPE parameters.

3.3.4.1 Logical Link Control

Several executor parameters regulate various aspects of transport operation. Specify the size of NSP receive buffers and transmit buffers (segment buffers) and the number of buffers used to transmit on all circuits. NCP provides three executor parameters for this purpose: BUFFER SIZE, SEGMENT BUFFER SIZE, and MAXIMUM BUFFERS. Be careful to set the values for these parameters to a reasonable level, or system performance may suffer. The parameters all have reasonable default values.

Setting Buffer Sizes

To specify the maximum size (in bytes) of NSP receive buffers, use the BUFFER SIZE parameter. For example, the following command sets the size of all receive buffers for the executor node to 576 bytes:

```
NCP>SET EXECUTOR BUFFER SIZE 576
```

This parameter also controls the maximum segment size of all NSP messages that the local node can receive and forward. The buffer size value that you select is used for all lines. You cannot use the BUFFER SIZE parameter to select individual values for individual lines. You can, however, use the BUFFER SIZE parameter in the SET LINE command to override the BUFFER SIZE value set in the executor for specific lines, such as a particular Ethernet or FDDI line. (See Section 3.6.2.2)

The default BUFFER SIZE value is equal to the SEGMENT BUFFER SIZE if specified; otherwise, the default size is 576 bytes. At a minimum, the buffer size must be 192 bytes. For more information in this area, refer to Chapter 5 and to the *Network Services Protocol Functional Specification*.

Managing and Monitoring the Network

3.3 Node Commands

Consider a number of things when selecting the buffer size value.

- These buffers require nonpaged memory pool.
- Faster lines perform better with large buffers and large user messages that reduce the processor load. (The smaller the segments, the more messages are processed.)
- Lines that are error prone (for example, telephone lines) should use small buffers (256 bytes) to reduce both the probability and the performance impact of retransmissions.
- The executor buffer size must not be larger than the maximum size supported by the datalink, for example, 1498 on Ethernet.

Note

Using the same buffer size for all nodes in your network is strongly recommended. Otherwise, nodes with smaller buffer sizes drop packets when you attempt to route through them.

Changing Buffer Sizes

You can change the size of the buffers on all nodes without bringing down the entire network by performing a two-pass conversion process involving a second parameter, the `SEGMENT BUFFER SIZE`, as well as the `BUFFER SIZE` parameter. The conversion process requires only that you set the local node to the `OFF` state while changing the buffer size.

The maximum size of the transmit buffer is specified in the `SEGMENT BUFFER SIZE` parameter. For example, the following command sets the maximum size of a transmit buffer to 576 bytes:

```
NCP>SET EXECUTOR SEGMENT BUFFER SIZE 576
```

The maximum size of the receive buffer is specified in the `BUFFER SIZE` parameter. The following command sets the maximum size of the receive buffer to 576 bytes:

```
NCP>SET EXECUTOR BUFFER SIZE 576
```

The `SEGMENT BUFFER SIZE` parameter normally has the same value as the `BUFFER SIZE` parameter, but may be set to less in order to perform the buffer size conversion process.

The steps in the conversion depend on whether you are increasing or decreasing the size of the buffers. To increase the size of the buffers, perform the following conversion:

1. Reset the value of the `BUFFER SIZE` parameter at each node to the larger size, permitting each node to receive a larger message.
2. Reset the value of the `SEGMENT BUFFER SIZE` parameter at each node to the larger size, permitting each node to transmit a larger message.

This two-step process ensures that all nodes are able to receive and forward larger messages before any node is able to transmit a larger message.

To decrease the size of the buffers, perform the following conversion:

1. Reset the value of the `SEGMENT BUFFER SIZE` parameter at each node to the smaller size, decreasing the size message that each node can transmit.

Managing and Monitoring the Network

3.3 Node Commands

2. Reset the value of the BUFFER SIZE parameter at each node to the smaller size, decreasing the size message all nodes can receive.

This process ensures that the size of messages that can be transmitted across the network is decreased before the size of the buffers that receive and forward messages is decreased.

An example of the conversion process involves increasing the size of messages that can be transmitted and received over the network from 576 bytes to 1000 bytes. First, enter the following command at each node in the network:

```
NCP>SET EXECUTOR BUFFER SIZE 1000
```

Then, enter the following command at each node in the network:

```
NCP>SET EXECUTOR SEGMENT BUFFER SIZE 1000
```

Each node will first be able to receive and forward 1000-byte messages, and then will be able to transmit them.

Maximum Number of Buffers

To specify the maximum number of buffers for the transmit buffer pool, use the MAXIMUM BUFFERS parameter. The value you assign determines the size of internal data structures for DECnet for OpenVMS software. For example, the following command sets the maximum number of buffers to 20:

```
NCP>SET EXECUTOR MAXIMUM BUFFERS 20
```

If you do not specify a value for this parameter, DECnet for OpenVMS provides a default value of 100. Thus, you do not have to specify a value unless you want to limit the amount of nonpaged pool used by DECnet for OpenVMS. For most operations, DECnet for OpenVMS allocates only as many buffers as it needs (even if you specify a greater number than the amount needed), and does not allocate more than the number of buffers you specify.

Maximum Number of Circuits

To specify the maximum number of circuits that the user can identify in the volatile database, use the MAXIMUM CIRCUITS parameter. This value determines the size of internal data structures used by DECnet for OpenVMS software. For example, the following command establishes an upper limit of 3 circuits that the local node can use:

```
NCP>SET EXECUTOR MAXIMUM CIRCUITS 3
```

The default value for this parameter is 16.

You cannot change the value of the MAXIMUM CIRCUITS parameter while the executor is in the ON state.

3.3.4.2 Operational State of the Local Node

Use the STATE parameter in conjunction with the SET EXECUTOR command to exercise control of the operational state of the local node. There are four states associated with this parameter:

Managing and Monitoring the Network

3.3 Node Commands

OFF	Allows no new logical links to be created, terminates existing links, and stops route-through traffic. The NETACP process exits.
ON	Allows new logical links to be created. The ON state is the normal operational state allowing route-through traffic.
RESTRICTED	Allows no new logical links from other nodes, yet does not inhibit route-through.
SHUT	Similar to RESTRICTED. However, after all logical links are terminated, the local node goes to the OFF state.

Any network user with the OPER privilege can initiate or confirm a logical link connection even though the local node is in the RESTRICTED or SHUT state. Thus, a system manager can use NCP and NML when the network is in either of these states.

Chapter 6 discusses executor states in terms of controlling the operation of the local node, and thus the network as a whole.

Note

Do not use the DEFINE EXECUTOR STATE OFF command for the permanent database because this command would cause the executor to enter the OFF state immediately after DECnet is started.

3.3.5 Copying Node Databases

You can update your node database by copying current information about remote nodes from the configuration database of any node to which you have access.

Use the NCP command COPY KNOWN NODES to copy the volatile or permanent node database entries from a remote node to either or both the volatile and permanent node databases on your node. If you specify the WITH CLEAR or WITH PURGE qualifier on the COPY command, the local node database to which the information is to be copied is cleared or purged before the information is copied. Only the executor node characteristics and the name and address of the remote node are retained when the database is cleared or purged before a copy operation.

The COPY KNOWN NODES command permits you to update your existing node database to reflect current data on remote nodes without having to shut down your node.

If your network is large, the COPY command provides you with a means of keeping up with frequent changes in the composition of the network. For example, one node on a broadcast circuit may serve as the master, keeping in its node database current information on all remote nodes that can be accessed over the network. Then, as other nodes come up on the same broadcast circuit, they can obtain the latest version of the node database by copying it from the master node.

If you did not specify any remote node entries when you configured your node, you can use the COPY command at any time to obtain the remote node entries that indicate the nodes to which you have access. If you want to copy the node database from a remote node that is not defined in your volatile database, you can specify the node's address in the COPY command; execution of the copy operation causes the name and address of the node to be defined in your database.

You cannot use COPY KNOWN NODES to copy a subset of a node database.

Managing and Monitoring the Network

3.3 Node Commands

An alternative method for copying node database information is to use the DCL COPY command to copy the existing permanent database file located in SYS\$SYSTEM:NETNODE_REMOTE.DAT, as described in Section 3.3.5.5.

3.3.5.1 COPY Command Parameters and Qualifiers

The COPY KNOWN NODES command causes the names and addresses of remote nodes to be copied from a remote database to the local node database or databases you specify. The FROM *node-id* parameter in the COPY command specifies the remote node from which the node database information is to be copied.

You can include explicit access control information in the node-id field, or default to a proxy or DECnet account on the remote node, as appropriate. The following command copies remote node data from node BOSTON on which user BROWN has an account with the password PASS123:

```
NCP>COPY KNOWN NODES FROM BOSTON"BROWN PASS123"
```

To indicate which node database at the remote node is to be copied, specify the USING VOLATILE or USING PERMANENT qualifier. If you do not specify the USING qualifier, the default value is USING VOLATILE.

You can indicate the local node database to which the information is to be copied by specifying the TO qualifier. The local node database can be the volatile or permanent database, or both. In the following command, the volatile database at node BANGOR is to be copied to both the volatile and permanent databases at the local node:

```
NCP>COPY KNOWN NODES FROM BANGOR USING VOLATILE TO BOTH
```

If you do not specify the TO qualifier, the local database defaults to VOLATILE.

To clear or purge the local database before the copy operation is performed, specify the WITH CLEAR or WITH PURGE qualifier in the COPY command. The WITH CLEAR qualifier is appropriate if the local database is volatile; the WITH PURGE qualifier is appropriate if it is permanent. Specify either WITH CLEAR or WITH PURGE if both the volatile and permanent databases are to be cleared. (In practice, you can specify either value of the WITH qualifier to clear or purge either or both of the local databases.) The following command indicates that the permanent node database at the local node is to be purged before the remote node data from node BANGOR is copied to the local database:

```
NCP>COPY KNOWN NODES FROM BANGOR USING PERMANENT -  
_ TO PERMANENT WITH PURGE
```

3.3.5.2 Clearing and Purging the Local Node Database

During a copy operation, if the volatile database is to be cleared, the entries for the executor node and any loop nodes are not cleared.

If the permanent database is to be purged, however, the entry for the executor node is purged. Therefore, before the purge occurs, the copy operation causes the executor node characteristics to be saved: a LIST EXECUTOR CHARACTERISTICS command is executed and the executor characteristics are stored. After the purge is executed, the executor characteristics are reinserted in the local node database.

In addition, the local node must retain the name and address of the remote node from which it is to copy the data. Before the clear or purge operation is performed, the name and address of the remote node are saved. This information is reinserted in the local node database after the clear or purge operation is

Managing and Monitoring the Network

3.3 Node Commands

completed. Thus, to purge your database without purging your executor database, use the COPY KNOWN NODES command with the WITH PURGE qualifier.

If the executor or remote node is not defined in the local node database, an error results.

If an error occurs during execution of the LIST EXECUTOR CHARACTERISTICS command, the purge is aborted. After the LIST operation is performed, purging continues even if errors are encountered.

Clearing or purging the local database as part of a copy operation is recommended. If a clear or purge operation is not performed before the remote node data is copied, conflicts can occur between original node entries in the local database and node entries being copied from the remote node database. A node must be identified uniquely, by one name and one address.

A conflict exists when the entries being copied on an existing database would cause one node address to be associated with two node names or two node addresses with one node name. When such a conflict occurs during the copy operation, the original node entry is not updated and an informational message is displayed. For example, if the local node database identified node A with address 3.1 and node B with address 3.3, an attempt to copy an entry that defines node A with address 3.3 would fail, and an informational message would be issued.

3.3.5.3 Copying the Node Database from a Remote Node

Entering a COPY KNOWN NODES command accomplishes the following tasks:

- If you indicate that the volatile node database at the remote node is to be copied (by specifying the USING VOLATILE qualifier in the COPY command), a SHOW KNOWN NODES command is executed at the remote node. If you indicate that the permanent node database is to be copied (by specifying the USING PERMANENT qualifier), a LIST KNOWN NODES command is executed at the remote node.
- The COPY operation extracts remote node names and addresses from data returned by the SHOW or LIST command.
- For each node name and address extracted, a SET or DEFINE NODE command is executed on the appropriate local node database. If you indicate in the COPY command that the information is to be copied to the volatile database, the following command is executed for each entry:

```
SET NODE ADDRESS address NAME name
```

If you indicate that the information goes to both local node databases, both SET NODE and DEFINE NODE commands are executed for each remote node entry. When the COPY operation receives the name and address of the local node, no SET or DEFINE command is performed.

When the name and address of the remote node from which the data is being copied is returned, the entry indicates that it is the executor node. When the remote node is defined in the local database, however, it is not listed as an executor node. Loop node names listed in the node database at the remote node are not defined in the local database.

After the COPY operation begins defining the remote nodes, it continues trying to define the nodes despite any errors it may encounter. It displays informational messages for errors in individual node entries.

Managing and Monitoring the Network

3.3 Node Commands

3.3.5.4 Example of Copying Remote Node Data

The following examples illustrate how to use the COPY command to copy remote node entries from the permanent node database at node ROBIN to the permanent node database at node LARK without purging the local node database.

In this example, node LARK has not defined the executor node or remote node ROBIN in its database; therefore, error messages are displayed. The copy operation is not performed for nodes A and C, because of a conflict between existing and updated addresses for these nodes. Informational messages display for the entries for nodes A and C. (In the first example, only the node entries resulting from the LIST commands are displayed.)

To determine the node entries on the permanent node database at the local node, enter the following command, which causes the node entries to be displayed. Note that, in this example, the executor is not defined.

```
NCP>LIST KNOWN NODES
Remote node = 2.1 (C)
Remote node = 2.3 (A)
```

You can determine the node entries in the permanent node database at remote node ROBIN (whose address is 2.20) by entering the following command, which causes the node entries to be displayed. You can reach node ROBIN by specifying its address in the NCP command, even though the node is not listed by name in the local node database.

```
NCP>TELL 2.20 LIST KNOWN NODES
Executor node = 2.20 (ROBIN)
Remote node = 2.1 (A)
Remote node = 2.2 (B)
Remote node = 2.3 (C)
```

To perform the copy operation, enter the following COPY command:

```
NCP>COPY KNOWN NODES FROM 2.20 USING PERMANENT
%NCP-W-UNRCMP, Unrecognized component, Node
%NCP-W-EXEABO, Executor characteristics not defined.
%NCP-W-UNRCMP, Unrecognized component, Node
%NCP-W-REMABO, Remote node not defined.
%NCP-W-INPVA, Invalid parameter value, Address
Remote node = 2.1 (C)
NODE 2.1 NAME A
%NCP-W-INPVA, Invalid parameter value, Address
Remote node = 2.3 (A)
NODE 2.3 NAME C
```

The error messages generated during the copy operation are displayed on your screen directly under the COPY command. Remote node entries successfully copied to the local node database (such as node B) are not displayed under the COPY command. The COPY command ignores these error messages because they do not affect the copy operation.

Managing and Monitoring the Network

3.3 Node Commands

To determine the final results of the copy operation, enter the `LIST KNOWN NODES` command at your node to obtain the following display of node entries:

```
NCP>LIST KNOWN NODES
Remote node = 2.1 (C)
Remote node = 2.2 (B)
Remote node = 2.3 (A)
Remote node = 2.20 (ROBIN)
```

3.3.5.5 Copying the Permanent Node Database Using DCL COPY

Rather than using the NCP command `COPY KNOWN NODES` to copy node database information, you can use the `DCL COPY` command to obtain the contents of an existing permanent node database residing on a remote node in the file `SYS$SYSTEM:NETNODE_REMOTE.DAT`. You must have the required privileges on the remote node to access this file.

When you enter the `DCL COPY` command to copy from the remote node, include the remote node-id in the file specification. You can include explicit access control information in the node-id field, or default to a proxy or DECnet account on the remote node, as appropriate. The following command copies remote node data from node BOSTON on which the user issuing the copy command has a proxy account.

```
$ COPY BOSTON::SYS$SYSTEM:NETNODE_REMOTE.DAT SYS$SYSTEM:*
```

This `COPY` command copies the permanent node database from the remote node, replacing your local database file. After you copy this permanent node database file to your local node, you can enter the node database information into the local NCP volatile database by entering the following `SET NODE` command:

```
NCP>SET KNOWN NODES ALL
```

3.3.6 Node Counters

DECnet software automatically collects certain statistics for nodes in the network. These statistics are known as node counters. Such information may include the number of connects sent and received, the number of messages sent and received, and the number of packets lost. This information may be useful either alone or in conjunction with logging information to evaluate the performance of a given node.

Refer to Section 2.7 for a discussion of logging. The network counter summary in the *DECnet for OpenVMS Network Management Utilities* describes the complete list of node counters.

You can use NCP to regulate how often counters are logged and when they are zeroed. To do so, you can use the `SET EXECUTOR` or the `SET NODE` command with the `COUNTER TIMER` parameter. For example, the following command causes a node counter logging event to take place every 600 seconds for the local node:

```
NCP>SET EXECUTOR COUNTER TIMER 600
```

The counters are then zeroed. Similarly, the following command specifies that counters for remote node TRNTO are to be logged at the local node every 600 seconds:

```
NCP>SET NODE TRNTO COUNTER TIMER 600
```

Managing and Monitoring the Network

3.3 Node Commands

These counters are maintained on the local node. To clear the COUNTER TIMER parameter, use the CLEAR EXECUTOR or CLEAR NODE command along with this parameter.

You can display node counter statistics at any time while the network is running by using the SHOW NODE COUNTERS command.

In addition, at any point when the network software is running, you can zero node counters for a given remote node, the local node, or for all known nodes. Use any of the following commands to zero node counters:

```
NCP>ZERO EXECUTOR COUNTERS
NCP>ZERO NODE BOSTON COUNTERS
NCP>ZERO KNOWN NODES COUNTERS
```

3.4 Using the DECdns Namespace

VAX

If your network has a DECdns namespace running on any DECdns server node, DECnet for OpenVMS can use this namespace for node name and address information. Using the namespace for DECnet for OpenVMS nodes is optional. ♦

3.4.1 Requirements

VAX

In order for a DECnet for OpenVMS Phase IV node to use DECdns for node-name-to-address mapping, the network must already have a namespace. This namespace can be set up on one or both of the following nodes:

- DNS Version 1 server that is a Phase IV node
- DECdns Version 2 server that is either a DECnet/OSI for OpenVMS system or a DECnet/OSI for ULTRIX system

In addition, your node must be configured as a DNS clerk. DECnet for OpenVMS software includes:

- DNS Version 1.1 clerk software
- The procedure to start it, SYS\$STARTUP:DNS\$CLERK_STARTUP.COM
- The procedure to configure it, SYS\$MANAGER:DNS\$CHANGE_DEF_FILE.COM ♦

3.4.2 How DECnet for OpenVMS Nodes Use DECdns

VAX

The following two examples show how a DECnet for OpenVMS Phase IV node gets node name information when you have enabled the DNS option. During lookups, Session Control first searches the volatile node database on the local DECnet for OpenVMS node for node names or node addresses and, if the information is not present, the DECdns namespace is then checked.

The following figures show this process. In the first instance, the needed information is stored in the local node database. In the second, this database does not contain the necessary information so Session Control then searches the DECdns namespace.

Managing and Monitoring the Network

3.4 Using the DECdns Namespace

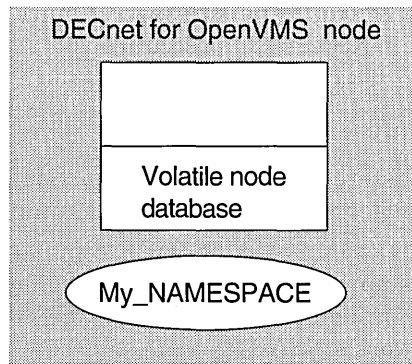

LKG-5121-91R

The requested information is in the volatile node database. The namespace is not accessed.

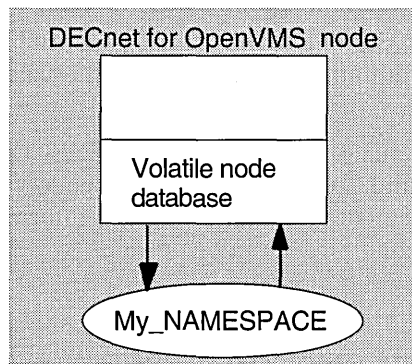

LKG-5122-91R

The requested information is not in the volatile node database.

1. The request is forwarded to the DECdns name server.
2. If the DECdns server can provide the requested information, the node places this information in its volatile node database and then makes the connection.
3. If the DECdns server does not have the information, the DECnet for OpenVMS node returns a status of `SS$_NOSUCHNODE` or displays the following message:

`%SYSTEM-F-NOSUCHNODE, remote node is unknown` ♦

3.4.3 Enabling and Disabling the DECdns Namespace Interface

VAX

Before DECnet for OpenVMS can use DECdns, you must perform the following steps:

1. From the DECdns manager or the network manager, get the following information:
 - The name of the namespace that your node will use.
 - The IDP of your network's network service access point (NSAP). The NSAP is the network's OSI-compliant global network address.
 - The node name of a DECdns server, preferably one on your LAN.
2. Start DECnet.
3. To configure your node as a DNS clerk execute the following command procedure:

```
$ @SYS$MANAGER:DNS$CHANGE_DEF_FILE.COM
```

The procedure asks you the name of the DECdns server node you want to use. Specify the node name with the namespace you want your node to use for node-name-to-address mapping.

Managing and Monitoring the Network

3.4 Using the DECDns Namespace

4. Add the DECDns startup procedure to the site-specific startup procedure before STARTNET.COM. The DNS startup procedure is:
SYS\$STARTUP:DNS\$CLERK_STARTUP.COM
Run the DNS startup procedure.
5. Ensure that your node is registered in the namespace. See the DECDns manager or the network manager responsible for maintaining the namespace. Issue the DEFINE EXECUTOR DNS NAMESPACE command to specify the name of the existing DECDns namespace you want to use for node name and address lookups. In addition, issue the DEFINE EXECUTOR IDP command to specify the IDP of the network's NSAP.
6. Enable the DNS interface option in the permanent database, thus enabling use of the DECDns namespace when the executor node is started.

```
NCP>DEFINE EXECUTOR DNS INTERFACE ENABLED
```

This command specifies that the node will obtain node and address information from the DECDns namespace to update the volatile node database.

To disable use of the namespace, use the SET/DEFINE EXECUTOR DNS INTERFACE DISABLED command. It specifies that the node will not use the DECDns namespace to search for node name and address information. Only the local node database will be searched for this information. ♦

3.5 Circuit Commands

The four classes of circuit that DECnet for OpenVMS supports are DDCMP, CI, Ethernet, and FDDI. The kind of circuit you use depends on your networking needs as well as the kind of hardware you use.

As network manager, use NCP commands to identify all DECnet circuits connected to the local node. Also, specify parameters that affect the operation of the circuits. The following sections describe circuit identification and discuss how to use NCP commands to specify circuit parameters.

3.5.1 Circuit Identification

Like lines, circuits must also have unique identifiers.

3.5.1.1 DDCMP Circuit Identification

VAX

On systems that support DDCMP, DDCMP circuit identification and line identification take one of the following formats:

```
dev-c dev-c-u dev-c.t dev-c-u.t
```

where:

Managing and Monitoring the Network

3.5 Circuit Commands

- dev** Is a device name.
- c** Is a decimal number (0 or a positive integer) that designates the hardware controller for the device.
- u** Is a decimal unit or circuit number (0 or a positive integer) that is included only if there is more than one unit associated with the controller.
- t** Is a decimal number (0 or a positive integer) that identifies a tributary on a multipoint circuit. This is a logical tributary number, not to be confused with the tributary address that is used to poll the tributary.

Note

Circuit devices that are similar in operation are referred to by the same mnemonic.

DDCMP Point-to-Point Addressing

The following command specifies a synchronous point-to-point circuit. The command identifies the DMB circuit device and controller number 0.

```
NCP>SET CIRCUIT DMB-0 STATE ON
```

The following command specifies an asynchronous point-to-point circuit. The command identifies the DZ11 asynchronous circuit device by the mnemonic TT, and specifies controller number 0 and unit number 0 (that is, TTA0).

```
NCP>SET CIRCUIT TT-0-0 STATE ON
```

Dynamic asynchronous DDCMP circuit names are supplied automatically when you establish a dynamic connection. Load the asynchronous driver NODRIVER before establishing a dynamic connection.

DECnet for OpenVMS maps network management circuit names to system-specific device names (for example, DMB-0 maps to SIA0). Network management circuit names provide network-wide circuit identification independent of individual operating system conventions.

DDCMP Multipoint Tributary Addressing

The following command identifies the DMP circuit device, controller number 0, and logical tributary 1:

```
NCP>SET CIRCUIT DMP-0.1 STATE ON
```

Use the SET CIRCUIT command to turn on the DMP circuit device as a multipoint tributary device.

DECnet for OpenVMS software uses a form of circuit identification called a tributary address to poll a tributary for a specified circuit. Use the SET CIRCUIT command to establish the tributary address. For example, the following command specifies an address of 5 to tributary 1 on DMP controller 0:

```
NCP>SET CIRCUIT DMP-0.1 TRIBUTARY 5
```

Values from 1 to 255 are valid for this parameter. The node at the controlling end of this multipoint circuit uses this address to poll this line. Set a corresponding tributary address on the remote node end of the circuit that will respond to a polling address of 5. For example:

```
NCP>SET CIRCUIT DMP-1.0 TRIBUTARY 5
```

Managing and Monitoring the Network

3.5 Circuit Commands

The logical tributary number (0 in this case) is not to be confused with the tributary address. Refer to the description of logical tributary numbers in the circuit identification at the beginning of this section. ♦

3.5.1.2 CI Circuit Identification

VAX

On systems that support the CI, the TRIBUTARY parameter is also used to identify the CI node on the other end of a CI circuit. In the following example, the tributary address 1 identifies the CI node on the other end of circuit CI-0.1:

```
NCP>SET CIRCUIT CI-0.1 TRIBUTARY 1
```

The tributary node address is the CI port number of the remote CI node, not the DECnet node address.

Load the CNDRIVER before running DECnet over a CI (see Section 2.2.3). ♦

3.5.1.3 Ethernet and FDDI Circuit Identification

Ethernet and FDDI circuit identification takes the following format:

```
dev-c
```

where:

dev Is a device name.

c Is a decimal number (0 or a positive integer) that designates the hardware controller for the device.

For example, the following command identifies the circuit device SVA and the controller number 2 for an Ethernet circuit:

```
NCP>SET CIRCUIT SVA-2 ON
```

The following command identifies the circuit device MFA and the controller number 2 for an FDDI circuit:

```
NCP>SET CIRCUIT MFA-2 STATE ON
```

3.5.2 Circuit Parameters

The configuration database contains circuit parameters for all circuits connected to the local node. Table 3-2 lists the types of circuit and the circuit parameters that apply to each type. The circuit parameters supply information used to control various aspects of a circuit's operation.

Table 3-2 Types of Circuit and Applicable Circuit Parameters

Type of Circuit	Applicable Circuit Parameter
All circuits	COST cost COUNTER TIMER seconds HELLO TIMER seconds SERVICE { ENABLED } { DISABLED } STATE { OFF } { ON } { SERVICE }

(continued on next page)

Table 3–2 (Cont.) Types of Circuit and Applicable Circuit Parameters

Type of Circuit	Applicable Circuit Parameter
DDCMP circuits	†ACTIVE BASE base
	†ACTIVE INCREMENT increment
	†BABBLE TIMER milliseconds
	†DEAD THRESHOLD number
	†DYING BASE base
	†DYING INCREMENT increment
	†DYING THRESHOLD number
	†INACTIVE BASE base
	†INACTIVE INCREMENT increment
	†INACTIVE THRESHOLD number
	†MAXIMUM BUFFERS number
	†MAXIMUM TRANSMITS number
	†POLLING STATE { ACTIVE AUTOMATIC DEAD DYING INACTIVE }
†TRANSMIT TIMER milliseconds	
†TRIBUTARY tributary-address	
DDCMP circuits	†VERIFICATION { ENABLED DISABLED INBOUND }
Ethernet and FDDI circuits	MAXIMUM ROUTERS number
	ROUTER PRIORITY number
†VAX specific	

Table 3–3 lists the circuit parameters by function.

Table 3–3 Circuit Parameters and Their Functions

Parameter Function	Parameter
Specifies the circuit cost for routing purposes	COST number
Specifies the interval between transmissions of routing layer hello messages	HELLO TIMER seconds
Specifies service operation (initiated locally or remotely) status for circuit	SERVICE { ENABLED DISABLED }
Sets operational state of circuit	STATE { OFF ON SERVICE }
Specifies how routing initialization passwords are handled	†VERIFICATION { DISABLED ENABLED INBOUND }
Sets timer for circuit counter event logging	COUNTER TIMER seconds
†VAX specific	

(continued on next page)

Managing and Monitoring the Network

3.5 Circuit Commands

Table 3-3 (Cont.) Circuit Parameters and Their Functions

Parameter Function	Parameter
Controls DDCMP multipoint operation	†ACTIVE BASE base †ACTIVE INCREMENT increment †BABBLE TIMER milliseconds †DEAD THRESHOLD number †DYING BASE base †DYING INCREMENT increment †DYING THRESHOLD number †INACTIVE BASE base †INACTIVE INCREMENT increment †INACTIVE THRESHOLD number †MAXIMUM BUFFERS number †MAXIMUM TRANSMITS number †POLLING STATE { ACTIVE AUTOMATIC DEAD DYING INACTIVE } †TRANSMIT TIMER milliseconds †TRIBUTARY tributary-address
Specifies number of routers permitted on LAN circuit	MAXIMUM ROUTERS number
Sets priority of router on LAN circuit for selection of designated router	ROUTER PRIORITY number
†VAX specific	

Use the SET CIRCUIT command to set and modify the parameters in Table 3-3. Use the CLEAR CIRCUIT command to reset or remove them. The circuit must be in the OFF state before you specify the ALL parameter in the CLEAR CIRCUIT command. Most circuit parameters cannot be modified while the circuit is in the ON state. However, you can modify the COST, COUNTER TIMER, HELLO TIMER, MAXIMUM ROUTERS, STATE, and TRANSMIT TIMER parameters while the circuit is ON.

Note

Not all circuit devices support all parameters listed in Table 3-2 and Table 3-3. If a particular device does not support a parameter, an error message may be displayed.

3.5.2.1 Operational State of the Circuit

Just as you can control the operational state of the local node, you can also control the operational state of circuits connected to it. There are three circuit states:

Managing and Monitoring the Network

3.5 Circuit Commands

OFF	Allows no traffic over a circuit. The circuit is unavailable for network activity.
ON	Allows traffic over the circuit. This is the normal operational state allowing for complete route-through and downline loading operations.
SERVICE	Restricts the circuit to service operations only. Only an Ethernet circuit allows logical link activity or route-through at the same time as service operations. Service operations include downline system loading, upline dumping, and loopback testing.

Use the **STATE** parameter to specify the operational state of a circuit. For example, the following command allows normal traffic over circuit SVA-0:

```
NCP>SET CIRCUIT SVA-0 STATE ON
```

DECnet for OpenVMS may automatically change the state of a circuit for certain functions. For example, assume that you have set a DDCMP circuit to ON. Later, someone performs a circuit-level loopback test on that circuit without first setting the circuit state to SERVICE. Network management software automatically turns the circuit to the appropriate internal state (or substate) for the test. If the circuit state were displayed at that point, it would register as ON-LOOPING. When the circuit is in this state, it is in use for an active circuit loop test.

This test is termed active because it was initiated on the local node. The local node enters the passive loopback state (ON-REFLECTING) whenever a remote node initiates a loopback test with the local node. When the test finishes, the circuit returns to the ON state. For a complete list of circuit states, substates, and their transitions, refer to the *DECnet for OpenVMS Network Management Utilities*.

Several circuit substates have the prefix AUTO. These substates can occur when an adjacent node is or is about to be in an automatic downline loading or triggering stage. For example, if circuit SVA-0 is in the ON state and the local node (BOSTON) receives a request for a downline load on that circuit, the network software on the local node automatically sets the circuit to the ON-AUTOSERVICE state.

For service operations, set the **SERVICE** parameter, which enables or disables service operations over a circuit. For example, the following command permits the circuit SVA-0 to be put in the SERVICE state, allowing service functions:

```
NCP>SET CIRCUIT SVA-0 SERVICE ENABLED
```

To disable service operations on a circuit, set the **SERVICE** parameter to **DISABLED**, which allows you to restrict the operation of a circuit for network users. The default for the **SERVICE** parameter is **DISABLED**.

3.5.2.2 Circuit Timers

Two timers exist for controlling message transmissions and checking the status of adjacent nodes. The first is a hello timer, which defines the frequency of Routing layer hello ("I'm still here") messages sent to the adjacent node on the circuit.

The second is a listen timer, which controls the maximum amount of time allowed to elapse before the Routing layer stops waiting for either a hello message or a user message from the adjacent node on the circuit. You cannot set the listen timer with an NCP command; the value of the listen timer is always twice the value of the hello timer at the local node.

To set the hello timer, enter the following command:

```
NCP>SET CIRCUIT SVA-0 HELLO TIMER 15
```

Managing and Monitoring the Network

3.5 Circuit Commands

This command sets a limit of 15 seconds between hello messages from the executor node to the adjacent node on circuit SVA-0. The listen interval is 30 seconds between messages from the node on circuit SVA-0 adjacent to the executor node. For the HELLO TIMER parameter, specify a value between 1 and 8191 seconds. The default value for the HELLO TIMER parameter is 15 seconds.

The value of the HELLO TIMER parameter should be the same on all adjacent nodes over the same circuit.

Digital recommends that you accept the default value for the HELLO TIMER parameter.

3.5.3 DDCMP Circuit Parameters

VAX

On systems that support DDCMP, some DDCMP circuit parameters relate to verification and control of tributaries. ♦

3.5.3.1 DDCMP Circuit Level Verification

VAX

The VERIFICATION parameter applies to DDCMP circuits.

The VERIFICATION parameter controls whether the local node checks the Routing layer passwords (RECEIVE PASSWORD and TRANSMIT PASSWORD) in the database entry for the remote node before it completes a node initialization request from that node.

To turn on verification, enter the following command:

```
NCP>SET CIRCUIT DMB-0 VERIFICATION ENABLED
```

This command specifies that the Routing layer will perform initialization of the remote node connected to circuit DMB-0. To turn verification off, enter the following command:

```
NCP>SET CIRCUIT DMB-0 VERIFICATION DISABLED
```

The default is DISABLED, which means that you need not specify a node in the configuration database to complete Routing layer initialization. To include a remote node in the configuration database, specify the NODE NAME and ADDRESS parameters; you can optionally specify the RECEIVE PASSWORD and TRANSMIT PASSWORD parameters.

When a remote node submits a node initialization request to the local node, the following rules apply:

- Nodes not defined in the remote node database at the local node cannot initialize over a circuit that has verification enabled.
- Nodes defined in the remote node database for which receive and transmit passwords are not specified are allowed to initialize whether or not verification is enabled on the circuit.
- Nodes defined in the remote node database for which receive and transmit passwords are specified are allowed to initialize over a circuit with verification enabled, provided the receive password in the local database matches the transmit password sent by the remote node.
- Any node is allowed to initialize over a circuit for which verification is disabled.

The VERIFICATION INBOUND parameter applies to any DDCMP point-to-point circuit. When you specify VERIFICATION INBOUND, the remote node submitting an initialization request to the local node must supply a transmit password that matches the receive password for that node in the local node database. The local node, however, does not send its initialization password to the requesting node.

The VERIFICATION INBOUND parameter provides added security for the local node, which can verify the password of a node requesting a connection without revealing its own password.

For example, to require that a remote node supply a password before it can initialize on circuit DMB-0 when the local node does not supply a password, enter the following command:

```
NCP>SET CIRCUIT DMB-0 VERIFICATION INBOUND
```

The VERIFICATION INBOUND parameter is supplied automatically for a dynamic asynchronous DDCMP circuit. When a dialup node requests a dynamic connection to the local node and the VERIFICATION INBOUND parameter is set for the circuit, specify the INBOUND parameter for the dialup node in the node database. If you do not specify VERIFICATION INBOUND, the INBOUND parameter in the dialup node entry is ignored.♦

3.5.3.2 DDCMP Tributary Control



On systems that support DDCMP, several circuit parameters enable you to regulate and control tributaries. Some of these parameters apply to polling, others to timers. Note that you specify these circuit parameters on the control station, not on the tributary itself.

Polling Over DDCMP Circuits

To control the polling state of a tributary, use the DYING THRESHOLD, DEAD THRESHOLD, or INACTIVE THRESHOLD parameters. There are four polling states: ACTIVE, INACTIVE, DYING, and DEAD. These parameters determine the number of times the control station polls the active, inactive, or dying tributary before changing its polling state. For example, the following command sets the polling threshold for circuit DMP-0.3:

```
NCP>SET CIRCUIT DMP-0.3 DYING THRESHOLD 5
```

The control station attempts to poll its tributary 5 times. If it gets receive timeouts for five consecutive polls, the control station changes the tributary's polling state from ACTIVE or INACTIVE to DYING. Values for the DYING THRESHOLD parameter range from 0 to 255 and the default is 2. The following command sets the polling threshold for circuit DMP-0.1:

```
NCP>SET CIRCUIT DMP-0.1 INACTIVE THRESHOLD 12
```

The control station attempts to poll its active tributary 12 times. If it receives only acknowledgments, but no data responses, the control station changes the active tributary's polling state to INACTIVE. The values for the INACTIVE THRESHOLD parameter range from 0 to 255 and the default is 8.

You can lock a tributary into one of the four states by using the POLLING STATE parameter. Usually, the tributary's state is allowed to vary according to the multipoint polling algorithm. This variance occurs when this parameter is set to AUTOMATIC. Use this parameter to lock a tributary into the ACTIVE, INACTIVE, DYING, or DEAD state. For example, the following command locks the tributary controlled by circuit DMP-0.1 into a DEAD state:

Managing and Monitoring the Network

3.5 Circuit Commands

```
NCP>SET CIRCUIT DMP-0.1 POLLING STATE DEAD
```

The base priority of a tributary is the lowest value to which that tributary can be set after a poll. A control station polls tributaries with high priorities first. A control station does not poll tributaries with priorities below 128.

To specify the base priority for a tributary, use the ACTIVE BASE, INACTIVE BASE, or DYING BASE parameters. After polling the tributary, the control station resets the base priority of the active, inactive, or dying tributary to this value. You can set a separate base value for each of the polling states, as shown in the following example:

```
NCP>SET CIRCUIT DMP-1.2 ACTIVE BASE 225
```

After a poll, this command resets the base priority of the tributary on circuit DMP-1.2 to 225. The values for all BASE parameters range from 0 to 255. The defaults are ACTIVE, 255; INACTIVE, 0; and DYING, 0.

You can also increment the priority of a tributary each time the line-scheduling timer expires. If, for instance, the polls pass over a tributary with a low priority, you can raise the priority of that tributary by using the ACTIVE INCREMENT, INACTIVE INCREMENT, or DYING INCREMENT parameter.

When the scheduling timer expires on an unpolled tributary, it increases the priority according to the value you set. You can set a separate increment value for each polling state, as shown in the following example:

```
NCP>SET CIRCUIT DMP-2.2 INACTIVE INCREMENT 200
```

This command adds 200 to the base priority of the tributary on circuit DMP-2.2. The increment values range from 0 to 255. The defaults are ACTIVE, 0; INACTIVE, 64; and DYING, 16. Note that if you set a 0 increment on a tributary with a base priority lower than 128, the tributary will never be polled. Active tributaries usually have a high base priority and, therefore, do not need a high increment value.

The MAXIMUM BUFFERS and MAXIMUM TRANSMITS parameters give you further control over the tributary. MAXIMUM BUFFERS specifies the maximum number of buffers that a tributary can use from the common buffer pool. If you do not set this parameter explicitly, the default is 4. Values for this parameter can be either integers ranging from 1 to 254 or the word UNLIMITED. For example, the following command sets an upper limit of 10 buffers that the tributary on this circuit can use from the common buffer pool:

```
NCP>SET CIRCUIT DMP-0.2 MAXIMUM BUFFERS 10
```

The MAXIMUM TRANSMITS parameter specifies the maximum number of data messages that the tributary can transmit in a single poll interval. Values range from 1 to 255; the default is 4. For example, the following command sets an upper limit of 2 data message transmits from the tributary on circuit DMP-0.1:

```
NCP>SET CIRCUIT DMP-0.1 MAXIMUM TRANSMITS 2
```

DDCMP Tributary Circuit Timers

Two timers exist for controlling message retransmission at the DDCMP tributary circuit level. The babble timer controls the amount of time that a tributary or remote half-duplex station can transmit; the transmit timer sets the amount of time to delay between data message transmissions. To specify these timers, enter the following commands:

Managing and Monitoring the Network

3.5 Circuit Commands

```
NCP>SET CIRCUIT DMP-0.1 BABBLE TIMER 8000
NCP>SET CIRCUIT DMP-0.1 TRANSMIT TIMER 4000
```

The first command limits transmission time to 8 seconds (8000 milliseconds) for the circuit's tributary. Values for the BABBLE TIMER parameter range from 1 to 65,535; the default is 6000 (6 seconds).

The second command sets a delay of 4 seconds (4000 milliseconds) between each transmission from the tributary. Values for the TRANSMIT TIMER parameter range from 0 to 65,535; the default is 0.♦

3.5.4 Ethernet and FDDI Circuit Parameters

Broadcast circuits have the following parameters in common with other DECnet for OpenVMS circuits: HELLO TIMER, COST, COUNTER TIMER and STATE. Parameters unique to broadcast circuits are ROUTER PRIORITY and MAXIMUM ROUTERS. The circuit must be in the OFF state to modify the ROUTER PRIORITY parameter.

If there are two or more routers on the same broadcast circuit, one is elected the designated router. The designated router provides message routing services for end nodes on the broadcast media (see Section 2.4.5.1). A designated router is selected even if there are currently no end nodes on the broadcast media. Routers are not required to send messages over the broadcast media; end nodes on the broadcast circuit are capable of communicating directly. However, routers are required to route messages from nodes on the LAN to nodes elsewhere in the network via other circuits.

Use the SET CIRCUIT command to set the ROUTER PRIORITY value in the applicable circuit database on the executor node, as shown in the following command:

```
NCP>SET CIRCUIT SVA-0 ROUTER PRIORITY 70
```

This command assigns a router priority of 70 to the local node on circuit SVA-0.

Each routing node on an Ethernet circuit or FDDI is assigned a router priority value in the range 0 through 127; the default value is 64. DECnet software compares the router priority values of the nodes and elects the router with the highest priority the designated router.

If two or more routing nodes on the Ethernet have the same highest router priority value, the node with the highest node address is selected as designated router. To learn which router is the designated router, enter a SHOW ACTIVE CIRCUITS CHARACTERISTICS command. The following information is displayed for the circuit:

```
Designated router      = 1.224 (ROBIN)
Router priority        = 70
```

The recommended limit on the number of routers on a broadcast circuit is 10, because of the control traffic overhead (composed of routing messages and hello messages) involved. The maximum number of routers allowed is 33.

The MAXIMUM ROUTERS parameter specifies the maximum number of routers that the Routing layer is to allow on a particular broadcast circuit. Use the SET CIRCUIT command to assign the MAXIMUM ROUTERS value for a broadcast circuit. For example, the following command sets a maximum value of 4 to the number of routers (in addition to the executor node) that are permitted on circuit SVA-0:

Managing and Monitoring the Network

3.5 Circuit Commands

```
NCP>SET CIRCUIT SVA-0 MAXIMUM ROUTERS 4
```

The default value is 33.

3.5.5 Ethernet Configurator Module Commands

Use the Ethernet configurator module to obtain a list of all systems on an Ethernet circuit or circuits. Approximately once every 10 minutes, each node on an Ethernet circuit that conforms to the DNA specifications transmits a system identification message to a multicast address that the configurator monitors. The configurator uses these messages to build the configuration list.

Use NCP commands to access and control the configurator module. When you request information about the current configuration of nodes on Ethernet circuits, the following is displayed for each system: its Ethernet physical and hardware addresses, the type of device connecting it to the circuit, maintenance functions it can perform, and the time of the last system identification message from the system.

The Ethernet configurator module requires a default nonprivileged DECnet account or an account associated with the \$NICONFIG object. The configurator runs as a separate process and, once it is started, becomes available to all users on the system. The configurator module continues to execute and maintains and updates its database of information on active nodes.

For a random distribution of nodes with possible loss of system identification datagrams, the configurator would require 40 minutes to collect all node addresses. In practice, the configurator normally requires about 12 minutes to complete a list.

To determine whether the configurator module is running, enter the following command:

```
NCP>SHOW MODULE CONFIGURATOR KNOWN CIRCUITS
```

3.5.5.1 Enabling Surveillance by the Ethernet Configurator

To create or modify Ethernet configurator module parameters in the volatile database, use the `SET MODULE CONFIGURATOR` command. The `SURVEILLANCE ENABLED` parameter in this command causes the configurator module to begin listening to system identification messages transmitted by all systems on the circuit or circuits specified in the command. The configurator collects this information and constructs a list of systems and their capabilities in the volatile database.

3.5.5.2 Obtaining a List of Systems on Ethernet Circuits

To obtain information about the current configuration of nodes on Ethernet circuits, use the `SHOW MODULE CONFIGURATOR` command. This command permits you to access the configurator volatile database, which contains the following information for each system:

- The Ethernet physical and hardware addresses of the system
- The device connecting the system to the Ethernet
- The maintenance version number of the system
- A list of maintenance functions that the node can perform
- The last time a system identification message was received from that system

Managing and Monitoring the Network

3.5 Circuit Commands

The **SHOW MODULE CONFIGURATOR** command causes the configurator to display this information along with the amount of time surveillance has been enabled on the circuit. For example:

```
NCP>SHOW MODULE CONFIGURATOR CIRCUIT SVA-0 STATUS
```

For circuit SVA-0, this command results in the following display:

```
Module Configurator Volatile Status as of 15-JUN-1992 09:15:25
```

```
Circuit name           = SVA-0
Surveillance flag      = enabled
Elapsed time           = 00:32:43
Physical address       = AA-00-04-00-A3-04
Time of last report    = 30-DEC 9:14:8
Maintenance version    = V3.0.0
Function list          = Loop, Primary loader
Hardware address       = AA-00-03-00-00-07
Device type            = SVA
```

```
Circuit name           = SVA-0
Surveillance flag      = enabled
Elapsed time           = 0:32:43
Physical address       = AA-00-04-00-A1-04
Time of last report    = 30-DEC 9:11:29
Maintenance version    = V3.0.0
Function list          = Loop, Primary loader
Hardware address       = AA-00-03-00-00-57
Device type            = SVA
```

3.5.5.3 Disabling Surveillance by the Ethernet Configurator

To cause the configurator to stop listening to system identification messages on specific Ethernet circuits, use the **SURVEILLANCE DISABLED** parameter in the **SET MODULE CONFIGURATOR** command. If you specify the **KNOWN CIRCUITS** parameter with this command, the configurator no longer listens to system identification messages being broadcast on any Ethernet circuit known to the local node.

For example, the following command causes the configurator to cease surveillance of all Ethernet circuits known to the local node:

```
NCP>SET MODULE CONFIGURATOR KNOWN CIRCUITS -
_ SURVEILLANCE DISABLED
```

After the configurator ceases surveillance of all Ethernet circuits it has been monitoring, the list of system information is deleted.

3.5.6 Circuit Counters

DECnet for OpenVMS automatically maintains certain statistics for circuits in the network. These statistics are known as circuit counters. For all circuits, counter information includes the number of data packets sent, received, and lost over the circuit; timeouts; and the amount of time since the counters were last zeroed.

DECnet includes additional counter information for systems that have specific kinds of circuits.

For systems with DDCMP circuits, counters are maintained for timeouts and data and buffer errors. For DDCMP, FDDI and Ethernet circuits, counters include the number of bytes and data blocks sent and received.

Managing and Monitoring the Network

3.5 Circuit Commands

Information obtained from counters may be useful either alone or in conjunction with logging information to measure the performance and throughput for a given circuit. See Section 2.7 for a discussion of logging. Refer to *DECnet for OpenVMS Network Management Utilities* for a complete list of circuit counters.

You can use NCP to regulate the frequency with which circuit counters are logged and when they are zeroed. At any point while the network is running, you can also display circuit counter statistics using the SHOW CIRCUIT COUNTERS command.

To set a timer whose expiration automatically causes the circuit counters to be logged at the logging sink and then zeroed, use the SET CIRCUIT command with the COUNTER TIMER parameter. The following command causes a circuit counter logging event to take place every 600 seconds:

```
NCP>SET CIRCUIT SVA-0 COUNTER TIMER 600
```

To clear this parameter, enter the following NCP command:

```
NCP>CLEAR CIRCUIT SVA-0 COUNTER TIMER
```

At any point when the network is running, you can zero counters for a given circuit or for all known circuits. Enter the following commands to zero circuit counters:

```
NCP>ZERO CIRCUIT SVA-0 COUNTERS  
NCP>ZERO KNOWN CIRCUITS COUNTERS
```

3.6 Line Commands

DECnet for OpenVMS supports four classes of line: DDCMP, CI, FDDI, and Ethernet. The kind of line you use depends on your hardware and the kind of configuration you have.

Use NCP commands to identify all physical lines connected to the local node and to specify parameters that affect operation of the lines. The following sections describe line identification and discuss the line parameters you can use.

3.6.1 Line Identification

As with nodes and circuits, lines must have unique identifiers. The line and circuit names identify a logical connection. Line identification takes one of the following formats:

```
dev-c dev-c[-u]
```

where:

- dev** Is the device name.
- c** Is the decimal number (0 or a positive integer) designating the device's hardware controller.
- u** Is the decimal unit or line number (0 or a positive integer) included if the device is a multiple unit line controller. For all non-multiplexed lines, the unit number is optional and, if specified, is always zero (0).

Note

Devices that are similar in operation are referred to by the same mnemonic.

DECnet maps network management line names to system-specific line names (for example, SVA-0 maps to ESA0:). Network management line names provide network-wide line identification independent of individual operating system conventions.

Commands in this section illustrate line identification.

The following command specifies the Ethernet line SVA-0:

```
NCP>SET LINE SVA-0 STATE ON
```



The following command specifies a synchronous DDCMP point-to-point line, identifying the DMB line device and controller number 0:

```
NCP>SET LINE DMB-0 STATE ON
```

The following command specifies an asynchronous DDCMP point-to-point line. It identifies the DMB asynchronous line unit by the mnemonic TX and specifies controller number 0 and unit number 0 (that is, TXA0).

```
NCP>SET LINE TX-0-0 RECEIVE BUFFERS 4 STATE ON
```

When you turn on an asynchronous line, you are advised to set the number of receive buffers to a value of 4 or more (see Section 3.6.3.1).

Dynamic asynchronous DDCMP line names are supplied automatically when a dynamic connection is established.

The following command specifies the CI line CI-0:

```
NCP>SET LINE CI-0 STATE ON◆
```

3.6.1.1 Line Protocols

As part of the process of identifying lines, specify the line protocol. To ensure that the data link protocol operates properly when information is transferred over a line, use the SET LINE command with the PROTOCOL parameter to specify a line protocol. Table 3-4 lists the line protocols.

Table 3-4 Line Protocols

†DDCMP CONTROL	Specifies the line as a multipoint control station. You can set multiple circuits for CONTROL lines. Each circuit must have a unique physical tributary address.
†DDCMP DMC	Specifies that the line is in DMC emulator mode. DMC is similar to DDCMP POINT protocol, except that DMC uses an older version of DDCMP (Version 3.2). This protocol should be set for the local line when the remote line is a DMC.
†DDCMP POINT	Specifies the line as one end of a point-to-point DDCMP connection. You may specify only one circuit per POINT line.
†DDCMP TRIBUTARY	Specifies that the line is a multipoint tributary end of a DDCMP multipoint group. You may specify only one circuit per TRIBUTARY line.
ETHERNET	Specifies that the line uses the Ethernet protocol.
FDDI	Specifies that the line uses the FDDI protocol.
†VAX specific	

If you do not specify a line protocol, the default values apply, according to the device specified. See Chapter 2 for device lists.

Managing and Monitoring the Network

3.6 Line Commands

VAX

You do not specify any protocol for a CI line. The CI uses its own private protocols for communication between nodes.

The SET LINE PROTOCOL examples that follow specify line protocols in the configuration database at the local node and on remote nodes other than DECnet for OpenVMS, such as DECnet-RSX. For example, the following command identifies line DMP-0 as a multipoint control station:

```
NCP>SET LINE DMP-0 PROTOCOL DDCMP CONTROL
```

You set this parameter in the database of the local node at the controlling end of this line. You could specify a tributary for this line, as follows:

```
NCP>SET LINE DMP-1 PROTOCOL DDCMP TRIBUTARY
```

You set this parameter in the database of the remote node connected to the tributary end of the control station for that line. ♦

3.6.2 Line Parameters

The configuration database should contain line parameters for all physical lines connected to the local node. These parameters supply information used to control various aspects of a line's operation. Table 3-5 lists the types of line and the line parameters applicable to them.

Table 3-5 Line Types and Applicable Line Parameters

Type of Line	Applicable Line Parameter
All lines	BUFFER SIZE number COUNTER TIMER seconds SERVICE TIMER milliseconds STATE { ON OFF SERVICE } RECEIVE BUFFERS number
All lines except CI	PROTOCOL { †DDCMP CONTROL †DDCMP DMC †DDCMP POINT †DDCMP TRIBUTARY ETHERNET FDDI }
Asynchronous DDCMP lines	†HANGUP { DISABLED ENABLED } †LINE SPEED number †SWITCH option { DISABLED ENABLED }

†VAX specific

(continued on next page)

Managing and Monitoring the Network

3.6 Line Commands

Table 3-5 (Cont.) Line Types and Applicable Line Parameters

Type of Line	Applicable Line Parameter
DDCMP lines	†CLOCK { EXTERNAL INTERNAL } †CONTROLLER { LOOPBACK NORMAL } †DEAD TIMER milliseconds †DELAY TIMER milliseconds †DUPLEX duplex-mode { FULL HALF } †RETRANSMIT TIMER milliseconds †SCHEDULING TIMER milliseconds †STREAM TIMER milliseconds
DMR11 lines	†TRANSMIT PIPELINE number
FDDI lines	ECHO { DATA hex-byte LENGTH count TARGET address } NIF TARGET p-address REQUESTED TRT microseconds RESTRICTED TOKEN TIMEOUT ##milliseconds RING PURGER ENABLE { ON OFF } SIF CONFIGURATION TARGET p-address SIF OPERATION TARGET p-address VALID TRANSMISSION TIME microseconds
†VAX specific	

The following four tables, Table 3-6, Table 3-7, and Table 3-8, list line parameters by function.

Table 3-6 Line Parameters and Their Functions

Parameter Function	Parameter
Specifies line's operational state	STATE { OFF ON SERVICE }
Specifies protocol	PROTOCOL { †DDCMP CONTROL †DDCMP POINT †DDCMP DMC †DDCMP TRIBUTARY ETHERNET FDDI }
Sets counter timer for line counter event logging	COUNTER TIMER seconds
Sets maximum receive buffer size for logical links over specific line	BUFFER SIZE number
†VAX specific	

(continued on next page)

Managing and Monitoring the Network

3.6 Line Commands

Table 3-6 (Cont.) Line Parameters and Their Functions

Parameter Function	Parameter
Sets maximum number of buffers in receive queue	RECEIVE BUFFERS number
Sets timer for service operations	SERVICE TIMER milliseconds

Table 3-7 FDDI Line Parameters and Their Functions

Parameter Function	Parameter
Specifies address for NIF request frame	NIF TARGET p-address
Specifies address for SIF configuration request frame	SIF CONFIGURATION TARGET p-address
Specifies address for SIF operation request frame	SIF OPERATION TARGET p-address
Specifies echo data	ECHO DATA hex-byte
Specifies echo length	ECHO LENGTH count
Specifies echo target address	ECHO TARGET address
Specifies limit on a single restricted mode dialog	RESTRICTED TOKEN TIMEOUT ##milliseconds
Specifies ring purger function	RING PURGER ENABLE { ON } { OFF }
Specifies maximum time between arrivals of a valid frame or unrestricted token	VALID TRANSMISSION TIME microseconds
Specifies value for token rotation timer	REQUESTED TRT microseconds

Table 3-8 DDCMP Line Parameters and Their Functions (VAX only)

Parameter Function	Parameter
Specifies clock type	†CLOCK { INTERNAL } { EXTERNAL }
Specifies physical line control parameters	†DUPLEX { FULL } { HALF } †DEAD TIMER milliseconds †DELAY TIMER milliseconds †RETRANSMIT TIMER milliseconds †SCHEDULING TIMER milliseconds †STREAM TIMER milliseconds
Specifies asynchronous line characteristics	†HANGUP { DISABLED } { ENABLED } †LINE SPEED number †SWITCH { DISABLED } { ENABLED }
†VAX specific	

Use the SET LINE command to establish and modify the parameters in Table 3-5, Table 3-6, Table 3-7, and Table 3-8. You must set the line to

OFF if you want to modify any parameters except COUNTER TIMER, SERVICE TIMER, and STATE.

STATE is a required parameter for all lines that you specify in the configuration database.

Use the CLEAR LINE command to reset or remove parameters. The line must be set to the off state before you specify the ALL parameter in the CLEAR LINE command.

Not all hardware platforms include devices that support all parameters listed in Table 3-5, Table 3-6, Table 3-7, and Table 3-8. If a particular parameter is not supported, an error message will be displayed.

3.6.2.1 Operational State of Lines

As with local node and circuit states, you can control the operational state of lines connected to the local node. There are three possible line states:

OFF	Allows no traffic over a line. The line is unavailable for network activity.
ON	Allows traffic over the line. The ON state is the normal operational state, which allows complete route-through and downline loading operations.

The ON and SERVICE states have substates; see the *DECnet for OpenVMS Network Management Utilities* for a complete list of line states, substates, and their transitions.

Use the STATE parameter to specify the operational state of a line. For example, to allow normal traffic over line SVA-0, enter the following command:

```
NCP>SET LINE SVA-0 STATE ON
```

The STATE parameter is optional and, by default, is set to OFF.

3.6.2.2 Buffer Size

You can increase the maximum size of receive buffers (and therefore the size of NSP messages) that can be transmitted over a particular line by specifying the BUFFER SIZE parameter in the SET LINE command. For certain logical links established over the line to adjacent nodes, this BUFFER SIZE value overrides the executor node BUFFER SIZE limit specified in the SET EXECUTOR command (see Section 3.3.4.1).

If you specify the BUFFER SIZE parameter for a line, the adjacent node on any new logical link initiated over that line can optionally accept an NSP message segment size that is based on the BUFFER SIZE value. If the remote node accepts the segment size, the logical link to that node is then tied to that circuit. If the circuit fails, the logical link does not automatically route the packet through an alternate circuit with a similar buffer size; that is, the logical link becomes nonadaptive.

For example, the following command sets the maximum size of receive buffers for line SVA-0 to 1400 bytes, but only for logical links to adjacent nodes that accept 1400 bytes as the NSP segment size:

```
NCP>SET LINE SVA-0 BUFFER SIZE 1400
```

If the adjacent node does not accept a segment size based on the BUFFER SIZE value, the default is the executor node's BUFFER SIZE value. The maximum and default line buffer size for an Ethernet or FDDI line is 1498 bytes. A large value for BUFFER SIZE will achieve maximum performance because all logical links between adjacent nodes will use this message size.

Managing and Monitoring the Network

3.6 Line Commands

This feature can also be used to maximize performance over the CI. However, on a CI the BUFFER SIZE parameter must be less than or equal to the SYSGEN parameter SCSMAXDG. Failure to do this will result in an unusable CI circuit.

Increasing line BUFFER SIZE may require that additional buffered I/O byte count quota (BYTLM) be allocated to the NETACP process. See Section 5.4.3 for information about adjusting NETACP's BYTLM quota.

3.6.3 DDCMP Line Parameters

VAX

On systems that support DDCMP, several parameters regulate various aspects of a DDCMP line's physical protocol operation. You can specify the number of receive buffers, the duplex mode, and the timers for both normal and service operations.

Parameters that apply specifically to asynchronous DDCMP lines indicate the speed of the line, whether modem signals are dropped when a line is shut down, and whether an asynchronous line is switched back to a terminal line when disconnected from the network. For a dynamic asynchronous line, DYN SWITCH supplies these parameters to NETACP automatically.

The following sections describe the DDCMP line parameters. ♦

3.6.3.1 Line Buffers

VAX

To allocate buffers for data reception by the device driver for a particular DDCMP line, use the RECEIVE BUFFERS parameter. The following command sets four buffers for an asynchronous line:

```
NCP>SET LINE TT-0-0 RECEIVE BUFFERS 4
```

Values for this parameter range from 1 to 32. The number of buffers you set depends on throughput requirements and available memory pool. A value in the range of 2 to 4 is adequate for line speeds of less than 56K bits. For asynchronous lines, a value of at least 4 is recommended. Megabit line speeds may require eight or more buffers, depending on the observed errors.

An insufficient number of receive buffers on asynchronous DDCMP lines can cause such network problems as timeouts and loss of packets. If these problems occur, you can enter the NCP command SHOW CIRCUIT to confirm whether an insufficient number of receive buffers was the cause:

```
$ RUN SYS$SYSTEM:NCP
NCP>SHOW CIRCUIT TT-0-0 COUNTERS
```

Check the Remote Buffer Errors listed for the circuit. If the counters show any Remote Buffer Errors that include the words "buffer unavailable," increase the number of receive buffers for the line. First, use the NCP command SHOW LINE <line-id> CHARACTERISTICS to determine the current number of receive buffers for the line, as in the following command:

```
NCP>SHOW LINE TT-0-0 CHARACTERISTICS
```

The resulting display lists the characteristics for the line, including the number of receive buffers. For example:

```
Line Volatile Characteristics as of 15-JUN-1992 9:32:50
Line = TT-0-0
```

Managing and Monitoring the Network

3.6 Line Commands

```
Receive Buffers      = 4
Controller           = normal
Duplex               = full
Protocol             = DDCMP point
Retransmit timer     = 3000
Line speed           = 9600
Switch              = disabled
Hangup              = disabled
```

Then use the NCP command **SET LINE** to change the number of receive buffers in the volatile database. In the following example, the number of receive buffers shown in the previous example (four buffers) is increased to six:

```
NCP>SET LINE TT-0-0 STATE OFF
NCP>SET LINE TT-0-0 RECEIVE BUFFERS 6
NCP>SET LINE TT-0-0 STATE ON
```

To change the number of receive buffers in the permanent database as well, use the NCP command **DEFINE LINE**. Increasing the number of line **RECEIVE BUFFERS** may require that additional buffered I/O byte count quota (**BYTLM**) be allocated to the **NETACP** process. Refer to Section 5.4.3 for information about adjusting **NETACP**'s **BYTLM** quota. ♦

3.6.3.2 Duplex Mode

VAX

To set the duplex mode for a **DDCMP** line, use the **DUPLEX** parameter. For example, the following command sets the mode of the **DMB** controller to full duplex for line **DMB-1**:

```
NCP>SET LINE DMB-1 DUPLEX FULL
```

Generally, you use full-duplex mode for local lines and permanently wired telephone lines; you usually use half-duplex mode for dialup remote telephone lines used with half-duplex synchronous modems. If you use a modem, consult the manufacturer's documentation for full- or half-duplex characteristics. ♦

3.6.3.3 Line Timers

VAX

Line timers control the frequency of message retransmission at the **DDCMP** level. There are six line timers:

- **Service timer**—sets the maximum amount of time allowed to elapse before a retransmission is necessary when service operations are under way.
- **Retransmit timer**—sets the maximum amount of time allowed to elapse before a retransmission is necessary on a multipoint line. This is the amount of time a control station will wait for a tributary to respond. For a **DMF32** tributary, it is the maximum amount of time the tributary will hold the line before returning control to the control station.
- **Dead timer**—sets the amount of time between polls of the dead tributaries.
- **Delay timer**—sets the amount of time to delay between polls of active tributaries.
- **Scheduling timer**—sets the time limit between recalculations of tributary polling priorities.
- **Stream timer**—sets the amount of time that a tributary or half-duplex remote station is allowed to hold the line.

Managing and Monitoring the Network

3.6 Line Commands

The DMP11 controller automatically handles message retransmission for normal operations. However, when a DDCMP circuit is in the SERVICE state, a line retransmission timer is necessary because the DMP11 does not handle retransmission in maintenance operation protocol (MOP) mode.

You can determine the optimum value to use for the retransmit timer for a synchronous DDCMP line. The formula involves a constant obtained from the calculation of the time required for transmission and reception of the contents of a single executor buffer over the line. To derive the constant, multiply the executor buffer size (in bytes) by 8 bits/byte, divide the result by the line speed (in bits per second), and multiply by 2 (for transmission and reception). To this result, add a factor representing the time allotted for transmission delay and processing overhead (for DDCMP lines, a factor of 1/2 is used). Convert the final value to milliseconds by multiplying by 1000 ms/sec. When the constants are multiplied out, the remaining constant is 20,000, which applies to the following retransmit timer calculation:

$$\text{RETRANSMIT TIMER} = (20000 * \text{buffer-size} * \text{number-of-buffers})/\text{bps-of-line}$$

In general, use this formula to calculate the best value for the retransmit timer (in milliseconds).

The number of buffers is the value specified for the MAXIMUM TRANSMITS parameter in the SET CIRCUIT command; it represents the maximum number of data messages that the tributary can transmit in a single poll interval (see Section 3.5.3.2).

Assume an example with an executor buffer size of 576, a line of 56K bits per second (bps), and four buffers per selection interval. The formula would be calculated as follows:

$$\text{RETRANSMIT TIMER} = (20000 * 576 * 4)/56000 = 820 \text{ milliseconds}$$

To set a retransmit timer for a DDCMP line, use the RETRANSMIT TIMER parameter, as follows:

```
NCP>SET LINE DMP-2 RETRANSMIT TIMER 820
```

This command sets the retransmission frequency for line DMP-2 to 820 milliseconds. If a message is not acknowledged in 820 milliseconds, it is retransmitted.

The preceding formula does not apply to the DMF32 tributary mode. The value of the retransmit timer is the maximum time the tributary will hold the line before returning control to the control station. For DMF32 tributary mode, therefore, the more active the tributary, the higher the value to which you should set the retransmit timer (a value of 2000 is recommended). For inactive tributaries, set the timer value lower (a value of 500 milliseconds is recommended).♦

3.6.3.4 Satellite Transmission Control

VAX

For a connection over a very long path, such as a satellite link, use the TRANSMIT PIPELINE parameter to establish the maximum number of DDCMP messages that may be transmitted over a line without waiting for a positive acknowledgment from the remote node. This parameter is useful for satellite transmissions because of the long round-trip delay between message transmission and acknowledgment. For example, the following command sets a maximum of 10 DDCMP messages for the line DMC-2:

```
NCP>SET LINE DMC-2 ... TRANSMIT PIPELINE 10
```

The TRANSMIT PIPELINE parameter is optional and, by default, takes the value 7.

Because of the system memory overhead involved, avoid arbitrarily setting this value higher than necessary. The optimum value for the TRANSMIT PIPELINE parameter for the DMR11 is equal to the number of DDCMP messages that can be transmitted before the first message in the sequence is acknowledged. You can calculate the optimum TRANSMIT PIPELINE value using the following algorithm:

$$\text{messages} = (\text{delay} * \text{rate}) / (\text{size} * 8)$$

where:

delay	Is the link's round trip delay time in seconds, which is the total time required for a message to reach the remote receiver and for the acknowledgment to be received by the transmitter. You can determine the delay value from information supplied by the carrier providing the leased circuit, or by observing the delay on suitable line-monitoring equipment.
rate	Is the line speed in bits per second.
size	Is the average DDCMP message size in bytes, which can be calculated by dividing the number of bytes transmitted by the number of messages transmitted. Use the SHOW LINE command with the COUNTERS parameter to determine the number of bytes and messages transmitted. Line counters are described in Section 3.6.6.

For example, to determine the optimum TRANSMIT PIPELINE value of a satellite link that has a round trip delay of 0.67 seconds, a line speed of 9.6K bits per second, and an average DDCMP message size of 40 bytes, calculate the following:

$$(0.67 * 9600) / (40 * 8) = 20$$

For this example, the optimum value for TRANSMIT PIPELINE is 20 messages. ♦

3.6.3.5 Asynchronous DDCMP Line Parameters

VAX

The LINE SPEED, HANGUP, and SWITCH parameters apply only to asynchronous DDCMP lines. Values for these parameters are provided automatically when a line is switched dynamically from a terminal line to an asynchronous DDCMP line. When you initiate a dynamic connection between two nodes over a telephone line, these parameters are included in the line entries supplied to the line database. For static asynchronous DDCMP lines, these parameters usually assume their default values.

The LINE SPEED parameter specifies in baud the speed of an asynchronous DDCMP line. The parameter defaults to the current speed of the line. If two asynchronous lines are connected, both lines must have the same line speed.

If a dynamic connection is made, this value is supplied automatically for each line. For a static asynchronous line, the default line speed value is the value of the /SPEED qualifier in the DCL command SET TERMINAL you specified to cause the terminal line to be converted to an asynchronous line.

The HANGUP parameter determines whether the modem signal is dropped when the line is shut down. When you shut down a dynamically switched asynchronous line, the modem carrier is dropped if the value of the parameter is ENABLED. This value, supplied automatically, corresponds to the /HANGUP qualifier in the SET TERMINAL command you specified to cause the terminal line to be switched to an asynchronous line. If the value supplied for the parameter is

Managing and Monitoring the Network

3.6 Line Commands

DISABLED, the modem signal is not dropped when the line is shut down. For a static asynchronous line, the parameter defaults to ENABLED.

The SWITCH parameter indicates whether an asynchronous DDCMP line is to be switched back to a terminal line after it is disconnected from the network (when the channel to the network is deassigned). The SWITCH parameter is enabled automatically for a dynamic asynchronous line so that the line can be switched back to a terminal line when the dynamic connection is broken. The parameter defaults to DISABLED for a static asynchronous line, which remains available as a communications line even when not assigned a channel to the network. Generally, you do not need to set the SWITCH parameter manually. ♦

3.6.4 Ethernet Line Parameters

Parameters the Ethernet lines have in common with other DECnet lines are COUNTER TIMER, PROTOCOL, STATE, RECEIVE BUFFERS and BUFFER SIZE.

When you enter the SHOW LINE command, the Ethernet address associated with the Ethernet line device controller is displayed as a read-only parameter, HARDWARE ADDRESS. For example:

```
NCP>SHOW LINE SVA-0 CHARACTERISTICS
```

This command results in the following information being displayed for SVA-0:

```
Line = SVA-0
Receive buffers   = 10
Controller       = normal
Protocol         = Ethernet
Service timer    = 4000
Hardware address  = 08-00-2B-23-AF-F3
Device buffer size = 1498
```

See the discussion of physical and hardware addresses in Section 2.1.2.

3.6.5 FDDI Line Parameters

Parameters the FDDI lines have in common with other DECnet lines are BUFFER SIZE, CONTROLLER, HARDWARE ADDRESS, PROTOCOL, STATE, RECEIVE BUFFERS and SERVICE TIMER.

You can use the BUFFER SIZE parameter to optimize performance over a high-speed link such as FDDI. (See section Section 3.6.2.2.)

3.6.5.1 Displaying the Hardware Address

The FDDI address associated with the FDDI line device hardware is displayed as a read-only parameter, hardware address, in response to the SHOW LINE command.

```
NCP>SHOW LINE MFA-0 CHARACTERISTICS
```

```
Line = MFA-0
```

Managing and Monitoring the Network

3.6 Line Commands

```
Receive buffers          = 10
Controller              = normal
Protocol                = FDDI
Service timer          = 4000
Hardware address        = 08-00-2B-1C-12-16
Device buffer size     = 1498
Requested TRT          = 0
Valid transmission time = 32768
Restricted token timeout = 0
Ring purger enable     = off
NIF target              = 00-00-00-00-00-00
SIF configuration target = 00-00-00-00-00-00
SIF operation target   = 00-00-00-00-00-00
Echo target             = 00-00-00-00-00-00
Echo data               = 00
Echo length             = 0
```

See the discussion of physical and hardware addresses in Section 2.1.2.

3.6.5.2 Displaying the Line Status

To display the FDDI line status enter the following command:

```
NCP>SHOW LINE MFA-0 STATUS
```

The command results in the following information display:

```
Line = MFA-0
State = on
Negotiated TRT = 99840
Duplicate address flag = unknown
Upstream neighbor = 08-00-2B-1C-0D-BB
Old upstream neighbor = 00-00-00-00-00-00
Upstream neighbor DA flag = unknown
Downstream neighbor = 00-00-00-00-00-00
Old downstream neighbor = 00-00-00-00-00-00
Ring purger state = off
Ring error reason = no error
Neighbor PHY type = A
Link error estimate = 15
Reject reason = none
```

Table 3-9 lists all FDDI line status read-only parameters and their functions.

Managing and Monitoring the Network

3.6 Line Commands

Table 3-9 FDDI Line Status Parameters and Their Functions

Parameter	Function
Negotiated TRT	Negotiated value of the token rotation timer
Duplicate address flag	The summary output from the duplicate address test algorithm
Upstream neighbor	Data link address of upstream neighbor MAC
Old upstream neighbor	The previous non-null value of upstream neighbor, or the null address if upstream neighbor has always been null
Upstream neighbor DA flag	The upstream neighbor's duplicate address status as reported by the NIF frame. Only meaningful if upstream neighbor is not null
Downstream neighbor	Data link address of downstream neighbor MAC
Old downstream neighbor	The previous non-null value of downstream neighbor, or the null address if downstream neighbor has always been null
Ring purger state	The state of the ring purger function
Ring error reason	The reason code for the most recent link error, or "no error" if no link error has ever occurred
Neighbor PHY state	The PHY type of the neighbor PHY or "unknown" if there is no connection yet
Link error estimate	The link error monitor current estimate of the link error rate
Reject reason	The reason why the PHY port is in the REJECTED state

3.6.6 Line Counters

DECnet software automatically maintains statistics for certain lines in the network. These statistics are known as line counters.

Counter information varies, depending on the kind of lines installed on your system. It includes information about the number of bytes and data blocks sent and received; local and remote process errors; and the amount of time since the counters were last zeroed.

Line counters for Ethernet and FDDI lines include the number of bytes, multicast bytes, data blocks, and multicast blocks sent and received; and the number of send failures and discarded frames. Line counters for FDDI lines also include counters for ring-specific information. Line counters for Ethernet include the number of blocks deferred or sent after collision.

Counters enable you to measure the performance and throughput for a given line. Counter information can be useful alone, and in conjunction with logging information. Refer to Section 2.7 for a discussion of logging.

You can use NCP to affect the frequency with which counters are logged and when the counters are zeroed. At any point while the network is running, you can also display line counter statistics using the `SHOW LINE COUNTERS` command.

To set a timer whose expiration automatically causes the line counters to be logged at the logging sink and then zeroed, use the `SET LINE` command with the `COUNTER TIMER` parameter. The following command causes a line counter logging event to take place every 600 seconds:

```
NCP>SET LINE SVA-0 COUNTER TIMER 600
```

To clear this parameter, enter the following NCP command:

```
NCP>CLEAR LINE SVA-0 COUNTER TIMER
```

At any point when the network is running, you can zero line counters for a given line or for all known lines. Enter the following commands to zero line counters:

```
NCP>ZERO LINE SVA-0 COUNTERS  
NCP>ZERO KNOWN LINES COUNTER
```

Refer to *DECnet for OpenVMS Network Management Utilities* for more detailed information on line counters.

3.7 Routing Commands

As network or system manager, you can use certain NCP commands to specify how the network is to be configured into routing and nonrouting nodes. Not all hardware platforms support routing. Check the DECnet for OpenVMS Software Product Description (SPD) to determine if routing is supported by software running on your hardware platform.

During configuration, you can use NCP parameters to indirectly control the path data takes through the network, and to control the timing of routing messages; these parameters have reasonable default values for most networks.

3.7.1 Specifying the Node Type

You specify the type of node in the TYPE parameter of the DEFINE EXECUTOR command. For DECnet Phase IV, DECnet for OpenVMS supports three values for the node type:

Node Type	TYPE Parameter
Phase IV end	NONROUTING IV
Phase IV level 1	ROUTING IV
†Phase IV level 2	AREA
†VAX specific	

To designate the executor as a Phase IV nonrouting node (end node), enter the following command:

```
NCP>DEFINE EXECUTOR TYPE NONROUTING IV
```

To specify the executor as a router, enter the following command:

```
NCP>DEFINE EXECUTOR TYPE AREA
```

This command creates a level 2 router in an area network configuration. ♦

You cannot change the executor node type while DECnet is running. Shut down the network, use the DEFINE command to change the executor node type, and then restart the network.

The SHOW EXECUTOR CHARACTERISTICS command displays the node type of the executor node. The SHOW NODE node-id STATUS command displays the node type of a specified adjacent node. The possible values for the node type are AREA, ROUTING IV, NONROUTING IV, ROUTING III, NONROUTING III, or PHASE II. A Phase IV node can be a level 2 router (AREA), a level 1 router (ROUTING IV), or an end node (NONROUTING IV). A Phase III node can be either a router (ROUTING III) or an end node (NONROUTING III).



Managing and Monitoring the Network

3.7 Routing Commands

3.7.2 Specifying the Area Number in a Node Address

To configure a network for area routing, assign each node to a specific area that has a unique number. The area number is a decimal number, in the range 1 through 63, which appears as a prefix on the decimal node number of the individual node. The node number must be unique within the area. The maximum value for node number is 1023. The area number and the node number are separated by a period. The format of a node address in an area network is as follows:

area-number.node-number

For example, node 300 in area 40 has a node address of 40.300.

To set the node address for the local node in an area configuration, use the SET EXECUTOR command with the ADDRESS parameter, as follows:

```
NCP>SET EXECUTOR ADDRESS 40.300
```

Configuration of a network requires that each node be assigned a node address containing an appropriate area number. If you do not specify an area number in a node address, the executor area number is used.

You can convert a Phase IV node address to a decimal equivalent for use in DCL commands, such as COPY, and in sending messages using the Mail Utility. This is useful if you have not yet added the node name to the node database. The algorithm to convert the address to its decimal equivalent is as follows:

$$(\text{area-number} * 1024) + \text{node-number}$$

You can also convert the address to its hexadecimal equivalent in order to determine the physical address of the node (see Section 2.1.2).

Referring to a node by name is generally more convenient.

3.7.3 Setting Routing Configuration Limits

On systems that support routing, you can establish certain limits related to routing over the network during network configuration. You can limit the number of routers allowed on a single LAN and the number of routing and end nodes permitted on all broadcast circuits to which the local node is attached. If the network is grouped into areas, you can limit the number of areas allowed.

3.7.3.1 Maximum Number of Routers and End Nodes Allowed

Certain NCP command parameter values limit the number of routers and end nodes that can be configured on broadcast circuits.

Use the SET CIRCUIT command with the MAXIMUM ROUTERS parameter to set the maximum number of routers permitted on a particular Ethernet or FDDI circuit. The largest number of routers allowed on a LAN is 33, which is the default value of the MAXIMUM ROUTERS parameter. Note that the recommended limit on the number of routers on a single broadcast circuit is 10, because of the control traffic overhead (routing messages and system identification messages) involved. For example, the following command specifies that no more than five routers can exist on Ethernet circuit SVA-0:

```
NCP>SET CIRCUIT SVA-0 MAXIMUM ROUTERS 5
```

Use the SET EXECUTOR command with the MAXIMUM BROADCAST ROUTERS parameter to specify the maximum number of routing nodes that will be permitted on all Ethernet and FDDI circuits to which the local node is attached.

Managing and Monitoring the Network

3.7 Routing Commands

Each routing node can be either a level 1 router (capable of routing within its own area, if routing IV is specified) or a level 2 router (capable of routing within its own area and outside of its area). For example, the following command specifies that a maximum of 12 routers is allowed on Ethernet and FDDI circuits to which the executor node is connected:

```
NCP>SET EXECUTOR MAXIMUM BROADCAST ROUTERS 12
```

The default value of this parameter is 32.

Use the SET EXECUTOR command with the MAXIMUM BROADCAST NONROUTERS parameter to set the maximum number of nonrouting nodes (end nodes) permitted on all Ethernet and FDDI circuits to which the local node is attached. For example, the following command specifies that no more than 20 end nodes can exist on all Ethernet and FDDI circuits to which the executor node is connected:

```
NCP>SET EXECUTOR MAXIMUM BROADCAST NONROUTERS 20
```

The default value is 64.

3.7.3.2 Maximum Number of Areas Allowed

VAX

When configuring an area network, use the SET EXECUTOR command with the MAXIMUM AREA parameter if you want to set a limit on the number of areas that the executor node's Routing layer will recognize. For example, if you want a maximum of 50 areas to be recognized, enter the following command:

```
NCP>SET EXECUTOR MAXIMUM AREA 50
```

If you do not specify this parameter, the Routing layer recognizes up to 63 areas. ♦

3.7.4 Routing Control Parameters

VAX

On systems that support routing, NCP supports routing parameters that provide for circuit cost control, of the total path between any two nodes (MAXIMUM COST, MAXIMUM HOPS), route-through control (MAXIMUM VISITS), and equal cost path splitting (MAXIMUM PATH SPLITS and PATH SPLIT POLICY).

For a network divided into areas, the area routing parameters for maximum cost and length of the paths between areas in the network (AREA MAXIMUM COST, AREA MAXIMUM HOPS) also apply. These parameters are used to control the path that data is likely to take when being transmitted through the network, and to minimize congestion at particular nodes in the network. For most networks, the default values for these parameters should be acceptable. ♦

3.7.4.1 Circuit Cost Control Parameter

Figure 3-2 illustrates sample circuit costs attributed to the network example. The following paragraphs discuss routing control parameters as they relate to Figure 3-2.

The COST parameter in the SET CIRCUIT command specifies the circuit cost. For example, the following command sets a cost for the circuit connecting node BOSTON to node NYC:

```
NCP>SET CIRCUIT SVA-0 COST 4
```

Numbers in the range of 1 to 25 are valid circuit costs. The default value is 10. Establishing a circuit cost standard that is uniform across the entire network is recommended.

Managing and Monitoring the Network

3.7 Routing Commands

Figure 3–2 Network Circuit Costs

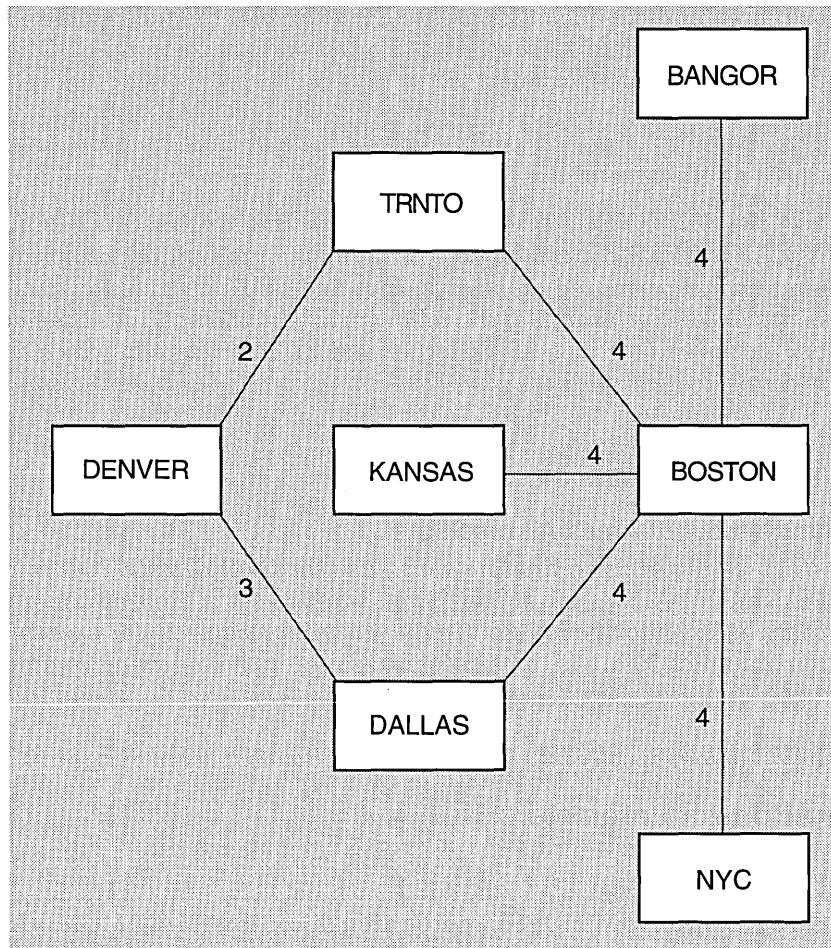

LKG-6701-92R

3.7.4.2 Maximum Path Control Parameters

You set both the maximum cost for all circuits to the destination node (MAXIMUM COST) and the maximum hops that a packet can make when routed to the destination node (MAXIMUM HOPS) using the SET EXECUTOR command. You use these parameters to ascertain whether a destination is reachable.

The value of the MAXIMUM HOPS parameter should always be equal to or greater than the longest possible path within the network. For the network example, a maximum hop parameter value of 6 is sufficient. Choose the maximum cost and hops values carefully, with regard to the intended use of the network, the actual network configuration, and possible failures.

The following example demonstrates the use of the SET EXECUTOR command to specify the maximum cost and hops allowed for network routing:

```
NCP>SET EXECUTOR MAXIMUM COST 100 MAXIMUM HOPS 6
```

Values in the range 1 to 1022 are valid for the MAXIMUM COST parameter; the default value is 1022. Values in the range 1 to 30 are valid for the MAXIMUM HOPS parameter; the default value is 30. The value for the MAXIMUM HOPS parameter must be less than or equal to the value for MAXIMUM VISITS.

Figure 3-2 illustrates the relationship between circuit costs and path costs. To send a packet from TRNTO to DALLAS, the system can route it over one of two paths, both of which require two hops; the first path is through BOSTON, the second through DENVER. However, because the path through BOSTON has a cost of 8 and the path through DENVER has a cost of 5, the system routes the packet through DENVER.

Under normal conditions, a MAXIMUM HOPS value of 3 would be sufficient for the network in Figure 3-2. However, if the MAXIMUM HOPS value were set to 3, a failure of the TRNTO-BOSTON circuit would render TRNTO unreachable from NYC, KANSAS, or BANGOR, even though a physical path still exists (the four-hop path NYC-BOSTON-DALLAS-DENVER-TRNTO). Consideration of possible failures is also important in establishing the MAXIMUM COST parameter.

3.7.4.3 Route-Through Control Parameter

The MAXIMUM VISITS parameter in the SET EXECUTOR command specifies the maximum number of nodes a packet can be routed through before arriving at the destination node. For example, the following command sets the maximum number of visits to 12:

```
NCP>SET EXECUTOR MAXIMUM VISITS 12
```

If the number of nodes that the data packet visits exceeds the value of MAXIMUM VISITS, the packet is discarded. Generally, use a value that is two or three times the value for the MAXIMUM HOPS parameter. At a minimum, the value for the MAXIMUM VISITS parameter must be equal to or greater than the value for the MAXIMUM HOPS parameter. The maximum value is 63, which is also the default value.

3.7.4.4 Equal Cost Path Parameters

VAX

Circuit costs are used by DECnet to determine the optimum path over which data is to be transmitted. DECnet selects the path with the lowest cost.

If there are multiple paths of equal lowest cost, you can split the routing of individual data packets among these equal cost paths. This method of equal cost path splitting improves network efficiency by ensuring that multiple equal cost paths are not idle when there is traffic to be routed. The MAXIMUM PATH SPLITS parameter of the SET EXECUTOR command specifies the maximum number of equal cost paths to be used for routing. For example, the following command sets the maximum number of equal cost paths to 2:

```
NCP>SET EXECUTOR MAXIMUM PATH SPLITS 2
```

The default value for MAXIMUM PATH SPLITS is 1. That is, all data will go over the lowest cost path, with no splitting.

Equal cost path splitting operates most efficiently for those nodes that run VMS Version 5.4 and communicate with nodes running DECnet for OpenVMS Version 4.6 or higher. Early DECnet for OpenVMS versions do not support out-of-order packet caching; any packets received out of order are discarded. Therefore, splitting traffic over all equal cost paths may result in poor network performance.

To control the equal cost path splitting for routing, you can set the executor parameter PATH SPLIT POLICY. By default, PATH SPLIT POLICY is set to NORMAL, which indicates that all traffic is to be split equally over all equal cost paths to a destination node.

Managing and Monitoring the Network

3.7 Routing Commands

To restrict the paths used for routing, you can set `PATH SPLIT POLICY` to `INTERIM`. The `INTERIM` value specifies that all traffic is to be split over all equal cost paths while forcing packets for individual network sessions over the same paths to guarantee that packets are received by the destination node in the correct order. For example, the following command specifies that all traffic for all network sessions is to choose the same paths:

```
NCP>SET EXECUTOR PATH SPLIT POLICY INTERIM
```

As a result of this command paths are not split for routing on all equal cost paths. ♦

3.7.4.5 Area Path Control Parameters

VAX

When a network is divided into areas, the `MAXIMUM COST` and `MAXIMUM HOPS` parameters described previously are used to control the path between each pair of nodes within each area.

A second set of routing parameters (`AREA MAXIMUM COST`, `AREA MAXIMUM HOPS`) is used to control the total cost and length of paths between level 2 routers within the whole network. In effect, these parameters control the total possible paths between areas in the network.

The `AREA MAXIMUM COST` parameter in the `SET EXECUTOR` command specifies the limit on the total path cost between the local level 2 router and any level 2 router in the network. This value is the maximum cost of circuits on the longest path between level 2 routers. The `AREA MAXIMUM HOPS` parameter in the `SET EXECUTOR` command specifies the maximum number of hops that a packet can make between the local level 2 router and any other level 2 router in the network.

Use the `AREA MAXIMUM COST` and `AREA MAXIMUM HOPS` parameters to determine whether an area is reachable. Select the values for these parameters carefully, with regard for the level 2 (area) topology of the network.

The following example illustrates the use of the `SET EXECUTOR` command to specify the maximum cost and hops permitted for routing between level 2 routers in the network:

```
NCP>SET EXECUTOR AREA MAXIMUM COST 500 AREA MAXIMUM HOPS 10
```

Values in the range 1 to 1022 are valid for the `AREA MAXIMUM COST` parameter; the default value is 1022. Values in the range 1 to 30 are valid for the `AREA MAXIMUM HOPS` parameter; the default value is 30. ♦

3.7.5 Routing Message Timers

On systems that support routing, routing messages exchanged between adjacent nodes contain information about the cost and hops to each node in the network. Routing update messages are sent automatically whenever there is a change in the information (for example, when a circuit goes down). Nodes that detect the change (for example, nodes at each end of a circuit that failed) are the first to send routing update messages. The changed routing information then propagates as far as necessary to update all routers.

Routing updates are also sent periodically under control of the routing timers. These periodic transmissions ensure that routing tables are kept up to date even in the unlikely event that a routing update message is lost.

You set the timer for transmission of routing messages by using the SET EXECUTOR command. For nodes on nonbroadcast circuits, the timer is called the routing timer. Changing the setting of the routing timer causes additional routing messages to be transmitted to all adjacent nodes from the local node, at a specified interval.

VAX

For example, the following command sets the frequency of transmission of routing messages to 240 seconds:

```
NCP>SET EXECUTOR ROUTING TIMER 240 ♦
```

When this timer expires, the local node sends a routing message to all adjacent nodes. Numbers in the range of 1 to 65,535 are valid for the ROUTING TIMER parameter; the default value is 600. The default is recommended.

For a node on a broadcast circuit, the timer is called the broadcast routing timer. When the timer expires, the local node sends a multicast routing configuration message to all nodes on the broadcast circuit. For example, the following command sets the frequency of routing message transmissions to 30 seconds:

```
NCP>SET EXECUTOR BROADCAST ROUTING TIMER 30
```

The broadcast routing timer for a node on a broadcast circuit is set to a much lower value (approximately 30 to 40 seconds) than the routing timer for a node on a non-broadcast circuit (every few minutes). Broadcast routing messages are sent more often so that full routing messages can be exchanged in case of datagram loss. The default value for this parameter is 180.

3.7.6 CI End Node Circuit Failover

VAX

On systems that support the CI, if you configure a VAXcluster using the CI as a DECnet datalink to include end nodes as well as routers, you can define a backup circuit in each end node that takes over should the primary circuit connecting the end node to its router fail.

An example is a three-node VAXcluster comprised of one router (R) and two end nodes (E1 and E2). Each end node should have a circuit defined to the router. You can define a second circuit in each end node that connects to the other end node. The backup circuit is defined with a higher cost than the primary circuit, and its state is set to ON.

Under normal circumstances, with all three nodes operational, the lower cost circuit (to the router) is used. If the router shuts down, this circuit also shuts down. The backup circuit will become the lowest cost circuit in the ON state, and will be used. The backup circuit allows the end nodes to communicate while the router is absent from the cluster.

If nodes E1, E2, and R have CI port addresses 1, 2, and 3, respectively, you could define this topology in node E1 as follows:

```
NCP>DEFINE CIRCUIT CI-0.3 TRIBUTARY 3 COST 1 STATE ON  
NCP>DEFINE CIRCUIT CI-0.2 TRIBUTARY 2 COST 10 STATE ON
```

The first circuit is the primary circuit; the second circuit is the backup circuit.

This technique can be extended to a larger VMScluster with two routers and several end nodes; in each end node, two circuits of different cost are defined, one to each router. The network could then survive the failure of one router, but not both. ♦

Managing and Monitoring the Network

3.8 Logical Link Commands

3.8 Logical Link Commands

Use the `SET EXECUTOR` command to set logical link parameters that define the maximum number of active links permitted and to set the timers that control NSP operation. Use the `DISCONNECT LINK` command to disconnect links while the network is running.

3.8.1 Maximum Number of Links

When defining parameters for the local node, you may specify the maximum number of logical links that can be active for that node. DECnet for OpenVMS uses this value to determine the size of internal data structures. The following command sets the maximum number of links at 30:

```
NCP>SET EXECUTOR MAXIMUM LINKS 30
```

This value includes both inbound and outbound logical links. In this example, you can have only 15 links if both ends of all links are terminated locally.

If an alias node identifier has been established, you may also specify the maximum number of logical links that can be active at the local node using the alias node identifier. For example, the following command sets the alias maximum links at 40:

```
NCP>SET EXECUTOR ALIAS MAXIMUM LINKS 40
```

When a node in a VMScluster uses an alias node identifier, two kinds of links (alias node and local node) are possible. These links are controlled by the appropriate parameter, `MAXIMUM LINKS` or `ALIAS MAXIMUM LINKS`. Refer to the *DECnet for OpenVMS Network Management Utilities* for information about logical link restrictions.

3.8.2 Disconnecting Logical Links

You can selectively disconnect logical links active on the local node while the network is running. The first of the following commands disconnects link 1827; the second disconnects all links active with all remote nodes:

```
NCP>DISCONNECT LINK 1827  
NCP>DISCONNECT KNOWN LINKS
```

Use the `SHOW KNOWN LINKS` command to obtain link status information, including link IDs, and to verify that links have been disconnected upon entering these commands (see Section 3.3). DECnet for OpenVMS maintains and uses link IDs.

Optionally, you can disconnect a single link or all known links to a particular node. For example, the following NCP command disconnects all links to node TRNTO:

```
NCP>DISCONNECT KNOWN LINKS WITH NODE TRNTO
```

3.8.3 Logical Link Protocol Parameters

A variety of parameters exist for controlling NSP-related logical link activity. These parameters regulate the bounds for NSP connect sequences, inactivity intervals, and message retransmission. Another parameter limits the amount of nonpaged pool NSP uses for logical link transmission. You can change these parameters at any time, without affecting existing logical links.

3.8.3.1 Incoming and Outgoing Timers

There are two timers that regulate NSP connect sequences: an incoming timer and an outgoing timer.

Use the INCOMING TIMER parameter to specify the maximum duration between the moment a logical link connection is received for a process on the local node and the moment the process accepts or rejects the connection. Using a value between 30 and 60 is recommended. To allow 30 seconds for connection confirmation, enter the following command:

```
NCP>SET EXECUTOR INCOMING TIMER 30
```

Expiration of this timer signals that a timeout has occurred. In effect, this timer protects the local node against a process that never responds to an inbound connection request.

The OUTGOING TIMER parameter specifies a timeout value for the duration between the time a connection is requested and the time it is acknowledged by the destination node. Using a value between 30 and 60 is recommended. For example, the following command allows 30 seconds to elapse before a timeout is assumed to have occurred:

```
NCP>SET EXECUTOR OUTGOING TIMER 30
```

A typical value for this timer ranges from 10 to 90 seconds, depending on line speed and network diameter. The network diameter is the maximum diameter over the set of shortest paths between all pairs of nodes in the network. In effect, this timer protects the user on the local node against a connection request that never completes.

3.8.3.2 Inactivity Timer

A logical link is inactive when no data is transmitted in either direction for a given interval of time. The inactivity timer regulates the frequency with which local DECnet software tests the viability of an inactive link, thereby protecting the user against a link that may be permanently unusable.

Use the INACTIVITY TIMER parameter to specify the maximum duration of inactivity before the local node tests the viability of the link. For example, the following command sets the inactivity interval to 60 seconds:

```
NCP>SET EXECUTOR INACTIVITY TIMER 60
```

When this timer expires, DECnet for OpenVMS generates artificial traffic to test the link. The timer starts after an incoming message for the link has been processed. The timer is reset if any messages are received on the link.

3.8.3.3 NSP Message Retransmission

A third group of parameters regulates the frequency of NSP message retransmission. These are the DELAY WEIGHT, DELAY FACTOR, and RETRANSMIT FACTOR parameters for the local node.

NSP estimates the current delay in the round-trip transmission to a node with which it is communicating. The value of the DELAY WEIGHT parameter is used to calculate a new value of the estimated round trip delay. The old round trip delay is weighted by a function of this statistical factor to calculate the new round trip delay. If the delay weight is set high, the retransmit time changes slowly. If the weight is set low, the observed round trip time can change quickly if the observed round trip delays vary widely, and thus the retransmit time can change more rapidly.

Managing and Monitoring the Network

3.8 Logical Link Commands

The value of the DELAY FACTOR parameter is multiplied by one-sixteenth of the estimated round trip delay time to determine the appropriate value for the time in seconds to retransmit certain NSP messages.

You use values in the range of 16 to 255 to specify values for the DELAY FACTOR parameter, as in the following example:

```
NCP>SET EXECUTOR DELAY WEIGHT 3 DELAY FACTOR 48
```

The default value is 80. For a complete discussion of these concepts, refer to the *Network Services Protocol Functional Specification*.

The value of the RETRANSMIT FACTOR parameter regulates the number of times NSP reattempts a transmission when its retransmission timer expires for a logical link. This value must be a number in the range of 1 to 65,535; the default value is 10. For example, the following command specifies that NSP should reattempt a transmission no more than 10 times:

```
NCP>SET EXECUTOR RETRANSMIT FACTOR 10
```

If RETRANSMIT FACTOR is set to 10, NSP will not try to retransmit an eleventh time, and will disconnect the logical link.

In the process of logical link connect sequences, the value of the RETRANSMIT FACTOR parameter takes precedence over the OUTGOING TIMER value. As a result, the actual time necessary for the specified number of retransmits may not match the setting of the OUTGOING TIMER parameter.

3.8.3.4 Pipeline Quota

The PIPELINE QUOTA parameter in the SET EXECUTOR command specifies the maximum number of bytes NSP can use from nonpaged pool to buffer logical-link transmit requests. In effect, this quota determines the number of packets NSP transmits on a single logical link before receiving a positive acknowledgment from the remote end of the link. You determine the number of packets by dividing the PIPELINE QUOTA value by the EXECUTOR BUFFER SIZE value.

The PIPELINE QUOTA value is not deducted from the byte count quota of the user process. Thus the system manager can set the process byte count quota to sensible values without concern for the nonpaged pool requirements of DECnet for OpenVMS. DECnet's nonpaged pool usage with respect to the transmission over logical links is bounded by the product of the values of the PIPELINE QUOTA and MAXIMUM LINKS parameters.

The following command sets a pipeline quota of 12000 bytes for the local node:

```
NCP>SET EXECUTOR PIPELINE QUOTA 12000
```

The default value for PIPELINE QUOTA is currently 10000. If satellite communication is being used, a value of 6000 or higher is recommended.

Note

The SET EXECUTOR parameter PIPELINE QUOTA should not be confused with the SET LINE parameter TRANSMIT PIPELINE. The PIPELINE QUOTA parameter relates to transmission over logical links, while TRANSMIT PIPELINE relates to data links. These parameters address different levels of the Digital Network Architecture.

3.9 Object Commands

Use the SET OBJECT command to establish and modify the object parameters listed in Table 3–10. To remove any or all object parameters from the volatile database, use the CLEAR OBJECT command.

Table 3–10 Object Parameters and Their Functions

Parameter Function	Parameter
Identifies object by number	NUMBER number
Identifies command procedure or image run when a connection is received for this object	FILE file-id
Specifies connect privileges for user-level access control	PRIVILEGES privilege-list
Specifies privileges a user must possess to make outbound connections to an object	OUTGOING CONNECT PRIVILEGES
Specifies optional default proxy login access control for the object	PROXY { INCOMING OUTGOING BOTH NONE }
Determines how the object will respond to incoming connect requests directed to the alias node identifier	ALIAS INCOMING { DISABLED ENABLED }
Associates outgoing connect requests for the object with the alias node identifier	ALIAS OUTGOING { DISABLED ENABLED }
Specifies optional default access control for inbound connects	ACCOUNT account PASSWORD password USER user-id

3.9.1 DECnet for OpenVMS Objects

Use the SET OBJECT command to establish and modify certain DECnet for OpenVMS objects.

3.9.1.1 DECnet for OpenVMS Object Identification

When defining or modifying object parameters, identify the name of the object. DECnet object names are descriptive alphanumeric strings of up to sixteen characters. DECnet software also uses object numbers as unique object identifiers. Object numbers have a range of 0 to 255. Most user-defined images are numbered 0. However, a user program should have a nonzero number assigned when it provides a known service. You may define an object name in the configuration database to a type 0 object if you want to associate required privileges or default inbound access control with the object.

Generic objects such as FAL and NML have nonzero object numbers that are recognized throughout the network. User-defined images may have unique nonzero object numbers; numbers between 128 and 255 are reserved for this purpose. (For a list of object numbers and their associated names, refer to the *DECnet for OpenVMS Network Management Utilities*.) Unlike objects with a 0 object type, you must set each nonzero object in the configuration database. Use the NUMBER parameter to specify a unique object number for nonzero objects. For example:

```
NCP>SET OBJECT FOO NUMBER 129
```

Managing and Monitoring the Network

3.9 Object Commands

The object name may not be unique to the generic services specified. Only object numbers are unique across systems. For consistency, however, using object names as they are normally referenced throughout the network is recommended.

3.9.1.2 Using the Cluster Alias Node Identifier for the Object

On VMScluster systems, parameters for the SET OBJECT and DEFINE OBJECT commands specify how certain objects treat incoming and outgoing connection requests associated with the alias node.

By specifying the ALIAS OUTGOING parameter for a particular object, you can indicate whether the object uses the alias node address in any outgoing connection request.

This parameter makes it possible to direct an object such as MAIL to use the alias node address rather than the executor address for outgoing connections. For example, to direct the object FOX to use the alias node identifier for all outgoing connection requests, enter the following command:

```
NCP>SET OBJECT FOX ALIAS OUTGOING ENABLED
```

By default, only the object MAIL is so enabled. All other objects are disabled unless specified as otherwise.

Objects such as PHONE, which use a protocol that depends on multiple links, should not have the ALIAS OUTGOING parameter enabled.

Use the ALIAS INCOMING parameter to specify how certain objects are to respond to incoming connection requests that are directed to the alias node. You can either enable or disable specific objects from receiving these incoming connections.

This parameter allows you to restrict incoming connections to only those objects that are appropriate. Do not enable any object that can receive multiple incoming links or whose resources are not available clusterwide. For example, to disallow the object FOO from receiving incoming connect requests directed to the alias node address, enter the following command:

```
NCP>SET OBJECT FOO ALIAS INCOMING DISABLED
```

By default, if you establish an alias node identifier for the node, ALIAS INCOMING is enabled for all objects except PHONE. If a user attempts to use an alias node address to connect to an object for which ALIAS INCOMING has been disabled, the following status message is returned:

```
%SYSTEM-F-NOSUCHOBJ, network object is unknown at remote node
```

3.9.1.3 Example of Using the Cluster Alias Node Identifier

The following scenario illustrates how use of an alias node identifier can facilitate communication between a node within a VAXcluster and a remote node.

A VAXcluster includes nodes THRUSH and ROBIN. The network manager establishes a node name CLUSTR in the database by entering the following DEFINE NODE command:

```
NCP>DEFINE NODE 2.13 NAME CLUSTR
```

To establish the node name CLUSTR as the alias node identification for the VAXcluster, the network manager then enters the following command:

```
NCP>DEFINE EXECUTOR ALIAS NODE CLUSTR
```

Managing and Monitoring the Network

3.9 Object Commands

Because an alias node identifier has been set, the ALIAS INCOMING parameter is enabled by default. This means that all incoming connect requests addressed to the alias node identifier are routed to a node that uses the alias.

The network manager also indicates that the MAIL object is to use the alias node identifier in its outgoing connect requests by entering the following command:

```
NCP>DEFINE OBJECT MAIL ALIAS OUTGOING ENABLED
```

After the network is started, a user with the user name JONES logs on to node THRUSH. JONES then sends a mail message to user SMITH on node BOSTON, which is outside the VAXcluster. Because MAIL is enabled for outgoing connect requests using the alias, it appears that JONES has sent mail from node CLUSTR. An hour later, when user SMITH reads the mail from JONES, the mail is associated with the user CLUSTR::JONES.

SMITH decides to reply to the mail from JONES. SMITH sends the mail message to JONES using the destination node CLUSTR.

Meanwhile, the node THRUSH has been taken down for maintenance, so JONES has logged on to node ROBIN. Because ROBIN has also been enabled for incoming connect requests addressed to the alias node identifier, JONES receives the mail from SMITH. The mail is addressed to CLUSTR::JONES, and is delivered to a node that uses the alias.

3.9.1.4 DECnet for OpenVMS Command Procedure Identification

For nonzero-numbered objects, the default name of this command file is SYS\$SYSTEM:*objectname*.COM. Nonzero objects are identified in the logical link connect message only by object number. Therefore, there must be an entry in the object volatile database that enables DECnet to locate the object name using the object number as a key.

When you install DECnet for OpenVMS, nonzero object network-defined command procedures are entered by default in the SYS\$SYSTEM directory, and NETACP knows about these command procedures. The supplied command files, named *objectname*.COM, include FAL, HLD, NML, EVL, DTR, MAIL, PHONE, and MIRROR. Except for those command procedures supplied by Digital, create a command procedure for every object that can be started by an inbound connection request. Name command procedures for nonzero objects *objectname*.COM and place them in SYS\$SYSTEM.

For zero-numbered objects, the default name of this command file is SYS\$LOGIN:*objectname*.COM. Zero objects are identified in the logical link connect message by object name. Therefore, there is no need for an entry in the object volatile database. You can, of course, specify an entry in the object database at any time. You are required to include an entry if you want special features such as default inbound access control information.

In either case, you can override the rules for locating the command file by explicitly specifying a command procedure file in the SET or DEFINE OBJECT command. This file is associated with the object in the object volatile database, as shown in the following example:

```
NCP>SET OBJECT FAL NUMBER 17 FILE SYS$MANAGER:TRIALFAL.COM
```

```
NCP>SET OBJECT USERS NUMBER 0 FILE SYS$SYSTEM:USERS.COM
```

Managing and Monitoring the Network

3.9 Object Commands

This technique can be particularly useful for zero-numbered objects. The command file would then be found in the same place, regardless of which access control information you use. If you do not specify the FILE parameter, copies of the command file would have to exist in the SYS\$LOGIN directory of every account in which the object may possibly run.

Note

Because REMACP is started by a RUN command in RTTLOAD.COM, there is no REMACP.COM procedure to start the object, and the software does not create a REMACP.LOG file.

You can also invoke an image directly to serve as a network object, rather than using a command procedure. To do this, specify the object file name as *objectname.EXE*, as in the following example:

```
NCP>SET OBJECT FAL NUMBER 17 FILE FAL.EXE
```

Place the image in SYS\$SYSTEM. This approach causes the object to be started up more quickly; it is useful in cases where no advantage is gained by invoking the image from a command procedure. The session log appears as part of the NETSERVER.LOG file.

3.10 Logging Commands

In order to log events, you must turn on logging. To do so, use the SET LOGGING command. Use the same command to modify any of the logging parameters. To remove any or all parameters from the volatile database, use the CLEAR LOGGING command. Turn the logging state to OFF before attempting to use the CLEAR LOGGING command.

Source-related and sink-related parameters are mutually exclusive. Therefore, you cannot use parameters from both categories in a single command. Use the SET LOGGING EVENTS command to specify source-related events, and the SET LOGGING STATE command to specify sink-related events.

For a summary of event class and types and information about the specific events that the operating system logs, see the *DECnet for OpenVMS Network Management Utilities*.

The logging component is defined by the device or process that records the events released by the event logger. The logging component can be a LOGGING CONSOLE, LOGGING FILE, or LOGGING MONITOR.

The LOGGING CONSOLE is a terminal or a file that receives events on the sink node in a format the user can read. A LOGGING FILE is a user-specified file on the sink node. The LOGGING FILE component receives events in the standard DNA binary format. (Refer to the *DNA Phase IV Network Management Functional Specification* for a description of this format.) Instead of specifying the console and a file, you can specify a system- or user-supplied LOGGING MONITOR program to receive and process DNA format-specific events. This program could possibly receive event data and adapt user application network activity to reflect this data.

Managing and Monitoring the Network

3.10 Logging Commands

If the logging sink is the LOGGING MONITOR, DECnet for OpenVMS uses the Operator Communication Manager (OPCOM) to display formatted event messages on all terminals enabled as NETWORK (using REPLY/ENABLE=NETWORK). This generally includes the operator console (OPA0). The format of event messages OPCOM displays is similar to that used for console logging; however, because of restrictions in the size of messages that OPCOM can display, some messages may be truncated slightly, and node, circuit, and line counters are not displayed at all.

To identify the name of the logging component on the local node, use the NAME parameter. For example, if the component is a logging console file, the following command creates the file EVENTS.LOG into which formatted events will be logged:

```
NCP>SET LOGGING CONSOLE NAME SYSS$MANAGER:EVENTS.LOG
```

To identify a logging monitor program as the logging component, use the NAME parameter followed by the program name. See Section 3.10.6.

Regardless of the logging component you use, parameter selection is the same. If you want to modify parameters for all logging on the network, then use the plural KNOWN LOGGING component when entering the SET LOGGING command.

Note

Because console logging uses normal OpenVMS RMS file I/O, if a terminal is specified as a sink name, the terminal should not be used or allocated for any other purposes. For example, if you log in using such a terminal, events will be lost until you log out.

For descriptions of LOGGING parameters, reference *DECnet for OpenVMS Network Management Utilities*.

3.10.1 Event Identification

Events are defined by class and type. You can specify the kinds of events to be logged by using the following event-list format:

class.type

where:

class Identifies the DNA or system-specific layer to which the event pertains.

type Identifies a particular form of event, unique within an event class.

For example, to specify an event in the Routing layer, you use **event class 4**. The **event types** for this class range from 0 to 14. Event type 0 indicates aged packet loss, event type 1 indicates unreachable node packet loss, and so forth. Refer to the *DECnet for OpenVMS Network Management Utilities* for a summary of events by class and type. Use the EVENTS parameter for the SET LOGGING command to specify those events to be logged. If you want to log all event classes and types, use the KNOWN EVENTS parameter. When defining the logging component, you must specify events to be logged.

When providing an event list for the EVENTS parameter, you can specify only one class for each instance of this parameter. However, several formats can define event types for a particular class. You can specify a single event type, a range of types, or a combination of the two. The following table illustrates these formats.

Managing and Monitoring the Network

3.10 Logging Commands

Event List	Meaning
4.4	Identifies event class 4, type 4
4.5-7	Identifies event class 4, types 5 through 7
4.5,7-9,11	Identifies event class 4, types 5, 7 through 9, and 11. Types must be specified in ascending order.

The following commands illustrate invalid event lists:

```
NCP>SET KNOWN LOGGING EVENTS 4.4,5.1      !INVALID COMMAND
NCP>SET KNOWN LOGGING EVENTS 4.7,3-4,1     !INVALID COMMAND
```

The first example specifies more than one event class. The second example specifies event types in numerically descending, rather than ascending, order.

You can use the asterisk (*) wildcard character in an event list. This character can replace only an event type. The following example illustrates the correct use of a wildcard character:

```
NCP>SET KNOWN LOGGING EVENTS 2.*
```

This command identifies all event types for class 2 events.

Two invalid uses of the wildcard character are as follows:

```
NCP>SET LOGGING FILE EVENTS *.2-5          !INVALID COMMAND
NCP>SET LOGGING FILE EVENTS 4.2-*         !INVALID COMMAND
```

The first command specifies specific event types for all classes, which is not allowed. Unless you use the **KNOWN EVENTS** parameter, you can specify event type information only for a single class. The second command uses a wildcard to specify a partial range of event types, also not allowed. The wildcard character denotes the entire range of event types for a given class.

Note

Although these commands are invalid, no error message is issued and the commands' results may not be what you intended.

3.10.2 Identifying the Source for Events

You can specify the particular source for which events apply, which can be either a node, a module, a circuit, or a line. For example, to monitor network activity for circuit SVA-0 connected to the local node, enter the following command:

```
NCP>SET LOGGING CONSOLE CIRCUIT SVA-0 EVENT 4.*
```

Events that pertain to activity over this circuit are logged at the console by the event logger. You can perform the same operation for any remote node. If you specify no source for a component, the event logger logs events for all circuits, lines, modules, and nodes known to the local node.

You can set only one source (a circuit, module, node, or line) as the source for events in a single command.

The command **CLEAR logging-component KNOWN EVENTS** clears only events that are not associated with any specific source. To remove an event associated with a specific source, use the **CLEAR logging-component** command that specifies that source.

3.10.3 Identifying the Location for Logging Events

You can log events either at the local node or a remote node. Use the **SINK** parameter to specify the location. For example, the following command routes all event information to the logging monitor program running on node **DENVER**:

```
NCP>SET LOGGING MONITOR SINK NODE DENVER . . .
```

If you do not specify a location, the local node is the default.

3.10.4 Controlling the Operational State of Logging

You can control the operational state of logging only for the local node. There are three logging states:

- HOLD** Indicates that the sink is temporarily unavailable. Events destined for that location are queued.
- OFF** Indicates that the sink is unavailable for receiving event information.. Events are not logged for that sink.
- ON** Indicates that the sink is available for receiving event information. This is the normal operational state.

Use the **STATE** parameter to specify the operational state of logging on the local node. The following command forces event information to be queued for all instances of the logging component on the local node:

```
NCP>SET KNOWN LOGGING STATE HOLD
```

This control over logging does not affect the operational state of the node. Setting the default state to **ON** in the permanent database is recommended.

Note

Specify the event logger object (number 26, name **EVL**) in the object database. If you experience difficulty with event logging, examine the event logger's own log file, **SYS\$MANAGER:EVL.LOG**, for possible problems.

3.10.5 Event Logging Example

The example in this section illustrates how to use NCP event logging commands. You may want to log events normally to **OPCOM** for each node in the network. In addition, you may want each node to transmit its events to a single node to be stored in a file. For the three nodes—**DENVER**, **TRNTO**, and **BOSTON**—you could enter the following commands at each node to do this.

At nodes **DENVER** and **BOSTON**:

```
NCP>SET LOGGING MONITOR STATE ON  
NCP>SET LOGGING MONITOR KNOWN EVENTS  
NCP>SET LOGGING MONITOR SINK NODE TRNTO KNOWN EVENTS
```

At node **TRNTO**:

```
NCP>SET LOGGING MONITOR STATE ON  
NCP>SET LOGGING MONITOR KNOWN EVENTS  
NCP>SET LOGGING CONSOLE NAME SYS$MANAGER:NETEVENTS.LOG  
NCP>SET LOGGING CONSOLE STATE ON  
NCP>SET LOGGING CONSOLE KNOWN EVENTS
```

Managing and Monitoring the Network

3.10 Logging Commands

Events from all three nodes are logged to all terminals enabled as network operator terminals (through the DCL command, `REPLY/ENABLE=NETWORK`) on node TRNTO. In addition, all local events are logged locally to the file `NETEVENTS.LOG` on node TRNTO. The transmitting node always specifies the destination of the event logger output and causes its locally generated events to be sent to the receiving sink node to be logged.

3.10.6 Using a Logging Monitor Program

Instead of using a logging console or a logging file, you can specify a logging monitor program to receive and process events. The logging monitor is a system- or user-supplied program. The advantage of using a logging monitor program is that it can be tailored to the specific needs of the network manager.

You can write logging monitor programs in high-level languages and design them to perform specific functions desired by the network manager. Thus, the logging monitor program can be simple or complex, depending on its design and objective.

The following logging monitor example is a BASIC program called `LOGGER.BAS`. It records events released by the event logger and prints them to a terminal. Detailed information about the format of the events can be found in the *DNA Phase IV Network Management Functional Specification*.

```
10 ! TITLE LOGGER.BAS
!
! This is a sample logging monitor program.
20 MAP (EVENT)                                &
      BYTE    FUNCTION_CODE,                  &
      BYTE    SINK_FLAGS,                     &
      WORD    EVENT_CODE,                     &
      STRING  EVENT_TIME = 12,                &
      WORD    SOURCE_NODE,                     &
      STRING  REST = 238

100 ! Record events released by the network event logger.
110 OPEN "SYS$NET" FOR INPUT AS FILE #1%, MAP EVENT
120 ON ERROR GOTO 998
200 ! Begin loop to extract events and write them to the terminal.
300 WHILE 1 = 1
400   GET #1%
410   EVENT_CLASS% = EVENT_CODE / 64%
420   EVENT_TYPE% = EVENT_CODE - 32% * (EVENT_CODE / 32%)
430   EVENT_CLASS$ = NUM1$ (EVENT_CLASS%)
440   EVENT_TYPE$ = NUM1$ (EVENT_TYPE%)
450   EVENT$ = EVENT_CLASS$ + "." + EVENT_TYPE$
460   PRINT "Event " ; EVENT$ ; " Reported"
499 NEXT
998 RESUME 999
999 END
```

To use a logging monitor, add the name of the program to the object database. For example, the following commands add the executable image `LOGGER` to the database and set `LOGGER` as the name of the logging monitor program:

```
NCP>SET OBJECT LOGGER NUMBER 0 FILE LOGGER.EXE
NCP>SET LOGGING MONITOR KNOWN EVENTS
NCP>SET LOGGING MONITOR NAME LOGGER
NCP>SET LOGGING MONITOR STATE ON
```

Sample output from the logging monitor program (LOGGER.EXE) is as follows:

```
Event 0.9 Reported  
Event 0.9 Reported  
Event 4.7 Reported  
Event 4.10 Reported  
Event 4.15 Reported
```

3.11 Network Access Control Commands

The system manager can specify NCP commands to provide for access control at the routing initialization level, at the system level during inbound logical link connections, and at the node level during inbound and outbound logical link connections.

You can also use NCP commands to control proxy login access to individual accounts and network objects at the local node. The following sections indicate the NCP commands and parameters that you can specify for access control. Refer to Section 2.8 for a description of DECnet for OpenVMS access control techniques.

3.11.1 Specifying Passwords for Routing Initialization

VAX

You can specify in your local configuration database transmit and receive passwords for each adjacent node. The transmit password is the one you send to the remote node and the receive password is the one you expect to receive from the remote node during the routing initialization sequence.

Use the SET NODE command to specify these passwords. Each password can be one to eight alphanumeric characters in length. For example, the following command establishes transmit and receive passwords for the circuit or circuits connecting the local node with node TRNTO:

```
NCP>SET NODE TRNTO TRANSMIT PASSWORD VAX_NODE -  
_ RECEIVE PASSWORD VAX_NODE
```

If the password contains one or more space characters, delimit it with quotation marks.

To remove transmit and receive passwords from the volatile database, use the CLEAR NODE command, as shown in the following example:

```
NCP>CLEAR NODE TRNTO RECEIVE PASSWORD TRANSMIT PASSWORD
```

To provide for increased security when a remote node requests a connection over a point-to-point circuit, you can use the circuit parameter VERIFICATION INBOUND to prevent your node from revealing its routing initialization password while requiring a password from the remote node.

When two nodes communicate over a point-to-point circuit, only one of the nodes can have the VERIFICATION INBOUND parameter set. The primary function of this parameter is to permit the system manager to restrict the nodes that can initialize over a particular circuit, especially over a dialup circuit.

When a dialup node attempts to establish a dynamic connection with your node, the dynamic asynchronous circuit entry is supplied automatically to your configuration database. This entry includes the circuit parameter VERIFICATION INBOUND, which prevents your node from supplying a password to the node requesting a dynamic connection, but requires a password from the node dialing in.

Managing and Monitoring the Network

3.11 Network Access Control Commands

If you specify VERIFICATION INBOUND for a circuit, you must also specify the node parameter INBOUND ROUTER or INBOUND ENDNODE, as appropriate, for the connecting node (see Section 3.11.3). This requirement applies to both dynamic and static asynchronous connections.

If, on the other hand, you are a user on a node with a terminal line (such as DECnet for OpenVMS on a MicroVAX) and you expect to form a dynamic asynchronous connection with another node, specify a transmit password in your node database. For example, if you are at node HELIUM and expect to form a dynamic connection with remote node VCLST1 on a VAXcluster, specify the following command to establish the transmit password for the dynamic circuit:

```
NCP>SET NODE VCLST1 TRANSMIT PASSWORD HOMENODE1
```

The remote node in a dynamic connection must specify the receive password it expects to receive from the local node. The system manager at remote node VCLST1 specifies the following command:

```
NCP>SET NODE HELIUM RECEIVE PASSWORD HOMENODE1
```

This indicates the password expected from node WORK. ♦

3.11.2 System-Level Access Control Commands

You can use the SET NODE command to specify default privileged and nonprivileged access control information for outbound logical link requests. Use the SET OBJECT command to specify privileges required to access certain objects during inbound logical link requests. You can also use the SET OBJECT command to specify default access information. For NCP commands to be executed at remote nodes, you can either supply explicit access control information in the node specification, as parameters in the command, or by default.

3.11.2.1 Establishing Default Privileged and Nonprivileged Accounts

Use the SET NODE command to specify default access control information for connecting to remote nodes. If you have not specified explicit access control information in an outbound logical link request, this default information is sent with the request. For example, the following command specifies both privileged and nonprivileged user names and passwords for node DENVER:

```
NCP>SET NODE DENVER -  
_ NONPRIVILEGED USER NETNONPRIV PASSWORD NONPRIV-  
_ PRIVILEGED USER NETPRIV PASSWORD PRIV
```

Specify default information for all remote nodes with which you want to have the option of using default access control.

3.11.2.2 Specifying Privileges for Objects

Use the SET OBJECT command with the PRIVILEGE parameter to specify those privileges that cause the privileged user account to be used rather than the nonprivileged user account.

For example, you may want to make the FAL object accessible to any network user, whereas you want to control access to the NML object. The following command specifies privileges for the NML object in this instance:

```
NCP>SET OBJECT NML PRIVILEGES OPER
```

You need not specify privileges for FAL because it requires only NETMBX and TMPMBX privileges.

Managing and Monitoring the Network

3.11 Network Access Control Commands

3.11.2.3 Specifying Privileges Required for Outgoing Connections to Objects

To prevent unauthorized access to objects, use the `OUTGOING CONNECT PRIVILEGES` parameter in the `SET OBJECT` and `DEFINE OBJECT` commands in NCP. This parameter specifies the privileges a user must possess to make outbound connections to an object.

Example 3–1 illustrates the use of the NCP command `SET OBJECT OUTGOING CONNECT PRIVILEGES`. At the DCL command prompt, the user sets privileges for the process. After invoking NCP, the user specifies the privileges necessary to connect to the object `TEST`. Because the object `TEST` requires the `READALL` privilege to make an outbound connection, the connection fails, resulting in an error message. After the user resets the privileges to include `READALL`, the process is able to connect to the object.

Example 3–1 Using the SET OBJECT OUTGOING CONNECT PRIVILEGES Command

```
$ SET PROCESS/PRIVILEGES=(NOALL,TMPMBX,NETMBX,OPER)
$ RUN SYS$SYSTEM:NCP
NCP> SET OBJECT TEST NUMBER 0 -
OUTGOING CONNECT PRIVILEGES READALL OPER
NCP> SET OBJECT TEST FILE SMITH$DISK:[SMITH]TEST.COM
NCP> EXIT
$ OPEN/READ LINK 0"SMITH CEADGUTY"::"0=TEST"
%DCL-E-OPENOUT, error opening 0"smith password"::"0=test" as
output -RMS-E-PRV, insufficient privilege or file protection
violation
$ SET PROCESS/PRIVILEGES=(NOALL,TMPMBX,NETMBX,OPER,READALL)
$ OPEN/READ LINK 0"SMITH CEADGUTY"::"0=TEST"
$ READ LINK RECORD
```

3.11.2.4 Setting Default Inbound Access Control Information

Use the `SET OBJECT` command with the `USER`, `ACCOUNT`, and `PASSWORD` parameters to specify default inbound access control information.

For example, the following command specifies default information that the local DECnet for OpenVMS node can use for inbound connects from SLD:

```
NCP>SET OBJECT HLD USER NETNONPRIV PASSWORD NONPRIV
```

3.11.2.5 Indicating Access Controls for Remote Command Execution

You use access control for remote NCP command execution. When you enter the `SET EXECUTOR NODE` and `TELL` commands, you can explicitly specify access control information, or you can default to information contained in the configuration database.

Two formats exist to supply access control information explicitly for these commands. You can use either a standard OpenVMS node specification `node"user password account"::` or the NCP parameters `USER`, `ACCOUNT`, and `PASSWORD`.

Note

The `ACCOUNT` field is ignored when received by an OpenVMS system.

For example, the following commands perform the same operation:

```
NCP>SET EXECUTOR NODE TRNTO"GRAY MARY"::
NCP>SET EXECUTOR NODE TRNTO USER GRAY PASSWORD MARY
```

Managing and Monitoring the Network

3.11 Network Access Control Commands

The same formats exist for the TELL command. Use of the standard OpenVMS node specification format allows you to use a logical name as the node-id for these commands. It is possible to override access control in a logical name with explicit access control information in the command.

You can also use access control information when specifying the executor node. Enter the following command for this purpose:

```
NCP>SET EXECUTOR NODE TRNTO"user-id password"
```

3.11.3 Node-Level Access Control Commands

At the node level, you can specify access control commands that determine what connections can be made. If your node expects to receive dialup dynamic asynchronous connection requests, you can check the type (end node or router) of the dialup node before permitting the connection.

The NCP commands SET NODE ACCESS and SET EXECUTOR DEFAULT ACCESS, when used together, allow you to limit access to specific nodes. For example, assume that there are 10 nodes in your network, named A through J. The executor is node A. Because most network traffic occurs among nodes A, B, and C, you could use the following commands to allow unrestricted incoming and outgoing logical link connections among those nodes:

```
NCP>SET NODE A ACCESS BOTH
NCP>SET NODE B ACCESS BOTH
NCP>SET NODE C ACCESS BOTH
```

Next, assume that you want to allow local users to initiate connections to node D, but restrict connections from that node. Enter the following command:

```
NCP>SET NODE D ACCESS OUTGOING
```

Finally, assume that you want to allow incoming logical link connections from all other remote nodes (E through J), but restrict outgoing connections from the executor node. Enter the following command:

```
NCP>SET EXECUTOR DEFAULT ACCESS INCOMING
```

Note

The executor checks for a node ACCESS entry before it checks for the DEFAULT ACCESS entry. Remember that, if the executor's state is set to OFF or SHUT, no logical links are allowed.

VAX

You can indicate the type of node that can connect to your node over a point-to-point circuit by specifying the INBOUND parameter with the SET NODE command. The INBOUND parameter enables you to check the type of a connecting node before you form a dynamic connection with the node. For example, if you expect the DECnet for OpenVMS node HELIUM to initiate a dynamic connection by dialing in to your node over a specific terminal line, you can specify the following in your node database:

```
NCP>SET NODE HELIUM INBOUND ENDNODE
```

If the node HELIUM dials in as a router, rather than as an end node, the dynamic connection is not formed. If you specify INBOUND ROUTER for the node and it dials in as an end node, the dynamic connection is permitted.

Managing and Monitoring the Network

3.11 Network Access Control Commands

When you specify the node parameter INBOUND, also set the circuit parameter VERIFICATION INBOUND for the circuit over which the connection is to be made (see Section 3.11.1). If you do not set VERIFICATION INBOUND for the circuit, the node parameter INBOUND is ignored. ♦

3.11.4 Proxy Login Access Control Commands

You can control proxy login access for accounts by modifying the executor database. To control proxy login for network objects, modify the object database.

Access to proxy accounts on the local node by proxy login is enabled by the INCOMING PROXY and OUTGOING PROXY settings in the executor database. The default values for these parameters permit both incoming and outgoing proxy access. The default setting is the recommended option. You can, however, use the SET EXECUTOR command to modify the INCOMING PROXY and OUTGOING PROXY values at the local node.

The default value of the INCOMING PROXY and OUTGOING PROXY entries in the executor database are equivalent to entering the following commands:

```
NCP>SET EXECUTOR INCOMING PROXY ENABLED
NCP>SET EXECUTOR OUTGOING PROXY ENABLED
```

The system manager has the option of changing the default values for proxy login. The following examples establish that any proxy login to or from the local node is prohibited:

```
NCP>SET EXECUTOR INCOMING PROXY DISABLED
NCP>SET EXECUTOR OUTGOING PROXY DISABLED
```

If proxy access has been enabled for specific network objects, the previous SET EXECUTOR commands would not prevent a user of that object from using a proxy account. Proxy access for network objects must also be explicitly disabled for the connection to the object to fail. The proxy access characteristics established in the object database take preference over the proxy access characteristics established in the executor database.

To display the value of the proxy entries for your node, enter the following command:

```
NCP>SHOW EXECUTOR CHARACTERISTICS
```

If proxy login access is enabled at your node, the resultant display includes the following:

```
Incoming Proxy           = Enabled
Outgoing Proxy           = Enabled
```

When incoming proxy login access is enabled, the remote user can access a file accessible to the local account to which he has default proxy access by using the node specification NODE:: in the standard OpenVMS file specification. For example, a remote user can specify the following form of file specification to access a file on an account on node TRNTO to which he has default proxy access:

```
TRNTO::filename
```

In the following example, the remote user requests access to the local account PROXY_N, assuming proxy access is allowed:

```
TRNTO"PROXY_N"::filename
```

In this example, PROXY_N may be the default proxy account, or it may be another proxy account established for the remote user.

Managing and Monitoring the Network

3.11 Network Access Control Commands

To override proxy login, the remote user with a proxy account on a node can specify `NODE" "::` in the file specification, causing the default nonprivileged DECnet account to be used, because explicit null access control is passed to the remote node.

The NCP `SET EXECUTOR` command enables or disables proxy login access to all accounts. Similarly, you can permit or deny proxy login access to specific network objects, by using the `SET OBJECT` command to modify the object database.

Access to a network object through a proxy account is controlled by the `PROXY` parameter in the object database. By default, DECnet for OpenVMS has set in the configuration database `PROXY` values for some network objects. These default values are the recommended values. To specify or modify the `PROXY` parameter for an object, use the `SET OBJECT` command with the `PROXY` parameter. In the following example, the outgoing proxy access option is set for the object `FAL`:

```
NCP>SET OBJECT FAL PROXY OUTGOING
```

To display the setting for the `PROXY` parameter in the database, use the `SHOW OBJECT` command with the `CHARACTERISTICS` parameter, as in the following command:

```
NCP>SHOW KNOWN OBJECT CHARACTERISTICS
```

The resulting display lists the database entries for each known object, indicating any proxy access that is enabled for the object. For object `MAIL`, the display is as follows:

```
OBJECT = MAIL
Number           = 27
User id          = NETNONPRIV
Password        = TREWQ
Proxy access     = outgoing
```

System managers use the Authorize Utility to manage the permanent proxy database, `NETPROXY.DAT`. Information in `NETPROXY.DAT` is used to construct a volatile database when DECnet is started up. You modify the volatile database when you add or delete proxies using the Authorize utility; you can also use the NCP command, `SET KNOWN PROXIES ALL`, to update the volatile proxy database. This command clears the contents of the volatile proxy database and rebuilds it from the permanent proxy database. `SET KNOWN PROXIES ALL` is executed as part of the `SYS$MANAGER:STARTNET` command procedure.

While `SET KNOWN PROXIES ALL` updates the volatile proxy database, all modifications of the permanent proxy database are handled by means of the Authorize Utility. You may not modify the individual entries in the volatile database.

3.12 Monitoring the Network

You can monitor network activity in one of two ways: by using the NCP command `SHOW` or by using the event logging facility and the `SET LOGGING` command. This section discusses the use of the `SHOW` and `LIST` commands. Refer to Section 2.7 for a discussion of events and event logging, and Section 3.10 for a description of the `SET LOGGING` command.

Managing and Monitoring the Network

3.12 Monitoring the Network

NCP provides commands to display information about network components, whether they are defined in the volatile or permanent database. The NCP command SHOW displays information about components of the volatile database. The NCP command LIST performs a similar function, except that it lets you display and verify information in the permanent database. In many cases, this information is a subset of the information displayed for the volatile database.

The SHOW command allows you to monitor the operation of the running network. For example, whenever someone changes the state of a circuit, the configuration of the running network in terms of reachable and unreachable nodes may be changed as well. A circuit failure could have the same effect. NCP allows you to display the status of network circuits, lines, modules, and nodes, and thereby to detect such conditions.

When you enter the SHOW and LIST commands, NCP allows you to select components and display types. You can choose among several display types, depending on the information you want. The display type determines the format and type of information NCP displays.

Table 3-11 describes the NCP display types:

Table 3-11 NCP Display Types

Display Type	Description
CHARACTERISTICS	Static information usually specified in the configuration database. This may include the identification of a local node and relevant routing parameters, the names and numbers of known network objects, and the identification and cost of circuits connected to the local node.
STATUS	Dynamic information that usually reflects network operations for the running network. This may include the local node and its operational state, reachable and unreachable nodes and their operational states, and circuits with their operational states.
SUMMARY	The most useful information derived from both static and dynamic sources. This is usually an abbreviated list of information provided for both the CHARACTERISTICS and STATUS display types.
EVENTS	Information about events currently being logged for the logging component. This display type is valid only for the SHOW LOGGING and LIST LOGGING commands.
COUNTERS	Counter information for circuits, lines, modules, and nodes, including the local node. Counters are discussed in Section 3.3.6, Section 3.5.6, and Section 3.6.6.

If you do not specify a display type when entering a SHOW or LIST command, SUMMARY is the default. Examples of these display types and their formats are given in the *DECnet for OpenVMS Network Management Utilities*.

When you display information about network components, you can use either the singular or plural form of the component, as shown in the following example:

```
NCP>SHOW NODE BOSTON CHARACTERISTICS
      .
      .
      .
```

Managing and Monitoring the Network

3.12 Monitoring the Network

```
NCP>SHOW KNOWN NODES CHARACTERISTICS
```

For several components, there is a second form of the plural. This form is the word ACTIVE. Whereas the word KNOWN displays information for components available to the local node, the word ACTIVE displays information for all active components—that is, components whose state is other than OFF.

Use the word ACTIVE with circuit, line, node, and logging components. For example, the following command displays the characteristics for all active nodes in the network:

```
NCP>SHOW ACTIVE NODES CHARACTERISTICS
```

The word ADJACENT is also used as a plural in the SHOW NODE command, as in the following example:

```
NCP>SHOW ADJACENT NODES STATUS
```

All NCP display commands optionally allow you to direct the information displayed to a user-specified output file. For example:

```
NCP>SHOW KNOWN LOGGING SUMMARY TO SYS$MANAGER:NET.LOG
```

This command creates the file SYS\$MANAGER:NET.LOG containing summary information of all known logging for the running network. The default file type is LIS. If the specified file already exists, NCP appends the display information to that file. If you do not specify an output file, SYS\$OUTPUT is the default.

DECnet for OpenVMS Host Services

DECnet for OpenVMS can act as the host node in performing the following services for unattended systems:

- Downline loading of an unattended system: transferring a copy of an operating system file image from an OpenVMS node to a target node.
- Downline loading of a satellite node in a VMScluster from an OpenVMS node.
- Downline loading of various servers from an OpenVMS node.
- Downline loading of an RSX-11S task from an OpenVMS node.
- Upline dumping of memory from an unattended system: transferring a copy of a memory image from an unattended target node to your OpenVMS node.
- Connecting to a remote console: permitting an OpenVMS terminal to act as the console for certain unattended systems.

This chapter describes these operations. Host services are not available over asynchronous lines.

4.1 Loading Unattended Systems Downline

DECnet for OpenVMS allows you to load an unattended system using the services provided by the Maintenance Operations Module (MOM). MOM provides a set of maintenance operations over various types of circuits by using the Maintenance Operations Protocol (MOP). Downline loading involves transferring a copy of the file image of a remote node's operating system from an OpenVMS node to the unattended target node. For example, DECnet for OpenVMS permits you to load an RSX-11S operating system file image from your OpenVMS node downline to a target node. Downline loading can be initiated by an operator at the OpenVMS node or by the target node. Both procedures are discussed in this section.

To understand downline loading, it helps to distinguish the nodes involved in the loading sequence. In the following node descriptions, the command node and the executor node can be the same or different nodes, but cannot be the target node.

- **Command node.** An operator-initiated downline load request originates at the command node. You use the NCP command `LOAD` or `TRIGGER` to initiate this request.
- **Executor node.** The executor node actually performs a downline load or trigger operation.
- **Target node.** The target node receives the bootstrap loaders and the system image file.

DECnet for OpenVMS Host Services

4.1 Loading Unattended Systems Downline

4.1.1 Downline System Load Operation

Downline loading is initiated in one of two ways:

- An operator initiates the operation with the NCP command LOAD or TRIGGER. This is called the operator-initiated mode.
- The target node initiates the operation by triggering its bootstrap ROM and sending a program load request to one or more potential executor node. This is called the target-initiated mode.

The operator-initiated mode is used to service maintenance operations generally requested by an interactive operator. The operator enters maintenance requests using NCP. NCP delivers the request to the Network Management Listener (NML). NML then passes the request to a MOM process. The MOM process then acts upon the request. With an operator-initiated load, the local node starts the operation by sending a trigger message to the target node. Essentially, the trigger message tells an unattended target node to reboot. After the target node is triggered, it loads itself in whatever manner its primary loader is programmed to operate. The target node can request a downline load from either the executor that just triggered it or from another adjacent node. The target node can also load itself from its own mass storage device.

The target-initiated mode is used to service unsolicited maintenance requests. In this mode, the host system listens to circuits with service enabled for any MOP request directed to the local node or to a multicast address. When such a request arrives, MOM is invoked, reads the request, and processes it.

There are some subtle differences in the two modes in which MOM can execute. In target-initiated mode, the information that MOM has for fulfilling the unsolicited request comes first from the request itself. This can be data such as the "software identification" requested by the node and the type of communication device that the requesting node is using to make the request. Additional information required to fulfill the request can be obtained from the volatile database on the local node. The information supplied in the MOP request takes precedence over the information in the volatile database.

In operator-initiated mode, the information for fulfilling a request can come from NCP parameters supplied by the operator, or from the volatile database. Information supplied in the command line takes precedence over information obtained from the volatile database.

4.1.1.1 Target-Initiated Downline Load

In a target-initiated downline load, the target node sends a maintenance operation protocol (MOP) request program message. This message is a request for any eligible node to perform the load. The request program message can potentially specify a number of fields, including a software identification, a software type, and a service device.

The SERVICE parameter must be set to ENABLED for a circuit in order for MOP messages received on that circuit to be processed. When DECnet receives a MOP request program message on a circuit enabled for service operations, it creates a Maintenance Operation Module (MOM) process to handle the MOP request. There is a limit of 10 concurrent MOM processes. When this limit is reached, no additional MOP downline load requests are processed by the local node until some others complete. The MOM processes are named *MOM-circuit-id_process-number*

DECnet for OpenVMS Host Services

4.1 Loading Unattended Systems Downline

(for example, MOM_SVA-0_1). Each process terminates when the load request it is processing completes.

If a point-to-point circuit connects the nodes, DECnet searches the node database for a node entry with a SERVICE CIRCUIT parameter matching the circuit over which the load was requested. DECnet uses the information from this node entry to perform the load.

If the connecting circuit type is Ethernet or FDDI, MOM determines if the request was directed to the multicast address or to the local node. If the request was directed at the local node, MOM performs the load. If the request was for the multicast address, MOM volunteers to perform the load. If a software identification is provided in the request or if a node entry is found that matches the hardware address of the target node, MOM sends a message to the requesting node volunteering to perform the load. If MOM does not get a response from the remote node, it drops the received packet and exits. Otherwise, it services the remainder of the load.

If the MOP message does not specify the target node's requested image (using a software identification field or program type field), the MOM process reads the volatile node database which associates the image file name with the target node name.

When the MOM process has enough information, it performs the load operation. If it does not have enough information, it logs an event.

There are four possible values for program type:

- Secondary loader
- Tertiary loader
- Operating system
- Management file

The secondary loader, tertiary loader, and operating system files designate image specifications, while the management file value designates a general data specification. You can use the management file to specify additional information for downline loading that certain systems may need.

After it knows the type of file being requested, NETACP can obtain a file specification in one of two locations. The first location searched is the request program message that MOM received. The second is the node database entry for the requesting node. If the file specification is not in the node entry or in the request program message, the MOM process aborts the service request and exits. MOM checks for the existence of the load file before volunteering to perform the load. If the file is not available, MOM aborts the service request and exits.

The downline load sequence varies when a request originates from a satellite node in a VMScluster. A node in a cluster may need more input parameters than are currently defined in the volatile node database. Thus, you need to be able to dynamically configure the image to be loaded, and to transfer more parameters to the target system than those accommodated by the Parameter Load and Transfer packet. To accommodate this need, MOM calls on the services of a **load assist agent** to help fulfill a downline load request. The load assist agent is an image that makes calls back to MOM with data that describes the image to be loaded on the target node.

DECnet for OpenVMS Host Services

4.1 Loading Unattended Systems Downline

For downline loads to satellite nodes in clusters, MOM delivers all load requests to load assist agents. The node parameter LOAD ASSIST AGENT identifies a specific agent by file name. Section 4.1.2.7 describes the procedure for specifying the LOAD ASSIST AGENT file specification. Another node parameter, LOAD ASSIST PARAMETER, passes an individual value to a load assist agent file. Section 4.1.2.8 describes the procedure for specifying the LOAD ASSIST PARAMETER value.

4.1.1.2 Operator-Initiated Downline Load

An operator-initiated load uses NCP to directly request MOM to perform the load operation. The target node's primary bootstrap may or may not have to be triggered depending on the state of the target. The target node is triggered primarily to put it into a known state and to force it to supply program request information.

Use the NCP command LOAD or TRIGGER to perform an operator-initiated downline load. The TRIGGER command allows you to directly trigger the remote node's bootstrap ROM, which causes the target node to send its host a request for a load operation. The programs to be loaded may come from a local disk file on the target node, another adjacent node, or the command node.

The TRIGGER command may or may not initiate a downline load. One of the functions of this command is to simulate the operation that occurs when you push the BOOT button on the target node. A bootstrap operation from the local disk may result.

When you use the LOAD command, the executor node proceeds with the load operation according to the options specified in the initial load request. You obtain any required information that has been defaulted from the volatile database. With this information, the executor is thereby able to control the load sequence.

Section 4.1.2 describes the TRIGGER and LOAD commands, their parameters, and examples of their use.

4.1.1.3 Load Requirements

Prior to attempting a downline load operation, ensure that nodes, lines, and circuits meet the following requirements:

- The target node must be connected directly to the executor node. The executor node provides the line- and circuit-level access.
- The primary loader must either be a cooperating program in the target or in the microcode of the target's device. The downline load operation usually involves loading a series of bootstraps, each of which requests the next program until the operating system itself is loaded.
- The executor must have access to the load files. The location of the files can be either specified in the load request or defaulted to in the volatile database. Remote files are obtained through remote file access operations.
- The target node must be able to recognize the trigger operation or must be triggered manually.
- The circuit involved in the load operation must be enabled to perform service functions. A point-to-point circuit must also be in the ON or SERVICE state; a broadcast circuit must be in the ON state. For example, the following command readies circuit SVA-0 for downline loading a node in this example:

```
NCP>SET CIRCUIT SVA-0 SERVICE ENABLED STATE ON
```

DECnet for OpenVMS Host Services

4.1 Loading Unattended Systems Downline

Refer to the *Maintenance Operation Protocol Functional Specification* for a complete description of MOP error recovery.

4.1.2 Downline Load Parameters

The most convenient method of downline loading involves setting default information in the volatile database. The operator can use the NCP command SET NODE to establish default information for the target node in the volatile database. These default parameters are also used for target-initiated downline loads, though the MOP request program message can override some of the defaults. (This default method is discussed later in this chapter.) Alternatively, you can override the default by specifying several parameters for the NCP command TRIGGER or LOAD. The following sections describe each parameter and illustrate their use.

4.1.2.1 TRIGGER Command

The TRIGGER command triggers the bootstrap mechanism of a target node, which causes the node to request a downline load. Because the system being booted is not necessarily a fully functional network node, the operation must be performed over a specific circuit. To bring up the system at the target node, use either the TRIGGER NODE or TRIGGER VIA command. If you use the TRIGGER NODE command and do not specify a loading circuit, the executor node obtains the circuit identification associated with the target node from its volatile database. If you use the TRIGGER VIA command, which indicates the loading circuit but not the node identification, the executor node uses the default target node identification in its volatile database. To identify the target node in the volatile database, specify the SET NODE command with the appropriate SERVICE CIRCUIT parameter, which establishes the circuit to be used for loading.

VAX

The following command triggers node BANGOR:

```
NCP>TRIGGER NODE BANGOR VIA DMB-0
```

This command specifies a DDCMP circuit over which the operation is to take place. ♦

If downline loading is to occur over an Ethernet or FDDI local area network (LAN), the executor node uses the physical address of the target node to distinguish it from other adjacent nodes on the same LAN. The PHYSICAL ADDRESS parameter for the target node is required in the TRIGGER VIA command and optional in the TRIGGER NODE command.

If you do not specify a physical address in the TRIGGER NODE command, DECnet for OpenVMS derives one from the target's DECnet address and attempts to trigger the node. A target node that is running DECnet software has set its physical address to a value derived from its DECnet address and will recognize messages sent to this address. If the target node is not yet running DECnet software, its physical address will have been set to the value of the device controller's hardware address and messages sent to a physical address derived from the target node's DECnet address will not be recognized. If unsuccessful in triggering the node using the physical address, DECnet for OpenVMS attempts to use the hardware address of the target node from the volatile database to trigger it. You can set in the volatile database the hardware address originally assigned to the target node's LAN adapter by specifying the HARDWARE ADDRESS parameter in the SET NODE command. (Refer to Section 2.1.2 for a description of LAN addressing.)

DECnet for OpenVMS Host Services

4.1 Loading Unattended Systems Downline

Figure 4-1 illustrates the use of the TRIGGER NODE command for downline loading a target node over Ethernet circuit SVA-0.

Figure 4-1 Operator-Initiated Downline Load over Ethernet Circuit (TRIGGER Command)

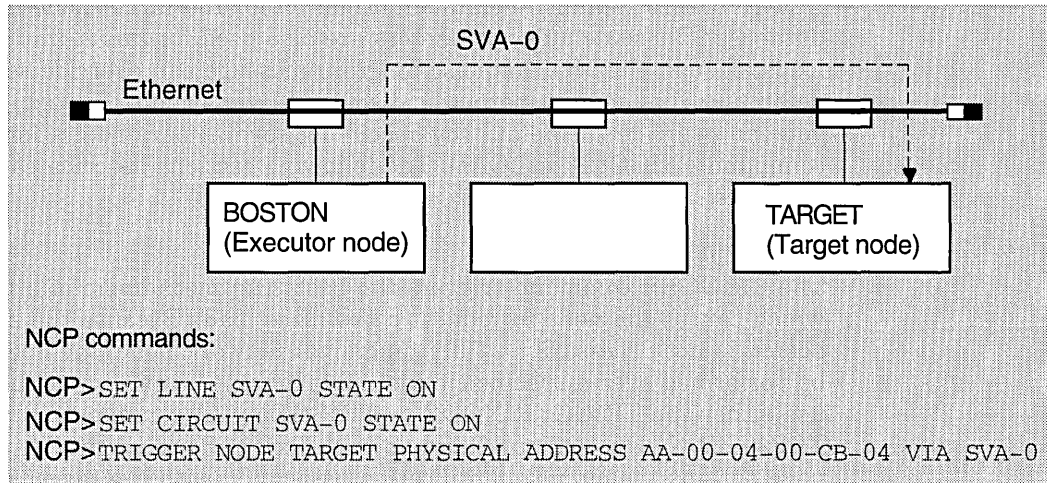

LKG-6700-92R

When you use the TRIGGER command, how the system load is performed may not always be obvious. Essentially, this command provides the trigger message that controls the restart capability for an unattended target node. After the target node is triggered, it loads itself in whatever manner its primary loader is programmed to operate. The target node can request a downline load from either the executor that just triggered it or another adjacent node, or the target node can load itself from its own mass storage device.

One parameter that you can specify for the TRIGGER command is SERVICE PASSWORD. This parameter supplies a boot password, which may be required by the target node (see Section 4.1.2.11). If you do not specify this parameter, a default value from the volatile database is used. Use the SET NODE command to establish a default value for this parameter in the volatile database. If no value is set in the volatile database, the value is 0.

4.1.2.2 LOAD Command

Use the LOAD NODE and LOAD VIA commands to load software downline to a target node. For example, the following command loads node TARGET:

```
NCP>LOAD NODE TARGET
```

The LOAD NODE command requires the identification of the service circuit over which to perform the load operation. If you do not explicitly specify a service circuit in this command, the executor node uses the SERVICE CIRCUIT from the volatile database entry for the target node. Use the SET NODE command to include the SERVICE CIRCUIT entry in the volatile database. Alternatively, you can explicitly include the circuit, for example:

```
NCP>LOAD NODE TARGET VIA SVA-0
```

DECnet for OpenVMS Host Services

4.1 Loading Unattended Systems Downline

You can also use the `LOAD VIA` command to specify the circuit over which to perform a downline load.

For example, to load using circuit `SVA-0` connected to the executor node, enter the following command:

```
NCP>LOAD VIA SVA-0 PHYSICAL ADDRESS AA-00-04-00-CB-04
```

The executor node obtains the rest of the necessary information from its volatile database. The `LOAD NODE` and `LOAD VIA` commands work only if the target node can be triggered by the executor or if the target has been triggered locally.

If the loading circuit is an Ethernet or FDDI circuit, the executor node uses the physical address of the target node to differentiate the node from other adjacent nodes on the same circuit. Specify the `PHYSICAL ADDRESS` parameter in the `LOAD VIA` command. The `PHYSICAL ADDRESS` parameter is optional in the `LOAD NODE` command.

If you do not specify the `PHYSICAL ADDRESS` parameter in the `LOAD NODE` command, DECnet for OpenVMS derives the physical address from the target node's DECnet address and attempts to load the target node.

A target node running DECnet software has set its own physical address and recognizes this address; otherwise, the target node recognizes only the hardware address set by the manufacturer. If unsuccessful in loading the node, the executor node attempts the load using the hardware address of the target node from the volatile database.

In the volatile database, you can set the hardware address originally assigned to the target node's LAN adapter. To do this specify the `HARDWARE ADDRESS` parameter in the `SET NODE` command. (Refer to Section 2.1.2 for a description of LAN addressing.)

Figure 4-2 illustrates how to use the `LOAD` command for downline loading over Ethernet circuit `SVA-0`.

DECnet for OpenVMS Host Services

4.1 Loading Unattended Systems Downline

Figure 4-2 Operator-Initiated Downline Load over Ethernet Circuit (LOAD Command)

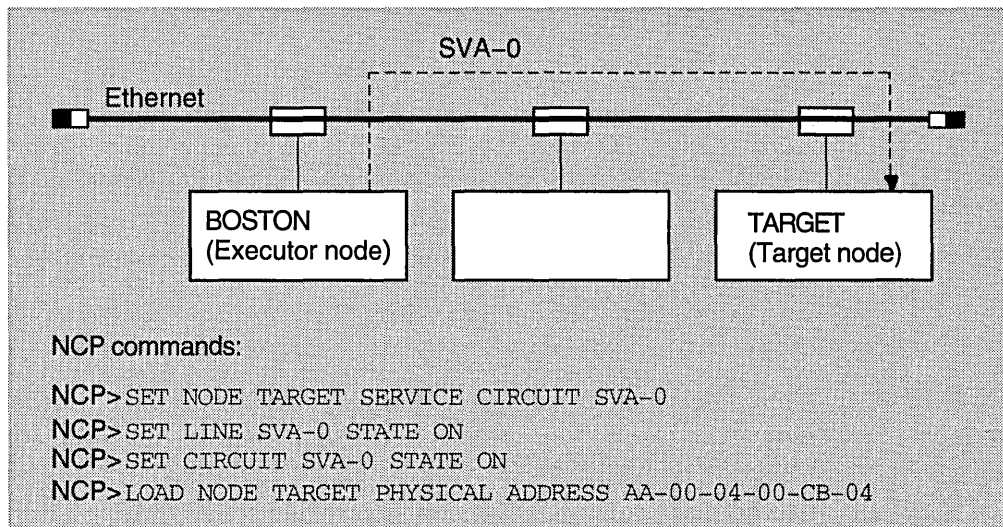

LKG-6699-92R

If you choose to override the default parameters for the LOAD commands, you can control the following aspects of the load sequence:

- The host node that the target node is to use when the target comes up
HOST node-id
- The identification of the load file
FROM file-id
- The identification of the loader programs
SECONDARY LOADER file-id
TERTIARY LOADER file-id
- The software type to be loaded downline first
SOFTWARE TYPE software-type

where:

software-type can be any of the following:

SECONDARY LOADER
TERTIARY LOADER
SYSTEM
MANAGEMENT FILE

Note

You must use the SOFTWARE IDENTIFICATION parameter if you specify the SOFTWARE TYPE parameter.

If you do not specify SOFTWARE TYPE in the first MOP request program message, the NCP command, or the volatile database, the default is SECONDARY LOADER.

DECnet for OpenVMS Host Services

4.1 Loading Unattended Systems Downline

- The identification of the CPU type and the corresponding software identification
CPU cpu-type
SOFTWARE IDENTIFICATION software-id
- The identification of the target node's line device type that is to handle service operations
SERVICE DEVICE device-type
- The identification of the service password for triggering the target node's bootstrap mechanism
SERVICE PASSWORD hex-password
- The identification of the image that defines system software for downline loading to a satellite node in a VMScluster
LOAD ASSIST AGENT file-spec
- The identification of an additional parameter to be included in a load assist agent file
LOAD ASSIST PARAMETER item

When entering the LOAD NODE and LOAD VIA commands, you can specify any or all of the preceding parameters. Any parameter not specified in the command defaults to whatever information is specified in the volatile database. Use the SET NODE command to establish default information for the target node's parameters in the volatile database.

4.1.2.3 Host Identification

At the end of the load sequence, the target receives a message with the name of the host and places that name in its volatile database. The target can then use the HOST node-id for downline task loading applications. The host can be the executor node or any other reachable node except for the target itself. Use the SET NODE command to specify a default host node where the target will find the files used to load tasks downline. For example, the following command sets the host to node NYC when node BANGOR comes up as a network node (if BANGOR has the necessary DECnet software):

```
NCP>SET NODE BANGOR HOST NYC
```

4.1.2.4 Load File Identification

The load files are the files to be loaded downline to the target node. These files include the secondary loader, the tertiary loader and the operating system image, and the file specification for the management file. You can specify default load file names in the volatile database with the corresponding SECONDARY LOADER, TERTIARY LOADER, LOAD FILE, and MANAGEMENT FILE parameters of the SET NODE NCP command.

4.1.2.5 Management File Identification

The management file specifies a data file containing additional management information necessary for downline loading to a target node. You can supply a management file by specifying the MANAGEMENT FILE parameter with a LOAD NODE or LOAD VIA command. You can also establish the management file value in the node database using the SET NODE command.

DECnet for OpenVMS Host Services

4.1 Loading Unattended Systems Downline

For example:

```
NCP>SET NODE BANGOR MANAGEMENT FILE MANAGE.DAT
```

4.1.2.6 Software Type

Along with identifying load files, you can specify the file types to be used for the initial load. For example, if the target node is already running a secondary loader program, you may only want to load the tertiary loader and operating system downline. To do this, you use the `SOFTWARE TYPE` parameter with the `LOAD` command. For example, to load a tertiary loader file, which in turn loads the operating system image, enter the following command:

```
NCP>LOAD NODE BANGOR SOFTWARE TYPE OPERATING SYSTEM
```

Use the `SET NODE` command to specify default software type information for the target node entry in the volatile database. If no software type information is specified in the volatile database, the default type is the secondary loader.

4.1.2.7 Load Assist Agent Identification

The load assist agent is the image that passes additional parameters to MOM to allow for downline loading to a satellite node in a VMScluster. To specify this image, use the node parameter `LOAD ASSIST AGENT` with a `LOAD NODE` or `LOAD VIA` command. You can also set the `LOAD ASSIST AGENT` value in the node database with the `SET NODE` command. For example:

```
NCP>LOAD NODE REDSOX LOAD ASSIST AGENT SYS$SHARE:NISCS_LAA.EXE
```

This command specifies a file containing a specific load assist agent.

4.1.2.8 Load Assist Parameter Identification

Load assist agents pass parameters to MOM. To add to the set of parameters already contained in the load assist agent file, use the node parameter `LOAD ASSIST PARAMETER`. You can set this parameter value using the `LOAD NODE`, `LOAD VIA`, or `SET NODE` command. For example:

```
NCP>SET NODE REDSOX LOAD ASSIST PARAMETER SYS$SYSDEVICE:[SYS9.]
```

This command passes an additional parameter to the load assist agent.

4.1.2.9 CPU and Software Identification

The software identification, an optional parameter, is the default program name of the operating system to be loaded downline. You can use the `SOFTWARE IDENTIFICATION` parameter to specify a *software-id* of up to 16 alphanumeric characters. For example, in the following command the CPU parameter specifies the default processor type to be loaded downline:

```
NCP>SET NODE BANGOR SOFTWARE IDENTIFICATION RSX_11S_V3.2
```

4.1.2.10 Service Circuit Identification

In terms of the executor, the service circuit is a circuit connecting the executor node with an adjacent target node. When you use the `LOAD` and `TRIGGER` commands, specify or default to a circuit over which the load operation is to take place. Use the `VIA` parameter to explicitly identify the circuit when entering these commands. If specifying an Ethernet or FDDI broadcast circuit in the `LOAD VIA` command, include the `PHYSICAL ADDRESS` parameter.

If you do not specify a circuit, this information defaults to the circuit specified by the target node's entry in the executor node's volatile database. To set a service circuit in the volatile database, use the `SET NODE` command.

DECnet for OpenVMS Host Services

4.1 Loading Unattended Systems Downline

4.1.2.11 Service Passwords

When defining nodes for downline loading in the local volatile database, the system manager can specify a default service password. This password may be required to trigger the primary bootstrap mechanism on the target node. If you enter a LOAD or TRIGGER command without a service password, then this default parameter is used if the target node requires one. To set a service password in the volatile database, use the SET NODE SERVICE PASSWORD command. For Ethernet or FDDI adapters that support the setting of service passwords, this password must be a hexadecimal number in the range of 0 to FFFFFFFFFFFFFFFF.

VAX

For DDCMP adapters, the range is 0 to FFFFFFFF.

For example:

```
NCP>SET NODE BANGOR SERVICE PASSWORD FEFEFEFE
NCP>LOAD NODE BANGOR◆
```

Note

To obtain service passwords from the permanent and volatile network databases, users must have OPER privilege.

4.1.2.12 Diagnostic File

After the target node is loaded downline, it can request diagnostics. Use the DIAGNOSTIC FILE parameter in the SET NODE command to identify in the volatile database the diagnostics file that the target node can read.

4.2 Dumping Memory Upline from an Unattended System

As a DECnet for OpenVMS system manager, you can include certain SET NODE parameters in the volatile database that allow an adjacent unattended node to dump its memory into a file on your node. This procedure is referred to as upline dumping. It is a valuable tool for crash analysis; that is, programmers can analyze the dump file and determine why the unattended system failed. If you configure a system for upline dumping, this unattended system requests an upline dump when it detects an impending system failure; for example, an RSX-11S operating system may request an upline memory dump to an OpenVMS node.

For upline dump operations, the local node is referred to as the executor and the adjacent unattended node as the slave.

4.2.1 Upline Dump Procedures

This section describes the procedures for an upline dump initiated by a slave node. DECnet uses the maintenance operation protocol (MOP) to perform an upline dump operation. MOP is a protocol that defines messages used for circuit testing, triggering, downline loading, and upline dumping. Refer to the *Maintenance Operation Protocol Functional Specification* for a more complete discussion.

There are four steps involved in the upline dump process. The actual dump takes place when step 3 is repeated.

1. When a slave node senses a system failure, it sends a memory dump request to the host node, or, on the Ethernet or FDDI LAN, to a dump assistance multicast address if a host is not available. The request is a MOP request

DECnet for OpenVMS Host Services

4.2 Dumping Memory Upline from an Unattended System

dump service message. This message may contain information about the slave's memory size (DUMP COUNT) and the upline dump device type at the slave.

2. If the message from the slave includes a DUMP COUNT value, the host node uses it. Otherwise, the host node checks the slave node's entry in its volatile database for the DUMP COUNT, the target address from which to start dumping (DUMP ADDRESS), and the file where the memory will be stored (DUMP FILE) for the slave. (If no entry exists for DUMP ADDRESS, the value defaults to 0.) The host node, which can now be considered the executor, sends a MOP request memory dump message to the slave with the starting address and buffer size values.
3. Using the values it receives from the executor, the slave returns the requested block of memory in a MOP memory dump data message. The executor receives the block of dump data, places it in the DUMP FILE, increments the DUMP ADDRESS by the number of locations sent, and sends another request memory dump message to the slave. This sequence is repeated until the amount of memory dumped matches the DUMP COUNT value. The executor then sends a MOP Dump Complete message to the target.
4. When the upline dump is complete, the executor node automatically attempts to downline load the slave system. It initiates the downline load by sending a TRIGGER message to the slave (see Section 4.1).

Figure 4-3 illustrates the upline dump procedure.

DECnet for OpenVMS Host Services

4.2 Dumping Memory Upline from an Unattended System

Figure 4-3 Upline Dumping of RSX-11S Memory

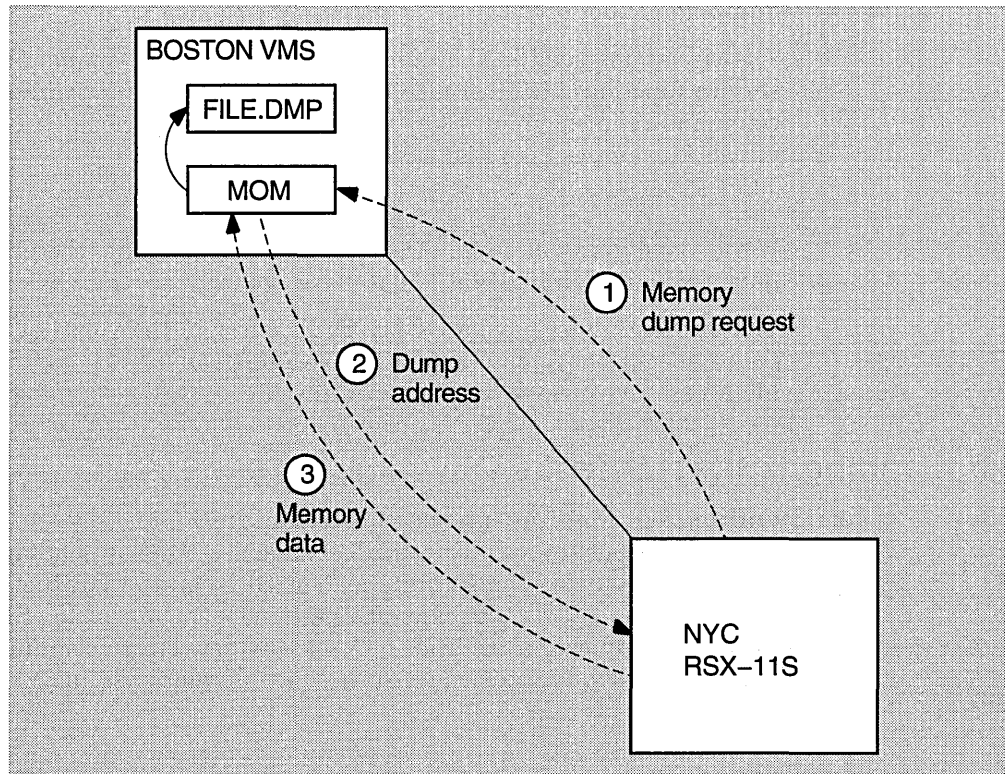

LKG-6695-92R

If the target node is on an Ethernet or FDDI circuit, the target will attempt to perform an upline dump to the node that originally loaded it downline. If that node is not available, the target node proceeds as follows:

1. The target node sends a memory dump request to the dump assistance multicast address AB-00-00-01-00-00 (described in Section 2.1.3). This message is a request for any node on the Ethernet or FDDI circuit to receive an upline memory dump.
2. The nodes on the LAN whose circuits are enabled to perform service functions check their own databases to determine if they can accept an upline dump. If so, they respond to the target node. The target chooses the node responding first to continue the dumping sequence. The target does not send a message to any other node. The loading sequence continues normally from there. Note, however, that you may have to look for event 0.3 in the event logs for all nodes on the Ethernet or FDDI circuit to determine which node received the dump. See the *DECnet for OpenVMS Network Management Utilities* for a summary of all NCP events.

4.2.2 Upline Dump Requirements

Prior to attempting an upline dump operation, ensure that the nodes, lines, and circuits meet the following requirements:

- The slave node must be directly connected to the executor node by a physical line. The executor node provides the line-level and circuit-level access.

DECnet for OpenVMS Host Services

4.2 Dumping Memory Upline from an Unattended System

- The slave node must be capable of requesting the upline dump when it detects a system failure. If the dumping program does not exist on the slave, upline dumping cannot occur.
- The circuit involved in the dump operation must be enabled to perform service functions. It must also be in the ON state. For example, the following command readies circuit SVA-0 for upline dumping node BANGOR in the network example:

```
NCP>SET CIRCUIT SVA-0 SERVICE ENABLED STATE ON
```

- If the slave does not supply the DUMP COUNT value, the executor must have this value in its volatile database.
- The executor must have a DUMP FILE entry in the volatile database. If the *file-id* specifies a remote node, the executor transfers the data using remote file access routines.

4.3 Loading RSX-11S Tasks Downline

Downline task loading extends nonresident initial task load, checkpointing, and overlay support to a DECnet RSX-11S node. You can load an RSX-11S task downline by using the satellite loader (SLD) on the DECnet-11S node and the host loader (HLD) on the DECnet for OpenVMS node. SLD uses the intertask communication facilities of RSX DECnet-11S to communicate with HLD. Figure 4-4 illustrates one instance of this relationship.

DECnet for OpenVMS Host Services 4.3 Loading RSX-11S Tasks Downline

Figure 4-4 Downline Task Loading

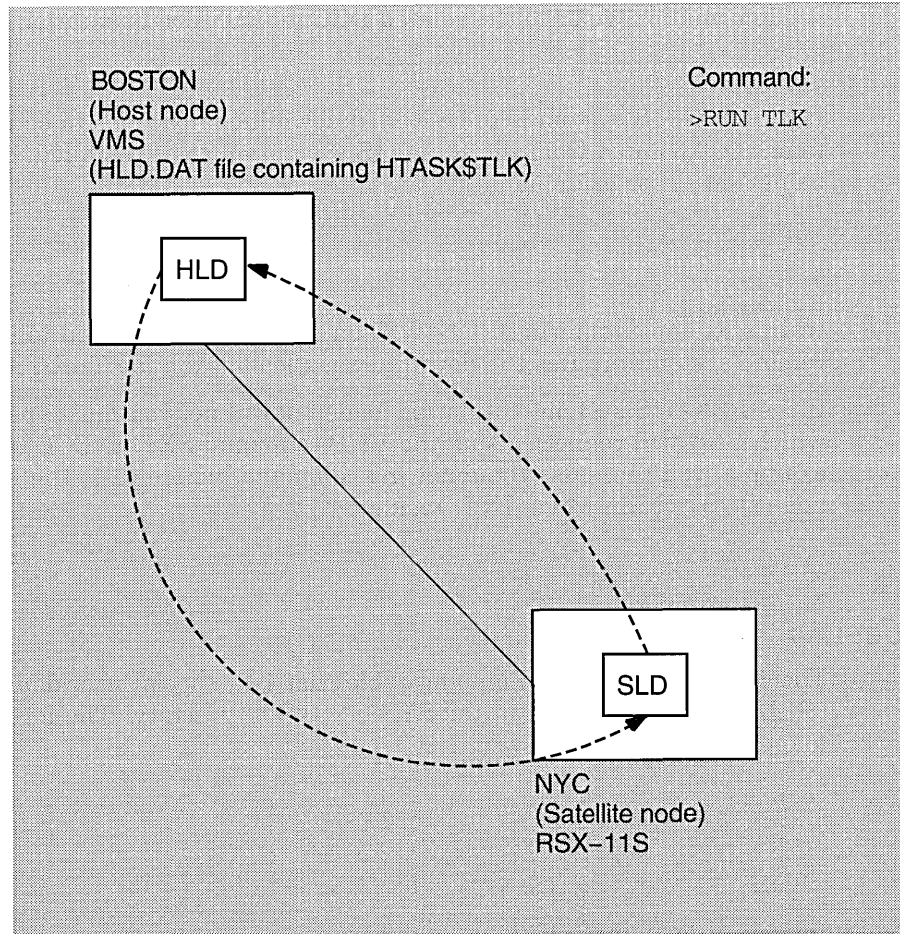

By entering RUN TLK at the operator's console of the satellite system, SLD requests HLD to load the task downline from a DECnet for OpenVMS node on which the file is located. Any request from the satellite or host node could also initiate this operation by means of SLD and HLD.

4.3.1 Setting Up the Satellite System

You build the SLD task during the RSX-11S NETGEN procedure. To allow downline task loading, enter the appropriate commands to the RSX-11S system image. Use VMR to install and fix SLD into the RSX-11S system, as follows:

```
>VMR
ENTER FILENAME:RSX11S
VMR>INS SLD
VMR>FIX LDR...
```

This sequence of commands establishes SLD as the loading task (LDR...) for the executive.

DECnet for OpenVMS Host Services

4.3 Loading RSX-11S Tasks Downline

Note

The information in this section is specific to DECnet-RSX. For more information, refer to the related DECnet-RSX documentation.

If the RSX-11S system is to be loaded downline, any tasks to be downline loaded to or checkpointed from the RSX-11S system must be installed, but not fixed, using VMR. For example:

```
>VMR
ENTER FILENAME:RSX11S
VMR>INS TLK
```

In this example, entering RUN TLK on a terminal connected to the RSX-11S remote system initiates the downline task load of the file TLK.TSK.

If the RSX-11S system will not be loaded downline, you must specify the node to which SLD will connect, using the VNP command SET EXECUTOR HOST. For example, you could use the following command, where 11 is the number of the node BOSTON on which HLD resides:

```
>VNP RSX11S
VNP>SET EXECUTOR HOST 11
```

4.3.2 Host Loader Mapping Table

The Host Loader has a mapping table that is a special user-defined file (HLD.DAT) that resides in the SYS\$SYSTEM directory. The format of the mapping table is as follows:

```
HLDTB$
HTASK$  TLK,<TRNTO::SYS$SYSDISK:[LOW]TLK>,UNM
HTASK$  TLK,<SYS$SYSDISK:[LOW.EXT]TLK>,MAP
HNODE$  BANGOR
HTASK$  NCP,<SYS$SYSDISK:[LOW]NCP11S>,LUN
HTASK$  ...LOA,<SYS$SYSDISK:[TEST]LOA>
HNODE$  NYC
HTASK$  ...MCR,<B:[RSX11S.UNMAPPED]BASMCR>
.END
```

The following are keywords for this table.

HLDTB\$ Defines the file as the HLD mapping table.

HTASK\$ Defines a task entry. The arguments for HTASK\$ are

taskname,<filespec>,[opt-arg]

taskname Is the installed task name used to run the task on the RSX-11S system.

filespec Is the task file specification on the host node. You must use angle brackets (<>) to enclose the file specification.

opt-arg Are optional arguments—MAP, UNM, LUN.

HNODE\$ Defines the exclusive target node upon which the HTASK\$ can execute.

This table is almost identical in structure to a MACRO-11 source module used by DECnet-RSX to define its downline task loading tables. Note, however, that HLD.DAT is accessed directly as a text file and is neither assembled nor task built. The organization of the mapping table and special features is as follows:

- A task entry contains the name of the installed task, a file specification, and an optional control argument. When you use the file specification in the

DECnet for OpenVMS Host Services

4.3 Loading RSX-11S Tasks Downline

HTASK\$ macro, you can omit the file type which defaults to TSK. A node entry contains only the node name.

- Any task entries that precede the first node entry are called general-purpose tasks. You can load a general-purpose task into any RSX-11S node in the network. Task entries that follow a node entry can be sent only to that particular node.
- The same task name can appear more than once in the general-purpose task list. This allows both mapped and unmapped RSX-11S systems to share installed task names. The control argument for a general-purpose task is either MAP or UNM. The default is MAP.
- Tasks to be loaded downline must be installed in the RSX-11S system, which initializes the task's logical unit number (LUN) assignments. LUN-fixing is an SLD feature that reinitializes the LUNs after the task has been loaded downline. This feature allows a single task to be loaded into multiple RSX-11S systems that may have different systemwide device assignments. SLD permits you to place a task in a general-purpose task list. You can downline load either a general-purpose task or a task after a node entry.
- If you place a task in a general-purpose task list, you can add new nodes to the network and can downline load general-purpose tasks to those nodes without changing the mapping table. Nodes that are to receive only general-purpose tasks need not be mentioned in HLD.DAT. Note, however, that general-purpose tasks cannot be checkpointed.

4.3.3 HLD Operation and Error Reporting

When SLD attempts to connect to HLD, NETACP on the DECnet for OpenVMS node uses the default inbound access control information specified for the HLD object by the system manager (see Section 3.11). Verify that the files associated with the tasks to be loaded or checkpointed are accessible from the resulting process created by this connection. The RSX-11S system must have read and write access to directories on the host system in which satellite tasks reside.

When the load operation completes, whether successfully or unsuccessfully, the log file SYS\$LOGIN:NETSERVER.LOG (described in Section 2.6.3) contains information describing the operation, the node, and the task. This information may consist of an error returned from RMS or certain HLD-specific messages that indicate either errors in HLD.DAT or inconsistencies in the file to be loaded. Messages associated with these inconsistencies are listed in the following section.

4.3.3.1 HLD Error Messages

The following is a list of HLD error messages.

Format error in HLD.DAT

The format of the HLD mapping table is incorrect. For example, this error could occur if HNODE\$ was expected but not found in the table. Re-create the table, using the appropriate format.

Syntax error in HLD.DAT

The syntax of an element in the HLD mapping table is incorrect. For example, the angle brackets needed to enclose the file specification are missing. Re-create the table.

Task name not found

The task to be loaded downline is not specified in the HLD mapping table. Re-create the table so that it contains this task name.

DECnet for OpenVMS Host Services

4.3 Loading RSX-11S Tasks Downline

No header in task file

The file was built with the /-HD switch. Therefore, it is an invalid RSX-11S task image. Rebuild the task.

Mapped task not on 4K boundary

The file was not built with the /MM switch. This error is for mapped RSX-11S systems only. Rebuild the task.

Unmapped partition mismatch

The TKB address does not correspond with the starting address of the partition in the RSX-11S system. This error is for unmapped RSX-11S systems only. Rebuild the task with a PAR= statement that specifies the correct starting address.

File too big for partition

The initial load size of the file is larger than the partition size in the RSX-11S system. Either make the partition larger or rebuild the file to use a smaller partition size.

Partition too big for checkpoint space

The partition size in the RSX-11S system is larger than the checkpoint space inside the file. Typically, this indicates that the partition size in your PAR= statement is smaller than the actual size of the partition in the RSX-11S system. Although the load size of a task may be much smaller than its partition, the entire partition is transferred during checkpoint operations. Rebuild the task with the exact partition size from the RSX-11S system.

4.3.4 Checkpointing RSX-11S Tasks

Checkpointing allows the execution of a task to be interrupted when a higher priority task installed in the same partition becomes active. The software writes the interrupted task from RSX-11S memory to a checkpoint file on the host (Checkpoint Write) and then loads the higher priority task into the partition and activates it. When the priority task exits, the software restores the interrupted task into main memory (Checkpoint Read), where it continues executing.

Checkpointing implies that a job is already running in the partition. Checkpoint space must be allocated inside the task being loaded downline (through the /AL switch during RSX-11S task build).

4.3.5 Overlaying RSX-11S Tasks

Overlaying allows the execution of segments of a task in order to reduce the memory or address space requirements for that task to run on an RSX-11S system. SLD and HLD handle the reading of overlay segments by satellite systems.

4.4 Connection to Remote Console

DECnet for OpenVMS allows you to set up a logical connection between your node and the console interface on certain unattended nodes, in effect permitting your terminal to act as the console for the remote system. For example, your terminal can act as the console for the Digital Ethernet Communications Server (DECSA) hardware and its resident software, such as the Router Server. The console carrier requester on the host connects to the console carrier server on the server.

DECnet for OpenVMS Host Services

4.4 Connection to Remote Console

You can set up the logical connection to the console using the remote console facility (RCF). Both your host node and the target node (that is, the server node) must be on the same Ethernet or FDDI LAN. You can use the RCF to force a crash if the server node becomes unresponsive. (To determine how to force a crash, see the appropriate documentation for the particular server product.) RCF also permits debugging under special circumstances.

To use the RCF to connect to a DECSA, be sure the console carrier server image and its loader file are present in the system directory on the host node. (The file name of the console carrier server image is PLUTOCC.SYS and that of the loader is PLUTOWL.SYS.) To invoke RCF, specify either the `CONNECT NODE` or `CONNECT VIA` command. The operating system then uses the loader file to downline load the console carrier server image into the Ethernet Communications Server hardware unit.

Use the `CONNECT NODE` command if the name of the target node is known. If the target node's service password and service circuit are defined in the host node's volatile database, you can use these default values. If the hardware address of the server node is not defined in the volatile database, you must specify the `PHYSICAL ADDRESS` parameter in the `CONNECT NODE` command. If you specify the physical address of the target node, DECnet for OpenVMS attempts to use it to load the image file. If you do not supply a `PHYSICAL ADDRESS` in the `CONNECT NODE` command, DECnet will obtain the hardware address for the target node in the volatile database, first attempting to use this address, and then attempting to use the physical address derived from the target node address in the volatile database.

To define default information in the volatile database for the target node, use the NCP command `SET NODE` to specify the `SERVICE PASSWORD`, `SERVICE CIRCUIT`, and `HARDWARE ADDRESS` parameters for the target node. You can override the target node parameter values currently defined in the volatile database by specifying new values in the `CONNECT` command.

For example, to connect your terminal to the console interface on server node `RTRDEV`, whose physical address on circuit `SVA-0` is `AA-00-04-00-38-00`, enter the following command:

```
NCP>CONNECT NODE RTRDEV SERVICE PASSWORD FEFEFEFEFEFEFEFEF -  
_ VIA SVA-0 PHYSICAL ADDRESS AA-00-04-00-38-00
```

Use the `CONNECT VIA` command if the node name of the target node is not known. In this command, specify the service circuit over which the logical connection is to be made and the physical address of the target node.

If you have not defined the hardware address of the server node in the volatile database and have not specified the physical address of the node in the `CONNECT` command, DECnet for OpenVMS displays an error message on your terminal, as follows:

```
Hardware address required
```

This message indicates that you must specify a physical address for the target node in your `CONNECT` command, because no hardware address is available in the volatile database.

In addition to the messages DECnet for OpenVMS NCP or MOM may issue during downline loading of the console carrier server code, other messages may be issued when you attempt to connect to a remote console. For example:

```
Console in use
```

DECnet for OpenVMS Host Services

4.4 Connection to Remote Console

This message indicates that the remote console has already been reserved for another purpose. Try to make the connection later.

Console connected (press Ctrl/D when finished)

The RCF is now ready for use. Ctrl/B is used to pass a *break* character to the remote console. Ctrl/D terminates the console session and causes the NCP prompt to be displayed.

Target does not respond

The remote console is supposed to respond quickly to inputs but is not doing so, or no connection can be made.

Ensure that a unique DECnet address is being used for the remote node. If this address is not supplied in the CONNECT command itself, it is obtained from the volatile node database of the local node.

Part III

Configuring, Installing, and Testing Networks

Configuring a Network

This chapter explains how to set up your operating system for use in a DECnet network and provides sample configuration examples for various types of networks. The *DECnet for OpenVMS Guide to Networking* provides a summary of basic instructions for bringing up a DECnet for OpenVMS node in the network.

5.1 Prerequisites for Establishing a Network

Before configuring your DECnet for OpenVMS node, there are certain prerequisites for DECnet for OpenVMS operation, such as setting up user accounts and directories, defining user privileges, and registering the Product Authorization Key (PAK) to enable your DECnet for OpenVMS license.

5.1.1 Required Privileges

To perform any kind of network activity, a process must have the appropriate privileges. As system manager, you define a user's privileges in the user authorization file (UAF). Table Table 5-1 lists common operations and their required privileges.

Table 5-1 Privileges for NCP Operations

Operation	Required Privileges
Start the network	ACNT, CMKRNL, SYSNAM, and DETACH
Perform task-to-task communication	NETMBX is required to assign a channel to the NET device. TMPMBX is required to optionally associate a temporary mailbox with a network channel.
Create a logical link	NETMBX
Declare a name or object number in a user task	SYSNAM (See <i>DECnet for OpenVMS Networking Manual</i> for information about user tasks.)
CLEAR parameters from the volatile database	NETMBX and OPER
Issue CONNECT commands	NETMBX
COPY KNOWN NODES	NETMBX, TMPMBX and OPER (SYSPRV is also needed if access to the permanent node database is required or if the WITH option is used.)
DEFINE parameters in the permanent database	SYSPRV and OPER ¹

¹You can perform operations requiring access to the permanent database without the SYSPRV privilege if you have read and write access to all configuration database files or hold BYPASS privilege. However, Digital recommends that you protect these network configuration files from unauthorized access by requiring SYSPRV to access these files.

(continued on next page)

Configuring a Network

5.1 Prerequisites for Establishing a Network

Table 5–1 (Cont.) Privileges for NCP Operations

Operation	Required Privileges
DISCONNECT LINKs	NETMBX and OPER
LIST parameters kept in the permanent database	SYSRV ¹
LIST service passwords kept in the permanent database	SYSRV and OPER ¹
LIST receive passwords, transmit passwords, and object and executor access control passwords kept in the permanent database	BYPASS
Issue LOAD commands	NETMBX, TMPMBX and OPER
Use LOOP CIRCUIT	NETMBX, TMPMBX and OPER
Use LOOP EXECUTOR	NETMBX and TMPMBX
PURGE parameters from the permanent database	SYSRV and OPER ¹
SET parameters kept in the volatile database	NETMBX and OPER
Issue SET EXECUTOR NODE	Requires NETMBX and TMPMBX privileges on the local node, and NML on the executor node must have appropriate privileges to perform the commands issued after the SET EXECUTOR NODE command.
Use "SET component ALL" to load parameters from the permanent database to the volatile database	NETMBX, OPER and SYSRV ¹
SHOW parameters kept in the volatile database	NETMBX
SHOW service passwords kept in the volatile database	NETMBX and OPER
SHOW receive passwords, transmit passwords, and access control passwords kept in the volatile database	NETMBX and BYPASS
Issue TELL commands	Requires NETMBX and TMPMBX on the local node, and NML on the executor node must have sufficient privileges to perform the command that follows TELL.
Issue TRIGGER commands	NETMBX, TMPMBX and OPER
ZERO counters	NETMBX and OPER

¹You can perform operations requiring access to the permanent database without the SYSRV privilege if you have read and write access to all configuration database files or hold BYPASS privilege. However, Digital recommends that you protect these network configuration files from unauthorized access by requiring SYSRV to access these files.

Refer to Section 3.11 for a further discussion of network user privileges and their function in relation to overall network security.

5.2 Configuration Procedures

This section discusses the tasks to prepare a networking environment.

Configure your DECnet for OpenVMS permanent database. Use the interactive procedure `SYS$MANAGER:NETCONFIG.COM` to configure a new system or to completely re-create the configuration database for an existing system. `NETCONFIG.COM` prompts you for all the information needed to configure the permanent database and, optionally, to set up DECnet object accounts on your system for certain network objects.

If you choose not to use the `NETCONFIG.COM` procedure, use NCP commands to build the permanent database. Or you can use the `NETCONFIG.COM` procedure to build the permanent database and then use NCP commands to tailor the database to your own needs.

Also, you can use the NCP command `COPY KNOWN NODES` to build or update the remote node entries in your node database.

To upgrade access control information on a node that has already been configured, you can use `SYS$UPDATE:NETCONFIG_UPDATE.COM` which changes only the default access options recorded in the node's configuration database, and leaves all other network environment settings intact. See Section 5.2.2.2 for information about the `NETCONFIG_UPDATE.COM` procedure.

You may have to perform additional configuration tasks depending upon your specific network requirements.

If you are planning to run DECnet for OpenVMS in a VMScluster, take special care when setting the system parameters `SCSNODE` and `SCSSYSTEMID`. Set `SCSNODE` to match the executor node name.

Set `SCSSYSTEMID` to match the executor address. When setting `SCSSYSTEMID`, use the algorithm for converting a node address to its decimal equivalent, as explained in Section 3.7.2. Section 5.4 provides additional information about setting up system parameters. Section 5.4.4 discusses special considerations that apply to configuration of the permanent database for systems that support cluster node capability.

VAX

If you plan to run DECnet for OpenVMS over a CI, load the DECnet driver `CNDRIVER`. If you will be using some of your terminal lines as DECnet for OpenVMS lines, load the asynchronous `DDCMP` driver `NODRIVER` and set up the static or dynamic asynchronous lines. Section 5.2.3 describes these tasks in detail. ♦

5.2.1 Default Access Options

When access control information has not been explicitly supplied by the network user, DECnet for OpenVMS uses either the the default account (if any) associated with a network object, or the default account specified for the executor.

The `NETCONFIG.COM` procedure provides four different ways to control default access.

1. The most restrictive approach is to configure the node's networking environment using the `NETCONFIG.COM` procedure, and instruct the procedure not to create any default DECnet accounts for the network objects or a default DECnet account. No incoming, default access would be permitted.

Configuring a Network

5.2 Configuration Procedures

2. A less restrictive approach is to grant default access for certain objects and to not create the default DECnet account. At your option, the NETCONFIG.COM procedure can create the following specific accounts for some network objects. You can specify that the NETCONFIG.COM procedure create any combination of these accounts. The accounts are:
 - MAIL\$SERVER [376,374]
 - FAL\$SERVER [376,373]
 - NML\$SERVER [376,371]
 - MIRRO\$SERVER [376,367]
 - PHONE\$SERVER [376,372]
 - VPM\$SERVER [376,370]

This scheme is different from the default DECnet account, which provides default access for all incoming links, unless overridden by other forms of access control. The specific default accounts, when used with other system security facilities, enable a network manager to monitor these accounts and more easily detect unauthorized access.

For each default account that you create, the NETCONFIG.COM procedure generates a password and registers it in your network configuration database. Such system-generated passwords are more secure than the passwords that users typically create.

3. A less restrictive approach is to create a default DECnet account, [376,376], for all network objects but to disable default access to a *type 0* object. A *type 0* object is also known as TASK object. This default access scheme is appropriate only for those systems with very low security requirements.
4. The least restrictive approach is to create an unrestricted default DECnet account that includes default access to all objects; this type of access is suitable for small systems with very low security requirements. To do so, you must override the defaults provided by the NETCONFIG.COM procedure.

5.2.1.1 Specific Default Accounts

MAIL provides personal mail service.

The file access listener (FAL) object, provides authorized access to the file system of a DECnet node on behalf of processes executing on any node in the network.

The FAL object can make a system vulnerable to unauthorized access by allowing network access by any remote user to any files with world read access. It also allows any remote user to create files in any directory with world write access. Digital recommends that you do not create any default account for FAL. Other, more secure access methods are available.

PHONE allows you to communicate with other users on your system or on other DECnet for OpenVMS systems.

A default DECnet account can allow unauthorized users to use Phone to get a list of users currently logged in to the local system. A user could then attempt to log in to the system by using the list of user names.

The network management listener (NML) object provides remote management of the local system. A default nonprivileged account for this object lets remote users issue NCP commands to gather and report network information from your node's DECnet databases.

The MIRROR object is used for loopback testing. To test DECnet for OpenVMS with the User Environment Test Package (UETP), a default account for the MIRROR object must exist.

The VPM object is used by the Monitor utility (MONITOR) in VMScluster configurations.

Refer to the *Guide to VMS System Security* for more information about these access methods and the security implications of these default accounts.

5.2.2 Using NETCONFIG.COM

You must have the privileges SYSPRV and OPER to execute NETCONFIG.COM.

To invoke the command procedure, enter the following command:

```
$ @SYS$MANAGER:NETCONFIG.COM
```

NETCONFIG.COM performs the following steps:

1. Prompts you for the name and address of your node.

```
What do you want your DECnet node name to be?      :  
What do you want your DECnet address to be?       :
```

The node name is a string of up to six alphanumeric characters, containing at least one alphabetic character. The node address is a numeric value in the format:

area-number.node-number

where:

area-number	Designates the area in which the node is grouped (in the range 1 to 63).
node-number	Designates the node's unique address within the area (in the range 1 to 1023).

If the network is not divided into two or more areas, you need not provide the area number; the system supplies the default area number 1.

VAX

2. On processors that support full routing capabilities, asks if you want to operate as a router.

```
Do you want to operate as a router?      [NO (nonrouting)]:
```

If you type NO (or take the default NO by pressing the RETURN key) in response to this question, the executor node is set up as a nonrouting node.

If you type YES, the EXECUTOR TYPE will be defined to ROUTING IV.

If you want the node to be an area router, type YES but choose not to start DECnet in step 9. Issue the NCP DEFINE EXECUTOR TYPE AREA command prior to starting DECnet. ♦

3. Displays the location of your object database file and asks if you want to purge it.

```
The network object database file is SYS$COMMON:[SYSEXE]NETOBJECT.DAT;4.
```

```
Do you want to purge the object database?      [YES]:
```

The default is to purge the database. However, if the node shares an object database with other nodes (as is commonly done with nodes in a VMScluster), and you want to preserve the common object database, answer NO to this question.

Configuring a Network

5.2 Configuration Procedures

4. Asks whether you want one or several default nonprivileged DECnet accounts. You may also indicate that no default accounts should be created on your system.

Do you want a default DECnet account? [NO]:

If you responded YES to a default DECnet account, you will see the following question:

Do you want default access to the TASK object disabled? [YES]:

The next four questions will be asked regardless of whether you responded YES or NO to a default DECnet account.

Do you want a default account for the MAIL object? [YES]:
Do you want a default account for the FAL object? [NO]:
Do you want a default account for the PHONE object? [YES]:
Do you want a default account for the NML object? [YES]:

The next two questions will be asked only if you responded NO to a default DECnet account.

Do you want a default account for the MIRROR object? [YES]:
Do you want a default account for the VPM object? [YES]:

5. Determines which DECnet devices you have on your system for use in building the line and circuit permanent databases.
6. Creates and displays a command procedure of the NCP, AUTHORIZE, and DCL commands required to configure your DECnet for OpenVMS node. The commands define the permanent database parameters for the executor; all lines, circuits, and objects; and all logging monitor events. The commands do not define the remote node database.
7. Asks if you want these commands to (be executed):

Do you want these commands to be executed? [YES]:

Carefully review the displayed commands. If you respond NO, the procedure returns a message indicating that no changes have been made. If you choose to run the command procedure, it does the following:

- Purges any existing information from the permanent executor, line, circuit, logging, and module configurator databases.
- Purges the object database unless you choose the option in step 3 to not purge the object database.
- Establishes the executor, line, circuit, and logging databases (but not the remote node database) in the permanent configuration database at your node.

8. NETCONFIG.COM estimates the amount of BYTLM quota the NETACP process will require to start your lines and circuits. NETCONFIG.COM issues a warning if the NETACP\$BUFFER_LIMIT system logical should be defined before DECnet is started, for example:

WARNING: NETACP will require more BYTLM process quota to start your lines and circuits properly. Before starting DECnet, define the NETACP\$BUFFER_LIMIT system logical to be at least 33460. Define an even higher BYTLM value if you will be raising the number of line receive buffers, increasing line buffer sizes, or enabling service on any circuits.

Configuring a Network

5.2 Configuration Procedures

See Section 5.4.3.1 for more information on NETACP process quota requirements.

9. The final question asks if you want the network started automatically. If you have registered the DECnet for OpenVMS Product Authorization Key (PAK) and the current BYTLM quota is adequate, answer YES. If you have not yet registered the DECnet for OpenVMS, answer NO. Register the PAK and start up the network manually by entering the following command:

```
$ @SYS$MANAGER:STARTNET
```

After the permanent database is established, you can use NCP commands to alter the parameters to correspond more closely to your configuration requirements.

VAX

If you use NETCONFIG.COM to establish the configuration database for a system that will be using only DDCMP asynchronous lines (for example, a MicroVAX system with a terminal line), NETCONFIG.COM does not configure the asynchronous DDCMP circuit and line parameters automatically. Instead, NETCONFIG.COM displays a message indicating that no circuits or lines have been configured. Set up the asynchronous lines separately (see Section 5.2.3.2).

Also, NETCONFIG.COM does not set up CI circuits. ♦

To ensure that the configuration is successful, you can run the User Environment Test Package (UETP) to test DECnet. For a description of the test procedure, reference the appropriate OpenVMS upgrade and installation procedure manual for your processor.

5.2.2.1 NETCONFIG.COM Example

Example 5-1 shows the interactive dialog that is displayed when you execute the NETCONFIG.COM procedure to configure VAX node URSUS as a level 1 routing node.

Note

Never use the sample system-generated passwords shown in the example for any accounts on your system.

Configuring a Network

5.2 Configuration Procedures

Example 5-1 Sample NETCONFIG.COM Dialogue for a Routing Node

DECnet for OpenVMS network configuration procedure

This procedure will help you define the parameters needed to get DECnet running on this machine. You will be shown the changes before they are actually executed, in case you wish to perform them manually.

```
What do you want your DECnet node name to be?      : URSUS 
What do you want your DECnet address to be?       : 2.3 
Do you want to operate as a router? [NO (nonrouting)]: YES 
```

The network object database file is SYS\$COMMON:[SYSEXE]NETOBJECT.DAT;4.

```
Do you want to purge the object database?         [YES]: 
Do you want a default DECnet account?             [NO]: 
Do you want a default account for the MAIL object? [YES]: 
Do you want a default account for the FAL object? [NO]: 
Do you want a default account for the PHONE object? [YES]: 
Do you want a default account for the NML object? [YES]: 
Do you want a default account for the MIRROR object? [YES]: 
Do you want a default account for the VPM object? [YES]: 
```

Here are the commands necessary to set up your system.

```
$ RUN SYS$SYSTEM:NCP
  PURGE EXECUTOR ALL
  PURGE KNOWN LINES ALL
  PURGE KNOWN CIRCUITS ALL
  PURGE KNOWN LOGGING ALL
  PURGE KNOWN OBJECTS ALL
  PURGE MODULE CONFIGURATOR KNOWN CIRCUITS ALL
$ DEFINE/USER SYS$OUTPUT NL:
$ DEFINE/USER SYS$ERROR NL:
$ RUN SYS$SYSTEM:NCP ! Remove existing entry, if any
  PURGE NODE 2.3 ALL
  PURGE NODE URSUS ALL
$ RUN SYS$SYSTEM:NCP
  DEFINE EXECUTOR ADDRESS 2.3
  DEFINE EXECUTOR STATE ON
  DEFINE EXECUTOR NAME URSUS
  DEFINE EXECUTOR MAXIMUM ADDRESS 1023
  DEFINE EXECUTOR TYPE ROUTING IV
  DEFINE OBJECT TASK NUMBER 0 USER ILLEGAL PASSWORD DISABLED
  DEFINE OBJECT MAIL NUMBER 27 USER MAIL$SERVER PASSWORD yadnifaj
$ DEFINE/USER_MODE SYSUAF SYS$SYSTEM:SYSUAF.DAT
$ RUN SYS$SYSTEM:AUTHORIZE
  ADD MAIL$SERVER /OWNER="MAIL$SERVER DEFAULT" -
  /PASSWORD=yadnifaj -
  /UIC=[376,374] /ACCOUNT=DECNET -
  /DEVICE=SYS$SPECIFIC: /DIRECTORY=[MAIL$SERVER] -
  /PRIVILEGE=(TMPMBX,NETMBX) -
  /DEFPRIVILEGE=(TMPMBX,NETMBX) -
  /FLAGS=(NOCAPTIVE,RESTRICTED,NODISUSER) /LGICMD=NL: -
  /NOBATCH /NOINTERACTIVE
  MODIFY MAIL$SERVER /PASSWORD=yadnifaj
$ CREATE/DIRECTORY SYS$SPECIFIC:[MAIL$SERVER] /OWNER=[376,374]
```

(continued on next page)

Configuring a Network 5.2 Configuration Procedures

Example 5-1 (Cont.) Sample NETCONFIG.COM Dialogue for a Routing Node

```
$ RUN SYSSYSTEM:NCP
    DEFINE OBJECT PHONE NUMBER 29 USER PHONE$SERVER PASSWORD dogbasow
$ DEFINE/USER_MODE SYSUAF SYSSYSTEM:SYSUAF.DAT
$ RUN SYSSYSTEM:AUTHORIZE
    ADD PHONE$SERVER /OWNER="PHONE$SERVER DEFAULT" -
    /PASSWORD=dogbasow -
    /UIC=[376,372] /ACCOUNT=DECNET -
    /DEVICE=SYSSPECIFIC: /DIRECTORY=[PHONE$SERVER] -
    /PRIVILEGE=(TMPMBX,NETMBX) -
    /DEFPRIVILEGE=(TMPMBX,NETMBX) -
    /FLAGS=(NOCAPTIVE,RESTRICTED,NODISUSER) /LGICMD=NL: -
    /NOBATCH /NOINTERACTIVE
    MODIFY PHONE$SERVER /PASSWORD=dogbasow
$ CREATE/DIRECTORY SYSSPECIFIC:[PHONE$SERVER] /OWNER=[376,372]
$ RUN SYSSYSTEM:NCP
    DEFINE OBJECT NML NUMBER 19 USER NML$SERVER PASSWORD kenrooka
$ DEFINE/USER_MODE SYSUAF SYSSYSTEM:SYSUAF.DAT
$ RUN SYSSYSTEM:AUTHORIZE
    ADD NML$SERVER /OWNER="NML$SERVER DEFAULT" -
    /PASSWORD=kenrooka -
    /UIC=[376,371] /ACCOUNT=DECNET -
    /DEVICE=SYSSPECIFIC: /DIRECTORY=[NML$SERVER] -
    /PRIVILEGE=(TMPMBX,NETMBX) -
    /DEFPRIVILEGE=(TMPMBX,NETMBX) -
    /FLAGS=(NOCAPTIVE,RESTRICTED,NODISUSER) /LGICMD=NL: -
    /NOBATCH /NOINTERACTIVE
    MODIFY NML$SERVER /PASSWORD=kenrooka
$ CREATE/DIRECTORY SYSSPECIFIC:[NML$SERVER] /OWNER=[376,371]
$ RUN SYSSYSTEM:NCP
    DEFINE OBJECT MIRROR NUMBER 25 USER MIRRO$SERVER PASSWORD ewxgamula
$ DEFINE/USER_MODE SYSUAF SYSSYSTEM:SYSUAF.DAT
$ RUN SYSSYSTEM:AUTHORIZE
    ADD MIRRO$SERVER /OWNER="MIRRO$SERVER DEFAULT" -
    /PASSWORD=ewxgamula -
    /UIC=[376,367] /ACCOUNT=DECNET -
    /DEVICE=SYSSPECIFIC: /DIRECTORY=[MIRRO$SERVER] -
    /PRIVILEGE=(TMPMBX,NETMBX) -
    /DEFPRIVILEGE=(TMPMBX,NETMBX) -
    /FLAGS=(NOCAPTIVE,RESTRICTED,NODISUSER) /LGICMD=NL: -
    /NOBATCH /NOINTERACTIVE
    MODIFY MIRRO$SERVER /PASSWORD=ewxgamula
$ CREATE/DIRECTORY SYSSPECIFIC:[MIRRO$SERVER] /OWNER=[376,367]
$ RUN SYSSYSTEM:NCP
    DEFINE OBJECT VPM NUMBER 51 USER VPM$SERVER PASSWORD galesobu
$ DEFINE/USER_MODE SYSUAF SYSSYSTEM:SYSUAF.DAT
$ RUN SYSSYSTEM:AUTHORIZE
    ADD VPM$SERVER /OWNER="VPM$SERVER DEFAULT" -
    /PASSWORD=galesobu -
    /UIC=[376,370] /ACCOUNT=DECNET -
    /DEVICE=SYSSPECIFIC: /DIRECTORY=[VPM$SERVER] -
    /PRIVILEGE=(TMPMBX,NETMBX) -
    /DEFPRIVILEGE=(TMPMBX,NETMBX) -
    /FLAGS=(NOCAPTIVE,RESTRICTED,NODISUSER) /LGICMD=NL: -
    /NOBATCH /NOINTERACTIVE
    MODIFY VPM$SERVER /PASSWORD=galesobu
$ CREATE/DIRECTORY SYSSPECIFIC:[VPM$SERVER] /OWNER=[376,370]
```

(continued on next page)

Configuring a Network

5.2 Configuration Procedures

Example 5-1 (Cont.) Sample NETCONFIG.COM Dialogue for a Routing Node

```
$ RUN SYSS$SYSTEM:NCP
  DEFINE LINE      BNA-0 STATE ON
  DEFINE CIRCUIT  BNA-0 STATE ON COST 4
  DEFINE LINE      SVA-0 STATE ON
  DEFINE CIRCUIT  SVA-0 STATE ON COST 4

  DEFINE LOGGING MONITOR STATE ON
  DEFINE LOGGING MONITOR EVENTS 0.0-9
  DEFINE LOGGING MONITOR EVENTS 2.0-1
  DEFINE LOGGING MONITOR EVENTS 4.2-13,15-16,18-19
  DEFINE LOGGING MONITOR EVENTS 5.0-18
  DEFINE LOGGING MONITOR EVENTS 128.0-4
```

Do you want these commands to be executed? [YES:]

The changes have been made.

If you have not already registered the DECnet for OpenVMS key, then do so now.

After the key has been registered, invoke the procedure
SYS\$MANAGER:STARTNET.COM to start up DECnet for OpenVMS with these changes.

(If the key is already registered) Do you want DECnet started? [YES:]

5.2.2.2 NETCONFIG_UPDATE.COM for Existing Network Configurations

Unlike NETCONFIG.COM, NETCONFIG_UPDATE.COM configures only default access control. It performs no other network configuration. Therefore, when you use NETCONFIG_UPDATE.COM to specify changes to default access control information, everything else in the configuration database remains unchanged. The NETCONFIG_UPDATE.COM procedure resides in SYS\$UPDATE. The SYSPRV and OPER privileges are required to run NETCONFIG_UPDATE.COM.

Like NETCONFIG.COM, NETCONFIG_UPDATE.COM generates passwords for each account that you create and for existing default accounts in your configuration database. For example, if you currently have a default account for MAIL, NETCONFIG_UPDATE.COM generates a new password for it and replaces the existing password with the new one. You never need to write down or memorize the default account's system-generated password. The password is recorded in that account's user authorization file (UAF) record and then added to that object's definition in the permanent database.

If you choose not to immediately execute the commands generated by NETCONFIG_UPDATE.COM, these commands will be written to a SYS\$MANAGER:UPDATE_NODEINFO.COM file so you can execute them later.

NETCONFIG_UPDATE.COM provides a secondary procedure for updating the default access of the databases of nodes that are VMScluster members. When you run NETCONFIG_UPDATE.COM on one node that is a member of a cluster, the procedure detects that it is a cluster member and instructs you to run SYS\$COMMON:[SYSMGR]UPDATE_CLUSTER_MEMBERS.COM on the other cluster members. This secondary procedure will modify the default access of each cluster member exactly as you modified that of the first member.

Configuring a Network 5.2 Configuration Procedures

Use the System Management utility (SYSMAN) to run the secondary procedure, and update the volatile database on all nodes. For example:

```
$ RUN SYS$SYSTEM:SYSMAN
SYSMAN> SET ENVIRONMENT/CLUSTER/USER=SYSTEM
Remote Password:

%SYSMAN-I-ENV, current command environment:
      Clusterwide on local cluster
      Username SYSTEM will be used on nonlocal nodes

SYSMAN> DO @SYS$COMMON:[SYSMGR]UPDATE_CLUSTER_MEMBERS.COM

SYSMAN> DO MCR NCP SET KNOWN OBJECTS ALL
SYSMAN> DO MCR NCP SET EXEC ALL

SYSMAN> EXIT
$
```

See the *OpenVMS System Management Utilities Reference Manual* for details on SYSMAN. You need OPER privilege to run SYSMAN.

Note

When you no longer need them, delete any SYS\$MANAGER:UPDATE_CLUSTER_MEMBERS.COM or SYS\$MANAGER:UPDATE_NODEINFO.COM files created by NETCONFIG_UPDATE.COM. These files contain password and account information which may present a security risk.

5.2.3 Tailoring the Configuration Database

You can configure the network using individual NCP commands. Examples of various configuration procedures are given in Section 5.3. You can also use NCP to add or delete entries in an existing permanent database.

VAX

Following are two examples of changes made to the network configuration that require corresponding modification of the permanent database:

- Running DECnet over the CI. The driver CNDRIVER must be loaded on the system and all CI lines and circuits must be defined in the configuration database.
- Running DECnet over terminal lines. The terminal driver, NODRIVER, must be loaded on the system, terminal lines must be converted to DDCMP lines, and all DDCMP lines and circuits must be defined in the configuration database.♦

The procedures for handling these changes are described in detail in the following sections.

5.2.3.1 Running DECnet over the CI

VAX

On systems that support the CI, to use the CI750, CI780, or CIBCI as a DECnet device, first load CNDRIVER, the DECnet driver associated with the CI. To load CNDRIVER, add the following commands to the site-specific startup procedure in the SYS\$MANAGER directory:

```
$ RUN SYS$SYSTEM:SYSGEN
CONNECT CNA0/NOADAPTER
```

Configuring a Network

5.2 Configuration Procedures

You are now ready to set up DECnet to use the CI. For example:

```
$ RUN SYS$SYSTEM:NCP
NCP>SET LINE CI-0 STATE ON
NCP>SET CIRCUIT CI-0.0 TRIBUTARY 0 STATE ON
NCP>SET CIRCUIT CI-0.1 TRIBUTARY 1 STATE ON
.
.
.
NCP>EXIT
$
```

The previous example illustrates how to use NCP commands to define the CI line and one or more CI circuits in the permanent database.♦

5.2.3.2 Running DECnet over Terminal Lines

VAX

On systems that support DDCMP, to use lines connected to terminal ports as DECnet communications lines, load the asynchronous DDCMP driver NODRIVER, set up the terminal lines to be converted to asynchronous DDCMP lines, and specify the appropriate lines and circuits in the NCP configuration database. The steps in converting terminal lines to asynchronous lines depend on the type of line you want to set up:

- A static asynchronous DDCMP line: a line permanently configured as a DECnet line
- A dynamic asynchronous DDCMP line: a line that is switched from terminal to DECnet use for the duration of a dialup call

Procedures for installing and shutting down each of these types of lines are described in Section 5.2.3.3 and Section 5.2.3.4. The complete DECnet for OpenVMS installation procedure, including establishment of asynchronous connections, appears in the *DECnet for OpenVMS Guide to Networking*.

Because dialup lines are more prone to noise problems than dedicated synchronous lines, set the executor buffer size and segment buffer size to a value of 192 for any end node that is connected to its router by a dialup line. Use of a relatively small buffer size reduces the effect of buffer retransmission on overall throughput.♦

5.2.3.3 Installing Static Asynchronous Lines

VAX

On systems that support DDCMP, you perform the following steps when setting up and shutting down static asynchronous lines on your system.

Setting Up Static Asynchronous DDCMP Lines

The following steps are necessary to set up lines connected to terminal ports on your system for use as static asynchronous DECnet lines. The system manager at the remote node must also perform steps similar to the following:

1. Load the asynchronous DDCMP driver NODRIVER by adding the following commands to the site-specific startup procedure in the SYS\$MANAGER directory or by interactively specifying the commands after the system is booted.

```
$ RUN SYS$SYSTEM:SYSGEN
SYSGEN> CONNECT NOA0/NOADAPTER
```

Configuring a Network

5.2 Configuration Procedures

2. Choose the terminal lines on your system that you will use as DECnet lines. For each terminal line that you configure as a static asynchronous DDCMP line, modify the site-specific startup procedure in your SYS\$MANAGER directory by adding the DCL command SET TERMINAL/PROTOCOL=DDCMP device-name before the command which invokes SYS\$MANAGER:STARTNET.

For example, to convert the terminal lines connected to ports TTA0 and TXB7 on your system into DECnet lines with no modem control, add the following commands to the site-specific startup procedure:

```
$ SET TERMINAL/PERMANENT/PROTOCOL=DDCMP/NOTYPE_AHEAD TTA0:
$ SET TERMINAL/PERMANENT/PROTOCOL=DDCMP/NOTYPE_AHEAD TXB7:
```

To convert the line connected to terminal port TXA1 (which can be used as a dialup line) to a DECnet line with modem control, add the following command to the site-specific startup procedure:

```
$ SET TERMINAL/PERMANENT/MODEM/NOHANGUP/NOAUTOBAUD -
_ $ /NOTYPE_AHEAD/PROTOCOL=DDCMP TXA1:
```

While the terminal line is in use as a DECnet communications line, you can change the line speed by resetting the speed and line using NCP.

3. Use NCP DEFINE commands to define all terminal lines and circuits in the permanent database, as shown in the following example:

```
$ RUN SYS$SYSTEM:NCP
NCP>DEFINE LINE TT-0-0 STATE ON RECEIVE BUFFERS 4 -
_ LINE SPEED 2400
NCP>DEFINE CIRCUIT TT-0-0 STATE ON
NCP>DEFINE LINE TX-1-7 STATE ON RECEIVE BUFFERS 4 -
_ LINE SPEED 2400
NCP>DEFINE CIRCUIT TX-1-7 STATE ON
NCP>DEFINE LINE TX-0-1 STATE ON RECEIVE BUFFERS 4 -
_ LINE SPEED 2400
NCP>DEFINE CIRCUIT TX-0-1 STATE ON
NCP>EXIT
$
```

Your changes will take effect when you restart DECnet. To change the volatile database, repeat the commands above, using SET rather than DEFINE.

Reasons for Failure of Static Asynchronous Connections

If static asynchronous DECnet lines are started but are left in the ON-STARTING state, check the following:

- The line speeds at both ends of the connection must be set to the same value.
- If you are using a dialup line, the modem characteristic must be set on the terminal before the line is used for asynchronous DDCMP.
- If the network is divided into areas, the two nodes being connected must be in the same area or must be area routers.
- Asynchronous DECnet requires the parity on the asynchronous line to be set to NONE and the terminal line to be set up to use 8-bit characters. If one of the systems is not running the OpenVMS operating system, check that the terminal line is set to the correct parity.

Configuring a Network

5.2 Configuration Procedures

If your terminal line cannot be set up as a static asynchronous DDCMP line, check whether the following condition exists:

- The terminal line is owned by another process. You can determine if the terminal line is owned by another process by using the SHOW DEVICE/FULL DCL command. If the "Owner process ID" displayed is not 0, then the terminal line is owned by another process. Before the local terminal line has been switched into a DDCMP line, DDCMP start messages sent from the remote node may be interpreted as a user attempting to login on the local terminal line and will result in the terminal line being owned by another process. The STOP/ID=pid DCL command can be used to terminate the process and free the terminal line.

To verify that the asynchronous line is connected properly, check the following:

- For local connections, verify that the cable is a null modem cable.
- For modem connections, verify that the cable is a straight-through cable and that if the modem is put in analog loopback, the circuit comes up with the local node as the adjacent node.
- For both types of connections, verify that the port is operational by resetting the port to terminal-type characteristics and plugging in a terminal and logging in.

If your connection is timing out or losing DDCMP packets, it may be that you do not have a sufficient number of receive buffers for the asynchronous line. To verify and correct this problem, see Section 3.6.3.1.

Shutting Down Static Asynchronous DDCMP Lines

To shut down a DECnet line and return it to a terminal line, enter the following commands:

```
$ RUN SYSS$SYSTEM:NCP
NCP>SET LINE TT-0-0 STATE OFF
NCP>CLEAR LINE TT-0-0 ALL
NCP>SET CIRCUIT TT-0-0 STATE OFF
NCP>CLEAR CIRCUIT TT-0-0 ALL
```

To switch a line for which modem control was not enabled back to a terminal line, enter the following command:

```
$ SET TERMINAL/PROTOCOL=NONE TTA0:
```

To switch a line for which modem control was enabled back to a terminal line, enter the following command:

```
$ SET TERMINAL/PERMANENT/MODEM/AUTOBAUD/TYPEAHEAD -
_ $ /PROTOCOL=NONE TXA1:◆
```

5.2.3.4 Installing Dynamic Asynchronous Lines

VAX

On systems that support DDCMP, to make a temporary connection to another node over an asynchronous connection (for example, a telephone line), the terminal lines at each node may be switched to dynamic asynchronous DDCMP lines for the duration of the connection. The procedure for establishing a dynamic connection, reasons why the connection might fail, and the actions that shut down the lines are described next. Dynamic switching is described in detail in Chapter 2.

Configuring a Network 5.2 Configuration Procedures

Setting Up and Switching Dynamic Asynchronous DDCMP Lines

The following steps illustrate how to set up a dynamic connection for dynamic asynchronous DECnet lines. This procedure illustrates commands used if a local DECnet for OpenVMS system installed on a MicroVAX (HELIUM) is establishing a dynamic connection with a remote DECnet for OpenVMS system (OXYGEN). The remote system is the node that initiates the switch.

1. The system manager at each node must load the asynchronous DDCMP driver NODRIVER by adding the following commands to the site-specific startup procedure in the SYS\$MANAGER directory or by interactively specifying the commands after the system is booted.

```
$ RUN SYSS$SYSTEM:SYSGEN
SYSGEN> CONNECT NOAO/NOADAPTER
```

2. The system manager at each node must install the shareable image DYN SWITCH, as follows:

```
$ INSTALL
INSTALL> CREATE SYS$LIBRARY:DYN SWITCH/SHARE -
_ /PROTECT/HEADER/OPEN
INSTALL> EXIT
```

DYN SWITCH is a DECnet for OpenVMS image only. If the image DYN SWITCH is not installed on the remote system, dynamic switching of lines is implicitly disabled.

3. The system manager at the remote node, OXYGEN, must enable the use of virtual terminals with these commands:

```
$ RUN SYSS$SYSTEM:SYSGEN
SYSGEN> CONNECT VTA0/NOADAPTER/DRIVER=TTDRIVER
```

The system manager on the remote system must also enable the disconnect option for the terminal port to be used by specifying the following command for the terminal:

```
$ SET TERMINAL/PERMANENT/MODEM/DISCONNECT TTB1:
```

4. For security, the user at the local node HELIUM must define in the node database the transmit password to be sent to remote node OXYGEN. For example:

```
$ RUN SYSS$SYSTEM:NCP
NCP>DEFINE NODE OXYGEN TRANSMIT PASSWORD password
```

The system manager at remote node OXYGEN must define node HELIUM in the node database with the appropriate receive password and INBOUND type (router or end node). For example:

```
$ RUN SYSS$SYSTEM:NCP
NCP>DEFINE NODE HELIUM INBOUND ENDNODE -
_ RECEIVE PASSWORD password
```

Figure 5-1 illustrates dynamic asynchronous switching occurring over a dialup line. The local node in Figure 5-1 is a standalone MicroVAX II system; the remote node is a VAX-11/780. After the user at the local node dials in to the remote node, he or she can cause the lines connected to terminal ports TTA1 and TXB1 to be switched to dynamic asynchronous DDCMP lines for use in DECnet communications.

Configuring a Network

5.2 Configuration Procedures

Figure 5-1 Dynamic Switching of Asynchronous DDCMP Lines

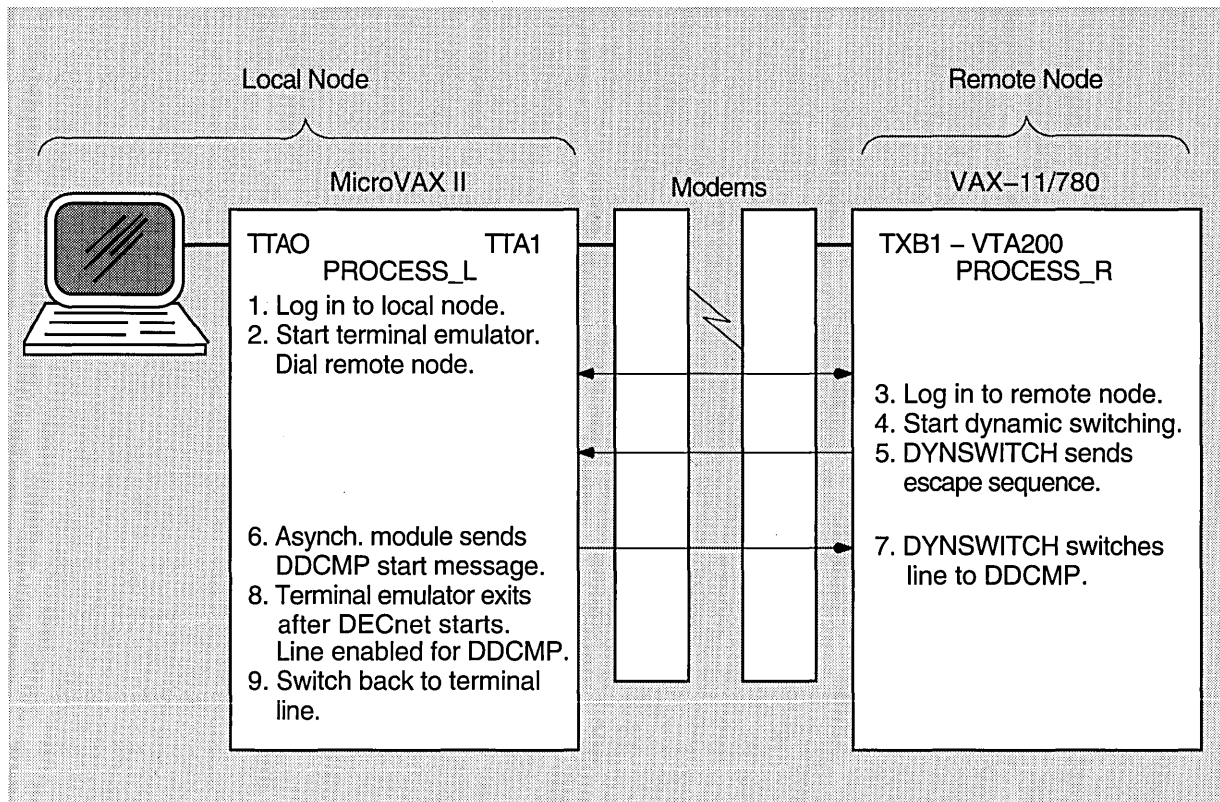

LKG-6709-92R

The following steps illustrate how to switch lines connected to terminal ports to dynamic asynchronous DECnet lines, as illustrated in Figure 5-1.

1. Log in to the operating system running on the MicroVAX II, causing a process to be created on your system. In Figure 5-1, this process is identified by the sample process name PROCESS_L.
2. To start the terminal emulator, enter the following DCL command:

```
$ SET HOST/DTE[/DIAL=NUMBER:number] TTA1:
```

This command causes a process on the local system to function as a **terminal emulator**, and causes the modem to dial the number of the remote system. The terminal emulator permits the local process to function as though it were a terminal line: characters can be read from one port and written to another port.

If you do not specify the /DIAL qualifier, dial the remote system manually.

For details about the SET HOST/DTE command, see the *OpenVMS DCL Dictionary*.

In Figure 5-1, the terminal emulator on the MicroVAX II transfers characters between ports TTA0 and TTA1. The /DIAL qualifier in the SET HOST/DTE command is optional and works only if you have a program to dial your modem. The default program supplied with the operating system dials a DF03 modem.

Configuring a Network

5.2 Configuration Procedures

3. After the dialup connection is made and you receive the remote system welcome message, perform the regular procedure for logging in to your account on the remote node. In this case, you would supply your userid and password to the remote operating system.

When you log in over a modem line, a process is created at the remote node and connected to a **virtual terminal** as well as the physical terminal. In Figure 5-1, this process is identified by the sample process name PROCESS_R. The virtual terminal permits PROCESS_R to continue running even if the physical terminal is disconnected (for example, if you lose the carrier signal on your telephone line).

4. You can then initiate dynamic switching by specifying the following DCL command from your account on the remote node:

```
$ SET TERMINAL/PROTOCOL=DDCMP/SWITCH=DECNET
```

The SET TERMINAL command is an OpenVMS DCL command. If you are not on an OpenVMS node, specify the equivalent function for your system.

If the terminal emulator does not recognize escape sequences (if the local node is not an OpenVMS operating system), specify the /MANUAL qualifier in the SET TERMINAL command.

```
$ SET TERMINAL/MANUAL/PROTOCOL=DDCMP/SWITCH=DECNET
```

The /MANUAL qualifier prevents DYN SWITCH at the remote node from sending the escape sequence. Instead, DYN SWITCH sends the following message to the local node:

```
%SET-I-SWINPRG, The line you are currently logged in  
over is becoming a DECnet line
```

After receiving this message, if you decide not to switch the line, you can press Ctrl/C or Ctrl/Y to abort the switch. If your local system is a VAX and you want to continue the switch, exit the terminal emulator and switch your terminal line to an asynchronous DDCMP line manually by entering the following command:

```
$ SET TERMINAL/PROTOCOL=DDCMP TTA1:
```

Then, you enter NCP commands to turn on your line and circuit. For example, enter the following commands:

```
NCP>SET CIRCUIT TT-0-1 STATE ON  
NCP>SET LINE TT-0-1 STATE ON
```

DYN SWITCH waits 60 seconds for the DDCMP start message and the transmit password and then times out the switch.

The SET TERMINAL command is an OpenVMS DCL command. If you are not on an OpenVMS node, specify the equivalent function for your system.

5. When the SET image at the remote node recognizes the /SWITCH=DECNET qualifier, it calls the shareable image DYN SWITCH. DYN SWITCH verifies that the device is a virtual terminal and then sends an escape sequence to the terminal emulator running on the MicroVAX II. The escape sequence notifies the terminal emulator that the line connected to the remote terminal port is becoming an asynchronous DDCMP line.

Configuring a Network

5.2 Configuration Procedures

6. When the terminal emulator at the local node receives the escape sequence, it calls the image DYN SWITCH, which causes the line connected to terminal port TTA1 to be switched to an asynchronous DDCMP line. It assigns a channel to the network and supplies the appropriate line and circuit entries to the NCP volatile database at the local node. (The modem line is not dropped; redialing is not required.)

The asynchronous DDCMP software module on the local node sends a DDCMP start message to DYN SWITCH on the remote node and sends the transmit password defined in the local node database.

7. DYN SWITCH at the remote node disconnects the physical terminal from the virtual terminal, and causes the line connected to the physical terminal port (in Figure 5-1, the port TXB1) to be converted to an asynchronous DDCMP line. DYN SWITCH assigns a channel to the network and supplies the appropriate line and circuit parameters to the volatile database to start up the line and circuit.
8. After DECnet is started on the local node, the terminal emulator is exited. When control is returned to the local node, the following message is displayed:

```
%REM-S-END, control returned to node _local-node-name::
```

A prompt appears on the local terminal and you can then use DECnet to perform operations over the network.

9. When you hang up the telephone, the line is switched back to a terminal line. (DECnet automatically clears the line and circuit entries from the volatile database). Alternatively, you can switch the asynchronous line back to a terminal line by issuing an NCP command to turn off the line or circuit.

To prevent the modem signal from dropping when you turn off the DECnet line in NCP, specify the /NOHANGUP qualifier in the SET TERMINAL command. If you use this qualifier, you need not redial the connection to the remote node when you want to convert your line to DECnet use.

Chapter 3 describes the NCP command parameters required for asynchronous connections. Section 2.8 summarizes security for dynamic asynchronous connections.

Reasons for Failure of Dynamic Asynchronous Connections

If dynamic switching is being performed and the asynchronous DECnet connection is not made, first check that the following conditions exist:

- DECnet must be started on both nodes.
- The asynchronous DDCMP class driver (NODRIVER) must be loaded by means of SYS\$SYSTEM:SYSGEN at each node.
- The dynamic switch image (DYN SWITCH) must be installed by means of SYS\$SYSTEM:INSTALL at each node.
- Virtual terminals must be enabled both on the remote node and, in particular, for the terminal at which you are logged in. The terminal line at the remote node must have the attribute DISCONNECT set.
- After you enter a SET TERMINAL command with the /MANUAL qualifier, you must specify NCP commands to turn on the DECnet line within approximately four minutes or the line returns to terminal mode.

Configuring a Network

5.2 Configuration Procedures

If the dynamic asynchronous lines are started but are left in the ON-STARTING state, check the following:

- If the network is divided into areas, the two nodes being connected must be in the same area or must be area routers.
- The routing initialization passwords on each node must be set correctly (see Section 3.11.1).
- The INBOUND parameter for the local node entry must be set correctly in the node database at the remote node (see Section 3.11.3).
- Asynchronous DECnet requires the parity on the asynchronous line to be set to NONE and the terminal line to be set up to use 8-bit characters. If you are not using an OpenVMS system, check that the terminal line is set to the correct parity.

Shutting Down Dynamic Asynchronous Lines

You have two options for ending a dynamic connection:

- Break the telephone connection.
- Enter one of the following NCP commands (either command causes both line and circuit entries to be cleared in the database):

```
NCP>SET LINE TT-0-0 STATE OFF
NCP>SET CIRCUIT TT-0-0 STATE OFF
```

The results of these commands vary depending on the side of the connection from which they are entered. If the command is entered at the local (originating) node, the port is immediately switched to the terminal driver. On the other side (the remote node), the line remains in the ON-STARTING state for approximately four minutes and then is switched to the terminal port. If the line or circuit is stopped by the remote node, the line and circuit on both sides of the connection immediately return to terminal mode.

If you specify the /NOHANGUP qualifier in the SET TERMINAL command with which you initiate dynamic switching, the modem carrier signal is not dropped when you shut down the DECnet line or circuit. The carrier signal is broken when you hang up the telephone.

If you specify the SET TERMINAL command with the /MANUAL qualifier to switch the terminal line manually, you can abort the switch by pressing Ctrl/C or Ctrl/Y.♦

5.3 Network Configuration Examples

This section discusses how you can use NCP commands to build your network configuration in the permanent database. The following table lists the network configuration examples and the sections in which they appear:

Configuring a Network

5.3 Network Configuration Examples

Network Configuration Example	Section
Ethernet Network Example	Section 5.3.1
FDDI Network Example	Section 5.3.2
†Synchronous DDCMP Point-to-Point	Section 5.3.3
†DDCMP Multipoint	Section 5.3.4
†Static Asynchronous DDCMP	Section 5.3.5
†Dynamic Asynchronous DDCMP	Section 5.3.6
†VAX specific	

Assume that these configuration examples are single-area networks using the default area 1. Figure 5-2 through Figure 5-7 correspond to the examples shown in each of the respective sections.

Combine the appropriate NCP commands in a command file that reflects your network configuration; then edit and run this procedure as many times as necessary to properly build the permanent database corresponding to your configuration and needs. After you configure the permanent database, invoke `SY$MANAGER:STARTNET.COM` to load these parameters into the volatile database, and to bring up the network.

5.3.1 Ethernet Network Example

The example in this section shows how to build a database for node Robin which is in a network configuration of three nodes connected by an Ethernet SVA line and circuit, as depicted in Figure 5-2. The NCP commands in this example configure the database for node ROBIN. Repeat the procedure to configure the databases for nodes THRUSH and LARK.

Figure 5-2 An Ethernet Network Configuration

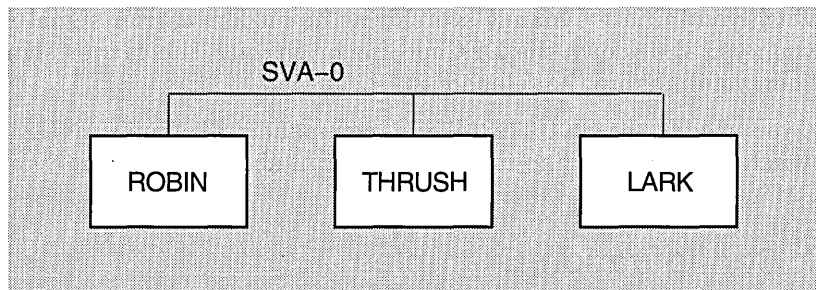

LKG-6098-92R

```
!
! Define executor-specific parameters for local node ROBIN.
!
DEFINE EXECUTOR      ADDRESS 20 -
                     BUFFER SIZE 576 -
                     STATE ON
                     TYPE NONROUTING IV
```

Configuring a Network

5.3 Network Configuration Examples

```
!
! Define common node parameters for the local node. Be sure
! to add the NETNONPRIV user to your system authorization
! file by using the Authorize utility.
!
DEFINE EXECUTOR      NAME ROBIN -
                    NONPRIVILEGED -
                    USER NETNONPRIV -
                    PASSWORD NONPRIV

!
! Define the remaining nodes. No default outbound
! access control information is specified. This assumes that
! the default access control information will be supplied by
! each remote node when it receives an inbound connect request.
!
DEFINE NODE 21      NAME THRUSH
DEFINE NODE 22      NAME LARK

!
! Define parameters for line/circuit SVA-0.
!
DEFINE LINE SVA-0    STATE ON
DEFINE CIRCUIT SVA-0 STATE ON

!
! The object database does not need to be defined because it defaults
! to the standard list of objects known to the operating system.
!
!
! Define transmitter-related logging parameters.
!
DEFINE LOGGING MONITOR KNOWN EVENTS

!
! Define receiver-related logging parameters.
!
DEFINE LOGGING MONITOR STATE ON
```

5.3.2 FDDI Network Example

The example in this section shows how to build a database for node SWAN which is in a network configuration of three nodes connected by an FDDI MFA line and circuit, as depicted in Figure 5-3. The NCP commands in this example configure the database for node SWAN. Repeat the procedure to configure the databases for nodes DOVE and ORIOLE.

```
!
! Define executor-specific parameters for local node SWAN.
!
DEFINE EXECUTOR      ADDRESS 20 -
                    BUFFER SIZE 576 -
                    STATE ON
                    TYPE NONROUTING IV

!
! Define common node parameters for the local node. Be sure
! to add the NETNONPRIV user to your system authorization
! file by using the Authorize utility.
!
```

Configuring a Network

5.3 Network Configuration Examples

Figure 5-3 An FDDI Network Configuration

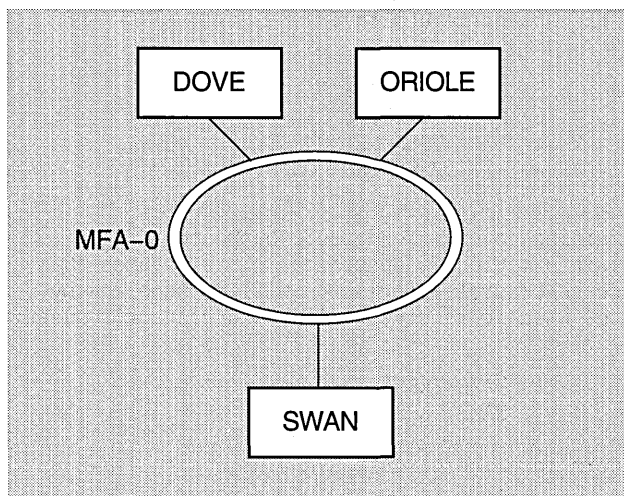

LKG-6708-92R

```
DEFINE EXECUTOR      NAME SWAN -
                     NONPRIVILEGED -
                     USER NETNONPRIV -
                     PASSWORD NONPRIV

!
! Define the remaining nodes. No default outbound
! access control information is specified. This assumes that
! the default access control information will be supplied by
! each remote node when it receives an inbound connect request.
!

DEFINE NODE 21      NAME DOVE
DEFINE NODE 22      NAME ORIOLE
!
! Define parameters for line/circuit MFA-0.
!

DEFINE LINE MFA-0   STATE ON
DEFINE CIRCUIT MFA-0 STATE ON
```

Configuring a Network

5.3 Network Configuration Examples

```

!
! The object database does not need to be defined because it defaults
! to the standard list of objects known to the operating system.
!
!
! Define transmitter-related logging parameters.
!
DEFINE LOGGING MONITOR KNOWN EVENTS
!
! Define receiver-related logging parameters.
!
DEFINE LOGGING MONITOR STATE ON

```

5.3.3 Synchronous DDCMP Point-to-Point Network Example

VAX

The example in this section shows how to build a database for node CHCAGO which is in a network configuration of four nodes connected by a DMC11, DMP11, or DMF32 line and circuit, as depicted in Figure 5-4. The NCP commands in this example configure the DDCMP point-to-point network. Node NEWARK is a nonrouting RSX-11S system to which node CHCAGO will perform a downline load.

Figure 5-4 A Synchronous DDCMP Point-to-Point Network Configuration

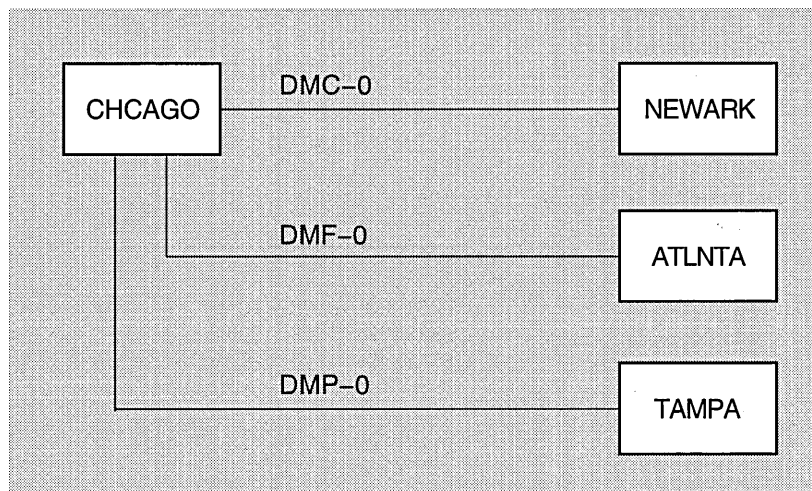

LKG-6094-92R

```

!
! Define executor-specific parameters for local node CHCAGO.
!
DEFINE EXECUTOR          ADDRESS 1 -
                        BUFFER SIZE 576 -
                        MAXIMUM HOPS 6 -
                        MAXIMUM VISITS 12 -
                        STATE ON
                        TYPE ROUTING IV

```

Configuring a Network

5.3 Network Configuration Examples

```
!
! Define common node parameters for the local node. Be sure
! to add the NETNONPRIV user to your system authorization
! file by using the Authorize utility.
!
DEFINE EXECUTOR          NAME CHCAGO -
                        NONPRIVILEGED -
                        USER NETNONPRIV -
                        PASSWORD NONPRIV

!
! Define parameters for remote node NEWARK (a nonrouting
! RSX-11S system). CHCAGO will be the load host for NEWARK.
!
DEFINE NODE 2           NAME NEWARK -
                        HOST NODE CHCAGO -
                        LOAD FILE NOD11S.SYS -
                        NONPRIVILEGED -
                        USER NETNONPRIV -
                        PASSWORD NONPRIV -
                        SERVICE CIRCUIT DMC-0 -
                        SERVICE PASSWORD FE -
                        SECONDARY LOADER SECDMC.SYS -
                        TERTIARY LOADER TERDMC.SYS

!
! Define the remaining nodes.
!
DEFINE NODE 3           NAME ATLNTA
DEFINE NODE 4           NAME TAMPA

!
! Define parameters for line/circuit DMC-0 to node NEWARK.
!
! Because this node will be loaded downline, the service
! parameters must be set up.
!
DEFINE LINE DMC-0       PROTOCOL DDCMP POINT -
                        SERVICE TIMER 4000 -
                        STATE ON

DEFINE CIRCUIT DMC-0    SERVICE ENABLED -
                        STATE ON

!
! Define parameters for line/circuit DMF-0 to node ATLNTA.
!
! (Give this line more receive buffers because it has a faster
! connection.)
!
DEFINE LINE DMF-0       PROTOCOL DDCMP POINT -
                        RECEIVE BUFFERS 8 -
                        STATE ON

DEFINE CIRCUIT DMF-0    STATE ON

!
! Define parameters for line/circuit DMP-0 to node TAMPA.
!
DEFINE LINE DMP-0       PROTOCOL DDCMP POINT -
                        STATE ON

DEFINE CIRCUIT DMP-0    STATE ON
```

Configuring a Network

5.3 Network Configuration Examples

```
!
! The object database does not need to be defined because it defaults
! to the standard list of objects known to the operating system.
!
!
! Define transmitter-related logging parameters.
!
DEFINE LOGGING MONITOR KNOWN EVENTS
!
! Define receiver-related logging parameters.
!
DEFINE LOGGING MONITOR STATE ON◆
```

5.3.4 DDCMP Multipoint Network Example

VAX

The example in this section shows how to build a database for node CHCAGO which is in a network configuration of five nodes connected by a combination of DMC, DMF, and DMP lines and circuits, as depicted in Figure 5-5. The NCP commands in this example configure the DDCMP multipoint network.

Figure 5-5 A DDCMP Multipoint Network Configuration

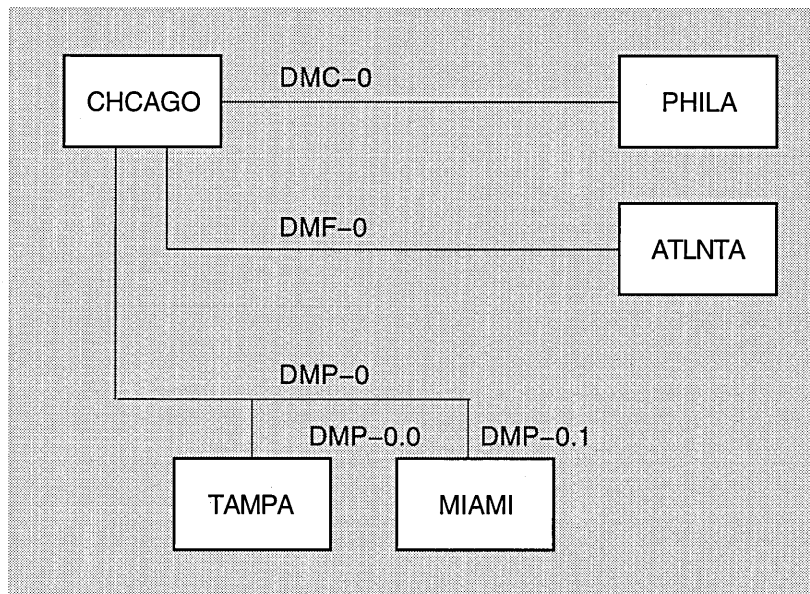

LKG-6095-92R

Configuring a Network

5.3 Network Configuration Examples

```

!
! Define executor-specific parameters for local node CHCAGO.
!
DEFINE EXECUTOR          ADDRESS 1 -
                        BUFFER SIZE 576 -
                        MAXIMUM HOPS 6 -
                        MAXIMUM VISITS 12 -
                        STATE ON
                        TYPE ROUTING IV
!
! Define common node parameters for the local node. Be sure
! to add the NETNONPRIV user to your system authorization
! file by using the Authorize utility.
!
DEFINE EXECUTOR          NAME CHCAGO -
                        NONPRIVILEGED -
                        USER NETNONPRIV -
                        PASSWORD NONPRIV
!
! Define the remaining nodes. No default outbound
! access control information is specified. This assumes that
! the default access control information will be supplied by
! each remote node when it receives an inbound connect request.
!
DEFINE NODE 2            NAME PHILA
DEFINE NODE 3            NAME ATLNTA
DEFINE NODE 4            NAME TAMPA
DEFINE NODE 5            NAME MIAMI
!
! Define parameters for line/circuit DMC-0 to node PHILA.
!
DEFINE LINE DMC-0        PROTOCOL DDCMP POINT -
                        STATE ON
!
DEFINE CIRCUIT DMC-0    STATE ON
!
! Define parameters for line/circuit DMF-0 to node ATLNTA.
!
DEFINE LINE DMF-0        PROTOCOL DDCMP POINT -
                        STATE ON
!
DEFINE CIRCUIT DMF-0    STATE ON
!
! Define parameters for line DMP-0 and circuits to nodes TAMPA
! and MIAMI.
!
! TAMPA is connected as tributary 3, DMP-0.0
! MIAMI is connected as tributary 4, DMP-0.1
!
! The DMP line runs at 56,000 bits per second. The proper
! setting for the retransmit timer is
!
!
! retransmit timer = 20,000 * buffer_size
!                   -----
!                   bps
!

```

Configuring a Network

5.3 Network Configuration Examples

```
!
! Thus, with a buffer size of 576, the retransmit timer should
! be 210 milliseconds.
!
! The dead timer is set to 30 seconds to avoid excessive delays
! when polling dead tributaries. The timer is set when a node
! goes down.
!
DEFINE LINE DMP-0      PROTOCOL DDCMP CONTROL -
                      DEAD TIMER 30000 -
                      RECEIVE BUFFERS 6 -
                      RETRANSMIT TIMER 210 -
                      STATE ON

DEFINE CIRCUIT DMP-0.0 COST 4 -
                      STATE ON -
                      TRIBUTARY 3

DEFINE CIRCUIT DMP-0.1 COST 4 -
                      STATE ON -
                      TRIBUTARY 4

!
! The object database does not need to be defined because it defaults
! to the standard list of objects known to the operating system.
!
!
! Define transmitter-related logging parameters.
!
DEFINE LOGGING MONITOR KNOWN EVENTS

!
! Define receiver-related logging parameters.
!
DEFINE LOGGING MONITOR STATE ON◆
```

5.3.5 Static Asynchronous DDCMP Network Example



The example in this section shows how to build a database for node CHCAGO, which is in a network configuration of four nodes connected by a DMR11 line and two terminal lines converted to static asynchronous DECnet lines, as depicted in Figure 5-6.

The NCP commands in this example configure the DDCMP point-to-point network that includes static asynchronous lines. To establish the static asynchronous connections, nodes YELLOW and BLUE must also specify in their configuration databases the circuits and lines connecting them to node CHCAGO. Before entering these commands, set up the terminal line with the appropriate characteristics (see Section 5.2.3.3).

```
!
! Define executor-specific parameters for local node CHCAGO.
!
DEFINE EXECUTOR      ADDRESS 1 -
                      BUFFER SIZE 576 -
                      MAXIMUM HOPS 6 -
                      MAXIMUM VISITS 12 -
                      STATE ON
                      TYPE ROUTING IV
```

Configuring a Network

5.3 Network Configuration Examples

Figure 5-6 A Static Asynchronous DDCMP Network Configuration

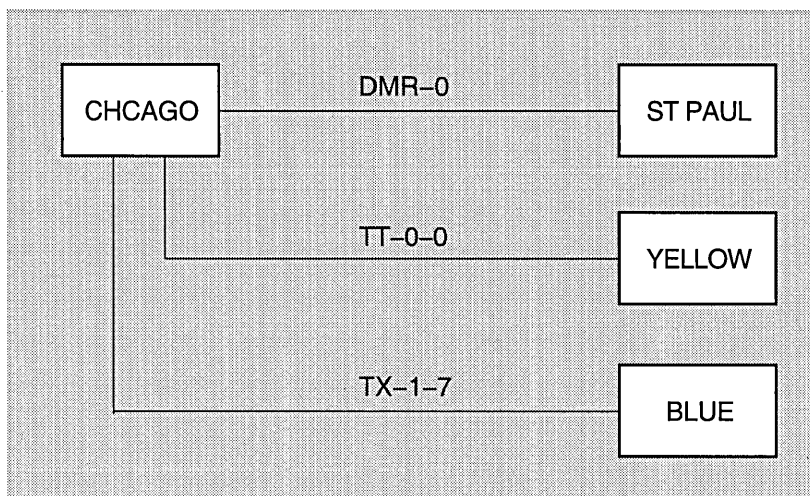

LKG-6096-92R

```

!
! Define common node parameters for the local node. Be
! sure to add the NETNONPRIV user to your system
! authorization file by using the Authorize utility.
!
DEFINE EXECUTOR          NAME CHCAGO -
                        NONPRIVILEGED -
                        USER NETNONPRIV -
                        PASSWORD NONPRIV

!
! Define the remaining nodes. No default
! outbound access control information is specified.
! This assumes that the default access control
! information will be supplied by each remote node
! when it receives an inbound connect request.
!
DEFINE NODE 2           NAME STPAUL
DEFINE NODE 3           NAME YELLOW
DEFINE NODE 4           NAME BLUE

!
! Define parameters for line/circuit DMR-0 to node
! STPAUL.
!
DEFINE LINE DMR-0       PROTOCOL DDCMP POINT -
                        STATE ON

DEFINE CIRCUIT DMR-0    STATE ON

!
! Define parameters for line/circuit TT-0-0 to node
! YELLOW.
!
DEFINE LINE TT-0-0      RECEIVE BUFFERS 4 -
                        STATE ON -
                        LINE SPEED 9600

DEFINE CIRCUIT TT-0-0   STATE ON
  
```

Configuring a Network

5.3 Network Configuration Examples

```
!
! Define parameters for line/circuit TX-1-7 to node
! BLUE.
!
DEFINE LINE TX-1-7          RECEIVE BUFFERS 4 -
                           STATE ON -
                           LINE SPEED 1200

DEFINE CIRCUIT TX-1-7      STATE ON

!
! The object database does not need to be defined
! because it defaults to the standard list of objects
! known to the operating system.
!
! Define transmitter-related logging parameters.
!
DEFINE LOGGING MONITOR KNOWN EVENTS

!
! Define receiver-related logging parameters.
!
DEFINE LOGGING MONITOR STATE ON♦
```

5.3.6 Dynamic Asynchronous DDCMP Network Examples

VAX

The examples in this section show how to configure two nodes connected by a terminal line converted to a dynamic asynchronous DECnet line.

The first example shows the NCP commands that configure the dynamic asynchronous DDCMP connection from node OXYGEN to node HELIUM; node OXYGEN is assumed to be a router.

The second example shows the NCP commands that configure the dynamic asynchronous DDCMP connection from node HELIUM to node OXYGEN; node HELIUM is assumed to be an end node, and the dynamic line is assumed to be a slow (1200 baud) modem line, as depicted in Figure 5-7.

Before entering these commands, refer to the procedure for installing dynamic asynchronous lines in Section 5.2.3.4.

Figure 5-7 A Dynamic Asynchronous DDCMP Network Configuration

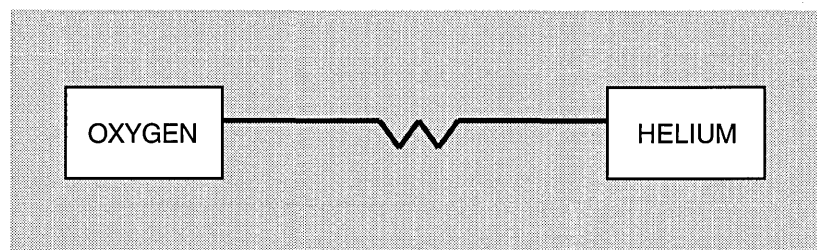

LKG-6097-92R

Configuring a Network

5.3 Network Configuration Examples

Node OXYGEN Database

```
!
! Define executor-specific parameters for local node
! OXYGEN.
!
DEFINE EXECUTOR          ADDRESS 1 -
                        BUFFER SIZE 576 -
                        MAXIMUM HOPS 6 -
                        MAXIMUM VISITS 12 -
                        STATE ON
                        TYPE NONROUTING IV
!
! Define common node parameters for the local node. Be
! sure to add the NETNONPRIV user to your system
! authorization file by using the Authorize utility.
!
DEFINE EXECUTOR          NAME OXYGEN -
                        NONPRIVILEGED -
                        USER NETNONPRIV -
                        PASSWORD NONPRIV
!
! Define the remote node. Use the INBOUND
! parameter to check whether dialup node HELIUM will
! operate as an end node or as a router. As an added
! security feature for a node using a dynamic asynchronous
! communications line, specify a receive
! password for node HELIUM. This will be compared with
! the transmit password supplied by HELIUM when it
! issues the connect request.
!
DEFINE NODE 2           NAME HELIUM -
                        INBOUND ENDNODE -
                        RECEIVE PASSWORD 10101010
!
! You do not need to define parameters for a
! line/circuit to node HELIUM. These parameters are
! provided automatically by the system when the dynamic
! connection is initiated.
!
! The object database does not need to be defined
! because it defaults to the standard list of objects
! known to the operating system.
!
! Define transmitter-related logging parameters.
!
DEFINE LOGGING MONITOR KNOWN EVENTS
!
! Define receiver-related logging parameters.
!
DEFINE LOGGING MONITOR STATE ON
```

Configuring a Network

5.3 Network Configuration Examples

Node HELIUM Database

```
!
! Define executor-specific parameters for local node
! HELIUM.
!
DEFINE EXECUTOR          ADDRESS 2 -
                        BUFFER SIZE 192 -
                        SEGMENT BUFFER SIZE 192 -
                        STATE ON -
                        TYPE NONROUTING IV
!
! Define common node parameters for the local node.
! Be sure to add the NETNONPRIV user to your system
! authorization file by using the Authorize utility.
!
DEFINE EXECUTOR          NAME HELIUM -
                        NONPRIVILEGED -
                        USER NETNONPRIV -
                        PASSWORD NONPRIV
!
! Define the remote node. Specify a transmit
! password which matches the receive password in the
! remote node database on node OXYGEN.
!
DEFINE NODE 1            NAME OXYGEN -
                        TRANSMIT PASSWORD 10101010
!
! You do not need to define parameters for a
! line/circuit to node OXYGEN. These parameters are
! provided automatically by the system when the dynamic
! connection is initiated.
!
!
! The object database does not need to be defined
! because it defaults to the standard list of objects
! known to the operating system. ♦
```

5.4 System Configuration Guidelines

Proper network operation, particularly in a routing environment, requires that you properly configure the system software running on each node in the network. Memory and processor time are two principal resources that you need to define.

5.4.1 Normal Memory Requirements

Most of the memory required by the network software is allocated from the nonpaged dynamic memory pool. You configure this pool by setting the system parameter NPAGEDYN.

The AUTOGEN utility sets system parameters when the operating system is first installed. They do not usually require modification. If, however, you find that you need to modify the system parameters to properly tune the system, edit the file SYS\$SYSTEM:MODPARAMS.DAT and run AUTOGEN.

The amount of nonpaged dynamic pool used by DECnet is related to the values of several EXECUTOR, LINE and CIRCUIT parameters. DECnet dynamically allocates and deallocates nonpaged dynamic pool as needed, so setting most of these parameters to have high values does not consume nonpaged pool until the resources are actually used. For example, setting EXECUTOR MAXIMUM

Configuring a Network

5.4 System Configuration Guidelines

LINKS to a high value does not use any additional pool until the additional links are actually created.

The following parameters have the greatest influence over the amount of nonpaged dynamic pool used by DECnet.

- EXECUTOR ALIAS MAXIMUM LINKS
- EXECUTOR BUFFER SIZE
- EXECUTOR MAXIMUM BUFFERS
- EXECUTOR MAXIMUM CIRCUITS
- EXECUTOR MAXIMUM LINKS
- EXECUTOR PIPELINE QUOTA
- EXECUTOR SEGMENT BUFFER SIZE
- LINE BUFFER SIZE
- LINE RECEIVE BUFFERS
- CIRCUIT SERVICE ENABLED

5.4.2 Critical Routing Node Requirements

For some critical VAX routing nodes in large networks, you may need to guarantee that user processes running on the node never interfere with the memory requirements of the network software. In this case, you may want to configure the system for worst-case use of the nonpaged dynamic pool.

If you run almost or completely out of pool, the consequences are apparent to system users: System performance will be very sluggish; processes will continually enter the MWAIT scheduling state while they wait for available free pool; and the SHOW MEMORY display will indicate almost no nonpaged free pool.

If the lack of pool causes the network software on the node to be unable to allocate a buffer fast enough to receive data from a communications line, the line may be considered unusable by another node in the network. When this happens, the network attempts to adaptively reconfigure itself, thereby resulting in network traffic consisting of configuration update messages.

If the node with pool problems is close to failing, without failing completely, it may alternate between working and not working, thereby causing the network to repeatedly reconfigure itself. Ultimately, these reconfigurations degrade the performance of the entire network.

5.4.3 CPU Time Requirements

Most of the procedures that control network routing are located in NETDRIVER. Because most of NETDRIVER runs at elevated interrupt priority level (IPL), normal user programs cannot preempt its execution. However, user-written drivers and privileged programs running at elevated IPL can affect the proper operation of NETDRIVER.

The *VMS Device Support Manual* provides guidelines for elevated IPL execution programming. In general, a program should run at elevated IPL only as long as necessary to synchronize correctly with other processes and devices. In particular, running at IPL IPL\$_SYNCH for more than a few hundred milliseconds or running at any IPL at or above IPL\$_MAILBOX for more than a few hundred milliseconds may adversely affect the network software. The effect

Configuring a Network

5.4 System Configuration Guidelines

of improper elevated IPL programming on the whole network is the same as having insufficient free nonpaged dynamic pool.

The NETACP process contains the procedure that handles the automatic network reconfiguration for a network node. Therefore, for proper network operation, the NETACP process must also be assured of sufficient processor time. It runs at a base priority of 9, which is well above the recommended base priority of 4 for normal users. However, real-time processes running at priorities 10 through 31 can preempt the execution of NETACP.

Just as for user-written drivers, the programming of real-time processes must account for the needs of the network software and other system software. A rule of thumb for real-time processes is that they should not normally preempt the execution of NETACP for more than a few hundred milliseconds at a time, and they should never preempt its execution for more than 5 to 10 seconds. This restriction allows NETACP sufficient processor time to run its routing algorithms properly.

If NETACP is unable to perform all of its functions, the effects on the whole network will be the same as having insufficient free pool or incorrect elevated IPL programming. If the preceding guidelines cannot be met for a particular real-time application, the application should probably not be used on a node that is also doing network routing.

The NETACP process, like all system processes, can be swapped and can page. However, because its base priority is 9, it is one of the last processes swapped when it is running and swapping becomes necessary. Also, NETACP receives high priority for paged disk I/O requests. Again, improper considerations for the disk I/O needs of NETACP can adversely affect the network as a whole. If the NETACP process continually enters the PFW or COMO scheduling state, it is probably not receiving sufficient priority for paging or swapping. To relieve the problem, modify other real-time or system programs.

5.4.3.1 Adjusting NETACP Quotas with the NETACP\$ Logical Names

To adjust the amount of resources allocated to the network ancillary control process (NETACP), you can define certain system logical names in SYS\$MANAGER:SYLOGICALS.COM prior to invoking SYS\$MANAGER:STARTNET.COM. These are the system logical names and their associated quotas:

System Logical Name	Quota
NETACP\$MAXIMUM_WORKING_SET	WSQUOTA
NETACP\$PAGE_FILE	PGFLQUOTA
NETACP\$EXTENT	WSEXTENT
NETACP\$ENQUEUE_LIMIT	ENQLM
NETACP\$BUFFER_LIMIT	BYTLM

For most systems, the default values for these quotas are adequate. Do not define these system logicals unless you observe performance or resource quota problems.

For example, if the NETACP process consistently exhibits an unacceptable page fault rate, adjust NETACP's WSQUOTA and WSEXTENT. The appropriate values for these quotas are configuration dependent, but in general, systems with relatively large node databases require higher values.

Configuring a Network

5.4 System Configuration Guidelines

The following specific symptoms indicate that you should adjust the NETACP process BYTLM quota:

- When you attempt to turn on a line, you receive the following message:
%SYSTEM_F_EXQUOTA, exceeded quota
- A circuit does not transition into the ON state but remains in ON-SYNCHONIZING state after you enable service. However, this circuit does start correctly after service is disabled.

Here is a rough calculation to estimate how much BYTLM quota NETACP requires:

1. Allow 3500 bytes to start up DECnet
2. Add to this the total, for all lines, of receive buffers multiplied by line buffer size
3. Increase BYTLM by 7200 bytes for each circuit that has service enabled

5.4.3.2 Adjusting NETACP Node Data Block Allocations with NET\$ Logical Names

When NETACP recycles an idle node counter block, it generates DECnet event 3.2 (Database Reused).

You can control the initial and the incremental values used for allocation of node counter blocks with the following two logical names:

- NET\$NODE_COUNTER_BLOCKS_INITIAL determines the number of node counter blocks initially allocated by NETACP during startup. The range is from 8 to 2048, and the default is 32.
- NET\$NODE_COUNTER_BLOCKS_INCREMENTAL determines the number of node counter blocks incrementally allocated by NETACP when needed to create connections. The range is from 8 to 512, and the default is 32.

To use these logical names, they must be in the system logical name table and defined before DECnet startup.

5.4.4 Permanent Database Considerations in VMSclusters

The permanent configuration database, resident on disk, consists of a number of files. These files are listed in Table 5-2.

Table 5-2 Permanent Configuration Database Files

File Name	Usage
SYS\$SYSTEM:NETNODE_REMOTE.DAT	Remote node
SYS\$SYSTEM:NETNODE_LOCAL.DAT	Executor and loop node
SYS\$SYSTEM:NETLINE.DAT	Line
SYS\$SYSTEM:NETLOGGING.DAT	Logging
SYS\$SYSTEM:NETOBJECT.DAT	Object
SYS\$SYSTEM:NETCIRC.DAT	Circuit
SYS\$SYSTEM:NETCONF.DAT	Configurator module
SYS\$SYSTEM:NETPROXY.DAT	Permanent proxy database

In a VMScluster, you may want to allow some of these files to be shared by members of the cluster. If so, move shared files to SYS\$COMMON:[SYSEXE] and

Configuring a Network

5.4 System Configuration Guidelines

leave files that are not to be shared in SYS\$SPECIFIC:[SYSEXE] (where they are normally created). NETNODE_LOCAL.DAT should not be shared because it contains executor information that is unique for each node in a cluster. Other files such as NETLINE.DAT, NETCONF.DAT, and NETCIRC.DAT should not be shared if the communications hardware configurations within the cluster are not identical on every node.

As an example, if the permanent object database is identical on every node in a cluster, you can make it shared by following these steps:

1. Copy the permanent object database from one node to the common system root, for example:

```
$ COPY SYS$SPECIFIC:[SYSEXE]NETOBJECT.DAT-  
_ $ SYS$COMMON:[SYSEXE]*;
```

2. Delete the permanent object database from the private system root on each node in the cluster, for example:

```
$ RUN SYS$SYSTEM:SYSMAN  
SYSMAN> SET ENVIRONMENT/CLUSTER  
  
%SYSMAN-I-ENV, current command environment:  
Clusterwide on local cluster  
Username SYSTEM will be used on nonlocal nodes  
  
SYSMAN>DO DELETE SYS$SPECIFIC:[SYSEXE]NETOBJECT.DAT;*
```

Installing a Network

This chapter describes how to start DECnet for OpenVMS. Refer to the *DECnet for OpenVMS Guide to Networking* for a description of the DECnet for OpenVMS installation procedure.

A network consists of two or more nodes linked together. If there is no existing network to which you can connect your node, work with the managers of other systems to create a new network. A new network is formed when two or more systems are connected by communications lines and each system is brought up as a network node.

The following sections describe how to register a DECnet for OpenVMS Product Authorization Key (PAK) and how to bring up your node on a new or existing network.

6.1 Installing a DECnet for OpenVMS Key

To permit your node to communicate with other nodes on the network, you must have a DECnet for OpenVMS license. Also, you must register the DECnet for OpenVMS PAK on your system using the License Management Facility (LMF).

Nodes configured as routers must have a routing license. An extended function license is available for some systems. This license allows level 1 routing to be enabled solely to support the use of a cluster alias. The PAK for the end node license permits you to configure your node only as an end node. A PAK for the routing or extended function licenses will permit you to configure your node as either an end node or a router.

AXP

Note

On AXP systems, Digital supports level 1 routing only for nodes acting as routers for a cluster alias. Digital does not support level 2 routing or routing between multiple circuits. ♦

You can register the DECnet for OpenVMS PAK before or after you configure DECnet for OpenVMS. If DECnet for OpenVMS is running when you register your license, you must stop and then restart DECnet for OpenVMS. If the license is not registered and activated, your use is limited to local DECnet only.

You can control which VMScluster nodes have access to routing or end node licenses.

Use an extended function or routing license to enable level 1 routing on VMScluster nodes that act as routers for the cluster alias. The extended function license does not support routing between multiple circuits.

Installing a Network

6.1 Installing a DECnet for OpenVMS Key

Use the `LICENSE MODIFY/INCLUDE=(node-name[,node-name,...])` command to assign licenses to nodes and limit access as needed. For example, you can assign a routing node license to only one cluster node and assign the end node licenses to the remaining cluster nodes. If you choose this approach, make sure you assign each end node license to the same list of nodes. That is, specify identical *include lists* for each license of the same type.

Refer to the *VMS License Management Utility Manual* for additional information on licensing.

6.2 Bringing Up Your Network Node Using STARTNET.COM

After you satisfy the prerequisites for establishing a network and define the necessary parameters in the configuration database (see Chapter 5), you are ready to bring up your DECnet for OpenVMS node. To do so, first define the local node (using the `DEFINE EXECUTOR` command) in the permanent database.

After you build the permanent database using either NCP or the `NETCONFIG.COM` interactive configuration procedure (see Chapter 5), enter the following command to bring up your network:

```
$ @SYS$MANAGER:STARTNET.COM
```

This command starts DECnet and configures the volatile database with the parameters that you defined in the permanent database. This procedure also turns on the local node and all lines and circuits connected to it. In addition, `STARTNET.COM` starts the network command terminal software. At this point, the local node is ready for network operations with itself and with adjacent nodes.

DECnet for OpenVMS uses OPCOM to display certain network-related messages on the network operator's console. When you turn on the local node, OPCOM displays a message similar to the following:

```
%%%%%%%%%% OPCOM 28-MAY-1992 11:36:48.83 %%%%%%%%%%  
Message from user DECnet on node BOSTON  
DECnet starting
```

After you bring up your DECnet for OpenVMS node, you use NCP commands to control the operational states of network components. You can control both local components and remote executions of NCP commands. This control allows you to dynamically reconfigure your network to control the use of the network and its resources.

Parameters in the permanent database are used to define network components each time you use the word `ALL` with the `SET` command. Typically, you use the `SET "component" ALL` command if you choose not to use `STARTNET.COM` to bring up the network. Section 6.4 discusses how to shut down the network.

6.3 Testing the Installation with UETP Test Procedure

To ensure that the DECnet for OpenVMS installation is successful, you can run the User Environment Test Package (UETP) to test DECnet. The test procedure is described in the OpenVMS installation and upgrade procedures manual.

6.4 Shutting Down Your DECnet for OpenVMS Node

Bringing down your operating system automatically brings down your DECnet for OpenVMS node as well. The next time you reboot the operating system, your network comes up automatically if the site-specific startup procedure invokes STARTNET.COM (see Section 6.2). However, if the network is running and you want to shut down your network node in an orderly manner or otherwise restrict its use, you can use NCP to control the operational state of the local node. NCP offers three options for shutting down the executor node.

- To shut down your local node without destroying active logical links, enter the following command:

```
NCP>SET EXECUTOR STATE SHUT
```

This command closes the node in an orderly fashion; new links are not allowed, and existing links are not terminated. When all logical links are disconnected, the executor is turned off.

When the last link terminates and is disconnected, the executor node in the SHUT state enters the OFF state. This action occurs whether or not the node is currently in use for route-through traffic. Consequently, the communication path between nodes using the local node for route-through may be broken.

- Instead of shutting down your local node, you can restrict network operations on that node. This restriction does not affect current logical link activity; however, no new inbound logical links can be created unless they originate locally or unless a process with the OPER privilege confirms them. Enter the following command to restrict local node operations:

```
NCP>SET EXECUTOR STATE RESTRICTED
```

- To shut down the local node regardless of current logical link activity, enter the following command:

```
NCP>SET EXECUTOR STATE OFF
```

This state allows no new logical links to be created, terminates existing links, and stops route-through traffic.

Note

Programs that have declared names or object numbers and that are started independently of DECnet for OpenVMS should be programmed to terminate when their mailboxes receive a MSG\$_NETSHUT message. This message appears when the node is shutting down.

Whenever the local node's state goes to OFF, DECnet for OpenVMS uses OPCOM to display the following message on the console:

```
Message from user DECNET on BOSTON  
DECnet shutting down
```

Table 6-1 summarizes local node states and basic network operation restrictions for them. These operations include network routing for nodes that support routing, confirming inbound connections from a remote node, and initiating outbound connections to a remote node.

Installing a Network

6.4 Shutting Down Your DECnet for OpenVMS Node

Table 6-1 Local Node States and Network Operations

State	Route-Through Traffic	Connect Confirm Operations	Connect Initiate Operations
ON	Unrestricted	Unrestricted	Unrestricted
RESTRICTED	Unrestricted	Unrestricted only if the partner node is the local node or if the confirming process has the OPER privilege	Unrestricted
SHUT	Unrestricted	Unrestricted only if the confirming process has the OPER privilege	Unrestricted only if the initiating process has the OPER privilege
OFF	Restricted	Restricted	Restricted

Testing the Network

NCP provides several kinds of tests to help you determine whether the network is operating properly. After you start DECnet for OpenVMS software, you may want to run some of these tests.

These tests let you exercise network software and hardware by sending data through various network components and then returning that data to its source. Digital supplies variations of these tests to exercise separate layers of the network. User-written processes or DECnet-supplied processes may also initiate the tests.

In general, problems that you encounter with the DECnet for OpenVMS network software probably arise from misconfigured system and DECnet parameters that you can fix using SYSGEN or NCP.

DECnet for OpenVMS tests fall into two categories: node-level loopback tests and circuit-level loopback tests. Use node-level tests to evaluate the operation of logical links, routing, and other network-related software. Use circuit-level tests to evaluate the operation of circuits.

VAX

Note

You cannot use all LOOP commands on asynchronous lines or circuits. ♦

Using node-level tests first is recommended; then, if necessary, use circuit-level tests. This chapter describes these variations as they relate to DECnet loopback capabilities and the NCP command LOOP, and provides a practical approach to their use.

Note

The ability to perform loopback tests on your system requires the existence of a default account for the MIRROR object, as described in Section 2.6.1 and Section 5.2.2.

7.1 Node-Level Tests

Node-level loopback tests examine the logical link capabilities of a node by exchanging test data between DECnet processes on two different nodes or between DECnet processes on the same node. There are two types of test:

- Loopback tests for logical link operation regardless of the circuit
- Loopback tests for operation over a specified circuit

Testing the Network

7.1 Node-Level Tests

The second test sends test messages over a specified circuit associated with a loop node name (see Section 7.1.2).

Both types of node-level loopback test allow you to test the functions of your DECnet for OpenVMS software. To test various aspects of this software, you may want to perform a series of operations, as follows:

1. In the first test, loop information to a remote loopback mirror process using a remote loopback test. This tests all local and remote network software up to the DNA user layer on the remote node.
2. If the first test fails, use a loop node name and loop information to the local node and to a remote node. The loop node name allows you to direct traffic over a specified circuit, which tests local and remote Routing layer software.
3. If the second test fails, set the circuit's line to "controller loopback" and repeat step 2.

Regardless of the type of test you choose, use the NCP command LOOP NODE to send test messages. This NCP function uses a cooperating process called the loopback mirror to facilitate the transmission and reception of test messages.

When you use this command, you have the option of controlling the type of binary information (MIXED, ONES, ZEROS); the number of blocks of information, which ranges from 1 to 65,535; and the length in bytes of each block to be looped, which ranges from 1 to 4096. (Digital recommends using a maximum block length of 4096 bytes to reduce the system load.) The default loop length is 4096. You can raise the maximum loop length beyond 4096 by defining the MIRROR\$SIZE logical as described in Section 7.3.

Refer to the *DECnet for OpenVMS Network Management Utilities* for the complete syntax of the LOOP NODE command.

If your message returns with an error, the test stops and NCP prints a message that indicates a test failure, specifies the reason for the failure, and provides a count of the messages that were not returned. For descriptions of NCP system messages, refer to the OpenVMS system messages documentation. You can use the DCL command HELP/MESSAGE to obtain online descriptions of system messages.

In the following example, the test attempts to send ten messages, each 4096 bytes long. The first two messages are sent successfully, but an error occurs on the third.

```
NCP>LOOP NODE BOSTON COUNT 10
%NCP-W-LINCOM, line communication error
Messages not looped = 8
```

7.1.1 Remote Loopback Test

Use the LOOP NODE command to test for a logical link connection between two nodes. When using this command, you must identify the node to which you want to loop test messages. Figure 7-1 illustrates a remote loopback test.

Figure 7-1 Remote Loopback Test

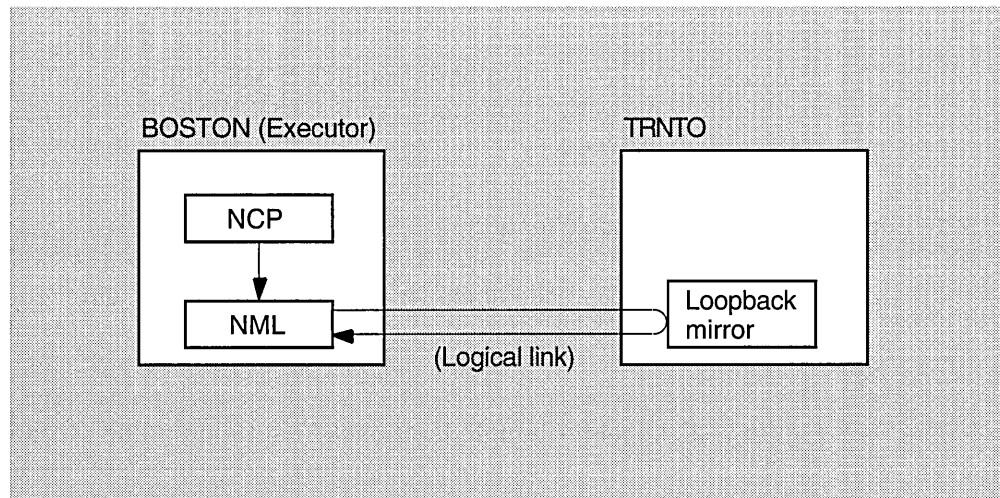

LKG-6103-92R

For this test, you first turn the selected remote node line and circuit to the ON state to allow for logical link activity. Then, you use the LOOP NODE command. For example, the following set of commands tests both local and remote DECnet software on nodes BOSTON and TRNTO:

```
NCP>SET LINE SVA-0 STATE ON
NCP>SET CIRCUIT SVA-0 STATE ON
NCP>LOOP NODE TRNTO COUNT 10
```

7.1.2 Local and Remote Loopback Tests Using a Loop Node Name

If the remote loopback test fails, then use the LOOP NODE command with a loop node name to test a logical link path over a specified circuit. You can loop test messages either over a logical link path and circuit within the local node or between two different nodes with a **loop node** specified for the circuit to be used. Use the latter method first in order to test remote Routing layer software. In each case, use the SET NODE command with the CIRCUIT parameter to establish a loop node name. For example, the following command establishes circuit SVA-0 as the circuit over which loop testing will take place:

```
NCP>SET CIRCUIT SVA-0 STATE ON
NCP>SET NODE TESTER CIRCUIT SVA-0
```

No parameters other than circuit are valid for loop nodes.

You cannot assign two loop node names to the same circuit. For example, after you establish TESTER as the loop node name for circuit SVA-0, enter a CLEAR NODE TESTER CIRCUIT command before assigning another loop node name to SVA-0.

When a logical link connection request is made to the loop node name, all subsequent logical link traffic is directed over the associated circuit. The destination of the traffic is whatever node address is associated with the loop node name. The loop node name is necessary because, under normal operation, DECnet Routing software selects which path to use when routing information. The loop node name overrides the routing function so that information can be routed over a specific circuit. To remove the association of the loop node name

Testing the Network

7.1 Node-Level Tests

with a circuit, use the `CLEAR NODE CIRCUIT` or `CLEAR NODE ALL` command, as in the following example:

```
NCP>CLEAR NODE TESTER CIRCUIT
```

A loop node name specified with the `SET NODE CIRCUIT` command may be used for any network traffic (for example, `COPY` requests or application program traffic). The loopback node name appears as a valid node name in the network for all purposes.

7.1.2.1 Local-to-Remote Loopback Testing

To test a logical link path over a circuit between the local node and a remote node, specify a loop node name for the given circuit and enter the `LOOP NODE` command. Figure 7-2 illustrates a local-to-remote loopback test using a loop node name.

Figure 7-2 Local-to-Remote Loopback Test Using a Loop Node Name

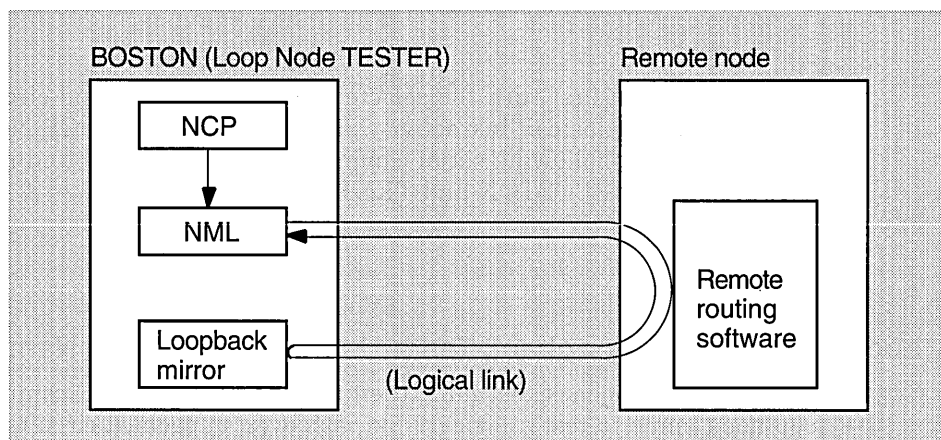

LKG-6692-92R

For this test, you first turn on the line and set a loop node name for the given circuit to the remote node. Next, turn on the circuit. Finally, enter the `LOOP NODE` command using the loop node name, as shown in the following example:

```
NCP>SET LINE SVA-0 STATE ON
NCP>SET NODE TESTER CIRCUIT SVA-0
NCP>SET CIRCUIT SVA-0 STATE ON
NCP>LOOP NODE TESTER COUNT 10
```

This set of commands tests both local and remote Routing layer software operation. Both end nodes and routing nodes have Routing layer software. The test messages are looped over the loopback circuit. Because the test actually tests the operation of the Routing layer on the remote node, the message may not come back on the circuit over which it was sent.

7.1.2.2 Local-to-Local Controller Loopback Testing

VAX

On devices that support controller loopback testing, if the local-to-remote test fails, try a local loopback test with the local node to test local Routing layer software exclusively. Both end nodes and routing nodes have Routing layer software. To test a logical link path over a specified line on the local node, specify a loop node name and set the device controller to loopback mode. Figure 7-3 illustrates a local-to-local loopback test using a loop node name.

Figure 7-3 Local-to-Local Loopback Test Using a Loop Node Name

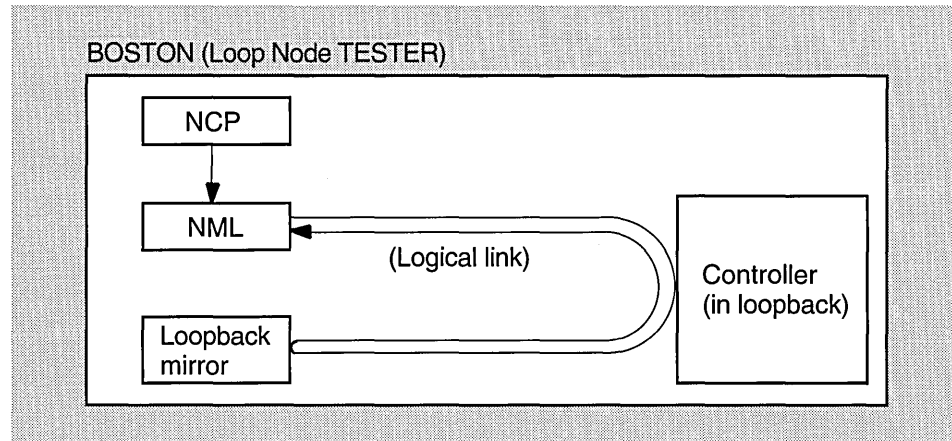

LKG-6691-92R

Note

DECnet for OpenVMS does not support controller loopback testing on all devices.

For this test, you first turn off the line, set the controller to loopback mode, and turn on the line and circuit. Finally, set a loop node name for the given circuit and enter the LOOP NODE command using the loop node name. The following set of commands tests the Routing layer software and the controller on the local node:

```
NCP>SET LINE DMC-0 STATE OFF
NCP>SET LINE DMC-0 CONTROLLER LOOPBACK
NCP>SET LINE DMC-0 STATE ON
NCP>SET CIRCUIT DMC-0 STATE ON
NCP>SET NODE TESTER CIRCUIT DMC-0
NCP>LOOP NODE TESTER COUNT 10 LENGTH 32
```

Because the device is set to loopback mode, the test messages are looped over the circuit and back to the local node. If this test fails, try a local loopback test to test local DECnet software.

Note that because of restrictions in the operation of the DMC controller, you must use a block length of fewer than 50 bytes for controller loopback tests. ♦

Testing the Network

7.1 Node-Level Tests

7.1.3 Local Loopback Test

If the loopback tests described in Section 7.1.2.2 fail, then use either the LOOP NODE command with the local node-id or the LOOP EXECUTOR command to test local DECnet software. This type of test uses DECnet for OpenVMS software to loop messages to the loopback mirror on the local node. Figure 7-4 illustrates a local loopback test.

Figure 7-4 Local Loopback Test

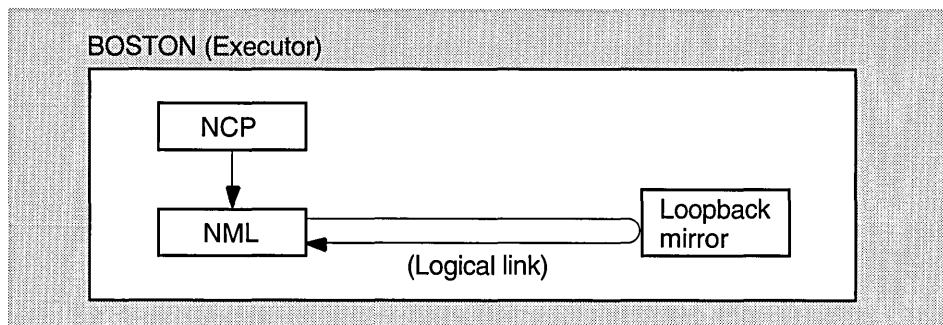

LKG-6106-92R

For this test, you enter the following command at the local node:

```
NCP>LOOP EXECUTOR COUNT 10
```

This test evaluates the local DECnet software using an internal logical link path. If this test succeeds and the other node-level tests fail, then try the circuit-level tests. If these tests fail, the executor's MIRRO\$SERVER account is probably set up incorrectly.

7.2 Circuit-Level Tests

Circuit-level loopback tests examine a DECnet circuit by looping test data through a hardware loopback device on the circuit, either through a modem (or loopback connector) or through a remote node. The tests that use a hardware loopback device are referred to as controller loopback tests. The tests that use a loopback connector or a modem are referred to as circuit loopback tests. The tests that use the software capabilities of the system are referred to as software loopback tests.

You may want to perform a series of operations to test various aspects of a circuit, as follows:

1. In the first test, perform a software loopback test to another node to determine whether the circuit is operational up to the remote circuit unit and controller.
2. If the first test fails, set the controller to loopback mode and use a controller loopback test to determine whether the controller works.
3. If the second test succeeds, then attach a modem (or loopback connector) to the controller and use a circuit loopback test to determine whether the unit is functional.

Testing the Network 7.2 Circuit-Level Tests

Regardless of the test type, use the NCP command LOOP CIRCUIT to perform a circuit-level loopback test. When you enter this command, you have the option of controlling the type of binary information (MIXED, ONES, ZEROS); the number of blocks of information, which ranges from 1 to 65,535; and the length in bytes of each block to be looped, which ranges from 1 to 4096. The default loop length is 4096. You can raise the maximum loop length beyond 4096 by defining the MIRROR\$SIZE logical as described in Section 7.3.

For the complete syntax of the LOOP CIRCUIT command, refer to the *DECnet for OpenVMS Network Management Utilities*.

If the test data message returns with an error, the test stops and NCP issues a message indicating a test failure, the reason for the failure, and a count of the messages that were not returned. For descriptions of NCP system messages, refer to the OpenVMS system messages documentation. You can use the DCL command HELP/MESSAGE to obtain online descriptions of system messages.

In the following example, the test attempts to send ten messages, each 50 bytes long. The first two messages are sent successfully, and an error occurs on the third.

```
NCP>SET LINE SVA-0 CONTROLLER NORMAL STATE ON
NCP>LOOP CIRCUIT SVA-0 COUNT 10

%NCP-W-LINPRO, line protocol error
Messages not looped = 8
```

7.2.1 Software Loopback Test

Use the LOOP CIRCUIT command to perform a software loopback test of a circuit connected to the local node. This type of test uses DECnet for OpenVMS software to loop through the circuit-to-circuit service software in the adjacent node and back to the local node. Figure 7-5 illustrates a software loopback test that checks whether the circuit is operational up to the remote unit and controller on the adjacent node.

Figure 7-5 Software Loopback Test

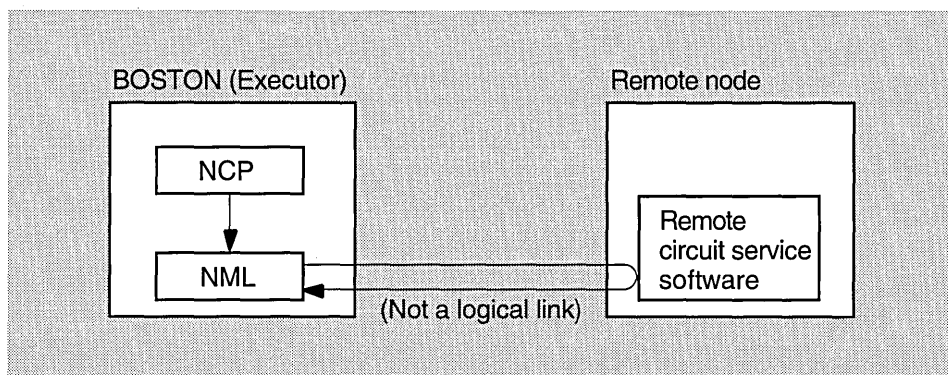

LKG-6107-92R

Testing the Network

7.2 Circuit-Level Tests

To perform this test, turn off the line. Next, set the controller to its normal operational mode and put the line and the circuit in the ON state. Finally, enter the LOOP CIRCUIT command, as shown in the following example:

```
NCP>SET LINE SVA-0 STATE OFF
NCP>SET LINE SVA-0 CONTROLLER NORMAL
NCP>SET LINE SVA-0 STATE ON
NCP>SET CIRCUIT SVA-0 STATE ON
NCP>LOOP CIRCUIT SVA-0 COUNT 10 NODE BOSTON
```

This set of commands tests the circuit SVA-0 up to the adjacent node. If this test fails, try a circuit loopback test to verify that the circuit is functional.

For additional detail about tests on broadcast circuits, see Section 7.2.3.

7.2.2 Controller Loopback Test

VAX

Use the LOOP CIRCUIT command to perform a controller loopback test of a physical line on the local node while the controller is in loopback mode. This type of test verifies whether the circuit up to the controller and the controller itself are functional. Figure 7-6 illustrates a controller loopback test.

Figure 7-6 Controller Loopback Testing

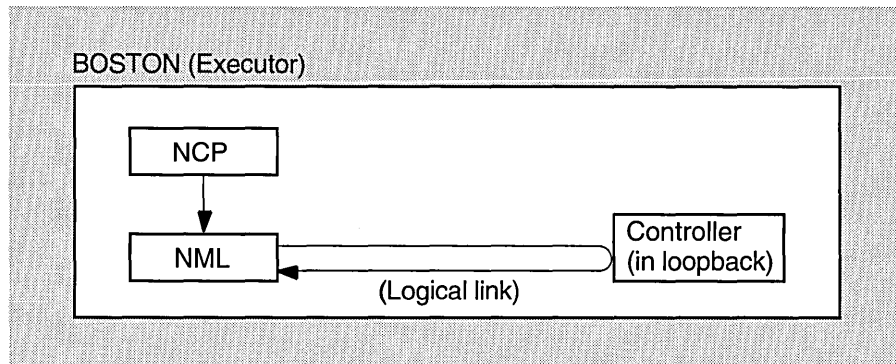

LKG-6108-92R

Note

DECnet for OpenVMS does not support controller loopback testing on all devices.

For this test, first turn off the line. Next, set the controller to loopback mode and put the line and circuit in the ON state. Finally, enter the LOOP CIRCUIT command. For example:

```
NCP>SET LINE DMC-0 STATE OFF
NCP>SET LINE DMC-0 CONTROLLER LOOPBACK
NCP>SET LINE DMC-0 STATE ON
NCP>SET CIRCUIT DMC-0 STATE ON
NCP>LOOP CIRCUIT DMC-0 COUNT 10 LENGTH 32
```

This set of commands tests the circuit up to the controller for physical line DMC-0 connected to the local node by circuit DMC-0.

Note

Because of restrictions in the operation of the DMC controller, you must use a block length of fewer than 50 bytes for controller loopback tests. ♦

7.2.3 Circuit-Level Loopback Testing

Loopback testing on point-to-point and multipoint circuits (DMCs and DMPs) requires two separate processors (one at each end), but broadcast circuit loopback testing requires only one processor. In broadcast circuit loopback testing, the target node's controller, rather than its processor, loops the messages.

In broadcast and point-to-point circuit-level loopback testing, network management accesses the Data Link layer directly, thus bypassing intermediate layers. One advantage of the loopback test is that it can be performed concurrently with other DECnet operations on the circuit.

7.2.3.1 Testing with the PHYSICAL ADDRESS and NODE Parameters

Typical broadcast circuit loopback testing involves looping messages to remote systems over the LAN; this tests the capability of both the local and the remote controllers to send and receive messages. In those cases, you are required to supply information such as the physical address or the node name or address of the circuit at the remote node that you want to test.

Note

To be tested, a broadcast circuit must be in the ON state and the SERVICE parameter must be set to ENABLED. (By default, the SERVICE parameter is set to DISABLED for broadcast circuits.)

Nodes on broadcast circuits are identified by unique physical addresses. A physical address is 48 bits in length and is represented by six pairs of hexadecimal digits (6 bytes), separated by hyphens (for example, AA-00-04-00-67-89). For more detail on physical addresses, see Section 2.1.2.

Each controller on the broadcast circuit has a hardware address (in read-only memory) that has been assigned to it by the manufacturer. Typically, DECnet sets a physical address for the controller, thereby replacing the hardware address as the address to which the controller currently responds. The controller's physical address continues to be the address to which it responds, unless it is reset to the hardware address value (for example, if the system is powered down and then powered up).

It is helpful to know the physical address of the controller on the remote node that you want to test. Because this is not always possible, plan to include the hardware address of each of the controllers on your broadcast circuit in the node database. You can then use the node-id in the LOOP command. When you specify node-id, the network management software retrieves the hardware address from the volatile database and attempts to transmit the loop message to the remote controller by alternately using the hardware address and the physical address that DECnet normally uses.

Testing the Network

7.2 Circuit-Level Tests

The following example contains a physical address:

```
NCP>LOOP CIRCUIT SVA-0 PHYSICAL ADDRESS AA-00-04-00-FF-04
```

Because, in this case, you know the physical address of the remote node that you want to test, you merely include the **PHYSICAL ADDRESS** parameter with its value. If, however, that physical address had changed (for example, if it had been reset to the hardware address value), the loopback would have failed. You would have received the following message:

```
%NCP-W-LINPRO, line protocol error  
Messages not looped = 8
```

If you also know the name or address of the remote node, you could test the controller on that node even though its physical address may have changed. The hardware address of the node to be tested must already have been entered in the database on the executor node. If the hardware address is included in the volatile database, and you test by supplying the node name or DECnet address, the loop test is attempted by the network management software to both the hardware address and the physical address derived from the DECnet address.

An example of a loopback test that specifies the **NODE** parameter is the following:

```
NCP>LOOP CIRCUIT SVA-0 NODE TEST
```

Assume that **TEST**'s physical address, which was **AA-00-04-00-F7-04**, is changed. Thus, any attempt to test **TEST** using the old physical address does not succeed. If, however, **TEST**'s hardware address (which was **08-00-2B-23-F6-8A**) is included in the volatile database on the executor node, the loopback test with the **NODE** parameter in its specification does succeed.

In the preceding example, you could alternatively supply the node address value (such as **1.247**) for the **NODE** parameter. For example, if you know the node-id but not the name of the node, you could enter the following:

```
NCP>LOOP CIRCUIT SVA-0 NODE 1.247
```

In this case, the node address is used to construct the physical address, and the hardware address (assuming that it is included in the volatile database) is used to access the circuit on the remote node and complete the loopback test. Thus, entering the hardware address in the volatile database is important.

If you want to examine the hardware address of your own controller (in this case **SVA-0**), you can use the NCP command **SHOW LINE CHARACTERISTICS**. For example:

```
NCP>SHOW LINE SVA-0 CHARACTERISTICS
```

When you enter this command, you receive a display such as the following:

```
Line Volatile Characteristics as of 15-JUN-1992 15:33:25
```

```
Line = SVA-0
```

```
Receive buffers      = 0  
Controller          = normal  
Protocol            = Ethernet  
Service timer       = 4000  
Hardware address    = 08-00-2B-55-43-F2  
Buffer size         = 1498
```

7.2.3.2 Loopback Assistance

DECnet supports the use of an assistant physical address and an assistant node to aid you in interrogating a remote node. To use this feature, you specify either the ASSISTANT PHYSICAL ADDRESS parameter or the ASSISTANT NODE parameter as an additional parameter to the LOOP CIRCUIT command.

You can use the “assistant” in three distinct ways: First, use it to assist you in receiving loop messages from a remote node. Second, use it in transmitting loop messages to a remote node. Third, use it in both transmitting messages to and receiving messages from a remote node.

There are various reasons why you might choose one form of assistance over another. For example, the target node to which you want to transmit a message may be located at a point where the signals are too weak to send a message. In this case, you could request assistance in transmitting the message to the target node. Similarly, you may be able to transmit messages to the target node, but not be able to receive messages from it. In such a case you can send a message directly to the target node and request an “assistant” to aid you in receiving a message from the target node. When you encounter difficulties in both sending and receiving messages, you can request an assistant node to help you to both transmit messages to and receive messages from the target node.

The following commands illustrate how to use the ASSISTANT PHYSICAL ADDRESS and ASSISTANT NODE parameters:

```
NCP>LOOP CIRCUIT SVA-0 PHYSICAL ADDRESS AA-00-04-00-18-04 -  
_ ASSISTANT PHYSICAL ADDRESS AA-00-04-00-15-04  
NCP>LOOP CIRCUIT SVA-0 NODE LOON ASSISTANT NODE THRUSH
```

In the first command, you are requesting the node described by the physical address AA-00-04-00-15-04 to assist you in testing the node described by the physical address AA-00-04-00-18-04. In the second command, you are requesting the node THRUSH to assist you in testing node LOON.

If you specify either the ASSISTANT PHYSICAL ADDRESS or ASSISTANT NODE parameter and you do not specify the HELP parameter, you receive FULL assistance; that is, you are assisted both in receiving and transmitting loop messages. In the preceding examples, because the ASSISTANT PHYSICAL ADDRESS and ASSISTANT NODE parameters are specified without the HELP parameter, the default is FULL assistance.

If you want to use an assistant node to only receive messages from the remote node, enter the following command:

```
NCP>LOOP CIRCUIT SVA-0 NODE LOON ASSISTANT NODE THRUSH HELP RECEIVE
```

In this example you are requesting the node THRUSH to assist you in receiving messages from node LOON. When you want to be assisted only in sending or transmitting loop messages, enter a command such as the following:

```
NCP>LOOP CIRCUIT SVA-0 NODE LOON ASSISTANT NODE 21 HELP TRANSMIT
```

In this case, the ASSISTANT NODE parameter contains the node address, rather than the name of the node as in the previous example. In each of the last two examples, the HELP parameter is included to specify the type of assistance desired.

Testing the Network

7.3 Using the MIRROR\$SIZE Logical

7.3 Using the MIRROR\$SIZE Logical

You can define the MIRROR\$SIZE system logical to raise the maximum loop message length from 4096 bytes up to a value no greater than 32,767 bytes. For example:

```
$DEFINE /SYSTEM MIRROR$SIZE 32767
$MCR NCP
NCP>LOOP EXECUTOR LENGTH 8192
```

Part IV

Network User Operations

Performing Network User Operations

DECnet for OpenVMS allows you to perform a variety of operations over the network:

- Retrieve information about the status of the nodes in your network.
- Establish communication with a remote DECnet node through the command terminal facility.
- Access files on remote nodes.
- Perform task-to-task operations.

This chapter describes each operation. The primary focus of this chapter, however, is on the use of task-to-task communication in network operations.

8.1 Retrieving Network Status Information

Before you perform a specific type of operation over the network, consider checking the status or availability of a particular node or nodes in your network. To retrieve such information, use the DCL command `SHOW NETWORK`. The `SHOW NETWORK` command displays the availability of the local node as a member of the network.

If routing is enabled on the local node, the `SHOW NETWORK` command also displays link and cost relationships between the local node and other nodes in the network. It displays the following characteristics about the current network:

Node	Identifies each available node in the network by its node address and node name.
Links	Shows the number of logical links between the local node and each available remote node.
Cost	Shows the total line cost of the path to a remote node. The system manager assigns the cost for each line in the network.
Hops	Shows the number of intervening nodes plus the target node.
Next hop to node	Shows the outgoing physical line used to reach the remote node. (The local node is identified by the term LOCAL.)
Area	Identifies each available area in the network by its area number. This characteristic is displayed only if the local node is an area router.
Next hop to area	Shows the outgoing physical line used to reach the remote area. This characteristic is displayed only if the local node is an area router. The local node is identified by the term LOCAL. The node address and node name of the next hop to the target area are also displayed.

Performing Network User Operations

8.1 Retrieving Network Status Information

When you enter the `SHOW NETWORK` command on a level 1 router (a router that is not an area router), you receive a display on your terminal similar in format to the following:

```
VMS Network status for local node 2.1 NYC on 15-JUN-1992 09:18:03.07
```

```
The next hop to the nearest area router is node 2.62 ZEUS.
```

	Node	Links	Cost	Hops	Next Hop to Node		
2.1	NYC	0	0	0	Local	->	2.1 NYC
2.2	RAEL	0	8	1	SVA-0	->	2.2 RAEL
2.3	PANGEA	0	8	1	SVA-0	->	2.3 PANGEA
2.4	TWDEE	0	10	2	SVA-0	->	2.63 AURORA
2.5	TWDUM	0	8	1	SVA-0	->	2.5 TWDUM
2.11	NEONV	0	8	1	SVA-0	->	2.11 NEONV
2.63	AURORA	0	8	1	SVA-0	->	2.63 AURORA

```
Total of 7 nodes.
```

If your node is an area router, the `SHOW NETWORK` command displays additional information about the area.

If your local node is an end node, and you enter the `SHOW NETWORK` command, you receive the following message on your terminal:

```
This is a nonrouting node, and does not have any network information.  
The designated router for node NYC is node 2.62 ZEUS.
```

If you enter the `SHOW NETWORK` command, but the network is unavailable at that time, you receive the following display:

```
Network unavailable
```

For more detailed information about the DCL command `SHOW NETWORK`, see its description in the *OpenVMS DCL Dictionary*.

8.2 Establishing Communication with a Remote Node

DECnet for OpenVMS supports a command terminal facility that permits users to establish communication with a remote node and to use the facilities of that system while physically connected to the local node. By means of this link, you can temporarily become a local user of the remote node and thereby perform functions that the remote node allows its local users to perform from a terminal.

In addition to communicating with remote DECnet for OpenVMS nodes, you can communicate with other nodes that support the DNA remote command terminal protocol facility (also referred to as the network virtual terminal facility). Consult the appropriate Software Product Descriptions for descriptions of other operating systems and their DECnet implementations.

If you want to use the command terminal facility to establish communication with a remote node, enter the DCL command `SET HOST` in the following format:

```
$ SET HOST nodename
```

where:

nodename Is a 1- to 6-character name or number specifying the remote node at which you want to log in.

The `SET HOST` command does not recognize the area prefix in a node number. Therefore, to specify by number a node in another area, convert the node number to its decimal equivalent, as described in Section 3.7.2.

Performing Network User Operations

8.2 Establishing Communication with a Remote Node

The operating system on the remote node prompts for a user name and password. If the information you supply is valid, you are logged in to the remote node. To return control to your local node, type LOGOUT.

If the remote node is an OpenVMS node, you receive the following message at your terminal after you type LOGOUT:

```
%REM-S-END, control returned to node _NODENAME::
```

This message indicates that control is returned to your local node.

The only special control character used for remote command terminal operations is Ctrl/Y. Except for Ctrl/Y, all control characters are handled as if they were issued at the local node.

Repeated, rapid pressing of Ctrl/Y generates a prompt asking if the remote connection should be broken. If you answer YES to the prompt, control returns to the local node. This technique is useful if for some reason you cannot return to the local node normally.

The following command sequence illustrates the operation of remote command terminals for the network topology example. The name of the local node is BOSTON.

```
$ SET HOST TRNTO
Username: SMITH
Password:

Welcome to VAX/VMS Version 5.5 on node TRNTO

.
.
.
$ LOGOUT
SMITH logged out at 15-JUN-1992 12:31:55:49
%REM-S-END, control returned to node _BOSTON::
$
```

When you are logged in at a remote node, use the SET HOST command to establish communication with another node. After logging in to node TRNTO, use SET HOST again to log in to another node (for example, node DENVER).

You will again be prompted for a user name and password. If you then supply a valid user name and password for node DENVER, you are logged in.

When you log out of node DENVER, control is returned to node TRNTO. You must log out of node TRNTO to return to your local node, BOSTON.

For more detailed information about the SET HOST command, see its description in the *OpenVMS DCL Dictionary*.

8.3 Accessing Files on Remote Nodes

DECnet for OpenVMS allows you to access files on remote nodes in your network as though these files were on your local node. DECnet for OpenVMS provides facilities to access remote files by means of DCL commands and command procedures, and higher-level language programs using OpenVMS RMS or system services directly.

Performing Network User Operations

8.3 Accessing Files on Remote Nodes

8.3.1 Using DCL Commands and Command Procedures

Most DCL commands that perform file operations at a local node also perform these operations on remote nodes. For example, use the same DCL commands to obtain directory listings, manipulate files, and execute command procedures on remote nodes. Generally, you need only prefix a node name followed by two colons to the standard OpenVMS file specification to access the remote file. For example:

```
$ TYPE TRNTO::WORK$:[DOE]LOGIN.COM
```

In this example, the `TYPE` command requests that the file `LOGIN.COM` in the directory `WORK$:[DOE]` at the remote node `TRNTO` be displayed on your local terminal.

Depending on the file protections that are established on the remote node, you may need to supply an access control string in the DCL command when performing the file operation. For example:

```
$ COPY TRNTO"DOE JE8V8DAJ"::WORK$:[DOE]LOGIN.COM *.*
```

In this example, an access control string is supplied as part of the request for the `COPY` operation. For OpenVMS operating systems, the access control string consists of a user name, followed by one or more spaces or tabs, and, optionally, one password.

As with DCL, remote file accessing by higher-level languages is accomplished in a way that is transparent to the user. The only additional information that you need to specify is the name of the remote node containing the file or files that you want to access. Like DCL, higher-level language programs also employ the OpenVMS RMS services to perform file access operations.

Command descriptions in the *OpenVMS DCL Dictionary* include restrictions that apply to individual commands and command qualifiers used in network operations.

8.3.2 Using Higher-Level Language Programs

Use the standard I/O statements of various higher-level languages to write programs that access remote files. Regardless of the programming language used, you access remote files exactly as you would access local files.

In the following example, assume that you want to design a FORTRAN program to transfer files from a local node to a remote node. Identify the source and destination files by defining the logical names `SRC` and `DST`, respectively, with the following commands:

```
$ DEFINE SRC TRNTO::INVENTDISK$:[STOCKROOM.PAPER]INVENTORY.DAT
$ DEFINE DST BOSTON::ARCDISK$:[ARCHIVE]TRNTO_INVENTORY.DAT
```

After you make the logical name assignments, the FORTRAN program can open the files by way of those logical names. Use the following FORTRAN open calls:

```
OPEN (UNIT=1,NAME='SRC',TYPE='OLD',ACCESS='SEQUENTIAL',
      FORM='FORMATTED')

OPEN (UNIT=2,NAME='DST',TYPE='NEW',ACCESS='SEQUENTIAL',
      FORM='FORMATTED')
```

Use standard I/O statements to transfer records from one file to another, for example, FORTRAN read and write statements.

Performing Network User Operations

8.3 Accessing Files on Remote Nodes

As shown in the next example, you can design a FORTRAN program to transfer a file from the local node to a line printer on the remote node. Define logical names for the source and destination, as follows:

```
$ DEFINE SRC TRNTO::INVENTDISK$: [STOCKROOM.PAPER] INVENTORY.DAT
$ DEFINE DSTLPR BOSTON::LPA0:
```

After you make the logical name assignments, the FORTRAN program can open the file and access the line printer by way of those logical names, as follows:

```
OPEN (UNIT=1, NAME='SRC', TYPE='OLD', ACCESS='SEQUENTIAL',
      FORM='FORMATTED')

OPEN (UNIT=2, NAME='DSTLPR', TYPE='NEW', ACCESS='SEQUENTIAL',
      FORM='FORMATTED', CARRIAGECONTROL='LIST',
      RECORDDTYPE='VARIABLE')
```

Use standard I/O statements to transfer records from one file to another, for example, FORTRAN read and write statements.

8.3.3 Using OpenVMS RMS Services from Programs

The operating system provides a programming interface for remote file access. Programs can use OpenVMS Record Management Services (RMS) calls or system service calls to access remote files. This section describes how to use RMS to access remote files. The system services, which also provide access to remote files, are described more completely in Section 8.5.4.

For remote file processing, RMS integrates the network software necessary to translate standard RMS calls, which provides a transparent user interface to the network.

The RMS service calls provide remote file-handling operations on entire files or access individual records. You need only supply the name of the remote node in your file specification.

As in the previous FORTRAN examples, use DCL commands to make logical name assignments to the source and destination files that you want to manipulate, for example:

```
$ DEFINE SRC TRNTO::INVENTDISK$: [STOCKROOM.PAPER] INVENTORY.DAT
$ DEFINE DST BOSTON::ARCDISK$: [ARCHIVE] TRNTO_INVENTORY.DAT
```

Before opening either the source (SRC) or destination (DST) file with the RMS \$OPEN statement, however, allocate the appropriate file access blocks (FABs) and record access blocks (RABs) in your program. To do this in the C programming language, use the following RMS structures:

```
struct FAB src_fab;
struct RAB src_rab;

src_fab = cc$rms_fab;
src_rab = cc$rms_rab;
char src_file[13] = "SRC_FILE.TXT";

src_fab.fab$b_fac = FAB$M_GET | FAB$M_PUT;
src_fab.fab$l_fna = &src_file;
src_fab.fab$b_fns = sizeof (src_file);
src_fab.fab$b_org = FAB$V_ORG;
src_fab.fab$b_rat = FAB$M_CR;
src_fab.fab$b_rfm = FAB$C_VAR;
```

Performing Network User Operations

8.3 Accessing Files on Remote Nodes

```
src_rab.rab$l_fab = &src_fab;
src_rab.rab$l_ubf = &data_blk;
src_rab.rab$l_rbf = &data_blk;
src_rab.rab$w_rsz = sizeof ( data_blk );
src_rab.rab$w_usz = sizeof ( data_blk );
```

These statements define the source file FAB and RAB control blocks. Also, define the destination file FAB and RAB control blocks, as follows:

```
struct FAB dst_fab;
struct RAB dst_rab;

dst_fab = cc$rms_fab;
dst_rab = cc$rms_rab;

char dst_file[13] = "DST_FILE.TXT";

dst_fab.fab$b_fac = FAB$M_PUT;
dst_fab.fab$l_fna = &dst_file;
dst_fab.fab$b_fns = sizeof ( dst_file );
dst_fab.fab$b_org = FAB$V_ORG;
dst_fab.fab$b_rat = FAB$M_CR;
dst_fab.fab$b_rfm = FAB$C_VAR;

dst_rab.rab$l_fab = &dst_fab;
dst_rab.rab$l_ubf = &data_blk;
dst_rab.rab$l_rbf = &data_blk;
dst_rab.rab$w_rsz = sizeof ( data_blk );
dst_rab.rab$w_usz = sizeof ( data_blk );
```

After defining the source and destination FABs and RABs, open the files for remote file processing. If your program accesses files sequentially, specify the sequential-only (SQO) option of the file options (FOP) field of the FAB. Specifying FOP=SQO enables RMS and the remote File Access Listener (FAL) to enter into file-transfer mode. In file-transfer mode there is no wait for message acknowledgment and, consequently, there is a significant increase in file-transfer performance.

The *Guide to OpenVMS File Applications* contains examples of complete programs using RMS to access remote files. Examples in this document also illustrate the network-specific features provided by OpenVMS RMS.

The *OpenVMS Record Management Services Reference Manual* describes the RMS fields and options that you must specify for DECnet for OpenVMS applications. These manuals also describe restrictions that apply to using RMS over the network. See Chapter 9 for a list of restrictions on operations involving other systems in a multivendor network.

Note

DECnet for OpenVMS does not support the use of RMS for operations on a remote magnetic tape volume.

8.4 Performing Task-to-Task Operations

Task-to-task communication is a feature common to all DECnet implementations. It allows two programs or tasks running under the same or different operating systems to communicate with each other regardless of the programming languages used. For example, a FORTRAN task running on the OpenVMS operating system at node BOSTON could exchange messages with a task running on the RSX-11M operating system at node DALLAS. Although these programs use different programming languages and run under different operating systems, the DECnet software translates system-dependent language calls into a common set of network protocol messages.

8.4.1 Transparent and Nontransparent Task-to-Task Communication

DECnet for OpenVMS supports both transparent and nontransparent task-to-task communication. Transparent communication provides the means for a DCL command procedure or a user program to communicate with other command procedures or user programs over the network. Nontransparent communication allows the programmer to use system service options to perform network-specific functions.

There are important differences between these two forms of communication. Transparent communication is a form of device-independent I/O in which you move data with little concern for the way the operation is accomplished. Likewise, transparent communication allows you to move data across the network without necessarily knowing that you are using DECnet software. Nontransparent communication, on the other hand, is a form of device-dependent I/O, in that you are interested in specific characteristics of the device that you want to access. A nontransparent task, in turn, can use network-specific features to monitor the communication process.

Note

While it is possible for a single task to create and maintain both transparent and nontransparent connections, each connection should be processed separately. That is, transparent-specific RMS and system services apply to transparent links, and nontransparent-specific system services apply to nontransparent links.

8.4.1.1 Transparent Communication

Transparent communication provides the basic functions necessary for a task to communicate with another task over the network. These functions include the initiation and completion of a logical link connection, the orderly exchange of messages between both tasks, and the controlled termination of the communication process.

Transparent access provides the functions necessary to communicate over the network using standard I/O operations. To perform communication functions, you can write cooperating tasks using any of the following:

- Any higher-level language that supports network operations using language I/O statements
- RMS service calls
- System service calls

Performing Network User Operations

8.4 Performing Task-to-Task Operations

- DCL commands

System service calls are described in Section 8.5.

8.4.1.2 Nontransparent Communication

Nontransparent communication provides the same functions as transparent communication plus additional system service and I/O features supported by DECnet for OpenVMS. In particular, a nontransparent task can create and use a mailbox to receive information that is not available to a transparent task with transparent communication. You can make use of network-specific features such as optional user data on connects and disconnects, and *interrupt messages*. Also, nontransparent tasks can receive and process multiple inbound connection requests. (See the description in Section 8.6.1.5.)

On a VMScluster node, nontransparent tasks that can receive multiple inbound connection requests should not use the cluster alias node address for outgoing connections. Also, they should not be enabled to receive incoming connections directed to the cluster alias node unless the same task is running on all nodes that allow incoming connections to the alias. Incoming links directed to a cluster alias node address can be assigned to any of the nodes in the cluster that accept that alias node address, without knowledge of the nodes on which a declared task may be running (see Section 2.6.2).

In general, nontransparent tasks can use a mailbox to receive information about particular network operations. There are four types of mailbox messages:

- Messages that result from the use of certain system service calls (including optional user data carried on logical link creation or termination)
- Interrupt messages
- Logical link status messages
- Network system messages

Nontransparent functions that indirectly cause mailbox messages to be placed in the receiver's mailbox include calls for initiating, completing and terminating logical links. Figure 8-1 illustrates how nontransparent tasks use mailboxes.

See Section 8.6.1.1 for a detailed description of mailbox messages.

Performing Network User Operations

8.4 Performing Task-to-Task Operations

Figure 8–1 Mailbox Messages

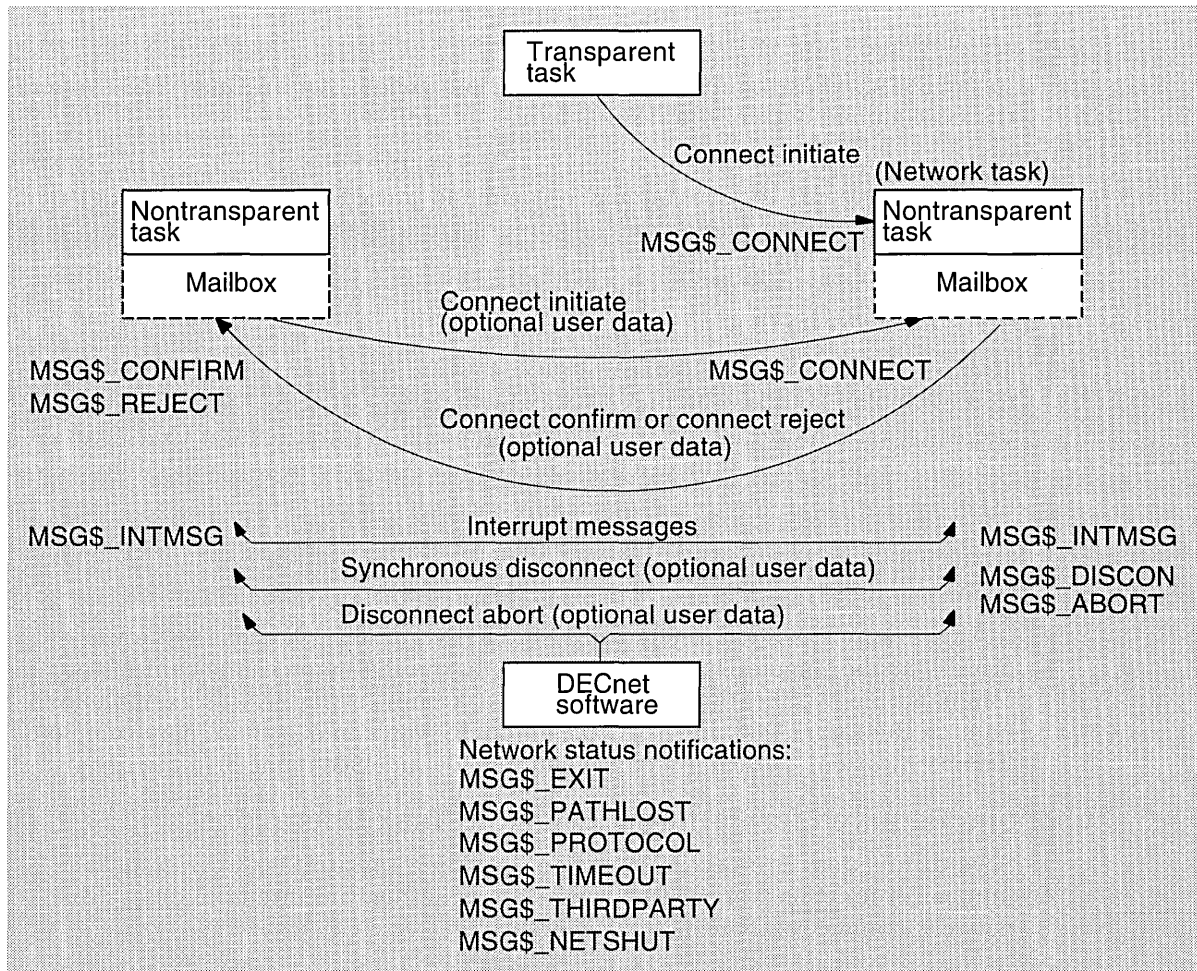

LKG-6109-92R

A nontransparent task can receive **network status notifications** in the mailbox. These notifications apply to physical and logical link conditions over the network. For example, DECnet for OpenVMS software can notify a nontransparent task of the following conditions:

- Third-party disconnections
- Network software- and hardware-related problems
- Processes exiting before I/O completion
- Connection request timeouts

8.4.2 Task Specification Strings in Task-to-Task Applications

Whether you are performing a transparent or nontransparent task-to-task operation, use a **task specification string** to identify the remote task with which you want to communicate. A task specification string is a quoted string that identifies the target task to which you attempt a logical link connection.

To establish a logical link connection with a target task addressed as object type 0, use either of the following forms of task specification string:

- "TASK=taskname"

Performing Network User Operations

8.4 Performing Task-to-Task Operations

- "0=*taskname*"

where:

taskname Can be from 1 to 16 characters.

"0" and "TASK" are equivalent. (If the remote node is not an OpenVMS system, the maximum length of the taskname may be different.)

If the remote node is running the OpenVMS operating system, the *taskname* usually represents the file name of a command procedure to be executed at the remote node. The *taskname* may also represent a specific image to be run. The command procedure invoked at the remote node can complete the logical link itself (using a DCL OPEN command), or it can include a DCL RUN command to execute a program that completes the logical link.

The examples that follow illustrate two uses of the task specification string. The first example identifies the task TEST2 by using the "TASK=" form for specifying target tasks. The second example is the same as the first, except that access control information is provided and the alternative "0=" form for specifying a task is used.

```
BOSTON::"TASK=TEST2"
```

```
BOSTON"SMITH JOHN"::"0=TEST2"
```

In this example, TEST2 refers to SYS\$LOGIN:TEST2.COM for the network process at the remote OpenVMS node. Only the file name component of the command file specification is used in the task name string in this example. When naming the target task in the object database, you can specify a more complete file specification. For example, you can include a device name or a file type.

8.4.3 Functions Required for Performing Task-to-Task Operations

Several functions are necessary for performing a task-to-task operation. The number of functions, of course, depends on whether you intend to access the network transparently or nontransparently.

Even a transparent task-to-task application requires a minimum number of operations to initiate and complete a logical link connection, to exchange messages, and to terminate the logical link. These operations are actually a subset of a larger group of functions defined for nontransparent communication. The entire set of functions is as follows:

- **Initiating a logical link connection**
 - Requesting a logical link to a remote task¹
 - Declaring a network name and processing multiple connection requests
- **Completing a logical link connection**
 - Rejecting a logical link connection request
 - Accepting a logical link connection request¹
- **Exchanging messages**
 - Sending and receiving data messages¹
 - Sending and receiving interrupt messages

¹ This operation represents the minimum subset for transparent task-to-task communication.

Performing Network User Operations

8.4 Performing Task-to-Task Operations

- **Terminating a logical link**
 - Synchronously disconnecting the logical link
 - Aborting the logical link¹

Nontransparent tasks can use any or all of these functions to extend the basic capabilities offered under transparent communication.

8.4.3.1 Initiating a Logical Link Connection

Whether you access the network transparently or nontransparently, establish a communication link to the remote node on which the target task runs before any message exchange can take place. You establish the link by issuing a source task call that requests a logical link connection. (The **source task** is the task that initiates a logical link connection request; the **target task** is the task with which you want to communicate.)

The interaction between the source task and the target task that takes place before the logical link is established is called a **handshaking sequence**. Upon receiving a call that requests a logical link connection, the local DECnet for OpenVMS node initiates a handshaking sequence with the target task. The following information is supplied in a connection request:

- An I/O channel. The I/O channel (commonly referred to as the channel) serves as the path over which messages are sent and received by the source task.
- The identification of the target node. Every node in a network has an identifier that distinguishes it from all other nodes in the network. Transparent communication uses a task specification string that includes the name of the target node. Nontransparent communication requires a user-generated data structure called the **network connect block (NCB)**, which also includes a task specification string.
- An object type descriptor.
- Access control information (optional).
- Optional user data. Nontransparent tasks have the option of sending up to 16 bytes of data to the target task (see the following information about NCBs).

After you issue a call that uses either a task specification string or an NCB, you access the network and, by definition, the DECnet for OpenVMS software.

8.4.3.2 Completing the Logical Link Connection

As part of the handshaking sequence, the target task completes the logical link connection in two steps. First, the DECnet software at the remote node processes the inbound logical link connection request. Second, the target task either accepts or rejects the link. These steps are performed differently, depending on whether the target task uses transparent or nontransparent I/O.

When a logical link request is received, a procedure called NETSERVER.COM is executed, which in turn invokes the image NETSERVER.EXE. This program works in conjunction with the network ACP (NETACP) to invoke the image or command procedure defined for the requested object.

When the logical link is terminated, the “object” program also terminates. This process, however, is not deleted. Instead, control is returned to NETSERVER.EXE, which waits for another incoming logical link request. NETSERVER.EXE waits until it encounters a timeout condition (the default is 5 minutes).

Performing Network User Operations

8.4 Performing Task-to-Task Operations

The system manager can specify the time that NETSERVER waits for another logical link request. The logical name NETSERVER\$TIMEOUT, when defined, determines the amount of time NETSERVER waits before reaching the timeout condition. The equivalence name must be in the standard delta time format, for example, 0:10:0, representing 10 minutes.

You can define a number of NETSERVER processes that never time out. This is useful on systems that are the target of significant amounts of network activity, such as mail or public file access. Two benefits are: improved response time for the user initiating the network access (because there is no waiting for a new process to be created) and reduced overhead on the target system by virtue of fewer process creations.

To allow for permanent servers, define the logical name NETSERVER\$SERVERS_ *username* in the login procedure for the account receiving the network connects. The translation of the logical name should be the number of permanent servers you want. For example, to define two permanent servers for an account named NML\$SERVER, enter the following command:

```
$ DEFINE NETSERVER$SERVERS_NML$SERVER 2
```

Note

The use of DECnet object accounts like NML\$SERVER and MAIL\$SERVER are described in Section 2.6.1 and Section 5.2.2.

Put this command in the login command procedure of the account; in this case, the SYS\$LOGIN directory for NML\$SERVER. You can also define it as a system logical name in SYS\$MANAGER:SYLOGICALS.COM. The account must have write access to its SYS\$LOGIN directory. Note that you gain little by defining only one permanent server, because a number of functions such as wildcard file copy require multiple logical links, each of which requires its own server.

If you use this mechanism, understand the interaction between proxy access and NETSERVER processes. The proxy information is used by LOGINOUT.EXE, after a process has been created. For this reason, any incoming connection that may have a proxy account on the local system will not be given to an existing NETSERVER process that was created for a different user. Permanent servers, in general, are used only by logical links that are not using proxy access.

In the following discussion, the remote node is assumed to be running an OpenVMS operating system. If the remote node on which your target task runs is not running OpenVMS, refer to the DECnet documentation for that system.

Completing the Connection Transparently

If the target task is transparent, the DECnet software at the remote node checks the access control information supplied in the connection request call.

Before you access the remote node, the system manager must have created the appropriate account in the UAF (refer to the information on access control). In addition, the command procedure file (*taskname.COM*) starting the remote task must exist in the default directory associated with the account identified by the access control information. For a description of the command procedure *taskname.COM*, see Section 8.7.1, which contains examples of command procedures designed for task-to-task communication.

Performing Network User Operations

8.4 Performing Task-to-Task Operations

Command procedures for objects existing in the OBJECT database (which is created using NCP commands) are located in the SYS\$SYSTEM directory. The Digital-supplied FAL.COM procedure is an example of such a command procedure. (The object command procedure is bypassed if the object definition specifies an EXE file.)

Completing the Connection Nontransparently

If the target task is nontransparent, then one of several things may occur. If the task has not declared itself a **network task** (and is therefore eligible to accept only one connection request at a time), then the DECnet software at the remote node performs the access checking procedure. After it starts, the target task retrieves the connection information by translating the logical name SYS\$NET using the \$TRNLNM system service call (see Section 8.6).

If the target task declares itself as an active network task, then DECnet for OpenVMS software places all connection requests addressed to the task in the mailbox associated with the channel being used. The first message in the mailbox is the NCB from the original connection request that started the task. This message appears in the mailbox after channel assignment and name declaration occur. After the task declares a network name or number, subsequent inbound connection requests are not checked by the remote node to verify access control information. (If the task is started without being part of a DECnet operation, access control is never checked.) Section 8.6 describes in more detail the nontransparent process of completing the logical link connection.

After examining the incoming connection request, the target task either accepts or rejects the request, and optionally can send 1 to 16 bytes of data back to the source task at the same time that it responds to the logical link connection request. Furthermore, a library routine, LIB\$ASN_WTH_MBX, which assigns a channel and associates a unique mailbox, can be used when accepting the connection.

8.4.3.3 Exchanging Messages

When you access the network transparently or nontransparently, DECnet for OpenVMS sends data messages over a logical link in response to a set of send and receive calls issued by the source and target tasks. For higher-level language tasks, use standard read and write statements to send and receive data messages. (In Example 8-1, the two FORTRAN tasks use READ and WRITE statements to exchange information. The equivalent RMS service calls are \$GET and \$PUT.)

After DECnet for OpenVMS creates a logical link, the two tasks are ready to exchange messages. This exchange can take place only if the two tasks cooperate in the transmission process. In other words, for each message sent by a task, the receiving task must issue a corresponding call to receive the message. Also, decide which task will disconnect the link. In addition, if the tasks are nontransparent, they must agree on whether or not the optional data will be passed. In the context of an established logical link, the task sending a message is the transmitter and the task receiving it is the receiver. Because logical links are inherently full duplex, each task may be a transmitter and a receiver simultaneously.

DECnet for OpenVMS distinguishes between two types of message: data messages and mailbox messages. Data messages are the normal mode of information exchange for both transparent and nontransparent communication. Mailbox messages such as interrupt messages, messages resulting from some DECnet operation (including optional user data), and network status notifications, can be used only in nontransparent communication.

Performing Network User Operations

8.4 Performing Task-to-Task Operations

Nontransparent communication frequently involves using a mailbox to obtain network-specific information. A task may receive three types of message in its mailbox:

- Messages that DECnet generates when the task initiates certain network operations. A task issues system service calls to initiate these operations. For example:
 - When one task requests a logical link connection, a notification message (and optional user data) may be placed in the mailbox of the target task.
 - When a target task accepts or rejects the logical link connection request, a notification message (and optional user data) is placed in the mailbox of the source task.
 - When one task synchronously disconnects or aborts a logical link, a notification message (and optional user data) is placed in the mailbox of the task from which it is disconnecting.
- Network status notification messages that inform a task of some unusual network occurrence (such as a third-party disconnect).
- Interrupt messages sent by the other task.

8.4.3.4 Terminating a Logical Link Connection

The termination of a logical link signals the end of the communication between tasks.

In transparent communication using programming language I/O statements, RMS service calls, or system service calls, either task can break the link. To terminate the link properly, the receiver, and not the transmitter, of the final message should issue the \$CLOSE service or other appropriate language call to break the link. The link termination process is complete when the other task issues a link termination request. In transparent communication using system service calls, the \$DASSGN system service call causes the link to be terminated.

Issuing the \$CANCEL service call followed by the \$DASSGN service call causes all pending operations to abort, then closes the link and deassigns the channel.

In nontransparent communication using system service calls, terminate I/O operations over a channel in one of three ways:

- **Synchronous Disconnect (\$QIO)**—Specifies that all messages sent by the local task are required to be received and acknowledged by the remote End Communication Layer (ECL) before the logical link is disconnected. Use this type of disconnect when the user of the logical link's services wants to ensure that the transmission of messages has completed before terminating the logical link. This service, however, cannot guarantee the delivery of the data received by the remote ECL to the remote task.
- **Disconnect Abort (\$QIO)**—Specifies that all messages sent by the local task are not required to be received or acknowledged by the remote ECL before the logical link is disconnected. Use this type of disconnect when the local task wants to reset the logical link to a known state. To ensure that the transmitted messages have been received and acknowledged by the remote ECL, the local task may issue the system service \$CANCEL on the channel before issuing the disconnect abort. These services, however, cannot guarantee the delivery of the data received by the remote ECL to the remote task.

Performing Network User Operations

8.4 Performing Task-to-Task Operations

- **Deassign Channel and Terminate Link (\$DASSGN)**—Specifies that all messages sent by the local task are not required to be received or acknowledged by the remote ECL before the logical link is disconnected. Link and deassign the channel to the network immediately.

After either a synchronous disconnect or a disconnect abort of a nontransparent link, you can issue a new connection request because you did not deassign the I/O channel but merely deaccessed the link. For further information about these system service calls, see Section 8.6.

When a connection to a nontransparent task terminates, a notification message indicating that the link is disconnected is placed in the mailbox of the affected task. A nontransparent task can send up to 16 bytes of optional user data, with the disconnect request. This optional user data is placed in the mailbox of the nontransparent task on the receiving end of the disconnect message.

Disconnect operations cannot guarantee to both partners that communication is complete. Therefore, Digital recommends that the communicating tasks agree on a protocol for terminating communication. In general, the receiver, not the transmitter, of the final message should disconnect the logical link.

Transparent communication allows you to create a logical link between tasks, send and receive data messages, and terminate the logical link at the end of the message dialog. The discussion covers general concepts implicit in DECnet for OpenVMS task-to-task communication and assumes familiarity with the QIO-related material in the *OpenVMS System Services Reference Manual*. The use of programming language I/O statements and RMS service calls in transparent task-to-task communication is described in Section 8.5.

8.5 Performing Transparent Task-to-Task Operations

This section describes the system service calls and functions that perform transparent task-to-task communication over the network. Use any of the following methods to perform these operations:

- Any higher-level language that supports network operations using language I/O statements
- RMS service calls
- System service calls
- DCL commands

See Section 8.7 for examples of transparent task-to-task operations.

8.5.1 Using DCL Commands and Command Procedures

To perform transparent task-to-task operations, use DCL commands to construct and execute command procedures.

For example, to display information about another system, you can design a command procedure that can be invoked as a remote task. Assume that a procedure called SHOWBQ.COM is designed to return status information about jobs entered in batch queues on the system where it executes. Assume also that SHOWBQ.COM resides on node TRNTO. Use SHOWBQ.COM for task-to-task communication by entering a task specification string in a TYPE command. For example:

```
$ TYPE TRNTO"BROWN JUNE"::"TASK=SHOWBQ"
```

Performing Network User Operations

8.5 Performing Transparent Task-to-Task Operations

See Section 8.7.1 for an example of a command procedure used for task-to-task communication. For additional information concerning the design, construction, and execution of command procedures, see *OpenVMS User's Manual*.

8.5.2 Using Programming Language I/O Statements

This section contains examples of programming language I/O statements that provide transparent task-to-task communication. Each programming language I/O statement contains a task specification string as part of its statement.

Higher-level language tasks can use standard file opening statements to request a logical link connection to a remote task. The following examples show how to specify a target task, TEST4, running on node TRNTO, in various languages supported on the operating system.

```
FORTRAN OPEN (UNIT=7,NAME='TRNTO::"TASK=TEST4" ',TYPE='NEW')
BASIC OPEN 'TRNTO::"TASK=TEST4" ' AS FILE #7
PL/I OPEN FILE(OUTPUT) TITLE ('TRNTO::"TASK=TEST4" ');
PASCAL OPEN (PARTNER,'TRNTO::"TASK=TEST4" ',NEW);
COBOL SELECT PARTNER ASSIGN TO "TRNTO::" "TASK=TEST4" ". OPEN
OUTPUT PARTNER.
C F1 = OPEN ("TRNTO::\" TASK=TEST4\" ",2);
```

To complete the logical link, the target task performs a file opening operation using the logical name SYS\$NET to establish a communications path back to the source task. The following examples show how to specify SYS\$NET from higher-level language calls.

```
FORTRAN OPEN (UNIT=2,NAME='SYS$NET',TYPE='OLD')
BASIC OPEN "SYS$NET" AS FILE #2
PL/I OPEN FILE(INPUT) TITLE ('SYS$NET');
PASCAL OPEN (PARTNER,'SYS$NET',OLD);
COBOL SELECT PARTNER ASSIGN TO "SYS$NET". OPEN INPUT PARTNER.
C F2 = OPEN ("SYS$NET",2);
```

Section 8.7.2 provides an example of a FORTRAN program designed for transparent task-to-task communication.

8.5.3 Using OpenVMS RMS Service Calls in Programs

You can write a program to perform transparent task-to-task communications, using RMS service calls. This section describes how to use RMS service calls in a program. All examples are written in the C programming language.

The RMS \$OPEN statement is equivalent to the higher-level language statements described in Section 8.5.2.

After you define the appropriate FAB and RAB control blocks, use the \$OPEN service to specify the target task, TEST4, running on node TRNTO. Initiate the link by specifying the following call in your program:

```
target_fab = cc$rms_fab;
target_rab = cc$rms_rab;
char target_task[21] = "NODE::\" TASK=TEST4\" ";
```

Performing Network User Operations

8.5 Performing Transparent Task-to-Task Operations

```

target_fab.fab$b_fac = FAB$M_GET | FAB$M_PUT;
target_fab.fab$l_fna = &target_task;
target_fab.fab$b_fns = sizeof (target_task);
target_fab.fab$b_org = FAB$V_ORG;
target_fab.fab$b_rat = FAB$M_CR;
target_fab.fab$b_rfm = FAB$C_VAR;

target_rab.rab$l_fab = &target_fab;
target_rab.rab$l_ubf = &target_data;
target_rab.rab$l_rbf = &target_data;
target_rab.rab$w_rsz = sizeof ( target_data );
target_rab.rab$w_usz = sizeof ( target_data );

return_status = sys$open ( &target_fab );

```

To complete the logical link, the target task performs a file-opening operation using the logical name SYS\$NET to establish a communications path back to the source task. For example:

```

req_fab = cc$rms_fab;
req_rab = cc$rms_rab;
char req_task[8] = "SYS$NET";

req_fab.fab$b_fac = FAB$M_GET | FAB$M_PUT;
req_fab.fab$l_fna = &req_task;
req_fab.fab$b_fns = sizeof (req_task);
req_fab.fab$b_org = FAB$V_ORG;
req_fab.fab$b_rat = FAB$M_CR;
req_fab.fab$b_rfm = FAB$C_VAR;

req_rab.rab$l_fab = &req_fab;
req_rab.rab$l_ubf = &req_data;
req_rab.rab$l_rbf = &req_data;
req_rab.rab$w_rsz = sizeof ( req_data );
req_rab.rab$w_usz = sizeof ( req_data );

return_status = sys$open ( &req_fab );

```

As in the case of the target task, the appropriate FABs and RABs must already be declared. On inbound connections, DECnet for OpenVMS defines SYS\$NET.

8.5.4 Using System Service Calls in Programs

You can write programs to perform transparent task-to-task communications, using system service calls. This section focuses on programs using system service calls for performing these operations.

Table 8–1 summarizes these calls and their network-related functions. Section 8.5.5 presents the format of these calls in more detail.

Table 8–1 System Service Calls for Transparent Communication

Call	Function
\$ASSIGN	Request a logical link connection
\$DASSGN	Terminate a logical link
\$QIO (IO\$_READVBLK)	Receive a message
\$QIO (IO\$_READVBLK!IO\$_M_MULTIPLE)	Receive a message in multiple receive requests
\$QIO (IO\$_WRITEVBLK)	Send a message
\$QIO (IO\$_WRITEVBLK!IO\$_M_MULTIPLE)	Send a message in multiple write requests

Performing Network User Operations

8.5 Performing Transparent Task-to-Task Operations

These calls allow you to perform task-to-task communication in much the same way as you would perform normal I/O operations. Use the \$ASSIGN call to assign a logical link I/O channel to a device, which in this case is a task that behaves like a full-duplex record-oriented device. You can perform read and write operations with this task either synchronously or asynchronously. To exchange messages, use the Queue I/O (QIO) requests supported by DECnet for OpenVMS. When all communication completes, use the \$DASSGN system service call to deassign the channel and thereby disconnect the logical link.

8.5.4.1 Requesting a Logical Link

To request a logical link and assign an I/O channel, use the \$ASSIGN system service. When you issue this call, include a task specifier for the remote node on which the *cooperating task* runs. The task specifier identifies the remote node and the target task to which you want to establish a logical link.

For example, to establish a logical link to target task TEST2 on node TRNTO to perform task-to-task communication, code the following C language statements in your source program.

```
short int netchan;

static $DESCRIPTOR ( target, "TRNTO::\" TASK=TEST2\" ");

return_status = sys$assign ( &target,
                             &netchan );
```

For debugging or for symmetry, develop and run the target task on the local node. Use the local node name (or node number 0) plus two colons to connect to the local node. This practice applies to DCL, higher-level languages and RMS, as well as system services.

After you establish a logical link, you refer to the assigned channel in any succeeding call in the program, either to send or receive messages, or to deassign the channel and terminate the logical link.

Until the connection operation completes, the process is in local event flag wait (LEF) state in kernel mode. Therefore, pressing Ctrl/Y does not return the process to DCL status. The maximum amount of time that the process will wait in this state is specified by the OUTGOING TIMER parameter of the NCP command SET EXECUTOR. If this timer cannot be set to an acceptable value, tasks that accept commands from the terminal should use \$QIO (IO\$_ACCESS) instead of the transparent \$ASSIGN call to initiate logical links.

8.5.4.2 Completing the Logical Link Connection

The target task completes the logical link by calling the SYS\$ASSIGN system service. The arguments include:

- The device name ("_NET:")
- The channel number which will be returned by SYS\$ASSIGN

The target task completes the logical link by calling the SYS\$ASSIGN system service with SYS\$NET specified as the devnam argument. For example:

```
static $DESCRIPTOR ( net_device, "_NET:" );
short int netchan;

return_status = sys$assign( &net_device,
                           &netchan,
                           0,
                           0);
```

Performing Network User Operations

8.5 Performing Transparent Task-to-Task Operations

8.5.4.3 Exchanging Messages

After DECnet for OpenVMS software establishes a logical link with the target task, either task can then send or receive messages. They must, however, cooperate with each other: for each message sent with the \$QIO (IO\$_WRITEVBLK), the other task must issue a corresponding \$QIO (IO\$_READVBLK) to receive the message.

On logical links, DECnet for OpenVMS supports sending and receiving data messages that are larger than the maximum size allowed by the \$QIO system service. You do this by allowing write and read requests to be fragmented across multiple \$QIO requests. To fragment writes and reads, include the modifier IO\$_MULTIPLE on the write or read \$QIO call.

When you supply the modifier on a write message request \$QIO (IO\$_WRITEVBLK!IO\$_MULTIPLE), it indicates that more data will be supplied for this message. To indicate the last fragment of the message being sent, issue the write request without a modifier \$QIO (use the QIO called IO\$_WRITEVBLK).

When you supply the modifier on a read message \$QIO (IO\$_READVBLK!IO\$_MULTIPLE), if the received data message contains more than enough data to fill the buffer supplied with the read request, then SS\$_BUFFEROVF is returned. This is not an error status. The next read posted receives the next fragment of the data message. If the received message fits into the buffer posted, then SS\$_NORMAL is returned. Tasks that require fragmentation should always supply the IO\$_MULTIPLE on read requests.

If you do not use the read multiple request to receive a data message, then you must ensure that the tasks allocate enough buffer space for receiving the messages. If the tasks do not, a SS\$_DATAOVERUN error occurs. Also, ensure that the end of the dialog can be determined.

One of the two tasks must disconnect the logical link. To terminate a logical link properly, the receiver, and not the transmitter, of the final message should break the link.

DECnet for OpenVMS does not provide an automatic timeout of read or write requests. If the task needs to stop a read or write request on a logical link, then it must do so by disconnecting or aborting the logical link.

8.5.4.4 Terminating the Logical Link

Use the \$DASSGN system service to deassign the channel and break the logical link with the cooperating task. This call terminates all pending calls for sending and receiving messages, aborts the link immediately, and frees the channel associated with that logical link.

8.5.4.5 Status and Error Reporting

When a system service completes execution, a status value is returned (does not apply to the \$EXIT service). The \$ASSIGN, \$DASSGN, and \$QIO system services place the return status information in register 0 (R0). For the \$QIO system service, a successful return status indicates only that the request was queued successfully. All I/O completion status information is placed in the I/O status block (IOSB). For example, a \$QIO system service read request to a task might be queued successfully (status return is SS\$_NORMAL) yet fail because the link was disconnected. (I/O status return is SS\$_LINKABORT.) The return status codes shown in the following sections may be returned both in R0 and in the IOSB.

Performing Network User Operations

8.5 Performing Transparent Task-to-Task Operations

When DECnet for OpenVMS returns the status `SS$_NORMAL` in the I/O status block on a write request, it means that the write was queued for transmission on the logical link. It does not mean that the write request has been received or acknowledged by the remote task. The logical link services of DECnet for OpenVMS provide the guaranteed delivery of transmitted messages to the remote node. If a message cannot be delivered, the user is notified by the disconnection of the logical link. The DECnet for OpenVMS services cannot guarantee the delivery of data received on the remote node to the remote task. It is the responsibility of cooperating tasks to agree on a protocol to ensure that data transmitted by the local task is received by the remote task.

The *OpenVMS System Services Reference Manual* and the *OpenVMS Programming Concepts Manual* both provide more information about `$QIO` system services.

8.5.5 Summary of System Service Calls for Transparent Operations

The following sections describe the system services that provide transparent task-to-task communication. Each description covers the use of the call, its format, the arguments associated with the call, and the return status information. For descriptions of NCP system messages, refer to the OpenVMS system messages documentation. You can use the DCL command `HELP/MESSAGE` to obtain online descriptions of system messages.

8.5.5.1 \$ASSIGN

The `$ASSIGN` system service assigns a channel to refer to the logical link. You can then use the channel returned in the *chan* argument in any succeeding call to send or receive a message, or to deassign the channel and thereby terminate the logical link.

Format

```
$ASSIGN devnam ,chan ,[acmode]
```

Arguments

<code>devnam</code>	Address of a quadword descriptor of a character string that identifies the remote task. The string contains either of the following: <ul style="list-style-type: none">• A task specification string if the call is by the source task. Both the string and its descriptor must be in read/write storage.• "SYS\$NET" if the call is by the target task.
<code>chan</code>	Address of a word that is to receive the assigned channel number. You use this channel number to send a message to a remote task, receive a message from a remote task, or to abort the logical link.
<code>acmode</code>	Access mode to be associated with this channel. The most privileged access mode used is the access mode of the caller. Perform I/O operations on the channel only from equal or more privileged access modes.

Return Status

<code>SS\$_CONNECFail</code>	The connection to a network object timed out or failed.
<code>SS\$_DEVOffline</code>	The physical link is shutting down.
<code>SS\$_FILALRACC</code>	A logical link already exists on the channel.
<code>SS\$_INSFMem</code>	There is not enough system dynamic memory to complete the request.

Performing Network User Operations

8.5 Performing Transparent Task-to-Task Operations

SS\$_INVLOGIN	The access control information was found to be invalid at the remote node.
SS\$_IVDEVNAM	The task specifier has an invalid format or content.
SS\$_LINKEEXIT	The network partner task was started, but exited before confirming the logical link (that is, \$ASSIGN to SYS\$NET).
SS\$_NOLINKS	No logical links are available. The maximum number of logical links as set for the NCP executor MAXIMUM LINKS parameter was exceeded.
SS\$_NOPRIV	The issuing task does not have the required privilege to perform network operations or to confirm the specified logical link.
SS\$_NOSUCHNODE	The specified node is unknown.
SS\$_NOSUCHOBJ	The network object number is unknown at the remote node; or for a TASK= connect, the named DCL command procedure file cannot be found at the remote node.
SS\$_NOSUCHUSER	The remote node could not recognize the login information supplied with the connection request.
SS\$_PROTOCOL	A network protocol error occurred, most likely because of a network software error.
SS\$_REJECT	The network object rejected the connection.
SS\$_REMOTE	The service completed successfully. (A logical link was established with the target task.)
SS\$_REMRSRC	The link could not be established because system resources at the remote node were insufficient.
SS\$_SHUT	The local or remote node is no longer accepting connections.
SS\$_THIRDPARTY	The logical link connection was terminated by a third party (for example, the system manager).
SS\$_TOOMUCHDATA	The task specified too much optional or interrupt data.
SS\$_UNREACHABLE	The remote node is currently unreachable.

8.5.5.2 \$QIO (Sending a Message to a Target Task)

The \$QIO system service with a function code of IO\$_WRITEVBLK or IO\$_WRITEVBLK!IO\$_MULTIPLE sends a message to a target task. The \$QIO call initiates an output operation by queuing a request to the channel associated with the logical link. Alternatively, you could use the \$QIOW system service to perform the same operation but also wait for I/O completion.

Format

```
$QIO [efn] ,chan ,func ,[iosb] ,[astadr] ,[astprm] ,p1 ,p2 $QIOW
```

Arguments

efn	Number of the event flag to be set at request completion.
chan	Word containing the channel number associated with the logical link. Use the same channel number returned in the \$ASSIGN call.
func	IO\$_WRITEVBLK or IO\$_WRITEVBLK!IO\$_MULTIPLE.
iosb	Address of a quadword I/O status block that is to receive the completion status.

Performing Network User Operations

8.5 Performing Transparent Task-to-Task Operations

astadr	Entry point address of an asynchronous system trap (AST) routine that executes when the I/O operation completes. If specified, the AST routine executes at the access mode from which the \$QIO service was requested.
astprm	AST parameter to be passed to the AST completion routine.
p1	Buffer address.
p2	Buffer length in bytes.

Return Status

SS\$_NORMAL	The service completed successfully.
SS\$_ABORT	The I/O request has been aborted by a \$DASSGN or \$CANCEL call.
SS\$_CANCEL	The I/O on this channel has been canceled.
SS\$_FILNOTACC	No logical link is associated with the channel.
SS\$_INSMEM	Enough memory to buffer the message could not be allocated.
SS\$_LINKABORT	The network partner task aborted the logical link.
SS\$_LINKDISCON	The network partner task disconnected the logical link.
SS\$_LINKEEXIT	The network partner task exited.
SS\$_PATHLOST	The path to the network partner task node was lost.
SS\$_PROTOCOL	A network protocol error occurred. This is most likely due to a network software error.
SS\$_THIRDPARTY	The logical link connection was terminated by a third party (for example, the system manager).

Reference the *OpenVMS System Services Reference Manual* for more information on \$QIO and the associated arguments.

8.5.5.3 \$QIO (Receiving a Message from a Target Task)

The \$QIO system service with a function code of IO\$_READVBLK receives a message from a target task. The \$QIO call initiates an input operation by queuing a request to the channel associated with the logical link. Alternatively, you could use the \$QIOW system service to perform the same operation but also wait for I/O completion.

Format

```
$QIO [efn] ,chan ,func ,[iosb] ,[astadr] ,[astprm] ,p1 ,p2
$QIOW
```

Arguments

efn	Number of the event flag to be set at request completion.
chan	Word containing the channel number associated with the logical link. Use the same channel number returned in the \$ASSIGN call.
func	IO\$_READVBLK or IO\$_READVBLK!IO\$_MULTIPLE.
iosb	Address of a quadword I/O status block that is to receive the completion status.

Performing Network User Operations

8.5 Performing Transparent Task-to-Task Operations

astadr	Entry point address of an AST routine that executes when the I/O operation completes. If specified, the AST routine executes at the access mode from which the \$QIO service was requested.
astprm	AST parameter to be passed to the AST completion routine.
p1	Buffer address.
p2	Buffer length in bytes.

Return Status

SS\$_NORMAL	The service completed successfully.
SS\$_ABORT	The I/O request has been aborted by a \$DASSGN or \$CANCEL call.
SS\$_CANCEL	The I/O on this channel has been canceled.
SS\$_DATAOVERUN	More bytes were sent than could be received in the supplied buffer. This status will not be returned when IO\$_M_MULTIPLE is used on the read request.
SS\$_FILNOTACC	No logical link is associated with the channel.
SS\$_INSFMEM	Enough memory to buffer the message could not be allocated.
SS\$_LINKABORT	The network partner task aborted the logical link.
SS\$_LINKDISCON	The network partner task disconnected the logical link.
SS\$_LINKEEXIT	The network partner task exited.
SS\$_PATHLOST	The path to the network partner task node was lost.
SS\$_PROTOCOL	A network protocol error occurred. This is most likely due to a network software error.
SS\$_THIRDPARTY	The logical link connection was terminated by a third party (for example, the system manager).
SS\$_BUFFEROVF	Data could not fit in the buffer supplied. Supply another read request to receive the next fragment of received data message.

Reference the *OpenVMS System Services Reference Manual* for more information on \$QIO and the associated arguments.

8.5.5.4 \$DASSGN (Disconnecting a Logical Link)

The \$DASSGN system service terminates all pending operations to send and receive data, disconnects the logical link immediately, and frees the channel associated with that link. Either task can terminate the logical link by calling \$DASSGN.

Format

\$DASSGN chan

Argument

chan Word containing the channel number to the logical link you want disconnected. Use the same channel number returned in the \$ASSIGN call.

Return Status

SS\$_NORMAL	The service completed successfully.
SS\$_IVCHAN	The process specified an invalid channel.
SS\$_NOPRIV	The specified channel was not assigned or was assigned from a more privileged access mode.

Reference the *OpenVMS System Services Reference Manual* for more information on \$QIO and the associated arguments.

Performing Network User Operations

8.6 Performing Nontransparent Task-to-Task Operations

8.6 Performing Nontransparent Task-to-Task Operations

This section describes the system service calls and functions that you use for nontransparent task-to-task communication. In general, the principles of nontransparent task-to-task communication are similar to those of transparent communication.

If you want to perform nontransparent task-to-task communication operations, you can write programs using system services in one of the higher-level languages, provided the language supports the use of system services.

DECnet for OpenVMS also provides additional services with extensions that allow you to use network-specific features for nontransparent network operations, such as the following:

- Creating and using mailboxes for receiving messages, including network status notifications
- Declaring a task as a network task, thus enabling it to process multiple inbound logical link connection requests
- Sending connection requests, optionally with user data
- Accepting or rejecting a connection request, optionally with user data
- Communicating between a transparent and a nontransparent task
- Sending or receiving an interrupt message
- Aborting or synchronously disconnecting a logical link, optionally with user data

The general concepts implicit in DECnet for OpenVMS task-to-task communication are covered in Section 8.5. Also be familiar with the material in the *OpenVMS System Services Reference Manual* and the *OpenVMS I/O User's Reference Manual*.

8.6.1 Using System Services for Nontransparent Operations

Nontransparent task-to-task communication over the network uses a set of system service calls available under the operating system. Table 8–2 summarizes these calls and their network-related functions. The \$QIO calls are distinguished by function code.

Table 8–2 System Service Calls for Nontransparent Communication

Call	Function
\$ASSIGN	Assign an I/O channel
\$CANCEL	Cancel I/O on a channel
\$CREMBX	Create a mailbox
\$DASSGN	Abort the logical link connection (deassigning an I/O channel)
\$GETDVI	Get information on device or volume
\$QIO (IO\$_ACCESS)	Request a logical link connection

(continued on next page)

Performing Network User Operations

8.6 Performing Nontransparent Task-to-Task Operations

Table 8–2 (Cont.) System Service Calls for Nontransparent Communication

Call	Function
\$QIO (IO\$_ACCESS)	Accept a logical link connection request
\$QIO (IO\$_ACCESS!IO\$_M_ABORT)	Reject a logical link connection request
\$QIO (IO\$_ACPCONTROL)	Assign a network name or number to a task eligible to accept multiple inbound connection requests
\$QIO (IO\$_DEACCESS!IO\$_M_ABORT)	Abort the logical link connection
\$QIO (IO\$_DEACCESS!IO\$_M_SYNCH)	Synchronously disconnect a logical link
\$QIO (IO\$_READVBLK)	Receive a message
\$QIO (IO\$_READVBLK!IO\$_M_MULTIPLE)	Receive a message in multiple receive requests
\$QIO (IO\$_WRITEVBLK)	Send a message
\$QIO (IO\$_WRITEVBLK!IO\$_M_MULTIPLE)	Write a message in multiple write requests
\$QIO (IO\$_WRITEVBLK!IO\$_M_INTERRUPT)	Send an interrupt message
\$TRNLNM	Translate logical names

8.6.1.1 Assigning a Channel to _NET: and Creating a Mailbox

To prepare for nontransparent task-to-task communication, assign a channel just as you would for transparent communication. In addition, create a mailbox to take advantage of optional network protocol features.

Assign a channel to the pseudodevice `_NET:`; use the `$ASSIGN` system service call for this purpose. This call normally contains a reference to a mailbox, thereby associating it with the channel assigned to `_NET:`. If you use a mailbox, you must create the mailbox before assigning a channel to `_NET:`. It is important to note that this use of the `$ASSIGN` system service differs from its use for transparent communication. Assigning a channel to `_NET:` does not transmit a logical link connection request to the remote node. Instead, the channel to `_NET:` provides a communication path to DECnet software. Use a separate `$QIO` call (`IO$_ACCESS` function using the same channel) to request a logical link to the remote task. Refer to Section 8.6.2.1 for details about the `$ASSIGN` system service.

To take advantage of optional network protocol features, create a mailbox to receive messages on behalf of logical link operations. For example, the mailbox receives a message indicating whether the cooperating task accepted or rejected a connection request issued by the source task. Use the `$CREMBX` system service to create a mailbox for these purposes. When you create the mailbox, you must specify the maximum message size adequate for the largest message expected, or DECnet will not be able to deliver messages. If your application does not need the information supplied in the mailbox, you need not create a mailbox.

For convenience, use the Run-Time Library routine `LIB$ASN_WTH_MBX` to create a temporary mailbox, assign a channel to it, and assign a channel to `_NET:`. This routine creates a unique mailbox on each call to the routine. Multiple copies of a task using this routine, in effect, use different mailboxes. If you were to create a mailbox with a logical name within the task, then all

Performing Network User Operations

8.6 Performing Nontransparent Task-to-Task Operations

copies of that task would use the same mailbox and thereby interfere with each other's mailbox messages. For a complete description of this routine, see the *OpenVMS RTL Library (LIB\$) Manual*.

8.6.1.2 Mailbox Message Format

The mailbox receives information specific to nontransparent communication with a remote task. Figure 8-2 illustrates the general format of the mailbox message.

Figure 8-2 Mailbox Message Format

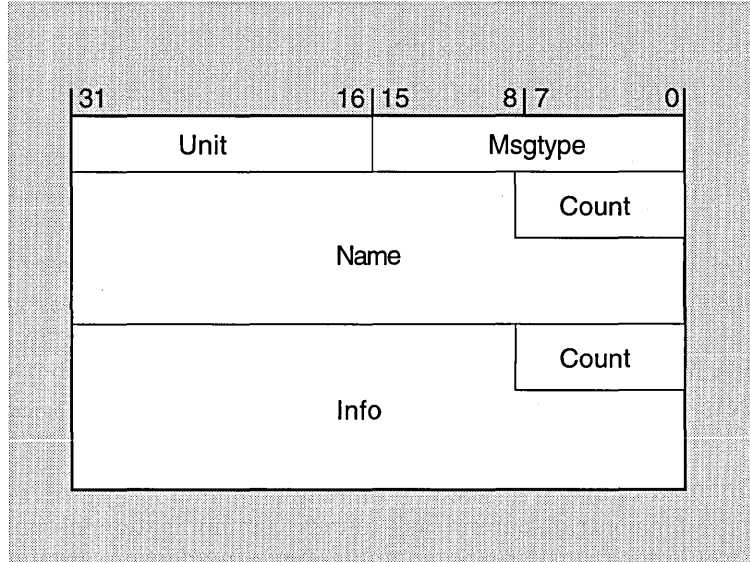

LKG-6110-92R

Notes on Figure 8-2

- MSGTYPE** Contains a code that identifies the message type.
- UNIT** Contains the binary unit number of the device for which the message applies.
- COUNT NAME** Contains a counted ASCII string that gives the name of the device for which the message applies. The \$ASSIGN system service creates devices having names beginning with NET.
- COUNT INFO** Contains a counted ASCII string of information, which depends on the message type.

All system mailbox messages contain, in the first word of the message, a constant that identifies the sender of the message. These constants have symbolic names representing the message types, and are defined in the \$MSGDEF macro. The message types are in the following format:

MSG\$_message_type

Table 8-3 summarizes the system mailbox messages that pertain to nontransparent task-to-task communication.

Performing Network User Operations

8.6 Performing Nontransparent Task-to-Task Operations

Table 8–3 System Mailbox Messages

Message Type	Meaning
MSG\$_TRMUNSOLIC	Unsolicited terminal data
MSG\$_CRUNSOLIC	Unsolicited card reader data
MSG\$_ABORT	Network partner aborted link
MSG\$_CONFIRM	Network connect confirm
MSG\$_CONNECT	Network inbound connect initiate
MSG\$_DISCON	Network partner disconnected; hang-up
MSG\$_EXIT	Network partner exited prematurely
MSG\$_INTMSG	Network interrupt message; unsolicited data
MSG\$_PATHLOST	Network path lost to partner
MSG\$_PROTOCOL	Network protocol error
MSG\$_REJECT	Network connect reject
MSG\$_THIRDPARTY	Network third party disconnect
MSG\$_TIMEOUT	Network connect timeout
MSG\$_NETSHUT	Network shutting down

8.6.1.3 Requesting a Logical Link Connection

After you assign the I/O channel, request a logical link connection to the target task. Use the \$QIO system service with a function code of IO\$_ACCESS. Identify the target task in the \$QIO call. Use a network connect block (NCB) to specify the target task identification string. In addition, you can optionally send one to 16 bytes of data in the NCB. The format of the NCB is discussed in Section 8.6.1.4.

After the source task issues the connection request, it can issue a \$QIO call with a function code of IO\$_READVBLK to read its mailbox. Checking the contents of the mailbox is one way to determine whether the target task accepted or rejected the connection request. The mailbox can contain a variety of information, including either the MSG\$_CONFIRM or MSG\$_REJECT messages, and possibly optional data in the mailbox buffer.

If specified, the IOSB argument of the \$QIO (IO\$_ACCESS) call will also contain the result of the connection request operation. Section 8.6.2.2 provides a complete list of I/O status messages for this call.

Read the mailbox to inspect any optional data sent from the target task upon accepting or rejecting the connection request.

8.6.1.4 Using the Network Connect Block

The network connect block (NCB) is a user-generated data structure that contains the information necessary to request a logical link connection or to accept or reject a logical link connection request. The NCB must be in read/write storage.

The NCB identifies a specific task using a task specification string. This task specification string specifies either an object name or an object number. The following are valid task specification strings:

```
"TASK=TEST2"  
"0=TEST2"  
"157="  
"TEST2="
```

Performing Network User Operations

8.6 Performing Nontransparent Task-to-Task Operations

For an inbound call, the contents of the task name portion of an NCB depends upon the remote DECnet implementation. If the remote node is running DECnet for OpenVMS, then the task name portion is a username. If not, then the task name portion is a system-specific string that identifies an executable unit (for example, job or task).

The task specification string must be enclosed in quotation marks. The final quotation mark of the task specification string follows the last item within the NCB. Section 8.4.2 provides additional information about task specification strings.

The following example, written in the C programming language, shows an NCB you could use when issuing an outgoing connection request call.

NCB Example With Optional Data:

```
static char ncb[] = { 'T', 'R', 'N', 'T', 'O', ':', ':',  
                    '"', 'T', 'A', 'S', 'K', '=',  
                    'T', 'E', 'S', 'T', '2', '"' };
```

For incoming connections, the NCB can be obtained by translating the SYS\$NET logical name. The contents of an NCB for an incoming connection request is described below.

1. A valid node-id and task specification string.
2. The slash character (/).
3. One word. This word must be 0 for a connection request operation. For a connect accept or reject operation, this word contains an internal DECnet link identifier.
4. Up to 16 bytes of optional data sent as a counted string. This string is stored in a fixed-length field that is 17 bytes long. DECnet for OpenVMS software ignores unused bytes.
5. A destination descriptor. This descriptor indicates how the connection was issued and is meaningful only to the task or object to which the connection is made. This information is useful where one program serves many functions and needs to know how it was invoked. The maximum length for the destination descriptor is 19 bytes. The format is as follows:
 - a. If byte 0 contains 0, then byte 1 is the binary value of the object number.
 - b. If byte 0 contains 1, then byte 1 is the binary object number, and bytes 2 through 18 contain a counted task name.
 - c. If byte 0 contains 2, then byte 1 is the binary object number; bytes 2 through 5 contain a UIC, the first two bytes of which contain a binary group code and the second two bytes contain a binary user code; and bytes 6 through 18 contain a counted task name.

8.6.1.5 Completing the Establishment of a Logical Link

A nontransparent target task completes the logical link connection in one of several ways, depending upon whether the task can process multiple inbound connection requests or just a single request. Furthermore, a nontransparent target task has the option of accepting or explicitly rejecting a logical link request.

Performing Network User Operations

8.6 Performing Nontransparent Task-to-Task Operations

Receiving Connection Requests

This section describes what happens when you receive single and multiple connection requests from a remote node running DECnet for OpenVMS. If the target task's remote node is not running DECnet for OpenVMS, please refer to the related DECnet documentation for that operating system.

When a remote node receives a call requesting a logical link, the DECnet for OpenVMS software constructs an NCB from the information contained in the call. At this point, one of two things occurs. If a task already running on the remote node has declared a network name or object number which is the same as the one identified in the constructed NCB, the software puts the NCB into that task's mailbox. If not, DECnet for OpenVMS must create a process to execute the task. The DECnet for OpenVMS software either uses a compatible netserver process (if one exists) or creates a netserver process (if one does not already exist) to execute NETSERVER.COM, which in turn runs NETSERVER.EXE.

If the task running on the remote node has not declared a network name or network object, SYS\$NET is equated to the NCB, and LOGIN.COM (if it exists) is invoked, followed by the *taskname*.COM command file. The name of this command file is determined as follows:

- If the connection request identifies a numbered (nonzero) object, then the appropriate record is located in the configuration database and the name of the file is found in this record. (The file is assumed to reside in SYS\$SYSTEM.)
- If the connection request identifies a named object with type 0 (TASK), then the file name (with a file type of COM) is assumed to be the name of the task connected to and is assumed to reside in the default directory associated with the access control information.

When executing, the target task can determine whether to accept or explicitly reject the connection request. Program the target task to base this assessment on the information contained in the NCB.

A nontransparent target task can accept only one connection request at a time, unless it declares itself as a network task. The target task may retrieve the connection information by translating the logical name SYS\$NET using the \$TRNLNM system service. After the task retrieves the logical name, it may decide whether to accept or explicitly reject the connection request.

If you require the following information, translate SYS\$NET:

- The optional data in the network connect block
- The identity of the connector
- The descriptor by which the connection was made

A target task can accept multiple inbound connection requests only if it declares itself a known network task. To make this declaration, first use the \$ASSIGN call to assign an I/O channel to _NET:. Then, use the \$QIO system service with the function code IO\$_ACPCONTROL to assign a network name or object number to the task, making it eligible to process multiple inbound connection requests. This system service requires SYSNAM privilege. Associate a mailbox with the channel if a name or number is to be declared.

Program tasks that have declared names or object numbers to terminate when their mailboxes receive a MSG\$_NETSHUT message. Restart such tasks when the network comes back up.

Performing Network User Operations

8.6 Performing Nontransparent Task-to-Task Operations

After you declare the target task as an active network task, DECnet places all connection requests addressed to the task in the mailbox associated with the channel over which the IO\$_ACPCONTROL was issued. The target task retrieves connection requests from the mailbox by issuing the \$QIO system service call with the function code IO\$_READVBLK. The first message in the mailbox is the NCB from the original connection request that put the task into a state of execution. After the task declares a network name or object number, subsequent inbound connection requests are not checked for their access control information.

You can start tasks that declare names or object numbers apart from the first inbound connection (that is, by a RUN command). If the network task, however, is started separately from a DECnet operation, access control is never checked.

Accepting or Rejecting a Connection Request

The target task can either accept or reject a connection request. To accept a connection request, thus completing the logical link connection, use the \$QIO system service with the function code IO\$_ACCESS. To reject the connection request, use the \$QIO system service with the function code IO\$_ACCESS!IO\$_M_ABORT. When it either accepts or rejects the connection request, the target task can also send 1 to 16 bytes of optional data within a modified NCB back to the source task.

Exchanging Data Messages and Interrupt Messages

The exchange of data messages between the two cooperating tasks is performed in the same way for both nontransparent and transparent communication. (Refer to Section 8.5.4.3 for information about exchanging messages on DECnet for OpenVMS logical links.)

The exchange of interrupt messages applies only to nontransparent communication. Either task can send a 1- to 16-byte interrupt message. Use this method to send a message to a target task outside the normal flow of data messages. DECnet for OpenVMS places the received interrupt message in the target task's mailbox. Use the \$QIO system service with the function code IO\$_WRITEVBLK!IO\$_M_INTERRUPT to send the interrupt message. If the target task needs to be notified that an interrupt message has been placed in its mailbox, then it should issue a \$QIO system service read request to the mailbox. The task may also specify an AST on the \$QIO request to cause the execution of a special routine to handle the received interrupt message. (AST routines are described in the *OpenVMS System Services Reference Manual*.)

8.6.1.6 Disconnecting or Aborting the Logical Link

A nontransparent task can terminate communication with a remote task either by disconnecting the link (synchronous disconnect or disconnect abort) or by deassigning the channel. In the first instance, issue a new connection request on the same channel because you do not deassign it. If you specifically use the IO\$_DEACCESS, as opposed to the \$DASSGN method of terminating a link, send an optional message of 1 to 16 bytes of data with the \$QIO call.

To disconnect a logical link synchronously, issue the \$QIO system service with the function code IO\$_DEACCESS!IO\$_M_SYNCH. The channel is then free for subsequent communication with either the same or a different remote task.

A synchronous disconnect may be useful for master/slave communication, in which one task always sends data and its partner task always receives data. If the receiving task is notified of a synchronous disconnection, then all the data that was sent has been received. (The sending task, on the other hand, is not

Performing Network User Operations

8.6 Performing Nontransparent Task-to-Task Operations

guaranteed that its partner received the data.) Because this notification is the only guarantee provided by this operation, using this operation is discouraged in favor of a user-defined protocol to ensure completion of communication. In general, the receiver of the final message should break the logical link.

To abort the logical link, issue the \$QIO system service with the function code IO\$_DEACCESS!IO\$_M_ABORT. This type of disconnect indicates that all messages transmitted by the local transmitter may not have been received or acknowledged by the remote ECL before the logical link was disconnected. Use this type of disconnect when the local task needs to reset the logical link to a known state. If the local task needs to ensure that the transmitted messages have been received and acknowledged by the remote ECL, the task can issue the system service \$CANCEL on the channel before issuing the disconnect abort. Note that this does not guarantee the delivery of the received data to the remote task. It is the responsibility of cooperating tasks to agree on a protocol to ensure that the received data is delivered to the remote task.

After either a synchronous disconnect or a disconnect abort, you can issue a new connection request if you did not deassign the I/O channel.

If you issue the \$CANCEL system service to a channel over which a network name or object has been declared, the declaration is removed from the network database.

8.6.1.7 Terminating the Logical Link

Issue the \$DASSGN system service call to deassign the channel and terminate the logical link immediately. You issue the call only after all communication between the tasks is complete. The call releases the I/O channel, disassociates the mailbox from the channel, and terminates the logical link immediately. This operation is equivalent to using \$CANCEL followed by \$QIO IO\$_DEACCESS!IO\$_M_ABORT.

The same status and error-reporting considerations apply to nontransparent as to transparent task-to-task communication. Refer to Section 8.5.4.5 for information about status and error reporting.

8.6.2 System Service Calls for Nontransparent Operations

The following sections describe the system services that provide nontransparent task-to-task communication over the network. Each description covers the use of the call, its format, the arguments associated with the call, and the return status information. The *OpenVMS System Messages and Recovery Procedures Reference Manual* lists the entire set of network system service error messages.

The following system services are not described in detail here, because their use does not change in a networking context. For a description of these system services, see the *OpenVMS System Services Reference Manual*.

- \$CANCEL (Cancel I/O on Channel)
- \$CREMBX (Create Mailbox and Assign Channel)
- \$GETDVI (Get Device/Volume Information)

After you issue a \$CANCEL on a DECnet for OpenVMS logical link, the only valid operation is to disconnect or abort the logical link.

Performing Network User Operations

8.6 Performing Nontransparent Task-to-Task Operations

8.6.2.1 \$ASSIGN (I/O Channel Assignment)

The \$ASSIGN system service assigns a channel to refer to a logical link. You use this channel in all \$QIO calls that communicate with a remote task. In addition, use the \$ASSIGN system service call to associate a mailbox with the channel.

Format

\$ASSIGN devnam ,chan ,[acmode] ,[mbxnam]

Arguments

devnam	Address of a quadword descriptor of a character string containing the string <code>_NET:</code> or a logical name for <code>_NET:</code> .
chan	Address of a word that is to receive the assigned channel number.
acmode	Access mode to be associated with this channel. The most privileged access mode used is the access mode of the caller. You can perform I/O operations on the channel only from equal or more privileged access modes.
mbxnam	Address of a character string descriptor for the physical name of the mailbox to be associated with the channel. This mailbox remains associated with the channel until the channel is deassigned (<code>\$DASSGN</code>).

Return Status

SS\$_NORMAL	The service completed successfully.
SS\$_INSFMEM	There is not enough system dynamic memory to complete the request.
SS\$_NOPRIV	The issuing task does not have the required privileges to create the channel.
SS\$_NOSUCHDEV	The network device driver is not loaded (for example, the DECnet for OpenVMS software is not currently running on the local node).

8.6.2.2 \$QIO (Requesting a Logical Link Connection)

The \$QIO system service with the function code `IO$_ACCESS` requests a logical link connection to a target task. Send 1 to 16 bytes of optional data to the target task at the same time that you issue the \$QIO system service.

Format

\$QIO [efn] ,chan ,func ,[iosb] ,[astadr] ,[astprm] ,[p1] ,p2

Arguments

efn	Number of the event flag to be set at request completion.
chan	Channel number associated with the logical link. Use the same channel number returned in the \$ASSIGN call.
func	<code>IO\$_ACCESS</code> .
iosb	Address of a quadword I/O status block that is to receive the completion status.
astadr	Entry point address of an AST routine that executes when the I/O operation completes. If specified, the AST routine executes at the access mode from which the \$QIO service was requested.
astprm	AST parameter to be passed to the AST completion routine.
p1	Not used (omit the argument).
p2	Address of a quadword descriptor of the NCB (see Section 8.6.1.4). Both the descriptor and the NCB must be in read/write storage.

Performing Network User Operations

8.6 Performing Nontransparent Task-to-Task Operations

Return Status

SS\$_NORMAL	The service completed successfully.
SS\$_CONNECFAIL	The connection to a network object timed out or failed.
SS\$_DEVOFFLINE	The physical link is shutting down.
SS\$_FILALRACC	A logical link is already accessed on the channel (that is, a previous connection is active on the channel).
SS\$_INSFMEM	There is not enough system dynamic memory to complete the request.
SS\$_INVLOGIN	The access control information was found to be invalid at the remote node.
SS\$_IVDEVNAM	The NCB has an invalid format or content.
SS\$_LINKEEXIT	The network partner task was started, but exited before confirming the logical link (that is, \$ASSIGN to SYS\$NET).
SS\$_NOLINKS	No logical links are available. The maximum number of logical links as set for the executor MAXIMUM LINKS parameter was exceeded.
SS\$_NOPRIV	The issuing task does not have the required privileges to create a logical link to the designated target.
SS\$_NOSUCHNODE	The specified node is unknown.
SS\$_NOSUCHOBJ	The network object number is unknown at the remote node; or for a TASK= connect, the named DCL command procedure file cannot be found at the remote node.
SS\$_NOSUCHUSER	The remote node could not recognize the login information supplied with the connection request.
SS\$_PROTOCOL	A network protocol error occurred. This error is most likely due to a network software error.
SS\$_REJECT	The network object rejected the connection.
SS\$_REMRSRC	The link could not be established because system resources at the remote node were insufficient.
SS\$_SHUT	The local or remote node is no longer accepting connections.
SS\$_THIRDPARTY	The logical link was terminated by a third party (for example, the system manager).
SS\$_TOOMUCHDATA	The task specified too much optional or interrupt data.
SS\$_UNREACHABLE	The remote node is currently unreachable.

8.6.2.3 \$QIO (Accepting Logical Link Connection Request)

The \$QIO system service with the function code IO\$_ACCESS accepts a logical link connection request from a source task. Send 1 to 16 bytes of optional data to the source task at the same time that you issue the \$QIO system service.

Format

\$QIO [efn] ,chan ,func ,[iosb] ,[astadr] ,[astprm] ,[p1] ,p2

Arguments

efn	Number of the event flag to be set at request completion.
chan	Channel number associated with the logical link. Use the same channel number returned in the \$ASSIGN call.
func	IO\$_ACCESS.

Performing Network User Operations

8.6 Performing Nontransparent Task-to-Task Operations

iosb	Address of a quadword I/O status block that is to receive the completion status.
astadr	Entry point address of an AST routine that executes when the I/O operation completes. If specified, the AST routine executes at the access mode from which the \$QIO service was requested.
astprm	AST parameter to be passed to the AST completion routine.
p1	Not used (omit the argument).
p2	Address of a quadword descriptor of the NCB (see Section 8.6.1.4). Both the descriptor and the NCB must be in read/write storage.

Return Status

SS\$_NORMAL	The service completed successfully.
SS\$_DEVALLOC	The process cannot access the logical link specified in the NCB because that link is intended for another process.
SS\$_EXQUOTA	The process does not have sufficient quota to complete the request.
SS\$_INSFMEM	There is not enough system dynamic memory to complete the request.
SS\$_IVDEVNAM	The NCB has an invalid format or content.
SS\$_LINKABORT	The network partner task aborted the logical link.
SS\$_LINKDISCON	The network partner task disconnected the logical link.
SS\$_LINKEEXIT	The network partner task exited.
SS\$_NOSUCHNODE	The specified node is unknown.
SS\$_PATHLOST	The path to the network partner task node was lost.
SS\$_PROTOCOL	A network protocol error occurred. This error is most likely due to a network software error.
SS\$_THIRDPARTY	The logical link connection was terminated by a third party (for example, the system manager).
SS\$_TIMEOUT	The connection request did not complete within the required time.
SS\$_UNREACHABLE	The remote node is currently unreachable.

8.6.2.4 \$QIO (Rejecting a Logical Link Connection Request)

The \$QIO system service with the function code IO\$_ACCESS!IO\$_M_ABORT rejects a logical link connection request. Send 1 to 16 bytes of optional data to the target task at the same time that you issue the \$QIO system service.

Format

```
$QIO [efn] ,chan ,func ,[iosb] ,[astadr] ,[astprm] ,[p1] ,p2
```

Arguments

efn	Number of the event flag to be set at request completion.
chan	Channel number associated with the logical link. Use the same channel number returned in the \$ASSIGN call.
func	IO\$_ACCESS!IO\$_M_ABORT.
iosb	Address of a quadword I/O status block that is to receive the completion status.

Performing Network User Operations

8.6 Performing Nontransparent Task-to-Task Operations

astadr	Entry point address of an AST routine that executes when the I/O operation completes. If specified, the AST routine executes at the access mode from which the \$QIO service was requested.
astprm	AST parameter to be passed to the AST completion routine.
p1	Not used (omit the argument).
p2	Address of a quadword descriptor of the NCB (see Section 8.6.1.4). Both the descriptor and the NCB must be in read/write storage.

Return Status

SS\$_NORMAL	The service completed successfully.
SS\$_DEVALLOC	The process cannot access the logical link specified in the NCB because that link is intended for another process.
SS\$_EXQUOTA	The process does not have sufficient quota to complete the request.
SS\$_IVDEVNAM	The NCB has an invalid format or content.
SS\$_LINKABORT	The network partner task aborted the logical link.
SS\$_LINKDISCON	The network partner task disconnected the logical link.
SS\$_LINKEEXIT	The network partner task exited.
SS\$_NOSUCHNODE	The specified node is unknown.
SS\$_TIMEOUT	The connection request did not complete within the required time.
SS\$_PATHLOST	The path to the network partner task node was lost.
SS\$_PROTOCOL	A network protocol error occurred. This error is most likely due to a network software error.
SS\$_THIRDPARTY	The logical link connection was terminated by a third party (for example, the system manager).
SS\$_UNREACHABLE	The remote node is currently unreachable.

8.6.2.5 \$QIO (Sending a Message to a Target Task)

The \$QIO system service with the function code IO\$_WRITEVBLK or IO\$_WRITEVBLK!IO\$_M_INTERRUPT or IO\$_WRITEVBLK!IO\$_M_MULTIPLE sends a message to a target task. Refer to Section 8.5.5.2 for the format of this call, its arguments, and possible return status codes.

8.6.2.6 \$QIO (Receiving a Message from a Target Task)

The \$QIO system service with the function code IO\$_READVBLK or IO\$_READVBLK!IO\$_M_MULTIPLE receives a message from a target task. Refer to Section 8.5.5.3 for the format of this call, its arguments, and possible return status codes.

8.6.2.7 \$QIO (Sending an Interrupt Message to a Target Task)

The \$QIO system service with the function code IO\$_WRITEVBLK!IO\$_M_INTERRUPT sends a 1- to 16-byte interrupt message to a target task. If the remote node is an OpenVMS operating system, the message is placed in the mailbox associated with the target task.

Format

\$QIO [efn] ,chan ,func ,[iosb] ,[astadr] ,[astprm] ,p1 ,p2

Performing Network User Operations

8.6 Performing Nontransparent Task-to-Task Operations

Arguments

efn	Number of the event flag to be set at event completion.
chan	Channel number associated with the logical link. Use the same channel number returned in the \$ASSIGN call.
func	IO\$_WRITEVBLK!IO\$_M_INTERRUPT.
iosb	Address of a quadword I/O status block that is to receive the completion status.
astadr	Entry point address of the AST routine that executes when the I/O operation completes. If specified, the AST routine executes at the access mode from which the \$QIO service was requested.
astprm	AST parameter to be passed to the AST completion routine.
p1	Buffer address.
p2	Buffer length (1 to 16 bytes).

Return Status

SS\$_NORMAL	The service completed successfully.
SS\$_ABORT	The I/O request has been aborted by a \$DASSGN or \$CANCEL call.
SS\$_FILNOTACC	No logical link is associated with the channel.
SS\$_INSFMEM	Enough memory to buffer the message could not be allocated.
SS\$_LINKABORT	The network partner task aborted the logical link.
SS\$_LINKDISCON	The network partner task disconnected the logical link.
SS\$_LINKEEXIT	The network partner task exited.
SS\$_NOSOLICIT	DECnet could not accept an interrupt message at this time.
SS\$_TOOMUCHDATA	The task specified too much interrupt data.
SS\$_PATHLOST	The path to the network partner task node was lost.
SS\$_PROTOCOL	A network protocol error occurred. This error is most likely due to a network software error.
SS\$_THIRDPARTY	The logical link connection was terminated by a third party (for example, the system manager).

8.6.2.8 \$QIO (Synchronously Disconnecting a Logical Link)

The \$QIO system service with the function code IO\$_DEACCESS!IO\$_M_SYNCH synchronously disconnects the logical link. All pending messages are transmitted to the remote node before the link is disconnected.

Send 1 to 16 bytes of optional data to the task from which you are disconnecting at the same time you issue this \$QIO system service.

Format

\$QIO [efn] ,chan ,func ,[iosb] ,[astadr] ,[astprm] ,[p1] ,[p2]

Performing Network User Operations

8.6 Performing Nontransparent Task-to-Task Operations

Arguments

efn	Number of the event flag to be set at event completion.
chan	Channel number associated with the logical link. Use the same channel number returned in the \$ASSIGN call.
func	IO\$_DEACCESS!IO\$_M_SYNCH.
iosb	Address of a quadword I/O status block that is to receive the completion status.
astadr	Entry point address of the AST routine that executes when the I/O operation completes. If specified, the AST routine executes at the access mode from which the \$QIO service was requested.
astprm	AST parameter to be passed to the AST completion routine.
p1	Not used (omit the argument).
p2	Address of a descriptor of a counted ASCII string of optional user data. Both the string and its descriptor must be in read/write storage.

Return Status

SS\$_NORMAL	The service completed successfully.
SS\$_FILNOTACC	No logical link is associated with the channel.

8.6.2.9 \$QIO (Aborting a Logical Link)

The \$QIO system service with the function code IO\$_DEACCESS!IO\$_ABORT terminates the logical link. The DEACCESS function, however, completes only after all pending I/O operations complete, even if you specify IO\$_ABORT. First, issue the \$CANCEL system service call to cancel I/O operations on the logical link and then issue this call to terminate the logical link.

Send 1 to 16 bytes of optional data to the task from which you are disconnecting at the same time that you issue this \$QIO system service call.

Format

\$QIO [efn] ,chan ,func ,[iosb] ,[astadr] ,[astprm] ,[p1] ,[p2]

Arguments

efn	Number of the event flag to be set at event completion.
chan	Channel number associated with the logical link. Use the same channel number returned in the \$ASSIGN call.
func	IO\$_DEACCESS!IO\$_M_ABORT.
iosb	Address of a quadword I/O status block that is to receive the completion status.
astadr	Entry point address of the AST routine that executes when the I/O operation completes. If specified, the AST routine executes at the access mode from which the \$QIO service was requested.
astprm	AST parameter to be passed to the AST completion routine.
p1	Not used (omit the argument).
p2	Address of a quadword descriptor of a counted string of optional user data. Both the string and its descriptor must be in read/write storage.

Return Status

SS\$_NORMAL	The service completed successfully.
SS\$_FILNOTACC	No logical link is associated with the channel.

Performing Network User Operations

8.6 Performing Nontransparent Task-to-Task Operations

8.6.2.10 \$QIO (Declaring a Network Name or Object Number)

The \$QIO system service with the function code IO\$_ACPCONTROL assigns a network name or object number to the task, thereby making it eligible to process multiple inbound connection requests. You must associate a mailbox with the I/O channel. All inbound connection requests are placed in the mailbox associated with the channel over which this I/O function is issued. You need the SYSNAM privilege to declare a name or object number.

Note

If the maximum message size of the associated mailbox is too small, the task may not be notified of all inbound connection requests.

Whenever a logical link is established, obtain its device unit number (for example, 18 from _NET18:) by using the \$GETDVI system service, because unit numbers (not channel numbers) appear in mailbox messages. Use this system service call where a single mailbox is being used for many logical links. The unit number could be used as a key into a database that keeps track of multiple links.

Format

\$QIO [efn] ,chan ,func ,[iosb] ,[astadr] ,[astprm] ,p1 ,p2

Arguments

efn	Number of the event flag to be set at event completion.
chan	Word containing the channel number associated with the logical link. Use the same channel number assigned in the \$ASSIGN call.
func	IO\$_ACPCONTROL.
iosb	Address of a quadword I/O status block that is to receive the completion status.
astadr	Entry point address of the AST routine that executes when the I/O operation completes. If specified, the AST routine executes at the access mode from which the \$QIO service was requested.
astprm	AST parameter to be passed to the AST completion routine.
p1	Address of a quadword descriptor of a 5-byte block consisting of a function type (one byte) and a longword parameter. The function type is a symbol defined by \$NFBDEF in SYS\$LIBRARY:LIB. The format of the 5-byte block for declaring a name can take one of the two following forms: .BYTE NFB\$_DECLNAME .LONG 0 .BYTE NFB\$_DECLOBJ .LONG object-number
p2	The object number is a number reserved for customer use in the range of 128 to 255. This 5-byte buffer and its descriptor should be in read/write storage. Address of a quadword descriptor of the object name (maximum of 12 characters). Do not supply this argument for the DECLOBJ function. Both the name and its descriptor must be in read/write storage.

Performing Network User Operations

8.6 Performing Nontransparent Task-to-Task Operations

Return Status

SS\$_NORMAL	The service completed successfully.
SS\$_BADPARAM	One of the QIO parameters has an invalid value.
SS\$_ILLCNTRFUNC	The control function is invalid.
SS\$_NOMBX	A name or object number is being declared using a channel without an associated mailbox.
SS\$_NOPRIV	The issuing process does not have the SYSNAM privilege.
SS\$_TOOMUCHDATA	The object could not be declared because the number of declared objects would exceed the value of the Executor MAXIMUM DECLARED OBJECTS parameter.

8.6.2.11 \$DASSGN (Terminating a Logical Link)

The \$DASSGN system service terminates all pending operations to send and receive data, aborts the logical link immediately, and frees the channel associated with that link. Refer to Section 8.5.5.4 for the format of this call, its arguments, and possible return status codes.

8.7 Designing Tasks

The following sections describe a command procedure and user program examples designed to perform task-to-task communications over the network.

The command procedure and the FORTRAN user program example illustrate transparent operations. The C language user program example illustrates nontransparent operation.

8.7.1 DCL Command Procedure for Task-to-Task Communication

As described in Section 8.5, you can write command procedures in DCL to perform transparent task-to-task operations. You can use the following command procedure, called SHOWBQ.COM, to perform such an operation. Use SHOWBQ.COM for task-to-task communication by entering a task specification string in a TYPE command. For example:

```
$ TYPE TRNTO"BROWN JUNE"::"TASK=SHOWBQ"
```

In this command procedure, SYS\$OUTPUT is equated to SYS\$NET to allow the SHOW QUEUE image to communicate over the logical link by opening SYS\$OUTPUT.

```
SHOWBQ.COM
$ !
$ ! This command procedure returns status information about
$ ! jobs entered in batch queues on the system where it
$ ! executes. It may be run interactively as a command
$ ! procedure, submitted as a local or remote batch job, or
$ ! invoked as a "remote task" to display information about
$ ! another system. For example:
$ !
$ ! $ @SHOWBQ
$ ! $ SUBMIT SHOWBQ
$ ! $ SUBMIT/REMOTE node::SHOWBQ
$ ! $ TYPE node::"TASK=SHOWBQ"
$ !
$ IF F$MODE() .EQS. "NETWORK" THEN GOTO NET
$ SHOW QUEUE/BATCH/BRIEF/ALL
```

Performing Network User Operations

8.7 Designing Tasks

```
$ EXIT
$NET:
$ DEFINE SYS$OUTPUT SYS$NET
$ SHOW QUEUE/BATCH/BRIEF/ALL
$ EXIT
```

8.7.2 FORTRAN Program for Task-to-Task Communication

Example 8-1 shows an example of FORTRAN transparent communication. In the FORTRAN source task that initiates the logical link request, you use a standard open statement to specify the remote task to which you want to connect. In turn, the remote task issues an open statement to complete the logical link connection. A coordinated set of read and write operations enable the exchange of information over the link. To terminate the connection, the source task executes a close statement to break the logical link. When the remote task receives this close statement, it issues a close statement, which completes the link termination process. The remainder of this section discusses the statements that you would use to develop such an application.

Performing Network User Operations 8.7 Designing Tasks

Example 8-1 FORTRAN Task-to-Task Communication

```
PROGRAM TEST3.FOR
C
C This program prompts the user for the part number of an item
C in inventory and responds with the number of units in stock.
C The information is obtained by communicating with a program
C (TEST4) on another node that has access to the inventory data.
C
C Before running this program, the logical name TASK must be
C defined to refer to the target program. For example:
C
C $ DEFINE TASK "TRNTO:":""TASK=TEST4""
C $ RUN TEST3
C
CHARACTER PARTNO*5
INTEGER PARTCOUNT
C
100 FORMAT (/, '$Enter part number: ')
200 FORMAT (A)
300 FORMAT (I4)
400 FORMAT ('0Inventory for part number ',A,' is: ',I4)
C
C Establish a logical link with the target task.
C
1 OPEN (UNIT=1,NAME='TASK',ACCESS='SEQUENTIAL',
1 FORM='FORMATTED',CARRIAGECONTROL='NONE',TYPE='NEW')
C
C Prompt the user for a part number, send it to the target task,
C read reply of quantity on hand, and finally display the answer
C for the user. Repeat the cycle until the user enters 'EXIT' for
C a part number.
C
10 TYPE 100
ACCEPT 200, PARTNO
IF (PARTNO .EQ. 'EXIT') GOTO 20
2 WRITE (1,200) PARTNO
READ (1,300) PARTCOUNT
TYPE 400, PARTNO, PARTCOUNT
GOTO 10
C
C Disconnect the logical link.
C
20 3 CLOSE (UNIT=1)
END
C
$ !
$ ! *****
$ !
$ !
$ ! TEST4.COM
$ !
$ ! This command procedure executes the program TEST4 after
$ ! being started by a task-to-task connection request issued
$ ! by TEST3.
$ !
4 $ RUN SYS$LOGIN:TEST4.EXE
$ EXIT
```

(continued on next page)

Performing Network User Operations

8.7 Designing Tasks

Example 8-1 (Cont.) FORTRAN Task-to-Task Communication

```
PROGRAM TEST4.FOR
C
C   Test4 is the target program that communicates with TEST3.
C   For each part number received from the source task, the
C   number of units in stock is determined, and this value is
C   returned.
C
C   To complete the logical link with its initiator, this program
C   uses the logical name SYS$NET as the file specification in an
C   open statement.
C
C   CHARACTER PARTNO*5
C   INTEGER PARTCOUNT
C
C 100  FORMAT (A)
C 200  FORMAT (I4)
C
C   Complete the logical link connection.
C
C ⑤ OPEN (UNIT=1,NAME='SYS$NET',ACCESS='SEQUENTIAL',
C 1     FORM='FORMATTED',CARRIAGECONTROL='NONE',TYPE='OLD')
C
C   Process requests until end-of-file is reached. (This is the
C   error condition returned when the source task breaks the
C   logical link connection.)
C
C 10 ② READ  (1,100,END=20) PARTNO
C
C   Perform appropriate processing to obtain the part count value
C   and transmit this back to the source task.
C
C   CALL INSTOCK (PARTNO,PARTCOUNT)
C ② WRITE (1,200) PARTCOUNT
C   GOTO 10
C
C   Disconnect the logical link.
C
C 20 ③ CLOSE (UNIT=1)
C   END
```

Notes on Example 8-1

- ① The source task, TEST3, requests a logical link connection to the target task, TEST4.
- ② TEST3 and TEST4 send and receive data messages.
- ③ TEST3 disconnects the logical link and thereby terminates the communication process.
- ④ When the remote node receives a connection request, the command procedure TEST4.COM is executed. This command procedure must reside in the default directory associated with the account being accessed. TEST4.COM contains a RUN statement that causes the program TEST4.EXE to be executed.
- ⑤ TEST4 completes the logical link connection through SYS\$NET. The unit numbers in the source and target programs need not be the same.

Because system-dependent language calls are translated into a common set of DECnet messages, a task written in one language can communicate with another task written in a different language.

8.7.3 Programs for Nontransparent Task-to-Task Communication

Online program examples of nontransparent task-to-task communications are available on the system distribution medium. The example programs are named as follows:

- `SYS$EXAMPLES:DB_REQUESTER.C`
- `SYS$EXAMPLES:DB_SERVER.C`

File Operations in a Multivendor Network Environment

This chapter contains material to assist you in using DECnet for OpenVMS to initiate remote file operations in a multivendor network environment. This chapter discusses restrictions on using Digital Command Language (DCL) commands and RMS service calls to access files on the following types of remote systems:

- OpenVMS to IAS
- OpenVMS to RSTS/E
- OpenVMS to RSX using RMS-based FAL
- OpenVMS to RSX using FCS-based FAL
- OpenVMS to RT-11
- OpenVMS to TOPS-10
- OpenVMS to TOPS-20
- OpenVMS to MS-DOS
- OpenVMS to ULTRIX
- OpenVMS to IBM
- OpenVMS to OpenVMS

The chapter is organized by operating-system type: one section for each multivendor system with which your system running DECnet for OpenVMS may communicate. Each section describes differences in file system operation between the two systems and constraints on the use of OpenVMS file processing commands. The restrictions on the remote file operations you can perform from an OpenVMS node to a particular multivendor node result from file system design differences and DECnet implementation restrictions between the systems.

The appropriate section for each remote system itemizes the OpenVMS Record Management Services (RMS) features that are supported between DECnet for OpenVMS systems, but are not supported when accessing files on the multivendor system. The chapter also discusses limitations on the DCL commands that you can use when communicating with the remote node. Throughout this chapter, comments are provided to help you handle the differences in file system design.

9.1 DECnet for OpenVMS Restrictions

This section is a brief summary of OpenVMS RMS features that are not supported by DECnet for OpenVMS for remote file access. The list is not complete; it is meant only to highlight the more important differences between local and remote file access capabilities. For more complete information on this subject, refer to the description of the various RMS control blocks in the *OpenVMS Record Management Services Reference Manual*.

- The following OpenVMS RMS service calls are not supported for network use:

File Operations in a Multivendor Network Environment

9.1 DECnet for OpenVMS Restrictions

\$ENTER \$NXTVOL \$REMOVE

- The Terminal XAB is not supported for network operations; it is ignored.
- Protection XAB fields that support access control lists are ignored for network operations.
- Only one data stream per open file is allowed. That is, the multistream (MSE) bit option of the file sharing (SHR) field of the FAB is not supported for network use.
- Access to files on magnetic tapes mounted on a remote OpenVMS operating system is not supported. You can, however, copy files from a local magnetic tape to disk on a remote node.
- When multiple Allocation XABs are linked to the FAB, they must be in ascending order by area number (AID field). Similarly, when multiple Key Definition XABs are used, they must be in ascending order by key of reference (REF field).
- File protection information may not be completely preserved if the two nodes do not fully support each other's protection attributes. An example of this incompatibility occurs between the RSX-11M or RSX-11M-PLUS and OpenVMS operating systems. Although both RSX and OpenVMS nodes represent their protection masks as RWED, RSX nodes interpret that as Read, Write, Extend, and Delete, while OpenVMS nodes interpret RWED as Read, Write, Execute, and Delete. This results in the "E" protection field being unmappable between these two systems.
- The Journaling XABs are not supported.
- File monitoring is not supported.

9.2 OpenVMS to IAS Network Operation

This section pertains to an OpenVMS node communicating with an IAS node running DECnet-IAS Version 3.0. The discussion focuses on file operations initiated from the OpenVMS node to access remote files by means of FAL at the IAS node.

The restrictions described in the following subsections are related to incompatible features in file system design between the two operating systems.

9.2.1 File Formats and Access Modes

The following types of file and access method are not supported by the OpenVMS operating system when communicating with an IAS node:

- File organizations and record formats

Sequential	Stream (STM) Stream_CR (STMCR) Stream_LF (STMLF) Variable with fixed control (VFC) where fixed header size is not 2 bytes
Relative	All formats
Indexed	All formats

File Operations in a Multivendor Network Environment

9.2 OpenVMS to IAS Network Operation

- Record attributes
 - Print file carriage control (PRN)
- File access modes
 - Random access by relative record number
 - Random access by key value
 - Random access by record file address
 - Block I/O

You can copy a sequential file in VFC format from an OpenVMS node to an IAS node, provided the file has a 2-byte fixed header with a carriage control attribute other than print file. To transfer a file that has print file carriage control, such as batch log file, enter the following command:

```
$ CONVERT/FDL=VAR.FDL input-file output-file
```

The FDL control file VAR.FDL contains the following information:

```
FILE
      ORGANIZATION      sequential
RECORD
      FORMAT             variable
      CARRIAGE_CONTROL   carriage_return
```

The CONVERT command and associated FDL control file transforms the input file to variable-length format with implied carriage control and copies it to the remote node according to the output file specification.

9.2.2 OpenVMS RMS Interface

The following OpenVMS RMS features, supported between two OpenVMS OpenVMS nodes, are not supported between an OpenVMS node and an IAS node:

- OpenVMS RMS service calls
 - \$DELETE \$DISPLAY \$EXTEND \$FIND
 - \$FREE \$READ \$RELEASE \$RENAME
 - \$REWIND \$SPACE \$TRUNCATE \$UPDATE
 - \$WRITE
- RMS extended attribute blocks
 - Allocation XAB
 - Key Definition XAB
 - Summary XAB
- Significant fields and bit options of the FAB
 - CBT (contiguous-best-try) bit of FOP field
 - DEQ (default extend quantity) field

9.2.3 File Specifications

The general format of a file specification for naming a file on a remote IAS system is as follows:

```
node::device:[directory]name.type;version
```

File Operations in a Multivendor Network Environment

9.2 OpenVMS to IAS Network Operation

The following are major differences in syntax between file specifications used on IAS and on OpenVMS:

- IAS does not support dollar sign (\$), underscore (_), and hyphen (-) characters in file name components.
- IAS does not recognize the percent sign (%) as a valid wildcard character.
- The directory component of an IAS file specification cannot be a named directory list, such as [A.B.C]; it must be in UIC (user identification code) format, such as [100,3].
- The file name component has a maximum length of nine characters and the file type cannot exceed three characters. IAS systems return an error if you specify a longer file name or file type.
- IAS uses octal version numbers in file specifications whereas OpenVMS uses decimal version numbers.

9.2.4 DCL Considerations

Of the OpenVMS DCL commands that you can use over the network, the following are not supported between OpenVMS and an IAS node:

- ANALYZE/RMS_FILE
- BACKUP
- OPEN/WRITE
- RENAME

9.2.4.1 APPEND

Using the APPEND command, you are limited to appending one local input file to the output file residing on the IAS node.

9.2.4.2 COPY

The /EXTENSION and /PROTECTION qualifiers for the COPY command are not supported and are ignored if specified.

File creation date and time information is not preserved on a file copy operation to an IAS node where wildcards are used in the output file specification. Instead, the current date and time are used as the file creation date and time.

Because the IAS operating system uses octal version numbers in file specifications, an attempt to copy a file with a version number containing an 8 or 9 is rejected by the remote system, as shown in the following example:

```
$ COPY A.DAT;9 IAS::.*.*
%COPY-E-OPENOUT, error opening _IAS::A.DAT;9 as output
-RMS-F-FNM, error in file name
```

There are two ways to circumvent this problem. You can either specify an appropriate octal version number in the output file specification, or you can specify a null or zero version number in the output file specification to force highest version number processing on the remote node. This latter technique is particularly useful when several files are copied with one DCL command. For example:

```
$ COPY A.DAT;9 IAS::A.DAT;11
$ COPY B.DAT;28 IAS::.*.*;
$ COPY B.DAT;28 IAS::.*.*;0
$ COPY *.DAT IAS::.*.*;0
```

9.3 OpenVMS to RSTS/E Network Operation

This section pertains to an OpenVMS node communicating with a RSTS/E node running DECnet/E Version 3.0. The discussion focuses on file operations initiated from the OpenVMS node, to access remote files by means of FAL at the RSTS/E node.

The following restrictions are related to incompatible features in file system design between the two systems.

9.3.1 File Formats and Access Modes

The following types of file and access method are not supported by OpenVMS when communicating with a RSTS/E node:

- File organizations and record formats
 - Sequential Stream_CR (STMCR)
 - Stream_LF (STMLF)
 - Indexed All prologue 3 formats
 - With 64-bit binary (BN8) key types
 - With 64-bit integer (IN8) key types
 - With collating (COL) key types
 - With descending key types (DSTG, DIN2, DBN2, DIN4, DBN4, DIN8, DBN8, DPAC, DCOL)
- Record attributes
 - Attributes are compatible.
- File access modes
 - Random access by key value
 - Random access by record file address

DECnet/E does not support record mode access to indexed files; it supports only block I/O access to indexed files.

An attempt to access an indexed file located on a RSTS/E node in record mode results in an RMS-F-BUG_DAP error instead of an RMS-F-SUPPORT error.

9.3.2 OpenVMS RMS Interface

The following OpenVMS RMS features, supported between two OpenVMS nodes, are not supported between an OpenVMS node and a RSTS/E node:

- OpenVMS RMS service calls
 - \$DISPLAY \$EXTEND \$FREE \$RELEASE
 - \$RENAME \$SPACE \$TRUNCATE
- RMS extended attribute blocks
 - Allocation XAB
 - Key Definition XAB
 - Summary XAB
- Significant fields and bit options of the FAB
 - CBT (contiguous-best-try) bit of FOP field
 - DEQ (default extend quantity) field

File Operations in a Multivendor Network Environment

9.3 OpenVMS to RSTS/E Network Operation

9.3.3 File Specifications

The general format of a file specification for naming a file on a remote RSTS/E operating system is as follows:

node::device:[directory]name.type

The following are major differences in syntax between file specifications used on RSTS/E and on OpenVMS:

- RSTS/E does not support dollar sign (\$), underscore (_) and hyphen (-) characters in file name components, except for the special use of the dollar sign at the start of a file name.
- RSTS/E does not recognize the percent sign (%) as a valid wildcard character.
- The directory component of a RSTS/E file specification cannot be a named directory list, such as [A.B.C]; it must be in UIC (user identification code) format, such as [1,2]. RSTS/E operating systems, however, express UICs in decimal radix, whereas OpenVMS operating systems use octal numbers. On the RSTS/E operating system, the UIC is referred to as a PPN (project programmer number).

To access a RSTS/E file whose directory component in PPN format contains decimal digits, use the quoted string form of the file specification. For example:

```
$ TYPE RSTS::"SY:[9,18]TEST.DAT"
```

- The file name component has a maximum length of six characters and the file type cannot exceed three characters. If you specify a longer file name, RSTS/E truncates the name to six characters.
- RSTS/E does not support version numbers. It accepts a file specification containing a version number without returning an error, but ignores the version number.

9.3.4 DCL Considerations

Of the OpenVMS DCL commands that you can use over the network, the following are not supported between OpenVMS and a RSTS/E node:

- PURGE
- RENAME

9.3.4.1 APPEND

In using the APPEND command, you are limited to appending one local input file to an output file on the RSTS/E node.

9.3.4.2 COPY

The /EXTENSION and /PROTECTION qualifiers for the COPY command are not supported and are ignored if specified.

File creation date and time information is not preserved on a file copy operation to a RSTS/E node where wildcards are used in the output file specification. Instead, the current date and time are used as the file creation date and time.

Because RSTS/E does not support version numbers in file specifications (it ignores any version number supplied), an attempt to copy a file with an explicit version number fails if a file with the same name and type already exists at the RSTS/E node. For example, if a file with the name RSTS::TEST.DAT already exists on the

File Operations in a Multivendor Network Environment

9.3 OpenVMS to RSTS/E Network Operation

remote node, an attempt to update it by copying a new version of that file to the node produces the following results:

```
$ COPY TEST.DAT;2 RSTS::*.*
%COPY-E-OPENOUT, error opening _RSTS::TEST.DAT;2 as output
-RMS-E-FEX, file already exists, not superseded
```

9.3.4.3 DELETE

If you use the DELETE command with a wildcard file specification to delete several files from a directory on a remote RSTS/E node, the operation may appear to complete successfully even though some of the files may remain in the directory. This behavior is caused by a file system incompatibility in the way OpenVMS and RSTS/E perform wildcard file deletion operations. This problem occurs only if the remote directory has at least 30 files cataloged.

To determine if all the files you specify have been deleted successfully, enter a DIRECTORY command to examine the remote directory. Then repeat the wildcard DELETE command if necessary to remove unwanted files. If the number of files you are attempting to delete is small, using the /LOG qualifier with the DELETE command may help you to determine if all the files have been deleted.

9.3.4.4 DIRECTORY

When you enter a DIRECTORY/FULL command to examine a RSTS/E file, the information displayed differs from that displayed for an OpenVMS file, in the following respects:

- The file owner is displayed as [0,0] if the owner of the file is identified by a UIC that contains decimal digits.
- The file REVISION number shown is either 0 or 1. A REVISION number of 0 indicates the file has not been revised; a REVISION number of 1 indicates the file has been revised.
- Under the attributes of an indexed file, information about the number of keys, the number of areas, and the prologue version number of the file is not displayed. This information is omitted because RSTS/E FAL does not return file attribute information stored in the prologue portion of an indexed file.
- Under the attributes of a relative file, the maximum record number is displayed as 0.

9.3.4.5 DUMP/RECORDS and TYPE Commands

Because RSTS/E does not support record mode access (nonblock I/O access) to indexed files, you cannot use the DCL commands DUMP/RECORDS and TYPE to examine indexed files located on the remote RSTS/E node.

9.4 OpenVMS to RSX Network Operation Using RMS-based FAL

This section pertains to an OpenVMS node communicating with an RSX node running either DECnet-11M Version 4.0 or DECnet-11M-PLUS Version 2.0 where RSX File Access Listener (FAL) calls RMS-11 to perform local file operations. The discussion focuses on file operations initiated from the OpenVMS node, to access remote files by means of FAL at the RSX node.

The following restrictions are related to incompatible features in file system design between the two systems.

File Operations in a Multivendor Network Environment

9.4 OpenVMS to RSX Network Operation Using RMS-based FAL

9.4.1 File Formats and Access Modes

The following types of file and record attributes are not supported by OpenVMS when communicating with an RSX node running RMS-based FAL:

- File organizations and record formats
 - Sequential Stream_CR (STMCR)
 Stream_LF (STMLF)
 - Indexed All prologue 3 formats
 - With 64-bit binary (BN8) key types
 - With 64-bit integer (IN8) key types
 - With collating (COL) key types
 - With descending key types (DSTG, DIN2, DBN2, DIN4, DBN4, DIN8, DBN8, DPAC, DCOL)
- Record attributes
 - Record attributes are compatible.
- File access modes
 - Modes are compatible.

9.4.2 OpenVMS RMS Interface

The following OpenVMS RMS features, supported between two OpenVMS nodes, are not supported between an OpenVMS node and an RMS-based RSX node:

- OpenVMS RMS service call
 - \$RELEASE
- Significant fields and bit options of the FAB
 - CBT (contiguous-best-try) bit of FOP

9.4.3 File Specifications

The general format of a file specification for naming a file on a remote RSX-11M or RSX-11M-PLUS system is as follows:

node::device:[directory]name.type;version

The following are major differences in syntax between file specifications used on RSX and OpenVMS:

- RSX operating systems do not support dollar sign (\$), underscore (_) and hyphen (-) characters in file name components.
- The directory component in an RSX file specification cannot be a named directory list, such as [A.B.C]; it must be in UIC (user identification code) format, such as [15,1].
- The file name component has a maximum length of nine characters and the file type cannot exceed three characters. RSX operating systems return an error if you specify a longer file name or file type.
- RSX operating systems use octal version numbers in file specifications whereas the OpenVMS operating system uses decimal version numbers.

File Operations in a Multivendor Network Environment

9.4 OpenVMS to RSX Network Operation Using RMS-based FAL

9.4.4 DCL Considerations

Of the OpenVMS DCL commands that you can use over the network, OPEN /WRITE is not supported between OpenVMS and an RMS-based RSX node.

9.4.4.1 COPY

Because RSX-11M and RSX-11M-PLUS operating systems use octal version numbers in file specifications, an attempt to copy a file with a version number containing an 8 or 9 is rejected by the remote system. For example:

```
$ COPY A.DAT;9 RSX:.*.*
%COPY-E-OPENOUT, error opening RSX::A.DAT;9 as output
-RMS-F-FNM, error in file name
```

There are two ways to circumvent this problem. You can specify an appropriate octal version number in the output file specification, or you can specify a null or zero version number in the output file specification to force highest version number processing on the remote node. This latter technique is particularly useful when several files are copied with one DCL command. For example:

```
$ COPY A.DAT;9 RSX::A.DAT;11
$ COPY B.DAT;28 RSX:.*.*;
$ COPY B.DAT;28 RSX:.*.*;0
$ COPY *.DAT RSX:.*.*;0
```

9.5 OpenVMS to RSX Network Operation Using FCS-based FAL

This section pertains to an OpenVMS node communicating with an RSX node running DECnet-11M Version 4.0 or DECnet-11M-PLUS Version 2.0 where RSX FAL calls the File Control Services (FCS-11) to perform file operations. The discussion focuses on file operations initiated from the OpenVMS node to access remote files by means of FAL at the RSX node.

The following restrictions are related to incompatible features in file system design between the two systems.

9.5.1 File Formats and Access Modes

The following types of file and access method are not supported by OpenVMS when communicating with an RSX node running FCS-based FAL:

- File organizations and record formats
 - Sequential
 - Stream (STM)
 - Stream_CR (STMCR)
 - Stream_LF (STMLF)
 - Variable with fixed control (VFC) where fixed header size is not 2 bytes
 - Relative
 - All formats
 - Indexed
 - All formats
- Record attributes
 - Print file carriage control (PRN)
- File access modes
 - Random access by relative record number
 - Random access by key value
 - Random access by record file address

File Operations in a Multivendor Network Environment

9.5 OpenVMS to RSX Network Operation Using FCS-based FAL

Block I/O

You can copy a sequential file in VFC format from an OpenVMS node to an FCS-based RSX node, provided the file has a 2-byte fixed header with a carriage control attribute other than print file. To transfer a file that has print file carriage control, such as an OpenVMS batch log file, enter the following command:

```
$ CONVERT/FDL=VAR.FDL input-file output-file
```

The FDL control file VAR.FDL contains the following information:

FILE	ORGANIZATION	sequential
RECORD	FORMAT	variable
	CARRIAGE_CONTROL	carriage_return

The CONVERT command and associated FDL control file transform the input file to variable-length format with implied carriage control and then copy it to the remote node according to the output file specification.

9.5.2 OpenVMS RMS Interface

The following OpenVMS RMS features, supported between two OpenVMS nodes, are not supported between an OpenVMS node and an FCS-based RSX node:

- OpenVMS RMS service calls

\$DELETE	\$DISPLAY	\$EXTEND	\$FIND
\$FREE	\$READ	\$RELEASE	\$RENAME
\$REWIND	\$SPACE	\$TRUNCATE	\$UPDATE
\$WRITE			

- RMS extended attribute blocks

- Allocation XAB
 - Key Definition XAB
 - Summary XAB

- Significant fields and bit options of the FAB

- CBT (contiguous-best-try) bit of FOP field
 - DEQ (default extension quantity) field

9.5.3 File Specifications

The general format of a file specification for naming a file on a remote RSX-11M or RSX-11M-PLUS system is as follows:

```
node::device:[directory]name.type;version
```

The following are major differences in syntax between file specifications used on RSX and on OpenVMS:

- RSX operating systems do not support dollar sign (\$), underscore (_) and hyphen (-) characters in file name components.
- The directory component in an RSX file specification cannot be a named directory list, such as [A.B.C]; it must be in UIC (user identification code) format, such as [15,1].
- The file name component has a maximum length of nine characters and the file type cannot exceed three characters. RSX operating systems return an error if you specify a longer file name or file type.

File Operations in a Multivendor Network Environment

9.5 OpenVMS to RSX Network Operation Using FCS-based FAL

- RSX operating systems use octal version numbers in file specifications whereas OpenVMS uses decimal version numbers.

9.5.4 DCL Considerations

Of the OpenVMS DCL commands that you can use over the network, the following are not supported between OpenVMS and an FCS-based RSX node:

- ANALYZE/RMS_FILE
- BACKUP
- OPEN/WRITE
- RENAME

9.5.4.1 APPEND

In using the APPEND command, you are limited to appending one local input file to an output file residing on the FCS-based RSX node.

9.5.4.2 COPY

The /EXTENSION and /PROTECTION qualifiers for the COPY command are not supported and are ignored if specified.

File creation date and time information is not preserved on a file copy operation to an RSX node where wildcards are used in the output file specification. Instead, the current date and time are used as the file creation date and time.

Because RSX-11M and RSX-11M-PLUS operating systems use octal version numbers in file specifications, an attempt to copy a file with a version number containing an 8 or 9 is rejected by the remote system, as follows:

```
$ COPY A.DAT;9 RSX:.*.*
%COPY-E-OPENOUT, error opening RSX::A.DAT;9 as output
-RMS-F-FNM, error in file name
```

There are two ways to circumvent this problem. You can either specify an appropriate octal version number in the output file specification, or you can specify a null or zero version number in the output file specification to force highest version number processing on the remote node. This latter technique is particularly useful when several files are copied with one DCL command. For example:

```
$ COPY A.DAT;9 RSX::A.DAT;11
$ COPY B.DAT;28 RSX:.*.*;
$ COPY B.DAT;28 RSX:.*.*;0
$ COPY *.DAT RSX:.*.*;0
```

9.6 OpenVMS to RT-11 Network Operations

This section pertains to an OpenVMS node communicating with an RT-11 node running DECnet-RT Version 2.1. The discussion focuses on file operations initiated from the OpenVMS node, to access remote files by means of FAL at the RT-11 node.

File Operations in a Multivendor Network Environment

9.6 OpenVMS to RT-11 Network Operations

9.6.1 File System Constraints

The file systems used by RT-11 and OpenVMS are dissimilar in many respects. A fundamental difference between them involves the handling of file attribute information. When you create a file on an OpenVMS operating system, attribute information about the file is stored in a header block on disk for use when the file is subsequently opened. The implication is that the structure of an established file cannot change. In contrast, RT-11 does not save attribute information such as file format with a file; it expects you to provide this information when you open the file. File attribute information, however, is not an input to OpenVMS RMS when you open a file.

To provide transparent access to files on a remote RT-11 operating system, OpenVMS RMS restricts the types of file that you can create and open on the remote node. When you access an RT-11 file in record mode, OpenVMS RMS treats the file as having stream format. Block I/O access is permitted; the remote file is viewed as having fixed length 512 byte records where virtual block number is translated to relative record number.

9.6.1.1 File Formats and Access Modes

The following types of file and access method are not supported by OpenVMS when communicating with an RT-11 node:

- File organizations and record formats
 - Sequential
 - Fixed length (FIX) without implied carriage control
 - Stream_CR (STMCR)
 - Stream_LF (STMLF)
 - Variable length (VAR) without implied carriage control
 - Variable with fixed control (VFC)
 - Relative
 - All formats
 - Indexed
 - All formats
- Record attributes
 - FORTTRAN carriage control (FTN)
 - Print file carriage control (PRN)
 - None specified (embedded carriage control)
- Record access modes
 - Random access by relative record number
 - Random access by key value
 - Random access by record file address

For record mode access, the only file type in common between the two systems is a sequential file in STM (stream) format. For convenience, however, when you are transferring a file to an RT-11 node, OpenVMS RMS automatically converts an OpenVMS file with fixed or variable format and implied carriage control to a sequential file with stream format and embedded carriage control. This automatic conversion is performed during a file create operation, and OpenVMS RMS returns an alternate success code RMS\$_CVT_STM to indicate that the file format has been modified.

In addition, when a stream format file is retrieved from an RT-11 node, OpenVMS RMS automatically changes the record attribute from embedded carriage control to implied carriage control.

File Operations in a Multivendor Network Environment

9.6 OpenVMS to RT-11 Network Operations

In general, you can copy text files created by the SOS Editor without line numbers being saved or by the EDT Editor to an RT-11 operating system. OpenVMS batch log files and files created by the SOS Editor with line numbers intact, however, are stored in VFC format and cannot be copied to an RT-11 system in that form. To transfer this type of file, enter the following DCL command:

```
$ CONVERT/FDL=STM.FDL input-file output-file
```

The FDL control file STM.FDL contains the following information:

```
FILE
      ORGANIZATION      sequential
RECORD
      FORMAT            stream
      CARRIAGE_CONTROL  none
```

The CONVERT command and associated FDL control file transform the input file to stream format with embedded carriage control and copies it to the remote node according to the output file specification.

9.6.1.2 OpenVMS RMS Interface

The following OpenVMS RMS features, supported between two OpenVMS nodes, are not supported between an OpenVMS node and an RT-11 node:

- OpenVMS RMS service calls
 - \$DELETE
 - \$DISPLAY
 - \$EXTEND
 - \$FIND
 - \$FREE
 - \$RELEASE
 - \$RENAME
 - \$REWIND
 - \$SPACE
 - \$TRUNCATE
 - \$UPDATE
- RMS extended attribute blocks
 - Key Definition XAB
 - Summary XAB
- Significant fields and bit options of the FAB
 - ALQ (allocation quantity) field
 - DEQ (default extend quantity) field
 - CBT (contiguous-best-try) bit of FOP field
 - CTG (contiguous) bit of FOP field
 - SCF (submit command file) bit of FOP field
 - SPL (spool file) bit of FOP field
- Significant fields and bit options of the RAB
 - EOF (position to end of file) bit of ROP field

9.6.2 File Specifications

The general format of a file specification for naming a file on a remote RT-11 operating system is as follows:

```
node::device:name.type
```

The following are major differences in syntax between file specifications on RT-11 and OpenVMS:

- RT-11 does not support dollar sign (\$), underscore (_) and hyphen (-) characters in file name components.
- RT-11 does not recognize the percent sign (%) as a valid wildcard character.

File Operations in a Multivendor Network Environment

9.6 OpenVMS to RT-11 Network Operations

- RT-11 does not have a directory component in its file specification.
- The file name component has a maximum length of six characters and the file type cannot exceed three characters. If you specify a longer file name or file type, RT-11 returns an error.
- RT-11 does not support version numbers. Specification of a version number, however, is permitted when you refer to an RT-11 file, because OpenVMS RMS discards any version number before sending the file specified to RT-11 FAL.

9.6.3 DCL Considerations

Of the OpenVMS DCL commands that you can use over the network, the following are not supported between OpenVMS and an RT-11 node:

- ANALYZE/RMS_FILE
- APPEND
- BACKUP
- OPEN/WRITE
- PRINT/REMOTE
- PURGE
- RENAME
- SUBMIT/REMOTE

9.6.3.1 COPY

The /ALLOCATION, /CONTIGUOUS, /EXTENSION, and /PROTECTION qualifiers for the COPY command are not supported and are ignored if specified.

Using COPY to merge several files into a single output file is not supported.

RT-11 does not support version numbers in file specifications and supersedes files by default. Therefore, if you attempt to copy a file with the same name and type as one that already exists on the remote RT-11 node, the new file supersedes the old one. No warning message is displayed.

9.6.3.2 DELETE

The DCL command DELETE requires that you specify an explicit or wildcard version number in the file specification. However, because RT-11 does not accept a file specification containing a version number, OpenVMS RMS removes the version number before sending the file specification to the RT-11 operating system. To satisfy the requirements of both systems, specify a null version number in the file specification, as follows:

```
$ DELETE RT::TEST.DAT;
```

9.7 OpenVMS to TOPS-10 Network Operations

This section pertains to an OpenVMS node communicating with a TOPS-10 node running DECnet-10 Version 4.0. The discussion focuses on file operations initiated from the OpenVMS node, to access remote files by means of FAL at the TOPS-10 node.

File Operations in a Multivendor Network Environment

9.7 OpenVMS to TOPS-10 Network Operations

9.7.1 File System Constraints

The file systems used by TOPS-10 and OpenVMS are dissimilar in many respects. A fundamental difference between them involves the handling of file attribute information. When you create a file on an OpenVMS operating system, attribute information about the file is stored in a header block on disk for use when the file is subsequently opened. The implication is that the structure of an established file cannot change. In contrast, TOPS-10 does not save attribute information such as file format with a file; it expects you to provide this information when you open the file. File attribute information, however, is not an input to OpenVMS RMS when you open a file.

To provide transparent access to files on a remote TOPS-10 system, OpenVMS RMS restricts the types of file that you can create and open on the remote node. When you access a TOPS-10 file in record mode, OpenVMS RMS treats the file as having stream format.

9.7.1.1 File Formats and Access Modes

Because of differences in file system design, the following types of file and access method are not supported by OpenVMS when communicating with a TOPS-10 node:

- File organizations and record formats

Sequential	Fixed length (FIX) without implied carriage control
	Stream_CR (STMCR)
	Stream_LF (STMLF)
	Variable length (VAR) without implied carriage control
	Variable with fixed control (VFC)
Relative	All formats
Indexed	All formats
- Record attributes
 - FORTRAN carriage control (FTN)
 - Print file carriage control (PRN)
 - None specified (embedded carriage control)
- Record access modes
 - Random access by relative record number
 - Random access by key value
 - Random access by record file address
 - Block I/O

For record mode access, the only file type in common between the two systems is a sequential file in STM (stream) format. For convenience, however, when you are transferring a file to a TOPS-10 node, OpenVMS RMS automatically converts an OpenVMS sequential file with fixed or variable format and implied carriage control to a sequential file with stream format and embedded carriage control. This automatic conversion is performed during a file create operation, and OpenVMS RMS returns an alternate success code (RMS\$_CVT_STM) to indicate that the file format has been modified.

When a stream format file is retrieved from a TOPS-10 node, OpenVMS RMS automatically changes the record attribute from embedded carriage control to implied carriage control.

File Operations in a Multivendor Network Environment

9.7 OpenVMS to TOPS-10 Network Operations

In general, you can copy text files created by the TPU or the EDT Editor to a TOPS-10 operating system. OpenVMS batch log files, however, are stored in VFC format, and cannot be copied in that form to a TOPS-10 operating system. To transfer this type of file, enter the following DCL command:

```
$ CONVERT/FDL=STM.FDL input-file output-file
```

The FDL control file STM.FDL contains the following information:

```
FILE
  ORGANIZATION      sequential
RECORD
  FORMAT            stream
  CARRIAGE_CONTROL  none
```

The CONVERT command and associated FDL control file transform the input file to stream format with embedded carriage control and then copy them to the remote node according to the output file specification.

9.7.1.2 OpenVMS RMS Interface

The following OpenVMS RMS features, supported between two OpenVMS nodes, are not supported between an OpenVMS node and a TOPS-10 node:

- OpenVMS RMS service calls

```
$DELETE    $DISPLAY    $EXTEND    $FIND
$FREE      $READ       $RELEASE    $RENAME
$REWIND    $SPACE      $TRUNCATE  $UPDATE
$WRITE
```

- RMS extended attribute blocks

```
Allocation XAB
Key Definition XAB
Summary XAB
```

- Significant fields and bit options of the FAB

```
ALQ (allocation quantity) field
DEQ (default extend quantity) field
CBT (contiguous-best-try) bit of FOP field
```

9.7.1.3 File Specifications

The general format of a file specification for naming a file on a remote TOPS-10 operating system is as follows:

```
node::device:[directory]name.type
```

The following are the major differences in syntax between file specifications on TOPS-10 and on OpenVMS:

- The directory component of a TOPS-10 file specification is in PPN (project programmer number) format, such as [3655,7031], where the two numbers are in octal radix. The directory component can also be in extended PPN format containing up to five levels of subdirectories. An example of a directory component in extended PPN format is [10,20,A,B,C,D,E].

The OpenVMS operating system cannot parse directory components in PPN format (with numbers larger than 377 octal) or handle extended PPN formats containing subdirectories. The DECnet-10 implementation, however, does accept directory components using period (.) instead of comma (,) delimiters, and converts commas to periods when returning file

File Operations in a Multivendor Network Environment

9.7 OpenVMS to TOPS-10 Network Operations

specifications to OpenVMS operating systems. Consequently, when you enter a file specification for a remote TOPS-10 operating system, use the OpenVMS named directory list format for expressing TOPS-10 PPNs and extended PPNs. For example, use [3655.7031] or [10.20.A.B.C.D.E] to specify a directory component.

- The file name component has a maximum length of six characters and the file type cannot exceed three characters. If you specify a longer file name, TOPS-10 truncates the name to six characters.
- TOPS-10 does not support version numbers. It accepts a file specification containing a version number without returning an error, but ignores the version number.

9.7.2 DCL Considerations

Of the OpenVMS DCL commands that you can use over the network, the following are not supported between OpenVMS and a TOPS-10 node:

- ANALYZE/RMS_FILE
- APPEND
- BACKUP
- OPEN/WRITE
- RENAME

9.7.2.1 COPY

The /ALLOCATION and /EXTENSION qualifiers to the COPY command are not supported and are ignored if specified.

9.7.2.2 DIRECTORY

When you enter a DIRECTORY/FULL command to examine a TOPS-10 file, the information displayed differs in the following respects from that displayed for an OpenVMS file:

- The file owner is displayed as [0,0] to indicate that this information is not available.
- The file REVISION number is not shown and file REVISION date and time information is not available from the TOPS-10 operating system.
- The blocks used and blocks allocated values displayed, which indicate the size of the file, refer to 128-word pages (providing 640 bytes of storage), not 512-byte blocks.

9.8 OpenVMS to TOPS-20 Network Operations

This section pertains to an OpenVMS node communicating with a TOPS-20 node running DECnet-20 Version 3.0. The discussion focuses on file operations initiated from the OpenVMS node, to access remote files by means of FAL at the TOPS-20 node.

File Operations in a Multivendor Network Environment

9.8 OpenVMS to TOPS-20 Network Operations

9.8.1 File System Constraints

The file systems used by TOPS-20 and OpenVMS are dissimilar in many respects. A fundamental difference between them involves the handling of file attribute information. When you create a file on an OpenVMS operating system, attribute information about the file is stored in a header block on disk for use when the file is subsequently opened. The implication is that the structure of an established file cannot change. In contrast, TOPS-20 does not save attribute information such as file format with a file; it expects you to provide this information when you open the file. File attribute information, however, is not an input to OpenVMS RMS when a file is opened.

To provide transparent access to files on a remote TOPS-20 operating system, OpenVMS RMS restricts the types of file that you can create and open on the remote node. When you access a TOPS-20 file in record mode, OpenVMS RMS treats the file as having stream format. Although block I/O is supported by DECnet-20, it is not supported between OpenVMS and TOPS-20 because the block sizes are different.

9.8.1.1 File Formats and Access Modes

Because of differences in file system design, the following types of file and access method are not supported by OpenVMS when communicating with a TOPS-20 node:

- File organizations and record formats

Sequential	Fixed length (FIX) without implied carriage control
	Stream_CR (STMCR)
	Stream_LF (STMLF)
	Variable length (VAR) without implied carriage control
	Variable with fixed control (VFC)
Relative	All formats
Indexed	All formats
- Record attributes
 - FORTRAN carriage control (FTN)
 - Print file carriage control (PRN)
 - None specified (embedded carriage control)
- Record access modes
 - Random access by relative record number
 - Random access by key value
 - Random access by record file address
 - Block I/O

For record mode access, the only file type in common between the two systems is a sequential file in STM (stream) format. For convenience, however, when you are transferring a file to a TOPS-20 node, OpenVMS RMS automatically converts an OpenVMS sequential file with fixed or variable format and implied carriage control to a sequential file with stream format and embedded carriage control. This automatic conversion is performed during a file create operation, and OpenVMS RMS returns an alternate success code (RMS\$_CVT_STM) to indicate that the file format has been modified.

File Operations in a Multivendor Network Environment

9.8 OpenVMS to TOPS-20 Network Operations

When a stream format file is retrieved from a TOPS-20 node, OpenVMS RMS automatically changes the record attribute from embedded carriage control to implied carriage control.

In general, you can copy text files created by the TPU or the EDT Editor to a TOPS-20 operating system. OpenVMS batch log files, however, are stored in VFC format, and cannot be copied in that form to a TOPS-20 operating system. To transfer this type of file, enter the following DCL command:

```
$ CONVERT/FDL=STM.FDL input-file output-file
```

The FDL control file STM.FDL contains the following information:

FILE	ORGANIZATION	sequential
RECORD	FORMAT	stream
	CARRIAGE_CONTROL	none

The CONVERT command and associated FDL control file transform the input file to stream format with embedded carriage control and then copy it to the remote node according to the output file specification.

9.8.1.2 OpenVMS RMS Interface

The following OpenVMS RMS features, supported between two OpenVMS nodes, are not supported between an OpenVMS node and a TOPS-20 node:

- OpenVMS RMS service calls
 - \$DELETE
 - \$DISPLAY
 - \$EXTEND
 - \$FIND
 - \$FREE
 - \$READ
 - \$RELEASE
 - \$RENAME
 - \$REWIND
 - \$SPACE
 - \$TRUNCATE
 - \$UPDATE
 - \$WRITE
- RMS extended attribute blocks
 - Allocation XAB
 - Key Definition XAB
 - Summary XAB
- Significant fields and bit options of the FAB
 - ALQ (allocation quantity) field
 - DEQ (default extend quantity) field
 - CBT (contiguous-best-try) bit of FOP field
 - CTG (contiguous) bit of FOP field
- Significant fields and bit options of the RAB
 - EOF (p)

9.8.1.3 File Specifications

The general format of a file specification for naming a file on a remote TOPS-20 system is as follows

```
node::device<directory>name.type.version
```

The following are the major differences in syntax between file specifications on TOPS-20 and on OpenVMS:

- TOPS-20 uses angle brackets (<>) to delimit the directory string instead of square brackets ([]). To facilitate communication with TOPS-20, OpenVMS RMS recognizes angle brackets as valid directory component delimiters.

File Operations in a Multivendor Network Environment

9.8 OpenVMS to TOPS-20 Network Operations

- TOPS-20 uses the period (.) to delimit the version number instead of the semicolon (;). However, you can specify either a period or a semicolon because OpenVMS RMS converts a semicolon version number delimiter to a period before sending the file specification to TOPS-20 FAL.

9.8.2 DCL Considerations

Of the OpenVMS DCL commands that you can use over the network, the following are not supported between OpenVMS and a TOPS-20 node:

- ANALYZE/RMS_FILE
- APPEND
- BACKUP
- OPEN/WRITE
- RENAME

9.8.2.1 COPY

The /ALLOCATION, /CONTIGUOUS, /EXTENSION, and /PROTECTION qualifiers to the COPY command are not supported and are ignored if specified.

File creation date and time are not preserved during a file copy operation.

Using COPY to merge several files into a single output file is not supported.

9.8.2.2 DIRECTORY

When you use a DIRECTORY/FULL command to examine a TOPS-20 file, the information displayed differs in the following respects from that displayed for an OpenVMS file:

- The file owner is displayed as [0,0] to indicate that this information is not available.
- The file REVISION number is not shown.
- The blocks used and blocks allocated values displayed, which indicate the size of the file, refer to 128-word pages (providing 640 bytes of storage), not 512-byte blocks.
- TOPS-20 does not have the equivalent of world protection, so this attribute is displayed as a null string.

9.9 OpenVMS to MS-DOS Network Operations

This section pertains to an OpenVMS node communicating with an MS-DOS node. The discussion focuses on file operations initiated from the OpenVMS node, to access remote files by means of FAL at the MS-DOS node.

9.9.1 File System Constraints

The file systems used by MS-DOS and OpenVMS are dissimilar in many respects. A fundamental difference between them involves the handling of file attribute information. When you create a file on an OpenVMS operating system, attribute information about the file is stored in a header block on disk for use when the file is subsequently opened. The implication is that the structure of an established file cannot change. In contrast, MS-DOS does not save attribute information such as file format with a file; it expects you to provide this information when you open the file. File attribute information, however, is not an input to OpenVMS RMS when a file is opened.

File Operations in a Multivendor Network Environment

9.9 OpenVMS to MS-DOS Network Operations

To provide transparent access to files on a remote MS-DOS system, OpenVMS restricts the types of file that you can create and open on the remote node. When you access an MS-DOS file in record mode, OpenVMS RMS treats the file as having stream format.

9.9.1.1 File Formats and Access Modes

Because of differences in file system design, the following types of file and access method are not supported by OpenVMS when communicating with an MS-DOS node:

- File organizations and record formats
 - Sequential
 - Fixed length (FIX) without implied carriage control
 - Stream_CR (STMCR)
 - Stream_LF (STMLF)
 - Variable length (VAR) without implied carriage control
 - Variable with fixed control (VFC)
 - Relative
 - All formats
 - Indexed
 - All formats
- Record attributes
 - FORTTRAN carriage control (FTN)
 - Print file carriage control (PRN)
 - None specified (embedded carriage control)
- Record access modes
 - Random access by relative record number
 - Random access by key value
 - Random access by record file address

For record mode access, the only file type in common between the two systems is a sequential file in STM (stream) format. For convenience, however, when you are transferring a file to an MS-DOS node, OpenVMS RMS automatically converts an OpenVMS sequential file with fixed or variable format and implied carriage control to a sequential file with stream format and embedded carriage control. This automatic conversion is performed during a file create operation, and OpenVMS RMS returns an alternate success code (RMS\$_CVT_STM) to indicate that the file format has been modified.

When a stream format file is retrieved from an MS-DOS node, OpenVMS RMS automatically changes the record attribute from embedded carriage control to implied carriage control.

In general, you can copy text files created by the TPU or EDT Editor to an MS-DOS operating system. OpenVMS batch log files, however, are stored in VFC format, and cannot be copied in that form to an MS-DOS operating system. To transfer this type of file, enter the following DCL command:

```
$ CONVERT/FDL=STM.FDL input-file output-file
```

The FDL control file STM.FDL contains the following information:

```
FILE
      ORGANIZATION      sequential
RECORD
      FORMAT            stream
      CARRIAGE_CONTROL  none
```

File Operations in a Multivendor Network Environment

9.9 OpenVMS to MS-DOS Network Operations

The CONVERT command and associated FDL control file transform the input file to stream format with embedded carriage control and then copy it to the remote node according to the output file specification.

9.9.1.2 OpenVMS RMS Interface

The following OpenVMS RMS features, supported between two OpenVMS nodes, are not supported between an OpenVMS node and an MS-DOS node:

- OpenVMS RMS service calls
 - \$DELETE \$DISPLAY \$EXTEND \$FIND
 - \$FREE \$RELEASE \$RENAME \$REWIND
 - \$TRUNCATE \$UPDATE \$WRITE
- RMS extended attribute blocks
 - Allocation XAB
 - Key Definition XAB
 - Summary XAB
- Significant fields and bit options of the FAB
 - ALQ (allocation quantity) field
 - DEQ (default extend quantity) field
 - CBT (contiguous-best-try) bit of FOP field

9.9.1.3 File Specifications

The general format of a file specification for naming a file on a remote MS-DOS operating system is as follows:

```
node::"device:\directory\name"
```

The major difference in syntax between file specifications on MS-DOS and on OpenVMS is that the directory components of an MS-DOS file specification are in an incompatible format. For example:

```
\directory\
```

As a result, use quoted strings when you access these MS-DOS files from an OpenVMS operating system.

On MS-DOS-based systems, the FAL object accepts incoming requests using file specifications in OpenVMS syntax and maps those requests to file specifications for MS-DOS. For example:

```
$ DIRECTORY PC::[REPORT]
```

This directory specification is mapped to the following directory specification:

```
$ DIRECTORY PC::\report\*.*
```

MS-DOS file specifications are restricted to file names of eight characters, file extensions of three characters, and do not support version numbers.

9.9.2 DCL Considerations

Of the OpenVMS DCL commands that you can use over the network, the following are not supported between OpenVMS and an MS-DOS node:

- ANALYZE/RMS_FILE
- APPEND
- BACKUP

File Operations in a Multivendor Network Environment

9.9 OpenVMS to MS-DOS Network Operations

- OPEN/WRITE
- RENAME

9.9.2.1 COPY

The /ALLOCATION and /EXTENSION qualifiers to the COPY command are not supported and are ignored if specified.

9.9.2.2 DIRECTORY

When you enter a DIRECTORY/FULL command to examine an MS-DOS file, the information displayed differs in the following respects from that displayed for an OpenVMS file:

- The file owner identifier is displayed as [0,0] to indicate that this information is not available.
- The file ID identifier is displayed as NONE to indicate that this information is not available.
- The file attributes version limit identifier is displayed as 0 to indicate that this information is not available.
- The file REVISION number is not shown and file REVISION date and time information is not available from the MS-DOS operating system.

9.10 OpenVMS to ULTRIX Network Operations

This section pertains to an OpenVMS node communicating with an ULTRIX node running DECnet-ULTRIX. The discussion focuses on file operations initiated from the OpenVMS node, to access remote files by means of FAL at the ULTRIX node.

9.10.1 File System Constraints

The file systems used by ULTRIX and OpenVMS are dissimilar in many respects. A fundamental difference between them involves the handling of file attribute information. When you create a file on an OpenVMS operating system, attribute information about the file is stored in a header block on disk for use when the file is subsequently opened. The implication is that the structure of an established file cannot change. In contrast, ULTRIX does not save attribute information such as file format with a file; it expects you to provide this information when you open the file. File attribute information, however, is not an input to OpenVMS RMS when a file is opened.

To provide transparent access to files on a remote ULTRIX operating system, OpenVMS RMS restricts the types of file that you can create and open on the remote node. When you access an ULTRIX file in record mode, OpenVMS RMS treats the file as having STREAM_LF (STMLF) format.

9.10.1.1 File Formats and Access Modes

Because of differences in file system design, the following types of file and access method are not supported by OpenVMS when communicating with an ULTRIX node:

- File organizations and record formats
 - Sequential Fixed length (FIX) without implied carriage control

File Operations in a Multivendor Network Environment

9.10 OpenVMS to ULTRIX Network Operations

- | | |
|----------|--|
| | Stream_CR (STMCR) |
| | Stream (STM) |
| | Variable length (VAR) without implied carriage control |
| | Variable with fixed control (VFC) |
| Relative | All formats |
| Indexed | All formats |
- Record attributes
 - FORTRAN carriage control (FTN)
 - Print file carriage control (PRN)
 - None specified (embedded carriage control)
 - Record access modes
 - Random access by relative record number
 - Random access by key value
 - Random access by record file address
 - Block I/O

For record mode access, the only file type in common between the two systems is a sequential file in STMLF (STREAM_LF) format. For convenience, however, when you are transferring a file to an ULTRIX node, OpenVMS RMS automatically converts an OpenVMS sequential file with fixed or variable format and implied carriage control to a sequential file with stream format and embedded carriage control. This automatic conversion is performed during a file create operation, and OpenVMS RMS returns an alternate success code (RMS\$_CVT_STM) to indicate that the file format has been modified.

When a STREAM-LF format file is retrieved from an ULTRIX node, OpenVMS RMS automatically changes the record attribute from embedded carriage control to implied carriage control.

To transfer files that cannot be directly copied, enter the following DCL command:

```
$ CONVERT/FDL=STMLF.FDL input-file output-file
```

The FDL control file STMLF.FDL contains the following information:

```
FILE
      ORGANIZATION      sequential
RECORD
      FORMAT            Stream_LF
      CARRIAGE_CONTROL  none
```

The CONVERT command and associated FDL control file transform the input file to stream format with embedded carriage control and then copy it to the remote node according to the output file specification.

9.10.1.2 OpenVMS RMS Interface

The following OpenVMS RMS features, supported between two OpenVMS nodes, are not supported between an OpenVMS node and an ULTRIX node:

- OpenVMS RMS service calls

\$DELETE	\$DISPLAY	\$EXTEND	\$FIND
\$FREE	\$RELEASE	\$RENAME	\$REWIND
\$TRUNCATE	\$UPDATE		

File Operations in a Multivendor Network Environment

9.10 OpenVMS to ULTRIX Network Operations

- RMS extended attribute blocks
 - Allocation XAB
 - Key Definition XAB
 - Summary XAB
- Significant fields and bit options of the FAB
 - ALQ (allocation quantity) field
 - DEQ (default extend quantity) field
 - CBT (contiguous-best-try) bit of FOP field

9.10.1.3 File Specifications

The general format of a file specification for naming a file on a remote ULTRIX operating system is as follows:

node::name

The following are the major differences in syntax between file specifications on ULTRIX and on OpenVMS:

- No explicit device names are allowed. Instead, ULTRIX has a concept of special files.
- File names on ULTRIX are case sensitive (uppercase or lowercase).

Because of these differences, most accesses to an ULTRIX operating system require a foreign file specification. Without the foreign file specification syntax, the name is converted to uppercase by OpenVMS, and is then unlikely to match files on the ULTRIX operating system. The OpenVMS concepts of device and directory do not match the ULTRIX concept of path, nor does ULTRIX support separate file type or version fields. Therefore, OpenVMS-related name processing does not work with ULTRIX file names.

9.10.2 DCL Considerations

Of the OpenVMS DCL commands that you can use over the network, the following are not supported between OpenVMS and an ULTRIX node:

- ANALYZE/RMS_FILE
- BACKUP
- OPEN/WRITE
- RENAME

9.10.2.1 COPY

The /ALLOCATION and /EXTENSION qualifiers to the COPY command are not supported and are ignored if specified.

9.10.2.2 DIRECTORY

When you enter a DIRECTORY/FULL command to examine an ULTRIX file, the information displayed differs in the following respects from that displayed for an OpenVMS file:

- The file owner is displayed as [0,0] to indicate that this information is not available.
- The file REVISION number is not shown and file REVISION date and time information is not available from the ULTRIX operating system.

File Operations in a Multivendor Network Environment

9.11 OpenVMS to IBM Network Operations

9.11 OpenVMS to IBM Network Operations

This section pertains to an OpenVMS node communicating with an IBM MVS or an IBM VM operating system.

To perform file operations, you must install DECnet/SNA Data Transfer Facility server (VMS/DTF server) software on any OpenVMS system in a DECnet network containing a DECnet/SNA Gateway or on any OpenVMS system running VMS/SNA.

The node that is running the VMS/DTF server software is referred to as the server node. All DTF file requests go through this server node which communicates with the appropriate DTF for IBM system by using a DECnet/SNA Gateway or by using VMS/SNA software.

Install either or both of the following Digital products on the IBM system:

- DECnet/SNA Data Transfer Facility for IBM MVS (DTF for MVS). This software is installed on the MVS node.
- DECnet/SNA Data Transfer Facility for IBM VM (DTF for VM) software. This software is installed on the VM node.

You can install the optional DECnet/SNA Data Transfer Facility utilities (VMS/DTF utilities) software on any OpenVMS system where users wish to transfer files using the recoverable copy feature.

The following discussion focuses on file operations initiated from the OpenVMS node, to access remote files on the MVS or VM operating system.

The following sections provide an overview about which file operations are possible and which are not. For a more detailed discussion, refer to the DTF documentation set.

9.11.1 File System Constraints

The DECnet/SNA Data Transfer Facility (DTF) software causes IBM datasets to appear to the OpenVMS operating system as remote RMS files that you can access using RMS calls or utilities (such as COPY) that are layered upon RMS. The underlying differences in the file systems used by IBM and OpenVMS impose a number of constraints on accessing IBM files.

9.11.1.1 File Formats and Access Modes

Because of differences in file system design, the following types of file and access method are not supported by OpenVMS when communicating with an IBM operating system:

- File organization and record format
 - Sequential
 - Stream (STM)
 - Stream_CR (STMCR)
 - Stream_LF (STMLF)
 - Undefined (UDF)

File Operations in a Multivendor Network Environment

9.11 OpenVMS to IBM Network Operations

Variable with fixed control (VFC). When creating a dataset on the IBM system, you may specify VFC format if you also specify the record attribute PRINT CARRIAGE_CONTROL. When this dataset is subsequently opened by RMS, it has record format VARIABLE and a record attribute of CARRIAGE_RETURN CARRIAGE_CONTROL. If this dataset is copied back to an OpenVMS operating system, the resultant OpenVMS file has similar attributes; that is, the FAB\$C_VFC FAB\$V_PRN options are transformed to FAB\$C_VAR and FAB\$V_CR.

Relative	All formats
Indexed	All formats

- Record attributes

No carriage control. Specify either FAB\$V_CR, FAB\$V_FTN or FAB\$V_PRN when creating a dataset on the IBM system.

- Record access modes

Random access by relative record number
Random access by key value
Random access by record file address

IBM sequential files that reside on disk or tape are created using the following access methods:

- BSAM (Basic Sequential Access Method)
- QSAM (Queued Sequential Access Method)

These IBM sequential files appear to OpenVMS as RMS sequential files. Partitioned Dataset (PDS) members (MVS) also appear to OpenVMS as RMS sequential files. Supported VSAM file types include: ESDS, RRDS, and KSDS. For VM systems, normal CMS sequential files, as well as MACLIB files are supported. Refer to the DTF Software Product Description (SPD) for complete details on IBM file support.

Files that you cannot copy to or from the IBM operating system using the DCL COPY command, because of the previously mentioned constraints, can be copied using the DCL CONVERT command and a suitable FDL control file. The CONVERT command and associated FDL control file transform the input file to a format supported by the remote IBM system by the DTF software.

For record mode access, the only file organization in common between the two systems is a sequential file.

9.11.1.2 OpenVMS RMS Interface

The following OpenVMS RMS features, supported between two OpenVMS nodes, are not supported between an OpenVMS node and an IBM node:

- OpenVMS RMS service calls

\$ENTER	\$EXTEND	\$FLUSH	\$NXTVOL
\$READ	\$REMOVE	\$RENAME	\$SPACE
\$TRUNCATE	\$WAIT	\$WRITE	

- RMS extended attribute blocks

Protection XAB
Revision Date and Time XAB
Terminal XAB

File Operations in a Multivendor Network Environment

9.11 OpenVMS to IBM Network Operations

9.11.1.3 File Specifications

An example of the general format of a file specification for naming a dataset on the remote IBM operating system is as follows:

```
DTF-server-node"SNADTF"::"aaa.bbb.ccc.../qual1:val1/qual2:val2..."
```

or

```
DTF-server-node"SNADTF"::"aaa.bbb.ccc...(ddd)/qual1:val1/qual2:val2..."
```

9.11.2 DCL Considerations

Most of the OpenVMS DCL file manipulation commands that can be used over the network can be used to access datasets on an MVS or VM system. Any commands that use RMS features, detailed previously as unsupported, do not work, for example:

- LIBRARIAN
- LINK
- RENAME

9.12 OpenVMS to VMS Network Operations

This section pertains to file operations initiated on an OpenVMS node where the remote system is a VMS node running a version of DECnet VAX prior to Version 5.0.

The following type of file is not supported by an OpenVMS node when communicating with a VMS node running a version of DECnet VAX prior to Version 5.0:

- File organization and record format
 - Indexed With collating (COL) key type
 - With descending collating (DCOL) key type

Glossary

access control

Validating connect, login, or file-access requests to determine whether they can be accepted. User name and password provide the most common means of access control.

account name

A string that identifies a particular account used to accumulate data on a job's resource use. This name is the user's accounting charge number, not the user's UIC.

active component

A component whose operational state is other than OFF. You can use the word ACTIVE with the SHOW command to display information about active lines, circuits, nodes, and logging.

adjacent node

A node removed from the local node by a single physical line.

alias node identifier

An optional node name or address, common to some or all nodes in a VMSCluster, that permits the VMSCluster to be treated as a single node.

area

A group of nodes in a network that can run independently as a subnetwork.

area router

A level 2 router. An area router is capable of routing packets between areas as well as within its own area.

area routing

A technique for grouping the nodes in a network into areas for routing purposes. Routing in a multiple-area network is hierarchical, with one level of routing within an area (level 1 routing) and a second, higher level of routing between areas (level 2 routing).

asynchronous transmission

A mode of data transmission in which the time intervals between transmitted characters may be of unequal length. Asynchronous transmission most commonly occurs over terminal lines.

bandwidth

The range of frequencies assigned to a channel or system (that is, the difference expressed in Hertz between the highest and lowest frequencies of a band).

broadcast addressing

A special type of multicast addressing, in which all nodes are to receive a message.

broadcast circuit

A circuit on which multiple nodes are connected and on which a message can be transmitted to multiple receivers, for example, Ethernet or FDDI.

carrier sense

A signal provided by the Physical layer to indicate that one or more stations (nodes) are currently transmitting on the Ethernet channel.

Carrier Sense, Multiple Access with Collision Detect (CSMA/CD)

A medium access control technique used by the Ethernet. Allows multiple stations to access the broadcast channel at will, avoids contention by means of carrier sense and deference, and resolves contention by means of collision detection and retransmission.

CCITT

The International Telegraph and Telephone Consultative Committee. An international consultative committee that sets international communications usage standards.

channel

A means of transmission.

characteristics

A display type for the SHOW and LIST commands. It refers to static information about a component that is kept in either the volatile or permanent database. Such information may include parameters defined for that component by either the SET or DEFINE command.

circuit

Virtual communication path between nodes. Circuits operate over physical lines and are the medium on which all I/O occurs.

collision

Multiple transmissions overlapping in the physical channel, resulting in garbled data and necessitating retransmission.

collision detect

A signal provided by the Physical layer to the Data Link layer to indicate that one or more stations (nodes) are contending with the local station's transmission.

command node

The node from which an NCP command is entered.

component

An element in the network that can be controlled and monitored. Components include lines, circuits, nodes, modules, logging, and objects. Components form part of the NCP command syntax.

configuration database

The combination of both the permanent and the volatile databases. It consists of information about the local node, and all nodes, modules, circuits, lines, and objects in the network.

congestion loss

A condition in which data packets are lost when Routing is unable to buffer them.

control station

The node at the controlling end of a multipoint circuit. The control station controls the tributaries for that circuit.

cost

An integer value assigned to a circuit between two adjacent nodes. According to the routing algorithm, packets are routed on paths with the lowest cost.

counters

Performance and error statistics kept for a component, such as lines or nodes.

datagram

A unit of data sent over the network that is handled independently of all other units of data as far as the network is concerned. When a route header is added, a datagram becomes a packet.

designated router

A routing node on the broadcast medium selected to perform routing services on behalf of end nodes.

disconnect abort

A method by which nontransparent tasks can deaccess a logical link without deassigning the channel. This form of disconnection indicates to the receiver that not all messages sent have necessarily been received.

downline system load

A DECnet for OpenVMS function that allows an unattended target node to receive an operating system file image from another node.

downline task load

A function that allows a remote target node to receive an RSX-11S task from another node.

end node

A node that can receive packets addressed to it and send packets to other nodes, but cannot route packets through from other nodes. Also called a nonrouting node.

equal cost path splitting

The process by which a packet load is split for routing over multiple equal cost paths to a destination node.

event

A network or system-specific occurrence for which the logging component maintains a record.

event class

A particular classification of events. Generally, this classification follows the DNA architectural layers; some layers may contain more than one class. Class also includes the identification of system-specific events.

event type

A particular form of event that is unique within an event class.

executor node

The node at which a network management function is actually performed. The executor node is the local node unless a SET EXECUTOR NODE command has been issued.

handshaking sequence

The exchange of logical link connection information between two tasks. This exchange takes place to enable the successful completion of a logical link connection.

hardware address

For an Ethernet or FDDI device, the unique address associated with a particular communications controller. It is permanently stored in read-only memory on the communication controller.

hop

The logical distance between two nodes. One hop is the distance from one node to an adjacent node.

host node

For DECnet, a node that provides services for another node (for example, the host node supplies program image files for a downline load).

inbound connection

Refers to the fact that a task receives logical link connection requests.

interrupt message

During nontransparent task-to-task communication, a user-generated message sent outside the normal exchange of data messages. This usage of the term *interrupt* is contrary to the normal usage, which means to designate a software or hardware interrupt mechanism.

known component

The classification for one or more of the same components. This classification includes all active and inactive occurrences of the component type. For example, known nodes include all active and inactive nodes in the network.

level 1 router

A node that can send and receive packets, and route packets from one node to another, only within a single area.

level 2 router

A node that can send and receive packets, and route packets from one node to another, within its own area and between areas. Also known as an area router.

line

The network management component that provides a distinct physical data path.

load assist agent

An image that provides additional data required to perform a downline system load to a satellite node in a VMScluster.

local node

The node at which you are physically located.

logical link

A carrier of a single stream of full-duplex traffic between two user-level processes.

logging

The network management component that routes event data to a logging sink such as a console, monitor, or file.

logging console

A logging sink that is to receive a human-readable record of events. Typically, a logging console is a terminal, such as the operator console (OPA0), or a user-specified file.

logging file

A logging sink that is to receive a machine-readable record of events for later retrieval. The logging file is user defined.

logging monitor

A logging sink that is to receive a machine-readable record of events. Typically, the logging monitor is the operator communication (OPCOM) facility.

loop node

A local node that is associated with a particular line and is treated as if it were a remote node. All traffic to the loop node is sent over the associated line.

maximum visits

The maximum number of nodes through which a packet can be routed before reaching its destination.

module

A network management component.

multiaccess channel

A medium, such as FDDI or Ethernet, that is accessible to many stations.

multicast addressing

An addressing mode in which a given message packet is targeted to a group of logically related nodes.

multicast group address

An address assigned to a number of nodes on a broadcast circuit and used to send a message to all nodes in the group in a single transmission.

multipoint circuit

A circuit connecting two systems, with one of the systems (the control station) controlling the circuit, and the other system serving as a tributary.

network connect block (NCB)

For DECnet, a user-generated data structure used in a nontransparent task to identify a remote task and optionally send user data in calls to request, accept, or reject a logical link connection.

network status notifications

Notifications that provide information about the state of both logical and physical links over which two tasks communicate. A nontransparent task can use this information to take appropriate action under conditions such as third-party disconnections and a partner's exiting before I/O completion.

network task

A nontransparent task that is able to process multiple inbound connection requests; that is, it has declared a network name or object number.

node

A network management component that supports DECnet software.

node address

The required, unique, numeric identification of a specific node in the network.

node name

An optional alphanumeric identification associated with a node address in a strict one-to-one mapping. A node name must contain at least one alphabetic character.

nonprivileged

In DECnet for OpenVMS terminology, a process having no privileges other than NETMBX and TMPMBX. NETMBX is the minimal requirement for any network activity.

nonrouting node

An end node.

object

A DECnet for OpenVMS process that receives a logical link request. It performs a specific network function (a nonzero object such as FAL or NML), or is a user-defined image for a special-purpose application (a zero-numbered object).

outbound connection

Refers to the fact that a task sends logical link connection requests.

out-of-order packet caching

The mechanism by which the Network Services Protocol (NSP) maintains a buffer of data packets received out of order so that they can be reassembled in the correct order before being forwarded to the destination node.

packet

A unit of data to be routed from a source node to a destination node.

parameter

An entry in the volatile or permanent database for a network management component.

path

The route a packet takes from source to destination.

path cost

The sum of the circuit costs along a path between two nodes.

path length

The number of hops along a path between two nodes; that is, the number of circuits along which a packet must travel to reach its destination.

permanent database

A file containing information about network management components. The permanent database is maintained by NML and can be manipulated using the NCP commands DEFINE, LIST, and PURGE.

physical address

A string of six pairs of hexadecimal digits separated by hyphens. The value is the unique physical address that a node on a broadcast medium has set for itself or, if the node has not set a physical address, the hardware address associated with the node's broadcast medium device controller.

point-to-point circuit

A circuit that connects two nodes, operating over a single line.

polling

The activity that the control station performs with a multipoint circuit's tributaries to grant the tributaries permission to transmit.

privileged

In DECnet for OpenVMS terminology, a process having any user privileges other than NETMBX and TMPMBX.

protocol

An agreed set of rules governing the operation of a communications link.

proxy login

The procedure that permits a remote user to access a specific account at the local node, without supplying the user name and password.

reachable node

A node to which the local node has a usable communications path.

remote node

To any one node in the network, any other network node.

router

A node that can send and receive packets, and route packets from one node to another.

routing

The network function that determines the path along which data travels to its destination.

routing node

A router.

sink node

A node where logging sink types, such as a file or console, are actually located.

source task

The task that initiates a logical link connection request in a task-to-task communication environment.

state

The functions that are currently valid for a given component. States include line, circuit, local node, module, and logging.

status

A display type for the SHOW and LIST commands. Status refers to dynamic information about a component that is kept in either the volatile or permanent database.

substate

An intermediate circuit state that is displayed for a circuit state display by means of the SHOW or LIST command.

summary

The default display type for the SHOW and LIST commands. A summary includes the most useful information for a component, selected from the status and characteristics information.

synchronous disconnect

The disconnect that occurs when a nontransparent task issues a call to terminate I/O operations over a logical link without deassigning the channel. Thus, the task can use the channel for subsequent I/O operations with the same or a different remote task.

synchronous transmission

A mode of data transmission in which the time of occurrence of each signal representing a bit is related to a fixed time frame.

target node

The node that receives a memory image during a downline load; a node that loops back a test message.

target task

The task that receives and processes a logical link connection request in a task-to-task communication environment.

task

In this manual, refers to an image running in the context of a process.

task specifier

Information provided to complete a logical link connection to a remote task. This information includes the name of the remote node on which the target task runs and the name of the task itself.

terminal emulator

A program that acts as a transparent interface between two ports, making it appear as though a terminal on the local processor is directly connected to a remote processor.

tributary

A physical termination on a multipoint circuit that is not a control station.

tributary address

A numeric address that the control station uses to poll a tributary.

upline dump

A DECnet for OpenVMS function that allows an adjacent unattended node to dump its memory to a file on an OpenVMS operating system.

virtual circuit

An association between two nodes whereby the two nodes are able to interact as if a specific circuit were dedicated to them throughout the transmission. When a virtual circuit is established, a logical connection is established, with the actual physical circuits being allocated according to route availability, overload conditions, and other factors.

virtual terminal

A pseudodevice that connects a process to a physical terminal device. The virtual terminal can be disconnected from the physical terminal and reconnected later.

volatile database

A memory image that contains information about network management components. The volatile database is maintained by NETACP and can be manipulated using the NCP commands SET, SHOW, and CLEAR.

Index

A

Access

- network, 1-20
- remote file, 1-17, 8-1
- remote task, 1-19

Access control, 8-11, 8-12

- commands, 3-67
- default, 2-30
- default for inbound connection, 2-33
- default nonprivileged, 1-22
- default nonprivileged DECnet account, 2-33
- default privileged, 1-22
- for a network, 2-29
- for an object, 2-26
- for inbound connections, 2-32
- for logical links, 2-30
- for network applications, 1-21
- for outbound connections, 2-30
- for remote command execution, 2-33, 3-69
- for remote file access, 1-20
- for task-to-task communication, 1-20
- LOGINOUT image, 2-31, 8-12
- NML (network management listener)
 - privileges for, 3-68
- node level, 2-33, 3-70
- nonprivileged string, 2-31
- privileged string, 2-31
- proxy login, 1-22, 2-29, 2-34, 3-71
- routing initialization, 2-29
- setting default information, 3-68
- system level, 2-30, 3-68
- use of NONPRIVILEGED parameter, 3-68
- use of PRIVILEGE parameter, 3-68
- user authorization file (UAF), 8-12

ACCESS parameter

- for SET NODE command, 2-34, 3-70

Accounts

- DECnet, 2-25, 2-26, 5-3, 5-6
- default nonprivileged DECnet, 1-22, 1-23, 2-33
- FAL\$SERVER, 2-25, 5-3, 5-6
- MAIL\$SERVER, 2-25, 5-3, 5-6
- MIRROR\$SERVER, 2-25, 5-3, 5-6
- NML\$SERVER, 2-25, 5-3, 5-6
- PHONE\$SERVER, 2-26, 5-3, 5-6
- VPM\$SERVER, 2-26, 5-3, 5-6

ACNT privilege, 5-1

- ACP (ancillary control process), 5-1, 6-2
- ACTIVE BASE parameter, 3-32
- ACTIVE INCREMENT parameter, 3-32
- ADDRESS parameter, 3-3
 - for SET EXECUTOR command, 3-8, 3-50
 - for SET NODE command, 3-8

Addresses

- area number, 2-1, 3-7, 3-50
- broadcast, 1-6
- conversion of node address, 2-18, 3-50
- hardware, 2-2, 2-14
- multicast, 1-4, 1-6
- node, 2-1, 2-18
- physical, 1-6, 2-2, 2-14

Adjacent nodes, 1-1

- on Ethernet, 2-7

ALIAS MAXIMUM LINKS parameter, 3-56

- Alias node addresses, 1-11, 2-5, 2-26, 3-9, 8-8
- Alias node identifiers, 1-11, 2-5, 3-9 to 3-11, 8-8
 - enabling, 3-10
 - restrictions, 2-6, 8-8
 - setting, 3-10
 - specifying maximum logical links, 3-56
 - use with objects, 2-26, 3-60

Alias node names, 1-11, 2-5, 2-26, 3-9

Alias nodes

- See Alias node identifiers

Ancillary control process

- See ACP

AREA MAXIMUM COST parameter, 3-54

AREA MAXIMUM HOPS parameter, 3-54

Area routing, 1-2, 2-16

- advantages, 2-18
- concepts, 2-18
- limiting number of areas, 3-51

Areas, 1-2

- default number, 2-1, 3-7
- definition, 2-18
- number, 2-1, 2-17, 2-18, 3-7, 3-50
- path control parameters, 3-54

ASSISTANT PHYSICAL ADDRESS parameter, 7-11

Asynchronous circuits, 1-3

- See also Circuits

Asynchronous connections
 correcting insufficient receive buffers, 3-42
 DDCMP, 1-9
 dynamic, 1-3, 1-7, 1-9
 dynamic line installation, 2-14, 5-14
 line installation, 5-12
 line parameters, 3-45
 static, 1-3, 1-7, 1-9
 static line installation, 2-13, 5-12

Asynchronous lines, 1-3

 See also Lines

AUTO prefix, 3-29

AUTOGEN utility, 5-31

B

Babble timer, 3-32

Base priority of circuit, 3-32

Bootstraps
 primary, 4-4, 4-11
 ROM, 4-4

Broadcast addresses, 1-6

Broadcast routing timer, 2-24

BROADCAST ROUTING TIMER parameter, 3-55

BUFFER SIZE parameter
 for executor, 3-14
 for line, 3-41

Buffer sizes
 changing for executor, 3-15
 decreasing, 3-15
 for executor, 2-4
 for line, 3-14, 3-41
 increasing, 3-15
 requirements, 3-15
 setting for executor, 3-14

BYPASS privilege, 5-1

C

Carrier Sense Multiple Access with Collision Detect
 See CSMA/CD

Carrier sense on Ethernet, 1-5

Central processing units
 See CPUs

Channels, 1-4, 1-7, 8-11
 assigning for logical link, 8-11, 8-20, 8-32
 deassignment of, 8-14, 8-19
 _NET:, 8-25

CHARACTERISTICS display type, 3-73

Checkpointing RSX-11S tasks, 4-18

CI (computer interconnect)
 as DECnet line, 5-11
 as VAXcluster connector, 1-10
 as VAXcluster data link, 1-10, 2-21
 cable, 1-10
 circuit, 2-6

CI (computer interconnect) (cont'd)
 circuit device, 2-10
 configuration, 1-3
 controller, 2-10
 driver, 2-10
 end node, 2-21
 end node backup circuit, 2-21, 3-55
 line, 2-11
 line device, 2-14
 node addressing, 3-26
 router, 2-21

CI-750 device, 2-10

CI-780 device, 2-10

CIBCA device, 2-10

CIBCI device, 2-10

Circuit-level loopback tests, 7-1
 LAN (local area network), 7-9

Circuits, 1-1, 1-17
 asynchronous DDCMP devices, 2-12, 5-12
 CI, 2-6
 commands, 3-24
 cost, 2-22, 3-51
 counters, 3-35
 database, 3-1
 DDCMP, 1-8, 2-6, 3-26
 definition, 2-6
 determining cost, 3-51
 device name, 3-24
 dynamic asynchronous, 2-8
 Ethernet, 1-4, 3-26
 FDDI, 3-26
 identification, 3-24, 3-26
 LAN, 2-6, 3-26
 loopback test, 7-6
 multiaccess, 2-7
 multipoint control, 2-6
 multipoint tributary, 2-6
 name, 2-7
 parameters, 3-26
 point-to-point, 2-6
 polling, 3-31
 service, 4-2
 service operations, 3-29
 setting base priority, 3-32
 state, 2-7, 3-28
 static asynchronous, 1-9
 synchronous DDCMP, 1-3, 2-7, 2-12
 timers, 3-29
 types, 3-26
 verification, 3-30
 virtual, 1-4, 1-8

Circuits and line devices
 FZA, 2-11
 MFA, 2-11

CLEAR EXECUTOR command, 3-14

CLEAR NODE command, 3-14, 7-4

- CMKRNL privilege, 5-1
- CNDRIVER DECnet driver
 - using over a CI, 5-3, 5-11
- Codes
 - system service status return, 8-19, 8-31
- Collision detects
 - Ethernet, 1-5
- Command procedures, 8-4, 8-39
 - example for task-to-task operations, 8-39
 - for object, 3-61
 - for starting object, 8-39
 - identification, 3-61
 - NETCONFIG.COM
 - dialog, 5-7e
- Command terminals, 8-1
- Communications
 - task-to-task, 1-2, 1-17, 8-1
- Component names
 - plural forms, 3-74
- Components, 3-1
- Computer interconnect
 - See CI
- Configuration databases, 2-1, 3-1, 5-20
 - circuit entry, 2-7
 - DECnet, 1-14, 3-1
 - line entry, 2-11
 - logging entry, 2-28
 - node entry, 2-1, 3-5
- Configurator module
 - disabling surveillance, 3-35
 - enabling surveillance, 3-34
 - Ethernet, 1-17, 2-11, 3-34
 - NICONFIG, 1-12
- Configuring
 - a DDCMP dynamic asynchronous network, 5-29
 - a DDCMP multipoint network, 5-25
 - a DDCMP point-to-point network, 5-23
 - a DDCMP static asynchronous network, 5-27
 - a DECnet node, 1-14
 - a multiple-area network, 1-2
 - a single-area network, 1-2
 - an Ethernet network, 5-20
 - an FDDI network, 5-21
 - CI, 1-3
 - end nodes, 2-18
 - Ethernet, 1-4
 - FDDI, 1-3, 1-6
 - guidelines for system, 5-31 to 5-35
 - introduction to NETCONFIG.COM, 1-14
 - introduction to NETCONFIG_UPDATE.COM, 1-14
 - LAN (local area network), 1-3
 - multipoint, 1-3, 1-8
 - network, 1-3, 5-1
 - overview of procedures, 5-3
 - point-to-point, 1-3, 1-8
 - Configuring (cont'd)
 - prerequisites, 5-1
 - procedure examples, 5-19 to 5-35
 - procedure for automatic, 5-5 to 5-11
 - required privileges, 5-1
 - routing considerations, 2-15
 - sample Phase IV DECnet, 1-4
 - typical VMScluster, 1-10
 - using NETCONFIG.COM, 5-5 to 5-11
 - CONNECT NODE command, 4-19
 - PHYSICAL ADDRESS parameter, 4-19
 - SERVICE PASSWORD parameter, 4-19
 - VIA parameter, 4-19
 - CONNECT VIA command, 4-19
 - Control stations, 1-8, 2-8
 - Controller loopback tests, 7-6, 7-8
 - Controlling
 - line traffic, 3-41
 - logical link activity, 2-24, 3-56
 - tributaries, 3-31
 - COPY KNOWN NODES command, 3-17
 - FROM parameter, 3-18
 - TO qualifier, 3-18
 - USING qualifier, 3-18
 - WITH CLEAR qualifier, 3-18
 - WITH PURGE qualifier, 3-18
 - Copying node database, 1-14, 2-5, 3-17, 3-21
 - COST parameter
 - for circuit, 3-51
 - Costs
 - circuit, 3-51
 - control for circuit, 2-22
 - definition, 2-21
 - determining for circuit, 3-51
 - equal cost path splitting, 2-22, 3-53
 - COUNTER TIMER parameter
 - for circuit, 3-36
 - for executor, 3-21
 - for node, 3-21
 - Counter timers, 3-21
 - Counters
 - circuit, 3-35
 - line, 3-48
 - logging, 3-21
 - node, 3-21
 - zeroing, 3-21
 - COUNTERS display type, 3-73
 - CPUs (central processing units)
 - identification for downline load, 4-10
 - time requirements, 5-32
 - CSMA/CD (Carrier Sense Multiple Access with Collision Detect), 1-5
 - access control, 1-4
 - CXY08 device, 2-7

D

Data Link layer

control, 2-4

Databases

circuit, 3-1

clearing or purging before copying node entries,
3-18

copying node, 1-14, 2-5, 3-17, 3-21

DECnet, 1-14

line, 3-1

logging, 3-1

module, 3-1

node, 3-1

object, 3-2

permanent, 1-13, 3-2, 5-34

volatile, 1-13, 3-2

Datagrams

Ethernet, 1-4

DCL commands, 1-18

DDCMP, 1-3

asynchronous, 1-3, 1-7, 2-12, 3-25, 5-12

asynchronous line, 1-4, 3-37

circuit, 2-6, 3-24, 3-26

configuration, 1-7

CONTROL line, 3-37

DMC line, 3-37

dynamic asynchronous network configuration,
5-29

formula for determining maximum number of
messages, 3-44

line, 2-11, 3-38

lines

receive buffers, 3-42

MOP, 4-11

multipoint, 1-8

multipoint network configuration, 5-25

multipoint tributary addressing, 3-25

POINT line, 3-37

point-to-point, 1-8

point-to-point addressing, 3-25

protocol, 1-8

static asynchronous network configuration,
5-27

synchronous, 1-3, 1-7, 2-7, 2-12

synchronous devices, 1-8

synchronous line, 1-4

synchronous point-to-point network
configuration, 5-23

TRIBUTARY line, 3-37

DEAD THRESHOLD parameter, 3-31

Dead timer, 3-43

DEBNA Ethernet device, 2-10

DEBNI Ethernet device, 2-10

DECdns

clerk, 3-23

DECnet use of, 3-22

DECdns (cont'd)

startup, 3-23

DECnet

See also Default nonprivileged DECnet accounts

configuration, 1-2

configuration database, 1-12

configuration prerequisites, 5-1

functions, 1-2

host services, 1-2, 1-12

license, 2-17

node, 2-1

over terminal lines, 5-11

over the CI, 5-11

software, 1-12

startup, 3-23

DECnet account

enabling default access, 2-25, 2-26, 5-3, 5-6

DECnet for OpenVMS

See DECnet

DECnet for OpenVMS licenses, 1-12

end node kit, 1-12, 6-1

full function kit, 1-12, 6-1

registering the key, 1-12, 5-7, 6-1

DECSA (Digital Ethernet Communications Server)

connection to remote console, 4-18

Default access, 5-3

DEFAULT ACCESS parameter, 2-34, 3-70

Default nonprivileged DECnet accounts

DECnet, 2-25, 2-26, 5-3, 5-6

example, 5-7

FAL\$SERVER, 2-25, 5-3, 5-6

MAIL\$SERVER, 2-25, 5-3, 5-6

MIRRO\$SERVER, 2-25, 5-3, 5-6

NML\$SERVER, 2-25, 5-3, 5-6

PHONE\$SERVER, 5-3, 5-6

use in access control, 2-33, 3-68

using NETCONFIG_UPDATE.COM, 5-10

VPM\$SERVER, 2-26, 5-3, 5-6

DEFINE OBJECT command

OUTGOING CONNECT PRIVILEGES

parameter, 3-69

DEFZA Ethernet device, 2-10

DEFZA FDDI device, 2-11

Delay timer, 3-43

DELQA Ethernet device, 2-10

DELUA Ethernet device, 2-10

DEMFA Ethernet device, 2-10

DEMFA FDDI device, 2-11

DEMNA Ethernet device, 2-10

DEQNA Ethernet device, 1-4, 2-10

Designated routers

See LANs (local area networks)

DESQA Ethernet device, 2-10

DESVa Ethernet device, 2-10

DETACH privilege, 5-1

- DEUNA Ethernet device, 1-4, 2-10
 - Devices
 - CI circuit, 2-10
 - DDCMP circuit, 2-7
 - DMC11, 1-9
 - DMF32, 1-9
 - DMP11, 1-9
 - DMR11, 1-9
 - DZ11, 1-9
 - Ethernet circuit, 2-10
 - FDDI circuit, 2-11
 - FDDIline, 2-14
 - LAN, 2-14
 - DHB32 device, 2-7
 - DHT32 device, 2-7
 - DIAGNOSE privilege, 5-2
 - Dialup lines, 5-12
 - Digital data communications message protocol
 - See DDCMP
 - Digital Distributed Name Service
 - See DNS
 - Digital Ethernet Communications Server
 - See DECSA
 - Digital Network Architecture
 - See DNA
 - DISCONNECT LINK command, 3-56
 - Disconnecting a logical link, 8-14
 - abort, 8-14, 8-30
 - synchronous, 8-14
 - Display types
 - CHARACTERISTICS, 3-73
 - COUNTERS, 3-73
 - EVENTS, 3-73
 - STATUS, 3-73
 - SUMMARY, 3-73
 - DIV32 device, 2-7
 - DMC11 device, 1-9, 2-7
 - DMF32 device, 1-9, 2-7
 - DMP11 device, 1-9, 2-7
 - DMR11 device, 1-9, 2-7
 - DMV11 device, 2-7
 - DNA (Digital Network Architecture)
 - layers, 1-3
 - protocols, 1-3
 - DNS
 - See DECDns
 - Downline system loads
 - definition, 4-1
 - load requirements, 4-4
 - network example, 5-23
 - operator-initiated, 4-1, 4-5
 - over a LAN, 4-5
 - over DDCMP circuit, 4-5
 - target-initiated, 4-2
 - unattended systems, 4-1
 - Downline task loads, 4-14
 - DSB32 device, 2-7
 - DSF32 device, 2-7
 - DSH32 device, 2-7
 - DST32 device, 2-7
 - DSV11 device, 2-7
 - DUMP ADDRESS parameter, 4-11
 - Dump assistance multicast address, 4-13
 - DUMP COUNT parameter, 4-11
 - DUMP FILE parameter, 4-11
 - Dumping unattended system memory, 4-11
 - Duplex mode, 3-42, 3-43
 - DUPLEX parameter, 3-42, 3-43
 - DYING BASE parameter, 3-32
 - DYING INCREMENT parameter, 3-32
 - DYING THRESHOLD parameter, 3-31
 - Dynamic asynchronous circuits, 2-8
 - use of VERIFICATION INBOUND parameter, 3-31, 3-67
 - Dynamic asynchronous connections, 1-3, 1-7
 - network configuration, 5-29
 - password, 2-29
 - reasons for failure, 5-18
 - Dynamic asynchronous lines, 1-9, 2-14, 5-12
 - installing, 5-14
 - shutting down, 5-19
 - use of HANGUP parameter, 3-45
 - use of LINE SPEED parameter, 3-45
 - use of SWITCH parameter, 3-45
 - Dynamic switching
 - manual switching of line, 5-17
 - procedure for line, 2-14
 - setting up lines, 5-15
 - DYNSWITCH image, 5-17
 - installing, 5-15
 - DZ11 device, 1-9
- ## E
-
- End nodes, 1-1, 1-12
 - caching on Ethernet, 2-20
 - configuration, 2-18
 - DECnet for OpenVMS license kit, 1-12, 6-1
 - definition, 2-15
 - LAN, 1-7, 2-19
 - non-LAN, 1-7
 - on VMScluster, 1-10
 - Phase IV, 2-17
 - reverse path caching, 2-20
 - Equal cost path splitting, 2-22, 3-53
 - Error messages
 - HLD, 4-17
 - loopback testing, 7-7
 - Error reporting, 8-19, 8-31
 - system service status, 8-19, 8-31
 - Ethernet, 1-4
 - See also LANs (local area networks)
 - broadcast address, 1-6

Ethernet (cont'd)

- cable, 1-4
- carrier sense, 1-5
- characteristics, 1-4
- circuit, 1-4
- circuit device, 2-10
- configuration, 1-4
- configurator module, 1-12, 1-17, 2-11, 3-34
- data rate, 1-4
- datagrams, 1-4
- hardware address, 3-46
- line parameters, 3-46
- line protocol, 3-37
- multiaccess, 1-4
- multicast address, 1-6
- network configuration, 5-20
- node, 1-4
- packets, 1-5
- physical address, 1-6
- protocol, 1-4
- service operations, 3-29
- specification, 1-4
- topology, 1-4

Event logger

See EVL

Event logging

example, 3-65

Events

- class, 3-63
- definition, 2-28
- identification of, 3-63
- identifying location of, 3-65
- identifying source for, 3-64
- list, 2-28
- sink-related, 2-28
- source-related, 2-28
- type, 3-63

EVENTS display type, 3-73

EVL (event logger), 1-12, 2-25, 2-28

Executor nodes, 2-1, 4-1

commands, 3-5

F

FAL (file access listener), 1-12, 2-25

FAL\$SERVER account

default access, 2-25, 5-3, 5-6

FAL\$SERVER account

enabling default access, 2-25, 2-26, 5-3, 5-6

FDDI

See also LANs (local area networks)

FDDI (Fiber Distributed Data Interface), 1-6

asynchronous data transmission in, 1-7

circuit, 1-3

circuit device, 2-11

circuit identification, 3-26

circuit parameters, 3-33

configuration, 1-3, 1-6

FDDI (Fiber Distributed Data Interface) (cont'd)

Data Link layer, 1-6

line device, 2-14

line protocol, 3-37

Logical Link Control sublayer, 1-6

Media Access Control sublayer, 1-6, 1-7

network configuration, 5-21

ring operation, 1-7

specification, 1-6

token passing, 1-7

Fiber Distributed Data Interface

See FDDI

File access

over network, 1-2

remote, 1-17

File access listener

See FAL

FILE parameter

for DECnet command procedure, 3-61

Files

default access control, 1-20

logical name in specification, 1-24

manipulation over the network, 1-17

specification, 1-19

specification access control string, 1-20

specification over the network, 1-20

FROM parameter

COPY KNOWN NODES command, 3-18

G

Guidelines

for system configuration, 5-31 to 5-35

H

HANGUP parameter, 3-45

HARDWARE ADDRESS parameter, 4-7

Hardware addresses

See Physical addresses

Hardware loopback device, 7-6

Hello timer, 3-29

HELP parameter

use with LOOP CIRCUIT command, 7-11

Higher-level language statements, 1-18

HLD (host loader), 1-13, 2-25, 4-14

mapping table, 4-16

HLDTB\$ macro

mapping table, 4-16

HNODE\$ macro

target node, 4-16

Hops

routing term, 2-21

Host loader

See HLD

Host services
 DECnet, 1-2, 1-12, 4-1
 HTASK\$ macro, 4-16

I

IAS nodes, 9-2
IDENTIFICATION parameter
 for local node, 3-8
Identifying
 circuits, 3-24
 events, 3-63
 lines, 3-36
 node address, 2-2, 3-7
 node name, 2-2, 3-7
 objects, 3-59
INACTIVE BASE parameter, 3-32
INACTIVE INCREMENT parameter, 3-32
INACTIVE THRESHOLD parameter, 3-31
INACTIVITY TIMER parameter, 3-57
Inbound logical link connections, 1-21
INBOUND parameter, 3-70
INCOMING PROXY parameter, 2-35, 3-71
INCOMING TIMER parameter, 3-57
Initializing
 DDCMP node, 1-8
 Ethernet node, 1-4
 Phase III node, 2-29
Installing
 DECnet for OpenVMS license, 6-1
 network, 6-1

K

Keys
 DECnet for OpenVMS license, 1-12, 2-17
KFE52 Ethernet device, 2-10

L

LANs (local area networks)
 multicast address definition, 2-3
LANs (local area networks), 1-3
 See also Ethernet
 See also FDDI
 adjacent node, 2-7
 broadcast routing timer, 3-55
 circuit, 1-3, 2-6, 2-7, 3-26
 circuit identification, 3-26
 circuit parameters, 3-33
 configuration, 1-3
 data link for VMScluster, 1-10
 designated router, 1-7, 2-15, 2-19, 3-33
 downline system load, 4-5
 dump assistance multicast address, 4-13
 end node, 1-7, 2-19, 3-33
 end node caching, 2-20
 hardware address, 7-9

LANs (local area networks) (cont'd)
 limiting end nodes, 3-51
 limiting routers, 3-50
 line, 2-11
 line device, 2-14
 loopback tests, 7-9
 physical address, 4-5, 7-9
 router, 1-7, 2-19, 3-33
 upline memory dump, 4-13
LEF (local event flag) state, 8-18
LES ancillary control process
 See LES\$ACP
LES\$ACP (LES ancillary control process), 1-13
Level 1 routers, 1-2, 2-15, 2-17
Level 2 routers, 1-2, 2-15, 2-17
LIB\$ASN_WTH_MBX library routine, 8-13, 8-25
License Management Facility
 See LMF
Licenses
 See DECnet for OpenVMS licenses
LINE SPEED parameter, 3-45
Lines, 1-1
 buffer size, 3-41
 buffers for DDCMP line, 3-42
 CI, 2-11
 commands, 3-36
 counters, 3-48
 database, 3-1
 DDCMP, 2-11
 definition, 2-11
 device name, 3-36
 dialup, 5-12
 dynamic asynchronous, 1-9, 2-14, 5-12
 dynamic switching, 2-14
 Ethernet, 3-46
 identification, 3-36
 installing dynamic asynchronous, 5-14
 installing static asynchronous, 5-12
 LAN, 2-11
 LAPB, 3-37
 LAPBE, 3-37
 multipoint, 2-12
 name, 2-12
 operational state, 3-41
 parameters, 3-38
 point-to-point, 2-12
 protocol, 3-37
 state, 2-12
 static asynchronous, 1-9, 2-13, 5-12
 synchronous DDCMP, 1-3
 terminal, 1-9
 timers, 3-43
 types, 3-38

Links
 See Logical links

- LIST command, 3-72
- LMF
 - installing DECnet for OpenVMS license, 6-1
- Load assist agent, 4-10
- LOAD ASSIST AGENT parameter, 4-10
- LOAD ASSIST PARAMETER parameter, 4-10
- LOAD NODE command, 4-2, 4-6
 - LOAD ASSIST AGENT parameter, 4-10
 - LOAD ASSIST PARAMETER parameter, 4-10
 - MANAGEMENT FILE parameter, 4-9
 - overriding default parameters, 4-8
 - SECONDARY LOADER parameter, 4-10
 - SERVICE PASSWORD parameter, 4-11
 - SOFTWARE IDENTIFICATION parameter, 4-10
 - SOFTWARE TYPE parameter, 4-10
 - TERTIARY LOADER parameter, 4-10
- LOAD VIA command, 4-6
 - LOAD ASSIST AGENT parameter, 4-10
 - LOAD ASSIST PARAMETER parameter, 4-10
 - MANAGEMENT FILE parameter, 4-9
 - PHYSICAL ADDRESS parameter, 4-7, 4-10
- Local area network
 - See LAN
- Local event flag state
 - See LEF state
- Local loopback tests, 7-6
- Local node, 1-12, 1-17
- Local nodes, 2-1, 3-5
 - operational state, 3-16
 - restrictions, 6-3
 - setting address, 3-8
 - states, 6-3
- Local-to-local loopback tests, 7-5
- Local-to-remote loopback tests, 7-4
- Logging, 1-17, 2-28
 - commands, 3-62
 - console, 2-28, 3-62
 - database, 3-1
 - file, 2-28, 3-62
 - monitor, 2-28, 3-62, 3-66 to 3-67
 - parameters, 3-63
 - sink, 2-28, 3-62
 - state, 3-65
- Logical links, 1-1, 1-17, 8-8, 8-10, 8-11, 8-14, 8-18
 - aborting, 8-10, 8-30, 8-31
 - access control information, 1-21
 - assigning channel for, 8-18, 8-32
 - commands, 3-56
 - completing connection of, 8-11, 8-18, 8-28, 8-33
 - control, 2-24, 3-14
 - controlling activity, 3-56
 - default access control information, 1-22
 - definition, 2-24
 - Logical links (cont'd)
 - disconnecting, 2-24, 3-56, 8-10, 8-14, 8-30, 8-36
 - handshaking sequence, 8-11
 - inactivity timer, 2-24
 - inbound, 1-21, 3-56
 - incoming timer, 2-24
 - maximum number, 2-24, 3-56
 - outbound, 1-21, 3-56
 - outgoing timer, 2-24
 - parameters, 2-24
 - protocol operation, 2-24
 - protocol parameters, 3-56
 - rejecting a request, 8-34
 - requests, 8-8, 8-11, 8-12, 8-18, 8-27, 8-28, 8-32
 - retransmission delay, 2-24
 - retransmission time, 2-24
 - SYS\$NET, 8-12
 - terminating, 8-10, 8-14, 8-19, 8-23, 8-31
 - timers, 3-57
- Logical names
 - as device name, 1-24
 - as node name, 1-24
 - in process logical name table, 1-24
 - translation, 1-24
 - use in network application, 1-24
- LOGINOUT image, 2-31, 2-33, 8-12, 8-29
- LOOP CIRCUIT command, 7-6
 - ASSISTANT NODE parameter, 7-11
 - ASSISTANT PHYSICAL ADDRESS parameter, 7-11
 - HELP parameter, 7-11
 - NODE parameter, 7-10
 - PHYSICAL ADDRESS parameter, 7-10
- LOOP EXECUTOR command, 7-6
- LOOP NODE command, 7-2
 - CIRCUIT parameter, 7-3
- Loop node name, 7-3
- Loopback assistance, 7-11
- Loopback connector, 7-6
- Loopback mirrors
 - See MIRRORS
- Loopback tests
 - circuit, 7-6
 - circuit-level, 7-1
 - controller, 7-6, 7-8
 - local node, 7-6
 - local-to-local, 7-5
 - local-to-remote, 7-4
 - node-level, 7-1
 - over Ethernet circuit, 7-9
 - software, 7-6, 7-7
 - to a remote node, 7-2
 - to remote system, 7-9
 - using a loop node name, 7-3

M

MACRO programs
in network application, 1-18

Mail utility (MAIL)
MAIL\$SERVER account, default access, 2-25, 5-3, 5-6
object, 2-5, 2-25, 2-26, 3-60, 5-3, 5-6

MAIL\$SERVER account
enabling default access, 2-25, 5-3, 5-6

Mailboxes, 8-8, 8-25, 8-26
creation of using SYS\$CREMBX, 8-25
message format, 8-26
system mailbox messages, 8-26

Maintenance operation module process
See MOM

Maintenance operation protocol
See MOP

Maintenance operations
over the network, 4-1

MANAGEMENT FILE parameter, 4-9

MAXIMUM AREA parameter, 3-51

MAXIMUM BROADCAST NONROUTERS
parameter
for broadcast circuits, 3-51

MAXIMUM BROADCAST ROUTERS parameter
for broadcast circuits, 3-50

Maximum buffers
for executor, 3-16

MAXIMUM BUFFERS parameter, 3-16, 3-32

MAXIMUM CIRCUITS parameter
for executor node, 3-16

MAXIMUM COST parameter, 3-52

MAXIMUM HOPS parameter, 3-52

MAXIMUM LINKS parameter, 3-56

MAXIMUM PATH SPLITS parameter, 3-53

MAXIMUM ROUTERS parameter, 3-33
for a broadcast circuit, 3-50

MAXIMUM TRANSMITS parameter, 3-32

Maximum visits
definition, 2-22

MAXIMUM VISITS parameter
for nodes, 3-53

Memory pool, 5-31

Memory requirements
normal, 5-31
worst-case, 5-32

Messages, 8-8, 8-13, 8-21, 8-22
data, 8-13
exchanging, 8-13, 8-19, 8-30
interrupt, 8-8, 8-30
mailbox, 8-8, 8-13
network status, 8-8
optional user data, 8-8, 8-11, 8-24

Microcode, 1-9

MIRRO\$SERVER account
enabling default access, 2-25, 5-3, 5-6

MIRRORS (loopback mirrors), 1-13, 2-25, 7-2
MIRRO\$SERVER account
default access, 2-25, 5-3, 5-6

Modems, 5-13, 7-6

Modules, 1-17
database, 3-1
Ethernet configurator, 1-17, 2-11, 3-34

MOM (maintenance operation module), 4-1, 4-2

Monitor utility (MONITOR)
use of VPM object in VMSclusters, 5-5

MOP (maintenance operation protocol), 4-1, 4-11
error recovery, 4-5
request memory dump message, 4-11

MS-DOS nodes, 9-20

Multiaccess circuits, 1-4, 2-7

Multicast addresses, 1-4, 1-6, 2-3
dump assistance, 4-13

Multiple inbound connects, 8-8, 8-29, 8-38

Multiple-area networks, 1-2

Multipoint circuits, 2-8
polling, 2-8
tributary, 2-8
tributary address, 2-8

Multipoint configurations, 1-3, 1-8, 5-25

Multipoint control circuits, 2-6

Multipoint control stations, 2-8

Multipoint lines, 2-12

Multipoint tributary addresses, 3-25

Multipoint tributary circuits, 2-6

MVS nodes, 9-26

N

NAME parameter
identifying logging device, 3-63
SET NODE command, 3-8

Namespaces
DECnet use of, 3-22

NCB (network connect block), 8-11, 8-27

NCP (Network Control Program), 1-13
command functions, 3-2
command syntax, 3-3
command words, 3-2
commands, 1-12
definition, 3-2
LIST command, 3-73
SHOW command, 3-73
specifying plural components, 3-3, 3-74
tailoring the configuration database, 5-11

TELL prefix, 3-6
users, 1-11
using commands, 3-1

NCP commands, 3-2
functions, 3-2
remote execution of, 3-6

NCP commands (cont'd)

- syntax, 3-3
- NET\$NODE_COUNTER_BLOCKS logical names, 5-34
- NETACP (network ancillary control program), 1-13, 4-2, 5-33
- NETACP\$BUFFER_LIMIT logical name, 5-33
- NETCONFIG.COM command procedure, 3-2
 - dialog, 5-7e
 - introduction, 1-14
 - supplying node address, 5-5
 - using, 5-5
- NETCONFIG_UPDATE.COM command procedure
 - introduction, 1-14
 - using, 5-10
- NETDRIVER (network driver), 1-13, 5-32
- NETMBX privilege, 2-31, 5-1
- NETPROXY.DAT file, 2-35
- NETSERVER (network server process), 2-26, 2-27, 8-11
 - timeouts, 2-26, 8-11
- NETSERVER\$TIMEOUT value, 2-27, 8-11
- NETSERVER.LOG file, 4-17
- NETUAF.DAT file, 2-31
- Network ancillary control program
 - See NETACP
- Network configuration procedure, 5-19 to 5-35
- Network Control Program
 - See NCP
- Network default access
 - for VMScluster members, 5-10
- Network driver
 - See NETDRIVER
- Network Information and Control Exchange
 - See NICE
- Network interface
 - to OpenVMS, 1-2
- Network management
 - functions, 1-2
 - responsibilities, 1-12
- Network management listener
 - See NML
- Network names
 - declaring, 8-29, 8-38
- Network process failures
 - potential causes, 2-27
- Network server process
 - See NETSERVER
- Network Services Protocol
 - See NSP
- Network tasks
 - declaring, 8-8, 8-13, 8-29
- Networks
 - access, 1-18
 - access control, 2-29
 - bringing up, 6-2

Networks (cont'd)

- configuration, 1-3, 5-1
 - CPU time requirements, 5-32
 - decentralized, 1-2
 - displaying, 8-1
 - example, 1-14
 - limiting number of areas, 3-51
 - monitoring, 3-72
 - multinode, 1-2
 - multiple-area, 1-2
 - normal memory requirements, 5-31
 - passwords, 2-33
 - restrictions on mixed, 2-16
 - security, 2-33
 - shutting down, 6-3
 - terminal, 3-62
 - testing, 7-1
 - topology, 1-14
 - user interface to, 1-17
 - user operations, 1-17, 8-1
 - worst-case memory requirements, 5-32
- ## Networks default access
- for existing systems, 5-10
- ## NICE (Network Information and Control Exchange), 3-2
- ## NICONFIG (Ethernet Configurator), 1-12
- ## NML (network management listener), 1-13, 2-25, 4-2, 6-2
- access control, 3-68
 - NML\$SERVER account
 - default access, 2-25, 5-3, 5-6
 - NML\$SERVER account
 - enabling default access, 2-25, 5-3, 5-6
- ## Node databases
- copying, 1-14, 2-5, 3-21
- ## NODE parameter, 7-9
- ## Node-level access control, 2-33
- ## Node-level loopback tests, 7-1
- logical link operation, 7-1
 - over specific circuit, 7-1
- ## Nodes, 1-1, 1-17, 3-6
- See also Alias node identifiers
 - address, 2-1, 2-18, 3-7, 3-50
 - address conversion, 3-50
 - addressing CI, 3-26
 - adjacent, 1-1, 2-16
 - area number, 2-1
 - bringing up, 6-2
 - changing local address, 3-9
 - checking type, 1-10, 2-36, 3-70
 - clearing or purging database before copying, 3-18
 - commands, 3-5
 - configuring for DECnet for OpenVMS, 1-14
 - conversion of Phase IV address, 2-18
 - copying database, 1-14, 2-5, 3-17
 - copying database using DCL COPY command, 3-21

Nodes (cont'd)

- counters, 3-21
 - database, 3-1
 - default access account, 1-22
 - definition, 2-1
 - display of type, 3-49
 - displaying network, 8-1
 - end node, 1-1
 - end nodes, 2-15
 - executor, 2-1, 3-5
 - identification, 2-1, 2-2, 2-18, 3-7
 - initialization request, 3-30
 - local node, 1-12, 1-17, 2-1, 3-5
 - logical name in file specification, 1-24
 - name, 2-1, 3-7
 - non-LAN, 1-7
 - nonrouting, 2-16
 - number, 2-1, 2-18, 3-7
 - parameters, 2-4, 3-11
 - phases, 2-16
 - reachable
 - definition, 2-21
 - remote node, 1-12, 1-17, 2-1, 3-5, 3-30
 - removing remote name and address, 3-9
 - routing, 1-1, 2-15, 2-16
 - shutting down, 6-3
 - specification access control string, 1-20
 - specification string for, 1-20
 - state, 2-4, 3-16
 - type, 2-16, 3-49
- NODRIVER asynchronous driver, 2-13, 2-14, 5-3, 5-11, 5-12, 5-15, 5-18
- Nonpaged dynamic memory pool, 5-31
- Nonprivileged access control strings, 2-31
- Nonrouting node
- See End node
- Nontransparent communications, 1-20
- Nontransparent user network operations, 1-17
- Nonzero objects, 2-25
- NPAGEDYN parameter, 5-31
- NSP (Network Services Protocol), 2-23, 2-24
 - message retransmission, 2-24, 3-57
 - receive buffers, 3-14
- NUMBER parameter
- for DECnet objects, 3-59

O

- Objects, 1-17, 2-25
- access control, 2-26
 - addressing, 2-25
 - command procedure for, 2-26, 3-61
 - commands, 3-59
 - database, 3-2
 - DECnet, 2-25
 - definition, 2-25
 - file name, 3-61
 - file name for, 3-61

Objects (cont'd)

- identification, 3-59
 - name, 3-59
 - nonzero, 2-25, 3-59
 - number, 8-29, 8-38
 - parameters, 3-59
 - privileges, 3-68
 - proxy login access, 2-36
 - specifying privileges, 3-68
 - TASK, 2-25, 3-59
 - type, 2-25, 8-11
 - type number, 2-25, 3-59
 - use with alias node identifier, 2-26, 3-60
 - user-defined, 2-25
 - zero-numbered, 2-25, 3-59
- OPCOM (Operator Communication Manager), 2-28, 3-62, 6-3
- OpenVMS systems
- communication with other OpenVMS systems, 9-28
 - communication with other systems, 9-1 to 9-28
 - network interface, 1-2
 - nonpaged dynamic memory pool, 5-31
- OpenVMS to MS-DOS network operations, 9-20
- OpenVMS to RT-11 network operations, 9-11
- OpenVMS to TOPS-10 network operations, 9-14
- OpenVMS to TOPS-20 network operations, 9-17
- OpenVMS to IAS network operations, 9-2
- OpenVMS to IBM network operations, 9-26
- OpenVMS to RSTS/E network operations, 9-5
- OpenVMS to RSX (using FCS-based FAL) network operations, 9-9
- OpenVMS to RSX (using RMS-based FAL) network operations, 9-7
- OpenVMS to ULTRIX network operations, 9-23
- OpenVMS to VMS network operation
- Version 5.4 to pre-V5.0 version, 9-28
- OPER privilege, 5-1
- using NETCONFIG.COM, 5-5
 - using NETCONFIG_UPDATE.COM, 5-10
 - using SYSMAN utility, 5-11
- Operator Communication Manager
- See OPCOM
- Operator-initiated downline load, 4-1, 4-5
- Outbound logical link connections, 1-21
- OUTGOING CONNECT PRIVILEGES parameter, 3-69
- OUTGOING PROXY parameter, 2-35, 3-71
- OUTGOING TIMER parameter, 3-57
- Overlying RSX-11S tasks, 4-18

P

- PAKs (Product Authorization Keys)
 - installing DECnet for OpenVMS license, 6-1
- Passwords
 - for dynamic connection, 2-29, 2-36
 - receive, 2-29, 3-67
 - routing initialization, 1-10, 2-16, 2-29, 3-67
 - transmit, 2-29, 3-67
- Path control parameters, 3-52
 - for areas, 3-54
- PATH SPLIT POLICY parameter, 3-53
- Paths
 - cost, 2-21
 - definition, 2-21
 - length, 2-21
- Permanent databases, 1-13, 3-2, 5-34
 - considerations, 5-34
 - copying node entries, 3-18
 - copying using DCL COPY command, 3-21
- Phase II nodes, 2-16
- Phase III nodes, 2-16
- Phase IV nodes, 2-16
 - end node, 2-17
 - node address, 2-18
 - router, 2-17
- PHONE objects, 2-6, 2-26, 3-60
 - PHONE\$SERVER account
 - default access, 5-3, 5-6
- PHONE\$SERVER account
 - enabling default access, 2-26, 5-3, 5-6
- PHYSICAL ADDRESS parameter
 - for LOOP CIRCUIT command, 7-9
 - for TRIGGER command, 4-5
- Physical addresses, 1-6
- PIPELINE QUOTA parameter, 3-58
- Pipeline quotas, 2-24, 3-58
- PMAD Ethernet device, 2-10
- Point-to-point circuits, 2-6
- Point-to-point configurations, 1-3, 1-8, 5-23
- Point-to-point connections
 - security, 2-36, 3-67
- Point-to-point DDCMP addressing, 3-25
- Point-to-point lines, 2-12
- Polling, 1-8, 2-8
- POLLING STATE parameter, 3-31
- Primary loader, 4-2
- Privileges
 - See System privileges
- Product Authorization Keys
 - see PAKs
- Program load request, 4-2
- Programming languages
 - in network application, 1-18
 - selecting for network operation, 1-18

PROTOCOL parameter, 3-37

Protocols, 1-3

Proxies

- access, 2-34
 - access display for executor, 3-71
 - access display for object, 3-72
 - access file specification, 3-71
 - account, 2-34
 - login, 2-34
- Proxy logins
- access control, 1-22, 2-34
 - access control commands, 3-71
 - account, 2-34
 - control, 2-35
 - enabling access, 2-35
 - INCOMING PROXY parameter, 2-35
 - NETPROXY.DAT, 2-35
 - OUTGOING PROXY parameter, 2-35
 - PROXY parameter, 2-36

PROXY parameter

- for SET OBJECT command, 2-36, 3-72
- PSDNs (packet switching data networks), 1-4
- Pseudodevices, 8-25
- PURGE EXECUTOR command, 3-14

Q

Quotas

- pipeline, 2-24, 3-58

R

RCF

- See Remote console facility
- Reachable node
- definition, 2-21
- Receive buffers, 3-14
- correcting insufficient number, 3-42
- RECEIVE BUFFERS parameter
- for DDCMP line, 3-42
- Receive passwords, 2-29
- Remote command execution, 3-6
- Remote console connections, 4-18
- Remote console facility (RCF)
- error messages, 4-19
 - invoking, 4-19
- Remote file access, 1-17, 8-1
- Remote file operations
- in a multivendor network, 9-1
 - OpenVMS to MS-DOS, 9-20
 - OpenVMS to RT-11, 9-11
 - OpenVMS to TOPS-10, 9-14
 - OpenVMS to TOPS-20, 9-17
 - OpenVMS to IAS, 9-2
 - OpenVMS to MVS, 9-26
 - OpenVMS to RSTS/E, 9-5
 - OpenVMS to RSX (using FCS-based FAL), 9-9
 - OpenVMS to RSX (using RMS-based FAL), 9-7

- Remote file operations (cont'd)
 - OpenVMS to ULTRIX, 9-23
 - OpenVMS to VMS
 - Version 5.4 to pre-V5.0 version, 9-28
 - restrictions on, 9-1
- Remote nodes, 1-12, 1-17, 2-1, 3-5
 - copying database, 2-5, 3-17
 - loopback test, 7-2
 - setting name and address, 3-8
- Responsibilities
 - of system manager, 1-12
- Retransmit timer, 3-43
 - formula for, 3-44
- Reverse path caching, 2-20
- RMS calls, 1-18
- Route-through control, 3-53
- ROUTER PRIORITY parameter, 3-33
- Routers, 1-1, 1-12, 2-15, 3-33, 6-1
 - area, 1-2, 2-17
 - definition, 2-15
 - designated, 1-7, 2-15, 2-19
 - LAN, 1-7, 2-19
 - level 1, 1-2, 2-15, 2-17
 - level 2, 1-2, 2-15, 2-17
 - on VMScluster, 1-10
 - Phase IV, 2-17
- Routing, 2-15
 - area, 1-2
 - broadcast message timer, 2-24
 - commands, 3-49
 - concepts, 2-21
 - configuration considerations, 2-15
 - control parameters, 3-51
 - cost, 2-21
 - definition, 1-1
 - equal cost path splitting, 2-22, 3-53
 - hop, 2-21
 - initialization passwords, 2-16, 2-29, 2-36, 3-67
 - maximum visits, 2-22
 - message, 2-23, 3-54
 - message timer, 2-24
 - parameters, 2-21
 - path, 2-21
 - path control parameters, 3-52
 - path cost, 2-21
 - path length, 2-21
 - reachable node, 2-21
 - route-through control parameters, 3-53
 - segmented message, 2-23
 - setting configuration limits, 3-50
 - timer, 3-54
 - timing of messages, 2-24
 - verification, 3-30
- Routing initialization password, 1-10
- Routing nodes
 - See Routers

- Routing timer, 2-24
- RSTS/E nodes, 9-5
- RSX nodes, 9-7, 9-9
- RSX-11S systems
 - checkpointing tasks, 4-18
 - downline load of system, 4-1
 - NETGEN procedure, 4-15
 - overlying tasks, 4-18
 - task load, 4-14
- RT-11 nodes, 9-11

S

- Satellite loader
 - See SLD
- Satellite transmission control, 3-44
- Scheduling timer, 3-43
- SECONDARY LOADER parameter, 4-10
- Secondary loaders, 4-8
- Security
 - for dynamic asynchronous connection, 1-10
 - for point-to-point connection, 2-36, 3-67
 - protecting network configuration files, 2-33
- SECURITY privilege, 5-1
- SEGMENT BUFFER SIZE parameter
 - for executor, 3-15
- SERVICE CIRCUIT parameter, 4-5
- Service operations, 3-29
 - circuit identification for downline load, 4-10
 - password for downline load, 4-11
 - system privileges for, 4-11
 - timer, 3-43
- SET CIRCUIT command
 - COST parameter, 3-51
 - COUNTER TIMER parameter, 3-35
 - MAXIMUM BUFFERS parameter, 3-32
 - MAXIMUM ROUTERS parameter, 3-33, 3-50
 - MAXIMUM TRANSMITS parameter, 3-32
 - polling control parameters, 3-31
 - POLLING STATE parameter, 3-31
 - ROUTER PRIORITY parameter, 3-33
 - SERVICE parameter, 3-29, 4-4, 4-13
 - STATE parameter, 3-29, 4-13
 - TRIBUTARY parameter, 3-25
 - VERIFICATION INBOUND parameter, 3-31, 3-67
 - VERIFICATION parameter, 3-30
- SET EXECUTOR command
 - ADDRESS parameter, 3-8, 3-50
 - ALIAS INCOMING parameter, 3-10
 - ALIAS MAXIMUM LINKS parameter, 3-56
 - ALIAS NODE parameter, 3-10
 - AREA MAXIMUM COST parameter, 3-54
 - AREA MAXIMUM HOPS parameter, 3-54
 - BROADCAST ROUTING TIMER parameter, 3-55
 - BUFFER SIZE parameter, 3-14
 - COUNTER TIMER parameter, 3-21

- SET EXECUTOR command (cont'd)
 - DEFAULT ACCESS parameter, 2-34, 3-70
 - DELAY FACTOR parameter, 3-57
 - DELAY WEIGHT parameter, 3-57
 - IDENTIFICATION parameter, 3-8
 - INACTIVITY TIMER parameter, 3-57
 - INCOMING PROXY parameter, 2-35, 3-71
 - INCOMING TIMER parameter, 3-57
 - local node address, 3-8
 - MAXIMUM AREA parameter, 3-51
 - MAXIMUM BROADCAST NONROUTERS parameter, 3-51
 - MAXIMUM BROADCAST ROUTERS parameter, 3-50
 - MAXIMUM BUFFERS parameter, 3-16
 - MAXIMUM CIRCUITS parameter, 3-16
 - MAXIMUM COST parameter, 3-52
 - MAXIMUM HOPS parameter, 3-52
 - MAXIMUM LINKS parameter, 3-56
 - MAXIMUM PATH SPLITS parameter, 3-53
 - MAXIMUM VISITS parameter, 3-53
 - OUTGOING PROXY parameter, 2-35, 3-71
 - OUTGOING TIMER parameter, 3-57
 - PATH SPLIT POLICY parameter, 3-53
 - PIPELINE QUOTA parameter, 3-58
 - RETRANSMIT FACTOR parameter, 3-57
 - ROUTING TIMER parameter, 3-55
 - SEGMENT BUFFER SIZE parameter, 3-15
 - STATE parameter, 3-16, 6-3
- SET EXECUTOR NODE command, 3-6
 - access control information, 3-69
- SET HOST command
 - command terminal, 8-2
 - heterogeneous command terminal, 1-18
- SET KNOWN PROXIES ALL command, 3-72
- SET LINE command
 - BUFFER SIZE parameter, 3-14, 3-41
 - DUPLEX parameter, 3-42, 3-43
 - PROTOCOL parameter, 3-37, 3-38
 - RECEIVE BUFFERS parameter, 3-42
 - SERVICE TIMER parameter, 4-4, 4-13
 - STATE parameter, 3-41
 - TRANSMIT PIPELINE parameter, 3-44, 3-58
- SET LOGGING command, 3-72
 - EVENTS parameter, 3-63, 3-65
 - NAME parameter, 3-63
 - STATE parameter, 3-65
- SET LOGGING EVENTS command, 3-62
- SET LOGGING MONITOR command
 - SINK parameter, 3-65
- SET LOGGING STATE command, 3-62
- SET MODULE CONFIGURATOR command
 - KNOWN CIRCUITS parameter, 3-35
 - STATUS display, 3-35
 - SURVEILLANCE DISABLED parameter, 3-35
 - SURVEILLANCE ENABLED parameter, 3-34
- SET NODE command, 7-4
 - ACCESS parameter, 2-34, 3-70
 - ADDRESS parameter, 3-3, 3-8
 - COUNTER TIMER parameter, 3-21
 - DIAGNOSTIC FILE parameter, 4-11
 - HARDWARE ADDRESS parameter, 4-5, 4-7
 - INBOUND parameter, 3-70
 - LOAD ASSIST AGENT parameter, 4-10
 - LOAD ASSIST PARAMETER parameter, 4-10
 - MANAGEMENT FILE parameter, 4-9
 - NAME parameter, 3-8
 - NONPRIVILEGED parameter, 3-68
 - PRIVILEGED parameter, 3-68
 - RECEIVE PASSWORD parameter, 3-67
 - remote node name and address, 3-8
 - SERVICE CIRCUIT parameter, 4-6
 - SERVICE PASSWORD parameter, 4-11
 - SOFTWARE IDENTIFICATION parameter, 4-10
 - SOFTWARE TYPE parameter, 4-10
 - TRANSMIT PASSWORD parameter, 3-67
- SET OBJECT command
 - ALIAS INCOMING parameter, 3-10, 3-60
 - ALIAS OUTGOING parameter, 3-10, 3-60
 - FILE parameter, 3-61
 - NUMBER parameter, 3-59
 - OUTGOING CONNECT PRIVILEGES parameter, 3-69
 - PASSWORD parameter, 3-69
 - PRIVILEGE parameter, 3-68
 - PROXY parameter, 2-36, 3-72
 - USER parameter, 3-69
- SGEC Ethernet device, 2-10
- SHOW command, 3-72
- SHOW EXECUTOR CHARACTERISTICS command
 - display of proxy access, 3-71
- SHOW EXECUTOR command, 3-8
 - display of executor type, 3-49
- SHOW LINE command
 - Ethernet hardware address, 3-46, 7-10
- SHOW MODULE CONFIGURATOR command, 3-34, 3-35
- SHOW NETWORK command, 8-1
 - display of network status, 8-1
- SHOW NODE command
 - COUNTERS parameter, 3-22
 - display of node type, 3-49
- SINK parameter, 3-65
- Sinks, 2-28
 - logging, 2-28, 3-62
 - name, 2-28
 - node, 2-28
 - related event, 2-28
 - state, 2-29
- Slave nodes, 4-11

SLD (satellite loader), 4-14
 building, 4-15
 SOFTWARE IDENTIFICATION parameter, 4-10
 Software loopback tests, 7-6, 7-7
 Source task, 8-11
 Source-related events, 2-28
 STARTNET.COM command procedure, 3-72, 5-20
 STATE parameter
 for circuit, 3-29
 for executor node, 3-16
 for line, 3-41
 States
 circuit, 2-7, 3-28
 line, 2-12
 lines, 3-41
 local node, 2-4
 logging, 3-65
 Static asynchronous connections, 1-3, 1-7, 1-9
 network configuration, 5-27
 reasons for failure, 5-13
 Static asynchronous lines, 1-9, 2-13, 5-12
 installing, 5-12
 shutting down, 5-14
 STATUS display type, 3-73
 Stream timer, 3-43
 SUMMARY display type, 3-73
 SWITCH parameter, 3-45
 Synchronous circuits
 See Circuits
 Synchronous connections, 1-3
 Synchronous disconnects, 8-10, 8-14, 8-30, 8-36
 Synchronous lines
 See Lines
 SYS\$ASSIGN system service, 5-1, 8-18
 format, 8-20, 8-32
 _NET: pseudodevice, 8-32
 nontransparent use of, 8-25
 transparent use of, 8-18
 SYS\$CANCEL system service, 8-31
 SYS\$CREMBX system service, 5-1, 8-25
 SYS\$CREPRC system service, 5-1
 SYS\$DASSGN system service, 8-14, 8-19, 8-23, 8-39
 SYS\$GETDVI system service, 8-31
 SYS\$LOGIN:NETSERVER.LOG file, 2-27, 4-17
 SYS\$MANAGER:EVL.LOG file, 3-65
 SYS\$MANAGER:NET.LOG file, 3-74
 SYS\$MANAGER:NETCONFIG.COM command procedure, 5-5
 SYS\$MANAGER:RTTLOAD.COM command procedure, 6-2
 SYS\$MANAGER:STARTNET.COM command procedure, 5-7, 5-20, 6-2
 SYS\$NET logical name, 8-12, 8-18, 8-29
 SYS\$QIO routines
 IO\$_ACCESS function code, 8-27, 8-30, 8-32, 8-33
 SYS\$QIO routines (cont'd)
 IO\$_ACCESS!IO\$_M_ABORT function code, 8-30, 8-34
 IO\$_ACPCONTROL function code, 8-29, 8-38
 IO\$_DEACCESS!IO\$_M_ABORT function code, 8-31, 8-37
 IO\$_DEACCESS!IO\$_M_SYNCH function code, 8-36
 IO\$_READVBLK function code, 8-22, 8-35
 IO\$_WRITEVBLK function code, 8-35
 IO\$_WRITEVBLK!IO\$_M_INTERRUPT function code, 8-30, 8-35
 IO\$_WRITEVBLK!IO\$_M_MULTIPLE function code, 8-21
 SYS\$TRNLOG system service, 8-13
 SYSGEN
 See System Generation utility
 SYSNAM privilege, 5-1, 8-29
 SYSPRV privilege, 5-1
 using NETCONFIG.COM, 5-5
 using NETCONFIG_UPDATE.COM, 5-10
 System configuration guidelines, 5-31 to 5-35
 System Generation utility
 NPAGEDYN parameter, 5-31
 running, 5-31
 updating parameters for DECnet, 5-31
 System management
 responsibilities, 1-12
 System privileges
 ACNT, 5-1
 BYPASS, 5-1
 CMKRNL, 5-1
 DETACH, 5-1
 DIAGNOSE, 5-2
 for access control, 2-31
 for network operations, 5-1
 NETMBX, 2-31, 5-1
 OPER, 5-1, 5-5, 5-10, 5-11
 SECURITY, 5-1
 SYSNAM, 5-1
 SYSPRV, 5-1, 5-5, 5-10
 TMPMBX, 2-31, 5-1
 to configure network, 5-1
 System service calls, 1-18, 8-14, 8-15, 8-24
 summary for nontransparent use, 8-24, 8-31
 summary for transparent use, 8-17, 8-20
 System-level access control, 2-30
 Systems
 See OpenVMS systems

T

Tailoring the configuration database, 5-11
 Target nodes, 4-1
 Target task, 8-11

- Target-initiated downline load, 4-2
- Task-to-task communications, 1-2, 1-17, 8-1, 8-15, 8-24
 - nontransparent, 8-7, 8-8, 8-24
 - nontransparent example, 8-43
 - transparent, 8-1, 8-15
 - transparent FORTRAN example, 8-40
- Tasks
 - declaring for network, 8-8
 - definition, 1-17
 - downline load, 4-14
 - general purpose, 4-16
 - identifier in specification, 1-20
 - installation, 4-16
 - source, 8-13
 - specification, 1-20
 - specification for task, 1-20
 - specification over the network, 1-20
 - specification string, 1-20, 8-9, 8-15, 8-27
 - target, 8-13, 8-21
- TELL prefix
 - description, 3-6
- Terminal connections
 - to remote console, 4-18
- Terminal emulators, 1-9, 5-16
- Terminal lines
 - conversion to DECnet line, 1-9, 2-13, 5-11
- Terminal servers
 - on Ethernet, 1-10
- Testing
 - the network, 7-1
- Tests
 - circuit loopback test, 7-6, 7-9
 - controller loopback test, 7-8
 - LAN (local area network) loopback, 7-9
 - local loopback test, 7-6
 - local-to-remote test, 7-4
 - node-level test, 7-1
 - remote loopback test, 7-2
 - software loopback test, 7-7
- Timers
 - babble, 3-32
 - broadcast routing, 3-55
 - counter, 3-21
 - dead, 3-43
 - delay, 3-43
 - hello, 3-29
 - inactivity, 2-24, 3-57
 - incoming, 2-24, 3-57
 - line, 3-43
 - logical link, 2-24
 - outgoing, 2-24, 3-57
 - retransmit, 3-43
 - routing, 2-24, 3-54
 - scheduling, 3-43
 - service, 3-43
 - stream, 3-43
 - transmit, 3-32

- TLK image, 4-15
- TMPMBX privilege, 2-31
- Topologies
 - of a multiple-area network, 1-14
 - of a single-area network, 1-14
- TOPS-10 nodes, 9-14
- TOPS-20 nodes, 9-17
- Transmit passwords, 2-29
- TRANSMIT PIPELINE parameter, 3-44
- Transmit timer, 3-32
- Transparent task-to-task communications, 1-20, 8-1
- Transparent user network operations, 1-17
- Tributaries, 1-8, 2-8
 - address, 2-8
 - circuit timers, 3-32
 - control, 3-31, 3-32
- TRIBUTARY parameter, 3-25
- TRIGGER command, 4-2, 4-5
 - PHYSICAL ADDRESS parameter, 4-5
 - SERVICE PASSWORD parameter, 4-6
- Trigger message, 4-2
- Trigger operations
 - bootstrap ROM, 4-4
 - primary bootstrap, 4-4
 - primary loader, 4-2
 - TRIGGER command, 4-5
- TRIGGER VIA command, 4-10

U

- UAFs (user authorization files), 8-12
 - creation of default nonprivileged DECnet account, 5-3
- UETPs (User Environment Test Packages), 6-2
 - MIRRO\$SERVER account, 5-5
- ULTRIX nodes, 9-23
- Unattended systems
 - memory dump, 4-11
 - slave, 4-11
- Upline memory dumps
 - definition, 4-11
 - over LAN, 4-13
 - procedures, 4-11
 - requirements, 4-13
 - RSX-11S operating system, 4-11
- User authorization files
 - See UAFs
- User Environment Test Packages
 - See UETPs
- User-defined objects, 2-25
- Users
 - interface to network, 1-17
 - network operations, 8-1
 - transparent network operations, 1-17

V

- VAXcluster environments
 - use of CI data link, 1-10
- VERIFICATION INBOUND parameter, 3-31, 3-67
- VERIFICATION parameter, 3-30
- Virtual circuits, 1-4, 1-8
- Virtual terminals, 1-9, 5-17
 - enabling, 5-15
- VMR utility, 4-15
- VMScluster environments
 - See also Alias node identifiers
 - configuration, 1-10
 - downline load sequence originating from, 4-3
 - end node, 1-10, 2-21
 - router, 1-10, 2-21
 - use of an alias node identifier, 1-11, 2-5, 2-26, 3-9, 8-8
 - use of DECnet data link, 1-10
- Volatile databases, 1-13, 3-2
 - copying node entries, 3-18
 - display information, 3-73
 - use of, 3-2
- VPM (virtual performance monitor)
 - VPM\$SERVER account

- default access, 5-3, 5-6
- VPM objects, 2-26
- VPM\$SERVER account
 - enabling default access, 2-26, 5-3, 5-6

W

- Wildcard characters
 - for events, 3-64
 - for NCP component names, 3-4

X

- X.25 networks
 - connecting to, 1-4

Z

- ZERO CIRCUITS command, 3-36
- ZERO EXECUTOR command, 3-22
- ZERO LINE command, 3-49
- ZERO NODE command, 3-22
- Zero-numbered objects, 2-25
- Zeroing
 - line counters, 3-49
 - node counters, 3-22

NOTES

NOTES

NOTES

NOTES

NOTES

NOTES

NOTES

NOTES

NOTES

NOTES

How to Order Additional Documentation

Technical Support

If you need help deciding which documentation best meets your needs, call 800-DIGITAL (800-344-4825) and press 2 for technical assistance.

Electronic Orders

If you wish to place an order through your account at the Electronic Store, dial 800-234-1998, using a modem set to 2400- or 9600-baud. You must be using a VT terminal or terminal emulator set at 8 bits, no parity. If you need assistance using the Electronic Store, call 800-DIGITAL (800-344-4825) and ask for an Electronic Store specialist.

Telephone and Direct Mail Orders

From	Call	Write
U.S.A.	DECdirect Phone: 800-DIGITAL (800-344-4825) FAX: (603) 884-5597	Digital Equipment Corporation P.O. Box CS2008 Nashua, NH 03061
Canada	Phone: 800-267-6215 FAX: (613) 592-1946	Digital Equipment of Canada Ltd. 100 Herzberg Road Kanata, Ontario, Canada K2K 2A6 Attn: DECdirect Sales
International	_____	Local Digital subsidiary or approved distributor
Internal Orders ¹ (for software documentation)	DTN: 241-3023 (508) 874-3023	Software Supply Business (SSB) Digital Equipment Corporation 1 Digital Drive Westminster, MA 01473
Internal Orders (for hardware documentation)	DTN: 234-4325 (508) 351-4325 FAX: (508) 351-4467	Publishing & Circulation Services Digital Equipment Corporation NR02-2 444 Whitney Street Northboro, MA 01532

¹Call to request an Internal Software Order Form (EN-01740-07).

Reader's Comments

DECnet for OpenVMS
DECnet for OpenVMS Networking Manual
AA-PV60A-TK

Your comments and suggestions help us improve the quality of our publications.

Thank you for your assistance.

I rate this manual's:	Excellent	Good	Fair	Poor
Accuracy (product works as manual says)	<input type="checkbox"/>	<input type="checkbox"/>	<input type="checkbox"/>	<input type="checkbox"/>
Completeness (enough information)	<input type="checkbox"/>	<input type="checkbox"/>	<input type="checkbox"/>	<input type="checkbox"/>
Clarity (easy to understand)	<input type="checkbox"/>	<input type="checkbox"/>	<input type="checkbox"/>	<input type="checkbox"/>
Organization (structure of subject matter)	<input type="checkbox"/>	<input type="checkbox"/>	<input type="checkbox"/>	<input type="checkbox"/>
Figures (useful)	<input type="checkbox"/>	<input type="checkbox"/>	<input type="checkbox"/>	<input type="checkbox"/>
Examples (useful)	<input type="checkbox"/>	<input type="checkbox"/>	<input type="checkbox"/>	<input type="checkbox"/>
Index (ability to find topic)	<input type="checkbox"/>	<input type="checkbox"/>	<input type="checkbox"/>	<input type="checkbox"/>
Page layout (easy to find information)	<input type="checkbox"/>	<input type="checkbox"/>	<input type="checkbox"/>	<input type="checkbox"/>

I would like to see more/less _____

What I like best about this manual is _____

What I like least about this manual is _____

I found the following errors in this manual:

Page	Description
_____	_____
_____	_____
_____	_____
_____	_____
_____	_____

Additional comments or suggestions to improve this manual:

For software manuals, please indicate which version of the software you are using: _____

Name/Title _____ Dept. _____
Company _____ Date _____
Mailing Address _____
_____ Phone _____

--- Do Not Tear - Fold Here and Tape ---

digital™



No Postage
Necessary
if Mailed
in the
United States

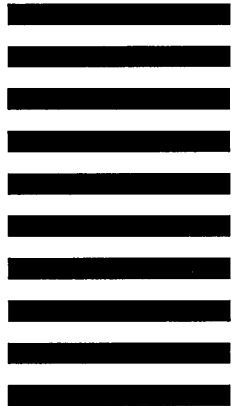

BUSINESS REPLY MAIL
FIRST CLASS PERMIT NO. 33 MAYNARD MASS.

POSTAGE WILL BE PAID BY ADDRESSEE

DIGITAL EQUIPMENT CORPORATION
Telecommunications and Networks Publications
LKG1-3/L12
550 King Street
Littleton, MA 01460-1289