

THE CORVUS SERVICE MANUAL

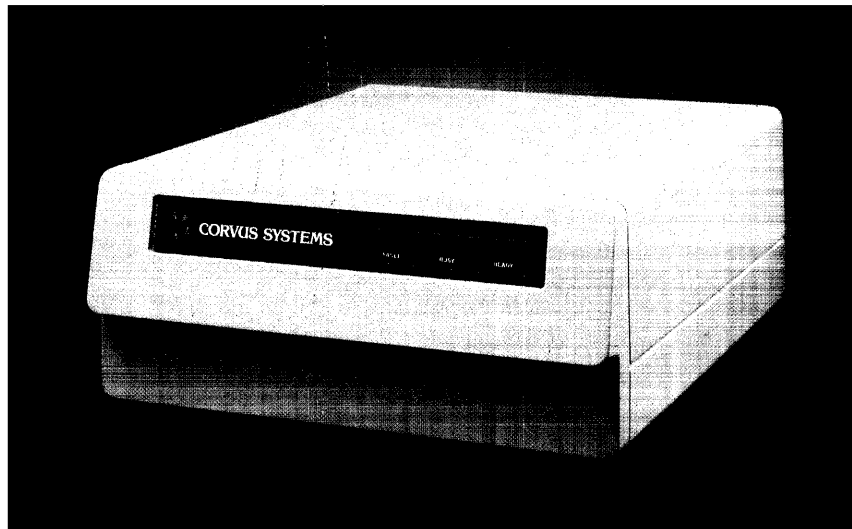

H-Series Drives

*** CORVUS SYSTEMS

DISCLAIMER OF ALL WARRANTIES & LIABILITIES

Corvus Systems, Inc. makes no warranties, either expressed or implied, with respect to this manual or with respect to the software described in this manual, its quality, performance, merchantability, or fitness for any particular purpose. Corvus Systems, Inc. software is sold or licensed "as is." The entire risk as to its quality or performance is with the buyer and not Corvus Systems, Inc., its distributor, or its retailer. The buyer assumes the entire cost of all necessary servicing, repair, or correction and any incidental or consequential damages. In no event will Corvus Systems, Inc. be liable for direct, indirect, incidental or consequential damages, even if Corvus Systems, Inc. has been advised of the possibility of such damages. Some states do not consequential damages, so the above limitation may not apply to you.

Every effort has been made to insure that this manual accurately documents the operation and servicing of Corvus products. However, due to the ongoing modification and update of the software along with future products, Corvus Systems, Inc. cannot guarantee the accuracy of printed material after the date of publication, nor can Corvus Systems, Inc. accept responsibility for errors or omissions.

NOTICE

Corvus Systems, Inc. reserves the right to make changes in the product described in this manual at any time without notice. Revised manuals and update sheets will be published as needed and may be purchased by writing to:

Corvus Systems, Inc.
2029 O'Toole Avenue
San Jose, CA 95131

Telephone: (408) 946-7700
TWX 910-338-0226

This manual is copyrighted and contains proprietary information. All rights reserved. This document may not, in whole or in part be copied, photocopied, reproduced, translated or reduced to any electronic medium or machine readable form without prior consent, in writing, from Corvus Systems, Inc.

Copyright© 1982 by Corvus Systems, Inc. All rights reserved.

Mirror® patent pending, The Corvus Concept,™ Transporter,™ Corvus OMNINET,™ Corvus Logicalc,™ Time Travel Editing,™ EdWord,™ Constellation,™ Corvus,™ Corvus Systems,™ Personal Workstation,™ Tap Box,™ Passive Tap Box,™ Active Junction Box,™ Omninet Unit™ are trademarks of Corvus Systems, Inc.

FCC WARNING

This equipment generates, uses, and can radiate radio frequency energy and if not installed and used in accordance with the instruction manual, may cause interference to radio communications. As temporarily permitted by regulation it has not been tested for compliance with the limits for Class A computing devices pursuant to Subpart J of Part 15 of FCC Rules, which are designed to provide reasonable protection against such interference. Operation of this equipment in a residential area is likely to cause interference in which case the user at his own expense will be required to take whatever measures may be required to correct the interference.

**CORVUS SYSTEMS
H-SERIES 5.25-INCH
WINCHESTER DISK DRIVE
SERVICE MANUAL**

**COVERING
MODEL 6, MODEL 11, MODEL 20**

This document contains three types of notations. These are, in increasing order of importance, **NOTE**, **CAUTION**, and **WARNING**. The **NOTE** indicates some action to be taken to speed or simplify a procedure. The **CAUTION** indicates that potential damage to the equipment or user data exists, and care should be taken to avoid this. The **WARNING** indicates that potential harm or injury to the service technician or operator exists, and extreme care should be taken to avoid these.

PART NO. 7100-04704
PUBLICATION NO. GEN/10.3-01/1.1
PUBLICATION DATE APRIL 1, 1983

TABLE OF CONTENTS

TABLE OF CONTENTS

List of Figures and Tables v
List of Assembly and Schematic Drawings vi
Specifications vii

CHAPTER 1 — GENERAL DESCRIPTION

1.1 Scope of Chapter 1
1.2 Introduction 1
1.3 Purpose of Equipment 1
1.4 Model Identification 1
1.5 Corvus Disk System 2
 1.5.1 Power Supply 2
 1.5.2 Data Backup 2
1.6 Winchester Disk Drive 2

CHAPTER 2 — INSTALLATION

2.1 Scope of Chapter 3
2.2 Introduction 3
2.3 Receiving a Drive 3
 2.3.1 Diagnostic Test 3
2.4 Environmental Considerations 5
2.5 Daisy-Chaining of Disk Drives 5

CHAPTER 3 — OPERATION

3.1 Scope of Chapter 7
3.2 Introduction 7
3.3 Controls 7
 3.3.1 Front Bezel LEDs 7
 3.3.2 Front Bezel Switches 7
3.4 Power-On Sequence 8
3.5 Environmental Requirements 8
 3.5.1 Static Electricity 8
 3.5.2 Line Noise 9
 3.5.3 Temperature 9
3.6 Periodic Maintenance 9
 3.6.1 Regular Checks 9

CHAPTER 4 — DRIVE DESCRIPTION

4.1 Scope of Chapter 10
4.2 Introduction 10
4.3 Drive Layout 10
 4.3.1 Power Supply 10
 4.3.2 dc Power Cables 11
4.4 General Description 11
4.5 Disk Sealed Mechanism 12
4.6 Controller Firmware 12
4.7 Data Storage 12

CORVUS DEALER SERVICE

4.8	Transportation Considerations	14
4.9	Theory of Operation	14
4.9.1	Power-Up	14
4.9.2	Controller PCA	16
4.9.2.1	Controller During Seek	16
4.9.2.2	Controller During Read and Write	16
4.9.3	Backplane PCA	18
4.9.4	Paddleboard PCA	18
4.9.5	Interface PCA	18
4.9.6	Read/Write PCA	19
4.9.7	Motor Control PCA	19

CHAPTER 5 — DISASSEMBLY

5.1	Scope of Chapter	20
5.2	Introduction	20
5.2.1	Tools Required	20
5.3	Plastic Package	20
5.3.1	Top Cover	20
5.3.2	Controller PCA	20
5.3.3	Backplane Cover	21
5.3.4	Drive Mechanism	21
5.3.5	Read/Write PCA	21
5.3.6	Motor Control PCA	21
5.3.7	Power Supply	24
5.3.8	Front Bezel	24

CHAPTER 6 — ADJUSTMENTS AND MAINTENANCE

6.1	Scope of Chapter	25
6.2	Introduction	25
6.3	Power Supply Voltage Check and Adjustment	25
6.3.1	Voltage Check (CP510)	25
6.3.2	Voltage Adjustment	25
6.4	Motor Brake Adjustment	26
6.5	Index Sensor Adjustment	28

CHAPTER 7 — DEALER SERVICE DIAGNOSTICS

7.1	Scope of Chapter	30
7.2	Introduction	30
7.3	Drive Diagnostics RevB	30
7.3.1	CRC	30
7.3.2	EXR	31
7.3.3	UPD	31
7.3.4	VSN	31
7.3.5	FMT	32
7.3.6	PRM	32
7.3.6.1	MUX	32
7.3.6.2	DRIVE	33
7.3.7	SET	33
7.3.8	PARK	33
7.3.9	QUIT	33

CORVUS DEALER SERVICE

7.4	Controller Diagnostic	34
7.4.1	General Description	34
7.4.2	Controller Diagnostic Commands	34
7.4.2.1	A) Abort Diagnostic	34
7.4.2.2	B) Macro Menu	35
7.4.2.3	C) Change Slot Number	35
7.4.2.4	D) Download Diagnostic	35
7.4.2.5	I) Analyze Servo	36
7.4.2.6	J) Single Do Seek	36
7.4.2.7	L) Full Cylinder Loopseek	36
7.4.2.8	P) Print Quiet Summary Report	36
7.4.2.9	Q) Sector Quiet Program	36
7.4.2.10	S) Read Scan Disk	37
7.4.2.11	T) Single Cylinder Seek Scan	37
7.4.2.12	X) Write Scan Disk	37
7.4.2.13	Y) Rezero Heads	37
7.4.3	Error Codes	38
7.5	Burn-In Program	38
7.5.1	C)ONT	38
7.5.2	L)IST	38
7.5.3	R)ESTART	38
7.5.4	Q)UIT	39
7.6	Read Burn-In Results	39
7.7	Track Diagnostic	39
7.7.1	C)ONT	39
7.7.2	L)IST	39
7.7.3	R)ESTART	40
7.7.4	Q)UIT	40

CHAPTER 8 — FAULT ISOLATION PROCEDURES

8.1	Scope of Chapter	41
8.2	Introduction	41
8.3	Tools	41
8.4	Error Codes	41
8.4.1	Interpreting Error Codes	41
8.5	Troubleshooting Procedures	45
8.5.1	On-Site Checks	45
8.5.2	Isolate the Problem	45
8.5.3	Drive Not Ready	46
8.5.3.1	Interface	46
8.5.3.2	Controller Firmware	46
8.5.3.3	Power Supply Voltages	46
8.5.3.4	Drive Electronics	46
8.5.3.5	Drive Sealed Mechanism	47
8.5.4	Link Inoperative	47
8.5.4.1	Check Link Action	47
8.5.4.2	Power Supply	47
8.5.4.3	CRC Test	47
8.5.4.4	Controller Communication	48
8.5.4.5	Servo Action	48
8.5.4.6	Controller Firmware	48

CORVUS DEALER SERVICE

	8.5.4.6	Boot ROM	48
	8.5.4.7	Interface Components	48
	8.5.4.8	Drive Initialization	48
8.6		Final Adjustments and Tests	49
	8.6.1	CRC Test	49
	8.6.2	Install and Test Mirror	49
	8.6.3	CRC Test	49
	8.6.4	Power Supply	49
	8.6.5	Burn-In Test	49
8.7		Trouble Shooting Flowchart	50
8.8		Common Symptoms and Recommended Solutions	51
Appendix A		Glossary	56
Appendix B		H-Series Parts List	58
Appendix C		Internal Cabling Chart	59

LIST OF FIGURES AND TABLES

LIST OF FIGURES AND TABLES

Illustrations

Figure 1	H-series drive	1
Figure 2	Mirror switches	4
Figure 3	Rear bezel	5
Figure 4	Controller address switches	6
Figure 5	Front bezel	8
Figure 6	Data configuration	11
Figure 7	Drive mechanism components	13
Figure 8	Sector interleaving	14
Figure 9	Drive mechanism block diagram	15
Figure 10	Stepper motor assembly	17
Figure 11	Read/Write PCA removal	22
Figure 12	Motor Control PCA removal	23
Figure 13	CP510 power supply	26
Figure 14	Brake mechanism adjustment	27
Figure 15	Index sensor adjustment	29

Tables

Table 1	Decimal disk error codes	42
Table 2	Hexidecimal disk error codes	43
Table 3	Signed decimal disk error codes	44

LIST OF ASSEMBLY AND SCHEMATIC DRAWINGS

LIST OF ASSEMBLY AND SCHEMATIC DRAWINGS

Final Assembly, H-Drive	60
Base Assembly, H-Drive	61
Cover Assembly, H-Drive	62
Backplane Assembly, H-Drive	63
CP510 Power Supply Assembly	64
CP510 Power Supply Schematic	65
CP510 Power Supply Parts List	(1 of 2) 66
CP510 Power Supply Parts List	(2 of 2) 67
Controller PCA, P/N 263-02323-xxx Schematic	(1 of 6) 68
Controller PCA, P/N 263-02323-xxx Schematic	(2 of 6) 69
Controller PCA, P/N 263-02323-xxx Schematic	(3 of 6) 70
Controller PCA, P/N 263-02323-xxx Schematic	(4 of 6) 71
Controller PCA, P/N 263-02323-xxx Schematic	(5 of 6) 72
Controller PCA, P/N 263-02323-xxx Schematic	(6 of 6) 73
Controller PCA, P/N 263-02323-xxx Assembly	74
Motor Control PCA, P/N 263-02410-xxx Schematic	(1 of 2) 75
Motor Control PCA, P/N 263-02410-xxx Schematic	(2 of 2) 76
Motor Control PCA, P/N 263-02410-xxx Assembly	77
Motor Control PCA, P/N 263-01908-xxx Schematic	(1 of 2) 78
Motor Control PCA, P/N 263-01908-xxx Schematic	(2 of 2) 79
Motor Control PCA, P/N 263-01908-xxx Assembly	80
Read/Write PCA, P/N 263-02381-xxx Schematic	(1 of 3) 81
Read/Write PCA, P/N 263-02381-xxx Schematic	(2 of 3) 82
Read/Write PCA, P/N 263-02381-xxx Schematic	(3 of 3) 83
Read/Write PCA, P/N 263-02381-xxx Assembly	84
Read/Write PCA, P/N 263-02157-xxx Schematic	(1 of 3) 85
Read/Write PCA, P/N 263-02157-xxx Schematic	(2 of 3) 86
Read/Write PCA, P/N 263-02157-xxx Schematic	(3 of 3) 87
Read/Write PCA, P/N 263-02157-xxx Assembly	88

SPECIFICATIONS

SPECIFICATIONS

Operational Specifications	MODEL 6	MODEL 11	MODEL 20
Disks per Drive	1	2	3
Disk Diameter (in/mm)	5.25/133	5.25/133	5.25/133
Data Surfaces per Drive	2	4	6
Heads per Surface	1	1	1
Data Heads	2	4	6
Number of Data Cylinders/Drive (including all spare tracks)	306	306	306
Sectors per Track	20	20	20
Track Density (TPI)	303	303	303
Bytes per Sector (Formatted)	512	512	512
Bytes per Track (Formatted)	10,240	10,240	10,240
Bytes per Drive (Formatted)	6.27MB	12.53MB	18.80MB
Bit Density, maximum (BPI)	9,706	9,706	9,706
Average Latency (ms)	8.3	8.35	8.3
Average Access Time (ms)	49	49	49
Maximum Access Time (ms)	99	99	99
Maximum Access Time, single-track	3	3	3
Data Transfer Rate (Kb/s)	625	625	625
Recording Format	MFM	MFM	MFM
Rotational Speed (RPM)	3,600	3,600	3,600
Start Time (s)	20	20	20
Stop Time (s)	15	15	15

Physical Dimensions

Height (in/cm)	5.75 / 14.6
Length (in/cm)	15.0 / 38.1
Width (in/cm)	12.0 / 30.5
Weight (lbs/kgs)	

Environmental Requirements

Operating Temperature (F/C)	39° to 122°/4° to 50°
Non-Operating Temperature (F/C)	-40° to 140°/-40° to 60°
Operating Relative Humidity (%)	8 to 80
Non-Operating Relative Humidity (%)	8 to 80
Operating altitude (ft)	-1,000 to +10,000
Non-Operating altitude (ft)	-1,000 to +50,000
Operating Vibration (g)	0.1 (5 cps linear increase to 100 cps)
Non-Operating Vibration (g)	1.0 (2 cps linear increase to 100 cps)
Non-Operating Shock (g)	5.0 for 5ms duration

CORVUS DEALER SERVICE

Power Requirements

Line Voltage, Domestic (VAC)	100-120, 48Hz-62Hz, Single-Phase
Line Voltage, Foreign (VAC)	220-240, 48Hz-62Hz, Single-Phase
Power Consumption (Watts)	125
Line Fuse (Amperes)	
for 100V-120V	2.0 slow-blow
for 220V-240V	1.0 slow-blow

Reliability

Mean Time Between Failures (MTBF)	10,000+ operational hrs., within above requirements
Maximum Repair Time	Not more than 0.5 hrs.

CHAPTER 1
GENERAL DESCRIPTION

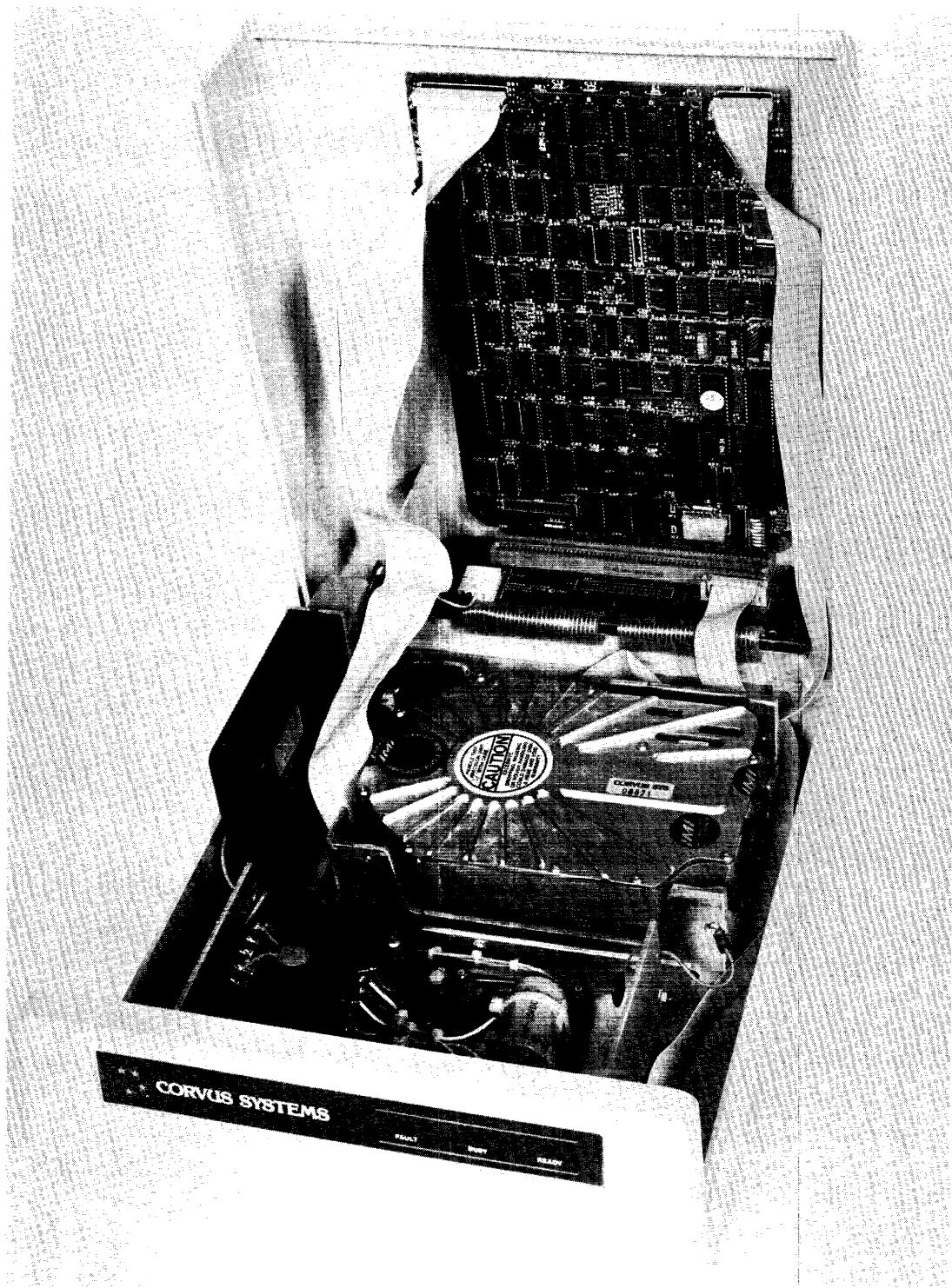

Figure 1. H-Series Drive

CHAPTER 1 GENERAL DESCRIPTION

1.1 Scope of Chapter

This chapter outlines the purpose of the Corvus Systems™ H-Series™ Model 6, Model 11 and Model 20 disk drives. A Brief description and layout is include, as is a definition of Winchester technology.

1.2 Introduction

This document contains instructions for maintenance and repair of the Corvus Systems H-Series, 5.25-inch disk drive. Repair procedures for A-series (8-inch, 11-megabyte Rev A) drives and B-series (8-inch, 11- and 20-megabyte Rev B, and all non-H-Series, 5.25-inch, 6-megabyte) drives as are networks and other Corvus equipment. Corvus(tm) Level I Dealer Service is on a modular replacement basis, and this manual is written to address this policy.

The H-Series drives are manufactured in three capacities: 6-megabytes (Model 6), 12-megabytes (Model 11), and 18-megabytes (Model 20). These drives all use the same grey high-impact foam-injection plastic cabinet. This is the same drive enclosure used by several of the B-series, 5.25-inch, 6-megabyte drives. Checking the serial number will identify the type of drive to be serviced. Instructions for troubleshooting and repair for all H-Series drives are detailed in this document.

Also included in this manual is documentation on the Dealer Service Diagnostic Utilities supplied to each Corvus Servicing dealer. These utilities provide for burn-in/reliability testing, adjustment, and troubleshooting of all Corvus disk drives. The initialization and diagnostic utilities for the H-Series drives are unique to the H-Series, and contain software specific to these drive models. Use the appropriate A-, B- and H-Series software only for the proper drives.

Installation and operation of the disk drive are not covered in detail in this manual. For instructions in installation and operation, see the Corvus "Disk Systems Installation Guide" and Corvus "Disk Systems User Guide."

1.3 Purpose of Equipment

The Corvus disk drive is a high-speed, intelligent mass-storage peripheral disk device designed to provide the host microcomputer with storage and retrival of digital information instantly at the request of the host system. The Corvus disk system consists of the 5.25-inch disk mechansim, a Z-80™ intelligent controller and power supply, and may be ordered with a host interface, 34-pin interface flatcable and Corvus Utility diskettes.

1.4 Model Identification

The three Corvus H-Series disk drives are identical, differing only in the internal layout of the drive sealed mechansim. The Model 6 uses one platter, the Model 11 uses two, and the Model 20 uses three. The drive type, capacity, and manufacture date may be determined from the serial number tag located at the rear of the drive cabinet.

The following is a sample serial number to be found on a Corvus H-Series, Model 11 disk drive:

023-BH350/M

and is decoded below:

02 represents the week of manufacture (week 02)

3 represents the year of manufacture (3 for 1983)

B represents a Model 11 drive (A=Model 6, C=Model 20)

H represents an H-Series drive

350 represents the serial number of that years' manufacture

/M represents that this drive was shipped with a Mirror™ installed internally

Whenever communicating with Corvus in reference to Corvus products, include the serial number of the equipment involved.

™Corvus Systems is a registered trademark of Corvus Systems, Inc.

™Mirror is a registered trademark of Corvus Systems, Inc.

™H-Series is a registered trademark of Corvus Systems, Inc.

™Z-80 is a registered trademark of Zilog, Inc.

1.5 The Corvus Disk System

The Corvus Mass-Storage Disk System utilizes a sealed 5.25-inch Winchester disk mechanism manufactured by International Memories, Inc (IMI). The drive, with its intelligent controller, is designed as a plug-in device, requiring minimal software setup. Interfacing to host computers is via 34-pin flat-cable interface. Installation and setup procedures are covered in the corresponding "Disk System Installation Guide" and "Disk System User Guide" for the appropriate computer system.

All H-Series drives consist of a 5.25-inch drive mechanism (with integral Read/Write PCA) and Motor Control PCA, single power supply, Z-80 Controller PCA, and cooling fan mounted in a grey plastic cabinet.

The Mirror PCA (when installed) and Z-80 intelligent Controller PCA are plugged into the two card slots of the backplane, located inside the top cover.

1.5.1 Power Supply

All H-Series drives operate from either 110-120VAC or 220-240VAC, 50Hz or 60Hz single-phase power, and use a single power supply. These power supplies are interchangeable between all H-Series drives.

1.5.2 Data Backup

Data backup is accomplished via the Corvus Mirror™. The Mirror converts the data from digital format to video format which is then stored on video cassette tape, using one of many commercial VCRs. The Corvus Mirror option comes internal to the drive when it is ordered, or added as an external device later. All Mirrors are available with a software-controlled, remote-control interface to a Panasonic™ VCR model NV-8200. Mirror troubleshooting and repair is covered in the Corvus Mirror Service Manual.

1.6 Winchester disk drive

The Corvus disk drive uses the IMI Winchester disk mechanism. This new generation of disk drive utilizes a sealed environment, and low-load, low-mass, aerodynamically-suspended read-write heads which rest directly on the disk surface after power-down. It is the contaminant-free environment that allows for reduction in clearance between head and recording media. This results in the heads riding on an 18-micro-inch air bearing, or air cushion. Since bit density is closely related to head-media clearance and head mass, disk drives utilizing Winchester technology can achieve large storage capacities at a premium of space. An added advantage of the Winchester sealed mechanism is that it requires no regular maintenance.

™Panasonic is a registered trademark of Panasonic, Inc.

CHAPTER 2
INSTALLATION

CHAPTER 2 INSTALLATION

2.1 Scope of Chapter

This chapter discusses installation of the disk drive hardware as it applies to environmental requirements, to insure proper operation. Installation and operation procedures for the Corvus disk system are outlined in the "Corvus Disk Systems Installation Guide" and "Corvus Disk Systems User Guide."

2.2 Introduction

Each drive, when it is received, should be checked for shipping damage, and tested for proper function. This chapter contains these check-out procedures as well as those for installing single drives and multiple-drive systems.

2.3 Receiving a Drive

Any time a drive is received, several checks should be performed before the drive is installed at the customer site. Each Corvus disk drive should be carefully unpacked and checked for shipping damage. External evidence of rough handling may be symptomatic of damage to fragile mechanisms within the drive.

NOTE:

Any damage claims must be reported to the local office of the shipper so an inspection may be made, and a damage report filed. Also, if the damaged equipment is a new product, Corvus Order Processing Department must be contacted for proper return procedures. If the damaged equipment is a recently serviced product being returned under an RMA number (Return Merchandise Authorization number), contact Corvus Customer Service Department for proper return procedures.

The disk drive mechanism in the Corvus disk system is an extremely sensitive device. Subjecting the drive to a one-g force (one gravity) will be amplified and transmitted to the heads, impacting them onto the platter with a 100-g force. This necessitates very careful handling of the drive mechanism both in shipping and operation.

When a drive is received, check that all chips in the Z-80 Controller PCA are seated well in their sockets. Chips coming loose during shipping account for a percentage of the failures upon receipt.

- 1) Remove the two screws securing the cabinet cover to the drive basepan at the rear, and remove the cover. Be careful not to stress the dc power cable and flatcables connecting to the Controller PCA and Backplane PCA.
- 2) Locate the Mirror PCA (if installed) plugged into the lower of the two card slots of the backplane, and remove it.
- 3) Locate the Controller PCA installed behind the Mirror PCA, and press firmly on all socketed chips, seating them securely into their sockets.
- 4) Replace Mirror PCA.
- 5) Replace drive cover and secure with screws.

2.3.1 Diagnostic Test

Upon receipt of a disk drive, several procedures must be exercised to verify the proper functioning of the equipment:

- 1) Verify front bezel switch positions
- 2) Verify Mirror Switch positions (on rear bezel)
- 3) Check Controller Firmware VERSION
- 4) Check power supply Voltages
- 5) Execute CRC Test
- 6) Check Parameters (drive and MUX) and record on paper
- 7) Execute EXERCISE Utility

- 8) Run BURN-IN Diagnostic (destructive to data)
- 9) Update Controller Firmware (drive Diagnostic option UPD) changing tables when prompted (answer "yes")

Any Corvus disk drive may be ordered with a Corvus Mirror PCA installed. In all 5.25-inch drives, the Mirror PCA plugs into the Backplane PCA alongside the Controller PCA, inside the cabinet cover. The drive has four DIP switches, located on the rear of the cabinet, which **MUST** be set to correctly reflect the internal Mirror configuration (whether installed or not). If these switches are not set properly, the drive may not function properly (refer to the chart below for proper switch configuration). Drives using a Mirror externally should use the "No Mirror Installed" switch combination.

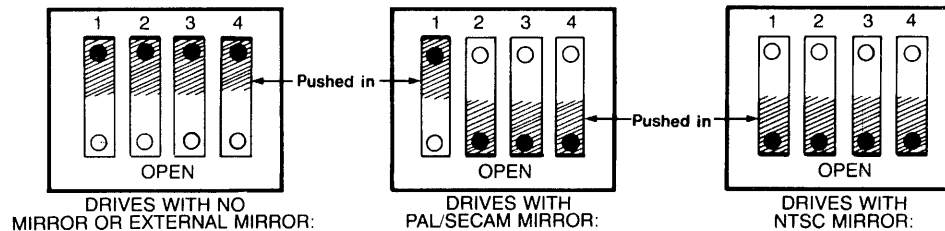

The shaded area indicates that the switch should be pushed in on that side.

Figure 2. Mirror Configuration Switches

Check the drive power supply voltages and adjust if necessary (refer to Chapter 6, "Adjustments and Maintenance" for details).

Next, thoroughly test the drive, using the Dealer Service Diagnostics (as outlined in Chapter 7 "Diagnostics" of this manual). Execute a CRC-Format Check, as well as verify the drive Parameters (specifically the Spare Track table and the Virtual drive Offset table). If either of these tables display values out of range, use the PARAMETERS diagnostic utility to reset them to their appropriate values.

A new drive may be shipped with up to twenty-four tracks spared. There are a total of thirty-one spare tracks available on a new drive, which leaves a minimum of seven (and most likely more) for use in the field. When the drive Parameters are first checked, the values should be noted, recorded on a label, and attached to the drive for future reference.

In the event that the drive format is disturbed in shipment, it may be necessary to reformat the drive. The FORMAT utility should be used only as a last resort. Using the PARAMETERS diagnostic utility, first try to restore the drive parameters before attempting the FORMAT utility. The format program will restore default parameters to the drive, and therefore necessitate re-initialization of these parameters with the original values (i.e. previously spared tracks).

Default parameters are:

Spare Track table: no tracks spared

VDO table: Model 6 drive 1 = 0

Model 11 drive 1 = 0

Model 20 drive 1 = 0

(drive 2 = 911 must be added after FORMAT)

Interleaving Spec: all H-Series drives = 9

Be sure to check the drive parameters before and after formatting the drive. If the drive has ever had a track spared, the Spare Track table and VDO table may need reconstructing before the data is restored. Knowing what tracks are spared prior to formatting the drive will simplify this procedure. Note on the label, any future tracks spared.

2.4 Environmental Considerations

All electronic equipment needs cooling and the Corvus disk drive is no exception. When installing, do not "pigeon-hole" the drive. There should be sufficient open area both front and rear. Place the drive on a level, hard surface without cushion or carpet; the air intake slots are on the bottom of the cabinet, and must not be restricted. Do not place a video monitor on top of, or near the Corvus drive. Electromagnetic fields generated by this device may cause drive malfunction.

Be sure the proper line voltage has been selected and proper fuse size is installed.

Insure the interface cable is properly connected between the connector on the interface card in the host computer, and the PROCESSOR connector on the rear bezel of the Corvus disk drive cabinet. Be sure the "one" edge (edge with dark stripe) is to the right, when facing the rear of the drive unit.

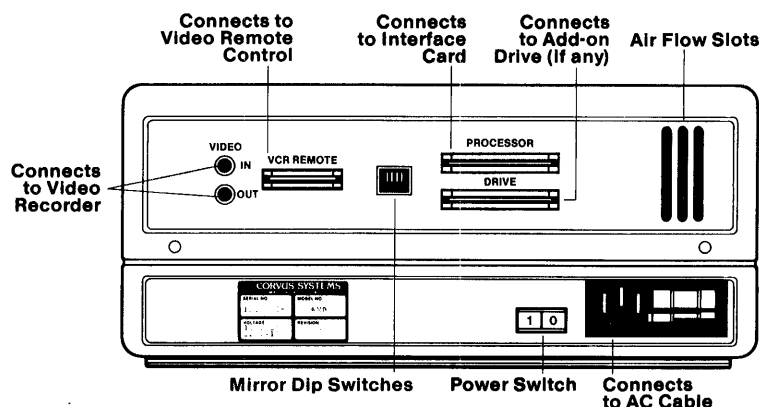

Figure 3. Rear Bezel

Check that all four front panel switches are in the correct position. Run your finger along from right to left, under the switches. All switches should be to the left, unless the disk drive is connected to a Corvus Multiplexer Network system, or to a DEC™ LSI-11™ computer. If so, the appropriate switches should be set.

Locate the power switch on the rear of the drive, and turn it on. The drive motor will begin to spin, and all LEDs (front bezel Light Emitting Diodes) will come on, and the BUSY LED will flash regularly. After approximately thirty seconds, the FAULT LED will go out, and the heads will rezero. LED activity will briefly alternate between READY and BUSY, after which the drive will set the READY signal, and all LED activity will cease, with the READY LED on. The disk drive is now ready for communication with the host system.

2.5 Daisy-Chaining of Disk Drives

A maximum of 80 megabytes of on-line storage may be achieved by daisy-chaining four Model 20 drives. This is accomplished by using a common input/output interface bus, commonly referred to as daisy-chaining. A special Corvus add-on drive flat cable is available specifically for this purpose. One add-on drive cable is required for each additional disk drive in the system. All series and Versions of disk drives may be daisy-chained together with the exception of the Rev A, 8-inch 11MB disk drive (Rev A drives may be daisy-chained only to other Rev A drives). All must use Controller Firmware version CF18.3 or later.

™DEC is a registered trademark of Digital Equipment Corporation

™LSI-11 is a registered trademark of Digital Equipment Corporation

Changing the unit-select switches (positions 1 and 4) on the drive Z-80 Controller PCA for each add-on drive is required when daisy chaining drives. New drives are shipped with the switches configured as drive 1. Additional drives should be set according to their position in the daisy-chain (2, 3 or 4). Refer to the Corvus "Disk System Installation Guide" for the appropriate computer system.

For complete installation and initialization procedures, refer to the appropriate Corvus "Disk System Installation Guide" and "Disk System User Guide."

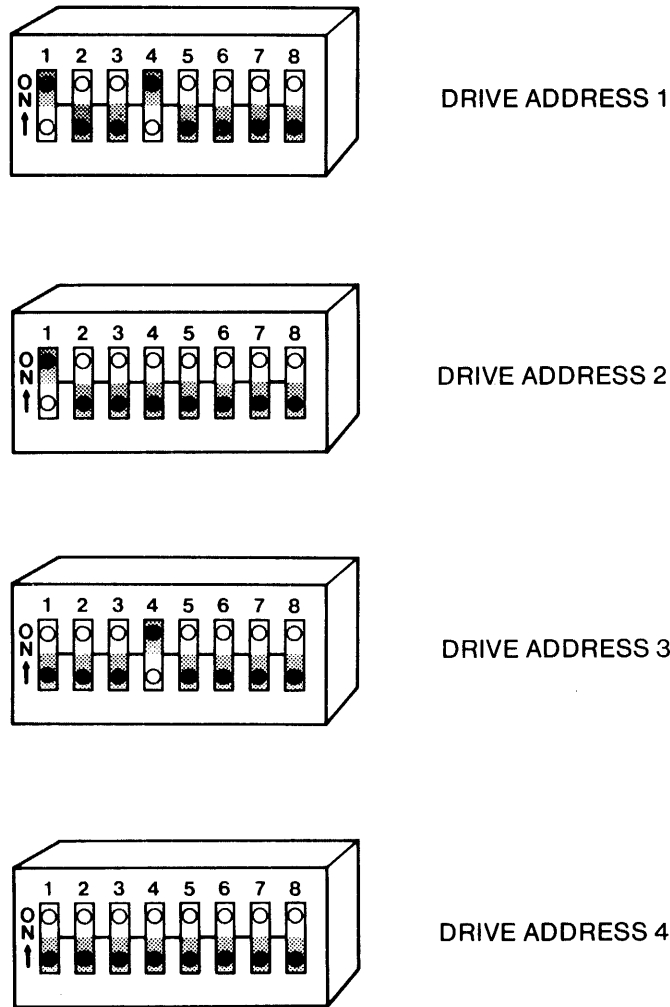

Figure 4. Controller Address Switches

CHAPTER 3
OPERATION

CHAPTER 3 OPERATION

3.1 Scope of Chapter

This chapter describes operator controls and their use as applies to troubleshooting and repair of the drive. Front bezel control switches and Light Emitting Diodes are described, and their functions detailed. Environmental requirements are discussed, and recommended regular checks for the drive are given.

Operation and initialization instructions are detailed in the Corvus "Disk System User Guide" for the appropriate host operating system.

3.2 Introduction

All Corvus 5.25-inch, H-Series drives have front bezel indicator lights and function switches. The switches must be set properly reflecting the system configuration in order for the drive to function properly. Indicator LEDs on the front bezel display the state of the drive, and help in diagnosing the condition of the drive at any time.

3.3 Controls

Operator controls are located on the front bezel of the enclosure. Three LEDs monitor the current state of the drive controller. Four function switches are located under the LEDs. Rear bezel components consist of fuse and power selection unit (CORCOM), power switch, video connectors, Mirror configuration DIP switches, connectors for host processor, daisy-chained drive, and remote control VCR interface cables.

3.3.1 Front Bezel LEDs

The LEDs are labeled READY, BUSY, and FAULT. During the power-up sequence all LEDs are on, and BUSY blinks while the drive motor reaches operating speed. After the drive has completed the power-up sequence, the READY signal will be set, the READY LED will be on, and the BUSY and FAULT LEDs will be off.

During normal operation, the READY LED is active when the drive is ready to receive a command from the host processor. The BUSY LED is active when the drive is currently executing a command received from the host processor. The FAULT LED is active when command execution has been interrupted due to the occurrence of an error. The FAULT LED is an indicator of drive malfunction or operational error, although some software may cause this LED to light during normal operation. FAULT LED function is accompanied by an error code displayed on the computer screen.

3.3.2 Front Bezel Switches

The function switches are located below the LEDs on the front bezel. These are (from left to right) LSI, MUX, FORMAT, RESET. During normal operation, in a single-user system without an LSI-11 computer, all switches should be set to the left.

All switches except for the RESET switch are polled by the controller ROM routines to determine system configuration. Only the RESET switch directly affects the hardware.

Located furthest to the left, the LSI switch is a two-position switch; the OFF (left) position is the normal position, the ON (right) position is for use with a DEC™ System LSI-11™. At power-on time, the controller polls this switch to determine if a DEC LSI-11 computer is attached, and loads the DEC RL01™ and RL02™ disk drive emulation routines from the Controller Firmware area into controller RAM.

The next switch, the MUX switch, is also a two-position switch; the OFF (left) position is the single-user position, the ON (right) position is for use with the Corvus Multiplexer Network™. At power-on time, the controller polls this switch to determine if a Multiplexer is attached, and loads the the Multiplexer polling routine from the Controller Firmware area into controller RAM.

™DEC RL01 and RL02 are registered trademarks of Digital Equipment Corporation

™Corvus Multiplexer Network is a registered trademark of Corvus Systems, Inc.

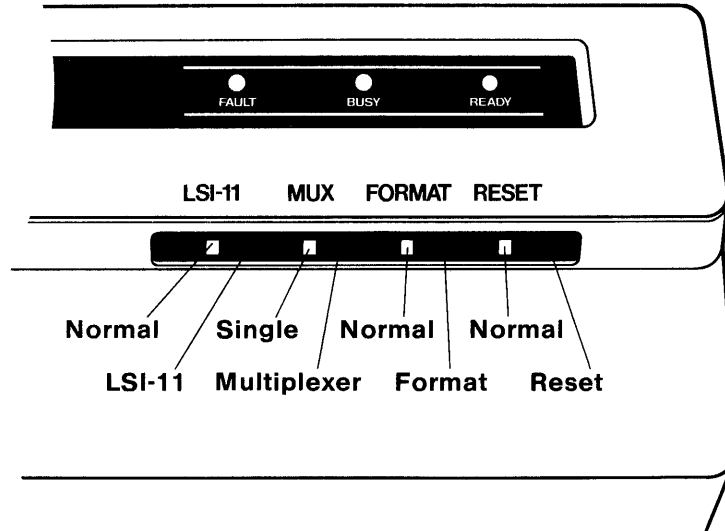

Figure 5. Front Bezel Configuration Switches

The FORMAT switch is a two-position switch; left position is OFF (normal), right position is ON. This switch serves two functions. First, when the drive is turned on, the controller checks all front bezel switches. If the FORMAT switch is ON (right) at this time, the drive will come READY if the ROM-based self-test completes successfully. If, however, this switch is OFF, the controller reads the Controller Firmware from cylinders 0 and 1 into the on-board controller RAM. If this procedure is successful, the controller sets the READY signal, and the READY LED is lit, and the BUSY and FAULT LEDs are extinguished. The drive is now ready to accept a command from the host system. Secondly, the FORMAT switch must be on for the diagnostic program F)ORMAT to execute (see chapter on DIAGNOSTICS). In this mode the switch acts only as a hardware safety switch. No one may execute the F)ORMAT program without having physical access to the drive. The switch being turned ON alone will not format the drive. Only the combination of the format software and the FORMAT switch will allow one to format the drive. If this switch is ON during normal operations, communication between the drive and the host system may be impaired.

Located furthest to the right, the RESET switch is a spring loaded, momentary-contact toggle switch. Toggling this switch initiates a reset signal which resets the intelligent controller in the drive to its original power-on state: the heads re-zero and disk Controller Firmware is again loaded in from the disk into the controller RAM. The drive is then ready to accept another command from the host processor.

3.4 Power-On Sequence

No specific sequence need be followed when powering on the Corvus disk system, with one exception. If the Corvus disk drive is used with an OMNINET local network, power on the Disk Server first. Next power on the disk drive, then the host computer. This procedure supersedes all other procedures that may be found in previous Corvus publications.

3.5 Environmental Requirements

All working environments contain possible hinderances to proper operation of electronic equipment. The following are some possible environmental problems and their solutions.

3.5.1 Static Electricity

Static voltages of thousands of volts can be generated in most office environments. If a system shows irregularities whenever an operator comes in contact with the host computer, network or peripheral equipment, supporting table or surface, static should be suspect.

Static is most easily generated in a cool and dry environment, usually associated with cold weather. Since increased humidity helps prevent static electricity buildup, some type of humidifying device can be helpful. Ideal relative humidity is 70 percent to 75 percent.

3.5.2 Line Noise

Electrical noise on the power line is a major cause of inconsistent equipment operation. Voltage spikes, "brownouts" and dropouts as well as low line voltage are just some of the common causes of drive malfunction.

Located in the CORCOM power selection unit is a line filter capable of handling most minor electrical noise on the power line. Also, the power supply is capable of handling dropouts of up to three complete power cycles.

If power is suspect, the problem may lie in poor continuity of the building wiring, noisy or high power-consumption devices on the same circuit, or poor external supply to the building. Power can be improved by including a constant voltage regulator or isolation transformer in the power circuit. The constant voltage regulator will help minimize the effect of line voltage fluctuations on the Corvus drive, while the isolation transformer will be effective in protecting the Corvus drive from line noise caused by other high-load electrical equipment such as photocopy machines, heating and cooling equipment, elevators, etc. To lessen the impact of frequent power interruption, the use of an uninterrupted power supply (UPS) is recommended.

3.5.3 Temperature

Although in most environments, the disk drive needs no actual warm-up time, there are temperature limits that the drive must operate within (see "Specification" at beginning of this manual). The temperature change maximum for the Corvus disk is 15 degrees fahrenheit per hour.

3.6 Periodic Maintenance

Inherent in the design of the Winchester technology disk devices, is the freedom from the need for regular preventive maintenance. The sealed disk mechanism of the Corvus disk drive requires no maintenance, and contains no field-serviceable components.

CAUTION:

Since contamination of the atmosphere in the mechanism necessitates replacement of the unit, removing the cover to the sealed mechanism voids all warranties.

3.6.1 Regular Checks

Power supply voltages will change with time, and should be checked periodically. Each time the Corvus drive cabinet is opened, check the power supply voltages to verify that they are within specified tolerances (refer to chapter 7 for adjustment procedures).

Due to slight oxidation build-up on cable connectors and IC pins, reseating the flatcable and power connectors and socketed controller ICs periodically will also help insure reliability.

CHAPTER 4
DRIVE DESCRIPTION

CHAPTER 4 DRIVE DESCRIPTION

4.1 Scope of Chapter

This chapter provides a description of the Corvus 5.25-inch, Model 6, Model 11 and Model 20 disk drives and their component interactions. Some terms are defined to help provide a foundation for the following descriptions.

4.2 Introduction

The Corvus H-Series drives are functionally identical except for the drive capacity. They are:

Model 6:	5.6MB
Model 11:	12.8MB
Model 20:	18.3MB

Each drive is divided into three modules: power supply, disk sealed mechanism, and controller electronics. The individual components of these modules are:

- Disk sealed mechanism
- Read/Write PCA
- Motor Control PCA
- power supply or Supplies
- Backplane PCA
- Controller PCA
- Paddleboard PCA
- Drive Cabinet

All drive components of the H-Series drives are identical and are completely interchangeable. These are the minimum accessible modules and are offered as replacement parts as listed above. No sub-assemblies are available as spares.

4.3 Drive Layout

The H-Series drive retains the high-impact plastic cabinet of the 6-megabyte Rev C through Rev E drives, but uses many new internal components. The new drive sealed mechanism can be identified by its aluminum casting (as opposed to the B-Series 6MB molded plastic drive mechanism). Mouted beneath the drive mechanism is a Read/Write PCA and a Motor Control PCA. These are also compatible between all three drive capacities.

The power supply is a single unit, supplying +12V and +5V. It is completely compatible with all H-Series drives.

The H-Series Backplane PCA is attached to the drive cover via standoffs. The Backplane PCA has two card slots which accept the Controller PCA (nearest the cover) and the Mirror PCA (when installed). The H-Series backplane is common to all three H-Series models, but cannot be interchanged between other 5.25-inch drives.

The Controller PCA is located in the uppermost slot (nearest the cover) of the drive Backplane PCA. This PCA is common to all three H-Series models, but cannot be interchanged between other 5.25-inch drives.

The Mirror PCA used with 5.25-inch drives is interchangeable between all Revisions of the H-Series drives as well as all other 5.25-inch drives.

The front bezel Paddleboard PCA is the same PCA used in all revisions of the 5.25-inch drive and most versions of the 8-inch drives, and is interchangeable between these drives.

4.3.1 Power Supply

Every Corvus H-Series drive comes with a power supply to provide all voltages required by the drive mechanism and drive electronics. The H-Series drives require only +12V and +5V. The CP512 is the only power supply required by all H-Series drive models.

4.3.2 dc Power Cables

All power supplies connect to a dc power cable which then connect to the disk mechanism and the drive Backplane PCA. All dc power cables attach to solder terminals on the power supply PCB. The H-Series drives use power cables which connect the single power supply to the Read/Write PCA on the underside of the disk mechanism, and to the Backplane PCA.

4.4 General Description

The recording media of the Corvus 5.25-inch Winchester disk drives consists of an nickel-oxide coating on aluminum disks called platters. There is one 5.25-inch platter in the Model 6 H-Series drive, two platters in the Model 11 drive, and three in the Model 20. All platter surfaces are utilized for data storage. One head rides above each surface on an 18-microinch air bearing (air cushion).

Data is stored magnetically on circular tracks, which are configured as concentric circles on each platter. Each track is further divided radially into 20 sectors, each sector containing one 512-byte block available for user data. The term track refers to a single head surface of a cylinder, each cylinder consisting of all tracks in common vertical alignment on all surfaces. There are 306 cylinders on the H-Series drives, with cylinder zero located furthest from the platter center.

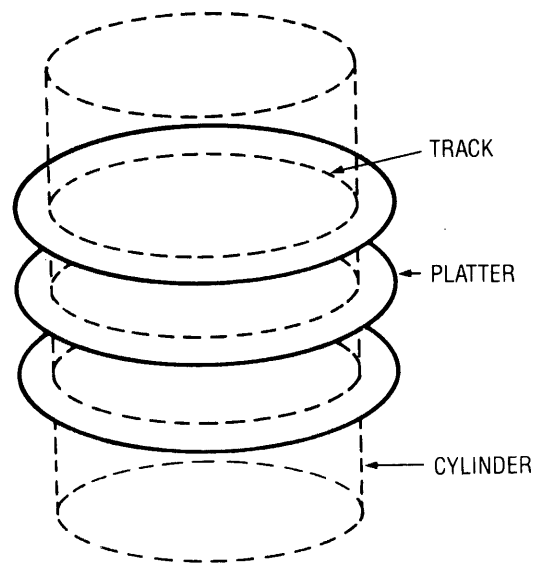

Figure 6. Data Configuration

A block is the smallest addressable unit within the drive. Internally, each block consists of 512 bytes of data. Externally, the drive handles data in sectors as defined by the host computer.

Typically, each host operating system defines a sector as 128 bytes, 256 bytes or 512 bytes. The Corvus interface software uses the appropriate read and write commands (one each for writing and reading 128, 256 or 512 bytes) depending on the requirements of the operating system.

This does not cause a conflict, since the drive simply stores 1, 2 or 4 host-defined sectors for each disk drive block. Read and write commands of less than 512 bytes are transparent to the host system, due to the intelligent controller's ability to handle data blocking internally.

4.5 Disk Sealed Mechanism

The Corvus mass-storage disk mechanism uses a combination of both new Winchester technology and traditional disk design.

The 5.25-inch platters revolve on a common spindle, driven by a brushless dc motor at 3600 RPM. Motor speed is monitored by the Motor Control PCA, located uppermost beneath the drive mechanism, and is independent of line frequency. The index pulse is generated by the magnetic index detector mounted to the underside of the drive base near the spindle. The Solenoid Brake is also located adjacent to the motor hub, and engages immediately after the drive is powered off. Adjustment procedure for the Solenoid Brake and index detector are located in the section titled "Adjustments and Maintenance."

Each head is suspended above the platter surface on an 18-microinch (.4572 microns) air bearing. A particle of smoke, dust, or a human hair could easily play havoc with these critical tolerances, and cause catastrophic failure of the disk device. The seal on the drive mechanism prevents this from occurring by keeping the internal atmosphere contaminant-free. Breaking this seal for any reason, voids the warranty.

There are two heads for each platter in the drive mechanism. The heads are held by flexure arms, attached to a common head stack casting which moves on precision bearings and stainless steel rails. Positioning of the heads over the appropriate cylinder is accomplished by a four-phase stepper motor, via a split stainless steel band. Seeking to a specific cylinder is accomplished by stepping the motor through four phases for each cylinder. Reversing the sequence of these motor phases will result in reverse head movement. Each increment of the motor is equal to 0.9 degrees rotation.

Two Printed Circuit Assemblies are Mounted beneath the drive mechanism. These are the Read/Write PCA and the Motor Control PCA. The Motor Control PCA is responsible for monitoring the spindle motor speed and altering it as necessary. Index and track 0 signals are also buffered on this board. The Read/Write PCA, contains a 6801 microprocessor IC which makes the drive mechanism itself an intelligent device, freeing the Z-80 controller from many rudimentary tasks. The Read/Write PCA sends data to and receives data from the drive mechanism and the Controller PCA. Many motor control signals are also generated on the Read/Write PCA.

4.6 Controller Firmware

Corvus reserves the first two cylinders of the drive for special code. This is referred to as Controller Firmware, and is not accessible to the host operating system. This Firmware contains programming and system information required by the Z-80 drive controller and is loaded into the disk drive RAM when the drive is powered on or when the RESET switch is toggled. The spare track table, Multiplexer parameters, Semaphore and Pipe information are contained in the Controller Firmware. Identical copies of Firmware reside in each of the two cylinders. The rest of the disk area is available to the host system for data storage, the configuration of which depends upon the type of host operating system. Only Controller Firmware version CF18.3 or later may be used with H-Series drives.

When daisy-chaining one or more H-Series disk drives, it is necessary to update Controller Firmware on all drives in the system using the latest version of firmware data file (CF18.3 or newer).

4.7 Data Storage

Data storage arrangement is by concentric tracks vertically aligned as cylinders. Each track is sectioned into 20 sectors, each sector has a data capacity of one 512 byte block. Logical sectors are numbered by using an interleaving specification (sector skewing scheme) of nine for all H-Series drives.

All surfaces are used for data storage. Since this drive uses a stepper motor for head positioning, no servo tracks are required.

Contained in the head stack is the microchip. This select microcircuitry is responsible for selecting which head is being used. The microchip is also responsible for preamplification, and transmitting of the signal to the drive electronics for further amplification.

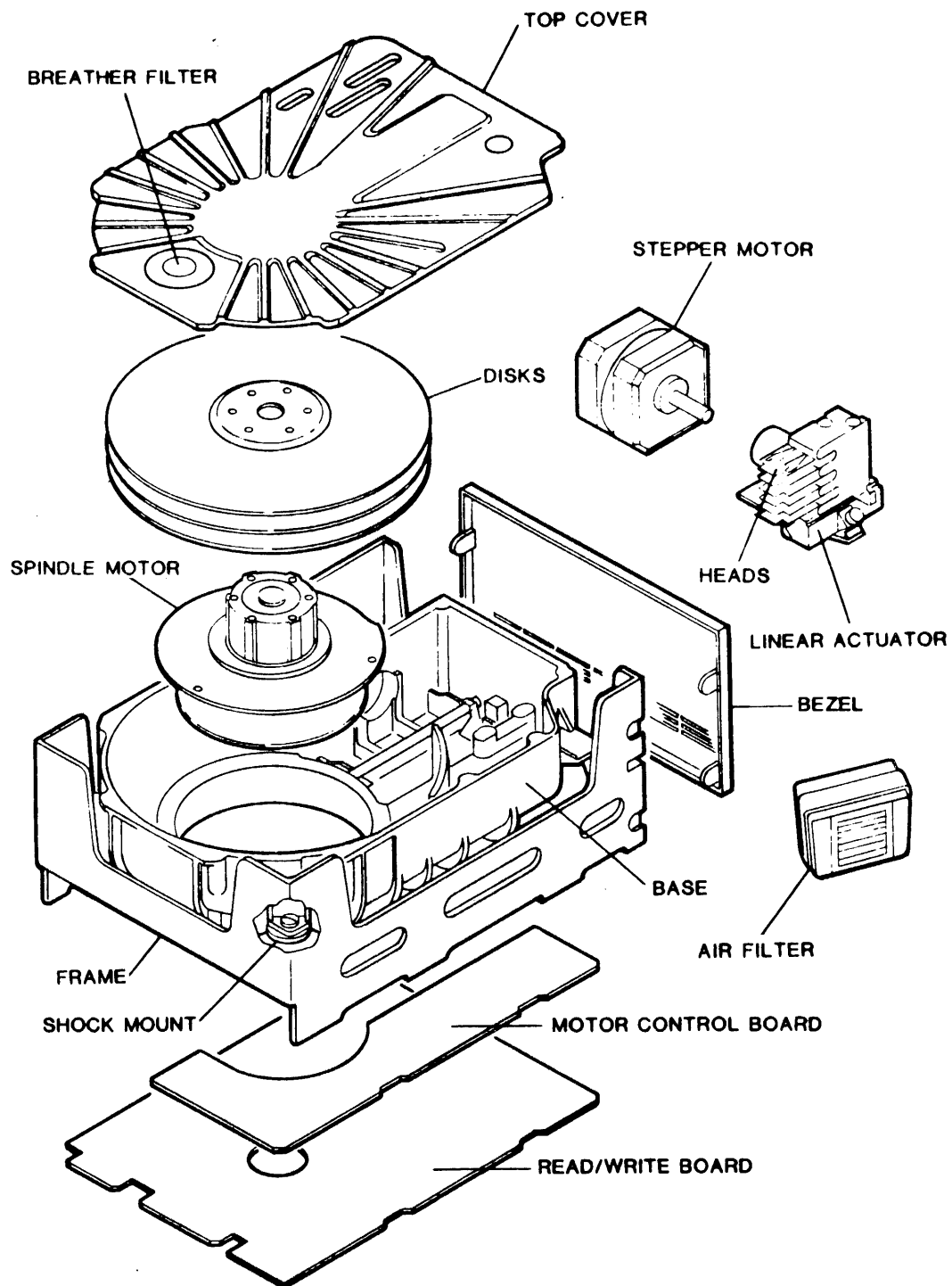

Figure 7. Drive Mechanism Components

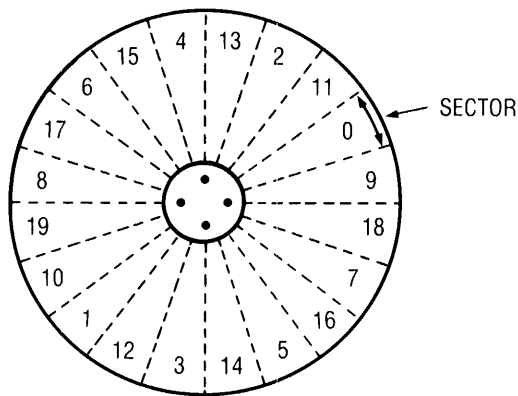

Figure 8. Sector Interleaving

4.8 Transportation Considerations

All Corvus H-Series, 5.25-inch disk drives have the capability of having the heads “parked” off of the data area of the platters. Refer to the chapter on “Diagnostics” in this document for the head parking procedure.

Parking the heads in this manner does not preclude the drive from the need for gentle handling. The disk drive is a delicate instrument. If, when the drive is transported, it is subjected to rough handling, the heads will impact the disk surface, possibly causing damage.

4.9 Theory of Operation

All communication between the drive and the host computer system is interfaced by the Controller Firmware, resident in the controller RAM after the drive is powered on. Without firmware the drive will not recognize commands sent from the host system.

The Corvus drive responds to a small list of commands generated by the disk interface software, which are patched into the host operating system when the drive is first initialized. These normal commands are:

- Read 128-, 256- or 512- byte sector
- Write 128-, 256- or 512- byte sector
- Enter Prep Mode (download special firmware to RAM)
- Mirror (Backup, Identify, Verify, Restore and Remote)
- Semaphore (Lock, Unlock, Retry, and Error report)
- Read Drive Parameters (Spare Track and Mux table)
- Pipes (Initialize, Open, Read, Write, Close and Purge)

All normal drive operations are accomplished using the above commands, as the Controller Firmware contains all Z-80 routines for decoding these commands. Other commands are possible, and are accomplished by first executing the Enter Prep Mode command which replaces Controller Firmware with special firmware containing routines for decoding these commands (i.e. diagnostics).

4.9.1 Power-Up

As soon as the power supply voltages have stabilized, the Z-80 controller board executes a ROM routine which initializes the Z-80 microprocessor and then tests the controller RAM and ROM. If the self-test fails, the Z-80 halts execution, leaving the FAULT and BUSY LEDs on, and READY LED off.

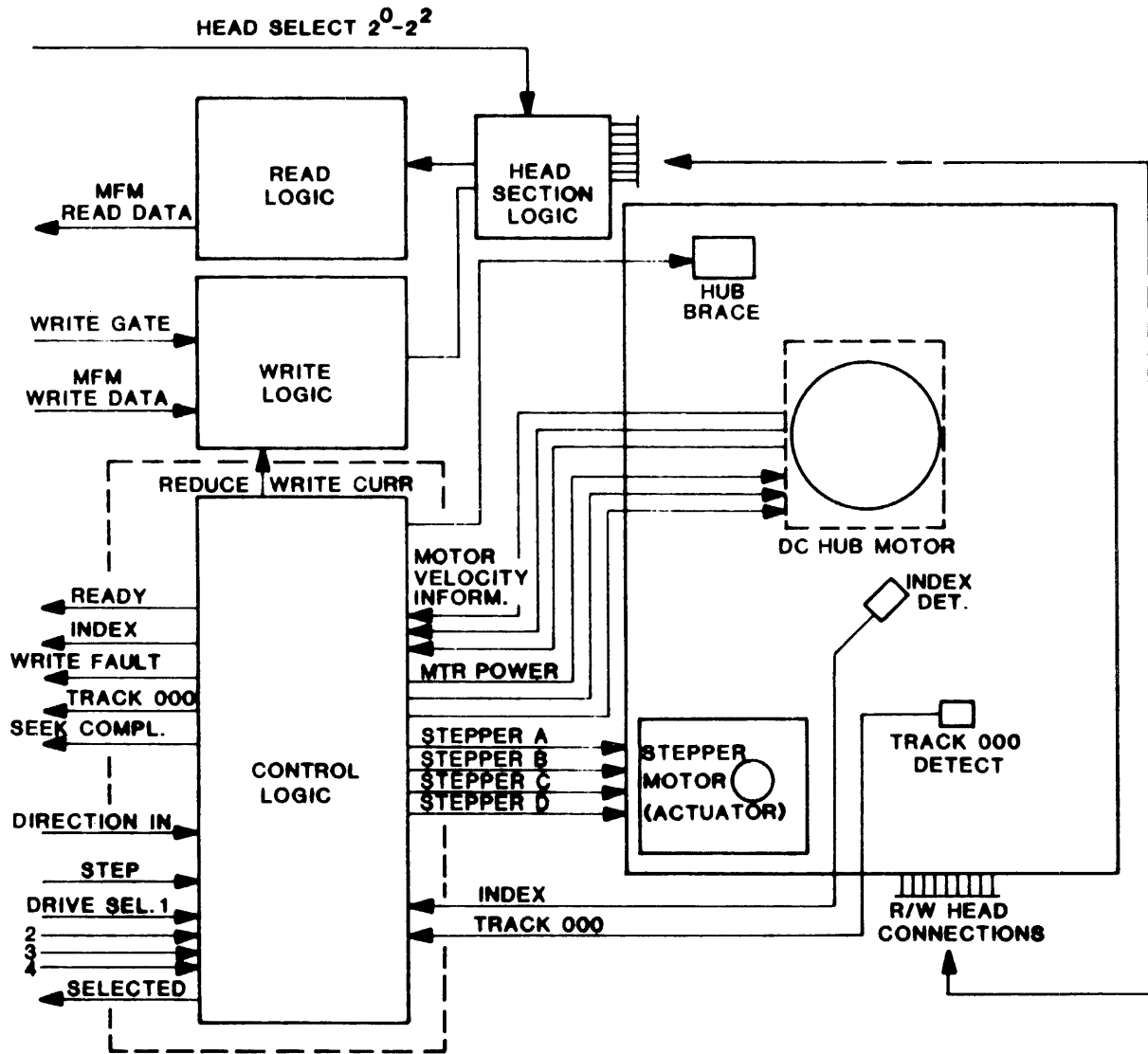

Figure 9. Drive Mechanism Block Diagram

If the self-test executes successfully, the drive begins the controller-boot routine. This consists of first re-zeroing the heads, bringing them over the first cylinder of the disk surfaces. The front bezel switches are then sampled. If the FORMAT switch is ON (right), the controller sets the READY signal. If it is OFF, the Controller Firmware is read from the first cylinder into the on-board RAM. If the Firmware is successfully read in, the drive comes READY. If a bad block (CRC error) is encountered while reading the firmware, the controller will attempt to read from the second copy, any bad sectors found in the first. It will continue to read alternate copies from the the first two cylinders until all Controller Firmware is successfully loaded into the controller RAM. The controller will then set the READY signal, and the READY LED will be on, with the BUSY and FAULT LEDs off.

4.9.2 Controller PCA

The Z-80 drive controller is responsible for interpreting commands sent from the host computer system and controlling the sub-assemblies (the drive mechanism and associated Read/Write PCA, and the Mirror PCA). The controller reports back to the Host Computer, via a 34-pin flatcable, the success of the command executed by means of a one byte return code. A return code of zero is returned if no errors occur. (See Error Code Chart in "Troubleshooting" section for non-zero return codes).

The Controller PCA contains the 4MHz Z-80A CPU and Z-80A support ICs as well as a 4K controller ROM (containing elementary procedural Z-80 code for the intelligent controller) and 5K of on-board RAM (used for buffering data to and from the disk, and storing utility code loaded from the Controller Firmware area of the disk). The three Z-80A PIO ICs are used to buffer signals to and from the host Interface PCA, Corvus Mirror and network devices, drive sealed mechanism, and the front bezel controller switches and LEDs. In addition, one of the PIO ICs monitors the on-board CRC generator/checker IC, and informs the Z-80 CPU in the case of a CRC error.

All disk-to-controller memory and controller memory-to-disk data transfers as well as all controller memory-to-Host Computer memory and Host Computer memory-to-controller memory data transfers are handled by discrete Direct Memory Access (DMA) circuitry. This DMA state machine is responsible for fast memory transfer during the execution of read and write commands.

The Controller PCA receives MFM read data from the Read/Write PCA and converts it to NRZ read data before passing it on to the Host Computer. Similarly, the controller receives NRZ data from the Host Computer and converts it to MFM format before passing it on to the Read/Write PCA for writing to the disk media.

4.9.2.1 Controller During Seek Command

The Host Computer operating system sends a command to the drive controller in a one-, two- or four-byte format. The controller, using decoding routines contained in the Controller Firmware, decodes the command. The Z-80 microprocessor then calculates the difference between the current cylinder number (always held resident in RAM) and the requested cylinder. The resultant difference is stored in a RAM memory location and later decremented once for each cylinder the heads are moved.

Read/Write PCA is then commanded to strobe the stepper motor windings (PHASE A-D). The controller decrements the cylinder count one for each full motor phase sequence (A-D) and halts the stepper motor at the appropriate cylinder. At each cylinder, the controller applies a lock current to counteract the motor's momentum. If the present cylinder is not the destination cylinder, this current is very low. When the destination cylinder is reached, full locking current is applied to the motor windings which keep the heads on cylinder.

The next sector to move past the heads is read to verify the success of the seek. If the incorrect cylinder was reached, the heads are re-zeroed and the seek is attempted again. If the seek fails during this re-try, the drive halts operation, and a seek error is returned to the host operating system.

4.9.2.2 Controller During Read and Write Commands

The read command begins with the command bytes are received from the Host Computer in parallel form, via the Interface PCA. This command will be unique for either a 128-, 256- or 512-byte sector read. The requested sector number will accompany the command bytes.

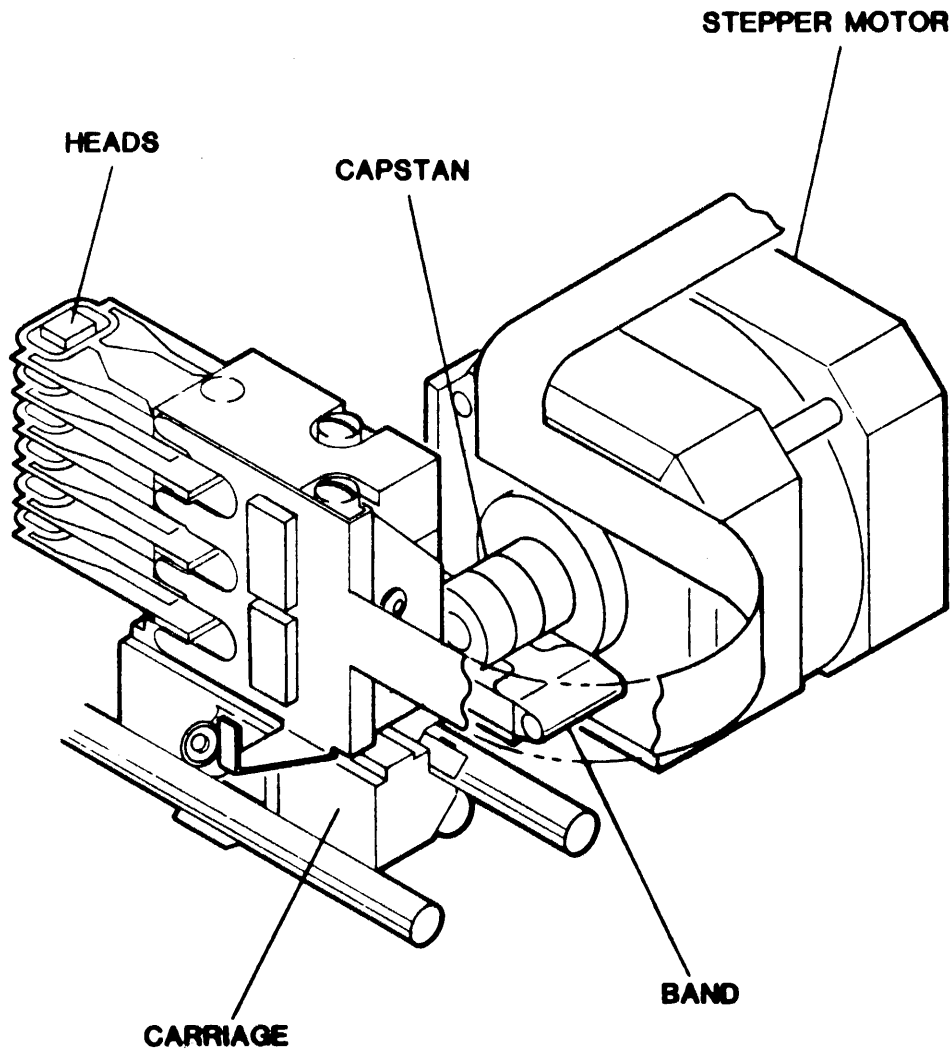

Figure 10. Stepper Motor Assembly

The controller will calculate a difference value between the current cylinder, and the cylinder containing the destination sector. The drive mechanism will be commanded to seek to the new cylinder, and the correct head selected. The controller is now ready to read in the data from the sector, and waits for the appropriate sector to be positioned under the head. READ GATE is asserted, and the Z-80 relinquishes control to the discrete DMA state machine which captures the data signal in MFM form from the headstack microchip via the bi-directional data bus. The data is amplified, filtered and shaped (squared) before being converted to NRZ format. The Controller PCA handles CRC error checking, parallel-to-serial conversion, and transfer of the data to on-board RAM and then to Host Computer RAM once control is returned to the Z-80. A return code is sent to the host computer identifying the success of the command.

The drive controller handles data in 512-byte quantities only. Host-defined sector sizes less than 512 bytes are handled by storing multiple sectors in each 512-byte Corvus sector.

Similarly, the write command begins when the command bytes, along with the associated sector address(es) are received. The Z-80 controller then determines whether the write command is for 128, 256 or 512 bytes (depending on the host system's standards), and relinquishes control to the DMA circuitry for transfer of the data from host memory to the on-board controller RAM.

Next, preparations are made for writing that block out to the disk. If the quantity of data to be written is less than 512 bytes, the sector is first read into controller RAM. When the proper sector comes around, the controller again turns control over to the DMA circuitry. The drive processor again is put into a wait state while the DMA transfers data bytes one at a time to the parallel-to serial converter. A CRC value is generated from the serial data and inserted in the data stream. The data is converted from NRZ format into MFM format and then directed to the read/write heads for writing to the sector. The CRC information is used during a read, for checking data integrity.

The disk write operation is concluded by reading in the block and its associated CRC byte to verify its success. Every write command is followed by a verify (read) command. A status byte is then sent to the host system indicating the result of the disk write.

4.9.3 Backplane PCA

The Backplane is responsible for transferring power and signals between the Controller PCA, Mirror PCA, Paddleboard PCA and the Host Interface PCA (via the rear bezel 34-pin connector). The upper slot of the Backplane is reserved for the Controller PCA, and the lower slot is reserved for the Mirror PCA. These two PCA positions may not be interchanged.

This two-piece printed circuit assembly accepts flatcables from the front bezel Paddleboard PCA as well as from the Host Computer System. A single dc power cable supplies voltage to the Backplane PCA via a four-pin connector.

The Backplane PCA for the H-Series drives is unique to these products, and is not interchangeable with other Corvus drive products. The Backplane PCA for the Model 6, Model 11 and Model 20 is interchangeable only between these three drives.

4.9.4 Paddleboard PCA

The Paddleboard PCA, located on the front bezel of the drive enclosure contains switches and LEDs. The function of these controls are detailed in chapter 2.

All Paddleboard PCA revisions are compatible with all drive revisions, and are interchangeable.

4.9.5 Interface PCA

The Corvus disk system will interface to many different microcomputer systems, and may be purchased with any of several interface cards available.

The typical interface card contains address decoding, bidirectional data buffering, and handshaking circuitry. Some interface cards also have ROMs containing boot routines for booting the microcomputer from the Corvus disk; some do not, and these computers must boot from floppy diskette.

Connected to the 34-pin flatcable, the Interface PCA contains two input ports, and one output port and address decoder. One input port is an eight-bit tristate data buffer, used for receiving data bytes during drive-to-host transfers. The other input port is the status port, used for determining the state of the disk drive. The output port is an eight-bit latch, used in host-to-drive data transfers.

When the host system needs to access the disk, it first checks the BUS DIRECTION signal, and if the bus is in the host-to-drive direction, and the READY signal is high, the drive is ready to accept a new command. The host then sends command bytes to the drive.

During a read or write command, the bus will remain in one direction without turning around, until all bytes have been transferred. The drive will acknowledge the acceptance and execution of commands by setting the bus direction bit of the status port. This is a signal that the return code is on the data bus, which must be retrieved before the drive will accept new commands.

All of the above handshaking is taken care of by the Corvus interface software and is totally transparent to the user.

4.9.6 Read/Write PCA

The Read/Write PCA is located beneath the drive mechanism. The Read/Write PCA is responsible for buffering, filtering the read data, and supplying write current. Also, the sector and track 0 signals are generated here.

The Read/Write PCA contains a 6801 microprocessor IC, which handles much of the servo motor control, write current control and most of the drive mechanism control schemes.

The Read/Write PCA is available as a spare part, and is interchangeable between all H-Series drive mechanisms, regardless of capacity.

4.9.7 Motor Control PCA

Spindle motor speed is monitored by the circuitry on the Motor Control PCA. A tachometer feedback loop helps maintain spindle speed within 0.5% of 3600 RPM. The magnetic index detector delivers pulses to the Motor Control PCA, which generates the index signal. The Motor Control PCA monitors this signal, and adjusts motor speed as required.

The Motor Control PCA is available as a spare part, and is interchangeable between all H-Series drive mechanisms, regardless of capacity.

Two Motor Control PCAs exist, one (p/n 811-02410) for use with the two-wire brake mechanism, and one (p/n 811-01908) for use with the three-wire brake mechanism. Each of these PCAs must be matched with the appropriate brake mechanism, and may not be substituted for one another.

CHAPTER 5
DISASSEMBLY

CHAPTER 5 DISASSEMBLY

5.1 Scope of Chapter

This chapter contains disassembly instructions for all H-Series drives. These three drive models (Model 6, Model 11, and Model 20) are all physically identical. The disassembly instructions that follow apply to all.

5.2 Introduction

The Corvus H-Series drive consists of a high-impact plastic shell, the top and bottom halves held together with two screws at the rear of the cabinet. The backplane has two edge-connector slots which accept the Mirror PCA (when installed) and Controller PCA, and a 20-pin flatcable connector which accepts the cable from the front bezel Paddleboard PCA. All these are mounted to the drive cover. The drive sealed mechanism and power supply are both attached to the cabinet basepan.

WARNING:

Before disassembling any disk equipment, be sure the power is disconnected.

5.2.1 Tools Required

The following tools are required for disassembly of all Corvus H-series drives:

- 1) #2 phillips screwdriver
- 2) 5/64-inch hex driver
- 3) 3/32-inch nut driver
- 4) 3/16-inch blade screwdriver

5.3 Plastic Package

The H-Series drives share the grey plastic drive cabinet with the Corvus Rev C, D and E, 6MB disk drives. Disassembly is similar.

5.3.1 Top Cover

1. Remove the two phillips screws at the rear of the cover.
2. Remove the cover by sliding it back and lifting it straight up. Be careful not to stress the dc cabling and flatcables connected to the Controller PCA and the Backplane PCB.

5.3.2 Controller PCA

1. Remove the drive mechanism flatcables from the upper connectors of the Controller PCA noting their orientation (one edge to the left).
2. Note the orientation of the two flatcables (one-edge to the left) connecting the drive mechanism to the Controller PCA, and disconnect them.
3. If the drive has a Mirror PCA installed in the Backplane, remove it by gently disengaging it from the standoffs and pulling it out of the backplane slot.
4. Remove the two nylon standoffs securing the controller to the cover.
5. Remove the controller by gently pulling it out of the backplane slot.

5.3.3 Backplane PCA

1. Disconnect the one dc power cable and one flatcable from the Backplane, noting their orientation (one edge to the left).
2. Release the forward half of the Backplane PCA from the nylon standoffs.
3. Remove the five nylon standoffs securing the Backplane to the cover.
4. Remove the Backplane PCA by moving it down and forward.

NOTE:

The ground wire connecting the drive mechanism to the power supply MUST be connected for the drive to perform properly.

5.3.4 Drive Mechanism

1. Disconnect the ground wire between the drive mechanism and the power supply.
2. Remove the four phillips screws securing the drive mechanism mounting brackets to the basepan.
3. Noting the orientation of the dc power cable and flatcables, disconnect them from the drive mechanism.
4. Remove the drive mechanism, with its brackets, up and out of the basepan.
5. Remove the four phillips screws securing the brackets to the drive mechanism, and remove the brackets.

5.3.5 Read/Write PCA

1. Remove the drive mechanism as outlined above.
2. Remove the mounting brackets.
3. Place the drive mechanism on its top, exposing the Read/Write PCA.
4. Disconnect the read-write/head-select mylar flatcable from the Read/Write PCA to the drive mechanism (see figure 11.)
5. Remove the three standoff securing the Read/Write PCA to the drive mechanism.

NOTE:

The central standoff securing the Read/Write PCA provides an electrical ground, and must be metal.

6. Gently lift the Read/Write PCA up, disconnecting the Motor Control PCA connector J-24 (refer to figure 11).
7. Once the Read/Write PCA is free of the Motor Control PCA connector, swing the PCA up to expose the stepper motor connector.
8. Noting the stepper motor cable orientation (yellow wire towards outside), disconnect it.

5.3.6 Motor Control PCA

1. Noting its position and orientation, unplug the brake mechanism connector (J-21) from the Motor Control PCA.
2. Noting its position and orientation, unplug the spindle motor connector (J-22) from the Motor Control PCA.
3. Noting its position and orientation, unplug the index sensor connector (J-25) from the Motor Control PCA.
4. Noting its position and orientation, unplug the track zero switch sensor connector (J-23) from the Motor Control PCA. This connector must be rotated 90 degrees from vertical before being re-connected.
5. Remove the two standoffs and one slot screw, noting their respective positions, and remove the Motor Control PCA.

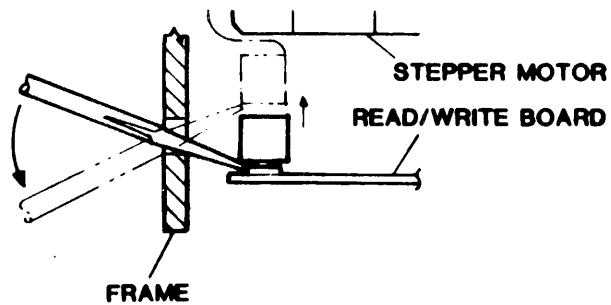
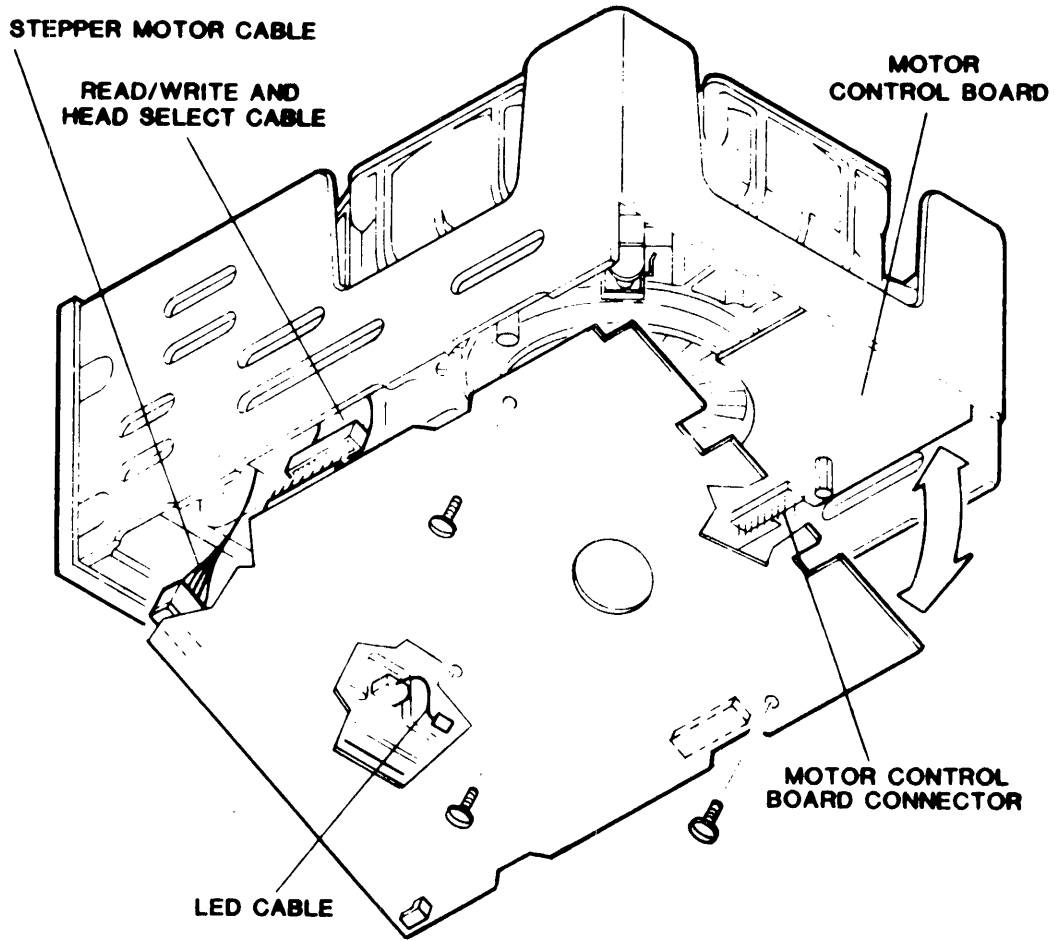

Figure 11. Read/Write PCA Removal

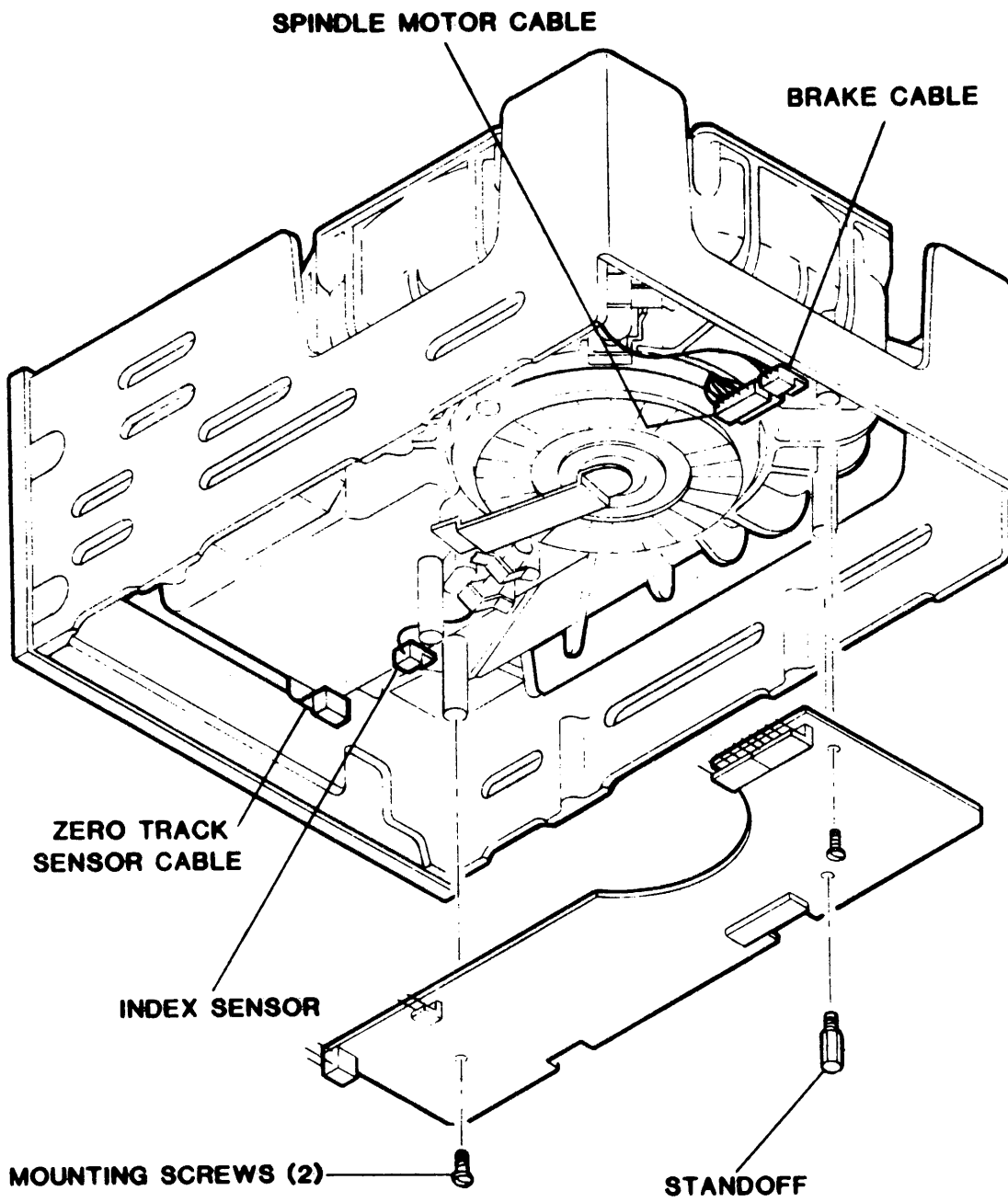

Figure 12. Motor Control PCA Removal

5.3.7 Power Supply

1. Disconnect the ac wiring harness connector from the rear bezel CORCOM unit and power switch.
2. Remove the screw securing the ac groundwire to the power supply.
3. Remove the screw securing the dc groundwire to the power supply.
4. Disconnect the dc wiring cables from the drive mechanism and the Backplane PCA.
5. Disconnect the ac fan cord from the cooling fan.
6. Remove the four phillips screws securing the power supply to the basepan.
7. Remove the power supply straight up and out of the basepan.

5.3.8 Front Bezel

1. Remove the flatcable from the front bezel Paddleboard PCA, noting its orientation (one edge down).
2. Remove the three phillips screws securing the front bezel to the basepan.
3. Remove the bezel straight forward.

CHAPTER 6
ADJUSTMENTS AND MAINTENANCE

CHAPTER 6 ADJUSTMENTS AND MAINTENANCE

6.1 Scope of Chapter

This chapter will cover check and adjustment of power supply voltages, brake solenoid and index detector.

6.2 Introduction

The Corvus disk system is based on a Winchester disk mechanism. Because of this storage device's sealed environment, the mechanism itself needs no preventive maintenance.

6.3 Power Supply Voltage Check and Adjustment

Aging of the power supply and normal heating and cooling of the drive electronics can cause the power supply voltages to drift. Voltages should be checked each time the installation is visited for system checkout.

All three H-Series drives use the same power supply, the CP510, and is interchangeable between all three H-Series drives.

WARNING:

Extreme caution should be exercised when adjusting the power supply. High voltages present a potential hazard.

6.3.1 Voltage Check (CP510):

1. Remove cover to the enclosure as outlined in chapter 5.
2. Locate voltage test points at the edge of the CP510 power supply. These are labeled +12V, +12V COM, +5V, +5V COM.
3. Turn on the ac power switch.
4. Using a DIGITAL voltmeter, check the power supply voltages at these connections, using the corresponding COMMON test point. All voltages must be within ± 0.1 volts of the specified voltage.
5. If any of the voltages are out of tolerance, follow the adjustment procedure for this supply.

6.3.2 Voltage Adjustment (CP510):

1. Remove cover to the enclosure as outlined in chapter 5.
2. Connect ac power to the disk drive, and turn on the ac power switch.
3. Monitoring the dc voltages as outlined above, adjust the +5V and +12V using the following adjustments:

CP510

R-9	+12V
R-16	+5V

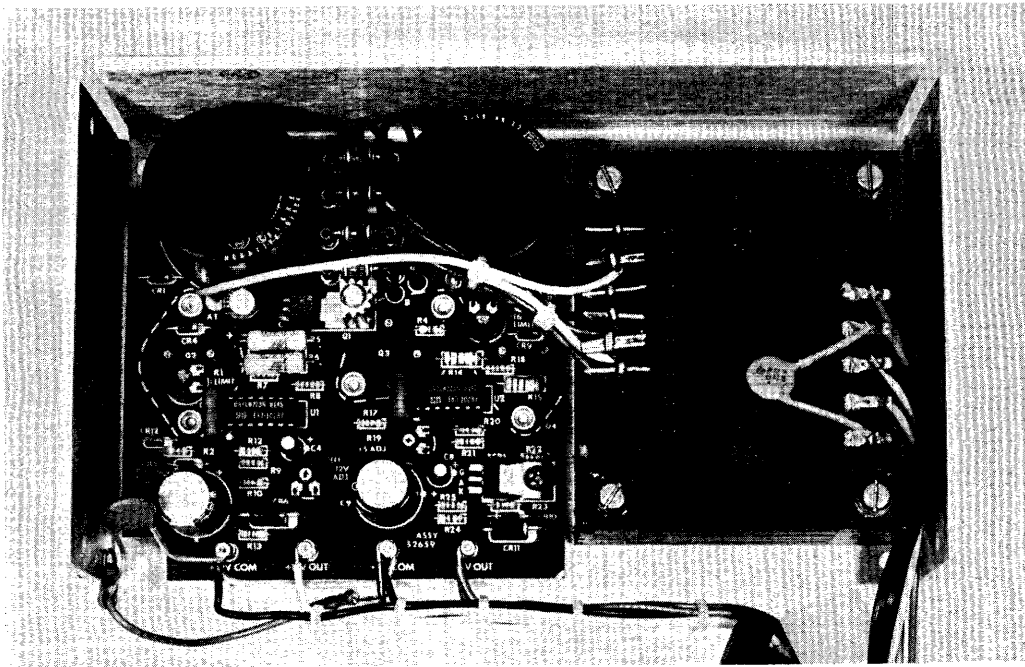

Figure 13. CP510 Power Supply

NOTE:

During adjustment, the +5V or +12V may drop to or near zero. This is due to the over-voltage protection circuitry being activated. To reset this condition, turn off the ac power switch, and bleed the +5V or +12V charge to ground using a 10-K resistor. Set the trim resistor to its original position, turn on ac power and proceed with the adjustment.

4. Remove ac power from the drive.
5. Replace the drive cover and screws.

CAUTION:

Do not manually spin the drive motor at any time.

6.4 Motor Brake Adjustment

1. Remove the drive mechanism from the cabinet and remove Read/Write PCA as described in Chapter 5.
2. Loosen the two brake mechanism assembly mounting screws.
3. Hold the brake solenoid assembly against the lateral location bosses.
4. Place the appropriate thickness gauge between the brake friction shoe and the motor hub.
 - 3-wire Motor Brake Assembly: 0.007" \pm 0.003"
 - 2-wire Motor Brake Assembly: 0.012" \pm 0.003"
5. While holding the brake plunger fully retracted, move brake assembly against thickness gauge and motor hub, and tighten brake mounting screws. Do not overtighten these screws.
6. Recheck the adjustment of the brake mechanism. With the brake plunger fully retracted, the hub-to-plunger clearance should be as described above.
7. Reinstall Read/Write PCA.

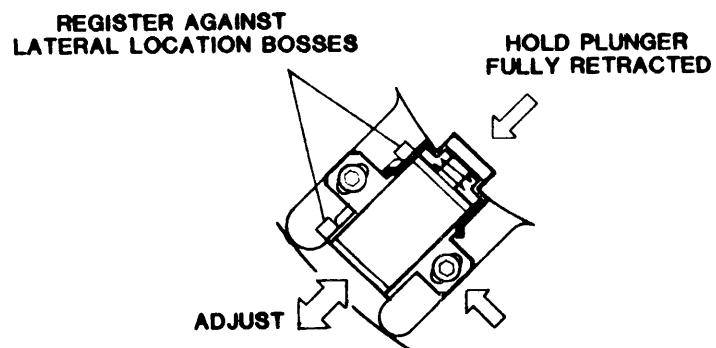
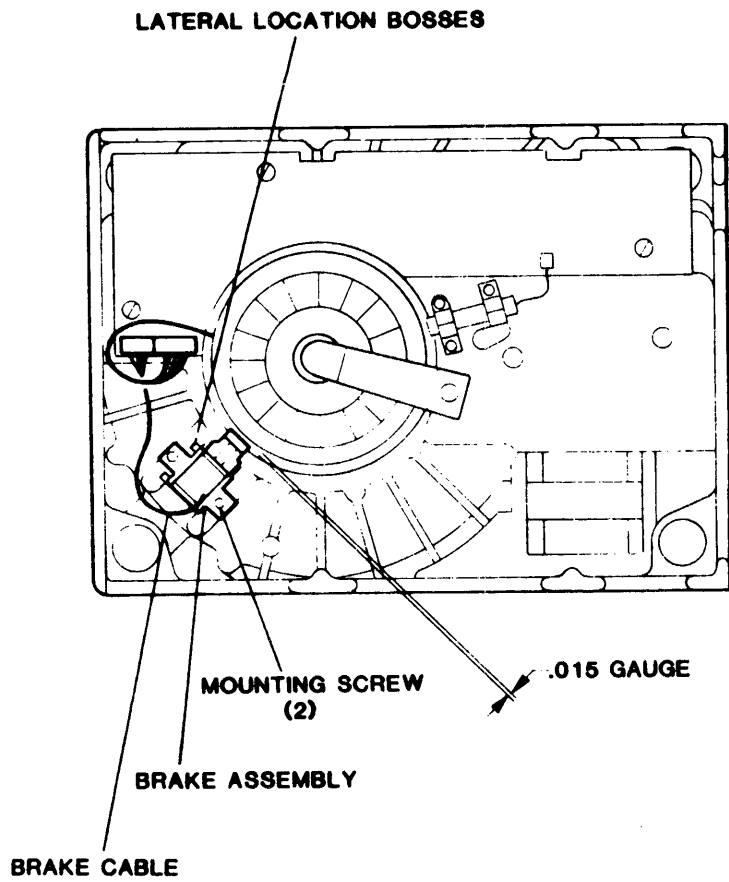

Figure 14. Brake Mechanism Adjustment

6.5 Index Sensor Adjustment

CAUTION:

Altering of the Index Sensor adjustment may cause loss of data on the drive mechanism. This adjustment should be attempted only if a backup of the drive data exists.

1. Remove the drive mechanism from the drive cabinet and remove Read/Write PCA as described in Chapter 5.
2. Loosen the two index sensor assembly screws.
3. Rotate motor until the the silver-colored timing tab lines up with the index sensor.
4. Place a 0.015" thickness gauge between the sensor and the index tab on the motor.
5. Move the index sensor against thickness gauge and tighten mounting screws.
6. Recheck the adjustment of the index sensor. With the index timing tab aligned with the index sensor, the clearance should be $0.015" \pm 0.003"$.
7. Reinstall Read/Write PCA.

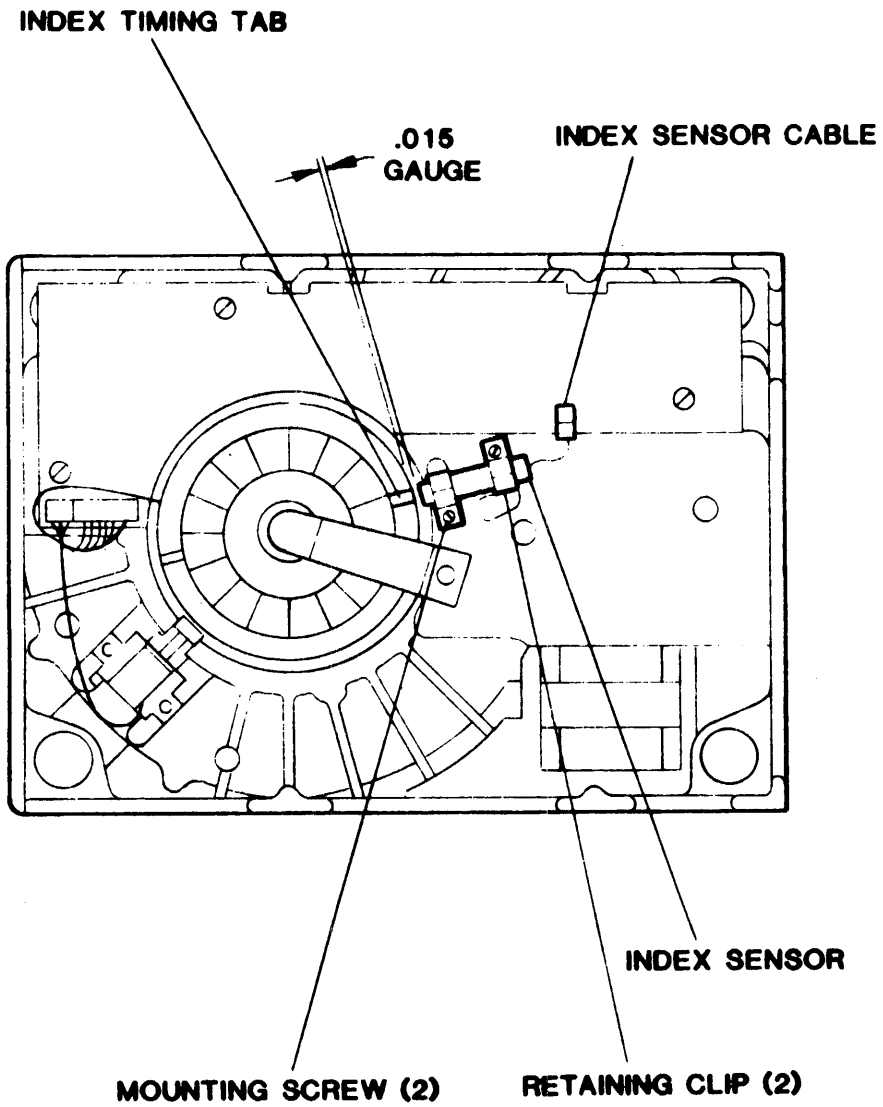

Figure 15. Index Sensor Adjustment

CHAPTER 7
DEALER SERVICE DIAGNOSTICS

CHAPTER 7 DEALER SERVICE DIAGNOSTICS

7.1 Scope of Chapter

The Dealer Service Diagnostic Utilities are supplied to aid the technician in tracing faults in the Corvus disk drive system, and speed the correction of these faults. The Drive Diagnostic, Controller Diagnostic and Track Diagnostic utilities are covered in this chapter. The Mirror and OMNINET Diagnostics are covered in the service manuals for those products.

7.2 Introduction

Each Authorized Corvus Dealer Service Center will be supplied with Dealer Service Utilities. These utilities will help the technician exercise and diagnose the Corvus disk and network systems.

The Dealer Service Utilities diskette is comprised of standard Drive Diagnostic for the all Corvus disk drives (including the H-Series drives), Controller Diagnostic which will exercise and diagnose the drive utilizing the drive Z-80 processor, and a rigorous Burn-In program which exercises and tests the drive system infinitely (i.e. overnight). Also included is a single-track read-write diagnostic, for determining the condition of an individual track.

Some versions of the diagnostic utilities display only 40 characters on the video monitor. When viewing the diagnostic menu under each specific item, typing a question mark (?) will display an additional 40 characters of menu options.

The latest release of Dealer Service Diagnostics cover all series of Corvus disk drives:

A-Series:

8-inch, 11-MB, Rev A drive

B-Series:

8-inch, 11-MB, Rev B drive

8-inch, 20-MB, Rev B drive

5.25-inch, 6MB, Rev A through Rev E

H-Series:

5.25-inch, 6-MB (Model 6) Rev A

5.25-inch, 12-MB (Model 11) Rev A, Rev B

5.25-inch, 18-MB (Model 20) Rev A, Rev B

Diagnose the H-Series drives using only diagnostics specifically labeled as service diagnostics for the H-Series drives. Previous diagnostics versions (pre-April 1, 1983) will not communicate with the Corvus disk drive properly.

7.3 Drive Diagnostics (DRVDIAG)

This program is essentially the same program provided on the Initialization Utility diskettes supplied with each Corvus drive. All options within this program are non-destructive to data on the drive, with the exception of the Format utility. While the PARAMETERS option of the diagnostic program does not actually destroy data, changing these values using this diagnostic option will change relative track and sector addresses which will make the data inaccessible.

7.3.1 CRC

A good sector is defined as one capable of retaining all bits in the order they were written. When a block is read from a sector, the CRC value is read with it and tested. Bit errors may occur due to a bad sector, damaged in one of two ways:

- 1) physically (faulty media resulting in dropped bits and mismatched CRC bytes)
- 2) magnetically (miscellaneous bits written to the block resulting in a mismatched CRC value)

The Cyclic Redundancy Code test is a non-destructive test which reads each block of data, and checks it against its CRC value. If for any reason, the CRC value in that sector does not match the block of data, the CRC checker/generator signals the controller that an error has been detected, and the processor halts operation. Any errors will be reported at the end of the program. CRC errors encountered during normal drive operation will halt disk drive operation with the error code displayed.

Run this test several times to determine whether the error is due to faulty media (where specific sectors will repeatedly will show errors) or random magnetic bit changes (where sectors will show one-time errors). Tracks containing sectors with repeated errors should be spared (using Drive Diagnostic utility PRM).

7.3.2 EXR

The exercise test (EXR) seeks random sectors and reads the header information from that sector to verify the success of the seek. Periods print to the video display for successful operations, asterisks for hard errors (errors that exist after ten retries) and question marks for soft errors (operations that succeed after at least one retry).

Pressing RETURN displays the error list, consisting of total number of passes (seeks), hard and soft errors. Any errors reported should be followed by a CRC test to check for faulty sectors.

7.3.3 UPD

This Controller Firmware Update utility rewrites a new copy of Controller Firmware into each of the first two cylinders of the drive. All H-Series drives must use Controller Firmware version CF18.3 or greater.

Since it is not possible to update the firmware on the boot drive, the system MUST first be booted from another boot device (another Corvus Drive, or floppy diskette).

The H-Series version of this utility will prompt you with:

Change Tables? (Y/N)

A negative answer to this question will not endanger data resident on the drive. Although the UPDate utility is non-destructive to the data itself, answering affirmatively to this will result in these tables being rewritten with default values:

```
Spare Track table   + No Tracks Spared
VDO table: Drive1  = 0
Interleaving Spec   = 9
```

Be aware that whenever these default table values are written to the firmware area (by answering YES to "Change Tables?"), they replace previous values that may have been written at an earlier time. These may include spared tracks, and virtual drives in addition to the default of 1 drive. If data is resident on the drive when these values are changed, all relative references to the data (absolute sector addresses) will be changed, and the data will be inaccessible afterwards.

The Format program will also rewrite these default table values.

Next, the program will display a Controller Firmware file name. This will be in the form of :

```
ENTER CONTROLLER CODE FILE: CFxx.x
```

The current level of Controller Firmware at this writing is CF18.4AP. If another version is to be used, it should be entered now. The version of Controller Firmware used on the drive should be none other than that supplied with the Corvus initialization diskettes that were used when the drive was originally initialized.

7.3.4 VSN

This utility displays the current versions of the Controller Firmware and controller ROMs:

```
DRIVE 1: Vxx.x CORVUS SYSTEMS DD-MMM-YY
CONTROLLER ROM VERSION: nn
```

where DD-MM-YY represents the release date of that Controller Firmware version, xx.x represents the Controller Firmware version (i.e. CF18.4AP) and nn represents the suffix of the controller ROM (i.e. 7.63). At this printing, the current versions are:

Controller Firmware: CF18.4AP
Controller ROM: 7.63

7.3.5 FMT

WARNING:

This utility will destroy data on the drive.

Although the Format utility should be used only as a last resort when attempting to reestablish normal drive operations, the drive may at some time need reformatting. This diagnostic-level, or bottom-level format writes the rudimentary magnetic pattern to the tracks required before data may be retained properly. This format must be intact before the drive may be initialized for any operating system or data storage using Corvus initialization software.

First turn the FORMAT to the ON (right) position, then execute the Format utility. Some versions of this utility request a password, which is HAI. When the Format has completed, the program will display:

```
FORMAT COMPLETE - NOW UPDATING FIRMWARE
ENTER CONTROLLER CODE FILE: CFxx.x
```

The program will now rewrite the Controller Firmware using the input file displayed. If another version of firmware is to be used, enter the filename now. Use only the Controller Firmware version appropriate for the drive (see UPDATE utility above).

The Format program writes default Drive Parameters to the drive:

```
Spare Track table   = No Tracks Spared
VDO table: Drive1  = 0
Interleaving Spec  = 9
```

and should be updated as necessary after the Format program terminates (see UPDATE above, and PARAMETERS below).

7.3.6 PRM

The Parameter option of the diagnostic program allows the checking and alteration of the Constellation Multiplexer parameters (including Master Multiplexer Configuration table and Polling Parameters) and Drive parameters (including Spare Track table, Sector Interleaving Specification and Virtual Drive Offset table)

7.3.6.1 MUX

Selecting this option displays the Multiplexer table:

```

M      M
M      M
M      M
M      M
      X
```

As displayed above, the Multiplexer table is not to be altered if the drive is not connected to a Corvus Multiplexer network, or is connected to a single, Host Multiplexer.

Only if a Master Multiplexer is used in the Multiplexer Network is this table to be changed. In the instance that a Master Mux is installed, each of the eight ports (M in the above table) should be changed to either "N" if no device is connected to the port, "C" if a computer other than a DEC-System LSI-11 is connected to the port, or "L" when an LSI-11 is used, or left an "M" if a Host Mux is connected to that port.

There is only one MUX table, and it should be changed to reflect the configuration of the Master Multiplexer only, or left unchanged if only a Host Mux is used.

Polling Parameters is the next option of the program. When the drive is used with a Corvus Multiplexer local network with Intertec Superbrain* or Radio Shack TRS-80* computers, the Polling Parameters should be changed:

Standard Polling parameters: 180,26,32,0

For Superbrain and TRS-80: 180,52,32,0

7.3.6.2 DRIVE

Selecting this option displays the Spare Track table, Sector Interleaving Specification, and Virtual Drive Offset table.

Whenever a track is found to contain a faulty sector (via the CRC test), that track must be removed from service, and a spare track used. These bad tracks are eliminated by listing them in the Spare Track table. This utility enables the user to:

ADD a track to the Spare Track table (remove it from use)

DELETE a track from the Spare Track table (restore it to use)

LIST the Spare Track table

QUIT or exit from the spare track routine

By selecting the ADD option, the track number returned by the CRC test (see CRC below) can be entered, thereby ignoring the track with the erring sector.

The Sector Interleaving Specification is the next option of the program. Interleaving, or skewing, is defined as the use of an offset constant in the logical numbering of sectors. This value for all H-Series drives is nine for all computer systems except the DEC System LSI-11 which uses a value of five. Sector Interleaving is shown in Figure 8.

Check the Interleaving Specification when the drive is first received, and whenever it is formatted.

Next, the Virtual Drive Offset table should read:

DRIVE 1 0

unless otherwise instructed by the Corvus "Disk System Installation Guide." This table should be checked when the drive is first received, and whenever the drive is formatted. Model 20 disk drives must be configured as two virtual (logical) drives. This is accomplished by adding a second virtual drive, beginning at track 911.

7.3.7 SET

This utility allows the user to change the slot number, drive number, or drive type of the drive to be diagnosed. This allows the technician to connect several drives to one host computer, and test any one.

7.3.8 PARK HEADS

Whenever the H-Series drives are to be transported, the heads must first be parked off the data area. The PARK HEADS command accomplishes this by moving the heads onto a non-critical area of the drive platters. All drive indicator LEDs will be off after executing this diagnostic option. This indicates that the heads are parked, and the drive should now be powered off immediately. To restore the drive from the park mode, either toggle the RESET switch or power the drive on.

7.3.9 QUIT

Selecting this option exits the program, and returns the user to the main Dealer Service menu.

7.4 Controller Diagnostic

The purpose of the Controller Diagnostic program is to provide comprehensive testing for the Corvus disk drives. Some of these utilities are designed for use when adjusting the servo mechanisms on the Corvus 8-inch, 11-megabyte and 20-megabyte disk drives, and will not be used with the H-Series drives. These few utilities are included here only because they are provided on all Dealer Service Diskettes.

7.4.1 General Description

The Controller Diagnostic program is a combination of Z-80, host system machine code and high-level language programs which allow the technician to directly communicate to the intelligent controller of the disk drive. The code breaks down into three parts as follows:

High-level language terminal program: The high-level portion of the program makes the host computer a semi-intelligent terminal which can communicate with the drive controller. There are several features implemented in the high-level program, such as base conversions, slot selection and the driver which downloads the code to the drive controller.

Host system machine code: The machine code provides the low-level interface to the drive controller. It transmits and receives data from the controller according to the parameters passed to it by the high-level program. It is slot selectable and contains a one second time-out feature which allows the program to recover if the drive is not responding.

Z-80 code: The Z-80 code is the heart of the diagnostic and is the largest portion of the program. It performs the commands which are passed to it by the high-level program via ASCII characters. It consists of three blocks of code which are loaded to different locations in the controller memory.

7.4.2 Controller Diagnostic Commands

The following is a detailed description of each function of the Controller Diagnostic. Please note that there should be no spaces in the commands unless the notation <space> is specified.

Whenever the entry of a Controller Diagnostic command results in the response

"x (Y/N)?"

where x is the command entered, be sure the continuation of this test is appropriate; these commands are destructive to data.

During normal operation, when an error is encountered, the controller will repeat the operation in an attempt to succeed. All errors returned by the Controller Diagnostic are reported without retrying the command.

7.4.2.1 A) ABORT DIAGNOSTIC:

This command allows the operator to leave the diagnostic and return to the command level of the operating system. The format for this command is:

A <return>

7.4.2.2 B) MACRO MENU:

This command allows the operator to create a Macro program. The computer will prompt you with:

WRITE MACRO X)ECUTE MACRO

Enter W to create a Macro program. The format for this command is:

W <return>

The computer will return with the prompt:

ENTER COMMANDS FOLLOWED BY <RETURN>
TO END ENTRY, TYPE 'END' <RETURN>

Enter single-letter Controller Diagnostic commands from this Controller Diagnostic menu, one at a time, each followed by <return>. The Macro list should begin with the DOWNLOAD command and terminate with "END." The computer will then prompt you with:

DATA OK?

Entering a "n" will return the Controller Diagnostic command prompt. Entering a "Y" will result in the computer prompt:

ENTER MACRO FILENAME =>

Enter the name you wish to call the Macro program you have just created (maximum 11 characters). The computer will respond with:

* MACRO FILE WRITTEN TO DISK *

The Macro file can be executed by selecting "X" from the Macro Menu. The computer will prompt you for the filename:

ENTER MACRO FILENAME =>

Enter the filename of the Macro program you have previously created, and press <return>. The Macro program will begin execution:

* EXECUTING MACRO ==> xx.MAC *

and finish with:

* END OF MACRO PROGRAM *

A sample Macro program with the name of "TEST" is on the Dealer Service Utilities diskette.

7.4.2.3 C) CHANGE SLOT NUMBER:

This command allows the operator to change the slot number of the drive under test. The default value is set to slot 2 at the start of execution. (Note: It is possible to have multiple drives under test by starting execution, then changing slot numbers. You will have to return to the original slot to view test results.) The format for this command is:

C <return>

The computer will prompt you for the slot number as follows:

ENTER SLOT NUMBER (DEFAULT=2) ?

Enter the slot number desired and press <return>.

7.4.2.4 D) DOWNLOAD DIAGNOSTIC:

This command must be executed before any of the tests can be performed on the drive. This command loads the Z-80 code into the memory of the drive controller. The FORMAT switch must be on before downloading the diagnostic in order for the program to function correctly. The format for this command is:

D <return>

7.4.2.5 I) ANALYZE SERVO:

This command allows the operator to measure the seek time of the servo without an oscilloscope. Since the 5.25-inch drives use a stepper motor servo mechanism which does not require any adjustment, this utility is for use with 8-inch Corvus drives only. The format of this command is as follows:

I <return>

The controller will perform 256 seeks and then report the average seek time in milliseconds. This number should be 70 ms \pm 2.5ms if the servo is within tolerance (8-inch drives only).

7.4.2.6 J) SINGLE DO SEEK:

This command instructs the controller to seek to the cylinder specified in the command. It is used to move the heads to a specific cylinder to observe servo tracks. The format for this command is:

ccc J <return>

where ccc represents the desired cylinder number in hexadecimal. Since the 5.25-inch drive has no servo tracks, this utility is limited to use on the 8-inch drives.

7.4.2.7 L) FULL CYLINDER LOOPSEEK:

This command instructs the controller to continuously seek from cylinder zero to maximum cylinder. This command can be used to check servo action and to adjust the servo board (8-inch drives only), or as a general servo exercise utility for all drives. The Controller will continue seeking until a new command is issued. The format for this command is:

L <return>

7.4.2.8 P) PRINT QUIET SUMMARY REPORT:

This command allows the operator to view the results of the sector quiet, seek scan, read scan and write scan commands. The results are printed in the following format:

- 1) SEEK ERRORS: Seek errors are represented in the following format:

ccc:ddd:ee

where ccc is the desired cylinder in decimal, ddd is the cylinder in decimal which was actually found and ee is the error code. See the error codes in section 8.4.3.

- 2) CRC ERRORS: CRC errors are represented in the following format:

ccc-h xxxxx

where ccc is the cylinder number in decimal, h is the head number in decimal, and xxxxx is the number of errors in decimal.

- 3) TOTAL SEEKS: This number represents the number of seeks the controller has performed so far. The number will be in decimal.
- 4) SEEK TIME: This number represents the total time spent performing seeks in milliseconds. The average seek time can be calculated by dividing seek time by the number of seeks.
- 5) RPM: These numbers represent the minimum and maximum speed of the drive during the execution of the sector quiet diagnostic.

7.4.2.9 Q) SECTOR QUIET PROGRAM:**CAUTION:**

This command will DESTROY data on the disk.

This command instructs the controller to begin executing the sector quiet diagnostic. This diagnostic is a very comprehensive test of the drive media and electronics. The controller performs continuous seeks, reads and writes at random locations on the disk. The results of this test are obtained by the command documented in 7.4.2.8. The format of this command is:

Q<return>

The controller will respond with:

Q (Y/N) ?

Enter Y<return> to begin the test, enter N to abort. The controller will continue this test until a new command is issued.

7.4.2.10 S) READ SCAN DISK:

This command instructs the controller to perform a sector verify pass (CRC check). The results of the scan will be added to the sector quiet results which are available thru the command documented in 7.4.2.8. The format for this command is:

S<return>

The controller will continue to read scan the disk until a new command is issued.

7.4.2.11 T) SINGLE CYLINDER SEEK SCAN:

This command instructs the controller to single step across the disk. This can be used to observe the servo tracks on the 8-inch drives as the heads move across the platters. The format of the command is:

T<return>

The controller will continue to seek scan until a new command is issued.

7.4.2.12 X) WRITE SCAN DISK:

CAUTION:

This command will DESTROY data on the disk.

This command instructs the controller to perform a bottom level format of the drive. This will not write Controller Firmware, it will simply format the entire disk. The format for this command is:

X<return>

The controller will respond with:

X (Y/N) ?

Enter Y to write scan the disk, enter N to abort. The controller will continue to write scan the disk until a new command is issued.

7.4.2.13 Y) REZERO HEADS:

This command instructs the controller to position the heads on cylinder zero. The format for this command is:

Y<return>

7.4.3 Error Codes

The errors codes returned by the command documented in 7.4.2.8 are as follows:

- 00 — Hardware detected fault in read or write
- 01 — heads move off track while not seeking
- 02 — seek time out
- 03 — Phase lock oscillator error (PLO)
- 04 — sector CRC error
- 05 — cylinder address mismatch
- 06 — read after write verify error
- 07 — guard band detected in data region
- 08 — read sector time out
- 09 — write sector time out
- 10 — bad track list overflow
- 11 — sector locate error

7.5 Burn-In Program

This program is destructive to data on the disk. Be sure a back-up of the data exists before proceeding.

Selecting the Burn-In program will automatically begin the polling of the host computer slots. The program determines the type of drive in that slot, and the burn-in procedure begins on all drives attached to the host system.

The Burn-In program is a rigorous read-write routine which steps through the drive one chunk (256-sector quantity) at a time, reading and writing specific patterns to each of the sectors. The program divides the disk media into chunks by dividing the total number of sectors by 256.

The Burn-In program begins with the highest chunk number. When the read/write test is completed for the current chunk, a random 256-sector read test is executed over the complete disk drive. When this is complete, the chunk number is decremented by one, and the test repeats.

The program may be halted at any time by pressing the <return> key or the SPACE bar. This displays a sub-menu:

```
C)ONT L)IST R)ESTART Q)UIT
```

7.5.1 C)ONT

Entering a "C" will cause the program to continue from where it left off.

7.5.2 L)IST

Entering a "L" will cause the error list to be displayed (for example):

```
*** SLOT NUMBER 2 ****
CURRENT TIME = 0,75
TOTAL ERRORS: 0
HARD ERRORS   : 0
SOFT ERRORS   : 0
DO YOU WANT A COMPLETE LIST (Y/N)?
```

Slot number refers to the host slot to which the disk drive is interfaced to. Current time refers to A) the pass number and B) the current chunk being tested.

Errors are those disk read or write errors which, after 15 re-reads or 3 re-writes, are still in error. Soft errors are those read or write errors which, after at least one retry, have been corrected. Requesting a complete list will result in a display of the specific tracks with the error results for each (refer to section 7.4 for detailed information on error codes).

7.5.3 R)ESTART

Entering an "R" will begin the program again from the beginning. All error counters will be re-zeroed.

7.5.4 QUIT

Entering a "Q" will return to the Dealer Service Diagnostic menu.

7.6 READ BURN-IN RESULTS

This program allows the burn-in results of all drives to be output to the video display or printer:

```
*** SLOT NUMBER n ***  
CURRENT TIME = p,cc  
TOTAL ERRORS: x  
HARD ERRORS : y  
SOFT ERRORS : z  
[followed by a detailed listing of all errors]
```

where n is the number of the slot that the drive is connected to, p is the pass number, cc is the current chunk being tested, and x,y and z are the total errors, hard errors, and soft errors, respectively.

7.7 Track diagnostic

The Track Diagnostic Utility is a helpful tool for exercising a particular track suspected of having media problems. This program is destructive to data, and should be used only if a backup of the data exists.

Selecting this option from the Dealer Service Diskette will result in the Slot Number and Drive Number prompts. Enter the appropriate values. Pressing <escape> will exit the program.

The prompt SERVO ACTION (Y/N)? is displayed. If The servo mechanism is not suspect, enter an "N."

For each pass (or "pattern"), the test displays the pattern number, the track being tested, and the beginning sector for that track.

The Track Diagnostic begins with the a read from the first sector on the specified track. This is followed by a write of a specific pattern to that sector, and then a verification of the write. If this is all successful, a dot is printed on the screen. If an error is detected, an asterisk is printed. The test is then repeated on the next sector.

Pressing the <return> key or SPACE BAR will halt the test, and display the submenu:

```
C)ONTINUE L)IST ERRORS R)ESTART Q)UIT
```

7.7.1 C)ONTINUE

Entering a "C" will cause the program to continue on as it was before interruption.

7.7.2 L)IST

Entering a "L" will display an error summary (for example):

```
*** ERROR SUMMARY ***  
PASS NUMBER: 0  
2160 TOTAL READS  
1080 TOTAL WRITES  
0 TOTAL HARD ERRORS  
0 TRACKS WITH HARD ERRORS  
0 TOTAL SOFT ERRORS  
0 TRACKS WITH SOFT ERRORS
```

The pass number refers to the total number of loops using 256 different patterns to write to those tracks.

The total reads and writes refers to the number of times the sector was written to and read from. The number of reads should always be twice the number of writes.

Hard errors are those disk read or write errors which, after 15 rereads or 3 re-writes, are still in error.
Soft errors are those read or write errors which, after at least one retry, have been corrected.

773 R)ESTART

Entering an "R" will begin the program again from the beginning. All error counters will be rezeroed.

774 Q)UIT

Entering a "Q" will return to the Dealer Service Diagnostic menu.

CHAPTER 8
FAULT ISOLATION PROCEDURES

CHAPTER 8 FAULT ISOLATION PROCEDURES

8.1 Scope of Chapter

This chapter contains procedures for diagnosing and testing the Corvus H-Series 5.25-inch disk drives. Recommended test equipment is listed, as are error codes. A list of common failures and procedures pertaining to this chapter may be found at the end of this chapter.

8.2 Introduction

The drive is a sophisticated electronic device, and may, at some time, fail. When failure occurs, it may be due to any of the drive components. The following procedures will aid the technician in isolating the faulty component.

8.3 Tools

The following test equipment is recommended as a minimum for troubleshooting and repair of the Corvus disk drive:

1. Digital voltmeter (± 0.1 percent accuracy), with test leads
2. Host microcomputer: Corvus Concept (256K) or Apple II+ (48K), Corvus Interface PCA and 34-pin flatcable
3. Corvus Dealer Service Diagnostic Utilities diskette (currently these are available for the Corvus Concept and Apple II computers)

8.4 Error Codes

For each command sent to the drive by the host operating system, a single-byte error code is returned after the command is completed. It is the responsibility of the operating system to interpret the error code and take appropriate action. All errors reported by the Corvus Diagnostic Utilities are in hexadecimal notation.

Errors returned by the controller are listed below. Errors less than or equal to 127 are non-fatal. Those errors greater than or equal to 128 are fatal errors.

The bit format of the error code is shown below:

bit		bit		bit		bit		bit		bit		bit		
7		6		5		4		3		2		1		0

The eight-bit error code is broken into four segments. Bit 7, when set, indicates that the reported error is a fatal error. Bit 6, when set, indicates that the reported error occurred during the verify (read after write) sequence of the write command. Bit 5, when set, indicates that one or more retries were attempted before the error was reported. Bits 0-4 represent one of the 21 codes which describe the error (refer to the error lists in this section).

8.4.1 Interpreting Error Codes

Depending on the condition of bits 5-7, there are up to four different error codes for each error condition. To determine the actual error condition, these procedures should be followed:

1. If the error code value is greater than or equal to 128, a fatal error occurred. Subtract 128 if the value is greater than or equal to 128.
2. If the remaining value is less than 64, the error occurred during a disk read. If the value is greater than or equal to 64, the error occurred during the verify portion of a write command. Subtract 64 if the value is greater than or equal to 64.
3. If the remaining value is less than 32, no retries were attempted. If the value is greater than or equal to 32, at least one retry was attempted before the error was reported.

If no error has occurred, the original error code value of zero will be returned.

Consistent 171 or 235 errors at the same block location indicates bad disk media. Execute the CRC test and follow the instructions for sparing tracks (PRM option, drive Diagnostics).

Consistent 255 errors indicate that the Controller PCA is not responding to commands sent from the Host Computer, and may need replacing.

Table 8-1. Decimal Disk Error Codes

≤ 127 Non-Fatal					≥ 128 Fatal
32					soft error
	128	160	192	224	error in preparing R/W
	129	161	193	225	seek timeout
	130	162	194	226	seek fault
	131	163	195	227	seek error
	132	164	196	228	header CRC error
	133	165	197	229	rezero timeout
	134	166	198	230	rezero fault
	135	167	199	231	drive not online
	136	168	200	232	write fault
	137	169	201	233	format protected
	138	170	202	234	read fault
	139	171	203	235	data CRC error
	140	172	204	236	sector locate error
	141	173	205	237	write protected
	142	174	206	238	illegal sector address
	143	175	207	239	illegal command op code
	144	176	208	240	spare track table overflow
	145	177	209	241	overlay failure
				254	verify error (burn-in test)
				255	controller timeout (diagnostic utilities)

Table 8-2. Hexidecimal Disk Error Codes

$\leq 7FH$ Non-Fatal	$\geq 80H$ Fatal			
20				soft error
80	A0	C0	E0	error in preparing R/W
81	A1	C1	E1	seek timeout
82	A2	C2	E2	seek fault
83	A3	C3	E3	seek error
84	A4	C4	E4	header CRC error
85	A5	C5	E5	rezero timeout
86	A6	C6	E6	rezero fault
87	A7	C7	E7	drive not online
88	A8	C8	E8	write fault
89	A9	C9	E9	format protected
8A	AA	CA	EA	read fault
8B	AB	CB	EB	data CRC error
8C	AC	CC	EC	sector locate error
8D	AD	CD	ED	write protected
8E	AE	CE	EE	illegal sector address
8F	AF	CF	EF	illegal command op code
90	B0	D0	F0	spare track table overflow
91	B1	D1	F1	overlay failure
			FE	verify error (burn-in test)
			FF	controller timeout (diagnostic utilities)

Table 8-3. Signed Decimal Disk Error Codes

≤ -129 Non-Fatal					≥ -128 Fatal
-224					soft error
	-128	-96	-64	-32	error in preparing R/W
	-127	-95	-63	-31	seek timeout
	-126	-94	-62	-30	seek fault
	-125	-93	-61	-29	seek error
	-124	-92	-60	-28	header CRC error
	-123	-91	-59	-27	rezero timeout
	-122	-90	-58	-26	rezero fault
	-121	-89	-57	-25	drive not online
	-120	-88	-56	-24	write fault
	-119	-87	-55	-23	format protected
	-118	-86	-54	-22	read fault
	-117	-85	-53	-21	data CRC error
	-116	-84	-52	-20	sector locate error
	-115	-83	-51	-19	write protected
	-114	-82	-50	-18	illegal sector address
	-113	-81	-49	-17	illegal command op code
	-112	-80	-48	-16	spare track table overflow
	-111	-79	-47	-15	overlay failure
				-2	verify error (burn-in test)
				-1	controller timeout (diagnostic utilities)

8.5 Troubleshooting Procedures

When a disk drive fails to function normally, the problem may range from a faulty sector to total drive failure. It is the responsibility of the service technician to interpret the symptoms, isolate the faulty component, substitute a replacement, and thoroughly test the drive before returning it to the user.

Corvus provides its Authorized Servicing Dealers with diagnostic utilities and service documentation to aid the technician in servicing Corvus products. The Dealer Service utility diskettes include diagnostics for testing all phases of drive operation. These utilities are described in the section titled "Diagnostics."

Also included in this chapter is a list of Common Symptoms and Solutions.

In using the troubleshooting aids provided, take the following precautions:

1. Make sure all drives have the appropriate version of Controller Firmware.
2. See that the drive has the latest release of controller ROMs.
3. Be sure to disconnect the ac power cord before replacing any modules.
4. Use only known good components when substituting.
5. Retest the system after each component has been substituted.

8.5.1 On-Site Checks

There are several quick checks that can be taken that do not require disassembly of the drive:

1. Be sure the ac power cable is plugged in, and the power switch is turned on.
2. Examine the front bezel switches to verify their proper settings.
3. On the rear bezel, check that the four Mirror DIP-switches are set correctly to reflect the internal Mirror configuration.
4. Check that the CORCOM unit (located on the rear bezel) has the correct line voltage and fuse selected.
5. Verify that the interface cable is not damaged, and has been properly connected at both ends.
6. Check to see that the Interface PCA is in the correct bus slot (where applicable) of the host computer.
7. Check that the drive's Controller Firmware is intact (section 8.5.3.2)

8.5.2 Isolate the Problem

Malfunctions in the Corvus disk system may be divided into three categories:

1. Magnetic, or software (Controller Firmware integrity, data integrity, format integrity, boot image integrity),
2. Physical media damage (imperfections in media surface)
3. Electronic (host computer function, Corvus drive sealed mechanism and associated Read/Write PXCA and Logic PCA, Z-80 controller, or power supply)
4. Environmental (power stability, temperature and humidity limits).

The first step in analyzing faults in the Corvus disk system is to isolate the drive from other devices. This includes removing networks (such as the Corvus Multiplexer and OMNINET local networks) and backup devices (such as the Corvus Mirror). Using a known good Interface PCA and flatcable, connect the Corvus disk drive to a known good host computer.

Before any diagnosis of the Corvus disk drive can be carried out, the symptom must be duplicated. If the problem does not reoccur within a reasonable amount of time, run the burn-in diagnostic program overnight to thoroughly test the drive.

8.5.3 Drive Not READY

In order to troubleshoot faults in the Corvus disk drive, it must first be in the READY condition, indicated by the READY LED being lit. First, power on the drive and wait approximately 90 seconds. The READY LED alone should light, and if this does not occur, steps must be taken to correct it.

8.5.3.1 Interface

The host computer Interface PCA or cable could be defective, not allowing the drive to reach the READY condition. Disconnecting the flatcable from the drive PROCESSOR connector will isolate the drive. If the READY LED now lights, replace the Interface PCA and cable, one at a time, to isolate the faulty module.

8.5.3.2 Controller Firmware

During the normal power-on sequence Controller Firmware is read into the controller RAM. If the Controller Firmware has been disrupted or contains bad blocks, the drive will not be READY after the power-on sequence completes.

To determine if this is the cause of the symptom, turn on the FORMAT switch and toggle the RESET switch. This will reset the Z-80 Controller, and if the drive passes the hardware self-test, will ignore the Controller Firmware. If the READY LED now lights, faulty Controller Firmware is indicated and the UPDATE utility must be executed to rewrite the Controller Firmware code. After this has been done, turn off the FORMAT switch and toggle the RESET switch. This again will reset the Z-80 controller which will read the newly-written Controller Firmware into the on-board RAM. The READY LED should now light.

8.5.3.3 Power Supply Voltages

If the fault has been determined to be a drive hardware failure, the first action taken should be to check the power supply voltages.

Check the voltages when the drive is first received, and because of line voltage variations between locations, at the customer site also. If any of the dc output voltages cannot be brought within tolerance, the power supply must be replaced.

Using a Digital Voltmeter, follow the voltage check and adjustment procedures outlined in the Adjustments section of this manual. The dc power connectors (located on the PCA(s) underneath the sealed mechanism and on the backplane), should be checked for a clean and tight fit. Measuring the voltages at the drive Backplane power pins as well as at the power supply will verify that the power connector and cable are in good condition. Inspect the dc power cable, checking for breaks at both ends. The power cable may be faulty if the voltages are not present at the drive Backplane.

Symptoms indicating power supply failure or misadjustment include front bezel LEDs failing to light, drive motor failing to turn or speed fluctuating, and drive going off-line (drive error 255), and CRC errors.

Dc output of the power supply is a function of the correct ac input; the dc voltages will not be correct if the improper line voltage is selected. To verify that the proper line voltage has been selected, locate the CORCOM unit on the rear bezel of the drive cabinet. This unit contains the fuse and voltage selection PCA. If the voltage is changed, be sure that the line fuse is also changed. Symptoms indicating incorrect line voltage selection include dim or dark LEDs, low motor speed, and extreme heat output.

8.5.3.4 Drive Electronics

If the READY LED will not light, and the power supply is operating properly and the voltages are within tolerance, it is probably due to a faulty component within the drive.

Sometimes symptoms indicating a faulty drive PCA are in fact caused by poor contact between connectors. Power supply connectors, PCA edge connectors, IC sockets and switch contacts are some of the connectors which may lose contact, and result in a malfunctioning drive. Reseating all connectors and using an eraser, clean on all gold edge connector pins to help eliminate any oxidation that may have built up, causing improper contact. Also, reseating socketed ICs on the drive Controller PCA will ensure good pin connections.

WARNING:

Always turn off ac power and disconnect power cord before replacing any components.

Replace the drive controller with a known good unit:

1. Remove power to the drive.
2. Disassemble the drive and remove the Controller PCA.
3. Install a known good Controller PCA.
4. Power on the drive.

If the controller was faulty, the READY LED will now light. If the READY LED still fails to light, the next step is to replace the drive sealed mechanism with a known good unit.

8.5.3.5 Drive Sealed Mechanism

The drive mechanism is a sealed unit with no internally servicable parts. Any malfunctions with the drive mechanism necessitate replacing the drive module.

Drive mechanism failure may be due to any one of the following:

1. Microchip failure
2. Drive motor failure
3. Servo stepper motor failure

8.5.4 Link Inoperative

If the drive powers on, spins up to speed, passes the self-test and the READY LED lights, certain basic circuits and sub-systems within the drive are working. The test does not, however, verify the integrity of the disk Operating System (DOS), the disk media or much of the drive electronics and power supply. If the DOS is damaged or not properly patched for communication to the Corvus disk drive (initialization procedures, Corvus User Guide), the drive will not function properly.

Linking is the process of booting the host computer with the Corvus-patched DOS. The type of DOS depends on the type of computer system, and should be a known good copy, patched for the Corvus drive. For those systems that do not store a DOS image on the Corvus drive and then boot directly from the Corvus (CP/M does not), booting the standard floppy-based DOS and executing the LINK program will establish the patch.

Corvus recommends that Corvus Dealer Service Centers keep on hand archival, known good Corvus-patched copies of the DOS for the specific computers serviced at that location. This will insure that a new DOS copy may be substituted for the users' DOS for troubleshooting purposes.

8.5.4.1 Check Link Action

Boot the computer using a known good boot image or link software. When this has been done, list the directory of the drive or volume. If this fails or a drive error is returned, steps must be taken to correct this.

8.5.4.2 Power Supply

The power supply voltages should be checked and adjusted if necessary before any further testing is done. Without proper voltages, the read amplifier on the Read/Write PCA will be referencing incorrect thresholds for the data signal, possibly mistaking a good sector for a CRC error.

8.5.4.3 CRC Test

Execute the CRC test. This will test the controller's ability to decode drive commands, as well as the stepper motor and read-write electronics. This test will also verify the condition of the drive media. The CRC test will report either no errors or the cylinder, head and sector numbers of the faulty sector. If the CRC errors are encountered, the complete track must be spared (PRM option, drive Diagnostics, Corvus User Guide).

Sometimes the CRC test will not begin (READY LED remains lit) or will not finish (BUSY LED flickers momentarily, and then the READY LED alone lights). A misadjusted power supply or improper format could cause this. Also, a damaged copy of the CRC program could cause problems, making it impossible to trace problems without a known good copy of the utilities.

8.5.4.4 Controller Communication

If the drive does not respond to the CRC test, this may be due to several causes. First, some simple oversight may be the cause (see On-Site Checks, above). Alternately, the controller may not be properly decoding the commands sent from the Host Computer (due to incomplete Controller Firmware resident in RAM, or to a defective component on the Controller PCA), or the drive mechanism itself may have a defective component.

Executing the Controller Diagnostic DOWNLOAD command will attempt to establish communication with the Controller PCA. The diagnostic software will respond with "Programs Loaded To Controller Memory" if this succeeds. Further diagnostic commands should then be executed to determine if the controller is communicating with the drive mechanism. If the diagnostic DOWNLOAD command responds with "Download Aborted" this indicates that the Host Computer and the Controller PCA are not communicating.

8.5.4.5 Servo Action

Once communication with the Controller PCA has been established drive mechanism performance should be checked. Executing the servo exercise command (Controller Diagnostic LOOPSEEK command) will verify the drive mechanism's ability to seek, read and write. Fatal errors encountered during this diagnostic command indicate a possible defective drive mechanism.

8.5.4.6 Controller Firmware

If the controller and drive mechanism respond positively at this point, the Controller Firmware should be rewritten and the drive parameters checked (drive Diagnostic utility PARAM) if this has not been done already. The Z-80 controller does not check each block in the Controller Firmware area to check that it is legitimate Controller Firmware code, and will attempt to load it into the on-board RAM when the drive is powered on. If the READY LED lights after power-on, this is only an indication that no CRC errors have been encountered. Rewriting firmware is non-destructive to data.

8.5.4.7 Boot ROM

Some computer systems use a boot ROM on the Interface PCA to boot a DOS image from the boot area of the drive. A faulty memory location in this ROM may cause the drive to fail at boot time. Replace only with a tested, known good replacement.

8.5.4.8 Interface Components

A defective Interface PCA or cable may be the cause of problems with the drive. Replace both, only with tested, known good replacements, and reinstall originals, one at a time, retesting the drive after each.

8.5.4.9 Drive Initialization

Corvus provides drive initialization software for each computer operating system (CP/M, Apple DOS, UCSD Pascal, NEWDOS, IBMDOS, CCOS, etc). These utilities initialize the platter surface for accepting a DOS boot image (where applicable) as well as directory and data area.

These areas of the disk, if disturbed either physically or magnetically, will no longer retain the correct information sought by the CATALOG or DIRECTORY listing commands. In this case, the initialization procedures (i.e. PUTGET, PSYSGEN or BSYSGEN) must again be executed to properly initialize the disk surface (refer to the Corvus User Guide for initialization procedures). Be sure to use archival, known good copies of all software whenever initializing the drive.

Any problems persisting at this point lie either with the drive electronics or the disk media. The electronics should be tested, and if this is not found to be the cause of the problem, the drive should be re-initialized, using a new copy of the software utilities.

8.6 Final Adjustments and Tests

When the faulty module in the drive has been replaced and the problem eliminated, the repair process is only halfway completed. Final checks and adjustments must be made and the drive tested thoroughly overnight before it may be returned to the user.

8.6.1 CRC Test

The drive media must be verified reliable before the drive can be certified as usable. The CRC test should be executed before and after the drive image is restored with the Mirror, to check that no sectors have been destroyed. Tracks with faulty sectors should be spared using the PARAM option of the drive Diagnostics.

8.6.2 Install and Test Mirror

If a Corvus Mirror back-up device was part of the original disk system, it should have been removed from system as one of the first steps in troubleshooting the drive. Having traced and replaced the faulty component in the drive, the Mirror should now be installed and tested. Refer to the Corvus Mirror Service Manual for procedures on troubleshooting and servicing the Mirror.

8.6.3 CRC Test

Executing the CRC test once again, verifies that elementary communication exists, and that no sectors were accidentally destroyed by restoring a faulty Mirror image.

8.6.4 Power Supply

After troubleshooting procedures have been completed, the power supply voltages must be checked once again before the drive can be tested. This is to insure that the Burn-In test is testing a properly adjusted drive.

8.6.5 Burn-In Test

The Burn-In test is the final endurance test of the drive, revealing any malfunctions as hard or soft errors. This program tests the seeking, reading and writing abilities of all drives connected to the host computer.

The Burn-In test should be run, at a minimum, overnight after all repairs and adjustments on the drive have been completed. If any sectors experience errors, the Track Diagnostic program should be executed for all tracks containing suspect sectors to determine if these are recurring errors. If the errors persist, the tracks should be spared (drive Diagnostic utility PARAM).

TROUBLESHOOTING FLOW CHART

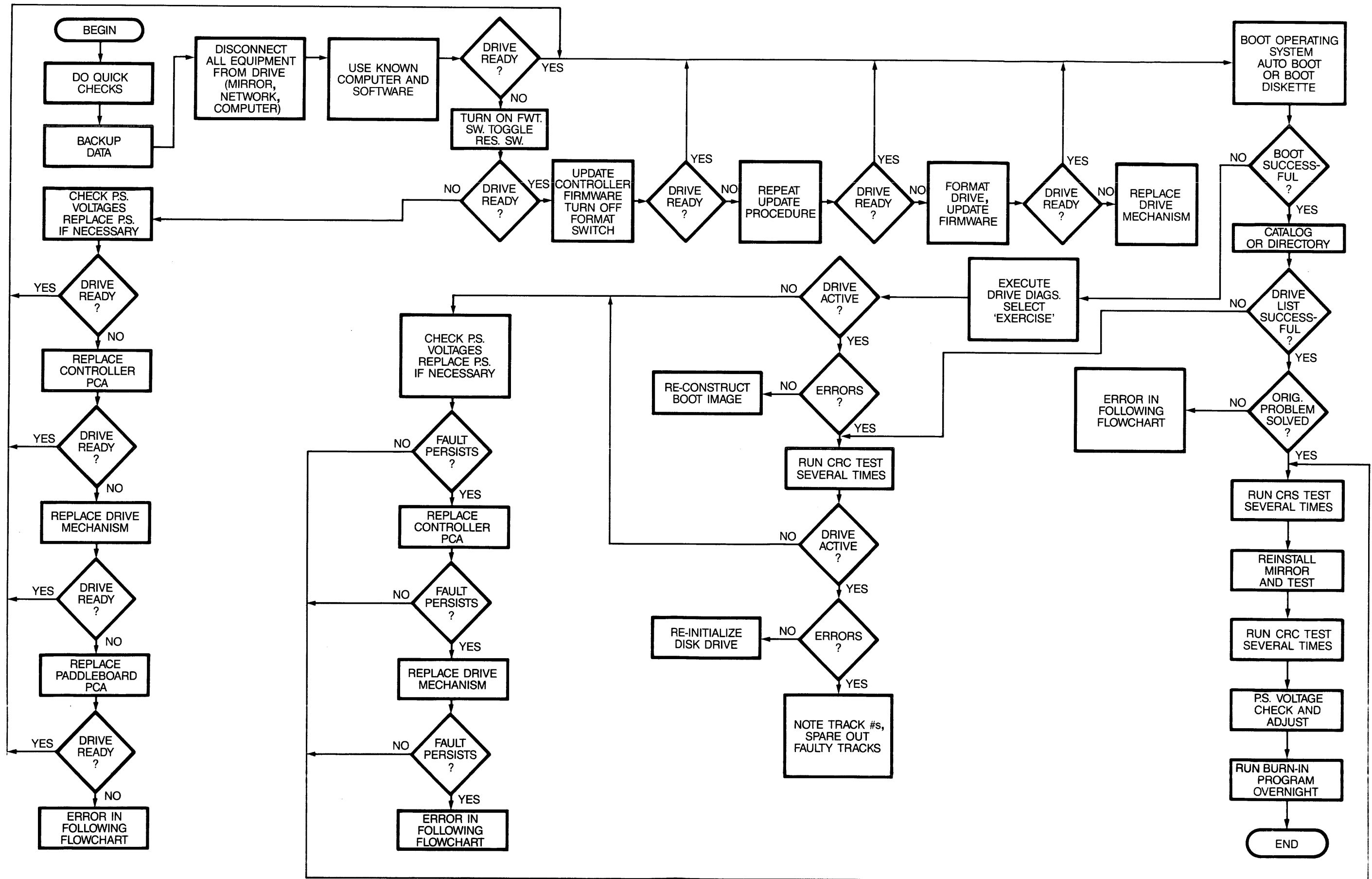

CORVUS DEALER SERVICE

SYMPTOM	CAUSES	RECOMMENDED REPAIR
1. Drive platters won't turn.		
A. All LEDs off and stay off.	ac power improperly selected. +12V misadjusted +12V not present at drive mechanism +12V not existent or not adjustable	Check and adjust. Check voltage and adjust. Check dc power connector for continuity and proper connection at drive Replace power supply
B. All LEDs light then BUSY alone remains lit	Brake solenoid not releasing Drive motor defective	Adjust brake mechanism Replace drive sealed mechanism
2. Unable to format drive		
A. READY remains lit	Mirror switches set wrong Interface card defective Interface cable defective Controller ROM defective Controller PCA defective Backplane defective	Check and set properly Replace interface card Replace interface cable Replace Controller ROM Replace Controller PCA Replace backplane
B. BUSY remains lit constantly	Controller unit address switches set incorrectly Controller ROM defective Controller PCA defective Drive mechanism defective	Set switches correctly Replace Controller ROM Replace Controller PCA Replace drive mechanism
3. Unable to update Controller firmware		
A. All LEDs go off, remain off	Drive not ready. Bad track in firmware area HDA Controller PCA defective Drive sealed mechanism defective	Turn on FORMAT switch, toggle RESET switch Replace drive sealed mechanism Replace Controller PCA Replace drive sealed mechanism
B. Busy LED lights and remains lit	Drive format blown Controller ROM defective Controller PCA defective Drive sealed mechanism defective	Reformat drive Replace Controller ROM Replace Controller PCA Replace drive mechanism

CORVUS DEALER SERVICE

SYMPTOM	CAUSES	RECOMMENDED REPAIR
4. CRC FORMAT CHECK will not begin or finish		
A. Busy LED lights and remains lit, or FAULT LED only remains lit	Front bezel switches incorrect Controller ROM defective	Check switch settings Replace Controller ROMs
	Format not intact Controller PCA defective Drive sealed mechanism defective	Reformat drive Replace Controller Replace drive mechanism
5. Unable to spare track		
A. All LEDs off and remain off	Controller ROM defective Controller PCA defective Drive sealed mechanism defective	Replace Controller ROM Replace Controller PCA Replace drive mechanism
	Maximum number of tracks already spared (31 total)	Replace drive mechanism
6. Drive will not execute Servo Exercise under Diagnostic		
A. Busy LED remains lit	Power supply voltages misadjusted Drive sealed mechanism defective	Check voltages, adjust or replace supply as needed Replace drive mechanism
7. Computer boots into monitor (Apple)		
A. Drive goes BUSY, then READY	Boot image corrupted Boot program on Corvus utility diskette corrupt Boot ROM on interface PCA bad Interface PCA defective	Recreate boot image (see Corvus user guide) Recreate boot image using good copy of utilities Replace Boot ROM Replace Interface PCA
8. Drive will not Boot		
A. Busy LED lights and remains lit	Drive does not contain boot image Boot ROM on interface PCA defective Interface PCA defective	Create boot image on drive (see user's manual) Replace Boot ROM Replace Interface PCA

CORVUS DEALER SERVICE

SYMPTOM	CAUSES	RECOMMENDED REPAIR
	Controller ROM defective	Replace Controller ROM
	Controller PCA defective	Replace Controller PCA
	Drive sealed mechanism defective	Replace drive mechanism
B. READY light remains lit	Mirror switches set incorrectly	Set switches properly
	Front panel switches set incorrectly	Set switches correctly
	Interface board defective	Replace interface board
	Interface cable defective	Replace interface cable
9. I/O errors during normal operation		
A. Normal LED display or all LEDs off and remain off	Software currently running on host system defective	Replace software with known good copy and reexecute
	Boot image corrupted	Recreate boot image (see user's manual)
	Defective track	Execute CRC FORMAT CHECK. Spare any tracks returning errors
	Controller ROM defective	Replace Controller ROM
	Controller PCA defective	Replace Controller PCA
	Power supply voltages out of tolerance	Adjust power supply
	Power supply voltages fluctuating	Replace power supply
	Drive sealed mechanism defective	Replace drive mechanism
10. Heads slam against inner crash stop (toward hub)		
A. Busy LED lights and remains lit	Controller Firmware corrupted	Update Controller Firmware
	Power supply voltages out of tolerance	Check voltages, adjust if necessary
	Power supply voltages intermittent or can't adjust	Replace supply
	Controller ROM defective	Replace Controller ROM
	Controller PCA defective	Replace Controller PCA
	Drive sealed mechanism defective	Replace drive mechanism
11. Sector destroyed during normal operation		
A. Busy LED lights and remains lit	Boot ROM (where applicable) or interface board defective	Replace boot ROM. If problem persists, replace Interface PCA

CORVUS DEALER SERVICE

SYMPTOM	CAUSES	RECOMMENDED REPAIR
	ac power surge during read/write operation	Determine quality of ac power supplied to Corvus and host. Determine types of devices on same ac circuit. Large power consuming devices should not share power with the disk drive.
	Power supply voltages out of tolerance	Check and adjust voltages
	Controller PCA defective	Replace Controller PCA
	Weak media spot on platter surface	Determine tracks affected and spare
	Defective drive sealed mechanism	Replace drive mechanism
12. Motor speed varies	+12V out of tolerance	Check and adjust voltage
	dc cable to drive defective	Check wiring, replace supply if bad
	Loose dc connection at drive	Clean connector pins, make sure connector is seated properly
	+12 V non-existent or not adjustable	Replace power supply
	Drive motor defective	Replace drive sealed mechanism
13. Low motor speed	ac input voltage set incorrectly	Check and adjust
	See #12. above	
14. Heads not rezero		
A. BUSY LED lights and remains lit	Firmware corrupted	Update firmware
	Format corrupted	Reformat drive and update firmware
	Low motor speed	See #12 and 13 above
	Controller unit address set wrong	Set switches correctly
	Controller PCA defective	Replace Contoller PCA
	Drive sealed mechansim defective	Replace drive mechanism
B. FAULT and BUSY LEDs stay on, READY goes off	Controller ROM defective	Replace Controller ROM
	Controller RAM defective	Replace 4118 RAM on Controller PCA
	Controller PCA defective	Replace Controller PCA
C. All LEDs stay off	Incorrect ac power setting	Check and adjust
	Power supply voltages incorrect	Adjust or replace supply as necessary
	Defective Controller ROM	Replace Controller ROM
	Defective Controller PCA	Replace Controller PCA

CORVUS DEALER SERVICE

SYMPTOM	CAUSES	RECOMMENDED REPAIR
D. All LEDs stay on	Paddleboard cable connected wrong	Check paddleboard cable connections
	Defective paddleboard	Replace paddleboard
	Defective paddleboard cable	Replace cable
	Defective drive sealed mechanism	Replace drive mechanism
	Defective backplane	Replace backplane
	Power supply voltages incorrect	Adjust or replace supply as necessary
	Defective Controller PCA	Replace Controller PCA
15. Head oscillates after drive is turned on A. BUSY LED lights and remains on	Defective drive sealed mechanism	Replace drive mechanism
	Controller Firmware corrupted	Update firmware
	Format corrupted	Reformat and update firmware
	Power supply voltages incorrect	Adjust power supply
	Power supply defective	Replace power supply
	Controller PCA defective	Replace Controller PCA
	Drive sealed mechanism defective	Replace drive mechanism

APPENDIX A
GLOSSARY

GLOSSARY

BACKPLANE OR MOTHERBOARD: two-slot printed circuit board which accepts the Mirror PCA (when installed) and Controller PCA.

BIT: single binary digit. Smallest representative unit of data, several of which make up characters (A-Z, 0-9, etc.). Bits may be either a one or a zero, on or off, set or reset. This may be shown by either a signal being present or not, or by a signal changing states or being constant.

BLOCK: a relative quantity of data bytes. The Corvus disk defines one block to contain 512 bytes of data, the smallest addressable unit within the drive. The host operating system may define a block as 128, 256 or 512 bytes in length. Externally, since the disk drive handles data in sectors, no apparent conflict appears to the host system.

BRAKE OR SOLENOID BRAKE: immediately after power-down, this mechanism engages, so as to minimize contact time between heads and disk surface, and brings the platters to a stop.

BYTE: any multi-bit digital value, usually eight bits long. The Corvus disk drives use eight-bit bytes.

CABINET OR ENCLOSURE: the cabinet which contains the IMI drive mechanism, power supply and fan. The front bezel attaches to the cabinet basepan. Two screws at the rear of the cabinet secure the cabinet top to the basepan.

CONTROLLER OR Z-80 CONTROLLER OR INTELLIGENT CONTROLLER: the disk controller circuitry including the Z-80 microprocessor and support logic.

CORCOM: the rear bezel unit which accepts the power cord, and contains the line filter, line voltage PCB and fuse.

CYLINDER: all data tracks in common vertical alignment. There are 306 concentric cylinders on all H-series drives. The Model 6 has two tracks per cylinder, the Model 11 has four, and the Model 20 has 6.

DISK MECHANISM OR SEALED MECHANISM: the IMI disk drive assembly consisting of platters, drive motor, head assembly and stepper-motor mechanism, all in a sealed, cast aluminum body. The above components inside the sealed mechanism are not field-servicable and the unit is not to be opened by any other than a Corvus factory facility, otherwise the warranty will be void.

DMA OR DIRECT MEMORY ACCESS: method by which data is transferred at a very high rate, independent of the processor. The processor is put into a "wait" state, where it does no data manipulation. The DMA circuitry takes care of all details, using the Z-80 address bus for destination or origin address for data transfer.

DVM: Digital Volt Meter. A meter used for measuring voltages, which shows output by means of a display consisting of changing digits, proportional to the voltage measured.

FIRMWARE or CONTROLLER FIRMWARE: Z-80 code contained in the first two cylinders of the drive consisting of routines for the Spare Track Table, Virtual Drive Offset table, Pipes, and Semaphore Status Flags. The appropriate routines are downloaded from the Firmware are into the on-board RAM for execution by the Z-80 Controller at power-on time.

FRONT BEZEL: the front panel of the cabinet, containing the Paddleboard PCA and logo.

GROUNDSTRAP: located at the lower end of the spindle in the drive sealed mechanism, the groundstrap consists of a copper metal strip terminating with a carbon button which rides on the spindle end. This device discharges any static charge which may build up on the platters or spindle.

HEAD: in the Winchester disk, very low-mass glass-ferrite, aerodynamic-shaped component, containing a wire winding. There is one head for each data surface which float 18 microinches above the platters on a cushion of air. When current passes through the winding, an electromagnetic flux is induced into the platter surface representing a bit.

HEADSTACK: casting to which all heads are attached. Located in the top of the headstack is the microchip responsible for head selection and signal buffering.

IC: Integrated Circuit. A hybrid, densely populated wafer of silicon containing many resistors and transistors.

MEGABYTE: one million bytes.

MFM (MODIFIED FREQUENCY MODULATION): a method of writing information on a magnetic surface which allows a higher bit density to be used, therefore increasing storage capacity while decreasing size.

MOTOR CONTROL PCA: printed circuit board responsible for monitoring the spindle motor speed and adjusting this as necessary.

NRZ (NON-RETURN TO ZERO): digital representation of information used by microprocessors.

PADDLEBOARD: the small PCA located on the front bezel, which contains the three LEDs and four function switches.

PCA: Printed Circuit Assembly. The Printed Circuit Board, assembled with all its components.

PCB: Printed Circuit Board. Epoxy board with a copper circuit etched onto it. The PCB is the bare board without the usual components such as resistors, transistors and integrated circuits.

PLATTER: circular disks coated with a magnetic oxide that will retain a magnetic flux induced by the read/write heads. Both surfaces of each platter contain data. The 10-megabyte drive has two platters, while the 20-megabyte has three.

REAR BEZEL: the rear most panel area of the cabinet, containing the flatcable connectors for the interface cable, video connectors, power cable and fuse holder. Serial number is located on the rear bezel, also.

SECTOR: each track is divided radially into 20 segments. Each segment is one sector, and contains one block of data, one CRC value, and header information required by the disk controller.

SINUSOIDAL WAVE: a wave form that represents periodic oscillations.

TRACK: all points on one surface with the same radius. Tracks are configured concentrically on each surface.

WINCHESTER TECHNOLOGY: a unique design first developed by IBM as a means to reduce the size of a disk drive while increasing its capacity and removing the possibility of contamination of the disk components. The result was a disk unit much smaller than the traditional 14-inch disk platters with equivalent capacity. This is due to new head design and the use of the sealed-environment used with the disk drive which does not allow the external atmosphere inside the disk mechanism. Inherent in this design is heads that rest on the platters after the drive is powered off. The Corvus disk system uses International Memories Incorporated (IMI) Winchester disk drives.

READ/WRITE PCA: the printed circuit assembly responsible for changing the data received from the heads in MFM format and amplifying and shaping the data signal before passing it on to the Controller circuitry for manipulation.

APPENDIX B
H-SERIES PARTS LIST

H-SERIES PARTS LIST

DESCRIPTION	PART NO.
CABINET COVER	8010-08056
CABINET BASE	8010-09321
FRONT BEZEL	3100-02071
IMI 5006H HDA	2200-02906
IMI 5012H HDA	2200-02907
IMI 5018H HDA	2200-02908
MOUNTING BRACKET	2400-02929
CONTROLLER PCA	8010-09348
BACKPLANE PCA	8010-08108
PADDLEBOARD PCA	8010-03029
5.25" MIRROR PCA	8010-08025
CP510 POWER SUPPLY	8010-09322
FAN, COOLING	2600-01145
FAN COWLING	2600-01707
DRIVE CABLE 34-PIN	8010-09074
DRIVE CABLE 20-PIN	8010-08046
PDLBD-BKPLN CABLE	8010-08046
AC POWER SWITCH	5100-02420
AC HARNESS	8010-08514
A/C POWER CORD	6010-01447
SCREW 8-32 X 3/8	2800-02975
SCREW 6-32 X 5/16	2800-02764
SCREW 4-40 X 3/8	2800-02650
SCREW 6-32 X 3/8	2800-01177
SCREW 8-32 X 3/8	2800-02776
SCREW 6-32 X 1 1/2	2800-02774
SCREW 8-23 X 1/2	2800-02765
SCREW 6-32 X 1/2	2800-02666
SCREW 6-32 X 3/8	2800-02664
SCREW 4-40 X 1/2	2800-02652
WASHER FLAT #6	2800-01198
KEPNUT 4-40	2800-01189
KEPNUT 6-32	2800-01188
WASHER FLAT	2800-01171
NUT 6-32	2800-01165

APPENDIX C
INTERNAL CABLING CHART

H-Series Drive Internal Cabling Chart

The following references of “left” and “right” are as seen from the front of the drive cabinet.

All H-Series Drives

Flatcables:

- Mechanism-to-Controller (34-pin)
 - Mechanism: One edge forward
 - Controller: one edge to the left
- Mechanism-to-Controller (20-pin)
 - Mechanism: one edge forward
 - Controller PCA: top connector only, one edge to the left
- Paddleboard-to-Backplane (20-pin)
 - Paddleboard: one-edge down
 - Backplane: one-edge to the left
- Backplane-to-Host Interface (34-pin)
 - Backplane: one edge to the left
 - Host Interface: refer to the Installation Guide

Dc Power Cables:

- To Drive Mechanism:
 - Yellow wire forward
- To Backplane:
 - Yellow wire right

The following references of “left” and “right” are to a drive mechanism that is held upside-down, with the IMI serial number label to the left.

Drive mechanism:

- Motor Control PCA:
 - Brake connector: located at left end
 - Drive motor connector: located at right end
 - Track zero switch flatcable connector: 90-degree rotation before connecting to molex pins

NOTE:

On Motor Control PCA assembly number 811-01908, the drive motor connector (J-22) will have an open pin after all connectors are attached. This open pin will be at the right end of the connector.

- Read/Write PCA:
 - Stepper motor connector: yellow wire nearest the case

REVISIONS					
PCO	REV	DESCRIPTION	DATE	APPROVED	
	805	A	REL FOR PROD	11-23-82	GKR

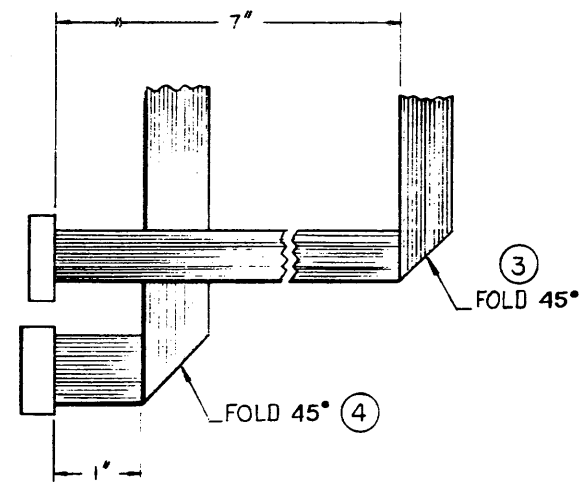
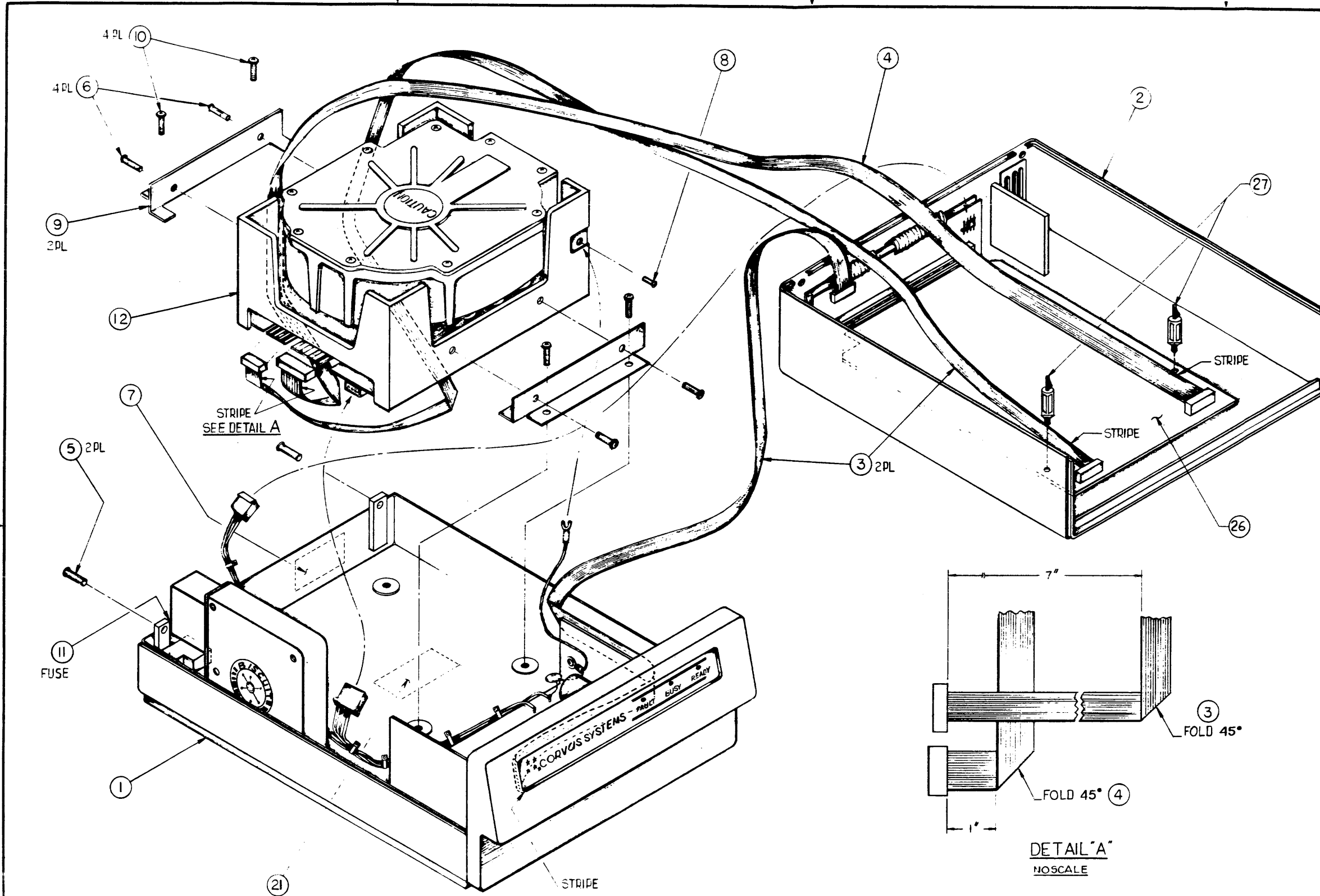

DRIVE	VOLTAGE	110 V	220V
6MB		8005-09152	8005-09158
6MB/M		09155	09161
11MB		09153	09159
11MB/M		09156	09162
20MB		09154	09160
20MB/M		09157	09163

UNLESS OTHERWISE SPECIFIED DIMENSIONS ARE IN INCHES TOLERANCES ON		This document contains proprietary information and is delivered upon the expressed condition that it will not be used directly or indirectly in any way detrimental to the interest of CORVUS SYSTEMS. DRAWN BY: HUY B. DATE OF DRAWING: 9-15-82 CHECKED BY: G. RYDQUIST ENGINEER	CORVUS SYSTEMS 2029 O'Toole Avenue, San Jose, CA 95131	
ANGLES	DECIMALS		FINAL ASSY 'H' DRIVE	
±	.XX ±	APPROVED		
	.XXX ±	APPROVED		
MATERIAL				
FINISH				
NEXT ASSY	USED ON			
APPLICATION				
		ASSEMBLY DWG.		8005-09152 THRU 8005-09163
		SCALE NONE		SHEET 1 OF 1

REVISIONS				
PCO	REV	DESCRIPTION	DATE	APPROVED
805	A	REL FOR PROD	11-23-82	

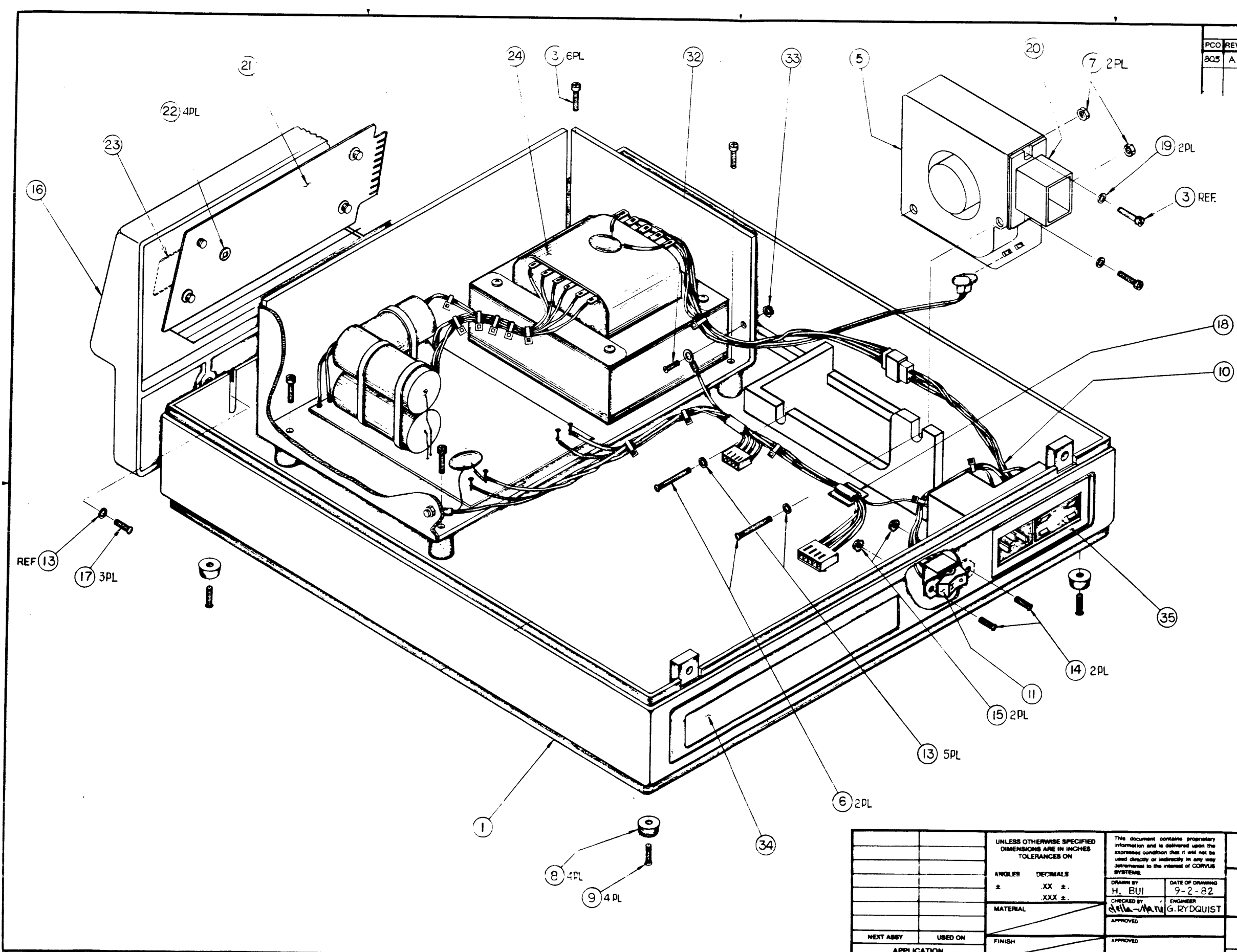

UNLESS OTHERWISE SPECIFIED DIMENSIONS ARE IN INCHES TOLERANCES ON		<small>This document contains proprietary information and is delivered upon the expressed condition that it will not be used directly or indirectly in any way detrimental to the interest of CORVUS SYSTEMS.</small>	CORVUS SYSTEMS <small>2029 O'Toole Avenue, San Jose, CA 95131</small>	
ANGLES \pm XX \pm MATERIAL	DECIMALS \pm .XX \pm \pm .XXX \pm		DRAWN BY H. BUI	DATE OF DRAWING 9-2-82
NEXT ASSY USED ON APPLICATION	FINISH	CHECKED BY G. RYDQUIST	APPROVED G. RYDQUIST	ASSY DWG. 8010-0932I
		APPROVED		SCALE NTS SHEET 1 OF 1

REVISIONS				
PCO	REV	DESCRIPTION	DATE	APPROVED
241	A	DEL. FOR PROD.		
210	B	HARDWARE CHANGE	1-7-82	
391C		NEW TOP COVER	4-30-82	

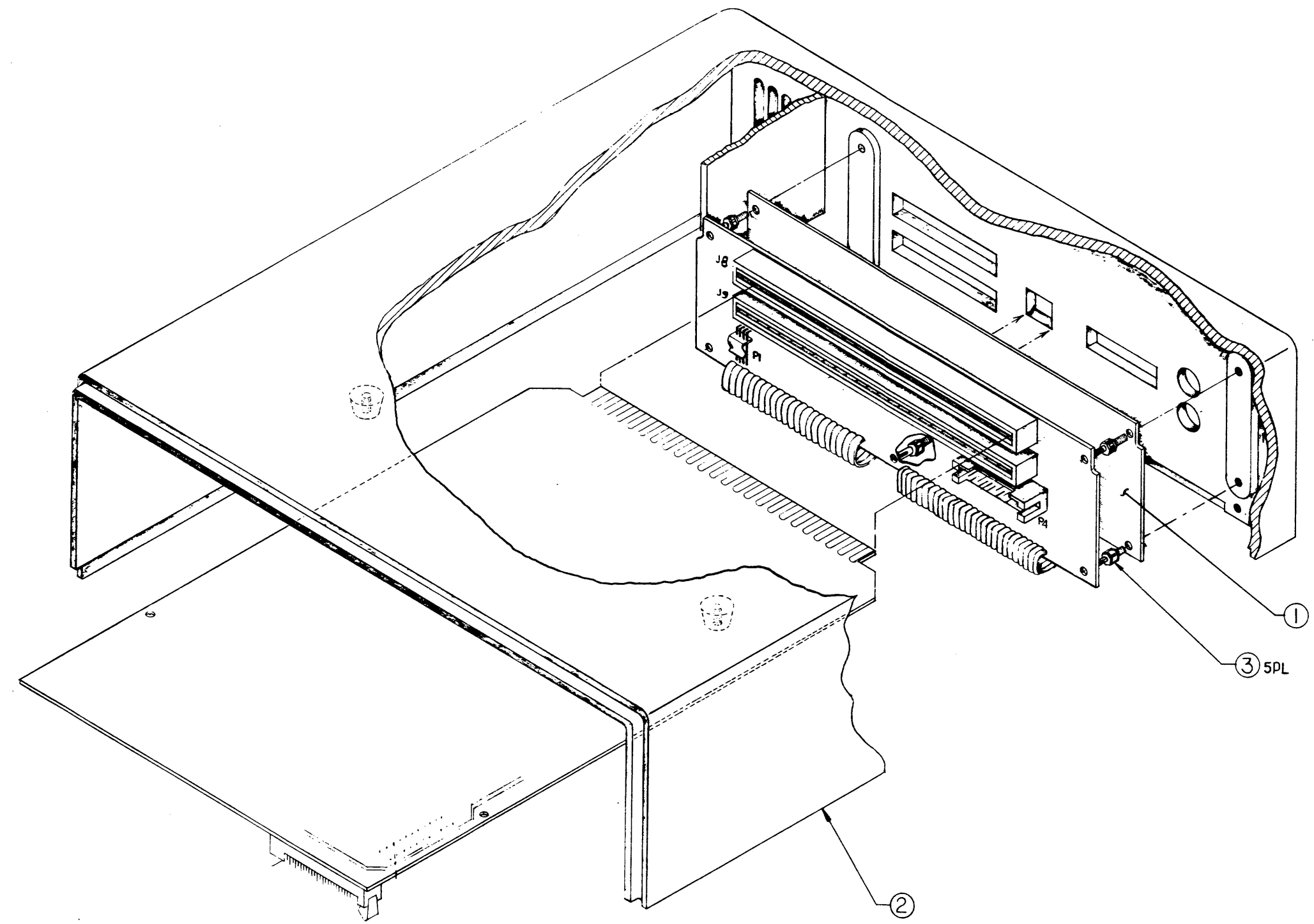

SEE PARTS LIST

		UNLESS OTHERWISE SPECIFIED DIMENSIONS ARE IN INCHES TOLERANCES ON	This document contains proprietary information and is delivered upon the expressed condition that it will not be used directly or indirectly in any way detrimental to the interest of CORVUS SYSTEMS	★ ★ CORVUS SYSTEMS ★ 2029 O'Toole Avenue, San Jose, CA 95131	
		ANGLES DECIMALS ± .XX ± XXX ±		DRAWN BY HUY B	DATE OF DRAWING 9-22-81
		MATERIAL	CHECKED BY	ENGINEER	ASSEMBLY DRAWING 8010-08056
		FINISH	APPROVED		
090	TOP	APPLICATION			SHEET 1 OF 1

REVISIONS				
PCO	REV	DESCRIPTION	DATE	APPROVED
24	A	REL. FOR PROD.		
32	B	REMOVE NOTCHES	2-26-82	JRS
38	C	DIP SW CHG-CORRECTIONS	4-14-82	JRS
68	D	CHG ITEM 2 ADD ITEM 10	11-1-82	EVK

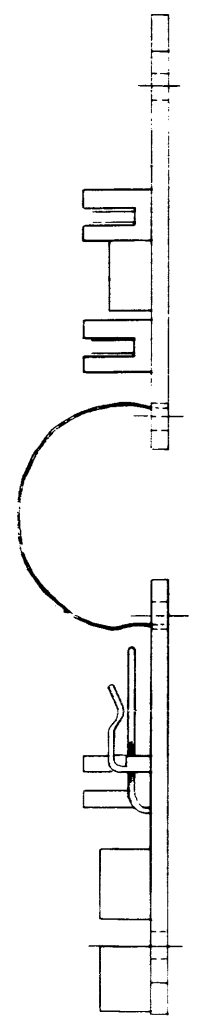
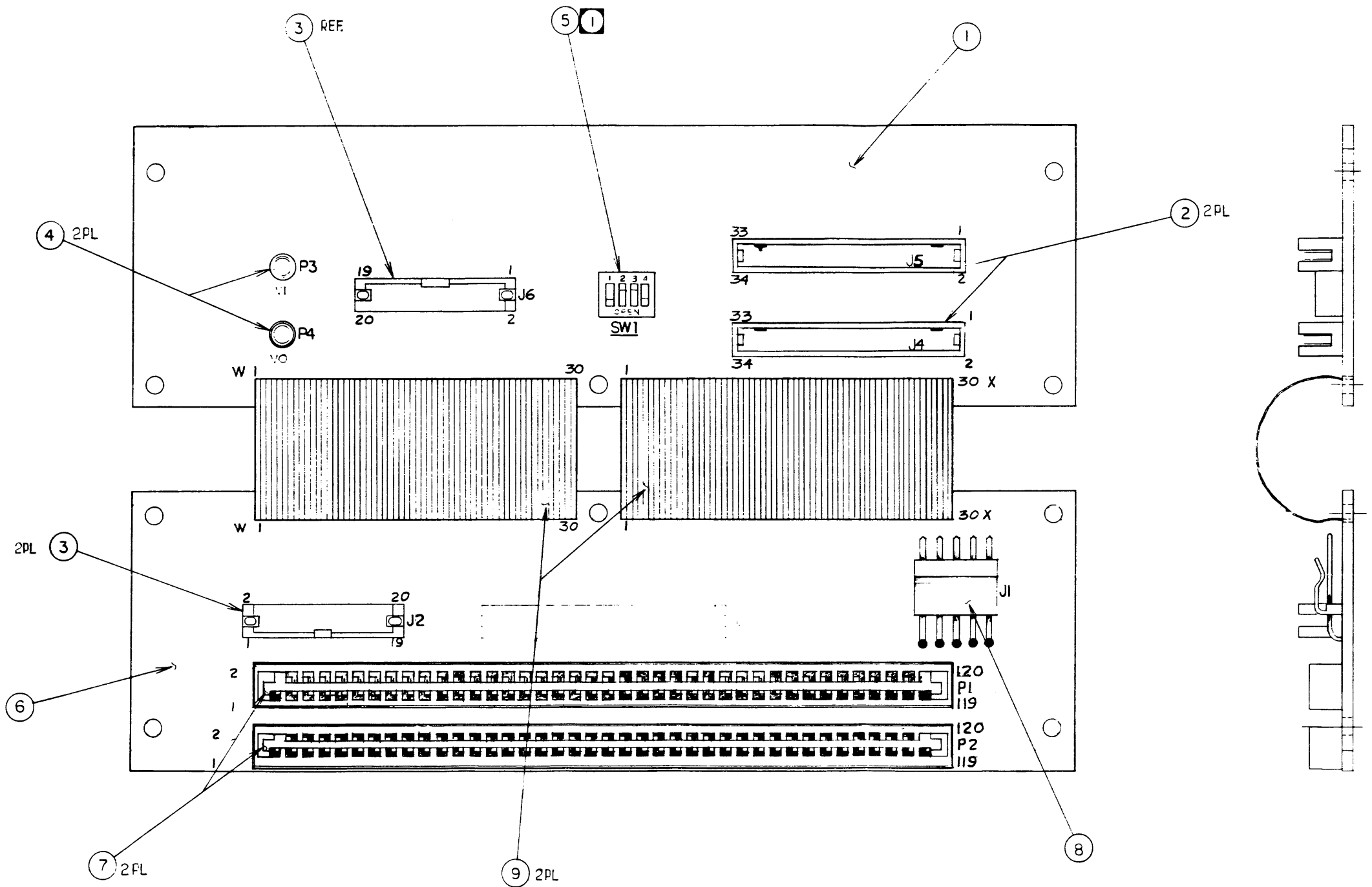

1 INSERT DIP SWITCH AS A SECONDARY OPERATION (AFTER WAVE SOLDERING)

UNLESS OTHERWISE SPECIFIED DIMENSIONS ARE IN INCHES TOLERANCES ON		This document contains proprietary information and is delivered upon the expressed condition that it will not be used directly or indirectly in any way detrimental to the interest of CORVUS SYSTEMS.	CORVUS SYSTEMS 2029 O'Toole Avenue, San Jose, CA 95131	
ANGLES	DECIMALS		60A 6MB BACKPLANE ASSEMBLY 6MB FOAM	
±	XX ±	DRAWN BY HILLY S.	DATE OF DRAWING 12-3-81	CORVUS SYSTEMS 8010-08108
	.XXX ±	CHECKED BY L. FROHMAN	ENGINEER L. FROHMAN	SCALE SHEET 1 OF 1
MATERIAL		APPROVED BY L. FROHMAN		
NEXT ASSY	USED ON	FINISH		
APPLICATION				

This drawing and specifications, herein, are the property of POWER-ONE INC. and shall not be reproduced or copied or used in whole or in part as the basis for the manufacture or sale of items without written permission.

REVISIONS				
ECO	LTR	DESCRIPTION	DATE	APPROVED
X2		RELEASE FOR MILIT. P.L.	12-29-94	K.C.

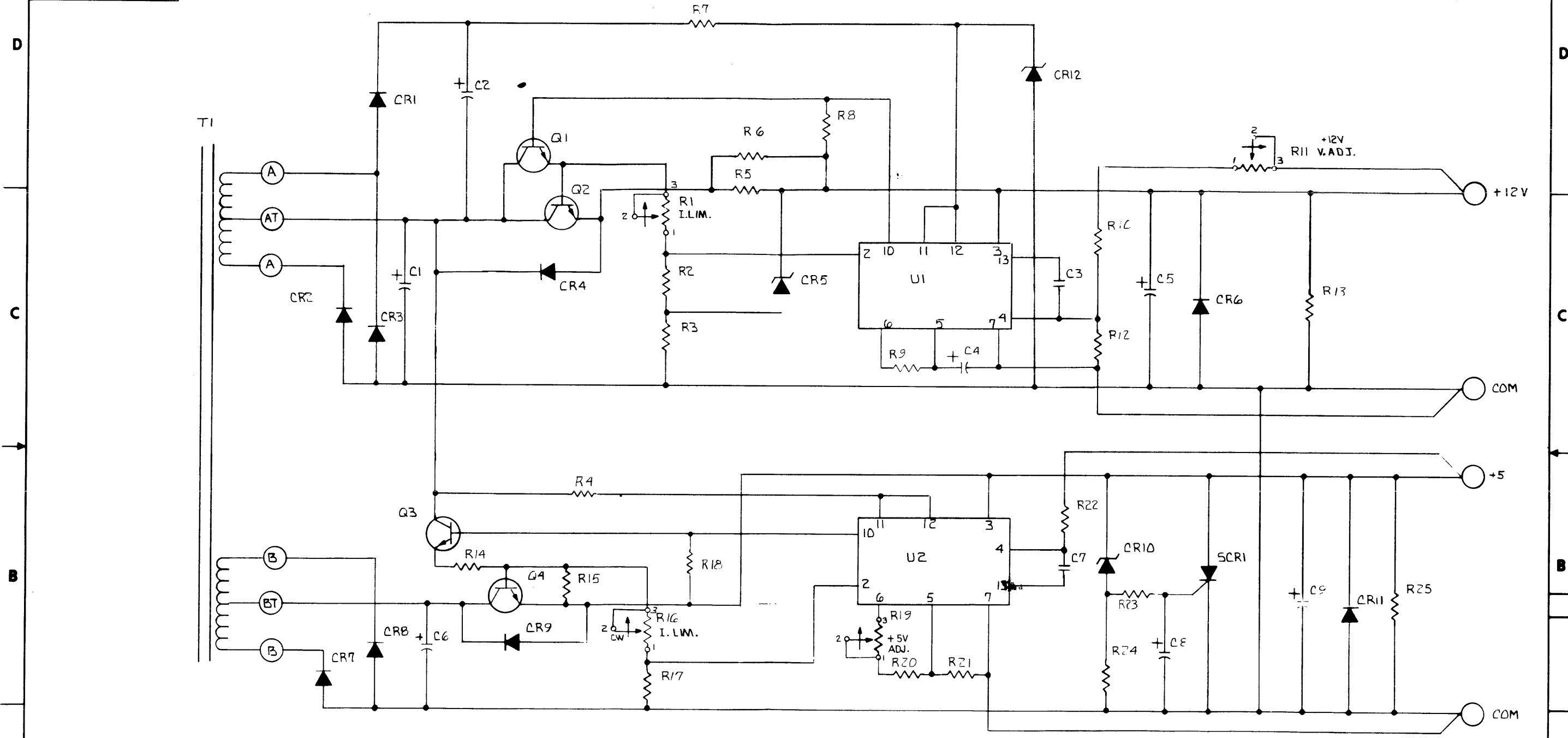

- 5 FOR PARTS LIST DASH NUMBER, SEE APPROPRIATE MODEL MDL
- 4. SEE PART LIST FOR COMPONENT VALUES
- 3 ALL RESISTORS ARE 1/4 W UNLESS OTHERWISE SPECIFIED
- 2. ALL CAPACITOR VALUES ARE IN MICROFARADS / VOLTS
- 1. ALL RESISTOR VALUES ARE IN OHMS.

NOTES: UNLESS OTHERWISE SPECIFIED

FOR PARTS LIST, SEE P/L 52659-5

QTY REQD	ITEM	PART OR IDENTIFYING NO.	NOMENCLATURE OR DESCRIPTION	POWER-ONE STD. P/N
PARTS LIST				
TOLERANCE XX = 0.30 XXX = 0.10		CONTRACT NO.		POWER-ONE CAMARILLO, CALIF. 93010 (805) 484-2000
MATERIAL		APPROVALS	DATE	TITLE
FINISH		DRAWN	10-19-94	SCHEMATIC
NEXT ASSY USED ON		CHECKED		
APPLICATION		ENG APPD		
DO NOT SCALE DRAWING		APPROVED		
		MFG APPD		
		SIZE	CODE IDENT NO.	DRAWING NO.
		D	54407	52659 X2
		SCALE		SHEET OF 1

This drawing and specifications, herein, are the property of POWER-ONE INC. and shall not be reproduced or copied or used in whole or in part as the basis for the manufacture or sale of items without written permission.

REVISIONS				
ECO	LTR	DESCRIPTION	DATE	APPROVED
	X2	PILOT RUN RELEASE	10-12-82	LC

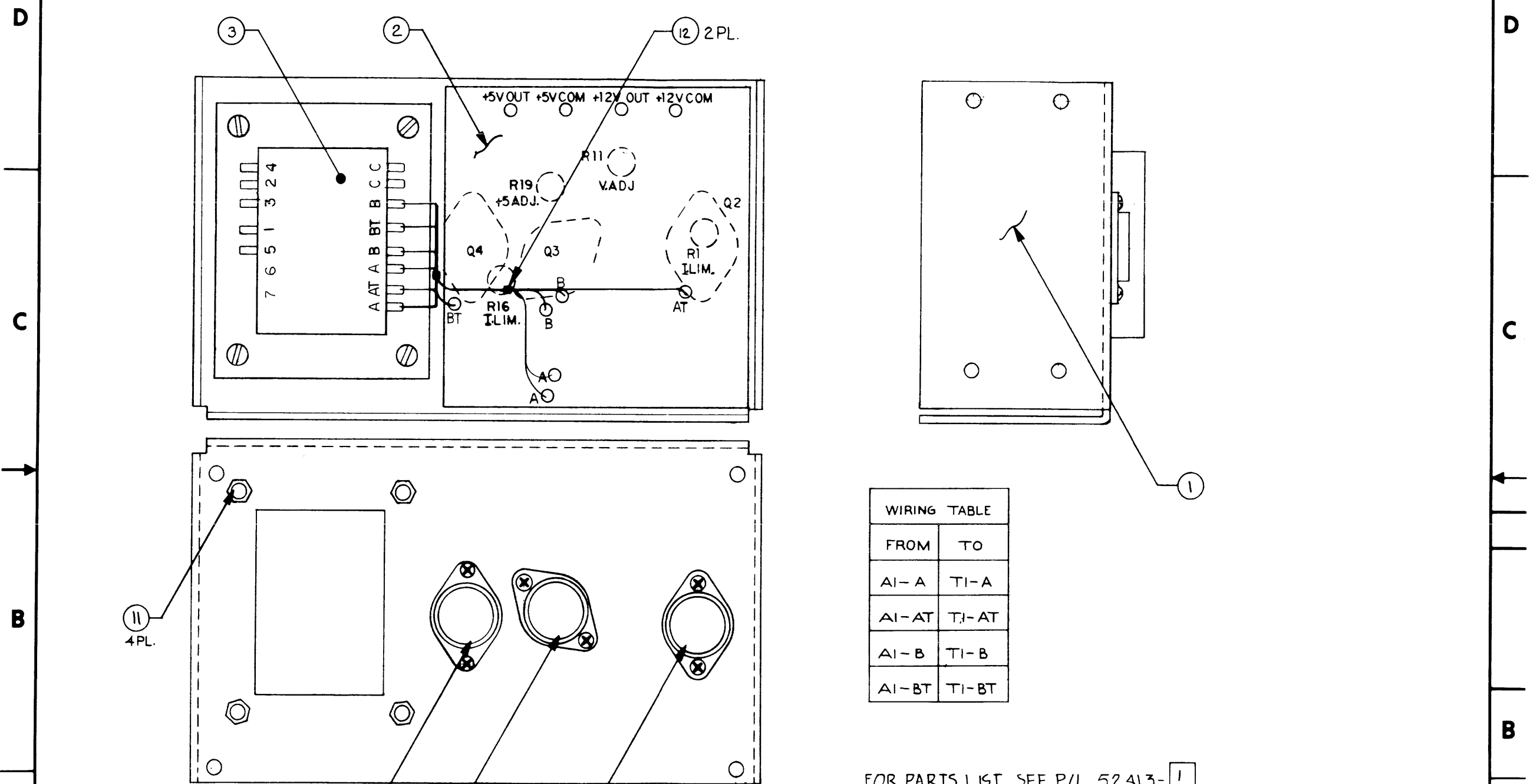

WIRING TABLE	
FROM	TO
AI-A	TI-A
AI-AT	TI-AT
AI-B	TI-B
AI-BT	TI-BT

FOR PARTS LIST SEE P/L 52413-1

- 2. TORQUE TO 6-9 IN LBS.
 - 1. FOR PARTS LIST DASH # SEE APPROPRIATE MDL.
- NOTES: UNLESS OTHERWISE SPECIFIED

QTY REQD	ITEM	PART OR IDENTIFYING NO.	NOMENCLATURE OR DESCRIPTION	POWER ONE STD PART NO.
PARTS LIST				
TOLERANCE .XX = .030 .XXX = .010 PCB SHEAR TOLERANCE XXX - .050		CONTRACT NO.		CAMARILLO, CALIF. 93010 (805)484-2808
MATERIAL		APPROVALS	DATE	TITLE
FINISH		<i>Colleen Ostig</i> 10-12-82 <i>K. H. Bell</i> 10-28-82		ASSEMBLY POWER SUPPLY
NEXT ASSY		MFG. APPD.	SIZE	CODE IDENT NO.
USED ON			C	54407
APPLICATION			DRAWING NO.	
			52413	
DO NOT SCALE DRAWING			SHEET	OF
				X2



PARTS LIST



DWG. NO. PL. 52413-101

SHEET 2 OF 2

REV. SEE SMT. 1

ITEM NO.	NOTE	QTY REQD	POWER ONE STD PART NO.	DESCRIPTION.	VENDOR NO.	REF. DES.	REV. SEE SMT. 1
1		1	412-52416	CHASSIS WISS	52415		
2		1	081-52659-101	PRINTED WIRING BOARD	52420	A1	
3		1	082-52775	TRANSFORMER		T1	
4							
5		1	171-10245	TRANSISTOR	2N3771	Q2	
6		1	171-10261	TRANSISTOR	2N16569	Q3	
7		1	171-10262	TRANSISTOR	2N3055	Q4	
8		3	320-10288	MICA,(INSULATOR)			
9		3	320-10290	MICNABS TD-3			
10		6	350-10206	SCREWS,BH. 6-32 x 1/16			
11		4	340-10602	NUTS,KEP 5/16		T1	
12		2	316-20664	TYWRAPS			
13		REF	52659	SCHEMATIC			

BISHOP GRAPHICS/ACUPRESS
REORDER NO. A1762

PARTS LIST



DWG. NO. PL. 52659-101

SHEET 2 OF 4

REV. SEE SMT. 1

ITEM NO.	NOTE	QTY REQD	POWER ONE STD PART NO.	DESCRIPTION.	VENDOR NO.	REF. DES.	REV. SEE SMT. 1
1		1	505-52421	PRINTED WIRING BOARD	52420	A1	
2							
3		REF	---	TRANSFORMER	52775	T1	
4							
5		2	154-20937	POTENTIOMETER 500Ω		R1,16	
6		2	154-20938	POTENTIOMETER 2K		R11,19	
7							
8		2	158-10719	RESISTOR .22Ω 2W BWH		R5,6	
9		1	151-10210	1Ω 1/2W 5% CF		R14	
10		1	151-10221	15Ω 1/2W 5% CF		R15	
11							
12		3	150-20361	RESISTOR 1.2K 1/4 W 5% CF		R8,18,22	
13		1	-20372	3.6K		R21	
14		3	-20393	220Ω		R9,25,7	
15		2	-20327	47Ω		R4,24	
16							
17		2	-20367	2.2K		R10,17	
18		1	150-20315	RESISTOR 4.7K 1/4W 5% CF		R12	

BISHOP GRAPHICS/ACUPRESS
REORDER NO. A1762

PARTS LIST		POWER-ONE ELECTRONIC SUPPLIES		DWG. NO. PL. 52659-101		SHEET 3 OF 4		REV. SEE SHT. 1	
ITEM NO.	NOTE	QTY REQD	POWER ONE STD PART NO.	DESCRIPTION.	VENDOR NO.	REF. DES.			
19		3	150-20356	RESISTOR 750Ω ¼W 5% CF		R13, 20, 3			
20		1	150-20307	RESISTOR 6.8Ω ¼W 5% CF		R23			
21		1	150-20373	RESISTOR 3.9K ¼W 5% CF		R2			
22		2	130-10287	IC VOLTAGE REGULATOR	UA723	U1, 2			
23									
24		1	172-10249	TRANSISTOR	2N6551	Q1			
25		REF	171-10245		2N3771	Q2			
26		REF	171-10261		2N6569	Q3			
27		REF	171-10262	TRANSISTOR	2N3055	Q4			
28									
29		3	111-10251	DIODE 1A 200V	1N4003	CR1, 4, 9			
30		4	111-10256	DIODE 6A 50V	MR750	CR 2, 3, 7, 8			
31		2	111-10252	DIODE 3A 100V	1N5401	CR6, 11			
32		1	112-10273	ZENER 10V	1N758A	CR5			
33		1	112-10006	DIODE ZENER 5.6V	1N752A	CR10			
34		1	112-10608	DIODE ZENER 36V	IN974B	CR12			
35		1	160-10013	SCR 8A 50V	50508L53	SCR1			
36									

PARTS LIST		POWER-ONE ELECTRONIC SUPPLIES		DWG. NO. PL. 52659-101		SHEET 4 OF 4		REV. SEE SHT. 1	
ITEM NO.	NOTE	QTY REQD	POWER ONE STD PART NO.	DESCRIPTION.	VENDOR NO.	REF. DES.			
37		1	101-20951	CAPACITORS ELECT	10000/35	C1			
38		1	101-10110		100/35	C2			
39		2	101-10111		1/50	C4, 8			
40		1	101-20812		1000/35	C5			
41		1	101-10108		1000/16	C9			
42		1	101-20950	ELECT	22000/16	C6			
43		2	104-10093	CAPACITOR MYLAR	001/100	C3, 7			
44									
45									
46		2	321-10679	I.C. SOCKET 14 PIN		FOR: U1, 2			
47		1	402-13920	HEATSINK		FOR: Q1			
48		1	350-10663	SCREW 6-32 x 1" SELF TAP		FOR: Q1			
49		1	352-10218	SCREW 6-32 x 5/16		FOR: SCR1			
50									
51		2	916-21208	WIRE 16AWG BLK 6" 3/16 x 3/8 T		A, A			
52		1	916-21032	WIRE 16AWG WHT 6 1/2" 3/16 x 3/8 T		AT			
53		2	916-21097	WIRE 16AWG BRN 5" 3/16 x 3/8 T		B, B			
54		1	916-21292	WIRE 16AWG WHT 4 1/2" 3/16 x 1/2 T		BT			

THIS DRAWING AND THE INFORMATION IT CONTAINS ARE THE PROPERTY OF IMI AND ARE TO BE USED ONLY FOR THE PURPOSE OF MANUFACTURING PARTS FOR IMI

AA-18-43, 467 LC

263-02323-100

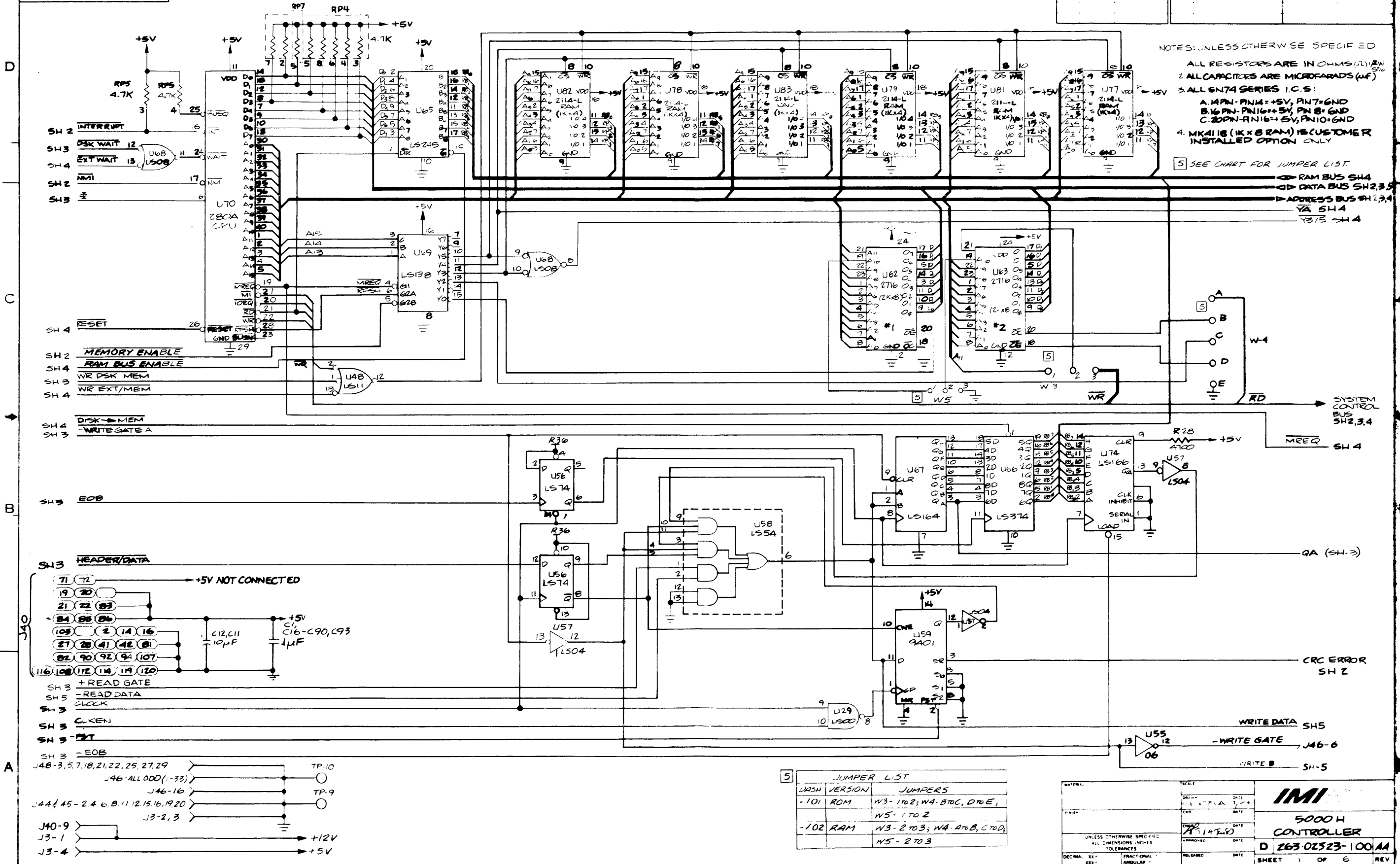

NOTES: UNLESS OTHERWISE SPECIFIED
 1. ALL RESISTORS ARE IN OHMS (Ω) UNLESS OTHERWISE SPECIFIED
 2. ALL CAPACITORS ARE MICROFARADS (μF)
 3. ALL 6N74 SERIES I.C.S.:
 A. 16PN-PIN4=+5V, PIN7=GND
 B. 16PN-PIN16=+5V, PIN8=GND
 C. 20PN-PIN16=+5V, PIN10=GND
 4. MK4118 (1K x 8 RAM) IS CUSTOMER INSTALLED OPTION ONLY
 5. SEE CHART FOR JUMPER LIST

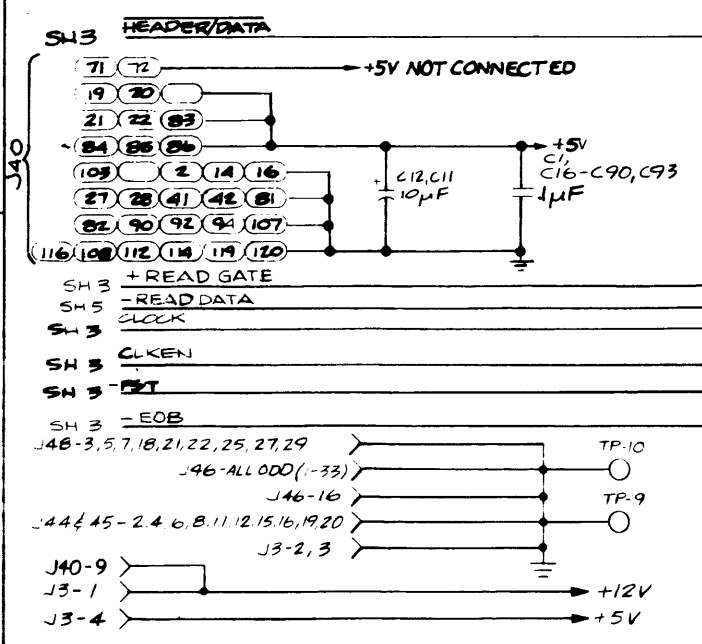

5 JUMPER LIST

VERSION	JUMPERS
-101 ROM	W3-1 TO 2; W4-B TO C, D TO E;
-102 RAM	W5-1 TO 2 W3-2 TO 3; W4-A TO B, C TO D;
	W5-2 TO 3

MATERIAL	SCALE	DATE	IMI
FINISH	CRD	DATE	
UNLESS OTHERWISE SPECIFIED ALL DIMENSIONS INCHES TOLERANCES			5000H CONTROLLER
DECIMAL XX.XX	FRACTIONAL XX 1/XX	RELEASED DATE	D 263-02323-100AA
			SHEET 1 OF 6 REV

THIS DRAWING AND THE INFORMATION IT CONTAINS ARE THE PROPERTY OF IMI AND ARE TO BE USED ONLY FOR THE PURPOSE OF MANUFACTURING PARTS FOR IMI.

REV	DATE	EC NO.	REV	DATE	EC NO.	263-02323-100
AA	11/10/81	46711				
						NEXT ASSEMBLY
						USED ON

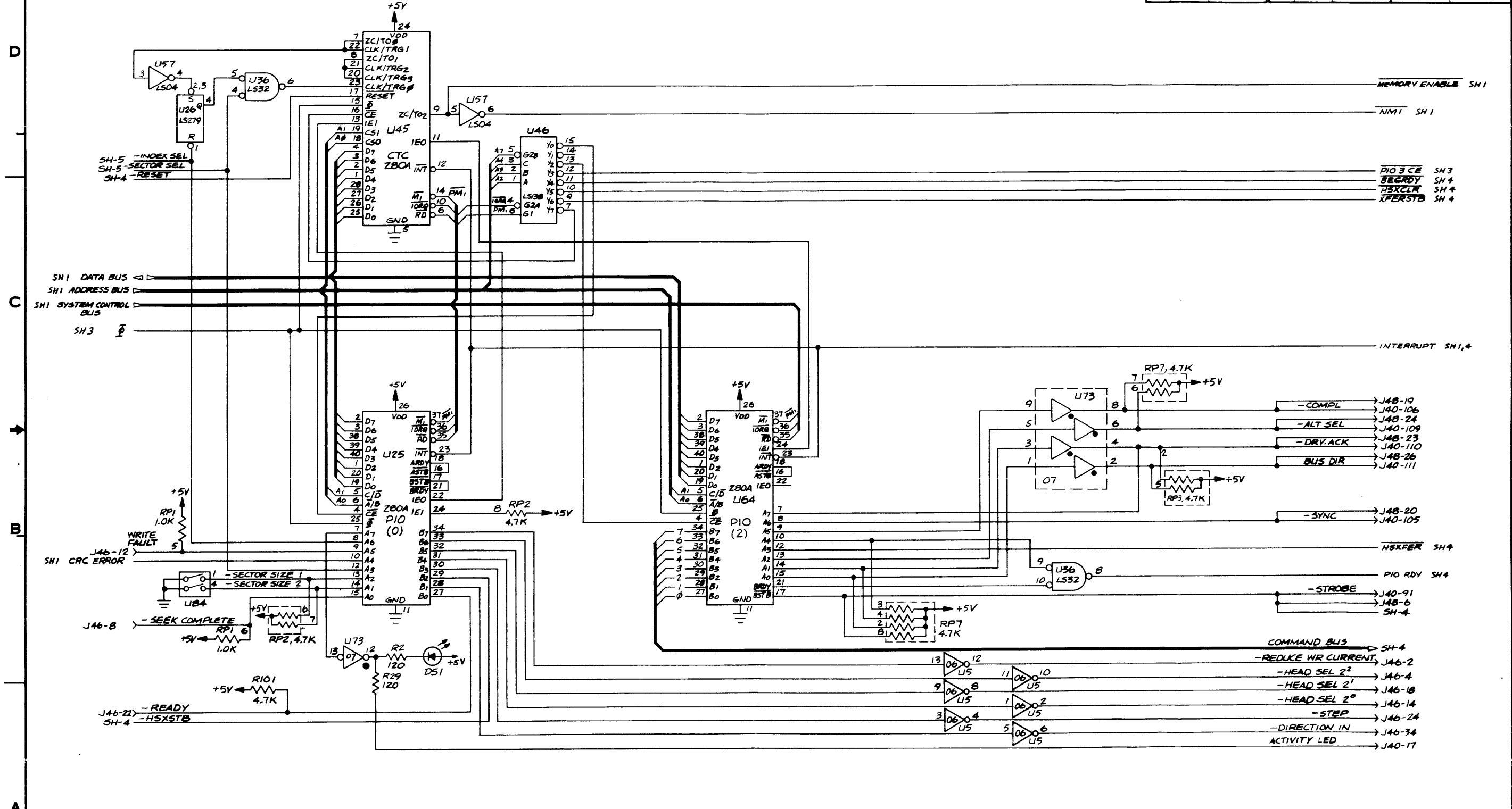

REVISION	NONE	DATE	4-21-81	 INTERNATIONAL MEMORIES INCORPORATED
DESIGNER	MIKE	DATE	4-21-81	
APPROVED	MS	DATE	11/25/83	5000H CONTROLLER
UNLESS OTHERWISE SPECIFIED ALL DIMENSIONS INCHES TOLERANCES				D 263-02323-100 AA
ORIGINAL SIZE	PRODUCTION SIZE	RELEASED	DATE	SHEET 2 OF 6 REV.

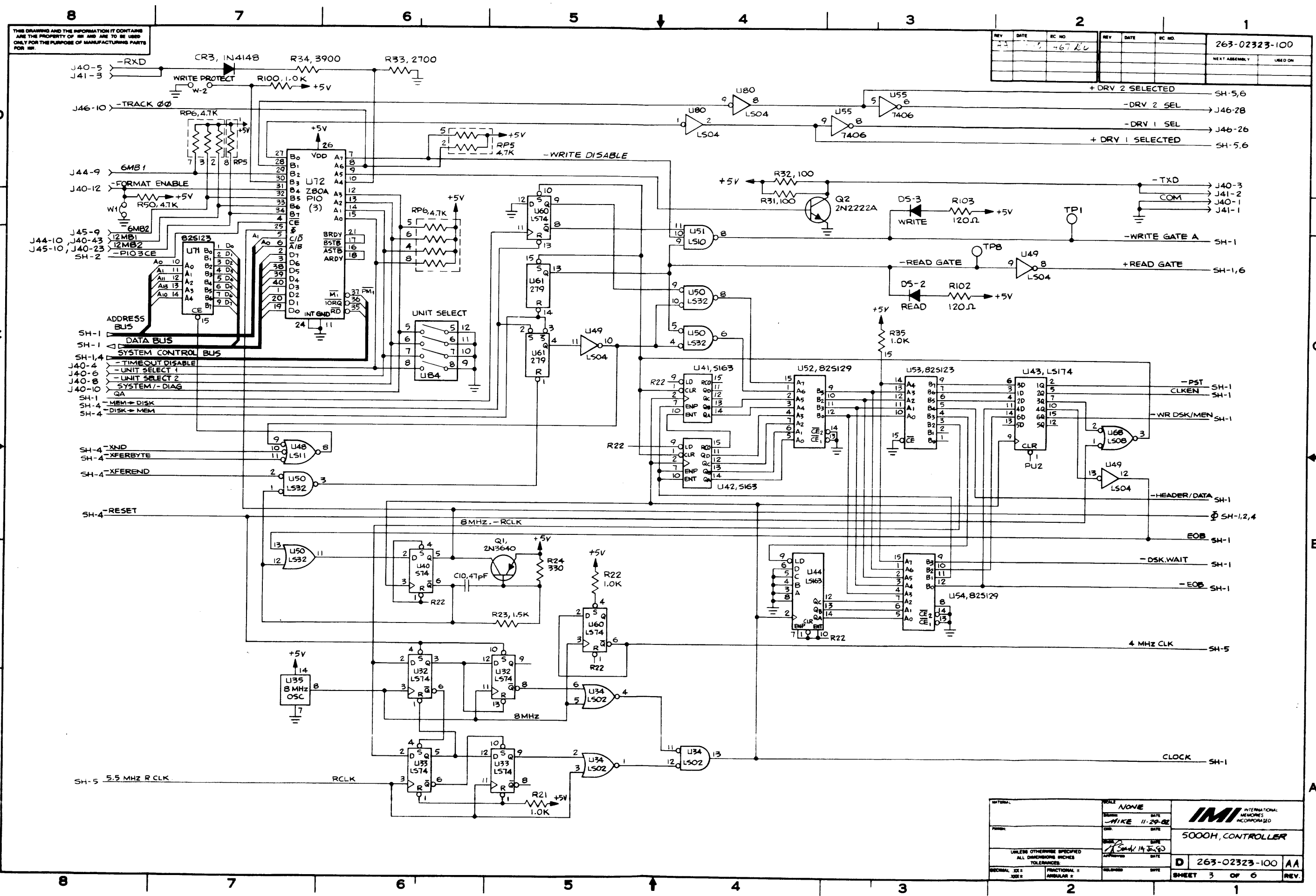

REV	DATE	EC NO	REV	DATE	EC NO	263-02323-100
1						
NEXT ASSEMBLY						USED ON

SCALE		NONE		 INTERNATIONAL MEMORIES INCORPORATED
DRAWN		MIKE 11-29-82		
CHECKED				5000H, CONTROLLER
UNLESS OTHERWISE SPECIFIED ALL DIMENSIONS IN INCHES TOLERANCES:				
DECIMAL SIZE	FRACTIONAL	ANGULAR	RELEASED	DATE
SHEET 3 OF 6				REV: AA

THIS DRAWING AND THE INFORMATION IT CONTAINS ARE THE PROPERTY OF IMI AND ARE TO BE USED ONLY FOR THE PURPOSE OF MANUFACTURING PARTS FOR IMI.

REV	DATE	EC NO	REV	DATE	EC NO	263-02323-00	
AA		467				NEXT ASSEMBLY	USED ON

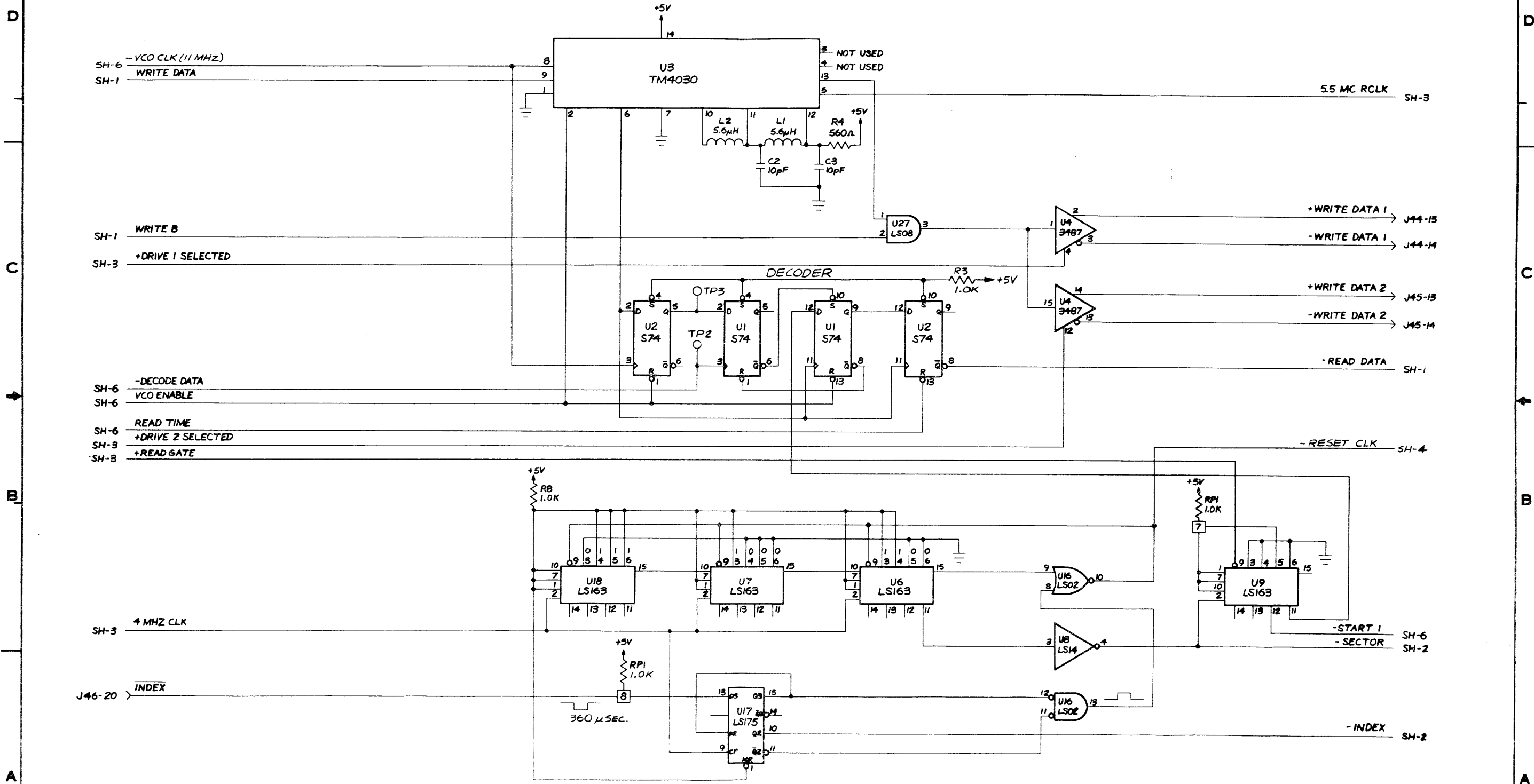

MATERIAL	SCALE	DATE	DATE	DATE	DATE	DATE	DATE
	1:1						
IMI INTERATIONAL MEMORIES INCORPORATED 5000H CONTROLLER			D 263-02323-100				
UNLESS OTHERWISE SPECIFIED ALL DIMENSIONS INCHES TOLERANCES			SHEET 5 OF 6				

THIS DRAWING AND THE INFORMATION IT CONTAINS ARE THE PROPERTY OF IMI AND ARE TO BE USED ONLY FOR THE PURPOSE OF MANUFACTURING PARTS FOR IMI.

REV	DATE	EC NO	REV	DATE	EC NO	263-02323-100	
AA	1-18	467				NEXT ASSEMBLY	USED ON

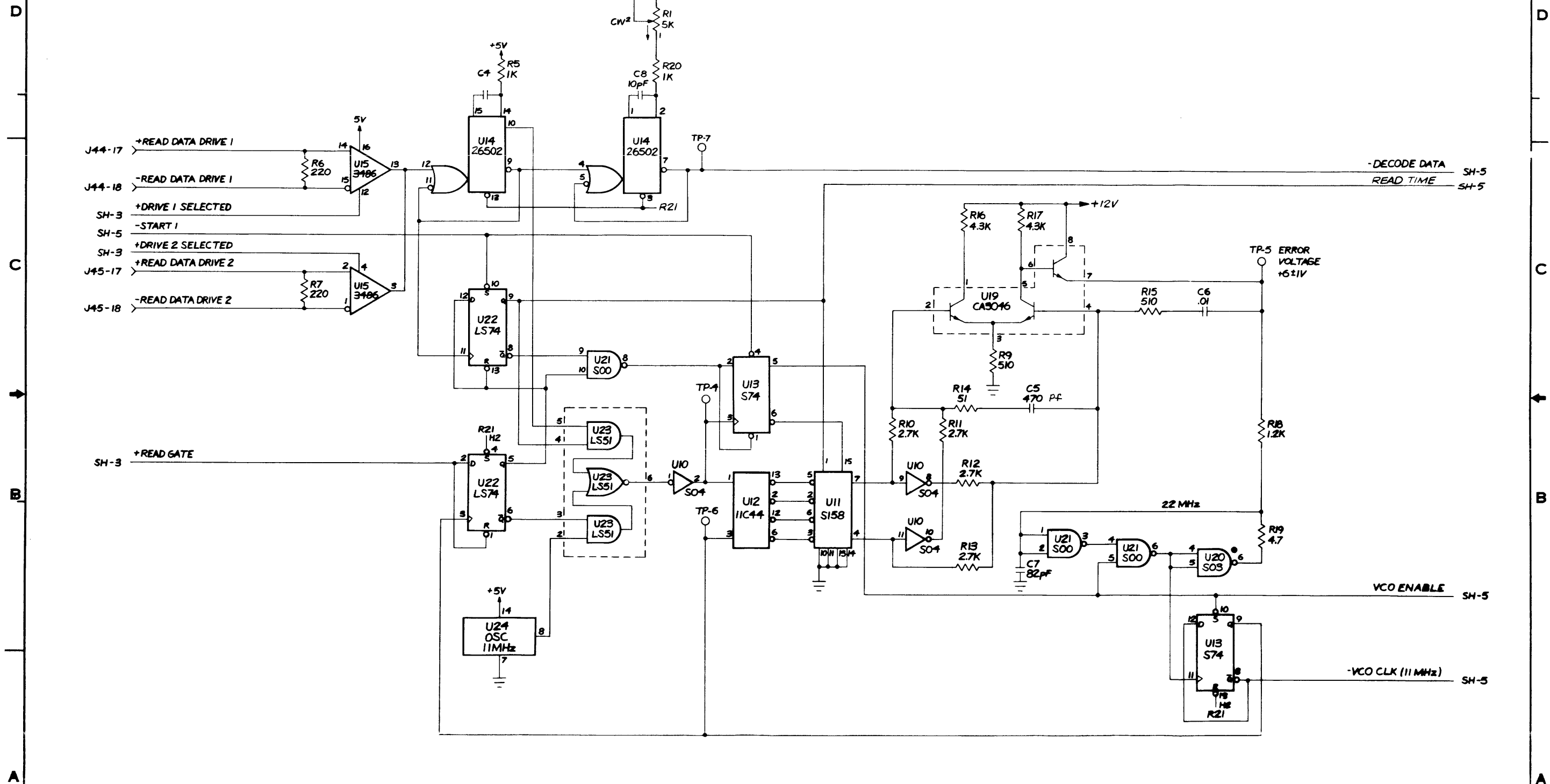

MATERIAL	SCALE	DATE	DATE	DATE	DATE	DATE	DATE
	1:1						
			INTERNATIONAL MICROSYSTEMS INCORPORATED				
CONTROLLER 500H			D 263-02323-100 AA				
SHEET 6 OF 6			REV.				

IMI CONTROLLER 5000H

ASM 811-02323-

REV

U54

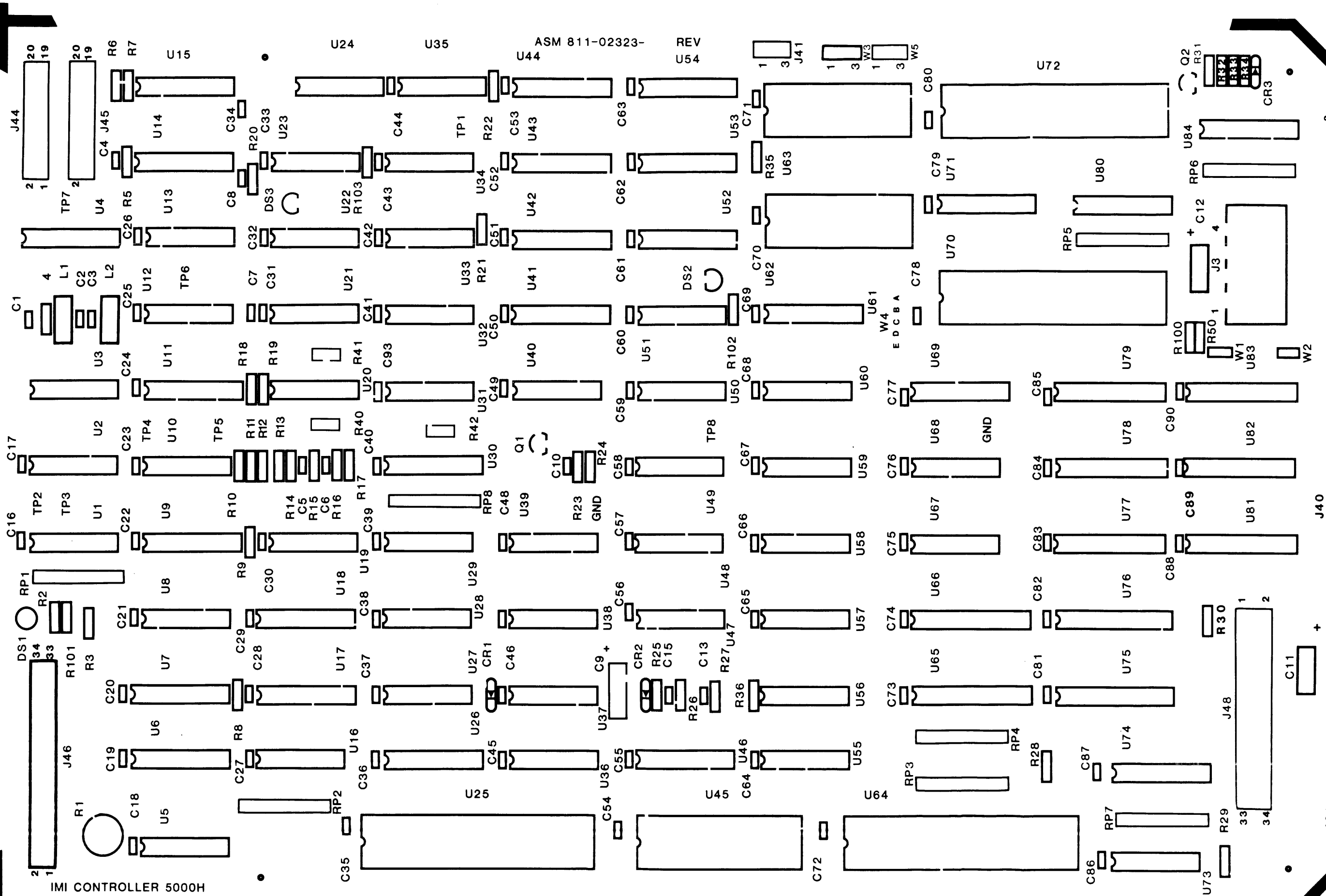

THIS DRAWING AND THE INFORMATION IT CONTAINS ARE THE PROPERTY OF IMI AND ARE TO BE USED ONLY FOR THE PURPOSE OF MANUFACTURING PARTS FOR IMI.

REV.	DATE	BY	CHKD	APP'D	DATE
AA	11-7-92	480	16		
BB	1-28-93	491			

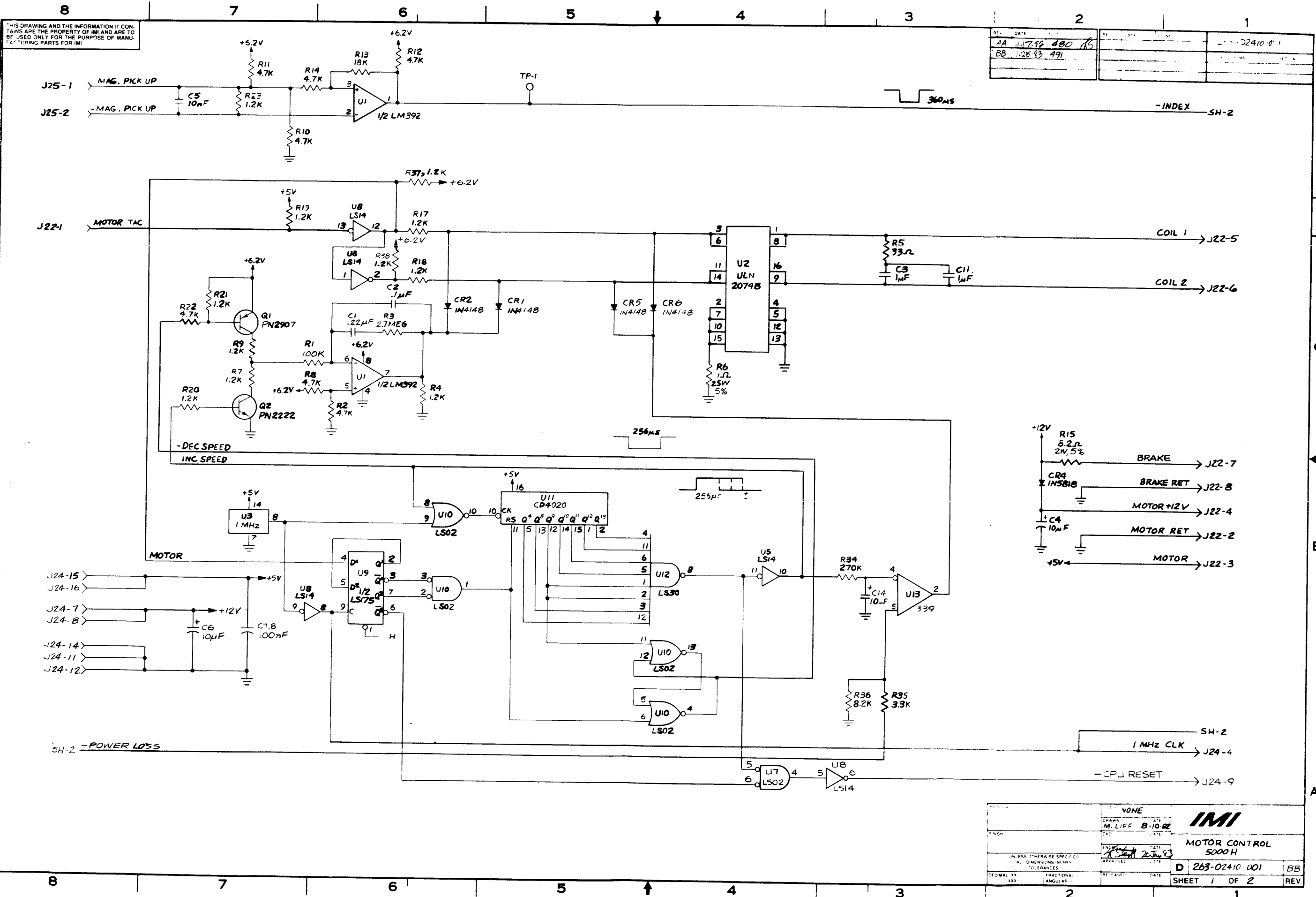

DESIGNER	NONE		
DRAWN	M. LIFF 8-10-92		
ENGR.	A. STEIN 2-26-93		MOTOR CONTROL 5000H
APPROVED			D 263-02410-001
DECIMAL TOL.	FRACTIONAL TOL.	RELEASED DATE	SHEET 1 OF 2
XXX	ANGULAR	DATE	REV.

THIS DRAWING AND THE INFORMATION IT CONTAINS ARE THE PROPERTY OF I.M. AND ARE TO BE USED ONLY FOR THE PURPOSES OF MANUFACTURING PARTS FOR I.M.

AA	480	15	263-02410-001
BB	491		

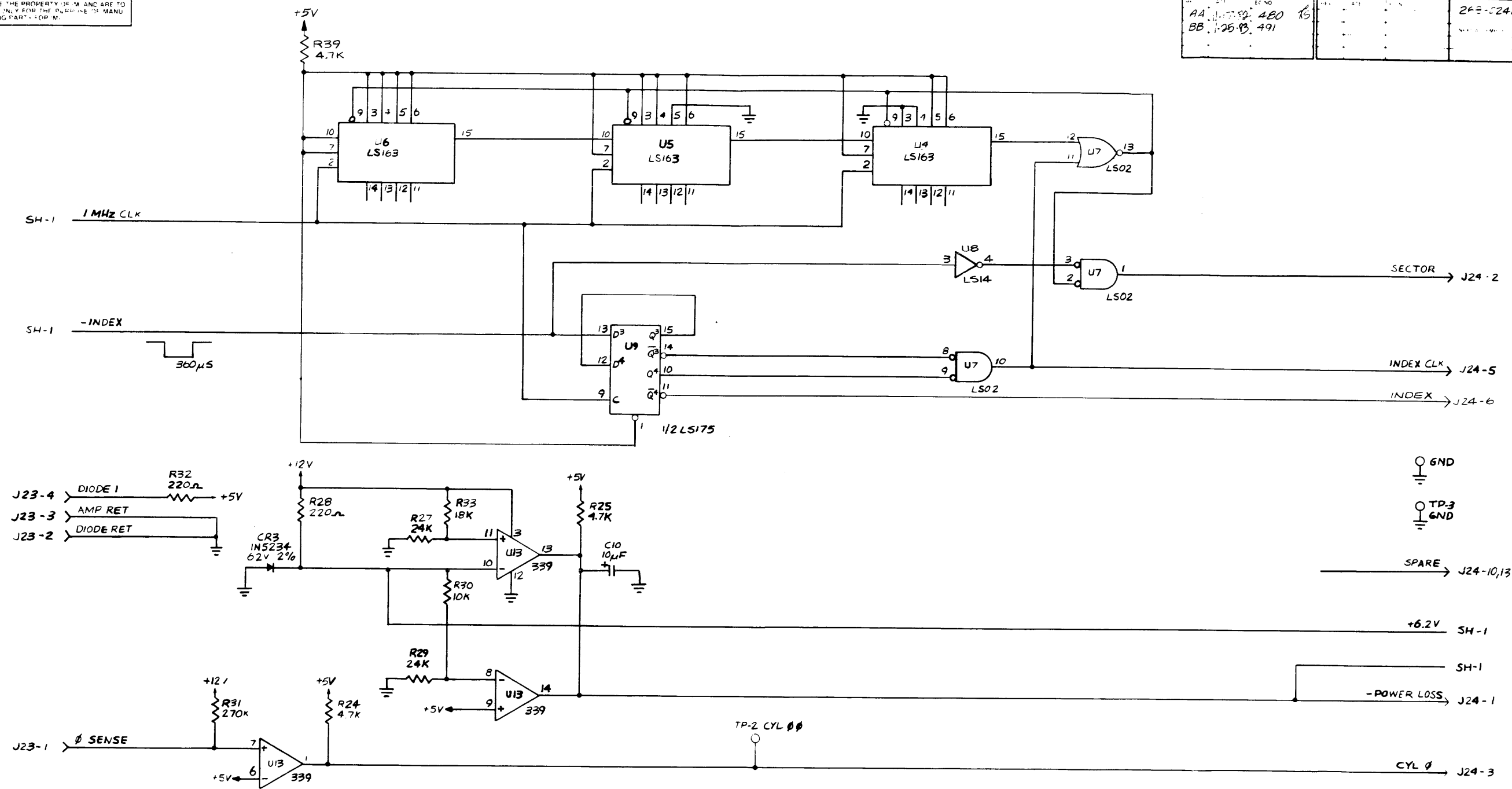

- NOTES: UNLESS OTHERWISE SPECIFIED.
1. ALL RESISTORS ARE IN OHMS (Ω), 1/4W, 5%.
 2. ALL CAPACITORS ARE MICROFARADS (μ F).
 3. NOT USED: C9, R16

MATERIAL		SCALE: NONE		
DRAWN: M. LIFF 9-12-52		DATE		
ENGR: [Signature]		DATE		MOTOR CONTROL 5000 H
UNLESS OTHERWISE SPECIFIED ALL DIMENSIONS IN INCHES TOLERANCES:		APPROVED		D 263-02410-001 BE
DECIMAL XX	FRACTIONAL XX	RELEASED	DATE	SHEET 2 OF 2 REV.

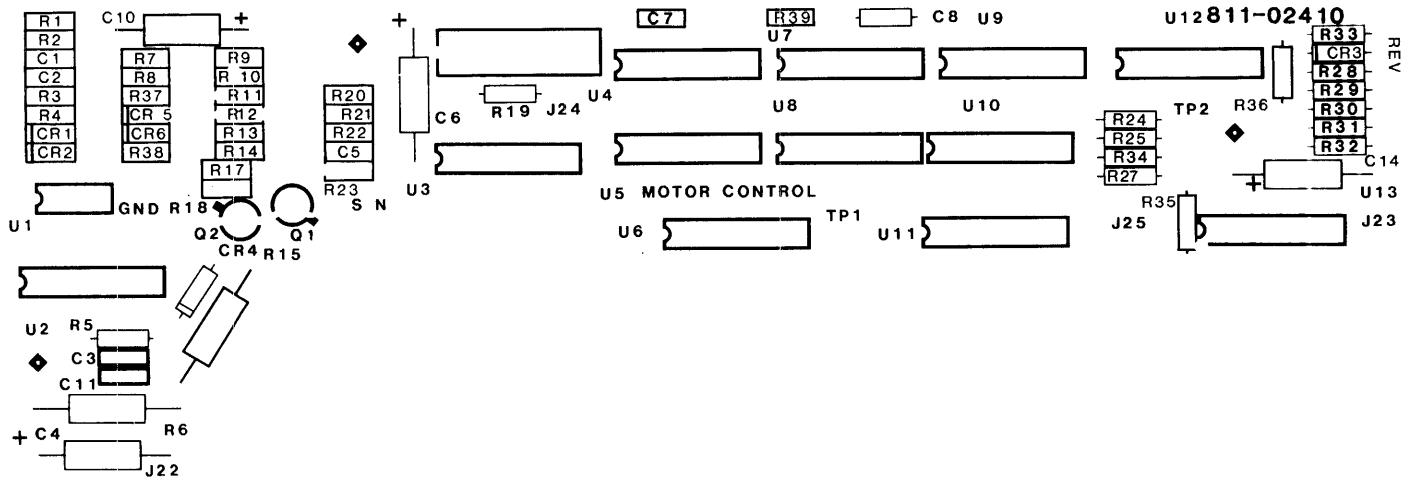

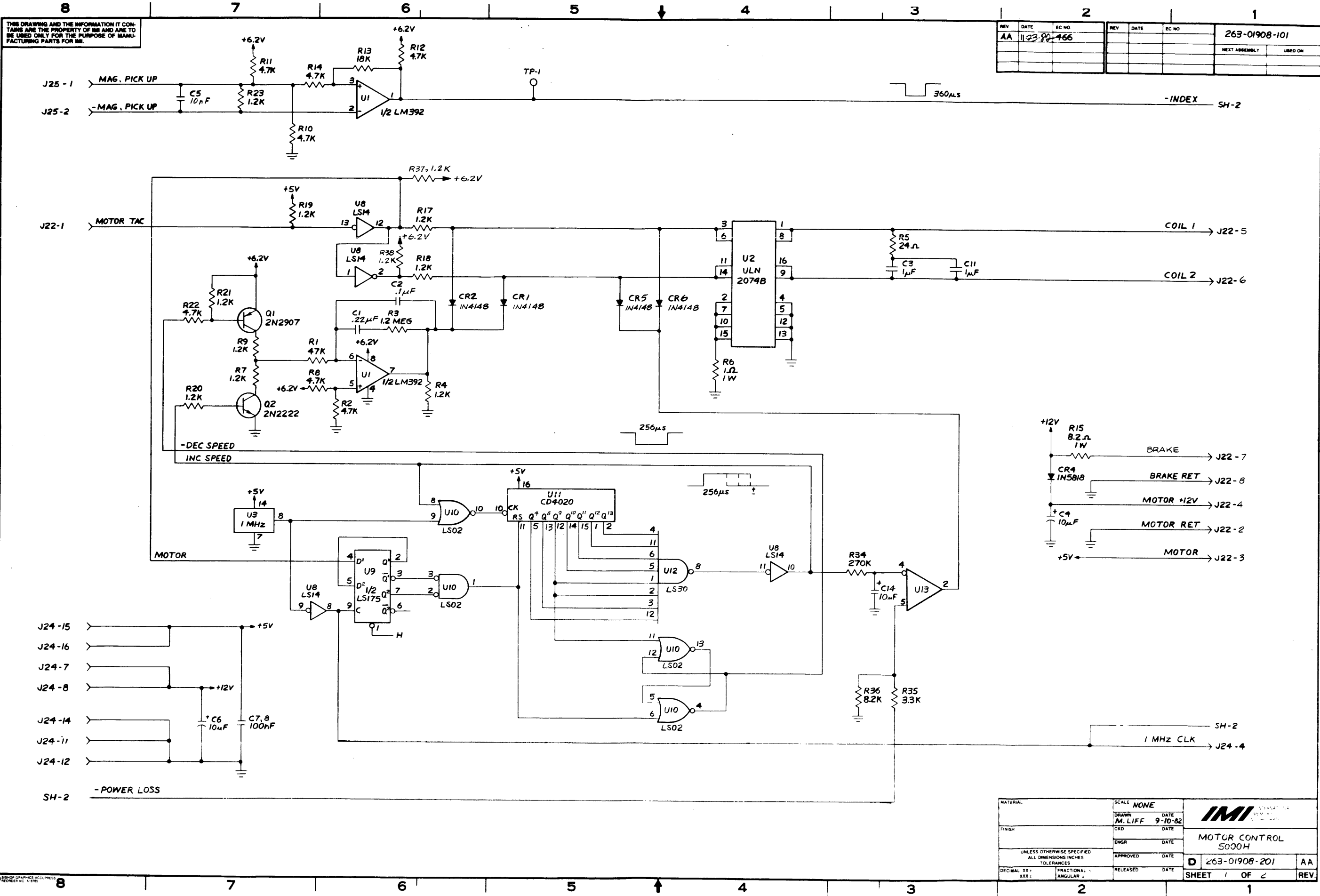

THIS DRAWING AND THE INFORMATION IT CONTAINS ARE THE PROPERTY OF IMI AND ARE TO BE USED ONLY FOR THE PURPOSE OF MANUFACTURING PARTS FOR IMI.

REV	DATE	EC NO	REV	DATE	EC NO	263-01908-101	
AA	11-23-80	166				NEXT ASSEMBLY	USED ON

MATERIAL	SCALE	NONE	DATE		IMI
FINISH	DRAWN	M. LIFF	9-10-82		
	ENGR				MOTOR CONTROL
	APPROVED				5000H
UNLESS OTHERWISE SPECIFIED ALL DIMENSIONS INCHES TOLERANCES	RELEASED				D 263-01908-201
DECIMAL XX: FRACTIONAL: ANGULAR:					AA
					SHEET 1 OF 2
					REV.

THIS DRAWING AND THE INFORMATION IT CONTAINS ARE THE PROPERTY OF IMI AND ARE TO BE USED ONLY FOR THE PURPOSE OF MANUFACTURING PARTS FOR IMI.

REV	DATE	EC NO.	REV	DATE	EC NO.	263-01908-101	
AA	11-23-82	466				NEXT ASSEMBLY	USED ON

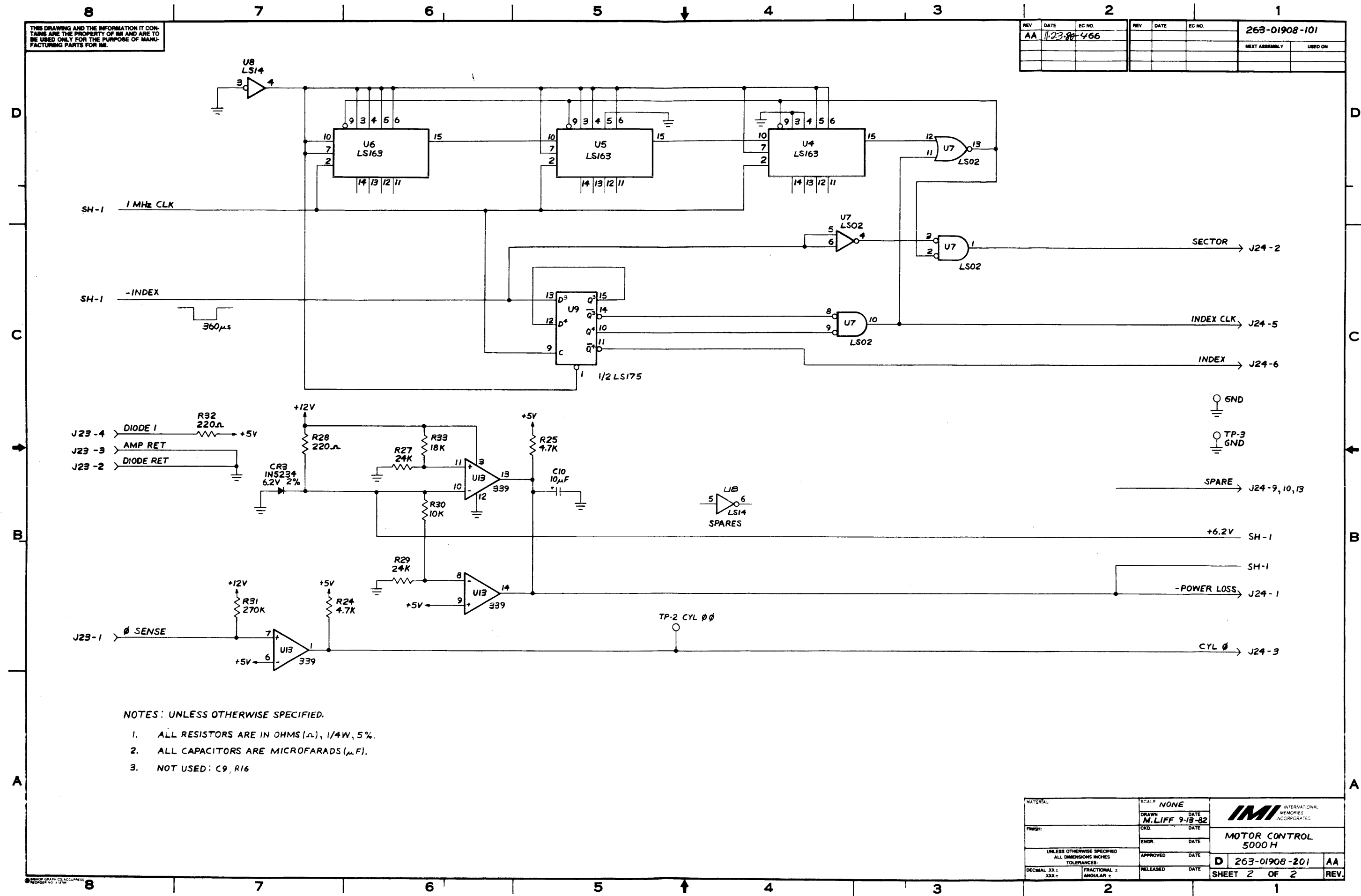

- NOTES: UNLESS OTHERWISE SPECIFIED.
1. ALL RESISTORS ARE IN OHMS (Ω), 1/4W, 5%.
 2. ALL CAPACITORS ARE MICROFARADS (μF).
 3. NOT USED: C9, R16

MATERIAL:	SCALE: NONE	 INTERNATIONAL MEMORIES INCORPORATED
FINISH:	DATE: M.LIFF 9-13-82	
UNLESS OTHERWISE SPECIFIED ALL DIMENSIONS INCHES TOLERANCES:	ENGR. DATE:	MOTOR CONTROL 5000 H
DECIMAL XX ±	APPROVED DATE:	D 263-01908-201
XX ±	RELEASED DATE:	AA
ANGULAR ±		SHEET 2 OF 2
		REV.

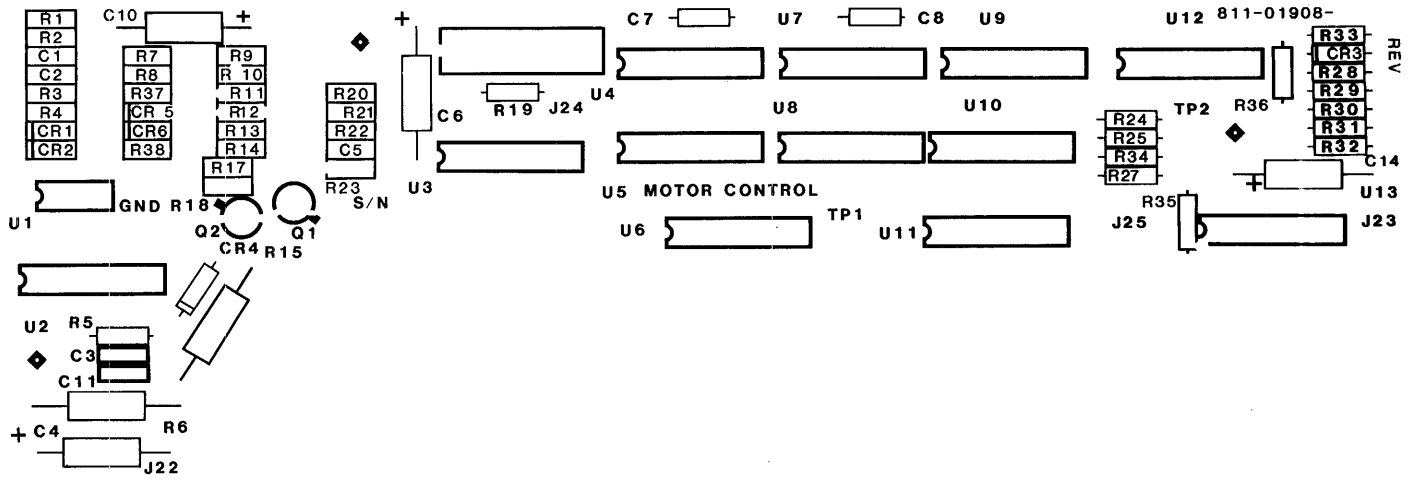

THIS DRAWING AND THE INFORMATION IT CONTAINS ARE THE PROPERTY OF IMI AND ARE TO BE USED ONLY FOR THE PURPOSE OF MANUFACTURING PARTS FOR IMI.

REV	DATE	EC NO	REV	DATE	EC NO	263-02381-201	
AA	2-1-83	50200				NEXT ASSEMBLY	USED ON

-STEP(RESET SEEK COMPLETE) SHT 2
-RESET SHT 2

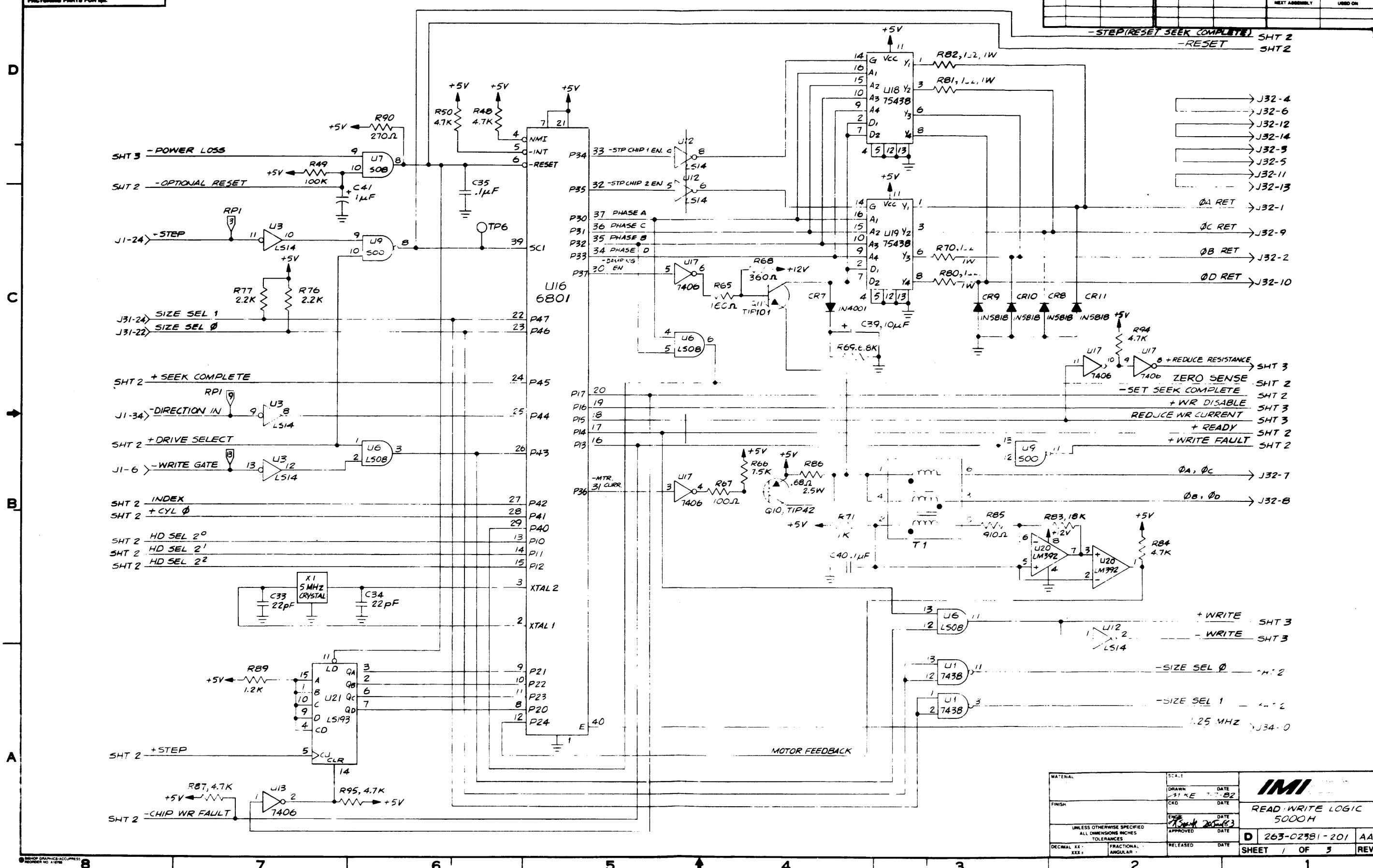

MATERIAL	SCALE	DATE	IMI
FINISH	DRAWN	DATE	
	CHKD	DATE	READ-WRITE LOGIC
	ENGR	DATE	5000H
	APPROVED	DATE	
UNLESS OTHERWISE SPECIFIED ALL DIMENSIONS INCHES TOLERANCES	RELEASED	DATE	D 263-02381-201 AA
DECIMAL XX.X	FRACTIONAL XX/XX	ANGULAR XX°XX'	SHEET 1 OF 3 REV.

18

THIS DRAWING AND THE INFORMATION CONTAINED HEREIN ARE THE PROPERTY OF IMI AND ARE TO BE USED ONLY FOR THE PURPOSES OF MANUFACTURING PARTS FOR IMI.

REV	DATE	BY	NO.	REV	DATE	BY	NO.
AA	2-1-83		502				

263-02381-201	
NEXT ASSEMBLY	USED ON

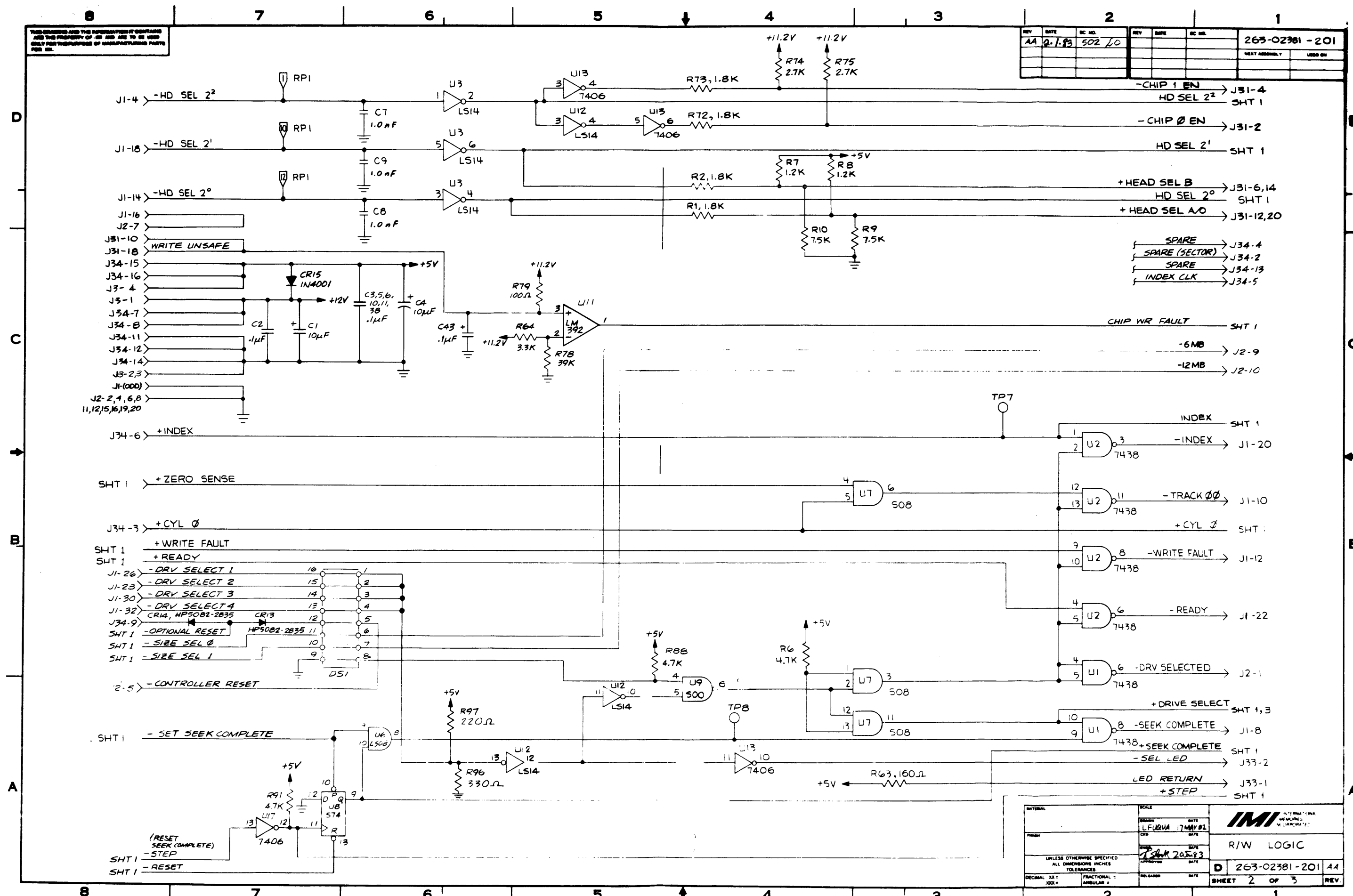

MATERIAL	SCALE	DATE	DATE
FINISH	LFURVA	17 MAY 82	
UNLESS OTHERWISE SPECIFIED ALL DIMENSIONS IN INCHES TOLERANCES		DATE	DATE
DECIMAL XX.1	FRACTIONAL 1/16	RELEASED	DATE
XXX.2	ANGULAR 2		

IMI	
R/W LOGIC	
D	263-02381-201
SHEET	2 OF 3
REV.	

(RESET SEEK COMPLETE)
SHT 1 - STEP
SHT 1 - RESET

REV	DATE	BY	NO.	REV	DATE	BY	NO.	263-02381-201	
AA	2-1-83		502/C					NEXT ASSEMBLY	USED ON

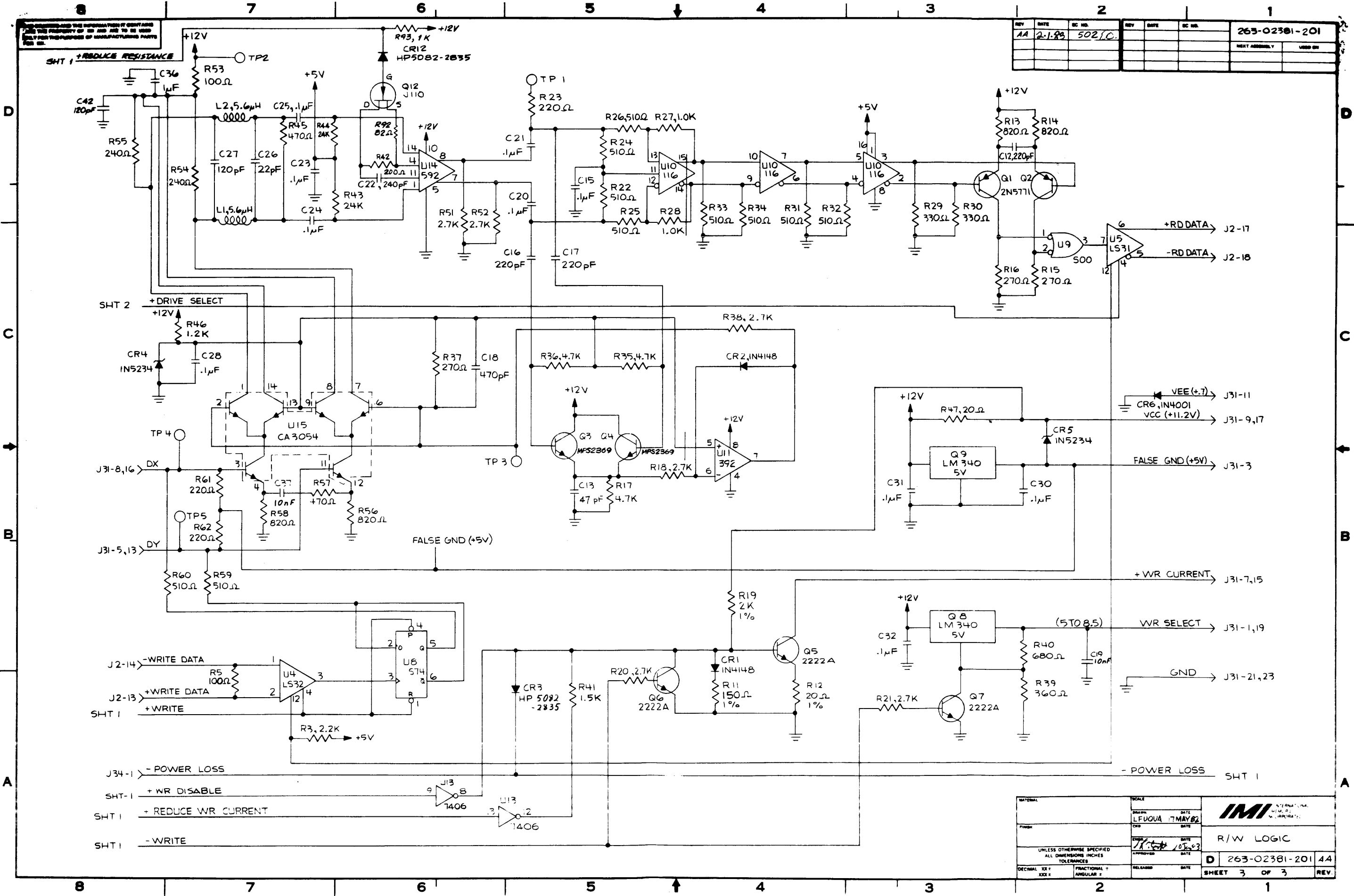

MATERIAL	SCALE	DATE	DATE	
FINISH	DATE	DATE	DATE	
UNLESS OTHERWISE SPECIFIED ALL DIMENSIONS INCHES TOLERANCES				R/W LOGIC
DECIMAL XX ±	FRACTIONAL ±	RELASSED	DATE	D 263-02381-201 44
XXX ±	ANGULAR ±			SHEET 3 OF 3 REV.

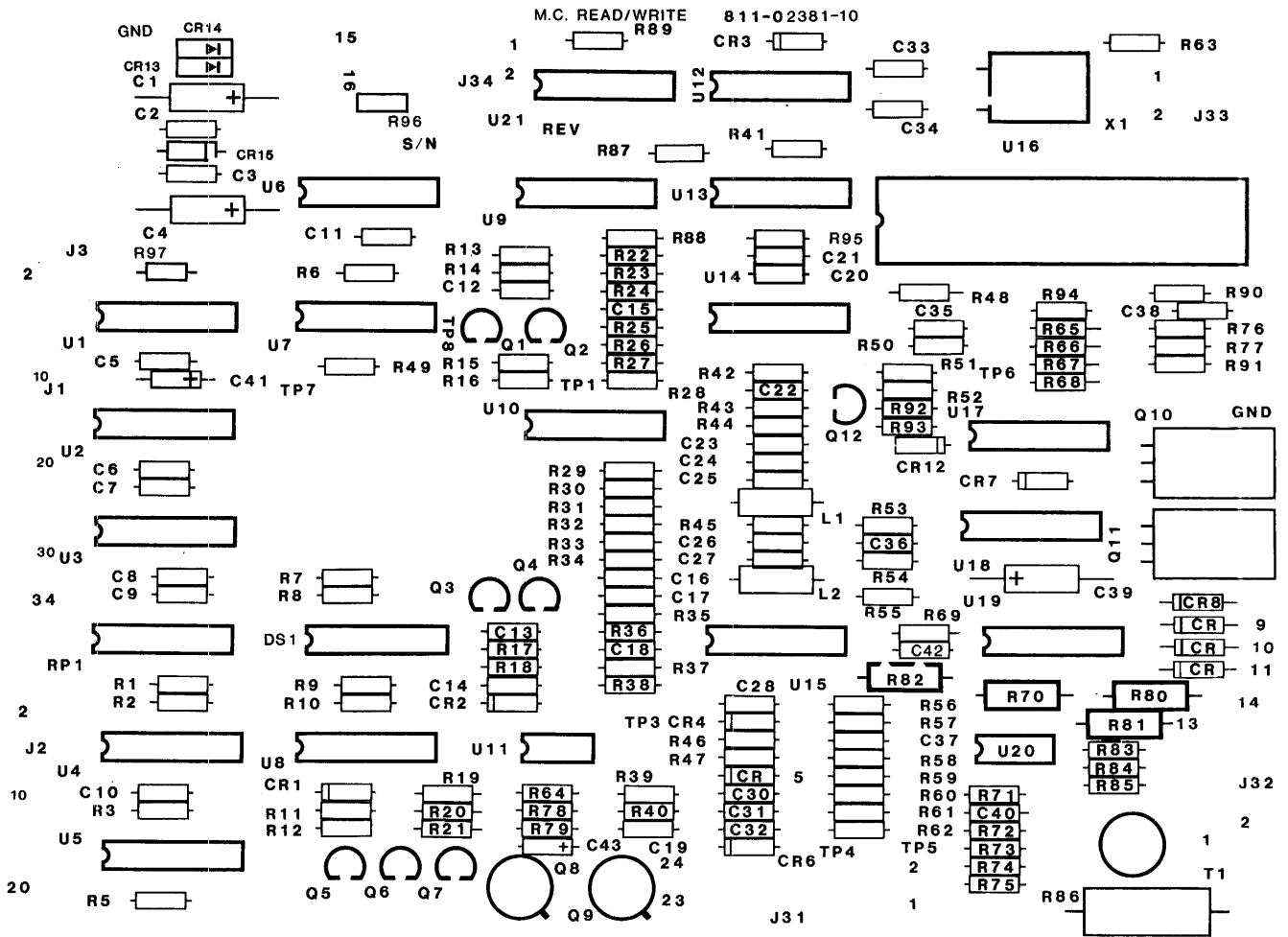

THIS DRAWING AND THE INFORMATION IT CONTAINS ARE THE PROPERTY OF IMI AND ARE TO BE USED ONLY FOR THE PURPOSE OF MANUFACTURING PARTS FOR IMI.

REV	DATE	EC NO.	REV	DATE	EC NO.
AA	10/15/82	465 VB			
263-02157-201					
				NEXT ASSEMBLY	USED ON

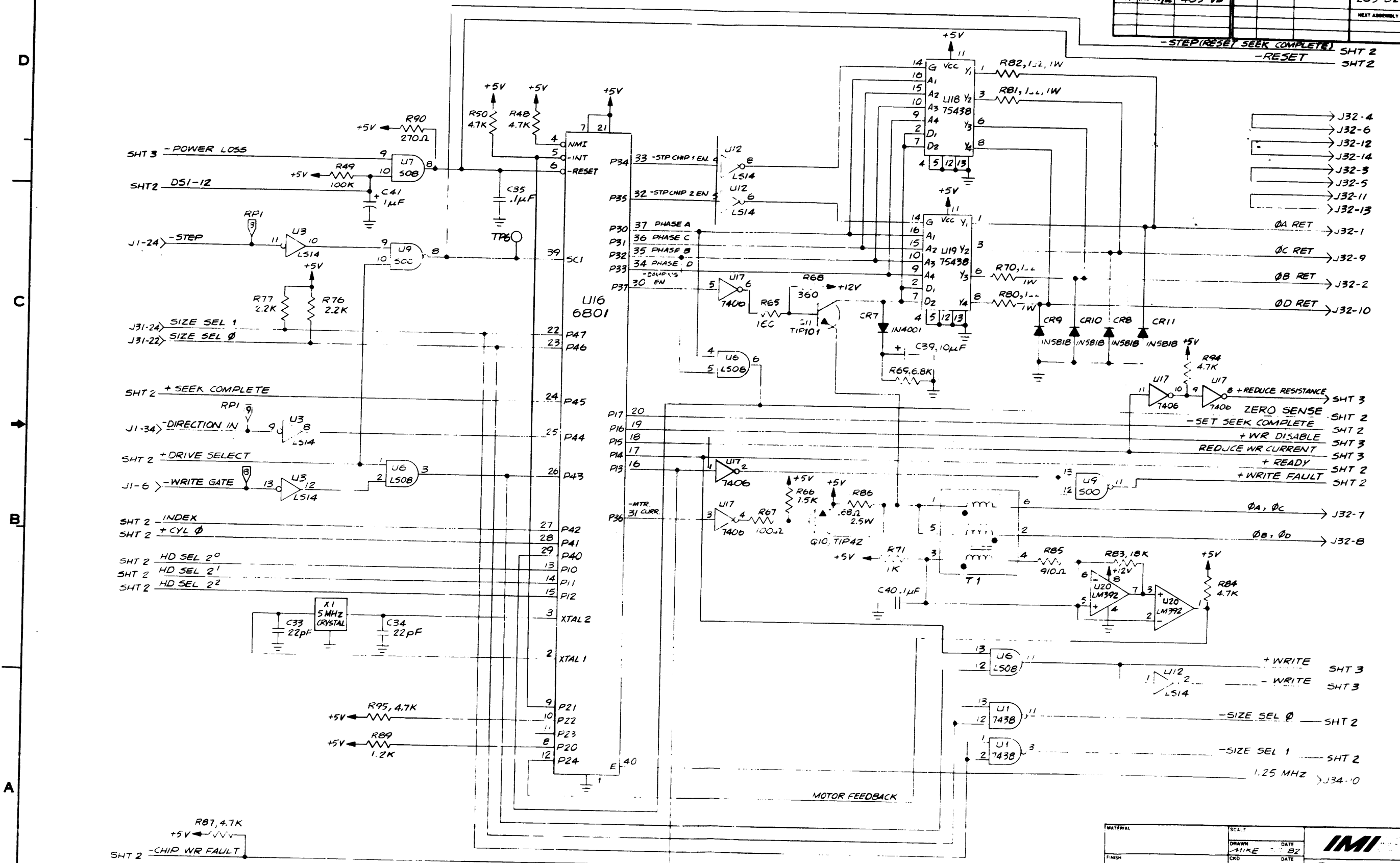

MATERIAL	SCALE	
FINISH	DRAWN DATE	
	CHKD DATE	READ, WRITE LOGIC
	ENGR DATE	5000H
UNLESS OTHERWISE SPECIFIED ALL DIMENSIONS INCHES TOLERANCES		D 263-02157-201 AA
DECIMAL XX	FRACTIONAL X	SHEET 1 OF 3 REV.
XXX	ANGULAR ±	

THIS DRAWING AND THE INFORMATION IT CONTAINS ARE THE PROPERTY OF IMI AND ARE TO BE USED ONLY FOR THE PURPOSES OF MANUFACTURING PARTS FOR IMI.

REV	DATE	BY	NO.	REV	DATE	BY	NO.	263-02157-201
AA	17 MAY 82		465					NEXT ASSEMBLY
								USED ON

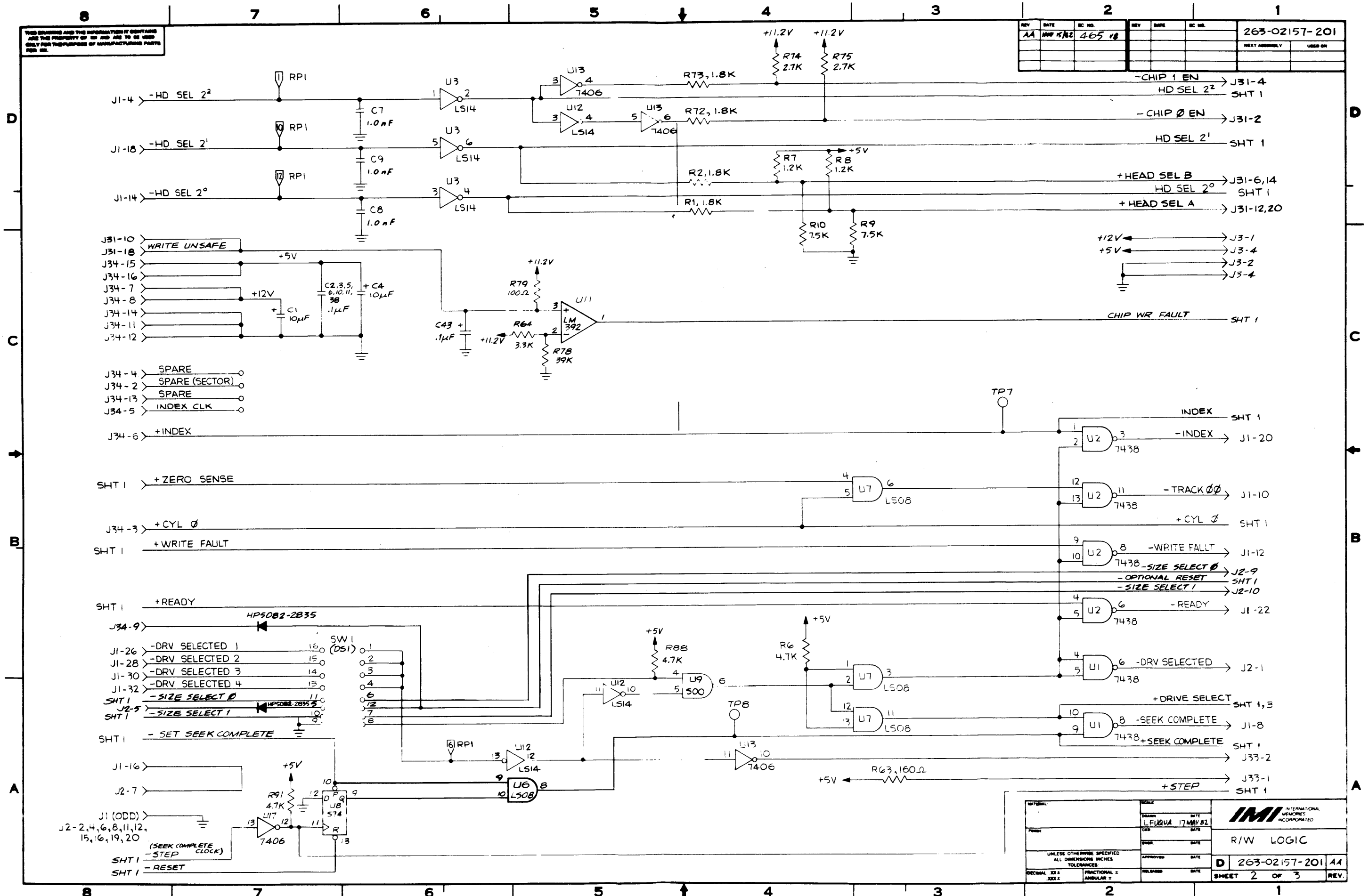

MATERIAL	DATE	DATE	DATE	DATE	DATE	DATE	DATE	DATE	DATE	DATE	DATE
	17 MAY 82										
R/W LOGIC											
UNLESS OTHERWISE SPECIFIED ALL DIMENSIONS IN INCHES TOLERANCES:											
DECIMAL XX ±	FRACTIONAL ±	REL. SURF.	DATE								
.XX ±	ANGULAR ±										
				D	263-02157-201	AA					
				SHEET 2 OF 3		REV.					

REV	DATE	BY	NO.	REV	DATE	BY	NO.	263-02157-201
AA	11/16/82		465	VB				

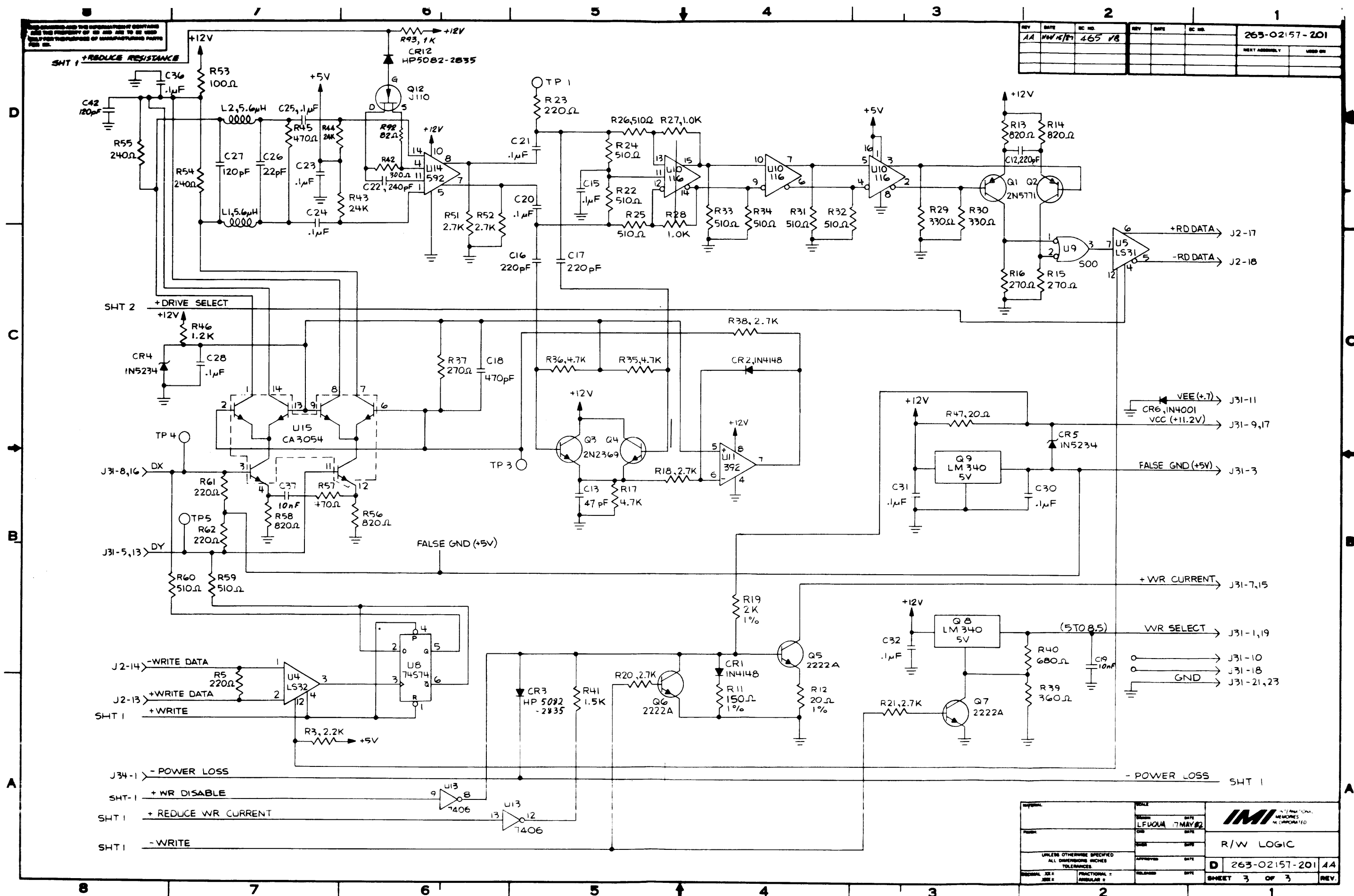

DESIGNED BY	DATE	REV	DATE	REV	DATE	REV	DATE	REV
LFUOQA	7 MAY 82							
UNLESS OTHERWISE SPECIFIED ALL DIMENSIONS INCHES TOLERANCES								
R/W LOGIC								D 263-02157-201 AA
SHEET 3 OF 3								REV.

