



.....
Elite 47 Disc Drive
.....

ST446452W
.....

.....
Product Manual, Volume 1
.....

.....
Elite 47 Disc Drive
.....

ST446452W
.....
.....

.....
Product Manual, Volume 1
.....

© 1998 Seagate Technology, Inc. All rights reserved
Publication number: 83329280, Rev. A
February 1998

Seagate, Seagate Technology, and the Seagate logo are registered trademarks of Seagate Technology, Inc. Elite, SeaFAX, SeaFONE, SeaNET, SeaTDD, and SeaBOARD are either trademarks or registered trademarks of Seagate Technology, Inc. or one of its subsidiaries. All other trademarks or registered trademarks are the property of their respective owners.

No part of this publication may be reproduced in any form without written permission from Seagate Technology, Inc.

Printed in the United States of America

Revision status summary sheet

Revision	Date	Writer/Engineer	Sheets Affected
A	01/09/98	L. Newman/B. Rathe	All

This manual is volume 1 of a two-volume document with the SCSI interface information in the volume 2 *SCSI Interface Product Manual*, part number 77738479.

If you need SCSI interface information, order the volume 2 *SCSI Interface Product Manual*, part number 77738479.

Contents

1.0	Scope	1
2.0	Applicable standards and reference documentation	3
2.1	Standards	3
2.1.1	Electromagnetic compatibility	3
2.2	Electromagnetic compliance	3
2.3	Reference documents	4
3.0	General description	5
3.1	Standard features	6
3.2	Media characteristics	7
3.3	Performance	7
3.4	Reliability	7
3.5	Unformatted and formatted capacities	7
3.6	Programmable drive capacity	7
3.7	Factory installed accessories	7
3.8	Options (factory installed)	8
3.9	Accessories (user installed)	8
4.0	Performance characteristics	9
4.1	Internal drive characteristics (transparent to user)	9
4.2	SCSI seek performance characteristics (visible to user)	9
4.2.1	Access time	9
4.2.2	Format command execution time (for ≥ 512 -byte sectors)	9
4.2.3	General performance characteristics	9
4.3	Start/stop time	11
4.4	Prefetch/multi-segmented cache control	11
4.5	Cache operation	11
4.5.1	Caching write data	12
4.5.2	Prefetch operation	12
5.0	Reliability specifications	15
5.1	Error rates	15
5.1.1	Environmental interference	15
5.1.2	Read errors	15
5.1.3	Write errors	15
5.1.4	Seek errors	16
5.2	Reliability and service	16
5.2.1	Mean time between failure	16
5.2.2	Preventive maintenance	17
5.2.3	Service life	17
5.2.4	Service philosophy	17
5.2.5	Service tools	17
5.2.6	S.M.A.R.T.	18
5.2.7	Product warranty	19
6.0	Physical/electrical specifications	21
6.1	AC power requirements	21
6.2	DC power requirements	21
6.2.1	Conducted noise immunity	22
6.2.2	Power sequencing	22
6.2.3	12 V current profile	22
6.3	Power dissipation	23
6.4	Environmental limits	23
6.4.1	Temperature	23
6.4.2	Relative humidity	25
6.4.3	Effective altitude (sea level)	25
6.4.4	Shock and vibration	25

6.4.5	Air cleanliness	27
6.4.6	Acoustics	27
6.4.7	Electromagnetic susceptibility	27
6.5	Mechanical specifications	27
7.0	Defect and error management	29
7.1	Drive internal defects and errors	29
7.2	Drive error recovery procedures	29
8.0	Installation	31
8.1	Drive ID/option select header	31
8.1.1	Notes for Figure 8	34
8.2	Drive orientation	35
8.3	Cooling	35
8.3.1	Air flow	35
8.4	Drive mounting	36
8.5	Grounding	36
9.0	Interface requirements	37
9.1	General description	37
9.2	SCSI interface messages supported	37
9.3	SCSI interface commands supported	38
9.3.1	Inquiry data	41
9.3.2	Mode Sense data	41
9.4	SCSI bus conditions and miscellaneous features supported	44
9.5	Synchronous data transfer	45
9.5.1	Synchronous data transfer periods supported	45
9.5.2	REQ/ACK offset	45
9.6	Physical interface	45
9.6.1	DC cable and connector	45
9.6.2	SCSI interface physical description	47
9.6.3	SCSI interface cable requirements	47
9.6.4	Mating connectors	47
9.7	Electrical description	52
9.7.1	Single-ended drivers/receivers	52
9.8	Terminator requirements	53
9.9	Terminator power	53
9.10	Disc drive SCSI timing	54
10.0	Seagate technical support services	57

List of Figures

Figure 1.	Elite 47 disc drive	1
Figure 2.	Elite 47 family drive	6
Figure 3.	Typical Elite 47 drive +5 V and +12 V current profile	22
Figure 4.	Location of PCBA components listed in Table 2	24
Figure 5.	Recommended mounting	26
Figure 6.	Mounting configuration dimensions	28
Figure 7.	Option select jumper connectors	32
Figure 8.	J4A connections for Activity, Fault, and Ready LED indicators	33
Figure 9.	Suggested air flow	35
Figure 10.	Physical interface	46
Figure 11.	SCSI daisy-chain interface cabling.	48
Figure 12.	Non-shielded 68-pin SCSI device connector	49
Figure 13.	Single-ended transmitters and receivers	52

1.0 Scope

This manual describes Seagate Technology®, Inc. Elite 47™ disc drives.

Elite 47 drives support the small computer system interface (SCSI) as described in the ANSI SCSI, SCSI-2, and SCSI-3 (Fast-20 or Ultra SCSI) interface specifications to the extent described in this manual. The *SCSI Interface Product Manual* (part number 77738479) describes general SCSI interface characteristics of this and other families of Seagate drives.

From this point on in this product manual the reference to Elite 47 models is referred to as “the drive” (unless references to individual models are necessary).

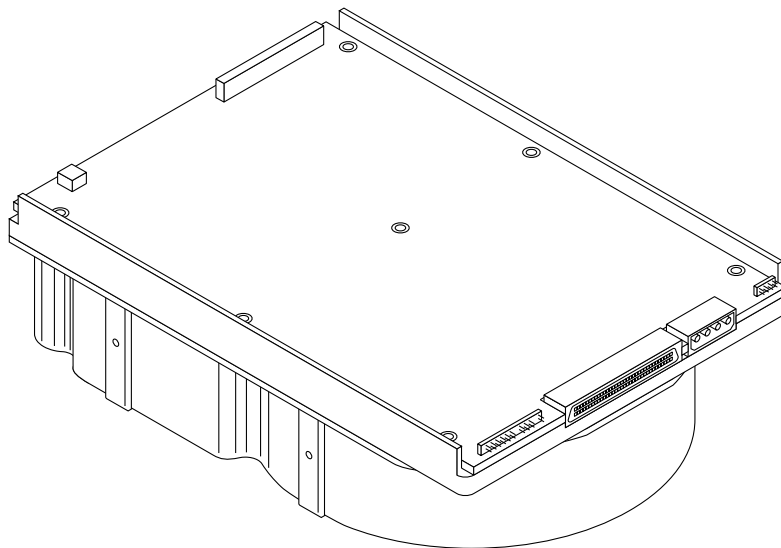

Figure 1. Elite 47 disc drive

2.0 Applicable standards and reference documentation

The drive is a system peripheral developed to the highest standards of design and construction. The drive depends on its host equipment to provide adequate power and environment to achieve optimum performance and compliance with applicable industry and government regulations. Special attention must be given in the areas of safety, power distribution, shielding, audible noise control, and temperature regulation. Also, the drive must be securely mounted to guarantee the specified performance characteristics.

2.1 Standards

The Elite 47 family complies with Seagate standards as noted in the appropriate sections of this manual and the Seagate *SCSI Interface Product Manual* (volume 2), part number 77738479.

The Elite 47 disc drive is a UL recognized component per UL1950, CSA certified to CSA C22.2 No. 950-789, and VDE certified to VDE 0805 and EN60950.

2.1.1 Electromagnetic compatibility

The drive, as delivered, is designed for system integration and installation into a suitable enclosure prior to use. As such, the drive is supplied as a subassembly and is not subject to Subpart B of Part 15 of the FCC Rules and Regulations nor the Radio Interference Regulations of the Canadian Department of Communications.

The physical design characteristics of the drive serve to minimize radiation when installed in an enclosure that provides reasonable shielding. As such, the drive is capable of meeting the Class B limits of the FCC Rules and Regulations of the Canadian Department of Communications when properly packaged. However, it is the user's responsibility to assure that the drive meets the appropriate EMI requirements in their system. Shielded I/O cables may be required if the enclosure does not provide adequate shielding. If the I/O cables are external to the enclosure, shielded cables should be used, with the shields grounded both to the enclosure and to the host controller.

2.1.1.1 Electromagnetic susceptibility

As a component assembly, the drive is not required to meet any susceptibility performance requirements. It is the responsibility of those integrating the drive within their systems to perform those tests required and design their system to ensure that equipment operating in the same system as the drive or external to the system does not adversely affect the performance of the drive. See Section 5.1.1 and Table 1, DC power requirements.

2.2 Electromagnetic compliance

Seagate uses an independent laboratory to confirm compliance to the directives/standard(s) for CE Marking and C-Tick Marking. The drive was tested in a representative system for typical applications. The selected system represents the most popular characteristics for test platforms. The system configurations include:

- 486, Pentium, and PowerPC microprocessors
- 3.5-inch floppy disc drive
- Keyboard
- Monitor/display
- Printer
- External modem
- Mouse

Although the test system with this Seagate model complies to the directives/standard(s), we cannot guarantee that all systems will comply. The computer manufacturer or system integrator shall confirm EMC compliance and provide CE Marking and C-Tick Marking for their product.

Electromagnetic compliance for the European Union

If this model has the CE Marking it complies with the European Union requirements of the Electromagnetic Compatibility Directive 89/336/EEC of 03 May 1989 as amended by Directive 92/31/EEC of 28 April 1992 and Directive 93/68/EEC of 22 July 1993.

Australian C-Tick

If this model has the C-Tick Marking it complies with the Australia/New Zealand Standard AS/NZS3548 1995 and meets the Electromagnetic Compatibility (EMC) Framework requirements of Australia's Spectrum Management Agency (SMA).

2.3 Reference documents

Elite 47 Installation Guide Seagate P/N 83329290

SCSI Interface Product Manual (Volume 2) Seagate P/N 77738479

ANSI small computer system interface (SCSI) document numbers:

X3.131-1994

SCSI-2

X3.253-1995

SCSI-3 Parallel Interface

Package Test Specification Seagate P/N 30190-001 (under 100 lb.)

Package Test Specification Seagate P/N 30191-001 (over 100 lb.)

In case of conflict between this document and any referenced document, this document takes precedence.

3.0 General description

Elite 47 drives combine magnetoresistive (MR) heads, partial response/maximum likelihood (PRML) read channel electronics, embedded servo technology, and a SCSI-3 (Fast-20) interface to provide high performance, high capacity data storage for a variety of systems including engineering workstations, network servers, mainframes, and supercomputers.

Fast-20 (also known as Ultra SCSI) is a negotiated transfer rate. This transfer rate will occur only if your host adapter also supports Fast-20 data transfer rates. This drive also operates at SCSI-1 and SCSI-2 data transfer rates for backward compatibility with non-Fast-20 capable SCSI host adapters.

This manual describes the Elite 47 model ST446452W. It has a 68-pin interface connector for a 16-bit data bus. The drive records and recovers data on 5.25-inch (133.4 mm) non-removeable discs.

The drive supports the Small Computer System Interface (SCSI) as described in the ANSI SCSI-2 interface specifications to the extent described in this manual (volume 1), which defines the product performance characteristics of the Elite 47 family of drives, and the *SCSI Interface Product Manual* (volume 2), part number 77738479, which describes the general interface characteristics of this and other families of Seagate SCSI drives.

The drive's interface supports multiple initiators, disconnect/reconnect, self-configuring host software, and automatic features that relieve the host from the necessity of knowing the physical characteristics of the targets (logical block addressing is used).

The head and disc assembly (HDA) is sealed at the factory. Air circulates within the HDA through a non-replaceable filter to maintain a contamination-free HDA environment.

Refer to Figure 2 for an exploded view of the drive. This exploded view is for information only—never disassemble the HDA and do not attempt to service items in the sealed enclosure (heads, media, actuator, etc.) as this requires special facilities. The drive contains no replaceable parts. Opening the HDA voids your warranty.

Elite 47 drives use a dedicated landing zone at the innermost radius of the media to eliminate the possibility of destroying or degrading data by landing in the data zone. The drive automatically goes to the landing zone when power is removed.

An automatic shipping lock prevents potential damage to the heads and discs that results from movement during shipping and handling. The shipping lock automatically disengages when power is applied to the drive and the head load process begins.

Elite 47 drives decode track 0 location data from the servo data embedded on each surface to eliminate mechanical transducer adjustments and related reliability concerns.

A high-performance actuator assembly with a low-inertia, balanced, patented, straight-arm design provides excellent performance with minimal power dissipation.

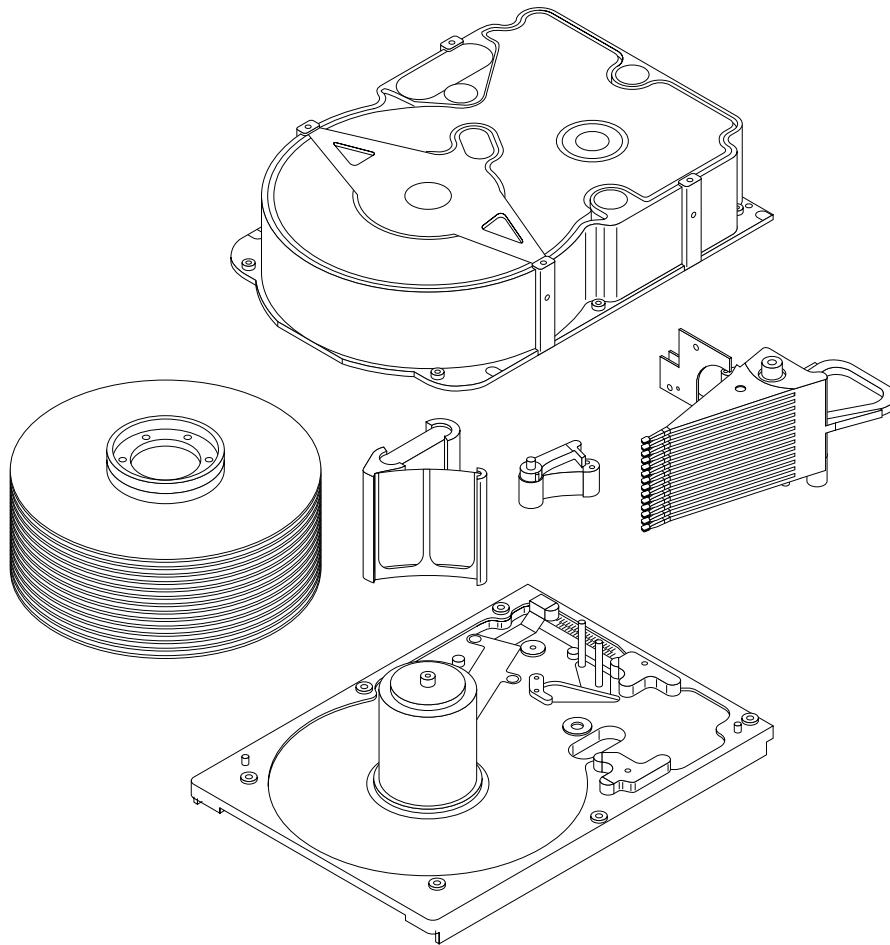

Figure 2. Elite 47 family drive

3.1 Standard features

Elite 47 drives have the following standard features:

- Integrated SCSI controller
- Single-ended SCSI drivers and receivers
- 16-bit I/O data bus
- Asynchronous and synchronous data transfer protocols
- Firmware downloadable using the SCSI interface
- Programmable drive capacity
- Selectable sector size from 512 to 4,096 bytes per sector
- Programmable sector reallocation scheme
- Flawed sector reallocation at format time
- Programmable auto write and read reallocation
- Reallocation of defects on command (post format)
- Reed-Solomon error-correction code for header and data fields; can correct up to 64-bit error
- Sealed head and disc assembly (HDA)
- No preventative maintenance or adjustment required
- Dedicated head landing zone
- Embedded servo data rather than a separate servo data surface
- Self-diagnostics performed when power is applied to the drive
- 1:1 interleave
- Zone bit recording (ZBR)
- Vertical, horizontal, or top-down mounting

- Dynamic spindle brake
- Active IC terminators enabled by jumper
- 4,096 Kbyte data buffer. See Section 4.5

3.2 Media characteristics

The media used on the drive has a diameter of approximately 5.25 inches (134 mm). The aluminum substrate is coated with a thin film magnetic material, overcoated with a proprietary protective layer for improved durability and environmental protection.

3.3 Performance

- Supports industry-standard Fast-20 SCSI interface (also called "Ultra SCSI")
- Programmable multi-segmentable cache buffer
- 5,357 RPM spindle; average latency = 5.60 msec
- Command queuing of up to 64 commands
- Background processing of queue
- Supports start and stop commands (spindle stops spinning)
- Low audible noise for office environment
- Low power consumption

3.4 Reliability

- 800,000 hour MTBF
- LSI circuitry
- Balanced low mass rotary voice coil actuator
- Incorporates industry-standard Self-Monitoring, Analysis and Reporting Technology (S.M.A.R.T.)
- Incorporates Seek To Improve Reliability algorithm (STIR)

3.5 Unformatted and formatted capacities

Formatted capacity depends on the number of spare reallocation sectors reserved and the number of bytes per sector. The following table shows standard OEM model capacities:

	Formatted [1]	Unformatted
ST446452	47.0 Gbytes [2]	62.6 Gbytes

Notes.

- [1] Standard OEM models are formatted to have 512-byte sectors. Users having the necessary equipment may modify the data block size before issuing a format command and obtain different formatted capacities than those listed. User available capacity depends on spare reallocation scheme selected. See Mode Select Command and Format Command in the *SCSI Interface Product Manual*, part number 77738479.
- [2] The number of data tracks per sparing zone and the number of alternate sectors (LBAs) per sparing zone can be determined by using the Mode Sense command and reading Mode page 03h.

3.6 Programmable drive capacity

Using the Mode Select command, the drive can change its capacity to something less than maximum. See Table 5.2.1-13 in the *SCSI Interface Product Manual*, part number 77738479. Refer to the Parameter list block descriptor number of blocks field. A value of zero in the number of blocks field indicates that the drive will not change the capacity it is currently formatted to have. A number in the number of blocks field that is less than the maximum number of LBAs changes the total drive capacity to the value in the block descriptor number of blocks field. A value greater than the maximum number of LBAs is rounded down to the maximum capacity.

3.7 Factory installed accessories

The *Elite 47 Installation Guide*, part number 83329290, is shipped with each standard OEM drive (unless otherwise specified). A small bag of jumpers are also shipped with the drive. Use these jumpers to configure the option headers. See Section 8.1.

SCSI terminators can be enabled or disabled.

3.8 Options (factory installed)

All options that a customer may request are incorporated during production or packaged at the manufacturing facility before shipping. Some of the options available are:

- The capacities shown in Section 3.5. You can order other capacities by selecting other sparing schemes and sector sizes.
- Single-unit shipping pack. The drive normally ships in bulk packaging to provide maximum protection against transit damage. Units shipped individually require additional protection as provided by the single-unit shipping pack. Specify this option if you are planning to ship single units to your customers.
- The *Elite 47 Installation Guide*, part number 83329290, is usually included with each standard OEM drive. Additional copies may be ordered.

3.9 Accessories (user installed)

The following accessories are available.

- Single-unit shipping pack.

4.0 Performance characteristics

4.1 Internal drive characteristics (transparent to user)

ST446452

Drive capacity	62.6 Gbytes (unformatted) [1]
Read/write heads	28
Bytes/track	223,855 Bytes (average, unformatted) [1]
Bytes/surface	2,238 Mbytes (unformatted)
Tracks/surface, total	9,996 Tracks (user accessible)
Tracks/inch	8,334 TPI
Peak bits/inch	178,847 BPI
Internal data rate	125-185 Mbits/sec (variable with zone)
Disc rotational speed	5,357 ± 0.5% r/min
Average rotational latency	5.60 msec

[1] Rounded off values

4.2 SCSI seek performance characteristics (visible to user)

Refer to Section 9.10 and to the *SCSI Interface Product Manual* (part number 77738479) for additional timing details.

4.2.1 Access time

		Including controller overhead (without disconnect) [1] [4]	
		Drive level	
		Read	Write
		ms	
Average	Typical [3]	13.2	14.2
Single track	Typical [3]	1.3	2.3
Full stroke	Typical [3]	28.2	28.2

4.2.2 Format command execution time (for ≥ 512-byte sectors)

Maximum (with verify)	10.0 hours
Maximum (no verify)	6.0 hours

4.2.3 General performance characteristics

Minimum sector interleave 1 to 1

Data buffer data transfer rate to/from disc media (one 512-byte sector) variable with zone/cylinder:

Minimum [4]	125 Mbits/sec
Maximum [4]	185 Mbits/sec

SCSI interface data transfer rate (asynchronous) [5]:

Maximum instantaneous (1-byte-wide transfer rate)	5.0 Mbytes/sec [6]
Maximum instantaneous (2-byte-wide transfer rate)	10.0 Mbytes/sec [7]

Synchronous transfer rate for SCSI Fast-20 (Ultra SCSI):

16 bit data bus	5.0 to 40 Mbytes/sec
-----------------	----------------------

[] All notes for Sections 4.2 are listed at end of Section 4.2.3.

Synchronous transfer rate for fast SCSI-2: 16 bit data bus	5.0 to 40 Mbytes/sec
Sector sizes:	
Default	512-byte data blocks
Variable in even-sector sizes	512 to 4,096 bytes per sector
Read/write consecutive sectors on a track	Yes
Flaw reallocation performance impact:	
For flaws reallocated at format time using spare sectors per track reallocation scheme	negligible
For flaws reallocated after format time using spare sectors per cylinder reallocation scheme	11.1 msec (minimum) 22.2 msec (maximum)
For flaws reallocated after format time using spare tracks per volume reallocation scheme	35 msec (typical)
Overhead time for head switch (512-byte sectors) in sequential mode	0.8 msec
Overhead time for one track cylinder switch in sequential mode	1.2 msec (typical)
Average rotational latency	5.60 msec

Notes for Sections 4.2.

- [1] Execution time is measured from receipt of the last byte of the Command Descriptor Block (CDB) to the request for a status byte transfer to the initiator (excluding connect/disconnect).
- [2] Maximum times are specified over the worst case conditions of temperature, voltage margins and drive orientation. When comparing specified access times, take care to distinguish between typical access times and maximum access times. Obtain the best comparison by conducting system benchmark tests under identical conditions. Maximum times do not include error recovery.
- [3] Typical access times are measured under nominal conditions of temperature, voltage, and horizontal orientation as measured on a representative sample of drives.
- [4] Assumes no errors and no sector reallocations.
- [5] Rate measured from the start of the first sector transfer to or from the host.
- [6] Assumes system ability to support the 1-byte-wide transfer rate listed and no cable loss.
- [7] Assumes system ability to support the 2-byte-wide transfer rate listed and no cable loss.

4.3 Start/stop time

Disabling the Motor Start option causes the drive to become ready within 45 seconds after DC power is applied at nominal voltage. This means the motor starts as soon as power is applied. If a recoverable error condition is detected during the start sequence, the drive will execute a recovery procedure and may cause the time to become ready to exceed 45 seconds. During this time the drive responds to some commands over the SCSI interface. Stop time is less than 40 seconds from removal of DC power.

Enabling the Motor Start option causes the internal controller to accept the commands listed in the *SCSI Interface Product Manual* (77738479) less than 3 seconds after applying DC power. After receiving the Motor Start command, the drive becomes ready for normal operations within 45 seconds (excluding an error recovery procedure). The Motor Start command can also be used to command the drive to stop the spindle in less than 40 seconds (see the Start/Stop command information in the *SCSI Interface Product Manual*).

There is no power control switch on the drive.

4.4 Prefetch/multi-segmented cache control

The drive provides prefetch (read look-ahead) and multi-segmented cache control algorithms that in many cases can enhance system performance. "Cache" as used herein refers to the drive buffer storage space when it is used in "cache" operations. To select prefetch and cache features the host sends the Mode Select command with the proper values in the applicable bytes in Mode Page 08h (see *SCSI Interface Product Manual*). Prefetch and cache operation are independent features from the standpoint that each is enabled and disabled independently via the Mode Select command. However, in actual operation the prefetch feature overlaps cache operation somewhat as is noted in Section 4.5.1 and 4.5.2.

All default cache and prefetch Mode parameter values (Mode Page 08h) for standard OEM versions of this drive family are given in Table 7.

4.5 Cache operation

Of the 4,096 Kbytes physical buffer space, approximately 3,442 Kbytes can be used as a cache. The cache can be divided into logical segments (Mode Select page 08h, byte 13) from which data is read and to which data is written.

The drive keeps track of the logical block addresses of the data stored in each segment of the cache. If the cache is enabled (see RCD bit = 0 in Mode page 08h, byte 2, bit 0 in the *SCSI Interface Product Manual*), data requested by the host with a read command is retrieved from the cache, if possible, before any disc access is initiated. If cache operation is not enabled, the buffer (still segmented with required number of segments) is still used, but only as circular buffer segments during disc medium read operations (disregarding Prefetch operation for the moment). That is, the drive does not check in the buffer segments for the requested read data, but goes directly to the medium to retrieve it. The retrieved data merely passes through some buffer segment on the way to the host. On a cache "miss," all data transfers to the host are in accordance with "buffer-full" ratio rules. On a cache "hit," the drive ignores the "buffer-full" ratio rules. See explanations associated with Mode page 02h (disconnect/reconnect control) in the *SCSI Interface Product Manual*.

The following is a simplified description of a read operation with cache operation enabled:

Case A - Read command is received and the first logical block is already in the cache.

1. Drive transfers to the initiator the first logical block requested plus all subsequent contiguous logical blocks that are already in the cache. This data may be in multiple segments.
2. When a requested logical block is reached that is not in any segment, the drive fetches it and any remaining requested logical block addresses from the disc and puts them in a segment of the cache. The drive transfers the remaining requested logical blocks from the cache to the initiator in accordance with the "buffer-full" ratio specification given in Mode Select Disconnect/Reconnect parameters, page 02h (see the *SCSI Interface Product Manual*).
3. The drive prefetches additional logical blocks contiguous to those transferred in step 2 above and stores them in the segment. The drive stops filling the segment when the maximum prefetch value has been transferred (see the *SCSI Interface Product Manual*).

Case B - Read command is received and the first logical block address requested is not in any segment of the cache.

1. The drive fetches the requested logical blocks from the disc and transfers them into a segment, then from there to the initiator in accordance with the “buffer-full” ratio specification given in Mode Select Disconnect/Reconnect parameters, page 02h (see the *SCSI Interface Product Manual*).
2. The drive prefetches additional logical blocks contiguous to those transferred in Case A, step 2 above and stores them in the segment. The drive stops filling the segment when the maximum prefetch value has been transferred.

During a prefetch, the drive crosses a cylinder boundary to fetch data only if the Discontinuity (DISC) bit is set to 1 in bit 4 of byte 2 of the Mode Select parameters page 08h. Default is zero for bit 4 (see the *SCSI Interface Product Manual*).

Each buffer segment is actually a self-contained circular storage (wrap-around occurs), the length of which is an integer number of disc medium sectors. The wrap-around capability of the individual segments greatly enhances the buffer’s overall performance as a cache storage, allowing a wide range of user selectable configurations, which includes their use in the prefetch operation (if enabled), even when cache operation is disabled (see Section 4.5.2). The number of segments may be selected using the Mode Select command, but the size cannot be directly selected. Size is selected only as a by-product of selecting the segment number specification. The size in Kbytes of each segment is not reported by the Mode Sense command page 08h, bytes 14 and 15. These bytes read 0xFFFF, regardless of the number of segments setting. If a size specification is sent by the host in a Mode Select command (bytes 14 and 15) no new segment size is set up by the drive, and if the “STRICT” bit in Mode page 00h (byte 2, bit 1) is set to one, the drive responds as it does for any attempt to change unchangeable parameters (see *SCSI Interface Product Manual*). The drive supports operation of any integer number of segments from 1 to 16. Divide the 3,442 Kbytes in the buffer by the number of segments to calculate the segment size. The default is three segments.

4.5.1 Caching write data

When the WCE (Write Cache Enable) bit is enabled, the drive uses a drive buffer storage area where the data to be written to the drive is stored in one or more segments while the drive performs the Write command. The write cache uses the same buffer space and segmentation as the read cache. The buffer segmentation scheme is set up or changed independently, having nothing to do with whether or not read and write caching is enabled or disabled.

If a 10-byte CDB write command (2Ah) is issued with the DPO (Data Page Out) bit set to one, no write data is cached but the cache segments are still checked and cleared (if needed) for any logical blocks that are being written.

When a write command is issued, the cache is first checked to see if any logical blocks that are to be written are already stored in the cache from a previous read or write command. If there are, the respective cache segments are cleared. The new data is cached for subsequent read commands.

If the number of write data logical blocks exceeds the size of the segment being written into when the end of the segment is reached, the data is written into the beginning of the same cache segment, overwriting the data that was written there at the beginning of the operation. However, the drive does not overwrite data that has not yet been written to the disc.

Table 7 shows Mode default settings for the drives.

Note. The WCE bit is disabled by default on OEM drives. To enable the WCE bit, change Mode Sense Page 08h, byte 2, bit 2 to a value of 1.

4.5.2 Prefetch operation

If the Prefetch feature is enabled, data in contiguous logical blocks on the disc immediately beyond that which was requested by a read command can be retrieved and stored in the buffer for immediate transfer from the buffer to the host on subsequent read commands that request those logical blocks (this is true even if “cache” operation is disabled). Though the prefetch operation uses the buffer as a “cache,” finding the requested data in the buffer is a prefetch “hit,” not a “cache” operation “hit.” Prefetch is enabled using Mode Select page 08h, byte 12, bit 5 (Disable Read Ahead - DRA bit). DRA bit = 0 enables prefetch. Since data that is prefetched replaces data already in some buffer segment(s), the host can limit the amount of prefetch data to optimize

system performance. The max prefetch field (bytes 8 and 9) limits the amount of prefetch. The drive does not use the prefetch “ceiling” field (bytes 10 and 11).

During a prefetch operation, the drive crosses a cylinder boundary to fetch more data only if the Discontinuity (DISC) bit is set to one in bit 4 of byte 2 of Mode parameters page 08h.

Whenever prefetch (read look-ahead) is enabled (enabled by DRA = 0), it operates under the control of ARLA (Adaptive Read Look-Ahead). If the host uses software interleave, ARLA enables prefetch of contiguous blocks from the disk when it senses that a prefetch “hit” will likely occur, even if two consecutive read operations were not for physically contiguous blocks of data (e.g. “software interleave”). ARLA disables prefetch when it decides that a prefetch “hit” will not likely occur. If the host is not using software interleave, and if two sequential read operations are not for contiguous blocks of data, ARLA disables prefetch, but as long as sequential read operations request contiguous blocks of data, ARLA keeps prefetch enabled.

5.0 Reliability specifications

The following reliability specifications assume correct host/drive operational interface, including all interface timings, power supply voltages, environmental requirements and drive mounting constraints (see Section 8.4).

Seek errors	Less than 10 in 10^8 seeks
Read error rates [1]	
Recovered data	Less than 10 errors in 10^{11} bits transferred (OEM default settings)
Unrecovered data	Less than 1 sector in 10^{14} bits transferred (OEM default settings)
Miscorrected data	Less than 1 sector in 10^{21} bits transferred
MTBF	800,000 hours
Service life	5 years
Preventive maintenance	None required

Note.

[1] Error rate specified with automatic retries and data correction with ECC enabled and all flaws reallocated.

5.1 Error rates

The error rates stated in this specification assume the following:

- The drive is operated per this specification using DC power as defined in this manual (see Section 6.2).
- The drive has been formatted with the SCSI format commands.
- Errors caused by media defects or host system failures are excluded from error rate computations. Refer to Section 7.0, "Defect and Error Management."
- Data is random.

5.1.1 Environmental interference

When evaluating systems operation under conditions of Electromagnetic Interference (EMI), the performance of the drive within the system is considered acceptable if the drive does not generate an unrecoverable condition.

An unrecoverable error, or condition, is defined as one that:

- is not detected and corrected by the drive itself;
- is not capable of being detected from the error or fault status provided through the drive or SCSI interface; or
- is not capable of being recovered by normal drive or system recovery procedures without operator intervention.

5.1.2 Read errors

Before determination or measurement of read error rates:

- The data that is to be used for measurement of read error rates must be verified as being written correctly on the media.
- All media defect induced errors must be excluded from error rate calculations.

5.1.3 Write errors

Write errors can occur as a result of media defects, environmental interference, or equipment malfunction. Therefore, write errors are not predictable as a function of the number of bits passed.

If an unrecoverable write error occurs because of an equipment malfunction in the drive, the error is classified as a failure affecting MTBF. Unrecoverable write errors are those which cannot be corrected within two attempts at writing the record with a read verify after each attempt (excluding media defects).

5.1.4 Seek errors

A seek error is defined as a failure of the drive to position the heads to the addressed track. There should not be more than 10 recoverable seek errors in 10^8 physical seek operations. After detecting an initial seek error, the drive automatically performs an error recovery process. If the error recovery process fails, a seek positioning error (15h) is reported with a Medium (3h) or Hardware error (4h) reported in the Sense Key. This is an unrecoverable seek error. Unrecoverable seek errors are classified as failures for MTBF calculations. Refer to Section 5.1.1.4 of *SCSI Interface Product Manual* (part number 77738479).

5.2 Reliability and service

You can enhance the reliability of Elite 47 disc drives by ensuring that the drive receives adequate cooling. Section 6.4.1 provides temperature measurements and other information that may be used to enhance the service life of the drive. Section 8.3.1 provides recommended air-flow information.

5.2.1 Mean time between failure

The production disc drive has a mature MTBF of 800,000 hours. MTBF includes failures in the time period from manufacturing installation to the end of product life.

The mean time between failure target is specified as device power-on hours (POH) for all drives in service per failure using the following equation:

$$\text{MTBF} = \frac{\text{Estimated power-on hours (POH) in the period}}{\text{Number of failures in the period}}$$

MTBF is based on the following assumptions:

- 8,760 power-on hours per year.
- 250 average on/off cycles per year.
- Read/seek/write operation 20% of POH.
- Operations at nominal voltages.
- Systems provide adequate cooling to ensure the case temperatures specified in Table 2 and Figure 4 are not exceeded. Short term excursions up to the specification limits of the operating environment will not affect MTBF performance.

A S.M.A.R.T. predictive failure indicates that the drive is deteriorating to an imminent failure and is considered an MTBF hit.

Drive failure means any stoppage or substandard performance caused by drive malfunction.

Data is calculated on a rolling average base for a minimum period of six months.

Field failure rate vs time

The maximum allowable field failure rate is listed below. Drive utilization will vary. An estimated range of utilization is:

- 720 power-on hours (POH) per month.
- 250 on/off cycles per year.
- Read/seek/write operation 20% of POH.
- Systems provide adequate cooling to ensure the case temperatures specified in Table 2 and Figure 4 are not exceeded. Short term excursions up to the specification limits of the operating environment will not affect MTBF performance.

Failure rate in parts per million

The failure rate is calculated as follows:

- No system-induced failures counted.
- Parts per million (PPM) targets include 30% no defect found and 0% handling failures.
- Based on 800,000 MTBF and 720 POH per month.

- Month 1 rate includes a 300 PPM installation failure factor.

Month	PPM
1	2,459
2	1,615
3	1,594
4	1,580
5	1,497
6	1,426
7	1,320
8+	1,200

5.2.2 Preventive maintenance

No routine scheduled preventive maintenance shall be required.

5.2.3 Service life

The drive has a useful service life of 5 years. Depot repair or replacement of major parts is permitted during the lifetime (see Section 5.2.4).

5.2.4 Service philosophy

Special equipment is required to repair the drive HDA. To achieve the 5-year service life, repairs must be performed only at a properly equipped and staffed service and repair facility. Troubleshooting and repair of PCBAs in the field is not recommended because of the extensive diagnostic equipment required for effective servicing. Also, there are no spare parts available for this drive. The drive warranty is voided if the HDA is opened.

5.2.5 Service tools

No special tools are required for site installation or recommended for site maintenance. Refer to Section 5.2.4. The depot repair philosophy of the drive precludes the necessity for special tools. Field repair of the drive is not practical because users cannot purchase individual parts for the drive.

5.2.6 S.M.A.R.T.

S.M.A.R.T. is an acronym for Self-Monitoring Analysis and Reporting Technology. This technology is intended to recognize conditions that indicate a drive failure and is designed to provide sufficient warning of a failure to allow data back-up before an actual failure occurs.

Note. The firmware will monitor specific attributes for degradation over time but cannot predict instantaneous drive failures.

Each attribute has been selected to monitor a specific set of failure conditions in the operating performance of the drive, and the thresholds are optimized to minimize “false” and “failed” predictions.

Controlling S.M.A.R.T.

The operating mode of S.M.A.R.T. is controlled by the DEXCPT bit and the PERF bit of the “Informational Exceptions Control Mode Page” (1Ch). The DEXCPT bit is used to enable or disable the S.M.A.R.T. process. Setting the DEXCPT bit will disable all S.M.A.R.T. functions. When enabled, S.M.A.R.T. will collect on-line data as the drive performs normal read/write operations. When the PERF bit is set, the drive is considered to be in “On-line Mode Only” and will not perform off-line functions.

The process of measuring off-line attributes and saving data can be forced by the RTZ command. Forcing S.M.A.R.T. will reset the timer so that the next scheduled interrupt will be two hours.

The drive can be interrogated by the host to determine the time remaining before the next scheduled measurement and data logging process will occur. This is accomplished by a log sense command to log page 0x3E. The purpose is to allow the customer to control when S.M.A.R.T. interruptions occur. As described above, forcing S.M.A.R.T. by the RTZ command will reset the timer.

Performance impact

S.M.A.R.T. attribute data will be saved to the disc for the purpose of recreating the events that caused a predictive failure. The drive will measure and save parameters once every two hours subject to an idle period on the SCSI bus. The process of measuring off-line attribute data and saving data to the disc is uninterruptable and the maximum delay is summarized below:

Maximum processing delay

	On-line only delay	Fully enabled delay
S.M.A.R.T. delay times	100 milliseconds	800 milliseconds

Reporting control

Reporting is controlled in the “Informational Exceptions Control Page” (1Ch). Subject to the reporting method, the firmware will issue to the “host” an 01-5D00 sense code. The error code is preserved through bus resets and power cycles.

Determining rate

S.M.A.R.T. monitors the rate at which errors occur and signals a predictive failure if the rate of degraded error rate increases to an unacceptable level. To determine rate, error events are logged and compared to the number of total operations for a given attribute. The interval defines the number of operations over which to measure the rate. The counter that keeps track of the current number of operations is referred to as the Interval Counter.

S.M.A.R.T. measures error rate, hence for each attribute the occurrence of an “error” is recorded. A counter keeps track of the number of errors for the current interval. This counter is referred to as the Failure Counter.

Error rate is simply the number of errors per operation. The algorithm that S.M.A.R.T. uses to record rates of error is to set thresholds for the number of errors and the interval. If the number of errors exceeds the threshold before the interval expires, then the error rate is considered to be unacceptable. If the number of errors does not exceed the threshold before the interval expires, then the error rate is considered to be acceptable. In either case, the interval and failure counters are reset and the process starts over.

Predictive failures

S.M.A.R.T. signals predictive failures when the drive is performing unacceptably for a period of time. The firmware keeps a running count of the number of times the error rate for each attribute is unacceptable. To accomplish this, a counter is incremented whenever the error rate is unacceptable and decremented (not to exceed zero) whenever the error rate is acceptable. Should the counter continually be incremented such that it reaches the predictive threshold, a predictive failure is signaled. This counter is referred to as the Failure History Counter. There is a separate Failure History Counter for each attribute.

5.2.7 Product warranty

Beginning on the date of shipment to customer and continuing for a period of time specified in the Standard Terms and Conditions of Purchase for Seagate products, Seagate warrants that each product (including components and subassemblies) or spare part that fails to function properly under normal use due to defect in materials or workmanship or due to nonconformance to the applicable specifications will be repaired or replaced, at Seagate's option and at no charge to customer, if returned by customer at customer's expense to Seagate's designated facility in accordance with Seagate's Warranty Procedure. Seagate will pay for transporting the repair or replacement item to customer. For more detailed warranty information, refer to the Standard Terms and Conditions of Purchase for Seagate products.

Shipping

When transporting or shipping a drive, a Seagate approved container must be used. Keep your original box. They are easily identified by the Seagate Approved Package label. Shipping a drive in a non-approved container voids the drive warranty.

Seagate repair centers may refuse receipt of components improperly packaged or obviously damaged in transit. Contact your Authorized Seagate Distributor to purchase additional boxes. Seagate recommends shipping by an air-ride carrier experienced in handling computer equipment.

Product repair and return information

Seagate customer service centers are the only facilities authorized to service Seagate drives. Seagate does not sanction any third-party repair facilities. Any unauthorized repair or tampering with the factory-seal voids the warranty.

6.0 Physical/electrical specifications

This section provides information relating to the physical and electrical characteristics of Elite 47 drives.

6.1 AC power requirements

None.

6.2 DC power requirements

The voltage and current requirements for a single drive are shown in the following table. Values indicated apply at the drive's power connector. The power requirements for single-ended models includes the internal disc drive SCSI I/O termination. Current values are in Amperes.

Table 1: DC power requirements

	Notes	ST446452W Single-ended	
Voltage		+5 V [8]	+12 V
Regulation	[5]	±5%	±5%[2]
Maximum operating current DC3 σ	[1]	1.0	1.8
Maximum starting current			
Peak DC DC3 σ	[3]	1.0	4.8 [6]
Peak AC AC3 σ	[3]		5.12
Delayed motor start (max) DC3 σ	[1] [4]	.85	.1
Peak operating current			
Typical DC \bar{X}	[1] [7]	.98	1.6
Maximum DC3 σ	[1]	1.0	1.8
Maximum (peak) AC3 σ		1.1	2.8
Track following at			
OD DC \bar{X}	[1]	.97	1.5
ID DC \bar{X}	[1]	.96	1.8
Read Track			
OD DC3 σ	[1] [10]	1.0	1.7
AC3 σ		1.1	1.9
Seeking			
Typical DC \bar{X}	[1] [9]	.96	1.95
Maximum DC3 σ	[1]	1.0	2.1
Maximum (peak) AC3 σ		1.1	2.8

Notes.

- [1] Measured with average reading DC ammeter. Instantaneous +12 V current peaks will exceed these values.
- [2] A drop of –10% is permissible during initial start of spindle, and must return to ±5% before 5,357 rpm is reached. The ±5% must be maintained after the drive signifies that its power-up sequence has been completed and that the drive is able to accept selection by the host initiator.
- [3] See +12 V current profile in Figure 3.
- [4] This condition occurs when the Motor Start Option is enabled and the drive has not yet received a Start Motor command.
- [5] See Section 6.2.1, “Conducted Noise Immunity.” Specified voltage tolerance is inclusive of ripple, noise, and transient response.
- [6] At power-up, the motor current regulator limits the 12 volt current to an average value of less than the value given here, although instantaneous peaks may exceed this value. These peaks should measure 5 msec duration or less.
- [7] Operating condition is defined as a third-stroke seek at OD and Read One track. A command is issued every 0.067 seconds.
- [8] No terminator power supplied to terminators by drive.

[9] Seeking is defined as a third-stroke seek at OD. A command is issued every 20 msec.

[10] Read track is defined as repeat reads of track 15 with a duty cycle of 63%.

General Notes from Table 1:

1. Minimum current loading for each supply voltage is not less than 4% of the maximum operating current shown.
2. The +5 and +12 volt supplies shall employ separate ground returns.
3. Where power is provided to multiple drives from a common supply, careful consideration for individual drive power requirements should be noted. Where multiple units are powered on simultaneously, the peak starting current must be available to each device.

6.2.1 Conducted noise immunity

Noise is specified as a periodic and random distribution of frequencies covering a band from DC to 10 MHz. Maximum allowed noise values given below are peak to peak measurements and apply at the drive power connector.

+5 V = 150 mV pp from 0 to 100 kHz and 100 mV pp from 100 kHz to 10 MHz.

+12 V = 150 mV pp from 0 to 100 kHz and 100 mV pp from 100 kHz to 10 MHz.

6.2.2 Power sequencing

The drive does not require power sequencing. The drive protects against inadvertent writing during power-up and down. Daisy-chain operation requires that power be maintained on the terminated device to ensure proper termination of the peripheral I/O cables. To automatically delay motor start based on the target ID (SCSI ID), enable the Spinup Delay option (install jumper) and disable the Start Command option (remove jumper) on the J4B connector. See Section 8.1 for pin selection information. To delay the motor until the drive receives a Start Unit command, enable the Enable Motor Start option on the J4B connector.

6.2.3 12 V current profile

Figure 3 identifies the drive +5 V and +12 V current profile. The current during the various times is as shown.

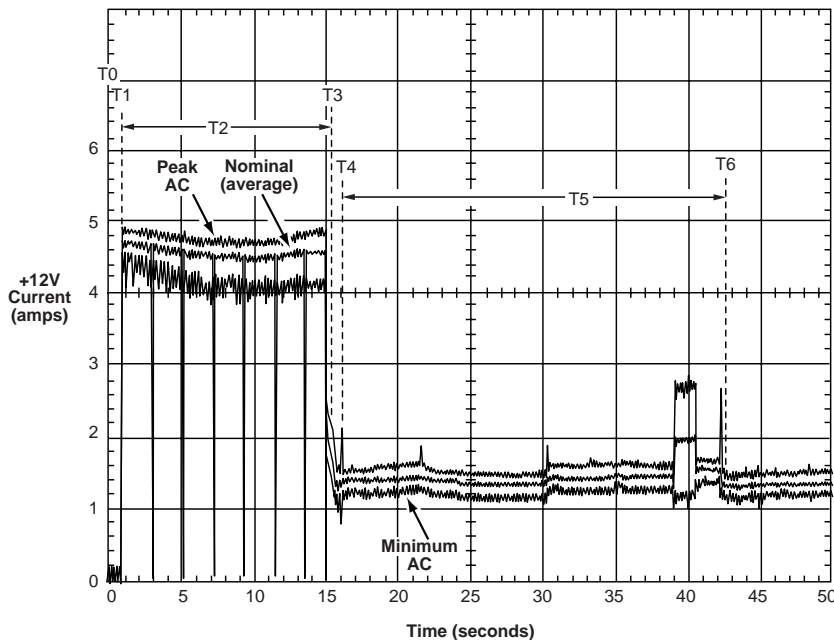

Figure 3. Typical Elite 47 drive +5 V and +12 V current profile

T0 - Power is applied to the drive.

T1 - Controller self-tests are performed.

T2 - Spindle begins to accelerate under current limiting after performing drive internal diagnostics. See Note 1 of Table 1.

- T3 - The spindle is up to speed and the head-arm restraint is unlocked.
- T4 - Heads move from the landing zone to the data area.
- T5 - The adaptive calibration sequence is performed.
- T6 - Calibration is complete and the drive is ready for reading and writing.

Note. All times and currents are typical. See Table 1 for maximum current requirements.

6.3 Power dissipation

ST446452W

Typical operating random read power dissipation is 24 watts (82 BTUs per hour) of DC power average at nominal voltages.

6.4 Environmental limits

Temperature and humidity values experienced by the drive must be such that condensation does not occur on any drive part. Altitude and atmospheric pressure specifications are referenced to a standard day at 58.7°F (14.8°C). Maximum wet bulb temperature is 82°F (28°C).

6.4.1 Temperature

a. Operating

The drive meets all specifications over a 41°F to 122°F (5°C to 50°C) drive ambient temperature range with a maximum gradient of 36°F (20°C) per hour. The enclosure for the drive should be designed such that the temperatures at the locations specified in Table 2 are not exceeded. Air flow may be needed to achieve these temperature values. Operation at case temperatures above these values may adversely affect the drives ability to meet specifications.

The MTBF specification for the drive is based on operating at an ambient temperature of 86°F (30°C). Occasional excursions to drive ambient temperatures of 122°F (50°C) or 41°F (5°C) may occur without impact to specified MTBF. To achieve the specified MTBF, the enclosure for the drive should be designed such that the temperature values of Table 2 are not exceeded. Air flow may be needed to achieve these temperatures. See Section 8.3.1. Continual or sustained operation at case temperatures above these values may degrade MTBF.

To confirm that the required cooling for the drive electronics and HDA is provided, place the drive in its final mechanical configuration, perform random write/read operations and, after the temperatures stabilize, measure the case temperature of the components listed on the next several pages.

Operation of the drive at the maximum case temperature is intended for short time periods only. Continuous operation at the elevated temperatures will reduce product reliability.

Table 2: PCBA and HDA temperatures

Component	Figure 4 reference	Maximum case [4] temperature at 50°C ambient [2]	Typical case [4] temperature at 35°C ambient [1]
Motor Controller	1	144°F (62°C)	117°F (47°C)
SCSI Controller	2	149°F (65°C)	122°F (50°C)
Bailey	3	151°F (66°C)	124°F (51°C)
4938A	4	131°F (55°C)	104°F (40°C)
HDA housing [3]		140°F (60°C)	112°F (45°C)

Note.

- [1] The air-flow pattern with which the typical case temperature guidelines were generated is shown in Figure 9. Local average air velocities were 200 lfm and inlet air temperature to the drive was 86°F (30°C).
- [2] The maximum case temperatures are calculated and may not reflect actual operating values. Sufficient cooling air may be required to ensure that these values are not exceeded.
- [3] Measure HDA temperature at point labeled “HDA Temp. Checkpoint” on Figure 4.
- [4] PCB mounted integrated circuit case.

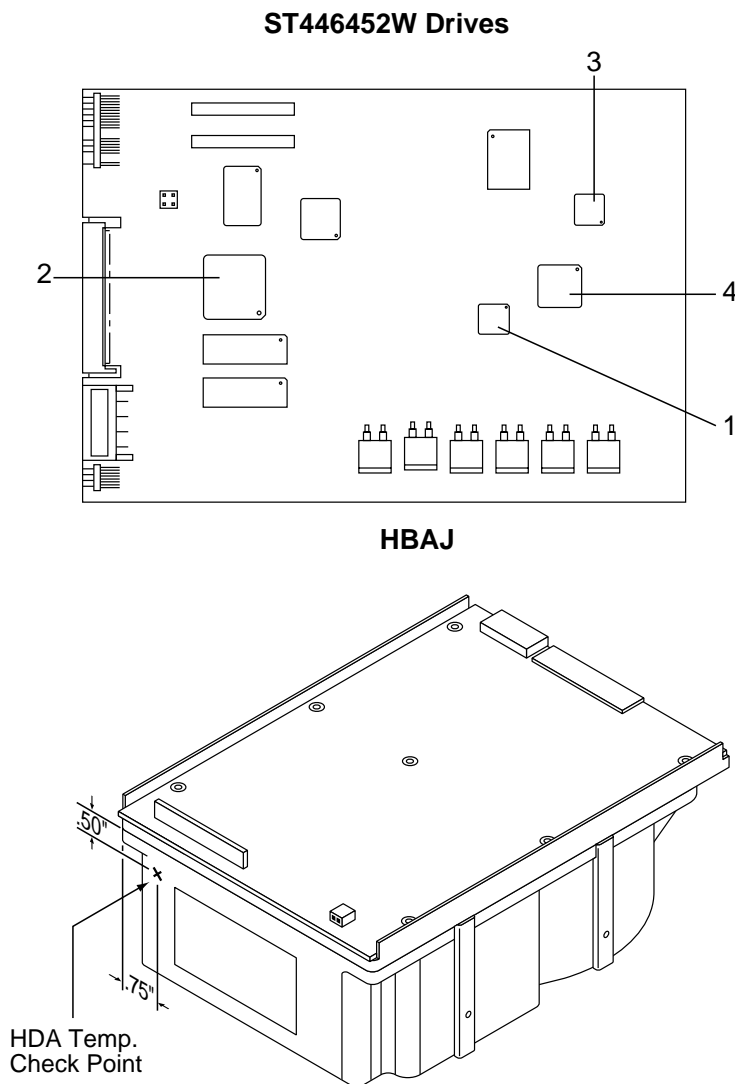

Figure 4. Location of PCBA components listed in Table 2

b. Non-operating

Non-operating temperature should remain between -40° to 158°F (-40° to 70°C) package ambient with a maximum gradient of 36°F (20°C) per hour. This assumes that the drive is packaged in the shipping container designed by Seagate.

6.4.2 Relative humidity

The values below assume that no condensation on the drive occurs.

a. Operating

5% to 90% non-condensing relative humidity with a maximum gradient of 10% per hour.

b. Non-operating/transit

5% to 95% non-condensing relative humidity with a maximum gradient of 10% per hour.

6.4.3 Effective altitude (sea level)

a. Operating

$-1,000$ to $+10,000$ feet (-305 to $+3,048$ meters)

b. Non-operating

$-1,000$ to $+40,000$ feet (-305 to $+12,210$ meters)

6.4.4 Shock and vibration

Shock and vibration limits specified in this document are measured directly on the drive. If the drive is installed in an enclosure to which the stated shock and/or vibration criteria is applied, resonances may occur internally to the enclosure resulting in drive movement in excess of the stated limits. If this situation is apparent, it may be necessary to modify the enclosure to minimize drive movement.

The limits of shock and vibration defined within this document are specified with the drive mounted by any of the four methods shown in Figure 5, and in accordance with the restrictions of Section 8.4. Orientation of the side nearest the LED may be up or down.

6.4.4.1 Shock

a. Operating—normal

The drive, as installed for normal operation, will operate error-free while subjected to intermittent shock not exceeding 2.0 g at a maximum duration of 11 msec (half sinewave). Shock may be applied in the X, Y, or Z axis.

b. Operating—abnormal

Equipment, as installed for normal operation, does not incur physical damage while subjected to intermittent shock not exceeding 10 g at a maximum duration of 11 msec (half sinewave). Shock occurring at abnormal levels may promote degraded operational performance during the abnormal shock period. Specified operational performance will continue when normal operating shock levels resume. Shock may be applied in the X, Y, or Z axis. Shock is not to be repeated more than two times per second.

c. Non-operating

The limits of non-operating shock applies to all conditions of handling and transportation. This includes both isolated drives and integrated drives.

The drive subjected to non-repetitive shock not exceeding 50 g at a maximum duration of 11 msec (half sinewave) does not exhibit device damage or performance degradation. Shock may be applied in the X, Y, or Z axis.

d. Packaged

Disc drives shipped as loose load (not palletized) general freight will be packaged to withstand drops from heights as defined in the table below. For additional details, refer to Seagate specifications 30190-001 (under 100 lbs/45 kg) or 30191-001 (over 100 lbs/45 kg).

Package Size

<600 cu in (<9,800 cu cm)
 600-1,800 cu in (9,800-19,700 cu cm)
 >1,800 cu in (>19,700 cu cm)
 >600 cu in (>9,800 cu cm)

Packaged/Product Weight

Any
 0-20 lb (0-9.1 kg)
 0-20 lb (0-9.1 kg)
 20-40 lb (9.1-18.1 kg)

Drop Height

60 in (1,524 mm)
 48 in (1,219 mm)
 42 in (1,067 mm)
 36 in (914 mm)

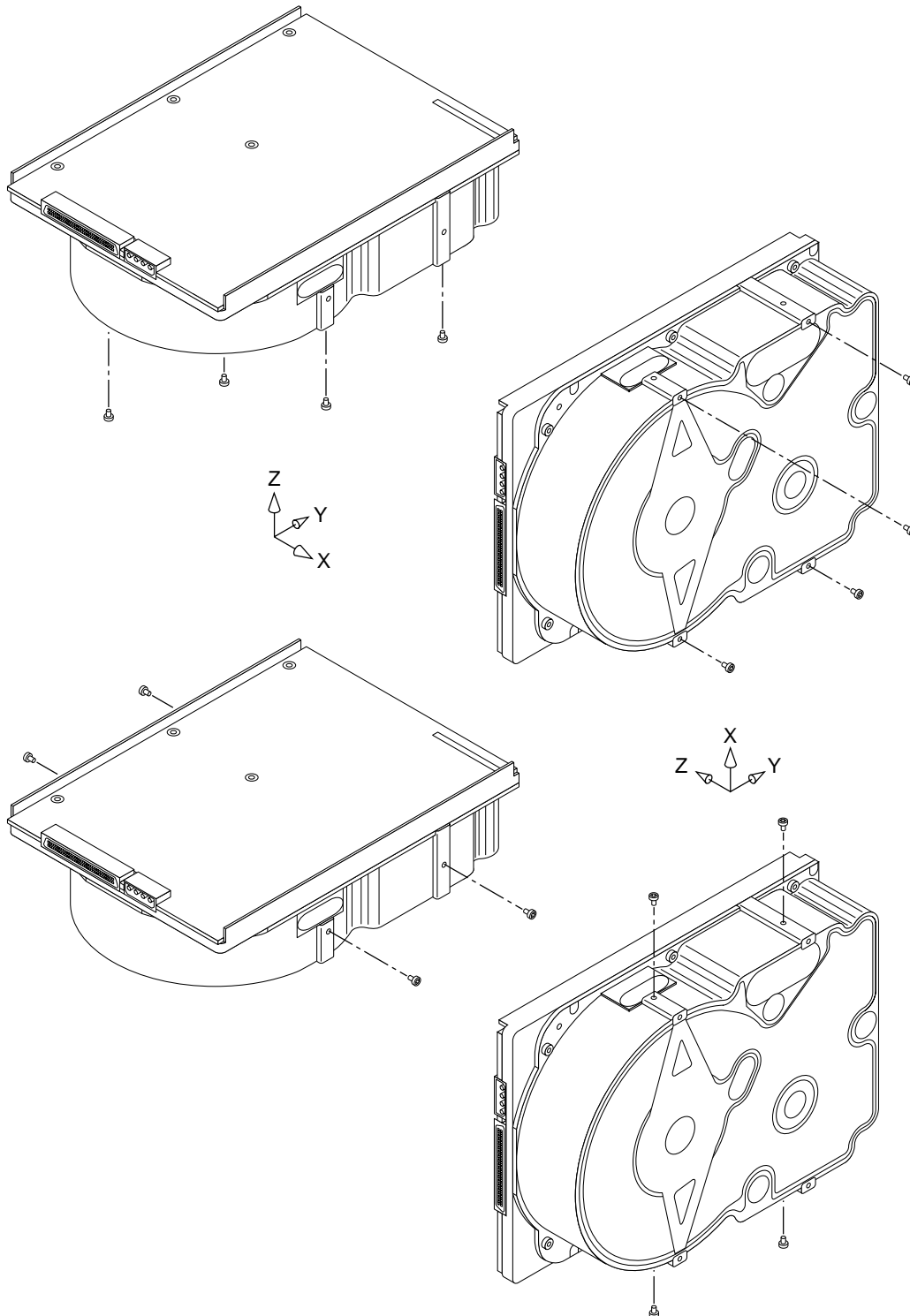

Figure 5. Recommended mounting

6.4.4.2 Vibration

a. Operating—normal

The drive, as installed for normal operation, complies with the complete specified performance while subjected to continuous vibration not exceeding:

5-300 Hz @ 0.5 g (X, Y, or Z axis)

b. Operating—abnormal

Equipment, as installed for normal operation, does not incur physical damage while subjected to periodic vibration not exceeding:

5-300 Hz @ 0.75 g (X, Y, or Z axis)

15 minutes of duration at major resonant frequency

Vibration occurring at these levels may degrade operational performance during the abnormal vibration period. Specified operational performance will continue when normal operating vibration levels are resumed. This assumes system recovery routines are available.

c. Non-operating

The limits of non-operating vibration apply to all conditions of handling and transportation. This includes both isolated drives and integrated drives.

The drive does not incur physical damage or degraded performance as a result of continuous vibration not exceeding:

5-22 Hz @ 0.040 inches (1.02 mm) displacement

22-400 Hz @ 1.00 g

Vibration may be applied in the X, Y, or Z axis.

6.4.5 Air cleanliness

The drive is designed to operate in a typical office environment with minimal environmental control.

6.4.6 Acoustics

Sound power during idle shall be 4.6 bels typical when measured to ISO 7779 specification. No prominent tones are allowed.

6.4.7 Electromagnetic susceptibility

See Section 2.1.

6.5 Mechanical specifications

The following nominal dimensions are exclusive of the decorative front panel accessory. However, dimensions of the front panel are shown in the figure below. Refer to Figure 6 for detailed mounting configuration dimensions. See Section 8.4, "Drive mounting."

	Typical	Maximum
Height:	3.25 in (82.6 mm)	3.268 in (83.0 mm)
Width:	5.75 in (146.1 mm)	5.76 in (146.3 mm)
Depth:	8.0 in (203.0 mm)	8.01 in (203.5 mm)
Weight:	7.0 pounds (3.17 kilograms)	–

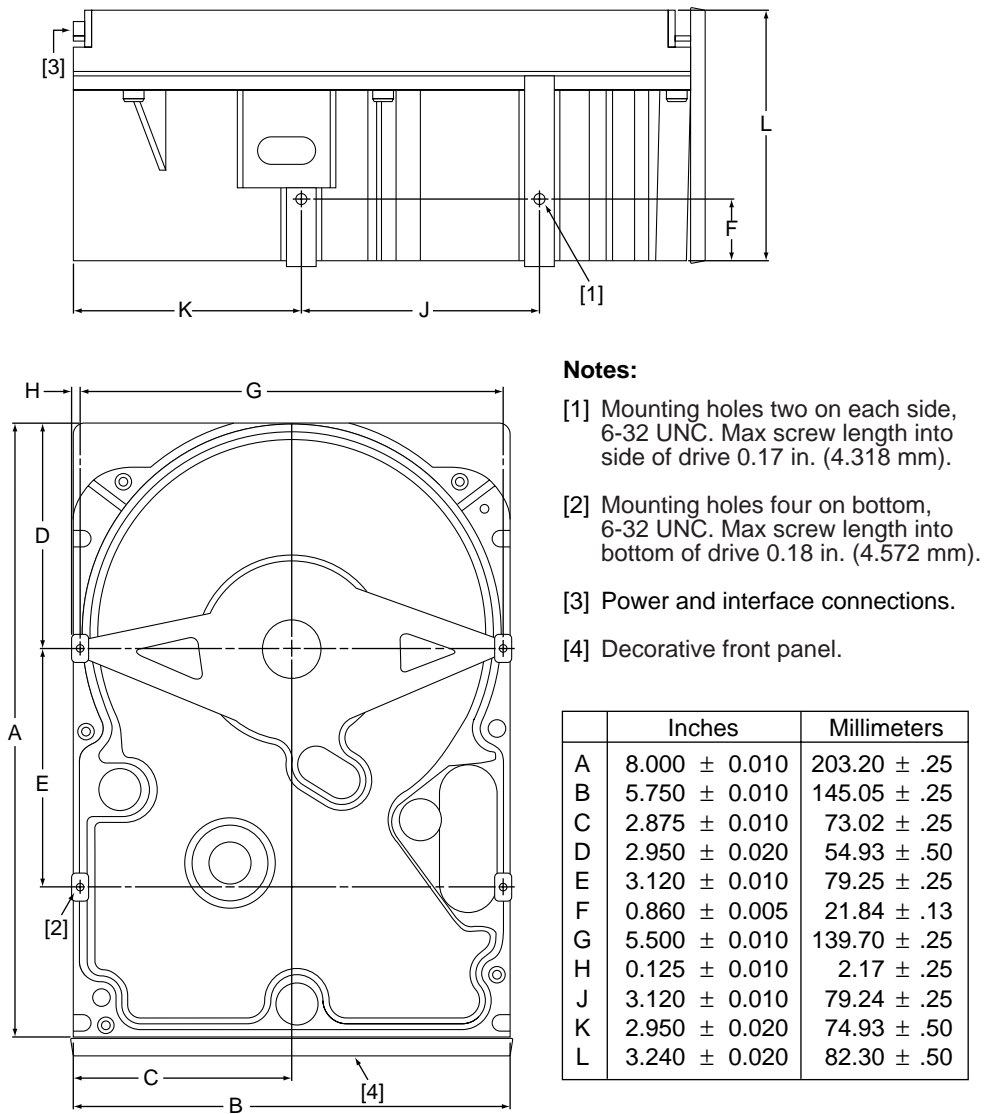

Figure 6. Mounting configuration dimensions

7.0 Defect and error management

The drive, as delivered, complies with this product manual. The read error rate and specified storage capacities are not dependent on using defect management routines by the host (initiator).

Defect and error management in the SCSI system involves the drive internal defect/error management and SCSI systems error considerations (errors in communications between initiator and the drive).

7.1 Drive internal defects and errors

During the initial drive format operation at the factory, media defects are identified, tagged as being unusable, and their locations recorded on the drive primary defects list (referred to as the “P” list and also as the EFT defect list). At factory format time, these known defects are also reallocated, that is, reassigned to a new place on the medium and the location listed in the defects reallocation table. The “P” list is not altered after factory formatting. Locations of defects found and reallocated during error recovery procedures after drive shipment are listed in the “G” list (defects growth list). The “P” and “G” lists may be referenced by the initiator using the Read Defect Data command (see Section 5.2.1.2 in the *SCSI Interface Product Manual*, part number 77738479).

7.2 Drive error recovery procedures

Whenever an error occurs during drive operation, the drive, if programmed to do so, performs error recovery procedures to attempt to recover the data. The error recovery procedures used depend on the options previously set up in the error recovery parameters mode page. Error recovery and defect management may involve the use of several SCSI commands, the details of which are described in the *SCSI Interface Product Manual*. The drive implements selectable error recovery time limits such as are required in video applications. For additional information on this, refer to Table 5.2.1-22 in the *SCSI Interface Product Manual* which describes the Mode Select/Mode Sense Error Recovery parameters.

The error recovery scheme supported by the drive provides a means to control the total error recovery time for the entire command in addition to controlling the recovery level for a single LBA. The total amount of time spent in error recovery for a command can be limited via the Recovery Time Limit bytes in the Error Recovery Mode Page. The total amount of time spent in error recovery for a single LBA can be limited via the Read Retry Count or Write Retry Count bytes in the Error Recovery Mode Page.

The drive firmware error recovery algorithms consist of 16 levels for read recoveries and 12 levels for writes. Each level may consist of multiple steps, where a step is defined as a recovery function involving a single re-read or re-write attempt. The maximum level used by the drive in LBA recovery is determined by the Read and Write Retry Counts.

Table 3 equates the Read and Write Retry Count with the maximum possible recovery time for read and write recovery of individual LBAs. The times given do not include time taken to perform reallocations, if reallocations are performed. The ARRE bit enables/disables reallocations, but if the RC bit is one, it takes precedence over ARRE to disable auto reallocation. When the drive has read all of the called for data, it does not go back and reallocate any sectors of erroneous data that were not reallocated because the RC bit was one. The drive does not report an unrecovered error when RC is one.

Table 3: Read and write retry count maximum recovery times

Read retry count [1]	Maximum recovery time per LBA (cumulative, msec)
0	56
1	89
2	123
3	167
4	245
5	289
6	356
7	489
8	534
9	600
10	700
11	900
12	1178
13	1845
14	3012
15	4178
16 (default)	4378

Write retry count [1]	Maximum recovery time per LBA (cumulative, msec)
0	56
1	89
2	123
3	189
4	234
5	245
6	289
7	356
8	456
9	589
10	1256
11	2423
12 (default)	3589

[1] Setting these retry counts to a value below the default setting could result in degradation of the unrecovered error rate below the product specification.

For example, suppose the read/write recovery page has the RC bit = 0, the read retry count set to 4, and the recovery time limit set to 456. A four block read command can take up to 197 msec recovery time for each block and a maximum of 456 msec recovery time for all four blocks. If either of these limits is reached and a block has not yet been recovered, the command will end with CHECK CONDITION status and an unrecoverable read error will be reported.

8.0 Installation

The first thing to do when installing a drive is to set the drive ID (select) on the SCSI bus and set up certain operating options. This is usually done by installing small shorting jumpers on the pins of connectors J01, J4A, and J4B on the PCB. Some users connect cables to the jumper headers and perform the set-up using remote switches.

If your system is “SCAM” (SCSI Configured Auto Magically) compliant, the system assigns the drive ID over the interface, so there is no need to be concerned about drive ID. Setting the drive ID jumpers doesn’t hurt anything, but is not necessary.

If your system is not “SCAM” compliant, you do need to set the drive ID using the ID jumpers.

Configure drive options

For option jumper locations and definitions refer to Figures 7 and 8. Drive default mode parameters are not normally needed for installation. Refer to Section 9.3.2 for default mode parameters if they are needed.

- Ensure that the SCSI ID of the drive is not the same as the host adapter. Most host adapters use SCSI ID 7. ID 7 is the highest priority on both 8 and 16 bit data buses.
- If multiple devices are on the bus, set the drive SCSI ID to one that is not presently used by other devices on the bus.
- If the drive is the only device on the bus, attach it to the end of the SCSI bus cable. Permanently installed terminators must be enabled on the drive using jumper plug **TE** if termination is not provided by the host equipment.
- If the drive is attached to a bus that contains other devices and the new drive is not attached to the end of the bus, the Terminator Enable jumper (**TE**) should be removed from the new drive.

Note. For additional information about terminator requirements, refer to Sections 9.8 and 9.9.

- Set all appropriate option jumpers for desired operation prior to power on. If jumpers are changed after power has been applied, recycle the drive power to make the new settings effective.
- Installation instructions are provided by host system documentation or with any additionally purchased drive installation software. If necessary, see Section 10.0 for Seagate support services telephone numbers.
- Do not remove the manufacturer’s installed labels from the drive and do not cover with additional labels, as the manufacturer labels contain information required when servicing the product.

Formatting

- It is not necessary to low level format this drive. The drive is shipped from the factory low level formatted in 512-byte sectors.
- Reformat the drive if a different spare sector allocation scheme is selected.
- High level formatting the drive involves assigning one or more partitions or logical drives to the drive volume. Follow the instructions in the system manuals for the system into which the drive is to be installed.

8.1 Drive ID/option select header

Figures 7 and 8 show views of the drive ID select and option select jumper connectors. The notes following the figures describe the functions of the various jumper positions on the connectors J01, J4A, and J4B.

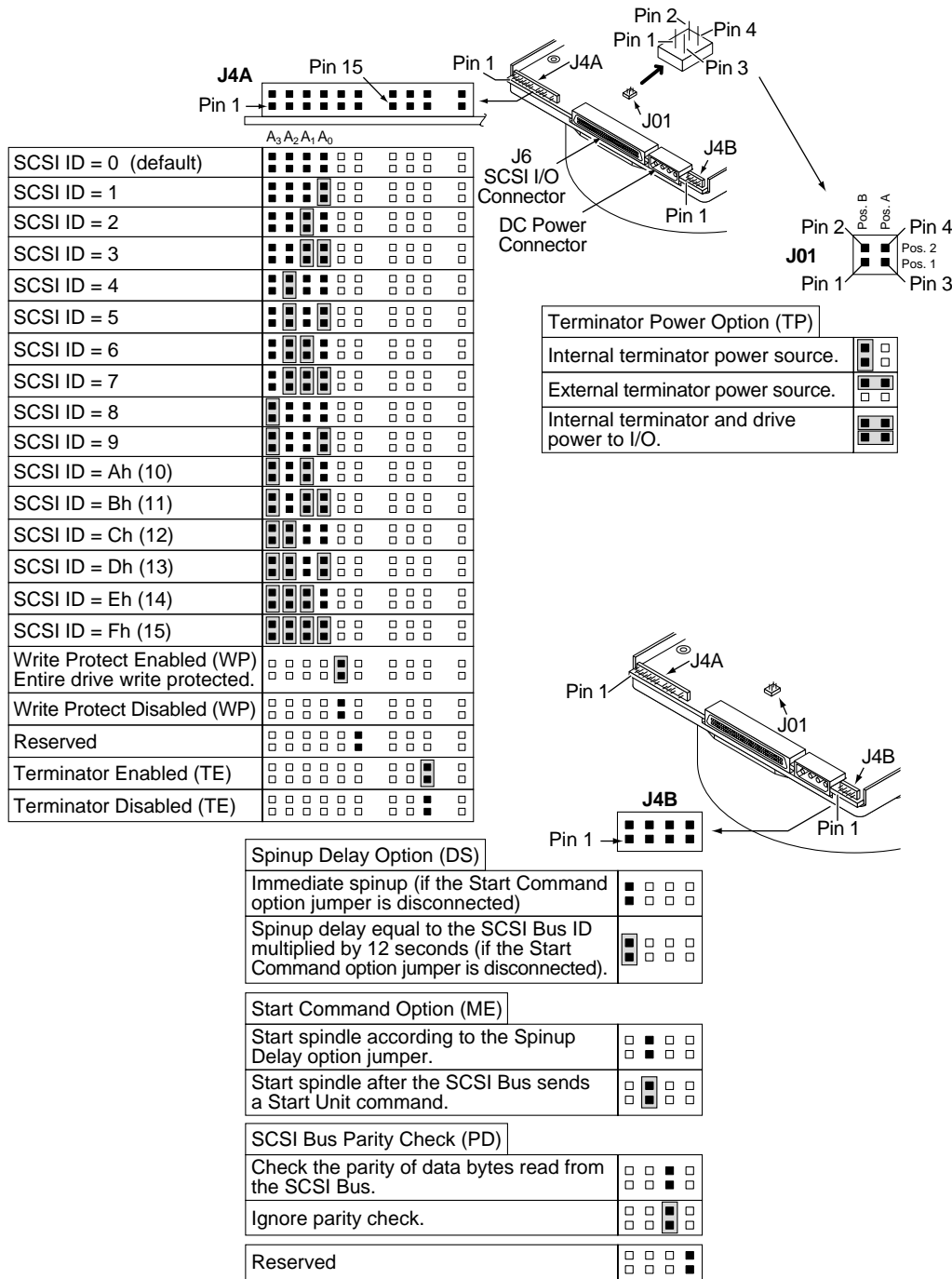

Figure 7. Option select jumper connectors

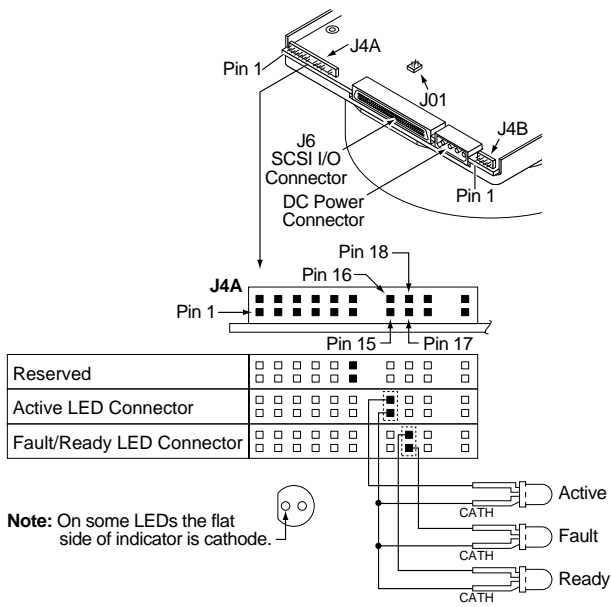

Figure 8. J4A connections for Activity, Fault, and Ready LED indicators

8.1.1 Notes for Figure 8

Notes explaining the functions of the various jumpers on jumper header connectors J01, J4A and J4B are given here. The term “**default**” means as standard OEM units are configured with a jumper on those positions when shipped from factory. “Off” means no jumper is installed; “On” means a jumper is installed. OFF or ON underlined is factory **default** condition.

Function description of configuration jumpers

J4A jumpers	Jumper function description	
A₃, A₂, A₁, A₀	SCSI ID jumpers. Drive ID address on the SCSI bus from 0 to 15 established by these jumpers as shown. Default is Drive ID = 0. ID = 7 is highest priority which is usually the SCSI host adapter. Priorities go ID7 to ID0, then ID15 to ID8.	
WP		
On	Entire drive is write protected.	
Off	Drive is not write protected. (Default)	
TE		
On	On-board (non-removable) terminator circuits are enabled. (Default)	
Off	On-board (non-removable) terminator circuits are disabled.	
J4B Jumpers		
DS	ME	
Off	Off	Spindle starts immediately after power up. (Default)
Off	On	Spindle does not start until a Start Unit command is received from the host.
On	Off	Startup is delayed by SCSI ID times 12 seconds after power is applied. For example: Drive with SCSI ID of 0 starts the spindle immediately when DC power is connected, drive with SCSI ID of 1 starts after a 12-second delay, drive with SCSI ID of 2 starts after 24-second delay, etc. Tolerance is plus 3 seconds, minus 0 seconds.
On	On	Spindle starts when the host sends a Start Unit command. Delayed start feature is overridden and does not apply when the ME jumper is installed.
PD		
On	SCSI parity checking and parity error reporting by the drive is disabled.	
Off	Drive checks for parity and reports the results of parity checking to host. (Default)	
J01 Jumpers [1]		
No jumpers on	No terminator power is connected to the drive terminators or the SCSI bus I/O cable.	
2-4	Drive terminator power comes from SCSI bus.	
1-3 and 2-4	Drive supplies terminator power to itself (internal connection) and to the SCSI bus I/O cable.	
1-2	Terminator power is supplied from the drive's internal power to the drive's internal terminators only.	

[1] See Table 11 for the I/O connector (J6) pins used for Termpower.

8.2 Drive orientation

The balanced rotary arm actuator design of the drive allows it to be mounted in any orientation. All drive performance characterization, however, has been done with the drive in horizontal (discs level) and vertical (drive on its side) orientations, and these are the two preferred mounting orientations.

8.3 Cooling

Cabinet cooling must ensure that the ambient temperature immediately surrounding the drive will not exceed temperature conditions specified in Section 6.4.1. Specific consideration should be given to make sure adequate air circulation is present around the printed circuit board assembly (PCBA) to meet the requirements of Section 6.4.1.

8.3.1 Air flow

The rack, cabinet, or drawer environment for the drive must provide cooling of the electronics and the head and disc assembly (HDA). You should confirm that adequate cooling is provided using the temperature measurement guidelines described below.

The drive should be oriented, or air flow directed, so that the least amount of air-flow resistance is created while providing air flow to the electronics and HDA. Also, the shortest possible path between the air inlet and exit should be chosen to minimize the travel length of air heated by the drive and other heat sources within the rack, cabinet, or drawer environment.

Possible air-flow patterns are shown in Figure 9. The air-flow patterns are created by one or more fans, either forcing or drawing air as shown in the illustrations. Other air-flow patterns are acceptable as long as the temperature measurement guidelines of Section 6.4.1 are met.

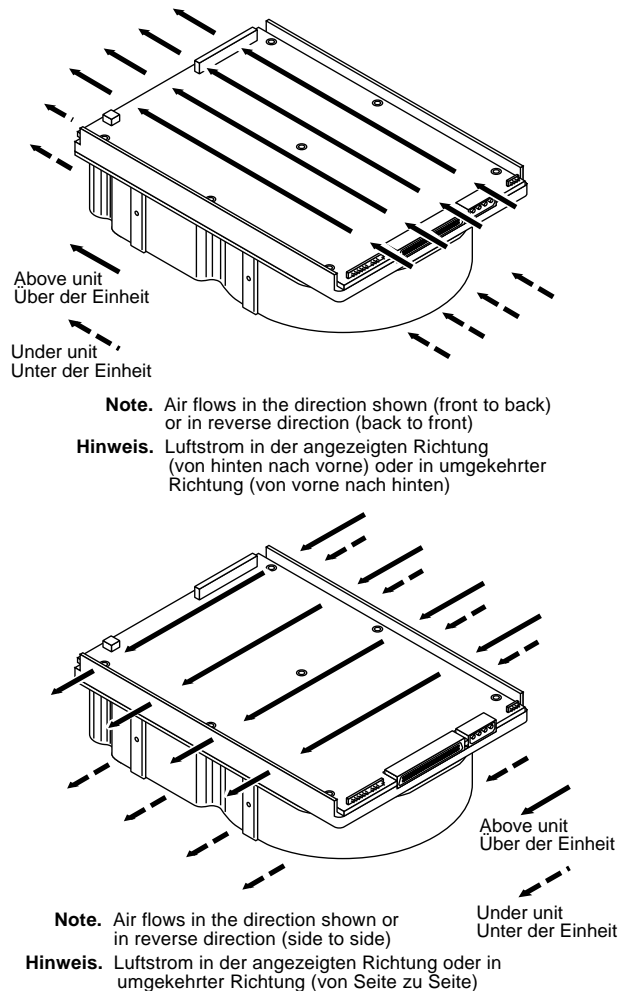

Figure 9. Suggested air flow

8.4 Drive mounting

Use the bottom or side mounting holes to secure the drive in the host enclosure.

8.5 Grounding

Signal ground (PCBA) and HDA ground are connected together in the drive and cannot be separated by the user. The equipment in which the drive is mounted is connected directly to the HDA and PCBA with no electrically-isolating shock mounts. If you do not want the system chassis to be connected to the HDA/PCBA ground, you must provide a nonconductive (electrically-isolating) method of mounting the drive in the host equipment. Increased radiated emissions may result if you do not provide the maximum surface area ground connection between system ground and drive ground. This is the system designer's and integrator's responsibility.

9.0 Interface requirements

This section describes Elite 47 interface requirements.

9.1 General description

This section partially describes the interface requirements as implemented on the drives. The major portion of the interface requirements/implementation is described in the *SCSI Interface Product Manual*, part number 77738479. This section has tables that give the Elite 47 family drive's version of the SCSI implementation described in the *SCSI Interface Product Manual*.

9.2 SCSI interface messages supported

Table 4 lists the messages supported by the SCSI-2 and SCSI-3 modes of the Elite 47 family drives.

Table 4: SCSI messages supported by Elite 47 family drives

Message Name	Message Code	Supported by SCSI-2
Abort	06h	Y
Abort-tag	0Dh	Y
Bus device reset	0Ch	Y
Clear queue	0Eh	Y
Command complete	00h	Y
Continue I/O process	12h	Y
Disconnect	04h	Y
Extended messages	01h[1]	Y
Identify	80h-FFh	Y
Ignore wide residue (two bytes)	23h	Y
Initiate recovery	0Fh	N
Initiator detected error	05h	Y
Linked command complete	0Ah	Y
Linked command complete with flag	0Bh	Y
Message parity error	09h	Y
Message reject	07h	Y
Modify data pointer	[1]	N
No operation	08h	Y
Queue tag messages (two bytes)		
Head of queue tag	21h	Y
Ordered queue tag	22h	Y
Simple queue tag	20h	Y
Release recovery	10h	N
Restore pointers	03h	Y
Save data pointer	02h	Y
Synchronous data transfer req.	[1]	Y
Target transfer disable	13h	Y
Terminate I/O process	11h	Y
Wide data transfer request	[1]	Y

Notes.

[1] Extended message (refer to the *SCSI Interface Product Manual*, part number 77738479).

9.3 SCSI interface commands supported

Table 5 lists the SCSI interface commands that are supported in the SCSI-2 and SCSI-3 modes of the drive. OEM standard drives are shipped set to operate in SCSI-2/SCSI-3 mode. Elite family drives can be changed back and forth between SCSI-1, SCSI-2, and SCSI-3 modes using the Change Definition command.

Table 5: Commands supported by Elite 47 family drive

Command Name	Command Code [5]	Supported by SCSI-2/3
Change definition	40h	Y
Compare	39h	N
Copy	18h	N
Copy and verify	3Ah	N
Format unit [1]	04h	Y
Block format		N
Bytes from index		Y
Physical sector format		Y
DPRY bit supported		Y
DCRT bit supported		Y
STPF bit supported		Y
IP bit supported		Y
DSP bit supported		Y
IMMED bit supported		Y
VS		N
Inquiry	12h	Y
Date code page (C1h)		Y
Firmware numbers page (C0h)		Y
Implemented operating definitions page (81h)		Y
Jumper settings page (C2h)		Y
Supported vital product data pages (0h)		Y
Unit serial number page (80h)		Y
Lock-unlock cache	36h	N
Log select	4Ch	Y
PCR bit		Y
DU bit		N
DS bit		Y
TSD bit		Y
ETC bit		N
TMC bit		N
LP bit		N
Log sense	4Dh	Y
Cache statistics page (37h)		Y
Non-medium error page (06h)		Y
Pages supported list (00h)		Y
Power-on time page (3Eh)		Y
Read error counter page (03h)		Y
S.M.A.R.T. status log page (2Fh)		N
S.M.A.R.T. attitude log page (30h)		N
Verify error counter page (05h)		Y
Write error counter page (02h)		Y

Table 5: Commands supported by Elite 47 family drive (continued)

Command Name	Command Code [5]	Supported by SCSI-2/3
Mode select (same pages as Mode Sense command, see below)	15h	Y [2] [3]
Mode select (10)	55h	Y
Mode sense	1Ah	Y [2] [3]
Caching parameters page (08h)		Y
Control mode page (0Ah)		Y
Disconnect/reconnect (02h)		Y
Error recovery page (01h)		Y
Format page (03h)		Y
Information exceptions control page (1Ch)		Y
Notch and partition page (0C)		N
Power condition page (1Ah)		Y
Rigid disc drive geometry page (04h)		Y
Unit attention page (00h)		Y
Verify error recovery page (07h)		Y
Xor control page (10h)		Y
Mode sense (10)	5Ah	Y
Prefetch	34h	N
Read	08h	Y
Read buffer (modes 0, 2, 3 supported)	3Ch	Y
Read capacity	25h	Y
Read defect data	37h	Y
Read extended	28h	Y
DPO bit supported		Y
FUA bit supported		Y
Read long	3Eh	Y
Reassign blocks	07h	Y
Receive diagnostic results	1Ch	Y
Supported diagnostics pages (00h)		Y
Translate page (40h)		Y
Release	17h	Y
Release (10)	57h	Y
Request sense	03h	Y
Actual retry count bytes		Y
Extended sense		Y
Field pointer bytes		Y
Reserve	16h	Y
3rd party reserve		Y
Extent reservation		N
Reserve (10)	56h	Y
3rd party reserve		Y
Extent reservation		N
Rezero unit	01h	Y
Search data equal	31h	N
Search data high	30h	N
Search data low	32h	N

Table 5: Commands supported by Elite 47 family drive (continued)

Command Name	Command Code [5]	Supported by SCSI-2/3
Seek	0Bh	Y
Seek extended	2Bh	Y
Send diagnostics page	1Dh	Y
Supported diagnostics pages		Y
Translate page		Y
Set limits	33h	N
Start unit/stop unit (start/stop spindle)	1Bh	Y
Synchronize cache	35h	Y
Test unit ready	00h	Y
Verify	2Fh	Y
DPO bit supported		Y
BYTCHK bit supported		Y
Write	0Ah	Y
Write and verify	2Eh	Y
DPO bit supported		Y
Write buffer (modes 0, 2 supported)	3Bh	Y
Firmware download option (modes 5, 7 supported) [4]		Y
Write extended	2Ah	Y
DPO bit supported		Y
FUA bit supported		Y
Write long	3Fh	Y
Write same	41h	Y
XD read	52h	Y
XD write	50h	Y
XP write	51h	Y

[1] The drive can format to any even number of bytes per sector from 512 to 4,096.

[2] Supports 6-byte and 10-byte versions.

[3] Table 7 shows how individual bits are set which are changeable by the host.

[4] **Warning:** A power loss during flash programming can result in firmware corruption. This usually makes the drive inoperable.

[5] 58-59h not used.
5B-5Fh not used.
60-BFh not used.
C0-DFh not used.
E0-FFh not used.

9.3.1 Inquiry data

Table 6 following lists the Standard Inquiry command data that the drive returns to the initiator per the format given in the *SCSI Interface Product Manual*, part number 77738479, section 5.1.1.3.

Table 6: Elite 47 family drive Standard Inquiry data

Bytes	Data (HEX)																
0-15	00	00	[02] ¹	[02] ²	8B	00	01	3E	53	45	41	47	41	54	45	20	VENDOR ID
16-31	53	54	[34	34	36	34	35	32	57] ³	20	20	20	20	20	20	20	PRODUCT ID
32-47	R#	R#	R#	R#	S#	S#	S#	S#	S#	S#	S#	S#	00	00	00	00	
48-63	00	00	00	00	00	00	00	00	00	00	00	00	00	00	00	00	
64-79	00	00	00	00	00	00	00	00	00	00	00	00	00	00	00	00	
80-95	00	00	00	00	00	00	00	00	00	00	00	00	00	00	00	00	
96-111	00	43	6F	70	79	72	69	67	68	74	20	28	63	29	20	[31]	COPYRIGHT
112-127	[39]	[39]	[38] ⁵	20	53	65	61	67	61	74	65	20	41	6C	6C	20	NOTICE
128-143	72	69	67	68	74	73	20	72	65	73	65	72	76	65	64	20	

Notes.

- []¹ The drive can be changed between these two configurations:
 01 = SCSI-1 implemented.
 02 = SCSI-2/SCSI-3 implemented (default is 02).
- []² The drive can be changed between these two configurations:
 01 = Response data is in SCSI-1 format and has compatibility with Common Command Set data.
 02 = Response data is in SCSI-2/SCSI-3 format (default).
- R# Four ASCII digits representing the last four digits of the product Firmware Release number. This information is also given in the Vital Product Data page C0h, together with servo RAM and ROM release numbers.
- S# Eight ASCII digits representing the eight digits of the product serial number.
- []³ Bytes 18 through 24 reflect model of drive.
- []⁴ Copyright Year - changes with actual year.

9.3.1.1 Inquiry Vital Product Data pages

Instead of the Standard Inquiry data shown in Table 6, the initiator can request several Vital Product Data pages by setting the Inquiry command EVPD bit to one. The *SCSI Interface Product Manual*, part number 77738479, section 5.1.1.3.1 lists the Vital Product Data pages supported and describes their formats. A separate Inquiry command must be sent to the drive for each Vital Product Data page the initiator wants the drive to send back.

9.3.2 Mode Sense data

The Mode Sense command provides a means for the drive to report its operating parameters to the initiator. The drive maintains four sets of mode parameters: default values, saved values, current values and changeable values.

Default values are hard-coded in the drive firmware that is stored in flash EPROM nonvolatile memory on the drive PCB. Default values can be changed only by downloading a complete set of new firmware into the flash EPROM. An initiator can request and receive from the drive a list of default values and use those in a Mode Select command to set up new current and saved values, where the values are changeable.

Saved values are stored on the disk media using a Mode Select command. Only parameter values that are allowed to be changed can be changed by this method. "Changeable values" are defined below. Parameters in the saved values list that are not changeable by the Mode Select command get their values from the default values storage.

Current values are volatile values currently being used by the drive to control its operation. A Mode Select command can be used to change these values (only those that are changeable). Originally, they are installed from saved or default values after a power on reset, hard reset, or Bus Device Reset message.

Changeable values form a bit mask, stored in nonvolatile memory, that dictates which of the current values and saved values can be changed by a Mode Select command. A “one” allows a change to a corresponding bit; a “zero” allows no change. For example, in Table 7 refer to Mode page 01, in the first row titled “CHG.” These are hex numbers representing the changeable values for Mode page 01. Note in columns 1 and 2 (bytes 00 and 01), there is 00h, which indicates that in bytes 00 and 01 none of the bits are changeable. Note also that bytes 04, 05, 06, and 07 are not changeable, because those fields are all zeros. In byte 02, hex value EF equates to the binary pattern 1110 1111. If there were a zero in any bit position in the field, it means that bit is not changeable. Bits 7, 6, 5, 3, 2, 1, and 0 are changeable, because those bits are all ones. Bit 4 is not changeable. In this particular example, it indicates 7 of 8 error recovery control bits are changeable. FF in column 4 indicates all bits in byte 3 are changeable.

The changeable values list can only be changed by downloading new firmware into the flash EPROM.

On drives requiring unique saved values, the required unique saved values are stored into the saved values storage location on the media prior to shipping the drive. Some drives may have unique firmware with unique default values also.

On standard OEM drives the saved values are taken from the default values list and stored into the saved values storage location on the media prior to shipping.

When a drive is powered up, it takes saved values from the media and stores them to the current values storage in volatile memory. It is not possible to change the current values (or the saved values) with a Mode Select command before the drive is up to speed and is “ready.” An attempt to do so results in a “Check Condition” status being returned.

Note. Because there may be several different versions of drive control firmware in the total population of drives in the field, the Mode Sense values given in the following tables may not exactly match those of some drives.

The following tables list the values of the data bytes returned by the drive in response to the Mode Sense command pages (see *SCSI Interface Product Manual*, part number 77738479).

Definitions:

SAV = Saved values are stored on the disk media using a Mode Sense command.

DEF = Default value; standard drives are shipped configured this way.

CHG= Changeable bits; indicates if current and saved values are changeable.

Table 7: Mode Sense data, ST446452 default values (SCSI-2/3 implementation)

Bytes	00	01	02	03	04	05	06	07	08	09	10	11	12	13	14	15	16	17	18	19	20	21	22	23
Mode Sense Data	B7	00	10	08	05	7A	A3	9C	00	00	02	00												
Mode Page	<-----Mode page headers and parameter data bytes----->																							
DEF 01	81	0A	CC	10	40	00	00	00	0C	00	FF	FF												
CHG 01	81	0A	FF	FF	00	00	00	00	FF	00	FF	FF												
DEF 02	82	0E	80	80	00	0A	00	00	00	00	00	00	00	00	00									
CHG 02	82	0E	FF	FF	00	00	00	00	00	00	00	00	87	00	00	00								
DEF 03	83	16	00	A8	00	52	00	00	00	00	01	48	02	00	00	01	00	28	00	7C	40	00	00	00
CHG 03	83	16	00	00	FF	FF	00	00	00	00	00	00	00	00	00	00	00	00	00	00	00	00	00	00
DEF 04	84	16	00	27	0C	1C	00	00	00	00	00	00	00	00	00	00	00	00	00	00	15	18	00	00
CHG 04	84	16	00	00	00	00	00	00	00	00	00	00	00	00	00	00	00	00	00	00	00	00	00	00
DEF 07	87	0A	00	10	40	00	00	00	00	00	FF	FF												
CHG 07	87	0A	0F	FF	00	00	00	00	00	00	00	00												
DEF 08	88	12	10	00	FF	FF	00	00	FF	FF	FF	FF	80	03	00	00	00	00	00	00				
CHG 08	88	12	B5	00	00	00	FF	FF	FF	FF	00	00	A0[1]	FF	00	00	00	00	00	00				
DEF 0A	8A	0A	02	00	00	00	00	00	00	00	00	00												
CHG 0A	8A	0A	03	F3	00	00	00	00	00	00	00	00												
DEF 10	90	16	00	00	00	00	04	B6	00	00	00	00	00	00	00	00	00	00	00	00	00	00	40	00
CHG 10	90	16	02	00	00	00	00	00	00	00	00	00	00	00	00	00	00	00	00	00	00	00	00	00
DEF 1A	9A	0A	00	00	00	00	00	01	00	00	00	04												
CHG 1A	9A	0A	00	03	00	00	00	00	00	00	00	00												
DEF 1C	9C	0A	00	04	00	00	00	00	00	00	00	01												
CHG 1C	9C	0A	8C	0F	00	00	00	00	00	00	00	00												
DEF 00	80	02	00	00																				
CHG 00	80	02	77	42																				
Read Capacity Data	05	7A	A3	9B	00	00	02	00																

[1] Though byte 12, bit 7 is shown as changeable, the FSW function governed by that bit is not implemented by this drive.

9.4 SCSI bus conditions and miscellaneous features supported

Asynchronous SCSI bus conditions supported by the drive are listed below. These conditions cause the SCSI device to perform certain actions and can alter the SCSI bus phase sequence. Other miscellaneous operating features supported are also listed here. Refer to the *SCSI Interface Product Manual*, part number 77738479 for details.

Table 8: SCSI bus conditions and other miscellaneous features

ESP	Conditions or feature
N	Adaptive caching
Y	Arbitrating system
Y	Asynchronous data transfer
Y	Asynchronous event notification
Y	Attention condition
Y	Contingent allegiance condition
Y	Capacity programming
Y	Deferred error handling
N	Differential interface circuits available
Y	Disconnect/reconnect
Y	Parameter rounding (controlled by the round bit in the Mode Select Page 0)
Y	Queue tagging (up to 64 queue tags supported)
Y	Reporting actual retry count in extended sense bytes 15, 16 and 17
Y	Reset condition
Y	Segmented caching
Y	SMP = 1 in Mode Select command needed to save RPL and rotational offset bytes (in Table 5.2.1-25 of the <i>SCSI Interface Product Manual</i>)
Y	Synchronous data transfer
N	Zero latency read

ESP	Status supported
Y	Good
Y	Check condition
Y	Condition met/good
Y	Busy
Y	Intermediate/good
Y	Intermediate/condition met/good
Y	Reservation conflict
Y	Queue full

9.5 Synchronous data transfer

The data transfer period to be used by the drive and the initiator is established by an exchange of messages during the Message Phase of operation. See the section on message protocol in the *SCSI Interface Product Manual*.

9.5.1 Synchronous data transfer periods supported

Table 9 lists synchronous data transfer periods supported by the drive.

Table 9: Synchronous data transfer periods supported

M (Decimal)	Transfer period (M times 4 nanoseconds)	Transfer rate (mega transfers/second)
12 [1]	50 [1]	20.0 [1]
15 [1]	62.5 [1]	16.0 [1]
18 [1]	75 [1]	13.33 [1]
25	100	10.0
31	125	8.0
37	150	6.66
50	200	5.0
62	250	4.0
75	300	3.33
87	350	2.86
100	400	2.5

[1] Fast-20 (Ultra SCSI) transfer rates.

9.5.2 REQ/ACK offset

The maximum REQ/ACK value supported by Elite 47 SCSI drives is 15 (0Fh).

9.6 Physical interface

Figure 10 shows the locations of the drive physical interface components. The locations of the DC power connector, the SCSI interface connector, and the drive select and option select headers are shown.

Details of the physical, electrical and logical characteristics are given in sections following, while the SCSI operational aspects of Seagate drive interfaces are provided in the *SCSI Interface Product Manual*, part number 77738479.

This section describes the connectors, cables, signals, terminators and bus timing of the DC and SCSI I/O interface. See Sections 9.8 and 9.9 for additional terminator information.

9.6.1 DC cable and connector

The drive receives DC power through a 4-pin connector (see Figure 10 for pin assignments) mounted at the rear of the main PCB. Recommended part numbers of the mating DC power connector are listed below, but equivalent parts may be used.

Type of Cable	Connector	Contacts (20-14 AWG)
14 AWG	AMP 1-480424-0	AMP 60619-4 (loose piece) AMP 61117-4 (strip)

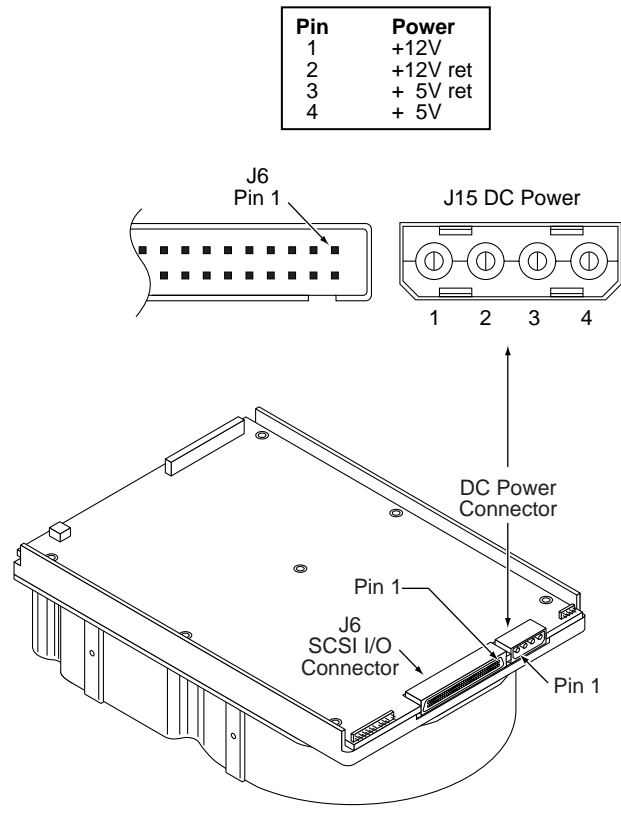

Figure 10. Physical interface

9.6.2 SCSI interface physical description

The drives may be daisy-chained together or with other compatible SCSI devices. Both ends of the cable must be terminated. The drives implement single-ended drivers and receivers. All signals are common between all SCSI devices. The drive may be daisy-chained only with SCSI devices having the same type drivers and receivers. Devices having single-ended interface circuits cannot be on the same daisy chain with devices having differential interface circuits. A maximum of 16 SCSI devices (including the host) may be daisy-chained together. However, please note the restrictions described in Section 9.6.3 about the number of devices allowed in a daisy chain. The SCSI devices at both ends of the daisy chain are to be terminated. Intermediate SCSI devices shall not be terminated (see Figure 11). To disable termination, remove the terminator enable jumper **TE** on J4A select header, not the terminator power source selector jumper **TP** on J01 (Figure 7).

9.6.3 SCSI interface cable requirements

In general, cables having the characteristic impedances given in Section 9.6.3.1 are not available; however, impedances that are somewhat lower are satisfactory. A characteristic impedance as shown in Table 10 is recommended for unshielded flat or twisted pair ribbon cable. However, most available cables have a somewhat lower characteristic impedance. To minimize discontinuances and signal reflections, cables of different impedances should not be used in the same bus. Implementations may require trade-offs in shielding effectiveness, cable length, the number of loads, transfer rates, and cost to achieve satisfactory system operation. If you mix shielded and unshielded cables within the same SCSI bus, the effect of impedance mismatch must be carefully considered. Proper impedance matching is especially important to maintain adequate margin at FAST and FAST-20 (Ultra SCSI) transfer rates.

Elite 47 drives use non-shielded cable connectors. Use a 68-conductor flat cable or 34 twisted pair cable with connectors listed in 9.6.4.1. Use a minimum conductor size of 28 AWG to minimize noise effects.

Suggested non-shielded flat cable part numbers are:

Flat cable - 35M-3365-68 Twisted pair - Spectra Twist in flat 455-248-68

9.6.3.1 Single-ended I/O circuits

The maximum total cable length allowed depends on several factors. Table 10 lists the maximum lengths allowed for different configurations of drive usage. These values are from the ANSI SCSI-3 Fast-20 (also called Ultra SCSI) specification X3T10/1071D. All device I/O lines must have equal to or less than 25 pf capacitance to ground, measured at the beginning of the stub.

Table 10: Cable characteristics for single-ended circuits

I/O transfer rate	Maximum number of devices on line	Maximum cable length allowed	Transmission line impedance	
			REQ/ACK	Other signals
≤10 M transfers/s	8 (reg. SCSI bus)	6 meters (19.7 ft.)	90 ± 6 Ohms	90 ± 10 Ohms
≤10 M transfers/s	16 (wide SCSI bus)	6 meters (19.7 ft.)	90 ± 6 Ohms	90 ± 10 Ohms
≤20 M transfers/s	4 (reg./wide SCSI bus)	3 meters (9.8 ft.)	90 ± 6 Ohms	90 ± 10 Ohms
≤20 M transfers/s	8 (reg./wide SCSI bus)	1.5 meters (4.9 ft.) [1]	90 ± 6 Ohms	90 ± 10 Ohms

Notes:

[1] The spacing of devices on the mainline SCSI bus should be at least three times the stub length (defined below) to avoid clustering (Refer to Annex C of X3T10/1071D). Based on this criteria, it may be that 8 devices will not actually work on 1.5 meters of line (.1 x 3 x 7 = 2.1 meters).

A stub length of no more than 0.1 meter (0.33 foot) is allowed off the mainline interconnection with any connected equipment. The stub length is measured from the transceiver to the connection to the mainline SCSI bus.

Single-ended I/O pin assignments are shown in Table 11.

9.6.4 Mating connectors

Part numbers for connectors that mate with the various Elite 47 I/O connectors are given in the sections following.

9.6.4.1 Mating connectors for ST446452W models

Use a non-shielded 68-conductor cable connector consisting of two rows of 34 male contacts with adjacent contacts 0.050 inch (1.27 mm) apart.

Recommended mating wide connector part numbers are:

Amp Model 786096-7	Female, 68-pin, panel mount
Amp Model 786090-7	Female, 68-pin, cable mount
Amp Model 749925-5	(.050 inch conductor centers, 28 or 30 AWG wire) Use two, 34 conductor, .050 inch center flat cable with this connector. This type connector can only be used on cable ends. [1]
Amp Model 88-5870-294-5	W/O Strain Relief (.025 inch conductor centers, 30 AWG wire). Use either on cable ends or in cable middle section for daisy-chain installations. [1]
Amp Model 1-480420-0	Power connector 4 circuit housing
Berg 69307-012	12-position, 2 x 6, 2 mm receptacle housing

[1] See Figure 11.

The drive device connector is a non-shielded 68-conductor connector consisting of two rows of 34 female pins with adjacent pins .050 inch apart. The connector is keyed by means of its shape (see Figure 12).

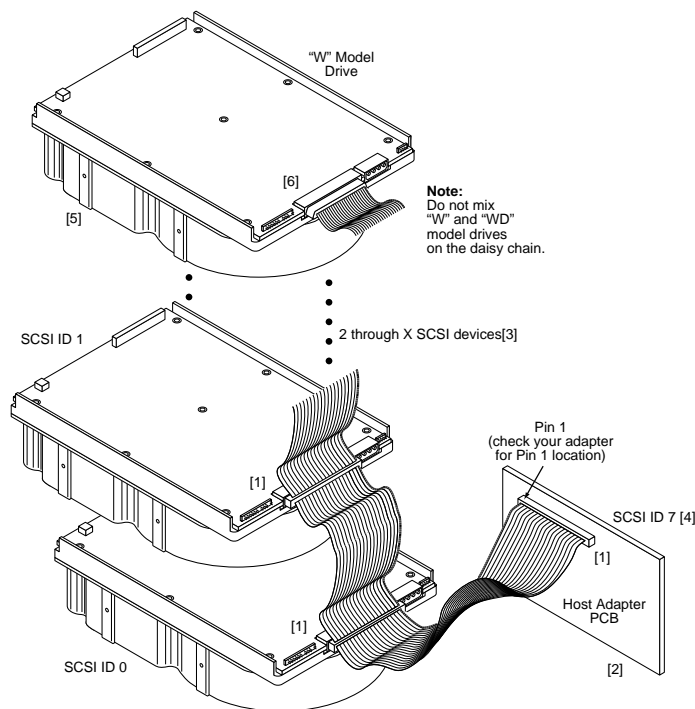

- [1] Open-end type (in-line application) connector used. Terminators disabled.
- [2] Host need not be on the end of the daisy chain. Another device can be on the end with the terminator, the host having no terminator.
- [3] Total interface cable length must not exceed that specified in Section 9.6.3.1 (including host adapter/initiator). The number of devices allowed depends on data transfer rate. See Table 10.
- [4] SCSI ID7 has highest arbitration priority. Priority is ID 7 to ID 0, then ID 15 to ID 8. (ID 8 has the lowest priority).
- [5] Last drive on daisy chain.
- [6] If end device, external terminator and closed-end type 68-pin connector used. Install terminator enable (TE) jumper plug.

Figure 11. SCSI daisy-chain interface cabling

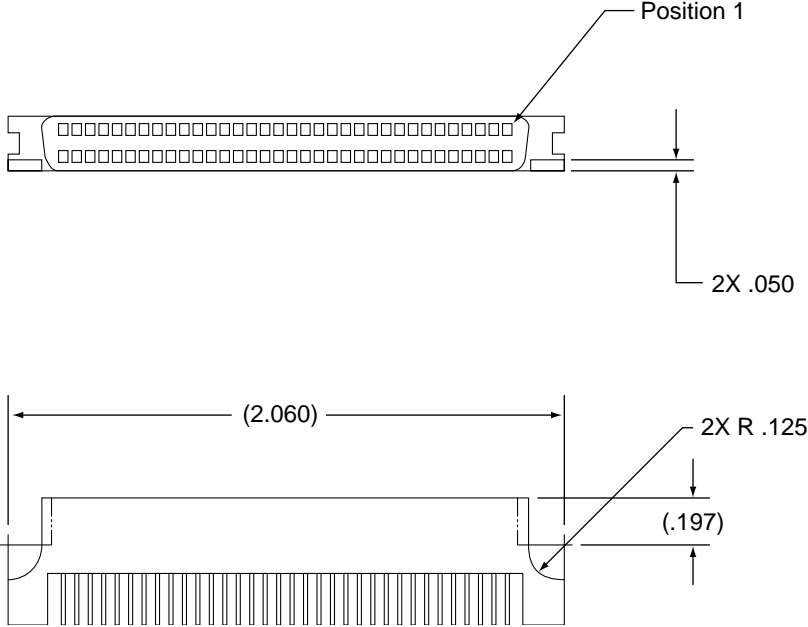

Figure 12. Non-shielded 68-pin SCSI device connector

Table 11: Single-ended wide cable assignments for ST446452W drives

Signal name [1]	Connector contact number [3]	Cable conductor number [2]		Connector contact number [3]	Signal name [1] [9]
GND	1	1	2	35	-DB12
GND	2	3	4	36	-DB13
GND	3	5	6	37	-DB14
GND	4	7	8	38	-DB15
GND	5	9	10	39	-DBP1
GND	6	11	12	40	-DB0
GND	7	13	14	41	-DB1
GND	8	15	16	42	-DB2
GND	9	17	18	43	-DB3
GND	10	19	20	44	-DB4
GND	11	21	22	45	-DB5
GND	12	23	24	46	-DB6
GND	13	25	26	47	-DB7
GND	14	27	28	48	-DBP
GND	15	29	30	49	GND
GND	16	31	32	50	GND
TERMPWR	17	33	34	51	TERMPWR
TERMPWR	18	35	36	52	TERMPWR
RESERVED	19	37	38	53	RESERVED
GND	20	39	40	54	GND
GND	21	41	42	55	-ATN
GND	22	43	44	56	GND
GND	23	45	46	57	-BSY
GND	24	47	48	58	-ACK
GND	25	49	50	59	-RST
GND	26	51	52	60	-MSG
GND	27	53	54	61	-SEL
GND	28	55	56	62	-C/D
GND	29	57	58	63	-REQ
GND	30	59	60	64	-I/O
GND	31	61	62	65	-DB8
GND	32	63	64	66	-DB9
GND	33	65	66	67	-DB10
GND	34	67	68	68	-DB11

Notes:

- [1] See Section 9.7.1 for detailed electrical characteristics of these signals.
- [2] The conductor number refers to the conductor position when using 0.025-inch (0.635 mm) centerline flat ribbon cable. Other cable types may be used to implement equivalent contact assignments.
- [3] Connector contacts are on 0.050 inch (1.27 mm) centers.
- [4] "NC" means no connection.
- [5] The conductor number refers to the conductor position (right to left in Figure 11) when using 0.050 inch (1.27 mm) centerline flat ribbon cable. Other cable types may be used to implement equivalent contact assignments.
- [6] Connector contacts are on 0.100 inch (2.54 mm) centers.
- [7] 8 bit devices which are connected to the 16 data bit differential I/O shall leave the following signals open:
-DB12 -DB13 -DB14 -DB15 -DBP1 -DB8 -DB9 -DB10 -DB11.
+DB12 +DB13 +DB14 +DB15 +DBP1 +DB8 +DB9 +DB10 +DB11.
8 bit devices which are connected to the 16 data bit single-ended I/O shall have the following signals connected as shown:
to ground: +DB12 +DB13 +DB14 +DB15 +DBP1 +DB8 +DB9 +DB10 +DB11.
open circuit: -DB12 -DB13 -DB14 -DB15 -DBP1 -DB8 -DB9 -DB10 -DB11.
All other signals shall be connected as defined.
- [8] GND provides a means for differential devices to detect the presence of a single-ended device on the bus.
- [9] A hyphen preceding a signal name indicates that the signal is active low.

9.7 Electrical description

ST446452W models use single-ended interface signals. These signals must be terminated with 110-ohm active termination circuits at each end of the total cable. Single-ended circuits use open collector or three state drivers. All of these models can be configured to provide the SCSI termination.

9.7.1 Single-ended drivers/receivers

Typical single-ended driver and receiver circuits are shown in Figure 13. Use terminator circuits only where the disc drive is first or last in the daisy chain. See Note 1 following Figure 13.

Transmitter characteristics

Single-ended drives use an ANSI SCSI compatible open collector single-ended driver. This driver is capable of sinking a current of 48 mA with a low level output voltage of 0.4 volt.

Receiver characteristics

Single-ended drives use an ANSI SCSI single-ended receiver with hysteresis gate or equivalent as a line receiver.

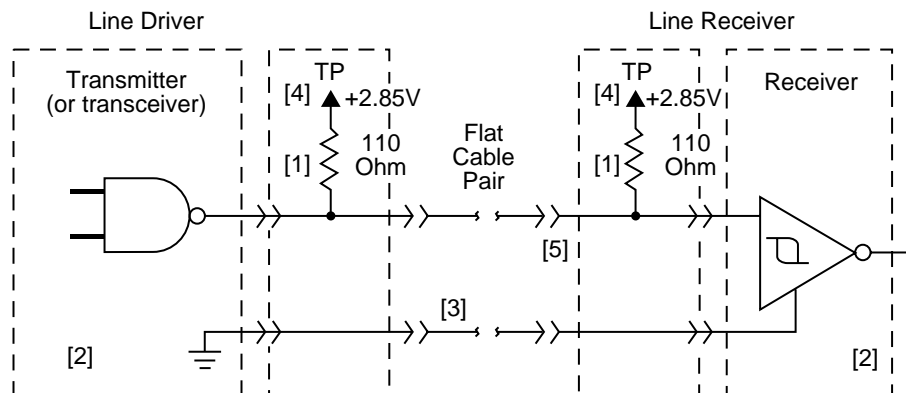

Figure 13. Single-ended transmitters and receivers

Notes.

- [1] Part of active terminator circuits. Non-removable LSI terminators, enabled in the drive with jumper plug **TE** when it is the first or last in the daisy chain.
- [2] ANSI SCSI compatible circuits.
- [3] Total interface cable length should not exceed that specified in Section 9.6.3.1.
- [4] Source of drive terminator power is an active circuit which has an input source voltage selected by jumper plug **TP**. See Figure 7.
- [5] Interface signal levels and logical sense at the drive I/O connector are defined as follows:
 V_{il} (low-level input voltage) = 1.0 V maximum (signal true); minimum = $V_{ss} - 0.5$ V.
 V_{ih} (high-level input voltage) = 1.9 V minimum (signal false); maximum = $V_{dd} + 0.5$ V.
 V_{ihys} (Input Hysteresis) = 425 mV minimum

9.8 Terminator requirements

Internal disc drive I/O termination consists of active circuits contained in an LSI module that is permanently mounted on the PCB. All single initiator/single target (non-daisy-chain) applications require you to terminate the initiator and drive.

Terminate both ends of the SCSI bus with ANSI SCSI-2 standard alternative 2 (active) termination. Do not mix active and passive terminators on the same SCSI bus.

Daisy-chain configurations require you to terminate only the units at each end of the daisy chain. Do not terminate any other peripherals on the chain.

Note. Remove the Enable SCSI Terminator (**TE**) jumper from J4A pins 19 and 20 when terminators are not required.

9.9 Terminator power

You can configure terminator power in four different ways. See Section 8.1 for illustrations that show how to place jumpers enabling each of the following terminator power configurations:

1. Drive accepts terminator power through SCSI bus pins 17, 18, 51, and 52.
2. Drive supplies power to the SCSI bus.
3. Drive provides power to its own terminators and to the SCSI bus terminator power line.

SCSI devices providing terminator power (TERMPWR) must have the following characteristics:

V TERM = 4.50 V to 5.25 V

800 mA minimum source drive capability

1.0 A maximum

9.10 Disc drive SCSI timing

Table 12: Disc drive SCSI timing

Description	Waveform symbol [1]	Waveform table [1]	Typical timing	Maximum timing
Target select time (no arbitration)	T00	N/A	<1 μ s	<250 μ s
Target select time (with arbitration)	T01	4.5-1,2	2.31 μ s	2.36 μ s
Target select to command	T02	4.5-1	3.33 μ s	3.34 μ s
Target select to MSG out	T03	4.5-2	1.51 μ s	1.54 μ s
Identify MSG to command	T04	4.5-3	3.34 μ s	3.36 μ s
Command to status	T05	4.5-5	Command dependent	Command dependent
Command to data (para. in)	T06	4.5-9	Command dependent	Command dependent
Command to data (para. out)	T07	4.5-10	Command dependent	Command dependent
Command to data (write to data buffer)	T08	4.5-10	Command dependent	Command dependent
Command to disconnect MSG	T09	4.5-6	Command dependent	Command dependent
Disconnect MSG to bus free	T10	4.5-6,14	0.64 μ s	0.68 μ s
Disconnect to arbitration (for reselect) This measures disconnected CMD overhead.	T11	4.5-6–b	Command dependent	Command dependent
Target win arbitration (for reselect)	T12	4.5-7		2.8 μ s
Arbitration to reselect	T13	4.5-7		1.8 μ s
Reselect to identify MSG in	T14	4.5-7		1.34 μ s
Reselect identify MSG to status	T15	4.5-8	Command dependent	Command dependent
Reselect identify MSG to data (media)	T16	4.5-11	Command dependent	Command dependent
Data to status	T17	4.5-15	Command dependent	Command dependent
Status to command complete MSG	T18	4.5-5,8,15		1.0 μ s
Command complete MSG to bus free	T19	4.5-5,8,15		0.75 μ s
Data to save data pointer MSG	T20	4.5-14		4.5 μ s
Save data pointer MSG to disconnect MSG	T21	4.5-14		0.75 μ s
Command byte transfer	T22	4.5-4		0.04 μ s
Next command byte access		4.5-4		
Next CDB byte access (byte 2 of 6)	T23.6.2	4.5-4	0.55 μ s	0.56 μ s
Next CDB byte access (byte 3 of 6)	T23.6.3	4.5-4	0.10 μ s	0.10 μ s
Next CDB byte access (byte 4 of 6)	T23.6.4	4.5-4	0.09 μ s	0.10 μ s
Next CDB byte access (byte 5 of 6)	T23.6.5	4.5-4	0.13 μ s	0.14 μ s
Next CDB byte access (byte 6 of 6)	T23.6.6	4.5-4	0.13 μ s	0.14 μ s
Next CDB byte access (byte 2 of 10)	T23.10.2	4.5-4	0.59 μ s	0.60 μ s
Next CDB byte access (byte 3 of 10)	T23.10.3	4.5-4	0.14 μ s	0.14 μ s
Next CDB byte access (byte 4 of 10)	T23.10.4	4.5-4	0.13 μ s	0.14 μ s
Next CDB byte access (byte 5 of 10)	T23.10.5	4.5-4	0.12 μ s	0.12 μ s
Next CDB byte access (byte 6 of 10)	T23.10.6	4.5-4	0.11 μ s	0.12 μ s
Next CDB byte access (byte 7 of 10)	T23.10.7	4.5-4	0.10 μ s	0.10 μ s
Next CDB byte access (byte 8 of 10)	T23.10.8	4.5-4	0.09 μ s	0.10 μ s

Description	Waveform symbol [1]	Waveform table [1]	Typical timing	Maximum timing
Next CDB byte access (byte 9 of 10)	T23.10.9	4.5-4	0.13 μ s	0.14 μ s
Next CDB byte access (byte 10 of 10)	T23.10.10	4.5-4	0.12 μ s	0.12 μ s
Data in byte transfer (parameter)	T24	4.5-12		0.04 μ s
Data out byte transfer (parameter)	T25	4.5-13		0.04 μ s
Next data in byte access (parameter)	T26	4.5-12	0.10 μ s	0.12 μ s
Next data byte out access (parameter)	T27	4.5-13	0.10 μ s	0.12 μ s
Data in byte transfer (media) [2]	T28	4.5-12	0.03 μ s	0.04 μ s
Data out byte transfer (media) [2]	T29	4.5-13	0.03 μ s	0.04 μ s
Next data in byte access (media) [2]	T30	4.5-12	0.10 μ s	0.12 μ s
Next data out byte access (media) [2]	T31	4.5-13	0.10 μ s	0.12 μ s
MSG IN byte transfer	T32	4.5-5,7, 4.5-8,14,15	0.09 μ s	0.04 μ s
MSG OUT byte transfer	T33	4.5-2		0.04 μ s
STATUS byte transfer	T34	4.5-5,8, 4.5-15		0.04 μ s
Synchronous data transfer characteristics:				
Request signal transfer period [3]	–	–	various	800 ns

Notes.

- [1] See the *SCSI Interface Product Manual*, part number 77738479, Section 4.5.
- [2] Maximum SCSI asynchronous interface transfer rate is given in Section 4.2.3.
- [3] Synchronous Transfer Period is determined by negotiations between an Initiator and a Drive. The Drive is capable of setting periods as given in Section 9.5. See also Sections 3.1.5.2 and 3.5.3.2 of the *SCSI Interface Product Manual*, part number 77738479, for a description of synchronous data transfer operation.

10.0 Seagate technical support services

If you need assistance installing your drive, consult your dealer. Dealers are familiar with their unique system configurations and can help you with system conflicts and other technical issues. If you need additional assistance with your Seagate® drive or other Seagate products, use one of the Seagate technical support services listed below.

SeaFONE® 1-800-SEAGATE

Seagate's 800 number (1-800-732-4283) allows toll-free access to automated self-help services, providing answers to commonly asked questions, troubleshooting tips, and specifications for disc drives and tape drives. This service is available 24 hours daily and requires a touch-tone phone. International callers can reach this automated self-help service by dialing 408-456-4496.

Online services

Using a modem, you can obtain troubleshooting tips, free utility programs, drive specifications and jumper settings for Seagate's entire product line. You can also download software for installing and analyzing your drive.

SeaNET™

You can obtain technical information about Seagate products over the Internet from Seagate's World Wide Web home page (<http://www.seagate.com>) or Seagate's ftp server (<ftp://ftp.seagate.com>). You can also send E-mail with your questions to **DiscSupport @ Seagate.com** or **TapeSupport @ Seagate.com**.

Seagate CompuServe forum

Online technical support for Seagate products is available on CompuServe. To access our technical support forum, type **go seagate**. This forum provides information similar to that found on SeaBOARD. In addition, you can type questions or browse through previous questions and answers on the forum messages.

SeaBOARD®

SeaBOARD is a computer bulletin board system that contains information about Seagate disc and tape drive products and is available 24 hours daily. Set your communications software to eight data bits, no parity, and one stop bit (8-N-1).

Location	Phone number
Australia	61-2-9756-2359
France	33 1-48 25 35 95
Germany	49-89-140-9331
Taiwan	886-2-2719-6075
Thailand	662-531-8111
UK	44-1628-478011
USA	Disc: 405-936-1600; Tape: 405-936-1630

FAX services

SeaFAX®

You can use a touch-tone telephone to access Seagate's automated FAX system to receive technical support information by return FAX. This service is available 24 hours daily.

Location	Phone number
Australia	61-2-9756-5170
Germany	49-89-1430-5102
UK	44-1628-894084
USA	Disc: 405-936-1620; Tape: 405-936-1640

Seagate technical support FAX

You can FAX questions or comments to technical support specialists 24 hours daily. Responses are sent during business hours.

Location	Phone number
Australia	61-2-9725-4052
France	33 1-46 04 42 50
Germany	49-89-1430-5100

Location	Phone number
Hong Kong	852-2368 7173
Japan	81-3-5462-2979
Korea	82-2-556-4251/7395
Singapore	65-488-7528
Taiwan	886-2-2715-2923
UK	44-1628-890660
USA	Disc: 405-936-1685; Tape: 405-936-1683

Direct-support services

Seagate technical support

For one-on-one help, you can talk to a technical support specialist during local business hours. Before calling, note your system configuration and drive model number (STxxxx).

Location	Phone number
Australia	61-2-9725-3366 (9:00 A.M. to 5:00 P.M., Eastern time, M–F)
France	33 1-41 86 10 86 (9:30 A.M. to 12:30 P.M., 2:00 P.M. to 5:00 P.M., M–F)
Germany	Disc: 49-89-140-9332; Tape: 49-89-140-9333 (9:30 A.M. to 12:30 P.M., 2:00 P.M. to 4:00 P.M., M–F)
Hong Kong	852-2368 9918
Korea	82-2-531-5800 (9:00 A.M. to 12:00 P.M., 1:00 P.M. to 6:00 P.M., M–F)
Singapore	65-488-7584 (9:00 A.M. to 12:00 P.M., 2:00 P.M. to 5:00 P.M., M–F)
Taiwan	886-2-2514-2237
UK	44-1628-894083 (10:00 A.M. to 1:00 P.M., 2:00 P.M. to 5:00 P.M., M–F)
USA	Please dial 1-800-SEAGATE or 408-456-4496 for the specific product telephone number. (8:00 A.M. to 1:15 P.M., 2:30 P.M. to 7:00 P.M., Central time, M–F)

SeaTDD™ 405-936-1687

Using a telecommunications device for the deaf (TDD), you can send questions or comments 24 hours daily and exchange messages with a technical support specialist between 8:00 A.M. to 12:15 P.M. and 1:30 P.M. to 6:00 P.M. (Central time) Monday through Friday.

Customer service centers

Seagate direct OEM, Distribution, and Systems Integrator customers should contact their Seagate service representative for warranty information. Other customers should contact their place of purchase. Seagate offers comprehensive customer support for all Seagate drives. These services are available worldwide.

Location	Phone number	FAX number
Asia Pacific and Australia	65-485-3595	65-488-7503
Europe, Middle East, and Africa	31-2031-67300	31-2065-34320
Japan	81-3-5462-2904	81-3-5462-2979
USA	1-800-468-3472	405-949-6740
Other Americas (Brazil, Canada, Mexico)	405-949-6706	405-949-6738
<i>Manufacturer's representatives</i>		
Brazil		
MA Informatica	55-21-516-6649	55-21-516-5280
Canada		
Memofix	905-660-4936	905-660-8738
Adtech	905-812-8099	905-812-7807
	1-800-624-9857	
Mexico		
Abicom Seamax SA DE CV	525-546-4888	525-546-4888
Southern Europe		
Caesar Italia	39-688-18149	39-688-02103

Index

Numerics

12 V current profile 22
3rd party reserve 39

A

abort
 SCSI message 37
abort-tag
 SCSI message 37
AC power requirements 21
access time 9
acoustics 27
actual retry count bytes 39
actuator 7
actuator assembly 5
adaptive caching 44
adaptive read look-ahead 13
air cleanliness 27
air flow 16, 23, 35
altitude 25
ambient temperature 35
ANSI SCSI documents 4
arbitrating system 44
asynchronous data transfer 44
asynchronous event notification 44
attention condition 44
Australia/New Zealand Standard 4
auto write and read reallocation 6
automatic shipping lock 5

B

backward compatibility 5
Barracuda 9 Installation Guide 4, 7, 8
bits 9
block format 38
buffer segment 12
buffer space 11
bus device reset
 SCSI message 37
busy status 44
BYTCHK bit 40
bytes 9
bytes from index 38
bytes per sector 40

C

cable characteristics
 single-ended circuits 47
cable requirements 47
cabling 48
cache buffer 7
cache control
 prefetch/multi-segmented 11

cache operation 11
cache statistics page 38
caching parameters page 39
caching write data 12
capacities 7
 unformatted 9
CDB 12
CE Marking 3
certifications 3
change definition command 38
changeable values 42
characteristics 9
check condition status 44
clear queue
 SCSI message 37
command complete
 SCSI message 37
command queuing 7
commands
 interface 38
compare command 38
condition met/good status 44
configuration jumpers, function 34
configure drive options 31
connector
 non-shielded 68-pin 49
contingent allegiance condition 44
continue I/O process
 SCSI message 37
control mode page 39
controller 6
cooling 16, 23, 35
copy and verify command 38
copy command 38
C-Tick Marking 3
current
 operating 21
 profile, 12 V 22
 values 42

D

daisy-chain interface cabling 48
data buffer 7
data page out 12
data rate 9
data transfer 9, 45
data transfer period 45
data transfer protocols 6
date code page 38
DC cable and connector 45
DC power connector 45
DC power requirements 21
DCRT bit 38
dedicated landing zone 5, 6
default 34
default mode parameter 31
default values 41

- defect and error management 29
- deferred error handling 44
- delayed motor start
 - power requirements 21
- description 5
- devices
 - multiple 31
- differential interface circuits available 44
- dimensions
 - physical 27
- disc drive SCSI timing 54
- disc rotational speed 9
- disconnect
 - SCSI message 37
- disconnect/reconnect 44
- disconnect/reconnect command 39
- documentation 4
- DPO bit 40
- DPRY bit 38
- drive characteristics 9
- drive default mode parameter 31
- drive ID 31
- drive ID select jumper connector 31
- drive internal defects and errors 29
- drive mounting 36
- drive orientation 35
- drive power 31
- drive primary defects list 29
- drive select headers 45
- drive volume 31
- drivers/receivers 6
 - single-ended 52
- DS bit 38
- DSP bit 38
- DU bit 38

E

- EFT defect list 29
- electrical description 52
- electrical specifications 21
- electromagnetic interference (EMI) 15
- electromagnetic susceptibility 27
- EMC compliance 3
- emissions 36
- environmental interference 15
- environmental limits 23
- environmental requirements 15
- error management 29
- error rates 15
- error recovery 29
- error recovery page 39
- error recovery process 16
- error-correction code 6
- errors 15, 16
- ETC bit 38
- European Union requirements 3
- extended messages

- SCSI message 37
- extended sense 39
- extent reservation 39

F

- fan 35
- Fast-20 5
- features 6
 - miscellaneous 44
- field pointer bytes 39
- firmware 6
- firmware corruption 40
- firmware download option 40
- firmware numbers page 38
- flash EPROM 41
- flaw reallocation performance 10
- format command execution time 9
- format page 39
- format unit command 38
- formatted capacities 7
- formatting 31
- function description, configuration jumpers 34

G

- good status 44
- ground 36

H

- hardware error 16
- HDA. See head and disc assembly
- head and disc assembly 5, 6, 35
 - ground 36
- head of queue tag
 - SCSI message 37
- high level format 31
- host adapter 31
- host system 31
- humidity 25

I

- I/O circuits
 - single-ended 47
- IC terminators 7
- identified defect 29
- identify
 - SCSI message 37
- ignore wide residue
 - SCSI message 37
- IMMED bit 38
- implemented operating definitions page 38
- information exceptions control page 39
- initiate recovery
 - SCSI message 37
- initiator detected error
 - SCSI message 37
- inquiry command 38

- Inquiry data 41
- Inquiry Vital Product Data pages 41
- installation 31
 - instructions 31
- interface 45
- interface cable requirements 47
- interface cabling 48
- interface commands 38
- interface data 9
- interface description 47
- interface messages 37
- interface requirements 37
- interface signals
 - single-ended 52
- interleave 6, 9
- intermediate/condition met/good status 44
- intermediate/good status 44
- internal data rate 9
- internal drive characteristics 9
- IP bit 38

J

- jumper 7, 31, 34
- jumper connectors 31
 - ST19171W/WD 32
- jumper function description 34
- jumper header 34
- jumper plug 31
- jumper settings page 38
- jumpers
 - function description 34

L

- linked command complete
 - SCSI message 37
- linked command complete with flag
 - SCSI message 37
- lock-unlock cache command 38
- log select command 38
- log sense command 38
- logical block address 11
- logical segments 11
- low level format 31
- LP bit 38
- LSI circuitry 7
- LSI module 53

M

- magnetoresistive heads 5
- mating connectors 47, 48
- mean time between failures 7, 15, 16, 23
- mechanical specifications 27
- media characteristics 7
- medium error 16
- message parity error
 - SCSI message 37

- message phase 45
- message reject
 - SCSI message 37
- messages
 - interface 37
- minimum sector interleave 9
- miscellaneous features 44
- mode parameters 41
- mode select command 39
- mode sense command 39, 41, 43
- modify data pointer
 - SCSI message 37
- motor start option 11
- mounting 6, 26, 36
- mounting configuration dimensions
 - "W" and "WD" models 28
- mounting orientation 35
- MR heads 5
- MTBF. See mean time between failures
- multiple devices 31

N

- no operation
 - SCSI message 37
- noise immunity 22
- non-medium error page 38
- non-shielded 68-pin SCSI device connector 49
- notch and partition page 39

O

- operating options 31
- option jumper 31
 - location 31
- option select headers 45
- option select jumper connector 31
- options 8
 - operating 31
- ordered queue tag
 - SCSI message 37

P

- pages supported list 38
- parameter rounding 44
- partition or logical drive 31
- PCB 31
 - component locations 24
- PCBA 35
 - ground 36
- PCR bit 38
- peak to peak measurements 22
- performance 7
- performance characteristics
 - detailed 9
 - general 9
- physical interface 45
 - "W" and "WD" model drives 46

- physical sector format 38
- physical specifications 21
- pin assignments
 - single-ended wide cable 50
- power condition page 39
- power dissipation 23
- power requirements 21
- power sequencing 22
- power-on 31
- prefetch 11
 - operation 12
- prefetch command 39
- preventive maintenance 15, 17
- printed circuit board assembly (PCBA) 35
- PRML read channel electronics 5

Q

- queue
 - background processing 7
- queue full status 44
- queue tag messages
 - SCSI message 37
- queue tagging 44

R

- radiated emissions 36
- random data 15
- RCD bit 11
- read buffer command 39
- read capacity command 39
- read command 39
- read defect data command 39
- read error counter page 38
- read error rates 15
- read errors 15
- read extended command 39
- read long command 39
- read look-ahead 13
- read retry count 29
- read/write heads 9
- reallocation of defects 6
- reassign blocks command 39
- receive diagnostic results command 39
- receiver characteristics 52
- receiver circuits
 - single-ended 52
- receivers 6
- reference documents 4
- regulatory requirements 3
- release
 - SCSI message 37
- release command 39
- reliability 7, 16
 - specifications 15
- remote switch 31
- repair 17
- reporting actual retry count 44

- REQ/ACK offset 45
- request sense command 39
- reservation conflict status 44
- reserve command 39
- reset condition 44
- restore pointers
 - SCSI message 37
- rezero unit command 39
- rigid disc drive geometry page 39
- rotational latency
 - average 9, 10

S

- S.M.A.R.T. 7, 18
- save data pointer
 - SCSI message 37
- saved values 41
- SCAM Plug-n-Play 31
- SCSI bus cable 31
- SCSI bus conditions 44
- SCSI command 29
- SCSI daisy-chain interface cabling 48
- SCSI ID 31
- SCSI interface cable requirements 47
- SCSI interface commands 38
- SCSI interface connector 45
- SCSI interface data 9
- SCSI interface messages 37
- SCSI interface physical description 47
- SCSI Interface Product Manual 1, 4, 5
- SCSI status supported 44
- SCSI timing 54
- SCSI-3 (Fast-20) interface 5
- Seagate support service 31
- search data equal command 39
- search data high command 39
- search data low command 39
- sector size 6, 10
- seek 9
- seek command 40
- seek errors 15, 16
- seek extended command 40
- segmented caching 44
- self-diagnostics 6
- Self-Monitoring Analysis and Reporting Technology.
 - See S.M.A.R.T.
- send diagnostics page 40
- service 16
 - life 15, 17
 - philosophy 17
 - tools 17
- servo data 5, 6
- set limits command 40
- shipping pack 8
- shock 25
 - non-operating 25
 - operating—abnormal 25

- operating—normal 25
- packaged 25
- signal ground 36
- simple queue tag
 - SCSI message 37
- single-ended drivers/receivers 52
- single-ended I/O circuits 47
- single-ended interface signals 52
- SMP = 1 in Mode Select command 44
- spare reallocation sectors 7
- specifications
 - electrical 21
 - mechanical 27
 - physical 21
 - reliability 15
- speed 9
- spindle 7
- spindle brake 7
- Standard Inquiry data 41
- standards 3
- start and stop commands 7
- start unit/stop unit command 40
- start/stop time 11
- status supported 44
- STIR algorithm 7
- STPF bit 38
- support services 57
- supported diagnostics pages 39, 40
- synchronize cache command 40
- synchronous data transfer 44, 45
 - periods supported 45
- synchronous data transfer req.
 - SCSI message 37
- synchronous transfer rate 9

T

- target transfer disable
 - SCSI message 37
- technical support services 57
- temperature
 - ambient 35
 - non-operating 25
 - operating 23
- terminate I/O process
 - SCSI message 37
- terminator 31, 53
 - circuits 52
 - enable jumper TE 31
 - power 53
 - requirements 31, 53
- test unit ready command 40
- TMC bit 38
- tracks 9
- transfer rate 9
- translate page 39, 40
- transmitter characteristics 52
- troubleshooting 17, 57

- TSD bit 38

U

- Ultra SCSI 5
- unformatted capacities 7
- unit attention page 39
- unit serial number page 38
- unrecoverable error 15
- unrecoverable write errors 15

V

- verify command 40
- verify error counter page 38
- verify error recovery page 39
- vibration 25, 27
- vital product data page 38, 41
- VS 38

W

- warranty 17
- wide data transfer request
 - SCSI message 37
- write and verify command 40
- write buffer command 40
- write cache enable 12
- write command 40
- write error counter page 38
- write errors 15
- write extended command 40
- write long command 40
- write retry count 29
- write same command 40

X

- XD read 40
- XD write 40
- Xor control page 39
- XP write 40

Z

- zero latency read 44
- zone bit recording 6



Seagate Technology, Inc.
920 Disc Drive, Scotts Valley, California 95066-4544, USA
Publication Number: 83329280, Rev. A, Printed in USA