

Electronic Design[®] 23

VOL. 25 NO.

FOR ENGINEERS AND ENGINEERING MANAGERS — WORLDWIDE

NOV. 8, 1977

Power transistors and thyristors depend heavily upon structural geometry to determine electrical properties. Yet manufacturers will use different configurations and

make unannounced changes—but keep the same JEDEC number. Limit specs may not change, but altered spec details frequently upset circuit operation. See p. 52.



Before You Read This Issue . . .
RENEW YOUR SUBSCRIPTION
Turn to card inside cover

Another Colorful Innovation...

Conductive Plastic Trimmers at Carbon Prices.

Just when you thought "low cost" also meant "low performance", along comes the dazzling new Bourns® Model 3355. Compare it to the CTS 201, Mepeco 46X or Piher PT15. Our revolutionary conductive plastic element vs. their carbon... fact is we outperform them all. To prove it, we spec important characteristics such as CRV at 1% and a TC of 500 PPM/°C... the others don't. And only the 3355 has board-wash capability, a UL-94V-1 flammability rating and an optional choice of nine rotor colors. The standard blue is priced at just 11¢ each (100,000 pieces)... about what you'd expect to pay for the lower performance carbon types.

Send today for complete details on a colorful new way to design in superior performance for your cost effective needs — the Model 3355 Trimmer. Direct or through your local distributor.

TRIMPOT PRODUCTS DIVISION, BOURNS, INC., 1200 Columbia Ave., Riverside, CA 92507. Phone: 714 781-5050 — TWX: 910 332-1252.

CATALOG SHEET SPECIFICATION COMPARISONS

CHARACTERISTIC	BOURNS 3355	CTS 201*	MEPCO 46X*	PIHER PT15*
Element	Conductive Plastic	Carbon	Carbon	Carbon
Temperature Coefficient	500 PPM/°C	No Spec	No Spec	1000 PPM/°C
Contact Resistance Variation	1.0% max.	No Spec	No Spec	No Spec
Power Rating	.25 W at 70°C	.25 W at 55°C	.25 W at 55°C	.25 W at 40°C
Flammability	UL-94V-1	No Spec	No Spec	UL-94
Board Wash Capability	Yes	No Spec	No Spec	No Spec

*Source: CTS Series 201 Data Sheet, Mepeco Data Sheet ME1004, Piher Data Sheet F-2002 Rev 7/73



International Marketing Affiliates: European Headquarters — Switzerland 042/23 22 42 • Belgium 02/218 2005 • France 01/2039633 • Germany 0711/24 29 36 • Italy 02/32 58 88 • Netherlands 70/87 44 00 • United Kingdom 01/572 6531 • Norway 2/71 18 72 • Sweden 764/20 110 • Japan 075/921 9111 • Australia 02/55-0411 03/95-9566 • Israel 77 71 15/6/7

For Immediate Application — Circle 130
For Future Application — Circle 230

SURPRISE!



Introducing HP's New Optically Coupled Line Receiver

Eliminate troublesome system ground loops and increase long distance communication noise immunity with HP's new easy-to-use optically coupled line receiver. An internal IC regulator serves as a line termination and allows direct connection to transmission lines without any additional components.

Use of a high-speed, high-gain output photo IC permits data rates in excess of 10 Mbits/second. An internal shield provides excellent common mode rejection even at these high data rates.

The HCPL-2602 is designed for high-speed data transmission applications such as computer-peripheral interface, instrumentation, and simplex/multiplex data transmission.

Priced at \$6.65* in quantities of 1000, the HCPL-2602 is in stock at any franchised distributor. In the U.S., contact Hall-Mark, Wilshire or the Wyle Distribution Group (Liberty-Elmar) for immediate delivery.

In Canada, just call Zentronics, Ltd. *U.S. Domestic price only

HEWLETT  PACKARD

1507 Page Mill Road, Palo Alto, California 94304

Did you get the message about our solid state SerenDIP relays?

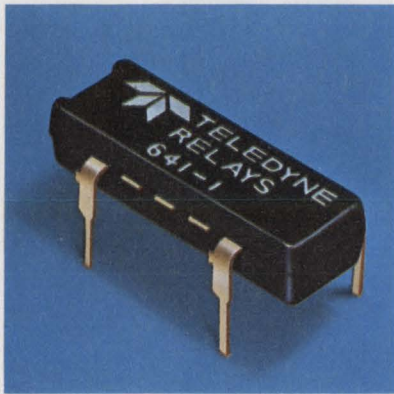

International telex communication switching systems often are expected to run on a 24-hour, seven-day shift. Continuous duty like that calls for dependable, long-life component reliability — the kind RCA requires from Teledyne SerenDIP® relays used in their trunk terminator modules. These all-solid-state DIP relays provide wear-free and bounce-free switching — features you don't get with electro-mechanical or reed relays.

What's more, our SerenDIP's offer high input/output isolation, low level logic input compatibility, and fast response time. And you get all of this in a low cost, low-profile TO-116 DIP package ready-made to replace any standard DIP reed relay. You also get your choice of output: bi-polar, AC (triac), or DC. There's lots more to a SerenDIP relay that you ought to know about. For detailed specs or applications assistance, contact your nearest Teledyne Relays sales office listed in EEM, Gold Book, or Electronic Buyers' Guide. You'll find we have the experience, products and technical support to meet all of your SSR needs.

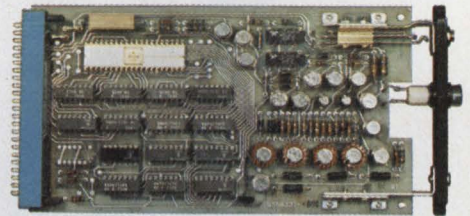

RCA Trunk Terminator Module



RCA CCT-3 Series
Telex Switching System
(Courtesy of RCA/Camden, N.J.)

 **TELEDYNE RELAYS**

3155 West El Segundo Boulevard, Hawthorne, California 90250
Telephone (213) 973-4545

CIRCLE NUMBER 3

NEWS

- 21 **News Scope**
- 26 **Radio receiver reaches 670 GHz** with quasioptics and new mixer mount.
- 27 **Standard Navy computer** has low power core memory.
- 28 **Shifting control to firmware** speeds computer operations.
- 30 **With new automobile radar** brakes, your car won't stop at every tree.
- 41 **Washington Report**

TECHNOLOGY

- 52 **FOCUS on power transistors and thyristors:** Despite the maturity of power semiconductors, specifications still abound with specsmanship and can lead to misunderstandings between user and manufacturer.
- 64 **Optical-fiber transmission links** offer a valuable alternative to conventional cables. You can easily lay out such a link with the right design aids.
- 72 **Heat switches the PTC thermistor.** And the large resistance swing of this positive tempco device makes it look almost like an ideal switch.
- 82 **Memory Technology: Part 3.** Break the 65-kbyte address barrier in microprocessor systems by using bank-switching and overlapping techniques.
- 88 **Let microprocessors communicate** directly with each other, register to register. When data exchange is moderate, it's often the simplest solution.
- 94 **Wilf Corrigan of Fairchild** speaks on aiming your engineers at objectives.
- 102 **Ideas for Design:**
Buffer circuit for line driver protects against shorts and ± 325 -V surges.
Circuit generates almost any sequence of fixed-width timing pulses.
Constant-bandwidth PLL tone decoder accepts wide range of input voltages.
- 108 **International Technology**

PRODUCTS

- 124 **Data Processing:** Firmware and software package shapes distributed systems network.
- 111 Micro/Mini Computing
- 116 ICs & Semiconductors
- 130 Power Sources
- 132 Microwaves & Lasers
- 134 Modules & Subassemblies
- 136 Components
- 140 Instrumentation
- 142 Packaging & Materials

DEPARTMENTS

- 47 **Editorial:** Roadwork
 - 7 Across the Desk
 - 144 Application Notes
 - 144 New Literature
 - 148 Vendors Report
 - 158 Advertiser's Index
 - 160 Product Index
 - 160 Information Retrieval Card
- Cover:** Photo by Bruce Hull, courtesy of RCA Solid State Div.

"Siliconix VMOS are down. Bipolars'

"VMOS power FETs, introduced by Siliconix in 1975, have always been better than bipolars—more rugged, more reliable, faster and simpler. Today, we're lowering our prices as we move further along the learning curve, and our economical plastic package brings superior VMOS technology within reach of all designers. At 96¢ apiece,* the new TO-202s will replace bipolars in a broad range of power applications, particularly in interfacing with computers and in telecommunications."

*VN46AF in quantities of 100-999

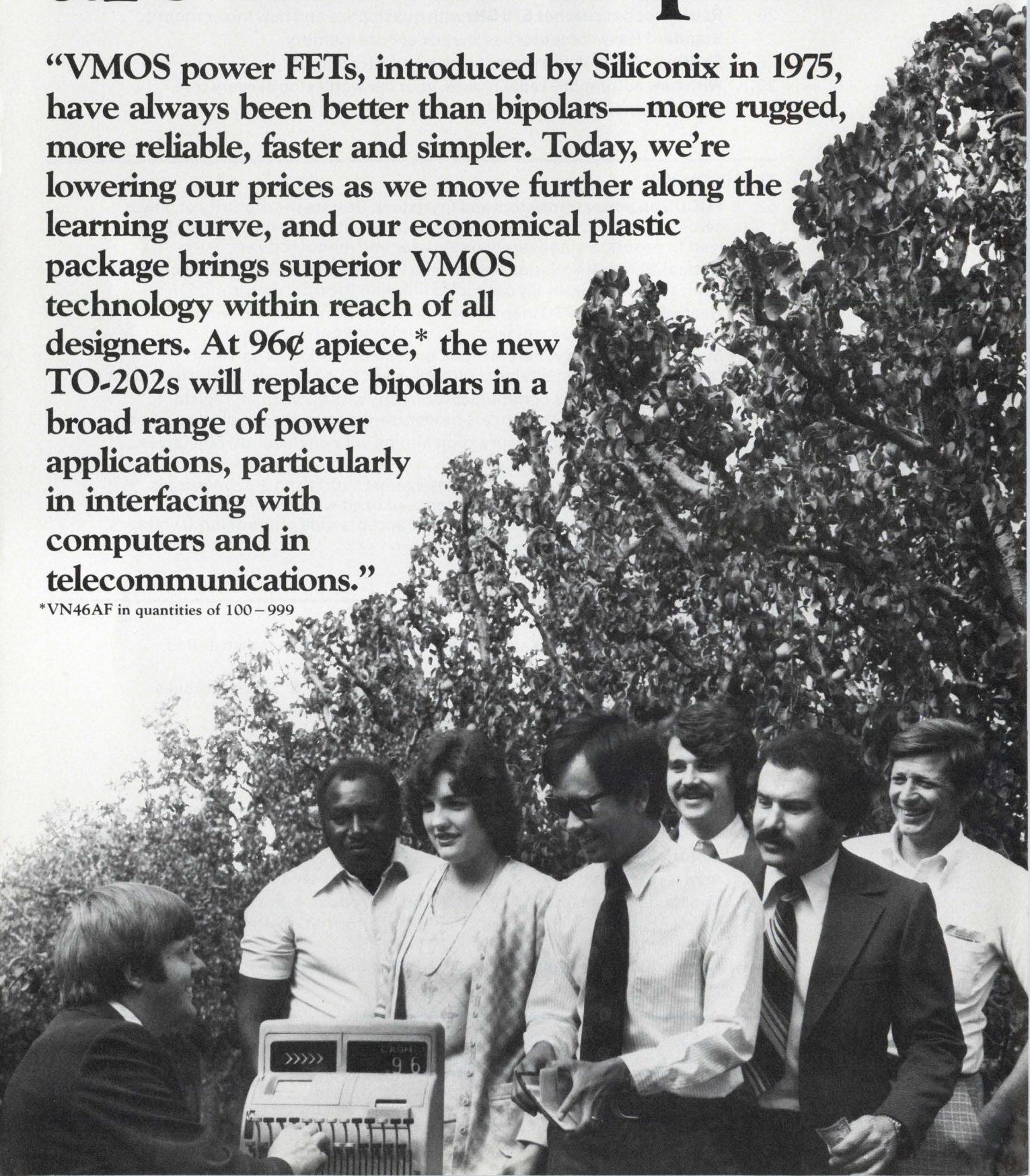

power FET prices time is up."

Siliconix VMOS power FETs in plastic: TO-202 package						Other VMOS power FETs introduced by Siliconix are also available:				
Part #	BV_{DSS}	$V_{DS(on)}$ ($I_D=1$ Amp)	Price:1-29	31-99	100-999	Part #	Package	P_{DISS}	BV_{DSS}	$V_{DS(on)}$ ($I_D=1.0$ Amps)
VN46AF	40	3.0V	\$1.33	\$1.12	\$0.96	2N6656	TO-3	25W	35	1.8V
VN66AF	60	3.0V	\$1.39	\$1.16	\$1.00	2N6657	TO-3	25W	60	3.0V
VN88AF	80	4.0V	\$1.54	\$1.29	\$1.10	2N6658	TO-3	25W	90	4.0V
All three devices are guaranteed over the temperature range of -55°C to 150°C ; their maximum power dissipation is 12.5 watts, and their current rating is 2.0 amperes.						2N6659	TO-39	6.25W	35	1.8V
						2N6660	TO-39	6.25W	60	3.0V
						2N6661	TO-39	6.25W	90	4.0V

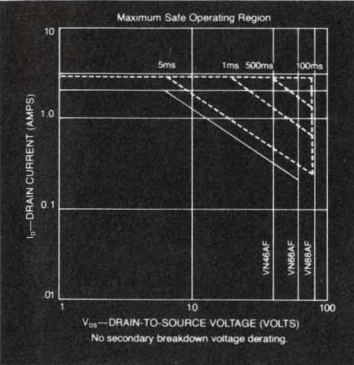

“Until 1975, MOS field-effect transistors (FETs) were restricted to small-signal, low-power applications. To control high currents, designers used bipolar devices. Then Siliconix, using Vertical MOS technology, introduced the VMOS power FET — combining the reliability of FETs with the power of bipolars.

“Today, Siliconix’ new plastic TO-202 package means that VMOS power FETs are not only superior to bipolars in performance, but also competitive with them in price. They’ll simplify designs and reduce component count in most systems because they eliminate pre-amplifiers, driver transistors, and external protective circuitry required for bipolars. And they can be inserted by machine, a time- and cost-saving advantage in high volume production.

“Anyone who has designed with bipolars knows the failures that can result from thermal runaway, secondary breakdown and current hogging. You don’t have to worry about these problems with VMOS power FETs; their positive temperature coefficient eliminates hot-spotting and provides uniform current density, making them fail-safe. Consider how this inherent reliability will reduce your system interruptions and maintenance costs. And VMOS power FETs are faster than bipolars in switching operations — as much as 100 times faster. With all these advantages packed into the low-cost TO-202, you’ll be able to eliminate bipolars’ problems completely from many system designs.

“The high input impedance of VMOS and its threshold voltage range allow it to interface directly with CMOS, MOS and TTL logic families. And the VMOS power FET is the only interface device with a switching time comparable to that of ECL, so it will interface with a simple

level shift — without losing speed. These features make the TO-202s ideal for data processing applications: computer peripherals, micro- and minicomputer systems, and process control equipment. They’re also ideal for use in telecommunications: as telephone relay replacements, Touch-Tone muting switches, audio amplifiers, central office systems and analog switches.

“Our new line of VMOS power FETs in plastic may mean the end of the line for bipolars. We want you to discover for yourself how they can improve system design, so use the coupon to send for our detailed brochure. To order parts, contact any of our franchised distributors: Alliance, Century, Components Plus, Future, Hamilton/Avnet, Industrial Components Inc., Pioneer Standard, Pioneer Washington, Quality Components, Semiconductor Specialists, Wilshire, Wyle/Elmar, Wyle/Liberty, or RAE.”

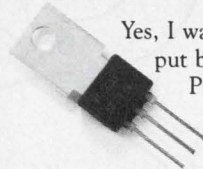

Yes, I want to find out for myself how Siliconix put bipolars on the list of endangered species. Please send me your brochure.

Name/title _____
 Company _____
 Address _____
 City/State/Zip _____

Siliconix Incorporated,
 2201 Laurelwood Road, Santa Clara, CA 95054,
 (408) 246-8000.



CAN YOUR POWER SUPPLY RUN THE GAUNTLET?

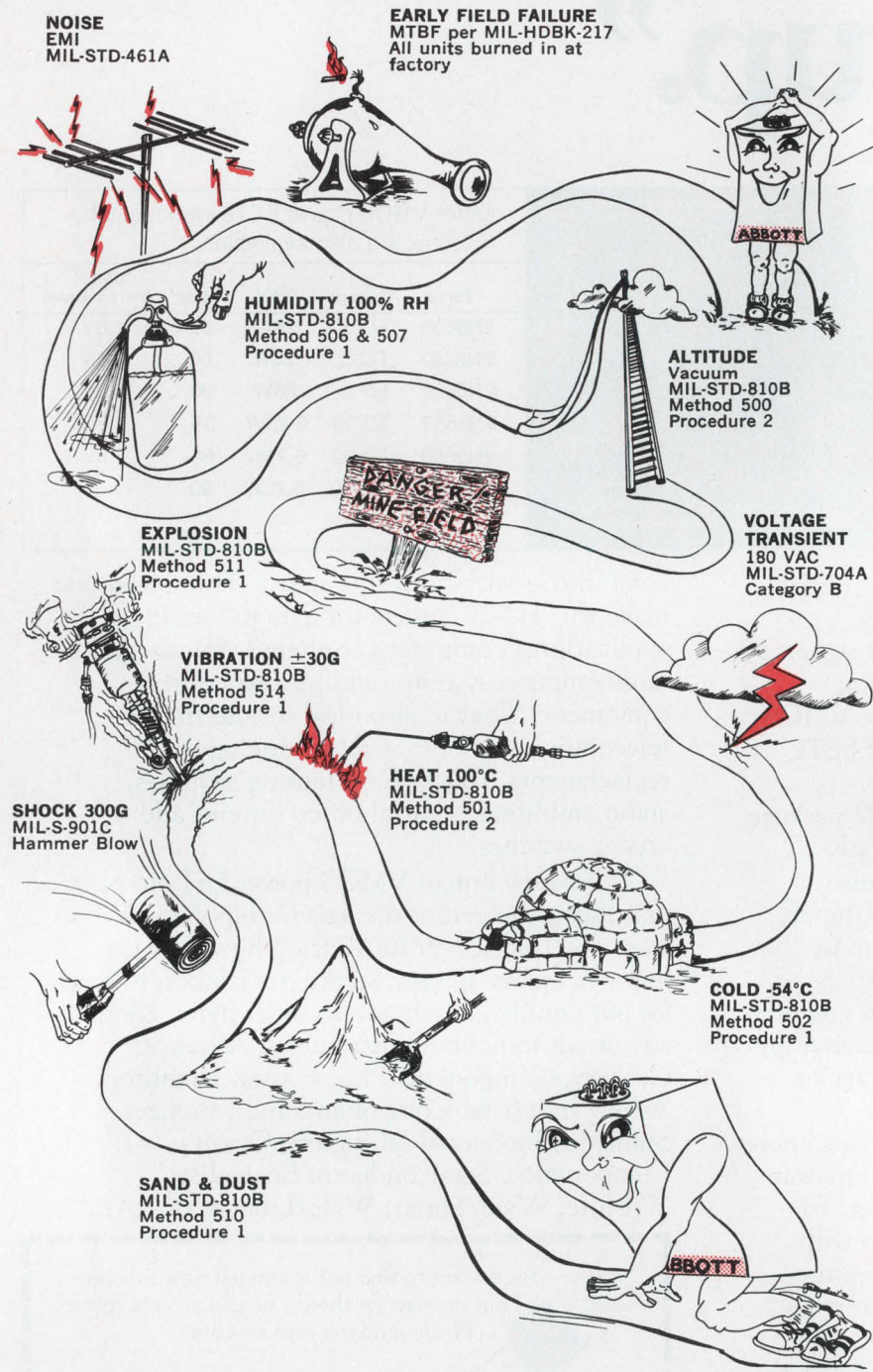

Abbott's hermetically sealed power supplies have run this gauntlet many times. Each and every unit is subjected to rigid quality control procedures and extensive testing at our factory to insure that it will pass the most important test — your gauntlet.

Please see pages 1836-1848 of your 1976-77 EEM (ELECTRON ENGINEERS MASTER Catalog) or pages 676-682 Volume 2 of your 1976-77 GOLD BOOK for information on Abbott Modules.

Send for our new 60 page catalog

abbott transistor
LABORATORIES, INCORPORATED

GENERAL OFFICES
5200 W. Jefferson Blvd.
Los Angeles, CA. 90016
(213) 936-8185
Telex 69-1398

EASTERN OFFICES
1224 Anderson Ave.
Fort Lee, N.J. 07024
(201) 224-6900
Telex 13-5332

CIRCLE NUMBER 5

Sr. Vice President, Publisher
Peter Coley

Editors

Editorial Offices
50 Essex St.
Rochelle Park, NJ 07662
(201) 843-0550
TWX: 710-990-5071
(HAYDENPUB ROPK)
Cable: Haydenpubs Rochellepark

Editor-in-Chief George Rostky

Managing Editors:
Ralph Dobriner
Michael Elphick

Senior Associate Editor
Stanley Runyon

Associate Editors:
Sid Adlerstein
Dave Bursky
Morris Grossman
Gene Heftman
Andy Santoni
Max Schindler

Contributing Editors:
Peter N. Budzilovich, Jules H. Gilder,
Sidney Moskowitz, Nathan Sussman

Editorial Field Offices

East

Jim McDermott, Eastern Editor
P.O. Box 272
Easthampton, MA 01027
(413) 527-3632

West

Dick Hackmeister, Western Editor
8939 S. Sepulveda Blvd., Suite 414
Los Angeles, CA 90045
(213) 641-6544
TWX: 1-910-328-7240
Dave Barnes, Western Editor
465 S. Mathilda, Suite 302
Sunnyvale, CA 94086
(408) 736-6667

Editorial Production

Marjorie A. Duffy, Production Editor
James Keane, Copy Editor

Art

Art Director, William Kelly
Richard Luce, Anthony J. Fischetto

Production

Manager, Dollie S. Viebig
Helen De Polo, Nancy Hurey

Circulation

Director, Barbara Freundlich

Information Retrieval

Paula Greenleaf

Advertising Promotion

Judith Nappo

Reprints

Maxine Correal

Across the desk

Me an editor?

If you'd like to be among the first to know (and write about) what's going on in the electronics industry, you might enjoy being an editor.

We have openings at our home office in Rochelle Park, NJ. Call Ralph Dobriner at (201) 843-0550.

Computer correction

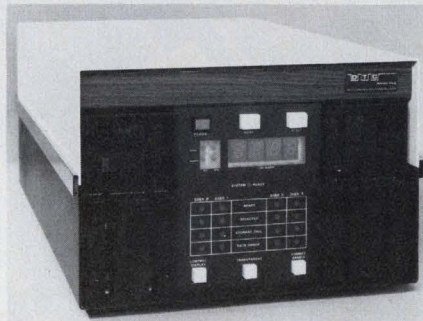

We ran the wrong caption with the photo that appeared on p. 28 of ED No. 13, June 21, 1977. The product shown is *not* a 64-k dynamic memory board. It is the MICROFILE computer from Data Terminals and Communications, Campbell, CA. The unit includes an 8080A microprocessor, two or four flexible discs with storage of 300 k characters per disc, 7 k of ROM, and 8 k of RAM expandable in 16 k-increments to 56 k. The computer sells for \$3650.

Burping circuit generates gas

The Idea for Design, "Timing Circuit Burps Battery" by John Okolowicz (ED No. 12, June 7, 1977, p. 116) was a very entertaining article. The positive attitude of its author is clear where he describes a momentary discharge of a

battery as "...a negative charge is dumped into the battery."

However, since the intended polarity of C_2 and C_3 is unclear, I can't be sure just when these capacitors will explode. Is it before, or is it after the relay K_1 , is activated by the 555 timer and the contacts of the former are fused permanently in the burp mode?

Perhaps, with a really run-down battery, the power transformer burns out first.

*William A. Kinghorn
Senior Engineer*

Auditory Devices
Telex Communications Inc.
9600 Aldrich Ave. South
Minneapolis, MN 55420

Mr. Okolowicz replies:

Like a burping battery, I believe Mr. Kinghorn is merely passing gas. True, capacitors C_2 and C_3 should have been shown back-to-back with their positive terminals tied together. This is Electronic Design's error, but one that should be readily recognized by anyone trained in the electronic arts. The circuit has worked well for me. It is self-limiting to a safe relay-contact current.

It must be remembered that electrolytic capacitors have relatively large equivalent series resistances. Furthermore, forward current must traverse the reverse resistance of one of the capacitors. More information on this subject can be obtained from Sprague Technical Papers No. TP-68-7 and TP68-3.

(continued on page 14)

Electronic Design welcomes the opinions of its readers on the issues raised in the magazine's editorial columns. Address letters to Managing Editor, Electronic Design, 50 Essex St., Rochelle Park, NJ 07662. Try to keep letters under 200 words. Letters must be signed. Names will be withheld upon request.



DIP
ISOLATORS

DIP
ISOLATORS
DIP
ISOLATORS

OPTRON's complete line of optically coupled plastic DIP isolators offers immediate availability of standard devices for almost every application ... plus competitive pricing, high reliability and excellent customer service.

Check these features and choose the device best suited for your application.



GENERAL PURPOSE

A full selection of DIP isolators with transistor and darlington outputs to match all popular industry standards. Current transfer ratios range from 2.0% to 500%.

HIGH VOLTAGE

For applications requiring an interface with high voltage circuits, select the OPI 6000 DIP isolator with a 300 volt output transistor.



AC OPERATION

The OPI 2500 DIP isolator features two input LED's operating in inverse parallel and is ideal for applications where the LED is driven from an AC line.

CUSTOM SELECTION

If your application demands "something a little different," OPTRON specializes in DIP isolators to meet special customer requirements.



For reliability data and technical specifications on OPTRON's complete line of plastic DIP isolators, contact your nearest OPTRON sales representative or the factory direct.



OPTRON, INC.

1201 Tappan Circle
Carrollton, Texas 75006, U.S.A.
TWX-910-860-5958
214/242-6571

CIRCLE NUMBER 6

single chip microcomputer

The 8748.

three programmable 8-bit I/O ports, 8 additional control/timing lines, programmable interval timer/event counter, priority interrupts, system clock generator and a full set of system controls. It's a single chip solution to a wide variety of applications, yet it's fully expandable by adding compatible MCS-80™/MCS-85™ I/O chips and Intel® standard memories.

There's also a new 8035 microcomputer that is exactly like the 8748/8048 but without resident program memory. It enables you to precisely match system memory size to your needs, using external ROM or EPROM.

The 8748 is the best supported single chip microcomputer you can buy. To speed development there's the Intel® Microcomputer Development System with assembly language programming, symbolic debugging, and full EPROM programming capability. The ICE-48™ In-Circuit Emulation module simplifies hardware/software integration and debugging. And the Intel Prompt-48™ Design Aid is a low cost, stand alone alternative for 8748 programming, simulation and debugging. Intel supports you from prototype to production with development software, documentation, training and application assistance.

The new 8748 will give manufacturers of instruments, terminals, communications equipment, controllers, electronic games, automotive products, home appliances and hundreds of other products the competitive edge. It will help you get better products to market ahead of the competition at lower cost.

The 8748, 8035 and all compatible components can be purchased now from franchised Intel distributors: Almac/Stroum, Components Specialties, Cramer, Elmar, Hamilton/Avnet, Harvey Electronics, Industrial Components, Liberty, Pioneer, Sheridan, L.A. Varah, or Zentronics.

Or, for a copy of our single-chip microcomputer brochure write: Intel Corporation, 3065 Bowers Avenue, Santa Clara, California 95051. Telephone: (408) 246-7501.

Part No.	Description	Availability
MCS-48 Components		
8748	Single chip μ C with 1K bytes EPROM	NOW
8048	Single chip μ C with 1K bytes masked ROM	NOW
8035	Single chip μ C without resident program memory	NOW
8243	I/O Expander with 16 high current drive I/O lines	NOW
8355	ROM, 2K bytes, 16 I/O lines	NOW
8155	RAM, 256 bytes, 22 I/O lines and timer	NOW
Compatible MCS-80/85 Components		
2316E	Standard ROM, 2K \times 8, 450 ns	NOW
2708	Standard EPROM, 1K \times 8, 450 ns, light erasable	NOW
2716	Standard EPROM, 2K \times 8, 450 ns, light erasable	NOW
2111A-4	Standard RAM, 256 \times 4, 450 ns, common I/O	NOW
2101A-4	Standard RAM, 256 \times 4, 450 ns, standard I/O	NOW
5101	Standard RAM, 256 \times 4, 850 ns CMOS	NOW
8255A	Programmable Peripheral Interface	NOW
8251	Programmable Communications Interface	NOW
8214	Priority Interrupt Controller	NOW
8253	Programmable Interval Timer	NOW
8259	Programmable Interrupt Controller	NOW
8279	Programmable Keyboard/Display Controller	NOW



intel® delivers.

If you're this kind of systems OEM,

You're building complex turnkey projects.

You need more than "iron".

You know that your best buy is not a mixed bag of bottom-priced components, but a proved system, with all essential support, from a supplier who becomes your working partner.

we're your kind of computer systems source.

We're different. Instead of selling you black boxes, we supply complete computer systems. We've been doing this for seven years.

We have a state-of-the-art line of standard processors, memories, I/O devices, terminals and other peripherals. Plus proved system operating software that speeds

Two Modcomp IV and four Modcomp II processors are the center of a new digital traffic control system for the city of Baltimore, engineered by TRW Inc. The TRW system has the capacity to control signals at 1200 key intersections in the city, and also provide surveillance of a five-mile section of the Jones Falls Expressway.

your application programming. Advanced network and transaction software. And we'll quote special hardware and software where needed.

You'll like our systems engineering help, because we understand system problems. And we don't love you and leave you, but supply full support — field service, documentation, personnel training, even sales support.

What you get from MODCOMP is a fully checked-out system, factory burned-in, ready to bring on-line quickly and efficiently.

Get the full MODCOMP OEM story, by asking for the brochure, "Power Tools For Building OEM Systems". Modular Computer Systems Inc., 1650 W. McNab Road, Fort Lauderdale, Fla. 33309. (305) 974-1380.

MODCOMP

The systems store.

European Headquarters:

Export House, Woking,
Surrey, England

Phone: (04862) 71471

CIRCLE NUMBER 47



Complete instructions on how to assemble a data acquisition system:

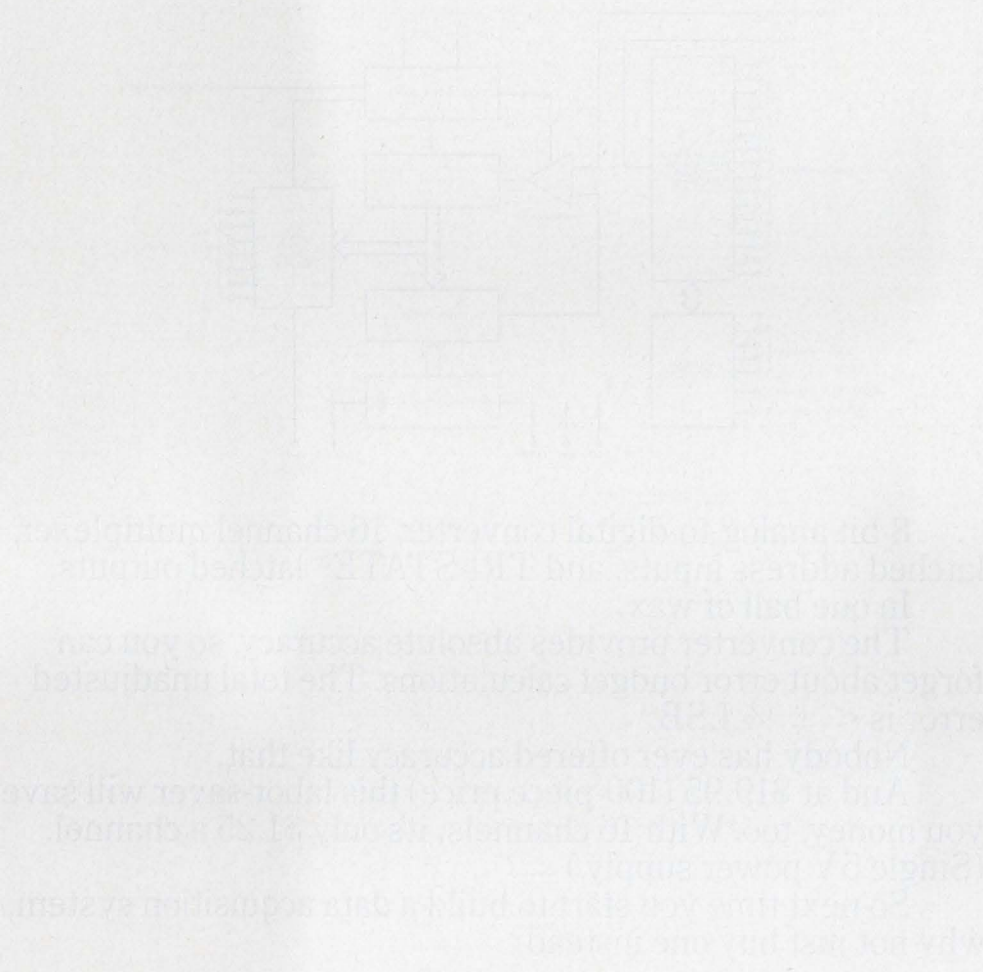

Buy National Semiconductor's new ADC0816 and plug it in.
It's a complete data acquisition system on a chip. (Details on reverse.)

Complete details on the data acquisition system on a chip.

Introducing a revolutionary new product from National.
The first data acquisition system on a chip.
ADC0816.

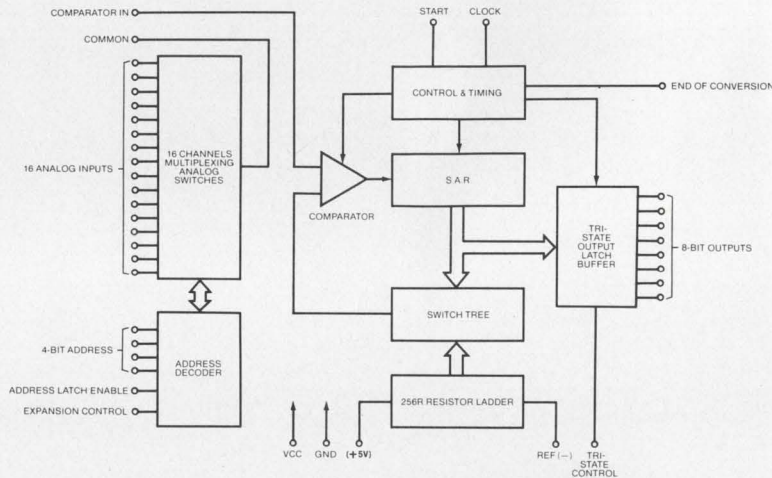

8-bit analog-to-digital converter, 16-channel multiplexer, latched address inputs, and TRI-STATE[®] latched outputs.

In one ball of wax.

The converter provides absolute accuracy, so you can forget about error budget calculations. The total unadjusted error is $< \pm \frac{1}{2}$ LSB.

Nobody has ever offered accuracy like that.

And at \$19.95 (100-piece price) this labor-saver will save you money, too. With 16 channels, it's only \$1.25 a channel. (Single 5V power supply.)

So next time you start to build a data acquisition system, why not just buy one instead?

National Semiconductor, 2900 Semiconductor Drive, Santa Clara, CA 85051

Gentlemen:

Please send data sheets on your:

data acquisition system references microprocessors

Name _____

Company _____ Address _____

City _____ State _____ Zip _____

ED 11/8

 **National Semiconductor**

POWERMINI'S FOR LOGIC OR OP AMPS



Terminal strip input/output connections on these miniature power modules eliminate the need for sockets or soldering. They mount in an area only 3.5 x 2.5". Ratings: 5 volt models to 2.5 amps, 15 volts to 5 amps. Other models from 1 to 75 volts, all with 3-day shipment guaranteed.

NEED A POWER SYSTEM?

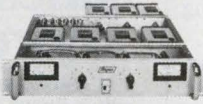

Order multiple output power systems without searching through a catalog, preparing mechanical layouts, item-by-item pricing and detailed purchase requisitions. Instead, call Acopian. We'll listen to your needs, quote a firm price, and then ship your built-to-order system, fully wired and tested, in just 9 days.

POWER FOR YOUR μ PROCESSOR



Single, dual, and triple output power supplies in a broad selection of output voltage combinations. Output current ratings from 20ma to 60 amps. Various package styles suitable for virtually every application. Any module you select will be shipped within 3 days; rack mounting models, within 9 days.

MATCHED OR DISSIMILAR DUAL OUTPUT



Select the combination of matched or dissimilar outputs that you require. Hundreds of ratings available, from 1.5 to 150 volts. Outputs are isolated, and may be used in the same or opposite polarities. Acopian's 3-day shipment promise applies for any combination.

HIGHLY ISOLATED POWER



For applications requiring a power supply with unusually high isolation, such as for powering strain gage or other transducer circuits. Acopian offers models with ratings from 5 to 36 volts. Input-output isolation: 10,000 megohms minimum, 1 pF maximum. Guaranteed 3-day shipment.

POWER FOR RELAYS AND DISPLAYS



Drive relays, lamps, small motors and similar loads with low-cost Acopian unregulated power modules. Built-in fusing protects against overloads or shorts. Series U models use terminal strip connections. Plug-in modules mount in standard octal sockets; many have adjustable outputs. Guaranteed 3-day shipment.

RACK MOUNT POWER ...TO 60 AMPS



Designed for mounting in standard 19" RETMA cabinet racks, these power supplies are available in 76 different output ratings from 1 to 50 volts, and from 5 to 60 amps. Regulation, $\pm 0.05\%$ or better; ripple, 1 mv rms or better. Options include metering and overvoltage protection. Shipment, 9 days after receipt of your order.

SOLDER TERMINAL MODULES



For applications where hard wiring is desired, Acopian offers modules with solder terminals. Included are single output models (regulated and unregulated) duals with two like or dissimilar voltages and high isolation supplies. Guaranteed 3-day shipment.

MULTIPLE VOLTAGES FOR PCB'S



Simplify pc board layout with multiple output power minis. Duals supply two isolated like or dissimilar outputs, 1 to 28 volts each. Op amp supplies provide 12 or 15 volts. Triples have two balanced, tracking outputs, a third for powering other circuits. Guaranteed 3-day shipment.

MIL-TESTED PLUG-IN POWER

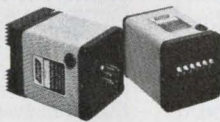

MIL-tested power supplies withstand unusually severe environmental conditions. These extended-temperature plug-in modules exceed MIL specs for humidity, altitude, vibration and shock. Hundreds of single output models, thousands of dual output combinations, all guaranteed for 3-day shipment.

BENCHTOP POWER ...FROM \$99



Reliable yet low-cost power supplies for circuit development and component evaluation. Single dual and triple output models. Ratings from 0.7 to 0-50 volts. All have adjustable current limiting, coarse and fine voltage adjustments and two meters. They may be stacked to conserve bench space. Regulation, 0.01% or 2 mv. Ripple, 0.25 mv rms.

SUPPLIES THAT FIT IN THIN SPACES



Measuring only 1.68" high, Acopian narrow-profile power supplies fit where many others cannot. Available in a wide range of ratings from 1 to 150 volts to 4 amps. Regulation to 0.005%. Tracking dual output models for op amps also available. Guaranteed 3-day shipment.

SINGLE, DUAL PLUG-IN POWER



A plug-in power module can be installed in seconds. Simply plug it into a standard octal-type socket. Single output models from 1 to 200 volts. Duals combining two matched or dissimilar outputs in one case available in over 10,000 combinations. Warranty: 5 years. Shipment: 3 days.

ACOPIAN

POWER SUPPLY CATALOG



Write for your copy of the Acopian 48-page catalog



Corp., Easton, Pennsylvania 18042 • Telephone (215) 258-5441

CIRCLE NUMBER 30

Across the desk

(continued from page 7)

Misplaced misplaced Caption

We are indebted (well, maybe a little) to J. Allen Oliver of Silver Spring, MD, who noticed the upside-down picture on page 21 of the July 19, 1977 issue (ED No. 15) and offered the following:

"Sorry. That's the Production Department's 'Pianocorder System Installed in an Upside Down Piano,' which now hangs above Ms. Duffy's desk."

Ms. Duffy is our Editorial Production Lady. She insists that the picture was sent rightside up to the printer, whom we routinely blame for such upsets. The picture here is, in fact, rightside up (we hope).

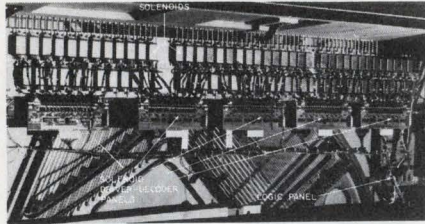

A 'subtle' suggestion

I recall from my undergraduate days the avoidance of many detailed analyses by invoking the maxim: "It is

Misplaced Caption Dept.

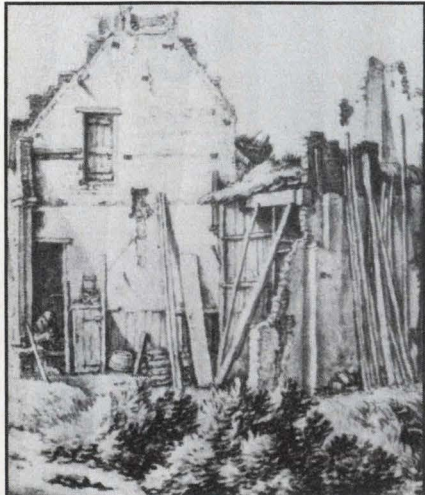

And this is where we used to test those big electrolytic capacitors.

Sorry. That's Herman Sattleven's "Ruins," which hangs in the National Gallery of Ireland in Dublin.

intuitively obvious to the most casual observer." So, too, are the points of your editorials. You write well, but Charlie is becoming an abject bore. Please turn your talents to something more subtle.

Steven M. Rudnick

3 Haven Rd.
Medfield, MA 02052

Sons of laetrile

Your July 19 editorial on "The Professionals" (ED No. 15, p. 51) was excellent. Although you specifically mentioned the FDA in the case of laetrile, the bureaucracy's role in engineering decisions is another parallel that could be drawn. The bureaucrats have already given us an automobile that is designed by decree, not based on sound engineering decisions. The same thing is in store for all engineering activities if bills such as S 825 are passed. This bill would put the government in control of the voluntary standards now being formulated by organizations such as NEMA and ASHRAE. This would result in some M.A. in political science or sociology telling the industry what the standards should be for ICs.

D.J. Morroni
President

Electric Equipment & Engineering Co.
40 W. 49th Ave.
P.O. Box 16383
Denver, CO 80216

As a faithful reader of both the articles and editorials in ELECTRONIC DESIGN, I was greatly disappointed to see George Rostky's editorial, "The Professionals." The pages of an excellent electronics magazine are no place to endorse a highly controversial compound (allegedly a vitamin). ELECTRONIC DESIGN usually does not accept either manufacturers' claims or glowing testimonials without further testing.

There is no objective test of good engineering management, and George's insight there is appreciated. There are, however, objective tests for drugs, and laetrile does very badly in all of them. Perhaps the FDA should create a new classification: "Placebo, effective in combination with faith." For an excellent review of the current evidence on laetrile, see *Science News*, No. 6, Aug. 6, 1977.

David Griesinger

David Griesinger Recordings
86 Washington Ave.
Cambridge, MA 02140

Call your nearest ISC sales representative.

ALABAMA: Huntsville
W. A. Brown Inst. Inc. 205/539-4411
ARIZONA: Phoenix
Thorson Co. 602/956-5300
CALIFORNIA: Goleta
Thorson Co. 805/964-8751
CALIFORNIA: Los Angeles
Thorson Co. 213/476-1241
CALIFORNIA: Mountain View
Thorson Co. 415/964-9300
CALIFORNIA: San Diego
Thorson Co. 714/298-8385
CALIFORNIA: Tustin
Thorson Co. 714/544-5121
COLORADO: Denver
Thorson Co. 303/759-0809
FLORIDA: Ft. Lauderdale
W. A. Brown Inst. Inc. 305/776-4800
FLORIDA: Melbourne
W. A. Brown Inst. Inc. 305/723-0766
FLORIDA: Orlando
W. A. Brown Inst. Inc. 305/425-5505
FLORIDA: Valparaiso
W. A. Brown Inst. Inc. 904/678-7932
GEORGIA: Atlanta
W. A. Brown Inst. Inc. 404/939-1674
ILLINOIS: Arlington Hts.
Future Systems 312/640-6091
LOUISIANA: Gretna
W. A. Brown Inst. Inc. 504/366-5766
MARYLAND: Bethesda
Bartlett Assoc. 301/656-3061
MASSACHUSETTS: Framingham
Bartlett Assoc. 617/879-7530
MICHIGAN: Madison Hts.
WKM Associates 313/588-2300
NEW MEXICO: Albuquerque
Thorson Co. 505/265-5655
NEW YORK: White Plains
Bartlett Assoc. 914/949-6476
NORTH CAROLINA: Durham
W. A. Brown Inst. Inc. 919/682-2383
OHIO: Cleveland
WKM Associates 216/267-0445
OKLAHOMA: Norman
Data Marketing Assoc. 405/364-8320
PENNSYLVANIA: Pittsburgh
WKM Associates 412/892-2953
PENNSYLVANIA: Wayne
Bartlett Assoc. 215/688-7325
SOUTH CAROLINA: Columbia
W. A. Brown Inst. Inc. 803/798-3297
TENNESSEE: Knoxville
McCain Elec. Equip. 615/584-8411
TEXAS: Austin
Data Marketing Assoc. 512/451-5174
TEXAS: Dallas
Data Marketing Assoc. 214/661-0300
TEXAS: Houston
Data Marketing Assoc. 713/780-2511
TEXAS: San Antonio
Data Marketing Assoc. 512/828-0937
WASHINGTON: Bellevue
Thorson Co. 206/455-9180
AUSTRALIA: Mt. Waverly, Victoria
Anderson Digital Elec. 03-543-2077
CANADA: Montreal
Cantec Rep. 514/620-3121
CANADA: Ottawa
Cantec Rep. 613/225-0363
CANADA: Toronto
Cantec Rep. 416/624-9696
EUROPE: England
Techex, Ltd. 0202-293-115
EUROPE: France
Peritex 749-40-37
EUROPE: Switzerland
Interrest, AG 031-224481
JAPAN: Tokyo
Munzing International 586-2701



Intelligent Systems Corp.

\$995



Unretouched
photograph
of screen

Get the jump on your competition without outspending your competition.

We're Intelligent Systems Corporation, and we've just lowered the price of our Intecolor 8001 to \$995. So now you can upgrade the terminals in the systems you're marketing to color at black and white prices.

The fact is that the Intecolor 8001 has the best price-performance ratio of any intelligent data entry terminal on the market—color or black and white. And that can really add some punch to your sales story. So can color, not because it looks better, but because it

communicates better than black and white.

And if you're marketing your systems by promoting the stand-alone capabilities of your terminals, we've got a list of options that'll give you just about any degree of sophistication you want. Including disk storage devices, bi-directional desk-top line printers and a brand new 2708/2716 PROM programmer.

Contact the ISC rep nearest you. We guarantee delivery of your Intecolor 8001 evaluation unit for \$995 (cash-with-order) within 30 days or your money back. Or if you've seen

the Intecolor 8001 in action and you're already sold on the price and performance, we'll give you the same \$995 price for orders of 100 units or more. Get the jump on your competition without outspending your competition. Get the Intecolor 8001.



Intelligent Systems Corp.

5965 Peachtree Corners East
Norcross, Georgia 30071
Telephone 404-449-5961 TWX: 810-766-1581

ComputerAutomation's NAKED MINI® 4/10 is the most exciting spread we've ever dished up: a high-speed, versatile, 16-bit processor; up to 4K words of RAM/PROM memory, and four distributed I/O channels. All on a single board. And this powerful, multi-register minicomputer sells for micro prices.

Value, however, is a lot of things. Such as performance, versatility, and a faster, lower cost way of getting a product to market. For the 4/10, your real savings just begin to start with the sale price. Its large instruction set (including multiply/divide as standard) pays off with exceptional programming versatility, faster development, less memory used. Options include floating-point instructions and double-register shifts.

Its four distributed I/O channels are another money saver, cutting interfacing costs by up to half. Our unique Intelligent Cables (19 available) give you interface capability with a broad variety of standard and nonstandard peripheral devices. Distributed I/O has other advantages. Its auto I/O instructions are easier to program, take less memory, and execute faster than traditional programmed I/O. And it has the advantages of DMA at about half the cost.

SMORGA

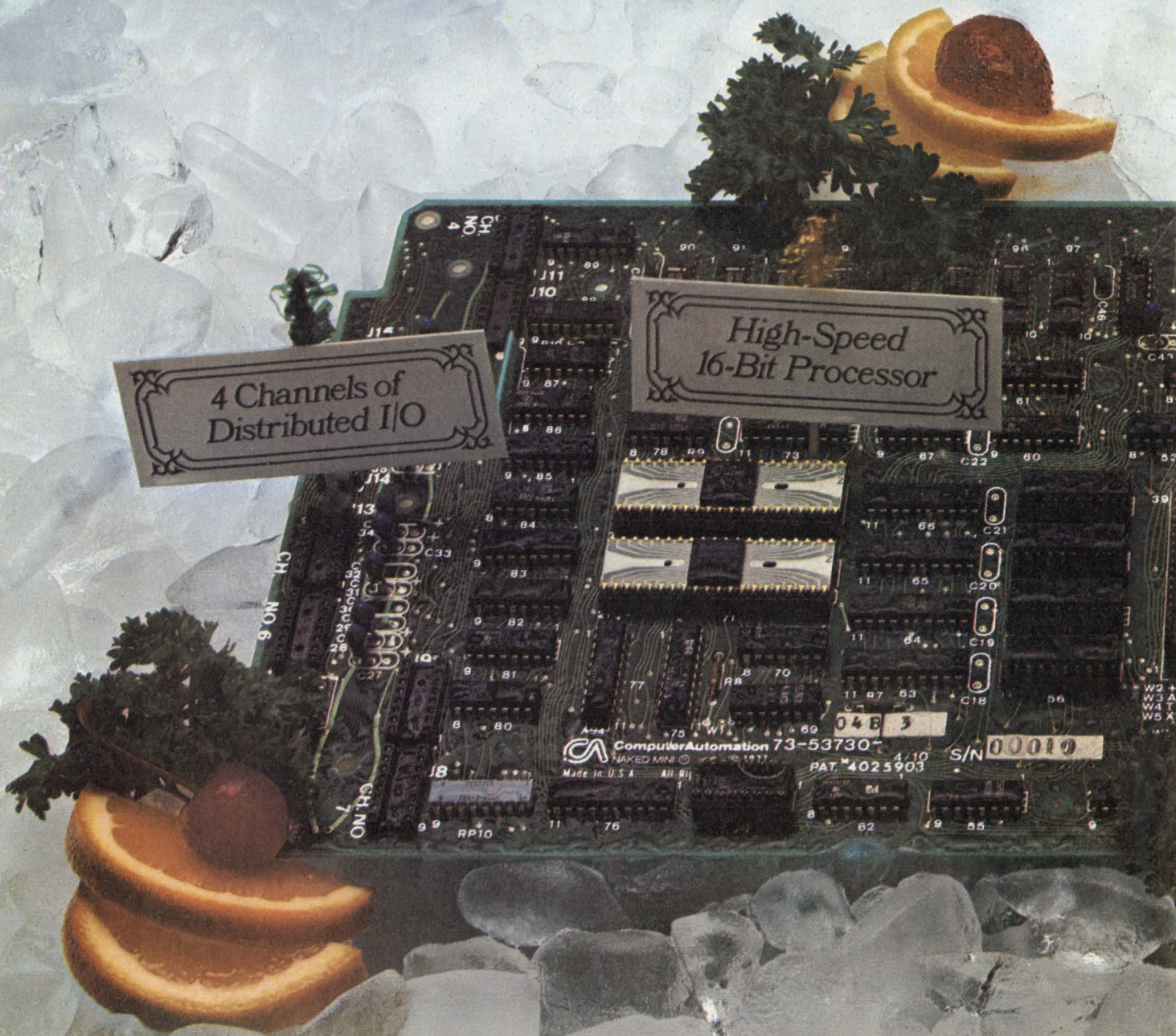

The 4/10 has 64K-word addressing and a MAXI-BUS that allows interfacing with the wide variety of interchangeable memories and I/O controllers in the NAKED MINI 4 family.

What about software? It's one of the 4/10's real strengths. Not only a wide range of software, but also software optimized individually for both development and execution needs.

Available software ranges from the simplest—a memory-based system that runs in as few as 4K

words—through the most sophisticated, a full-blown, disk operating system that supports FORTRAN IV, BASIC, PASCAL, and MACRO 4 assembler.

In terms of hardware and software, the 4/10 is fully compatible with its higher performance brothers, the 4/30 and 4/90.

Okay, we've served up our new 4/10 mini with lots of standard and optional hors d'oeuvres. Still hungry for information? Contact Department 1161, NAKED MINI Division, 18651 Von Karman, Irvine, CA 92713, (714) 833-8830, for our new brochure. It's quite a bit of food for thought.

SBOARD.



ComputerAutomation
Naked Mini. Division

CIRCLE NUMBER 12



NAKED MINI products are sold only under volume purchase agreements.

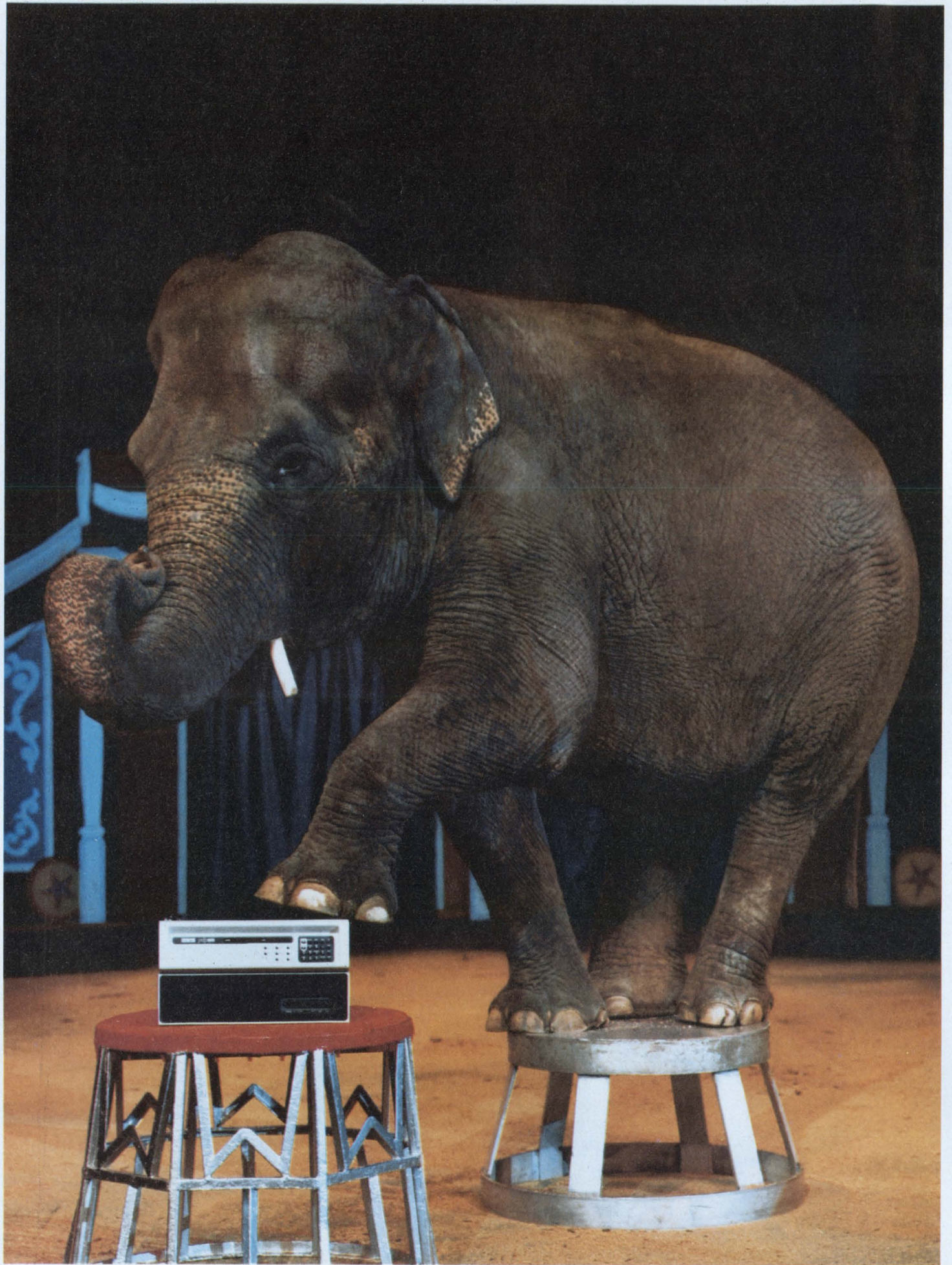

Digital announces a PDP-8 with an enormous memory.

Something big has just happened to the world's most famous small computer. In fact, something enormous.

Digital has just put 128K of memory into the PDP-8.

This act is brought to you by a powerful new memory management option called KT8-A. And by two new MOS memory modules that fit large amounts of memory into small amounts of space. Simply by adding these 16K or 32K modules in whatever combination you choose, you now expand your PDP-8/A into something bigger. What's even better, you can mix MOS and core. And that means you can protect your program in non-volatile core while you expand your data base in MOS.

And thanks to the KT8-A all this memory is under new management. Not only does the KT8-A let you address up to 128K words of memory, but it also offers you memory relocation and memory protection, while asking little in operating system overhead so you get faster system performance.

What's the cost of these enormous advancements? That's the next attraction.

The new PDP-8A MOS memory models are available at prices that are as crowd-pleasing as their performance. For a 16K 8A205 you'll pay as little as \$3900 (quan. 1). 8A425 with 64K

is as low as \$11,000. And the top of the line 8A625 with 128K is yours for as little as \$18,050.

They're the new big-memory Eights from Digital. Step right up.

Large memories aren't our only new trick.

New hardware and software improvements are also in the PDP-8 spotlight.

The VK8-A is a new low cost PDP-8A option that provides high quality video output plus keyboard and printer interfaces. Video character generation uses a super-sharp 9x9 dot matrix for high resolution on single or multiple CRT monitors up to one thousand feet away.

Also new for PDP-8 users is MACREL/LINKER — a sophisticated assembler with MACRO facilities that lets you implement, expand and update your system faster while reducing software development time.

And last but not least there's DECNET 8 — a series of software protocols that let you

form your own PDP-8 network.

The PDP-8. Bigger. Smaller. And better than ever.

A short while ago, we made big news with DECstation 78. A low-end system that set new highs for ease of use and simplicity.

Now we're expanding the PDP-8 family up, as well as down, and that means new opportunities for OEMs and end-users alike. Look into what's happening with PDP-8s. Call your nearest Digital sales office today.

Or send the coupon to PDP-8 Marketing Communications, Digital Equipment Corporation, 129 Parker Street, PK3-1/M34, Maynard, Massachusetts 01754. European headquarters: 12, av. des Morgines, 1213 Petit-Lancy/Geneva. In Canada: Digital Equipment of Canada, Ltd.

digital

PDP-8 Marketing Communications
Digital Equipment Corporation, 129 Parker Street, PK3-1/M34,
Maynard, MA 01754
Please send additional information about the PDP-8 family.

Name _____ Title _____

Company _____

Address _____

City _____ State _____ Zip _____

Phone _____ OEM _____ End-User _____

Application _____

ED1187

The minifloppy from number 1

**Proven in 10,000 installations
and never more affordable.**

A year ago we introduced our minifloppy, we frankly didn't expect the revolution that was about to happen. Now we've delivered 10,000 units and our production experience allows us to pass along a nice 15% price reduction. Naturally, we are flattered by the acceptance the little drive has received (and by all the imitations). There are a lot of good reasons why our minifloppy has been accepted as number 1.

35 Tracks. A format with a future. The minifloppy provides fast, random access to the industry accepted 35 recording tracks. This format will help you grow *compatibly* and reliably into double density and double sided recording later, when you are ready. The compact minidiskette® media carries 110 KB of information. **Reliable Storage.**

The Shugart minifloppy drive has the proven mechanical reliability and data integrity of standard flexible disk drives. It reads and writes with the same glass bonded ferrite/ceramic head used in Shugart's standard-sized SA800 flexible disk drives. Die cast construction offers high mechanical integrity. A DC drive motor with precision servo speed control using an integral tachometer eliminates AC power requirements.

The unique stepping motor actuator uses a direct drive spiral cam with ball bearing V-groove positive indent. This assures perfect head registration every time.

Data Integrity. The Shugart minifloppy drive improves error rate by two orders of magnitude compared to cassettes. Soft errors are only one in 10^8 , and seek errors one in 10^6 . Write protect circuitry prevents loss of recorded information. It's standard with every Shugart SA400. The minidiskette media is recorded at 20% less density than our standard floppy. This generous safety

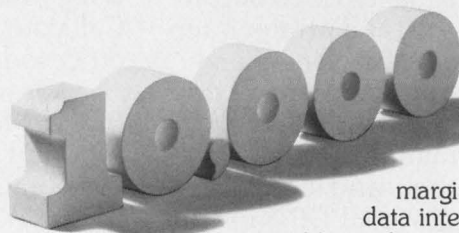

margin is your assurance of data integrity and the lowest possible media costs. **Maintainable**

Performance. Simple, modular components reduce Mean-Time-To-Repair to minutes. The self-aligning head eliminates the need for head alignment tools in the field.

Inexpensive Storage. Applying floppy technology in a compact size reduces OEM and end user cost. And with our recent

15% price reduction minifloppy disk storage has never been more affordable. Small drive size (5.75" wide, 3.25" high and 9.0" deep) reduces total system cost.

Low unit weight of three pounds offers OEM system designers new application opportunities, too. Low power consumption. **The SA4400 ministreaker™ Controller.**

The SA4400 ministreaker controller controls up to three minifloppy drives, providing up to 241.8 kilobytes of on-line data storage. **Support.** Shugart has made the floppy smaller and product support bigger. We give you more support—systems design, technical service, documentation and applications help. Two out of three OEM's specify Shugart. They get more experience, more technology, more support.

So talk to number one in low cost disk storage. Talk to Shugart.



**The Leader
In Low Cost
Disk Storage**

 **Shugart Associates**

415 Oakmead Parkway, Sunnyvale, California 94086

Telephone: (408) 733-0100

West Coast Sales/Service: Telephone (408) 252-6860

East Coast Sales/Service: Telephone: (617) 890-0808

Europe Sales/Service: 3, Place Gustave Eiffel, Silic 311

94588 Rungis, France Telephone: (1) 686-00-85

™ ministreaker is a Shugart trademark

Two DPM makers earn Underwriters' recognition

Two lines of 3 1/2-digit, ac line-powered digital panel meters have gained acceptance by Underwriters' Laboratories as recognized components, and will be easier to incorporate into equipment that must be rated by UL.

Models in the 2460 series from Weston Instruments and the Model 4424 from LFE Corp. will, in most cases, no longer have to be tested as if they were just another part of the circuitry in order for an end product to be granted UL listing. This recognition applies to commercial and industrial applications as well as medical applications that don't involve direct connection to a patient.

When the final product is a patient-connected medical instrument such as a heartbeat or respiration monitor, Underwriters' will still examine all DPMs. But the tests for the recognized

ones will most likely be limited to current leakage and dielectric withstand.

Most other tests on the DPMs, like flammability and face-plate resistance to shattering, have been performed to gain component recognition—a process that takes about six months, says Mark Rehnberg, product marketing manager at Weston Instruments in Newark, NJ. Aside from the time, "there's quite an expense involved," says Mike Ryan, digital instrument product specialist at LFE in Waltham, MA. Recognition cost his firm about \$20,000.

The LFE 4424 costs \$135. Weston's recognized 2460 series meters go for \$139 and nonrecognized versions for \$127.50. The accepted versions have a thermal fuse in the power transformer, and a new PC board layout to increase clearances between current-carrying lines.

Double memory catches hidden logic glitches

With two memories—one to store logic transitions and one to store glitches—a logic analyzer can capture and display glitches even when they occur in the same sample period as a normal logic transition. Transients as short as 5 ns can be uncovered.

Most logic analyzers have "pulse stretching" circuitry that stores a transient and displays it at the next system-clock transition. But should a glitch occur just before or just after a normal transition in the signal line—ringing, for example—it will be masked in the resulting display, which shows only the transition.

By storing transition and glitch data in its own 256 × 8-bit memories, the

Model 1615A logic analyzer from Hewlett-Packard Co., Palo Alto, CA, can be set to begin storing or displaying the activity in digital systems when a glitch or a particular logic pattern—or both—occurs. Glitches during data transitions are displayed as brightened edges on the transition.

In the timing-analyzer mode, the 1615A samples at 2 Hz to 20 MHz, and displays 249 of the 256 stored data transactions. Up to eight data lines can be accommodated.

In the state-analyzer mode, the 1615A handles 24 lines at up to 20 MHz. A 6-bit clock qualifier allows the analyzer to display specific data such as read and write commands, and input/output transactions.

The HP analyzer can also be configured to display 16 bits of state information and eight bits of timing

information simultaneously. And when a specific state or timing sequence—or both—has occurred, the analyzer can be triggered to operate, then display either or both sets of information.

Input threshold levels are either TTL-compatible or adjustable from -10 to +10 V.

CIRCLE NO. 315

Photocell tells if army weapons are on-target

A specially designed photocell that is sensitive to the light of a particular frequency is helping the Army check the effectiveness of its weapons during training exercises. For this application, the silicon light detector produced by International Rectifier is tuned during fabrication to react to pulsed infrared light at a wavelength of 900 nm.

During an exercise, quarter-sized photocells are worn by troops and placed on vehicles, installations and weapons. When the weapons are fired, 900-nm light sources on them are triggered in place of live ammunition. "Hits" are registered on the detectors.

The precision needed for the Army application requires a photocell with a capacitance of just 4.5 nf, and a variation of ±0.4 nf. This highly specialized cell, which ordinarily would be too expensive to buy, is picked out from among the conventional wafers that the company uses in making other products, notes Harold Weinstein, project manager of International Rectifier, El Segundo, CA.

The photocell is immune to stray electromagnetic radiation because its opening is covered by an electrically grounded, chemically milled, stainless steel screen, says Weinstein. This screen permits a high level of shielding from interference while letting the infrared signal get through easily.

Since its sensitivity to light can be tuned, this photocell can be made to respond only to certain weapons. For example, tanks equipped with a modified cell might register hits from artillery but not small arms.

Computer locates objects on production line

A new worker has joined the production line at General Motor's Delco Electronics Div.—a computer system that sees.

Right now the computer, called Sight-1, is used to locate transistor chips and calculates their positions as they are being processed for use in GM's high-energy automotive ignition systems. Sight-1 also verifies a chip's structural integrity and rejects those that are defective. But the system can also be used to find and calculate the position of any object on a production line.

Both overlapping and nonoverlapping objects can be recognized by the computer, says GM's Dr. Michael L. Baird, co-developer of the system. For both types, an image is sensed by a TV camera, digitized, then sent to the computer. At that point, if the object isn't overlapping other objects, a program can help the computer find it rapidly and reliably by "sharpening" the computer's sight.

Using the digitized data, the computer works through a series of image enhancements to produce a silhouette that emphasizes the outline of the non-overlapping object.

Squares of the digitized picture are intensified, along the object's edges, Baird explains. Next, the program helps get rid of the rough edges by smoothing the data.

This approach doesn't call for specific mathematical formulas. In fact, the computer doesn't even have to know what it is looking for, since it just locates and emphasizes the edges.

However, specific mathematical models are used to help the computer

detect overlapping and partially obscured chips. When such objects are shown to the computer, it analyzes them and stores the data needed to identify the objects in memory.

Audio compass tells you when you're out-of-line

A belt-worn audio compass system warns its user when he isn't walking in the right direction. The 5-oz unit contains an unusual magnetic field sensor—a sensitive magnetic reed relay. The reed relay is the active element of a subaudio frequency oscillator that produces the warning sound, a series of sharp clicks.

The compass can be very useful to the blind as well as to hikers and search parties in remote areas. The wearer turns a compass dial to the bearing he wishes to track. So long as he maintains his course within 4° of this bearing, the compass is silent. But at the 4° limit, a warning of 2 to 4-Hz clicks sounds. As the user goes farther off course, the clicks, which are produced by a barium-titanate ceramic unit, come more quickly.

The reed-relay sensor in the compass system is highly sensitive when biased with magnets, notes inventor Ray W. Hoeppel of Oak View, CA. It responds to a change in the field of about 1 milligauss, or better than 1/500 of the earth's magnetic field.

The reed relay acts like a single-pole, double-throw unit. When it is aligned with the magnetic North, the reed remains in a neutral position between its two contacts. As the compass and reed relay turn away from North, the flexible reed attempts to remain aligned with the field, closing a circuit through one of the two contacts at about $\pm 4^\circ$. Once contact is made, a transistor amplifier energizes the reed-relay coil, pulls the reed away and breaks the contact. It also applies a sharp pulse to the ceramic unit. This allows the reed to spring back and make contact again. Oscillations continue until the reed and compass are again pointed to North, within the 4° limit.

Maximum sensitivity of the reed system is achieved with the oscillator period of 2 to 4 Hz. The oscillator's long time constant is obtained with high capacitance in the transistor circuit. The compass is powered by two mercury cells.

Moreover, should the compass system's magnetic bearing deviate from true North, a provision in the compass will bring it back.

Earphones can be plugged in for use in noisy environments, and a neon lamp for night use. The lamp operates off a dc-to-dc converter.

The principle upon which the compass works is being applied to developing position, or distance-measuring, transducers. Here, a change in oscillator frequency—as the reed sensor moves to or from a magnet—is calibrated as distance.

PLL IC for televisions eliminates H and V knobs

Working with a ceramic-resonator frequency reference, a phase-locked-loop integrated circuit that costs less than \$1 in large quantities eliminates the need for horizontal and vertical-hold controls in television sets.

Most television receivers use an LC or RC voltage-controlled oscillator, operating at about 15 kHz, as a frequency reference. And "because of the inherent inaccuracies in most LC or RC-based oscillators, the pull-in range is seldom sufficient for accurate operation without hold controls of some sort," says Matt Wilcox, design engineer at National Semiconductor Corp., Santa Clara, CA, which makes the PLL chip. With the LM1880 and a 503.5-kHz ceramic resonator made by MuRata Corp. of America, Rockmart, GA, the horizontal-oscillator frequency does not have to be adjusted to ensure lock-up to a sync signal applied to the PLL. And vertical lock-up is guaranteed, since the vertical signal is derived from the same source.

The LM1880, fabricated with an 8- μ epitaxial-layer, mixed-linear and integrated-injection-logic digital process, has a 32-times horizontal-frequency VCO accurate to within 2 kHz of a 503.5-kHz center frequency. The VCO signal is divided to produce a predriver output that is locked into negative sync by an on-chip phase detector. The vertical-output ramp is injection-locked by a vertical sync, which is subject to a sync window derived from a 546-element countdown section. If no sync pulse arrives following the 514th count, the counter continues to 546, when an automatic reset occurs. If the horizontal output is locked to 15.734 kHz, the vertical output can be injection-locked from 57.63 to 61.22 Hz.



Dr. Michael Baird (adjusting camera) and Dr. Walton Perkins have developed a system that helps computers locate and calculate the position of parts on an assembly line.

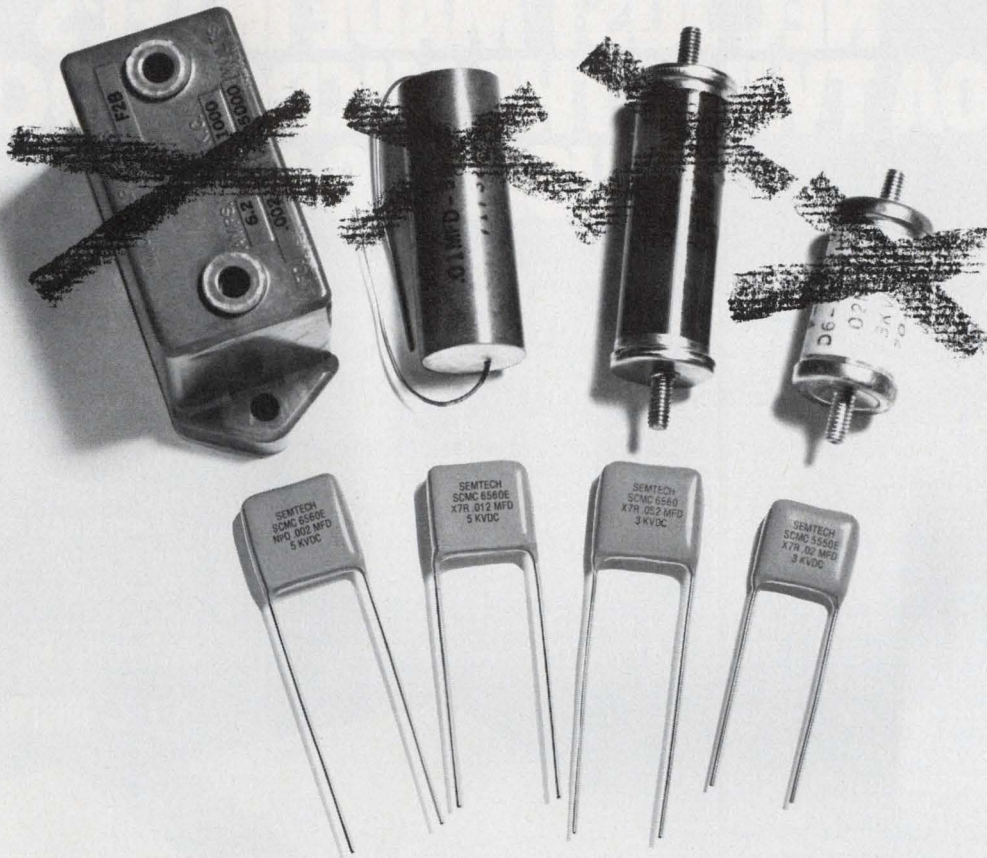

HIGH VOLTAGE MONOLITHIC CERAMIC CAPACITORS

Ideal for High Voltage High Density Power Supplies

We have a high density high voltage monolithic capacitor that meets present day equipment design criteria. Offering higher volumetric efficiencies and voltage stability over wider temperature ranges.

Higher Current Capabilities

In addition to high voltage the inherent design offers higher current carrying capabilities than previously available in ceramic monolithic capacitors of similar size.

"GOLD CAP" Radials

Construction: Monolithic radial leaded and dip coated
 Voltage: 1, 2, 3, 4 & 5 KV
 Capacitance: 18pF to .39μFd.
 Dimensions: (Body) From .40"L x .35"H x .25"T to .80"L x .75"H x .35"T

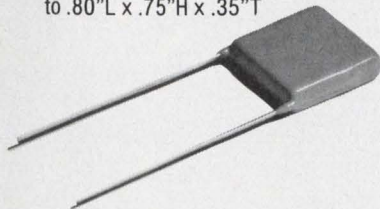

"MONO" Chips

Construction: Monolithic with end terminations
 Voltage: 1, 2, 3, 4 & 5 KV
 Capacitance: 18 pF to .39μFd
 Dimensions: (Body) from .25"L x .20"W x .15"T to .65"L x .60"W x .25"T

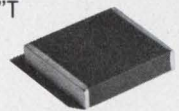

Semtech capacitors are now available in quantity from stock at pricing low enough for use in commercial applications.

Contact your nearest Semtech office for our new High Voltage Capacitor Catalog.

Two Dielectric Types

Dielectric	NPO	X7R
Temperature Coefficient (T.C.)	Less than 30 ppm/°C; -55°C to +125°C	± 15% -55 to +125°C
Dissipation Factor (D.F.)	Less than .0015 (.15%) at 1 KHZ, 1 VAC, 25°C	2.5% max 1 KHZ 1 VAC, 25°C
Insulation Resistance (I.R.)	100K megΩ or 1000 megΩ microfarads, whichever is less (25°C, 500 VDC)	100 K megΩ or 1000 megΩ microfarads, whichever is less (25°C, 500 VDC)
Aging	0	1% per decade
Dielectric Withstanding Voltage	1.2 Times Rated Voltage*, at 25°C	1.2 Times Rated Voltage*, at 25°C
Dimensional Tolerance	±.010 or ±5%, whichever is greater	±.010 or ±5%, whichever is greater

*Dielectric Withstanding Voltage Tests are conducted with charging current limited to 10 mA and the discharge current limited to 5A.

1975 NATIONAL SBA SUBCONTRACTOR OF THE YEAR



652 Mitchell Road, Newbury Park, California 91320
 (805) 498-2111 • (213) 628-5392 • TWX: 910-336-1264
 CHICAGO: (312) 352-3227 • DALLAS: (214) 234-6523
 DAYTON: (513) 274-8356 • FLORIDA: (305) 644-5404
 MARYLAND: (301) 937-0070 • NEW JERSEY: (201) 654-4884
 SAN FRANCISCO: (415) 494-0113 • SEATTLE: (206) 455-4807
 EUROPEAN SALES: Bourns AG Zug, Switzerland (042) 232-242

NEC JUST MADE INTEL'S 8080A TWICE THE MICROPROCESSOR IT USED TO BE.

Introducing the μ PD8080AF.
From NEC Microcomputers.

Now you can get a microprocessor
that's absolutely identical to Intel's
8080A.

And we can prove it.

In three separate tests using
standard Intel programs, conducted
by three independent laboratories,
the μ PD8080AF was demonstrated
to be, both parametrically and functionally,
exactly the same as the
8080A. (The certified results of the
tests are available upon request).

Which means that now there's a
microprocessor that's pin for pin and
program compatible to the Intel 8080A.
And available in plastic or ceramic.

Of course, we continue to offer

our original μ PD8080A—a microprocessor
with enhanced arithmetic capability
and logical flags.

With either an μ PD8080AF or
 μ PD8080A comes our complete line
of standard peripheral chips. Plus
state-of-the-art support chips like the
8K Electrically Erasable PROM
(μ PD458), a Universal Synchronous
Receiver/Transmitter Data Commu-
nications Controller (μ PD379), a
450ns 32K ROM (μ PD2332) and a
Floppy Disc Controller (μ PD372)

that can control up to four IBM 3740-
compatible drives, and a complete
line of the most reliable memories
you can buy.

All backed up by applications sup-
port available nationwide.

The μ PD8080AF from us. And
the 8080A from them.

Even with a program, you won't
be able to tell them apart.

NEC Microcomputers, Inc., Five
Militia Drive, Lexington, MA 02173.
(617) 862-6410.

NEC microcomputers, inc.

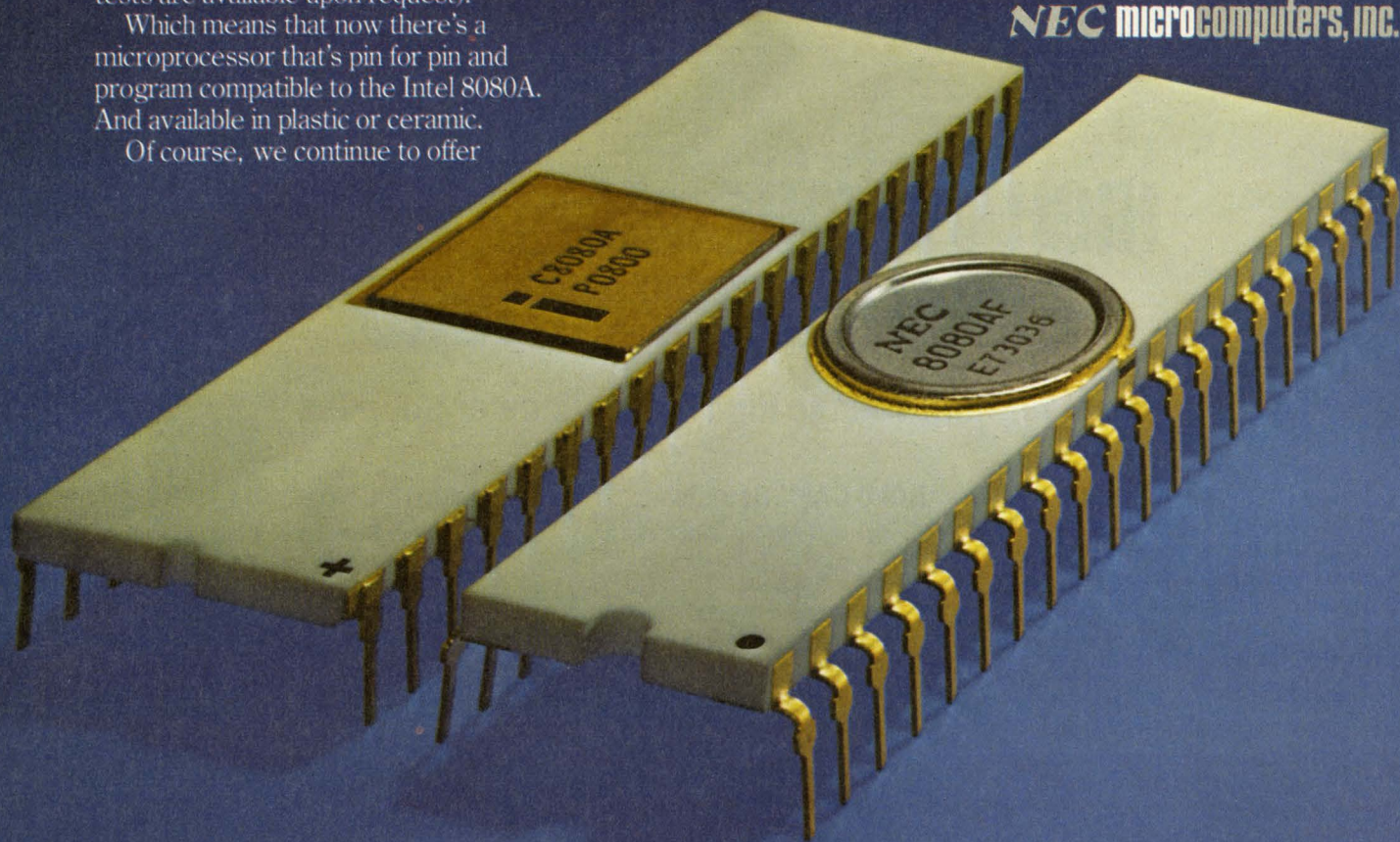

REPS: East—C&D Sales 301-296-4306, Contact Sales 617-273-1520, Harry Nash Assoc. 215-857-2213, Rome 516-249-0011, Tech-Mark 607-748-7473, 716-223-1252, 315-652-6229, Trionic Assoc. 516-466-2300, South—Perrott Assoc. 305-792-2211, 813-585-3327, 305-275-1132, 20th Century Mktg. 205-772-9237, Wolffs Sales Serv. Co. 919-781-0164, Midwest—Electronic Innovators 612-884-7471, W. Pat Fralla Co. 817-640-9101, 817-649-8981, 713-772-1572, Imtech 216-826-3400, 513-278-6507, K-MAR Eng. & Sales 816-763-5385, R.C. Nordstrom & Co. 313-559-7373, 616-429-8560, Technology Sales 312-438-3300, West—Carco 714-560-9143, D/Z Assoc. 303-534-3649, Electronic Component Mktg. 714-879-9460, Summit Sales 602-994-4587, Trident Assoc. 408-734-5900, Tri Tronix 206-232-4993, 505-265-8409, Canada—R.F.Q. Ltd. 416-626-1445, 514-626-8324.

DISTRIBUTORS: ASI Electronics (Baltimore), Bell Ind. (Bellevue WA), Century Electronics (Albuquerque, Salt Lake City, Wheatridge CO), Diplomat (Chicopee Falls MA, Clearwater FL, Elk Grove Village IL, Farmington MI, Minneapolis, Mt. Laurel NJ, Salt Lake City, St. Louis, Sunnyvale, Totowa NJ, Woodbury NY), Future Electronics (Montreal, Ottawa, Rexdale Canada), Harvey Electronics (Fairfield NJ, Lexington MA, Norwalk CT, Woodbury NY), Intermark Electronics (San Diego, Santa Ana, Sunnyvale), G.S. Marshall (Sunnyvale), Mirco Electronics (Phoenix), Resco (Raleigh), R-M Electronic (Kentwood MI, Madison Hgts MI), Semicomp (Costa Mesa CA), Semiconductor Specialists (Burlington MA, Chicago, Dallas, Dayton, Farmington MI, Hazelwood MO, Indianapolis, Kansas City, Milwaukee, Minneapolis, Pittsburgh, Malton Canada), Sterling Electronics (Albuquerque, Dallas, Houston, New Orleans, Phoenix, San Diego, Seattle, Sun Valley CA, Watertown MA), Summit Distributors (Buffalo), Summit Electric (Rochester), Technico (Columbia MD, Roanoke VA), Western Microtechnology Sales (Sunnyvale), Zeus Components (Elmsford NY).

What we put in makes ours better

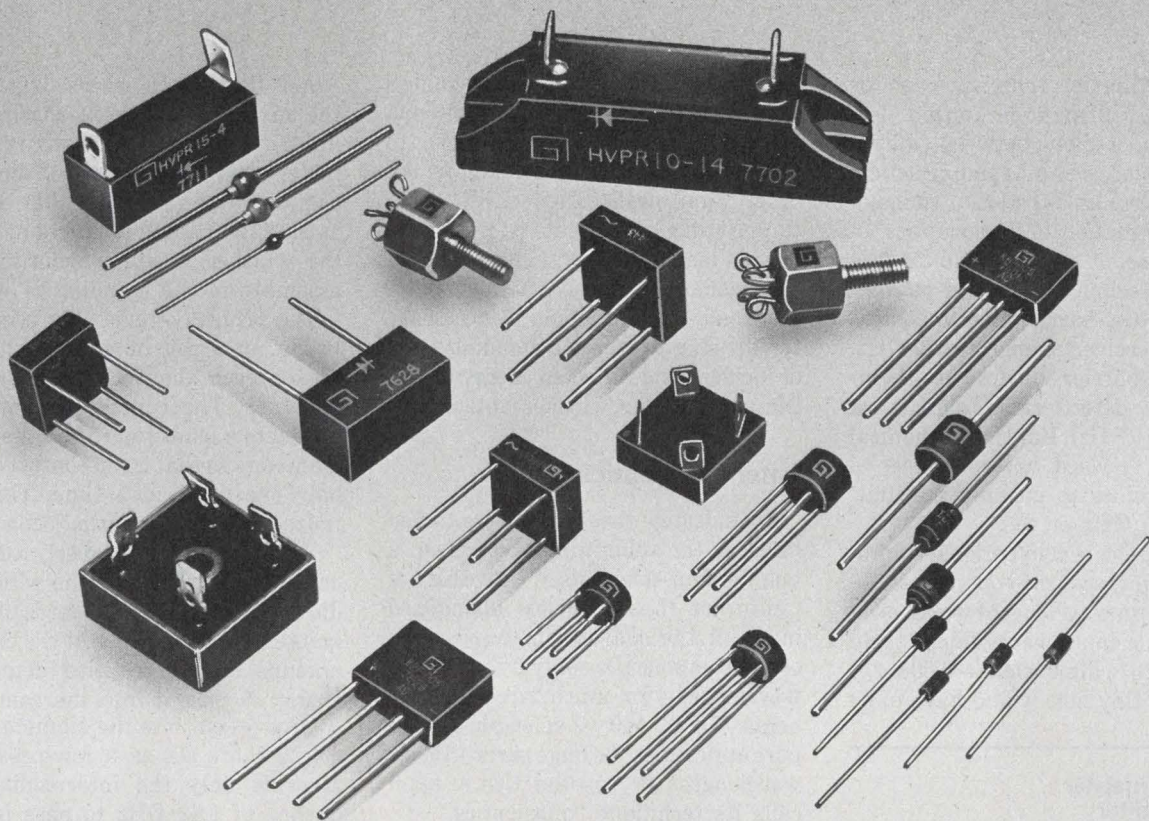

That's why leading manufacturers worldwide are switching to General Instrument's rectifiers and bridges.

You shouldn't have to worry about rectifier failures—during assembly or after your products are in use. That's our job. But we don't like to worry either, so we build them better from the start.

SUPERRECTIFIER:

The world's best rectifier. Metallurgically bonded by brazing (at greater than 600°C) at both leads and junction to eliminate component failures caused by stresses from automatic insertion and wave soldering. Glass passivated, providing extra reliability exceeding military and environmental requirements. And finally, encapsulated with our UL listed flame retardant epoxy, for uniform

size, clear marking, and easy handling. And all this at a low, low price.

Plus a complete selection of plastic and glass axial leaded rectifiers rated up to 6 amps, and 5000 volts, including fast recovery and controlled avalanche types.

BRIDGES:

For those applications requiring bridge circuits, General Instrument's complete line of silicon bridges offers most configurations from 0.5 amp to 35 amp—including center taps, doublers, controlled avalanche and fast recovery units. For additional information, call or write for our complete catalog.

GENERAL INSTRUMENT CORPORATION
DISCRETE SEMICONDUCTOR DIVISION
600 West John Street, Hicksville, New York 11802 (516) 733-3333



Radio receiver reaches 670 GHz with 'quasioptics' and new mixer mount

A submillimeter radio receiver, or radiometer, will put the unused electromagnetic region between microwaves and infrared to some practical uses, including anti-terrorist technology. A combination of "quasioptics"—lenses made of Teflon—and a new mounting technique for the conventional Schottky-barrier diode mixer extends the receiver's range to 670 GHz.

Schottky-barrier diodes by themselves can detect radio signals at terahertz (10^{12} Hz). But the mechanical "plumbing" needed has long been a stumbling block to pushing the limit beyond 100 GHz or so.

For example, a conventional microwave receiver, scaled to operate at 600 GHz (1/2-mm wavelength) would need a rectangular input waveguide of truly hair-breadth dimensions— 0.008×0.014 in. A tiny hole would have to be

drilled through one of the waveguide's 8-mil walls and a whisker antenna positioned across the waveguide, to contact a Schottky diode chip on the other 8-mil wall. Then a lilliputian tuning slug (back-short) would be needed inside the waveguide to reflect the incident rf energy. A tiny micrometer adjustment would be necessary for the slug to create a standing wave of incident and reflected energy just at the point of the whisker antenna.

Enter quasioptics

To sidestep these problems, when building the submillimeter receiver, a team of four scientists at University of California (Los Angeles) abandoned many of the conventionally sized receiver components—only fractions of a wavelength—for much larger components—10 to 100 wavelengths. Since pure optics calls for huge parts—10,000 wavelengths or so—the UCLA team calls its technique "quasioptics."

A Teflon lens in the receiver focuses the submillimeter wavelength energy into a spherical resonant cavity. Micrometer tunable (see photo), the cavity contains a pair of cones that act both as an antenna and as a mount to hold the whisker antenna/Schottky diode assembly in the standing rf wave.

The Schottky-diode chip used is actually an array of several thousand diodes, each about 1000 angstroms in diameter. The contacting whisker is etched to a point finer than the diodes' diameters so that it can contact one and only one diode at a time. This minimizes signal-attenuating capacitance.

With the cavity properly tuned, rf energy is coupled into the whisker. A diode touching the whisker is ohmically mounted to one apex of the biconical antenna, and the rectified (detected) rf energy is passed into the cone.

Grooves cut into the diameter of the cone's shaft act as a low-pass filter, allowing only the intermediate frequency of 1.42 GHz to pass into the

Dick Hackmeister
Western Editor

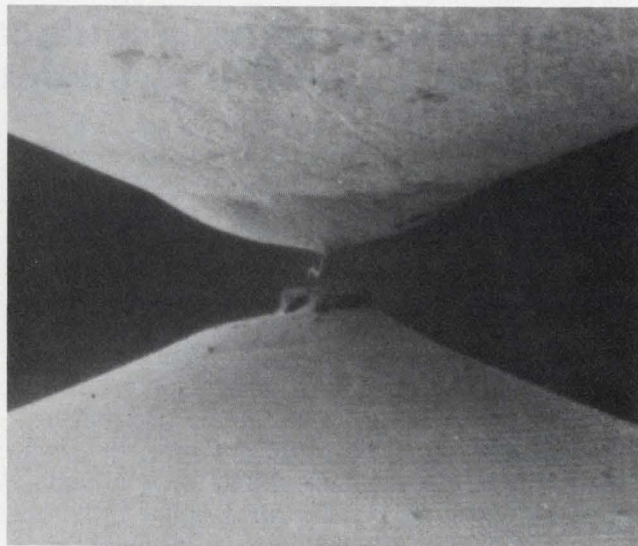
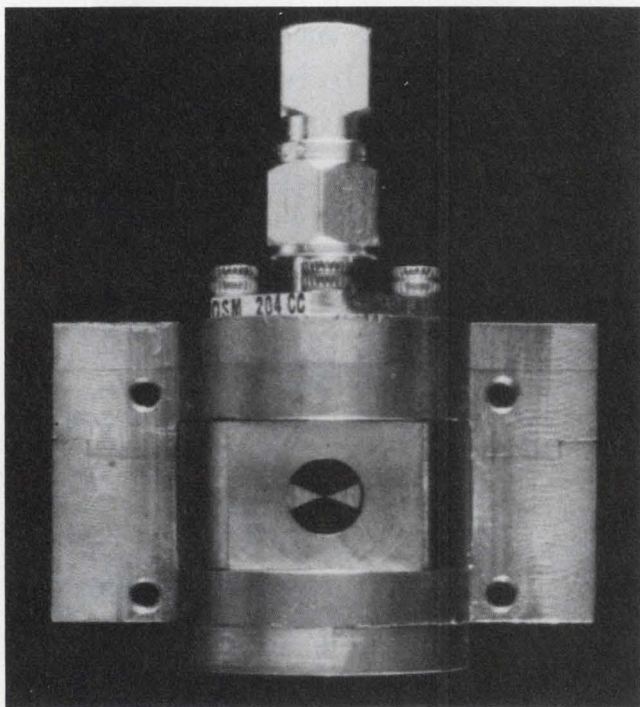

Quasioptical radiometer mixer (left) uses a biconical antenna for the Schottky-diode/Whisker-antenna mount. It detects microwave signals approaching a THz. Built by Aerospace Corp., the radiometer is expected to find use in thermonuclear plasma and security applications.

next stage. All other parts of the radiometer are conventional.

New signatures, new uses

The number of applications for sub-millimeter radiometric imaging is growing, according to Dr. Dean Hodges, staff scientist at Aerospace Corp., El Segundo, CA, and a member of the developing team. Beyond

monitoring the goings-on within a magnetically contained thermonuclear plasma, quasioptical radiometers are expected to be pressed into service as anti-terrorist security monitors.

"The clothes we wear are opaque in visible light," explains Hodges. "But passive radiometric monitoring at sub-millimeter wavelengths can detect weapons, explosives and other contraband items without X-rays."

Already, radioastronomers looking for life in deep space have used a radiometer to find water vapor in the Orion constellation (water has strong spectral lines at 180 and 320 GHz, notes Hodges). A quasioptic radio receiver can also help keep tabs on air pollution and the earth's ozone layer by monitoring the signatures of gases in the earth's atmosphere between 100 and 1000 GHz according to Hodges. ■■

Standard Navy computer has low-power core memory

A core memory system that is twice as dense and uses 40% less power than earlier military core memories, yet costs only 15% more, is being built by two suppliers as part of the Navy's program to standardize on the AYK-14 avionics computer.

The AYK-14 is already scheduled to go into the F-18 fighter being developed for the Navy by McDonnell Douglas Corp. in St. Louis. It is being considered for the Navy's Lamps helicopter, EP-3 intelligence aircraft, and for updates of the P-3 patrol aircraft.

Control Data Corp. of Minneapolis is building the AYK-14 for the Navy, which required that CDC find a second source for the memory and power supply systems. Electronic Memories & Magnetics Corp.'s Severe Environment Products division, Chatsworth, CA, has signed an agreement with CDC to build identical core memory systems.

Each bit in the memory system is a toroid of iron oxide to which lithium, cobalt and copper trace quantities have been added. The additives change the core's temperature-response curve so that, with the proper mixture, the core operates over the military temperature range (-55 C to 125 C) with little variation in performance.

In the AYK-14 core memory, the response curve is a straight line, but tilted to compensate for the variation in resistance with temperature of the copper stringing wire that feeds current through the toroids.

The cores are 13 mils in diameter, the



The standard computer for future Navy avionics programs, the AYK-14 is being developed by Control Data Corp. and, it is hoped, will be available from other vendors as well. The first application is in the F-18 fighter.

smallest used in military systems. This core size has been used by Ampex Corp., Redwood City, CA, but in commercial systems not designed to operate over the military temperature range. Most standard military and commercial cores are 18 mils in diameter.

Cutting current drain

Drive current through the cores is 300 mA, less than half that of conventional memory cells, which use lithium alone as an additive. As a result of the lower drive current, power consumption is cut from between 105 and 110 W to less than 65 W under worst-case conditions: an operating temperature

of -55 C and a stored pattern of all zeros.

The major benefit of lower power consumption is higher reliability. Temperatures at the semiconductor junctions in the sense amplifiers that drive and read the memory elements have been cut from 125 to 110 C, even when, as in the AYK-14, the core memory system is cooled only by conduction—without fans. The surface on which the memory card is mounted is specified at 85 C, so the temperature rise in the system can be no more than 25 C.

At the same time the AYK-14 memory consumes less power than its predecessor, it can store twice as much data. The AYK-14 core system stores 32 kwords of data, each word 18 bits wide. The earlier unit stores 16 kwords of data.

With all these advances, "you don't give up anything," says Don Ballantyne, engineering manager at EMM Severe Environment Products. The price of the newer memory, which EMM calls the SEMS-16, is only about 15% higher than that of the 16-k SEMS-9PI, he adds.

The lower cost-per-bit is the result of smaller cores—13 vs. 18 mils—as well as LSI sense amplifiers replacing hybrid and discrete circuitry. In addition to lower initial cost, the Navy should benefit from lower operating costs since the alternative versions of the AYK-14 core memory system are identical in all respects—whether built by EMM or by CDC.

The Navy, as part of the AYK-14 contract, required CDC to establish an alternate source for the memory card,

Andy Santoni
Associate Editor

but the alternate had to be equivalent in form, fit and function at the board level, not necessarily an exact copy, explains Rich Bolestra, hardware engineer on the AYK-14 project for the Avionics Division of the Naval Air System Command Headquarters in Washington. "Our goal is to duplicate functions at the board level so that we can second-source on the SRA (shop replaceable assembly) level," he says.

Since EMM was already working on 13-mil military core development, the firm found it convenient to approach CDC and agree to build an exact duplicate, says EMM's director of marketing, Dean Knutson. If the Navy finds it desirable, it can therefore stock spares beyond the SRA level for field repairs.

Later, the Navy will be looking for alternate sources for the rest of the AYK-14. At present, CDC is in the reproduction phase of the contract,

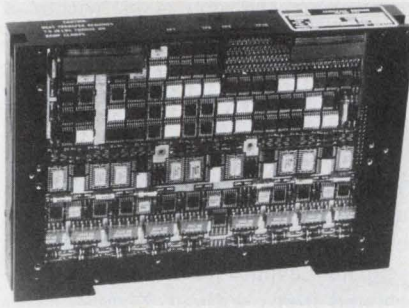

The standard memory for the AYK-14 is already available from two sources: CDC and EMM. It uses 13-mil cores to cut power consumption by almost half.

with testing to be performed through most of next year. A provisional application for service use is expected by the end of next year, says the Navy's Bolestra, with production to begin in 1979.

Over the ten year production cycle

the Navy expects for the AYK-14, the computer could be used on a wide variety of projects. "There could be as many as 10,000 built by the time it's over with," says Bolestra.

Standardization to be the norm

"I think there's a real effort now from the Department of Defense to standardize," says EMM's Knutson. Five years from now it's going to be the normal way of doing business at DOD, he adds.

Earlier DOD efforts to standardize have failed because of politics, a not-invented-here attitude, or because the standard product was not tailored to doing any specific job—a "standard" product might have all the bells and whistles for current applications yet lack adequate flexibility for future tasks. Perhaps this time the Navy will be successful. ■■

Shifting control to firmware speeds computer operations

Moving more of a computer's control program from software into firmware cuts the time it takes to perform basic functions by as much as two-thirds.

As a result, the Royale small-business computer system from Microdata Corp., Irvine, CA, can perform central-processor calculations two to three times faster than Microdata's older Reality system and can handle terminal input/output functions twice as fast. Access to disc-stored data takes about as long.

Semi memory beats core

Speed is increased, in part, by storing instructions in semiconductor ROM rather than in core. Cycle time of the semiconductor memory used in the Royale system is about 200 ns, compared with 1 μ s for core, says Ted Ellison, project manager. In addition, the Royale contains about 8 kwords of firmware in ROM, each word 16 bits long. The Reality system has only about 2 kwords of firmware.

In the Royale's 8-kword firmware space, six kwords are used for the computer's operating system, which determines the architecture of the ma-

chine, and controls virtual-memory operation and terminal input/output interactions. With virtual memory, there is more room to store programs and work in progress than there is actual memory space in the computer's resident memory—some of the stored data can be shifted out of the resident memory.

But virtual memory is normally controlled by disc or core-based software, and data are usually shifted back and forth to disc storage in "pages," which can be very time-consuming. In the Royale system, the ROM-stored firmware speeds operations by re-using some of the pages that are already in resident memory, instead of constantly calling up new pages.

An additional 512 words of Royale firmware contain an operating system that makes the computer look like Microdata's older 1600 series machines. Consequently, the Royale can use diagnostic programs developed and debugged on Microdata's older machines for tracking down computer and peripheral faults.

Moreover, a special diagnostic program housed in the rest of the Royale's 8-kword firmware can be called up not

only by Microdata service technicians but also by users. Such programs are usually unavailable to users, but are stored on cards that a technician must bring to the ailing system and plug in, according to Ellison. With resident diagnostics, users can quickly pinpoint a problem without waiting for a technician to arrive. A service call may be eliminated altogether if the problem is in a peripheral, not in the computer, Ellison explains.

A step beyond reality

Microdata can convert a Reality system to a Royale system by changing a ROM card, adding a few resistors, and upgrading any boards already in the system that are not current enough to be compatible with the new equipment. Programs already written for the Reality system can then be run without modification, although they might not be as efficient as possible because they do not take advantage of the latest changes in the operating system, says Ellison, adding that conversion would keep Microdata's older Reality system down one or two work shifts. ■■

NEW!

INTRODUCING . . .

CL IPLITE™

THE INDUSTRY'S ONLY 1-PIECE T 1¾ LED
COMBINATION LENS/MOUNTING SYSTEM

CL IPLITE™ OFFERS
6 ADVANTAGES OVER
OUTMODED CLIP-AND-RING MOUNT:



PAT. PEND. U.S. & FOREIGN

1. **EASIER TO INSTALL** — simple 2-step mounting requires no tools. Just snap CLIPLITE into panel hole and insert LED. That's all there is to it. . . . installs in just 6 seconds!

INSERT LED - NO TOOLS NEEDED.

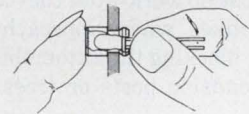

2. **LOWER COST** — including installation and labor, you save 20% per unit.
3. **GREATER VISIBILITY** — CLIPLITE provides 180 degrees visibility using a point source LED and is 5 times brighter than normal diffused LED. Comes in 5 colors, red, amber, green, yellow and clear.
4. **SECURE MOUNTING** — No LED back-out.
5. **COMPLETE LED PROTECTION** — CLIPLITE completely encloses LED.
6. **MOISTUREPROOFS & INSULATES** — No more worries about spilled liquids or water damage. No more logic failures due to static electricity.

Cliplites are also available in Incandescent and Neon models.

PLACE YOUR TRIAL ORDER TODAY

Special Pricing for Trial Order Only

ED11-8

PLEASE SHIP: 100 CLIPLITES \$10.00 LITERATURE

NAME _____ COMPANY _____

ADDRESS _____

CITY _____ STATE _____ ZIP _____



VISUAL COMMUNICATIONS COMPANY
P.O. BOX 986 EL SEGUNDO, CALIFORNIA 90245 (213) 822-4727

With new radar braking system, your car won't stop at every tree

An automobile radar braking system using a small antenna beam width and a limited radar range is virtually unhampered by the false alarms plaguing other automatic-radar braking systems being developed.

According to Department of Transportation studies, automatic radar braking systems would prevent rear-end and head-on auto crashes, or at least reduce the seriousness of injuries received in those accidents. Non-cooperative radar systems developed for this purpose do work—but they also apply the brakes when approaching obstacles not blocking the automobile's path—like roadside posts or trees.

Down to almost nothing

These false alarms have been reduced almost to zero, however, by an unusual radar braking system developed for the DOT by Bendix.

Tests conducted by the company revealed that false alarms could be effectively suppressed by using a very narrow antenna beam and by limiting the radar detector range to restrict the distance at which brakes would be applied. Indeed, with a 2.5° beam width, false alarms were all but eliminated for a detection range between 100 and 300 ft. For example, the number of false alarms occurring on a divided highway was less than 2 at 200 feet for 57 runs.

To determine the value of small antenna beam width and radar-detection range cutoff, Bendix used a 22.125-GHz radar that fed range and rate-of-range-change signals into processing electronics. Car speed and steering angle were also fed in. Antenna beam width was varied between 10° and 2.5°, and radar-detection-range cutoff between 100 and 300 ft.

After 36 brake-system configurations were evaluated using computer models, Bendix concluded that a 300-ft radar was best for preventing head-

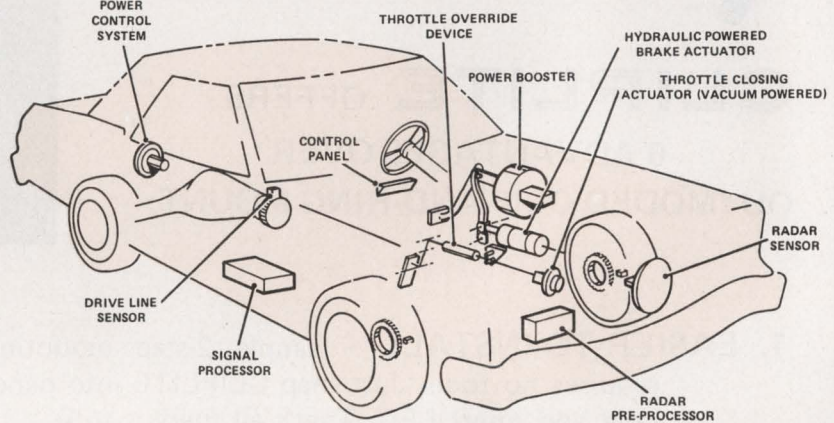

An automatic noncooperative radar braking system by Bendix prevents the driver from crashing into cars, pedestrians or obstacles in the road. System elements are located in various parts of the car.

on crashes. But because of the unsatisfactory number of false alarms projected at this range, a compromise had to be made. Based on the computer evaluations, the cut-off range was reduced to 150 ft. Eventually, however, the range was increased to 250 ft so that an early-warning function could be added.

To achieve a beam width of 2.5 to 4° with a 6-in. radar horn that wouldn't look too big on a compact car or require front-end modification to be installed, Bendix decided on a low-power, solid-state radar with a 25-mW Gunn oscillator operating at 36 GHz. A millimeter-wave band (above 40 GHz) had been considered, since the antenna would have been even smaller. But back scatter from heavy rain would have been a problem.

A nonstandard system

To obtain range information, the Bendix radar is not a standard FM-CW system, but what is termed a dplexed-CW system. Transmitted rf bursts in the system are alternately displaced 410 kHz above and 410 kHz below the 36-GHz carrier.

The Bendix radar system tends to

provide more accurate, noise-free velocity data than conventional FM-CW systems, which calculate velocity with successive measurements. This dplexed-CW radar provides an accurate Doppler signal reconstruction, according to Carl P. Tresselt, senior staff engineer at Bendix Communications Division in Baltimore, and coauthor of an Eascon '77 paper entitled, "Highway Collision Avoidance—A Potential Large-Scale Application of MM Radar."

Braking commands are generated by both range rate and range data. Sampled data are produced by a homodyne receiver system that mixes the pulsed radar returns with the 36-GHz oscillator frequency. Doppler amplifiers, one for each alternate pulse, provide continuous Doppler signals from the vehicle or object ahead.

Range is obtained by comparing the phase between the two channels, while the relative velocity is obtained from the Doppler information in one of the channels. Whether the car is gaining on a car ahead or dropping back is signaled by a lead or lag between channel phases.

If, a car bearing the radar approaches another at an excessive speed, a warning sounds for the driver to start

Jim McDermott
Eastern Editor



BENDIX BRISTLE BRUSH BUNCH.

Opens new horizons for PCB design.

70%-90% Reduction in Mating and Unmating Forces

- simpler board support systems
- fewer damaged boards

Extended Circuit Count Potential

- up to 400 Bristle Brush contacts per connector



Extensive Product Line

- mother board, daughter board, input/output, PC receptacle body styles
- 2-, 3-, and 4-row configurations
- 90° and straight PC, solderless wrap, crimp removable, willowy tail terminations

For complete information, contact The Bendix Corporation, Electrical Components Division, Sidney, New York 13838.

Bendix

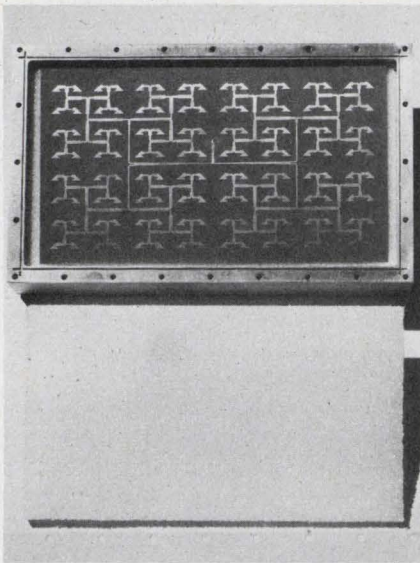

Printed-circuit transmit/receive antenna is part of RCA's microprocessor-controlled, noncooperative X-band automobile radar system.

braking. If he does not and the distance between the two closes to the computed danger limit, the brakes are automatically applied.

Although the returns from targets 250 ft away from the radar will be intermingled with more false alarms than would have occurred at 150 ft, actual braking will not be permitted by the Bendix system until the range is within the shorter, near-error-free distances.

Others working on problems

A number of other research organizations, notably RCA here and Standard Elektrik Lorenz AG in West Germany, are working on the auto-radar problem.

RCA's system is being incorporated in a Research Safety Vehicle sponsored by the DOT. The objective is to develop a safe car in the 2000-lb class for the mid-1980s. The RCA contribution is a microprocessor-controlled noncooperative radar and an electronic dashboard display.

The radar is an X-band (10.575-GHz) FM-CW type with a sweep rate of 1 kHz and a frequency deviation of 25 MHz. Its printed-circuit transmit/receive antenna is mounted under a radome in the car hood. Beam width is larger than the Bendix system's—5° in azimuth and 10° in elevation. Shielding and damping material are located ahead of the antenna aperture to reduce side lobes to below -20 dB to eliminate false alarms. RCA is expected to go to

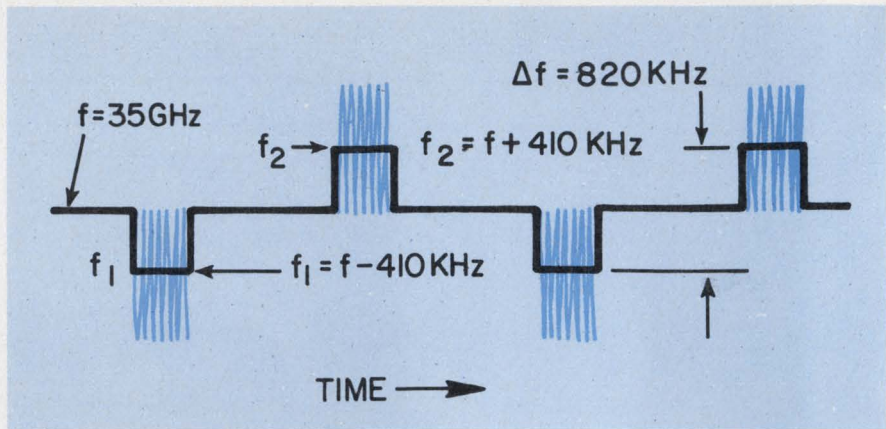

Wrong off periods between alternate rf transmission bursts of this Bendix duplexed-CW radar give range gating and suppress targets more than 250 ft ahead of the car.



This radome for an experimental radar braking system protects radar elements from the weather. Small antenna beam width and range gating minimize false alarms that have plagued similar systems.

higher frequencies in future versions of the radar.

False alarms from roadside and other targets are minimized in the RCA system by algorithms in a COSMAC CDP1801 microprocessor, which samples and evaluates the frequency content of the returns.

Targets rejected at 10 m

Standard Elektrik Lorenz, a German subsidiary of ITT, has been working on an anticollision radar with Daimler-Benz. The Lorenz system is an FM-CW radar operating on 16.5 GHz. To suppress false targets, the radar system rejects targets outside a moving range window of 5 to 10 m. To eliminate false

targets appearing at curves in the road, the radar range is so limited that only targets in the driver's lane can be detected. Targets at turns—such as trees and lampposts—are distinguished in time with the help of a parameter that is proportional to the car's turn radius, which is signaled by a sensor on the steering gear.

The Lorenz FM-CW system is particularly suitable for suppressing false alarms caused by extended targets such as reflector fences. Their distance is indicated almost as a constant, whereas distance from a fixed obstruction on the highway decreases continuously.

Eventually, the 15.5-GHz unit will be replaced by a 35-GHz radar head. ■

Choice grips from TI.

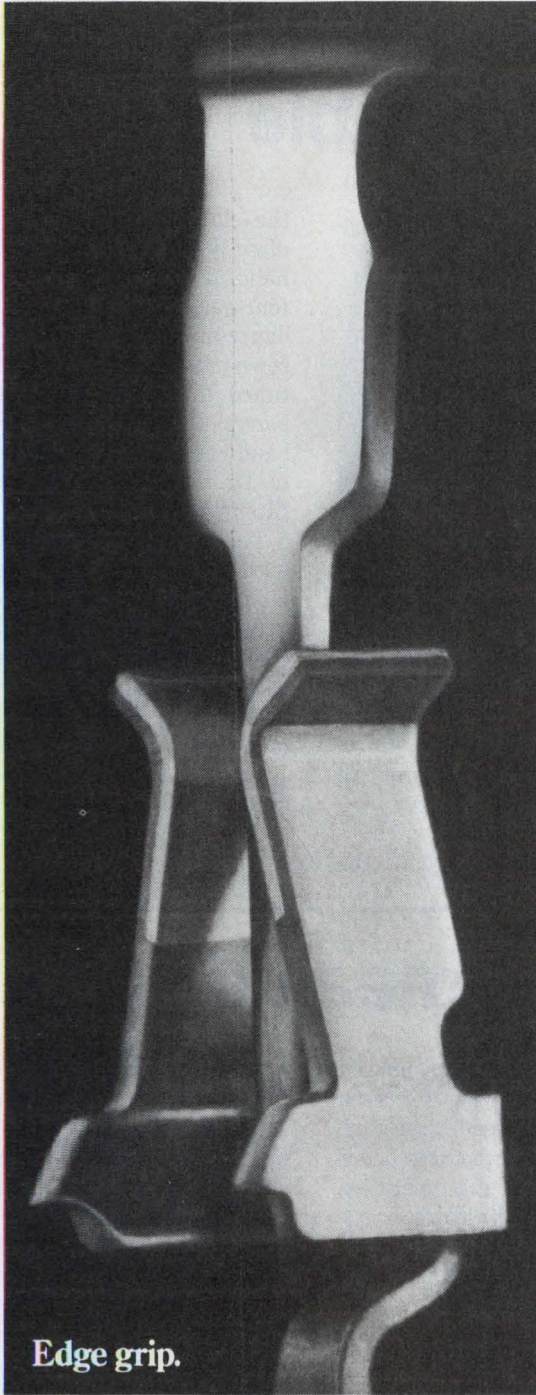

Edge grip.

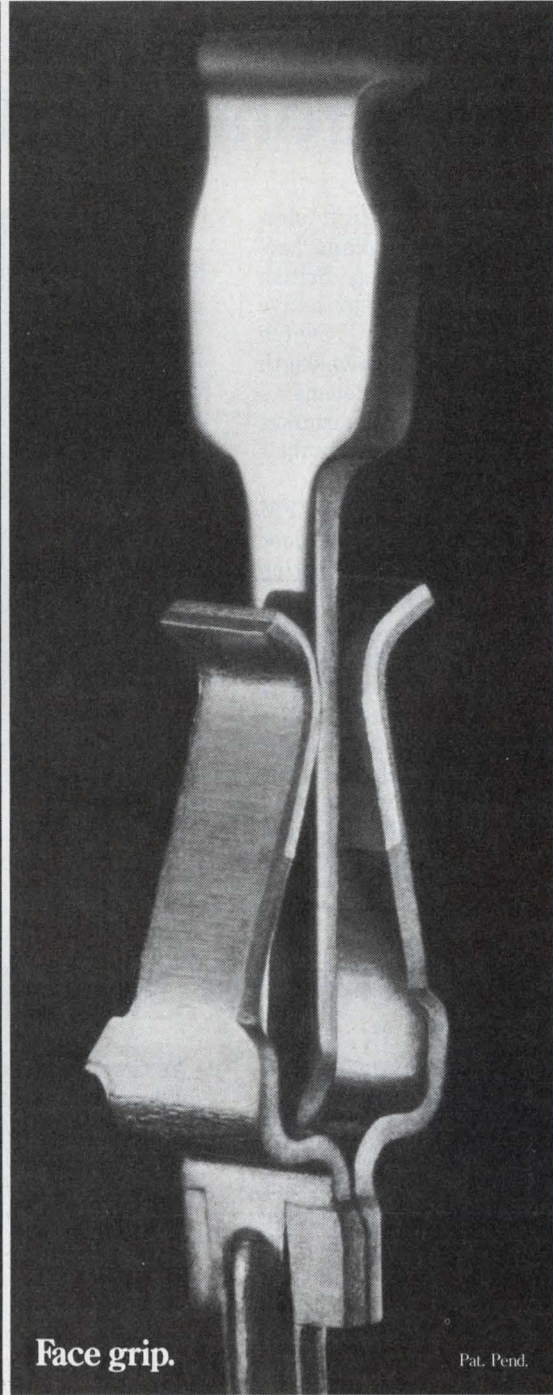

Face grip.

Pat. Pend.

Choose your grip from the world leader in dual-in-line sockets. We offer the best values in both face grip and edge grip designs from the most complete line of low profile solder tail IC sockets in the industry. Get off-the-shelf delivery from your local TI distributor. Write Mail Station 2-16, Attleboro, MA 02703. Or call Connector Systems Marketing, (617) 222-2800, Extension 268 or 269.

Edge grip: Gold or tin contact surfaces • 8-40 positions • 94V-0 insulator material • 75 μ " min. gold or 200 μ " min. tin inlay • CA 725 copper alloy • Optimum contact pressure • Facilitates automatic insertion • Dual beam contact construction • Chamfered entry design

Face grip: Optimum insertion/withdrawal ratio • 8-64 position • 94V-0 insulator material • 75 μ " min. gold or 200 μ " min. tin inlay • CA 725 copper alloy • Facilitates automatic insertion • Dual beam contact construction • Open insulator design • Ribbed contact termination • Chamfered entry design

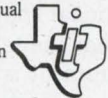

TEXAS INSTRUMENTS
INCORPORATED

Indoor FM antenna is tunable and 'electronically directable'

The Beam Box is "the first electronically directable FM antenna," according to its manufacturer, British Industries Co., yet it contains no active circuitry. A four-position switch selects which of four 1/8-wavelength extruded aluminum antenna elements will be paired, and thereby determines the orientation of the antenna's figure-8 pickup pattern.

The Beam Box is designed for FM listeners who cannot install outdoor antennas, but want better reception than they can get with common folded-dipole indoor antennas, explains Andrew Carduner, vice-president of the Westbury, NY, firm. "Most owners of FM receivers and tuners never realize the full reception capability of their equipment," he says. "The wire dipole antenna generally used with FM receivers can't be oriented easily to pick up strong signals from all the stations



FM antenna gains directionality by selecting a pair of dipoles.

in a given area. Outdoor antennas are costly to install, impractical or, for apartment dwellers, prohibited—and they require a rotator in order to receive adequate signals from more than one direction."

Beyond the orientation switch, a wide/narrow bandwidth switch feeds

the signal to an FM receiver either directly or through the Beam Box's handful of electronic components—a four-gang tuning capacitor and impedance-matching capacitors. In the narrowband mode, the antenna can be tuned to the station desired with a bandpass filter that has a 3-MHz bandwidth at the -3 dB points and 10 to 12 dB of suppression beyond the filter's skirt.

The antenna was designed by BIC with help from Channel Master, Ellenville, NY, which also makes antennas and has extensive antenna-testing facilities. Channel Master and BIC are both divisions of New York-based Avnet, Inc. The Beam Box will be manufactured at BIC's plant in St. Joseph, MI, where the firm also makes automatic turntables.

Suggested retail price for the Beam Box is \$89.95. ■■

Tester 'learns' what it measures

Using known-good printed circuit boards as references, an automatic test system can program itself not only for the values that are acceptable, but also for the tolerances on those values. This self-learning method for generating test programs works with in-circuit PC board testers to check for open and short circuits, correct component values, and proper orientation of inserted components.

To generate a program for a particular board type, the operator keys in a list of all components connected to each node on the board. The tester then makes resistance and impedance measurements at each node on a known-good board and stores the results. Additional known-good boards are run through the tester. Whenever a new measurement is different from previous data, the tester alters its program to adjust the median value and the tolerance band for each measurement.

At first, the test system assumes a "default" tolerance of 5% for each measurement. But the wider the variation a functionally acceptable board can have, the wider the tolerance, which can reach 40% or more.

Developed at Teradyne Inc., Boston, the technique is used in the firm's Model L-529 test system. The system interfaces with a board under test via a bed-of-nails fixture that consists of a matrix of pins that are spring-loaded to make contact with test nodes.

Self-learn saves time

With self-learning, a test program for analog boards, where in-circuit testing is most valuable, can be written and be ready to run in about a day, says Jeff Hotchkiss, Teradyne product manager for in-process test equipment. Without self-learning, writing a program generally takes about three days and debugging the program another six.

In-circuit testers like the \$54,500 L-529 are generally employed at the end of a production line to detect common assembly faults before the board is run through a functional tester. In this way many of the errors that a functional tester otherwise would have spent a great deal of time tracking down are weeded out. "By putting an in-circuit tester in front of a functional tester, you increase the yield of the functional tester," says Hotchkiss.

While in-circuit testers find only about 87 or 88% of the faults on a board, a functional tester can find 95% or more. However, a functional test system can cost an order of magnitude more.

For digital circuit boards, which have fewer discrete components and whose most common faults are shorts and opens, more effective prescreening can be done with a continuity testing system than with an in-circuit tester. ■■



If you're involved in data communications at 2400 bps or below, Universal Data Systems has modems that give you the confidence you need. UDS also offers the technical competence, service expertise and pride of craftsmanship that will keep your datacomm network up and running.

Specify 103s, 201s, 202s or ACUs and reap all the benefits of Universal's advanced CMOS technology. If you need two-wire full duplex communication at 1200 bps, try our 12 • 12. For multi-channel operations, ask for our RM-16; it accommodates up to 16 modem boards in any configuration mix you may need. Finally, we're pleased to announce the availability of our own FCC-approved DAA's (1001F and 1001D). Use them to connect any automatic-answer modem directly to the dial-up telephone network.

Your datacomm problems have a Universal solution. Write or phone today for technical details.



4900 Bradford Drive • Huntsville, Alabama 35805
Telephone (205) 837-8100 • TWX 810-726-2100

Confidence In Communications

TEKTRONIX

Portable Oscilloscopes

22 high-performance models
that go where you go.

Here's how to choose the TEKTRONIX Portable that's right for your application.

Tektronix offers an unmatched selection of 22 portable oscilloscopes, including six storage models, designed to meet the testing requirements of the electronics industry. These high-quality scopes are used for computer servicing, communication system maintenance, research, education, and production testing.

Your specific measurement needs should guide you in selecting the TEKTRONIX Portable that's best for you. First consider your performance, price and weight requirements. Then choose a model from one of our four oscilloscope lines. Each combines portability, reliability and ruggedness with unique features and capabilities.

400-Series Performance Leaders

Take lab quality into the field with TEKTRONIX 400-Series Portable Oscilloscopes. Choose from nine models, including the 350-MHz 485, the widest bandwidth portable available today.

If you need to capture fast, non-repetitive events, the TEKTRONIX 466 is the only portable that can store a single-shot waveform at its full 100-MHz bandwidth. For military applications, consider the 465M, the new commercial equivalent of the AN/USM 425 triservice standard 100-MHz Oscilloscope.

The factory-installed DM44 Delta Delayed-Sweep Option adds a direct numerical readout to five TEKTRONIX 400-Series Scopes. At \$445,* it's the least expensive, most accurate way to make digital-voltage, current, temperature and differential-time measurements. In the photograph, the DM44 is shown with the high-performance 475A, our new, moderately priced 250-MHz oscilloscope.

Each TEKTRONIX 400-Series Portable weighs less than 26 pounds.

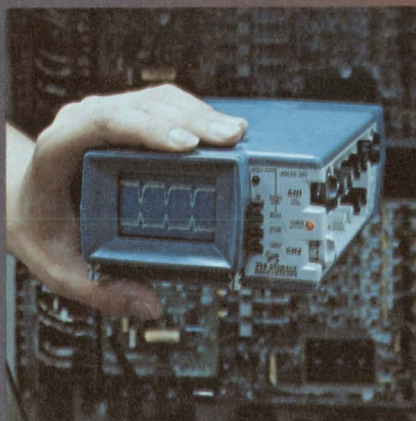

200-Series Miniscopes

These go-anywhere miniscopes are the perfect traveling companions. Powered by internal batteries or external ac, and weighing less than 3.7 pounds, 200-Series Portables fit easily into your briefcase or toolbox. Four models, with bandwidths to 5 MHz, are available. If you need to make numerical-voltage and current measurements, select the unique 1-MHz 213 DMM/Oscilloscope.

All 200-Series Miniscopes are ruggedized to withstand the high-shock conditions and extreme temperatures of remote locations.

300-Series Portables — Excellent Size/Weight/Performance Combinations

Four models from SONY/TEKTRONIX make up the 300-Series Family. All weigh less than 11 pounds, yet offer bandwidths to 35 MHz (the SONY/TEKTRONIX 335). Various oscilloscopes feature dual trace, delayed sweep, battery operation, and long-term storage.

Take SONY/TEKTRONIX 300-Series Portables with you for servicing industrial control systems, on-board ship equipment and remote computer terminals—wherever light-weight, medium-bandwidth scopes are required.

T900-Series Low-Cost Oscilloscopes

Priced from \$695,* T900 Scopes are ideal for cost-sensitive education, ser-

ving, and manufacturing applications. Choose from five bench-top models including four dual-trace and one delayed-sweep oscilloscope.

If your requirements call for a versatile, low-cost rackmount scope on your production line, the 15-MHz T922R, our new rackmount version of the popular T922, is an excellent selection. For capturing low rep-rate waveforms, examine the T912 10-MHz Dual-Trace Storage Oscilloscope.

All T900-Series Oscilloscopes are designed for ease-of-operation, simple maintenance, reliability and long life. They're the quality, low-cost scopes from Tektronix.

Service and Support Programs

Purchasing a TEKTRONIX Oscilloscope means more than buying an instrument from the industry leader. Applications assistance, training programs, worldwide service, and a large family of probes and accessories are available to help you get the most out of your TEKTRONIX Instrument. Classes in product theory and maintenance are also offered. The Long-Term Support Program insures continued parts availability. And your Tektronix Field Engineer will work with you to solve even the toughest servicing problems.

Here's How To Purchase a TEKTRONIX Portable.

To order a TEKTRONIX Portable Oscilloscope, contact your Tektronix Field Engineer. He can also arrange for a demonstration and provide complete specifications. Or for our latest Portable Oscilloscope Brochure, write: Tektronix, Inc., P.O. Box 500, Beaverton, OR 97077. In Europe: Tektronix Limited, P.O. Box 36, St. Peter Port, Guernsey, Channel Islands.

For accurate, reliable service instruments, you can depend on us.

Tektronix[®]
COMMITTED TO EXCELLENCE

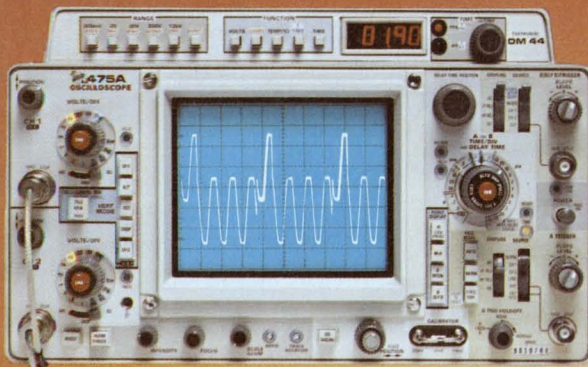

475A DM44

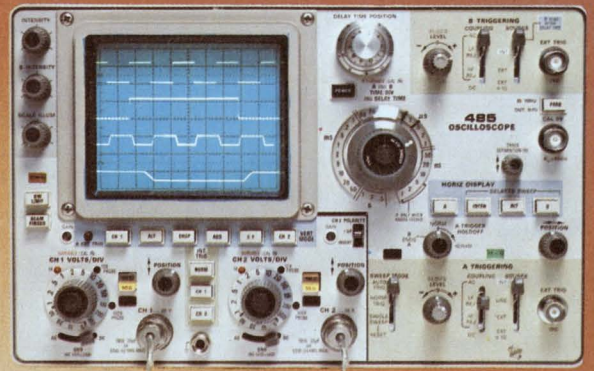

485



213

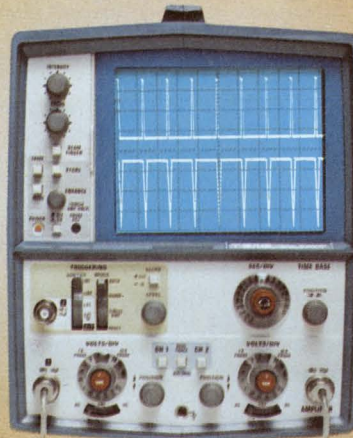

T912

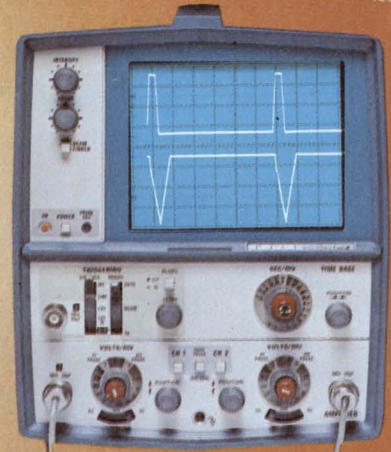

T922

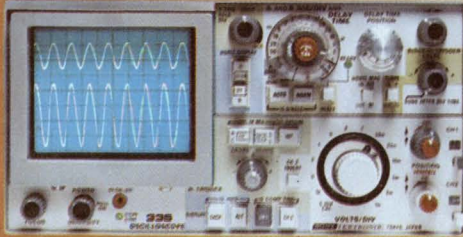

335

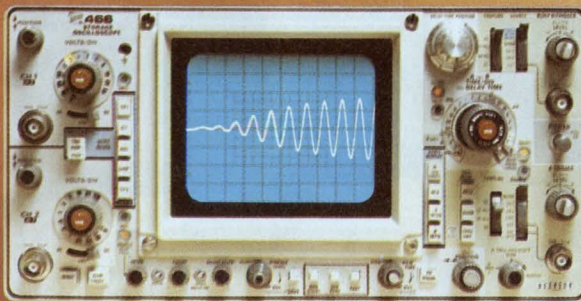

466

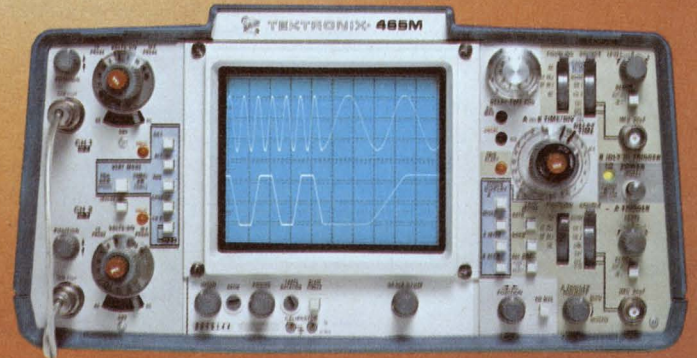

465M

	Product	Bw	Dual Trace	Delayed Sweep	Fastest Sweep Rate	Other Special Features	Price*
Storage Models	466	100 MHz @ 5 mV/div	yes	yes	5 ns/div	3000 div/ μ s stored writing speed	\$4750
	464	100 MHz @ 5 mV/div	yes	yes	5 ns/div	110 div/ μ s stored writing speed	3995
	434	25 MHz @ 10 mV/div	yes		20 ns/div	Split-screen storage	3150
	314	10 MHz @ 1 mV/div	yes		100 ns/div	Only 10.5 lbs.	2385
	214	500 kHz @ 10mV/div	yes		1 μ s/div	Only 3.5 lbs.	1475
	T912	10 MHz @ 2 mV/div	yes		50 ns/div	Low-cost bistable storage	1300
Nonstorage Models	485	350 MHz @ 5 mV/div	yes	yes	1 ns/div	Widest bw in a portable	5075
	475A (New)	250 MHz @ 5 mV/div	yes	yes	1 ns/div	High-performance 250-MHz portable	3450
	475	200 MHz @ 2 mV/div	yes	yes	1 ns/div	Highest gain-bw in a portable	3100
	465	100 MHz @ 5 mV/div	yes	yes	5 ns/div	Cost effective for 100-MHz bw	2225
	465M (New)	100 MHz @ 5 mV/div	yes	yes	5 ns/div	Triservice standard 100-MHz scope	2275
	455	50 MHz @ 5 mV/div	yes	yes	5 ns/div	Cost effective for 50-MHz bw	1795
	335	35 MHz @ 10 mV/div	yes	yes	20 ns/div	Only 10.5 lbs.	1895
	326	10 MHz @ 10 mV/div	yes		100 ns/div	Internal battery	1995
	323	4 MHz @ 10 mV/div			500 ns/div	Only 7 lbs.	1445
	221	5 MHz @ 5 mV/div			100 ns/div	Only 3.5 lbs.	995
	213	1 MHz @ 20 mV/div			400 ns/div	DMM/Oscilloscope @ 3.7 lbs.	1475
	T12	500 kHz @ 10 mV/div	yes		1 μ s/div	Low cost for dual trace & battery	1050
	T935	35 MHz @ 2 mV/div	yes	yes	10 ns/div	Low-cost delayed-sweep model	1395
	T932	35 MHz @ 2 mV/div	yes		10 ns/div	Variable trigger-holdoff	1125
	T922	15 MHz @ 2 mV/div	yes		20 ns/div	Low-cost dual-trace scope	850
T922R (New)	15 MHz @ 2 mV/div	yes		20 ns/div	Rackmount version of T922	1175	
T921	15 MHz @ 2 mV/div			20 ns/div	Lowest-cost TEKTRONIX Portable	695	
Time Interval Readout	DM44	Optional, factory-installed, direct numerical readout of time intervals and DMM functions for the 464, 465, 466, 475, and 475A					445

*U.S. sales prices are F.O.B. Beaverton, OR. For price and availability outside the United States, please contact the nearest Tektronix Field Office, Distributor or Representative. Prices are subject to change without notice.

FOR DEMONSTRATION CIRCLE #22 ON READER SERVICE CARD

Specify the panel meter you'd be proud to have designed yourself

Panel meters from General Electric can add a lot to the overall quality of your product. Accuracy. Reliability. Attractiveness.

How do you design this kind of quality?

Start with the *suspension system*. The moving parts. You'll want one of two kinds (depending on what kinds of physical abuse your panel meter may be exposed to). In a *taut band suspen-*

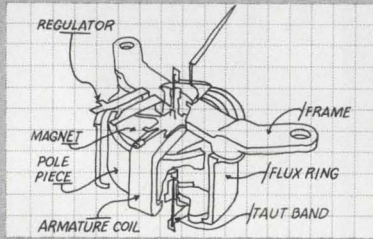

sion system, the moving mechanism is suspended between two ribbons of platinum-nickel alloy welded securely to a resilient, shock-resistant anchor. This suspension system design keeps friction to an absolute minimum.

The aluminum pointer is attached to an oversized, high-torque armature coil of fine copper wire, for fast response and accuracy you can count on.

Pivot-&-jewel suspension maintains high performance and reliability in high vibration environments. The armature assembly is supported by highly polished, hardened-steel pivots selected

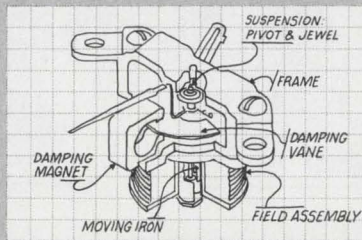

for wearability. The pivots are designed with a radius that will minimize friction level to give maximum performance. The 1/10-carat jewel bearings are of ceramic material that is stronger than glass jewels and has greater scratch and impact abrasion resistance.

Pointers are tapered to a radius point as small as .38 mm, combining high readability with superior reading accuracy. Scales on the meter face are available with mirror backing that will align the reader's eye perpendicular to the face, eliminating parallax error.

Self-protecting features are important, too. All GE panel meters are housed in a tough, *molded case* of high-impact, styrene. Special gaskets are available for assembly in **BIG LOOK®** type panel meters between the window and case to keep out contaminants. Ultrasonically placed mounting studs assure that the meter will fit your panel exactly. Choice of meter styling (**BIG LOOK®** or **HORIZON LINE®**) lets you

pick the shape and appearance that will best enhance your product. (Color masks are also available for **HORIZON LINE®** in red, blue, green, black, yellow and white.)

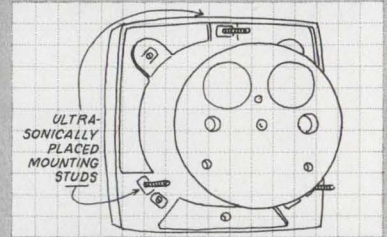

Hundreds of GE panel meters are available for almost any conceivable monitoring or measurement task.

And when you buy a GE panel meter, you also get more than 80 years of meter manufacturing experience and a sales network that is literally worldwide. For a free guide entitled, "Pick the Right Panel Meter," write to General Electric Co., Section 592-82, Schenectady, N.Y. 12345.

Specify General Electric... just for good measure.

GENERAL  ELECTRIC

CIRCLE NUMBER 23

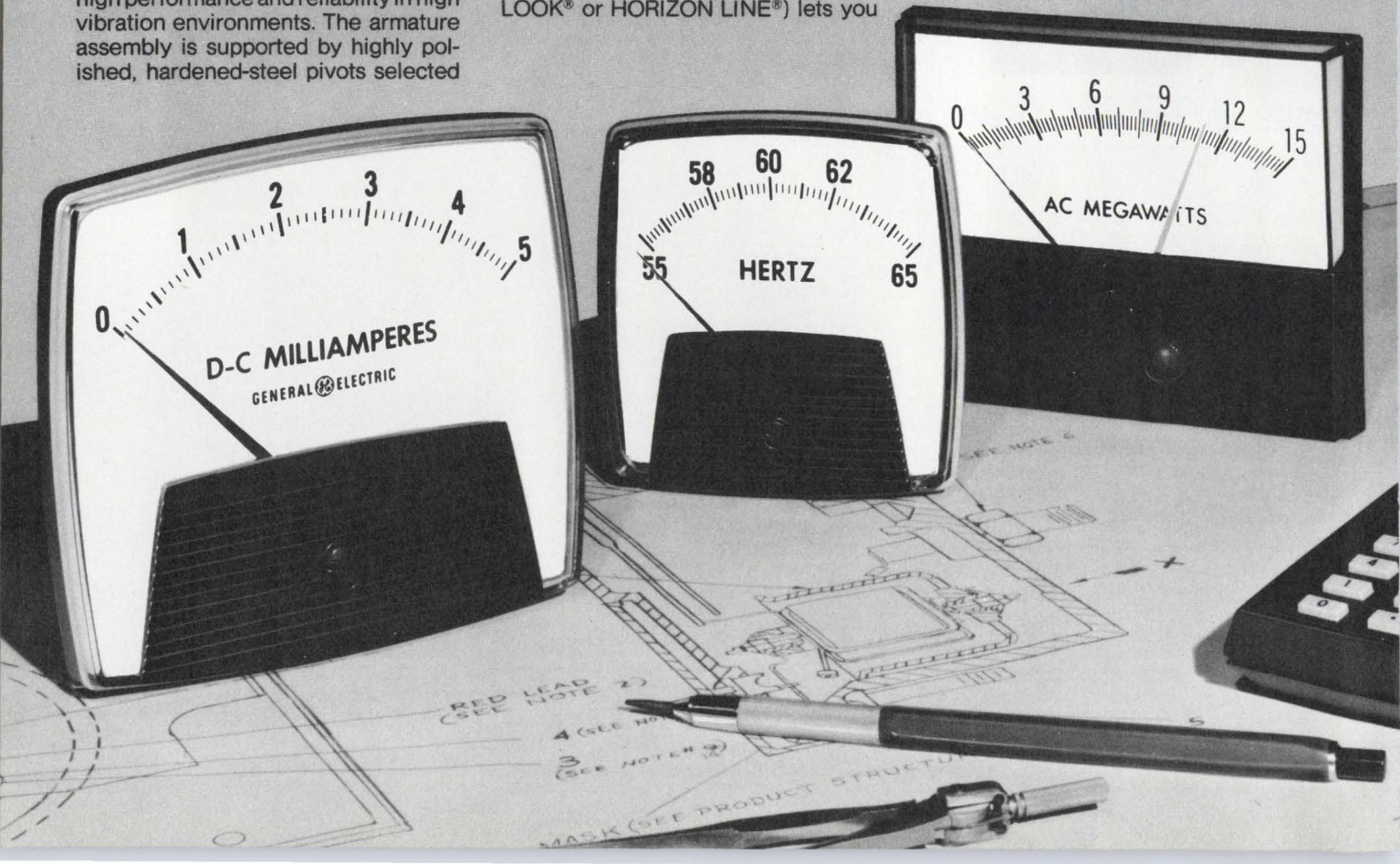

NOW



A magnetic circuit breaker that proves

LESS is MORE!

The Airpax T11 is a single pole, single throw, series trip magnetic circuit breaker that combines power switching and accurate, reliable protection in one aesthetically pleasing package. It features a patented snap-action that assures immediate and positive opening or closing of the contacts. This snap-action results in an increase in operational life of up to 5 times that previously available. It also eliminates possible operator "teasing" of the contacts and minimizes arcing.



Airpax T11 Snap-Action Magnetic Circuit Breaker.

LESS COST. The T11 costs less than any other magnetic circuit breaker on the market today . . . under \$5.00 in small quantities. Even less as the quantity increases. And the traditional Airpax Five-year warranty.

Result: MORE protection for your money.

LESS SPACE. The T11 combines power switching and current protection in one tiny package about 1 cubic inch in size. That's smaller than any other magnetic breaker. In addition, the T11 offers a choice of six attractive paddle handle colors and a variety of mounting hardware.

Result: MORE design flexibility.

LESS INSTALLATION COST. The T11 does the job of a power switch, fuse and fuse holder—all in one easy-to-mount unit. This

means only one item to be installed instead of three, less assembly time, and one-third the inventory.

Result: MORE Productivity . . . and profit . . . for you.

LESS SERVICE REQUIRED. The T11 is immediately resettable to check if a fault has been removed. There's nothing to burn out. Nothing to replace. No annoying service calls.

Result: MORE happy customers for you.

LESS GUESSWORK. Airpax has a bulletin fully describing the T11 snap-action magnetic circuit breaker, including rating, delays,

complete specifications, and a handy how-to-order chart.

Result: MORE information for you.

To get your bulletin, call your local Airpax representative or contact Airpax Electronics, Cambridge Division, Cambridge, MD 21613. Phone: (301) 228-4600. Telex: 8-7715. TWX: 865-9655. Other factories in Europe and Japan.



AIRPAX™

THE PRO IN PROTECTION

if you're designing ATE systems
you really ought to talk to
our power supplies



... hundreds of models
interface the IEEE 488 BUS
through the
KEPCO SN-488 programming system

Write Dept. BYF-05 for all the details

KEPCO®

131-38 SANFORD AVENUE • FLUSHING, N.Y. 11352 U.S.A. • (212) 461-7000 • TWX # 710-582-2631 • Cable: KEPCOPOWER NEWYORK

CIRCLE NUMBER 26

Washington report

DOD's flying air-traffic control works with FAA's

Two new airborne air-traffic control systems are electromagnetically compatible, according to flight tests conducted jointly by the Defense Department and Federal Aviation Administration.

The DOD is developing a new secure data link for communications and navigation in the 960 to 1215-MHz range under the Joint Tactical Information Distribution System (JTIDS) program. The FAA is testing a new direct-address beacon system (DABS), which has a VOR/TACAN format and is expected to replace the agency's current air-traffic control beacon system.

Since DABS will use a two-way digital data link instead of the vhf and uhf voice channels on the present FAA air-traffic control system, the all-digital JTIDS with capacities up to 57.6 kbits/s is considered a logical match for an integrated system. After more than 1000 hours of flight tests conducted this year, the agencies believe the JTIDS signal format will be compatible with the DABS's VOR/TACAN format, witnesses from the two agencies told the House transportation subcommittee.

In addition, while the FAA's current control system interrogates all transponder-equipped aircraft within the beam width of an air surveillance radar, DABS will selectively interrogate each aircraft as required.

Hughes wins second 14/12-GHz comsat award

By the end of the year, Hughes Aircraft Co. should receive a contract estimated to be worth about \$60-million to build three 14/12-GHz communications satellites for Satellite Business Systems, Washington, DC. This is the second time Hughes has been selected for this type of contract over RCA and General Electric.

While both RCA and GE offered three-axis-stabilized aircraft, Hughes proposed a spin-stabilized satellite equipped with 10 transponders, each providing a 43-MHz bandwidth and operating with at least 20 W of output power. Launches, due to begin in 1980, will use either the Space Shuttle or a conventional Delta launch vehicle.

Hughes earlier beat the same two companies to a \$70-million procurement of 14/12-GHz communications satellites for Telesat Canada. But that program has been held up by the refusal of the Canadian Radio-Television and Telecommunications Commission to permit Telesat Canada to join the Trans-Canada Telephone System.

Compass Tie ECM system to shield Air Force's F-4, A-10

The Air Force has chosen the Compass Tie electronic-countermeasures system to protect its F-4 fighters and A-10 close-support aircraft from radar-directed weapons. The system is supposed to not only warn against potential threats but also jam the incoming missiles.

One of the Air Force ground rules that the new system had to satisfy was to fit into the aircraft as modules so that no modifications to the airframe would be required. Compass Tie mounts the Westinghouse Electric Corp. ALQ-119 countermeasures pod on the wing and the ALR-69 radar warning receiver inside

the aircraft. Parts of the receiver's detection subsystem are provided by the Applied Technology Div. of Itek and the Dalmo Victor Div. of Bell Aerospace Textron, which also contributes the digital processor.

British fault finder uses μ Ps, floppy discs

A British-developed fault-finding test set employing floppy discs and micro-processors will soon be available in this country. Earmarked initially for field maintenance of military radios and other tactical electronics equipment, it will later be geared to commercial applications as well.

Diagnostic routines written in simple English are stored on discs in the set to help semiskilled maintenance personnel check their progress at each step of a field repair job. A typical routine uses 45 of the 70 tracks on a disc (3000 bits per track), and the interactive graphics are displayed on a ruggedized CRT display controlled by a Motorola 6800.

Prototype models of the system were demonstrated by Racal-Tacticom Ltd., Reading, England, at the company's own trade show in London. Although the initial applications are military and Racal is trying to sell the system to NATO armies, company officials say the same simple diagnostic routines could be adapted to medical purposes or to checking out consumer items, such as television sets. Production cost for each unit should be about £7000, or almost \$12,000.

Dutch, British to help keep NASA telescope in space

With the help of The Netherlands and Great Britain, a NASA cryogenically cooled infrared telescope will be orbiting the earth in 1981 and mapping the entire sky at infrared wavelengths. Such wavelengths can't be detected by earth-based telescopes because of the obscuring effects of the earth's atmosphere.

The IR telescope will be built for NASA by Ball Brothers Research Corp. of Boulder, CO. The orbiting satellite will be provided by the Netherlands Agency for Aerospace Programs, and the United Kingdom Science Research Council will operate a command, control and data-acquisition facility from the Appleton Laboratory near London.

Capital Capsules: The Cost Accounting Standards Board will relax its regulation of government contractors effective next March 10 unless its new guidelines are overturned by Congress. In the past all contractors have had to follow the board's accounting procedures, but **the new regulations will excuse companies determined by the Small Business Administration to be small business concerns The first fire-control unit for the U.S. version of the European Roland antiaircraft missile system will be delivered this month to the Army.** The unit was built by Boeing, subcontractor to Hughes Aircraft Co., which is building Roland under license to Euromissile, a Franco-German joint venture. Tests will be conducted at the White Sands Missile Range in New Mexico, the Aberdeen Proving Ground in Maryland, and in Alaska and Panama Under a \$20.7-million grant from the National Science Foundation, Cornell University has begun building a **12-billion electron-volt synchrotron to search for quarks in the nucleus of the atom.** The system, due to be completed by the fall of 1979, will store the energy of electron beams for several hours at a time in a 10-foot-long, 6-foot-diameter superconducting magnet NASA has given up on launching a spacecraft to investigate Halley's Comet when it approaches the earth in 1986, but is putting an extra \$3-million into its planned **1982 launch of spacecraft to orbit Jupiter and to fire instrumented probes into the Jovian atmosphere.** The money was taken out of funds previously earmarked for additional spacecraft missions to Mars.



Fill in the Blank.

If you're concerned about fitting your test and measurement equipment to a specific application, take this test. There's only one question so give it a try.

See if you can answer this: The TEKTRONIX TM 500 family of modular instruments includes (check one)

- DMMs
- Counters
- Generators
- Amplifiers
- Power Supplies
- Oscilloscopes
- Logic Analyzers
- Word Recognizers
- Digital Delay
- All of the above, plus

If you checked "All of the above, plus _____," nice going. You're close. But what did you put in The blank? An analog multiplier? Relay circuit? Switches for signal routing? Test oscillators at pre-set frequencies? Digital logic circuits? Converters? Special processors?

To be completely correct, your answer should include any one of these, or some other non-standard item, because TM 500 configurabil-

ity not only allows you to choose from over 30 ready-to-go, compact plug-ins for testing and measuring, but the mainframe also makes room for compatible custom plug-ins you assemble yourself with a TM 500 custom Plug-in Kit.

A TM 500 custom Plug-in Kit includes a perforated main circuit board, all mechanical components to assemble a complete plug-in, plus instructions on mainframe electrical compatibility.



The kits are available in both single and double compartment sizes. One single compartment version includes all the components for 3 voltage regulators at the rear of the board. With your TM 500 you can receive on request TM 500 Construction Notes to build special-purpose instruments including parts lists and schematics.

So, by just filling in a blank plug-in, your TM 500 can measure up to just about any highly specialized application, saving you hours of set-up time.

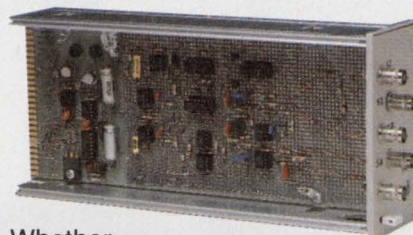

Whether you need a rackmount, roll-around or go-anywhere portable, the TM 500 gives you one tidy instrument with a lot of plug-ins, not a lot of plugs. It's configurable other ways, too.

Ask your local Tektronix Field Engineer. He can fill in all the blanks.

TM 500 Designed for Configurability

For configurable, accurate and reliable test and measurement instrumentation, contact: Tektronix, Inc., P.O. Box 500, Beaverton, Oregon 97077, (503) 644-0161 Ext. 5283. In Europe: Tektronix Limited, P.O. Box 36, St. Peter Port, Guernsey, Channel Islands.

Tektronix
COMMITTED TO EXCELLENCE

**AMP has many high powered solutions
to your high current problems.**

**And they include our people as well as
our products.**





Because we believe that when you specify AMP high current connectors, you are entitled not only to the best components we can build but also to the best technical support we can provide. That's why it's our policy to work with you in production, in quality control, in sampling for prototyping and on future improvements, whenever you require or request it. We want to become involved early enough to make sure you'll find a better way to get the most out of your products with our products.

And our power connector line can do that. Take AMP Power Lock Connectors. They feature hermaphroditic contacts and snap-together housings that provide unlimited variations and reduce inventory at the same time.

Then there are our economical rectangular High Current Commercial Connectors that incorporate a positive locking feature and silo construction housings. They are suitable for both free hanging and panel mounted applications and are UL recognized for 35A, 125V circuit breaking.

Or perhaps our Circular Plastic Connector series, rated up to 35A, can best solve your current problem. Or our Hi-current Edge Connectors for printed circuit applications up to 30A.

Why not learn more about all the product and people solutions we have for your high current problems. Just call Customer Service at (717) 564-0100. Or write AMP Incorporated, Harrisburg, PA 17105.

AMP has a better way.

AMP
INCORPORATED

CIRCLE NUMBER 27

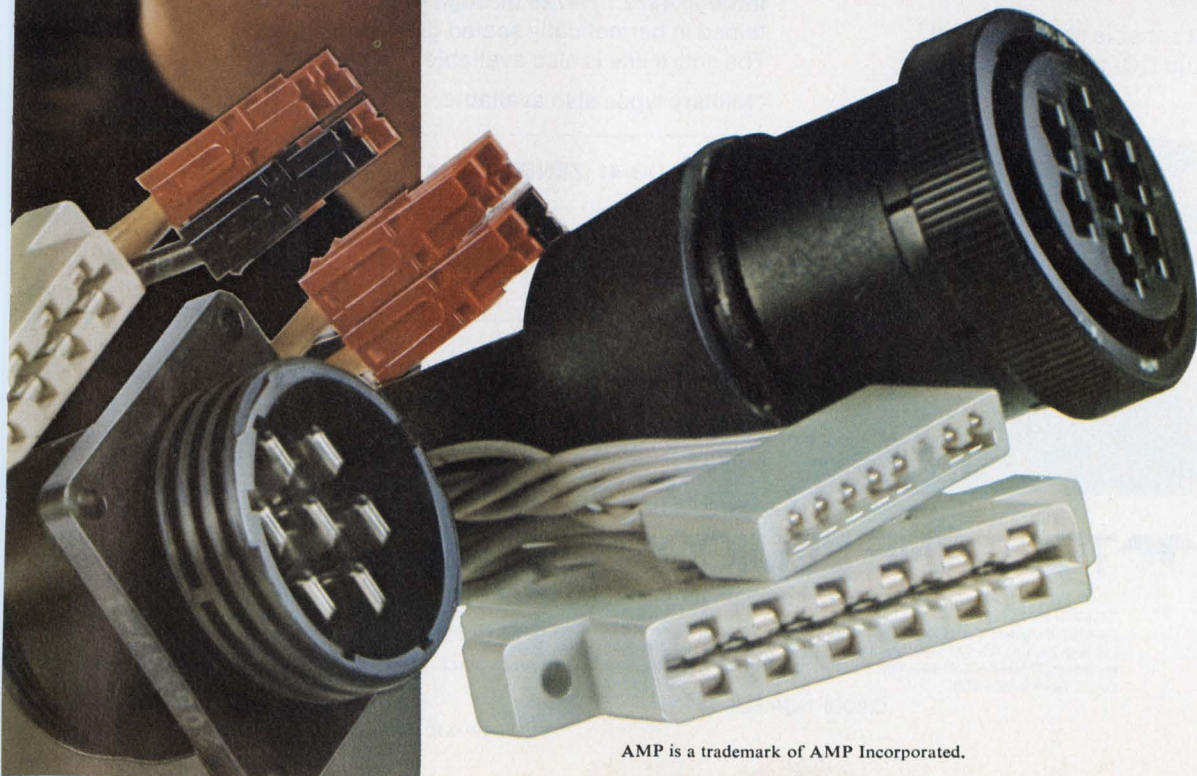

AMP is a trademark of AMP Incorporated.

OUR ZENERS HAVE BEEN PART OF EVERY MAJOR HI REL PROGRAM FOR 17 YEARS.

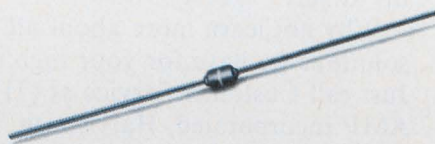

Our 400 mW zeners have been integral to Hi Rel programs ever since we started building them 17 years ago. You'll find them on Hawk, Minuteman, Trident, F-14 to name just a few. But they make up only a small part of our total zener line. Others range from 250 mW to one watt, from 2.4 volts to 100 volts, include a wide range of T.C. types, and are competitively priced for commercial applications.

Our popular one-watt zener is shown here. It features the PowerStud DO-41 package design

with extra large 55 mil studs for improved heat transfer from the die. The rugged, hermetically sealed glass body provides improved reliability over the full operating temperature range.

The following zener diodes are immediately available: **1N702 through 732, *1N746 through 759, 1N957 through 961, *1N962 through 984, 1N3506 through 3534, 1N4099 through 4123, *1N4370 through 4372, 1N4725 through 4764.** All are contained in hermetically sealed glass packages. The entire line is also available in dice form.

*Military types also available.

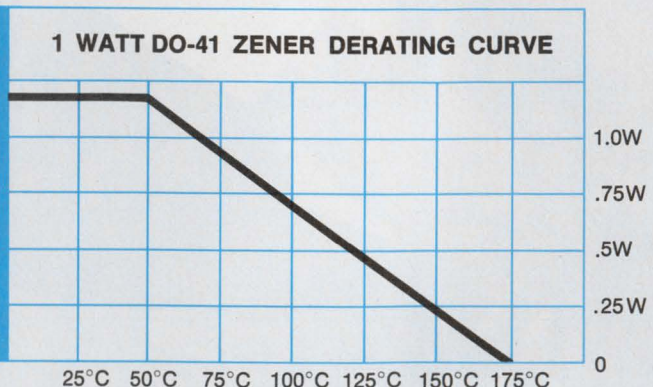
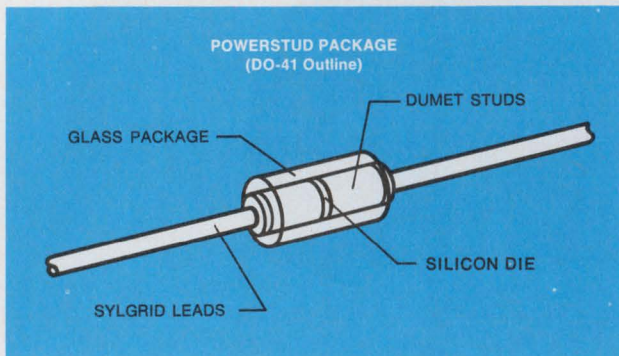

TELEDYNE SEMICONDUCTOR

1300 Terra Bella Avenue, Mountain View, California 94043 Tel: (415) 968-9241 TWX: 910-379-6494 Telex: 34-8416

SALES OFFICES:

DOMESTIC: Salem, N.H. (603) 893-9551; Stony Brook, N.Y. (516) 751-5640; Des Plaines, IL (312) 299-6196;

Los Angeles, CA (213) 826-6639; Mountain View, CA (415) 968-9241 • INTERNATIONAL: Hounslow,

Middlesex, England (44)-01-897-2503; Tiengen, West Germany 7741-5066; Kowloon, Hong Kong 3-240122;

Tokyo, Japan 03-405-5738.

CIRCLE NUMBER 28

'Road work'

At one stage in my army career, I managed to become a member of the camp's boxing team. I did this, not because I am overly fond of punching people—or being punched. Rather, it afforded special advantages on Saturday mornings when everybody else was engaged in policing the camp grounds or in close-order drill—activities that never ranked among my favorites.

At such times, if an officer telephoned the gym to check on members of our team, one of us would be on hand to say that we were out doing "road work." We never bothered to undeceive those officers who took this to mean that we were jogging or running to improve our stamina in preparation for matches with boxers from other camps. In fact, I now confess, our "road work" took the form of hitchhiking to the nearest city, where some of us wandered along Maiden Lane, seeking one.

Nobody suffered then from our improving the meaning of words, and some of us, indeed, derived pleasure from it. But today many of us are injured when words are used to mislead. When a power-supply manufacturer tells a customer, "This supply can deliver 5 volts and 40 amperes," and fails to add, "but not at the same time," he's hurting with our "road work" gimmick. When an instrument manufacturer hails his ultra-low "percent error," without telling the percent of what, he's injuring with our "road work" ploy. When an employer promises a salary hike, then reneges with "I meant next year," or "when business gets better," he's using "road work" to deceive and exploit.

"Road work" doesn't always hurt, even when it may deceive. A photographer friend who used to sell baby photographs to mothers was often compelled to comment on the attractiveness of an infant. Usually he had little trouble enthusing with "My, what a beautiful baby!" But sometimes the best he could manage was "My, that *is* a baby!" An admirable use of "road work."

But it's unfortunate that our language and morality are so flexible that they can be bent to hurt. It's unfortunate, too, that most of us must waste precious effort digging for the real meaning of "road work."



George Rostky

GEORGE ROSTKY
Editor-in-Chief

INTRODUCING DELCO ELECTRONICS' MONOLITHIC OPERATIONAL AMPLIFIER

If you're now using discrete power output transistors, we've got an alternative that gives you design versatility.

It's the DA-101—Delco's Monolithic Operational Amplifier—with all the circuitry you need in one compact package.

The Monolithic Operational Amplifier (MOA) has two separate gain and power stages contained in a modified dual-in-line package.

The DA-101 operates from a 10- to 16-volt DC supply and can be used in an audio bridge configuration with floating speaker output, or as two separate amplifier-speaker systems.

The MOA means weight savings in more ways than one. Besides reducing the total number of components you need, the MOA has a copper mounting surface to assure ample heat transfer to the convector. The tab negative or ground connection eliminates the need for mica insulation.

In fact, the design of one power megaphone showed a components weight savings of 65 percent.

Our new MOA means added design application flexibility, too. In automotive and home entertainment systems, two-way communication systems, power

megaphones, motor controls, various H switch applications, and more.

Another advantage of our Monolithic Operational Amplifier is its durability. It has integral protective circuitry for not only overvoltage, but temperature, current conditions and shorted outputs as well.

And it can be mounted by either direct soldering to a printed circuit board or through

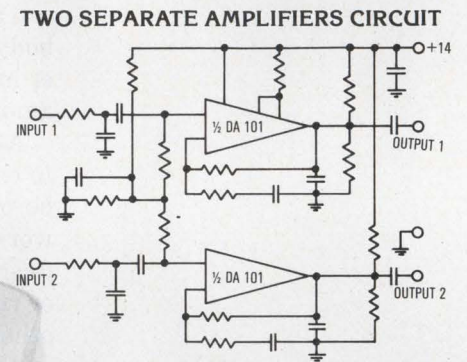
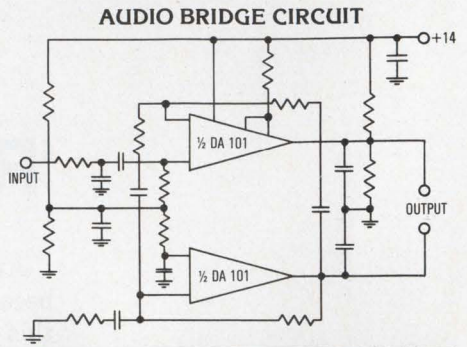
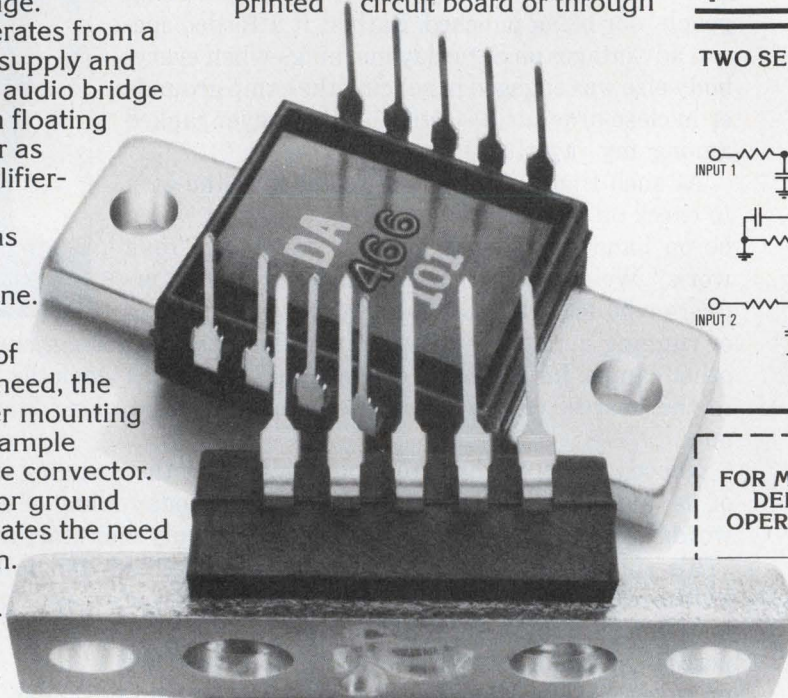

FOR MORE INFORMATION ABOUT DELCO'S NEW MONOLITHIC OPERATIONAL AMPLIFIER, MAIL THIS COUPON TO:

Delco Electronics Division
General Motors Corporation
Marketing Services MS A-213
700 E. Firmin Street
Kokomo, Indiana 46901

NAME _____ TITLE _____
COMPANY _____
ADDRESS _____
CITY _____ STATE _____ ZIP _____
PHONE _____

Delco Electronics



01

ED11/8

ABSOLUTE MAXIMUM RATINGS

Supply Voltage	24V
Operating Voltage	16V
Peak Current	3A
Storage Temperature	-55°C to 150°C
Power Dissipation	22W

ELECTRICAL CHARACTERISTICS

	TYPICAL
V _{CC} = 14V dc	
I _{idle} , P _{out} = 0W	40mA
Differential Input Bias Current	0.80 μA
Open Loop Gain	90dB
Power Out @ 5% Distortion	
4Ω Bridge	6W
4Ω Non-bridge	3.5W

THERMAL CHARACTERISTICS

Thermal Resistance, R _{θJC} (Typical)	4° C/W
------------------------------------------------	--------

the use of a suitable socket.

For more information, return the coupon on the right, contact an authorized Delco distributor, or call your nearest Delco sales office: Kokomo, Ind. (317) 459-1271; Charlotte, N.C. (704) 527-4444; or Van Nuys, Cal. (213) 988-7550.

DERATING CURVE

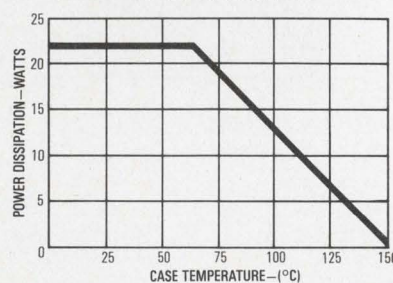

The catalog designers can't buy.*

The new 448-page PMI catalog is packed with parts—MUX's, REF's, op amps, comparators, DAC's, and plenty of others, including a big section on chips that you can order by grade to guaranteed specs. It also provides 91 pages of application notes, an explanation of PMI's QA program, and selection guides that make it easy to find the best device for your application. For example, we include a guide for op amps that lets you find the one you need **by function**.

If you're involved in design, we'll be glad to send the catalog without charge. Just fill out the coupon and send it. It'll be our pleasure.

Here's the subject index:

- Numerical Index
- Ordering Information
- Q. A. Program
- Industry Cross Reference
- Functional Replacement Guide
- Operational Amplifiers
- Comparators
- Matched Transistors
- Voltage References
- D/A Converters - Linear
- D/A Converters - Companding
- Multiplexers
- Definitions
- Chips
- Application Notes
- Package Information
- Notes

Mail to:
Precision Monolithics, Inc., 1500 Space Park Drive
Santa Clara, CA 95050

I'm involved in design. Send me the new PMI catalog.

My name: _____

Title _____

Company _____

Department/division _____

Address _____ Mail Stop _____

City _____ State _____ Zip _____

Phone (_____) _____ - _____

Precision Monolithics Incorporated
1500 Space Park Drive
Santa Clara, California 95050
Telephone: (408) 246-9222
TWX: 910-338-0528
Cable: MONO



CIRCLE NUMBER 9

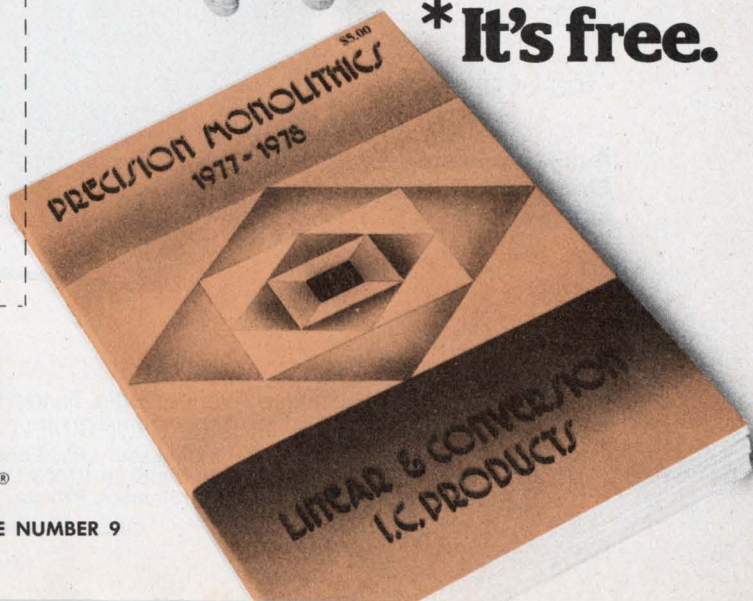

*** It's free.**

There's a Simpson DPM that's right for your application

All Simpson DPM's feature:

- 0.1% accuracy
- 3-1/2 digit readout
- Automatic zero and polarity
- Dependable LSI circuitry
- Choice of 120/240 V AC or 5 V DC operation
- Panel cutout 1.682" x 3.622". Adaptors available for IEC/DIN and other domestic cutouts
- Input/output edge connector included
- Full 200 hour burn-in
- Backed by the Simpson one-year warranty



Model 2860

The Dedicated DPM

New Series 2860—high performance at a low price

from **\$49***

- 9 stock ranges available
- Bright 0.43" LED readout

The Systems DPM

Deluxe Series 2850—printer/computer interfacing capability and options for custom applications

\$92*

- 9 stock ranges
- Specials available including AC ranges
- Choice of 0.43" LED or 0.55" planar gas discharge display
- BCD output standard

*100-lot OEM prices

Available From
Electronic Distributors
Everywhere

Write for Bulletin P612
containing complete
technical specifications.



Model 2850



Model 2852

SIMPSON ELECTRIC COMPANY

853 Dundee Avenue, Elgin, Illinois 60120

(312) 697-2260 • Cable SIMELCO • Telex 72-2416

IN CANADA: Bach-Simpson, Ltd., London, Ontario

IN ENGLAND: Bach-Simpson (U.K.) Ltd., Wadebridge, Cornwall

IN INDIA: Ruttonsha-Simpson Private, Ltd., Vikhroli, Bombay

CIRCLE NUMBER 31



A-B quality trimmers for the same price as "B" trimmers.

Accept nothing less than Allen-Bradley quality in trimmers, especially when it doesn't cost you any more. The real decision is whether to use our Type 90 or Type D. Both are cermet, single-turn with a choice of top, side or through-the-board adjustment.

We have what you need; our distributors have it when your need is now. Ask for Publication 5242 (Type 90) and 5240 (Type D).

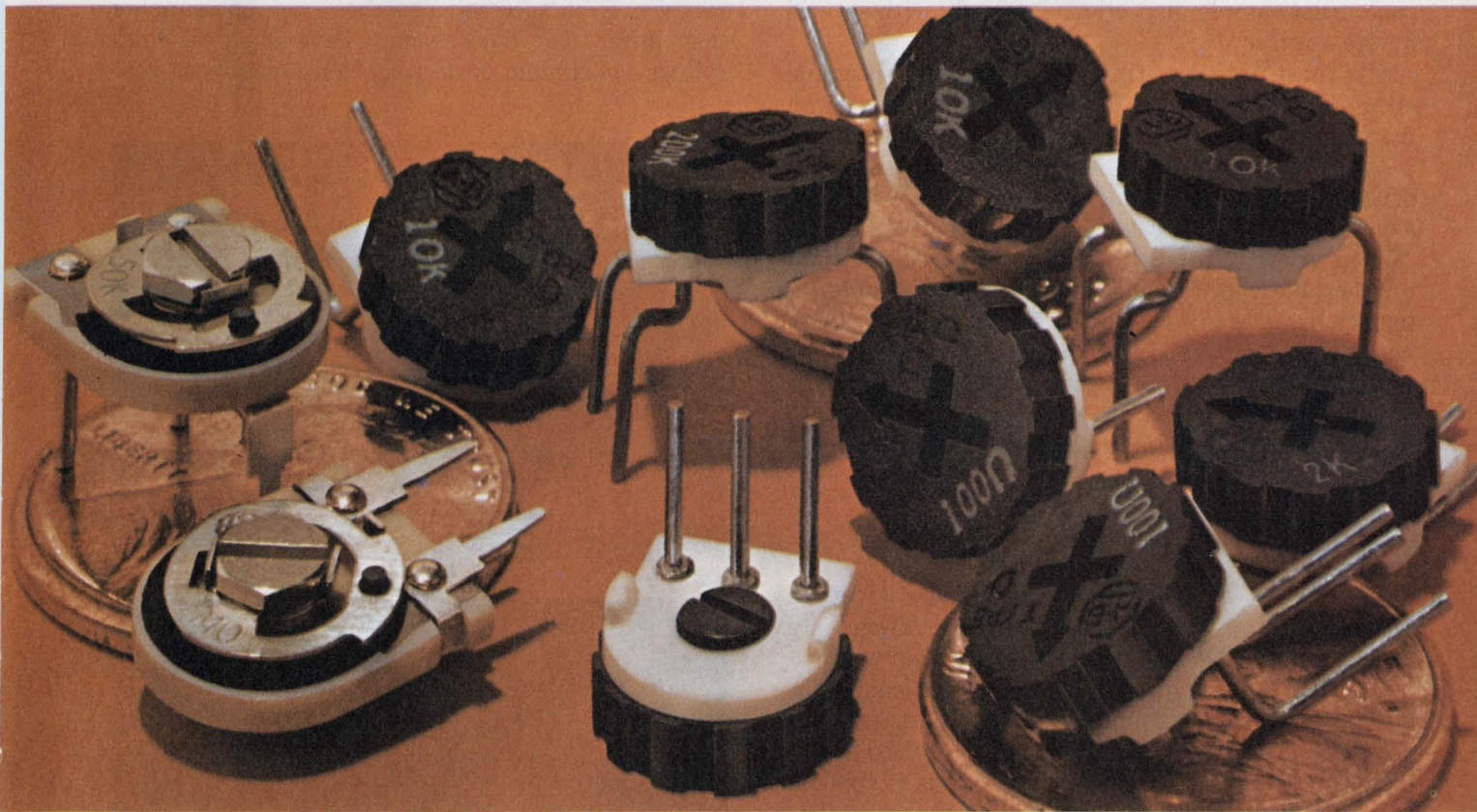
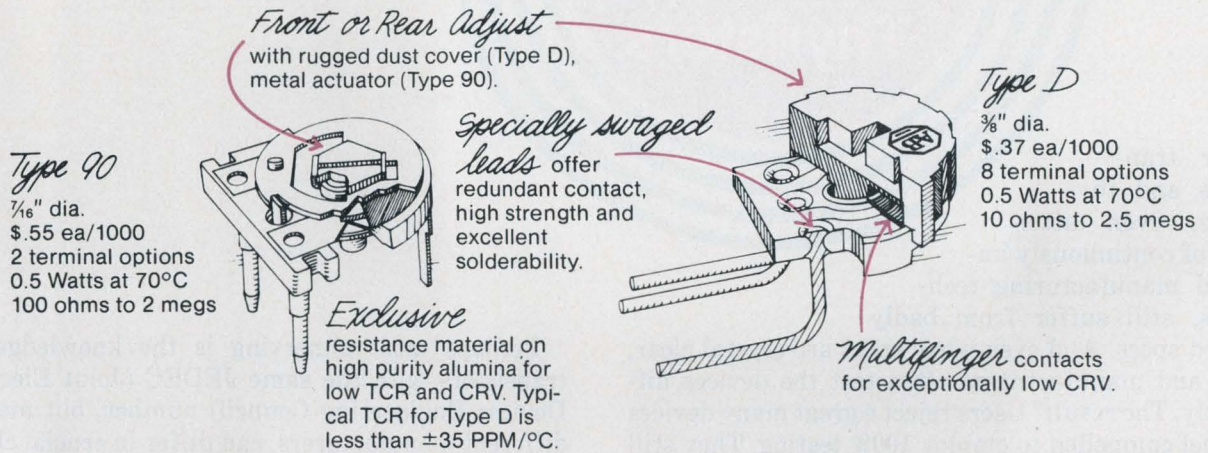

Quality in the best tradition.



ALLEN-BRADLEY
Milwaukee, Wisconsin 53204

CIRCLE NUMBER 32

Focus on Power Transistors and Thyristors

Power transistors and thyristors, even after years of continuously improved manufacturing techniques, still suffer from badly defined specs. And even when specs are crystal clear, users and manufacturers often test the devices differently. The result? Users reject a great many devices and feel compelled to employ 100% testing. They still can't trust sample inspection, especially with several device sources.

Mix the different testing methods in with perennial spec misunderstandings and you have all the ingredients for costly errors and unreliable equipment.

Moreover, spec sheets are often primarily sales-oriented. "Power-semiconductor specs are written in a positive sense," one advertising executive admits. "When properly interpreted, the spec need not state unfavorable specifications or reveal undesirable interactions. Design engineers should know enough about power-semiconductor performance so that, for example, they won't expect all maximums to be available at the same time," he explains. In other words: Be careful! What a spec sheet doesn't tell you can be hazardous to your circuit.

Let the buyer beware

Even when data for power semis are given in abundance, the specified operating conditions are usually unrealistic and almost never fit your particular needs. However, in fairness to semiconductor manufacturers, semiconductor-device characteristics are complicated, and spec sheets have limited space. Manufacturers will supply you with reams of application notes and other engineering aids, when asked. The response is often overwhelming in detail. But then, the problem is to separate the factual data from the sales pitch.

Perhaps most unnerving is the knowledge that transistors with the same JEDEC (Joint Electronic Devices Engineering Council) number, but made by different manufacturers, can differ in crucial characteristics. Even successive batches from one supplier may differ. The devices may have identical limit ratings—maximum open-base, collector-to-base volt-

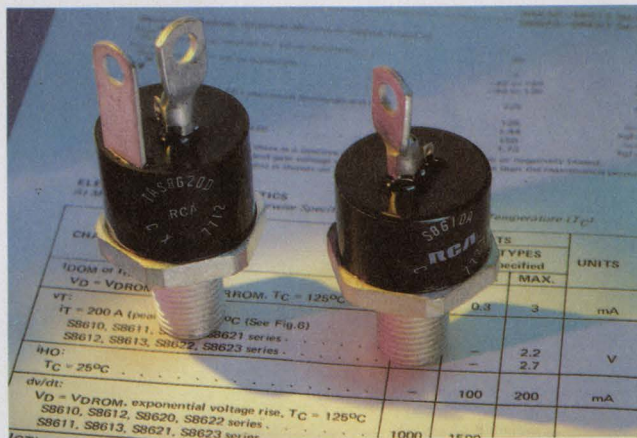

Morris Grossman
Associate Editor

age (V_{cbo}), maximum collector current (I_c), etc. But temperature effects, various derating factors and detailed switching characteristics can be very dissimilar.

"Cut open and closely examine samples from each batch of devices you receive," advise many power-semiconductor users. "You could be getting satisfactory results from a manufacturer for months, even years. Suddenly, thousands of your widgets start coming back because of out-of-spec performance, or even worse, failure in the field." Unknown to you, the semiconductor-device manufacturer has changed his manufacturing process, perhaps quite subtly. So despite meeting published limit specs and satisfying even your own tests, the devices behave improperly in your circuit.

Chip size, structural geometry, dopant processing—even testing—may have been changed. What were

formerly single-diffusion devices now may be made by double or triple-diffusion methods. And single or multiple-epitaxial processing may have been used instead of diffusion to form some of the device's elements. Mesa structures may have been replaced with planar, or vice versa. Your power transistor may indeed be improved—faster, for example—but in your circuit, the improvements can spell disaster.

For example, an old and widely used transistor, the npn 2N3055, is listed by RCA as having a single-diffused (Hometaxial) structure that yields a gain-bandwidth product, f_T , of 0.8 MHz (RCA now also makes an epitaxial design, designated with an H suffix). But the same-numbered unit from Motorola, made with an epitaxial-base structure, has an f_T of 2.5 MHz. Fairchild doesn't say what structure it uses, and doesn't list a value for f_T in its "Power Data Book."

Try to compare the functional differences that

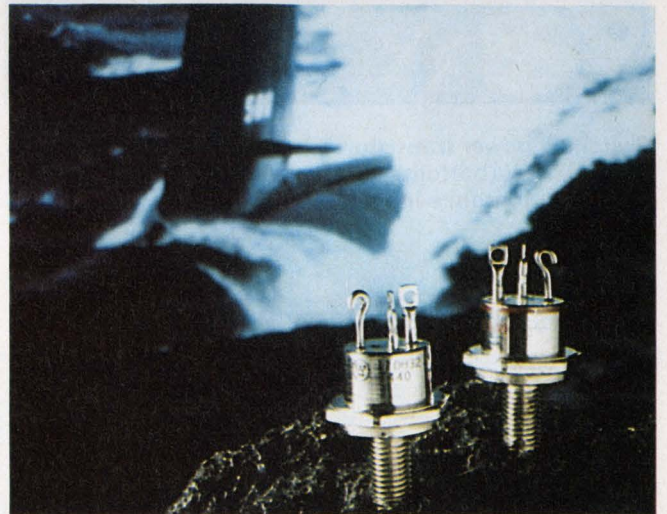
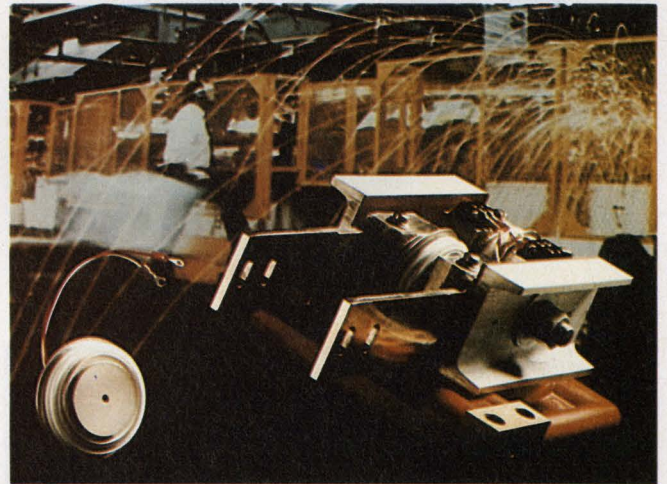
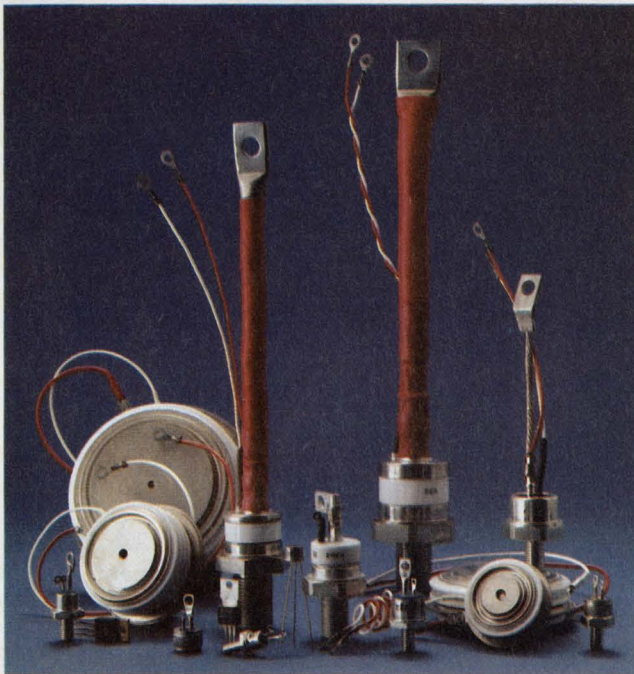

Many companies make both power transistors and thyristors. RCA concentrates on the lower and middle end of the power spectrum with a very extensive line of linear and switching power transistors, triacs, and SCRs (far left). Westinghouse, however, tends to handle mainly larger devices for power supplies, inverters and vehicle controls (right). And International Rectifier's devices overlap both groups (center).

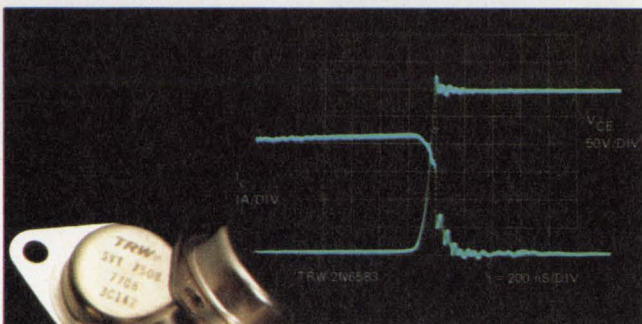
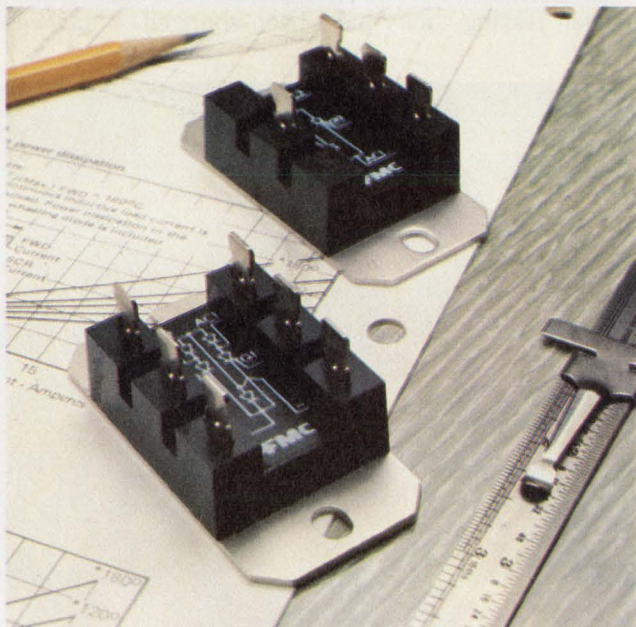
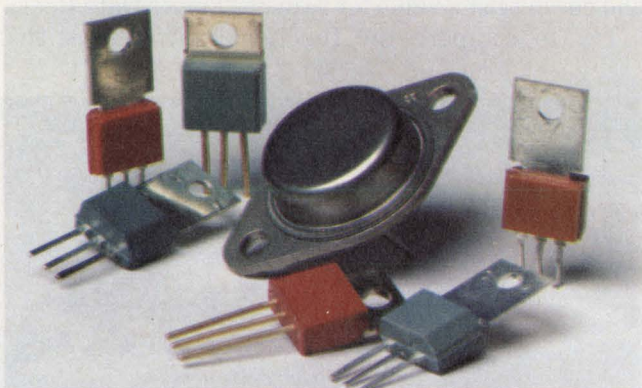
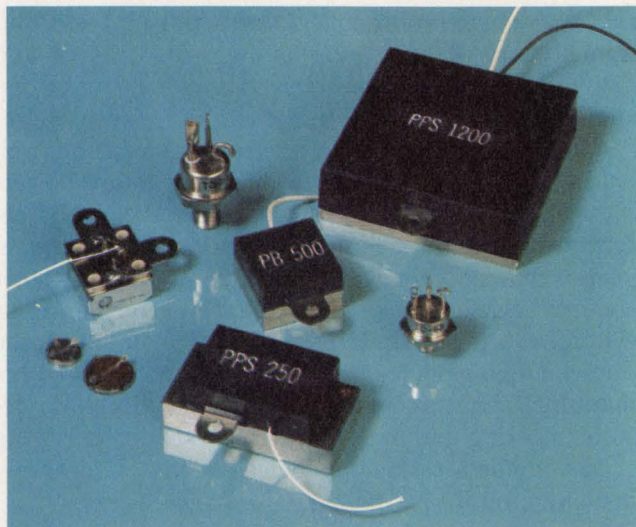
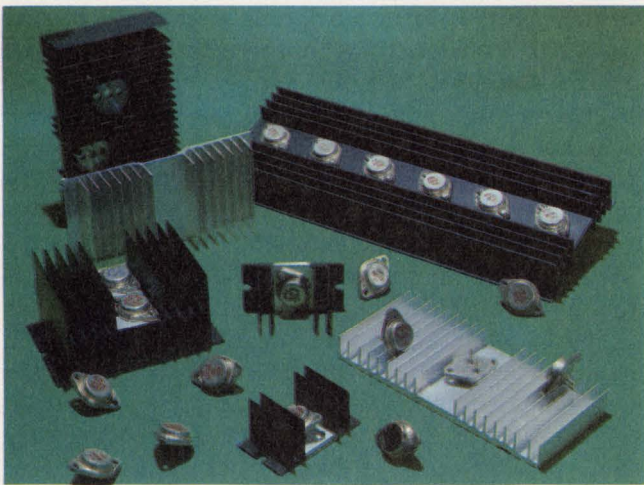

Switching power transistors, such as made by Delco (top), GE and TRW (bottom), fill the needs of switching-power-supply, automobile-ignition and solid-state relay applications.

Specially packaged power devices for conveniently mounting or even eliminating heat sinks help ease design engineer's problems. PowerTech's blocks of matched series and parallel singly-diffused power transistors (top) allow you to handle higher currents and voltages than you can manage with single transistors. And FMC Corporation's encapsulated SCR assemblies (bottom), like these 30-A-rated bridges, cut costs by mounting several SCRs and diodes in a single assembly.

Transistor physical trade-offs

Physical variables		Electrical characteristics									
		f_T	t_r, t_f	V_{ce0}	$V_{ce(sat)}$	V_{be}	h_{fe}	I_C	$I_{s/b}$	$E_{s/b}$	
Base width	↑	↓	↑	↑	↑	↑	↓	↓	↑	↑	
Base resistivity	↑	—	↑	—	↓	↑	↑	↓	↓	↓	
Collector width	↑	↓	↑	↑	↑	↑	—	↓	—	↑	
Collector resistivity	↑	↓	↑	↑	↑	↑	—	↓	↓	↓	
Emitter width (finger)	↑	↓	↑	—	—	↑	—	↓	↓	↓	
Emitter ballast	↑	↑	↓	—	↑	↑	—	↑	↑	—	
Collector ballast	↑	↓	↑	—	↑	—	—	↓	—	↑	

follow from this difference in f_T . Study the three manufacturers' data books closely and you will discover that each has elected to publish a different set of characteristics curves—almost none corresponding to another. RCA's curves for the single-diffused 2N3055 appear more useful for general-purpose linear power-amplifier work. Motorola's curves are aimed at power-switching applications. And Fairchild's few curves are aimed both ways. Even taken together, the curve sets fail to describe all the device's properties.

You can have one or the other

If variations within a single type number make it difficult to compare devices from several sources, imagine how difficult it is to compare different types. For one thing, the trade-off possibilities are many. If you want speed, transistor base widths must be made thin and breakdown voltages must go down. If you want high gain, you must usually sacrifice high-current-handling capability. But the trade-offs aren't simple exchanges of desirable properties: Parameter interactions abound—and they are complicated (see trade-off tables). And the lack of clarifying data in the manuals and spec sheets doesn't help.

However, a data curve that is seldom missing, thanks to JEDEC, is the safe-operation-area (SOA) curve. But be careful: The curve is usually drawn for a case temperature of 25 C, and must be derated to get practical values.

Although 25 C is almost a universal standard, it is a completely unrealistic temperature for power semiconductors. Ambient temperature in the typical power assembly can easily run to 80 C; consequently, case temperature is enough to fry eggs.

"One of the most common misunderstandings of design engineers is to believe that maximum ratings are practical normal operating values," observes Pete Woods, application manager at TRW. "Some manufacturers' power ratings are at best only figures of merit," he warns. So, if a transistor's spec sheet claims "115-W dissipation at 25-C case temperature," don't jump to the conclusion that you really can use the transistor at 115 W. You can't even get near it.

Simple multiplication shows that if 115 W were dissipated with a typical thermal resistance of 1.5 C/W, a power transistor's case temperature would be 172.5 C above the junction temperature. To maintain the case at 25 C, the junction would somehow have to be held at -147.5 C. So now you are faced with having to derate the 25-C rating to get a practical value. And the derating is usually drastic.

After you are through derating the unit—you'll usually find the derating factor in the fine print, or a derating curve, on the next page—only about 10% of the 25-C values can be attained. And even this 10% provides hardly any safety factor.

Say the case-to-ambient thermal resistance for the unit rated at 115 W is 10 C/W and junction-to-case is 1.5 C/W. Then, for only a 10-W dissipation in an

Transistor electrical trade-offs

Major electric characteristics	f_T	t_d, t_r t_f, t_s	$V_{ce(sat)}$	h_{fe} (peak)	$I_{c(max)}$	Cost
$I_{s/b}$	↑	↓	↑	↓	↑	↑
$E_{s/b}$	↑	↓	↑	↓	↓	↑
$V_{ceo(sus)}$	↑	↓	↑	—	↓	↑

Transistor processing trade-offs

Impurity and structural processing techniques	Ruggedness ($E_{s/b}$)	Switching speed	Voltage (V_{ceo})	Production cost
Single diffused (mesa)	most (6 to 10 J)	slow (5 kHz)	lowest (to 250 V)	least
Triple diffused	medium (1 to 3 J)	medium (20-40 kHz)	medium (to 800 V)	med.
Epitaxial (planar)	least (0.1 to 0.6 J)	fast (to 100 kHz)	highest (to 2000 V)	most

ambient of 80 C, the case temperature rises to 180 C. Also, the transistor junction temperature rises to 195 C, which is perilously close to the limit of 200 C for silicon units in metal cans.

Be safe instead of sorry

Other rating parameters, which many design engineers fail to appreciate are not practical design data, are the maximum values for V_{ceo} , V_{cer} and V_{cex} . The V_{ceo} rating is lowest when all three are measured under similar test conditions—usually with an I_c between 10 and 200 mA. However, at operational currents, which are usually much larger than the test current, V_{cer} and V_{cex} limits approach V_{ceo} . So, despite the claim by some manufacturers that V_{cer} and V_{cex} are more representative of operational conditions, for high currents—particularly, in inductive-switching applications—in general, choose a device based upon the lower V_{ceo} rating. But remember, V_{ceo} is a figure of merit, not a design value. Some manufacturers, however, now define V_{cex} under high-current conditions, and even at a more realistic case temperature of 100 C than the usual 25 C.

Another specification many engineers don't understand is reverse-bias secondary-breakdown ratings ($E_{s/b}$). Many believe that you can determine $E_{s/b}$ from the SOA. Not so: Rating $E_{s/b}$ is divorced from anything that appears on SOA curves. This breakdown rating measures the energy (in joules) that can be "safely" absorbed when collector current avalanches under reverse-bias conditions. This secondary break-

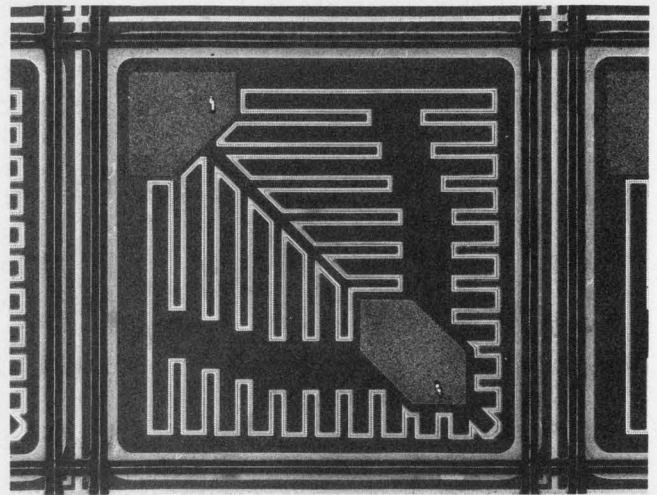
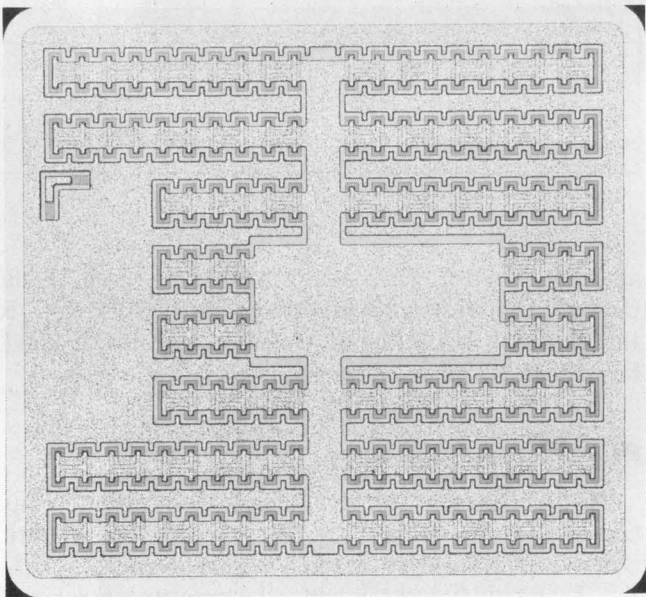
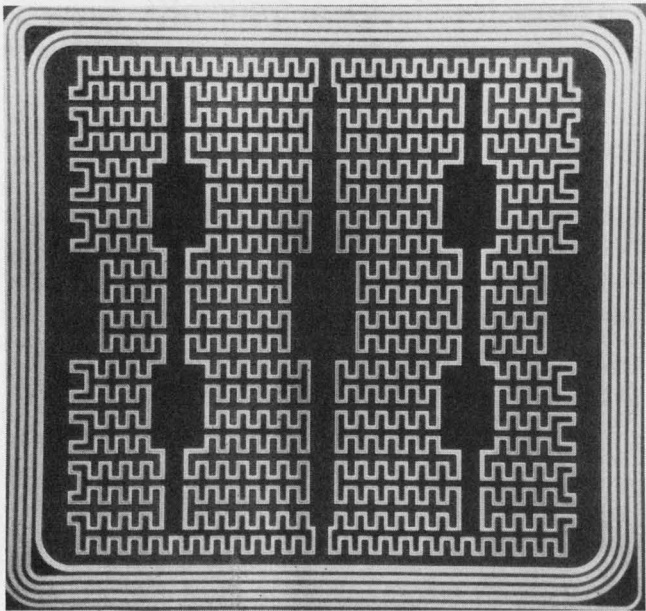

Emitter geometry greatly affects power-transistor characteristics. The patterns are designed to maximize emitter periphery and reduce area so that $V_{ce(sat)}$ is reduced and current handling capability increased. General Semiconductor industries' pattern (top left) contains charge-control rings (C²R) in its XGSR15030/35/40 units. Fairchild's uses an "H" pattern in its 2N5840/6306 epitaxial-base mesa-constructed units (bottom left). And SGS/ATES prefers the distinctive pattern in its type B200—800-V, 10-A—pnp multiepitaxial mesa units (right).

Since your transistor will probably operate under conditions different from those used in the vendor's test setup, check with the manufacturer to provide $E_{s/b}$ data for your specific use.

For these reasons, some manufacturers actually contend that $E_{s/b}$ is almost useless as a circuit-design parameter. They recommend instead that transistors never be operated anywhere near the primary breakdown voltage. Repeated primary breakdown shortens a transistor's life. It may be only coincidental that most of the criticism of $E_{s/b}$ ratings comes from power-transistor manufacturers whose devices don't have good $E_{s/b}$ ratings. But the manufacturers do have considerable technical justification to downplay $E_{s/b}$.

Still, no matter how they feel, manufacturers generally are forced to trade off high $E_{s/b}$ to get high speed. However, with the help of external networks you often can achieve what the transistor alone can't provide. In power-switching applications, for example, you can get both speed and high-voltage handling by "snubbing" inductive surges with suppressor devices and networks to relieve your transistor of the stresses of both high reverse voltages and high surge-power dissipation.

Although fast fall times inherently reduce the power that a switching transistor must dissipate when turning off—a major source of power loss (see illustration)—a snubber arrangement can cut the dissipation in half and reduce the power surges to 1/10 that of unprotected circuits. Moreover, relieving such high stresses improves reliability and removes a major source of "unexplained" field failures.

Of course, the price you pay for speed and reliability is the cost of the external snubbing network and the

down occurs after the reverse collector-to-emitter voltage exceeds the primary breakdown voltage of the transistor. After primary breakdown the current concentrates in the central portion of the emitter, and a current-avalanche, regeneration process (secondary breakdown) forms a hot spot, especially in inductive circuits. The avalanche must be limited to a certain amount of energy to prevent destruction of the transistor.

Furthermore, the $E_{s/b}$ rating given by manufacturers greatly depends on the test circuit used. The interrelated effects of inductance, turn-off base current (I_{b2}), base impedance and clamping voltage (if a clamp circuit is used) make this spec almost impossible to specify graphically. Therefore, the value given applies only to a single set of conditions. And since different manufacturers use different test conditions to make the measurement, the $E_{s/b}$ they give you can't be trusted—even as a figure of merit.

The better they are, the faster they fall

Traditionally, collector-current fall time, t_f , is a major power-transistor figure of merit for both designers and manufacturers: In switching applications, a major portion of a power transistor's losses occur during t_f . During t_f , the collector voltage is 90% of the supply (or clamp) voltage or higher, and the collector current falls from 90% of its maximum to 10%. Consequently, the power dissipated in the transistor is substantial (see figure).

But often ignored is the "tail" that some transistors exhibit on the collector-current waveform, before the collector current falls to zero. The tail's duration, t_t , usually is measured between the 10% and 2% points. Energy loss during this interval can be significant, if the tail extends a long time, since full voltage appears between collector and emitter. Unfortunately, tail time is rarely mentioned on spec sheets.

In addition, the emitter-collector voltage rise time, t_r , at turn-off also can contribute considerable loss, but this time usually is short. And since t_r varies little among different power transistors, and depends heavily on the circuit load, it isn't usually cited as a figure of merit.

For maximum safety, therefore, include all the turn-off times— t_r , t_t and t_f —in an over-all timing specification for your power transistors, from the 10% point of the collector-emitter voltage to the 2% point of the tail.

As a matter of fact, especially for high volume applications, you are well advised to develop your own

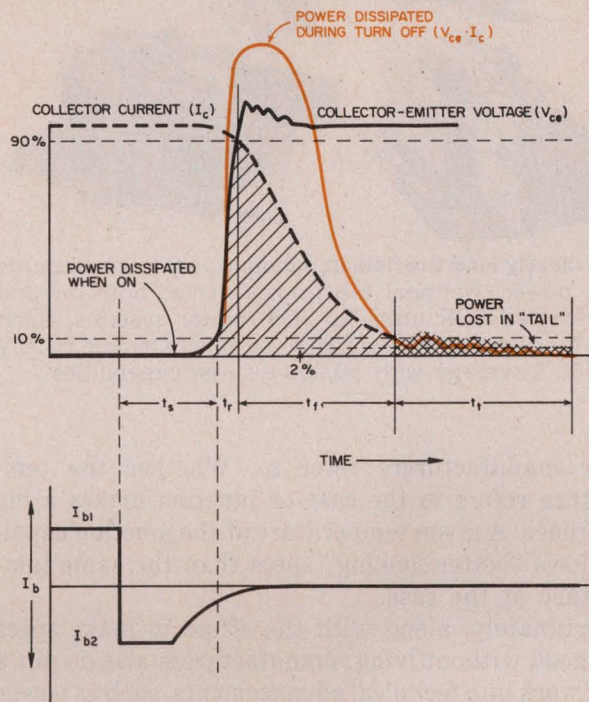

set of specs. Of course, the manufacturer should be called in to help. And obviously, don't overspecify: Besides raising your cost, overspecifying some characteristics can unexpectedly result in undesirable performance in other important areas.

usually even higher cost of a fast transistor. Nevertheless, while you're searching for reliability, you should go a bit further: You will usually be pleasantly surprised to find that, within a device family, the cost of a higher V_{ce0} rated unit—say, a 300-V vs a 200-V unit—is very moderate. But what you get is a vastly more reliable device.

You can't get something for nothing

You pay more for a "fast" power transistor, so make sure you get speed where it counts. In power switching, the critical speed parameter is fall time (t_f). In addition, don't overlook the test circuit and the reverse-drive current used by a manufacturer to measure t_f . Test turn-off current, I_{b2} , is often much higher than you would likely use, which makes the t_f spec look better than it actually is.

Also, as is the case with most specs, note the temperature at which the transistor's speed is specified—here, too, a 25-C case temperature is unrealistic. Some companies, like Unitrode, supply values at a much more practical 100 C.

Although high turn-off drive current (I_{b2}) shortens t_f , excessive turn-on base drive (I_{b1}) lengthens it.

Therefore, in switching applications, the base drive should be just enough to drive the transistor into saturation at a specified collector current.

Of course, a low $V_{ce(sat)}$ spec is desirable for efficient switching, but make sure that the manufacturer determines the $V_{ce(sat)}$ under normal I_{b1} drive conditions. A long t_f is a major cause of power loss, which can easily cancel out any savings from an artificially lowered $V_{ce(sat)}$. Clearly, then, you should provide only just enough I_{b1} to minimize saturation losses, but have high enough I_{b2} to get a short t_f .

Another aspect of turn-off drive current that is often overlooked is its effect on the reverse-bias SOA. Very few manufacturers mention I_{b2} , here. One exception: General Semiconductor Industries not only makes a point of specifying the I_{b2} conditions for its XGSR1530-40 transistors on the reverse-bias SOA ($I_{b2} \leq 0.2 I_c$), but also provides an $E_{s/b}$ -vs-base-bias-voltage (V_{bb}) curve.

Interestingly, General Semiconductor is one of a very few companies to provide a forward-bias SOA curve for 100 C in addition to the usual 25-C curves. But the General Semiconductor temperatures used for these curves, and most of its other specs, are junction temperatures—not the usual case temperatures most

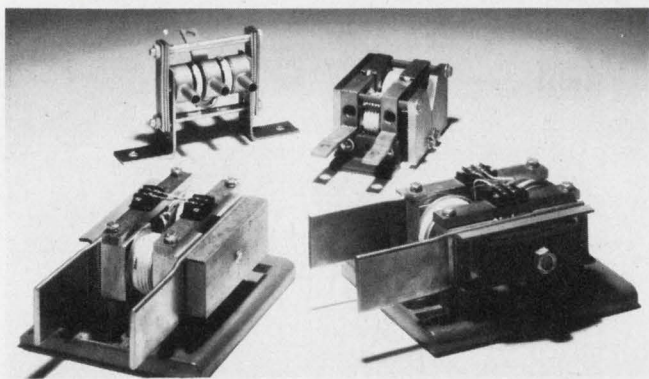

SCRs clearly lead the field in handling very large amounts of ac power. National Electronics makes both air and water-cooled SCR units for high power systems. Such SCRs for phase control will soon be able to handle 5000-V at 3500-A-average with 50,000-A-surge capabilities.

other manufacturers refer to. Whether the temperature refers to the case or junction makes a big difference. A given temperature at the junction usually allows "better looking" specs than the same temperature at the case.

Fortunately, along with the effort to make specs look good without lying, manufacturers also do put a lot of work into technical advancements, such as power Darlington transistors.

You can't have everything

To get high V_{ce0} in power transistors, current gain (h_{fe}) is usually sacrificed. To get both properties with high capabilities requires high-resistivity silicon material. But then current capability and power efficiency are reduced. Drastically.

One solution to the high-gain problem is a power Darlington. Today's Darlington transistors can handle 2 to over 20 A and have switching speeds that approach fast power transistors. But much possible gain is still sacrificed to get high switching speed. Still, Darlington transistors substantially reduce the heavy loads that driver-transistor circuits encounter with ordinary power transistors. And power Darlington transistors easily operate from logic-level signals.

A power Darlington can be considered a standard power transistor having "high" current gain. However, many potential users have expressed a desire for a fourth lead-out from the Darlington's output-transistor base to allow the base charge to be "pulled out." Also, switching speeds that are slower and saturation voltages that are higher than in standard power transistors still restrict the use of Darlington transistors. Nevertheless, their future is considered bright.

Power FETs offer bright prospects too. Their very high input impedance requires very low drive power, which allows direct drive from CMOS, TTL and other logic families. And the secondary-breakdown problems of bipolars are absent. However, drain-source saturation resistances, and thus, voltages are still high—values of 1 to 2 Ω , or 2 to 10 V—and maximum

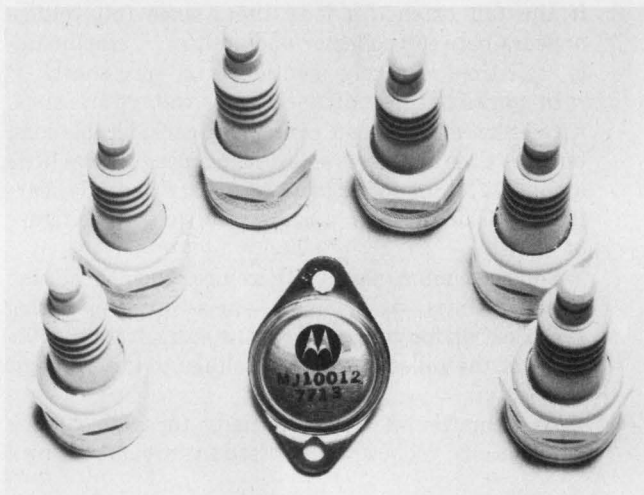
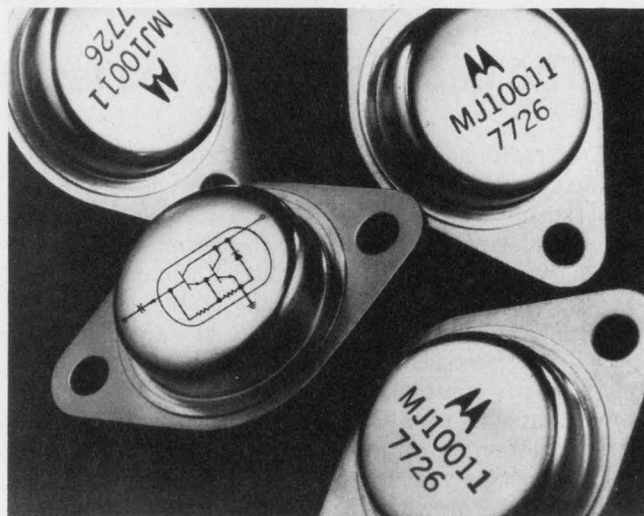

Monolithic Darlington transistors made by Motorola, MJ10012s, handle the high voltage, high current and harsh environment of automotive ignition systems. Other Darlington transistors, such as the MJ10011 with built-in dampers, are specifically designed for TV-deflection circuits. They feature a gain of 40 and a 1400-V breakdown voltage.

allowed drain-source voltages are still low when compared to standard power transistors—around 80 V.

Although FET availability is still limited, almost every major power-semiconductor company is working on them and expecting to offer units, soon. But Siliconix has a brand new series of power FETs, now. They are VMOS (vertical metal-oxide semiconductor) n-channel units designated VN-46, 66 or 88-AF for 40, 60 or 80-V maximum drain-source voltages, respectively. They can handle a maximum 2-A continuous drain-current and operate with under 10-ns switching speeds. The V in VMOS comes from a V-shaped gate that gives the device a much higher current density than the conventional lateral construction of MOSFETs.

Power FETs still have some distance to go to effectively compete with power transistors—at least a 200-V capability is needed. But FETs could eventually exceed the capabilities of Darlington transistors.

While both power FETs and Darlington transistors have some

way to go to compete strongly in the power semiconductor market, thyristors (triacs, SCRs, etc.) have been in there for a long time successfully slugging it out. While low-power dc requirements generally are met with transistors, most ac power-line-frequency applications employ triacs and SCRs, from very-low to very-high-power. However, a grey area is growing in the medium-power range—about 200 to 600 V and to about 450 A—where both transistors and SCRs compete head on.

Competition is healthy

Power-transistors, generally faster than SCRs, are getting more and more competition from new, fast SCRs for switching-power-supply applications in the 20-kHz range. And gate-turn-off SCRs can operate effectively on dc-power loads. But don't reach for a thyristor without weighing such factors as efficiency,

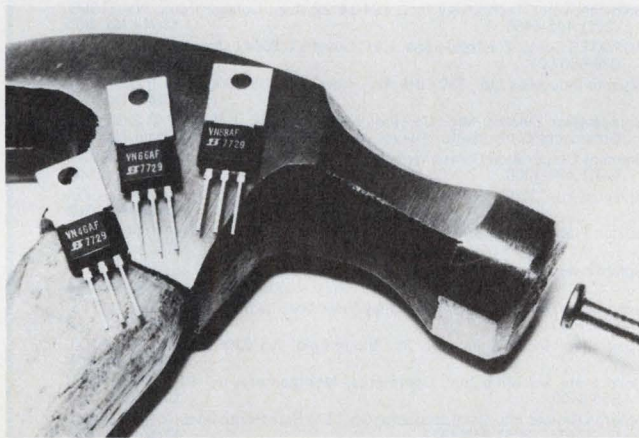

Power FETs promise to give bipolars and Darlington's stiff competition. While many companies are still working on them, Siliconix has recently announced a new series of VMOS power FETs packaged in low-cost TO-202 plastic.

reliability, size, cost and auxiliary circuitry needed.

Tricky commutation, surge and overload-protection circuits needed in some thyristor applications can argue against their use. Also, thyristors in phase-controlled circuits create radio-frequency interference (RFI), which can obliterate most AM radio stations and play havoc with other control circuits on the same power line. Suppressing networks can eliminate almost all such interference—for a price. However, special loading requirements, such as needed by induction heating, might point to thyristors. The advantages of thyristors often justify the cost of any suppressors and commutation circuits.

The games people play

Thyristor manufacturers play the same games with specs as transistor makers, such as specing at unrealistic 25-C case temperatures. And many specs desirable in transistors are also desirable in thyristors

—for example, fast turn-off and low forward-voltage drops. But both the turn-off and turn-on properties of thyristors are much more complicated than in transistors, so thyristor makers have more ways to play the game of "making it look good."

You might expect that the recommended gate current and voltage is enough to ensure that a thyristor is turned on. Not so. The conditions given on a spec sheet may not reflect your application. For one thing, anode and gate interactions are rarely described in full. Your anode circuit, for example, may not provide adequate latching current quickly enough, so the



Thyristors and SCRs from Teccor are in the low and medium-power range. They are appliance-grade units, some with lugs, others with push-on terminals and ruggedly packaged in TO-3 cases.

thyristor will fail to stay on consistently. Also, the rate of rise of the input-gate trigger current (di/dt) must be limited to prevent damage to the thyristor, a fact not always understood by design engineers. Transistors don't have such a limit spec.

Turn-off properties are even more complicated. As many as 12 test conditions have been shown to have a measurable effect on turn-off performance. Not only that, but a thyristor may turn on when you don't want it to, because of too high a dv/dt at the anode that capacitively couples back to the input gate. The dv/dt spec is another you must carefully pay attention to. But you have no such spec with transistors.

Nevertheless, except for some special single-diffused high-power transistors—to 1200 A at about 80 V, and to 40 A at about 600 V—assembled in matched series and parallel power blocks by companies like PowerTech, Inc., you'll have to use thyristors in the 100 or 1000-A range, especially above 600 V. ■■

(continued on page 60)

Need more information?

For further information on power transistors and thyristors readers may consult the manufacturers listed here by circling the appropriate numbers on reader service card. More vendors and information may be found in ELECTRONIC DESIGN's GOLD BOOK.

AEG Telefunken, 570 Sylvan Ave., Englewood Cliffs, NJ 07632. (201) 568-8570.
Circle No. 451

Ampere Electronic Corp., Providence Pike, Slatersville, RI 02876. (401) 762-9000.
Circle No. 452

Ampower Semiconductor Corp., 375 Kings Highway, Smithtown, NY 11787. (516) 582-6767.
Circle No. 453

Calvert Semiconductors Inc., Semiconductor Div., 220 E. 23rd St., New York, NY 10010. (212) 889-8150.
Circle No. 454

Crimson Semiconductor Inc., 440 Park Ave. S, New York, NY 10016. (212) 686-7590.
Circle No. 455

Delco Electronics Div., 700 E. Firmin St., Kokomo, IN 46901. (317) 457-8461.
Circle No. 456

Dionics Inc., 65 Rushmore St., Westbury, NY 11590. (516) 997-7474.
Circle No. 457

Electramation, 666 E. 17 St., Santa Ana, CA 92701. (714) 541-4434.
Circle No. 458

Electrol Co. Inc., 321 Dewey St., York, PA 17404. (717) 843-0242.
Circle No. 459

Electronic Control Systems Inc., P.O. Box 1232, Fairmont, WV 26554. (304) 363-8632.
Circle No. 460

Electronic Transistor Corp., 153-13 Northern Blvd., Flushing, NY 11354. (212) 539-6700.
Circle No. 461

Elite Semiconductor Prod. Inc., 440 W. Merrick Rd., Valley Stream, NY 11580. (516) 825-1010.
Circle No. 462

Emerson Electric Co., 7841 Thomas, Pittsburgh, PA 15208. (412) 242-6400.
Circle No. 463

Fairchild Semiconductor, 464 Ellis St., Mountain View, CA 94042. (415) 962-5011.
Circle No. 464

Ferranti Ltd., Hollinwood Lancashire OL97JS, England. 061-681-2000.
Circle No. 465

EMC Corp., Semiconductor Prod Op., 800 Hoyt St., Broomfield, CO 80020. (303) 469-2161.
Circle No. 466

General Electric Semiconductor Products, Elecs. Pk. Bldg. 7-49-Box-1122, Syracuse, NY 13201. (315) 456-2798.
Circle No. 467

General Semiconductor Industries Inc., 2001 W. 10 Pl., Tempe, AZ 85281. (602) 968-3101.
Circle No. 468

Germanium Power Devices, P.O. Box 65, Shawsheen Village Sta., Andover, MA 01810. (617) 475-5982.
Circle No. 469

Hitachi Ltd., 5-1 1-Chome Marunouchi Chiyoda-ku, Tokyo 100, Japan. 3-212-1111.
Circle No. 470

Carl E. Holmes Co., 107 North Ave. 64, Los Angeles, CA 90042. (213) 256-2255.
Circle No. 471

Hunt Electronics Co., Semiconductor Div., P.O. Box 20697, 2619 Andjion Dr., Dallas, TX 75220. (214) 350-5571.
Circle No. 472

Hutson Industries Inc., 2019 W. Valley View, Dallas, TX 75234. (214) 241-3511.
Circle No. 473

International Rectifier, Semiconductor Div., 233 Kansas St., El Segundo, CA 90245. (213) 678-6281.
Circle No. 474

International Semiconductor Corp., 27 rue Yves Kermen, 92100 Boulogne, France. 01-604-5275.
Circle No. 475

ITT Semiconductors, 74 Commerce Way, Woburn, MA 01801. (617) 935-7910.
Circle No. 476

Kerton Inc., 7516 Central Ind Dr., Riviera Beach, FL 33404. (305) 848-9606.
Circle No. 477

LTT, 89 rue de la Faisanderie, Paris 75782, Cedex 16 France. (1) 504-4550.
Circle No. 478

Motorola Semiconductor Prod. Inc., P.O. Box 20912, Phoenix, AZ 85036. (602) 244-6900.
Circle No. 479

Mouser Electronics, 11511 Woodside Ave., Lakeside, CA 92040. (714) 449-2220.
Circle No. 480

National Electronics, P.O. Box 269, Geneva, IL 60134. (312) 232-4300.
Circle No. 481

National Semiconductor Corp., 2900 Semiconductor Dr., Santa Clara, CA 95051. (408) 732-5000.
Circle No. 482

NEC America Inc., 505 W. Olive Ave., Suite 310, Sunnyvale, CA 94086. (408) 738-2180.
Circle No. 483

Newmarket Transistors Ltd., Exning Rd., Newmarket, Suffolk, UK. 0638 3381.
Circle No. 484

NJ Semiconductor Products, 20 Commerce, Springfield, NJ 07081. (201) 376-2922.
Circle No. 485

North American Semiconductors Co. Inc., 76 Eureka Sq. Center, Pacifica, CA 94044. (415) 359-0300.
Circle No. 486

Nucleonic Products Co., NPC Electronics, 6660 Variel Ave., Canoga Park, CA 91303. (213) 887-1010.
Circle No. 488

Philips Inds., Electronic Components and Materials Div., Eindhoven, Netherlands.
Circle No. 489

Power Hybrids Inc., 1742 Crenshaw Blvd., Torrance, CA 90501. (213) 320-6160.
Circle No. 490

Power Physics Corp., 542 Indl. Way W., Eatontown, NJ 07724. (201) 541-1393.
Circle No. 491

Power Semiconductors Inc., 90 Munson St., Devon, CT 06460. (203) 874-6747.
Circle No. 492

PowerTech Inc., 9 Baker Court, Clifton, NJ 07011. (201) 478-6205.
Circle No. 493

Power Transistor Co., 800 W. Carson St., Torrance, CA 90502. (213) 320-1190.
Circle No. 494

Precision Transformer, 1804 N. Lemon, Anaheim, CA 92801. (714) 871-4941.
Circle No. 495

Raytheon Co., Semiconductor Div., 350 Ellis St., Mountain View, CA 94042. (415) 968-9211.
Circle No. 496

RCA Solid State Div., Box 3200, Somerville, NJ 08876. (201) 685-6000.
Circle No. 497

RSM Electron Power Inc., Sensitron Semiconductor Div., 221 W. Industry Court, Deer Park, NY 11729. (516) 586-7600.
Circle No. 498

RTC La Radiotechnique-Compelec, 130 Ave. Ledru-Rollin, 75540 Paris Cedex 11, France. 355-4499.
Circle No. 499

Sarkes Tarzian Inc., Semiconductor Div., 415 N. College Ave., Bloomington, IN 47401. (812) 332-1435.
Circle No. 500

Semicoa, 333 McCormick Ave., Costa Mesa, CA 92626. (714) 979-1900.
Circle No. 501

Semiconductor Services Inc., One Peabody St., Salem, MA 01970. (617) 745-2450.
Circle No. 502

Semiconductor Technology Inc., 124-14 22 Ave., College Point, NY 11355. (212) 445-4466.
Circle No. 503

SGS/ATES Comp. Electronic Spa, via C Olivetti 1/20041, Agrate Brianza, Italy. 039-650-501.
Circle No. 504

Shigoto Industries Ltd., 350 Fifth Ave., New York, NY 10001. (212) 695-0200.
Circle No. 505

Shindengem Electric Mfg. Co. Ltd., New-Ohtemachi Bldg. 2-1 2-Chrome Ohtemachi C hiyoda-Ku, Tokyo, Japan. (03) 794431.
Circle No. 506

Siemens Corporation Components Group, 186 Wood Ave. S., Iselin, NJ 08830. (201) 494-1000.
Circle No. 508

Siliconix Inc., 2201 Laurelwood Rd., Santa Clara, CA 95054. (408) 246-8000.
Circle No. 509

Silicon Transistor Corp., Katrina Rd., Chelmsford, MA 01824. (617) 256-3321.
Circle No. 510

Solid Power Corp., 440 Eastern Pky., Farmingdale, NY 11735. (516) 694-2883.
Circle No. 511

Solid State Devices Inc., 14830 Valley View Ave., La Mirada, CA 90638. (213) 921-9660.
Circle No. 512

Solid State Inc., 46 Farrand St., Bloomfield, NJ 07003. (201) 429-8700.
Circle No. 513

Solid State Scientific Inc., Commerce, Montgomeryville, PA 18936. (215) 855-8400.
Circle No. 514

Soliton Devices Inc., Semiconductor Gp, 1177 Blue Heron Blvd., Riviera Beach, FL 33404. (305) 848-4311.
Circle No. 515

Sprague Electric Co., 645 Marshall St., North Adams, MA 01247. (413) 664-4411.
Circle No. 516

Systems Matrix Inc., Box 2420, Trenton, NJ 08607. (609) 394-7124.
Circle No. 517

Tecor Electronics Inc., 1101 Pamela Dr., P.O. Box 669, Eules, TX 76039. (817) 267-2601.
Circle No. 518

Teledyne Crystallonics, 147 Sherman St., Cambridge, MA 02140. (617) 491-1670.
Circle No. 519

Temtron Electronics Ltd., 138-69 Francis Lewis Blvd., Rosedale, NY 11422. (212) 978-5896.
Circle No. 520

Texas Instruments Ltd., Manton Ln., Bedford, England. 6-7466.
Circle No. 521

Texas Instruments Inc., P.O. Box 5012, Mail Station 84, Dallas, TX 75222. (214) 238-2011.
Circle No. 522

Thomson-CSF, 23 rue de Courcelles-BP 96-08, 75362 Paris Cedex 08, France. (1) 25652-52.
Circle No. 523

Thyrotek Corp., P.O. Box 5407, Arlington, TX 76011. (817) 265-7381.
Circle No. 524

Transitron Electronic Corp., 168 Albion St., Wakefield, MA 01880. (617) 245-4500.
Circle No. 525

Triac Electronic Systems Inc., Suite 303E, 200 Park Ave., New York, NY 10017. (212) 687-0620.
Circle No. 526

TRW Semiconductor, 14520 Aviation Blvd., Lawndale, CA 90260. (213) 679-4561.
Circle No. 527

United-Page Inc., UPI Semiconductor Div., 481 Getty Ave., Paterson, NJ 07503. (201) 279-7500.
Circle No. 528

Unitrode Corp., 580 Pleasant St., Watertown, MA 02172. (617) 926-0404.
Circle No. 529

Unity Electronics, Lewis & Kaufman Ltd., 107 Trumbell St., Elizabeth, NJ 07206. (201) 351-4200.
Circle No. 530

USI Corp., International Devices, 3370 Livonia Ave., Los Angeles, CA 90034. (213) 559-4741.
Circle No. 531

Varian Associates, 611 Hansen Way, Palo Alto, CA 94303. (415) 493-4000.
Circle No. 532

Varo Semiconductor Inc., 1000 N. Shiloh, Garland, TX 75042. (214) 272-4551.
Circle No. 533

Westinghouse/Semiconductor Div., Youngwood, PA 15697. (412) 925-7272.
Circle No. 534

Workman Electronics Prods Inc., P.O. Box 3228, Sarasota, FL 33578. (813) 371-4242.
Circle No. 535

Why does a little GE Press-Pak SCR handle more current than a big one?

More pellet power.



The larger the pellet, the greater the current. The basics behind General Electric's new 1/2-inch Press-Pak SCR package are just that simple.

You get all the performance, and more, of a 1-inch Press-Pak SCR . . . plus lower profile, reduced cabinet space, more room for heat-sinking. Lower thermal impedance through a 33% improvement in thermal resistance add up to improved heat transfer for higher reliability.

New GE 1/2-inch Press-Pak SCR's are interchangeable with standard 1/2-inch Press Paks. Thus, you can use them to upgrade equipment without redesign. And higher surge current in the 1/2-inch packages means you're buying a higher margin of safety.

Models include C430 (1200v, 1000A) and C431

(1800v, 1000A) phase controllers; and C435 (800v, 1000A) and C438 (1200v, 850A) inverters.

High current performance in a small SCR package is the kind of innovation you expect from the world's leading manufacturer of power semiconductors. For more information, call your nearby GE electronic components sales engineer, or write General Electric Co., Electronics Park 7-49, Syracuse, NY 13201.

222-03

**There's more
to GE semiconductors
than meets the eye**

GENERAL  ELECTRIC

CIRCLE NUMBER 33

How does our broad line of discrete semiconductors fit your growing line of switching power supplies?



IOR
FAST RECOVERY RECTIFIERS
 8 SERIES
 6-12 Amps
 50-1000 Volts



IOR
RECTIFIERS
 28 SERIES
 1-40 Amps
 50-1000 Volts



IOR
ZENERS
 26 SERIES
 250mW-50W
 2.4-280 Volts



IOR
TEMP. COMP. VOLTAGE REFERENCES
 16 SERIES
 250mW-1.6W
 5.9-49.6 Volts



IOR
POWER SCHOTTKYS
 6 SERIES
 20-50 Amps
 10-50 Volts
 150°C Junction Temp



IOR
SCR's
 22 SERIES
 4-70 Amps (RMS)
 15-1200 Volts



IOR
INVERTER SCR's.
 4 SERIES
 35 Amps (RMS)
 20-400 Volts



IOR
POWER TRANSISTORS
 34 High Gain Types
 1-10 AMPS
 15 Fast Switching Types
 5-15 AMPS

IOR
HIGH VOLTAGE POWER DARLINGTONS
 25 High Gain Types
 10-20 AMPS
 9 Fast Switching Types
 10-20 AMPS



Beautifully.

When you're breaking new ground in switching power supplies you need a vendor who can solve most of your problems.

In discrete semiconductors, only a broad-line supplier like International Rectifier can help you in so many ways. Both in design and later in production.

Design Tradeoffs. Like your own circuits, each of our discrete semiconductors has its own limitations as well as advantages. If a part number you've previously specified doesn't seem to do the job, we can probably suggest one that will. We can also select standard devices with the special parameters you need, or start fresh with a new design.

If you need a capability trade-off between different types of discrettes, no one has more knowledge to assist you with than IR.

Applications Assistance. We know it takes more than data sheets and application notes to keep your design and production running smoothly. No matter what your questions, if it has to do with discrete semiconductors we can help. And we do help. Our application engineers will come when you call.

High, and consistent quality. For 28 years we have been specializing in discrete semiconductors. They have earned a reputation for consistently high quality, ruggedness, dependability, and good performance. Our manufacturing, test and QC procedures are sound, and painstakingly adhered to.

One source. We can save you design time. We can keep your production running smoothly. We can deliver the kind of performance that will help increase your sales.

For information, just give us a call. At the factory (213) 322-3331, at our 30 local sales offices, or at any of our nationwide distributors. Write to International Rectifier, 233 Kansas Street, El Segundo, CA 90245.



SEMICONDUCTOR HEAT EXCHANGERS

12 Types
readily available.

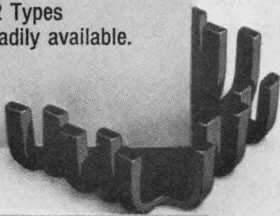

SEMICONDUCTOR FUSES

130 and 250 Volts
5-800 AMPS (RMS)

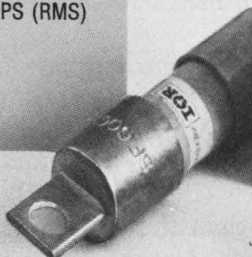

DIODE BRIDGES

1.8 to 25 Amps
50-1000 Volts

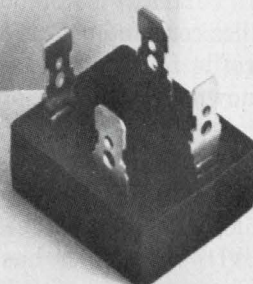

Mail this Coupon for Design Data today !

Please send information on the devices checked to:

- Power Transistors
- High Voltage Power Darlington
- Power Schottkys
- SCR's
- Inverter SCR's
- Rectifiers
- Fast Recovery Rectifiers
- Zeners
- Temp. Comp. Voltage References
- Diode Bridges
- Semiconductor Fuses
- Semiconductor Heat Exchangers

Name _____

Title _____ Phone _____

Company _____

Address _____

City _____

State/Zip _____

International Rectifier

... the innovative semiconductor people



Optical-fiber transmission links

offer a valuable alternative to conventional cables. You can easily lay out such a link with the right design aids.

Whether you want to transmit analog or digital signals, you now have an alternative to conventional cables—optical fibers. Still in its infancy, optical-fiber communication already offers a number of performance advantages.

Bandwidth, for instance, is often wider than that of conventional links, and terminal or repeater spacing can be larger. Fiber "cables" need very little space (Fig. 1), and they are absolutely immune to electromagnetic interference. Nor do they cause any radiation themselves. Electrical isolation of the glass fibers is, of course, absolute—problems like ground loops or sparking simply don't exist. And in an increasing number of applications, fiber-optic links are proving to be cost-competitive with cable installations.

Once you are familiar with the basics of fiber-optic transmission, it's quite easy to lay out an optical link. A transmitter converts the digital or analog input by modulating the output of a light source, usually by varying the source drive current. Solid-state light-emitting diodes (LEDs) and laser diodes are suitable transmitters because their output can be rapidly controlled by varying their bias current. They also offer high brightness, small size, a desirable emission wavelength, and low drive voltage. Peak emission of these devices is often in the near infrared (about 840 nm), because at this wavelength optical fibers are most transparent, and silicon detectors are most sensitive. Lasers can produce over 10-dB higher optical power output than LEDs. Where the light leaves the source and enters the transmission fiber, coupling losses occur, the extent of which depends on the characteristics of the fiber and the light source.

Because lasers have both greater power output and a narrower emission angle, they typically couple 18 dB more power into a fiber than LEDs. But lasers must be operated in a restricted current range, just above the lasing threshold current, since this threshold may change with time and temperature, laser drivers need compensation circuitry. When the lasers' high coupled power is not required, therefore, LEDs are usually preferable because of their lower

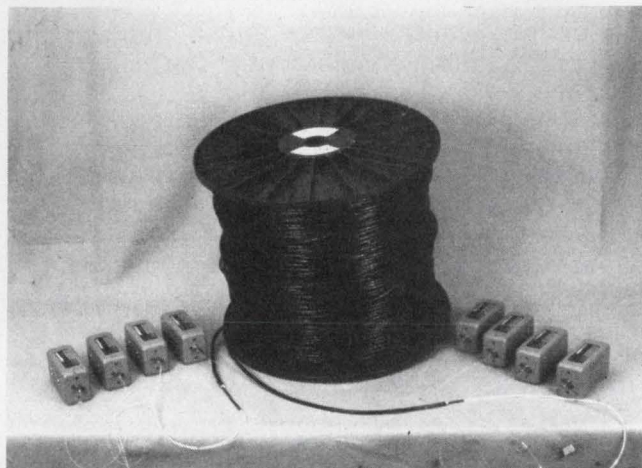

1. **Fiber-optic links** come in small packages. Shown are four transmitter and receiver modules, and 1 km of cable.

cost, longer life, wider temperature range, and greater long-term stability.

In either case, the driver must supply the required current to the source's low dynamic impedance, at the desired modulation rate, and without exceeding recommended peak and average currents. For lasers, the recommended peak power output must also be observed.

Not just a piece of glass

As an optical signal propagates along a fiber, its amplitude and bandwidth are reduced, but less so than in conventional electrical transmission lines. The bandwidth reduction, generally called dispersion, increases with cable length and is usually expressed in MHz-km. The resulting time spreading for pulse signals is generally given in ns/km. Attenuation is expressed in dB/km.

Three major kinds of low and medium-loss fibers are currently available. One is composed of a pure-silica core and plastic cladding, which produces a step profile for the refractive index. This configuration, known as plastic-clad silica (PCS), generally has higher loss and dispersion than the other types.

The second configuration also features a step index profile, but consists of a doped-silica core and doped-silica cladding produced by chemical vapor deposition (CVD). This fiber has very low loss and moderate dispersion.

Dr. Thomas A. Eppes, Manager, Systems and Applications Group and **James H. Bowen**, Applications Engineer, ITT Electro-Optical Products Div., 7635 Plantation Road B 7065, Roanoke, VA 24019

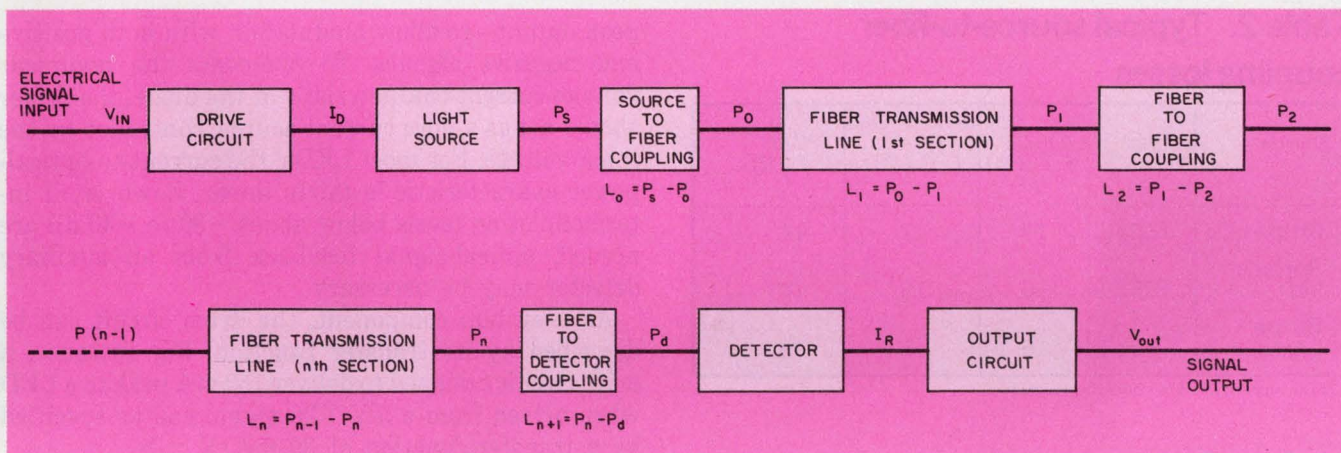

2. The basic fiber-optic transmission system must be broken down into all its components for proper system design.

The third configuration, also produced by CVD, consists of a doped silica core whose doping level varies in the radial direction. The refractive-index profile of this fiber is graded and tailored to compensate for multimode dispersion. Graded-index fibers offer the lowest dispersion of the three, and loss as low as that of step-index CVD fibers.

Optical fibers can be joined either with connectors or splices. Connectors are defined as demountable junctions, while splices are permanent junctions. Both connectors and splices produce optical loss due to the discontinuity at the junction. And in both cases, losses depend on fiber alignment and waveguide characteristics. Splice losses are typically lower than connector losses because in splices, precision fixtures are used and the fibers are permanently bonded together with a bonding agent that reduces discontinuity reflections.

Back to the signal

At the receiver, the optical signal is converted back to an electrical signal by an optical detector. After its conversion the signal is electronically restored to its original form. Detector and amplifier design determine the input noise level, and hence the receiver sensitivity.

The two solid-state detectors most suited for optical-fiber receivers of moderate to high bandwidth are the PIN diode and the avalanche photodiode (APD). Both diode types offer high efficiency and speed, but the

APD's sensitivity is greater, due to its avalanche gain effect. However APDs are more expensive, and require an auxiliary high-voltage power supply.

For strong optical signals, the advantage of the APD over the PIN is meaningless because the signal-to-noise ratio of strong signals is determined by signal quantum noise stemming from the random arrival of the optical-signal photons.

The "front end" amplifier that's connected to the detector must provide low noise over the signal's bandwidth. To reduce noise, front ends are often intentionally designed with bandwidths smaller than the signal bandwidth. Equalization in successive amplifier stages flattens the over-all response. Such an amplifier is called an integrating front-end.

Another amplifier type is the resistively loaded front-end in which the detector-load resistor is chosen to give a time constant that's small enough to pass the desired bandwidth. In the transimpedance front end, however, the detector load resistor becomes the feedback resistor of the amplifier. The result is a low effective value of load resistance, combined with a less noisy feedback resistor of higher value.

FETs versus bipolars

All front-ends must accommodate the capacitance and current-source properties of the detector. At present, FETs are usually more sensitive below 10 MHz, and bipolar transistors above 10 MHz. Dynamic

Table 1. Semiconductor light sources from ITT

Device	Type	Rise/Fall Time (ns)	Suggested Peak Drive Current I_D (mA)	Peak Output Power, P		Typical Transfer Function (mW/A)	Peak Emission Wave-Length
				(mW)	(dBm)		
Stripe LED	T801-E	10	200	.8	-1	4	840 nm
Surface LED	T851-S	20	200	1.5	+2	7.5	840 nm
Stripe Laser	T901-L	4*	350	7.5	+9	21	840 nm

* Without prebias

Table 2. Typical source-to-fiber coupling losses

Device*	Type	Glass Step GS-02 (L_o) (dB)	Glass Graded GG-02 (L_o) (dB)	PCS PC-05 (L_o) (dB)
Stripe LED	T801-E	14	17	11
Surface LED	T851-S	16	19	10
Stripe Laser	T901-L	5	8	3

* Can be supplied with pre-aligned fiber pigtailed

range, possible data-pattern dependence, low frequency cut-off, temperature stability, and isolation from extraneous noise sources must also be considered.

Each of the functional blocks in an optical-fiber transmission system (Fig. 2) can be specified by a transfer function. For convenience, each transfer function, L , is expressed in dB, where

$$L = 10 \log (P_{IN}/P_{OUT}).$$

The power relationships are noted in Fig. 2. A more detailed analysis of the system components follows:

The drive circuit accepts an input signal and converts it to a current drive for a specific light source. The drive circuit should supply no more than the recommended peak or average drive current for the chosen diode.

In digital signal transmission, the driver usually consists of a high speed pulser, which switches the diode on and off. Sometimes the driver is designed to produce turn-on and turn-off current spikes to shorten optical rise and fall times, thus compensating for the effect of diode capacitance.

For laser-diode sources, the driver may be designed to supply an additional pre-bias current, just below the lasing threshold. The diode can then be switched more rapidly into the lasing mode. Drive-current compensation may be necessary for the laser diodes, because the threshold current is temperature dependent. An auxiliary optical detector in the laser drive circuit can be used to compensate for possible threshold drift, and also to limit optical output power.

In contrast to pulse modulation, baseband analog-signal transmission requires that the driver supply a quiescent drive current to the diode—about half the

peak output—to allow modulation with both positive and negative signals. To overcome the nonlinear voltage-current characteristic of the diode, the driver should act as a pure current source, controlled by the input voltage. For most LEDs, the current-to-optical-power characteristic is fairly linear; however, if intermodulation levels below about -30 to -40 dB are needed, optical-signal feedback from an auxiliary detector may be necessary.

As a system component, the drive circuit can be described by its transfer function. For instance, a drive circuit designed to deliver 150 mA peak to a LED when driven from a 5-V TTL signal can be specified by a transfer function of 30 mA/V.

Lasers have the edge

Light-source selection (LED or laser) depends on wavelength, modulation speed, optical-power output, and coupling efficiency. Low-cost wide-area LEDs (GaAsP for red and GaAs for infrared) can sometimes be used as light sources if the low coupled power of 1 μ W or less is acceptable.

For high-performance systems, bright GaAlAs LEDs and laser diodes are available (Table 1). They inject much more optical power into the fiber than wide-area sources, at wavelengths where fiber attenuation is low.

Source-to-fiber coupling depends on both source geometry and fiber characteristics. A matrix of coupling losses for several sources and fibers is given in Table 2. Such diodes are often supplied with integral, pre-aligned fiber pigtailed.

Fibers for an optical-fiber transmission system include a variety of types (Table 3). One or more fibers are normally incorporated into a strengthened cable for protection. The tabulated attenuation (dB/km) and bandwidth data apply to fibers that have been incorporated in cables, and are used at a wavelength of 840 nm. The total attenuation of the fiber in a system is found by multiplying its length in km, with the tabulated attenuation factor.

Don't overlook dispersion

The fibers' bandwidth factor is expressed in MHz-km, and represents the 1-dB bandwidth factor. For

a given system, the tabulated bandwidth factor is divided by the fiber length in km. The 3-dB bandwidth for a fiber is approximately twice the 1-dB bandwidth. Table 4 also lists the fibers' multimode dispersion factor and the rise-time factor, expressed in ns/km.

Fiber-to-fiber joints have a coupling loss transfer characteristic, L (Table 4), which varies from fiber to fiber. Right now, standard cables are supplied in continuous lengths up to 1 km, so at least one joint per km is required.

Fiber-to-detector coupling loss can be assumed as 1 dB for all fiber and detector types.

Detectors that match the existing light sources are PIN-diode and the APD types. Note that the APD detector has an inherent internal gain, which leads to higher responsivity (Table 5). The detectors' transfer function (optical power to electrical current) is expressed in A/W.

Receiver circuits have an over-all input-to-output transfer function that's defined at a given signal level by the ratio of output voltage to input current from the detector. The transfer function is also known as "transimpedance," since it is dimensionally equivalent to an impedance. For example, a receiver may be designed to produce a 5-V signal output when receiving a 1-nW optical signal with an APD detector of 50 A/W responsivity. The receiver transfer function is then 1×10^8 V/A, equivalent to a receiver transimpedance of $1 \times 10^8 \Omega$.

It's what's up front that counts

The first stage of an optical-fiber receiver is a low-noise front-end amplifier, optimized for use with a specific detector. The detector current produces a voltage across a load resistor, or across a feedback resistor. It is calculated by multiplying the received power, the diode responsivity, and the effective load resistance.

The receiver must have enough additional voltage gain to boost this signal to a usable voltage—typically the same voltage level as the input to the transmitter. For this, several amplifier stages with automatic or manual gain control are needed to adjust signal level. The gain control has to vary the over-all transimpedance by an amount sufficient to convert both the highest and lowest anticipated input signal to the desired output voltage. Pulse-code modulated receivers may also include additional electronic signal processing circuits that restore the output pulse's height and shape.

In a well-designed receiver, sensitivity is set by input stage noise. Wideband, high-gain, low-noise transistors in the front-end will minimize noise. Due to the very weak signals present at the input, electrical shielding and extensive power-supply decoupling are often required to achieve good sensitivity.

As with electrical-transmission systems, noise leads to errors in digital data, and reduces the S/N ratio in analog systems. The total noise increases with

receiver bandwidth, so a receiver front-end should therefore be designed for the specific bandwidth at which it will be used.

The most important performance parameter for a digital system is the bit-error rate (BER), which is defined as the ratio of incorrect bits to total bits in a received data system. The BER decreases dramatically as the receiver's S/N ratio passes through the neighborhood of 20 dB. For instance, if a system is operating at a BER of 10^{-8} , an increase in received optical power of only 1 dB reduces the BER to about 10^{-10} .

In analog systems, noise and harmonic distortion are important measures of a received signal's quality.

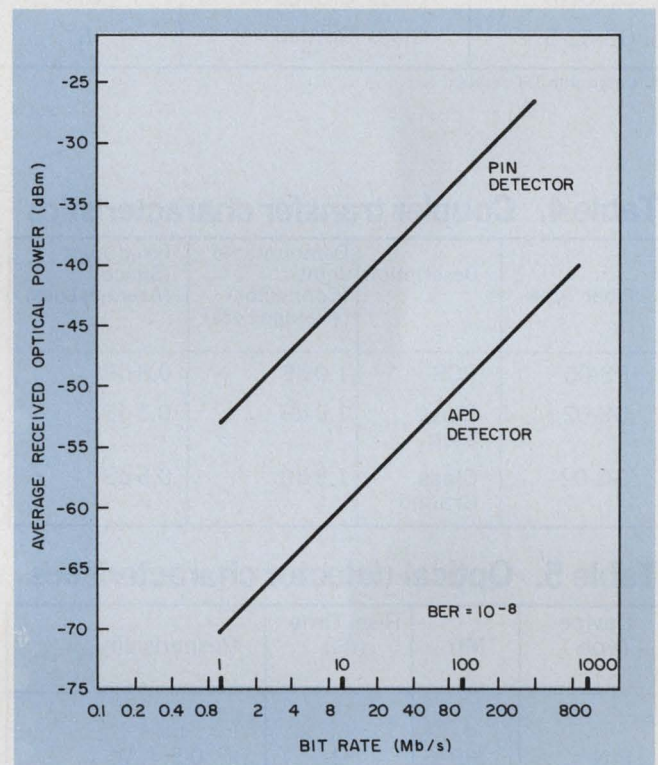

3. Required optical power for digital receivers depends on both the bit rate and the acceptable bit error rate.

While a properly designed receiver is highly linear, a light-source's nonlinearity can cause harmonic distortion. Since in analog systems the signal level can vary widely, the S/N ratio in these applications is defined as the ratio of signal rms to noise rms for maximum signal excursions.

Graphs for the nitty-gritty

Fig. 3 shows the receiver sensitivity at a BER of 10^{-8} for digital receivers as a function of bit rate. The sensitivity (average received optical power at a given bit rate) is roughly the same for return-to-zero (RZ) and nonreturn-to-zero (NRZ) digital data. The graph is calculated from data for available APD and PIN detectors and receiver front-end components, and

Table 3. Transmission data for various fibers

Fiber Type	Description	Attenuation (L) (dB/km)	Multimode Dispersion (-3dB points) (ns/km)	Rise Time (ns/km) (10%-90%)	Bandwidth (MHz-km) -1 dB
PS-05-35	PCS	45	30	21	7.5
PS-05-20	PCS	35	30	21	7.5
PS-05-10	PCS	20	30	21	7.5
GS-02-12	Glass Step	20	15	-11	15
GS-02-8	Glass Step	10	15	11	15
GS-02-5	Glass Step	6	15	11	15
GG-02-12	Glass Graded	20	2.5	1.8	90
GG-02-8	Glass Graded	10	2.5	1.8	90
GG-02-5	Glass Graded	6	2.5	1.8	90

* If used with ITT sources

Table 4. Coupler transfer characteristics

Fiber Type	Description	Demountable Joint (Connector) (Average Loss)	Fixed Joint (Splice) (Average Loss)
PS-05	PCS	1.0 dB	0.3 dB
GS-02	Glass Step	1.0 dB	0.3 dB
GG-02	Glass Graded	1.5 dB	0.5 dB

Table 5. Optical-detector characteristics

Device Type	Mfr.	Rise Time (ns)	Responsivity
PIN Diode	HP	>1	0.5 A/W
APD	RCA	2	5-100 A/W

assumes that the front end is re-optimized for each bit rate. Manufacturers' data sheets contain specific data on a particular receiver.

In baseband analog systems, the receiver S/N ratio is determined by the received optical power and the front-end noise. For current APD receivers, Fig. 4 shows the receiver sensitivity vs bandwidth, for a range of S/N ratios. Fig. 5 gives similar representative curves for receivers with PIN diodes, while curves for specific systems are found in manufacturers' data sheets.

The over-all bandwidth for fiber-optic transmission systems can be approximated from the bit rate. In the NRZ-mode, 1 Mbit/s corresponds to 1 MHz, while the RZ-method requires only half as much bandwidth. But in digital transmission systems it's usually more

convenient to express bandwidth in terms of rise and fall times (Fig. 6).

In any cascade-connected system, such as an optical-fiber transmission system, the over-all rise time is approximately 1.1 times the square root of the sum of the squares of the cascaded components' individual rise times. For a digital system, the rise time should be less than a bit interval for NRZ data, or half a bit interval for RZ data. To allow for the finite rise time of the amplifiers, the rise time of the system up to and including the detector should be no more than 70% of a bit interval for NRZ data, or 35% of a bit interval for RZ data. (One bit interval is defined as the reciprocal of the bit rate.)

Analog future is bright

Analog signals are usually transmitted by amplitude (or intensity) modulation, but pulse-width, pulse-position, and frequency modulation are also used. With intensity modulation, LED-driven systems have a bandwidth of about 100 MHz (15 TV channels), while that of injection-laser systems is several times larger.

The over-all rise time for an analog system, including the optical receiver, must be less than the specified rise time for the transmission link alone. Receiver rise time (in s) is given approximately by 0.35 divided by the receiver's 3-dB bandwidth in Hz. Refer to manufacturers' data sheets for more precise data.

By tailoring the receiver's bandpass characteristic to equalize dispersion and source rise times, total system rise time can be reduced below the rise time of the received optical signal. But this form of equalization results in a large sensitivity loss at the receiver, and should therefore be avoided.

The rise times for those components that can significantly limit system speed are given in Table 1 for the light sources, Table 3 for the optical fibers,

and Table 5 for the detectors.

In addition to the multimode dispersion given in Table 3, the fiber exhibits a material dispersion which may be significant when a LED is used as the light source. Material dispersion depends on the spectral width of the source—with available fibers, it is significant for LEDs but not for lasers. For LEDs with about 40-nm spectral width, the material dispersion is approximately 5 ns/km, leading to an additional rise time of approximately 3.5 ns/km.

Fiber-optics design—made easy

Now that you are familiar with fiber-optics terminology, try yourself on this design example. Your inputs for the design of a fiber-optical transmission system are normally the following parameters:

- The signal to be transmitted.
- The link length.
- The tolerable signal impairment levels such as S/N ratio, BER, and/or rise time.
- Cost constraints.

You must now select a combination of source, fiber and detector which best meets all system requirements. To simplify the design, make out worksheets for alternative approaches as in Fig. 7. Begin by entering the required system bandwidth and SNR (if analog) or bit rate and BER (if digital), and link distance. Then, select a fiber type based on attenuation and rise time.

For an analog system, the fiber's 1-dB bandwidth should equal or exceed the over-all 3-dB bandwidth specified for the system. If you divide the fiber bandwidth in MHz-km by the required system bandwidth, you get the maximum distance for which

the selected fiber can be used. But the final fiber selection is still subject to a comprehensive rise-time analysis. However, power analysis and rise-time analysis should be carried out in parallel.

As the first step in the power analysis you have to determine the power margin—the difference between the light source output power and the required received power. Once a fiber has been chosen, you can determine the power margin by selecting a light source and a detector.

The light source's average output must be adjusted as a function of duty cycle and sometimes reduced to improve life. For digital data with 50% density of ONEs, the average source output power is 3 dB less than the peak power given in Table 2 for NRZ signals, and 6 dB less for RZ signals. For an analog system, the average output power is 3 dB less than the peak power given in Table 1.

Again, it may be desirable to reduce peak drive current to extend source life. In this case, you must reduce the average output power appropriately. Enter the resulting average source output power in the space provided. Next, determine the receiver sensitivity from the source output power.

Adding up your losses

Now you can tackle total link loss. After you decide on the source type, determine total fiber loss by multiplying the fiber loss per km by the total fiber length. Identify the number of connectors required in the system and multiply by the loss per connector to determine total connector loss. Do likewise for any required permanent splices. Allow typically 1 dB for detector-coupler loss.

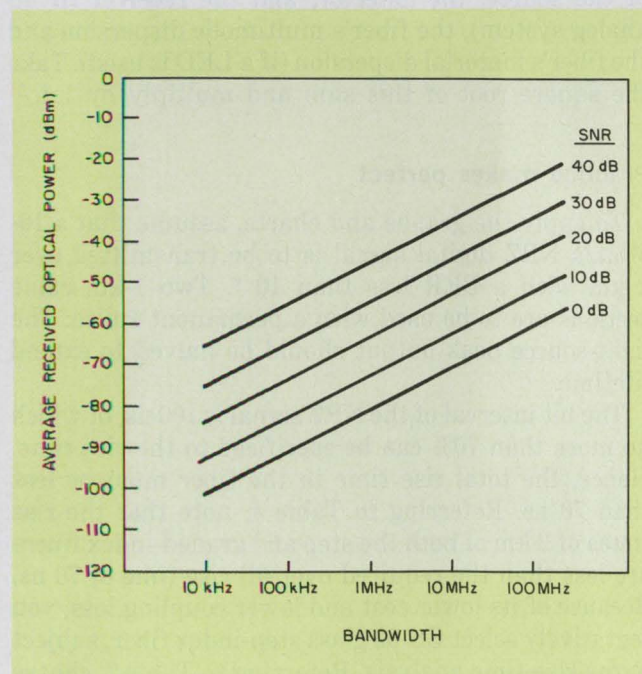

4. The power required by analog receivers is a function of the bandwidth and the signal-to-noise ratio.

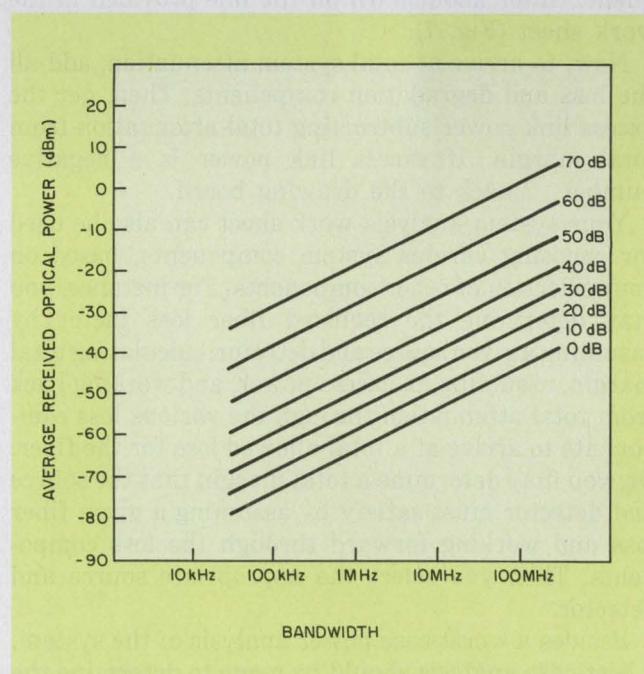

5. Optical-power requirements for PIN-detectors in an analog receiver depend on the bandwidth and S/N ratio.

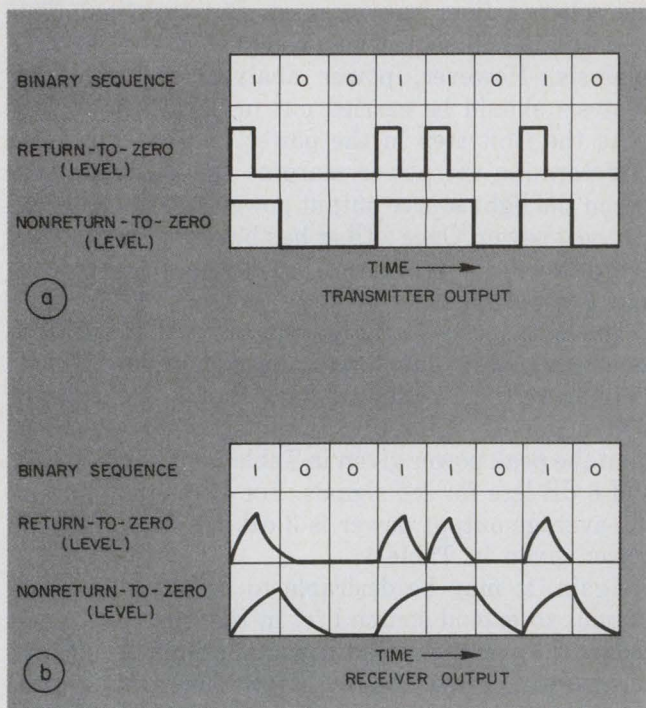

6. Return-to-zero binary signals have about twice as many transitions as the nonreturn-to-zero mode. The latter therefore tolerates longer rise times (bottom).

Degradations from room temperature values can occur in optical fiber systems that haven't been temperature compensated. Both transmitter-output power and receiver sensitivity can vary over a given operating temperature range. For a typical range of -30 to $+70$ C, include 3 dB to cover these effects.

Source output and receiver sensitivity may also degrade with time. Allow for such degradation so that component-replacement cycles are not overly frequent. Enter about 3 dB on the line provided in the work sheet (Fig. 7).

Now, to arrive at total system attenuation, add all the loss and degradation components. Then, get the excess link power subtracting total attenuation from total margin. If excess link power is a negative number. . .back to the drawing board.

Your system analysis work sheet can also be used for choosing various system components, based on your selection of other components. For instance, you may determine the required fiber loss factor by assuming a given source and detector, calculating total margin, assuming an excess power, and working back from total attenuation through the various loss components to arrive at a total allowed loss for the fiber. Or, you may determine a total margin that the source and detector must satisfy by assuming a given fiber loss and working forward through the loss components. Then you select the appropriate source and detector.

Besides a worst-case power analysis of the system, a best-case analysis should be made to determine the required optical dynamic range of the receiver. And you need a complete rise-time analysis of the system

POWER THROUGHPUT ANALYSIS WORKSHEET

Required bandwidth orbit rate: 10 Mbits/s NRZ

Required distance: 2 km

Required BER or S/N ratio: 10^{-9}

Fiber type: GS-02-8

Total fiber bandwidth $\frac{15 \text{ MHz} \cdot \text{km}}{5 \text{ MHz}} = 9 \text{ km}$

Source type: T-801E Average source output power, P_s : -7 dBm

Detector type: Receiver sensitivity, P_R : -59 dBm

Total Margin, $(P_R - P_s)$: 52 dBm

Source coupling loss, L_o : 14 dB

Total fiber loss @ dB/km: 25 dB

connectors: 2 Total connector loss @ 1 dB/conn: 2 dB

splices: 3 Total splice loss @ .3 dB/splice: 1 dB

Detector coupling loss: 1 dB

Allowance for temperature degradation: 3 dB

Allowance for time degradation: 3 dB

Total Attenuation: 49 dB

Excess power (total margin-total attenuation): 3 dB

REFER TO:

Table 3

Table 1, Text

Figs. 2, 3, 4

Table 2

Table 3

Table 4

Table 4

Text (1 dB typ.)

Text

Text

7. Use this power-analysis worksheet when you design a fiber-optic transmission system.

to ensure that the selected components will have the required speed.

A rise-time analysis work sheet (Fig. 8) helps you compare alternative approaches. To obtain the total system rise time, add the squares of the rise times of the source, the detector, and the receiver (if an analog system), the fiber's multimode dispersion and the fiber's material dispersion (if a LED is used). Take the square root of this sum and multiply by 1.1.

Practice makes perfect

To apply the graphs and charts, assume that a 10-Mbit/s NRZ digital signal is to be transmitted over 2 km with a BER less than 10^{-9} . Two 1-km cable sections are to be used with a permanent splice. The light-source peak output should be halved to extend lifetime.

The bit interval of the NRZ signal is 100 ns, of which no more than 70% can be sacrificed to the rise time. Hence, the total rise time in the fiber must be less than 70 ns. Referring to Table 4, note that the rise times of 2 km of both the step and graded-index fibers are less than the required over-all rise time of 70 ns. Because of its lower cost and lower coupling loss, you tentatively select GS-02 glass step-index fiber, subject to the rise-time analysis. Referring to Table 2, choose a T801E LED with a peak output power of 1 dBm. Since the data-transmission format is NRZ, the aver-

RISE TIME ANALYSIS WORKSHEET

Required system rise time:
Required fiber length, type:

Source type:

Total fiber rise time due to multi-mode dispersion @ ns/km:

Total fiber rise time due to material dispersion @ 3.5 ns/km:
(Typically 3.5 ns/km for LEDs, negligible for lasers.)

Detector type: APD

Receiver:

RISE TIME	RISE TIME SQUARED	REFER TO:
ns		Table 1
ns		Table 3
ns		Text
ns		Table 5
ns		Text, Data Sheets

SUM OF SQUARES

System rise time, (1.1) (Square root of sum): ns

Analog system -3dB bandwidth, (.35 ÷ system rise time): MHz

8. A rise-time analysis worksheet simplifies the chore of selecting the right components.

POWER THROUGHPUT ANALYSIS WORKSHEET

Required bandwidth orbit rate:

Required distance:

Required BER

Fiber type:

Total fiber bandwidth ___ MHz - km ÷ ___ MHz = ___ km

Source type: T-801E Average source output power, P_s: dBm

Detector type: Receiver sensitivity, P_R: dBm

Total Margin, (P_R-P_s): dBm

Source coupling loss, L_o: dB

Total fiber loss @ dB/km: dB

connectors: Total connector loss @ 1 dB/conn: dB

splices: Total splice loss @ dB/splice: dB

Detector coupling loss: dB

Allowance for temperature degradation: dB

Allowance for time degradation: dB

Total Attenuation: dB

Excess power (total margin-total attenuation): dB

REFER TO:

Table 3
Table 1, Text
Figs. 2, 3, 4
Table 2
Table 3
Table 4
Table 4
Text (1 dB typ.)
Text
Text

9. The power worksheet for the design example indicated no excess power, but 3 dB have been included to allow for degradation.

age LED output is 3 dB less (for a data stream containing approximately 50% ONEs). For extended lifetime, the peak drive current is halved, which reduces power an additional 3 dB. The 10-ns rise time of the LED is fast enough by far.

Assume you have chosen an APD receiver for the system. From Fig. 2, the receiver sensitivity for an

RISE TIME ANALYSIS WORKSHEET

Required system rise time: 70 ns (70% of bit interval)

Required fiber length, type: 2 km

Source type: T-801E

Total fiber rise time due to multi-mode dispersion @ 11 ns/km:

Total fiber rise time due to material dispersion @ 3.5 ns/km:
(Typically 3.5 ns/km for LEDs, negligible for lasers.)

Detector type: APD

Receiver:

RISE TIME	RISE TIME SQUARED	REFER TO:
10 ns	100	Table 1
22 ns	484	Table 3
7 ns	49	Text
2 ns	4	Table 5
50 ns	2500	Text, Data Sheets

SUM OF SQUARES

3137

System rise time, (1.1) (Square root of sum): 62 ns

Analog system -3dB bandwidth, (.35 ÷ system rise time): MHz

10. System rise time for the design example is well below that required.

APD receiver operating at 20 Mbit/s and at 10⁻⁸ BER is found to be -57 dBm. For a BER of 10⁻⁹, only a fraction of a dB of additional optical power is required. The receiver sensitivity, therefore, is at least -56 dBm. Subtracting sensitivity from output power, you find the total system margin to be 49 dB (Fig. 9).

To determine the maximum acceptable fiber attenuation, assume an excess power of 0 dB, which gives a total attenuation of 49 dB. Referring to Table 3, you find that the source-coupling loss for the selected source and fiber is 14 dB. A connector is required at the transmitter and one more at the receiver. Table 5 indicates a connector loss of 1 dB each, or a total of 2 dB. One cable-to-cable splice is required at 0.3 dB loss (Table 4). Allow a generous 1 dB for splices—enough for two possible repairs. The detector coupling loss is 1 dB, and you allow time and temperature degradations of 3 dB each. The total loss, not including the fiber, is thus 24 dB, which leaves 25 dB, or 12.5 dB/km for fiber loss. A cable with fiber type GS-02-8 satisfies the requirements, with an excess power of 5 dB (see Table 3).

Now use the rise-time analysis work sheet (Fig. 10) to verify that the system rise time will be rapid enough to properly pass the data. With NRZ data, the rise time must be no more than 70% of the bit width of 100 ns, i.e., 70 ns. From Table 2 you find the rise time of the T-801E to be 10 ns. From Table 3, the GS-02-8 fiber rise-time factor is 11 ns/km. For 2 km, the total fiber rise time due to multimode dispersion is 22 ns. But since a LED is used, material dispersion will contribute an additional rise-time factor of 3.5 ns/km in the fiber, or an additional 7 ns. The APD detector has a rise time of 2 ns.

The sum of the squares of all rise times is 637 ns². By taking the square root and multiplying with 1.1, you obtain a total system rise time of 28 ns at the detector output—much less than the required 70 ns. You're home free.■



TIME INTERVAL MULTIMETER HEWLETT • PACKARD

LINE
OFF ON



V

A

2.83

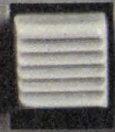
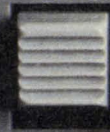

SCOPE (275 MHz)

INTENSITY

TIME INTERVAL

START

STOP

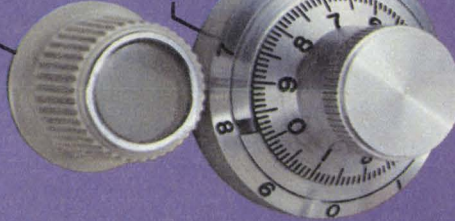

1 You simply set two intensified markers at the desired points using the START and STOP controls.

2 For maximum accuracy, switch to delayed sweep and use the STOP control to overlap the expanded traces.

SIGNAL
OVERLAY
($\Delta T=0$)

ΔT
OFF

CH A
START

CH B
START



1725A OSCILLOSCOPE (275 MHz) HEWLETT • PACKARD

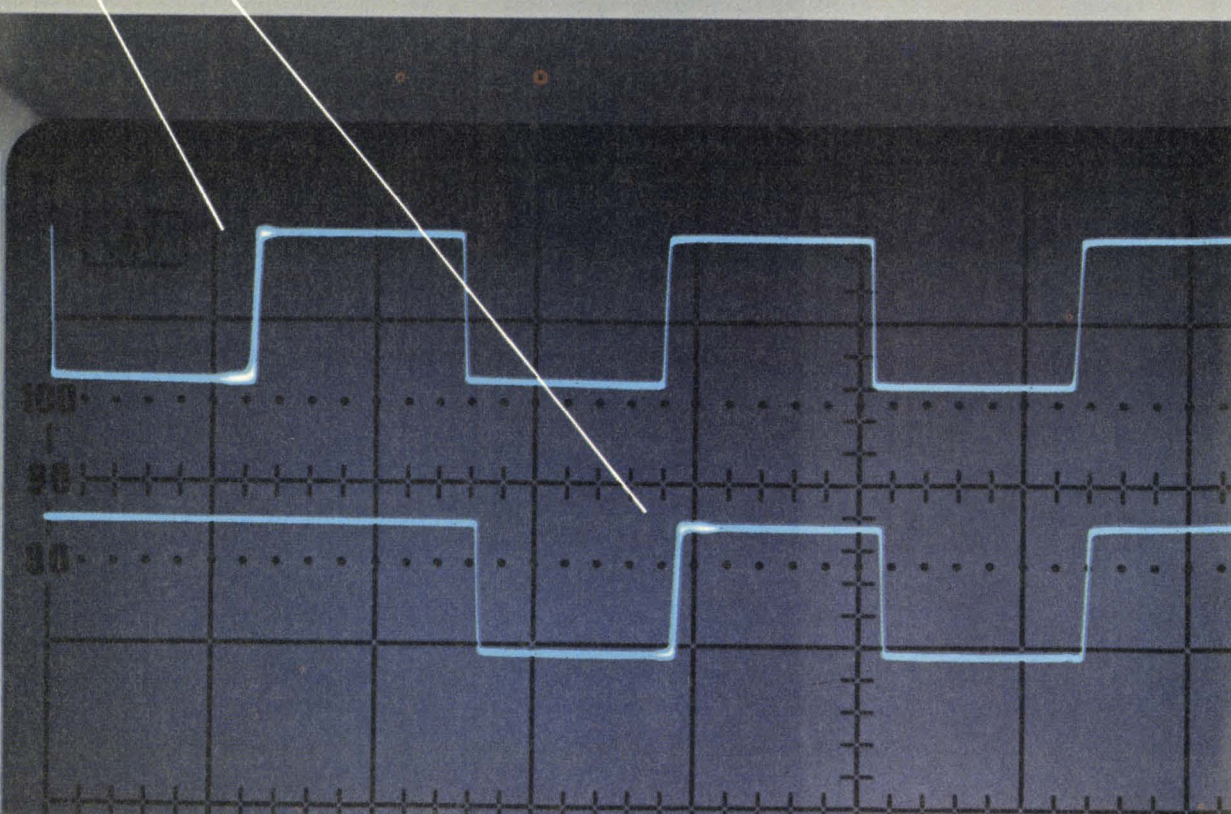

MULTIMETER
ME INTERVAL
RANGE
Ω AUTO HOLD

EXT TRIG
1MO

3 Read the time interval directly on the digital display. (Without the DMM option, read the interval directly from the STOP control dial.)

For improved Δ -time measurements, plus autoranging AC/DC volts, amps and ohms ...

HP's the Answer.

Now you can choose from two new scopes with improved Δ -time capability: The 200 MHz **1715A** priced at \$3000* or the 275 MHz **1725A** for \$3300*. Both offer an optional built-in DMM for direct Δ -time readout, plus autoranging AC/DC volts, amps, and ohms.

Δ -time measurements are now faster with the 1715A and 1725A. They're more accurate because scope and operator errors are significantly reduced. Plus you have switch selection of channel A or B as the starting point for Δ -time measurements, often eliminating the need to move probes and simplifying trace overlap for zeroing. But you can still select conventional delayed sweep with the flip of a switch, for brighter low-rep-rate traces and convenient trace expansion.

The optional autoranging 3½ digit DMM is priced at \$325* factory installed. Or, for easy field installation, there's a kit priced at \$375*. Another option, HP's "Gold Button" for \$150*, gives you pushbutton selection of either time domain or data domain when the 1715A or 1725A is used with HP's 1607A Logic State Analyzer.

Like all new high-frequency HP scopes, the 1715A and 1725A have switch selectable 50 ohm or 1 Megohm inputs. And the 1725A, with 275 MHz

bandwidth, is the fastest 1 Megohm-input scope available. That reduces the need for active probes when working with fast logic near maximum fan-out.

The story with both of these scopes is user convenience—from front-panel controls to the minimum of adjustments for servicing. Your local HP field engineer can give you all the details.

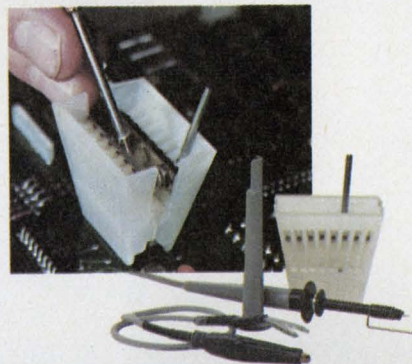

And here's something NEW for scopes. HP's **Easy-IC Probes**. A new idea for probing high-density IC circuits that eliminates shorting hazards, simplifies probe connection to DIPs and generally speeds IC troubleshooting. The probes are standard equipment with these two scopes.

*Domestic U.S.A. price only.



HEWLETT  PACKARD

1507 Page Mill Road, Palo Alto, California 94304

For assistance call: Washington (301) 948-6370, Chicago (312) 255-9800, Atlanta (404) 955-1500, Los Angeles (213) 877-1282

087/6

CIRCLE NUMBER 35

Introducing the SMALLEST BROADBAND MIXERS in the world - 40 kHz - 2 GHz

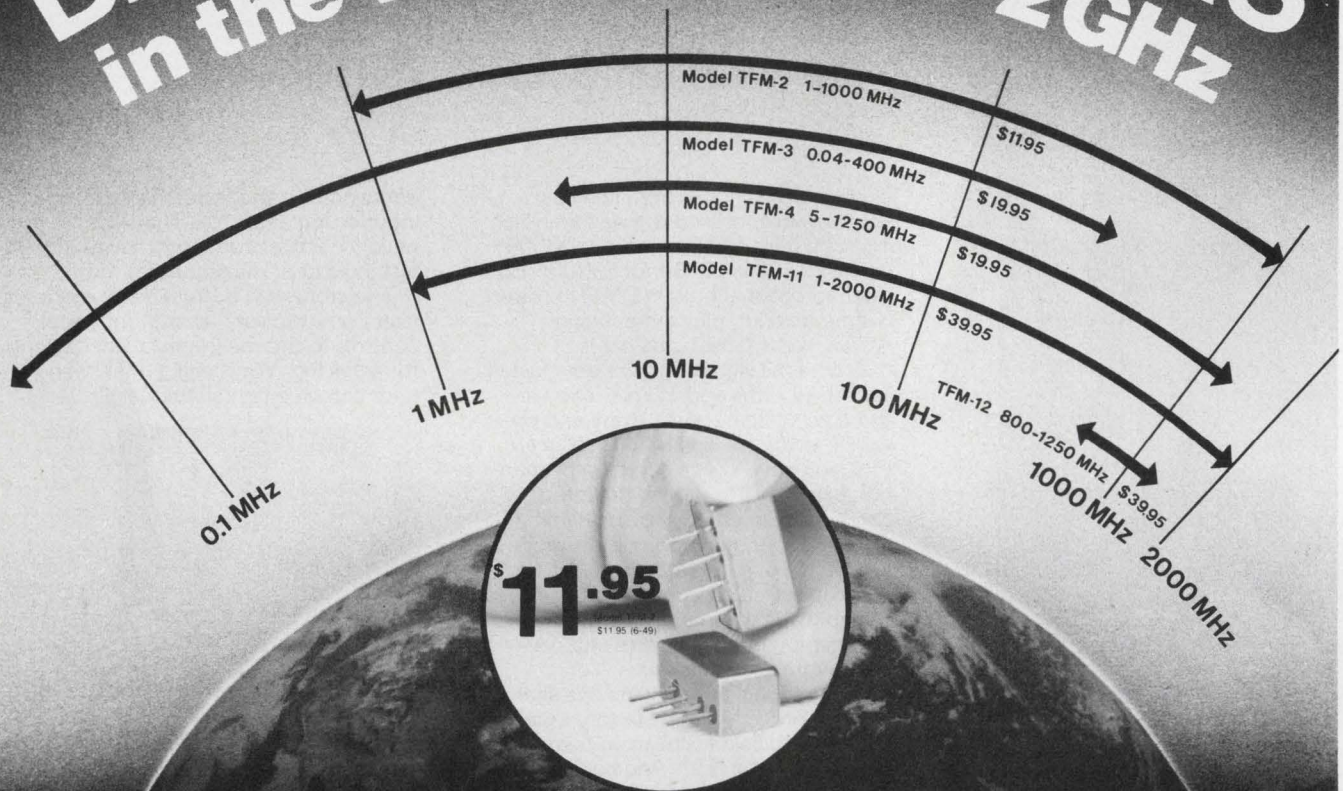

Act now to improve your system designs, increase your packaging density, and lower your costs... specify Mini-Circuits new microminiature TFM series. These tiny units, the smallest off-the-shelf Double Balanced Mixers available today, cover the 40 kHz - 2 GHz range and offer isolation greater than 45 dB and conversion loss of 6 dB. Each unit carries with it a 1-year guarantee by MCL. Upgrade your new system designs with the TFM, rapidly becoming the new industry standard for high performance at low cost.

Model No.	Frequency Range MHz			Conversion Loss, dB			Isolation, dB												Quantity	Price
	LO	RF	IF	One Octave From Band Edge		Total Range	Lower Band Edge To one Decade Higher				Mid Range				Upper Band Edge To Octave Lower					
				Typ	Max		Typ	Min	Typ	Min	Typ	Min	Typ	Min	Typ	Min	Typ	Min		
TFM-2	1-1000	1-1000	DC-1000	6.0	7.5	7.0	8.5	50	45	45	40	25	35	25	30	25	20	6-49	\$11.95	
TFM-3	0.4-400	0.4-400	DC-400	5.3	7.0	6.0	8.0	60	50	55	40	50	35	45	30	35	25	5-49	\$19.95	
TFM-4	5-1250	5-1250	DC-1250	6.0	7.5	7.5	8.5	50	45	45	40	30	35	25	30	25	20	5-49	\$19.95	
TFM-11	1-2000	1-2000	5-600	7.0	8.5	7.5	9.0	50	45	45	40	35	25	27	20	25	20	1-24	\$39.95	
TFM-12	800-1250	800-1250	50-90	-	6.0	7.5	35	25	30	20	35	25	30	20	35	25	20	1-24	\$39.95	

Signal: 1 dB compression level: +1 dBm. Impedance: all ports 50 ohms. Total input power 50 mW. Total input current peak 40 mA. Operating and storage temperature: -55°C to +100°C. Pin temperature 510°F (10 sec).

Simple mounting options offer optimum circuit layout.

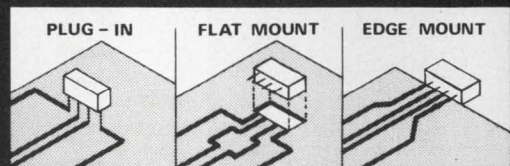

Use the TFM series to solve your tight space problems. Take advantage of the mounting versatility—plug it upright on a PC board or mount it sideways as a flatpack.

World's largest manufacturer of Double-Balanced Mixers

Mini-Circuits

MINI-CIRCUITS LABORATORY
A Division of Scientific Components Corp.

2625 East 14th Street Brooklyn, New York 11235 (212) 769-0200
Domestic and International Telex 125460 International Telex 620156

OUR NEW ADDRESS
AND PHONE NO. IS:

WE'VE GROWN

Customer acceptance of our products has been so overwhelming, we've been forced to move to larger facilities — THANKS.

International Representatives: **AFRICA:** Afrita (PTY) Ltd P.O. Box 9813, Johannesburg 2000, S. Africa. **AUSTRALIA:** General Electronic Services, 99 Alexander Street, New South Wales, Australia 2065. **ENGLAND:** Dale Electronics, Dale House, Wharf Road, Frimley Green, Camberley Surrey. **EASTERN CANADA:** B. D. Hummel, 2224 Maynard Avenue, Utica, NY 13502 (315) 736-7821. **FRANCE:** S.C.I.E. - D.I.M.E.S. 31 Rue George - Sand 91120 Palaiseau France. **GERMANY, AUSTRIA, SWITZERLAND, DENMARK:** Industrial Electronics GmbH 6000 Frankfurt/Main Klüberstrasse 14 West Germany. **INDIA:** Gaekwar Enterprise, Kama Mahal, M.L. Dananukar Marg, Bombay 400 026, India. **ISRAEL:** Vectronics, Ltd., 69 Gordon Street, Tel-Aviv, Israel. **NETHERLANDS, BELGIUM, LUXEMBOURG:** Coimex, Veldweg II, Hattem, Holland.

NORWAY: Datamatik AS, Ostensjoveien 62, Oslo 6, Norway. **SINGAPORE & MALAYSIA:** Electronics Trading Co. (PTE) Ltd, 87 Bukit Timah Road, Singapore 9, Malay Peninsula. **SWEDEN:** Integerad Elektronik AB, Box 43, S-18251, Djursholm, Sweden.

U.S. Distributors: **NORTHERN CALIFORNIA:** PENN-STOCK Co., Foothill Office Center, 105 Fremont Avenue, Los Altos, CA 94022 (415) 948-6533. **SOUTHERN CALIFORNIA, ARIZONA:** Crown Electronics, 11440 Collins Street, No. Hollywood, CA 91601 (213) 877-3550. **NEW YORK:** NEW YORK MICROWAVE DISTRIBUTORS COMPANY, 61 Mall Drive, Commack, N.Y. 11725 516 543-4776.

24 Rev/A

Now... the Coolest Fastest Biggest Bipolar Multipliers you can buy

*feature MIL chips in commercial temperature ranges
(at no increase in price)*

MPY-8AJ
130 ns
8 x 8 bits

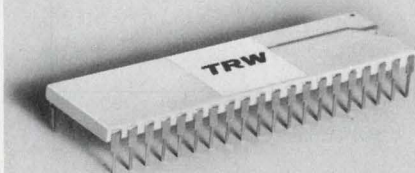

Only \$70 in 100's

MPY-12AJ
150 ns
12 x 12 bits

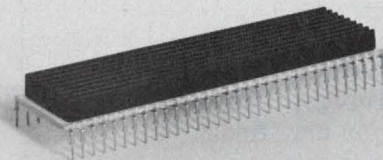

Only \$115 in 100's

MPY-16AJ
160 ns
16 x 16 bits

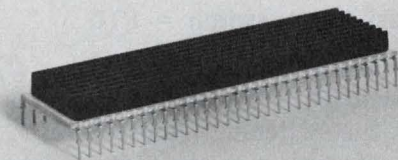

Only \$175 in 100's

We've cut out all excess power... to offer you MIL chip reliability and performance in commercial temperature range parts. Consider these advantages for Digital Signal Processing:

- low power
- no air flow requirement (0°C to 70°C in still air)
- high reliability (for example a recent test indicated an MTBF greater than 200 years at max. oper. temp.)
- reduced output delay

No increase in price! A great increase in reliability! We have the details in our new reliability brochure. For your copy, send the coupon today. Or you can call us at (213) 535-1831.

TRW LSI Products

An Electronic Components Division of TRW, Inc.
P.O. Box 1125
Redondo Beach, CA 90278

Please send Reliability Brochure and updated data on your "cool" Multipliers.

NAME _____

COMPANY _____

DIV/DEPT _____

MAIL CODE _____

ADDRESS _____

CITY _____

STATE _____

ZIP _____

ED-11

TRW LSI PRODUCTS

For Digital Signal Processing

CIRCLE NUMBER 37

Heat switches the PTC thermistor.

And the large resistance swing of this positive tempco device makes it look almost like an ideal switch.

A positive-temperature-coefficient thermistor (PTC) works like an ordinary resistor for most of its temperature range. But when sufficient heat is applied, it switches abruptly to a very high resistance. And unlike the resistance of its more popular cousin, the negative-temperature-coefficient thermistor, a PTC's resistance can change by as many as seven orders of magnitude over a 100-C temperature span. Over the same range, an NTC will change by less than three orders of magnitude.

PTCs can replace bimetal switches, fuses, heating elements and even capacitors. But to apply a PTC properly, you must have a thorough understanding of its electrical, mechanical and thermal specifications. Then you'll see why its range of applications covers motor starting, color TV degaussing and even working as a carburetor choke heater in automobiles.

Resistor + switch = PTC

The temperature at which a PTC changes from a low to a high resistance element is called appropriately, the switching temperature, T_s . But you may find it referred to as the Curie or anomaly temperature, depending on whose catalog you're reading. Furthermore, notice in the resistance-temperature plot of Fig. 1 that a PTC's resistance increases sharply at the switch temperature, which in this case, is about 120 C. Devices can be made with switching temperatures ranging from 0 C to over 150 C, but the largest temperature coefficients are found in the 120-C units.

When a PTC is internally heated to a temperature below T_s , it has an approximately linear voltage-current characteristic between the origin and the switch current, I_s , (see Fig. 2). In this region, a PTC operates somewhat like an ordinary resistor. Power dissipation within the device causes the internal temperature to rise. When the current reaches I_s , enough heat is produced for the PTC to reach the switching temperature. Any further increase in the voltage required to produce I_s causes current flow through the device to be reduced abruptly as shown in Fig. 2.

The exact value of I_s is a function of ambient temperature, T_s , of the PTC and the thermal re-

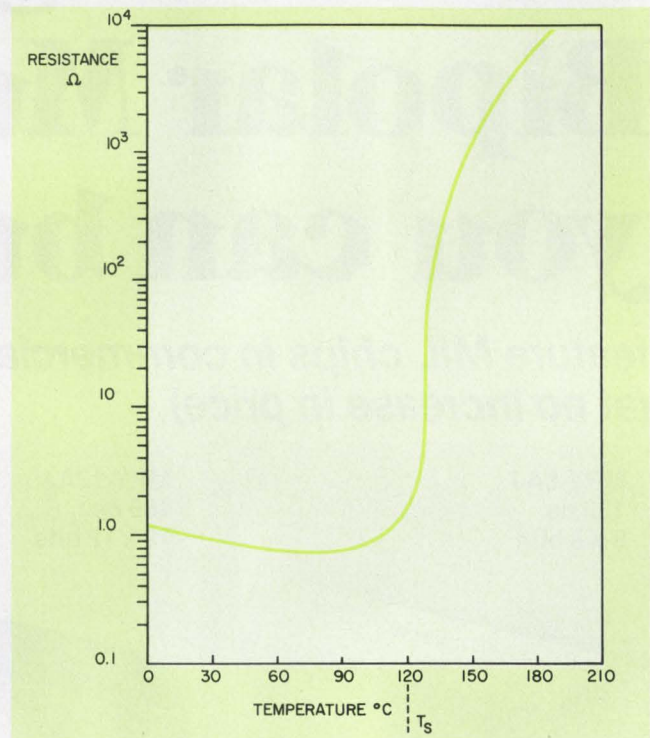

1. A PTC thermistor switches abruptly when heated to the switching temperature. Resistance changes by four decades as shown in this resistance-temperature graph.

sistance of the PTC to ambient. If a PTC is internally heated, an approximate equation for its behavior is

$$P = K_{dc} (T_p - T_A) \quad (1)$$

where P = power generated in the PTC in mW
 K_{dc} = dissipation constant in mW/°C
 T_p = body temperature of the PTC in °C
 T_A = ambient temperature in °C.

The dissipation constant K_{dc} is a measure of how efficiently a PTC sheds heat to its surroundings. It is a function of any parameter that can change heat flow, such as mounting method, air flow, or PTC size. Strictly speaking, K_{dc} is a constant only under a given set of conditions. However, using one value of K_{dc} for the entire operating temperature range gives sufficiently accurate results for most engineering problems.

An ideal model of the PTC gives you a good idea of its operating characteristics when internally

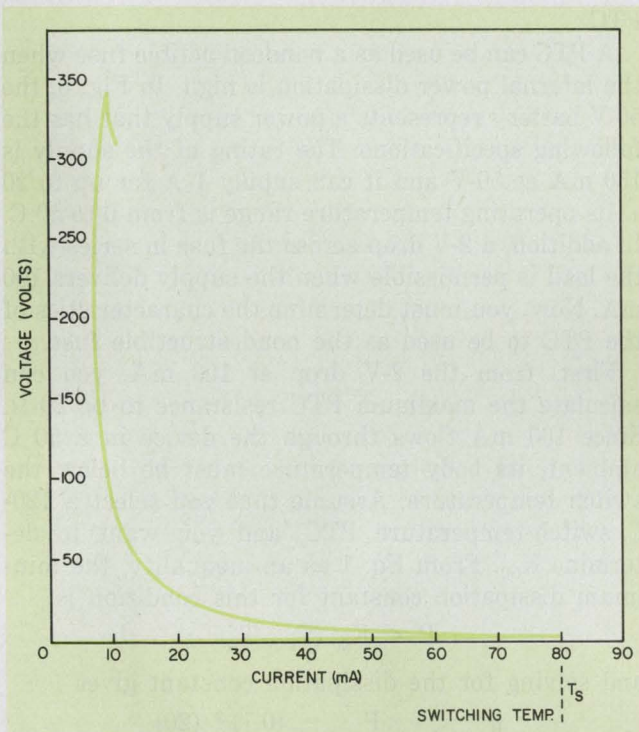

2. Two operating regions are possible for a PTC as the V-I curve shows. Note the colored line near the horizontal axis to show the linear region clearly.

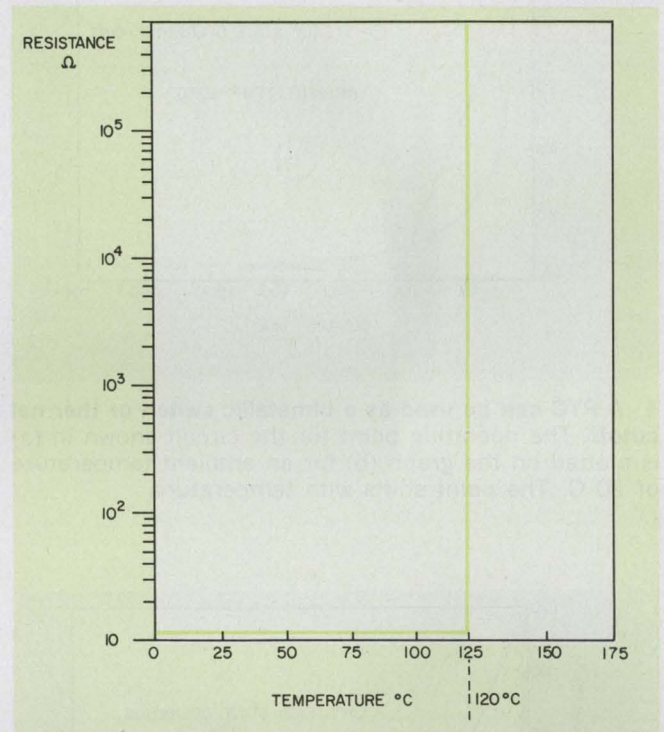

3. An ideal PTC has an ideal R/T graph. The mathematical model is used only to illustrate the basic operation of a theoretical thermistor.

heated. The following assumptions are made for the ideal device:

$$R = \text{Constant, for } T < T_s \quad (2)$$

$$R = \infty, \text{ for } T > T_s \quad (3)$$

$$\text{Power generated} = V \times I = K_{dc} (T - T_A) \quad (4)$$

The resistance-temperature graph of Eqs. 2 and 3 is shown in Fig. 3. From Eqs. 2 and 4, the following conditions emerge: Below the switching temperature, the temperature rise of a PTC is directly proportional to the power being generated within the device. That is, the current flowing through is proportional to the voltage across the PTC and it acts like an ordinary resistor. When the switching temperature (T_s) is reached, the power remains constant and any increase in voltage reduces the current.

Armed with the fundamentals of PTC operation, let's examine two typical applications. In one, where power generation in the PTC is minimized, the device

is used as a temperature sensor, much like a thermocouple or NTC thermistor. In the other, where internal power generation is large, the device works as a current limiter or temperature limiting heater.

PTCs in action

When internal power dissipation is kept low, and ambient allowed to rise, a PTC can replace a bimetallic switch. In the simple series circuit of Fig. 4a, the PTC has a cold (i.e., 25 C, ambient) resistance of 10 Ω and the series R selected is 490 Ω . Approximately 200 mA will flow in the circuit at ambient conditions and the operating point of the PTC will be the one shown on the graph of Fig. 4b. As the ambient temperature increases, the V-I curve of Fig. 4b will move towards the left until the switching temperature is reached. Beyond this temperature, no low-resistance stable operating point exists for the PTC and most of the available voltage is impressed across it. This condition

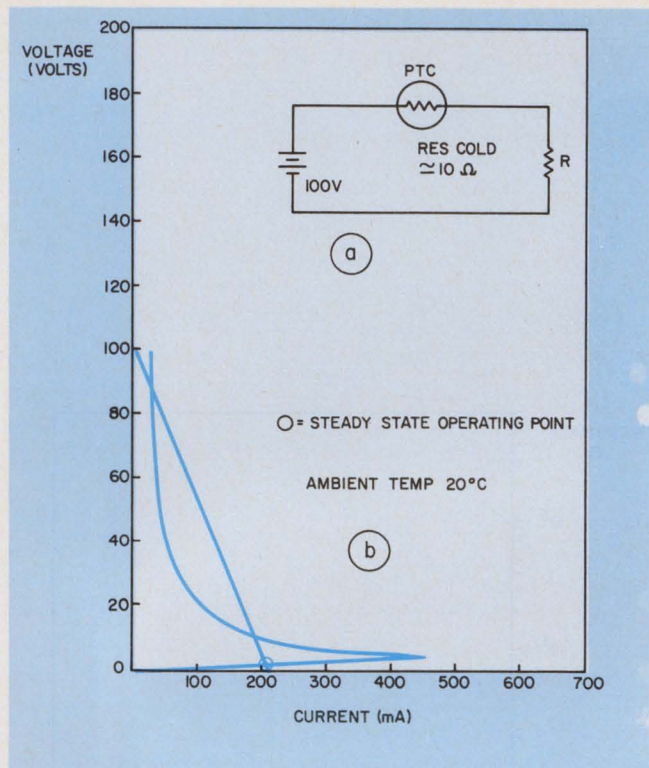

4. A PTC can be used as a bimetallic switch or thermal cutoff. The operating point for the circuit shown in (a) is plotted on the graph (b) for an ambient temperature of 20 C. The point shifts with temperature.

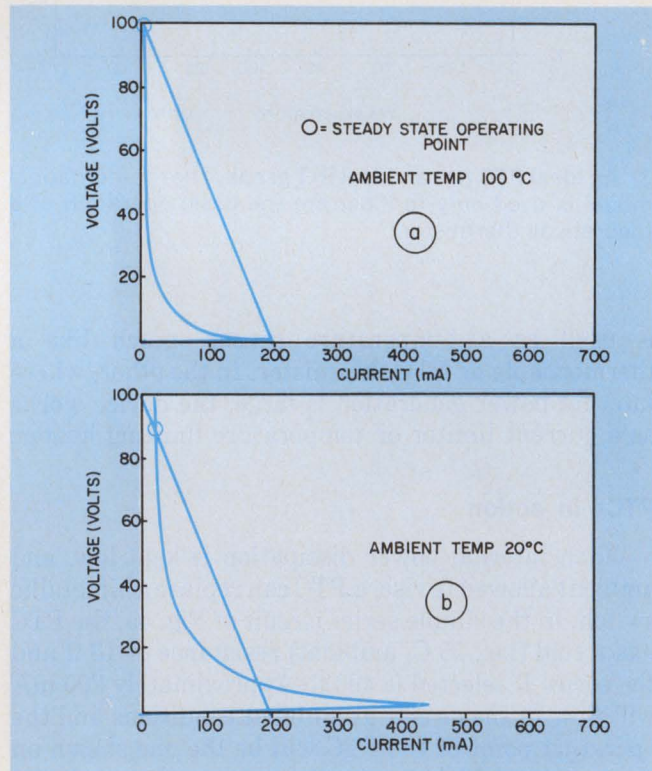

5. External heating causes a shift in the operating point. This swings the low resistance point of Fig. 4b up to the high resistance point shown in (a). Internal heating keeps the PTC at a high resistance (b), even after the high temperature condition has passed and the ambient returns to 20 C.

is shown in Fig. 5a.

When the ambient temperature drops, the V-I curve moves to the right as shown in Fig. 5b. But the PTC is kept in a high resistance state by the heat generated within itself. To get the device to return to its original state in Fig. 4b you've got to either decrease power input to it, or provide additional cooling. In this example, with a load resistance of only 490 Ω, the PTC works quite well. For high values of load resistance, less self-heating takes place and switching becomes less pronounced. The high-load-resistance application requires a more sophisticated detection circuit for this PTC.

A PTC can be used as a nondestructible fuse when the internal power dissipation is high. In Fig. 6, the 50-V battery represents a power supply that has the following specifications: The rating of the supply is 150 mA at 50-V and it can supply 1 A for up to 20 s. Its operating temperature range is from 0 to 50 C. In addition, a 2-V drop across the fuse in series with the load is permissible when the supply delivers 100 mA. Now, you must determine the characteristics of the PTC to be used as the nondestructible fuse.

First, from the 2-V drop at 100 mA, you can calculate the maximum PTC resistance to be 20 Ω. Since 100 mA flows through the device in a 50 C ambient, its body temperature must be below the switch temperature. Assume that you select a 120-C switch-temperature PTC, and you want to determine K_{dc} . From Eq. 1 as an inequality, the minimum dissipation constant for this condition is

$$P < K_{dc} (T_s - T_A).$$

and solving for the dissipation constant gives

$$K_{dc} > \frac{P}{T_s - T_A} = \frac{(0.1)^2 (20)}{120 - 50}$$

$$K_{dc} > 2.86 \text{ mW/C.}$$

To ensure that the PTC will switch at the coldest ambient under fault conditions, the minimum resistance and maximum dissipation constant must be selected to allow the inequality below to be true.

$$P > K_{dc} (T_s - T_A).$$

And since $P = I^2R$, substituting for P gives

$$\frac{R}{K_{dc}} > \frac{T_s - T_A}{I^2} \quad (5)$$

where $I = 1.0A$,

$$T_s = 120 \text{ C}$$

$$T_A = 0 \text{ C} = (\text{lowest power-supply ambient}).$$

A trial value for the minimum PTC resistance, R is selected to be 10 Ω. Solving Eq. 5 for K_{dc} gives a value of K_{dc} less than 83.3 mW/°C.

Having calculated upper and lower limits for K_{dc} , you must specify the heat capacity of the PTC, which is found from the following relationship.

$$\text{Power } dt > \text{Heat capacity } dT + (T - T_A) dt \quad (6)$$

But in most practical cases the $(T - T_A)$ term can

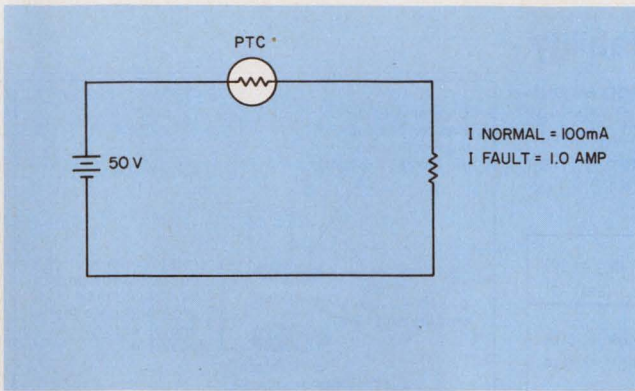

6. Operating as a nondestructible fuse, the PTC can dissipate considerable power under fault conditions.

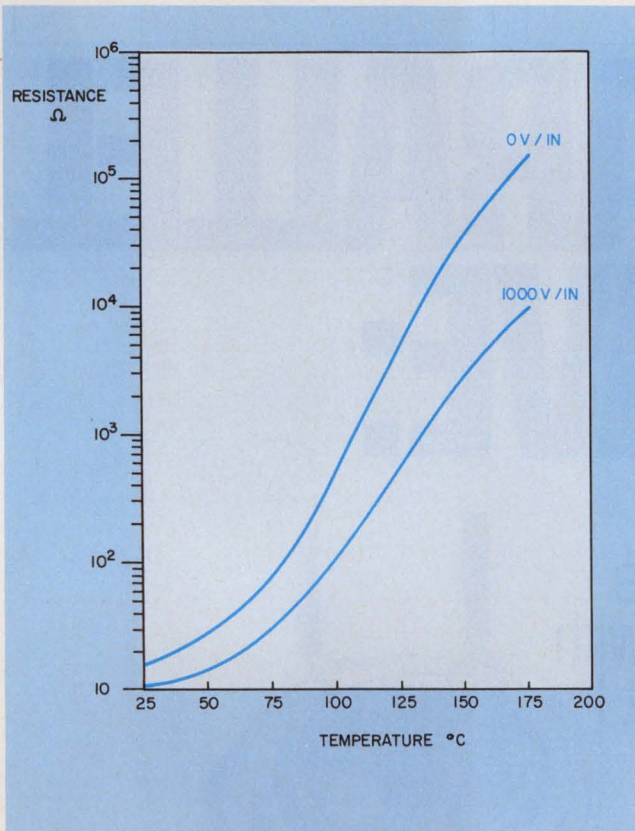

7. Voltage gradient determines resistivity of a PTC. Using curves similar to this one helps optimize designs.

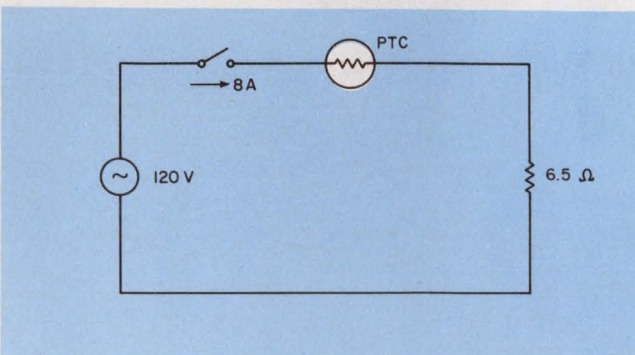

8. You need more than Ohm's Law to find the PTC's resistance in this circuit. A graph of voltage sensitivity of resistance should also be used.

be neglected. Replacing the dt by Δt and dT by ΔT , and solving for heat capacity gives,

$$\text{Heat capacity} < \frac{\text{power } \Delta t}{\Delta T} = \frac{I^2 R (\Delta t)}{\Delta T} \quad (7)$$

where $I = 1.0 \text{ A} = \text{fault current}$

$R = 10 \text{ } \Omega = \text{trial value of resistance}$

$\Delta t = 20 \text{ s} = \text{fuse timing requirement}$

$\Delta T = 120 \text{ } ^\circ\text{C}$

Solving Eq. 7 gives a value of heat capacity less than $1.67 \text{ W}/^\circ\text{C}$.

Now you have calculated all the important parameters for specifying your PTC.

1. $10 \text{ } \Omega < R < 20 \text{ } \Omega$.

2. $2.86 \text{ mW}/^\circ\text{C} < K_{dc} < 83.3 \text{ mW}/^\circ\text{C}$.

3. Heat capacity $< 1.67 \text{ W}/^\circ\text{C}$.

4. $T_s = 120 \text{ } ^\circ\text{C}$.

You're almost ready to begin designing the PTC into your circuit. But first, look at some not so obvious characteristics of this device. Understanding them will allow you to optimize the selection of your PTC.

Voltage specs can be tricky

Below the switching temperature, the PTC behaves, as you've seen, very much like a resistor. But the device also exhibits a non-ohmic characteristic as the voltage across it increases. The materials used to make PTCs—powders containing barium titanate, strontium or lead and traces of rare earth elements—are responsible for a PTC behaving somewhat like a varistor.

In Fig. 7, the sensitivity of resistance to voltage is shown for a PTC having voltage gradients of 0 V/in. and 1000 V/in. It's not uncommon for resistance to decrease by an order of magnitude due to voltage sensitivity.

To see how to use the resistance-voltage characteristic, examine the circuit of Fig. 8. When the switch is closed, the required peak-surge current is 8 A . The peak value of the 120-V-rms waveform is approximately 170 V , and from Ohm's Law you can see that the total circuit resistance required to give 8 A is $21.25 \text{ } \Omega$. You would assume that the maximum PTC resistance allowed is $14.75 \text{ } \Omega$. But because of the voltage sensitivity of resistance, devices with zero-power resistance as high as $30 \text{ } \Omega$ will produce surge currents of 8 A . Not being aware of this characteristic could lead you to specify unnecessarily tight tolerances for your PTCs. When you read a spec sheet, beware of maximum voltage ratings. They're normally specified in dc volts or 60-Hz, rms volts. Because of the voltage sensitivity of resistance, rms values have little meaning unless you know what your waveform will be.

When you're ready to install the PTC in your circuit, don't use any coatings or potting compounds to cover it, until you check with the manufacturer. This also applies to operating the device in any atmosphere other than air. And if you are going to mount it rigidly, select expansion coefficients of your materials that will prevent the PTC from being fractured. ■■

Save Space. Save Weight. Increase Reliability.

Paralleling transistors doesn't pay —not when an inherently rugged single device can do the job far more reliably, using much less space, weight, and at lower total system cost. That's why PowerTech's unique single-chip NPN silicon high-power transistor is the *one* way to go.

Used alone, our space-saving single-chip device eliminates multiple failure sources while reducing the environmental testing costs inherent in parallel arrays. Because of their simplicity they're available off-the-shelf pre-rated, pre-tested and inventoried to meet virtually any hi-rel JAN and JAN-TX hi-current requirements without custom prices and long custom waits.

For information, application assistance, and free design guide call Sales Engineering. PowerTech, Inc., 0-02 Fair Lawn Avenue, Fair Lawn, New Jersey 07410; Tel. (201) 791-5050.

Type #	(pk.) I_c	V_{ce0}	($h_{fe} = 10$) $V_{ce} \text{ (sat) @ } I_c$
JAN-TX 2N5926	90A	120V	0.6V @ 50A
PT-7511	90A	200V	0.6V @ 50A
JAN-TX 2N5927	120A	120V	0.6V @ 70A
PT-6502	200A	80V	0.7V @ 100A
PT-9502*	500A	80V	0.5V @ 300A

350 Watt Power Rating
*625 Watt Power Rating
Guaranteed SOAR

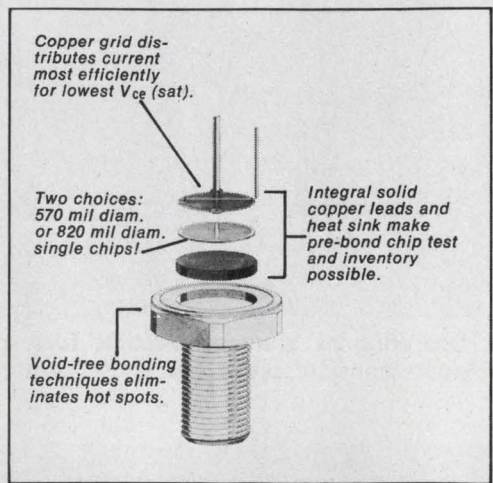

TO UNPARALLEL IS TO SAVE:

Silicon transistors
to 500 amps with
lowest $V_{CE} \text{ (sat)}$



PowerTech, Inc.
"BIG IDEAS IN
BIG POWER"

Safety. Long life. Reliability. Pour it on.



Now there's an all-purpose encapsulant that gives you silicone performance at the price of organics. Dow Corning Sylgard® 170 A&B silicone elastomer. A two-part liquid encapsulant that cures at room temperature or can be heat accelerated to increase production rates.

Sylgard 170 carries the UL 94VO rating, the very highest rating for flame retardancy for this type of product.

Sylgard 170 offers excellent temperature stability. It is

reversion resistant at high temperatures. And that means greater reliability and longer product life under the most severe environmental conditions.

Sylgard 170 has great dielectric properties, too. So it's perfect for general potting and encapsulating jobs like modules, relays, power supplies, amplifiers, ferrite cores and connectors. At a price that'll let you keep a margin of profit in your product as you build in an extra margin of safety.

So add it up. Safety and reliability throughout the temperature range. Longer product life. Reasonable price. Sylgard 170 silicone elastomer. Pour it on.

Call your Dow Corning representative or write Dow Corning Corporation, Department A7-511, Midland, Michigan 48640.

DOW CORNING

DOW CORNING

Break the 65-kbyte address barrier in microprocessor systems by using addressing techniques that make use of bank switching and overlapping to add an Mbyte or more.

Don't let the 65-k direct-addressing range of most microprocessors stop you from addressing larger memories. With memory-bank switching memory mapping, overlapping and multiplexed addressing, you can add a megabyte or more of randomly accessible memory.

Right now, most popular microprocessors can address no more than 65 kbytes of memory. This figure results from using a 16-bit address bus, which leads to $2^{16} = 65,536$. The 16-bit address was selected by the pioneer μ P manufacturers. One reason was that since the number of bits associated with an address increases as the address size increases, address size was pin-limited because of the small size of the chips available then.

Address-bus multiplexing (half the address now, half later) would have solved the size problem, but also would have added more complexity and cost to the system than was warranted by the applications of the day. So while a 24-bit directly addressable address eventually would have proven more useful, the 16-bit address and its implied limit of 65 kbytes of memory became the *de facto* standard.

Today, however, with technology improving, capabilities increasing and costs going down, microprocessors are being used in many applications that require more and more memory capacity. Moreover, the use of higher-level languages also demands more storage capacity.

The small-computer problem

Random-access memory—without which you can't run your computer—is very expensive. It costs more per byte than either tape (cassette) or rotating (disc) memory. But it's faster than both—and that's what you pay for.

Today, you need at least 16 kbytes of RAM storage to do something that's fairly complex or to run a high-level language such as Fortran. And for many applications, 65 kbytes of storage—and more—is what you really need.

As a way to increase memory storage, bank

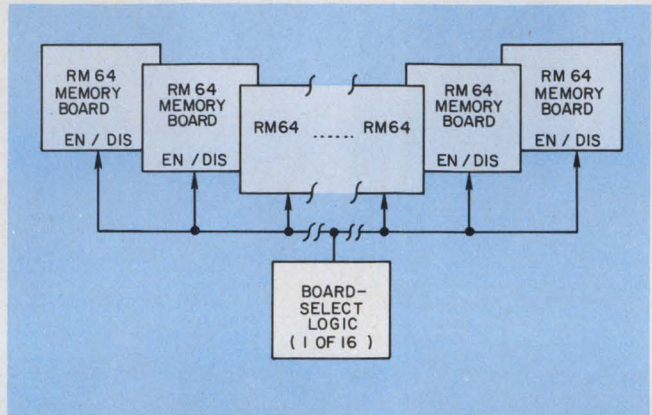

1. **Bank-switching control logic** can be distributed through a microcomputer system. Each memory board contains enable/disable logic, but the board-select board actually selects a given bank. Under software control, it can select any one of 16 boards.

switching is an old technique used for years in large, mainframe machines. In bank switching, one of many memory modules is selected (switched on-line and enabled), while all other modules are de-selected (disabled). A software routine tells the CPU when to switch to the next memory bank, and where it is located—that is, which memory module to select.

Currently, two microcomputer memory boards feature bank switching. Introduced late in the spring of this year, both use S-100 microcomputer-bus protocol, and normally handle as much as 65 kbytes of usable semiconductor random-access memory on a single board. One bank-switching board, marketed by Imsai of San Leandro, CA, costs more than \$3500. The other board, the RM64 from Extensys, costs about half as much, even though it uses twice as many memory chips.

The price gap is directly related to the RAM chip each manufacturer uses. The Imsai uses the more expensive Intel 2116, 16-k dynamic RAM. But the Extensys uses the less expensive Intel 2108—an 8-k RAM derived from the 2116.

Board-control logic can be kept minimal

Either board holds part of the logic necessary to enable and disable the board. But the logic that actually bank-switches a given memory board is

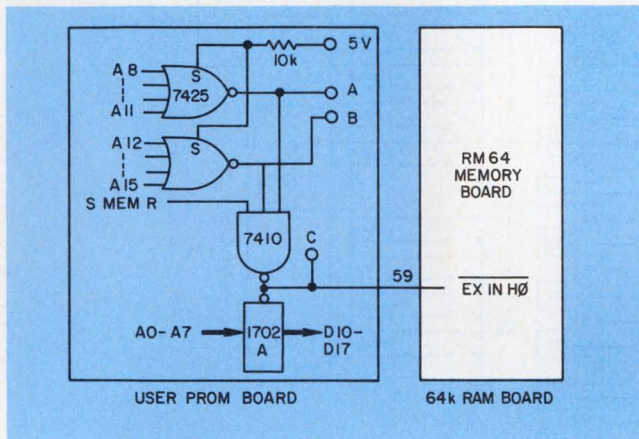

2. Memory overlap prevents bus conflicts by inhibiting the memory board's bus drivers. $\overline{\text{EXINH0}}$ is an Extensys-defined signal located at pin 59 of the S-100 bus.

external. After all, it can be in only one place in any one system.

Much of the Extensys control logic—the enable/disable function—has been distributed to each RM64 board. An external 1-of-16 decoder selects the desired memory bank (Fig. 1).

Beware, however. Bank-switching to expand your μP 's memory capacity may cause a problem during operation. When frequently used code resides, say, in PROM, you don't want to hand-load RAM in order to fetch larger routines from other storage media. Avoid this problem with a bootstrap approach using a memory-overlap technique—simply apply the system PROM's chip-select signal to the RAM card's select input. When the signal is Low, it turns off the RAM board's bus drivers and prevents bus conflicts. The signal that does this on an Extensys RAM board is designated $\overline{\text{EXINH0}}$.

"Memory overlap" is special to the RM64 board. It allows you to designate a piece of memory in your system to have precedence over any memory board that you select. As a result, you can store instructions—such as a memory-manipulating program—in some desired address range within a memory dedicated to that purpose. You don't have to duplicate the program in any other memory. The dedicated memory can be a portion of another RM64 board, or it can be external

ROM or RAM. Once the program is accessed, all other memory boards that share the same address range are disabled by the $\overline{\text{EXINH0}}$ signal.

One megabyte, anyone?

You don't lose much storage with the memory overlap technique because the forbidden address range (the overlapped memory area) is ordinarily no more than 256 bytes. But if the program gets very large, the technique proves self-defeating. Should it need, say, 32 kbytes, you end up using only half the capacity of each memory board. And with multiple memories, you can indeed write a very small piece of code that will do the job.

Fig. 3 shows a one-megabyte memory system that includes a signal for disabling all boards so that PROM takes precedence over RAM in the memory-overlap state. Bank-switching via the 75154 decoder controls the 16 RM64 boards.

If, by the way, you store the memory-manipulating program on an RM64 board, you can use bank-switching to store data in the other boards in the previously forbidden address range. The data remain accessible because of the RM64's board-disable capability—which most ROM and other RAM modules don't have.

In the circuit of Fig. 3, output port 0 is used to select one of 16 modules. A Power on Clear signal from the system bus clears a 74175 latch, so bank 0 can be accessed after every power-on. A 7410 gate provides address decoding and gating for the processor's Write pulse. The gate, in conjunction with signals A, B and SOUT, fixes the address of the latch as output port 0. (There are, of course, other ways to do the job.)

Signal C disables all boards to permit a memory-overlap state. As a result, a ROM or PROM read can take place.

The memory-control-board pinouts shown are for the S-100 bus developed by MITS for the Altair microcomputer. However, pins 59 through 66 and 13 through 20 of the bus are lines that may be used with the Imsai microcomputer system. If you use any of these lines, make sure they haven't already been assigned functions in the system: Some companies set aside these "unassigned" pins for special functions.

To switch from one 65-k memory bank to another;

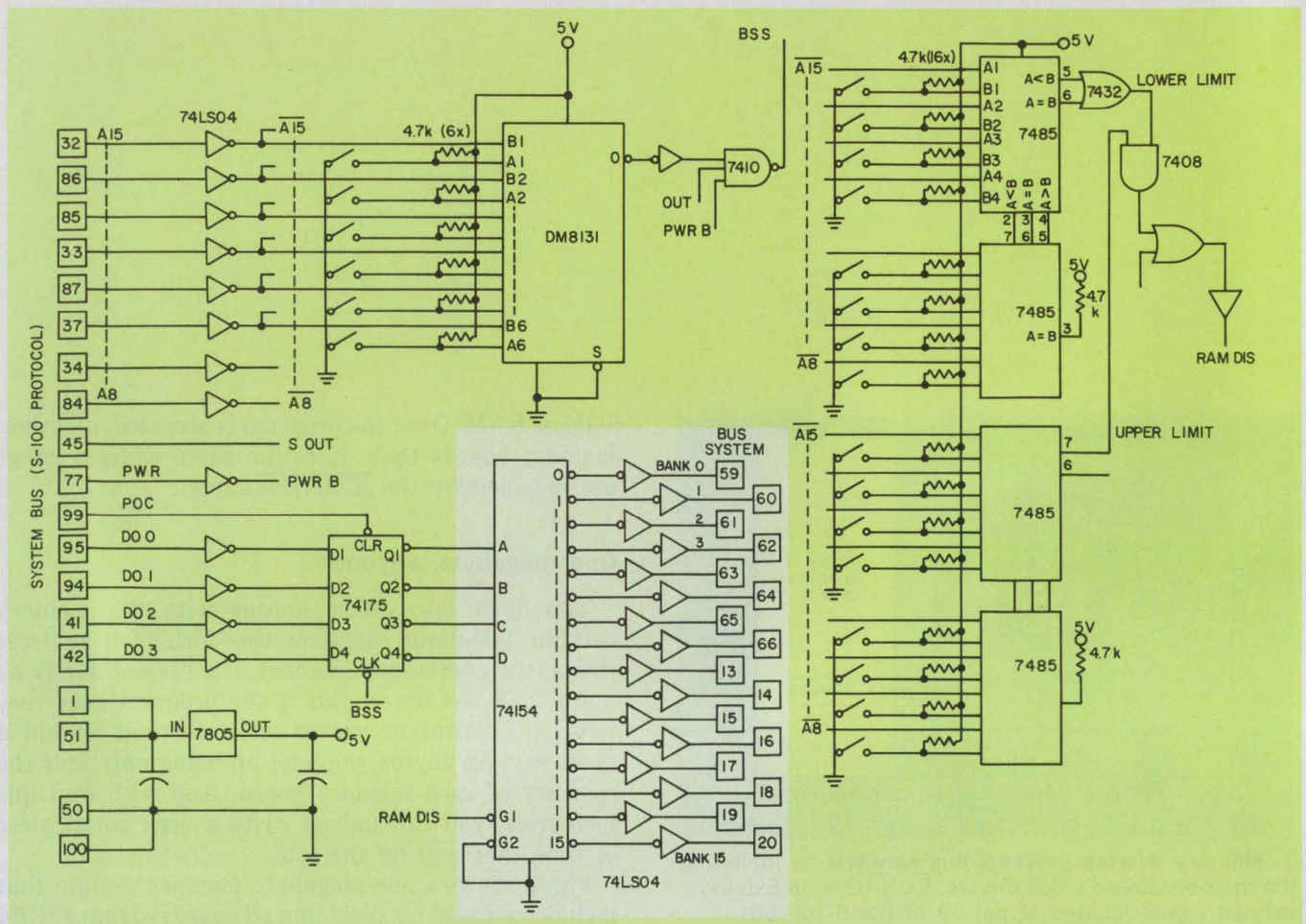

3. This 1-Mbyte RAM system consists of 16 RM64 65-k RAM modules, and uses bank switching, the EXINHØ RAM-

module-select line, and a user-provided output port to select one of the 16 RAM modules.

you must develop a software routine that writes to port Ø. The routine to generate the needed hardware signals should be similar to the following:

```
MVI A, BANK# ; BANK# FROM BELOW
```

```
OUT PORTØ ; WRITE PORT
```

The bank numbers and data representation are

BANK#	DATA
Ø	ØØH
1	Ø1H
.	.
.	.
.	.
.	.
.	.
14	ØEH
15	ØFH

The routine produces an immediate switch and fetch of the next instruction from the selected board. Therefore, to prevent the program from jumping to an unknown address, you will need a transfer code located at the same address in each board.

For example, you can use a portion of a 1702A PROM for the common bank-switch code. Both the address of the bank being jumped to and the return address of the main program should be loaded into the CPU to facilitate the jump and the return. The routine listed in Fig. 4 is an example of the bank-switch software necessary for an 8080A processor.

When large blocks of data are being transferred between peripherals and RAM memory, as happens in large-scale applications, data-transfer rates under memory-mapped control can slow system operation. But direct memory access permits fast and efficient data transfers, improves the system's data throughput, and increases the efficiency of its management capabilities.

You can easily implement a system that features both bank switching and DMA (Fig. 5). To do the interface, the controller board can be expanded to include the DMA-control circuitry. The MM16 board from Extensys has both these capabilities.

In particular, DMA provides efficient transfers to and from I/O boards and between multiple memory boards. Suitable programs in your microprocessor will set up the DMA channels and allow the DMA transfers

What is the S-100 bus?

Many different bus protocols are used today: the IEEE Digital Group protocol, 6800 protocol, 6502, among others. But the RM64 memory board makes use of the S-100 protocol structure.

Introduced by MITS for its Altair microcomputer, S-100 protocol is now used very widely and is almost a *de facto* standard.

A product compatible with the S-100 bus will work properly in any S-100 bus machine—in theory. In reality, however, some modifications may have to be made. The S-100 scheme defines a 100-pin structure and assigns certain signals to certain of these pins, as shown in the table. But from machine to machine, the number of required signals, the type of signals, and the timing of the signals can vary. What's more, there may be differences among the various specified signals in I/O structures and peripheral equipment.

The 100-pin structure of the S-100 bus is split into two groups of signals: One group consists of the basic machine-operating signals—address and data-bus lines, power-supply lines and basic control signals for reading and writing data. This group accounts for 53 of the 100 pins. The memory boards use pin 59 of the bus—a pin that hasn't been "officially" assigned a specific function (a spare). This pin is used for the $\overline{EXINH0}$ signal, which enables or disables the board. Other pins on the bus have been assigned for interrupt functions, others for special reset and timing signals and others for spares.

For more information about the S-100 bus structure and protocols, contact

MITS
Imsai

CIRCLE NO. 318
CIRCLE NO. 319

Main Program, Bank 0.

```

.
.
LXI      H, (JUMP ADDRESS)
LXI      D, (RETURN ADDRESS)
MVI      B, (CURRENT BANK)
JMP      SWITCH
NEXT INSTRUCTION (RETURN ADDRESS)
The PROM code is
SWITCH:  OUT      0
          PUSH    B
          PUSH    D
          PCHL
RETURN:  POP     H
          POP     B
          MOV     A, B
          OUT    0
          PCHL
The program in the new bank is
CODE:   PROGRAM
.
.
JMP RETURN
    
```

4. **Software for this bank-switching program** can be stored in a PROM and accessed when needed by using jump and return instructions. The example shown is for an 8080.

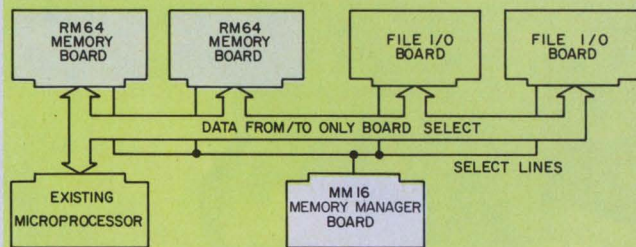

5. **Direct memory access combined with bank switching** yields a multiple-memory system with high-speed memory-to-memory moves and highly efficient data-processing. Most control logic can be put on a separate board.

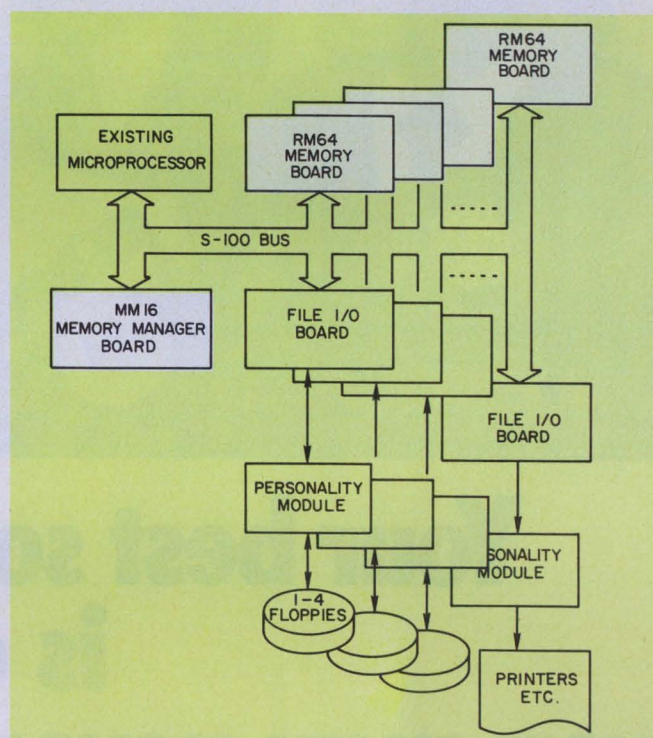

6. **Simultaneous I/O transfers** from multiple File I/O and memory boards result in extremely high I/O rates. This complete and very powerful system disperses its data through a large memory array.

to take place.

An even larger, more powerful processing system can be configured by adding memory boards (totaling more than a megabyte) and File I/O boards (Fig. 6). The MM16 memory manager board contains the system control logic necessary for selecting the memory boards and the File I/O boards.

With the system's multiple File I/O boards and memory boards, several I/O transfers can be made simultaneously. As a result, this system is capable of extremely high I/O rates. And with its ability to handle multiple RM64 boards, the system can disperse data into large arrays of memory for high-speed data processing. ■■



Your best source for SCRs is one you may never have heard of.

Would you believe Teccor? That's right. Teccor.

We're not a small components company. In fact, with over 1,000 employees, 3 plants, and over 16 million dollars in sales, we're not small at all.

Our reputation for dependable quality is known around the world. Has been for 13 years.

To give you the design flexibility you want, we offer the widest selection of SCR package designs in the industry.

At the same money you're paying now — maybe less.

Contact your local Teccor representative or call us at 817-267-2601. Tell us about your specific SCR applications. We'll get you the information or samples you need for evaluation.

You may not know us, but we figure it's only a matter of time.

Just think of us as the world's largest unknown source for SCRs.

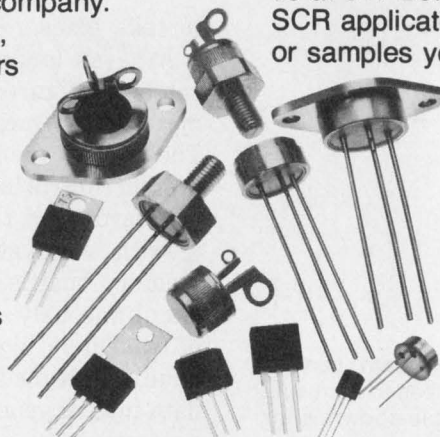

CIRCLE NUMBER 40

TECCOR
TECCOR ELECTRONICS, INC.
P.O. Box 669 Eules, Texas 76039

When you need indicator lights or more than indicator lights...



Come to the Number 1 supplier in the world—Dialight—for the widest choice of indicators for your every application.

You'll find the largest selection of UL & CSA listed, and QPL approved, indicator lights.

Whether small or large, LED, incandescent or neon, you have over 1,500,000 design combinations to choose from. And your choices include a full range of lens shapes, finishes, legends and colors from red, green

and amber to blue, yellow, white and clear. Designed for consumer, industrial and MIL-SPEC requirements.

We've developed a particularly easy way for you to find out exactly what you need out of the millions of indicators we have. It's a special 60-page Indicator Light Selector Guide. For your free copy, which includes a list of stocking distributors in the U.S. and Canada, contact us today.

DIALIGHT
A North American Philips Company

Dialight meets your needs.

Dialight, 203 Harrison Place, Brooklyn, N.Y. 11237 (212) 497-7600

CIRCLE NUMBER 41

Let microprocessors communicate

directly with each other, register to register. When data exchange is moderate, it's often the simplest solution.

When the central processing units of "mainframe" computers were large and expensive, it made a lot of sense to time-share them for many tasks. With the low price of μ Ps, however, you can feel free to use a separate CPU for each separate task your system has to perform—and to link the μ Ps only when information must be passed. Therefore, multiprocessor systems are becoming very popular.

One way to let μ Ps communicate with each other is by common memory (Fig. 1a). In such a system, certain memory locations act as "mail boxes" for the individual processors.¹ Each processor periodically scans its "mailbox" to see if any of the other processors has placed an "order."

This method is practical for systems requiring sizable information transfers between processors, but becomes wasteful if interprocessor transactions are no more than a few status or data words.

"Registered mail" is cheaper

Instead of sending its "mail" to shared memory, a processor can simply send it right to the other processors' registers (Fig. 1b). One processor talks to the other by preloading its communication register with data and generating a transfer signal. A receiving processor responds through interrupts or by polling the activation line periodically. When the receiving processor is ready, it fetches the data and controls the activity specified by the message. Because the communication protocol can be tailored to fit specific applications, this approach provides a high degree of flexibility.

Suppose that the system in Fig. 2a is the heart of a magnetic-disc controller. As supervisor, processor A is responsible for interfacing with the driving computer and for servicing the data-transfer logic. Processor B monitors the disc's rotational speed and controls the carriage movement for accessing a specific track.

When processor A receives an instruction from the driving computer requiring action by processor B, it decodes the instruction, modifies it to comply with established protocol, loads it into communication channel 2 (Fig. 1b), and generates an interrupt. This

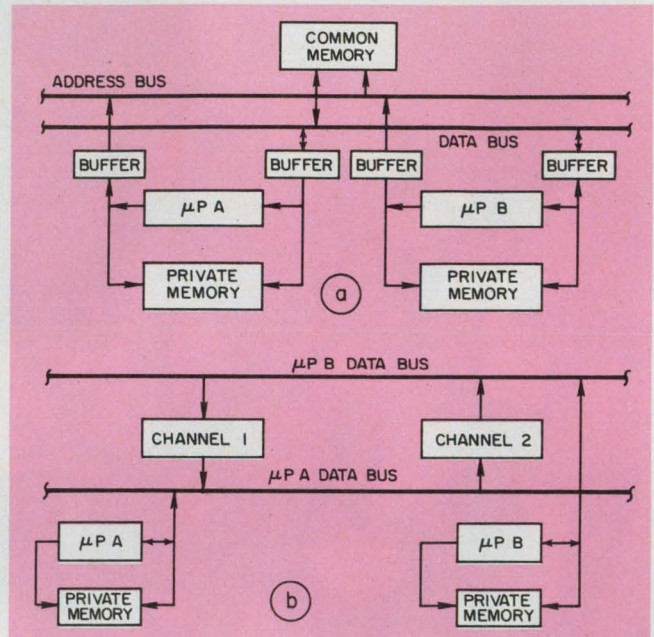

1. Multiprocessor systems often use a common memory to communicate with each other (a). But in many cases the μ Ps' registers can serve the same need (b).

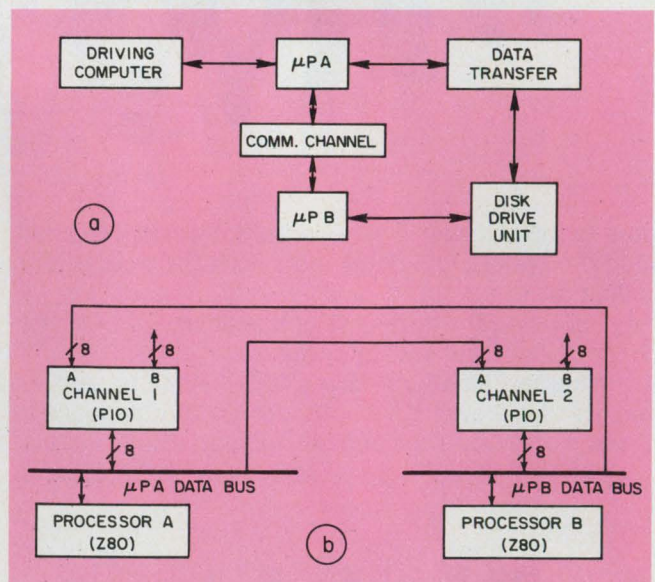

2. In a disc controller, μ P A takes care of the data transfer. It passes the host computer's instructions on to μ P B, which monitors disc speed and carriage movement for track selection (a). You can implement the circuit with two Z80s and two PIO chips (b).

Robert M. Pond, Electronic Engineer, Naval Surface Weapon Center, Dahlgren, VA 22448

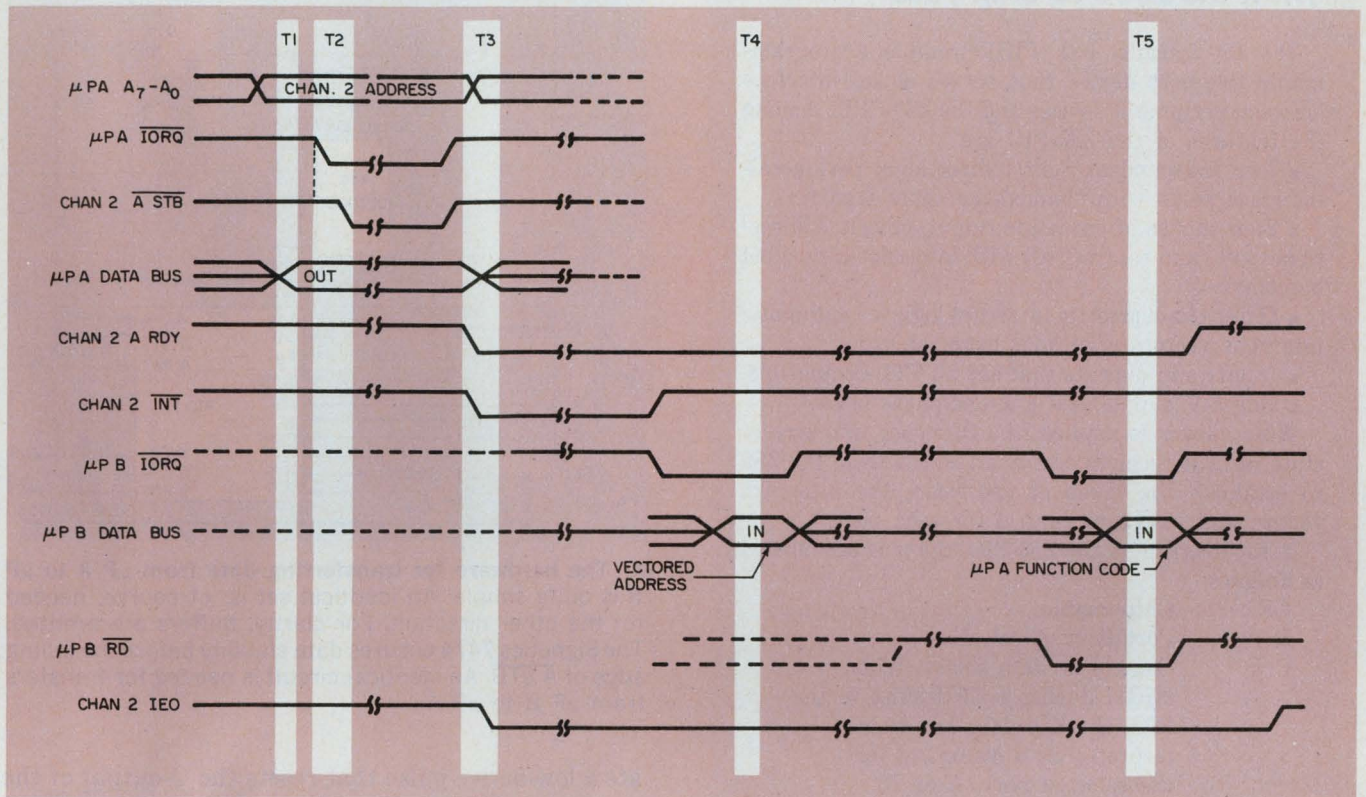

3. A simple handshaking procedure starts a data exchange. In this timing diagram, the transfer is from μP A

A to μP B, using the circuit of Fig. 4. Time points T_1 through T_5 are further described in the text.

signal informs processor B that a valid function word is located in channel 2.

If processor B accepts the interrupt, it fetches the information from channel 2 and acknowledges the transaction with status bits in channel 1. Processor B performs the task (e.g., Direct seek to track), then informs processor A by updating the job status in channel 1.

In the example of Fig. 2, the function code may consist of a 4-bit op code and a data 4-bit word count. If this count is greater than zero, a data-word transfer is performed after each subsequent interrupt from A until the word count equals the specified number. Once the count is completed, B interprets the next interrupt by A to be a new request. Processor B's status information may be included in the op code, or it may occupy bit positions set aside for the data-word count.

Any microprocessor with interrupt capability can be used in the example. The Zilog Z80, for instance, allows three kinds of maskable interrupts, one of which (mode 2) requires that an 8-bit vectored address be placed on the data bus by the interrupting device during the interrupt-acknowledge cycle. The address is concatenated with the interrupt page address register (I-Register) to form a 16-bit pointer to the starting location of the servicing routine. The Z80 can therefore be used as the CPU in processor A and

processor B (Fig. 2b).

The Parallel I/O (PIO) chip uses the Z80's interrupt system. It contains two independent programmable ports that can operate in four modes: byte output, byte input, bidirectional byte or bit control. The byte-input mode allows a peripheral device to write data into a PIO port (Fig. 2b). An active-low signal on the strobe-pulse line loads the data into the port and generates an interrupt to the CPU. If the interrupts are enabled, the CPU responds by generating a special memory cycle that fetches a vectored address from the PIO through the bidirectional CPU/PIO interface. This address has been written earlier into the PIO—preferably during the power-up initialization sequence—and resides there until it is altered under program control, or until the power is turned off. Communication channels 1 and 2 in the PIO are set to the byte-input mode.

Handshake before execution

"Handshaking" begins when processor A wishes to transfer a decoded instruction to processor B (Figs. 3 and 4). When processor A executes an output instruction to channel 2 (T_1), the address of channel 2's port A is placed onto the lower half (A_0 - A_7) of processor A's address bus. At T_2 , lines A_7 , Input/output request (IORQ), and Write (WR) gener-

What the Z80-PIO chip does

The Z80 Parallel I/O (PIO) circuit is a programmable two-port device that serves as an interface between peripheral devices and the Z80-CPU. Among the features of the Z80-PIO are:

- Two independent 8-bit bidirectional peripheral interface ports with "handshake" data transfer.

- Four modes of operation (input, output, bidirectional bus, and control), all with interrupt-controlled handshake.

- Daisy-chain priority interrupt logic for automatic interrupt vectoring without external logic.

- Inputs and outputs that are all TTL-compatible.

- One 5-V supply and a single-phase clock.

When power is applied, the PIO goes into a reset state until it receives command words from the Z80 to establish the mode of operation, the interrupt vector, and interrupt control for each port.

In the diagram of the Z80-PIO, the pins are labeled as follows:

CE	Chip enable.
B/A	Port B or A select.
C/D	Control or data select: When HIGH during a CPU-write to the PIO, the Z80 data bus is interpreted as a command for the selected port (A or B); a LOW level indicates a data transfer between the CPU and PIO.
Φ	System clock.
D ₇ -D ₀	Z80-CPU data bus.
\overline{RD}	Read-cycle status: a signal from the CPU that indicates a memory read or I/O read is in progress.
\overline{MI}	Machine cycle one: a sync pulse from the CPU to control internal PIO operations.
\overline{IORQ}	Input/output request: signal from the CPU to transfer commands and data between the CPU and PIO.
IEI, IEO	Interrupt enable: signals used to form a priority-interrupt daisy chain.
\overline{INT}	Interrupt request.
A ₇ -A ₀	Port A bus.
A STB:	Port A strobe pulse: for input mode a signal sent by a peripheral device to load data into port A.
A RDY:	Register A ready: for input mode the signal indicates that the port A register is ready to accept data.
B ₇ -B ₀ :	Port B bus.
B STB:	Port B strobe pulse (see A STB).
B RDY:	Register B ready (see A RDY).

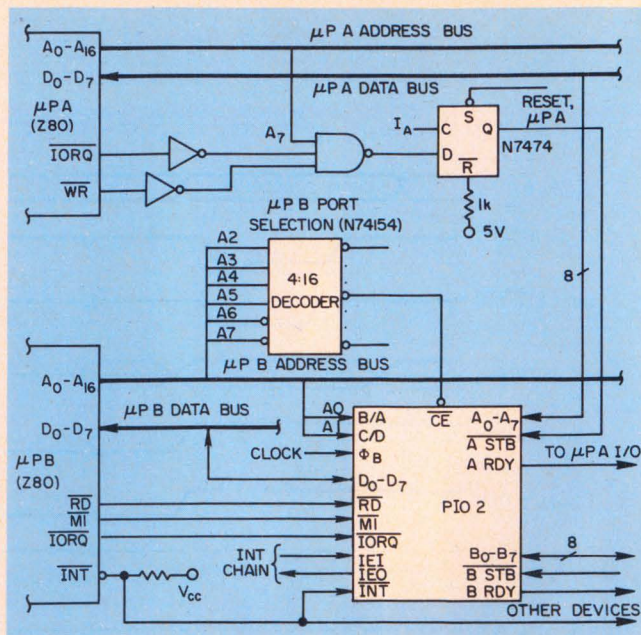

4. The hardware for transferring data from $\mu P A$ to $\mu P B$ is quite simple. An identical set is, of course, needed for the other direction. For clarity, buffers are omitted. The Signetics 7474 ensures data stability before the falling edge of A STB. An identical circuit is needed for transfers from $\mu P B$ to $\mu P A$.

ate a low-active pulse that resets the Q-output of the handshake flip-flop. The falling edge of Q (A STB in PIO 2) loads the data from processor A's data bus into PIO-port A. The rising edge of an STB generates an interrupt (T_3) to processor B and deactivates channel 2 with "A RDY" (I/O port A ready in PIO 2). When the interrupt-acknowledge response (T_4) occurs, the PIO places the vectored address onto the CPU/PIO interface. Now processor B starts the servicing routine that reads channel 2. An input instruction to PIO 2 loads the information into the CPU and activates PIO 2's A RDY (T_5). This action informs processor A that information sent to channel 2 has been received. The PIO port is now able to accept new data.

While register-to-register communication is ideally suited to a dual-microprocessor system that requires small amounts of servicing data, it may not be the best solution for a system of three or more processors. If you anticipate expansion, decide which method affords a simpler more economical approach. Ask yourself:

- What are the present requirements of each processor?
- Will expansion affect servicing data throughput? If so, how will this affect processor response time and software?
- Which method is easier to maintain and service? The last point is often overlooked, much to the grief of all concerned—especially if you are dealing with a critical path within a military-defense system. ■■

Reference

1. Chung, D., "Microprocessor Control Systems," *Electronic Design*, June 7, 1976, p. 132.

1/8 oz. to 1/2 oz. electrodeposited thin copper foil?



Impossible!

Not impossible if you're Gould — the world's leader in electrodeposited copper foil production.

We anticipated the trend towards more complex, denser circuit board configurations. Last year, we perfected thin foil and delivered over 30 million sq. ft. of TC treated 1/2 oz. to our customers. And Gould was the *only* company that could produce a consistent quality product.

Now we're producing 3/8 oz., 1/4 oz. and 1/8 oz. foil.

With the miniaturization of electronic products, even thinner foils are needed. The new Gould Thin Copper (GTC) product line

includes foils ranging from 1/2 oz. (153 gr/M²) to 1/8 oz. (38 gr/M²).

These thinner foils give you even more freedom of design and allow much finer definition of circuits. And they are available *now*.

Proven performance.

When Gould says a new product is available that product has been proven against tough quality control standards. *Before* it reaches you. *Before* you incorporate it into your design. So count on these advantages in every square foot of GTC you order!

- reduced etching time
- less undercutting

- reduced pollution
- finer lines, more control
- increased production yields
- cost reduction.

Send for GTC Data.

We've just given you the bare facts on the new GTC line. Send for a technical folder, showing the physical characteristics of Gould Thin Copper circuit grade foils. Write: Gould Inc., Foil Division, 17000 St. Clair Ave., Cleveland, Ohio 44110.

 **GOULD**

It's a stand-alone sweep-signal generator that provides all the performance of much higher priced competitive instruments.

To back up that sweeping statement, consider the following: The Model 2002 sweeps from 1 MHz to 2.5 GHz in four bands with 20 milliwatt output, $\pm 1\%$ display linearity, and ± 0.5 dB flatness. Consider also that it includes an internal 10 dB per step attenuator which in conjunction with a continuously variable pin diode attenuator

results in an output power range of +13 to -77 dBm. Plus a band-stacking option that lets you cover the entire 1 to 2500 MHz frequency range in one sweep. A ± 2 dB amplitude slope adjustment that compensates for frequency dependent variations in test set-ups is also available along with a deluxe marker module containing 1, 10, 50 and 100 MHz harmonic markers that operate over the entire frequency range of the unit. Finally, consider the price: \$2,700 for the basic

unit and only a total of \$3,200 if ordered with the bandstacking, deluxe marker module and slope adjustment options. Compare the prices against those of available competitive units.

WAVETEK Indiana Incorporated,
66 N. First Ave., P.O. Box 190
Beech Grove, Indiana 46107
Telephone: (317) 783-3221
TWX 810-341-3226

WAVETEK®

CIRCLE NUMBER 42

A sweeping statement about our Model 2002:



P&B W58 series thermal circuit breakers provide positive "snap" action protection...

even under impact, vibration or heat!

Potter & Brumfield W58 series single pole circuit breakers feature thermally responsive bimetal contact blades. The contacts wipe on make and break to help insure positive, clean contact. In operation, blade contact pressure actually increases under heat to the very instant of break. Chattering and arcing are virtually eliminated. Impact and vibration can't cause an inadvertent "snap." Circuit breaker reliability is greatly increased.

W58 series breakers in 1, 2, 3, and 4 amp ratings, have a trip time of 9 to 40 seconds at 200% of rating. Resistance is less than 1-1/4 ohms. Other ratings of 5 through 35 amps have trip time of 5.8 to 30 seconds at 200% of rating. Resistance is less than 3/10 ohms. All ratings will continuously carry 100% of rating and must trip between 101% and 145% of rating at 25°C. Maximum operating voltages are 50V DC or 250V AC. Interrupt capacities range from 200A to 3,000A.

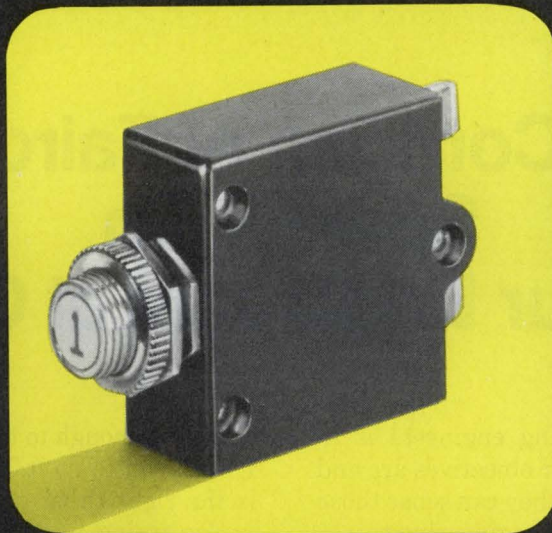

Trip-free construction assures against accidental reset. Before a fault has been corrected or current returned to normal holding, the reset button will not allow the contacts to remain closed as long as the overload exists. And, being a push to reset device only, it cannot be operated manually to break the circuit. No nonsense, no mistakes.

P&B low cost W58 series circuit breakers provide protection and high reliability, and add value to your product. They're ideal for aviation, automotive and

appliance applications—or wherever a thermally responsive, positive snap-action is required.

For a full description, see your P&B representative or any of the more than 100 authorized P&B distributors. Or call Potter & Brumfield Division AMF Incorporated, 200 Richland Creek Drive, Princeton, Indiana 47671. 812/386-1000.

AMF

Potter & Brumfield

Potter & Brumfield



Wilf Corrigan of Fairchild Speaks On Aiming Your Engineers at Objectives

The essential point in managing engineers is to make certain they know what your objectives are and to push them high enough so that they can sense those objectives. You've got to integrate engineering thinking into the over-all thrust of the business, so it's important to make your engineers part of the over-all business plan.

Then, to make sure your engineers know how to assign priorities, you have to measure what they do. That's not easy. So it's essential to get the engineer to want to do what's needed by the corporation. You have to get inside him and try to get him to understand the objectives of the business. Then you can assume that he'll do what's consistent with the objectives.

That's a lot different from saying, "I want this guy to do the following and I will manipulate him to do these things." That you can't do.

It's not enough to tell an engineer: "Do this because I want you to do it." You must persuade him that it is the right thing to do. He must understand what you're trying to do.

If he doesn't understand the priorities, he will decide that his own priorities are right. Once he decides that, it's almost impossible to turn him back.

This is important because you can look back and say that every major successful product in history had five fathers. But how many major products were killed five times by management and kept alive by a bootleg in the back room? Of course, years later, the president explains it as a magnificent strategic decision. So you have to keep an eye open for the rebel with brilliant foresight.

Nevertheless, in general, you have to make sure that you're all going in the same direction. If the engineer and his management can't agree on objectives, there

must inevitably be a parting of the ways. But, once you feel you share the same objectives—you still have the problem of how to measure a man's performance. And that also isn't very easy.

It starts with priorities and the obvious question is, "How do we prioritize?" We're dealing with human beings. And most individuals, even engineers, tend to do first what they like to do. So you have to keep exposing them to the numbers and explaining the market implications of what they do.

And then you have to check. You attempt to do it with a few adroit questions, but none of us is adroit enough. The answers an engineer provides may not always reflect the reality of what he's doing. Once the engineer knows what you want to hear, he will probably tell it to you.

If you say, "I want you to spend 80% of your time on this project, and 20% of your time on that project," he'll probably say, "Sure, that's what I'm doing."

However, if the project you want on second priority happens to be first on his priority list, that's where all the attention goes. So the only way to cope with that is to come up with estimates of how long it's going to take to do something—say, develop a particular product—and what the product performance will be. Then you must frequently review progress against that objective.

But you must let the engineer prepare his own milestones. And that brings us back to the basic point that you must involve the man in your objectives as much as you possibly can. You can't simply give instructions. And of course, you can't put him in a boat without a paddle. You have to make sure he has sufficient control over his work so that he can meet the objectives.

Now this brings you back to an old problem: You discuss objectives with the engineer and he agrees in all sincerity that he wants to do this. But he's agreeing to what he thinks he heard you say. So we're down to our ability to communicate and this, we must all admit, is relatively poor. But if our communications are 20% better than they are in another company, we are going to do one helluva lot better over-all.

Once you realize that your communications may not be perfect, you can take measures to check—not only on a man's understanding of the objectives, but also on the wisdom of those objectives.

You can ask a man which product he's working on. Then you look at the list of his projects and ask yourself how much future revenue there is for the company in each. You must ask what is the certainty of success for each project and how much it will cost. Then you must ask yourself the paramount question—how much you really will have to invest to get into a particular business. Too frequently, too many of us get into a business without asking those questions.

When you plan to extend an engineer's project into

a real investment, you often forget the follow-on implications—the amount of capital that gets tied up in receivables, inventory and so on. So you have to get your engineers to work more and more towards disciplined forecasting.

You must ask yourself if you are willing to step up to success in a business, and sometimes you have to say no. But then you shouldn't spend the engineering effort.

You also have to ask yourself if a product has synergism with other things you're doing. Might a new product, for example, provide support for an end-product marketplace that you're developing? Or, perhaps, do you have a strategy that can donate instant market to your product.

Once you've asked all the important questions and developed the right answers, you must organize to develop your objectives into reality. But there's no single concept that's good for everybody.

A popular one, the program-manager concept, has an individual with nobody reporting to him, and he

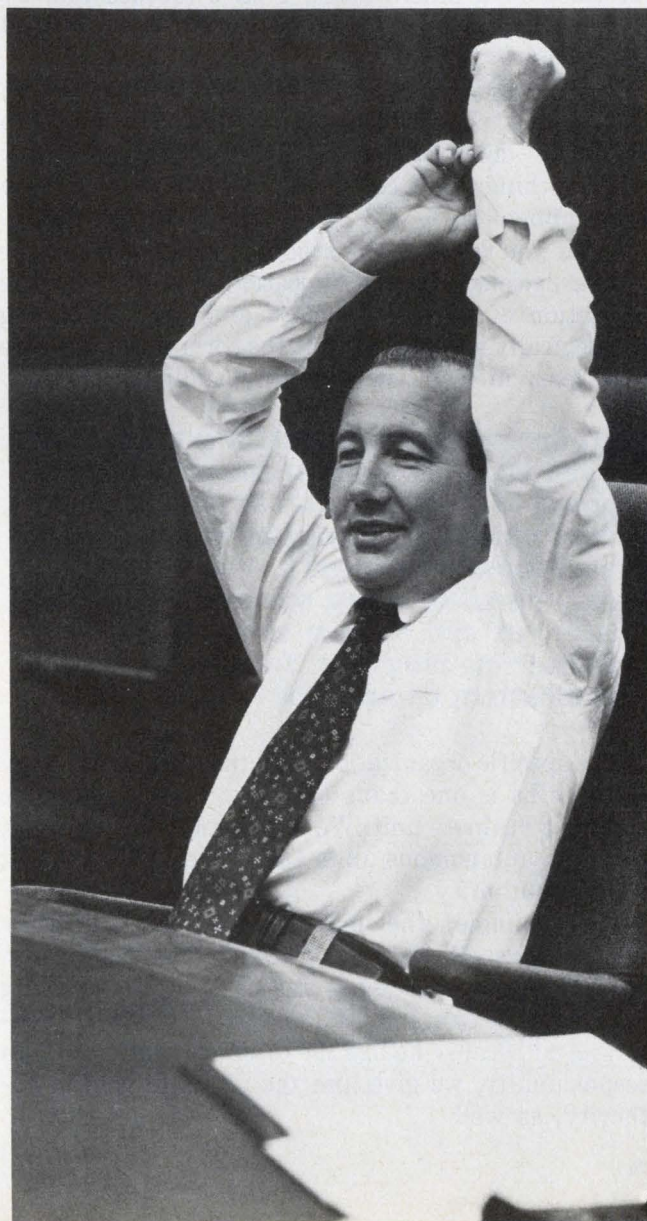

cuts across several different organizations. That's been very effective for a number of aerospace companies, but we have never been able to make it work.

If you have a seven or 10-year task—as you might in the aerospace industry—and if you have a very stable structure, the program manager might work out beautifully. Eventually everybody gets to know who he is and everybody gets to know what the program is. Everybody knows that he'll have the same assignment two years after. So the program manager can keep track of everybody. An individual might be able to wriggle out of something for a while, but eventually, things catch up with him. In the semiconductor business we don't have the time.

I think the difference lies in the time constants. We have to get things done in a very short time. And we have a highly mobile industry. People move around within the organization and they move a lot between organizations. That's the nature of the semi business.

We need an organization structure like a train on the tracks. As long as a fellow is on the right train, he's going to move down the right tracks. There's no danger that an engineer in our transistor division, for example, will be trying to develop a new MOS memory. At least on a macro basis, I have focused him by making him part of an organization with defined objectives.

Now an individual engineer might move too fast; he might be trying to reach too far beyond what we're capable of doing at this moment. But he won't work on something that's completely away from where we want him to go.

Once you've got such a structure, you can make macro decisions by the allocation of capital, by the allocation of spending budget and by determining strategically where you want the corporation to move—at least in terms of over-all spending.

In other words, if you want Division A to have three times as much manufacturing emphasis as Division B, you can give Division A three times as much capital. Whether or not the people there spend it wisely is a secondary discussion. In a somewhat narrower way, you can use the same approach in engineering programs. You can double the emphasis by doubling the funding.

The specific organization structure that works very well for us is one that's based on what we call the strategic business unit. We break our company down to small, autonomous units and give each one a great deal of authority.

For example, the manager of our Transistor Division has complete control over that business on a worldwide basis. He has authority over everything relating to design, manufacture and sales of transistors. And because he has the ultimate profit-and-loss responsibility, we give him the ultimate pricing authority, as well.

Each division manager has his own product-marketing people, his own engineering people and his own manufacturing people. He can buy the services of one of our offshore plants. But he retains the authority to specify how a product is to be made. He's the one who specifies what the production people—in the United States or abroad—must do to reduce cost, for example. And he's also the one who gets the engineer intimately involved with the P&L of his division.

The engineering manager of a division will be closely coupled with the division manager, who will be closely coupled with the marketing guys. There will be ongoing discussions among them about costs, market price, cost reduction, new-product development and so on. Because the business units are fairly small, there is a high degree of identity between the engineer, engineering manager and the division manager.

What we're doing is making the business unit smaller while we're pushing the engineer's responsibilities higher than they might be in a company where he might simply be a cog.

Now our pushing an engineer closer to profit-and-loss consideration isn't valid for, say, an engineer working in research and development. But even there, we tend to relate that R&D activity to a team on a given task with defined objectives.

There's another aspect to our business-unit structure. In many corporations there's a vice-president of engineering and a vice-president of manufacturing and, perhaps, a vice-president of marketing. They tend to come together only in meeting with the chief executive. Now that approach might be appropriate for a single-product company or one with a small number of products.

But in the semiconductor business we are essentially a thousand little companies. Each product line has almost its own marketplace, its own structure, its own set of competitors. So we try to group our products into logical groupings that then make up strategic business units or divisions. And we further try to pull the divisions together into logical groupings. Our semiconductor business, for example, has two pieces—Components, which includes transistors, diodes, digital and linear circuits; and LSI Products, which includes bipolar and MOS-based products.

Now George Wells, who is Group Vice-President for Components, has his own engineering and sales force. And Dave Marriott, who is Group Vice-President for LSI has his. We have two entirely different engineering and sales forces, so when I have a discussion with Marriott or Wells, it's a clear discussion. One guy can't complain that the salesmen or engineers are spending too much time on the other guy's products.

Of course, this means that we may have two salesmen calling on the same customer. But we get compensating advantages. Consider this:

Everybody goes through life with a set of lists. We all make up lists that show what's the number one

Who is Wilf Corrigan?



Right after he obtained his BS in Chemical Engineering at the Imperial College of Science in London, Wilfred J. Corrigan hitchhiked around the United States, then settled in Boston. Almost immediately, the 22-year-old son of a Liverpool dockworker married Sigrun Walla and joined Transistron as a production engineer on grown-junction silicon transistors.

He stayed at Transistron only six months before Dr. C. Lester Hogan, then executive vice-president of Motorola, invited him to Motorola Semiconductor in Phoenix. There he did much of the basic research on epitaxial growth and earned a patent for his original work in hydrogen chloride gas etching. He was soon running Motorola's silicon transistor operations.

In 1968, almost seven years after he had joined Hogan at Motorola, he left Motorola as one of "Hogan's Heroes" who followed him when he was appointed president of Fairchild.

Corrigan started his career at Fairchild as group director of discrete devices. He was elected executive vice-president and a member of the board of directors in September 1973, president and chief executive officer in July 1974, and chairman of the board in May 1977. Last year, Fairchild enjoyed revenue exceeding \$450 million.

In his spare time, what little there is of it, Corrigan likes to read—almost anything. His greatest pleasure, aside from work, comes from the time he spends on weekends with his wife and their four children, 8 to 15, Elsa, Sean, Erik and Christine.

thing we want to do and what's the number two thing, and so on. Now, when you have an engineer customer and a salesman sitting across the desk, each has his own list, whether it's on paper or in his head.

One engagement of these individuals may be good for covering, perhaps, Items 1, 2 and 3 on a list. If that relationship is to encompass everything from a diode through a memory system, what happens to the fourth item on either fellow's list? It gets shoved down the ladder.

One would think that the engineer would like to have everything taken care of all at once. But I don't believe that's what really happens. If you narrow the scope of a sales call, you have a much higher degree of focus.

Further, if the customer has a problem, he might spend the first 30 minutes talking, perhaps, about late delivery or nonresponsiveness to a request for a quote, or whatever. After that, it's pretty hard for the salesman to say, "OK, now let's talk about my product line." And still further, if you have a broad line, it's extremely difficult for a salesman to develop great proficiency in everything. He can't be an expert in everything from diodes to microprocessor systems, and the engineer might be very comfortable buying

his MOS from one place and his TTL from another. Finally, the duration of a meeting can be very wearing when you're trying to sell or buy a wide range of types of products.

So our system pays off, even if it seems inefficient to have two salespeople call on the same engineer. It's even possible to have a different kind of individual selling each line. A fellow selling newer products can aim at design-ins while a fellow selling more mature products can go after immediate orders.

Let me show you another advantage of the business-unit structure. Years ago we had a very large central R&D organization. Those were the days when there was a raging controversy over whether you could move a product from a lab in one location to a production facility a few miles away.

Today we completely dodge that question. Each division develops its own technology and its own products. We do have an R&D facility, but that's concerned with the next generation of technology. A few years ago, for example, R&D was working on charge-coupled devices. Now that CCDs are a real, manufacturable product, we've moved that responsibility into the MOS division. Today R&D focuses on injection logic. When we have that as a well-defined product, we'll move that into one of the divisions.

Of course, you can't divorce R&D completely from

**If you're trying to do
— some other way —
what these power amps
are designed to do,
your system probably
costs too much.**

In the DC to 30KHz range, Crown power amps are practically unbeatable. They're rugged, reliable, and can handle almost any load — right or wrong. Their performance has been proven in many different kinds of systems, under wildly different conditions. Designed for 19" rack mount and quick, simple hook-up. And they are almost always cheaper than whatever you think is an alternative. For more information, write or call the Crown Industrial department.

The Better Way Amps



M-600 Single-channel, 750 watts into 8 ohms, 1000 watts into 4 ohms.



DC-300A
Two-channel, 190 watts/ch into 8 ohms, 340 watts/ch into 4 ohms, (switch convertible to single-channel, 650 watts into 8 ohms).



D-150A
Two-channel, 75 watts/ch into 8 ohms, (switch convertible to single channel, 250 watts into 8 ohms).



1718 Mishawaka Rd., Elkhart, Indiana 46514 • 219/294-5571

CIRCLE NUMBER 44

product ideas because you can't normally develop technology in a vacuum. You usually need a product vehicle. But in the R&D group, the product is not the reason; it's just the vehicle. The product becomes almost irrelevant, but we naturally try to pick one that makes sense for a particular technology.

The R&D effort highlights still another advantage of our business-unit structure. If you go back to the 1950s and 1960s, you can see that we were all in a phase that I call serial development. You start by making a diode and the next step is a transistor—say, a germanium transistor. Everybody makes that. You start with a germanium mesa and then you try to make a germanium planar and that doesn't work. So you try for a silicon planar. And that works.

So you move on to a switching circuit and you develop DTL. Then TTL. Then MSI and LSI. For a long period you had serial development; you developed things step by step by step. And everybody moved along pretty much the same path—maybe at a different pace. Everybody's central R&D was pretty much two steps ahead of where he was in production.

But in the past 10 years or so, as the technology broadened, you had to go into parallel development where you have multiple technology that can do the same thing—low-power Schottky, high-voltage CMOS, low-voltage CMOS, n-channel and p-channel MOS. And you have injection logic. And ECL. And silicon on sapphire. And all these technologies are available in parallel.

Now if you tell a single R&D organization that it must be at the leading edge of six or seven technologies, there's no way to manage it. The only way I can see is to tell my MOS division manager that he is responsible for extrapolating MOS technology. And I tell my bipolar-memory-division manager that he's responsible for extrapolating bipolar-memory work. And now if there's a technology that doesn't have a home and a tree to grow on, we put it in R&D.

All of this becomes part of the over-all philosophy of maximizing the individual engineer's decision-making influence. We try to push his every decision higher and closer to the over-all objectives. One reason is that the rate of obsolescence of semiconductor products gets higher all the time. The life cycle in consumer products is even shorter.

The time constant of any phase in the system—research, development, pilot production, manufacturing—becomes equal to the whole product life cycle. We must find a way to reduce the time constant. The only way to do that is to operate within a relatively small unit.

That's what happens in small companies. They don't have the breadth that we have, but they can give us a hard time in an individual product or market area. So we try to cope with that, in effect, by having a bunch of our own small companies. Even if this had no other advantage, it helps us push our engineers up where they count. ■■

Planar High Power

Solitron Expands Its High Current, High Voltage NPN Power Transistor Line!

Nearly fifty planar power transistors have been developed by Solitron to meet your high current, high voltage needs. They're high reliability devices and feature low saturation voltages. All are manufactured with a single planar chip! Best of all, these units are reasonably priced. For example, the popular SDT 96301-306 Series ranges from \$7.70 to \$13.51 each in 100 quantity orders.

Although these transistors are available in standard JEDEC packages, they also may be ordered in Square Pack versions from Solitron. Just write or call us toll-free (800-327-8462) for complete information including data sheets, application notes and prices. Do it today.

SOLITRON PLANAR HIGH POWER TRANSISTORS

TYPE NO.	I _C (Max)	V _{CEO}	CASE	TYPE NO.	I _C (Max)	V _{CEO}	CASE
SDT 55405	75A	150V	TO-63	SDT 96301	70A	60V	TO-3*
SDT 55407	75A	200V	TO-63	SDT 96302	70A	100V	TO-3*
SDT 55456	75A	250V	TO-63	SDT 96303	70A	140V	TO-3*
SDT 55460	75A	300V	TO-63	SDT 96304	70A	200V	TO-3*
SDT 55462	50A	350V	TO-63	SDT 96305	70A	250V	TO-3*
SDT 55464	50A	400V	TO-63	SDT 96306	70A	300V	TO-3*
SDT 55470	40A	450V	TO-63	SDT 96401	70A	60V	TO-63
SDT 55472	40A	500V	TO-63	SDT 96402	70A	100V	TO-63
SDT 55474	25A	550V	TO-63	SDT 96403	70A	140V	TO-63
SDT 55476	25A	600V	TO-63	SDT 96404	70A	200V	TO-63
SDT 55503	150A	100V	TO-68	SDT 96405	70A	250V	TO-63
SDT 55504	150A	125V	TO-68	SDT 96406	70A	300V	TO-63
SDT 55505	100A	150V	TO-114	SDT 96501	100A	60V	TO/68
SDT 55507	100A	200V	TO-114	SDT 96502	100A	100V	TO/68
SDT 55556	75A	250V	TO-68	SDT 96503	100A	140V	TO/68
SDT 55560	75A	300V	TO-68	SDT 96504	100A	200V	TO/68
SDT 55903	150A	100V	TO-114	SDT 96505	100A	250V	TO/68
SDT 55904	150A	125V	TO-114	SDT 96506	100A	300V	TO/68
SDT 55905	100A	150V	TO-114	SDT 96901	100A	60V	TO-114
SDT 55907	100A	200V	TO-114	SDT 96902	100A	100V	TO-114
SDT 55956	75A	250V	TO-114	SDT 96903	100A	140V	TO-114
SDT 55960	75A	300V	TO-114	SDT 96904	100A	200V	TO-114
				SDT 96905	100A	250V	TO-114
				SDT 96906	100A	300V	TO-114

*AVAILABLE WITH 60 mil pins

Solitron
DEVICES, INC.

1177 Blue Heron Blvd. • Riviera Beach, Florida 33404 • (305) 848-4311/TWX: (510) 952-7610/TELEX: 51-3435

From the House of Power

The New 1977-1978 **GOLD BOOK** Has Just Been Published

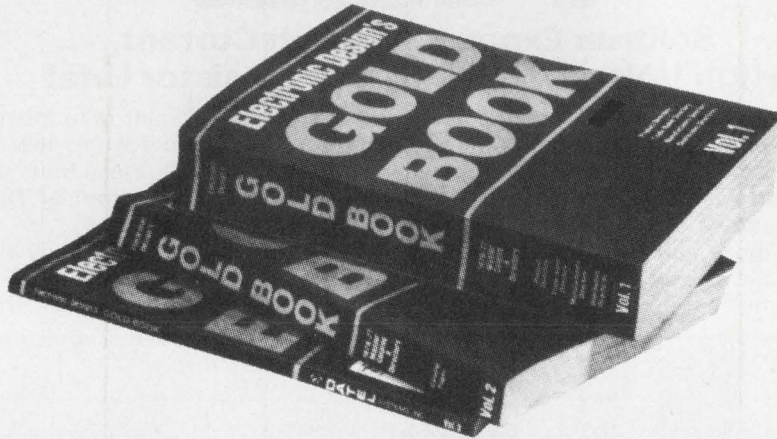

And Completely Outdates Last Year's Edition

If you were a subscriber on **ELECTRONIC DESIGN's** qualified circulation file in July 1977, you have been automatically sent your new **GOLD BOOK**. If you wish additional copies for other members of your company, you may order them now using the convenient coupon form below.

If you were not an **ELECTRONIC DESIGN** subscriber on our controlled circulation list, you may order your own multi-section set of the new **GOLD BOOK** by completing the form below. Shipment will be made promptly on receipt of your payment or company purchase order.

**HERE IS WHAT YOU AND YOUR COMPANY
WILL FIND IN THE UPDATED 1977-78**

GOLD BOOK

- **Three sections** containing 2,496 pages of information to quickly locate products used by the electronics industry.
- **A Product Directory** with 5,434 product categories.
- **A Trade Name Directory** of 9,814 listings.
- **A Manufacturers' Directory** listing 8,057 companies in the electronics industry.
- **Two Distributors' Directories** with 2,050 distributors listed.
- **A Giant Compendium of Manufacturers' Data Pages** with specifications.

MAIL TODAY WITH PURCHASE ORDER

Electronic Design's GOLD BOOK 449R
Hayden Publishing Co., Inc.
P.O. Box 13803, Philadelphia, Pa. 19101 U.S.A.

Here is our purchase order for _____ sets of the 1977-1978 GOLD BOOK at \$30.00 per set—for U.S., Canada and Mexico. (All other countries: \$40.00 per set)

Check enclosed for \$_____. Bill us.

Name (Print) _____

Title _____

Company _____

Address _____

City/Province _____

State/Country _____

Zip or Postal Code No. _____

QUANTITIES ARE LIMITED. PLACE ORDER TODAY!

Put our new UART and BIT RATE GENERATOR together and what have you got?

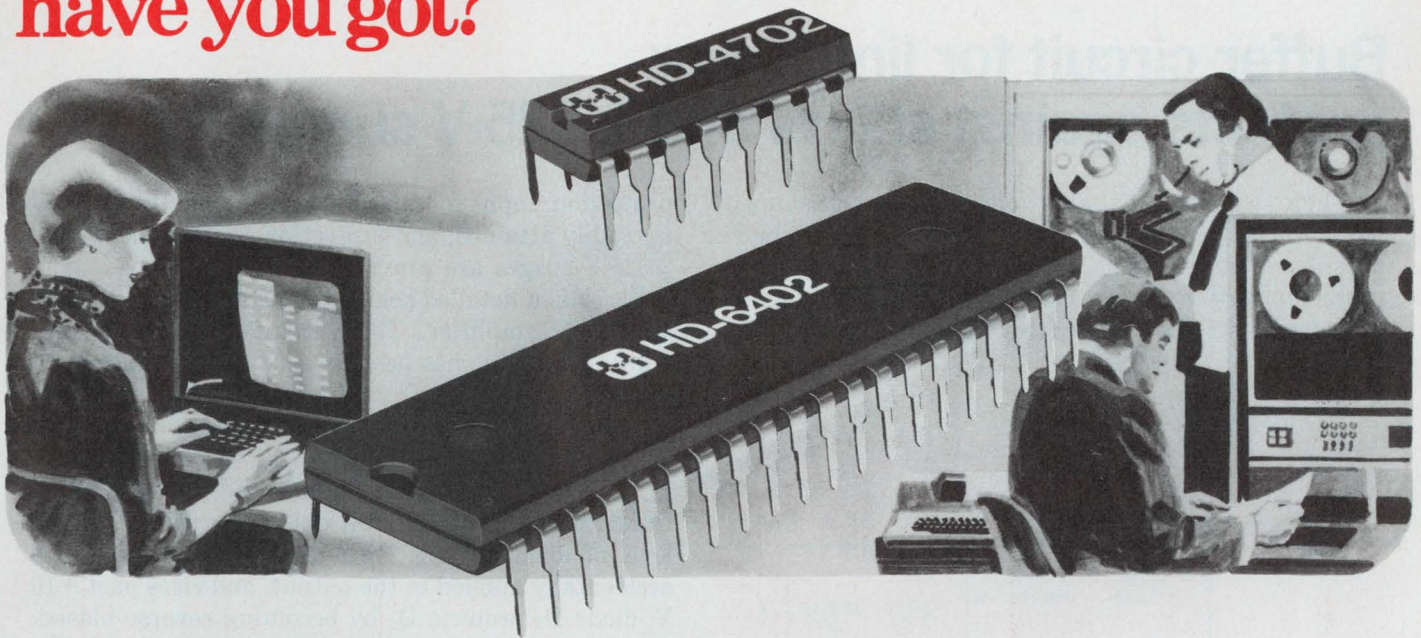

The first programmable CMOS Communications System.

With the Harris HD-6402/6402A CMOS/LSI, and HD-4702/6405 CMOS Bit Rate Generator, you can convert parallel data to serial and back again asynchronously, substantially reducing the amount of interconnect in your data acquisition systems.

Now, all it takes is two lines to connect terminals to computers, for example, instead of the spaghetti of wire used in older systems.

And, only with Harris do you enjoy the benefits of all-CMOS technology. Like less power consumption, permitting remote, hand-held battery-operated systems. Faster speed. Fewer and smaller components for added economy in equipment costs. Plus full temperature ranges, including military.

The Harris HD-6402/6402A, designed to replace the older and slower P-channel types, is the industry's first CMOS UART. It features an industry standard pinout. Single power supply—operates on 4 to 11 volts. And it's fast... 125K Baud... the *fastest* UART in operation today.

The Harris all-CMOS Bit Rate Generator provides the necessary clock signals for the UART. The HD-4702 generates 13 commonly used bit rates, while the HD-6405 provides two additional bits and consumes significantly less power, with no pull-up resistors.

If you've been waiting for CMOS for your modems, printers, peripherals, and remote data acquisition systems designs, your wait is over! Now Harris technology has something you can really work with. And you can start *today!*

For full details, call the Harris Hot Line, or write:
Harris Semiconductor, P.O. Box 883, Melbourne, FL 32901.

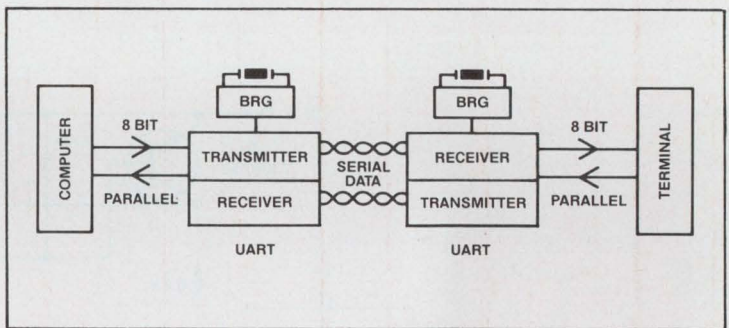

HD-4702/6405 FEATURES

- CMOS
- TTL Compatible
- Low Power Dissipation: 4.0mW TYP. (6405); 4.5mW TYP. (4702)
- Conforms to EIA RS-404
- One unit controls up to eight transmission channels
- On-chip input pull-up circuit (4702 only)
- 16 pin Cerdip and Epoxy dual-in-line packages
- Second source available

HD-6402/6402A FEATURES

- CMOS
- Operation from D.C. to 4.0MHz
- Low power—TYP. 10 mW @ 2.0MHz
- 4V to 11V operation
- Programmable word length, stop bits and parity
- Automatic data formatting and status generation
- Compatible with industry standard UART's
- Second source available

HARRIS HOT LINE!
1-800-528-6050, Ext. 455

Call toll-free for phone number of your nearby Harris sales office, authorized distributor or expedited literature service.

Harris Technology...Your Competitive Edge



HARRIS
SEMICONDUCTOR
PRODUCTS DIVISION

CIRCLE NUMBER 108

Buffer circuit for line driver protects against shorts and $\pm 325\text{-V}$ surges

When you send an analog voltage to remote equipment, to make sure that a fault at the remote end doesn't damage the sending circuit, use a protector/buffer circuit. Simplified in Fig. 1, such a buffer consists of a voltage follower with added output

protection. Input-to-output accuracy to within 1.5 mV is readily attained, and protection against shorts and $\pm 325\text{-V}$ surges are provided.

Fig. 2 is a detailed schematic of a buffer that uses an OP-05 amplifier. This circuit's input-to-output transfer function has been measured to provide unity gain within $\pm 1.5\text{ mV}$ from 0 to 70 C. The op amp feeds a complementary output circuit that can drive a load as low as 1 k Ω shunted by 0.1 μF to $\pm 10\text{ V}$.

If the output is shorted, the base and emitter biasing resistors of Q_2 and Q_4 limit output current to a safe level of about 15 mA. If a positive-fault voltage is accidentally applied to the output, and rises past +10 V, diode D_5 protects Q_2 by becoming reverse-biased. And although Q_2 's complementary transistor, Q_4 , conducts, the circuit's current-limiting bias resistors prevent dissipation of excessive power.

Should the fault voltage rise above +40 V, zener diode VR_2 turns on and provides base current to Q_3 , which saturates and cuts off transistor Q_4 . When cut off, Q_4 can withstand about 350 V on its collector. Thus, positive fault voltages to 325 V should definitely cause

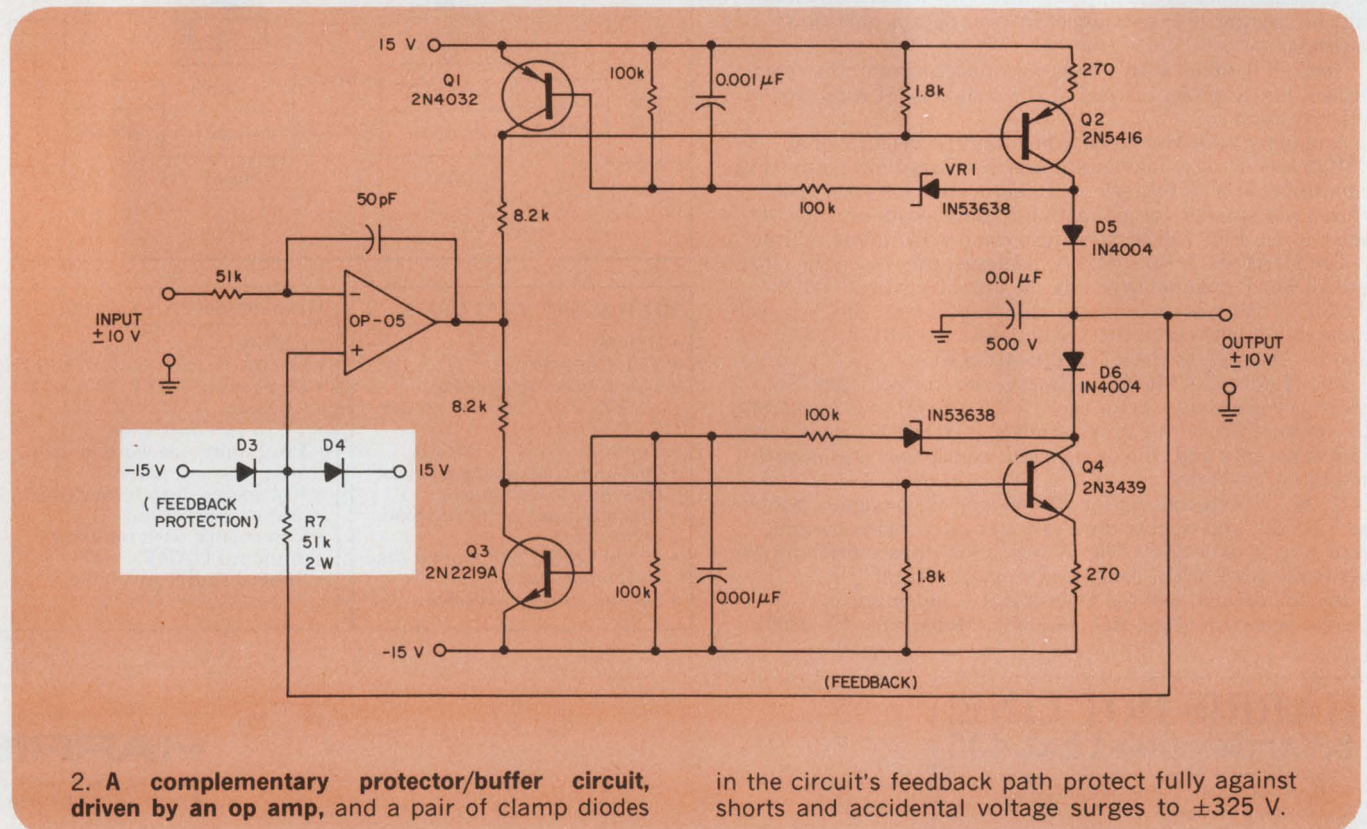
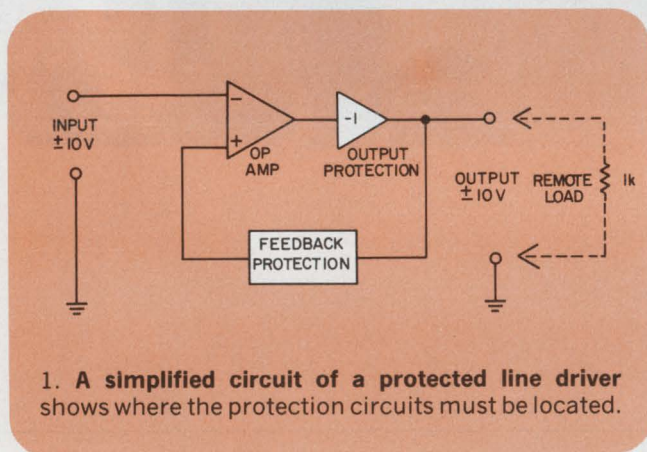

When it comes to SOT-23 and SOT-89 microminiature semiconductors...



- ① PURE (NEUTRAL) EPOXY
- ② GOLD WIRE LEAD
- ③ GOLD METALLIZED CHIP
- ④ GOLD PLATED LEAD FRAME

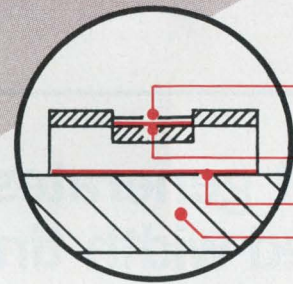

- Gold top layer for a pure wire bond
- Titanium prevents metallurgical contact deterioration
- Gold-Silicon eutectic die bond
- Gold plated lead frame

SIDE VIEW OF CHIP

it's what's inside that counts

It's no big deal to package semiconductors in tiny rectangular plastic packages. We developed that process more than five years ago when we introduced these two standard shapes to the hybrid marketplace. But, as any experienced circuit designer knows, a highly reliable semiconductor offering all the economies of a plastic package is something else again.

Today, others are just starting to build SOT-23 look-alikes; but Amperex, with five years of experience with the product and its applications, long ago succeeded in adapting the semiconductor chip to this new environment. The result of our efforts is a broad line of highly reliable, fully characterized semiconductors in two standardized microminiature packages that are ideally suited to automatic assembly and reflow soldering on thick or thin film substrates or on conventional PC boards.

We solved the "plastic transistor reliability problem" with an exclusive "monometallic" system that uses Gold-over Titanium at the chip contacts. We bond Gold wire directly to Gold surfaces; and we encapsulate the chip in a high-purity, neutral plastic. There's no aluminum

in our SOT-23's and SOT-89's; thus, all of the major failure mechanisms such as intermetallics, electromigration and corrosion have been eliminated. Semiconductors manufactured by our process are projected to have life expectancies in the order of 10 times greater than devices made by standard manufacturing processes.

The product line consists of just about everything today's circuit designer needs—in both standard and reverse pinout (at no extra cost), appreciably extending layout flexibility of low cost circuitry. ■ Dual silicon switching diodes ■ Zener Diodes ■ Tuning and bandswitch diodes ■ General purpose low level transistors ■ High level and driver transistors ■ Fast switching transistors ■ High frequency and wideband transistors ■ Special purpose transistors.

Many of the drivers and switches can dissipate up to 1 watt. These are available in the SOT-89 package, which is slightly larger than the SOT-23 and can be intermixed on the same substrates and PC boards with the small devices.

For more information, contact Amperex Electronic Corporation, Slatersville Division, Slatersville, Rhode Island 02876, Telephone: 401-762-3800.

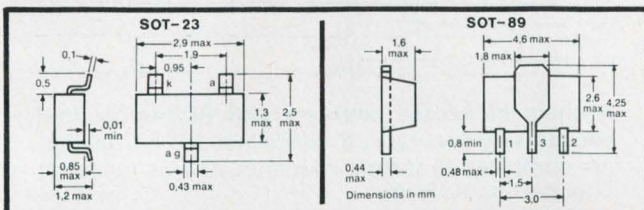

Amperex®

TOMORROW'S THINKING IN TODAY'S PRODUCTS

A NORTH AMERICAN PHILIPS COMPANY

no damage to the output stage.

For negative swings of the fault voltage, diode D_6 , zener VR_1 , and transistors Q_1 and Q_2 perform just like their counterparts in the complementary part of the circuit just described.

The feedback path to the op amp's noninverting input terminal is protected by a simple resistor-diode clamp, which limits the terminal to maximums of about ± 15.7 V. The bypassing and shunting capacitors in the circuit keep the circuit stable.

Where less accuracy and only a unipolar signal voltage are involved, a simpler circuit employing a 741 can be used. Only half the output protection is needed. Fig. 3 shows a minimum circuit that provides 0 to +10-V output at about 10-mV accuracy. Nevertheless, the circuit can provide ± 325 -V protection.

Roxton Baker, Design Engineer, C-E Power Systems, Combustion Engineering, Inc., 1000 Prospect Hill Rd., Windsor, CT 06095.

CIRCLE NO. 311

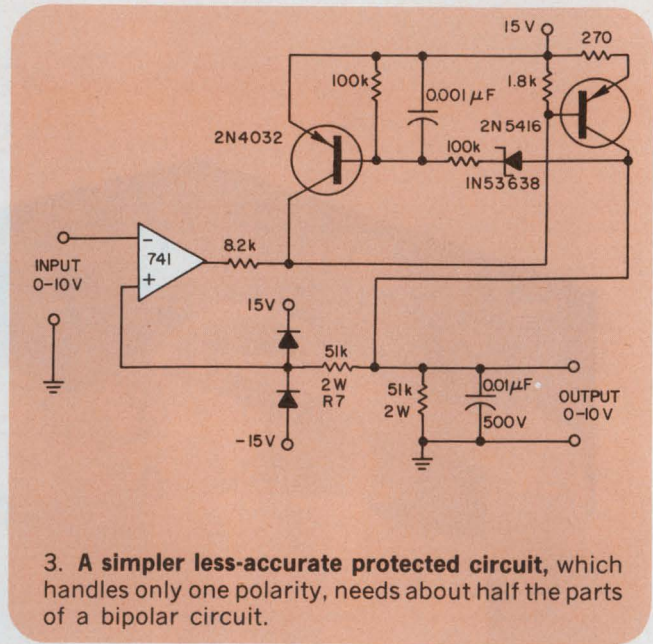

3. A simpler less-accurate protected circuit, which handles only one polarity, needs about half the parts of a bipolar circuit.

Circuit generates almost any sequence of fixed-width timing pulses

Very often, logic systems need a sequence of narrow pulses at specific, selectable times that start after an initiating signal and then can repeat after self-generated reset pulses. The circuit in Fig. 1 produces sequences of 1- μ s fixed-width pulses at almost any repetition rate. The timing parameters are chosen simply by picking different selections from three decades of timing pulses and connecting them to three-input positive-NOR gates.

In Fig. 1, a TTL-compatible 1-MHz oscillator drives three 74192 decade counters. The counters' BCD outputs are converted to decimally related intervals by three 7442 decoders. Thus, each output pulse, A, B, C or D, can be made up of selections, as needed, from each of the decade decoders by "ANDing" one output pulse from each of the decoders. Each output pulse occurs only once per sequence, and has the same width as that of the oscillator period.

The sequence is started by releasing the Reset line. In the example of Fig. 1, pulses A, B and C are generated at 26, 245 and 760 μ s, respectively. At 900 μ s, a Clear pulse, D, resets the counters causing the sequence to repeat.

Of course, circuitry can be added to control the start of the sequence externally and to generate only a single sequence. Also, switches can be added to simplify selecting the timing.

Ronald Winter, Santa Barbara Research Center, 75 Coromar Dr., Goleta, CA 93017.

CIRCLE NO. 312

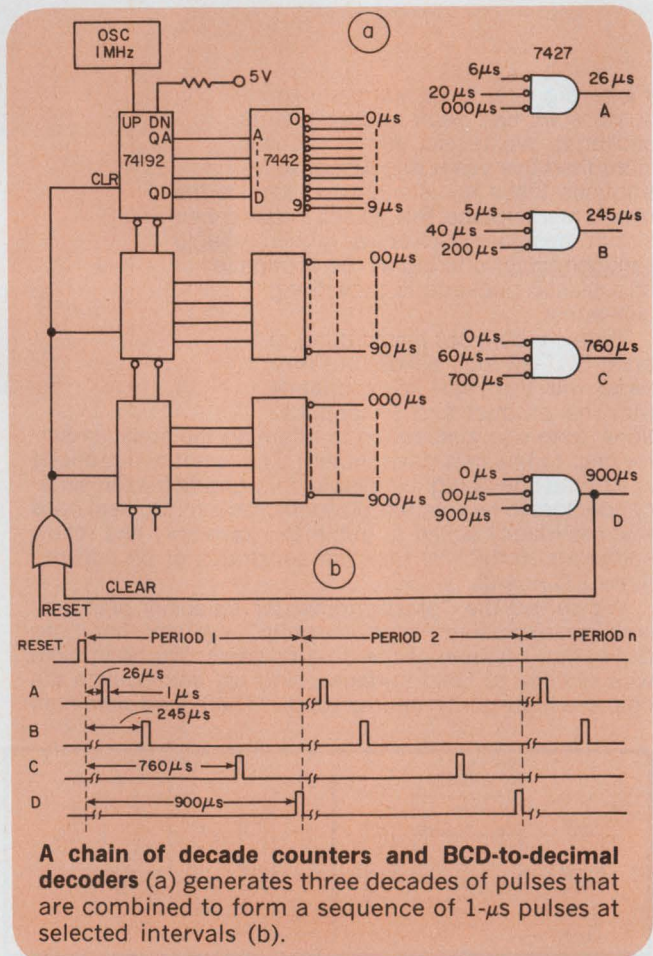

A chain of decade counters and BCD-to-decimal decoders (a) generates three decades of pulses that are combined to form a sequence of 1- μ s pulses at selected intervals (b).

Datel's 8080 A/D-D/A Advantage

SINETRAC 800

- ▶ 32 channel A/D - D/A input card slides directly into Intel's MDS-800 or SBC-80/10/20 Microcomputers.
- ▶ Only 2 cards needed for 80 single-ended or 64 differential A/D channels!
- ▶ Super-software supplied on paper tape with full listings in manuals.
- ▶ On-board channel counters and scan-timers reduce CPU housekeeping for fastest speed: True 40 kHz total I/O rate using DMA.
- ▶ Expandable in increments of 48 A/D or 8 D/A channels up to 256 channels each.

COVERED BY GSA CONTRACT

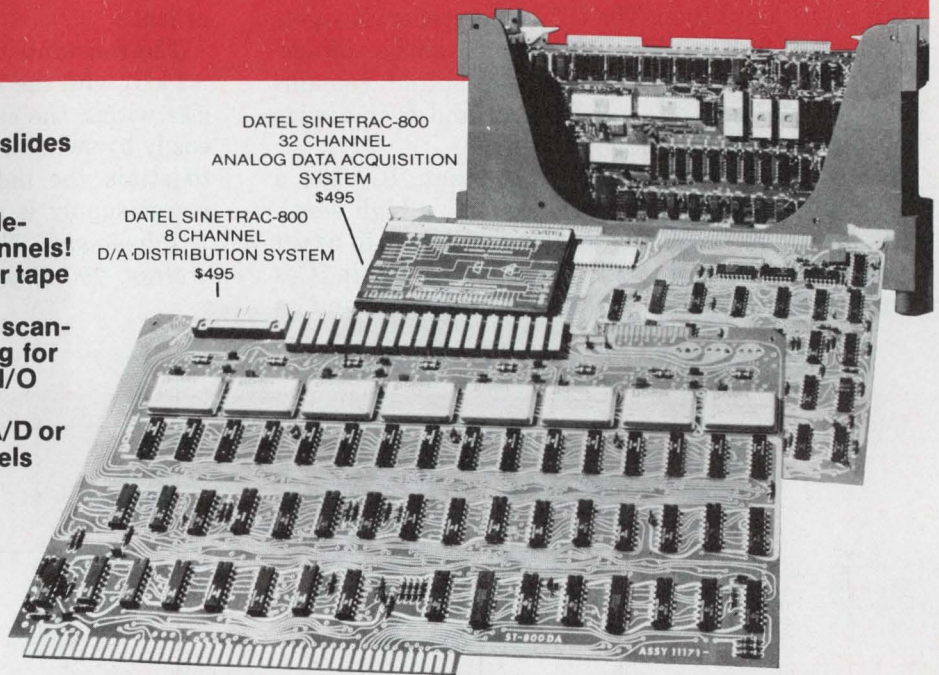

You'll find complete specifications on this product and more than 300 data conversion circuits and systems in Gold Book.

Just check Gold Book's Volume 3. That's Datel's complete Engineering Product Handbook, in its own separate volume. More than 290 pages of D/A & A/D Converters, Multiplexers, Sample-Holds, Op Amps, Power Supplies, Digital Panel Meters, and Printers, Digital Calibrators, Data Loggers, Digital Cassette Recorders, and Data Acquisition Systems. Each fully detailed on individual data sheets.

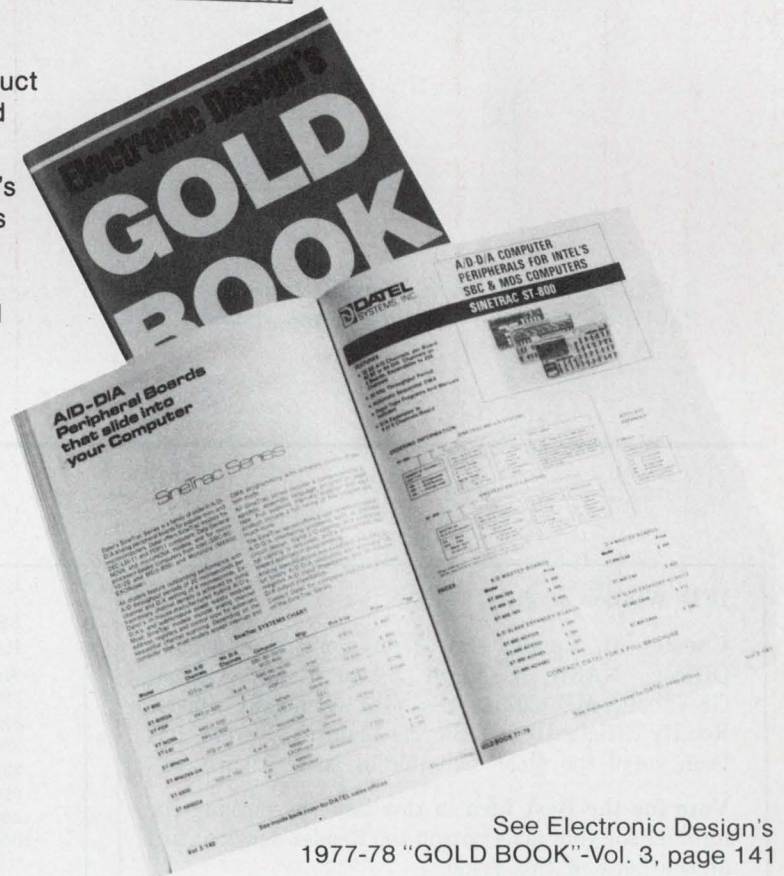

DATEL
SYSTEMS, INC.

1020 Turnpike St., Canton, MA 02021
Phone: (617) 828-8000

See Electronic Design's
1977-78 "GOLD BOOK"-Vol. 3, page 141

Santa Ana, CA (714) 835-2751, (L.A.) (213) 933-7256 • Sunnyvale, CA (408) 733-2424 • Gaithersburg, MD (301) 840-9490 • Houston, TX (713) 932-1130
OVERSEAS: DATEL (UK) LTD—TEL: ANDOVER (0264) 51055 • DATEL SYSTEMS SARL 620-06-74 • DATELEK SYSTEMS GmbH (089) 78-40-45

CIRCLE NUMBER 49

Constant-bandwidth PLL tone decoder accepts wide range of input voltages

The circuit in the figure solves two problems encountered when using a 567 tone-decoder phase-locked loop (PLL): the need for a relatively high input-signal voltage and the annoyance of a bandwidth that varies with input amplitude. The 567 tone decoder, IC₂, gets its input from IC₁, a 565 PLL that contains a voltage-controlled oscillator (VCO), whose output remains constant over a 3-mV-to-1-V input and over a wide input-frequency range.

Since the VCO's output is constant, IC₂ has a constant bandwidth. Furthermore, IC₁'s high sensitivity and very broad capture range allow it to be set outside IC₂'s capture range, yet be pulled within IC₂'s range. When IC₁ locks onto the desired signal and its

VCO frequency pulls into the capture range of IC₂, less than 10 cycles are needed for IC₂'s output to go cleanly to zero and indicate that a signal has been captured. And the circuit's noise immunity is excellent.

The constants in the figure tune the circuit to 20 ±1 kHz with the VCO set to about 18.5 kHz. Frequencies within the capture range of IC₁ can be selected easily by switching-in other values of R₁₀ and C₉. But to attain the indicated stability, regulation of the power supply is a must.

Raymond K. Ferris, Supervisor, Program Support, Actron, 700 Royal Oaks Dr., Monrovia, CA 91016.

CIRCLE NO. 313

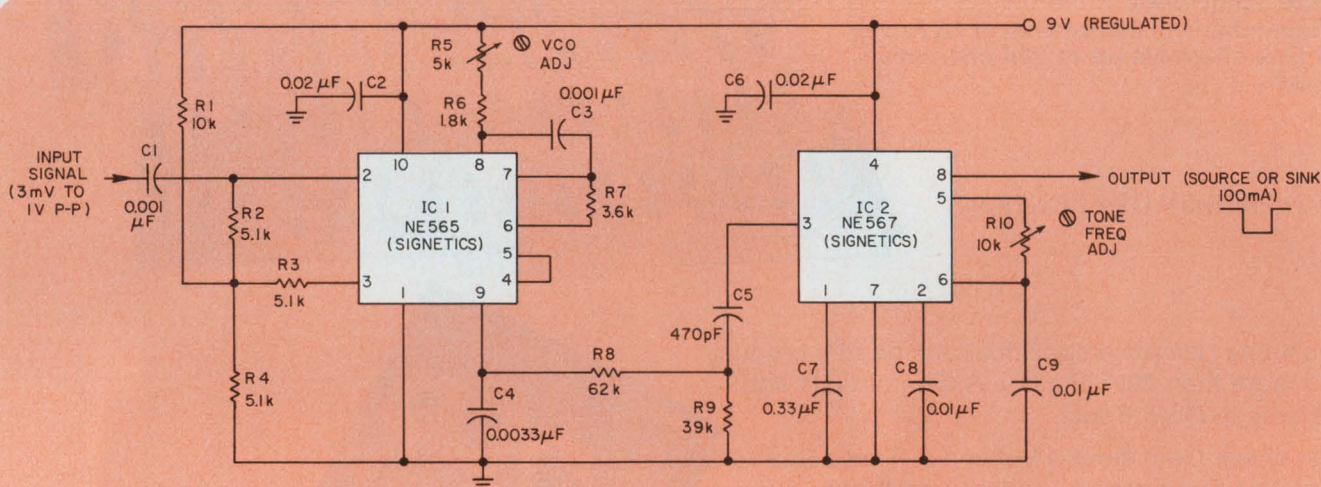

A PLL with a constant VCO output converts another PLL into constant-bandwidth tone decoder. The

circuit accepts a wide range of input volts—from 3 mV to 1 V—and is tuned to 20 ±1 kHz.

IFD Winner of July 5, 1977

Chesley H. Looney Jr., Equipment Management Officer, NASA, Goddard Space Flight Center, Greenbelt, MD 20771. His idea "Schottky Diodes Rectify Efficiently in a Bicycle-Lighting System" has been voted the Most Valuable of Issue Award.

Vote for the Best Idea in this issue by circling the number for your selection on the Reader Service Card at the back of this issue.

SEND US YOUR IDEAS FOR DESIGN. You may win a grand total of \$1050 (cash)! Here's how. Submit your IFD describing a new or important circuit or design technique, the clever use of a new component or test equipment, packaging tips, cost-saving ideas to our Ideas for Design editor. Ideas can only be considered for publication if they are submitted exclusively to ELECTRONIC DESIGN. You will receive \$20 for each published idea, \$30 more if it is voted best of issue by our readers. The best-of-issue winners become eligible for the Idea of the Year award of \$1000.

Datel's A/D-D/A I/O Peripheral Boards for the M6800 Microcomputers

MODEL ST-6800

- ▶ Slides directly into Motorola's M6800 EXOR-ciser Microcomputer
- ▶ Includes 32 Single-ended or 16 Differential A/D Channels plus 2 D/A Channels on one board
- ▶ Expandable up to 128 A/D and/or D/A Channels
- ▶ Powerful paper tape diagnostic software included!
- ▶ Comprehensive systems manual included!
- ▶ Prices from \$335

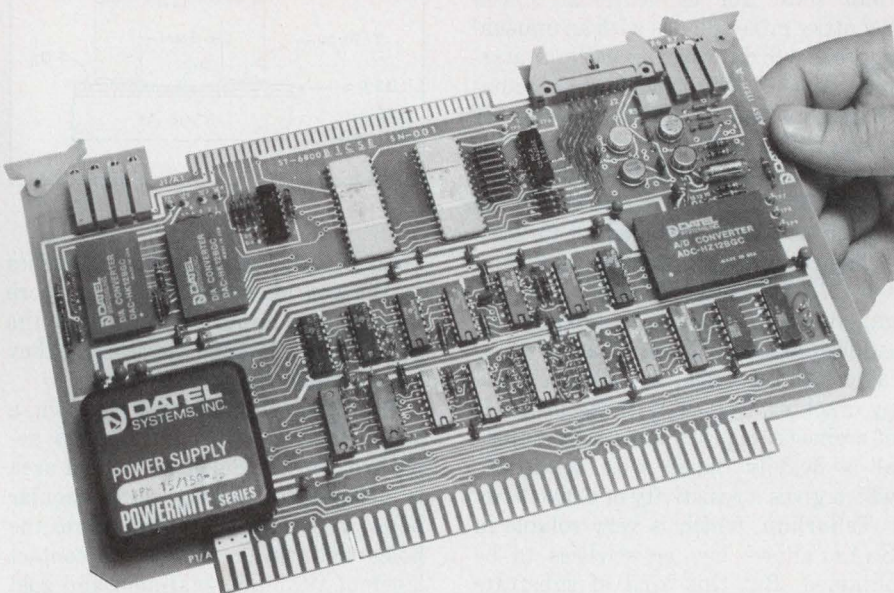

You'll find more specifications on this product and more than 300 data conversion circuits and systems in Gold Book.

Just check Gold Book's Volume 3. That's Datel's complete Engineering Product Handbook, in its own separate volume. More than 290 pages of D/A & A/D Converters, Multiplexers, Sample-Holds, Op Amps, Power Supplies, Digital Panel Meters and Printers, Digital Panel Instruments, Data Loggers, Digital Cassette Recorders, and Data Acquisition Systems. Each fully detailed on individual data sheets. And it's available to you in Gold Book.



D **DATEL**
SYSTEMS, INC.

1020 Turnpike St., Canton, MA 02021
Phone: (617) 828-8000

See Electronic Design's
1977-78 "Gold Book"-Vol. 3, page 146

Santa Ana, CA (714) 835-2751, (L.A.) (213) 933-7256 • Sunnyvale, CA (408) 733-2424 • Gaithersburg, MD (301) 840-9490 • Houston, TX (713) 932-1130
OVERSEAS: DATEL (UK) LTD—TEL: ANDOVER (0264) 51055 • DATEL SYSTEMS SARL 620-06-74 • DATELEK SYSTEMS GmbH (089) 78-40-45

CIRCLE NUMBER 50

Noise factors improve with gallium arsenide diodes

Noise figures are 10 to 20% better than those for conventional silicon Schottky mixer diodes with an unusual approach to fabricating gallium arsenide devices. The mixer noise factors of gallium arsenide diodes tested over a range of 4 to 40 GHz are 0.5 to 1 dB better than those for the best silicon diodes. For example, a noise factor of 5.2 dB has been obtained at 40 GHz.

The technique, developed by Thomson-CSF in Orsay, France, uses organometallic cracking to produce the gallium-arsenide diodes on an epitaxial layer 0.25 μm thick. The layer is made by cracking $\text{Ga}(\text{CH}_3)_3$ in the presence of arsine (AsH_3). The substrate material is heavily doped with tellurium, which gives a resistivity of 0.006 $\Omega\text{-cm}$.

Tellurium, which is very soluble in GaAs, allows low resistivities to be obtained. But this kind of substrate cannot be used in conventional atmospheric-pressure epitaxy processes because an autodoping effect resulting from gas-phase impurities prevents a sharp transition between substrate and epilayer.

The Thomson process uses a low pressure of 76 torr and a large 18-

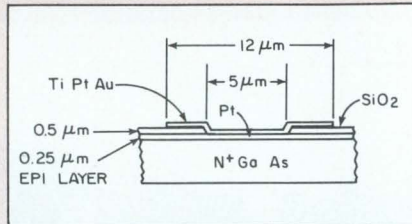

litre/min. flow of hydrogen. Impurities in the gas phase diffuse much more rapidly, and impurities that leave the substrate are carried away before they can re-enter the growth area.

Once the epitaxial layer is grown, a 500- \AA layer of silicon dioxide is deposited and the Schottky contact area is defined by etching 5- μm circular holes. Platinum is sputtered into the holes and sintered. Then a contact layer of titanium, platinum and gold is deposited. The result is easy contact metallization and good adherence to the oxide layer, which help make the gallium arsenide diodes highly reliable. Circular patterns of 12- μm diameter are then etched to form the completed device as shown in the figure.

metal electrode. Typical deposition thickness is 0.5 μm . Tungsten or molybdenum-point contacts are applied to the top surface of the material.

The experimental amorphous device is mounted in an X-band waveguide of reduced height. A Gunn oscillator supplies 1.5 mW or input power at 9.3 GHz. With a driving voltage of 10 to 30 V applied to the modulator contacts through a limiting resistor, outputs of 10 mV are obtained for modulation frequencies from 100 kHz to 1 MHz, with no detectable switching delay in this frequency band.

The modulation mechanism is straightforward. When the driving voltage is below the threshold value of about 10 V, the amorphous switch is in its off state and exhibits a high impedance. Above the threshold, the switch presents a low impedance that increases the amount of microwave power reflected back down the waveguide. The result is more loss.

The switch is as efficient as that of p-i-n diodes. Insertion loss is 0.5 to 0.6 dB with 18-dB isolation for 100-mA operating current (see figure). Frequency response can be extended to 10 MHz with delay times less than 10 ns if the switching voltage is 50% greater than the threshold voltage.

μW modulator replaces p-i-n diodes with semis

An efficient microwave modulator that exploits the impedance variation of amorphous semiconductors rather than single-crystal p-i-n or varactor diodes has been demonstrated at the Indian Institute of Science, Bangalore. The amorphous switch can be manufactured by simple, thin-film evaporation techniques instead of precise impurity diffusions into single-crystal growths.

Although p-i-n diode isolation is better, the easy way to manufacture amorphous switches could lead to their widespread use in low-cost, low-power microwave-switching applications

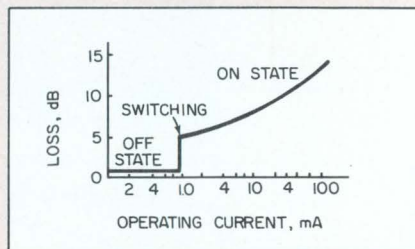

where high reverse-breakdown voltages are not required.

Amorphous semiconductors, or chalcogenides, consist of germanium-tellurium-arsenic materials deposited by electron-beam evaporation onto a

Entry controlled with magnetically coded cards



Sipass, a computerized access control system developed by Siemens, uses a Siemens 300 minicomputer to read a magnetically coded card that identifies its user. The system checks the computer's memory before authorizing entry.

Datel's New Low Priced Digital Panel Meter

MODEL DM-3100

FEATURES

- ▶ Miniature case with 0.5" LED display
- ▶ Bipolar, differential ± 2 VFS input
- ▶ 3 $\frac{1}{2}$ Digit resolution with Autozeroing
- ▶ LCD display available at additional cost
- ▶ Additional ranges — customer programmable
- ▶ 4 $\frac{1}{2}$ digit resolution also available—\$59 (100's)
- ▶ Additional current and ohmmeter capability — customer programmable

\$29*

*\$35 (1-99) \$29 (100-499)



You'll find complete specifications on this product and more than 300 data conversion circuits and systems in Gold Book.

Just check Gold Book's Volume 3. That's Datel's complete Engineering Product Handbook, in its own separate volume. More than 290 pages of D/A & A/D Converters, Multiplexers, Sample-Holds, Op Amps, Power Supplies, Digital Panel Meters, and Printers, Digital Panel Instruments, Data Loggers, Digital Cassette Recorders, and Data Acquisition Systems. Each fully detailed on individual data sheets.

And it's available to you in Gold Book.

**DATEL**
SYSTEMS, INC.

1020 Turnpike St., Canton, MA 02021
Phone: (617) 828-8000



See Electronic Design's 1977-78
"GOLD BOOK"—Vol. 3, page 226

Santa Ana, CA (714) 835-2751, (L.A.) (213) 933-7256 • Sunnyvale, CA (408) 733-2424 • Gaithersburg, MD (301) 840-9490 • Houston, TX (713) 932-1130
OVERSEAS: DATEL (UK) LTD—TEL: ANDOVER (0264) 51055 • DATEL SYSTEMS SARL 620-06-74 • DATELEK SYSTEMS GmbH (089) 78-40-45

CIRCLE NUMBER 51

There's a better way to measure or monitor mechanical motion—

magnetically-activated 'Hall effect' integrated circuits

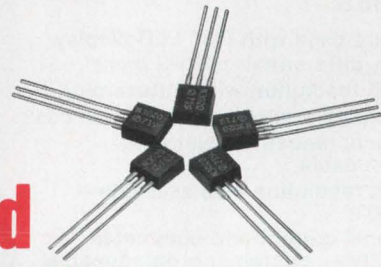

- Convert mechanical motion to electronic signals by sensing changing magnetic fields.
- Excellent for position sensing, thickness determination, weight measurement, speed control, pressure monitoring.
- Provide contactless switching—no contacts to wear, no contact welding.
- Highly reliable under adverse environmental conditions.

- None of the contamination problems suffered by mechanical or photo-electric switches.
- No moving parts to cause spurious signals often associated with conventional switches.
- Economical transistor-style package.
- Ideal interface between mechanical motion and electronic controls, counters, etc.

TYPE UGN-3020T DIGITAL SENSORS

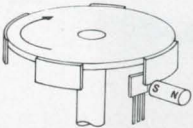
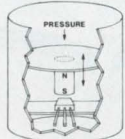
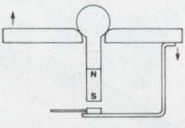
TYPICAL APPLICATIONS		
		
VANE INTERRUPTER (ignition switch, etc.)	LIMIT SWITCH (pressure monitor, etc.)	ANGLE SENSING (tilt switch, etc.)

- Designed for use with readily-available samarium cobalt or sintered alnico VIII permanent magnets.
- Operate at any voltage from 4.5 to 24 VDC.
- Constant amplitude output, independent of frequency up to at least 100 kHz.
- Higher sensitivity, wider operating temperature range, smaller physical size, more economical than any other device of its type.

TYPE UGN-3501T LINEAR SENSORS

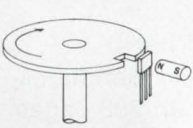
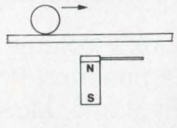
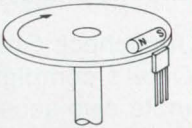
TYPICAL APPLICATIONS		
		
CHANGE IN FLUX PATH (notch sensor, etc.)	FERROUS METAL SENSOR (pinball detector, etc.)	ANGLE OF ROTATION (antenna position, etc.)

- Voltage output of these devices is proportional to magnetic field intensity.
- Will operate if slightest change in flux path is made.
- Operate at any voltage from 8 to 12 VDC.
- Hall cell and linear differential amplifier integrated in one monolithic device to simplify problems relating to handling of millivolt analog signals.
- Exceptional temperature stability.

Call your nearest Sprague stocking distributor (see opposite page) for price and delivery information. For easy-to-understand application engineering assistance, write or call John Haussler, Hall Cell IC Product Manager, Sprague Electric Co., 70 Pembroke Rd., Concord, N.H. 03301; telephone 603/224-1961. For complete technical data, write for Engineering Bulletins 27404.11 and 27500 to: Technical Literature Service, Sprague Electric Co., 347 Marshall St., North Adams, Mass. 01247.

45S-7131



THE BROAD-LINE PRODUCER OF ELECTRONIC PARTS

CIRCLE NUMBER 52

New products

Cost-effective systems are for users and OEMs



Texas Instruments, P.O. Box 1444, M/S 784, Houston, TX 77001. (512) 258-7305.

Three new members of the DS990 family of disc-based minicomputer systems, Models 4, 6 and 8, are specifically structured for commercial end users and systems OEMs. They offer extensive file management capabilities that support multiple interactive users in a multilanguage environment. The Model 4 serves as a small multistation, full-function software development system or a medium-scale application system. It includes a 128-kbyte 990/10 processor, a 1920-character Model 911 video display featuring function keys and a separate numeric pad, a 5-Mbyte fixed platter and 5-Mbyte removable cartridge disc drive. The Model 6 includes a 128-kbyte 990/10 processor, a 911 video terminal, and two 25-Mbyte removable-pack disc drives. The Model 8 is for applications requiring a large data base and includes a 128-kbyte processor, a 911 video terminal, and two 50-Mbyte disc drives.

CIRCLE NO. 301

Use single card for programmed logic

Pro-Log, 2411 Garden Rd., Monterey, CA 93940. (408) 372-4593. \$195 (100 qty).

A single card 8080A-based programmed-logic system has 1 k of RAM, sockets for an additional 1 k of RAM and sockets for 8 k of TMS-2716 PROM. The PLS-888 card also includes an 8080A microprocessor, a crystal clock, built-in power-on reset, 16-k lines of TTL input and 24 lines of TTL output.

CIRCLE NO. 302

μ C is on one card for low-cost system

Fairchild Camera and Instrument, 1725 Technology Dr., San Jose, CA 95110. Gordon Daggy (415) 962-2521. \$295; stock.

A low-cost microcomputer board, OCM/1, for use with Fairchild F8-based systems, is a one-card microcomputer that can be used as a stand-alone board. It consists of four major sections; the processor, the memory, the I/O and the interrupt. The processor section consists of the 3850 CPU, the 3853 static memory interface, clock generation and reset circuitry. The memory section can use four different types of memory. Contained on the board are 1 kbytes of RAM. The I/O portion consists of the 3850 CPU and the 3851 PSU, each containing two 8-bit I/O ports.

CIRCLE NO. 303

Mini tape transport gives maxi bits-per-buck



Quantex, 200 Terminal Dr., Plainview, NY 11803. Leon Malmed (516) 681-8600. \$250; 4 wk.

Model 200 Minidrive storage module, a low-cost, compact tape transport for the 3M Company's miniature data cartridge, forms the basic electromechanical building block for data-storage systems. It measures $3 \times 4 \times 4\frac{1}{8}$ in. with cartridge in place, weighs about 1 lb and stores up to 720 kbytes of unformatted data on the cartridge's 140 ft of magnetic tape. One version provides single track recording at 800 bits/in. to yield 168 kbytes unformatted capacity and 24 kbits/s read/write rate. A dual-track version can provide 772 kbytes on two tracks, at 1.6 kbit/in. and 48 kbit/s data-transfer rate.

CIRCLE NO. 304

Box claustrophobia gone using data collector

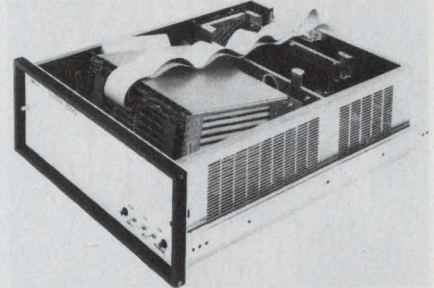

ADAC, 15 Cummings Park, Woburn, MA 01801. A.L. Grant (617) 935-6668.

The 1000 system can be used in a variety of applications as a stand-alone control/monitoring data-acquisition system. It also can work as a satellite data-collection system, communicating bidirectionally to a host computer. Some of the features are its LSI-11 configured backplane and its capability of accommodating either 11 quad-size or 22 half-quad-size or any combination of LSI-11 compatible cards. Compatible cards can be inserted into the system's backplane. Some of the cards from ADAC include low-level cards, 1108 and 1116, which feature 250-V common-mode isolation, and a programmable-gain amplifier with six gain codes that can be changed on a channel-to-channel basis.

CIRCLE NO. 305

Print 40 columns with μ C-compatible printer

Datel Systems, 1020 Turnpike St., Canton MA 02021. (617) 828-8000. \$425 to \$695.

AIP-40 is a stand-alone impact printer for teletypewriter use with mini and microcomputers. It includes printhead, paper-feed mechanism, choice of electronics, and power supply. Both 8-bit parallel and full serial interfaces are accepted to print the standard 64-character ASCII font. Average printing rate is 50 characters/s (1.25 lines/s). Serial interfaces can sustain a continuous 300-baud printing rate. Each unit includes a choice of interface electronics.

CIRCLE NO. 306

RF Power Amplifiers?

One unit may be all you'll ever need.



If you have the ENI Model 440LA ultra-wideband solid state power amplifier, all you need is a laboratory signal generator and you've got the ultimate in linear power for such applications as RFI/EMI testing, NMR/ENDOR, RF transmission, ultrasonics and more.

Capable of supplying more than 40 watts of RF power into any load impedance, the 440LA covers the frequency range of 150 kHz to 300 MHz.

We could mention unconditional stability, instantaneous failsafe provisions and absolute protection from overloads and transients, but that's what you expect from any ENI power amplifier, and the 440LA is no exception!

Our catalog contains complete specifications on the 440LA as well as the entire line of ENI amplifiers, and is available without obligation, of course.

For further information or a demonstration, contact ENI, 3000 Winton Road South, Rochester, New York 14623. Call 716-473-6900, or Telex 97-8283 ENI ROC.

ENI

The World's Leader
in Power Amplifiers

CIRCLE NUMBER 53

MICRO/MINI COMPUTING

Do away with EPROMs by using bipolar PROMs

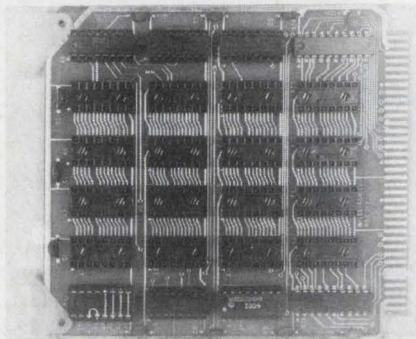

MilerTronics, 303 Airport Rd., Greenville, SC 29607. Miles Eudy (803) 242-9232. \$115; 4 wk.

The PDC-311 bipolar PROM card is bus and card-size compatible with the National ISP or MilerTronics PDC family of cards. It is an inexpensive substitute for more costly EPROMs. The card uses any standard open-collector or three-state 256×4 or 512×4 bipolar PROM. 2 k of memory is possible with 256×4 PROMs, 4 k is possible with 512×4 PROMs. It allows full 65 k address decoding, comes complete with PROM sockets, and requires just a 5-V supply.

CIRCLE NO. 307

Interface S-100 bus μ Cs with breadboarding card

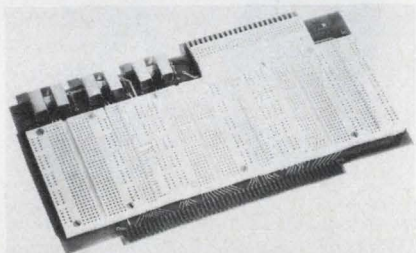

E & L Instruments, 61 First St., Derby, CT 06418. R. Vuillequez (203) 735-8774. \$75; stock.

A universal breadboarding card for interfacing S-100 bus μ Cs with peripheral devices or experimental circuitry makes it easy to integrate add-on memory. Audio cassettes or floppy-disc drives, and other compatible devices from different manufacturers can also be interfaced. Lines on the S-100 card are divided into address, data and control sections and the user has access to every signal generated by the μ C. Each card is equipped with three voltage regulators: +5, +12, and -12 V, as well as points for obtaining unregulated voltage.

CIRCLE NO. 308

Test μ P prototypes with development system



Tektronix, P.O. Box 500, Beaverton, OR 97077. Wyn Giluck (503) 644-0161. \$7650.

Prototype testing for five μ P types with one development system can be done with the 8001 μ P Development Lab. It provides in-prototype emulation for an expanding set of 8 and 16-bit μ Ps including the 8080, 6800, Z-80, TMS9900 and 8085. Functions of the system are: accept program load from an RS-232-C source, interactive software emulation, in-prototype hardware and software emulation, debug control, memory mapping, real-time trace (optional) and built-in PROM programming (optional).

CIRCLE NO. 309

Test and debug PACE designs at low cost



National Semiconductor, 2900 Semiconductor Dr., Santa Clara, CA 95051. Howard Raphael (408) 737-5956. \$585.

The low-cost LCDS development system, on one PC card, tests and debugs PACE hardware and software. The board contains a 16-bit PACE μ P, 1 kword of RAM, sockets for 1 kword of PROM, a 20-key dual-function keyboard, a 6-digit LED display, a system timing element, I/O buffers and bidirectional-transceiver elements. Build application routines by entering code directly through the LCDS keyboards or an external terminal. View, print and modify the content of memory and registers. Check out programs in either the single-step mode or continuous mode with break points.

CIRCLE NO. 310

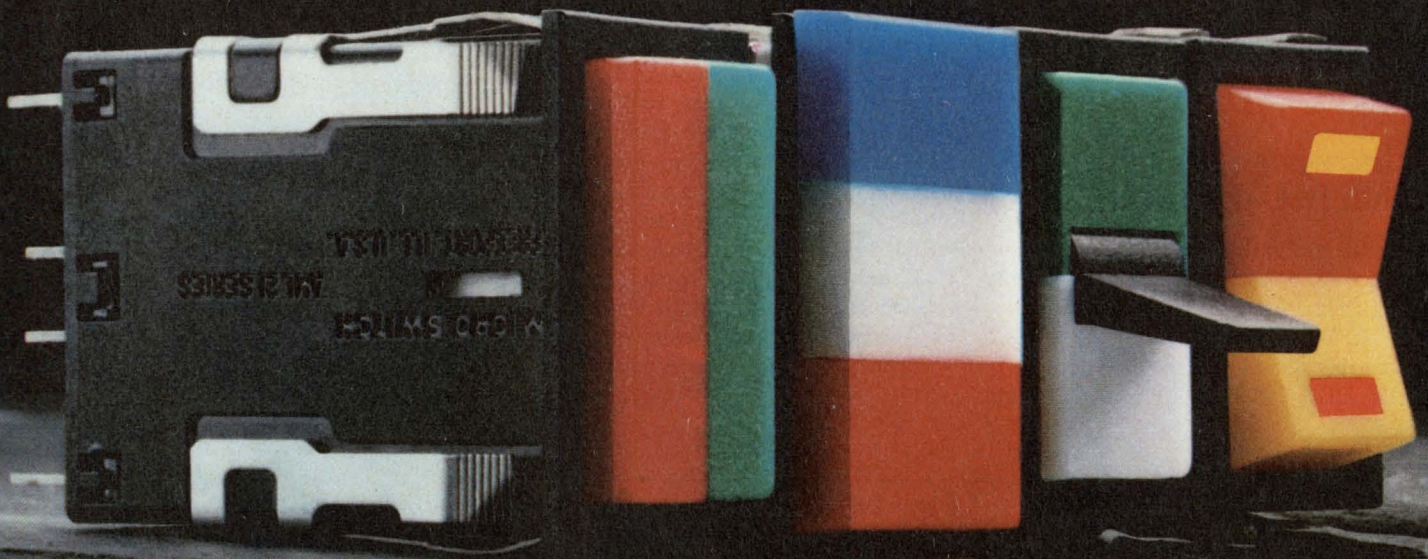

To make a complete line of pushbutton controls, you need more than pushbuttons.

Pushbuttons from MICRO SWITCH's AML (Advanced Manual Line) have always been attractive to designers. Because they look so good.



And because they're so easy to mount and wire.

But now, the AML series is even more appealing. Because now there's a variety of rocker and paddle switches to choose from, including dual lamp and dual color. Which means now you can perform just about any function with a harmonious display. You don't have to compromise.

AML controls also look appealing to the people who have to do the wiring. All are designed with the same depth for single level termination, regardless of switch or terminal type.

There's easy snap-in mounting from the front, PC board mounting or sub-panel mounting using individual, strip or matrix hardware.

Which means mounting is simpler. Wiring is simpler. Engineering time is reduced. And total installed cost is lower.

Plus, they offer solid state, electronic control or power switching in the same size housing. All AML devices are designed to meet international, UL and CSA standards.

Displays include split screen, hidden color, and a unique three-segment lens cap indicator. The choice of lamps includes T-1 $\frac{3}{4}$ wedge base, neon and LED.

AML has it all — pushbuttons, indicators, and now, paddles and

rockers. But to see how good-looking AML really is, contact us for a personal demonstration.

MICRO SWITCH will provide you with field engineers for application assistance and a network of authorized distributors for local availability. Write us for details or call 815/235-6600.

MICRO SWITCH products are available worldwide through Honeywell International.

MICRO SWITCH

FREEMONT, ILLINOIS 61032

A DIVISION OF HONEYWELL

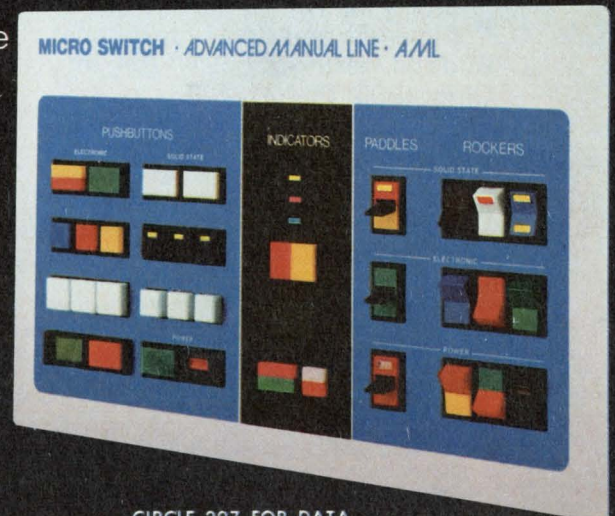

CIRCLE 297 FOR DATA

MICRO/MINI COMPUTING

Disc system interfaces with DEC computer

DIVA, 607 Industrial Way W., Eatontown, NJ 07724. William Thomas (800) 631-2141. See text.

DD70 Series disc system features a computroller that interfaces directly to the DEC PDP 11/70 computer and

communicates directly with the cache-bus controller. This interface allows the disc system to transfer full 32-bit words directly into the memory without Unibus intervention. The DD70 consists of a microprocessor-based disc controller, 4-board PDP-11/70 interface, and a choice of disc drives ranging in capacity from 80 to 300 Mbytes per spindle. Single-drive systems are priced from \$22,000 to \$30,000, depending on capacity.

CIRCLE NO. 320

Small controller is for micro-size diskettes

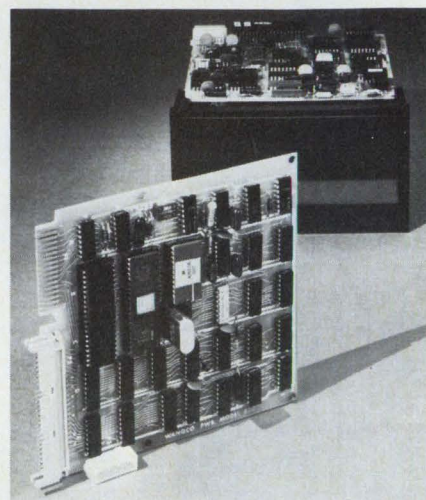

Wangco, 5404 Jandy Pl., Los Angeles, CA 90066. (213) 390-8081. \$490; 4 wk.

In a compact 5½-in. square, the 8201 Micro-Controller provides a general purpose host interface for use in 6800 and 8080-based microcomputers, minicomputers and other byte-oriented systems. The principal component is the Intel MCS 8048, a microprocessor providing 1k of ROM, plus RAM and I/O ports on a single chip. It facilitates a nine macro-command structure in the system. Formatting is of a soft-sectored, modified IBM type of 16 sectors per track, 128 bytes per sector. It provides for a 128-byte sector buffer or multiple sector transfer without buffering.

CIRCLE NO. 321

COMMANDER



MODULAR
WORK STATIONS
BY BUD

The new Commander comes in one, two and three-bay styles, each with a choice of various rear compartments, cabinets, drawers and shelves. It's the work station that gives you the options to choose what you need for storage or housing equipment. Comes in 19 standard colors.

For a full-color brochure on the Commander and Concorde, phone Bud toll free: (800) 321-1764; in Ohio, (800) 362-2265.



Complete manufacturing facilities at two locations:

BUD

Bud Industries, Inc.
4605 East 355th Street
Willoughby, Ohio 44094
Bud West, Inc.
3838 North 36th Avenue
Phoenix, Arizona 85019

CIRCLE NUMBER 55

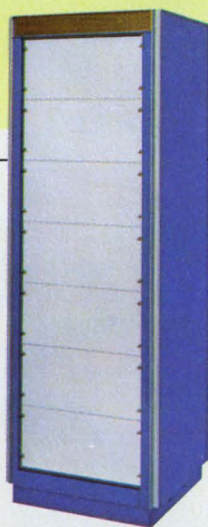

CONCORDE SERIES

A new contemporary-styled rack from Bud! Designed as a companion piece for the Commander; yet, can stand on its own in any system.

μC system is 12-bit and thrifty

Pacific Cyber/Metrix, 3120 Crow Canyon Rd., San Ramon, CA 94583. Ted Netoff (415) 837-5400. \$989; 3 wk.

A μC system, Model IM6100, is software-compatible with DEC's PDP-8 mini family. The system includes an IM6100 12-bit CMOS μP, memory expandable to 32 k, front-panel module with built-in bootstrap loader and control PROMs, power supply, backplane-bus structure, aluminum cabinet with slots for up to 15 plug-in modules, and a set of user manuals. The system can add vectored priority interrupts and has direct memory access. Other features are 80-line TTL compatible bus with 18 unassigned lines and address space for up to 63 I/O devices.

CIRCLE NO. 322

Now the selection, availability, price, and performance you want in Open Frame Power Supplies

- Fifty-five models; single and dual outputs.
- Seven industry-standard sizes.
- In stock.
- Full performance over a wide 100-125 or 200-250 VAC input range.
- More power per package size.
- Full rated current with 50 Hz input.
- True remote sense capabilities.
- Fully adjustable current limit.
- Overload and shortcircuit protection.
- UL recognized, standard 478.

More power conversion products:
Our Power House line includes a wide selection of encapsulated and ferroresonant power supplies as well as programmable solid state loads for testing. Write for our free master catalog.

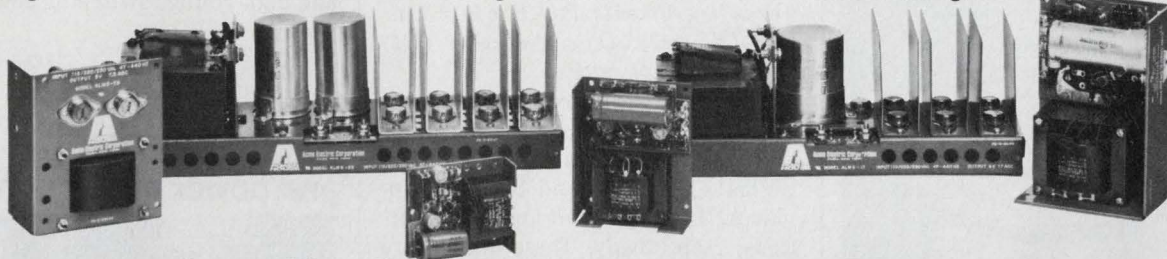

Common Specifications:

AC Input: 100-125 or 200-250 VAC, 47-440 Hz.

Ripple and Noise: 1.5 mV RMS, 5 mV P to P.

Transient Response: 50 μ sec.

Regulation — Line or Load: 0.1%.

Operating Temperature: 0°-60°C.

Cooling: Convection.

Stability: \pm 0.2%.

ALM Single Output Units:

A Series Price: \$27

Nominal Output Voltage	Current Rating @ 40°C.	Model No.
2	1.5	ALM 2-1.5
5	1.5	ALM 5-1.5
6	1.3	ALM 6-1.3
12	0.7	ALM 12-0.7
15	0.7	ALM 15-0.7
20	0.5	ALM 20-0.5
24	0.5	ALM 24-0.5

Overvoltage Protector — OVM-1 \$8.00
Overall dimensions: 3.03 x 3.78 x 1.28.

D Series Price: \$72

Nominal Output Voltage	Current Rating @ 40°C.	Model No.
2	11.0	ALM 2-11
5	11.0	ALM 5-11
6	10.0	ALM 6-10
12	6.0	ALM 12-6
15	5.0	ALM 15-5
20	4.0	ALM 20-4
24	3.8	ALM 24-3.8

Overvoltage Protector — OVM-2 \$16.00
Overall dimensions: 4.90 x 7.03 x 2.78

F Series Price: \$106

Nominal Output Voltage	Current Rating @ 40°C.	Model No.
2	20.0	ALM 2-20.0
5	20.0	ALM 5-20.0
6	17.0	ALM 6-17.0
12	13.0	ALM 12-13.0
15	10.7	ALM 15-10.7
20	9.0	ALM 20-9.0
24	8.2	ALM 24-8.2

Overvoltage Protector — OVM-2 \$16.00
Overall dimensions: 4.88 x 4.88 x 13.75

B Series Price: \$31

Nominal Output Voltage	Current Rating @ 40°C.	Model No.
2	4.0	ALM 2-4.0
5	4.0	ALM 5-4.0
6	3.3	ALM 6-3.3
12	2.0	ALM 12-2.0
15	1.7	ALM 15-1.7
20	1.4	ALM 20-1.4
24	1.3	ALM 24-1.3

Overvoltage Protector — OVM-1 \$8.00
Overall dimensions: 4.00 x 4.87 x 1.76

E Series Price: \$88

Nominal Output Voltage	Current Rating @ 40°C.	Model No.
2	15.0	ALM 2-15.0
5	15.0	ALM 5-15.0
6	12.5	ALM 6-12.5
12	8.8	ALM 12-8.8
15	8.0	ALM 15-8.0
20	7.0	ALM 20-7.0
24	6.5	ALM 24-6.5

Overvoltage Protector — OVM-2 \$16.00
Overall dimensions: 4.87 x 9.00 x 2.75

G Series Price: \$128

Nominal Output Voltage	Current Rating @ 40°C.	Model No.
2	25.0	ALM 2-25.0
5	25.0	ALM 5-25.0
6	23.0	ALM 6-23.0
12	16.0	ALM 12-16.0
15	14.0	ALM 15-14.0
20	11.5	ALM 20-11.5
24	10.5	ALM 24-10.5

Overvoltage Protector — OVM-2 \$16.00
Overall dimensions: 4.88 x 4.88 x 16.75

C Series Price: \$54

Nominal Output Voltage	Current Rating @ 40°C.	Model No.
2	7.5	ALM 2-7.5
5	7.5	ALM 5-7.5
6	6.5	ALM 6-6.5
12	4.0	ALM 12-4.0
15	3.5	ALM 15-3.5
20	3.2	ALM 20-3.2
24	3.0	ALM 24-3.0

Overvoltage Protector — OVM-1 \$8.00
Overall dimensions: 4.87 x 5.62 x 2.50

ALM Dual Output Units:

Adjust Range	Current Rating @ 40°C.	Model No.	Series	Price
12-15	0.55	ALM 15D-0.55	B	\$ 45.00
12-15	1.10	ALM 15D-1.1	C	55.00
12-15	2.20	ALM 15D-2.2	D	68.00
12-15	3.30	ALM 15D-3.3	E	91.00
12-15	4.40	ALM 15D-4.4	F	114.00
12-15	8.00	ALM 15D-8.0	G	136.00

Overvoltage Protector — Two OVM-1 \$8.00 Each.



Phone (716) 968-2400 TELEX 91-6451 TWX 510-245-2700

Acme Electric Corporation

Cuba, N.Y. 14727

CIRCLE NUMBER 56

Get .09 to
117.0 lb.-in.
Torque
100 million
times



A rotary solenoid will give you direct rotary stop-and-go action without complicated linkages or circuitry. It's simple, has superior shock and vibration resistance, high torque to size ratios, and provides rated torque over the full stroke.

Ledex invented it. We invented the way to make it smaller and more efficient. We invented the way to improve reliability and extend duty life. We're the primary source when reliable quality and delivery are important.

250 standard models in stock for prototype work, ship in 48 hours. 117.0 to .09 lb.-in. torque range. 25°, 35°, 67½°, and 95° strokes, DC or 115VAC rectified power.

Send your requirements for any prototype unit.

Ledex Inc., 123 Webster Street,
Dayton, Ohio 45401.
Phone: 513-224-9530.



CIRCLE NUMBER 57

ICs & SEMICONDUCTORS

Dual peripheral drivers boast 70-V outputs

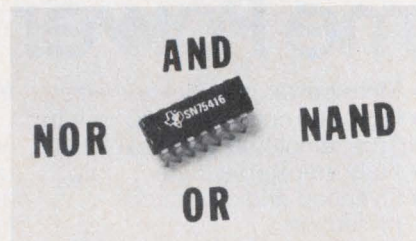

Texas Instruments, P.O. Box 5012, Dallas, TX 75222. Dale Pippenger (214) 238-3527. \$1.21; stock.

Four dual-peripheral-driver ICs deliver high current, high output voltage and fast switching times. The SN75416, SN75417, SN75418 and SN75419 provide AND, NAND, OR and NOR functions, respectively. These drivers are characterized for use to 500 mA for each output. They feature 500-mA, 70-V outputs and 50-ns typ transition time for high-to-low-level output. Inputs are TTL or MOS compatible and feature pnp inputs for low-input current. Each device dissipates 2 W. Output diodes suppress inductive voltage spikes.

CIRCLE NO. 323

IC μ P clock replaces hybrids and discretes

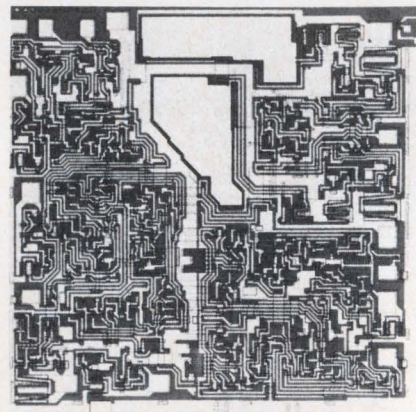

Motorola Linear Prod., 2200 W. Broadway, Mesa, AZ 85202. Bill Carns (602) 962-2294. \$3.45/1000; stock.

The monolithic MC6875 is an alternative to hybrid or discrete clock generators for μ Ps. Using an external quartz crystal, the series-compatible clock provides buffered two-phase outputs, internal control logic (implementing all popular modes of direct memory accessing), internal "handshaking" logic (needed to interface with slow memories and I/O peripherals), and a power-on and reset control function. The package is a ceramic 16-pin DIP.

CIRCLE NO. 324

Darlington's are rated 1000 V and 125 W

International Rectifier, 233 Kansas St., El Segundo, CA 90245. (213) 322-3331.

A series of high-voltage monolithic Darlington's with power ratings to 125 W, IR5063 through IR5066, has collector-to-base ratings to 1000 V and collector-to-emitter ratings to 900 V. Peak collector current for all units is 20 A. The devices are suited for high voltage inverters, motor-drive circuits and high-voltage switching power supplies.

CIRCLE NO. 325

RAMs upgrade speed and power performance

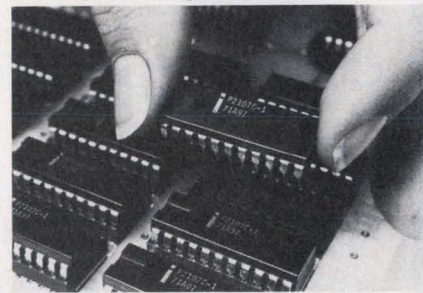

Intel, 3065 Bowers Ave., Santa Clara, CA 95051. Rob Walker (408) 246-7501. \$7.90 to \$17.25; stock.

The 2107 C family of 22-pin 4-k RAMs in ceramic and plastic offers upgraded speed and power and noise immunity with no changes required in system designs. The family offers a range of access times from 150 to 250 ns, 10% supply tolerances, and low-power requirements. They are available in three speed categories ranging from 150-ns-max access, 380-ns read or write cycles and 450-ns read-modify-write (RMW) cycle to 250-ns maximum access, 430-ns read or write cycles and 550-ns RMW cycle. Typical power dissipation is 420 mW in active operation.

CIRCLE NO. 326

Multigate chips operate to 7 MHz

International Microcircuits, 3004 Lawrence Expressway, Santa Clara, CA 95051. Orhan Tozun (408) 735-9370.

MasterMos family has 10 semi-custom chips ranging in size from the equivalent of 50 two-input gates to 550 two-input gates in 50-gate intervals. They operate up to 7 MHz at 15 V. Each chip includes additional buffers for interfacing with LS-TTL or TTL logic.

CIRCLE NO. 327

What's TRW up to now?

Optimizing metal film.

TRW thin film resistors optimize parameters like real estate, accuracy, speed, reliability, and resistance range.

In discrete devices, sets, or networks.

For instance, our ultra-precision MAR series does all of the above with absolute TC's and tolerances to ± 5 ppm/ $^{\circ}$ C, $\pm 0.01\%$. Our smallest discrete uses $< .016$ in² of PCB space. Complex sets and networks include 16 Bit Binary Ladders, input

attenuators and others up to 28 pins.

In straightforward precision, we have a range of standards in R2R Ladder, MIL-R-83401 flat pack, and RNC resistors with a verified MTBF of 280×10^6 unit hours.

Contact TRW/IRC Resistors, 4222 South Staples, Corpus Christi, Texas 78411. (512) 854-4872, Dept. M. For standards in all types of resistors, call your local TRW distributor.

TRW IRC RESISTORS
ANOTHER PRODUCT OF A COMPANY CALLED TRW

Drive thermal printheads with linear IC

Texas Instruments, P.O. Box 5012, M/S 308, (Attn; SN75490), Dallas, TX 75222. Dale Pippenger (214) 238-3527. See text; stock.

A linear IC, the SN75490, drives

many popular thermal printheads. The circuit, offered as either a 16-pin plastic or ceramic DIP, features six AND drivers with a common strobe. Operation is from ± 15 -V supplies. This allows the totem-pole outputs a -4.75 to $+3.5$ -V nominal range. Inputs are compatible with TTL and 5-V CMOS. At 0 to 70 C the device sources 30 mA and sinks 50 mA. Prices (100-qty): \$2.82 for plastic and \$3.53 for ceramic.

CIRCLE NO. 328

Drive LCD displays as large as 8 inches

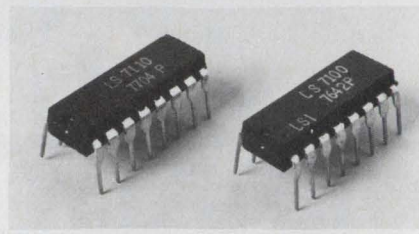

LSI Computer Systems, 1235 Walt Whitman Rd., Melville, NY 11746. Ron Colino (516) 271-0400. \$1.19 to \$1.39 (1000 qty).

The LS7100 and LS7110 are p-channel-MOS circuits capable of driving large LCDs that require 5 to 60-V segment drives. The circuits are input compatible with CMOS and TTL. The LS7100 is a BCD to 7-segment latch/decoder/driver that operates at 5 to 80 V. With little added circuitry it interfaces with a 120-V-ac line and drives an LC or gas-discharge display. The LS7110 is a combination binary-addressable, latched 8-channel multiplexer, demultiplexer and driver operating at 5 to 80 V.

CIRCLE NO. 329

When you take the high (voltage) road, we take the low (cost) road.

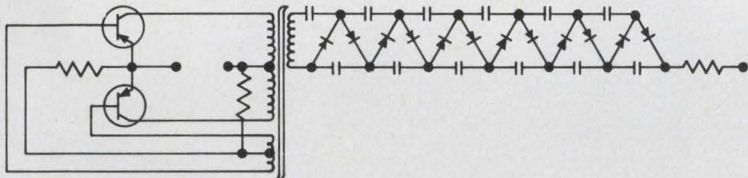

A switching oscillator coupled with an SCI Cascade Multiplier makes a reliable, low cost, compact high voltage DC power supply. Let SCI assist you in the design of your new generation high voltage DC supply.

SCI multipliers are available with outputs ranging from 50 μ A @ 15 kV to 15 mA @ 70 kV.

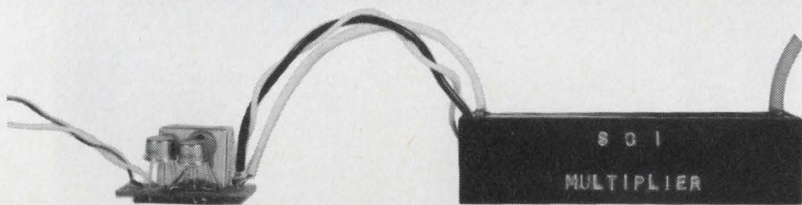

SCI multipliers are an attractive alternative to conventional circuits in designing high voltage supplies for such applications as:

DC

CRT and radar displays, radiographic equipment, photo-multiplier, tubes, electrostatic paint sprayers, test equipment.

Pulse

Starting arc welders, lasers, photo flash, igniting oil and gas burners.

For more details, ask for Joe LaBruna:



Scientific Components, Inc.
Subsidiary of CODI Corporation
350 Hurst Street
Linden, New Jersey 07036
201-791-9500

CIRCLE NUMBER 59

Device does the job of five or more memories

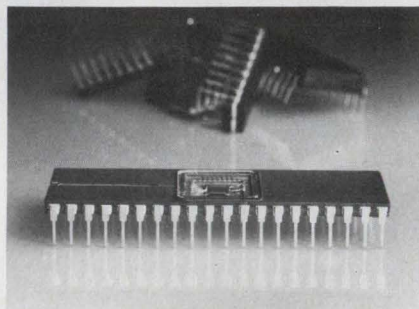

National Semiconductor, 2900 Semiconductor Dr., Santa Clara, CA 95051. Hash Patel (408) 737-5175. \$8.75; stock.

An n-channel LSI device combines memory storage and peripheral-interface capability and does the job of five or more standard memory and I/O parts. The INS8154, a combined RAM and I/O chip, is suited for low-end microprocessor-based systems that may require a relatively small memory capacity but still need a number of peripheral interfaces. The 40-pin circuit, which directly interfaces with SC/MP II, INS8080A and other μ Ps, contains 128 eight-bit words of static RAM together with two 8-bit parallel I/O ports that are bit-programmable to provide maximum flexibility.

CIRCLE NO. 330

Four very small ways to improve on your PC design.

With four types of switches—rockers, pushbuttons, toggles and DIPs—Cutler-Hammer offers one of the industry's broadest and most unique selections of PC subminiatures.

Each of the hundreds of available styles provides the reliability you've come to expect from Cutler-Hammer. With ratings to 6 amps, each conforms to standard circuit board mounting requirements.

PC switches, along with accessories and decorative hardware, are distributor stocked for local availability. And since most are manufactured in the United States, we offer fast reaction time on solder lug and wire wrap terminal variations, as well.

To improve your next design in any number of small ways, contact your Cutler-Hammer Sales Office or Switch Distributor.

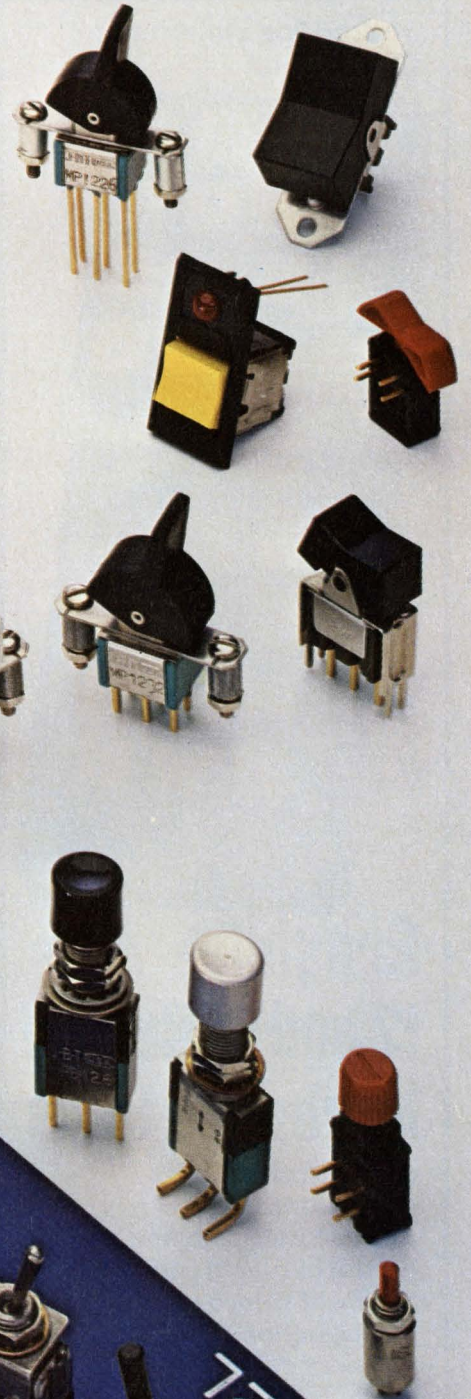

 Switch to No.1

CUTLER-HAMMER
SPECIALTY PRODUCTS DIVISION, Milwaukee, Wis. 53201
CIRCLE NUMBER 60

Tested for Millions of Operations

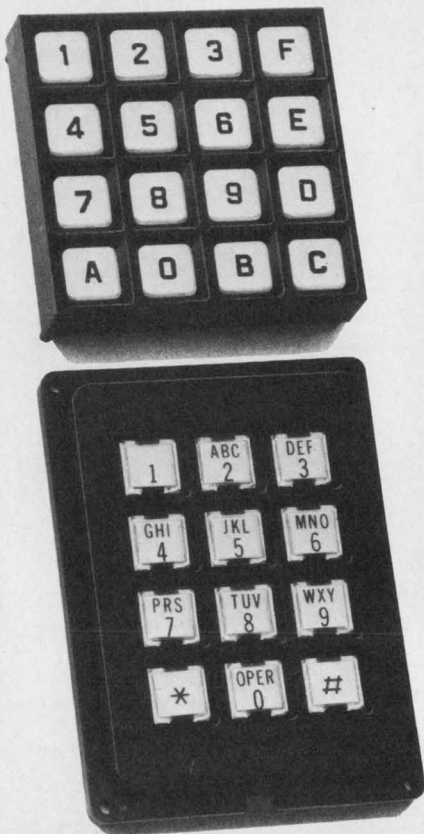

Grayhill 12 and 16 Button Keyboard Pads

choice of circuitry

- XY matrix
 - single pole/common bus
 - 2 out of 7 (or 8) coded output
- choice of 1/2-inch or 3/4-inch button centers

Grayhill's 3 x 4 Keyboard Pads earned instant popularity for their positive tactile and audio feedback and performance. Now the line is broadened by the addition of 4 x 4 Keyboards, featuring the same low profile, patented snap-action dome contact, and 3 million operation per button contact system life-rating. Readily interfaced with logic circuitry. Total button travel of only .015 inch. Standard post or flange mounting; top or sub panel mounting. Molded of tough ABS plastic; buttons with black on white molded-in legends a standard, other legend options available, including clear snap-on caps for user legending. Send for complete specifications, truth table, and information about our full line of Keyboard products, from Grayhill, Inc., 561 Hillgrove, La Grange, Illinois 60525. (312) 354-1040



CIRCLE NUMBER 61

ICs & SEMICONDUCTORS

Line driver features three-state outputs

Texas Instruments, P.O. Box 5012, M/S 308 (Attn: SN75159), Dallas, TX 75222. Dale Pippenger (214) 238-3527. \$2.47 to \$2.82; stock.

SN75159, a dual-differential line-driver IC, meeting EIA RS-422 standards, features three-state outputs and addition input logic. The three-state-output feature with individual disable controls permits connecting many devices on the same line. The outputs can neither drive nor load the bus in the disabled or high-impedance state. The outputs are capable of sinking and sourcing 40 mA with 0.25-V (low) and 3.0-V (high) levels. Transition time: 4 ns, delay time: 13 ns.

CIRCLE NO. 331

One chip gives all CB channel frequencies

National Semiconductor, 2900 Semiconductor Dr., Santa Clara, CA 95051. (408) 737-5000. \$7.00; stock.

Designated DS8900, a 28-pin device is a single-chip frequency synthesizer/programmer for CB equipment. It is the equivalent of a 40-channel phase-locked loop and programmer. Also included on the chip are LED driver/decoders. Some features are: a 40-MHz input capability without using external mixers; 2-speed channel selection; mask-programmable i-f code capability; channel memory capability.

CIRCLE NO. 332

Photodiodes detect full visible spectrum

EMDEX, 540 New Haven Ave., Milford, CT 06460. Seymour Merrin (203) 877-3271.

A family of enhanced-silicon photodiodes responds throughout the visible range of the spectrum. The devices will not exceed a responsivity ratio of 2.5 between 800 and 400 nm. Other characteristics are compatibility with 2 to 15-V logic high-temperature stability. The device's active areas measure 1.2 to 5.8 sq mm and the units are packaged in TO-18 and TO-5 metal cases with dual terminals.

CIRCLE NO. 333

Sense and hold analog peak voltages

Optical Electronics, P.O. Box 11140, Tucson, AZ 85734. Mrs. Mac (602) 624-8358. \$4.5; stock.

The main purpose for the 5902 IC device is to sense and hold positive analog peak voltages. The 100-ns-max acquisition time allows it to peak-sense high-speed pulse-type signals. It may also be used for envelope detection and, with the addition of one external op amp, performs dc restoration. Digital command inputs are TTL and 5-V CMOS compatible. Sensing error is ± 1 -mV max.

CIRCLE NO. 334

Amplifier/detector tunes from 0.15 to 3 MHz

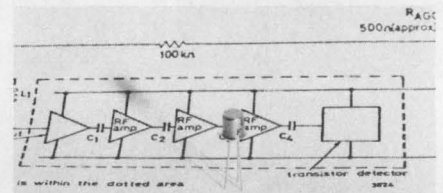

Ferranti Electric, E. Bethpage Rd., Plainview, NY 11803. Ken Kushman (516) 293-8383. \$0.49 (1000 qty); stock to 4 wk.

Monolithic AM/i-f amplifier/detector, type ZN414, can be tuned with external components from 150 kHz to 3 MHz. The TO-18 packaged unit operates from 1.2 to 1.6 V dc, drawing only 300 μ A. Threshold sensitivity is 50 μ V with the supply voltage at 1.3 V. Power gain is 72 dB.

CIRCLE NO. 335

IC puts more 4-bit μ C functions on chip

Panasonic, 1 Panasonic Way, Secaucus, NJ 07094. William Bottari (201) 348-7276. \$8.50 (1000 qty); stock to 4 wk.

Three μ Ps, Models MN1400, MN1402, and MN1498 built with the n-channel E/D MOS process, have a number of functions previously included in auxiliary circuitry. These include an 8-bit presetable counter-timer, a clock generator, a 1024 \times 8-bit-instruction ROM, 64 \times 4-bit RAM with four directly addressable words, I/O ports, and the arithmetic-logic unit. Depending on the model, they are available in 28, 40, or 64-pin DIPs. An "evaluator chip," Model MN1499, can perform various tests on the μ Ps.

CIRCLE NO. 336

COMPARE YOUR IDEA OF A WORKHORSE RECORDER TO OURS.

The rugged Gould 105 General Purpose Strip Chart Recorder delivers such reliable performance, with so many unexpected features, that it goes beyond the traditional definition of a workhorse unit.

Die-cast to handle the day-to-day rigors industrial analytical instrumentation must face, the 105 still offers you a full complement of features you might not expect on such a competitively priced recorder.

Full scale accuracy is $\pm 0.1\%$. Rectilinear data presentation is available on either single or dual 10-in. channels. Response time (10% to 90% full scale) is less than 350 ms.

The Model 105 uses disposable felt tip pens avail-

able in four colors. It easily takes Z-fold or roll paper without modification. Chart speeds range from 1 in./hr. to 20 in./min. It even makes chart annotation simpler with a flatbed, "write-on" design and event marking standard.

And of course you have the Gould/Brush sales and service organization should you ever need us. Check Gould's 105 — a workhorse of a recorder with a tradition of thoroughbreds.

For more information contact, Gould Inc., Instruments Division, 3631 Perkins Ave., Cleveland, Ohio 44114. Or Gould Alco S.A., 57 rue St. Sauveur, 91160, Ballainvilliers, France. **For brochure, call toll free (800) 325-6400, Ext. 77.** In Missouri: (800) 342-6600.



 **GOULD**

CIRCLE NUMBER 62

Now you can mass terminate with ribbon connectors.

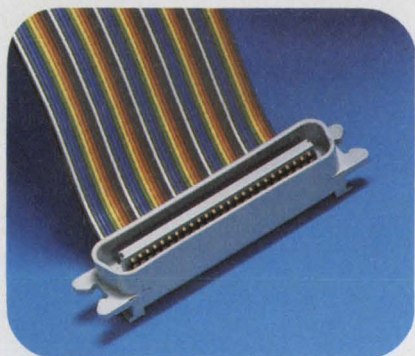

Here's another industry first from 3M that's good news for you: the Scotchflex brand Delta Ribbon Connector System for intra-system or I/O interconnections. In computer applications, in telecommunications, in any place or any way you want to use flat cable and ribbon connectors, this versatile system can do the job at sharply reduced assembly time and labor costs.

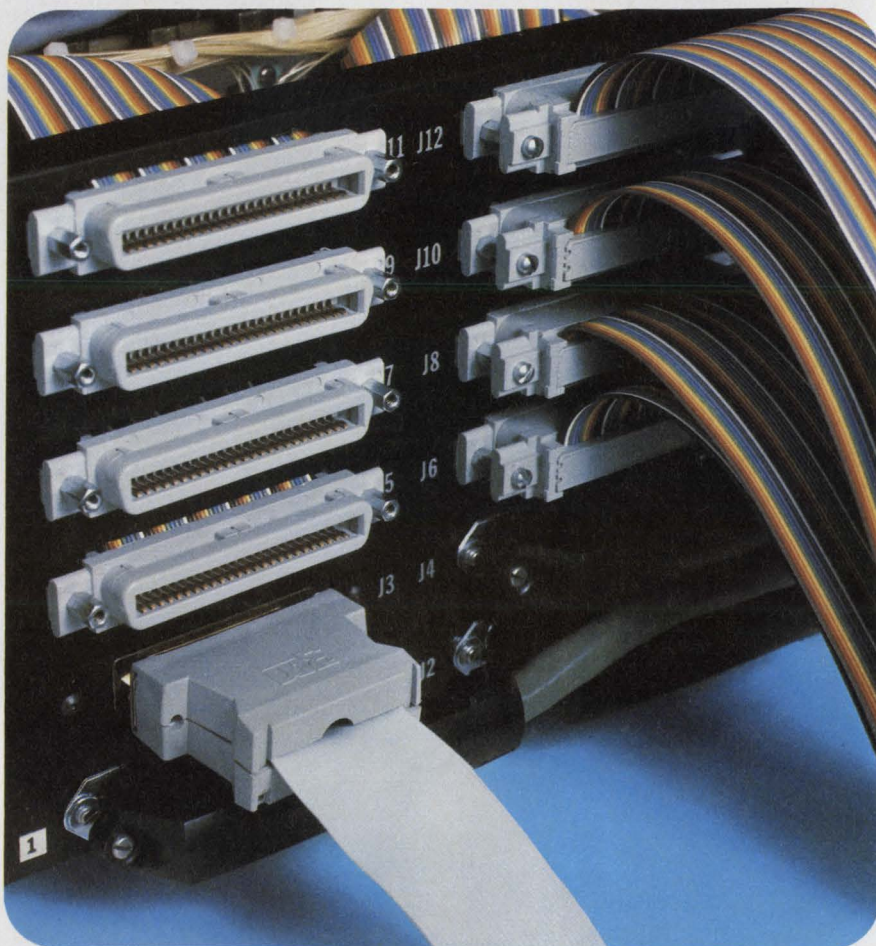

With Scotchflex Delta Ribbon Connectors, no stripping, soldering or other wire preparation is necessary. You can mass terminate a parallel-lay 50-conductor (25-pair) .0425" center-spaced flat cable in less than 30 seconds with one step. That's about ten times faster than other available methods. And thanks to 3M's field-proven, gold-plated beryllium copper U-contacts,

all connections are reliably corrosion-resistant and gas-tight.

After termination, there are more savings. You can buss from point to point without disassembling or breaking existing cables. And there's no need to redesign or rework first generation components. This Scotchflex system mates perfectly with all standard miniature ribbon connectors.

..in 30 seconds or less!

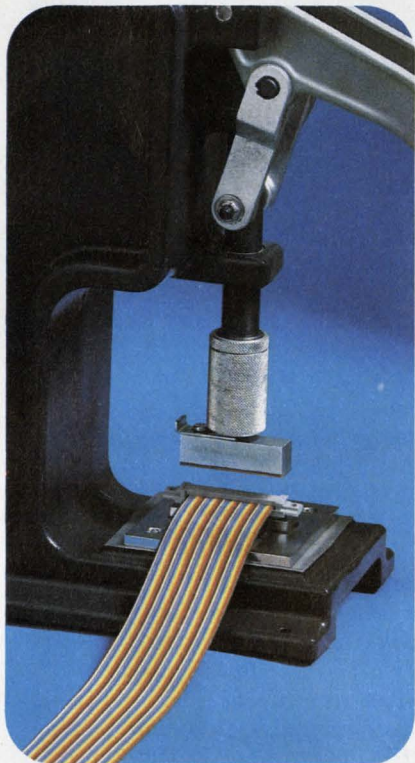

There's no costly investment to make in equipment or training. All you need are two locator plates and the Scotchflex manual or pneumatic assembly press. You can start mass terminating assemblies quickly and economically. No special operator skills are required. Rejects and reworking are greatly minimized.

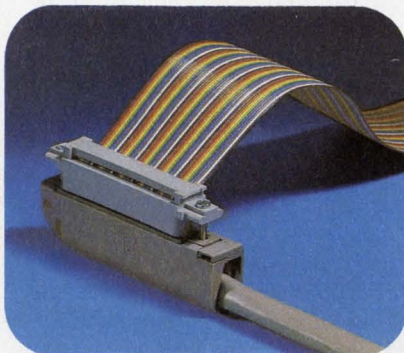

The Scotchflex Delta Ribbon system includes 50-position male and female connectors, plus appropriate bail mount, screw mount and jack screw kits, strain relief clips and dust covers. Color-coded flat cable is available in parallel-lay conductors #28 AWG stranded or #26 AWG solid.

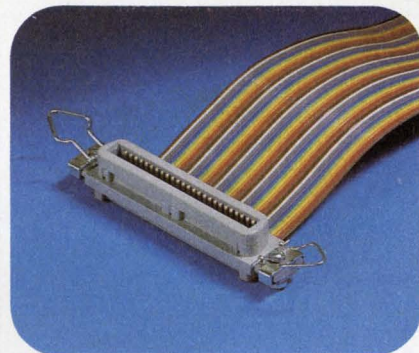

Only 3M offers you so broad a range of flat cable and system components. A nationwide network of stocking distributors. Best off-the-shelf availability. Proven performance. And the unmatched experience of the people who pioneered mass terminations.

"Scotchflex" is a registered trademark of 3M Co.

Scotchflex[®]
systems
from 3M.
The source.



See our
catalog in EEM,
page 2256

Better flux.

Fewer bucks.

Superior No. 30 is a different kind of flux—an organic flux. It strips joints clean of oxides. It washes off easily with water. It's non-hygroscopic, non-conductive, non-corrosive, and free of fumes or disagreeable odors. And it costs you less.

Especially now. Because we'll not only tell you all about the advantages of Superior No. 30 flux, we'll let you try it yourself. Free. Just send the coupon and you'll soon see how our better flux can cost you fewer bucks.

Superior Supersafe No. 30
Non-corrosive soft solder
liquid organic flux.

Better flux for fewer bucks since 1932.



The Superior Flux
and Manufacturing Company

95 Alpha Park
Cleveland, Ohio 44143

Free Sample!
Just send to:
Superior Flux

95 Alpha Park
Cleveland, Ohio
44143
(216) 461-3315

- Send free sample and literature
 Send literature only

Name _____

Address _____

Company _____

City _____

State _____ Zip _____

CIRCLE NUMBER 64



DATA PROCESSING

Firmware, software package shapes distributed systems network

Hewlett-Packard, 1501 Page Mill Rd., Palo Alto, CA 94304. (415) 493-1501. P & A: See text.

With Distributed System/1000's software and firmware package, HP-1000 systems can interconnect in an almost unlimited number of interconnections. What's more, high-level intercommunication is now possible, such as interconnecting the HP-1000, HP-2026, and HP-3000 Series II computer systems. With the DS/1000 package, networks can be formed from HP-1000 systems that use the memory-based RTE-M, as well as the older RTE-III, operating system.

The DS/1000 package's nodal-addressing scheme gives store-and-forward capability to each node. Any HP-1000 can thus address any other HP-1000, and communicate through any other nodes that may intervene. So, networks can readily be configured as a star, a ring, a string, or a combination of these. Since node addresses stay valid, nodes can share links (reducing line costs), and networks can be reconfigured without affecting previous application programs.

The HP-1000's console can also be a virtual terminal, with full access to the power of the HP-3000, or it can operate unattended. The DS/1000 contains a microcoded driver that is so fast that it can concurrently service multiple communications lines from HP-1000s.

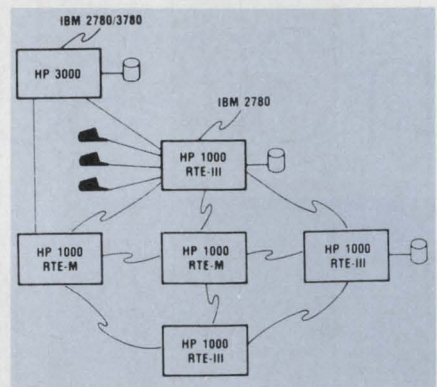

The previous limit of two concurrently active lines no longer applies. At any node, the HP-1000 can access records in remote files (or transfer whole files) on other 1000s, or on a remote HP-3000, using simple calls.

Data integrity in the network is protected with parity checking: Once received, blocks of data are checked, vertically, horizontally, and diagonally, for parity. This checking method can be implemented in microcode, while preserving high line integrity.

In single quantities, the DS/1000 firmware and software used to form one network link between two HP-1000s, cost \$6200. Additional network links are \$3700 each. Linking an HP-1000 to an HP-3000 series II system costs \$500. First customer deliveries are expected in December.

CIRCLE NO. 337

Acoustic coupler gives high data speed

Omnitec, 2405 S. 20th St., Phoenix, AZ 85034. Paul Shatusky (602) 258-8244.

The 401D originate-only acoustic coupler operates with the latest high-speed conversational terminals at data speeds in excess of 300 baud, or optionally to 600 baud. In addition to this speed capability, the 401D offers TTY and EIA RS232 interfacing acoustic, half or full duplex operation, and ultra-high sensitivity. Each coupler has built-in 20-mA TTY current loop and RS232 interfaces.

CIRCLE NO. 338

Computer file system quadruples storage

Inforex, 21 North Ave., Burlington, MA 01803. (617) 272-6470.

Disc-storage capacity of System 5000, a computerized file and records management system, has been quadrupled by the addition of dual-density disc storage units. They are the 62-Mbyte, Model 5303, and the 235-Mbyte, Model 5304. Up to four drives of either density can be attached to each System-5000 terminal control unit, providing maximum capacity of 940 Mbytes.

CIRCLE NO. 339



Operation from replaceable battery or AC adapter.
Industry standard 10 M Ω input impedance.

Technical Specification

DC Volts (4 ranges)

Range: 1 mV to 1000 V.

Accuracy of reading: 1.0% \pm 1 count.

Note: 10 M Ω input impedance.

AC Volts (40 Hz-5 kHz)

Range: 1 V to 500 V. Accuracy of reading: 1.0% \pm 2 counts.

DC Current (6 ranges)

Range: 1 nA to 200mA.

Accuracy of reading: 1.0% \pm 1 count.

Note: Max. resolution 0.1 nA.

Resistance (5 ranges)

Range: 1 Ω to 20 M Ω .

Accuracy of reading: 1.5% \pm 1 count.

Note: Also provides 5 junction-test ranges.

Dimensions: 6 in x 3 in x 1 1/2 in.

Weight: 6 1/2 oz.

Power supply: 9 V battery

or Sinclair AC adapter.

Sockets: Standard 4 mm for resilient plugs.

Supplied with: Leads, test prods, operating instructions, carrying wallet.

Options: AC adapter for 117 V 60 Hz power. De Luxe padded carrying wallet. 30kV high-voltage probe.

The Sinclair PDM35. A personal digital multimeter at only \$49.95

A digital multimeter used to mean an expensive, bulky piece of equipment.

The Sinclair PDM35 changes that. It's got all the functions and features you want in a digital multimeter, yet they're neatly packaged in a rugged but light pocket-size case, ready to go anywhere.

The Sinclair PDM35 gives you all the benefits of an ordinary digital multimeter – quick clear readings, high accuracy and resolution, high input impedance. Yet at \$49.95 it costs less than you'd expect to pay for an analog meter!

The Sinclair PDM35 is tailor made for anyone who needs to make rapid measurements. Development engineers, field service engineers, lab technicians, and computer specialists will find it ideal.

With its rugged construction and battery operation, the PDM35 is perfectly suited for hand work in the field, while its angled display and

optional AC power facility make it just as useful on the bench.

Features of the PDM35

3 1/2 digit resolution.

Sharp, bright, easily read LED display, reading up to \pm 1.999.

Automatic polarity selection.

Resolution of 1 mV and 0.1 nA.

Direct reading of semiconductor

forward voltages at 5 different currents.

Resistance measurement up to 20 M Ω .

1% of reading accuracy.

The Sinclair credentials

Sinclair have pioneered a whole range of electronic world-firsts – from programmable pocket calculators to miniature TVs – holding a world-lead in innovative electronics. The PDM35 embodies six years' experience in digital multimeter design, in which time Sinclair have become one of the world's largest producers.

Find out more!

You can see the PDM35 at any of the Sinclair distributors listed on this page. Or, if you'd like full details of operation and performance, and a complete distributor list, just send the coupon below. We'll send you all the facts by return.

The Sinclair PDM35 will make your life a lot easier – send the coupon today!

Send to: Sinclair Radionics Inc, Galleria, 115 East 57th Street, New York, N.Y. 10022, U.S.A.
Please send me full illustrated details of the Sinclair PDM35 personal digital multimeter, without obligation.

Name.....

Position.....

Company.....

Address.....

ED

sinclair
World leaders in fingertip electronics



Sinclair Radionics Inc, Galleria, 115 East 57th Street, New York, N.Y. 10022, U.S.A.

See the PDM 35 at: Carter McCormick & Peirce Inc., Farmington, Mich. 313 477 7700; Crane & Egert Corp., Elmont, N.Y. 516 488 2100; F. L. W. Inc., Costa Mesa, California. 714 751 7512; International Standard Components, Los Altos, California. 415 941 2600; Ossmann Instruments Inc., Syracuse, N.Y. 315 437 6666; Par Associates, Denver, Colorado. 303 355 2363; PVA Company, La Grange, Ill. 312 352 1037; Scientific Associates, Washington D.C. 703 573 8787; Southern Peripherals & Instruments Inc., Atlanta, Georgia. 404 455 3518.

CIRCLE NUMBER 65

Dual-channels generate 16-bit words



Dytech, 2725 Lafayette St., Santa Clara, CA 95050. (408) 241-4333. \$995; stock to 6 wk.

A 16-bit word length is the capability of the Model 8000 dual-channel word generator. Both RZ and NRZ data are available from each word output at all times. Two rows of data-content switches control each bit of both words. First and last bits are available for both words at all times. Serial and parallel modes are provided and a fine-delay control provides for delay between serial words or between successive parallel A and B cycles.

CIRCLE NO. 340

Expand DEC capability with core memory

Ampex, 200 N. Nash St., El Segundo, CA 90245. Clyde Cornwell (213) 640-0150. See text; stock.

Three models of ARM-1170 plug-compatible core memory are offered to expand DEC PDP-11/70 memory. These memories are available in increments of 64-k processor words (16 bit) ranging in size from 64 k to 2048 k. Throughput enhancement is possible with the two or four-way internal interleaving features in the three models. Using four-way interleaving, the effective cycle time is 345 ns, and PDP-11/70 throughput is typically increased by 16% or more for system-job configurations that are now memory limited. The memory modules employed use 13-mil temperature-independent Unibit cores to ensure wide operating margins and performance stability. Prices are \$12,875 for 128 kwords, \$23,865 for 256 kwords, and \$43,205 for 512 kwords.

CIRCLE NO. 341

Compact printer runs at rates to 120 char/s

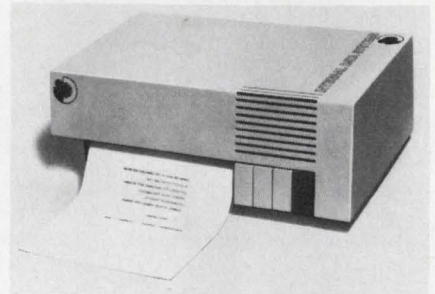

Integral Data Systems, 5 Bridge St., Watertown, MA 02172. (617) 926-1011. \$745; 4-8 wk.

A dot-matrix impact printer, Integral Impact, prints at rates to 120 char/s with up to 132 char/line. It includes an RS-232 and current-loop serial interface, enhanced-mode characters and selectable character and line sizes. Multiple copy on both fan-fold and roll paper is provided. The printer can be integrated into any mini or microcomputer system by connecting it to any serial port.

CIRCLE NO. 342

CLASSIC

Essex/Stancor transformers have that special quality, that classic quality.

From our miniature transistor transformers to our power transformers, we engineer them for performance and doublecheck them for dependability. And our products are available off-the-shelf from electronic distributors everywhere. For super performance at a basic cost, see your local distributor or write us for our free catalog: Essex/Stancor, 3501 W. Addison St., Chicago, IL 60618, 313 / 643-7400.

ESSEX GROUP



Subsidiary of
UNITED TECHNOLOGIES

Gotcha, DEC!

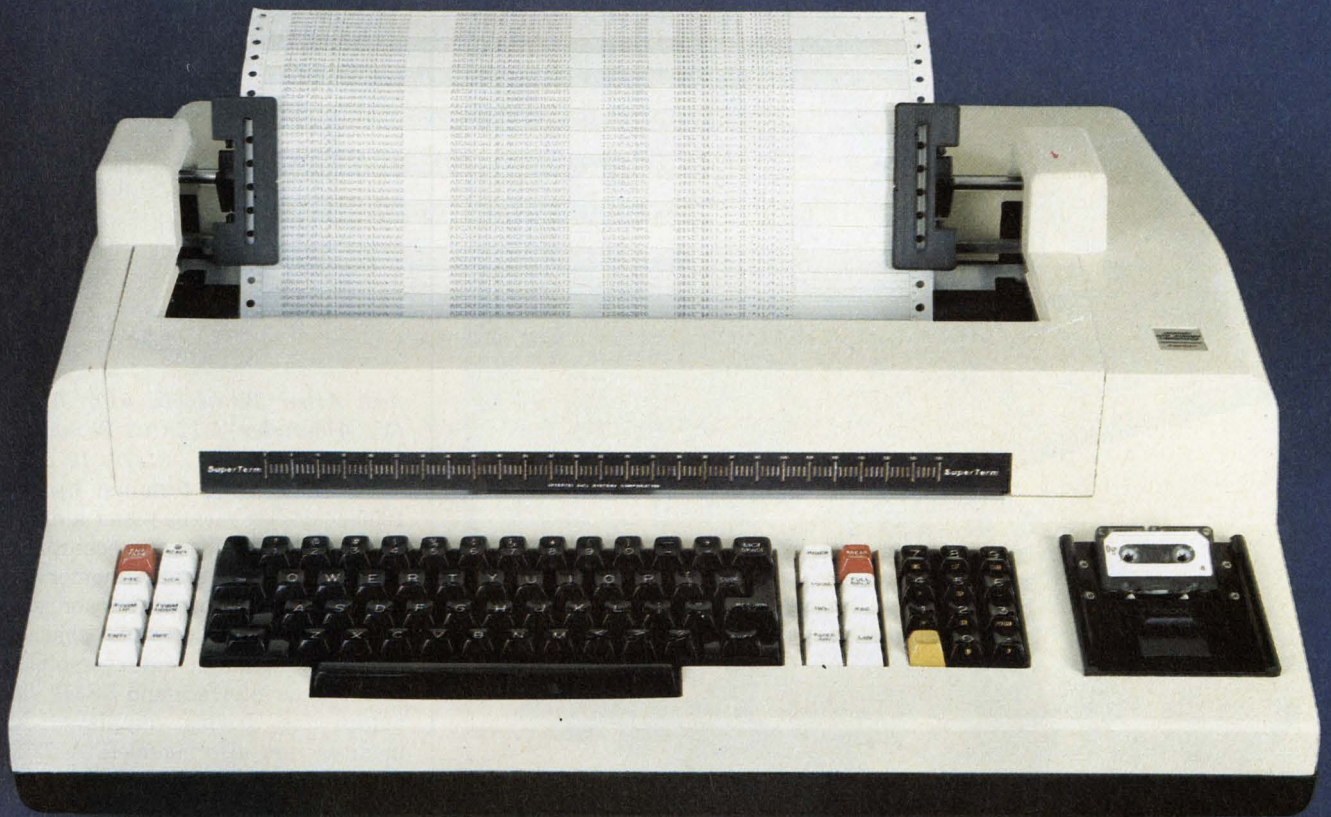

SuperTerm™

Yes, we gotcha DECwriter and we did it with such standard features as: matrix impact printing, 132 column print width, microprocessor electronics, portability (SuperTerm weighs less than 50 lbs.), high speed (10, 15, 30, 45 and 60 characters per second are standard with 120 and 200 CPS being optional), an IBM Selectric configured keyboard, a "gear shifted" alphanumeric key pad, a quick loading cartridge ribbon system, horizontal tabs (variable and fixed), vertical tabs, programmable keyboard lockout, text-optimized printing and forms control—all standard.

In addition, SuperTerm's unique "ballistic" printhead design is warranted for an entire year. This means that during the warranty period, should you ever encounter defects in printhead workmanship, Intertec will replace or repair the defective component *free!*

It's really just that simple and that super — a printhead warranty 4 times longer than DEC's.

End users will be pleased to learn that the Intertec SuperTerm provides all of this capability and more at a price of only \$1995 — quantity one.

Low cost options available on every SuperTerm include: 200 CPS printing, super and subscripting, variable vertical pitch, pagination (automatic top of form), direct X/Y addressing, adjustable left and right margins, automatic reverse printing, double-width characters, automatic CR on end of line, a font programmable character set, and a 1200 baud communications package consisting of 120 CPS printing, dynamic buffer control, 202C interface compatibility (w/reverse channel) and automatic reverse printing.

If your application calls for APL/ASCII, Super Term has that too. In fact, Super Term has got just about everything — except competition.

Want more? You've got it! A built-in micro-cassette (Supercette™) is available for only \$900 in single quantities with OEM discounts available.

In addition to unparalleled price and performance, every SuperTerm is backed by Intertec's nationwide factory trained service network with over 160 service centers strategically located coast to coast.

For more information on the total performance and unparalleled low price that make the Intertec SuperTerm the very best buy for your terminal dollar, just call Intertec Data Systems, the only company with international sales, service and the revolutionary SuperTerm.

INTERTEC DATA SYSTEMS

Corporate Headquarters

1851 Interstate 85 South
Charlotte, North Carolina 28208
704/377-0300

Eastern Regional Marketing

19530 Club House Road
Gaithersburg, Maryland 20760
301/948-2400

Western Regional Marketing

17952 Sky Park Blvd.
Irvine, California 92714
714/957-0300

See Us at Booth 1765

CIRCLE NUMBER 67

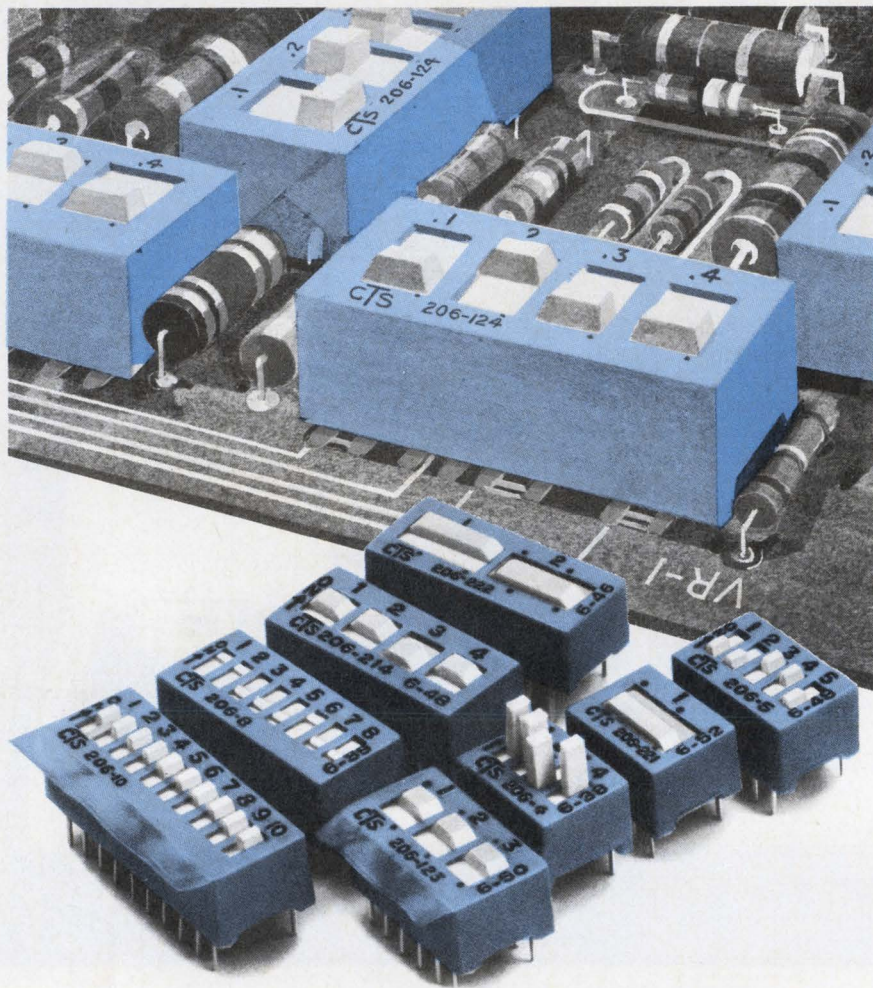

CTS Offers You the DIP Switches You Need!

Choose from the finest line of DIP switches and options available. The CTS family of quality Series 206 DIP switches provides every imaginable electrical and mechanical configuration.

New configurations include 2 DPDT's... 2 SPST's including a 2 and a 3 circuit package... and 1 each 2 circuit SPDT and DPST switch, all in addition to the 15 standard DIP switches previously available... high (extended) or low (flush) switch actuators... and sealed versions for contaminant-free operation after flow soldering and cleaning.

All are designed for standard DIP socket insertion; feature crisp, positive *slide detent actuation*; reliable gold plated contacts and are economically priced.

CTS DIP switches are used in all areas of the electronics industry including communication, data processing, instrumentation and consumer applications. For prompt, efficient assistance for your DIP switch requirements, contact **CTS KEENE, INC.**, 3230 Riverside Avenue, Paso Robles, California 93446. Phone: (805) 238-0350.

CTS CORPORATION
ELKHART, INDIANA



CIRCLE NUMBER 68

DATA PROCESSING

CRT-terminal remembers 2000 characters

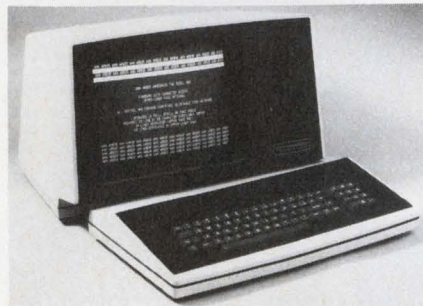

Ann Arbor Terminals, 6107 Jackson Rd., Ann Arbor, MI 48103. Sarah Freeman (313) 769-0926. \$1470; 12 wks.

The 400D CRT terminal boasts a 2000-character memory and a display format with 24 lines of 80 characters. An extra line of hidden memory can be accessed in either roll or scroll modes. The 400D has three character accents—blink, dim and reverse-video. RS232 data interface and RS170 video output for driving auxiliary video monitors are also included. A 72-key detachable keyboard generates the full 128-character ASCII set and has cursor control keys with separate numeric pad.

CIRCLE NO. 343

Convert media with floppy-disc unit

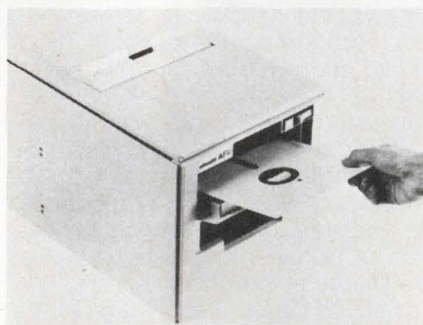

Olivetti, 500 Park Ave., New York, NY 10022. Mike Manno (212) 371-5500. \$4,560.

With the automatic floppy-disc unit, data from various diskette recording stations can be pooled and converted into magnetic-tape media for input to a mainframe. It is made up of an automatic loader, dual read/write floppy-disc unit, and a power supply. It holds a maximum of 20 diskettes, stacked one on top of the other. The length of the loading cycle is about 5.5 s. A separate feed slot is available for changing diskettes manually.

CIRCLE NO. 344

Display the 669th bit...

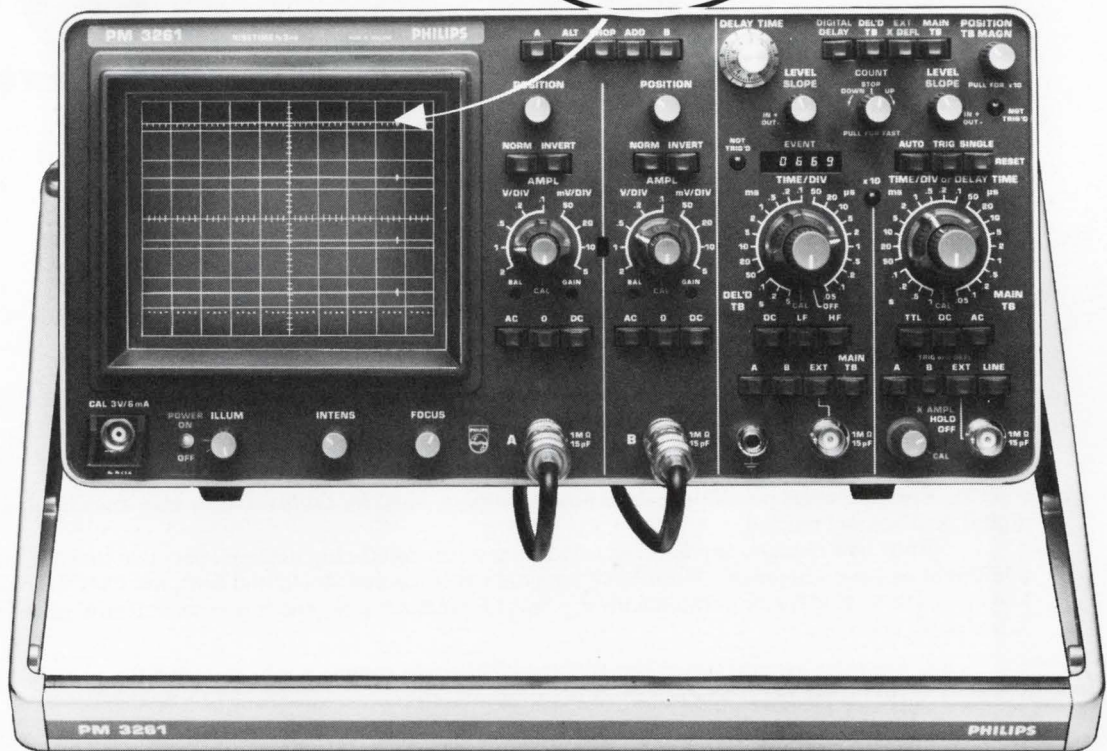

and be sure it's not the 670th or the 671st...



Finding the 669th bit takes quite a while, and then you're not sure you have the right one. The solution is **programmed digital delay**. On the Philips PM 3261, you can program the delayed timebase to start on the *n*th bit.

By means of an internal variable-speed clock, the events counter can be preset from 1 to 99,999 events, with complete trigger level setting control. Press DEL'D TB and there you see the 669th bit big and rock steady to measure or photograph.

Special TTL triggering selection allows the PM 3261 to react just as logic does, a TTL level window prevents false triggering on rising or falling edges.

Another addition to the Philips family of HF portable oscilloscopes, the 120 MHz PM 3261 adds easily programmable digital delay to the already completely separate delayed timebase control section found on its predecessors.

The PM 3261 list price is only \$ 2795.00 **U.S. domestic price only**. Utilize our tollfree HOT LINE number 800 631-7172. New Jersey residents call (201) 529-3800 collect.

For further information contact
**Philips Test & Measuring
Instruments, Inc.**

In the United States:
85 McKee Drive
Mahwah, New Jersey 07430
(201) 529-3800

In Canada:
6 Leswyn Road
Toronto, Ontario Canada M6A 1K2
(416) 789-7188

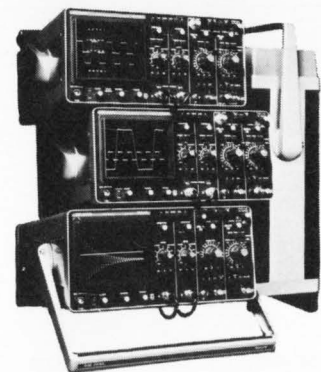

**Test & Measuring
Instruments**

PHILIPS

CIRCLE NUMBER 10

Put it all together for as little as \$12.*

Intersil's new single chip 3½-digit 7106 and 7107 A/D converters for LCD or LED displays.

Meet the latest in A/D converters: Intersil's 7106, the first single-chip CMOS A/D for driving LCD displays—including backplane—directly.

And the 7107, first single-chip CMOS A/D for driving instrument-size LED displays directly without buffering.

Each provides parallel seven segment outputs, ideal for DVMs, DPMs and anywhere modern digital displays are needed.

Both new devices provide cost advantages over multi-chip designs, because they require no additional active components. Both have internal reference and clock, and both are CMOS so you get low noise (12 to 15 μ V) comparable with the finest bipolar devices, and low power (10mW max. @ 10V). A few more features:

- ± 1 -count accuracy over the entire ± 2000 -count range.
- Guaranteed to read Zero for 0 Volts input.
- Provides true polarity at Zero count for precise null detection.
- Differential input from 200mV to 2.000V full scale.

Get additional technical information, including detailed data sheet and application notes, from Intersil, 10710 North Tantau Ave., Cupertino, CA 95014.

Build a working DPM in ½ hour with these complete evaluation kits.

Test these new parts for yourself with Intersil's low-cost prototyping kits, complete with A/D converter and LCD display (for the 7106) or LED display (for the 7107). Kits provide all materials, including PC board, for a functioning panel meter. Available from Intersil stocking distributors.

Kit No. ICL7106EV/KIT (LCD) \$29.95 complete.

Kit No. ICL7107EV/KIT (LED) \$24.95 complete.



Intersil sales offices: Boston (617)861-6220; Chicago (312)986-5303; Dallas (214)387-0539; Dayton (513)278-4837; Denver (303)750-7004; Los Angeles (213)532-3544; Ft. Lauderdale (305) 772-4122; Minneapolis (612)925-1844; New York (201)567-5585; San Francisco Bay Area (408) 996-5000.

INTERSIL

CIRCLE NUMBER 16

Remote batch and key entry from same terminal



Consolidated Computer Int., 275 Wyman St., Waltham, MA 02154. P.L. Shannon (617) 890-0920. \$1350/mo lease.

Key-Edit 80 is a modular data entry system that enables the user to prepare, edit, sort, merge, reformat and check key-to-disc data input prior to mainframe entry. It will interface with any mainframe system's output from a remote site. A system can accommodate 2 to 8 data terminals with English language programming to define input formats, edit and validate data and/or previously entered background material. The unit is a 32-k CPU, 1.4-Mbyte disc unit with speeds of 2000 to 9600 baud. Also included is a 300 cards/min card reader and a 300 lines/min line printer.

CIRCLE NO. 345

Modem needs no Ma Bell protective device

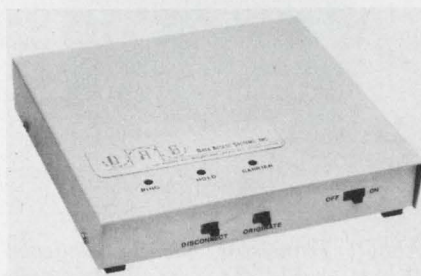

Data Access Systems, 100 Route 46, Mountain Lakes, NJ 07046. Sandra Watkins (201) 335-3322. \$375; stock.

The 68-01 modem may be directly connected to the telephone network without the use of telephone-company installed protective devices (DAA). The unit can replace acoustic couplers. Because the modem is hardwired into the telephone network, ambient noise and machine vibration is eliminated. The unit conforms to FCC rule 68.

CIRCLE NO. 346

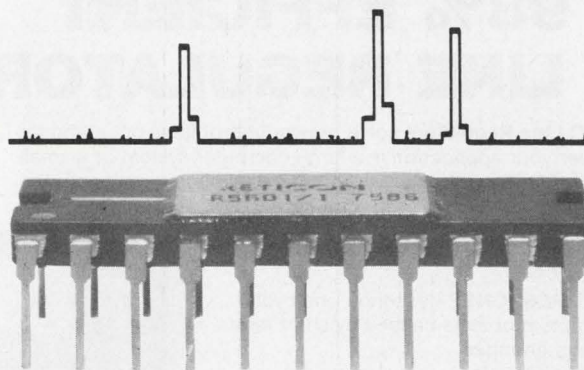

The spectrum analyzer on a chip.

Where else but from Reticon.

What was previously thought impossible will now be an everyday occurrence. Moving up to the next stage of complexity in CCD devices has resulted in the Reticon R5601, a 512 point Discrete Fourier Transformer. This technology offers a spectrum analyzer with small size, light weight, low power, high reliability, and a remarkable low cost. Along with its associated circuitry, it performs the Chirp Z algorithm to give a 256 spectral line display in less than 250 μ sec. It's small enough to fit into your system, yet powerful enough to have a signal-to-noise ratio in excess of 70db. The numerous applications possible include speech recognition, target identification, vibration analysis, bandwidth compression, communications, and general signal analysis.

Currently available is a self-contained evaluation module on two printed circuit cards just 80 square inches. Just hook up your ± 20 volts, display and you're on the air. Use the on-board oscillator or externally control the sampling rate.

The R5601 is the latest in our growing family of discrete time analog signal processing devices. All available through our worldwide network of over 20 distributors and more than 70 salesmen.

Discover the IC that does it all.

RETICON[®]

AN  COMPANY

910 Benicia Ave • Sunnyvale, California 94086
(408) 738-4266

CIRCLE NUMBER 69

98% EFFICIENT AC LINE REGULATORS

TOPAZ AC Line Regulators solve brownout problems once and for all. Whether your application is a large computer system or a small instrument, TOPAZ regulators are the best solution.

Here's why:

- **98% EFFICIENCY** reduces heat losses and feeder costs.
- **FAST RESPONSE** (less than one cycle) prevents problems caused by short term voltage changes.
- **NO DISTORTION** is added to the output wave form.
- **SMALL SIZE AND WEIGHT** ease handling and reduce space requirements.
- **SILENT OPERATION** permits use in office areas without the annoying noise common to constant voltage transformers.
- **OUTPUT VOLTAGE** is unaffected by input frequency variations.

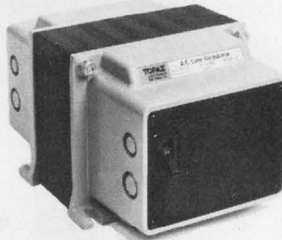

600 VA to 100 kVA
Priced from \$360.

All this plus TOPAZ noise suppression and quality at prices lower than you'd pay for regulators without these features. Put an end to brownout problems. Send for our brochure or give us a call today.

TOPAZ SOLUTIONS TO POWER PROBLEMS
ELECTRONICS

3855 Ruffin Road, San Diego, California 92123—(714) 279-0831—TWX (910) 335-1526

CIRCLE NUMBER 70

POWER SOURCES

Power generators provide 3 and 4.8 kW to 111 kHz

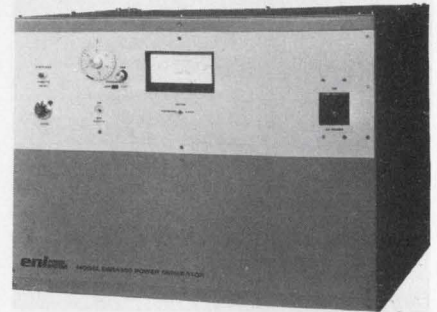

ENI Power Systems, 3000 Winton Rd. S., Rochester, NY 14623. L.M. Salmen (716) 473-7330. \$5475-\$7460; 4-5 mo.

Operating over a frequency range of 8 to 111 kHz, and with output powers of 3 and 4.8 kW, the EGR3200 and EGR4800 frequency sources offer variable tuning and power output control. Long-term stability is 0.1% over an ambient temperature range of 0 to 40 C and resolution is ± 2 Hz. A power meter permits monitoring of the output and the power actually absorbed by the load.

CIRCLE NO. 347

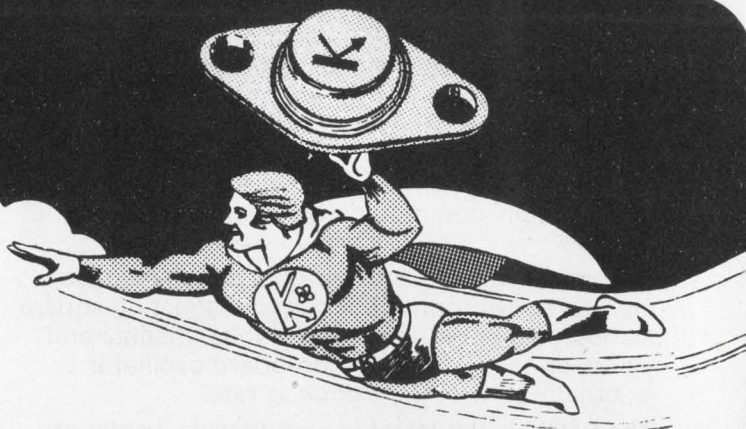

Power Transistors? We've got em!

High Current

Part #	BVCEO	Ic max	hFE @ Ic
2N5685	60	50A	15-60 25A
2N5686	80	50A	15-60 25A
2N6274	100	50A	30-120 20A
2N6275	120	50A	30-120 20A
2N6276	140	50A	30-120 20A
2N6277	150	50A	30-120 20A

*.060" pins

High Voltage

Pkg.	Part #	BVCEO	Ic max	hFE @ Ic	Pkg.
*TO-3	2N6542	300	5.0A	12-60 2A	TO-3
*TO-3	2N6543	400	5.0A	12-60 2A	TO-3
*TO-3	2N6544	300	8.0A	12-60 2A	TO-3
*TO-3	2N6545	400	8.0A	12-60 2A	TO-3
*TO-3	2N6546	300	15A	12-60 2A	TO-3
*TO-3	2N6547	400	15A	12-60 2A	TO-3
	2N6249	200	10A	10-50 3A	TO-3
	2N6250	275	10A	8-50 3A	TO-3
	2N6251	350	10A	6-50 3A	TO-3

All Kertron power transistors are manufactured with high reliability construction techniques. Kertron can screen your transistors to special environmental and electrical requirements. For quick dependable delivery call:



KERTRON INCORPORATED

7516 Central Industrial Dr. Riviera Beach, Fla. 33404 U.S.A.
Tel. 305/848-9606 TWX 510/952-7611

CIRCLE NUMBER 71

Power transformer mounts on PC board

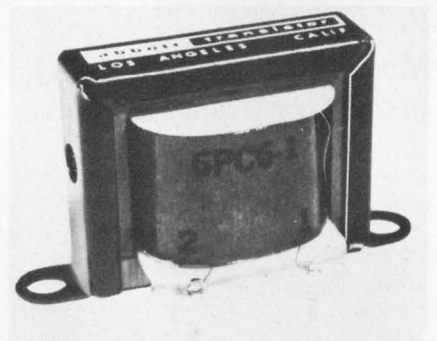

Abbott Transistor, 639 S. Glenwood Pl., Burbank, CA 91506. W. Lovett (213) 841-3630. \$5.10 (1-9 qty); stock to 10 days.

A PC-board power transformer, the Model 6PC5-1, supplies 5 V ac at 300 mA or 10-V center-tapped at 150 mA. Output-voltage tolerance is within 5% when measured at full load and 115 V ac. Voltage regulation is 20%, no load to full load. Insulation tested at 1000-V ac. The transformer operates at 85-C ambient. Input: 115 or 230-V-ac, 50 to 400-Hz, single phase.

CIRCLE NO. 348

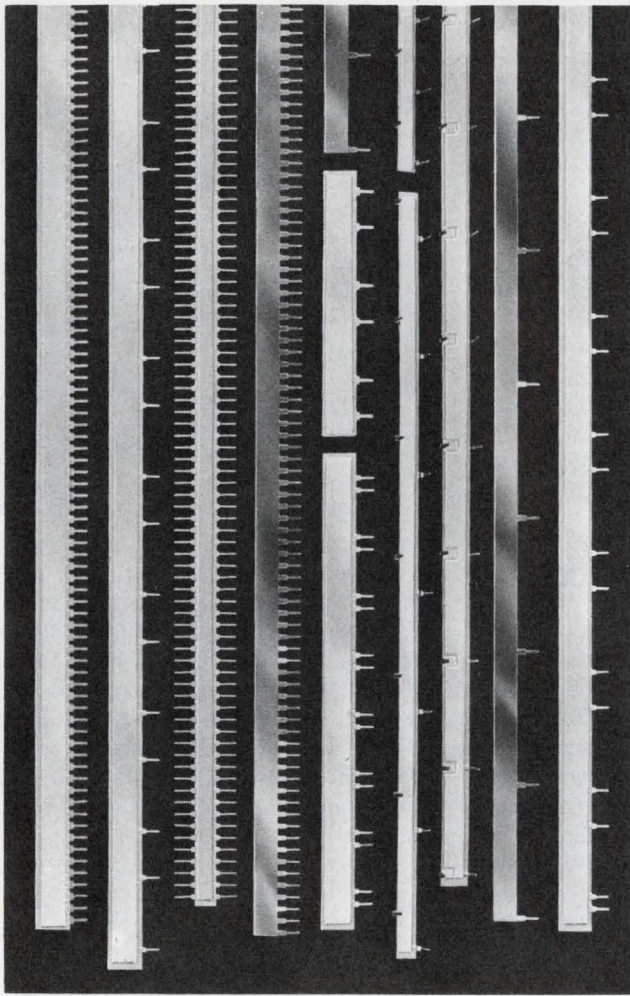

MINI/BUS[®] Printed Circuit Board Bus Bars STANDARDS IN STOCK

Low-cost, noise-reducing voltage distribution comes in a wide variety of ready-to-ship designs.

Call or write Product Specialist for a listing of Rogers' Mini/Bus standards.

Prototype kits also available from stock — \$25.00

ROGERS

ROGERS CORPORATION

Chandler, AZ 85224 (602) 963-4584

EUROPE: Mektron NV, Gent, Belgium. JAPAN: Nippon Mektron, Tokyo.

CIRCLE NUMBER 72

ELECTRONIC DESIGN 23, November 8, 1977

Socket Center

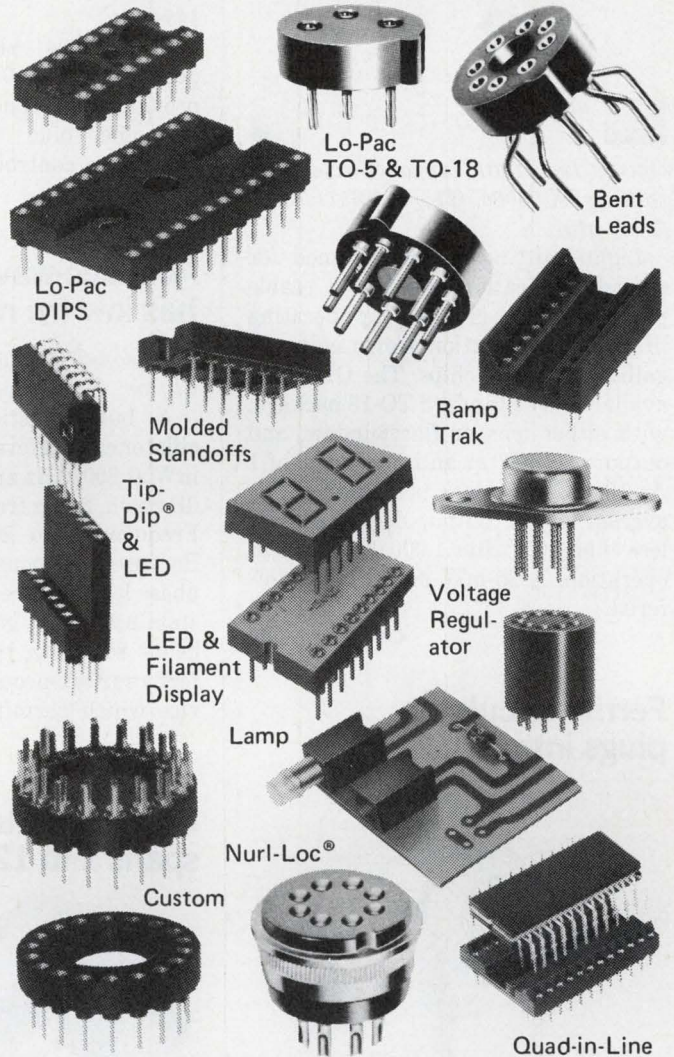

EMC HAS IT ALL!

Seeking sockets? EMC stocks the widest variety with the most options you can buy! 6 to 48 pins. Short, long or extra long terminals. Straight or bent leads. Thermoset molded materials. Platings. Standoffs. Short or standard contacts. Solder or Wire-Wrap[®] terminals. Special sockets custom-molded . . . even fabricated if you need it. All of the finest, highest quality workmanship, at the lowest prices, in any quantity. EMC does have it all. For you. Today. Call or write for new Catalog '76. Electronic Molding Corp., 96 Mill Street, Woonsocket, R.I. 02895. Phone (401) 769-3800.

Wire-Wrap[®] Gardner-Denver Co.

EMC[®]
Interconnection Specialists

CIRCLE NUMBER 73

Infrared LEDs last 10 years

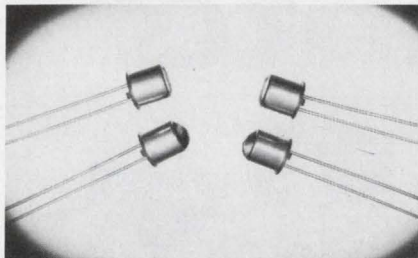

Optron Inc., 1201 Tappan Circle, Carrollton, TX 75006. (214) 242-6571. \$1.44 (1000 qty).

Light-emitting diodes designed for pulsed applications feature a stable power output over a 10-year operating life by using solution-grown epitaxial gallium-arsenide chips. The OP 135 is available in a standard TO-18 package, with either lens or flat window, and outputs 20 mW at an input pulse of 1 A, 10 μ s, 10 pulses per second. The average power output degradation is less than 10% after 1,000,000 hours of operation. A 35-mW model is also offered.

CIRCLE NO. 349

Ferrite circulator plugs into stripline

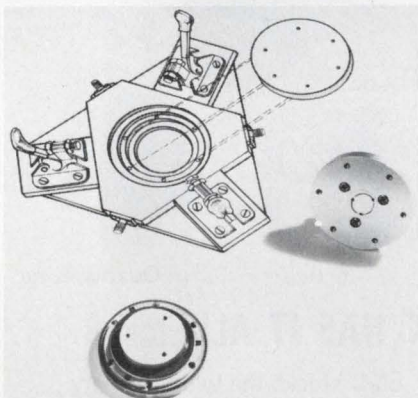

Microwave Associates, South Ave., Burlington, MA D. Landry (617) 272-3000.

Operating at 3.5 to 4.2 GHz, the MA-7L801 plug-in ferrite circulator is designed for direct insertion into strip transmission-line circuits. It provides simultaneous center-conductor and ground-plane contact, which minimizes electrical and mechanical interface problems. Major features include a VSWR of 1.25:1, 19dB min isolation, 0.5-dB insertion loss and dimensions of 11/16 in. (dia) \times 1/2 in.

CIRCLE NO. 350

Photodetector gets turned on by blue

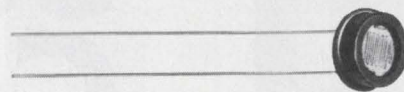

Hamamatsu Corp., 120 Wood Ave., Middlesex, NJ 08846. R. Eno (201) 469-6640.

The P1024 photoconductive cell peaks between 400 and 500 nm and thus provides high sensitivity in the near-UV and blue visible range, for brightness controls and colorimeters.

CIRCLE NO. 356

Acoustic-wave source has low fm noise

Thomson-CSF, 750 Bloomfield Ave., Clifton, NJ 07015. (201) 779-1004.

A bulk-acoustic-wave (BAW) oscillator can achieve output power to 250 mW at 800 MHz and its fm noise is 100 dB down, 2 kHz from center frequency. Frequencies to 2 GHz are feasible. Because the acoustic cavity acts as a phase lock on a free-running oscillator, stability is very good. For frequencies below 800 MHz, the company also offers a surface-acoustic-wave (SAW) device which permits tuning.

CIRCLE NO. 357

Fast p-i-n attenuator spans 1 to 12.4 GHz

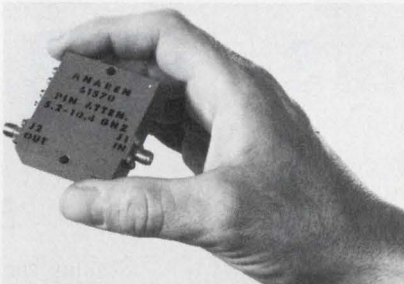

Anaren Microwave, Inc., 185 Ainsley Dr., Syracuse, NY 13205. (315) 476-7901.

Seven models of absorptive, voltage-variable p-i-n attenuators cover 1 to 12.4 GHz. They provide 60 dB attenuation, with low VSWR at any level. Switching speed is less than 500 ns at 400 mW rf input power. Input control function is 6 dB/V with typical linearity \pm 1 dB. The series meets Level B of MIL-STD-883, and temperature variation is typically \pm 1 dB from -55 to $+95$ C.

CIRCLE NO. 358

Two-way power divider covers 2 to 18 GHz



Technical Research & Mfg., Grenier Field, RFD #3, Manchester, NH 03103. Art Marin (603) 668-0120. \$299; stock.

A two-way power divider, DMS 221, covers the frequency range of 2 to 18 GHz. Specifications include: 20-dB isolation from 2 to 10 GHz, 18-dB from 10 to 12.4 GHz and 15-dB from 12.4 to 18 GHz. VSWR goes from 1.4:1 at 12.4 GHz to 1.8:1 at 18 GHz. Insertion loss over the band is 1.5 dB with an amplitude balance of 0.4 dB and phase balance of 10 degrees.

CIRCLE NO. 359

Amp delivers 4 W from 1 to 1000 MHz



Amplifier Research, 160 School House Rd., Souderton, PA 18964. (215) 723-8181. See text; 4 wk.

Model 4W1000 is an ultra-wideband, solid-state power amplifier that can deliver 4 W of swept power from 1 to 1000 MHz instantaneously. The amp provides up to 6 W and a min of 4 W of linear power at less than 1-dB gain compression. Fixed power gain is 36 dB min and is flat to within 1.5 dB. In the linear mode, harmonics in the output are at least 20 dB below the fundamental frequency. The amplifier is available as a lab unit complete with power supply or as an OEM module. Lab model price is \$2700; OEM model, \$2100.

CIRCLE NO. 360

now, coax and waveguide ferrite circulators from one source

...it's the winning combination from Merrimac

HIGH POWER COAXIAL FERRITE CIRCULATORS AND ISOLATORS 140 MHz TO 3 GHz

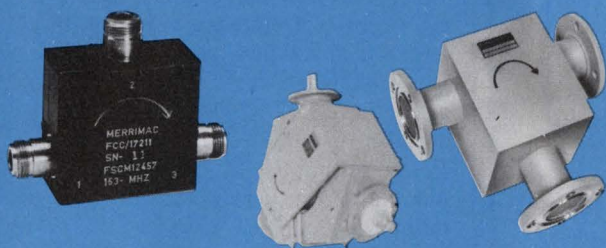

The winning combination is 39 different, standard, 3 port coaxial junction circulators and isolators capable of handling high average and peak powers, with low insertion loss.

Models with various connectors such as N, HN, 7/8", 1 5/8" and 3 1/8" EIA are available.

Following are 4 coaxial circulators, illustrating Merrimacs' capability in high power ferrite components.

MODEL NO.	FREQUENCY RANGE	AVERAGE POWER	PEAK POWER (WATTS)	CONNECTORS
FCC-11230	205-225 MHz	4.5KW	70KW	1 5/8" EIA
FCC-1203-460	450-470 MHz	350 W	—	N FEMALE
FCC-1115	890-940 MHz	3 KW	100KW	1 5/8" EIA
FCC-1109	1.7-2.4 GHz	1.2KW	CW	1 5/8" EIA

HIGH POWER WAVEGUIDE FERRITE CIRCULATORS AND ISOLATORS 1 TO 18 GHz

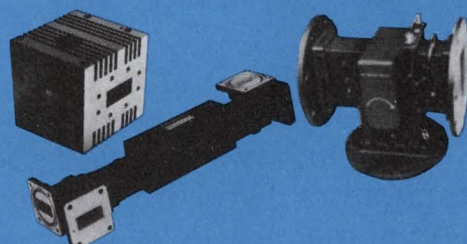

The winning combination is 60 different 3 port junction and 4 port differential phase shift circulators capable of handling extremely high average and peak powers with low insertion loss.

A wide variety of waveguide types/flanges are available and are suited for the proper waveguide cut-off frequencies.

Following are 4 standard high power waveguide circulators popular in the fields of industrial heating, earth stations and radar systems.

MODEL NO.	FREQUENCY RANGE(GHz)	AVERAGE POWER	PEAK POWER	NO. OF PORTS
FCW-1521	2.425-2.475	6 KW	CW	3
FCW-1528	5.9-6.4	3 KW	CW	3
FCW-1914	7.9-8.4	3 KW	CW	4
FCW-1937	8.5-9.6	1.2 KW	1.2 MW	4



SPORTS ILLUSTRATIONS SUITABLE FOR FRAMING.

Football, Basketball, Soccer and Hockey, Two Color reproductions FREE on request.

CIRCLE NUMBER 143

For additional detailed information on Merrimacs' high power ferrites or other IF and microwave components, please request the following Merrimac catalogs.

- M-129-High Power Ferrite Catalog; CIRCLE NUMBER 141
- M77-3-Condensed Catalog of all Merrimac Signal Processing Components.

CIRCLE NUMBER 142



now there is one...in signal processing

EXPORT REPRESENTATIVES DAGE CORP.
STAMFORD, CONNECTICUT 06902
(203) 324-3123 TWX 710-474-2490 Telex: 96-5928

Merrimac
INDUSTRIES, INCORPORATED
POST OFFICE BOX 986, 41 FAIRFIELD PL., W. CALDWELL, N.J. 07006
• 201 575-1300 • TWX 710-734-4314

Arthur, I hope you didn't forget to take our CAPAR capacitors!

Of course not, my sweet, you know I can't go anywhere without them.

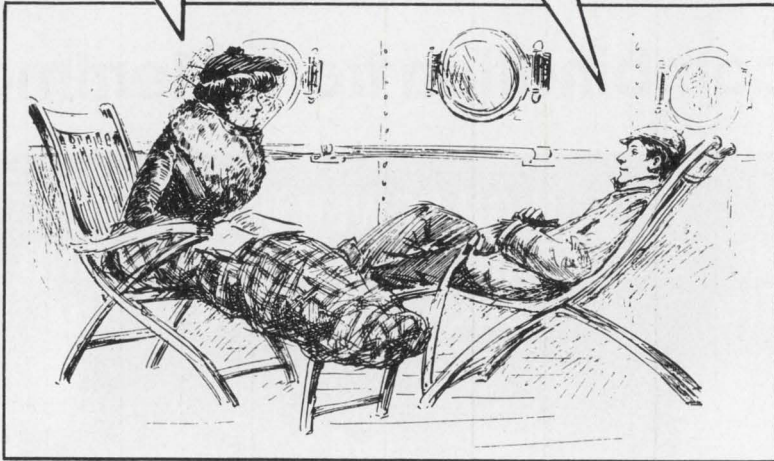

You can always have a good supply of capacitors if you order from us. We can give you immediate delivery on all of our devices. We have subminiature axial and radial lead aluminum electrolytic capacitors that are excellent for industrial and commercial application. Our epoxy dipped solid tantalum capacitors are ideal for applications where low cost, high reliability and small sized benefit the product. Our polyester film capacitors have four coats of epoxy for better insulation. And they are economically priced.

Send for more information on our complete line of components. If you find out more about us, we know you'll try us once. And be back for more. Call us at our toll free number (800) 645-7474.

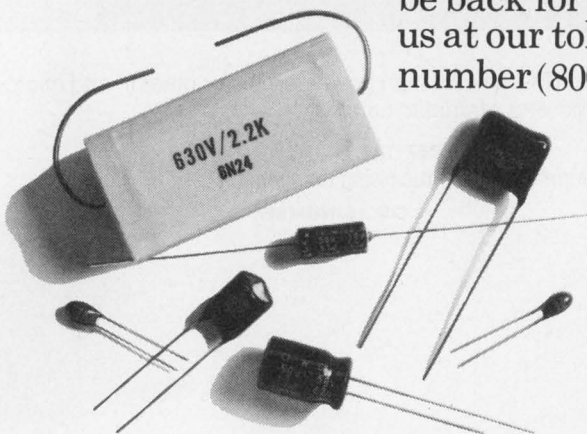

303 Crossways Park Drive, Woodbury, New York 11797;
Telephone (516) 364-2610; (800) 645-7474; Telex No. 144678

"See us at MIDCON Booth 526"

CIRCLE NUMBER 74

MODULES & SUBASSEMBLIES

Small VCO swings in phase-lock loops

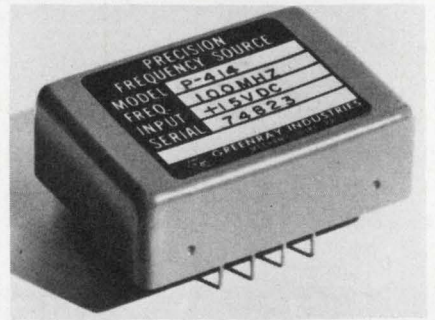

Greenray Industries, 840 W. Church Rd., Mechanicsburg, PA 17055. (717) 766-0223. \$70 (1000 qty); 8 to 10 wk.

For phase-locked loops, the Model P-414 voltage-controlled LC oscillator offers $\pm 10\%$ frequency deviation in a $1.63 \times 2.25 \times 0.5$ -in. package. The unit is available at any frequency in the range from 20 to 200 MHz and offers stability of $\pm 0.5\%$ from 10 to 60 C. Power output is +7 dBm into 50 Ω . Modulation rate is up to 1% of the output frequency.

CIRCLE NO. 361

12-bit converters run with fast synchros

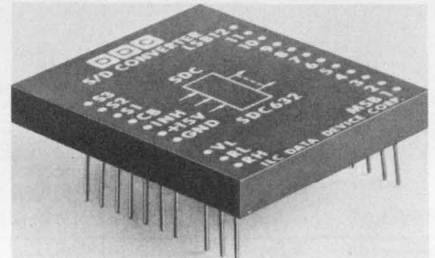

ILC Data Device, Airport International Plaza, Bohemia, NY 11716. (516) 567-5600. From \$345; 4 wks.

The SDS-632 series convert continuously three-wire-synchro or four-wire-resolver outputs into 12-bit angle data, error-free at rates to 300 rpm. These third generation modular converters use a true Type-two servo loop. The converters operate on inputs of between 360 Hz and 1 kHz and produce ± 8.5 -arc minutes accuracy insensitive to voltage and frequency variations. Data is always fresh and available: Converter Busy and Inhibit signals ease interfacing with computers. The 4-oz encapsulated modules draw 225 mW. Units are fully trimmed at the factory and require no adjustments or calibrations in the field. $3.13 \times 2.53 \times 0.42$ in.

CIRCLE NO. 362

the only one of its Kind

...AN ALTERNATIVE TO NICKEL CADMIUM

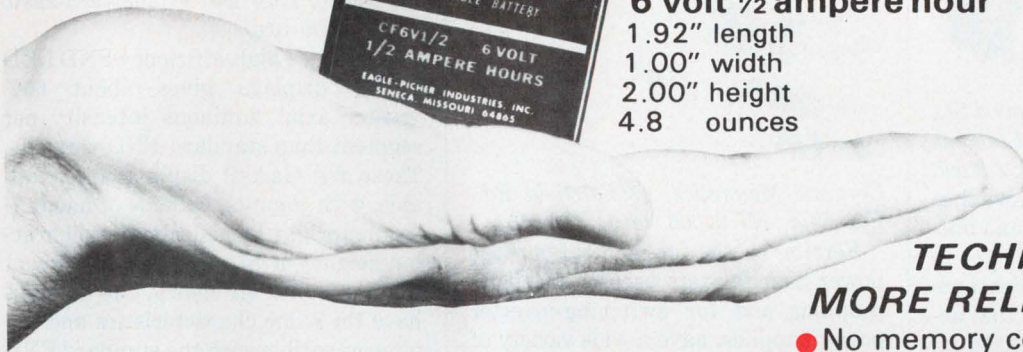

6 volt 1/2 ampere hour
 1.92" length
 1.00" width
 2.00" height
 4.8 ounces

**THE NEW
 IMMOBILIZED
 ELECTROLYTE
 TECHNOLOGY THAT'S
 MORE RELIABLE THAN GEL**

- No memory conditioning required
- No cell reversal
- Less expensive
- Better float life
- Entirely maintenance-free
- Spill-proof and rechargeable

EAGLE P ICHER
 SINCE 1843

EAGLE-PICHER INDUSTRIES, INC.
 Commercial Products Department ED
 P.O. Box 130, Seneca, Mo. 64865
 Telephone (417) 776-2258

Also available in 30 other sizes from 1/2 to 40 ampere hours
 CIRCLE NUMBER 75

Replace your PDP-8 with a microprocessor without changing a line of software.

For less than half the cost of DEC®-built machines, our 12000 series microprocessor modules (and fully packaged PCM-12 microcomputer) can modernize your PDP®-8 oriented products... and increase reliability to boot!

Designed around the 6100 microprocessor, our modules execute the same binary instruction set as the PDP-8 minicomputer family, and save space through use of modern MSI and LSI technology.

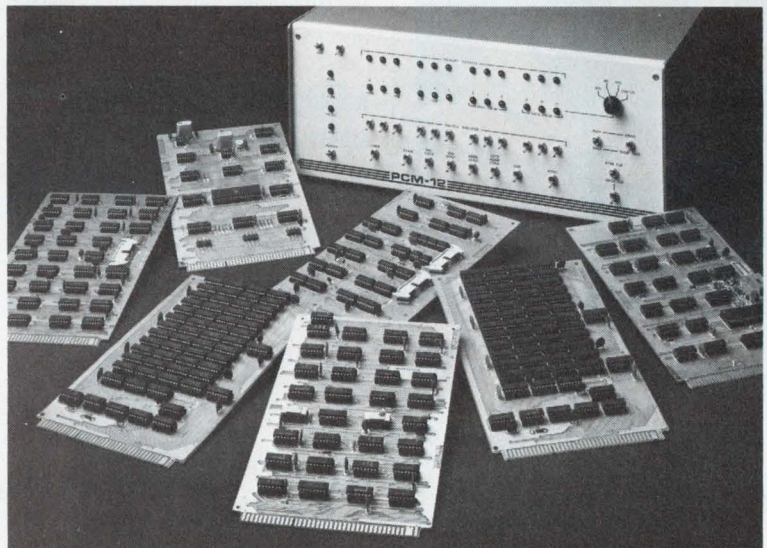

Low-cost PCM microcomputer modules offer full TTL bus compatibility, a variety of static and non-volatile memory modules expandable to 32K words, and a wide selection of I/O interfaces. Ask for complete product information.

®registered trademark of Digital Equipment Corp.

PCM

Pacific Cyber/Metrix, Inc.
 3120 Crow Canyon Road
 San Ramon, CA 94583
 Phone (415) 837-5400.

COMPONENTS

Get high safety factor with pushbutton switch



Alco Electronic Prod., 1551 Osgood St., North Andover, MA 01845. Clemens Czapinski (617) 685-4371. \$1.48; 2-3 wk.

SPV pushbutton power switches have fully insulated bushings and buttons to provide a high safety-factor in service to 250 V ac and 5 A. Features include wide-spaced terminals that accept two 18-gauge wires or 0.110-in. quick-connect receptacles. Switching is positive snap-action for long contact life and tactile feel. Switches are available in six colors.

CIRCLE NO. 363

Use mini-ferrite cores for RFI coils



Siemens, 186 Wood Ave. S., Iselin, NJ 08830. T. Pate (201) 494-1000. \$0.05; stock.

A series of ferrite cores, for use as miniature rf choke coils, covers a frequency range of 10^3 to 10^8 Hz. Four sizes of bobbin cores and two sizes of drum cores are available. The cores range in size from 0.125×0.25 in. to 0.275×0.3 in., and have inductance values ranging from 13 to 85 mH/N². Basic shapes are cylindrical cores featuring a single layer winding and axial leads. Cores with side flanges, that can be wound in multilayer construction, are available for higher inductance values.

CIRCLE NO. 364

Power transformer cores have unusual forms

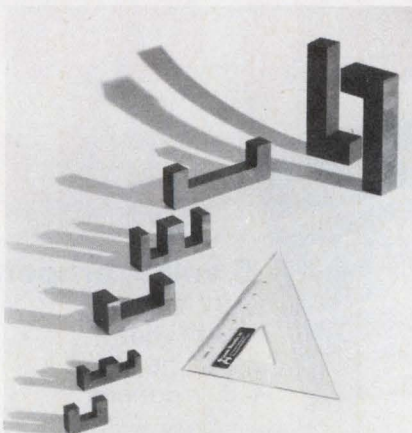

Ceramic Magnetics, 87 Fairfield Rd., Fairfield, NJ 07006. (201) 227-4222.

Ferrite cores, for general-purpose power transformers used in wideband coupling and for switching-inverter power supplies, have a wide variety of configurations. Typical of these cores are E, U, and L shapes in any size with square or round posts. They provide the exact geometry for maximum transformer performance to avoid compromises resulting from use of standard shapes. Prototypes in any geometry are available. Precision ferrites used for these cores are chosen for their low loss and high permeability, or very high flux density and high Curie temperature, depending on the performance parameters desired.

CIRCLE NO. 365

LED indicator snaps into panel hole

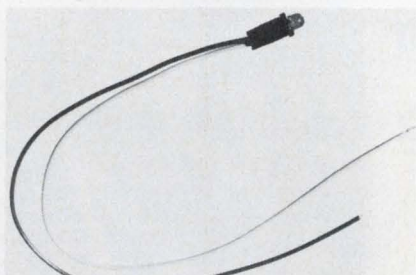

Sloan, 7704 San Fernando Rd., Sun Valley, CA 91352. (213) 875-1123. \$0.65 (1000 qty); 2-3 wk.

LED indicator lights, 5L4 series, snap into 0.156-in. panel holes without the use of mounting hardware. Recommended center to center mounting is 1/4 in. They are available with a T-1 size red diffused LED and offer light outputs of 0.5 mcd minimum at 20 mA. Forward voltage is 1.8 V at 20 mA and maximum continuous forward current is 70 mA. No lens is required.

CIRCLE NO. 366

LED digital displays have high efficiency

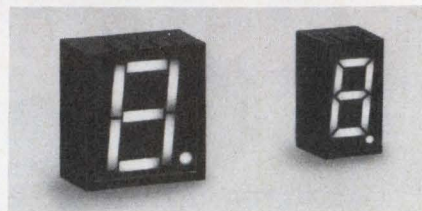

ITAC, 2045 Martin Ave., Santa Clara, CA 95050. Dan Davis (408) 985-2290. \$1.35 (5000 qty).

A series of high-efficiency FND LED digital displays gives about 60% greater axial luminous intensity per segment than standard FND versions. These red GaAsP displays are available, with common cathode or anode 7-segment right-hand decimal, in character heights of 3/8 and 1/2 in. Except for the higher efficiency, the displays have the same characteristics and are pin-compatible with the standard FND versions.

CIRCLE NO. 367

Speed installation time of small terminal block

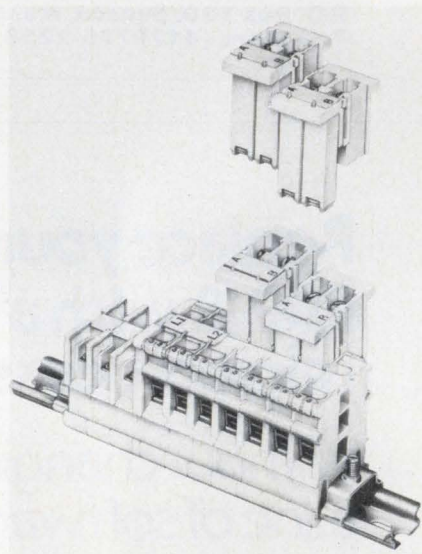

Underwriters Safety Device, 7300 W. Wilson Ave., Chicago, IL 60656. James Van Cura (312) 867-4600.

Medium-duty 600-V terminal blocks, Series 32000, speed installation time and reduce space requirements. They are UL 1059 recognized for #8 to #22-AWG-wire sizes. Features of the blocks include: captive-connector screws to meet UL/NEMA probe test, edge-tab markings for error-free installation, panel or track mounting, two and three-circuit quick-disconnects, tabs for snap-out removal of internal sections, nylon-block construction.

CIRCLE NO. 368

Don't waste money and ruin PROMs. Move up to a first-rate programmer.

What defines a first-rate programmer?

A first-rate programmer is easy to use, safe (U.L. listed), reliable, backed with a long-term warranty, and flexible enough to handle advances in PROM technology, a combination you get only with a Pro-Log programmer.

Our systems take the mistakes out of programming.

Our Series 90 PROM Programmer walks you through the programming process so there's less chance for misprogramming. Separate sockets for master and copy PROMs make it impossible to accidentally destroy a valuable master.

Vendor-approved programming, full portability, free 2-year warranty.

Using vendor-approved PROM personality modules, Pro-Log's field-proven programmers program every major MOS and bipolar PROM. They also program generic PROM families and do gang programming.

They weigh less than 20 pounds so they go where you need them. And they're backed by the longest warranty in the industry, 2 full years parts and labor.

A first-rate programmer is economical, too.

A Series 90 master control unit costs only \$1,800. A Series 92 PROM Duplicator master control unit costs only \$1,145. Single PROM personality modules cost from \$325 to \$450. Generic modules start at \$350. Gang modules which program 8 PROMs simultaneously are \$895. All modules come U.L. listed and fit both the Series 90 and the Series 92. Options include CMOS RAM buffer (to 4K bytes), RS-232 (terminal or modem) interface, TTY, parallel interfaces, paper tape reader, U.L. listed erase light, check-sum option, and Auto-baud.*

Find out what else a truly first-rate programmer has to offer.

Call or write for a free pamphlet giving you comparison checkpoints. Pro-Log Corporation, 2411 Garden Road, Monterey, CA 93940. Phone (408) 372-4593.

 **PRO-LOG**
CORPORATION

Microprocessors at your fingertips.

*Trademark, Pro-Log Corporation.

CIRCLE NUMBER 77



GE miniature lamps offer you gigantic design advantages.

With 11 new wedge base GE lamps, you have more choices than ever.

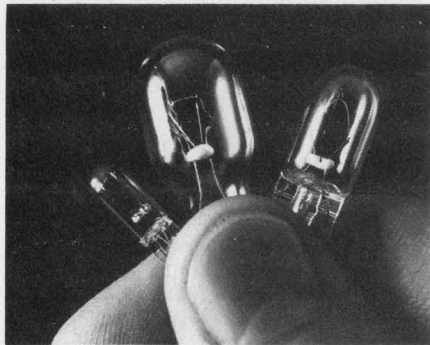

Enjoy new design freedom with this expanded line of GE all-glass wedge base lamps. And keep enjoying the inherent benefits of the line: savings in weight, space, time and costs. GE now offers more than 30 wedge base lamps in three sizes: miniature lamps T-3/4 (10 mm diam.) and T-5 (15 mm diam.); subminiature lamp T-1 3/4 (6 mm diam.). Voltages range from 2.5 V to 28 V. Candlepower from 0.03 to 21 cd.

Use GE wedge base lamps with confidence for indicator, marker and general illumination applications, especially where space is at a premium. You may enjoy lower systems cost than with metal-based lamps and LED's. They're easy to insert and remove; have no soldered connections to corrode or break; and the filament is always oriented the same in relation to the base.

To start saving with GE wedge base lamps now, send for the latest bulletin on GE's expanded line. Order #3-5259R2. It's free.



For whiter, brighter light use GE halogen-cycle lamps.

GE halogen-cycle lamps offer you very high light output from a very small package. They can provide better light efficiency because the bulb doesn't blacken and because of accurate filament placement. Many have uniform bulb tops (no tip).

You get a whiter light than from comparable incandescent lamps because of higher color temperature operation. And they maintain their high initial output level for virtually the life of the lamp.

Because of their lower electrical power requirements, you also save on operating costs vs. comparable incandescent lamps. Some halogen lamps have long design life for low maintenance costs, too.

You can use GE halogen-cycle lamps with confidence when your design needs call for a lot of light in restricted space. For greatly expanded information on GE halogen-cycle lamps, send for your free copy of the new GE bulletin #3-5257-R.

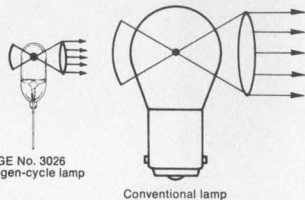

How to order lamp samples and important new free catalogs.

For catalogs and information on how to get lamp samples, call your local GE Miniature Lamp Products Representative or write: General Electric, Miniature Lamp Products Department #3382, Nela Park, Cleveland, Ohio 44112.

GENERAL  **ELECTRIC**

CIRCLE NUMBER 78

COMPONENTS

Indicators produce mere pinpoint of light

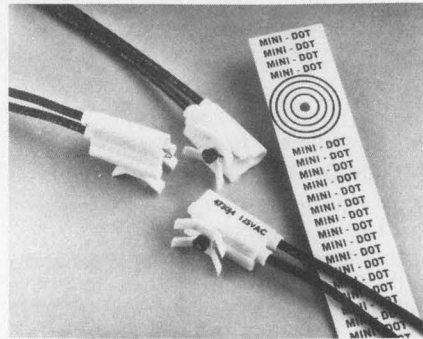

Industrial Devices, 7 Hudson Ave., Edgewater, NJ 07020. (201) 224-4700.

Indicator lights, which produce pinpoint of light, are called the Mini-Dot 4730 series. These assemblies produce spots of light measuring only 3/64 in. diameter. A panel-mounting hole the size of a #16 drill is all that is required to mount them. Each unit is a two-piece light consisting of a lens assembled from the front of the panel, plus a lamp-housing which slides on from the rear. The neon or incandescent lamp is positioned directly behind the lens to provide maximum brightness. A variety of clear and colored polycarbonate lenses are available.

CIRCLE NO. 369

Coax plug has resistor termination

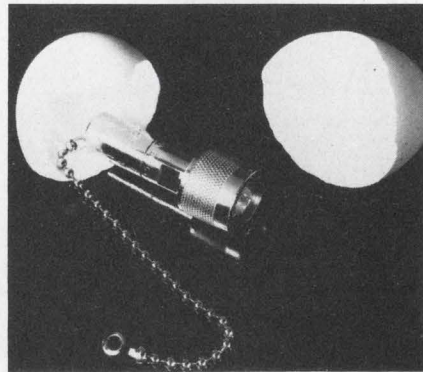

ITT Pomona Electronics, 1500 E. 9th St., Pomona, CA 91766. Carl Musarra (714) 623-3463. \$8.85; 2 wk.

Model 4240, a type-N resistor-terminated plug, terminates coaxial lines and is available in 50, 75, 93, 100 and 600 Ω resistance. It has a 1%, 1-W deposited-carbon resistor, Teflon insulation, nontarnish finish and a gold-plated male contact. The VSWR is 1.15 maximum from dc to 100 MHz.

CIRCLE NO. 370

The \$500,000 secret:

We have just landed contracts to supply \$500,000 worth of long range sync/async. baseband modems, modem sharing devices with built-in automatic backup switching, remote controlled network diagnostic systems and data line amplifiers with AGC/squelch.

All the big guys went for these jobs but we got them.

Why?

Because we were the only ones who could *guarantee* that our equipment would be virtually indestructible by lightning and other surges originating from the signal/data/telephone lines.

The secret?

Our patented Line Surge Absorber (LSA®) is connected to everything we make. Shouldn't the LSA® be connected to your equipment, too?

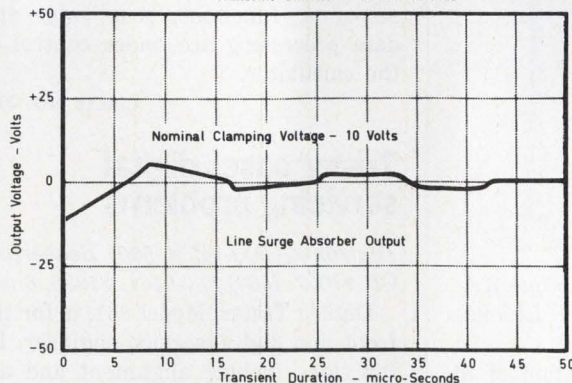
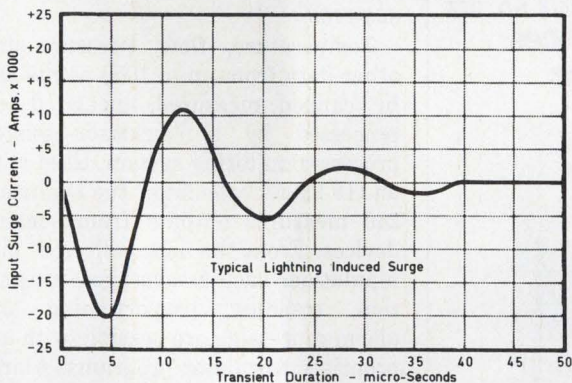

- FAILSAFE — the LSA® shorts when damaged.
- ULTRA FAST — responds in less than 1 picosec.
- HIGH POWER — 20 000 Amps. surge rating
- CLAMPING VOLTAGE — 7V to 200V
- PRICE — from US \$140



KAPUSI LABORATORIES (PTY) LTD
ELECTRONICS CONSULTING DESIGN AND MANUFACTURE

BOX 51312, RANDBURG 2125, REP. OF SOUTH AFRICA
TELEPHONES: 48-7436 AND 48-1178 JOHANNESBURG

CIRCLE NUMBER 79

ELECTRONIC DESIGN 23, November 8, 1977

GEOMETRY PROBLEMS?

Pincushion distortion on CRT displays can be solved by the Syntronic problem solvers when electronic circuit correction is out of reach.

A Syntronic yoke with carefully calibrated and accurately positioned magnets will "push" in the corners and "pull" out the sides for near-perfect geometry. Any remaining distortion or defocusing is corrected with Syntronic's stator core design combined with special coil turns distribution.*

To see the difference 28 years experience makes, let Syntronic solve your geometry problem.

* Write for
Syntronic Instruments
AP Note No. 1 "Pincushion
Distortion, a Significant Factor in
CRT Displays"

SYNTRONIC INSTRUMENTS, INC.
100 Industrial Road
Addison, IL 60101
Phone (312) 543-6444

CIRCLE NUMBER 80

INSTRUMENTATION

Logic analyzer catches high-speed glitches

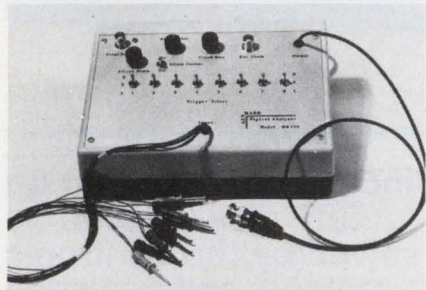

Kenmark Development Group, 6 Meadowlark Dr., East Northport, NY 11731. Mark Chomet (516) 368-3314. \$225; stock to 4 wk.

A real-time digital logic analyzer, Model RK 778, has high-speed glitch-catching on each of its eight channels, and works with any triggered oscilloscope. It provides eight-channel logic-timing display with the following features: eight channels of input, either sampled by an internal adjustable clock or external clock; self-triggered alternate mode; adjustable glitch-width-display control; catches and displays positive and negative-going glitches on all channels; buffering of each input.

CIRCLE NO. 371

Portable counter can resolve 0.01 Hz



Ballantine Lab, P.O. Box 97, Boonton, NJ 07005. (201) 335-0900. \$195; stock.

Frequency counter, Model 5720A, covers a direct-count range from 10 Hz to more than 80 MHz and features an audio-tone multiplier circuit that provides resolution of 0.01 Hz in 1-s measurement time. Frequency and ratios are read out on a nonblinking 8-digit LED display. Direct readings are in MHz, kHz and Hz as selected by a front panel switch. In the three modes, the decimal point in the readout is automatically positioned to give resolutions of 1 kHz, 1 Hz and 0.01 Hz.

CIRCLE NO. 372

Find cable faults to 80,000 ft with radar

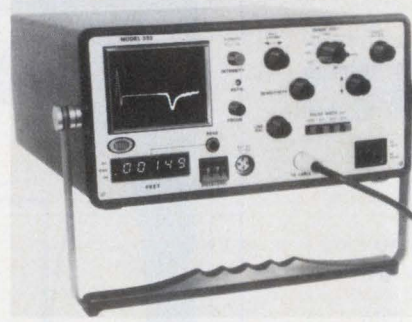

James G. Biddle, Plymouth Meeting, PA 19462. (215) 646-9200.

Two radar cable test sets offer simple operation and true digital readout. Using the pulse reflection principle, the distance to the fault is shown on a digital display. The sets will locate faults from 3 to 80,000 ft in any type of cable, regardless of the insulation, with accuracies better than 1% of range. Two models are available: a general-purpose set and a telephone set for locating faults on twisted pairs. They are completely portable with internal rechargeable batteries.

CIRCLE NO. 373

Test ultrasonic devices with echo calibrator

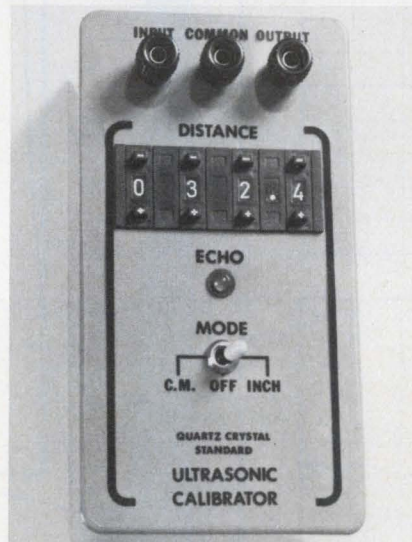

NASA Instrument, 425 Capitola Ave., Capitola, CA 95010. Carl Levonius (408) 475-0518.

Calibration and verification of ultrasonic level and flow measuring equipment can be done by substituting the calibrator for the transducer and dialing in the desired reading. An echo LED flashes each time an echo is returned. 0.05% accuracy is maintained by the use of a quartz-crystal time reference. The unit is powered by an internal 9-V battery.

CIRCLE NO. 374

Measure pressures in the 10⁻³ to 10⁻¹⁰ Torr range

Aremco Products, P.O. Box 429, Ossining, NY 10562. Herb Schwartz (914) 762-0685. \$47 to \$56; stock.

Ionization gauges used for precision measurement of high-vacuum pressures in the 10⁻³ to 10⁻¹⁰ Torr range are available in six standards. The type 126 gauges have two filament styles; the burnout-proof thoria-coated iridium and the twin-tungsten filament, each in 3/4 in. Nonex, Pyrex and Kovar tubes.

CIRCLE NO. 375

Monitor process system with calculator control



Doric Scientific, 3883 Ruffin Rd., San Diego, CA 92123. Mike Vaughn (800) 854-2708.

Temperature, flow, pressure and other data from up to 1000 points can be scanned, measured, linearized and processed by a calculator-assisted process-monitoring system. Used with an HP 9825A calculator, the Digitrend 240 measures outputs from sensing devices. From the data collected, manipulations such as averages, integration, trending, proportioning and alarm processing are possible with appropriate calculator programs. Alarm setpoints, functions, scan rates and data processing are under control of the calculator.

CIRCLE NO. 376

Tester eases digital servicing problems

Tektronix, P.O. Box 500, Beaverton, OR 97007. (503) 644-0161. \$1995; 8 wk.

Digital Tester, Model 851, is for the front-line digital-service engineer. Its functions include alignment and adjustment and electromechanical/electronic troubleshooting. Voltage, timing, resistance, temperature and logic states can be measured and gated counting performed. Some features are: 13-lb weight, digital readout, automatic ranging, single-function switch, logic-state indicators, color-coded probes, and front-panel controls.

CIRCLE NO. 377

There are two places in Wabash, Indiana with economical, high volume production capability.

Knee's Rabbitry is one. Wabash Transformers is the other. And it's a generally held local opinion that Wabash has got the edge. Not just in sheer numbers—but in variety. While Knee's Rabbitry can produce only two genders of rabbits, Wabash produces literally thousands of different types of transformers.

Not only that—Wabash custom designs their product to precisely suit the application—any type of transformer or high voltage power

supply application. A few where Wabash is a leader are air cleaners, photocopying and VRT equipment.

With their engineering expertise, sophisticated products, automated winding and high volume production capability, Wabash is a standout among the hundreds of transformer manufacturers. But, in turning out sheer numbers, Knee's Rabbitry is pretty stiff competition.

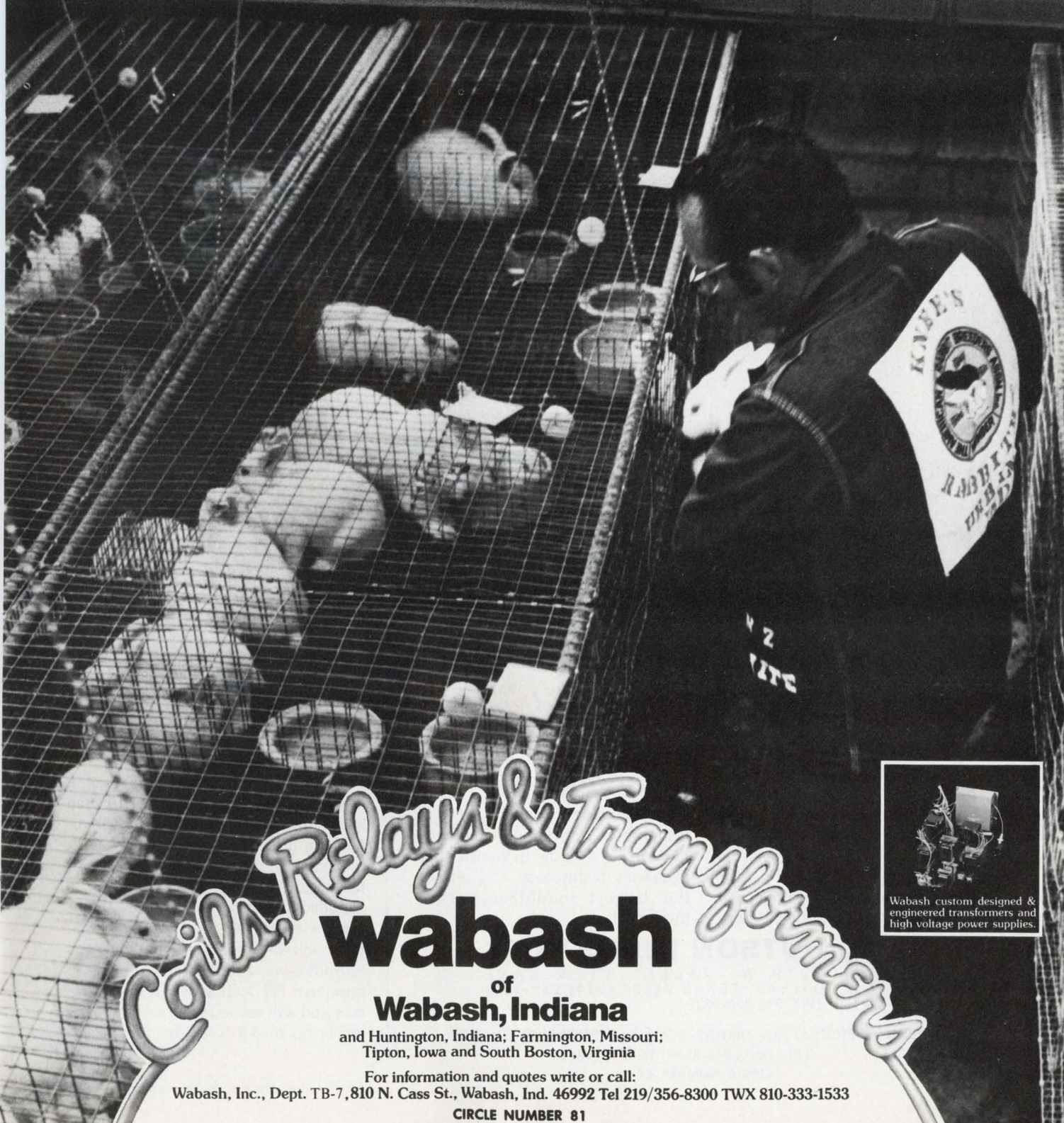

Coils, Relays & Transformers
wabash
of
Wabash, Indiana
and Huntington, Indiana; Farmington, Missouri;
Tipton, Iowa and South Boston, Virginia
For information and quotes write or call:
Wabash, Inc., Dept. TB-7, 810 N. Cass St., Wabash, Ind. 46992 Tel 219/356-8300 TWX 810-333-1533
CIRCLE NUMBER 81



Wabash custom designed & engineered transformers and high voltage power supplies.

Get hold of the new TO-220, TRIAC's, SCR's from Hutson

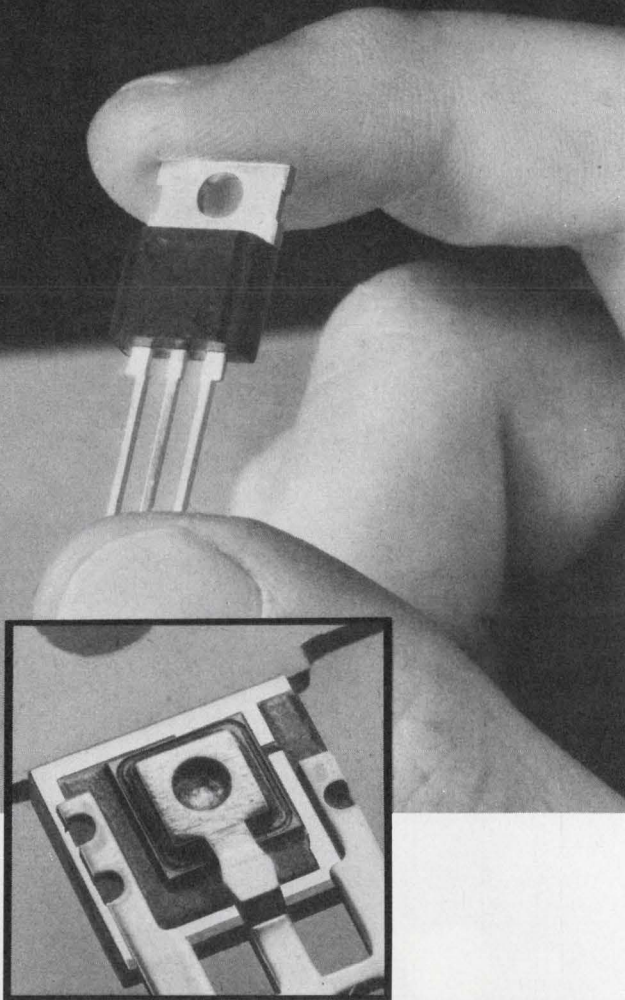

... the first with a face down chip for high volume production!

Hutson is first with the TO-220 isolated device with face down chip that gives you improved thermal, electrical and mechanical performance. Hutson can produce more devices per day than ever before.

So call Hutson for your needs and remember . . . you got it first from Hutson . . . a leader in thyristor applications technology and one of the largest manufacturers of thyristors!



HUTSON INDUSTRIES
2019 W. VALLEY VIEW LANE
DALLAS, TEXAS 75234 (214) 241-3511
TWX 910-860-5537

EUROPEAN OFFICE: 30 RUE PIERRE SEMARD. YERRES, 91, FRANCE
TEL: Paris 948-8258 TELEX 21311
CIRCLE NUMBER 83

PACKAGING & MATERIALS

DIP test-clip eases testing dense packages

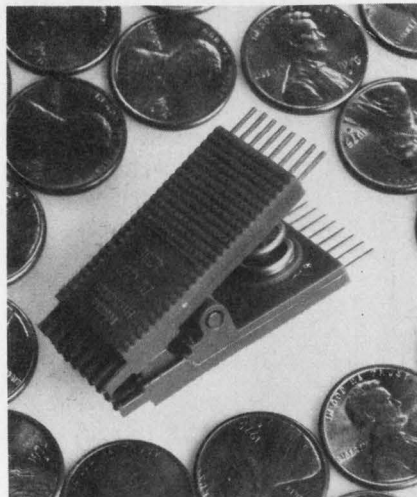

ITT Pomona Electronics, 1500 E. Ninth St., Pomona, CA 91766. Carl Musarra (714) 623-3463. \$5.75; 2 wk.

Model 4236 is a 14 or 16-pin dual in-line test clip with reduced thickness for testing ultra-dense packages. It measures 1.5 × 0.8 in. and contains non-tarnish nickel-silver contacts. The serrated contacts at the DIP end provide a positive electronic connection and assist in the removal of foreign material from the DIP. The serrated test points on the upper end will accept wrapped wires or mini test-clips. A molded barrier between each contact allows connections to be made on live boards without accidental shorting of adjacent contacts.

CIRCLE NO. 378

Vacuum-formed case houses digital displays

Electronics Inc., 171 Bridge Rd., Hauppauge, NY 11787. (516) 234-0400. \$25.70 (unit qty); stock.

Verocase 75-1800J is the first of a series of attractive vacuum-formed enclosures, specifically designed to house a digital display together with a keyboard. Made of 0.118-in. thick textured A.B.S. plastic, the case is supplied as a two-piece assembly complete with a 0.062-in. thick 5.7 × 5.9-in. anodized-aluminum panel and four self-adhesive rubber feet. The case measures 8.7 × 10.9 × 3.9 in. at the rear and will accommodate a PC board inside up to 6.3 × 8.7 in. in size.

CIRCLE NO. 379

FREE.

The world's most comprehensive source book of Solder Terminals.



The world's largest independent manufacturer of Non-Insulated Machined Solder Terminals wants to give you, *free*, a publication that is so much more than a catalog, it's called the Terminal Textbook. CAMBION wants you to have at your finger tips all the information about its Non-Insulated Solder Terminals and related products.

In the CAMBION Terminal Textbook you'll find everything from solder terminals to wrappable terminals. Dimensions are given in inches with metric cross-references. This extraordinary catalog-source book is easy-to-use and up-to-date. And it's yours *free!* Write to: CAMBRIDGE THERMIONIC CORPORATION, 445 Concord Avenue, Cambridge, Mass. 02138—ATT: Terminal Textbook. Offer good as long as supplies last. Better write now.

Standardize on
CAMBION[®]
The Guaranteed Electronic Components

CIRCLE NUMBER 84

A stepper drive system for only \$12.60!



A quality stepper motor and IC driver that cuts design costs, simplifies circuitry, minimizes space

We've just put the cost of an incremental drive stepping system within reach! And we've simplified your job in doing so. The \$12.60 includes our K82701-P2 12V dc stepper motor and our SAA1027 IC driver in 100 piece quantities, basically all you need for a complete system, if you supply dc voltage and stepping pulse. The motor has a 7½° step angle, 200 steps/sec pull-in rate and 6.0 oz-in working torque. If these specs don't suit your proposed application, we have 7 other motors to choose from with pull-in rates and working torque values to satisfy most drive applications. 15° step angles are also available, as are 5V dc models. Any one of the 7 can be driven by the IC driver without the need for discrete power stages. Use of the driver, in fact, cuts the cost and complexity of your circuitry to the bone. It's small in size, low in cost and assures maximum stepping accuracy in conjunction with our stepper motors. Find out more about NAPCC stepper systems.

Write for information today!

NORTH AMERICAN PHILIPS CONTROLS CORP.

Cheshire, Conn. 06410 • (203) 272-0301

CIRCLE NUMBER 85

ELECTRONIC DESIGN 23, November 8, 1977

The SOT-23's are here! In stock—In quantity

- Fast Delivery
- R.F., I.F., V.H.F., U.H.F.
- Varactors (Standard and Hyperabrupt)
- Switching
- 5% Zeners (4.7V-47V)
- Dual Diodes
- Low Noise
- "Standard" and "R" lead bend available

Featuring:

Silicone Plastic, Operational to 150°C Junction temperature, 100% tested, Ease of substate repair.

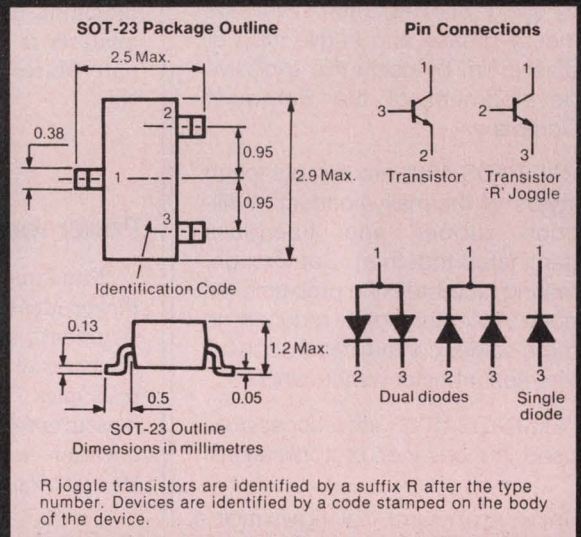

better by design



FERRANTI
semiconductors

FOR COMPLETE SPECIFICATIONS, CONTACT:
FERRANTI ELECTRIC, INC. / SEMICONDUCTOR PRODUCTS,
EAST BETHPAGE ROAD, PLAINVIEW, NEW YORK 11803
PHONE: (516) 293-8383 / TWX: 510-224-6483

CIRCLE NUMBER 86

COME ON UP TO...

"SIL-PADS 400":
THE SUPERB
SOLID STATE
HEAT SINK
INSULATORS...
TEST 'EM!

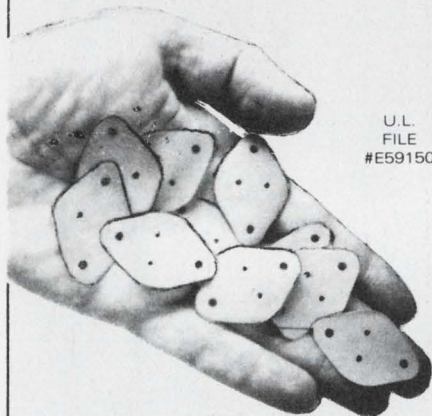

U.L.
FILE
#E59150

Overcome your heat-sink problems by using "SIL-PADS 400". Eliminate messy grease and fragile mica or plastic film by using this exclusive development of the Bergquist Company.

"SIL-PADS 400" are thin but tough layers of thermally-conductive silicone rubber and fiberglass (laminated together). Cut-through, tearing, and breaking problems are gone. Assembly time is reduced; no more solder contamination; consistent heat transfer performance.

"SIL-PADS 400" are successfully used in thousands of applications.

Many standard configurations; also custom capability.

**FREE SAMPLES,
TECHNICAL DATA,
and LITERATURE!**

BERGQUIST CO.
4350 WEST 78TH STREET
MINNEAPOLIS, MN 55435
(612) 835-2322
TWX 910-576-2423

CIRCLE NUMBER 88

Application notes

Quartz-analog timekeeping

The three basic functions of all quartz-analog timekeeping systems—the crystal-controlled oscillator, the frequency divider, and the electromechanical-clock movement—are detailed in a 16-page catalog. Solid State Scientific, Montgomeryville, PA

CIRCLE NO. 380

Thyristor gating

"Thyristor Gating for Microprocessor Applications," an 11-page report, covers the use of common thyristors, triacs and SCRs, in microprocessor-based control systems for appliance and industrial control applications. Texas Instruments, Dallas, TX

CIRCLE NO. 381

Spectrum analyzers

Impedance measurement and matching using the TF2370 spectrum analyzer is described in an application note. Marconi Instruments, Northvale, NJ

CIRCLE NO. 382

Power measurements

"Fundamentals of Rf and Microwave Power Measurements" reviews the instruments used for measuring power, discusses error mechanisms, and gives principles for calculating over-all measurement accuracy. An HP application note index is also available. Hewlett-Packard, Palo Alto, CA

CIRCLE NO. 383

Spike suppressors

A fine analysis of important (and sometimes hidden) characteristics of voltage-surge suppressors and a comparison of the company's TransZorbs with metal-oxide varistors appear in a new printing of an eight-page app note. General Semiconductor Industries, Tempe AZ

CIRCLE NO. 384

New literature

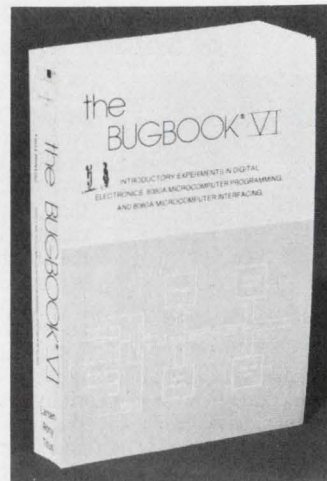

Microcomputer course

A two-volume course, Bugbook V and VI integrates introductory experiments in digital electronics with programming and interfacing an 8080A-based microcomputer. Bugbook V contains 15 chapters in 493 pages and covers the basics of 8080A microcomputer programming. Bugbook VI has eight chapters in 490 pages and covers digital concepts of 8080A microcomputer interfacing and programming. Either Bugbook costs \$9.50. E&L Instruments, Inc., Derby, CT

CIRCLE NO. 385

Transistors

Multiple-transistor and Darlington arrays are listed, in capsule form, in a short-form catalog. Sprague Electric, North Adams, MA

CIRCLE NO. 386

Transformers

A wide variety of transformers is described in a 12-page catalog. Electrical data, load curves and mounting data are provided. Dormeyer Industries, Chicago, IL

CIRCLE NO. 387

Nematic-liquid crystals

Physical and optical properties of nematic-liquid crystals, electronic grade, are described in an information sheet. 3M, Industrial Optics, St. Paul, MN

CIRCLE NO. 388

NEW! TWO AND THREE POSITION SWITCHES



MODEL MLB

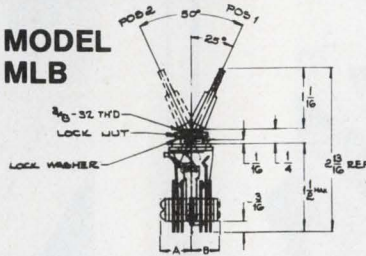

MLB is a true two-position switch, no center-neutral position; lock-lock action.

MLC is a three-position switch.

MODEL MLC

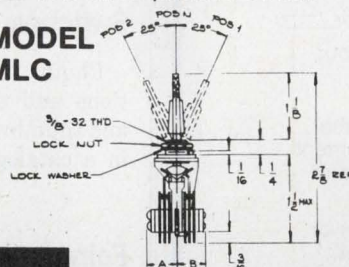

New brochure with full specs for lever action positions, contacts and stack dimensions.

CAPITOL

The Capitol Machine & Switch Co.
87 Newtown Road,
Danbury, CT 06810
203-744-3300

CIRCLE NUMBER 89

NEW! Y-R-LOC™ OPEN-SLOT WIRING DUCT

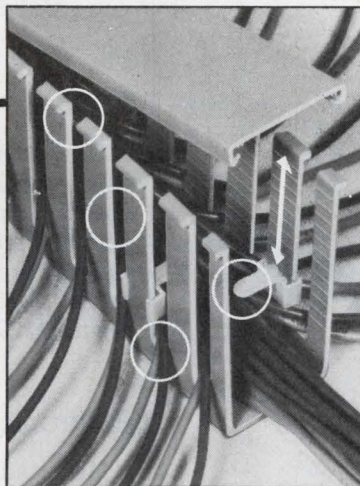

The new open-slot Y-R-LOC vinyl wiring duct by Taylor offers all the benefits below, and more. Unique Y-R-LOC nylon clips ratchet on duct ribbing to provide selective wire control with no interference. Write for details from the originator of plastic wiring duct.

Recognized under the Components Program of Underwriters' Laboratories, Inc.

MEETS ALL J.I.C. STANDARDS

Approved by

- Wider, non-tapering slots
- Faster wire placement
- Deeper slot openings (FOR "FLAT" WIRING)
- Greater wiring density (MORE OPENINGS PER FOOT)
- Simpler wire insertion



TAYLOR ELECTRIC, INC.

DIV. OF TAYLOR INDUSTRIES, INC.
P. O. BOX 729 MARBLE FALLS, TEXAS 78654

CIRCLE NUMBER 90

ELECTRONIC DESIGN 23, November 8, 1977

Design it for safety

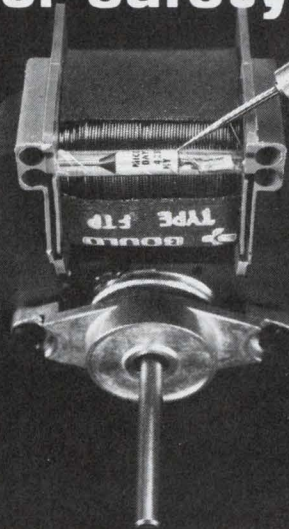

4000 Series MICROTEMP® thermal cutoff in small motor

Guard your products and profits with MICROTEMP® thermal cutoffs

Small motors do big jobs in many kinds of design application. This motor is not only ready to work hard, it's ready to work safely—protected by a MICROTEMP® thermal cutoff from the hazards of overheating.

Those who use this motor and those who make and sell it are all protected by the design decision to use a low-cost MICROTEMP® thermal cutoff.

If the temperature near the motor winding reaches the designated danger point, the MICROTEMP® thermal cutoff immediately opens the circuit to cut off power and avoid more serious problems.

After cutoff, the motor must be repaired and the MICROTEMP® thermal cutoff replaced before it can be used again.

In addition to motors and transformers, MICROTEMP® thermal cutoffs are designed to protect a wide range of electrical and electronic products. Choose any cutoff temperature rating from 60 to 240°C with operating accuracy within +0-4°C.

Millions of our MICROTEMP® thermal cutoffs are now protecting hundreds of different products. Write or call us to get more details and test samples.



MICRO DEVICES

DIVISION OF EMERSON ELECTRIC CO.
1881 SOUTHTOWN BLVD.
DAYTON OH 45439 513-294-0581

CIRCLE NUMBER 91

IS YOUR COMPUTER ON A PARTY LINE ?

Other equipment in your facility can cause your computer to make errors, lose its memory, wipe out a program, or stop operating.

The Topaz line 2 power line conditioner:

- **Regulates incoming voltage**
- **Removes lightning spikes**
- **Removes equipment transients caused by air conditioners, elevators, X-ray equipment, office machines or factory equipment.**

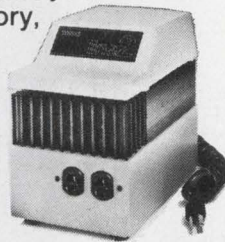

TOPAZ
line2

Now you can have clean, noise-free, regulated power without the expense and delay of installing an independent power source. The Topaz line 2 is a completely self-contained, portable line voltage regulator and Ultra-Isolation Transformer. Simply plug it into any 120 volt outlet, then plug your equipment into the line 2. It costs less than a "dedicated" power line and does so much more.

If you've been having random problems with your computer or electronic cash register, or are about to install one, find out how the Topaz line 2 can protect your equipment and provide the clean power you need. Send for our brochure or call today.

TOPAZ SOLUTIONS TO POWER PROBLEMS
ELECTRONICS

3855 Ruffin Road, San Diego, California 92123—(714) 279-0831—TWX (910) 335-1526

CIRCLE NUMBER 92

NEW LITERATURE

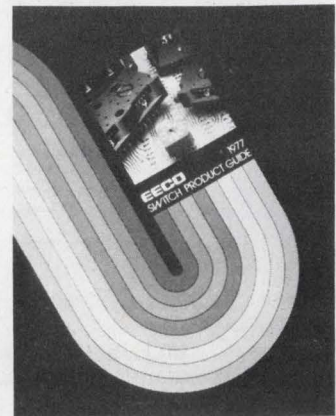

Switches

Photos, descriptions, features, options and specifications of PC-board and thumbwheel switches are provided in a catalog. EECO, Santa Ana, CA

CIRCLE NO. 389

Faire proceedings

Proceedings of "The First West Coast Computer Faire" held April 15 to 17 includes copies of the original papers and a list of most commercial exhibitors. Copies of the Proceedings are available for \$12. Peoples Computer Co., Menlo Park, CA

CIRCLE NO. 390

SCRs

Photos of silicon-controlled rectifiers for electronic and phase-control applications, dimensional drawings and electrical and mechanical specifications are given in a four-page catalog. International Rectifier, Semiconductor Div., El Segundo, CA

CIRCLE NO. 391

Electronic components

More than 8000 electronic components are presented in an 80-page catalog. Mallory Distributor Products, Indianapolis, IN

CIRCLE NO. 392

Programmable calculators

Forty new books provide owners of HP-67 and HP-97 programmable calculators with solutions to problems in such fields as personal finances, statistics and the natural sciences. The books are priced at \$10 each. Hewlett-Packard, 1501 Page Mill Rd., Santa Clara, CA 95051

INQUIRE DIRECT

Solderable Heat Sinks

Eliminate costly hand work on your production line.

You can now mount your plastic power devices to Thermalloy solderable heat sinks before board insertion, then solder in place on your automated equipment. Solderable heat sinks save hand labor, improve thermal performance, and protect semiconductor leads. Available for most plastic power packages.

Number one in Semiconductor Accessories

Thermalloy, Inc.
Post Office Box 34829
2021 West Valley View Lane
Dallas, TX 75234 • (214) 243-4321

Free sample and all products catalog with your response

CIRCLE NUMBER 93

MOUNT PCB'S TO METAL CHASSIS

Sealectro Spacer / Bushings

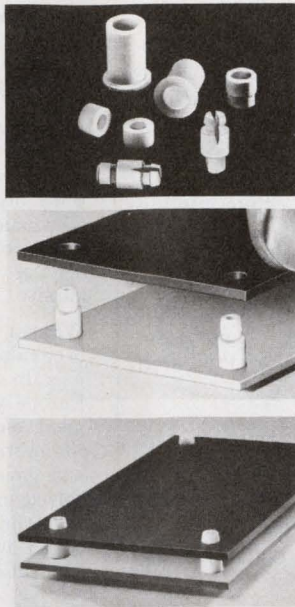

Eliminates nuts, bolts, lock-washers, insulators, metal spacers and tapping. Get fast, economical, simple and secure mounting and insulation with Sealectro spacer/bushings. Machined from virgin Teflon, units are inserted into chassis in one simple operation. Just snap the grommet end into a pre-drilled or punched chassis hole and it's in for good. Write for catalog.



CIRCUIT COMPONENTS DIVISION
SEAELECTRO CORPORATION
MAMARONECK, N.Y. 10543
PHONE 914 698-5600 TWX 710-566-1110

Sealectro West
14011 Ventura Blvd., Suite 215, Sherman Oaks, Ca 91423 (213) 990-8131
1901 Old Middlefield Way, Suite 19, Mountain View, Ca 94043 (415) 965-1212
Sealectro Ltd., Portsmouth, Hants, England
Sealectro S.A., Zone Industrielle Touzin Est, 83087 Touzin Cedex, France

CIRCUIT COMPONENTS ■ R.F. COMPONENTS ■ PROGRAMMING DEVICES

CIRCLE NUMBER 94

Free!

fixed ceramic capacitor catalog

There's a Nichicon ceramic capacitor designed to let you meet or beat almost every electro-mechanical requirement... in reliability, in dependability, in specialty applications.

OTHER PRODUCTION ITEMS INCLUDE: electrolytic capacitors, film capacitors, oil filled capacitors—without P.C.B., metallized paper capacitors, and wax paper capacitors,



nichicon The pulse of the industry.

NICHICON AMERICA CORPORATION
Division of NICHICON CAPACITOR LTD., Kyoto, Japan
6435 N. Proesel, Chicago, Ill. 60645 (312) 679-6530

CIRCLE NUMBER 95

ELECTRONIC DESIGN 23, November 8, 1977

New for OEM...EPSON's FEM

LIQUID CRYSTAL DISPLAY

2 1/2" x 1 1/2"

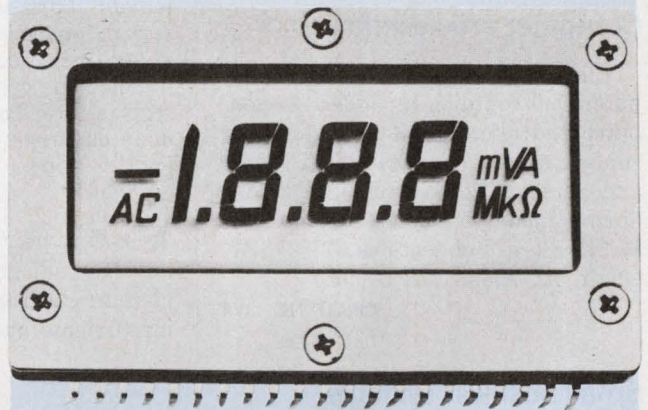

with an integral one-chip

C-MOS LSI A-D CONVERTER

The world's largest manufacturer of Liquid Crystal Displays for hand-held calculators now offers the full-size panel display Model LD-E702 for OEM.

Compare these value features:

- Four numerals, each 10mm high X 5.5mm wide.
- AC or - displayed before numerals.
- m, V, A, M, K, and Ω after numerals.
- C-MOS LSI combines linear/digital C-MOS plus oscillation/driving circuits for LCD.
- Several hundred hours operation when DMM or DPM is battery driven.

EPSON products are made by Shinshu Seiki Co., Ltd., Japan

Write or call for complete information

EPSON

EPSON AMERICA, INC.

23844 Hawthorne Blvd., Torrance, CA 90505
Telephone (213) 378-2220 · TWX 910 344-7390

CIRCLE NUMBER 96

VMOS

VMOS (V-groove metal-oxide-silicon) technology is the topic of a 16-page brochure. American Microsystems, Santa Clara, CA

CIRCLE NO. 393

Computer article index

The "Periodical Guide for Computerists" contains an index of computer and microcomputer articles, by subject, that have appeared in 23 trade and personal computing publications during January to June, 1977. It costs \$3. E. Berg Publications, 1360 S.W. 199th Ct., Aloha, OR 97005.

CIRCLE NO. 394

Small business systems

ANSI-standard COBOL, interactive real-time systems features, the range of applications, and sample configurations of the recently announced CS/40 system are discussed in a brochure. Data General, Westboro, MA

CIRCLE NO. 395

Rental instruments

A 76-page catalog illustrates the latest in analyzers, frequency counters and timers, generators, oscilloscopes and microprocessor design and test systems available for rental. U.S. Instrument Rentals, San Carlos, CA

CIRCLE NO. 396

Cable ties

Cable ties, clamps, marker ties, push-mount ties, and cable-tie-installation tooling are covered in an eight-page brochure. Panduit, Tinley Park, IL

CIRCLE NO. 397

Solenoids

A 40-page solenoid-design manual and catalog includes data on U frame, box frame and cylindrical types in a complete range of sizes and force characteristics. Each model is comprehensively described including operational graphs for each operating mode. Regdon, Brookfield, IL

CIRCLE NO. 398

**Vendors
report**

Annual and interim reports can provide much more than financial position information. They often include the first public disclosure of new products, new techniques and new directions of our vendors and customers. Further, they often contain superb analyses of segments of industry that a company serves.

Selected companies with recent reports are listed here with their main electronic products or services. For a copy, circle the indicated number.

Tech-Ops. Radiation monitoring; industrial radiographic equipment; solid-state electronic controls; scientific instruments and broadcasting.

CIRCLE NO. 403

Ocean Data Systems. Minicomputer-based information storage and display systems.

CIRCLE NO. 404

Youngwood Electronic Metals. High-precision metal stampings for semiconductor components.

CIRCLE NO. 405

Analogic. A/d converters; precision instrumentation; data acquisition and processing; special-purpose computers, and closed-loop control systems.

CIRCLE NO. 406

Cubic Corp. Precision measuring devices and systems; telemetry products; communications equipment; data processing and peripheral equipment, and computer services and software.

CIRCLE NO. 407

CTS Corp. Variable resistors; cermet resistor networks; cermet microcircuits; switches; loudspeakers and quartz crystals.

CIRCLE NO. 408

Storage Technology. Computer data-storage subsystems.

CIRCLE NO. 409

Recognition Equipment. Optical character-recognition products.

CIRCLE NO. 410

Electronic Design

ELECTRONIC DESIGN's function is:

- To aid progress in the electronics manufacturing industry by promoting good design.
- To give the electronic design engineer concepts and ideas that make his job easier and more productive.
- To provide a central source of timely electronics information.
- To promote communication among members of the electronics engineering community.

Want a subscription? ELECTRONIC DESIGN is circulated free of charge to those individuals in the United States and Western Europe who function in design and development engineering in companies that incorporate electronics in their end product and government or military agencies involved in electronics activities. For a free subscription, use the application form bound in the magazine or write for an application form.

If you do not qualify, paid subscription rates are as follows: \$30.00 per year (26 issues) U.S./Canada/Mexico, \$40.00 per year (26 issues) all other countries. Single copies are \$2.50 U.S. and all other countries. The Gold Book (27th issue) may be purchased for \$30.00 U.S./Canada/Mexico, and \$40.00 all other countries.

If you change your address, send us an old mailing label and your new address; there is generally a postcard for this in the magazine. You will have to requalify to continue receiving ELECTRONIC DESIGN free.

The accuracy policy of ELECTRONIC DESIGN is:

- To make diligent efforts to ensure the accuracy of editorial matter.
- To publish prompt corrections whenever inaccuracies are brought to our attention. Corrections appear in "Across the Desk."
- To encourage our readers as responsible members of our business community to report to us misleading or fraudulent advertising.
- To refuse any advertisement deemed to be misleading or fraudulent.

Individual article reprints and microfilm copies of complete annual volumes are available. Reprints cost \$6.00 each, prepaid (\$.50 for each additional copy of the same article), no matter how long the article. Microfilmed volumes cost \$23 for 1976 (Vol. 24); \$30 for 1973-75 (Vols. 21-23), varied prices for 1952-72 (Vols. 1-20). Prices may change. For further details and to place orders, contact Customer Services Dept. University Microfilms, 300 N. Zeeb Rd., Ann Arbor, MI 48106. (313) 761-4700.

Want to contact us? If you have any comments or wish to submit a manuscript or article outline, address your correspondence to:

Editor
ELECTRONIC DESIGN
50 Essex St.
Rochelle Park, NJ 07662

Just Delivered:

Elxon's Spanking New Switcher

This new 8 pound baby has really arrived. You couldn't ask for more (or less) in a 250 Watt Switching Power Supply. Full rated operation up to 50° C (Derated to 70° C). Complete built-in protection against overload, short circuit, or over voltage with foldback current limiting. And state-of-the-art design utilizing IC controls to minimize component count... which maximizes reliability.

Forget about brownouts. It's full-rated in the worst. Temperature rise? It's protected with a unique self cooling design. And it's quiet with its super efficient 20KHZ switching frequency.

Ideal for complex digital and memory systems, this new Elxon Switcher really delivers. What you need. When you need it. Efficiently. Quietly. Reliably. A light weight little package with a great big heart!

Another Ugly™ Made Beautifully by ELPAC.



ELPAC ELECTRONICS, INC.
ELPAC Power Systems
3131 So. Standard Avenue
Santa Ana, Calif. 92705
(714) 979-4440
TWX 910-595-1513

CIRCLE NUMBER 97

MOUNT A ZEBRA CONNECTOR ON ANY PC BOARD

- ZEBRA is constructed of alternating layers of conductive and nonconductive elastomers
- Electrical contact is achieved by deflecting the ZEBRA between two contacts
- No soldering required
- Eliminates contact pad abrasion.



- ZEBRA connector elements are used in assemblies for stacking connectors as well as edge and flat mount LCD's to PC boards.

Send for Connector Catalog.

EASTERN DIVISION — 129 DERMODY STREET, CRANFORD, N. J. 07016 (201) 272-5500
WESTERN DIVISION — 427 OLIVE STREET, SANTA BARBARA, CA. 93101 (805) 963-1867

CIRCLE NUMBER 98

AUTHOR'S GUIDE

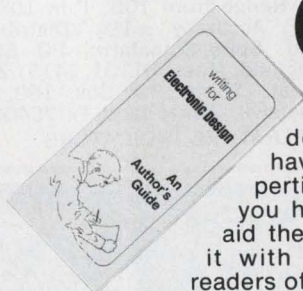

If you've solved a tricky design problem, if you have developed special expertise in a specific area, if you have information that will aid the design process... share it with your fellow engineer-readers of *Electronic Design*.

Articles you have authored not only raise your own professional status, but help build your company image as well. The readers benefit, your company benefits.

To help you prepare material that meets *Electronic Design's* high editorial standards, our editors have prepared a special author's guide entitled "Writing for *Electronic Design*." It covers criteria for acceptability, form, length, writing tips, illustrations, and payment for articles published. It's available without cost.

It's easy to write for *Electronic Design*, but it's often hard to get started. Send for your copy of our Author's Guide today.

Circle No.
250

BI-DIRECTIONAL PUSHBUTTON

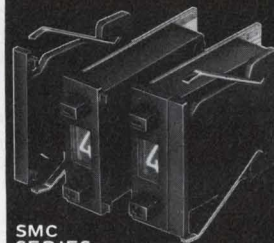

SMC SERIES

Smallest size ever with large easy-to-read numerals. Occupies only 0.3 sq. in. of panel space, impractical with thumbwheels.

Heavy gold plated contacts. Available in a variety of coded outputs (includes decimal) and mating accessories. Matte black finish. Detailed information on this and larger mating types available upon request.

CIRCLE NUMBER 99

1/2" ROTARY SWITCH



MRB SERIES

Rugged, Compact and Dependable describes Alco's new rotary switch series. Featuring adjustable stops and molded-in terminals.

Available in a choice of 1, 2, 3 or 4 poles and up to 10 positions with either 30° or 36° detent action. Available with PC or wired terminals, or waterproof feature optional. Equipped with 1/8" diameter shaft, with or without black phenolic knob.

CIRCLE NUMBER 100

ALCO ELECTRONIC PRODUCTS, INC.
1551 DASHWOOD STREET, NORTH ANDOVER, MA 01845 U.S.A.

Tel: (617) 685-4371 TWX: 710 342-0552

A SUBSIDIARY OF AUGAT INC.

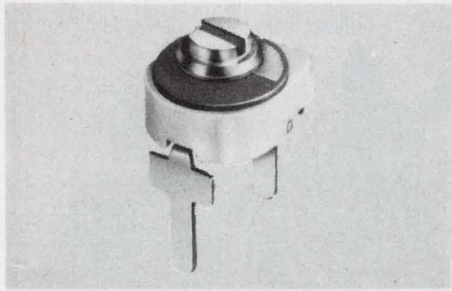

MINIATURE CERAMIC TRIMMER CAPACITORS 9371 series of ceramic trimmer capacitors are compact, economical and rugged. They are 50% smaller than other trimmers of this type yet provide high capacitance values. Available in 4 capacitance ranges, 1.5 to 4, 3.0 to 10, 3.5 to 18 and 5.0 to 25 pf with Q's > 300 at 10 MHz. They have an overall diameter of .225" with .215" above board height. JOHANSON MANUFACTURING CORPORATION, Rockaway Valley Road, Boonton, N.J. 07005 201-334-2676

TRIMMER CAPACITORS

181

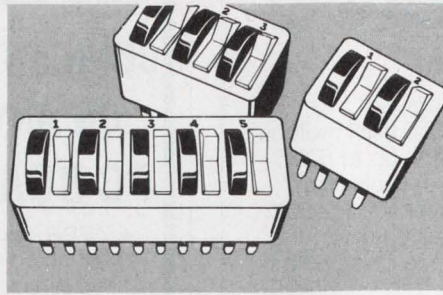

Dependable LED DIP switch from AMP combines the capabilities of the LED with the reliability of AMP low profile, miniature DIP switches. Available in SPST "on" or "off" and momentary contact types, they are ideal for many visual applications. For more information, call AMP Customer Service at (717) 564-0100. Or write AMP Incorporated, Harrisburg, PA 17105.

LED DIP SWITCH

184

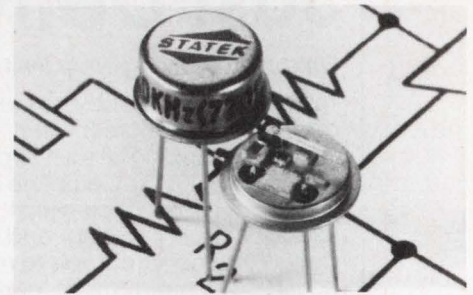

CMOS Crystal Oscillators in Low profile TO-5. Frequency range is 10 kHz to 300 kHz (divided outputs to 1 kHz, low as one cycle per month available). Low milli-amp current consumption. Accuracy $\pm 0.01\%$. Shock 1000 g. Hybrid thick and thin film chip and wire design is rugged and ideally suited for portable equipment. Details in Gold Book & EEM * STATEK CORP * 512 N. Main, Orange, Ca. 92668 * (714) 639-7810 * Telex 67-8394.

CRYSTAL OSCILLATOR

187

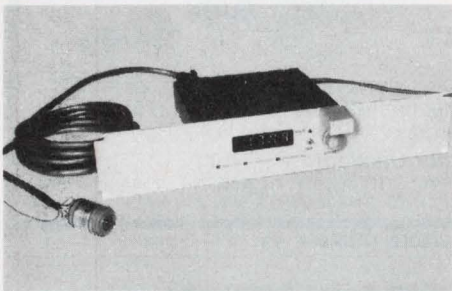

ABSOLUTE ENCODER— ± 1 Part in 3600 System Accuracy, Electro-Magnetic Transducer + LED Display + BCD, Binary, and DC Output—Infinitely Adjustable Scale Factor (0 to 9999)—Hi Noise Immunity—Zero Offset—Single and Multi-Channel Units From \$375/Axis (1 pc.) Other CCC products are Synchro to Digital, Synchro to Linear DC, Digital or DC to Synchro Converters, and Solid State C.T.'s or CDX's. Send for Free Catalog & Application Notes. Computer Conversions Corp., East Northport, N.Y. 11731 (516) 261-3300.

ENCODER

182

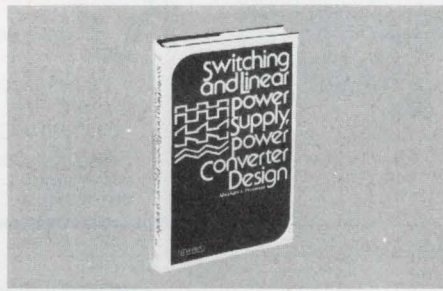

SWITCHING AND LINEAR POWER SUPPLY, POWER CONVERTER DESIGN, by Abraham I. Pressman. A "how-to-design" book written from a power supply designer's point of view. Provides all the circuits, systems, magnetics, and thermal design skills you need to design a modern power supply system. #5847-0, 384 pp., \$19.95. Circle the Info Retrieval Number to order your 15-day exam copy. When billed, remit or return the book with no obligation. Hayden Book Co., 50 Essex St., Rochelle Park, N.J. 07662. Offer good in USA and Canada only.

185

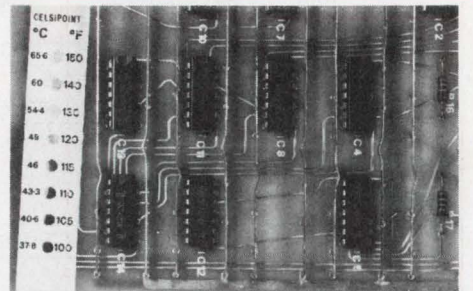

CELSIPOINT® temperature recording dots and strips do indicate by irreversible colour change (white→black) that a specific rated temperature was exceeded in the past of a component, equipment or any other item. Ideal for control of guarantee claims against overheating damages. Range from 100° F in 10° steps to 500°F. Accuracy $\pm 1\%$. Distributors required. Spirig-Signalarm, PO Box 3128, Springfield, Mass. 01101, (413) 788-0224. Internat: Spirig PO Box 160, CH8640 Rapperswil, Switzerland Tx 75400

TEMPERATURE INDICATORS

188

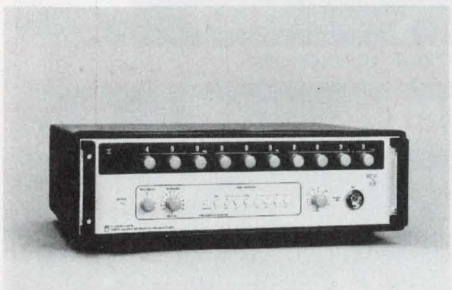

FREQUENCY SYNTHESIZERS. GenRad offers the best combination of low-phase noise, fast switching speed and price. Frequency range is dc to 500 MHz. Important features: non-harmonic spurs > 80 dB down; a-m, fm and pm capabilities; built-in search sweep; programmable (BCD parallel) frequency control; and optional resolution to 0.1 Hz. GenRad, 300 Baker Ave., Concord, MA 01742, (617) 369-8770.

FREQUENCY SYNTHESIZERS

183

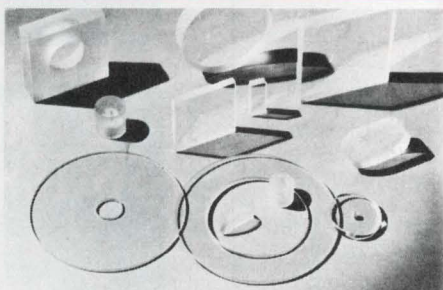

FREE 32 PAGE CATALOG. WINDOWS - PLATES - DISCS - OPTICS. Fused quartz, optical glasses, pyrex Ultra-low expansion materials, highly resistant to thermal shock. High UV and IR transmission. Chemically inert to most corrosive materials. Stocking center for lenses, prisms and laser accessories. Complete fabricating facilities. ESCO PRODUCTS, 181 Oak Ridge Rd., Oak Ridge, N.J. 07438. (201) 697-3700

LENSE, PRISM CATALOG

186

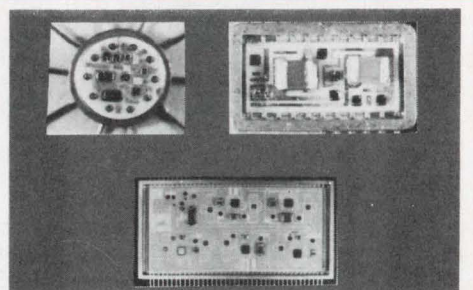

Custom hybrids for Space and Military applications built from customer's designs, or designed and built to customer's specifications. Ball Brothers Research Corporation with years of experience in the Aerospace business, is offering this service to all customers in related fields. In-house Q.A. and DCAS personnel ensure highest quality and compliance to applicable MIL and NASA Standards. Western Aerospace Laboratories of BBRC, 1488 West 178th St., Gardena, CA 90247. (213) 327-2221

CUSTOM HYBRIDS

189



DORMEYER COACH'S NEW 12-PAGE CATALOG ON COMMERCIAL USE TRANSFORMERS offers quick reference application help. A wide variety of channel frame and bracket mount open coil 120/30 VAC transformers; Universal Mount control units with 5, 10, 12, 20, 40 and 55 VA ratings are described. Electrical data, load curves and mounting data is given on these U/L and CSA listed or recognized transformers. Dormeyer Industries, Dept. QA 3418 N. Milwaukee Avenue, Chicago, IL 60641, (312) 283-4000.

TRANSFORMER CATALOG 190



MAGNETIC SHIELDING Take advantage of Eagle's 23-year background in shield design and production. Custom and standard models. Full service includes design, engineering, fabrication, heat treating, finishing, testing. Also wide selection of sheet and foil so you can form your own shields. For helpful design and cost data, request Bulletin E-77. Eagle Magnetic Co., Inc., Box 24283, Indianapolis, IN 46224, 317-297-1030.

MAGNETIC SHIELDING 193

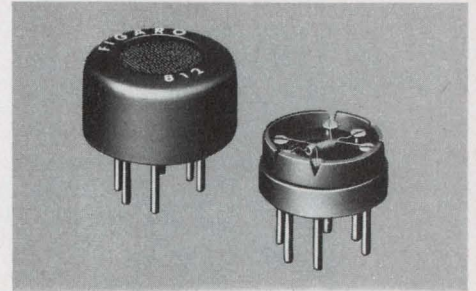

FIGARO GAS SENSOR TGS is a gas sensitive semiconductor. When combustible gas is absorbed on the sensor surface, a marked decrease of electrical resistance occurs. Major features of the sensor include high sensitivity, long term reliability and low cost. The applications are: GAS-LEAK ALARM, AUTOMATIC FAN CONTROL, FIRE ALARM, ALCOHOL DETECTOR, etc. Figaro Engineering Inc., North America Office-3303 Habor Boulevard, Suite D-8, Costa Mesa, Calif. 92626 Tel: (714) 751-4103 Telex: 678396

GAS SENSOR 196



KAGER PNEUMATIC COMPONENT PREFORMING MACHINE is a compact and extremely powerful tool. At last there is a fully developed, yet inexpensive cropping and forming machine intended for small and medium size work loads. Renders complex and costly equipment obsolete. Wire is cut to solder size and is simultaneously crimped. Makes for easy mounting of components. KAGER INTERNATIONAL, 1180 Beverly Dr., Suite 710, Los Angeles, CA 90035. (213) 879-1575. TWX: 910-490-2121.

COMPONENT PREFORMER 191

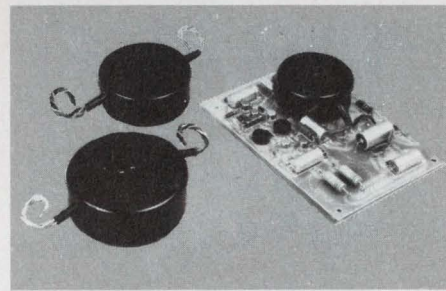

Off-the-shelf, in any quantity, toroidal line transformers are available with 75 most commonly used (6 to 40V) secondaries, 2 x 115V primaries, in 15, 30, 50, 90 and 130VA ratings. Toroids can solve your problems - they have an 8:1 smaller hum field - are 50% lighter - with 50% smaller volume over electrical equivalents - and fully encapsulated in resin filled tough thermoplastic shells. High efficiency saves power, cuts temperature. Martin Audio-Video 320W. 46th St. N.Y. 10036. Telephone (212) 541-5900.

TOROIDAL TRANSFORMERS 194

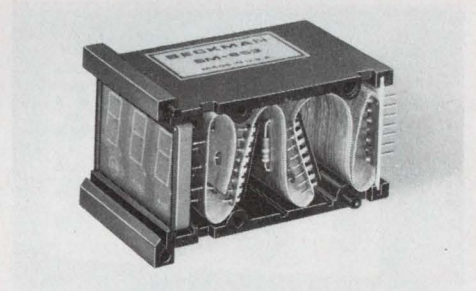

New way to pack added security into your design. R/flex circuits do several jobs at once and accordion fold to fit. Eliminate multiple circuit boards and jumpers; mount components directly on circuit. Made in 1 to 6 layers, various sizes and shapes, with or without plated-through holes. Rogers Corp., Chandler, AZ 85224 (602) 963-4584. (EUROPE: Mektron NV, Ghent, Belgium; JAPAN: Nippon Mektron, Tokyo)

FLEXIBLE CIRCUITS 197

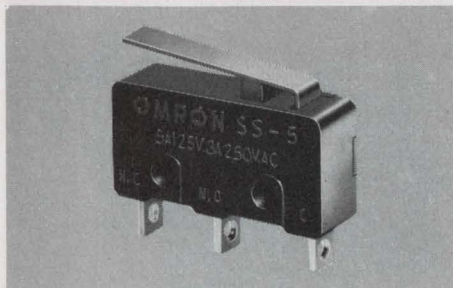

OMRON SUBMINIATURE SNAP-ACTION SWITCHES. Economy and wide selection of actuators for volume OEM requirements. SPDT snap-action rated at 5A, 125 VAC. Operating force 75 to 150 gms. Overtravel: .009" to .031". UL approved and CSA listed. Handles up to 20A inrush current. N.C. Metric mounting. Easy to install. OMRON ELECTRONICS, INC., 233 South Wacker Drive, Chicago, Illinois 60606. Phone (312) 876-0800.

ECONOMICAL SS SWITCHES 192

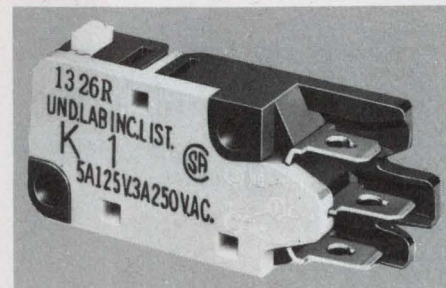

ECONOMICAL MINI-SWITCH FOR VOLUME USERS. Terminal insulator guard provides exceptional insulation resistance. Full range of types available. UL approved and CSA listed. SPDT type with 5A at 125 VAC rating. Snap-action for stable operation. 100 M ohm min. insulation resistance. Operating force 10 to 35 grams. 187 series quick connect terminals. One million mech. operations min. OMRON ELECTRONICS, INC. 233 South Wacker Drive, Chicago, Ill. 60606. Phone (312) 876-0800.

MINIATURE "K" SWITCHES 195

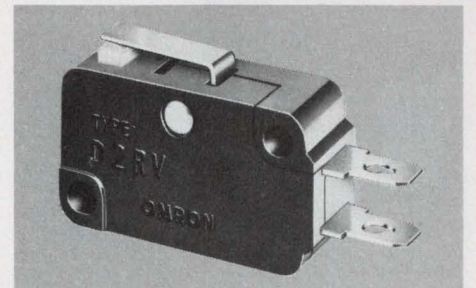

OMRON'S MINIATURE D2RV CLEAN SWITCH. High contact reliability is provided in a N.O. reed switch for dependable operation in adverse environments. Bounce time 20X shorter than conventional mech. devices. Ranges from low current to 10W contact capacity. Operating force of 25 to 100 gms. 187 series quick connect terminals. Wide selection of actuator types available. Metric mounting. OMRON ELECTRONICS, INC., 233 S. Wacker Dr., Chicago, IL 60606. (312) 876-0800.

D2RV SWITCH 198

quick ads

New and current products
for the electronic designer
presented by their manufacturers.

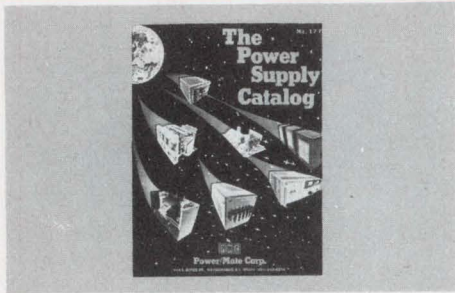

Free New '77 catalog contains over 34,500 quality power supplies from the world's largest manufacturer, Power/Mate Corp. Power Supplies for every application including submodulars, open frame, variorated, encapsulated, laboratory & system. All units UL approved and meet most military and commercial specs for industrial and computer uses. Power/Mate Corp., 514 S. River St., Hackensack, NJ 07601 (201) 343-6294

POWER SUPPLIES

199

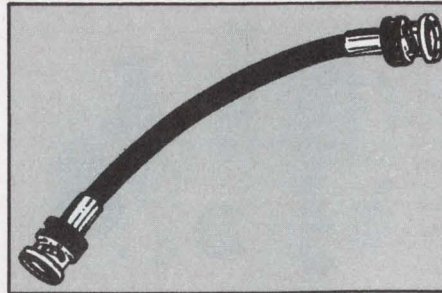

COAXIAL CABLE ASSEMBLIES. \$3.99 each. BNC to BNC Male, 50 Ohm, RG-58 Series. Model No. PE3067-12, 12", PE-3067-24, 24", PE3067-36, 36", PE3067-48, 48", PE3067-60, 60". 75 Ohm, RG-59 Series and 93 Ohm, RG-62 Series same price. Shipped same day order received. Types BNC, TNC, SMA, N, UHF available. Sale ends 12/31/77. Minimum order, \$50.00. Call for complete catalog. FOB: Pasternack Enterprises, 21062 Brookhurst Street, Suite #206, Huntington Beach, CA 92646 (714) 962-9306

COAXIAL CABLE ASSEMBLIES

202

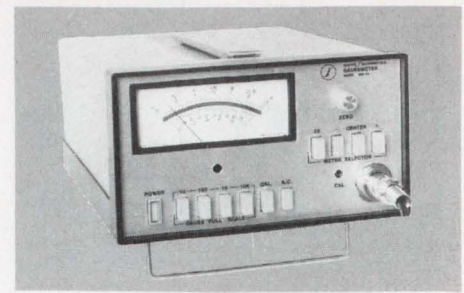

BROAD RANGE GAUSSMETERS. Measure AC and DC magnetic fields. Read from milligauss to kilogauss to analyze magnetic circuits, measure residual fields, stray fields, absolute and differential fields. Models available: MG-2A analog display, 8 F.S. ranges from 10 G to 30 KG; MG-3A, analog display, 11 F.S. ranges from 1 G to 100 KG; MG-3D, digital display, 5 F.S. ranges from 10 G to 100 KG. Write Walker Scientific, Inc., Dept. QA/Rockdale Street, Worcester, MA 01606/(617) 852-3574.

BROAD RANGE GAUSSMETERS

205

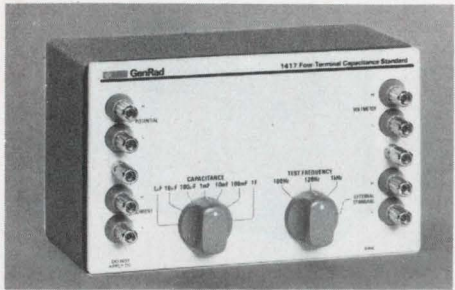

IMPEDANCE STANDARDS AND PRECISION BRIDGES. GenRad's extensive line is composed of capacitance, resistance, inductance, coaxial, attenuation, voltage divider, precision bridge, slotted line standards and related accessories. A broad variety of decade boxes with wide range and high resolution are very useful for laboratory, design and test groups. GenRad standards enjoys worldwide acceptance for quality and accuracy. GenRad, 300 Baker Ave., Concord, MA 01742, Tel: (617) 369-8770

IMPEDANCE STANDARDS

200

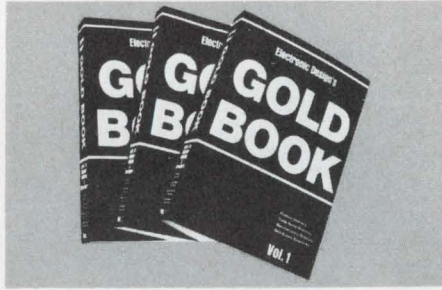

THE '77-'78 GOLD BOOK IS NOW OFF THE PRESS. Contains 2,496 pages of up-to-the-minute information about the entire electronics industry. Complete with Product, Trade Name, Manufacturers, Distributors Directories and Catalogue Compendium. Price: \$30-U.S., Canada and Mexico. Other countries \$40-Overseas postage included. To order, send check or company purchase order to GOLD BOOK, Dept. #437-R, Hayden Publishing, 50 Essex St., Rochelle Park, NJ, 07662.

'77-'78 GOLD BOOK

203

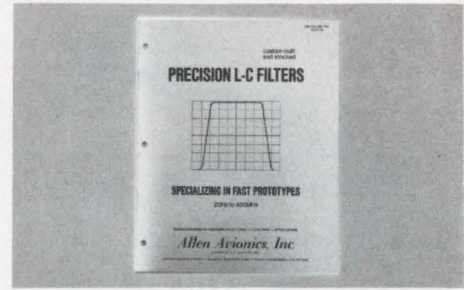

L-C FILTERS - FAST PROTOTYPES. Custom-built Filters often shipped in 3 days. We specialize in Linear Phase Lowpass & Linear Phase Bandpass Filters in a variety of shape factors and bandwidths. Our catalog contains extensive listings of Lowpass, Highpass, Bandpass & Band Reject Filters, some with sharpest cut-offs in industry. Delay Lines Catalog also available. Allen Avionics, Inc., 224 E. 2nd St., Mineola, N.Y. 11501, Tel: 516-248-8080

SEE US AT MIDCON, BOOTH 425

206

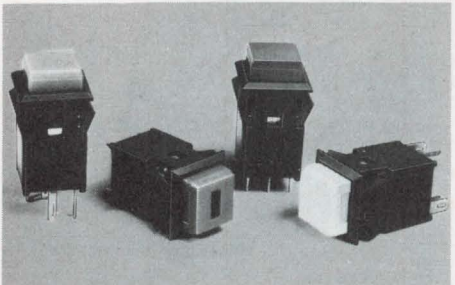

LPB SWITCH/NEW FEATURES SPDT (Form C) momentary and SPDT (Form C) maintains action switching added to Series 05 LPB switches. 1 and 2 pole N.O. Series 05 momentary action switches accept T-1-3/4 Bi-Pin lamps. Non-lighted and L.E.D. versions. Colored lens caps plus new concave shape. .110 quick disconnect or PC board terminals. .25 Amp., 125 VAC Max. U.L. Listed. Contact Licon, A Division of Illinois Tool Works Inc., 6615 W. Irving Park Rd., Chicago, IL 60634. (312) 282-4040.

NEW LPB SWITCH FEATURES

201

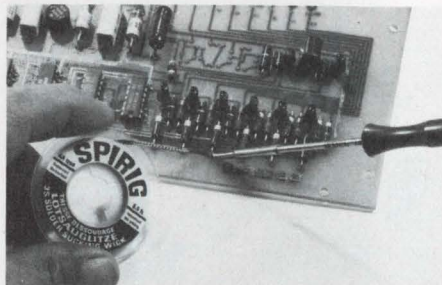

3S-WICK® De-solder Braid. Spigir produces the vacuumized (pat. pend.) solder removal wick in unequalled technology to meet any standards worldwide. 3S-Wicks unique three dimension combination solves all electronics desoldering problems. 3S-Wick pat. pend. Spigir also produces pencil soldering irons. Dealers and distributor inquiries welcomed. USA: Spigir-Signalarm, PO Box 3128, Springfield, Mass. 01101, (413) 788-0224 Internat: Spigir, PO Box 160, CH-8640 Rapperswil, Switzerland TX 75400

3S-WICK DE-SOLDER BRAID

204

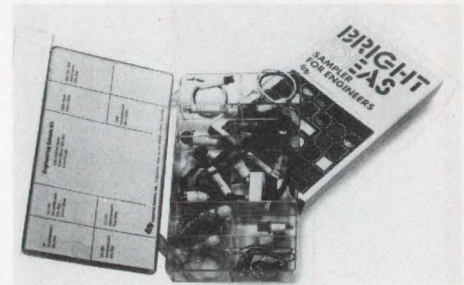

Indicator light Engineer's Kit. Ideal for engineers and designers of data-processing equipment, communications equipment, appliances, anything requiring indicator lights, this compartmented plastic box is filled with more than \$30 worth of lights—neon, incandescent, solid-state. A variety of sizes, colors, designs, leads, voltages. Send \$10 (check or money order) to Industrial Devices, Inc., Edgewater, N.J. 07020.

ENGINEER'S KIT

207

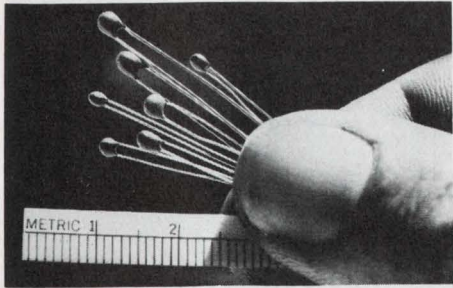

THERMISTORS with leads and coating are highly reliable low cost components in small dimensions more compatible with modern circuit design. R @ 25°C 100Ω to 1 meg Ω ±10% to ±1%. CURVE MATCHED INTERCHANGEABLES to ±.25°C. POINT MATCHED INTERCHANGEABLES to ±.2°C. Call or write for HP97 or TI SR52 THERMISTOR LINEARIZATION PROGRAM. WESTERN THERMISTOR CORPORATION, 354 Via Del Monte, Ocean-side, CA 92054. (714) 433-4484.

THERMISTOR

208



ATOMIC FREQUENCY STANDARD for communications/navigation systems & lab/field calibration. Model FRT outputs 10-5-1-0.1 MHz and 1 PPS optional. Long term stability 1×10^{-11} /month; short term is 1×10^{-11} for 1 sec, 1×10^{-12} /100 sec. avg. times. Low noise option available. Unit operates from -10°C to +50°C with relative frequency change of $< 1 \times 10^{-10}$. Internal battery provides 3 hours operation. EFRATON CALIFORNIA, INC., 18851 Barden Ave., Irvine, CA 92715 (714) 752-2891

ATOMIC FREQUENCY STANDARD

211



KAGER KL 3000 SINGLE-HANDED SOLDERING PISTOL — The Revolutionary Way To Solder. By squeezing the trigger, solder is automatically fed through the pistol to a heated tip. The amount of solder fed to a particular joint is fully adjustable. Tremendous time savings as well as reductions in user fatigue. Extremely lightweight and reliable. Uses any available brand of solder. Solder reels small to very large in size offered. KAGER INTERNATIONAL, 1180 S. Beverly Dr., Suite 710, Los Angeles, CA 90035. (213) 879-1575.

ONE-HAND SOLDERING PISTOL

209

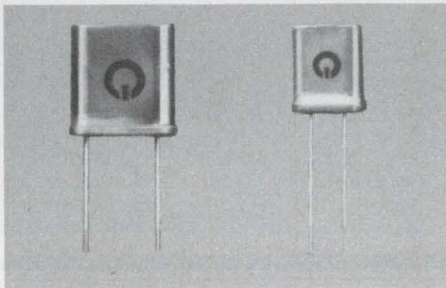

HIGH STABILITY LOW COST QUARTZ CRYSTAL for μ -processor and clock oscillator. Accuracy is $\pm 0.002\%$ at 25°C. Frequency change over -10 to +55°C is within ± 20 ppm. 1.000, 1.8432, 2.000, 2.097152, 2.4576, 3.2768, 4.0000, 5.0000, 5.0688, 5.1850, 5.7143, 6.5536, 10.0000, 18.0000, 18.4320, 20.0000, 22.1184 Immed. Dlv. \$1.85 ea. 10 MHz up in HC-18/u; (Min. 100 pcs.) Q-MATIC CORP., 3194-D Airport Loop Dr., Costa Mesa, CA 92626, (714) 545-8233, Telex 678389

CRYSTAL

212

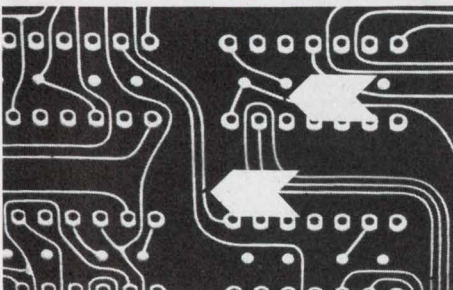

ID/INSPECTION ARROWS Identify problem and action areas at a glance with colorful pressure sensitive arrows. Use for inspection, QC, flagging, repair identification, assembly drawings and instruction. Permanently affix or reposition. Die cut from paper or vinyl tape. Won't fade, dry out, or lift. Standard and fluorescent colors in $\frac{1}{4}$ ", $\frac{3}{8}$ ", and $\frac{3}{4}$ " lengths. As low as \$2.40/M. Webtek Corporation, 4326 W. Pico Blvd., Los Angeles, CA 90019

ID/INSPECTION ARROWS

210

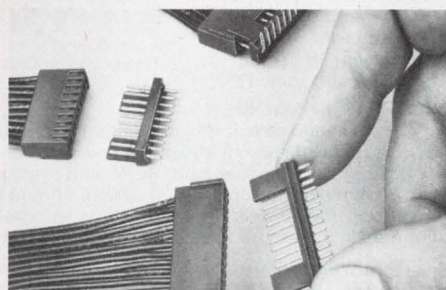

NEW "POL-R-LOK" MINIATURE CONNECTORS FEATURE POLARIZED LOCKING INTERCONNECTS ON .100 CENTERS for consumer electronic applications. Locking polarizing header and mating crimp receptacle available with 2-28 positions. Straight or right angle .025" square pins. Receptacle bellow contacts accommodate 22-30 AWG leads. Flame retardant 94V-0 thermoplastic molded connector bodies. 3.5 amp nominal at 250VAC. METHODE ELECTRONICS, INC 1700 Hicks Road, Rolling Meadows, ILL 60008. (312) 392-3500.

MINIATURE CONNECTORS

213

Electronic Design

Advertising Sales Staff

Susan G. Apolant
Sales Coordinator

Rochelle Park, NJ 07662

Robert W. Gascoigne
Thomas P. Barth
Stan Tessler
Constance McKinley
50 Essex St.
(201) 843-0550
TWX: 710-990-5071
(HAYDENPUB ROPK)

Philadelphia

Thomas P. Barth
(201) 843-0550

Boston 02178

Gene Pritchard
P.O. Box 379
Belmont, MA 02178
(617) 489-2340

Chicago 60611

Thomas P. Kavooras
Berry Conner, Jr.
200 East Ontario
(312) 337-0588

Cleveland

Thomas P. Kavooras
(312) 337-0588

Los Angeles 90045

Stanley I. Ehrenclou
Burt Underwood
8939 Sepulveda Blvd.
(213) 641-6544

Texas

Burt Underwood
(213) 641-6544

San Francisco

Robert A. Lukas
465 S. Mathilda, Suite 302
Sunnyvale, CA 94086
(408) 736-6667

England

Constance McKinley
50 Essex St.
Rochelle Park, N.J. 07662
Phone: (201) 843-0550

Europe

Sanders, W. J. M.
Raadhuisstraat 24
Graft-De Ryp, Holland
Phone: 02997-1303
Telegrams: Euradteam-Amsterdam
Telex: 13039-SIPAS

G. Nebut

Promotion Presse Internationale
7 ter Cour des Petites Ecuries
75010 Paris, France
Telephone: 5231917, 1918, 1919

Dieter Wollenberg

Erikastrasse 8
D-8011 Baldham/Muenchen
Germany
Telephone: 0 8106/4541

Tokyo

Haruki Hirayama
EMS, Inc.
5th Floor, Lila Bldg.,
4-9-8 Roppongi
Minato-ku, Tokyo, Japan
Phone: 402-4556
Cable: EMSINCPERIOD, Tokyo

★ABP

BPA

Electronic Design

recruitment and classified ads

PLACE YOUR AD AT ONLY \$45 PER COLUMN INCH IN

Electronic Design

— GET A REPEAT AD FREE!

With our 2 for 1 plan, your net cost in *Electronic Design* is only \$22.50 per column inch, lowest among all the national newspapers and electronics media. You get a total of 165,402 exposures to OEM engineers and engineering managers (not counting 10,600 more among general or corporate managers) at only 27¢ per thousand! You can't beat the price. You can't beat the coverage and you can't beat the quality.

YOU REACH ENGINEERS WITH TITLES LIKE THESE:

- Chief Engineer • Development Engineer • Design Engineer • Project Engineer • Electronic Engineer • Engineer-Supervisor • Section Leader • Staff Engineer • Systems Engineer • Test Engineer • Standards Engineer • Master Engineer

Electronic Design RECRUITMENT ADVERTISING RATES

15% commission to recognized agencies supplying offset film negatives. 2% 10 days, net 30 days. Four column makeup. Column width 1-3/4" x 10".

SPACE	DIMENSIONS		COST
	Wide	Deep	
One column inch	1-3/4" x 1"		\$45.
2 col. in.	1-3/4" x 2"		\$90.
1/16 page (1/4 col.)	1-3/4" x 2-1/2"		\$112.
1/8 page (1/2 col.)	1-3/4" x 5"		\$225.
1/4 page (1 col.)	1-3/4" x 10" Vert.		\$450.
	3-1/2" x 5" Hor.		
1/2 page (2 cols.)	3-1/2" x 10" Vert.		\$900.
	7" x 5" Hor.		
3/4 page (3 cols.)	5-1/4" x 10"		\$1350.
1 page	7" x 10"		\$1800.

NOTE: EACH RECRUITMENT AD YOU PLACE WILL BE REPEATED FREE OF CHARGE!

LATE CLOSING DATES

Electronic Design is mailed every two weeks. Because of its timeliness, personnel recruitment advertising closes only two weeks before each issue's mailing date.

1977 Mailing Date	Recruitment Closing Date	Issue Date on Cover
Oct. 21	Oct. 7	Nov. 8
Nov. 4	Oct. 21	Nov. 22
Nov. 18	Nov. 4	Dec. 6
Dec. 2	Nov. 18	Dec. 20



HOW TO PLACE YOUR AD

CALL THE RECRUITMENT HOT LINE 201-843-0550

Camera-ready film (right reading negatives, emulsion side down) or camera-ready mechanicals must be received by deadline. Or, if you wish us to set your ad (typesetting is free) simply pick up the phone and call our RECRUITMENT HOT LINE — (201) 843-0550. Ask for:

Constance McKinley
RECRUITMENT ADVERTISING MANAGER
ELECTRONIC DESIGN

50 Essex Street, Rochelle Park, New Jersey 07662

R & D ENGINEERS
\$20 - \$40K

- MICROPROCESSORS
- CPU'S
- PERIPHERALS
- RADAR
- NAVIGATION
- MICROWAVE
- PROCESS CONTROLS

Engineers - All Disciplines
National Listings
PATHFINDER
ENGINEERING AGENCY
P.O. Box 34 Commack, N.Y. 11725

ENGINEERS

Needed for FEE-PAID positions THROUGHOUT THE U.S. Over 1,000 client companies. Send resume and salary history or request confidential application today.

ATOMIC PERSONNEL, INC.
Suite D-2, 1518 Walnut St., Phila., Pa. 19102
Empl. Agcy. - All Technical Fields - Est. 1959

WELLS ELECTRONIC SEARCH INC.
NATIONWIDE

SYS ARCHITECTURE - HARD/SOFTWARE
Mini/Micro Terms from Concept 38,000
SR SYS ENG/ANALYST - Elmt. Sgnt. Commnt 25-35,000
BIOMED - Ultra Sound, X-Ray, CT Scanner, Gamma Camera, Pacemakers, Implantables, Sensors, Fluid Handling, Computer based Analyzers 16-32,000
PROJ. LEADER - Business Machines 34,000
MGR. FIRM HARDWARE DEV - Mini/Micro based Term Sys. 32,000
CONTROLS ENGS - (1) 1/4 to 300 hp Motors (2) Lighting Sys. Thyristor family 20-29,000
DPS ENGS - Digital Modems 24,000
TELEPHONY ENGS - Hard/Software 18,000
R&D & DESIGN - Video Games - Analog Video Circuits, Modems, CRT displays, Micro computer Syst. 18-35,000
DIGITAL COMM. ENGS - Signal Processing, Info Theory, Phase Locked Loops, Digital filters, Coding, Switching Syst. 18-33,000
MINICOMPUTER Programmers: Nationwide 18-32,000
CONTACT
D.L. Sweeney 212 949 8498 Dept. F
WELLS RECRUITING SYSTEMS, INC.
545 5th Ave., NYC, NY 10017 (AGENCY)

Our corporate goals have challenged us with very ambitious growth plans. You, as part of our team, can "make it happen" and be rewarded accordingly.

DIGITAL DESIGN ENGINEER . . . responsible for design and checkout of microcomputer controlled data collection systems. Should have BEE with three years of direct design experience with state-of-the-art digital circuits and preferably microcomputer design and debugging experience.

ANALOG DESIGN ENGINEER . . . perform new design of analog circuits related to industrial instrumentation, data acquisition systems and telemetry equipment for severe environment operation. Requires knowledge of instrumentation techniques, low level power transfer and some RF.

INSTRUMENTATION ENGINEER . . . responsible for system and circuit design of standard products used in the industrial telemetry field. Should have BEE or Physical Science Degree with experience in RF and analog, emphasizing wide temperature, worst-case design. Should be capable of analyzing and communicating in accordance with customer requirements. Potential management opportunity.

If you are motivated and seek a challenging career with tremendous growth potential and full benefits package, please send your resume in confidence with salary history to:

Recruiting Department
TESDATA / INMET, INC.
987 Pinetree Drive
Indian Harbour Beach, Florida 32937
(305) 773-2370
We Are An Equal Opportunity Employer



NATIONAL to 35K

Electrical/Electronic placement specialists.

Design _____ Test _____
Production _____ Project _____
F/S _____ Mfg. _____ Analog _____
Digital _____ RF _____ Radar _____
UHF _____ VHF _____ Power _____
Instructors _____

Various positions at all levels.
Forward resume to:

Gilbert Lane, Dept. 2
505 Fifth Avenue
N.Y., N.Y. 10017
or call 212 867 8100

TEXAS POSITIONS

Engineering, EDP & technical openings throughout Texas & the U.S. 100% fee paid. Send your resume in confidence to ENGINEERING/EDP SEARCH (Agency)
84 N.E. Loop 410, Suite 124E
San Antonio, Texas 78216

ELECTRONIC design project management ENGINEERS

fee paid nationwide

F-O-R-T-U-N-E

- 2200 Century Center
Atlanta, GA 30329
404/325-1600
- 11 Beacon St.
Boston, MA 02108
617/523-3530
- 500 N. Michigan Ave.
Chicago, ILL 60611
312/467-9130
- 2720 Stemmons Freeway
Dallas, TX 75207
214/630-9411
- 301 Fifth Ave. Bldg.
Pittsburgh, PA 15222
412/261-1826

1

ADVANCED
TECHNICAL
DIVERSIFI-
CATION

Engineers — Software Design

3 Reasons Why You Should Look Into the Career Opportunities at GTE Automatic Electric!

Career challenge: the opportunity to make significant contributions at the beginning of a new era in a major industry.

The technical evolution in telecommunications is underway. We're working in many areas of software design in an on-line, real-time environment. Definition, design and implementation projects include CAD, Data Base Systems, Simulation, Fault Recovery, Diagnostics, and very complex switching networks using distributed control system technology. These are the forerunners of even more advanced systems that will be designed for the next generation.

2

PROFESSIONAL
GROWTH

SOFTWARE DESIGN

We're looking for an in-depth background in the development of systems software and a minimum of 3 years' experience in structured design, testing and documentation of programs running on large data base, multi-file systems in real-time. Familiarity with HIPO design documentation, TSO usage and software simulation techniques as well as PL1, Fortran and assembler languages for the 8080 and PDP 11 programming is also important.

COMPUTER AIDED DESIGN

We are looking for an extensive background in the design of CAD/CAM systems and the development of interactive access by the users of CAD/CAM functions. Required is 5-10 years' experience in both hardware and software aspects; DA systems operations, and design, and systems engineering. Your initial responsibilities will include evaluation of existing systems, and working with a project team in the Architectural Planning of a major new system.

DATA BASE DESIGN

This position requires a minimum of 5 years' experience in the planning development, design and implementation of data base software, including data base management systems administration. Your primary responsibilities will be the development of data base system for a large on-going project including the implementation, support and administration of systems.

MINI-COMPUTER PROGRAMMERS

We have specific assignments available on project development teams responsible for the design implementation of various telecommunication processing systems utilizing mini-computers as the processing element. Responsibilities will include the development of software programs for real-time operating systems as well as unique hardware elements incorporated into the systems.

3

OUTSTANDING
CAREER
PACKAGE

Call now and let us fill-in more details. . .

CALL (800) 323-1966

In Illinois call (800) 942-0491 Sunday thru Friday, from 8 am to 4 pm cdt

If you have current experience in one of these areas, a BS, MS or PhD in Electrical Engineering, Computer Sciences, Math, or other appropriate discipline, let us count out more of the benefits and challenges you receive as a member of the GTE family.

**If unable to call, please send your resume to:
Manager of Technical Employment, Dept. 471 A6**

**GTE AUTOMATIC ELECTRIC
LABORATORIES**

400 N. Wolf Road
Northlake, Ill. 60164

An Equal
Opportunity
Employer
M/F

MODCOMP[®]

HARDWARE DEVELOPMENT CAREER OPPORTUNITIES

We are seeking experienced professionals to join us and be a part of our rapid expansion in the booming mini-computer industry. There's never been a better time to consider the outstanding career opportunities with MODCOMP and the good life in sunny Ft. Lauderdale, Florida.

MANAGER, COMPUTER DEVELOPMENT

We are seeking an aggressive thinker to lead the entire computer design activity in an environment providing rapid advancement. Immediate responsibilities include, system conceptual design of all new processors and memory systems, technical management and guidance of a team of senior and junior computer designers and significant contribution to definition and development of a new distributed intelligence network system.

COMPUTER DEVELOPMENT ENGINEER

To explore new concepts in mini and midi-computer architectures and develop for the marketplace. This is an opportunity to participate in the specification design of multiprocessor networks. Requires design experience.

We offer highly competitive salaries, substantial fringe benefits, challenge and the opportunity to move out in front of the pack with a leader. If you are interested in finding out more about the exciting career openings with MODCOMP, please send your resume including salary history, or call (800) 327-8997.

Mr. Robert M. Coyner

MODULAR COMPUTER SYSTEMS, INC.

1650 West McNab Road
Ft. Lauderdale, Florida 33309
An Equal Opportunity Employer M/F

MODCOMP[®]

ENGINEERS

AVIONICS SYSTEMS & DEVELOPMENT

Florida and Gulf Coast opportunities
with a technology leader!

Smiths Industries, an international manufacturer of commercial, and military avionics systems, is expanding its research and development activities at the aviation division engineering center at Clearwater. We are looking for degreed engineers at all levels with state-of-the-art credentials in the following areas:

- Display Systems
- Electromechanical Flight Instruments
- Electronic Packaging
- Microprocessor Applications
- Analog/Digital Circuits
- Reliability/Maintainability

For confidential consideration, please forward your resume including salary history to:

Mrs. Brenda Jolly
Personnel Department

Smiths Industries, Incorporated
P.O. Box 5389
Clearwater, Florida 33518

An Equal Opportunity Employer M/F

ENGINEERS SEEKING A FUTURE IN THE FAST GROWING VIDEO FIELD

Sony Corporation of America, the largest supplier of video equipment in the world, is expanding its technical staff to service broadcast and industrial users of state-of-the-art video equipment. We are looking for engineers with strong technical backgrounds and maintenance experience with video products such as VTRs, studio color cameras, time-base correctors, and related signal-processing equipment.

Job openings as follows:

MANAGER OF INSTALLATION AND SERVICE: Direct a staff of product engineers in providing full support of all broadcast product lines. Formulate procedures to ensure that all installations are carried out according to spec and provide technical guidance to see that field people are properly trained and equipped to maintain the product with a high degree of efficiency. Candidate should possess an EE degree, have proven ability to manage a technical group and have several years of direct involvement in servicing broadcast customers.

Location — N.Y.C. area

VTR PRODUCT ENGINEERS: Assume complete product-support responsibility for specialized video tape recorders. Evaluate field problems, prepare service literature in rough form for engineering change notices, field modifications and service bulletins. Train regional engineers to understand and maintain new products. Candidates should possess an EE degree and have thorough technical knowledge of studio-type recorders and maintenance procedures with at least three years of direct maintenance experience.

Location — N.Y.C. area

COLOR-CAMERA PRODUCT ENGINEERS: Assume complete product-support responsibility for state-of-the-art ENG cameras. This includes follow-up on field and application problems, training of field people and the generation of technical support literature such as service/modification bulletins and engineering change notices. Candidates should possess an EE degree and have in-depth knowledge of modern multiple pick-up tube cameras and alignment techniques with a minimum of three years experience in direct maintenance.

Location — N.Y.C. area

VIDEO ENGINEERS: Work with customers to service video equipment at customer's location and on the bench in regional service labs. Provide on-site training for customer technicians. Candidates should possess an associate degree or equivalent, have an in-depth knowledge of video and VTR systems, and have a minimum of three years direct maintenance experience.

Locations — N.Y.C., Los Angeles, Chicago, Dallas, Atlanta

All positions offer excellent salaries and growth potential. Employment benefits are fully paid by the company and include family-coverage hospitalization, pension plan, profit sharing, life insurance and tuition refund.

This may be your opportunity to join a technically-oriented team in which the opportunities to move forward professionally are better than can be found in most areas of the profession today.

Send your resume in complete confidence to Mr. Jerry McGinty at:

SONY
CORPORATION OF AMERICA
47-47 Van Dam Street, Long Island City, N.Y. 11101
an equal opportunity employer m/f

ELECTRICAL ENGINEERS

Excellent opportunities for computer oriented engineers to join this expanding division of ITT in suburban Chicago and work on hardware design of computer related projects.

Activities will consist of development or peripheral controllers, analysis of semiconductor memories utilizing 1K, 4K and 16K Ram devices. Work also consists of design of modem and peripheral equipment interfaces for a special purpose computer associated with central office switching systems. Requires one plus years design experience on computer projects.

If qualified send complete resume including salary history to: Tom Edminson, ITT Telecommunications, 2000 S. Wolf Road, Des Plaines, Illinois 60018.

TELECOMMUNICATIONS **ITT**
Switching Center

An Equal Opportunity Employer, M/F

PASSIVE COMPONENTS ENGINEER

For the evaluation and application of passive components, parts, and subassemblies. Should possess knowledge of keyboards switching circuits, and cooling devices and the manufacturing and application techniques of these devices. An ability to interface effectively with Engineering, Manufacturing, Purchasing, etc. is an important asset.

A technical degree and about 2 years Engineering experience will qualify you for consideration; the need is now and your reply will be given an early response.

P.O.S. TERMINAL DESIGN ENGINEER

To perform hardware design and some systems work on a next generation hospitality terminal including communications from the terminal to the CPU and peripherals. Some microprocessor architecture knowledge would be helpful.

A degree plus 2 or more years design experience will qualify.

SYSTEMS ENGINEER

You will perform and/or conduct system evaluation related to performance characteristics of computer based Point-of-Sale systems and subsystem elements (terminals, computers, peripherals, etc.). Candidates must be familiar with micro and minicomputer systems hardware and they should bring 2 or more years experience including exposure to isolating and solving problems related to RFJ-EMI.

LOGIC DESIGN ENGINEER

For digital implementation of algorithm required for video signal processing using TTL and/or microprocessor circuits. NCR's P.O.S. division is located in east central Ohio and offers an inviting work and family living environment.

Robert W. Donovan
Terminal Systems Division
NCR Corporation
Box 728
Cambridge, Ohio 43725
(614) 439-0293



An Equal Opportunity Employer

You're a Microprocessor Professional And You Have a Problem!

Certainly, the problem is not marketability nor is it money. But how will you differentiate genuine professional growth from those companies that will treat you like just another hired hand.

If you're better than your present employer acknowledges and wish to confidentially explore special situations worldwide, contact:

Management Recruiters

Attn: Ed Murphy, National Accounts Manager, 607 Boylston Street, Boston, MA 02110 (617) 262-5050

or Attn: Rick Keane, General Manager, 1500 Main Street, Springfield, MA 01115 (413) 781-1550

or Attn: Al Keleher, Senior Associate, 10 Industrial Park Drive, Nashua, NH 83060 (603) 883-3323

DEVELOPMENT ENGINEERS

Our growth as a leading manufacturer of measuring and controlling instrumentation, computers and systems for the process industry, provides outstanding career opportunities for exceptional individuals interested in contributing to the advance design and development of our electronic instrumentation and computer systems.

We are looking for talented professionals with experience in the following areas:

- Microprocessor/Computer based systems with applications to process control
- LSI design and manufacturer
- Programmable logic circuitry
- Digital logic design and firmware development
- Design of data transmission systems establishing protocol, formatting and error checking
- Specification, design and development of software for computerized process control systems
- Application of computers for process control and data acquisition in the process industries

Qualified individual may forward resume and salary requirements in confidence to:

Technical and Professional Personnel
Taylor Instrument Company
SYBRON | Taylor

95 Ames Street
Rochester, N.Y. 14601

An Equal Opportunity Employer M/F

Constance McKinley
RECRUITMENT ADVERTISING MANAGER
ELECTRONIC DESIGN
50 Essex Street, Rochelle Park, New Jersey 07662
(201) 843-0550

I'm interested in placing recruitment
advertising in *Electronic Design*

Issue _____ Size of ad _____

My copy is enclosed I need more information

Name _____

Title _____

Company _____

Address _____

Available Now!

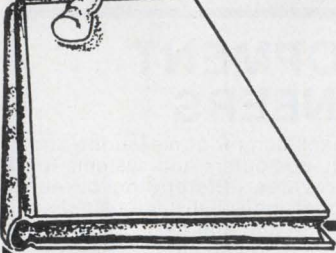

□ MICROPROCESSOR

BASICS, edited by Michael S. Elphick. Here's the nitty-gritty on design selected from *Electronic Design* for the eight currently popular microprocessors: 8080, 6800, F8, PACE, IMP, 2650, 1802, and 6100. Each chapter discusses one model, detailing its advantages, disadvantages, architecture, capabilities, and includes many illustrations of its applications.
#5763-6 paper 224 pp., \$10.95

□ ORGANIZING AND DOCUMENTING DATA PROCESSING INFORMATION,

by Thomas R. Gildersleeve. Write sharp, precise DP documents that command attention. This book will show you how to... prepare a first draft... shape your sentences for reading ease... organize a document for quick study. Filled with examples of great DP writing and scores of exercises for practice.
#5739-3 paper, 160 pp., \$7.95

Please send the book(s) checked on 15-day examination. At the end of that time, I will send payment, plus postage and handling, or return the book(s) and owe nothing. On all prepaid orders, publisher pays postage. Prices are subject to change without notice. Offer good in U.S.A. and Canada only.

NAME _____

COMPANY _____

ADDRESS _____

CITY _____

STATE/ZIP _____

Send to:

Hayden Book Company, Inc.
50 Essex Street, Rochelle Park
New Jersey 07662

*77-62

Advertiser's index

Advertiser	Page	Advertiser	Page
AMP, Incorporated.....	44, 45, 150	Merrimac Industries, Incorporated....	133
Abbott Transistor Laboratories, Inc.....	6	Methode Electronics, Inc.....	153
Acme Electric.....	115	Micro Devices Corp.....	145
Acopian Corp.....	13	Microswitch, A Division of Honeywell.....	113
Airpax Electronics, Cambridge Division.....	39	Mini-Circuits Laboratory, A Division of Scientific Components Corp.....	74
Alco Electronic Products, Inc.....	149	Modular Computer Systems, Inc.....	101
Allen Bradley Co.....	51	Moxon/SRC Division.....	Cover III
Allen Avionics, Inc.....	152	National Semiconductor Corporation.....	11, 12
Amperex Electronics Corporation.....	103	NEC Microcomputer.....	24
B & K Precision Dynascan Corporation.....	32A-H	Nichicon Corporation.....	147
Bendix Corporation, The, Electrical Components Division.....	31	North American Philips Controls Corp.....	143
Bergquist Co.....	144	Optron Electronics, Inc.....	151
Bodine Electric Company.....	159	Optron, Inc.....	7
Bourns, Inc., Trimpot Products Division.....	Cover II	Pacific Cyber/Metrix.....	135
Bud Industries, Inc.....	114	Pasternak Enterprises.....	152
CTS Corporation.....	128	Philips Test & Measuring Instruments, Inc.....	128A
Cambridge Thermionic Corporation.....	143	Potter & Brumfield, Division of AMF, Incorporated.....	93
Capar Components Corporation.....	134	Power/Mate Corp.....	152
Capitol Machine & Switch Co., Inc., The.....	145	Power Tech, Inc.....	80
Citizen America Corporation.....	159	Precision Monolithics Incorporated....	49
Computer Automation, Inc.....	16, 17	Pro-Log Corporation.....	137
Computer Conversions Corp.....	150	Q-Matic Corp.....	153
Coto Coil Company, Inc.....	160	RCA Solid State.....	Cover IV
Crown Industrial.....	98	Reader Service Card.....	160A-B
Cutler-Hammer, Specialty Products Division.....	119	Reticon.....	129
Datel Systems, Inc.....	105, 107, 109	Rogers Corporation.....	131, 151
Delco Electronics, Division of General Motors Corporation.....	48	*SGS Ates Semiconductor Corporation.....	51
Dialight, A North American Philips Company.....	87	Scientific Components Inc.....	118
Digital Equipment Corporation.....	18, 19	Sealectro Corporation.....	147
*Digitronics Israel, Ltd.....	24	Semtech Corporation.....	23
Dormeyer Industries, Inc.....	151	Shugart Associates.....	20
Dow Corning Corporation.....	81	Siliconix, Incorporated.....	4, 5
Eagle Magnetic, Inc.....	151	Simpson Electric Company.....	50
Eagle-Picher Industries, Inc.....	135	Sinclair Radionics Inc.....	125
Efratton California, Inc.....	153	Solitron Devices, Inc.....	99
Electronic Design.....	149	Spirig Signalarm.....	150, 152
Electronic Molding Corporation.....	131	Sprague Electric Company.....	110
Electronic Navigation Industries.....	112	Statek Corp.....	150
Elpac Components.....	149	Superior Flux and Mfg. Co.....	124
Epson America, Inc.....	147	Syntronic Instruments, Inc.....	139
Esco Products.....	150	TRW/IRC Resistors.....	117
Essex/Stancor.....	126	TRW/LSI Products.....	75
Ferranti Semiconductors.....	143	Taylor Industries, Inc.....	145
Figaro Engineering, Inc.....	151	Teccor Electronics Inc.....	86
GenRad.....	150, 152	Tecknit.....	149
General Electric Company.....	38, 61	Tektronix, Inc.....	36, 37, 43
General Electric Company, Miniature Lamp Products Department.....	138	Teledyne Relays, A Teledyne Company.	2
General Instrument Corporation.....	25	Teledyne Semiconductor.....	46
Gold Book, The.....	100, 152	Tenney Engineering, Inc.....	159
Gould, Inc., Foil Division.....	91	Texas Instruments, Incorporated.....	33
Gould, Inc., Instrument Systems Div..	121	Thermalloy Inc.....	146
Grayhill, Inc.....	120	Topaz Electronics.....	130, 146
Harris Semiconductor.....	101	U.S. Components, Inc.....	160
Hayden Book Company, Inc.....	150, 158	Universal Data Systems.....	35
Hewlett-Packard.....	1, 72, 73	Visual Communications Company.....	29
Hutson Industries.....	142	Wabash, Inc.....	141
Industrial Devices, Inc.....	152	Walker Scientific, Inc.....	152
Intel Corporation.....	8, 9	Wavetek Indiana Incorporated.....	92
Intelligent Systems, Inc.....	14, 15	Webtek Corp.....	153
International Rectifier Corporation.	62, 63	Western Aerospace Laboratories of BBRC.....	150
Intersil.....	128B	Western Thermistor Corporation.....	153
Intertec Data Systems.....	127		
JFD Electronics Corporation.....	159		
Johanson Manufacturing Corp.....	150		
Kagar International.....	151, 153		
Kapusi Laboratories Ltd.....	139		
Kepeco, Inc.....	40		
Kertron, Incorporated.....	130		
*Knurr, KG, Hans.....	49		
Ledex, Inc.....	116		
Licon, Division of Illinois Tool Works, Inc.....	152		
3M Company.....	122, 123		
*M-O Valve Co.....	13		
Martin Audio-Video.....	151		
*Matsuo Electronics of America, Inc..	49		

RECRUITMENT

GTE Automatic Electric Laboratories.	155
ITT Telecommunications.....	156
Management Recruiters.....	157
Modular Computer Systems, Inc.....	156
NCR Corp.....	157
Sony Corporation of America.....	156
Smiths Industries.....	156
Sybron & Taylor.....	157
Tesdata/Inmet.....	154

*Advertisers in non-U.S. edition

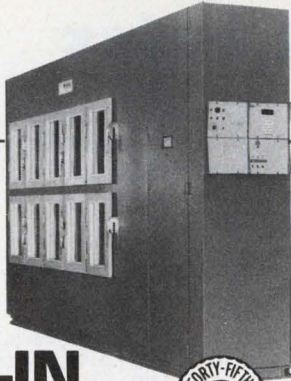
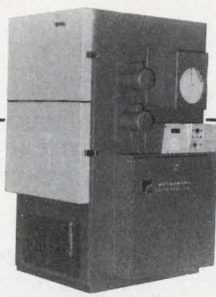

BURN-IT-IN... SHOCK IT!



Shock it with . . .

- **Digi** Microprocessor Programmer Standard
- Vertical or Horizontal ■ 2 or 3 compartments
- -100° +400°F. ■ 1 switch operation
- No counters or timers necessary

Burn-it-in!

Custom performance and design based on our 45 years of experience.



Tenney

ENGINEERING, INC.

1090 Springfield Rd., Union, N. J. 07083 (201) 686-7870
Oldest and largest manufacturer of Environmental Equipment

748

CIRCLE NUMBER 101

JFD where it's at!

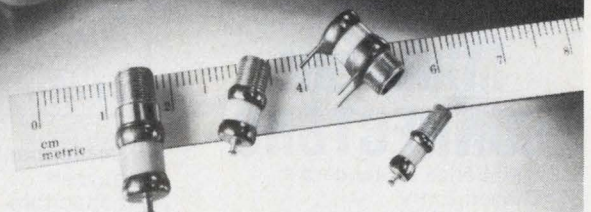

MVM®/AIR VARIABLE CAPACITORS

JFD air variable capacitors are specially designed for high frequency applications that demand extreme stability, small size and high Q—greater than 5000 measured at 10 pf and 100 MHz. These rugged, miniature units are offered in both printed circuit and panel mounting models in capacitance ranges of 0.35-3.5 pf; 0.4-6 pf; 0.8-10 pf; and 1-20 pf measured at 1 MHz. These units which measure less than 1/2" in length are completely interchangeable with competitive devices.

JFD where the miniature precision capacitor began . . . and where it's at!

JFD ELECTRONICS COMPONENTS CORPORATION

15th Avenue at 62nd Street, Brooklyn, N. Y. 11219
212-331-1000 TWX 710-584-2462

CIRCLE NUMBER 103

FREE CATALOGS on PM and SHUNT-WOUND adjustable speed drive systems



Catalog CDC-PM describes PM systems, 1/12-1/4 Hp. 20 pages, 57 drawings, photos and tables.

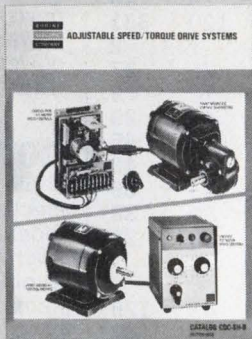

CDC-SH describes shunt-wound systems, 1/50-1/4 Hp. 16 pages, 51 photos, drawings and tables.

... from Bodine and Bodine Distributors

Designed and built by Bodine to give you *perfectly matched* speed/torque control characteristics—provide reliability and performance you might expect only from far more costly and complex systems.

**BODINE
ELECTRIC
COMPANY**

BODINE MOTORS
GEAR MOTORS
SPEED CONTROLS

Send for catalogs today.

Bodine Electric Company, 2500 W. Bradley Place, Chicago, IL 60618

CIRCLE NUMBER 102

ELECTRONIC DESIGN 23, November 8, 1977

Buzzzzz.

(Write for new catalog.)



Solid state electronic MICRO-BUZZER from CITIZEN: High reliability, competitively priced with immediate delivery.

A complete range: **SMB** 1.5, 6, 12, 24, VDC
RMB 3, 6, 12, 24, VDC
IMB (Intermittent) 6, 12, VDC

CITIZEN

CITIZEN AMERICA CORPORATION
1710 - 22nd St.
Santa Monica,
CA 90404

Toll Free (800) 421-6516
In Calif. (213) 829-3541
TWX: (910) 343-6450

Name _____
Company _____
Address _____
City _____ State _____
Zip _____ Phone _____

CIRCLE NUMBER 104

USC'S UMI most compact ULTRA MINIATURE CONNECTORS

7 UMI Series -- Standard & Closed-Entry MIL-C-28748/7, 8 and others.

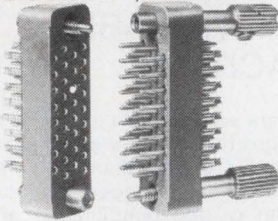

Highest reliability -- proved in Gemini/Apollo flights! 1 of over 20,000 types of connectors. Write or phone for UMI Series catalog -- today!

U.S. COMPONENTS, INC.



Leader in advanced engineering & design
1320 Zerega Avenue, Bronx, N.Y. 10462
(212) 824-1600 TWX: 710-593-2141
Cable: COMPONENTS, NYK

CIRCLE NUMBER 105

Cost Effective Data Scanning

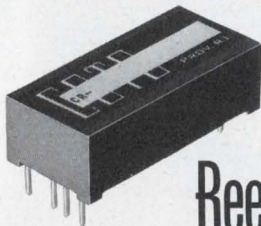

Reed Relays

NEW GENERATION
LOW-COST, ULTRA
LOW-THERMAL EMF

- New simpler design reduces cost, maintains performance and reliability
- Switches signals to 1 μ V resolution
- Low, stable contact resistance
- High control/signal circuit isolation
- Graded and priced to the thermal offset you need . . . pay no more.

Write or Call for Bulletin 10.4



**COTO-COIL
COMPANY, INC.**
59 Pavilion Ave.
Providence, R. I. 02905
Tel: (401) 467-4777

CIRCLE NUMBER 106

Product index

Information Retrieval Service. New Products, Evaluation Samples (ES), Design Aids (DA), Application Notes (AN), and New Literature (NL) in this issue are listed here with page and Reader Service numbers. Reader requests will be promptly processed by computer and mailed to the manufacturer within three days.

Category	Page	RSN	Category	Page	RSN
Components			mixers, broadband	74	36
buzzers	159	104	oscillator	132	357
capacitors	159	163	photodetector	132	356
capacitors, ceramic	147	95	Modules & Subassemblies		
circuit breaker	39	24	a/d, d/a input card	105	49
coils, relays, Xformers	141	81	converter, s/d	134	362
displays, liquid-crystal	147	96	drive systems	159	102
indicator lights	87	41	line-surge absorber	139	79
ink-jet writing system	121	62	oscillator, VC	134	361
keyboard pads	120	61	peripheral boards	107	50
lamps, miniature	138	78	power amplifiers, rf	112	53
panel meter	38	23	power amps	98	44
relays, DIP	2	3	stepper drive	143	85
relays, reed	160	105	Packaging & Materials		
resistors, thin-film	117	58	buses	131	72
solenoids	116	57	bushings	147	94
switches	119	60	case, digital-display	142	379
switches	145	89	connectors	31	19
switches, PB	113	297	connectors	45	27
switches, PB	149	99	connectors	149	98
switches, rotary	149	100	connectors	160	106
thermal cutoffs	145	91	connectors, ribbon	123	63
transformers	126	66	elastomer	81	39
trimmers	51	32	flux	124	64
yokes	139	80	heat-sink insulators	144	88
Data Processing			heat sinks	146	93
minifloppies	20	14	solder terminals	143	84
PROM programmer	137	77	test clip, DIP	142	378
terminal	127	67	transistor packaging	103	48
terminals	15	11	work stations	114	55
ICs & Semiconductors			Power Sources		
ICs, Hall-effect	110	52	batteries	135	75
isolators, DIP	7	6	generator, power	130	347
LEDs	29	18	power supplies	6	5
line driver	120	331	power supplies	40	26
line receiver	1	2	power supplies	49	30
multipliers, bipolar	75	37	transformer, power	130	348
op amps	12	9	new literature		
op amps	48	29	cable ties	148	397
power transistors	99	45	electronic components	146	392
SCRs	86	40	index, article	148	394
semiconductors	143	86	microcomputer course	144	385
transistors, silicon	80	38	mini-DIP switches	146	389
zeners	46	28	nematic-liquid crystals	144	388
Instrumentation			proceedings, faire	146	390
counter/timer	43	125	rental instruments	148	396
generator, sweep-signal	92	42	silicon-controlled		
oscilloscopes	13	10	rectifiers	146	391
oscilloscopes	73	37	small-business systems	148	395
test chamber	159	101	solenoids	148	398
Micro/Mini Computing			transformers	144	387
card, breadboarding	112	308	transistors	144	386
card, logic	111	302	VMOS	148	393
microcomputer	9	7	application notes		
minicomputer	101	47	power measurements	144	383
Microwaves & Lasers			quartz-analog		
amplifier	132	360	timekeeping	144	380
attenuator, PIN	132	358	spectrum analyzer	144	382
divider, power	132	359	spike suppressors	144	384
ferrite circulator	132	350	thyristor gating	144	381
ferrite circulators	133	141			
LED, infrared	132	349			

New Data Generator

Lets you program and edit with keyboard,
then display Hex-Octal-Binary and timing formats.



ides 16 parallel channels - 64 bits deep -
bits serial...at data rates to 20 MHz.

Model
tes
ing

one bit or a continuous run of pre-programmed data at TTL levels.

MICROPROCESSOR INTER-FACE... The Microprocessor control allows easy interface with other instruments or systems.

MODEL 720, only \$3,950
complete. Write or call Tom Clark
for additional information.



Add a **MODEL 741** Logic Analyzer... the perfect companion to the Data Generator... and observe/analyze parallel or serial data from many subsystems... only **\$2,750**... much below stand-alone cost.



92664 • Phone: (714) 833-2000 • TWX: 910-596-1362

Hot new circuit ideas with RCA op amps and arrays.

When you put RCA BiMOS op amps together with other RCA op amps and arrays, they have a way of making circuits easier, more effective and often less expensive.

One-knob function generator.

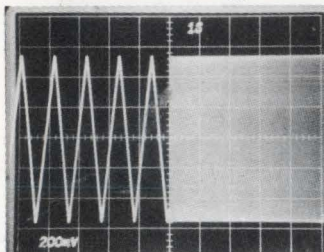

1,000,000/1 frequency range—1 Hz to 1 MHz—with a single control knob and just three op amps. Two CA3080 variable op amps (one on input, one as output hysteresis switch), plus one CA3160 internally compensated BiMOS op amp as buffer.

Electronic alarm.



Wide signal swing of the CA3130 combined with the variable gain control features of the CA3094 produce yelp, wail, two-tone and other sounds in sirens and alarms.

Low-power timing signal.

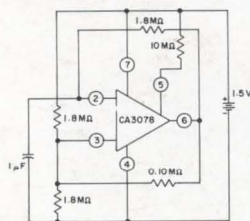

Multivibrator using CA3078 micropower op amp generates a timing signal from a 1.5 V battery supply with just 3 microwatts of power. A CA3078 exclusive.

Bandgap reference supply.



For power supplies and DVMs, it provides 2.35 V reference. Uses a CA3078 micropower op amp as a buffer for the bandgap reference, the CA3086 transistor array. Eliminates need for discrete diodes.

Audio power amp.

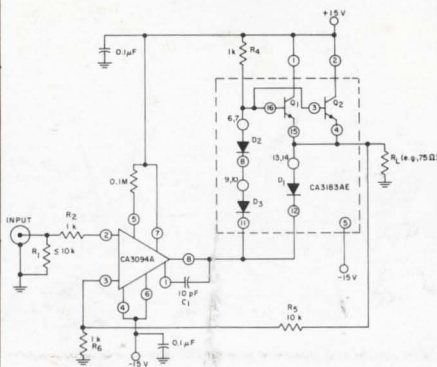

A CA3094 variable op amp plus a CA3183 transistor array provide push-pull output of 100 mA average. Drives high impedance speakers.

Sample-and-hold system.

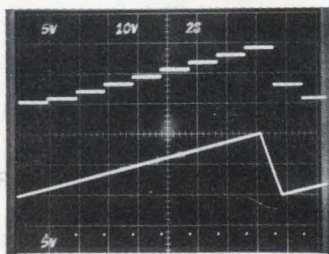

Ideal for single supply, low-cost applications. Samples inputs ranging from 0 to 10 V. The BiMOS CA3140 makes it possible.

Wien bridge oscillator.

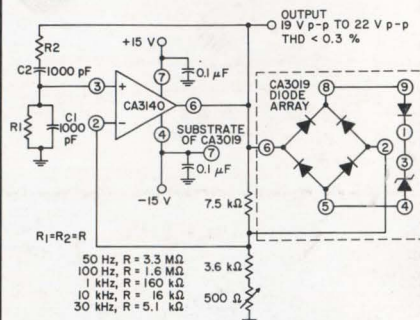

CA3140 op amp and CA3019 diode array combine to produce a low-cost wien bridge with 50 Hz to 30 kHz range.

Battery voltage monitor.



CA3097 array hysteresis transistors, SCR need to provide signal indicating charge.

There's a lot more with RCA's full line. Get complete information in our other useful brochures. Contact your local RCA headquarters in Sunbury, England; Munich, Germany; or Quebec, Canada; or Tokyo, Japan.