

Electronic Design

FOR ENGINEERS AND ENGINEERING MANAGERS

VOL. 22 NO.

7

APRIL 1, 1974

Strange structures appear inside microwave tubes. An example is the contra-wound dual helix, used for some travelling-wave tubes. Improved designs yield

better performance in less space. For a review of the advances in TWTs, planar triodes, klystrons, magnetrons, cross-field amplifiers and BWOs, turn to page 30.



Can your resistors handle emergencies?

Here's how to make sure:

When a resistor is confronted by a high energy pulse current, it should do one of two things: "Open"...in order to protect valuable circuit components or shrug off the pulse to assure that the circuit remains functional.

In a simple "open or shut" case like this, it's not hard to decide which choice is best for your product. But the going gets tougher when you try to match your "worst case" requirements with a resistor that's functional in performance, size and price. At this basic selection level, you often find you need to know a lot more about a resistor's emergency capabilities than most companies can tell you.

Which is why we get a lot of phone calls at Dale... and also why we've prepared some helpful new information on resistive pulse handling and fusing.

Let's say, for example, that you're planning to use one of Dale's 5-watt RS wirewounds in a transistor emitter circuit. These

new tables and formulas will show that it can

withstand millisecond pulses up to 24,000 watts! However, if you want the same circuit

24,000 Watts
...learn how to
figure the pulse handling
capability of your resistors.

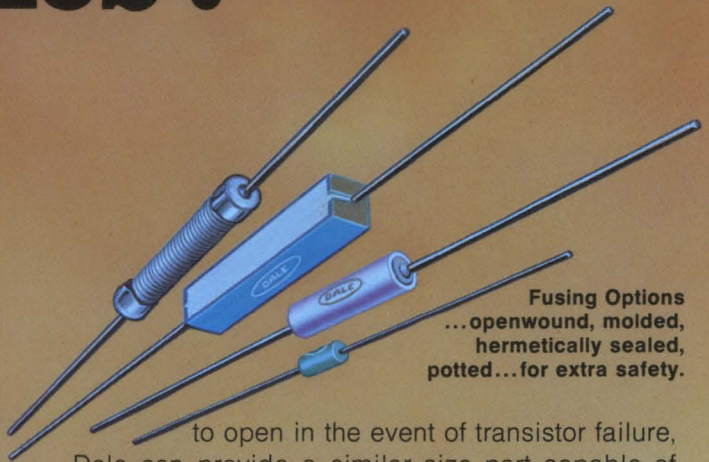

Fusing Options
...openwound, molded,
hermetically sealed,
potted...for extra safety.

to open in the event of transistor failure, Dale can provide a similar size part capable of opening in milliseconds at a pulse time/size level you specify.

This kind of "open or shut" option lets you be certain you're designing in the kind of extra protection that can make your products more valuable...and it's available throughout Dale's broad resistor line. Drop us a line or give us a call. In this sophisticated world, you'll be glad to find that someone is working at making the basics better.

DALE
Pulse handling capabilities of wirewound resistors.

DALE
Effective use of fuse resistors.

Write for these new publications.

DALE ELECTRONICS, INC.
1300 28th Avenue, Columbus, Nebraska 68601
A subsidiary of The Lionel Corporation In Canada:
Dale Electronics Canada Ltd. In Europe: Dale Electronics GMBH,
8 Munchen 60, Falkweg 51, West Germany

INFORMATION RETRIEVAL NUMBER 246



SURPRISE!

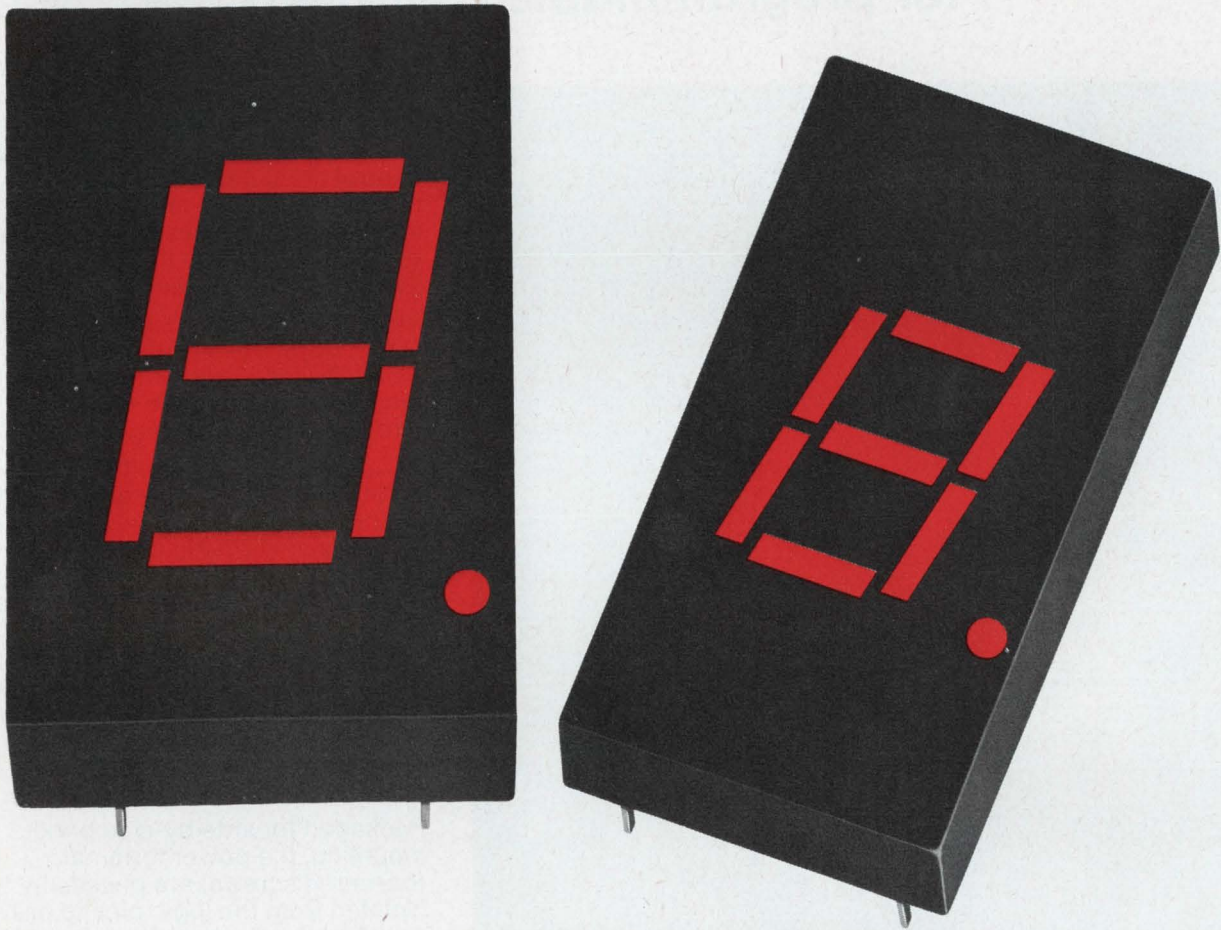

HP displays are bigger than ever!

Now you can get a big, readable 0.43 inch LED display without sacrificing the simplicity and economy of single chip per segment design. Bright enough to clearly see 20 feet away. HP's 5082-7750 series display features the same wide viewing angle, excellent readability and the same pin configuration as our 0.3 inch 5082-7730 series displays.

Just \$3.50 each in 100 quantities*.

Contact Schweber, Hall-Mark or the Wyle Distribution Group for immediate delivery. Or, write us for more details. This is one display you won't want to miss.

01403

*Domestic USA price only.

INFORMATION RETRIEVAL NUMBER 2

HEWLETT  **PACKARD**

Sales and service from 172 offices in 65 countries.
1501 Page Mill Road, Palo Alto, California 94304

Teledyne in solid control

AC and DC I/O converters for programmable controllers

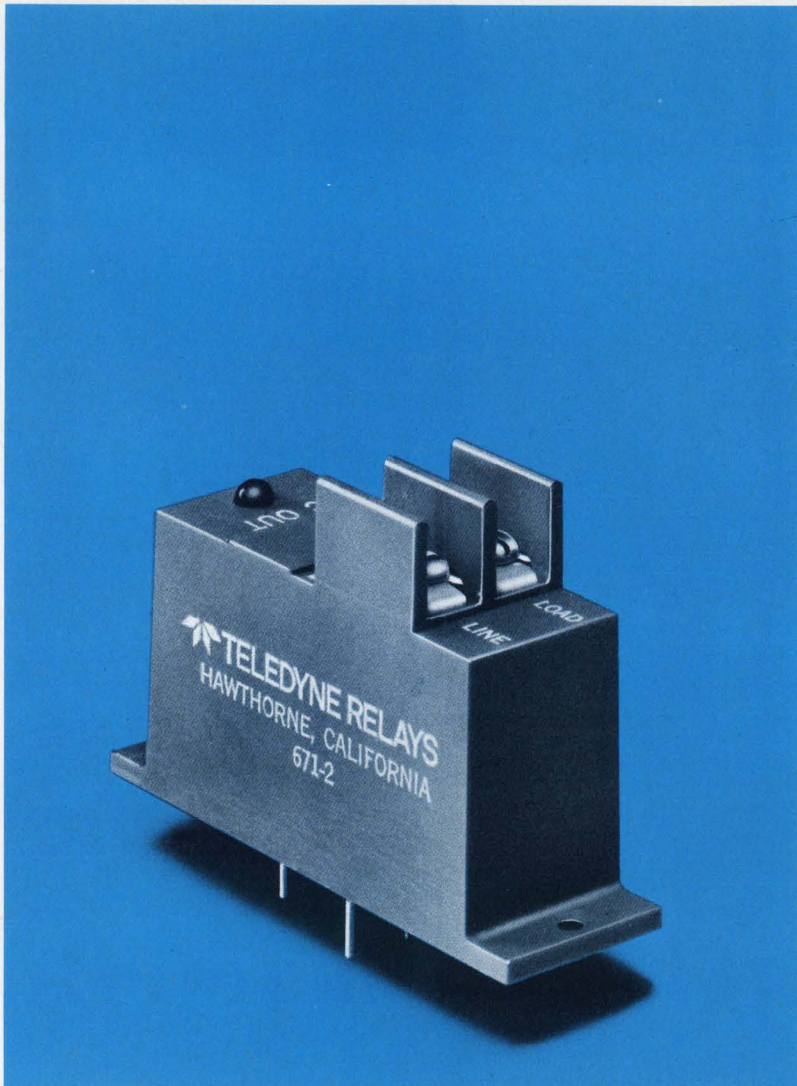

The boundary of the minicomputer mainframe or CPU world — of sensitive IC logic families — and the process control or machine tool world of motors, solenoids, lamps, and electro-mechanical switches is a tough place, demanding devices for fast quiet switching and load sensing — reliably.

Teledyne, the world's leader in solid state relays, offers the 671 series AC or DC input and output converter modules — state of the art in circuitry and packaging.

ALL SOLID STATE, the 671's are optically isolated between logic and AC or DC power; high noise immunity prevents misfiring in industrial atmospheres. Output converters have high surge ratings for inductive loads; an AC output unit is available with zero voltage switching to minimize RFI. There's more: easy multiplex operation, LED status indicators for simple troubleshooting, and solid state reliability . . . *minimum* life of 10^8 operations.

Packaged for side-by-side panel mounting, the power terminals (barriered screws) are physically isolated from the logic pins to prevent accidental intrusions; side-by-side units mean no terminal strips and interconnect wiring.

If you're in the mainframe business and want to offer process control, or if you're in the processing world and want computer control, write or call about the 671 series; our application engineers will put you in solid control.

 **TELEDYNE RELAYS**

3155 West El Segundo Boulevard Hawthorne, California 90250
Telephone (213) 973-4545

INFORMATION RETRIEVAL NUMBER 3

NEWS

- 25 **News Scope**
- 30 **A special report on microwave tubes**—The struggle to raise efficiency and power while dropping costs.
- 40 **Alternative to multilayers proposed:** Stacked PC boards at half the cost.
- 40 **Rugged computer tape** said to be immune to edge damage.
- 45 **Washington Report**

TECHNOLOGY

- 50 **Software for MOS/LSI microprocessors** differs from one circuit to another. A careful analysis of instruction sets helps establish a processor's capabilities.
- 58 **A 1000-W solid-state power amplifier?** You bet. It's done with four 320-W sections. Here are key transistor parameters and the transformer winding details.
- 64 **A/d and d/a converter testing:** It isn't as hard as you think. The two major specifications, linearity and accuracy, can be tested fast and automatically.
- 70 **Using consultants takes consultation,** says this technical director, who lists their disadvantages as well as the obvious advantages they offer.
- 74 **Ideas for Design:** Transistor bleeder gives opto-isolator a wide temperature range of operation . . . Multiple-feedback bandpass circuit allows use of standard capacitors in elliptic filter . . . One-shot adds the clock pulses to help recover phase-encoded data.
- 80 **International Technology**

PRODUCTS

- | | | | |
|----|-------------------------|-----|-------------------------|
| 83 | Microwaves & Lasers | 94 | Data Processing |
| 86 | Instrumentation | 98 | ICs & Semiconductors |
| 90 | Discrete Semiconductors | 100 | Modules & Subassemblies |
| 92 | Components | 102 | Packaging & Materials |

Departments

- | | | | |
|-----|---|-----|----------------------------|
| 49 | Editorial: Opera and engineering | | |
| 7 | Across the Desk | 112 | Advertisers' Index |
| 104 | New Literature | 114 | Product Index |
| 108 | Bulletin Board | 114 | Information Retrieval Card |
| 108 | Vendors Report | | |

Cover: Photo by Garo Enjaian, courtesy of Hughes Aircraft Co.

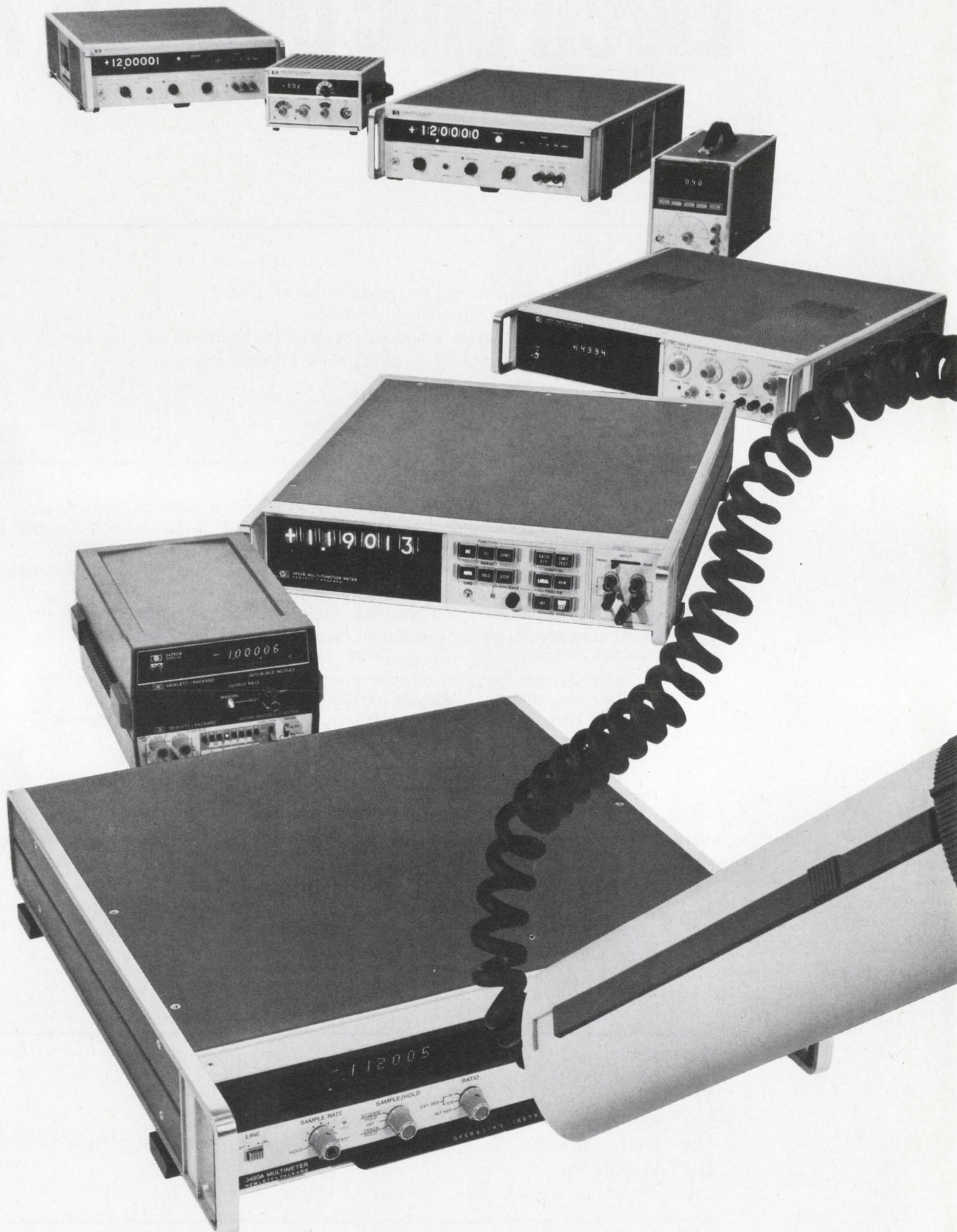

HP's Family Planning Means A DVM To Match Your Budget And Your Needs.

An HP DVM Built For Your Needs . . . all the way from troubleshooting in the field to complex systems in the plant. Whether you need a general-purpose instrument or one dedicated to a specific task such as measuring true RMS, we can supply it. With our modular and plug-on approach we can even combine general-purpose and specialized functions. HP's innovation and advanced technology are on your side to help solve your measurement problems. Look at the capability you can obtain in just five instruments from our broad product line.

Low-cost 970A Probe Multimeter packs a lot of performance in a seven-ounce package. Probably the easiest-to-operate probe multimeter ever made,

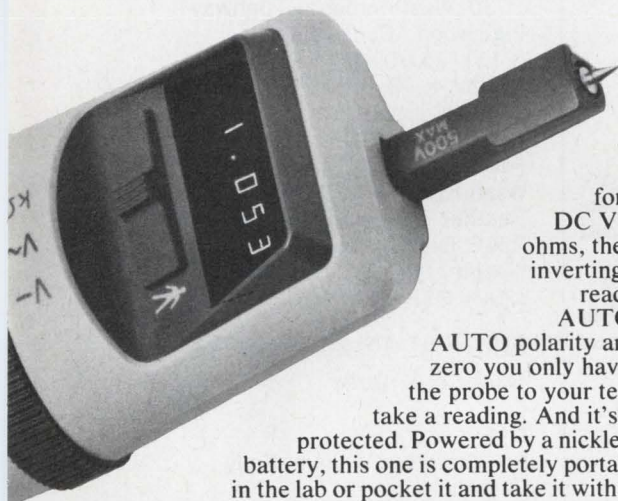

this 3½-digit instrument has only two selectors; one for choosing DC V, AC V or ohms, the other for inverting the LED readout. With

AUTO ranging, AUTO polarity and AUTO zero you only have to touch the probe to your test point to take a reading. And it's overload-protected. Powered by a nickle-cadmium battery, this one is completely portable. Use it

in the lab or pocket it and take it with you in the field. It's designed to simplify your measurement tasks from start to finish. You can operate it single-handed, right side up or upside down. The inverting switch lets you read the display either way. And you read it right at the test point. At just \$310* the 970A probe multimeter is a real bargain.

Self-Test 3490A makes double use of its internal ICs to bring you HP's "Self-Test" capability without extra cost. The basic 5-digit 3490, ready to measure AC, DC and ohms, sells for only \$1,650*. At low added cost you can have isolated BCD output and remote control or the versatile General Purpose Interface Bus for systems applications. Compare the 3490A with any other multimeter in its class and you'll find an unusual blend of features and performance for the money.

Snap-On 3470 Series lets you custom-build your own measurement system. Starting with a 4½- or 5½-digit LED display unit, you add only those modules you need. Get 4½-digit DC only for \$475*, or 5½-digit DCV/DCA/Ohms for

\$1,100*. Add a battery pack for \$200*, BCD output for \$175* or an HP "Self-Test" accessory for only \$50*. With this series you don't have to worry about obsolescence.

Multi-Mode 3450B lets you add up to 12 modes of high-accuracy measurement capability to your automated system. You can have true RMS, 4-terminal ohms and the unique limit test in addition to the usual functions. The 3450 is both fast and accurate. You get 15 readings/sec. and DC accuracy to ±(0.008% of reading + 0.002% of range). Prices start at \$3,500* for the 5-digit DC volts and Ratio model, go to \$6,105* for total 12-mode capability.

Speed Star 3480C/D is systems oriented, but fine for the bench as well. This 4-digit, ±0.01% unit in DC delivers a fast 1,000 reading/sec. Get the exact capability you need by selecting plug-ins. For example, you can have DC, ohms and true RMS AC for \$3,090* (isolated BCD output and remote control are low-cost options). Sample and hold option lets you take peak readings or do transient analysis.

HP's family of DVM's also includes high-performance AC V, DC A and ohms (Model 3469B at \$700.), resolution of 1 PPM (Model 3462A at \$5,390*), true RMS to 100 MHz (Model 3403C from \$1,680*) and for systems use, the 2402A with outstanding noise rejection at high measurement speeds from \$7,000*. No matter what your measurement needs, check HP for a solution to your problem. For more information on how HP's DVM family can help you, contact your local HP field engineer or fill out the coupon below and mail it in.

For helpful information on DVM measurement techniques, send for our 72-page application note AN-158 entitled "Selecting the Right DVM."

*Domestic U.S.A. prices.



Sales and service from 172 offices in 65 countries.
1501 Page Mill Road, Palo Alto, California 94306

I'm interested in your DVM line. Please send me:
 More information on the 970A Probe Multimeter.
 More information on the DVM family.
 Application Note 158 "Selecting the Right DVM."

Name _____ Dept. _____

Company _____

Street _____

City _____ State _____ Zip _____

Mail coupon to:

Hewlett-Packard, 1501 Page Mill Road, Palo Alto, California 94306

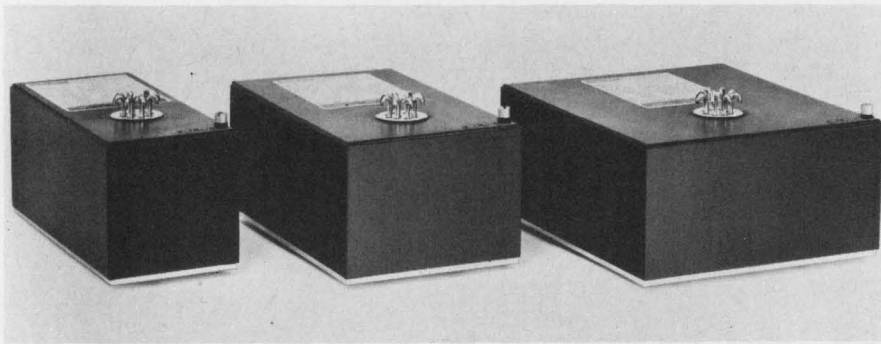

Save 5 Ways with Abbott's New 77% Efficient Power Supplies!

Abbott has a Hi-Efficiency series of power modules that can save 5 ways in your system. The Model "VN" series converts 47-440 Hz AC lines to regulated DC power and uses a new approach in switching technology that provides a highly reliable line of 63 high efficiency power modules.

The Model "VN" series saves in the following 5 ways:

- 1 SAVES POWER** — High frequency pulse width modulation and C/MOS digital IC control circuitry allow efficiencies of up to 80% in the Model "VN" series. This high efficiency realizes 75% more output power per input watt than dissipative regulators.
- 2 SAVES SIZE** — Off line techniques and IC technology combine for packages of 70% less volume compared to dissipative regulators.
- 3 SAVES WEIGHT** — High efficiency means less power dissipated and less heat generated, thereby reducing or eliminating the need for bulky heat-sinking and forced air cooling. This translates into less total weight and smaller system size.
- 4 SAVES TIME** — You can quickly get the power supply you need because we have an extensive line of models to choose from. Outputs of 25w, 50w and 100w are available at any voltage between 4.7 and 50.0 VDC. With popular voltages in stock, chances are the unit you need is available immediately.
- 5 SAVES MONEY** — At only \$239 for 25w, \$255 for 50w, and \$275 for 100w in small quantities, the "VN's" are among the lowest priced Hi-efficiency units on the market.

Abbott also manufactures 3,500 other models of power supplies with output voltages from 2.7 to 740 VDC and output currents from 4 milliamps to 20 amps. They are all listed, with prices, in the new Abbott Catalog. Included are:

60 μ to DC
 400 μ to DC
 28 VDC to DC
 28 VDC to 400 μ
 12-38 VDC to 60 μ

Please see pages 581-593 of your 1973-74 EEM (ELECTRONIC ENGINEERS MASTER Catalog) for complete information on Abbott Modules.

Send for our new 60 page FREE catalog.

abbott transistor

LABORATORIES, INCORPORATED
 general offices eastern office

5200 W. Jefferson Blvd./Los Angeles 90016
 (213) 936-8185 Telex: 69-1398

1224 Anderson Ave./Fort Lee, N.J. 07024
 (201) 224-6900 Telex: 13-5332

INFORMATION RETRIEVAL NUMBER 5

Vice President, Publisher
 Peter Coley

Editors

Editorial Offices
 50 Essex St.
 Rochelle Park, N.J. 07662
 (201) 843-0550
 TWX: 710-990 5071
 Cable: Haydenpubs Rochellepark

Editor-in-Chief George Rostky

Managing Editors:

Ralph Dobriner
 Michael Elphick

Associate Editors:

Dave Bursky
 Jules H. Gilder
 Morris Grossman
 Seymour T. Levine
 John F. Mason
 Stanley Runyon
 Edward A. Torrero
 Richard L. Turmail

Contributing Editors:

Peter N. Budzilovich
 Robert Willins

Editorial Field Offices

East

Jim McDermott, Eastern Editor
 P.O. Box 272
 Easthampton, Mass. 01027
 (413) 527-3632

West

David N. Kaye, Senior Western Editor
 2930 West Imperial Highway
 Inglewood, Calif. 90303
 (213) 757-0183
 Northe K. Osbrink, Western Editor
 112 Coloma St.
 Santa Cruz, Calif. 95060
 (408) 426-3211

Washington

Heather M. David, Bureau Chief
 2506 Eye St., N.W.
 Washington, D.C. 20037
 (202) 338-3470

Editorial Production

Marjorie A. Duffy

Art

Art Director, William Kelly
 Richard Luce
 Anthony J. Fischetto

Production

Manager, Dollie S. Viebig
 Helen De Polo
 Anne Molfetas
 Christopher G. Hill

Circulation

Manager, Nancy L. Merritt

Information Retrieval

Peggy Long

Promotion

Manager, Jeffrey A. Weiner
 Karen Kerrigan

Trees 'spruce up' Navy designs

The revealing article, "It's a Tree . . . a Pole . . . a Man, No! A Short-Range hf Antenna" (ED No. 26, Dec. 20, 1973, pp. 52-55) has created great interest in our Shipboard Antenna Unit here. The Navy, of course, has long experienced severe problems in attempting to place antennas in the extremely hostile, constricted environment presented aboard ship. The use of trees never occurred to us—apparently, because of the cluttered topside, we've missed seeing trees for the forest.

In addition to possible improvements in the transmission and reception of rf energy, the rather drab, gray surroundings might be

"spruced up," and the entire ship might easily be disguised as an island. Finally the crew could enjoy the fruits of its labor—for example, homegrown nuts, dates, fruits and vegetables.

Accordingly we've begun to sprout new ideas to apply Dr. Ik-rath's work to shipboard antenna design. Submitted herewith is a preliminary sketch of our Forest Improved Radiation ship, the USS Evergreen, FIR-1.

When the Evergreen comes into port, incidentally, it would be appropriate for her to tie up at the Hickory-Dickory Dock.

Preston E. Law, Jr.

Albert C. Riggs, III

Naval Ship Engineering Center
Hyattsville, Md. 20782

(continued on page 15)

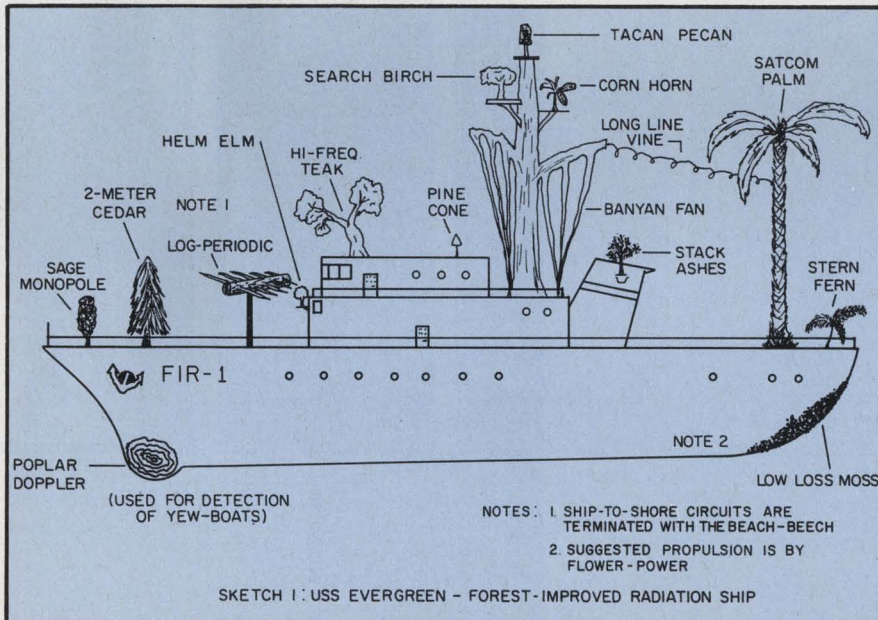

Electronic Design welcomes the opinions of its readers on the issues raised in the magazine's editorial columns. Address letters to Managing Editor, Electronic Design, 50 Essex St. Rochelle Park, N.J. 07662. Try to keep letters under 200 words. Letters must be signed. Names will be withheld on request.

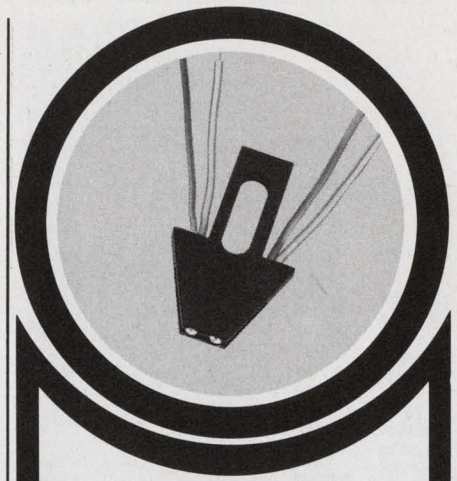

OPTRON OPTOELECTRONIC ASSEMBLIES

LOW PRICED
IMMEDIATE DELIVERY
CUSTOM DESIGNS AVAILABLE

OPTRON transmissive optical switch and reflective transducer assemblies consist of infrared LED's coupled with silicon phototransistors or photodarlington. Both use discrete hermetically sealed devices for maximum reliability and sensitivity. The assemblies feature non-contact switching, TTL compatibility and fast switching speeds. Low priced standard assemblies are immediately available and custom designed versions for special applications are available on request.



OPB 120 TRANSMISSIVE OPTICAL SWITCH uses an infrared LED aligned across a gap with a silicon phototransistor. The

OPB 120 replaces mechanical switching elements with solid state dependability. Typical applications include rotary encoders, tachometers and motion sensors. Standard gap widths are 0.125 and 0.200 inches.



OPB 125 OPTOELECTRONIC REFLECTIVE TRANSDUCER consists of a gallium arsenide infrared LED coupled with a silicon phototransistor in compact low-

cost molded plastic housing. It has extremely high sensitivity and is ideal for such applications as EOT/BOT sensing, line finding, and edge and flaw detection.

Detailed technical information on these and other OPTRON optoelectronic products . . . chips, components and PC board arrays . . . is available from your nearest OPTRON sales representative or the factory direct.

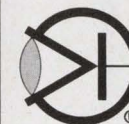

OPTRON, INC.

1201 Tappan Circle
Carrollton, Texas 75006
214/242-6571

Find your control system interface problem here...

1. Incompatible Logic Families

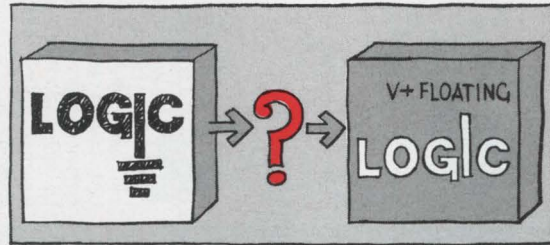

2. AC-to-DC Control

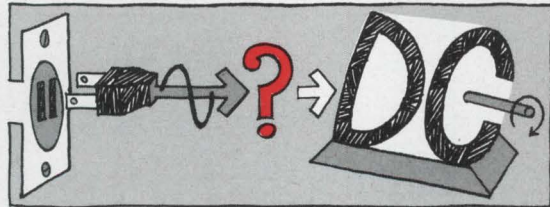

3. Controlling Remote Power Supplies

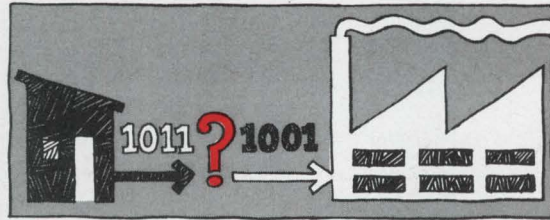

4. Voltage Transient Feedback

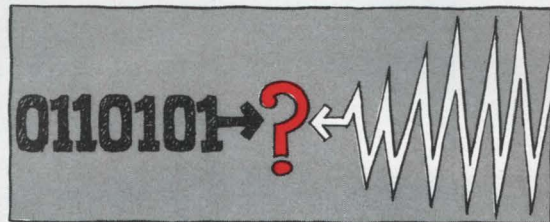

5. DC-to-AC Control

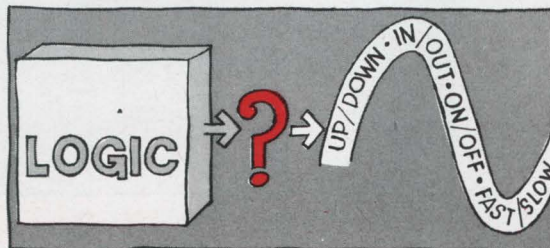

Then solve it with an optical coupler

1. Logic-to-Logic Interfacing

Optical couplers afford total flexibility in logic family interfacing. Logic supplies can float with respect to each other, ground loops and intricate interface techniques involving voltage translators are eliminated.

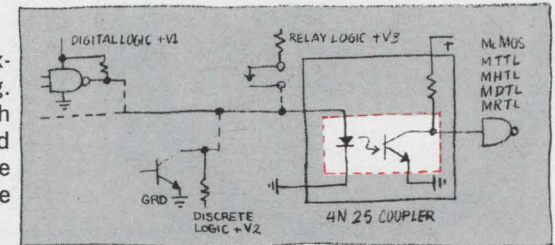

2. AC-to-DC Interfacing

AC signals actuate the optical coupler which controls the current through the DC load. Highly economical, the coupler replaces step-down transformers and obviates transient feedback.

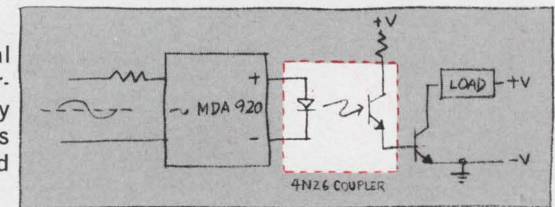

3. Remote Control Of Digitally-Programmed Power Supply

100-billion-ohm isolation affords control of a remote floating power source from the computer/peripheral without intricate biasing networks.

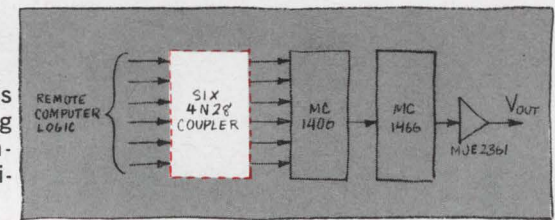

4. Logic-to-High Power Interfacing

One unidirectional optical coupler minimizes transient feedback from high power loads conventionally isolated through bidirectional transformers or RC coupling.

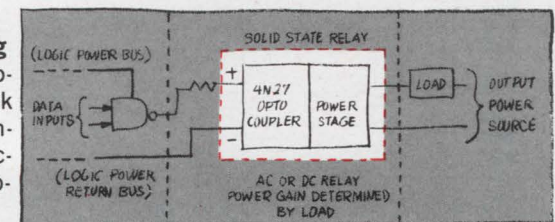

5. Logic-to-AC Control/Motor

Easy, economical control of high-level AC power without electro-mechanical relays and transformers is possible using low-level, 500-2500 V optical isolation. Miniature packaging and PCB plug-in are bonuses.

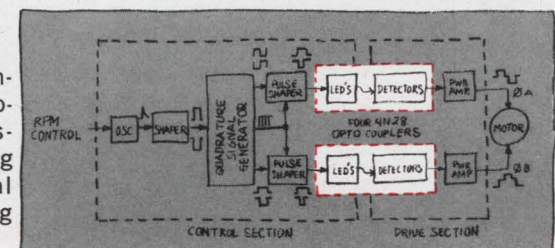

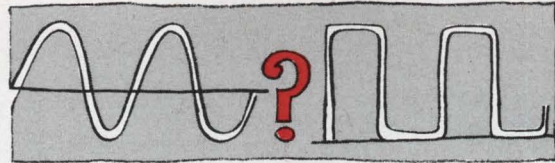
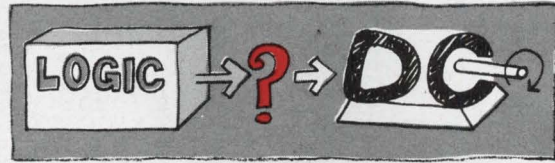
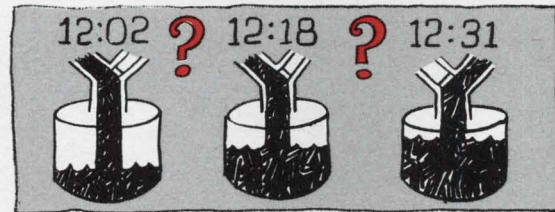
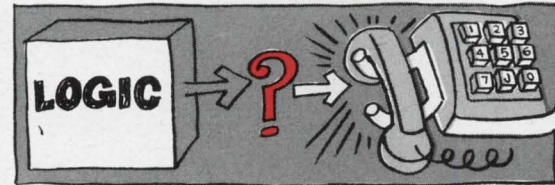
6. Zero-Crossing Detection**7. Logic Control Of DC Motors****8. Logic-to-AC Relays****9. Long Time Delay Relays****10. Telephone Ringing Current Interrupt****6. Zero-Crossing Detection**

For applications requiring use of line voltage for synchronization purposes, an economical approach uses a coupler in place of a transformer.

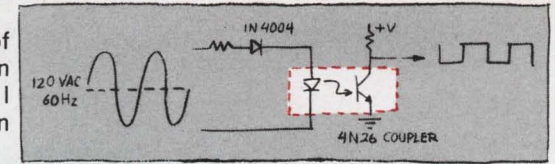
**7. Logic-to-DC Motors**

Traditional, long-term solid-state operation without arcing, bounce or wear-out is ensured with a no-moving-parts optical coupler and power Darlington transistor.

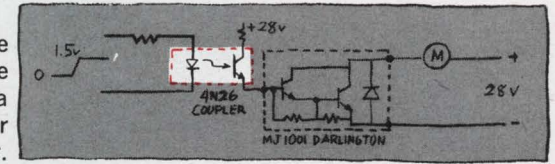
**8. Logic-to-AC Relay**

Control of AC loads from logic is easily implemented using optical isolation. Speed for zero-crossing actuation unavailable through E-M means, is provided by the total solid-state approach.

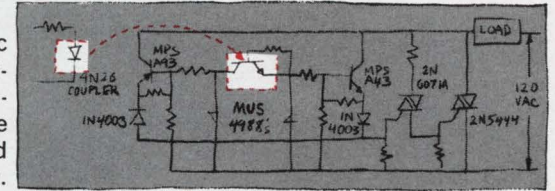
**9. Long Time Delay Relays**

Processing requirements needing precise mixing/metering through time delay can be met using the MC1555 timer and a coupler to isolate the logic/AC power source.

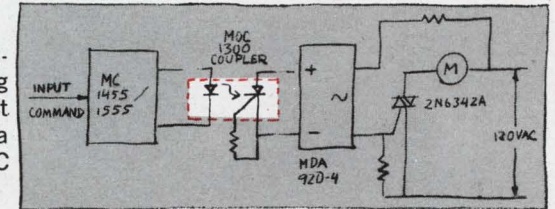
**10. Telephone Bell Ringing Actuator**

Limited contact life, high maintenance and EMI problems are eliminated with an optically-coupled bell actuator.

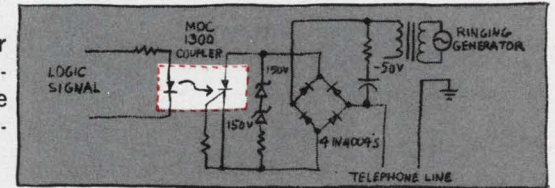

Quick. Simple. Reliable. Optical couplers furnish today's optimized answer to control system interfacing or isolation. Prices

low as 94¢, 1000-up. Find out all about them. Send for "Optical Couplers At Work" P. O. Box 20912, Phoenix, Arizona,

85036. You'll get better answers on interfacing...

INFORMATION RETRIEVAL NUMBER 7

Problem solving

from Motorola, the semiconductor source.



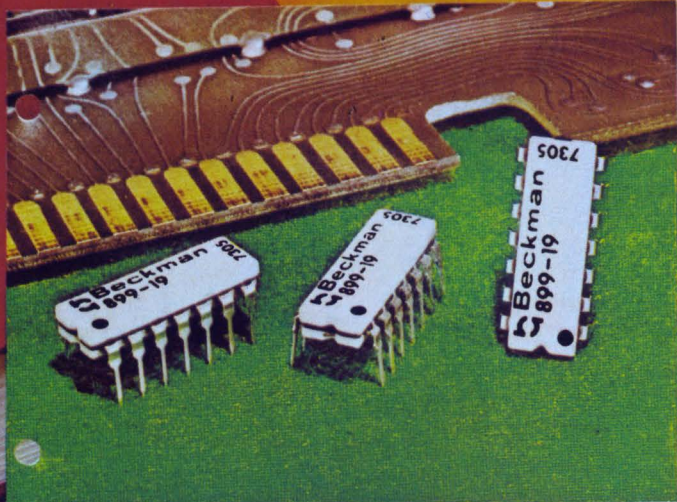
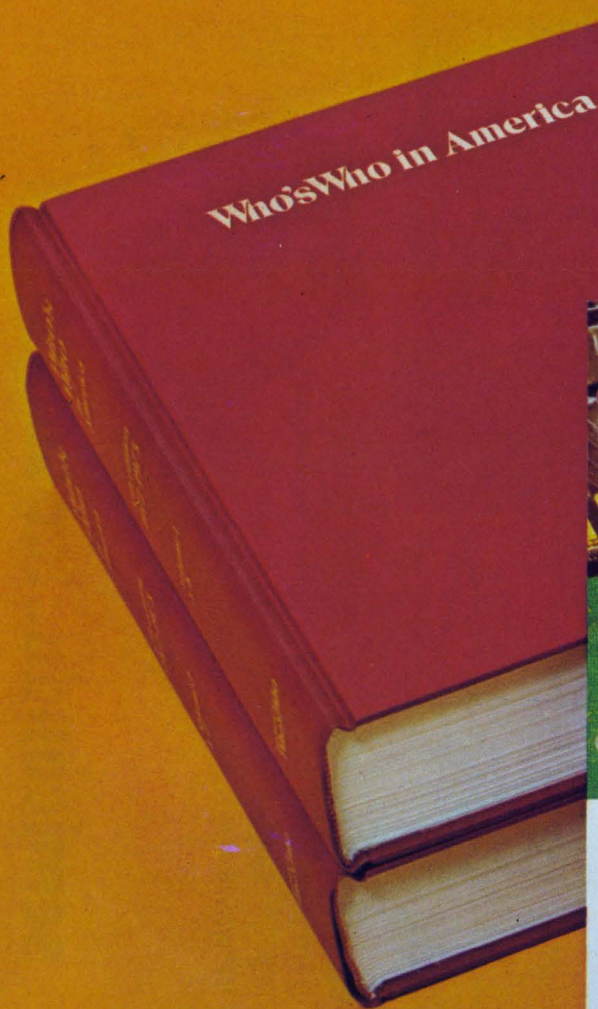

Beckman Resistor Networks
Technical Bulletin • December 1973

Beckman®

The two-volume set is famous as a living, changing record of persons whose accomplishments are notable and important in American life. The catalog is growing famous, too. Because it details the Beckman RESNET™ DIP resistor network line—No. 1 in worldwide brand preference.

For good reasons, you should think of Beckman resistor networks, too, for any applications involving pull-up/pull-down, digital pulse squaring, line termination, current limiting, ECL terminators, and interface networks.

Why? Consider this. Production is totally automated. Laser tailoring is computer-controlled. Every part is 100% inspected, in process and during final assembly. Packages are dimensionally uniform, which means Beckman RESNET DIPs are ideal for automatic insertion techniques.

Then, we offer the broadest available line of standard resistor networks—both 14- and 16-pin versions. And these are kept in full stock by our distributors all around the country.

Another reason we're No. 1 in preference is our materials technology. We have 20 years in developing, improving and manufacturing our cermet materials. This shows up on your end as performance... accuracy... reliability.

Of course, if you need custom resistor networks, think of Beckman again. We offer them to suit virtually any market application. And custom applications assistance, as well. (If you need immediate literature, or the phone number of your local Beckman/Helipot representative, call toll-free 800-437-4677.)

Look into Beckman RESNET DIPs. Our achievement can help you with your achievement.

There's a standard source for What's What in resistor networks, too.

Beckman Electronic Component Distributors

EASTERN REGION

Arrow/Angus

P.O. Box 126
Moorestown, N.J.
(609) 235-1900
(215) 928-1800

Arrow Electronics, Inc.

5207 East Dr.
Baltimore, Md.
(202) 737-1700
(301) 247-5200

Arrow Electronics, Inc.

900 Route 110
Farmingdale, N.Y.
(516) 694-6800

Arrow Electronics, Inc.

295 Treadwell St.
Hamden, Conn.
(203) 248-3801

Arrow Electronics, Inc.

No. 15 A Street
Burlington, Mass.
(617) 273-0100

Arrow Electronics, Inc.

285 Midland Ave.
Saddle Brook, N.J.
(201) 797-5800

Harvey R & D Electronics

44 Hartwell Ave.
Lexington, Mass.
(617) 861-9200

Kierulff Electronics, Inc.

49 Bestpage Rd.
Hicksville, N.Y.
(516) 433-5530

Kierulff Electronics, Inc.

5 Industrial Dr.
Rutherford, N.J.
(201) 935-2120

Lynch-Gentry Associates, Inc.

1932 Drew Street
Clearwater, Fla.
(813) 443-2697

Lynch-Gentry Associates, Inc.

3470 Bowman Dr.
Winter Park, Fla.
(305) 671-7649

Marshall Industries G. S. Marshall Products Group

88 Needham St.
Newton Highlands, Mass.
(617) 965-5115

Marshall Industries

G. S. Marshall Products Group

230 Sherwood Ave.
Farmingdale, L.I., New York
11735
(516) 293-4141

M & C Sales

1106 Burke St.
Winston-Salem, N.C.
(919) 723-1001

M & C Sales

904 Bob Wallace Ave.
Huntsville, Ala.
(205) 539-8476

Ossmann Component Sales Corp.

395 Cleveland Dr.
Buffalo, N.Y.
(716) 832-4271

Ossmann Component Sales Corp.

411 Washington Ave.
Kingston, N.Y.
(914) 338-5505

Ossmann Component Sales Corp.

280 Metro Park
Rochester, N.Y.
(716) 442-3290

Ossmann Component Sales Corp.

132 Pickard Building
Syracuse, N.Y.
(315) 454-4477

Ossmann Component Sales Corp.

1911 Vestal Parkway East
Vestal, N.Y.
(607) 785-9949

CENTRAL REGION

Magnuson Electronics

2420 Oakton St.
P.O. Box 130
Mount Prospect, Ill.
(312) 956-0700

Magnuson Electronics

1246 West 7th St.
St. Paul, Minn.
(612) 227-8495

Norvell Electronics

10210 Monroe Dr.
Dallas, Tex.
(214) 350-6771

Norvell Electronics

6440 Hillcroft Ave.
Houston, Tex.
(713) 774-2568

Norvell Electronics

3340 S. Memorial Dr.
Tulsa, Okla.
(918) 663-1247

Sheridan Sales Co.

Box 37826
Cincinnati, Ohio
(513) 761-5432

Sheridan Sales Co.

Box 4457
Cleveland, Ohio
(216) 524-8120

Sheridan Sales Co.

Box 423
Dayton, Ohio
(513) 277-8911

Sheridan Sales Co.

33708 Grand River Ave.
Farmington, Mich.
(313) 477-3800

Sheridan Sales Co.

P.O. Box 677
Florissant, Mo.
(314) 837-5200

Sheridan Sales Co.

Suite 5009
1717 Penn Ave.
Wilksburg, Penn.
(412) 244-1640

WESTERN REGION

Almac/Stroum Electronics

8888 S.W. Canyon Rd.
Portland, Ore.
(503) 292-3534

Almac/Stroum Electronics

5811 Sixth Ave. South
Seattle, Wash.
(206) 763-2300

Marshall Industries G. S. Marshall Products Group

5633 Kendall Court
Arvada, Colo. 80002
(303) 423-9670

Marshall Industries G. S. Marshall Products Group

835 W. 22nd Street
Tempe, Ariz. 85282
(602) 968-6181

Marshall Industries G. S. Marshall Products Group

9674 Telstar Ave.
El Monte, Ca.
(213) 686-0141

Marshall Industries G. S. Marshall Products Group

8057 Raytheon Rd.
San Diego, Ca.
(714) 278-6350

Marshall Industries G. S. Marshall Products Group

788 Palomar Ave.
Sunnyvale, Ca.
(408) 732-1100

Wyle Distribution Group:

Elmar Electronics
6777 East 50th Avenue
Commerce City, Colo.
(303) 287-9611

Elmar Electronics
2288 Charleston Road
Mt. View, Ca.
(415) 961-3611

Liberty Electronics
124 Maryland Street
El Segundo, Ca.
(213) 322-8100

Liberty Electronics
3130 North 27th Avenue
Phoenix, Ariz.
(602) 257-1272

Liberty Electronics
8248 Mercury Court
San Diego, Ca.
(714) 565-9171

Liberty Electronics
5305 Second Avenue South
Seattle, Wash.
(206) 763-8200

Beckman

HELIPOT DIVISION

INFORMATION RETRIEVAL NUMBER 8



TECHNICAL RESEARCH and MANUFACTURING, Inc.

Kelly Avenue, Grenier Field, Manchester, N. H. 03103

Tel. 603-668-0120

Cable: TRAM Manchester, N. H., USA

TWX 710-220-6765

MICROWAVE COMPONENTS

1.8 KHz to 18 GHz



IN PHASE
OUTPUTS

POWER DIVIDERS / COMBINERS

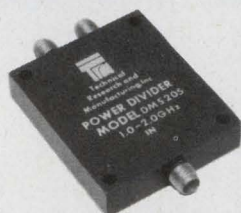
OUT OF PHASE
OUTPUTS

FERRITE	COAXIAL	STRIPLINE																													
DL SERIES 2, 3, 4, 6, 8 & 12 Ways <table border="1"> <tr><th>FREQ. BANDS</th></tr> <tr><td>.02 - 20 MHz</td></tr> <tr><td>0.1 - 100</td></tr> <tr><td>20 - 200</td></tr> <tr><td>100 - 400</td></tr> <tr><td>0.2 - 200</td></tr> <tr><td>5.0 - 500</td></tr> <tr><td>10 - 1,000</td></tr> </table> <table border="1"> <tr><th>TYP. SPEC.</th></tr> <tr><td>Loss 0.5dB</td></tr> <tr><td>Isolation 30dB</td></tr> <tr><td>VSWR 1.3:1</td></tr> <tr><td>Input Power 2.5W</td></tr> </table>  <p>IMPEDANCE Avail. 50 or 75 Ω</p>	FREQ. BANDS	.02 - 20 MHz	0.1 - 100	20 - 200	100 - 400	0.2 - 200	5.0 - 500	10 - 1,000	TYP. SPEC.	Loss 0.5dB	Isolation 30dB	VSWR 1.3:1	Input Power 2.5W	DM & DH SERIES 2, 3, 4, 6 & 8 Ways F center 100 to 1,500 MHz Bandwidths = ±20%, ±30% INPUT POWER DM = 60w CW 1Kw Peak DH = 500w CW 5Kw Peak  <table border="1"> <tr><th>TYP. SPEC.</th></tr> <tr><td>Loss 0.3dB</td></tr> <tr><td>Isol. 30dB</td></tr> <tr><td>VSWR 1.3:1</td></tr> </table>	TYP. SPEC.	Loss 0.3dB	Isol. 30dB	VSWR 1.3:1	DMS SERIES 2, 4 & 8 Ways <table border="1"> <tr><th>FREQ. BANDS</th></tr> <tr><td>OCTAVE</td></tr> <tr><td>.125 - 12.4 GHz</td></tr> <tr><td>MULTI-OCTAVE</td></tr> <tr><td>1.0 - 12.4 GHz</td></tr> <tr><td>7 - 18 GHz</td></tr> <tr><td>2 - 18 GHz</td></tr> </table> <table border="1"> <tr><th>TYP. SPEC.</th></tr> <tr><td>Loss 0.5dB</td></tr> <tr><td>Isolation 20dB</td></tr> <tr><td>VSWR 1.3:1</td></tr> <tr><td>Phase 0°</td></tr> </table>  <p>INPUT POWER 50 watts CW 1K watt Peak</p>	FREQ. BANDS	OCTAVE	.125 - 12.4 GHz	MULTI-OCTAVE	1.0 - 12.4 GHz	7 - 18 GHz	2 - 18 GHz	TYP. SPEC.	Loss 0.5dB	Isolation 20dB	VSWR 1.3:1	Phase 0°
FREQ. BANDS																															
.02 - 20 MHz																															
0.1 - 100																															
20 - 200																															
100 - 400																															
0.2 - 200																															
5.0 - 500																															
10 - 1,000																															
TYP. SPEC.																															
Loss 0.5dB																															
Isolation 30dB																															
VSWR 1.3:1																															
Input Power 2.5W																															
TYP. SPEC.																															
Loss 0.3dB																															
Isol. 30dB																															
VSWR 1.3:1																															
FREQ. BANDS																															
OCTAVE																															
.125 - 12.4 GHz																															
MULTI-OCTAVE																															
1.0 - 12.4 GHz																															
7 - 18 GHz																															
2 - 18 GHz																															
TYP. SPEC.																															
Loss 0.5dB																															
Isolation 20dB																															
VSWR 1.3:1																															
Phase 0°																															

BROADBAND 0, 90, 180° HYBRIDS OCTAVE; MULTI-OCTAVE 0, 90, 180°

FERRITE	COAXIAL	STRIPLINE																																					
HS 150 SERIES 0/180° <table border="1"> <tr><th>MODEL FREQ.(MHz)</th></tr> <tr><td>HS 151 .02 - 20</td></tr> <tr><td>HS 152 0.1 - 100</td></tr> <tr><td>HS 153 20 - 200</td></tr> <tr><td>HS 154 100 - 400</td></tr> <tr><td>HS 155 .2 - 200</td></tr> <tr><td>HS 156 5 - 500</td></tr> </table> <table border="1"> <tr><th>TYP. SPEC.</th></tr> <tr><td>Loss 1.0dB</td></tr> <tr><td>Isolation 30dB</td></tr> <tr><td>VSWR 1.5:1</td></tr> <tr><td>Phase Bal. 3°</td></tr> <tr><td>Amp. Bal. 0.3dB</td></tr> <tr><td>Input Power 2.5w</td></tr> </table>  <p>IMPEDANCE Avail. 50 or 75 Ω</p>	MODEL FREQ.(MHz)	HS 151 .02 - 20	HS 152 0.1 - 100	HS 153 20 - 200	HS 154 100 - 400	HS 155 .2 - 200	HS 156 5 - 500	TYP. SPEC.	Loss 1.0dB	Isolation 30dB	VSWR 1.5:1	Phase Bal. 3°	Amp. Bal. 0.3dB	Input Power 2.5w	HS 100 SERIES 0/180° Center Frequency 100 - 1,500 MHz Bandwidth ±10, 20, 30% <table border="1"> <tr><th>TYP. SPEC.</th></tr> <tr><td>Loss .3dB</td></tr> <tr><td>Isolation 30dB</td></tr> <tr><td>VSWR 1.3:1</td></tr> <tr><td>Phase Bal. 2°</td></tr> <tr><td>Amp. Bal. .2dB</td></tr> <tr><td>In Power 60 w</td></tr> </table>  <p>Schematic</p>	TYP. SPEC.	Loss .3dB	Isolation 30dB	VSWR 1.3:1	Phase Bal. 2°	Amp. Bal. .2dB	In Power 60 w	<table border="1"> <tr> <th>HQ 500 SERIES 90°</th> <th>HS 500 SERIES 180°</th> </tr> <tr> <td colspan="2">FREQ. BAND</td> </tr> <tr> <td colspan="2">.125 - 18 GHz OCTAVE .5 - 12 GHz</td> </tr> <tr> <td colspan="2">TYP. SPEC.</td> </tr> <tr> <td>Loss 0.2dB</td> <td>Loss 0.5dB</td> </tr> <tr> <td>Isolation 20dB</td> <td>Isolation 20dB</td> </tr> <tr> <td>VSWR 1.2:1</td> <td>VSWR 1.5:1</td> </tr> <tr> <td>Phase Bal. 1.5°</td> <td>Phase Bal. 5.0°</td> </tr> </table> 	HQ 500 SERIES 90°	HS 500 SERIES 180°	FREQ. BAND		.125 - 18 GHz OCTAVE .5 - 12 GHz		TYP. SPEC.		Loss 0.2dB	Loss 0.5dB	Isolation 20dB	Isolation 20dB	VSWR 1.2:1	VSWR 1.5:1	Phase Bal. 1.5°	Phase Bal. 5.0°
MODEL FREQ.(MHz)																																							
HS 151 .02 - 20																																							
HS 152 0.1 - 100																																							
HS 153 20 - 200																																							
HS 154 100 - 400																																							
HS 155 .2 - 200																																							
HS 156 5 - 500																																							
TYP. SPEC.																																							
Loss 1.0dB																																							
Isolation 30dB																																							
VSWR 1.5:1																																							
Phase Bal. 3°																																							
Amp. Bal. 0.3dB																																							
Input Power 2.5w																																							
TYP. SPEC.																																							
Loss .3dB																																							
Isolation 30dB																																							
VSWR 1.3:1																																							
Phase Bal. 2°																																							
Amp. Bal. .2dB																																							
In Power 60 w																																							
HQ 500 SERIES 90°	HS 500 SERIES 180°																																						
FREQ. BAND																																							
.125 - 18 GHz OCTAVE .5 - 12 GHz																																							
TYP. SPEC.																																							
Loss 0.2dB	Loss 0.5dB																																						
Isolation 20dB	Isolation 20dB																																						
VSWR 1.2:1	VSWR 1.5:1																																						
Phase Bal. 1.5°	Phase Bal. 5.0°																																						

AMPLIFIERS

AN SERIES NARROW BAND IF AMPLIFIER

Center Frequency 5 - 500 MHz
 Bandwidth (-1dB) 40%
 1dB Compression Point +3dBm
 Available Gain 10, 25, 50 & 65dB

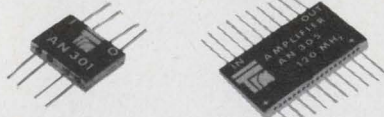

AP SERIES HIGH POWER AMP.

Center Frequency 400 - 480 MHz
 Bandwidth (-1dB) 10MHz
 Input Power (min.) 50MW

MODEL	OUTPUT POWER
AP 200	25w CW, 40w Peak
AP 250	100w CW, 200w Peak

AD SERIES HIGH DYNAMIC RANGE

FREQ. BANDS
0.5 - 100 MHz
1 - 100
10 - 300

Avail. Gain 10, 20, 30dB
 1dB Comp. Point +20dBm
 Noise Fig. 5dB Typical



DOUBLE BALANCED MIXERS SINGLE BALANCED

MD SERIES

FREQ. BANDS
.2 - 200
5 - 500
10 - 1,000

TYP. SPEC.
Conv. Loss 7dB
Isolations 25dB

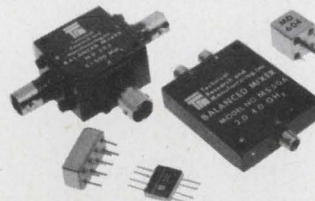

MDS SERIES

MULTI-OCTAVE & OCTAVE BANDS
 .125 - 12 GHz

TYP. SPEC.
Conv. Loss 9dB
Isolations 18dB

WIDE BAND DIRECTIONAL COUPLERS BI-DIRECTIONAL DUAL DIRECTIONAL

STRIPLINE SERIES
 DCS DIRECTIONAL
 DBS BI-DIRECTIONAL
 DDS DUAL DIRECTIONAL

AVAILABLE COUPLING
 6, 10, 20, 30dB

MULTI-OCTAVE & OCTAVE BANDS
 .125 - 18 GHz

TYP. SPEC.
Loss 0.25dB
Directivity 25dB
VSWR 1.3:1

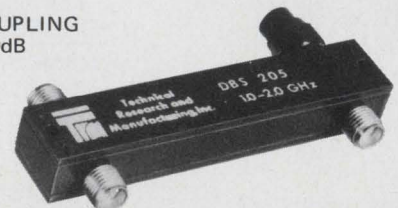

FREQUENCY DOUBLERS 0.1 MHz - 6.2 GHz

MATCHING TRANSFORMERS .02 - 1,000 MHz

CONTACT US FOR DATA SHEETS AND PRICES.

NOW AVAILABLE IN THE U.S.A.— FUTABA FLUORESCENT READOUTS KEYBOARDS

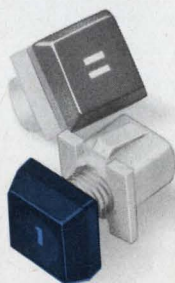
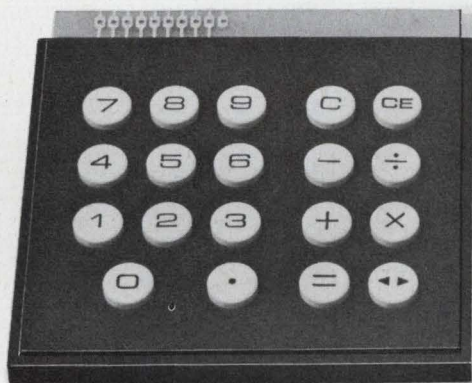

With over 35 years of electronics experience, FUTABA is well known for high quality, reliable fluorescent readouts and compact, attractive keyboards. Widely used by most major electronic calculator manufacturers in Japan and other countries, these items are now available for the first time in the U.S.A. in quantity. FUTABA guarantees prompt delivery!



• For additional information, please contact:

FUTABA INDUSTRIES U.S.A.
630 West Carob Street, Compton, California 90220, U.S.A.
Phone: (213) 537-9610 Telex: 69-1227

FLUORESCENT READOUTS

※CT, CR Series for Hand Calculators

..... Available in 6, 8 and 9 digits with or without symbol.

FEATURES:

- Compact.
- Bright blue/green.
- Easy to read.
- Low voltage, low power.
- Direct LSI drive.

※MT, MR Series for Desk-top Calculators

..... Available in 8, 10, 12, 14, and 16 digits.

FEATURES:

- Plug-in type flat package.
- Easy to read blue/green readouts (0.3" high).
- Low voltage, low power.

KEYBOARDS

M-2B: Individual mechanical switch, plug-in mounting.

M-3: Same as M-2B, but smaller.

FX, SD Series: Thin keyboards for hand calculators.

Standard keyboard switches and key tops available from FUTABA stock for instant keyboard layout on your mounting plate.

OTHER FUTABA PRODUCTS:

- Press die sets.
- Mold bases for plastics.
- Material feeders for press work.
- Automatic stopping devices for automatic machinery.
- Radio control for hobby aircraft, race cars, etc.

"FUTABA—THE BRIGHT PRODUCER"

FUTABA ELECTRONIC INDUSTRIES LIMITED
Super Bldg., 1-11-5, Sotokanda, Chiyoda-ku, Tokyo, Japan. Phone: 255-5881
Telex: J26532

INFORMATION RETRIEVAL NUMBER 10

**We've got a remedy
to stop the bleeding.**

POWER SUPPLY

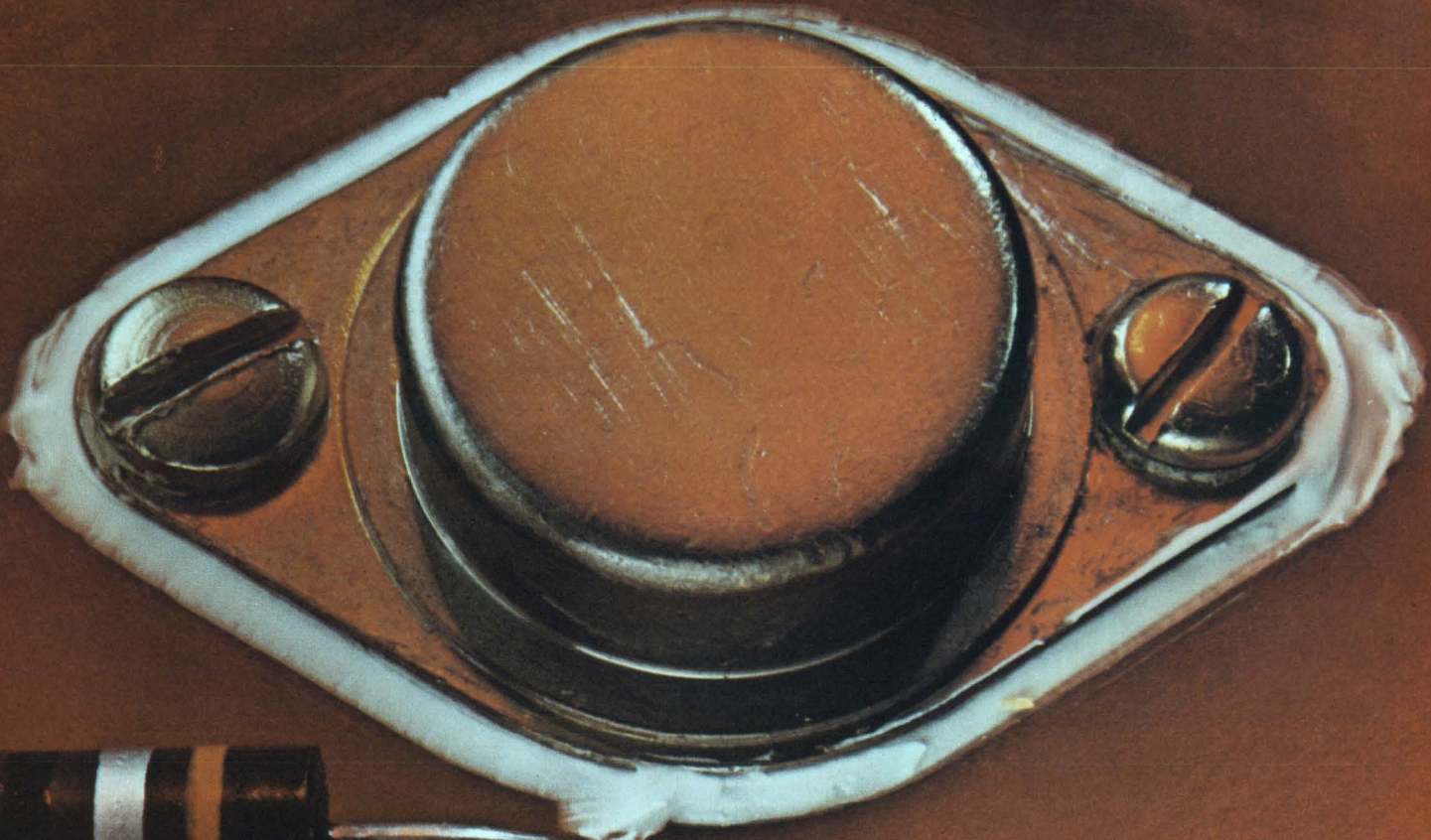

— 8

A curable silicone heat sink.

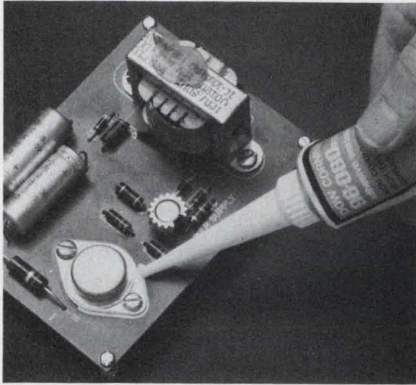

New from Dow Corning: a silicone adhesive/sealant which is perfect for small areas that get hot. Just squeeze it on. It'll flow into the smallest spots and cure in place. And it never bleeds.

It has high thermal conductivity. It's noncorrosive with excellent dielectric properties.

This silicone adhesive/sealant will handle temperatures from -65°F to 500°F continuously. The range can even extend to 600°F for short periods of time.

Add to this no mixing, no toxic fumes. It comes as one component, in collapsible tubes. And it cures at room temperatures, on exposure to atmospheric moisture.

Dow Corning's new adhesive/sealant utilizes a curing system which does not evolve corrosive by-products. That makes it perfect for use on corrosion sensitive electronic equipment and devices where rapid heat transfer is required.

For a free sample and our Self-Curing Heat Sink Adhesive literature, write Dow Corning Corporation, Dept. C-3324, Midland, Michigan 48640.

Silicone adhesives from

DOW CORNING

DOW CORNING

INFORMATION RETRIEVAL NUMBER 12

ACROSS THE DESK

(continued from page 7)

'White noise' idea creates noisy dissent

Three flaws in Kamil Kraus' Idea for Design, "Measuring System Uses White Noise to Indicate Temperature from 10 to 2500°K " (ED No. 24, Nov. 22, 1973, p. 190) should keep his circuit from performing as proposed.

First, the current from V_0 does not increase the Nyquist noise of the sensor resistor, R_s . Rather, one gets $1/f$ noise from resistance changes due to temperature fluctuations (assuming a nonzero temperature coefficient for R_s).

Second, R_1 and the $500\text{-}\Omega$ resistors in the bridge have Nyquist noise of their own. Since they are presumably kept at room temperature ($\approx 300\text{ K}$), their noise power is 1500 times greater than that of $R_s = 100\ \Omega$ at 10 K .

Finally, the noise from the 741 itself is far greater than the Nyquist noise of $R_s = 100\ \Omega$. One needs a sensor resistance of $\approx 1\text{ M}\Omega$ and a low-noise preamp to do noise thermometry at less than room temperature.

Michael L. Rappaport
University of California, Berkeley
Department of Physics
Berkeley, Calif. 94720

The Idea for Design "Measuring System Uses White Noise to Indicate Temperature from 10 to 2500°K " is completely ridiculous. The circuit shown will not work as described. Points of factual error are:

1. The noise temperature of a 741 op amp is typically $500,000\text{ K}$ at 20 Hz from a $100\text{-}\Omega$ source. So one could not even resolve room-temperature Johnson noise from R_s , let alone measure it to an accuracy of 0.1 K .

2. The Johnson noise of a resistor is not increased by biasing with a small direct current. Temperature-independent shot noise might be, however.

These facts are quite elementary, even to someone not a professional engineer.

Daniel E. Prober

Harvard University
Gordon Mc Kay Laboratory
9 Oxford St.

Cambridge, Mass. 02138

Ed. Note: Although we tend to agree with the criticisms of Mr. Rappaport and Mr. Prober, and find it difficult to follow Mr. Kraus' logic, we nevertheless present his reply below.

The author replies

The writers fully misunderstand my ideas, for these reasons:

1. As the readers pointed out, and as shown by the Nyquist formula at the beginning of my article, the Johnson noise does not depend on the voltage V_0 . The source voltage V_0 is designed to enable you to balance the bridge at a given temperature—thus, in effect, raising the level of the measured noise signal.

2. The noise temperature of the 741 amplifier ($\approx 500\text{ K}$) doesn't influence the measurement of the noise signal at room temperature. If it did, it would be impossible to incorporate the op amp in any temperature-measuring system.

When I tested the circuit, I found that the problem lay in the rather high time constant. The solution was the use of a band-pass filter that operates in the frequency range from 10 to 60 Hz . With these improvements, the device proved to be more flexible. The use of a phase-sensitive detector between A_2 and A_3 , such as the Signetics SE 565, was out of my reach.

Kamil Kraus

SPSE Koterovska 85,
307 00 Plzen, Czechoslovakia

'Too many bugs' in NIXONFET

I wonder if you could furnish me with a supplier of samples of the NIXONFET (see "From the Watergate . . ." ED No. 1, Jan. 4, 1974, p. 7).

(continued on page 18B)

FIVE CMOS DECODERS

THE FULL COMPLEMENT
FOR 2, 3, AND 4-BIT
BINARY TO 1 OF 2^N
LINE DECODING

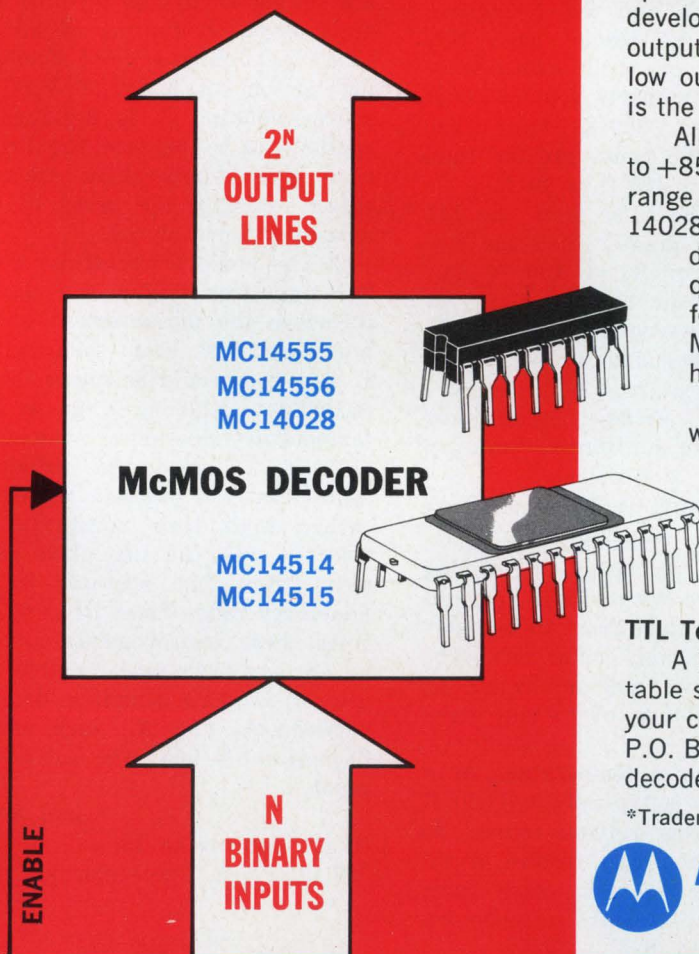

There's a McMOS* decoder for the job, whatever your need for two, three, or four-bit decoding in code conversion, data routing, memory selection, and similar CMOS systems applications. Only Motorola's user oriented CMOS family supplies this full complement.

MC14555 and MC14556 A pair of dual two-bit binary to 1 of 4 decoders. The '55 is the CMOS equivalent to a couple of popular TTL functions, with active high outputs. The '56 is the same function, but with active low outputs where the selected line goes to the low state. Expansion of the decoding function, such as binary to hexadecimal, is achieved by connecting additional units.

MC14028 This three-bit binary to 1 of 8 line decoder is versatile, also serving as a BCD to 1 of 10 line decoder. It has active high outputs and an enable input.

MC14514 and MC14515 Here are two output options of a 4 to 16 line decoder with latched inputs, developed by Motorola. The 14514 has active high outputs and the opposite number 14515 has active low outputs, but the important thing to remember is the four-bit input latches (R-S type flip-flops).

All five types are available in both McMOS' -40° to +85°C commercial (CL) and wide (AL) temperature range dual in-line ceramic packaging, and the MC14028, MC14555, and MC14556 are also available in dual in-line plastic (CP). CL and CP 100-999 quantity prices are in the \$3.12 to \$3.67 range for the 555, 556, and 028 decoders, and the MC14514 and 515CLs are understandably higher at \$13.75.

These decoders, as with all Motorola CMOS whether it be second source or the predominant Motorola designed 14500 series, share the outstanding characteristics of the McMOS family of which they are all a part. They are available from Motorola distributors and sales offices.

TTL To McMOS Function Reference Available

A brand new TTL to McMOS function conversion table suitable for wall mounting is just out. Send for your copy to Motorola Semiconductor Products Inc., P.O. Box 20912, Phoenix, Arizona 85036. We'll send decoder data too.

*Trademark of Motorola Inc.



MOTOROLA MOS

Expanding dimensions in digital design

McMOS

LOGIC
OF
THE
70's

Five Reasons Why GE Planar Ceramic Triodes Deliver Acknowledged* State-of-the-Art Performance —

1 GE Planar Triodes are computer-designed to provide highest ratio of power, efficiency, reliability, and gain bandwidth to product size and weight. Result: The kind of performance which makes GE the first choice for the new broadbanded micro-TACAN/DME systems.

2. Unique etched-frame grids deliver uniform, extra reliable, predictable performance.

3. Close grid-to-cathode spacing for lower noise levels, more efficient operation at higher frequencies — to x band.

4. GE's bonded heater-cathode provides fast warmup — 3-5 sec., high tolerance to extreme mechanical environments, simplified circuitry.

*In a recent Brand Recognition Study by a leading business publication, designers expressed a 20% greater preference for General Electric Planar Ceramic Triodes than the next leading brand. (Copies of the Study report are available upon request).

5. GE's leadership in materials and techniques — plus the short, rigid construction, large seal areas, and small size of the tube — assure exceptional tolerance to the most adverse thermal, shock, and vibration environments.

General Electric . . . your "Best Buy" in Planar Ceramic Tubes. If we don't have the exact tube you need, we will build it . . . or tell you where to get it.

We also make Microwave Circuit Modules (MCMs) . . . precision circuits built around GE Planar Triodes.

Contact: Microwave Devices, General Electric Company, 316 E. 9th St., Owensboro, Ky. 42301. Or use the reader service card.

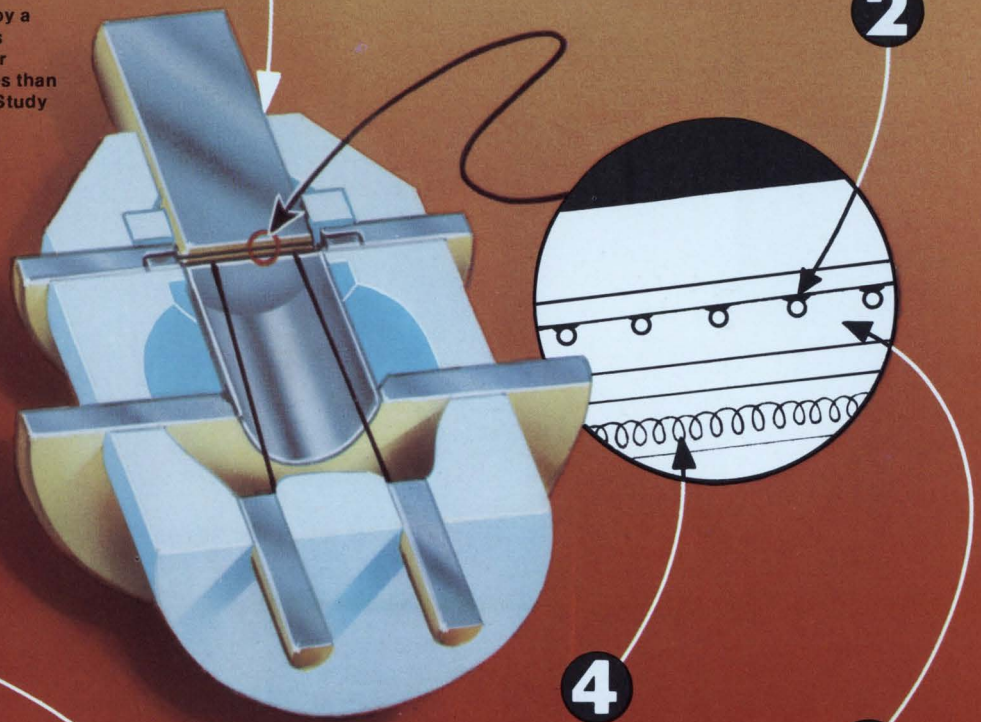

Specialists demand the best tools of their trade.

You didn't become an electronic specialist overnight. It took years of training and great determination to reach your goal. But now, as a specialist, you can demand the best tools available to your trade.

It also takes years of special skills to bring you top-quality instruments. RCA offers more than 50 years of engineering and manufacturing experience

in the electronics field to assure you of the highest quality and performance from any RCA electronic instrument you select.

Whatever your specialty . . . radio/TV/hi-fi servicing, medical, industrial or military electronics . . . RCA offers a broad line of electronic instruments to meet your special needs in school, shop, factory, field or laboratory. These electronic instruments offer

built-in dependability, at a very economical price.

Want all the facts on RCA's multi-meters, oscilloscopes, generators, testers, and power supplies? Contact any one of the more than 1,000 RCA Distributors worldwide, or RCA Electronic Instruments Headquarters, 415 South 5th Street, Harrison, N.J. 07029. Request RCA's 1974 Electronic Instruments catalog. It's free for the asking.



RCA Electronic Instruments

INFORMATION RETRIEVAL NUMBER 15

It's nice to know that there's a super source for large quantities of 12 and 50 Volt ceramic capacitors. Nichicon can meet your immediate needs, or help you plan for long range requirements. When 30 weeks lead time seems to be a stock answer from almost every capacitor manufacturer, it's nice to know you can count on Nichicon for fast delivery. And when we make a delivery promise, we deliver as promised.

We've got millions more where these came from.

12V.DC Disc Capacitors—Y5S

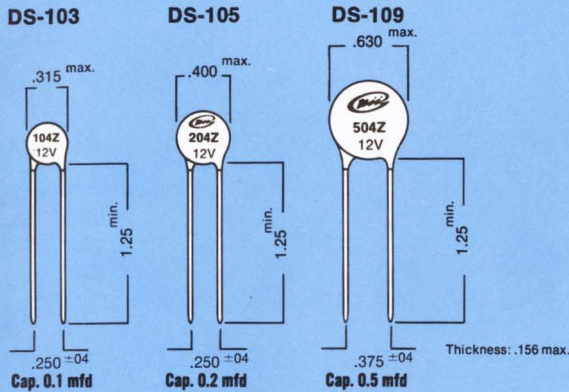

SPECIFICATIONS

Temperature Characteristics: Y5S
 Operating Temperature Range: -30°C to $+85^{\circ}\text{C}$
 Lead Wire: #22
 Applications: By-pass and audio couplings in transistorized circuits.
 Equivalent to: Centralab's "Ultra-Kap" UK series, and RMC's "Magna-Cap" M-12 series.

50V.DC Disc Capacitors—Z5P, Z5U and Z5V

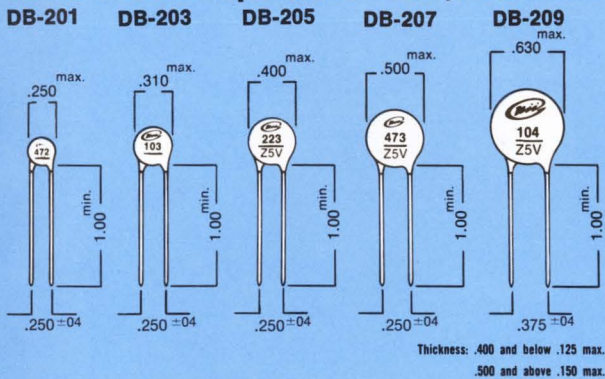

SPECIFICATIONS

	Capacitance Range	Capacitance Tolerance
Z5P	180 pF thru 10,000 pF	$\pm 10\%$ or $\pm 20\%$
Z5U	1,000 pF thru 22,000 pF	$\pm 20\%$
Z5V	1,000 pF thru 100,000 pF	+ 80% - 20%

TYPICAL CAPACITANCE vs TEMPERATURE

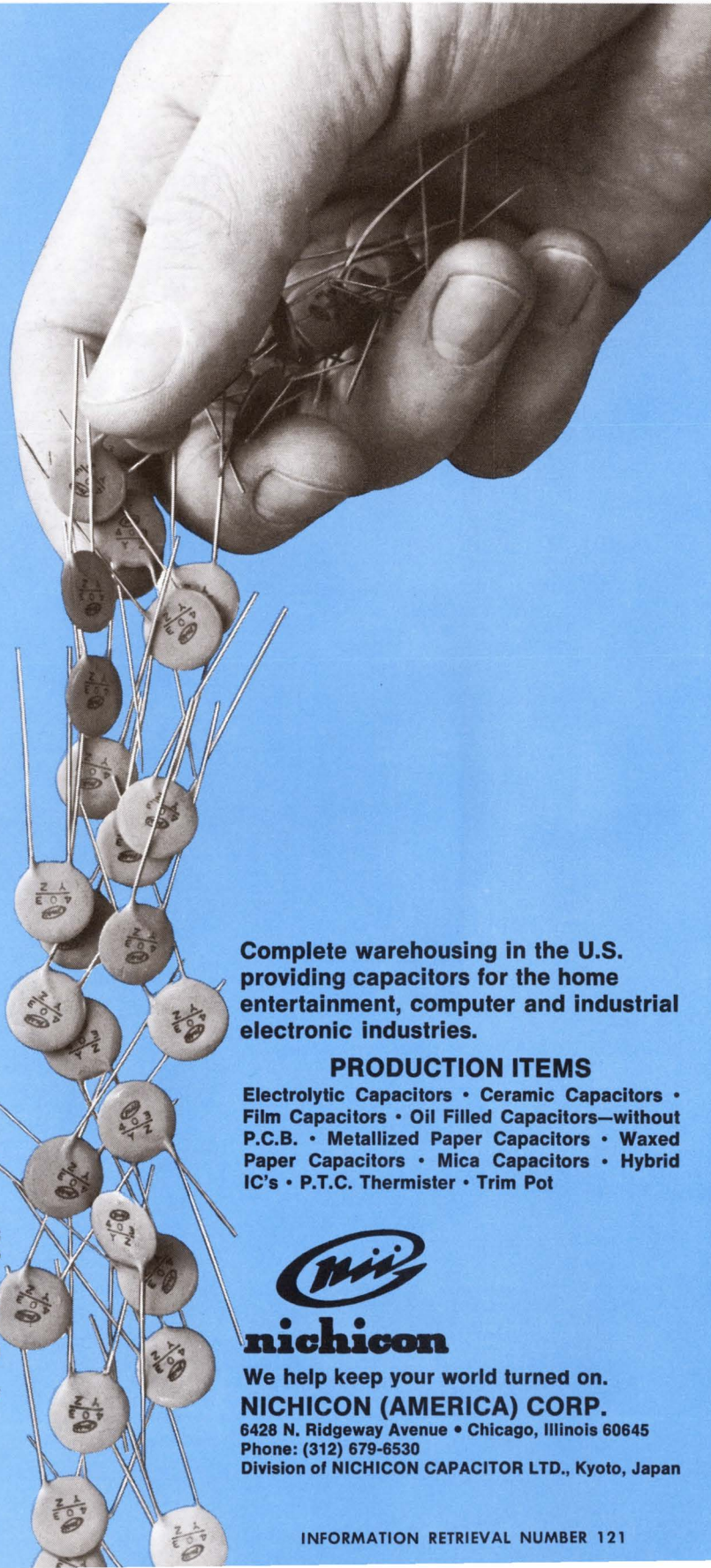
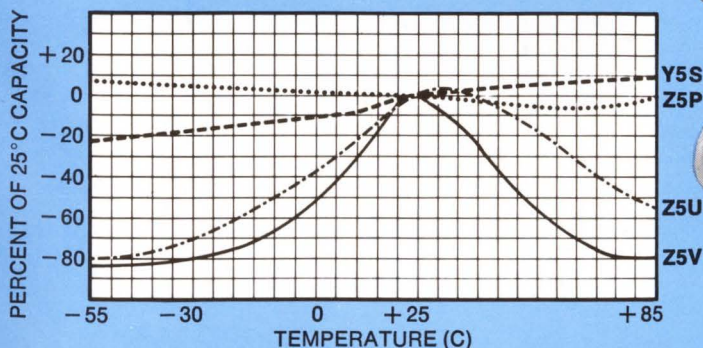

Complete warehousing in the U.S. providing capacitors for the home entertainment, computer and industrial electronic industries.

PRODUCTION ITEMS

Electrolytic Capacitors • Ceramic Capacitors • Film Capacitors • Oil Filled Capacitors—without P.C.B. • Metallized Paper Capacitors • Waxed Paper Capacitors • Mica Capacitors • Hybrid IC's • P.T.C. Thermister • Trim Pot



nichicon

We help keep your world turned on.
NICHICON (AMERICA) CORP.
 6428 N. Ridgeway Avenue • Chicago, Illinois 60645
 Phone: (312) 679-6530
 Division of NICHICON CAPACITOR LTD., Kyoto, Japan

It seems to me that the device currently has too many bugs in it to be of any practical use. In particular, depletion-mode operation is most inconvenient and should be investigated. I believe that what we are seeing is oil depletion, due to highly charged Middle East states in the silicon. This can be cured possibly by the well-known Kissinger process. Alternatively, this is general-resource depletion, which would restrict device operation to low-power modes.

Futhermore there is a strong possibility of White House leakage from the unimpeachable source to the economic drain, even with the Watergate biased off, possibly leading to administrative breakdown. This phenomenon is due to CREEP, and could be reduced by lowering the bias on the political body. (This terminal was curiously omitted from the announcement.) If the leakage is not controlled, minority carriers (plumbers) become trapped at the watergate and the device self-destructs.

Please withhold my name and address, as I already have enough trouble with the I.R.S.

Name Withheld

Using the diagram supplied by the researcher, Ray N. Lubow, we fabricated a NIXONFET for testing at our facility.

We used an off-the-shelf Ziegler clamp circuit to maintain the unimpeachable source at zero-potential credibility. In this configuration the current through the economic drain was surprisingly large and unaffected by signals at the watergate. This large current is undoubtedly the cause of the rapid heat buildup that we observed. We attempted to control the heat by mounting the device in dissipative media, but it developed significant leaks and showed signs of fragmentation.

Our conclusion is that while the NIXONFET may be interesting technologically, it is uncontrollable and unreliable. It would undoubtedly lead to circuit failure.

Robert S. Bell

300 Hillmoor Dr.
Silver Spring, Md. 20901

Who invented radar? Define invention first

The battle over the invention of radar is ridiculous (see "Who Invented Radar? Well, It Seems That—," ED No. 1, Jan. 4, 1974, p. 7). It is obviously a British invention. Reject R.D. Tomkins' assumption that an invention "is the first step in an essentially continuous investigation of a concept" and substitute: Invention is the first working model that transforms the concept into physical reality.

With all due respect to Taylor and Young and their observations, it was the British who had the first equipment that translated "interference phenomenon" into direction-finding and ranging.

If we agree with Tomkins' assumptions, then we will have to accept the following also:

1. Credit for the invention of the airplane should go to Leonardo da Vinci (Italy) or to Sir George Cayley (Britain) or to a host of unnamed aerial theorists.

2. Credit for the development of the atom bomb should go to Sir Ernest Rutherford (Britain) or to Pioncare, Lorentz, Planck, Debye, Nerst, Bohr, Born, Fermi, etc.

3. Credit for invention of the transistor should be taken away from Shockley, Brattain and Bardeen and given to an unnamed person—way back beyond the cat's-whisker period of 1906.

F.W. Stevens

Underseas Systems Dept.
Naval Undersea Center
San Diego, Calif. 92132

2 claim design credit for line-driver circuits

In reference to the article, "Build Power Amplifiers With IC Drivers" (ED No. 21, Oct. 11, 1973, p. 80), the record needs to be set straight regarding Figs. 8a and 8b and the words that accompany them.

In copying a couple of my circuits (and words), Signetics has committed two oversights, outright errors and has failed obviously to give credit.

Fig. 8a first appeared in "The
(continued on page 19)

Your closest SIGNETICS distributor is...

ARIZONA
Phoenix: Hamilton/Avnet Electronics (602) 275-7851
Phoenix: Kieruff Electronics (602) 273-7331

CALIFORNIA
Culver City: Hamilton Electro Sales (213) 870-7171
El Segundo: Liberty Electronics (213) 322-8100
Los Angeles: Kieruff Electronics (213) 685-9525
Mountain View: Hamilton/Avnet Electronics (415) 961-7000
Palo Alto: Kieruff Electronics (415) 968-6292
San Diego: Cramer Electronics (714) 565-1881
San Diego: Hamilton/Avnet Electronics (714) 279-2421
San Diego: Kieruff Electronics (714) 278-2112
Sunnyvale: Cramer Electronics (408) 739-3011

CANADA
Downsview: Cesco Electronics (416) 661-0220
Downsview: Cramer Electronics (416) 661-9222
Montreal: Cesco Electronics (514) 735-5511
Montreal: Hamilton/Avnet Electronics (514) 735-6393
Ottawa: Cesco Electronics (613) 729-5118
Ottawa: Hamilton/Avnet Electronics (613) 725-3071
Quebec: Cesco Electronics (418) 524-3518
Vancouver: Bowtek Electric Co. Ltd. (604) 736-7677

COLORADO
Denver: Cramer Electronics (303) 758-2100
Denver: Hamilton/Avnet Electronics (303) 534-1212

CONNECTICUT
Hamden: Arrow Electronics (203) 248-3801
Georgetown: Hamilton/Avnet Electronics (203) 762-0361
North Haven: Cramer Electronics (203) 239-5641

FLORIDA
Hollywood: Hamilton/Avnet Electronics (305) 925-5401
Hollywood: Schweber Electronics (305) 927-0511
Orlando: Hammond Electronics (305) 241-6601

GEORGIA
Atlanta: Schweber Electronics (404) 449-9170
Norcross: Hamilton/Avnet Electronics (404) 448-0800

ILLINOIS
Elk Grove: Schweber Electronics (312) 593-2740
Elmhurst: Semiconductor Specialists (312) 279-1000
Schiller Park: Hamilton/Avnet Electronics (312) 678-6310

INDIANA
Indianapolis: Semiconductor Specialists (317) 243-8271

KANSAS
Lenexa: Hamilton/Avnet Electronics (913) 888-8900

MARYLAND
Hanover: Hamilton/Avnet Electronics (301) 796-5000
Rockville: Pioneer Washington Electronics (301) 424-3300
Rockville: Schweber Electronics (301) 881-2970

MASSACHUSETTS
Burlington: Hamilton/Avnet Electronics (617) 273-2120
Newton: Cramer Electronics (617) 969-7700
Waltham: Schweber Electronics (617) 890-8484

MICHIGAN
Detroit: Semiconductor Specialists, Inc. (313) 255-0300
Livonia: Hamilton/Avnet Electronics (313) 522-4700
Troy: Schweber Electronics (313) 583-9242

MINNESOTA
Edina: Hamilton/Avnet Electronics (612) 941-3801
Minneapolis: Semiconductor Specialists (612) 854-8844

MISSOURI
Hazelwood: Hamilton/Avnet Electronics (314) 731-1144

NEW MEXICO
Albuquerque: Hamilton/Avnet Electronics (505) 765-1500

NEW YORK
Buffalo: Summit Distributors (716) 884-3450
Farmingdale, L.I.: Arrow Electronics (516) 694-8800
Rochester: Schweber Electronics (716) 328-4180
Syracuse: Hamilton/Avnet Electronics (315) 437-2642
Westbury: Hamilton/Avnet Electronics (516) 333-5800
Westbury: Schweber Electronics (516) 334-7474

NORTHERN NEW JERSEY
Cedar Grove: Hamilton/Avnet Electronics (201) 239-0800
Saddlebrook: Arrow Electronics (201) 797-5800

SOUTHERN NEW JERSEY AND PENNSYLVANIA
Cherry Hill, N.J.: Milgray-Delaware Valley (609) 424-1300
Moorestown: Arrow/Angus Electronics (609) 235-1900
Mt. Laurel, N.J.: Hamilton/Avnet Electronics (609) 234-2133

CENTRAL NEW JERSEY AND PENNSYLVANIA
Somerset, N.J.: Schweber Electronics (713) 526-6008

NORTH CAROLINA
Greensboro: Hammond Electronics (919) 275-6391

OHIO
Beechwood: Schweber Electronics (216) 464-2970
Dayton: Hamilton/Avnet Electronics (513) 433-0610
Cleveland: Arrow Electronics (216) 464-2000
Cleveland: Pioneer Standard Electronics (216) 587-3600
Kettering: Arrow Electronics (513) 253-9176

TEXAS
Dallas: Cramer Electronics (214) 350-1355
Dallas: Hamilton/Avnet Electronics (214) 661-8661
Houston: Component Specialties (713) 771-7237
Houston: Hamilton/Avnet Electronics (713) 526-4661

UTAH
Salt Lake City: Alta Electronics (801) 486-7227
Salt Lake City: Hamilton/Avnet Electronics (801) 262-8451

WASHINGTON
Bellevue: Hamilton/Avnet Electronics (206) 746-8750
Seattle: Cramer Electronics (206) 762-5722

Now, a 576-bit RAM for men of few words.

Target-designed 64 x 9 for 45ns buffers and scratch pads.

Making small talk just got easier. With still another world's first from Signetics. Our 82S09 RAM of 576 bits: the largest bit count ever put into a bipolar RAM with more than one bit per word. This 64 x 9 is available now in volume, and multiple-sourced.

What's in it for you? Say you've got a scratch pad or buffer that only calls for 16 to 128 words. Till now your choices were all bad news. Either you wasted memory capacity with oversized organization and gadgety multiplexing schemes, or you strung together a lot of little RAMs. Either way, you lost. In terms of high tabs for extra circuitry, bigger boards, and the power to keep them going. Not to mention penalties in memory speed.

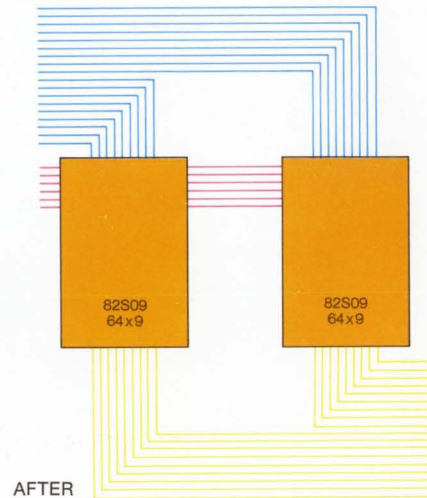
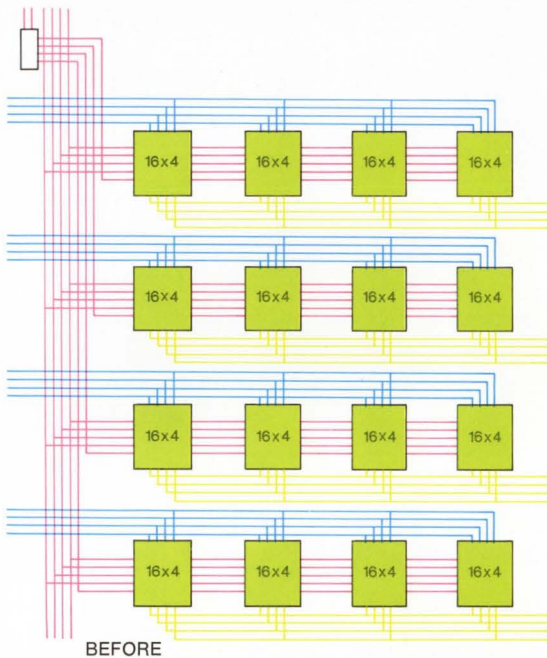

		"Before"	"After"
Parts Cost*	8225/7489	\$96.00	\$85.20
	Decoder	2.80	0
		\$98.80	\$85.20
Board Space		1.5	1.0
Access Time (1)	Decoder	20ns	0
	8225/7489	50ns	45ns
		70ns	45ns
Power Dissipation	Decoder	0.1 Watt	0
	8225/7489	6.4 Watts	1.7 Watts
		6.5 Watts	1.7 Watts
Solder Connections	Decoder	16	0
	8225/7489	256	56
		272	56

(1) Even with 3101A (35ns), the total 16x4 access time is 55ns.
*Signetics 100-up published price.

For small, dense memory applications, the unique 82S09 RAM—with new cell design and enhanced 64 x 9 organization—shrinks board space requirements, lowers component count and power cost, but slams out all the speed you can handle. (Schottky technology delivers 45ns, worst case.) With all the traditional bipolar RAM features in the bargain. Full decoding. Chip enable. Open collector. And a vital bonus, the ninth bit for parity.

If the picture still needs a little focussing, take a minute to scan our Comparison Chart, based on production of 200 systems.

Okay, talk may be cheap. So make us lay it on the line. Today, from your local distributor.

CLIP THIS COUPON AND ATTACH TO LETTERHEAD FOR FAST ACTION.

Signetics—RAMs
P.O. Box 3004-18
Menlo Park, California 94025

Spec sheets first, please, on the 82S09, the new bipolar 45ns Schottky RAM you've raved about and said is available now.

Name _____

Title _____ Mail Stop _____

Signetics Corporation, a subsidiary of Corning Glass Works

signetics

As MOS Circuits Reach 50 MHz

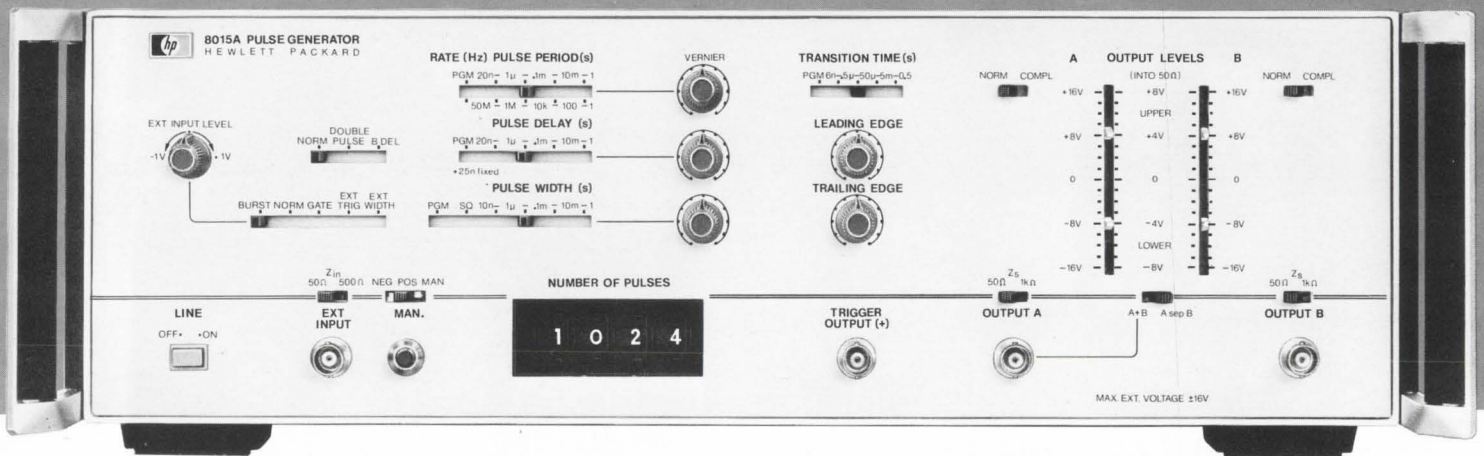

HP's New 8015A Pulser Will Still Be On The Job.

But for now, your 8015A will do double duty by helping with your bipolar as well as your MOS testing. In fact, you'll find the 8015A just about the most versatile test set you've ever used. Its two outputs give you up to 16V each or a 30V swing (within a $\pm 16V$ window)—just what you need for testing most forms of MOS plus CMOS. And with the 8015A's speed of up to 50 MHz, you can easily check HTL, TTL, and other popular types of bipolar logic circuits—and satisfy many linear circuit testing requirements as well.

But that's not all. You can vary the period, delay, width, and transition of the output pulses to set up your testing procedure exactly as the IC manufacturer recommends. With independently adjustable output level controls, you can also set the upper and lower levels of your waveforms to the levels you need. And the 8015A has a selectable 50 ohm output impedance for driving those high-capacitance MOS lines as it serves as your two-phase system clock.

If you need still greater capability, add the optional pulse-burst unit to your 8015A and generate a predetermined number

of pulses from 0 to 9999. Or if you feel you can't use two outputs, we'll provide a single output 8015A at lower cost. Versatility, economy—the 8015A gives you exactly what you need.

Contact your local HP field engineer for more information on the the 8015A, or its even higher-speed, lower-voltage companion units 8007B (100MHz), 8008A (200MHz).

083/7

**For new standards in
pulse generators, think HP.**

HEWLETT  PACKARD

Sales, service and support in 172 centers in 65 countries.
Palo Alto, California 94303. Offices in principal cities throughout the U.S.

Pitfalls of the General Purpose IC Operational Amplifier as Applied to Audio Signal Processing," presented at the September, 1972, Audio Engineering Society Convention. It is available as AES preprint #893, having appeared in the *AES Journal* (November, 1973). In this circuit, there should be a 1-k resistor between the 50- μ F cap and the op-amp summing point.

Fig. 8b first appeared in "A New IC Approach to Audio Power" in the October, 1972, issue of *Broadcast Engineering*. The original circuit contained a component value error that was perpetuated in Fig. 8b. The 200-pF capacitor on A_2 should be 2000 pF.

Walter G. Jung

1946 Pleasantville Rd.
Forest Hill, Md. 21050

Please be advised that the circuit diagram in the article "Build Power Amplifiers with IC Drivers" corresponds nearly exactly to a disclosure made by Tronac, Inc., which seeks to patent the idea. The patent is pending under File No. B2503, March 15, 1973.

William W. Bullock
President

Tronac, Inc.
1804 S. Columbia Lane
Orem, Utah 84057

Ed Note: A Signetics spokesman conveys the company's apologies to Mr. Jung for failing to publish a credit line acknowledging his contribution to the development of two of the circuits described in the article. Also inadvertently omitted was a reference to Mr. Jung's October, 1972, article in Broadcast Engineering. Signetics argues, however, that the disputed circuits were essentially improvements on two circuits published in a 1970 Signetics application booklet. Furthermore the company contends that Mr. Jung made his improvements with the assistance of Werner Hoeft, one of the authors of the Electronic Design article. In reply, Mr. Jung says that he did talk to Hoeft but that the conversation took place after the Broadcast Engineering article had been written.

FLAT INTERCONNECTS YOUR COMPLETE SOURCE

Ribbon Cable / IC Interconnects / Custom Harnesses

You're sold on flat cable, now buy it at its best. Precise, compact cable packages to fit your specifications perfectly, computer-loomed for unmatched versatility by Woven Electronics.

Handling ease of independent non-bonded leads speeds production, cuts cost, while technical characteristics outrank other flat cable forms.

Make Woven your source for jumpers, continuous rolls, special harnesses, all your interconnect needs.

WOVEN ELECTRONICS

P.O. Box 189 Mauldin, South Carolina 29662

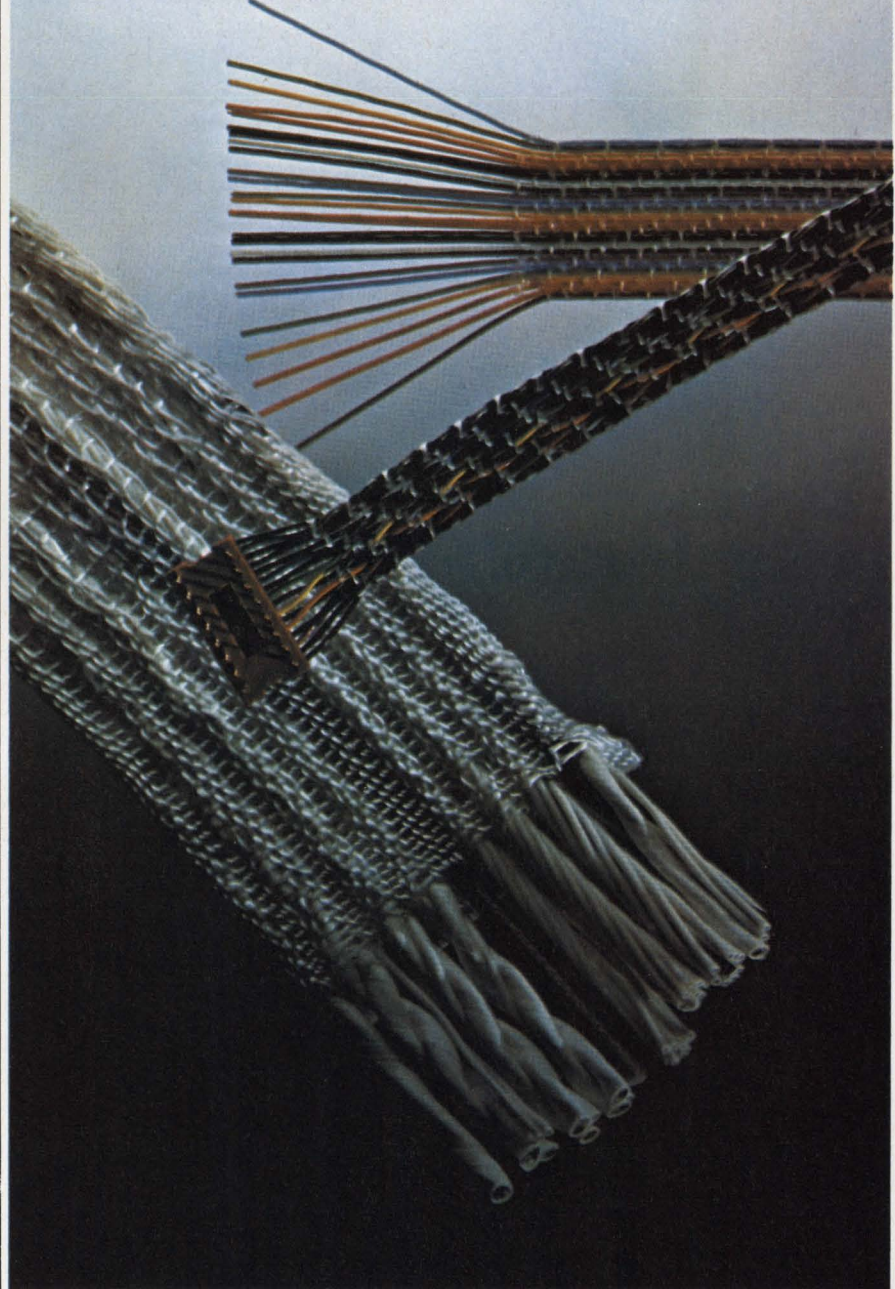

Hewlett-Packard presents a small miracle, the HP-65:



the only fully programmable pocket-sized computer calculator, \$795.

Once you had to know a "computer" language, work at a desk and have a large budget to use programming. No longer.

The HP-65 is fully programmable.

It's the first fully programmable pocket-sized computer calculator in the world.

With an HP-65 you can write programs just by pressing the keys in sequence, without using a special "computer" language. You can edit programs, i.e. add or delete steps at will. And you can record your programs on magnetic cards for subsequent use anywhere.

The HP-65's 100-step program memory, in combination with its 51 pre-programmed arithmetic, logarithmic, trigonometric and exponential functions, its operational stack and its nine addressable memory registers, permits you to write exceedingly complex programs.

Its user definable keys let you program up to five routines using any of the machine's pre-programmed capabilities. You can also label portions of your program so the calculator can branch to a specific instruction or choose between alternate computational paths based on logical comparisons ($x=y$, $x \neq y$, $x > y$, $x \leq y$) or the condition of the HP-65's two flags.

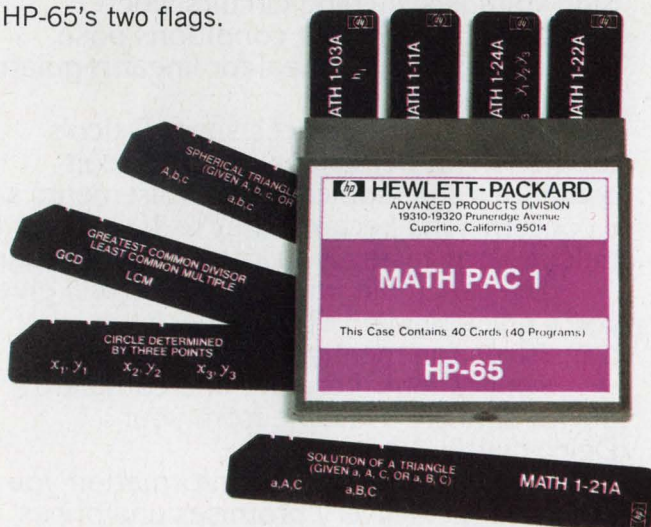

The HP-65 also lets you use pre-recorded programs.

HP offers a series of pre-recorded program packages called Application Pacs at \$45* each. Each Pac contains as many as 40 programs dedicated to a specific discipline (currently Electrical Engineering, Mathematics, Statistics, Medicine and Surveying, with more to come).

We also maintain a Users' Library of owner-contributed HP-65 programs which are itemized in catalogs distributed periodically to subscribing owners. Programs may be ordered from the Library for a small handling fee.

The HP-65 is a powerful pocket-sized calculator.

The HP-65 ranks with our popular and powerful HP-45 as a keyboard-operated calculator. It's pre-programmed to handle 51 functions and operations.

The HP-65 is priced at just \$795.*

What you gain in time, precision and flexibility may well save you that amount in a matter of weeks. The price includes one 11-ounce HP-65 with rechargeable battery pack, AC adaptor-recharger, carrying cases, a year's subscription to the Users' Library, Owner's Handbook, Quick Reference Guide and a Standard Application Pac that contains 17 representative pre-recorded programs, 2 diagnostic cards, 20 blank cards, a head-cleaning card and instruction booklet.

The HP-65 may be ordered on a 15-day trial basis. For details send the coupon. Or call Customer Service at (408) 996-0100 for the outlet nearest you.

Hewlett-Packard makes the most advanced pocket-sized computer calculators in the world.

614/08



Sales and service from 172 offices in 65 countries
Dept. 232F, 19310 Pruneridge Ave., Cupertino, CA 95014

Hewlett-Packard
Dept. 232F
19310 Pruneridge Ave., Cupertino, CA 95014

Please send me:

- HP-65(s) including Standard Application Pac at \$795 (domestic U.S.A.) each plus applicable state and local taxes. (Check enclosed.)
- Detailed specifications on your HP-65 and available Application Pacs.
- Detailed specifications on your full line of pocket-sized and pre-programmed desktop calculators.

Name _____

Company _____

Address _____

City/State/Zip _____

*All prices domestic U.S.A., not including applicable state and local taxes.

NEW VALUES HIGH ENERGY

TYPE	$I_c(\text{max.})$	V_{CE0}	V_{CEV}	$V_{CE0}(\text{sus.})$	$V_{CE}(\text{sat.})$ @ I_c, I_B	Power Dissipation (max.)	$h_{FE} \text{ min./max.}$ @ I_c, V_{CE}
DTS-701	1.0 Amp	800V	—	600V	—	50W	20/— @ 150mA, 5V
DTS-708	3.0 Amp	900V	900V	600V	2.0 max. @ 1 amp, 250mA	50W —	—
DTS-709	3.0 Amp	900V	900V	600V	1.0 max. @ 2A, 800mA	50W	—
DTS-710	3.0 Amp	900V	—	600V	—	50W	10/50 @ 150mA, 5V
DTS-712	3.0 Amp	900V	1200V	700V	—	50W	2.5/— @ 2.0A, 5V
DTS-714	3.0 Amp	900V	1400V	700V	—	50W	2.5/— @ 2.0A, 5V
DTS-723	3.0 Amp	1000V	1200V	750V	0.8 max. 1.0 amp, 250mA	50W	10/— @ 500mA, 5V
DTS-801	2.0 Amp	800V	—	700V	—	100W	20/ @ 200mA, 5V
DTS-812	5.0 Amp	900V	1200V	700V	—	100W	2.2/ @ 3.5A, 5V
DTS-814	5.0 Amp	900V	1400V	700V	—	100W	2.2/ @ 3.5A, 5V

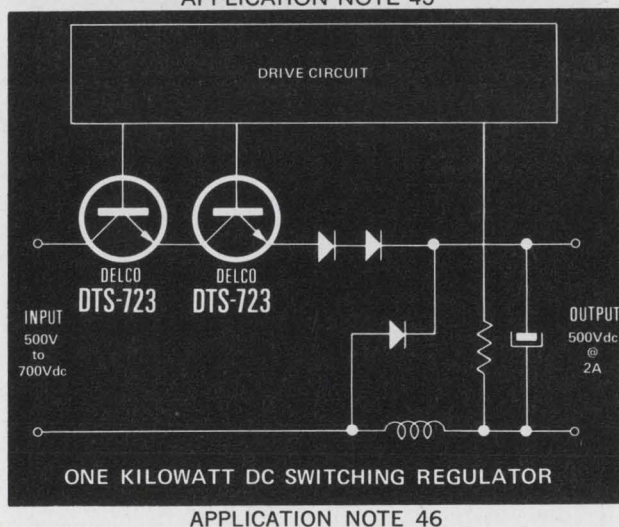
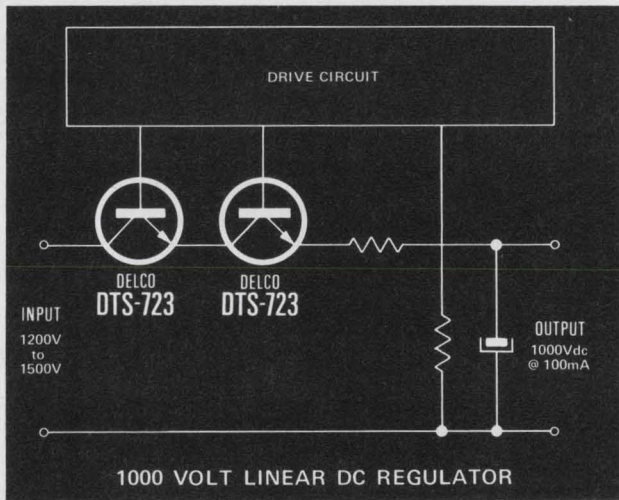

Delco Electronics has made it possible for your Delco distributor to offer you better values than ever on these ten silicon high-power transistors. What's more, he has them in stock now and there's a healthy factory inventory to back him up.

These high quality, high voltage devices are all NPN, triple diffused, and packaged in Delco's solid-copper TO-204MA (TO-3) case.

Some are specifically designed for use in high voltage switching circuits where inductive loads or fault conditions pose problems. Some are ideal for linear regulators and power amplifiers.

In fact, all the devices share Delco's reputation for being ideal where circuit conditions and high energy requirements are a concern. And because they're 100 percent pulse energy tested, you know they're rugged.

The circuit diagrams in this ad will give you a quick reading of how these ten transistors can meet your needs.

Applications literature and complete device data are available from your Delco distributor.

Give him a call for the information you need and the delivery promises and prices you'll like.

**NOW AVAILABLE FROM THESE DISTRIBUTORS
IN PRODUCTION QUANTITIES.**

ALABAMA, Birmingham
Forbes Distributing Co., Inc.
(205) 251-4104

ALABAMA, Huntsville
Powell Electronics
(205) 539-2731

ON DELCO'S TRANSISTORS.

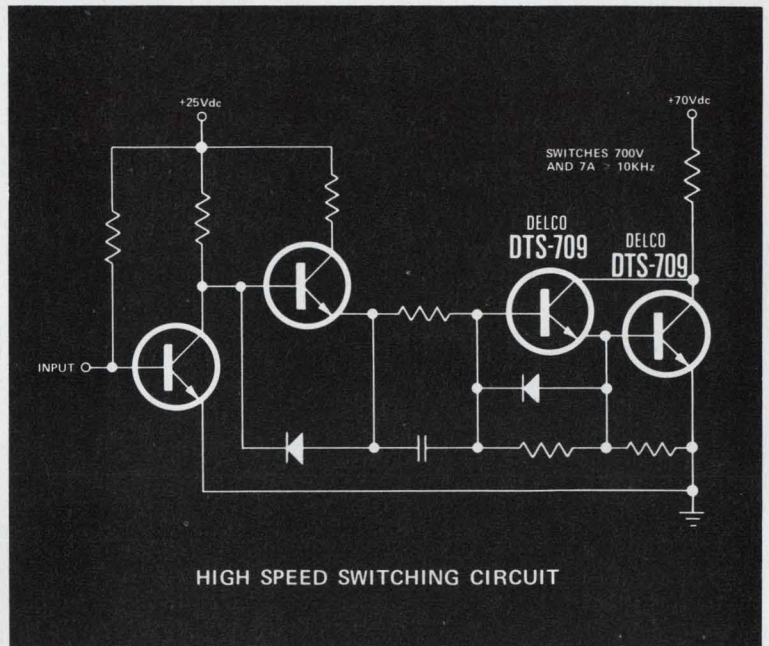
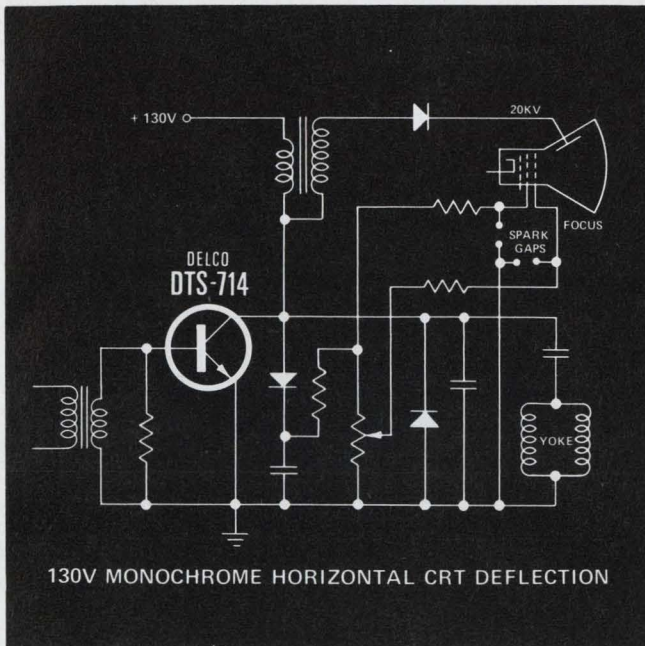

APPLICATION NOTE 54

ARIZONA, Phoenix
Sterling Electronics, Inc.
(602) 258-4531

CALIFORNIA, Goleta
R.P.S. Electronics, Inc.
(805) 964-6823

CALIFORNIA, Los Angeles
Kierulff Electronics, Inc.
(213) 685-5511

CALIFORNIA, Los Angeles
R.P.S. Electronics, Inc.
(213) 748-1271

CALIFORNIA, Palo Alto
Kierulff Electronics, Inc.
(415) 968-6292

CALIFORNIA, San Diego
Kierulff Electronics, Inc.
(714) 278-2112

CALIFORNIA, San Diego
R.P.S. Electronics, Inc.
(714) 292-5611

COLORADO, Denver
Kierulff Electronics, Inc.
(303) 371-6500

CONNECTICUT, Norwalk
Harvey/Connecticut
(203) 853-1515

FLORIDA, Miami Springs
Powell Electronics/Florida
(305) 592-3260

FLORIDA, Orlando
Powell Electronics/Florida
(305) 859-1450

ILLINOIS, Rosemont
Kierulff Electronics, Inc.
(312) 678-8560

ILLINOIS, Skokie
Bell Industries
Electronics Distributors Div.
(312) 282-5400

INDIANA, Indianapolis
Graham Electronics Supply, Inc.
(317) 634-8202

INDIANA, Indianapolis
Harvey/Indiana
(317) 297-4910

MARYLAND, Baltimore
Radio Electric Service Co.
(301) 823-0070

MASSACHUSETTS, Needham Heights
Kierulff Electronics, Inc.
(617) 449-3600

MASSACHUSETTS, Newton
The Greene-Shaw Co., Inc.
(617) 969-8900

MICHIGAN, Farmington
Harvey/Michigan
(313) 477-1650

MINNESOTA, Minneapolis
Stark Electronics Supply Co.
(612) 332-1325

MISSOURI, Kansas City
Walters Radio Supply, Inc.
(816) 531-7015

MISSOURI, North Kansas City
LCOMP-Kansas City
(816) 221-2400

MISSOURI, St. Louis
LCOMP-St. Louis
(314) 647-5505

NEW JERSEY, Clifton
Wilshire Electronics/New Jersey
(201) 365-2600 (212) 244-8930

NEW YORK, Binghamton
Harvey/Federal
(607) 748-8211

NEW YORK, Farmingdale
Wilshire Electronics/Long Island
(516) 293-5775

NEW YORK, Woodbury
Harvey/New York
(516) 921-8700 (212) 895-9260

OHIO, Cincinnati
United Radio, Inc.
(513) 761-4030

OHIO, Cleveland
Pattison Supply Co.
Industrial Electronics Division
(216) 441-3000

PENNSYLVANIA, Philadelphia
Almo Electronics
(215) 676-6000

PENNSYLVANIA, Pittsburgh
RPC Electronics
(412) 782-3770

SOUTH CAROLINA, Columbia
Dixie Radio Supply Co., Inc.
(803) 253-5333

TEXAS, Dallas
Adleta Electronics Company
(214) 741-3151

TEXAS, Fort Worth
Adleta Electronics Company
(817) 336-7446

TEXAS, Garland
Kierulff Electronics, Inc.
(214) 271-2471

TEXAS, Houston
Harrison Equipment Co., Inc.
(713) 224-9131

VIRGINIA, Richmond
Meridian Electronics, Inc.
(804) 353-6648

WASHINGTON, Seattle
Kierulff Electronics, Inc.
(206) 763-1550

IN CANADA
ONTARIO, Scarborough
Lake Engineering Co., Ltd.
(416) 751-5980

ALL OVERSEAS INQUIRIES:
General Motors Overseas Operations
Power and Industrial Products Dept.,
767 Fifth Avenue, New York, N.Y.
10022. Phone: (212)-486-3723.

Delco Electronics Regional Sales Offices

Union, New Jersey 07083
Box 1018 Chestnut Station
(201) 687-3770

Van Nuys, California 91404
Box 2968
(213) 988-7550

General Sales Office
700 E. Firmin, Kokomo, Ind. 46901
(317) 459-2175
Operator (317) 457-8461



Delco Electronics, Division of General Motors.

The New Jermyn Heat-Pipes.

What they are and what they do.

First, a little sales talk: A heat-pipe is a clever device with about 400 times the thermal conductivity of solid copper.

An $\frac{1}{8}$ " diameter heat-pipe can carry away about 20 watts; one $\frac{1}{2}$ " diameter can carry 500 watts.

With a heat-pipe you can pack your components closer and remove the heat to a sink somewhere else.

A heat-pipe, or its relative the heat-plate, can keep dozens of devices at the same temperature.

It can operate as low as -170° or as high as 400°C .

And a complete range of heat-pipes can now be obtained from your favorite manufacturer, Jermyn.

How it Works:

The heat-pipe is a tube, made of copper, stainless steel or sometimes pyrex glass, with an inner lining, or 'wick,' of capillary material.

Both ends are sealed; inside is a small amount of fluid (it might be water or it might be all sorts of things), in a partial vacuum.

When one end of the pipe is made hot, the fluid boils off, and the molecules shoot along the pipe at high speed. They hit the other end, condense, give up their latent heat, and the capillary lining gently sucks them back to the beginning again.

Although that last paragraph took about ten seconds to read, in fact it all happens in an amazingly short time. Molecules are whizzing along at thousands of miles an hour; and that's how you get the enormous rate of heat transfer.

Stick a heat-pipe into your morning coffee and see how your fingers hurt immediately.

As you can imagine, by using different fluids at different pressures, one can make heat-pipes to operate at a wide range of temperatures.

And different shapes and sizes of pipes, or flat plates, or sandwiches etc., give a huge variety of uses and applications.

What to do next:

You can write for our heat-pipe leaflet.

But essentially this is a problem and solution business. You tell us the sort of circuit, the watts, and operating temperatures required. We'll recommend a heat-pipe to do the job.

Jermyn

712 Montgomery Street
San Francisco CA 94111
San Francisco (415) 362-7431

How to use your heat-pipes:

Connect a power diode to a distant heat sink.

Pack your transistors closer without heat problems.

Put your airborne electronics where you want them and pipe the heat to somewhere cooler.

Use one cooling fan and one sink, to cool hundreds of hot spots.

Keep a lot of ganged devices all at the same temperature.

Paris 744 29-71

Munich (089) 39 88 01

London (0732) 58271

MOS memory capability built into IBM typewriter

A typewriter that uses a two-stage, semiconductor, magnetic-tape memory and remembers everything typed on it has been introduced by the Office Products Div. of IBM in Franklin Lakes, N.J.

Called the IBM Memory Typewriter, the machine uses an n-channel MOS memory to store one fully typed page and an internal magnetic tape to store up to 50 pages of text. The semiconductor, random-access memory is organized into a 4-k-by-7-bit array. Seven memory modules, each containing two 2-k chips, are used.

The semiconductor memory allows a typist to manipulate the typed text rapidly. Corrections can be made instantly if the backspace key is depressed; this automatically erases material from both the original page and the electronic memory.

Typed material can be played back from the semiconductor memory at 150 words a minute or stored in the typewriter's magnetic tape loop.

The tape memory has 50 storage positions, each capable of being selected by a storage dial. Each position can hold up to 4000 characters, or one page of typewritten material.



New memory typewriter from IBM can store 50 typewritten pages of information on an internal magnetic tape. Page location is selected by the knob at the right.

A page that is already in the semiconductor RAM can be stored in any position on the magnetic tape in 7.4 sec. The information can be recalled from the tape into the RAM in 3.7 sec. Once in the RAM, the text can be revised if the changes are just typed. Line lengths are automatically readjusted during playback, to accommodate the changes.

In addition to the memory, the typewriter contains n-channel MOS modules to perform the logic operations. TTL is used in the timing and control circuitry.

Prices for the typewriter begin at \$5400, with monthly rentals starting at \$165 and extended term leases \$145 a month.

Seminar to evaluate displays of the future

A brain-storming session on what information displays of the future will need and what they may look like will be the climax of an open-panel seminar on "Display Technologies for Different Applications" in New York City.

Presented by the mid-Atlantic chapter of the Society for Information Display, the seminar, according to Dr. I. F. Chang, technical program chairman and member of the research staff at IBM Watson Laboratories, Yorkville, N.Y., will present controversial views by a panel of industry experts in both display technology and display application.

The seminar, open to all interested, will be held May 29 at 8 p.m. in the Skytop Room of the Statler-Hilton Hotel. Chang points out that this session, the final one of a series by the Society for Information Display, will be held one week after the society's symposium in San Diego, to include the latest

concepts and information.

Applications, limitations, and conflicts of present and future display requirements among the leading technologies will be discussed by the panel. The technologies include storage, refresh and matrix CRTs; electron-beam and laser-beam light valves; gas-discharge, electroluminescent and liquid-crystal displays, and the recently developed electrochromic displays.

Plug-ins turn DPM into many instruments

Just plug in the appropriate card and Analogic's new, 3-1/2 digit DPM—called the Pluggable-Transform DPM—becomes any one of a variety of different instruments, without the need for external hardware.

For instance, you can turn the DPM into a ph meter, a compensated cold-junction thermocouple digitizer, a load-cell meter, a watt-meter or a voltmeter/ammeter.

Both the analog-input and the digital-output interfaces of the unit, the Model AN2533/53, can be tailored to a user's needs.

The input can accommodate practically any analog transducer—from strain-gauge to linear variable differential transformer potentiometer. And the digital output can take many forms—from ASCII to telemetry or modern format to data compression, linearization and scaling.

Thus users in such diverse industries as process-control, machine-tool automation, data-acquisition and medicine—along with many others—can stock the 2533 as a single-model DPM and use it to tailor a wide range of applications.

Passive system tames high static electricity

A unique passive system has been developed for discharging high-voltage static electricity from paper or plastic webs or sheets being fed at high speed through processing machinery.

The key element of the system, according to its inventor, Anthony Testone, president of Static, Inc., Lee, Mass., is an aluminum neu-

tralizing bar—called the Autostat—which supports a series of grounded metal discharge points. Each plate is surrounded by an insulated conducting ring set in Plexiglas.

The conducting ring forms one element of a capacitor, whose function is to build up and maintain an ionizing voltage between the cylinder and its central discharge point. The static charge on the moving material—the Autostat bar is placed a fraction of an inch above the material—charges the capacitor. Once the capacitor reaches an ionization voltage, a broad ionic discharge takes place in the air between the ring and its central point. The discharge provides a conducting path for the static charge on the moving material to leak off to ground.

This new concept overcomes a prime fault of earlier induction-bar systems that were comprised simply of a series of grounded discharge points; the induction bar would not work in these systems when the static charge on the material happened to be lower than the ionization voltage of some 800 V. Because ionization stopped, the material was left with enough unwanted charge to require additional high voltage equipment to eliminate the charge.

With Static's system, Testone explains, sufficient voltage is induced in and maintained between the capacitor rings and their central points to reduce any remaining static charge on the material to tolerable values. The system is self-regulating, Testone points out, because the higher the voltage to which the capacitors are charged, the greater the ionizing current flow.

The system also does not produce high-voltage discharge spikes that—unlike other equipment—can interfere with sensitive computer controls.

Microwave ovens safe, IEEE panel reports

Almost a year ago Consumers Union published a report stating that Government standards regulating microwave ovens were inadequate and that it would be better for consumers not to use these

devices. Now, the IEEE's Committee on Man and Radiation has categorically stated that microwave ovens are not a health hazard.

According to H. Mark Grove, chairman, the committee disputes the notion that a microwave appliance cannot be considered acceptable unless there is no detectable radiation. He points out that there are many common sources of detectable radiation in use today. These include radio and television receivers that use the superheterodyne technique, automobile and lawn-mower ignition systems, fluorescent lamps and light switches.

"The real question is not the level at which radiated energy becomes detectable, but rather the level at which it becomes hazardous," he says.

Grover asserts that the radiation level of a properly functioning microwave oven is too low and the exposure of too short duration to cause physical damage to humans.

London parley to weigh tomorrow's electronics

An impressive panel of scientists and engineers from the United States, Europe and Japan will describe "Tomorrow in World Electronics" at an international conference in London on May 14 and 15.

Scheduled to coincide with the International Instruments, Electronic and Automation Exhibition in the British capital, the conference will deal with current and future technological developments and assess the challenges they pose for management, marketing and financial echelons.

The conference is being sponsored by ELECTRONIC DESIGN, The Financial Times (of London), Electronics Weekly (of London) and the British Overseas Airways Corp.

Among the speakers: C. Lester Hogan, president of Fairchild Camera and Instrument, who will discuss "Prospects for Semiconductors;" Earl Wantland, president of Tektronix, who will give his views on "Prospects for Electronic Instruments;" Edward David, executive vice president of Gould and former adviser to President Nixon, who will talk on "Electronics and

Energy," and J. Fred Bucy Jr., executive vice president of Texas Instruments, who will examine "Vertical Integration: Components to Systems."

Sebastian de Ferranti, chairman and managing director of Ferranti Ltd., England, will give his views on "Electronics in the 1980s." Edward Fennessy, managing director of Post Office Telecommunications in Britain, will describe "Prospects for Telecommunications." Gordon Haley, manager of the ICL Computer Development Div. of Systems Technology, will speak on "Future Computer Technology."

J. C. Akerman, managing director of Mullard Ltd., a division of Philips of the Netherlands, will analyze the "Performance and Prospects in the World's Electronics Industries." And from France, Edouard Guignonis, director delegue and directeur commercial general of Thomson CSF, will discuss "International Cooperation in Electronics."

Registration for the conference, for which there is a \$200 fee, is being handled through Electronic Design/Financial Times Conference, Financial Times Publications, Ltd., Suite 1006, 516 Fifth Ave., New York, 10036.

MW sensor detects oil slicks in sea

Natural blackbody microwave emission from oil slicks on the surface of the sea can be detected by airborne passive sensors with sufficient accuracy to determine not only that oil is present but how thick it is, according to James P. Hollinger principal investigator of the project at the Naval Research Laboratory in Washington, D.C.

The microwave sensor—or pair of sensors—detects the oil because when the fuel is present in the sea, the water emits stronger signals than usual.

"The oil forms a dielectric match between the sea and free space which allows more of the energy from the sea to get out," Hollinger says. "You get a better impedance match between the antenna and the bulk radiation from the sea. It's like a transformer."

The sensors used so far receive at 19, 30 and 70 GHz.



Debug Your System Design Before You Build It.

Stable? Oscillatory? Unstable? With an HP 9830 Calculator, you'll know exactly how your control system will perform – long before you've committed to an expensive prototype.

The secret to this cost-saving performance is our new State-Variable Dynamic Analysis Software. It's a carefully developed set of programs that can ensure you a stable system – often in less time than it takes to evaluate one or two computations by other methods.

Consider the benefits! No more struggling with Laplace transforms. No hassling with computer programming and interfacing. You just key in system component values directly from your block diagram, and the 9830 does the rest, automatically.

In ten minutes or less, you get a high resolution plot of transient response and printed documentation of system parameters. And if your

design needs adjustment, the handy post-modification routine lets you change components or parameters with a few keystrokes.

Electronic, hydraulic, mechanical, optical or hybrid controls: The HP 9830 Dynamic Analysis System can quickly save you enough on design costs to repay its \$435* per month lease price. And through our extensive software library, you can compound its profitability with savings on the whole spectrum of engineering tasks.

But why not see for yourself. For complete details, or a hands-on demonstration, call your local HP Sales Office. Or send us the coupon below:

*Domestic U. S. A. price only. Lease, where available, includes service contract.



Sales and service from 172 offices in 65 countries.
P.O. Box 301, Loveland, Colorado 80537

Please tell me more about your Dynamic Analysis System. ED 3/74

Hands-on demonstration Information only.

I analyze these kinds of systems _____

Name _____

Firm _____

Address _____

Telephone _____ Zip _____

Hewlett-Packard Co.
P.O. Box 301, Loveland, Colorado 80537

MOS breakthrough... from MOSTEK

the 4K RAM in a 16-pin package!

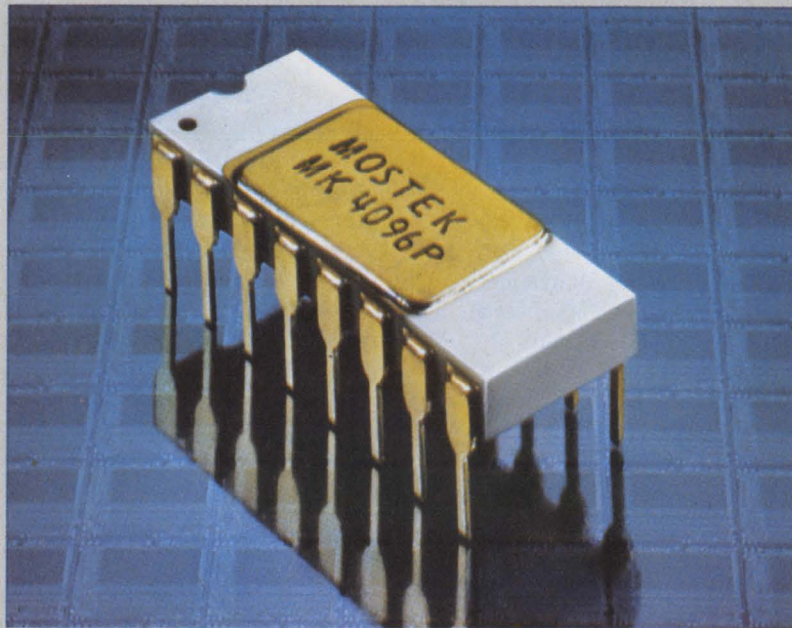

MOSTEK's 4K RAM is No.1 in ease of use, performance, and volume availability

MOSTEK's top design and process engineers worked nearly three years to produce a 4096-bit RAM with the optimum combination of ease of use, performance, and volume availability. The MK4096P is the result.

Easy to use. Most important, the MK4096P was designed to a 16-pin dual in-line configuration, enabling memory engineers to achieve the greatest possible memory storage in the smallest area. For example, using conservative PCB layout rules, the 16-pin package can provide 56% more memory storage per unit area than the alternate 22-pin package; 83% more using more dense PCB layouts.

Other design advantages include:

- readily available automatic insertion equipment can be used in board assembly

- voltage pins are located on the corners to simplify PCB layout
- all inputs including clocks are directly TTL compatible with low capacitance of 8 picofarads
- outputs are TTL compatible, three state
- the circuit is extremely tolerant of noisy system environments

Performance.

MOSTEK's MK4096P features an access time of 350 nsecs and read or write cycle times of 500 nsecs. Active power is under 100 μ W/bit. Refresh time for each of the 64 row addresses is 2 milliseconds. All specifications are guaranteed over a temperature range of 0° to +70°C.

Volume availability. A major MOSTEK design goal was to make the MK4096P a high-yield, mass-producible MOS circuit. To accomplish this, a special N-channel self-aligned gate, polysilicon-interconnect process was developed to eliminate all contacts

from the storage matrix. Also, the single transistor cell design markedly reduces chip size. Design layout rules were intentionally conservative to allow for further manufacturing efficiencies.

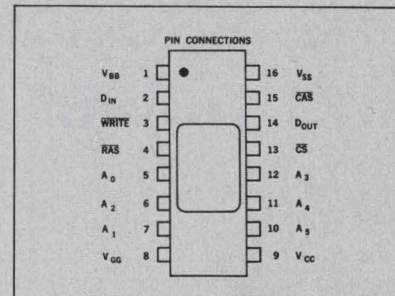

MOSTEK's capability in volume RAM production is proven by past production experience. MOSTEK is now one of the largest producers of MOS RAMs, having delivered a total of over 2 billion bits. The present RAM production level is over 250 million bits per month.

Want to know more? Then call your local MOSTEK distributor or representative or contact MOSTEK, 1215 West Crosby Road, Carrollton, Texas 75006, (214) 242-0444.

MOSTEK®

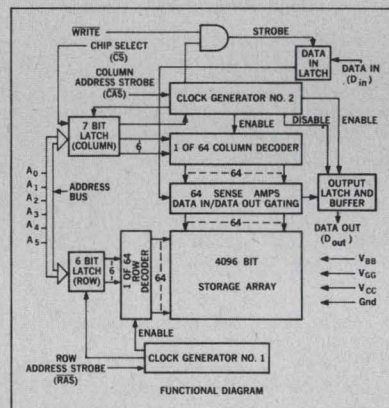

MOSTEK moves forward...in memories.

REPORT ON MICROWAVE TUBES

The struggle to raise efficiency and power while dropping cost

With solid-state microwave oscillators and amplifiers encroaching on territory long held by microwave tubes, tube manufacturers are moving to increase the efficiency of their devices, jack up power output, increase bandwidth and, of course, slash costs.

Recent progress toward these goals includes the following:

David N. Kaye
Senior Western Editor

- The efficiency of traveling-wave tubes (TWTs) has been raised from an 18-to-20% range to 50% and higher. At low microwave frequencies, 90% efficiency is expected in a few years.

- Dual-mode TWTs are being improved to the point where a 10-to-1 ratio of pulse to cw power is attainable in the near future. This would make the use of such tubes practicable in electronic warfare.

- Printed-circuit structures under development will reduce the parts count of microwave tubes by a factor of 10, thereby lowering costs significantly.

- Improved cooling techniques are allowing microwave tubes to run at far greater power levels.

TWTs: Better and better

Most of the action today is in TWTs. The tube consists of an electron gun, a slow-wave structure and a beam collector. Microwave energy travels down the slow-wave structure at a velocity slower than that of the electron beam. This energy interacts with the beam, and energy is transferred to the rf signal from the beam.

The efficiency of the energy transfer is, to a large extent, dependent upon the efficiency of collection of the spent beam electrons after they have passed through the slow-wave structure. The latter is also known as the interaction region of the tube. To collect the electrons efficiently, the collector must be at a lower potential than the cathode potential in the electron gun. This type of collector is referred to as a depressed collector. Its potential is typically about 50% lower than that of the cathode.

Robert Woods, marketing manager for electron tubes at the Hughes Electron Dynamics Div., Torrance, Calif., notes: "If more than one stage of collector depression is used, significant increases in efficiency can be achieved. In the last few years the efficiency of TWTs has progressed from 18 to 20% to levels as high as 35 to 50% and more."

In addition to Hughes, multi-

INFORMATION RETRIEVAL NUMBER 22 ►
ELECTRONIC DESIGN 7, April 1, 1974



Typical microwave tubes in use today and produced by Litton include (from the top and moving clockwise): Re-entrant beam, distributed emission crossed-field amplifier; pulse magnetron for weather avoidance radar; low-noise, cw traveling wave tube; high-power, coupled cavity TWT; high-power pulse magnetron for military radar applications; high gain, 1-kW TWT. The small cube in the center is a solid-state microwave oscillator.



If you're into control applications, We'll give you one-million good reasons to spend 19¢.

Here they are. MA47110s, MA47111s and MA47120s. Hermetically sealed-glass packaged PIN diodes from Microwave Associates. 19¢ apiece in quantities of 1,000,000.

These rugged, application-oriented diodes are designed for use as switches and current controlled attenuators in constant impedance AGC circuits, such as those found in CATV and other communications systems. But the MA47111 gives you even lower intermodulation products than the MA47110.

The MA47120 is what you're looking for if you work with modulating circuits and matrix switching at frequencies as low as 1 MHz.

And all three of them give you uniformity and

repeatable performance. Even under extreme environmental conditions.

That means they're ideally suited for control applications. Like RF switching, limiting, duplexing, phase shifting, variable attenuation, modulation and pulse forming.

If you have a prototype to test, we'll be glad to send you some free samples. Because we're sure you'll be more than satisfied with what you can get for 19¢.

Microwave Associates, Inc., Northwest Industrial Park, Burlington, Mass. 01803, 617-272-3000; Dunstable Woodside Estate, Dunstable, Beds., United Kingdom, Tel: Dunstable 601441.

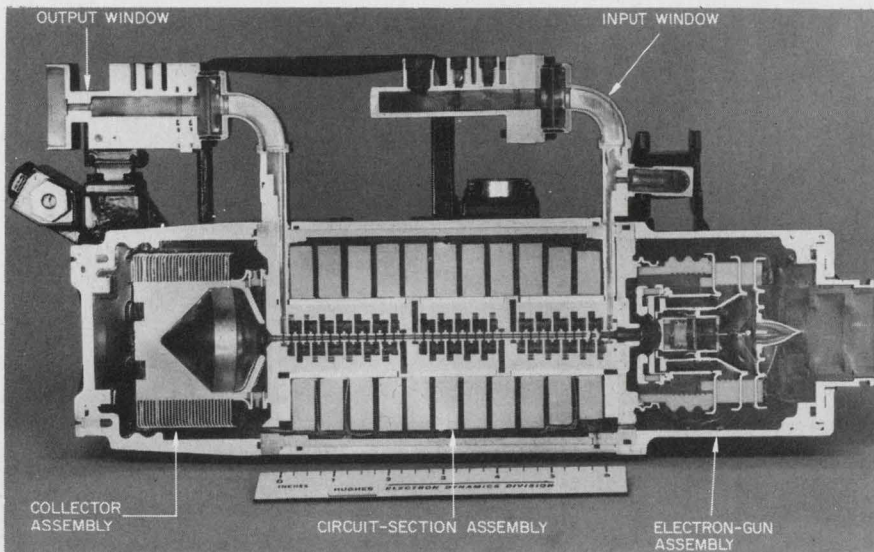

A typical high-power, coupled-cavity TWT from Hughes operates in X-band. The cavities are coupled by slow-wave irises.

stage depressed collector improvements are being pursued by such companies as the Litton Electron Tube Div. in San Carlos, Calif., and Sperry Microwave Systems, Gainesville, Fla.

Much of the extremely high efficiency work on TWTs is being done at NASA. Efficiency becomes critical on a satellite or spacecraft, where prime power is at a premium and communications must span great distances. Dr. Henry Kosmahl, head of the Power Amplifier Section at the NASA Lewis Research Center in Cleveland is looking for TWT efficiencies in the next few years to reach 90% at low microwave frequencies, 60 to

65% at 12 GHz and 50% at millimeter frequencies of 40 GHz and above. He points out: "At X-band and below we are working with 10 stages of depressed collector."

Tubes built by Litton and Hughes have achieved 50% efficiency at 12 GHz and a 200-W cw power level. NASA plans to use a tube of this type on the upcoming Communication Technology Satellite.

"To make multistage depressed-collection work," Kosmahl notes, "it is necessary to use a magnetic taper-beam refocusing scheme to decrease the current density in the beam prior to collection."

Sperry is pursuing an Air

Force program to produce a high-efficiency, dual-mode TWT for electronic warfare. Dual mode means a single tube can be run in a high-power pulse mode and also a lower-power cw mode.

Thomas B. Elfe, a senior development engineer at Sperry, explains: "We have not yet reached the hardware stage of our program. So far we are doing a computer study of a C or X-band helix type TWT that will handle several hundred watts, have a 10-dB ratio of modal powers and a high efficiency. We are using the magnetic field to do velocity sorting of the beam electrons prior to collection. These velocity packets will then be directed to the proper stages of a 3-to-5-stage depressed collector. We are also using the magnetic field to suppress secondary electrons. The collector will be unique, in that it will not have axial symmetry."

Dr. Larry Yarrington, head of TWT development at the Air Force Avionics Laboratory, Wright-Patterson Air Force Base, Ohio, emphasizes: "Although 5 to 7 dB of mode ratio has been achieved to date, 10 dB is necessary for effective barrage-jamming in the cw mode and pulse-jamming for deceptive targets in the pulse mode."

Barrage-jamming is a technique that utilizes maximum power output to jam enemy radars. Pulse jamming is a technique that makes enemy ground-based radars "see"

Microwave tubes: The basic types

Two main technologies divide the world of microwave tubes: linear beam and crossed-field. The linear beams include traveling-wave tubes (TWTs), klystrons and O-type backward-wave oscillators (BWOs). A third tube is the space-charge-controlled type.

A linear-beam tube is defined by the International Electrotechnical Commission in these words: "A space-charge-wave tube in which the directions of the electron beam, the electric field and the static magnetic field, if

any, are parallel (co-linear). In this type of tube the kinetic energy of the electron beam is converted into rf energy."

Crossed-field tubes include magnetrons, crossed-field amplifiers (CFAs) and M-type BWOs. The commission defines the crossed-field tube this way.

"A space-charge-wave tube in which the directions of the static magnetic field, the static electric field and the electron beam are mutually perpendicular. In this type of tube the potential energy of

the electron beam is converted into rf energy."

Space-charge-controlled tubes are normally of the ceramic planar triode type and the closest to a conventional low-frequency vacuum tube in operation. They function by controlling a space-charge-limited current with a grid electrode.

Most microwave tubes are used in military or aerospace applications.

Of the commercial applications, microwave heating and data communications are the most active.

The new Keithley Model 168 autoranging DMM... ...vive la différence!

There really is a difference in Digital Multimeters, and once you've experienced Keithley's 168 you'll know why we say *vive*! If you're tired of "general-purpose" promises that turn into run-of-the-mill

performances; if you want that bit extra that'll make your job easier, then *vive la différence*... here's the DMM for you! Send for our DMM Selector Guide or call us for demo now. **Phone (216) 248-0400.**

AC VOLTS
DC **AMPS**
OHMS

5 functions
100 μ V to 1000 V dc
100 μ V to 500 V ac
0.1 μ A to 1 A dc
0.1 μ A to 1 A ac
100 m Ω to 20 M Ω

price
Enough said? Order one... or two... or three now!

\$299⁰⁰

two-terminal input

Simple to connect. You can't get it wrong. Eliminates the word "whoops" from your vocabulary. Saves temper, too.



options & accessories

Rechargeable batteries that you can install anytime. An RF probe for high frequencies. Test leads. A 50-amp current shunt too.



hi-lo ohms

Select either of two voltage levels, 1 V or 100 mV, for ohms measurements. You can have your PN junctions either way you want 'em... on or off.



automatic ranging

You just connect the signal and push the function. The decimal point pops into position automatically and the display is direct reading. That does save time!

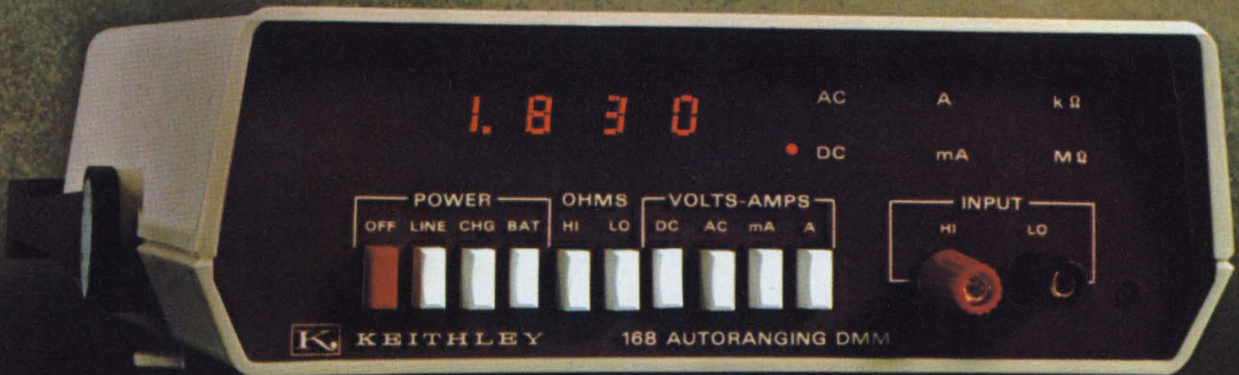

KEITHLEY INSTRUMENTS
U.S.A.: 28775 AURORA ROAD, CLEVELAND, OHIO 44139
EUROPE: 14, AVENUE VILLARDIN, 1009 PULLY, SUISSE

deceptive targets.

Several approaches to solve the dual-mode problem have been proposed by Hughes. Varian in Palo Alto, Calif., Watkins-Johnson in Palo Alto, Raytheon in Waltham, Mass., and Warnecke Electron Tubes, Des Plaines, Ill. The most promising methods use a special dual-mode electron gun, which produces a high-gain, hollow beam for the cw mode and a low-gain, solid beam for the pulsed mode. One approach uses a dual-mode gun and a pair of slow-wave structures, either bifilar or contrawound helices, of different phase velocities. Several other approaches use a variety of dual helix or field-tailoring techniques.

Printed-circuit TWTs sought

John Tancredi, a physicist at the Army Electronic Technology and Devices Laboratory, Fort Monmouth, N.J., reports that to cut the cost and increase the efficiency of systems that have microwave tubes, the Army is sponsoring printed-circuit TWT development at Varian. The program calls for a 2-kW, 8% duty cycle, S-band tube in which the entire structure is printed on a ceramic substrate. John Sullivan, engineering manager for TWTs at Varian, notes that the goal is to reduce the parts count of the tube by a factor of 10. Prototypes have been built with about 15% bandwidth and 1.5 kW of output.

Tancredi is also involved in a

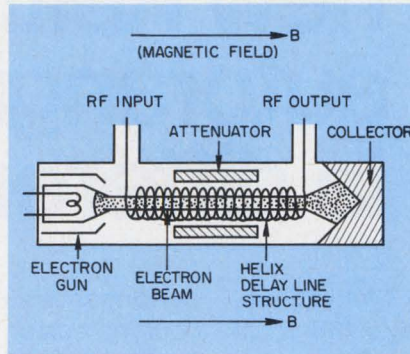

TWTs are linear beam tubes. Energy is transferred from an electron beam to an rf signal propagating down a slow-wave structure such as a helix.

program that is aiming for a low-cost, wideband medium-power, low-voltage TWT. This tube, also being developed by Varian, is a radial-beam TWT—that is, a beam that radiates out from the center of an equiangular spiral to the outer perimeter. The spiral is deposited on a beryllia substrate, and the collector is a continuous cylinder. Tancredi is hoping for a tube in the 500-to-1000-MHz range with 500 W of output and capable of operating at only 200 to 300 V. The latter would be a tenfold reduction from more conventional voltage levels. The first hardware on the new tube is due for evaluation in June.

In addition the Army is funding a program at Hughes to develop a single tube with two parallel contrawound helix structures (see cover photo). Such a tube would deliver higher output

power at lower beam voltage.

While most low and medium-power TWTs use broadband helix structures and most high-power TWTs use coupled-cavity structures, other types of structures are being investigated. Several TWT companies have tried ring-bar and ring-loop structures. These consist of solid rings connected alternately on the top and bottom with either bars or metal loops. In terms of power and bandwidth, they may fill a gap between helix and coupled-cavity tubes. Typical helix TWTs can deliver up to about 10 kW and coupled-cavity up to about 500 kW of peak power.

For reception at 5 GHz and above, microwave receiving tubes are still the way to go. TWTs for this purpose are built by Watkins-Johnson, Varian and Teledyne MEC in Palo Alto, among others. These tubes are being used for low-noise radar reception, communications and active and passive electronic warfare applications.

Most of developmental efforts seem aimed at K, K_A and K/K_A bands in the frequency spectrum of 18 to 40 GHz. Noise figures of less than 15 dB are being achieved, with gains in excess of 40 dB.

Klystrons for super power

When many megawatts of peak power are needed, klystrons are often the only choice. They have been built with peak powers in excess of 40 MW by companies like Litton, Sperry, Raytheon, ITT in Easton, Pa.; RCA, Harrison, N.J.; GE, Owensboro, Ky., and Varian. These high-power tubes are all used as amplifiers. The small reflex klystrons that have been around for so many years as oscillators are slowly being replaced by solid-state sources.

According to Armand Staprans, manager of high-power microwave operations at Varian, the main advantages of klystrons, in addition to higher power capabilities, are high efficiency, lighter weight than a TWT and noise-free operation. Klystrons are considered the most noise-free of all microwave transmitting tubes.

Efforts are under way to improve the efficiency and bandwidth of the klystron. An example is a

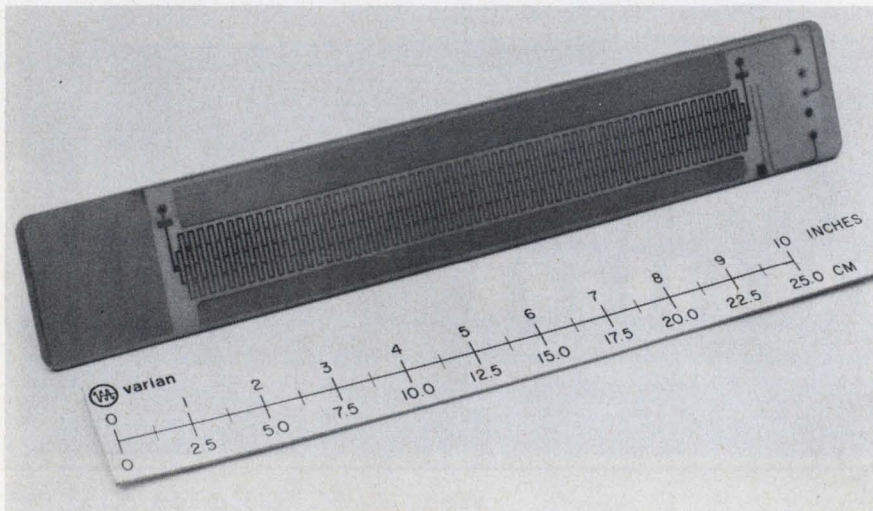

Printed circuit TWTs such as this one are being developed by Varian. This tube puts out 2 kW from 3.1 to 3.5 GHz.

It's good to undersell. It's great to out-perform. New Cinch P.C. edge connectors do both.

Only in this new group of Cinch connectors with .031" x .062" wire wrap* terminals do you find all of these key features: readily removable contacts; switching contacts; preloaded cantilevered, bifurcated contacts; and shorting protection. Yet, Cinch's unique capabilities in selective plating, substantially reducing the amount of gold in non-wearing areas, and the simultaneous insertion of an entire row of contacts get the price of these new P.C. Edge Connectors way down.

Three termination lengths are available for one, two or three wraps that will also accept clip type attachments for rapid wiring modifications. Contacts are pre-loaded to provide gap uniformity and shorting protection when the board is removed.

Contacts are phosphor-bronze, selectively plated with 30 micro-inches of gold in the contacting area. GP impact phenolic is used for the insulator. The new Cinch connectors have the same cross sectional area as .045" square tail terminals, and can generally be substituted for .045" units.

These connectors are available from stock in 10, 15, 18, 22, 25 and 30 position double readout, through all TRW/Cinch edge connector distributors. Contact them, or your local TRW/Cinch sales office, or write to TRW/Cinch Connectors, an Electronic Components Division of TRW Inc., 1501 Morse Ave., Elk Grove Village, Illinois 60007; phone (312) 439-8800. Ask for Product Bulletin PBC-183.

CM7308

*Trademark Gardner-Denver

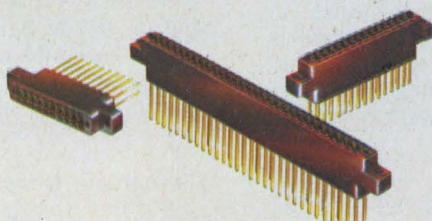

TRW CINCH CONNECTORS

INFORMATION RETRIEVAL NUMBER 24

Varian project in which a 2540-MHz klystron with 50 kW of cw power output achieved output efficiency of 74%. This tube used harmonic bunching of the electron beam to increase the rf beam current. A cascaded pre-buncher system with two second-harmonic cavities was used.

Typical klystron bandwidth is less than 8%, but in another Varian project almost 16% was achieved at 7.9 GHz. This tube used a two-cavity output filter, in which one of the cavities was coupled to the electron beam and the other to the output load of the system.

At Fort Monmouth, experiments have been conducted to improve the cooling techniques used with klystrons and TWTs. Good results have been achieved with vapor-phase cooling. The tube is dunked in a coolant bath inside a closed evaporative chamber. Such coolants as Freon 215 and Dow 209 have been used. Some researchers are looking into the use of heat pipes to draw the heat away from the microwave tubes.

BWOs marking time

BWOs? Very little development work is reported for the two types available: a linear-beam type, also called an O-type, and a crossed-field type, also called an M type.

The O type has the higher power, and it can also operate at higher frequencies. The M type is more efficient, and it can be tuned more rapidly. Both have more-than-octave tuning ranges and relatively high efficiencies—more than 35% has been noted for the M type BWOs.

Both types used to be the tubes used in swept microwave oscillator test equipment. However, that application has now been taken over by tunable solid-state sources. They are still used as drivers in power-amplifier chains and in some higher-power swept test instruments.

BWOs are being made by Litton, Sperry, Raytheon, Varian and Watkins-Johnson.

Magnetrons: A lot for a little

When a low-cost, high-power microwave oscillator is needed, the

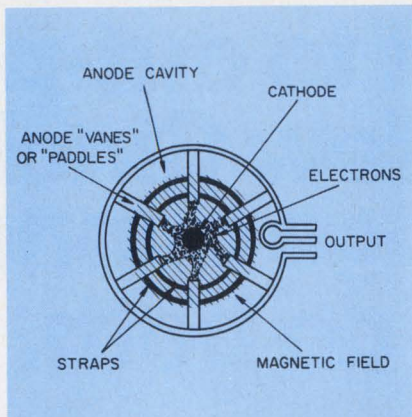

Magnetrons are crossed-field tubes. Electrons spiral out from a central cathode to a set of anode vanes. The whole structure is a resonant cavity in which electron-beam energy is transferred to a coupled rf signal.

choice is still a magnetron. The power stretches into the megawatts. Mechanical tuning is easily achieved, and the tube's life is very long. Most of the new magnetrons made today are of a coaxial type that last a minimum of 10,000 hours.

Magnetrons are built all the way from 2 GHz to 93 GHz. Efficiencies of the coaxial type reach 70% and more. Typical manufacturers are GE, Litton, Raytheon, RCA and Varian.

Chester G. Lob, general manager of Varian's Eastern Tube Div. in Beverly, Mass., notes that work is being pursued on techniques for dither tuning magnetrons in frequency-agile electronic warfare and radar applications. Dither tuning refers to rapid tuning of the magnetron back and forth through its tunable band. This is being done mechanically

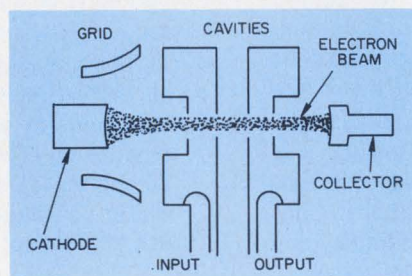

Klystrons are the most noise-free of all microwave amplifier tubes in high-power applications. Energy is transferred from an electron beam to an rf signal traveling through a coupled-cavity structure.

at present. A motor-driven dielectric disc (Varian) or series of vanes (Litton) is spun in the external cavity of the tube. Typical tuning ranges are a few percent, and tuning rates are approaching 1 kHz.

"Current development work," reports Lob, "is in the area of replacing the motor-driven tuners with electronic tuners. Either YIG or other ferrite materials will probably be used. Tuning diodes are also a possibility. This work should come to fruition in the next couple of years."

Another developmental area for magnetrons is microwave ovens. According to Paul W. Crapuchettes, vice president and technical director at Litton's Electron Tube Div.: "We charge about \$25 to \$30 for a microwave oven tube. Most tubes last at least 10 years." Most of this work is aimed at lowering the price. The tubes typically put out either 600 or 1000 W at 2450 MHz.

CFAs: Feverish activity

After TWTs, the most active area of development may be cross-field amplifiers (CFAs). Nelson J. Wilson, a physicist at the Army Electronics Command, Fort Monmouth, notes that CFAs offer efficiency in excess of 50%, a convenient cylindrical, compact form, multi-megawatt peak power and the need for only low voltages (about a third those required for klystrons).

Wilson points to these, however, as major problems: The rf gain is too low (typically 10 to 15 dB); the anode is hard to cool (in a CFA the anode is also the beam collector); and cold cathode current densities are not sufficiently uniform (a materials problem).

Major manufacturers of CFAs include Litton, Varian, Raytheon and Warnecke. Many of these are working on two basic types of tubes: a distributed-emission cathode tube and an injected-beam tube.

Injected-beam tubes show promise of higher gains, and much of the work on them is being supported by the Air Force. Dr. Yarrington of the Air Force Avionics Laboratory tells of a program to develop an S-band, 5-to-6-kW peak CFA with over 20 dB of gain.

HUGHES TWTs. THE SKY'S THE LIMIT.

How good are Hughes TWTs? Well, for years Hughes has worked to perfect some of the most powerful, efficient and lightweight TWTs in the business. From 1 GHz to 100 GHz and at power levels up to 500 kW, Hughes covers your needs.

How good are Hughes TWTs? How high is up?

To order these problem solvers, write Hughes Electron Dynamics Division, 3100 West Lomita Blvd., Torrance, California 90509. Or call (213) 534-2121.

HUGHES

HUGHES AIRCRAFT COMPANY
ELECTRON DYNAMICS DIVISION

LIGHT FLIGHT

Hughes Model 774H is a high-gain, grid-controlled TWT operating in the frequency range of 8.0 to 16.0 GHz, weighing only 5 pounds. Its peak power output is greater than one kW at up to 4% duty, while utilizing conduction cooling. Its rugged, compact construction makes it well suited for operation in airborne and missile environments. (RS 241)

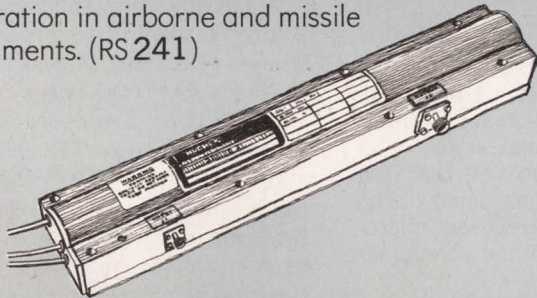

SPACE TRAVELER

Hughes Model 275H is not only the travelingest TWT, but it is destined to be the workhorse of space. This TWT is on board the Anik spacecraft, which is the Canadian communications satellite, and will in the near future be utilized by Westar, Amsat, Comsat domestic, Intelsat IV, Marisat, RCA Globecom, and others that aren't even named yet. (RS 242)

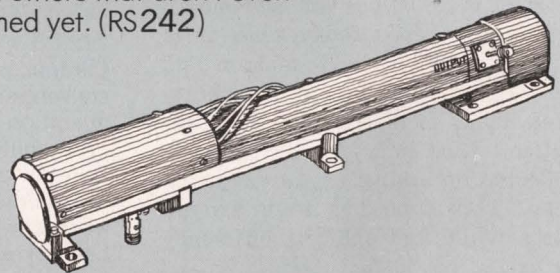

BIG SHOT

A heavy punch from the Hughes 786H TWT. It has a 50 kW peak and an integral solenoid (for reduced weight and size). Model 786H gives you a 7.5 percent bandwidth, 54 dB gain, liquid cooling and a non-intercepting shadow grid for modulation. All that with a 10 percent duty and a weight of less than 50 pounds. (RS 243)

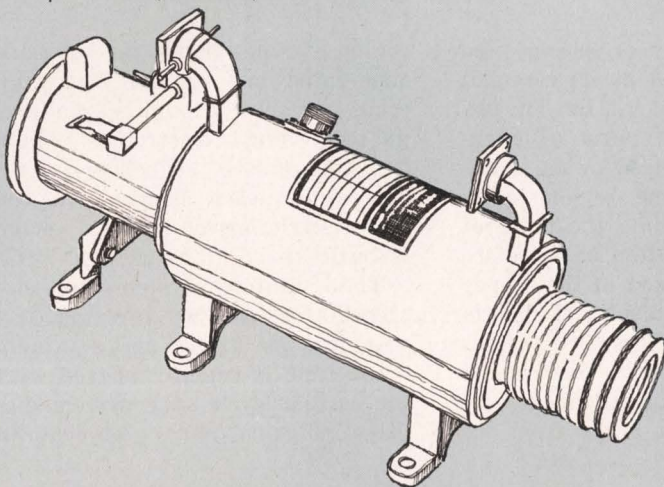

SKY KING

Hughes Model 796H TWT reigns over the skies with its 40 kW minimum peak power at a 5 percent duty cycle. (That's about 3 times higher than any other PPM focussed tube at this level). Weighing just 29 pounds, the liquid-cooled 796H gives you a 7.5 percent bandwidth, 54 dB gain, and a non-intercepting shadow grid for modulation. (RS 244)

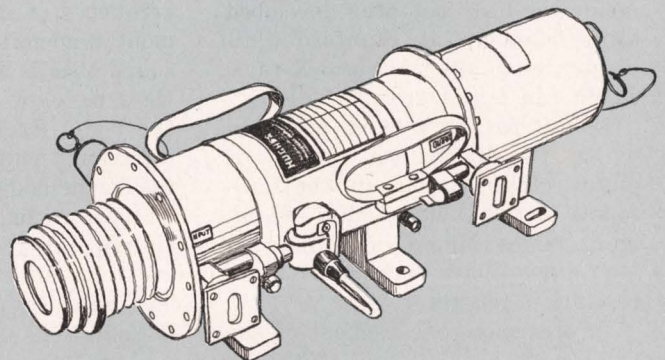

"One of the problems," he explains, "is to produce a sever [the network at the point of beam injection] to isolate the input from the output and make the tube more stable at high gain."

Yarrington also looks for improvements in the beam characteristics at the injection point. A cathode development program is looking at nickel-matrix cathodes for more uniform beam emission.

The Navy is supporting a Raytheon program in which rf is being fed on the cathode instead of the anode to achieve up to 26 dB of gain. Sonny Maynard, a senior technical staff member at the Naval Electronics Center in San Diego, notes that the service is very interested in dc-operated, self-modulating tubes. Such a tube is turned on and off by the presence or absence of the rf signal. With a self-modulated tube in a high-power pulsed system, the over-all dissipation of the system would be greatly reduced.

Two main types of self-modulating tubes exist today. One, from Litton, is called the Dematron and the other, from Varian, the Auto-Mod. The Dematron is a non-reentrant tube in which the beam is collected on a single pass down the tube. This tube has been around for a while and exhibits efficiency in excess of 30%.

Auto-Mod is a re-entrant tube in which the beam continues to circulate until it is all collected. The efficiency of the Auto-Mod is potentially in excess of 50%. It is a much newer tube than the Dematron, and development is centering

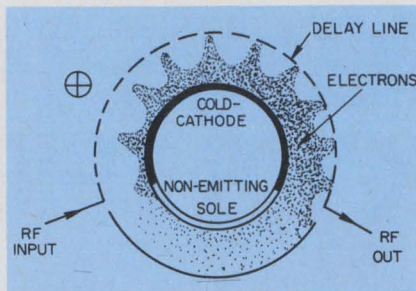

Distributed-emission crossed-field amplifiers spew electrons from a long curved cathode. The electrons tend to bunch as they travel along a slow-wave delay line to the anode. During this travel, energy is transferred from the electron flow-stream to a coupled rf signal to give gain.

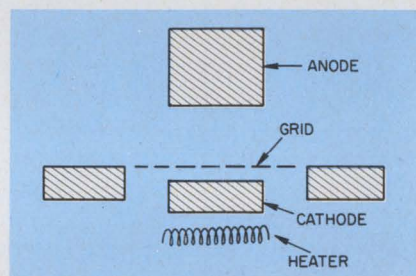

Ceramic planar triodes are much like conventional vacuum tubes in their operation. A modulated signal on a grid controls a space charge flow from a cathode to an anode. The tube is mounted to a resonant microwave cavity in which the rf interaction takes place.

on the dc bias electrode that controls the tube's re-entrant window.

General Electric, Raytheon and Varian Eimac in San Carlos, Calif., are the only American manufacturers of the space-charge-control-

led ceramic planar triodes. According to James Rush, manager of applications engineering at GE: "The planar triode offers the highest power output at the lowest cost of any microwave tube. For example, we can put out 50 kW of 1-to-2-GHz pulse power from a tube of about 1-cubic-inch volume."

Don Preist, chief advisory engineer at Varian Eimac, points out that these tubes are mostly used in aircraft for pulsed navigation and communications systems.

Typically triodes are not used above 6 GHz and cost under \$100. The usual bandwidth of the tubes is 10% to 20%, with efficiency ranging from 65% at lower frequencies to 20% at 6 GHz. GE reports that the tubes are useful to X band and the company has produced oscillators that operate at 9 GHz.

Used as amplifiers, triodes normally have gain of only about 6 dB.

A GE program sponsored by the Army is seeking to produce tubes whose grids are deposited on the cathodes. Strips of boron nitride insulating layer are deposited directly on the cathode, Rush explains, and these strips are covered with conducting strips to form a non-intercepting grid. Since the grid runs at about the same temperature as the cathode, the ratio of the grid to the plate current drops significantly. The advantages, Rush says, are greater mechanical stability, the ability to form a very large grid in the tube and much higher potential power at much lower cost. ■■

Body displayed sonically in real time

An ultrasonic method for producing real-time images of organs inside the body has been developed by researchers at Stanford University as an alternative to X-rays, which can be hazardous.

Using the ultrasound produced by a two-dimensional array of piezoelectric transducers, the California researchers—James Plummer, James Meindl and Maxwell Maginness—have produced high-resolution images.

In operation, one element of the

piezoelectric array is selected and electrically excited at its resonant frequency of about 3 MHz. The element transmits a burst of ultrasound that is focused by an acoustic lens onto some region inside the body. Each time the pulse of ultrasound encounters an interface inside the body, part of the energy is reflected back toward the piezoelectric array. These reflections are then refocused by an acoustic lens onto the transmitting array.

Reflections that occur from the

region of focus inside the body are time-gated out of the returning echos and sent through special signal-processing electronics. This transmit-receive sequence is repeated for each element in the piezoelectric array and an image is built up point by point.

The Stanford system was designed for cardiac imaging. By scanning the entire array rapidly—the time is small compared with the cardiac cycle—the system displays images of moving objects. ■■



Our
priority
is you!

When you deal with Piher you know you are dealing with one of Europe's foremost component manufacturers – and that's important to you, the customer. Because we only manufacture for you. No question of giving you long delivery dates because we divert components for our own product lines. We haven't any. Our component manufacture is for you – totally.

We have a wide range of high quality components – at really competitive prices. Demand for our carbon film resistors, for instance, is so high that our current production is committed months ahead. Our new manufacturing plant in the U.S.A. – operational early in 1974 – will help speed resistor deliveries. But we have other, shorter-term delivery components available. Trimmer,

spindle and rotary potentiometers, semi-conductors, ferrites, capacitors – all high quality items.

Send for our data sheets if you want to be kept in touch with the Piher range. Find out more about us, it pays.



Head Office—Spain - Riera Cañadó, s/n. Apartado de Correos 53, Badalona (Barcelona) Spain. Tel: 389 03 00. Telex: 59521

PIHER International Corp. 1239 RAND ROAD, DES PLAINES, ILLINOIS 60016. Tel: 312-297 1560. Telex 282514

Alternative to multilayers proposed: Stacked PC boards at half the cost

An alternative to conventional multilayer boards was suggested by two product engineers at the Nepcon conference in Anaheim, Calif.

Instead of conventional multilayer boards, the packaging can be done with a stack of more economical, double-sided PC boards, according to Michael D. Lazar, co-author of a paper with Heinz Piorunneck. Both engineers are with Burndy Corp. of Norwalk, Conn. The PC boards are linked with small stacking connectors that are randomly positioned on the intermediate board surfaces. Such a stack, Lazar said, comes apart easily to provide access to all lay-

ers for repair or circuit changes. And active components can be packaged on any of the surfaces.

In addition, he noted, any of the boards can use a wide variety of wiring methods, including solderless wrap. The height of the stacking connector permits ample space between boards for accommodation of typical DIPs.

The product engineer estimated that the cost of double-sided PC boards would be less than half that of multilayer boards.

Lazar pointed out that multilayer boards have been used for many years but that they are still plagued by problems. They're expensive, hard to repair and manu-

facturers take a long time to deliver them, he said. They're difficult to manufacture, and the choice of quality suppliers is limited, he added.

In the typical multilayer board, the inner layers are buried and not accessible for testing, inspection or repairs. Most are made from copper-clad, glass-epoxy laminate materials, and components are mounted on one outer side only. The other outer side is reserved for wave-soldering of the component leads. The result is that a relatively large surface plane is required to accommodate all components.

The stacking connectors proposed by Lazar feature Burndy's "gas-tight, high-pressure contact" (GTH) system, expressly designed to mate with solder-coated pads on the PC boards. The Burndy contact uses low-cost base metals that perform "as good as gold," according to Lazar.

"Although some applications may demand multilayer boards for electrical reasons," he said, "disadvantages of lower production yields, high cost and long delivery should be weighed before deciding to use multilayer boards." ■■

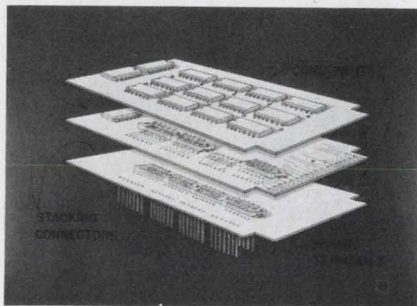

With stacked PCs you can mount parts on all board surfaces.

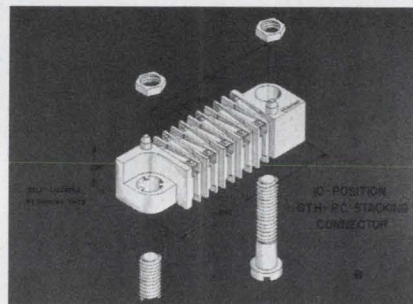

Burndy's GTH connector tips pierce pads to make low-ohm contact.

New computer tape resists edge damage

Although tape technology has kept pace with higher computer speeds, higher data densities and the use of more tracks for data recording, the physical quality of many tapes today can't take the rough handling that is required. A new thicker-based computer tape is said to be practically immune to edge damage from transport tape guides—the No. 1 cause of tape failure.

Called "Cubic" by its manufac-

turer, Memorex Corp. of Santa Clara, Calif., the tape is produced on a 1.7-mil polyester base. This compares with the 1.35-to-1.4-mil base that most computer tapes have. By use of a thinner coating, the nominal thickness of the finished tape remains at 2 mils—the industry standard.

A 25% increase in thickness produces 50% greater resistance to bending and side-load forces, according to Memorex. The thicker

base is also said to permit more accurate slitting of the edges as well as greater strength.

Among the advantages reported for the new material are improved amplitude stability on outer data tracks and less track displacement as well as improved self-loading characteristics.

The company believes that a similar tape will be produced by all major companies, "just as soon as they see how good it is." ■■

FOR NEW STANDARDS IN SWEEPERS, THINK HP

5 big reasons to choose the HP sweeper

1. Coverage.

The HP 8620 family of solid-state sweepers covers 3 MHz to 18 GHz with unparalleled flexibility. Choose from 9 single-band plug-ins or combinations of RF modules to get multi-band coverage conveniently and compactly.

2. Performance.

HP sweepers invite comparison in such important areas as frequency accuracy and linearity, signal purity and stability. And they offer versatile modulation and leveling choices for even more value.

3. Power.

Overall, the HP 8620 family delivers higher output power than any other solid-state sweeper. Standard units provide guaranteed 40 mW to 4.2 GHz and at least 10 mW all the way to 18 GHz.

4. Price.

HP sweepers are really competitively priced. Mainframes start at \$1025. Single band RF units range from \$1475 to \$2950, and a multi-band configuration such as a 0.1 to 6.5 GHz plug-in is only \$6475. It only takes three RF plug-ins to span from 0.1 to 18 GHz at a price of just \$14,250.

5. Availability.

Six weeks or less for everything in the 8620 family. You can plan your swept measurements with the assurance that your schedules will be met.

No other line of sweepers can match these 5 big reasons. We'll be glad to send you full details on the value-priced HP 8620 Sweeper line. Contact your nearest HP field office. Or write.

Domestic USA prices only.

04405

HEWLETT  **PACKARD**

Sales and service from 172 offices in 65 countries.
1501 Page Mill Road, Palo Alto, California 94304

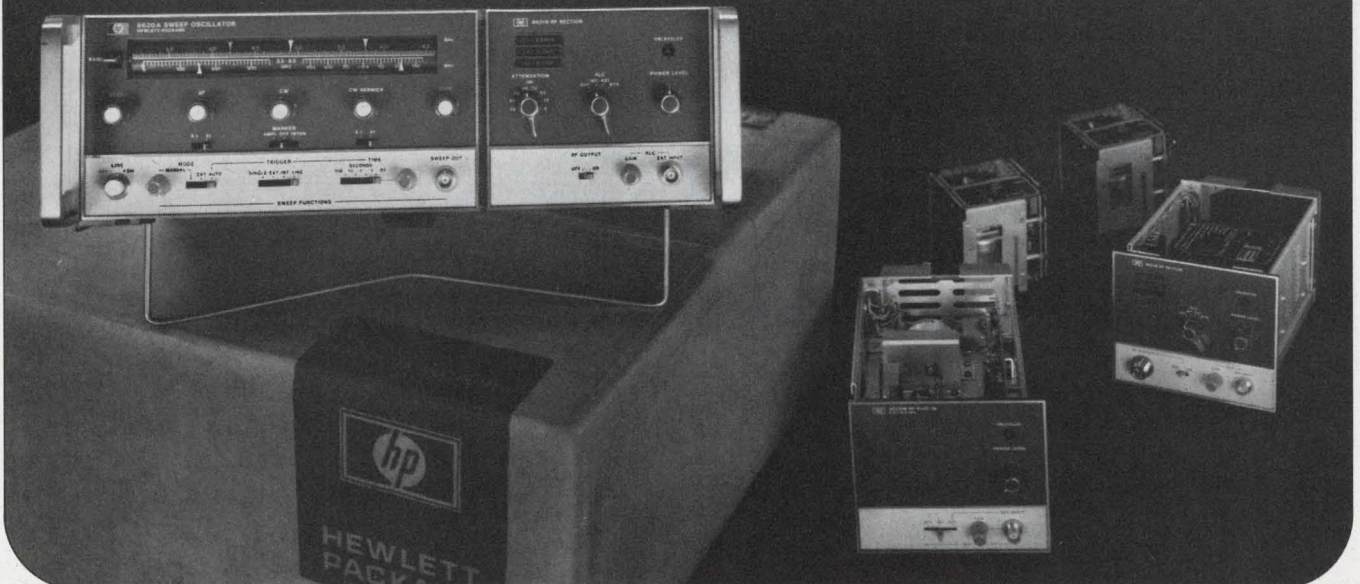

INFORMATION RETRIEVAL NUMBER 27

Varian has a great

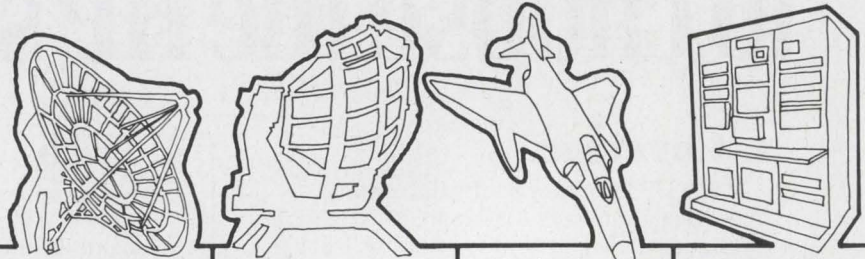

	Communications	Radar	Electronic Warfare	Instrumentation and Others
Power Tubes				
Crossed-Field Amplifiers		X	X	X
Klystrons	X	X	X	X
Magnetrons		X	X	X
Power Grid Tubes	X	X	X	X
Traveling Wave Tubes	X	X	X	X
Traveling Wave Tube Amplifiers	X	X	X	X
Twystron® Amplifiers		X		
X-Ray Tubes				X
Microwave Sources				
Beacon Magnetrons	X	X		
Extended Interaction Oscillators	X			X
Frequency Multipliers	X	X		
Gunn-Effect Oscillators				
Fixed Frequency	X	X		X
Varactor Tuned	X	X	X	X
Yig Tuned		X	X	X
Impatt Oscillators	X	X		
Klystron Oscillators	X	X	X	X
Planar Triodes	X	X	X	X
Power Transistors	X	X	X	X
Voltage-Tunable Magnetrons			X	X
Yig-Tuned Harmonic Generators			X	X
Yig-Tuned Transistor Oscillators		X	X	X

This chart shows what we mean when we say "Varian has more of what you need now." For complete details on any of the product lines shown, contact one of the more

than thirty Varian Electron Tube and Device Group Sales Offices located throughout the world. Executive offices: 611 Hansen Way, Palo Alto, California 94303.

product line for you.

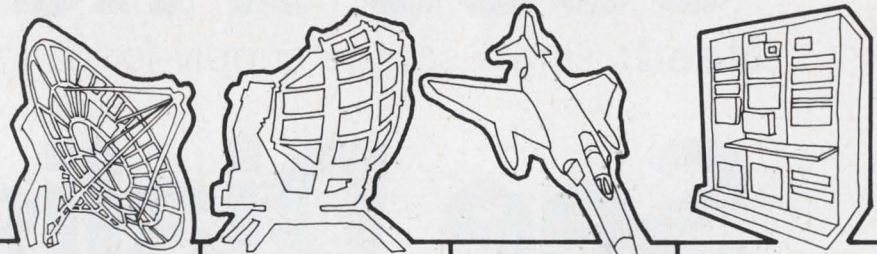

	Communications	Radar	Electronic Warfare	Instrumentation and Others
Signal Processing and Control Components				
Diode Switches		X	X	
Ferrite Diode Limiters		X		
Frequency Converters	X	X		
Gas Tube Rectifiers	X			X
High-Power Microwave Filters	X	X	X	X
High-Power Microwave Waterloads	X	X	X	X
IF Amplifiers	X	X	X	X
Image Intensifiers			X	X
Limiter-Discriminators		X	X	
Logarithmic Amplifiers		X	X	X
Microchannel Plates (MCP)				X
Microwave Cavities	X	X		X
Microwave Diodes	X	X	X	X
Microwave Mixers	X	X	X	X
Microwave Transistor Amplifiers	X	X	X	X
Mixer-Preamplifiers	X	X	X	
Photomultipliers	X		X	X
Readout Tubes and Displays				X
Silicon Controlled Rectifiers (SCR)				X
TR Tubes		X		
Xenon Illuminators	X			X
Yig-Tuned Filter/Preselectors		X	X	X
Subsystems				
Monopulse Receivers		X		
Receivers	X	X	X	X
Scanning Tuner and Receiver Subsystems			X	
Tracking Local Oscillators		X		
Traveling Wave Tube Amplifier Subsystems	X	X	X	X

varian

Dialight sees a need:

(**Need:** Single source supply for all indicator lights.)

See Dialight.

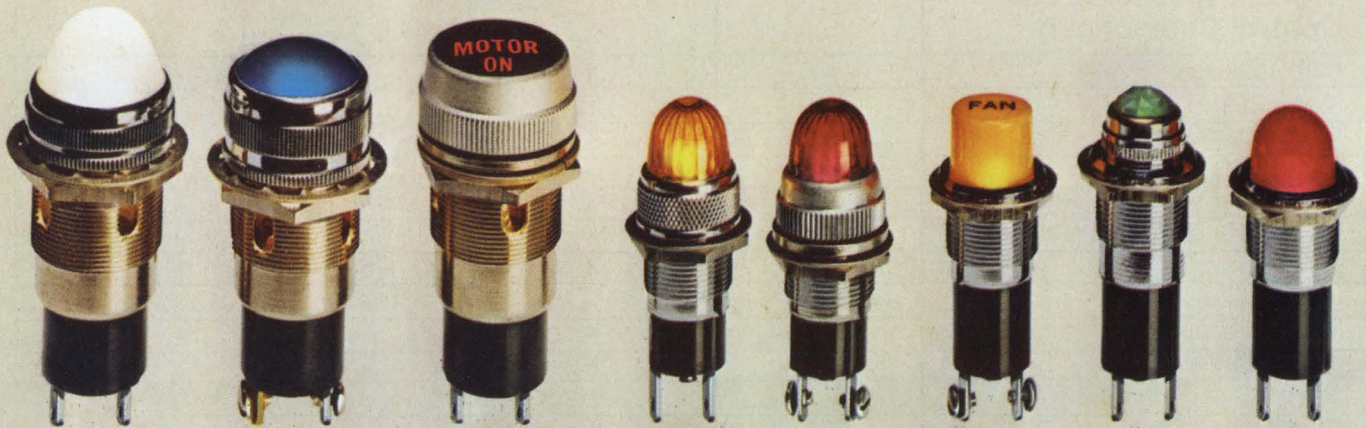

INCANDESCENT OR NEON MINIATURE AND LARGE INDICATORS

Designed to accommodate either incandescent (2-250V) or neon (105-250V) lamps for panel mounting in 11/16" or 1" clearance holes. Units meet or exceed MIL-L-3661 requirements; all are listed in Underwriter's Recognized Components Index. Wide selection of lens shapes, colors,

finishes and terminations. Many lenses may be hot stamped, engraved or offered with film legend discs. Oil-tight units with unique "O" ring construction make them oil, water and dust tight on the face of the panel. Available off the shelf for prompt delivery.

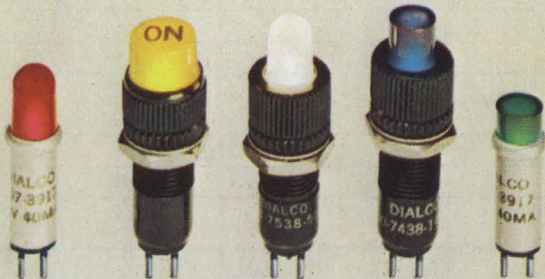

LED, INCANDESCENT OR NEON ULTRA-MINIATURE DATALITES®

Meet or exceed MIL-L-3661. Replaceable plug-in cartridges for 1.35-125V operation. Indicators mount as close as 1/2" centers; available with red, green, amber, blue, white translucent, light yellow or colorless lenses in wide range of lens shapes, legends and finishes. Off-the-shelf.

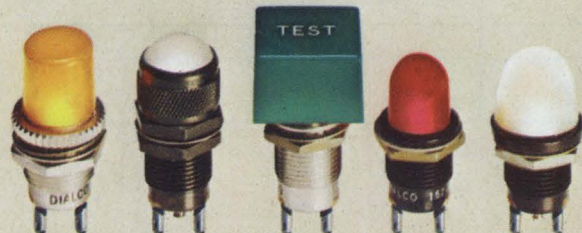

INCANDESCENT OR NEON SUB-MINIATURE INDICATORS

Meet or exceed MIL-L-3661. Mounts in 15/32", 1/2" or 17/32" clearance holes. Incandescent for 1.35-28V; neon has patented built-in current limiting resistor. Choice of cylindrical, faceted, convex, flat, square and round lens shapes, colors, finishes, legends. Off-the-shelf.

DIALIGHT

Dialight, A North American Philips Company
203 Harrison Place, Brooklyn, N. Y. 11237 (212) 497-7600

SEND ME FREE INDICATOR LIGHT PRODUCT SELECTOR GUIDE.



washington report



Heather M. David
Washington Bureau

Key pension legislation nearing passage

The Senate and House are moving toward passage of milestone legislation to protect the pensions rights of privately employed individuals. Both bodies have passed separate bills, and representatives will meet in conference to work out the differences. Both bills hold to basic provisions that should be welcomed by engineers and other professionals who tend to move about in the job market. They establish vested rights to money paid by employees into a pension fund. They also establish standards for managers of such funds and require that adequate funding be maintained for all current and prior liabilities.

Estimates given to Congress are that as many as two-thirds of the American labor force has no vested right to pensions and that employees may forfeit all benefits if they leave a company. At present there is also no safeguard against the loss of pensions because of the failure of a concern, a merger, or arbitrary termination of a pension plan by a company. Another hazard is insufficient funding, which results in the plan's inability to pay pensions as they fall due.

Pentagon testing communications for nuclear damage

The Defense Nuclear Agency and the Defense Communications Agency are evaluating the effect of a high-altitude nuclear burst on the defense communications system, with all its switches, terminals and connections. The two agencies are testing components and hope to create an analytical model so responses by any part of the system can be predicted. Preliminary tests on switching equipment indicate "the system will have some serious problems but no catastrophic breakdown," according to Dr. Malcolm Currie, Director of Defense Research and Engineering.

Remotely piloted vehicles get a boost

Several ambitious programs to substitute remotely piloted vehicles for aircraft have been initiated as a result of RPV studies by the services last year. The Air Force is asking Congress for \$11-million in supplemental fiscal 1974 funds and \$4-million in fiscal 1975 funds to prototype an existing AQM-34 drone with three interchangeable configurations. This would permit the drone to (1) Carry cameras or side-looking radar for reconnaissance, (2) Perform electronic warfare jamming and sending of decoys, or (3) Drop bombs or launch missiles, such as the TV-guided Maverick, to targets.

The Army is asking \$5.5-million for development of small, simple, ground-launched RPVs similar to model airplanes. They would carry

small cameras or other sensors for reconnaissance missions. The Navy also is interested in mini-RPVs and is planning development of a laser-equipped, ship-launched vehicle that could designate targets beyond the ship's horizon for attack by laser-guided missiles. The Defense Dept. also is requesting \$21.1-million for drone and RPV control systems and a new data link.

Congress to argue technology exports

The case against exports of computers, semiconductors and other highly sophisticated technology will be presented to the Senate Finance Committee by Rep. Ben Blackburn (R-Ga.). Blackburn will charge that sales of large scientific computers, precision ball-bearing manufacturing machines and technology agreements imperil U.S. superiority in military technology. Blackburn charged earlier that the sale of a U.S. scientific computer had helped the Soviets shave two years off their development time for Multiple Independently Targeted Vehicle (MIRV) warheads. A Blackburn staff member identified the computer as having been sold to the Soviets by a British Subsidiary of Control Data Corp. However, the ICL 1906A he referred to is produced by a British company that has no ties with Control Data Corp. Industry sources also said that the two computers the Soviets actually bought were accessible to British technicians. Therefore, they noted, it is unlikely the computers would be used in MIRV applications.

Capital Capsules: Industry lobbying for Government aid to companies in converting to the metric system could end up killing metric legislation, Rep. Robert McClory (R-Ill.) fears. He charges no other country in the world that has undergone conversion has found such aid necessary. . . . The Air Force Flight Dynamics Laboratory is planning to investigate the feasibility of integrating the flight-control and fire-control systems in a tactical aircraft, with the idea of improving the accuracy of unguided air-to-air and air-to-ground weapons. . . . A new meteorological spacecraft—with sensors for atmospheric density and microwave soundings, as well as the visual and infrared sensors now carried by satellites in orbit—is nearing development under Air Force sponsorship. . . . NASA has asked a number of firms to bid on a study of the transmission of microwave power from space to earth. . . . The Defense Nuclear Agency plans a pilot demonstration of the effectiveness of military electronics built with radiation-hardened CMOS technology. The agency has developed several methods by which radiation hardness can be achieved. . . . McDonnell Douglas Astronautics Co. has received a \$3.33-million Air Force contract to develop major system components of a high data-rate, satellite-to-satellite laser digital communications system. . . . The National Science Foundation will award as many as seven contracts, at up to \$100,000 each, for the design of an experiment or package of experiments to improve the delivery of local urban social services by cable television. . . . The Federal Aviation Administration's chief, Alex Butterfield, has set up a special task force to analyze the engineering, development and procurement activities of the agency. "I have concluded that our operations, development and procurement activities are in need of a thorough overhaul," he says. . . . Philco-Ford Corp. has received a contract from Mitsubishi Electric Corp. to design an experimental communications satellite system for Japan. The satellite system is to be used for telephone tests in both C and K band. . . . The Army has chosen Raytheon to integrate the first military digital microwave system. The company, under a \$2.1-million contract, will put in links between three cities in Germany.

measurements on the move...

With TEKTRONIX you make your measurements quicker and with greater accuracy. The light-weight 465 and 475 portables combine ease-of-operation with laboratory precision to reduce your repair time at your customer's location.

Some of the functions that make the 465 and 475 value leaders are: push-button trigger view, ground reference button at probe tips, delayed and mixed sweep, CRT positioned between the vertical and horizontal controls, easy to interpret push-button mode selection, and more.

With 200 MHz at 2 mV/div, the 475 offers lasting measurement capability. A linear 8 x 10-cm display and one nanosecond sweep speed

illustrate the ability to make complex, precise time measurements.

The 465 with a bandwidth of 100 MHz at 5 mV/div and 5 ns/div qualify it for most of today's measurement needs.

A different approach to battery operation. A 12 and 24 VDC option combined with a detachable battery pack provide continuous operation under a variety of situations. Measurements can be made when power availability is restricted to 12 and 24 VDC, or when commercial power is limited, or when isolation from line or ground is desired. With the detachable battery pack you carry the weight of the batteries only when needed.

Also available are rackmount versions of both the 465 and 475.

- 465 Oscilloscope \$1725
(Includes delayed sweep and probes)
- 475 Oscilloscope \$2500
(Includes delayed sweep and probes)
- DC Operation (Option 7) . Add \$75
- 1106 Battery Pack \$250
- Rackmount Add \$75

Let us help you make your measurements. To see one of these scopes, call your local Tektronix field engineer, he'll be glad to demo one for you. If you prefer, for additional information write Tektronix, Inc., P.O. Box 500, Beaverton, Oregon 97005. In Europe, write Tektronix Ltd., P.O. Box 36, St. Peter Port, Guernsey, C.I., U.K.



TEKTRONIX®
committed to
technical excellence

"the value leaders"

U.S. Sales Prices FOB Beaverton, Oregon

INFORMATION RETRIEVAL NUMBER 31
FOR DEMONSTRATION, CIRCLE 245

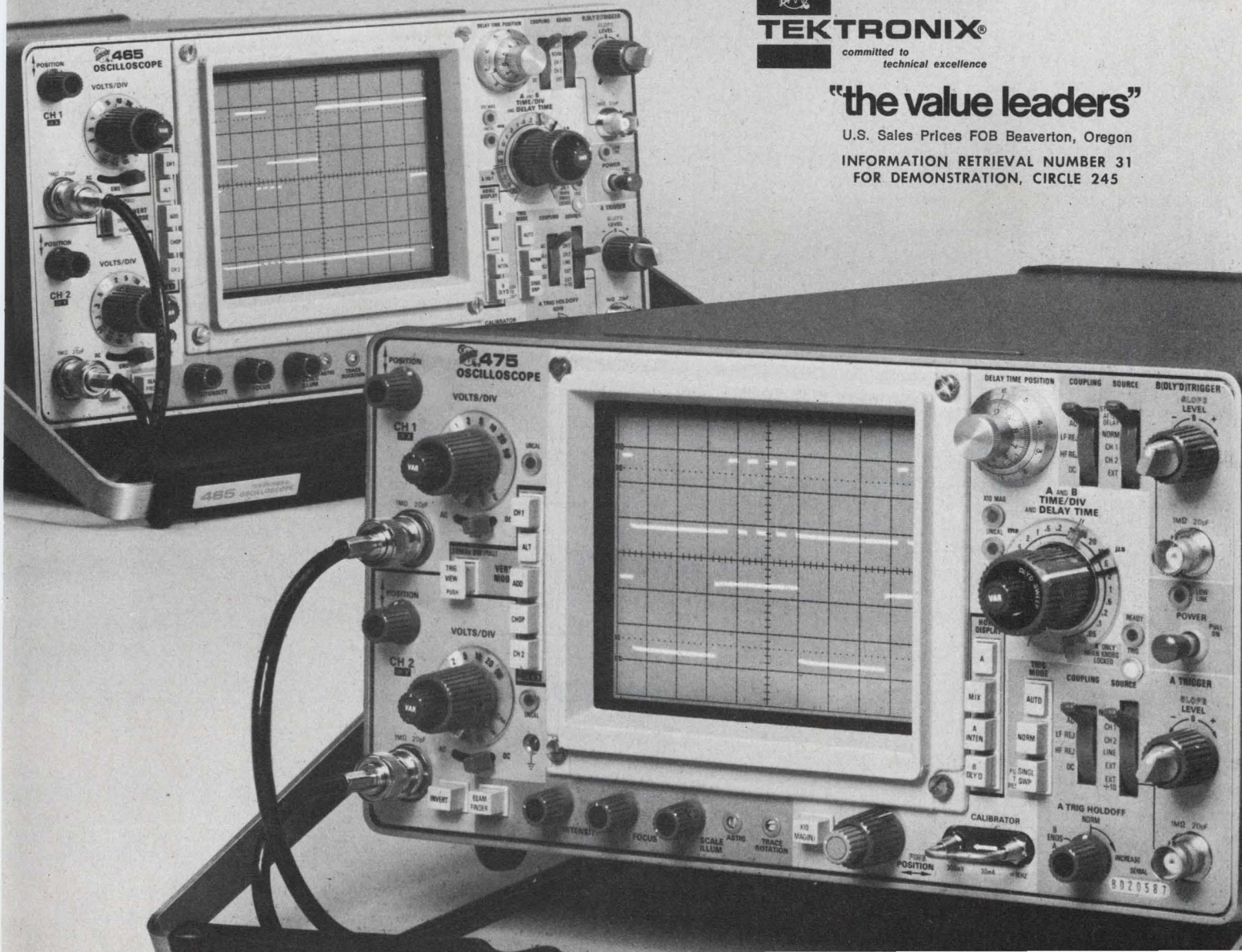

150 Microwatt Triple Op Amp

The L144 monolithic triple op amp draws only $50\mu\text{A}$ of current per amplifier, from a $\pm 1.5\text{ V}$ supply. What's more, it is

AVAILABLE NOW FROM YOUR LOCAL DISTRIBUTOR!

L144 features include:

- Monolithic triple op amp in DIP or Flatpac packages
- Wide power supply range— $\pm 1.5\text{ V}$ to $\pm 15\text{ V}$
- Internal compensation
- Programmable power dissipation
- Programmable input bias current
- Single programming resistor
- 80 dB gain with $20\text{ K}\Omega$ load
- Cost effective: \$1.63 per single op amp⁽¹⁾

⁽¹⁾L144CJ 100-piece price

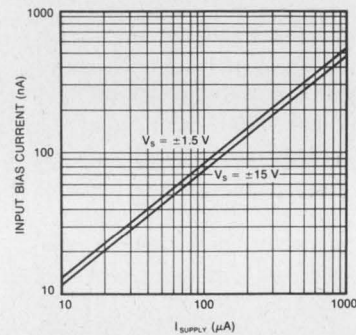

Applications examples:

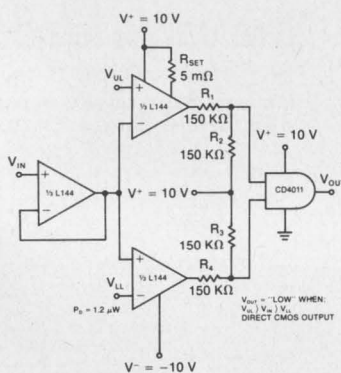

DOUBLE-ENDED LIMIT COMPARATOR

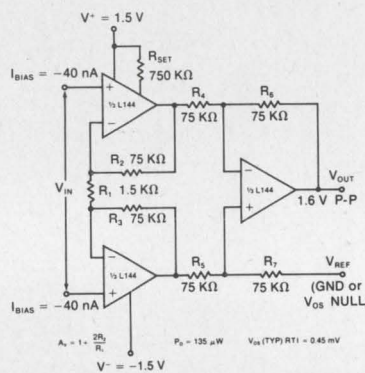

INSTRUMENTATION AMPLIFIER

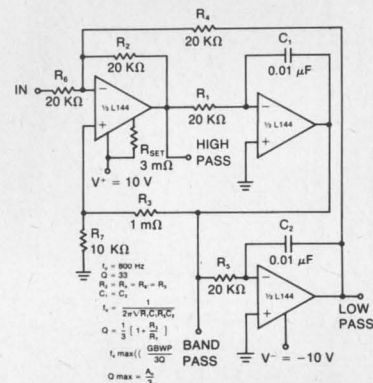

ACTIVE FILTER

The L144 is a practical industry-standard operational amplifier for use when low current drain, low voltage, low power, or very small physical size are controlling criteria. If your circuit requirements are unique—and whose aren't—our applications people are eager to help.

For complete information

write for data

IC Applications: (408) 246 8000, Ext. 120



Siliconix incorporated

2201 Laurelwood Road, Santa Clara, California 95054

INFORMATION RETRIEVAL NUMBER 32

Opera and engineering

"I noticed that you like opera," said Kaisa, a Swedish girl in our office. "In my country," she went on, "we had a man who sang opera and we thought he was very good. I wonder if you've ever heard of him." Since I don't know every Swedish singer, I naturally asked for his name. And in a tone you'd use to ask a man from Brooklyn if he knows your old chum, she said, "His name was Jussi Bjorling."

Well, asking an opera lover if he's heard of Bjorling is like asking a baseball fan if he's heard of Babe Ruth. Bjorling was one of the world's greatest tenors. Kaisa didn't know of his stature because she was too close. She saw him only as a fellow Swede who sang.

In our own field, are we less provincial? How many of us recognize that our buddy made stellar contributions to the engineering art? It's too easy for us to say: "Joe Smith? Oh, *that* Joe Smith. Sure, I remember him. Pretty good engineer."

With this attitude toward our colleagues, we demean engineering. While we mouth pious protests that we are indeed professionals, we emasculate our professionalism and promote the feeling that we are mere paycheck seekers. Not always, unfortunately, but in essence, engineering is one of the great creative arts. It's a difficult art because it's bound by grueling constraints. Other artists are bound, too, but not so severely.

The painter is bound by his pigment and canvas, the singer by his score and the actor by his script. But sometimes they escape these constraints. Michelangelo may paint a ceiling instead of a canvas, and enthrall the world for centuries. Caruso or Bjorling could miss a note, but their magnificent artistry could overshadow the lapse. Or an actor could try to "improve" and "modernize" Shakespeare, with the bard unable to defend himself against the atrocity. But the show might be a success.

The engineer's constraints are tougher. He can't abandon Ohm's Law—even for a moment. He can't create an elegant design without a steady eye on the dollar. He can't build with components he can't get. Like other artists, he works with imperfect materials—leaky capacitors, noisy resistors, drift amplifiers. And sometimes he is constrained by a boss who is a fool.

What are his rewards? A salary. Stock options, perhaps (though their value may be questionable). And, greatest of all, the respect and admiration of his peers. Let's not take that away from him.



A handwritten signature in dark ink, which appears to read "George Rostky". The signature is fluid and cursive, written in a professional style.

GEORGE ROSTKY
Editor-in-Chief

Software for MOS/LSI microprocessors

differs from one circuit to another. A careful analysis of instruction sets helps establish a processor's capabilities.

First of three articles

The use of microprocessors, or MOS/LSI "computers-on-a-chip," requires programming skills. And that may seem to be a disadvantage. Hardware designers once concerned with such matters as latch selection, clock phases and propagation delay must now consider less familiar software-oriented factors like subroutine nesting, indirect addressing and computational algorithms.

However, a review of the basic vocabulary of microcomputer programming can help start you on the way to a microprocessor design. Moreover a review of the differing microprocessor instruction sets can establish a particular microprocessor's capabilities.

From a programmer's point of view, microprocessor instructions break down conveniently into the following:

- Data movement.
- Data manipulation.
- Decision and control.
- Input/output.

Data can be moved about between a variety of internal sources and destinations. The primary places are shown in Fig. 1. The most complex locations are those in memory—usually a RAM or RAM bank—since a variety of addressing modes can be used to specify location.

The *effective address* of a memory location to be read or written can be given *immediately* by bits in the instruction being executed (Fig. 2). In current microprocessors the immediate data may be 4, 8, 12 or even 16 bits long. Immediate data may be interpreted as a location (or displacement) in a previously selected page (or location) of memory.

The technique of *indexed addressing* permits a 16-bit address to be generated without providing all 16 bits in a current instruction. Were all 16 bits required, the instruction would necessarily be multiworded. The effective address is obtained when the instruction adds immediate data—say, 8 bits—to a designated register usu-

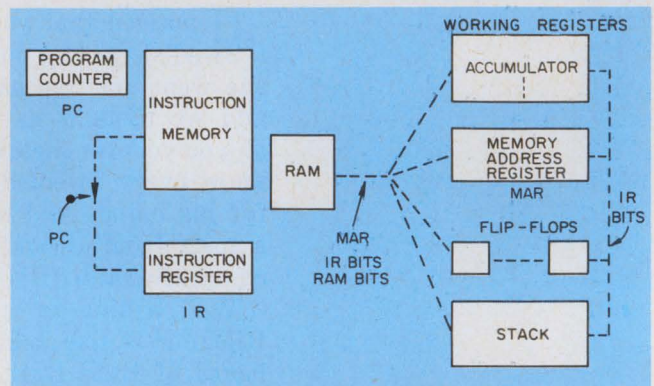

1. Data flow among the major storage areas is shown by broken lines. Bits in the storage locations control the flow.

ally called the index register.

In computers the index register may contain fewer bits than the immediate address. Hence the register appears to be a displacement with respect to the immediate address. Though the reverse is usually true with microprocessors, the same view can be taken, since we usually increment the index register to access successive words in memory. The index register can be thought of as a base register plus variable displacement.

An effective address may also be formed by *indirection*. In this case, a memory address is first computed by use of immediate data or by indexed addressing. Call this a direct address. Then, its contents are taken as the address of the actual memory location to be read or written. This is indirect addressing, a powerful technique that allows any memory location to serve as a memory address register; its content can be used to point to another possibly arbitrary word in memory.

Use addressing modes to advantage

An example follows on the use of various addressing modes (Fig. 3). Assume we write a routine to manipulate data stored in memory locations $A_1, A_2 \dots A_n$. All references to these locations are by immediate addressing.

How to compute effective address

1. Use immediate data, given in the current instruction word.
2. Use the contents of the memory-address register, which can be manipulated separately.
3. Add together immediate data and a base, or index, register. This technique is called indexed addressing.
4. Use the contents of a memory location which itself is computed using all of the above. This technique is indirect addressing. An example follows:

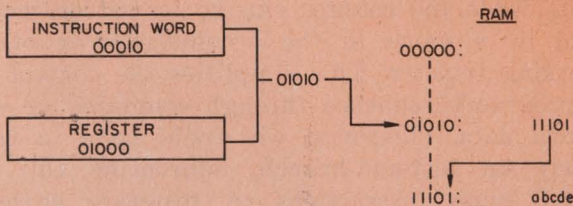

The final address is 11101 and the data finally accessed are abcde.

2. An effective RAM address can be formed from immediate data, address register, index register or a combination of techniques.

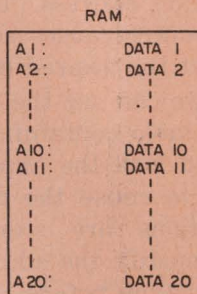

Computation required:
 $G_1 = F(\text{Data } 1, \dots, \text{Data } 10)$
 $G_2 = F(\text{Data } 11, \dots, \text{Data } 20)$

- In the program to compute G_1 and G_2 , data must be referred to by addresses.
- If A_1, \dots, A_{10} appear as immediate addresses in the program to compute G_1 , this program will not compute G_2 .
- If the program uses a memory-address register to point to Data, the register can be initialized either to A_1 or A_{11} . The program then increments the register to compute G_1 or G_2 .
- If indexed addressing is available, then a program which computes G_1 will do G_2 if we first add 10 to the appropriate index register.
- Indirect addressing would provide the most flexibility in this kind of problem.

3. An example of data movement illustrates the effect of different addressing modes.

We can apply the routine to different blocks of data, either by successively loading each block in locations $A_1 \dots A_n$, or by modifying the instructions in the routine to refer to new memory locations. Either alternative can lead to inefficient programming, while the latter alternative is, in fact, impossible if the program is stored in a ROM.

Now consider the case where the original routine used indirect addressing, so that $A_1 \dots A_n$ contain addresses of data. A simple change of the contents of $A_1 \dots A_n$ allows the routine to operate on a new block of data located in a different block of memory. Of course, indexed addressing can be used to achieve the same flexibility.

If the new data locations have the same relative displacements as the original block of data, a reinitialization of the index register allows the routine to access new data. Indirect addressing is not even required in this case. But when the relative displacements are not the same, indirect addressing becomes more useful.

Accumulator—the essential register

Microprocessors generally have several working registers. However only a single register, usually called an accumulator, is essential, so long as it has access to read/write memory and there are instructions permitting immediate addressing and data manipulation between the accumulator and a memory word. With indirect addressing, even the function of index registers can be accomplished with memory.

The major significance of working registers lies in access time and the bit efficiency of instruction words. It takes far fewer bits to specify one of several previously defined working registers than a memory location. Whether these registers are in an external memory or in the CPU is irrelevant, so long as they can be referenced efficiently. But a faster execution time can be obtained with registers that are separate from memory. They can be accessed for read and write operations without users incurring excessive memory-cycle delays.

The quantity of registers may not be as significant as their quality. For example, can each register be incremented and tested for zero, or is only the accumulator so equipped? If each can, then each register can be used for counting and program loop control.

Which registers can you use for indexed addressing, if any? Can all registers be loaded directly from memory, or can they be loaded only from the accumulator? Which registers can be used as a source or destination for arithmetic/logic operations?

It's difficult to say how many registers are

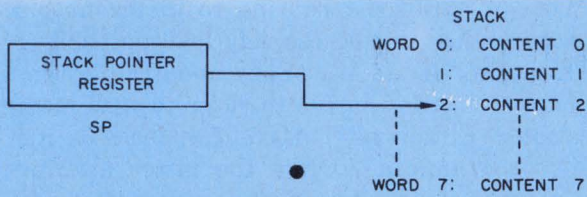

Current SP value	Operation	Next SP value
2	PUSH	3
7	PUSH	0
2	POP	1
0	POP	7

- TO WRITE data, or PUSH onto Stack, store in location addressed by SP. Then increment SP.
- TO READ data, or POP from Stack, decrement SP. Then read data from location addressed by SP.

4. **Last-in, first-out stacks** are a common feature of microprocessors. The order of instructions contains address information within the stack.

DATA FORMATS

width: 4, 8, 16 bits, 25 digits
encoding: binary, BCD

ARITHMETIC FUNCTIONS

add { with or without carry bit
between accumulator and register, memory or immediate data
multiple precision possible
possibly with skip if carry out used

subtract - not always.

multiply { by subroutine or special purpose
divide { hardware

increment/decrement

LOGIC FUNCTIONS

complement

rotate } with or without extra carry/link bit
shift }

AND

OR

EXCLUSIVE-OR

compare accumulator (with register, memory or immediate data) and skip

5. **Data manipulation instructions.** Missing instructions may be performed by a subroutine.

needed in general, or even in any particular application, and the number varies widely in current microprocessors. Some have stack-oriented registers that can only be accessed in a last-in, first-out basis (Fig. 4). This orientation is not a serious limitation, since algorithms can often be planned so the required data always are on top of the stack. Stacked registers have the advantage of being more numerous than individually addressed registers. Also, instruction bits

are not required to address them. A stack instruction can refer to only one register, the top register of the stack.

Memory-address registers may be the ordinary working registers, or specially designated ones, such as the program counter. A key register in any computer, this counter points to the next location in memory for an instruction-fetch operation. In addition it's common to have an independently controlled register that points to a read/write memory location. Instructions to load and store the program counter are extremely important, since they permit modification of the instruction sequence. A special advantage results when the counter can be loaded or modified by a value in the accumulator or other working register. This simplifies the control of a program's sequence through computed or external data. Otherwise we would have to rely solely on test-and-branch, subroutine call or fixed jump instructions in program store—where the instructions may not be modifiable.

For example, suppose a microcomputer system must perform certain functions that are selected by an input data word, interpreted as a command for some service. How do we translate this input-bit configuration into the desired computer response? We want to go to a certain program location associated with that command. If we can load the program counter with data, the input command word can be encoded directly as an instruction address. The loading of a portion of the counter causes sequencing to begin immediately at the desired program location.

Alternatively, we can use the input data as an index to enter a table containing program location addresses and load the appropriate address into the counter to cause the desired jump. If program instructions are stored in writable memory, we can modify the address information in a jump instruction before executing it, according to the requirements of the input data.

But if the program is in read-only memory, and the program counter cannot be loaded with data, we must resort to something as complex as the execution of a possibly lengthy decision routine. This routine consists of a sequence of stored instructions that contain all possible desired jumps. Repeated testing of the input data sequences through the decision routine in such a way as to arrive at the desired jump instruction.

One of the most sophisticated addressing modes is found in the National IMP-16. It uses immediate and indexed addressing, either with respect to the program counter or one of two index registers. In addition the IMP-16 permits indirect addressing, either with or without the use of indexing, to compute the effective address. The 256 lower order addresses in the RAM can also

be specified with use of an 8-bit field in the current instruction word.

The simplest data-movement instructions are found in 4-bit microprocessors, such as the Rockwell Microelectronics PPS and Intel 4004. These, as well as the 8-bit Intel 8008 machine, also require separate instructions to load or manipulate a memory-address register, through which all memory references are made. The 8008 contains a single 16-bit memory address register, with 14 bits actually used. The Intel 8080 permits six 8-bit working registers to be used in pairs to provide three 16-bit memory address registers. In addition a 16-bit address for memory reference can be specified by two immediate bytes in certain load and store instructions.

The Fairchild PPS-25 has a unique instruction field for memory references. A mask-programmed repertory of six fields permits assignment of one of six predefined fields in each 25-digit (100-bit serial) register. Only the selected data field is affected by the data movement or arithmetic instruction. A separate program-controlled pointer permits access to any single-digit (4-bit) field.

Data manipulation capabilities

Generally the arithmetic capabilities of microprocessors are limited to addition and subtraction, and usually in a binary format (Fig. 5). The Fairchild PPS-25, however, features decimal arithmetic performed on 4-bit BCD-encoded digit fields. And several other machines include special instructions for handling BCD fields. Apart from the PPS-25, data words vary from 4 to 16 bits, so that multiple-word arithmetic is often required. Care must be taken that carry bits are added into the successively more significant fields—a capability that is always available.

Multiply and divide functions must be performed by subroutines in most systems. Or they can be performed in microcode for microcomputers like the National Semiconductor GPC/P, which are microprogrammable.

Microprocessors, especially those designed primarily for calculator applications, may not allow logic operations. For example, the Intel MCS-4 and Fairchild PPS-25 don't have operations like AND, OR, EXCLUSIVE-OR. However, they do permit complement, shift and rotate operations. The usual rotate or shift is by 1, but the National IMP-16 features rotation by an arbitrary amount in a single 16-bit instruction containing immediate data. The execution time is, of course, a function of the number of shifts called out. However, the instruction bit efficiency is high.

When shift and logic operations are omitted, they can usually be accomplished by a sequence

JUMP
CALL
RETURN } can be conditional or unconditional

BRANCH
SKIP } always conditional

JUMP	
Location	Instruction
k:	i
k+1:	i+1
*k+2:	i+2 = JUMP to location m
m:	j

*At this point, the PC was loaded with m rather than being incremented to k+3.

CALL

Same as JUMP except that PC content is saved so we can return to instruction at k+3. A RETURN instruction performs the restoration.

A user can select either an on-page (short) or arbitrary (long) JUMP address in the Rockwell PPS, Intel 4004 and Fairchild PPS-25.

6. Some instructions change the order in which other instructions are executed.

of other instructions that are available. For example, "shift left by 1" is equivalent to the addition of a binary number to itself. As long as an individual register bit can be tested—say, by rotation into a carry flip-flop—all logic operations can also be performed whether or not individual instructions for them exist. However, considerable additional time will be spent.

Increment and/or decrement—critical arithmetic functions—can be accomplished along with test-and-skip functions. Such multiple-function instructions are particularly useful in controlling passes through program loops. For example, the Rockwell PPS has a 1-byte instruction that adds a 4-bit immediate field—say, the number 1—to the accumulator. If a carryout is generated (when the register reaches its maximum value), the next instruction word is skipped, but the carry flip-flop itself is not disturbed. The National IMP-16 has an analogous 1-word (16-bit) instruction.

A similarly powerful instruction in the Intel 4004 permits incrementing any one of 16 4-bit registers. If the result is zero, the next instruction in sequence is taken; if nonzero, a jump occurs to an immediate location on the same ROM page designated by the second byte of the current instruction. Again, the accumulator and carry flip-flops are not affected. Here, a 2-byte instruction is used that provides a more flexible jump instead of a skip.

An interesting extension of the increment/

decrement capability occurs in the National IMP-16. A memory location can be incremented or decremented with skip if the contents become zero. This feature permits efficient use of memory locations as counters for control functions. Also, the processor's addressing modes specify the effective address of the memory word to be incremented or decremented.

The Intel 8080 also permits a single memory location to be incremented or decremented. Internal flip-flops are affected, so a conditional jump instruction can be used later to test the memory content for zero.

An unusual and powerful feature of the decimal arithmetic in the Fairchild PPS-25 is the ability—through mask-programmed options—to

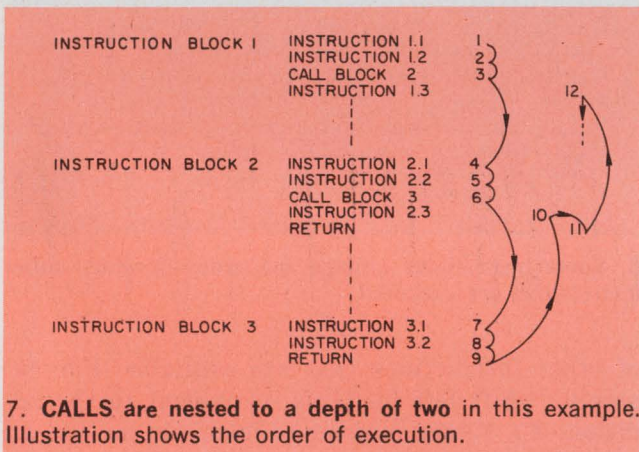

specify one of six fields over which any arithmetic function is to operate. The words are organized with a maximum of 25 decimal BCD 4-bit fields. Hence part of a register can be treated as a mantissa and part as an exponent. Appropriate arithmetic can be performed on these fields under program selection. Otherwise we would have to mask out or store different data separately. An individual decimal field can also be singled out by reference to a pointer register, which is itself under program control.

Decision and control capabilities

Microprocessors use the common convention of sequencing through instructions in order, unless directed otherwise by a decision-and-control type of instruction. The instruction changes the value of the program counter (Fig. 6).

Microprocessors execute JUMPS, CALLS or BRANCHES. The program counter may be changed unconditionally by a JUMP or CALL instruction, or conditionally, depending on the outcome of a specified test. These instructions are called conditional JUMPS, conditional CALLS or BRANCHES.

The difference between a JUMP or BRANCH

on the one hand and a CALL on the other (conditional or otherwise) has to do with whether or not the program counter is saved. In a CALL, the program counter (or counter plus 1) is saved. Thus the counter can conveniently be restored to point to the instruction that would have followed the CALL had the instruction stream not been changed by the CALL. The RETURN instruction restores the counter to the instruction following the last executed CALL. RETURNS can be conditional, as well. If the condition is not satisfied, the counter is not restored but is simply incremented once again. It then points to the instruction stored after the conditional RETURN.

A further distinction can be made as to the ability to nest CALLS. Such nesting is illustrated in Fig. 7, where a series of CALLS transfers the program counter to a sequence of instruction blocks. By an execution of a series of RETURNS, the counter eventually returns to a location in the original block.

CALLS and JUMPS can be crucial

The use of conditional CALLS and JUMPS is absolutely crucial to programming (Fig. 8). Essentially they allow programs to respond to inputs rather than simply to deliver the same answers to the same programmed questions. A program must do different things, depending on the condition of the machine: Has a carry been generated? What is the current computer result? Is the number zero? (If it is, don't divide by it.) Has an interrupt or new command been issued? And so on.

All microprocessors allow such conditions as "carry bit set?" and "accumulator = 0?" to determine whether or not a JUMP, CALL or BRANCH is to be executed. Some permit branching as a result of logic levels presented on direct input lines, or individual bits in registers, or program-set flip-flops, or register parity, or a stack-full condition, or still other requirements. Again, the absence of one condition can almost always be overcome by the use of extra program steps. In a common situation, JUMP or CALL occurs if a condition is TRUE. But a symmetrical instruction in which the FALSE condition triggers the JUMP or CALL does not exist. By use of an extra unconditional JUMP or CALL, of course, the deficiency can be overcome.

The address loaded into the program counter when an unconditional JUMP or CALL is executed—or when a conditional JUMP or CALL or BRANCH is executed—may be specified in the same variety of ways in which memory is addressed: immediate or indexed direct; or indirect, through a memory location which itself is

TYPES OF CONDITIONS (JUMP, CALL, RETURN)

True or False on

- carry FF
- zero register (usually Accumulator)
- sign (most significant bit) of register
- parity of register
- programmer controlled flip-flop
- test input

If condition fails, do next instruction in sequence.

3-WAY BRANCH CONDITIONS (FAIRCHILD PPS-25)

example: if (A) < (R), PC ← PC + 4 bit immediate

- (A) > (R), PC ← PC + another 4-bit data field
- (A) = (R), PC ← PC + 1

SKIP CONDITIONS

- if (R) ∩ M = 0, skip
 - if (R) > M, skip
 - if (R) ≠ M, skip
 - if Flip-Flop = 1, skip
 - if R (lower) = 4-bit immediate data, skip
- } National IMP-16
- } Rockwell PPS

COUNT AND JUMP/SKIP

- increment R and if ≠ 0, do short JUMP (Intel 4004)
 - increment (decrement) M and skip if zero (National IMP-16)
 - (A) ← (A) + M and skip if carry out
 - (A) ← (A) + 4 bit immediate field and skip if carry out
- } Rockwell PPS

NOTE: (A) = contents of accumulator
(R) = contents of register R
M = contents of memory location currently addressed.

8. A summary of conditional instructions shows the variations possible for JUMP, CALL, RETURN, BRANCH and SKIP.

specified by an immediate or indexed mode. The obvious reason for using JUMPS is to get to a new section of the program. For example, all work routines in some systems may report back to a main executive routine by an unconditional JUMP.

Unconditional CALLS allow us to use one copy of a sequence of instructions, a subroutine, and to enter it from many different routines. For example, a multiply subroutine can be called whenever required in any instruction sequence. With a CALL, a single RETURN as the last subroutine instruction causes the program counter to return to the sequence immediately following the CALL. A nesting facility enables the programmer to write subroutines that themselves call on other subroutines to perform operations. Thus several arithmetic subroutines might call a still simpler subroutine that shifts a register a certain number of places.

The Rockwell PPS microprocessor allows unconditional JUMPS to one of 64 locations on the current 64-word page. The locations are specified by 6 bits of data in the 12-bit JUMP instruction. Unconditional *long* JUMPS provide an immediate 12-bit address in the two successive words of the instruction. The CALL and

RETURN instructions are also unconditional.

The short CALL in Rockwell's PPS is an example of indexed immediate and indexed indirect program-counter addressing. The instruction itself specifies an immediate partial address consisting of the six low-order bits of an address. These bits are indexed by a fixed page address, called page 60. When the directly addressed word on memory page 60 is read, its 8-bit content is used as the low-order bits of the program counter. The high-order 4 bits of the counter are automatically set to 1110. Thus the first JUMP is made to an address given indirectly by any one of 64 locations on page 60.

The final JUMP seeks any one of the 256 locations on pages 56 through 59—pages with 6-bit addresses whose high-order 4 bits are 1110. When the CALL is executed, the current program counter is pushed, or placed in the upper register of a two-level stack. The current contents of the top stack register displaces to the second stack register, whose contents, in turn, are lost. Execution of the next RETURN instruction pops the stack.

All conditional instructions in the Rockwell PPS microcomputer are of the form "SKIP next instruction if condition holds." The skipped instruction could be chosen to be an unconditional CALL or JUMP, thereby giving the equivalent of a conditional CALL or JUMP for the complementary condition.

The Intel 8008 has conditional and unconditional JUMP, CALL and RETURN instructions. The CALL and JUMP use 14-bit, immediate addresses only (and thus a 3-byte instruction), and CALL uses a seven-level stack for pushing and popping the program counter. There is, however, a single byte unconditional CALL instruction that pushes the counter and replaces it with an address consisting of all zeros except for bit positions 3 through 5. These are given as immediate data in the instruction. Hence eight short, but frequently used, subroutines can be located in the lower order 64 locations of memory, accessible by exceptionally fast and short CALLS. The 8008 accepts and executes such an instruction on its input bus upon receipt of an interrupt signal. This feature enables direct control by external devices of JUMPS to routines that handle interrupts.

Microprocessor has stack pointer

The Intel 8080 contains a 16-bit register called a stack pointer, which is incremented and decremented automatically by CALL and RETURN instructions. The current program counter is stored in (for a CALL) or loaded from (for a RETURN) a RAM location whose address is given by the contents of the stack-pointer regis-

ter. This permits arbitrary depth nesting of CALLS. But since the memory locations must be reserved for this use, a limit must be set on the depth.

In the National IMP-16, all registers and condition flip-flops can be pushed or popped from the internal 16-level stack, thus providing a convenient way to save the entire state of the processor. Registers and condition flip-flops can also be saved in or restored from the RAM stack area in the Intel 8080, but not in the Intel 8008. This capability is particularly important in interrupt-handling applications.

An unusual feature of conditional instructions in the Intel 8008 and 8080 is the way in which three of the condition flags—ZERO, PARITY EVEN, and SIGN BIT 1—are interpreted. They refer to the register last referenced by an instruction that might change a condition.

The Fairchild PPS-25 has a very flexible control structure. It uses unconditional JUMPS to an address within the same ROM, as specified by 8 bits of immediate data from the JUMP instruction. These 8 bits are interpreted as a signed-2's-complement number that is added to the address of the current ROM location. The feature permits jumping forward or backward a specified amount from the current location. A separate ROM-select instruction changes the high-order bits of the program counter, permitting a JUMP to a new ROM page.

Conditional JUMPS can lead to either two-way or three-way branches. A two-way BRANCH is an ordinary JUMP instruction. Three-way BRANCHES involve either two different modifications of the program counter (both using immediate data) or execution of the next sequential instruction. A pair of instructions selects the desired conditional mode.

CALLS in the PPS-25 are accomplished in two steps. First, the current program-counter value plus 1 must be stored in one of two fields in a special status register. Then an unconditional JUMP or conditional JUMP or BRANCH is executed. The execution does not itself save the content of the counter. A RETURN is accomplished by reloading the counter with the current content of the appropriate status-register field, again after the counter automatically increments once. This second incrementing ensures a skip over the JUMP or BRANCH instruction that followed the original counter storage instruction.

The National IMP-16 exploits its 16-bit instruction word to permit flexibility in generating the addresses for unconditional JUMP and CALL instructions. The counter is loaded with an effective address that is computed from an 8-bit immediate-data field (a signed-2's-complement displacement) that is added to the 16-bit

content of an index register. If the indirect mode is selected, this address is used to access a memory location whose content becomes the value for the counter. In the CALL instructions the current counter value is saved in a 16-level stack. The RETURN instruction retrieves the counter value from the top of the stack and adds to it 7 bits of immediate data from the instruction itself.

The Intel 8080 has an instruction that transfers the 16-bit content of two working registers into the program counter, thus causing an unconditional JUMP. The JUMP address originally in the working register could have been obtained by a computation or table look-up operation. The National IMP-16 provides this same flexibility, since the effective JUMP address can be based on an index register content. Or it can be based on the content of one of the 256 lower order RAM locations, in which case an indirect memory-reference mode would be selected.

The conditional instruction in the IMP-16 is a JUMP and provides an 8-bit displacement (7-bit magnitude plus sign) that is added to the current counter value. One of 16 condition flags can be tested, including several externally and internally controlled flip-flops.

Input/output capabilities

The nature of the microcomputer interface and the I/O instructions vary considerably from one system to another (Fig. 9).

A basic scheme employed in the Intel 8008, 8080 and the National IMP-16 provides bits on the address bus for both input and output instructions. With an INPUT or OUTPUT enable pulse, these instructions can be used to select an I/O device. Then the microprocessor either puts out the accumulator contents as OUTPUT data or gates the input bus content to the accumulator. The address-bus bits in the Intel machines come from the current instruction word; in the IMP-16, they are more general, being formed by an addition of immediate data from the instruction and the content of an internal working register.

The Rockwell PPS system uses immediate data for device selection, but then it provides a bidirectional data exchange in the same cycle. The 4 bits in the accumulator go out on 4 bits of the instruction-data bus. This is followed by a loading of the accumulator from the remaining 4 bits of the same 8-bit bus. The INPUT instruction for the Intel 8008 also outputs the accumulator before loading it from the main instruction-data bus. Hence every executed INPUT instruction can also be used to output data to the same peripheral address.

The Intel-4004 uses I/O ports that are asso-

Example: Intel 4004

(I/O ports are associated with special ROM and RAM devices bus-connected to the 4004 microprocessor)

Ports

- a RAM output port (4 bit, latched)
- a ROM I/O port (4 bits, mask programmable to specify direction)

Selection

- one (or two) set-up instructions select a ROM and RAM device

Data transfer

- (A) ← input port bits on ROM
- ROM output PORT bits ← (A)
- RAM output latch ← (A)

Example: National IMP-16

Selection

- (R) + 7 bit immediate field is transmitted as a 16-bit device address/enable, accompanied by an I/O enable signal. It is sent to the Address Register.

Data transfer

- A ← (external device)
- (external device) ← A

9. Input/output instructions combine a selection and data-transfer operation. These can be triggered by successive instructions or by a single combined instruction.

ciated with the ROM and RAM devices of a complete MCS-4 system. A ROM and RAM are

selected by separate instructions. The I/O port of the ROM—each of 4 bits is mask-programmed as either an input or output terminal—and the latched RAM OUTPUT port can be read or written with an appropriate 8-bit instruction.

The Fairchild PPS-25 uses a set of I/O commands to control special I/O devices designed for use in this system. In addition it contains an unusual direct 8-bit (serial) input to the ROM address register. Data on this input are added to the ROM address register. Also, a special instruction loads serial data into the active status register, where each bit can be interrogated as an individual flag. ■■

The second article in the series will deal with software development.

Bibliography:

- “IMP-16C Application Manual,” Publication No. 4200021B, June, 1973, National Semiconductor, Santa Clara, Calif. 95051.
- “MCS-4 Microcomputer Set Users Manual,” Revision 4, February, 1973, Intel Corp., Santa Clara, Calif. 95051.
- “PPS-25, Programmed Processor System Preliminary Users Manual,” October 25, 1972, Fairchild Semiconductor, Mountain View, Calif. 94040.
- Wickes, W. E., “Parallel Processing System (PPS), Application Notes,” Publication 2518-D-17, January, 1973, Rockwell Microelectronics Div., Anaheim, Calif. 92803.
- “8008 8-bit Parallel Central Processor Unit, Users Manual,” Revision 4, November, 1973, Intel Corp.
- “8080 Preliminary Specifications,” Revision 1, Intel Corp.

The standard power supply is a minor consideration... until it fails.



One little power supply can put a big piece of equipment out of commission. And, that's when "bargain-level power" can get very expensive.

Besides downtime and repairs, the cost of 'unreliability' may also include some loss of reputation.

That's why it will pay you to take a good look at North. We've been the leading producer of custom power units for over 40 years. And our standard modules get the same reliability treatment—including rugged life tests, EMI analysis plus shock, vibration and humidity tests.

If reliability is worth more to you, send for a bulletin, or call your North Standard Power Manager at 419/468-8874.

Listed here are the more popular models—many other voltages are available.

MODEL	11000	12000	13000	14000	15000	16000	17000	18000
VDC	AMPERES							
5.0	3.9	5.3	11.3	13.0	20.0	32.5	49.0	82.0
12.0	2.8	4.2	8.0	10.5	15.0	23.0	36.0	58.0
15.0	2.4	3.7	7.5	9.5	14.0	20.5	27.0	47.0
18.0	2.1	3.3	6.0	8.0	13.0	18.0	26.0	40.0
24.0	1.5	2.8	4.2	7.0	11.0	15.0	21.0	33.0
28.0	1.4	2.4	4.0	6.3	9.0	14.0	20.0	29.0
36.0	1.2	2.2	3.1	5.6	8.0	11.0	14.0	23.0
48.0	95	1.8	2.6	4.2	6.0	8.0	10.0	18.0

MODEL	10000
VDC	AMPS
0-7.5	2.10
0-16	1.25
0-25	0.85
0-33	0.68

DUAL OUTPUT SUPPLIES	
MODEL	N03052
VDC	AMPS
+15-12	400MA
MODEL	N60052
VDC	AMPS
+15-12	1.0A

NORTH 
ELECTRIC COMPANY

North Electric Company / Galion, Ohio 44833 / A United Telecom Co.

SP-20

A 1000-W solid-state power amplifier? You bet. It's done with four 320-W sections. Here are key transistor parameters and the transformer winding details.

If you want to build a 1000-W broadband power amplifier, what do you use for active devices? If your answer is—almost automatically—tubes, hold on. You can build a solid-state 1000-W amplifier today, with all of the obvious advantages that solid state implies.

The design employs a building-block approach, in which you first construct a 320-W linear power amplifier, then combine four of these to get an amplifier that will put out 1000 W with ease.

Only recently has it become possible to do this, though solid state has been used in the commercial design of low-level amplifiers for some time now. The hangup in high-level applications was caused by lack of transistors that could meet the design requirements without need for extensive derating, elaborate temperature compensation and precise power output control during high-load VSWR.

Recently, however, transistors have been developed for high-frequency linear operation that are tolerant of mismatch, overdrive and temperature variations. These devices offer continuous duty, single-tone operation without the need to remove bias or to derate specifications. Among the suppliers are Communications Transistor Corp., Motorola and TRW (see "30-MHz Power Transistors Yield More Watts Per Dollar," ED No. 20, Sept. 27, 1973, p. 122).

One such device is the TRW PT6665A/PT5788 rf power transistor, which is rated at 100 W, both peak envelope power and cw. The PT5788 is stud-mounted, while the PT6665A is flange-mounted. Four of these transistors can be used to design a 320-W linear power amplifier (LPA) with a power gain of about 17 dB. This four-device, push-pull amplifier, in turn, forms the basic building block. Four of the 320-W units can be combined, by use of commercially available summing circuitry, to make an amplifier with a conservative 1000-W output, ideal for mobile and marine single-sideband hf radio as

well as base-station radios for long-range broadcasting.

The broadband amplifier operates directly from a 28-V dc source with a minimum power output of 1 kW from 1.5 to 30 MHz. Intermodulation distortion (IMD) is -36 to -38 dB at 1 kW. This provides a significant margin of safety; it is possible to achieve the 1-kW output with three amplifiers, but in that case the IMD is about -30 dB. The collector load impedance of each transistor is 2.4 Ω , and the junction temperature coefficient is 0.875 C/watt.

Designing the building block amplifier

In the design of the 320-W LPA, some major objectives must be set. The goal is to design an untuned amplifier covering five octaves. Harmonics are of major importance, since Class B or AB linear amplifiers are linear only with regard to power-transfer characteristics. Unlike Class A amplifiers, the output signal is not a true reproduction of the input signal. Instead, the output contains harmonics that are a function of the ratio of cutoff frequency to operating frequency and of the selectivity of the output matching network.

This consideration indicates that two pairs of transistors should be operated in a push-pull configuration. With this configuration, 40-dB rejection of the even-order harmonics is readily achieved, and the odd-order harmonic outputs can be easily filtered.

A schematic of the 320-W, 28-V amplifier is shown in Fig. 1. The two pairs of PT6665A/PT5788 transistors are operated push-pull and then combined in 0-degree hybrid transformers T_1 and T_2 . This arrangement converts the normal 50- Ω source and load impedance to two 100- Ω ports that are in phase. Any imbalance in amplitude or phase causes power to be diverted to resistors R_1 and R_2 .

Transformers T_3 , T_4 , T_5 and T_6 each employ two ferrite-loaded brass tubes, which form center-tapped, U-shaped windings. The high-impedance winding is threaded in continuous turns through the brass tubing until the desired turns

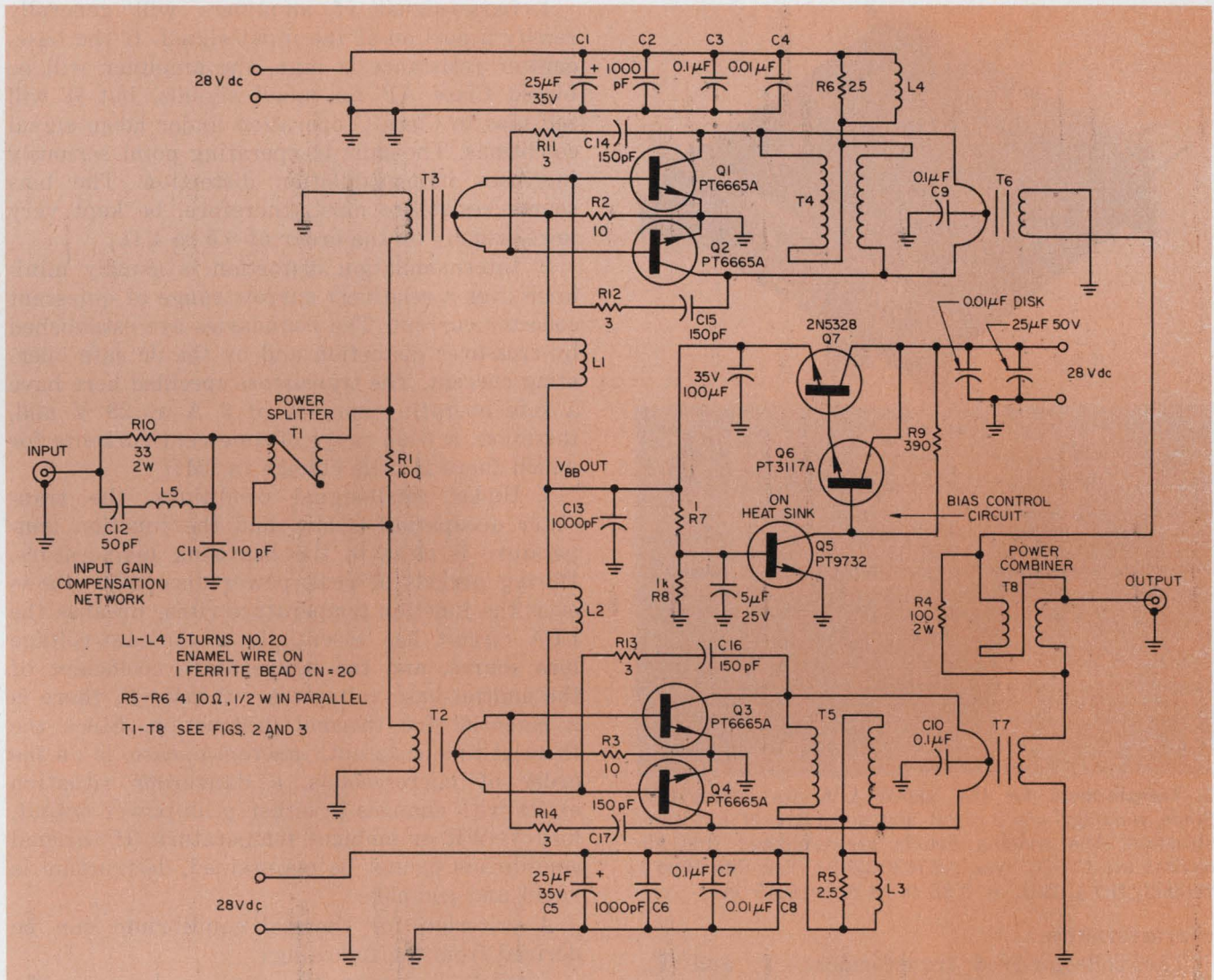

1. Two pairs of PT6665A/PT5788 transistors are arranged in a push-pull configuration to provide a 320-

W, 28-V amplifier. Four such modules are combined to form a 1000-W linear power amplifier (LPA).

ratio is achieved. The transformers and construction details are shown in Figs. 2 and 3.

The turns ratio is determined for the collector by the following equation:

$$\frac{N_1}{N_2} = \text{integer} \sqrt{\frac{Z_L' P_o}{2(V_{cc} - V_{sat})^2}} = 4, \quad (1)$$

where:

- Z_L' = Summing port impedance (100 Ω),
- P_o = Combined output power for the pair of transistors (200 W),
- V_{cc} = Collector supply voltage (29 V),
- V_{sat} = rf saturation voltage (1.5 V).

The turns ratio of the input transformer is determined by

$$\frac{N_1'}{N_2'} = \sqrt{\frac{Z_{in}'}{2Z_{nom}}} = 4, \quad (2)$$

where:

- Z_{in}' = Summing port impedance (100 Ω),
- $Z_{nom}' = Z_{LF} Z_{HF}$. (3)

The quantities Z_{LF} and Z_{HF} are the complex input impedance of the transistors at the low-frequency and high-frequency extremes, respective-

ly. For PT6665A/PT5788, these values are:

$$Z_{LF} = 8.1 - j0.8 \approx | 11.3 | \Omega \quad (4)$$

1.5 MHz

$$Z_{HF} = 2 + j0.2 \approx | 2.83 | \Omega \quad (5)$$

30 MHz

The output transformer chosen for the amplifier uses the calculated-turns ratio. The input transformers, however, use a 3:1 ratio in place of the calculated 4:1, because it improves the match at the high end of the band.

Gain vs frequency response and the input match have been tailored by the addition of L_1 , R_1 and C_1 at the amplifier input. C_1 compensates at high frequencies for some of the leakage inductance present in T_2 and T_3 . As the frequency decreases, XL_1 decreases and R_1 is allowed to absorb a portion of the input driver power.

This approach for improving gain vs frequency response is rudimentary. The amplifier design in Fig. 1 can be made to yield improved results by incorporation of a more complex network to optimize the input match and gain frequency

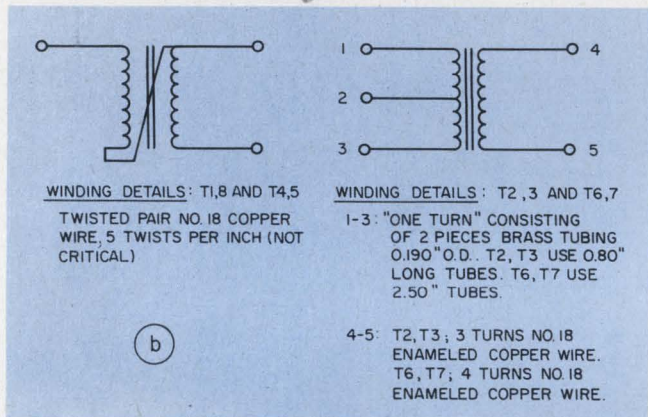
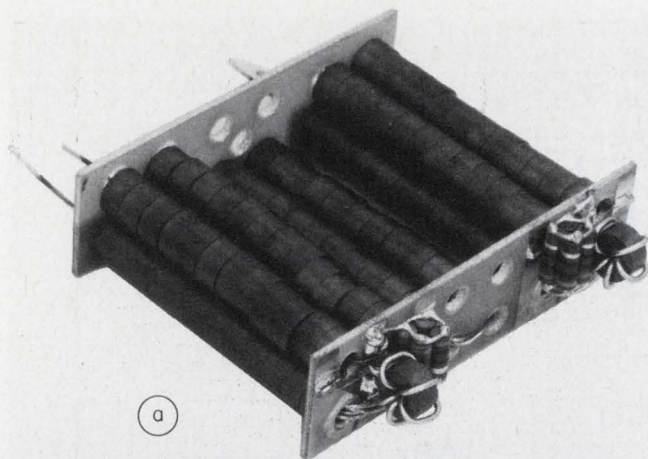

2. Transformers for the 320-W LPA are shown (a). Some windings are toroidal and some are of rod construction. The winding details are tabulated (b). All ferrites are CN-20, type #2643002401 (Fair-Rite Prod., Wallkill, N.Y.), O.D. = 0.38 in., I.D. = 0.19 in.

characteristics.

The collector-feed transformers, T₄ and T₅, combine with the output-matching transformers to form a modified 180-degree hybrid combiner, as described by Pitzalis and others.¹ The ballast resistor, which would normally be 1.2 Ω, is replaced by the bus.

The design now minimizes the differences in phase or amplitude that would otherwise exist at the collectors by allowing the difference current to be bypassed to ground. The resulting output currents in T₆ and T₇ are closely balanced and provide exceptional second-harmonic rejection.

The details of transformer construction are in Figs. 2 and 3. The ferrite material used has an initial permeability of 800 and remains above 200 at 30 MHz. Losses in the ferrite are quite low, and the ferrite temperature rise is typically less than 20 C at full-rated output. The Curie temperature is 150 C minimum (165 C typical).

Factors influencing bias and stability

One of the most demanding aspects of linear-power-amplifier design is the bias network and associated temperature stability. Three major factors are of importance:

1. Large-signal rf amplifiers will generally rectify a portion of the input signal. If the base-emitter resistance is high, the amplifier will be biased Class AB for small signals, but it will self-bias to Class C operation under large signal conditions. The shift in operating point seriously increases intermodulation distortion. The bias source resistance must, therefore, be kept very low—usually on the order of 0.5 to 1 Ω.

2. Intermodulation distortion is usually minimum over a relatively narrow range of quiescent collector current. The boundaries are established by crossover distortion and by the dc safe operating current. The transistors specified here have a safe operating current of 9 A at 28 V and, therefore, a wide range of quiescent currents for which there is little change in IMD.

3. Under small-signal conditions, the transistor dissipation is low, and the junction temperature is close to the heat-sink temperature. During periods of peak power dissipation, however, the junction temperature rises. Because the LPA circuit has essentially a constant-voltage bias source, and the temperature coefficient of the emitter-base voltage is $-2 \text{ mV}/^\circ\text{C}$, there is a potential for thermal destruction. Since the thermal time constant, junction-to-case, is on the order of microseconds, a dangerous situation exists with changes in either peak power output, load VSWR or ambient temperature. If thermal equilibrium cannot be maintained, destruction is rapid and complete.

A criterion for thermal equilibrium can be derived from the following:

$$d(I_c) = g_m dV_B \quad (6)$$

$$d(I_c) V_{cc} = g_m V_{cc} dV_B \quad (7)$$

$$d(P_{diss}) = g_m V_{cc} dV_B \quad (7a)$$

$$d(P_{diss}) \Theta_T = g_m V_{cc} \Theta_T dV_B \quad (8)$$

$$d(T_j) = g_m V_{cc} \Theta_T dV_B \quad (8a)$$

$$d(T_j) = g_m V_{cc} \Theta_T \quad (8b)$$

The normal variation of V_B with temperature is $-2 \text{ mV}/^\circ\text{C}$. Thus:

$$\frac{dT_j}{dV_B} (\text{Critical}) = 500 \text{ C/volt},$$

and any condition which causes dT_j/dV_B to exceed 500 C/volt will induce thermal runaway.

Eq. 8b provides insight into the thermal stability of the transistors and is an excellent guide to the circuit designer. As an example, the TRW PT6665A/PT5788 transistor incorporates improvements for each of the terms in Eq. 8b that enhance the LPA design:

- g_m —The transconductance of PT6665A/PT5788 is typically 2 Ω and is essentially constant at currents up to 5 A. This is achieved by the extensive use of emitter ballast resistors at each emitter site.

- V_{cc} —PT6665A/PT5788 is designed to operate at 28 V with excellent thermal stability.

- Θ_T —PT6665A/PT5788 employs a double chip

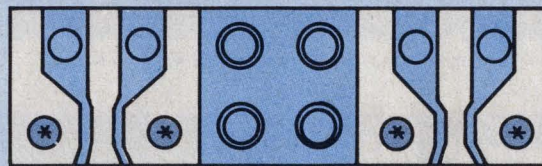
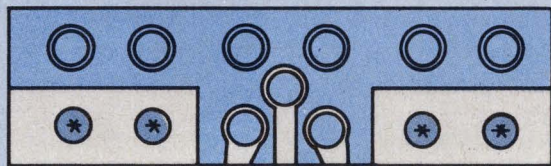
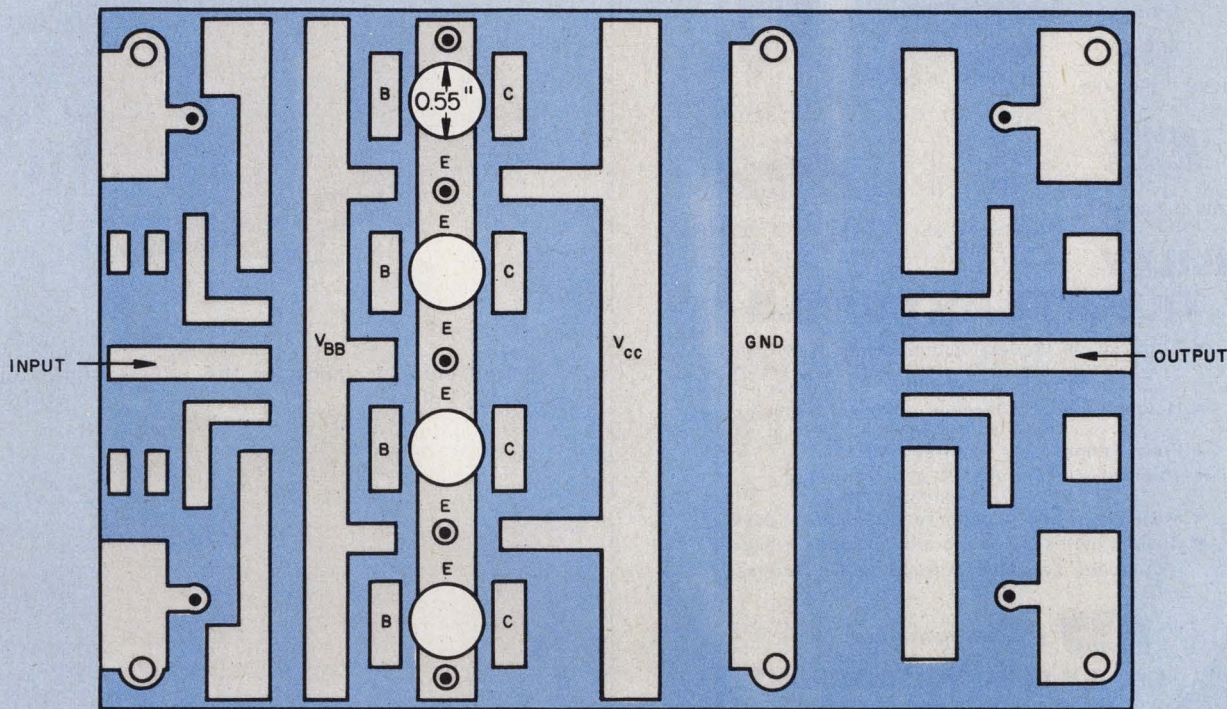

* BRASS TUBING - T₂, T₃, T₆, T₇

3. Layout of the 320-W LPA circuit board (top) and construction details for T₂, T₃, T₆ and T₇ (above).

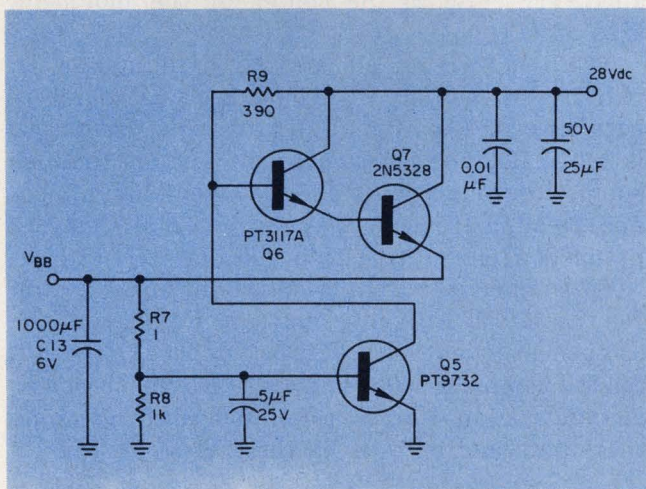

4. The temperature-sensing transistor (Q₅) in the bias-control circuit is mounted in the center of the heat sink, close to the center mounting area of Q₁ to Q₄. This arrangement provides temperature tracking.

with a number of thermally isolated cells. Heat buildup due to thermal interaction is prevented, and improved thermal impedance is achieved. The transistor has a maximum θ_{j-c} of 0.875 C/watt.

The thermal stability factor for the PT6665A/PT5788 is:

$$\frac{d(T_j)}{dV_B} = g_m \times V_{cc} \times \theta_T = 1 \times 28 \times 0.875 = 24.5.$$

Using a transistor with these characteristics, you can obtain performance usually available only in low-level stages. In addition the LPA is tolerant of both open and short-circuit load conditions at full power output. Load mismatch is nondestructive, even though there is no external temperature compensation, and the total LPA dissipation exceeds 200 W under short-circuit conditions.

The bias-control circuit employed for the 320-W LPA is of the temperature-tracking, fixed-



BLILEY
QUARTZ CRYSTALS

- Applications: General communication, aerospace, QPL/MIL-Type C-3098F & precision reference/high stability glass units
- Holder Types: Solder seal, coldweld & glass sealed holders
- Freq. Range: 1000 Hz to 200 MHz
- Tolerance/Ambient: ± 100 ppm (range) ± 1 ppm (oven)
- Maximum Aging: 40 ppm to .003 ppm/30 days
- Custom high shock & vibration designs available

Complete Data Sheets Supplied On Request

Bliley *if you buy quality*

BLILEY ELECTRIC COMPANY
2545 West Grandview Boulevard
Erie, Pennsylvania 16512

INFORMATION RETRIEVAL NUMBER 34

Heath 15 MHz scope with triggered sweep...

just \$329.95*
in Kit form...

only \$475*
Factory Assembled & Calibrated



An excellent bench or design scope at low cost. DC-15 MHz vertical bandwidth with 24 ns risetime...10 mV input sensitivity...12 calibrated vertical attenuator positions up to 50 V/cm...1 megohm/40 pf input Z protected up to 600 VDC...22 calibrated time bases from 2 s/cm to 0.2 μ s/cm...x5 magnifier...normal or auto triggering...AC/DC coupling...ext. trigger input...built-in calibrator...6 x 10 cm screen...120/240 VAC operation. Send for FREE catalog for complete details & specs.

Kit IO-104, 44 lbs. \$329.95*
Factory assembled & calibrated SO-106A, 40 lbs. \$475.00*

Send for **FREE catalog NOW!**

Heath Company, Dept. 60-4
Benton Harbor, MI 49022
 Please send latest Heathkit catalog.

Name _____
Address _____
City _____
State _____ Zip _____
*Mail order prices; FOB factory TE-304

INFORMATION RETRIEVAL NUMBER 35

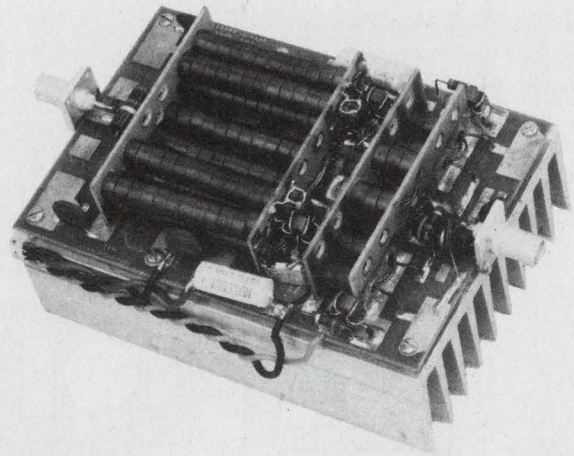

5. Component placement for the LPA is shown on the assembled unit.

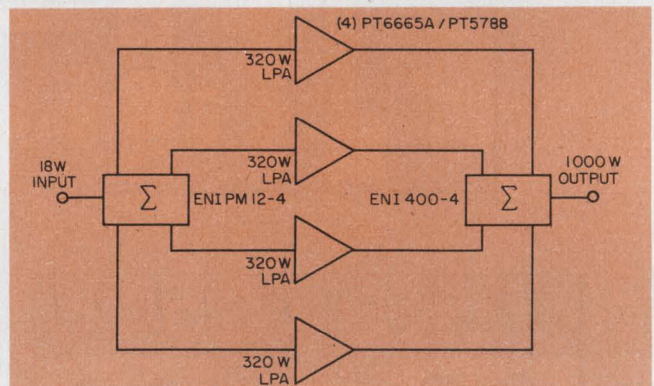

6. 1000-W LPA output is available from four 320 W LPA units, combined with commercially available summing circuits and mechanical links.

voltage, variable-current type, as shown in Fig. 4. The temperature-sensing transistor, Q_5 (TRW PT9732), is mounted in the center of the heat sink very close to the center of the mounting area of $Q_{1,2,3,4}$.

The best IMD for all power and voltage levels, with use of the four LPA modules, was found by adjusting R_9 experimentally; for this design, R_9 is 390 Ω . The bypass capacitor, C_{13} , from the bias supply to ground, must exhibit a very low impedance to all rf frequencies and prevent any mixing products from getting into the bias circuits.

To summarize: Details of the circuit diagram for the 320-W LPA are shown in Fig. 1, and the component layout is in Fig. 5. The block diagram for the complete 1000-W, solid-state linear power amplifier is in Fig. 6. Summing units combine the inputs and outputs of the LPAs. ■■

Reference:

1. Pitzalis Jr., O., and Couse, T., "Broadband Transformer Design for RF Transistor Power Amplifiers," Army Electronics Command, Fort Monmouth, N.J.

MV5050-series GaAsLITEs: Worth looking into.

Viewing angle for various devices ranges from 50 to 110 degrees. Choose from full-flooded diffused, or pinpoint lens effects, either red or clear.

Long life and shock resistance are inherent to the GaAsLITE design. No filament or glass to break. .001"-dia. gold connecting wire is bonded by thermo-compression to die and anode lead, and encapsulated.

Automated handling becomes a possibility with a new cylindrical barrel design that makes the MV5050-series lamps fit precisely into .200-inch aperture. Flattened flange, denoting cathode, speeds handling.

High brightness GaAsP chip is eutectically bonded to header.

The virtually unbreakable "bulb" can take temperatures up to 125°C without deforming. It's made from a unique formulation of a modified bisphenol Type A epoxy system.

Bendable, solderable, wire-wrappable leads are plated copper for best heat transfer and stability characteristics. They mount easily in PC boards on 100-mil centers.

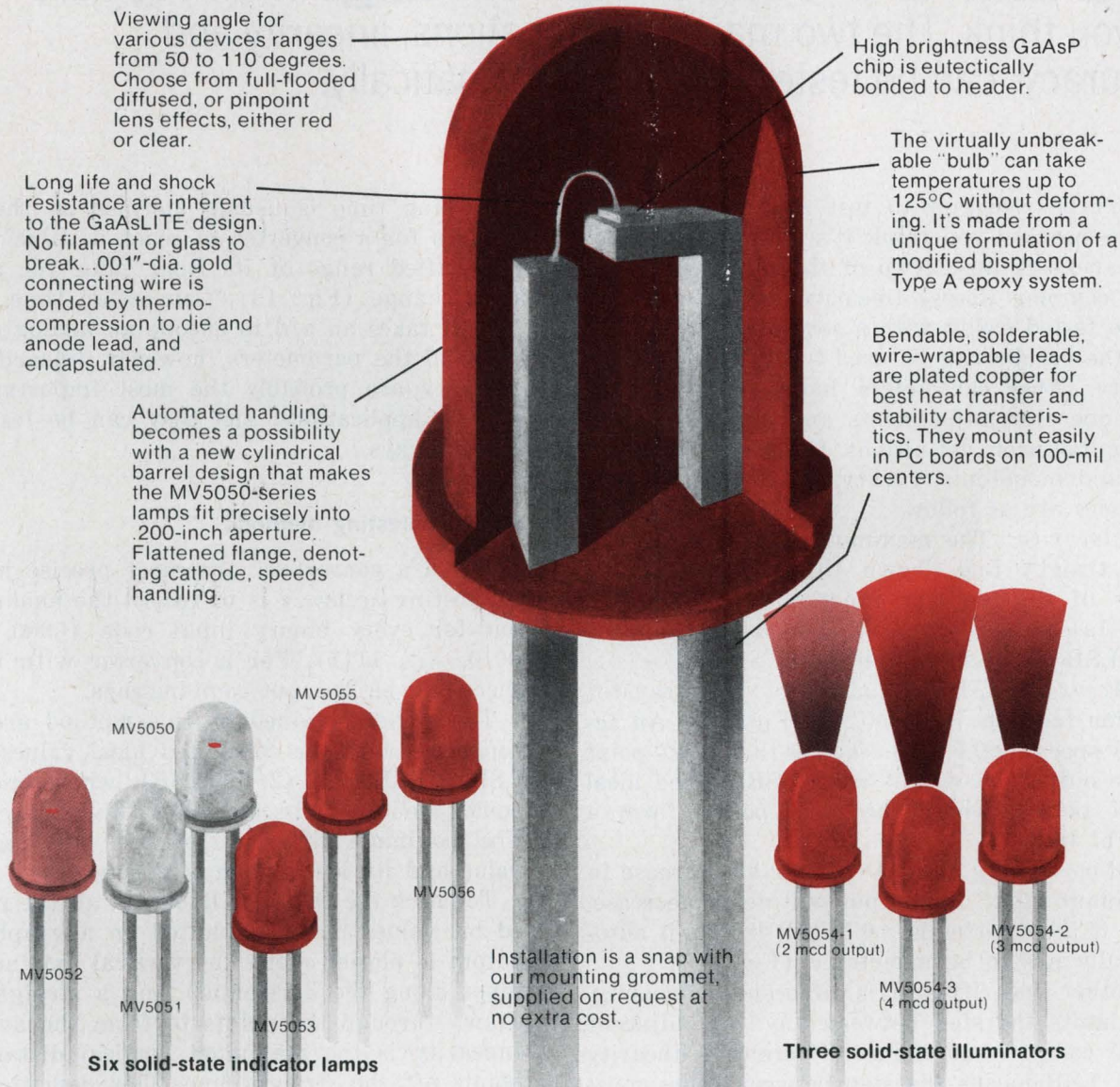

Six solid-state indicator lamps

Three solid-state illuminators

Installation is a snap with our mounting grommet, supplied on request at no extra cost.

Here's our newest family of low-cost, long-life solid-state indicators and illuminators. They're all IC-compatible and use new high brightness materials. Like all our GaAsLITEs, they shine with very little power and are a snap to design into your equipment. Compact, rugged and reliable, the MV5050-series gives you the widest selection of lens effects in the industry. Pin-point. Soft diffused. Flooded. And your choice of viewing angles. All the details are on the data sheet.

For illumination, our MV5054-series GaAsLITEs use high-performance GaAsP to light up a ¼"-dia. circle. Choice of three brightness levels. And the MV5054-1 has a *new reduced price*. For complete specs and pricing information, ask any of our distributors or write
Monsanto Commercial Products Company
 Electronics Special Products
 3400 Hillview Avenue
 Palo Alto, CA 94304
 (415) 493-3300/

Putting innovation to work

Monsanto

INFORMATION RETRIEVAL NUMBER 36

A/d and d/a converter testing: It isn't as hard as you think. The two major specifications, linearity and accuracy, can be tested fast and automatically.

Don't be reluctant to test a/d and d/a converters because you think it's a time-consuming and expensive task. Two of the most important more common specs—linearity and accuracy—can be tested easily with a semiautomatic setup. And the results can be used to check for monotonicity. Other parameters, however, usually require operator adjustments and more time.

Manufacturer definitions for linearity, accuracy and monotonicity vary, but the more common ones are as follows:

- *Linearity*: The maximum deviation from a best straight line drawn through the plotted values of the transfer function. The deviation (Fig. 1a) is usually specified to a maximum of ± 0.5 LSB (least-significant bit).

- *Accuracy*: The deviation of the transfer function from its ideal output (Fig. 1b). An accuracy spec of ± 0.5 LSB requires that every point of the output be within ± 0.5 LSB of the ideal set of points, where the ideal points form a straight line.

- *Monotonicity*: In a DAC, for an increase in the binary input, the output will never decrease. Thus, if a converter is ± 0.5 LSB linear, it automatically has to be monotonic (Fig. 1c).

Another linearity spec is differential linearity. This limits the step between any two adjacent digital codes. A maximum differential linearity of ± 1 LSB means the step between codes must be either 1 LSB, ± 1 LSB, or some other value between no step and two steps.

The temperature coefficient specifies how well the linearity and accuracy specifications hold over a specified temperature range. Power consumption is the maximum power the converter will draw under worst-case conditions.

Settling time, conversion time and power consumption are other important design parameters of converters. These three are usually considered design features of the converters, and the values of each will not vary considerably among individual converters of a given design.

Settling time is usually defined as the time it takes for a converter to reach a value within a specified range of its final value for a full-scale change (Fig. 1d). Conversion time is the time it takes an a/d to encode an analog signal.

Of all the parameters, however, linearity and accuracy are probably the most important for general applications, and they can be tested in several ways.

Precision testing methods

For d/a converters, the most precise method for testing accuracy is to record the analog output for every binary input code (0000, 0001, 0010, . . . 1111). For a converter with n bits, there will be 2^n input combinations.

The values obtained by this method are then compared with the calculated ideal values (0, 1 LSB, 2 LSB, . . . $(2^n - 1)$ LSB), where one LSB equals the ideal full-scale voltage divided by $2^n - 1$. The maximum difference between any recorded value and its ideal value is the accuracy.

To check the DAC for linearity, all the recorded bit values must be plotted on a graph (the output is plotted along the vertical axis and the input along the horizontal) and a straight line drawn through the points to form the average. Linearity is the maximum vertical distance to points off the straight line. This deviation distance is usually expressed in LSB steps.

Since the accuracy spec defines the deviation of the transfer function and linearity specifies that all these points form a straight line, the worst-case error occurs at the end points. Therefore, rather than checking every point on the line for accuracy, examine just the end points if the converter is known to be linear. The accuracy of the end points will be the converter accuracy.

Other tests for linearity

A more efficient method for testing linearity is the bit-scan technique. Here each bit is turned on individually, and the output voltage is recorded (eight values for an 8-bit converter). By adding the bit values together and then adding

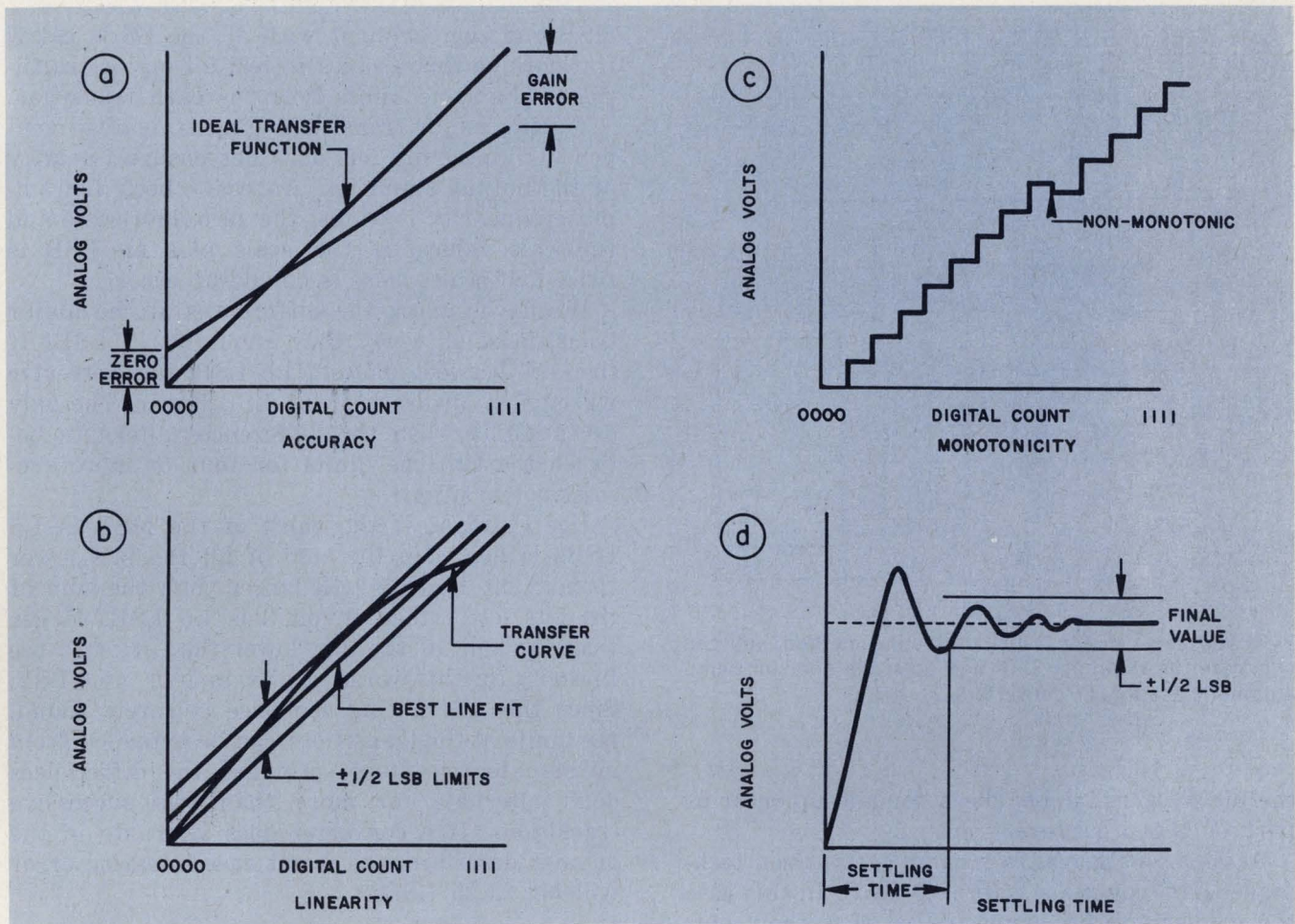

1. Transfer curves of linearity (a), accuracy (b), monotonicity (c) and settling time (d) show some of the

problems you face when testing converters. Usually, linearity and accuracy are primary considerations.

an additional LSB, you get the full-scale value.

Any offset caused by the output amplifier, or intentional offset if the unit is bipolar, must be subtracted to get the actual value. Then you divide the full scale by 2 as many times as there are bits in the converter. Take the difference of the calculated bit values from the recorded ones, and add up the magnitudes (disregarding sign) of all the differences. Divide this sum by 2, and the result is the linearity. The answer will usually be in millivolts and should be changed into a fraction of an LSB. For example, if an 8-bit converter delivers a 10-V output, each LSB represents a 39-mV increment. If the total of the differences divided by 2 equals 10 mV, the linearity would be ± 0.25 LSB. Although this method only requires n values, rather than 2^n as in the point-by-point method, it still takes considerable time to test a DAC.

The bit-scan method also assumes there is no "add-up" error in the converter. This error refers to the difference between the mathematical sum of each bit value and the value of the output when all bits are on. The error can stem from interaction of internal components or a non-linearity in the output amplifier. When using

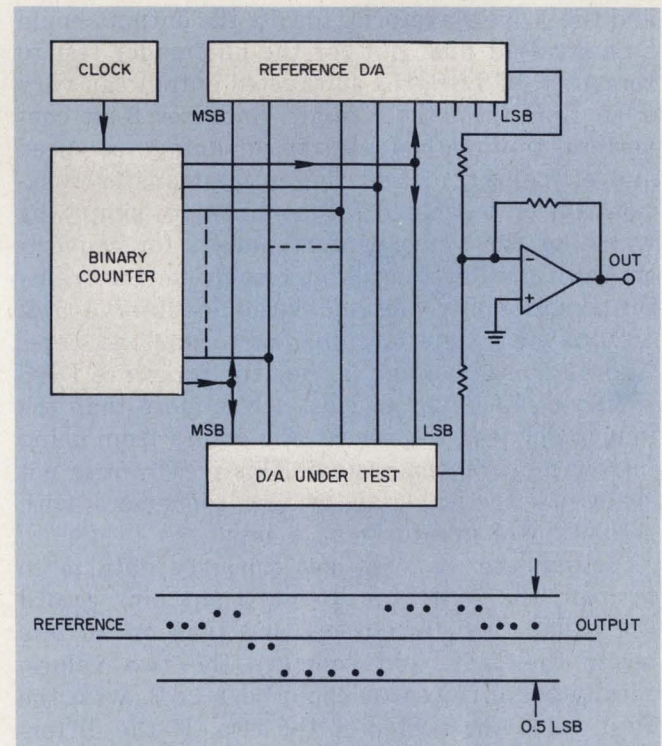

2. The ramp-conversion technique for testing DACs requires a reference DAC that is at least 4-bits more accurate to prevent additional measurement errors.

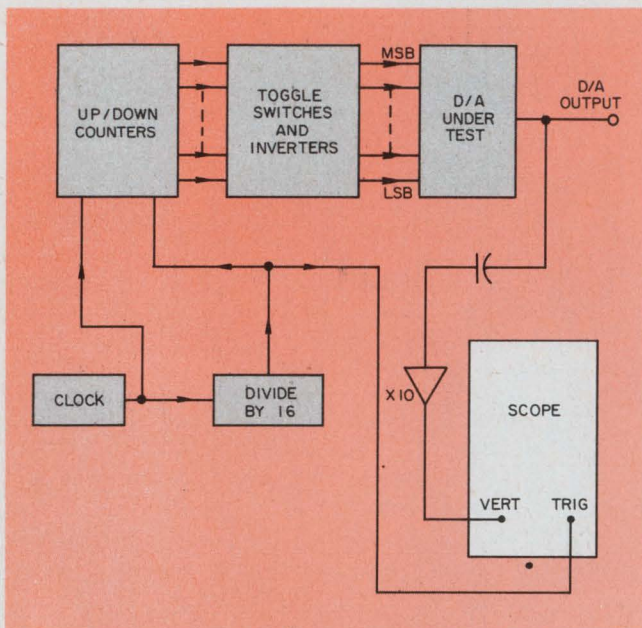

3. If you use a major transition testing method, you can eliminate the reference DAC and open the door for semi-automatic testing of converters.

the bit scan technique, check for add-up error as part of the procedure.

A faster method uses a ramp-comparison technique that requires a reference DAC. In this case the converters are connected so that their outputs are dynamically subtracted on an oscilloscope, while the inputs are tied together and cycled through by a binary counter.

Fig. 2 shows both the schematic connections and the scope waveform. Ideally the output should be a straight line. But for the unit under test to remain ± 0.5 LSB, the subtracted output can vary ± 0.5 LSB from the straight line. For 8-bit converters, this method has the advantage of speed and efficiency, in that the entire transfer function can be examined for nonlinearity simply by watching the scope. Unfortunately, for converters with greater than 8-bit resolution, the transfer function becomes too large to observe 512, 1024 or more steps on a single sweep of the scope. Another disadvantage is that the reference DAC should be linear by at least 4 bits more than the unit under test, to prevent any errors from being introduced into the system. This is why it is not really a practical way to test converters with resolution of greater than 8 bits.

Yet another way to get linearity data is to turn on the MSB (most-significant bit) record the value, then turn it off and turn on all bits below the MSB and compare the two values. Ideally the difference should be 1 LSB, with the first value the larger of the two. If the difference is zero or 2 LSBs, the converter is still ± 0.5 LSB linear.

Now repeat this procedure using the second

MSB and comparing it with all the LSBs below it. Continue this process to test all major transitions. The same limits hold for each transition.

Testing major transitions guards against component interaction but does not ensure linearity of the output amplifier. An easy check for amplifier linearity is to test the zero, half-scale and full-scale values. If full scale plus an LSB is twice half scale, there is no add-up error.

When you check the differences at the major transitions, at worst they should be 1 LSB. If they are between 0.5 and 1.5 LSB, the converter will almost always be ± 0.5 LSB linear. The only exception is when the differences alternate between the extreme limits for four or more successive transitions.

For example, if the value of the MSB is 1.5 LSBs larger than the sum of all the bits lower than it, bit 2 is 0.5 LSB larger than the sum of the bits lower than it, bit 3 is 1.5 LSBs larger than the sum of the bits lower than it, etc.; the linearity for this worst-case example is ± 0.6 LSB. Since this alternating sequence is rarely found, the limits at the transitions can be extended from no step to two steps, provided the differences don't alternate for more than two successive transitions. If a converter does alternate in the manner described, the worst case linearity error will be ± 1.25 LSBs.

Automating the tests

A main objective in the design of test equipment is to get a universal test set at minimal cost. The box should be capable of testing high as well as low-resolution converters with a minimum of calibration. Ideally, for testing d/a converters, the bit-comparison scheme would be the best to automate, since no reference unit is required and the bits can be easily programmed.

Fig. 3 outlines the circuitry for the test set. By programming the up/down counters to step above and below each major transition, you can observe the difference between any bit and the sum of the lower bits.

Initially the clock starts stepping the counters down. As the divide-by-16 output inverts, the counter reverses direction. This causes the d/a converter to step up and down eight levels. The counter has to be set up to count around each major transition.

The programming circuit of Fig. 4a controls the counter. As the 7493 binary counter counts through all the states, the one shot is triggered on the falling edge of the D output of the 7493. The pulse loads the 74193 up/down counters to the 00...011 state, if all the inputs of the 74193s are low except the last two. When this occurs, the clock is fed into the down input until the counter steps to the 11...1011 state, where the

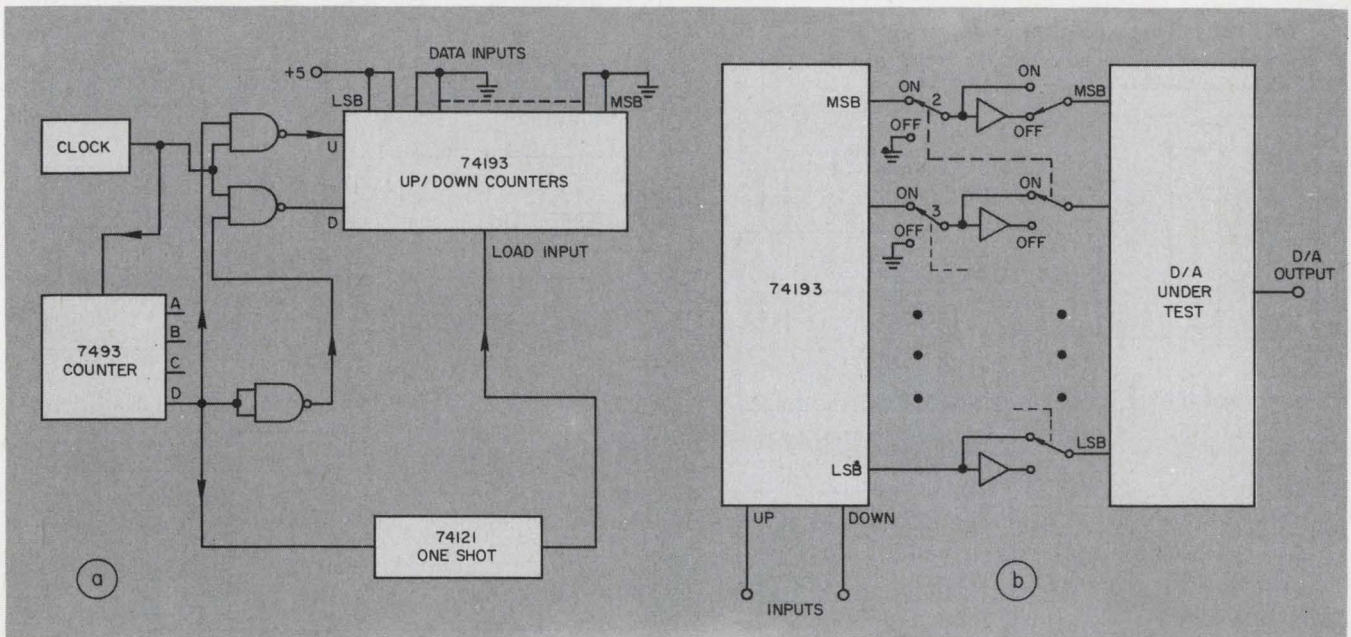

4. With a few extra gates, the up/down counters can be programmed so we can see the major transitions (a).

Some switches and inverters can modify the counters' output so all major transitions can be checked.

counter reverses. To observe the major transition, invert the MSB of the DAC input.

The toggle switches and inverters in Fig. 4b control the major transition display. The counter outputs are each fed through inverters and dpdt switches. If the MSB is off and all the others are on the digital input will start at the 100...011 state and count down to the 011...1011 state. This allows observation of the MSB transition. The resulting display is shown in Fig. 5. This procedure can be repeated for each successive MSB until all major transitions are observed. Remember, keep the switches for the MSBs that have been tested in the off position.

When the converter is cycled, it changes in LSB steps at each major transition where the ideal difference also is an LSB. With a tolerance of ± 0.5 LSB linearity, the step can be as much as 2 LSBs or as little as no step at all. If it is 2

LSBs, then 01111 is 0.5 LSB below ideal and 10000 is 0.5 LSB above, and vice versa for no step. Once again, if the differences at three or more successive major transitions alternate between extremes, the unit is ± 1 LSB linear.

Gain can be added to the converter output, thus making it easier to see on a scope. For example, the output of a 12-bit d/a converter would typically change in 2.5-mV steps (with 10 V full scale). If an amplifier with a gain of 10 is placed after the output, the scope would show 25-mV changes. To prevent the op amp from saturating, the converter output should be ac-coupled. A typical clock frequency of 10 kHz would allow the converter 100 μ s for settling at each step. A bank of 12 switches could then test a 12-bit DAC for linearity, accuracy, monotonicity and add-up error in about 30 seconds. This test can be modified to test 16-bit units by adding four more switches and an extra 74193.

Also, for some applications, the temperature coefficient is critical. With the test set used for checking the major transitions you can also easily test the temperature coefficient.

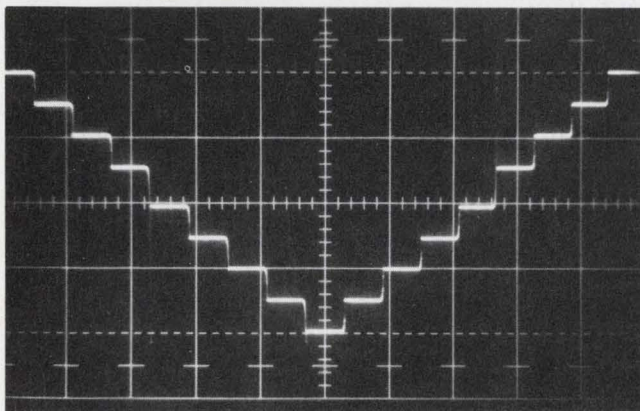

5. The DAC output looks like a staircase when programmed around the major transitions.

More complex test circuits for a/d converters

A/d converters require slightly more complex testing circuits, since their digital outputs must be reconverted for display on a scope.

To test an a/d, the analog input voltage is varied until the correct digital code desired is outputted. Remember, the correct analog input is when the digital code is first turned on, even though the input can be varied without a change

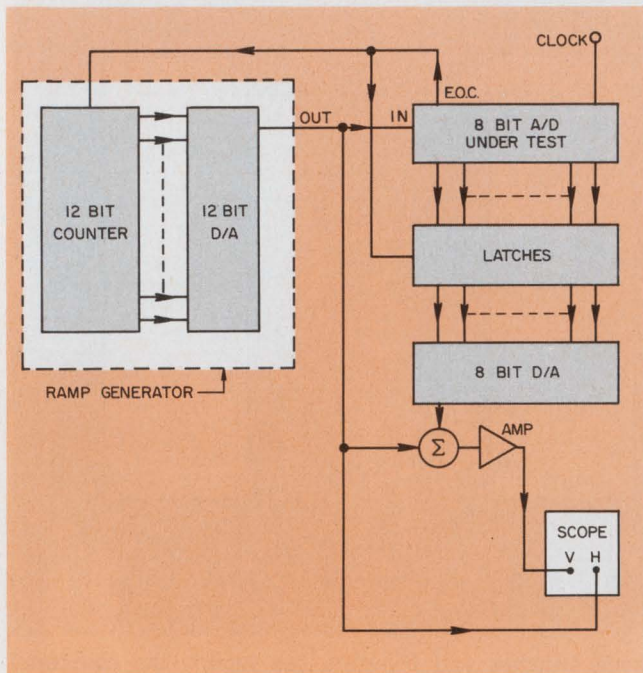

6. A test set for a/d converters requires more complex circuitry, even for low resolution units.

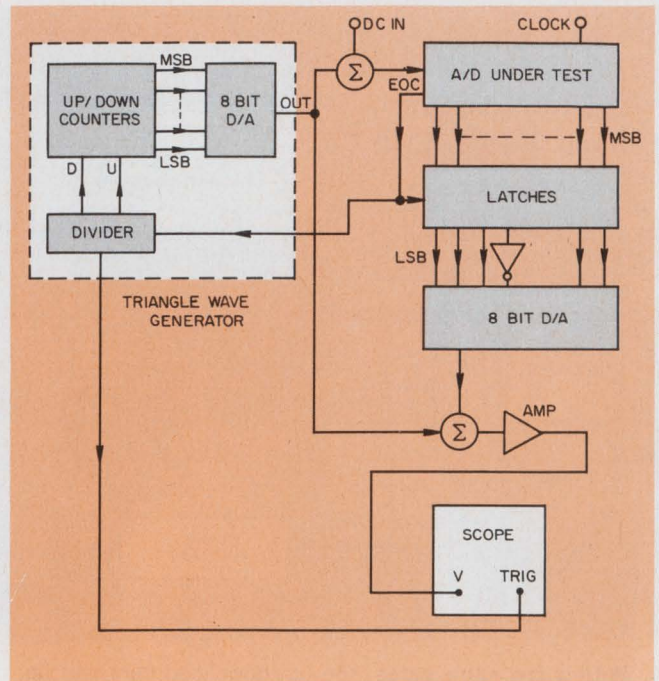

9. The dither method checks for linearity at the major transitions of the a/d converter.

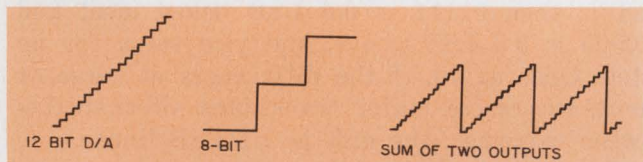

7. By summing the outputs of a 12-bit d/a and an 8-bit d/a, you can get a staircase sawtooth wave.

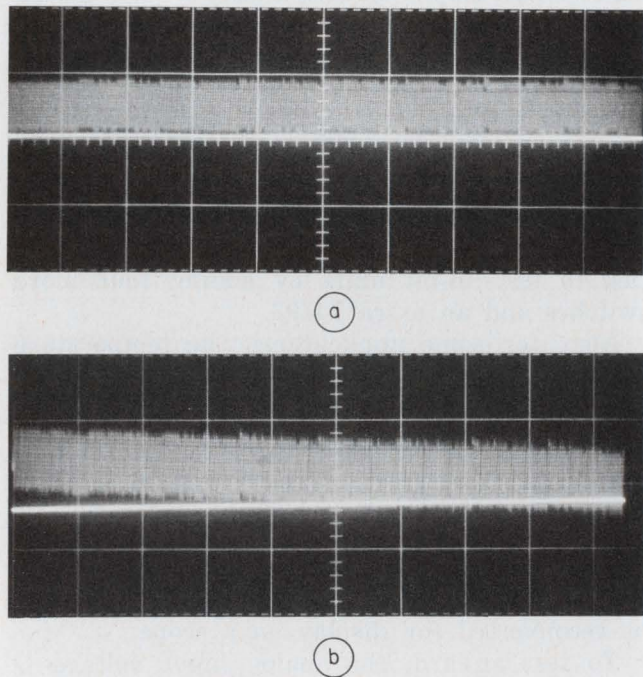

8. Testing the output of an 8-bit a/d converter for linearity produces a completely horizontal waveform (a) if it's linear, and a distorted, tilted, waveform (b) if it has a ± 0.5 LSB or greater linearity error.

of output code. For example, an 8-bit a/d can handle a 0-to-10-V input signal, but if the analog input is between 5.000 and 5.039 V, only the MSB will be on. Thus, the value for the MSB is 5.000 V.

Linearity and accuracy can be tested in almost the same ways as those for DACs, with the same advantages and disadvantages. However, in tests for accuracy the problem of zero error arises when the input is less than 1 LSB, since all bits will be off. For most practical purposes, the zero error is defined as the error of the LSB.

For low-resolution a/d converters (8 bits or less), a ramp-comparison technique can be used. Fig. 6 shows a test set for converters with up to 8-bit resolution.

Every time the a/d unit under test converts the 12-bit counter increments, it increases the d/a converter output and the analog input to the a/d. The d/a output is a ramp with 4096 steps and the same full-scale output as the device under test. This will make the a/d converter go through every digital output combination. The 8-bit d/a provides a ramp with 256 steps whose sum is a sawtooth display (Fig. 7).

If the slope of the sawtooth varies, the inaccuracy is the difference between the reference and the bottom of the band (Fig. 8a). The band height is an LSB step. A discontinuity in the band (Fig. 8b) would indicate that the unit is not perfectly linear. For the a/d to be within the ± 0.5 LSB linearity, the difference has to be less than the width of the error band. This type of measurement system suffers from many internal calibrations that must be done to maintain accuracy. The 12-bit d/a has to be at least ± 0.5 LSB linear

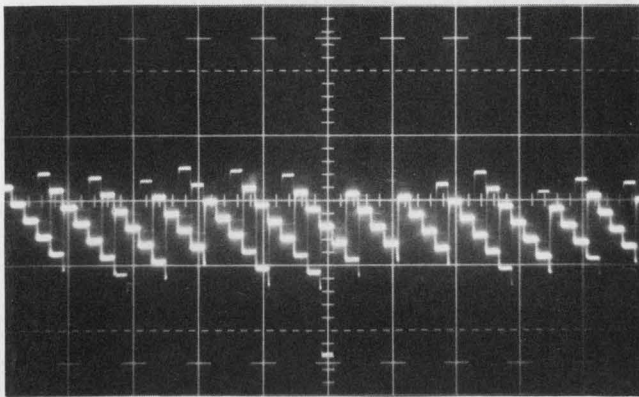
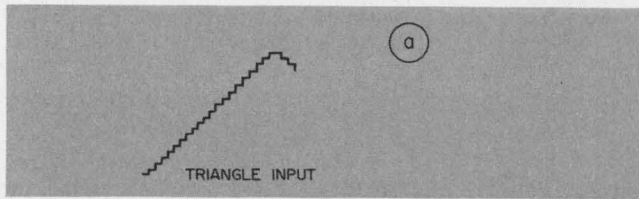

10. The triangular-ramp waveform (a), when inputted to the circuit of Fig. 9, tests an a/d for linearity error (b).

and 0.01% accurate. The 8-bit d/a also has to be 0.01% accurate, so as not to contribute any errors to the measurements.

The test circuit of Fig. 6 uses three 7493s in the 12-bit counter to drive an MN415 d/a converter. The counter is triggered by the end-of-conversion pulse from the a/d converter under test. This prevents the a/d input from changing while it is still converting. The latches are 7475s, and the other d/a is also an MN415. A 741 op amp is used as the summing amplifier.

Higher-resolution converters can also be tested on a similar test set by use of the "dither," or major transition, method (Fig. 9). In this circuit, every time the a/d converter steps the up/down counter, the input level changes by 0.25 of an LSB. The counting up and down produces a triangular wave that is summed with the input. The summed output then is a sawtooth with steps.

If there are any nonlinearities, the level of the 100...00 will be shifted, but it must always remain within 1 LSB of the 011...11 step. To observe the other major transitions (Fig. 10), you must change the dc level. And to check the accuracy of the end points, switch the triangle wave out and input only a dc level. Now check when all bits are on and off.

The divider circuit uses two 7493 counters driven by the end-of-conversion pulse from the a/d under test. The d/a converters used in this test set are MN321s. Their outputs must be attenuated to make the LSB of the 321 a quarter of the value of an LSB from the converter under test. This makes the a/d convert four times before the digital output changes. ■■

Need to know where it's at?

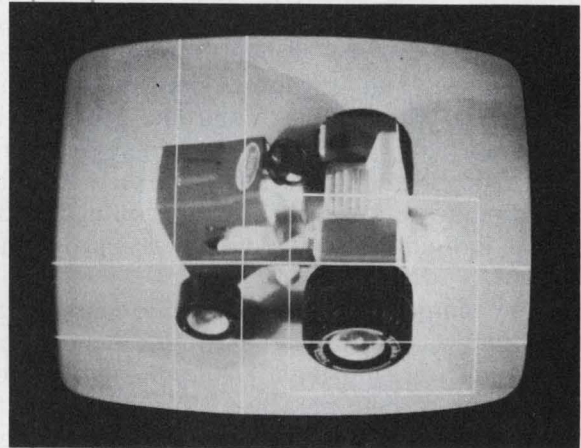

CVI video instruments provide X-Y coordinate information from TV signals — produce boresight reticules — digitize target location — analyse scenes — and more. If you use television and need to reduce data, add special markers, or perform other operations, please call us.

We make things like:

- 304 Motion Detector
- 321 Video Analyser
- 603 Data Insertion Generator
- 610 Video Pointer
- 621 X-Y Indicator
- 622 X-Y Digitizer
- 630 Anomaly Detector

cvi

Colorado Video, Incorporated
P.O. Box 928
Boulder, Colorado 80302
(303) 444-3972

Video instruments for data acquisition, processing, Transmission, and display.

Using consultants takes consultation, says this technical director, who lists their disadvantages as well as the obvious advantages they offer

There's an adage going around the electronics industry that says that if you can't make it as a design engineer, you become a process maintenance engineer, and if you can't make that, you become a consultant. I've found the opposite is true. People who can't make it in the industry usually drop down a position or drop out altogether. It takes a strong-willed, disciplined, self-confident individual to survive as an engineering consultant.

But the competence of engineering consultants is not what worries an engineering manager and his staff most. Hiring them has its disadvantages in other ways: Their presence often causes staff morale problems; their job is hard to fill when they leave; and a manager often has trouble controlling them.

Before you can understand fully the problems that consultants present and the solutions to these problems, you should know who consultants are, where to find them and how to select them. You should also know why they're used which includes some obvious advantages.

Betting on his brains

There are three levels of engineering consultants in the industry. There's the bench engineer, or contract engineer, who works on an hourly basis—about \$20 an hour. He usually builds hardware or an end product. He may work at your company, but often as not, he'll work at home. He usually works on more than one job at a time. He's seldom asked to discuss the philosophy of the design he's working on.

The second group of consultants works on a daily basis—\$200 to \$500 a day, depending on experience and expertise. This type of consultant usually works on software, and he's paid for his design philosophy. He's confident, up to date and almost always able to handle any situation.

Paul N. Risinger, Technical Director and Staff Operations Manager, TRW Semiconductors, Lawndale, Calif. 90260.

Paul N. Risinger

One way or another, Paul Risinger has been up to his BSEE in transistors all of his professional life. After graduating from USC 15 years ago, he joined TRW Semiconductor in Lawndale, Calif., as an applications and design engineer in special diodes and various transistors. And, if that wasn't enough, he was soon selling and developing transistors and managing the production of rf power transistors.

Later he managed the advanced marketing and technology operations of TRW Semiconductors and eventually managed the communication products subdivision which produces all rf products. He also found time to write a few technical articles and application notes on rf power transistors.

In contrast to his career in technology Paul's hobbies include history, house remodeling, and music. He even finds time to fool around with sports cars. He's married and has a 10 year old daughter.

Today, Paul is technical director and staff operations manager for TRW Semiconductors. He's responsible for new business developments, R&D, and staff support to semiconductor product operations.

The third kind of consultant works strictly on a fixed-fee basis. He'll give you a dollar quotation for the job. He's betting on his brains to get the work done fast.

The majority of the engineers in the latter two groups work with associates and operate in loosely knit groups of two or three. In general, they are not held responsible to company employment rules. They include the cost of fringe benefits in their fees. I usually set a certain figure per day, ask the consultant to give me an estimate, and we compromise on the final price. We also select project milestones. If there are



Company specializes in rf power devices

TRW Semiconductors was founded in 1954 as Pacific Semiconductors, Inc., a subsidiary of the Ramo-Woolridge Corporation, to produce diodes. In 1960, some general-purpose, rf and power transistors were added to its product lines. TRW's basic TTL patents were also used to start IC production in 1962. This market orientation was dropped in 1964 in favor of two specific specialty markets in rf power devices and military power transistors and diodes.

PSI became TRW Semiconductors and leads the industry in production of rf power devices. TRW produces rf power, linear, and microwave transistors, hybrid and monolithic ICs, specialty diodes, and power transistors and diodes in three locations, including Lawndale, California, Bordeaux, France, and Ogallala, Nebraska. Its newest products are Darlington power transistors, Schottky power diodes, and high power microwave transistors.

six of them, I usually pay the consultant after each is reached, which may be every two days or every two weeks. Consulting fees always seem high. But we forget that consultants have to support dead time, a library, a wage and a profit on their gamble.

Perfecting the selection

When I'm thinking of hiring a consultant, I stop and evaluate if that's what I really need. Often managers hire consultants when they shouldn't. They know they've got a particular

problem, but they don't always know what causes it. It might not be an engineering problem; it might instead be a personnel problem or a systems problem, or it might even be the whole approach.

After I've decided I really need a consultant, my biggest challenge in hiring one is finding someone who can give me the best possible answers for the questions I have to ask. I keep a list of the people I've heard about or used before. Sometimes the higher-level engineering consultants will even come to me with other proposals.

(continued on page 72)

If you're a brand new company with no list and no visiting consultants, the engineering societies that are involved in the areas you're interested in will know who in their group is consulting. I've also gotten recommendations at conferences and from manufacturing societies. If I need a consultant between society meetings, believe it or not, I've even called competitors for help.

After I have a list, I never choose from just one consultant. I always look at two or three. I'm never overly impressed with past credentials, because I've learned that while credentials may be factual, they may also be dated. Communication is the forte of a consultant. If he can't describe himself with clarity, how clearly will he be able to advise me on my project? He must be able to communicate.

For engineering advice, I prefer an individual consultant rather than a consulting firm. If I was concerned with general management or marketing, I would probably choose a consulting firm, because more opinions are better. A single consultant is better for engineering, because he has to live by his wits. If he doesn't maintain a high percentage of success, his value will drop; reputation is paramount to him. The individual consultant will want to do the best job in the quickest time and then get out.

I hire a consultant like I hire an engineer, which means asking his previous employers what he's done. Although much recommendation is subjective, I usually get an opinion from the managers that helps me. If I get four positive responses in five, I figure I have a winner.

Why hire an engineering consultant?

If you have the budget and the time, or if you need a continuous expertise, don't hire a consultant; hire a full-time engineer. You might hire a consultant to start a project if you need it started immediately or if you're having trouble finding an engineer.

Cost is not a major reason for hiring consultants. Consulting is a short-term affair. The timing and expertise vs the return on your investment and the leverage are usually the reasons for hiring a consultant. He offers the following special advantages:

- *Expertise*—Besides providing technology, consultants can help your company decide on new products or what other product line to purchase when this ability is unavailable in-house.

- *Objectivism*—He can give you a fresh look at your system. You may already have the expertise, but maybe you're getting a story about the project that's too good to believe.

- *Speed in meeting deadlines*.—Consultants can help you develop a product in time to beat

a government deadline, or help you with a production yield problem. In small companies, you need him in a hurry, and you don't have time to hire a full-time engineer.

- *Availability*—There's no search, indoctrination or moving expenses when you hire a consultant. When the job's finished, there's no hangover. For example, sometimes you need advice to design a facility with the newest techniques in the industry. You could hire engineers for that job, but when it's over, you no longer need those engineers.

- *Industrial liaison*—The consultant has more knowledge of the competition than your staff could have. He has been in and out of competing houses, and he knows what the industry trends are. He can be an ethical liaison between competitors.

- *Stand-by advice*—Sometimes you'll hire a consultant on a continual basis. If he's a professor and if it's a small company, you'll put him on the board of directors. Or you'll hire him as a special assistant to the president. He's not there every day, of course, but you have access to his expertise and, in many cases, to his school's facilities.

The flip side of consultation

Now for those disadvantages I told you about. Consultants can create the following problems:

- *Morale*—Often your staff engineers may mistrust a consultant and have no confidence in him. The secret is to get the engineers involved in the project so they feel it's theirs. Often they've already worked on it and failed. If you plot it well enough, you can get them to tell you that they don't know how to do it. At that point you tell them that maybe you'd better get someone to help, and you try to get them to agree. What usually happens is that your people try to help you pull someone in to do the job and give him the tools he needs. One of the biggest problems for a manager is when he dictates the assignment of a consultant into an area and resentment from the staff takes the form of minimum cooperation. The consultant may not even know there's something wrong at a time when communication is all important.

- *Maintenance and control difficulties*—With the exception of the contract engineer, the consultant isn't in your direct employ; he operates independently. For example, he offers advice, but he feels that he shouldn't have to implement it. If the implementation is wrong, it hurts his reputation. Consultants I've talked to list this as one of their most serious problems; it threatens their credibility. But it may be that his solution is impractical or may not work, for one reason or another. Whenever a consulted project in un-

successful, the question of whose fault it is always comes up. It's often difficult to evaluate a consultant's contribution until he's long gone. And, of course, if you don't use his advice, you can never evaluate it.

■ *Gaps after departure*—After the consultant leaves, you may find that you didn't get all the information you needed. Either you didn't ask all the questions necessary or he didn't offer them all. Many consultants have pat answers that they've used for years, and the industry may have passed them in that area. The consultant's reputation is the governing factor.

■ *Narrow-mindedness*—Some consultants do not quickly understand why the problem exists, and they have trouble putting it into the context of your total needs. Some are so used to working in one area, such as chemicals or electronics, that while they understand the narrow problem, they have trouble seeing the overview.

■ *Conflicts of interest*—Consultants may be working on other jobs besides yours; their concentration is divided. The manager's trouble is doubled if he must, first, bring the consultant up to date on major problems and then brief some company engineer behind him to continue the job after the consultant leaves.

How many charlatans?

Consultants have limitations. I wouldn't hire one, for example, to do a system for me. I'd have him work on a subsystem or in the product area or production area. Consultants are usually best used in a field where there is a wide breadth of knowledge.

The answers they give you may not always be what you're looking for, but if the consultant is the best in the field, listen to him. Don't listen only to your own people; they're emotionally involved. And don't expect a consultant to make your decisions for you. He gives you advice or hardware. You make the decisions.

I think that most consultants are sincere in their efforts; I don't think there are many charlatans in the field. If you're wary about a consultant, the first thing to look for is how many jobs he had in the past year or so in the same field you're interested in. If you suspect him, don't use his references; backtrack by calling the companies he worked for and talk to people other than the ones he used for references. You can also talk with other consultants in the field; privately, they'll give you some recommendations.

I've found that it's a lot easier to hire the next consultant after I've been able to review the results of the preceding one. I've also found that it's difficult to blame any consultant for what goes wrong when I'm the one who makes the decisions. ■■

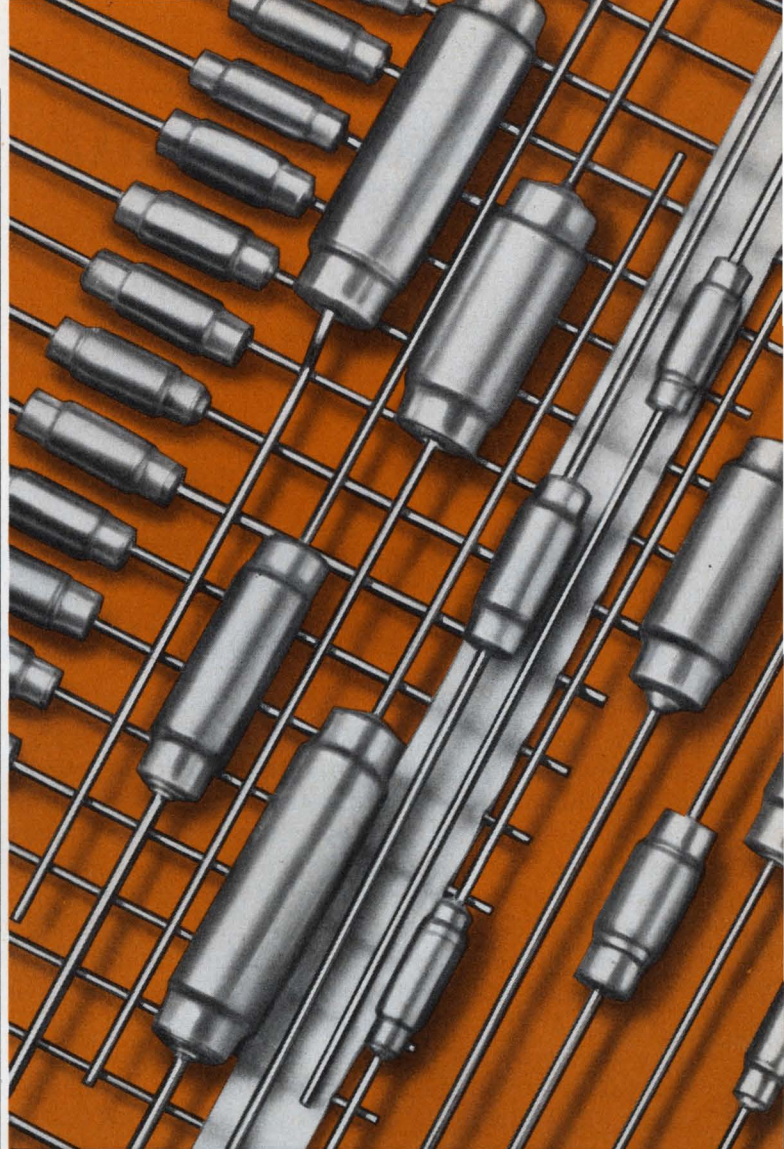

Last year these
Paktron® film capacitors
were revolutionary.

Now they are the standard.

And for good reasons. The Micromatic® capacitor, revolutionary for being wound on its own leads—and for its self-encased construction. Both polyester and polypropylene versions are widely accepted in industrial applications. Tape reeled for automatic insertion. Send for test samples and data.

PAKTRON, Division Illinois Tool Works Inc.,
900 Follin Lane, S. E., Vienna, Virginia 22180.
Phone (703) 281-2810. TWX 710-833-0682.



itw **PAKTRON®**
innovators in film capacitors

The Innovative Electronic Group of ITW...
PAKTRON ■ LICON ■ EMCON

Transistor bleeder gives opto-isolator a wide temperature range of operation

A Darlington opto-isolator circuit can operate over wide ranges of temperature—25 to 100 C—with the addition of a transistor current bleeder. The transistor clamps the base-emitter voltage of the output transistor in the absence of signal current, yet allows transfer of almost 100% of the signal current.

The leakage current $I_{CEO(Q1)}$ allows Q_3 to saturate. And the voltage across Q_3 is well below $V_{BE(ON)}$ of Q_2 . Although $I_{CEO(Q1)}$ increases at higher temperatures, Q_3 remains saturated and its saturation voltage decreases. Hence Q_2 remains cut off. With drive current applied to the LED, Q_1 conducts and I_1 rises rapidly. Now Q_3 is no longer saturated, and $V_{CE(Q3)}$ increases to the point where Q_2 turns on. Once Q_2 turns on, the base drive to Q_3 is decreased and more current enters the base of Q_2 . In this state Q_3 bleeds very little emitter current from Q_1 , so full Darlington gain is obtained.

For design purposes, $V_{CE(SAT)}$ of Q_3 need only be less than $V_{BE(ON)}$ for Q_2 at the maximum leakage current for Q_1 . Resistor R_1 provides saturation bias for Q_3 and is calculated from

$$R_1 \leq \frac{V_{CC} \times [H_{FE(Q3)}]_{MIN}}{[I_{CEO(Q1)}]_{MAX}}$$

With values for $(H_{FE})_{MIN}$ and $(I_{CEO})_{MAX}$ of 250 and 1 mA, respectively,

$$R_1 \leq (200 \times 250) / 1 \times 10^{-3},$$

or 50 M Ω . A value of 10 M Ω was selected.

For the ON state, the current drained from Q_1 is given by

$$I_{CE(Q3)} = \frac{[V_{CE(Q2)}]_{SAT} \times H_{FE(Q3)}}{R_1},$$

from which

$$I_{CE(Q3)} = \frac{1.5 \times 250}{10 \times 10^6} = 37.5 \mu A,$$

with the saturation voltage of Q_2 equal to 1.5 V.

An alternative approach, the use of a single resistor instead of Q_3 , sacrifices circuit gain and

offers less leakage protection. As the leakage current increases, the base-emitter voltage of Q_2 increases and the output transistor eventually conducts.

Zag Kadah, Senior Design and Process Engineer, Monsanto Commercial Products Co., 3400 Hillview Ave., Palo Alto, Calif. 94304.

CIRCLE No. 311

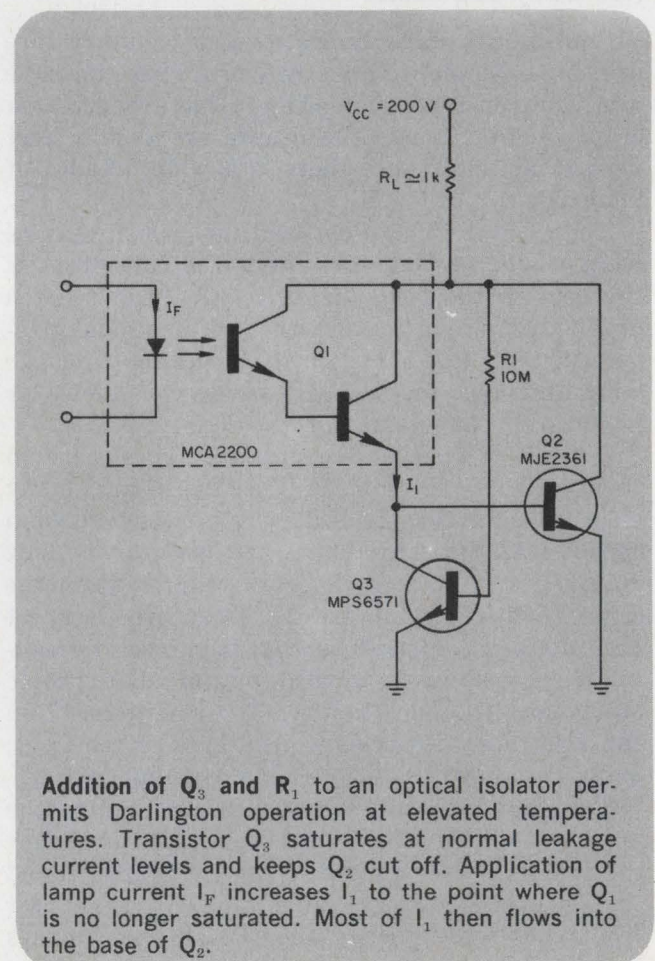

POWER FOR YOUR IC'S OR OP AMPS

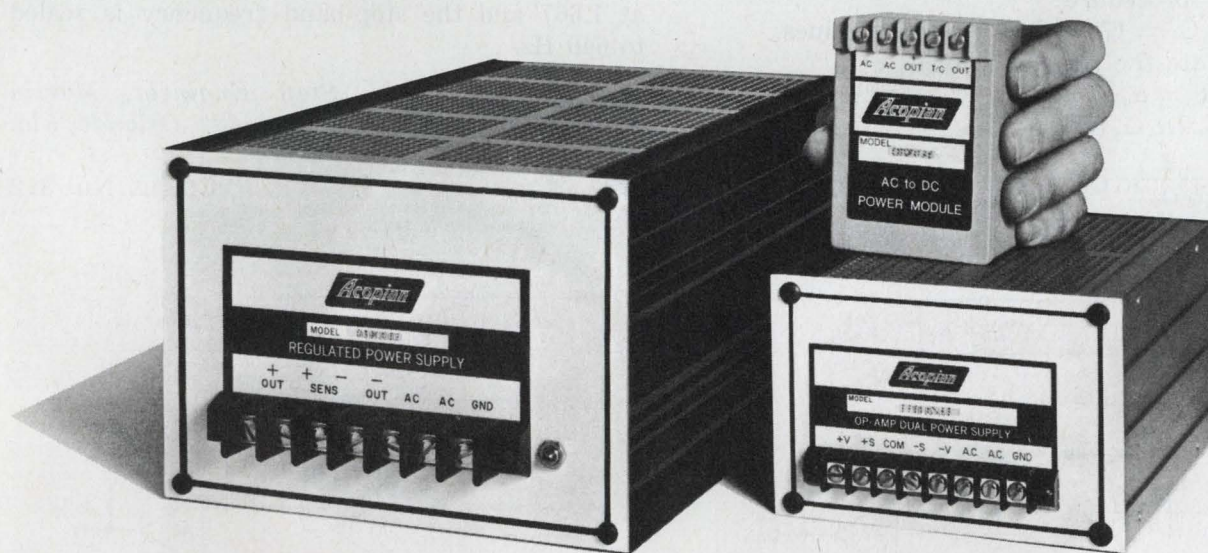

5 VOLTS

OUTPUT CURRENT AMPS	SIZE INCHES	PRICE	MODEL
.5	3.5 x 2.5 x 1.4	\$55	5EB50
1.0	3.5 x 2.5 x 1.6	75	5EB100
2.0	3.5 x 2.5 x 2.4	115	5EB200
2.5	3.5 x 2.5 x 2.4	130	5EB250
5.1	3.4 x 5.1 x 6.6	150	A5MT510
9.0	3.4 x 5.1 x 9.3	180	A5MT900
12.0	3.4 x 5.1 x 13.3	200	A5MT1200
22.0	5.1 x 7.4 x 11.3	270	A5HT2200
32.0	5.1 x 7.4 x 16.0	320	A5HT3200

±15 VOLTS

OUTPUT CURRENT AMPS	SIZE INCHES	PRICE	MODEL
.1	3.5 x 2.5 x 1.4	\$55	DB15-10
.15	3.5 x 2.5 x 1.4	65	DB15-15
.2	3.5 x 2.5 x 1.4	75	DB15-20
.4	3.4 x 5.1 x 5.1	85	TD15-40
1.0	3.4 x 5.1 x 5.1	125	TD15-100
1.6	3.4 x 5.1 x 6.6	150	TD15-160
2.5	3.4 x 5.1 x 9.3	160	TD15-250
4.5	3.4 x 5.1 x 13.3	225	TD15-450
8.5	5.1 x 7.4 x 11.3	299	TD15-850

Line/Load Regulation: $\pm 1\%$ or better; Ripple: 1.5 mv or less; Input: 105-125 VAC

Three day shipment guaranteed. Complete details on these plus a comprehensive line of other power supplies and systems are included in the Acopian 73-74 catalog. Request a copy.



Corp., Easton, Pa. 18042. Telephone: (215) 258-5441.

INFORMATION RETRIEVAL NUMBER 39

Multiple-feedback bandpass circuit allows use of standard capacitors in elliptic filter

A low-pass elliptic function can be generated from the sum of a low-pass transfer function and a synchronously tuned bandpass function. The resulting circuit contains two op amps and permits the use of standard capacitance values (Fig. 1).

The voltage at the error node, v_e , of a multiple-feedback bandpass configuration provides a non-inverted low-pass transfer function. The output, V_B , of op amp A_1 provides an inverted bandpass function. Op amp A_2 sums the two voltages to give, for properly chosen component values, the second-order elliptic transfer function:

$$\frac{V_{OUT}}{V_{IN}} = -H \frac{s^2 + \omega_n^2}{s^2 + \alpha_d \omega_d s + \omega_d^2} \quad (1)$$

For given values of H , α_d , ω_n and ω_d , follow this design procedure:

1. Select $C_1 = C_2 = C$ as standard values.

2. Calculate the resistor values

$$R_1 = R_2 = \alpha_d / (\omega_d C),$$

$$R_3 = 2 / (\alpha_d \omega_d C),$$

$$R_4 = \frac{2}{\alpha_d \omega_d C} [(\omega_d^2 / \omega_n^2) - 1],$$

$$R_5 = \frac{\alpha_d}{\omega_d C} [(\omega_d^2 / \omega_n^2) - 1],$$

$$R_6 = H \cdot R_5.$$

A catalog of low-pass prototypes ("Filter Design Tables and Graphs," by E. Christian and E. Eisenman, published by John Wiley, New York, 1966) lists elliptic filters by stop-band attenuation, peak-to-peak ripple and order of equation. The elliptic prototype

$$G(p) = \frac{p^2 + 2.270^2}{(p^2 + 0.6226p + 1.138^2)(p + 0.8312)}$$

provides an f_s of 2.0, A_s of 28.6 dB and 0.3-dB ripple.

Frequency and impedance scaling provide the final design (Fig. 2). In this instance, H is set at 1.667 and the stop-band frequency is scaled to 640 Hz.

Robert J. Martin, Staff Engineer, Martin Marietta Aerospace, P.O. Box 5837, Orlando, Fla. 32805.

CIRCLE NO. 312

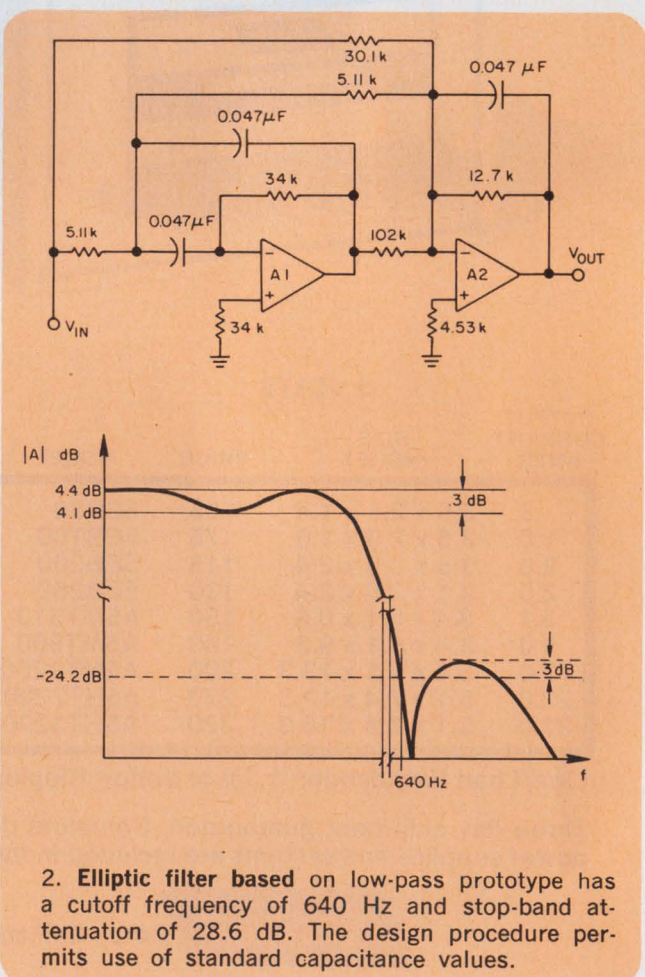
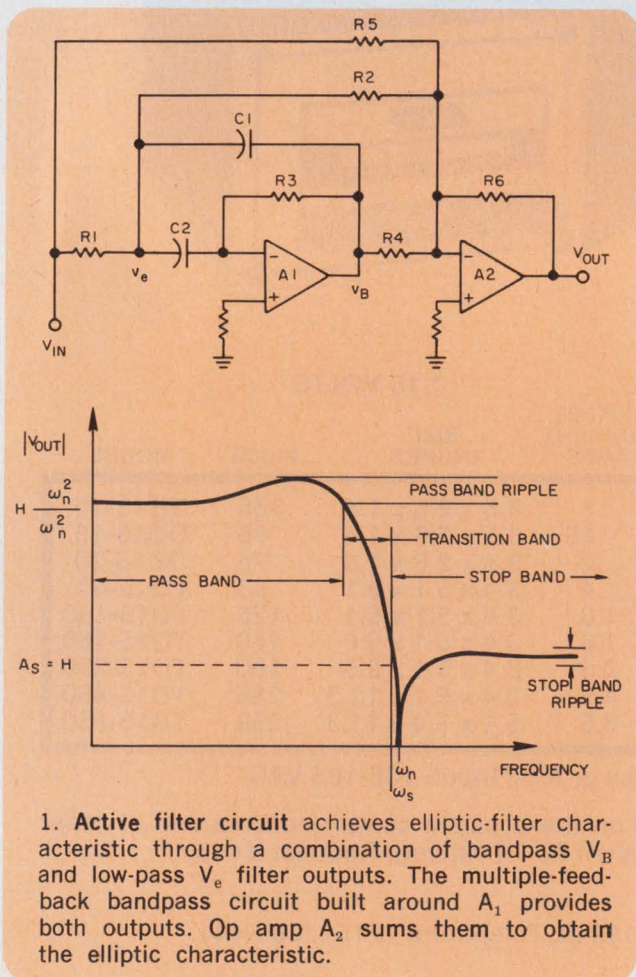

Proven Ideal for Instrumentation Manufacturers!

High Frequency Counters from PLESSEY.

Most leading manufacturers of 512 MHz counters have one great thing in common: Plessey high-speed divider circuits in the front end of their instruments. The reason for their unanimous choice? Plessey makes the best possible device for their application. Yours, too.

In fact, Plessey Semiconductors offers a comprehensive line of high-frequency dividers up to 1 GHz... all state-of-the-art... all ideal for virtually every counter application.

Divide by 2, 4, 5 or 10

You can specify Plessey counter IC's to divide by 2, 4, 5 or 10. With some decade devices, you get BCD outputs, too. And you get guaranteed frequency of operation over the entire temperature range of 0°C to +70°C on commercial grades, -55°C to +125°C on MIL Grades.

Higher Frequency, Lower Power Consumption

You've probably heard this statement from Plessey before. As usual, nobody even comes close to our input frequencies of up to 1,000 MHz. With an incredibly low power drain, as you can see from the tables.

Plessey offers Custom Counters, too

Send for our data sheet with all the facts. Whatever your counter application, we bet you'll find Plessey has the best approach. And, in the rare case where we don't have a standard counter for your exact requirements, let us quote on a custom. For more information, write or call today. **You'll find it pays to specify Plessey.**

YOUR CHOICE OF HIGH FREQUENCY COUNTERS

Type*	Modulus	Speed (MHz)**	Power Drain (mA typ)
SP600A & B	÷ 4	250	16
SP601A & B	÷ 4	150	16
SP602A & B	÷ 2	500	12
SP603A & B	÷ 2	400	12
SP604A & B	÷ 2	300	12
SP607B	÷ 2	600	12
SP613B	÷ 4	700	60
SP614B	÷ 4	800	60
SP615B	÷ 4	900	60
SP616B	÷ 4	1,000	60
SP620B	÷ 5	400	55
SP621B	÷ 5	300	55
SP622B	÷ 5	200	55
SP630B	÷ 10	600	70
SP631B	÷ 10	500	70
SP632B	÷ 10	400	70
SP634B	÷ 10 w/BCD outputs	700	80
SP635B		600	80
SP636B		500	80
SP637B		400	80

* Guaranteed operating temperature for "A" types—55°C to +125°C, "B" types 0°C to +70°C.

** Guaranteed input frequency range (sine wave).

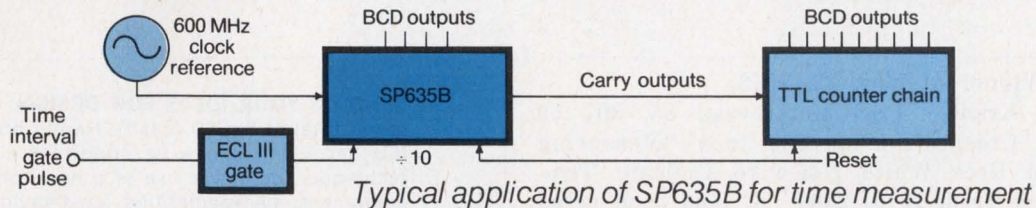
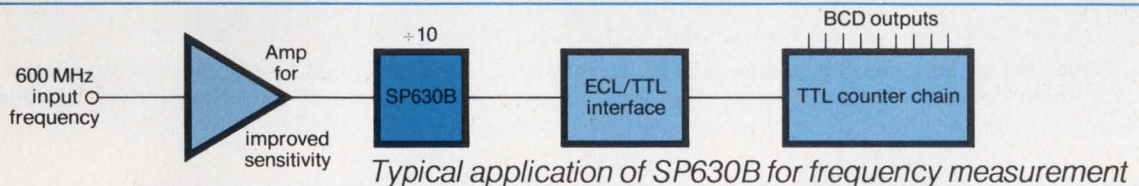

PLESSEY SEMICONDUCTORS

1674 McGaw Avenue, Santa Ana, California 92705, (714) 540-9945

INFORMATION RETRIEVAL NUMBER 40

One-shot adds the clock pulses to help recover phase-encoded data

A circuit, built around a single retriggerable one-shot, inserts missing pulses for clock recovery of phase-encoded data. The inserted pulses define the missing bit boundaries in the incoming NRZ pattern (see illustration).

Each edge pulse, derived from the transition points of the NRZ waveform, first clears and then triggers one-shot MM₁, whose period is set to 75% of the bit period.

Also, the edge pulse appears at the output of the NAND gate as a "total clock" pulse. If the

next pulse does not arrive in time to set MM₁, an additional pulse is generated by the network of C, R₂ and R₃, when Q goes low.

Choose values of C₂, R₂ and R₃ to provide an output pulse whose period approximates that of an edge pulse. The circuit shown handles variations in time position of the incoming pulse train of up to ±25% of the bit period.

Ronald Millar, Senior Engineer, Tri-Data Corp., 800 Maude Ave., Mountain View, Calif. 94043.

CIRCLE NO. 313

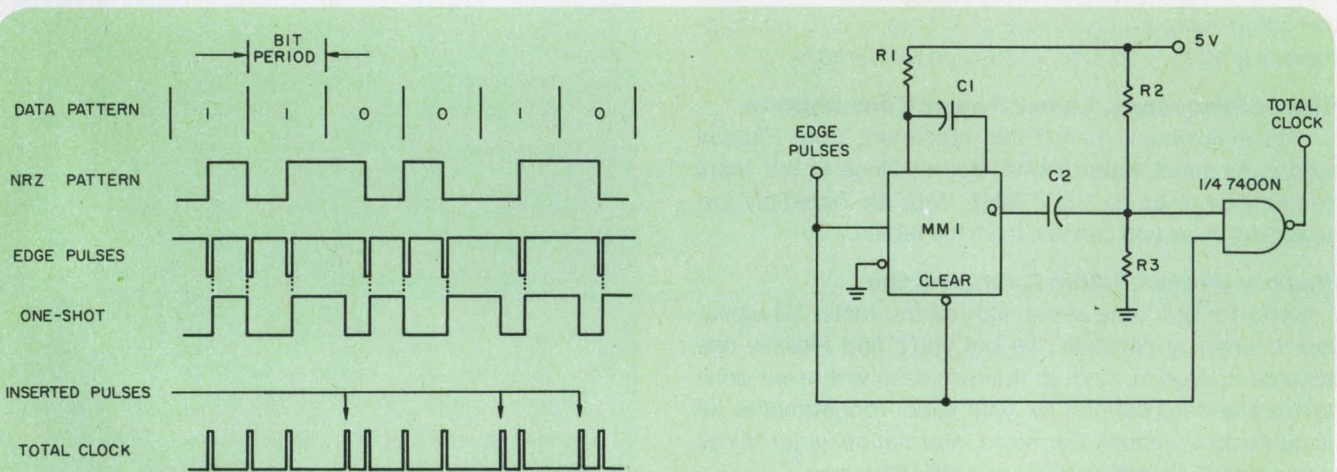

NOTE: MM1 = 74122N OR 1/2 74123N

One-shot inserts missing pulses in NRZ waveform to help define the bit boundaries. The edge pulses

are generated by external circuitry from the transition points of the original NRZ waveform.

IFD Winner of Nov. 22, 1973

Kamil Kraus, SPSE Koterovska 85, 307 00 Plzen, Czechoslovakia. His idea "Measuring System Uses White Noise to Indicate Temperature from 10 to 2500° K" has been voted the most valuable of Issue Award.

Vote for the Best Idea in this issue by circling the number for your selection on the Information Retrieval Card at the back of this issue.

SEND US YOUR IDEAS FOR DESIGN. You may win a grand total of \$1050 (cash)! Here's how. Submit your IFD describing a new or important circuit or design technique, the clever use of a new component or test equipment, packaging tips, cost-saving ideas to our Ideas for Design editor. Ideas can only be considered for publication if they are submitted exclusively to ELECTRONIC DESIGN. You will receive \$20 for each published idea, \$30 more if it is voted best of issue by our readers. The best-of-issue winners become eligible for the Idea of the Year award of \$1000.

TRAK RAPID RESPONSE LINE

(813) 884-1411

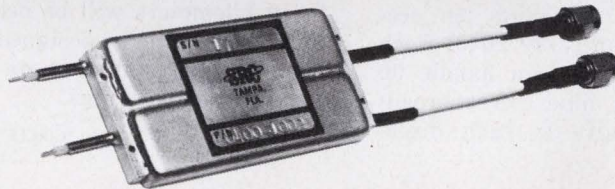

GAIN AND PHASE MATCHED IF AMPLIFIER MODEL 8400-1003

Frequency: 60 MHz
3 db Bandwidth: 10 MHz
Selectivity: 20 db/octave
Band Pass Ripple: ± 0.5 db nominal
Small Signal Gain: 60 db minimum
Small Signal Dynamic Range: 40 db min: at any AGC setting
AGC Range: 50db min.
Noise Figure: 3 db max.
Gain Tracking: ± 2 db
Phase Tracking: $\pm 8^\circ$
Video Gain Tracking: ± 1 db (Note: IF tracking

error can be cumulative with video gain error)
Video Output Level: 5 volts max. across 2K ohm resistive load
IF Output Level: $+6$ dbm min. at 1 db compression point
Input Impedance: 50 ohms nominal
Input VSWR: 1.5: 1 max.
Supply: $+12$ VDC at 50 ma max/amplifier
Size: 2.27 x 1.28 x .04 inches
IF Input and Output: 3" RG 188 (connectors optional)
Supply, AGC, and Video Output Connections: Solder terminals

Dual channel miniature IF amplifier was designed for applications requiring gain and phase matched amplifier pairs operating over a large input dynamic range. These AGC'd low noise amplifiers have both IF and detected video outputs. Each amplifier is mounted in its own shield enclosure and the matched pair is mounted on a common baseplate.

SCIENTIFIC RESEARCH CORPORATION. A SUBSIDIARY OF TRAK MICROWAVE CORPORATION,
4726 EISENHOWER BOULEVARD, TAMPA, FLORIDA 33614, TELEX: 52-827

CALL TODAY FOR ADDITIONAL SPECIFICATIONS, PRICES, DELIVERY, QUOTATIONS, LITERATURE, APPLICATION ASSISTANCE, INFORMATION ON CIRCULATORS, ISOLATORS, SOLID STATE SOURCES, HYBRID THIN FILM OSCILLATORS AND IF AMPLIFIERS, CUSTOM SUBSYSTEMS AND SYSTEMS

6-GHz radio-relay system undergoing field tests

A 6-GHz, digital radio-relay system is receiving final field evaluation in Britain. Developed by GEC Telecommunications Ltd. for the British Post Office, the radio-relay system operates between 5.850 and 5.925 GHz. This band is directly below the 500-MHz band used for 6-GHz analog microwave systems.

The digital band accommodates six two-way circuits. Four have a capacity of 6336 kilobits per second and two can carry 2048. Each 6336-kilobit circuit can handle 90 speech circuits, nine stereo broadcast-channel pairs in each direc-

tion, a viewphone signal or any number of data signals up to the channel bit rate.

A 20-GHz digital microwave radio system is also being developed by GEC. It is intended to operate between 17.7 and 19.7 GHz and to be modulated by 132-mega-bit-per-second digit streams that use four-phase phase-shift keying. Because of atmospheric effects at these frequencies, short hops of 5 to 10 kilometers will be necessary. The equipment is designed to be mounted, with antennas, on 75-foot poles or on buildings.

CIRCLE NO. 317

Nitrogen laser enhances kilovolt measurement

When a spark gap used for high-voltage measurements is irradiated with the beam from a pulsed nitrogen UV laser, fivefold improvement in measurement accuracy results, according to researchers at the Hochspannungsinstitut der Universitaet Karlsruhe in West Germany.

The university's Dr. Adolf Schwab says that voltages of greater than 100 kV are generally measured with spark gaps. When short pulses are measured, the

lack of free carriers in the gap can prevent the spark from firing, even though the peak voltage exceeds that for the gap width. For this reason, ionization within the gap is generally aided by irradiation with radio-active sources—by X-rays or by the radiation from mercury vapor lamps. These conventional methods of gap irradiation yield at best a mean deviation of 1.4%, while that for the nitrogen laser is substantially lower—about 0.24%.

New dielectrics sought for microwave uses

A range of zirconate-ceramic microwave dielectrics is under development at the Hirst Research

Centre of the General Electric Co., Ltd., in Britain.

The ceramics are solid solutions

composed of a zirconate that has a positive temperature coefficient of permittivity plus other zirconates and titanates that have negative temperature coefficients. The composition is adjusted to give the minimum coefficient and low losses. The use of solid solutions rather than mixtures ensures that the materials are homogeneous.

These materials can be used as microwave-IC substrates up to 5 GHz, as dielectric-disc resonators for miniature multistage filters and as dielectric loading in microwave ferrite phase shifters.

The zirconate ceramics are of high temperature stability, have a relative permittivity of about 35 and low dielectric loss at microwave frequencies.

CIRCLE NO. 318

Laser device measures velocity accurately

The air-flow patterns in a jet engine or the velocity of a berthing supertanker can be measured by an instrument developed by Cambridge Consultants in Cambridge, England.

The instrument measures modulation frequencies of light scattered by small particles as they move through an interference pattern generated at the intersection of two laser beams. The light scattered by the particles is picked up by a photodetector that produces electrical signals in the form of gaussian-modulated doppler bursts. These bursts contain about 30 consecutive cycles of signals whose frequency is measured to give the velocity. Successive bursts may be randomly related in amplitude, frequency, time of arrival and phase.

Velocities on solids, liquids and gases from less than 1 mm/sec to more than 100 m/sec can be made. The instrument can be used on hot metals and glass, on surfaces emitting harmful radiation and on other inaccessible or dangerous areas. The instrument can also make precise measurement of length under these adverse conditions. Consequently it may have applications in process control.

CIRCLE NO. 319

Electronic Design, The Financial Times (London)
 Electronics Weekly (London) and BOAC
 announce the sponsoring of

"TOMORROW IN WORLD ELECTRONICS"

a major international conference to coincide
 with the International Instruments, Elec-
 tronics and Automation Exhibition (IEA).

GROSVENOR HOUSE, LONDON – MAY 14-15, 1974

This conference, to be addressed by a panel of the electronics commu-
 nity's most distinguished members, will consider current and future
 technological developments in the world, and assess the challenges they
 pose for management, marketing and financial functions in the interna-
 tional electronics industry.

Day One - May 14

Chairman: Dr. C. Lester Hogan
 President, Fairchild Camera and
 Instrument Corporation

Mr. Earl Wantland
 President, Tektronix, Inc.

Mr. Edward Fennessy, CBE
 Managing Director
 Post Office Telecommunications

Mr. Sebastian de Ferranti
 Chairman and Managing Director
 Ferranti Ltd.

Speaker to be announced

Dr. Ieuan Maddock, CB, OBE
 Chief Scientist
 Department of Trade and Industry

Mr. David Price, MP
 Chairman, The Parliamentary
 Committee for Technology

Speaker to be announced from
 Commission of the
 European Communities

Mr. Gordon Haley
 Manager, Systems Technology
 ICL Computer Development Div.

**Prospects for
 Semiconductors**

**Prospects for
 Electronic Instruments**

**Prospects for
 Telecommunications**

**Electronics
 in the 1980's**

**The International
 Military Market for
 the Electronics Industry**

**The Commercial
 Exploitation of
 Electronics Research**

**Government Policies
 for Electronics
 (Luncheon Speaker)**

**The Growth Potential
 of Electronics in the
 European Community**

**Future Computer
 Technology**

Day Two - May 15

Chairman: M. R. J. Clayton, CBE
 Technical Director
 The General Electric Company Ltd.

Dr. J. Fred Bucy, Jr.
 Executive Vice President
 Texas Instruments Inc.

Mr. J. C. Akerman
 Managing Director
 Mullard Limited

Dr. Robert Heikes
 Managing Director
 Motorola Europe, Switzerland

Speaker to be announced

Mr. John Fluke, Sr.
 Chairman
 John Fluke Manufacturing Co., Inc.

Dr. Edward David
 Executive Vice President
 Gould, Inc.
 Former Science Adviser to the
 President of the United States

Dr. William Hittinger
 Executive Vice President
 RCA Corporation

Monsieur Edouard Guigonis
 Directeur Delege and Directeur
 Commercial General, Thomson CSF

**Vertical Integration:
 Components to Systems**

**Performance and
 Prospects in the World's
 Electronics Industries**

**The Role of an
 American Multi
 National in Europe**

**Japanese Electronics
 in World Markets**

**New Challenges to the
 Instrument Industry
 (Luncheon Speaker)**

Electronics and Energy

**The Future of World
 Consumer Electronics**

**International
 Cooperation
 in Electronics**

To register for the conference use the coupon below. We will be pleased to assist
 you in securing trans-atlantic flight reservations and London hotel accommodations.
 Registration fee for "Tomorrow in World Electronics" is \$200.

REGISTRATION FORM

"TOMORROW IN WORLD ELECTRONICS"

A major international conference sponsored by Electronic Design, The Financial Times, Electronics Weekly and BOAC.
 Please register the following individual:

Name _____ Title _____

Additional registrations:

Name _____ Title _____

Name _____ Title _____

Company _____ Division _____

Address _____ Telephone _____

City _____ State _____ Zip _____

Mail this registration form to:

Ms. Gay Donnelland
 Electronic Design/Financial
 Times Conference
 Financial Times
 Publications, Ltd.
 Suite 1006
 516 Fifth Avenue
 New York, N.Y. 10036
 (212) 869-3971

Registration fee: \$200 per person.

Make check payable to: Financial Times Ltd.

Payment enclosed. Please bill me. I would like assistance in flight hotel reservations.

FEEL FREE TO USE OUR NAME...

(when specifying sweepers).

Wavetek has a sweeper for just about every use imaginable —with frequency coverage from 0.5 to 1400 MHz. All are all-solid-state with excellent linearity characteristics. Crystal-controlled markers and pin-diode leveling are standard. So is the remote programming capability. And to complement our line of sweepers, we've introduced a new X-Y display scope that sells for just \$475. It has a 12" diagonal CRT and four ranges of sensitivity to 1 mV/division. Attenuators and detectors to complete your test set-up are also available. To get more information, be sure to use our complete name: Wavetek Indiana, Inc., P.O. Box 190, Beech Grove, Indiana 46107. Tel: (317) 783-3221 TWX 810-341-3226

SWEEPER MODELS		
1001A	0.5 MHz to 300 MHz	\$ 995
1002	1 MHz to 500 MHz	1095
1004	500 MHz to 1 GHz	995
1005	700 MHz to 1.4 GHz	995
1801A	1 MHz to 950 MHz	1445
2000	1 MHz to 1.4 GHz	1375
2001	1 MHz to 1.4 GHz	1695
SCOPE MODEL		
1901A	12" X-Y Display	\$475
ATTENUATOR MODELS		
5001	0-1 dB in 0.1 dB steps	\$80
5010	0-10 dB in 1 dB steps	80
5070	0-70 dB in 10 dB steps	80
5080	0-80 dB in 1 dB steps	185

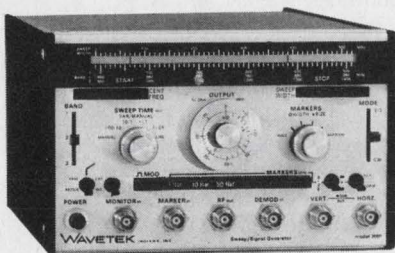

WAVETEK®
INDIANA INCORPORATED

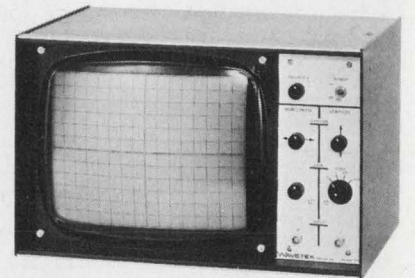

INFORMATION RETRIEVAL NUMBER 43

new products

Solid-state sweeper delivers BWO power

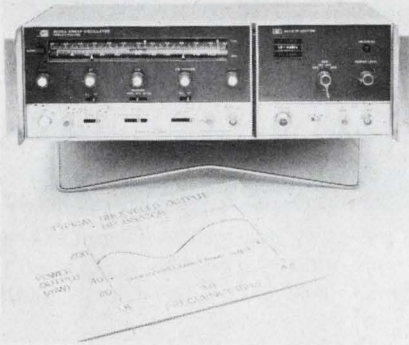

Hewlett-Packard, 1501 Page Mill Rd., Palo Alto, Calif. 94304. (415) 493-1501. 86330B: \$2050; 86331B: \$2300; 6 wk.

Power modules for the 8620-series microwave-sweep oscillators are reportedly the first solid-state units able to deliver power levels typical of BWOs at frequencies above 2 GHz. Equipped with a Model 86330B module, an HP solid-state sweeper puts out a guaranteed minimum of 40 mW leveled, from 1.8 to 4.2 GHz. A second new power module—the Model 86331B—extends that range 100 MHz on either end (from 1.7 to 4.3 GHz) with some power reduction at band edges.

CIRCLE NO. 250

4.2-5.2-GHz amplifier has 8-dB noise figure

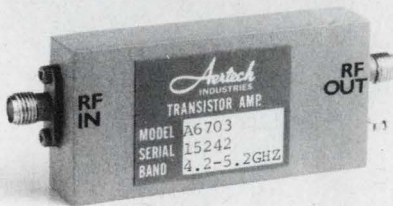

Aertech Industries, 825 Stewart Dr., Sunnyvale, Calif. 94086. (408) 732-0880.

The Model A6703 transistor amplifier features a maximum noise figure of 8 dB and a frequency range of 4.2 to 5.2 GHz. The amplifier has a minimum gain of 25 dB and a gain variation of ± 1 -dB. The unit's 1-dB compression output is +5 dBm and its typical intercept point is +15 dBm.

CIRCLE NO. 251

S-band amp has 0.8-GHz bandwidth

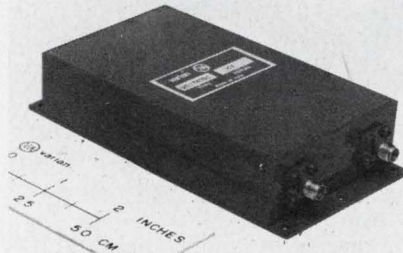

Varian, 611 Hansen Way, Palo Alto, Calif. 94303. (415) 493-4000.

An S-band solid-state amplifier, called the VSS-7455C, lists over 400-mW output and a frequency range of 2.8 to 3.6 GHz. The unit measures $1.0 \times 2.5 \times 4.25$ inches and weighs 10 oz. The unit meets the general requirements of MIL-E-5400 and MIL-E-17400.

CIRCLE NO. 252

Portable laser system has 1-mile range

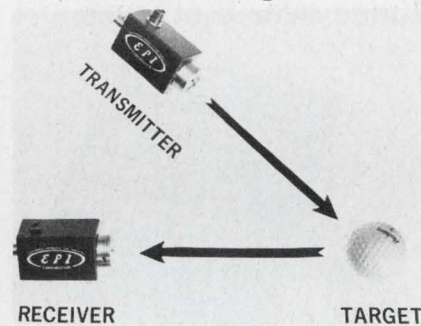

Electronic Products for Industry, 1241 Birchwood Dr., Sunnyvale, Calif. 94086. (408) 734-8235. \$300 up.

A line of solid-state injection lasers and receivers can be operated with small, rechargeable batteries at ranges exceeding 1 mile even under haze and dust conditions. Short, high energy light pulses of 6 W peak power and pulse width of 15×10^{-9} seconds separate the signal from the background. Laser repetition rate is controllable to 20,000 pulses/second for pulse-position modulation communications. Rise time is 600×10^{-12} seconds. The light is in the infrared region at $0.9\text{-}\mu$ wavelength.

CIRCLE NO. 253

Isolators measure only 3.5 in.

Com Dev, Ltd., 6 Ronald Dr., Montreal 263, Quebec, Canada.

Wideband isolator, Model WI-42123, is designed specifically for common-carrier requirements and offers greater than 23 dB isolation over 3.54 to 4.2 GHz. Other specifications include -26 dB input and output match and less than 0.1 dB insertion loss. The device measures 3.5 in. flange to flange.

CIRCLE NO. 254

Interferometer has $\pm 4\text{-}\mu\text{m}/\mu\text{s}$ precision

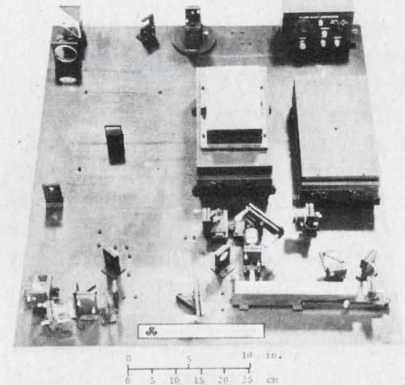

Systems, Science and Software, P.O. Box 1620, La Jolla, Calif. 92037. (714) 453-0060. 3SLVI-401 (without laser): \$18,900; 90 days.

A laser velocity interferometer, called VISAR, can be used to measure velocity and displacement of diffusely reflecting surfaces, such as impact-stressed composite and porous materials. The unit has a precision of $\pm 0.004\text{ mm}/\mu\text{s}$. It can measure velocities during accelerations greater than 10^9 g without loss of accuracy. The VISAR consists of two velocity interferometers having different sensitivities.

CIRCLE NO. 255

I-f preamp lists 1.8-dB noise figure

Trak Microwave, 4726 Eisenhower Blvd., Tampa, Fla. 33614. (813) 884-1411. \$185; 45 days.

Fabricated with thin-film hybrid technology, the Model 8313-1000 preamplifier operates at 60 MHz with a 3-dB bandwidth of 20 MHz. Noise figure is 1.8 dB nominal and 2-dB guaranteed maximum. The unit has a gain of 15 dB minimum and operates from -54 to +71 C.

CIRCLE NO. 256

Transistor oscillators tune over full X band

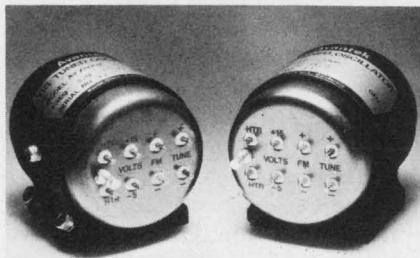

Avantek, Inc., 3175 Bowers Ave., Santa Clara, Calif. 95051. (408) 249-0700. AV-7800M: \$1160; AV-7700M: \$1215; AV-7600M: \$1195 (100); 45-60 days.

A series of YIG-tuned oscillators span the frequency range of 6 to 12.4 GHz. The AV-7700M provides a minimum power output of 10 mW from 7 to 11 GHz. The Model AV-7800M offers 5 mW over the 8-to-12.4-GHz band, and the Model AV-7600M covers the entire 6-to-12.4-GHz range also with a 5-mW output. Tuning linearity is $\pm 0.05\%$. Because transistors are used, dc circuit power dissipation is about 1/8 of that required by currently available bulk-effect devices. And power output variation over the operating frequency ranges is held to ± 2 dB for all three models. Oscillator Qs of greater than 4000 result in pulling figures of less than 0.3% into all phases of a 1.5:1 VSWR. Frequency drift is less than 25 MHz over the temperature range of 0 to 65 C.

CIRCLE NO. 257

TO-18-type package holds GaAs IR diode

RCA Electronic Components, 415 S. Fifth St., Harrison, N.J. 07029. (201) 485-3900. \$2.50; stock.

A gallium-arsenide infrared-emitting diode, the SG1009, emits a narrow beam of radiant flux (power output) at 940 nm. It comes in an hermetically sealed modified TO-18 package and has an operating case temperature range of -40 to $+125$ C. In continuous operation, the diode provides a typical power output of 3.5 mW at 100 mA. In pulse operation, typical power outputs are 26 mW at 1 A and 115 mW at 8 A, for a case temperature of 27 C.

CIRCLE NO. 258

Phase shifters cover octave bands to 18 GHz

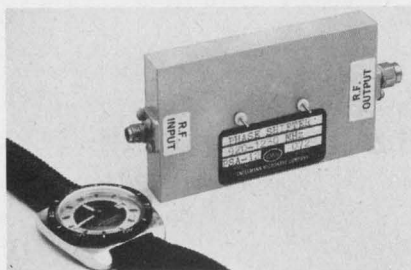

Englemann Microwave, Skyline Dr., Montville, N.J. 07045. (201) 334-5700. \$250 to \$300 per cell; 10 wk.

A series of analog phase shifters, Model SD, uses stripline modular multiple cell construction, with each cell providing continuous phase shift up to 50 degrees. Salient operating characteristics include a frequency range to 18 GHz in octave bands, phase shift to 360 degrees continuous and a VSWR of 1.25:1. The maximum insertion loss is 0.5 dB per cell and typical power handling is 1 W cw.

CIRCLE NO. 259

YIG-tuned multiplier tunes over 6 octaves

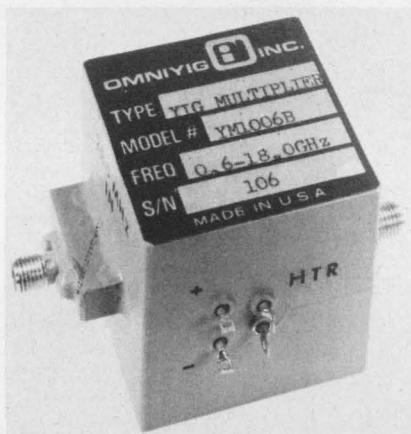

Omnigig Inc., 2325 De La Cruz Blvd., Santa Clara, Calif. 95050. (408) 241-1226. \$995 to \$1250 (small qty.); 45 days.

The YM 1006B YIG-tuned harmonic multiplier can be tuned electronically over six octaves. The multiplier output frequency ranges from 0.6 MHz to 18 GHz. It accepts an input frequency of 200 MHz. Other features include input rf power of 0.5 to 1 W, adjacent harmonic rejection greater than 60 dB and minimum output power at 18 GHz of 36 dBm.

CIRCLE NO. 260

Gunn oscillators rated at 175 mW

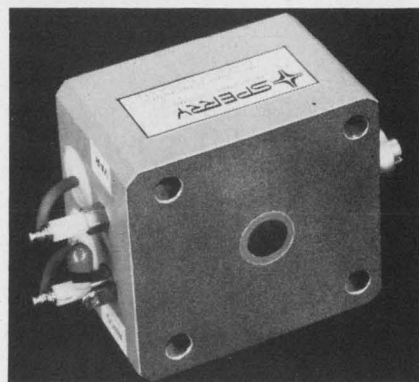

Sperry Microwave Components, Dept. 9000, Gainesville, Fla. 32601. (904) 372-0411. 45 days (small qty.).

The SSX-12012 Gunn-effect oscillator, representative of an 8-to-12-GHz series, operates at 9.65 GHz with a mechanical tuning range of ± 50 MHz. Varactor tuning is 25 MHz at minimum output power of 175 mW. Typical power is 200 mW. The SSX-12012 has a 100-Hz-bandwidth FM noise of less than 10 Hz, 2 kHz from carrier; and 100-Hz-bandwidth AM noise of less than -115 dB, 2 kHz from the carrier.

CIRCLE NO. 261

Gunn oscillators cover 12-18-GHz range

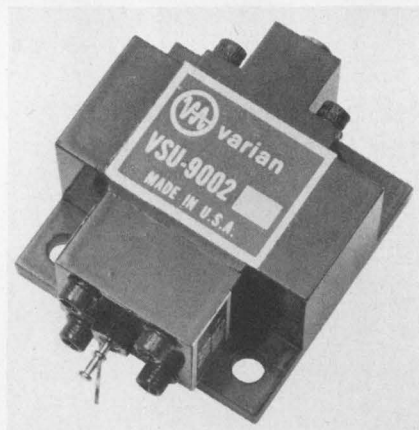

Varian, Solid State West, 611 Hansen Way, Palo Alto, Calif. 94303. (415) 493-4000.

The VSU-9002 series of Gunn-effect oscillators, primarily intended for parametric amplifiers, deliver cw output power ranging from 5 to 250 mW. Standard models are tunable ± 100 MHz from any specified frequency between 12.4 and 18.0 GHz.

CIRCLE NO. 262

Greater RFI/EMI shielding in new, narrow-width contact strips from Instrument Specialties

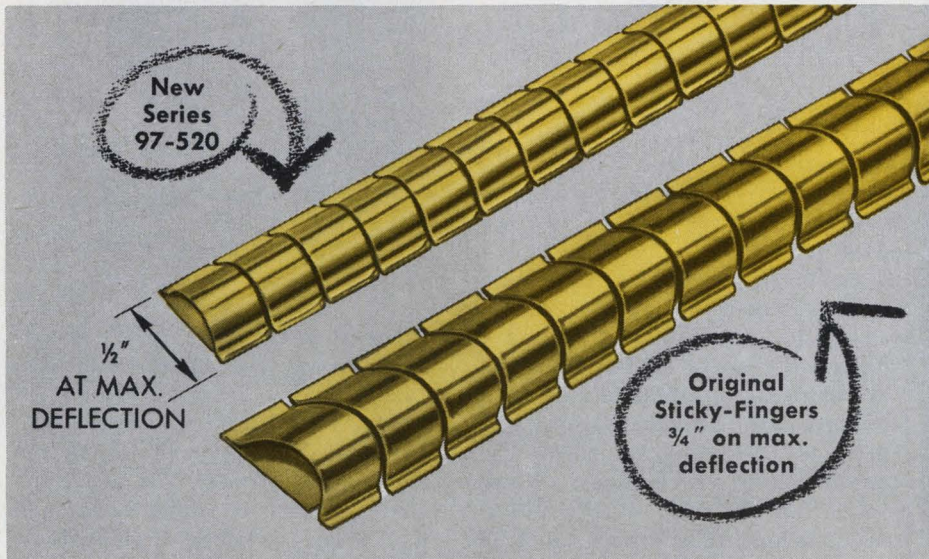

Latest addition to **stickn fingers**® line!

Instrument Specialties now offers Sticky-Fingers self-adhesive, beryllium copper contact strips in three variations to solve your most critical RFI/EMI problems.

Comparable to the shielding effectiveness of the original Sticky-Fingers, our newest series 97-520* offers shielding effectiveness of 92 dB at 10 GHz plane wave or greater than 92 dB at 1 MHz magnetic, and has a dynamic range of 0.10". Yet, it measures a scant 3/8" wide, and 1/2" at maximum deflection.

Supplied in standard 16" lengths, series 97-520 is ideal for metal cabinets and electronic enclosures where variations exist in the space to be shielded, and where high shielding effectiveness must be maintained in narrow spaces, even with frequent opening and closing of the cabinet.

Select the exact series that fits your application best. Write today for a complete catalog, list of finishes available, and our latest Independent Shielding Evaluation Report. Address: Dept. ED-68

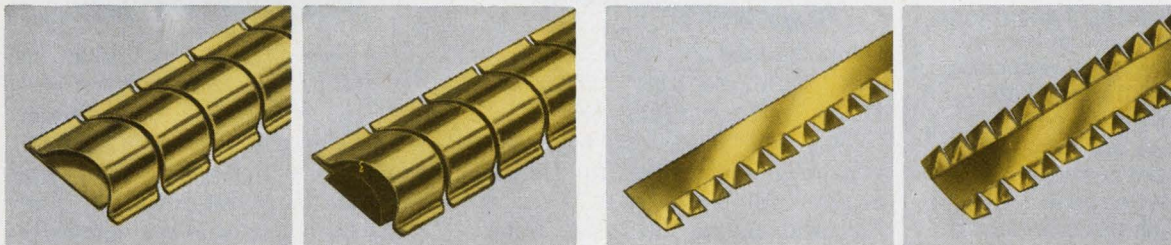

Series 97-500*—the original 3/4" wide Sticky-Fingers. Specify when you require greatest possible shielding and where space permits. Also, supplied as 97-510 with Magnifil® for optimum magnetic shielding.

For those all-purpose applications where economy and space are both factors, specify the 3/8" wide single-twist series 97-555, or 1/2" wide double-twist series 97-560 Sticky-Fingers.

Specialists in beryllium copper springs since 1938

*Patented

INSTRUMENT SPECIALTIES CO., INC.
Little Falls, New Jersey
Phone 201-256-3500



INFORMATION RETRIEVAL NUMBER 44

Grayhill quality in 1/4 amp lighted switches



- **Self-cleaning wiping contacts for logic circuits**

- Momentary and alternate actions—SPST, SPDT, and DPDT circuitry—operates in any position or attitude.

- Shown actual size—decorator-designed for compact panels—wide color choice—matching unlighted switches and indicator lights.

- Choice of mountings— front panel bezel, sub-panel or bushing.

Not all lighted push-button switches are created equal! Grayhill's low-level lighted switches are designed for applications where *switch* quality is what really counts. They out-perform butt contact or snap action switches... yet offer the style and appearance options you need, competitively priced. Write for complete technical data on these switches, and consult EEM for data on other Grayhill switches.



561 Hillgrove Avenue • LaGrange, Illinois 60525
(312) 354-1040

INFORMATION RETRIEVAL NUMBER 45

INSTRUMENTATION

Microwave synthesizers output to 12.4 GHz



Systron-Donner, One Systron Dr., Concord, Calif. 94518. (415) 682-6161. \$12,000 to \$18,000; 90-120 days.

Series 1600 is a new family of programmable microwave frequency synthesizers that feature octave bandwidth signal sources instead of external multipliers. Levelled outputs are provided from 500-MHz to 12.4-GHz. All models use phase-locking techniques. Noise specs for the 2 to 4 GHz Model 1603 include: phase noise of -85 dB at 1 kHz from carrier in a 1-Hz bandwidth; spurious of -60 dBm min; and harmonics of -20 dBm min. Series 1600 also feature frequency selection to 1 Hz and frequency stabilities as high as 3×10^{-9} per 24 hours.

CIRCLE NO. 263

4-1/2-digit DMM offers BCD output

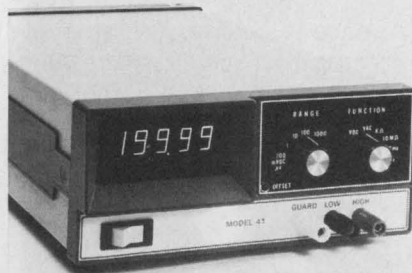

Data Technology, 2700 S. Fairview St., Santa Ana, Calif. 92704. (714) 546-7160. \$595; stock.

This 20,000 count, 4-1/2-digit instrument provides full multimeter capability plus BCD output for systems applications. Called the Model 41, the meter is a 24-range instrument. Included are four ac V ranges with $100\text{-}\mu\text{V}$ resolution, five dc V ranges with $10\text{-}\mu\text{V}$ resolution, five resistance ranges with $100\text{-m}\Omega$ resolution and five ac and dc current ranges with 10-nA resolution.

CIRCLE NO. 264

\$295 buys 5-inch 10-MHz scope

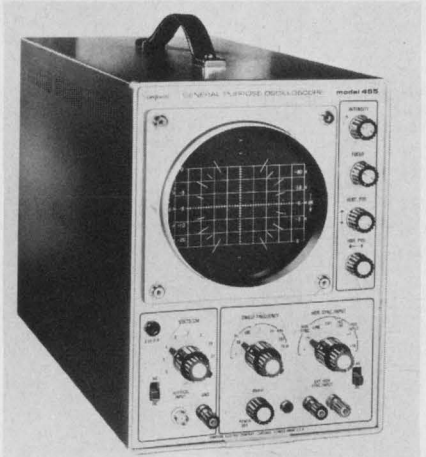

Simpson Electric, 5200 W. Kinzie St., Chicago, Ill. 60644. (312) 379-1121. \$295.

This new 5-in. scope, Model 455, has a 10-MHz bw and 10 mV/cm vertical sensitivity. The scope accepts camera or light hood, and has a low parallax, high-contrast graticule with both amplitude and vector display index. Sweep frequency is adjustable from 1 Hz to 200 kHz in five overlapping ranges. For TV work there is a special sweep rate for horizontal sync, and R-Y/B-Y inputs for vector alignment. Horizontal sensitivity is 300 mV/cm with bandwidth from dc to 500 kHz.

CIRCLE NO. 265

Build your own function generator

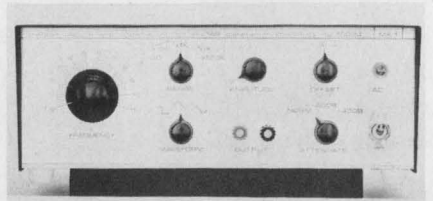

American Circuits and Systems, Inc., P.O. Box 149, Planetarium Station, New York, N.Y. 10024. \$195 (wired); \$135 (kit); stock.

Mk1 Function Generator comes complete or in kit form. The unit has sine, square and triangle waveforms from 10 Hz to 1 MHz, 20 V pk-pk output and continuously variable dc-level shift. All waveforms can be frequency modulated or swept across the frequency band by applying a modulation voltage to a rear jack. An auxiliary TTL output is also provided.

CIRCLE NO. 266

Light-beam oscillograph records 6 channels

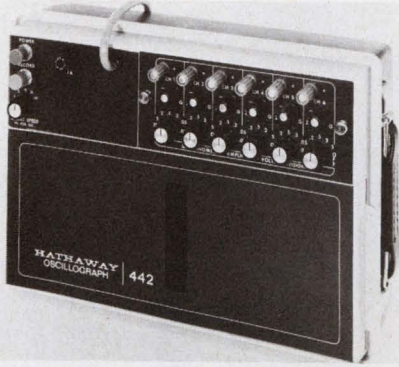

Hathaway Industries, 11616 E. 51st, Tulsa, Okla. 74101. (918) 663-0110. Starts at \$950 without galvanometer; 45-60 days.

Model 442 portable light-beam oscillograph will record up to six channels of data at frequencies from dc up to 2000 Hz. The Model 219 galvanometers in the unit are easily adjustable and the 3-5/8 in. Spec 1 Spooling paper drops into the unit with no threading required. A self-contained amplifier has a sensitivity of 0.02 to 5.0 V/div. in six fixed steps, with an off position and vernier control.

CIRCLE NO. 267

Logic probe also counts pulses

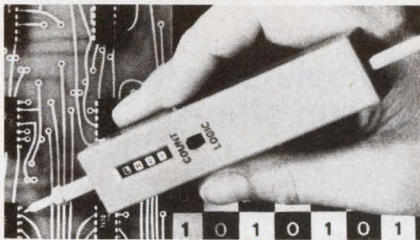

Zi-Tek Div., Aikenwood Co., 223 Forest Ave., Palo Alto, Calif. 94301. (415) 326-2151. \$66.60; stock.

The DP-6000 digital probe displays logic states and also functions as a pulse counter, with display. As a high/low discriminator, the probe indicates logic states and identifies faults in ICs. When switched to the counting mode, pulse-counting circuitry detects multiple clock and trigger pulses and indicates the presence of spurious oscillations. The three-bit counter is reset by a pushbutton. The probe may be operated from any 5-V power supply and is over-voltage protected.

CIRCLE NO. 268



syntronic

1..10..or 1,000

Precision yokes ... produced to your exact requirements ... to perform just like the prototype. We have the know-how, specialized experience and production flexibility to make one part, or a thousand. If you are designing or building a display, ask us to put our 25 years of experience to work for you.

SYNTRONIC INSTRUMENTS, INC.
100 Industrial Road, Addison IL 60101
Phone (312) 543-6444

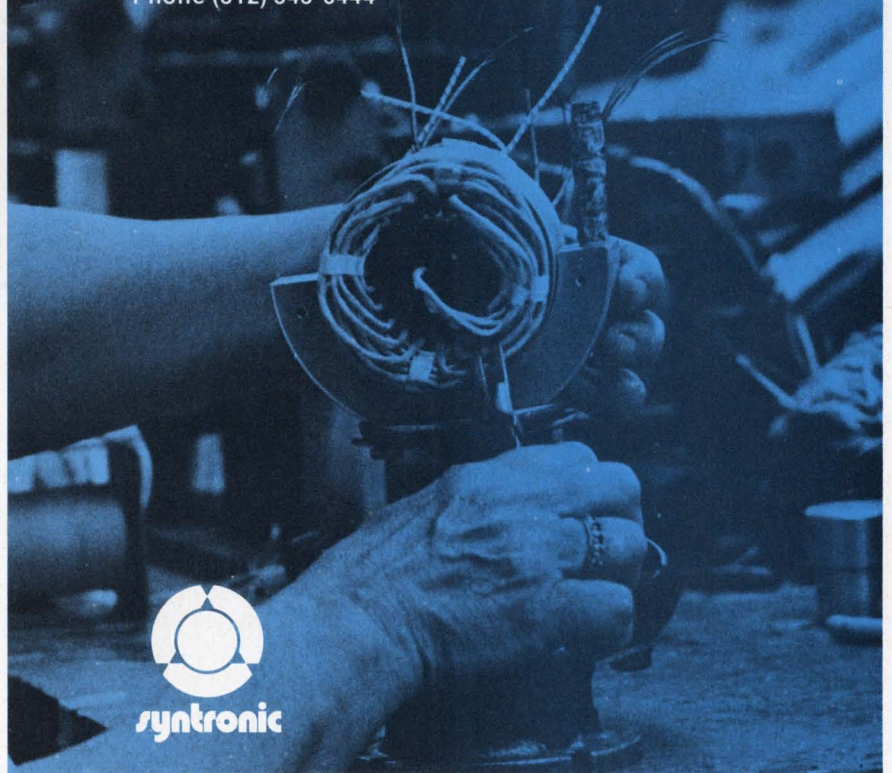

INFORMATION RETRIEVAL NUMBER 46

INSTRUMENTATION

Unit stretches scope trace to 128 times

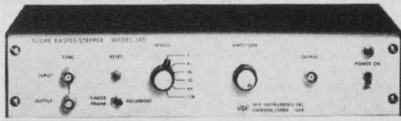

W-P Instruments, 2600 State St., Hamden, Conn. 06517. (203) 288-3132. \$425; 2 wk.

Model 140 Scope Raster/Stepper expands the capability of oscilloscopes to provide a more comprehensive display of data. Used with either camera mounted or memory type scopes, the unit allows for up to 128 separate traces in a single frame. Applications include raster, dot, contour and average-rate display. The output voltage is nominally 1 V max. in 4, 8, 16, 32, 64 or 128 steps and can be adjusted to any arbitrarily smaller value.

CIRCLE NO. 269

Tester checks terminals and teleprinters

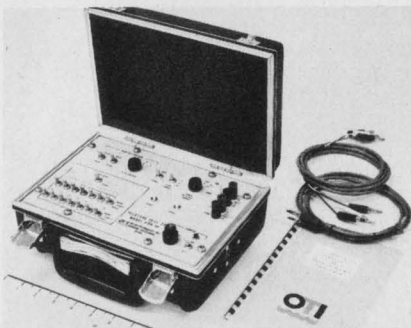

Ocean Technology, 2835 N. Naomi St., Burbank, Calif. 91504. (213) 849-7111. \$575 (quan.); 30-60 day.

Portable Pattern Generator Model URO-10 simulates telegraph data signals to test receive-only terminals operating on either five-unit International Telegraph Alphabet No. 2 (Baudot) or the eight-unit American Standard Code for Information Interchange (ASCII). The unit features selectable mark or space distortion in 5% increments from 0 to 20%. The operator may select one of four modulation rates, one of three stop lengths, and one of the two codes for any two characters. The characters are transmitted either continuously or one at a time.

CIRCLE NO. 270

Rf power amplifier delivers 2 W to 250 MHz



RF Power Labs, 11013 - 118th Pl. N.E., Kirkland, Wash. 98033. (206) 822-1251. \$390 (OEM); \$540 (instrument).

Model FK250-2MC is a broad-band rf power amplifier capable of linear amplification of any AM, FM, cw, SSB, or complex pulse or waveform. It can be driven from a standard signal or sweep generator to full output of 2 W into 50 Ω . The instrument is capable of driving any load impedance and is fully protected against mismatch and overdrive.

CIRCLE NO. 271

Tachometer-counter ignores noise



Newport Labs, 630 E. Young St., Santa Ana, Calif. 92705. (714) 540-4914. \$250; 2 wk.

Model 6110 Industrial Tachometer-Counter accurately counts rpm, frequency, time interval, spindle shaft speed and other industrial frequency and rotational parameters, even under conditions of high ambient noise. The unit features optically coupled and multishielded low level input circuitry, a field-adjustable internal delay circuit, which prevents errors caused by contact bounce from mechanical transducers, and internal normalization for direct display in engineering units. The 6110 also features buffered, isolated and gated BCD data outputs.

CIRCLE NO. 272

Transistor tester needs no set up



Sencore, 3200 Sencore Dr., Sioux Falls, S.D. 57107. (605) 339-0100. \$140.

TF26 Touch Tone Cricket is a pushbutton transistor and FET tester that requires no set-up book or knowledge of lead configuration. Test leads can be connected in any order. Pushbutton operation, coupled with an npn/pnp button, tests all possible combinations of basing for any transistor or FET. In fact, the type and basing of a transistor or FET can be directly obtained from the tester by referring to a basing chart in the instruction manual. An audible "chirp" indicates a good test.

CIRCLE NO. 273

Multiplexed a/d system offered

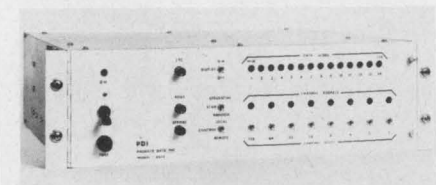

Phoenix Data, 3384 W. Osborn Rd., Phoenix, Ariz. 85017. (602) 278-8528. \$3925; 16 single-ended channels; 60-75 days.

Model 6814 is a new multiplexed a/d converter subsystem. The unit scans at the rate of 70 kHz with a resolution of 14 binary bits and a throughput accuracy of 0.01% of full-range input. The multiplexers are rear-loaded into a hinged backplane. Model 6814 will accept up to 256 single-ended channels or 128 differential inputs. The a/d converter has a total conversion time of 4 μ s.

CIRCLE NO. 274

Design refresher on Metal Glaze™ resistors

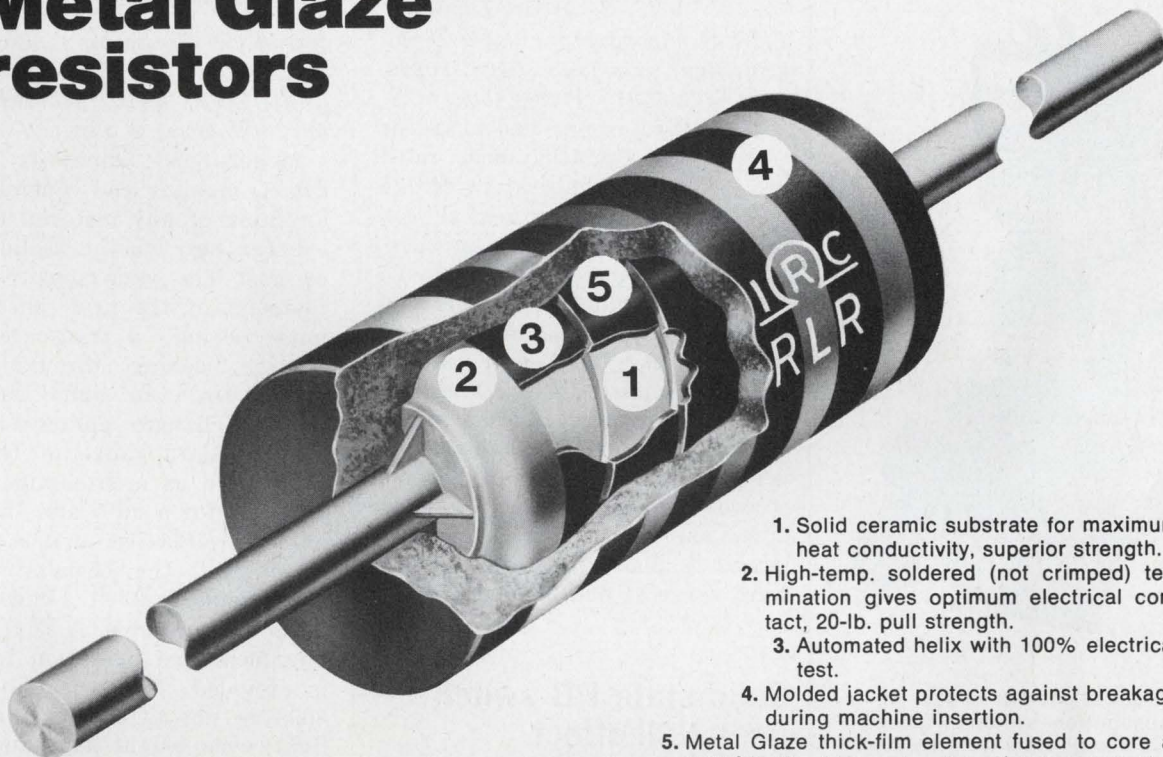

1. Solid ceramic substrate for maximum heat conductivity, superior strength.
2. High-temp. soldered (not crimped) termination gives optimum electrical contact, 20-lb. pull strength.
3. Automated helix with 100% electrical test.
4. Molded jacket protects against breakage during machine insertion.
5. Metal Glaze thick-film element fused to core at 1000°C. Provides a tough resistor system that withstands overloads, environmental extremes.

An all-purpose resistor? Not *quite*. But if you're designing any type of low-power circuitry, it usually pays to look at Metal Glaze.

Mechanically, these resistors are nut tough. Electrically, they offer excellent load life stability. And thermal characteristics are outstanding, giving you lower operating temperatures, greater reliability. In fact, you can often *double-rate* Metal Glaze resistors. So you can use smaller resistors, save board space.

The quality and cost effectiveness of Metal Glaze resistors have been proven *billions* of times over—in all types of electronic equipment, worldwide. Available in ratings ≤ 5 watts, $\geq 1\%$ tolerance, and ranges as low as 1 ohm.

Complete resistor choice. TRW offers you a total resistor capability—carbon comp., thin-film, Metal Glaze, wirewound, networks. For complete specs and application data on Metal Glaze, contact your local TRW sales representative (or TRW/IRC's Boone, N.C., plant—(704) 264-8861). Or write TRW/IRC Resistors, an Electronic Components Division of TRW, Inc., 401 N. Broad St., Philadelphia, Pa. 19108.

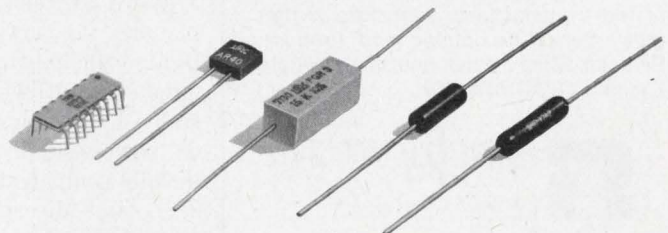

TRW® IRC RESISTORS

™Metal Glaze is TRW/IRC's trademark for its thick-film resistors.

INFORMATION RETRIEVAL NUMBER 48

Stacoswitch stacks up with the finest

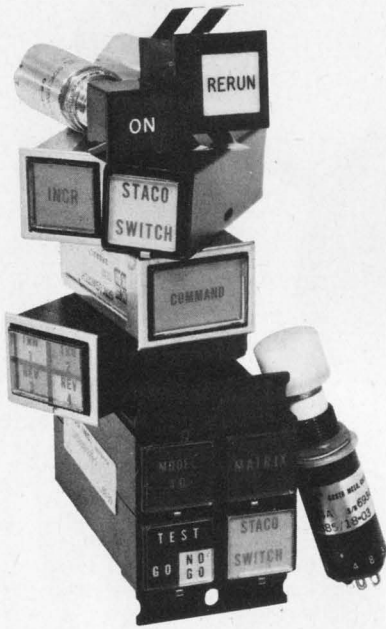

Here's a stack of answers to your illuminated pushbutton switch problems. Staco's full line of pushbutton switches and indicators provides a wide selection of circuitry, size, switch action, legend display style, and mounting method. Whatever your control panel design requirements...whether its an individually mounted switch or sixty in a matrix mount, low cost commercial/computer grade or rugged Mil Spec reliability...there's a Stacoswitch to correctly fit the need.

In addition to the finest in design and performance features, Stacoswitch gives you realistic delivery schedules. Many switches are available from factory stock in one week. Optional switch features are assembled to order from factory parts in four to six weeks.

Check out Staco's stack of fine illuminated switches and indicators. Write today for GC-5 Catalog and Product Selector Guide. When you think switch...think STACOSWITCH.



1139 BAKER STREET, COSTA MESA, CALIF. 92626
(714) 549-3041 TWX 910-595-1507

Other STACO Company products: Fixed Ratio Transformers, STACO, INCORPORATED, Richmond, Indiana; Variable Transformers, STACO, INCORPORATED, Dayton, Ohio.

DISCRETE SEMICONDUCTORS

Schottky diode operates at 125 C

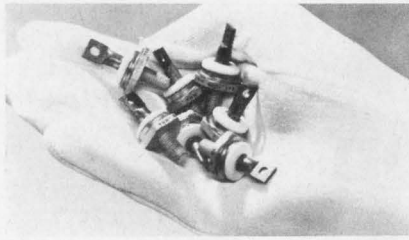

TRW Semiconductors, 14520 Aviation Blvd., Lawndale, Calif. 90260. (213) 679-4561. \$11.20 (100).

The SD-51 is reported to be the first power Schottky diode rated for a junction temperature of 125 C. At that temperature, it can handle 50 A average forward current with a forward voltage of 0.5 V. The new unit is said to extend the operating temperature range by more than 25% over conventional Schottky diodes. The new diode also features a blocking voltage of 35 V and a maximum reverse current of 200 mA. Reverse recovery time in inverter circuits is less than 10 ns. The device withstands a nonrepetitive peak forward surge of 500 A single cycle.

CIRCLE NO. 275

Solid-state PB switch uses Hall effect

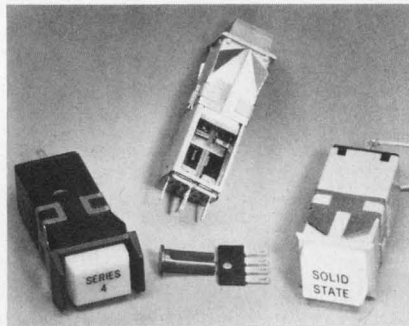

Micro Switch, Div. of Honeywell, Inc., 11 W. Spring St., Freeport, Ill. 61032. (815) 232-1122. \$2.89 (OEM qty).

Micro Switch's Series-4 line now includes a low-price, solid-state lighted pushbutton. It uses a regulated Hall-effect chip to provide stable operation from a 6 to 16-V-dc power supply. The pushbutton is fully compatible with DTL, RTL, TTL and discrete transistor circuits, and it is externally identical to the other switches and indicators in the Series-4 line.

CIRCLE NO. 276

Sensor can detect color and texture changes



Scientific Technology, Inc., 1157 San Antonio Rd., Mountain View, Calif. 94040. (415) 965-0910. \$96.-50 (unit qty); 3 wks.

Model 3093 Omniprox sensors detect, monitor and control almost anything of any material that the eye can see, whether solid, liquid or gas. The wide sensitivity adjustment of the new sensors permits "seeing" a transparent surface or "looking" through it. The sensor can even signal color and texture changes and read codes. The standard range of the unit, when used as a proximity sensor, is 24 in. for a 90% and 15 in. for an 18% reflective surface. With a retrotarget, the beam's make or break range is 20 ft. Longer range units are available. A visible LED alignment and operation indicator is provided. The operation of the 3093 is not affected by ambient light, even bright sun. And it ignores environmental contaminants such as dust or fog.

CIRCLE NO. 277

SCR lists 1950-A rms rating

General Electric, Electronics Park, Bldg. #7, Mail Drop 49, Syracuse, N.Y. 13201. (315) 456-2021. C701-PA: \$187 (10-99).

The C701 SCR uses a newly developed multidiffusion process and a large 53-mm diameter silicon pellet to achieve ratings of 1250 A average and 1950 A rms with peak voltage ratings up to 1800 V. An amplifying-gate structure gives 800-A/ μ s di/dt rating. The SCR also achieves an 18,000-A surge rating. Advantages over competitive devices reportedly include 20% less power dissipation of 700 A average, plus the ability to run with 20-C higher heat-sink temperature.

CIRCLE NO. 278

100-W Darlington list beta of 1000

Fairchild Semiconductor, 464 Ellis St., Mountain View, Calif. 94042. (415) 962-3816. 90¢ to \$1.76 (100-999); stock.

A line of six power Darlington transistors designed primarily for automotive electronics consists of three transistor types packaged in TO-3 metal and TO-220 plastic power packages. The metal can units, called the SE9300, SE9301 and SE9302, can dissipate up to 100 W of power, while the equivalent plastic packaged SE9303, SE9304 and SE9305 are rated at 70 W. All six devices are npn types that can safely handle up to 10 A of collector current and have high current-gain characteristics—beta is 1000 at 4 A.

CIRCLE NO. 279

Green LED display replaces red units

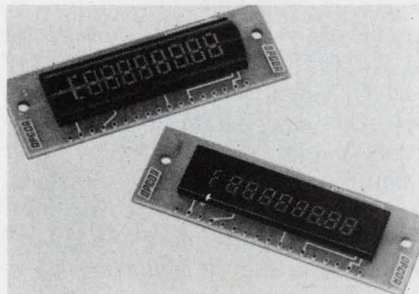

AVX Corp., 330 Talmadge Rd., Edison, N.J. 08817. (201) 287-0355.

LED numeric displays in green, 0.120 in. high, made of gallium-phosphide are capable of directly replacing equivalent red gallium-arsenide-phosphide displays in most circuits. Luminous intensity is 30 μ cd, typical, at 1-mA average current per segment. A nine-digit version, G9B125, is supplied on a PC board $3/8 \times 2-3/8$ in. with two 0.098 in D mounting holes on 2-1/8 in. centers, and is a direct mechanical replacement for several existing red GaAsP devices. Center-to-center digit spacing is 0.150 in. Initial models are supplied with a clear plastic cover to allow flexibility in filter choice. Versions with less digits and special configurations are available. A unit with a magnifier to provide 0.180-in. apparent character height is scheduled for production.

CIRCLE NO. 280

Now, get more insertion loss from a smaller- volume filter.

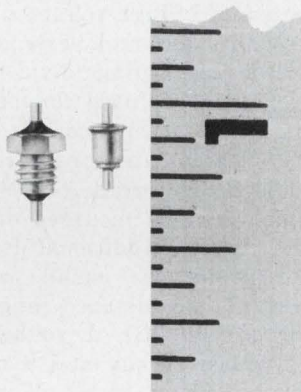

You can get it from these RFI/EMI low-pass feedthrough filters from AMP. Because of their unique ferrite-titanate composition, they provide suppression and environmental

characteristics never before available in miniature-sized filters at an economic cost.

It's all made possible by single-piece construction which distributes inductance, capacitance and resistance over the filter, making it act like a lossy transmission line. And provides superior mechanical strength, in the bargain.

These filters are free of the usual resonance effects of conventional lumped-element filters. And, through the use of special solders, can be joined safely to bulkheads at temperatures to 260°C, without damage or change in performance. Their operating range is -55°C to +125°C. No voltage derating is required at the higher temperature.

A variety of center-conductor, terminal-type and solder- or bolt-in mounting-type filters is available in two families of filters: "55" Series—the standard maximum suppression line—and the "25" Series—miniature and subminiature filters.

For more information on AMP low-pass feedthrough filters, write to **Capitron Division, AMP Incorporated, 1595 S. Mount Joy Street, Elizabethtown, Pa. 17022.**

Capitron is a trademark of AMP Incorporated.

AMP INCORPORATED

Manufacturing and direct sales facilities worldwide: Barcelona, Brussels, Buenos Aires, Frankfurt, London, Mexico City, Paris, Puerto Rico, Sao Paulo, s'Hertogenbosch (Holland), Sydney, Stockholm, Tokyo, Toronto, Turin, Vienna.

INFORMATION RETRIEVAL NUMBER 50

Fuse indicator provides visual display

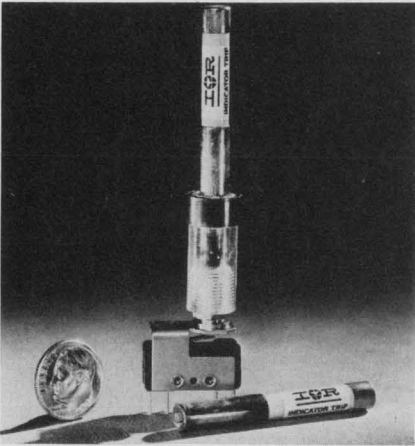

International Rectifier Corp., 233 Kansas St., El Segundo, Calif. 90245. (213) 678-6281. Type 11000: \$2.30 (1 to 24); stock.

IRC's new cleared-fuse indicators are used to provide local and remote visual indication of the status of a fuse. They can activate a switch or trip-bar to operate a circuit breaker or illuminate a warning lamp. Type 11000 is rated at 700 V rms and Type 1700 at 500 V rms. The indicator is connected in parallel with a protective fuse. If the fuse blows, the full current flows through the indicator. The current is then interrupted by operation of the indicator, which acts as a small current fuse. The sequence ends with a red pin extending from the indicator.

CIRCLE NO. 281

Two slide switches occupy one housing

Stackpole Components Co., P.O. 14466, Raleigh, N.C. 27610. (919) 828-6201.

Model SS91-21 slide switch combines two complete switching functions inside one miniature switch housing. For use in small calculators as an on-off or mode-change switch, two SPDT switches have been enclosed in a housing that occupies the space originally needed by a single DPDT miniature switch (0.628 × 0.421 × 0.260 in.). The switches offer the same options in terminals, toggles and mountings as the conventional slide-switch line.

CIRCLE NO. 282

Thick-film resistor has high volt/ohm rating

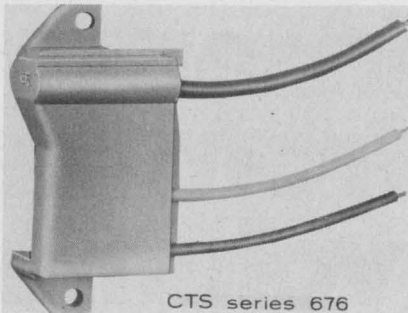

CTS Corp., 1142 Beardsley Ave., Elkhart, Ind. 46514. (219) 523-0210. \$1.04 for ±30% tolerance (OEM qty).

The series 676 Cermet, high-resistance, high-voltage thick-film resistors, although designed for TV bleeder and voltage divider applications, may be used for many other high-voltage applications as well. The new unit features a completely molded SE-0 grade polyester package, which is mounted directly to the chassis. Additional design features include: small volumetric content, a resistance range of 100 kΩ to 500 MΩ, a voltage rating of 30,000-V max and a maximum power rating of 3.5 W at 60 C. Additionally, the resistors can be supplied with one tap with the two sections ratioed to within ±10%.

CIRCLE NO. 283

Solid-state timer sets with thumbwheel switch

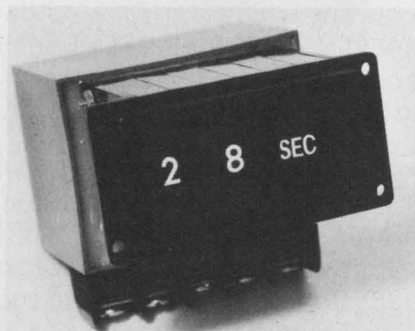

Tripp Research Corp., 1523 Quito Rd., Saratoga, Calif. 95070. (408) 354-1916. \$76.50 to \$116.50; stock to 4 wks.

The TTM series timers are mounted in a thumbwheel switch and its IC design achieves accuracies of better than 1%. The timers are compatible with TTL or CMOS logic levels (5 to 15 V dc). Five models provide maximum time intervals from 29 s to 9.9 min.

CIRCLE NO. 284

Dc potentiometer works without a wiper

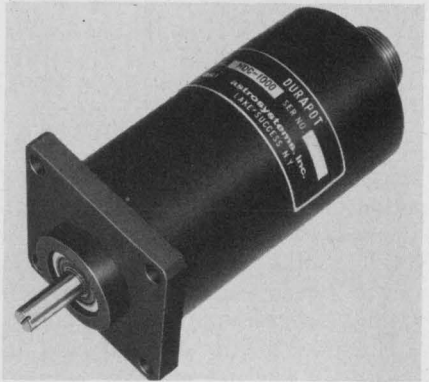

Astrosystems, Inc., 6 Nevada Dr., Lake Success, N.Y. 11040. (516) 328-1600. 30 day.

Wiperless dc potentiometers, known at Durapots, can provide an unusually high reliability and low noise level. Durapot produces a smooth, continuous, dc output that is proportional to shaft rotation with a linearity of 0.05% and a dead-band of less than 0.02 degrees. Starting torque is 0.1 oz-in., and the unit is ideally suited for servo applications. Its output voltage for a 360 degree rotation is 0 to 10 V dc. Optional output voltages of 0 to -10 and -5 to +5 V dc are also available. The input power requirement is ±15 V dc at 50 mA each. The unit is available either in a heavy-duty NEMA 12 or standard servo mounting package. Each unit contains an electromagnetic rotary transducer, and all solid-state excitation and conditioning electronics.

CIRCLE NO. 285

Reed relays are DIP and IC compatible

Cosar Corp., 3121 Benton St., Garland, Tex. 75042. (214) 276-9487. \$2.25 (100 up); stock.

Too often reed relay performance has been compromised just to offer a DIP package. Series 270 Zestron reed relay is said to be uncompromising. Coils can be gated by standard TTL or DTL logic with only 9 mA at 4.5 V and contacts are rated at 10 VA. Pin 14 can be bussed as V_{cc} and pin 7 as ground. Alternate pin patterns also are available to replace competitor's units. Life expectancy is greater than 10^7 operations at rated load.

CIRCLE NO. 286

Why square ferrite cores?

save up to 40% in space
save up to 40% in assembly time
save up to 30% in inventory

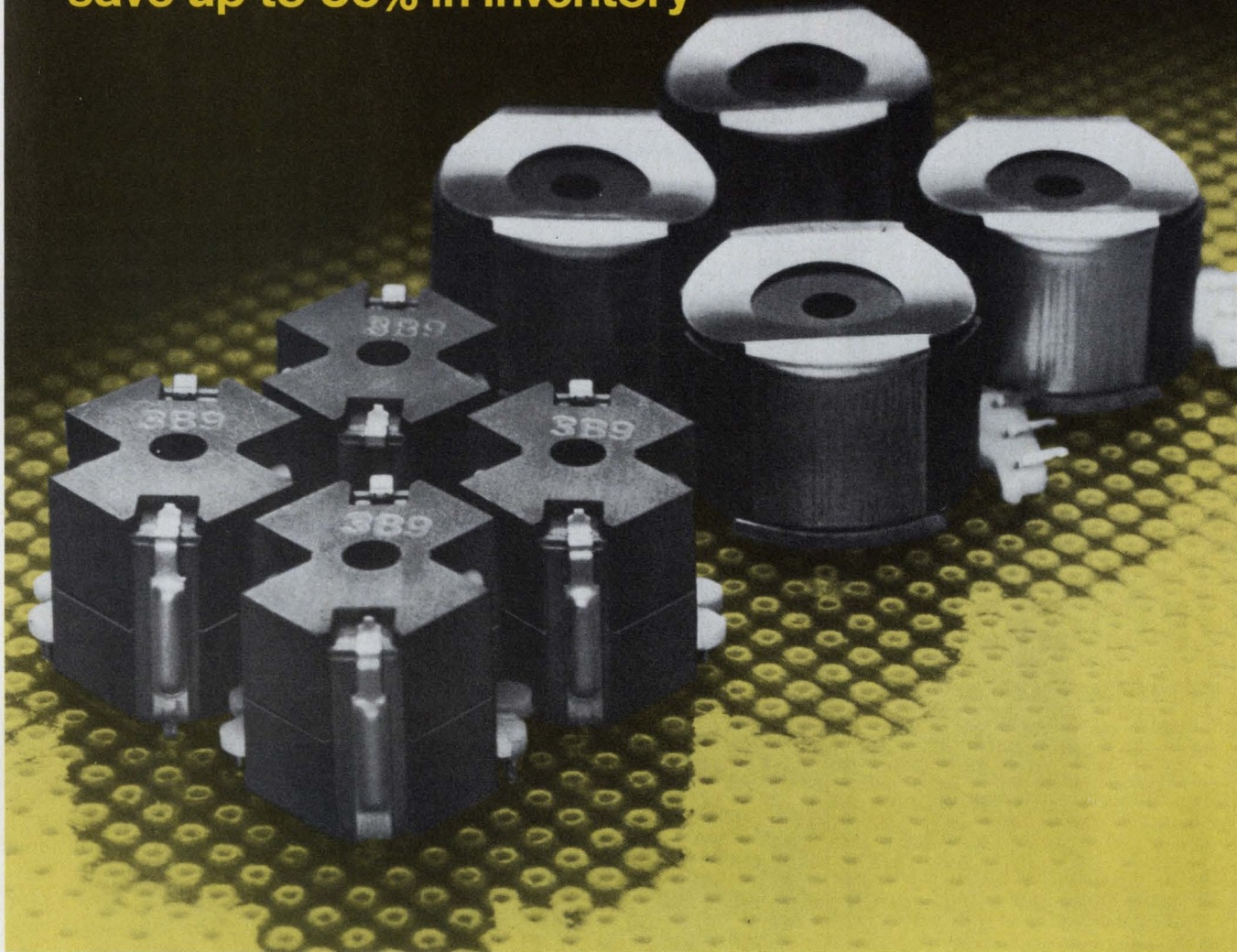

Ferroxcube's new RM Series square cores save up to 40% in pc board space over round pot cores. Furthermore, RM Series saves up to 40% in assembly and mounting time. Two simple, gold-plated clips hold them together and readily snap them into place on the pc board.

Your parts inventory is reduced since the economical mounting clips replace more expensive pot core mounting assemblies.

Ferroxcube's RM cores are available

with a choice of ferrite material: choice of ungapped, fixed-gap or adjustable-gap types, with smooth precise tuning of inductance to an accuracy of better than 0.03% in adjustable models.

RM cores now in stock. For complete information call 914•246-2811, TWX 510-247-5410 or write Ferroxcube, Saugerties, N.Y. 12477.

Ferroxcube linear ferrites—made in Saugerties, N.Y. and stocked in seven U.S. locations.

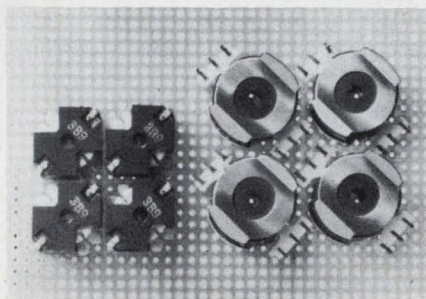

FERROXCUBE CORPORATION, SAUGERTIES, N.Y. 12477

A NORTH AMERICAN PHILIPS COMPANY

Distributed through North American Philips Electronic Components Corporation with warehouses in Boston 617•449-1406; New York, 516•538-2300; Saugerties, 914•246-5861; Philadelphia 215•927-6262; Chicago 312•593-8220; Santa Clara, 408•249-1134; San Diego, 714•453-9250

INFORMATION RETRIEVAL NUMBER 52

CLOCKING WITH A DELAY LINE?

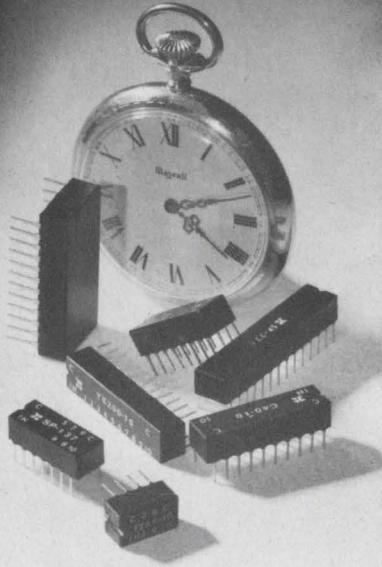

TRY US!

TWO TYPICAL EXAMPLES

Total delay = 7.5 nano sec. } 14 lead "DIP"
 Five taps @ 500 pico sec. }

Total delay = 42 ns } 12 lead "DIP"
 Twelve taps @ 3 ns }
 Four taps @ 1.5 ns }

- Frequency capabilities to 300 MHz
- Temperature coefficient of 70 PPM/°C
- Operating temperature from -55°C to +125°C
- Tap stabilities to ±250 ps

PLUS . . .

- Tap capabilities from 500 ps to 25 ns
- Delays from 5 ns to 1000 ns
- Rise time ratios from 5:1 to 30:1
- Standard impedances of 50, 75 and 100 ohms (±5%)
- All Dual In-line packaged (8 to 28 leads)

Custom clocking applications are available—within the series—without engineering costs. **Phone, wire or write for more information today!**



RHOMBUS INDUSTRIES INC.

22119 S. Vermont Ave., Torrance, Ca. 90505
 (213) 325-7440 • TWX 910-349-7512

DATA PROCESSING

Digitizer tablet offers 0.005-in. accuracy

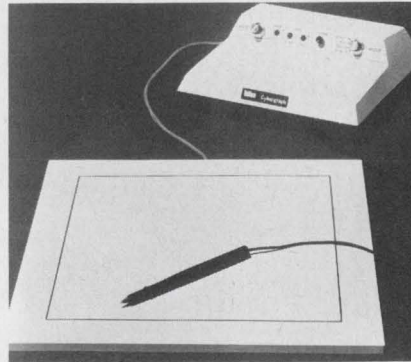

Talos Systems Inc., 7311 E. Evans Rd., Scottsdale, Ariz. 85260. (602) 948-6540. See text.

The cybergraphic tablet converts hand-generated graphics to analog or digital form with an accuracy and repeatability of ±0.005 in. The units available in sizes from 5×7-in. to 22×22-in. provide resolution to 200 lines/in. and conversion rates up to 200 coordinates pairs/s. The control console can display data in binary, octal or BCD. The user can select from a variety of single or continuous conversion modes. Price for the various tablet sizes ranges from below \$1000 to over \$2500.

CIRCLE NO. 287

4800-bps modem trains in less than 50 ms



GTE Lenkurt Inc., 1105 County Rd., San Carlos, Calif. 94070. (415) 591-8461.

A 4800-bit/s modem, the 262A, operates over unconditioned 3002 type channels. The unit is capable of half-duplex or full-duplex operation over privately-owned or leased transmission facilities. The adaptive equalization facility requires an initial training time of less than 50 ms. The 262A complies with EIA Standard RS-232-C and CCITT Recommendation V.24. The modem operates end-to-end and is interchangeable with the Western Electric type 208A Data Set.

CIRCLE NO. 288

Real-time tasks tackled by 125-ns mini system

CSP Inc., 209 Middlesex Turnpike, Burlington, Mass. 01803. (617) 272-6020. \$50,000.

The basic CSP-125 computer system includes the CPU, operational software and keyboard/display module. The 16-bit CPU features a 125 ns cycle time, an IC memory capacity of 32-k and overall capacity of 160-k words. The computer, developed by CSP, is programmed in extended Fortran IV; no assembly language is necessary. Four I/O channels are available that accommodate a total of 32 peripheral devices. Direct memory access rate is 16 M byte/s; programmed I/O rate is 6-Mbyte/s. A 16-bit by 16-bit multiplication takes but 1.25 μs. Sophisticated software adds to the processing speed by allowing background operations to be executed while the applications program executes in the IC memory.

CIRCLE NO. 289

Bare-boned cassette drive stores 1.5-M bits

Ross Controls Corp., 257 Crescent St., Waltham, Mass. 02154. (617) 891-9600. \$216 (quan); 6 wk.

The model B10 memory unit provides 1.5-M bit data storage capacity on a conventional 300-foot Philips-type cassette. Access time to any stored data averages 10 s. The unit uses a reel-to-reel tape drive rather than the conventional capstan-and-pinch roller. A patented analog servo that uses motor back-emf holds the tape speed constant at 20 in/s ±5% over the entire length of tape, despite changing reel diameters. The same servo drives the tape in either direction at 100 in/s for rewind and fast-data-search modes of operation. The tape transport can reach the 20 ips read/write speed in 30 milliseconds and stop within 50 milliseconds. The B10 package does not include read/write electronics, which may be added as an optional printed-circuit card. Standard recommended bit rate is 500 bit/in., which gives a data transfer rate of 10,000 bits-per-second. The entire assembly measures 4.75 × 5 × 4.5-in. (WHD) and weighs two pounds.

CIRCLE NO. 290

Synchronous controller boasts high throughput

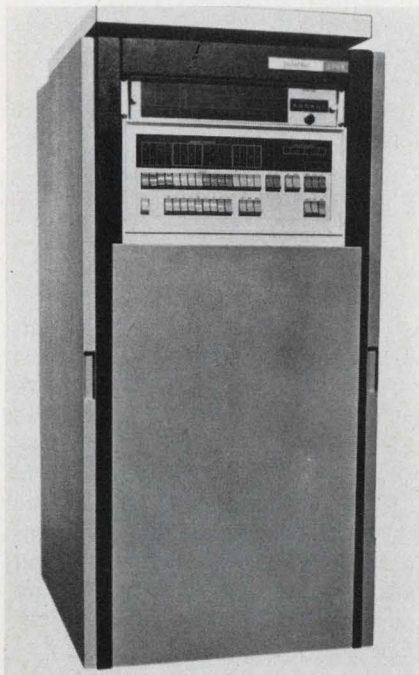

Telefile Computer Products, 17131 Daimler St., Irvine, Calif. 92705. (714) 557-6660. \$53,360.

Internal use of direct memory access (DMA)—instead of character-by-character processing—is said to improve the total throughput of the TCP-64-3 synchronous communications control system. The 16-line unit allows half or full duplex communication at rates up to 50-k baud for each remote terminal. The programmable control system can support most terminals. A 16-bit general purpose computer provides over-all system control, data-buffer storage, code conversion, editing, blocking and deblocking.

CIRCLE NO. 291

System package adds 600-lpm printer to mini

Custer Research, Inc., P.O. Box 305, Fleetwood, Pa. 19522. (215) 376-2842. \$2500; 30 days.

The S2531 subsystem package includes an 8-bit parallel interface kit and complete software to operate the DATA PRINTER V132C line printer with any HP 2100 series processor. All mechanical, electronic, and program components of the S2531 subsystem are covered under the price of \$2500 with a 90-day warranty from the day of delivery.

CIRCLE NO. 292

We chose to call our new Real-Time Spectrum Analyzer **Omniscient*** and we'll continue to!

With a name like that you have to measure up, and the EMR Model 1510 does. It goes anywhere, does any job ... It's a Fourier Analyzer, a Spectrum Averager and a Display in one convenient, portable package. And most important, it performs its tasks digitally ... no interactive controls to fumble with ... no complicated computer interface problems.

But to be Omniscient there must be more ... and there is!

- Switch it on, it's ready to operate without calibration
- Analyze a signal repeatedly and get repeatable answers ... over and over again
- 60 dB dynamic range at the input and no gimmickry
- Foolproof LED display of signal amplitude, frequency and averaging time
- Control setting status appears on graticule of CRT for permanent photographic record
- Availability of many options ... Peak Hold, 3-D Display, Computer Interface, Low Frequency Sync, Any Window, etc.

*Possessed of universal or complete knowledge —

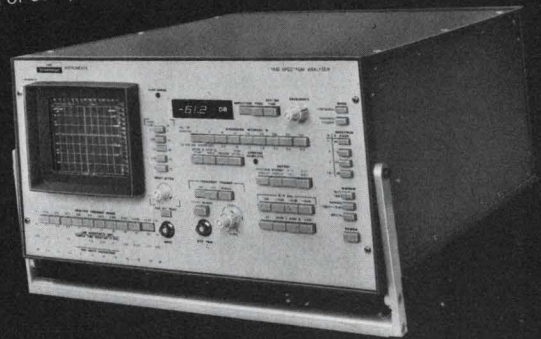

Well... What else could we call it?

Write today for a comprehensive technical brochure or call for a demonstration.

EMR EMR Schlumberger

EMR Telemetry
Weston Instruments, Inc.
Box 3041, Sarasota, Florida 33578
813-958-0811

Disc drives offer choice of speed and capacity

Wango, Inc., 5404 Jandy Pl., Los Angeles, Calif. 90066. (213) 390-8081.

Models 2212, 1211 and 1212 disc drives provide additional choices of capacity and transfer rates for the Series-N line. The 2212 features 200 track/in, 50 M

bit capacity and a transfer rate of 2500-k bit/s at 2400 rpm. The 1211 provides 25 M bits on 100 track/in with a 1562 k bit/s transfer rate. The 1212 has the storage capacity of the 1211 but transfers data at a 2500-k bit/s rate. All drives use a single fixed disc in conjunction with a voice-coil positioner. Track-to-track access is 15 ms. The drives are 5.25-in. high and mount in a 19-in. rack.

CIRCLE NO. 293

Single PC board has 16 k × 18 core memory

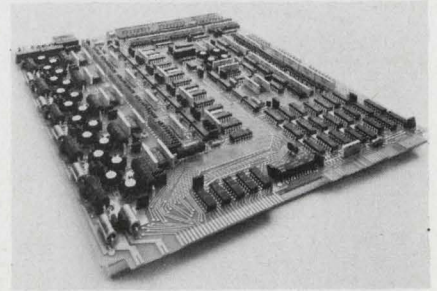

Dataram Corp., Princeton-Hightstown Rd., Cranbury, N.J. 08512. (609) 799-0071. \$3150.

The 16-k × 18 DR-102 core memory is packaged on a single 11.5 × 13.7-in. PC board—no control card is required. The system is plug-compatible with the earlier 8-k × 20 DR-101 system. The single board contains all address and data registers, as well as timing and control. The core stack is pluggable from the solder side of the board, making all components easily accessible. Cycle/access times are 850/300 nsec; interface is completely TTL. Only two voltages are required, +5 and -18 V. Chassis of 3.5, 5.25 or 12.25-in. hold 2, 4, or 8 modules, respectively, along with an optional power supply and tester.

CIRCLE NO. 294

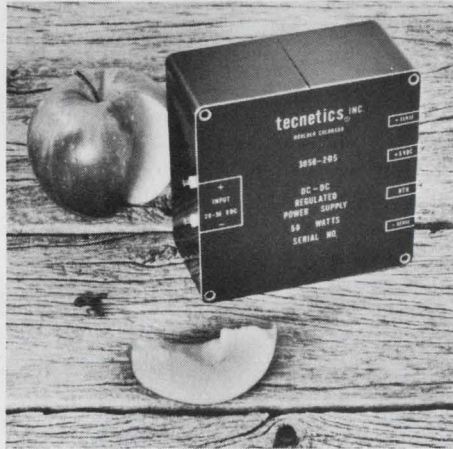

28 VDC High Efficiency High Density

DC-DC regulated power supplies

tecnetics 3000 series 28VDC input DC-DC regulated power supplies feature high efficiency up to 75% and high packaging density up to 1.56 watts/in³.

Output voltages in 5V to 48V models

Regulation: Line (V_{in} 20 to 36V) 0.15%
Load (1/2 L to FL) 0.15%
Temperature 0.015%/°C max.

Dimensions 4x4x2 inches

Input-output isolation

Short circuit and overload protected

EMI filter reduces reflected power line ripple

Availability: Four weeks

Price \$395

Write or call for more details on specifications, applications and the new 1974 catalog from tecnetics.

tecnetics The Power Conversion Specialists

P. O. Box 910 1625 Range Street, Boulder, Colorado 80302
(303) 442-3837 TWX 910-940-3246

Reader handles IBM-type magnetic cards

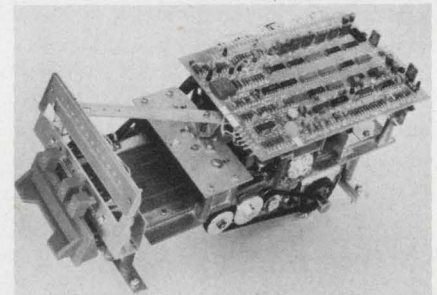

Redactron Corp., 100 Parkway Dr. S., Hauppauge, N.Y. 11787. (516) 543-8700. \$525; stock.

A magnetic card transport reads and writes IBM-compatible cards. Called the 270/280, the 50-track magnetic card transport can be interfaced with a variety of office, typesetting and laboratory equipment. The transport has a 5000 character memory and can access a block of material in approximately 1.8 seconds. Each IBM-compatible card stores up to 5000, 8-bit characters.

CIRCLE NO. 295

Circuit board adds memory-protect to mini

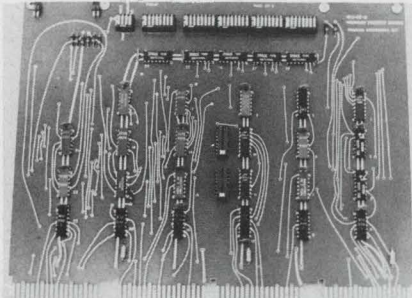

Douglas Electronics, Inc., 718 Marina Blvd., San Leandro, Calif. 94577. (415) 483-8770.

A circuit board called the 103-DE-8 protects switch selectable areas of core by prohibiting the writing of new information into these areas. If an attempt to write into the protected area is made, the board will ignore the instruction and cause either a halt or an interrupt. Switches at the top of board control the operation of the memory protect. When operating in page mode, 32 switches select individual pages for protection. Alternatively, the board can protect each of the thirty-two 1024 word areas of the maximum PDP-8/e memory. Several boards may be used in a PDP-8/e at the same time to protect various areas.

CIRCLE NO. 296

Low-cost interface makes scope a graphics display

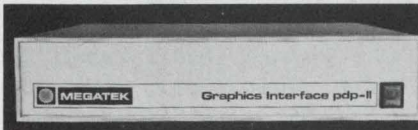

Megatek Corp., 1055 Shafter St., San Diego, Calif. 92106. (714) 224-2721.

Designed for PDP-11 minicomputers, the BP-733 interface allows any laboratory X-Y oscilloscope or larger X-Y display to provide full graphics display capability. The unit handles a minimum of 256 point/lines and is expandable to 1024 point/lines. The unit enables the PDP-11 user to plot points, lines, alphanumerics and real-time dynamic displays. Optional equipment includes an X-Y plotter drive for hard-copy output. Software is supplied for programming in BASIC commands.

CIRCLE NO. 297

Instrument readings converted for dp use



Data Graphics Corp., 8402 Speedway Dr., San Antonio, Tex. 78230. (512) 342-9486.

A user altered program counter and multiplexer allow the DATOS 303/4 interface to convert lab instrument outputs to usable computer or tape format codes. The unit matches code, speed signal levels and formats to most recording devices or computers.

CIRCLE NO. 298

OUR ANGLE: More Synchro Conversion For Less Cost



with our
S/D and
D/S modules

How does a choice of 14-bit resolution (greater for 2-speed S/D), 60 or 400 Hz data frequency, high accuracy, 11.8V to 90V line-line voltages and all kinds of self-protection circuitry — look from your angle? Not to mention that as few as 5 modules make up a complete S/D or D/S converter, or that all modules are replaceable one-for-one without trimming! And, economically too!

New 2-speed S/D sets are now available with accuracies typically better than 20 seconds from all error sources including resolution. D/S specifications include 4 minute accuracy, 1.25 VA output with optional 20 VA output for torque receiver applications.

Key performance specifications for both converters include 14-bit (0.022°) resolution over 360°, 4000°/sec analog data rates and 0-70°C operation. Some units available for operation from -55°C to +105°C. All units are DTL and TTL compatible.

Prices start at \$650.00 for a set of modules. Delivery from stock. Call toll-free (800) 645-9200 for the name and address of your local sales engineering representative.



NORTH ATLANTIC industries, inc.

200 Terminal Drive, Plainview, New York 11803 • Phone (516) 681-8600
California District Office: 13418 Wyandotte Street, N. Hollywood, CA 91605 • Phone (213) 982-0442

INFORMATION RETRIEVAL NUMBER 56

WIPE OUT..

- TC Error
- External Adjustment
- Specification Degradation
- Bulk
- High Cost . . .

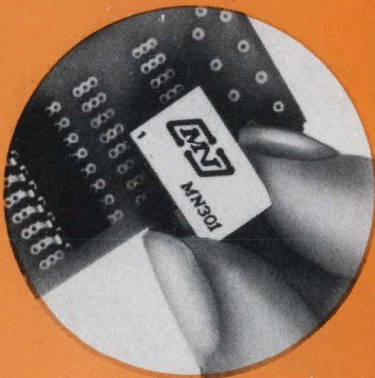

with Micro Networks low cost dip D/A's.

6 bit D/A (MN301)	... \$12.95*
8 bit D/A (MN3002R)	... \$22.00*
10 bit D/A (MN3003R)	... \$25.00*
12 bit D/A (MN312R)	... \$33.00*

*Unit price for min of 250

MNC "R" units guarantee worst case linearity ± 1 LSB from 0 to +55C. Each unit is completely factory trimmed for offset and range — and requires no external components.

MICRO NETWORKS has the broadest line of hermetically sealed D/A converters in the entire industry. MIL temperature units available on all models. Call or write today.

Tel: 617 753-4756



Micro Networks
CORPORATION

5 Barbara Lane
Worcester, Mass. 01604

ICs & SEMICONDUCTORS

Xtal osc offers choice of 3 outputs

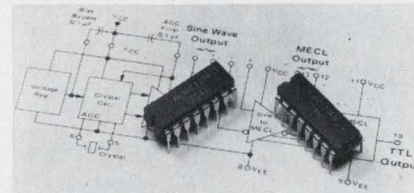

Motorola Semiconductor Products, P.O. Box 20924, Phoenix, Ariz. 85036. (602) 244-3466. 12060L/12061L: \$4.35 (100-999); stock.

A crystal oscillator features a choice of complementary sine wave, single-ended MTTL, and complementary MECL outputs from a single IC chip. Called the MC12060/12560, for 100-kHz-to-2.0-MHz operation and the MC-12061/12561, for the 2-to-20-MHz range, these devices operate with a fundamental series mode crystal. Stability averages -0.08 ppm/ $^{\circ}$ C (the MC12060/12560) and -0.16 ppm/ $^{\circ}$ C (the MC12061/12561). External components required include the crystal and two bypass capacitors. Operation is from a single power-supply. Sine wave output voltages range from 800 mV pk-pk (no load) to 500 mV pk-pk at full load.

CIRCLE NO. 299

FM-i-f radio system comes on a chip

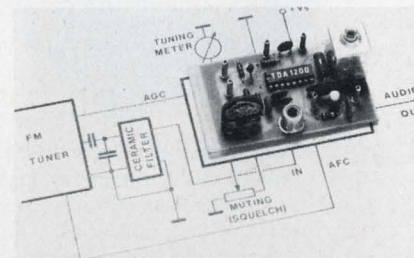

SGS-ATES Semiconductor, 435 Newtonville Ave., Newtonville, Mass. 02160. (617) 969-1610. \$2.40 (100-999); stock.

The TDA 1200 monolithic silicon IC contains a subsystem for amplification and detection of FM signals. Called the TD 1200, the IC is equivalent to the RCA CA3089 and features a three-stage FM-i-f amplifier/limiter quadrature detector. The unit also has inter-channel controlled muting, afc and delayed agc for an FM tuner, and switching and driving circuitry.

CIRCLE NO. 300

CMOS RAM boosts size to 512 bits

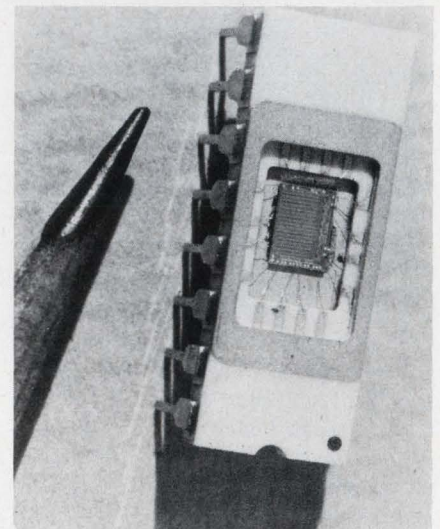

American Microsystems, 3800 Homestead Rd., Santa Clara, Calif. 95051. (408) 246-0330. \$45.60 (100-999); stock.

The largest CMOS static RAM—AMI's S2222 512-bit memory—achieves a 200-ns typical access and standby power of 4 nW/bit, thus setting the pace for competing 256-bit RAMs. The silicon-gate device has a single read/write control line, and read/write cycle times are 420 ns minimum. Typical operating power is less than 5 μ W/bit at room temperature and operation is from a single +10-V supply.

CIRCLE NO. 301

Op amp ICs include FET, bipolar types

Datel Systems, 1020 Turnpike St., Canton, Mass. 02021. (617) 828-6395. \$11.50 to \$17.95 (1-9); stock.

The AM-400 Series of monolithic op amps offers a choice of FET or bipolar inputs with either high-speed or high-gain transfer characteristics. The FET input models have a differential input impedance of 10^9 . The high speed versions have full power bandwidths of 2 MHz, slew rates of 120 V/ μ s and settling times of 200 ns. The high gain versions provide an open-loop dc gain of 150,000 and a gain-bandwidth product of 100 MHz. All models feature ± 10 -V minimum common-mode voltage with typical common-mode rejection ratios of 90 dB. Outputs are ± 10 V at ± 10 mA minimum.

CIRCLE NO. 302

FET op amp spec'd at 100 MHz

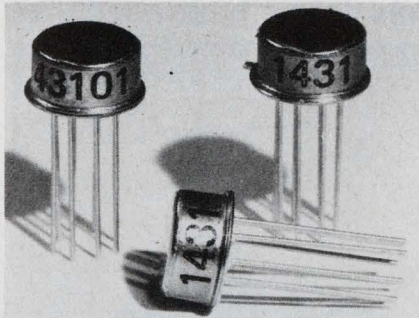

Teledyne Philbrick, Allied Dr. at Route 128, Dedham, Mass. 02026. (617) 329-1600. 1431: \$13.50 (100-999); stock.

The 1431 and 143101 wideband FET-input op amps come in TO-99 packages with 741-type pinouts and feature a full 100-MHz gain-bandwidth product measured at a closed-loop gain of 10 and a slew rate of 35 V/ μ s. True differential op-amps, they also boast an open loop gain at dc of 150,000, a ± 10 -V common-mode voltage range and a 90-dB CMRR. The FET input provides input impedances of 10^{12} Ω and bias currents of 1 pA, while the output circuit provides ± 18 -mA current.

CIRCLE NO. 303

IC interfaces MOS and TTL data busses

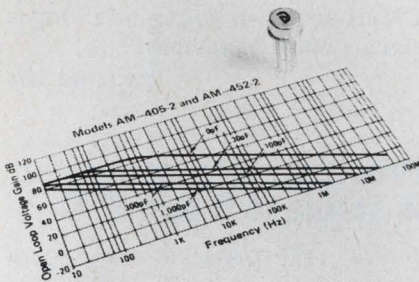

Signetics, 811 E. Arques Ave., Sunnyvale, Calif. 94086. (408) 739-7700. \$1.88 (100).

A dual bidirectional bus interchange circuit interfaces MOS and TTL data busses. Called the 8T30, the IC features an emitter-follower driver rated at 4.25 V and 1.6 mA, and it has a current base input of 200 μ A. The unit also has current outputs of 60 mA with open collectors and TTL or DTL transmitter outputs of 24 mA. A power-down sequence has no effect on the transmit outputs when V_{cc} is varied from 5.25 V to zero.

INQUIRE DIRECT

Another Sprague Breakthrough!

PRODUCTION-ORIENTED SOLID TANTALUM CAPACITORS

Solid flame-retardant epoxy with precise dimensions for automatic insertion. Completely shock and vibration resistant.

Flat surface permits clear easy-to-read marking.

No rundown to interfere with seating of capacitors on printed wiring board.

Rugged 0.025" dia. tinned leads maintain alignment. 0.100" lead spacing for standard PWB grids.

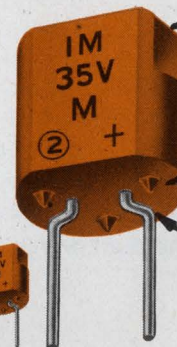
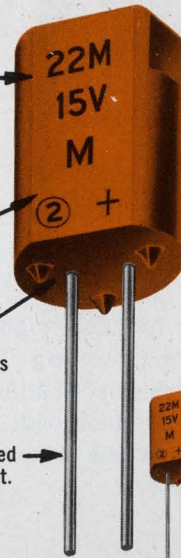

ACTUAL SIZE

Top flat for easy identification of positive lead either visually or by touch.

Standoff feet on base to eliminate moisture entrapment and facilitate cleaning of wiring boards.

Formed leads with either 0.200" or 0.250" spacing to permit interchangeability with dipped capacitors.

Type 198D Low-cost Econoline* Tantalum Capacitors Lead in Performance!

When it comes to low-cost solid tantalum capacitors, the new Sprague Type 198D Econoline Capacitors outperform all other designs. Here are some additional advantages:

- Low d-c leakage
- Low dissipation factor
- Wide voltage range, 4 to 50 VDC
- Capacitance range from 0.1 to 100 μ F
- Withstand severe temperature cycling and temperature shock over -55 C to $+85$ C
- Speedier handling for insertion
- Easier-to-read markings

The new Sprague Type 198D epoxy-encased Econoline Capacitor is tooled for mass production and priced competitively with imported dipped units. Investigate this new Sprague breakthrough without delay.

Call your nearest Sprague district office or sales representative, or write for Engineering Bulletin 3546 to: Technical Literature Service, Sprague Electric Co., 347 Marshall Street, North Adams, Mass. 01247.

*Trademark

THE BROAD-LINE PRODUCER OF ELECTRONIC PARTS



IN CALCULATOR CHIPS...

CL-565...
a super-powerful, four function, eight digit calculator chip with direct segment LED drive, full right justification and zero suppression, supplied with the digit driver, at a super-low price.

For complete information call (516) 733-3354 or write:
General Instrument Corporation, Microelectronics,
600 West John Street, Hicksville, N.Y. 11802

GI'S GOT IT!

INFORMATION RETRIEVAL NUMBER 59



EFRATOM'S

RUBIDIUM FREQUENCY STANDARD

A new generation in time and frequency systems.

- Low cost
- Stability: 2×10^{-11} /month
- Size: $4 \times 4 \times 4\frac{1}{2}$ inches
- Warm up time: < 10 minutes
- 3 year warranty



Model FRK

For complete specifications and prices, write or call today.



EFRATOM
CALIFORNIA, INC.

3303 Harbor Blvd., E1, Costa Mesa, CA 92626
(714) 556-1620, Telex 685635

Name _____ Title _____

Company _____

Address _____

City _____ State _____ Zip _____

ED4-1

In Europe: Efratom Elektronik GMBH, München

INFORMATION RETRIEVAL NUMBER 60

MODULES & SUBASSEMBLIES

Sample-and-hold amp has 10 ns hold aperture

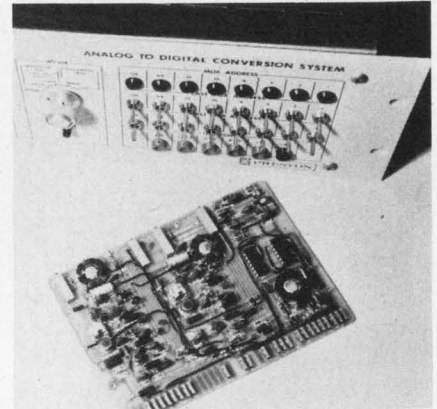

Preston Scientific, Inc., 805 E. Cerritos Ave., Anaheim, Calif. 92805.
(714) 776-6400.

The Model GMSH-10 sample-and-hold amplifier operates at unity gain with input levels up to ± 10 V. It has a hold aperture time of 10 ns with a maximum droop of only ± 1 mV over a hold period as long as 1 ms. In combination with high speed, 15-bit a/d converters, this unit delivers 0.015% accuracy even with nonrecurrent and very high frequency input signals. The input impedance of the GMSH-10 is greater than 10 M Ω , the output voltage is ± 10 V and the output impedance is less than 1 Ω . An optional differential input buffer amplifier can be included with the GMSH-10 when differential input signals must be sampled.

CIRCLE NO. 304

Precision a/d converter is stable to 5 ppm/ $^{\circ}$ C

Intech, 1220 Coleman Ave., Santa Clara, Calif. 95050. (408) 244-0500. \$420 (1 to 9).

The A-852 12-bit a/d converter has a resolution of 1 part in 4096. It uses successive approximation to achieve a conversion speed of 4 μ s. It is a completely self-contained unit with a precision voltage reference that removes all errors due to external power supply line and load regulation variations. The temperature stability is ± 5 ppm/ $^{\circ}$ C. Outputs of the unit are TTL compatible and are delivered in a parallel format. The converter is packaged on a $4.5 \times 4 \times 0.6$ in. PC board.

CIRCLE NO. 305



We have "on the shelf" Jet Order Availability on the following items. Call your sales representative or factory today.

- Sweep Signal Generators from DC to 6.5 GHz
- Spectrum Analyzers from 1 MHz to 13 GHz
- Attenuators
- Oscillators
- Filters

Texscan

A WORLD LEADER IN ELECTRONICS
"And Coming On Strong"

Texscan Corporation
2446 North Shadeland Avenue
Indianapolis, Indiana 46219
Ph: 317 357-8781
TWX: 810-341-3184 Telex: 272110

INFORMATION RETRIEVAL NUMBER 61

From SOLITRON

thick film S.I.P. (Single In-line Package) resistor networks

Available
by the
handful
or the
carload!

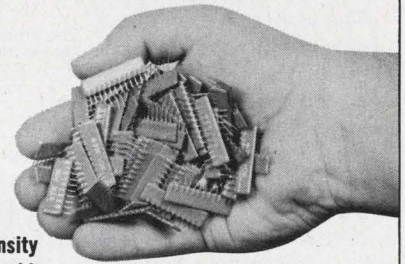

- Increased component density
- Decreased handling/assembly time
- Unlimited circuit configurations
- Excellent delivery

Also available:

- Voltage divider networks for up to 10,000 WV dc.
- RC networks for greater component density.
- Micro-networks for complete circuit component requirements.

Technical data:

- Resistance to 100 Megohms.
- Tolerances to $\pm 0.5\%$.
- Power ratings to 1 Watt/Resistor.
- T.C.'s to $\pm 50\text{PPM}/^\circ\text{C}$.
- Temperature range -55 to $+150^\circ\text{C}$.
- Up to 20 terminals.

For further information, contact:

Solitron devices, inc. Hybrid Products Division
256 Oak Tree Road, Tappan, N.Y. 10983
Tel. 914-359-5050 TWX: 710-576-2654 Telex: 137346

INFORMATION RETRIEVAL NUMBER 62



Fast TurnAround

25 days from your design to prototype circuits

Low Cost

Save 80% over a fully custom design

Easy Design

Simply wire the pre-designed master slice

Proven Process

Standard CMOS assures high yields and dependable delivery

INTERNATIONAL MICROCIRCUITS INC
3000 Lawrence Expwy Santa Clara, Ca 95050 (408) 735-9370



INFORMATION RETRIEVAL NUMBER 63

ELECTRONIC DESIGN 7, April 1, 1974

environmental test chambers

complete program testing facilities for: high and low temperature, altitude and humidity.
temperature ranges from: -150° to $+500^\circ\text{F}$

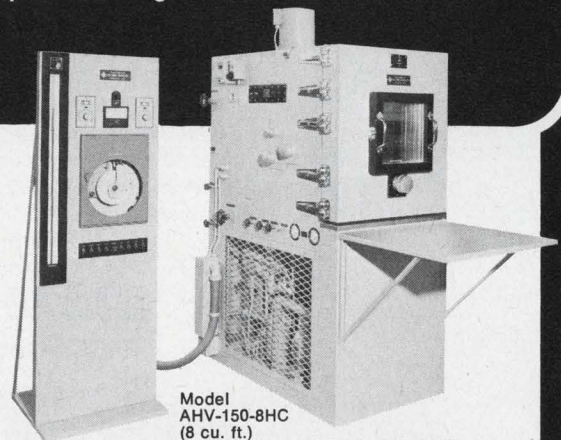

Model AHV-150-8HC (8 cu. ft.)
Temperatures -150°F to $+500^\circ\text{F}$

Custom units, designed and built to your specifications. For FREE, NO OBLIGATION quote, send us your temp. range, size and chamber needs.

Get the facts today. Send for our new FREE test chamber brochure.

CINCINNATI SUBZERO PRODUCTS INC.

2612 Gilbert Ave., Cincinnati, Ohio 45206
Phone: (513) 751-8810

INFORMATION RETRIEVAL NUMBER 64

Our single-chip concept:

Copper grid distributes current most efficiently for lowest $V_{CE(sat)}$.

Integral solid copper leads and heat sink make pre-bond chip test and inventory possible.

Meet stringent MIL requirements best with the NPN silicon transistor that's single-minded about performance. The concept: a unique single-chip design that packs the highest current rating in its class... keeps saturation voltage low and eliminates second breakdown problems. $V_{CE(sat)}$ is .75V max. @ 70 Amps, and guaranteed at 120 Amps. $E_{S/b}$ is 6 joules. And because its very simplicity allows pre-rating

One bigger, beefier chip.

Void-free bonding techniques eliminates hot spots.

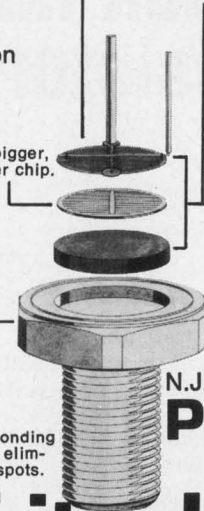

and pre-testing, you can order our JAN & JAN-TX-2N5927 device off-the-shelf for switching regulators, motor controls and other hi-rel power circuits. For tech. data and application assistance, write or call, PowerTech, Inc., 9 Baker Ct., Clifton, N.J. 07011; (201) 478-6205

PowerTech
BIG IDEAS IN
BIG POWER

Top of its class.
120v @ 120A transistor
JAN & JAN-TX

INFORMATION RETRIEVAL NUMBER 65

Connector withstands 20,000 mating cycles

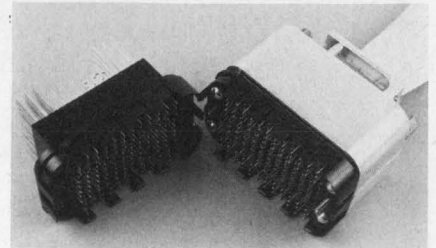

AMP Inc., Harrisburg, Pa. 17105. (717) 564-0101.

A graphite coating technique enables the hemaphroditic miniature Dualatch connector's contacts to withstand over 20,000 cycles of mating and unmating without plating wear-through, according to AMP. In addition to this 2-to-1 increase in mating cycles over standard products, this coating provides a reduction in mating and unmating forces. The miniature Dualatch requires only 3 oz per contact for mating, and 0.1 oz per contact for unmating. The connectors are available with a full compliment of accessory hardware. Connector sizes range from 24 to 396 contact positions and contact terminations include crimp barrels, solder eyelets, solderless wrapping posts and posts for Termini-Point clips.

CIRCLE NO. 320

Ceramic is electrical conductor above 1500 F

Aremco Products Inc., P.O. Box 429, Ossining, N.Y. 10562. (914) 762-0685. \$40 per quart; 3 wks.

Ultra-Cast 553, a zirconia-base ceramic, can be readily cast into complex shapes with temperature resistance to 4000 F. The ceramic has some unusual features: It contains no alkaline metal ions and is therefore for suitable high-vacuum systems; although it is an excellent thermal insulator, it becomes electrically conductive above 1500 F. Ultra-Cast 553 is a two-component casting system consisting of powder base and liquid hardener. After a simple mixing procedure and heat cure, the material is ready for service at 4000 F. Also, the material can be machined, before final firing, by the use of conventional machine tools.

CIRCLE NO. 321

A complete line of CUSTOMIZED ROTARY CERAMIC SWITCHES...

For RF and POWER APPLICATIONS

RSC switches are available in a variety of switching models. RSC high precision, quality built units are designed for applications requiring long life maintenance-free service. Types include shorting and non-shorting, single and multi-deck, up to 18 pole positions. Features include, 10 to 100 amp current carrying capacity, 20° to 90° detents, 2000 to 24000 volts flashover and corrosion-proof construction.

Write for catalog no. 960 and complete information.



RADIO SWITCH CORPORATION

Rt. 79, Marlboro, N. J. 07746

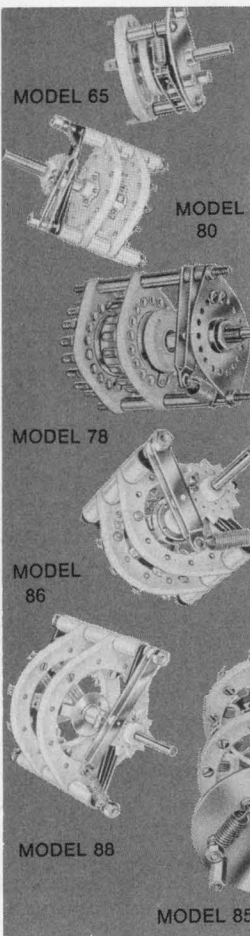

INFORMATION RETRIEVAL NUMBER 66

Pads and washers are thermally conductive

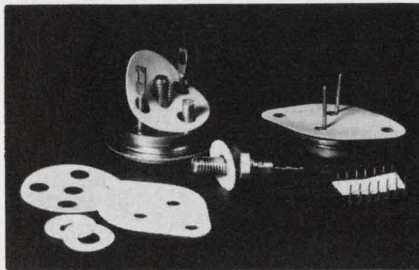

Chomerics, 77 Dragon Court, Woburn, Mass. 01801. (617) 935-0173. 1661: \$45; 1662: \$38; 1663: \$16.25 (100 sheets).

Cho-Therm formulations, thermally-conductive silicone dielectrics, conform to the mating surfaces between power devices and heat sinks for maximum heat transfer, but do not bleed or cold-flow. Precut Cho-Therm washers and pads offer performance and application advantages over thermal greases. Cho-Therm 1662, with a thermal impedance of 0.45 C/W, is available at a reduced price. A new Cho-Therm 1663 material is rated at 0.27 C/W and the premium grade material, 1661, is rated at 0.19 C/W.

CIRCLE NO. 322

Desoldering kit comes with eight tips



Enterprise Development Corp., 5127 E. 65th St., Indianapolis, Ind. 46220. (317) 251-1231. \$21.55 (unit qty).

A new 12-piece desoldering kit, Model 500 K, with everything needed to handle virtually any desoldering and resoldering job includes a desoldering/resoldering iron, eight different-sized tips, a stand for the iron and a cleaning tool. The inside diameter of the tips range from 0.025 to 0.09 in. The kit comes in a sturdy metal storage box.

CIRCLE NO. 323

Right-angle contacts hold daughter board

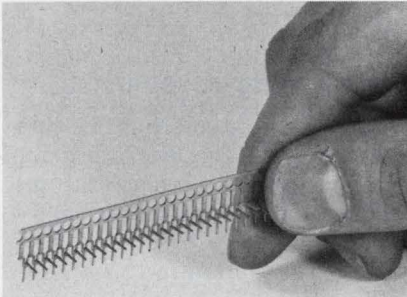

Burndy Corp., Norwalk, Conn. 06852. (203) 838-4444.

Burndy's TS right-angle contact strip connects a component or daughter board to a PC board's backplane. To apply, the contact strip is reflow soldered to the backplane and the selvage strip is removed. A molded plastic housing is not required for use with this contact. TS strips made of brass and preplated tin are supplied in varying strip lengths on 0.1-in. centers.

CIRCLE NO. 324

Small torch performs precision heating

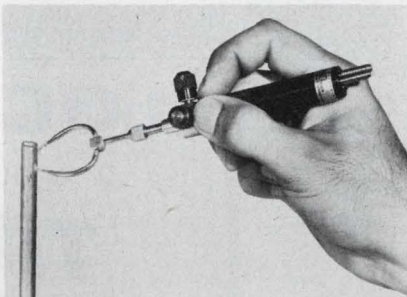

Tescom Corp., 2600 Niagara Lane North, Minneapolis, Minn. 55441. (612) 546-4351.

Trends toward miniaturization have created a need for tools capable of doing precision, small-scale work. Little Torch is such a tool. It performs a wide variety of welding, soldering and heating tasks. Operating on oxygen and fuel gas (acetylene, hydrogen, LP or natural gas), this precision instrument can produce a flame with temperatures as high as 6300 F and small enough to pass through a needle's eye. Interchangeable tips allow the torch to weld metals as small as 0.002-in. wire and as heavy as 16-gauge steel. The Little Torch operates with gas pressures from 2 to 4 lb/in² and consumes gas at the rate of 0.023 to 2.54 ft³/h.

CIRCLE NO. 325

WIDE BAND RF TRANSFORMERS

Great Value at

\$2.95
10 piece quantities

Some Models \$3.45

0.1 - 500 MHz
50 Ohm impedance
1:1 to 16:1
impedance ratio
micro-miniature case

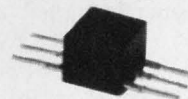

A breakthrough in technology and high production volume enables Mini-Circuits Laboratory to offer these new products at an unprecedented low price.

Ruggedness and durability are built in the T-series transformers. These new units are packaged within a 1/3 D.I.P. package. They use uniquely designed transmission line transformers for extra wide bandwidth.

Impedance ratios of standard models are 1:1, 2:1, 4:1, 9:1 and 16:1. MCL kit TK-1 includes 2 units of each type and sells for \$32.

We invite you to convince yourself. Place your order now and check our delivery, product performance and reliability.

Mini-Circuits Laboratory

2913 Quentin Rd., Brooklyn, N.Y. 11229
(212) 252-2522, Int'l Telex 620156
A Division Scientific Components Corp.

*FRANCE: S.C.I.E., *31, rue, George-Sand, Palaiseau 91, France. *GERMANY, AUSTRIA, SWITZERLAND: Industrial Electronics GMBH, *Klüberstrasse 14, 6000 Frankfurt/Main, Germany. ENGLAND: Dale Electronics, Dale House, Wharf Road, Frimley Green, Camberley, Surrey. JAPAN: Densho Kaisha Ltd. Eguchi Building, 8-1 1-Chrome, Hamamatsucho, Minato-Ku, Tokyo. *ISRAEL: Hamashbir Electronics, 76 Giborei Israel St., Tel-Aviv, Israel
*UNIT IN STOCK

INFORMATION RETRIEVAL NUMBER 67

new literature

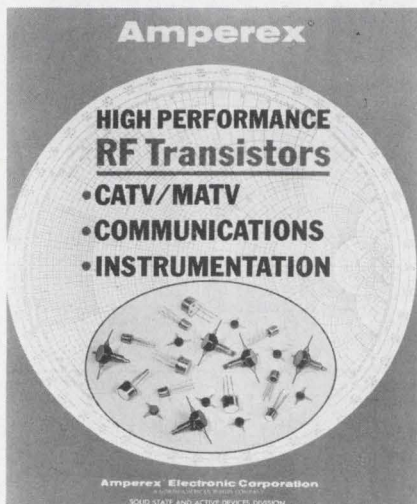

Rf transistors

Technical and application data on 18 high-performance rf transistors for CATV/MATV, communications and instrumentation service are presented in a four-page catalog. Amperex Electronic, Solid State and Active Devices Div., Slatersville, R.I.

CIRCLE NO. 326

IC packaging assemblies

Packaging assemblies for integrated circuits, sockets, terminals and accessories such as enclosures, rack assemblies, tools and connectors are described in a 28-page catalog. Garry Manufacturing, New Brunswick, N.J.

CIRCLE NO. 327

Digital panel meters

An eight-page brochure highlights a series of digital panel meters, designed with high visibility field-effect liquid crystal displays. Tekelec, Westlake Village, Calif.

CIRCLE NO. 328

High-density connectors

A 20-page data sheet updates 200 items of the high-density 20 and 22 connector family. Electrical and physical specifications are provided for both connector densities. AMP, Harrisburg, Pa.

CIRCLE NO. 329

FFT analyzers

A 14-page short-form catalog illustrates instruments and systems for analyzing the spectra of noise, vibration and shock. Spectral Dynamics of San Diego, San Diego, Calif.

CIRCLE NO. 330

Power supplies

Econopac power supplies, power modules, power cards and power supply systems are illustrated in a catalog. Prices are given. Power Pac, Norwalk, Conn.

CIRCLE NO. 331

Calculations

The first issue of a new quarterly publication, *Calculations*, concentrates on statistics from early history to present-day applications. Tektronix, *Calculations Magazine*, Beaverton, Ore.

CIRCLE NO. 332

Sapphire products

Specifications and prices for sapphire products are given in data sheets. Crystal Systems, Salem, Mass.

CIRCLE NO. 333

The Ballantine 512 MHz DIGITAL COUNTER

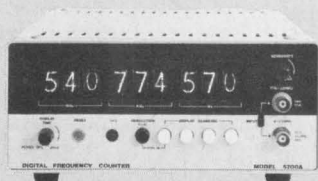

The 5700A Frequency Counter. Range 10 Hz to more than 512 MHz. Nine digit display. Carrier measurements to 1 Hz resolution in 2 seconds of keyed transmitter time. Selective signal tone checks to 0.1 Hz resolution. Sensitivity 10 mV rms with AGC. Stability 3/10⁷/month. 3/10⁹/day optional.

- HIGHEST SENSITIVITY
- BEST RESOLUTION
- FASTEST COUNT RATE
- LOWEST PRICE **\$895**

Meets FCC Requirements



Ballantine Laboratories, Inc.
P.O. Box 97, Boonton, New Jersey 07005
201-335-0900, TWX 710-987-8380

LOCK, LOCK...

WITH
TIP
AND
TAB

For A
DOUBLE LOCKING
Circuit Board Support

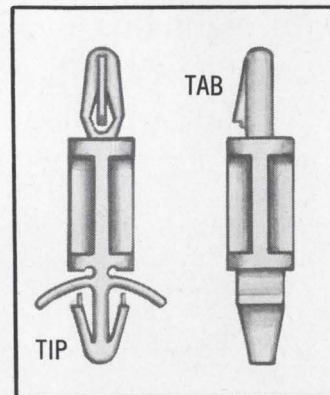

Richlok's Series LCBS circuit board supports plug into the chassis and lock themselves into position. Permanently, thanks to a "Barbed Arrow" locking tip.

Snap the board on and a tension tab expands to lock it to the support. The locking tab withstands up to 100 lbs. of pull, yet allows removal of the board with finger tip pressure. Which is just what you want, isn't it?

A double locker from Richlok. In 12 spacing heights from 3/16" to 1-3/8". High dielectric strength nylon or flame retardant material.

FREE Samples

RICHLOK® CORPORATION

5835 N. Tripp Ave. • Chicago, Ill. 60646 • (312) 539-4061

Adhesives

A brochure covers the company's services related to the selection of adhesive, formulation, adhesive audits, make-or-buy decisions, effect of adhesive on ecology and troubleshooting adhesive problems. Arthur D. Little, Cambridge Mass.

CIRCLE NO. 334

Nylon bushings

A 20-page catalog illustrates strain-relief bushings, insulating, bushings, hole plugs, cable clamps, lab kits, construction bushings, terminal bushings and assembly tools. All dimensions, applications and installation instructions are covered. Heyman Manufacturing, Kenilworth, N.J.

CIRCLE NO. 335

Long-life klystrons

A full range of reflex klystrons is described in a 12-page catalog. EMI Electronics and Industrial Operations, Middlesex, England.

CIRCLE NO. 336

Trimmer resistors

A 16-page catalog describes trimmer resistors with PC mounts. The catalog features an easy-to-specify part-numbering system which simplifies ordering of standard trimmer resistors and options. Centralab, Milwaukee, Wis.

CIRCLE NO. 337

Rf connectors

Subminiature coaxial connectors—offering 0-to-6-GHz performance—are described in a brochure. The six-page brochure provides electrical, environmental and mechanical details, along with appropriate VSWR/frequency charts. Ampenol Rf Div., Danbury, Conn.

CIRCLE NO. 338

Wrapped-wire modules

Two high density wrapped-wire modules for users of the PDP-11 series computers and logic modules are described in a bulletin. The bulletin contains features along with specifications, prices and a delivery schedule. Photographs, application notes and a comparison between the company's and equivalent DEC boards are included. California Data Processors, Santa Ana, Calif.

CIRCLE NO. 339

High freq instrumentation

Ten instruments for rf and microwave applications are described in a 12-page pamphlet. Included are specifications for reflectometers, admittance meters, standing-wave meters, bridges, slotted lines, detectors, amplifiers and precision directional couplers. General Radio, Concord, Mass.

CIRCLE NO. 340

Instrumentation amplifiers

The AM-200 series of differential input instrumentation amplifiers is detailed in a six-page brochure. The brochure contains application information, including typical wiring diagrams. Datel, Canton, Mass.

CIRCLE NO. 341

Lexan

The 14 outstanding properties of Lexan that account for its growing use in the electronics industries—complete with "case history" uses—are described in an eight-page brochure. Commercial Plastics & Supply Corp., Cornwells Heights, Pa.

CIRCLE NO. 342

HP Journal index

An index to five years' issues of the HP Journal is available. The issues of Sept., 1968, through Aug., 1973, are indexed chronologically and by subject in a 16-page leaflet. Hewlett-Packard, Palo Alto, Calif.

CIRCLE NO. 343

Digital multipoint recorder

A 64-page brochure describes the evolution of multipoint data logging through the usual analog and digital approaches to the modern Digitrend 200 method. Doric Scientific, San Diego, Calif.

CIRCLE NO. 344

Minicomputer interfacing

A 196-page reference source, "Minicomputer Interfacing," is based upon an international symposium held at the Polytechnic of Central London and has been compiled from the edited papers and from invited supplementary material. Copies are available at a price of £7. Miniconsult, 35 Richmond Ave., London N1 England.

INQUIRE DIRECT

Position Sensing Detectors

UDT manufactures a wide variety of light and laser position sensing detectors.

Unique LSC series offers continuous single axis detection up to nine inches in length with resolution accuracy of .0001".

The POSICON SPOT CONTINUOUS series offers exact light spot position indication over a complete surface of the detector.

UDT SPOT SERIES two or four element detectors are ideally suited for null indication and conventional position indication. Write for paper, "Techniques For Using The Position Sensitivity of Silicon Photodetectors To Provide Remote Machine Control," by Brian O. Kelly and Robert I. Nemhauser.

Write or call today, United Detector Technology, 1732 21st St., Santa Monica, Calif. 90404, telephone number: (213) 829-3357.



UNITED DETECTOR TECHNOLOGY, INC.

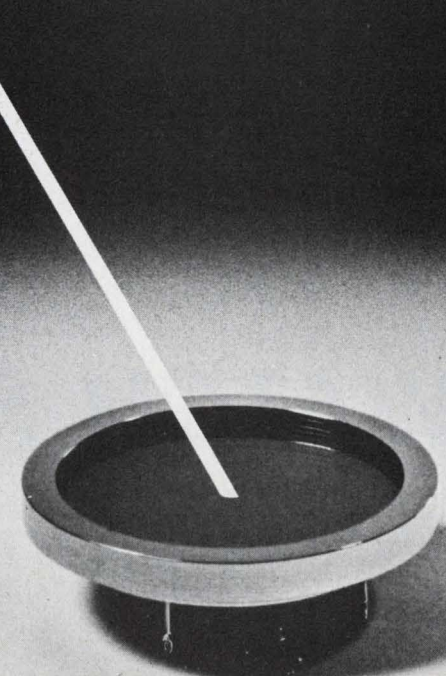

Electronic Design's

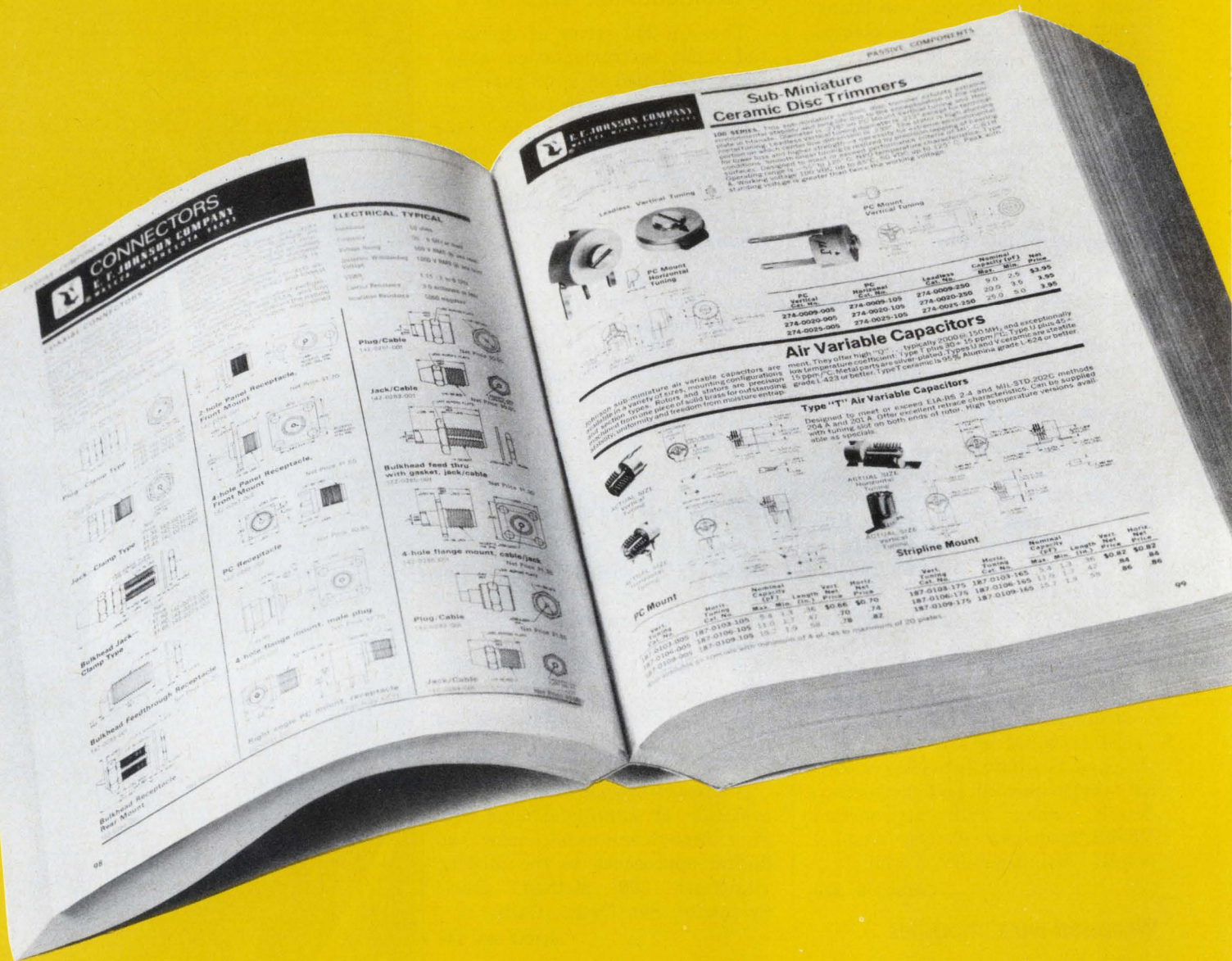

CONNECTORS E.F. JOHNSON COMPANY SOLDERS: 1954, 1957, 1961, 1967

ELECTRICAL TYPICAL

- Resistance: 50 ohms
- Impedance: 50 or 75 ohms
- Capacitance: 100 pF max. @ 100 MHz
- Insulation Resistance: 1000 MΩ min.
- Dielectric Constant: 2.0
- Temperature Coefficient: 100 ppm/°C max.

Plug/Cable (Part No. 101)

Jack/Cable (Part No. 102)

2-hole Panel Receptacle, Front Mount (Part No. 103)

4-hole Panel Receptacle, Front Mount (Part No. 104)

PC Receptacle (Part No. 105)

4-hole Flange mount, cable/jack (Part No. 106)

Plug/Cable (Part No. 107)

Jack/Cable (Part No. 108)

4-hole Flange mount, male plug (Part No. 109)

Bulkhead Jack, Clamp Type (Part No. 110)

Bulkhead Feedthrough Receptacle (Part No. 111)

Bulkhead Receptacle, Rear Mount (Part No. 112)

E.F. JOHNSON COMPANY SOLDERS: 1954, 1957, 1961, 1967

Sub-Miniature Ceramic Disc Trimmers

100 SERIES. This sub-miniature trimmer uses common electronic ceramic materials and is available in both 100 and 200 ohm values. It is designed for use in a wide variety of applications where a trimmer is required. The trimmer is available in both 100 and 200 ohm values. It is designed for use in a wide variety of applications where a trimmer is required. The trimmer is available in both 100 and 200 ohm values. It is designed for use in a wide variety of applications where a trimmer is required.

Leadless Vertical Tuning

PC Mount Horizontal Tuning

PC Mount Vertical Tuning

PC Cat. No.	PC Mount Cat. No.	Leadless Cat. No.	Nominal Capacitance (pF)	Max. Price
274-0009-005	274-0009-105	274-0009-250	9.0	\$3.95
274-0020-005	274-0020-105	274-0020-250	20.0	3.50
274-0025-005	274-0025-105	274-0025-250	25.0	3.95

Air Variable Capacitors

Sub-miniature air variable capacitors are available in a variety of sizes, mounting configurations and mounting types. Rotors and stators are precision machined from the best of solid brass for outstanding stability, uniformity and freedom from moisture entrapment. They offer high Q's - typically 20000; 150 MHz, and exceptionally low temperature coefficient. Type U gives 30 - 10 ppm/°C. Type U also available with tuning slot on both ends of rotor. High temperature versions available as special.

Type "T" Air Variable Capacitors

Designed to meet or exceed EIA-195 2-A and MIL-STD-202C methods 204 A and 201 B. Offer excellent reverse characteristics. Can be supplied with tuning slot on both ends of rotor. High temperature versions available as special.

PC Mount

Part No.	Max. Min. Length (in.)	Max. Min. Price
187-0103-105	1.0 - 1.7	\$0.66 - \$0.70
187-0106-105	1.0 - 1.7	70 - 74
187-0109-105	1.0 - 1.9	78 - 82

Stripline Mount

Part No.	Max. Min. Length (in.)	Max. Min. Price
187-0103-175	0.4 - 1.3	\$0.82 - \$0.88
187-0106-175	0.4 - 1.3	84 - 86
187-0109-175	0.4 - 1.3	86 - 88

WATCH FOR IT... JULY 1974

GOLD BOOK

MASTER CATALOG AND DIRECTORY OF SUPPLIERS TO ELECTRONICS MANUFACTURERS

PUTS THE ELECTRONICS INDUSTRY AT YOUR FINGERTIPS

- **MAKES ALL OTHER MASTER DIRECTORIES SEEM OBSOLETE**
- **A COMPLETE ONE-STEP PURCHASING TOOL**
- **MORE DIRECTORY LISTINGS AND INFORMATION THAN EVER PUBLISHED BEFORE**
- **52 PRODUCT CATEGORIES**

If you've never used a directory before, *Electronic Design's* GOLD BOOK will amaze you with its convenience and utility. Manufacturers' catalogs, spec sheets, and application data notes will be right on your desk in one convenient package. The directory listings are the most complete and detailed to date. From mid-year on you'll be referring to it daily for purchasing information and catalog data. It's the most massive compendium of product information ever compiled . . . the one-step purchasing and reference source that can save you untold hours in the search, selection and specification of the products you need.

Another FREE Service for Readers From...

Electronic Design

ATTENUATORS

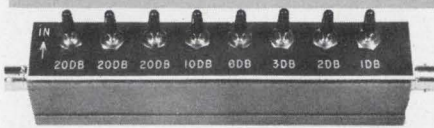

MODEL AT-42 1-9 QUANTITY \$70.00
 • ATTENUATION RANGE 0-42 DB IN 1 DB STEPS
 • IMPEDANCE 50 Ω OR 75 Ω
 • FREQUENCY RANGE DC TO 300 MC

MODEL AT-82 1-9 QUANTITY \$85.00
 • ATTENUATION RANGE 0-82 DB IN 1 DB STEPS
 • IMPEDANCE 50 Ω OR 75 Ω
 • FREQUENCY RANGE DC TO 300 MC

CHECK READER SERVICE #71

CRYSTAL OSCILLATORS

MODEL EXO-10

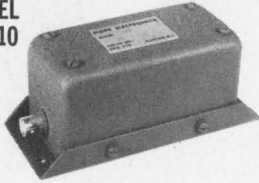

FROM
\$85.00

Stability 0.005%
 Operating Temperature Range 0°C to +70°C
 Power Out >10 Milliwatts into 50 Ω
 Spurious & Harmonic
 Distortion >25 db down
 Frequency Range 1-300 mc
 Input Power -15 vdc

CHECK READER SERVICE #72

HOPE ELECTRONICS

BOX 773, CLIFTON, N.J. 07013 (201) 777-3522

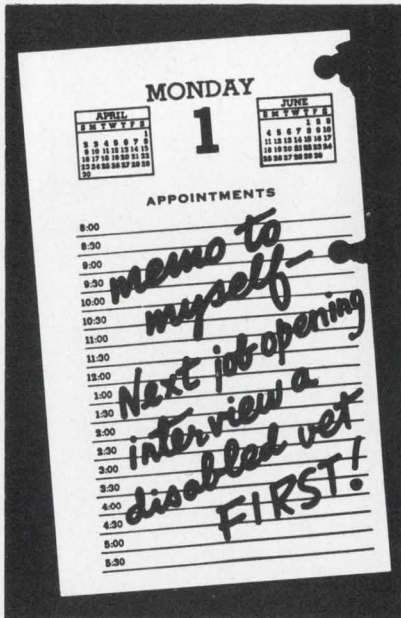

The President's Committee
 on Employment of the Handicapped
 Washington, D.C. 20210

bulletin board

Philips has introduced a prototype service called "Quick Street" that can provide a customer with up to 10 complex PC boards in a matter of days.

CIRCLE NO. 345

Grayhill has expanded its series 71 miniature rotary switch line to include a PC mountable version that has all terminals on one side of the switch so it can be inserted into a single PC board.

CIRCLE NO. 346

A series of monolithic CMOS three-state interface circuits for use in common bus design applications has been announced by Harris Semiconductor. The devices, designated HD-4800, are an extension of the 4000 series and form circuits with gating functions that allow information to pass through a system or be disconnected from the system.

CIRCLE NO. 347

Complete services for the fabrication of thick-film hybrid micro-electronic circuits to customer specifications are now offered by Tek-wave.

CIRCLE NO. 348

Price reductions

Prices have been cut up to 37% on four of Hewlett-Packard's microwave silicon IMPATT diodes. Prices of two 1-W units, Models 5082-0424/0425, have been reduced from \$150 to \$95 (1-9) and from \$110 to \$75 (10-99). Two 1/2-W IMPATT diodes, Models 5082-0400/0401, have been reduced from \$95 to \$70 (1-9) and from \$75 to \$55 (10-99).

CIRCLE NO. 349

Fairchild Camera & Instrument Corp. has reduced the price of its 95410 256-bit ECL RAM from \$27 to \$21 (100 to 999). The single unit price is \$31.50. Fairchild has also reduced the price of a 10-k compatible memory, the F10405 ECL 128-bit device, from \$48 to \$15 (100 to 999).

CIRCLE NO. 350

vendors report

Annual and interim reports can provide much more than financial-position information. They often include the first public disclosure of new products, new techniques and new directions of our vendors and customers. Further, they often contain superb analyses of segments of industry that a company serves.

Selected companies with recent reports are listed here with their main electronic products or services. For a copy, circle the indicated number.

Redactron. Editing typewriters and peripheral equipment.

CIRCLE NO. 351

Coherent Radiation. Commercial laser products.

CIRCLE NO. 352

Recognition Equipment. Ink-jet printers, financial transaction processing systems, postal automation systems, data-entry systems and point-of-sale wands.

CIRCLE NO. 353

Bendix Corp. Automotive electronics and aerospace equipment.

CIRCLE NO. 354

Varian Associates. Power and special-purpose tubes, solid-state products, test and measurement instrumentation, medical electronics, computer systems, vacuum equipment and surface-coating systems.

CIRCLE NO. 355

Veeco Instruments. High vacuum and power-supply products and power monolithic integrated circuits.

CIRCLE NO. 356

Globe-Union. Batteries, monolithic ceramic capacitors, automotive electronics and telecommunications.

CIRCLE NO. 357

Wavetek. Electronic test instruments and data communications equipment.

CIRCLE NO. 358

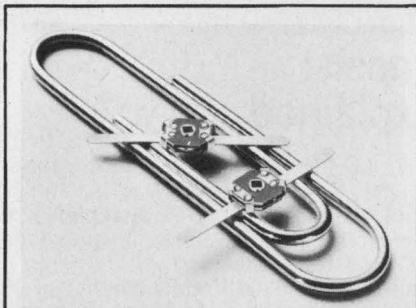

Thin-Trim variable capacitors provide a reliable means of adjusting capacitance without abrasive trimming or interchange of fixed capacitors. Series 9401 has high Q's and a range of capacitance values from 0.2-0.6 pf to 3.0-12.0 pf and 250 WVDC working voltage. Johanson Manufacturing Corporation, Boonton, New Jersey (201) 334-2676.

INFORMATION RETRIEVAL NUMBER 181

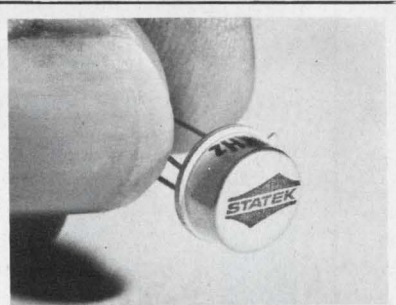

Don't count down. Use SX-1 10 kHz - 300 kHz Quartz Crystals • 20 stock frequencies • 0.185" high TO-5 • 1000g shock & 50g vibration • \$2.00 ea. in 1000 qty. ($\pm 0.01\%$ accuracy) • STATEK CORP. • 1233 Alvarez Ave. • Orange, Calif. 92668 • (714) 639-7810 • Telex 65-5430.

INFORMATION RETRIEVAL NUMBER 182

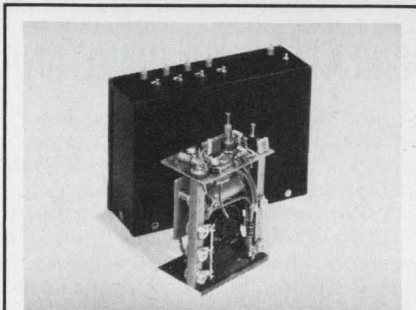

Modular DC-DC power converters. Designed to meet military/aerospace specs . . . priced for industrial applications. 12, 28, 48, 115 VDC inputs. 1-6 isolated, regulated (1% & 0.1%) outputs. 1-500 watts. Efficiencies to 85%. 1200 design-as-you-order configurations using standard modules. Arnold Magnetics, Culver City, Ca. (213) 870-7014.

INFORMATION RETRIEVAL NUMBER 183



A collector's item . . . 20th anniversary issue of Electronic Design (11/23/72) salutes 25th anniversary of the transistor, features milestones in design over past quarter century. Rare nostalgic view of industry. Fascinating reading. \$2 per copy pre-paid. Checks, money orders: Electronic Design, Promotion Mgr., 50 Essex St., Rochelle Park, N.J. 07662.

INFORMATION RETRIEVAL NUMBER 184

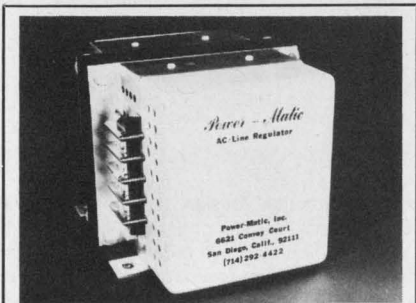

Ultra high efficient ac regulators for BROWN-OUT and nominal ac power. Features: 99% efficiency, $\frac{1}{2}$ cycle step response, no generated noise or distortion, small size and low cost. Write or call for literature and application notes. Models from 250VA to 15KVA. POWER-MATIC, INC., 8057 Raytheon Rd., San Diego, Ca. 92111, (714) 292-4422.

INFORMATION RETRIEVAL NUMBER 185

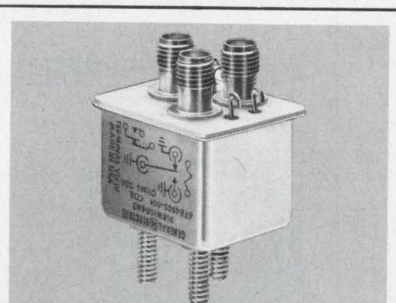

For critical RF switching GE offers space-proven relays with co-axial connections. Welded construction, hermetically sealed, removes dangers of exposed arcing of open relays. Reliability failure rates to .01%/10,000. RF switching up to 150 watts and auxiliary contacts for microvolt signals to 2 amps. Less than 1 cu. in. GE, Waynesboro, Va.

INFORMATION RETRIEVAL NUMBER 186

Advertisers wishing to reserve Quick Ad units should note the following mechanical requirements: Specs—Supply glossy photo of product and approximately 40 words which will set no more than 10 lines of 34 characters each. AFTER SUBMISSION NO COPY CHANGES CAN BE ACCEPTED. Quick Ads cost only \$300 per insertion, less for frequency advertisers.

RATES:

1x
\$300

7x
\$280

13x
\$255

19x
\$250

26x
\$245

39x
\$240

52x
\$235

104x
\$230

ELECTRONIC DESIGN's function is:

- To aid progress in the electronics manufacturing industry by promoting good design.
- To give the electronic design engineer concepts and ideas that make his job easier and more productive.
- To provide a central source of timely electronics information.
- To promote communication among members of the electronics engineering community.

Want a subscription? ELECTRONIC DESIGN is sent free to qualified engineers and engineering managers doing design work, supervising design or setting standards in the United States and Western Europe. For a free subscription, use the application form bound in the magazine. If none is included, write to us direct for an application form.

If you do not qualify, you may take out a paid subscription for \$30 a year in the U.S.A., \$40 a year elsewhere. Single copies are \$1.50 each.

If you change your address, send us an old mailing label and your new address; there is generally a postcard for this bound in the magazine. You will have to requalify to continue receiving ELECTRONIC DESIGN free.

The accuracy policy of ELECTRONIC DESIGN is:

- To make diligent efforts to ensure the accuracy of editorial matter.
- To publish prompt corrections whenever inaccuracies are brought to our attention. Corrections appear in "Across the Desk."
- To encourage our readers as responsible members of our business community to report to us misleading or fraudulent advertising.
- To refuse any advertisement deemed to be misleading or fraudulent.

Microfilm copies are available of complete volumes of ELECTRONIC DESIGN at \$19.00 per volume, beginning with Volume 9, 1961. Work is now in process to complete the microfilm edition of Volumes 1-8. Reprints of individual articles may be obtained for \$2.00 each, prepaid (\$.50 for each additional copy of the same article) no matter how long the article. For further details and to place orders, contact the Customer Services Department, University Microfilms, 300 North Zeeb Road, Ann Arbor, Michigan 48106 telephone (313) 761-4700.

Want to contact us? If you have any comments or wish to submit a manuscript or article outline, address your correspondence to:

Editor
ELECTRONIC DESIGN
50 Essex Street
Rochelle Park, N.J. 07662

Noise/Vibration Diagnosis: Real-Time Analysis Explained

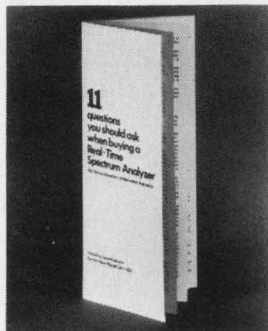

Informative booklet answers the 11 most-asked questions on what a real-time analyzer is, and how it can be used to diagnose complex machinery and trace sources of noise. It answers such questions as:

- Why do I need real time?
- How much resolution do I really need?
- Can I calibrate frequency and amplitude quickly and accurately?
- Do I need spectrum averaging?
- How can I compare past data with new data?
- How do I know I am analyzing (or averaging) valid data?
- Can I interface to my computer?

Federal Scientific Corp.

An affil. of Nicolet Instrument
615 West 131st St., New York, N.Y. 10027 (212) 286-4400

CIRCLE NO. 171

SELECTIVE AMPLIFIER/OSCILLATOR AND WAVE ANALYZER

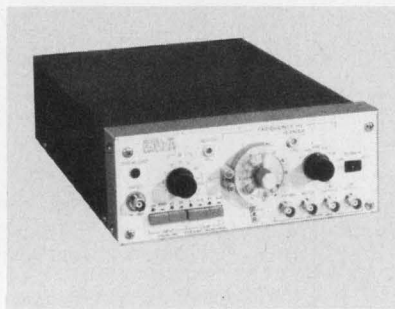

A new selective amplifier/oscillator, the Model 189, providing bandpass, notch, high-pass, and low-pass filtering with tunable center/corner frequency and variable Q is described in Princeton Applied Research's bulletin T-326. The bulletin will be of interest to everyone involved in the measurement of weak signals in the presence of wideband noise or strong interfering signals, or in other applications requiring narrowband filtering. It will also be of interest to those requiring an economical wave/distortion analyzer, narrowband noise source or two-phase oscillator.

Princeton Applied Research Corporation

P.O. Box 2565
Princeton, New Jersey 08540 (609) 452-2111

CIRCLE NO. 172

400 IDEAS FOR DESIGN Volume 2

Edited by Frank Egan

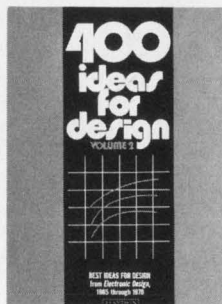

A unique sourcebook of practical design techniques and approaches using the latest components, representing the best contributions to *Electronic Design's* "Ideas for Design" column. All selected for their practical value in solving the design engineer's most common, everyday problems. They have proved useful as parts of larger designs or as aids in measuring the parameters and testing the effectiveness of existing designs. 288 pp., 7 1/8 x 9 3/4, illus., cloth, \$11.95. **Circle the reader-service number to order a 15-day examination copy.**

CIRCLE NO. 173



HAYDEN BOOK COMPANY, INC., 50 Essex St., Rochelle Park, N.J. 07662

Manufacturers

Advertisements of booklets, brochures, catalogs and data sheets. To order use Reader-Service Card
(Advertisement)

DIGITAL FOURIER ANALYSIS SYSTEM 306

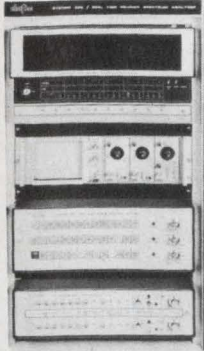

Provides complete spectral, cross spectral, correlation, cross correlation and related analysis.

- One Push Button per function eliminates programming.
- Simultaneous display of two spectra or phase and magnitude.
- Digital storage provides uninterrupted display (flicker-free).
- Drives two XY Plotters simultaneously (doubles throughput).
- Zoom FFT analysis for super high resolution.
- Unique Fourier-Fortran™ for your own non-standard or automated analysis.
- 1/3 and 1/15 octave analysis.

OPTIONAL: Magnetic tapes and discs, high speed plotters, multi processor configurations, multi channel analog multiplexer, teletypes and CRT Terminals.

ALSO AVAILABLE: Medium and high speed hardwired FFT and general purpose array processors for Data General Nova Computers.

ELSYTEC INC.

212 Michael Drive, Syosset, N.Y. 11791
Phone (516) 364-0560

CIRCLE NO. 174

PRACTICAL RELAY CIRCUITS

By Frank J. Oliver

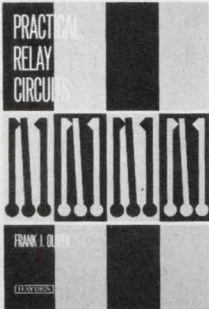

Uniquely groups various relay circuits according to the functions they perform, enabling the systems designer to quickly select the best circuit for his specific purposes. Includes arc and RFI suppression systems; time delay function; audio tone control and resonant-reed relays; sequential relays; protective functions of relays against overload overvoltage, and overcurrent, pulse generation and detection; logic circuits; and more. Particularly important is coverage of pulse-operated relay systems now extensively used with automated control systems. Illustrated with many circuit diagrams using the latest American National Standard graphical symbols. 363 pp., 6 x 9 1/4, illus., cloth, \$14.95. **Circle the reader-service number to order a 15-day examination copy.**

CIRCLE NO. 175



HAYDEN BOOK COMPANY, INC., 50 Essex St., Rochelle Park, N.J. 07662

Free—25 Ideas—How to use a Spectrum Analyzer

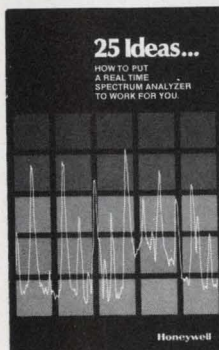

New 32-page booklet describes ways of putting a real time spectrum analyzer (RTA) to work. Explains spectrum analysis, real time analysis and digital integration. 25 IDEAS suggests uses in machinery vibration, acoustics, industrial noise, speech analysis, medicine, military, research and many more applications ideas.

SIGNAL ANALYSIS OPERATION HONEYWELL, INC.

595 Old Willets Path, Hauppauge, N. Y. 11787 (516) 234-5700

CIRCLE NO. 176

Electronic Design

Advertising Sales Staff

Tom W. Carr
Vice President &
Sales Manager

Rochelle Park, N.J. 07662

Robert W. Gascoigne
Daniel J. Rowland
(Recruitment, Quick Ads, Classified)
50 Essex Street
(201) 843-0550
TWX: 710-990-5071

Philadelphia

Thomas P. Barth
50 Essex Street
Rochelle Park, N.J. 07662
(201) 843-0550

Boston 02178

Gene Pritchard
P.O. Box 379
Belmont, Mass. 02178
(617) 489-2340

Chicago 60611

Thomas P. Kavooras
Berry Conner, Jr.
200 East Ontario
(312) 337-0588

Cleveland

Thomas P. Kavooras
(Chicago)
(312) 337-0588
(call collect)

Los Angeles 90303

Stanley I. Ehrenclou
Burt Underwood
2930 Imperial Highway
Inglewood, Calif.
(213) 757-0183

San Francisco 94022

Jerry D. Latta
P.O. Box 1248
Los Altos, Calif.
(415) 965-2636

London

For United Kingdom and Europe
John Ashcraft
John Ashcraft & Co.
12, Bear St.
Leicester Square
London WC2H 7AS England
Phone: 01-930-0525
W. J. M. Sanders
John Ashcraft & Co.
Herenracht 365
Amsterdam C., Holland
Phone: 020-24-09-08

Tokyo

Haruki Hirayama
Electronic Media Service
5th Floor, Lila Bldg..
4-9-8 Roppong
Minato-ku
Phone: 402-4556
Cable: Electronicmedia, Tokyo



DO COLLEGES HELP BUSINESS AS MUCH AS BUSINESS HELPS COLLEGES?

Yes, they do. But not in the same proportion.

Business contributes about 15% of the total voluntary support received by colleges.

But today, business gets half the college-trained people who are employed. Tomorrow, it will need even more.

As a result, businessmen should think seriously about increasing the level of corporate giving to education. Can you, as a businessman, think of a better investment?

For the latest national figures on corporate giving to higher education, write on your letterhead for "CFAE Survey of Corporation Support of Higher Education," and enclose \$2.00 to help cover costs. Mail to: Council for Financial Aid to Education, 6 East 45th Street, New York, N.Y. 10017.

Give to the college of your choice. Now.



Advertising contributed for the public good.

advertiser's index

Advertiser	Page	Advertiser	Page
AMP, Incorporated	91	Mini-Circuits Laboratory	103
Abbott Transistor Laboratories, Inc.	6	Monsanto Commercial Products Co.	63
Acopian Corp.	75	Mostek Corporation	28, 29
Arnold Magnetics Corp.	109	Motorola Semiconductor Products, Inc.	8, 9, 16
Ballantine Laboratories, Inc.	104	Nichicon Corporation	18A
Beckman Instruments, Inc.		North Atlantic Industries, Inc.	97
Helipot Division	10, 11	North Electric Company	57
Bliley Electric Co.	62	Optron, Inc.	7
Cincinnati Sub-Zero Products, Inc.	101	Paktron, Division Illinois Tool Works, Inc.	73
Colorado Video, Incorporated	69	Piher International Corp.	39
Connecticut Hard Rubber Co., The ..	114	Plessey Semiconductors	77
Dale Electronics, Inc.	Cover II	Power Tech, Inc.	102
Delco Electronics, Division of General Motors Corporation	22, 23	Powermatic	109
Dialight Corporation	44	Princeton Applied Research Corp.	110
Dow Corning Corporation	14, 15	RCA Electronic Instruments	18
EMR Telemetry, Weston Instruments, Inc.	95	RCA Solid State Division	Cover IV
Efratom California, Inc.	100	Radio Research Instrument Co., Inc.	102
Electronic Design	81, 109	Rhombus Industries, Inc.	94
Elsytec, Inc.	111	Richlok Corporation	104
Federal Scientific Corporation	110	Scientific Research Corp.	79
Ferroxcube Corporation	93	Signal Analysis Operation	111
Futaba Industries	13	Signetics Corporation	18B, 18C
General Electric Company	17, 109	Siliconix, Incorporated	48
General Instrument Corporation	100	Solitron Devices, Inc.	101
Gold Book, The	106, 107	Sprague Electric Company	99
Grayhill, Inc.	86	Stacoswitch	90
Hayden Book Company, Inc.	10, 11, 110, 111	Statek Corp.	109
Heath Company	62	Syntronic Instruments, Inc.	87
Hewlett-Packard	1, 4, 5, 18D, 20, 21, 27, 41	TRW/Cinch Connectors, an Electronic Components Division of TRW, Inc.	35
Hope Electronics	108	TRW/IRC Resistors, an Electronic Components Division of TRW, Inc.	89
Hughes Aircraft Company, Electron Dynamics Division	37	Tecnetics, Inc.	96
Instrument Specialties Company, Inc.	85	Technical Research and Manufacturing, Inc.	12
International Microcircuits, Inc.	101	Tektronix, Inc.	47
Jermyn Industries	24	Teledyne Relays, A Teledyne Company	2
Johanson Manufacturing Corp.	109	Test & Measuring Instruments, Inc.	42, 43
Keithley Instruments, Inc.	33	Texscan Corporation	101
3M Company	Cover III	United Detector Technology, Inc.	105
Micro Networks Corporation	98	Varian Electron Tube and Device Group	42, 43
Microwave Associates	31	Wavetek Indiana Incorporated	82
		Woven Electronics	19

recruitment
and
classified ads

COILS TOROIDS - BOBBINS
Self-Supporting



OLIVAX
GRANBY, QUEBEC
CANADA
Tel: (514) 378-9977 - TWX 610-532-6510

IMMEDIATE DELIVERY
Minis & Peripherals
DEC - HIS - NOVA
SEL - HP - MOHAWK

CPU, Card, Printer, Tape, Disk
NEW • MOHAWK 4320
PRINTERS

PDP11 PERIPHERALS
CPU, MEMORY

PDP 8 CPU \$1500

\$750 Minis

TELETYPE 35 & 37
DEC & HONEYWELL Modules
617/261-1100

Send for Free Report "Maintenance of Computers"

AMERICAN USED COMPUTER CORP.
P.O. Box 68, Kenmore Sta.
Boston, MA 02215
"Members Computer Dealers Association"

CIRCLE NO. 210

SCOPES UNLIMITED IS NOT LIMITED TO SCOPES
Complete line of new and used electronic test equipment.
SCOPES UNLIMITED, INC.
1938 S. Anaheim Blvd.
Anaheim, Ca. 92805
(714) 772-0330
East Coast Office (617) 894-5670

ENGINEERS
Over 15 years of Engineering and Professional placement coast to coast. Entry level to Management with openings cutting the spectrum of the engineering disciplines. All fees paid.
E. B. HENDRICK ASSOCIATES, INC.
"The Village Mall", Vine Street
Liverpool, NY 13088
Phone: 315-451-0121



Take stock in America.

Buy U. S. Savings Bonds

Now E Bonds pay 5½% interest when held to maturity of 5 years, 10 months (4% the first year). Bonds are replaced if lost, stolen, or destroyed. When needed they can be cashed at your bank. Interest is not subject to state or local income taxes, and federal tax may be deferred until redemption.



The U. S. Government does not pay for this advertisement, it is presented as a public service in cooperation with The Department of the Treasury and The Advertising Council.

FOR LESS THAN
\$6.00

SUB-ASSEMBLIES
Per loaded hour



OLIVAX
GRANBY, QUEBEC
CANADA
Tel: (514) 378-9977 - TWX 610-532-6510

**PERSONNEL
RECRUITMENT
ADVERTISING**

IN

Electronic Design

**REACHES THE
RIGHT PEOPLE
AT A LOWER COST
PER THOUSAND**

*Call the
HOTLINE
today
for complete
information:
(201) 843-0550
extension 203*



flame out



Flame retardant, polyester TEMP-R-TAPE M67 passes U/L and ASTM requirements. This outstanding flame retardant safety feature, in combination with the excellent electrical and physical properties of polyester film backing provides you with a self-adhering tape for use in a wide variety of coil winding, coil holding, harness wrapping and other electrical/mechanical applications. It is especially valuable for radio and tv appliances to reduce fire and electrical shock hazards.

Find your nearest distributor in the "Yellow Pages" or in industrial directories. Or write The Connecticut Hard Rubber Company, New Haven, Connecticut 06509.



an ARMCO company

INFORMATION RETRIEVAL NUMBER 73

product index

Information Retrieval Service. New Products, Evaluation Samples (ES), Design Aids (DA), Application Notes (AN), and New Literature (NL) in this issue are listed here with page and Information Retrieval numbers. Reader requests will be promptly processed by computer and mailed to the manufacturer within three days.

Category	Page	IRN	Category	Page	IRN
Components			scope, 15-MHz	62	35
capacitors	73	38	standard, frequency	100	60
capacitors	99	58	sweeper	82	43
coupler, optical	9	7	synthesizers	86	263
indicator, fuse	92	281	tester, telegraph	88	270
opto-electronics	7	6	tester, transistor	88	273
potentiometer, dc	92	285			
quartz crystals	62	34	Microwaves & Lasers		
resistor	11	246	attenuators	108	71
resistor, high volt.	92	283	amplifier, S-band	83	252
resistor networks	11	8	amplifier, transistor	83	251
resistors	18	15	isolators, microwave	83	254
switch, slide	92	282	laser system, port.	83	253
switches, pushbutton	90	49	multiplier, YIG-tuned	84	260
switches, rotary	102	66	oscillators, Gunn	84	261
transformers, rf	103	67	oscillators, Gunn	84	262
timer, solid-state	92	284	oscillators, YIG-tuned	84	257
yokes, precision	87	46	preamplifier, i-f	83	256
			shifters, phase	84	259
			sweeper, solid-state	83	250
Data Processing					
calculators, prog.	23	19	Modules & Subassemblies		
controller, data com	95	291	amplifier, s/h	100	304
delays, clock	94	53	converter, a/d	100	305
digitizer, tablet	94	287	filters, low-pass	91	50
interface, computer	97	296	amplifier, i-f	79	41
memory, cassette	94	290	modules, s/d and d/s	97	56
memory, core	96	294			
memory, disc	96	293	Packaging & Materials		
minicomputer	94	289	ceramic, zirconic	102	321
modem, data	94	288	chambers, test	101	64
reader, card	96	295	connector, multipin	102	320
readings, instrument	97	298	connector system	111	247
			contact strips	85	45
Discrete Semiconductors			heat sink	15	12
diode, Schottky	90	275	interconnects	19	16
SCR	90	278	kit, desolder	103	323
sensor, noncontact	90	277	torch, gas	103	325
switch, pushbutton	90	276			
transistors	5	4	Power Sources		
transistors, Darlington	91	279	supplies, power	6	5
transistors, silicon	102	65	supply, power	57	33
Integrated Circuits			new literature		
CMOS	101	63	adhesives	105	334
chips, calculator	100	59	amplifiers, instrum.	105	341
decoders, CMOS	16	13	analyzers, FFT	104	330
IC, monolithic	98	300	calculations	104	332
op amp, monolithic	98	302	connectors, high-density	104	329
oscillator, crystal	98	299	connectors, rf	105	338
RAM, CMOS	98	301	DPMs	104	328
			HP journal index	105	343
Instrumentation			instrumentation		
amplifier	88	271	high frequency	105	340
analyzer, spectrum	95	54	klystrons, long-life	105	336
converter, a/d	88	274	modules, wrapped-wire	105	339
counter	88	272	recorders, digital	105	344
counter	104	68	resistors, trimmer	105	337
DMM	86	264	sapphire products	104	333
DMM, autoranging	33	23	supplies, power	104	331
generator, function	86	266	transistors, rf	104	326
probe, logic	87	268			
recorder	87	267			
scope	86	265			

“Scotchflex” Flat Cable Connector System makes 50 connections at a time.



“SCOTCHFLEX” IS A REGISTERED TRADEMARK OF 3M CO.

Build assembly cost savings into your electronics package with “Scotchflex” flat cable and connectors. These fast, simple systems make simultaneous multiple connections in seconds without stripping or soldering. Equipment investment is minimal; there’s no need for special training. The inexpensive assembly press, shown above, crimps connections tightly, operates easily and assures error free wiring.

Reliability is built in, too, with “Scotchflex” interconnects. Inside of connector bodies, unique U-contacts strip through flat cable insulation, grip each conductor for dependable gas-tight connections.

“Scotchflex” offers you design freedom, with a wide choice of cable and connectors. From off-the-shelf stock you can choose: 14 to 50-conductor cables. Connectors to interface with standard DIP sockets, wrap posts on standard grid patterns, printed circuit boards Headers for de-pluggable connection between cable jumpers and PCB. Custom assemblies are also available on request.

For more information, write Dept. EAH-1, 3M Center, St. Paul, Minn. 55101.

**“Scotchflex” Your
systems approach
to circuitry.**



COS/MOS is Power Conscious

Plagued by expensive power supplies and cooling systems? Having a rough time trying to cram too many system functions into a mini-package? Heat causing a reliability problem?

"Yes" to any of these problems means you have a need for RCA COS/MOS IC's.

COS/MOS power dissipation is negligible at dc and increases linearly with frequency. Since many logic elements in a digital system are idle much of the time, or switch at lower rates than the maximum clock frequency, a substantial net power saving can be achieved with COS/MOS in comparison with other logic families whose dissipation remains constant with frequency.

For example, a Digital Clock with 21 COS/MOS IC's takes only 6.3 milliwatts for the countdown from a 262 KHz crystal and the logic to drive an hours, minutes and seconds display. A comparable TTL

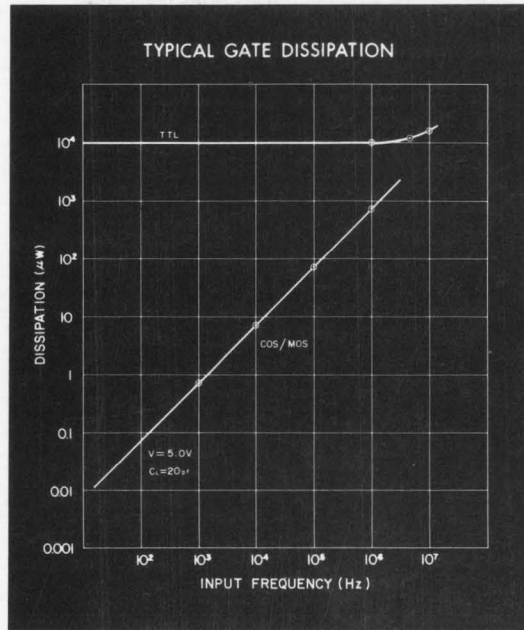

system will consume 600 milliwatts—a difference of almost 100 to 1 in power cost savings with COS/MOS.

Power conscious? You bet it is. But ultra-low power consumption is not the only great feature you get.

□ COS/MOS circuits

work from 3 to 15 volts, eliminating expensive regulators.

□ COS/MOS noise immunity is among the highest of any technology (typically 45% of supply voltage).

□ COS/MOS features stable transfer characteristics—less than 3.0% change over the full temperature range of -55°C . to $+125^{\circ}\text{C}$.

It all adds up to ease of use and cost-effective designs. Try it. You'll

be convinced that the digital world is a COS/MOS world.

Send for your guide to the ever-growing COS/MOS Product Family. Write: RCA Solid State, Section 57D-1,

Box 3200, Somerville, N.J. 08876.

Or phone: (201) 722-3200, Ext. 2565.

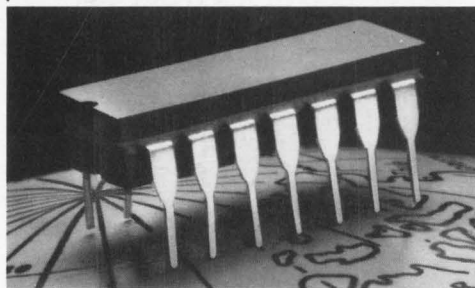

RCA Solid State
products that make products pay off