

Instrumentation is retreating? A strong advance to the rear is shaping up, with performance reduced for meters, counters, scopes and signal sources. But

reduced prices may help you appreciate this trend. For a look at what to watch for and what to watch out for in instrumentation, start reading Focus on page 50.



Testing digital IC's?

8013A, \$625



8007A, \$1600

HP's new pulsers give you the most capability per dollar

If digital IC's are your big interest, HP's new 8000-Series pulse generators are for you. You not only get **versatile capability**, but you **save money** as well! These new pulsers offer you a choice of price/performance packages to meet your needs, within your budget—whether you're working with computers, communications, telemetry, or any other digital system.

The new 8007A gives you rep rates from 1 kHz to **100 MHz**, **variable transition times** (2.5 ns to 250 μ s), ± 5 V amplitude, and ± 2.5 V dc offset—all for **\$1600**. With the 8007A, you can design and test the fastest of today's digital devices—ECL IC's and bi-polar memories—and have "speed to spare" for tomorrow's advances.

If you don't need 100 MHz, you can save. For only **\$875**, you can get the new 8012A, which gives you rep rates from **1 Hz to 50 MHz**. Like the 8007A, it offers **variable transitions** from 5 ns to 0.5 s, with ± 5 V amplitude and ± 2.5 V dc offset.

If you don't need variable transitions, you can save even more. Our 8013A gives you rep rates from **1 Hz to 50 MHz** with a fixed transition time of **< 3.5 ns**, ± 5 V with dc offset, and dual outputs—all for **\$625**.

All three of these new pulsers give you pulse-shaping capabilities, allowing control of NRZ or RZ waveform parameters with the output width determined by the input waveform width. Normal external triggering and gating are also supplied.

The 8007A also gives you a double-
INFORMATION RETRIEVAL NUMBER 242

pulse mode, and all three models have square-wave capabilities. And the 8013A offers simultaneous positive and negative outputs, with ± 5 V amplitude across 50 Ω (± 10 V open-circuit or with high-impedance internal source).

Other HP pulse generators, listed in the catalog, begin as low as **\$225**.

For further information on any of these new 8000-Series pulsers, contact your local HP field engineer. Or write Hewlett-Packard, Palo Alto, California 94304. In Europe: 1217 Meyrin-Geneva, Switzerland.

081/11

HEWLETT  PACKARD
SIGNAL SOURCES

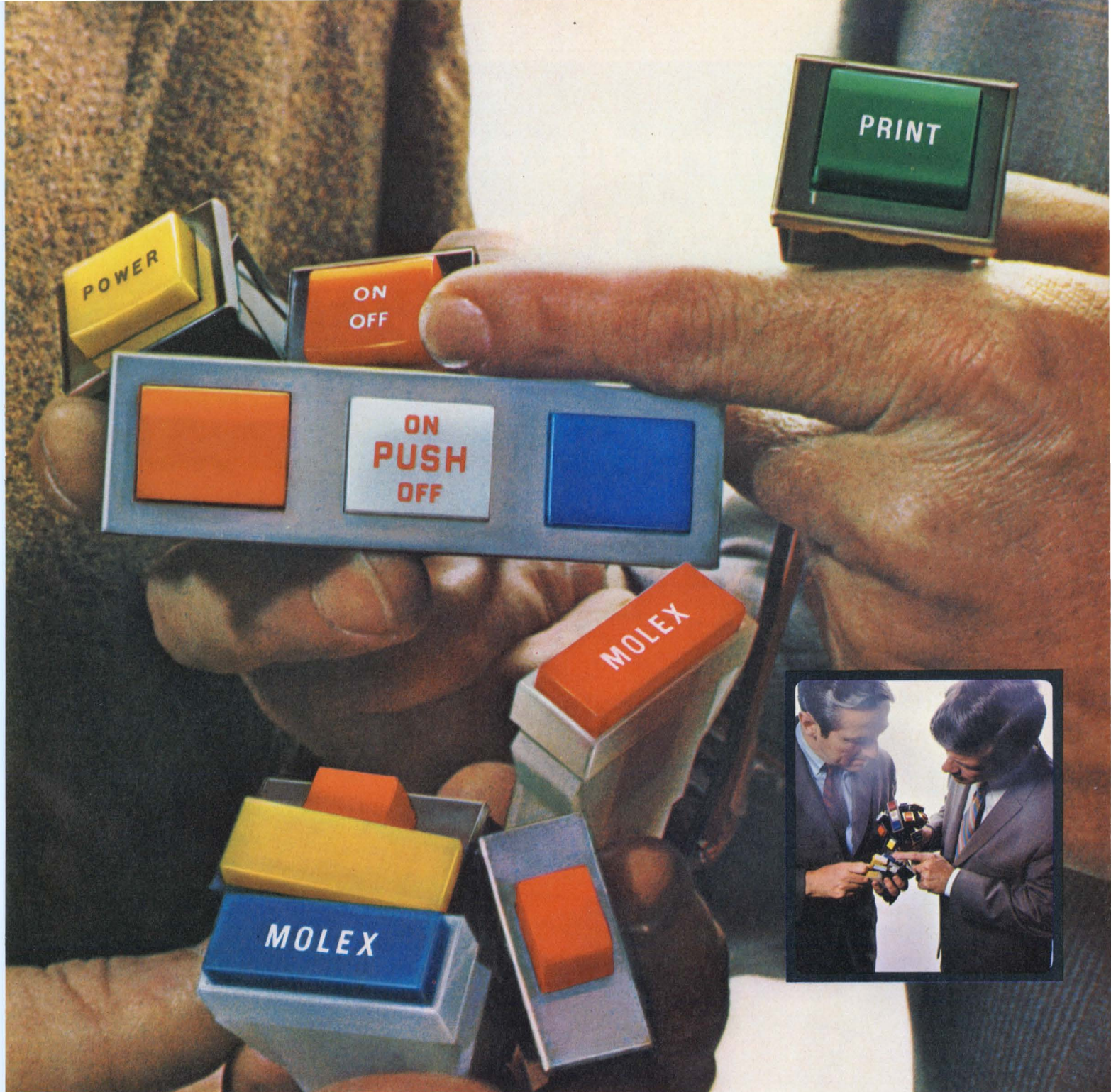

HERE ARE TWO EASY WAYS TO SOLVE LIGHTED PUSH BUTTON SWITCH PROBLEMS. Economically. Reliably. Fast. The Molex 1175 snap mounts. Offers spade or wire terminals for fast, easy assembly. A choice of nine colors, 500 variations. And look at the Molex 1820. You can use one, or a gang of them, for an infinite variety of applications. Lighted push button can be wired to light independently of the switch. And it's available in colors galore. Best of all . . . both switches are priced considerably under one

dollar in quantity. ■ These components are good examples of the Molex creative approach to design problems. And we have the ability to design reliability and ease of assembly into a product without letting costs run wild due to over-engineering. ■ If this makes sense, and you would like a *free sample* of either the 1175 or 1820 switch, write: Molex Incorporated, Downers Grove, Illinois 60515. Or phone (312) 969-4550.

... creating components that simplify circuitry



TRW introduces... RF Power Transistors using *Integrated Circuitry* for Greater Bandwidth... and Higher Power.

12.5 Volts				28 Volts			
Type	P _{in} (W)	P _{out} (W)	Freq. (MHz)	Type	P _{in} (W)	P _{out} (W)	Freq. (MHz)
J03025	10	25	406-512	J01001	17.5	70	30-200
J03030	12	30	406-512	J02005	5	20	200-400
J03040	15	40	406-512	J02000	7.5	30	200-400
J04025	4	25	136-175	J02001	10	40	200-400
J04030	5	30	136-175	J02401	7	35	400-600
J04040	7.5	40	136-175	J02601	4	20	600-1000

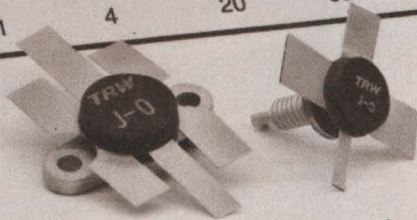

With the TRW J-zero you reduce RF Amplifier manufacturing costs!

TRW offers a new state-of-the-art line of broadband high power transistors. These transistors incorporate integrated circuitry to reduce the reactive part of the input impedance to nearly zero (hence J-zero). These devices allow extreme bandwidth and provide consistent reliable performance from simple matching circuits. Exceptionally low input Q's

allow octave bandwidths from fixed tuned circuits without costly individual circuit trimming for simplicity and ease of manufacture.

Two or more of the devices can be easily paralleled for higher power levels. Emitter stabilization is designed into the J-zero transistor for reliable operation under severe mismatch conditions.

Call toll free 800-421-2061 for immediate delivery! (In California call collect (213) 679-4561, ext. 455). TRW Semiconductor Div., 14520 Aviation Blvd., Lawndale, California 90260

TRW[®]

Electronic Design 14

VOL. 19 NO.

FOR ENGINEERS AND ENGINEERING MANAGERS

JULY 8, 1971

NEWS

- 19 **News Scope**
- 22 **Electronics at Mid-1971**—A special report:
- 22 **Semiconductor field picking up the pieces.**
- 23 **Consumer industry bounces back strong.**
- 24 **Minis soar in an edgy computer market.**
- 26 **Component makers dig in for a tight year.**
- 28 **Industrial electronics looks for recovery.**
- 30 **A comeback expected in instrument sales.**
- 32 **Technology Abroad**
- 39 **Washington Report**

TECHNOLOGY

- 50 **Focus on Instrumentation: A Special Report on the tradeoffs and trends in today's test and measuring instruments.**
- 66 **Microstrip amplifiers can be simple** to design, easy to build and inexpensive, to boot. Here's a low noise S-band example with almost an octave of bandwidth.
- 70 **Simplify sequential circuit designs** with programmable ROMs. You can often reduce the total IC package count by 90%.
- 74 **SSB-FM: When should you use it?** Unlike single-sideband AM, it not only eliminates one set of sidebands; it alters the set that remains.
- 78 **Ideas for Design.**

PRODUCTS

- 85 **Instrumentation:** DMMs are priced at more than 50% under competitors.
- 88 **Components:** A numerical display tube has short, 1.5-in. high characters.
- 92 **ICs & Semiconductors:** New JFETs can switch ± 15 -V analog signals at 4 MHz.
- 95 Data Processing 103 Packaging & Materials
- 98 Microwaves & Lasers 116 Product Index
- 100 Modules & Subassemblies

Departments

- 49 **Editorial:** Let's open our eyes and take stock of ourselves.
- 7 Letters 106 New Literature
- 13 Designer's Calendar 109 Bulletin Board
- 104 Evaluation Samples 114 Advertisers' Index
- 104 Design Aids 116 Information Retrieval Card
- 104 Application Notes

Cover: Designed by Art Director Bill Kelly.

ELECTRONIC DESIGN is published biweekly by Hayden Publishing Company, Inc., 50 Essex St., Rochelle Park, N.J. 07662. James S. Mulholland, Jr., President. Printed at Brown Printing Co., Inc., Waseca, Minn. Controlled circulation postage paid at Waseca, Minn., and New York, N.Y. Copyright © 1971, Hayden Publishing Company, Inc. 82,501 copies this issue.

end your signal pollution problems

Beldfoil® ISO-Shielded™ Cable

It's the cable with virtually perfect shielding. It's a Belden exclusive. Beldfoil ISO-Shield is like a continuous metal tube enclosing each pair of conductors in a cable. It locks out crosstalk or interference . . . whether from outside sources or between shielded elements in the cable.

Beldfoil is a layer of aluminum foil bonded to a tough polyester film (for insulation and added strength.) To form an ISO-Shield, we apply it in any one of several unique ways to meet the requirements of different applications. (See Figures 1 and 2, for example). Each gives more physical shield coverage than braided wire or spiral wrapped (served) shields. And greater shield effectiveness . . . even after repeated flexing.

Beldfoil ISO-Shielded Cables are small, lightweight. They terminate easily. They're modest in price. Your Belden Distributor stocks a wide variety of standard Beldfoil shielded cables as listed in the "Belden Electronic Wire and Cable Catalog" (ask him for the latest edition). And, should you have specifications no standard product can meet, ask him to quote on a specially engineered design. Or, if you choose, contact: Electronic Sales Service Dept., Belden Corporation, Richmond, Indiana 47374.

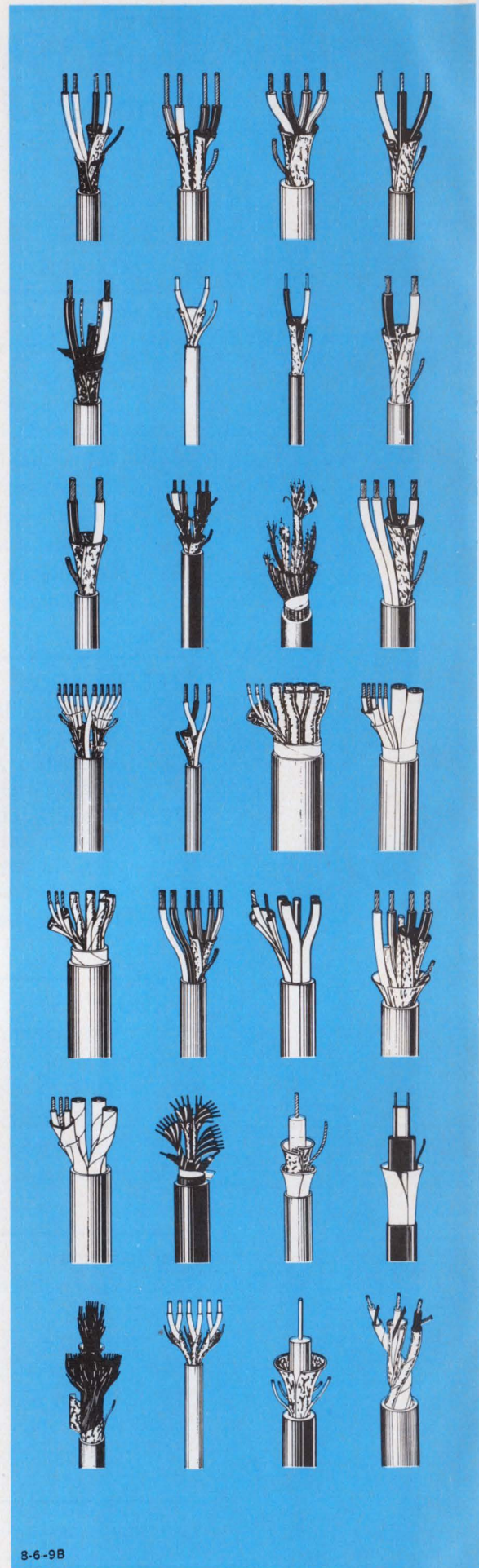

8-6-9B

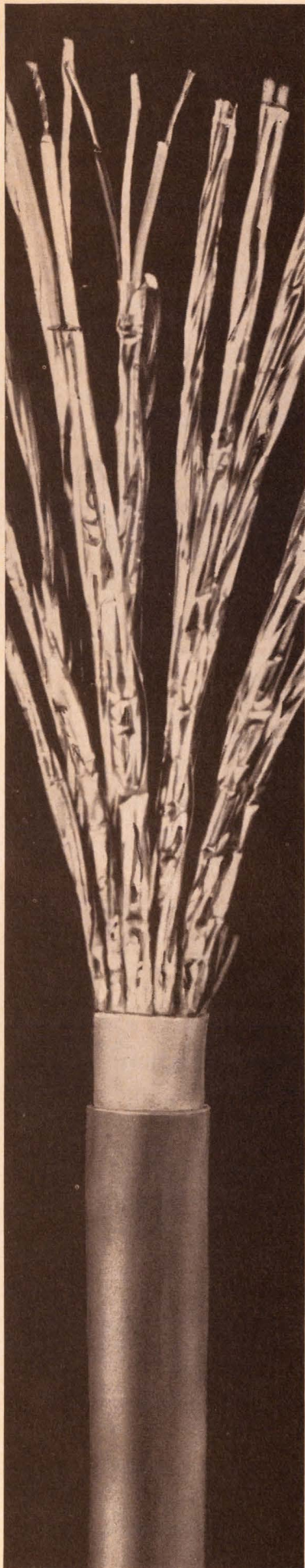

Metal (shield) foil, folded to assure metal-to-metal contact.

FIGURE 1

Polyester insulating layer folded to assure isolation between shields.

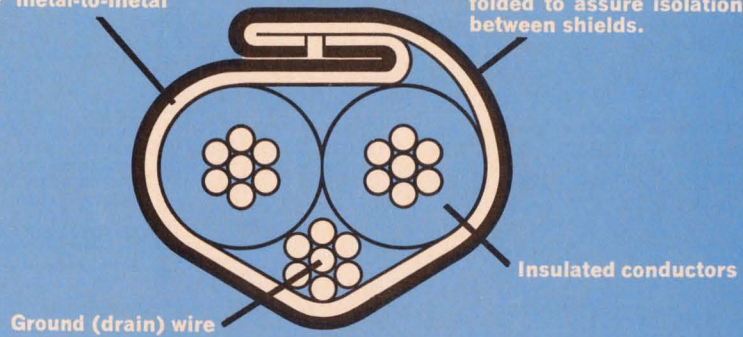

Beldfoil Multiple Pair Individually Shielded Cable

The Figure 1 cross-section shows Belden's exclusive Z-folded Beldfoil ISO-Shield. Note the metal-to-metal contact between the two edges of the aluminum foil. In essence, you have a continuous aluminum tube. And the polyester layer on the outside of the fold assures the isolation between shields so necessary for best performance in the field.

Technical Data

Nominal values for multiple pair individually shielded cables containing 3 to 27 pairs (including 8769 and 8773 through 8778 Series cables)

Suggested working voltage: 300 volts rms max.

Working voltage between adjacent shields: 50 volts rms max.

Capacitance between conductors in a pair: 30 pf per ft. nom.

Capacitance between one conductor and other conductor connected to shield: 55 pf per ft. nom.

Capacitance between shields on adjacent pairs: 115 pf per ft. nom.

Insulation resistance between shields on adjacent pairs: 100 megohms per 1000 ft. nom.

Metal (shield) foil, folded to assure metal-to-metal contact.

FIGURE 2

Polyester insulation layer folded to provide bonus insulation between conductors and shield.

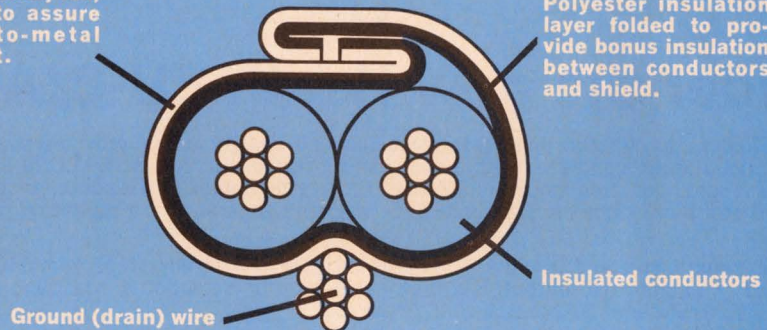

Beldfoil Shielded Single Pair Cable

The Figure 2 cross-section shows the exclusive Belden Z-fold with the polyester insulating layer inward. This makes use of the high dielectric strength of the polyester film as bonus insulation between the conductors and the shield. (The cable jacket provides the primary insulation of the shield from outside objects or adjacent cables.)

Technical Data

Nominal values for 8451 Shielded Pair Cable

Suggested working voltage: 200 volts rms max.

Capacitance between conductors: 34 pf per ft. nom.

Capacitance between one conductor and other conductor connected to shield: 67 pf per ft. nom.

BELDEN

new ideas for moving electrical energy

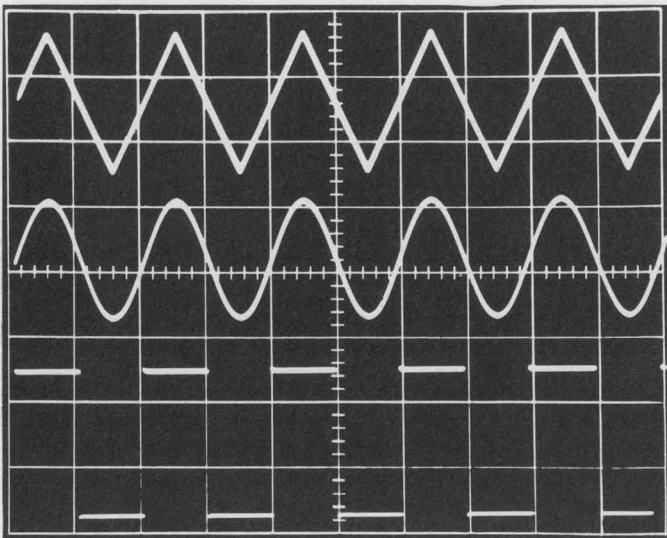

actual unretouched photograph of triangle, sine and square waves generated by the Heath EU-81A and displayed on the Heath EU-70A dual trace scope. Frequency 1 kHz.

How to get a 0.1 Hz to 1 MHz function generator with VCO for only \$245:

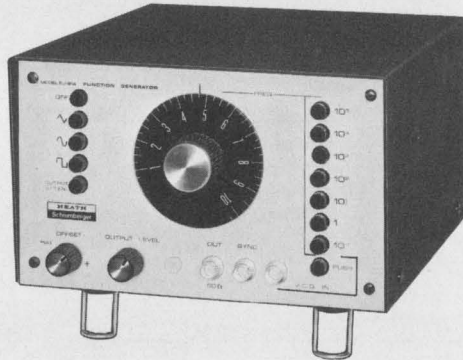

order the new Heath EU-81A

Unmatched as a versatile, moderate price lab and design tool... provides sweep and/or modulating signals... tests servo system response... use as a VCO in PLL systems... provides frequency multiplication... tests amplifier response, distortion and stability... use as a variable BFO... a tone generator... a repetition rate generator.

Provides square, sine and triangle waveforms variable in 7 decade steps from 0.1 Hz to 1 MHz... 50 ohm BNC output. Frequency and function selection are fast and accurate with front panel pushbuttons and linear dial.

Additional features include front panel DC offset variable to maximum signal amplitude... variable 20 dB output level... pushbutton 20 dB attenuator... TTL-compatible front panel sync output... AND external voltage control or sweep with a 10:1 dynamic range at no extra cost! Order your EU-81A now.

Assembled EU-81A, 9 lbs. \$245.00*

EU-81A SPECIFICATIONS: Output: All modes, 50 ohm output impedance. 20 V P-P open circuit. Adjustable DC offset continuously variable to maximum signal amplitude. Frequency range: 0.1 Hz to 1 MHz in 7 decades; continuously adjustable with linear dial. Triangular waveform: 95% linearity to 100 kHz. Sine waveform: Harmonic distortion - 1%, 5 Hz to 100 kHz (1/2% typical); less than 2% to 1 MHz. Square wave: 125 ns rise or fall time. Waveform symmetry: ±2% to 100 kHz. Frequency dial accuracy: ±3% of full scale. Frequency stability after 1 hour with external voltage control: 1 Hz to 1 MHz, ±0.05% for 10 minutes; ±0.3% for 24 hours. 0.1 Hz to 1 MHz, ±0.25% for 10 minutes. Vertical precision: Triangular amplifier - 0.2 dB to 1 MHz. Square amplifier - 0.2 dB to 1 MHz. Sine amplifier - 0.2 dB to 100 kHz, down 3 dB at 1 MHz. External frequency control: Sweep mode, ±10 V maximum into 10 k ohms. Voltage control mode, 0 to 10 V into 100 k ohms. Operating temperature: 10 to 40 degrees C. Power consumption: 18 watts. Power requirements: 120/240 VAC, 50/60 Hz. Dimensions: 5 5/8" H x 8 7/8" W x 11 5/8" D. Net weight: 6 lbs.

FREE HEATH SCIENTIFIC INSTRUMENTATION CATALOG

Investigate these and other new ideas in Spectroscopy, Digital Instrumentation, Lab Equipment and Test Equipment. Send for your FREE catalog now.

HEATH COMPANY, Dept. 520-26
Benton Harbor, Michigan 49022

Schlumberger

- Please send free Heath Scientific Instrumentation Catalog
 Please send free EU-81A Specification Sheet.

Name _____
Address _____
City _____ State _____ Zip _____

*Mail order prices; FOB factory.
Prices & specifications subject to change without notice. EK-303

Publisher

Peter Coley

Editors

Editorial Offices
50 Essex St.
Rochelle Park, N.J. 07662
(201) 843-0550
TWX: 710-581-2874
Cable: Haydenpubs Rochellepark

Editor: Frank Egan
Managing Editor: Ralph Dobriner
Managing Editor: Raymond D. Speer
Microelectronics, Steven A. Erenburg
Computers, Raymond D. Speer
Microwaves, Michael J. Riezenman
Circuits, Edward A. Torrero
Special Projects, George Rostky
Management, Richard L. Turmail
Military-Aerospace, John F. Mason
News, Michael P. London
New Products, Roger Allan

Field Offices

Massachusetts
Jim McDermott
P.O. Box 272
Easthampton, Mass. 01027
(413) 527-3632

West Coast
David Kaye
2930 Imperial Highway
Inglewood, Calif. 90303
(213) 757-0183

Washington
Don Byrne
1111 S. Army Navy Drive
Arlington, Va. 22202
(202) 296-8982

Editorial Production

Dollie S. Viebig

Art

Art Director, William Kelly
Richard Luce

Production

Manager, Thomas V. Sedita
Helen De Polo
Kathleen McConkey

Circulation

Manager, Nancy L. Merritt

Information Retrieval

Peggy Long

letters

A bit of clarification on 'Bits and Bauds'

In attempting to eliminate confusion concerning "Bits and Bauds" (ED 9, April 29, 1971, p. C 11), you may have confused some readers concerning the American Standard Code for Information Interchange (ASCII). Each character of ASCII contains seven bits of useful information; the eighth bit is reserved for parity checking. Therefore a signaling speed of 110 baud would send information at a 70 b/s rate, not 80 b/s.

Although there has been some consideration by certain international groups of "code expansion" to permit use of all eight bits for information transfer, no eight-bit version of ASCII has been adopted.

G. V. Rodgers

Chief

Data Transfer Systems Branch
R.D. 230
Federal Aviation Administration
Washington, D.C. 20590

Laser cloth cutter draws an objection

The article describing a laser cloth cutter provides continuing evidence of "solutions in search of problems" (see News Scope, ED 8, April 15, 1971, p. 22). In this case the laser, a highly publicized laboratory tool, has solved another "problem"—or has it?

The arguments in favor of this device in the garment industry—no job layoffs, lower costs (to whom?), greater American penetration of the total garment industry and quicker response to fashion changes—just don't hold water. The biggest flaw has to do with layoffs. Sure, the laser, the computer and the industrial control manufacturers would realize increased business, but at the expense of blue-collar workers now doing the cloth cutting and other work. This

job in the clothing industry—and similar nonprofessional jobs in other industries, like food, construction, etc.—must not become the victim of technical gadgets. This approach is partly responsible for the increase of blue-collar workers on welfare and unemployment rolls.

I would rate the advantages of this technological breakthrough as minimal. As far as benefitting certain segments of our ailing electronics industry, that's another story.

Joseph B. Wible

1012 Tracy Road
Lancaster, Pa. 17601

A plea to be logic instead of logical

Sir:

I've had it up to here, and I've gotta say something before I bust! The advent of logic circuits has engendered an error in grammatic usage that drives me up the wall every time I see it in print. The error appears in virtually every publication, including data sheets put out by manufacturers of logic elements. Needless to say, I spend a good bit of time hanging from the ceiling. It is a LOGIC ONE, dammit, NOT a logicAL one!

Is so little time spent on grammatics in our schools today that our engineers no longer know how to communicate in English—or plain American yet? Ungrammatic English is illogical English. If they can call it a logic table instead of a logical table, isn't it illogical that they insist on defining the condition as a "logical one" or "logical zero"? Using their logic, they may as well start referring to a logic zero as an *illogical one*.

Roy J. Krusberg

Design Engineer
University of Georgia
Athens, Ga. 30601

Five of our 16 edgewise meter models: 1. Model 2150, ruggedized 5"-scale type in 22% the space of a 6" rectangular type. 2. Model 1140, 4"-scale, greater sensitivity. 3. Model 2520, shielded dual movements, interchangeable scales. 4. Model 1122, 1.24" scale, 26 std. ranges. 5. Model 1136, 2"-scale, 1/2 the space of 3 1/2" meters.

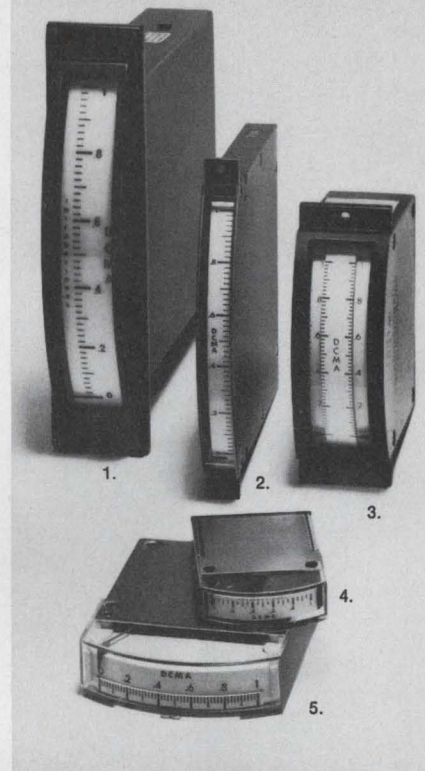

Edgewise meters:

- most sizes
- dual movements
- custom designs

The patented, pivot-jewel flat movement used in these integrally-shielded meters not only allows maximum space economy by flush stacking, but provides higher vibration immunity and greater ruggedness as well. Unique dual-movement models save even more space, simplify comparison of two variables, have optional interchangeable slide-in scales. Ruggedized 5"-scale models are ideal for adverse military and production/process environments. Write for data on any of 16 models in 40 standard ranges . . . or movements custom-designed for your needs.



**INTERNATIONAL
INSTRUMENTS**

DIVISION OF SIGMA INSTRUMENTS, INC.
88 MARSH HILL RD., ORANGE, CONN. 06477.

INFORMATION RETRIEVAL NUMBER 6

Electronic Design welcomes the opinions of its readers on the issues raised in the magazine's editorial columns. Address letters to Managing Editor, Electronic Design, 50 Essex St., Rochelle Park, N. J. 07662. Try to keep letters under 200 words. Letters must be signed. Names will be withheld on request.

**Reliability is 756 little dents
and one big one.**





The big squeeze.

The heelpiece and frame are the backbone of our Class H relay. The slightest squiggle or shimmy out of either and the whole relay is out of whack.

756 tiny dents on the heelpiece, plus one big one on the frame, make sure this'll never happen.

They're the result of planishing, a big squeeze. Planishing is an extra step we go through in forming the pieces to add strength and stability by relieving surface strain. It also makes the parts extra flat.

This takes the biggest press in the industry and the biggest squeeze. Both exclusively ours.

A different kind of coil.

The heart of a relay is the coil. If ours looks different, it's because we build it around a glass-filled nylon bobbin. It costs us more, but you know how most plastic tends to chip and crack.

Also, moisture and humidity have no effect on glass-filled nylon. No effect means no malfunctions for you to worry about. No current leakage, either.

The coil is wound on the bobbin automatically. No chance of human error here.

We didn't forget the solder.

We use a solderless splice. That's because solderless splice connections are sure-fire protection against the coil going open under temperature changes, stress, or electrolysis.

A solderless splice is more expensive to produce, so it's usually found only on the most reliable relays. AE is the only manufacturer to use this method on all of its relays.

Finally, we wrap the whole assembly with extra-tough, mylar-laminated material. A cover is not really necessary here; but why take chances?



Springs and other things.

We don't take any chances with our contact assembly, either. Even things like the pileup insulators (those little black rectangles) get special attention. We precision mold them. Other manufacturers just punch them out.

It makes a lot of difference. They're stronger, for one thing; and because they're molded, there's no chance of the insulators absorbing even a droplet of harmful moisture. Finally, they'll withstand the high temperatures that knock out punched insulators.

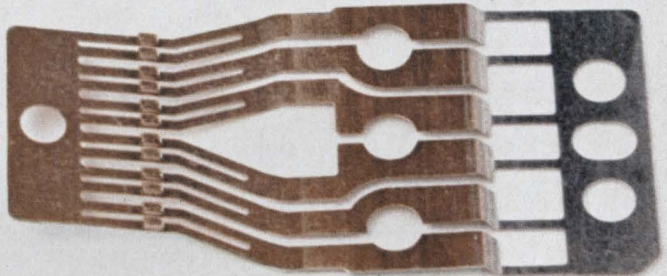

Then there are the contact springs. Ours are phosphor-bronze. Others use nickel-silver. Our lab gave this stuff a thorough check, but found nickel-silver too prone to stress-corrosion. Atmospheric conditions which cause tarnish and ultimately stress corrosion have almost no effect on phosphor-bronze.



Two are better than one.

Our next step was to make sure our contacts give a completed circuit every time. So we bifurcate both the make and break springs.

Each contact works independently to give you a completed circuit every time.

Edge-tinned contact springs save you the job of solder tinning them later. Also, edge-tinning enables you to safely use the same relay with sockets or mounted directly to a printed circuit board. A simple thing, but it takes a big chunk out of the inventory you have to stock.

Etc. Etc. Etc.

There's a lot more to tell about what makes our Class H relay reliable. Now we're waiting to hear from you. GTE Automatic Electric, Industrial Sales Division, Northlake, Illinois 60164.

GTE AUTOMATIC ELECTRIC

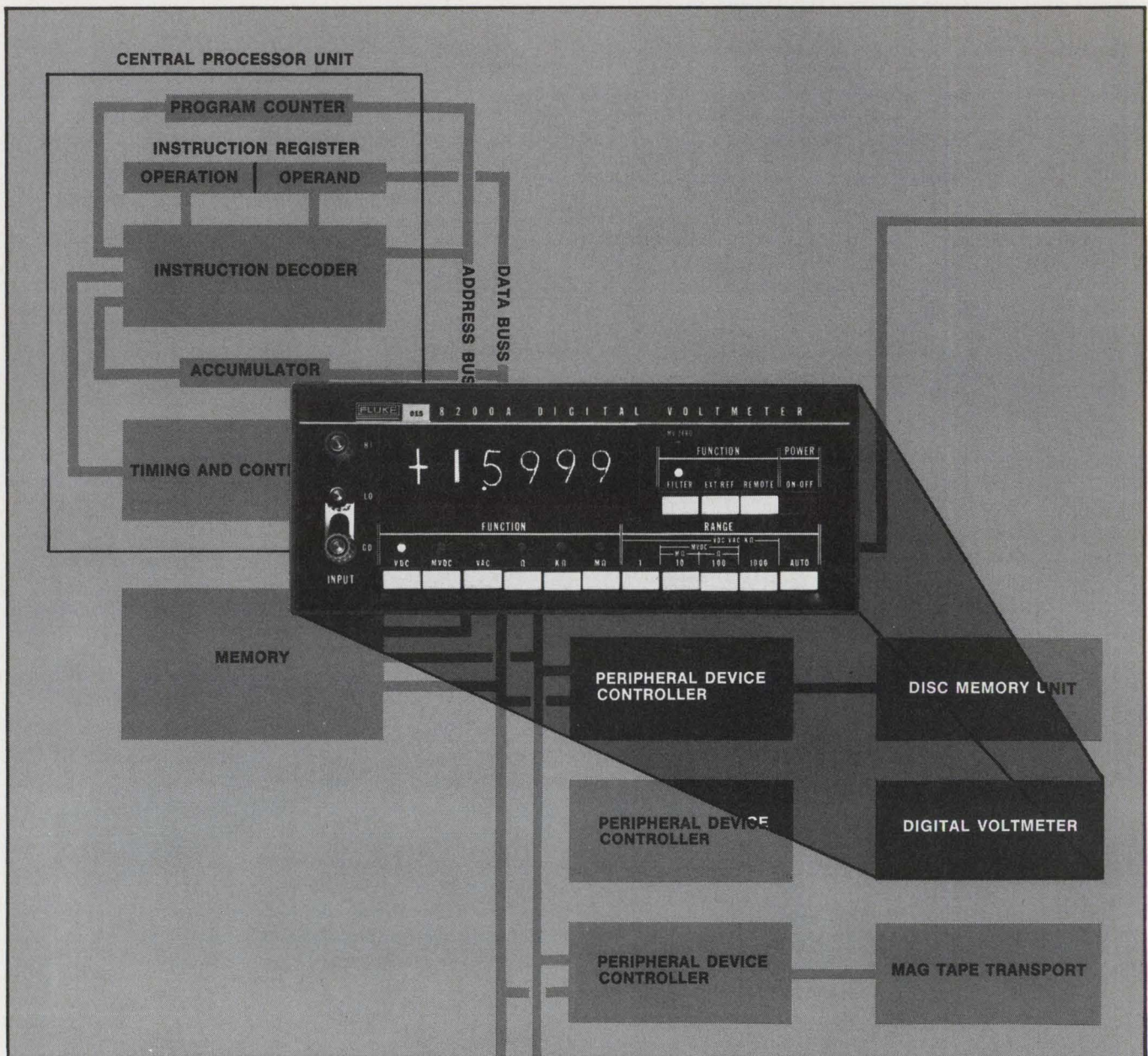

The only fast new systems DVM (400 samples per second, 60% overranging, autoranging and remote programming with memory).

The new Fluke 8200A DVM will give you years of topflight performance in either systems use or on the bench. A fast four digit instrument with an accuracy of 0.01%, the Fluke 8200A is small and lightweight.

We designed it to give you maximum flexibility. All the options can be added in the field so that it's easy to satisfy your changing requirements.

The Fluke 8200A gives you high accuracy, overranging, and high sampling

speed. Standard features include autoranging (**millivolts through volts and ohms through megohms**), 1 millisecond sample and hold, half-rack width of 3½" high, modular construction with vertical plug-in boards, switched four pole filter in volts and millivolts, dc capability from 100 microvolts to 1100 volts, full guarding for 140 db common mode rejection dc to 60 Hz, 2 millisecond response time, and overload proof design.

The basic instrument goes for \$995. Many options are available: two ranges of millivolts for **1 microvolt resolution**, six ranges for measurements from 10 milliohms to 16 megohms, four ranges of ac, true 4 wire ratio, isolated digital or printer output, and isolated remote control **with memory** for direct computer interface. A full bore Fluke 8200A with all options goes for \$2,395.

For the full story, see your Fluke sales engineer or contact us directly.



Fluke, Box 7428, Seattle, Washington 98133. Phone: (206) 774-2211. TWX: 910-449-2850
In Europe, address Fluke Nederland (N.V.) P.O. Box 5053, Tilburg, Holland.
Phone: (04250) 70130. Telex: 884-50237/In the U.K., address Fluke International Corp.,
Garnett Close, Watford, WD2 4TT. Phone: Watford 27769. Telex: 934583.

Take a turn for the better in rotary switches.

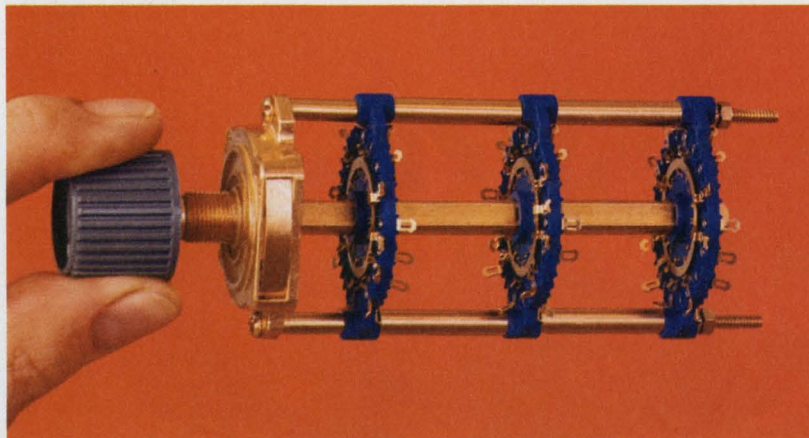

Oak continues to market the broadest line of rotary switches in sizes and configurations to fit your applications.

For example:



Our 1/2-inch subminiature rotary switch.

Ultra-compact, yet provides superior insulating qualities and dimensional stability in demanding environments at lowest competitive price.

A new 12-position Acorn rotary for printed circuits.

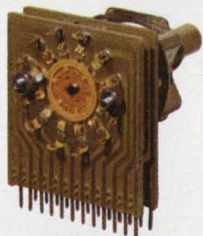

A size-saving design. Crisp, uniform detenting with Oak's patented Unidex™ indexing. Has glass epoxy wafer and tinned PC terminals ready for soldering.

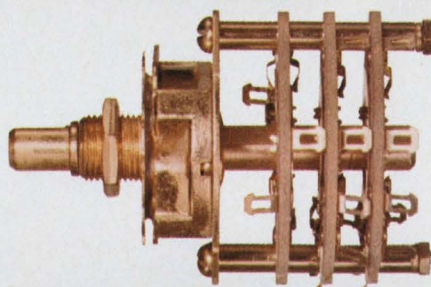

Rotary switches with Unidex indexing, too.

Our F and JKN series. Versatile, economical. And Unidex detent means uniform torque, crisp feel.



And our Multidex® rotary: the almost-universal switch.

Versatile enough to replace 7 old-style rotary designs. Thousands of variations available. With Unidex detent for sure switching time after time. Multidex cuts the cost of engineering design.

There's more.

Miniaturized lever switch: Type 184. Improved dielectric properties plus more clips per stator.



Miniature rotary trim switch. For SPDT trim switching in tight PC-board locations. Long life. Low cost.

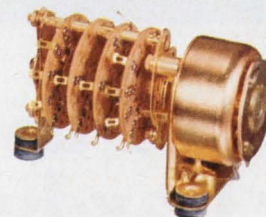

Stepping switches: Compact, lightweight. Subminiature to extra-heavy-duty types. Fast response.

Now: order Moduline™ Switches from your distributor.

Choose from 2-million possible switch combinations. 72-hour delivery. Write for the Moduline Catalog.



OAK MANUFACTURING CO.

CRYSTAL LAKE, ILLINOIS 60014 • A DIVISION OF OAK ELECTRO/NETICS CORP

Telephone: 815-459-5000

TWX: 910-634-3353

TELEX: 722-447

INFORMATION RETRIEVAL NUMBER 9

For basic industrial connectors



think of us as your hardware store.

Plugs, sockets, connectors, hardware and accessories—for relays, tubes, cable connections, sound systems or whatever—a whole raft of things you'd never expect from us. They've been in our industrial product line for many years. In fact, it's the broadest line available anywhere. So next time you need something

in basic black, think of us as your connector hardware store. Drop us a line and we'll send you our latest 32-page II-1 Catalog along with the name of your closest Amphenol distributor. Write to Amphenol Industrial Division, The Bunker-Ramo Corporation, 1830 South 54th Avenue, Chicago, Illinois 60650.

**BUNKER
RAMO** AMPHENOL

designer's calendar

AUGUST 1971

S	M	T	W	T	F	S
1	2	3	4	5	6	7
8	9	10	11	12	13	14
15	16	17	18	19	20	21
22	23	24	25	26	27	28
29	30	31				

Aug. 17 - 19

Conference on High Frequency Generation and Amplification—Devices and Applications (Ithaca, N. Y.) Sponsors: Cornell Univ. et al. Joseph L. Rosson, Cornell Univ., Phillips Hall, Ithaca, N. Y. 14850.

CIRCLE NO. 418

Aug. 24 - 27

Western Electronic Show & Convention (San Francisco) Sponsors: IEEE, WEMA, WESCON Office, 3600 Wilshire Blvd., Los Angeles, Calif. 90005.

CIRCLE NO. 419

Aug. 25-27

International- Geoscience Electronics Symposium (Washington, D. C.) Sponsor: IEEE. M. T. Miyasaki, Johns Hopkins Univ., 8621 Georgia Ave., Silver Spring, Md. 20910.

CIRCLE NO. 420

SEPTEMBER 1971

S	M	T	W	T	F	S
			1	2	3	4
5	6	7	8	9	10	11
12	13	14	15	16	17	18
19	20	21	22	23	24	25
26	27	28	29	30		

Sept. 8-10

International Conference on Urban Transportation (Pittsburgh, Pa.) Sponsors: U. S. Dept. of Transportation et al. Arthur V. Harris, P.O. Box 2149, Pittsburgh, Pa. 15230.

CIRCLE NO. 421

VACTEC

"PLASTIC" PHOTOCELLS

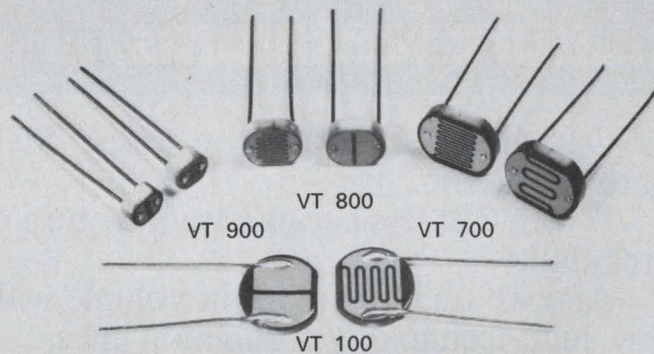

Actual size, priced as low as .25 each ($\pm 33\%$ tolerance) in 10,000 quantities.

EVEN LOWER FOR $\pm 50\%$ TOLERANCE

Low Cost Way to Meet Most Photocell Requirements

Here is a complete line made with the same quality characteristics and precise tolerances by the originator of the first **stable** plastic coated cell. Six different thin-film materials of CdS and CdSe deposited on ceramic substrates. A VACTEC development with almost 10 years of production experience. When others said it couldn't be done — we were doing it! NOW improved passivation processes make them better than ever. Why experiment — buy where the experience is. The proof — they have been used in **millions** of cameras all over the world!

Costing less than $\frac{1}{2}$ of hermetically sealed cells, they have excellent resistance to humidity, eliminating need for hermetic cells in **most** applications. VACTEC "plastic" photocells are conveniently controlled by ambient light or from closely coupled low voltage lamps. Industrial and commercial applications, like controlling relays in line voltage circuits; switching SCR's on or off; phase control and proportional circuits; audio controls; and feedback elements for motor speed controls in consumer appliances.

Series Type	Substitutes for hermetic type
VT 100	TO-8
VT 700	TO-8
VT 800	TO-5
VT 900	TO-18

Write for Bulletin PCD-5, PCD-41, 57, 58, and 59



VACTEC, INC.

2423 Northline Ind. Blvd. • Maryland Heights, Missouri 63043
(314) 872-8300

Specializing in standard CdS, CdSe, and Se cells. Custom engineering for every photocell need. Listed in EBG under "Semi-Conductors" and EEM Sec. 3700.

We spent a lot of money on improved equipment and technology. So you could spend up to 35% less on miniature tantalums.

On our KEMET® Micron series, "Mylar" cased, solid-tantalum capacitors, to be specific.

Which cost less because we now turn out Microns in volume with uniform reliability.

And we turn them out in volume with uniform reliability because of our new, high-technology production lines.

You can buy KEMET subminiature tantalums off-the-shelf, from our million-unit stock. In a variety of case styles, sizes and lead configurations. From .001 through 220 uf, 2 through 50 volts dc. And they meet Mil-C-39003 where applicable.

If you want maximum electrical performance and CV product for hybrid thick-film and other applications requiring maximum packaging, do this. Check the sizes and styles on the popular rectangular and cylindrical shapes below. Then, write us at Box 5928, Greenville, S. C. 29606 for KEMET Micron Series literature and test data.

T370		T372		Polar Rectangular 3-35 VDC							
RADIAL LEAD		AXIAL LEAD		Case Dimensions—Inches			Price Each (±20%*)				
Case Size	H Case Height Max.	W Case Width Max.	T Thickness Max.	S Lead Spacing	Capacitance uf	1-24	25-49	50-99	100-499	500-999	OEM
A	.125	.070	.040	.050	.001-1.5	.69	.55	.47	.40	.36	.26
B	.165	.120	.070	.100	.001-10	.64	.50	.44	.37	.34	.24
C	.225	.185	.075	.150	.68-22	.80	.63	.55	.46	.42	.30
D	.290	.220	.110	.180	2.2-47	.90	.71	.62	.52	.48	.34
E	.310	.230	.130	.200	6.8-68	.90	.71	.62	.52	.48	.34
F	.475	.375	.150	.300	10-220	2.23	1.76	1.53	1.29	1.18	.84
T374		T376		Polar Cylindrical 2-35 VDC							
RADIAL LEAD		AXIAL LEAD		Case Dimensions—Inches			Price Each (±20%*)				
Case Size	L Case Length Max.	D Case Diameter Max.	S Lead Spacing	Capacitance uf	1-24	25-49	50-99	100-499	500-999	OEM	
A	.125	.070	.050	.001-2.2	.67	.53	.46	.39	.35	.25	
B	.160	.070	.050	.001-4.7	.67	.53	.46	.39	.35	.25	
C	.200	.080	.050	.33-10	.64	.50	.44	.37	.34	.24	
D	.225	.100	.070	.68-22	.69	.55	.47	.40	.36	.26	
E	.250	.150	.120	1.5-47	.88	.69	.60	.51	.46	.33	

*For ±10% & ±5% Tolerance units use the following multipliers ±10%-1.3; ±5%-2.0



COMPONENTS DEPARTMENT

New! Fail-safe N-key rollover



This new Licon® N-Key rollover keyboard eliminates transmission of false codes.

Thanks to a unique new design approach, Licon now offers perfected N-Key rollover. Available right now. Each key transmits its signal in the sequence in which it is struck, *regardless* of the condition of preceding keys . . . whether still depressed or in return travel. It's "failsafe". That's typical of the complete Licon keyboard. Example? Candidly, everybody's electronics exhibit about the same level of reliability. The critical element is the

key itself. And Licon's is based on a reliable, low-cost ferrite core. Solid-state, but simple!

Essentially immune to temperature change, vibration, voltage variations, etc. "Bounce"-free. Requires very little power, yet provides high level output, with outstanding signal-to-noise ratio. Encoding can be changed without touching the electronics. For service, buttons and PC cards simply snap out, snap in. Interface with

your equipment is a simple plug-in connector, and we'd like to give you a plugged-in demonstration on your equipment. Send for brochure or demonstration. **Licon, Division Illinois Tool Works Inc., 6615 W. Irving Park Road, Chicago, Ill. 60634. Phone (312) 282-4040.**



itw LICON

The Innovating Electronic Group of ITW...LICON ■ ELECTRO MATERIALS ■ PAKTRON

A better way to get quick delivery on monolithic filters.

The better way is you. You tell us when you need the filters. It's that simple. And it's the best way to prevent a supplier from saying one week delivery when he means one month.

Seven standard models are available in ranges from 5MHz to 26MHz. Insertion losses are a nominal 2 to 4db. Each filter is shock protected and hermetically sealed. Other frequencies developed to your order. Specs available from Motorola Component Products Dept., 4545 W. Augusta Blvd., Chicago, Illinois 60651.

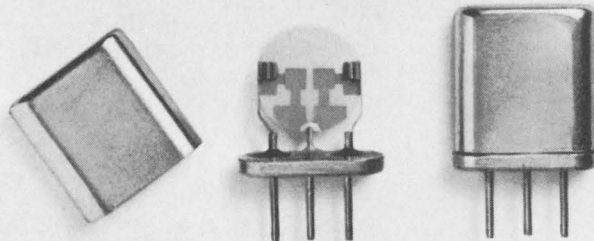

LED displays are here! And Litronix is leading the way. If you're designing anything from a counter to a calculator, a digital clock or any other instrument requiring an economical, highly visible, reliable display, take a look at the Litronix line:

The MAN-1's identical twin, Data-Lit 10. It's a true second for the MAN-1. Same DIP package, .270 inch character height and high brightness, but we've added Litronix's guaranteed quality. The Data-Lit 10A, basically the same device as the Data-Lit 10, but with a low, low price tag. Their companions are the Data-Lit 101 and Data-Lit 101A, polarity and overflow displays.

Largest character size in a LED display, Data-Lit 6. Here's a wide angle, front plane, very visible .600 inch high character display. Great for distance viewing type displays. Mounts vertically into a standard 1/16 inch PC board connector.

Biggest bargain in LED displays, Data-Lit 8. Here's a money saver. Consumes half the power of DIP type display at the same brightness. Mounts on 0.3 inch centers which saves up to 40 percent on center to center spacing. Its companion, the Data-Lit 81, provides + and - 1, decimal point left or right, colon and % sign.

The stand-up and be counted display, the Data-Lit 3. This .240 inch numeric plugs into a printed circuit board edge card connector for vertical display. Exhibits a high brightness and consumes very little power.

And now, introducing the low cost "skinny DIP," the Data-Lit 300. It has 1/8 inch character height and comes in a small dual inline package. Has a high brightness, low power and best of all, low cost. You can also buy it in any size array you want from 2 to 16.

So, if you're looking for a display, give us a whistle.

You can stop whistling nixie*

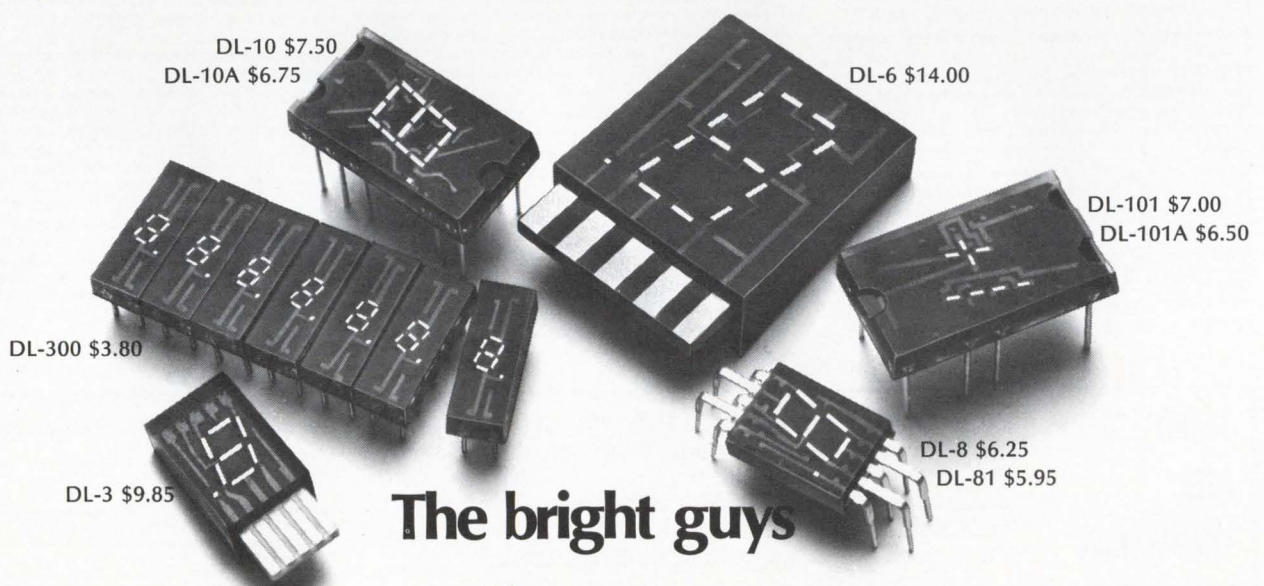
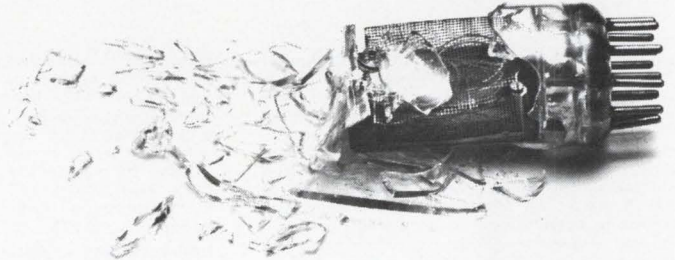

DL-10 \$7.50
DL-10A \$6.75

DL-6 \$14.00

DL-101 \$7.00
DL-101A \$6.50

DL-300 \$3.80

DL-3 \$9.85

DL-8 \$6.25
DL-81 \$5.95

The bright guys
litronix

Prices given for 1000 piece quantities.

LITRONIX, INC., 19000 Homestead Road, Cupertino, California 95014 Telephone: (408) 257-7910 TWX: 910-338-0022
*NIXIE is the registered trade mark of the Burroughs Corp.

INFORMATION RETRIEVAL NUMBER 96

The Data Communications Breakthrough in a New Practical Guide from Hayden

JUST PUBLISHED! Modern Data Communications: Concepts, Language and Media

WILLIAM P. DAVENPORT

This comprehensive and practical source provides an up-to-date working knowledge of how business and technical information is transmitted and received. It enables the data systems manager, engineer, student, or technician to evaluate current transmitting techniques and their potential applications. The book gets to the core of intricate theories and concepts, such as coding, channel capacity, and modulation and multiplexing, without losing the essence of their meaning. It

clearly explains how stored information is moved from point to point in machine language. Both an in-depth introduction and a practical working guide, the book eliminates complex mathematics and provides an extensive glossary of terms. Space has been provided in the many illustrative lists and tables so the reader may enter additional information of particular interest.

208 pp., 6 x 9, illus., cloth, #5810, \$7.95

OTHER VALUABLE BOOKS IN CONTEMPORARY COMPUTER TECHNOLOGY

Basic BASIC: An Introduction to Computer Programming in Basic Language James S. Coan. Written in a precalculus mathematics setting, this new text is designed to work in conjunction with a math course or as a separate programming course. Progressing from short complete programs to more sophisticated problems, the text encourages the use of flowcharts as an aid in program-writing. Solutions to even-numbered problems appear in the text; the remainder, in a separate teacher's guide. 272 pp., 6 x 9, illus., paper, #5872, \$5.95; cloth, #5873, \$7.95

Comprehensive Standard Fortran Programming James N. Haag. This up-to-date course teaches how to program effectively using the full version of FORTRAN IV as standardized by the U.S.A. Standards Institute. From the outset, portions of the language are applied in writing programs drawn from a variety of disciplines. This well-organized, clearly written book is ideally suited for either self-study or classroom use. 312 pp., 7 1/4 x 9 3/4, illus., paper, #5811, \$6.95; cloth, #5812, \$8.95.

Comprehensive Fortran Programming James N. Haag. The highly successful course in FORTRAN II teaches the language as used by the IBM 1620 computer with an attached 1311 Disk Drive, with adaptations to suit other systems. 246 pp., 7 3/8 x 10 1/8, illus., paper, #5645, \$5.95.

Basics of Digital Computers Revised Second Edition, John S. Murphy. Offering a complete foundation in today's equipment and systems, the fully updated edition of this three-volume work is excellent for self-teaching or classroom use. Free of needlessly confusing jargon, it includes over 300 all-new illustrations to drive home its discussion of concepts relevant to all systems. The first volume explains how in-

formation is programmed into the machine to produce an answer or to be stored for later use. Volume two covers the construction and function of the various components. The linkup and control of an overall system, covered in volume three, completes the background needed to master specific systems. 391 pp., 6 x 9, illus., 3 vol. set, paper, #0737, \$11.25; 3 vol. combined cloth, #0741, \$9.95; indiv. paper vols., #0738, #0739, #0740, \$3.75.

Understanding Digital Computers Ronald Benrey. A comprehensive guide for those who need in-depth understanding of computers, but not a technical grasp of the equipment. Describing computers in terms of similar, and simple building blocks that make up a system, the book stresses the function of these elements, rather than their actual electronic construction. Programming, binary arithmetic, logical design, and other key topics are fully explained. 166 pp., 6 x 9, illus., paper, #0473, \$4.75

Digital Magnetic Tape Recording Bernard B. Bycer. This unique design tool fully describes functions and operations, also providing valuable data for specification, purchase and use of the equipment. 328 pp., 6 x 9, illus., cloth, #5031, \$12.50

Computer Arithmetic Henry Jacobowitz. A refresher course in the basic operations of all positional number systems with applications in computers, this compact volume explains binary, octal, hexadecimal, and ternary arithmetic, along with conversion methods. 128 pp., 5 1/2 x 8 1/2, illus., paper, #0297, \$3.75

Computer Numbering Systems and Binary Arithmetic Training Systems, Inc., and Stanley L. Levine. This programmed course proceeds gradually through all the required mathematical processes. No previous knowledge of

binary or octal numbering systems, or computers, is needed, 232 pp., 6 x 9 paper, #0380, \$5.45

Discovering Basic: A Problem Solving Approach Robert E. Smith. This new course starts the reader programming on page three, pinpointing the vocabulary of BASIC as it develops skill and confidence. Clear explanations speed the reader through the brief exercises and reviews which reflect this language's growing importance in timesharing systems. More than thirty-five pages of programs for the lessons and reviews are easily located at the back of the book. 224 pp., 5 3/8 x 8 1/4, illus., paper, #5783, \$5.95; cloth, #5784, \$7.95

Basics of Digital Computer Programming John S. Murphy. This invaluable introduction to business-data programming uses general programming examples to illustrate practical computer applications. Discussion is clarified through continual reference to the internal organization of a typical computer. 118 pp., 6 x 9, illus., paper, #0405, \$3.95

Standard Dictionary of Computers and Information Processing Martin H. Weik. Widely praised for its broad scope, detailed definitions, and illustrative examples, this essential reference encompasses more than 10,000 hardware and software terms in general use throughout the burgeoning field of computers and their applications. Thorough cross-referencing permits complete mastery of the vocabulary of hundreds of topics: programming and computer engineering to input-output devices and checking systems. The Computer Tree, reproduced on the endpapers, traces the lineage of more than 500 computer models built to date. 336 pp., 6 x 9, illus., cloth, #5677, \$10.95

15-DAY

FREE

EXAMINATION

Please send the book(s) listed on a 15-day free examination basis. At the end of that time, I will remit payment, plus postage, or return the book(s) without further obligation.

CAT. # TITLE PRICE

Name _____

Firm/Institution _____

Address _____

City/State _____ Zip _____

\$10.00 minimum for free exam orders. Because of higher billing and collection costs, we must ask for payment in full with any order for less than \$10.00. Books will be shipped postpaid. Same 15-day return privilege for full refund if not satisfied. On all overseas orders, payment in U.S. dollars must be enclosed.

Save Money! On all pre-paid orders Hayden pays postage — same return guarantee!

71-59



HAYDEN BOOK COMPANY, INC., 116 W. 14 St., N.Y., N.Y. 10011

CUTLER-HAMMER'S BIG NEW LINE OF COMMERCIAL MINIATURES.

Toggles. Pushbuttons. Rockers. Rotaries. Available in a vast array of operator styles, colors, and shapes. Including illuminated pushbuttons and rockers. Many featuring snap-in mounting. And all in stock for fast delivery!

Now the same great quality, service and availability you've come to expect from Cutler-Hammer is available in miniature size—at a competitive price!

Make your selection. Standard or watertight. Single or multiple pole. A wide range of decorator caps, buttons, bezels that extend application flexibility. And for their size, hefty electrical/mechanical ratings.

Before you place that next order, check with your new source for commercial miniature switches—your nearest Cutler-Hammer Sales Office or Authorized Stocking Distributor.



CUTLER-HAMMER
SPECIALTY PRODUCTS DIVISION, Milwaukee, Wis. 53201



Switch
to No.1

More than just switches;
prompt availability,
field help, innovation,
quality assurance, too.

DOWN WITH CONNECTIONS... OUT WITH WELDS

8-16 DIGITS YOUR ONLY CHOICE IS **PANAPLEX™** NUMERIC PANEL DISPLAY

Burroughs leads today's display revolution with a whole new way of looking at numeric displays — a total cost savings package designed to eliminate all your display problems. Check these advantages:

✓ LOW COST — Your initial investment is lower because PANAPLEX panels are the lowest cost panel displays available. Your circuitry costs go down because PANAPLEX panels are specifically designed for time sharing from low cost MOS, LSI circuitry.

✓ HIGH RELIABILITY — Your instrument will be more reliable because PANAPLEX panels are one-piece construction and contain NO internal welds. PANAPLEX panels are impervious to shock and vibration. No other multiple digit device has this proven life and failure free operation.

✓ CUSTOMER DESIGNED PACKAGING — Your installation costs are lowered because PANAPLEX panels are supplied in packaged units containing your complete display —

prealigned and ready to be plugged into, or soldered onto a mating board. No individual digit alignment required and only two connections per digit.

✓ HUMAN ENGINEERED READOUT — Your selling costs go down because of the PANAPLEX panel's esthetic selling features, including large (0.4") easily read characters in perfect alignment; superior brightness characteristics; a 150° viewing angle; and a nine segment format that permits a centered digit "1". The thin package allows you design freedom — a must in today's competitive market.

✓ AVAILABILITY NOW — Production quantities are being shipped now and we can respond to your volume requirements faster than any other source.

*For additional information, call or write:
Burroughs Corporation, Electronic Components Division,
P.O. Box 1226, Plainfield, New Jersey 07061.
Tel: (201) 757-3400.*

\$156*
PER DIGIT

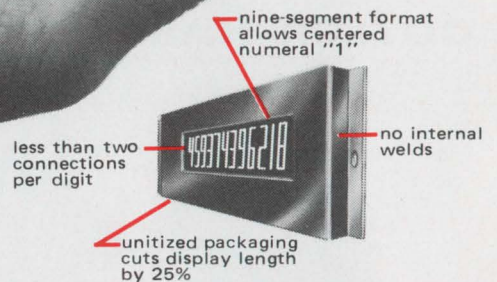
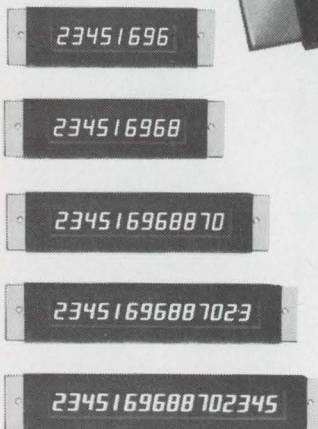
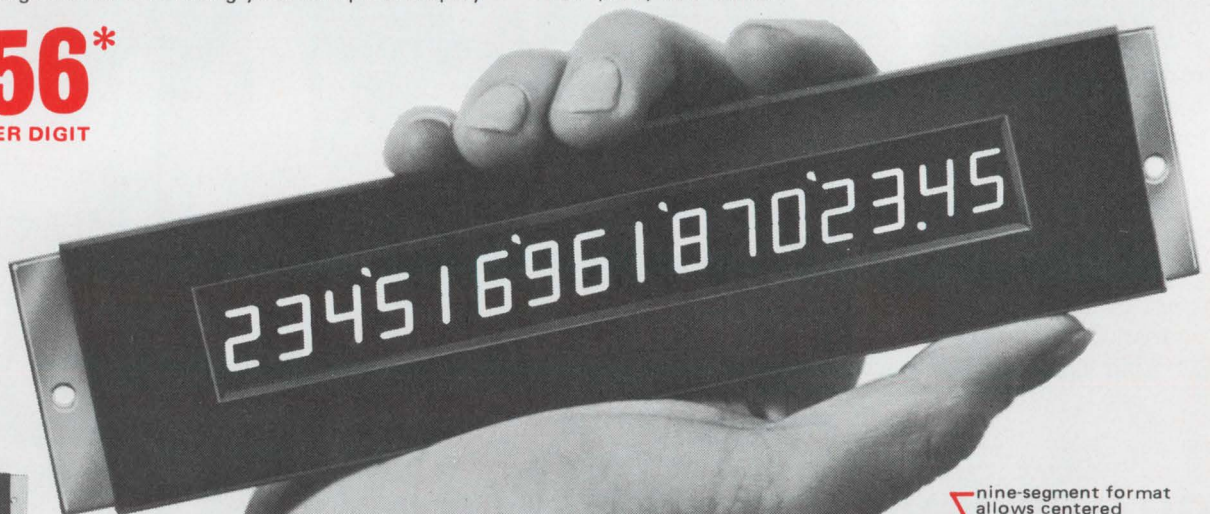

— CALL BURROUGHS TODAY

Burroughs



*16 digit unit, 1000 quantity.

Microwave industry sees market gains this year

At midyear, the picture for the microwaves industry is brighter than last year at this time, due primarily to the Federal Communications Commission's decision in late May to permit open competition in the data and specialized services communications field. Both tube and solid-state manufacturers are scrambling for a piece of the action in the new market for microwave carrier communications equipment. The market is estimated at more than \$1-billion.

This new development is overshadowing small, but consistent, gains in microwave systems sales for transportation systems, automobiles and other civilian needs.

But the military business still remains an important source of money for several manufacturers, particularly those in microwave tubes. While all queried by ELECTRONIC DESIGN agree that tubes will at some point in the future be replaced by solid-state devices, microwave tubes are still showing gains. The military and NASA require power and bandwidths not yet available at certain microwave frequencies with solid-state devices.

Increases in foreign business are also brightening the outlook of several manufacturers.

Philip Baslin, general manager of microwaves at the Fairchild Microwave and Optoelectronics Div., Palo Alto, Calif., says Fairchild already is involved in new projects as a result of the FCC decision. The company's telecommunications microwave business "is about to explode," he reports, with sales in the first half of the year 20% ahead of those in the first half of 1970.

Baslin notes that within the last two months Fairchild has increased its new orders from about 20 to close to 200. And he points out that

the FCC initially accepted 17 applications for microwave data links that will require some \$400-million worth of microwave components.

The civilian market is being emphasized at Hewlett-Packard's Microwave Div., Palo Alto, Calif. Douglas Chance, the division's marketing manager, says that while military business is valuable, it has never accounted for a large proportion of the division's sales. He reports that HP's sales abroad, "regularly a big contributor," remain firm, with prospects opening up for swept uhf instrumentation.

In the microwave military area, spare-parts procurement has been hard hit in the last six months, according to Thomas Sege, vice president of Varian Associates' TWT Div. in Palo Alto, Calif. Since the company's business is primarily in components rather than systems, sales have been down some 10 to 15% from last year's to date. But Sege predicts a flurry in military "fiscal year-end" procurement.

In other military areas, Sege says that Varian is generally optimistic because of a number of major system upgradings and new procurements. He notes that in one recent procurement "we have participated handsomely in the microwave tube area."

U.S. Industry cautious on Red China trade

"It's much too early to tell" seems to be the consensus among industry and Government spokesmen as to what the removal of some of the trade barriers with Red China will mean to the U. S. electronics industry.

President Nixon has issued a list of commodities for which special export licenses are no longer needed. The products include air-condi-

tioning, refrigerating and electrical equipment in general commercial use, some tubes (excluding microwave), resistors, capacitors, transistors, radio and TV receivers, telephone equipment and voice and music recording devices. American exporters still face many problems, not the least of which is the matter of payment and the taking of orders.

A spokesman for General Electric told ELECTRONIC DESIGN that it was simply "much too early to assess the effects of the President's order." This was echoed by Commerce Dept. and other Government officials.

RCA network to offer video unit for phone

A video attachment for the telephone to enable commercial users to transmit pictures or diagrams of products or other subjects as they talk will be available for customers of RCA, Global Communications in the next two months.

The attachment, called Video-Voice, will rent for about \$300 a month and will transmit still pictures only. RCA says it is intended primarily for use by corporations with worldwide operations for conducting international conferences.

Because of the limited bandwidth requirements for Video-Voice—about 3 kHz vs the 1 mHz needed for AT&T's Picturephone, service charges amount to only \$3 to \$4 a minute, compared with \$1000 a minute for Picturephone.

The RCA device uses silicon ICs to store a frozen TV image. It transmits the image over standard voice-bandwidth channels. The system has a silicon target storage



Video-Voice system developed by RCA will transmit still pictures over voice channels.

tube—an RCA Laboratories development—at both the transmitting and receiving end and a standard kinescope display tube.

Video-Voice's main advantage over facsimile systems already in use are its speed and its ability to freeze a moving subject. In operation, the subject for transmission is displayed on a small monitor, and a transmitting button is pushed when the image is approved. The received picture can be displayed for several minutes, or a new view can be transmitted every 30 seconds. But if only one circuit is being used, voice conversation must be discontinued during the transmission period. With a duplex system, discussions are possible while the picture is being transmitted.

In addition to equipment rental and service charges, the user also must lease a voice channel from RCA Globcom. An individual channel via cable or satellite from New York to London, for example, would cost \$10,000 per month.

A holographic system to detect skyjackers?

A new type of holographic system that uses coherent electromagnetic radiation in the millimeter range (70 GHz), instead of laser radiation, may help detect weapons on the person or in the luggage of potential airliner hijackers.

Because these millimeter waves readily penetrate clothing and dielectric materials, but are reflected from metal surfaces, research scientists at the University of Pennsylvania have been able to create a prototype camera system to produce an image of concealed metal.

The system, constructed by Wayne Guard, a doctoral candidate at the school, has successfully produced a visual image of a toy metal gun hidden inside a tweed jacket and a synthetic leather pocketbook.

The new system was developed from research by Dr. Nabil H. Farhat, associate professor of electrical engineering, on close-range imaging radars for use in landing planes and in docking ships under zero-visibility conditions. It is based on the fact that if the exact phase of coherent radiation reflected from an object can be deter-

mined over a specific planar area (aperture), a holographic image can be constructed from the phase information.

With the present system, the images are made in two steps. First, the target is illuminated with 70-GHz waves. Radiation reflected from the concealed object is mapped, on a point-by-point basis, by scanning the receiving aperture in a spiral pattern with a special horn and receiver.

The received signals contain both amplitude and phase information. The amplitude information is removed by passing the signal through a limiter. The phase signals are then combined with a reference rf signal to produce an amplitude-varying signal that modulates the Z-axis of an oscilloscope.

The picture on the scope, which is an exact representation of the phase of the wavefronts arriving at the various points throughout the receiving aperture, is photographed with a Polaroid camera.

The developed picture, which looks like a crude bullseye, is photographically converted into a negative transparency, or a "phasigram."

To obtain the final image, the phasigram is illuminated with a laser, and the resulting image is projected onto a screen or photographed.

Although the present process takes up to six minutes, Dr. Farhat says that several methods exist that eventually may make the system one working in real time.

Western Union files for new digital link

The Western Union Telegraph has filed an application with the Federal Communications Commission to build a digital microwave system between Pittsburgh, Cincinnati and Chicago. This would be a hybrid (analog and digital) system with a 8.3-megabit capacity and 300 voice analog channels.

The application is part of Western Union's plan to provide a digital network on its 7900-mile nationwide microwave system—an analog system over which 67% of the traffic is digital.

In October, 1970, the telegraph company filed an application with

the FCC to build a digital microwave system between New York and Philadelphia as part of its New York to Washington, D.C., digital extension. The plan specified that the company would enlarge its existing analog microwave network between these two cities, adding a 20-megabit per second digital capacity to the network's present 1200 voice-channel (4 kHz analog) capacity.

A 20-megabit capacity will carry up to 4600 synchronous data channels (2400 baud each) or 110,000 low-speed data channels (75 baud each).

The proposed New York to Philadelphia system will make it possible to transfer a large portion—at least several hundred channels—of existing digital traffic from the analog system.

The company expects about 50% of its customers that are now using the analog microwave system to switch to the digital when it is completed.

A broader role urged for city communications

Telecommunications better applied to such fields as health care, education, and transportation could make the nation's cities more livable and reduce the need for high-density living in the future, according to a report by the National Academy of Engineering.

The report, "Communications Technology for Urban Improvement," was prepared after a 16-month study of city operations and discussions with officials in representative U. S. cities. It recommends that cities and the Federal Government cooperatively launch 18 pilot projects to test the effectiveness of communications in improving the quality of health, education, transportation and municipal services for urban residents.

The report was prepared under the direction of Prof. William L. Everitt, dean emeritus of the College of Engineering, University of Illinois, and Dr. Peter C. Goldmark, president and director of research at CBS Laboratories. Copies are available, at \$3 each, from the National Technical Information Service, U. S. Dept. of Commerce, Springfield, Va. 22151.

Best for Hybrid Circuits...

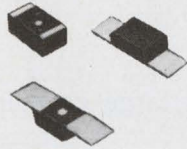

PIPS OF CHIPS

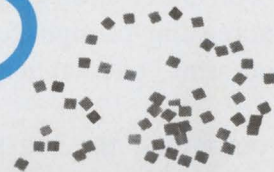

DOMINO[®] Molded Solid-electrolyte Tantalum Capacitors

Designed for hybrid circuit and low-profile flatpak printed circuit board applications. Fully-molded construction for superior mechanical and humidity protection. Excellent stability. Compatible with automatic insertion equipment. Available with and without extended tab terminals.

INFORMATION RETRIEVAL NUMBER 17

Write for Engineering Bulletin 3532.

MONOLYTHIC[®] Chip Ceramic Capacitors

Offer a unique combination of high volumetric efficiency, wide selection of capacitance ranges and body formulations, and moderate cost. Excellent adherence of metallized terminations eliminates problems often encountered with other chip ceramic capacitors. Available in four EIA-preferred chip sizes.

INFORMATION RETRIEVAL NUMBER 18

Write for Engineering Bulletin 6200.

Technical Literature Service
Sprague Electric Company
347 Marshall Street
North Adams, Mass. 01247

45-0148

SPRAGUE[®]
THE MARK OF RELIABILITY

THE BROAD-LINE PRODUCER OF ELECTRONIC PARTS

Electronics at Mid-1971

The silver lining begins to appear

At this time last year the national economy was bogged down in a recession, and the electronics industry was seriously affected. Now there are signs that the turnaround is under way. What are the prospects for the rest of the year? The editors of *ELECTRONIC DESIGN* queried companies and their staffs in key electronic areas in the U.S. Their findings include these:

- In semiconductors, where the bottom has literally fallen out, the outlook for the rest of the year is largely gloomy, with only isolated areas of improvement.

- The consumer industry, though still worried by increasing foreign competition, is having a good year, particularly in sales of color TV sets.

- In computers, the big story continues to be minis, with sales up substantially over last year. Small systems and peripherals are also on

the upswing, but large computers continue to lag.

- Component sales are disappointing, with a decline in overseas sales, further defense and aerospace cutbacks and a lack of orders from computer instrument and system users.

- Industrial electronics manufacturers expect a definite improvement in sales for the remainder of the year, particularly in less-expensive equipment.

- In instruments, the second half of the year is expected to be better than the first six months. Overseas business is still growing but not as rapidly as it was last year.

- The microwave industry, which has been hit hard by military cutbacks, nevertheless expects some gains this year. Overseas business is good, and the outlook for business in the specialized communications areas is even better (see *News Scope*, p. 19).

Semiconductor field picking up the pieces

Much of the glowing optimism that pervaded the semiconductor industry two years ago is gone. The bottom fell out in the spring of 1970, about six months after the national economy began to slide. But if you believe the National Bureau of Economic Research, the national recession ended in November. Allowing for six months to reflect the upturn, semiconductor manufacturers should be noticing a turnaround now.

Already there are isolated signs of improvement. The General Instrument Corp. in Hicksville, N.Y., is heavily in MOS, and Lew Solomon, vice president of marketing and sales for the company's Semi-

conductor Products Group, says: "Our position began to improve in about April. Our business is up about 25% compared to the first quarter last year." (General Instrument's first quarter runs from March through May.)

Solomon is expecting MOS sales of \$114-million to \$120-million this year, against \$70-million last year. He reports the company's engineering employment is up, too. "We are hiring and have open requisitions for engineering personnel," he says.

Signetics also is optimistic. While noting a downturn in the first quarter, it expects a sharp pickup for the rest of the year.

But otherwise the picture isn't very bright yet. Fairchild reports "drastic decreases in sales." And the vice president and manager of Texas Instruments' Components Group, J. Fred Bucy, groans:

"The depression in this industry may turn into a recession, but that's the most optimistic I can be."

Some companies, like Philco-Ford's Micro-Electronics Div. and Sylvania's Semiconductor Div. are no longer around. They, like the half dozen other companies that folded within the last year, couldn't afford to wait out the slump.

In an address to investment analysts last month, Dr. C. Lester



Sales of semiconductor products are expected to reach \$284-million this year, down about 16% from 1970 figures. A Texas Instruments production line is shown here.

Hogan, president and chief executive officer of the Fairchild Camera and Instrument Corp., said that in March, 1970, "Fairchild was concluding the second highest bookings month in our Semiconductor Division's history; then came April and an abrupt and surprising slump in our major semiconductor markets.

"We were staffed to operate at the level of the first quarter of 1970," Hogan said, "and then were hit by drastic decreases in sales." Fairchild whose Semiconductor Div. in Mountain View, Calif., is the company's biggest employer, has since cut back its worldwide work force from 23,000 employees to 14,000.

The numbers tell the story. Sales of all semiconductor products fell 34% last year, from \$337-million to \$224-million. The first quarter

of 1971 has shown a recovery that, if it persists, should put the year's sales total at \$284-million, but this is still 16% below last year.

ICs haven't fared much better, but, according to Rolland Smith, manager of marketing research for Signetics Corp. in Sunnyvale, Calif., a turnaround has started and should be dramatic before the year is out.

Although industry-wide IC sales are down for the first quarter—about \$77-million this year, compared with \$115-million for the first quarter of 1970—Smith projects that 396 million ICs will be shipped this year compared with 198.8 million in 1970. Applying the traditional 30% drop in price when the industry doubles unit volume, he says sales revenue this year should jump 40% over 1970's.

Smith, who keeps tabs by com-

puter on the entire IC industry for Signetics, has also forecast sales of 575 million units for 1972. But he isn't too optimistic on what these numbers will mean in terms of industry employment. He estimates "the whole industry will have to hire back 7000 to 8000 people between now and the middle of next year." But he figures that only about 10-15% of these will be engineers.

Smith contends that the IC industry is getting itself into a "fixed-cost box," where it "tends to mechanize the business as far as possible."

"And that," he explains, "runs your fixed-costs up. Then when you hit a slump, the only place you can reduce costs is to eliminate people; so they cut the labor back. Because they still have substantial expenses, they turn around and mechanize further during the next growth period. It's like a ratchet system—you ratchet out labor, but you never pick it back up."

An 8% drop in business

Bucy at Texas Instruments, Dallas, feels that 1971 "is going to be more critical to semiconductor manufacturers than 1970."

TI cut its work force 25% last year, laying off 14,000 of its 55,000 workers.

"I expect the semiconductor industry business will be down 6 to 8% this year, compared with 1970," he says.

The long-range outlook for semiconductors? Fairchild's Dr. Hogan turns out to be among the most optimistic industry spokesmen. He expects "the semiconductor industry—and electronics in general—to help set the pace in the financial recovery which is inevitable for this country." ■■

Consumer industry bounces back strong

Last year at this time the consumer electronics industry was down across the board. The picture was made even gloomier by increasing foreign competition—particularly from Japan. But this year an upturn is in sight, even though foreign competition remains a formidable threat.

At the end of the first quarter

of this year, total unit sales in the U.S. of all categories of consumer electronics were up substantially over the same period of 1970, according to the Electronic Industries Association. Color television is leading the way.

Total sales of color TV sets increased from 1,162,422 to 1,536,959, a gain of over 30%. Mono-

chrome TV sales increased by 19.7%. Radio sales were up 4.1%, phonograph sales 2.3%, and tape recorders 2.8% over the same period last year.

But the specter of foreign competition has increased. For example, while sales of American manufactured color TV sets increased from 979,596 in the first quarter

of 1970 to 1,287,889 in the same period this year—a gain of 31.4%—imports, particularly Japanese, made still greater gains, going from 93,454 sets to 178,466—a rise of over 91%.

Ways to beat the foreign competition range from producing U.S. products with advanced technological features and more innovative design to developing more American-owned foreign manufacturing plants, according to Joseph S. Wright, chairman and chief executive officer of the Zenith Corp., Chicago. In a recent speech to the 24th Annual Conference of the Financial Analysts Federation in Cleveland, he said that in the next five years the impact of Japanese and other foreign competition will continue to increase unless there is some major change in the Government's policy to "inhibit" the imports. Wright predicted that the foreign color TV sales would grow to as much as 15 or 17% of the total U.S. market by 1975.

Zenith's employment in the U.S., Wright pointed out, will be down 5000 jobs this year, in comparison with 1968, due to the necessity for manufacturing abroad products that it once made in this country. Zenith has opened its first manufacturing plant on Taiwan.

But despite the foreign competition and price increases, all of the major U.S. TV manufacturers look for a good year for consumer electronics.

Donald Johnstone, acting manager of the General Electric Television Receiver Products Dept., Portsmouth, Va., reports: "Overall, things look brighter for the TV industry than in the last two years. The emphasis is in the portable color TVs of 19-inch screens and under, like the trend of monochrome sets in the late 50s and

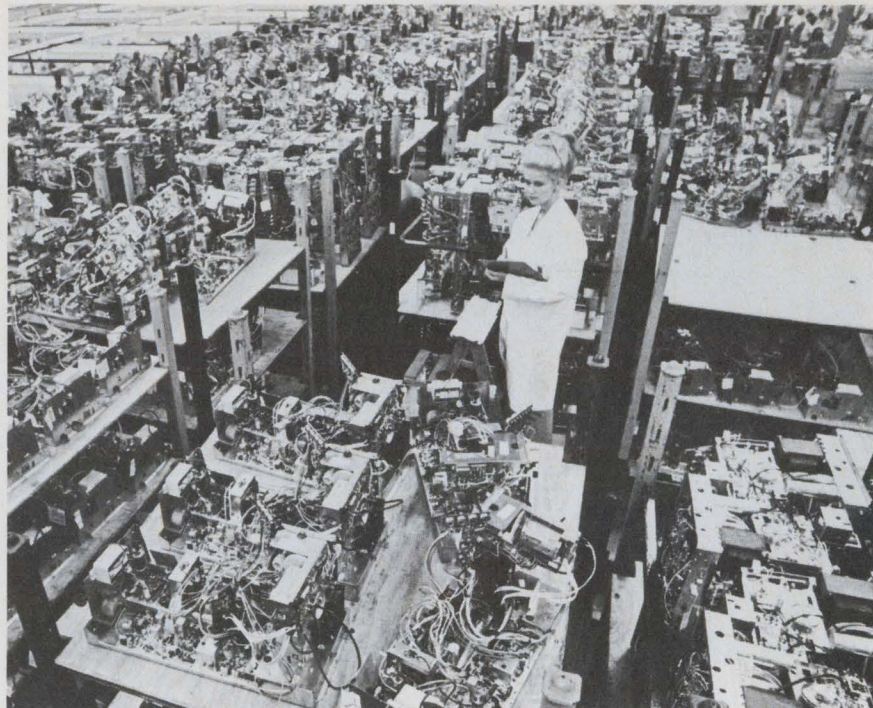

Thousands of solid-state color television chassis await final assembly at GTE Sylvania's production line in Smithfield, N.C.

early 60s. Already over 50% of the color sales are in this category."

But the TV console is still big in terms of units and dollar volume, Johnstone points out. This year, he says, the 23-inch and 25-inch sets will account for well over 50% of the industry's dollar volume and 40% of the unit sales.

GE has been forecasting industry color TV sales of \$6.2-million this year, or 13% more than in 1970, Johnstone says that estimate looks very conservative.

Richard Kraft, video products manager of the Motorola Consumer Products Div., Franklin Park, Ill., agrees.

"We've been forecasting 1971 as a five-million unit year for color television," he says. "But as of now, it will exceed six million and

could approach seven million.

Sales of stereo modules and components and tape-recording equipment are running well ahead of last year, according to Charles Grill, audio products marketing manager for Philco-Ford Corp., Philadelphia. The company's stereo sales are 100% ahead of last year's and growing "by leaps and bounds," he reports. Most of the sales are being made to young people. They can buy good-quality stereo components for less than furniture, he says, and they're making the components do double duty as apartment furniture, because of their attractive contemporary design.

At the same time, Grill says, Philco-Ford is running about 25% ahead of the industry on stereo console sales. And it is looking forward to continued growth. ■■

Minis soar in an edgy computer market

Sales of minicomputer equipment are hot. But the rest of the computer industry? What you make will pretty much determine how well you do this year, marketing men believe. In general, small systems and peripherals are on the

upswing. But sales of larger computers have yet to perk up.

Minis have taken off again, in many cases doubling the sales figures reached at this time last year. One company three years new in the business—Data General Corp.

of Southboro, Mass.—reports its "biggest strain is to increase production as fast as we can." This intelligence is from Data General's director of marketing, Allan Kluchman, who says there has been a "substantial increase in orders

since January, and an almost 100% increase in mini systems."

Eli Milakovich, director of administration for the Data Products Div. of Lockheed Electronics, Los Angeles, sees his business as generally down this year. But he adds: "Minis are up, and we expect mini business this year to be double that of last."

Only 25% of Lockheed's business is in minis, however. Some 50% is in computer memories, and the other 25% in printed-circuit boards.

Sales and rentals are down

Honeywell, Inc., Minneapolis, reports computer sales and rental revenues at \$429-million for the first quarter of 1971, a 7% decline from the \$461-million of a year ago. Earnings were down 50%—from \$14-million to \$7-million.

James H. Binger, chairman of Honeywell, has attributed the first-quarter decline, in part, to "a reduction in aerospace and defense revenues, as expected, and a drop in the level of computers sold outright compared to those leased."

Honeywell wasn't the only one to be hit by the decline in Government business. Control Data Corp. of Minneapolis, whose total sales for the first quarter rose to \$141-million from \$125-million a year ago, also lost aerospace business. According to Samuel Cantwell, assistant treasurer:

"The aerospace industry, which has been a good customer of ours in the past, is well down, if not decimated, and we don't expect that it will improve markedly in the near term."

Scientific computers suffer

Scientific machines were among the hardest hit. Systems Engineering Laboratories, Fort Lauderdale, Fla., has had "a heavy shift toward markets like automotive, electric power, and other pure commercial business," according to Mel Couchman, director of marketing. The company's president, C. E. Griffin, says:

"The industry will not soon forget 1970. It was a sobering experience, and we are all glad to see it pass."

Systems Engineering expects to finish this year with around \$13-

million to \$14-million in sales, as opposed to more than \$20-million last year.

Though some computer companies are hiring selectively, the industry picture isn't too bright for unemployed engineers. Systems Engineering reports employment down 30% since last year and holding steady at that level.

Cantwell says that Control Data has "cut down significantly in the number of people employed, but that pretty much reached a plateau around the end of the year, and there has been no significant change since."

Milakovich reports that Lockheed's engineering employment has leveled off at about 10% below last year's.

Honeywell is in a unique situation because of its merger with General Electric's Computer Div. in October, but it, too, isn't hiring. Since its assimilation of GE's work force, it has had a duplication problem in jobs and has not been hiring engineers.

Among the few bright spots in employment are Digital Equipment Corp. in Maynard, Mass., and Data General. Nick Mazzaresse, vice president and group manager at Digital Equipment, reports:

"Our engineering work force has increased over the past year, and we have been hiring steadily."

Kluchman says that Data General "is doing extremely well, much better than average, and has been hiring in all areas—engineering, manufacturing and marketing."

Most computer companies are optimistic about the future, and many believe that new products and foreign sales will spur healthy expansion. Data General is now selling in Europe and has just concluded a licensing agreement with the Japanese; technology will be exported to Japan, and she, in turn, will manufacture and export to Asia.

A bright outlook overseas

Binger of Honeywell predicts that "overseas, or non-U.S. growth, will exceed the domestic rate." Cantwell attributes about 30% of Control Data's 1970 revenue to overseas subsidiaries and expects it to increase this year.

That foreign exchange is a double-edged sword was made clear by Mazzaresse. He says Digital Equipment "has been expecting to see minicomputer competition from Japan and Europe." But, he con-

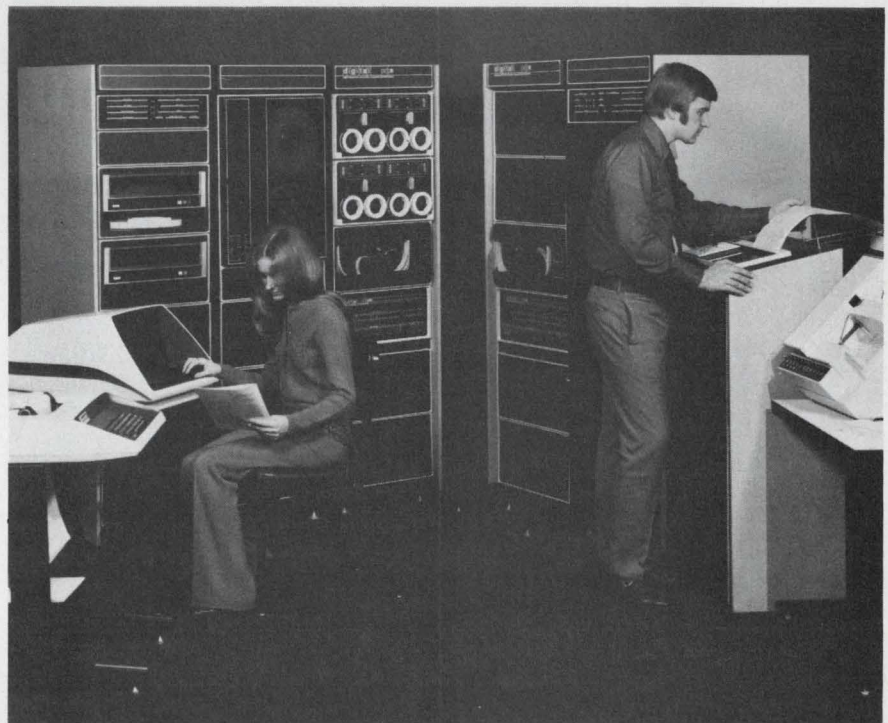

The two minis and full range of peripherals here illustrate the new systems marketing philosophy that is going strong this year. Digital Equipment Corp. is offering (left to right) a teleprinter, CRT keyboard terminal, disc cartridges, magnetic tape, mini-magnetic tape, two paper tape readers and mini computers, high-speed printer, high-speed punch card reader, and modem.

tinues, "our foreign business has been growing quite rapidly; we had been experiencing a 40 to 50% growth rate in the past few years, but last year's was less."

For Systems Engineering Laboratories, Europe has been a weak market. "The London office says their dip is following ours by about six months," Couchman reports.

"They are at the bottom, and mainland Europe is only a little better." He adds, however, that "business in South America is booming right now." ■■

Component makers dig in for a tight year

"Disappointing sales for the first six months of 1971 and only modest gains predicted for the rest of the year, at best" is the way one executive has summed up the prospects for component manufacturers in the country.

In the survey by *ELECTRONIC DESIGN*, this appraisal was repeated often, with variations in wording. Manufacturers of resistors, capacitors, connectors, display tubes and hybrid components attributed their static sales to a sluggish national economy and a lack of confidence in spending by computer, instrument and systems users; to defense and aerospace cutbacks, and to an on-coming economic decline in Europe—a delayed reaction to the recent decline in this country.

Nixie tubes holding level

John Pittman, product marketing manager of the Burroughs Corp., Plainfield, N. J., reports that sales of Burroughs' Nixie tubes have held so far this year to the same level as last year's.

"We are used to an annual overall growth rate of 25 to 30%," he explained. "This year we are holding our own, with only modest sales increases over last year. This has come as a disappointment to us, because, like many component makers, we were used to business going up every year.

"Our newer product lines are simply not taking off as well as we expected them to. Many of our customers are asking for small samples, with no large follow-up orders. This reflects their conservative spending attitudes in the face of an uncertain economy."

Pittman feels that component users are keeping their inventories at very conservative levels.

Shelton Wilson, manager of the IRC Operations Div. of TRW,

Boone, N.C., echoes this view. In addition he adds an important element that is causing sluggish resistor business for IRC: foreign competition, both offshore and domestic.

"At one time resistors made here had an edge in quality over less-expensive foreign imports," he notes. "But even this edge has been largely disappearing.

"Competition is on the increase from Japan, Holland, and Italy for sophisticated metal-glaze, tin-oxide resistors used in computers and industrial applications. In the computer field alone, our sales are off this year by 30% over last year."

He explains that radio and TV manufacturers, such as General Electric, RCA and Zenith, are turning to overseas plants to have their products assembled at low labor costs. This has caused a loss of business for U.S. resistor makers.

When queried about its sales figures for receiving tubes, RCA Corp., Harrison, N. J. would only admit that there has been a decline in total sales, both domestic and foreign, during the first half.

According to the receiving tube operations marketing manager K. B. Bryden, the domestic decline in receiving tube sales has been caused by off-shore procurement of TVs and tubes and by the inroads solid state devices are making to replace them.

Beating overseas competition

One company that has been trying to counter the foreign competition by joining it is Sprague Electric of North Adams, Mass. Over the last few years it has been opening plants all over the world in such countries as Germany, Taiwan, Hong Kong, France, Scotland and Belgium to produce capacitors at low cost.

Glen Foss, assistant to the pres-

ident, says that Sprague has gradually been moving its operations overseas while supplying the same customers. As for its over-all sales this year, Foss reports that the Sprague sales curve is mostly flat.

"Our initial expectations last year," he notes, "were for a slight loss for the first and second quarters of 1971, a touch-and-go situation for the third quarter and a slightly profitable fourth quarter. This was revised in January, 1971, to a flat sales-curve forecast for all of the second half of 1971.

"Unless our customers—such as computers, telecommunications and instrument manufacturers, who themselves are experiencing depressed sales markets—start doing better, our sales will remain largely flat."

A more optimistic outlook

One not-so-dismal view of the components business is held by Ray Stata, president of Analog Devices, Cambridge, Mass. His company manufactures sophisticated signal-conditioning hybrid components, such as a/d and d/a converters and op amps.

Stata says that the low points in bookings for Analog Devices came in the middle of last year. Since then, he adds, sales have grown at a conservative rate.

"While we had a 25% growth rate in 1970, our growth rate this year was slightly under that of 1970," he reports.

Last year Analog Devices laid off 25% of its work force, across the board. This year, according to Stata, there were no cutbacks, and some personnel were even hired.

"We have concentrated heavily on new products, using monolithic hybrid designs to increase our component sales," Stata says. These are more reliable and cost less than discrete-type components.

CAPACITORS
FILTERS

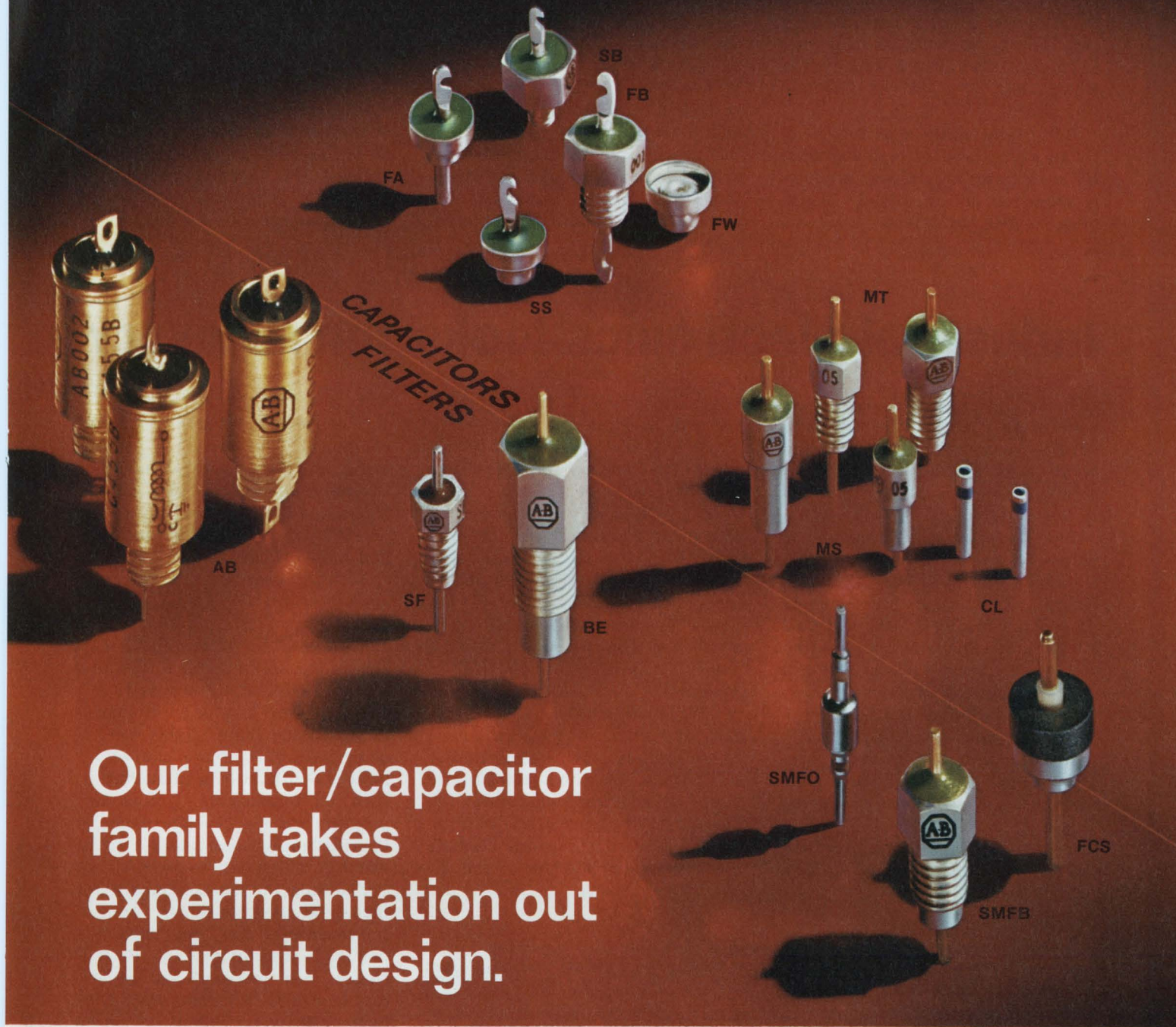

Our filter/capacitor family takes experimentation out of circuit design.

We provide the comprehensive data you need for every one of our filter and capacitor components. Attenuation curves (by current, voltage or in combination at room temperature and maximum). Test procedures. Application aids. Specs. Dimension drawings. That's why the Allen-Bradley family is easier to work with. We also give you high volumetric efficiency and

a wide variety of styles. Backed by our famous track record for quality and improved performance. Request your personal copies of our literature. Call our nearest appointed electronics distributor, or write: Allen-Bradley Electronics Division, 1201 South Second Street, Milwaukee, Wisconsin 53204. Export: Bloomfield, New Jersey 07003. Canada: Galt, Ontario.

Publication 5409: type FA, FB, FW, SB, SS ceramic disc capacitors for VHF/UHF.
 Publication 5410: type FCS, SMFB, SMFO filters for the 50 MHz to 10 GHz range.
 Publication 5411: type CL multi-layer, coaxial capacitors for connectors.
 Publication 5414: type MT, MS by-passing capacitors for 50 KHz to 1 GHz.
 Publication 5416, 5417: type BE, SF filters for RFI/EMI suppression.
 Publication 5418: type AB broad band filters in Pi, T and L configurations.



Actual Size

NEW DIMENSION ELECTRONICS
ALLEN-BRADLEY 

"A bright area for us has been the foreign markets in England, Germany, France and Japan, into which went 35% of our business last year."

But Stata cautions on too much reliance on these foreign markets. He anticipates a European economic recession and is already beginning to feel the effects.

Another segment of the component industry experiencing soft markets is the connector industry. It has been particularly hard hit with the cancellation of the SST and C-5A aircraft programs.

Steve Kelleher, vice president of marketing for Amphenol Connector Div., Chicago, says that for some circular connector manufac-

turers, like his company, aerospace and missile programs constitute 50% of the business.

According to Kelleher, the \$93-million circular connector market will more than likely remain flat, as it has been for some time, for at least two to three years more because of large-scale defense and aerospace cutbacks. ■■

Industrial electronics looks for recovery

Industrial electronics sales were poor in 1970 and in the first half of this year, but they should improve over the next six months, according to most manufacturers in the field.

The increase should amount to 6 to 8%, according to John Rock, a staff scientist with Quantum Science Corp., market researchers with offices in New York and Palo Alto, Calif. Industrial test-equipment sales were \$162-million last year, he says, and sales of electronics in process-control equipment amounted to \$357-million.

Instrumentation for process-control systems "has been better than expected, and we believe this trend will hold," says George Heller, vice president of marketing for the Taylor Instrument Process Control

Div., Rochester, N. Y. "We have not cut back on our engineering staff and don't plan to," he reports. "In fact, we may hire a few people."

G. H. Gleason, vice president in charge of marketing for the Foxboro Co., Foxboro, Mass., estimates the entire process-control market at \$2-billion a year. He believes business will remain constant for the remainder of the year. No layoffs are planned by Foxboro.

"Big individual systems that cost \$1-million or more are hard to sell right now," says Robert A. Morgan, Westinghouse Electric Corp.'s marketing manager for the Industrial Systems Div., Buffalo, N. Y. The big systems include computer-controlled plants and di-

rect numerical control.

"The less expensive industrial equipment, however, is selling well," Morgan notes, "things such as numerical control and adjustable speed drives. These things are necessary in a period of inflation and higher wages."

Nick Scallon, vice president of marketing for the Fisher Controls Co., Marshalltown, Iowa, sees a \$225-million to \$250-million market in minicomputers for digital process-control systems this year—up 15% over last year. He hopes to get a good share of this market, along with part of the market for process-control instrumentation, such as transducers, probes and pressure gauges. Scallon estimates the instrumentation market to be worth \$250-million a year.

The sale of semiconductors for industrial products shows "signs of improvement over the next six months," according to W. C. Hittinger, vice president and general manager of RCA's Solid-State Div., Somerville, N. J. "And we see a definite upturn in 1972," he adds.

The semiconductor business usually lags behind major equipment sales, Hittinger explains. "They wait for definite orders before piling up an inventory of components."

COS/MOS on the move

Another product expected to move is COS/MOS. "There is tremendous interest here," Hittinger reports. "We're getting many inquiries, although the action hasn't quite started yet." COS/MOS components will be used in automobiles, clocks, automation, instrumentation and industrial controls.

Motorola Semiconductor Prod-

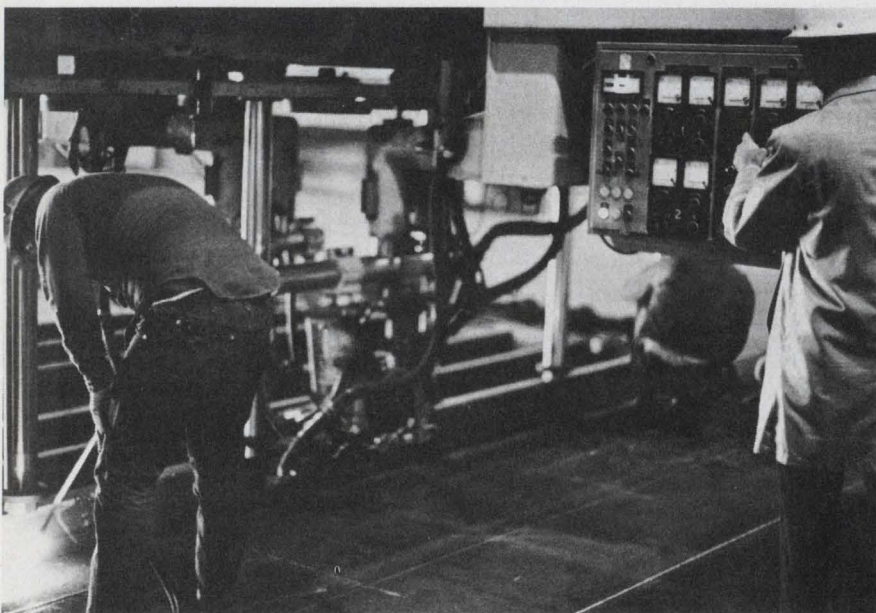

Electronically controlled welding gantry at Litton Industries' shipyard in Pascagoula, Miss., is one of many automated industrial systems now being sold to cut rising labor and production costs.

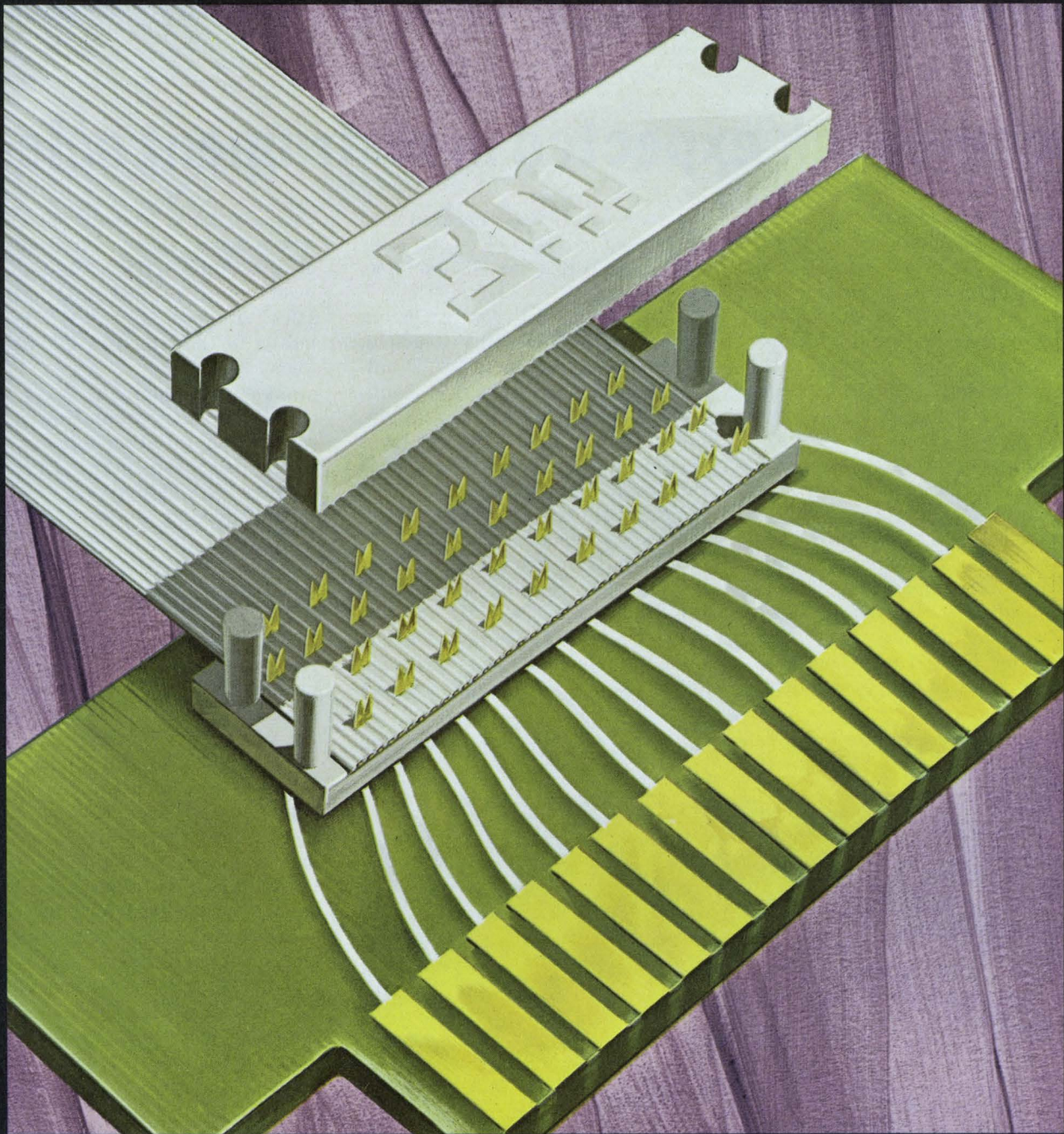

3M's Flat Cable and Connectors... your systems approach to circuitry.

Speed and dependability are yours for your circuitry system assemblies. 3M's "Scotchflex" Flat Cable and Connector Systems provide fast simultaneous circuitry transitions.

"Scotchflex" Flat Cable and Connector Systems win on every count • No stripping or soldering • Reduce wiring errors • Permit easy trouble-shooting •

Provide predictable electrical characteristics • Speed production. • Transitions available for printed circuit board, dual in-line plug, WWP and PCB edge card. For complete information, write: Dept. EAH-1, 3M Company, 3M Center, St. Paul, Minn. 55101.

"SCOTCHFLEX" IS A REGISTERED TRADEMARK OF 3M CO.

3M
COMPANY

ucts, Phoenix, Ariz., goes along with RCA in predicting an upturn in semiconductor sales for industrial products, as does Sprague Electric Co., North Adams, Mass.

Texas Instruments in Dallas, however, expects a recession.

General Electric's Electronic Components Business Div., Syracuse, N. Y., expects an upturn in

business during the second half of the year, and has expanded its sales force by 20% in preparation, says the division's vice president, T. A. Vanderslice. ■■

A comeback expected in instrument sales

Instrumentation sales dipped in the first half of the year, but the outlook for the rest of the year is slightly optimistic. "Things are picking up a little" is the general feeling among marketing men in such companies as Wavetex, Tektronix, Triplet, Simpson, Beckman, Hewlett-Packard, Systron-Donner, E-H Research, Exact Electronics and Weston.

While the market was down as much as 3% in the first half, it will rise as much as 6% in the last half, according to John Rock, staff scientist for Quantum Science Corp., a market research organization with offices in Palo Alto, Calif., and New York. That's up 6% over sales in the first half of

the year—or up 3% compared with the second half of 1970. Total sales last year came to \$850-million, Rock says.

Last year sales for oscillators amounted to \$165-million; meters, \$95-million; recorders, \$164-million; signal generators, \$57-million; time and frequency equipment, \$66-million. All of these should be up a bit by the end of this year, Rock predicts.

Business overseas, which represents approximately 25% to 30% of the total instrumentation market, is still growing but not as rapidly as it has been. In the last quarter of 1970, Hewlett-Packard relied on international sales for 40% of its \$350-million-a-year

business, while domestic sales were going down. In the first quarter of this year, HP's domestic sales went up 22% and international sales dropped 10%. What this means in the long run HP doesn't know.

"It seems apparent," a company spokesman says, "that Europe has caught the inflation ailment that we've had" (see "For European Electronics, Things are Looking Down," ED 12, June 10, 1971, p. 22).

Knowing customers' needs

HP is hiring engineers to replace normal attrition only; no expansion in personnel is foreseen for the remainder of this year. But the company is interviewing.

With the volume of sales over the next six months expected to hold steady, or even increase slightly, the important thing for market men to know is what changes are taking place in customer preferences. What changes are being sought in voltage-current-resistance meters, counters, scopes and signal sources? (see "Focus On Instrumentation," p. 50 this issue).

In E-I-R meters, for example, the big change is toward digital readouts. Digital integrated circuits are cheaper now. The customer finds a digital meter to have more sales appeal than an analog. It offers an unambiguous, quick reading. It can offer a digital readout in the form of a code that can be printed or recorded on tape or fed into a computer. This satisfies the growing demand for automatic measurements. ■■

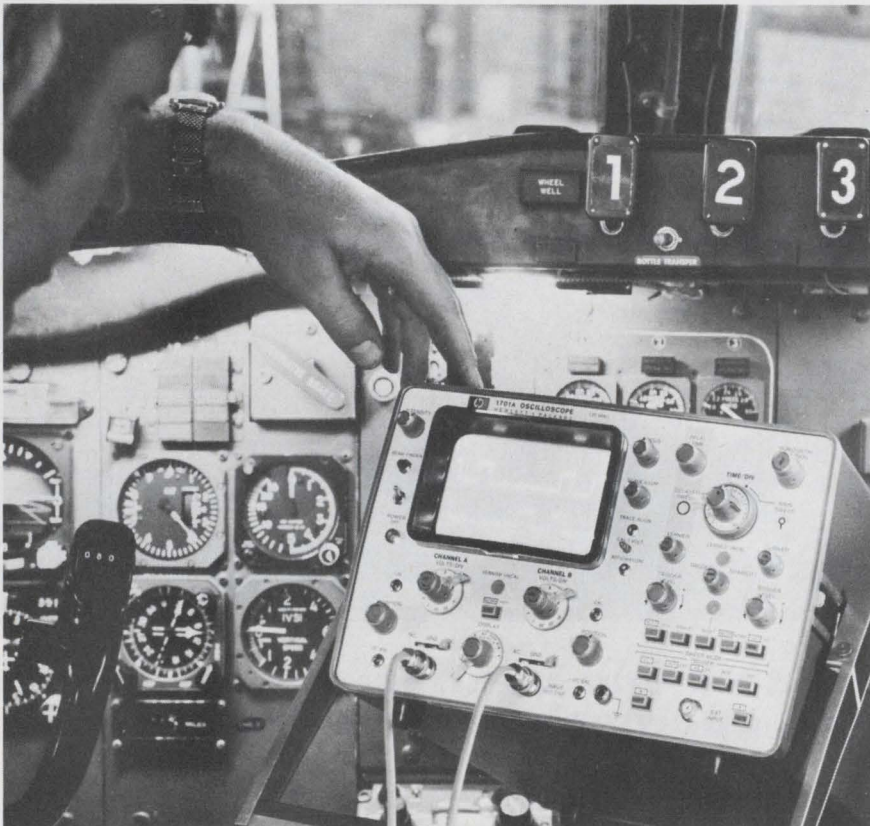

Hewlett-Packard's domestic instrument sales went up 22% during the first quarter, while international sales dropped 10%. The company's Model 1701A oscilloscope is shown here.

The following editors contributed to this report: Roger Allan, Michael P. London, John F. Mason and Jim McDermott

DESIGN **IDEAS** FROM SYLVANIA

Look for the silicon lining.

Even though we've stopped making devices, GTE Sylvania still has a slice of the semiconductor business. We're continuing to make the stuff that diodes, transistors, IC's and MOS's are made of.

Silicon.

We've been working with the hyperpure material since its birth. And we'll produce any kind you need. P-type. N-type. With resistivities ranging from .008 to 100 ohm cm. Diameters to 3 inches. Sliced from 13 to 20 mils thick. Doped to your specs.

And polished by our special combination of mechanical and chemical steps so that you get a surface second to none in the industry.

Something to grow on.

(Your devices can't be any better than the silicon they start with. Our material is made for maximum yields.)

Now we supply you with the same top-notch material we always made for our own people when we were making devices.

Our cloud, maybe. But your silicon lining.

Our silicon people can be reached at 717-265-2121. Ask for Al Alexander. Or write to him at: GTE Sylvania, Chemical & Metallurgical Division, Towanda, Pa. 18848.

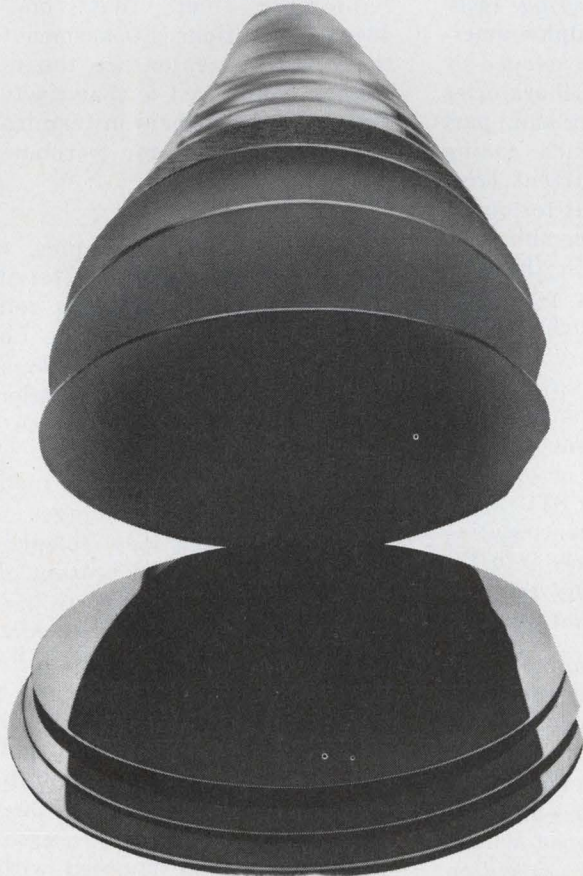

Single-crystal silicon by the slice.

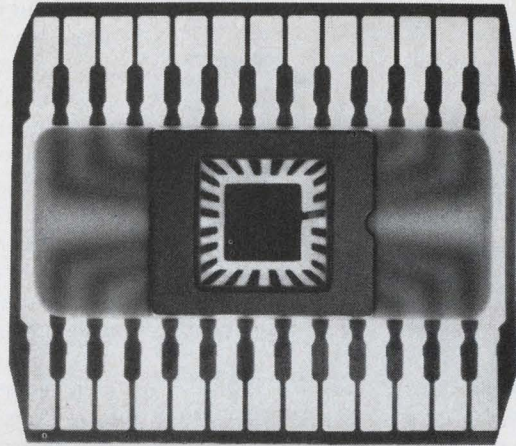

Getting it all together.

What a relief when you've finished the excruciating business of mass-producing IC and LSI chips. You're tempted to lean back, but there's one more step that's just as critical as making them: putting those micro-leads in contact with the macro world.

We've got the packages to help you do it.

Our one-piece lead frames bring strong metal fingers to the edge of the chips. (We manufactured more than 100 million lead frames last year.)

We embed the frames in molten ceramic and end up with a high-strength monolithic sandwich. (Our special glass-ceramic has the same coefficient of expansion as the metal, so they stick together like Siamese twins.)

We make all our own parts and assemble the packages ourselves. (Some manufacturers have to buy frames, lids and bases for assembly.)

We test our packages till they beg for mercy. We examine them for insulation, thermal shock resistance, hermeticity, internal shorts and strict conformity to blueprint.

We have a full line of packages with 14, 16, 24 and 28 leads, and we have different versions of each. We're in the midst of developing other variations to meet the foreseeable needs of MOS/LSI users.

Chances are we'll have what you need right off the bat.

Our prices are reasonable; you don't have to pay a bundle for a package.

Sound good?

Then let's get together and get them together:

Our packages. And your chips.

For more about IC packages, call Bill Williamson at 207-947-8386. Or write to him at: GTE Sylvania, Parts Division, Bangor, Maine 04401.

GTE SYLVANIA

We're always glad to talk to you about our electronic parts, processes and high-purity chemical products.

Uncommonly good sense

from our Tachometer Generators. They're temperature-compensated, miniaturized, and perfect for precision indicators and velocity servos requiring a highly linear speed/voltage relationship with minimum ripple. Linearity from 0 to 12,000 rpm is better than 1/10 of 1% of voltage output at 3600 rpm. The ripple value will not exceed 3% rms of the D-C value at any speed in excess of 100 rpm. The low-driving torque makes them excellent as damping or rate signals in all types of servos. Brushes and commutators are guaranteed for 100,000 hours of operation — more than ten years — at 3600 rpm. Various models are available with outputs as high as 45v/1000 rpm and can be supplied with an indicator as a complete Speed Indicating System.

SERVO-TEK PRODUCTS COMPANY
1086 Goffle Road, Hawthorne, New Jersey 07506.

SERVO-TEK
PRODUCTS COMPANY

For full technical details
write for Catalog 1163
with Test Report
and show
good sense.



technology abroad

An ac plasma display panel with a memory built into it is being investigated by STL Laboratories in Harlow, England. The gas discharge plasma panel was originally conceived by D. L. Tizer of the University of Illinois. Its low cost lies in the device's inherent memory. The memory has no reinsertion circuitry because a voltage can be permanently applied to the display, sufficient to maintain a discharge but insufficient to initiate it. The panel consists of a thin, gas-filled space between two glass plates. Discharges form at the crossover point when pulses at the appropriate row and column conductors are superimposed on the maintaining waveform. An ac signal was chosen because a capacitive impedance can easily be built into the structure, thus limiting current flow to a reasonable value.

A novel and space-saving technique for addressing alphanumeric displays has been developed by researchers at STL Laboratories of Harlow, Essex, England, part of the ITT group. Such coding matrices distribute current from one of a series of input terminals to a predetermined combination of output terminals. In the STL version, however, the p-n junction diodes from which display junctions are made are diffused straight through a silicon slice, only 20- μ m thick. Because of the material thinness, connections to the diode can be made on opposite sides of the material. STL is investigating ways of incorporating a layer of Ovonic glass into the matrix, thus providing the display with a built-in memory.

A laser capable of radiating at 13 visible and 13 infrared frequencies has been developed by the French-based Chromatix Co. To achieve this frequency spread — from 0.54 to 3.5 μ m — a pulsed YAG laser was equipped with a frequency doubler and a Q-switch. Applications include stimulating

selective chemical reactions, pumping dye lasers, fluorescence studies, Raman studies and interferometry.

Ion implantation will be used in a four-stage, 20-MHz decade counter to be produced by Emihus in Glenrothes, Scotland, a company formed jointly by Hughes Aircraft Corp. and EMI. Emihus has designed the high-speed counter from scratch. The company will use ion-implantation facilities at Harwell, England.

Composite materials useful in manufacturing ferromagnetic items, as well as high-temperature turbine components, are being developed by Brown Boveri of Baden, Switzerland. Fabrication consists of directionally solidifying certain alloys in a manner that produces a clean, anisotropic structure. The composites contain reinforcing fibers that run in desired directions. Spokesmen for the research center see the new method being used to manufacture oriented cobalt fibers in ferromagnetic composites, for permanent magnets.

Improved circuit techniques, using transistor logic and ferrite-core storage, will improve reliability and flexibility in the London telephone system this summer as GEC-AEI Telecommunications, Coventry, begins installations in a \$22-million modernization program. The company will install three switching exchanges to handle trunk and local telephone traffic in London. At present older equipment in 13 trunk exchanges within a mile of London's center handle about 3.5 million calls a day; the volume is expected to swell to 6 million a day by 1975. Each switching center will initially handle a million trunk calls a day, using 30 or more stored-program processors. Capacity is to be doubled within two years.

The *Thrust* in Linear Circuits

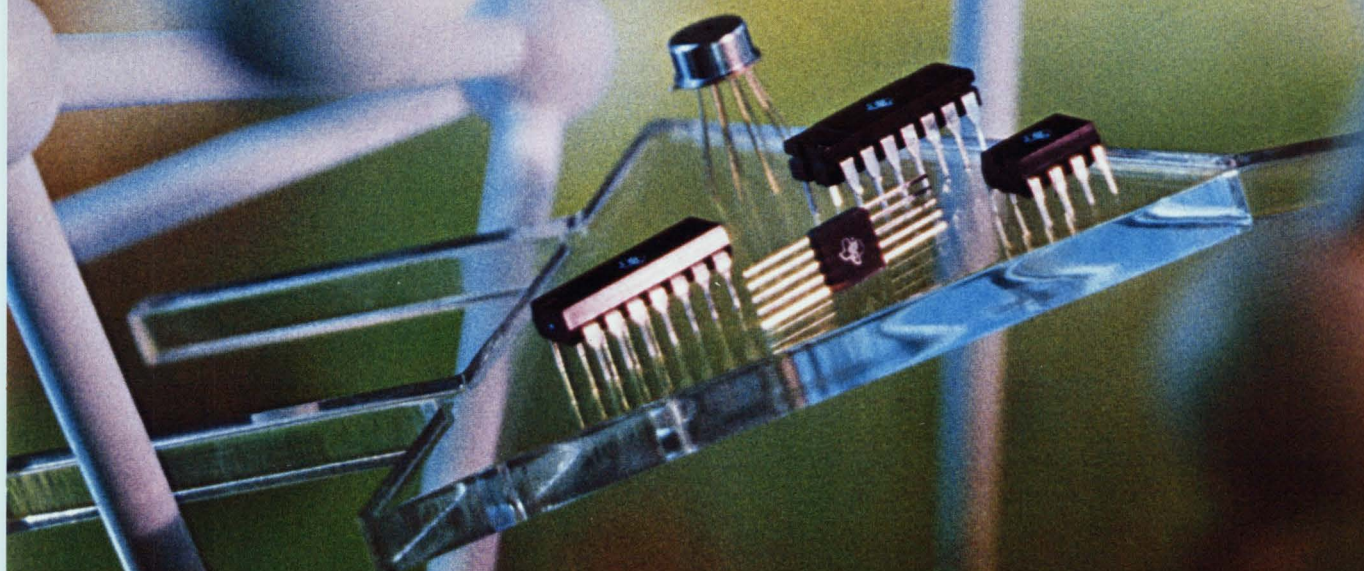

Plus news from Texas Instruments about

Schottky TTL – Growing line, full availability

MOS/LSI – Specs on industry's broadest line

Optoelectronics – New P-DIP couplers

Power transistors – Increased reliability

Transistors – Two new Darlington



Linear circuits: 40 new functions announced this year.

TI has the capability—across the board.

Your choice of linear ICs at TI is growing fast. In the past six months we've introduced 40 new functions—that's more than one per week. And more are coming.

Now a broad, economical, dependable selection, TI's current line includes 12 operational amplifiers, 10 voltage comparators, 5 video amplifiers, 2 communications circuits and 37 consumer circuits. And there are 32 functions in our related interface circuits line. Check the product list under the foldout. Prices are competitive and delivery is immediate—from distributor stocks or from TI's big in-house inventories.

Op amps — top performance, all packages

TI has carefully structured a broad line of op amps.

It's a useful, accommodating line. Suppose you want state-of-the-art super betas. TI has two brand-new ones—the SN52108/72308 and the SN52108A/72308A. High performance devices, they are ideal for applications requiring extremely low input offset voltages. They join the two super betas — SN52/72770 and SN52/72771—recently announced by TI.

As for precision op amps, your choice includes the internally compensated, general purpose SN52/72741; the SN52/72558, SN52/72747—dual 741s— and the SN52/72748—an extended bandwidth, general purpose device. The SN52101A/72301A are pin-for-pin replacements for the LM101A/LM301A, while the general purpose, internally compensated SN52107/72307 are direct replacements for the LM107/LM307.

Rounding out your op amp choice are the popular, general purpose SN52/72702 and SN52/72709.

And TI's package selection is industry's widest: 8- and 14-pin plastic DIP; 14-pin ceramic DIP; TO-5; ceramic and metal flatpacks.

Voltage comparators — a 10-device choice

In voltage comparators, TI gives you a choice of

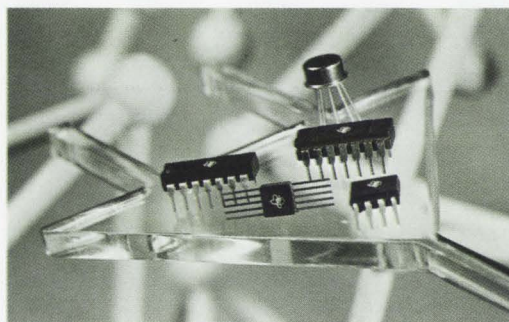

singles and duals from industry standards to super comparators.

Singles include the SN52/72710 as well as new super comparators: SN52/72510 and SN52/72810, each featuring high gain and low offset voltage. The SN52/72510 is a single comparator with strobe.

The SN52106/SN72306 are pin-for-pin replacements for the LM106/LM306.

In duals, you can select the SN52/72711 or the SN72720 differential comparators; or any of the new supers—SN52/72811, SN52/72514 and SN52/72820. A replacement for the MC1514/MC1414, the SN52/72514 has greatly improved performance. Like a response time of 30 ns. And soon: SN52/72506, a dual 52/72106.

Video amplifiers — a full bandwidth range

TI offers a complete range of video amps (see table). The new SN55/7512 is the only monolithic video amplifier having offset null capability. And TI's new SN55/7514 outperforms competition with a typical gain of 300 and an 80-MHz bandwidth. The SN55/7511 offers the best gain-bandwidth product.

TI Video Amp	Bandwidth
SN55/7511	3 MHz
SN55/7510	40 MHz
SN55/7512	80 MHz
SN55/7514	80 MHz
SN52/72733	200 MHz

Consumer circuits

For color TV, AM/FM radios/phonos and other consumer applications, you can satisfy your requirements with TI's line of 37 consumer circuits. If your application still requires special features, consult us on our custom capabilities.

For linear circuits brochure, circle 283; for consumer circuits brochure, circle 284.

TI Operational Amplifiers					
Type	Features	Input Offset Voltage (Max)	Input Offset Current (Max)	Input Bias Current (Max)	Slew Rate at Unity Gain (Typ)
		mV	nA	nA	V/ μ s
SN52/72702	Wide BW, General Purpose	5	500	10,000/15,000	1.7
SN52/72709	General Purpose	5/7.5	200/500	500/1500	0.3
SN52/72741	Internally Compensated General Purpose	5/6	200	500	0.5
SN52/72747	Dual SN52/72741	5/6	200	500	0.5
SN52/72748	Extended BW, General Purpose	5/6	200	500	0.5
SN52/72558	Dual 741 in 8-pin package	5/6	200	500	0.5
SN52101A/SN72301A	Precision Op Amp	2/7.5	10/50	75/250	0.5
SN52107/SN72307	Internally Compensated General Purpose	2/7.5	10/50	75/250	0.5
SN52/72770	Super β	4/10	2/10	15/30	2.5
SN52/72771	Super β , Internally Compensated	4/10	2/10	15/30	2.5
SN52108/SN72308	Super β	1/10	0.4/1.5	3/10	0.25
SN52108A/SN72308A	Super β	1/0.73	0.4/1.5	3/10	0.25

Broadest choice—by far—at TI.



MOS/LSI

TI offers most comprehensive MOS catalog line.

TI's standard line of MOS/LSI circuits is your biggest, most comprehensive choice. There are 64 separate functions—each produced in volume for quick delivery and maximum economy.

TI's static shift registers have speeds from DC to 3 MHz, complexities to 500 bits, at an average small quantity price of 2¢

per bit. Dynamic registers have speeds to 10 MHz, complexities to 1000 bits, at an average small quantity price of 0.8¢ per bit.

In read only memories, TI offers speeds from 350 ns to 1 µsec (fully decoded) and complexities from 1024 to 4096 bits. Prices in small quantities are from 0.9¢ per bit to 0.25¢ per bit.

Access times for TI random access memories range from 280 to 750 ns, with very low power dissipations. Complexities from 256 to 2048 bits, prices average 0.8¢ per bit in small quantities.

Package choice includes 14- to 40-pin plastic, 16- to 40-pin ceramic, TO-100 and TO-8.

For data sheets, circle 286.

SRs	Organization	Bits	MHz	Logic	V _T	Power			φ	Clock Swing	Pwr (mW at 1 MHz)		Pkg
						V _{SS}	V _{DD}	V _{GG}			Pkg	Per Bit	
TMS 3000 LR	Dual 25	50	0-1	stat	High	+14	0	-14	2	+14 to -14	240	4.8	TO-100
TMS 3001 LR	Dual 32	64	0-1	stat	High	+14	0	-14	2	+14 to -14	270	4.2	TO-100
TMS 3002 LR	Dual 50	100	0-1	stat	High	+14	0	-14	2	+14 to -14	185	1.9	TO-100
TMS 3003 LR	Dual 100	200	0-1	stat	High	+14	0	-14	2	+14 to -14	280	1.4	TO-100
TMS 3012 JR/NC	Dual 128	256	0-1	stat	High	+14	0	-14	1	+14 to 0	380	1.5	CDIP/plastic
TMS 3016 LR	Dual 16	32	0-1	stat	High	+14	0	-14	2	+14 to -14	130	4	CDIP
TMS 3021 LR	21-bit	21	0-1	stat	High	+14	0	-14	2	+14 to -14	140	7	TO-100
TMS 3028 LR	Dual 128	256	0-1	stat	High	+14	0	-14	1	+14 to 0	380	1.5	TO-100
TMS 3101 LC/NC	Dual 100	200	0-2.5	stat	Low	+5	0	-12	2	+5 to -12	270	1.35	TO-100/plastic
TMS 3102 LC/NC	Dual 80	160	0-2.5	stat	Low	+5	0	-12	2	+5 to -12	216	1.35	TO-100/plastic
TMS 3103 LC/NC	Dual 64	128	0-2.5	stat	Low	+5	0	-12	2	+5 to -12	170	1.35	TO-100/plastic
TMS 3112 JC/NC	Hex 32	192	0-1	stat	Low	+5	0	-12	1	0 to +5	255	1.33	CDIP/plastic
TMS 3113 JC/NC	Dual 133	266		stat	Low	+5	0	-12	1	0 to +5	260	1.0	CDIP/plastic
TMS 3114 JC/NC	Dual 128	256		stat	Low	+5	0	-12	1	0 to +5	260	1.0	CDIP/plastic
TMS 3304 LR	Triple 66	198	0.01-5	dyn	High	+14	0	-14	2	+14 to -14	100	0.5	TO-100
TMS 3305 LR	Triple 64	192	0.01-5	dyn	High	+14	0	-14	2	+14 to -14	100	0.52	TO-100
TMS 3309 JC/NC	Dual 512	1024	0.01-5	dyn	High	+12	0	-12	4	+12 to -12	90	0.09	CDIP/plastic
TMS 3314 JC/NC	Triple (6014)	192	0.01-2	dyn	High	+14	0	-14	2	+14 to -14	210	1.1	CDIP/plastic
TMS 3401 LC/NC	Single 512	512	0.02-5	dyn	Low	+5	0	-12	2	+5 to -12	70	0.17	TO-100/plastic
TMS 3402 LC/NC	Single 500	500	0.02-5	dyn	Low	+5	0	-12	2	+5 to -12	70	0.17	TO-100/plastic
TMS 3406 LR	Dual 100	200	0.01-2	dyn	Low	+5	0	-12	2			0.4	TO-100
TMS 3409 JC/NC	Quad 80	320	0.05-5	dyn	Low	+5	0	-12	1	0 to +5	250	0.8	CDIP/plastic
TMS 3412 JC/NC	Quad 256	1024	0.01-6	dyn	Low	+5	0	-12	1	+5 to -12	100	0.1	CDIP/plastic
TMS 3413 LC/NC	Dual 512	1024	0.01-6	dyn	Low	+5	0	-12	1	+5 to -12	100	0.1	TO-100/plastic
TMS 3414 LC/NC	Single 1024	1024	0.01-6	dyn	Low	+5	0	-12	1	+5 to -12	100	0.1	TO-100/plastic
TMS 3417	Quad 64	256	0.05-5	dyn	Low	+5	0	-12	1	0 to +5	210	0.8	CDIP/plastic
TMS 3419 JC/NC	9 × 128	1024	0.01-3	dyn	Low	+5	0	-12	1	0 to +5	600	0.6	CDIP/plastic

RAMs	Organization	Decode	Logic	φ	V _T	Access (ns)	Cycle Time (ns)	Refresh (ms)	Power Supply				Power Dissipation		Package	Pins
									V _{DD}	V _{SS}	V _{GG}	V _{BB}	Total	mW/bit		
TMS 1101 JC/NC	256 × 1	yes	stat	—	Low	750	800	NA	-10	+5	-10		480	2	CDIP, plastic	16
TMS 1103 NC	1024 × 1	yes	dyn	3	Low	300	580	2	0	+17			300	0.3	Plastic	18
TMS 4000 JC/NC	16 × 8	no	stat	—	High	80	150	NA	-12	0	-12		120	1	CDIP/plastic	40
TMS 4003 JC/NC	256 × 1	no	stat	—	High	60	120	NA	-18	0			300	1	CDIP/plastic	40
TMS 4020 JC/NC	1024 × 2	yes	dyn	2	Low	320	640	2	-16	0	+2		300	0.15	Plastic	24/22
TMS 4022 JC/NC	1024 × 1	yes	dyn	2	Low	650	1000	2	-20	0	+2		180	0.18	CDIP/plastic	24/22
TMS 4023 JC/NC	1024 × 1	yes	dyn	4	Low	500	900	2	-20	0	+2		80	0.08	CDIP/plastic	24/22
TMS 4025 JC/NC	1024 × 2	yes	dyn	3	Low	280	640	2	-16	0	+2		160	0.08	Plastic	24
TMS 4026 NC	64 × 4	yes	stat	—	Low	1000	1500	NA	-5	+5	-15		650	2.5	Plastic	28

ROMs	Organization	Bits	Access (ns)	V _T	Power			Power (mW at 1 MHz)	CDIP/Plastic Pkg No. of Pins
					V _{SS}	V _{DD}	V _{GG}		
TMS 2000 JC/NC	Programmable Logic Array	3840	3000	Low	+5	0	-12	350	40
TMS 2200 JC/NC	Programmable Logic Array	5482	3000	Low	+5	0	-12	350	28
TMS 2300 JC/NC	256 × 10 ROM	2560	550	Low	+5	0	-12	300	24
TMS 2400 JC/NC	64 × 7 × 5 ROM	2240	700	High	+14	0	-14	350	28
TMS 2403 JC/NC	USASCH 7 × 5 CG	2240	700	High	+14	0	-14	350	28
TMS 2404 JC/NC	EBCDIC 7 × 5 CG	2240	700	High	+14	0	-14	350	28
TMS 2500 JC/NC	256 × 10 or 512 × 5 ROM	2560	350	Low	+5	0	-12	270	24
TMS 2501 JC/NC	64 × 7 × 5 USASCH CG	2500	350	Low	+5	0	-12	270	24
TMS 2600 JC/NC	256 × 8 or 512 × 4 ROM	2048	900	High	+12	0	-12	200	24
TMS 2601 JC/NC	Test Pattern	2048	900	High	+12	0	-12	200	24
TMS 2602 JC/NC	USASCH-to-Selectric, Selectric-to-USASCH	2048	900	High	+12	0	-12	200	24
TMS 2603 JC/NC	EBCDIC-to-USASCH	2048	900	High	+12	0	-12	200	24
TMS 2604 JC/NC	USASCH-to-Selectric and EBCDIC	2048	900	High	+12	0	-12	200	24
TMS 2605 JC/NC	Quick Brown Fox	2048	900	High	+12	0	-12	200	24
TMS 2700 JC/NC	256 × 12 ROM	3072	900	Low	+5	0	-12	350	28
TMS 2800 JC/NC	256 × 4 ROM	1024	900	High	+12	0	-12	180	16
TMS 2801 JC/NC	Priority Encoder	1024	900	High	+12	0	-12	180	16
TMS 2900 JC/NC	128 × 10 or 156 × 5	1280		Low	+5	0	-12	250	24
TMS 4100 JC/NC	64 × 5 × 7 or 32 × 5 × 14	2240	700	High	+14	0	-14	280	28
TMS 4103 JC/NC	USASCH 7 × 5 CG	2240	700	High	+14	0	-14	280	28
TMS 4177 JC/NC	USASCH 10 × 7 CG	2240	700	High	+14	0	-14	280	28
TMS 4178 JC/NC	USASCH 10 × 7 CG	2240	700	High	+14	0	-14	280	28
TMS 4179 JC/NC	EBCDIC 7 × 5 CG	2240	700	High	+14	0	-14	280	28
TMS 4400 JC/NC	512 × 8 or 1024 × 4 ROM	4096	1500	High	+12	0	-12	250	24
TMS 4401 JC/NC	Test Pattern	4096	1500	High	+12	0	-12	250	24
TMS 4880 JC/NC	76 × 35 CG	2736	800	High	+14	0	-14	400	28/40
TMS 4886 JC/NC	64 × 25 USASCH CG	2736	800	High	+14	0	-14	400	40
TMS 5000 JC/NC	90 × 4 Keyboard Encoder	3600	1000	Low	+5	0	-12	350	40

NOTE: All TI ROMs are static except TMS 2300 JC/NC.

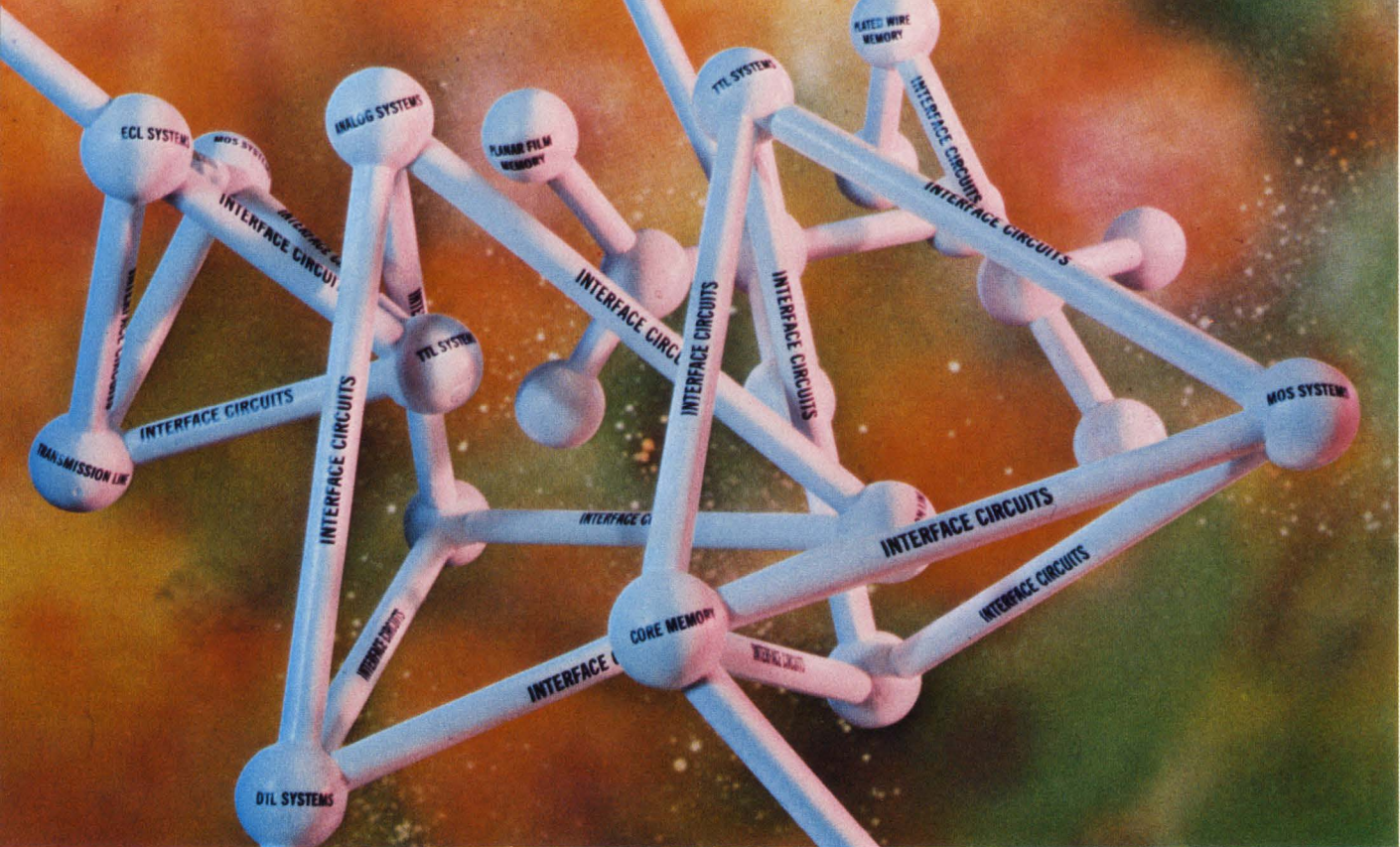

The thrust in computer interface — more circuits to do more jobs.

Thirteen new interface circuits have been announced by TI in the past few months: 4 sense amps, 2 line circuits, 2 memory drivers, and 5 general purpose drivers.

TI's total computer interface IC line—broadest in the industry—now includes 32 separate functions. And it's still growing and improving. These compatible functions are specifically designed to reduce costs, connections, package counts and design time—while increasing interface performance. Here's the latest wrap-up:

Sense amps—now, inverted outputs

Just added to TI's sense amp selection are four new devices having an output gate which provides an inverted output. Designated SN-75234, 235, 238 and 239, they are general purpose functions having identical pin-outs and features as the popular SN7524, 25, 28 and 29. In addition, they are internally-compensated.

Completing your current choice of 14 sense amps are the SN7520, 21, 22, 23, 26 and 27.

General purpose drivers—new, improved models

Significant advancements have recently taken place in TI's choice of general purpose peripheral drivers. Three new devices have been added—the SN75452, SN75453 and SN75454—while the new SN75450A and SN75451A represent distinct improvements over previous versions, including

logic input clamping diodes and improved output breakdown voltage. Each features a minimum transistor collector-emitter breakdown voltage of 30V.

New memory drivers shrink PC boards

Two new TI memory drivers can reduce PC board area as much as 20% when replacing discrete circuitry.

The 600-mA SN75325 is designed primarily for use with 2½ D and 3 D core memories. The 600-mA SN75308 is an eight-transistor array for two-dimension memory systems.

TI's IC memory line also includes the 400-mA SN75324 with on-chip decoding and the 150-mA SN75303 monolithic transistor array.

Line circuits for cooler MODEMs

Most EIA-compatible ICs suffer severe heat build-up problems, but TI's SN75150 dual line driver and SN75154 quad line receiver cool that headache. *Both meet all EIA RS-232-C specs completely.* The SN75150 can endure sustained shorts to ground or any voltage up to ±25 V.

And broadening your choice are the SN75107/SN75108, SN75100 and SN75109/SN75110 for data transmission applications.

For complete information on any TI interface circuit, circle 283 on the Reader Service Card.



Integrated Circuits: you'll find your br

TI's full line-up of linear ICs

LINEAR CIRCUITS		SN76540	TV jungle for NPN tuners and Ge diode detection
OPERATIONAL AMPLIFIERS			
SN52/72702	Wide bandwidth, gen. purp.	SN76541	TV jungle for NPN and low level detection
SN52/72709	General purpose	SN76542	TV jungle for PNP tuners and Ge diode detection
SN52/72741	Internally compensated, gen. purp.	SN76564	Automatic fine tuning
SN52/72747	Dual SN72741	Regulators for varactor tuners	
SN52/72748	Extended bandwidth, gen. purp.	SN76550	33V at 5mA
SN52/72558	Dual 741 in 8-pin package	SN76552	22V at 5mA
SN52101A/72301A	Precision	SN76553	12V at 5mA
SN52107/72307	Internally compensated, gen. purp.	IF circuits for radio and TV	
SN52/72770	Super β	SN76600	1st and 2nd video IF stages
SN52/72771	Super β , internally compensated	SN76603	RF/IF amplifier
SN52108/72308	Super β	SN76619	RF amplifier/FM detector
SN52108A/72308A	Super β	SN76640	Sound IF/limiter, slope detector, audio driver, voltage regulator
VOLTAGE COMPARATORS			
SN52106/72306	Single differential comparator with dual strobes	SN76641	IF limiting amplifier
SN52/72506	Dual differential comparator with strobes	SN76642	Sound IF/detector
SN52/72510	Single differential comparator with strobe	SN76643	Sound IF/detector
SN52/72514	Dual differential comparator with strobes	SN76650	1st and 2nd video IF with keyed AGC
SN52/72710	Single differential comparator	SN76653	SN76650 with inverted AGC
SN52/72711	Dual-channel differential comparator with strobe	SN76660	Sound IF/amplifier limiter, balanced coincidence detector, d-c volume control
SN72720	Dual differential comparator	SN76670	Sound IF/amplifier limiter, detector, attenuator, audio driver, voltage regulator
SN52/72810	Single differential comparator	SN76675	SN76660 with open-collector output
SN52/72811	Dual-channel differential comparator with strobe	SN76676	FM IF amplifier limiter
SN52/72820	Dual differential comparator	SN76680	SN76660 with audio driver and voltage regulator
VIDEO AMPLIFIERS			
SN52/72733	Amplifier with adjustable gain (200 MHz BW @ gain of 10) 40 MHz bandwidth	COMPUTER INTERFACE CIRCUITS	
SN55/7510	High gain-bandwidth product amplifier (gain of 3000 @ 3 MHz)	SENSE AMPLIFIERS	
SN55/7511	Amplifier with offset null capability 80 MHz bandwidth	SN7520/SN7521	Dual-channel with complementary outputs
SN55/7512	Amplifier with offset null capability 80 MHz bandwidth	SN7522/SN7523	Dual-channel with open-collector output
SN55/7514	Amplifier with offset null capability 80 MHz bandwidth	SN7524/SN7525	Dual (two independent sense amps)
COMMUNICATIONS CIRCUITS			
SN56/76502	Logarithmic amplifier	SN7526/SN7527	Dual with register output
SN56/76514	Balanced mixer	SN75234/SN75235	Dual with inverted outputs
CONSUMER CIRCUITS			
Audio amplifiers			
SN76001	1W audio at 9V and 8 Ω	SN7528/SN7529	Dual with preamplifier outputs as test points
SN76003	3W audio at 30V and 16 Ω	SN75238/SN75239	Dual with test points and inverted outputs
SN76005	5W audio at 35V and 16 Ω	PERIPHERAL DRIVERS	
SN76013	3W audio at 24V and 8 Ω	SN75450	Dual positive-AND
Dual channel and stereo			
SN76104	Stereo multiplex decoder	SN75450A	Improved dual positive-AND
SN76105	Stereo multiplex decoder	SN75451	Dual positive-AND
SN76110	Stereo multiplex decoder	SN75451A	Improved dual positive-AND
SN76131	Stereo preamplifier	SN75452	Dual positive-NAND
SN76149	Stereo preamplifier	SN75453	Dual positive-OR
SN76149	Stereo preamplifier	SN75454	Dual positive-NOR
Chroma circuits			
SN76242	Chroma sub-carrier regenerator	LINE DRIVERS AND RECEIVERS	
SN76243	Chroma amplifier	SN75100	Dual differential line receiver
SN76246	Chroma demodulator	SN55/75109	Dual differential line driver
SN76630	Chroma demodulator with PAL switch	SN55/75110	Dual differential line driver
Complex TV functions			
SN76532	TV jungle (suitable for horizontal deflection with tubes)	SN75150	Dual EIA line driver
SN76533	TV jungle (suitable for horizontal deflection with semiconductors)	SN55/75107	Dual differential line receiver
		SN55/75108	Dual differential line receiver
		SN75154	Quadruple EIA line receiver
		MEMORY DRIVERS	
		SN75303	150-mA 2 x 4 transistor array
		SN75308	600-mA 2 x 4 transistor array
		SN75324	400-mA with decode inputs, dual sink/source
		SN75325	600-mA, dual sink/source

For data sheets, specify device number and write to Inquiry Answering Service, Texas Instruments Incorporated, P.O. Box 5012, M.S. 308, Dallas, Texas 75222.

3 ns Schottky TTL Immediate delivery on TI's entire line of Schottky TTL ICs.

Availability is now excellent on TI's entire line of 3 ns at 20 mW Schottky-clamped TTL ICs.

Advanced, highly automated production facilities have been placed into Schottky TTL production to keep in-house inventories up and distributor stocks filled—assuring on-time delivery of this fast-growing line.

Recent announcements in the Schottky line have expanded your choice to 16 functions. The latest additions are two new dual J-K edge-triggered flip-flops—the SN54S/74S113 and SN54S/74S114. Plug in either and you upgrade present systems to 100 MHz.

Also in the Schottky family are two quadruple 2-input NAND gates, a hex inverter, two triple 3-input AND gates, a triple 3-input NAND gate, two dual 4-input NAND gates, two 4-wide, 4-2-3-2 input AND-OR-INVERT gates, a dual 4-input NAND buffer, a dual 4-input 50-ohm line driver/NAND buffer, a dual D-type flip-flop and a dual J-K flip-flop.

In addition to being readily available and faster than any other TTL family, the Schottky-clamped family provides many other benefits. For example, a 125-MHz typical J-K flip-flop input clock frequency. Compatibility with nearly all saturated digital devices. Switching times virtually insensitive to variation in power supply or temperature. For data sheets, circle 285.

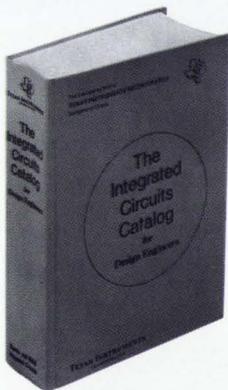

NEW—The integrated circuits catalog for design engineers.

All the design data you need—not just summaries, but full data sheet information...1,616 pages in all.

Covers everything in industry's broadest line—Schottky TTL, High-speed TTL, Standard TTL, Low-power TTL, MOS, ECL, DTL, SUHL, High-Noise-Immunity Logic, Radiation-hardened circuits, Hybrid circuits, Systems Interface circuits, Linear circuits, and the

MACH IV high-reliability procurement system.

Fast, easy to use—indexed by number and function. Cross-reference guides, too. Full-size book with big, readable type.

For your copy—send \$4.95 (check or money order only please) to Texas Instruments Incorporated, P. O. Box 5012, M.S. 84, CN9083, Dallas, Texas 75222.

New semiconductors expand your broad choice at TI.

Optoelectronics

New optical couplers in low-cost, reliable 6-pin plastic DIP.

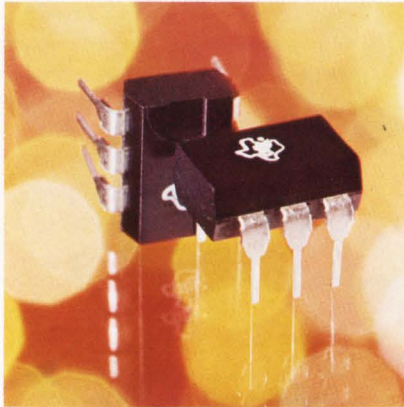

TI's two newest optically coupled isolators are in a new 6-pin dual-in-line plastic package – which pays off for you in lower component costs and lower assembly costs.

These two new couplers – TIXL111 and TIXL112 – can be handled with the same automated assembly equipment and can use the same sockets and PC board design as the most popular IC packages.

TI's new TIXL111 has an input-to-output voltage of ± 1.5 kilovolts and is DTL/TTL compatible. Price is \$3.35 (100-999).

The TIXL112, with ± 500 volts isolation, is industry's lowest priced coupler. Only \$1.70 in 100-999 quantities.

The new couplers are suitable for use as solid-state relays, for voltage isolation, as interface devices between systems, and as line driver/receiver combinations.

For data sheets on the TIXL111 and TIXL112, circle 287 on the Reader Service Card.

Power transistors

Nine new HV types have glass-passivated chip for greater reliability.

You'll get superior performance from all of TI's new high-voltage transistors. A glass passivated

	V_{CB0}	Continuous Collector Current	Package
2N3902	400 V	2.5 A	TO-3
2N3583	250 V	1 A	TO-66
2N3584	330 V	2 A	TO-66
2N3585	440 V	2 A	TO-66
2N3540	440 V	2 A	TO-66
2N3439	450 V	1 A	TO-5
2N3440	300 V	1 A	TO-5
2N5157	700 V	3.5 A	TO-3
2N5241	400 V	5 A	TO-3

chip (see drawing) provides a protected collector-base junction that increases reliability and lowers leakage. It also better equips each device to handle inversion.

And this unique chip combines with the collector guard ring to heighten temperature stability. The 2N3902, for instance, will pass such reliability requirements as MIL-S-19500/371 which calls for 300 V_{CE} at 150°C reverse bias test for 48 hours.

TI's new high-voltage power transistors are useful in direct rectified line operations as inverters, converters, amplifiers and switches.

For data sheets on all nine, circle 288 on the Service Card.

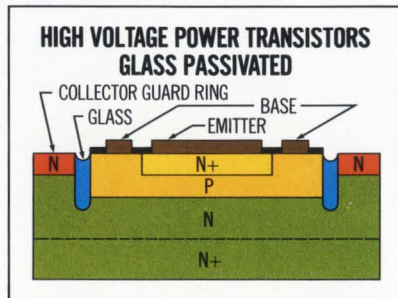

Transistors

Darlington connections boost h_{FE} to new highs for single package devices.

At best, a single, volume-produced bipolar transistor can produce a maximum h_{FE} of 1000. That's just the *minimum* for TI's new 2N5526. And for our new 2N5525, the minimum h_{FE} is 5000.

Both are NPN Darlington-connected epitaxial planar silicon transistors. Each has high input

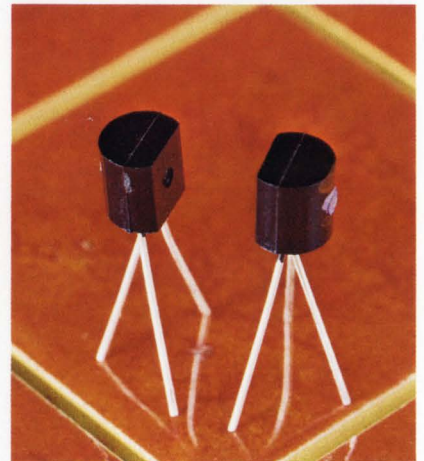

impedance to prevent circuit loading; high gain over a wide range of collector current up to 200 mA; plus all the cost-, labor- and space-saving advantages inherent in using one package instead of two.

You can put these benefits to work in such applications as high gain-low noise audio preamps; complementary output pair drivers; remote control amplifiers where space is critical; high gain DC amplifiers; strain gauge amplifiers; and sensing amps for power supplies.

For data sheet, circle 289 on the Reader Service Card.



For more information on any TI product, call your local TI sales engineer or authorized distributor. Or write Inquiry Answering Service, Texas Instruments Incorporated, P.O. Box 5012, M.S. 308, Dallas, Texas 75222.

TEXAS INSTRUMENTS
INCORPORATED

"Guaranteed specs, one more reason you should be using Fluke synthesizers."

Fluke Product Manager Paul Beihl tells you what to look for in a frequency synthesizer.

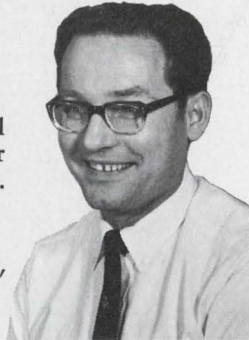

"At Fluke, we insist on clear, truthful, doubt-free instrument specifications. We know you depend on them, so we don't kid around. We guarantee not only the more easily measured specs; we guarantee the exotic specs, too.

"Take the case of our Model 645A and Model 645M (militarized) Frequency Synthesizers, for instance.

"We guarantee a non-harmonic spurious response greater than 100 db below the fundamental. We guarantee a noise floor less than -132 db. We guarantee switching times of less than 20 microseconds. As a matter of fact, we guarantee all the specs without weasel words, without 'ifs', 'ands' or 'buts'.

"It's part of our thing about customers and specs.

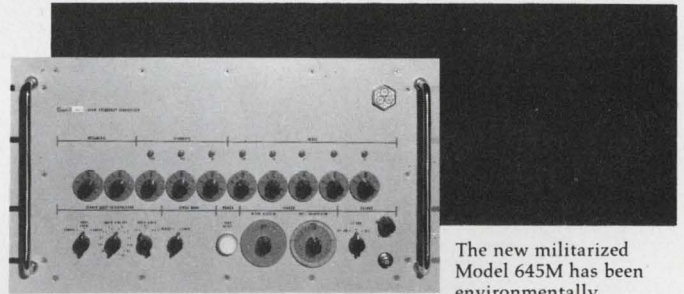

The new militarized Model 645M has been environmentally hardened to meet all environmental requirements of MIL E 16400F, Amendment 5, Class IV. Electrically, it's equivalent to the Model 645A.

"Obviously, specs aren't everything in an instrument. Convenience counts, too. We built in a symmetrical search oscillator for filter and resonator testing. Automatic remote output leveling, BCD or 10 line code inputs make programming easy. Modular design makes service easy. Functional front panel controls simplify operation. Summing up, Fluke synthesizers are easy to use.

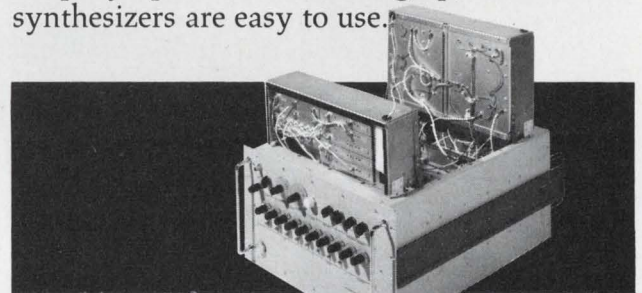

Model 645M with swing-out trays opened to demonstrate access to modular circuitry.



Frequency range of the Model 645A is DC to 50 MHz in increments of 0.01 Hz.

"Every synthesizer is designed and built to the Fluke standard of quality. Fluke Instruments are known world-wide for their reliability and accuracy. And we price them as though we were buying them with our own money.

"Let us send you the full details and arrange a demonstration. Call us here at the factory or better yet, contact your nearby Fluke representative."



Fluke, Box 7428, Seattle, Washington 98133. Phone: (206) 774-2211. TWX: 910-449-2850/In Europe, address Fluke Nederland (N.V.), P. O. Box 5053, Tilburg, Holland. Phone: (04250) 70130. Telex: 884-50237/ In the U. K., address Fluke International Corp., Garnett Close, Watford, WD2 4TT. Phone: Watford, 27769. Telex: 934583.

Emcor's new generation

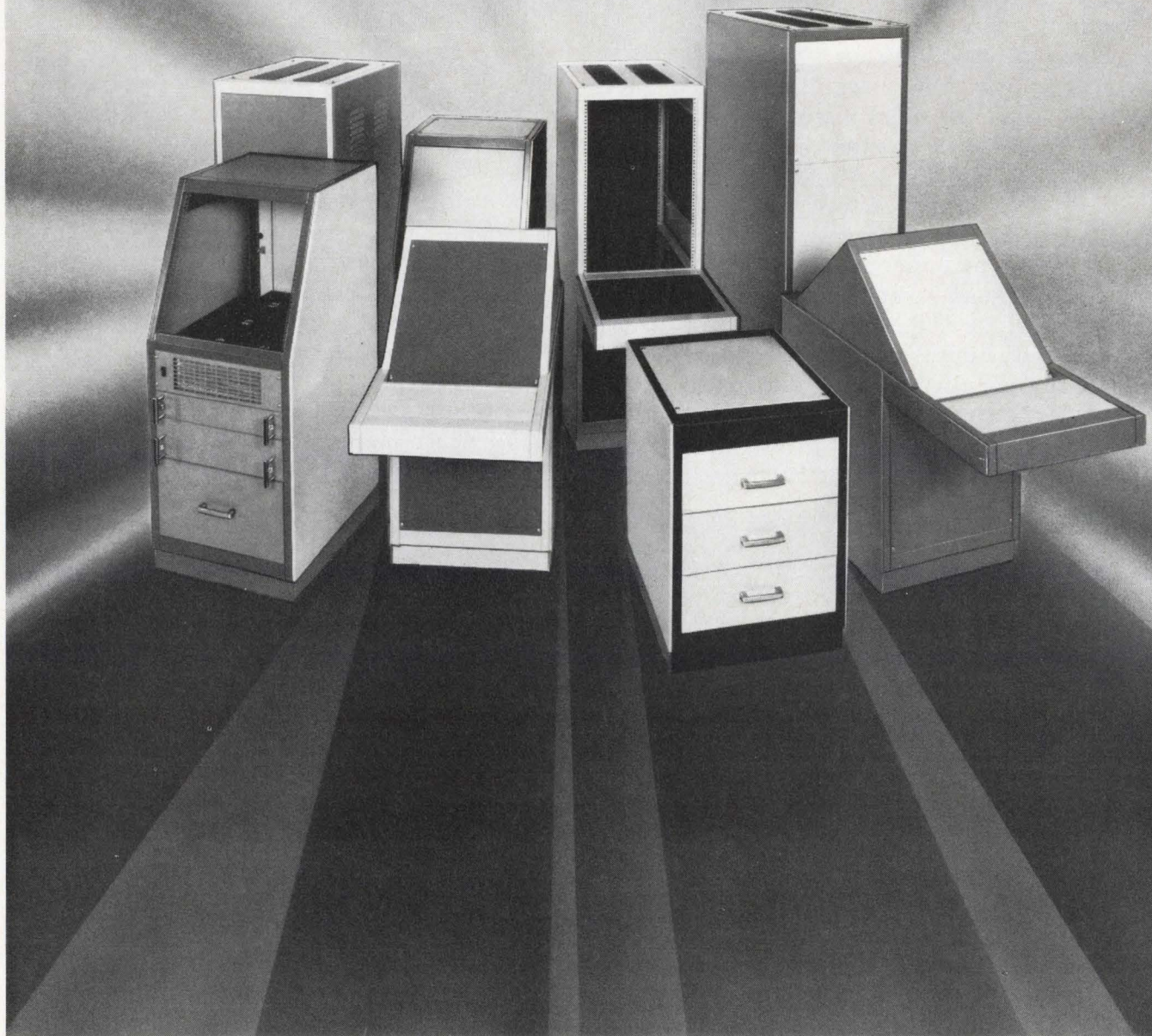

of electronic enclosures...

ESQ.

ESQ. Modular Enclosures combine the Economy of EMCOR I and the Modern Styling of EMCOR II . . . plus all the EMCOR quality you've learned to expect.

ESQ. adds another exciting dimension to the world of electronic enclosures . . . with new colors, new sizes, new hardware and new styling!

ESQ. is available in four basic configurations: vertical, sloped front, low silhouette and steel work/writing top models.

New 30 $\frac{3}{4}$ " deep frames are available in both vertical and sloped front models to house the new, deeper electronic packages.

Hundreds of basic frames, in both 19" and 24" panel widths, and a wide array of accessories offer virtually unlimited combinations to house a whole world of equipment: electrical, electronic, controls, computer, computer peripheral, instrumentation, to name but a few.

EMCOR offers you a choice of three outstanding lines . . . the economical EMCOR I . . . the top of the line EMCOR II . . . and now ESQ, the new series that combines the best of both . . . at a cost that makes it another great EMCOR value.

Write today for a copy of the new ESQ catalog and the name of your nearest EMCOR representative. Ingersoll Products, Division of Borg-Warner Corp., 1000 West 120th Street, Chicago, Illinois 60643.

Ingersoll Products



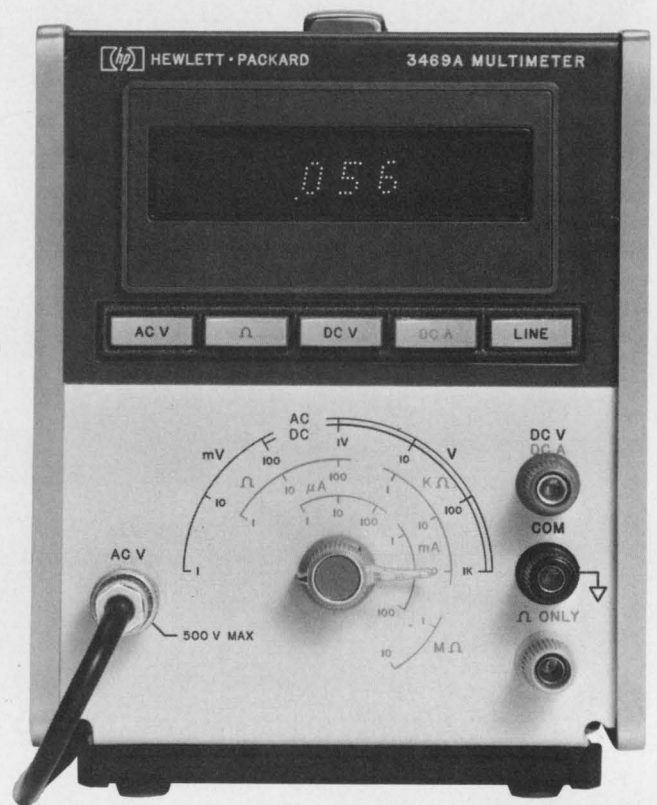
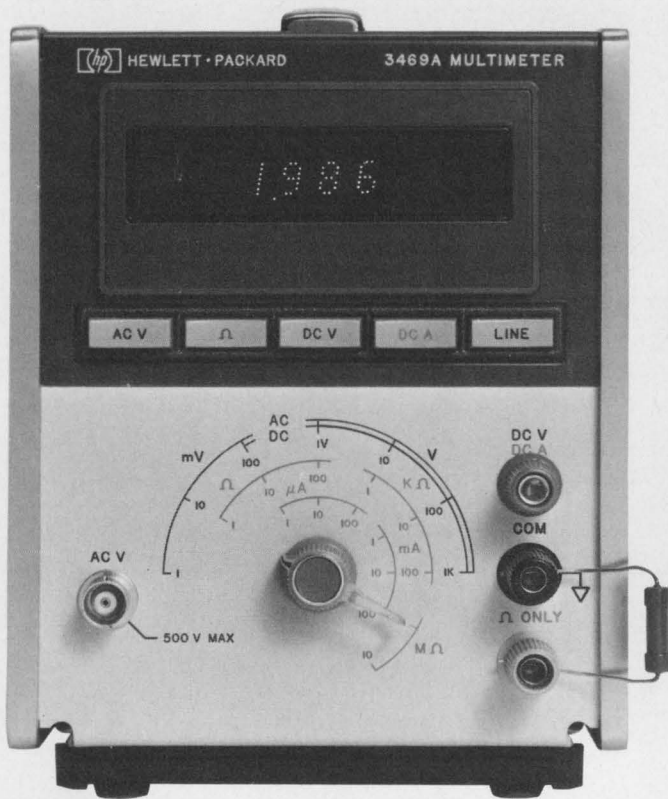

A full-function digital multimeter + A lab-quality digital AC voltmeter

...both for \$595

HP's new 3469A gives you a general-purpose digital multimeter *plus* a lab-quality digital AC voltmeter—for the price of the AC voltmeter alone. Now, you don't have to buy two (or more) instruments to get the capabilities you need—or compromise on quality to stay within your budget.

As a general-purpose multimeter, the 3469A gives you exceptional capabilities. Its 1Ω range lets you measure low-resistance components and even contact resistances of a few milliohms, with an accuracy of ±0.25% reading ±0.5% range. To make the low range easily useable, a unique offset adjustment lets you compensate for lead resistance. In

the higher ranges (100Ω to 10 MΩ), accuracy is ±0.3% reading ±0.2% range. The 3469A also gives you five DC voltage ranges (100 mV to 1000 V) and six DC ampere ranges (1 μA to 100 mA), with accuracy of ±0.2% reading ±0.2% range or better, depending on range.

As an AC voltmeter, the 3469A is unmatched at any price. You get seven voltage scales, ranging from 1000 V full-scale down to 1 mV full-scale—100 times the sensitivity of other digital meters. You also get a 10 MHz bandwidth capability—100 times greater than other digital multimeters—with a basic accuracy of ±0.3% reading ±0.3% range. And

you get a bright, ultra-reliable, shaped-character GaAsP display, that's easier to read than tubes or bar-segment numerals.

Compare the 3469A's specs with any other meter's — and you'll agree that there's no better value, at any price. For further information on the 3469A, contact your local HP field engineer, or write Hewlett-Packard, Palo Alto, California 94304. In Europe: 1217 Meyrin-Geneva, Switzerland.

091/16

HEWLETT *hp* PACKARD

DIGITAL VOLTMETERS

GOODBYE SOLID STATE.



Hello better switching alternatives.

If you consider solid state the only approach in switching applications like multiplexing, counting, programming or power-up and power-down sequencing, you have a choice you've been overlooking. Clare rotary stepping switches.

There's a place for both, and if your "place" calls for a straightforward, inexpensive solution to switching problems, you're calling for a Clare stepping switch. Other engineers are using them in everything from office copiers to system checkout on inter-continental ballistic missiles.

UGLY IS BEAUTIFUL

Each Clare stepping switch is a marvel of complex parts yet simple operation. It can contain ten, eleven, twenty or twenty-six contacts per level and hold up to sixteen levels. So you can have a stepping switch with 416 contacts if you need it.

Put quite simply, Clare stepping switches allow you to select, interrupt or change connections in a succession of circuits in response to current impulses. You establish the parameters and the stepping switch will do the job—with better input/output isolation than solid state.

COMPACT, TOO

A single stepping switch can replace hundreds of discrete components such as diodes and transistors—performing the same function at a fraction of the size and cost.

ALL THE LIFE EXPECTANCY YOU NEED

Clare stepping switches may not be as long lasting as solid state devices, but you don't pay for it either. When you evaluate your application, you may find you don't need almost infinite life. If a rated life of eighteen million operations will satisfy your requirements, then a Clare stepping switch

will cost about one-sixth as much as solid state. So—how much life are you willing to pay for?

ALL THE GOODIES YOU WANT

Clare stepping switches are available in five series plus direct drive. You can order them with hermetically sealed enclosures or dust-proof covers, bridging or non-bridging wipers and a wide variety of accessories. We could go on forever.

For enough stepping switch data to take up a whole coffee break, circle our reader service number or write us. C. P. Clare & Co., 3101 Pratt Ave., Chicago, Illinois 60645.



a GENERAL INSTRUMENT company

Siemens

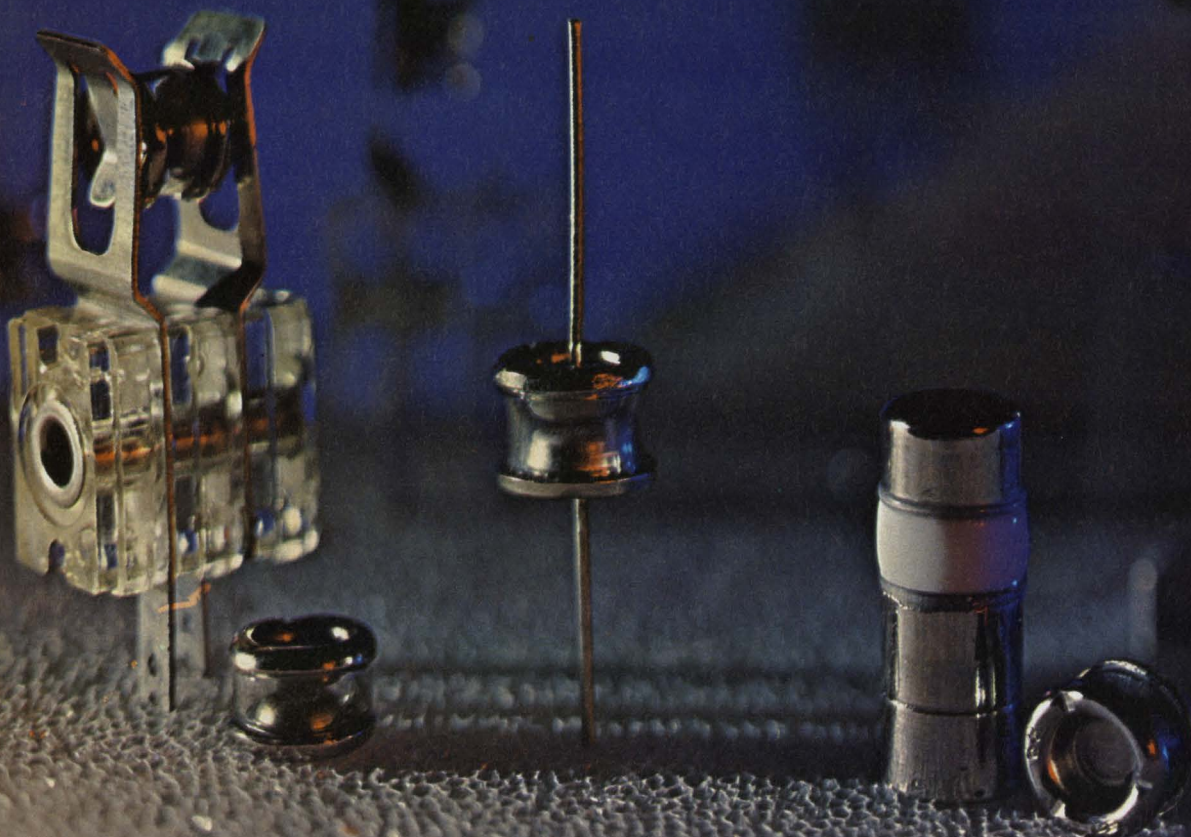

Low-cost SVP™ devices can save your valuable equipment from destruction by voltage transients.

You can no longer overlook the need for protecting your circuits. New sources of transients are cropping up every day. And any one of them might cause operational failure of your equipment.

Now there is an easy low-cost way to protect your circuitry from these transients. It's a simple little

gas-filled surge voltage protector. We call it an SVP. Only this Siemens SVP offers high-current capability (up to 50 kiloamps) in such a small package and a high impedance when not conducting (10^{10} ohms, 1 to 6.8 pF depending on model).

Siemens is the world's largest manufacturer of surge voltage

protectors. More engineers are using them every day. You can benefit by doing the same.

Siemens Corporation, 186 Wood Avenue South, Iselin, N.J., 08830. (201) 494-1000. Siemens. A three billion dollar name in quality products.  **SIEMENS**

washington report

DON BYRNE, WASHINGTON BUREAU

B-52 to get \$200-million avionics package

The Air Force plans to spend \$200-million equipping B-52s with low-level electronic penetration devices. The spending would include \$53.4-million for an electro-optical viewing system, which uses low-light TV and forward-looking infrared mounted in a turret to supplement its terrain-following radar. A total of \$33.5-million more would go for what is called a Phase 6 countermeasure system—to combat electronic defenses, which have become a growing hazard.

In Congressional testimony, the Air Force has revealed that its airborne warning and control system—Awacs—being built by Boeing, will cost \$63-million an aircraft.

Awacs is considered the “giant” of military electronics aircraft. Just what avionics means to aircraft cost is shown by a Navy statement that 24% of the cost of the A-3 is for avionics—a total of \$480,000 per aircraft. In all, the Navy estimates, it will spend \$273.3-million on avionics programs for four models of aircraft in the coming fiscal year.

AF plans all-weather gear for some A-X support fighters

The Air Force now plans to equip at least a portion of its forthcoming A-X close-air-support fleet with all-weather avionics. This will push the hoped-for cost of \$1.8-million for each aircraft to about \$4-million, informed sources say. Initially, and one of the main reasons for the program, the aircraft was to cost less than \$1-million. A fly-off competition between Northrop and the Fairchild Industries Republic Div. is under way, with the first flights due in about a year.

The Air Force had been trying to keep costs low by designing a daylight-only aircraft, because it was, in effect, competing with the Army's Cheyenne armed helicopter for the support role. But Congress is showing reluctance to approve funds, and the Air Force now speaks freely about a “B” model of the A-X, which would include the all-weather avionics system.

Chairman says FCC will ease CATV rules

Dean Burch, chairman of the Federal Communications Commission, has told the Senate Commerce Committee that his agency will issue new regulations that will greatly ease the current restrictions on cable television. Burch said the announcement probably would be made in August.

He told the committee that the FCC now believes that CATV operators should be allowed to offer subscribers two television channels not normally received locally.

The channels could be brought in via microwave and then relayed by cable to CATV homes. The television broadcasting industry has firmly opposed permission for CATV operators to “import” distant signals, and an

industry source predicted a round of court battles over the FCC ruling when it is issued. Broadcasters have argued that the "foreign" programs would dilute their markets by luring viewers away from existing stations. CATV operators have maintained that they cannot really attract subscribers without the "imports".

House Committee urges unified communications

The House Armed Services Investigative Subcommittee has urged that all defense communications be integrated and placed under the Assistant to the Secretary of Defense, Telecommunications. This is the second time in a year that the military communications establishment has been singled out for inefficiency. A special White House panel late last year urged consolidating the various communications activities under the Secretary's Assistant. David L. Solomon has been named Acting Assistant to the Secretary, Telecommunications, following the death of Louis A. de Rosa last month. De Rosa was the first man to hold the top telecommunications post in the Pentagon.

Navy asks more study on surveillance system

The Navy has asked the 11 bidders on its Moored Surveillance System for six more months of study before advanced development begins. The project was originally planned for completion in early 1973. The Navy asked for bids on the project last September, and unofficial estimates are that the over-all cost will run as high as a half billion dollars.

The system is designed to be placed in vital waterways to warn of movements by hostile submarines. The bidders include Bendix, Bunker-Ramo, Emerson Electronics and Space Div., General Dynamics, General Electric, Hazeltine Electro-Acoustics Laboratory, Western Electric, Sanders Associates, Litton Data Systems Div., Raytheon Submarine Signal Div. and Honeywell Aerospace and Defense Div.

Capital Capsules: The Aerospace Industries Association has compiled a **four-part study of Government procurement problems** and prepared a set of 30 recommendations that, it says, could bridge the "comprehension gap" around procurement matters. You can get copies by writing to the AIA at 1325 de Sales St., Washington D.C. 20036. . . The Dept. of Transportation has awarded yet another contract for mass-transit work to an aerospace concern. **Boeing's Vertol Div. will receive \$10.5-million over three years** for system management of the urban rapid-rail vehicle and systems program. Vertol will produce two transit cars equipped with the latest subsystems for testing by the department. Transportation Secretary John A. Volpe said: "We are hopeful that aerospace techniques, such as airframe construction and component modularity, can now be applied to transit cars". . . The Dept. of Health, Education and Welfare and the Corporation for Public Broadcasting will join the National Aeronautics and Space Administration in testing education and health applications of communications satellites. **The Applications Technology Satellite-F, due in 1973, will be used to pipe education and health programs into schools in the Rocky Mountain region and Alaska.**

NEW Interactive Computer Terminal

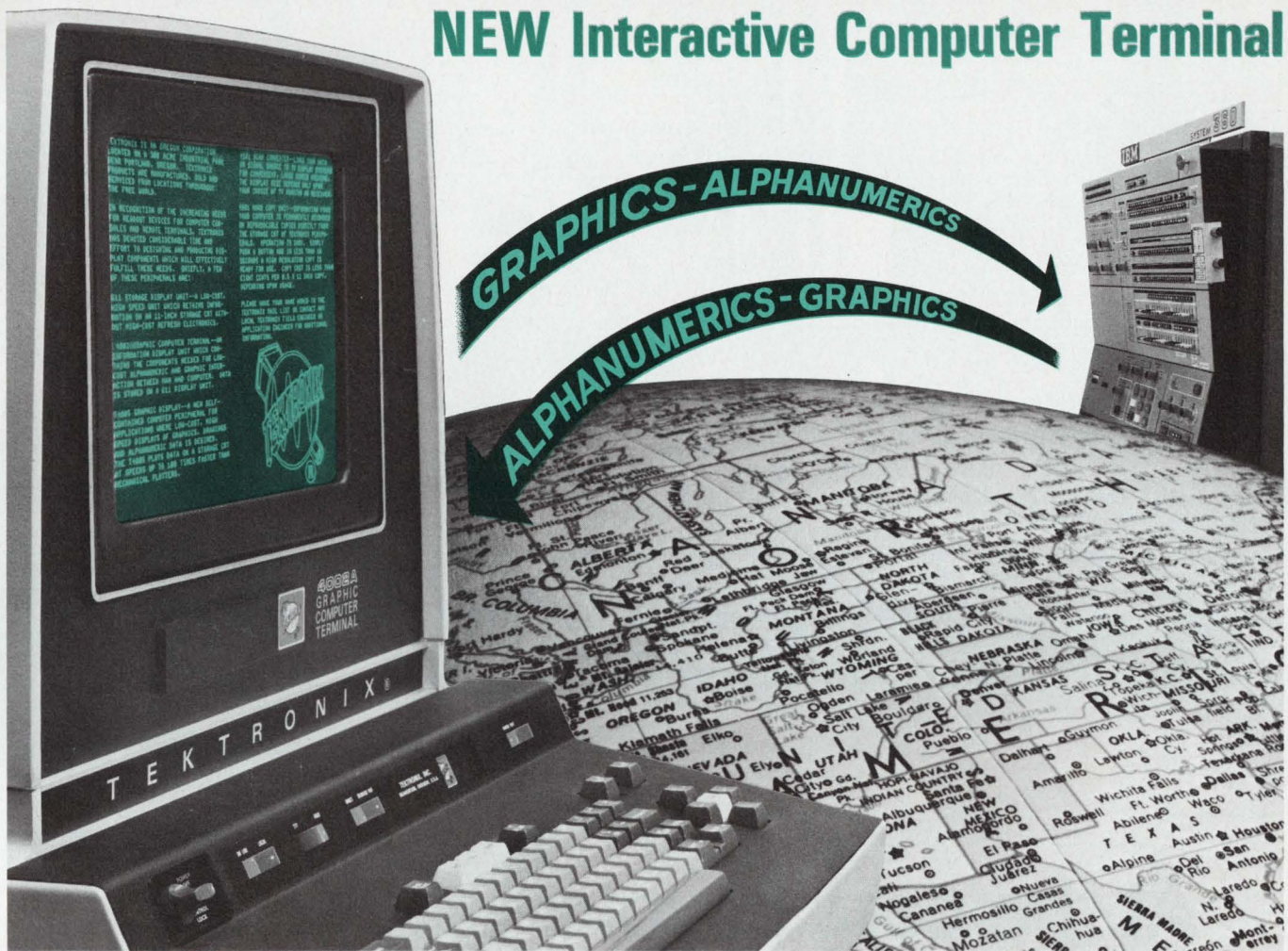

■ HIGH DENSITY ALPHANUMERIC AND COMPLEX GRAPHIC DISPLAYS

Alphanumerics—39 lines with 85 characters per line
 Graphics—1024 x 1024 addressable points
 761 x 1024 viewable points

■ NEW COMPUTER ADDRESSABLE REFRESHED SCRATCH PAD

Dynamic Composition and Extensive Editing
 Selective Transmission of Contents

■ NEW BRIGHT ELEVEN-INCH SPLIT SCREEN CRT DISPLAY

Benefits of both Storage and Refreshed Displays
 Storage Displays without flicker or drift
 Split screen refreshed scratch pad area

■ FULL INTERACTIVE GRAPHICS

Versatile Plug-In Interactive Graphic Units
 Unique Graphic Input Joystick

■ NEW GRAPHICS SOFTWARE PACKAGES

FORTRAN software for Data Communications Interfaces
 Assembly Language for new Teletype Port Interfaces
 Tektronix Graphics Software/360 System

**HARD-COPY
 COMPATIBLE**

Copy Complex Graphics
 and Alphanumerics

Low Cost
 8½ x 11 copies

Fast and Simple
 Push-Button Operation

For additional information call or write: Any
 Tektronix Field Office (57 U.S. and 21 Inter-
 national), or Tektronix, Inc., Beaverton, Oregon
 97005.



TEKTRONIX®

committed to
 technical excellence

4601 Hard Copy Unit



INFORMATION RETRIEVAL NUMBER 29

LET'S START AT THE
BEGINNING. WITH TELEVISION.
STACKPOLE DID.

SINCE 1947, STACKPOLE
HAS BEEN A LEADING
SUPPLIER OF CRT Y
CORES TO THE TELE
INDUSTRY. FIRST
AND WHITE

At the core of yoke technology

cores to the television industry. First, black and white. Now color. This makes us the oldest ferrite yoke core manufacturer in the U.S.

Now this knowledge and experience have been applied to the precision components necessary for CRT information displays. Whole rings. Quarter segments. Stator yokes.

What you get is a greater choice. First, tooling. Many configurations are already available. If not, Stackpole can develop precision tooling for you. Secondly, a family of ferrite materials permits greater flexibility in design, tighter control over results.

Stackpole also offers machining facilities for grinding to close tolerances.

TYPICAL CERAMAG® MATERIALS FOR INFORMATION DISPLAY YOKES

	7B	11	12	24
Initial Permeability	450	125	35	2500
Saturation Flux Density	2600	2550	2400	4500
Residual Flux Density	1650	1420	750	1700
Coercive Force	0.48	2.8	4.7	0.25
Curie Temperature	160	385	450	205

We've been around cathode ray tubes for a long time. Why not take advantage of the technology that can be yours at Stackpole. We may have the answer you've been looking for, or know how to get it. Simply contact: Stackpole Carbon Company, Electronic Components Division, St. Marys, Pa. 15857. Phone: 814-834-1521. TWX: 510-693-4511.

Stackpole Ceramag® Ferrite Yoke Cores for CRT Displays

Let's start at the beginning. With television. Stackpole did.

Since 1947, Stackpole has been a leading supplier of CRT yoke



Finally...

there's a new and better way to transmit high-speed digital data.

Ampeconomation
COST SAVINGS BY DESIGN WORLDWIDE



Better than ribbon cable, twisted pairs, shielded and coaxial cable.

It's AMP-manufactured flat-conductor transmission cable assemblies.

With impedance and cross talk matched to user requirements. Closely controlled by our own design and flat-cable manufacturing process.

Which brings us to terminations. Connectors specially designed for flat-conductor transmission cable.

Result? Flat-conductor transmission cable assemblies, custom made in sizes up to 32 conductors, in lengths up to 50 continuous feet, with matched impedance from end to end—ready for installation.

That's it. The whole story except for some technical details on our flat-conductor transmission cable assemblies which we'll be happy to supply when you write:

**AMP Incorporated, Industrial Division,
Harrisburg, Pa. 17105.**

AMP

INCORPORATED

Manufacturing and Direct Sales Facilities in: Australia, Canada, France, Great Britain, Holland, Italy, Japan, Mexico, Puerto Rico, Spain, Sweden, United States and West Germany.

INFORMATION RETRIEVAL NUMBER 31

The SCR Power Supplies are high efficiency, high power units designed for a wide range of applications where both precise constant current and constant voltage operation are required. Competitive comparison shows E/M power supplies have lowest voltage ripple, more watts per cubic inch and per pound.



The EMX Power Supplies are specifically designed as constant current sources for Xenon and other high pressure lamps. The EMX series provides stable light output and features automatic starting, igniter pulse timing control, output current adjustment and provisions for certain remote functions. Low lamp current ripple insures maximum life.

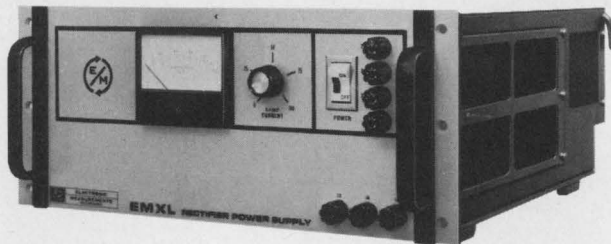

The EM Power Supplies have the same advantages and the same applications where the precise regulation of the SCR Power Supply is not required. The EM Power Supplies are a low-cost 1% regulated voltage and current DC source in the medium power ranges up to 10 kw.

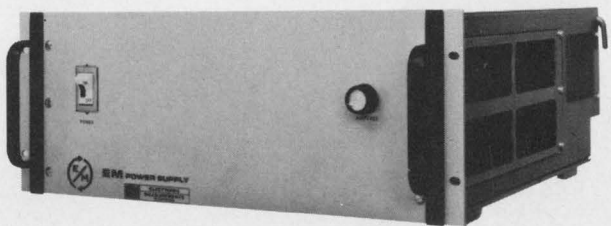

GUARANTEED FOR FIVE YEARS

Applications:

Precision Welding	CW and Pulse Lasers
Semiconductor Aging	Focusing Coils for Accelerators
Diode Testing	Electroplating
Relay Testing	Battery Charging
IC and Transistor Testing	Electronic Memory Systems
Capacitor Forming	Cryogenic Magnet Applications
High Pressure Lamps	

CALL TOLL FREE (800) 631-4298

Write today for your copy of our 1971 Power Supply Catalogs. Complete specifications, accessories and prices for your ready reference.



ELECTRONIC MEASUREMENTS INC.
405 Essex Road, Neptune, New Jersey 07753

WHEN THINKING PRECISE kw POWER SUPPLIES . . . it's E/M

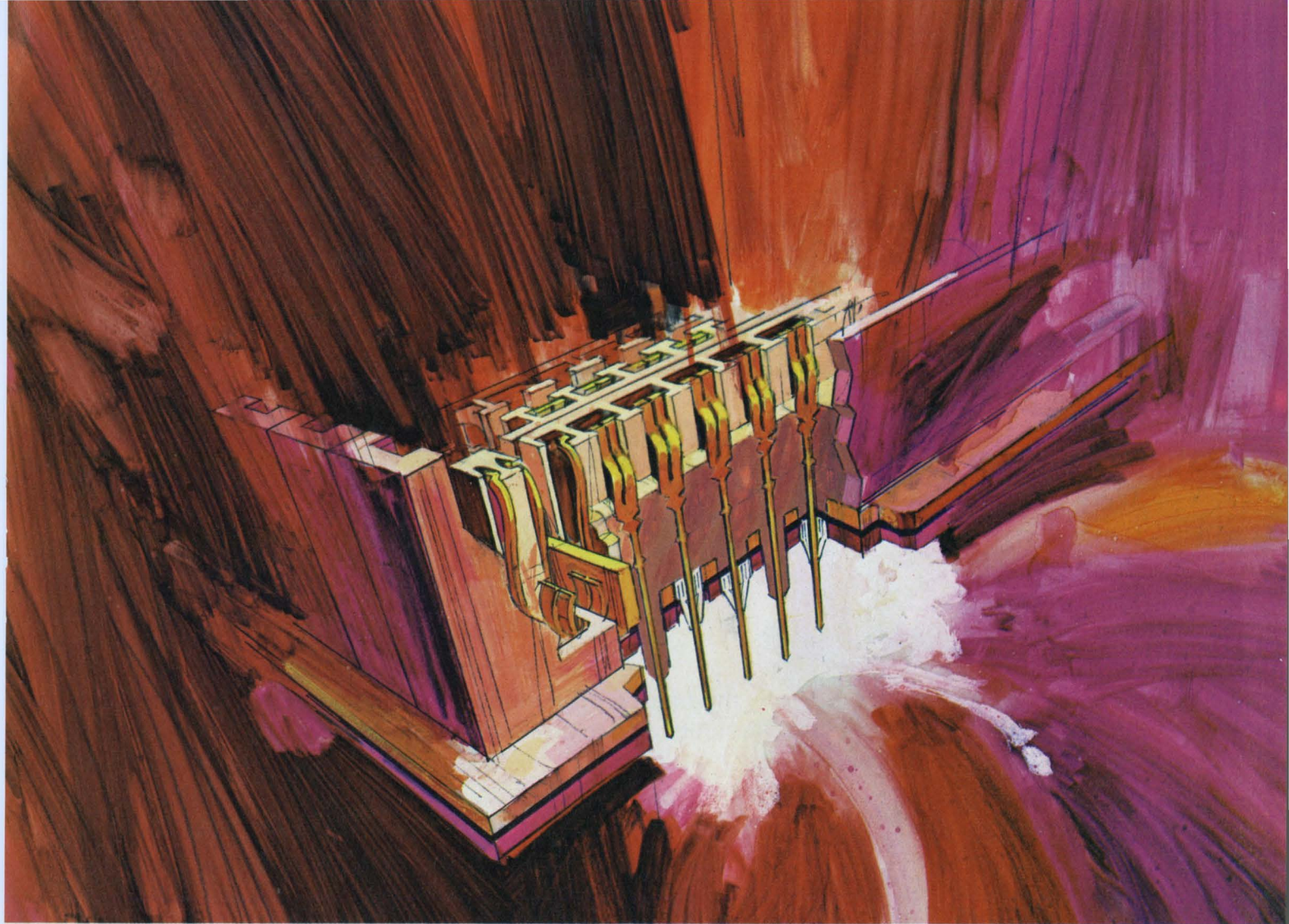

IMITATED—BUT NOT EQUALLED.

CINCH BACK PLANE CONNECTOR SYSTEM

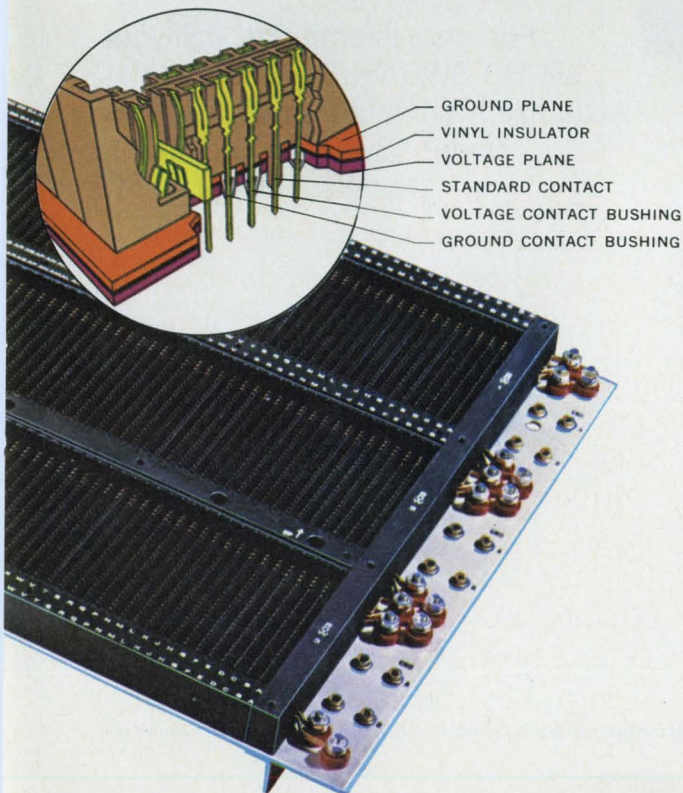

GROUND PLANE
VINYL INSULATOR
VOLTAGE PLANE
STANDARD CONTACT
VOLTAGE CONTACT BUSHING
GROUND CONTACT BUSHING

Today, most back plane connector systems are being modified to include features first developed by Cinch. But only the Cinch back plane was designed to incorporate these innovations as basic design considerations, not modifications of already existing devices.

Cinch design leadership produced the *first* back plane connector system with these important features:

1. Replaceable buss bars that permit removal and replacement of bussing contacts.
2. Easily replaceable voltage plane and ground contacts, including bussing.
3. Precision monoblock insulators that eliminate modular construction.
4. Cantilevered, preloaded contacts.

Cinch didn't stop with the product. Special design molded styro-foam carriers completely eliminated damage during transit.

Combined with cost reducing techniques of selective gold plating, simultaneous insertion of contact rows and a unique method of terminal positioning, these features result in the most efficient and most economical back plane connectors system you can buy.

For information on this or other Cinch interconnection devices, write to Cinch Manufacturing Company, 1501 Morse Avenue, Elk Grove Village, Illinois 60007.

CM-7134



There's plenty more where these

came from.

Literally, thousands more.

Actually, the odds are in your favor that we have the unlighted pushbuttons you need, right-off-the-shelf.

Our secret is interchangeable parts. Pushbutton modules. Switch modules (including hermetically sealed units and high/low temperature versions). Facenuts. Even a selection of colored buttons.

We also give you a choice of momentary or alternate action. Or a combination of both. And finally, a pick of one, two, three or four pole circuitry.

Which gives you the opportunity to customize your panel — front and back. To make it the way you want it. And to do it economically.

For more information, call your MICRO SWITCH Branch Office or Authorized Distributor (Yellow Pages under "Switches, Electric"). Or write for Catalog 51.



MICRO SWITCH

FREEPORT, ILLINOIS 61032

A DIVISION OF HONEYWELL

MICRO SWITCH products are available worldwide through Honeywell International.

INFORMATION RETRIEVAL NUMBER 34

INFORMATION RETRIEVAL NUMBER 35 ►

ERIE EMI Filters

WORLD'S BROADEST LINE OF MINIATURE CERAMIC FILTERS
AND FILTER SYSTEMS

- FIRST-** in subminiature design capability
- FIRST-** in total in-house production capability
- FIRST-** in Quality and Volume Production
- FIRST-** to develop a complete line of subminiature EMI Filters

ERIE's stature as undisputed world leader in subminiature high performance Ceramic EMI Filters has been earned by our ability to apply 35 years of sophisticated ceramic and related technology to developing superior EMI Filters. Virtually all other presently known ceramic EMI filters are a copy of an Erie design. Yet, no firm has been able to equal Erie's combined in-house filter capability and proprietary ceramic technology.

Today these miniature filters "do their thing" in noise pollution control, eliminating extraneous noises and emissions from air waves.

There's an application for reliable Erie filters in your communications, aerospace, aircraft and industrial equipments. We'll be happy to help solve the problem.

Write for our new EMI Filter brochure
ERIE TECHNOLOGICAL PRODUCTS
Erie, Pennsylvania 16512



Exact's New Twins

TWIN SIZES ...only 27/8" high, 73/8" wide, 81/2" deep.

TWIN PRICES ...only \$395 each.



miniemaxi

(down to 1 millivolt)

(up to 100 volts)

Model 122 VCF Waveform Generator produces as low as a 1 millivolt signal for low-level applications, and offers a balanced 600-ohm output for communications work. Does the work of an oscillator at oscillator prices, but offers sine, square, triangle and sync waveforms and many other features, such as:

- Frequency range 0.1 Hz to 3 MHz.
- Full 80 db attenuation in 10 db steps, with 20 db continuously variable.
- Selectable output impedance, either 50 ohms or 600 ohms balanced.
- Kelvin-Varley divider for accurate frequency control.
- Manual search or external frequency sweeping over 3 decades without changing range.
- 20K range permits sweeping entire audio frequency spectrum without a range change.
- $\pm 10V$ D.C. offset open circuit or $\pm 5V$ into 50 ohms.
- VCF input usable to 1 MHz for external frequency control over 1000:1 range.
- Price \$395.

Model 170 Power Amplifier can deliver up to 100V p-p to drive high voltage devices when driven by signals from Exact waveform generators or other signal-producing equipment. Output can deliver 25 watts, 50V p-p into 50 ohms. Other features of this new amplifier include:

- X1 and X5 gain.
- 600-ohm input impedance.
- 50 and 600 ohm output impedance.
- Floating output.
- Output short circuit protection.
- Hum and noise greater than 70 db down.
- Slew rate 70V/microsecond.
- Price \$395.

Waveform generators from \$295



Box 160
Hillsboro, Oregon 97123
Telephone (503) 648-6661
TWX 910-460-8811
A subsidiary of
Vector Management Corp.

SEE US AT WESCON, BOOTH 1118-1119
INFORMATION RETRIEVAL NUMBER 36

Let's open our eyes and take stock of ourselves

To see ourselves as others do can prove enlightening, as evidenced by the following letter recently received from Europe:

The Editor
Electronic Design
850 Third Avenue
New York, N. Y. 10022



Dear Sir,

What the hell are you up to over there? A frighteningly large number of your engineers are unemployed; your balance-of-payments deficit is twice as great as it was five years ago; over 30% of your domestic market is dominated by foreign imports—mostly from Japan—and the all-mighty dollar is being tossed around in European money markets like some soiled and tatty Cadillac.

The wealthiest and most powerful nation in the world is behaving like some mighty warship floundering with an uncontrollable rudder—just like the ill-fated Bismark did during the last war.

The financial wealth of General Motors alone is greater than that of many European countries; and yet you decide to drop the SST—in spite of the progress made in Britain, France and Russia. This from a country which left the rest of the world gasping with its incredible achievements in space. Surely, if only to maintain your image and acknowledged technological leadership, you should have developed such an aircraft—probably during those slack periods when you weren't sending men to the moon!!!

How is it that a country with such a wealth of talent, ingenuity and enviable ability for hard work, can allow itself to get into such a deplorable state? The way things are going, I wouldn't be surprised to hear that Liberace had been offered a Presidential nomination.

For God's sake, shake yourself out of this degrading decline and set about regaining your irritating, but grudgingly admired, cockiness—and your rightful place at the top of the world league.

Yours faithfully,
H. A. Cole
M.I.E.R.E.

Reading, Berkshire
England



FOCUS

on
Instrumentation

Tradeoffs are what engineering is all about. But the real problems in selecting instruments come with the hidden tradeoffs we don't know we're making.

Specsmanship, the old art of concealing a product's weakness, is still with us. But it varies in form and intensity with the artistry of the spec writer, the type of product, the competitive environment and the business climate.

Nevertheless many aspects of specsmanship are shared by almost all instruments. Accuracy specifications are still given in terms of a percentage of range rather than a percentage of reading. Stability is listed in terms of "mean," "median," "average" and "typical" when what we'd really like is "guaranteed better than."

Perhaps more important are the specs that never appear on a data sheet. We must determine if an instrument is easy to use or if we have to study it again each time we approach it. Does an entire reading, complete with units, appear on a dial or digital readout? Or must we combine a readout presentation with a knob setting? Does the knob give us the readout's range? Or does it give a multiplier for the readout?

Do we get outputs from input jacks? Do our high-input-impedance digital meters give us kick-back currents? Do our high-sensitivity counters spit out spurious garbage resulting from internal logic transitions?

What about workmanship? It's a rare spec sheet that says: "Our labor, materials and design are awful, but we hope the instrument works when it reaches you." Yet we do find kluges. We find switches that won't take many switching cycles, lamps that burn out right away, meter movements that stick. We find boxes that look impossible to troubleshoot, calibrate or repair.

All such problems reflect problems faced by

the instrument designer. They often show the tradeoffs *he* had to make.

As we glance backward, we get a picture of some of the tradeoffs of the past (for they serve as a guide to the future) as well as some of the technical and economic breakthroughs.

We can see that, at this moment, there are two very clear, very divergent trends for almost all types of instruments. The weaker trend is toward higher performance. The stronger is toward somewhat lower performance at substantially lower prices. This stems from the fact that when the plug was pulled on military and aerospace spending, many engineers began to spend money as if it were their own.

There's another trend—toward digital programming—but nobody is quite sure what form it will take. There is much dispute on the relative merits of single-line and binary-coded programs. There is argument over the merits of parallel and serial bits and characters. And there is argument over the best logic levels. These can form the basis for a later article.

In the lines that follow, we will see specific embodiments of some general tradeoffs and a few unique ones. For four basic classes of popular instruments—E-I-R meters, oscilloscopes, counters and signal sources—we should find fast answers to three questions:

1. Where have we been?
2. Where are we going?
3. How can we get hurt on the way?

Industry authorities agree there are two basic trends in instrumentation: super performance at high prices and stripped-down performance at low prices. They also see some problems. Their views, summarized by ELECTRONIC DESIGN, accompany this report.

George Rostky
Special-Projects Editor

Who they are

Companies mentioned in this report include:

Beckman Instruments Inc., Schiller Park, Ill.

Calico (California Instrument Corp.), San Diego, Calif.

Dana Laboratories Inc., Irvine, Calif.

Data Precision Co., Wakefield, Mass.

Data Technology Corp., Palo Alto, Calif.

Datapulse Div., Systron-Donner Corp., Culver City, Calif.

Dumont Oscilloscope Laboratories, Inc., West Caldwell, N. J.

Dynasciences Div., Whittaker Corp., Chatsworth, Calif.

E-H Research Laboratories, Inc., Oakland, Calif.
EIP, Inc., Santa Clara, Calif.

ElectroLogic, Venice, Calif. (Company no longer in business.)

Electro-Numerics Corp., Santa Clara, Calif.

Exact Electronics, Inc., Hillsboro, Ore.

Federal Scientific Corp., New York City

Fluke, John, Mfg. Co., Inc., Seattle, Wash.

General Radio Co., West Concord, Mass.

Heath Co., Benton Harbor, Mich.

Hewlett-Packard, Palo Alto, Calif.

Hickock Electrical Instrument Co., Cleveland, Ohio

Interstate Electronics Corp., Anaheim, Calif.

Iwatsu Electric Co., Ltd., Tokyo

LogiMetrics, Greenville, N. Y.

Microdot, Inc., City of Industry, Calif.

Non-Linear Systems, Inc., Del Mar, Calif.

PRD Electronics, Inc., Westbury, N. Y.

Philips Electronics Corp., Mount Vernon, N. Y.

Polarad Electronics Corp., Lake Success, N. Y.

Sencore Corp., Addison, Ill.

Simpson Electric Co., Chicago

Systron-Donner Corp., Concord, Calif.

Tau-Tron, Inc., Lowell, Mass.

Telonic Industries, Inc., Laguna Beach, Calif.

Tektronix, Inc., Beaverton, Ore.

Time Systems Corp., Mountain View, Calif.

Triplett Corp., Bluffton, Ohio

Wavetek, San Diego, Calif.

Weston Instruments Inc., Newark, N. J.

E-I-R Meters: Digitals threaten takeover, but specialized analog meters hold their own

When Andy Kay gave the world the first DVM in 1952, he couldn't know that its descendants would one day challenge analog multimeters. The founder and president of Non-Linear Systems could scarcely dream that the industry he started with the crude, \$4000 Model 419 would lead to good meters for \$300.

Early digital voltmeters, ohmmeters and ratimeters proved extremely useful to people who needed automatic, high-resolution, high-accuracy measurements. But they were expensive.

Too cheap too soon

Then, in 1961, Vincent Van Praag started ElectroLogic and startled the industry with a \$300 DVM. It strobed the correct three-digit reading on a constantly rotating number drum. But sales of the unit never got off the ground; no good rep would drop a \$2500 DVM to sell

one for \$300. And people may not have been ready for a \$300 DVM.

They were ready in early 1967, when Fairchild hit the market with the 7050 at \$299. That was just a bit more costly than the United Systems servo-pot, numbered-wheels DVM. Accustomed to the semiconductor business, Fairchild offered quantity price breaks; at the 25-piece level, the 7050 went for \$249.

Though Fairchild soon upped the list price to \$350 (and Systron-Donner lowered it to \$319 after it acquired the line in June, 1969) the 7050 left its mark. It used dual-slope integration (which Fairchild had pioneered in 1965) to cut noise and cost. It used ICs extensively. And the three-digit meter offered four dcV ranges and five resistance ranges.

The industry began adjusting to the 7050. It offered three-digit multimeters at lower prices or at higher prices with much more performance

—more ranges, more sensitive ranges, data outputs.

Then came another pacesetter—the four-digit Fluke 8100. It hit the market in August, 1969, at \$695, equaling the price of Data Technology's dcV-only Model 350. Using cyclic conversion to cut power requirements and cost, the Fluke 8100 had four dcV and acV ranges and five resistance ranges. The 8100 and the five-digit 8300, which was introduced at the same time, instantly made Fluke an important factor in the DVM field.

While these developments shook the industry, older leaders in the field—like Non-Linear Systems, HP and Dana—entered lower-cost and much-higher-cost meters.

Dana introduced a computing converter to ap-

The lowest-cost digitals certainly compete with top-of-the-line analog multimeters. But they don't come near the performance of specialized analog meters at anything like the same price. You can't find a \$300 or \$350 digital to give 1-mV full-scale sensitivity or 10-MHz bandwidth. Nor can you find one that competes with a good RLC bridge or differential voltmeter.

William Tippet, Product Manager, Analog Meters, Loveland Div., Hewlett-Packard.



The market has grown enough so that we'll see digital meters designed for relatively narrow segments. There's a good example in a recent true-rms DVM. It measures dc, but its primary function is measuring ac. While this happens, users will pay more attention to digital-multimeter characteristics that generally don't appear on the spec sheet — kickback currents, component quality (the use of \$12 JFETs instead

of 80¢ op amps), ease of troubleshooting and servicing, workmanship.

Roger Youngberg, Product Manager, DVMs, Loveland Div., Hewlett-Packard.

As prices continue to decline, users will have to study DMM specs more carefully. Headline accuracies generally apply to dc voltage only. For system applications, they'll have to check isolation and reading speed. High-speed DVMs may prove awfully slow for ac readings or for dc readings through a noise filter.

Charles Marsh, Vice President Marketing, Non-Linear Systems.

proximate true-rms response at prices only slightly higher than those associated with average-responding meters. HP introduced several true-rms thermopile DVMs, one of which offered response to an astounding 100 MHz. Tektronix brought out a DMM plug-in for its 7000-series scopes, and the unit measured temperature, too.

Non-Linear Systems and others brought out lines of good low-cost multimeters. And Weston, better known for its pioneering of the digital panel meter, kept pumping out the 1240, a three-digit \$395 instrument with five dcV and acV ranges, five dc and ac current ranges and six resistance ranges.

The industry attracted some two dozen ven-

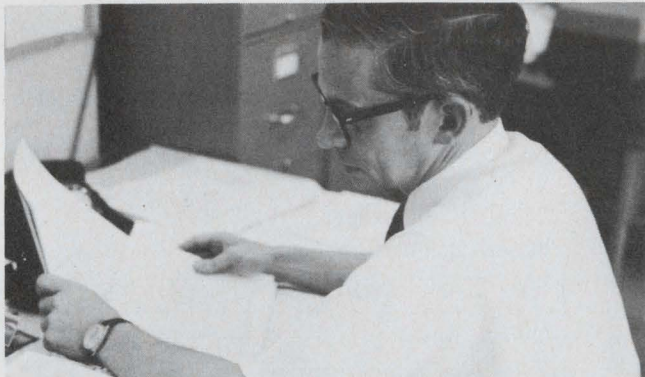

Low power consumption is much more important in a DVM than most engineers realize — even in a line-operated instrument. If the designer can cut heat rise, he can save money on components like zeners, precision resistors, offset and buffer amplifiers—that temperature affects. And he cuts warmup time.

James Key, New Product Manager, Voltage Measuring Instruments, Fluke.

DVM designers will have to decide at the start — not as an afterthought—whether an instrument is aimed at bench or systems applications. Users will have to make sure they can easily install options later, in the field, without having to return an instrument to the manufacturer.

Jerry Hartman, Product Manager, DVMs, Systron-Donner.

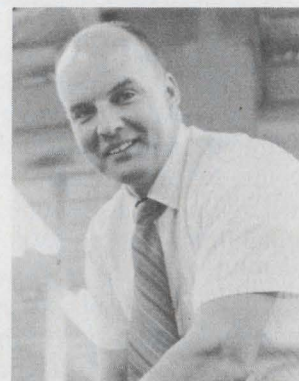

Guarded construction in DVMs can certainly reduce noise, but it can present other problems. It may be impossible to drive the large capacitance presented by many guard terminals. These terminals can also deliver currents from the power line or from internal logic transitions and the currents can disrupt low-level floating measurements.

Garry Gillette, Product Engineer, Dana.

dors—including the leading old-line analog multimeter companies—Simpson, Triplett and Weston. And we began to see some rather unusual products and problems.

The half digit emerges

Just about everybody had a "1" in front of the most significant digit. Most people called it a half-digit. It provided over-range, so a three-digit meter could read 1199 for 20% over-range, 1299 for 30% over-range, or, in a growing number of cases, 1999 for 100% over-range. The "1" was generally a tall neon, so it wasn't very expensive, and it didn't demand much of the electronics in the instrument.

But then Electro-Numerics came along with an over-range "3" to provide 300% over-range, and, more recently, Triplett introduced an under-range "0" and "5," doubling the resolution.

Unfortunately the proliferation of partial digits made for problems in interpreting accuracy specs. DVM and DMM manufacturers traditionally gave accuracy as a percent of reading \pm one digit. Then many began to give the spec in terms of a percent of reading \pm a percent of full scale (or range). But what's full scale? If a meter has 100% over-range, is full scale 999 or 1999 on a "3-1/2 digit" meter? Is the scale accuracy 0.1% or 0.05%?

The meter manufacturers themselves sometimes get confused. One vendor, in fact, marks the scales 2, 20, 200 and 1000 to eliminate some confusion and to show that over-range does not apply to the 1000-V range (though it does to 1000 Ω and 1000 mA). But his spec sheet talks about 100% over-range anyway.

The problem is compounded when a manufacturer has, say, 20% over-range and quotes scale accuracy of 0.00835% for a four-digit (or 4-1/2 digit) meter. That looks better than the usual 0.01%, until we realize that it simply represents one count in 12,000 instead of one count in 10,000.

Other spec problems in digital multimeters can prove more serious. DMMs often come with impressively large input resistances on some ranges. But manufacturers don't always tell us how much current can kick back out of the input terminal.

We still find temperature coefficients spelled out for dc voltage, but not for ac or other functions. We find meters that auto-range nicely between several ranges—but not all. So the meters work well in systems whose voltages stay within, say, the 10, 100 and 1000-V ranges without excursions down into the 1-V or 0.1-V. We even find a range or two that may require moving a lead to a different front-panel jack.

For systems jobs, where reading speed be-



comes important, we find headlined speeds that apply only within one range—and only for dc voltage, and only with the input filter out of the circuit. Vendors tend to write noise-rejection specs, but these may apply only to dc-voltage measurements and only to 60-Hz noise. Further, manufacturers and users alike tend to confuse resolution with accuracy and forget that accuracy specs may not include the effects of temperature and time.

Fortunately users are becoming more aware of spec problems, and manufacturers are taking more pains to make their specs clear and explicit.

More performance comes with less cost

Meanwhile vendors keep introducing features to boost performance and convenience and to cut cost. Digilin was probably first to rezero automatically 60 times a second, drastically cutting drift. More recently a new company, Data Precision, brought out a line of DMMs that accumulate analog offsets and feed them to an integrator to rezero for every reading.

The Data Precision meters use several shrewd techniques to reduce the parts count and cut the cost while boosting performance. For example, the company threw out the expensive high-stability op amp that traditionally follows the zener reference in bipolar meters. Instead, Data Precision uses one capacitor (charged by one zener) as both positive and negative reference, depending on how the capacitor is switched to the comparison circuitry.

Triplett added an unusual feature—the ability to store a reading for later recall. Time Systems, a few years ago, and Simpson, a few months ago,

brought out answers to the objection that digitals, unlike analog meters, don't show directions of change.

Time Systems added a horizontal string of 20 neons that could form a moving bar of light to show signal changes. Simpson simply added a small pointer meter.

Analogs alive and kicking

Where are the analogs? Though they've been wounded, analog meters are far from dead. The bulk of the market has been in multimeters, so that's where digital technology has been applied. But analog and digital prices are still far apart. At about \$250, the bottom-priced digital multimeters meet the top-priced analogs.

The special-purpose or special-performance analog meters haven't been scarred. Since they represent narrower markets, digital vendors haven't even fired at them—yet.

We all know the advantages of digitals. They can offer higher resolution, higher accuracy, data output and zero parallax and ambiguity. But analog meters readily show direction of change. And that's important when you want to null or peak a circuit or match a response to an operator's action. You can get a needle to move to the right when he turns a knob clockwise.



Users are getting more convenience features in the passive VOM. They want separate battery compartments, plug-in rather than solder-in fuses, and ruggedness.

Harold Moore, Product Manager, Simpson.



Sampling techniques will become more and more popular for nondisruptive, high-accuracy measurements of voltage and phase in microwave systems.

Donald Stock, Project Engineer, PRD Electronics.



Too many DVMs still spec speed with the filter out, and normal-mode rejection with the filter in, which can give a response time as long as a second. When an engineer switches the filter, he finds that his instrument got almost all its noise rejection from the filter. He loses a digit to noise, so his four digits become three and his five become four.

Takashi Mori, Chief Engineer, Instrumentation Div., Data Technology.

Top-performance and top-price analog meters have traditionally been line-operated. But the most popular meters have been 2% or 3% VOMs that evolved from the Weston and Jewell meters of the 1920s, though many feel the big move came when Simpson introduced the venerable 260 in 1935.

Since they're not tied to the wall outlet, VOMs are free of line noise and are extremely convenient to use—any place. They offer many ranges, including some that practically nobody uses (like 10 Adc or 5 kVdc).

But many engineers never developed much trust in them, except for quick checks, because they loaded down circuits. Many preferred the 10 or 11-M Ω input resistance of vacuum-tube voltmeters to the 20,000 ohms per volt (dc) of very popular meters like the Simpson 260 or the Triplet 630.

The VOM goes active

The picture changed in 1966 and 1967 when Amphenol, and then Triplet, Philips, Sencore and Simpson, introduced FET VOMs. For the first time, one could get the convenience of a VOM with the accuracy, sensitivity and high input resistance of traditional, line-operated bench instruments. Along with their advantages the

The FET VOM gives the engineer everything he always needed in a bench instrument — high impedance, high sensitivity, high accuracy and lots of ranges — in addition to portability and freedom from line noise. Now he will have to examine less obvious qualities — like freedom from scale clutter, overvoltage protection (even on resistance ranges), component quality and the same input resistance on all ranges, so he doesn't get different readings for the same voltage when he switches to another range.

Walter Cerveny, Manager of Engineering, Electronics Dept., Triplet.



VOM designers will have to pay more attention to real failure modes. An instrument gets cremated when a user checks line voltage, forgetting to switch when he just checked a fuse on the "X1 Ohms" range. The instrument gets hurt when it falls on its back from a vertical position. Or it gets smashed when it walks off the bench to follow a man who has a clip lead caught on a pocket or belt loop.

Thomas Kelly, Chief Engineer, Weston.



FET VOMs brought a few problems, too.

Early instruments (and some of the newer ones) were drift prone. The drift could be alleviated, in part, by using very stable and costly batteries. Further, several meters chewed up battery power rather hungrily. But these problems have largely been licked, and new features make the FET VOM even more desirable. Several units, for example, offer low-power ohms—a feature that allows in-circuit resistance measurements without shunting by semiconductors.

More recently, Weston brought out a line of break-proof VOMs, reminding engineers of an old problem they often overlook.

There's little doubt that the FET VOM will replace most general-purpose bench multimeters that are tied to the line. In the future, we're likely to see units that consume so little power that batteries, even cheap carbon zincs, will be replaced only after three-to-five-year intervals.



Oscilloscopes: All-purpose test 'center' chips away at the top of the line, while better low-frequency units chew away at the bottom

The wit who said, "Tektronix has 80% of the U. S. scope market, HP has 20%, and all others share the rest," may not have scored high in arithmetic. But he recognized that Tek and Hewlett-Packard enjoy overwhelming dominance in the field—at least in the United States. Many important contributions have come from these two. But not all.

The oscilloscope industry started in 1931, when General Radio offered a three-piece instrument that included a CRT, a power supply and a "linear" sweep circuit. By 1934 the company had added features, improved the basic elements and mounted them in a single housing. This was the 687-A Electron Oscillograph, the first complete scope ever marketed.

GR followed this with the 770-A, then stopped production of scopes completely, feeling that, unless they are extremely expensive, they'd be useful mainly to radio servicemen, a market GR didn't serve. Today GR admits that dropping oscilloscopes was "a considerable error in product judgment."

Meanwhile, in 1933, Du Mont Laboratories introduced the Model 130—a four-piece instrument

with a 3-inch CRT on a stand, a sweep package (with rates to 5 kHz), a signal-amplifier package (with bandwidth of 20 Hz to 10 kHz and sensitivity of 1 V full scale) and a power-supply package—all for \$250. With this scope and its successors, Du Mont happily watched its market expand dramatically.

A \$700 scope, but will it sell?

At the 1948 Institute of Radio Engineers show, Dr. Allen B. Du Mont admired the 511—the first 10-MHz, 10-mV/cm scope; the first commercial scope with calibrated vertical and calibrated, triggered sweep; and the first scope from two-year-old Tektronix. Dr. Du Mont congratulated the man at the booth, 35-year-old Charles Howard Vollum, founder and president of Tektronix, then added a friendly tip: "Nobody will ever spend \$700 for a scope."

During the 50s Du Mont made several dramatic contributions, including the first dual-beam scope, the first storage scope and the first scope with delaying and mixed sweeps. But later contributions came mainly from others.

Tek took a speed crown in 1959 with the single-trace 581 and 585 mainframes, with Type 80 plug-in and P80 probe. The 581/585 boasted bandwidth of "dc to approximately 100 mc" with top-frequency sensitivity of 100 mV/cm. Five years later (four years after a 1960 merger), Fairchild-Dumont introduced the 7902A dual-trace—100-MHz, 10 mV/cm plug-in for the 765.

That instrument was the first 100-MHz solid-state scope, thanks to a creative interpretation of "solid state" that included seven nuvistor tubes and, of course, the CRT. (Nuvistors, in fact, didn't leave "solid-state" scopes until 1969, when FETs replaced them.)

The bandwidth crown moved back to Tektronix in 1967 (for the very popular 150-MHz portable 454), to Iwatsu in 1969 (for the 200-MHz SS211), to Hewlett-Packard later in 1969 (for the 250-MHz 183), back to Iwatsu in late 1970 (for the 300-MHz SS311), then firmly back to Tektronix in March, 1971 (for the 500-MHz 7904).

Though Iwatsu commands most of the oscillo-

scope market in Japan, the company's products are little known in the U. S. This may be due to their lack of plug-in versatility, their high cost or the reticence of their U. S. representative, E-H Research Laboratories, a company not known for timidity in pulse generators.

With Tektronix holding bandwidth leadership today, HP may derive some solace, perhaps, from the fact that Tek's 7A19 plug-in for the 7904 uses a 50-ohm input—a system first used in real-time scopes in HP's 1802, a dual-trace 100-MHz plug-in for the 180/181.

50 ohms or 1 megohm?

And therein lies a clash of opinions and some tradeoffs. At high frequencies, should we use 50-ohm or 1-M Ω input systems? HP uses 50 ohms for its 100-MHz and 250-MHz scopes. Tek uses 50 ohms for its 500-MHz scope. Iwatsu has a 50-ohm input for one of its 200-MHz scopes and 1 M Ω for two others and for its 300-MHz scope.

We all know that shunt capacitance wipes out

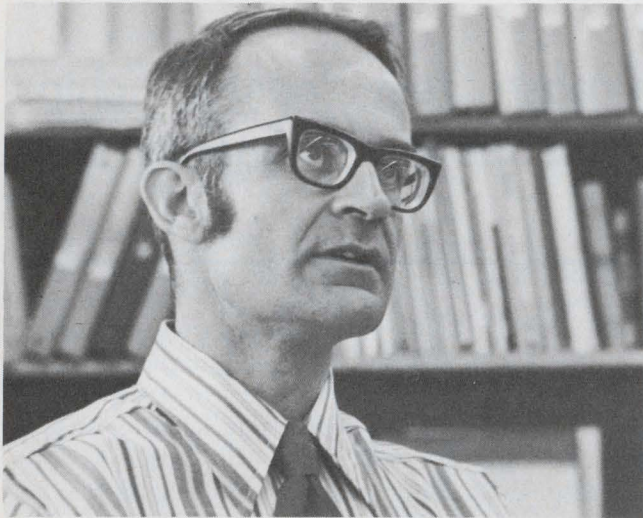

Sure, we'll see greater-bandwidth real-time scopes. But we'll also see more performance in battery-operated portables. People used to want big and heavy scopes that weren't likely to be borrowed for somebody else's job. Now they want the convenience, noise rejection and cool, low-drift operation of a good, high frequency portable.

Chuck Donaldson, Product Manager, Oscilloscopes, Colorado Springs Div., Hewlett-Packard.



The middle of the scope market can no longer be neglected. We'll see more capability and more sophistication at lower cost where most engineers need them — around 50 MHz.

Robert Coultas, General Manager, Dumont.

Many engineers tend to buy far more capability than they really need. They seem to think that if a scope is good to 100 MHz, it ought to be fabulous at 10 MHz. They forget that extra bandwidth can buy them extra sensitivity to noise.

Neal Turner, Sales Manager, Scientific Instrumentation, Heath.



The scope has entered a new era — aside from bandwidths considered impossible a few years ago. With plug-in peripherals like digital multimeters, counters and, no doubt, other measuring devices, it will become a completely integrated test system. We'll be able to make measurements that are impossible or extremely difficult with separate instruments.

William Walker, Vice President Engineering, Tektronix.

high resistance at high frequencies. (At 100 MHz, 10 pF works out to 160 ohms, which makes 1 M Ω disappear.) We know too, that high input RC degrades the rise time of fast pulses, causes reflections that create aberrations in the signals we see on a screen and gives us phase shift. These arguments favor the 50-ohm input.

But 50-ohm inputs load down signals, too. And 50-ohm systems can't take the high dc voltages that our small ac signals might ride on. So we're often forced to discard some 50-ohm advantages and use attenuators with special high-R, low-C probes in front of our 50-ohm systems (just as we might use 50-ohm probes in front of our "high-impedance" systems).

FET probes, usable with 50-ohm or high-impedance systems, are costly. They suffer from small dynamic range. And sooner or later, people burn up expensive FETs.

The choice between 50-ohm systems with "high-impedance" terminations and "high-impedance" systems with 50-ohm terminations isn't easy—until we get to 1 GHz, where sampling scopes take over. All use 50-ohm inputs. But samplers pose other problems: They're tricky to use.

Though there's been much progress (HP and Iwatsu both have 18-GHz units), it's still too easy to lose the signal or to get weird displays and snowstorms when the triggers aren't just right.

HP recently introduced a 1-GHz sampler that's much easier to use than most. But others, including Tek, Philips and Iwatsu, are trying to simplify sampling scopes so engineers can feel more at home with them.

What about the bottom end?

While the bandwidth race is by no means ended, there's growing activity at lower frequencies, where most of us aren't watching. Dumont, for one, has aimed its two-year-old 50-MHz Model 1050 and its just-introduced 60-MHz 1060 at "the middle of the market." The company hails the importance of its separation of the vertical-amplifying function from the trigger, allowing a user to dc-couple a trigger without any effect by position controls. For less common applications, the separation allows one to display waveforms that are not harmonically related.

Tektronix, too, feels that low-frequency needs haven't received as much attention as they should. The company's vice president for engineering, William Walker, points out that many engineers have been forced to buy high-frequency mainframes to get features that weren't available in low-frequency scopes, though they didn't need the bandwidth. He cites features like delaying sweeps, calibrated long offsets and good differential performance.



At lower frequencies, many engineers are beginning to consider low-cost, low-frills scopes from companies like Hickok and Heath, which, until a few years ago, restricted their activities to TV servicemen and hobbyists.

Just a different H axis?

There's another kind of scope, if we can call it that, which has received too scant attention—the swept spectrum analyzer. In 1969, HP coined the term "frequency-domain oscilloscope" to describe a line of spectrum analyzers that has grown, in four plug-ins for the 140/141 mainframes, to cover 20 Hz to 40 GHz.

HP hoped to convey the idea that every man working in the frequency domain should have an FDO next to his CRO. HP hoped, too, to focus attention on the extent of its "absolute calibration" of amplitude and scan width.

Though Polarad holds the lead in frequency range, covering 10 MHz to 90 GHz in 12 bands on its SA-2650, HP is notably proud of a recent contribution: the 8443 tracking generator/counter, which can be slaved to a spectrum analyzer. Roderick Carlson, instrumentation engineering manager of HP's Microwave Div., admits that the technique has been common in wave analyzers for many years, though it's new to spectrum analyzers.

Basically it's a selective detection system that's immune to harmonics. The system acts like a moving narrowband sweeper that tracks along with the detector. It goes far to eliminate image-response problems that plague all spectrum analyzers today.

The system has a big drawback, however. It costs \$3500, and that's in addition to the price of

the spectrum analyzer. At that price it begins to approach the cost of real-time spectrum analyzers. These instruments, unlike swept spectrum analyzers, are not at all like scopes. In different ways, they've seen so much progress in recent years that they merit separate treatment. In fact, they've received such treatment (see "Spectrum

Analyzers—Let's Look at the Field," by Harold Klipper of Federal Scientific, ED 24, Nov. 22, 1970, pp. 74-77.)

The designers of tomorrow's spectrum analyzers will probably concentrate on producing less sophisticated instruments at substantially lower cost.

Counters: It's higher frequencies and shorter time intervals vs less versatility and lower cost

Counters are almost too good. Now that military and aerospace pressures (and dollars) have largely subsided, the principal thrust is toward lower-cost—not higher performance. Already we can measure almost any time-related phenomena quickly, easily and accurately.

The achievements of counter designers have been impressive. Systron-Donner, for example, has an automatic transfer oscillator that permits frequency measurements to 40 GHz with virtually no operator intervention. Tektronix and Beckman have 500-MHz direct counters. General Radio has a reciprocal-taking computing counter that gives fast measurements of very low frequencies to high resolution. These represent some major pushes to frequency extremes.

Other developments may prove more fascinating. HP's 5360 reciprocal-taking 320-MHz counter uses a built in computer that permits all sorts of data massage. And two unique instrument marriages suggest intriguing synergism.

Wholes greater than the parts

The first takes the form of a 500-MHz counter plug-in, the 7D14, for Tek's 7000-series scopes. The counter's eight-digit readout appears right on the scope screen—immediately above the waveform, though it can be used without the waveform display. The combination does more than save the cost of a display. It makes it possible to use the scope to see exactly where the counter is triggered, completely eliminating ambiguity in rf-burst measurements, for example.

HP's combination, the 5326 or 5327 counter/timer/DVM may prove even more versatile. Counter/DVM combinations have been around since early 1969, the first being Heath's EU-805A. But the Heath instrument, and the Calico 8300 which followed, merely took advantage of

common circuitry, readout and package. The HP unit does more.

For example, you can set the counter's trigger level much higher than the amplitude of a signal you'd like to measure—and, of course, the counter won't count. Then you can gradually back down the trigger control till the counter starts counting, then switch to the DVM to measure the internal trigger level, which is now identical to the signal amplitude.

Or you can use the DVM to set a positive-slope trigger level to channel A and a negative-slope trigger level to channel B, then read the time interval between them precisely with the counter—a neat way to measure pulse width or cable length.

Any number of plug-ins?

HP has a newer counter with even more fascinating possibilities. A too-quick glance might suggest that the 5300 system is merely another plug-in counter—with a mainframe, a choice of four plug-ins and an optional battery pack. But they're not plug-ins, they're *plug-ons*.

The 'top member, the \$395 mainframe, has a six-digit light-emitting-diode display and a 10-MHz crystal time base. The bottom member, at prices from \$125 to \$750, furnishes the desired counter function. A rechargeable battery pack can form a middle member—like the meat in a ham sandwich.

But will HP stop there—without lettuce and tomatoes and cheese? Ian Band, project leader for the 5300 series, admits that HP will add at least four additional modules each year. But he won't describe them.

Going back to Tektronix, people have said that much of the company's great success stems not only from its fine scopes but from its ability

to sell holes—starting with its 1954 introduction of the 531, the first plug-in scope. That scope could accommodate a single plug-in. Later scopes were two-holers and, in August, 1969, with the 7000 series, Tek offered four-holers. At times, one or more “7000” holes could serve simply as convenient parking spaces for DVM or counter plug-ins. In fact, a Tek engineer recently described such plug-ins as scope “peripherals.” What next?

Now if we look again at HP’s 5300 system, we see that it differs from other plug-in instruments in that it’s not restricted to one plug-in, or two—or four. If we ignore the strange form factor that could result, we can imagine almost any number of plug-ons, all of which HP might one day regard as “peripherals.”

It should be pointed out that neither Hewlett-Packard nor Tektronix will say anything about such wild speculation. However, if one listens



We’re too easily mesmerized by high-frequency direct counters. We forget that we can measure awfully high frequencies with prescalers, transfer oscillators or other techniques if we’re willing to sacrifice some time or some resolution. Most of us don’t need all the resolution we get, anyway. How many people really need to resolve 1 Hz in 100 MHz?

Richard Hall, Chief Engineer, Frequency & Time, Systron-Donner.



It shouldn’t be long before we’re able to measure pulsed rf automatically at frequencies to 18 GHz and higher. Meanwhile we still must worry about problems in measuring the frequency of signals with residual fm. And we must remember that we have to wait a long time if we want extreme resolution in measuring microwave frequencies.

Werner Schuerch, Chief Engineer, EIP.



People are more serious about time-interval measurements today. Traditionally, unless we used expensive interpolation techniques, the best resolution we could get in time-interval measurements was one period of the clock; with a 10-MHz clock, we were stuck with resolution no better than 100 ns. Now, if the pulse train we’re looking at is not harmonically related to the clock frequency, we can use time-interval averaging to resolve intervals down to 100 ps. So we can measure the rise time, width and prop delay of super-speed logic.

Richard Anderson, Engineering Manager, Santa Clara Div., Hewlett-Packard.

Too many of us forget that high sensitivity can be bad. Unless we’re in a screen room, high sensitivity makes it too easy to measure noise — especially with a wideband counter. We forget that manufacturers tend to include a safety margin; if they promise 10 mV, they might give us 5 mV. So we often pay extra for extra sensitivity, then buy attenuators to throw it away. It’s like buying a fine Persian rug and a puppy.

Lee Smith, Engineering Manager, Test Equipment Products, Beckman.

We’ve been pushing higher count rates and more and more functions into our universal counter/timers. Times have changed. Today’s pressures are on price, not performance. We’ll see more single-function instruments with a few performance characteristics optimized to a price.

Arthur J. Winter, Chief Engineer, Instrument Systems Div., Dynasciences.



very carefully

While we speculate on the possibilities of synergistic instruments and ever-expanding instruments, and instruments that keep crashing through higher and higher frequency barriers, many counter manufacturers are beginning to pay attention to the needs of the nonelectronics industry, where frequencies of 100 kHz are very high.

We may be going back to the Model 554 Events Per Unit Time (EPUT) Meter. It gave five digits of columnar readout and a frequency range of 20 Hz to 100 kHz when it was offered for \$775 by Berkeley Scientific in 1950. That was two years before the company became the Berkeley Div. of Beckman Instruments and 16 years before the Berkeley name disappeared into what is now the Electronic Instruments Div. of Beckman Instruments.

While most industrial applications don't need, and don't want, large bandpass or high sensitivity, there are some tough requirements. Users want high immunity to noise, and they want extreme levels of reliability, even in noisy and dirty

environments. If a counter quits, it can shut down a production line for an hour, and that can easily cost \$6000 or so.

Meanwhile electronics users in the computer field or communications, or those who work with fast semiconductors, still need sophisticated, fast counters. So we still have to study specs carefully, including some specifications that don't appear on data sheets.

We have to see that input circuits don't have sensitivity holes or hot spots across the frequency range. We have to see if headlined sensitivity and bandwidth apply to only one channel. We have to see if cited frequency coverage applies also to totalize and accumulate functions. We have to determine how long it takes the time-base drift to catch up with our last digit, if we want to compare today's measurements with those we took a month ago.

We have to see that trigger errors don't dominate our counts and that time-base stability is commensurate with the number of digits we buy. Finally, we have to make certain our instruments can be repaired easily.

Signal Sources: Signal generators are being challenged by expensive synthesizers as well as inexpensive function generators

Almost any waveform we'd like, we can get from the function generator. But the shape may not be as good as we'd like. At relatively low cost, the function generator can provide sine, square and triangle waves; variations on these; amplitude and frequency modulation; sweep; and voltage and digital control of frequency, amplitude and function.

The function generator is an extremely versatile instrument. But if we need really clean sine waves, we do far better with a Wien Bridge oscillator. If we need clean, fast-rise square waves, we do better with a good pulse generator. If we need higher than 10 MHz, we have to wait till the function-generator manufacturers move up again. In their 10-year history, function generators have scored enormous improvements in performance and flexibility—many, but not all, from Wavetek.

We've seen top frequencies move from 10 kHz

to 10 MHz, and sine-wave distortion levels move to better than 0.5%. We haven't seen comparable advances in conventional sine-wave oscillators, which have enjoyed distortion levels in the 0.01% range. Instead, we see performance leaps and price declines in synthesizers—instruments that create all their frequencies by mathematical manipulation from a single reference frequency.

At the top, the synthesizer

Synthesizers offer the highest stability, the highest accuracy and the best setability available in an adjustable signal source. They permit very rapid switching from one frequency to another, and they lend themselves beautifully to digital control. They suffer two drawbacks: They're expensive, running into thousands of dollars, and unless great care is taken, they have garbage in the outputs.



Engineers will have to look again at the function generator. Its spectral purity has begun to approach that of limited-purpose oscillators while its flexibility and frequency range continue to expand.

William Zongker, Vice President Marketing, Wavetek.



While most function-generator manufacturers have been in a bandwidth race, pausing for breath at 10 MHz, some of the generators offer poor performance. Some 10-MHz square waves look more like sine waves. Rise and fall times can be so long that they occupy most of the period. Glitches on sine-wave peaks (due to reversal in the triangles from which the sinusoids are derived) can cause ringing in circuits under test. And waveshapes at very low voltage levels can look dreadful.

Ernie Lutfy, Sales Manager, Krohn-Hite.



Function-generator performance is certainly improving, but we can still trip over specs. We still have to watch for distortion specs, for example, that are expressed as a percent of range rather than percent of setting. We still must watch for asymmetry when we want symmetrical waveforms, and for aberrations at triangle peaks giving sine-wave distortion.

Jerry F. Foster, Vice President Marketing, Exact Electronics.

Though function generators keep getting better, it's wise for a user to check a few features. Some instruments, for example, have limited dynamic range; they may not deliver full output or undistorted output over the entire frequency range, especially if we use voltage offset. We have to check, too, to see that the output is short proof. Also, in some applications it's essential that the output be grounded (without damage, of course) during range changes.

Ron Hill, Senior Project Engineer, Instrumentation Div., Microdot.

The best we can get today offer spurious content 100 dB down from the signal we select. Synthesizer manufacturers are working to make their signals even more pure for those few applications where money is no object. They're also cutting back on specs to compete with top-of-the-line signal generators.

Signal generators themselves are simply holding their own. Pressed from below by low-cost function generators (whose performance is improving) and from above by high-speed, easy-to-program synthesizers (whose prices are coming down), signal generators seem to have no place to go.

And yet, they've undergone some changes. One of the more interesting came in late 1968 when LogiMetrics introduced a line, the 900 series, with a built-in counter. This lessened the pressure toward higher and higher stability, since a user could instantly observe any frequency drift. Further, it made the generator more like a synthesizer, in that it was possible to set frequency exactly, without dependence on a crudely calibrated dial. Other manufacturers may soon adopt the LogiMetrics idea.

Pulse-generator manufacturers are delivering some outstanding performance. In rep rate, E-H Research (with 500 MHz) and Datapulse (with 250 MHz) lead the field, with HP not far behind at 125 MHz.

All vendors can offer impressively clean pulses, very fast transition times and, in many models, variable transition times. In addition there are special features like offsets, delays and programming of just about everything. And while they work towards faster rep rates, shorter rise and fall times and even greater control of their

As we develop new variations on the pulse generator, we'll need new specs. For example, a digital signal source provides variable-pattern pulse trains and synchronized clock signals. Here we'll need specs to show the effect of pattern changes in our train on the data in an adjacent channel.

J. B. Connolly, Tau-Tron.



Nobody could have imagined a few years ago that we'd have 500-MHz pulse generators today. Yet I'm sure we'll see gigahertz pulsers in the future. Meanwhile lots of people want much lower rep rates, without all the bells and whistles and without all the bucks.

Richard Aston, Vice President, E-H Research.

pulses, manufacturers are also cutting out some of the finer features and going back to lower rep rates to cut cost.

Sweeper progress starts at microwave

The sweep generator, a special case of the signal generator or oscillator, is one of the few instruments that began its advances in performance in the microwave region. That's because microwave engineers needed good sweeps far more desperately than anybody else did since there can be so many blind spots in the curve of any microwave device (from a length of transmission line to a receiver) due to stray Ls and Cs. Features like start-stop (in contrast with delta-f) started in microwave sweepers.

The conventional oscillator and signal generator are losing ground at both ends. They're losing at the bottom to low-cost function generators. At the high end they're losing to synthesizers, whose prices are coming down while their spectral purity is improving. The accelerating trend towards programmable instrumentation forces greater attention to the synthesizer's high stability and high switching speed.

William Parzybok, Product Manager, Signal Sources, Loveland Div., Hewlett-Packard.

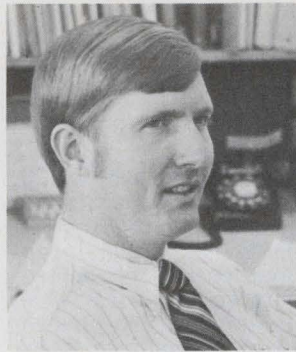

We've begun to see specialized pulse generators in different forms. Whatever form they take we still have to see that pulse shapes are suitable — they're often not very "pulsey" at very high frequencies — and that output levels are adequate.

Richard Cochran, Product Manager, Pulse Generators, Colorado Springs Div., Hewlett-Packard.

We'll see more truly programmable pulse generators; manual control will be the extra-cost option. But we'll have to get some standardization on the meaning of programmable. If you ask 10 engineers what the word means, you'll probably get 10 answers.

Howard W. Mette, Marketing Manager, Datapulse Div., Systron-Donner.

The big move in sweepers, most of it in the last two or three years, has been toward solid-state devices—YIG oscillators, microwave transistors, bulk-effect devices—all aimed at pushing the backward-wave oscillator out of the picture. The move has succeeded. We don't find many BWOs in the new sweepers for frequencies this side of X band, unless we need the higher output (100 mW) they can furnish. Fortunately the 10 mW we can get from solid-state sweepers is adequate for most applications, and we're likely to see more as better devices are made.

Like other instruments, the sweeper and its more pure but less versatile brother, the signal generator, are moving in two directions—to still better performance and to still lower price. ■■



If you use a synthesizer as a local oscillator for a transmitter, low spurious becomes even more important than it is in lab or production environments. You pay lots of dollars for every kilowatt you transmit; so you don't want to transmit spurious energy.

Paul Biehl, Product Manager, Time and Frequency Instrumentation, Fluke.



Thanks to more sensitive detectors, high power output is becoming less important for sweep oscillators. So solid-state sweepers are growing more and more important right through X band. Sweepers still don't give us the nicely located, clean signals we can get from a signal generator. Nor do they provide such well-defined output levels. If we wanted to combine some of the best features of sweeper and signal generator, we probably could — by liberal application of dollars.

Roderick Carlson, Manager, Signal Analyzer and Generator Lab, Microwave Div., Hewlett-Packard.

Never before so much Function Generator for \$495!

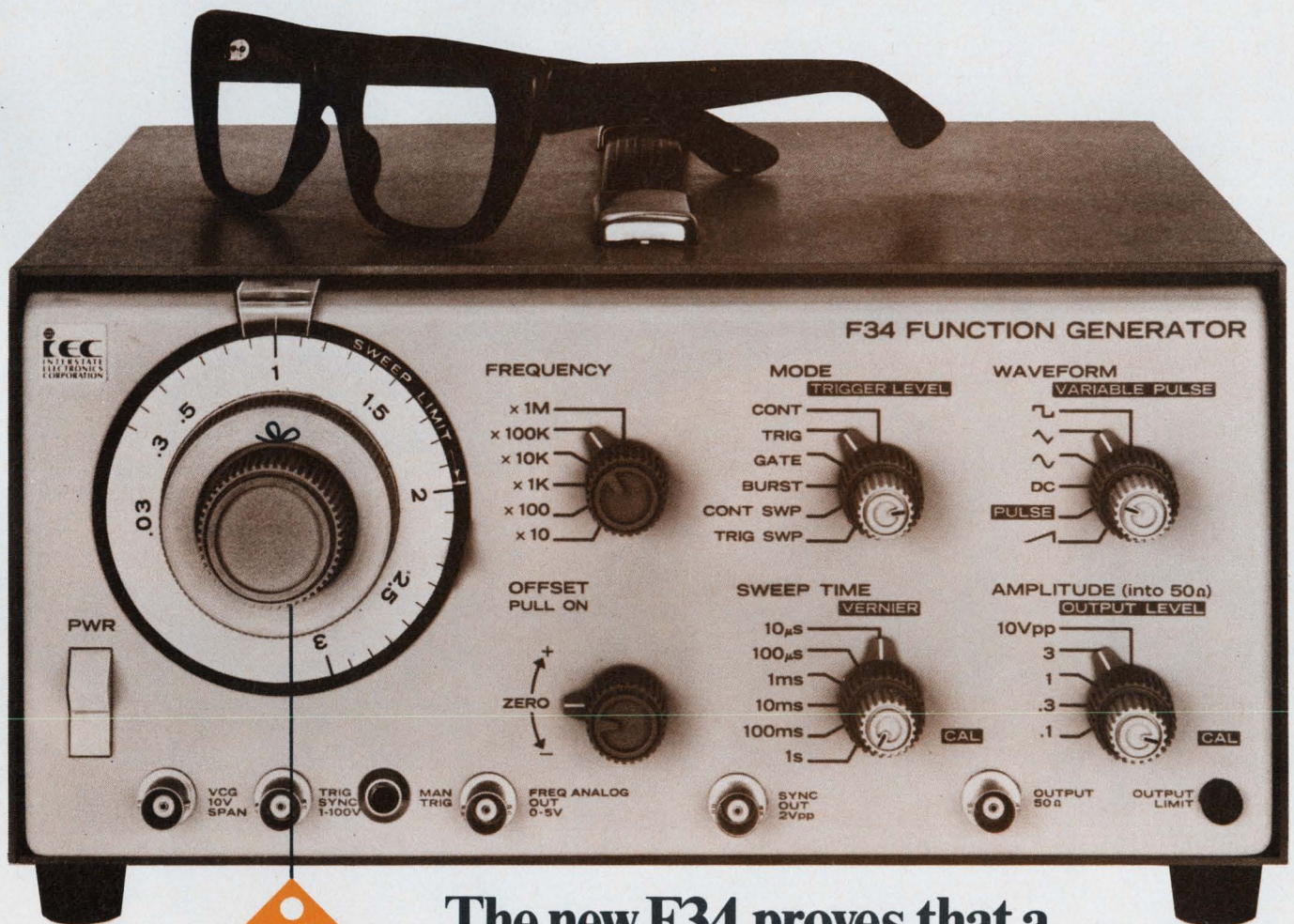

**INTERSTATE
ELECTRONICS
CORPORATION**
 A Subsidiary Of A-T-O Inc.
 Dept. 7000, Box 3117
 Anaheim, Calif. 92803
 (714) 772-2811,
 TWX 714-776-0280
 Telex Nos.
 655443, 655419

The new F34 proves that a Function Generator doesn't have to be expensive to be great!

Read the panel! The Output Limit indicator Light — unique! It guarantees you an unclipped waveform. The Sweep Width control — foolproof and calibrated. Frequency analog output, variable width pulse and manual trigger — they're all there and more. See for yourself! For details on IEC's complete Function Generator line, contact John Norburg today.

The new SERIES 30 includes 3 other models costing even less, starting at just \$295!

INFORMATION RETRIEVAL NUMBER 37



SAMPLE RATE

RESET

10.0000

HEWLETT · PACKARD

5300A MEASURING SYSTEM

SENSITIVITY

TIME BASE

FUNCTION

SENSITIVITY

PERIOD / T.I.

FREQ

PERIOD B

50 MHz

.1 μs

1 μs

10 μs

.1 ms

1 ms

AUTO

A

B

T A TO B

MVG B

CHECK

OPEN / CLOSE B

5302A 50 MHz UNIVERSAL COUNTER

Introducing the little counter that can.

It can become four different systems.

It can go anywhere you do.

It can protect you against obsolescence.

It can make buying and maintaining a counter less expensive than ever before.

Meet the Hewlett-Packard 5300, the snap-together counter that's not much bigger than the palm of your hand. It has six digit accuracy, solid state display and autoranging. It'll make period, frequency, time interval and ratio measurements, operate on its own snap-on battery pack and drive a printer. Prices start at only \$520.

If everything sounds too good to be true, we'll tell you how we did it: snap-together construction that lets you choose the module that makes the counter you want and also avoid obsolescence. Plus the most advanced LSI circuitry ever used in a counter. That means you get a compact instrument with high reliability, performance and versatility at a cost lower than ever before.

To make the counter you need, take the \$395 mainframe and add any of the following 4 modules (more are on the way). They lock right onto the mainframe in an instant.

- 10 MHz frequency module. Direct frequency counting to greater than 10 MHz. Model 5301A, just \$125.

- 50 MHz all-purpose module with period average, time interval,

and ratio functions. Model 5302A, \$250.

- 500 MHz frequency module, both 50 Ω and 1 M Ω impedances. DC to 500 MHz. Model 5303A, only \$750!

- Time interval module with features you'd expect to pay twice as much for: 100 ns resolution; attenuators and slope and trigger level controls on both channels; counting to better than 10 MHz; period averaging. A unique "time interval holdoff" feature lets you ignore electrical pulses between the events you want to measure. Model 5304A, \$300.

You ought to be able to take a counter as small and useful as the 5300 anywhere. And you can. All you have to do is snap on the battery pack (Model 5310A, \$175) for 4 to 8 hours worth of cord-free operation. The pack fits between the mainframe and any module. The system's rugged dust-proof aluminum case resists almost any of the bumps it might get in the field.

The 5300 is one system you have to use to appreciate; there is simply no other way. To get you started we'd like to send you more information on this amazing instrument. Just call your nearby HP field representative or write to Hewlett-Packard, Palo Alto, California 94304; Europe: 1217 Meyrin-Geneva, Switzerland.



HEWLETT  PACKARD

ELECTRONIC COUNTERS

INFORMATION RETRIEVAL NUMBER 38

02104

Microstrip amplifiers can be simple

to design, easy to build and inexpensive, to boot. Here's a low-noise S-band example with almost an octave of bandwidth.

One of the easiest and most economical ways to build a microwave amplifier is to do it in microstrip, using the common-emitter configuration and a quarter-wave transformer as an impedance-matching network. For applications below C-band, the amplifier is not only easy to construct, it is also much less sensitive to parameter variations than amplifiers that use open or shorted-stub matching techniques.^{1,2,3}

Although the design does not provide the ultimate in gain for a given transistor, it has a low noise figure, a broad bandwidth and excellent stability.

Two-stage amplifier needs no isolation

The basic design (Fig. 1) centers on a quarter-wave input matching network built on an alumina substrate. Monolithic chip resistors and capacitors are used for both the rf and dc circuitry.

Note that no isolation has been employed between the transistors (Fig. 1b). Feedback and stray radiation did not appear to be critical problems for the two-stage microwave amplifier. However, a similar amplifier with three stages did require a metal partition between adjacent transistor stages to eliminate instabilities caused by stray radiation. The three-stage amplifier also required a decoupling resistor between the base of each transistor and the dc bias network to reduce the effects of feedback.

Designing the input matching network

Both the noise figure and the gain are extremely sensitive to changes in the impedance match at the input. For maximum gain, a perfect conjugate match is necessary; best noise performance generally is obtained with an imperfect match.⁴ The input network, therefore, will of necessity reflect a tradeoff between maximizing

the gain and minimizing the noise figure.

The quarter-wave transmission line impedance-matching network provides a simple way to get a flat gain response over octave bandwidths. If the line is properly matched at the upper end of the passband, then the increasingly poor match that arises as the frequency is lowered is compensated for by the increasing gain of the transistor. Further, the increasing mismatch seems to help keep the noise figure low across the entire frequency band.

If the transistor has an input impedance Z_o , and it must be matched to a source impedance Z_i , then the quarter-wave matching line should have an impedance, Z_m , given by $Z_m = (Z_i Z_o)^{1/2}$.

Once the quarter-wave transmission line has been fabricated, some additional cut-and-try time will be required. Propagation along microstrip is not purely in the transverse electro-magnetic mode, and an exact analysis of this particular type of propagation is difficult.

Improper grounding can cause instability

When working with low-frequency silicon transistors, you can usually ignore the problem of dc stability because of the devices' extremely low leakage currents. However, microwave transistors can have leakage currents in the vicinity of $0.5 \mu\text{A}$ at 25°C , and so, if they are expected to operate above 50°C , the dc stability factor should be considered.

Ac stability can be calculated with a variety of mathematical approaches.^{5,6} However, these usually require a more accurate knowledge of the transistor's parameters than is ordinarily available. Therefore, as a matter of practice, ac stability is often determined experimentally.

When the analytical approaches are used, the result is usually a Smith chart, on which the ranges of source and load impedance that permit stable operation are indicated.^{7,8}

Probably the most important thing to remember is that even the most carefully calculated stability analysis will prove meaningless unless a proper rf ground is provided for the amplifier substrate and the transistor emitter. Any im-

George D. O'Clock Jr., Senior Member, Engineering Staff, RCA Advanced Technology Labs., 8500 Balboa Blvd., MD44, Van Nuys, Calif. 91409.

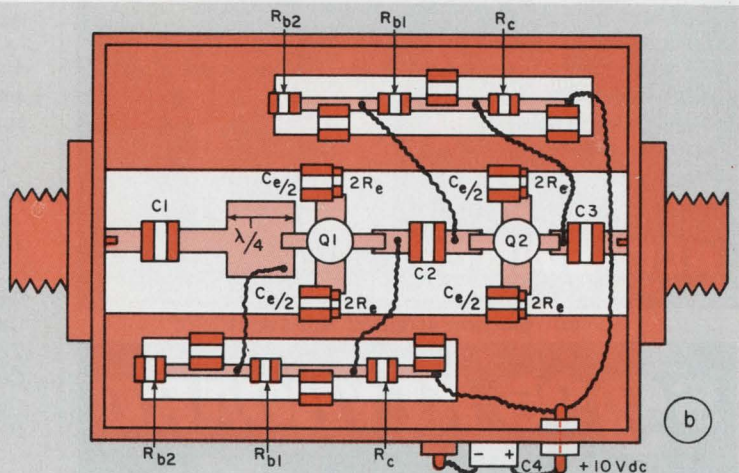
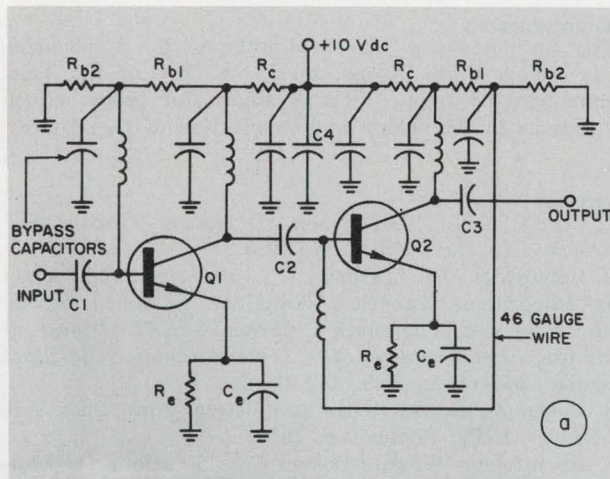

1. **Stability, wide bandwidth and ease of fabrication** are the outstanding features of this microstrip microwave amplifier design. The rf-choke inductances in the sche-

matic (a) are realized by the wire leads in the actual amplifier (b). The transistors each have two parallel emitter leads to reduce their emitter-to-ground inductance.

proper grounding will produce fluctuations in the output power level and, in most cases, will cause severe oscillations.

It's an exceptionally stable design

To evaluate this design approach, several two and three-stage microwave amplifiers were built and tested. All of the units performed extremely well over the temperature range of -20°F to $+160^{\circ}\text{F}$ (see Table for data on the performance of the two-stage amplifiers).

Stability was maintained under source and load impedance variations for all of the amplifiers tested. The amplifiers did not appear to oscillate under extreme mismatch conditions for either source or load. In fact, they remained stable even when the source and/or load were unterminated.

The frequency response (Fig. 2) is primarily limited by the gain-bandwidth product (f_t) of the transistor and the quality of the chip capacitor elements. In this case, Nippon Electric (NEC) 2N5761 transistors were used ($f_t = 3.7$ GHz to 4.5 GHz) along with American Technical Ceramic porcelain chip capacitor elements. The frequency response of the amplifier indicates an f_t of approximately 3.5 GHz for each transistor stage. Therefore the frequency-response degradation caused by the capacitor chips appears to be minimal.

The frequency response curve shows a gain of approximately 15 dB in the 1.5-to-2.75 GHz frequency range. The lower portion of the curve, not shown, lies between 450 and 900 MHz. In

Table. Performance data at 2.1 GHz

	0°F	75°F	120°F
Amplifier gain (dB)	14.9	15.0	14.6
Noise figure (dB)	4.6	4.7	5.0
VSWR (Input)	1.3	1.3	1.3
Current drain (mA)	7.0	8.7	10.5
Gain variation vs. power supply variation at $12\text{V} \pm 1\text{V}$	— 1 dB/V —		

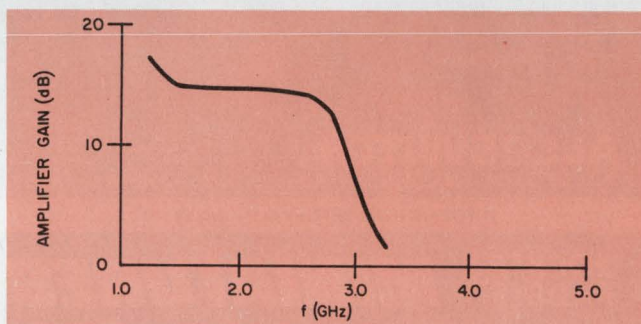

2. **The amplifier is essentially flat** from 1.5 GHz to about 2.75 GHz. Above the passband the gain drops, because the transistor's cut-off frequency is about 4.0 GHz.

this region the gain is approximately 28 dB.

It appears that the quarter-wave transformer levels out a portion of the frequency response of the first transistor stage, providing a flat response over a frequency range determined by the microstrip transmission line lengths. The low-frequency cut-off point is determined pri-

BIGGEST VALUE FOR A REED **KEYSWITCH**

Reed switch is actuated by a permanent magnet. Close tolerance is maintained in operating pressure so operating points are uniform. Optional keytops are similar to electric typewriters. Call, write or wire for production pricing. (Area 617) 686-3887.

RSM-41



ALCOSWITCH®

DIV. OF ALCO ELECTRONIC PRODUCTS, INC., LAWRENCE, MASS.

INFORMATION RETRIEVAL NUMBER 91

\$995 KEYBOARD

Economy priced! N.O. momentary action; rated 100 ma @ 24 VDC. Gold clad contacts, long operational life. Two models 0-9 and Decimal or 1-12 numeral keyboard. Two shot molded keytops. CR Series.

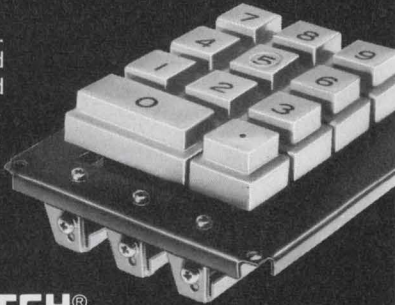

ALCOSWITCH®

DIV. OF ALCO ELECTRONIC PRODUCTS, INC., LAWRENCE, MASS.

INFORMATION RETRIEVAL NUMBER 92

SLIDE SWITCHES

Miniature series offers multiple circuit switching in limited P. C. space. Choice of upright mounting or right-angle mounting. Compact size for P. C. cards. Economically priced.

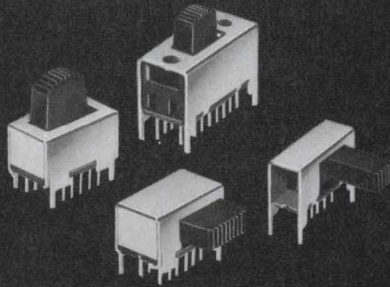

IDEAL SIZE FOR PRINTED CIRCUITS

ALCOSWITCH®

DIV. OF ALCO ELECTRONIC PRODUCTS, INC., LAWRENCE, MASS.

INFORMATION RETRIEVAL NUMBER 93

ROCKER & PADDLE MINIATURES

New series of economy "snap-in" switches have high 6 amps rating. Features ease of installation in .49 x .59" hole. Choice of SPDT & DPDT in 4 colors, adds distinction to front panel. Molded "silver" terminals & contacts.

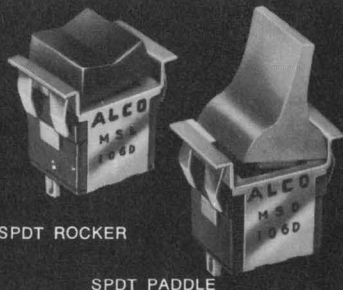

SPDT ROCKER

SPDT PADDLE

ALCOSWITCH®

DIV. OF ALCO ELECTRONIC PRODUCTS, INC., LAWRENCE, MASS.

INFORMATION RETRIEVAL NUMBER 94

marily by the grounding of the lower frequencies through the input transistor's base-bias circuit. ■■

Acknowledgments

The author would like to thank A. G. Stephenson, D. L. Adley, R. K. Asato and F. W. Yee of the Telecommunications Dept., TRW Systems, for their helpful suggestions in the design and fabrication of the device.

References

1. Cuccia, C. L., "Low Noise Microwave Transistors," *Microwave Journal*, February, 1968.
2. Gelnovatch, V. G., Chase, I. L. and Arell, T., "A 2-4 GHz Integrated Transistor Amplifier Designed by an Optimal Seeking Computer Program," *IEEE Digest of Technical Papers for the 1970 International Solid-State Circuits Conference*, Feb. 18, 1970.
3. Cushman, R. H., "GHz Amplifiers, Now They Are Practical," *EDN*, September, 1970.
4. Rheinfelder, W. A., "Design Considerations for Low-Noise Transistor Input Stages," *Electronic Design*, September 13, 1961, pp. 48-53.
5. Bakhtin, N. A. and Shurtz, N.Z., "Study of the Stability of Transistor Microwave Amplifiers by Means of Oriented Curves," *Radio Engineering and Electronic Physics*, USSR Academy of Sciences, July, 1969.
6. Besser, L., "Combine S Parameters with Time Sharing," *Electronic Design*, Aug. 1, 1968.
7. Bodway, G. E., "Two Port Power Flow Analysis Using Generalized Scattering Parameters," *Microwave Journal*, May, 1969.
8. Froehner, W. H., "Quick Amplifier Design with Scattering Parameters," *Electronics*, Oct. 16, 1967.

Bibliography

- Ayaki, K., Igarashi, E. and Kajiwara, Y., "A 4-GHz Multistage Transistor Amplifier," *IEEE Trans. On Microwave Theory and Techniques*, December, 1969.
- Baechtold, W. and Strutt, M. J. O., "Simplified Equivalent Circuit For The Noise-Figure Calculation of Microwave Transistors," *Electronic Letters*, May, 1968.
- Baechtold, W. and Strutt, M. J. O., "Noise In Microwave Transistors," *IEEE Transactions On Microwave Theory and Techniques*, September, 1968.
- Class, W., "Super Smooth Substrates," *Research Development*, March, 1971.
- Cook, H., "Microwave Transistors, Part 2: Small Signal Devices," *Microwaves*, February, 1970.
- Disman, R. I., "Low-Noise Transistor Amplifiers, A State-of-the-Art Report," Presented at Session 9 of *The 1970 Wescon*, August 25-28, 1970.
- EDN Editorial Staff, "Minicomponents Building Blocks For Hybrids," *EDN*, September, 1970.
- Feldman, N. E., "Syllabus On Low-Noise Microwave Devices," *The Microwave Journal*, July, 1969.
- Gelnovatch, V., "Design of Distributed Transistor Amplifiers At Microwave Frequencies," *The Microwave Journal*, January, 1967.
- Kamnitsis, C., "Broadband Matching of UHF Microstrip Amplifiers," *Microwaves*, April, 1969.
- Klein, C. F., "Designing with Microstrip is Easy," *Electronic Design*, Jan. 4, 1970.
- Letzter, S. and Webster, N., "Noise In Amplifiers," *IEEE Spectrum*, August, 1970.
- Moreno, T., *Microwave Transmission Design Data*, Dover, New York, 1948.
- Schilling, W., "The Real World of Micromin Substrates—Part 1," *Microwaves*, December, 1968.
- Tarowsky, N., "How to Assemble Hybrid Microwave ICs," *Microwaves*, August, 1969.
- Watson, H. A., *Microwave Semiconductor Devices and their Circuit Applications*, McGraw Hill, New York, 1969.
- Weinberg, L., "Fundamentals of Scattering Matrices," *Electro-Technology*, July, 1967.

Simplify sequential circuit designs

with programmable ROMs. You can often reduce the total IC package count by 90%.

Second of two articles

Asynchronous sequential circuits are often, and with reasonable accuracy, described as combinational circuits with feedback. When this description is coupled with the combinational logic capabilities of a programmable read-only memory (as described in the first article in this two-part series¹), it is easy to conceive of the possibility of feeding signals from the outputs of the memory back to its inputs to synthesize an asynchronous circuit.

In those cases where a synchronous logic circuit is required, the programmable ROM offers a method for storing the flip-flop programs that such circuits require.

Asynchronous circuits with programmable ROMs are designed in exactly the same way as standard asynchronous circuits except for the step in which a combinational logic network is specified. At that point the memory is program-

med to implement the required logic function. The result is that complicated asynchronous logic networks are synthesized in a simple, straightforward manner.

To see how this procedure works let's consider the design of the circuit of Fig. 1a. The circuit has two inputs—a clock oscillator (Signal C) and a control signal (Signal B). The control signal is a push-button switch that supplies a long-duration logic ONE to the circuit when it is pushed. When not pushed, it supplies a logic ZERO. Each time the control button is pushed the circuit is to pass one, and only one, clean clock pulse to the output (Z).

The design procedure is as follows:

Step 1. Translate the word statement of the problem into a **primitive state diagram** (Fig. 1b). This diagram contains eight numbered circles, each of which corresponds to a possible stable state of the circuit. The states of the inputs and the output and the arrows that connect them are described by a CB/Z notation. Thus the 01/0 label on the arrow that goes from State 1 to State 4 indicates that the control signal has gone high

William I. Fletcher and Alvin M. Despain,
Utah State University, Logan, Utah 84321.

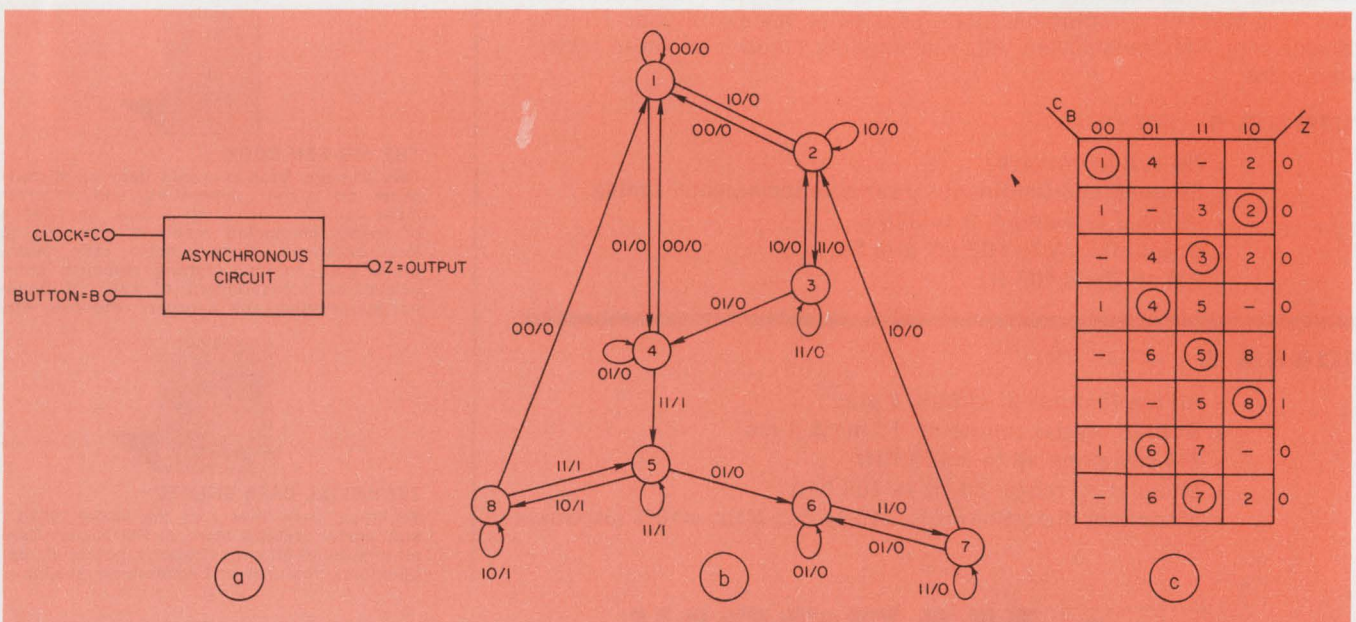

1. A single clean clock pulse passes from the clock input to the output of the asynchronous circuit (a) every time the button is pushed. This operation is de-

scribed by the primitive state diagram (b) which leads to the primitive flow table (c). The stable states are indicated by the circled numbers in the flow table.

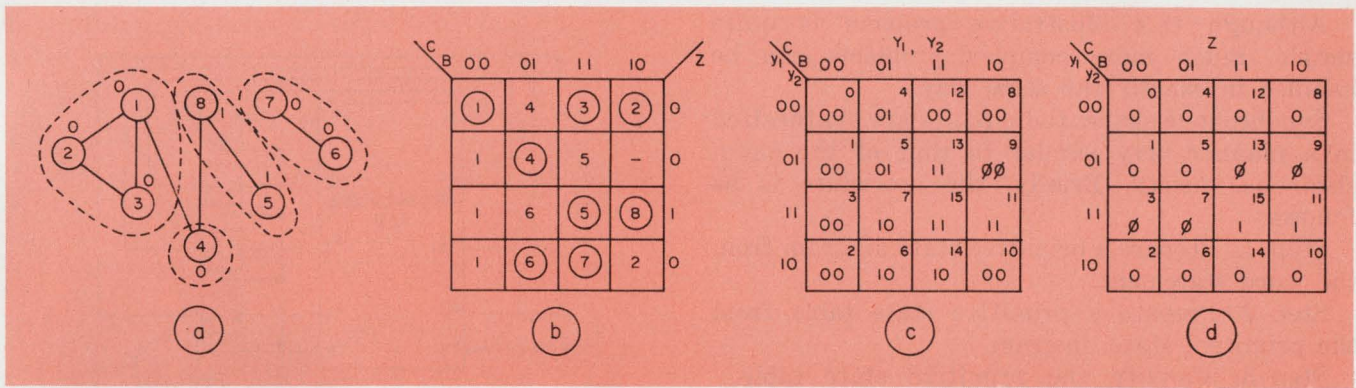

2. The merger diagram (a) simplifies the task of preparing the merged flow table (b) from the primitive flow table of Fig. 1c. The excitation map (c) defines the excitation

variables, Y_1 and Y_2 , in terms of the secondary and input variables. The output map (d) is prepared directly from the merged and primitive flow tables.

with the clock low, and no output is to occur.

Step 2. Construct a **primitive flow table** (Fig. 1c) from the primitive state diagram. The table is constructed by assigning one, and only one, row to each nonredundant stable state. The stable states are indicated by circled numbers.

Step 3. Prepare a **merger diagram** (Fig. 2a) from the primitive flow table of Step 2. This diagram represents each row of the table by its circled stable state, and all possible mergers as links. The final choice of merging is indicated by the dashed lines. (Merging is as much an art as a science. For an excellent discussion of it, the reader is urged to see pp 206-209 of the book by Marcus cited as Reference 2.

Step 4. Draw a **merged flow table** (Fig. 2b) by merging the rows of the primitive flow table with the aid of the merger diagram. All of the states enclosed by the same dashed line in the merger diagram are merged into the same row in the merged flow table.

Step 5. Make a **secondary state assignment**, for the binary encoding of each state, from the merged flow table. Care should be taken, in making the assignment, to avoid critical races. The most straightforward way to do this is to allow only one secondary variable to change for each state transition, if possible. Making a Grey-code assignment to each row of the merged flow table is an easy way to accomplish this.

When multiple transitions cannot be avoided, a "cycle" or "noncritical race" must be devised. Alternatively, additional secondary variables may be assigned.

Step 6. Prepare an **excitation map** (Fig. 2c) by redrawing the merged flow table with the stable states represented in the chosen binary code of the secondary variables y_1 and y_2 . The unstable states are represented by the code of the row to which the operating point will next transfer. In this way the excitation variables, Y_1 and Y_2 , are defined in terms of the secondary

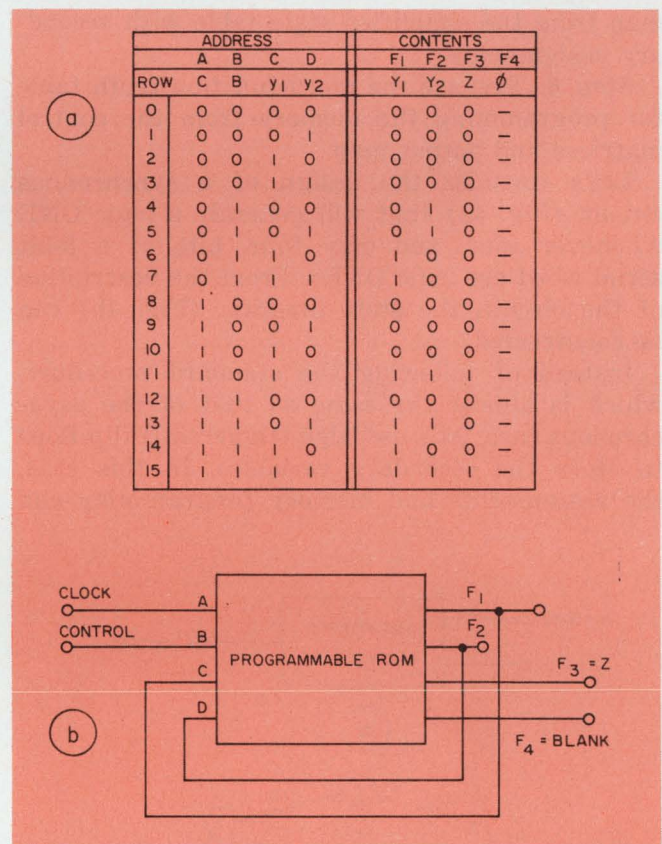

3. The memory is programmed from this multi-function truth table (a) which is a complete specification of the contents of the ROM. Note that the feedback connections around the memory (b) make $y_1 = Y_1$ and $y_2 = Y_2$.

variables, y_1 and y_2 , and the inputs C and B.

Step 7. Draw an **output map** (Fig. 2d) directly from the merged and primitive flow tables. The row assignments should be made such that each state produces the desired output.

Step 8. Construct a **multi-function truth table** (Fig. 3a) from the excitation and output maps. This table specifies the memory contents. It contains all of the information needed to program the ROM.

Although this illustrative problem is quite simple, much more complex problems can be handled in exactly the same way.

Synchronous sequential circuits are synthesized in a manner very similar to that of the asynchronous variety. Briefly, the procedure is as follows:

Step 1. Prepare a primitive state diagram from the word statement.

Step 2. Prepare a primitive state table from the primitive state diagram.

Step 3. Simplify the primitive state table.

Step 4. Prepare a simplified state table with secondary assignments and outputs. This step requires a partition approach to efficiently specify the secondary assignments.

Step 5. Using the specified flip-flop excitation table, prepare the control matrices and output map from the simplified state table with secondary assignments.

Step 6. Prepare the multi-function truth table for programming the memory from the control matrices and output map.

Let's consider the design of a synchronous circuit (Fig. 4a) that will generate a logic ONE whenever four, and only four, bits of a 5-bit serial word are logic ONES. From the description of the circuit, the state diagram (Fig. 4b) can be constructed.

Instead of following the standard procedure, which is almost the same as that of the asynchronous case, let's use edge-triggered D flip-flops to store the secondary variables. In this case, the assignments and memory programming can

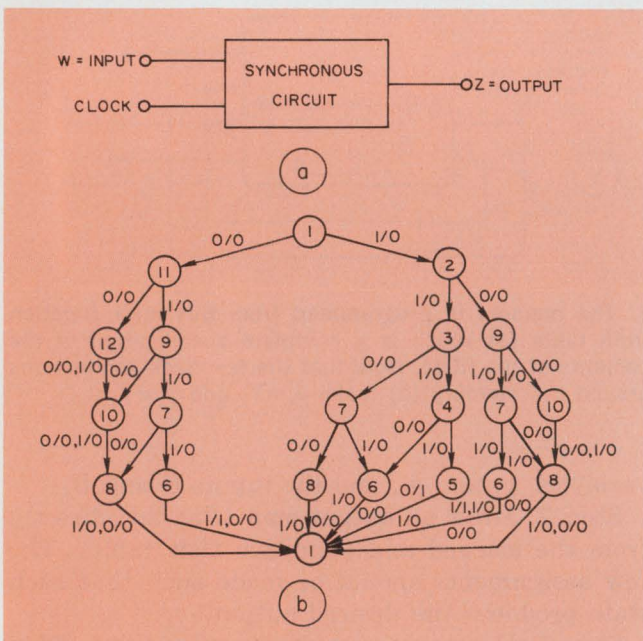

4. This synchronous circuit (a) is to produce a ONE output whenever four, and only four, bits of a 5-bit input serial word are ONES. The simplified primitive state diagram (b) is constructed from the verbal description of the circuit.

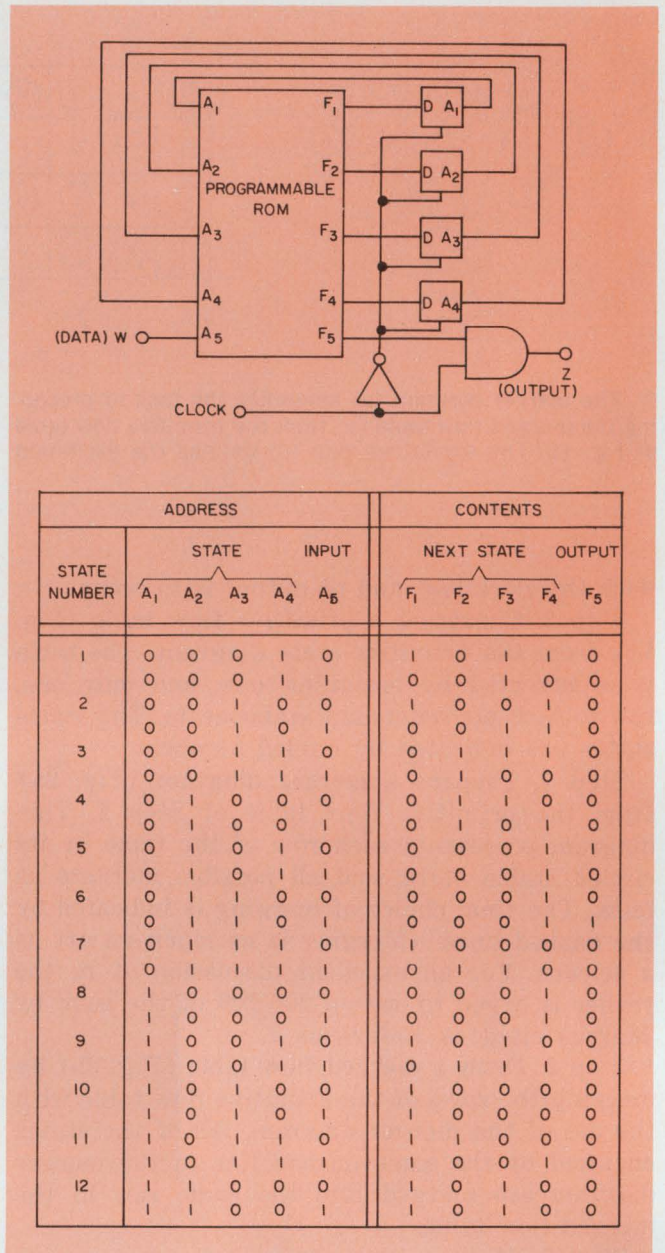

5. Four D flip-flops combine with a programmable ROM (top) to realize the circuit of Fig. 4a. The multi-function truth table (bottom) defines the contents of the memory.

be directly derived from the state diagram. Fig. 5a is a circuit realization of the synthesis problem and Fig. 5b defines the contents of the programmable ROM.

Note that in each address in the memory, the next state and output value are stored as derived directly from the state diagram (Fig. 4b). This technique may not use the programmable ROM as efficiently as the previously-presented method, but it is expedient. ■■

References

1. Fletcher, William I., and Despain, Alvin M., "Simplify Sequential Circuit Designs," *Electronic Design*, June 24, 1971, pp 72-73.
2. Marcus, M. P., *Switching Circuits for Engineers*, Prentice-Hall, Inc., Englewood Cliffs, N. J. 1967.

And now, from the ROM capital of the world...

...4096 and 3072 bits.

With seven ROMs, we were already on top in the read-only-memory market.

Our two newest ROMs will keep us on top for a long time to come.

Each is worthy of special note.

The MM4232/MM5232 is a 4096 bit static ROM organized in either a 512 word x 8 bit or 1024 word x 4 bit configuration controlled by a mode control input. With an access time of 1 microsecond. It features two mask programmable chip enable lines (CE₁ and CE₂), a clever innovation which provides logic control up to 16K bits *without external logic*.

Our other new ROM is the MM4241/MM5241 Vertical Scan Character Generator. A 3072 bit static read-only-memory organized in a 64 x 6 x 8 format with an access time of 750nS. The MM4241AAN/MM5241AAN is a standard 5 x 7 font available off-the-shelf.

Both of our newest ROMs use standard supplies (+5, -12V) and are bipolar compatible at the inputs and outputs. In addition, both have been designed with Tri-State™ logic outputs. (Another innovation, and one which gives you wire OR'd capability without loading common

data lines or reducing the 750nS access time.)

Finally, both the MM4232/MM5232 and MM4241/MM5241 are mask programmable. Thereby allowing you to submit your own programs for processing in a paper tape or punched card format.

That's a look at our two newest ROMs. For more details on them, our other seven read-only-memories, our line of standard code converters and look-up tables, or a handsome picture postcard of the ROM capital of the world, contact us today.

National Semiconductor Corporation,
2900 Semiconductor Drive, Santa Clara,
California 95051. Phone (408) 732-5000.
TWX: (910) 339-9240. Cable: NATSEMICON.

Note: MM42xx refers to -55°C to +125°C temperature range devices; MM52xx to -25°C to +70°C



National

INFORMATION RETRIEVAL NUMBER 44

SSB-FM: When should you use it?

Unlike single-sideband AM, it not only eliminates one set of sidebands; it alters the set that remains.

Single-sideband techniques are used widely in AM communications systems to conserve both power and bandwidth. It seems logical, therefore, to ask whether they can be used to similar advantage in FM systems. The answer, we shall see, is that SSB-FM does provide bandwidth savings, but it becomes very wasteful of power when the modulation index is large.

By considering the block diagrams for an SSB-FM generator and detector (Fig. 1), we can see that the large dynamic ranges required for the exponentiator in the generator and the logarithmic amplifier in the detector are practical limitations in the design of these systems.

Compare SSB-FM with DSB-FM

Mathematically the SSB-FM signal is given by $e_{ssb}(t) = \exp(-\beta \cos \omega_m t) \cos(\omega_c t + \sin \omega_m t)$. (1)

By taking the real part of the complex analytic signal (see box on Hilbert transforms), this may be shown to be equivalent to

Irwin Feerst, Consultant, 368 Euclid Ave., Massapequa Park, N. Y. 11762.

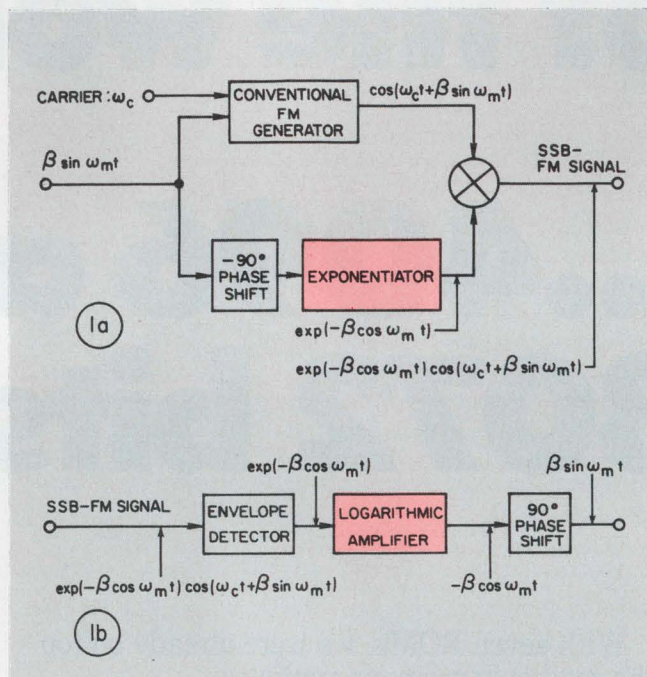

1. High-modulation indexes are difficult to obtain in SSB-FM because they require that the exponentiator in the generator (a) and the logarithmic amplifier in the detector (b) have very large dynamic ranges. For $\beta=2$, for example, the required dynamic range is 34 dB.

The mathematics: Hilbert transforms and analytic signals

An understanding of the spectral components of a single-sideband, frequency-modulated (SSB-FM) signal requires a rudimentary knowledge of Hilbert transforms and analytic signals.

In the frequency domain, the Hilbert transform of a signal is obtained by a simple 90° phase shift, as given below:

$$F_h(\omega) = \begin{cases} -jF(\omega) & \omega > 0 \\ +jF(\omega) & \omega < 0 \end{cases}$$

For the case in which the original signal is $\sin \omega_m t$, its Hilbert transform is $-\cos \omega_m t$.

The corresponding time relation between the function and its Hilbert transform is therefore one of convolution of $f(t)$ with $1/\pi t$ —

$$f_h(t) = f(t) * 1/\pi t$$

An analytic signal is a complex function

whose imaginary part is the Hilbert transform of its real part. A characteristic of all analytic signals, one that is of fundamental importance in the analysis of any single-sideband system, is that its frequency spectrum (Fourier transform) is zero for negative frequencies. Therefore an analytic signal always exhibits the desired single-sideband property.

The concept of an analytic signal makes it possible to handle an otherwise formidable expression by using the simpler complex exponential notation. The desired signal is taken to be the real part of the complex signal. This technique is analogous to one that is quite familiar to electrical engineers, in which a desired voltage is equal to the real part of a complex phasor.

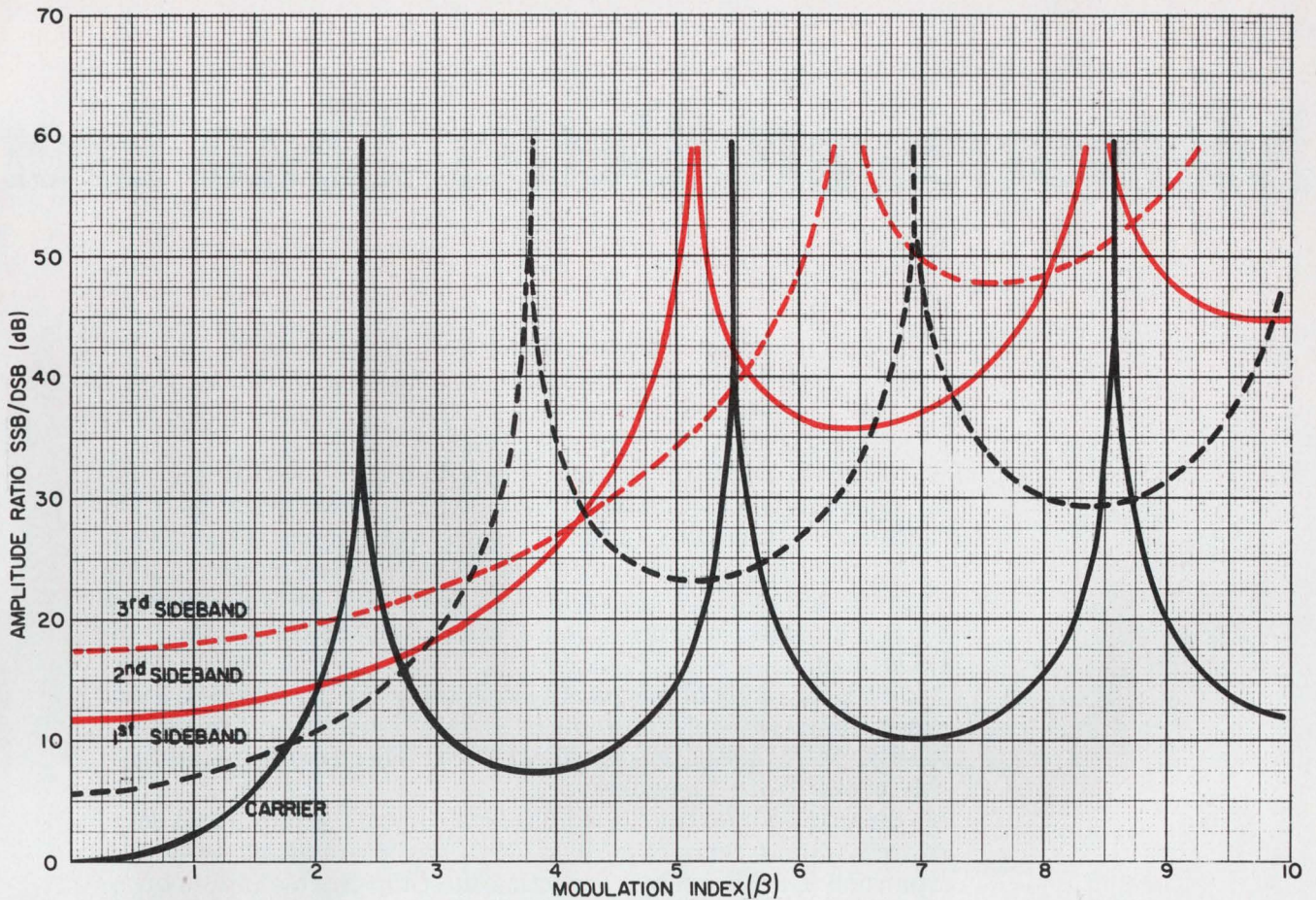

2. SSB-FM uses more power than DSB-FM. Just how much more is shown on this plot of the ratio of the amplitudes of corresponding sidebands as a function of

the modulation index. The points at which the ratio goes infinity are the values of β at which the amplitude of the conventional DSB sidebands are zero.

$$e_{\text{ssb}}(t) = \sum_{n=0}^{\infty} (\beta^n/n!) \cos(\omega_c + n\omega_m)t. \quad (2)$$

The corresponding expressions for a conventional double sideband FM (DSB-FM) signal are:

$$e_{\text{dsb}}(t) = \cos(\omega_c t + \beta \sin \omega_m t) \quad (3)$$

and

$$e_{\text{dsb}}(t) = \sum_{n=-\infty}^{+\infty} J_n(\beta) \cos(\omega_c + n\omega_m)t, \quad (4)$$

where $J_n(\beta)$ is the usual Bessel function of the first kind of order n and argument β . These are well tabulated.

Examination of these equations discloses four important properties of SSB-FM signals:

1. As is indicated by Eq. 1, the so-called SSB-FM signal has an amplitude-modulation term, $\exp(-\beta \cos \omega_m t)$. Therefore, it is not, strictly speaking, an FM signal at all.

2. A comparison of Eqs. 2 and 4 shows that the SSB-FM signal is not one in which those frequency components below the carrier have been eliminated while those above the carrier remain unchanged (as is the case with SSB-AM). The process of single-sideband frequency modu-

lation, while eliminating those frequency components below the carrier, also alters those components that remain (the carrier and the upper sidebands) from what they were in conventional DSB-FM.

3. As shown in Eq. 4, it is possible in conventional DSB-FM for some frequency components to be equal to zero for certain values of β . For example, the amplitude of the first sideband, $J_1(\beta)$ is zero for $\beta = 3.83, 7.02, 10.17$, etc. This is not the case for SSB-FM, as is made clear by Eq. 2.

4. Any upper sideband component of an SSB-FM signal is always at least 6n dB larger than its conventional DSB-FM counterpart, where n is the sideband number. This is made clear by Fig. 2, in which the ratio of the SSB-FM to DSB-FM signal is plotted as a function of β .

As the graph indicates, SSB-FM signals become very wasteful of power for modulation indexes much above $\beta=2$. Thus the technique is primarily of value for narrowband applications, such as telemetry, where bandwidth conservation is important and a high modulation index is not necessary. ■■

Memories are Better Than Ever..

Yes, memories are better than ever — the MCM4064L MTTL 64-Bit RAM proves it! Organized as a 16-word by 4-bit array, the MCM4064L features an access time of less than 60 ns, all for 50% less than what you have been paying.

Address decoding is incorporated on chip providing 1-of-16 decoding from four address lines. Separate Data In and Data Out lines, together with a Chip Enable, provide for easy expansion of Memory capacity. A Write Enable is provided to enable data presented at the Data In lines to be entered at the addressed storage cells. When writing, Data Out is the complement of Data In.

Let's take a look at a typical system using the MCM4064L as a main frame store of 128-words by 16-bits. Total devices involved are 32 MCM4064L RAMs, 9 MC7404P Hex Inverters, and 1 MC4006P 1-of-8 Decoder.

To directly address the 128 words of memory would require seven address inputs. Since the MCM4064L has four address inputs, expansion is achieved by connecting the Chip Enable inputs of each device in a row, treating the system as an 8 row by 4 column array, and driving the 8 row lines with a 1-of-8 decoder (MC4006P).

Address lines A0 thru A3 are brought to all memory devices in the system via address drivers using a TTL fanout of 8. Each inverter/driver represents four, one for each bit A0 thru A3; thus sixteen inverters are required. The same scheme is used for the data input and output buffers. The four address bits A0 thru A3 are common to each memory and are used to address the corresponding word in each MCM4064L.

The output bit lines in each column are wire-ORed because the devices chosen by the Chip Enable signal are dominant. Lines B1 thru B4 in the leftmost column are brought out to four inverter/buffers as are the four data lines in the other three columns.

Other organizations can be used but in wire-ORing MCM4064L outputs, eight was chosen as an optimum trade-off between decreasing decoding time versus increasing access time due to capacitance. The system provides a total access time of less than 100 ns typical and interestingly, a typical cycle time of less than 85 ns.

Data is written into the memory by selecting one memory device in each row with the Chip Enable as was done for the read operation.

. at **MOTOROLA**

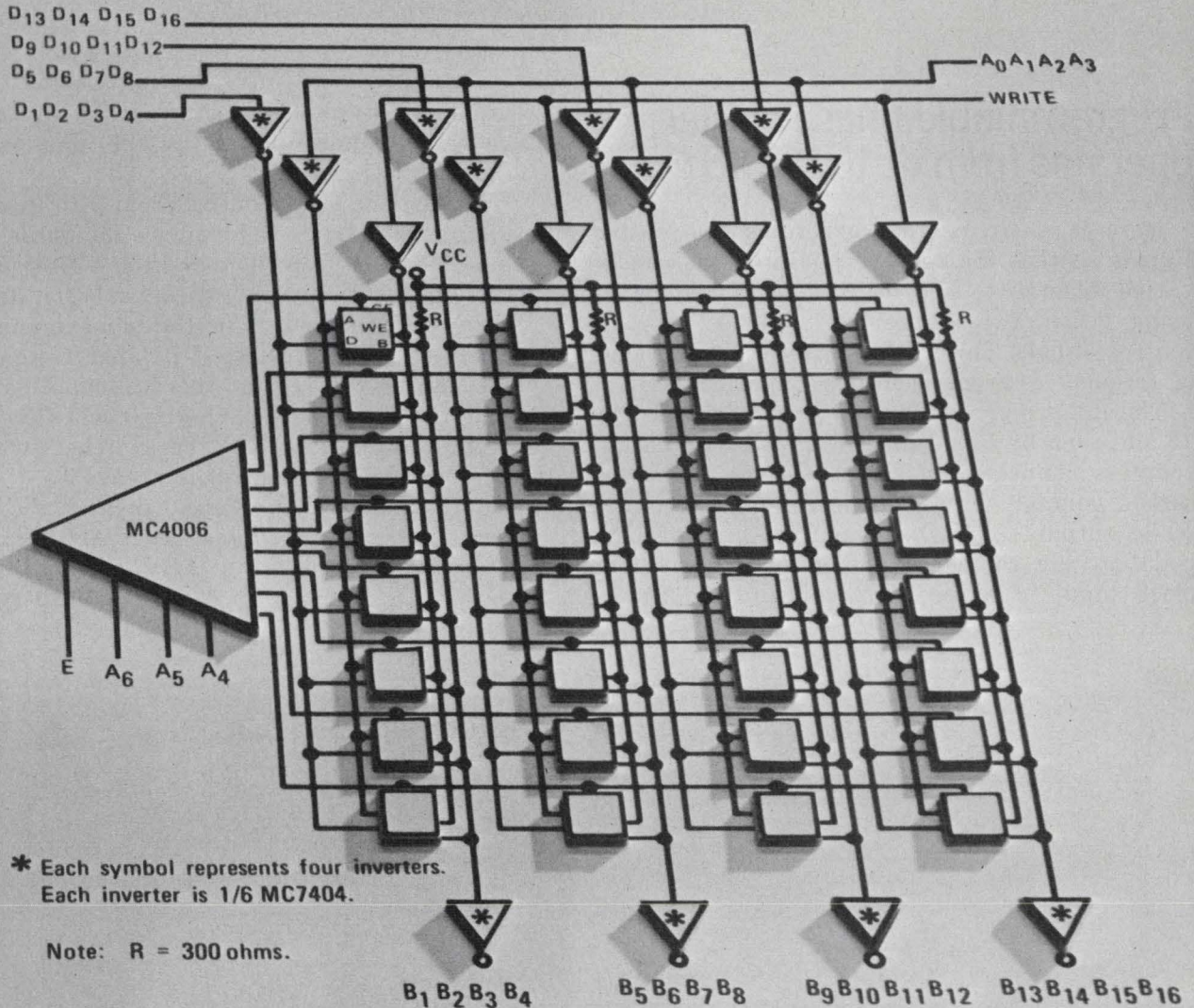

128-WORD BY 16-BIT HIGH SPEED BUFFER MEMORY

This application demonstrates the versatility of the MCM4064L. Write for complete specifications to Motorola Semiconductor Products, Inc., P.O. Box 20912, Phoenix, Arizona 85036. We'll include another application describing a 512-word by 8-bit memory.

And to prove that speed isn't costly, the MCM4064L is now available at a 100-up price of \$11.55. Evaluate now and you'll see that Memories are better than ever ... at Motorola.



MOTOROLA MEMORIES

IC Systems for the 70's!

Programmable phase shifter operates from dc to 100 kHz

Here is a circuit that generates two output signals so that the relative phase of one can be varied from 0 to 360 degrees in 100 steps by using either two 10-position switches or logic control signals. This phase-shifter covers a range of frequencies from dc to more than 100 kHz.

The input signal frequency is first divided by 10 and then by 5 and then by 2 with two decade counters connected in series. Output A_2 of the second counter serves as the reference channel, while outputs A_1, B_1, C_1, D_1 , and B_2, C_2, D_2 of both counters are compared and gated to drive the clock input of a master-slave flip-flop. The Q

output of the flip-flop is then gated by an EXclusive-OR whose output is the phase-shifted signal.

Varying the units control from 0 to 9 and the tens control from 0 to 4 changes the phase of the signal channel from 0 to π in the first 50 settings of the switches. Phase variation from π to 2π is accomplished in the same manner by commuting the EXclusive-OR input from ZERO to ONE for the rest of the 50 switch settings. Logic control signals having the codes indicated by the table can replace the switches when remote or automatic control is needed.

S. K. Kan and D. Bloyet, Institut d'Electronique Fondamentale, Faculte des Sciences, (91) Orsay, France.

VOTE FOR 311

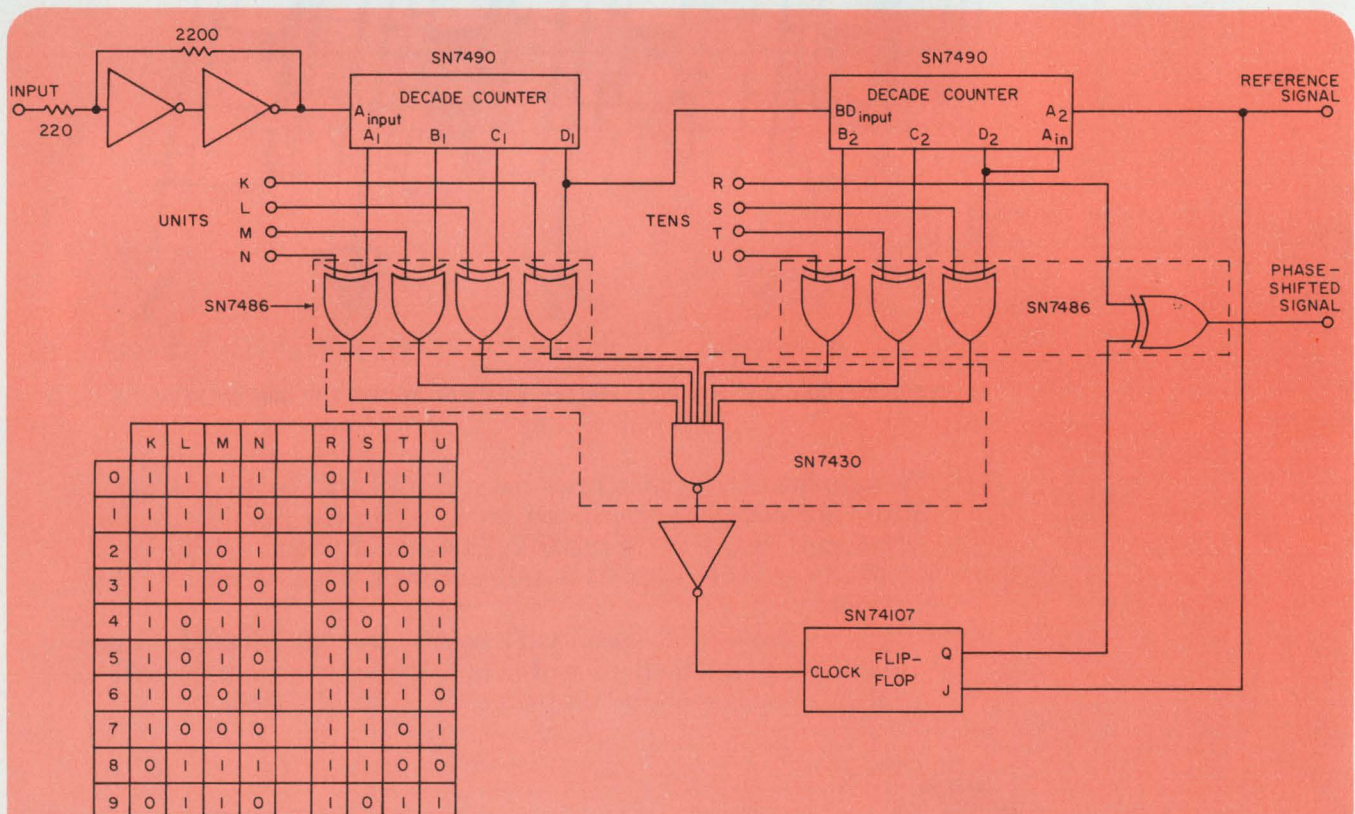

Employing decade counters and EXclusive-OR gates, a digital phase shifter provides full 360-degree phase

control. Either logic signals or two 10-position switches are used to program the circuit.

Expand your Measurement Horizon

with a Beckman Programmable Counter/Timer

136 MHz and "hands off"! These remarkable counter/timers have single-point programming, replacing *all* front-panel control settings. Plus, simultaneous remote sequencing back and forth between channels. In other words, all functions are programmable for maximum system compatibility...and you don't have to touch the dials.

Both instruments offer the complete range of universal counter/timer functions—including "Burst Mode". Their

two input channels each have a separate attenuator. And dependable plug-in IC construction makes maintenance easy and costs low.

Now consider cost of ownership! The Model 6401 is only \$1,375*; the Model 6401A (has the added feature of 10 ns period and time interval) only \$1,875*. As with all Beckman EID products, they are also available through our new factory direct rental and lease program. Ask your local Beckman representative for details or call us direct (312) 671-3300.

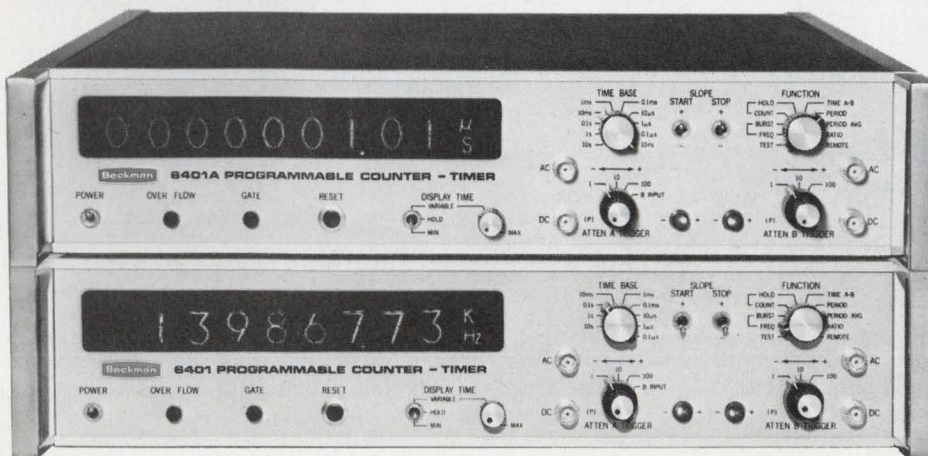

Beckman[®]

INSTRUMENTS, INC.

ELECTRONIC INSTRUMENTS DIVISION

Schiller Park, Illinois 60176

Helping science and industry
improve the quality of life.

Subtract two digital signals with an easy-to-build circuit

It's possible to subtract continuously two digital signals with only an ordinary gate and a bistable multivibrator whenever the input pulse sequences are regularly distributed in time and have negligibly few coincident pulses.

If gate G in the block diagram (a) is open and there are no pulses from N₁, then only pulses from signal N₂ pass through the gate. When a pulse due to N₁ appears, its trailing edge triggers the bistable BC, closing gate G.

The next pulse from N₂ does not pass through the gate, but its differentiated trailing edge switches BC and the gate opens. Further pulses from N₂ reach the output, until another pulse from N₁ closes the gate and the cycle repeats.

The error of subtraction due to overlapping pulses can be estimated by looking at the number of random coincidences that occur:

$$N_c = N_1 N_2 (T_1 + T_2),$$

where N₁ and N₂ are the rates of the input pulse trains, and T₁ and T₂ are their respective widths. The percentage of pulses from N₁ that will not be subtracted is

$$N_{oc} < N_2 (T_1 + T_2) 100\%.$$

One needs only seven NAND gates and two RC differentiating networks (b) to build the suggested subtraction circuit. Gates G₃ and G₆ create the bistable BC, while gate G₇ is the block-diagram gate G. The other gates help form pulse-shaping circuitry.

Both pulse shapers, PS₁ and PS₂, have differentiating RC networks in between the NAND gates. Since the input pulses from N₁ and N₂ are shortened by the pulse shapers before entering the bistable, the subtraction error is decreased.

Waveforms at several significant points of the circuit are indicated by the timing diagram (c). A subtraction error is shown for the second pulse of train N₁ and the third pulse of train N₂.

If the difference signal, N_o, must be determined with absolute accuracy, an auxiliary circuit for eliminating the coincident pulses from the two input pulse trains has to precede the subtraction circuit. However, when input pulses are irregularly distributed in time, it is usually sufficient to provide the subtraction circuit with a suitable memory.

Jozef Sabol, Technical University of Prague, Faculty of Nuclear Science and Physical Engineering, Brehova 7, Prague 1, Czechoslovakia.

VOTE FOR 312

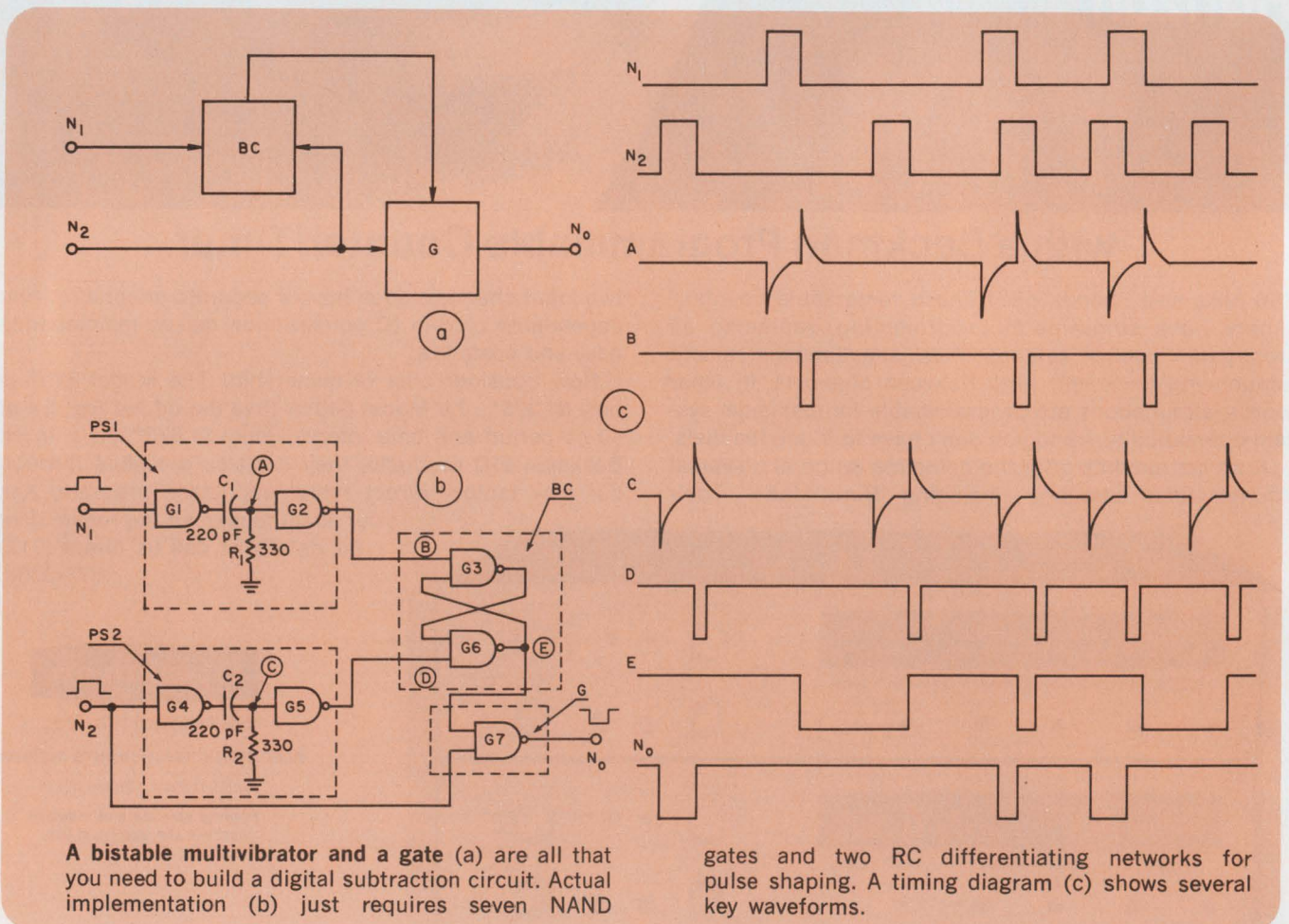

Tubeless, Tireless

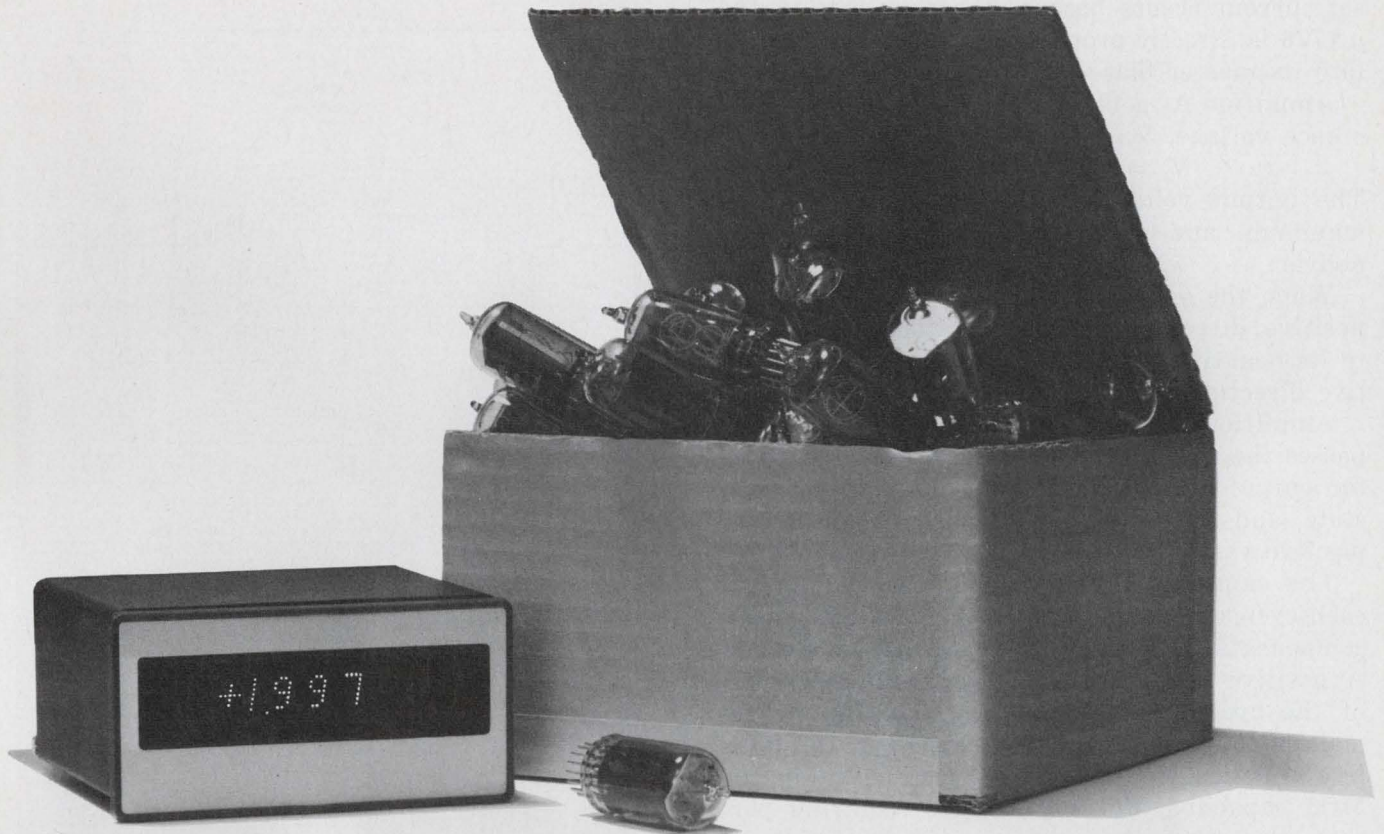

HP's new 3431A panel meter has no tubes to burn out; its shaped-character LED display will perform tirelessly, almost forever. To further increase its reliability, Hewlett-Packard has "designed out" many components, replacing them with proprietary LSI and MSI circuits. And the 3431A's solid-state power supply helps reduce power requirements to only 5 watts. As a result, electrical and thermal stress is minimized, for longer life. Battery operation is optional, allowing portable applications.

Size, too, is minimized by the 3431A's advanced circuitry. It measures only 1.7" high by 3.5" wide by 2.9" deep—including power supply.

All others are 25% to 650% larger in volume.

The 3431A is also the best-looking DPM available. Its display is brighter and easier to read than tube or bar-type displays — and cannot give erroneous readouts. Its pop-out front panel covers all mounting fixtures and adjustment controls, and can be painted or silk-screened with any color or nomenclature.

The 3431A is the new performance leader. Accuracy is $\pm 0.1\%$ rdg, ± 1 digit, with 1 mV sensitivity. The operating temperature range is 0°C to 60°C . Exclusive HP features include full scale and 10% FS autoranging signals, 55 ms zero-to-FS response

time, sample rate display, and remote digital control of sample rates.

Any way you look at it, the 3431A is your only choice in DPM's, if you're looking for instrument quality. Yet it costs only \$225, in quantities of 100. For full details, contact your local HP field engineer, or write Hewlett-Packard, Palo Alto, California 94304. In Europe: 1217 Meyrin-Geneva, Switzerland.

091/11

HEWLETT  PACKARD

COMPONENTS

INFORMATION RETRIEVAL NUMBER 47

Current-controlled oscillator sweeps five-decade band

A current-controlled oscillator can be built to operate over five decades of frequency in response to a similar range of input set current applied to pin 8 of amplifier A_1 (see illustration). This linear change in frequency as a function of set current occurs because the slew rate of the $\mu A776$ is directly proportional to the current fed into its master bias-setting pin.

Amplifier A_2 acts as a comparator whose reference voltage, V_r , is

$$V_r = V_o R_2 / (R_1 + R_2).$$

The output voltage, V_o , oscillates between the maximum and minimum voltages that A_2 can deliver.

When the output of A_1 just exceeds V_r in the positive direction, the comparator output flips to its negative extreme. A_1 now slews in a negative direction and V_r changes polarity.

Amplifier A_1 continues to slew until it just passes the negative extreme of V_r . The comparator output and V_r then return to their original state, and A_1 again slews toward the maximum positive value of V_r . The cycle can now repeat.

The capacitor actually being charged during each cycle is the internal 30-pF MOS frequency-compensating capacitor in the second stage of A_1 . A positive ramp exists for approximately 41% of the cycle and a negative ramp for the remaining 59% due to non-symmetry in the positive and negative current sources charging the MOS capacitor. For applications requiring perfect symmetry, A_1 's output may be fed to a divide-by-two flip-flop triggered by either the positive or negative-going edge of V_o .

Because of its high input impedance, the $\mu A-740$ is used for the comparator to prevent loading the $\mu A776$ output, whose impedance increases markedly when the set current is less than 1 nA. For audio applications, the $\mu A740$ is replaced with a low-cost $\mu A741$ or with a second $\mu A776$ running at a full 50- μA set current.

Inserting a type 2N3687 FET between pin 8 of A_1 and ground changes the circuit into a voltage-

controlled oscillator that can cover the five decades of frequency in response to a change in control voltage of approximately 0.5 V. A light-controlled oscillator can be made by replacing the FET with a Fairchild FPT100 phototransistor.

Marvin K. Vander Kooi, Fairchild Semiconductor, 464 Ellis St., Mountain View, Calif.

VOTE FOR 313

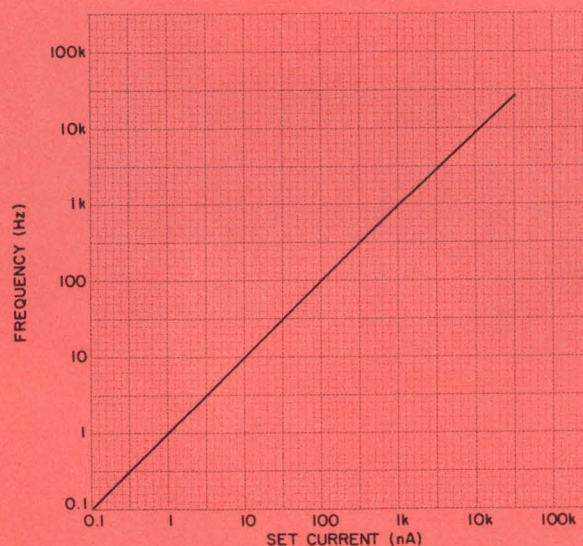
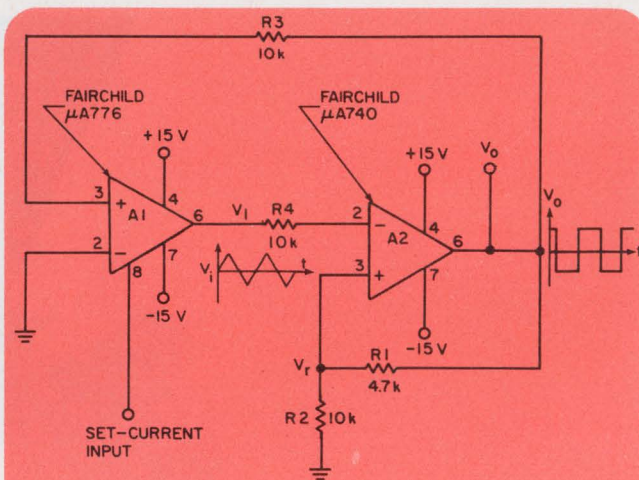

Get a linear change in frequency by varying the input set current of this wide-range oscillator. It can span five decades of frequency, from 0.1 Hz to 10 kHz, for control currents of 0.1 nA to 10 μA . A simple input modification converts it to a voltage or light-controlled oscillator.

IFD Winner for March 15, 1971

William Fletcher, Assistant Professor of Electrical Engineering, Utah State University and **William Harris**, Electrical Engineer, Utah State University, Logan, Utah 84321. Their idea "Single Differential Amplifier Shifts Phase Full 360 Degrees" has been voted the Most Valuable of Issue award.

Vote for the Best Idea in this issue.

VOTE! Go through all Idea-for-Design entries, select the best, and circle the appropriate number on the Reader-Service-Card.

SEND US YOUR IDEAS FOR DESIGN. You may win a grand total of \$1050 (cash)! Here's how. Submit your IFD describing a new or important circuit or design technique, the clever use of a new component or test equipment, packaging tips, cost-saving ideas to our Ideas-for-Design editor. You will receive \$20 for each accepted idea, \$30 more if it is voted best-of-issue by our readers. The best-of-issue winners become eligible for the Idea Of the Year award of \$1000.



The only 160-MHz synthesizer with a full-range sweep!

If you're testing amplifiers, filters, or delay lines, GR's new 1065 Sweeping Frequency Synthesizer has the built-in full-range sweep capability, remote programmability, and low residual fm that you need. The 1065 gives you 24 calibrated sweep widths from 5 Hz to 160 MHz with sweep times from 20 ms to 50 s, plus a step-attenuated output from +13 to -67 dBm. The fixed-frequency characteristics include 1-Hz resolution and stability better than one part in 10^9 /day. Harmonic spurs are more than 30 dB below signal level and non-harmonics are more than 60 dB down. The 1065 does the whole job for just \$8950.*

and two just for fixed-frequency work

For those applications that require the stability and accuracy of a synthesizer, but don't need the sweep capability, there's the new 1168 Frequency Synthesizer. The 1168 gives you the same fixed-frequency characteristics as the 1065, with a continuously adjustable output from +13 to -7 dBm and a substantial cost savings — the 1168 with its precision internal oscillator is only \$6400. If you already have a stable 5- or 10-MHz source, you can save even more by ordering the \$5900 slave version of the 1168 to operate from your external source.

Should you need the synthesizer, but require only 100-Hz resolution, then the 1165 Frequency Synthesizer will fill the bill with still more savings because of its \$5900 price tag. The 1165 is also available in a slave version for \$5400.

If these three synthesizers don't provide just the performance you need, then let GR tailor a fixed-frequency or sweeping synthesizer to your specs. Complete information on the standard synthesizers or on special models is available from the nearest GR office or from 300 Baker Ave., Concord, Mass. 01742. In Europe write to Postfach 124, CH 8034, Zurich, Switzerland.
*Prices are net FOB, Concord, Mass.



General Radio

BOSTON 617 646-0550 / CHICAGO 312 992-0800 / LOS ANGELES 714 540-9830
NEW YORK (N.Y.) 212 964-2722 (N.J.) 201 943-3140 / WASHINGTON, D.C. 301 881-5333
TORONTO 416 252-3395 / ZURICH (051) 47 70 20

INFORMATION RETRIEVAL NUMBER 48

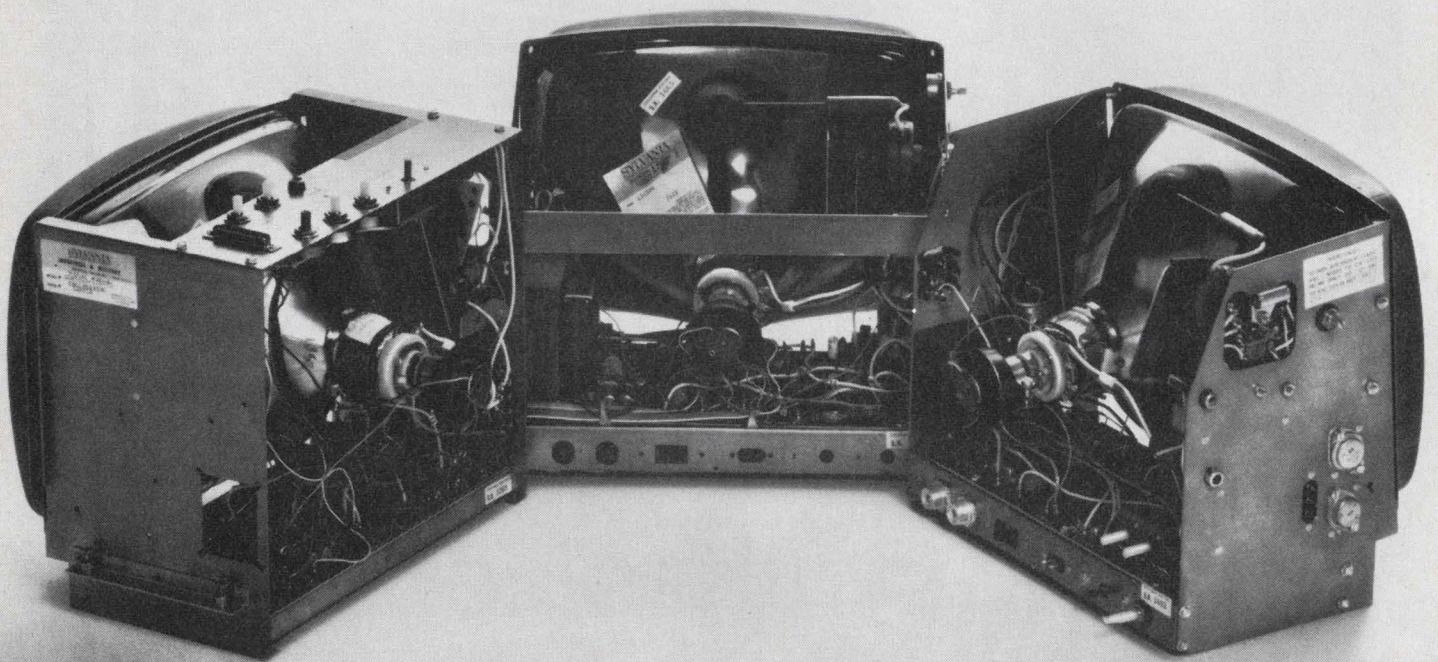

We have only one standard 12" monitor. All three are shown above.

A 12" monitor is standard in everybody's line.
Except in GTE Sylvania's.

The only thing standard about our 12" monitor is
the size of the CRT.

We can't work magic with a 12" hunk of picture
tube, but you'll be amazed at what we can do with
the rest of the unit.

Would you like the controls on the top? Back?
Front? Side?

Do you need more space in the upper right-hand
corner? Or the lower left? Or maybe you need a little
extra space on top.

That's no problem for us because our standard
monitor is designed to be flexible.

If you can find the space for a 12" CRT, we'll find
the space for the electronics.

Three versions of our standard monitor are shown
above.

Yours could be number four.

Sylvania Electronic Components, Seneca Falls,
New York 13148.

GTE SYLVANIA

new products

Triphasic-conversion DMMs reduce costs over 50%



Data Precision Co., subs. of Gordon Engineering, Audubon Rd., Wakefield, Mass. Phone: (617) 246-0200. P&A: see text; summer 1971.

Using a conversion technique known as Triphasic and a Ratiohmic resistance measurement technique, Data Precision's new series 2000 4-1/2 and 5-1/2-digit high-performance multimeters are available at prices over 50% under those of equivalent instruments on the market.

A 4-1/2-digit unit with dc volts, ratio and data I/O costs \$585 and a 5-1/2-digit model with dc and ac volts, ohms, a preamp and data I/O costs only \$1295—prices that are some \$200 to \$4000 below equivalent-performance digital multimeters available today.

The Triphasic design avoids expensive, precision components. In the conversion process, the three major sources of error found in conventional DMM circuits—zero offset and offset drift, resistance tolerance and drift and ramp-time constant tolerance and drift—are nulled out.

In the first phase of operation FET switches, whose switching time is determined by an internal clock, short the inputs of the differential buffer amplifier input to ground, and all errors associated with the buffer and the differential integrator are fed into an error update and memory section.

This provides an automatic true-zero setting at least once every 250 ms during all measurements.

The second phase involves the comparison of the input analog voltage with the error update section. This comparative error is fed into a differential integrator's inputs and integrated.

The input measurement taken is the difference between all errors due to internal components and the actual input signal amplitude, negating the error effects.

In the third phase the integrator is returned to its original zero state through the switching action of the FETs. The time required for this recycling is measured, using a crystal oscillator, and the decoded clock pulses are displayed as the digital readout.

Expensive, precision reference conversion amplifiers are avoided, and the Ratiohmic resistance measurement technique eliminates expensive constant-current sources.

Multimeters in both the 2400 series (4-1/2 digits) and the 2500 series (5-1/2 digits) are available in four standard models: with dc, ratio, ac and ohms; dc, ratio and ac; dc, ratio and ohms; or with dc and ratio functions.

Dc accuracies are $\pm 0.004\%$ of reading for both series. Resolutions are 100 μV for the 2400 series and 10 μV for the 2500 series. Each series has five options.

CIRCLE NO. 250

3-MHz generator has simultaneous AM and FM



Microdot, Inc., Instrumentation Div., 19535 E. Walnut Dr., City of Industry, Calif. Phone: (213) 965-4511. P&A: \$1195; 3 wks.

The model F231 function generator features simultaneous amplitude and frequency-modulation capability. It covers 0.005 Hz to 3 MHz and generates the following types of signals: sine, square, triangle, ramp, sawtooth, pulse, sweep, tone-burst, FM, AM, and suppressed-carrier AM. Repetition rates are from 0.001 Hz to 100 kHz, and pulse widths start from 167 ns.

CIRCLE NO. 251

Pulse analyzer system is accurate to 1%



Hewlett-Packard, 1501 Page Mill Rd., Palo Alto, Calif. Phone: (415) 493-1501. P&A: \$40,500(A), \$47,000(B); 16 wks.

Using a statistical approach to waveform analysis, a new computer-controlled automatic measurement system yields highly detailed information about pulse waveforms with 1% accuracy. The 1960 A/B, which has applications in pulse testing of ICs and characterization of multiport black boxes, makes frequency-domain as well as time-domain measurements.

CIRCLE NO. 252

AUTO-RANGING DVM

... the DART IV, the new digital auto-ranging tester from Non-Linear Systems ... the first low cost systems compatible ... (also portable) ... multifunction 4-digit DVM to bridge the gap between low cost, manual range and the high cost automatic range units ... now only



\$795

Be on target with faster, automatically selected readings ... better accuracy ... greater stability ... and more measurement capability. All at the lowest available cost per measurement!



... the DART IV, Digital Auto-Ranging Tester ... available now!



NON-LINEAR SYSTEMS, INC.
DEL MAR, CALIFORNIA
(714) 755-1134 /
TWX 910-332-1132

INFORMATION RETRIEVAL NUMBER 50

1-to-500-MHz generator sweeps its entire band

Wavetek, Indiana, Inc., Box 1987, Indianapolis, Ind. Phone: (317) 783-3221. P&A: \$1095; 2 to 4 wks.

The new 1002 sweep/signal generator covers 1 to 500 MHz sweeping any part of its entire range and is available in 50 to 75 Ω output impedances. It includes an electronic attenuator that is continuously variable over a 20-dB range. Frequency, bandwidth and output may be dc controlled. The 1002 may be used as a swept or as a cw generator.

CIRCLE NO. 253

Portable oscillograph operates anywhere

Bell & Howell, Electronics & Instruments Div., 360 Sierra Madre Villa, Pasadena, Calif. Phone: (213) 796-9381.

A new rugged, portable oscillograph can accurately record data in virtually any mobile application. The 5-130 recording oscillograph is a direct print-out multi-channel recorder that can operate at altitudes of up to 25,000 feet. It also can operate in virtually any attitude, including upside down. It has writing speed of 50,000 in./s.

CIRCLE NO. 254

Stable reference sources are accurate to 0.02%

Electronic Development Corp., 11 Hamlin St., Boston, Mass. Phone: (617) 268-9696. P&A: \$450, \$525; stock.

Two new constant-voltage sources offer 0.02% accuracy with stability of 0.0025%. Model E-10-D provides a selectable output from 0 to ± 11 V dc. Output current is 50 mA. The model E-100-D provides two output voltage ranges: ± 10 V and ± 100 mV plus 10% overrange in both cases. Output current is 50 mA at 10 V.

CIRCLE NO. 255

Scope module analyzes 1-to-500-MHz spectrum



Tektronix, Inc., Box 500, Beaverton, Ore. Phone: (503) 644-0161.

The 1041A module, used with the 8-lb portable Sony/Tektronix 323 or 324 provides measurements in the 1-to-500-MHz spectrum. Amplitude and frequency calibration with intermodulation distortion of 60 dB of full screen is featured. A gated mode allows the 1401A to be used in viewing time related signals, such as pulsed and sync signals. A built-in calibrator includes frequency and amplitude reference.

CIRCLE NO. 256

Pocket-size logic probe uses LED indicators

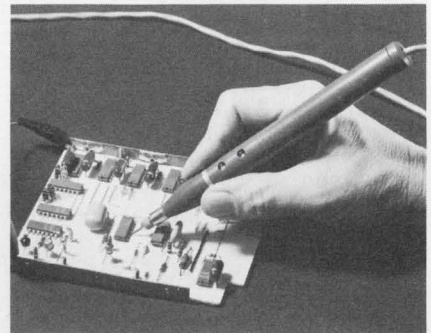

Aqua Survey & Instrument Co., Inc., 7041 Vine Street, Cincinnati, Ohio. Phone: (513) 821-2514. Price: \$35.

A new pocket-size tester for visual observation of pulsed logic up to 120 Hz (pulse rate is divided by four) includes two LED indicators. The Digi-Test probe model L-2000 consumes only 50 mA at 5 V dc from the system under test and is reverse-polarity protected. The probe is operative from +1 to +30-V levels, ac or dc.

CIRCLE NO. 257

Boxcar detector unit resolves 10-ns waveform

Keithley Instruments, Inc., 28775 Aurora Rd., Cleveland, Ohio. Phone: (216) 248-0400. Price: \$2500.

The new system 88 boxcar detector recovers both amplitude and waveform of signals hidden by noise with a waveform-segment resolution as short as 10 ns. The system 88 provides a time-expanded display of a repetitive waveform which can easily be examined using an X-Y recorder, oscilloscope, or other readout. Input of 100 mV gives full scale output of 10 V, at a linearity of 0.1%.

CIRCLE NO. 258

Digital voltmeter doubles as counter

Northeast Electronics Corp., Airport Rd., Concord, N.H. Phone: (603) 224-7466.

Designed for laboratory as well as for field use, the model 2000 digital voltmeter-counter provides in one compact instrument an auto-ranging digital voltmeter for both ac and dc, a digital dB presentation, and a fully automatic counter. For dc and ac, resolution is 100 μ V. The 2000 also measures from -60 to +60 dB. Frequency range extends from 10 Hz to 500 kHz.

CIRCLE NO. 259

Precision digital phase meter costs \$1000

Universal Ad-Yu Electronics, Inc., 249 Terhune Ave., Passaic, N.J. Phone: (201) 472-5622. Price: see text.

A new precision phase meter covering 1 Hz to 100 kHz with an accuracy of better than 3 degrees costs less than \$1000 and features a digital read-out. The model 408 has a wide dynamic range—10 mV to 200 V rms—in two 60-dB steps. It measures directly the loss tangent of reactive components and two-terminal networks.

CIRCLE NO. 260

1200 SOLD IN 8 MONTHS

proves new Omnigraphic[®] recorder offers

Versatility,
Reliability
and Price

and now...
for added
versatility

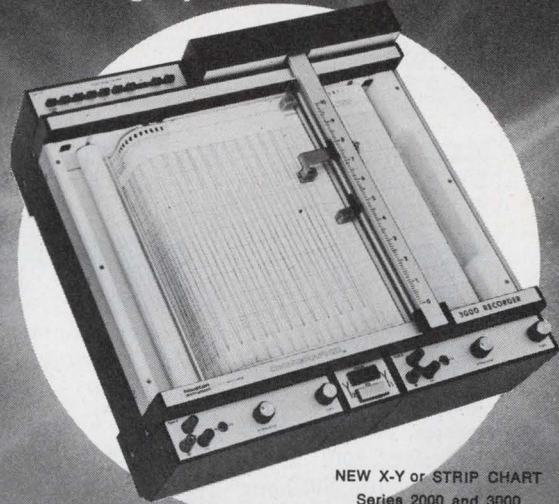

NEW X-Y or STRIP CHART
Series 2000 and 3000

3 NEW FUNCTIONAL UNITS INTRODUCED

2 Pen Strip Chart

... for those applications requiring two simultaneous full scale recordings, the series 2-3300 is the ideal, economical recording tool.

Paper size: 10" (25cm) x 100"
9 pushbutton speeds: .05 to 20 in/min.

Plug-in modules: a dozen different signal conditioning modules are interchangeable between Y₁ and Y₂ axes.

Electric pen lift and event marker:
Price:

standard
Model 2-3300-52 \$1205.
plus selected Y axes modules.

Automatic Integration for GC

... is possible simply by plugging the new type 13 module into the Series 2-3300-52 recorder. The integral is recorded in the Y₂ channel, using the full 10" chart width for recording. The trace is "folded" at the bottom and top of the chart grid so that integration continues indefinitely, providing improved resolution. Type 13 Module costs \$475. Write for brochure which fully describes the recorder, integration and peak area measurement.

Economical Point Plotter

... is achieved by plugging two modules into your standard model 3000 strip chart recorder. Modules 16 and 17 convert the strip chart to a true point plotter for handling data from Pulse Height Analyzer, Digital Oscilloscope or Averaging Computer. The cost is nominal, only \$1695.

- 4 resolution selections: .025", .050", .075" and .100".
- Interchangeable Fibre Tip Colored Pen Points
- Maximum sensitivity setting 1 mv/in.
- At resolution setting of 40/in. plotting rate is 15 points/sec. (will plot 400 channels in approximately 27 sec.)

Write today for the newest Houston Instrument brochure describing the expanded variety of functions available to present users of the HI model 2000 X-Y and model 3000 strip chart recorders. Twelve plug-in modules available... and more in R&D.

®A registered trademark of Houston Instrument

**houston
instrument**

DIVISION OF BAUSCH & LOMB

4950 TERMINAL AVENUE, BELLAIRE, TEXAS 77401
(713) 867-7403 CABLE HOINCO

houston
instrument

European Office 8043 Unterfohring, Johanneskirchner Strasse 17,
München, W. Germany (0811) 97-1673

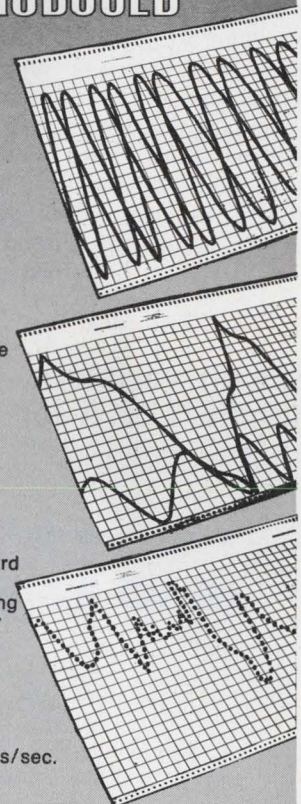

Numeric display tube is only 1.5-in. high

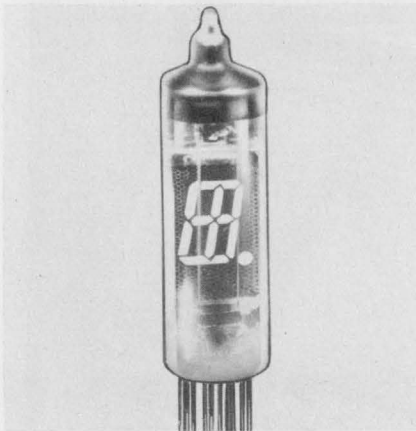

National Electronics, Inc., Geneva, Ill. Phone: (312) 232-4300.

A new long-life (100,000-hour MTBF) segmented numerical display tube with phosphor coating on the characters features only 1.5-in. of seated height and is 0.45 in. in dia. The NL-DGIOE is compatible with MOS circuits and can be driven by MOS LSI arrays. Its 8-segment characters of 0 to 9 are 0.34-in. high with independent right-hand decimal. The NL-DGIOE is designed to operate in dc, strobe or time-shared modes.

CIRCLE NO. 261

Silicon varistors handle 125 A for 1 ms



General Semiconductor Industries Inc., 230 W. 5th St., Tempe, Ariz. Phone: (602) 966-7263. P&A: 35¢ (100 quantities); stock.

A new series of silicon junction varistors, for the protection of electronic equipment from power surges, are rated at 125 A peak-pulse currents for 1 ms. The GSV series features breakdown voltages typically from 0.35 to 0.5 V at 10 mA and 0.74 to 0.85 V at 100 mA. Units are in axial-lead packages.

CIRCLE NO. 262

Tiny rotary switches are thimble-sized

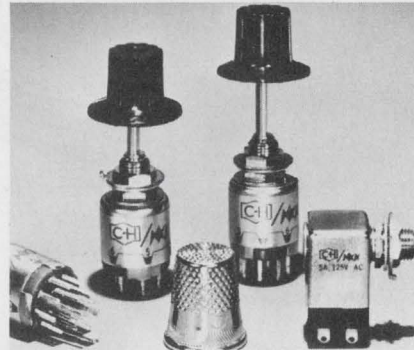

Cutler-Hammer, Inc., 4201 N. 27 St., Milwaukee, Wis. Phone: (414) 442-7800. P&A: from \$1.45 to \$4.45; 4 wks.

A new line of miniature rotary thimble-sized switches are available for application on computers and electronic test equipment. The line includes 16 round base switches and two heavy duty rectangular-base devices. The round-base switches are available in 1, 2 and 4-pole configurations. The heavy-duty rectangular-base switches are available in double-pole styles.

CIRCLE NO. 263

Resistor decade modules are BCD building blocks

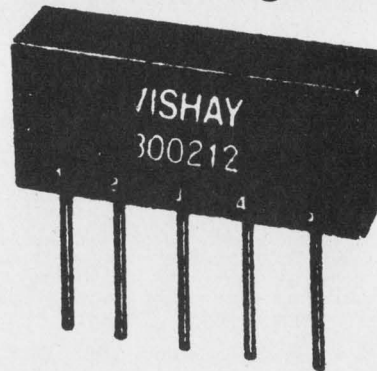

Vishay Resistor Products, 63 Lincoln Highway, Malvern, Pa. Phone: (215) 647-5115. Price: \$5.64, \$9.27 (100 quantities).

A new line of building-block BCD resistor decade modules are available in double-pole styles 300222) and high-accuracy (series 300212) individual decades. The former are 0.1% matched and track at 5 ppm/°C while the latter are 0.01% matched and track at 2 ppm/°C. Resistors range from 2 to 75 kΩ.

CIRCLE NO. 264

0.1%-linear servo pot has infinite resolution

EMI Electronics, Ltd., Hayes, Middlesex, England.

A 10-V 400-Hz linear potentiometer for use in precision servo applications achieves a linearity of 0.01% with virtually infinite resolution. Designated type 15 ACP 4a, this ac potentiometer has a max speed of 300 rev/min with an output impedance of 1 Ω.

CIRCLE NO. 265

Tiny laser pulser has 40-ns rise/fall

Washington Technological Assoc., Inc., 979 Rollins Ave., Rockville, Md. Phone: (301) 881-2050. P&A: \$270; 90 days.

Model LP-102 laser pulser provides a 100-ns-wide, 15-A peak current pulse with 40-ns rise and fall times generated by an internal clock. Other pulsers are available in hybrid IC form.

CIRCLE NO. 266

Three display CRTs enhance computers

General Electric Co., 2100 Gardiner Lane, Louisville, Ky. Phone: (502) 452-4241.

Three new rectangular CRT display tubes are available for computer displays. They are the electrostatic-focus 7.6-in. Y4083 with 85° deflection, the 15-in. magnetic-focus Y4066 with 70° deflection and the 17-in. magnetic focus Y4067 with 70° deflection.

CIRCLE NO. 267

400-Hz-transformer kit has PC plug-in-units

Microtran Co., Inc., 145 E. Mineola Ave., Valley Stream, N. Y. Phone: (516) 561-6050. P&A: \$37.95; stock.

A 400-Hz plug-in power-transformer kit is available. Model 4000K consists of 10 400-Hz transformers supplied in two sizes: 1/3 and 4-W ratings. All primaries are 115 V.

CIRCLE NO. 268

*If your problem
is in-circuit
testing of
transistorized
and integrated
circuits . . .
Solve it with
Triplett's 601*

Model 601

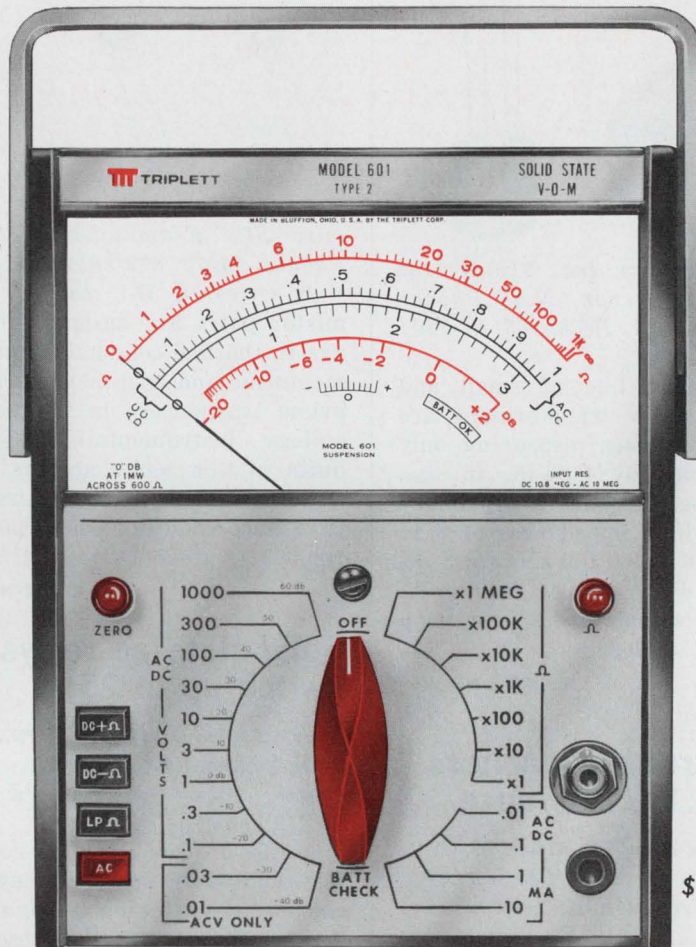

1. Low power ohms — 7 ranges with 75 mV power source.
2. High sensitivity — 10 mV AC full scale at 10 megohm input impedance; 100 mV DC at 11 megohm input resistance.
3. Simplified scale — only 4 arcs for all 53 ranges.

It has 7 low-power resistance ranges that apply only 75 mV to the device under test . . . does not activate or damage solid-state component . . . full-scale DC measurements down to 100 mV and 10 μ A and AC as low as 10 mV and 10 μ A, it's obvious the Model 601 was designed for in-circuit testing.

Add such features as 10 megohm input impedance on AC

and 11 megohm input resistance on DC, voltage readings to 2% DC and 3% AC (current: 3% DC and 4% AC), separate range-selection and function-selection switches, and a simplified dial on which all 53 ranges are read on only 4 scales, and it's equally obvious that here's a V-O-M that has what you need to do the job better, faster and more easily.

See the capable Model 601 —

priced at \$166 — at your local Triplett distributor. For more information, or for a free demonstration, call him or your Triplett sales representative right away. Triplett Corporation, Bluffton, Ohio 45817.

TRIPLETT

The World's most complete line of V-O-M's...
choose the one that's just right for you

INFORMATION RETRIEVAL NUMBER 52

Tiny audio transformers are the size of a dime

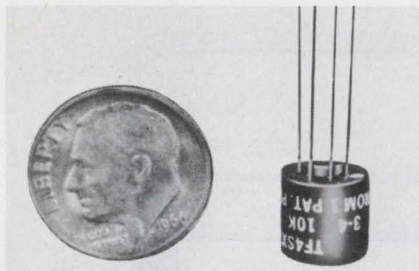

Pico Electronics, Inc., 316 W. 1st St., Mount Vernon, N.Y. Phone: (914) 699-5514. P&A: \$3 to \$10; stock to 1 wk.

A standard line of small and efficient audio transformers are available in cases measuring only 0.34-in. long by 0.34-in. in dia. Typical specifications are primary and secondary impedances of 3 to 100 k Ω , 400 Hz to 100 kHz for 3-dB points and power of 600 mW. Plug-in terminals are spaced on a 0.2-in.-dia circle.

CIRCLE NO. 269

Polystyrene capacitors have 0.1% tolerance

Wesco Electrical Co., Inc., 27 Olive St., Greenfield, Mass. Phone: (413) 774-4358. Availability: stock to 4 wks.

Type 54PX precision polystyrene film-foil capacitors, feature tolerances up to $\pm 0.1\%$ and stability or retrace of less than 0.05%. This series is designed to maintain uniformity in size for mounting primarily in PC board applications. Capacitances are from 0.001 through 0.022 mfd at 100 V dc. Standard tolerances are $\pm 5\%$.

CIRCLE NO. 270

Thin-film ladders come in chip form

Hycomp, Inc., 146 Main St., Maynard, Mass. Phone: (617) 897-4578. P&A: \$25 (8-bit), \$36 (10-bit); stock.

New 8 and 10-bit thin-film nichrome ladders are available in chip form. They feature TC tracking of 0.5 ppm/ $^{\circ}$ C, current noise of 1 μ V/V/decade of frequency, and settling time to 0.1% of 25 ns.

CIRCLE NO. 271

Thermistor pairs are E-I matched

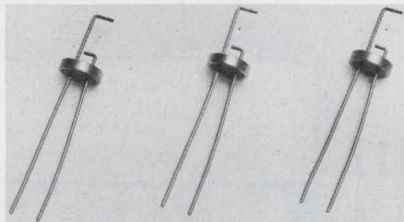

Fenval Electronics Inc., 63 Fountain St., Framingham, Mass. Phone: (617) 872-8841.

A series of E-I matched thermistor pairs are designed for use in thermal conductivity instrumentation and adaptable for use as prime transducers in the field of ecology instrumentation. Typical units in this series are the G112, G126 and G128 matched pairs with resistance values of 8000, 2000 and 100,000 Ω at 25 $^{\circ}$ C, respectively.

CIRCLE NO. 272

Solid-state ac relays switch up to 25 A

International Rectifier Corp., 1521 Grand Ave., El Segundo, Calif. Phone: (213) 322-4987. P&A: \$8 to \$12; stock.

A line of new computer-compatible solid-state spst ac relays are capable of switching 2, 10, and 25 A at 120 and 240 V. These normally open units feature zero voltage switching and achieve full four-terminal isolation through the use of an optical link. They operate from a minimum 1.5-mA, 3-V-dc signal. Each relay is in a 2.2 by 1.7 by 0.9-in. case.

CIRCLE NO. 273

Ceramic chip capacitors are temperature stable

Johanson Technology, Inc., sub. of Johanson Mfg. Corp., Box 8, Boonton, N.J. Phone: (201) 334-2676. P&A: from 18 ϕ (1000 quantities); 2 wks.

A new series of miniature monolithic ceramic chip capacitors for microwave and hybrid circuit applications have stable temperature characteristics. Dissipation factor ranges from 2.5 to 0.01%. Capacity ranges are available from 0.1 pF to 0.38 mfd.

CIRCLE NO. 274

Wideband transformers take TO-5/DIP forms

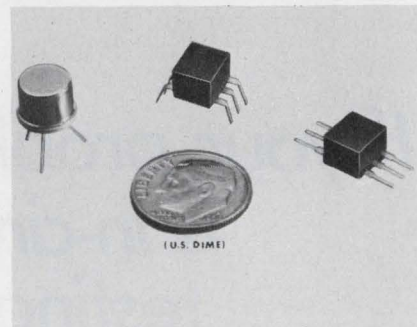

Vari-L Co., 3883 Monaco Pkwy., Denver, Colo. Phone: (303) 321-1511.

Two new Z-Match series miniature wideband transformers are available in TO-5 and 1/3-DIP cases. The latter version has leads that may be formed in different attitudes for PC insertion, or microstrip-reflow solder techniques. Both types use Kovar solder-plated terminals. Balanced and unbalanced types are available with various impedance ratios.

CIRCLE NO. 275

Video delay lines

New base video delay lines combine wide bandwidth and low noise. Worst-case 3-dB bandwidth of 12 MHz for a 64- μ s delay and low 40-dB attenuation. Price: \$100. Corning Glass Works, Raleigh, N. C. (919) 876-1100.

CIRCLE NO. 276

Proximity switches

A new line of magnetic proximity switches senses ferrous metal targets from 1/2 to 1-1/16 in. Maglock switches are in three models: miniature, standard and vane. National Acme, Cleveland, Ohio. (216) 268-4200.

CIRCLE NO. 277

Solid-state relays

PSG solid-state relays are available in various mountings, for panel and plug-in. They switch 1.5 to 25 A at 115/220 V ac and 28 V dc. P&A: \$4.40 to \$19.25; stock. PSG Industries, Perkasie, Pa. (215) 257-3621.

CIRCLE NO. 278

“...the best 2N3055 power transistors come from Germany...”



Our sales manager says that EEP's 2N3055 is best. Of course, he is German and our 2N3055 is German-made. But "made in Germany" has become a synonym for quality and reliability. EEP's 2N3055 is no exception. In addition, EEP offers immediate delivery, from stock, at surprisingly low prices. Place your order today.

EEP 2N3055	1-24	25 up	100 up	500 up	1000 up
	\$1.60	1.30	.98	.88	.78

**The best
2N3055
price
& delivery
comes from EEP!**

Also from EEP

EEP also offers fast delivery, high quality and low prices for these standard transistor types:

	1-24	25 up	100 up		1-24	25 up	100 up
2N697	\$.40	\$.35	\$.25	2N2904A	.52	.47	.32
2N699	1.00	.90	.70	2N2905	.51	.46	.31
2N706	.33	.30	.20	2N2905A	.53	.48	.33
2N708	.45	.40	.27	2N2906	.40	.36	.25
2N709	.85	.75	.50	2N2906A	.41	.37	.26
2N709A	1.70	1.50	1.10	2N2907	.40	.36	.25
2N744	.48	.43	.30	2N2907A	.41	.37	.26
2N753	.52	.48	.33	2N3053	.50	.45	.30
2N834	.50	.45	.30	2N3107	1.10	1.00	.65
2N914	.55	.50	.30	2N3108	1.10	1.00	.65
2N918	.66	.60	.40	2N3109	1.10	1.00	.65
2N929	.44	.40	.26	2N3110	1.10	1.00	.65
2N930	.44	.40	.26	2N3390	.75	.70	.50
2N930A	1.30	1.20	.90	2N3391	.35	.32	.25
2N1132	.70	.60	.40	2N3392	.25	.23	.16
2N1303	.38	.35	.27	2N3393	.24	.22	.16
2N1305	.50	.45	.34	2N3395	.32	.30	.20
2N1307	.55	.50	.40	2N3396	.24	.22	.16
2N1420	.60	.55	.40	2N3397	.23	.21	.15
2N1613	.50	.45	.30	2N3398	.23	.21	.15
2N1711	.52	.47	.32	2N3442	4.50	4.20	3.00
2N1893	.95	.85	.50	2N3614	1.20	1.10	.80
2N1990	1.60	1.40	.95	2N3645	.32	.30	.22
2N2192	1.30	1.10	.50	2N3702	.30	.28	.20
2N2193	1.00	.90	.60	2N3703	.29	.27	.19
2N2218	.50	.45	.30	2N3707	.30	.28	.20
2N2218A	.60	.54	.35	2N3708	.26	.24	.18
2N2219	.50	.45	.30	2N3710	.30	.28	.20
2N2219A	.52	.47	.32	2N3711	.30	.28	.20
2N2221	.50	.45	.30	2N3794	.45	.40	.30
2N2221A	.51	.46	.31	2N3819	.50	.45	.35
2N2222	.30	.27	.20	2N3964	1.40	1.25	.85
2N2222A	.50	.45	.30	2N4227	.55	.50	.35
2N2368	.45	.40	.30	2N4286	.40	.35	.25
2N2369	.40	.36	.25	2N4288	.40	.35	.25
2N2405	1.40	1.20	.80	2N4293	.70	.65	.45
2N2475	1.10	1.00	.70	2N4416	1.60	1.40	1.00
2N2476	1.00	.90	.70	2N5172	.19	.18	.11
2N2483	.65	.60	.40	2N5447	.35	.33	.30
2N2484	.65	.60	.40	2N5448	.33	.31	.28
2N2708	1.10	1.00	.70	2N5449	.33	.31	.28
2N2890	7.00	6.30	4.50	2N5450	.28	.26	.24
2N2891	7.50	7.00	5.00	2N5451	.26	.24	.23
2N2904	.50	.45	.30	2N5779	1.00	.90	.70



**EUROPEAN
ELECTRONIC
PRODUCTS**
CORPORATION

10150 W. JEFFERSON BLVD.
CULVER CITY
CALIFORNIA 90230 U.S.A.
PHONE (213) 838-1912

INFORMATION RETRIEVAL NUMBER 53

P-channel JFETs switch ± 15 V analog at 4 MHz

National Semiconductor Corp., 2900 Semiconductor Dr., Santa Clara, Calif. Phone: (408) 732-5000. P&A: \$5.50 (1000) \$6 (1001), \$4.25 (1002) for 100-unit quantities; stock.

For switching dc to 100-MHz analog signals up to ± 15 V, a new series of JFET devices are available with toggle rates as high as 4 MHz.

Series AM1000 switches are monolithic p-channel devices that eliminate switching transients in the signal output. Transients are routed into the drive and bias supply lines, where they are disposed of by conventional supply bypass capacitors.

Important characteristics of the new switches are pico-amperes of error current, no offset voltage, no channel-resistance modulation with signal level changes and excellent ON-to-OFF ratios.

There are three devices in the series—the AM1000, AM1001, and AM1002—which differ basically in their ON-resistance and leakage-current characteristics.

The AM1000 has ON resistance of 30 Ω , and the AM1001 has ON resistance of 50 Ω . Both have 250

pA maximum leakage current. For less demanding applications the AM1002 is available, with ON resistance of 100 Ω and leakage current of 1 nA max.

The ON resistance of the switches is not effected by changes in signal amplitudes, as with p-channel MOS devices, which have an inherent bulk gate-channel modulation characteristics.

For example, the AM1000's typical ON resistance is 25 $\Omega \pm 5 \Omega$. If a 1-k Ω load is used, this variation is effectively only $\pm 0.5\%$. A p-channel MOS switch can have a typical ON resistance of 275 Ω and vary by approximately $\pm 125 \Omega$ —an effective variation of $\pm 12.5\%$ for the same 1-k Ω load.

External drive circuitry is required for all three switches. To achieve the maximum toggle rate of 4 MHz, discrete-component drives are necessary. A monolithic driver, such as the National DM-8800, will work at toggle rates up to 1 MHz.

Packaging is in four-terminal TO-72 cases. All three switches operate at junction temperatures from -55 to $+150^\circ\text{C}$.

CIRCLE NO. 279

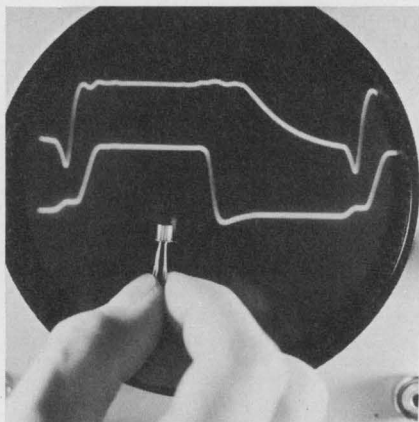

A new p-channel JFET circuit switches a +10-V analog signal in 100 ns (lower trace), markedly faster than a contemporary p-channel MOS switch (upper trace). Both switches are driven from identical circuitry. Circuit diagram (right) of the JFET device shows how switching transients are reduced—the upper JFET acts as the analog-signal pass transistor, while the other two transistors act as turn-on circuits.

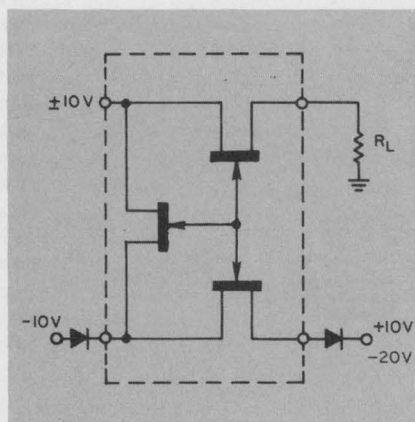

CMOS 128-bit register has built-in control

Ragen Semiconductor, Inc., 53 S. Jefferson Rd., Whippany, N.J. Phone: (201) 887-4141. Availability: stock.

A new CMOS 128-bit static shift register features built-in control logic. The 10-MHz model MS-625 includes a four-bit digital comparator for chip select, a "power on" gate which disables the internal clock, and the option of load or transfer to select either recirculation or the introduction of fresh data. It also has clock outputs for driving additional registers.

CIRCLE NO. 280

Dynamic 1024-bit RAM replaces core memories

Signetics Corp., 811 E. Arques Ave., Sunnyvale, Calif. Phone: (408) 739-7700. Price: \$30.75 (100 quantities).

A new dynamic RAM, organized as 1024 by 1 bit, is available to replace magnetic-core memories for buffer and bipolar-compatible storage. Designated as the 2508NX, this four-phase RAM is fully decoded and contains built-in automatic refresh amplifiers. Min write/read cycle time is 460 ns and read access time is 330 ns. Power dissipation is 100 μW .

CIRCLE NO. 281

IC op amp pair use little current

Raytheon Semiconductor, 350 Ellis St., Mountain View, Calif. Phone: (415) 968-9211. Availability: stock.

Two new low-current op amps are the RM4131 and RM4132. The former features only 1.6 mA current drain at +20 V. Its slew rate is 2 V/ μs , unity-gain bandwidth is 4 MHz and large-signal voltage gain is 160 V/mV. The latter features 35- μA current drain from ± 3 to ± 20 V. Its required input offset current is only 2 nA and unity-gain bandwidth is 150 kHz. Both amplifiers operate over -55 to $+125^\circ\text{C}$.

CIRCLE NO. 282

Solve trickiest RFI problems with this new twist!

Super
A **stickn** *fingers*[®]

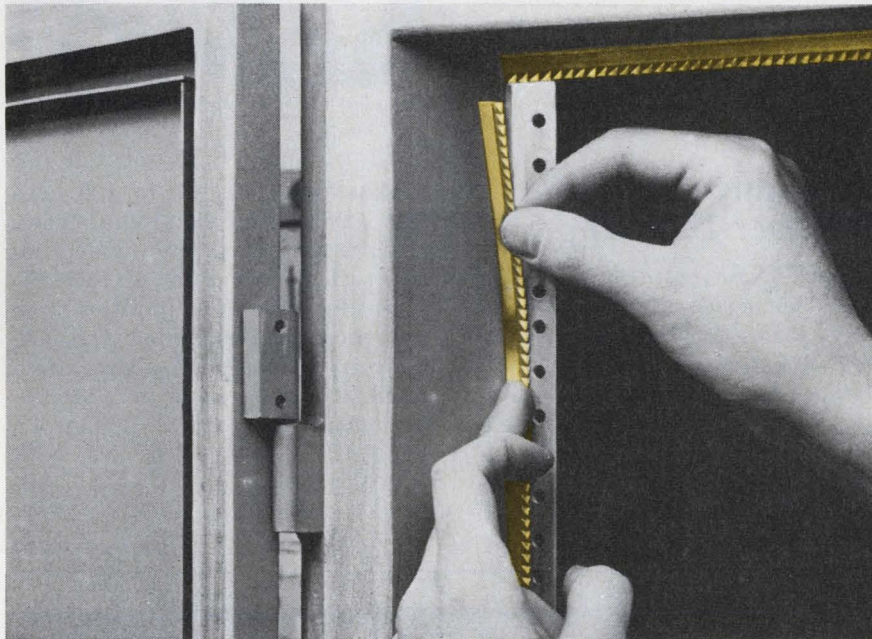

Latest addition to the Sticky Fingers line!

We've made STICKY FINGERS beryllium copper contact strips narrower; given them a new twist; and a new super adhesive—to make even your trickiest RFI/EMI problems practically disappear.

Take our series 97-555. It measures a scant 3/8" wide, yet offers shielding effectiveness with a dynamic range of 1/16"! It's the ideal all-purpose contact strip for just about any type panel or equipment shielding, where space is at a premium.

For equally effective shielding of equipment in panel-divider bar cabinets, specify series 97-560. Only 1/2" wide, its unique design permits any unit to be easily removed without chance of damage to the strip itself.

And a new, stickier, stronger, self-adhesive makes application quick and simple...no holes to drill...no mechanical fasteners to use.

Just cut strip to size...peel off the protective backing...mount firmly in place. Holds instantly; bonds permanently.

New twist-series SUPER STICKY FINGERS are available in a variety of surface finishes. Even if you've already seen samples of STICKY FINGERS, write today for complete technical information and free samples of the new SUPER STICKY FINGERS. Address: Dept. ED-61.



97-555



97-560



INSTRUMENT SPECIALTIES CO., INC.
Little Falls, New Jersey
Phone 201-256-3500

INFORMATION RETRIEVAL NUMBER 54

Bipolar 24-pin ROM houses 8192 bits

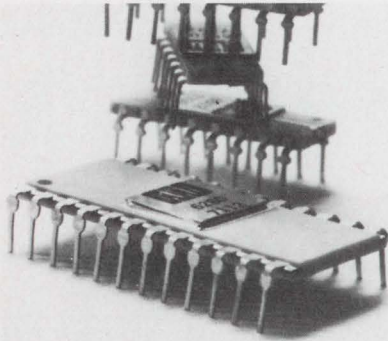

Monolithic Memories, Inc., 1165 E. Arques Ave., Sunnyvale, Calif. Phone: (408) 739-3535. Price: from 0.9¢/bit (100 quantities).

An 8192-bit bipolar ROM is available in a 24-pin package. The MM6280/MM5280 is organized as 1024 words by 8 bits, has an access time of 100 ns and low power dissipation of 60 μ W/bit. It can provide the entire 128 standard ASCII alphanumeric code, in upper and lower case in a 5 by 7 font, with row or column scan or 64 characters in 7 by 9 font.

CIRCLE NO. 290

Silicon suppressors behave as germaniums

Codi Semiconductor, Pollit Dr. S., Fair Lawn, N.J. Phone: (201) 797-3900. P&A: see text.

A breakthrough has been achieved in manufacturing click-suppressors made of silicon having electrical characteristics comparable to those made of germanium. The new click-suppressors have all the advantages of silicon at less than one half the cost of germanium devices, off-the-shelf.

CIRCLE NO. 291

TO-8 unity-gain buffers slew over 1500 V/ μ s

National Semiconductor Corp., 2900 Semiconductor Dr., Santa Clara, Calif. Phone: (408) 732-5000. Price: \$43, \$29.

Two high-performance unity-gain buffers in TO-8 cans, the LH0033 and LH0033C, slew in excess of 1500 V/ μ s with a guaranteed minimum at 1000 V/ μ s.

CIRCLE NO. 292

MOS keyboard encoder works in four modes

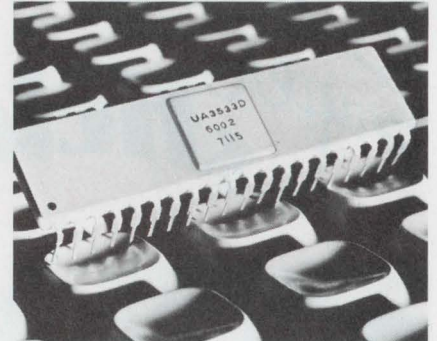

Unisem Corp., Street Rd., Trevose, Pa. Phone: (215) 355-5000.

A new 40-pin keyboard encoder translates signals up to 128 keys into any of four different modes. Each mode is completely independent, providing a total of 512 different 9-bit word possibilities from the encoder. Designated UA3533, the encoder is actually a specialized MOS ROM. The ROM may be programmed for BCD, USASCII, EBCDIC, or any other code with 9 bits/word or less. Two-key roll-over is included.

CIRCLE NO. 293

DIP-LITE[®]

NEW - LOW COST - READOUTS

- CONVENIENT DUAL-IN-LINE MOUNTING
- LOW VOLTAGE — 5 volts
- LOW CURRENT — under 20 milliamps
- LONG LIFE — over 100,000 hours
- MULTICOLORS
- BRIGHTNESS — up to 9,000 ft. lamberts
- LED REPLACEMENT (PIN-FOR-PIN)
- BOTH 7 SEGMENT DIGITAL AND 16 SEGMENT ALPHANUMERIC AVAILABLE

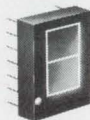

DIP. 650
5/16"

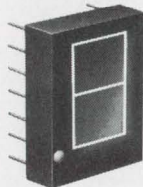

DIP. 850
1/2"

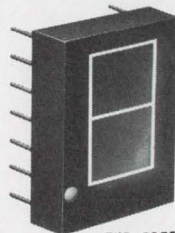

DIP. 1050
5/8"

(201) 226-7724

Pinlites
DIVISION OF REFAC

P.O. BOX 453, CALDWELL, NEW JERSEY 07006 U.S.A.

INFORMATION RETRIEVAL NUMBER 55

The
"Hot"
One

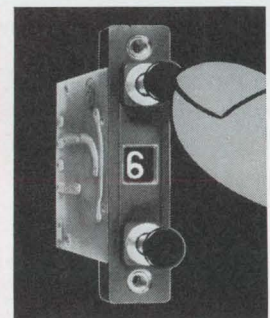

JANCO'S PUSH-BUTTON ROTARY SWITCH

Janco's "hot" one includes a whole series of push-button rotary switches designed to create more control in less space and engineered with a wide variety of custom features that have always been standard!

- 8, 10, 12, or 16 positions
- Plastic, aluminum or beryllium copper construction for RFI shielding
- Lighted or unlighted
- Interchangeable colored buttons
- Black or white digits
- Codes galore! . . . There's more! Write for new catalog sheets. Ask for the "hot" one!

JANCO
CORPORATION

3111 Winona Ave., Burbank, Calif. 91504
Phone 213-845-7473 • TWX 910-498-2701

INFORMATION RETRIEVAL NUMBER 56

ELECTRONIC DESIGN 14, July 8, 1971

16-bit computer system point-plots in 2 colors



Digital Equipment Corp., Maynard, Mass. Phone: (617) 897-5111. Price: \$27,900.

The new Lab-11 computer system features a low-priced two-color (red and green) point-plot display. This two-color display, VR20, has an 11-in.-diagonal viewing surface. Its computer is the 16-bit PDP-11. The Lab-11 includes a programmable range a/d converter, a real-time (crystal-controlled) clock, a high-speed paper-tape reader and punch and the color display.

CIRCLE NO. 294

8 and 16-bit 4k minis cost \$2800 and \$3550



Computer Automation, Inc., Newport Beach, Calif. Phone: (714) 642-9630, P&A: see text; Nov. 1971.

The Alpha series of new mini-computers includes the Alpha 16 which sells for \$3550 for 16 bits of data, a 1600-ns cycle time, 4k core memory, hardware multiply/divide, three direct memory channels and three vectored priority interrupts. The 8-bit Alpha 8, with 4k memory, 1600-ns cycle time, direct memory channels and priority interrupts costs only \$2800.

CIRCLE NO. 295

thin metal parts problems?

**Recording Head Laminations - Springs - Washers
Grids - Clips - Timing Discs - Shields - Fluidic Gates**

without question, ask Hamilton!

Leader in Precision Photoforming®

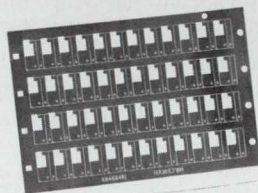

computer head laminations

Photoformed by Hamilton offer a level of dimensional repeatability not available through any other process. Volume production of magnetic alloys, beryllium copper, brass and other alloys in gages as thin as 0.00025" with thickness tolerances of ± 0.00005 " is standard. Only Hamilton can offer melt selection, controlled processing of the thin strip and annealing to desired permeability levels. With Photoforming®, guaranteed permeability levels are available. Fret spraying and stacking, under the tightest controls, is also available.



instrument springs

are a natural application for Photoforming®. Part after Photoformed part, springs like the Archimedes spiral shown here exhibit physical consistencies that other manufacturing methods cannot duplicate. Through Hamilton's stringent control of thickness and flatness tolerances, and materials testing procedures, instrument sensitivity and accuracy is enhanced.



fluidic laminations

and other precision parts being developed at the leading edge of technology are well within the capabilities of Hamilton's Photoforming® engineers. In prototype discussions, they provide the parts manufacturing technology required for sound decisions.

Hamilton gives the design engineer long experience in materials selection, processing controls and manufacturing feasibility needed in new applications.

More than just a photoetching house, Hamilton Photoforming® combines the newest, most advanced chemical machining facilities and equipment with years of thin metals technical experience. Fully equipped metallurgical and magnetic laboratories provide the backup that assures highest quality . . . Hamilton Photoformed quality. Call or write for immediate assistance or complete literature.



PRECISION METALS DIVISION
HAMILTON
WATCH COMPANY • LANCASTER, PA. 17604
PHONE 717/569-0451

INFORMATION RETRIEVAL NUMBER 57

Printing calculator has 320-step program



KG Diehl Calculating Systems, 527 Madison Ave., New York, N.Y. Phone: (212) 751-7374.

The algotronic LSI printing calculator has 64 memory registers of which 32 may be used as program registers giving an internal program capacity of 320 steps. Programs are speeded and simplified because there are special function keys for log, sine, cosine, arc tan, exponential and square root as well as an index register for dynamic addressing of the registers.

CIRCLE NO. 296

CRT display terminals produce hardcopy



Photophysics, Inc., 1601 Stierlin Rd., Mountain View, Calif. Phone: (415) 969-9500. P&A: \$6600 to \$8900; 60 days.

Two new IBM-compatible CRT terminals produce a hard copy of the CRT display in a matter of seconds. Designated models 40 and 44, the interactive desk-top units combine keyboard entry with 2400-baud operation. The model 40 displays 25 lines of 40 alphanumeric characters each. The 44 displays 12 lines of 80 characters each.

CIRCLE NO. 297

Multi-speed data set offers 4 data rates

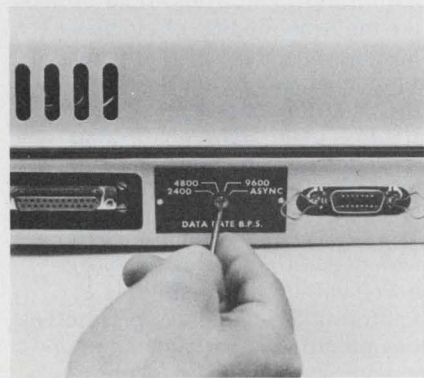

Computer Transmission Corp., 1508 Cotner Ave., Los Angeles, Calif. Phone: (213) 477-5020. P&A: \$1850; 30 days.

The new model 911 Intertran data set offers synchronous data rates of 2400, 4800 and 9600 bits/s and a fourth switch position accommodating any asynchronous rate up to 1800 bits/s. The switch, located on the back of the unit, is screwdriver operated and is clearly marked for use by non-technical users. Transmission is in half or full-duplex modes.

CIRCLE NO. 298

Computer peripheral lets phones speak up

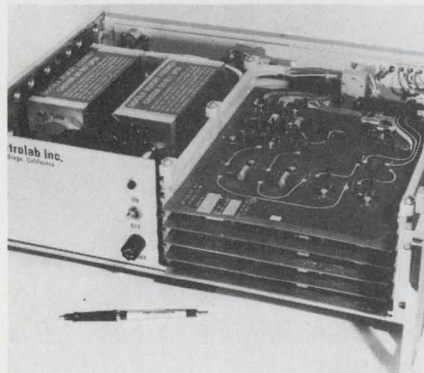

Metrolab, Inc., sub. of Cubic Corp., 9233 Balboa Ave., San Diego, Calif. Phone: (714) 277-6780. P&A: \$5000; 90 days.

A new computer peripheral system can turn a simple telephone into a talking computer terminal requiring no data processing equipment. Called the Digitalk 4000 Voice Response System, it makes it possible to call directly into a computer using a Touch-Tone telephone or telephone pad. The caller receives an answer to his call with a human voice.

CIRCLE NO. 299

Low-cost core memory stores 1 kbits/in.³

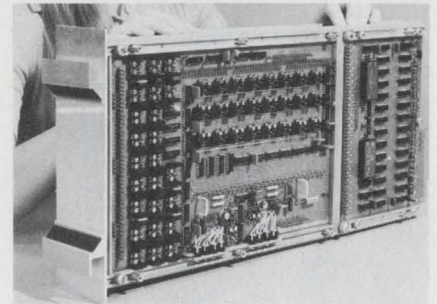

Ampeex Corp., 9937 W. Jefferson Blvd., Culver City, Calif. Phone: (213) 836-5000. P&A: see text; 90 days.

A low-cost computer core memory stores 1000 bits of data per cubic inch. The model 3600 series memory is priced at less than 2¢/bit in quantity. It offers cycle times of 650 and 900 ns in sizes ranging from 16,384 to 131,072 words of 36 bits each. The largest size memory of 16,384 36-bit words measures 9.75 by 21 by 2.8 in.

CIRCLE NO. 300

7200-bit/s data modem has 3 throughput rates



International Communications Corp., 7620 N.W. 36 Ave., Miami, Fla. Phone: (305) 691-1220.

The new 4800/72 modem is an adaptively equalized 7200-bit/s data set with 3 independent 2400-bit/s rates. It uses a new multi-level encoding technique. With an optional forward error-correction feature installed, the new modem provides 4800-bit/s data at ultra-low error rates. Improvement in error rate is better than 1000:1 over previously available 4800-bit/s data sets.

CIRCLE NO. 301

A funny thing happened on the way to the bench.

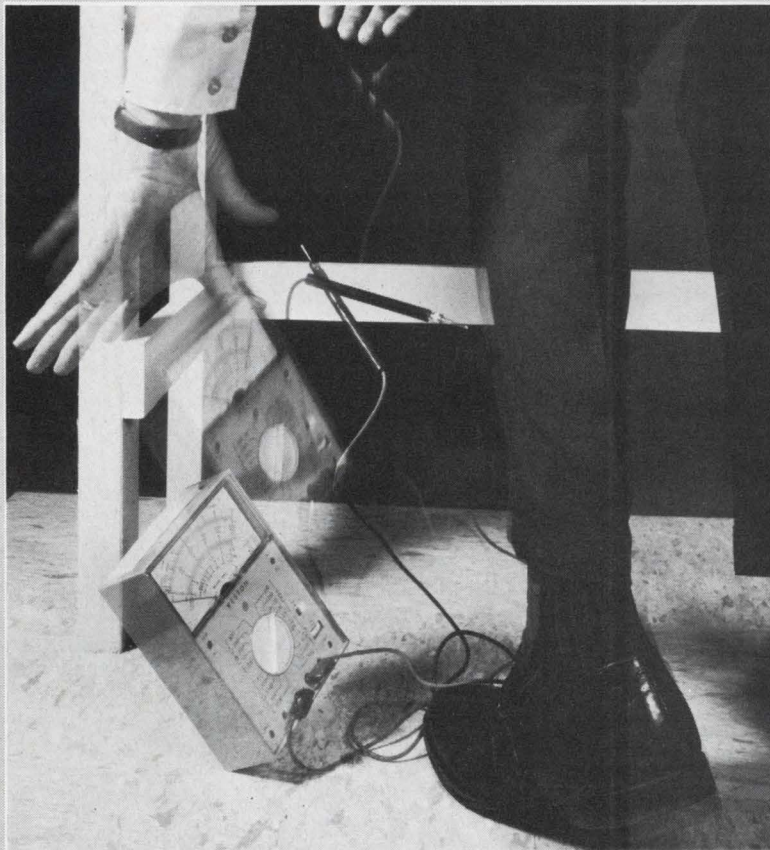

Photo courtesy Electronic Engineer

This Weston VOM will come through a five-foot fall and continue to work. We *engineered* our new 660 series VOMs to be virtually indestructible. And we back up this claim with a written warranty.

In addition to sparing you the embarrassment and inconvenience of a broken instrument, we've designed in all the features you expect in a modern VOM—plus a few more that may surprise you, considering that you pay no more for industry's smallest precision multitester.

For example: all models have diode-protected meter movements, with full

circuit overload protection optional. All are equipped with a custom taut-band mechanism, self-storing handle, polarity reversal switch, externally replaceable fuse, and a single range selector switch.

Basic accuracy is 2% on DC and 3% on AC ranges—an accuracy they'll maintain in extreme environments because they're *temperature compensated*, too.

The 660 series drop-proofed line includes a 35-range general-purpose VOM, a VOM with resettable relay for 220-volt circuit overloads, and a high-

accuracy version of each. There's also a high impedance unit with four push-button selectable modes and 37 ranges designed especially for semiconductor troubleshooting, but rugged enough for any field servicing need as well.

See your Weston distributor, or write for details on these "bouncing" new baby VOMs with more of everything . . . except price.

WESTON®
WESTON INSTRUMENTS
614 Frelinghuysen Ave., Newark, N.J. 07114
a Schlumberger company

Microwave relay system uses Gunn oscillators

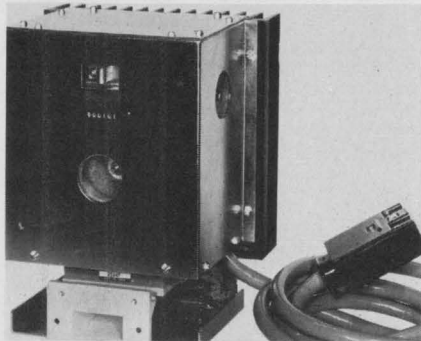

Hitachi, Ltd., No. 5-1, 1-Chome Marunouchi Chiyoda-Ku, Tokyo, Japan.

A microwave system has been made in which a newly developed Gunn-effect oscillator and Gunn diodes are used instead of vacuum tubes. The new oscillators, imbedded in passive stabilized cavities, have long-term frequency stability. In addition, circuitry is simplified and noise ratio cut down substantially. The system will convert uhf waves to 7-GHz microwaves.

CIRCLE NO. 302

GaAs IR diodes handle 3 mW at 50 mA

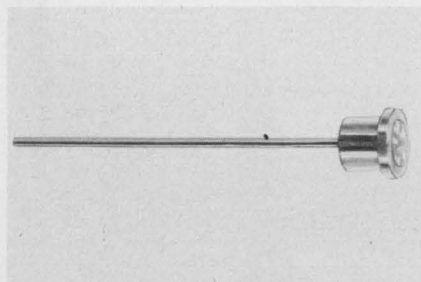

RCA Solid State Div., Route 202, Somerville, N.J. Phone: (201) 485-3900. Price: \$1.95, \$2.50 (1000 quantities).

New high-efficiency GaAs IR-emitting diodes with performance up to 3 mW at 50 mA have been developed. The new LEDs, types 40843R and 40844R, are available in the compact OP-10 package which includes a parabolic reflector for focused output with a controlled beam-emission pattern. Typical output powers are 2.1 mW at 50 mA for the 40843R and 3 mW at 50 mA for the 40844R.

CIRCLE NO. 303

L and S-band amplifiers have low noise figures

Avantek, Inc., 2981 Copper Rd., Santa Clara, Calif. Phone: (408) 739-6170. P&A: \$900; 30 days.

Two transistor amplifiers feature low noise figure and high dynamic range. The AM-1542N and AM-2302N amplifiers operate over 1435 to 1540 and 2200 to 2300 MHz with noise figures of 4.5 and 5.5 dB, respectively. Gains are 20 and 23 dB within ± 0.3 dB, respectively. Output powers, for 1-dB gain compression, are +8 and +10 dBm, respectively.

CIRCLE NO. 304

Sensitive photodiodes operate at 1.06 microns

EG&G, Inc., 35 Congress St., Salem, Mass. Phone: (617) 745-3200.

A new series of silicon photodiodes feature enhanced sensitivity and fast pulse response at 1.06 microns. They provide quantum efficiencies of 55% and pulse responses of 4 ns. Three standard devices are available: the YAG-100 with an active area of 0.051 cm² and rise and fall times of 10 ns; the YAG-444 with an active area of 1.0 cm² and rise and fall times of 10 ns; and the YAG-444-4 which is a quadrant version of the YAG-444.

CIRCLE NO. 305

0.5 to 1-GHz YIG filter tunes its band in 80 μ s

Advanced Microwave Labs, 825 Steward Dr., Sunnyvale, Calif. Phone: (408) 245-5770.

The new P4005F YIG filter will tune through 500 MHz to 1 GHz in only 80 μ s. A 4-stage device, it has 3-dB bandwidth of 20 to 35 MHz and only 4-dB insertion loss. Off resonance isolation is greater than 80 dB. Package size is 1.7 by 2 in., and is under 8 oz in weight. Applications include surveillance receivers and test systems.

CIRCLE NO. 306

\$69 high-gain amplifier spans 10 to 300 MHz

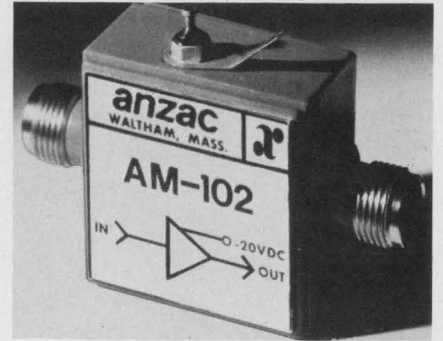

Anzac Electronics, 39 Green St., Waltham, Mass. Phone: (617) 899-1900. Price: see text.

The combination of low price (\$69) and high performance is provided by a new 10-to-300-MHz amplifier. The AM-102 has gain of 9.4 ± 0.4 dB and flat frequency response within 0.8 dB over the full range from 10 to 300 MHz. Typical third-order intermodulation distortion is -65 dB, measured with two -10-dBm input tones at 30 and 28 MHz.

CIRCLE NO. 307

Tiny variable capacitor tunes in through 5 GHz

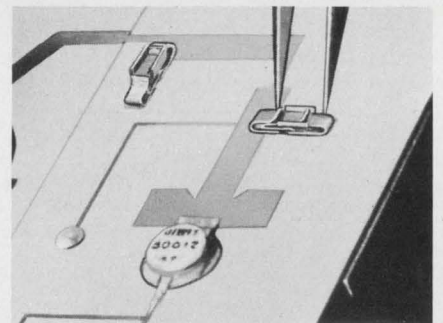

Voltronics Corp., West St., Hanover, N.J. Phone: (201) 887-1517.

A new subminiature variable capacitor tunes microelectronic circuits through the 5-GHz range. Measuring only 0.2-in. long by 0.08-in. wide and 0.04-in. high, the model CP2 has min. capacitance of less than 0.1 pF and max. capacitance greater than 2.5 pF. Its Q factor is over 1000 at 250 MHz. Q at 2 GHz has been measured at over 100. Tuning the entire range is accomplished from the top.

CIRCLE NO. 308

A couple of things you ought to know about Boeing's custom hybrid circuits.

1. High quality.
2. High quantity.

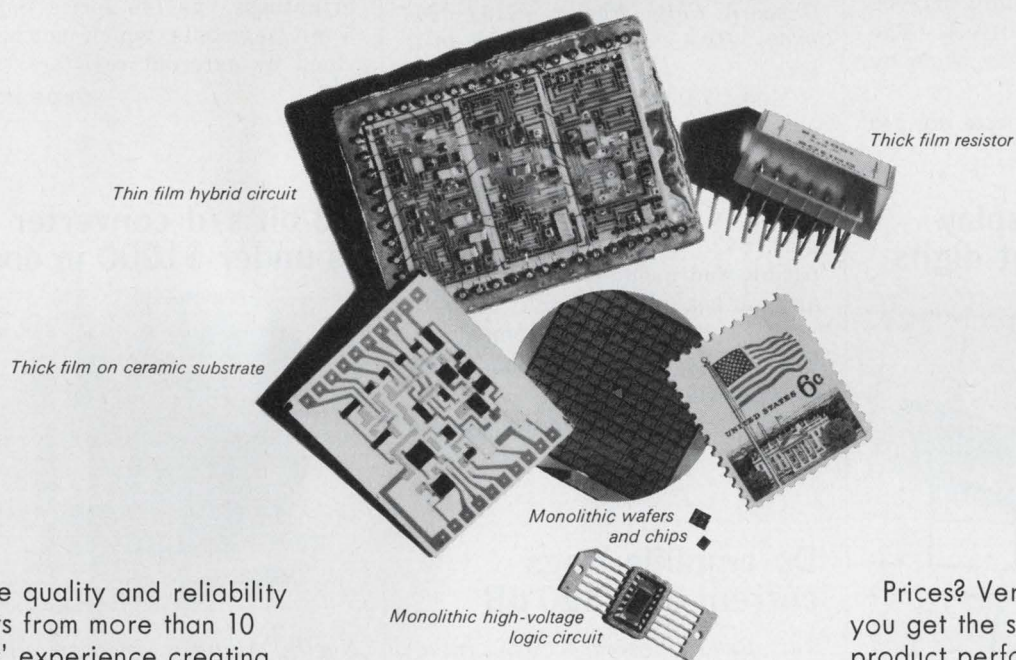

The quality and reliability results from more than 10 years' experience creating electronic parts and systems for demanding aerospace programs. Some \$600 million worth of electronic products thus far.

The quantity is possible because of our extensive facilities and manpower resources. Consider our delivery capability. We can make hybrid microcircuits to your specifications and production rate using the technologies shown above.

We're organized to respond quickly and efficiently. Our 700-man team has all the engineering, manufacturing, QC, contract and sales specialists needed to give you direct service. They're backed by a company that has the unique ability to custom design your microcircuitry and to select the technology that is right for your custom requirements.

Prices? Very competitive. Yet you get the same excellent product performance, quality control and schedule control for which Boeing is famous.

Contact us for more information. Call Herb Broadwell at 206-773-6116. Or write him at P.O. Box 3999, Seattle, Washington 98124.

We can do a lot for you.

**BOEING
ELECTRONIC
PRODUCTS**

INFORMATION RETRIEVAL NUMBER 59

Tiny driver/decoder supplies 300 mA at 30 V

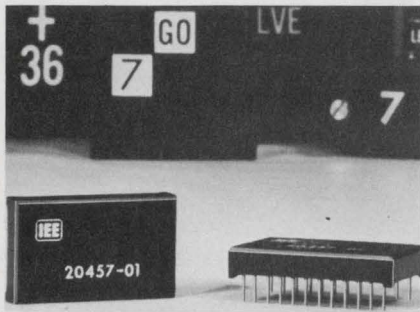

Industrial Electronic Engineers, Inc., 7720-40 Lemona Ave., Van Nuys, Calif. Phone: (213) 787-0311. P&A: \$16.65; 4 to 6 wks.

Series 20457 hybrid circuit driver/decoder is a miniature 24-pin DIP with a high drive capability of 300 mA at 30 V. Operating from a 5-V logic supply, it is designed to decode standard 8-4-2-1 BCD data to 12 outputs. If only 10 decoded outputs are required, the two remaining may be converted as lamp buffers. The circuit measures 0.762-in. wide by 1.277-in. long.

CIRCLE NO. 340

DIP numeric display has 6 7-segment digits

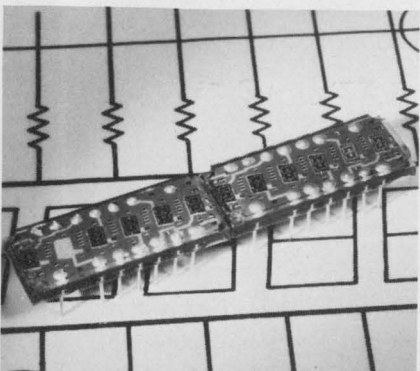

Texas Instruments, Inc., 13500 N. Central Expressway, Dallas, Tex. Phone: (214) 238-2011. P&A: \$27 (1000 quantities); stock.

A new display with a row of six seven-segment numeric digits in a single 14-pin DIP is the TIXL360 which is designed for small calculators or other multiplexed displays. It has 0.1-in. characters with spacings of 0.172 in. The displays can be stacked end-to-end for an unlimited number of digits, at consistent character spacings.

CIRCLE NO. 341

Difference converter produces analog output

Computer Central, Box 5194, Detroit, Mich. Phone: (313) 837-5515. Price: \$195 to \$990.

The DD/A840 is a digital-difference-to-analog converter that retains accuracy of 1 part in 19,999,999 over 0 to +70°C. It computes the difference between two parallel numbers (TTL compatible) and converts this difference to a proportional analog voltage. Its dynamic range is 1 MHz and linear output range is ± 10 V. Conversion factor is 50 mV/unit difference.

CIRCLE NO. 342

12-bit d/a converter retails at only \$49

Zeltex, Inc., 1000 Chalomar Rd., Concord, Calif. Phone: (415) 686-6660. P&A: see text; stock to 2 wks.

Model ZD432 12-bit d/a converter features linearity of $\pm 1/2$ LSB, settling time of 20 μ s, TC of 20 ppm/°C, and full-scale accuracy of 0.05%, all at a price of only \$49. It is TTL/DTL compatible and includes selectable voltage ranges of ± 10 , ± 5 , or 0 to +10 V. It is also DIP compatible. Output is either two's complement or straight binary.

CIRCLE NO. 343

Dc amplifier logs current over 120 dB

Burr-Brown Research Corp., International Airport Industrial Park, Tucson, Ariz. Phone: (602) 294-1431. P&A: \$95; stock.

Model 4116 modular dc amplifier can log voltage over an 80-dB range, and current over a 120-dB range. Its output voltage is proportional to the logarithm of the input. No external amplifiers are needed for the 4116. Just set the scale factor and reference current to match the signal range, apply ± 15 V dc power, and the amplifier is ready to operate.

CIRCLE NO. 344

BCD decoder drives 7-segment readouts

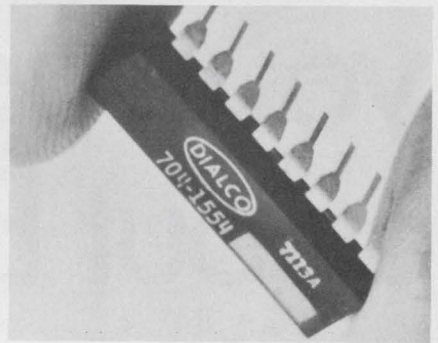

Dialight Corp., 60 Stewart Ave., Brooklyn, N.Y. Phone: (212) 497-7600. P&A: \$5.95; stock.

A new BCD-to-seven-segment decoder is the model 704-1554 which converts four lines of BCD into appropriate outputs for driving series 745 solid-state readouts. Typical source currents of 2 mA are provided by the decoder's active high outputs. For optimum brightness, the 745 series requires 5 mA/segments, which can be provided by external resistors.

CIRCLE NO. 345

13-bit s/d converter is under \$1000 in cost

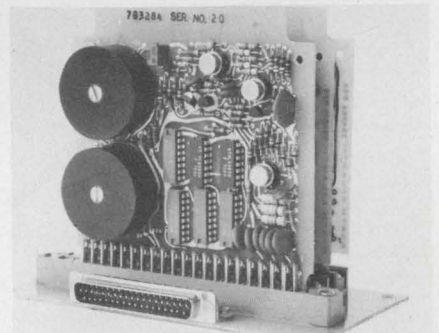

North Atlantic Industries, Inc., Terminal Dr., Plainview, N.Y. Phone: (516) 681-8600. P&A: see text; stock.

Series 711 13-bit s/d converter card sets are designed as low-cost components for do-it-yourself systems design. They consist of three PC cards and plug-in motherboard at a price under \$1000 for the entire card set. The converters employ tracking principles rather than sampling methods, for utmost rejection of harmonics, quadrature, and noise.

CIRCLE NO. 346

BETCHA CAN'T RESIST OUR CHIPS...

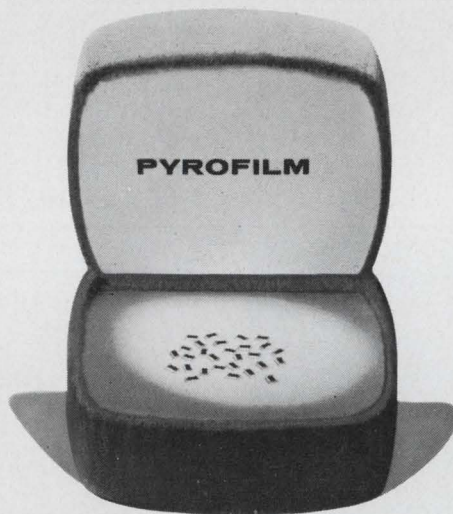

so we're tempting you with
25 free thick film chip resistors

We feel that the quickest way to make confirmed Pyrofilm chip users out of you is to let you try them . . . free. Just drop us a line on your company letterhead requesting the free chip kit. We'll have one of our application engineers bring it around.

What you'll see when you get your kit is:

- 25 chips with a range of values from 100 ohms to 1 megohm
- 4 different sizes ranging from .050" x .050" to .235" x .235"

What you won't know until you've tried these chips is:

- Pyrofilm quality control maintains precise resistor values
- Alumina substrates can be custom fabricated since ceramic is diced rather than snapped apart

- Resistive film is protected from damage and possible change of values by keeping it away from the vulnerable chip edges
- Terminals are platinum gold for the most reliable soldering characteristics possible.

Take our DARE, write today for your free resistor chip kit to: DARE, Pyrofilm Corporation, 60 South Jefferson Road, Whippany, New Jersey 07981 or call (201) 887-8100 if you're in a hurry. If you're not quite ready for a kit but would like to have literature circle the information number below.

903

Setting New Standards in Reliability
PYROFILM

INFORMATION RETRIEVAL NUMBER 60

Regulated supplies

Series A 0.005%-regulated modular supplies include models in six case sizes with dc outputs from 1 to 150 V and 50 mA to 32 A. P&A: \$60 to \$320, 3 days. Acopian, Easton, Pa. (215) 258-5441.

CIRCLE NO. 347

Thumbwheel switches

A new line of 20-mm-wide thumbwheel switches carry alpha-numeric displays up to seven characters. Type R switches are 1.3-in. high and can be assembled in groups up to 25. Interswitch, Burlingame, Calif. (415) 347-8217.

CIRCLE NO. 348

Versatile controllers

The new 601 controllers feature low-cost, micro-programmed assemblies and are fully programmable. Include a 260-ns processor, 200-ns program memories and 1- μ s main memories. Atron. St. Paul, Minn. (612) 454-6150.

CIRCLE NO. 349

Fiberoptic readouts dissipate 100 mW/char.

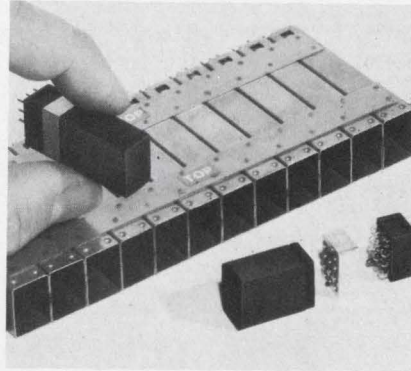

Shelly Assoc., Inc., 1562 Reynolds Ave., Santa Ana, Calif. Phone: (714) 557-3942. P&A: \$10 (1000 quantities); 4 wks.

A new series of subminiature fiberoptic readouts feature low power requirements (100 mW/character) and non-ambiguous reliability (one lamp/character). Designated the FRO series, they provide variable character or numeral-readout intensities. Illumination is for readout up to 15 feet and character height is 0.475 in.

CIRCLE NO. 350

Stable amp offsets 15 μ V

A-242 chopper-stabilized op amp offsets 15 μ V and drifts 0.25 μ V/ $^{\circ}$ C. Input bias is 50 pA. Intech, Santa Clara, Calif. (408) 244-0500. Price: \$69.

CIRCLE NO. 351

Optical-pairs assembly

Optical-pairs assembly has a source side consisting of IR LED array and a detector side with phototransistors. Output from sensors can drive decoding circuits. P&A: \$3/pair, stock to 3 wks. HEI, Chaska, Minn. (612) 448-3510.

CIRCLE NO. 352

Digital 5-V displays

TR-5 series cold-cathode digital display modules operate directly from a 5-V supply. They feature the RCA Numitron tubes with 0.6-in.-high characters. Price: \$23 per digit. Tronix, Phillipsburg, N. J. (201) 859-3944.

CIRCLE NO. 353

We make 100+ different kinds of termination hardware but that's not the end

We are in termination hardware because our customers asked us. They had some definite ideas about miniature posts, sockets, plugs or test clips. Binding post caps that don't melt at soldering temperatures, for example.

Most of our termination products were developed for superior insulation, dielectric strength, contact resistance. (Transistor sockets with minimum insulation resistance of 500,000 megohms at 100 VDC.)

But despite the length of our line, it's not the

end. We will develop new hardware for new applications with the same commitment to quality in design, materials and workmanship that has fed the growing demand for our rotary and push button switch lines.

Like to know more? Write or phone for our latest general engineering catalog. Grayhill, Inc., 565 Hillgrove Ave., La Grange, Ill. 60525, (312) 354-1040.

Grayhill
pioneers in miniaturization

INFORMATION RETRIEVAL NUMBER 61

series AS-A

Tiny performers join KYOWA family of miniature acceleration transducers

series AS-B for lower G's **triaxial series AS-TA** **triaxial series AS-TB**

Light weight & small size construction comparable to piezo-electric crystal types Simply mounted with adhesive Flat frequency response from DC to 3,500Hz Sufficient overload protection No performance deterioration after 10⁷ repeated full scale loadings AC and DC bridge excitation possible Free from drift Wide G ranges: 0 to ± 10 , ± 20 , ± 50 , ± 100 , ± 200 , ± 500 & $\pm 1,000$ G.

KYOWA ELECTRONIC INSTRUMENTS CO., LTD.
1219 Shimofuda-cho, Chofu-shi, Tokyo, Japan

INFORMATION RETRIEVAL NUMBER 62

ELECTRONIC DESIGN 14, July 8, 1971

Power connector blocks assemble easily

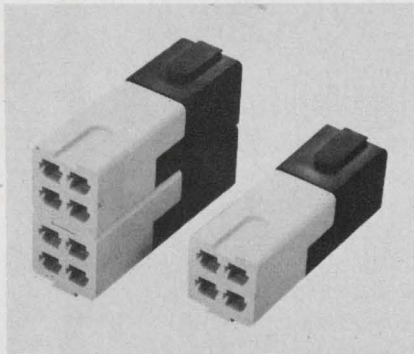

ITT Cannon Electric, Los Angeles, Calif. Phone: (213) 225-1251.

New Electri-Blox connectors which feature ease of assembly can be used in computer and peripheral equipment, test equipment, power supplies and test panels. Their contacts, terminated to wires with a standard crimp tool, are inserted by hand and removed with a simple extraction tool. They will accommodate solid or stranded wire in sizes 12 through 18 AWG.

CIRCLE NO. 354

50-Ω hermetic package is ideal for stripline

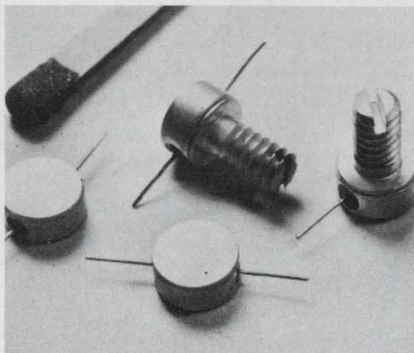

Alpha Industries, Inc., 20 Sylvan Rd., Woburn, Mass. (617) 935-5150.

Type 190 package is a 50-Ω hermetically sealed stripline unit designed for use from uhf through Ku-band. It is especially useful in balanced stripline circuits employing 1/16-in. dielectrics and is available either with or without a heat-sink stud. Several types of microwave semiconductors can be supplied in this package. These include step-recovery, varactor, limiter, p-i-n, avalanche and Gunn diodes.

CIRCLE NO. 355

Edgeboard connector enhances wirewrapping

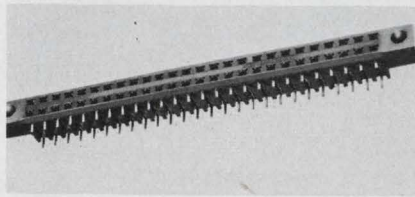

Hugh H. Eby Co., 4701 Germantown Ave., Philadelphia, Pa. Phone: (215) 324-7000.

A new plug-in edgeboard female connector with dip-solder terminals mates with 0.025-in. square or round pins in wirewrap applications. Designated the Eb-Con edgeboard female connector No. 9775-68, it is designed primarily for use with PC boards and is suited for mother-board solderless wirewrap packaging and rack-and-panel flat-cable applications.

CIRCLE NO. 356

Standard DIP cases include many options

Metalized Ceramics Corp., West River Industrial Park, Providence, R. I. Phone: (401) 331-9800.

A variety of configurations and options can be specified as standard for Metalized Ceramic's DIP family of 24, 28 and 40-lead packages on 600-mil centers. These include wrap-around lead frames, kovar seal rings and any specified lead-to-dice attach pad connections.

CIRCLE NO. 357

PC laminating material withstands 500°F

General Electric Co., Insulating Materials Dept., 1 Campbell Rd., Schenectady, N.Y. Phone: (518) 374-2211. Price: \$5.50/square yard (1/16-in. sheet).

New GEMON L polyimide prepreg laminating material for PC boards exhibit superior dimensional stability over epoxy type materials. It has excellent dimensional stability and thermal resistance at temperatures up to 500°F—yet can be laminated at temperatures as low as 350°F and pressures ranging from 15 to 1000 psi.

CIRCLE NO. 358

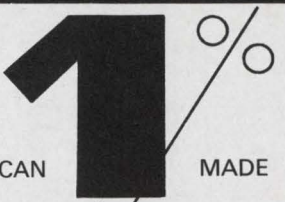

AMERICAN MADE

Tolerance
SCHAUER
1-Watt
ZENERS

Immediate Shipment
Low Prices

ANY voltage from 2.0 to 18.0

Quantity	Price each
1-99	\$1.07
100-499	.97
500-999	.91
1000-4999	.86
5000 up	.82

All welded and brazed assembly
No fragile nail heads



Gold plated leads

Write for complete rating data and other tolerance prices.

**Buy the kit-
Save a lot**



SCHAUER 1 WATT ZENER DIODES
KIT NO. SCH 51
Y SCHAUER MFG. CORP.

Kit contains a 51-piece assortment of SCHAUER 1% tolerance 1-watt zeners covering the voltage range of 2.7 to 16.0. Three diodes of each voltage packaged in reusable poly bags. Stored in a handy file box. Contact your distributor or order direct.

A \$54.57 value for
ONLY \$24⁵⁰

Semiconductor Division
SCHAUER
Manufacturing Corp.
4511 Alpine Ave. Cincinnati, Ohio 45242
Telephone: 513/791-3030

evaluation samples

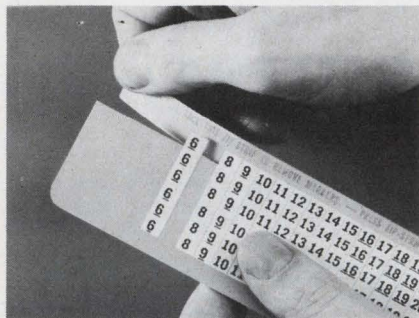

Wire markers

Type B-700 vinyl film self-sticking wire markers may now be included on military requirements because of their new Type V classification of MIL-M-22106A which calls for a non-reinforced vinyl film marker. The B-700 markers are mounted on dispenser cards for easy handling and storing. They are especially resistant to oils and solvents. Just 0.006-in. thin, they perform within a temperature range of -20 to 300°F . Legends are etched into the material for permanence. Catalog and samples are available. W. H. Brady Co.

CIRCLE NO. 359

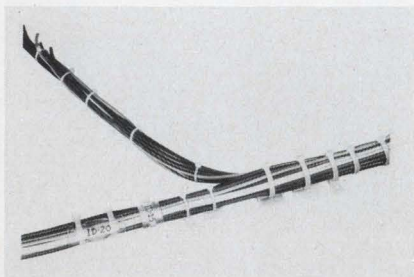

Wire clamp

A new one-piece nylon band clamp, known as Ny-Grip, provides new convenience in wire bundling and banding. Positive holding is provided by a locking design which engages its ratchet teeth on the inside of the band and prevents loosening or back slipping. Once the clamp is locked, it has to be cut loose. Ny-Grip clamps are available from stock in three standard sizes. Complete details, prices and samples are available. Weckesser Co.

CIRCLE NO. 360

design aids



Metric templates

A line of 30 metric templates, incorporating the most popular and widely used template designs, is available. Symbols included in the line are circles, squares, screw threads, triangles and diamonds, hexagon bolts and nuts, a radius guide and parallel spacer. Also included is a unique isometric ellipse which allows drawing of all three axes without turning the template. In addition, the line includes the No. 2070 ellipse series of 10 templates from 15 to 60 degrees in five-degree increments. Ten templates are available as a set or individually. RapiDesign, Inc.

CIRCLE NO. 361

Digital displays

Sperry Information Displays Division announces the availability of a free designer's aid for their new digital display devices. This useful aid, which is an actual size printed version of the Sperry SP-730 series display, is ideal for use on new equipment design mock-ups and other preproduction applications. The orange-and-black, 16-digit strip with pressure-sensitive backing, can be easily cut apart to meet individual display requirements. Sperry Information Displays Division.

CIRCLE NO. 362

Lettering nibs

Nib crushing and subsequent wobbling, and wavery letters—always a danger when plastic shank ribs are used in scribes—are eliminated with a new series of lettering nibs with metal shanks. Designed for use in the 990 technical pen, the new series is recommended for popular scribe systems and can be used with all major brands of technical fountain pens. Nine line widths are available: 0.3, 0.35, 0.4, 0.5, 0.6, 0.8 and 1.0 mm. A. W. Faber-Castell Pencil Co.

CIRCLE NO. 363

application notes

Thermistor design

A complete glossary of thermistor terms as well as a step-by-step procedure for designing thermistor circuits are contained in a bulletin. All necessary relationships and equations, in addition to thermistor sensitivity and output curves are included. The bulletin also contains a list of thermistor probe assemblies. Omega Engineering, Inc.

CIRCLE NO. 364

Automated testing

A new technical bulletin, "Small Computer Automated Testing Facilities," reviews a methodology for obtaining precise information on how communications and other electronic equipments will function in a variety of environments. It describes how automation can aid in testing of concepts as well as devices in a number of areas. It shows that by automating an experimental data-gathering function, it becomes possible to amass large amounts of data and to process it in real-time, as opposed to customary techniques, of costly real-life installations and tests. Computer Sciences Corp.

CIRCLE NO. 365

Plastic DIP heat sinking

A three-page technical report, complete with thermal curves and equations, discusses the use of a cooling fin on plastic dual-in-line packages for heat-sinking applications. AEG-Telefunken Corp.

CIRCLE NO. 366

Analog Dialogue

The latest issue of "Analog Dialogue" is crammed with juicy morsels of technical information. This ranges from the applications for a new monolithic IC voltage switch to the use of analog multipliers for measurement of sine wave amplitudes, without averaging. Analog Devices, Inc.

CIRCLE NO. 367

**A few words to those
who design circuits
without a gaussmeter.**

Good luck.

If you design or work with magnetic circuits, a gaussmeter can save you a lot of time. It converts flux density into voltage for measurement. So, you can check faults both magnetically and electrically to track down any trouble as quickly as possible. Our gaussmeter brochures are the place to start. Write: 4949 Freeway Drive East, Columbus, Ohio 43229

E.W. Bell Inc.

A subsidiary of The Arnold Engineering Co.

INFORMATION RETRIEVAL NUMBER 64

UP TIGHT **50%**
SHRINKDOWN AT ONLY 160°F
with PENNTUBE[†] VII-B

Neoprene*
SHRINKABLE
TUBING

Tough! Flexible! Protective!
Inexpensive! Shrinks down in hot water above 140°F. Good electrical and mechanical strength. Resists corrosion and chemicals and will not support a flame. Used for electrical insulation on wires, mechanical protection for pipes and fittings. Effective as scuff resistant jacketing for electrical cables and harness... and much more. Sizes 1/4" to 4". Black only.

PENNTUBE Plastics Co., Inc.

SEND FOR FREE SAMPLE
and Bulletin #71SN-B

P | **D** SUBSIDIARY OF
DIXON INDUSTRIES

Madison Ave. & Holley St.
Clifton Heights, Pa. 19018
(215) 622-2300

Export Div. • 5710 Empire State Bldg., N.Y. 10001
*Du Pont Reg. TM. †Penntube Plastics Co. Reg. TM.

INFORMATION RETRIEVAL NUMBER 65

ELECTRONIC DESIGN 14, July 8, 1971

**SAVE MONEY AND SPACE
WHILE ELIMINATING ALL
THESE OPERATIONS**

- Multi-component receiving inspection
- Sorting for TC or Ratio match
- Pre-packaging or binning
- Multi-insertions: With only ONE INSERTION you can assemble up to 4 resistors on a PC board, and in 1/8 the space!

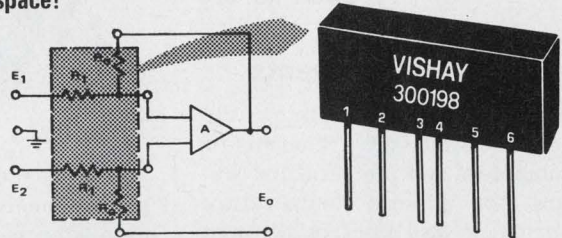

Typical op-amp feedback resistors showing how one VISHAY (actual size) pre-packaged 4 resistor assembly can be used to replace precision wirewounds.

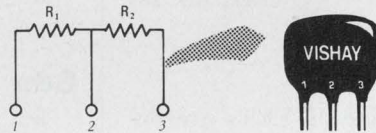

VISHAY (actual size) pre-packaged 2 resistor voltage divider. Other configurations available with up to 4 discreet resistors.

VISHAY UNITIZED RESISTOR CIRCUITS

SPECIFICATIONS	TYPICAL PRICES (QTY. 100)
<p>HIGH ACCURACY RATIO MATCH</p> <ul style="list-style-type: none"> ■ Each Resistor: 100Ω to 75K ■ Absolute Tol. each R: To .005% ■ Absolute TC each R: ± 5 ppm/°C (-55°/125°C) ■ Tol. Match: To .005% ■ TC Match: Within 3 ppm/°C (-55°/125°C) 	<p>\$9.52 each (0.01% match; tracking within 3 ppm/°C)</p>
<p>MEDIUM ACCURACY RATIO MATCH</p> <ul style="list-style-type: none"> ■ Each Resistor: Up to 50K ■ Absolute Tol. each R: To .05% ■ Absolute TC each R: ± 10 ppm/°C (-55°/125°C) ■ Tol. Match: To .1% ■ TC Match: Within 5 ppm/°C (0°/60°C) 	<p>\$1.56 each (1% match; tracking within 5 ppm/°C)</p>

For details on other Unitized Resistor Circuits for use as bridges, rectifiers, attenuators, ladders, etc., contact:



VISHAY RESISTOR PRODUCTS

A DIVISION OF VISHAY INTERTECHNOLOGY, INC.

63 LINCOLN HIGHWAY ■ MALVERN, PENNA. 19355
TELEPHONE: (215) 644-1300 ■ TWX: 510-668-8944

PRECISION RESISTORS • NETWORKS • DECADE BOXES • TRIMMERS

INFORMATION RETRIEVAL NUMBER 66

105

new literature

Consumer ICs

A new consumer IC bulletin provides a selection of 39 ICs ideal for use in AM/FM radio-phonograph and color television systems. Texas Instruments, Inc.

CIRCLE NO. 368

Temperature instruments

A new four-page catalog describes and illustrates thermistor thermometers and temperature controllers for precise temperature measurement and control through -80 to $+150^{\circ}\text{C}$. Yellow Springs Instrument Co.

CIRCLE NO. 369

FETs

An entire line of FETs are detailed in a 16-page brochure. Intersil, Inc.

CIRCLE NO. 370

Electrometers

A 12-page brochure describes a new line of multi-range electrometers. Princeton Applied Research Corp.

CIRCLE NO. 371

Drafting instruments

New drafting instruments such as drawing protectors, slide rules and scales are detailed in a brochure. Devonics Inc.

CIRCLE NO. 372

Hybrid power amplifiers

Twenty-four pages of application data describe uses and performance of high-power hybrid audio amplifiers. Sanken Electric Ltd.

CIRCLE NO. 373

Transducers

A new six-page catalog describes characteristics of a variety of semiconductor and foil strain-gauge subminiature pressure transducers. Sensotec, Inc.

CIRCLE NO. 374

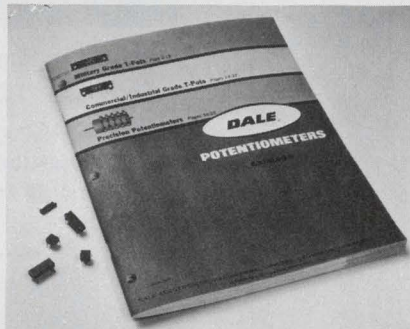

Trimmers

An expanded 36-page catalog of potentiometers features complete details on more than 50 wirewound and film-element trimmers. Dale Electronics, Inc.

CIRCLE NO. 376

Gear motors

Fractional-horsepower and gear motors are described in two bulletins. Bodine Electric Co.

CIRCLE NO. 377

Plastic optics

An illustrated four-page brochure gives optical data for plastics and discusses criteria for choosing between glass and plastic optics. U.S. Precision Lens and Plastics, Inc.

CIRCLE NO. 378

Subminiature lamps

A complete line of subminiature incandescent lamps is described in a new catalog. Alcolite Div. of Alco Electronic Products.

CIRCLE NO. 379

Chokes and coil forms

Rf molded chokes and tunable coil forms are listed in a 28-page catalog. Gowanda Electronics Corp.

CIRCLE NO. 380

Emi/rfi filters

A new 17-page catalog for emi/rfi filters is available. U.S. Capacitor Corp.

CIRCLE NO. 381

Interface drivers

A data sheet package details a complete line of hybrid 5-V DTL/TTL interface driver circuits. Tele-dyne Semiconductor.

CIRCLE NO. 382

Potentiometers

Guidelines for ordering customized precision potentiometers are presented in a new brochure. Trim-pot Products Div., Bourns, Inc.

CIRCLE NO. 383

Ceramic capacitors

A new 12-page catalog describes a line of miniature radial-lead monolithic ceramic capacitors. Electro Materials Division of Illinois Tool Works, Inc.

CIRCLE NO. 384

Semiconductor devices

A new 16-page semiconductor condensed catalog describes a wide variety of power semiconductor components ranging from commercially available high-voltage thyristors, rectifiers and transistors to power control and rectifier assemblies. Westinghouse Electric Corp.

CIRCLE NO. 385

Neon indicators

Complete specifications for a broad range of neon indicator lamps are given in chart form in a new brochure. Novelite Corp.

CIRCLE NO. 386

Op amps

A new data sheet describes a line of op amps. Melcor Electronics Corp.

CIRCLE NO. 387

Multiplexer

An expandable eight-channel multiplex module is detailed in a brochure. Analog Devices, Inc.

CIRCLE NO. 388

STRIP BUS by Rogers

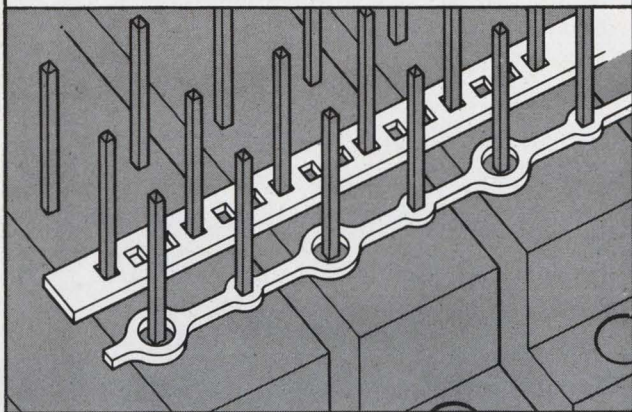

Low Cost Bussing Systems
Easy Installation
Reliable Solder Joints
Greater Pin Exposure



Write or call for details

Rogers Corporation / Rogers, Conn. 06263 (203) 774-9605

INFORMATION RETRIEVAL NUMBER 67

Our new jumbo
general catalog
is appropriately
numbered 747.

And it's free!

This new catalog supersedes our previous Catalog 700. It contains 43 more pages and over 1300 new CAMBION electronic components. And it's been re-arranged so that it's easier to use. Now that we've brought the world's standard in electronic hardware and accessories up to date, you can too. We'll also include our new Digital Products Catalog so you'll be covered with the fast growing area of handling devices for IC's. Write today for your free copy.

Standardize on

CAMBION

The Guaranteed Electronic Components

TO: Mr. William G. Nowlin, General Marketing Manager
Cambridge Thermionic Corporation
445ED Concord Avenue, Cambridge, Mass. 02138
Please rush Catalog 747.

Name _____
Company _____
Address _____
City _____ State _____ Zip _____

INFORMATION RETRIEVAL NUMBER 68

ELECTRONIC DESIGN 14, July 8, 1971

First LOOK
at the
SPECS...

then take a
**DOUBLE
LOOK** at the
NEW LOW PRICES!!!

Precision thin film resistor
ladder networks for as little
as \$8 for hermetically sealed
mil spec units...and even less
for commercial quality!!!

**BOTH R-2R VOLTAGE DIVIDERS
and CURRENT DIVIDERS**

PACKAGE: 16 LEAD DIP (.690 × .250)
and FLAT PACK (.375 × .250)

TEMPERATURE RANGE: -55° C to +125° C

T. C. TRACKING: < 1 ppm/° C

LADDER RESISTANCE VALUE (R) : 500*,
5K, 10K, 25K or 50K

*Current divider ladder only.

APPLICATION RESISTORS INCLUDED

MODEL NO.	DESCRIPTION	PRICE (1000 UP)	RATIO ACCURACY
HC 1000	12 Bit Voltage Divider	\$16.60	0.012%
HC 1050	12 Bit Current Divider	16.60	0.012
HC 1005	10 Bit Voltage Divider	14.00	0.05
HC 1055	10 Bit Current Divider	14.00	0.05
HC 1010	8 Bit Voltage Divider	9.00	0.2
HC 1060	8 Bit Current Divider	9.00	0.2

LADDER RESISTANCE VALUE (R) : 10K WITH NO APPLICATION RESISTORS

HC 100	12 Bit Voltage Divider	15.50	0.012
HC 105	10 Bit Voltage Divider	12.50	0.05
HC 110	8 Bit Voltage Divider	8.00	0.2

For fast action contact nearest sales rep.

LEXINGTON, MASS.

Contact Sales Inc.

(617) 861-1550

NORRISTOWN, PA.

Denco-Data Engineering Co.

(215) 272-1444

MOUNTAINSIDE, N. J.

JJS Assoc.

(201) 233-4562

SYRACUSE, N. Y.

W. H. Zimmerman Inc.

(315) 474-4889

CEDAR RAPIDS, IA.

Lorenz Sales Inc.

(319) 366-0774

RICHARDSON, TEX.

Thornton Electronic Sales Co.

(214) 231-6891

PASADENA, CAL.

Mar-Land Enterprises

(213) 681-9440

CUPERTINO, CAL.

Trident Assoc.

(408) 245-7884

Custom networks also available,
for further information contact:
Norm Palazzini at (617) 897-4578

HyComp

HyComp, Inc.

146 Main Street, Box 250

Maynard, Massachusetts 01754



INFORMATION RETRIEVAL NUMBER 69

Together...
ness...

DIALCO DATALITES[®]

mount as close as
1/2 inch center to center

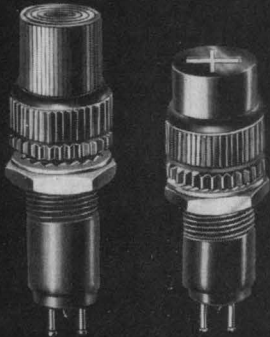

SHOWN ACTUAL SIZE

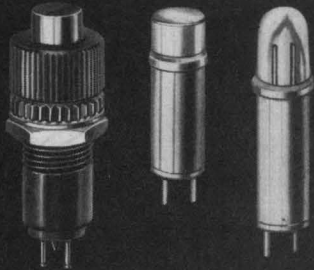

Designed to meet or exceed requirements of MIL-L-3661B.

Replaceable plug-in cartridges: Incandescent for 1.35-120V; neon—high-brightness operation 110-125V AC, and standard brightness operation 105-125V AC-DC.

Wide range of lens shapes, colors and finishes.

Broad selection of positive or negative legends.

Available off-the-shelf for prompt delivery.

Send for free catalog



Dialight Corporation
60 Stewart Ave., Brooklyn, N. Y. 11237.
(212) 497-7600



A NORTH AMERICAN PHILIPS COMPANY
INFORMATION RETRIEVAL NUMBER 70

NEW LITERATURE

Power supplies

A new catalog describes a family of power supplies designed particularly for packaged digital displays. Instrument Displays, Inc.

CIRCLE NO. 389

A/d/a converters

A/d and d/a converter modules are featured in a four-page selection guide. Teledyne Philbrick.

CIRCLE NO. 390

Solenoids

Detailed technical data on 65 stock model push and pull solenoids is given in a 27-page catalog. Ledex, Inc.

CIRCLE NO. 391

Data processing

A new 56-page catalog covers amplifier, signal-conditioning and data-processing products. SRC Division/Moxon, Inc.

CIRCLE NO. 392

Wiring products

Products in five lines of components, wire harnesses, and industrial controls are illustrated and described in a new catalog. Burcliff Industries, Inc.

CIRCLE NO. 393

Laser system

The latest ruby and glass laser systems are described in a 19-page bound brochure. Apollo Lasers, Inc.

CIRCLE NO. 394

Relays

A new data-file kit contains six brochures which describe and illustrate a complete line of reed and standard relays. Wheelock Signals, Inc.

CIRCLE NO. 395

Neon indicators

Cold-cathode Elfin neon indicators and indicator assemblies along with their decoder/drivers are described in a brochure. Alcolite Div. of Alco Electronic Products.

CIRCLE NO. 396

Voltage regulators

A handy, one-page voltage regulator guide is available for use in determining the correct monolithic or hybrid regulator. Teledyne Semiconductor.

CIRCLE NO. 397

54/74 TTL

A new 5400/7400 TTL supplement is available. Signetics.

CIRCLE NO. 398

Surge protectors

A complete line of gas-filled surge voltage protectors is described and illustrated in a four-page bulletin. Siemens Corp.

CIRCLE NO. 399

TWX

A four-page brochure describes TWX—Western Union's Teletypewriter Exchange Service. Western Union.

CIRCLE NO. 400

Crystal oscillators

A 24-page catalog describes a full line of crystal oscillators and frequency standards. Vectron Laboratories, Inc.

CIRCLE NO. 401

TTL ICs

A comprehensive 68-page handbook describes a family of TTL ICs. Raytheon Semiconductor.

CIRCLE NO. 402

Lock-in amplifiers

A guide to evaluating and selecting lock-in amplifiers is available. Keithley Instruments, Inc.

CIRCLE NO. 403

Capacitors

A new 12-page catalog describes a complete line of subminiature ceramic capacitors. Republic Electronics Corp.

CIRCLE NO. 404

bulletin board



CATV users can now have interference-free TV reception thanks to a new converter known as Gamut 26 for vhf and CATV channels. The converter uses up-conversion techniques for the incoming TV signals, instead of the usual down-conversion methods, to eliminate crosstalk and imaging effects. Twenty-six channels are provided.

CIRCLE NO. 405

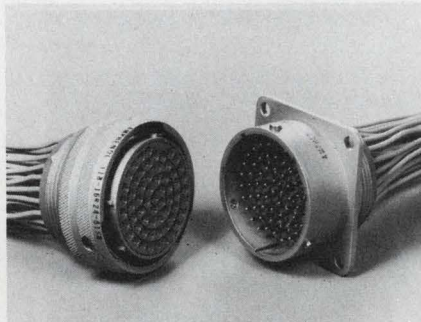

Amphenol Connector Div. has introduced a new rear-release circular connector for MIL-C-26482 requirements, that is said to be lighter, shorter and 20% cheaper than its competitors. Known as Merlin I, it achieves these characteristics with the use of Astrel 360 material and the elimination of conventional metal-retention contact clips.

CIRCLE NO. 406

Victory Engineering, Springfield, N.J. is making available a compact medium-power panel temperature controller. Designated model 1500, it can sense up to 3000 W and 3000°F via thermocouples, at an accuracy of $\pm 1\%$, and costs only \$99.50.

CIRCLE NO. 407

FREE EMI/RFI FILTER CATALOG FROM USCC/CENTRALAB

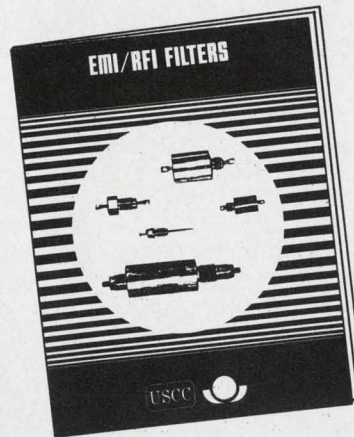

A new 20-page catalog of EMI/RFI Filters is now available from USCC/CENTRALAB.

The catalog includes: Button, Subminiature, Miniature, and Feed-thru types, which meet or exceed all applicable requirements of MIL-F-15733; and a new line of filters designed to meet all UL and European requirements for electronic data processing units and systems.

Listed are all mechanical and environmental specifications, typical insertion loss curves and complete ordering information.

For your free copy write:
USCC/CENTRALAB, 2151 N. Lincoln St., Burbank, California 91504.
(213) 843-4222 — or circle the information retrieval number below.



U.S. CAPACITOR CORPORATION



CENTRALAB Electronics Division • GLOBE-UNION INC.

INFORMATION RETRIEVAL NUMBER 71

VECTOR-PAK SYSTEM SOLVES PACKAGING PROBLEMS

NEW

- CAGES NOW AVAILABLE FULLY OR PARTIALLY ASSEMBLED.
- NEW EASY-TO-ORDER NUMBERING SYSTEM.
- BUILT IN ADJUSTABILITY AND FLEXIBILITY TO SOLVE YOUR PACKAGING PROBLEMS.

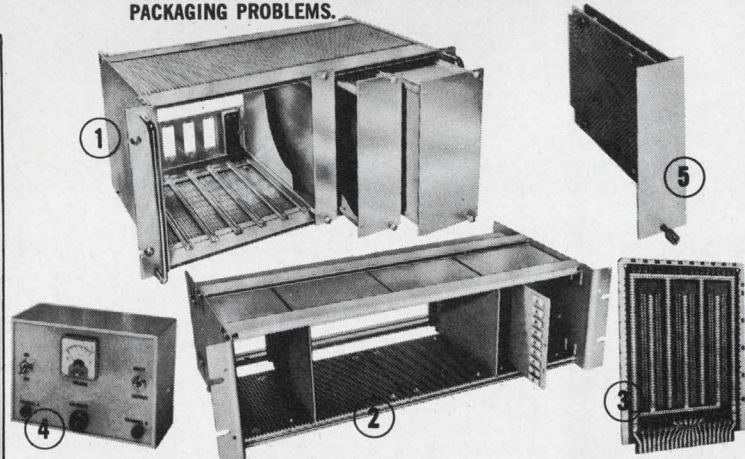

- ① New "NIM" Bins and Modules for cost saving interchangeability — exclusive Vector Card Mounting System.
- ② Rugged all aluminum Vector-Pak Card Cages with extruded guides located at .50" or .750" spacing — easily adjusted.
- ③ Dozens of new Plugboards for building Plug-In Cards — IC and discrete types.
- ④ Multi-Mod Cases — sleek functional aluminum cases for instruments and other circuitry. 4 slotted interior surfaces for cards, mounting plates.
- ⑤ Front Panel Card Mount Plates supplied ready for cards, "pots" and switches — Mount plates in Vector-Pak Cages.

Send for new specification sheets.

VECTOR ELECTRONIC CO., INC.

12460 Gladstone Ave., Sylmar, California 91342

NEW Phone (213) 768-6080 ■ TWX (910) 496-1539



INFORMATION RETRIEVAL NUMBER 72

Design Data from Manufacturers

Advertisements of booklets, brochures, catalogs and data sheets. To order use Reader-Service Card.
(Advertisement)

NEW RELAY SOCKET ASSEMBLIES CATALOG

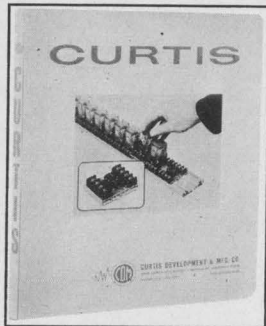

The new Curtis line of printed circuit snap-in track-mounted relay socket assemblies is completely illustrated in this new 2-color, 6 page catalog. Variations include RS8 octal relay sockets, as well as RS11 and RS15 with eleven and fifteen pin relay sockets. Complete dimensional drawings and list prices are included. All units snap in or pop out vertically from prepunched vinyl track and feature Curtis barrier terminal blocks. CSA approved. Send today for your free copy.

See us at WESCON—Booth 2310

CIRCLE NO. 171

Curtis Development & Mfg. Co.
3236 North 33rd Street
Milwaukee, Wisconsin 53216

How To Write Technical Articles

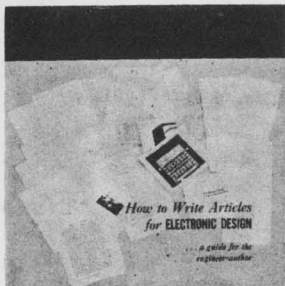

A guide for the engineer-author, "How to Write Articles for Electronic Design" shows how easy it is to write for publication—once the engineer knows what to write and how to write it. The Author's Guide includes a complete run-down of the types of articles published by Electronic Design—plus detailed instructions on how to prepare technical articles and short special features. A MUST for every "would-be-writer" in the electronics industry. Send for your complimentary copy by circling the number to the right.

CIRCLE NO. 172

Electronic Design
850 Third Avenue
New York, N.Y. 10022

Free . . . Electromagnetic Delay Line Catalog



20 pages of completely updated data, making this source tool even more valuable than our previous catalog. Delay line applications in data processing, sonar (ASW), traffic control systems, aerospace and missiles, and many others.

Complete specifications on: Subminiature nanosecond delay lines, millisecond delay lines, variables, and tapped delay lines, custom delay lines, standard military types, and many others.

CIRCLE NO. 173

ESC Electronics Corporation
534 Bergen Blvd.
Palisades Park, NJ 07650
(201) 947-0400

Electronic Design

ELECTRONIC DESIGN's function is:

- To aid progress in the electronics manufacturing industry by promoting good design.
- To give the electronic design engineer concepts and ideas that make his job easier and more productive.
- To provide a central source of timely electronics information.
- To promote two-way communication between manufacturer and engineer.

Want a subscription? ELECTRONIC DESIGN is sent free to qualified engineers and engineering managers doing design work, supervising design or setting standards in the United States and Western Europe. For a free subscription, use the postfree application form inside the back cover. If none is included, write to us direct for an application form.

If you do not qualify, you may take out a paid subscription for \$25 a year in the U.S.A., \$35 a year elsewhere. Single copies are \$1.50 each.

If you change your address, send us an old mailing label and your new address; there is generally a prepaid postcard for this inside the back cover. You will have to requalify to continue receiving ELECTRONIC DESIGN free.

The accuracy policy of ELECTRONIC DESIGN is:

- To make reasonable efforts to ensure the accuracy of editorial matter.
- To publish prompt corrections whenever inaccuracies are brought to our attention. Corrections appear at the end of the Letters column.
- To refuse any advertisement deemed to be misleading or fraudulent.

Microfilm copies are available of complete volumes of ELECTRONIC DESIGN at \$19.00 per volume, beginning with Volume 9, 1961. Work is now in process to complete the microfilm edition of Volumes 1-8. Reprints of individual articles may be obtained for \$2.00 each, prepaid (\$.50 for each additional copy of the same article) no matter how long the article. For further details and to place orders, contact the Customer Services Department, University Microfilms, 300 North Zeeb Road, Ann Arbor, Michigan 48106; telephone (313) 761-4700.

Want to contact us? If you have any comments or wish to submit a manuscript or article outline, address your correspondence to:

Editor
ELECTRONIC DESIGN,
850 Third Avenue,
New York, N.Y. 10022.

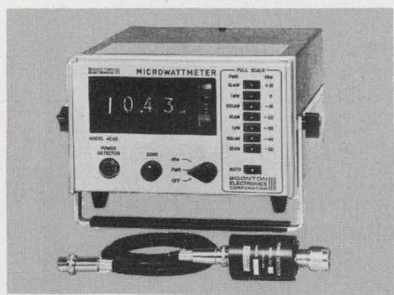

One nanowatt to ten milliwatts, 12.4 GHz to 200 kHz, with Model 42AD Digital RF Microwattmeter. Digital readout, BCD and linear outputs, programmable, stable. Options: dBm readout, autoranging, logic-level programming. Boonton Electronics Corp., Parsippany, N. J. (201) 887-5110.

INFORMATION RETRIEVAL NUMBER 181

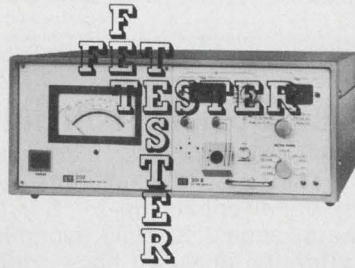

IPT-200 bench-top field effect transistor tester for discretes, dual gates, and matched pairs — MOS/JFET's plus some bipolars, package or chip form, Ipa f.s. leakage, program 4th lead, pulse 300 ma. IPT Corporation, Mountain View, Ca 94040. (415) 961-9521.

INFORMATION RETRIEVAL NUMBER 182



Heat Spy infrared thermometer. $\pm 1\%$ non-contact surface temp measurements. 0 to 1100°F. Instantly detect temp of electronic components without contact. New 6-pg. catalog. William Wahl Corp., Los Angeles. (213) 391-7234.

INFORMATION RETRIEVAL NUMBER 183

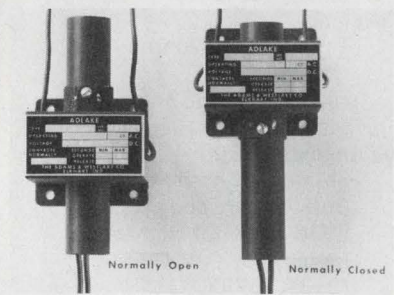

Time delay relays available with fixed time delay in either make or break. Also available BOTH make and break. Meets time requirements of seconds up to maximum delay of 20 minutes. The Adams & Westlake Company, Elkhart, Indiana. (219) 264-1141.

INFORMATION RETRIEVAL NUMBER 184



The Signetics Model 1420 Linear IC Tester. Tests VR's, OP Amps, Comparators, Sense Amps, Video Amps, PLL's, etc. Ideal for volume testing. Also available with Option 440 Transfer Function Generator for Lab use. \$7,950. Signetics Corp., Measurement/Data Division, 341 Moffett Blvd., Mtn. View, Calif. 94040. 415/961-9384.

INFORMATION RETRIEVAL NUMBER 185

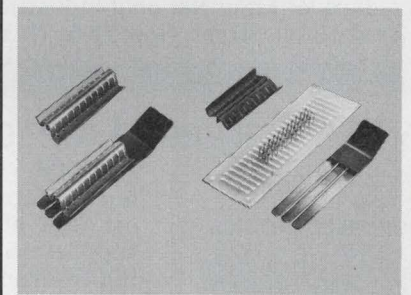

New Digi-Klip fiber strip holds up to 22 Digi-Klips for simple location in circuit board. Wave-solder Klips and discard fiber holder. Full DIGI-KLIP facts from Components Corporation, Denville, New Jersey. Telephone: 201-627-0290.

INFORMATION RETRIEVAL NUMBER 186

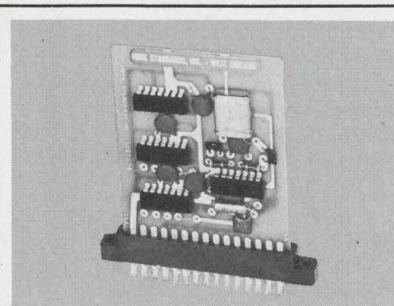

PC CARD CRYSTAL OSCILLATOR MODEL CQ IS CARD SOCKET MOUNTED. Standard or special frequencies 1Hz to 15MHz, Acc to .001%. TTL compatible, Tweakable, Multiple output. \$50-90 singly. Fork Standards, Inc., 217 Main St., West Chicago, IL 60185. (312) 231-3511.

INFORMATION RETRIEVAL NUMBER 187

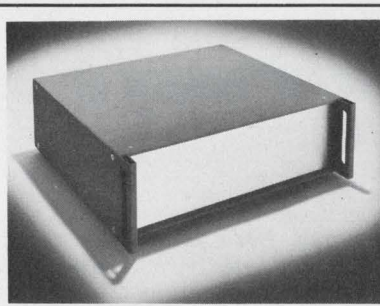

Electronic Enclosures by Janise achieve that expensive look at low cost. The "VERSAPAC" Series with rich, colorful suede finishes offers flexibility in instrument design. Prices from \$24.00 in quantity. Janise, Inc., 3033 Jefferson Street, San Diego, California 92110. Telephone: 714-295-1320.

INFORMATION RETRIEVAL NUMBER 188



EICO Model 443 Solid State Semiconductor Curve Tracer

Display diode & transistor curves on your general purpose scope with EICO 443 curve tracer. Diode measurements include relationship between forward V & I, PIV to 1400V, reverse leakage I. Power & signal tests for h_{FE} , h_{OE} , I_{CEO} , BV_{CEO} , etc. \$99.95 kit, \$149.95 wired. EICO, 283 Malta St., Bklyn., N. Y. 11207. (212) 949-1100.

INFORMATION RETRIEVAL NUMBER 189

Design Data from Manufacturers

Advertisements of booklets, brochures, catalogs and data sheets. To order use Reader-Service Card.
(Advertisement)

Fight Fuzziness with New Real-Time 256-point Correlator

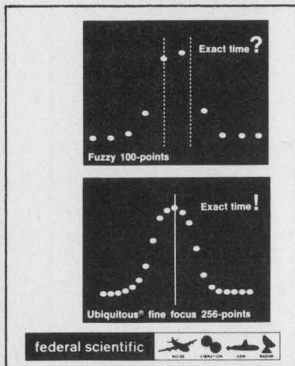

UC-201A Ubiquitous® Correlator is a complete time-domain measurement lab for real-time auto & cross-correlation, signal enhancement, & probability. For underwater acoustics, fluid dynamics, medical research, vibration analysis, noise source identification. Features: exact time measurements with digital dial; computes integral & differential of any stored function (converts probability density to cumulative distribution without rerunning data); pre-computational delay built-in (256 samples); sampling increments from 1/2 usec to 2 sec; complete ext. (computer) control plus digital outputs; built-in test signals for all modes; small, portable, easy to use; reasonably priced. Many options.

CIRCLE NO. 174

Federal Scientific Corporation

a subsidiary of Elgin National Industries, Inc.
615 West 131st Street, New York, N. Y. 10027

World's Largest Line of Smallest Supplies

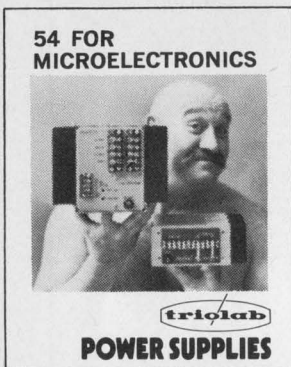

Now the world's smallest power supplies for microelectronics are available in the world's largest line of high power density, high efficiency supplies: 54 off-the-shelf models. From 100W to 500W; from 3VDC to 30VDC; single, dual, triple outputs; commercial, military, export models. Now in use by such leaders as Burroughs, Control Data, Honeywell, IBM, Litton, NCR, RCA, Univac, and many Government installations. Shown (left): Model SP631, 5VDC/100A, typical efficiency 70%, 8.50" x 6.81" x 8.85", 21.5 lbs., \$695. (Right): Model SP601, 5VDC/20A, typical efficiency 65%, 3.25" x 6.50" x 7.50", 6 lbs., \$400. Custom development and production also available.

CIRCLE NO. 175

Trio Laboratories, Inc.

80 Dupont Street,
Plainview, L. I., N. Y. 11803

Free Catalog of Technical Books

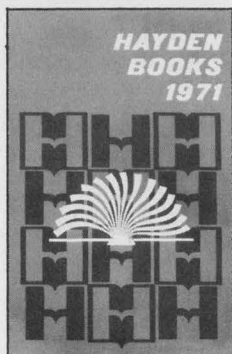

Hayden Book Company's 1971 Catalog describes a wide range of guidebooks, texts, and references of interest to engineers. Among areas covered are electrical and electronics engineering, professional engineering examinations, and computer technology and programming. Also included are texts, references, and guides for training and updating technical personnel. Circle the reader service number for a free copy.

CIRCLE NO. 176

Hayden Book Company, Inc.

116 West 14th Street
New York, N. Y. 10011

Electronic Design

Advertising Sales Staff

Keith Aldrich
Sales Manager

New York 10022

Robert W. Gascoigne
Samuel M. Deitch
Daniel J. Rowland
850 Third Avenue
(212) Plaza 1-5530
TWX: 710-581-2874

Philadelphia 19025

Mort Sullivan
P.O. Box 126
Dresher, Pa.
(215) 884-6880

Boston 02154

Joseph F. Palmer
1268 Main Street
Waltham, Mass.
(617) 894-2700

Chicago 60611

Thomas P. Kavooras
Berry Conner, Jr.
200 East Ontario
(312) 337-0588

Cleveland

Thomas P. Kavooras
(Chicago)
(312) 337-0588
(call collect)

Los Angeles 90303

Stanley I. Ehrenclou
Burt Underwood
2930 Imperial Highway
Inglewood, Calif.
(213) 757-0183

San Francisco 94022

Jerry D. Latta
95 Main Street
Los Altos, Calif.
(415) 941-3084

London W. 1

For United Kingdom and Holland
Brayton C. Nichols
For Eastern Europe
Peter Kehr

The American Magazine Group

27 Maddox Street
London, W. 1, England
Phone: 499-0180
Cable: Ammagnic, London

Verviers, Belgium

For Continental Europe
Andre Jamar
1, Ru Mallard, 1
(087) 253.83 Telex 41563

Tokyo

Haruki Hirayama
Electronic Media Service
5th Floor, Lila Bldg.,
4-9-8 Roppongi
Minato-ku
Phone: 402-4556
Cable: Electronicmedia, Tokyo



General Electric has an SCR or TRIAC in the price-performance range you need!

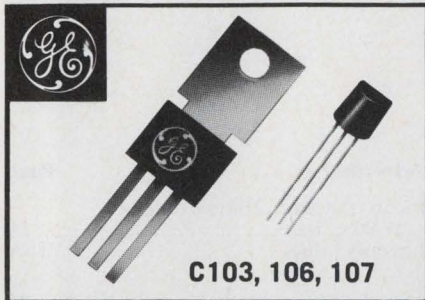

C103, 106, 107

SILICONE ENCAPSULATED SCR'S PRICED FOR VOLUME APPLICATIONS. C103-8A up to 200V in TO-18 configuration. C106 and 107-4A up to 400V in Power Tab packages. Millions already being used in sensing, controlling, amplifying, timing and switching applications. RETRIEVAL NO. 101 FOR SPECIFICATION SHEETS.



SC40, SC45, SC50

6, 10 and 15A TRIACS up to 500V. Available in three packages. Inherent immunity from transient voltage damage. For industrial and consumer applications performing heat, light, speed and power switching functions. RETRIEVAL NO. 102 FOR SPECIFICATION SHEETS.

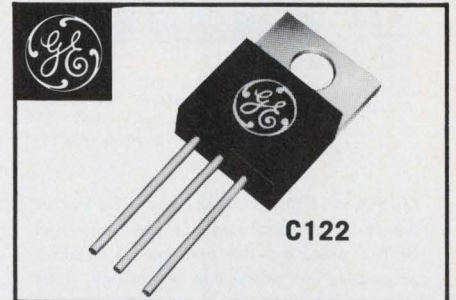

C122

8A SCR with GLASSIVATED pellet in silicone encapsulated package featuring round leads and TO-66 interchangeability. Ratings up to 400V. Priced for volume automotive, consumer, and industrial applications. Designed for either printed circuit board or chassis mounting. RETRIEVAL NO. 103 FOR SPECIFICATION SHEETS.



C20, C30

INEXPENSIVE medium current SCR's for high volume industrial and consumer applications. C20-7.4A up to 400V. C30-25A up to 400V. High surge capability. Available in stud, isolated stud, or press-fit packages. RETRIEVAL NO. 104 FOR SPECIFICATION SHEETS.



C35

THE CLASSIC SCR backed by 13 years of design and field experience. 35A up to 800V. 125°C T_J max. TO-48 package outline. JEDEC Types 2N681-692. JAN and JANTX Types available. RETRIEVAL NO. 105 FOR SPECIFICATION SHEETS.



C137

SCR WITH VALUE-PLUS! 35A up to 1200V operating temperature range -65 to 125°C. di/dt = 150 A/μsec when switching from 600V. Min. dv/dt = 100V/μsec. High voltage and excellent dynamic characteristics with no peak voltage limitations. RETRIEVAL NO. 106 FOR SPECIFICATION SHEETS.



C144

FOR HIGH POWER SWITCHING. 35A, 500-800V capability characterized for rectangular and sine wave operation at frequencies up to 10 kHz. Excellent for chopper, inverter, regulated power supply and pulse modulator applications. RETRIEVAL NO. 107 FOR SPECIFICATION SHEETS.



C397/398, C387/388

HIGH SPEED INVERTER SCR's in GE's efficient PRESS-PAK. Amplifying gate construction for superior ratings. C397/398-700A rms up to 1200V. C387/388-550A rms up to 1200V. Designed for power switching up to 3 kHz sinusoidal. RETRIEVAL NO. 108 FOR SPECIFICATION SHEETS.



C600, 601, 602

2600V PHASE CONTROL SCR. Highest ratings available domestically. Packaged in GE's efficient and reliable PRESS-PAK. Ideal for phase control of large motors and high current contactor replacements. RETRIEVAL NO. 109 FOR SPECIFICATION SHEETS.

Semiconductor Products Department, Syracuse, N.Y. 13201

Low Frequency MECHANICAL FILTERS



(actual size)

- Applications:
- Paging systems
 - Remote control systems
 - Remote supervisory systems

Mechanical filters distributed by Seiko Instruments Inc. are derivatives of world renowned SEIKO precision, the outcome of exacting processes and production technology. With almost a decade of experience in the manufacturer of mechanical filters, DAINI SEIKOSHA is able to offer miniature types exhibiting truly high performance. Reliability? Not questionable if you're talking about one of our products.

Many types are available. On special order, we can satisfy a wide range of specifications.



• Sole distributor in the United States:
SEIKO INSTRUMENTS, INC.
14333, South Figueroa Street, Gardena, Calif.
90247 Phone: 213-770-0152
Telex No. 673686

INFORMATION RETRIEVAL NUMBER 74

Attention Advertisers:

Can't you just see your fantastic advertisements in living color before your eyes? Then order your reprints directly from us; the minimum unit order is 500 copies.

Please specify if you would like the reprint line omitted on your copies and mail your written order to ELECTRONIC DESIGN, Production Dept., 50 Essex Street, Rochelle Park, New Jersey 07662.

500 1,000 Add'l M
8x10 or smaller

1 color, 1 side	\$74.70	82.95	18.15
2 color, 1 side	95.47	108.00	25.28
4 color, 1 side	311.03	342.00	44.33

Spreads

1 color	113.66	126.65	25.98
2 color	191.19	205.98	29.58
4 color	354.17	380.76	53.19

Prices FOB Waseca, Minn.

advertiser's index

Advertiser	Page	Advertiser	Page
AMP, Incorporated	43	Licon Division Illinois Tool Works, Inc.	15
Adams & Westlake Company, The ..	111	Litronix, Inc.	16A
Alco Electronic Products, Inc.	68	3M Company	29
Allen-Bradley Co.	27	Marconi Instruments Division of English Electric Corporation	69
Amphenol Components Group	12	Meguro Denpa Sokki K. K.	116
Beckman Instruments, Inc.	79	MicroSwitch, A Division of Honeywell	46
Belden Corporation	4, 5	Molex, Incorporated	1
Bell, Inc., F. W.	105	Motorola Component Products Dept.	16
Boeing Electronic Products	99	Motorola Semiconductor Products, Inc.	76, 77
Boonton Electronics Corporation	111	National Semiconductor Corporation	73
Burroughs Corporation	18	Non-Linear Systems, Inc.	86
Cambridge Thermionic Corporation	107	Oak Manufacturing Co.	11
Cinch Manufacturing Company	45	Philips Electronic Components and Materials Division	38
Clare & Co., C. P.	37	Pinlites, Inc.	94
Components Corporation	111	Precision Metals Div., Hamilton Hatch Company	95
Curtis Development & Mfg. Co.	110	Pyrofilm Corporation	101
Cutler-Hammer Specialty Products Division	17	RCA Electronic Components and Devices	Cover IV
Dale Electronics, Inc.	Cover III	Rogers Corporation	107
Dialight Corporation	108	Schauer Manufacturing Corp.	103
Dixon Industries/Penntube Plastics ..	105	Seiko Instruments, Inc.	114
EICO Electronic Instrument Co., Inc.	111	Servo-Tek Products Company	32
ESC Electronics Corporation	110	Siemens Corporation	38
Edmund Scientific Company	115	Sigma Instruments, Inc., International Instrument Division	7
Electronic Design	110, 114, 115	Signetics Corporation	111
Electronic Measurements, Inc.	44	Sprague Electric Company	21
Erie Technological Products, Inc.	47	Stackpole Carbon Company	42
European Electronic Products Corporation	91	TRW, Inc.	2
Exact Electronics, Inc.	48	Tektronix, Inc.	41
Federal Scientific Corporation	112	Texas Instruments Incorporated, Components Group	32A-F
Fluke Mfg. Co., Inc., John	10, 33	Trio Laboratories, Inc.	112
Fork Standards, Inc.	111	Triplett Corporation	89
GTE Automatic Electric	8, 9, 84	Union Carbide, Components Dept.	14
GTE Sylvania	31	U. S. Capacitor Corporation	109
General Electric Company	113	Vactec Inc.	13
General Radio Company	83	Vector Electronic Co., Inc.	109
Grayhill, Inc.	102	Victoreen Instrument Division	115
Hayden Book Company, Inc. 16B, 112		Vishay Resistor Products, A Division of Vishay Intertechnology, Inc.	105
Heath Company	6	Wahl Corp., William	111
Hewlett-Packard	Cover II, 36, 64, 65, 81	Weston Instruments, Inc.	97
Houston Instrument	87		
HyComp, Inc.	107		
IPT Corporation	111		
Ingersoll Products, Division of Borg Warner Corporation	34, 35		
Instrument Specialties Company, Inc.	93		
Interstate Electronics Corporation	63		
Janco Corporation	94		
Janise, Inc.	111		
Kyowa Electronic Instruments Co. Ltd.	102		

Miniature High Voltage Resistors



new Mini-Mox resistors offer 100 ppm TCR plus low noise characteristics

Mini-MOX resistors have all the ingredients you need for new designs for ultra-critical applications. For instance, Mini-MOX resistors are a fraction the size of conventional types; they meet or exceed MIL-R-10509-F for environmental parameters . . . 100 ppm or less; T.C.R. stability better than $\pm 2\%$ for 2,000 hours at full load; low-voltage coefficient less than 5 ppm/volt, measured between 100 volts and full-rated voltage; in addition typical quantech noise at 20 megohms is less than 0.5 microvolt/volt.

Available off-the-shelf, Mini-MOX resistors are ideally-suited for high-voltage applications where long-term stability and power-to-size ratios are critical.

Model	Resistance	Rating @70°C	*Max. Oper. Volts	Length Inches	Diameter Inches
MOX-400	1-2500 megs	.25W	1000V	.420	.130
MOX-750	1-5000 megs	.50W	2000V	.790	.130
MOX-1125	1-10,000 megs	1.00W	5000V	1.175	.130

Write for complete Technical Data Sheet on Mini-MOX Resistors: Victoreen Instrument Div. of VLN Corp., 10101 Woodland Ave., Cleveland, Ohio 44104. Telephone: 216/795-8200.



DMA 558 Expertise in high voltage

INFORMATION RETRIEVAL NUMBER 75



FREE CATALOG!

148 PAGES • MORE THAN 4000 UNUSUAL BARGAINS
SCIENCE • OPTICS • SPACE

1000's OF HARD-TO-FIND BUYS FOR INDUSTRY.

Speed your work! Improve quality! Cut development and production costs! Completely new edition loaded with on-the-job helps, quality control aids, unique items available nowhere else. 148 easy-to-read pages packed with new products, charts, diagrams, illustrations. A treasure house of optical and scientific equipment available direct from stock for industry, research labs, design engineers, experimenters, hobbyists.

AMERICA'S GREATEST ONE-SOURCE MARKET PLACE
Hard-to-get surplus bargains. Ingenious scientific tools. Thousands of components: lenses, prisms, wedges, mirrors, mounts, accessories of all descriptions. Hundreds of instruments: lasers, comparators, magnifiers, microscopes, projectors, telescopes, binoculars, photo attachments, black light equipment and the largest selection of unique lighting items in the country.

ORDER DIRECT WITH ABSOLUTE CONFIDENCE
Edmund ships more than 5,000 orders monthly to the country's largest industrials. Every item completely guaranteed. You must be satisfied with any purchase or return it in 30 days for your money back. Shop the catalog of America's largest Science-Optics-Space Mart. Send for your free copy today. Absolutely no obligation. No salesman will call. Request FREE catalog "DA".

EDMUND SCIENTIFIC CO.
300 EDSCORP BLDG.
BARRINGTON, NEW JERSEY 08007

MAIL COUPON FOR GIANT FREE CATALOG!

EDMUND SCIENTIFIC CO.
300 Edscorp Building, Barrington, N. J. 08007
Please send Free Giant Catalog "DA"

NAME _____
COMPANY _____
ADDRESS _____
CITY _____ STATE _____ ZIP _____

INFORMATION RETRIEVAL NUMBER 76

a new space unit from Electronic Design

A NEW 1/9 PAGE SIZE FOR ONLY \$300 INCLUDING PRODUCTION CHARGES!

Quick Ads will be placed in their own special section, attractively laid out to insure maximum attention. Each will have its own Information Retrieval Number, assuring many inquiries, many sales leads. You simply provide an 8 x 10" glossy photograph, plus approximately 40 words of copy. We do the rest at no cost to you.

For full information, including even lower frequency rates, mail the form at right to Peter D. Coley, Publisher, Electronic Design, 50 Essex Street, Rochelle Park, N.J. 07662

Quick Ads

PLEASE RUSH ME FULL DETAILS ON QUICK ADS IN ELECTRONIC DESIGN

NAME _____ FIRM _____
STREET _____ CITY _____ STATE _____ ZIP _____
TITLE _____

**HIGH
RELIABILITY
INSTRUMENTS**

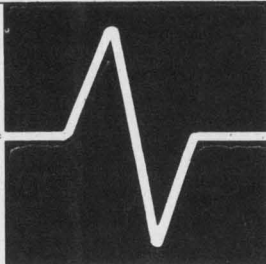

*** MAIN PRODUCTS**

- SIGNAL GENERATOR
- GENESCOPE
- FREQUENCY ANALYZER
- WOW FLUTTER METER
- L.C.R. BRIDGE
- OSCILLATOR (SWEEP)
- DISTORTION METER
- PHASE METER
- Q METER
- VTVM, LEVEL METER

MODEL—
MO-190

5 MHz

X-Y

OSCILLOSCOPE

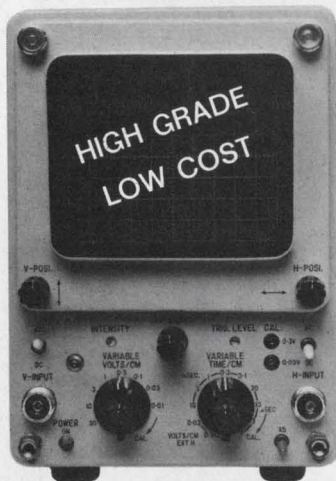

□ USES:

MO-190 is a compact laboratory type 13cm (5") triggered oscilloscope engineered with particular attention to the phase and response characteristics.

It is well suited where low phase distortion at any gain setting is demanded, especially in the display of complex waveforms in stereo circuits. Within limits of operation, it can be used as a high grade oscilloscope.

□ FEATURES:

Wide bandwidth—DC to 5MHz.
Calibrated time base—1μs to 10ms/cm.
Sensitivity—0.01 to 30V/cm.

© Catalog sheet on request.



INFORMATION RETRIEVAL NUMBER 77

product index

Information Retrieval Service. New Products, Evaluation Samples (ES), Design Aids (DA), Application Notes (AN), and New Literature (NL) in this issue are listed here with page and Information Retrieval numbers. Reader requests will be promptly processed by computer and mailed to the manufacturer within three days.

Category	Page	IRN	Category	Page	IRN
Components			converter, s/d	100	346
capacitors, chip	90	274	decoder, BCD	100	345
capacitors, polystyrene	90	270	display, six-digit	100	341
CRTs, display	88	267	displays, digital	102	353
decades, BCD resistor	88	264	driver/decoder	100	340
delay lines, video	90	276	op amp, chopper	102	351
ladder networks	90	271	optical-pairs assembly	102	352
potentiometer, ac	88	265	power supplies	102	347
pulsar, laser	90	266	readouts, fiberoptic	102	350
relays, solid-state	90	278	switches, thumbwheel	102	348
switches, proximity	90	277			
switches, rotary	88	263	Packaging & Materials		
thermistors	90	272	connector, edgeboard	103	356
transformer kit	88	268	connector blocks	103	354
transformers, DIP/TO-5	90	275	DIP packages	103	357
tube, display	88	261	laminating material	103	358
varistors, silicon	88	262	package, stripline	103	355
Data Processing					
calculator, printing	96	296			
computer system	95	294	new literature		
data set	96	298	capacitors, ceramic	106	384
memory, core	96	300	chokes	106	380
minicomputers	95	295	converters, a/d/a	108	390
modem, data	96	301	electrometers	106	371
peripheral, computer	96	299	FETs	106	370
terminals, CRT	96	297	filters, rfi/emi	106	381
			ICs, consumer	106	368
ICs & Semiconductors			ICs, TTL	108	398
buffers, unity-gain	94	292	ICs, TTL	108	402
encoder, keyboard	94	293	indicators, neon	106	386
op amps, IC	92	282	indicators, neon	108	396
RAM, dynamic	92	281	lamps, subminiature	106	379
ROM, bipolar	94	290	op amps	106	388
shift register	92	280	potentiometers	106	383
suppressors, click	94	291	relays	108	395
switches, JFET	92	279	transducers	106	374
			trimmers	106	376
Instrumentation					
analyzer, spectrum	86	256			
detector, box car	87	258	application notes		
generator, function	85	251	heat sinking, plastic	104	366
generator, sweep/signal	86	253	testing, automated	104	365
measurement system	85	252	thermistor design	104	364
multimeters, digital	85	250			
oscillograph, portable	86	254	design aids		
phase meter, digital	87	260	displays, digital	104	362
probe, logic	86	257	nibs, lettering	104	363
sources, reference	86	255	templates, metric	104	361
voltmeter-counter	87	259			
			evaluation samples		
Microwaves & Lasers			clamp, wire	104	360
amplifier, 300-MHz	98	307	markers, wire	104	359
amplifiers, L/S-band	98	304			
capacitor, variable	98	308			
filter, YIG	98	306			
LEDs, GaAs IR	98	303			
photodiodes	98	305			
relay system, microwave	98	302			
Modules & Subassemblies					
amplifier, log	100	344			
controllers	102	349			
converter, d/a	100	343			
converter, difference	100	342			

QPL/PDQ

from DALE

It's a fact that Dale can quickly supply more QPL resistors and trimmers than any other source. It's also a fact that we don't turn off the quality when we produce these same parts to fill your non-DESC needs. Wirewound or film, military, industrial or commercial, standard or special, we have a resistive capability that you can use to save time and money for your company. No bragging — It's a fact!

Write for more information including Dale's Military Resistor Identification Guide and QPL or phone 402-564-3131.



DALE ELECTRONICS, INC.
1300 28th Ave., Columbus, Nebr. 68601
In Canada: Dale Electronics Canada, Ltd.
A subsidiary of The Lionel Corporation

POWER WIREWOUND

MIL-R-26E/MIL-R-39007B: RW20V to 24V, 29V to 33V, 35V to 38V, 47V, 67V to 69V, 70U, 74U, 78U, 80U, 81U. RWR71, 74, 78, 80, 81, 82, 84, 89 (including both "S" & "W" suffixes).



POWER WIREWOUND HOUSED

MIL-R-18546D/MIL-R-39009A: RE60, 65, 70, 75, 77, 80 (including both "G" & "N" suffixes); RER40, 45, 50, 55, 60, 65, 70, 75 (includes "F" suffix).



PRECISION WIREWOUND

MIL-R-93D/MIL-R-39005B: RB52CE to 56CE, RB71CE; RBR52 to 55.



ADJUSTABLE POWER WIREWOUND

MIL-R-19365C: RX29V, 32V, 33V, 35V, 36V, 37V, 38V, 47V.

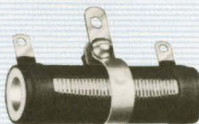

FIXED FILM

MIL-R-10509F/MIL-R-55182D: RN50 (C&E), 55 (C, D, E), 60 (C, D, E), 65 (C, D, E), 70 (C, D, E, F), 75 (B), 80 (B). RNR, RNC & RNN50, 55, 60, 65 (H, J, K), to "R" failure rate.

FIXED FILM INSULATED

MIL-R-22684B: RL07S, 20S.



VARIABLE WIREWOUND

MIL-R-27208C/MIL-R-39015A: RT10, 11, 12 (C2P, C2L suffixes); RT22, 24, (C2P, C2L, C2W, C2X suffixes); RTR12DP, RTR12DL.

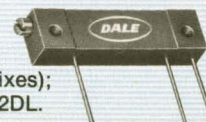

INFORMATION RETRIEVAL NUMBER 243

VERSAWATT POWER

NEW NPN

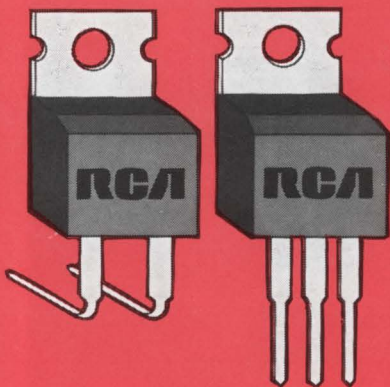

Stepped-up Performance

(2N6098-6103)

NEW PNP

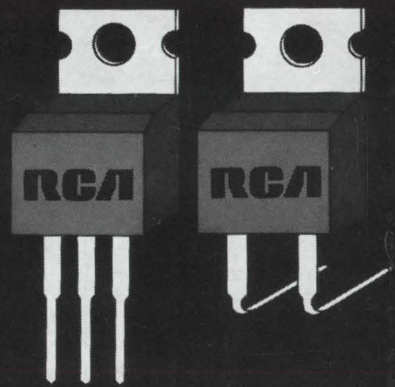

Expanded Versatility

(2N6106-6111)

RCA's 2N6103 series is new! It now makes available to designers an extended current capability in the RCA VERSAWATT line—from 0.5 to 8.0 Amp. Utilizing a chip similar to the 2N3055, this silicon power n-p-n family is the next step up from the 2N5298 and 2N5496. You get all the advantages of Hometaxial-base construction, backed by thermal cycle ratings and safe area operating curves. The 1000-unit prices in the family start at 65¢.

The 2N6103 family is recommended for such applications as hammer drivers, series regulators, motor speed controls, inverters, and output stages of audio amplifiers to 40 W.

Also new, the 2N6111 family is another in the series of RCA epitaxial-base p-n-p power transistors, offering designers new p-n-p versatility in the popular VERSAWATT package. Intended for complementary use with 2N5298 and 2N5496, these epitaxial devices are backed by RCA's exclusive thermal cycle

ratings and complete safe area operating specifications. The 1000-unit prices in the family start at 70¢.

Ideal in a variety of circuits, the 2N6111 will especially interest those working with audio amplifiers to 25 W, vertical deflection circuitry, high frequency inverters, positive/negative series regulators, and automotive applications.

To be confident of plastic power transistor quality and reliability, look to RCA. We engineer and build our economy-priced plastic power to the exacting standards that have made our hermetic products your bench mark for power transistor dependability.

For more information, see your local RCA Representative or your RCA Distributor. For technical data, write: RCA, Commercial Engineering Section 57G-8/UTL19, Harrison, N.J. 07029. International: RCA, Sunbury-on-Thames, U.K., or P.O. Box 112, Hong Kong.

RCA Solid
State