

# MICRO SWITCH

# Sealed Solid State Keyboards



# MICRO SWITCH Sealed Solid State Keyboards ...an ideal solution to your data input needs.

MICRO SWITCH now offers a line of truly effective, Sealed Solid State Keyboards for applications in industrial, aerospace, marine, military and other severe environments. These ruggedly constructed, sealed keyboards are especially designed to provide protection against accidental spills of coffee or sodas, splash-over or drip through of oil and moisture, and accumulation of sand, dust, chips or other contaminants which can damage or cause failure of non-sealed units. In addition, this custom designed sealing capability protects the expensive electronics usually located behind or underneath the keyboard.

MICRO SWITCH sealed keyboards are designed to operate in or out of doors and at temperatures of  $-40^{\circ}\text{C}$  to  $+75^{\circ}\text{C}$  ( $-40^{\circ}\text{F}$  to  $+167^{\circ}\text{F}$ ). Sealed keyboards meet the requirements of NEMA 2, 3, 3R, 12 and 13, and military specifications (MIL-STD-202) for sealing, vibration and shock which is a must for applications such as: vehicle mounted equipment, machine tools, material handling etc.

All sealed keyboards utilize the time-proven Hall effect technology and reliability that have made MICRO SWITCH the number one solid state keyboard manufacturer. Every aspect of these keyboards is designed for operator acceptance, convenience, and maximum throughput. This in-

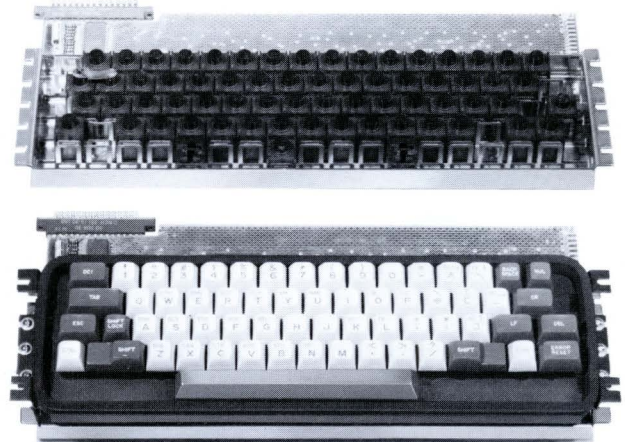

cludes operating force displacement characteristics with a positive tactile feel, key spacing, button shapes and legending.

Panel-sealed keyboards are available with a wide range of options and features including:

- MOS, TTL and DTL encoding
- Choice of standard touch typing, alphanumeric or block arrays
- Choice of over 10,000 key legends
- 30 different key colors
- Various key shapes, including standard and re-legendable

## OFF-THE-SHELF AVAILABILITY

The keyboard market has traditionally required customized keyboards, usually for high volume applications. Machine control, process control, and the communications markets require smaller quantities of a greater variety. Start-up costs have been invested in the keyboard design and electronics and effective sealing has been prohibited by the additional cost of tooling and related costs.

Now MICRO SWITCH offers a variety of Sealed Solid

State Keyboards at off-the-shelf prices. You can select one of these without a start-up investment and, adapt it to your application with only minor changes to your circuits.

MICRO SWITCH can seal any of its solid state keyboards. However, consider the listings included in this brochure to save start-up charges. Contact your nearest MICRO SWITCH Branch Office for complete details.

## SEALED KEYBOARD MOUNTING METHODS

The cut-away drawings illustrate two methods of mounting MICRO SWITCH sealed keyboards. The low-seal method is recommended, especially where space behind the control panel is limited. Where space behind the panel is available the high-seal version can be used for better front of panel appearance.

MICRO SWITCH sealed keyboards are 100% sealed against leakage between the keyboard and panel, thru the keyboard and around each key plunger.

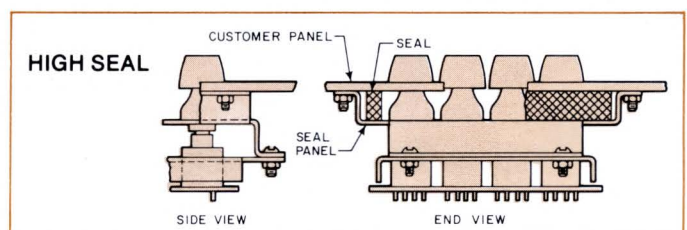
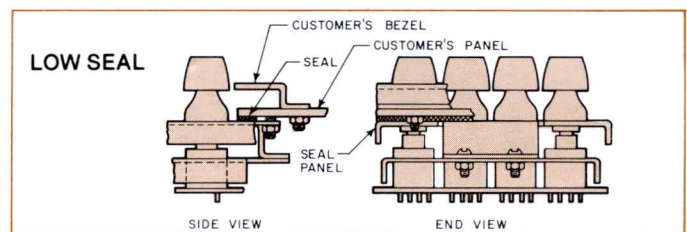

# MICRO SWITCH Sealed Solid State Keyboards offer New economy for demanding applications.

Quality, Reliability and Technology are just as important today as they were in 1968 when MICRO SWITCH first introduced its Hall effect, solid state keyboard. Hall effect solid state switching, the heart of MICRO SWITCH keyboard was selected because it offered:

**Greater Reliability** - Inherent in an integrated circuit, proven both in the laboratory and field.

**Logic Level Interface** - No bounce or timing problems, transistor output.

**Overall Economy** - Drastic cost reduction in integrated circuit manufacture, reduced service cost, and economy in encoding with two isolated circuits.

**Ultimate Fidelity** - Assured switch operation.

Now add the capability of individually sealed keys and panel-sealing for a keyboard that meets the most demanding environmental requirements.

MICRO SWITCH sealed keyboards are the culmination of many years of design experience and incorporate the following proven features.

## TECHNOLOGY

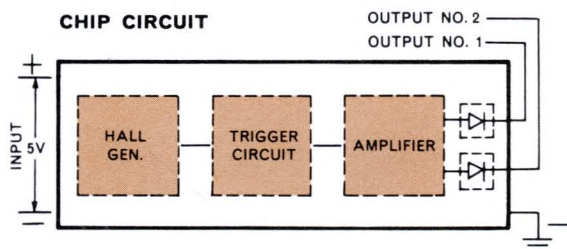

Using the Hall effect, MICRO SWITCH pioneered and developed the first practical application of an integrated circuit as a keyboard switching element. A Hall generator, trigger circuit and amplifier are integrated on a single silicon chip, approximately forty thousandths of an inch square as illustrated by the Chip Circuit diagram above. This integrated circuit is actuated with a magnet mounted on the plunger.

The switch delivers a bounce-free digital output which can be fed directly to card-edge termination or thru an encoder on the PC board. The switch output is directly compatible with all common logic families with no special buffering or electronic circuitry needed. The rise and fall characteristics of MICRO SWITCH Hall effect switching make it very compatible with the latest RFI-EMI (radio frequency interference - electromotive interference) requirements.

## TYPICAL APPLICATIONS

- Numerically Controlled Machine Tools
- Computerized Numerical Control Machine Tools
- Programmable Logic Controllers
- Computerized Automatic Warehouses
- Military Terminals
- Airborne Data Input
- Telephone Switching
- Guidance Control Equipment
- Cargo Handling
- Air Traffic Control

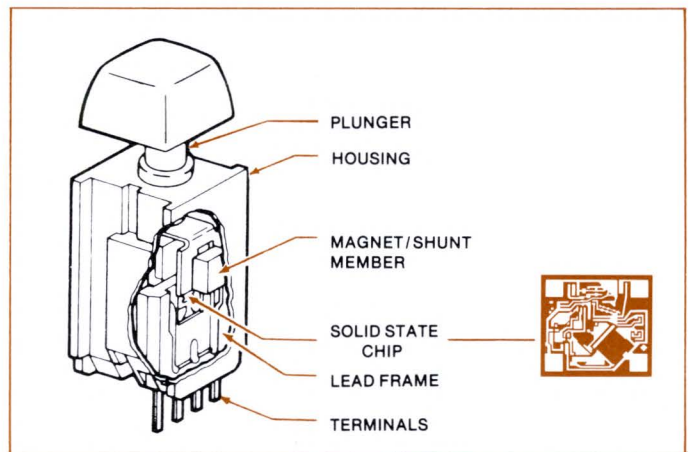

## QUALITY

To make sure you get the quality and trouble-free product you demand, MICRO SWITCH designed and built a computerized quality assurance system called CAKE (Computer Assisted Keyboard Evaluator). CAKE performs measurements (both static and dynamic), faster and more accurately than a manual system. It is capable of making over 100 functional tests per key or over 6,000 tests per keyboard in a two minute cycle. CAKE is just part of our rigorous quality control system that begins at the design concept, continues with tough inprocess inspections and lasts right through shipping.

As a result, we are able to offer you an incoming AQL (acceptable quality level) of 1% on the total keyboard assembly.

## CAPABILITY

Our manufacturing facilities cover the entire spectrum, from very high production to prototype custom designs. Much of our machinery was designed and built by our special equipment group because there simply was nothing on the market to do the job. This includes automatic module packaging and assembly, solid state chip handling, and computerized quality control equipment. To evaluate the keyboard design we have a complete engineering test laboratory that includes monitoring as well as environmental testing equipment.

## RELIABILITY

The inherent reliability of MICRO SWITCH keyboards has been confirmed by extensive laboratory testing. We have on file at our Freeport, Illinois headquarters, objective evidence of testing. For instance, since 1968 Hall effect switches have an indicated MTBF (mean time between failures) of 1 million hours and a MCBF (mean cycles between failure) of 2 billion operations. This means fewer service calls and reduced life cycle costs. To support our faith, we offer a two-year warranty on the TOTAL keyboard.

## SERVICEABILITY

MICRO SWITCH sealed keyboards are modular in design to offer flexibility and allow for ease of servicing, either in your plant or in the field. The keyboard can be removed from the panel without damaging the panel-sealing integrity. Any individual key station module can be replaced without special tools.

## PEOPLE

This is by far our strongest resource. When your order is received, it is handled by a team of people representing many years of experience in keyboard marketing, design and manufacturing. This kind of expertise comes only from working on keyboard problems for every conceivable application.



CAKE Performs Final Inspection

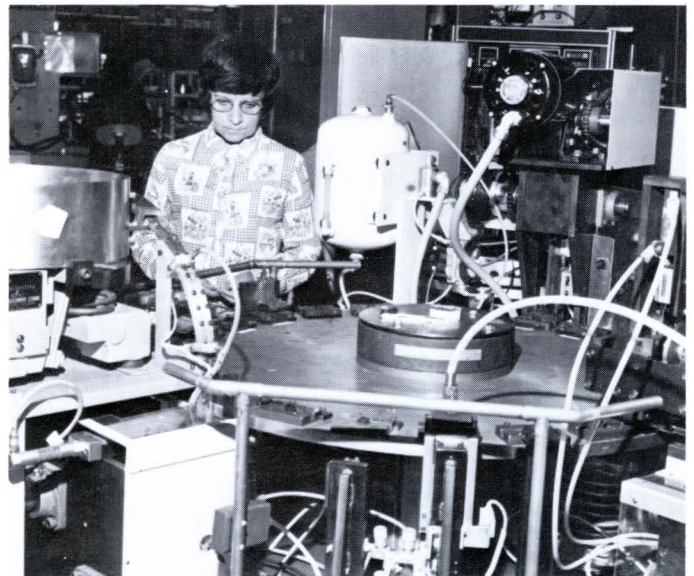

Automatic Module Assembly

## ENVIRONMENTAL RATINGS PASSED BY MICRO SWITCH SEALED SOLID STATE KEYBOARDS

TEST DESCRIPTION	PURPOSE	NEMA / MIL-S TYPES
Dripproof-Indoor	Intended for use indoors to protect enclosed equipment against falling non-corrosive liquids and falling dirt.	2
Dusttight, Raintight, and Sleet (Ice) Resistant - Outdoor.	Intended for use outdoors to protect enclosed equipment against windblown dust and water.	3
Rainproof and Sleet (Ice) Resistant - Outdoor.	Intended for use outdoors to protect enclosed equipment against rain and meet UL 508, "rainproof enclosures."	3R
Industrial Use - Dusttight and Driptight - Indoors.	Intended for use indoors to protect enclosed equipment against fibers, lint, dust and dirt, light splashing, seepage, dripping and external condensation of non-corrosive liquids.	12
Oiltight and Dusttight - Indoor.	Intended for use indoors to protect against lint and dust, seepage, external condensation, spraying of water, oil or coolants.	13
Vibration	3 hours in each of the 3 major axes between 10 and 500 Hz at 5 g's acceleration (MIL-STD-202, Method 204, Test Condition A, except 5 g's).	MIL-STD-202
Shock	18, 11 millisecond duration half sine pulses, 30 g's in magnitude (MIL-STD-202, Method 213, Test Condition J, 30 g's).	MIL-STD-202

# 16SW3-2-S Current Sinking Sealed Solid State Keyboard

## MOUNTING DIMENSIONS (For Reference Only)

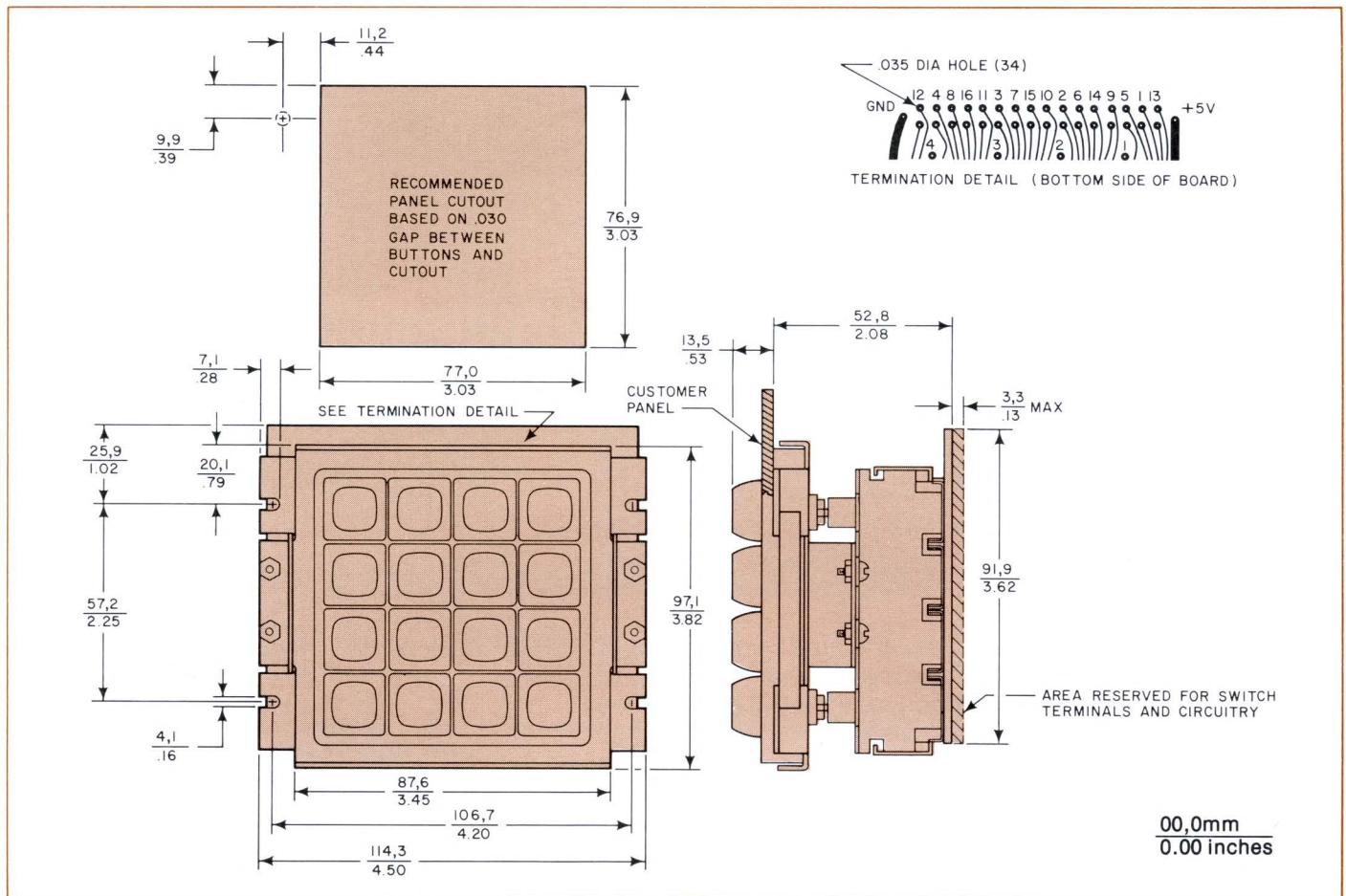

The 16SW3-2-S is a sealed 16-key, block array solid state keyboard ideally suited for application in adverse environments. Each key module is individually sealed and provides two current sinking isolated outputs. The wired-only, non-encoded outputs are terminated at printed circuit board holes.

Key modules are supported by rigid mounting rails which are riveted to the printed circuit board and welded to mounting brackets. The mounting rails provide a system ground because the rivets connect to the printed circuit ground conductor.

### ELECTRICAL DATA

Power Requirements	Vcc = +5 volts DC, regulated 10%
Output Specifications	<b>Unoperated:</b> Leakage Current (Sink to keyboard ground) 1.0uA max. at Vo = Vcc. Absolute Maximum voltage applied to output: 15 VDC <b>Operated:</b> +0.4 volts DC Max. sinking 4.0 Milliamperes per output (8.0 Milliamperes without outputs paralleled).
Switch Rise and Fall Times (10% to 90% of Steady State Value)	1.0 Microsecond Max. using a 1.5K resistor to Vcc and 100 pica farad capacitance to ground.

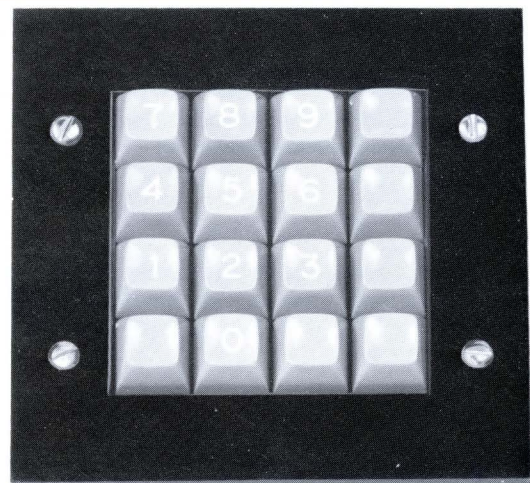

### CURRENT SINKING

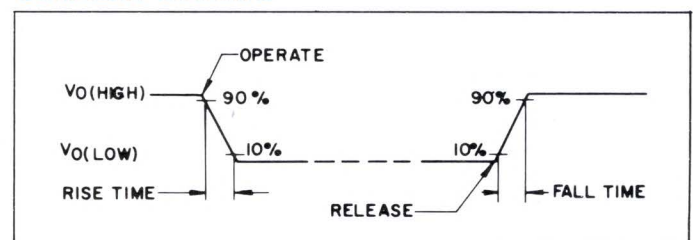

# 26SW3-2-S Sealed Single-Mode Solid State Keyboard

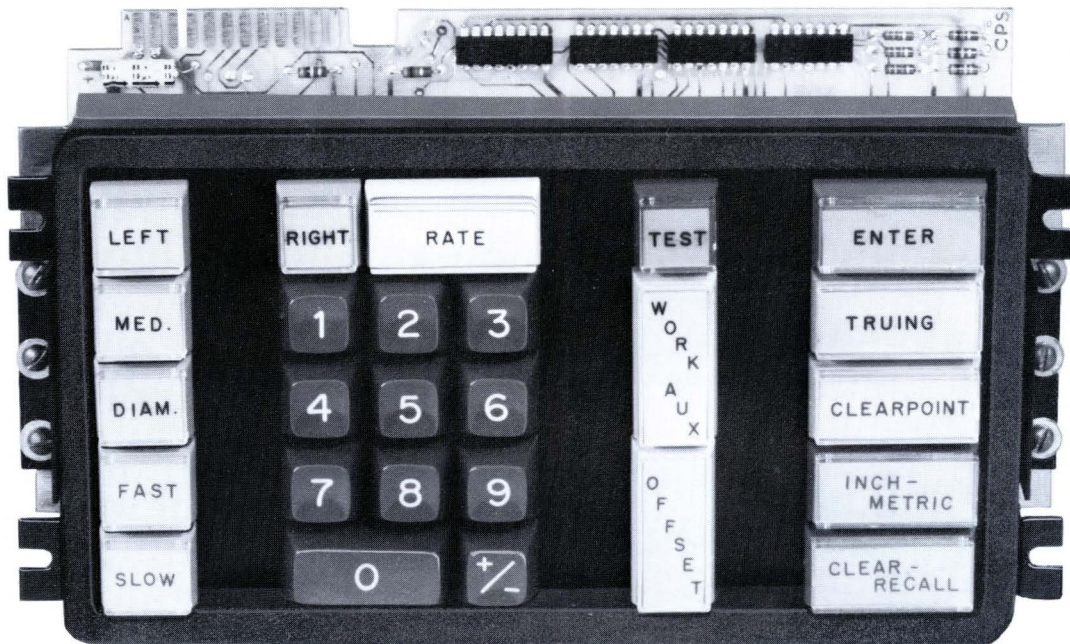

The 26SW3-2-S is a sealed 26-key single mode solid state keyboard. The keyboard is encoded with a 6 bit address code. The output interface is a card-edge with gold plated terminals that accept standard connectors. An electronic N-key lockout option is provided which prevents the entry of erroneous codes when two or more keys are operated at the same time. The first key depressed is recognized. Any other key depressions are ignored until all keys are released. The one-character-storage feature allows the system ample time to read the keyboard output.

To increase the versatility of the 26SW3-2-S many of the keys have relegendable keytops that accept film legends. This enables customizing at the job site, which is especially important for new installations.

## OUTPUT INTERFACE

Card-edge outputs with gold plated terminals accept standard connectors such as: Cinch Jones #251-12-30-16 or equivalent (connector furnished with this listing).

## INTERLOCK

N-key lockout for all keys. The first key depressed is recognized, other key depressions are ignored until all keys are released.

## ELECTRICAL DATA

Power Requirements	+ 5 volts DC $\pm$ 5% at 350 milliamperes max. Keyboard ground at 0 volts. NOTE: Tolerances include ripple.
Data Key Outputs (Positive logic)	<b>Logic "0"</b> : +0.4 volts DC max. at 16 milliamperes (Sinking). <b>Logic "1"</b> : +2.4 volts DC min. at 0.4 milliamperes max. (Sourcing). Data bits are held in memory until next key depression
Function Key Outputs	<b>Key Unoperated</b> : +2.4 volts DC min. at .2 milliamperes (Sourcing). <b>Key Operated</b> : +0.4 volts DC max. at 8 milliamperes (Sinking).
Strobe Output (For Data Keys Only).	<b>Key Unoperated</b> : +0.45 volts DC max. at 12 milliamperes (Sinking). <b>Key Operated</b> : +2.4 volts DC min. at 0.12 milliamperes (Sourcing).

## MOUNTING DIMENSIONS (For Reference Only)

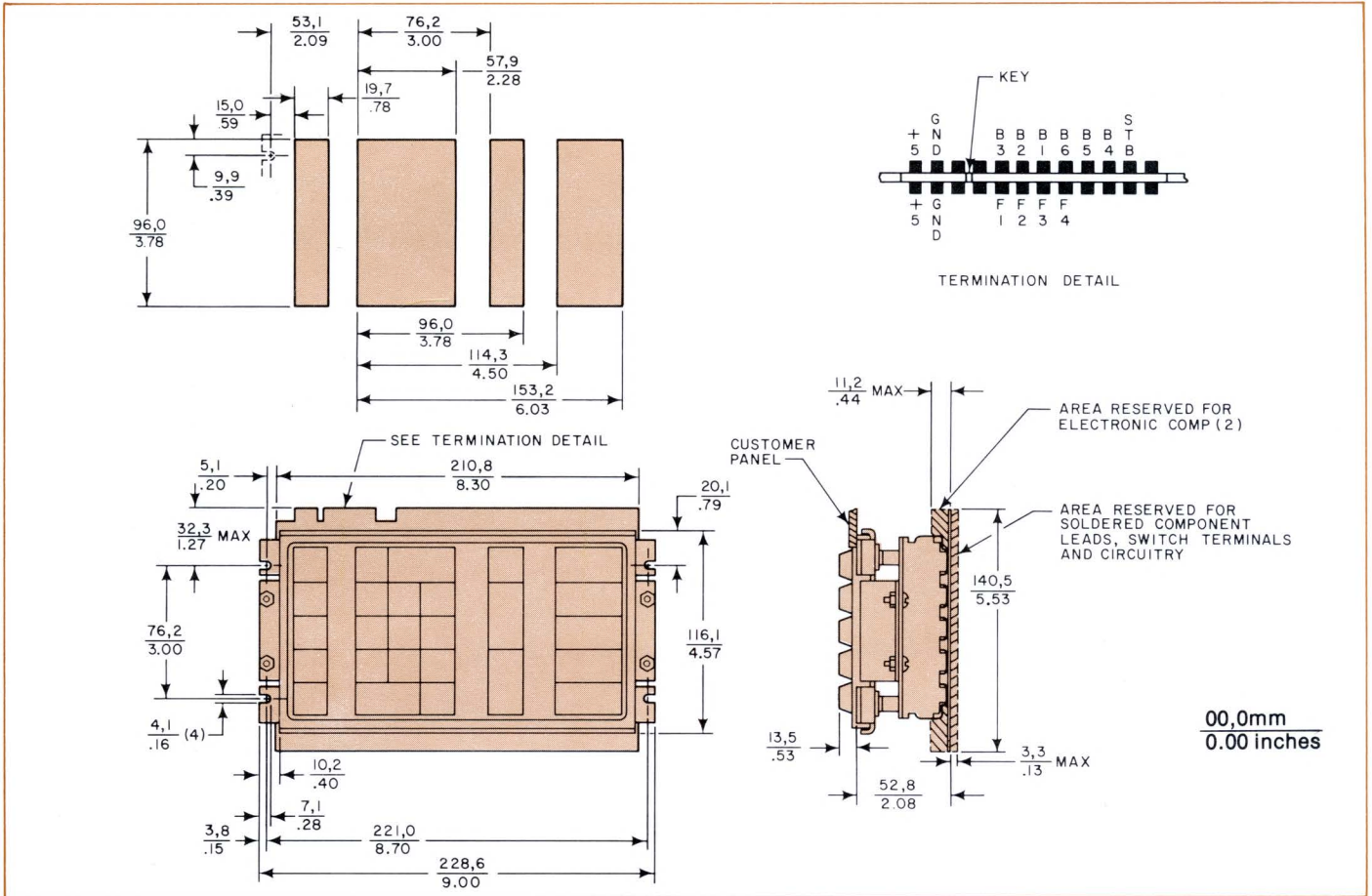

## CHARACTER ASSIGNMENT

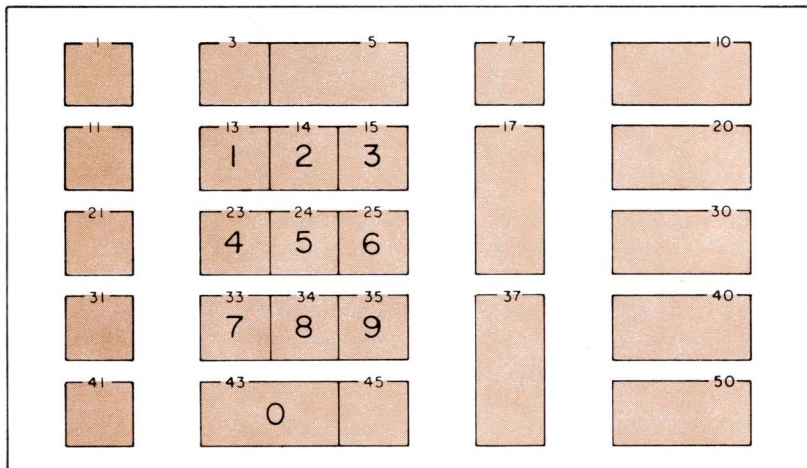

## SIX BIT ADDRESS CODE

KEY NO.	BITS					
	6	5	4	3	2	1
1	0	1	0	0	0	1
3	1	0	0	0	0	0
5	FUNCTION					
7	1	0	0	0	1	1
10	FUNCTION					
11	0	1	0	0	1	0
13	0	0	0	0	0	1
14	0	0	0	0	1	0
15	0	0	0	0	1	1
17	1	0	0	1	1	1
20	1	0	1	0	1	0
21	0	1	0	0	1	1
23	0	0	0	1	0	0
KEY NO.	BITS					
	6	5	4	3	2	1
24	0	0	0	1	0	1
25	0	0	0	1	1	0
30	1	0	1	1	1	1
31	0	1	0	1	0	0
33	0	0	0	1	1	1
34	0	0	1	0	0	0
35	0	0	1	0	0	1
37	FUNCTION					
40	1	1	0	0	1	1
41	0	1	0	1	0	1
43	0	0	0	0	0	0
45	0	0	1	0	1	0
50	FUNCTION					

# 63SW5-15-S Sealed 3-Mode, MOS Encoded Solid State Keyboard



The 63SW5-15-S is a 3-mode, sealed 63-key Hall effect solid state keyboard. The keyboard incorporates MOS encoding with the seven bit ASCII code plus odd parity. MOS encoding increases the number of functions the keyboard performs, while at the same time allows significant cost reduction.

The output interface is a card-edge with gold plated terminals that accept standard connectors.

Standard features of the 63SW5-15-S are:

1. Two-key rollover---allows the operator to roll keys during "burst" speed typing without entering an erroneous code.
2. One-character storage---holds the data bits at the output for the last valid key depression.
3. Error signal---indicates a key has been operated in the third mode which does not have a control character.
4. Keyboard disable---strobe output and data bits go to logic "0" output when a signal is provided from the system. This feature permits data entry from only one keyboard at a time.

## KEYBOARD DISABLE

Signal From System	Keyboard Output
0.70 volts DC max at 2.0 mA max. (Sinking)	All data bits and strobe go to logic "0".
(Keyboard Vcc-1.7). Min. at 0.12 mA max. (Sourcing) or open circuit.	Data bits and strobe signal presented to system.

NOTE: When the system enables the keyboard, the data from the last key depressed will be present at the output. This is true regardless of whether the key was operated before or after the output was disabled.

## ELECTRICAL DATA

Power Requirements	+ 5 volts DC $\pm$ 5% at 1.0 ampere max. -12 volts DC $\pm$ 20% at 5 milliamperes max. Keyboard Ground at 0 volts Note: Tolerances include ripple.
Data Key Outputs (Positive logic)	<b>Logic "0":</b> + 0.6 volts DC max. at 1.6 milliamperes (Sinking) <b>Logic "1":</b> + 2.55 volts DC min. at 0.12 milliamperes max. (Sourcing)
Function Key Outputs	<b>Key Unoperated:</b> + 0.25 volts DC max. with load resistance of 2500 ohms or less. <b>Key Operated:</b> + 2.8 volts DC min. 1 to 10 milliamperes (Sourcing).
Strobe Output (For Data Keys Only)	<b>All keys in unoperated state:</b> + 0.6 volts DC max. at 1.6 milliamperes (Sinking) <b>One Key Operated:</b> + 2.55 volts DC min. at 0.12 milliamperes max. (Sourcing) <b>Two Key Rollover condition:</b> + 0.6 volts DC max. at 1.6 milliamperes (Sinking)
Error Bit Signal (Bit 8)	Output same as Data key outputs (See termination details)

## TIMING

Strobe is true (logic "1") 500 nanoseconds minimum after bits are true. Strobe falls when key is released. If a second key is depressed prior to release of first key, strobe will fall. Upon release of the first key, strobe will come true 500 nanoseconds minimum after new data comes true.



# MOUNTING DIMENSIONS (For Reference Only)

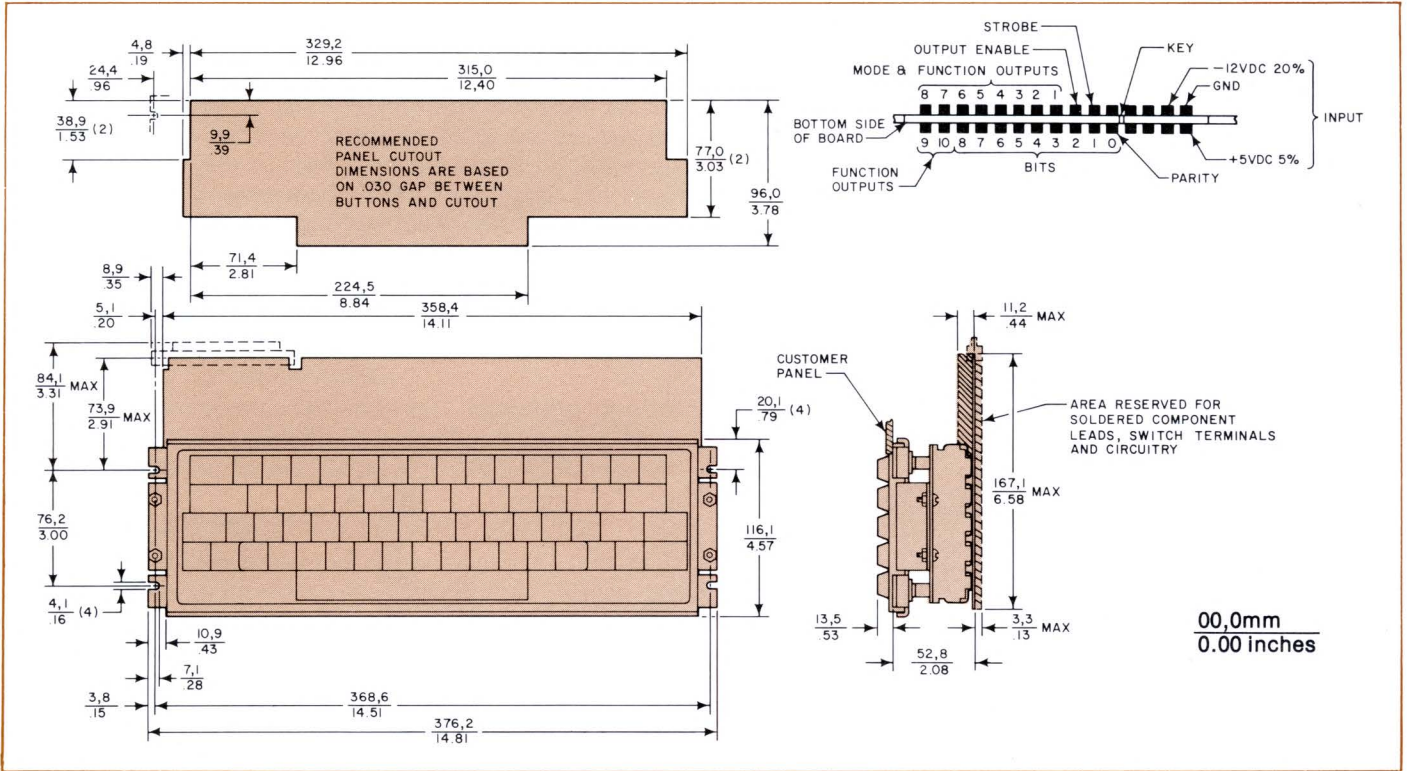

## ASCII CODE ODD PARITY

KEY NO.	MODE 1					MODE 2					MODE 3				
	CHAR	Error Bit	765	4321	P	CHAR	Error Bit	765	4321	P	CHAR	Error Bit	765	4321	P
3	DC1	0	001	0001	1	DC1	0	001	0001	1	DC1	0	001	0001	1
4	1	0	011	0001	0	1	0	010	0001	1	1	1	011	0001	0
5	2	0	011	0010	0	2	0	010	0010	1	2	1	011	0010	0
6	3	0	011	0011	1	#	0	010	0011	0	3	1	011	0011	1
7	4	0	011	0100	0	\$	0	010	0100	1	4	1	011	0100	0
8	5	0	011	0101	1	%	0	010	0101	0	5	1	011	0101	1
9	6	0	011	0110	1	&	0	010	0110	0	6	1	011	0110	1
10	7	0	011	0111	0		0	010	0111	1	7	1	011	0111	0
11	8	0	011	1000	0	(	0	010	1000	1	8	1	011	1000	0
12	9	0	011	1001	1	)	0	010	1001	0	9	1	011	1001	1
13	0	0	011	0000	1	0	0	011	0000	1	0	1	011	0000	1
14	-	0	010	1101	1	=	0	011	1101	0	-	1	010	1101	1
15	~	0	101	1110	0	~	0	111	1110	1	RS	0	001	1110	1
16	\	0	101	1100	1		0	111	1100	0	FS	0	001	1100	0
17	BS	0	000	1000	0	BS	0	000	1000	0	BS	0	000	1000	0
18	NUL	0	000	0000	1	NUL	0	000	0000	1	NUL	0	000	0000	1
23	TAB	0	000	1001	1	TAB	0	000	1001	1	TAB	0	000	1001	1
24	q	0	111	0001	1	Q	0	101	0001	0	DC1	0	001	0001	1
25	w	0	111	0111	1	W	0	101	0111	0	ETB	0	001	0111	1
26	e	0	110	0101	1	E	0	100	0101	0	ENQ	0	000	0101	1
27	r	0	111	0010	1	R	0	101	0010	0	DC2	0	001	0010	1
28	t	0	111	0100	1	T	0	101	0100	0	DC4	0	001	0100	1
29	y	0	111	1001	0	Y	0	101	1001	1	EM	0	001	1001	0
30	u	0	111	0101	0	U	0	101	0101	1	NAK	0	001	0101	0
31	i	0	110	1001	1	I	0	100	1001	0	HT	1	000	1001	1
32	o	0	110	1111	1	O	0	100	1111	0	SI	0	000	1111	1
33	p	0	111	0000	0	P	0	101	0000	1	DLE	0	001	0000	0
34	@	0	100	0000	0	\	0	110	0000	1	NUL	1	000	0000	1
35	-	0	101	1011	0	{	0	111	1011	1	ESC	1	001	1011	1
36	-	0	101	1111	1	-	0	101	1111	1	US	0	001	1111	0
37	CR	0	000	1101	0	CR	0	000	1101	0	CR	0	000	1101	0
42	ESC	0	001	1011	1	ESC	0	001	1011	1	ESC	0	001	1011	1

KEY NO.	MODE 1					MODE 2					MODE 3				
	CHAR	Error Bit	765	4321	P	CHAR	Error Bit	765	4321	P	CHAR	Error Bit	765	4321	P
43	SHIFT (MODE SELECTION KEY)														
44	a	0	110	0001	0	A	0	100	0001	1	SOH	0	000	0001	0
45	s	0	111	0011	0	S	0	101	0011	1	DC3	0	001	0011	0
46	d	0	110	0100	0	D	0	100	0100	1	EOT	0	000	0100	0
47	f	0	110	0110	1	F	0	100	0110	0	ACK	0	000	0110	1
48	g	0	110	0111	0	G	0	100	0111	1	BEL	0	000	0111	0
49	h	0	110	1000	0	H	0	100	1000	1	BS	1	000	1000	0
50	j	0	110	1010	1	J	0	100	1010	0	LF	1	000	1010	1
51	k	0	110	1011	0	K	0	100	1011	1	VT	0	000	1011	0
52	l	0	110	1100	1	L	0	100	1100	0	FF	0	000	1100	1
53	.	0	011	1011	0	+	0	010	1101	1	.	1	011	1011	0
54	:	0	011	1010	1	*	0	010	1010	0	:	1	011	1010	1
55	<	0	101	1101	0	}	0	111	1101	1	GS	0	001	1101	1
56	LF	0	000	1010	1	LF	0	000	1010	1	LF	0	000	1010	1
58	DEL	0	111	1111	0	DEL	0	111	1111	0	DEL	0	111	1111	0
62	CTRL (MODE SELECTION KEY)														
64	SHIFT (MODE SELECTION KEY)														
65	z	0	111	1010	0	Z	0	101	1010	1	SUB	0	001	1010	0
66	x	0	111	1000	1	X	0	101	1000	0	CAN	0	001	1000	1
67	c	0	110	0011	1	C	0	100	0011	0	ETX	0	000	0011	1
68	v	0	111	0110	0	V	0	101	0110	1	SYN	0	001	0110	0
69	b	0	110	0010	0	B	0	100	0010	1	STX	0	000	0010	0
70	n	0	110	1110	0	N	0	100	1110	1	SO	0	000	1110	0
71	m	0	110	1101	0	M	0	100	1101	1	CR	1	000	1101	0
72	.	0	010	1100	0	<	0	011	1100	1	.	1	010	1100	0
73	.	0	010	1110	1	>	0	011	1110	0	.	1	010	1110	1
74	/	0	010	1111	0	?	0	011	1111	1	/	1	010	1111	0
75	SHIFT (MODE SELECTION KEY)														
77	CTRL (MODE SELECTION KEY)														
78	ERROR RESET (FUNCTION KEY)														
81	SP	0	010	0000	0	SP	0	010	0000	0	SP	0	010	0000	0

### NOTE:

- Keys that do not have control character in Mode 3, have a logic "1" error bit which may be used to drive an error signal.
- If the shift key and CTRL key are held depressed the keyboard will be in Mode 3.

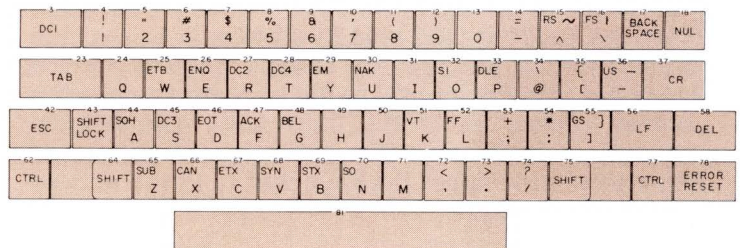

# 75SW12-19-S Sealed 2-Mode, MOS Solid State Keyboard

## MOUNTING DIMENSIONS (For Reference Only)

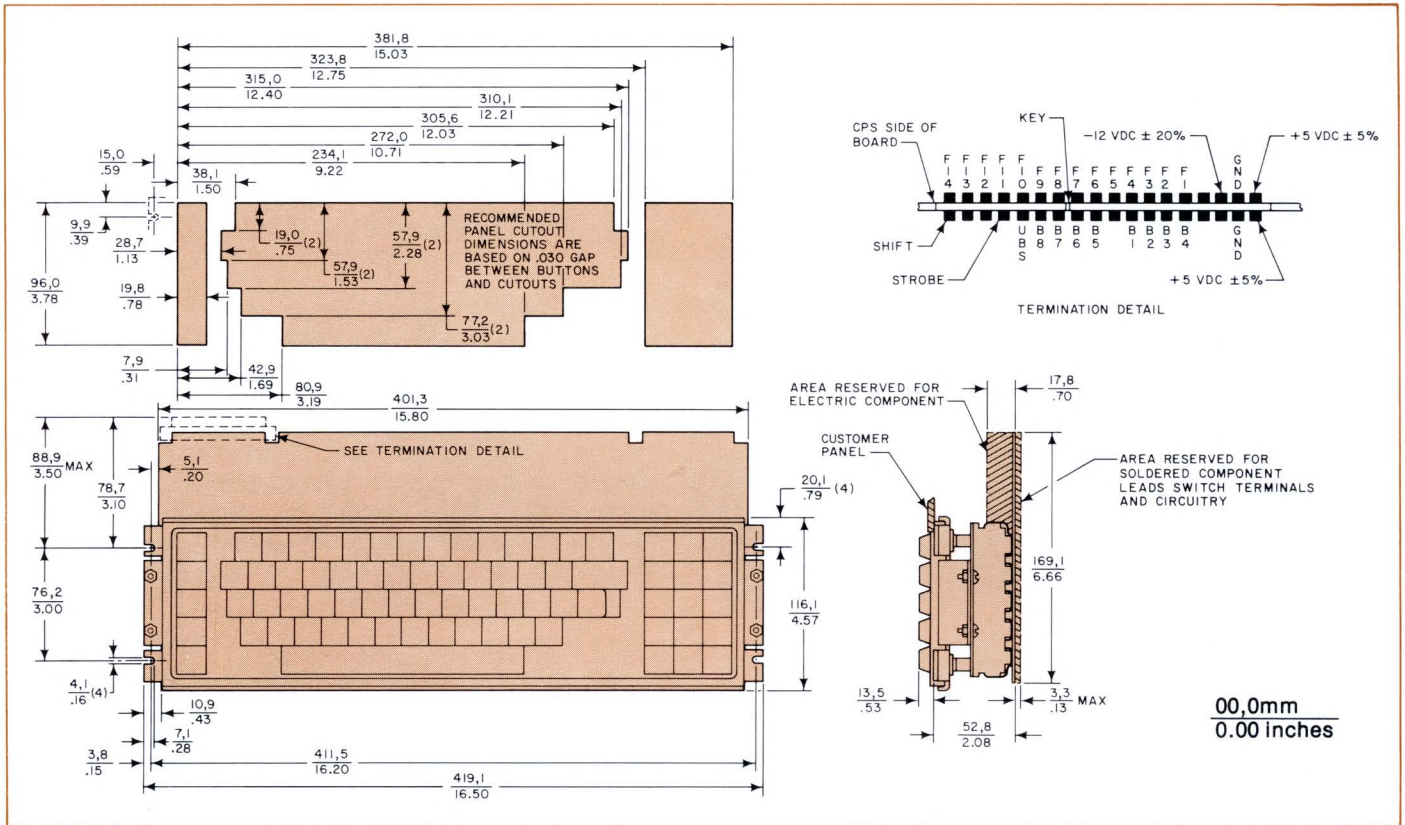

The 75SW12-19-S is a 2-mode, sealed 75-key Hall effect solid state keyboard incorporating MOS encoding. The touch typing key arrangement provides instant familiarity for operators trained on office typewriters.

The 75SW12-19-S features N-key rollover. Data bits are set by a pulse from the down stroke of each key depressed and stored in the MOS memory. When a second key is operated, new data is set into the memory even though the first key may be still depressed. Thus, there is no possibility of missing a character or of transposing characters as the result of the order of key release. With N-key rollover any number of keys may be depressed and held depressed and the sequence of release doesn't affect the proper sequence of data entry. The pulsed output is part of the solid state chip within each key, rather than a pulse network of discrete components. This adds significantly to the reliability of the keyboard.

For quick identification the control keys are set apart from the touch typing area in a block array. In this type of format the operator doesn't have to put the keyboard into the control mode in order to generate control codes, as is the case with conventional 3-function keyboards. The controls are generated regardless of whether the keyboard is in the shifted or unshifted mode.

## ELECTRICAL DATA

Power Requirements	+ 5 volts DC $\pm 5\%$ at 1.2 amperes max. -12 volts DC $\pm 20\%$ at 5 milliamperes max. Keyboard Ground at 0 volts Note: Tolerances include ripple.
Data Key Outputs (Positive logic)	<b>Logic "0":</b> + 0.6 volts DC max. at 1.6 milliamperes (Sinking) <b>Logic "1":</b> + 2.55 volts DC min. at 0.12 milliamperes max. (Sourcing). Data bits are held in memory until the next key depression.
Function Key Outputs	<b>Key Unoperated:</b> + 0.25 volts DC max. with load resistance of 2500 ohms or less. <b>Key Operated:</b> + 2.8 volts DC min. 1 to 10 milliamperes (Sourcing).
Strobe Output (For Data Keys Only)	<b>All keys in unoperated state:</b> + 0.6 volts DC max. at 1.6 milliamperes (Sinking). <b>Key Operated:</b> + 2.55 volts DC min. at 0.12 milliamperes max. (Sourcing) pulsed output <b>Pulse Duration:</b> 10 microseconds min. Data bits are true 500 nanoseconds prior to strobe pulse.

## OUTPUT INTERFACE

Card-edge output with gold plated terminals accept standard connectors such as: Cinch Jones #251-18-30-160 with between-contact key or equivalent.

## CODE AND CHARACTER ASSIGNMENT

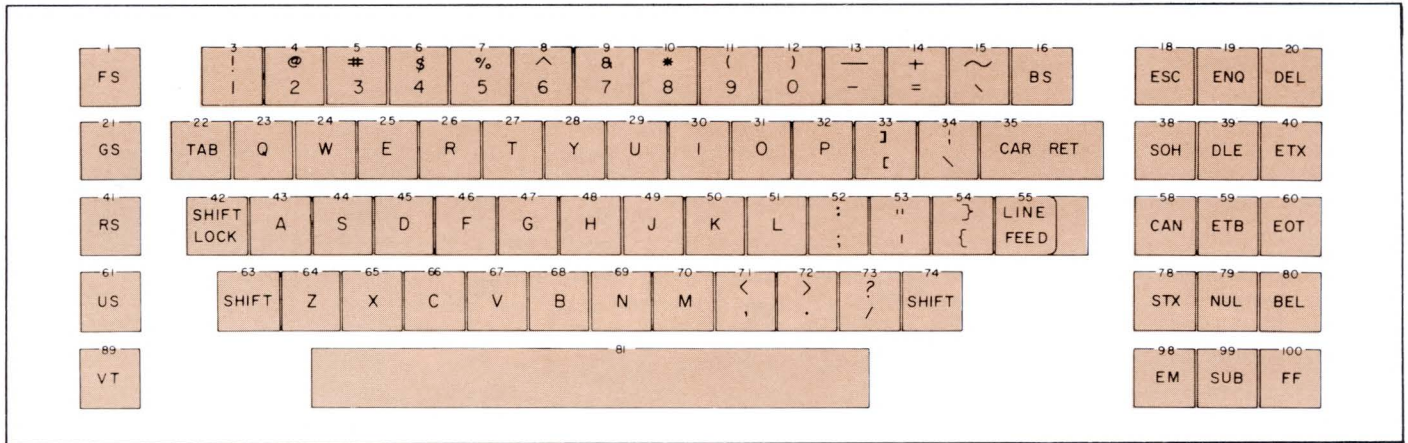

## ASCII CODE TYPEWRITER PAIRED ODD PARITY

KEY NO.	UNSHIFTED					SHIFTED				
	CHAR	UBS*	P**	765	4321	CHAR	UBS*	P**	765	4321
1	FS	0	0	001	1100	FS	0	0	001	1100
3	!	1	0	011	0001	!	1	1	010	0001
4	2	1	0	011	0010	@	0	0	100	0000
5	3	1	1	011	0011	#	1	0	010	0011
6	4	1	0	011	0100	\$	1	1	010	0100
7	5	1	1	011	0101	%	1	0	010	0101
8	6	1	1	011	0110	^	0	0	101	1110
9	7	1	0	011	0111	&	1	0	010	0110
10	8	1	0	011	1000	*	1	0	010	1010
11	9	1	1	011	1001	(	1	1	010	1000
12	0	1	1	011	0000	)	1	0	010	1001
13	-	1	1	010	1101	_	0	1	101	1111
14	=	1	0	011	1101	+	1	1	010	1011
15	\	1	1	110	0000	~	1	1	111	1110
16	BS	0	0	000	1000	BS	0	0	000	1000
18	ESC	0	1	001	1011	ESC	0	1	001	1011
19	ENQ	0	1	000	0101	ENQ	0	1	000	0101
20	DEL	1	0	111	1111	DEL	1	0	111	1111
21	GS	0	1	001	1101	GS	0	1	001	1101
22	TAB	0	1	000	1001	TAB	0	1	000	1001
23	q	0	1	111	0001	Q	0	0	101	0001
24	w	0	1	111	0111	W	0	0	101	0111
25	e	0	1	110	0101	E	0	0	100	0101
26	r	0	1	110	0011	R	0	0	101	0010
27	t	0	1	111	0100	T	0	0	101	0100
28	y	0	0	111	1001	Y	0	1	101	1001
29	u	0	0	111	0101	U	0	1	101	0101
30	i	0	1	110	1001	I	0	0	100	1001
31	o	0	1	110	1111	O	0	0	100	1111
32	p	0	0	111	0000	P	0	1	101	0000
33		0	0	101	1011		0	0	101	1101
34	\	0	1	101	1100		1	0	111	1100
35	CR	0	0	000	1101	CR	0	0	000	1101
38	SOH	0	0	000	0001	SOH	0	0	000	0001
39	DLE	0	0	001	0000	DLE	0	0	001	0000
40	ETX	0	1	000	0011	ETX	0	1	000	0011
41	RS	0	1	001	1110	RS	0	1	001	1110
42	SHIFT									

KEY NO.	UNSHIFTED					SHIFTED				
	CHAR	UBS*	P**	765	4321	CHAR	UBS*	P**	765	4321
43	a	0	0	110	0001	A	0	1	100	0001
44	s	0	0	111	0011	S	0	1	101	0011
45	d	0	0	110	0100	D	0	1	100	0100
46	f	0	1	110	0110	F	0	0	100	0110
47	g	0	0	110	0111	G	0	1	100	0111
48	h	0	0	110	1000	H	0	1	100	1000
49	j	0	1	110	1010	J	0	0	100	1010
50	k	0	0	110	1011	K	0	1	100	1011
51	l	0	1	110	1100	L	0	0	100	1100
52	;	1	0	011	1011	;	1	1	011	1010
53	'	1	1	010	0111	'	1	1	010	0010
54	{	1	1	111	1011	}	1	1	111	1101
55	LF	0	1	000	1010	LF	0	1	000	1010
58	CAN	0	1	001	1000	CAN	0	1	001	1000
59	ETB	0	1	001	0111	ETB	0	1	001	0111
60	EOT	0	0	000	0100	EOT	0	0	000	0100
61	US	0	0	001	1111	US	0	0	001	1111
63	SHIFT									
64	z	0	0	111	1010	Z	0	1	101	1010
65	x	0	1	111	1000	X	0	0	101	1000
66	c	0	1	110	0011	C	0	0	100	0011
67	v	0	0	111	0110	V	0	1	101	0110
68	b	0	0	110	0010	B	0	1	100	0010
69	n	0	0	110	1110	N	0	1	100	1110
70	m	0	0	110	1101	M	0	1	100	1101
71	.	1	0	010	1100	<	1	1	011	1100
72	,	1	1	010	1110	>	1	0	011	1110
73	/	1	0	010	1111	?	1	1	011	1111
74	SHIFT									
78	STX	0	0	000	0010	STX	0	0	000	0010
79	NUL	0	1	000	0000	NUL	0	1	000	0000
80	BEL	0	0	000	0111	BEL	0	0	000	0111
81	SP	1	0	010	0000	SP	1	0	010	0000
89	VT	0	0	000	1011	VT	0	0	000	1011
98	EM	0	0	001	1001	EM	0	0	001	1001
99	SUB	0	0	001	1010	SUB	0	0	001	1010
100	FF	0	1	000	1100	FF	0	1	000	1100

\*Upper bit 6 (UBS) is an alternate bit for customer choice at the card edge termination. Thus the keyboard simultaneously generates lower case and upper case alphabet characters in the unshifted mode. Whenever the upper bit 6 is used, the parity bit should not be used.

\*\*Parity bit is provided for use with bits 1 through 7 when upper bit 6 is not used.

# Additional Sealed-Key Options from MICRO SWITCH

## 500SW90-1 SEALED KEY PLUNGER

The 500SW90-1 sealed key plunger unit consists of a custom design neoprene boot, a cross-shaped plunger for maximum stability, a bushing, and a bowed E-ring for secure retention. The 500SW90-1 sealed plunger is designed to meet the requirements of NEMA 2, 3, 3R, 12 and 13, and the military specifications (MIL-STD-202) for sealing, vibration and shock. These seal packets are available separately for customers desiring to seal their own solid state keyboards. No special tools or accessories are required for installation, simply mount in a properly punched hole and install the seal unit over any key switch station with a maximum travel of .187".

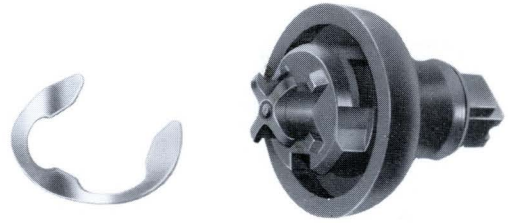

## KS SEALED KEY SWITCH

The KS sealed key switch is plunger and front-of-panel sealed against oil, moisture, sand, dust and other contaminants. The switching function is performed by a long life single pole, double throw switch, available with gold or silver contacts. The switch will handle application loads ranging from low energy (.5VDC at 1mA) to 7 amperes, at either 28VDC or 115VAC. Operating force is 227 grams (8 oz.) maximum, providing feel similar to an electric typewriter or computer input keyboard.

The KS switch can be individually or matrix mounted and replaced from front-of-panel. The adjustable mounting lugs will accommodate panel thicknesses from 1,57 mm (.062 in.) to 6,4 mm (.250 in.). The KS sealed key switch accepts truncated, square or rectangular buttons, permitting a wide choice of legends and individualized panel layouts. For additional information request Product Sheet KS Sealed Key Switch.

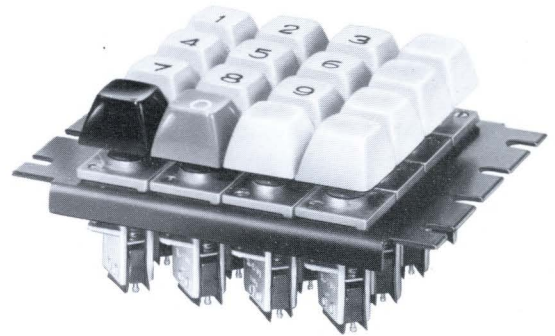

## PX BLOCK ARRAY KEYBOARDS

PX Block Array Keyboards are designed for use in adverse environments. The one-piece elastomer cover (neoprene or silicone) is designed without cavities to seal out and prevent fill-up of oils, grease, water, dust, sand and chips.

Operating the keys exerts force directly on gold contacts for reliable switching of low energy circuits with dependable operation over a wide range of electronic voltages.

The keys provide tactile feedback and the internal and external construction makes them jam-proof. Permanent legends remain readable in the grimmest environments. The standard legends (as illustrated) are double-shot molded for durability. Special legends can be hot-stamped. The inserts are interchangeable for varying formats.

These low profile, compact keyboards require minimum panel space. They install quickly and easily with mounting studs. Solder pin terminals are grouped in the center of the board for convenient wiring and simple panel preparation. For additional information request Product Sheet PX Numeric Keyboards.

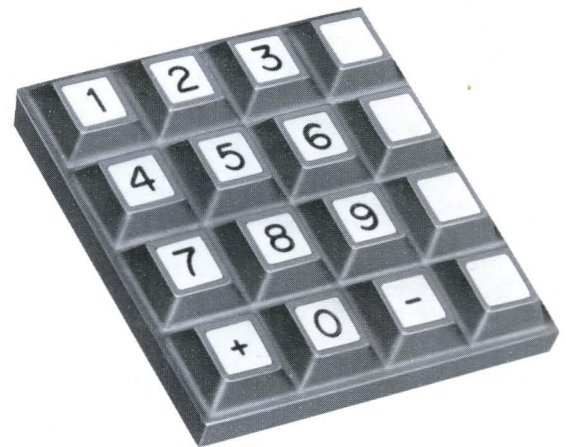

## ORDERING INFORMATION

Contact your nearest MICRO SWITCH Branch Office and an experienced Field Engineer will help you satisfy your sealed keyboard requirements: proper selection, pricing, and delivery scheduling. These experts will provide sound and practical answers to your needs.

# MICRO SWITCH

FREEPORT, ILLINOIS 61032

A DIVISION OF HONEYWELL

IN CANADA: 740 Ellesmere Road, Scarborough, Ontario.

INTERNATIONAL: Sales and service offices in all principal cities of the world.