

COMMUNICATION ICS

DATA
BOOK
1996

mixed signal connectivity solutions



The Level One Credo

Our Mission: We shall strive to be the leader in supplying Silicon Connectivity Solutions and to provide a fair return on investment to our shareholders while being a responsible corporate citizen in our community.

Our Quality Goal: We shall strive to achieve Total Customer Satisfaction.

Our Pledge: We pledge to both external and internal customers that we shall strive to anticipate, understand, and fulfill their needs. We shall continuously improve each of our work functions to enhance the value of our products and services.

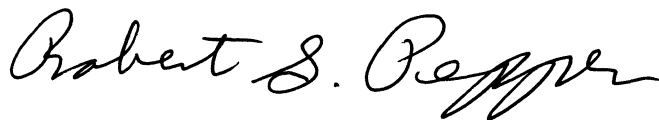
A handwritten signature in black ink that reads "Robert S. Pepper". The signature is written in a cursive style with a large, prominent "P" at the end.

**Robert S. Pepper, Ph.D.
President and Chief Executive Officer**



A leading producer
of mixed-signal Silicon Connectivity Solutions
for high-speed digital communications networks

1996
Data Book

Current Product Information

Here are two ways to obtain the most current product information:

Literature Request Hotline: (916) 854-1155

Web Site URL: <http://www.level1.com>

Product Status Indicators

For Level One product documentation, the term "Preliminary Information" has the following meaning:

Preliminary Information: Indicates a product which has not been released to production. Some specifications may be changed or added until full qualification and production release.

Disclaimer of Warranty:

Level One Communications, Incorporated, assumes no responsibility for errors or omissions in these materials. These materials are provided "as is" without warranty of any kind, either express or implied, including but not limited to, any implied warranties of merchantability, fitness for a particular purpose, or non-infringement. Level One does not warrant the accuracy or completeness of any text or graphic information contained in the material presented herein. Level One shall not be liable for any special, indirect, incidental, or consequential damages, including without limitation, lost revenues or lost profits, which may arise from any person's use of these materials. Level One may make changes to these materials, or to the products described by these materials, from time to time, without notice. Level One is not obligated to update these materials.

Patent Information:

The products listed in this publication are covered by one or more of the following patents. Additional patents pending.

5,008,637; 5,028,888; 5,057,794; 5,059,924; 5,068,628; 5,077,529; 5,084,866; 5,148,427; 5,153,875; 5,157,690; 5,159,291; 5,162,746; 5,166,635; 5,181,228; 5,204,880; 5,249,183; 5,257,286; 5,267,269; 5,267,746

Level One and  are registered trademarks of Level One Communications, Incorporated

TABLE OF CONTENTS

GENERAL INFORMATION	1
T1/E1 SHORT-HAUL TRANSCEIVERS AND RECEIVERS & GENERAL SPECIFICATIONS	2
T1/E1 CLOCK ADAPTERS	3
T1/E1 REPEATERS	4
SWITCHED 56/DDS PRODUCTS	5
T1/E1 LONG-HAUL TRANSCEIVERS	6
DIGITAL SUBSCRIBER LINE (DSL) PRODUCTS	7
PDH MULTIPLEXERS	8
TRANSMISSION APPLICATION NOTES	9
TRANSMISSION PRODUCT EVALUATION BOARDS	10
ETHERNET PHY PRODUCTS	11
ETHERNET HUB AND REPEATER PRODUCTS	12
LAN APPLICATION NOTES	13
PACKAGE SPECIFICATIONS AND ORDERING INFORMATION	14
SALES OFFICES	15

TABLE OF CONTENTS

1	General Information	
	About Level One	1-1
	Quality and Reliability	1-5
	Product Reference Guide	1-11
2	T1/E1 Short-Haul Transceivers and Receivers and General Specifications	
	LXT300/301 Integrated T1/E1 Transceivers	2-1
	LXT300Z/301Z Advanced T1/E1 Transceivers	2-19
	LXT304A Low-Power T1/E1 Transceiver with Receive Jitter Attenuation	2-39
	LXT305 Integrated T1/E1 Transceiver with Transmit Jitter Attenuation	2-57
	LXT305A Low-Power T1/E1 Transceiver with Transmit Jitter Attenuation	2-73
	LXT307 Low-Power E1 Integrated Transceiver	2-91
	LXT325 T1/E1 Integrated Quad Receiver	2-111
	LXT332 Dual T1/E1 Line Interface Unit with Crystal-less Jitter Attenuation	2-121
	LXT350/351 Integrated T1/E1 Transceivers with Crystal-less Jitter Attenuation	2-153
3	T1/E1 Clock Adapters	
	LXP600A/2/4 Low-Jitter Clock Adapters (CLADs)	3-1
	LXP610 Low-Jitter Multi-Rate Clock Adapter (CLAD)	3-11
4	T1/E1 Repeaters	
	LXT312/315 Low-Power T1 PCM Repeaters/Transceivers	4-1
	LXT313/316 Low-Power E1 PCM Repeaters/Transceivers	4-9
5	Switched 56/DDS Products	
	LXT400 All Rate Extended Range Switched 56/DDS Transceiver	5-1
	LXT441 Switched 56/DDS Integrated DSU/CSU	5-17
6	T1/E1 Long-Haul Transceivers	
	LXT310 T1 CSU/ISDN PRI Transceiver	6-1
	LXT317 DECT Twisted-Pair LIU Transceiver	6-17
	LXT318 E1 NTU/ISDN PRI Transceiver	6-33
	LXT360/361 Integrated T1/E1 Long-Haul/Short-Haul Transceivers for DS1/DSX-1/CSU or NTU/ISDN PRI Applications	6-55
7	Digital Subscriber Line (DSL) Products	
	SK70704/70706 784 kbps HDSL Data Pump Chip Set	7-1
	SK70704/70707 1168 kbps HDSL Data Pump Chip Set	7-39
8	PDH Multiplexers	
	SXT6234 E-Rate Multiplexer	8-1
9	Transmission Application Notes	
	AN-21 LXT304A Transceiver	9-1
	AN-25 LXT300 and LXT310 Interchangeability	9-3
	AN-26a LXT310 Line Protection Circuitry	9-5
	AN-29 LXT30x Transceiver/Framer Interface	9-7
	AN-31a LXT318 Long-Haul E1 Transceiver Solution	9-9
	AN-32 T1 Jitter Performance Measurement	9-11
	AN-34 LXT30x and LXT318 Interchangeability	9-17
	AN-36 LXT318 Long-Haul E1 Transceiver	9-19
	AN-38 LXT332 Dual Channel T1/E1 Transceiver Solution	9-21

TABLE OF CONTENTS

	AN-39	LXT332 Dual Channel T1/E1 Transceiver Solution	9-27
	AN-41	Level One Short-Haul Devices	9-33
	AN-42	Crystal-less T1 Long-Haul Solutions	9-37
	AN-44	Jitter Performance Requirements for E1 Leased Lines	9-43
	AN-46	LXT300/300Z/304A/305A Integrated Short-Haul Transceivers	9-47
	AN-47	LXT360/361 Line Protection Circuitry	9-49
	AN-48	SCR Latch-up Model	9-53
	AN-50	Crystal-less E1 Long-Haul Solutions	9-55
	AN-9501	SXT6234 E-Rate Multiplexer	9-61
	Transformers	Transformer Specifications	9-71
	Crystals	Quartz Crystals for T1/E1 Transceivers	9-73
10	Transmission Product Evaluation Boards		
	LDB300	Evaluation Board for T1/E1 Transceivers	10-1
	LDB332	Evaluation Board for T1/E1 Applications	10-2
	LDB360	Evaluation Board for T1/E1 Short- and Long-Haul Applications	10-3
	SDB6234	Evaluation Board for the SXT6234	10-4
	LDB70206	HDSL Evaluation Kit for 784 kbps Applications	10-5
	LDB70207	HDSL Evaluation Kit for 1168 kbps Applications	10-6
11	Ethernet PHY Products		
	LXT901	Universal Ethernet Interface Adapter (Internal MAU)	11-1
	LXT902	Ethernet Twisted-Pair Media Attachment Unit	11-31
	LXT904	Ethernet Interface Adapter with EnDec and AUI	11-45
	LXT905	Universal Ethernet Interface Adapter (Internal MAU)	11-61
	LXT906	Ethernet Twisted-Pair/Coax Adapter	11-83
	LXT907	Universal Ethernet Interface Adapter (Internal MAU)	11-93
	LXT944	Universal Quad Ethernet Interface Adapter	11-123
12	Ethernet Hub and Repeater Products		
	LXT914	Flexible Quad Ethernet Repeater	12-1
13	LAN Application Notes		
	AN-23	LXT902 and 906 Line Impedance Matching	13-1
	AN-35	Design Guide for LXT901/907 Ethernet Interface	13-3
	AN-45	Design Guide for LXT914 Flexible Quad Ethernet Repeater	13-7
	AN-51	MAC Interface Design Guide	13-13
	Source List	Transformer Manufacturers	13-15
14	Package Specifications and Ordering Information		
	Package Specifications		14-1
	Key to Part Numbers (Package and Temperature Range Designations)		14-7
	Literature Request Form (Sample – Please call to request current form)		14-9
15	Sales Offices		
	Corporate Offices		15-1
	Sales Representatives (North America)		15-2
	Sales Representatives (Europe)		15-7
	Sales Representatives (Asia/Pacific)		15-9
	Sales Representatives (South America)		15-10
	Distributors (North America)		15-11

General Information





Providing Silicon Connectivity Solutions for Communications Systems

Background

Level One Communications, Incorporated of Sacramento, California, is a leading supplier of Silicon Connectivity Integrated Circuit (IC) Solutions for complex analog and digital (mixed-signal) transmission and networking applications. The company specializes in the development of integrated circuit Application Specific Standard Products (ASSPs), such as transceivers, repeaters and related devices used in two key areas of the telecommunications and data communications industry. These are:

1. Interface solutions for digital access and transport transmission systems, including fast-growing T1/E1, and
2. Local/Wide Area Networking (LAN and WAN) solutions, including Ethernet LAN, and datacom.

A majority of Level One's products contain complex functions integrated onto a single silicon chip for applications formerly requiring multiple chip or board level solutions.

The company's products target the mixed-signal communications IC market which was estimated to be \$4.9 billion in 1995. This market is expected to reach \$10.8 billion by 2000, according to VLSI Research.

History & Revenue Growth

Level One was founded in November 1985. The company completed an initial public offering in August, 1993, followed by a secondary offering which was completed in February, 1994. Level One is traded on the NASDAQ exchange under the symbol LEVL. As its name implies, Level One's initial focus was related to the physical layer (layer one) of the Open Systems Interconnection (OSI) seven-layer network reference model developed by the International Standards Organization.

In April 1994, Level One moved from its original Folsom, California location to a new 87,000 square foot facility in Sacramento, California. In April 1996, company operations were expanded with the addition of a 51,000 square foot building in the same industrial park.

During 1995, the company acquired San Francisco Telecom of San Francisco, California, a design firm specializing in system and IC level designs related to SONET/SDH, cable modems, and wireless applications. The company also made an investment in Maker Communications of

Waltham, Massachusetts, which specializes in ATM cell processing.

Level One achieved 131% compound revenue growth from 1991 to 1995. The company's revenues were \$78 million in 1995, and it has been profitable in each quarter since the first quarter of 1992. Total assets were \$100 million at year end 1995.

The Electronic Communications Infrastructure

Level One's advanced Silicon Connectivity Solutions are key building blocks for digitized voice, data and multimedia networks, linking homes and businesses across the nation and around the world. While the telephone and cable TV operating companies in North America today have a total installed plant of 430,000 miles of coaxial cable and 12 million miles of fiber optic cable, there is a total of 1.2 billion miles of copper phone wire in place.

Demand is increasing for mixed-signal Silicon Connectivity Solutions. Level One will continue to leverage the installed base of copper wire to implement the growing number of advanced interactive, multimedia, and enterprise networking applications. These include videoconferencing, Group IV Fax, telecommuting, image retrieval, teleconferencing, wide area connectivity, leased line backup, file transfer, PC access, remote LAN, CAD, CAE, and CAM. Simultaneously, the company has initiated programs to provide solutions which serve the growing needs of the future mixed-media, coax cable, fiber and wireless environments.

New Products

Level One continues to add to its portfolio of more than 50 products by integrating higher layers of the OSI model into its IC functions, such as data transfer/conditioning functions (layer two), as well as network switching, routing and control functions (layer three). Level One's products are aimed directly at the rapidly growing digital telecom/datacom market. These Level One Silicon Connectivity Solutions are essential in an age when new technologies and customer demands are increasing the need for higher transmission speeds and greater system performance.



As demand increases for higher data transmission speeds—(beyond 64 kilobits per second) to megabit and gigabit levels—Level One continues to implement its product migration strategy by developing mixed-signal devices required at these higher bit rates. The technologies and IC design techniques Level One has perfected for current mixed-signal communication markets are also applicable for the development of solutions addressing broadband coaxial cable or fiber optic transmission environments.

Industry Leadership

Major ingredients of a firm's success can be found in the number of industry leadership positions a company achieves for itself, as well as by the number of industry "firsts" and proprietary products it develops. With a growing list of patents, Level One maintains an extensive research and development program to develop state-of-the-art Silicon Connectivity Solutions for the mixed-signal transmission and networking markets. Level One's R&D program has already yielded significant successes, as evidenced by the following partial list of accomplishments:

TRANSMISSION ACHIEVEMENTS

- A world leader in twisted-pair telecom/datacom transceivers
- World's first supplier of long-haul T1 transceivers with a one-chip CSU for networking applications
- A complete line of fully integrated T1/E1 short-haul transceivers (Level One is the number one supplier in this market)
- The industry's first fully integrated quad T1/E1 receivers used in the growing SONET multiplexing and T1/E1 test, monitoring and performance market
- Exclusive worldwide provider of integrated Clock Rate Adapters for E1 and T1 interfaces
- The world's only integrated T1 and E1 repeater chips (Level One offers four repeaters: single T1, dual T1, single E1 and dual E1)
- Organized consortium of leading manufacturers to develop chips compliant with the new industry standard for High bit rate Digital Subscriber Line (HDSL) interface at T1 or E1 speeds: our Level One HDSL data pump is the world's most integrated solution

NETWORKING ACHIEVEMENTS

- Developed the world's first fully integrated extended range transceivers for Digital Data Service (DDS)—originally called Dataphone Digital Service by AT&T—and Switched 56 service

- Assisted in the rapid growth of the LAN market with 10BASE-T Ethernet network interface connectivity designs
- Introduced a single-chip Media Attachment Unit (MAU) used to connect to an Ethernet LAN and a hub transceiver for multipoint repeaters. Level One is one of the world's top three 10BASE-T transceiver suppliers (Source: DataQuest)
- Introduced the industry's first Ethernet twisted-pair-to-coaxial cable adapter IC
- The first firm (in 1992) to address the data communications industry's electromagnetic interference needs by integrating transmit filter functions onto a chip
- Developed the first multiport quad hub repeater chip, the LXT914, with integrated transmit filters for 10BASE-T networks

UNIQUE DESIGN AND MODELING/SIMULATION SYSTEMS

At the heart of Level One's product development effort is a world-class team of silicon designers specializing in mixed-signal communications. This rare breed of IC design engineer is very much in demand among original equipment manufacturers and also among developers of telecom/datacom chip-level components. To assist this team in its R&D pursuits, Level One is using a state-of-the-art Computer Aided Design (CAD) system as well as a proprietary software modeling and simulation system (LxWAVE™). This unique design environment enables Level One to develop fully simulated mixed-signal products quickly, taking the characteristics of target transmission lines into account.

LxWAVE is a very effective proprietary software simulation tool used to model both the physical-level communications system and the associated metallic transmission networks. It is composed of two modules: LxNET™ and LxSYS™. LxNET is transmission simulation software used to model dispersion and attenuation of baseband signals for a given set of twisted-pair transmission line characteristics. The LxSYS software module simulates interrelated functional blocks as a system, and models the transceiver's resulting behavior and performance. Together LxNET and LxSYS accurately predict system-level performance of Silicon Connectivity Solutions in actual transmission networks. These software tools, combined with very powerful automatic test equipment, enable Level One to test its ICs as if they were transmitting in the real world.

MULTIPLE FOUNDRY STRATEGY

Level One's flexible design methodology utilizes multiple independent wafer foundries to fabricate its integrated circuits. This enables Level One to optimize its manufacturing base to take advantage of process innovations and production schedules. The Company has entered into long-term wafer supply agreements with some of its suppliers.

Quality and Reliability Assurance

Extremely stringent quality and reliability standards are every employee's responsibility. Level One's quality and reliability assurance focus starts at the product definition stage and continues through every aspect of product design, manufacture, testing and customer support.

The company has developed an exacting quality assurance process that has proven successful in reducing failure rates to an absolute minimum for the more than fifteen million ICs produced by the company to date. A rigorous program of wafer foundry and assembly subcontractor selection, audit, qualification and monitoring — as well as internal controls — ensures a consistent supply of high quality and reliable devices.

To qualify to be a Level One wafer foundry or assembly subcontractor, each site must meet an established benchmark performance level. Once qualified, all parties must continue to comply with these benchmarks to maintain Level One's exacting, state-of-the-art manufacturing and production standards. Level One is currently in the process of ISO 9000 certification.

LOW FAILURE RATES

The success of Level One's quality and reliability assurance program is demonstrated by the company's extremely low failure/return rate. Level One's defect return rate is less than 0.2 percent of annual sales. The average Mean Time Before Failure (MTBF) for Level One's ICs is in excess of 10 million hours.

Summary

Level One's goal is to become the prime source for the best-performing, highest quality communication IC products. Our goal will be achieved by delivering products on time with strong field sales and application support, and better customer service than any other semiconductor provider in the market. The company is focused on developing the most cost-effective Silicon Connectivity Solutions. To maintain its leadership position, Level One strives to continue to reduce the cost of its products and to provide its customers with higher added-value Silicon Connectivity Solutions.

* LxWAVE, LxNET, and LxSYS are trademarks of Level One Communications, Incorporated.

QUALITY AND RELIABILITY

1

Designing in Quality

Level One has developed a unique approach to transceiver design and testing. This approach enables us to ensure that all of the devices we manufacture meet performance specifications. We use LxWAVE™, our proprietary simulation tool, to generate analog signals that model transmission through various networks and systems. This enables Level One to test designs and finished devices under simulated conditions to ensure performance to specifications in extremely demanding scenarios.

LxWAVE consists of two simulation tools: LxNET™ and LxSYS™. LxNET starts with a transmission line model using stored transmission line parameters, many of which are actual laboratory measured values. Level One has constructed a wide variety of line models of various gauges, including single and multi-pair bundles. The transmission loop environment can then be modeled by simulating the effect of topology on the transmission network. The topology can include transformers, inductors, capacitors, resistors, active circuitry, bridge taps and other external disturbers. With a given line model, LxNET calculates the response of the loop anywhere along the loop.

LxSYS, the second part of LxWAVE, simulates the behavior of the transceiver in design. To construct the behavior model, LxSYS uses software modules corresponding to circuitry in the Level One design library. Jitter and noise, analog offsets and non-linearities, and bandwidth limitations may also be added.

In the design stage, Level One engineers use LxWAVE to simulate the response of the transceiver for various inputs and under various operating conditions. With these responses, we develop a template defining the range into which the transceiver's output should fall. These templates are saved for later testing.

Designing In Reliability

During design, the reliability aspect of the device is as important to Level One as performance, die size, and yield. Therefore, Level One has established design/layout rules and guidelines aimed at ensuring reliability. These guidelines are followed carefully for all Level One designs; they are updated as required by processing and packaging advances, as well as failure analysis history.

Design and layout guidelines used for Level One designs are intended to ensure reliable circuit operation. Included in the guidelines are rules intended to reduce susceptibility

to latch-up, enhance circuit ESD robustness, avoid trace and contact electromigration, ensure dielectric integrity, reduce metal stress, and provide compatibility with packaging. These guidelines are determined in conjunction with the wafer foundries to guarantee compatibility with their processes. Packaging and assembly related guidelines are developed with the assembly house to enhance package reliability and die protection.

In addition, Level One designs are conservative. Chip components are not designed to the limits of process capabilities or operated under conditions that could lead to instability. Designs are subjected to in-depth circuit simulation at temperature, voltage and processing extremes before being committed to silicon. In order to guarantee operation at these extremes, circuit designs must be conservative.

Level One devices are designed for fabrication at more than one targeted foundry. The processes used by these different foundries are similar, but not identical. Therefore, our designs must be able to encompass the process differences between foundries. This results in devices less sensitive to variations that may occur during processing or during the life of the device.

Foundry and Assembly House Qualification

The process of choosing and qualifying a wafer foundry or an assembly house starts long before any product is built at the facility. Each subcontractor is studied in detail to assure compatibility with Level One requirements. Factors examined at an assembly house include: package capabilities, attach types, temperature profiles, mold compound and epoxy types, inspections, process control, and quality procedures.

Foundries are evaluated for their ability to produce Level One designs. The foundry's device models or Level One generated models are used to determine the foundry's compatibility. Extensive simulation is performed at process, voltage and temperature extremes to ensure circuit functionality. The process flow and construction topology are evaluated for top coat effectiveness, glassivation and metallization step coverages, effectiveness of planarization, electromigration performance, etc. Reliability data is evaluated for compliance with Level One reliability requirements.

The manufacturing and quality procedures followed by the foundry are evaluated carefully to be sure they can control the process to Level One specifications. Also, complete lot traceability must be retained.

Finally, both the foundry and the assembly house must be committed to constant quality improvement through the use of control charts, quality groups, and corrective/preventive actions on anomalies reported by customers. Currently, the company has qualified foundries in North America, Europe and Asia. Multiple foundries reduce the risks associated with dependency on a single vendor.

Level One assembly in plastic DIP, PLCC, TQFP and PQFP packages is currently being handled by assembly houses in Asia, Europe and the USA.

Subcontractor Control

Subcontractor control is important to ensure consistent performance. Control is a continuous process, accomplished through a multifaceted approach. Subcontractor surveillance is an important part of the Level One standard product flow. Electrical measurements of basic transistor and topology structures are examined for each wafer lot received. Each incoming packaged device lot is subjected to material verification and QC monitor report review. In addition, incoming wafers and packaged devices are visually inspected on a sample basis. Any anomalies or trends are detected and reported early in the process.

Periodically, Level One audits foundry and assembly house process monitor and control procedures, quality and reliability monitoring, incoming material quality assurance, and process capability indexes.

Product Reliability Qualification

Level One products must undergo a strenuous reliability qualification procedure before production shipments begin. Product reliability qualification includes: establishment of functional and parametric test procedures; reliability qualification of the device; reliability qualification of the process to be used; and reliability qualification of the package.

A device built using a new foundry or a new assembly house must undergo the most encompassing reliability qualification procedure. Because subsets of the reliability qualification procedure are specific to foundry processes and packages, products using pre-qualified processes or packages require qualification only of the portions of the procedure not satisfied by prior qualification. Every qual-

ified product is capable of meeting each applicable reliability qualification requirement.

Among the tests and stresses included in the reliability qualification procedure are the following:

- operating life tests
- Temperature Humidity Bias (THB)
85 °C/85% RH or 130 °C/85% RH
- autoclave
- temperature cycling
- thermal shock
- latch-up immunity
- ESD susceptibility
- package and lead mechanical integrity
- moisture sensitivity evaluation

Such comprehensive testing stresses the device design, process and package. For example, operating life tests stress the device with bias (in a static or dynamic mode) at elevated temperatures to accelerate possible failure mechanisms that could occur during the life of the device. Failure mechanisms accelerated during life testing include parameter shifts, leakages, electromigration and oxide defects. These failure mechanisms have been thoroughly studied, and found to follow the Arrhenius relationship for reaction rate acceleration with temperature. This enables Level One to simulate life at a nominal operating temperature in a relatively short time.

Autoclave and THB tests are used to evaluate the resistance to moisture of devices packaged in plastic. The ability of the package to protect the die is evaluated in autoclave, in an unbiased, high temperature, pressurized steam environment. Metallization corrosion is the dominant failure mechanism. Bias-dependent moisture effects are enhanced through THB, which is a humid (85% RH), high temperature (85 °C or 130 °C) environment. Failure mechanisms include metallization corrosion, leakages and voltage shifts. The package, process, and circuit design are all stressed with THB.

Package and bond integrity are evaluated using temperature cycling, thermal shock, and package and lead mechanical testing. Level One also evaluates the moisture sensitivity of surface mount devices according to JEDEC and IPC standards.

Destructive physical analysis (DPA) is used to evaluate the details of construction, workmanship, and potential reliability. In this analysis, the package and/or die is dissected and examined in detail, using X-ray, optical microscopy, and scanning electron microscopy. Items such as bond wire dress, ball formation, die attach, lead frame, package or

mold compound, passivation integrity, die construction and workmanship are analyzed.

Product Monitoring

After a product is qualified, Level One's product monitoring program continues to verify quality and long-term reliability. Under this program, the Quality and Reliability Department takes periodic samples of the product from finished goods and subjects them to selected product qualification tests. Process related tests are performed on a quarterly basis. Each process/foundry used in production is monitored separately. Package reliability testing is performed biannually-annually. Each production package type/assembly is monitored individually.

The results of the reliability testing performed for the product monitoring program are published in Level One Reliability Reports.

An important area of product monitoring is reviewing failure history for indications of process or assembly anomalies. If trends are seen, the anomaly is identified through failure analysis, pinpointing possible process or assembly influences. Level One then implements corrective actions, working with the foundry or assembly house. Design rules and guidelines are modified, if necessary, to prevent future recurrence of the failure mechanism.

Production Flow

The Level One production flow is shown in Figure 1. Level One participates in quality and reliability monitoring through each aspect of the production cycle by reviewing electrical and inspection data from the foundry and assembly house. All device testing and lot certification, as well as wafer and package inspections, are performed by Level One and certified subcontractors.

With each wafer lot, the foundry sends results of electrical measurements of basic transistor and topology structures. These measurements are reviewed and compared to specified values for the process. If the deviation falls outside the specification limits, the material is held by the foundry until disposition by Level One. Feedback to the foundry is immediate, and a mutually-agreed-upon corrective action plan is executed.

A similar inspection and QC monitoring report is received with each assembled lot from the assembly house. This report is reviewed for each incoming lot.

Before disposition to finished goods, the lot traveler is reviewed by Quality Assurance to ensure that all test, inspection and production steps have been performed.

A sample of the product must pass a rigorous quality acceptance test before authorization to ship is given. Upon successful completion of this test, authorization to ship is given by Quality Assurance.

By maintaining close working relationships with the foundries and assembly houses, Level One is involved throughout the production of the product.

Testing

All devices are 100% tested using parametric and functional tests using analog waveforms and digital test vectors. Test vectors are downloaded to the production tester for incorporation into test programs. The analog and digital signals transmitted through various networks are reconstructed by the tester and used as stimuli to the device under test (DUT). Noise can be added to further evaluate the device's response under less than optimum operating conditions. The response is sampled by the tester and compared to the template constructed for the particular input stimulus. Using the reconstructed waveforms, the DUT is also tested for response to various line lengths and superimposed noise amplitudes.

These dynamic functional tests, combined with parametric tests, ensure that the devices are rigorously tested under various operating conditions without the use of cable spools or other hardware.

Product Traceability

To ensure traceability, each lot traveler tracks the product history as follows: foundry lot, assembly, inspections, tests, burn-in monitor, quality control and quality acceptance testing, and shipping destination. This documentation is retained for future reference. The lot traveler enables Level One to determine which lots were shipped to a particular customer. In addition, each device is branded with the lot number and a special trace code to enable complete traceability.

Figure 1: Level One Production Flow

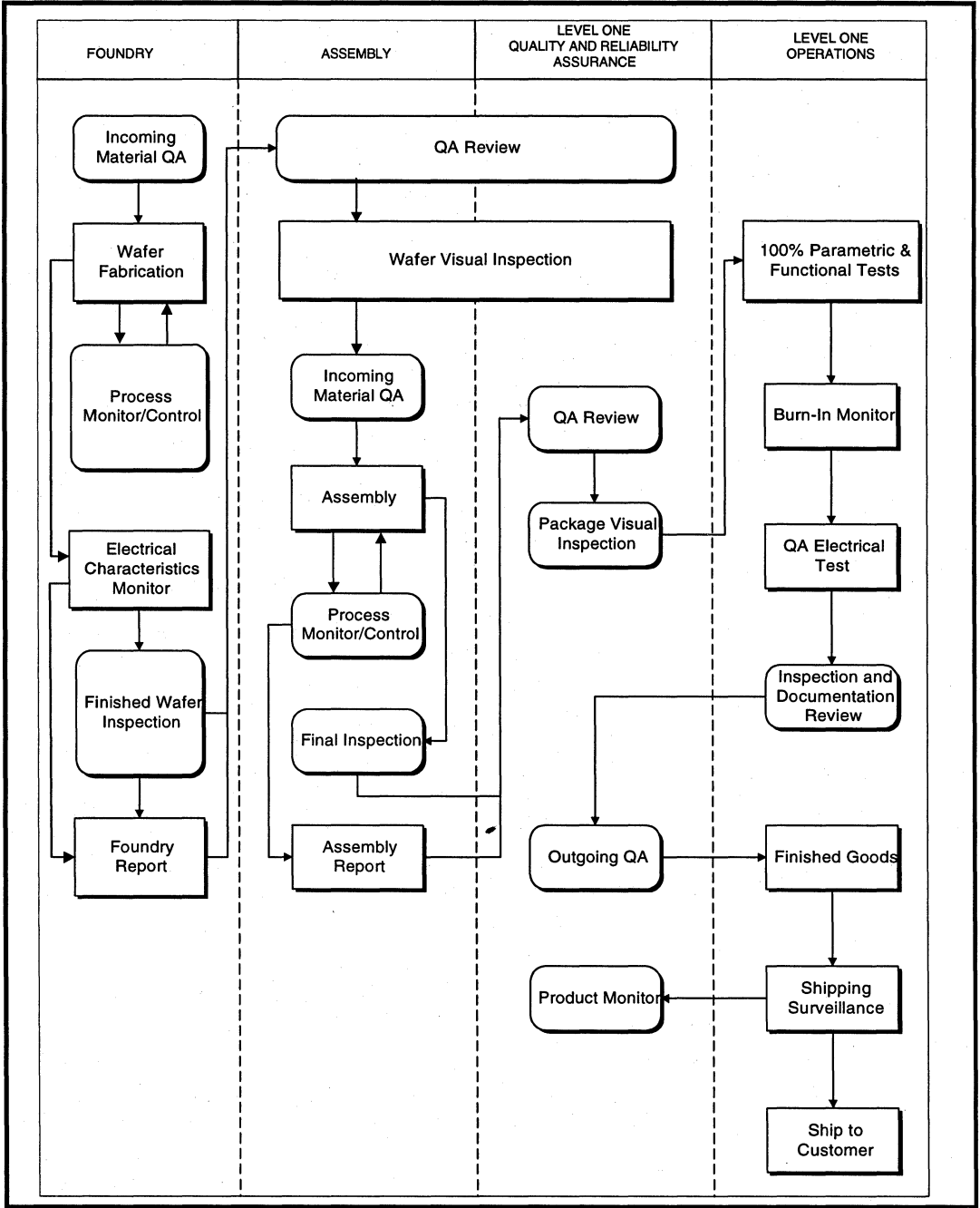

Electrostatic Discharge

Electrostatic discharge (ESD) can damage sensitive semiconductor devices. Damage occurs unless precautions are taken to eliminate the generation of dangerous static levels, and to design robust circuitry with sufficient protection. Level One uses both approaches to ensure that the devices shipped to our customers are not compromised, and that they will survive industry accepted handling for semiconductor devices.

Level One's design guidelines for ESD protection produce devices which tolerate nominal ESD levels without damage. Before use in device designs, we test the susceptibility to ESD damage of standard input and output cells. In addition, the ESD susceptibility of each device type is determined as part of the product qualification before release to production.

Proper ESD handling of devices is policy at Level One. Those who handle devices are fully trained in the proper procedures for handling static-sensitive devices and know that handling devices incorrectly may damage them. Packaged devices are handled only at special workstations designed to eliminate damaging static levels. Packaged devices are shipped in containers designed to eliminate risk of damage caused by ESD.

Constant Improvement Program

To assure shipment of high-quality, highly reliable devices, Level One pursues constant improvement in all aspects of production and testing. Small group problem-solving teams have been assembled. The teams consist of personnel from both operations and quality, working together to solve problems and improve our manufacturing flow.

Periodic quality system reviews examine the effectiveness of internal Level One quality, manufacturing, and product development systems. Recommendations for improvement are made to and approved by Level One senior management.

LEVEL ONE PRODUCT REFERENCE GUIDE

1

APPLICATIONS	PRODUCT FAMILY	PART NUMBERS	COMMENTS
<p>ACCESS SYSTEMS:</p> <ul style="list-style-type: none"> ▪ MUX ▪ PBX ▪ DSU ▪ CSU ▪ Router ▪ Concentrator ▪ Bridge ▪ PC ▪ Video Conferencing ▪ Channel Extender <p>TRANSPORT SYSTEMS:</p> <ul style="list-style-type: none"> ▪ Channel Bank ▪ DAC ▪ Trunk Card for C.O. and PBX ▪ DLC System ▪ PDH/SDH MUX 	<p><i>Short-Haul T1/E1 Transceivers</i></p>	<p>LXT300</p>	<ul style="list-style-type: none"> ▪ Includes Receive Jitter Attenuation (JA)
		<p>LXT301</p>	<ul style="list-style-type: none"> ▪ Similar to LXT300 without Jitter Attenuator
		<p>LXT300Z</p>	<ul style="list-style-type: none"> ▪ Constant output impedance independent of marks and spaces ▪ Low power consumption (400 mW typ.) ▪ Enhanced DPM monitor detects single line shorts ▪ Output tristate capability ▪ Pulse amplitude stabilization ▪ Includes Receive Jitter Attenuation starting at 3 Hz
		<p>LXT301Z</p>	<ul style="list-style-type: none"> ▪ Similar to LXT300Z without Jitter Attenuator ▪ Meets BAPT E1 short circuit limit of 50 mA with ext. resistors
		<p>LXT304A</p>	<ul style="list-style-type: none"> ▪ Includes Receive Jitter Attenuation starting at 3 Hz ▪ Low power consumption of 400 mW max ▪ Constant low output impedance driver for high return loss ▪ Meets new ETSI TBR 12 standard on output jitter ▪ Low receive clock quantization jitter of < 1/6 U.I. ▪ Analog/digital LOS processor meets G.775 ▪ Programmable Transmit Return Loss using ext. resistors ▪ Output driver tristate capability
		<p>LXT305</p>	<ul style="list-style-type: none"> ▪ Similar to LXT300 but with Jitter Attenuator on Transmit side

LEVEL ONE PRODUCT REFERENCE GUIDE

APPLICATIONS	PRODUCT FAMILY	PART NUMBERS	COMMENTS
<p>ACCESS SYSTEMS:</p> <ul style="list-style-type: none"> ▪ MUX ▪ PBX ▪ DSU ▪ CSU ▪ Router ▪ Concentrator ▪ Bridge ▪ PC ▪ Video Conferencing ▪ Channel Extender <p>TRANSPORT SYSTEMS:</p> <ul style="list-style-type: none"> ▪ Channel Bank ▪ DAC ▪ Trunk Card for C.O. and PBX ▪ DLC System ▪ PDH/SDH MUX 	<p><i>Short-Haul T1/E1 Transceivers</i></p>	<p>LXT305A</p>	<ul style="list-style-type: none"> ▪ Includes Transmit Jitter Attenuation starting at 3 Hz ▪ Low power consumption of 400 mW max ▪ Constant low output impedance driver for high return loss ▪ Meets new ETSI TBR-12 standard on output jitter ▪ Low receive clock duty cycle variation ▪ Low intrinsic receive clock quantization jitter ▪ 32-bit FIFO accommodates up to 28 U.I. of gapped clocks without overflow ▪ Output driver tristate capability ▪ Analog/digital LOS processor meets G.775 ▪ Meets BAPT E1 short circuit limit of 50 mA with external resistors
		<p>LXT307</p>	<ul style="list-style-type: none"> ▪ E1-only transceiver without Jitter Attenuation ▪ Analog/digital LOS processor meets G.775 ▪ Meets BAPT short circuit limit of 50 mA with ext. resistors ▪ 75/120 Ω operation without component changes ▪ Low 2.048 MHz reference clock ▪ Constant low output impedance driver for high return loss ▪ Low receive clock duty cycle variation ▪ Output driver tristate capability
<p>TEST EQUIPMENT</p> <p>LINE MONITORS</p> <p>LINE INTERFACES</p>	<p><i>Quad Receiver</i></p>	<p>LXT325</p>	<ul style="list-style-type: none"> ▪ Industry's first quad receiver ▪ Incorporates four independent receivers in 28-pin DIP or PLCC ▪ Sensitivity allows for up to 20 dB of jack/cable attenuation ▪ Includes LOS indication output for each receiver

LEVEL ONE PRODUCT REFERENCE GUIDE

1

APPLICATIONS	PRODUCT FAMILY	PART NUMBERS	COMMENTS
<p>ACCESS SYSTEMS:</p> <ul style="list-style-type: none"> ▪ MUX ▪ PBX ▪ DSU ▪ CSU ▪ Router ▪ Concentrator ▪ Bridge ▪ PC ▪ Video Conferencing ▪ Channel Extender <p>TRANSPORT SYSTEMS:</p> <ul style="list-style-type: none"> ▪ Channel Bank ▪ DAC ▪ Trunk Card for C.O. and PBX ▪ DLC System ▪ PDH/SDH MUX 	<p><i>Short-Haul T1/E1 Transceivers</i></p>	<p>LXT332</p>	<ul style="list-style-type: none"> ▪ Single chip dual T1/E1 transceiver ▪ Tx/Rx switchable crystal-less Jitter Attenuator ▪ On-chip driver short circuit monitoring (DFM) ▪ On-chip encoder/decoder ▪ QRSS detector/generator ▪ AIS/BPV insert and detect ▪ Software-switchable between T1 and E1 operation ▪ Low-frequency reference clock (1.544 or 2.048 MHz)
		<p>LXT350</p>	<ul style="list-style-type: none"> ▪ Single channel version of LXT332 ▪ Serial microprocessor control port
		<p>LXT351</p>	<ul style="list-style-type: none"> ▪ Single channel version of LXT332 ▪ 8-bit parallel microprocessor control port

LEVEL ONE PRODUCT REFERENCE GUIDE

APPLICATIONS	PRODUCT FAMILY	PART NUMBERS	COMMENTS
<p>ACCESS SYSTEMS:</p> <ul style="list-style-type: none"> ▪ Network Access ▪ ISDN PRI ▪ CSU ▪ NTU <p>TRANSPORT SYSTEMS:</p> <ul style="list-style-type: none"> ▪ Office Repeater ▪ Cellular Bay ▪ Base Station Networking 	<p><i>Long-Haul T1 Transceiver</i></p>	<p>LXT310</p>	<ul style="list-style-type: none"> ▪ Industry's first fully compliant T1 CSU/ISDN transceiver ▪ Operates over 6,000 feet of twisted-pair cable ▪ Jitter Attenuator switchable from transmit to receive
	<p><i>Long-Haul DECT Transceiver</i></p>	<p>LXT317</p>	<ul style="list-style-type: none"> ▪ Industry's first fully integrated long-haul transceiver @ 1.152 Mbps ▪ Operates over 3.5 km of 0.6 mm cable ▪ Optimized to address Digital European Cordless Telecommunications (DECT) and Personal Communications Service (PCS) standards
	<p><i>Long-Haul E1 Transceiver</i></p>	<p>LXT318</p>	<ul style="list-style-type: none"> ▪ Similar to LXT310 but for E1 operations ▪ Fully compliant with ITU-T specifications for E1 short-haul (6 dB) or long-haul (43 dB) applications ▪ Meets new ETSI TBR12/13 standard on output jitter
	<p><i>Short-Haul and Long-Haul T1/E1 Transceiver</i></p>	<p>LXT360/361</p>	<ul style="list-style-type: none"> ▪ T1/E1 short-haul and long-haul transceiver ▪ Software-programmable T1/E1 operation ▪ On-chip QRSS, BPV and AIS generator/detector ▪ Analog/digital LOS processor meets G.775 ▪ Crystal-less Jitter Attenuator ▪ Serial (LXT360) and parallel (LXT361) control port

LEVEL ONE PRODUCT REFERENCE GUIDE

1

APPLICATIONS	PRODUCT FAMILY	PART NUMBERS	COMMENTS
REPEATERS SMART REPEATER	<i>T1 Repeaters</i>	LXT312	<ul style="list-style-type: none"> ▪ Industry's only fully integrated dual T1 repeater ▪ Requires only a crystal and a few other components to complete a repeater design ▪ No tuning coil required ▪ Low power consumption ▪ 0 to 36 dB dynamic range
OFFICE REPEATERS		LXT315	<ul style="list-style-type: none"> ▪ Single version of LXT312
REPEATERS SMART REPEATER/ TRANSCEIVER	<i>E1 Repeaters/</i> <i>Transceivers</i>	LXT313	<ul style="list-style-type: none"> ▪ Industry's only fully integrated dual E1 repeater/transceiver ▪ Requires only a crystal and a few other components to complete a repeater design ▪ No tuning coil required ▪ Low power consumption ▪ 0 to 43 dB dynamic range
OFFICE REPEATER/ TRANSCEIVER		LXT316	<ul style="list-style-type: none"> ▪ Single version of LXT313

LEVEL ONE PRODUCT REFERENCE GUIDE

APPLICATIONS	PRODUCT FAMILY	PART NUMBERS	COMMENTS
<p>ACCESS SYSTEMS:</p> <ul style="list-style-type: none"> ▪ PBX ▪ NTU ▪ CSU <p>TRANSPORT SYSTEMS:</p> <ul style="list-style-type: none"> ▪ MUX ▪ Channel Bank ▪ CO Switch ▪ DAC ▪ Office Repeater Bay ▪ Mobile Switch 	<p><i>Low-Jitter T1/E1 Clock Rate Adapters</i></p>	<p>LXP600A</p>	<ul style="list-style-type: none"> ▪ Industry's first Clock Adapter (CLAD) for use as internal system timing generator ▪ Converts between T1 and E1 ▪ Patented locking method enables frequency conversion with no external devices ▪ Meets AT&T 62411 and ITU-T G.732 jitter specs when teamed with Level One transceivers ▪ Provides 6 MHz High Frequency Output (HFO)
		<p>LXP602</p>	<ul style="list-style-type: none"> ▪ Similar to LXP600A, but provides 8 MHz HFO
		<p>LXP604</p>	<ul style="list-style-type: none"> ▪ Converts between 1.544 MHz and 4.096 MHz, with 6 and 8 MHz HFO
		<p>LXP610</p>	<ul style="list-style-type: none"> ▪ Multi-rate Clock Adapter ▪ Pin-selectable frequency conversion between 11 different rates (1.544 MHz to 8 MHz) ▪ Accepts seven CLKI input frequencies and provides five HFO output frequencies
<p>FRAME RELAY DDS and SW/56 DSU</p>	<p><i>DDS/Switched-56 Transceiver</i></p>	<p>LXT400</p>	<ul style="list-style-type: none"> ▪ Fully integrated all-rate extended range transceiver ▪ Receive equalizer filter can handle up to 40 dB at rates below 56 kbps, and up to 49 dB at 56 kbps and 72 kbps

LEVEL ONE PRODUCT REFERENCE GUIDE

1

APPLICATIONS	PRODUCT FAMILY	PART NUMBERS	COMMENTS
<p>HDSL:</p> <ul style="list-style-type: none"> ▪ T1 or E1 (2-pair) and fractional T1 or E1 transport ▪ Digital pair-gain ▪ Wireless base station to switch interface ▪ Campus and private networking ▪ High-speed digital modems 	<p><i>High Bit-Rate Digital Subscriber Line (HDSL) Products</i></p>	<p>SK70704/70706</p>	<ul style="list-style-type: none"> ▪ HDSL chip set for 784 kbps data transmission ▪ Fully integrated analog core chip ▪ Integrated activation/start-up ▪ Optimized for one-pair operation
		<p>SK70704/70707</p>	<ul style="list-style-type: none"> ▪ HDSL chip set for 1168 kbps data transmission ▪ Fully integrated analog core chip ▪ Integrated activation/start-up ▪ Optimized for one-pair operation
<p>PDH MUX:</p> <ul style="list-style-type: none"> ▪ E1, E2, E3 multiplexer ▪ T1 multiplexer (point-to-point applications) 	<p><i>PDH Multiplexer</i></p>	<p>SXT6234</p>	<ul style="list-style-type: none"> ▪ Performs four-E1 to E2 or four-E2 to E3 multiplexing ▪ Compliant with ITU-T G.742 and G.751 recommendations ▪ Usable for four T1 multiplexing ▪ Optimized for microwave radio

LEVEL ONE PRODUCT REFERENCE GUIDE

APPLICATIONS	PRODUCT FAMILY	PART NUMBERS	COMMENTS
<p>UNIVERSAL ETHERNET INTERFACE ADAPTER:</p> <ul style="list-style-type: none"> ▪ Computer/Laptop/ Workstation Interface Boards ▪ LAN Repeaters ▪ Printer Network Attachments ▪ PCMCIA LAN Cards ▪ Workstation/ Graphic Terminals ▪ PC-PC Servers (Adapter/MB) ▪ 10BASE-T Interconnects (MAU) ▪ Bridges/Routers ▪ Terminal Servers ▪ Point-Of-Sale Machine Interfaces ▪ Switching Networks 	<p><i>Ethernet Transceiver for AUI and 10BASE-T</i></p>	<p>LXT901</p>	<ul style="list-style-type: none"> ▪ Industry first with integrated filters ▪ Provides all active circuitry for interfacing 802.3 controllers to an Attachment Unit Interface (AUI) or 10BASE-T media ▪ Includes Manchester encoder/decoder, reversed polarity detection/correction ▪ LED drivers ▪ Compatible with shielded or unshielded twisted-pair ▪ Full duplex capability
	<p><i>Ethernet Transceiver for AUI and 10BASE-T</i></p>	<p>LXT907</p>	<ul style="list-style-type: none"> ▪ Integrated filters ▪ Provides all active circuitry for interfacing 802.3 controllers to an Attachment Unit Interface (AUI) or 10BASE-T media ▪ Includes Manchester encoder/decoder, reversed polarity detection/correction ▪ LED drivers ▪ Full duplex capability ▪ Signal Quality Error (SQE) can be disabled for hub and switch applications
<p>ETHERNET TWISTED-PAIR MAU:</p> <ul style="list-style-type: none"> ▪ External AUI to TP Transceivers ▪ Internal MAUs 	<p><i>10BASE-T Media Attachment Unit (MAU)</i></p>	<p>LXT902</p>	<ul style="list-style-type: none"> ▪ Six LED drivers for diagnostics and status reporting ▪ Full duplex capability ▪ Signal Quality Error (SQE) can be disabled for hub and switch applications ▪ Automatic AUI/RJ45 selection for internal MAU applications

LEVEL ONE PRODUCT REFERENCE GUIDE

APPLICATIONS	PRODUCT FAMILY	PART NUMBERS	COMMENTS
<p>ETHERNET INTERFACE ADAPTER:</p> <ul style="list-style-type: none"> ▪ Bridges, Routers ▪ LAN-to-WAN access equipment 	<p><i>Ethernet Transceiver for AUI Connections</i></p>	<p>LXT904</p>	<ul style="list-style-type: none"> ▪ Provides all active circuitry for interfacing 802.3 controllers to an Attachment Unit Interface (AUI) ▪ Includes Manchester encoder/decoder ▪ LED drivers ▪ Full duplex capability
<p>UNIVERSAL ETHERNET INTERFACE ADAPTER:</p> <ul style="list-style-type: none"> ▪ Portable computers; PDAs ▪ Switching Hubs ▪ Printer Adapter Cards ▪ PCMCIA Cards 	<p><i>Ethernet Transceiver for 10BASE-T, with EnDec and filters</i></p>	<p>LXT905</p>	<ul style="list-style-type: none"> ▪ 3.3V or 5V operation ▪ Power down mode for battery operation ▪ Provides all active circuitry for interfacing 802.3 controllers to 10BASE-T media ▪ Includes Manchester encoder/decoder, reversed polarity detection/correction, integrated filters ▪ LED drivers ▪ Full duplex capability ▪ Signal Quality Error (SQE) can be disabled for hub and switch applications
<p>ETHERNET TWISTED-PAIR COAX ADAPTER:</p> <ul style="list-style-type: none"> ▪ BNC-TP External Converter 	<p><i>Coax-to-TP Adapter</i></p>	<p>LXT906</p>	<ul style="list-style-type: none"> ▪ Industry exclusive ▪ Direct interface to coax Ethernet transceiver and RJ45 twisted-pair connector ▪ Level-shifted data pass-through ▪ Collision detection/correction ▪ Reversed polarity detection/correction ▪ LED drivers for Tx, Rx, collision, reversed polarity and link functions

LEVEL ONE PRODUCT REFERENCE GUIDE

APPLICATIONS	PRODUCT FAMILY	PART NUMBERS	COMMENTS
<p>UNIVERSAL QUAD ETHERNET INTERFACE ADAPTER:</p> <ul style="list-style-type: none"> ▪ Ethernet Switch ▪ Multiport File Server and Print Server 	<p><i>Quad Ethernet Transceiver for 10BASE-T</i></p>	<p>LXT944</p>	<ul style="list-style-type: none"> ▪ Four independent 10BASE-T transceivers with integrated filters, Manchester encoder/decoders ▪ Four LED drivers per port ▪ Full duplex capability on each port ▪ Signal Quality Error (SQE) can be disabled for hub and switch applications
<p>FLEXIBLE QUAD HUB REPEATER</p> <ul style="list-style-type: none"> ▪ 4 or 5-Port "Personal" Hub ▪ 8, 9, 10 or 12-Port Hub (stackable and standalone) ▪ Multiport File Server ▪ Print Server ▪ Terminal Server ▪ Multiport Router ▪ Intelligent Repeater (PHY Layer Management) 	<p><i>4-Port 10BASE-T Ethernet Repeater Device with AUI Port</i></p>	<p>LXT914</p>	<ul style="list-style-type: none"> ▪ Four 10BASE-T ports ▪ Integrated filters ▪ One AUI port (DTE/MAU) ▪ Synchronous or asynchronous backplane ▪ Serial port for programmable options ▪ Seven LED drivers ▪ Programmable squelch level ▪ Supports "Hot Swapping" ▪ Cascadeable backplane links up to 128 ports ▪ Easily connects to any MAC's AUI port to increase port connectivity

T1/E1 Short-Haul Transceivers and Receivers



**and General
Specifications**

1.544 MBPS T1 PULSE MASK (DS1 AND DSX-1)

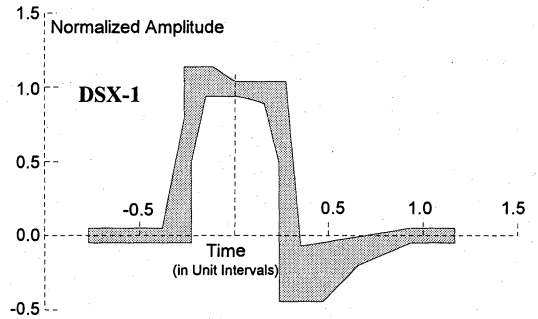
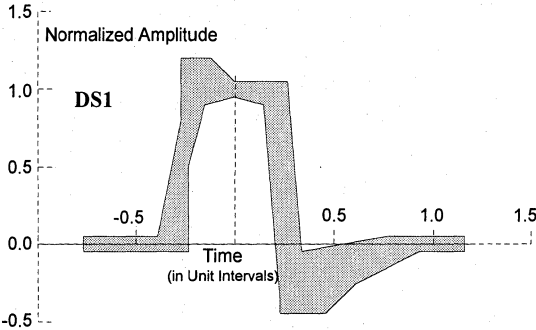

1.544 Mbps T1 Pulse Mask Corner Point Specifications

DS1 Template (per ANSI T1. 403-1995)				DSX-1 Template (per ANSI T1. 102-1993)			
Minimum Curve		Maximum Curve		Minimum Curve		Maximum Curve	
Time (UI)	Amplitude	Time (UI)	Amplitude	Time (UI)	Amplitude	Time (UI)	Amplitude
-0.77	-0.05	-0.77	0.05	-0.77	-0.05	-0.77	0.05
-0.23	-0.05	-0.39	0.05	-0.23	-0.05	-0.39	0.05
-0.23	0.50	-0.27	0.80	-0.23	0.50	-0.27	0.80
-0.15	0.90	-0.27	1.20	-0.15	0.95	-0.27	0.80
0.0	0.95	-0.12	1.20	0.0	0.95	-0.27	1.15
0.15	0.90	0.0	1.05	0.15	0.90	0.0	1.05
0.23	0.50	0.27	1.05	0.23	0.50	0.27	1.05
0.23	-0.45	0.34	-0.05	0.23	-0.45	0.35	-0.07
0.46	-0.45	0.77	0.05	0.46	-0.45	0.93	0.05
0.61	-0.26	1.16	0.05	0.66	-0.20	1.16	0.05
0.93	-0.05			0.93	-0.05		
1.16	-0.05			1.16	-0.05		

2.048 MBPS E1 PULSE MASK

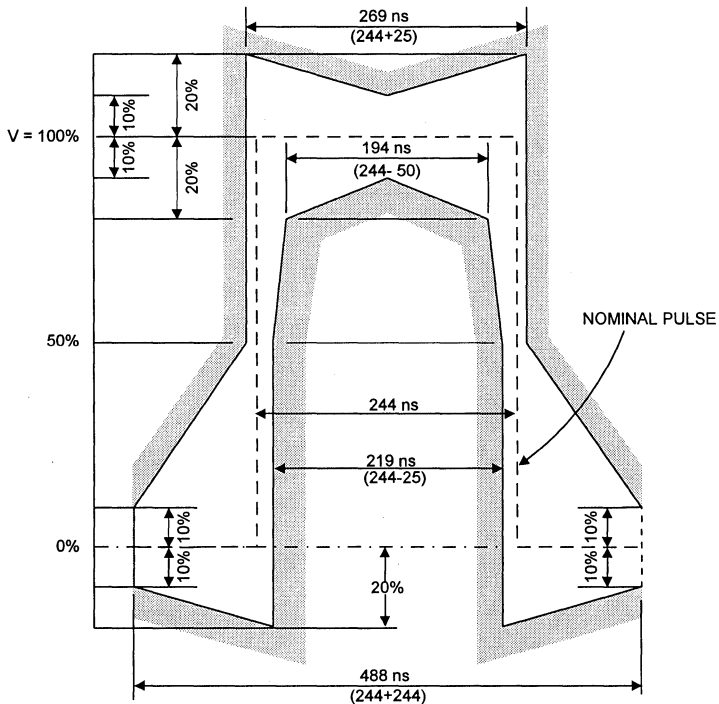

2.048 Mbps E1 Pulse Mask Specifications

Parameter	Coaxial Cable	Shielded Twisted-Pair	Units
Test load impedance	75	120	Ω
Nominal peak mark voltage	2.37	3.0	V
Nominal peak space voltage	0 ± 0.237	0 ± 0.30	V
Nominal pulse width	244	244	ns
Ratio of positive and negative pulse amplitudes at center of pulse	95-105	95-105	%
Ratio of positive and negative pulse amplitudes at nominal half amplitude	95-105	95-105	%

T1/E1 Primary Rate Specifications

NOTES:

LXT300 / LXT301

Integrated T1/E1 Short-Haul Transceivers

General Description

The LXT300 and LXT301 are fully integrated transceivers for both North American 1.544 Mbps (T1) and International 2.048 Mbps (E1) applications. Transmit pulse shapes (DSX-1 or E1) are selectable for various line lengths and cable types.

The LXT300 provides receive jitter attenuation starting at 3 Hz, and is microprocessor controllable through a serial interface. The LXT301 is pin compatible, but does not provide jitter attenuation or a serial interface.

Both transceivers offer a variety of diagnostic features including transmit and receive monitoring. Clock inputs may be derived from an on-chip crystal oscillator or from digital inputs. They use an advanced double-poly, double-metal CMOS process and require only a single 5-volt power supply.

Applications

- PCM / Voice Channel Banks
- Data Channel Bank / Concentrator
- T1 / E1 multiplexer
- Digital Access and Cross-connect Systems (DACs)
- Computer to PBX interface (CPI & DMI)
- High-speed data transmission lines
- Interfacing Customer Premises Equipment to a CSU
- Digital Loop Carrier (DLC) terminals

Features

- Compatible with most popular PCM framers
- Line driver, data recovery and clock recovery functions
- Receive jitter attenuation starting at 3 Hz meets or exceeds AT&T Pub 62411 (LXT300 only)
- Minimum receive signal of 500 mV
- Selectable slicer levels (E1/DSX-1) for improved SNR
- Programmable transmit equalizer shapes pulses to meet DSX-1 pulse template from 0 to 655 ft
- Local and remote loopback functions
- Transmit Driver Performance Monitor (DPM) output
- Receive Monitor with Loss of Signal (LOS) output
- Receiver jitter tolerance 0.4 UI from 40 kHz to 100 kHz
- Microprocessor controllable (LXT300 only)
- Available in 28-pin DIP or PLCC

LXT300 Block Diagram

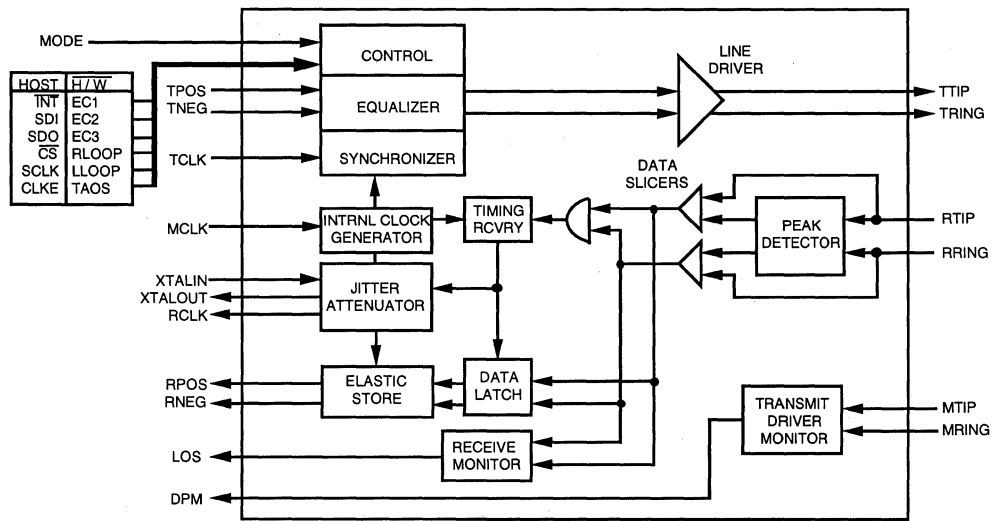

LXT300/301 Integrated T1/E1 Short-Haul Transceivers

Figure 1: Pin Assignments

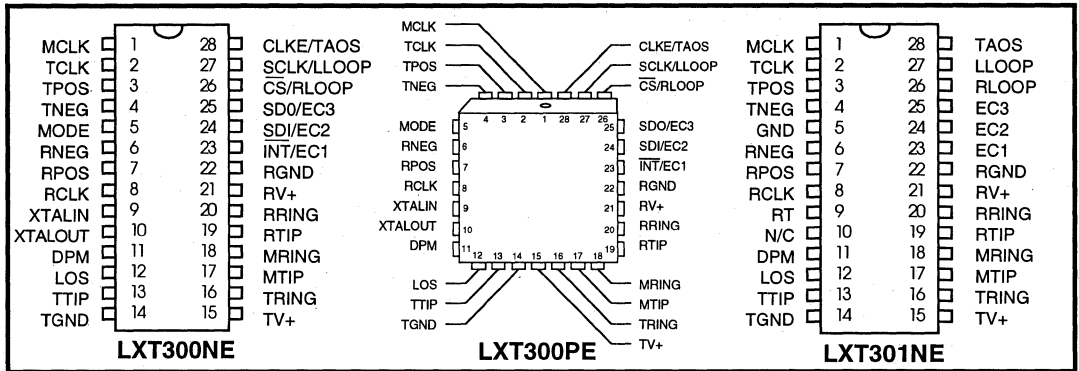

Table 1: Pin Descriptions

Pin #	Sym	I/O ¹	Name	Description
1	MCLK	DI	Master Clock	A 1.544 or 2.048 MHz clock input used to generate internal clocks. Upon Loss of Signal (LOS), RCLK is derived from MCLK. <i>LXT300 Only: If MCLK is not applied, this pin should be grounded.</i>
2	TCLK	DI	Transmit Clock	Transmit clock input. TPOS and TNEG are sampled on the falling edge of TCLK. If TCLK is grounded, the output drivers enter a high-Z state, except during Remote Loopback.
3	TPOS	DI	Transmit Positive Data	Input for positive pulse to be transmitted on the twisted-pair line.
4	TNEG	DI	Transmit Negative Data	Input for negative pulse to be transmitted on the twisted-pair line.
5	MODE	DI	Mode Select <i>(LXT300)</i>	Setting MODE High puts the LXT300 in the Host Mode. In the Host Mode, the serial interface is used to control the LXT300 and determine its status. Setting MODE Low puts the LXT300 in the Hardware (H/W) Mode. In the Hardware Mode, the serial interface is disabled and hard-wired pins are used to control configuration and report status.
	GND	S	<i>(LXT301)</i>	Tie to Ground.
6	RNEG	DO	Receive Negative Data	Received data outputs. A signal on RNEG corresponds to receipt of a negative pulse on RTIP and RRING. A signal on RPOS corresponds to receipt of a positive pulse on RTIP and RRING. RNEG and RPOS outputs are Non-Return-to-Zero (NRZ). Both outputs are stable and valid on the rising edge of RCLK.
7	RPOS	DO	Receive Positive Data	<i>LXT300 Only: In the Host Mode, CLKE determines the clock edge at which these outputs are stable and valid. In the Hardware Mode both outputs are stable and valid on the rising edge of RCLK.</i>
8	RCLK	DO	Recovered Clock	This is the clock recovered from the signal received at RTIP and RRING.

1. I/O column entries: DI = Digital Input, DO = Digital Output, AO = Analog Output, AI = Analog Input, S = Supply.

Table 1: Pin Descriptions - continued

Pin #	Sym	I/O ¹	Name	Description
9	XTALIN	AI	Crystal Input	An external crystal operating at four times the bit rate (6.176 MHz for DSX-1, 8.192 MHz for E1 applications with an 18.7 pF load) is required to enable the jitter attenuation function of the LXT300. These pins may also be used to disable the jitter attenuator by connecting the XTALIN pin to the positive supply through a resistor, and floating the XTALOUT pin.
10	XTALOUT	AO	Crystal Output (LXT300)	
9	RT	AI	R Termination (LXT301)	Connect to RV+ through a 1 kΩ resistor.
10	N/C	–	No Connect (LXT301)	No connection.
11	DPM	DO	Driver Performance Monitor	DPM goes High when the transmit monitor loop (MTIP and MRING) does not detect a signal for 63 ±2 clock periods. DPM remains High until a signal is detected.
12	LOS	DO	Loss Of Signal	LOS goes High when 175 consecutive spaces have been detected. LOS returns Low when a mark is detected.
13	TTIP	AO	Transmit Tip	Differential Driver Outputs. These outputs are designed to drive a 25 Ω load. The transmitter will drive 100 Ω shielded twisted-pair cable through a 1:2 step-up transformer without additional components. To drive 75 Ω coaxial cable, two 2.2 Ω resistors are required in series with the transformer.
16	TRING	AO	Transmit Ring	
14	TGND	S	Transmit Ground	Ground return for the transmit drivers power supply TV+.
15	TV+	S	Transmit Power Supply	+5 VDC power supply input for the transmit drivers. TV+ must not vary from RV+ by more than ±0.3 V.
17	MTIP	AI	Monitor Tip	These pins are used to monitor the tip and ring transmit outputs. The transceiver can be connected to monitor its own output or the output of another LXT300 or 301 on the board. <i>LXT300 Only: To prevent false interrupts in the host mode if the monitor is not used, apply a clock signal to one of the monitor pins and tie the other monitor pin to approximately the clock's mid-level voltage. The monitor clock can range from 100 kHz to the TCLK frequency.</i>
18	MRING	AI	Monitor Ring	
19	RTIP	AI	Receive Tip	The AMI signal received from the line is applied at these pins. A center-tapped, center-grounded, 2:1 step-up transformer is required on these pins. Data and clock from the signal applied at these pins are recovered and output on the RPOS/RNEG and RCLK pins.
20	RRING	AI	Receive Ring	
21	RV+	S	Receive Power Supply	+5 VDC power supply for all circuits except the transmit drivers. (Transmit drivers are supplied by TV+.)
22	RGND	S	Receive Ground	Ground return for power supply RV+.

1. I/O column entries: DI = Digital Input, DO = Digital Output, AO = Analog Output, AI = Analog Input, S = Supply.

LXT300/301 Integrated T1/E1 Short-Haul Transceivers

Table 1: Pin Descriptions - continued

Pin #	Sym	I/O ¹	Name	Description
23	$\overline{\text{INT}}$	DO	Interrupt (Host Mode)	This <i>LXT300 Host Mode</i> output goes Low to flag the host processor when LOS or DPM go active. $\overline{\text{INT}}$ is an open-drain output and should be tied to power supply RV+ through a resistor. $\overline{\text{INT}}$ is reset by clearing the respective register bit (LOS and/or DPM).
	EC1	DI	Equalizer Control 1 (H/W Mode)	The signal applied at this pin in the <i>LXT300 Hardware Mode</i> and <i>LXT301</i> is used in conjunction with EC2 and EC3 inputs to determine shape and amplitude of AMI output transmit pulses.
24	SDI	DI	Serial Data In (Host Mode)	The serial data input stream is applied to this pin when the <i>LXT300</i> operates in the <i>Host Mode</i> . SDI is sampled on the rising edge of SCLK.
	EC2	DI	Equalizer Control 2 (H/W Mode)	The signal applied at this pin in the <i>LXT300 Hardware Mode</i> and <i>LXT301</i> is used in conjunction with EC1 and EC3 inputs to determine shape and amplitude of AMI output transmit pulses.
25	SDO	DO	Serial Data Out (Host Mode)	The serial data from the on-chip register is output on this pin in the <i>LXT300 Host Mode</i> . If CLKE is High, SDO is valid on the rising edge of SCLK. If CLKE is Low, SDO is valid on the falling edge of SCLK. This pin goes to a high-impedance state when the serial port is being written to and when $\overline{\text{CS}}$ is High.
	EC3	DI	Equalizer Control 3 (H/W Mode)	The signal applied at this pin in the <i>LXT300 Hardware Mode</i> and <i>LXT301</i> is used in conjunction with EC1 and EC2 inputs to determine shape and amplitude of AMI output transmit pulses.
26	$\overline{\text{CS}}$	DI	Chip Select (Host Mode)	This input is used to access the serial interface in the <i>LXT300 Host Mode</i> . For each read or write operation, $\overline{\text{CS}}$ must transition from High to Low, and remain Low.
	RLOOP	DI	Remote Loopback (H/W Mode)	This input controls loopback functions in the <i>LXT300 Hardware Mode</i> and <i>LXT301</i> . Setting RLOOP High enables the Remote Loopback mode. Setting both RLOOP and LLOOP High causes a Reset.
27	SCLK	DI	Serial Clock (Host Mode)	This clock is used in the <i>LXT300 Host Mode</i> to write data to or read data from the serial interface registers.
	LLOOP	DI	Local Loopback (H/W Mode)	This input controls loopback functions in the <i>LXT300 Hardware Mode</i> and <i>LXT301</i> . Setting LLOOP High enables the Local Loopback Mode.
28	CLKE	DI	Clock Edge (Host Mode)	Setting CLKE High causes RPOS and RNEG to be valid on the falling edge of RCLK, and SDO to be valid on the rising edge of SCLK. When CLKE is Low, RPOS and RNEG are valid on the rising edge of RCLK, and SDO is valid on the falling edge of SCLK.
	TAOS	DI	Transmit All Ones (H/W Mode)	When High, TAOS causes the <i>LXT300 (Hardware Mode)</i> and <i>LXT301</i> to transmit a continuous stream of marks at the TCLK frequency. Activating TAOS causes TPOS and TNEG inputs to be ignored. TAOS is inhibited during Remote Loopback.

1. I/O column entries: DI = Digital Input, DO = Digital Output, AO = Analog Output, AI = Analog Input, S = Supply.

FUNCTIONAL DESCRIPTION

NOTE

This functional description is for design aid only.

The LXT300 and 301 are fully integrated PCM transceivers for both 1.544 Mbps (DSX-1) and 2.048 Mbps (E1) applications. Both transceivers allow full-duplex transmission of digital data over existing twisted-pair installations. The first page of this data sheet shows a block diagram of the LXT300; Figure 2 shows the LXT301. The LXT301 is similar to the LXT300, but does not incorporate the Jitter Attenuator and associated Elastic Store, or the serial interface port.

The LXT300 and 301 transceivers each interface with two twisted-pair lines (one twisted-pair for transmit, one twisted-pair for receive) through standard pulse transformers and appropriate resistors.

POWER REQUIREMENTS

The LXT300 and 301 are low-power CMOS devices. Each operates from a single +5 V power supply which can be connected externally to both the transmitter and receiver. However, the two inputs must be within ± 0.3 V of each other, and decoupled to their respective grounds separately. Refer to Application Information for typical decoupling circuitry. Isolation between the transmit and receive circuits is provided internally.

Reset Operation (*LXT300 and 301*)

Upon power up, the transceiver is held static until the power supply reaches approximately 3 V. Upon crossing this threshold, the device begins a 32 ms reset cycle to calibrate the transmit and receive delay lines and lock the Phase Lock Loop to the receive line. A reference clock is required to calibrate the delay lines. The transmitter reference is provided by TCLK. MCLK provides the receiver reference for the LXT301. The crystal oscillator provides the receiver reference in the LXT300. If the LXT300 crystal oscillator is grounded, MCLK is used as the receiver reference clock.

The transceiver can also be reset from the Host or Hardware Mode. In Host Mode, reset is commanded by simultaneously writing RLOOP and LLOOP to the register. In Hardware Mode, reset is commanded by holding RLOOP and LLOOP High simultaneously for 200 ns. Reset is initiated on the falling edge of the reset request. In either mode, reset clears and sets all registers to 0 and then begins calibration.

2

Figure 2: LXT301 Block Diagram

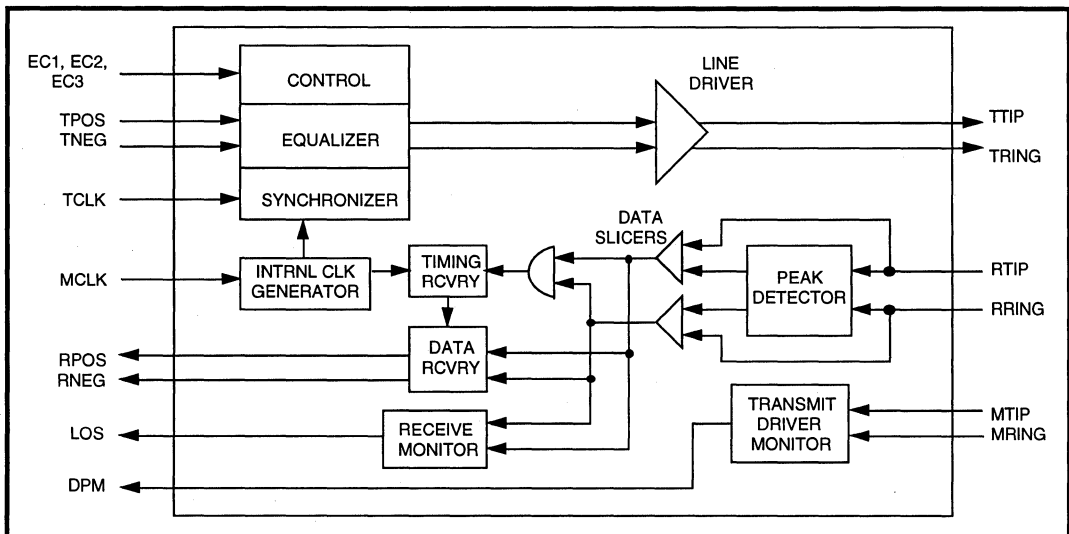

RECEIVER

The LXT300 and LXT301 receivers are identical except for the Jitter Attenuator and Elastic Store. The following discussion applies to both transceivers except where noted.

The signal is received from one twisted-pair line on each side of a center-grounded transformer. Positive pulses are received at RTIP and negative pulses are received at RRING. Recovered data is output at RPOS and RNEG, and the recovered clock is output at RCLK. Refer to the Test Specifications section for receiver timing.

The signal received at RPOS and RNEG is processed through the peak detector and data slicers. The peak detector samples the inputs and determines the maximum value of the received signal. A percentage of the peak value is provided to the data slicers as a threshold level to ensure optimum signal-to-noise ratio. For DSX-1 applications (determined by Equalizer Control inputs EC1-EC3 \neq 000) the threshold is set to 70% of the peak value. This threshold is maintained above 65% for up to 15 successive zeros over the range of specified operating conditions. For E1 applications (EC inputs = 000) the threshold is set to 50%.

The receiver is capable of accurately recovering signals with up to -13.6 dB of attenuation (from 2.4 V), corresponding to a received signal level of approximately 500 mV. Maximum line length is 1500 feet of ABAM cable (approximately 6 dB). Regardless of received signal level, the peak detectors are held above a minimum level of 300 mV to provide immunity from impulsive noise.

After processing through the data slicers, the received signal is routed to the data and clock recovery sections, and to the receive monitor. The receive monitor generates a Loss of Signal (LOS) output upon receipt of 175 consecutive zeros (spaces). The receiver monitor loads a digital counter at the RCLK frequency. The count is incremented each time a zero is received, and reset to zero each time a one (mark) is received. Upon receipt of 175 consecutive zeros the LOS pin goes High, and the RCLK output is replaced with the MCLK.

(In the LXT300 only, if MCLK is not supplied the RCLK output will be replaced with the centered crystal clock.)

The LOS pin will reset as soon as a one (mark) is received.

Jitter Attenuation (LXT300 Only)

In the LXT300 only, recovered clock signals are supplied to the jitter attenuator and the data latch. The recovered data is passed to the elastic store where it is buffered and synchronized with the dejittered recovered clock (RCLK).

Jitter attenuation of the LXT300 clock and data outputs is provided by a Jitter Attenuation Loop (JAL) and an Elastic Store (ES). An external crystal oscillating at 4 times the bit rate provides clock stabilization. Refer to Application Information for crystal specifications. The ES is a 32 x 2-bit register. Recovered data is clocked into the ES with the recovered clock signal, and clocked out of the ES with the dejittered clock from the JAL. When the bit count in the ES is within two bits of overflowing or underflowing, the ES adjusts the output clock by 1/8 of a bit period. The ES produces an average delay of 16 bits in the receive path.

TRANSMITTER

The transmitter circuits in the LXT300 and 301 are identical. The following discussion applies to both models. Data received for transmission onto the line is clocked serially into the device at TPOS and TNEG. Input synchronization is supplied by the transmit clock (TCLK). The transmitted pulse shape is determined by Equalizer Control signals EC1 through EC3 as shown in Table 2. Refer to the Test Specifications section for master and transmit clock timing characteristics. Shaped pulses are applied to the AMI line driver for transmission onto the line at TTIP and TRING. Equalizer Control signals are hard-wired to the LXT301.

LXT300 Only: Equalizer Control signals may be hardwired in the Hardware Mode, or input as part of the serial data stream (SDI) in the Host Mode.

Pulses can be shaped for either 1.544 or 2.048 Mbps applications. DSX-1 applications with 1.544 Mbps pulses can be programmed to match line lengths from 0 to 655 feet of ABAM cable. The LXT300 and 301 also match FCC specifications for CSU applications. Pulses at 2.048 Mbps can drive coaxial or shielded twisted-pair lines using appropriate resistors in line with the output transformer.

Driver Performance Monitor

The transceiver incorporates a Driver Performance Monitor (DPM) in parallel with the TTIP and TRING at the output transformer. The DPM output level goes high upon detection of 63 consecutive zeros. It is reset when a one is detected on the transmit line, or when a reset command is received.

Line Code

The LXT300 and 301 transmit data as a 50% AMI line code as shown in Figure 3. Power consumption is reduced by activating the AMI line driver only to transmit a mark. The output driver is disabled during transmission of a space.

OPERATING MODES

The LXT300 and 301 transceivers can be controlled through hard-wired pins (Hardware Mode). Both transceivers can also be commanded to operate in one of several diagnostic modes.

LXT300 Only: The LXT300 can be controlled by a microprocessor through a serial interface (Host Mode). The mode of operation is set by the MODE pin logic level.

Host Mode Operation (LXT300 Only)

To allow a host microprocessor to access and control the LXT300 through the serial interface, MODE is set to 1. The serial interface (SDI/SDO) uses a 16-bit word consisting of an 8-bit Command/Address byte and an 8-bit Data byte. The Test Specifications section shows serial interface data structure/timing.

The Host Mode provides a latched Interrupt output ($\overline{\text{INT}}$) which is triggered by a change in the Loss of Signal (LOS) and/or Driver Performance Monitor (DPM) bits. The Interrupt is cleared when the interrupt condition no longer exists, and the host processor enables the respective bit in the serial input data byte. Host Mode also allows control of the serial data and receive data output timing. The Clock Edge (CLKE) signal determines when these outputs are valid,

relative to the Serial Clock (SCLK) or RCLK as listed in Table 3.

The LXT300 serial port is addressed by setting bit A4 in the Address/Command byte, corresponding to address 16. The LXT300 contains only a single output data register so no complex chip addressing scheme is required. The register is accessed by causing the Chip Select ($\overline{\text{CS}}$) input to transition from High to Low. Bit 1 of the serial Address/Command byte provides Read/Write control when the chip is accessed. A logic 1 indicates a read operation, and a logic 0 indicates a write operation. Table 4 lists serial data output bit combinations for each status. Serial data I/O timing characteristics are shown in the Test Specifications section.

Hardware Mode Operation (LXT300 and 301)

In Hardware Mode the transceiver is accessed and controlled through individual pins. With the exception of the $\overline{\text{INT}}$ and CLKE functions, Hardware Mode provides all the functions provided in the Host Mode. In the Hardware Mode RPOS and RNEG outputs are valid on the rising edge of RCLK. The LXT301 operates in Hardware Mode at all times.

LXT300 Only: To operate in Hardware Mode, MODE must be set Low. Equalizer Control signals (EC1 through EC3) are input on the Interrupt, Serial Data In and Serial Data Out pins. Diagnostic control for Remote Loopback (RLOOP), Local Loopback (LLOOP), and Transmit All Ones (TAOS) modes is provided through the individual pins used to control serial interface timing in the Host Mode.

Figure 3: 50% AMI Coding Diagram

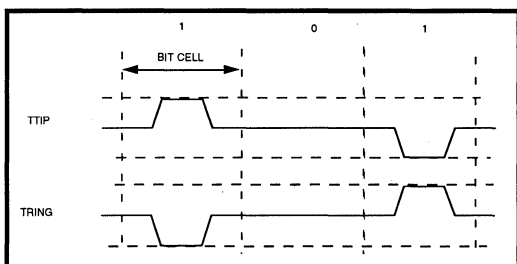

Table 2: Equalizer Control Inputs

EC3	EC2	EC1	Line Length ¹	Cable Loss ²	Application	Bit Rate
0	1	1	0 ~ 133 ft ABAM	0.6 dB	DSX-1	1.544 Mbps
1	0	0	133 ~ 266 ft ABAM	1.2 dB		
1	0	1	266 ~ 399 ft ABAM	1.8 dB		
1	1	0	399 ~ 533 ft ABAM	2.4 dB		
1	1	1	533 ~ 655 ft ABAM	3.0 dB		
0	0	0	ITU Recommendation G.703		E1	2.048 Mbps
0	1	0	FCC Part 68, Option A		CSU	1.544 Mbps

1. Line length from transceiver to DSX-1 cross-connect point.

2. Maximum cable loss at 772 kHz.

Table 3: Valid Clock Edges for Data Outputs

CLKE	Output	Clock	Valid Edge
LOW	RPOS	RCLK	Rising
	RNEG	RCLK	Rising
	SDO	SCLK	Falling
HIGH	RPOS	RCLK	Falling
	RNEG	RCLK	Falling
	SDO	SCLK	Rising

Table 4: LXT300 Serial Data Output Bits (See Figure 4)

Bit D5	Bit D6	Bit D7	Status
0	0	0	Reset has occurred, or no program input
0	0	1	TAOS active
0	1	0	Local Loopback active
0	1	1	TAOS and Local Loopback active
1	0	0	Remote Loopback active
1	0	1	DPM has changed state since last Clear DPM occurred
1	1	0	LOS has changed state since last Clear LOS occurred
1	1	1	LOS and DPM have both changed state since last Clear DPM and Clear LOS occurred

Figure 4: LXT300 Serial Interface Data Structure

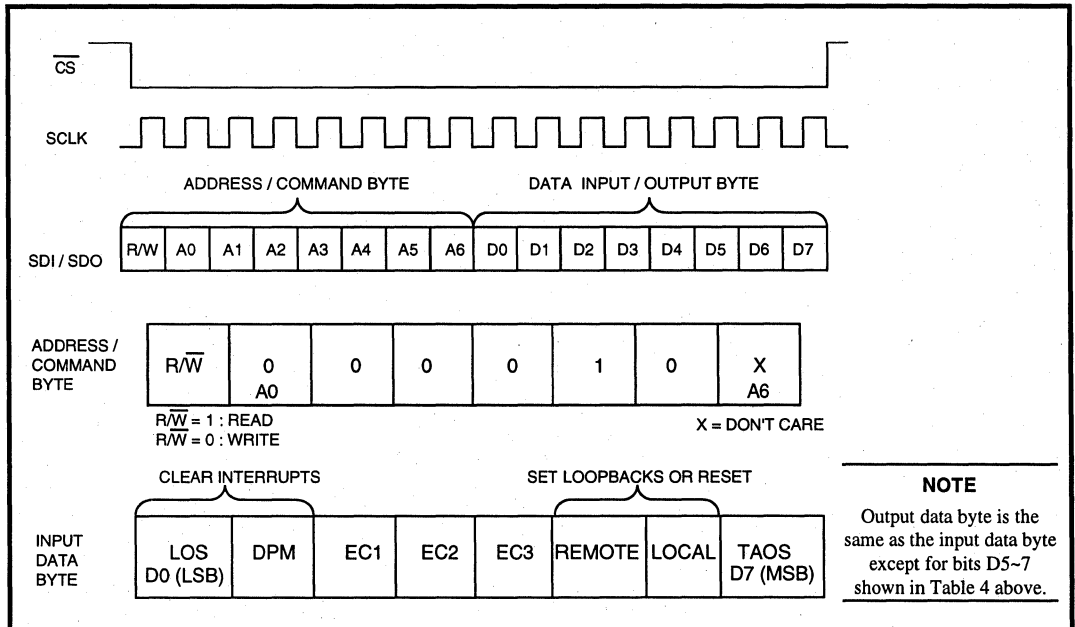

Diagnostic Mode Operation

TRANSMIT ALL ONES

In Transmit All Ones (TAOS) mode the TPOS and TNEG inputs to the transceiver are ignored. The transceiver transmits a continuous stream of ones when the TAOS mode is activated. TAOS can be commanded simultaneously with Local Loopback, but is inhibited during Remote Loopback.

REMOTE LOOPBACK

In Remote Loopback (RLOOP) mode, the transmit data and clock inputs (TPOS, TNEG and TCLK) are ignored. The RPOS and RNEG outputs are looped back through the transmit circuits and output on TTIP and TRING at the RCLK frequency. Receiver circuits are unaffected by the RLOOP command and continue to output the RPOS, RNEG and RCLK signals received from the twisted-pair line.

LOCAL LOOPBACK

In Local Loopback (LLOOP) mode, the receiver circuits are inhibited. The transmit data and clock inputs (TPOS, TNEG and TCLK) are looped back onto the receive data and clock outputs (RPOS, RNEG and RCLK) through the Rx jitter attenuator. The transmitter circuits are unaffected by the LLOOP command. The TPOS and TNEG inputs (or a stream of ones if the TAOS command is active) will be transmitted normally.

LXT300 Only: When used in this mode with a crystal, the transceiver can be used as a stand-alone jitter attenuator.

APPLICATION INFORMATION

NOTE

This information is for design aid only.

LXT300 HOST MODE 1.544 MBPS T1 INTERFACE APPLICATION

Figure 5 is a typical 1.544 Mbps T1 application. The LXT300 is shown in the Host Mode with a typical T1/ESF framer providing the digital interface with the host controller. Both devices are controlled through the serial interface. An LXP600A Clock Adapter (CLAD) provides the 2.048 MHz system backplane clock, locked to the recovered 1.544 MHz clock signal. The power supply inputs are tied to a common bus with appropriate decoupling capacitors installed (68 μ F on the transmit side, 1.0 μ F and 0.1 μ F on the receive side).

Figure 5: Typical LXT300 1.544 Mbps T1 Application (Host Mode)

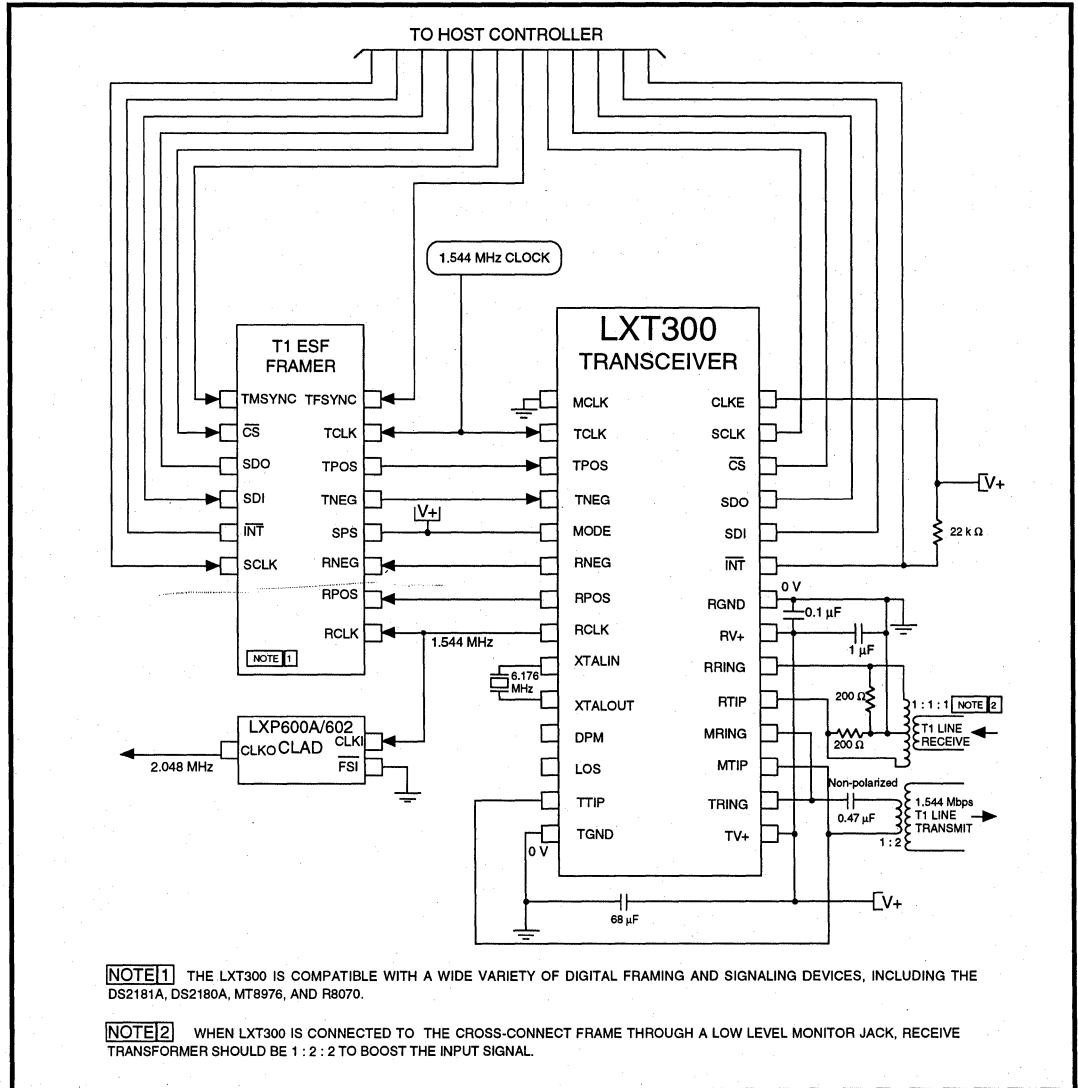

LXT300 HARDWARE MODE E1 INTERFACE APPLICATION

Figure 6 is a typical 2.048 Mbps E1 application. The LXT300 is shown in Hardware Mode with a typical E1/CRC4 framer. Resistors are installed in line with the transmit transformer for loading a 75 Ω coaxial cable. The in-line resistors are not

required for transmission on 120 Ω shielded twisted-pair lines. As in the T1 application Figure 5, this configuration is illustrated with a crystal in place to enable the LXT300 Jitter Attenuation Loop, and a single power supply bus. The hard-wired control lines for TAOS, LLOOP and RLOOP are individually controllable, and the LLOOP and RLOOP lines are also tied to a single control for the Reset function.

Figure 6: Typical LXT300 75 Ω E1 Application (Hardware Mode)

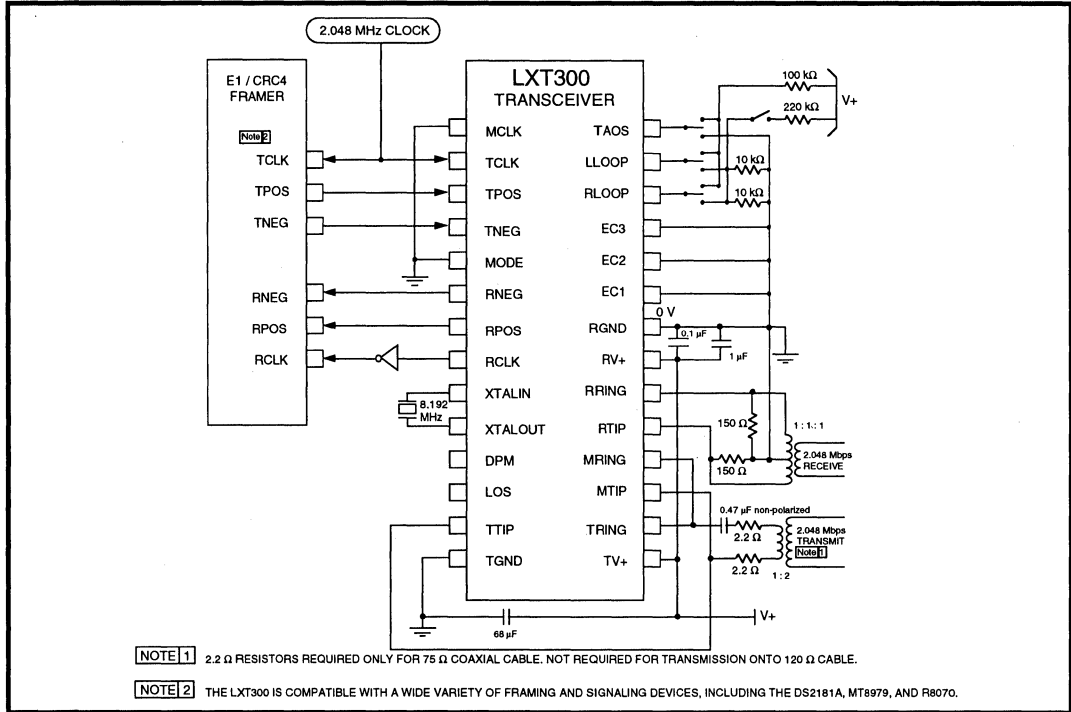

Table 5: LXT300 Crystal Specifications (External)

Parameter	T1	E1
Frequency	6.176 MHz	8.192 MHz
Frequency Stability	± 20 ppm @ 25 °C ± 25 ppm from -40 °C to 85 °C (Ref 25 °C reading)	±20 ppm @ 25 °C ± 25 ppm from -40 °C to + 85 °C (Ref 25 °C reading)
Pullability	CL = 11 pF to 18.7 pF, +ΔF = 175 to 195 ppm CL = 18.7 pF to 34 pF, -ΔF = 175 to 195 ppm	CL = 11 pF to 18.7 pF, +ΔF = 95 to 115 ppm CL = 18.7 pF to 34 pF, -ΔF = 95 to 115 ppm
Effective series resistance	40 Ω Maximum	30 Ω Maximum
Crystal cut	AT	AT
Resonance	Parallel	Parallel
Maximum drive level	2.0 mW	2.0 mW
Mode of operation	Fundamental	Fundamental
Crystal holder	HC49 (R3W), Co = 7 pF maximum Cm = 17 fF typical	HC49 (R3W), Co = 7 pF maximum Cm = 17 fF typical

LXT301 1.544 MBPS T1 INTERFACE APPLICATION

Figure 7 is a typical 1.544 Mbps T1 application of the LXT301. The LXT301 is shown with a typical T1/ESF framer. An LXP600A Clock Adapter (CLAD) provides the 2.048 MHz system backplane clock, locked to the recovered 1.544 MHz clock signal. The power supply inputs are tied to a common bus with appropriate decoupling capacitors installed (68 μ F on the transmit side, 1.0 μ F and 0.1 μ F on the receive side).

Figure 7: Typical LXT301 1.544 Mbps T1 Application

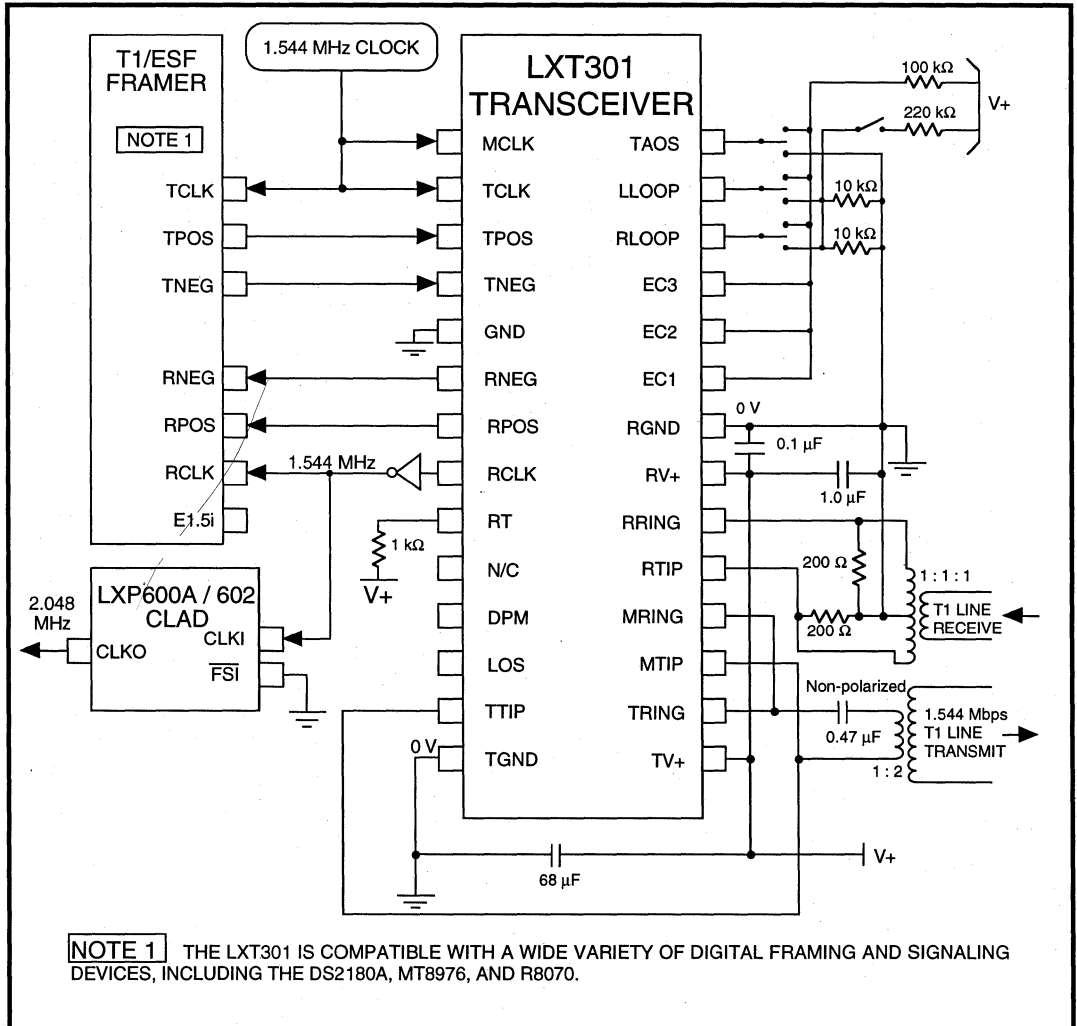

LXT301 2.048 MBPS E1 INTERFACE APPLICATION

Figure 8 is a typical 2.048 Mbps E1 application of the LXT301. The LXT301 is shown with a typical E1/CRC4 framer. Resistors are installed in line with the transmit transformer for loading a 75 Ω coaxial cable. The in-line resistors are not required for transmission on 120 Ω shielded twisted-pair lines. As in the T1 application Figure 7, this configuration is illustrated with a single power supply bus. The hard-wired control lines for TAOS, LLOOP and RLOOP are individually controllable, and the LLOOP and RLOOP lines are also tied to a single control for the Reset function.

Figure 8: Typical LXT301 75 Ω E1 Application

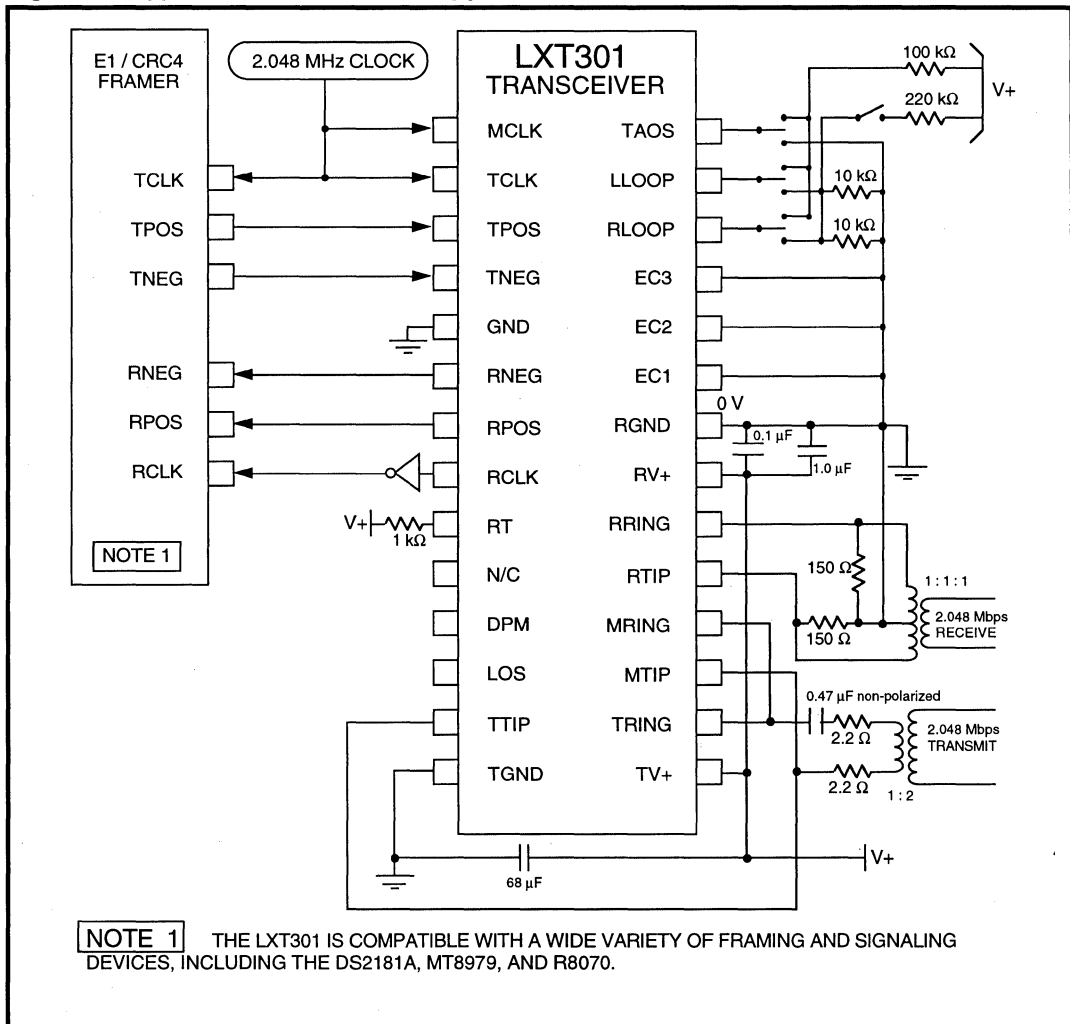

TEST SPECIFICATIONS

NOTE

Minimum and maximum values in Tables 6 through 13 and Figures 9 through 13 represent the performance specifications of the LXT300/301 and are guaranteed by test except, as noted, by design.

Table 6: Absolute Maximum Ratings

Parameter	Sym	Min	Max	Units
DC supply (referenced to GND)	RV+, TV+	-0.3	6.0	V
Input voltage, any pin ¹	V _{IN}	RGND - 0.3	RV+ + 0.3	V
Input current, any pin ²	I _{IN}	-10	10	mA
Storage temperature	T _{STG}	-65	150	°C

CAUTION
Operations at or beyond these limits may result in permanent damage to the device.
Normal operation not guaranteed at these extremes.

- Excluding RTIP and RRING, which must stay between -6 V and (RV+ + 0.3) V.
- Transient currents of up to 100 mA will not cause SCR latch-up. TTIP, TRING, TV+ and TGND can withstand a continuous current of 100 mA.

Table 7: Recommended Operating Conditions

Parameter	Sym	Min	Typ	Max	Units	Test Conditions
DC supply ¹	RV+, TV+	4.75	5.0	5.25	V	
Ambient operating temperature	T _A	-40	25	85	°C	

- TV+ must not exceed RV+ by more than 0.3 V.

Table 8: Electrical Characteristics (Under Recommended Operating Conditions)

Parameter	Sym	Min	Typ ¹	Max	Units	Test Conditions
High level input voltage ^{2,3} (pins 1-5, 10, 23-28)	V _{IH}	2.0	-	-	V	
Low level input voltage ^{2,3} (pins 1-5, 10, 23-28)	V _{IL}	-	-	0.8	V	
High level output voltage ^{2,3} (pins 6-8, 11, 12, 23, 25)	V _{OH}	2.4	-	-	V	I _{OUT} = -400 μA
Low level output voltage ^{2,3} (pins 6-8, 11, 12, 23, 25)	V _{OL}	-	-	0.4	V	I _{OUT} = 1.6 mA
Input leakage current	I _{LL}	-10	-	+10	μA	
Three-state leakage current ² (pin 25)	I _{3L}	-10	-	+10	μA	
Total power dissipation ⁴	P _D	-	620	-	mW	100% ones density & maximum line length @ 5.25 V

- Typical values are at 25 °C and are for design aid only; not guaranteed and not subject to production testing.
- Functionality of pins 23 and 25 depends on mode. See Host / Hardware Mode descriptions.
- Output drivers will output CMOS logic levels into CMOS loads.
- Power dissipation while driving 25 Ω load over operating temperature range. Includes device and load. Digital input levels are within 10% of the supply rails and digital outputs are driving a 50 pF capacitive load.

Table 9: Analog Characteristics (Under Recommended Operating Conditions)

Parameter		Min	Typ ¹	Max	Units	Test Conditions
AMI Output Pulse Amplitudes	DSX-1	2.4	3.0	3.6	V	measured at the DSX
	E1	2.7	3.0	3.3	V	measured at line side
Recommended Output Load at TTIP and TRING		–	25	–	Ω	
Jitter added by the transmitter ²	10 Hz - 8 kHz	–	–	0.01	UI	
	8 kHz - 40 kHz	–	–	0.025	UI	
	10 Hz - 40 kHz	–	–	0.025	UI	
	Broad Band	–	–	0.05	UI	
Sensitivity below DSX (0 dB = 2.4 V)		13.6	–	–	dB	
		500	–	–	mV	
Loss of Signal threshold		–	0.3	–	V	
Data decision threshold	DSX-1	63	70	77	%peak	
	E1	43	50	57	% peak	
Allowable consecutive zeros before LOS		160	175	190	–	
Input jitter tolerance	10 kHz - 100 kHz	0.4	–	–	UI	
Jitter attenuation curve corner frequency ³		–	3	–	Hz	

1. Typical values are at 25 °C and are for design aid only; not guaranteed and not subject to production testing.
2. Input signal to TCLK is jitter-free.
3. Circuit attenuates jitter at 20 dB/decade above the corner frequency.

Table 10: LXT300 Receive Timing Characteristics (See Figure 9)

Parameter		Sym	Min	Typ ¹	Max	Units	Test Conditions
Receive clock duty cycle		RCLKd	40	–	60	%	
Receive clock pulse width	DSX-1	tpw	–	324	–	ns	
	E1	tpw	–	244	–	ns	
RPOS / RNEG to RCLK rising setup time	DSX-1	tsUR	–	274	–	ns	
	E1	tsUR	–	194	–	ns	
RCLK rising to RPOS/ RNEG hold time	DSX-1	tHR	–	274	–	ns	
	E1	tHR	–	194	–	ns	

1. Typical values are at 25 °C and are for design aid only; not guaranteed and not subject to production testing.

Figure 9: LXT300 Receive Clock Timing Diagram

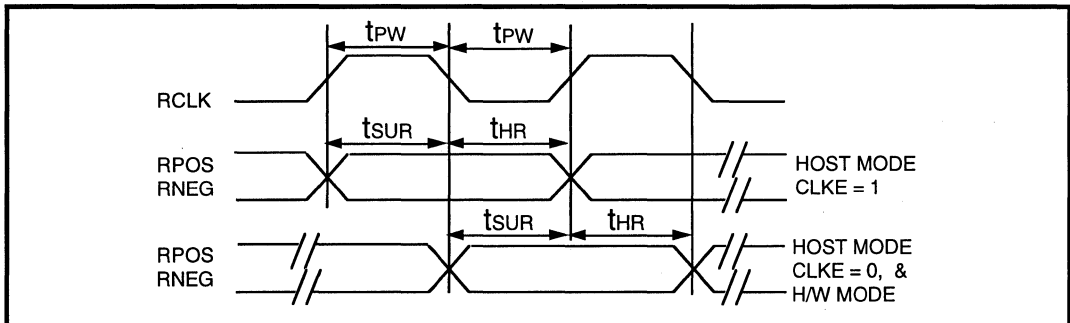

Table 11: LXT301 Receive Timing Characteristics (See Figure 10)

Parameter		Sym	Min	Typ ¹	Max	Units	Test Conditions
Receive clock duty cycle ²	DSX-1	RCLKd	40	50	60	%	
	E1	RCLKd	40	50	60	%	
Receive clock pulse width ²	DSX-1	tpw	594	648	702	ns	
	E1	tpw	447	488	529	ns	
Receive clock pulse width high	DSX-1	tpWH	–	324	–	ns	
	E1	tpWH	–	244	–	ns	
Receive clock pulse width low	DSX-1	tpWL	270	324	378	ns	
	E1	tpWL	203	244	285	ns	
RPOS / RNEG to RCLK rising setup time	DSX-1	tsUR	50	270	–	ns	
	E1	tsUR	50	203	–	ns	
RCLK rising to RPOS/ RNEG hold time	DSX-1	tHR	50	270	–	ns	
	E1	tHR	50	203	–	ns	

1. Typical values are at 25 °C and are for design aid only; not guaranteed and not subject to production testing.
2. RCLK duty cycle widths will vary depending on extent of received pulse jitter displacement. Max and Min RCLK duty cycles are for worst case jitter conditions (0.4 UI clock displacement for 1.544 MHz, 0.2 UI clock displacement for 2.048 MHz).

Figure 10: LXT301 Receive Clock Timing Diagram

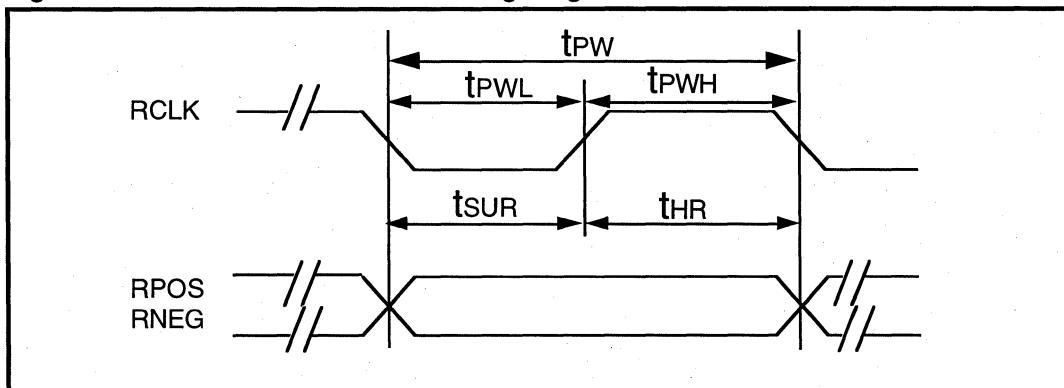

Table 12: LXT300/301 Master Clock and Transmit Timing Characteristics
(See Figure 11)

Parameter		Sym	Min	Typ ¹	Max	Units	Test Conditions
Master clock frequency	DSX-1	MCLK	–	1.544	–	MHz	
	E1	MCLK	–	2.048	–	MHz	
Master clock tolerance		MCLKt	–	±100	–	ppm	
Master clock duty cycle		MCLKd	40	–	60	%	
Crystal frequency <i>LXT300 only</i>	DSX-1	fc	–	6.176	–	MHz	
	E1	fc	–	8.192	–	MHz	
Transmit clock frequency	DSX-1	TCLK	–	1.544	–	MHz	
	E1	TCLK	–	2.048	–	MHz	
Transmit clock tolerance		TCLKt	–	–	±50	ppm	
Transmit clock duty cycle		TCLKd	10	–	90	%	
TPOS/TNEG to TCLK setup time		t _{SUT}	25	–	–	ns	
TCLK to TPOS/TNEG Hold time		t _{HT}	25	–	–	ns	

1. Typical values are at 25 °C and are for design aid only; not guaranteed and not subject to production testing.

2

Figure 11: LXT300 and 301 Transmit Clock Timing Diagram

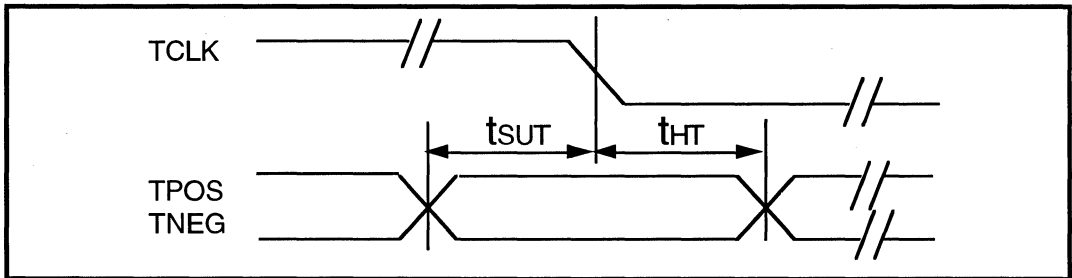

Table 13: LXT300 Serial I/O Timing Characteristics (See Figures 12 and 13)

Parameter	Sym	Min	Typ ¹	Max	Units	Test Conditions
Rise/Fall time - any digital output	t_{RF}	-	-	100	ns	Load 1.6 mA, 50 pF
SDI to SCLK setup time	t_{DC}	50	-	-	ns	
SCLK to SDI hold time	t_{CDH}	50	-	-	ns	
SCLK low time	t_{CL}	240	-	-	ns	
SCLK high time	t_{CH}	240	-	-	ns	
SCLK rise and fall time	t_r, t_f	-	-	50	ns	
\overline{CS} to SCLK setup time	t_{CC}	50	-	-	ns	
SCLK to \overline{CS} hold time	t_{CCH}	50	-	-	ns	
\overline{CS} inactive time	t_{CWH}	250	-	-	ns	
SCLK to SDO valid	t_{CDV}	-	-	200	ns	
SCLK falling edge or \overline{CS} rising edge to SDO high Z	t_{CDZ}	-	100	-	ns	

1. Typical figures are at 25 °C and are for design aid only; not guaranteed and not subject to production testing.

Figure 12: LXT300 Serial Data Input Timing Diagram

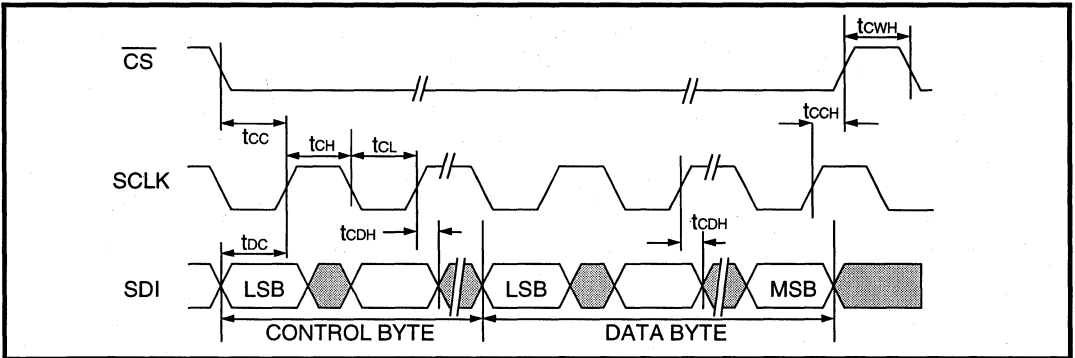
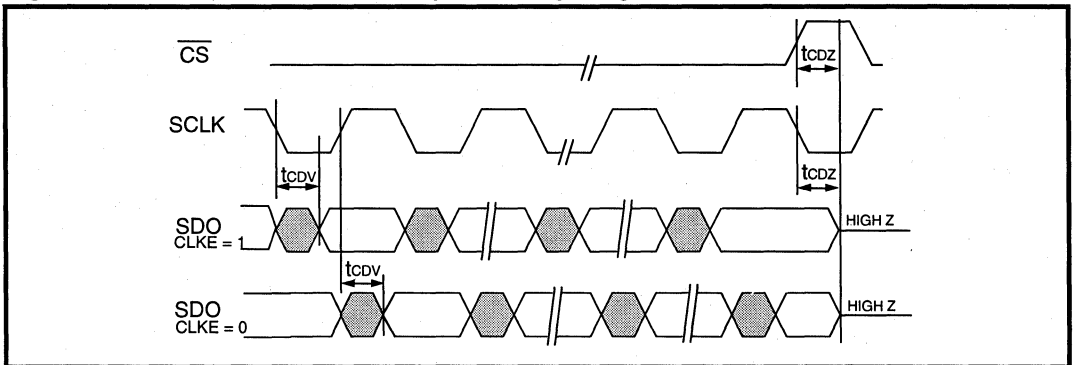

Figure 13: LXT300 Serial Data Output Timing Diagram



LXT300Z / LXT301Z

Advanced T1/E1 Short-Haul Transceivers

General Description

The LXT300Z and LXT301Z are fully integrated transceivers for both North American 1.544 Mbps (T1) and International 2.048 Mbps (E1) applications. They are pin and functionally compatible with standard LXT300/301 devices, with some circuit enhancements.

The LXT300Z provides receive jitter attenuation starting at 3 Hz, and is microprocessor controllable through a serial interface. The LXT301Z is pin compatible, but does not provide jitter attenuation or a serial interface. An advanced transmit driver architecture provides constant low output impedance for both marks and spaces, for improved Bit Error Rate performance over various cable network configurations. Both transceivers offer a variety of diagnostic features including transmit and receive monitoring. Clock inputs may be derived from an on-chip crystal oscillator or from digital inputs. They use an advanced double-poly, double-metal CMOS process and require only a single 5-volt power supply.

Applications

- PCM / Voice Channel Banks
- Data Channel Bank / Concentrator
- T1 / E1 multiplexer
- Digital Access and Cross-connect Systems (DACS)
- Computer to PBX interface (CPI & DMI)
- High-speed data transmission lines
- Interfacing Customer Premises Equipment to a CSU
- Digital Loop Carrier (DLC) terminals

Features

- Data recovery and clock recovery functions
- Receive jitter attenuation starting at 3 Hz exceeds AT&T Pub 62411, Pub 43801, Pub 43802, ITU G.703, and ITU G.823 (LXT300Z only)
- Line driver with constant low mark and space impedance (3 Ω typical)
- Minimum receive signal of 500 mV
- Adaptive and selectable (E1/DSX-1) slicer levels for improved SNR
- Programmable transmit equalizer shapes pulses to meet DSX-1 pulse template from 0 to 655 ft
- Local and remote loopback functions
- Digital Transmit Driver Monitor
- Digital Receive Monitor with Loss of Signal (LOS) output and first mark reset
- Receiver jitter tolerance 0.4 UI from 40 kHz to 100 kHz
- Microprocessor controllable (LXT300Z only)
- Compatible with most popular PCM framers
- Available in 28-pin DIP or PLCC

2

LXT300Z Block Diagram

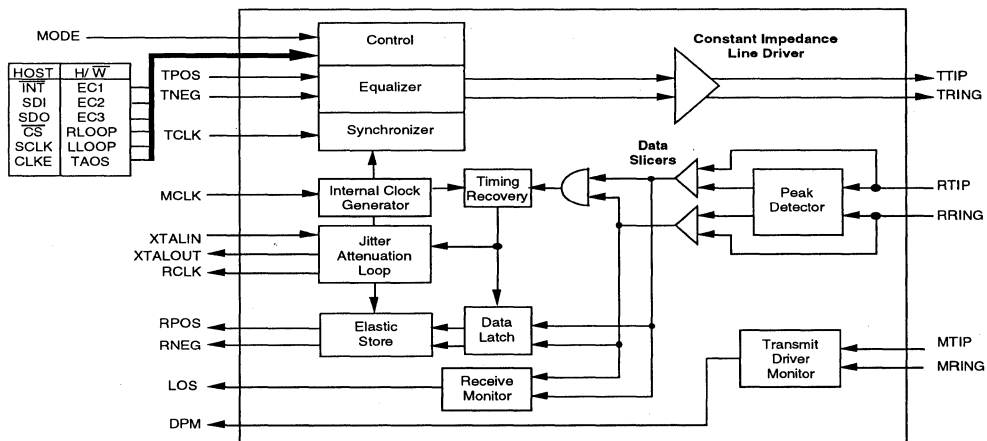

Figure 1: Pin Assignments

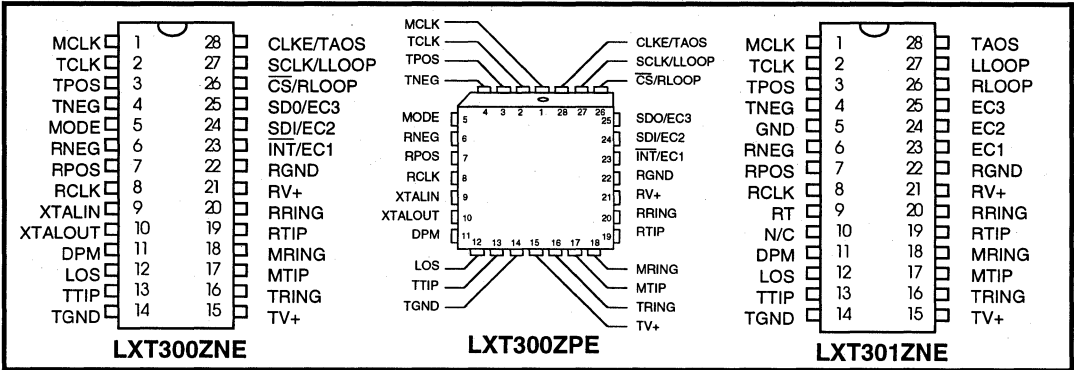

Table 1: Pin Descriptions

Pin #	Sym	I/O ¹	Name	Description
1	MCLK	DI	Master Clock	A 1.544 or 2.048 MHz clock input used to generate internal clocks. Upon Loss of Signal (LOS), RCLK is derived from MCLK. <i>LXT300Z Only:</i> If MCLK is not applied, this pin should be grounded.
2	TCLK	DI	Transmit Clock	Transmit clock input. TPOS and TNEG are sampled on the falling edge of TCLK. If TCLK is grounded, the output drivers enter a high-Z state, except during Remote Loopback.
3	TPOS	DI	Transmit Positive Data	Input for positive pulse to be transmitted on the twisted-pair line.
4	TNEG	DI	Transmit Negative Data	Input for negative pulse to be transmitted on the twisted-pair line.
5	MODE	DI	Mode Select <i>(LXT300Z)</i>	Setting MODE High puts the LXT300Z in the Host Mode. In the Host Mode, the serial interface is used to control the LXT300Z and determine its status. Setting MODE Low puts the LXT300Z in the Hardware (H/W) mode. In the Hardware Mode, the serial interface is disabled and hard-wired pins are used to control configuration and report status.
	GND	S	<i>(LXT301Z)</i>	Tie to Ground.
6	RNEG	DO	Receive Negative Data	Received data outputs. A signal on RNEG corresponds to receipt of a negative pulse on RTIP and RRING. A signal on RPOS corresponds to receipt of a positive pulse on RTIP and RRING. RNEG and RPOS outputs are Non-Return-to-Zero (NRZ). Both outputs are stable and valid on the rising edge of RCLK. <i>LXT300Z only:</i> In the Host Mode, CLKE determines the clock edge at which these outputs are stable and valid. In the Hardware Mode both outputs are stable and valid on the rising edge of RCLK.
7	RPOS	DO	Receive Positive Data	
8	RCLK	DO	Recovered Clock	This is the clock recovered from the signal received at RTIP and RRING.

1. I/O Column entries: DI = Digital Input, DO = Digital Output, AI = Analog Input, AO = Analog Output, S = Supply.

Table 1: Pin Descriptions - continued

Pin #	Sym	I/O ¹	Name	Description
9	XTALIN	AI	Crystal Input	An external crystal operating at four times the bit rate (6.176 MHz for DSX-1, 8.192 MHz for E1 applications with an 18.7 pF load) is required to enable the jitter attenuation function of the LXT300Z. These pins may also be used to disable the jitter attenuator by connecting the XTALIN pin to the positive supply through a resistor, and floating the XTALOUT pin.
10	XTALOUT	AO	Crystal Output (LXT300Z)	
9	RT	AI	R Termination (LXT301Z)	Connect to RV+ through a 1 kΩ resistor.
10	N/C	-	No Connect (LXT301Z)	No connection.
11	DPM	DO	Driver Performance Monitor	DPM goes High when the transmit monitor loop (MTIP and MRING) does not detect a signal for 63 ±2 clock periods. DPM remains High until a signal is detected.
12	LOS	DO	Loss Of Signal	LOS goes High when 175 consecutive spaces have been detected. LOS returns Low when a mark is detected.
13	TTIP	AO	Transmit Tip	Differential Driver Outputs. These outputs are designed to drive a 25 Ω load. The transmitter will drive 100 Ω shielded twisted-pair cable through a 1:2 step-up transformer without additional components. To drive 75 Ω coaxial cable, two 2.2 Ω resistors are required in series with the transformer.
16	TRING	AO	Transmit Ring	
14	TGND	S	Transmit Ground	Ground return for the transmit drivers power supply TV+.
15	TV+	S	Transmit Power Supply	+5 VDC power supply input for the transmit drivers. TV+ must not vary from RV+ by more than ±0.3 V.
17	MTIP	AI	Monitor Tip	These pins are used to monitor the tip and ring transmit outputs. The transceiver can be connected to monitor its own output or the output of another LXT300Z or 301Z on the board.
18	MRING	AI	Monitor Ring	
19	RTIP	AI	Receive Tip	The AMI signal received from the line is applied at these pins. A center-tapped, center-grounded, 2:1 step-up transformer is required on these pins. Data and clock from the signal applied at these pins are recovered and output on the RPOS/RNEG and RCLK pins.
20	RRING	AI	Receive Ring	
21	RV+	S	Receive Power Supply	+5 VDC power supply for all circuits except the transmit drivers. (Transmit drivers are supplied by TV+.)
22	RGND	S	Receive Ground	Ground return for power supply RV+.

1. I/O Column entries: DI = Digital Input, DO = Digital Output, AI = Analog Input, AO = Analog Output, S = Supply.

Table 1: Pin Descriptions - continued

Pin #	Sym	I/O ¹	Name	Description
23	$\overline{\text{INT}}$	DO	Interrupt (Host Mode)	This LXT300Z Host Mode output goes Low to flag the host processor when LOS or DPM go active. INT is an open-drain output and should be tied to power supply RV+ through a resistor. INT is reset by clearing the respective register bit (LOS and/or DPM).
	EC1	DI	Equalizer Control 1 (H/W Mode)	The signal applied at this pin in the LXT300Z Hardware Mode and LXT301Z is used in conjunction with EC2 and EC3 inputs to determine shape and amplitude of AMI output transmit pulses.
24	SDI	DI	Serial Data In (Host Mode)	The serial data input stream is applied to this pin when the LXT300Z operates in the Host Mode. SDI is sampled on the rising edge of SCLK.
	EC2	DI	Equalizer Control 2 (H/W Mode)	The signal applied at this pin in the LXT300Z Hardware Mode and LXT301Z is used in conjunction with EC1 and EC3 inputs to determine shape and amplitude of AMI output transmit pulses.
25	SDO	DO	Serial Data Out (Host Mode)	The serial data from the on-chip register is output on this pin in the LXT300Z Host Mode. If CLKE is High, SDO is valid on the rising edge of SCLK. If CLKE is Low SDO is valid on the falling edge of SCLK. This pin goes to a high-impedance state when the serial port is being written to and when $\overline{\text{CS}}$ is High.
	EC3	DI	Equalizer Control 3 (H/W Mode)	The signal applied at this pin in the LXT300Z Hardware Mode and LXT301Z is used in conjunction with EC1 and EC2 inputs to determine shape and amplitude of AMI output transmit pulses.
26	$\overline{\text{CS}}$	DI	Chip Select (Host Mode)	This input is used to access the serial interface in the LXT300Z Host Mode. For each read or write operation, $\overline{\text{CS}}$ must transition from High to Low, and remain Low.
	RLOOP	DI	Remote Loopback (H/W Mode)	This input controls loopback functions in the LXT300Z Hardware Mode and LXT301Z. Setting RLOOP High enables the Remote Loopback mode. Setting both RLOOP and LLOOP High causes a Reset.
27	SCLK	DI	Serial Clock (Host Mode)	This clock is used in the LXT300Z Host Mode to write data to or read data from the serial interface registers.
	LLOOP	DI	Local Loopback (H/W Mode)	This input controls loopback functions in the LXT300Z Hardware Mode and LXT301Z. Setting LLOOP High enables the Local Loopback Mode.
28	CLKE	DI	Clock Edge (Host Mode)	Setting CLKE High causes RPOS and RNEG to be valid on the falling edge of RCLK, and SDO to be valid on the rising edge of SCLK. When CLKE is Low, RPOS and RNEG are valid on the rising edge of RCLK, and SDO is valid on the falling edge of SCLK.
	TAOS	DI	Transmit All Ones (H/W Mode)	When High, TAOS causes the LXT300Z (Hardware Mode) and LXT301Z to transmit a continuous stream of marks at the TCLK frequency. Activating TAOS causes TPOS and TNEG inputs to be ignored. TAOS is inhibited during Remote Loopback.

1. I/O Column entries: DI = Digital Input, DO = Digital Output, AI = Analog Input, AO = Analog Output, S = Supply.

FUNCTIONAL DESCRIPTION

NOTE

This functional description is for design aid only.

The LXT300Z and 301Z are fully integrated PCM transceivers for both 1.544 Mbps (DSX-1) and 2.048 Mbps (E1) applications. Both transceivers allow full-duplex transmission of digital data over existing twisted-pair installations. The first page of this data sheet shows a simplified block diagram of the LXT300Z; Figure 2 shows the LXT301Z. The LXT301Z is similar to the LXT300Z, but does not incorporate the Jitter Attenuator and associated Elastic Store, or the serial interface port.

The LXT300Z and 301Z transceivers each interface with two twisted-pair lines (one twisted-pair for transmit, one twisted-pair for receive) through standard pulse transformers and appropriate resistors.

POWER REQUIREMENTS

The LXT300Z and 301Z are low-power CMOS devices. Each operates from a single +5 V power supply which can be connected externally to both the transmitter and receiver. However, the two inputs must be within $\pm .3$ V of each other, and decoupled to their respective grounds separately. Refer to Application Information for typical decoupling circuitry. Isolation between the transmit and receive circuits is provided internally.

Reset Operation (LXT300Z and 301Z)

Upon power up, the transceiver is held static until the power supply reaches approximately 3 V. Upon crossing this threshold, the device begins a 32 ms reset cycle to calibrate the transmit and receive delay lines and lock the Phase Lock Loop to the receive line. A reference clock is required to calibrate the delay lines. The transmitter reference is provided by TCLK. MCLK provides the receiver reference for the LXT301Z. The crystal oscillator provides the receiver reference in the LXT300Z. If the LXT300Z crystal oscillator is grounded, MCLK is used as the receiver reference clock.

The transceiver can also be reset from the Host or Hardware Mode. In Host Mode, reset is commanded by simultaneously writing RLOOP and LLOOP to the register. In Hardware Mode, reset is commanded by holding RLOOP and LLOOP High simultaneously for 200 ns. Reset is initiated on the falling edge of the reset request. In either mode, reset clears and sets all registers to 0 and then begins calibration.

Figure 2: LXT301Z Block Diagram

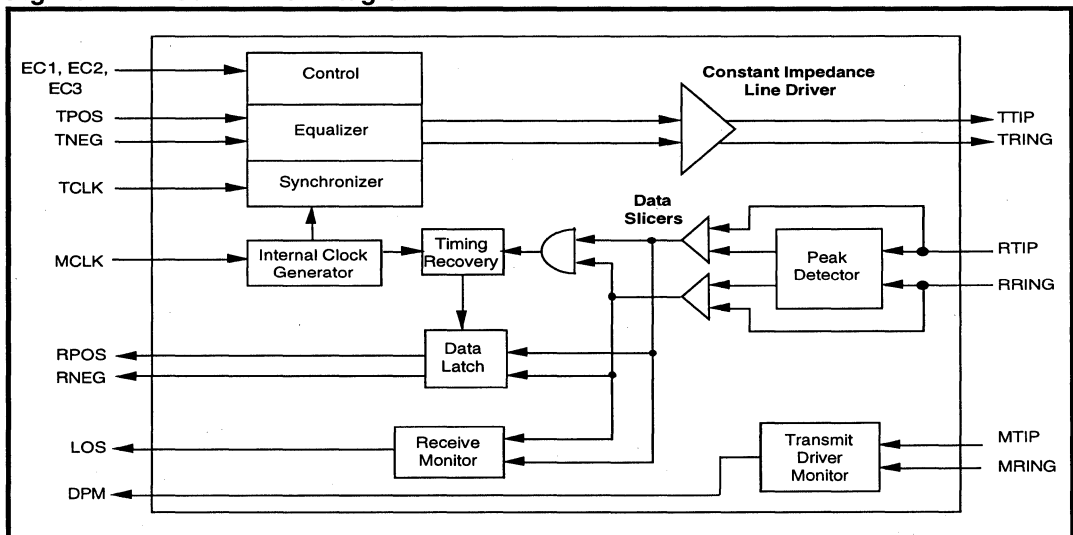

RECEIVER

The LXT300Z and LXT301Z receivers are identical except for the Jitter Attenuator and Elastic Store. The following discussion applies to both transceivers except where noted.

The signal is received from one twisted-pair line on each side of a center-grounded transformer. Positive pulses are received at RTIP and negative pulses are received at RRING. Recovered data is output at RPOS and RNEG, and the recovered clock is output at RCLK. Refer to the Test Specifications section for receiver timing.

The signal received at RPOS and RNEG is processed through the peak detector and data slicers. The peak detector samples the inputs and determines the maximum value of the received signal. A percentage of the peak value is provided to the data slicers as a threshold level to ensure optimum signal-to-noise ratio. For DSX-1 applications (determined by Equalizer Control inputs EC1~EC3 \neq 000) the threshold is set to 70% of the peak value. This threshold is maintained above 65% for up to 15 successive zeros over the range of specified operating conditions. For E1 applications (EC inputs = 000) the threshold is set to 50%.

The receiver is capable of accurately recovering signals with up to -13.6 dB of attenuation (from 2.4 V), corresponding to a received signal level of approximately 500 mV. Maximum line length is 1500 feet of ABAM cable (approximately 6 dB). Regardless of received signal level, the peak detectors are held above a minimum level of 300 mV to provide immunity from impulsive noise. (During LOS, RPOS and RNEG are squelched if the received input signal drops to 300 mV.)

After processing through the data slicers, the received signal is routed to the data and clock recovery sections, and to the receive monitor. *In the LXT300Z only, recovered clock signals are supplied to the jitter attenuator and the data latch. The recovered data is passed to the elastic store where it is buffered and synchronized with the dejittered recovered clock (RCLK).* The data and clock recovery circuits have an input jitter tolerance significantly better than required by Pub 62411.

Receive (Loss of Signal) Monitor

The receive monitor generates a Loss of Signal (LOS) output upon receipt of 175 consecutive zeros (spaces). The receiver monitor loads a digital counter at the RCLK frequency. The count is incremented each time a zero is received, and reset to zero each time a one (mark) is received. Upon receipt of 175 consecutive zeros the LOS pin goes High, and the RCLK output is replaced with the MCLK. LOS is reset when the first mark is received.

(In the LXT300Z only, if MCLK is not supplied the RCLK output will be replaced with the centered crystal clock.)

Jitter Attenuation (LXT300Z Only)

In the LXT300Z only, recovered clock signals are supplied to the jitter attenuator and the data latch. The recovered data is passed to the elastic store where it is buffered and synchronized with the dejittered recovered clock (RCLK). Jitter attenuation of the LXT300Z clock and data outputs (see Figure 4) is provided by a Jitter Attenuation Loop (JAL) and an Elastic Store (ES). An external crystal oscillating at 4 times the bit rate provides clock stabilization. Refer to Application Information for crystal specifications. The ES is a 32 x 2-bit register. Recovered data is clocked into the ES with the recovered clock signal, and clocked out of the ES with the dejittered clock from the JAL. When the bit count in the ES is within two bits of overflowing or underflowing, the ES adjusts the output clock by 1/8 of a bit period. The ES produces an average delay of 16 bits in the receive path.

TRANSMITTER

The transmitter circuits in the LXT300Z and 301Z are identical. The following discussion applies to both models. Data received for transmission onto the line is clocked serially into the device at TPOS and TNEG. Input synchronization is supplied by the transmit clock (TCLK). The transmitted pulse shape is determined by Equalizer Control signals EC1 through EC3 as shown in Table 2. Refer to the Test Specifications section for master and transmit clock timing characteristics. Shaped pulses are applied to the AMI line driver for transmission onto the line at TTIP and TRING. Equalizer Control signals are hard-wired to the LXT301Z.

LXT300Z Only: Equalizer Control signals may be hard-wired in the Hardware Mode, or input as part of the serial data stream (SDI) in the Host Mode.

Pulses can be shaped for either 1.544 or 2.048 Mbps applications. DSX-1 applications with 1.544 Mbps pulses can be programmed to match line lengths from 0 to 655 feet of ABAM cable. The LXT300Z and 301Z also match FCC specifications for CSU applications. Pulses at 2.048 Mbps can drive coaxial or shielded twisted-pair lines using appropriate resistors in line with the output transformer.

Driver Performance Monitor

The transceiver incorporates an advanced Driver Performance Monitor (DPM) in parallel with the TTIP and TRING at the output transformer. The DPM circuitry uses four comparators and a 150 ns pulse discriminator to filter glitches.

The DPM output level goes high upon detection of 63 consecutive zeros, and is cleared when a one is detected on the transmit line, or when a reset command is received. The DPM output also goes High to indicate a ground on TTIP or TRING. A ground fault induced DPM flag is automatically cleared when the ground condition is corrected (chip reset is not required).

Line Code

The LXT300Z and 301Z transmit data as a 50% AMI line code as shown in Figure 3. Power consumption is reduced by activating the AMI line driver only to transmit a mark. The output driver is disabled during transmission of a space.

OPERATING MODES

The LXT300Z and 301Z transceivers can be controlled through hard-wired pins (Hardware Mode). Both transceivers can also be commanded to operate in one of several diagnostic modes.

LXT300Z Only: The LXT300Z can be controlled by a microprocessor through a serial interface (Host Mode). The mode of operation is set by the MODE pin logic level.

Host Mode Operation (LXT300Z Only)

To allow a host microprocessor to access and control the LXT300Z through the serial interface, MODE is set to 1. The serial interface (SDI/SDO) uses a 16-bit word consisting of an 8-bit Command/Address byte and an 8-bit Data byte. Figure 4 shows the serial interface data structure and relative timing.

The Host Mode provides a latched Interrupt output (\overline{INT}) which is triggered by a change in the Loss of Signal (LOS) and/or Driver Performance Monitor (DPM) bits. The Interrupt is cleared when the interrupt condition no longer exists, and the host processor enables the respective bit in the serial input data byte. Host Mode also allows control of the serial data and receive data output timing. The Clock Edge (CLKE) signal determines when these outputs are valid, relative to the Serial Clock (SCLK) or RCLK as listed in Table 3.

The LXT300Z serial port is addressed by setting bit A4 in the Address/Command byte, corresponding to address 16. The LXT300Z contains only a single output data register so no complex chip addressing scheme is required. The register is accessed by causing the Chip Select (\overline{CS}) input to transition from High to Low. Bit 1 of the serial Address/Command byte provides Read/Write control when the chip is accessed. A logic 1 indicates a read operation, and a logic 0 indicates a write operation. Table 4 lists serial data output bit combinations for each status. Serial data I/O timing characteristics are shown in the Test Specifications section.

Figure 3: 50% AMI Coding Diagram

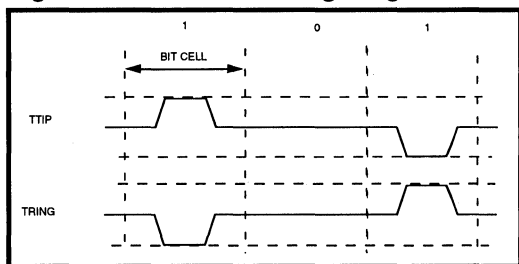

Table 2: Equalizer Control Inputs

EC3	EC2	EC1	Line Length ¹	Cable Loss ²	Application	Bit Rate
0	1	1	0 ~ 133 ft ABAM	0.6 dB	DSX-1	1.544 Mbps
1	0	0	133 ~ 266 ft ABAM	1.2 dB		
1	0	1	266 ~ 399 ft ABAM	1.8 dB		
1	1	0	399 ~ 533 ft ABAM	2.4 dB		
1	1	1	533 ~ 655 ft ABAM	3.0 dB		
0	0	0	ITU Recommendation G.703		E1	2.048 Mbps
0	1	0	FCC Part 68, Option A		CSU	1.544 Mbps

1. Line length from transceiver to DSX-1 cross-connect point.

2. Maximum cable loss at 772 kHz.

Table 3: Valid Clock Edges for Data Outputs

CLKE	Output	Clock	Valid Edge
LOW	RPOS	RCLK	Rising
	RNEG	RCLK	Rising
	SDO	SCLK	Falling
HIGH	RPOS	RCLK	Falling
	RNEG	RCLK	Falling
	SDO	SCLK	Rising

Table 4: LXT300Z Serial Data Output Bits (See Figure 4)

Bit D5	Bit D6	Bit D7	Status
0	0	0	Reset has occurred, or no program input
0	0	1	TAOS active
0	1	0	Local Loopback active
0	1	1	TAOS and Local Loopback active
1	0	0	Remote Loopback active
1	0	1	DPM has changed state since last Clear DPM occurred
1	1	0	LOS has changed state since last Clear LOS occurred
1	1	1	LOS and DPM have both changed state since last Clear DPM and Clear LOS occurred

Figure 4: LXT300Z Serial Interface Data Structure

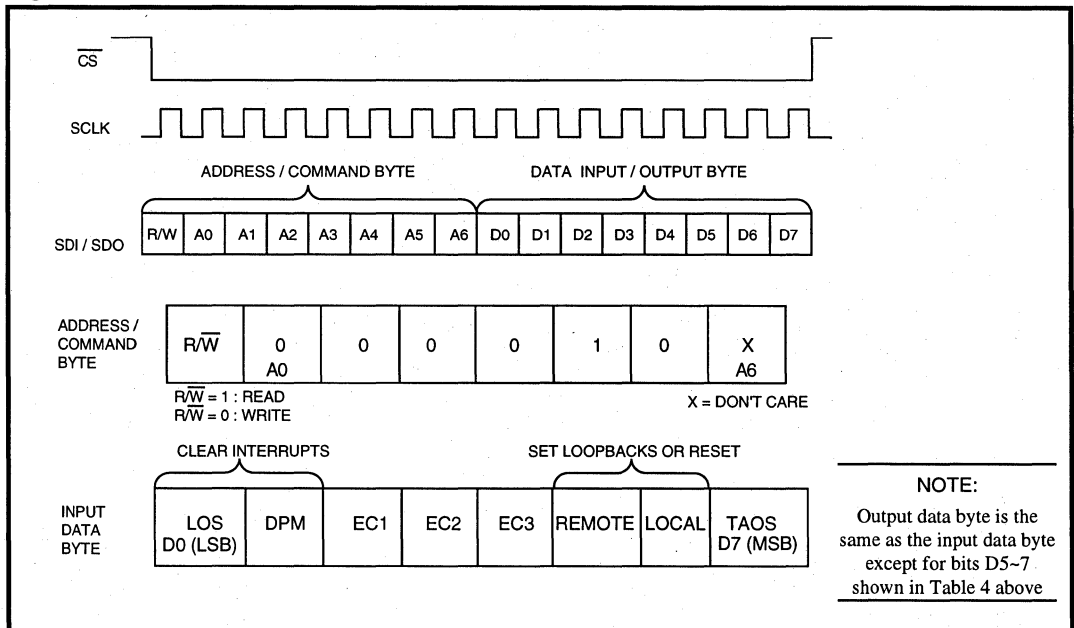

Hardware Mode Operation (LXT300Z and 301Z)

In Hardware Mode the transceiver is accessed and controlled through individual pins. With the exception of the $\overline{\text{INT}}$ and CLKE functions, Hardware Mode provides all the functions provided in the Host Mode. In the Hardware Mode RPOS and RNEG outputs are valid on the rising edge of RCLK. The LXT301Z operates in Hardware Mode at all times.

LXT300Z Only: To operate in Hardware Mode, MODE must be set Low. Equalizer Control signals (EC1 through EC3) are input on the Interrupt, Serial Data In and Serial Data Out pins. Diagnostic control for Remote Loopback (RLOOP), Local Loopback (LLOOP), and Transmit All Ones (TAOS) modes is provided through the individual pins used to control serial interface timing in the Host Mode.

Diagnostic Mode Operation

TRANSMIT ALL ONES

In Transmit All Ones (TAOS) mode the TPOS and TNEG inputs to the transceiver are ignored. The transceiver transmits a continuous stream of ones when the TAOS mode is activated. TAOS can be commanded simultaneously with Local Loopback, but is inhibited during Remote Loopback.

REMOTE LOOPBACK

In Remote Loopback (RLOOP) mode, the transmit data and clock inputs (TPOS, TNEG and TCLK) are ignored. The RPOS and RNEG outputs are looped back through the transmit circuits and output on TTIP and TRING at the RCLK frequency. Receiver circuits are unaffected by the RLOOP command and continue to output the RPOS, RNEG and RCLK signals received from the twisted-pair line.

LOCAL LOOPBACK

In Local Loopback (LLOOP) mode, the receiver circuits are inhibited. The transmit data and clock inputs (TPOS, TNEG and TCLK) are looped back onto the receive data and clock outputs (RPOS, RNEG and RCLK) through the Rx jitter attenuator. The transmitter circuits are unaffected by the LLOOP command. The TPOS and TNEG inputs (or a stream of ones if the TAOS command is active) will be transmitted normally.

LXT300Z Only: When used in this mode with a crystal, the transceiver can be used as a stand-alone jitter attenuator.

APPLICATION INFORMATION

NOTE

This information is for design aid only.

LXT300Z HOST MODE 1.544 MBPS T1 INTERFACE APPLICATION

Figure 5 is a typical 1.544 Mbps T1 application. The LXT300Z is shown in the Host Mode with a typical T1/ESF framer providing the digital interface with the host controller. Both devices are controlled through the serial interface. An LXP600A Clock Adapter (CLAD) provides the 2.048 MHz system backplane clock, locked to the recovered 1.544 MHz clock signal. The power supply inputs are tied to a common bus with appropriate decoupling capacitors installed (68 μ F on the transmit side, 1.0 μ F and 0.1 μ F on the receive side).

Figure 5: Typical LXT300Z 1.544 Mbps T1 Application (Host Mode)

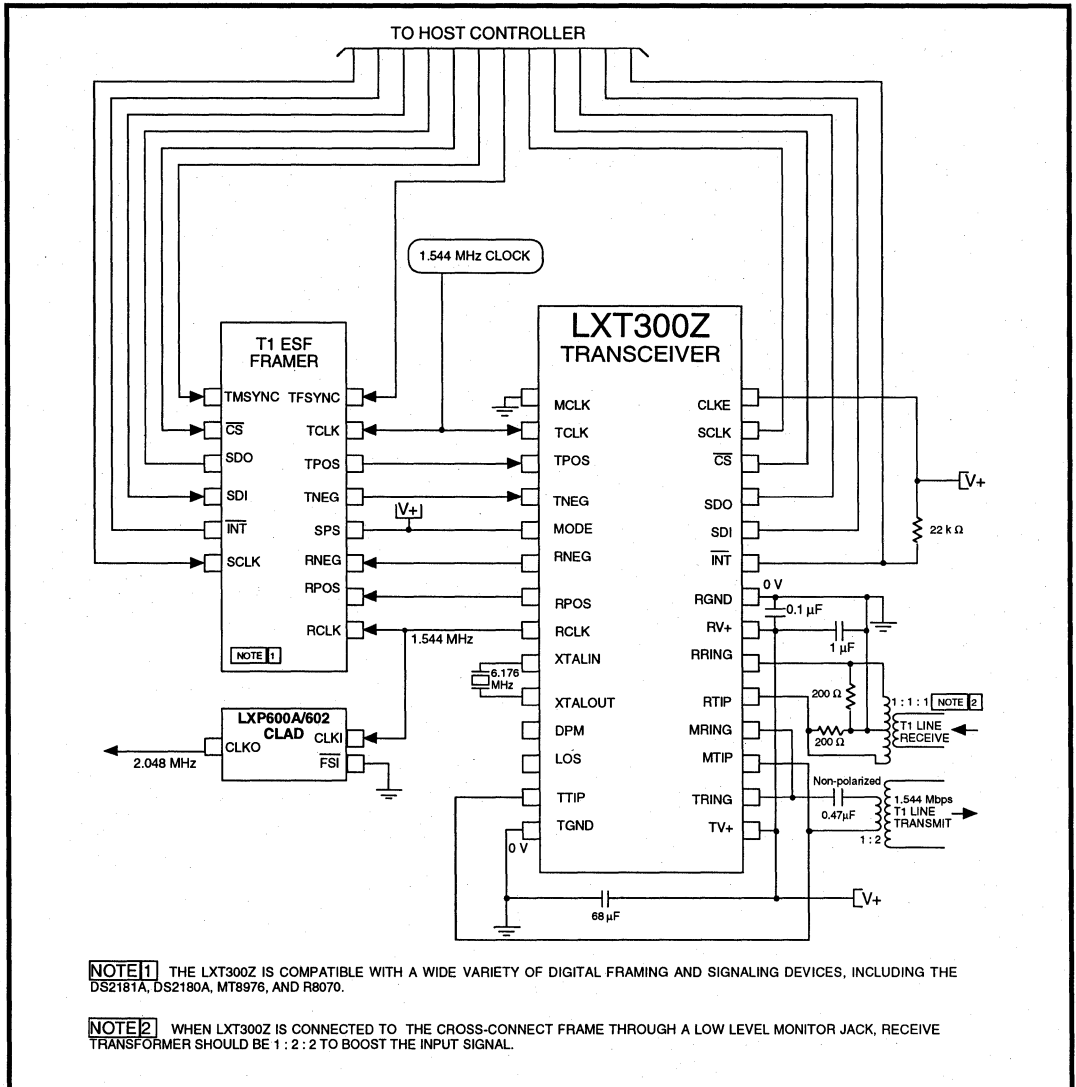

LXT300Z HARDWARE MODE E1 INTERFACE APPLICATION

Figure 6 is a typical 2.048 Mbps E1 application. The LXT300Z is shown in Hardware Mode with a typical E1/CRC4 framer. Resistors are installed in line with the transmit transformer for loading a 75 Ω coaxial cable. The in-line resistors are not

required for transmission on 120 Ω shielded twisted-pair lines. As in the T1 application Figure 5, this configuration is illustrated with a crystal in place to enable the LXT300Z Jitter Attenuation Loop, and a single power supply bus. The hard-wired control lines for TAOS, LLOOP and RLOOP are individually controllable, and the LLOOP and RLOOP lines are also tied to a single control for the Reset function.

Figure 6: Typical LXT300Z 75 Ω E1 Application (Hardware Mode)

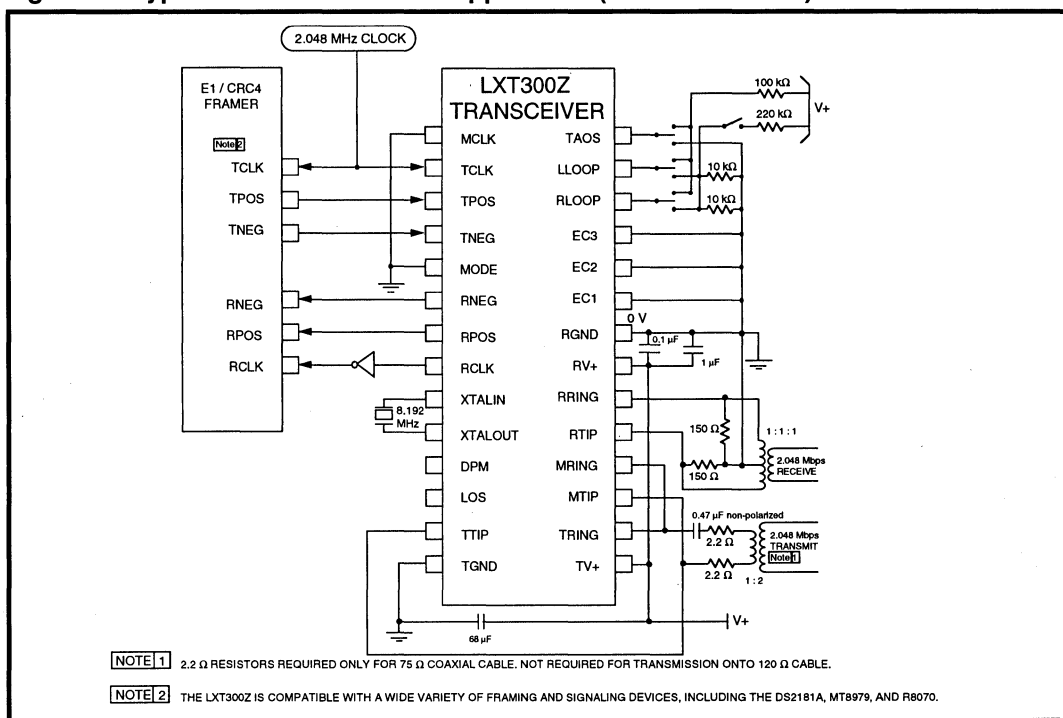

Table 5: LXT300Z Crystal Specifications (External)

Parameter	T1	E1
Frequency	6.176 MHz	8.192 MHz
Frequency Stability	± 20 ppm @ 25 °C ± 25 ppm from -40 °C to 85 °C (Ref 25 °C reading)	±20 ppm @ 25 °C ± 25 ppm from -40 °C to + 85 °C (Ref 25 °C reading)
Pullability	CL = 11 pF to 18.7 pF, +ΔF = 175 to 195 ppm CL = 18.7 pF to 34 pF, -ΔF = 175 to 195 ppm	CL = 11 pF to 18.7 pF, +ΔF = 95 to 115 ppm CL = 18.7 pF to 34 pF, -ΔF = 95 to 115 ppm
Effective series resistance	40 Ω Maximum	30 Ω Maximum
Crystal cut	AT	AT
Resonance	Parallel	Parallel
Maximum drive level	2.0 mW	2.0 mW
Mode of operation	Fundamental	Fundamental
	HC49 (R3W), Co = 7 pF maximum Cm = 17 fF typical	HC49 (R3W), Co = 7 pF maximum Cm = 17 fF typical

LXT301Z 1.544 MBPS T1 INTERFACE APPLICATION

Figure 7 is a typical 1.544 Mbps T1 application of the LXT301Z. The LXT301Z is shown with a typical T1/ESF framer. An LXP600A Clock Adapter (CLAD) provides the 2.048 MHz system backplane clock, locked to the recovered 1.544 MHz clock signal. The power supply inputs are tied to a common bus with appropriate decoupling capacitors installed (68 μ F on the transmit side, 1.0 μ F and 0.1 μ F on the receive side).

Figure 7: Typical LXT301Z 1.544 Mbps T1 Application

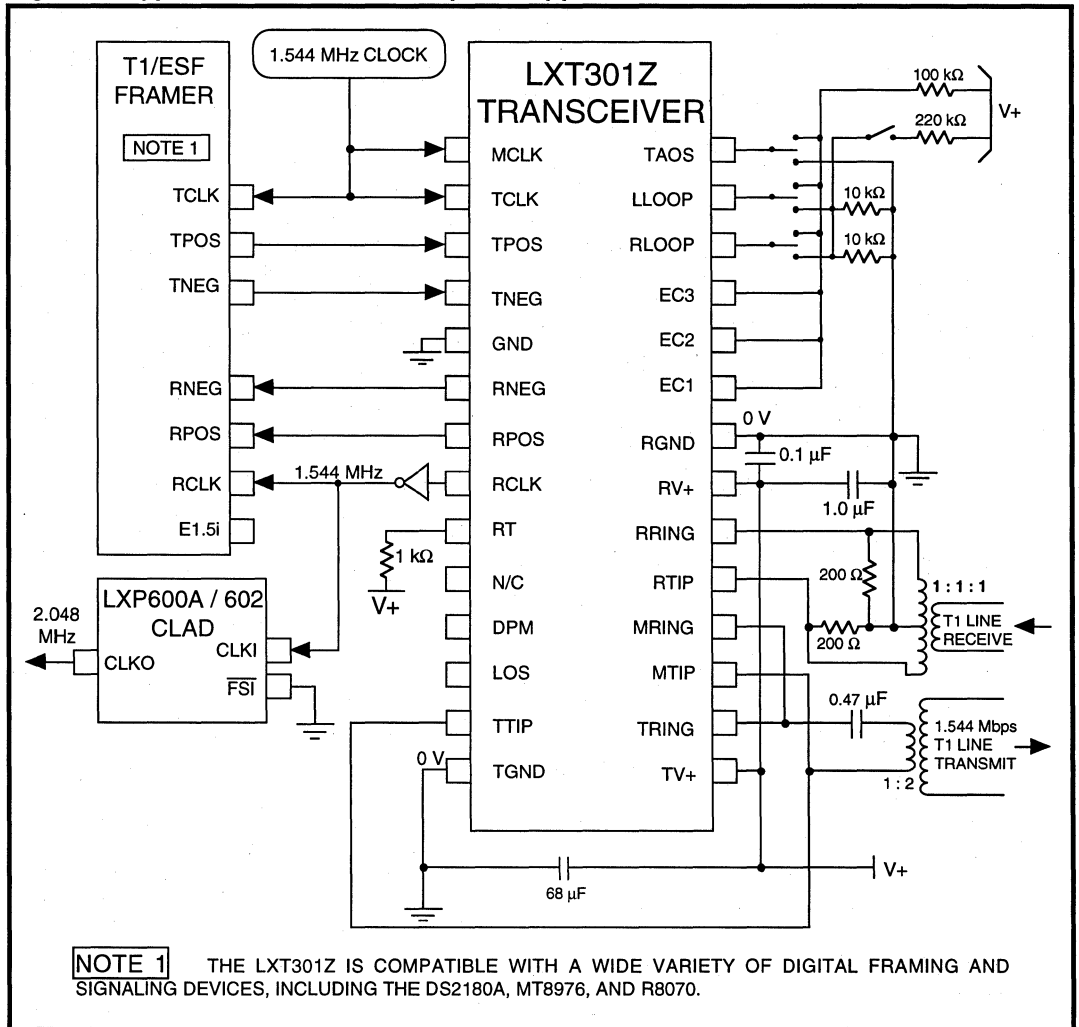

LXT301Z 2.048 MBPS E1 INTERFACE APPLICATION

Figure 8 is a typical 2.048 Mbps E1 application of the LXT301Z. The LXT301Z is shown with a typical E1/CRC4 framer. Resistors are installed in line with the transmit transformer for loading a 75 Ω coaxial cable. The in-line resistors are not required for transmission on 120 Ω shielded twisted-pair lines. As in the T1 application Figure 7, this configuration is illustrated with a single power supply bus. The hard-wired control lines for TAOS, LLOOP and RLOOP are individually controllable, and the LLOOP and RLOOP lines are also tied to a single control for the Reset function.

Figure 8: Typical LXT301Z 75 Ω E1 Application

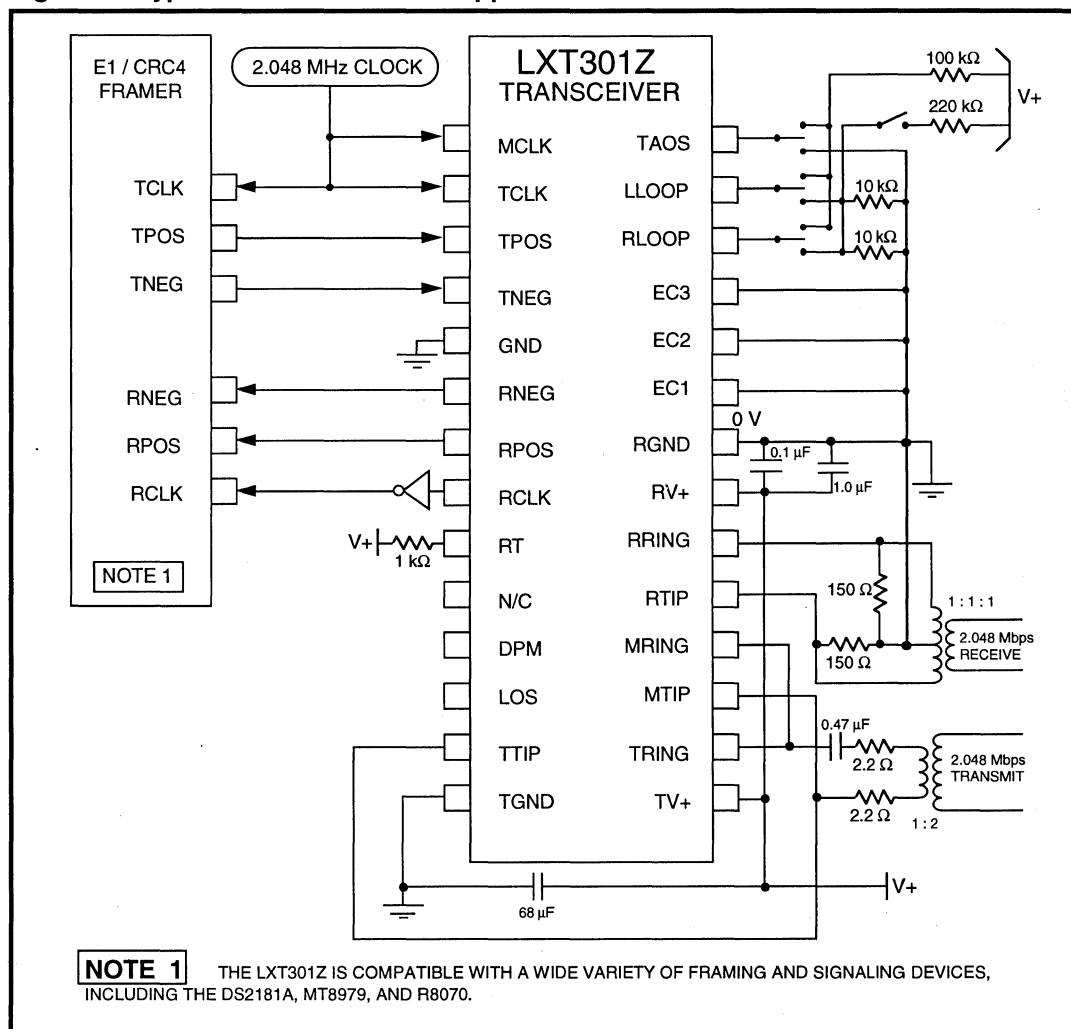

TEST SPECIFICATIONS

NOTE

Minimum and maximum values in Tables 6 through 13 and Figures 9 through 15 represent the performance specifications of the LXT300Z/301Z and are guaranteed by test except, as noted, by design.

Table 6: Absolute Maximum Ratings

Parameter	Sym	Min	Max	Units
DC supply (referenced to GND)	RV+, TV+	-0.3	6.0	V
Input voltage, any pin ¹	V _{IN}	RGND - 0.3	RV+ + 0.3	V
Input current, any pin ²	I _{IN}	-10	10	mA
Storage temperature	T _{STG}	-65	150	°C

CAUTION
Operations at or beyond these limits may result in permanent damage to the device.
Normal operation not guaranteed at these extremes.

1. Excluding RTIP and RRING, which must stay between -6 V and (RV+ + 0.3) V.
2. Transient currents of up to 100 mA will not cause SCR latch-up. TTIP, TRING, TV+ and TGND can withstand a continuous current of 100 mA.

Table 7: Recommended Operating Conditions

Parameter	Sym	Min	Typ	Max	Units	Test Conditions
DC supply ¹	RV+, TV+	4.75	5.0	5.25	V	
Ambient operating temperature	T _A	-40	25	85	°C	

1. TV+ must not exceed RV+ by more than 0.3 V.

Table 8: Digital Characteristics (Under Recommended Operating Conditions)

Parameter	Sym	Min	Typ	Max	Units	Test Conditions
High level input voltage ^{1,2} (pins 1-5, 10, 23-28)	V _{IH}	2.0	-	-	V	
Low level input voltage ^{1,2} (pins 1-5, 10, 23-28)	V _{IL}	-	-	0.8	V	
High level output voltage ^{1,2} (pins 6-8, 11, 12, 23, 25)	V _{OH}	2.4	-	-	V	I _{OUT} = -400 μA
Low level output voltage ^{1,2} (pins 6-8, 11, 12, 23, 25)	V _{OL}	-	-	0.4	V	I _{OUT} = 1.6 mA
Input leakage current (pins 1-5, and 23-28)	I _{LL}	-10	-	+10	μA	
Input leakage current (pins 9, 17, 18)	I _{LL}	-50	-	+50	μA	
Three-state leakage current ¹ (pin 25)	I _{3L}	-10	-	+10	μA	
Total power dissipation ³	P _D	-	-	700	mW	100% ones density & maximum line length @ 5.25 V

1. Functionality of pins 23 and 25 depends on mode. See Host / Hardware Mode descriptions.
2. Output drivers will output CMOS logic levels into CMOS loads.
3. Power dissipation while driving 25 Ω load over operating temperature range. Includes device and load. Digital input levels are within 10% of the supply rails and digital outputs are driving a 50 pF capacitive load.

Table 9: Analog Characteristics (Under Recommended Operating Conditions)

Parameter		Min	Typ ¹	Max	Units	Test Conditions
AMI output pulse amplitudes	DSX-1	2.4	3.0	3.6	V	measured at the DSX
	E1 (120 Ω)	2.7	3.0	3.3	V	measured at line side
	E1 (75 Ω)	2.14	2.37	2.6	V	@ 772 kHz
Transmit amplitude variation with supply		–	1	2.5	%	
Recommended output load at TTIP and TRING		–	25	–	Ω	RTIP to RRING
Driver output impedance ²		–	3	10	Ω	@ 10 kHz
Jitter added by the transmitter ³	10 Hz - 8 kHz ²	–	–	0.01	UI	
	8 kHz - 40 kHz	–	–	0.025	UI	
	10 Hz - 40 kHz	–	–	0.025	UI	
	Broad Band	–	–	0.05	UI	
Output power levels ²	@ 772 kHz	12.6	–	17.9	dBm	
	DS1 2 kHz BW @ 1544 kHz ⁵	- 29.0	–	–	dB	
Positive to negative pulse imbalance		–	–	0.5	dB	
Sensitivity below DSX ⁶	(0 dB = 2.4 V)	13.6	–	–	dB	
		500	–	–	mV	
Receiver input impedance		–	40	–	kΩ	
Loss of Signal threshold		–	0.3	–	V	
Data decision threshold	DSX-1	63	70	77	%peak	
	E1	43	50	57	% peak	
Allowable consecutive zeros before LOS		160	175	190	–	
Input jitter tolerance	10 Hz	–	1200	–	UI	
	750 Hz	14	–	–	UI	
	10 kHz - 100 kHz	0.4	–	–	UI	
Jitter attenuation curve corner frequency ⁴		–	3	–	Hz	
Jitter attenuation		–	50	–	dB	
Jitter attenuator tolerance before FIFO overflow ²		28	–	–	UI	

1. Typical values are at 25 °C and are for design aid only; not guaranteed and not subject to production testing.
2. Not production tested but guaranteed by design and other correlation methods.
3. Input signal to TCLK is jitter-free.
4. Circuit attenuates jitter at 20 dB/decade above the corner frequency.
5. Referenced to power in 2 kHz band.
6. With a maximum of 6 dB of cable attenuation.

Figure 9: LXT300Z Rx Jitter Tolerance (Typical)

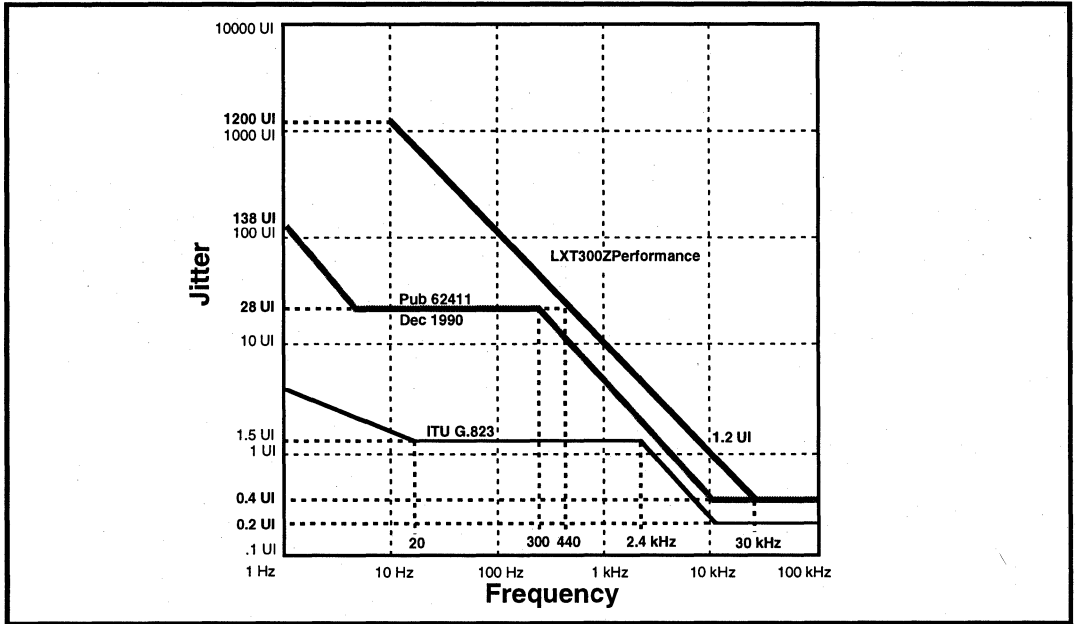

Figure 10: LXT300Z Rx Jitter Transfer Performance (Typical)

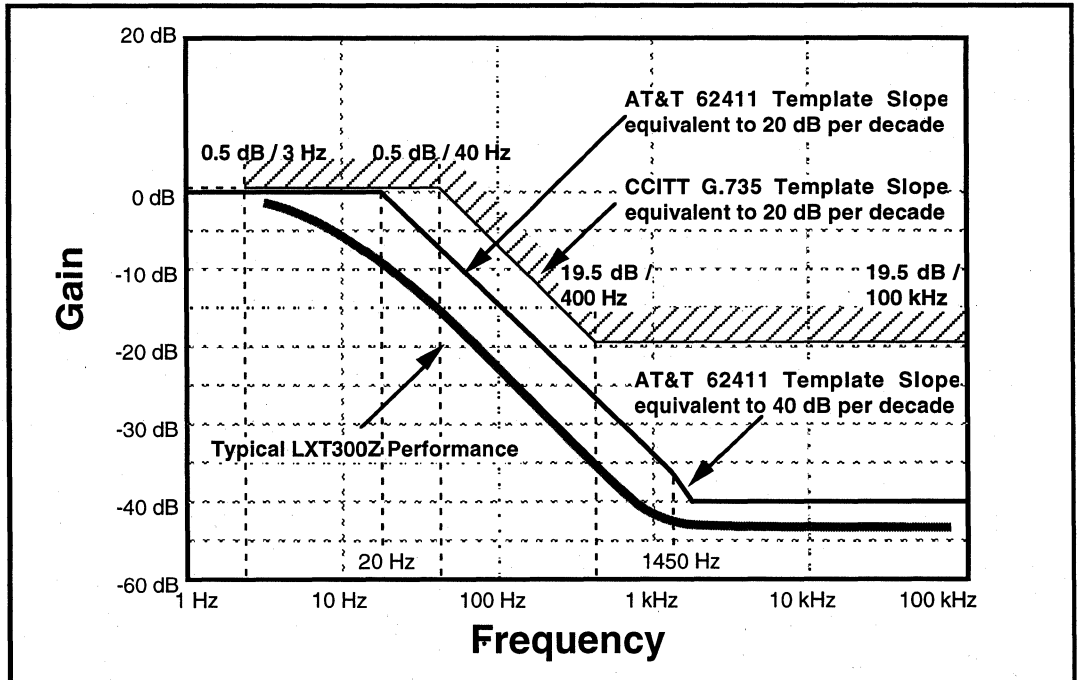

Table 10: LXT300Z Receive Timing Characteristics (See Figure 11)

Parameter	Sym	Min	Typ ¹	Max	Units	Test Conditions
Receive clock duty cycle	RCLKd	40	-	60	%	
Receive clock pulse width	DSX-1	tpw	-	324	-	ns
	E1	tpw	-	244	-	ns
RPOS / RNEG to RCLK rising setup time	DSX-1	tsur	-	274	-	ns
	E1	tsur	-	194	-	ns
RCLK rising to RPOS/ RNEG hold time	DSX-1	t _{HR}	-	274	-	ns
	E1	t _{HR}	-	194	-	ns

1. Typical values are at 25 °C and are for design aid only; not guaranteed and not subject to production testing.

2

Figure 11: LXT300Z Receive Clock Timing Diagram

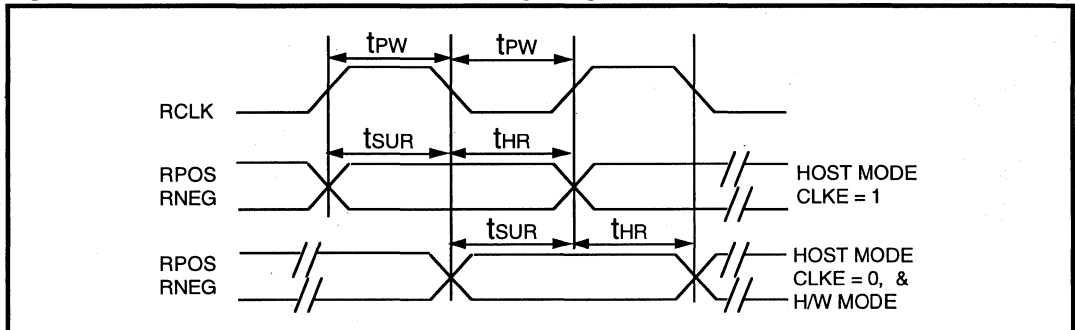

Table 11: LXT301Z Receive Timing Characteristics (See Figure 12)

Parameter		Sym	Min	Typ ¹	Max	Units	Test Conditions
Receive clock duty cycle ²	DSX-1	RCLKd	40	50	60	%	
	E1	RCLKd	40	50	60	%	
Receive clock pulse width ²	DSX-1	tpw	594	648	702	ns	
	E1	tpw	447	488	529	ns	
Receive clock pulse width high	DSX-1	tpWH	–	324	–	ns	
	E1	tpWH	–	244	–	ns	
Receive clock pulse width low	DSX-1	tpWL	270	324	378	ns	
	E1	tpWL	203	244	285	ns	
RPOS / RNEG to RCLK rising setup time	DSX-1	tsUR	50	270	–	ns	
	E1	tsUR	50	203	–	ns	
RCLK rising to RPOS/ RNEG hold time	DSX-1	tHR	50	270	–	ns	
	E1	tHR	50	203	–	ns	

1. Typical values are at 25 °C and are for design aid only; not guaranteed and not subject to production testing.
2. RCLK duty cycle widths will vary depending on extent of received pulse jitter displacement. Max and Min RCLK duty cycles are for worst case jitter conditions (0.4 UI clock displacement for 1.544 MHz, 0.2 UI clock displacement for 2.048 MHz).

Figure 12: LXT301Z Receive Clock Timing Diagram

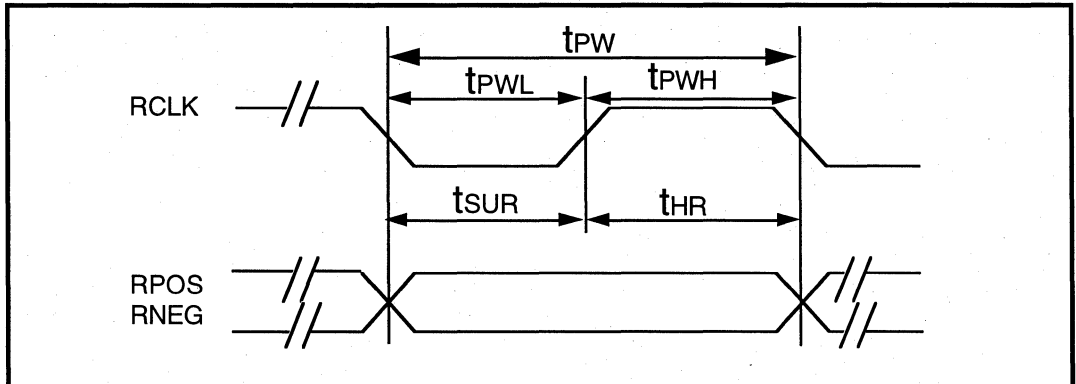

Table 12: LXT300Z/301Z Master Clock and Transmit Timing Characteristics
(See Figure 13)

2

Parameter	Sym	Min	Typ ¹	Max	Units	Test Conditions
Master clock frequency	DSX-1	MCLK	-	1.544	-	MHz
	E1	MCLK	-	2.048	-	MHz
Master clock tolerance	MCLKt	-	±100	-	ppm	
Master clock duty cycle	MCLKd	40	-	60	%	
Crystal frequency <i>LXT300Z only</i>	DSX-1	fc	-	6.176	-	MHz
	E1	fc	-	8.192	-	MHz
Transmit clock frequency	DSX-1	TCLK	-	1.544	-	MHz
	E1	TCLK	-	2.048	-	MHz
Transmit clock tolerance	TCLKt	-	±50	-	ppm	
Transmit clock duty cycle	TCLKd	10	-	90	%	
TPOS/TNEG to TCLK setup time	t _{SUT}	25	-	-	ns	
TCLK to TPOS/TNEG Hold time	t _{HT}	25	-	-	ns	

1. Typical values are at 25°C and are for design aid only; not guaranteed and not subject to production testing.

2. Not production tested but guaranteed by design and other correlation methods.

Figure 13: LXT300Z and 301Z Transmit Clock Timing Diagram

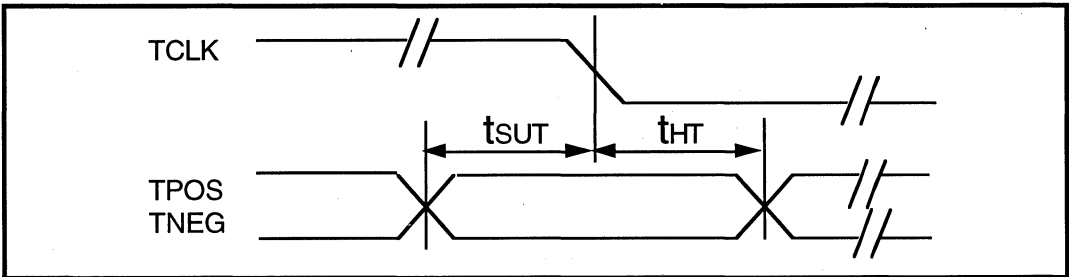

Table 13: LXT300Z Serial I/O Timing Characteristics (See Figures 14 and 15)

Parameter	Sym	Min	Typ ¹	Max	Units	Test Conditions
Rise/Fall time - any digital output	t _{RF}	-	-	100	ns	Load 1.6 mA, 50 pF
SDI to SCLK setup time	t _{DC}	50	-	-	ns	
SCLK to SDI hold time	t _{CDH}	50	-	-	ns	
SCLK low time	t _{CL}	240	-	-	ns	
SCLK high time	t _{CH}	240	-	-	ns	
SCLK rise and fall time	t _R , t _F	-	-	50	ns	
\overline{CS} to SCLK setup time	t _{CC}	50	-	-	ns	
SCLK to \overline{CS} hold time	t _{CCH}	50	-	-	ns	
\overline{CS} inactive time	t _{CWH}	250	-	-	ns	
SCLK to SDO valid	t _{CDV}	-	-	200	ns	
SCLK falling edge or \overline{CS} rising edge to SDO high Z	t _{CDZ}	-	100	-	ns	

1. Typical values are at 25 °C and are for design aid only; not guaranteed and not subject to production testing.

Figure 14: LXT300Z Serial Data Input Timing Diagram

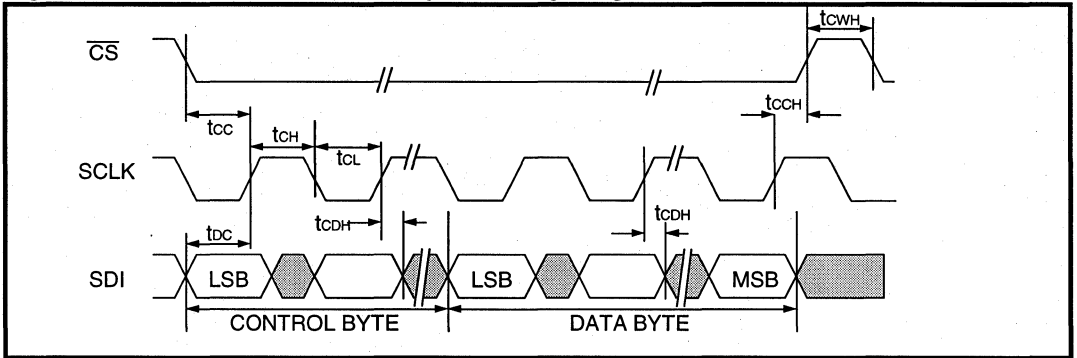
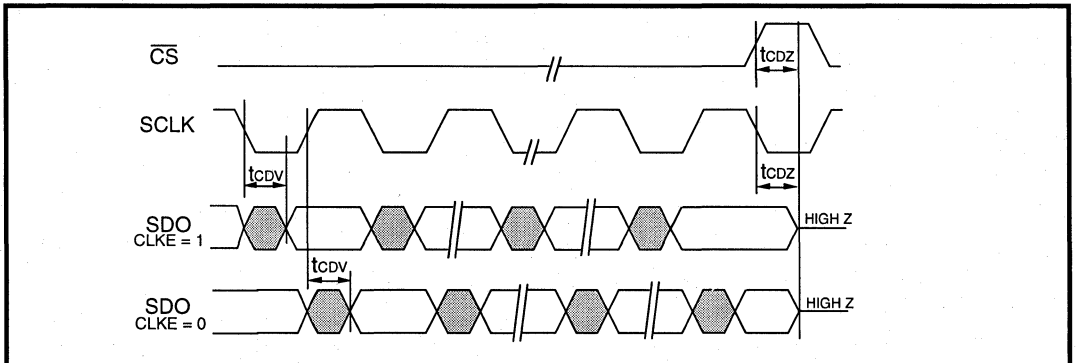

Figure 15: LXT300Z Serial Data Output Timing Diagram



LXT304A

Low-Power T1/E1 Short-Haul Transceiver with Receive JA

General Description

The LXT304A is a fully integrated low-power transceiver for both North American 1.544 Mbps (T1), and International 2.048 Mbps (E1) applications. It features a constant low output impedance transmitter allowing for high transmitter return loss in T1/E1 applications. Transmit pulse shapes (DSX-1 or E1) are selectable for various line lengths and cable types.

The LXT304A provides receive jitter attenuation starting at 3 Hz, and is microprocessor controllable through a serial interface.

It offers a variety of diagnostic features including transmit and receive monitoring. The device incorporates an on-chip crystal oscillator, and also accepts digital clock inputs. It uses an advanced double-poly, double-metal CMOS process and requires only a single 5-volt power supply.

Applications

- PCM / Voice Channel Banks
- Data Channel Bank / Concentrator
- T1 / E1 multiplexer
- Digital Access and Cross-connect Systems (DACS)
- Computer to PBX interface (CPI & DMI)
- High-speed data transmission lines
- Interfacing Customer Premises Equipment to a CSU
- Digital Loop Carrier (DLC) terminals

Features

- Low power consumption (400 mW maximum) 40% less than the LXT300
- Constant low output impedance transmitter regardless of data pattern (3 Ω typical)
- High transmit and receive return loss exceeds ETSI ETS 300166 and G.703 recommendations
- Meets or exceeds all industry specifications including ITU G.703, ANSI T1.403 and AT&T Pub 6241 1
- Compatible with most popular PCM framers
- Line driver, data recovery and clock recovery functions
- Minimum receive signal of 500 mV
- Selectable slicer levels (E1/DSX-1) improve SNR
- Programmable transmit equalizer shapes pulses to meet DSX-1 pulse template from 0 to 655 ft
- Local and remote loopback functions
- Transmit / Receive performance monitors with DPM and LOS outputs
- Receiver jitter tolerance 0.4 UI from 40 kHz to 100 kHz
- Receive jitter attenuation starting at 3 Hz meets TBR12/13 specification
- Serial control interface
- Analog/digital LOS monitor per G.775
- Available in 28-pin DIP or PLCC

LXT304A Block Diagram

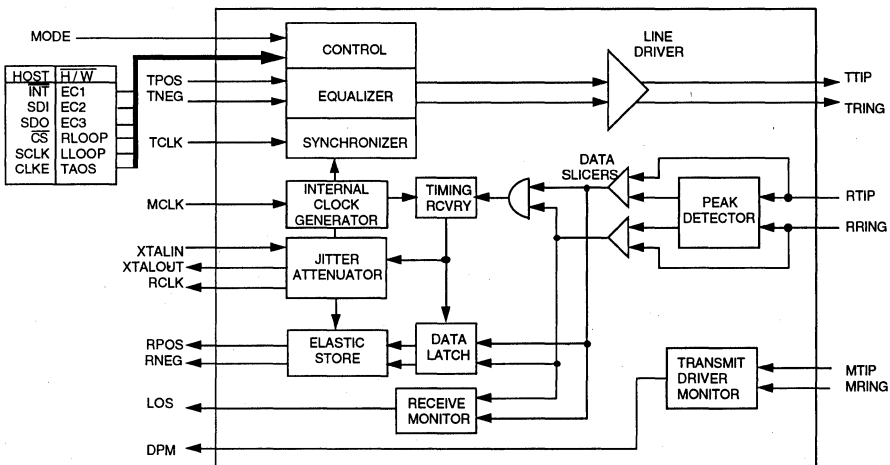

LXT304A Low-Power T1/E1 Short-Haul Transceiver with Receive JA

Figure 1: Pin Assignments

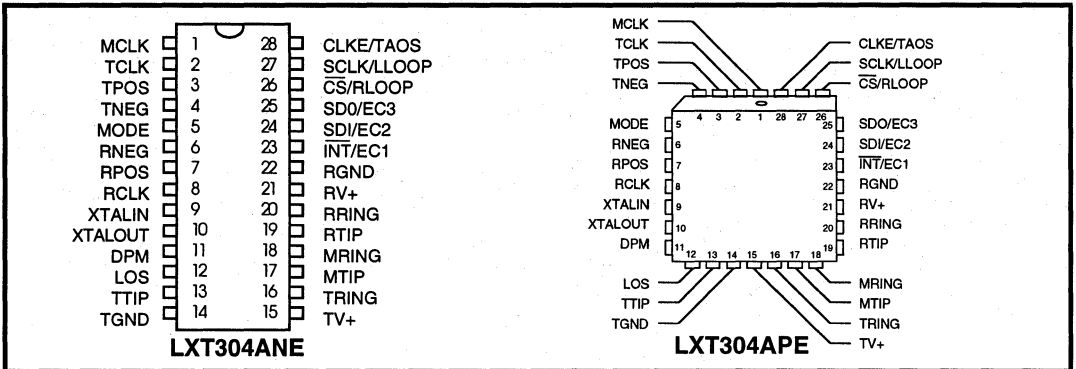

Table 1: Pin Descriptions

Pin #	Sym	I/O ¹	Name	Description
1	MCLK	DI	Master Clock	A 1.544 or 2.048 MHz clock input used to generate internal clocks. Upon Loss of Signal (LOS), RCLK is derived from MCLK. If MCLK is not applied, this pin should be grounded.
2	TCLK	DI	Transmit Clock	Transmit clock input. TPOS and TNEG are sampled on the falling edge of TCLK. If TCLK is not supplied, the transmitter remains powered down.
3	TPOS	DI	Transmit Positive Data	Input for positive pulse to be transmitted on the twisted-pair line.
4	TNEG	DI	Transmit Negative Data	Input for negative pulse to be transmitted on the twisted-pair line.
5	MODE	DI	Mode Select	Setting MODE to logic 1 puts the LXT304A in the Host Mode. In the Host Mode, the serial interface is used to control the LXT304A and determine its status. Setting MODE to logic 0 puts the LXT304A in the Hardware (H/W) Mode. In the Hardware Mode, the serial interface is disabled and hard-wired pins are used to control configuration and report status.
6	RNEG	DO	Receive Negative Data	Received data outputs. A signal on RNEG corresponds to receipt of a negative pulse on RTIP and RRING. A signal on RPOS corresponds to receipt of a positive pulse on RTIP and RRING. RNEG and RPOS outputs are Non-Return-to-Zero (NRZ). Both outputs are stable and valid on the rising edge of RCLK. In the Host Mode, CLKE determines the clock edge at which these outputs are stable and valid. In the Hardware Mode both outputs are stable and valid on the rising edge of RCLK.
7	RPOS	DO	Receive Positive Data	
8	RCLK	DO	Recovered Clock	This is the clock recovered from the signal received at RTIP and RRING.

1. I/O Column entries: DI = Digital Input, DO = Digital Output, AO = Analog Output, AI = Analog Input, S = Supply

Table 1: Pin Descriptions - continued

Pin #	Sym	I/O ¹	Name	Description
9	XTALIN	AI	Crystal Input	An external crystal operating at four times the bit rate (6.176 MHz for DSX-1, 8.192 MHz for E1 applications with an 18.7 pF load) is required to enable the jitter attenuation function of the LXT304A. These pins may also be used to disable the jitter attenuator by connecting the XTALIN pin to the positive supply through a resistor, and tying the XTALOUT pin to ground.
10	XTALOUT	AO	Crystal Output	
11	DPM	DO	Driver Performance Monitor	DPM goes to a logic 1 when the transmit monitor loop (MTIP and MRING) does not detect a signal for 63 ± 2 clock periods. DPM remains at logic 1 until a signal is detected.
12	LOS	DO	Loss Of Signal	LOS goes to a logic 1 when 175 consecutive spaces have been detected. LOS returns to a logic 0 when the received signal reaches 12.5% ones density, based on 4 ones in any 32-bit period with no more than 15 consecutive zeros.
13	TTIP	AO	Transmit Tip	Differential Driver Outputs. These low impedance outputs achieve maximum power savings through a 1:1.15 transformer (T1), or a 1:1 (75 Ω) or 1:1.26 (120 Ω) transformer (E1) without additional components. To provide higher return loss, resistors may be used in series with a transformer as specified in Application Information.
16	TRING	AO	Transmit Ring	
14	TGND	S	Transmit Ground	Ground return for the transmit drivers power supply TV+.
15	TV+	S	Transmit Power Supply	+5 VDC power supply input for the transmit drivers. TV+ must not vary from RV+ by more than ± 0.3 V.
17	MTIP	AI	Monitor Tip	These pins are used to monitor the tip and ring transmit outputs. The transceiver can be connected to monitor its own output or the output of another LXT304A on the board. To prevent false interrupts in the Host Mode if the monitor is not used, apply a clock signal to one of the monitor pins and tie the other monitor pin to approximately the clock's mid-level voltage. The monitor clock can range from 100 kHz to the TCLK frequency.
18	MRING	AI	Monitor Ring	
19	RTIP	AI	Receive Tip	The AMI signal received from the line is applied at these pins. A center-tapped, center-grounded, 2:1 step-up transformer is required on these pins. Data and clock from the signal applied at these pins are recovered and output on the RPOS/RNEG and RCLK pins.
20	RRING	AI	Receive Ring	
21	RV+	S	Receive Power Supply	+5 VDC power supply for all circuits except the transmit drivers. (Transmit drivers are supplied by TV+.)
22	RGND	S	Receive Ground	Ground return for power supply RV+.

1. I/O Column entries: DI = Digital Input, DO = Digital Output, AO = Analog Output, AI = Analog Input, S = Supply

2

Table 1: Pin Descriptions - continued

Pin #	Sym	I/O ¹	Name	Description
23	$\overline{\text{INT}}$	DO	Interrupt (Host Mode)	This LXT304A Host Mode output goes Low to flag the host processor when LOS or DPM go active. $\overline{\text{INT}}$ is an open-drain output and should be tied to power supply RV+ through a resistor. $\overline{\text{INT}}$ is reset by clearing the respective register bit (LOS and/or DPM.)
	EC1	DI	Equalizer Control 1 (H/W Mode)	The signal applied at this pin in the LXT304A Hardware Mode is used in conjunction with EC2 and EC3 inputs to determine shape and amplitude of AMI output transmit pulses.
24	SDI	DI	Serial Data In (Host Mode)	The serial data input stream is applied to this pin when the LXT304A operates in the Host Mode. SDI is sampled on the rising edge of SCLK.
	EC2	DI	Equalizer Control 2 (H/W Mode)	The signal applied at this pin in the LXT304A Hardware Mode is used in conjunction with EC1 and EC3 inputs to determine shape and amplitude of AMI output transmit pulses.
25	SDO	DO	Serial Data Out (Host Mode)	The serial data from the on-chip register is output on this pin in the LXT304A Host Mode. If CLKE is High, SDO is valid on the rising edge of SCLK. If CLKE is Low, SDO is valid on the falling edge of SCLK. This pin goes to a high-impedance state when the serial port is being written to and when $\overline{\text{CS}}$ is High.
	EC3	DI	Equalizer Control 3 (H/W Mode)	The signal applied at this pin in the LXT304A Hardware Mode is used in conjunction with EC1 and EC2 inputs to determine shape and amplitude of AMI output transmit pulses.
26	$\overline{\text{CS}}$	DI	Chip Select (Host Mode)	This input is used to access the serial interface in the LXT304A Host Mode. For each read or write operation, $\overline{\text{CS}}$ must transition from High to Low, and remain Low.
	RLOOP	DI	Remote Loopback (H/W Mode)	This input controls loopback functions in the LXT304A Hardware Mode. Setting RLOOP High enables the Remote Loopback Mode. Setting both RLOOP and LLOOP causes a Reset.
27	SCLK	DI	Serial Clock (Host Mode)	This clock is used in the LXT304A Host Mode to write data to or read data from the serial interface registers.
	LLOOP	DI	Local Loopback (H/W Mode)	This input controls loopback functions in the LXT304A Hardware Mode. Setting LLOOP High enables the Local Loopback Mode.
28	CLKE	DI	Clock Edge (Host Mode)	Setting CLKE High causes RPOS and RNEG to be valid on the falling edge of RCLK, and SDO to be valid on the rising edge of SCLK. When CLKE is Low, RPOS and RNEG are valid on the rising edge of RCLK, and SDO is valid on the falling edge of SCLK.
	TAOS	DI	Transmit All Ones (H/W Mode)	When set High, TAOS causes the LXT304A (Hardware Mode) to transmit a continuous stream of marks at the TCLK frequency. Activating TAOS causes TPOS and TNEG inputs to be ignored. TAOS is inhibited during Remote Loopback.

1. I/O Column entries: DI = Digital Input, DO = Digital Output, AO = Analog Output, AI = Analog Input, S = Supply

FUNCTIONAL DESCRIPTION

NOTE

This functional description is for design aid only.

The LXT304A is a fully integrated PCM transceiver for both 1.544 Mbps (DSX-1) and 2.048 Mbps (E1) applications. It allows full-duplex transmission of digital data over existing twisted-pair installations.

The LXT304A transceiver interfaces with two twisted-pair lines, one twisted-pair for transmit, one twisted-pair for receive.

POWER REQUIREMENTS

The LXT304A is a low-power CMOS device. It operates from a single +5 V power supply which can be connected externally to both the transmitter and receiver. However, the two inputs must be within $\pm .3$ V of each other, and decoupled to their respective grounds separately. Refer to Application Information for typical decoupling circuitry. Isolation between the transmit and receive circuits is provided internally. During normal operation, TAOS or LLOOP, the transmitter powers down if TCLK is not supplied.

Reset Operation

Upon power up, the transceiver is held static until the power supply reaches approximately 3 V. Upon crossing this threshold, the device begins a 32 ms reset cycle to calibrate the transmit and receive delay lines and lock the Phase Lock Loop to the receive line. A reference clock is required to calibrate the delay lines. The transmitter reference is provided by TCLK. MCLK provides the receiver reference. If the crystal oscillator is grounded, MCLK is used as the receiver reference clock.

The transceiver can also be reset from the Host or Hardware Mode. In Host Mode, reset is commanded by simultaneously writing RLOOP and LLOOP to the register. In Hardware Mode, reset is commanded by holding RLOOP and LLOOP High simultaneously for 200 ns. Reset is initiated on the falling edge of the reset request. In either mode, reset clears and sets all registers to 0 and then begins calibration.

RECEIVER

The LXT304A receives the signal input from one twisted-pair line on each side of a center-grounded transformer. Positive pulses are received at RTIP and negative pulses are received at RRING. Recovered data is output at RPOS and RNEG, and the recovered clock is output at RCLK. Refer to Test Specifications for LXT304A receiver timing.

The signal received at RPOS and RNEG is processed through the peak detector and data slicers. The peak detector samples the inputs and determines the maximum value of the received signal. A percentage of the peak value is provided to the data slicers as a threshold level to ensure optimum signal-to-noise ratio. For DSX-1 applications (determined by Equalizer Control inputs EC1 - EC3 \neq 000) the threshold is set to 70% of the peak value. This threshold is maintained above 65% for up to 15 successive zeros over the range of specified operating conditions. For E1 applications (EC inputs = 000 or 001) the threshold is 50%.

The receiver is capable of accurately recovering signals with up to -13.6 dB of attenuation (from 2.4 V), corresponding to a received signal level of approximately 500 mV. Maximum line length is 1500 feet of ABAM cable (approximately 6 dB of attenuation). Regardless of received signal level, the peak detectors are held above a minimum level of .3 V to provide immunity from impulsive noise.

After processing through the data slicers, the received signal is routed to the data and clock recovery sections, and to the receive monitor. The data and clock recovery circuits are highly tolerant with an input jitter tolerance significantly better than required by Pub 62411. Refer to Test Specifications for additional information.

The receiver monitor loads a digital counter at the RCLK frequency. The count is incremented each time a zero is received, and reset to zero each time a one (mark) is received. Upon receipt of 175 consecutive zeros the LOS pin goes high, and a smooth transition replaces the RCLK output with the MCLK. (If MCLK is not supplied the RCLK output will be replaced with the centered crystal clock.) The LOS pin is reset when the received signal reaches 12.5% ones density (4 marks in 32 bits) with no more than 15 consecutive zeros.

Recovered clock signals are supplied to the Jitter Attenuator and the data latch. The recovered data is passed to the Elastic Store where it is buffered and synchronized with the dejittered recovered clock (RCLK).

Jitter Attenuation

Jitter attenuation of the LXT304A clock and data outputs is provided by a Jitter Attenuation Loop (JAL) and an Elastic Store (ES). An external crystal oscillating at 4 times the bit rate provides clock stabilization. Refer to Application Information for crystal specifications. The ES is a 32 x 2-bit register. Recovered data is clocked into the ES with the recovered clock signal, and clocked out of the ES with the dejittered clock from the JAL. When the bit count in the ES is within two bits of overflowing or underflowing, the ES adjusts the output clock by 1/8 of a bit period. The ES produces an average delay of 16 bits in the receive path.

TRANSMITTER

Data received for transmission onto the line is clocked serially into the device at TPOS and TNEG. Input synchronization is supplied by the transmit clock (TCLK). If TCLK is not supplied the transmitter remains powered down, except during remote loopback. Refer to Test Specifications for master and transmit clock timing characteristics.

The transmitted pulse shape is determined by Equalizer Control signals EC1 through EC3 as shown in Table 2. Equalizer Control signals may be hardwired in the Hardware mode, or input as part of the serial data stream (SDI) in the Host mode. Shaped pulses are applied to the AMI line driver for transmission onto the line at TTIP and TRING. The line driver provides a constant low output impedance of 3 Ω (typical). This well controlled output impedance provides excellent return loss (> 18 dB) when used with external 9.1 Ω precision resistors (± 1% accuracy) in series with a transmit transformer with a turns ratio of 1:2.3 (± 2% accuracy). Series resistors also provide increased surge protection and reduce short circuit current flow.

Pulses can be shaped for either 1.544 or 2.048 Mbps applications. 1.544 Mbps pulses for DSX-1 applications can be programmed to match line lengths from 0 to 655 feet of ABAM cable. The LXT304A also matches FCC and ECSA specifications for CSU applications. A 1:1.15 transmit transformer is used for 1.544 Mbps systems. For higher return loss in DSX-1 applications, use 9.1 Ω resistors in series with a 1:2.3 transmit transformer.

2.048 Mbps pulses can drive coaxial or shielded twisted-pair lines. For E1 systems, a 1:2 transmit transformer and series resistors are recommended. This design meets or exceeds all ITU and ETSI specifications for transmit and receive return loss. A 1:1 or 1:1.26 transformer may be used without series resistors.

Driver Performance Monitor

The transceiver incorporates a Driver Performance Monitor (DPM) in parallel with TTIP and TRING at the output transformer. The DPM output goes High upon detection of 63 consecutive zeros. It is reset when a one is detected on the transmit line, or when a reset command is received.

Line Code

The LXT304A transmits data as a 50% AMI line code as shown in Figure 2. The output driver maintains a constant low output impedance regardless of whether it is driving marks or spaces.

OPERATING MODES

The LXT304A can be controlled through hard-wired pins (Hardware Mode) or by a microprocessor through a serial interface (Host Mode). The mode of operation is set by the MODE pin logic level. The LXT304A can also be commanded to operate in one of several diagnostic modes.

Host Mode Operation

To allow a host microprocessor to access and control the LXT304A through the serial interface, MODE is set High.

Figure 2: 50% AMI Coding Diagram

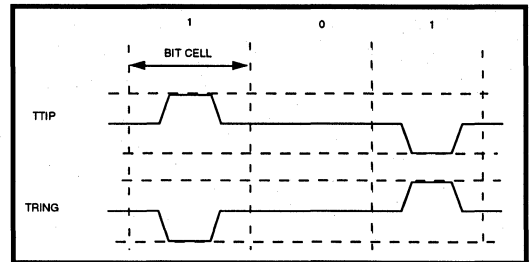

Table 2: Equalizer Control Inputs

EC3	EC2	EC1	Line Length ¹	Cable Loss ²	Application	Bit Rate
0	1	1	0 - 133 ft ABAM	0.6 dB	DSX-1	1.544 Mbps
1	0	0	133 - 266 ft ABAM	1.2 dB		
1	0	1	266 - 399 ft ABAM	1.8 dB		
1	1	0	399 - 533 ft ABAM	2.4 dB		
1	1	1	533 - 655 ft ABAM	3.0 dB		
0	0	0	ITU Recommendation G.703		E1 - Coax (75 Ω)	2.048 Mbps
0	0	1			E1 - Twisted-pair (120 Ω)	
0	1	0	FCC Part 68, Option A		CSU (DS-1)	1.544 Mbps

1. Line length from transceiver to DSX-1 cross-connect point.

2. Maximum cable loss at 772 kHz.

The serial interface (SDI/SDO) uses a 16-bit word consisting of an 8-bit Command/Address byte and an 8-bit Data byte. Figure 3 shows the serial interface data structure and relative timing.

The Host Mode provides a latched Interrupt output (\overline{INT}) which is triggered by a change in the Loss of Signal (LOS) and/or Driver Performance Monitor (DPM) bits. The Interrupt is cleared when the interrupt condition no longer exists, and the host processor enables the respective bit in the serial input data byte. Host Mode also allows control of the serial data and receive data output timing. The Clock Edge (CLKE) signal determines when these outputs are valid, relative to the Serial Clock (SCLK) or RCLK as listed in Table 3.

Table 3: Valid Clock Edges for Data Outputs

CLKE	Output	Clock	Valid Edge
LOW	RPOS	RCLK	Rising
	RNEG	RCLK	Rising
	SDO	SCLK	Falling
HIGH	RPOS	RCLK	Falling
	RNEG	RCLK	Falling
	SDO	SCLK	Rising

Table 4: LXT304A Serial Data Output Bits (See Figure 3)

Bit D5	Bit D6	Bit D7	Status
0	0	0	Reset has occurred, or no program input
0	0	1	TAOS active
0	1	0	Local Loopback active
0	1	1	TAOS and Local Loopback active
1	0	0	Remote Loopback active
1	0	1	DPM has changed state since last Clear DPM occurred
1	1	0	LOS has changed state since last Clear LOS occurred
1	1	1	LOS and DPM have both changed state since last Clear DPM and Clear LOS occurred

Figure 3: LXT304A Serial Interface Data Structure

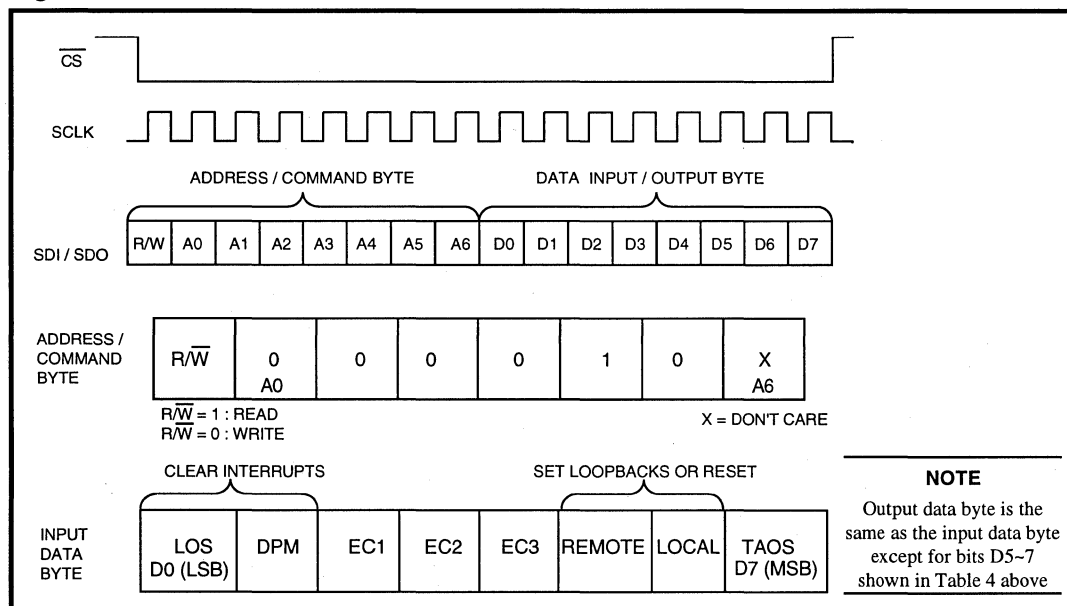

The LXT304A serial port is addressed by setting bit A4 in the Address/Command byte, corresponding to address 16. The LXT304A contains only a single output data register so no complex chip addressing scheme is required. The register is accessed by causing the Chip Select (CS) input to transition from High to Low. Bit 1 of the serial Address/Command byte provides Read/Write control when the chip is accessed. A logic 1 indicates a read operation, and a logic 0 indicates a write operation. Table 4 lists serial data output bit combinations for each status. Serial data I/O timing characteristics are shown in the Test Specifications section.

Hardware Mode Operation

In Hardware Mode the transceiver is accessed and controlled through individual pins. With the exception of the INT and CLKE functions, Hardware Mode provides all the functions provided in the Host Mode. In the Hardware Mode RPOS and RNEG outputs are valid on the rising edge of RCLK. To operate in Hardware Mode, MODE must be set Low. Equalizer Control signals (EC1 through EC3) are input on the Interrupt, Serial Data In and Serial Data Out pins. Diagnostic control for Remote Loopback (RLOOP), Local Loopback (LLOOP), and Transmit All Ones (TAOS) modes is provided through the individual pins used to control serial interface timing in the Host Mode.

Diagnostic Mode Operation

TRANSMIT ALL ONES

In Transmit All Ones (TAOS) mode the TPOS and TNEG inputs to the transceiver are ignored. The transceiver transmits a continuous stream of ones when the TAOS mode is activated. TAOS can be commanded simultaneously with Local Loopback, but is inhibited during Remote Loopback.

REMOTE LOOPBACK

In Remote Loopback (RLOOP) mode, the transmit data and clock inputs (TPOS, TNEG and TCLK) are ignored. The RPOS and RNEG outputs are looped back through the transmit circuits and output on TTIP and TRING at the RCLK frequency. Receiver circuits are unaffected by the RLOOP command and continue to output the RPOS, RNEG and RCLK signals received from the twisted-pair line.

LOCAL LOOPBACK

In Local Loopback (LLOOP) mode, the receiver circuits are inhibited. The transmit data and clock inputs (TPOS, TNEG and TCLK) are looped back onto the receive data and clock outputs (RPOS, RNEG and RCLK) through the Rx jitter attenuator. The transmitter circuits are unaffected by the LLOOP command. The TPOS and TNEG inputs (or a stream of ones if the TAOS command is active) will be transmitted normally.

Table 5: LXT304A Crystal Specifications (External)

Parameter	T1	E1
Frequency	6.176 MHz	8.192 MHz
Frequency Stability	±20 ppm @ 25 °C ± 25 ppm from -40 °C to + 85 °C (Ref 25 °C reading)	±20 ppm @ 25 °C ± 25 ppm from -40 °C to + 85 °C (Ref 25 °C reading)
Pullability	CL = 11 pF to 18.7 pF, +ΔF = 175 to 195 ppm CL = 18.7 pF to 34 pF, -ΔF = 175 to 195 ppm	CL = 11 pF to 18.7 pF, +ΔF = 95 to 115 ppm CL = 18.7 pF to 34 pF, -ΔF = 95 to 115 ppm
Effective series resistance	40 Ω Maximum	30 Ω Maximum
Crystal cut	AT	AT
Resonance	Parallel	Parallel
Maximum drive level	2.0 mW	2.0 mW
Mode of operation	Fundamental	Fundamental
Crystal holder	HC49 (R3W), Co = 7 pF maximum C _M = 17 fF typical	HC49 (R3W), Co = 7 pF maximum C _M = 17 fF typical

APPLICATION INFORMATION

NOTE

This information is for design aid only.

1.544 MBPS T1 INTERFACE APPLICATIONS

Figure 4 is a typical 1.544 Mbps T1 application. The LXT304A is shown in the Host Mode with a T1/ESF Framer providing the digital interface with the host controller. Both devices are controlled through the serial interface. An LXP600A Clock Adapter (CLAD) provides the 2.048 MHz system backplane clock, locked to the recovered 1.544 MHz clock signal. The power supply inputs are tied to a common bus with appropriate decoupling capacitors installed (68 μ F on the transmit side, 1.0 μ F and 0.1 μ F on the receive side).

2

Figure 4: Typical LXT304A 1.544 Mbps T1 Application (Host Mode)

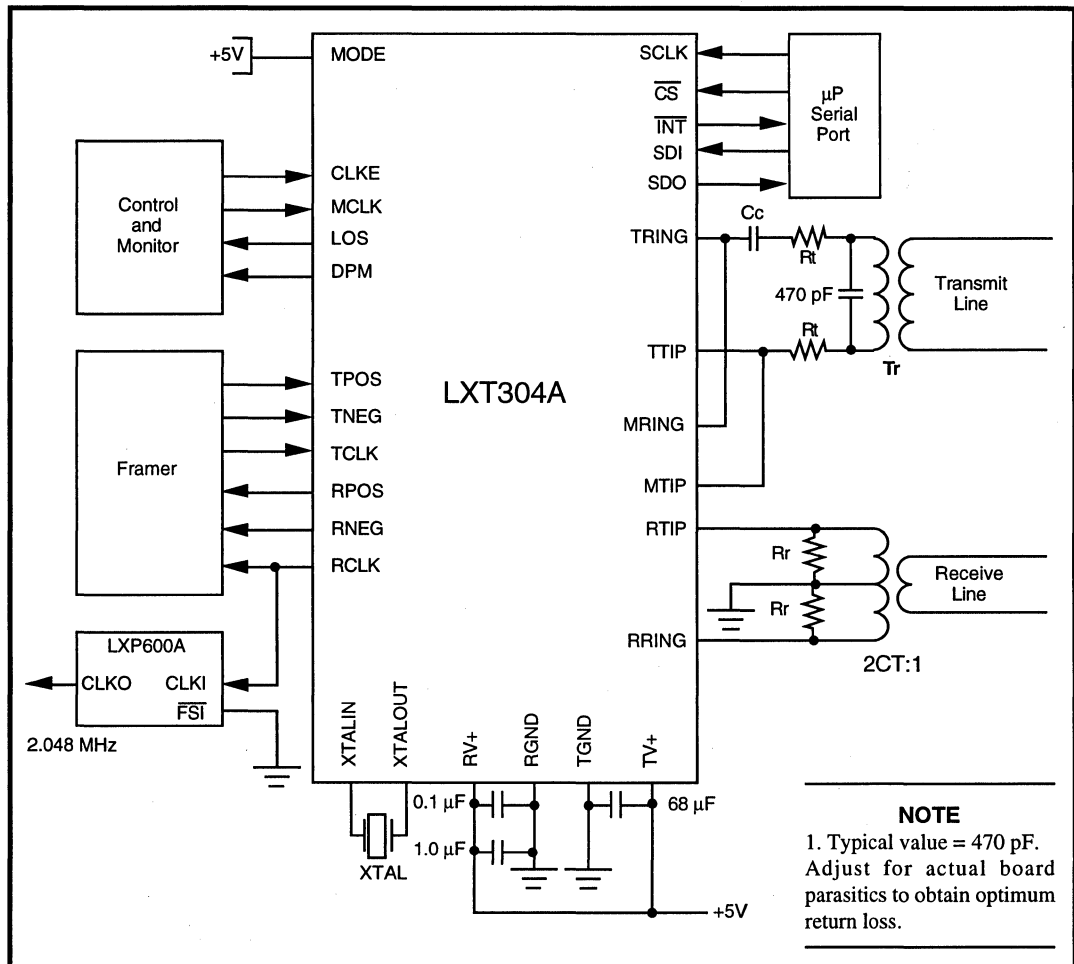

2.048 MBPS E1 INTERFACE APPLICATIONS

Figure 5 is a 2.048 Mbps E1 TWP application using 15 Ω Rt resistors in line with the transmit transformer to provide high return loss and surge protection. When high return loss is not a critical factor, a 1:1 or 1:1.26 transformer without in-line resistors provides maximum power savings. The LXT304A is shown in Hardware Mode with a typical E1/CRC4 Framer. The hard-wired control lines for TAOS, LLOOP and RLOOP are individually controllable, and the LLOOP and RLOOP lines are also tied to a single control for the Reset function. This configuration is illustrated with a crystal in place to enable the LXT304A Jitter Attenuation Loop, and a single power supply bus.

LLOOP and RLOOP are individually controllable, and the LLOOP and RLOOP lines are also tied to a single control for the Reset function. This configuration is illustrated with a crystal in place to enable the LXT304A Jitter Attenuation Loop, and a single power supply bus.

Figure 5: Typical LXT304A E1 2.048 Mbps 120 Ω Application (Hardware Mode)

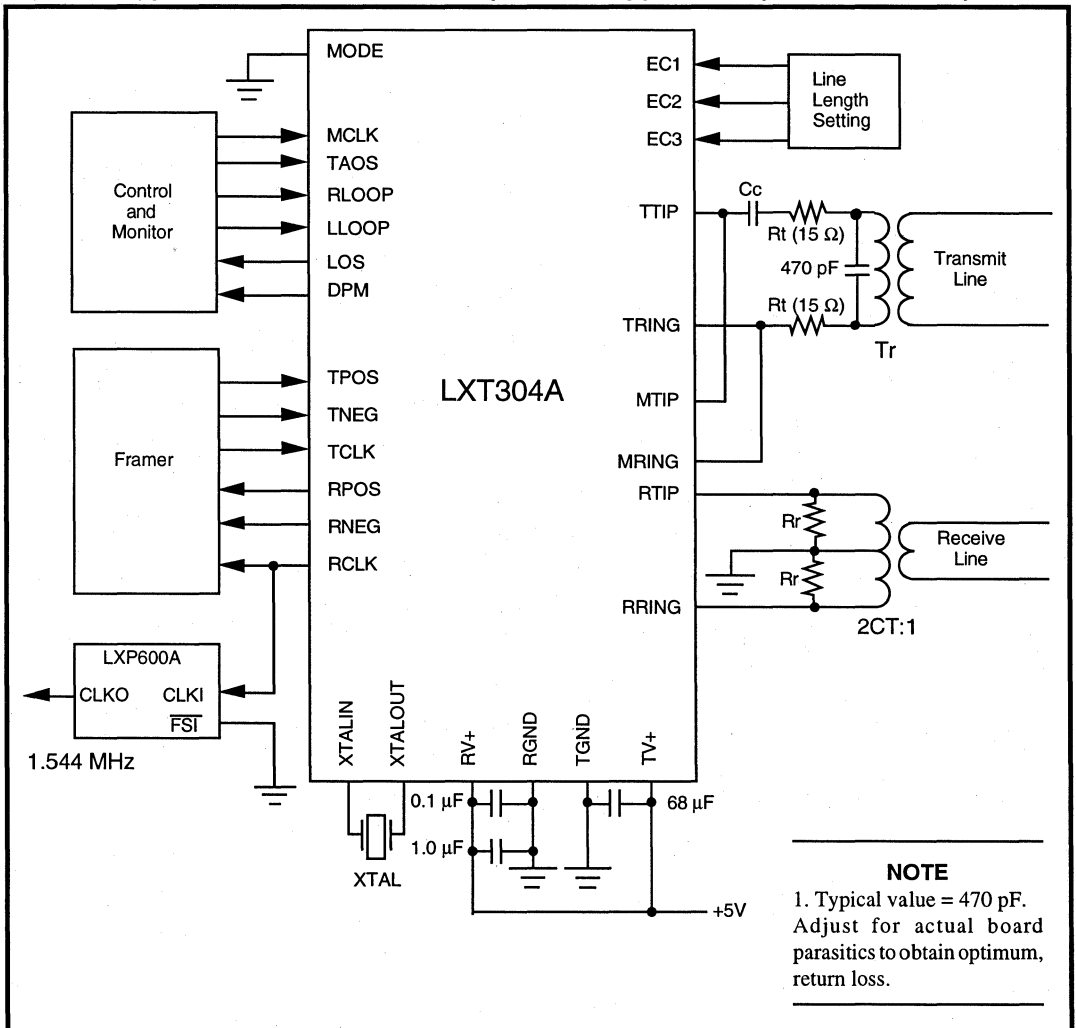

D4 CHANNEL BANK APPLICATIONS

Existing D4 Channel Bank architectures frequently employ: (1) a plug-in card for T1 pulse generation (6.0 V peak); and (2) a separate card for pulse shaping and Line Build-Out (LBO). The LXT304A integrates the functions of both cards on a single chip producing a DSX-1 compatible, 3.0 V peak output pulse with a standard transformer. In new designs, the LXT304A can replace two cards with one. However, the LXT304A is also compatible with existing dual-card architectures. With an appropriate output transformer, the

LXT304A can produce full 6.0 V peak amplitude pulses suitable for D4 Channel Bank applications with separate pulse shaping/LBO cards.

To achieve the 6.0 V peak output, the FCC Part 68-010 Equalizer Code setting is used. (EC = 010.) With the standard 1:1.15 transformer, this code produces a 3.0 V peak pulse. However, doubling the transformer turns ratio to 1:2.30 produces the desired 6.0 V peak pulse.



Table 6: T1/E1 Input/Output Configurations

Bit Rate (Mbps)	Crystal XTAL	Cable (Ω)	Rr ² (Ω)	EC3/2/1	Transmit Transformer ¹ (Tr)	Rt ² (Ω)	Typical TX Return Loss ³ (dB)	Cc (μ F)
1.544 (T1)	LXC6176	100	200	0/1/1 - 1/1/1	1:1.15	0	0.5	0.47
					1:2	9.1	18	0
				0/1/0 ⁴	1:2.3	9.1	18	0
					1:2.3	0	0 ⁴	0.47
2.048 (E1)	LXC8192	120	240	0/0/0	1:1.26	0	0.5	0.47
				0/0/0	1:2	9.1	12	0
				0/0/1	1:1	0	0.5	0.47
				0/0/1	1:2	15	18	0
		75	150	0/0/0	1:1	0	0.5	0.47
				0/0/0	1:2	9.1	18	0
				0/0/1	1:1	10	5	0
				0/0/1	1:2	14.3	10	0

1. Transformer turns ratio accuracy is $\pm 2\%$.
2. Rr and Rt values are $\pm 1\%$.
3. Typical return loss, 51 kHz to 3.072 MHz band.
4. D4 Channel Bank application.

TEST SPECIFICATIONS

NOTE

Minimum and maximum values in Tables 7 through 13 and Figures 6 through 11 represent the performance specifications of the LXT304A and are guaranteed by test except, as noted, by design.

Table 7: Absolute Maximum Ratings

Parameter	Sym	Min	Max	Units
DC supply (referenced to GND)	RV+, TV+	-0.3	6.0	V
Input voltage, any pin ¹	V _{IN}	RGND - 0.3	RV+ + 0.3	V
Input current, any pin ²	I _{IN}	-10	10	mA
Storage temperature	T _{STG}	-65	150	°C

CAUTION
Operations at or beyond these limits may result in permanent damage to the device.
Normal operation not guaranteed at these extremes.

1. Excluding RTIP and RRING, which must stay between -6 V and (RV+ + 0.3) V.
2. Transient currents of up to 100 mA will not cause SCR latch-up. TTIP, TRING, TV+ and TGND can withstand a continuous current of 100 mA.

Table 8: Recommended Operating Conditions

Parameter	Sym	Min	Typ	Max	Units	Test Conditions
DC supply ¹	RV+, TV+	4.75	5.0	5.25	V	
Ambient operating temperature	T _A	-40	25	85	°C	

1. TV+ must not exceed RV+ by more than 0.3 V.

Table 9: Electrical Characteristics (Under Recommended Operating Conditions)

Parameter	Sym	Min	Max	Units	Test Conditions
Total power dissipation ^{1,3}	P _D	-	400	mW	100% ones density & max line length @ 5.25 V
High level input voltage ^{2,3} (pins 1-5, 10, 23-28)	V _{IH}	2.0	-	V	
Low level input voltage ^{2,3} (pins 1-5, 10, 23-28)	V _{IL}	-	0.8	V	
High level output voltage ^{2,3} (pins 6-8, 11, 12, 23, 25)	V _{OH}	2.4	-	V	I _{OUT} = - 400 μA
Low level output voltage ^{2,3} (pins 6-8, 11, 12, 23, 25)	V _{OL}	-	0.4	V	I _{OUT} = 1.6 mA
Input leakage current ⁴	I _{LL}	0	±10	μA	
Three-state leakage current ² (pin 25)	I _{3L}	0	±10	μA	

1. Power dissipation while driving 75 Ω load over operating temperature range. Includes device and load. Digital input levels are within 10% of the supply rails and digital outputs are driving a 50 pF capacitive load.
2. Functionality of pins 23 and 25 depends on mode. See Host / Hardware Mode descriptions.
3. Output drivers will output CMOS logic levels into CMOS loads.
4. Except MTIP and MRING I_{LL} = ± 50 μA.

Table 10: Analog Characteristics (Under Recommended Operating Conditions)

Parameter		Min	Typ ¹	Max	Units	Test Conditions	
AMI Output Pulse Amplitudes	DSX-1	2.4	3.0	3.6	V	measured at the DSX	
	E1	2.7	3.0	3.3	V	measured at line side	
Recommended output load at TTIP and TRING		–	75	–	Ω		
Jitter added by the transmitter ²	10 Hz - 8 kHz	–	–	0.01	UI		
	8 kHz - 40 kHz	–	–	0.025	UI		
	10 Hz - 40 kHz	–	–	0.025	UI		
	Broad Band	–	–	0.05	UI		
Sensitivity below DSX (0 dB = 2.4 V)		13.6	–	–	dB		
		500	–	–	mV		
Loss of Signal threshold		–	0.3	–	V		
Data decision threshold	DSX-1	63	70	77	%peak		
	E1	43	50	57	% peak		
Allowable consecutive zeros before LOS		160	175	190	–		
Input jitter tolerance	10 kHz - 100 kHz	0.4	–	–	UI		
Jitter attenuation curve corner frequency ³		–	3	–	Hz		
Minimum Return Loss ^{4,5}		Transmit		Receive			
			Min	Typ	Min	Typ	
		51 kHz - 102 kHz	18	–	20	–	dB
		102 kHz - 2.048 MHz	18	–	20	–	dB
	2.048 MHz - 3.072 MHz	18	–	20	–	dB	

1. Typical values are at 25 °C and are for design aid only; not guaranteed and not subject to production testing.
2. Input signal to TCLK is jitter-free.
3. Circuit attenuates jitter at 20 dB/decade above the corner frequency.
4. In accordance with ITU G.703/ETS 300166 return loss specifications when wired per Figure 7 (E1).
5. Guaranteed by design.

2

Figure 6: Typical Receiver Input Jitter Tolerance (Loop Mode)

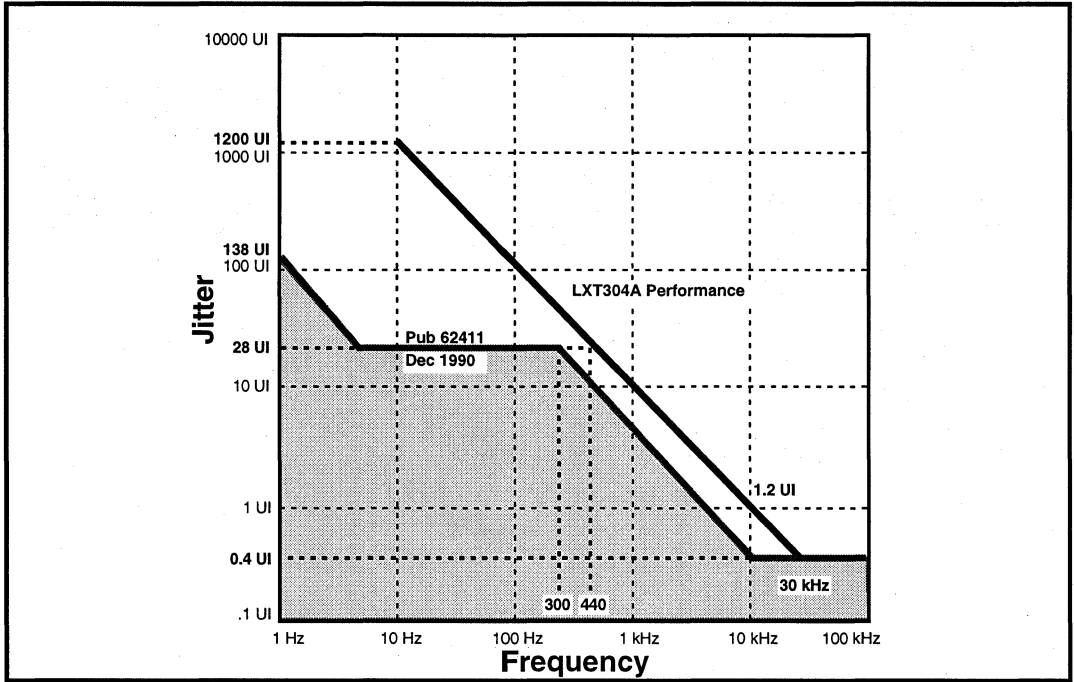

Figure 7: LXT304A Receive Jitter Transfer Performance (Typical)

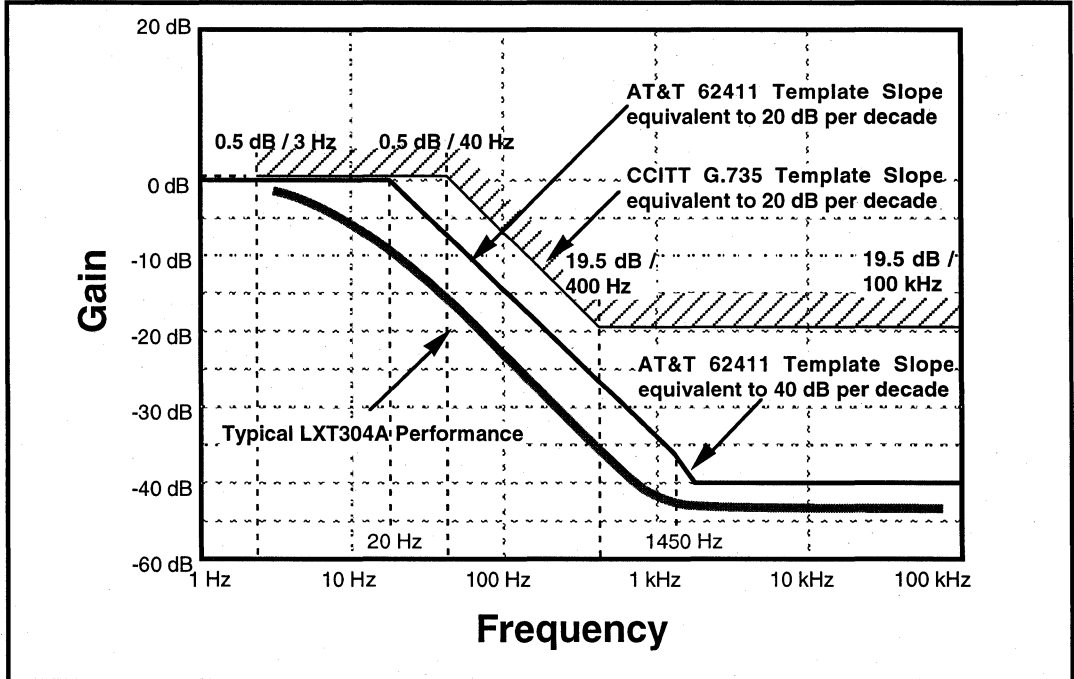

Table 11: LXT304A Receive Timing Characteristics (See Figure 8)

Parameter	Sym	Min	Typ ¹	Max	Units	Test Conditions
Receive clock duty cycle	RCLKd	40	–	60	%	
Receive clock pulse width	DSX-1	tpw	–	324	–	ns
	E1	tpw	–	244	–	ns
RPOS / RNEG to RCLK rising setup time	DSX-1	tsur	–	274	–	ns
	E1	tsur	–	194	–	ns
RCLK rising to RPOS/ RNEG hold time	DSX-1	tthr	–	274	–	ns
	E1	tthr	–	194	–	ns

1. Typical values are at 25 °C and are for design aid only; not guaranteed and not subject to production testing.

2

Figure 8: LXT304A Receive Clock Timing Diagram

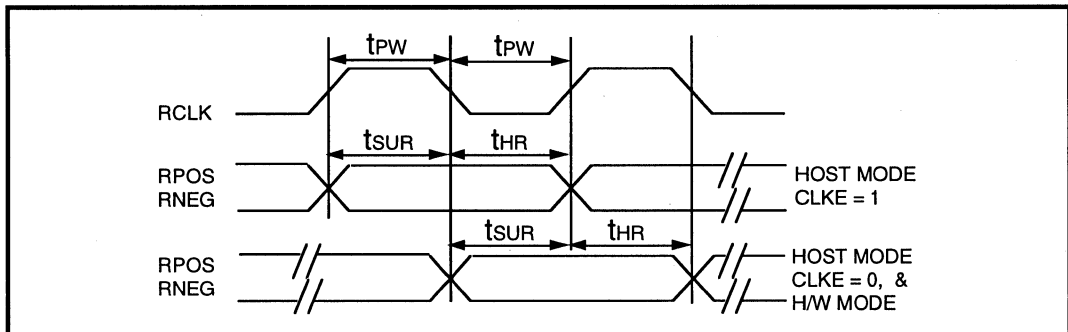

Table 12: LXT304A Master Clock and Transmit Timing Characteristics
(See Figure 9)

Parameter		Sym	Min	Typ ¹	Max	Units	Test Conditions
Master clock frequency	DSX-1	MCLK	-	1.544	-	MHz	
	E1	MCLK	-	2.048	-	MHz	
Master clock tolerance		MCLKt	-	±100	-	ppm	
Master clock duty cycle		MCLKd	40	-	60	%	
Crystal frequency	DSX-1	fc	-	6.176	-	MHz	
	E1	fc	-	8.192	-	MHz	
Transmit clock frequency	DSX-1	TCLK	-	1.544	-	MHz	
	E1	TCLK	-	2.048	-	MHz	
Transmit clock tolerance		TCLKt	-	±50	-	ppm	
Transmit clock duty cycle		TCLKd	10	-	90	%	
TPOS/TNEG to TCLK setup time		t _{SUT}	25	-	-	ns	
TCLK to TPOS/TNEG Hold time		t _{HT}	25	-	-	ns	

1. Typical figures are at 25 °C and are for design aid only; not guaranteed and not subject to production testing.

Figure 9: LXT304A Transmit Clock Timing Diagram

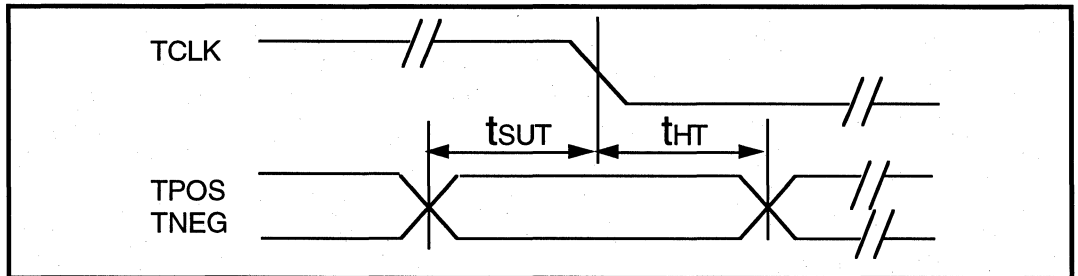

Table 13: LXT304A Serial I/O Timing Characteristics (See Figures 10 and 11)

Parameter	Sym	Min	Typ ¹	Max	Units	Test Conditions
Rise/Fall time - any digital output	t_{rF}	-	-	100	ns	Load 1.6 mA, 50 pF
SDI to SCLK setup time	t_{dc}	50	-	-	ns	
SCLK to SDI hold time	t_{cdH}	50	-	-	ns	
SCLK low time	t_{cL}	240	-	-	ns	
SCLK high time	t_{cH}	240	-	-	ns	
SCLK rise and fall time	t_r, t_f	-	-	50	ns	
\overline{CS} to SCLK setup time	t_{cc}	50	-	-	ns	
SCLK to \overline{CS} hold time	t_{cch}	50	-	-	ns	
\overline{CS} inactive time	t_{cwh}	250	-	-	ns	
SCLK to SDO valid	t_{cdv}	-	-	200	ns	
SCLK falling edge or \overline{CS} rising edge to SDO high Z	t_{cdz}	-	100	-	ns	

1. Typical figures are at 25 °C and are for design aid only; not guaranteed and not subject to production testing.

Figure 10: LXT304A Serial Data Input Timing Diagram

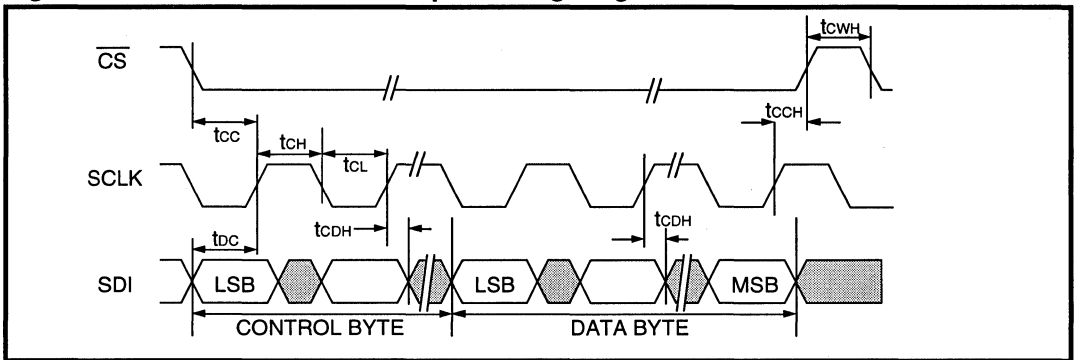
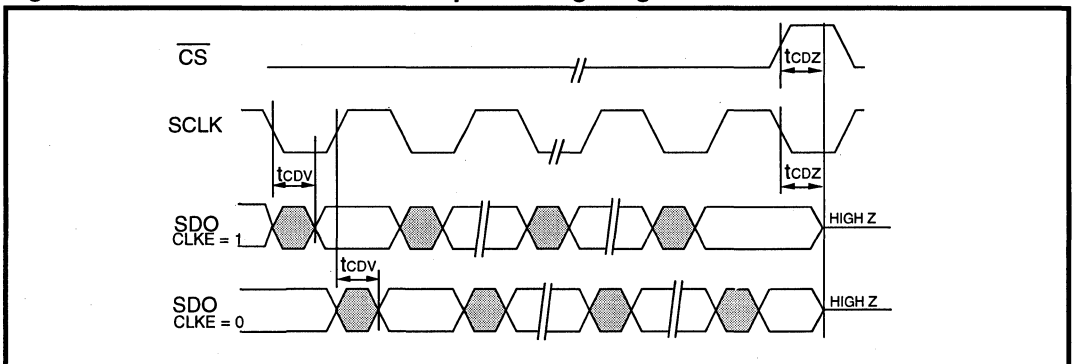

Figure 11: LXT304A Serial Data Output Timing Diagram



NOTES:

LXT305

Integrated T1/E1 Short-Haul Transceiver with Transmit Jitter Attenuation

2

General Description

The LXT305 is a fully integrated transceiver for both North American 1.544 Mbps (T1) and International 2.048 Mbps (E1) applications. Transmit pulse shapes (T1 or E1) are selectable for various line lengths and cable types.

The LXT305 provides transmit jitter attenuation starting at 3 Hz, and is microprocessor controllable through a serial interface. It is especially well suited for applications involving T1 and higher rates such as M13 Mux, SONET, etc. A variety of diagnostic features including transmit and receive monitoring are incorporated. Clock inputs may be derived from an on-chip crystal oscillator or digital inputs.

The LXT305, an advanced double-poly, double-metal CMOS device, requires only a single 5-volt power supply.

Applications

- SDH / SONET Equipment
- M13 Multiplexers
- PCM / Voice Channel Banks
- Data Channel Bank / Concentrator
- T1 / E1 multiplexer
- Digital Access and Cross-connect Systems (DACs)
- Computer to PBX interface (CPI & DMI)
- High-speed data transmission lines
- Interfacing Customer Premises Equipment to a CSU
- Digital Loop Carrier (DLC) terminals

Features

- Compatible with most popular PCM framers
- Line driver, data recovery and clock recovery functions
- Minimum receive signal of 500 mV
- Selectable slicer levels (T1/E1) improve SNR
- Programmable transmit equalizer shapes pulses to meet DSX-1 pulse template from 0 to 655 ft
- Local and remote loopback functions
- Transmit Driver Performance Monitor (DPM) output
- Receive monitor with Loss of Signal (LOS) output
- Receiver jitter tolerance 0.4 UI from 40 kHz to 100 kHz
- Transmit jitter attenuation starting at 3 Hz
- Microprocessor controllable
- Available in 28-pin DIP and PLCC

LXT305 Block Diagram

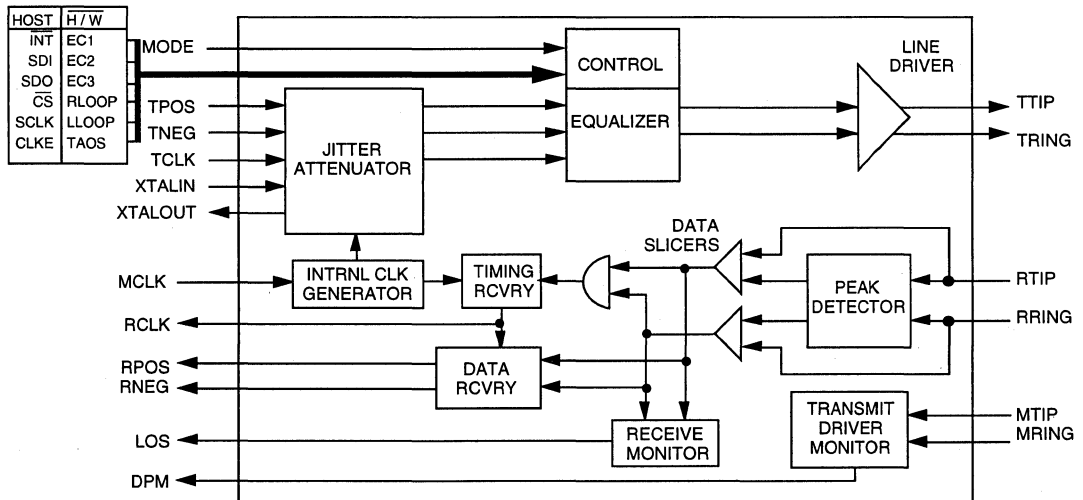

LXT305 Integrated T1/E1 Short-Haul Transceiver with Transmit Jitter Attenuation

Figure 1: Pin Assignments

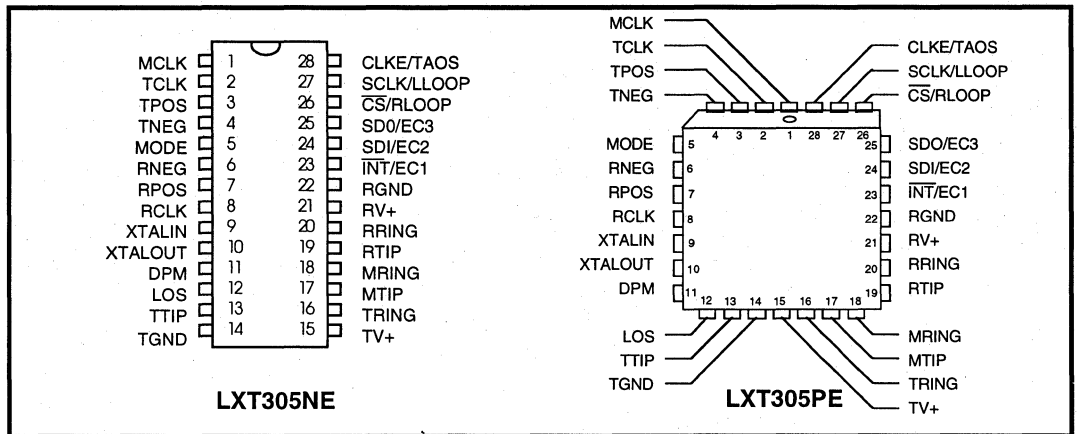

Table 1: Pin Descriptions

Pin #	Sym	I/O ¹	Name	Description
1	MCLK	DI	Master Clock	A 1.544 or 2.048 MHz clock input used to generate internal clocks. Upon Loss of Signal (LOS), RCLK is derived from MCLK. If MCLK is not applied, this pin should be grounded.
2	TCLK	DI	Transmit Clock	Transmit clock input. TPOS and TNEG are sampled on the falling edge of TCLK. Except during remote loopback, the transmitter remains powered down if TCLK is not supplied.
3	TPOS	DI	Transmit Positive Data	Input for positive pulse to be transmitted on the twisted-pair line.
4	TNEG	DI	Transmit Negative Data	Input for negative pulse to be transmitted on the twisted-pair line.
5	MODE	DI	Mode Select	Setting MODE High puts the LXT305 in the Host Mode. In the Host Mode, the serial interface is used to control the LXT305 and determine its status. Setting MODE Low puts the LXT305 in the Hardware (H/W) Mode. In the Hardware Mode, the serial interface is disabled and hard-wired pins are used to control configuration and report status.
6	RNEG	DO	Receive Negative Data	Received data outputs. A signal on RNEG corresponds to receipt of a negative pulse on RTIP and RRING. A signal on RPOS corresponds to receipt of a positive pulse on RTIP and RRING. RNEG and RPOS outputs are Non-Return-to-Zero (NRZ). In the Host Mode, CLKE determines the clock edge at which these outputs are stable and valid. In the Hardware Mode, both outputs are stable and valid on the rising edge of RCLK.
7	RPOS	DO	Receive Positive Data	
8	RCLK	DO	Recovered Clock	This is the clock recovered from the signal received at RTIP and RRING.

1. Entries in I/O column are: DI = Digital Input; DO = Digital Output; AI = Analog Input; AO = Analog Output; S = Supply.

Table 1: Pin Descriptions - continued

Pin #	Sym	I/O ¹	Name	Description
9	XTALIN	AI	Crystal Input	An external crystal operating at four times the bit rate (6.176 MHz for T1, 8.192 MHz for E1 applications with an 18.7 pF load) is required to enable the jitter attenuation function of the LXT305. These pins may also be used to disable the jitter attenuator by connecting the XTALIN pin to the positive supply through a resistor, and tying the XTALOUT pin to ground.
10	XTALOUT	AO	Crystal Output	
11	DPM	DO	Driver Performance Monitor	DPM goes High when the transmit monitor loop (MTIP and MRING) does not detect a signal for 63 ± 2 clock periods. DPM remains High until a signal is detected.
12	LOS	DO	Loss Of Signal	LOS goes High when 175 consecutive spaces have been detected. LOS returns Low when a mark is received.
13	TTIP	AO	Transmit Tip	Differential Driver Outputs. These outputs are designed to drive a 25 Ω load. The transmitter will drive 100 Ω shielded twisted-pair cable through a 2:1 step-up transformer without additional components. To drive 75 Ω coaxial cable, two 2.2 Ω resistors are required in series with the transformer.
16	TRING	AO	Transmit Ring	
14	TGND	S	Transmit Ground	Ground return for the transmit drivers power supply TV+.
15	TV+	S	Transmit Power Supply	+5 VDC power supply input for the transmit drivers. TV+ must not vary from RV+ by more than ± 0.3 V.
17	MTIP	AI	Monitor Tip	These pins are used to monitor the tip and ring transmit outputs. The transceiver can be connected to monitor its own output or the output of another LXT305 on the board. <i>Host Mode only:</i> To prevent false interrupts in the Host Mode if the monitor is not used, apply a clock signal to one of the monitor pins and tie the other monitor pin to approximately the clock's mid-level voltage. The monitor clock can range from 100 kHz to the TCLK frequency.
18	MRING	AI	Monitor Ring	
19	RTIP	AI	Receive Tip	The AMI signal received from the line is applied at these pins. A center-tapped, center-grounded, 2:1 step-up transformer is required on these pins. Data and clock from the signal applied at these pins are recovered and output on the RPOS/RNEG and RCLK pins.
20	RRING	AI	Receive Ring	
21	RV+	S	Receive Power Supply	+5 VDC power supply for all circuits except the transmit drivers. (Transmit drivers are supplied by TV+.)
22	RGND	S	Receive Ground	Ground return for power supply RV+.

1. Entries in I/O column are: DI = Digital Input; DO = Digital Output; AI = Analog Input; AO = Analog Output; S = Supply.

LXT305 Integrated T1/E1 Short-Haul Transceiver with Transmit Jitter Attenuation

Table 1: Pin Descriptions - continued

Pin #	Sym	I/O ¹	Name	Description
23	$\overline{\text{INT}}$	DO	Interrupt (Host Mode)	This LXT305 Host Mode output goes Low to flag the host processor when LOS or DPM goes active. $\overline{\text{INT}}$ is an open-drain output and should be tied to power supply RV+ through a resistor. $\overline{\text{INT}}$ is reset by clearing the respective register bit (LOS and/or DPM.)
	EC1	DI	Equalizer Control 1 (H/W Mode)	The signal applied at this pin in the LXT305 Hardware Mode is used in conjunction with EC2 and EC3 inputs to determine shape and amplitude of AMI output transmit pulses.
24	SDI	DI	Serial Data In (Host Mode)	The serial data input stream is applied to this pin when the LXT305 operates in the Host Mode. SDI is sampled on the rising edge of SCLK.
	EC2	DI	Equalizer Control 2 (H/W Mode)	The signal applied at this pin in the LXT305 Hardware Mode is used in conjunction with EC1 and EC3 inputs to determine shape and amplitude of AMI output transmit pulses.
25	SDO	DO	Serial Data Out (Host Mode)	The serial data from the on-chip register is output on this pin in the LXT305 Host Mode. If CLKE is High, SDO is valid on the rising edge of SCLK. If CLKE is Low, SDO is valid on the falling edge of SCLK. This pin goes to a high-impedance state when the serial port is being written to and when $\overline{\text{CS}}$ is High.
	EC3	DI	Equalizer Control 3 (H/W Mode)	The signal applied at this pin in the LXT305 Hardware Mode is used in conjunction with EC1 and EC2 inputs to determine shape and amplitude of AMI output transmit pulses.
26	$\overline{\text{CS}}$	DI	Chip Select (Host Mode)	This input is used to access the serial interface in the LXT305 Host Mode. For each read or write operation, $\overline{\text{CS}}$ must transition from High to Low, and remain Low.
	RLOOP	DI	Remote Loopback (H/W Mode)	This input controls loopback functions in the LXT305 Hardware Mode. Setting RLOOP High enables the Remote Loopback Mode. Setting both RLOOP and LLOOP causes a Reset.
27	SCLK	DI	Serial Clock (Host Mode)	This clock is used in the LXT305 Host Mode to write data to or read data from the serial interface registers.
	LLOOP	DI	Local Loopback (H/W Mode)	This input controls loopback functions in the LXT305 Hardware Mode. Setting LLOOP High enables the Local Loopback Mode.
28	CLKE	DI	Clock Edge (Host Mode)	Setting CLKE High causes RPOS and RNEG to be valid on the falling edge of RCLK, and SDO to be valid on the rising edge of SCLK. When CLKE is Low, RPOS and RNEG are valid on the rising edge of RCLK, and SDO is valid on the falling edge of SCLK.
	TAOS	DI	Transmit All Ones (H/W Mode)	When set High, TAOS causes the LXT305 (Hardware Mode) to transmit a continuous stream of marks at the MCLK frequency.

1. Entries in I/O column are: DI = Digital Input; DO = Digital Output; AI = Analog Input; AO = Analog Output; S = Supply.

FUNCTIONAL DESCRIPTION

NOTE

This functional description is for design aid only.

The LXT305 is a fully integrated PCM transceiver for both 1.544 Mbps (T1) and 2.048 Mbps (E1) applications which allows full-duplex transmission of digital data over existing twisted-pair installations.

The first page of this data sheet shows a simplified block diagram of the LXT305. The LXT305 transceiver interfaces with two twisted-pair lines (one twisted-pair for transmit, one twisted-pair for receive) through standard pulse transformers and appropriate resistors.

POWER REQUIREMENTS

The LXT305 is a low-power CMOS device. It operates from a single +5 V power supply which can be connected externally to both the transmitter and receiver. However, the two inputs must be within ± 3 V of each other, and decoupled to their respective grounds separately. Refer to Application Information for typical decoupling circuitry. Isolation between the transmit and receive circuits is provided internally. Except during remote loopback, the transmitter powers down if TCLK is not supplied.

Reset Operation

Upon power up, the transceiver is held static until the power supply reaches approximately 3 V. Upon crossing this threshold, the device begins a 32 ms reset cycle to calibrate the transmit and receive delay lines and lock the Phase Lock Loop to the receive line. A reference clock is required to calibrate the delay lines. MCLK provides the receiver reference. The crystal oscillator provides the transmitter reference. If the LXT305 crystal oscillator is grounded, MCLK is used as the transmitter reference clock.

The transceiver can also be reset from the Host or Hardware Mode. In Host Mode, reset is commanded by simultaneously writing RLOOP and LLOOP to the register. In Hardware Mode, reset is commanded by holding RLOOP and LLOOP High simultaneously for 200 ns. Reset is initiated on the falling edge of the reset request. In either mode, reset clears and sets all registers to 0 and then begins calibration.

RECEIVER

The signal is received from one twisted-pair line on each side of a center-grounded transformer. Positive pulses are received at RTIP and negative pulses are received at RRING. Recovered data is output at RPOS and RNEG, and the recovered clock is output at RCLK. Refer to Test Specifications for LXT305 receiver timing.

The signal received at RPOS and RNEG is processed through the peak detector and data slicers. The peak detector samples the inputs and determines the maximum value of the received signal. A percentage of the peak value is provided to the data slicers as a threshold level to ensure optimum signal-to-noise ratio. For T1 applications (determined by Equalizer Control inputs EC1 - EC3 \neq 000) the threshold is set to 70% of the peak value. This threshold is maintained above 65% for up to 15 successive zeros over the range of specified operating conditions. For E1 applications (EC inputs = 000) the threshold is set to 50%.

The receiver is capable of accurately recovering signals with up to -13.6 dB of attenuation (from 2.4 V), corresponding to a received signal level of approximately 500 mV. Maximum cable length is 1500 feet of ABAM cable (approximately 6 dB). Regardless of received signal level, the peak detectors are held above a minimum level of .3 V to provide immunity from impulsive noise.

After processing through the data slicers, the received signal is routed to the data and clock recovery sections, and to the receive monitor. The receive monitor generates a Loss of Signal (LOS) output upon receipt of 175 consecutive zeros (spaces). The receiver monitor loads a digital counter at the RCLK frequency. The count is incremented each time a zero is received, and reset to zero each time a one (mark) is received. Upon receipt of 175 consecutive zeros the LOS pin goes High, and the RCLK output is replaced with the MCLK. The LOS output is reset when a mark is received.

TRANSMITTER

Data received for transmission onto the line is clocked serially into the device at TPOS and TNEG. Input synchronization is supplied by the transmit clock (TCLK). If TCLK is not supplied, the transmitter remains powered down (except during remote loopback). The transmitted pulse shape is determined by Equalizer Control signals EC1 through EC3 as shown in Table 2. Refer to Test Specifications for master and transmit clock timing characteristics. Shaped pulses are applied to the AMI line driver for transmission onto the line at TTIP and TRING. Equalizer Control signals may be hardwired in the Hardware Mode, or input as part of the serial data stream (SDI) in the Host Mode.

Pulses can be shaped for either 1.544 or 2.048 Mbps applications. 1.544 Mbps pulses for DSX-1 applications can be programmed to match line lengths from 0 to 655 feet of ABAM cable. The LXT305 also matches FCC and ECSCA specifications for CSU applications. 2.048 Mbps pulses can drive either coaxial or shielded twisted-pair lines using appropriate resistors in line with the output transformer.

Jitter Attenuation

Jitter attenuation of the LXT305 transmit outputs is provided by a Jitter Attenuation Loop (JAL) and an Elastic Store (ES). An external crystal oscillating at 4 times the bit rate provides clock stabilization. Refer to Application Information for crystal specifications. The ES is a 32 x 2-bit register. Transmit data is clocked into the ES with the transmit clock (TCLK) signal, and clocked out of the ES with the dejittered clock from the JAL. When the bit count in the ES is within two bits of overflowing or underflowing, the ES adjusts the output clock by 1/8 of a bit period. The ES produces an average delay of 16 bits in the transmit path.

Table 2: Equalizer Control Inputs

EC3	EC2	EC1	Line Length ¹	Cable Loss ²	Application	Bit Rate
0	1	1	0 ~ 133 ft ABAM	0.6 dB	DSX-1	1.544 Mbps
1	0	0	133 ~ 266 ft ABAM	1.2 dB		
1	0	1	266 ~ 399 ft ABAM	1.8 dB		
1	1	0	399 ~ 533 ft ABAM	2.4 dB		
1	1	1	533 ~ 655 ft ABAM	3.0 dB		
0	0	0	ITU Recommendation G.703		E1	2.048 Mbps
0	1	0	FCC Part 68, Option A		CSU	1.544 Mbps

1. Line length from transceiver to DSX-1 cross-connect point.

2. Maximum cable loss at 772 kHz.

Driver Performance Monitor

The transceiver incorporates a Driver Performance Monitor (DPM) connected in parallel with TTIP and TRING at the output transformer. The DPM output level goes High upon detection of 63 consecutive zeros. It is reset when a one is detected on the transmit line, or when a reset command is received.

Line Code

The LXT305 transmits data as a 50% AMI line code as shown in Figure 2. Power consumption is reduced by activating the AMI line driver only to transmit a mark. The output driver is disabled during transmission of a space.

Figure 2: 50% AMI Coding Diagram

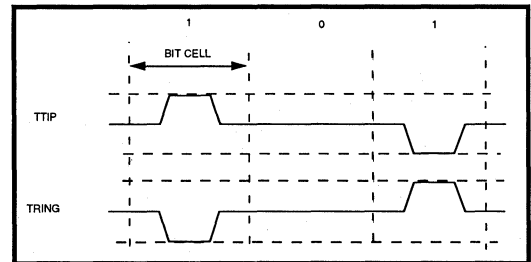

OPERATING MODES

The LXT305 transceiver can be controlled by a microprocessor through the serial interface (Host Mode), or through hard-wired pins (Hardware Mode). The mode of operation is set by the MODE pin logic level. The transceivers can also be commanded to operate in one of several diagnostic modes.

Host Mode Operation

To allow a host microprocessor to access and control the LXT305 through the serial interface, MODE is set High. The serial interface (SDI/SDO) uses a 16-bit word consisting of an 8-bit Command/Address byte and an 8-bit Data byte.

The Host Mode provides a latched Interrupt output ($\overline{\text{INT}}$) which is triggered by a change in the Loss of Signal (LOS) and/or Driver Performance Monitor (DPM) bits. The Interrupt is cleared when the interrupt condition no longer exists, and the host processor enables the respective bit in the serial input data byte. Host Mode also allows control of the serial data and receive data output timing. The Clock Edge (CLKE) signal determines when these outputs are valid, relative to the Serial Clock (SCLK) or RCLK as follows:

Table 3: Clock Edge (CLKE)

CLKE	Output	Clock	Valid Edge
LOW	RPOS	RCLK	Rising
	RNEG	RCLK	Rising
	SDO	SCLK	Falling
HIGH	RPOS	RCLK	Falling
	RNEG	RCLK	Falling
	SDO	SCLK	Rising

The LXT305 serial port is addressed by setting bit A4 in the Address/Command byte, corresponding to address 16. The LXT305 contains only a single output data register so no complex chip addressing scheme is required. The register is accessed by causing the Chip Select ($\overline{\text{CS}}$) input to transition from High to Low. Bit 1 of the serial Address/Command byte provides Read/Write control when the chip is accessed. A logic 1 indicates a read operation, and a logic 0 indicates a write operation. Table 4 lists serial data output bit combinations for each status. Serial data structure is shown in Figure 3. Refer to Test Specifications for I/O timing characteristics.

Hardware Mode Operation

In Hardware Mode the transceiver is accessed and controlled through individual pins. With the exception of the $\overline{\text{INT}}$ and CLKE functions, Hardware Mode provides all the functions provided in the Host Mode. In the Hardware Mode RPOS and RNEG outputs are valid on the rising edge of RCLK.

To operate in Hardware Mode, MODE must be set Low. Equalizer Control signals (EC1 through EC3) are input on the Interrupt, Serial Data In and Serial Data Out pins. Diagnostic control for Remote Loopback (RLOOP), Local Loopback (LLOOP), and Transmit All Ones (TAOS) modes is provided through the individual pins used to control serial interface timing in the Host Mode.

Diagnostic Mode Operation

TRANSMIT ALL ONES

In Transmit All Ones (TAOS) Mode the TPOS and TNEG inputs to the transceiver are ignored. The transceiver transmits a continuous stream of ones at the TCLK frequency when TAOS is activated. TAOS can be commanded simultaneously with Local Loopback, but is inhibited during Remote Loopback. During TAOS, the transmitter is locked to MCLK.

REMOTE LOOPBACK

In Remote Loopback (RLOOP) Mode, the transmit data and clock inputs (TPOS, TNEG and TCLK) are ignored. The RPOS and RNEG outputs are looped back through the transmit circuits and output on TTIP and TRING at the RCLK frequency. Receiver circuits are unaffected by the RLOOP command and continue to output the RPOS, RNEG and RCLK signals received from the twisted-pair line.

LOCAL LOOPBACK

In Local Loopback (LLOOP) Mode, the receiver circuits are inhibited. The transmit data and clock inputs (TPOS, TNEG and TCLK) are looped back onto the receive data and clock outputs (RPOS, RNEG and RCLK). The transmitter circuits are unaffected by the LLOOP command. The TPOS and TNEG inputs will be transmitted normally. (A stream of ones will be transmitted if the TAOS command is active.)

LXT305 Integrated T1/E1 Short-Haul Transceiver with Transmit Jitter Attenuation

Table 4: LXT305 Serial Data Output Bits (See Figure 3)

Bit D5	Bit D6	Bit D7	Status
0	0	0	Reset has occurred, or no program input
0	0	1	TAOS active
0	1	0	Local Loopback active
0	1	1	TAOS and Local Loopback active
1	0	0	Remote Loopback active
1	0	1	DPM has changed state since last Clear DPM occurred
1	1	0	LOS has changed state since last Clear LOS occurred
1	1	1	LOS and DPM have both changed state since last Clear DPM and Clear LOS occurred

Figure 3: LXT305 Serial Interface Data Structure

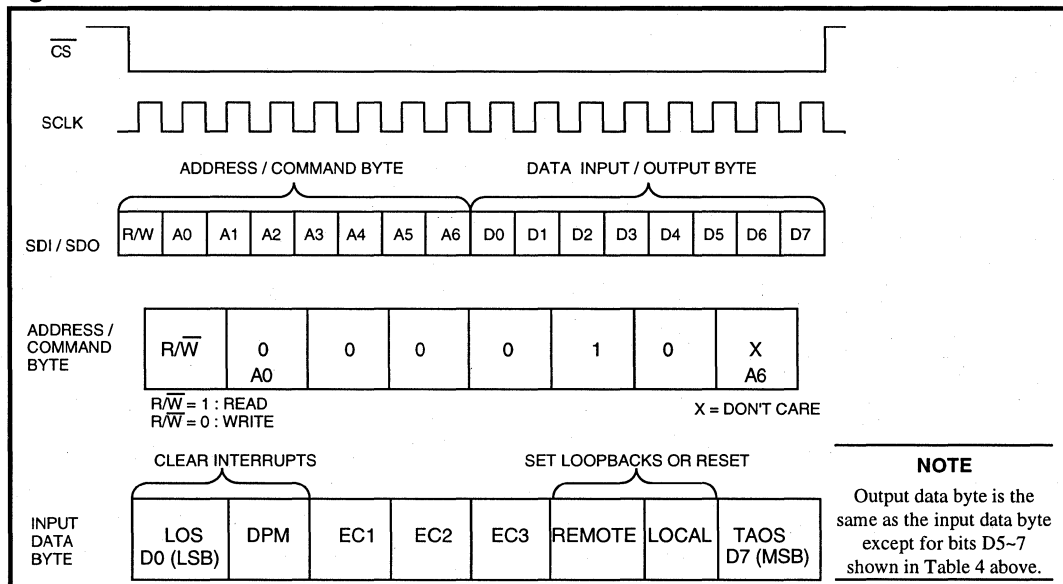

Table 5: LXT305 Crystal Specifications (External)

Parameter	T1	E1
Frequency	6.176 MHz	8.192 MHz
Frequency Stability	± 20 ppm @ 25 °C ± 25 ppm from -40 °C to 85 °C (Ref 25 °C reading)	±20 ppm @ 25 °C ± 25 ppm from -40 °C to 85 °C (Ref 25 °C reading)
Pullability	CL = 11 pF to 18.7 pF, +ΔF = 175 to 195 ppm CL = 18.7 pF to 34 pF, -ΔF = 175 to 195 ppm	CL = 11 pF to 18.7 pF, +ΔF = 95 to 115 ppm CL = 18.7 pF to 34 pF, -ΔF = 95 to 115 ppm
Effective series resistance	40 Ω Maximum	30 Ω Maximum
Crystal cut	AT	AT
Resonance	Parallel	Parallel
Maximum drive level	2.0 mW	2.0 mW
Mode of operation	Fundamental	Fundamental
Crystal holder	HC49 (R3W), Co = 7 pF maximum CM = 17 fF typical	HC49 (R3W), Co = 7 pF maximum CM = 17 fF typical

APPLICATION INFORMATION

NOTE

This information is for design aid only.

1.544 MBPS DSX-1 INTERFACE APPLICATIONS

Figure 4 is a typical 1.544 Mbps DSX-1 application. The LXT305 is shown in the Host Mode with a typical T1/ESF framer providing the digital interface with the host controller. Both devices are controlled through the serial interface. An LXP600A Clock Adapter (CLAD) provides the 2.048 MHz system backplane clock, locked to the recovered 1.544 MHz clock signal. The power supply inputs are tied to a common bus with appropriate decoupling capacitors installed (68 μ F on the transmit side, 1.0 μ F and 0.1 μ F on the receive side).

2

Figure 4: Typical LXT305 1.544 Mbps T1 Application (Host Mode)

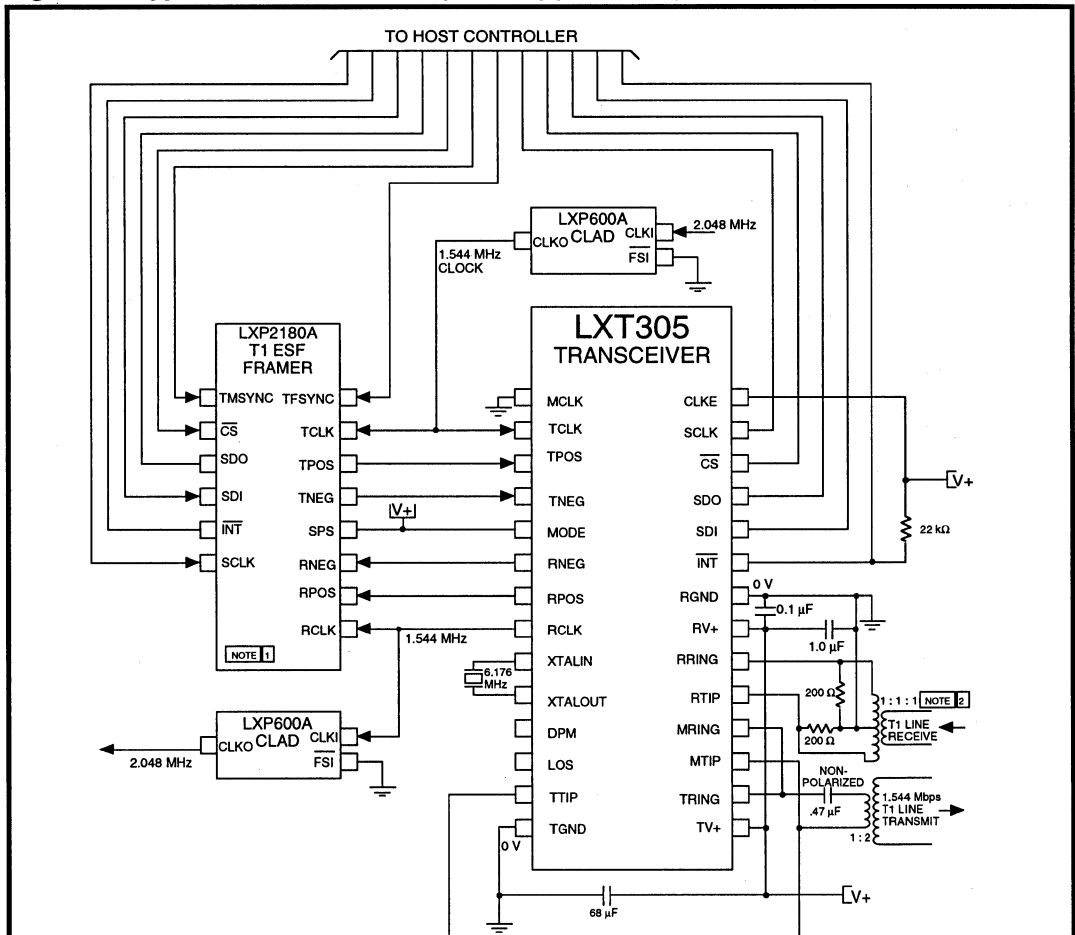

NOTE 1 IN ADDITION TO THE LXP2180A, THE LXT305 IS COMPATIBLE WITH A WIDE VARIETY OF DIGITAL FRAMING AND SIGNALING DEVICES, INCLUDING THE LXP2181A, DS2180A, MT8976, AND R8070.

NOTE 2 WHEN LXT305 IS CONNECTED TO THE CROSS-CONNECT FRAME THROUGH A LOW LEVEL MONITOR JACK, RECEIVE TRANSFORMER SHOULD BE 1 : 2 : 2 TO BOOST THE INPUT SIGNAL.

LXT305 Integrated T1/E1 Short-Haul Transceiver with Transmit Jitter Attenuation

2.048 MBPS E1 INTERFACE APPLICATIONS

Figure 5 is a typical 2.048 Mbps E1 application. The LXT305 is shown in Hardware Mode with a typical E1/CRC4 framer. Resistors are installed in line with the transmit transformer for loading a 75 Ω coaxial cable. The in-line resistors are not

required for transmission on 120 Ω shielded twisted-pair lines. As in the DSX-1 application Figure 4, this configuration is illustrated with a crystal in place to enable the Jitter Attenuation Loop, and a single power supply bus. The hard-wired control lines for TAOS, LLOOP and RLOOP are individually controllable, and the LLOOP and RLOOP lines are also tied to a single control for the Reset function.

Figure 5: Typical LXT305 75 Ω E1 Application (Hardware Mode)

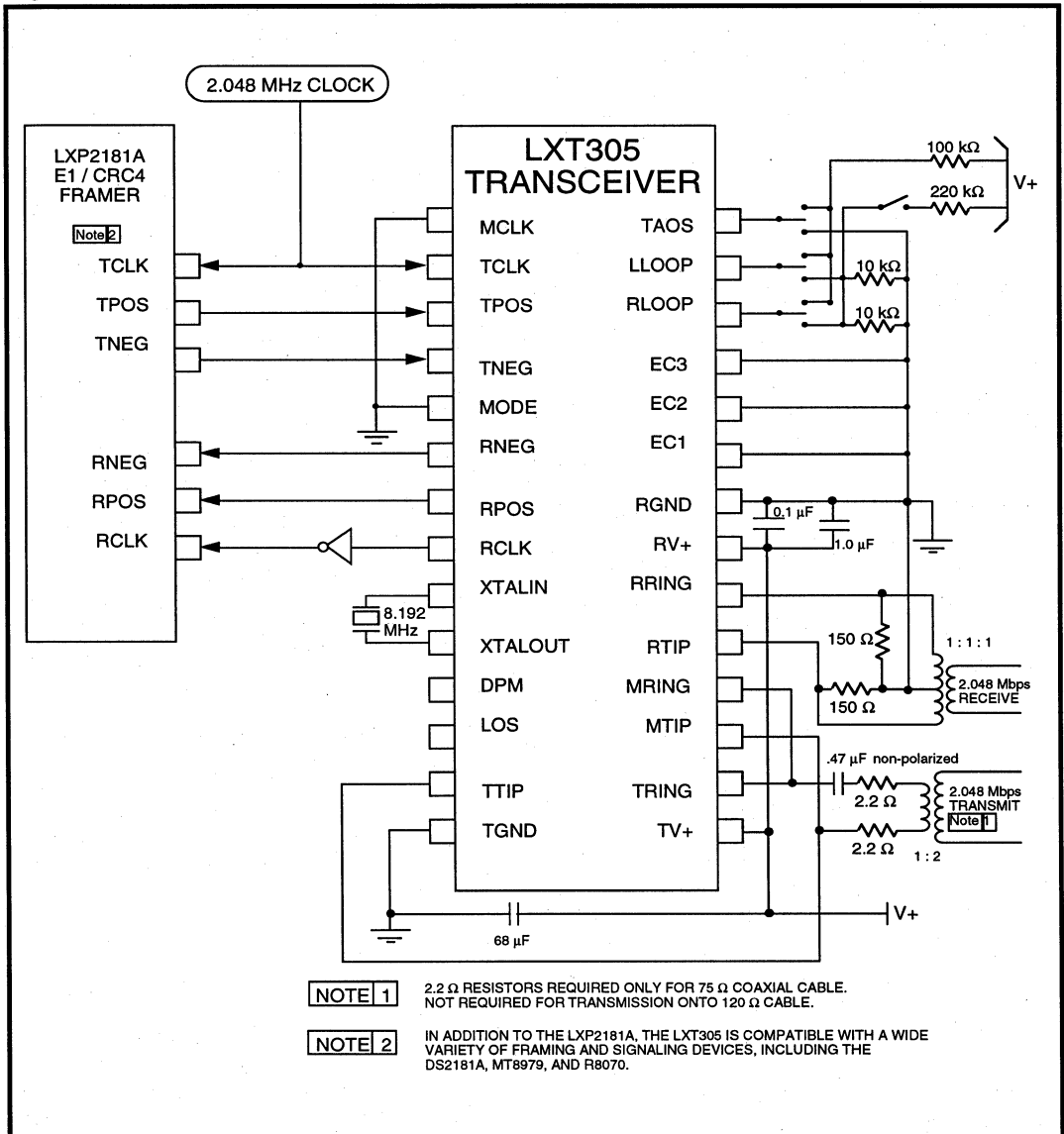

TEST SPECIFICATIONS

NOTE

Minimum and maximum values in Tables 6 through 12 and Figures 6 through 9 represent the performance specifications of the LXT305 and are guaranteed by test except, as noted, by design.

2

Table 6: Absolute Maximum Ratings

Parameter	Sym	Min	Max	Units
DC supply (referenced to GND)	RV+, TV+	-0.3	6.0	V
Input voltage, any pin ¹	V _{IN}	RGND - 0.3	RV+ + 0.3	V
Input current, any pin ²	I _{IN}	-10	10	mA
Storage temperature	T _{STG}	-65	150	°C

CAUTION
Operations at or beyond these limits may result in permanent damage to the device.
Normal operation not guaranteed at these extremes.

1. Excluding RTIP and RRING, which must stay between -6 V and (RV+ + 0.3) V.
2. Transient currents of up to 100 mA will not cause SCR latch-up. TTIP, TRING, TV+ and TGND can withstand a continuous current of 100 mA.

Table 7: Recommended Operating Conditions

Parameter	Sym	Min	Typ	Max	Units	Test Conditions
DC supply ¹	RV+, TV+	4.75	5.0	5.25	V	
Ambient operating temperature	T _A	-40	25	85	°C	

1. TV+ must not exceed RV+ by more than 0.3 V.

Table 8: Digital Characteristics (Under Recommended Operating Conditions)

Parameter	Sym	Min	Typ ¹	Max	Units	Test Conditions
High level input voltage ^{2,3} (pins 1-5, 10, 23-28)	V _{IH}	2.0	-	-	V	
Low level input voltage ^{2,3} (pins 1-5, 10, 23-28)	V _{IL}	-	-	0.8	V	
High level output voltage ^{2,3} (pins 6-8, 11, 12, 23, 25)	V _{OH}	2.4	-	-	V	I _{OUT} = -400 μA
Low level output voltage ^{2,3} (pins 6-8, 11, 12, 23, 25)	V _{OL}	-	-	0.4	V	I _{OUT} = 1.6 mA
Input leakage current	I _{LL}	-10	-	+10	μA	
Three-state leakage current ² (pin 25)	I _{3L}	-10	-	+10	μA	
Total power dissipation ⁴	P _D	-	620	-	mW	100% ones density & maximum line length @ 5.25 V

1. Typical values are at 25 °C and are for design aid only; not guaranteed and not subject to production testing.
2. Functionality of pins 23 and 25 depends on mode. See Host / Hardware Mode descriptions.
3. Output drivers will output CMOS logic levels into CMOS loads.
4. Power dissipation while driving 25 Ω load over operating temperature range. Includes device and load. Digital input levels are within 10% of the supply rails and digital outputs are driving a 50 pF capacitive load.

Table 9: Analog Characteristics (Under Recommended Operating Conditions)

Parameter		Min	Typ ¹	Max	Units	Test Conditions
AMI Output Pulse Amplitudes	T1	2.4	3.0	3.6	V	measured at the DSX
	E1	2.7	3.0	3.3	V	measured at line side
Recommended Output Load at TTIP and TRING		–	25	–	Ω	
Jitter added by the transmitter ²	10 Hz - 8 kHz	–	–	0.01	UI	
	8 kHz - 40 kHz	–	–	0.025	UI	
	10 Hz - 40 kHz	–	–	0.025	UI	
	Broad Band	–	–	0.05	UI	
Sensitivity below DSX (0 dB = 2.4 V)		13.6	–	–	dB	
		500	–	–	mV	
Loss of Signal threshold		–	0.3	–	V	
Data decision threshold	T1	63	70	77	%peak	
	E1	43	50	57	% peak	
Allowable consecutive zeros before LOS		160	175	190	–	
Input jitter tolerance 10 kHz - 100 kHz		0.4	–	–	UI	
Jitter attenuation curve corner frequency ³		–	3	–	Hz	

1. Typical values are at 25 °C and are for design aid only; not guaranteed and not subject to production testing.
2. Input signal to TCLK is jitter-free.
3. Circuit attenuates jitter at 20 dB/decade above the corner frequency.

Table 10: LXT305 Receive Timing Characteristics (See Figure 6)

Parameter		Sym	Min	Typ ¹	Max	Units	Test Conditions
Receive clock duty cycle ²	T1	RCLKd	40	50	60	%	
	E1	RCLKd	40	50	60	%	
Receive clock pulse width ²	T1	tpw	594	648	702	ns	
	E1	tpw	447	488	529	ns	
Receive clock pulse width High	T1	tpWH	–	324	–	ns	
	E1	tpWH	–	244	–	ns	
Receive clock pulse width Low	T1	tpWL	270	324	378	ns	
	E1	tpWL	203	244	285	ns	
RPOS / RNEG to RCLK rising setup time	T1	tsUR	50	270	–	ns	
	E1	tsUR	50	203	–	ns	
RCLK rising to RPOS/ RNEG hold time	T1	tHR	50	270	–	ns	
	E1	tHR	50	203	–	ns	

1. Typical values are at 25 °C and are for design aid only; not guaranteed and not subject to production testing.
2. RCLK duty cycle widths will vary depending on extent of received pulse jitter displacement. Max and Min RCLK duty cycles are for worst case jitter conditions (0.4 UI clock displacement for 1.544 MHz, 0.2 UI clock displacement for 2.048 MHz).

Figure 6: LXT305 Receive Clock Timing Diagram

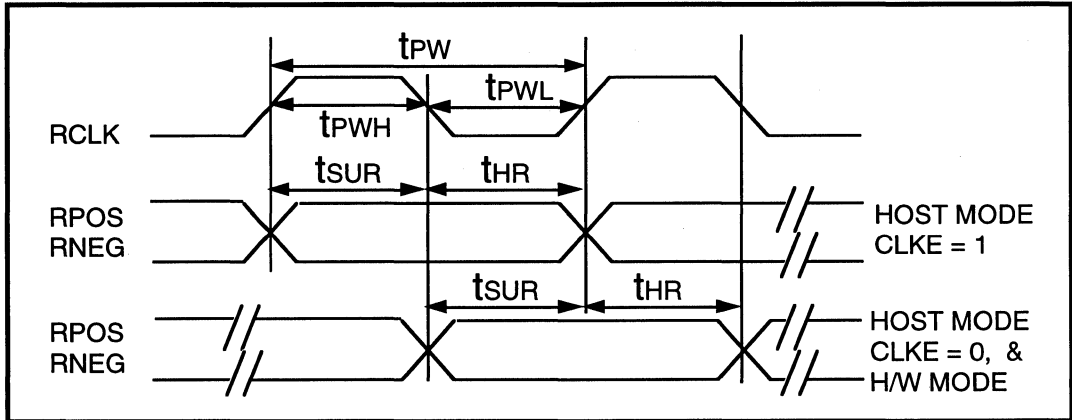

2

Table 11: LXT305 Master Clock and Transmit Timing Characteristics (See Figure 7)

Parameter		Sym	Min	Typ ¹	Max	Units	Test Conditions
Master clock frequency	T1	MCLK	-	1.544	-	MHz	
	E1	MCLK	-	2.048	-	MHz	
Master clock tolerance		MCLKt	-	±100	-	ppm	
Master clock duty cycle		MCLKd	40	-	60	%	
Crystal frequency	T1	fc	-	6.176	-	MHz	
	E1	fc	-	8.192	-	MHz	
Transmit clock frequency	T1	TCLK	-	1.544	-	MHz	
	E1	TCLK	-	2.048	-	MHz	
Transmit clock tolerance		TCLKt	-	-	±50	ppm	
Transmit clock duty cycle		TCLKd	10	-	90	%	
TPOS/TNEG to TCLK setup time		t _{SUT}	25	-	-	ns	
TCLK to TPOS/TNEG Hold time		t _{HT}	25	-	-	ns	

1. Typical figures are at 25 °C and are for design aid only; not guaranteed and not subject to production testing.

Figure 7: LXT305 Transmit Clock Timing Diagram

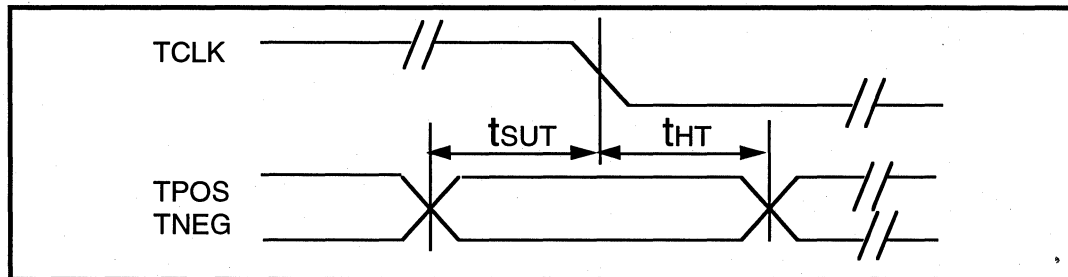

Table 12: LXT305 Serial I/O Timing Characteristics (See Figures 8 and 9)

Parameter	Sym	Min	Typ ¹	Max	Units	Test Conditions
Rise/Fall time - any digital output	t_{rF}	-	-	100	ns	Load 1.6 mA, 50 pF
SDI to SCLK setup time	t_{dC}	50	-	-	ns	
SCLK to SDI hold time	t_{dH}	50	-	-	ns	
SCLK low time	t_{cL}	240	-	-	ns	
SCLK high time	t_{cH}	240	-	-	ns	
SCLK rise and fall time	t_r, t_f	-	-	50	ns	
\overline{CS} to SCLK setup time	t_{cC}	50	-	-	ns	
SCLK to \overline{CS} hold time	t_{cCH}	50	-	-	ns	
\overline{CS} inactive time	t_{cWH}	250	-	-	ns	
SCLK to SDO valid	t_{cDv}	-	-	200	ns	
SCLK falling edge or \overline{CS} rising edge to SDO high Z	t_{cDz}	-	100	-	ns	

1. Typical values are at 25 °C and are for design aid only; not guaranteed and not subject to production testing.

Figure 8: LXT305 Serial Data Input Timing Diagram

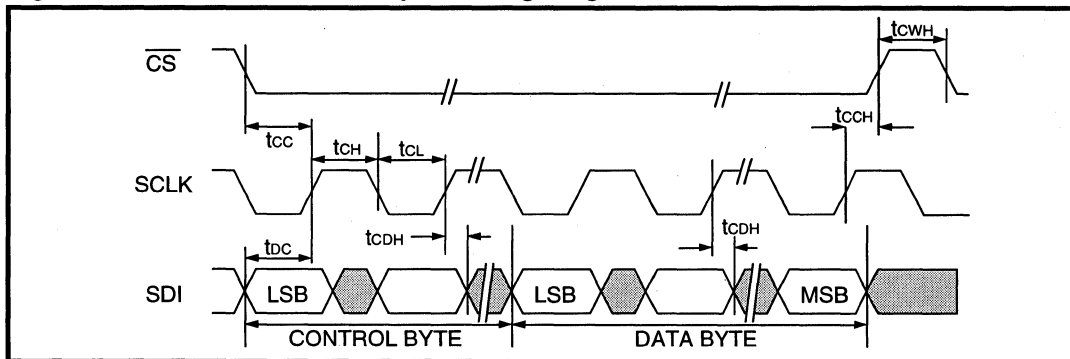
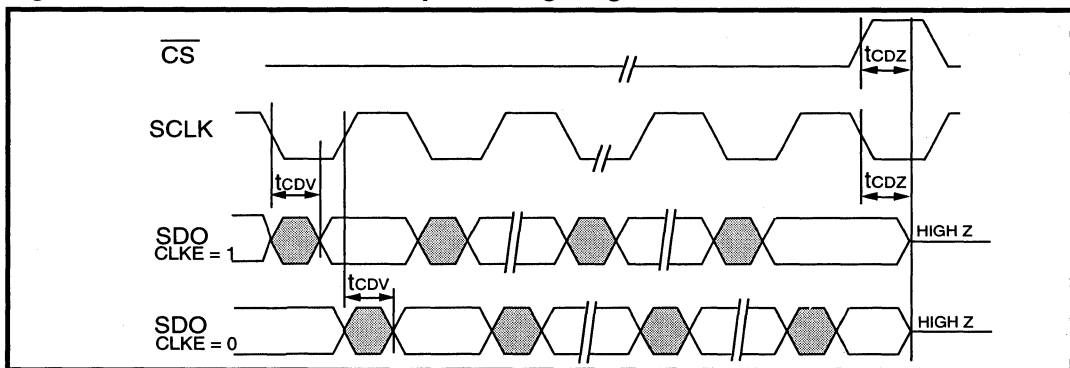

Figure 9: LXT305 Serial Data Output Timing Diagram



NOTES:

LXT305A

Low-Power T1/E1 Short-Haul Transceiver with Transmit JA

General Description

The LXT305A is a fully integrated transceiver for both North American 1.544 Mbps (T1) and International 2.048 Mbps (E1) applications. Transmit pulse shapes (T1 or E1) are selectable for various line lengths and cable types.

The LXT305A provides transmit jitter attenuation starting at 3 Hz, and is microprocessor controllable through a serial interface. It is especially well suited for applications in which the T1/E1 signals are demultiplexed from a higher rate service such as DS3 or SONET/SDH. This demultiplexing results in a "gapped" clock which the 305A smooths out.

The LXT305A, an advanced double-poly, double-metal CMOS device, requires only a single 5-volt power supply.

Applications

- SDH / SONET Equipment
- M13 Multiplexers
- Digital microwave Radio
- PCM / Voice Channel Banks
- Data Channel Bank / Concentrator
- T1 / E1 multiplexer
- Digital Access and Cross-connect Systems (DACs)
- Computer to PBX interface (CPI & DMI)
- High-speed data transmission lines
- Interfacing Customer Premises Equipment to a CSU
- Digital Loop Carrier (DLC) terminals

Features

- Low power consumption (400 mW maximum) 40% less than the LXT305
- Constant low output impedance transmitter, regardless of data pattern (3 Ω typical)
- High transmit and receive return loss exceeds ETS 300166 and G.703
- Compatible with most popular PCM framers
- Line driver, data recovery and clock recovery functions
- Minimum receive signal of 500 mV
- Selectable slicer levels (T1/E1) improve SNR
- Programmable transmit equalizer shapes pulses to meet DSX-1 pulse template from 0 to 655 ft
- Local and remote loopback functions
- Transmit Driver Performance Monitor (DPM) output
- Receive monitor with analog/digital Loss of Signal (LOS) output per G.775
- Receiver jitter tolerance 0.4 UI from 40 kHz to 100 kHz
- Transmit jitter attenuation starting at 3 Hz
- Serial control interface
- Available in 28-pin DIP and PLCC

2

LXT305A Block Diagram

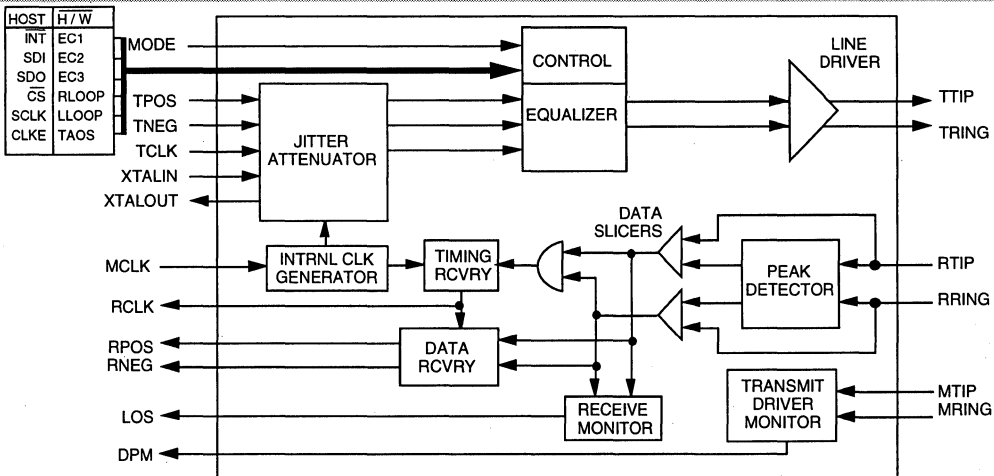

LXT305A Low-Power T1/E1 Short-Haul Transceiver with Transmit JA

Figure 1: Pin Assignments

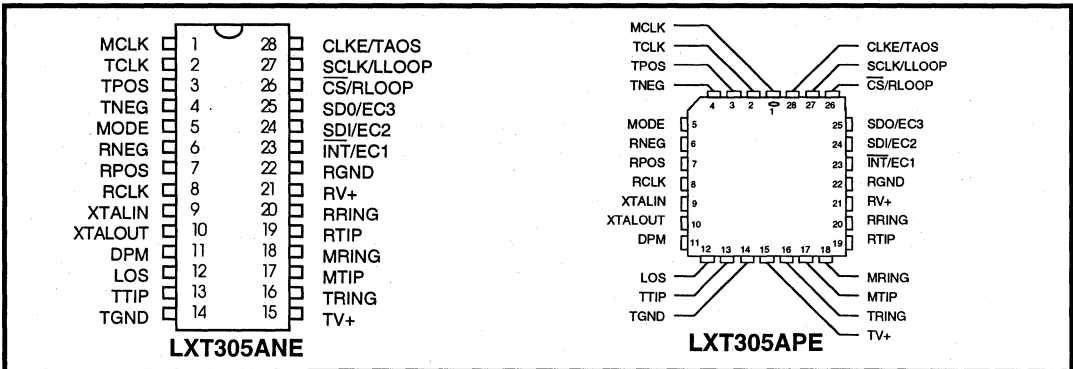

Table 1: Pin Descriptions

Pin #	Sym	I/O ¹	Name	Description
1	MCLK	DI	Master Clock	A 1.544 or 2.048 MHz clock input used to generate internal clocks. Upon Loss of Signal (LOS), RCLK is derived from MCLK. If MCLK is not applied, this pin should be grounded.
2	TCLK	DI	Transmit Clock	Transmit clock input. TPOS and TNEG are sampled on the falling edge of TCLK.
3	TPOS	DI	Transmit Positive Data	Input for positive pulse to be transmitted on the twisted-pair line.
4	TNEG	DI	Transmit Negative Data	Input for negative pulse to be transmitted on the twisted-pair line.
5	MODE	DI	Mode Select	Setting MODE High puts the LXT305A in the Host Mode. In the Host Mode, the serial interface is used to control the LXT305A and determine its status. Setting MODE Low puts the LXT305A in the Hardware (H/W) Mode. In the Hardware Mode, the serial interface is disabled and hard-wired pins are used to control configuration and report status.
6	RNEG	DO	Receive Negative Data	Received data outputs. A signal on RNEG corresponds to receipt of a negative pulse on RTIP and RRING. A signal on RPOS corresponds to receipt of a positive pulse on RTIP and RRING. RNEG and RPOS outputs are Non-Return-to-Zero (NRZ). Both outputs are stable and valid on the rising edge of RCLK. In the Host Mode, CLKE determines the clock edge at which these outputs are stable and valid. In the Hardware Mode both outputs are stable and valid on the rising edge of RCLK.
7	RPOS	DO	Receive Positive Data	
8	RCLK	DO	Recovered Clock	This is the clock recovered from the signal received at RTIP and RRING.

1. Entries in I/O column are: DI = Digital Input; DO = Digital Output; AI = Analog Input; AO = Analog Output; S = Supply.

Table 1: Pin Descriptions - continued

2

Pin #	Sym	I/O'	Name	Description
9	XTALIN	AI	Crystal Input	An external crystal operating at four times the bit rate (6.176 MHz for DSX-1, 8.192 MHz for E1 applications with an 18.7pF load) is required to enable the jitter attenuation function of the LXT305A. These pins may also be used to disable the jitter attenuator by connecting the XTALIN pin to the positive supply through a resistor, and tying the XTALOUT pin to ground.
10	XTALOUT	AO	Crystal Output	
11	DPM	DO	Driver Performance Monitor	DPM goes High when the transmit monitor loop (MTIP and MRING) does not detect a signal for 63 ± 2 clock periods. DPM remains High until a signal is detected.
12	LOS	DO	Loss Of Signal	LOS goes High when 175 consecutive spaces have been detected. LOS returns Low when the received signal reaches 12.5% ones density (based on 4 ones in any 32-bit period) with no more than 15 consecutive zeros.
13	TTIP	AO	Transmit Tip	Differential Driver Outputs. These low impedance outputs achieve maximum power savings through a 1:1.15 transformer (T1), or a 1:1 (75 Ω) or 1:1.26 (120 Ω) transformer (E1) without additional components. To provide higher return loss, resistors may be used in series with a transformer as specified in Application Information.
16	TRING	AO	Transmit Ring	
14	TGND	S	Transmit Ground	Ground return for the transmit drivers power supply TV+.
15	TV+	S	Transmit Power Supply	+5 VDC power supply input for the transmit drivers. TV+ must not vary from RV+ by more than ± 0.3 V.
17	MTIP	AI	Monitor Tip	These pins are used to monitor the tip and ring transmit outputs. The transceiver can be connected to monitor its own output or the output of another LXT305A on the board. <i>Host Mode only:</i> To prevent false interrupts in the Host Mode if the monitor is not used, apply a clock signal to one of the monitor pins and tie the other monitor pin to approximately the clock's mid-level voltage. The monitor clock can range from 100 kHz to the TCLK frequency.
18	MRING	AI	Monitor Ring	
19	RTIP	AI	Receive Tip	The AMI signal received from the line is applied at these pins. A center-tapped, center-grounded, 2:1 step-up transformer is required on these pins. Data and clock from the signal applied at these pins are recovered and output on the RPOS/RNEG and RCLK pins.
20	RRING	AI	Receive Ring	
21	RV+	S	Receive Power Supply	+5 VDC power supply for all circuits except the transmit drivers. (Transmit drivers are supplied by TV+.)
22	RGND	S	Receive Ground	Ground return for power supply RV+.

1. Entries in I/O column are: DI = Digital Input; DO = Digital Output; AI = Analog Input; AO = Analog Output; S = Supply.

LXT305A Low-Power T1/E1 Short-Haul Transceiver with Transmit JA

Table 1: Pin Descriptions - continued

Pin #	Sym	I/O ¹	Name	Description
23	$\overline{\text{INT}}$	DO	Interrupt (Host Mode)	This LXT305A Host Mode output goes Low to flag the host processor when LOS or DPM go active. $\overline{\text{INT}}$ is an open-drain output and should be tied to power supply RV+ through a resistor. $\overline{\text{INT}}$ is reset by clearing the respective register bit (LOS and/or DPM).
	EC1	DI	Equalizer Control 1 (H/W Mode)	The signal applied at this pin in the LXT305A Hardware Mode is used in conjunction with EC2 and EC3 inputs to determine shape and amplitude of AMI output transmit pulses.
24	SDI	DI	Serial Data In (Host Mode)	The serial data input stream is applied to this pin when the LXT305A operates in the Host Mode. SDI is sampled on the rising edge of SCLK.
	EC2	DI	Equalizer Control 2 (H/W Mode)	The signal applied at this pin in the LXT305A Hardware Mode is used in conjunction with EC1 and EC3 inputs to determine shape and amplitude of AMI output transmit pulses.
25	SDO	DO	Serial Data Out (Host Mode)	The serial data from the on-chip register is output on this pin in the LXT305A Host Mode. If CLKE is High, SDO is valid on the rising edge of SCLK. If CLKE is Low SDO is valid on the falling edge of SCLK. This pin goes to a high-impedance state when the serial port is being written to and when $\overline{\text{CS}}$ is High.
	EC3	DI	Equalizer Control 3 (H/W Mode)	The signal applied at this pin in the LXT305A Hardware Mode is used in conjunction with EC1 and EC2 inputs to determine shape and amplitude of AMI output transmit pulses.
26	$\overline{\text{CS}}$	DI	Chip Select (Host Mode)	This input is used to access the serial interface in the LXT305A Host Mode. For each read or write operation, $\overline{\text{CS}}$ must transition from High to Low, and remain Low.
	RLOOP	DI	Remote Loopback (H/W Mode)	This input controls loopback functions in the LXT305A Hardware Mode. Setting RLOOP High enables the Remote Loopback Mode. Setting both RLOOP and LLOOP High causes a Reset .
27	SCLK	DI	Serial Clock (Host Mode)	This clock is used in the LXT305A Host Mode to write data to or read data from the serial interface registers.
	LLOOP	DI	Local Loopback (H/W Mode)	This input controls loopback functions in the LXT305A Hardware Mode. Setting LLOOP High enables the Local Loopback Mode.
28	CLKE	DI	Clock Edge (Host Mode)	Setting CLKE High causes RPOS and RNEG to be valid on the falling edge of RCLK, and SDO to be valid on the rising edge of SCLK. When CLKE is Low, RPOS and RNEG are valid on the rising edge of RCLK, and SDO is valid on the falling edge of SCLK.
	TAOS	DI	Transmit All Ones (H/W Mode)	When set High, TAOS causes the LXT305A (Hardware Mode) to transmit a continuous stream of marks at the MCLK frequency. Activating TAOS causes TPOS and TNEG inputs to be ignored. TAOS is inhibited during Remote Loopback.

1. Entries in I/O column are: DI = Digital Input; DO = Digital Output; AI = Analog Input; AO = Analog Output; S = Supply.

FUNCTIONAL DESCRIPTION

NOTE

This functional description is for design aid only.

The LXT305A is a fully integrated PCM transceiver for both 1.544 Mbps (DSX-1) and 2.048 Mbps (E1) applications. It allows full-duplex transmission of digital data over existing twisted-pair installations.

The first page of this data sheet shows a simplified block diagram of the LXT305A. The LXT305A transceiver interfaces with two twisted-pair lines (one twisted-pair for transmit, one twisted-pair for receive) through standard pulse transformers and appropriate resistors.

POWER REQUIREMENTS

The LXT305A is a low-power CMOS device. It operates from a single +5 V power supply which can be connected externally to both the transmitter and receiver. However, the two inputs must be within $\pm .3$ V of each other, and decoupled to their respective grounds separately. Refer to Application Information for typical decoupling circuitry. Isolation between the transmit and receive circuits is provided internally.

The transmitter powers down to conserve power when the required clock input is not supplied. The LXT305A enters the power down mode during normal operation and local loopback if *TCLK* is not supplied, and during *TAOS* if *MCLK* is not supplied.

Reset Operation

Upon power up, the transceiver is held static until the power supply reaches approximately 3 V. Upon crossing this threshold, the device begins a 32 ms reset cycle to calibrate the transmit and receive delay lines and lock the Phase Lock Loop to the receive line. A reference clock is required to calibrate the delay lines. *MCLK* provides the receiver reference. The crystal oscillator provides the transmitter reference. If the crystal oscillator is grounded, *MCLK* is used as the transmitter reference clock.

The transceiver can also be reset from the Host or Hardware Mode. In Host Mode, reset is commanded by simultaneously writing *RLOOP* and *LLOOP* to the register. In Hardware Mode, reset is commanded by holding *RLOOP* and *LLOOP* High simultaneously for 200 ns. Reset is initiated on the falling edge of the reset request. In either mode, reset clears and sets all registers to 0 and then begins calibration.

RECEIVER

The LXT305A receives the signal input from one twisted-pair line on each side of a center-grounded transformer. Positive pulses are received at *RTIP* and negative pulses are received at *RRING*. Recovered data is output at *RPOS* and *RNEG*, and the recovered clock is output at *RCLK*. Refer to Test Specifications for LXT305A receiver timing.

The signal received at *RPOS* and *RNEG* is processed through the peak detector and data slicers. The peak detector samples the inputs and determines the maximum value of the received signal. A percentage of the peak value is provided to the data slicers as a threshold level to ensure optimum signal-to-noise ratio. For T1 applications (determined by Equalizer Control inputs *EC1* - *EC3* \neq 000 or 001) the threshold is set to 70% of the peak value. This threshold is maintained above 65% for up to 15 successive zeros over the range of specified operating conditions. For E1 applications (*EC* inputs = 000 or 001) the threshold is 50%.

The receiver is capable of accurately recovering signals with up to -13.6 dB of attenuation (from 2.4 V), corresponding to a received signal level of approximately 500 mV. Maximum line length is 1500 feet of ABAM cable (approximately 6 dB of attenuation). Regardless of received signal level, the peak detectors are held above a minimum level of .3 V to provide immunity from impulsive noise.

After processing through the data slicers, the received signal is routed to the data and clock recovery sections, and to the receive monitor. The data and clock recovery circuits are highly tolerant with an input jitter tolerance significantly better than required by Pub 62411. Refer to Test Specifications for additional information.

The receiver monitor loads a digital counter at the *RCLK* frequency. The count is incremented each time a zero is received, and reset to zero each time a one (mark) is received. Upon receipt of 175 consecutive zeros the *LOS* pin goes High, and a smooth transition replaces the *RCLK* output with the *MCLK*. Received marks are output regardless of the *LOS* status, but the *LOS* pin will not reset until the ones density reaches 12.5%. This level is based on receipt of at least 4 ones in any 32-bit period with no more than 15 consecutive zeros.

TRANSMITTER

Data received for transmission onto the line is clocked serially into the device at TPOS and TNEG. Input synchronization is supplied by the transmit clock (TCLK). The transmitted pulse shape is determined by Equalizer Control signals EC1 through EC3 as shown in Table 2. Refer to Test Specifications for master and transmit clock timing characteristics. Shaped pulses are applied to the AMI line driver for transmission onto the line at TTIP and TRING. Equalizer Control signals may be hardwired in the Hardware Mode, or input as part of the serial data stream (SDI) in the Host Mode.

Pulses can be shaped for either 1.544 or 2.048 Mbps applications. 1.544 Mbps pulses for DSX-1 applications can be programmed to match line lengths from 0 to 655 feet of ABAM cable. The LXT305A also matches FCC and ECSA specifications for CSU applications. 2.048 Mbps pulses can drive coaxial or shielded twisted-pair lines.

Jitter Attenuation

Jitter attenuation of the LXT305A transmit outputs is provided by a Jitter Attenuation Loop (JAL) and an Elastic Store (ES). An external crystal oscillating at 4 times the bit rate provides clock stabilization. Refer to Application Information for crystal specifications. The ES is a 32 x 2-bit register. Transmit data is clocked into the ES with the transmit clock (TCLK) signal, and clocked out of the ES with the dejittered clock from the JAL. When the bit count in the ES is within two bits of overflowing or underflowing, the ES adjusts the output clock by 1/8 of a bit period. The ES produces an average delay of 16 bits in the receive path.

Driver Performance Monitor

The transceiver incorporates a Driver Performance Monitor (DPM) in parallel with TTIP and TRING at the output transformer. The DPM output goes High upon detection of

63 consecutive zeros. It is reset when a one is detected on the transmit line, or when a reset command is received.

Line Code

The LXT305A transmits data as a 50% AMI line code as shown in Figure 2. The output driver maintains a constant low output impedance regardless of whether it is driving marks or spaces. This well controlled output impedance provides excellent return loss (> 18 dB) when used with external 9.1 Ω precision (± 1 % accuracy) in series with a transmit transformer with a turns ratio of 1:2.3 (± 2% accuracy). Series resistors also provide increased surge protection and reduced short circuit current flow.

OPERATING MODES

The LXT305A can be controlled through hard-wired pins (Hardware Mode) or by a microprocessor through a serial interface (Host Mode). The mode of operation is set by the MODE pin logic level. The LXT305A can also be commanded to operate in one of several diagnostic modes.

Host Mode Operation

To allow a host microprocessor to access and control the LXT305A through the serial interface, MODE is set High.

Figure 2: 50% AMI Coding Diagram

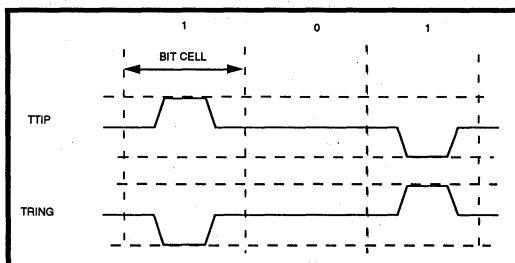

Table 2: Equalizer Control Inputs

EC3	EC2	EC1	Line Length ¹	Cable Loss ²	Application	Bit Rate
0	1	1	0 - 133 ft ABAM	0.6 dB	DSX-1	1.544 Mbps
1	0	0	133 - 266 ft ABAM	1.2 dB		
1	0	1	266 - 399 ft ABAM	1.8 dB		
1	1	0	399 - 533 ft ABAM	2.4 dB		
1	1	1	533 - 655 ft ABAM	3.0 dB		
0	0	0	ITU Recommendation G.703		E1 - Coax (75 Ω)	2.048 Mbps
0	0	1			E1 - Twisted-pair (120 Ω)	
0	1	0	FCC Part 68, Option A		CSU (DS-1)	1.544 Mbps

1. Line length from transceiver to DSX-1 cross-connect point.

2. Maximum cable loss at 772 kHz.

The serial interface (SDI/SDO) uses a 16-bit word consisting of an 8-bit Command/Address byte and an 8-bit Data byte. Figure 3 shows the serial interface data structure and relative timing.

The Host Mode provides a latched Interrupt output ($\overline{\text{INT}}$) which is triggered by a change in the Loss of Signal (LOS) and/or Driver Performance Monitor (DPM) bits. The Interrupt is cleared when the interrupt condition no longer exists, and the host processor enables the respective bit in the serial input data byte. Host Mode also allows control of the serial data and receive data output timing. The Clock Edge (CLKE) signal determines when these outputs are valid, relative to the Serial Clock (SCLK) or RCLK as listed in Table 3.

Table 3: Valid Clock Edges for Data Outputs

CLKE	Output	Clock	Valid Edge
LOW	RPOS	RCLK	Rising
	RNEG	RCLK	Rising
	SDO	SCLK	Falling
HIGH	RPOS	RCLK	Falling
	RNEG	RCLK	Falling
	SDO	SCLK	Rising

2

Table 4: LXT305A Serial Data Output Bits (See Figure 3)

Bit D5	Bit D6	Bit D7	Status
0	0	0	Reset has occurred, or no program input
0	0	1	TAOS active
0	1	0	Local Loopback active
0	1	1	TAOS and Local Loopback active
1	0	0	Remote Loopback active
1	0	1	DPM has changed state since last Clear DPM occurred
1	1	0	LOS has changed state since last Clear LOS occurred
1	1	1	LOS and DPM have both changed state since last Clear DPM and Clear LOS occurred

Figure 3: LXT305A Serial Interface Data Structure

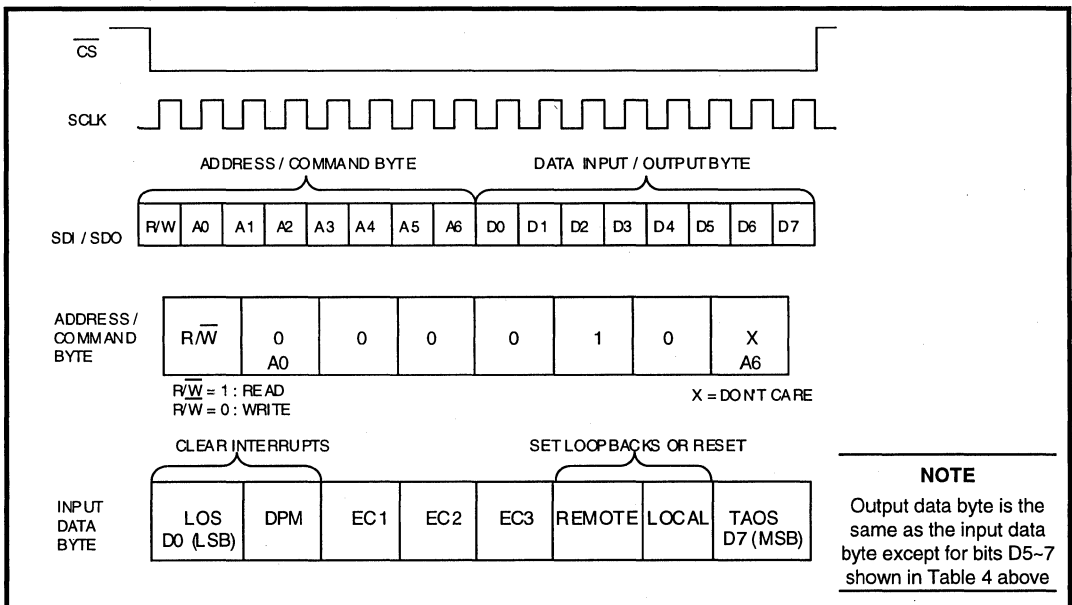

The LXT305A serial port is addressed by setting bit A4 in the Address/Command byte, corresponding to address 16. The LXT305A contains only a single output data register so no complex chip addressing scheme is required. The register is accessed by causing the Chip Select (\overline{CS}) input to transition from High to Low. Bit 1 of the serial Address/Command byte provides Read/Write control when the chip is accessed. A logic 1 indicates a read operation, and a logic 0 indicates a write operation. Table 4 lists serial data output bit combinations for each status. Serial data I/O timing characteristics are shown in the Test Specifications section.

Hardware Mode Operation

In Hardware Mode the transceiver is accessed and controlled through individual pins. With the exception of the \overline{INT} and CLKE functions, Hardware Mode provides all the functions provided in the Host Mode. In the Hardware Mode RPOS and RNEG outputs are valid on the rising edge of RCLK.

To operate in Hardware Mode, MODE must be set Low. Equalizer Control signals (EC1 through EC3) are input on the Interrupt, Serial Data In and Serial Data Out pins. Diagnostic control for Remote Loopback (RLOOP), Local Loopback (LLOOP), and Transmit All Ones (TAOS) modes is provided through the individual pins used to control serial interface timing in the Host Mode.

Diagnostic Mode Operation

TRANSMIT ALL ONES

In Transmit All Ones (TAOS) Mode the TPOS and TNEG inputs to the transceiver are ignored. The transceiver transmits a continuous stream of ones when the TAOS mode is activated. TAOS can be commanded simultaneously with Local Loopback, but is inhibited during Remote Loopback. During TAOS, the transmitter is locked to MCLK. If MCLK is not supplied, the transmitter powers down.

REMOTE LOOPBACK

In Remote Loopback (RLOOP) Mode, the transmit data and clock inputs (TPOS, TNEG and TCLK) are ignored. The RPOS and RNEG outputs are looped back through the transmit circuits and output on TTIP and TRING at the RCLK frequency. Receiver circuits are unaffected by the RLOOP command and continue to output the RPOS, RNEG and RCLK signals received from the twisted-pair line.

LOCAL LOOPBACK

In Local Loopback (LLOOP) Mode, the receiver circuits are inhibited. The transmit data and clock inputs (TPOS, TNEG and TCLK) are looped back onto the receive data and clock outputs (RPOS, RNEG and RCLK). The transmitter circuits are unaffected by the LLOOP command. The TPOS and TNEG inputs (or a stream of ones if the TAOS command is active) will be transmitted normally. During local loopback if TCLK is not supplied, the transmitter powers down. If LOS and LLOOP are both active, LLOOP takes precedence, forcing RCLK = TCLK.

Table 5: LXT305A Crystal Specifications (External)

Parameter	T1	E1
Frequency	6.176 MHz	8.192 MHz
Frequency Stability	± 20 ppm @ 25 °C ± 25 ppm from -40 °C to 85 °C (Ref 25 °C reading)	± 20 ppm @ 25 °C ± 25 ppm from -40 °C to 85 °C (Ref 25 °C reading)
Pullability	CL = 11 pF to 18.7 pF, $+\Delta F = 175$ to 195 ppm CL = 18.7 pF to 34 pF, $-\Delta F = 175$ to 195 ppm	CL = 11 pF to 18.7 pF, $+\Delta F = 95$ to 115 ppm CL = 18.7 pF to 34 pF, $-\Delta F = 95$ to 115 ppm
Effective series resistance	40 Ω Maximum	30 Ω Maximum
Crystal cut	AT	AT
Resonance	Parallel	Parallel
Maximum drive level	2.0 mW	2.0 mW
Mode of operation	Fundamental	Fundamental
Crystal holder	HC49 (R3W), Co = 7 pF maximum C _M = 17 fF typical	HC49 (R3W), Co = 7 pF maximum C _M = 17 fF typical

APPLICATION INFORMATION

NOTE

This information is for design aid only.

1.544 MBPS T1 INTERFACE APPLICATIONS

Figure 4 is a typical 1.544 Mbps T1 interface application. Use a 1:1.15 transmit transformer without in-line resistors for maximum power savings. The LXT305A is shown in the Host Mode with a T1/ESF Framer providing the digital interface with the host controller. An LXP600A Clock Adapter (CLAD) provides the 2.048 MHz system backplane clock, locked to the recovered 1.544 MHz clock signal. The power supply inputs are tied to a common bus with appropriate decoupling capacitors installed (68 µF on the transmit side, 1.0 µF and 0.1 µF on the receive side).

For DSX-1 applications, series resistors can be used in line with the transmit transformer to provide higher return loss.

2.048 MBPS E1 INTERFACE APPLICATIONS

Figure 5 is a typical 2.048 Mbps E1 application. The LXT305A is shown in Hardware Mode with an E1/CRC4 Framer. As in the DSX-1 application Figure 4, this configuration is illustrated with a crystal in place to enable the LXT305A Jitter Attenuation Loop, and a single power supply bus. The hard-wired control lines for TAOS, LLOOP and RLOOP are individually controllable, and the LLOOP and RLOOP lines are also tied to a single control for the Reset function. With the 1:1 transformer ratio and code 000 selected on the EC inputs, the LXT305A outputs the ITU specified 2.37 V pulse onto 75 Ω coaxial cable. Simply changing the EC code to 001 allows the LXT305A to match the 3.0 V pulse specification for 120 Ω shielded twisted-pair cable. No transformer change is required. For situations where at 1:1.26 transformer is desired, EC code 000 selects the correct output for 120 Ω twisted-pair cable.

To achieve higher return loss, increased surge protection and lower output short circuit current, series resistors can be used in line with the transmit transformer.



Table 6: T1/E1 Input/Output Configurations

Bit Rate (Mbps)	Crystal XTAL	Cable (Ω)	Rr ² (Ω)	EC1/2/3	Transmit Transformer ¹	Rt ² (Ω)	Typical TX Return Loss ³ (dB)	Cc (µF)
1.544 (T1)	LXC6176	100	200	0/1/1 - 1/1/1	1:1.15	0	0.5	0.47
					1:2	9.1	18	0
					1:2.3	9.1	18	0
2.048 (E1)	LXC8192	120	240	0/0/0	1:1.26	0	0.5	0.47
				0/0/0	1:2	9.1	12	0
				0/0/1	1:1	0	0.5	0.47
				0/0/1	1:2	15	18	0
		75	150	0/0/0	1:1	0	0.5	0.47
				0/0/0	1:2	9.1	18	0
				0/0/1	1:1	10	5	0
				0/0/1	1:2	14.3	10	0

1. Transformer turns ratio accuracy is ± 2%.
 2. Rr and Rt values are ± 1%.
 3. Typical return loss, 51 kHz to 3.072 MHz band.

Figure 4: Typical LXT305A 1.544 Mbps T1 Application (Host Mode)

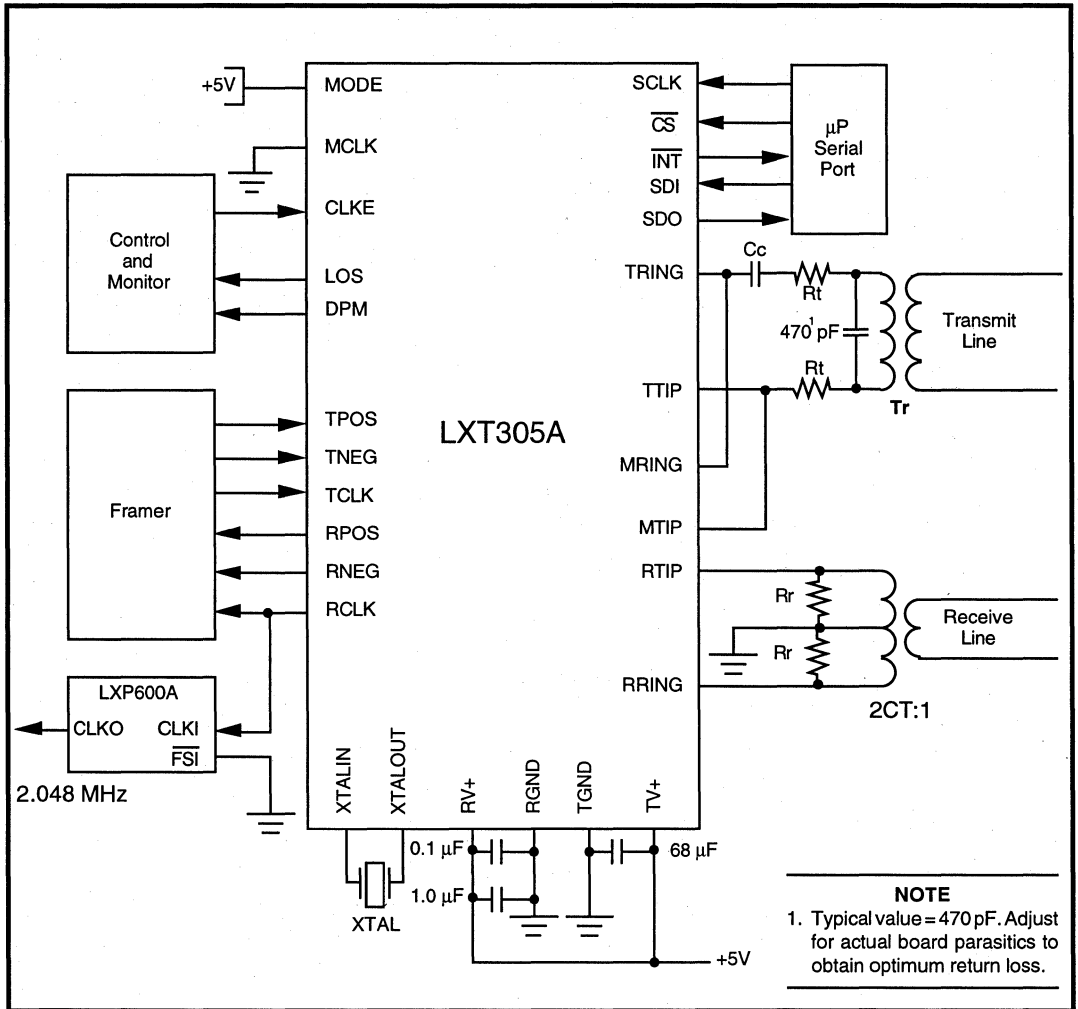
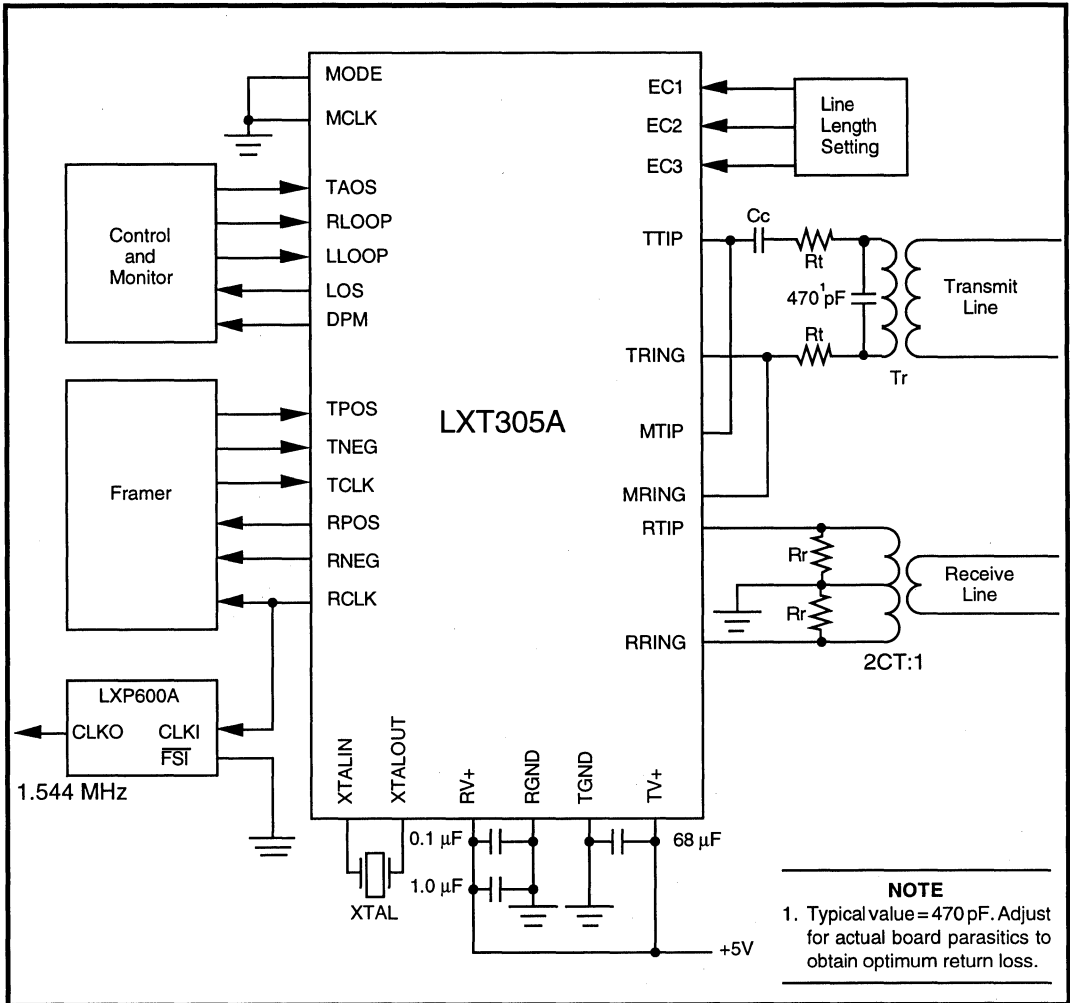

Figure 5: Typical LXT305A 2.048 Mbps 120 Ω Application (Hardware Mode)



2

TEST SPECIFICATIONS

NOTE

Minimum and maximum values in Tables 7 through 13 and Figures 6 through 11 represent the performance specifications of the LXT305A and are guaranteed by test except, as noted, by design.

Table 7: Absolute Maximum Ratings

Parameter	Sym	Min	Max	Units
DC supply (referenced to GND)	RV+, TV+	-0.3	6.0	V
Input voltage, any pin ¹	V _{IN}	RGND - 0.3	RV+ + 0.3	V
Input current, any pin ²	I _{IN}	-10	10	mA
Storage temperature	T _{STG}	-65	150	°C

CAUTION
Operations at or beyond these limits may result in permanent damage to the device.
Normal operation not guaranteed at these extremes.

1. Excluding RTIP and RRING, which must stay between -6 V and (RV+ + 0.3) V.
2. Transient currents of up to 100 mA will not cause SCR latch-up. TTIP, TRING, TV+ and TGND can withstand a continuous current of 100 mA.

Table 8: Recommended Operating Conditions

Parameter	Sym	Min	Typ	Max	Units	Test Conditions
DC supply ¹	RV+, TV+	4.75	5.0	5.25	V	
Ambient operating temperature	T _A	-40	25	85	°C	

1. TV+ must not exceed RV+ by more than 0.3 V.

Table 9: Electrical Characteristics (Under Recommended Operating Conditions)

Parameter	Sym	Min	Max	Units	Test Conditions
Total power dissipation ¹	P _D	–	400	mW	100% ones density & max line length @ 5.25 V
High level input voltage ^{2,3} (pins 1-5, 10, 23-28)	V _{IH}	2.0	–	V	
Low level input voltage ^{2,3} (pins 1-5, 10, 23-28)	V _{IL}	–	0.8	V	
High level output voltage ^{2,3} (pins 6-8, 11, 12, 23, 25)	V _{OH}	2.4	–	V	I _{OUT} = - 400 μA
Low level output voltage ^{2,3} (pins 6-8, 11, 12, 23, 25)	V _{OL}	–	0.4	V	I _{OUT} = 1.6mA
Input leakage current ⁴	I _{LL}	0	±10	μA	
Three-state leakage current ² (pin 25)	I _{3L}	0	±10	μA	

1. Power dissipation while driving 75 Ω load over operating temperature range. Includes device and load. Digital input levels are within 10% of the supply rails and digital outputs are driving a 50 pF capacitive load.
2. Functionality of pins 23 and 25 depends on mode. See Host / Hardware Mode descriptions.
3. Output drivers will output CMOS logic levels into CMOS loads.
4. Except MTIP and MRING I_{LL} = ± 50 μA.

Table 10: Analog Characteristics (Under Recommended Operating Conditions)

Parameter		Min	Typ ¹	Max	Units	Test Conditions		
AMI Output Pulse Amplitudes	DSX-1	2.4	3.0	3.6	V	measured at the DSX		
	E1	2.7	3.0	3.3	V	measured at line side		
Recommended output load at TTIP and TRING		–	75	–	Ω			
Jitter added by the transmitter ²	10 Hz - 8 kHz	–	–	0.01	UI			
	8 kHz - 40 kHz	–	–	0.025	UI			
	10 Hz - 40 kHz	–	–	0.025	UI			
	Broad Band	–	–	0.05	UI			
Sensitivity below DSX (0 dB = 2.4 V)		13.6	–	–	dB			
		500	–	–	mV			
Loss of Signal threshold		–	0.3	–	V			
Data decision threshold	DSX-1	63	70	77	%peak			
	E1	43	50	57	% peak			
Allowable consecutive zeros before LOS		160	175	190	–			
Input jitter tolerance 10 kHz - 100 kHz		0.4	–	–	UI			
Jitter attenuation curve corner frequency ³		–	3	–	Hz			
Minimum Return Loss ^{4,5}		Transmit Min Typ		Receive Min Typ				
		51 kHz - 102 kHz		18	–	20	–	dB
		102 kHz - 2.048 MHz		18	–	20	–	dB
		2.048 MHz - 3.072 MHz		18	–	20	–	dB
1. Typical values are at 25 °C and are for design aid only; not guaranteed and not subject to production testing. 2. Input signal to TCLK is jitter-free. 3. Circuit attenuates jitter at 20 dB/decade above the corner frequency. 4. In accordance with ITU G.703/ETS 300166 return loss specifications when wired per Figure 5 (E1). 5. Guaranteed by design.								

2

Figure 6: Typical Receive Jitter Tolerance

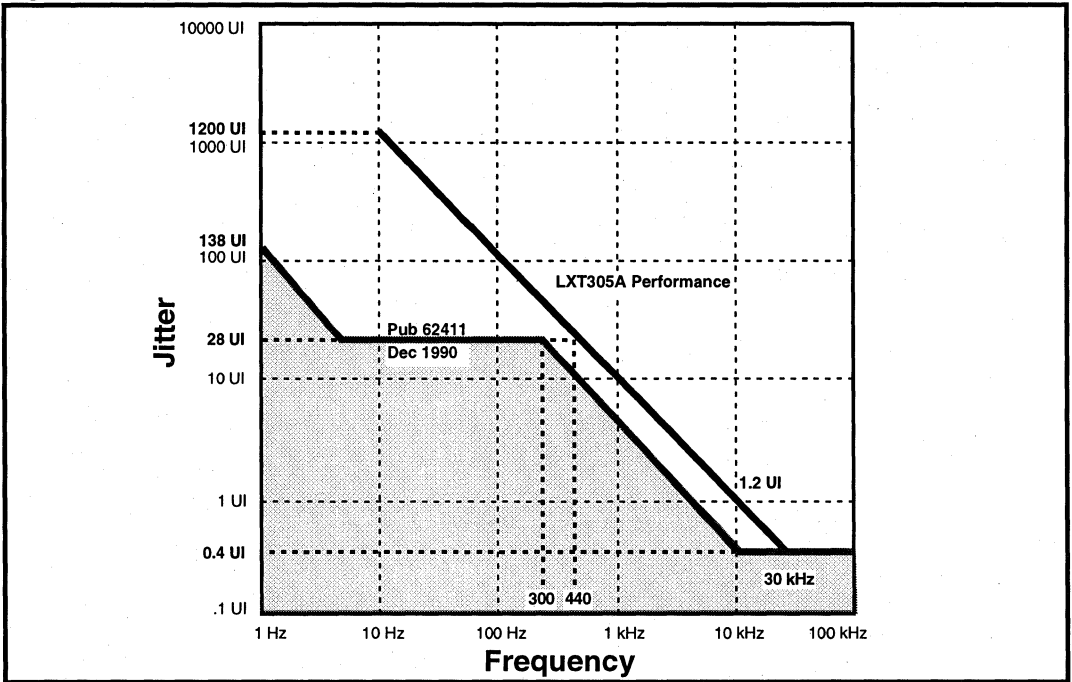

Figure 7: LXT305A Transmit Jitter Transfer Performance (Typical)

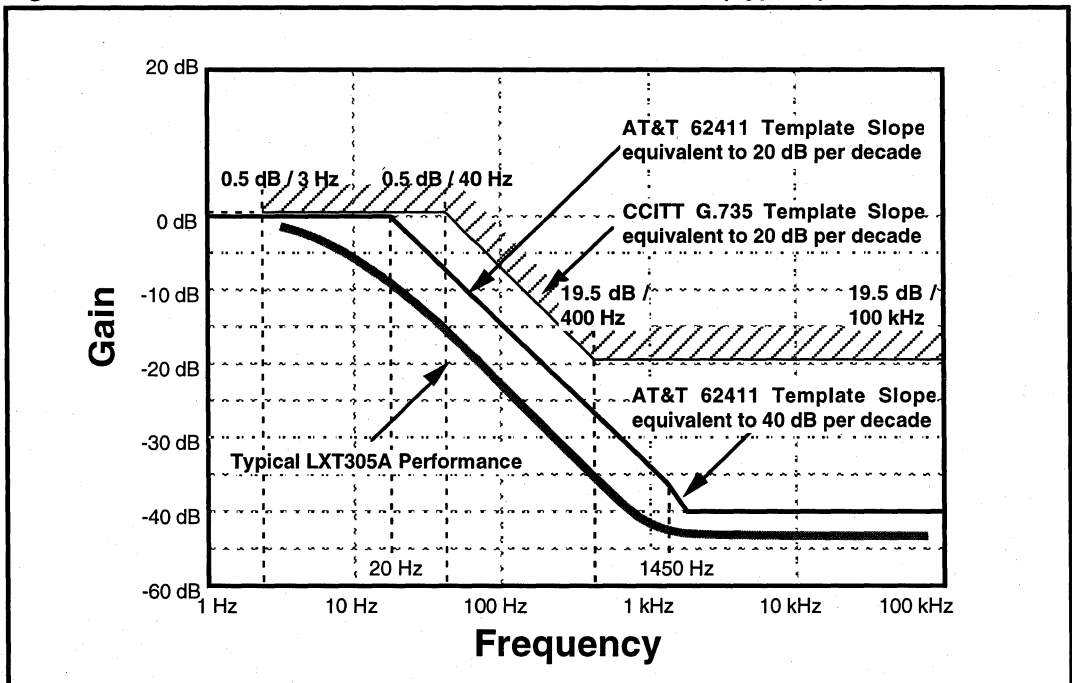

Table 11: LXT305A Receive Timing Characteristics (See Figure 8)

Parameter		Sym	Min	Typ ¹	Max	Units
Receive clock duty cycle ²	T1	RCLKd	40	50	60	%
	E1	RCLKd	40	50	60	%
Receive clock pulse width ²	T1	tpw	594	648	702	ns
	E1	tpw	447	488	529	ns
Receive clock pulse width high	T1	tpWH	–	324	–	ns
	E1	tpWH	–	244	–	ns
Receive clock pulse width low	T1	tpWL	270	324	378	ns
	E1	tpWL	203	244	285	ns
RPOS / RNEG to RCLK rising setup time	T1	tsUR	50	270	–	ns
	E1	tsUR	50	203	–	ns
RCLK rising to RPOS / RNEG hold time	T1	tHR	50	270	–	ns
	E1	tHR	50	203	–	ns

1. Typical values are at 25 °C and are for design aid only; not guaranteed and not subject to production testing.
 2. RCLK duty cycle widths will vary depending on extent of received pulse jitter displacement. Max and Min RCLK duty cycles are for worst case jitter conditions (0.4 UI clock displacement for 1.544 MHz, 0.2 UI clock displacement for 2.048 MHz).

2

Figure 8: LXT305A Receive Clock Timing Diagram

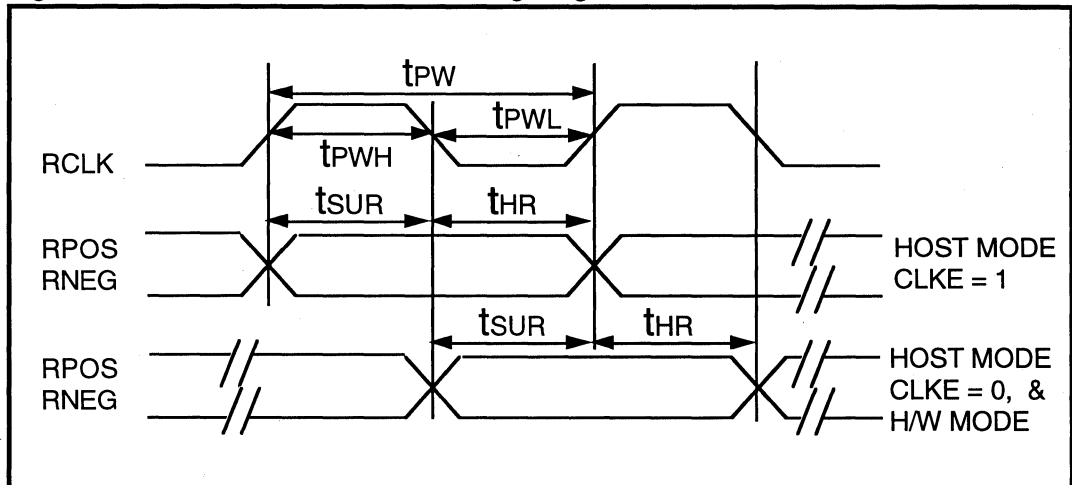

Table 12: LXT305A Master Clock and Transmit Timing Characteristics
(See Figure 9)

Parameter	Sym	Min	Typ ¹	Max	Units	Test Conditions
Master clock frequency	DSX-1 MCLK	-	1.544	-	MHz	
	E1 MCLK	-	2.048	-	MHz	
Master clock tolerance	MCLKt	-	±100	-	ppm	
Master clock duty cycle	MCLKd	40	-	60	%	
Crystal frequency	DSX-1 fc	-	6.176	-	MHz	
	E1 fc	-	8.192	-	MHz	
Transmit clock frequency	DSX-1 TCLK	-	1.544	-	MHz	
	E1 TCLK	-	2.048	-	MHz	
Transmit clock tolerance	TCLKt	-	±50	-	ppm	
Transmit clock duty cycle	TCLKd	10	-	90	%	
TPOS/TNEG to TCLK setup time	t _{SUT}	25	-	-	ns	
TCLK to TPOS/TNEG Hold time	t _{HT}	25	-	-	ns	

1. Typical figures are at 25 °C and are for design aid only; not guaranteed and not subject to production testing.

Figure 9: LXT305A Transmit Clock Timing Diagram

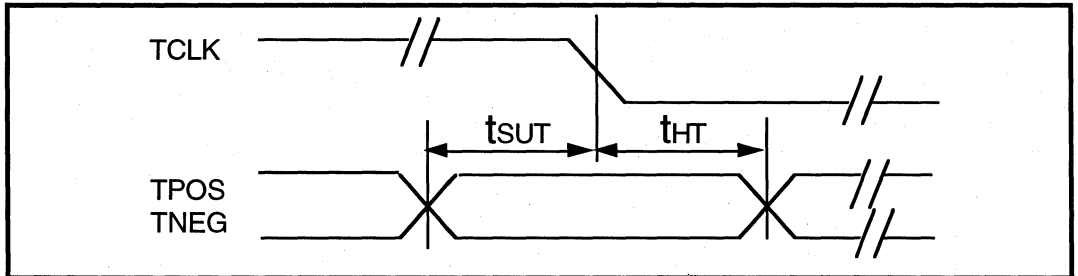

Table 13: LXT305A Serial I/O Timing Characteristics (See Figures 10 and 11)

Parameter	Sym	Min	Typ ¹	Max	Units	Test Conditions
Rise/Fall time - any digital output	t_{rF}	-	-	100	ns	Load 1.6 mA, 50 pF
SDI to SCLK setup time	t_{dc}	50	-	-	ns	
SCLK to SDI hold time	t_{cdH}	50	-	-	ns	
SCLK low time	t_{cl}	240	-	-	ns	
SCLK high time	t_{ch}	240	-	-	ns	
SCLK rise and fall time	t_r, t_f	-	-	50	ns	
\overline{CS} to SCLK setup time	t_{cc}	50	-	-	ns	
SCLK to \overline{CS} hold time	t_{cch}	50	-	-	ns	
\overline{CS} inactive time	t_{cwh}	250	-	-	ns	
SCLK to SDO valid	t_{cdv}	-	-	200	ns	
SCLK falling edge or \overline{CS} rising edge to SDO high Z	t_{cdz}	-	100	-	ns	

1. Typical figures are at 25 °C and are for design aid only; not guaranteed and not subject to production testing.

Figure 10: LXT305A Serial Data Input Timing Diagram

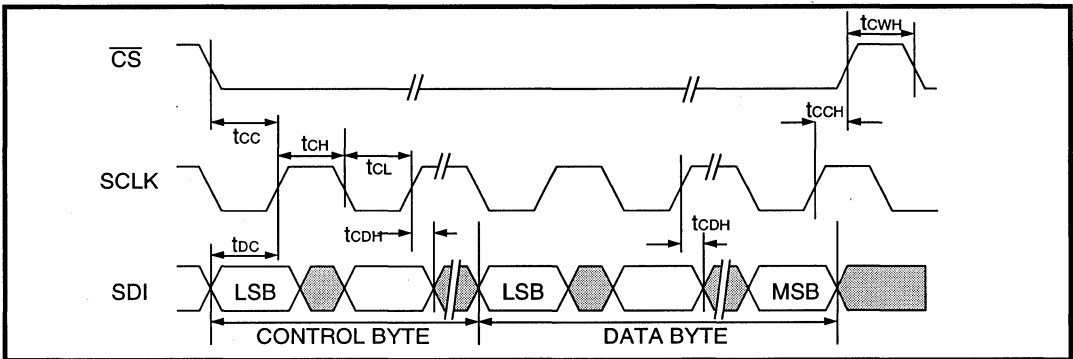
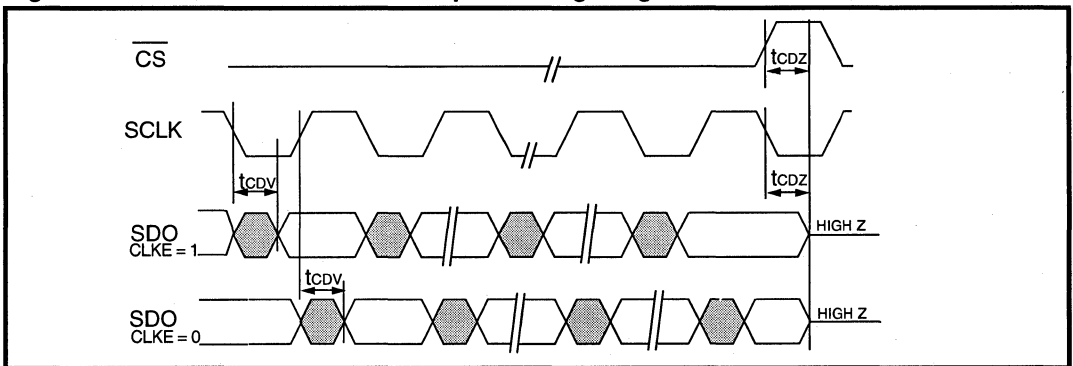

Figure 11: LXT305A Serial Data Output Timing Diagram



LXT305A Low-Power T1/E1 Short-Haul Transceiver with Transmit JA

NOTES:

LXT307

Low-Power E1 Integrated Short-Haul Transceiver

2

General Description

The LXT307 is a fully integrated low-power transceiver optimized for G.703 2.048 Mbps (E1) applications. It features a constant low output impedance transmitter allowing for high transmitter return loss. Transmit pulse amplitudes are selectable for various cable types. It is designed to exceed the latest international specifications, including G.775 and ETS 300 166.

The LXT307 is microprocessor controllable through a serial interface. It can also be controlled through individual pins in Hardware Mode.

The LXT307 offers a variety of diagnostic features, including transmit and receive monitoring. The device requires a single 2.048 MHz clock reference for the on chip high performance clock recovery system. It uses an advanced double-poly, double-metal CMOS process and requires only a single 5-volt power supply.

Applications

- PCM G.703 Interfaces
- E1 multiplexer
- Digital Access and Cross-connect Systems (DACs)
- G.703 Trunk line cards for Public Switching Systems and PABX
- High-speed data transmission lines

Features

- Low power dissipation 260 mW typical
- Constant low output impedance transmitter regardless of data pattern (3 Ω typical)
- Low speed reference clock to reduce PC board noise coupling
- Driver short circuit current limited to 50 mA per OFTEL/BABT recommendations
- 75/120 Ω Operation without component changes
- Transmit and receive return loss exceeds ETSI ETS 300 166 and G.703
- Meets or exceeds all ITU specifications including G.703, G.823 (03/93) and G.775
- Compatible with most popular PCM framers
- Line driver, data recovery and clock recovery functions
- Minimum receive signal of 500 mV
- Programmable transmit amplitude for 75 Ω and 120 Ω operation without component changes
- Local and remote loopback functions
- Transmit performance monitor with DPM detecting single line shorts for improved reliability
- Analog/digital LOS monitor per G.775
- Receiver jitter tolerance 0.4 UI from 40 kHz to 100 kHz
- Serial Control Interface
- Available in 28-pin DIP or PLCC

LXT307 Block Diagram

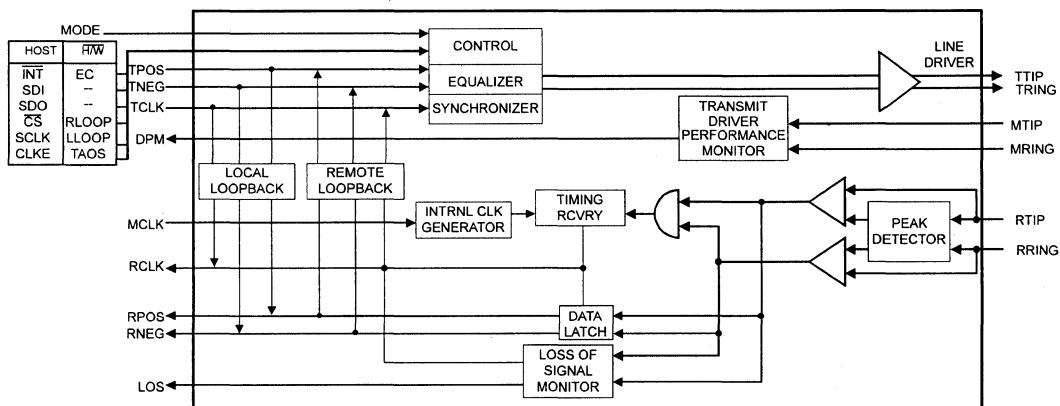

LXT307 Low-Power E1 Integrated Short-Haul Transceiver

Figure 1: Pin Assignments

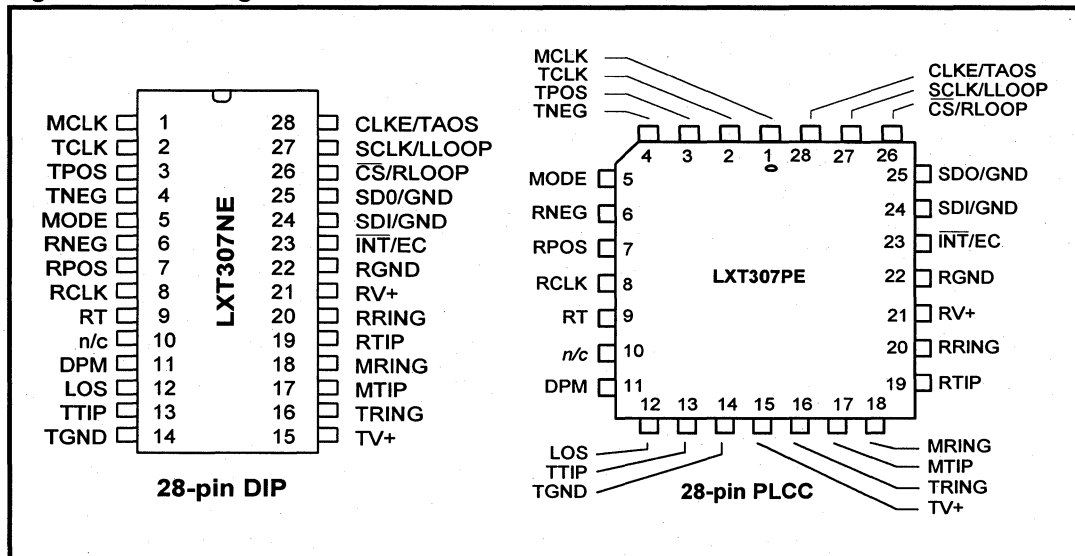

Table 1: Pin Assignments and Signal Descriptions

Pin #	Sym	I/O ¹	Description
1	MCLK	DI	Master Clock. A 2.048 MHz clock input used to generate internal clocks. Upon Loss of Signal (LOS), RCLK is derived from MCLK.
2	TCLK	DI	Transmit Clock. Transmit clock input. TPOS and TNEG are sampled on the falling edge of TCLK. If TCLK is not supplied, the transmitter remains powered down.
3	TPOS	DI	Transmit Positive Data. Input for the positive pulse to be transmitted on the line.
4	TNEG	DI	Transmit Negative Data. Input for the negative pulse to be transmitted on the line.
5	MODE	DI	Mode Select. Setting MODE High puts the LXT307 in the Host Mode. In the Host Mode, the serial interface is used to control the LXT307 and determine its status. Setting MODE Low puts the LXT307 in the Hardware (H/W) mode. In the Hardware mode the serial interface is disabled and hard-wired pins are used to control configuration and report status.
6	RNEG	DO	Receive Negative Data; Receive Positive Data. Received data outputs. A signal on RNEG corresponds to receipt of a negative pulse on RTIP and RRING. A signal on RPOS corresponds to receipt of a positive pulse on RTIP and RRING. RNEG and RPOS outputs are Non-Return-to-Zero (NRZ). In the Host mode, CLKE determines the clock edge at which these outputs are stable and valid. In the Hardware mode, both outputs are stable and valid on the rising edge of RCLK.
7	RPOS	DO	
8	RCLK	DO	Recovered Clock. This is the clock recovered from the signal received at RTIP and RRING.
9	RT	AI	Resistor Termination. Connect to RV+ through a 1 kΩ resistor.

1. Entries in I/O column are: DI = Digital Input; DO = Digital Output; AI = Analog Input; AO = Analog Output; S = Supply.

Table 1: Pin Assignments and Signal Descriptions – continued

Pin #	Sym	I/O ¹	Description
10	N/C	–	No connection.
11	DPM	DO	Driver Performance Monitor. DPM goes High when the transmit monitor (MTIP and MRING) does not detect a signal for 63 ± 2 clock periods. DPM remains High until a signal is detected. It is reset to Low with the first transition on MTIP and MRING.
12	LOS	DO	Loss of Signal. LOS goes High when the signal falls below 20 dB below nominal for more than 175 consecutive bit periods. LOS returns Low when the received signal detects 4 transitions in any 32-bit window (12.5% 1s density) with no more than 15 consecutive 0s.
13	TTIP	AO	Transmit Tip; Transmit Ring. Differential Driver Outputs. These low-impedance outputs achieve high return loss with resistors used in series with a transformer as specified in Tables 9 and 10.
16	TRING	AO	
14	TGND	–	Transmit Ground. Ground return for the transmit drivers power supply TV+.
15	TV+	S	Transmit Power Supply. +5 VDC power supply input for the transmit drivers. TV+ must not vary from RV+ by more than ± 0.3 V during all operating conditions including start-up.
17	MTIP	AI	Monitor Tip; Monitor Ring. These pins are used to monitor the TTIP and TRING transmit outputs. The transceiver can be connected to monitor its own output or the output of another LXT307 on the board. To prevent false interrupts in the host mode if the monitor is not used, apply a clock signal to one of the monitor pins and tie the other monitor pin to approximately the clock's midrange voltage. The monitor clock can range from 100 kHz to the TCLK frequency.
18	MRING	AI	
19	RTIP	AI	Receive Tip; Receive Ring. The AMI signal received from the line is applied at these pins. A center-tapped, center-grounded, 2:1 step-up transformer for 75 Ω and 120 Ω is required on these pins. Data and clock from the signal applied at these pins are recovered and output on the RPOS/RNEG and RCLK pins.
20	RRING	AI	
21	RV+	S	Receive Power Supply. +5 VDC power supply for all circuits except the transmit drivers. (Transmit drivers are supplied by TV+.)
22	RGND	S	Receive Ground. Ground return for power supply RV+.
23	$\overline{\text{INT}}$	DO	Interrupt (Host Mode). This LXT307 Host mode output goes Low to flag the host processor when LOS or DPM go active. $\overline{\text{INT}}$ is an open-drain output and should be tied to power supply RV+ through a resistor. $\overline{\text{INT}}$ is reset by clearing the respective register bit (LOS and/or DPM).
	EC	DI	Equalizer Control (H/W Mode). The signal applied at this pin in the LXT307 Hardware mode is used to determine the amplitude of AMI output transmit pulses.
24	SDI	DI	Serial Data In (Host Mode). The serial data input stream is applied to this pin when the LXT307 operates in the Host mode. SDI is sampled on the rising edge of SCLK.
	GND	DI	GND (H/W Mode). Signal ground.
25	SDO	DO	Serial Data Out (Host Mode). The serial data from the on-chip register is output on this pin in the LXT307 Host mode. If CLKE is High, SDO is valid on the rising edge of SCLK. If CLKE is Low, SDO is valid on the falling edge of SCLK. This pin goes to a high-impedance state when the serial port is being written to and when $\overline{\text{CS}}$ is High.
	GND	DI	GND (H/W Mode). Signal ground.

1. Entries in I/O column are: DI = Digital Input; DO = Digital Output; AI = Analog Input; AO = Analog Output; S = Supply.

2

LXT307 Low-Power E1 Integrated Short-Haul Transceiver

Table 1: Pin Assignments and Signal Descriptions – continued

Pin #	Sym	I/O ¹	Description
26	$\overline{\text{CS}}$	DI	Chip Select (Host Mode). This input is used to access the serial interface in the LXT307 Host mode. For each read or write operation, $\overline{\text{CS}}$ must transition from High to Low, and remain Low.
	RLOOP	DI	Remote Loopback (H/W Mode). This input controls loopback functions in the LXT307 Hardware mode. Setting RLOOP to a logic H enables the Remote Loopback mode. Setting both RLOOP and LLOOP High causes a Reset.
27	SCLK	DI	Serial Clock (Host Mode). This clock is used in the LXT307 Host mode to write data to or read data from the serial interface registers.
	LLOOP	DI	Local Loopback (H/W Mode). This input controls loopback functions in the LXT307 Hardware mode. Setting LLOOP High enables the Local Loopback Mode.
28	CLKE	DI	Clock Edge (Host Mode). Setting CLKE High causes RPOS and RNEG to be valid on the falling edge of RCLK, and SDO to be valid on the rising edge of SCLK. When CLKE is Low, RPOS and RNEG are valid on the rising edge of RCLK, and SDO is valid on the falling edge of SCLK.
	TAOS	DI	Transmit All Ones (H/W Mode). When set High, TAOS causes the LXT307 (Hardware mode) to transmit a continuous stream of marks at the TCLK frequency. Activating TAOS causes TPOS and TNEG inputs to be ignored. TAOS is inhibited during Remote Loopback.
1. Entries in I/O column are: DI = Digital Input; DO = Digital Output; AI = Analog Input; AO = Analog Output; S = Supply.			

FUNCTIONAL DESCRIPTION

NOTE

This functional information is for design aid only.

The LXT307 is a fully integrated PCM transceiver for G.703 2.048 Mbps (E1) applications. A simplified block diagram of the transceiver appears on page 1. The LXT307 allows full-duplex transmission of digital data over existing twisted-pair or coax installations. It interfaces with two lines, one for receive, one for transmit.

POWER REQUIREMENTS

The LXT307 is a low-power CMOS device. It operates from a single +5 V power supply which can be connected externally to both the transmitter and receiver. However, the two inputs must be within ± 0.3 V of each other, and decoupled separately to their respective grounds. Isolation between transmit and receive circuits is provided internally. During normal operation, and LLOOP, the transmitter powers down if TCLK is not supplied. The transmitter also powers down during TAOS operation if TCLK is not supplied.

RESET OPERATION

Upon power up, the transceiver is held static until the power supply reaches approximately 3 V. Upon crossing this threshold, the device begins a 32 ms reset cycle to calibrate the transmit and receive delay lines and locks the Phase Lock Loop to the receive line. A reference clock is required to calibrate the delay lines. The transmitter reference is provided by TCLK. MCLK is used as the receiver reference clock.

The transceiver can also be reset from the Host or Hardware mode. In Host mode, reset is commanded by simultaneously writing RLOOP and LLOOP to the register. In Hardware mode, reset is commanded by holding RLOOP and LLOOP high simultaneously for 200 ns. Reset is initiated on the falling edge of the reset request. In either mode, reset clears and sets all registers to 0 and then calibration begins.

RECEIVER

The LXT307 receives the signal input from one line on each side of a center-grounded transformer. Positive pulses are received at RTIP and negative pulses are received at RRING.

The signal received at RTIP and RRING is processed through the peak detector and data slicers. The peak detec-

tor samples the inputs and determines the maximum value of the received signal. A percentage of the peak value is provided to the data slicers as a threshold level to ensure optimum signal-to-noise ratio. The threshold is 50% and is maintained over the whole input range.

The receiver is capable of accurately recovering signals with up to -13.6 dB of attenuation (from 2.4 V), corresponding to a received signal level of approximately 500 mV. Regardless of received signal level, the peak detectors are held above a minimum level of 0.3 V to provide immunity from impulsive noise.

After processing through the data slicers, the received signal is routed to the data and clock recovery sections, and to the receive monitor. The data and clock recovery circuits are highly tolerant with an input jitter tolerance significantly better than required by G.823, as shown in Figure 17. Recovered clock signals are supplied to the data latch. Recovered data is output at RPOS and RNEG, and the recovered clock is output at RCLK. Refer to Table 15 and Figure 13 for LXT307 receiver timing.

LOSS OF SIGNAL PROCESSOR

Declaring the LOS Condition

Recommendation G.775 defines basic criteria for detection and clearance of Loss of Signal (LOS) defects.

LXT307 uses a digital-and-analog detection scheme to comply with G.775. If the signal level falls below 20 dB typical, the LXT307 begins to count consecutive bit times and declares LOS after approximately 175 (160 to 190) consecutive zeros. Refer to Table 2.

Clearing the LOS Condition

LXT307 clears LOS with a three-step process:

1. The signal must first exceed the 20 dB signal level.
2. Then a 32-bit repeating window checks for 12.5% 1s density. (To meet this parameter, there must be at least four 1s out of the 32 bits in the window.)
3. Finally, there must be no more than 15 consecutive 0s to clear the LOS condition.

LXT307 Low-Power E1 Integrated Short-Haul Transceiver

TRANSMITTER

Data received for transmission onto the line is clocked serially into the device at TPOS and TNEG. Input synchronization is supplied by the transmit clock (TCLK). If TCLK is not supplied, the transmitter remains powered down, except during remote loopback and TAOS. Refer to Table 16 and Figure 14 for master and transmit clock timing characteristics.

Line Code

The LXT307 transmits data as a 50% AMI line code as shown in Figure 2. The output driver maintains a constant low output impedance under dynamic conditions regardless of whether it is driving marks or spaces.

The transmitted pulse amplitude is determined by the equalizer control signal EC as shown in Table 3.

The equalizer control signal may be hardwired in Hardware mode or input as part of the serial data stream (SDI) in Host mode. Shaped pulses are applied to the AMI line driver for transmission onto the line at TTIP and TRING.

The line driver provides a constant low output impedance of 3 Ω (typical). This well-controlled output impedance provides excellent return loss when used with external precision resistors (±1% accuracy) in series with a transmit transformer. Series resistors also provide increased surge protection and reduce short circuit current flow.

Pulses can drive coaxial or shielded twisted-pair lines. A 1:2 transmit transformer and series resistors are recommended. This design meets or exceeds all ETSI 300 166 and European PTT specifications for transmit and receive return loss when series resistors are used.

Figure 2: 50% AMI Coding

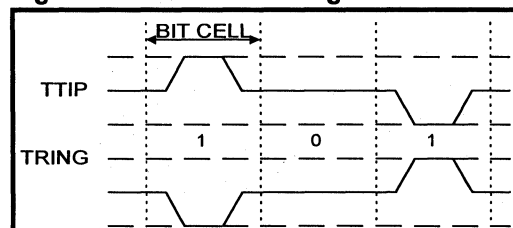

Table 2: G.775 Requirements and LXT307 Implementation of LOS Detection

Condition	G.775 Recommendation	Level One Implementation
Detect LOS	Signal with no transitions ¹ less than or equal to signal level of 35 dB below nominal for N consecutive intervals where 10 ≤ N ≤ 255.	Signal level below 20 dB and no consecutive transition for 160 to 190 (typical 175) pulse intervals.
Clear LOS	Signal has transitions ¹ and level greater than or equal to 9 dB below nominal for N consecutive pulse intervals where 10 ≤ N ≤ 255.	Signal level above 20 dB with bit density greater than 12.5% for 32-bit positions, and with fewer than 15 consecutive zeros.

1. A signal with "transitions" corresponds to a G.703 compliant signal.

Table 3: Equalizer Control Inputs for Pulse Amplitude Selection

EC	Line Length & Cable Loss	Application
0	ITU Recommendation G.703	E1 - Coax (75 Ω)
1	ITU Recommendation G.703	E1 - Twisted-Pair (120 Ω)

DRIVER PERFORMANCE MONITOR

The transceiver incorporates an advanced Driver Performance Monitor (DPM) that can be connected in parallel with the TTIP and TRING at the output transformer. The DPM circuitry uses four comparators and a 150 ns pulse discriminator to filter glitches. The DPM output level goes High upon detection of 63 consecutive zeros, and is cleared when a transition is detected on the transmit line or when a reset command is received. The DPM output also goes High to indicate a signal line short to ground on TTIP or TRING. A ground fault induced DPM flag is automatically cleared when the ground condition is corrected (chip reset is not required).

OPERATING MODES

The LXT307 transceiver can be controlled through hardwired pins (Hardware Mode—default) or by a microprocessor through a serial interface (Host Mode) depending on the input to pin 5 (MODE). The mode of operation is set by the MODE pin logic level. The LXT307 can also be commanded to operate in one of several diagnostic modes.

Hardware Mode Operation

In Hardware mode the transceiver is controlled through individual pins. With the exception of the $\overline{\text{INT}}$ and CLKE functions, Hardware mode provides all the functions provided in the Host mode. In the Hardware mode RPOS and RNEG outputs are valid on the rising edge of RCLK. To operate in Hardware mode, the MODE must be set to 0. Diagnostic Control for Remote Loopback (RLOOP), Local Loopback (LLOOP), and Transmit All 1s (TAOS) modes is provided through the individual pins.

If MODE is set Low, LXT307 operates in Hardware Mode. In Hardware Mode the transceiver is controlled through individual pins; a microprocessor is not required. RPOS and RNEG are valid on the rising edge of RCLK.

The equalizer is controlled through pin 23 (EC). Diagnostic control for Remote Loopback (RLOOP), Local Loopback (LLOOP), and Transmit All 1s (TAOS) is provided through pins 26, 27, and 28.

Host Mode Control

The LXT307 operates in the Host mode when pin 5 (MODE) is asserted High. In Host mode a microprocessor controls the LXT307 through the serial I/O port (SIO) which provides access to the LIU. The LIU contains a pair of data registers, one for command inputs and one for status outputs. An SIO transaction is initiated by a falling edge on the Chip Select pin. A High-to-Low transition on $\overline{\text{CS}}$ is

required for each subsequent access to the Host mode registers.

The LIU responds by writing the incoming serial word from the SDI pin into its command register. Figure 3 shows an SIO write operation. The 16-bit serial word consists of an 8-bit Command/Address byte and an 8-bit Data byte. If the command word contains a read request, the LIU subsequently outputs the contents of its status register onto the SDO pin. Figure 4 shows an SIO read operation. The Clock Edge (CLKE) signal determines when the SDO and receive data outputs are valid, relative to the Serial Clock (SCLK) or RCLK as listed in Table 4. Table 17 and Figures 15 and 16 show SIO timing.

2

SERIAL INPUT WORD

Figure 3 shows the Serial Input data structure. The LXT307 is addressed by setting bit A4 in the Address/Command byte, corresponding to address 16. Bit 1 of the serial Address/Command byte provides Read/Write (R/\overline{W}) control when the chip is accessed. The R/\overline{W} bit is set to logic 1 to read the data output byte from the chip, and set to logic 0 to write the input data byte to the chip.

The second eight bits of a write operation, clear Loss of Signal (LOS) and Driver Performance Monitor (DPM) interrupts, reset the chip, and control diagnostic modes. The first 2 bits (D0 - D1) clear and/or mask LOS and DPM interrupts. The last three bits (D5 - D7) control operating modes (normal and diagnostic) and chip reset. Refer to Table 5 for details on bits D5 - D7.

SERIAL OUTPUT WORD

Figure 4 shows the Serial Output data structure. SDO is high impedance when SDI receives an Address/Command byte. If SDI receives a read command ($R/\overline{W} = 1$), then SDO becomes active after the last Command/Address bit (A6) and remains active for eight SCLK cycles. Typically the first bit out of SDO changes the state of SDO from high-Z to a Low/High.

The first five bits (D0-D4) of the output data byte reports Loss of Signal (LOS) and Driver Performance Monitor (DPM) conditions, equalizer settings, and operating modes (normal or diagnostic). The last three bits (D5 through D7) report operating modes and interrupt status.

If the $\overline{\text{INT}}$ line is High (no interrupt is pending), bits D5 through D7 report the status of the operating mode as listed in Table 6. If the $\overline{\text{INT}}$ line is Low, the interrupt status overrides all other reports and bits D5 - D7 reflect the interrupt status as listed in Table 6.

Interrupt Handling

The Host mode provides a latched Interrupt output pin, $\overline{\text{INT}}$. Any change in the LOS or DPM bits (D0 and D1 of the output data byte, respectively) triggers an interrupt. As shown in Figure 5, writing a one to the respective bit of the input data byte (D0 = LOS, D1 = DPM) masks either or both interrupt generators. When an interrupt has occurred the $\overline{\text{INT}}$ output pin is pulled Low. The output stage of the $\overline{\text{INT}}$ pin consists of a pull-down device. Hence, an external pull-up resistor is required. clear the interrupt as follows:

1. If one or both interrupt bits (LOS or DPM, D0 and D1 of the output data byte) = 1, writing a 1 to the input bit (D0 or D1, respectively), of the input data byte will clear the interrupt. Leaving a 1 in either of these bit positions will effectively mask the associated interrupt. To re-enable the interrupt capability, reset D0 and/or D1 to 0.
2. If neither LOS or DPM = 1, the interrupt will be cleared by resetting the chip. To reset the chip, set data input bits D5 and D6 = 1, and D7 = 0.

Table 4: CLKE Settings

CLKE	Output	Clock	Valid Edge
LOW	RPOS/RNEG SDO	RCLK SCLK	Rising Falling
HIGH	RPOS/RNEG SDO	RCLK SCLK	Falling Rising

Table 5: SIO Input Bit Settings

(see Figure 3)

Mode	RLOOP Bit D5	LLOOP Bit D6	TAOS Bit D7
RLOOP	1	0	–
LLOOP	0	1	0
LLOOP + TAOS	0	1	1
TAOS	0	0	1
RESET	1	1	0

Table 6: Serial Data Output Bit Coding

Bit D5	Bit D6	Bit D7	Status
0	0	0	Reset has occurred, or no program input. (i.e., normal operation)
0	0	1	TAOS is active.
0	1	0	Local Loopback is active.
0	1	1	TAOS and Local Loopback are active.
1	0	0	Remote Loopback is active.
			Interrupt Status
1	0	1	DPM has changed state since last clear DPM occurred.
1	1	0	LOS has changed state since last clear LOS occurred.
1	1	1	LOS and DPM have both changed state since last clear DPM and clear LOS occurred.

Figure 3: LXT307 SIO Write Operation

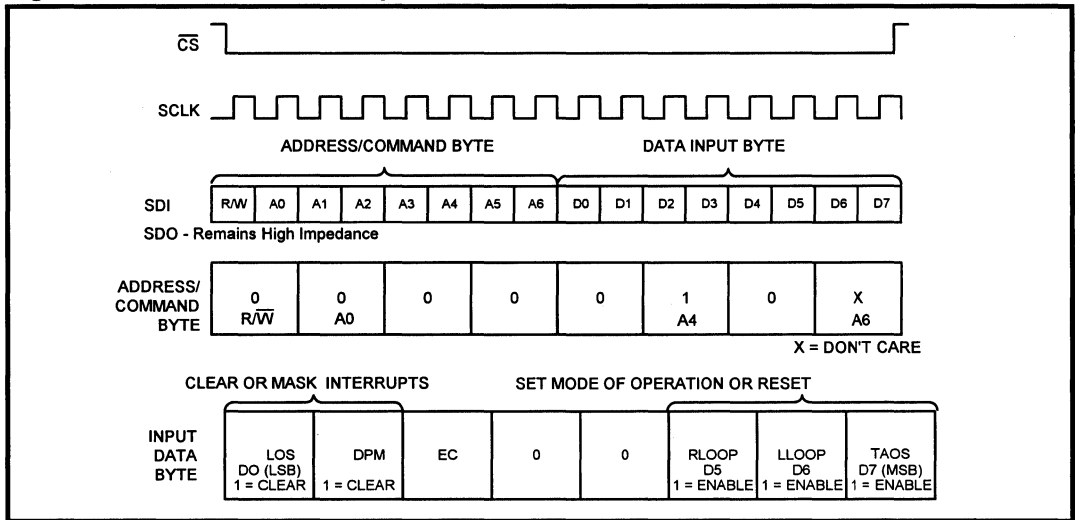

2

Figure 4: LXT307 SIO Read Operation

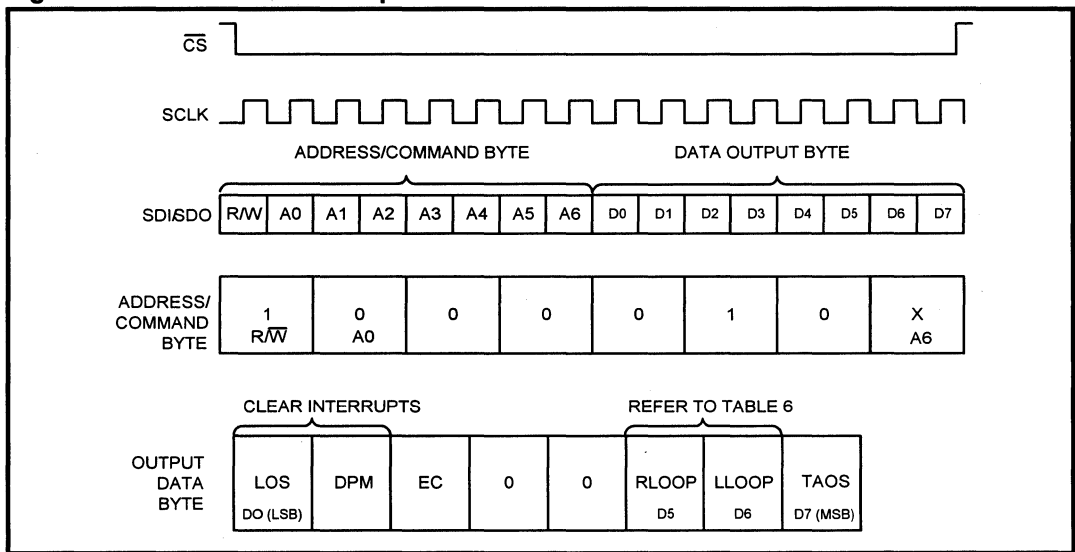
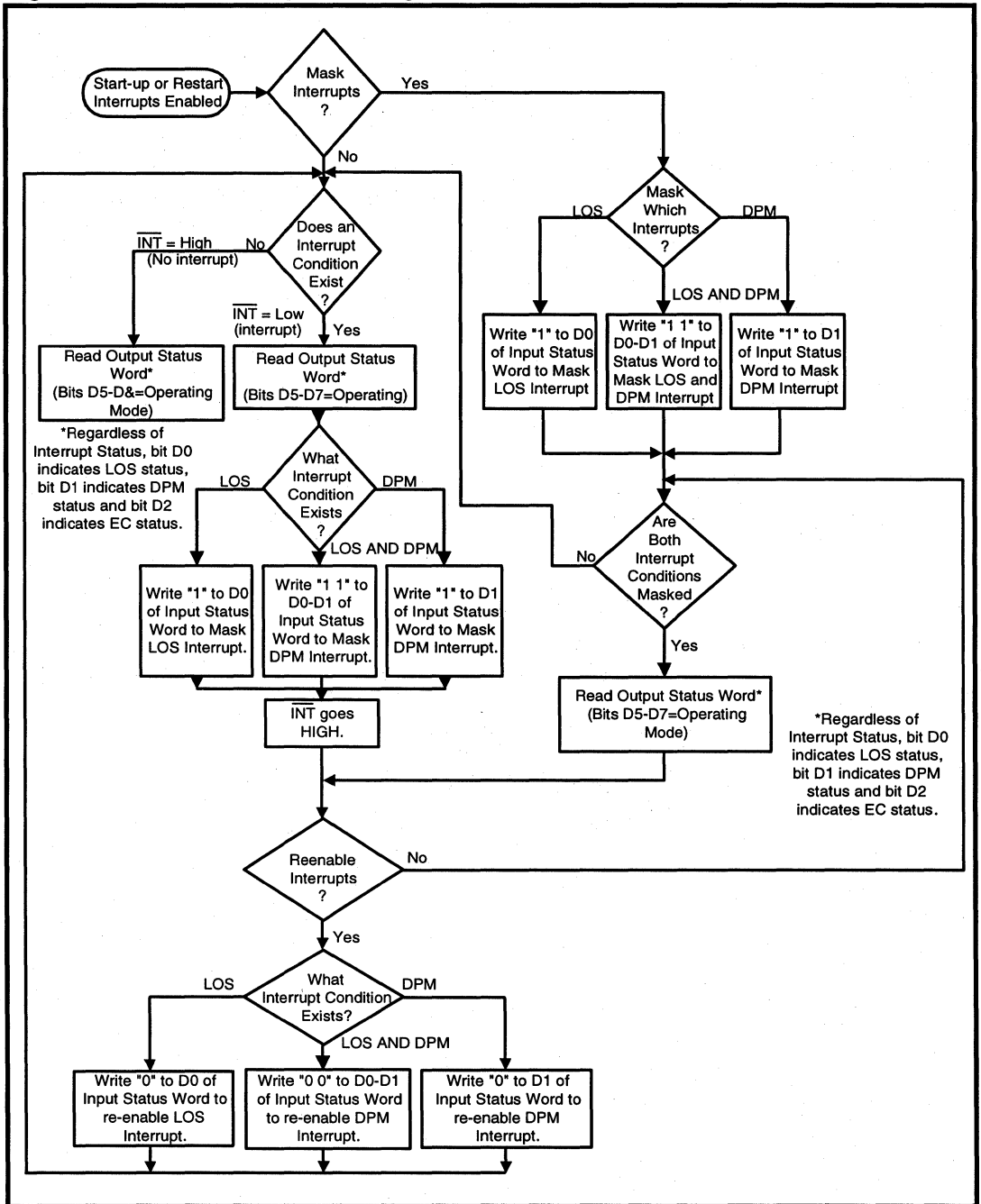

Figure 5: LXT307 Interrupt Handling



Diagnostic Mode Operation

TAOS

See Figures 6 and 7. In Transmit All Ones (TAOS) mode, the TPOS and TNEG inputs to the transceiver are ignored. The transceiver transmits a continuous stream of 1s at the TCLK frequency when TAOS is activated. TAOS can be commanded simultaneously with Local Loopback, but is inhibited during Remote Loopback.

Figure 6: TAOS

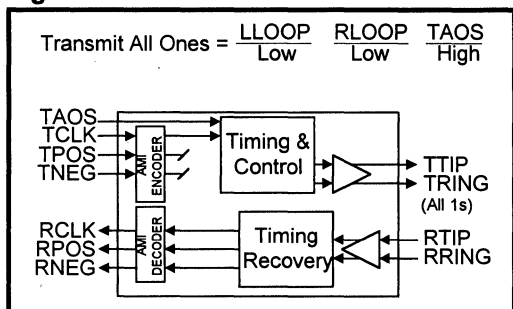
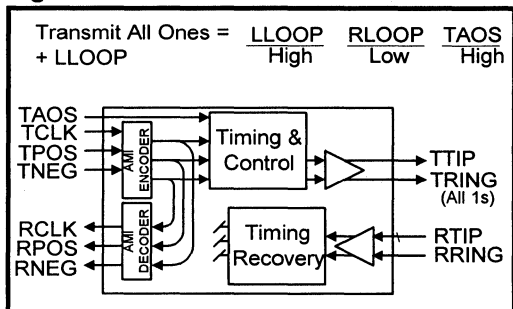

Figure 7: TAOS with LLOOP



LLOOP

See Figure 8. In Local Loopback (LLOOP) mode, the receiver circuits are inhibited. The transmit data and clock inputs (TPOS, TNEG and TCLK) are looped back onto the receive data and clock outputs (RPOS, RNEG and RCLK). The transmitter circuits are unaffected. The TPOS and TNEG inputs (or a stream of 1s if the TAOS command is active) will be transmitted normally.

Figure 8: Local Loopback

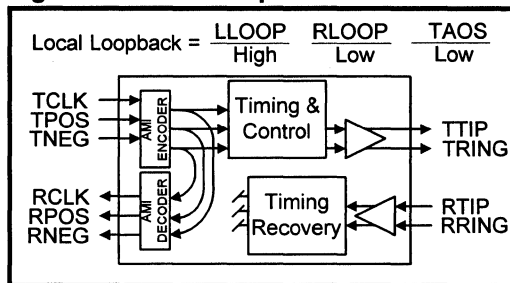

RLOOP

See Figure 9. In Remote Loopback (RLOOP) mode, the transmit data and clock inputs (TPOS, TNEG and TCLK) are ignored. The RPOS and RNEG outputs are looped back through the transmit circuits and output on TTIP and TRING at the RCLK frequency. Receiver circuits are unaffected by the RLOOP command and continue to output the RPOS, RNEG and RCLK signals received from the twisted-pair line.

Figure 9: Remote Loopback

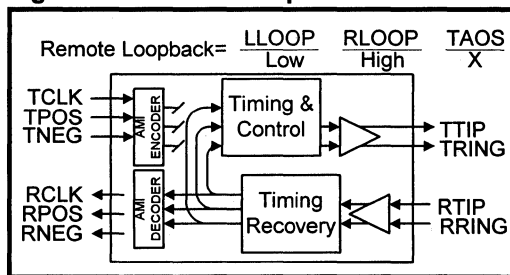

LXT307 Low-Power E1 Integrated Short-Haul Transceiver

APPLICATION INFORMATION

NOTE

This application information is for design aid only.

Figure 10 is a 2.048 Mbps E1 120 Ω Twisted-Pair Wire application using EC code 1 and 15 Ω Rt resistors in line with the transmit transformer to provide high return loss and surge protection. When high return loss is not a critical

factor, a 1:1 transformer without in-line resistors provides maximum power savings. Tables 7 and 8 list typical return loss figures for various transformer ratios, Rt values and the associated EC code for 75 Ω coax and 120 Ω twisted-pair applications, respectively. The LXT307 is shown in Hardware mode with a general G.704 Framer. The hardware control lines for TAOS, LLOOP and RLOOP are individually controllable, and the LLOOP and RLOOP lines are also tied to a single control for the Reset function.

Figure 10: LXT307 120 Ω Application (Hardware Mode)

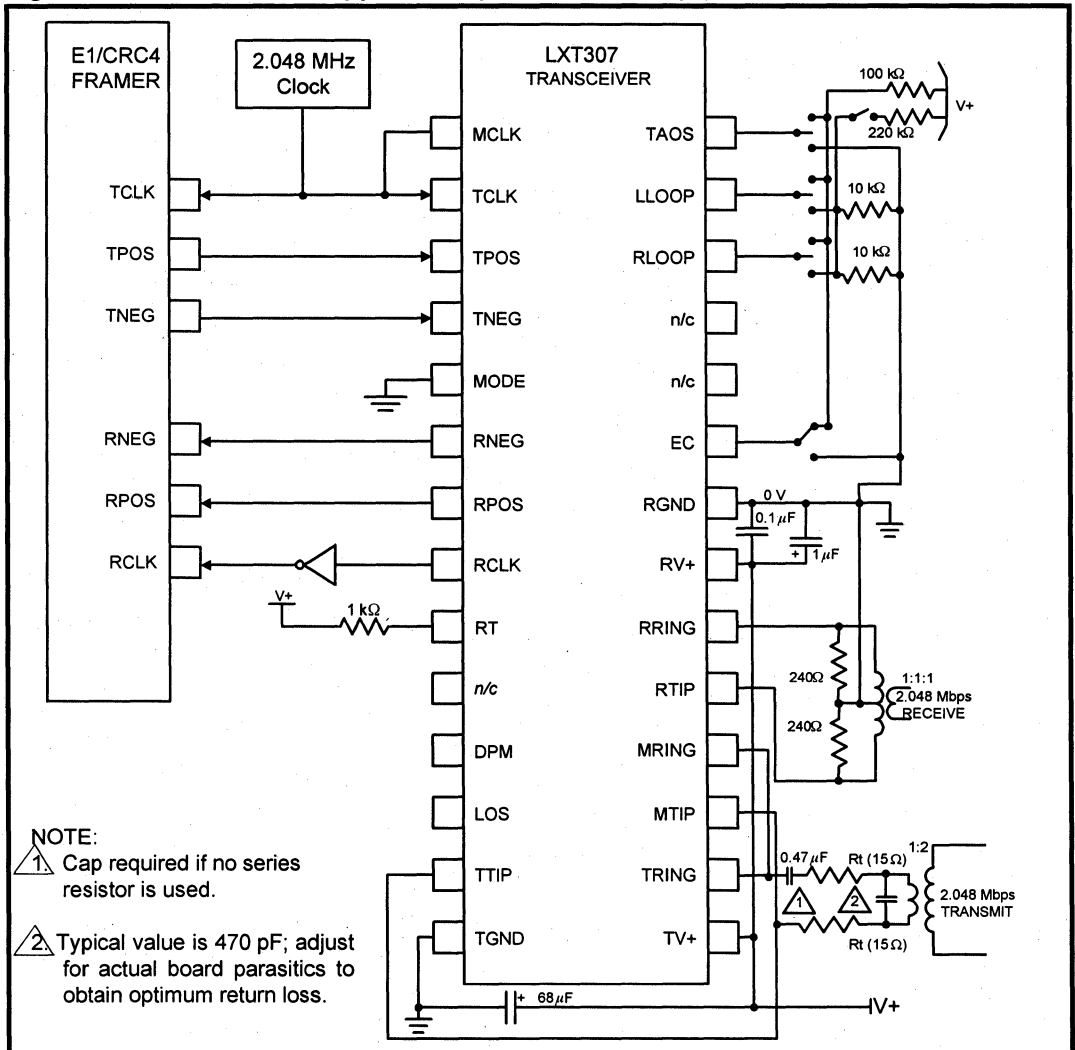

E1 COAXIAL APPLICATIONS

Figure 11 shows the line interface for a typical E1 coaxial (75 Ω) application. The EC code should be set to 0 for coax. With 9.1 Ω Rt resistors in line with the 1:2 output transformers, the LXT307 produces 2.37 V peak pulses as required for coax applications. A 1:1:1 transformer is used on the receive side.

Table 7: Transformer Specifications

Parameter	Value
Turns Ratio Tx	1:2 (±2%)
Primary Inductance	1.2 mH min
Leakage Inductance	0.5 μH max
Interwinding Capacitance	25 pF max
Series Resistance	1.0 Ω PRI

Table 8: Transformer Selection Guide

Transformer Manufacturer	Part Number	Turns Ratio	Description
Pulse Engineering	PE65861	1:2	Dual SMD
	PE 65351	1:2	Single through hole
Bel Fuse	0553-5006	1:2	Dual
Schott	67127370	1:2	Single through hole
Midcom	671-5832	1:2	Single through hole

Figure 11: Line Interface for E1 Coax Applications

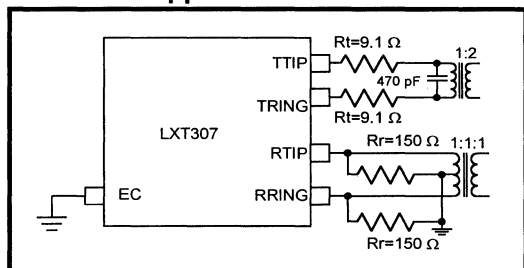

Table 9: 75 Ω Output Combinations

EC	Xfmr Ratio ¹	Rt Value ²	Rtn Loss ³
1	1: 1	Rt = 10 Ω	5 dB
1	1: 2	Rt = 14.3 Ω	10 dB
0	1: 1	Rt = 0 Ω ⁴	0.5 dB
0	1: 2	Rt = 9.1 Ω	18 dB

1. Transformer turns ratio accuracy is ±2%.
2. Rt values are ±1%.
3. Typical return loss, 51 kHz - 3.0728 kHz.
4. Cap required if no series resistor is used.

Table 10: 120 Ω Output Combinations

EC	Xfmr Ratio ¹	Rt Value ²	Rtn Loss ³
1	1: 1	Rt = 0 Ω ⁴	0.5 dB
1	1: 2	Rt = 15 Ω	18 dB
0	1: 2	Rt = 9.1 Ω	10 dB

1. Transformer turns ratio accuracy is ±2%.
2. Rt values are ±1%.
3. Typical return loss, 51 kHz - 3.0728 kHz.
4. Cap required if no series resistor is used.

2

LXT307 Low-Power E1 Integrated Short-Haul Transceiver

TEST SPECIFICATIONS

NOTE

The minimum and maximum values in Tables 11 through 17 and Figures 12 through 17 represent the performance specifications of the LXT307 and are guaranteed by test, except where noted by design.

Table 11: Absolute Maximum Ratings

Parameter	Sym	Min	Max	Units
DC Supply (referenced to GND)	RV+, TV+	-	6.0	V
Input Voltage, any pin ¹	V _{IN}	RGND - 0.3	RV+ + 0.3	V
Input Current, any pin ²	I _{IN}	-10	10	mA
Storage Temperature	T _{STG}	-65	150	°C
CAUTION				
Operations at or beyond these limits may result in permanent damage to the device. Normal operation is not guaranteed at these extremes.				
1. Excluding RTIP and RRING which must stay between -6V and (RV+ + 0.3) V.				
2. Transient currents of up to 100 mA will not cause SCR latch up. TTIP, TRING, TV+ and TGND can withstand a continuous current of 100 mA.				

Table 12: Recommended Operating Conditions and Characteristics

Parameter	Sym	Min	Typ	Max	Units
DC Supply ¹	RV+, TV+	4.75	5.0	5.25	V
Ambient Operating Temperature	TA	-40	25	85	°C
1. TV+ must not exceed RV+ by more than 0.3 V.					

Table 13: Electrical Characteristics (Over recommended operating conditions)

Parameter	Sym	Min	Typ	Max	Units	Test Conditions	
Total power dissipation ^{1, 2}	75 Ω (EC = 0)	P _D	-	260	320	mW	50% 1s density
	120 Ω (EC = 1)	P _D	-	270	320	mW	
Total power consumption ³	120 Ω (EC = 1)	P _D	-	400	T.B.D.	mW	100% 1s density
High level input voltage ⁴ (pins 1-5, 23)	V _{IH}	2.0	-	-	V		
Low level input voltage ⁴ (pins 1-5, 23)	V _{IL}	-	-	0.8	V		
High level output voltage ^{4, 5} (pins 6-8, 11, 12, 23, 25)	V _{OH}	2.4	-	-	V	I _{OUT} = -400 μA	
Low level output voltage ^{4, 5} (pins 6-8, 11, 12, 23, 25)	V _{OL}	-	-	0.4	V	I _{OUT} = 1.6 mA	
Input leakage current ⁶	I _{LL}	0	-	±10	μA		
Three-state leakage current (pin 25)	I _{3L}	0	-	±10	μA		
1. Device power dissipation while driving a 75 or 120 Ω load over operating temperature range. Digital input levels are within 10% of the supply rails and digital outputs are driving a 50 pF capacitive load. R _t = 0 Ω; transformer ratio = 1:1.							
2. Guaranteed by design and other correlation methods.							
3. Power consumption while driving a 60 Ω effective load. Includes device and load. R _t = 15 Ω; transformer ratio = 1:2; EC = 1.							
4. Functionality of pin 23 depends on mode. See Host/Hardware Mode Descriptions.							
5. Output drivers will output CMOS logic levels into CMOS loads.							
6. Except MTIP and MRING I _{LL} = ±50 μA.							

Table 14: Analog Characteristics (Over recommended operating conditions)

Parameter		Min	Typical ¹	Max	Units	Test Conditions	
AMI Output Pulse Amplitudes	75 Ω	2.14	2.37	2.6	V	G.703	
	120 Ω	2.7	3.0	3.3	V	G.703	
Peak Voltage of a space	75 Ω	-0.237	0	+0.237	V		
	120 Ω	-0.3	0	+0.3	V		
Ratio of the widths of positive and negative pulses at the nominal half amplitude		95	–	105	%		
Ratio of the amplitudes of positive and negative pulses at the center of the pulse interval		95	–	105	%		
Recommended output load at TTIP and TRING		–	75	–	Ω		
Driver output impedance ⁴			3	10	Ω		
Driver short circuit current ²				50	mA		
Jitter added by the transmitter	10 Hz - 8 kHz ⁴	–	–	0.01	UI	G.823	
	18 kHz - 100 kHz ⁴	–	–	0.025	UI	G.823	
	20 Hz - 100 kHz ⁴	–	–	0.025	UI	G.823	
	Broad Band ³	–	0.025	0.050	UI		
Receiver sensitivity	(0 dB = 2.4 V)	13.6	–	–	dB		
		500	–	–	mV		
Receiver input impedance		–	40	–	kΩ		
Signal to interference ratio (FEXT) ⁴		15	–	–	dB	G.703, O.151	
Input jitter tolerance 18 kHz - 100 kHz		0.4	–	–	UI	G.823	
Loss of Signal threshold		–	20	–	dB	below nominal	
Data decision threshold ⁴		43	50	57	% peak		
Allowable consecutive zeros before LOS ⁴		160	175	190	–	G.775	
LOS reset transition window ⁴		–	32	–	bit	four transitions	
		Transmit		Receive			
		Min	Typ ¹	Min	Typ ¹		
Minimum Return Loss ⁴	51 Hz – 102 kHz	18	20	20	–	dB	Dynamic conditions per ETS 300 166 and ITU G.703. See Figures 10, 11.
	102 kHz – 2.048 MHz	18	20	20	–	dB	
	2.048 MHz – 3.072 MHz	18	20	20	–	dB	

1. Typical values are measured at 25 °C and are for design aid only. Not guaranteed or subject to production testing.
 2. Per OFTEL OTR-001/BABT BS4650 with 15 Ω termination resistors and a 1:2 transmit transformer on a 0.5 Ω test load.
 3. Input signal to TCLK is jitter-free.
 4. Guaranteed by design or other correlation methods.

Figure 12: 2.048 Mbps Pulse Mask Template

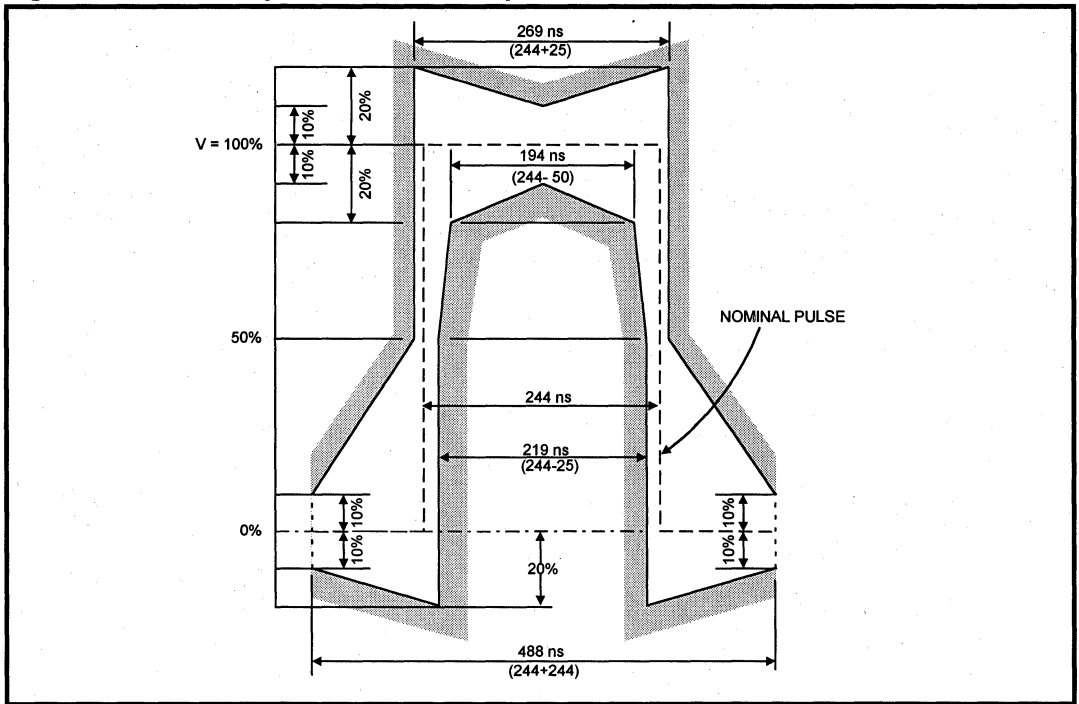

Table 15: Receive Timing Characteristics (Over recommended operating conditions)

Parameter	Sym	Min	Typ ¹	Max	Units	Test Conditions
Receive clock duty cycle	RCLKd	40	–	60	%	
Receive clock pulse width	tPW	–	244	–	ns	
RPOS/RNEG to RCLK rising setup time	tSUR	–	194	–	ns	
RCLK rising to RPOS/RNEG hold time	tHR	–	194	–	ns	

1. Typical values are at 25 °C and are for design aid only; they are not guaranteed and not subject to production testing.

Figure 13: LXT307 Receive Clock Timing

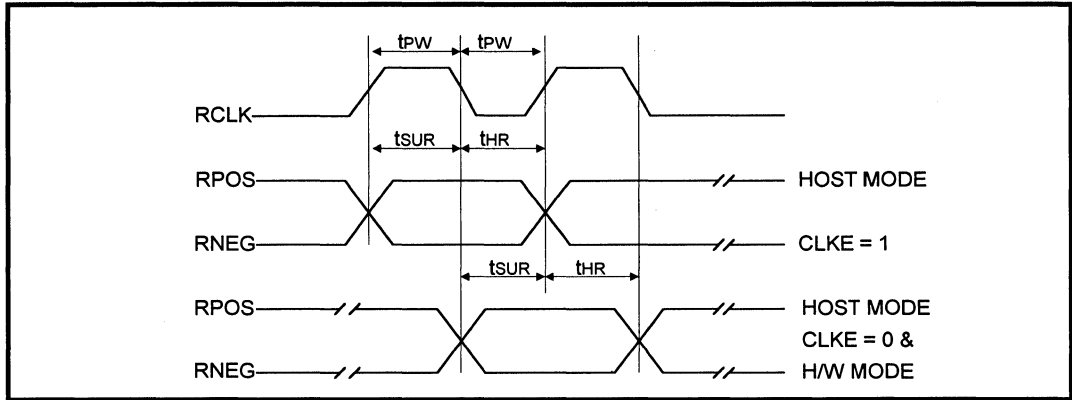

Figure 14: LXT307 Transmit Clock Timing

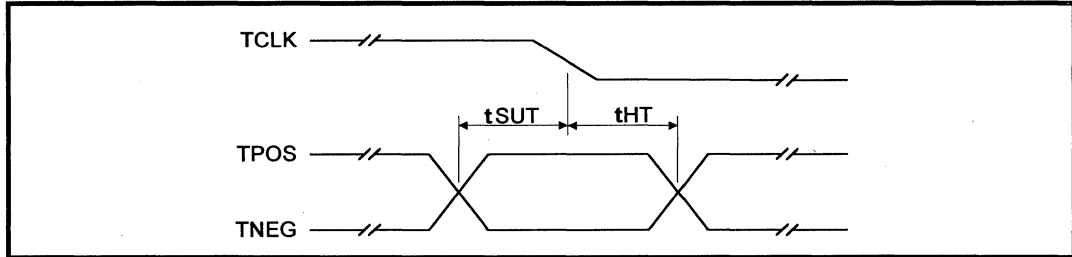

Table 16: Transmit Timing Characteristics (over recommended operating conditions)

Parameter	Sym	Min	Typ ¹	Max	Units
Master clock frequency	MCLK	–	2.048	–	MHz
Master clock tolerance	MCLKt	–	±100	–	ppm
Master clock duty cycle	MCLKd	40	–	60	%
Transmit clock frequency	TCLK	–	2.048	–	MHz
Transmit clock tolerance	TCLKt	–	±50	–	ppm
Transmit clock duty cycle	TCLKd	10	–	90	%
TPOS/TNEG to TCLK setup time	tsut	25	–	–	ns
TCLK to TPOS/TNEG Hold time	tht	25	–	–	ns

1. Typical values are at 25 °C and are for design aid only; they are not guaranteed and not subject to production testing.

LXT307 Low-Power E1 Integrated Short-Haul Transceiver

Table 17: Serial I/O Timing Characteristics (Over recommended operating conditions)

Parameter	Sym	Min	Typ ¹	Max	Units	Test Conditions
Rise time - any digital output	t _R	-	-	100	ns	Load 1.6 mA, 50 pF
Fall time - any digital output	t _F	-	-	100	ns	Load -400 μA, 50 pF
SDI to SCLK setup time	t _{DC}	50	-	-	ns	
SCLK to SDI hold time	t _{CDH}	50	-	-	ns	
SCLK low time	t _{CL}	240	-	-	ns	
SCLK high time	t _{CH}	240	-	-	ns	
SCLK rise and fall time	t _R , t _F	-	-	50	ns	
\overline{CS} to SCLK setup time	t _{CC}	50	-	-	ns	
SCLK to \overline{CS} hold time	t _{CCH}	50	-	-	ns	
\overline{CS} inactive time	t _{CWH}	250	-	-	ns	
SCLK to SDO valid	t _{CDV}	-	-	200	ns	
SCLK falling edge or \overline{CS} rising edge to SDO high Z	t _{CDZ}	-	100	-	ns	

1. Typical values are at 25° C and are for design aid only; they are not guaranteed and not subject to production testing.

Figure 15: LXT307 Serial Data Input Timing Diagram

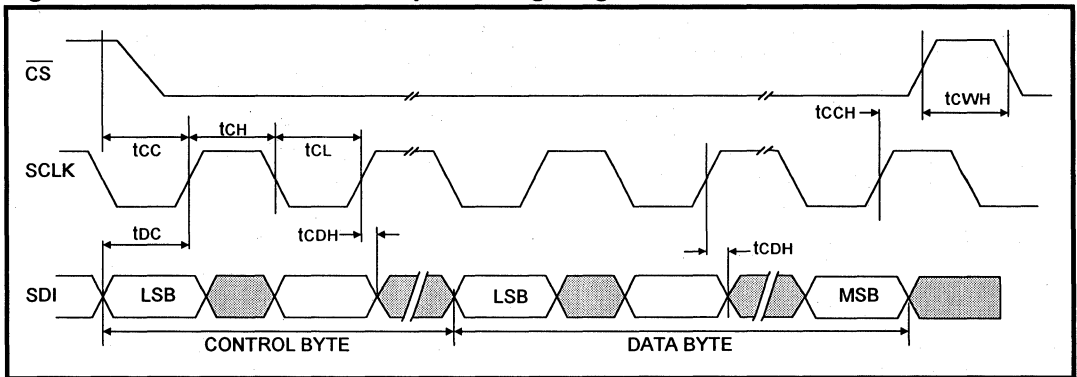
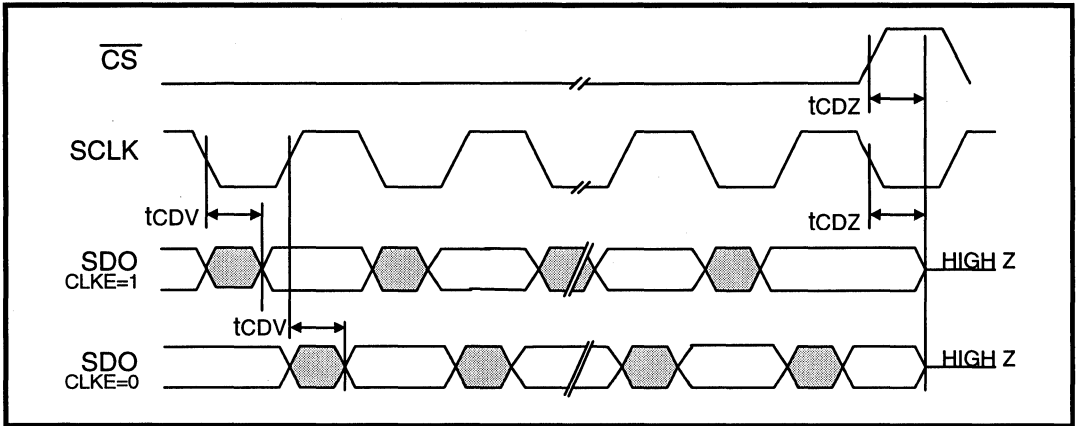
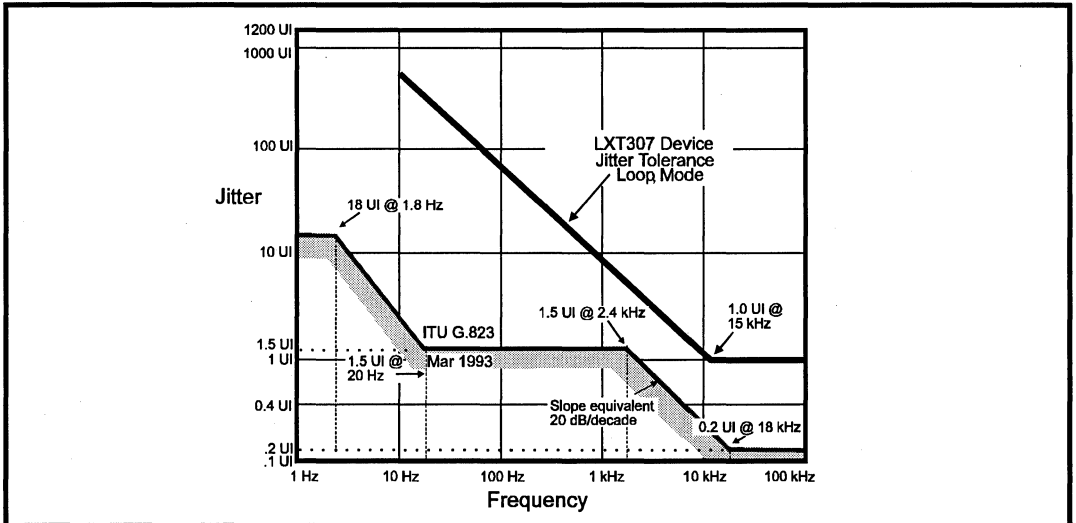

Figure 16: LXT307 Serial Data Output Timing Diagram



2

Figure 17: Typical Receiver Input Jitter Tolerance (Loop Mode)



NOTES:

LXT325

T1/E1 Integrated Quad Receiver

General Description

The LXT325 quad receiver is a fully-integrated, quadruple-PCM receiver for both 1.544 Mbps, and 2.048 Mbps applications. It incorporates four independent receivers in a single 28-pin DIP or PLCC, or a 44-pin QFP. Each LXT325 receiver also incorporates a Loss Of Signal (LOS) detection circuit and output driver. The operating frequency is pin selectable.

These receivers perform data and timing recovery, and use peak detection and a variable threshold to reduce impulsive noise. Receiver sensitivity down to 500 mV allows for up to 13.6 dB of attenuation.

The LXT325 quad receiver is an advanced, double-poly, double-metal CMOS device and requires only a single 5-volt power supply.

Applications

- High-density T1/E1 line cards
- M13, E13 line interfaces
- Test equipment
- Line monitoring
- Receive line interface

Features

- Four independent 1.544/2.048 Mbps receivers
- Loss Of Signal (LOS) output for each receiver
- Circuit functions include data and clock recovery
- Single Master Clock input
- Meets or exceeds AT&T PUB 62411 ITU-T G.703 and ITU G.823 requirements for jitter tolerance
- Unipolar RPOS and RNEG outputs
- Minimum receive signal of 500 mV
- Selectable slicer levels (DSX-1/E1) to provide improved SNR
- CMOS technology requires only single 5 V power input
- Available in 28-pin plastic DIP and PLCC and 44-pin QFP packages
- -40 °C to 85 °C operating temperature range

LXT325 Block Diagram

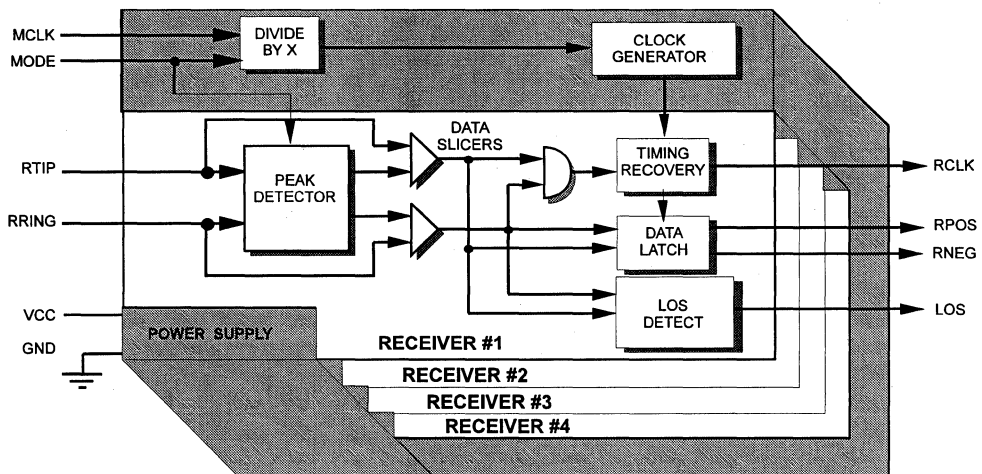

LXT325 T1/E1 Integrated Quad Receiver

Figure 1: LXT325 Pin Assignments

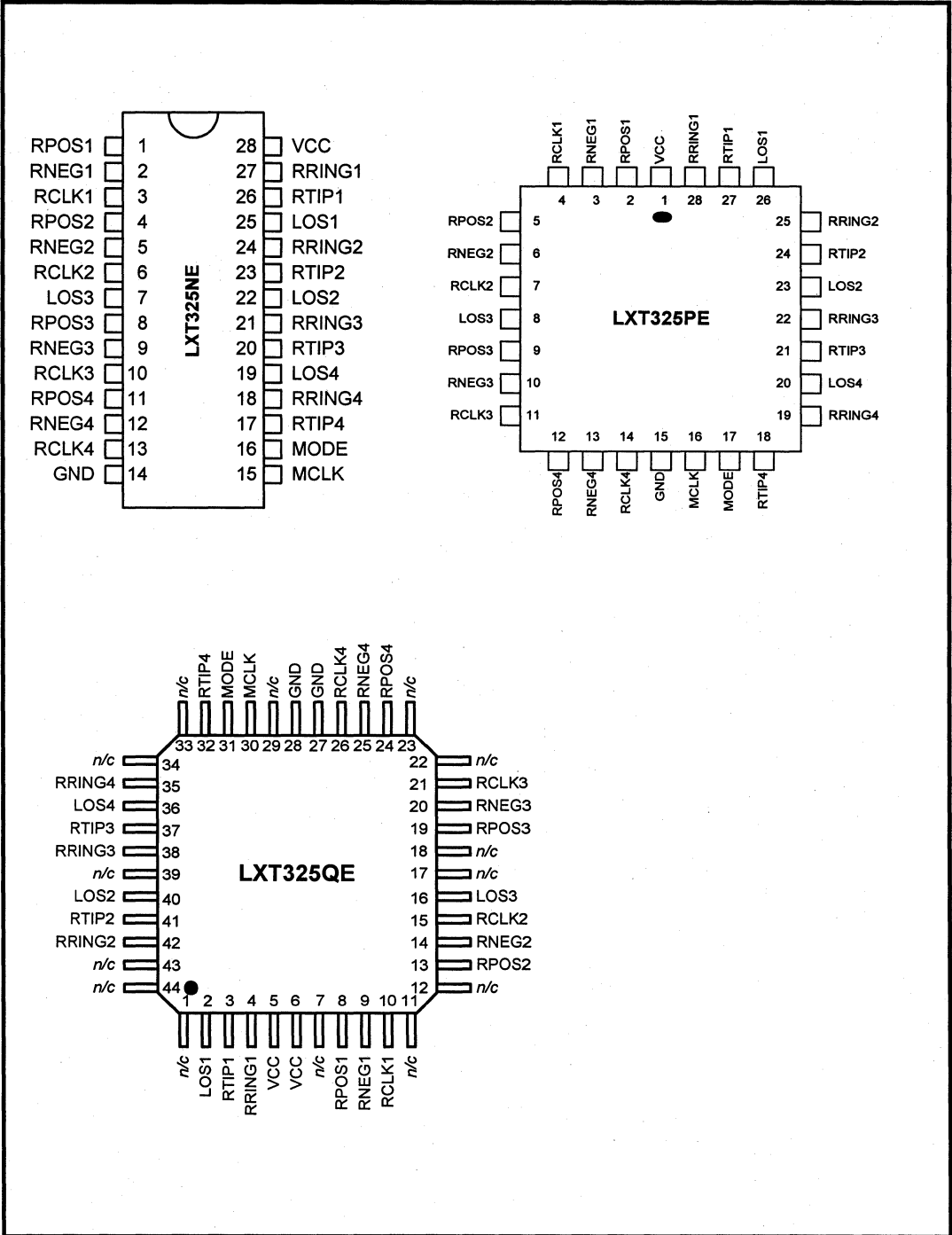

Table 1: Pin Assignments and Descriptions

Pin #			Symbol	I/O ²	Description
DIP	PLCC	QFP ¹			
1 2	2 3	8 9	RPOS1 RNEG1	DO	Receiver 1 Positive and Negative Data outputs. A signal on RNEG _x corresponds to receipt of a negative pulse on RTIP _x and RRING _x . A signal on RPOS _x corresponds to receipt of a positive pulse on RTIP _x and RRING _x . RNEG _x and RPOS _x outputs are Non-Return-to-Zero (NRZ) signals. Both outputs are stable and valid on the rising edge of RCLK _x .
3	4	10	RCLK1	DO	Receiver 1 Recovered Clock. Clock recovered from the inputs to RTIP1 and RRING1. See RPOS1/RNEG1.
4 5 6	5 6 7	13 14 15	RPOS2 RNEG2 RCLK2	DO	Receiver 2 Data and Clock outputs. Signals recovered from the inputs to RTIP2 and RRING2. See RPOS1/RNEG1/RCLK1.
7	8	16	LOS3	DO	Receiver 3 Loss of Signal Detector. LOS _x pins go high when the associated receiver detects 175 consecutive spaces. The LOS output returns low when a mark is received.
8 9 10	9 10 11	19 20 21	RPOS3 RNEG3 RCLK3	DO	Receiver 3 Data and Clock outputs. Signals recovered from the inputs to RTIP3 and RRING3. See RPOS1/RNEG1/RCLK1.
11 12 13	12 13 14	24 25 26	RPOS4 RNEG4 RCLK4	DO	Receiver 4 Data and Clock outputs. Signals recovered from the inputs to RTIP4 and RRING4. See RPOS1/RNEG1/RCLK1.
14	15	27 28	GND	–	Ground.
15	16	30	MCLK	DI	Master Clock. A 1.544 MHz or 2.048 MHz clock input used to generate internal clocks. Upon loss of signal, MCLK serves as the source for all the RCLK _x signals.
16	17	31	MODE	DI	Mode Selection. Set MODE high for 50% slicer level. This setting is mandatory for 2.048 Mbit/s operation and provides maximum sensitivity in 1.544 Mbit/s designs. Where undershoot will exceed 45% in 1.544 MHz applications, pull MODE low to set the slicer levels to 70%.
17 18	18 19	32 35	RTIP4 RRING4	AI	Receiver 4 Tip and Ring. The AMI signal received from the 4 th twisted-pair line is applied at these pins. A center-tapped, center-grounded transformer is required on these pins. Data and clock from the signal applied at these pins are recovered and output on the RPOS _x /RNEG _x , and RCLK _x pins.
19	20	36	LOS4	DO	Receiver 4 Loss of Signal Detector. See LOS3.
20 21	21 22	37 38	RTIP3 RRING3	AI	Receiver 3 Tip and Ring Inputs. See RTIP4/RRING4.
22	23	40	LOS2	DO	Receiver 2 Loss of Signal detector. See LOS3.

1. Pins 1, 7, 11, 12, 17, 18, 22, 23, 29, 33, 34, 39, 43 and 44 have no function in the 44-pin QFP package. All applications should leave them unconnected.
2. Entries in the I/O column are DI = Digital Input; DO = Digital Output; AI = Analog Input.

LXT325 T1/E1 Integrated Quad Receiver

Table 1: Pin Assignments and Descriptions – continued

Pin #			Symbol	I/O ²	Description
DIP	PLCC	QFP ¹			
23	24	41	RTIP2	AI	Receiver 2 Tip and Ring Inputs. See RTIP4/RRING4.
24	25	42	RRING2		
25	26	2	LOS1	DO	Receiver 1 Loss of Signal Detector. See LOS3.
26	27	3	RTIP1	AI	Receiver 1 Tip and Ring Inputs. See RTIP4/RRING4.
27	28	4	RRING1		
28	1	5,6	VCC	–	+5 VDC Power Supply

1. Pins 1, 7, 11, 12, 17, 18, 22, 23, 29, 33, 34, 39, 43 and 44 have no function in the 44-pin QFP package. All applications should leave them unconnected.
 2. Entries in the I/O column are DI = Digital Input; DO = Digital Output; AI = Analog Input.

FUNCTIONAL DESCRIPTION

NOTE

This functional information is for design aid only.

The LXT325 quad receiver is a fully-integrated, PCM receiver for both 1.544 Mbit/s (DSX-1) and 2.048 Mbit/s (E1) applications. The MCLK frequency and the MODE pin input level set the mode of operation. The LXT325 is a low-power CMOS device operating from a single +5 V power supply.

The figure at the front of the Data Sheet shows a simplified block diagram of the LXT325. The input signal is received from the twisted-pair line on each side of a center-grounded transformer. (Positive pulses are received at RTIP and negative pulses are received at RRING.) This differential signal is processed through the peak detector and data slicers. The peak detector samples the inputs and determines the maximum value of the received signal. A percentage of the peak value is provided to the data slicers as a threshold level to ensure optimum signal-to-noise ratio.

For E1 applications the threshold is set to 50% of the peak value (MODE set High). In 1.544 Mbit/s applications where undershoot does not exceed 45%, MODE may be set High (50% of the peak value) for the maximum sensitivity and noise margin. In applications where the undershoot exceeds 45% the MODE must be set Low. With MODE Low, the slicer threshold is set to 70% of the peak value. This threshold is maintained above 65% for up to 15 consecutive zeros over the range of specified operating conditions.

The slicer threshold is maintained through a capacitive storage arrangement and a combination of Refresh and Bleed-off circuitry. This design balance prevents the refresh circuitry from driving the threshold too high, while ensuring that it is maintained over long strings of successive zeros.

These receivers are capable of accurately recovering signals with up to 13.6 dB of attenuation (from 2.4 V), corresponding to a received signal level of 500 mV. Maximum cable length is 1500 feet of ABAM cable (approximately 6 dB), with the additional attenuation being resistive flat loss. Regardless of received signal level, the peak detectors are held above a minimum level of 150 mV to provide immunity from impulsive noise.

After processing through the data slicers, the received signal is routed to the data and clock recovery sections. Recovered clock signals are supplied to the data latch. The recovered data is synchronized with the recovered clock (RCLK), then output at RNEG and RPOS. RPOS and RNEG outputs are valid on the rising edge of RCLK.

LINE INTERFACE

The LXT325 quad receiver interfaces with four twisted-pair lines (one twisted-pair for each receiver) through standard pulse transformers and appropriate resistors. Recommended transformer characteristics are listed in Table 2.

2

Table 2: Recommended Transformer Characteristics

Parameter		1:1:1	1:2:2	Unit
DC Resistance	Primary	1.0 Maximum	1.0 Maximum	Ω
	Secondary	1.0 Maximum	1.0 Maximum	Ω
Primary inductance (Line Side)		1.2 typical	0.5 Maximum	mH
Leakage inductance		0.5 Maximum	1.0 Maximum	μH
Interwinding capacitance		25 Maximum	40 Maximum	pF

APPLICATION INFORMATION

NOTE

This application information is for design aid only.

The LXT325 quad receiver is compatible with both DSX-1 and E1 systems. Low, +5 V only, power consumption simplifies design considerations where multiple receivers are required. The LXT325 is well-suited for use in both line interface equipment and monitor applications. The primary

difference in circuit design between these two applications is the input transformer. The typical DSX-1 pulse seen in test equipment requires a 1:1:1 transformer at the receiver input. The attenuated pulse seen in monitor applications may require a 1:2:2 transformer to boost the input signal. Figure 2 is a typical 1.544 Mbit/s DSX-1 application. The LXT325 is shown tapped into the cross connect frame with 800 Ω resistors across each leg of the center-tapped, center-grounded, 1:2:2 step-up transformer.

Figure 2: Typical T1 Test/Monitor Equipment Application

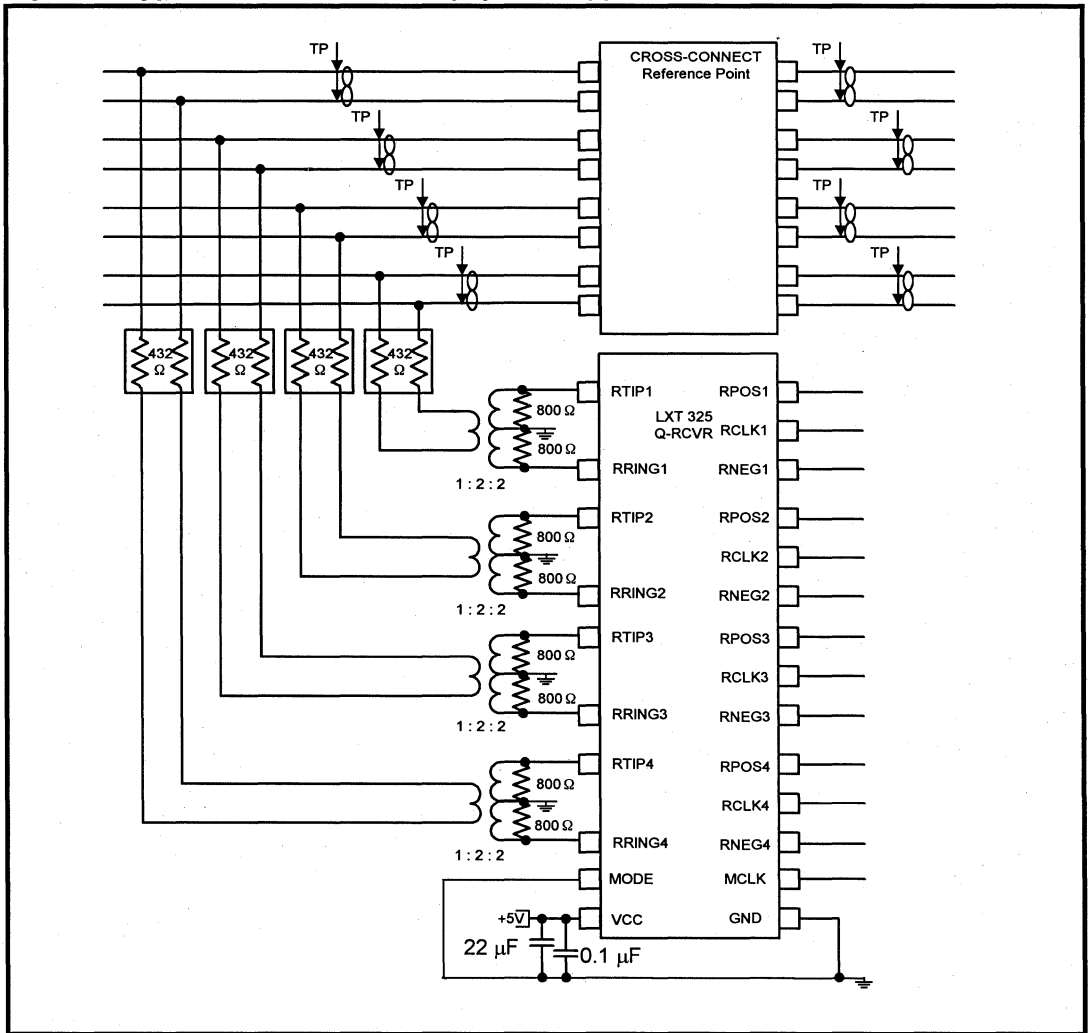
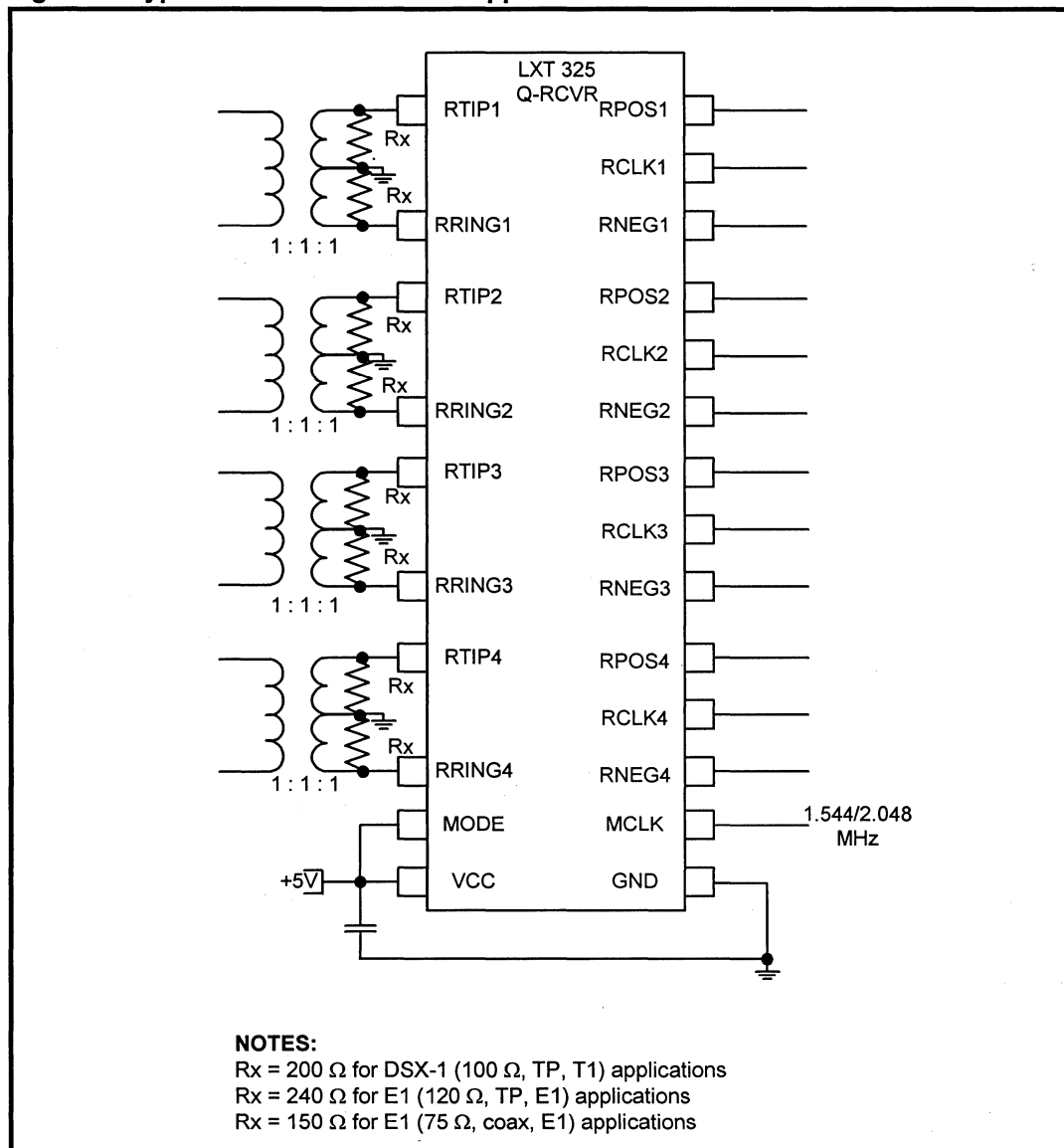

Figure 3: Typical DSX-1/E1 Receiver Application



LXT325 T1/E1 Integrated Quad Receiver

TEST SPECIFICATIONS

NOTE

The minimum and maximum values in Tables 3 through 6 and Figures 5 through 7 represent the performance specifications of the LXT325 and are guaranteed by test, except where noted by design.

Table 3: Absolute Maximum Ratings

Parameter	Symbol	Min	Max	Units
Supply Voltage	VCC	-0.3 V	6 V	V
Input Voltage, any I/O pin ¹	VI/O	GND - 0.3 V	VCC + 0.3 V	V
Input Current, any I/O pin ²	II/O	-10	10	mA
Storage Temperature	TST	-65	150	°C

CAUTION

Exceeding these values may cause permanent damage to the device. Operation under these conditions is not implied. Exposure to absolute maximum rating conditions for extended periods may affect device reliability.

1. Excluding RTIP and RRING which must stay within -6 V to VCC + 0.3 V
2. Transient currents of up to 100 mA will not cause SCR latch-up.

Table 4: Recommended Operating Conditions

Parameter	Symbol	Min	Typ	Max	Units
Supply Voltage ¹	VCC	4.75	5	5.25	V
Power dissipation	PD	1	–	1	W
Operating Temperature	TOP	-40	–	85	°C

1. Voltages are with respect to ground unless otherwise stated.

Table 5: DC Electrical Characteristics¹

Parameter	Sym	Min	Typ	Max	Units	Test Conditions
Supply current	ICC	–	–	40	mA	
Input High voltage	VIH	2.0	–	–	V	Digital Inputs
Input Low voltage	VIL	–	–	0.8	V	Digital Inputs
Output High voltage	VOH	2.4	–	–	V	Io = 0.4 mA
Output Low voltage	VOL	–	–	0.4	V	Io = 1.6 mA
Input leakage current	ILL	–	–	±10	µA	Digital inputs
Output current	IH	–	–	1.6	mA	Vo = 0.4 V
Output rise/fall time	TRF	–	–	25	ns	15 pF load

1. Clocked operation over recommended temperature and power supply ranges.

Table 6: Receiver Characteristics

Parameter		Sym	Min	Typ ¹	Max	Units	Test Conditions
Slicer ratio	Mode=Low	SRD	63	70	77	%	
	Mode=High	SRC	43	50	57	%	
Dynamic Range		DR	0.50	–	3.6	V _{PEAK}	
Undershoot		US	–	–	62	%	
Sensitivity below DSX (0 dB = 2.4 V)		–	13.6	–	–	dB	maximum of 6 dB cable loss, with balance being resistive loss.
		–	500	–	–	mV	
Error-Free Signal-to-Crosstalk ratio	2.048 MHz	S/X	14	–	–	dB	Single frequency interference production test guarantees error-free operation as specified in G.703, f 6.3.4 (Testing for 1.544 MHz systems uses a 1.544 Mbit/s QRSS interfering signal; MODE = 1.)
	1.544 MHz	S/X	12	–	–	dB	

1. Typical figures are at 25 °C and are design aids only; not guaranteed and not subject to production testing.

Figure 4: Clock Timing Diagram

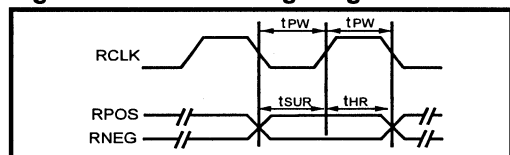

Table 7: Master and Receive Clock Timing Characteristics (See Figure 4)

Parameter		Sym	Min	Typ ¹	Max	Units	Test Conditions
Master Clock Frequency	DSX-1	MCLK	–	1.544	–	MHz	
	E1	MCLK	–	2.048	–	MHz	
Master Clock Tolerance		MCLKt	–	±100	–	ppm	
Master Clock duty cycle		MCLKd	40	50	60	%	
Receive Clock duty cycle		RCLKd	40	50	60	%	
Receive Clock pulse width	1.544 Mbit/s	tpw	270	325	378	ns	
	2.048 Mbit/s	tpw	203	244	285	ns	
RPOS/RNEG to RCLK rising setup time	1.544 Mbit/s	tsur	50	270	–	ns	
	2.048 Mbit/s	tsur	50	203	–	ns	
RCLK rising to RPOS/RNEG hold time	1.544 Mbit/s	thr	50	270	–	ns	
	2.048 Mbit/s	thr	50	203	–	ns	
Rise/fall time—any digital output		Trf	–	–	25	ns	

1. Typical figures are at 25 °C and are design aids only; not guaranteed and not subject to production testing.

NOTES:

LXT332

Dual T1/E1 Line Interface Unit with Crystal-less Jitter Attenuation

General Description

The LXT332 is a fully integrated Dual Line Interface Unit (DLIU) for both 1.544 Mbps (T1) and 2.048 Mbps (E1) applications. It features B8ZS/HDB3 encoders and decoders, and a constant low output impedance transmitter for high return loss. Transmit pulse shape is selectable for various line lengths and cable types.

The LXT332 incorporates an advanced crystal-less digital jitter attenuator, switchable to either the transmit or receive side. This eliminates the need for an external quartz crystal. It offers both a serial interface (SIO) for microprocessor control and a hardware control mode for stand-alone operation.

The LXT332 offers a variety of advanced diagnostic and performance monitoring features. It uses an advanced double-poly, double-metal CMOS process and requires only a single 5-volt power supply.

Applications

- PCM / Voice Channel Banks
- Data Channel Bank / Concentrator
- T1 / E1 multiplexer
- Digital Access and Cross-connect Systems (DACS)
- Computer to PBX interface (CPI & DMI)
- SONET/SDH Multiplexers
- Interfacing Customer Premises Equipment to a CSU
- Digital Loop Carrier (DLC) terminals

Features

- Digital (crystal-less) jitter attenuation, selectable for receive or transmit path, or may be disabled
- High transmit and receive return loss
- Constant low output impedance transmitter with programmable equalizer shapes pulses to meet DSX-1 pulse template from 0 to 655 ft
- Meets or exceeds industry specifications including ITU G.703, ANSI T1.403 and AT&T Pub 62411
- Compatible with most industry standard framers
- Complete line driver, data recovery and clock recovery functions
- Minimum receive signal of 500 mV, with selectable slicer levels (E1/DSX-1) to improve SNR
- Local, remote, and dual loopback functions
- Built-In Self Test with QRSS Pattern Generator
- Transmit / Receive performance monitors with Driver Fail Monitor (DFM) and Loss of Signal (LOS) outputs
- Receiver jitter tolerance 0.4 UI from 40 kHz to 100 kHz
- Available in 44-pin PLCC and 44-pin QFP

2

LXT332 Block Diagram

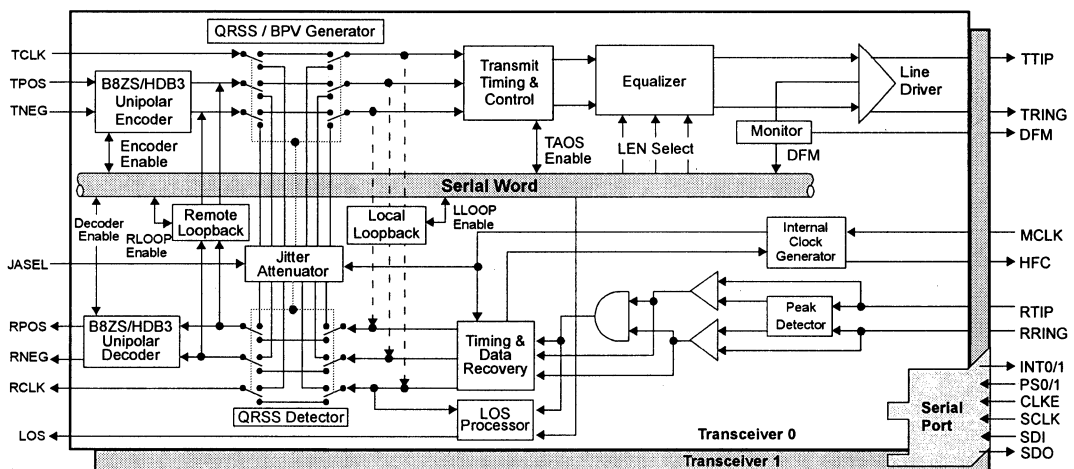

OVERVIEW

In addition to the inherent advantages of a DLIU, the LXT332 also provides several advanced features which are not available in other LXT30x-series devices. All of the added features are easily implemented. Many require only a clock pulse to change from one mode to another. Some features are available in Host Mode only.

- Two complete LIUs in a single PLCC or QFP package
- Simplifies board design, saves real estate
- Proven architecture (LXT3xx series)
- Crystal-less Jitter Attenuation
- New Features

STANDARD LXT332 FEATURES

- **Tri-state Outputs**
 - All LXT332 output pins can be forced to a high-Z Tri-state mode. The Tri-state mode is enabled or disabled by the TRSTE pin.
- **Bipolar or Unipolar Data I/O**
 - The LXT332 / Framer interface can be either bipolar (default) or unipolar (selectable). The unipolar mode is selected by applying MCLK to the TRSTE pin.
- **B8ZS or HDB3 Zero Suppression**
 - The LXT332 incorporates zero suppression encoders and decoders for use in the unipolar data I/O mode. The encoders/decoders can be activated or deactivated by changing the logic level on the remapped TNEG pin.
- **Selectable Jitter Attenuation**
 - Jitter attenuation can be placed in either the transmit or receive path or deactivated. The Jitter Attenuation Select (JASEL) pin determines the jitter attenuation mode. No crystal required.
- **Dual Loopback**
 - This option enables simultaneous loopbacks to both the framer and the line. The TCLK, TPOS and TNEG framer inputs are routed through the jitter attenuator and looped back to the RCLK, RPOS and RNEG outputs. The RTIP/RRING line inputs are looped back through the timing recovery block and line driver onto the TTIP/TRING outputs.

ADDITIONAL HOST-MODE FEATURES

- **High Frequency Clocks**
 - The LXT332 provides a pair of high frequency clock outputs, one for each LIU. These 8x clocks (12.352 MHz for T1, 16.384 MHz for E1) are tied to the de-jittered clock from the JA of the respective LIU.
- **Bipolar Violation Insertion**
 - The same pins which provide the High Frequency Clocks can also be used to insert bipolar violations into the outgoing data stream. Violations can be inserted into each LIU channel independently.
- **Built-In Self Test (QRSS)**
 - The LXT332 can generate and transmit a QRSS pattern to Built-In Self Test (BIST) applications. Logic errors and bipolar violations can be inserted into the QRSS output. The LXT332 also detects QRSS pattern synchronization and reports bit errors in the received QRSS pattern data stream.
- **AIS Detection**
 - The LXT332 detects the AIS alarm signal on the receive side independent of the loopback modes. When AIS is detected (less than 3 zeros in 2048 bits), the LXT332 provides an indicator output.

SIGNAL DESCRIPTION

Figures 1 and 2 show the pinout diagrams for the PLCC and QFP packages, respectively. Table 1 describes the Host Mode signal functions, except signals that change when in Unipolar Host Mode. Table 2 describes signal functions that change when in Unipolar Most Mode. Table 3 describes all Hardware Mode signal functions, except signals that change when in Unipolar Mode. Table 4 describes signal functions that change when in Unipolar Hardware Mode.

Figure 1: LXT332 Pin Assignments (PLCC Package)

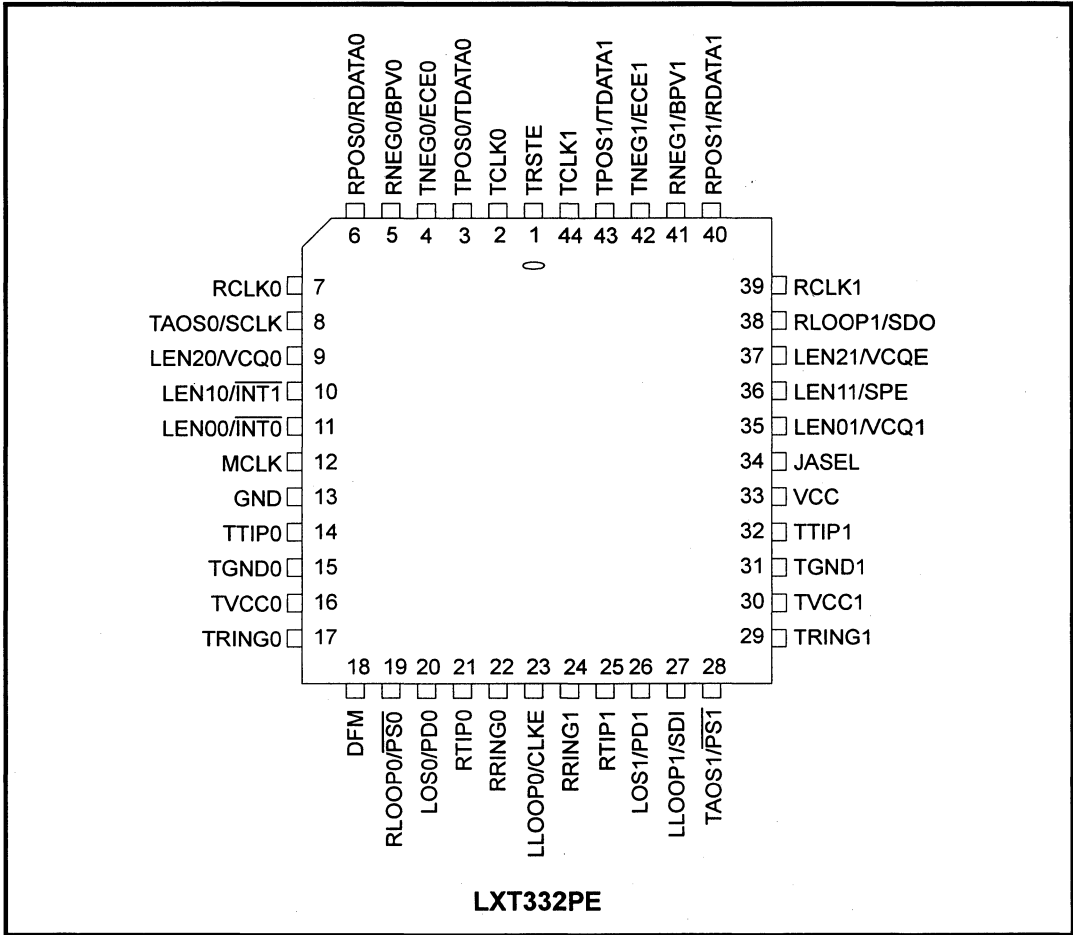

LXT332 Dual T1/E1 Line Interface Unit with Crystal-less Jitter Attenuation

Figure 2: LXT332 Pin Assignments (QFP Package)

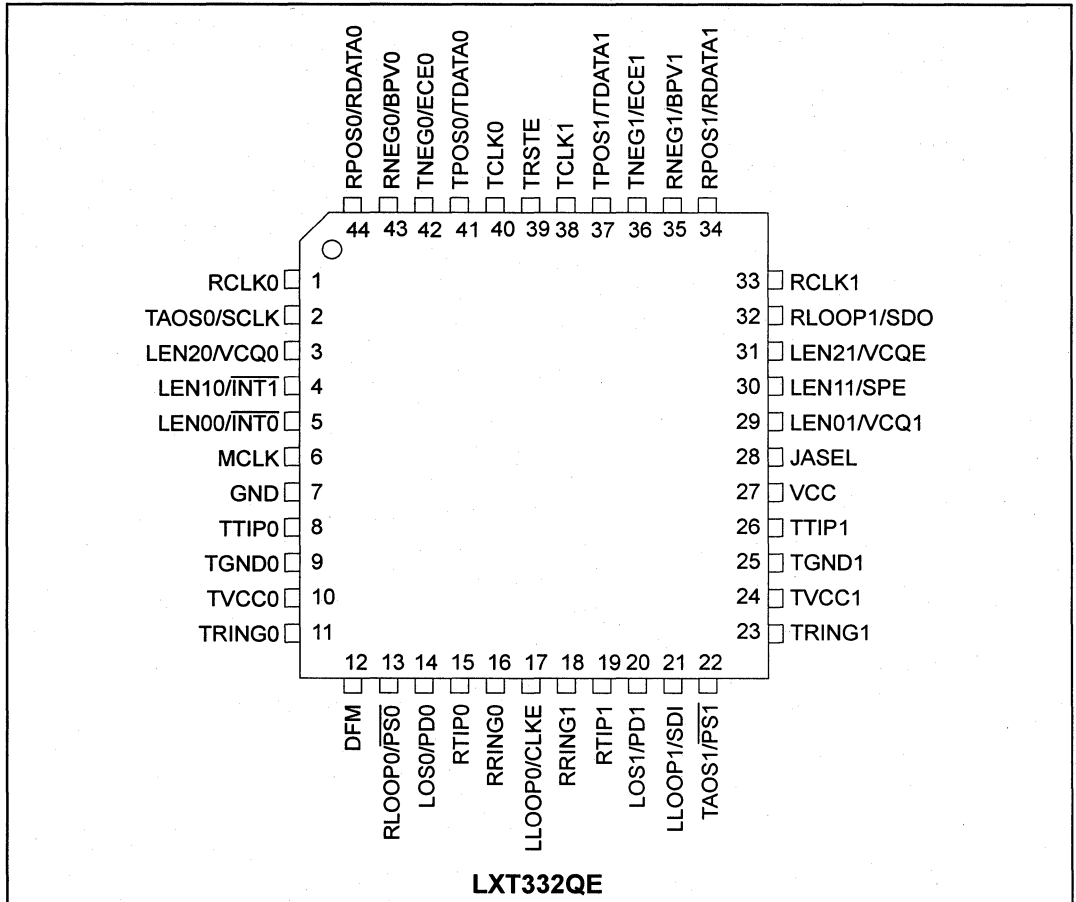

Table 1: Host Mode Pin and Bipolar Host Mode Pin Descriptions

Pin QFP	Pin PLCC	Symbol	I/O ¹	Description
39	1	TRSTE	DI	Tristate Output Enable Input Pin. Forces all output pins to high-Z tri-state when held High. Enables Bipolar I/O mode when held Low. In this mode the framer interface is bipolar (TPOS/TNEG and RPOS/RNEG), and the B8ZS/HDB3 encoders are disabled. Enables Unipolar I/O mode when clocked by MCLK. In this mode the framer interface is unipolar (TDATA and RDATA), and the TNEG and RNEG pins are re-mapped. The TNEG pins are re-mapped as Encoder Enable (ECE) to individually enable the B8ZS/HDB3 encoder/decoder for each port. The RNEG pins are re-mapped as Bipolar Violation (BPV) indicators to report BPVs received at the respective ports.
40	2	TCLK0	DI	Transmit Clock - Port 0. 1.544 MHz for T1, 2.048 MHz for E1. The transmit data inputs are sampled on the falling edge of TCLK.

¹ DI = Digital Input; DO = Digital Output; D/I/O = Digital Input/Output; AI = Analog Input; AO = Analog Output

Table 1: Host Mode Pin and Bipolar Host Mode Pin Descriptions – continued

Pin QFP	Pin PLCC	Symbol	I/O ¹	Description
41	3	TPOS0 (Bipolar)	DI	Transmit Positive and Negative Data - Port 0. In the Bipolar I/O mode, these pins are the positive and negative sides of a bipolar input pair for port 0. Data to be transmitted onto the twisted-pair line is input at these pins. However, when the TRSTE pin is clocked by MCLK, the LXT332 switches to a unipolar mode. Table 2 describes Unipolar mode pin functions.
42	4	TNEG0 (Bipolar)	DI	
43	5	RNEG0 (Bipolar)	DO	Receive Positive and Negative Data - Port 0. In the Bipolar I/O mode, these pins are the data outputs from port 0. A signal on RNEG corresponds to receipt of a negative pulse on RTIP/RRING. A signal on RPOS corresponds to receipt of a positive pulse on RTIP/RRING. RNEG/RPOS outputs are Non-Return-to-Zero (NRZ). In Host mode, CLKE determines the clock edge at which these outputs are stable and valid.
44	6	RPOS0 (Bipolar)	DO	
1	7	RCLK0	DO	Receive Clock - Port 0. This clock is recovered from the input signal. Under Loss of Signal (LOS) conditions, this output is derived from MCLK.
2	8	SCLK	DI	Serial Clock. The Serial Clock shifts data into or out from the serial interface register of the selected port.
3	9	VCQ0	DI/O	<p>Provides Violation insert, High Frequency Clock, or QRSS generation/detection functions for Port 0. Pin operation is determined by the VCQE pin.</p> <p>Violation Insertion Function. When the Violation insertion function is enabled, this pin is sampled on the falling edge of TCLK to control bipolar violation (BPV) insertion. If High, a BPV is inserted at the next available mark transmitted from port 0. A Low-to-High transition is required for each subsequent violation insertion. (B8ZS and HDB3 zero suppression codes are not violated.)</p> <p>Clock Function. When the Clock function is enabled, this pin outputs a High Frequency Clock (12.352 MHz for T1, 16.384 MHz for E1) tied to the jitter attenuated clock of port 0. If no JA clock is available, HFC is locked to the 8x receive timing recovery clock.</p> <p>Quasi Random Signal Source (QRSS) Function. When the QRSS function is enabled, a High on this pin enables the QRSS detection circuit and causes the LXT332 to transmit the QRSS pattern onto the twisted-pair line from port 0. For error-free QRSS transmission, TPOS0 must be held Low. To insert errors into the pattern, TPOS must transition from Low to High (TPOS is sampled on the falling edge of MCLK). A Low-to-High transition is required for each subsequent violation insertion. (B8ZS and HDB3 zero suppression codes are not violated.)</p>
4	10	$\overline{\text{INT1}}$	DO	Interrupt Outputs. The interrupt outputs go Low to flag the host processor that the respective port has changed state. INT0 and INT1 are open drain outputs. Each must be tied to VCC through a resistor.
5	11	$\overline{\text{INT0}}$	DO	
6	12	MCLK	DI	Master Clock. The master clock (1.544 MHz for T1, 2.048 MHz for E1) input must be independent, free-running, continuously active and jitter free for receiver operation. Since the transceivers derive their RCLK timing from the MCLK input on Loss of Signal (LOS), MCLK cannot be derived from RCLK.

1. DI = Digital Input; DO = Digital Output; DI/O = Digital Input/Output; AI = Analog Input; AO = Analog Output

LXT332 Dual T1/E1 Line Interface Unit with Crystal-less Jitter Attenuation

Table 1: Host Mode Pin and Bipolar Host Mode Pin Descriptions – continued

Pin QFP	Pin PLCC	Symbol	I/O ¹	Description
7	13	GND	–	Ground. Ground return for power supply VCC.
8 11	14 17	TTIP0 TRING0	AO AO	Transmit Tip and Ring - Port 0. The tip and ring pins for each port are differential driver outputs designed to drive a 35 - 200 Ω load. Line matching resistors and transformers can be selected to give the desired pulse height. See Figures 19 through 21.
9	15	TGND0	–	Ground. Ground return for power supply TVCC0.
10	16	TVCC0	I	+ 5 volt power supply input for the port 0 transmit driver. TVCC0 must not vary from TVCC1 or VCC by more than ± 0.3 V.
12	18	DFM	O	Driver Fail Monitor. This signal goes High to indicate a driver output short in one or both ports.
13	19	$\overline{\text{PS0}}$	I	Port Select - Port 0. This input accesses the serial interface registers for port 0. For each read or write operation, PS must transition from High to Low, and remain Low.
14	20	PD0	DO	Pattern Detect - Port 0. Unless the QRSS function is selected by the VCQE pin, PD0 functions as an AIS alarm indicator. The AIS pattern is detected by the receiver, independent of any loopback mode. AIS goes High when less than three zeros have been detected in any string of 2048 bits. AIS returns Low when the received signal contains more than three zeros in 2048 bits. (LOS is available via the SIO register and interrupt.) If the QRSS function is enabled by the VCQE pin, PD0 remains High until pattern sync is reached with the received signal. Once pattern lock is obtained, PD0 goes Low. (The sync/out-of-sync criteria is less than 3/4 errors in 128 bits.) After sync acquisition, bit errors cause PD0 to go High for half a clock cycle. This output can be used to trigger an external error counter.
15 16	21 22	RTIP0 RRING0	DI DI	Receive Tip and Ring - Port 0. RTIP and RRING comprise the receive line interface. This input pair should be connected to the line through a center-tapped 1:2 transformer.
17	23	CLKE	DI	Clock Edge Select. When CLKE is High, RPOS/RNEG or RDATA outputs are valid on the falling edge of RCLK, and SDO is valid on the rising edge of SCLK. When CLKE is Low, RPOS/RNEG or RDATA outputs are valid on the rising edge of RCLK, and SDO is valid on the falling edge of SCLK.
18 19	24 25	RRING1 RTIP1	AI AI	Receive Tip and Ring - Port 1. RTIP and RRING comprise the receive line interface. This input pair should be connected to the line through a center-tapped 1:2 transformer.
20	26	PD1	DO	Pattern Detect - Port 1. Reports AIS and QRSS pattern reception. See PD0 signal description for details.
21	27	SDI	DI	Serial Data Input. SDI is sampled on the rising edge of SCLK.
22	28	$\overline{\text{PS1}}$	DI	Port Select - Port 1. This input accesses the serial interface registers for port 1. For each read or write operation, PS must transition from High to Low, and remain Low.

1. DI = Digital Input; DO = Digital Output; DI/O = Digital Input/Output; AI = Analog Input; AO = Analog Output

Table 1: Host Mode Pin and Bipolar Host Mode Pin Descriptions – continued

Pin QFP	Pin PLCC	Symbol	I/O ¹	Description
23 26	29 32	TRING1 TTIP1	AO AO	Transmit Tip and Ring - Port 1. The tip and ring pins for each port are differential driver outputs designed to drive a 35 - 200 Ω load. Line matching resistors and transformers can be selected to give the desired pulse height. See Figures 13 through 15.
24	30	TVCC1	AI	+ 5 volt power supply input for the port 1 transmit driver. TVCC1 must not vary from TVCC0 or VCC by more than ± 0.3 V.
25	31	TGND1	–	Ground. Ground return for power supply TVCC1.
27	33	VCC	AI	+5 VDC power supply input for all circuits, except the transmit drivers.
28	34	JASEL	DI	Jitter Attenuation Select. Selects jitter attenuation for both ports. When JASEL = 1, JA circuits are placed in the receive paths. When JASEL = 0, JA circuits are placed in the transmit paths. When JASEL is clocked with MCLK, the JA circuit is disabled.
29	35	VCQ1	DI/O	Violation insert, Clock, or QRSS. Function (Violation insert, Clock, or QRSS) is determined by the VCQE pin. Provides Violation Insertion, High Frequency Clock or QRSS Generation functions for Port 1. Refer to VCQ0 signal description for details.
30	36	SPE	DI	Serial Port Enable. SPE must be clocked with MCLK to enable Host Mode control through the serial port.
31	37	VCQE	DI	Violation - Clock - QRSS Enable. When set High, enables the Bipolar Violation Insert functions of VCQ0 and VCQ1 pins. When set Low, enables the High Frequency Clock functions of VCQ0 and VCQ1. When clocked with MCLK, enables the QRSS functions of VCQ0 and VCQ1, and enables the QRSS Generate and Detect function of PD0 and PD1 pins.
32	38	SDO	DO	Serial Data Output. If CLKE is High, SDO is valid on the rising edge of SCLK. If CLKE is Low, SDO is valid on the falling edge of SCLK.
33	39	RCLK1	DO	Receive Clock - Port 1. This clock is recovered from the input signal. Under Loss of Signal (LOS) conditions, this output is derived from MCLK.
34	40	RPOS1 (Bipolar)	DO	Receive Positive and Negative Data - Port 1. In the Bipolar I/O mode, these pins are the data outputs from port 1. A signal on RPOS corresponds to receipt of a positive pulse on RTIP/RRING. A signal on RNEG corresponds to receipt of a negative pulse on RTIP/RRING. RNEG/RPOS outputs are Non-Return-to-Zero (NRZ). CLKE determines the clock edge at which these outputs are stable and valid.
35	41	RNEG1 (Bipolar)	DO	
36	42	TNEG1 (Bipolar)	DI	Transmit Positive and Negative Data - Port 1. In the Bipolar I/O mode, these pins are TPOS and TNEG, the positive and negative sides of a bipolar input pair for port 1. Data to be transmitted onto the twisted-pair line is input at these pins. However, when TRSTE is clocked by MCLK, the LXT332 switches to a unipolar mode. Unipolar mode pin functions are described separately.
37	43	TPOS1 (Bipolar)	DI	
38	44	TCLK1	DI	Transmit Clock - Port 1. 1.544 MHz for T1, 2.048 MHz for E1. The transmit data inputs are sampled on the falling edge of TCLK.

1. DI = Digital Input; DO = Digital Output; DI/O = Digital Input/Output; AI = Analog Input; AO = Analog Output

LXT332 Dual T1/E1 Line Interface Unit with Crystal-less Jitter Attenuation

Table 2: Unipolar Host Mode Pin Descriptions¹

Pin QFP	Pin PLCC	Symbol	I/O	Description
41	3	TDATA0	DI	Transmit Data - Port 0. In the Unipolar mode, the data to be transmitted onto the twisted-pair line from port 0 is input at this pin.
42	4	ECE0	DI	Encoder Enable - Port 0. In the Unipolar mode, a High on this pin enables the B8ZS or HDB3 encoder and decoder for port 0.
43	5	BPV0	DO	Bipolar Violation - Port 0. In the Unipolar mode this indicator output goes High when a bipolar violation is received at port 0.
44	6	RDATA0	DO	Receive Data - Port 0. In the Unipolar mode, RDATA is a Non-Return-to-Zero (NRZ) output. CLKE determines the RCLK edge which RDATA is stable and valid.
34	40	RDATA1	DO	Receive Data - Port 1. In the Unipolar mode, RDATA is a Non-Return-to-Zero (NRZ) output. CLKE determines the RCLK edge which RDATA is stable and valid.
35	41	BPV1	DO	Bipolar Violation - Port 1. In the Unipolar mode this indicator output goes High when a bipolar violation is received at port 1.
36	42	ECE1	DI	Encoder Enable - Port 1. In the Unipolar mode, a High on this pin enables the B8ZS or HDB3 encoder and decoder for port 1.
37	43	TDATA1	DI	Transmit Data - Port 1. In the Unipolar mode, the data to be transmitted onto the twisted-pair line from port 1 is input at this pin.

1. Table 1 describes the pins that do not change function in Unipolar Host Mode and functions of pins unique to Bipolar Mode.

Table 3: Hardware Mode Pin and Bipolar Hardware Mode Pin Descriptions¹

Pin QFP	Pin PLCC	Symbol	I/O ²	Description
39	1	TRSTE	DI	Tristate Output Enable Input Pin. Forces all output pins to high-Z Tri-state when held High. Enables Bipolar I/O mode when held Low. In this mode the framer interface is bipolar (TPOS/TNEG and RPOS/RNEG), and the B8ZS/HDB3 encoders are disabled. Enables Unipolar I/O mode when clocked by MCLK. In this mode the framer interface is unipolar (TDATA and RDATA), and the TNEG and RNEG pins are re-mapped. The TNEG pins are re-mapped as Encoder Enable (ECE) to individually enable the B8ZS/HDB3 encoder/decoder for each port. The RNEG pins are re-mapped as Bipolar Violation (BPV) indicators to report BPVs received at the respective ports.
40	2	TCLK0	DI	Transmit Clock - Port 0. 1.544 MHz for T1, 2.048 MHz for E1. The transmit data inputs are sampled on the falling edge of TCLK.
41	3	TPOS0 (Bipolar)	DI	Transmit Data Positive and Negative - Port 0. In the Bipolar I/O mode, these pins are the positive and negative sides of a bipolar input pair for port 0. Data to be transmitted onto the twp line is input at these pins. However, when TRSTE is clocked by MCLK, the LXT332 switches to a unipolar mode. Unipolar mode pin functions are described separately.
42	4	TNEG0 (Bipolar)		

1. Table 4 describes the pins used in Unipolar Hardware Mode.
 2. DI = Digital Input; DO = Digital Output; DI/O = Digital Input/Output; AI = Analog Input; AO = Analog Output

Table 3: Hardware Mode Pin and Bipolar Hardware Mode Pin Descriptions¹ – continued

Pin QFP	Pin PLCC	Symbol	I/O ²	Description
43	5	RNEG0 (Bipolar)	DO	Receive Data Positive and Negative - Port 0. In the Bipolar I/O mode, a signal on RNEG corresponds to receipt of a negative pulse on RTIP/RRING. A signal on RPOS corresponds to receipt of a positive pulse on RTIP/RRING.
44	6	RPOS0 (Bipolar)		RNEG/RPOS outputs are Non-Return-to-Zero (NRZ). RPOS and RNEG are stable and valid on the rising edge of RCLK.
1	7	RCLK0	DO	Receive Clock - Port 0. This clock is recovered from the input signal. Under Loss of Signal (LOS) conditions, this output is derived from MCLK.
2	8	TAOS0	DI	Transmit All Ones Enable - Port 0. When TAOS is High and RLOOP is Low, the TPOS/TNEG or TDATA input is ignored and port 0 transmits a stream of ones at the TCLK frequency. If TCLK is not provided, the MCLK input is used as the transmit reference.
3	9	LEN20	DI	Line Length Equalizer Inputs - Port 0. This pins determine the shape and amplitude of the transmit pulse.
4	10	LEN10	DI	
5	11	LEN00	DI	
6	12	MCLK	DI	Master Clock. The master clock (1.544 MHz for T1, 2.048 MHz for E1) input must be independent, free-running, continuously active and jitter free for receiver operation. Since the transceivers derive their RCLK timing from the MCLK input on Loss of Signal (LOS), MCLK cannot be derived from RCLK.
7	13	GND	–	Ground. Ground return for power supply VCC.
8	14	TTIP0	AO	Transmit Tip and Ring - Port 0. The tip and ring pins for each port are differential driver outputs designed to drive a 35 - 200 Ω load. Line matching resistors and transformers can be selected to give the desired pulse height. See Figures 13 through 15.
11	17	TRING0	AO	
9	15	TGND0	–	Ground. Ground return for power supply TVCC0.
10	16	TVCC0	AI	+ 5 volt power supply input for the port 0 transmit driver. TVCC0 must not vary from TVCC1 or VCC by more than ± 0.3 V.
12	18	DFM	DO	Driver Fail Monitor. This signal goes High to indicate a driver output short in one or both ports.
13	19	RLOOP0	DI	Remote Loopback Enable - Port 0. When RLOOP = 1, the port 0 clock and data inputs from the framer are ignored and the data received from the twisted-pair line is transmitted back onto the line at the RCLK frequency. (LLOOP0 must be Low for RLOOP0 to occur.)
14	20	LOS0	DO	Loss of Signal - Port 0. LOS goes High when 175 consecutive spaces have been detected. LOS returns Low when the received signal reaches a mark density of 12.5% (determined by receipt of four marks with a sliding 32-bit period with no more than 15 consecutive zeros). Received marks are output on RPOS/RNEG or RDATA even when LOS is High.
15	21	RTIP0	AI	Receive Tip and Ring - Port 0. RTIP and RRING comprise the receive line interface. This input pair should be connected to the line through a center-tapped 1:2 transformer.
16	22	RRING0	AI	
17	23	LLOOP0	DI	Local Loopback Enable - Port 0. When LLOOP is High, the RTIP/RRING inputs from the port 0 line are disconnected and the transmit data inputs are routed back into the receive inputs (through JA if enabled). (RLOOP0 must be Low for LLOOP0 to occur.)

1. Table 4 describes the pins used in Unipolar Hardware Mode.
 2. DI = Digital Input; DO = Digital Output; DI/O = Digital Input/Output; AI = Analog Input; AO = Analog Output

LXT332 Dual T1/E1 Line Interface Unit with Crystal-less Jitter Attenuation

Table 3: Hardware Mode Pin and Bipolar Hardware Mode Pin Descriptions¹ – continued

Pin QFP	Pin PLCC	Symbol	I/O ²	Description
18 19	24 25	RRING1 RTIP1	AI AI	Receive Tip and Ring - Port 1. RTIP and RRING comprise the receive line interface. This input pair should be connected to the line through a center-tapped 1:2 transformer.
20	26	LOS1	DO	Loss of Signal - Port 1. LOS goes High when 175 consecutive spaces have been detected. LOS returns to a logic 0 when the received signal reaches a mark density of 12.5% (refer to LOS0 signal description for details).
21	27	LLOOP1	DI	Local Loopback Enable - Port 1. (RLOOP1 must be Low for LLOOP1 to occur.)
22	28	TAOS1	DI	Transmit All Ones Enable - Port 1. (RLOOP1 must be Low for TAOS1 to occur.)
23 26	29 32	TRING1 TTIP1	AO AO	Transmit Ring - Port 1. The tip and ring pins for each port are differential driver outputs designed to drive a 35 - 200 Ω load. Line matching resistors and transformers can be selected to give the desired pulse height. See Figures 19 through 21.
24	30	TVCC1	AI	+ 5 volt power supply input for the port 1 transmit driver. TVCC1 must not vary from TVCC0 or VCC by more than ± 0.3 V.
25	31	TGND1	-	Ground. Ground return for power supply TVCC1.
27	33	VCC	AI	+5 VDC power supply input for all circuits, except the transmit drivers.
28	34	JASEL	DI	Jitter Attenuation Select. Selects jitter attenuation for both ports. When JASEL = 1, JA circuits are placed in the receive paths. When JASEL = 0, JA circuits are placed in the transmit paths. When JASEL is clocked with MCLK, the JA circuit is disabled.
29 30 31	35 36 37	LEN01 LEN11 LEN21	DI DI DI	Line Length Equalizer inputs - Port 1. These pins determine the shape and amplitude of the transmit pulse.
32	38	RLOOP1	DI	Remote Loopback Enable - Port 1. (LLOOP1 must = 0 for RLOOP to occur.)
33	39	RCLK1	DO	Receive Clock - Port 1. This clock is recovered from the twisted-pair input signal. Under Loss of Signal (LOS) conditions, this output is derived from MCLK.
34 35	40 41	RPOS1 (Bipolar) RNEG1 (Bipolar)	DO DO	Receive Data Positive and Negative - Port 1. In the Bipolar I/O mode, these pins are the data outputs from port 1. A signal on RPOS corresponds to receipt of a positive pulse on RTIP/RRING. A signal on RNEG corresponds to receipt of a negative pulse on RTIP/RRING. RNEG/RPOS outputs are Non-Return-to-Zero (NRZ). RPOS and RNEG are stable and valid on the rising edge of RCLK.
36 37	42 43	TNEG1 TPOS1	DI DI	Transmit Data Positive and Negative - Port 1. In the Bipolar I/O mode, these pins are TPOS and TNEG, the positive and negative sides of a bipolar input pair for port 1. Data to be transmitted onto the twisted-pair line is input at these pins. However, when the TRSTE pin is clocked by MCLK, the LXT332 switches to a unipolar mode. Unipolar mode pin functions are described separately.
38	44	TCLK1	DI	Transmit Clock - Port 1. 1.544 MHz for T1, 2.048 MHz for E1. The transmit data inputs are sampled on the falling edge of TCLK.

1. Table 4 describes the pins used in Unipolar Hardware Mode.

2. DI = Digital Input; DO = Digital Output; DI/O = Digital Input/Output; AI = Analog Input; AO = Analog Output

Table 4: Unipolar Hardware Mode Pin Descriptions¹

Pin QFC	Pin PLCC	Symbol	I/O	Description
41	3	TDATA0	DI	Transmit Data - Port 0. In the Unipolar mode, the data to be transmitted onto the line from port 0 is input at this pin.
42	4	ECE0	DI	Encoder Enable - Port 0. In the Unipolar mode, a High on this pin enables the B8ZS or HDB3 encoder and decoder for port 0.
43	5	BPV0	DO	Bipolar Violation - Port 0. In the Unipolar mode this indicator output goes High when a bipolar violation is received at port 0.
44	6	RDATA0	DO	Receive Data - Port 0. In the Unipolar mode, RDATA is a Non-Return-to-Zero (NRZ) output. RDATA is stable and valid on the rising edge of RCLK.
34	40	RDATA1	DO	Receive Data - Port 1. In the Unipolar mode, RDATA is a Non-Return-to-Zero (NRZ) output. RDATA is stable and valid on the rising edge of RCLK.
35	41	BPV1	DO	Bipolar Violation - Port 1. In the Unipolar mode this indicator output goes High when a bipolar violation is received at port 1.
36	42	ECE1	DI	Encoder Enable - Port 1. In the Unipolar mode, a High on this pin enables the B8ZS or HDB3 encoder and decoder for port 1.
37	43	TDATA1	DI	Transmit Data - Port 1. In the Unipolar mode, the data to be transmitted onto the line from port 1 is input at this pin.

1. Table 3 describes the pins that do not change function in Unipolar Hardware Mode and the functions of pins unique to Bipolar Mode.

FUNCTIONAL DESCRIPTION

NOTE

This Functional Description is intended for design aid only.

The figure at the beginning of this Data Sheet shows a simplified block diagram of the LXT332. The LXT332 is a fully integrated Dual Line Interface Unit (DLIU) which contains two complete transceivers. The DLIU is designed for both 1.544 Mbps (DSX-1) and 2.048 Mbps (E1) applications. Both transceivers operate at the same frequency, which is determined by the MCLK input.

Each DLIU transceiver front end interfaces with two twisted-pair lines, one pair for transmit, one pair for receive. These two twisted-pair lines comprise a digital data loop for full duplex transmission. The integrated crystal-less jitter attenuator may be positioned in either the transmit or receive path, or disabled.

Each DLIU transceiver back-end interfaces with a framer through either bipolar or unipolar data I/O channels. The DLIU may be controlled by a microprocessor through the serial port (Host control mode), or by hard-wired pins for stand-alone operation (Hardware control mode).

RECEIVER

The two receivers in the LXT332 DLIU are identical. The following paragraphs describe the operation of one.

The twisted-pair input is received via a center-tapped 1:2 transformer. Positive pulses are received at RTIP, negative pulses at RRING. Recovered data is output at RPOS and RNEG in the bipolar mode and at RDATA in the unipolar mode. The recovered clock is output at RCLK. RPOS/RNEG or RDATA outputs are valid on the rising edge of RCLK. Refer to the Test Specifications Section for receiver timing.

The receive signal is processed through the peak detector and data slicers. The peak detector samples the received signal and determines its maximum value. A percentage of the peak value is provided to the data slicers as a threshold level to ensure optimum signal-to-noise ratio. For DSX-1 applications (line length inputs LENO - LEN2 = 000 or 001) the threshold is set to 70% (typical) of the peak value. This threshold is maintained above the specified level for up to 15 successive zeros over the range of specified operating conditions. For E1 applications (LEN inputs = 000 or 001), the threshold is 50% (typical).

The receiver is capable of accurately recovering signals with up to -13.6 dB of attenuation (from 2.4 V),

corresponding to a received signal level of approximately 500 mV. Maximum line length is 1500 feet of ABAM cable (approximately 6 dB of attenuation). Regardless of received signal level, the peak detectors are held above a minimum level of 0.3 V (typical) to provide immunity from impulsive noise.

After processing through the data slicers, the received signal goes to the data and timing recovery section, and to the receive monitor. The data and timing recovery circuits provide an input jitter tolerance better than required by Pub 62411 or ITU G.823, as shown in Test Specifications.

The receiver monitor loads a digital counter at the RCLK frequency. The count is incremented each time a zero is received, and reset to zero each time a one (mark) is received. Upon receipt of 175 consecutive zeros the LOS flag is set, and the recovered clock is replaced by MCLK at the RCLK output in a smooth transition. (MCLK is required for receive operation.) When the received signal reaches 12.5% ones density (4 marks in a sliding 32-bit period) with no more than 15 consecutive zeros, the LOS flag is reset and another smooth transition replaces MCLK with the recovered clock at RCLK. During LOS conditions, received data is output on RPOS/RNEG (or RDATA if unipolar I/O is selected).

Depending on the options selected, recovered clock and data signals may be routed through the jitter attenuator, through the B8ZS/HDB3 decoder, and may be output to the framer as either bipolar or unipolar data. In unipolar data I/O mode, the LXT332 reports bipolar violations via an output for one RCLK period on the respective BPV pin.

TRANSMITTER

The two transmitters in the LXT332 DLIU are identical. The following paragraphs describe the operation of a single transmitter.

Transmit data from the framer is clocked serially into the device at TPOS/TNEG in the bipolar mode or at TDATA in the unipolar mode. The transmit clock (TCLK) supplies the input synchronization. The transmitter samples TPOS/TNEG or TDATA inputs on the falling edge of TCLK. If TCLK is not supplied, the transmitter remains powered down and the TTIP/TRING outputs are held in a high-Z state, except during RLOOP, DLOOP, QRSS or TAOS modes. A separate power supply (TVCC0 or TVCC1) supplies each output driver. Current limiters on the output drivers provide short circuit protection. Refer to the Test Specifications Section for MCLK and TCLK timing characteristics. The LXT332 transmits data as a 50% AMI line code as shown in Figure 3. Enabling the zero suppression

encoders/decoders overrides the default and the transmission complies with the selected encoding scheme.

Zero suppression is available only in Unipolar Mode. The two zero-suppression types are B8ZS, used in T1 environments, and HDB3, used in E1 environments. The scheme selected depends on whether the application is T1 or E1.

Bipolar Violation Insertions

In the Host mode with unipolar data I/O selected, a Bipolar Violation (BPV) insert function is available. When the VCQE pin is held High, VCQ0 and VCQ1 pins control bipolar Violation Insertion (VI) for ports 0 and 1, respectively. TDATA and VI are both sampled on the falling edge of TCLK. If VI is High, the next available mark is transmitted as a BPV, except as follows:

1. B8ZS and HDB3 zero suppression is not violated.
2. If Local Loopback (LLOOP) and Transmit All Ones (TAOS) are both active, the BPV is looped back to RDATA but the line driver transmits All Ones (no violations).
3. During Remote Loopback (RLOOP = 1), BPV Insert is disabled.

A Low-to-High transition on VI is required for each subsequent BPV insertion.

Figure 3: 50% AMI Coding

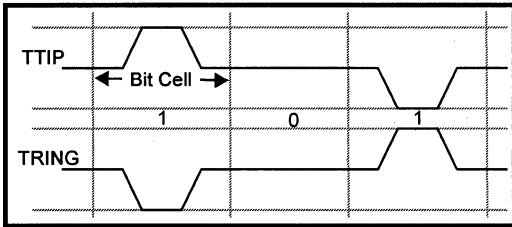

Table 5: Equalizer Control Inputs

LEN2	LEN1	LEN0	Line Length ¹	Cable Loss ²	Application	Transmit Rate
0	1	1	0 – 133 ft. ABAM	0.6 dB	DSX-1	1.544 Mbps
1	0	0	133 – 266 ft ABAM	1.2 dB		
1	0	1	266 – 399 ft ABAM	1.8 dB		
1	1	0	399 – 533 ft ABAM	2.4 dB		
1	1	1	533 – 655 ft ABAM	3.0 dB		
0	0	0	ITU Recommendation G.703		E1 – Coax (75Ω)	2.048 Mbps
0	0	1			E1 – Twisted-pair (120Ω)	
0	1	0	FCC Part 68, Option A		CSU	1.544 Mbps

1. Line length from LXT332 to DSX-1 cross-connect point
 2. Maximum cable loss at 772 kHz

Pulse Shape

The transmitted pulse shape is determined by Line Length equalizer control signals LEN0 through LEN2 as shown in Table 5. Equalizer codes are hardwired in Hardware mode. In Host mode the LEN codes are input through the serial interface. Shaped pulses are applied to the AMI line driver for transmission onto the line at TTIP and TRING. The line driver provides a constant low output impedance of 3Ω (typical), regardless of whether it is driving marks or spaces. This well controlled impedance provides excellent return loss when used with external precision resistors ($\pm 1\%$ accuracy) in series with the transformer. Table 8 lists recommended transformer specifications. The Application Information Section lists transformer specifications, recommended transformer ratios, series resistor (Rt) values, and typical return losses for various LEN codes. To minimize power consumption the LXT332 can be tied directly to a 1:1.15 transformer without series resistors.

Pulses can be shaped for either 1.544 Mbps or 2.048 Mbps applications. 1.544 Mbps pulses for DSX-1 applications can be programmed to match line lengths from 0 to 655 feet of 22 AWG ABAM cable. A combination of 9.1 Ω resistors and a 1:2.3 transformer is recommended for DSX-1 applications. The LXT332 also matches FCC pulse mask specifications for CSU applications.

The LXT332 produces 2.048 Mbps pulses for both 75Ω coaxial (2.37 V) or 120Ω shielded (3.0 V) lines through an output transformer with a 1:2 turns ratio. For coaxial systems, 9.1Ω series resistors are recommended. For twisted-pair lines, use 15Ω resistors.

DRIVER FAILURE MONITOR

The transceiver incorporates an internal Driver Failure Monitor (DFM) in parallel with TTIP and TRING. A capacitor, charged via a measure of the driver output current and discharged by a measure of the maximum allowable current detects driver failure. Shorted lines draw excess current, overcharging the cap. When the capacitor charge deviates outside the nominal charge window, a driver fail is reported. In Host mode the DFM bit is set in the serial word. In Hardware mode the DFM pin goes High. During a long string of spaces, a short-induced overcharge eventually bleeds off, clearing the DFM flag. In host mode, when the LXT332 detects an open circuit, it asserts the interrupt line and sets the interrupt status bits but leaves the DFM bit unchanged. This interrupt condition can be cleared by writing a 1 to the D1 bit.

JITTER ATTENUATION

A digital Jitter Attenuation Loop (JAL) combined with an Elastic Store (ES) provides Jitter attenuation. The JAL is internal and requires no external crystal nor high-frequency (higher than line rate) clock. When JASEL = 1, the JAL is positioned in the receive path. When JASEL = 0, the JAL is positioned in the transmit path. With JASEL clocked by MCLK, the JAL is disabled. MCLK is the reference for the JAL.

The ES is a 32 x 2-bit register. Data is clocked into the ES with the associated clock signal (TCLK or RCLK), and clocked out of the ES with the dejittered JAL clock. When the ES is within two bits of overflowing or underflowing, the ES adjusts the output clock by 1/8 of a bit period. The ES produces an average delay of 16 bits in the associated path.

Host Mode provides a dejittered High Frequency Clock (HFC). This 8x clock (12.352 MHz for T1, 16.384 MHz for E1) is tied to the output clock from the JAL. With JA active in the receive path, HFO is tied to RCLK and under LOS conditions defaults to MCLK. With JA active in the transmit path, HFO is tied to TCLK and defaults to MCLK if TCLK is not available. If JA is disabled, HFO is tied to MCLK.

BUILT-IN SELF TEST

In Host mode, the LXT332 provides a Built-In Self Test (BIST) mode. Quasi-Random Signal Source (QRSS) generation and detection circuitry is integrated into the LXT332. When the QRSS BIST mode is selected, the LXT332 detects and reports QRSS pattern sync on the incoming signal. When triggered, the LXT332 also transmits the QRSS pattern onto the line. Pattern transmission

and detection is independently triggered and reported for each port. Refer to Diagnostic Mode Operation for detailed description.

CONTROL MODES

The LXT332 transceiver operates in stand alone Hardware (default) Mode or Host Mode depending on the input to the SPE pin. When tied to SPE, MCLK acts as a Serial Port Enable signal to force the LXT332 into its Host mode. The data I/O mode, bipolar or unipolar, is controlled by the TRSTE pin. With TRSTE Low, bipolar I/O is selected. With TRSTE clocked, unipolar I/O is selected. Several diagnostic modes are available on command.

Host Mode Control

The LXT332 operates in the Host mode when the SPE pin is clocked with MCLK. In Host mode a microprocessor controls the LXT332 through the serial I/O port (SIO) which provides common access to both LIUs. Each of the two LIUs contains a pair of data registers, one for command inputs and one for status outputs. Only one LIU can be selected at a time. If both PS0 and PS1 are active, Port 0 has priority over Port 1. An SIO transaction is initiated by a falling pulse on one of the two Port Select pins, PS0 or PS1. A High-to-Low transition on PS0/1 is required for each subsequent access to the Host mode registers. If both PS0 and PS1 are active simultaneously, Port 0 has priority over Port 1.

The LIU addressed by the PS pulse responds by writing the incoming serial word from the SDI pin into its command register. Figure 4 shows an SIO write operation. The 16-bit serial word consists of an 8-bit Command/Address byte and an 8-bit Data byte. If the command word contains a read request, the addressed LIU subsequently outputs the contents of its status register onto the SDO pin. Figure 5 shows an SIO read operation. The Clock Edge (CLKE) signal determines when the SDO and receive data outputs are valid, relative to the Serial Clock (SCLK) or RCLK as listed in Table 6. Refer to the Test Specifications section for SIO timing.

Serial Input Word

Figure 4 shows the Serial Input data structure. The LXT332 is addressed by setting bit A4 in the Address/Command byte, corresponding to address 16. Bit 1 of the serial Address/Command byte provides Read/Write (R/W) control when the chip is accessed. The R/W bit is set to logic 1 to read the data output byte from the chip, and set to logic 0 to write the input data byte to the chip.

The second 8 bits of a write operation, the Data Input byte, clear Loss of Signal (LOS) and Driver Fail Monitor (DFM) interrupts, reset the chip, and control diagnostic modes. The first 2 bits (D0 – D1) clear and/or mask LOS and DFM interrupts, and the last 3 bits (D5 - D7) control operating modes (normal and diagnostic) and chip reset. Refer to Table 7 for details on bits D5 – D7 Serial Output Word.

Serial Output Word

Figure 4 shows the Serial Output data structure. SDO is high impedance when SDI receives an Address/Command byte. If SDI receives a write command (R/W = 0), SDO remains in high impedance. If the command is a read (R/W = 1), then SDO becomes active after the last Command/Address bit (A6) and remains active for eight SCLK cycles. Typically the first bit out of SDO changes the state of SDO from high-z to a Low/High. This occurs approximately 100 μ s after the eighth following edge of SCLK.

The output data byte reports Loss of Signal (LOS) and Driver Fail Monitor (DFM) conditions, equalizer settings, and operating modes (normal or diagnostic). The first 5 bits (D0 - D4) report LOS and DFM status, and the Line Length Equalizer settings. The last 3 bits (D5 - D7) report operating modes and interrupt status.

If the $\overline{\text{INT}}_x$ line for port x is High (no interrupt is pending), bits D5 - D7 report the operating modes listed in Table 8. If the $\overline{\text{INT}}_x$ line for port x is Low, the interrupt status overrides all other reports and bits D5 - D7 reflect the interrupt status as listed in Table 8.

Table 8: LXT332 Serial Data Output Bit Coding (See Figure 5)

Bit			Operating Modes
D5	D6	D7	
0	0	0	Reset has occurred, or no program input (<i>i.e.</i> , normal operation) or DLOOP active. ¹
0	0	1	TAOS active
0	1	0	LLOOP active
0	1	1	TAOS and LLOOP active
1	0	0	RLOOP active
Interrupt Status			
1	0	1	DFM has changed state since last Clear DFM occurred
1	1	0	LOS has changed since last Clear LOS occurred
1	1	1	DFM and LOS have changed since last Clear DFM and Clear LOS occurred

¹ No explicit status information is available on DLOOP.

Table 6: CLKE Settings

CLKE	Output	Clock	Valid Edge
LOW	RPOS/RNEG RDATA SDO	RCLK RCLK SCLK	Rising Rising Falling
HIGH	RPOS/RNEG RDATA SDO	RCLK RCLK SCLK	Falling Falling Rising

Table 7: SIO Input Bit Settings

(See Figure 4)

Mode	RLOOP Bit D5	LLOOP Bit D6	TAOS Bit D7
RLOOP	1	0	N/A
LLOOP	0	1	N/A
DLOOP	1	1	1
TAOS	0	<i>n/a</i>	1
RESET	1	1	0

LXT332 Dual T1/E1 Line Interface Unit with Crystal-less Jitter Attenuation

Figure 4: LXT332 SIO Write Operation

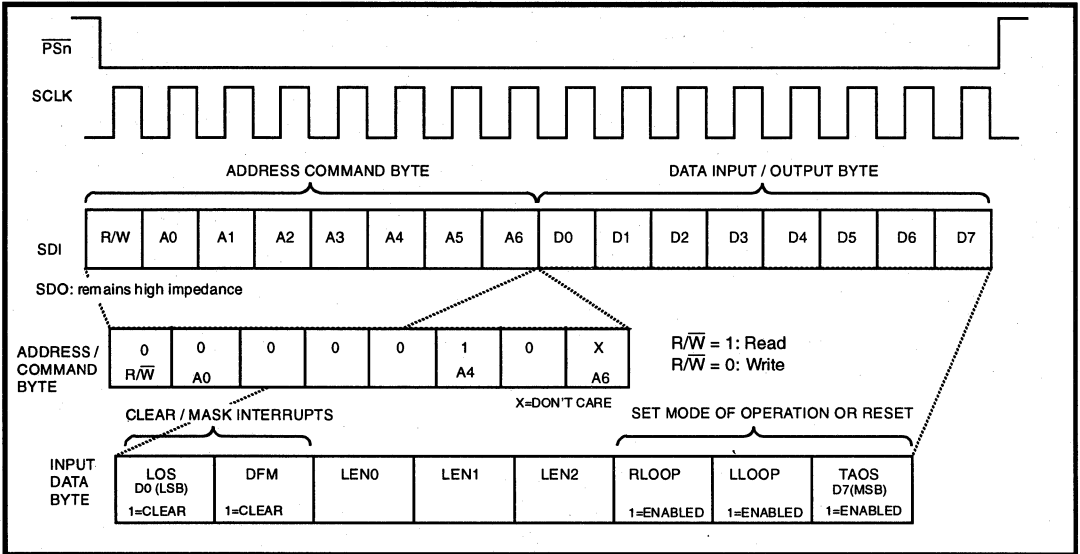
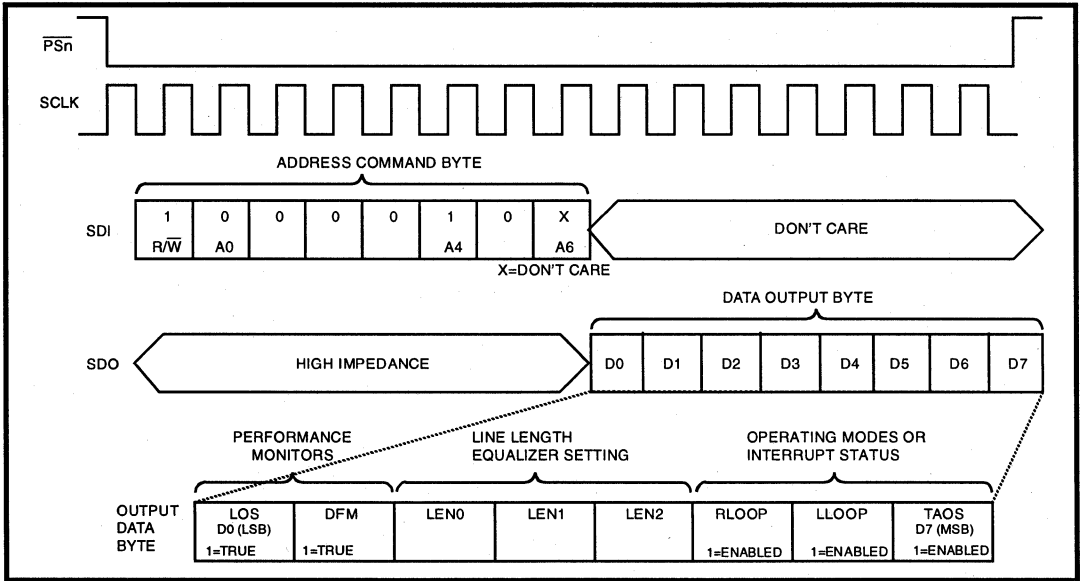

Figure 5: LXT332 SIO Read Operation



Interrupt Handling

The Host mode provides two latched Interrupt output pins, INT0 and INT1, one for each LIU. An interrupt is triggered by a change in the LOS or DFM bits (D0 and D1 of the output data byte, respectively). As shown in Figure 6, either or both interrupt generators can be masked by writing a one to the respective bit of the input data byte (D0 = LOS, D1 = DFM). When an interrupt has occurred, the INTx output pin is pulled Low. The output stage of each INTx pin consists only of a pull-down device. Hence, an external pull-up resistor is required. The interrupt is cleared as follows:

1. If one or both interrupt bits (LOS or DFM, D0 and D1 of the output data byte) = 1, writing a 1 to the respective input bit (D0 or D1, respectively, of the input data byte) will clear the interrupt. Leaving a 1 in either of these bit positions will effectively mask the associated interrupt. To re-enable the interrupt capability, reset D0 and/or D1 to 0.
2. If neither LOS or DFM=1, the interrupt will be cleared by resetting the chip. To reset the chip, set data input bits D5 and D6 = 1, and D7 = 0.

HARDWARE MODE CONTROL

Hardware control is the default operating mode; the LXT332 operates in Hardware mode unless LEN11/SPE pin is clocked. In Hardware mode the transceiver is controlled through individual pins; a μ P is not required. The SIO pins are re-mapped to provide control functions. (Data I/O mode selection is unaffected by the control mode. The TRSTE pin selects either unipolar or bipolar data I/O.) In Hardware mode the RPOS/RNEG or RDATA/BPV outputs are valid on the rising edge of RCLK.

DIAGNOSTIC MODE OPERATION

The LXT332 offers multiple diagnostic modes. Local Loopback (LLOOP), Remote Loopback (RLOOP), Dual Loopback (DLOOP) and Transmit All Ones (TAOS) are available under both Host and Hardware control. An additional Quasi-Random Signal Source (QRSS) mode is available under Host control only.

Under Host control, diagnostic modes are selected by writing the appropriate SIO bits. Under Hardware control, diagnostic modes are selected by a combination of pin settings. The pins must be held at the specified levels for a minimum of 20 ns. The SIO bit names (Host Mode) and pin identifiers (Hardware Mode) for diagnostic functions are identical. Where a particular function can be enabled in either mode, 1=High and 0=Low.

Figure 6: LX332 Interrupt Handling

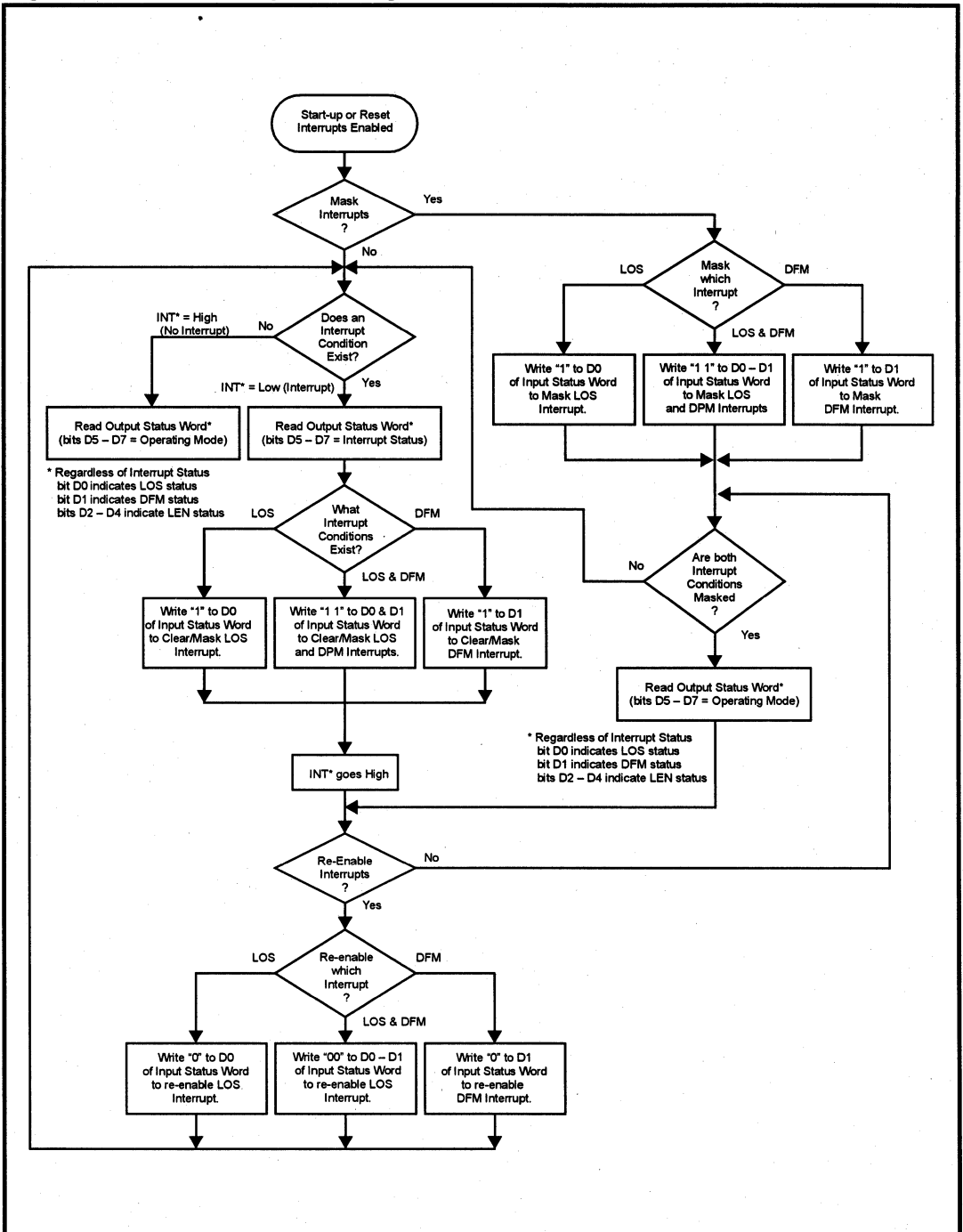

LXT332 Dual T1/E1 Line Interface Unit with Crystal-less Jitter Attenuation

Transmit All Ones. See Figure 7. Transmit All Ones (TAOS) is selected when TAOS = 1 and RLOOP = 0. In TAOS mode the TPOS and TNEG inputs are ignored, but the transmitter remains locked to the TCLK input. When TAOS is selected, the transceiver transmits a continuous stream of 1's at the TCLK frequency. If TCLK is not supplied, MCLK is used as the transmit reference.

TAOS can be commanded simultaneously with Local Loopback as shown in Figure 8, but is inhibited during Remote and Dual Loopback.

Local Loopback. See Figures 8 and 9. Local Loopback (LLOOP) is selected when LLOOP = 1 and RLOOP = 0. In LLOOP mode the receiver circuits are inhibited. The transmit clock and data inputs (TCLK and TPOS/TNEG or TDATA) are looped back and output at RCLK and RPOS/RNEG or RDATA. During local loopback, the JASEL input functions as follows: If JASEL=0, JA is enabled and active in both the Transmit path and the loopback circuit. If JASEL=1, JA is enabled in the Loopback circuit only. If JASEL = MCLK, JA is disabled.

The transmitter circuits are unaffected by LLOOP. The TPOS/TNEG or TDATA inputs (or a stream of 1s if the TAOS command is active) will be transmitted normally. When used in this mode, the transceiver can be used as a stand-alone jitter attenuator.

Remote Loopback. See Figure 10. Remote Loopback (RLOOP) is selected when RLOOP = 1 and LLOOP = 0. (Under this condition, TAOS is ignored. TAOS cannot be commanded simultaneously with RLOOP.) In RLOOP mode, the transmit clock and data inputs (TCLK and TPOS/TNEG or TDATA) are ignored. The RPOS/RNEG or RDATA outputs are looped back to the transmit circuits and output on TTIP and TRING at the RCLK frequency. Receiver circuits are unaffected by the RLOOP command and continue to output the data and clock signals received from the line. During remote loopback, the JASEL input functions as follows: If JASEL = 1, JA is enabled and active in both the Receive path and the loopback circuit. If JASEL = 0, JA is enabled in the Loopback circuit only. If JASEL = MCLK, JA is disabled.

Dual Loopback. See Figure 11. Dual Loopback (DLOOP) is selected when RLOOP = 1, LLOOP = 1 and TAOS = 1. In DLOOP mode, the transmit clock and data inputs (TCLK and TPOS/TNEG or TDATA) are looped back through the jitter attenuator (unless disabled by a clock input to the JASEL pin) and output at RCLK and RPOS/RNEG or RDATA. The data and clock recovered from the line are looped back through the transmit circuits and output on TTIP and TRING without jitter attenuation. Unlike the other diagnostic modes, no explicit SIO status indicator is available for DLOOP in the SIO status register.

Figure 7: TAOS Data Path

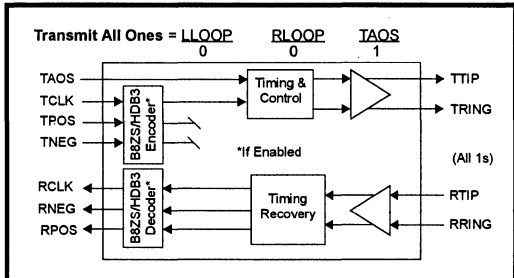

Figure 8: TAOS with LLOOP & Selectable JA

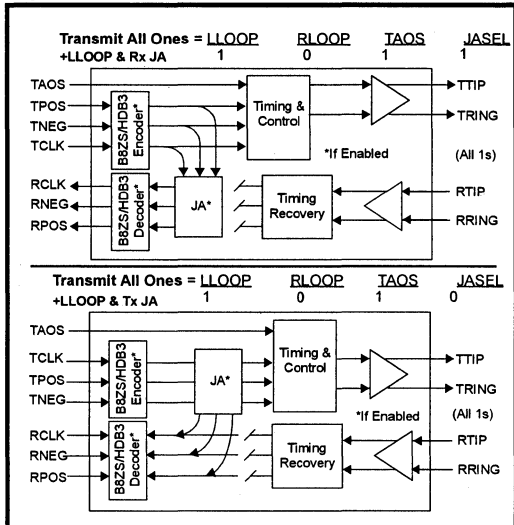
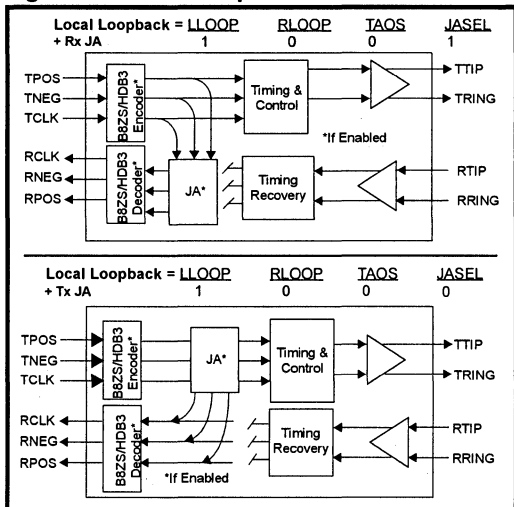

Figure 9: Local Loopback with Selectable JA



2

LXT332 Dual T1/E1 Line Interface Unit with Crystal-less Jitter Attenuation

QRSS Built-In Self Test (Host Mode only). See Figure 12. The QRSS Built-In Self Test (BIST) mode is available only under Host control. The QRSS BIST mode is selected by clocking the VCQE pin with MCLK. Once the QRSS BIST mode is selected, the VCQ0 and VCQ1 pins are re-mapped to trigger the QRSS transmission. A High on one of these pins triggers QRSS pattern transmission from the appropriate port. The QRSS pattern for DSX-1 systems is $2^{20}-1$, with no more than 14 consecutive zeros. For CEPT systems the QRSS pattern is $2^{15}-1$. The QRSS pattern is locked to MCLK. Once the QRSS transmission is activated, errors can be inserted into the transmit data stream by causing a Low-to-High transition on the TPOS/TDATA pin for the respective port. In Bipolar mode, Low-High transitions cause both a logic error and a bipolar violation to be inserted into the QRSS data stream. In Unipolar mode, only a logic error is inserted.

The Pattern Detect circuitry is activated by the QRSS BIST mode, although the basic receive circuits are unaffected. The Pattern Detect (PD n) pins indicate QRSS pattern sync. The Pattern Detect pin stays High until synchronization is achieved on the QRSS pattern. The QRSS pattern is considered in sync when there are fewer than 4 errors in 128 bits. The PD pin goes High indicating an out-of-sync conditions if 4 or more errors are detected in 128 bits (i.e. sync is defined as fewer than 4 errors in 128 bits).

INITIALIZATION/RESET OPERATION

Upon initial power up, the transceiver is held static until the power supply reaches approximately 3 V. Upon crossing this threshold, the device clears all internal registers and begins calibration of the delay lines. A reference clock is required to calibrate the delay lines. TCLK is the transmit reference, and MCLK is the receive reference. The PLLs are continuously calibrated.

The transceiver can be reset from the Host or H/W mode. In Host mode, reset is commanded by writing 1s to RLOOP and LLOOP, and a 0 to TAOS (bits D5, D6 and D7, respectively, of the SIO input data byte). In H/W mode, reset is commanded by simultaneously holding RLOOP and LLOOP High, and TAOS Low, for approximately 200 ns. Reset is initiated on the falling edge of the reset request. In either mode, each port is reset independently. Reset clears and sets all SIO registers to 0 at the affected port. Reset is not generally required for the port to be operational.

Figure 10: Remote Loopback with Selectable JA

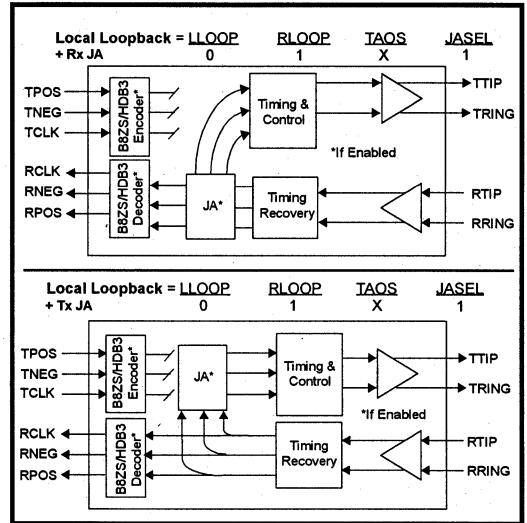

Figure 11: Dual Loopback

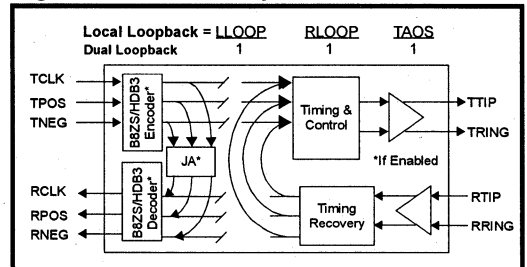
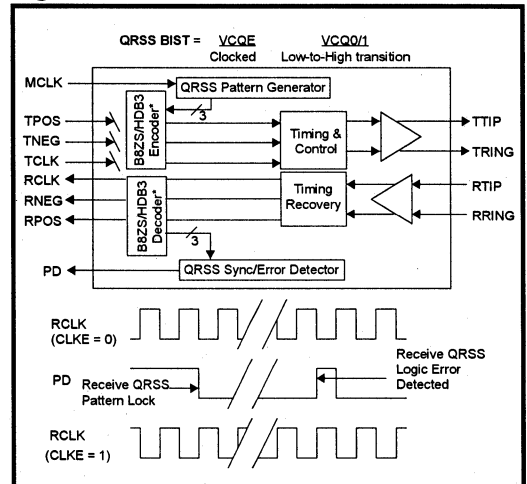

Figure 12: QRSS BIST Mode



APPLICATION INFORMATION

NOTE

This information is intended as a design aid only.

POWER REQUIREMENTS

The LXT332 is a low-power CMOS device. It operates from a single +5 V power supply which can be tied to all three VCC inputs. However, all inputs must be within $\pm .3$ V of each other, and decoupled to their respective grounds separately. Isolation between the transmit and receive circuits is provided internally. During normal operation or local loopback, the transmitter powers down if TCLK is not supplied.

TRANSFORMERS

The transformer specifications listed in Table 9 give the correct impedance matching for balanced transmit or receive lines. Table 10 shows the combinations of resistors and transformers to produce a variety of return loss values depending on the LEN code settings chosen for a specific design

1.544 MBPS T1 APPLICATIONS

Figure 13 shows a typical host mode application. The eight serial interface pins are grouped at the top. Host mode is selected by the clock input to SPE. Other mode selection pins are shown at the bottom. With the TRSTE pin switched Low, the LXT332 operates in the bipolar I/O mode. Driving JASEL Low switches the jitter attenuation circuits into the transmit paths for both LIU ports.

Figure 13 shows a pair of framers (a dual framer could also be used). A LXP600A Clock Adapter (CLAD) converts the 2.048 MHz backplane clock to provide the 1.544 MHz input to the MCLK and TCLK inputs of both LIU ports.

The DFM and PD indicators and High frequency clocks are grouped in the diagram lower left. These outputs are available to drive optional external circuits. The driver power supply inputs (lower right) are tied to a common bus with 1.0 μ F decoupling capacitors installed. The power supply for the remaining (non-driver) circuitry is shown at center right with 68 μ F and 0.1 μ F decoupling capacitors.

The line interface circuitry is identical for both LIU ports. The precision resistors in line with the transmit transformer provide optimal return loss. The recommended transformer/resistor combinations are listed at the bottom of Figure 15. Center tapped 2:1 transformers are used on the receive side.

Table 9: Recommended Transformer Values

Parameter	Value
Turns Ratio (T1)	1:2.3 (Tx) / 1:2 CT (Rx)
Turns Ratio (E1)	1:2 (Tx) / 1:2 CT (Rx)
Primary Inductance	1.2 mH maximum
Leakage Inductance	0.5 μ H maximum
Interwinding Capacitance	25 pF maximum
DC Resistance (Pri.)	1 Ω maximum
ET (Breakdown Voltage)	1 kV minimum

Table 10: Transformer Combinations

LEN	Xfmr Ratio ¹	Rt Value ²	Rtn Loss ³
For T1/DSX-1 100 Ω Twisted-Pair Applications:			
011 – 111	1:2	Rt = 9.1 Ω	14 dB
011 – 111	1:2.3	Rt = 9.1 Ω	18 dB
011 – 111	1:1.15	Rt = 0 Ω	18 dB
For E1 120 Ω Twisted-Pair Applications:			
001	1:2	Rt = 15 Ω	18 dB
000	1:2	Rt = 9.1 Ω	10 dB
For E1 75 Ω Coaxial Applications:			
001	1:2	Rt = 14.3 Ω	10 dB
000	1:2	Rt = 9.1 Ω	18 dB

1. Transformer turns ratio accuracy is ± 2 %.
 2. Rt values are ± 1 %.
 3. Typical return loss, 51 kHz – 3.072 MHz, with a capacitor in parallel with the primary side of the transformer.

LXT332 Dual T1/E1 Line Interface Unit with Crystal-less Jitter Attenuation

Figure 13: Typical LXT332 T1 Application (Host Control Mode, Bipolar I/O)

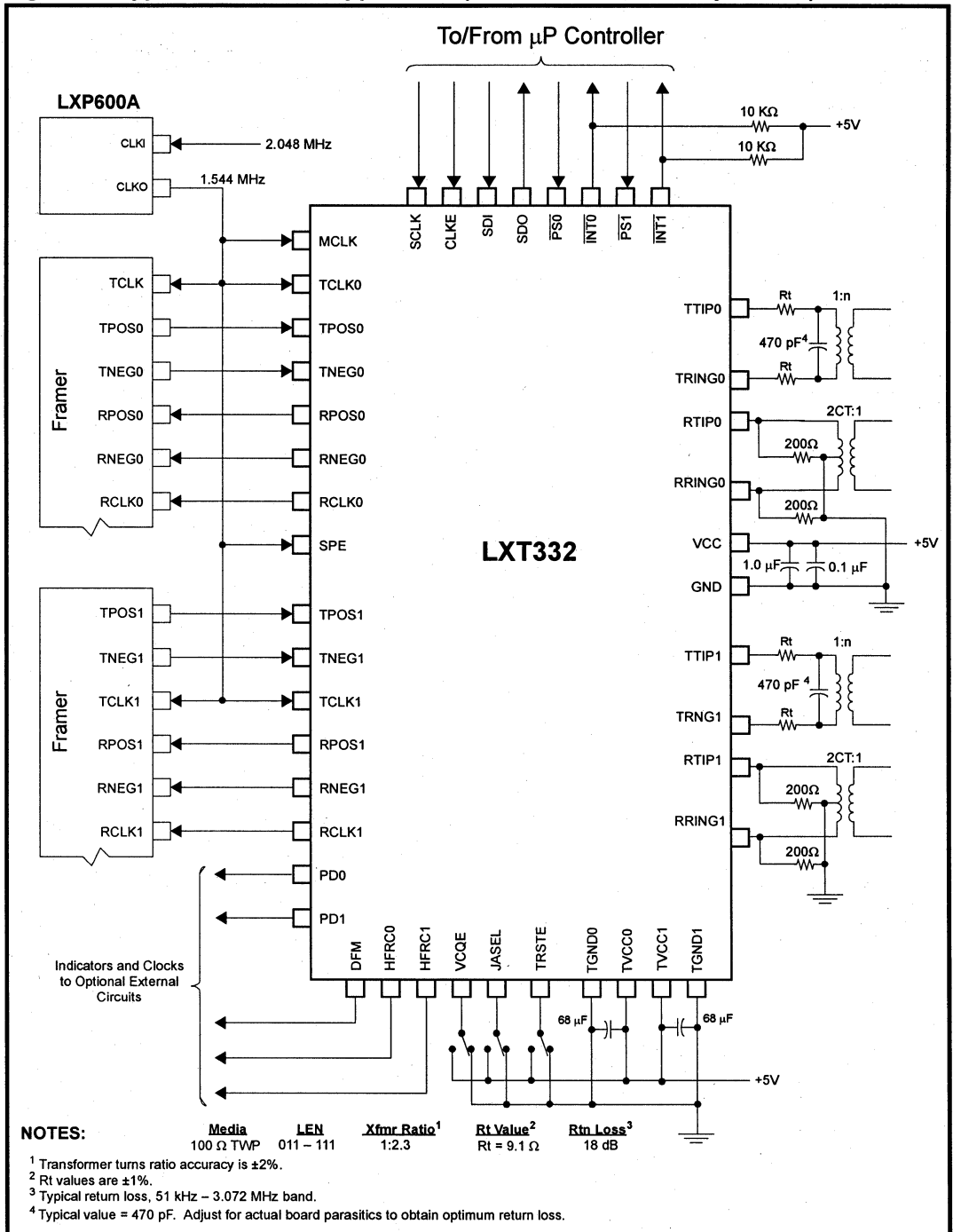

2.048 MBPS E1/CEPT INTERFACE APPLICATIONS

E1 Coaxial Applications

Figure 14 shows the line interface for a typical 2.048 Mbps E1 coaxial (75Ω) application. The LEN code should be set to 000 for coax. With 9.1Ω Rt resistors in line with the 1:2 output transformers, the LXT332 produces 2.37 V peak pulses as required for coax applications. As in the T1 application shown in Figure 13, center tapped 1:2 transformers are used on the receive side.

E1 Twisted-Pair Applications

Figure 15 shows a typical 2.048 Mbps E1 twisted-pair (120Ω) application. With the TRSTE pin tied to ground the LXT332 operates in the bipolar data I/O mode. The JA circuit is placed in the transmit path by the Low on JASEL. The line length equalizers are controlled by the hardwired LEN inputs. With the LEN code set to 001 and 15Ω Rt resistors in line with the 1:2 output transformers, the LXT332 produces the 3.0 V peak pulses required for this application. Center tapped 1:2 transformers are used on the receive side.

A single clock source provides the 2.048 MHz input to MCLK and TCLK. The DFM pin may be routed to an LED driver or other indicator, or be left unconnected. Switches on the TAOS, LLOOP and RLOOP inputs provide mode control and hardware reset capability.

As in Figure 15, the power supply inputs are tied to a common bus with appropriate decoupling capacitors installed (1.0 μF on the transmit side, 68 μF and 0.1 μF on the receive side.)

2

Figure 14: Line Interface for E1 Coax Applications

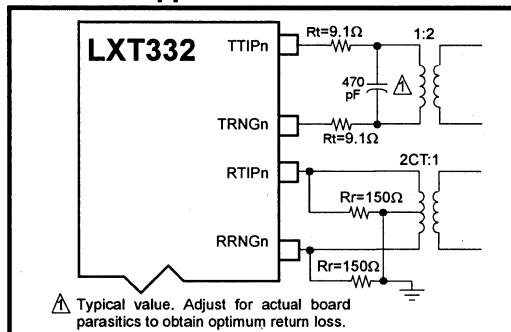

LXT332 Dual T1/E1 Line Interface Unit with Crystal-less Jitter Attenuation

Figure 15: Typical LXT332 E1 120 Ω Application (Hardware Control Mode)

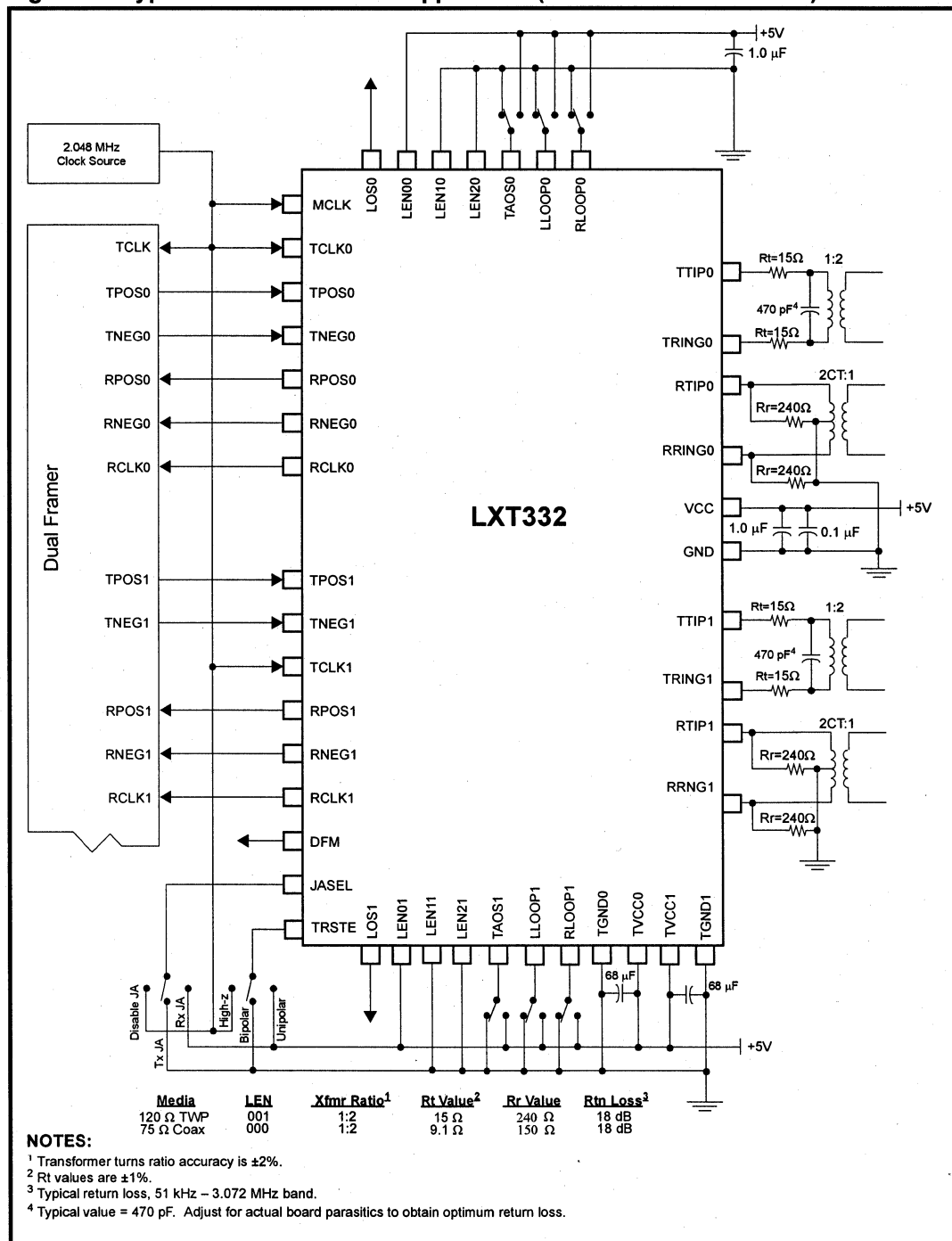

TEST SPECIFICATIONS

NOTE

Information in Tables 11 through 17 and Figures 16 through 21 represent the performance specifications of the LXT332 Dual Line Interface Unit and are guaranteed by test, except as noted, by design.

Table 11: Absolute Maximum Ratings

Parameter	Sym	Min	Max	Units
DC supply (referenced to GND)	VCC, TVCC0, TVCC1	–	6.0	V
Input voltage, any pin ¹	V _{IN}	GND - 0.3	V _{CC} + 0.3	V
Input current, any pin ²	I _{IN}	-10	10	mA
Storage temperature	T _{STG}	-65	+150	°C

CAUTION
Operations at or beyond these limits may result in damage to the device.
Normal operation not guaranteed at these extremes.

1. Excluding RTIP and RRING which must stay between -6 V and V_{CC} + 0.3 V.
2. Transient currents of up to 100 mA will not cause SCR latch-up. TTIP, TRING, TV+, and TGND can withstand continuous current of 100 mA.

Table 12: Recommended Operating Conditions

Parameter	Symbol	Minimum	Typical	Maximum	Units
DC supply ¹	VCC, TVCC0, TVCC1	4.75	5.0	5.25	V
Ambient operating temperature	T _A	-40	25	85	°C

1. Variation between TVCC0, TVCC1 and VCC must be within ±0.3 V of each other during steady state and transient conditions.

Table 13: Electrical Characteristics (Over Recommended Range)

Parameter	Sym	Min	Typ	Max	Units	Test Conditions
Total power dissipation – T1 ¹ (Maximum line length)	P _D	–	700	900	mW	100% ones density
	P _D	–	550	700	mW	50% ones density
Total power dissipation – E1 ¹	P _D	–	575	700	mW	100% ones density
	P _D	–	490	600	mW	50% ones density
High level input voltage ^{2,3}	V _{IH}	2.0	–	–	V	
Low level input voltage ^{2,3}	V _{IL}	–	–	0.8	V	
High level output voltage ^{2,3}	V _{OH}	2.4	–	–	V	I _{OUT} = -400 μA
Low level output voltage ^{2,3}	V _{OL}	–	–	0.4	V	I _{OUT} = 1.6 mA
Input leakage current ⁴	I _{LL}	0	–	±10	μA	
Three-state leakage current ²	I _{SL}	0	–	±10	μA	
Input pull down current (MCLK) ⁵			–	100	μA	

1. Total power dissipation includes the device power consumption and load power dissipation while driving a 75 Ω load on the secondary side. The T1 test circuit is a 100 Ω line load connected to the driver outputs via a 1:1.15 turns ratio transformer without series resistors.
2. Functionality of pins depends on mode.
3. Output drivers will output CMOS logic levels into CMOS loads.
4. Except for MCLK, RTIP0, RRING0, RTIP1, and RRING1.
5. Applies to pins 8,11,23,26

LXT332 Dual T1/E1 Line Interface Unit with Crystal-less Jitter Attenuation

Table 13: Electrical Characteristics (Over Recommended Range) – continued

Parameter	Sym	Min	Typ	Max	Units	Test Conditions
TTIP/TRING leakage current	I _{TR}	–	–	1.2	mA	In tri-state and power down modes
<p>1. Total power dissipation includes the device power consumption and load power dissipation while driving a 75 Ω load on the secondary side. The T1 test circuit is a 100 Ω line load connected to the driver outputs via a 1:1.15 turns ratio transformer without series resistors.</p> <p>2. Functionality of pins depends on mode.</p> <p>3. Output drivers will output CMOS logic levels into CMOS loads.</p> <p>4. Except for MCLK, RTIP0, RRING0, RTIP1, and RRING1.</p> <p>5. Applies to pins 8,11,23,26</p>						

Table 14: Analog Specifications (Over Recommended Range)

Parameter		Min	Typ	Max	Units	Test Conditions
AMI Output Pulse Amplitudes	DSX-1	2.4	3.0	3.6	V	measured at the DSX
	E1 (120 Ω)	2.7	3.0	3.3	V	measured at line side
	E1 (75 Ω)	2.13	2.37	2.61	V	measured at line side
Transmit Amplitude Variation with supply ³		-	1	2.5	%	
Recommended output load at TTIP and RRING		-	75	-	Ω	
Driver Output Impedance ³		-	3	10	Ω	@ 772 kHz
Jitter added by the transmitter ¹	10 Hz - 8 kHz ³	-	0.005	0.01	UI	T1 Jitter based
	8 kHz - 40 kHz ³	-	0.015	0.025	UI	
	10 Hz - 40 kHz ³	-	0.02	0.025	UI	
	Broad Band	-	0.03	0.05	UI	
Jitter added by the transmitter ¹	20 Hz – 100 kHz	-	-	0.05	UI	E1 Jitter Band
Output Power Levels ³ DS1 2 kHz BW	@772 kHz	12.6	-	17.9	dBm	
	@ 1544 kHz	-29	-	-	dB	referenced to power in 2 kHz band at 772 kHz
Positive to Negative Pulse Imbalance		-	-	0.5	dB	
Receive Input Impedance		-	40	-	kΩ	
Sensitivity below DSX (max 6 dB cable attenuation)	(0 dB = 2.4 V)	13.6	-	-	dB	
		500	-	-	mV	
Loss of Signal threshold		-	0.3	-	V	
Data decision threshold	DSX-1	60	50	77	% peak	
	E1	43	50	57	% peak	
Input Jitter Tolerance	10 Hz	-	1200	-	UI	
	750 Hz	14	-	-	UI	
	10 kHz – 100 kHz	0.4	-	-	UI	
Allowable consecutive zeros before LOS		160	175	190	-	
Jitter attenuation curve corner frequency ^{2,3}	T1	-	6	-	Hz	
	E1	-	10	-	Hz	
Attenuation input jitter tolerance before FIFO overflow ³		28	-	-	UI	
Jitter attenuation @ 10 kHz			45	-	dB	

1. Input signal to TCLK is jitter-free.
 2. Circuit attenuates jitter at 20 dB/decade above the corner frequency.
 3. Not production tested, but guaranteed by design and other correlation models.

2

LXT332 Dual T1/E1 Line Interface Unit with Crystal-less Jitter Attenuation

Table 15: LXT332 Serial I/O Timing Characteristics (See Figures 16 and 17)

Parameter	Sym	Min	Typ ¹	Max	Units	
Rise/Fall time - any digital output	t_{RF}	–	–	100	ns	Load 1.6 mA, 50 pF
SDI to SCLK setup time	t_{DC}	50	–	–	ns	
SCLK to SDI hold time	t_{CDH}	50	–	–	ns	
SCLK Low time	t_{CL}	240	–	–	ns	
SCLK High time	t_{CH}	240	–	–	ns	
SCLK rise and fall time	t_R, t_F	–	–	50	ns	
PS to SCLK setup time	t_{PC}	50	–	–	ns	
SCLK to PS hold time	t_{CPH}	50	–	–	ns	
PS inactive time	t_{PWH}	250	–	–	ns	
SCLK to SDO valid	t_{CDV}	–	–	200	ns	
SCLK falling edge or PS rising edge to SDO high-z	t_{CDZ}	–	100	–	ns	

1. Typical figures are at 25 °C and are design aid only; not guaranteed and not subject to production testing.

Figure 16: LXT332 Serial Data Input Timing Diagram

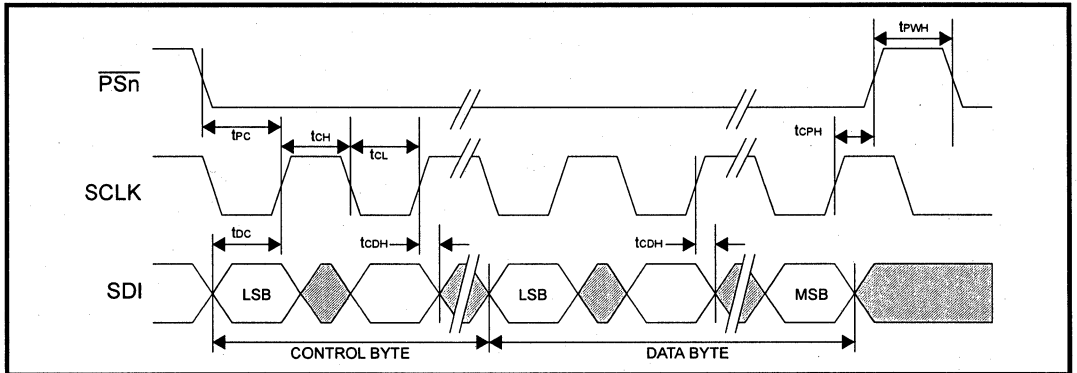
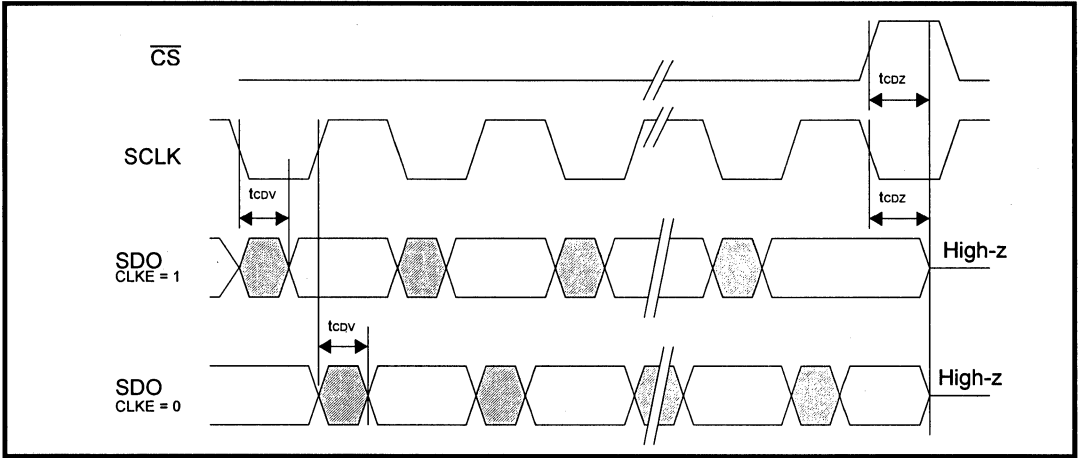

Figure 17: LXT332 Serial Data Output Timing Diagram



2

Figure 18: LXT332 Receive Clock Timing

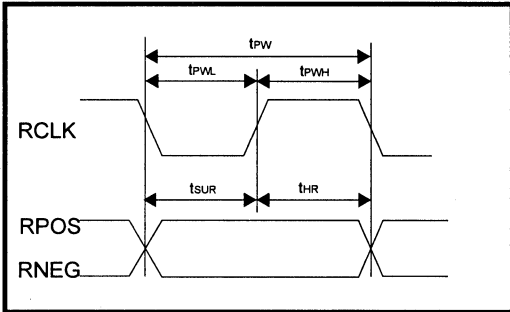
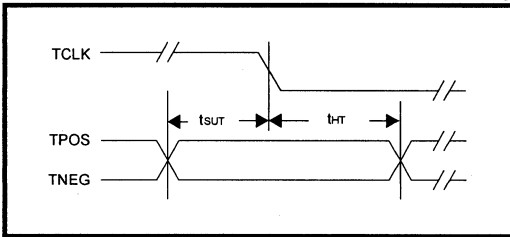

Figure 19: LXT332 Transmit Clock Timing



LXT332 Dual T1/E1 Line Interface Unit with Crystal-less Jitter Attenuation

Table 16: LXT332 Receive Timing Characteristics (See Figure 18)

Parameter		Sym	Min	Typ ¹	Max	Units	Test Conditions
Receive clock period	DSX-1	tpw	583	648	713	ns	Elastic store not in overflow or underflow.
	E1	tpw	439	488	537	ns	
Receive clock duty cycle		RCLKd	40	50	60	ns	
Receive clock pulse width High	DSX-1	tpWH	259	324	389	ns	
	E1	tpWH	195	244	293	ns	
Receive clock pulse width Low	DSX-1	tpWL	259	324	389	ns	
	E1	tpWL	195	244	293	ns	
RPOS / RNEG to RCLK rising setup time	DSX-1	tsUR	50	274	–	ns	
	E1	tsUR	50	194	–	ns	
RCLK rising to RPOS / RNEG hold time	DSX-1	tHR	50	274	–	ns	
	E1	tHR	50	194	–	ns	

1. Typical figures are at 25 °C and are for design aid only; not guaranteed and not subject to production testing.

Table 17: LXT332 Master Clock and Transmit Timing Characteristics (See Figure 19)

Parameter		Sym	Min	Typ ¹	Max	Units
Master clock frequency	DSX-1	MCLK	–	1.544	–	MHz
	E1	MCLK	–	2.048	–	MHz
Master clock tolerance		MCLKt	–	±50	–	ppm
Master clock duty cycle		MCLKd	40	–	60	%
Transmit clock frequency	DSX-1	TCLK	–	1.544	–	MHz
	E1	TCLK	–	2.048	–	MHz
Transmit clock tolerance		TCLKt	–	±50	–	ppm
Transmit clock duty cycle		TCLKd	10	–	90	%
TPOS/TNEG to TCLK setup time		tsUT	25	–	–	ns
TCLK to TPOS/TNEG Hold time		tHT	25	–	–	ns

1. Typical figures are at 25 °C and are for design aid only; not guaranteed and not subject to production testing.

Figure 20: Typical Receiver Input Jitter Tolerance (Loop Mode)

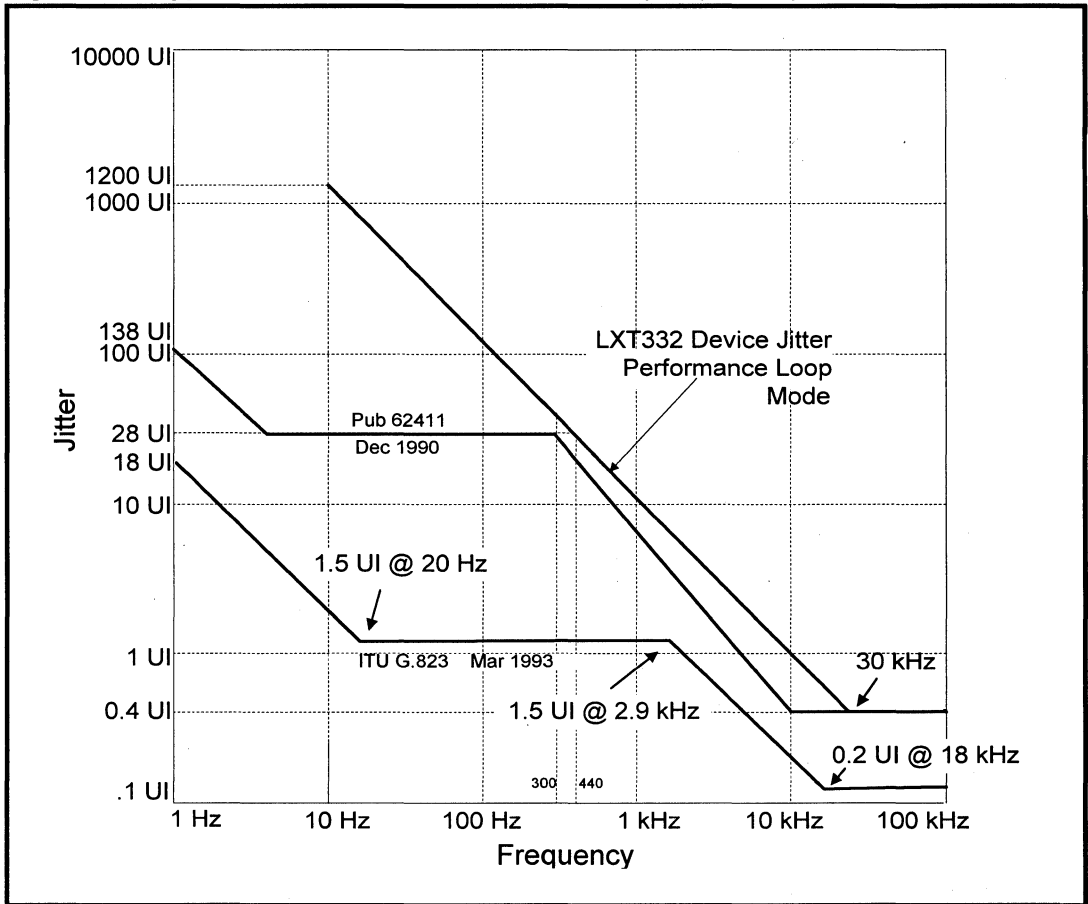
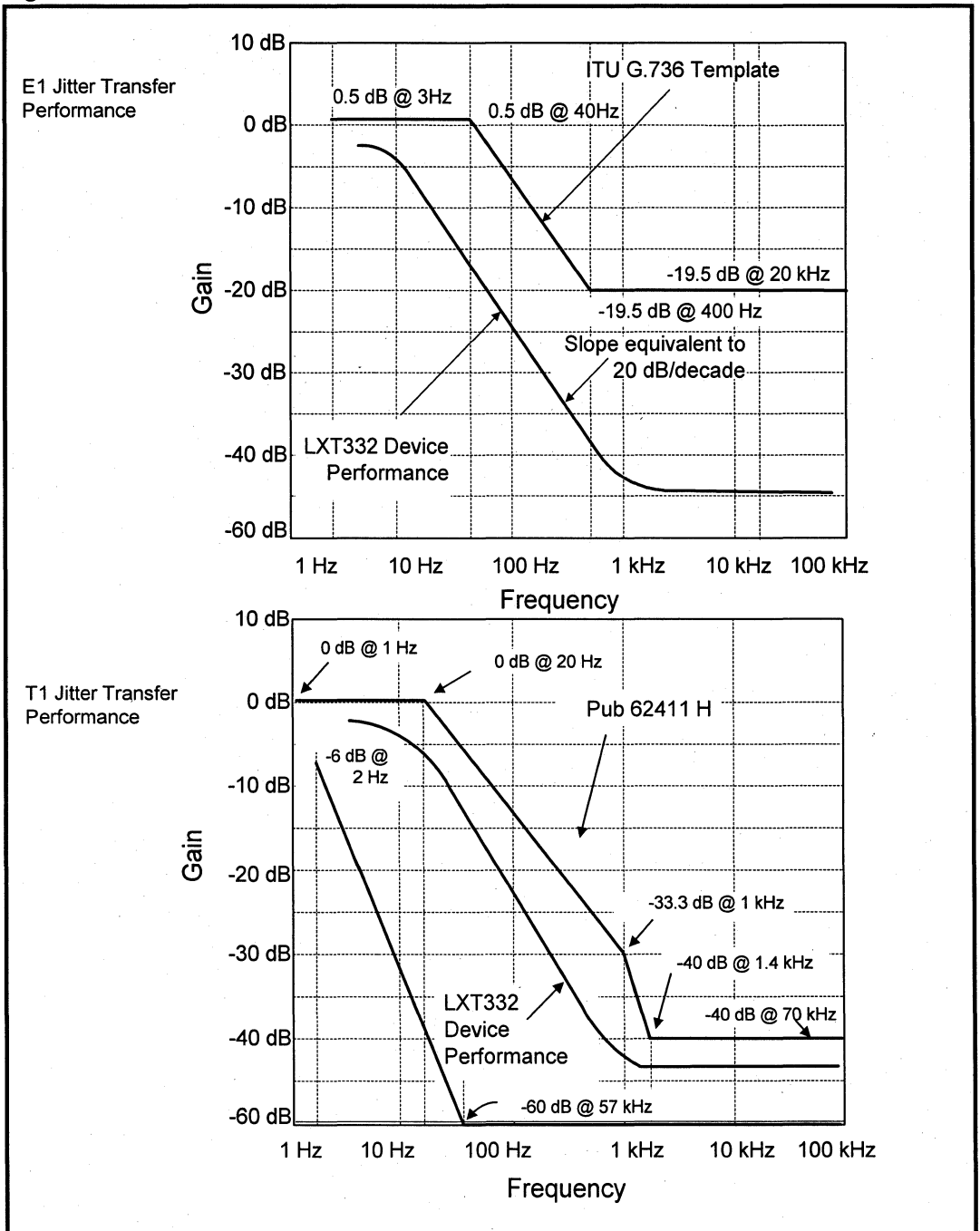

Figure 21: Jitter Transfer Performance



LXT350/351 Integrated T1/E1 S/H Transceivers with Crystal-less Jitter Attenuation

2

General Description

The LXT350 and LXT351 are full-featured, fully-integrated transceivers for T1 and E1 short-haul applications. They are software switchable between T1 and E1 operation, and offer pulse equalization settings for all short-haul T1 and E1 line interface (LIU) applications.

The LXT350 and LXT351 are identical except for their control interface. The LXT350 provides both a serial I/O port for microprocessor control and a hardware control mode for stand alone operation. The LXT351 offers an Intel- or Motorola-bus compatible parallel I/O port for microprocessor control. Both incorporate advanced crystal-less digital jitter attenuation in either the transmit or receive data path starting at 3 Hz. B8ZS/HDB3 encoding/decoding and unipolar or bipolar data I/O are available. Both LIUs provide loss of signal monitoring and a variety of diagnostic loopback modes.

The LXT350/351 design uses an advanced double-poly, double-metal fabrication process and requires only a single 5-volt power supply.

Applications

- T1/E1 Asynchronous Multiplexers
- Digital Loop Carrier - Subscriber Carrier Systems
- SDH/SONET Multiplexers
- T1/E1 LAN/WAN interfaces for Bridges
- Digital Cross Connects

Features

- Fully integrated transceiver for short-haul T1 or E1 interfaces
- Crystal-less digital jitter attenuation
 - Selectable either transmit or receive path
 - No crystal or high-speed external clock required
- Meet or exceed specifications in ANSI T1.403 and T1.408; ITU G.703, G.736, G.775 and G.823; ETSI 300-166 and 300-233; and AT&T Pub 62411
- Support 75 Ω (E1 coax), 100 Ω (T1 twisted-pair) and 120 Ω (E1 twisted-pair) applications
- Fully restores the received signal after transmission through a cable with attenuation of 18dB, at 1024 kHz
- Five Pulse Equalization Settings for T1 short-haul applications
- Transmit/receive performance monitors with Driver Fail Monitor Open (DFM) and Loss of Signal (LOS) outputs
- Selectable unipolar or bipolar data I/O and B8ZS/HDB3 encoding/decoding
- QRSS generator/detector for testing or monitoring
- Output short circuit current limit protection
- Local, remote and analog loopback capability
- Multiple-register serial- or parallel-control interface
- Fully compatible with Level One's LXT360/361 Long Haul/Short Haul Transceiver
- Available 28-pin DIP and PLCC packages

LXT350 Transceiver Block Diagram

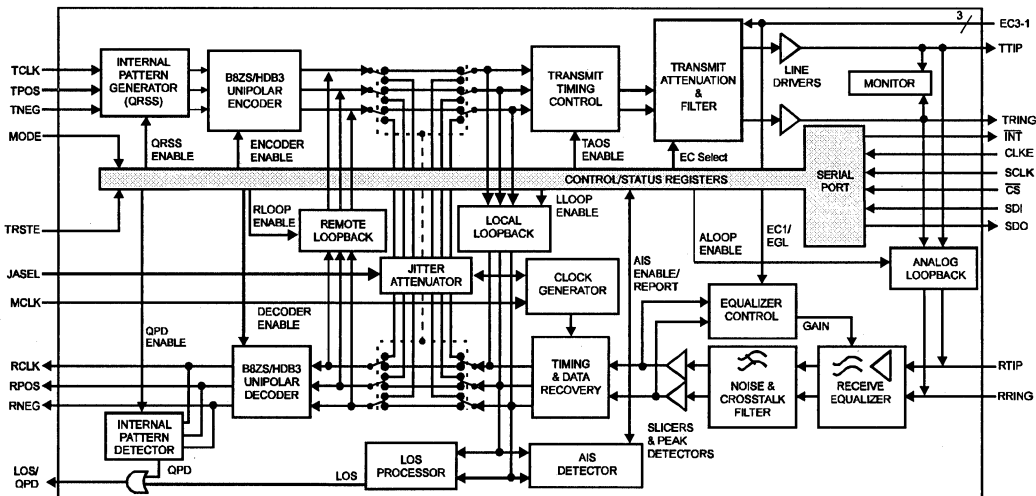

LXT350/351 Integrated T1/E1 S/H Transceivers With Crystal-less Jitter Attenuation

Figure 1: LXT350 Hardware Controlled Bipolar Mode Pin Assignments

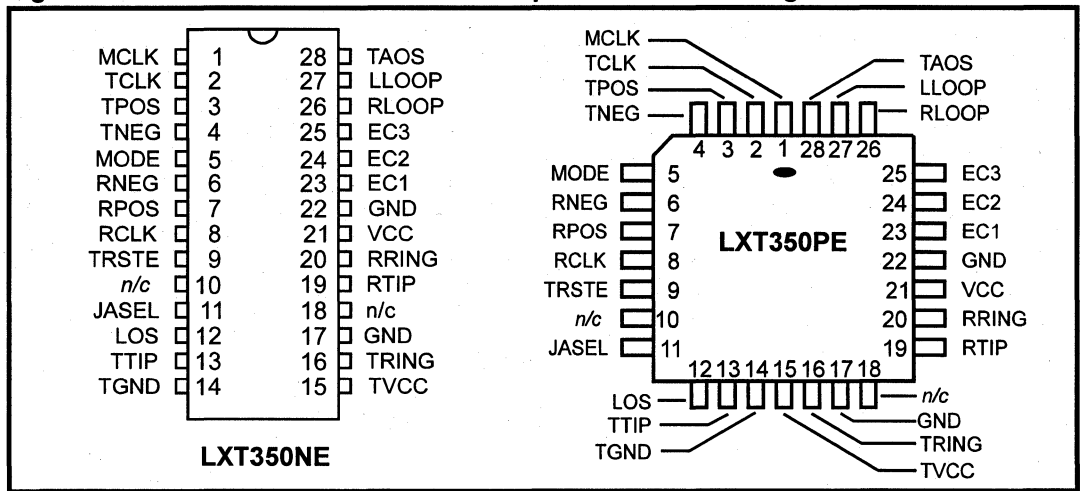

Table 1: LXT350 Clock and Data Pin Assignments by Mode¹

Pin #	External Data Modes		QRSS Modes	
	Bipolar Mode	Unipolar Mode	Bipolar Mode	Unipolar Mode
1	MCLK			
2	TCLK			
3	TPOS	TDATA	INSLER	
4	TNEG	INSBPV	INSBPV	
6	RNEG	BPV	RNEG	BPV
7	RPOS	RDATA	RPOS	RDATA
8	RCLK			
13	TTIP			
14	TGND			
15	TVCC			
16	TRING			
19	RTIP			
20	RRING			
21	VCC			
22	GND			

1. Data pins change based on whether external data or internal QRSS mode is active. Clock pins remain the same in both Hardware and Host Modes

Table 2: LXT350 Control Pins by Mode

Pin #	Hardware Modes		Host Modes		Pin #	Hardware Modes		Host Modes	
	Unipolar/Bipolar	QRSS	Unipolar/Bipolar	QRSS		Unipolar/Bipolar	QRSS	Unipolar/Bipolar	QRSS
5	MODE		MODE		24	EC2		SDI	
9	TRSTE		TRSTE		25	EC3		SDO	
11	JASEL		Low		26	RLOOP		\overline{CS}	
12	LOS	LOS/QPD	LOS	LOS/QPD	27	LLOOP		SCLK	
23	EC1		\overline{INT}		28	TAOS	QRSS	CLKE	

Table 3: LXT350 Hardware Controlled Bipolar Mode Signal Descriptions

Pin #	Symbol	I/O ¹	Description
1	MCLK	DI	Master Clock. Connect to 1.544 MHz for T1 operation; to 2.048 MHz for E1. MCLK requires an external, independent input to generate internal clocks. Required accuracy is better than ± 32 ppm with a typical duty cycle of 50%. Upon Loss of Signal (LOS), RCLK is derived from MCLK.
2	TCLK	DI	Transmit Clock. 1.544 MHz or 2.048 MHz clock input. Transceiver samples TPOS and TNEG on the falling edge of TCLK
3 4	TPOS TNEG	DI	Transmit Data – Positive and Negative. In the Bipolar I/O mode, these pins are the positive and negative sides of a bipolar input pair. Data to be transmitted onto the line is input at these pins. Table 4 describes Unipolar Mode functions.
5	MODE	DI	Mode Select. Connecting MODE Low puts the LXT350 in Hardware Mode. In Hardware Mode, the serial interface is disabled and hardwired pins are used to control configuration and report status. Leaving MODE open activates Hardware Mode and enables the B8ZS/HDB3 encoder/decoder and Unipolar Mode. Connecting MODE High puts the LXT350 in Host Mode. In Host Mode, the serial interface controls the LXT350 and displays its status.
6 7	RNEG RPOS	DO	Receive Data – Negative and Positive. In the Bipolar I/O mode, these pins are the positive and negative sides of a bipolar output pair. Data recovered from the line interface is output on these pins. A signal on RNEG corresponds to receipt of a negative pulse on RTIP/RRING. A signal on RPOS corresponds to receipt of a positive pulse on RTIP/RRING. RNEG/RPOS outputs are Non-Return-to-Zero. Both outputs are stable and valid on the rising edge of RCLK. Refer to Table 4 for Unipolar mode function descriptions.
8	RCLK	DO	Recovered Clock. The clock recovered from the line input signal is output on this pin. Under LOS conditions there is a smooth transition from RCLK to MCLK output.
9	TRSTE	DI	Tristate. Connecting TRSTE High forces all output pins to a high-impedance state. Connecting TRSTE Low sets the LXT350 to the Hardware Bipolar Mode. Leaving TRSTE open enables the Unipolar Mode. (See Table 4 for Unipolar function descriptions.)
10	n/c	DO	<i>No connection. Leave this pin floating.</i>

1. I/O Column entries: DI–Digital Input; DO–Digital Output; DI/O–Digital Input/Output; AI–Analog Input; AO–Analog Output

LXT350/351 Integrated T1/E1 S/H Transceivers With Crystal-less Jitter Attenuation

Table 3: LXT350 Hardware Controlled Bipolar Mode Signal Descriptions – continued

Pin #	Symbol	I/O ¹	Description
11	JASEL	DI	Jitter Attenuation Select. Selects jitter attenuation location. Connecting JASEL High activates the jitter attenuator in the receive path. Connecting JASEL Low activates the jitter attenuator in the transmit path. Leaving JASEL open disables JA.
12	LOS	DO	Loss of Signal Indicator. In T1 mode, LOS goes High on receipt of 175 consecutive spaces and returns Low when the received signal reaches a mark density of 12.5% (determined by receipt of 16 marks within a sliding window of 128 bits with fewer than 100 consecutive zeros). In E1 modes, LOS goes High on receipt of 32 consecutive spaces, and returns Low when the receiver detects 12.5% mark density (determined by receipt of 4 marks within a sliding window of 32 bits with fewer than 16 consecutive zeros). The transceiver outputs receives marks on RPOS and RNEG even when LOS is High.
13 16	TTIP TRING	AO	Transmit Tip and Ring. Differential Driver Outputs. These outputs are designed to drive a 50 - 200 Ω load. The transformer and line matching resistors should be selected to give the desired pulse height and return loss performance.
14	TGND	–	Ground. Ground return for the transmit driver power supply TVCC.
15	TVCC	DI	+5 VDC Power Supply input for the transmit drivers. TVCC must not vary from VCC by more than ± 0.3 V.
17	GND	–	Ground. Tie this pin to ground.
18	n/c	–	<i>Leave this pin open.</i>
19 20	RTIP RRING	AI	Receive Tip and Ring. The AMI signal received from the line is applied at these pins. A 1:1 transformer is required. Data and clock from the signal applied at these pins are recovered and output on the RPOS/RNEG, and RCLK pins.
21	VCC	–	+5 VDC Power Supply for all circuits except the transmit drivers. (Transmit drivers are supplied by TVCC.)
22	GND	–	Ground. Ground return for power supply VCC.
23 24 25	EC1 EC2 EC3	DI	Equalization Control 3-1. These pins define the Pulse Equalization settings. See Table 12 for additional details.
26	RLOOP	DI	Remote Loopback. When held High, the clock and data inputs from the framer (TPOS/TNEG or TDATA) are ignored and the data received from the line is transmitted back onto the line at the RCLK frequency. During remote loopback, the device ignores the in-line encoders/decoders. See Figure 8.
27	LLOOP	DI	Local Loopback. When held High, the data on TPOS and TNEG loops back digitally to RPOS and RNEG outputs (through JA if enabled). Leaving this pin open enables Analog Loopback (TTIP and TRING looped back to RTIP and RRING). See Figures 5, 6, and 7.
28	TAOS	DI	Transmit All Ones. When held High the transmit data inputs are ignored and the LXT350 transmits a stream of 1s at the TCLK frequency. (If TCLK is not supplied, MCLK is the transmit clock reference.) TAOS is inhibited during Remote Loopback. Leaving this pin open enables QRSS pattern generation and detection. See Figures 5, 10, and 11.

1. I/O Column entries: DI–Digital Input; DO–Digital Output; DI/O–Digital Input/Output; AI–Analog Input; AO–Analog Output

Table 4: LXT350 Hardware Controlled Unipolar Mode Signal Assignments

Pin #	Symbol	I/O ¹	Description
3	TDATA	DI	Transmit Data. Unipolar input for data to be transmitted onto the line.
4	INSBPV	DI	Insert Bipolar Violation. This pin is sampled on the falling edge of TCLK to control Bipolar Violation Insertions in the transmit data stream. A Low-to-High transition is required to insert subsequent BPVs.
6	BPV	DO	Bipolar Violation. BPV goes High to report receipt of a bipolar violation from the line. This is an NRZ output, valid on the rising edge of RCLK.
7	RDATA	DO	Receive Data. RDATA is a unipolar NRZ output of data recovered from the line interface. In Hardware Mode RDATA is stable and valid on the rising edge of RCLK.

1. I/O Column entries: DI–Digital Input; DO–Digital Output; DI/O–Digital Input/Output; AI–Analog Input; AO–Analog Output

Table 5: LXT350 Hardware Controlled QRSS Unipolar Mode Signal Assignments

Pin#	Symbol	I/O ¹	Description
3	INSLER	DI	Insert Logic Error. When this pin goes from Low to High, the transceiver inserts a logic error into the transmitted QRSS data pattern. The error follows the data flow in whatever loopback mode is in effect. The LXT350 samples this pin on the falling edge of TCLK (or MCLK, if TCLK is not present).
4	INSBPV	DI	Insert Bipolar Violation. When this pin goes from Low to High, the transceiver inserts a bipolar violation error into the transmitted QRSS data pattern. A subsequent insertion requires another Low to High transition. The LXT350 samples this pin on the falling edge of TCLK (or MCLK, if TCLK is not present).
6	BPV ²	DO	Bipolar Violation. BPV goes High to report receipt of a bipolar violation from the line. This is an NRZ output, valid on the rising edge of RCLK.
7	RDATA ²	AO	Received Data. RDATA is a unipolar NRZ output of data recovered from the line interface. In hardware Mode, RDATA is stable and valid on the rising edge of RCLK.
12	LOS/QPD	DO	Loss of Signal/QRSS Pattern Detect. This pin acts as a QPD indicator as well as LOS indicator. The QRSS Pattern synchronization criterion is fewer than four errors in 128 bits. In this mode, as long as the transceiver does not detect a QRSS pattern QPD stays High. As soon as the device does detect a QRSS pattern, the pin goes Low; any bit errors cause QPD to go High for half a clock cycle. This output can trigger an external error counter. An LOS condition also makes this pin go High. See Figure 11.
28	QRSS	DI	QRSS. Leaving this pin open, enables QRSS pattern generation and detection. The transceiver transmits the QRSS pattern at the TCLK rate (or MCLK, if TCLK is not present).

1. I/O Column entries: DI–Digital Input; DO–Digital Output; DI/O–Digital Input/Output; AI–Analog Input; AO–Analog Output
 2. In QRSS Bipolar Mode, pins 6 and 7 act as RNEG and RPOS output, respectively.

LXT350/351 Integrated T1/E1 S/H Transceivers With Crystal-less Jitter Attenuation

Table 6: LXT350 Host Controlled Bipolar Mode Signal Assignments ^{1,2}

Pin #	Symbol	I/O ³	Description
6 7	RNEG RPOS	DO	Received Data—Negative and Positive. In the Bipolar I/O Mode, these pins are the negative and positive sides of a bipolar output pair. The transceiver outputs the data recovered from the line interface on these pins. A signal on RNEG corresponds to receipt of a negative pulse on RTIP/RRING. A signal on RPOS corresponds to receipt of a positive signal on RTIP/RRING. RNEG/RPOS outputs are Non-Return-to-Zero (NRZ). CLKE determine the clock edge at which these outputs are stable and valid. See Figure 19.
9	TRSTE	DI	Tristate. Connecting TRSTE High forces all output pins to high-impedance state. Connect this pin Low for normal operation.
10	<i>n/c</i>	–	<i>Not connected.</i>
11	GND	–	<i>Tie this pin to ground.</i>
17	GND	–	<i>Tie this pin to ground</i>
23	$\overline{\text{INT}}$	DO	Interrupt (Active Low—Maskable). $\overline{\text{INT}}$ goes Low to flag the host when any of LOS, AIS, QRSS or DFMO changes state or when there is an Elastic Store overflow or underflow. $\overline{\text{INT}}$ is an open drain output which requires a connection to power supply VCC through a resistor. Reset $\overline{\text{INT}}$ by writing a one to the respective bit in the Interrupt Clear Register.
24	SDI	DI	Serial Data Input. Input port for the 16-bit serial address/command and data word. LXT350 samples SDI on the rising edge of SCLK. See Figure 20.
25	SDO	DO	Serial Data Output. If CLKE is High, SDO is valid on the rising edge of SCLK. If CLKE is Low, SDO is valid on the falling edge of SCLK. This pin goes to a high-impedance state when the serial port is being written to or when $\overline{\text{CS}}$ is High. See Figure 21.
26	$\overline{\text{CS}}$	DI	Chip Select (Active Low). This input is used to access the serial interface. For each read or write operation, $\overline{\text{CS}}$ must transition from High to Low, and remain Low.
27	SCLK	DI	Serial Clock. This clock is used to write data to or read data from the serial interface registers. The clock frequency can be any rate up to 2.048 MHz.
28	CLKE	DI	Clock Edge. Setting CLKE High causes RPOS and RNEG to be valid on the falling edge of RCLK, with SDO valid on the rising edge of SCLK. Setting CLKE Low makes RPOS and RNEG valid on the rising edge of RCLK and SDO valid on the falling edge of SCLK.
<p>1. For pins not described in this table, see Table 3. Pin out for data pins in Unipolar and QRSS Modes remains the same as in Tables 4 and 5. In Host Mode, the control pins (23-28) change as shown in Table 6.</p> <p>2. In QRSS Bipolar Mode, pins 6 and 7 seven act as RNEG and RPOS, respectively.</p> <p>3. I/O Column entries: DI—Digital Input; DO—Digital Output; DI/O—Digital Input/Output; AI—Analog Input; AO—Analog Output</p>			

Figure 2: LXT351 Bipolar Mode Pin Assignments

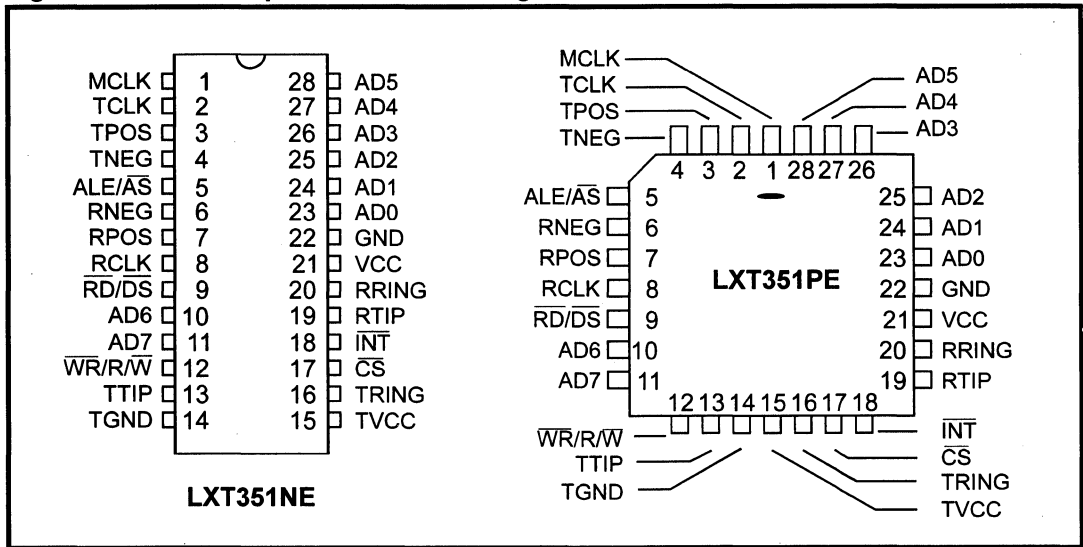

2

Table 7: LXT351 Clock and Data Pin Assignments by Mode¹

Pin #	External Data Modes		QRSS Modes	
	Bipolar Mode	Unipolar Mode	Bipolar Mode	Unipolar Mode
1	MCLK			
2	TCLK			
3	TPOS	TDATA	INSLER	
4	TNEG	INSBPV	INSBPV	
6	RNEG	BPV	RNEG	BPV
7	RPOS	RDATA	RPOS	RDATA
8	RCLK			
13	TTIP			
14	TGND			
15	TVCC			
16	TRING			
19	RTIP			
20	RRING			
21	VCC			
22	GND			

1. Data pins change based on whether external data or internal QRSS mode is active. These pins remain the same in both Hardware and Host Modes.

LXT350/351 Integrated T1/E1 S/H Transceivers With Crystal-less Jitter Attenuation

Table 8: LXT351 Processor Interface Pins

Pin #	Address/Data Bus Type		Pin #	Address/Data Bus Type	
	Intel	Motorola		Intel	Motorola
5	ALE	\overline{AS}	25	AD2	
9	\overline{RD}	DS	26	AD3	
12	\overline{WR}	R/ \overline{W}	27	AD4	
17	\overline{CS}		28	AD5	
18	\overline{INT}		10	AD6	
23	AD0		11	AD7	
24	AD1				

Table 9: LXT351 Bipolar Mode Signal Assignments

Pin #	Symbol	I/O ¹	Description
1	MCLK	DI	Master Clock. Connect to 1.544 MHz for T1 operation; to 2.048 MHz for E1. MCLK requires an external, independent input to generate internal clocks. Required accuracy is better than ± 32 ppm with a typical duty cycle of 50%. Upon Loss of Signal (LOS), the transceiver derives RCLK from MCLK.
2	TCLK	DI	Transmit Clock. 1.544 MHz or 2.048 MHz bit rate clock input. The transceiver samples TPOS and TNEG on the falling edge of TCLK
3 4	TPOS TNEG	DI	Transmit Data – Positive and Negative. In the Bipolar I/O Mode, these pins are the positive and negative sides of a bipolar input pair. Data for transmission onto the line is input at these pins.
5	\overline{ALE} \overline{AS}	DI	Address Latch Enable/Address Strobe (Active Low). Connects to Intel (ALE) or Motorola (\overline{AS}) signal. On Motorola bus, this signal is Active Low. Leaving this pin floating forces all output pins into a high impedance state.
6 7	RNEG RPOS	DO	Receive Data – Negative and Positive. In the Bipolar I/O mode, these pins are the positive and negative sides of a bipolar output pair. Data recovered from the line interface is output on these pins. A signal on RNEG corresponds to receipt of a negative pulse on RTIP/RRING. A signal on RPOS corresponds to receipt of a positive pulse on RTIP/RRING. RNEG/RPOS outputs are Non-Return-to Zero. Both outputs are stable and valid on the rising edge of RCLK. Refer to Table 10 for Unipolar mode function descriptions.
8	RCLK	DO	Recovered Clock. The output on this pin is the clock recovered from the line input signal. Under LOS conditions there is a smooth transition from RCLK to MCLK output.

1. I/O column entries DI = Digital Input; DO = Digital Output, DI/O = Digital Input and Output; AI = Analog Input, AO = Analog Output.

LXT350/351 Integrated T1/E1 S/H Transceivers With Crystal-less Jitter Attenuation

Table 9: LXT351 Bipolar Mode Signal Assignments – continued

Pin #	Symbol	I/O ¹	Description
9	\overline{RD} DS	DI	Read (Active Low)/Data Strobe (Active Low). On an Intel bus, this signal, Read, goes Low to command a read operation. On a Motorola bus, this signal, Data Strobe, goes Low when data is being driven on the address/data bus. Data is valid on the rising edge of DS.
10	AD6	DI/O	Address/Data bus lines 6 and 7. Used with pins 24-28 as the address/data bus.
11	AD7	DI/O	
12	\overline{WR} R/W	DI	Write (Active Low) or Write/Read. On an Intel bus, driving this signal (Write) Low enables a write operation on the Address/Data bus. On a Motorola bus, driving this signal (Read/Write) High commands a read operation, driving it Low commands a write operation.
13 16	TTIP TRING	AO	Transmit Tip and Ring. Differential Driver Outputs. The design load for these outputs is 50 - 200 Ω . Select the transformer and line matching resistors to give the desired pulse height.
14	TGND		Ground. Ground return for the transmit drivers power supply TVCC.
15	TVCC		+5 VDC Power Supply input for the transmit drivers. TVCC must not vary from VCC by more than ± 0.3 V.
17	\overline{CS}	DI	Chip Select (Active Low). For each read or write on the Address/Data bus, this pin must go Low during the operation. See Figures 22 and 23 for timing requirements. In the case of a single processor controlling several chips, this is the line it uses to command a specific transceiver.
18	\overline{INT}	DO	Interrupt (Active Low). This pin goes Low to signal an interrupt on the chip. To identify the specific interrupt, read the Performance Status Register. To clear or mask an interrupt, write a one to the appropriate bit in the Clear Interrupt Register.
19 20	RTIP RRING	AI	Receive Tip and Ring. The AMI signal received from the line is applied at these pins. A 1:1 transformer is required. Data and clock from the signal applied at these pins are recovered and output on the RPOS/RNEG, and RCLK pins.
21	VCC		+5 VDC Power Supply for all circuits except the transmit drivers. (Transmit drivers are supplied by TVCC.)
22	GND		Ground return for power supply VCC.
23 24 25 26 27 28	AD0 AD1 AD2 AD3 AD4 AD5	DI/O	Address/Data Lines 0-5. (Also pins 10, 11–AD6 and 7) Conform to Intel and Motorola Address/Data bus specifications.

1. I/O column entries DI = Digital Input; DO = Digital Output, DI/O = Digital Input and Output; AI = Analog Input , AO = Analog Output.

2

Table 10: LXT351 Unipolar Mode Signal Assignments¹

Pin #	Symbol	I/O ²	Description
3	TDATA	DI	Transmit Data. Unipolar data for transmission onto the line.
4	INSBPV	DI	Insert Bipolar Violation. Controls bipolar violation insertions, requires Low-to-High transition to insert each violation, the LXT351 samples the signal on the falling edge of TCLK.
6	BPV	DO	Bipolar Violation. BPV goes High on receipt of a bipolar violation from the line. This is an NRZ output, valid on the rising edge of RCLK.
7	RDATA	DO	Received Data. RDATA is an NRZ output of the data recovered from the line interface. RDATA is valid on the rising edge of RCLK.

1. For the descriptions of pins not identified in this table, see Table 9: LXT351 Bipolar Mode Signal Assignments.
 2. I/O column entries DI = Digital Input; DO = Digital Output, DI/O = Digital Input and Output; AI = Analog Input , AO = Analog Output.

Table 11: LXT351 QRSS Unipolar Mode Signal Assignments^{1,2}

Pin #	Symbol	I/O ³	Description
3	INSLER	DI	Insert Logic Error. When this pin goes from Low to High, the transceiver inserts a logic error into the transmitted QRSS data pattern. The error follows the data flow in whatever loopback mode is in effect. The LXT351 samples this pin on the falling edge of TCLK (or MCLK, if TCLK is not present).
4	INSBPV	DI	Insert Bipolar Violation. When this pin goes from Low to High, the transceiver inserts a bipolar violation error into the transmitted QRSS data pattern. A subsequent insertion requires another Low to High transition. The LXT351 samples this pin on the falling edge of TCLK (or MCLK, if TCLK is not present).
6	BPV	DO	Bipolar Violation. BPV goes High on receipt of a bipolar violation from the line. This is an NRZ output, valid on the rising edge of SCLK.
7	RDATA	DO	Received Data. RDATA is an NRZ output of the data recovered from the line interface. RDATA is valid on the rising edge of RCLK.

1. For the descriptions of pins not identified in this table, see Table 9: LXT351 Bipolar Mode Signal Assignments.
 2. In QRSS Bipolar Mode, pins 6 and 7 act as RNEG and RPOS, respectively.
 3. I/O column entries DI = Digital Input; DO = Digital Output, DI/O = Digital Input and Output; AI = Analog Input, AO = Analog Output.

LXT350/351 Integrated T1/E1 S/H Transceivers With Crystal-less Jitter Attenuation

Figure 3: LXT351 Block Diagram

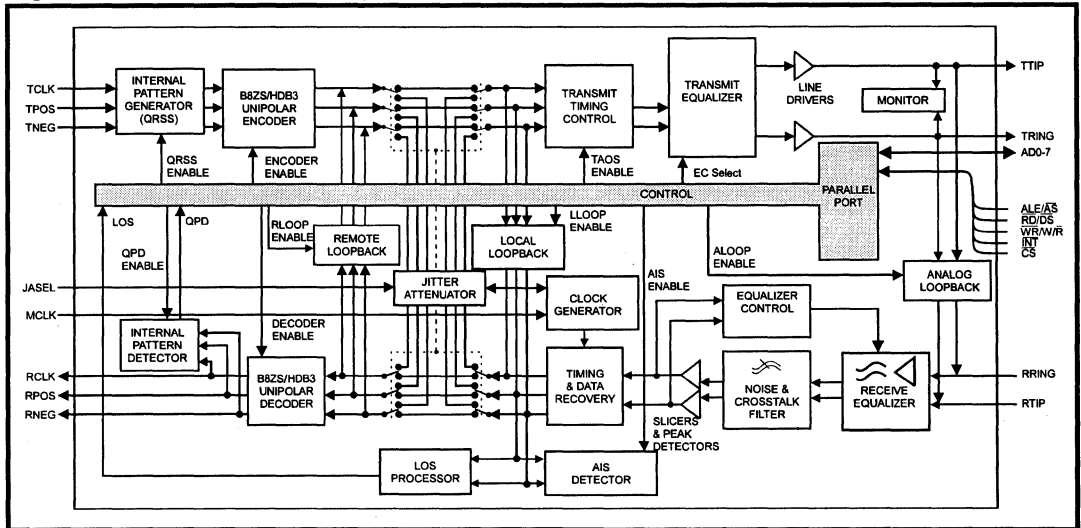

2

FUNCTIONAL DESCRIPTION

NOTE

This functional information is for design aid only. Unless specified otherwise, all descriptions, tables and figures apply equally to both the LXT350 and LXT351 transceivers.

The LXT350 and LXT351 are fully-integrated, PCM transceivers for or short-haul, 1.544 Mbps (T1) or 2.048 Mbps (E1) applications allowing full-duplex transmission of digital data over existing twisted-pair installations. They interface with two lines (one pair each for transmit and receive) through standard pulse transformers and appropriate resistors.

The figure on the front of this Data Sheet shows a block diagram of the LXT350. In Host Mode the device is controlled through a serial microprocessor. In Hardware Mode it is controlled via individual pins. Figure 3 is a block diagram of the LXT351. The LXT351 has a parallel port for microprocessor control. Both transceivers provide a high-precision, crystal-less jitter attenuator. The user may place it in the transmit or receive path, or bypass it completely. The transceivers meet or exceed ANSI, ITU and E1 requirements.

INITIALIZATION

During power up, the transceiver remains static until the power supply reaches approximately 3 V. On crossing this threshold, the device begins a 32 ms reset cycle to calibrate the Phase Locked Loops. The transceiver uses a reference clock to calibrate the PLL—the transmitter reference is TCLK, and the receiver reference clock is MCLK. MCLK is mandatory for chip operation.

Reset Operation

Reset clears and sets all registers to 0 and resets the status and state machines for the LOS, AIS and QRSS blocks. In Hardware Mode, holding pins RLOOP, LLOOP and TAOS High for at least one clock cycle resets the device. Writing a 1 to the bit CR2.RESET commands reset in Host Mode. Allow 32 ms for the device to settle after removing all reset conditions.

TRANSMITTER

Digital Data Interface

Input data for transmission onto the line is clocked serially into the device at the TCLK rate. TPOS and TNEG are the bipolar data inputs. TDATA accepts unipolar data. (Leaving TRSTE open enables Hardware Unipolar Mode.)

Input data may pass through either the Jitter Attenuator or B8ZS/HDB3 encoder or both. Bit CR1.ENCENB = 1 enables B8ZS/HDB3 encoding in Host Mode. In Hardware Mode, leaving the MODE pin open selects zero suppression coding. With zero suppression enabled, the ECx inputs (see Table 12) determine the coding scheme (B8ZS for T1 or HDB3 for E1 mode). For the HDB3 scheme, set EC3-1 to 000 or 001. Other ECx settings select the B8ZS option. The transmit clock (TCLK) supplies input synchronization. The Test Specifications section defines the transmit timing requirements for TCLK and the Master Clock (MCLK).

Short Circuit Limit

The transmitter includes a short-circuit limiter. This limits the current sourced into a low-impedance load. It automatically resets when the load current drops below the limit. The current is determined by the interface circuitry (total resistance on transmit side).

In Host Mode, the Performance Status Register flags open circuits in bit PSR.DFMO. A transition on DFMO will provide an interrupt and the transition sets bit TSR.DFMO = 1. Writing a 1 in bit ICR.CDFMO clears the interrupt; leaving a 1 in the bit masks that interrupt.

Output Drivers

The transceivers transmit data as a 50% line code as shown in Figure 4. Activating the line driver only during a mark reduces power consumption. The output driver is disabled during transmission of a space. Biasing of the transmit DC level is on-chip.

Figure 4: 50% Duty Cycle Coding Diagram

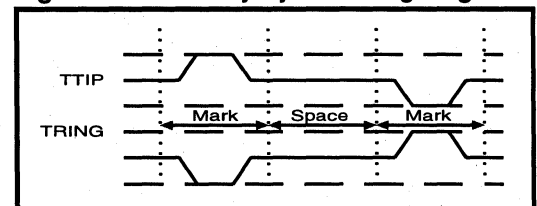

Idle Mode

Transmit Idle Mode is a normal operational mode (as opposed to modes) which allows multiple transceivers to be connected to a single line for redundant applications. TTIP and TRING remain in a high impedance state when TCLK is not present. Remote or Dual Loopback, TAOS or any internal transmit patterns temporarily disable the high impedance state.

Pulse Shape

The Equalizer Control inputs (EC3 through EC1) determine the transmitted pulse shape. In Host Mode, the I/O port controls the ECx values. For the LXT350 in Hardware Mode, three individual pins provide the ECx inputs.

Shaped pulses meeting the T1 DSX-1 and E1 specifications are applied to the AMI line driver for transmission onto the line at TTIP and TRING. Refer to the Test Specifications section for pulse mask specifications.

RECEIVER

A 1:1 transformer provides the interface to the line. Recovered data is output at RPOS/RNEG (RDATA in Unipolar mode), and the recovered clock is output at RCLK. The Test Specifications section shows receiver timing.

The transceiver filters the equalized signal and applies it to the peak detector and data slicers. The peak detector samples the inputs and determines the maximum value of the received signal. The data slicers are set at 50% of the peak value to ensure optimum signal-to-noise performance for T1 or E1 operation.

After processing through the data slicers, the received signal goes to the data and timing recovery section, then to the B8ZS/HDB3 decoder (if selected) and to the receive monitor. The data and timing recovery circuits provide input jitter tolerance significantly better than required by AT&T Pub 62411 and ITU G.823. See the Test Specifications section.

Table 12: Equalizer Control Input Settings

EC3	EC2	EC1	Function	Pulse	Cable	Coding ¹
0	0	0	E1	ITU Rec G.703	75 Ω Coax/120 Ω TP	HDB3
0	1	1	T1	0-133 ft / 0.6 dB	100 Ω TP	B8ZS
1	0	0	T1	133-266 ft / 1.2 dB	100 Ω TP	B8ZS
1	0	1	T1	266-399 ft / 1.8 dB	100 Ω TP	B8ZS
1	1	0	T1	399-533 ft / 2.4 dB	100 Ω TP	B8ZS
1	1	1	T1	533-655 ft / 3.0 dB	100 Ω TP	B8ZS

1. When enabled.

Digital Data Interface

In either Host or Hardware Control Mode the recovered data goes to the Loss of Signal (LOS) Monitor. In Host Control Mode, it also goes through the Alarm Indication Signal (AIS, Blue Alarm) Monitor. The jitter attenuator circuit may be enabled or disabled in the receive data path or the transmit path. Received data may go through either the B8ZS or HDB3 decoder or neither. Finally, the device may send the digital data to the framer as either unipolar or bipolar data.

When transmitting unipolar data to the framer, the device reports receiving bipolar violations by driving the BPV pin High. During E1 operation in Host Control Mode, the device can report HDB3 code violations and Zero Substitution Violations on the BPV pin. The diagnostics section explains these options in more detail.

JITTER ATTENUATION

A Jitter Attenuation Loop (JAL) with an Elastic Store (ES) provides jitter attenuation as shown in the Test Specifications section. The JAL requires no special circuitry, such as an external quartz crystal or high-frequency clock (higher than the line rate). Its timing reference is the master clock, MCLK.

In Hardware Control Mode the ES is a 32 x 2-bit register. Setting the JASEL pin High places the JA circuitry in the received data path; setting JASEL Low places the JA in the transmit data path; leaving it open disables the JA.

In Host Mode, bit CR1.JASEL0 enables or disables the JA circuit. With bit CR1.JASEL0 = 1, bit CR1.JASEL1 controls the JA circuit placement (see Table 17). The ES can be either a 32 x 2-bit or 64 x 2-bit register depending on the value of bit CR3.ES64 (see Table 19.)

The device clocks data into the ES using either TCLK or RCLK depending on whether the JA circuitry is in the transmit or receive data path, respectively. Data is shifted out of the elastic store using the dejittered clock from the JAL. When the FIFO is within two bits of overflowing or underflowing, the ES adjusts the output clock by $\frac{1}{8}$ of a bit period. The ES produces an average delay of 16 bits (or 32 bits, with the 64-bit ES option selected in Host Control Mode) in the associated data path. When the Jitter Attenuator is in the receive path, the output RCLK transitions smoothly to MCLK in the event of an LOS condition.

The Transition Status Register bits TSR.ESOVR and TSR.ESUNF indicate an overflow or underflow, respectively in the ES. These are sticky bits: Once set to 1, they remain set until the host reads the register. The ES can also provide a maskable interrupt on either overflow or underflow.

DIAGNOSTIC MODE OPERATION

LXT350/351 offers multiple diagnostic modes as shown in Table 13. In Hardware Mode, the diagnostic modes are selected by a combination of pin settings. In Host Mode, the diagnostic modes are selected by writing appropriate bits in the Diagnostic Control Register.

Table 13: Diagnostic Mode Availability

Diagnostic Mode	Availability ¹		Host Mode ² Maskable
	H/W	Host	
Loopback Modes			
Local Loopback (LLOOP)	Yes	Yes	No
Analog Loopback (ALOOP)	Yes	Yes	No
Remote Loopback (RLOOP)	Yes	Yes	No
Dual Loopback (DLOOP)	Yes	Yes	No
Internal Data Pattern Generation and Detection			
Transmit All Ones (TAOS)	Yes	Yes	No
Quasi-Random Signal Source (QRSS)	Yes	Yes	Yes
Error Insertion and Detection			
Bipolar Violation Insertion (INSBPV)	Yes	Yes	No
Logic Error Insertion (INSLER)	Yes	Yes	No
Bipolar Violation Detection (BPV)	Yes	Yes	No
Logic Error Detection, QRSS (QPD)	Yes	Yes	No
HDB3 Code Violation Detection (CODEV)	No	Yes	No
HDB3 Zero violation Detection (ZEROV)	No	Yes	No
Alarm Condition Monitoring			
Receive Loss of Signal (LOS) Monitoring	Yes	Yes	Yes
Receive Alarm Indication Signal (AIS) Monitoring	No	Yes	Yes
Transmit Driver Failure Monitoring—Open (DFMO)	No	Yes	Yes
Elastic Store Overflow and Underflow Monitoring	No	Yes	Yes
Built-In Self Test (BIST)	No	Yes	Yes

1. In Hardware Control Mode, a combination of pin settings selects the Diagnostic Modes; in Host Control Mode, writing appropriate bits into the Control Registers selects the Diagnostic Modes.

2. Host Control Mode allows interrupt masking by writing a “1” to the corresponding bit in the Interrupt Clear Register. Hardware Control Mode has no interrupt masking feature.

2

LOOPBACK MODES

NOTE

Hardware Mode pins discussed in this section refer to the LXT350 only.

Local Loopback

See Figures 5 and 6. In Hardware Mode, Local Loopback (LLOOP) is selected by tying LLOOP High; in Host Mode, by setting CR2.ELLOOP to 1. LLOOP inhibits the receiver circuits. The transmit clock and data inputs (TCLK and TPOS/TNEG or TDATA) loop back through the jitter attenuator (if enabled) and show up at RCLK and RPOS/RNEG or RDATA. (During LLOOP, the JASEL input is strictly an Enable/Disable control; it does not affect the placement of the JAL. If JA is enabled, it is active in the loopback circuit. If JA is bypassed, it is not active in the loopback circuit.)

The transmitter circuits are unaffected by LLOOP. LXT350/351 transmits the TPOS/TNEG or TDATA inputs (or a stream of 1s if TAOS is asserted) normally. When used in this mode, the transceiver can function as a stand-alone jitter attenuator.

Figure 5: TAOS with LLOOP (JA Selected)

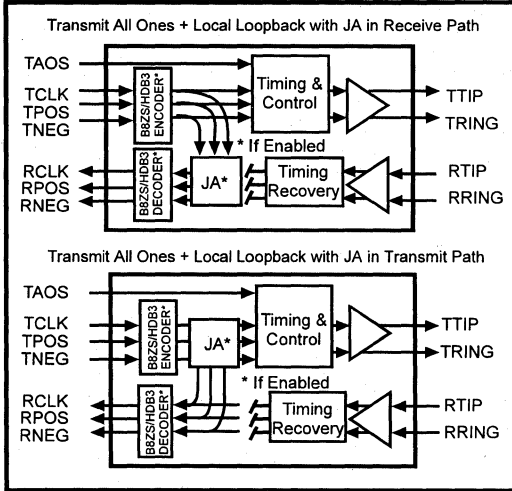
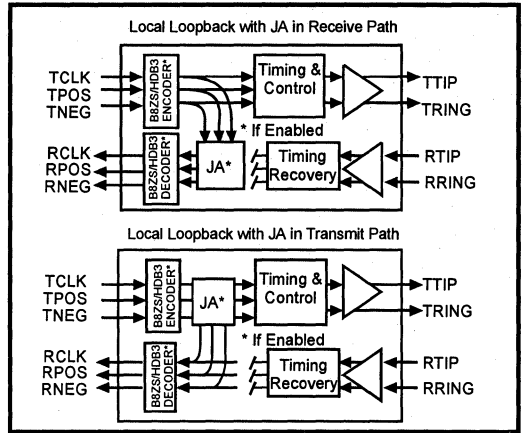

Figure 6: Local Loopback (JA Selected)



Analog Loopback

See Figure 7. Analog Loopback (ALOOP) exercises the maximum number of functional blocks. ALOOP operation disconnects the RTIP/RRING inputs from the line and routes the transmit outputs back into the receive inputs. This tests the encoders/decoders, jitter attenuator, transmitter, receiver and timing recovery sections. In Hardware Mode, leaving pin 27 open commands Analog Loopback; in Host Mode, writing a 1 to bit CR2.EALOOP enables the function. The ALOOP function overrides all other loopback modes.

Figure 7: Analog Loopback (JA Selected)

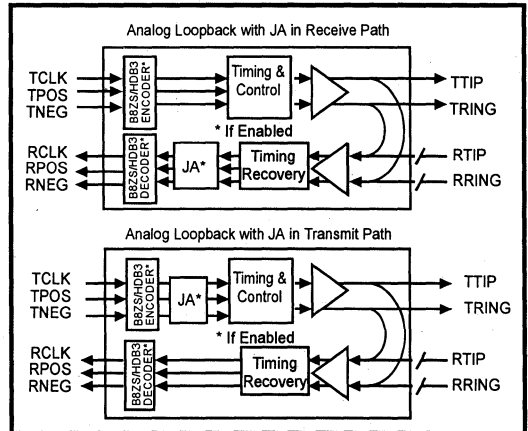

Remote Loopback

See Figure 8. In Remote Loopback (RLOOP) mode, the device ignores the transmit data and clock inputs (TCLK and TPOS/TNEG or TDATA), and bypasses the in-line encoders/decoders. The RPOS/RNEG or RDATA outputs loop back through the transmit circuits to TTIP and TRING at the RCLK frequency. The RLOOP command does not affect the receiver circuits which continue to output the RCLK and RPOS/RNEG or RDATA signals received from the twisted-pair line. In Host Mode, command RLOOP by writing a 1 to bit CR2.ERLOOP. In Hardware Mode, RLOOP is commanded by setting pin 26 High.

Dual Loopback

See Figure 9. To select Dual Loopback (DLOOP), set both RLOOP and LLOOP High in Hardware Mode or set bits CR2.ERLOOP and CR2.ELLOOP to 1 in Host Mode. In DLOOP mode, the transmit clock and data inputs (TCLK and TPOS/TNEG or TDATA) loop back through the Jitter Attenuator (unless disabled) to RCLK and RPOS/RNEG or RDATA. The data and clock recovered from the line loop back through the transmit circuits to TTIP and TRING without jitter attenuation.

Figure 8: Remote Loopback (JA Selected)

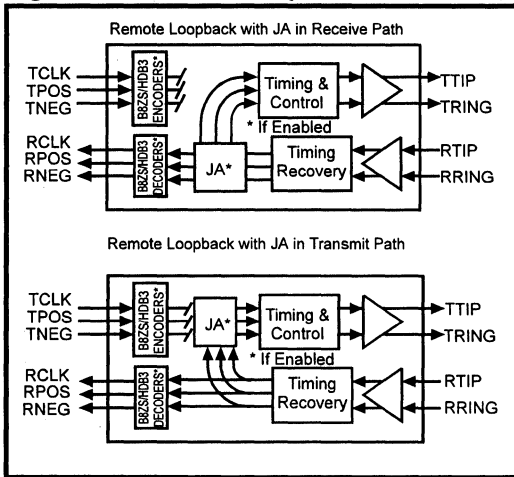
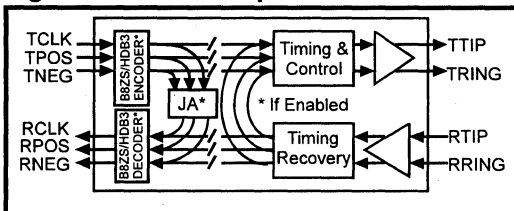

Figure 9: Dual Loopback



INTERNAL PATTERN GENERATION AND DETECTION

Transmit All Ones

See Figure 10. In Transmit All Ones (TAOS) Mode the transceiver ignores the TPOS and TNEG inputs and transmits a continuous stream of 1s at the TCLK frequency. (With no TCLK, the TAOS output clock is MCLK.) This can be used as the Alarm Indication Signal (AIS—also called the Blue Alarm). In Host Mode, TAOS is commanded by writing a 1 to bit CR2.ETAOS. In Hardware Mode setting pin 28 High does so. Both TAOS and Local Loopback can occur simultaneously as shown in Figure 5, but Remote Loopback inhibits TAOS. When both TAOS and LLOOP are active, TCLK and TPOS/TNEG loop back to RCLK and RPOS/RNEG through the jitter attenuator (if enabled), and an all ones pattern goes to TTIP/TRING.

Figure 10: TAOS Data Path

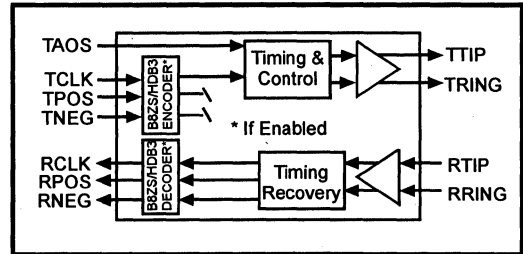

Quasi-Random Signal Source (QRSS)

For T1 operation the Quasi-Random Signal Source (QRSS) is a $2^{20}-1$ pseudo-random bit sequence (PRBS) with no more than 14 consecutive zeros. For E1 operation, QRSS is $2^{15}-1$ PRBS with inverted output.

Both Hardware and Host Modes allow QRSS Mode. The QRSS pattern is normally locked to TCLK; but if there is no TCLK, MCLK is the clock source. Bellcore Pub 62411 defines the T1 QRSS transmit format and ITU G.703 defines the E1 format.

Leaving TAOS (pin 28) open enables QRSS transmission in Hardware Mode. In Host Mode, setting bits CR2.EPAT0 = 0 and CR2.EPAT1=1 enables this function.

With QRSS transmission enabled, it is possible to insert a logic error into the transmit data stream by causing a Low-to-High transition on INSLER (pin 3). However, if no logic or bit errors are to be inserted into the QRSS pattern, INSLER must remain Low. Logic Error insertion waits until the next bit if the current bit is "jammed". (When there are more than 14 consecutive 0s, the output is jammed to a 1.)

Furthermore a bipolar violation in the QRSS pattern is possible by causing a Low-to-High transition on INSBPV (pin 4) without regard to whether the device is in bipolar or unipolar operating mode.

Figure 11: QRSS Mode

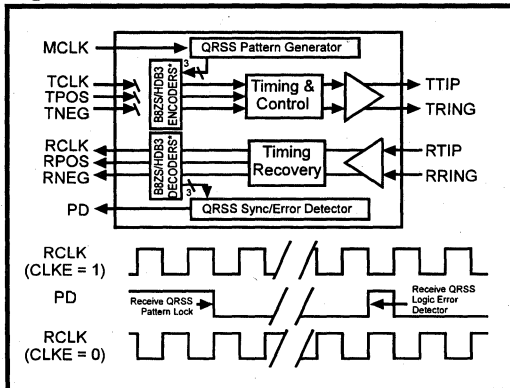

Choosing QRSS Mode also enables the QRSS Pattern Detection (QPD) in the receive path. The QRSS pattern is synchronized when there are fewer than four errors in 128 bits. After achieving synchronization the device drives QPD (pin 12) Low (QPD output is available on LXT350 only). The LXT351 does not support bit error detection in QRSS Mode. In the LXT350 QRSS Mode, any subsequent bit error in the QRSS pattern causes QPD to go High for half an RCLK clock cycle (the precise relationship to RCLK depends on the value of CLKE—when CLKE is Low, QPD goes High while RCLK is High; if CLKE is High, QPD goes High while RCLK is Low). This signal edge can serve as a trigger for an external bit-error counter. An LOS condition or a loss of QRSS synchronization will cause this output to go High continuously. In this case, and with either Unipolar Mode or the encoders/decoders enabled, the BPV pin indicates BPVs, CODEVs or ZEROVs as chosen.

Host Mode offers an additional interrupt to indicate that QRSS detection and synchronization have occurred, or that synchronization is lost. This interrupt is available when bit ICR.CQRSS = 0. If the QPD signal triggers a bit error counter, the interrupt could start or reset the counter.

Also in Host Mode, the PSR.QRSS bit provides an indication of the QRSS pattern synchronization. This bit goes Low with no QRSS pattern detected (*i.e.*, when there are more than four errors in 128 bits). The TQRSS bit in the Transition Status Register indicates that QRSS status has changed since the last QRSS Interrupt Clear command.

ERROR INSERTION AND DETECTION

Bipolar Violation Insertion (INSBPV)

In Unipolar Mode, both Hardware and Host Modes provide for Bipolar Violation Insertion (INSBPV). Choosing Unipolar Mode configures pin 4 as INSBPV. Bipolar violation insertion requires a Low-to-High transition on INSBPV. Sampling occurs on the falling edge of TCLK. When INSBPV goes High a BPV is inserted on the next available mark except in the three following situations:

- Zero suppression (HDB3 or B8ZS) is not violated
- If LLOOP and TAOS are both active, the BPV is looped back to RNEG/BPV indicator and the line driver transmits all ones with no violation.
- BPV insertion is disabled with RLOOP (remote loopback) active.

With the LXT350/351 configured to transmit internally generated QRSS data patterns a BPV can be inserted on the transmit pattern independent of whether the device is in the unipolar or bipolar mode of operation.

Logic Error Insertion (INSLER)

When configured to transmit internally generated QRSS data patterns, the device can insert a logic error on the transmit data pattern when there is a Low-to-High transition on INSLER. The transceiver treats data patterns the same way it treats data applied to TPOS/TNEG, so the inserted logic error will follow the data flow path as defined by the loopback mode in effect.

Logic Error Detection (QPD) (LXT350 Only)

After receiving pattern synchronization when configured in the QRSS Mode, LXT350 reports logic errors on QPD (pin 12). To indicate a logic error, this pin goes High for half an RCLK cycle (during the High period of RCLK if CLKE is Low but during the Low RCLK period if CLKE is High). To monitor logic errors, connect an error counter to QPD. A continuous High level on this pin indicates loss of either the QRSS pattern lock or LOS condition. The QRSS section has additional details on QRSS pattern lock criteria.

Bipolar Violation Detection (BPV)

With the internal encoders/decoders enabled or when configured in Unipolar Mode, the LXT350/351 reports received Bipolar Violations at BPV (pin 6). The pin goes High for a full clock cycle to indicate receipt of a BPV. However, if the encoders/decoders are enabled, LXT350/351 does not report bipolar violations due to the line coding scheme.

HDB3 Code Violation Detection (CODEV)

LXT350/351 can detect HDB3 code violations in Host Mode with HDB3 encoders enabled. This requires CR1.ENCENB = 1 and CR1.EC3-1 = 000, 001 or 010, which establishes E1 operation. To enable CODEV, set bit CR4.CODEV = 1.

An HDB3 code violation (CODEV) occurs when the device receives two consecutive bipolar violations of the same polarity (refer to ITU O.161). With CODEV detection enabled, LXT350/351 reports a violation on the BPV pin along with received BPVs and ZEROVs (if these options are enabled). LXT350/351 forces the BPV pin High for a full RCLK cycle to report a CODEV.

HDB3 Zero Substitution Violation Detection (ZEROV)

With encoders/decoders enabled, the LXT350/351 can detect HDB3 zero substitution violations (ZEROV) in Host Mode. This requires CR1.ENCENB = 1 and CR1.EC3-1 = 000, 001, or 1010, which establish E1 operation, and CR4.ZEROV = 1.

LXT350/351 forces the BPV pin High for a full RCLK cycle to report a ZEROV. An HDB3 ZEROV is the receipt of four or more consecutive zeros. This does not occur with correctly encoded HDB3 data unless there are transmission errors. With ZEROV detection enabled, the device reports a violation on the BPV pin along with received BPVs and CODEVs (if these options are enabled).

ALARM CONDITION MONITORING

Loss of Signal (LOS)

The LXT350/351 Loss of Signal (LOS) monitor function is compatible with ITU G.775 and ETSI 300233. They use a combination analog and digital detection scheme. The receiver LOS monitor loads a digital counter at the RCLK frequency. The counter increments with each received 0 and it resets to 0 on receipt of a 1. Any signal that remains 25 dB typical below the nominal 0dB signal for n consecutive pulse generates an internal LOS condition. For T1 operations, $n = 175$; for E1 operations, $n = 32$. In Host Mode, either number can be changed to 2048 by setting bit CR4.LOS2048 to 1. MCLK replaces the recovered clock at the RCLK output in a smooth transition.

For T1 operation, when the received signal has 12.5% 1s density (16 marks in a sliding 128-bit period, with fewer than 100 consecutive 0s), the LOS flag returns Low and the recovered clock replaces MCLK at the RCLK output in another smooth transition.

For E1 operation, the LOS condition is cleared when the received signal rises above 25 dB typical below the minimum 0 dB level and has 12.5% 1s density (four 1s in a sliding 32-bit window with fewer than 16 consecutive 0s). In Host Mode E1 operation, the out-of-LOS criterion can be modified from 12.5% marks density to 32 consecutive marks by setting bit CR4.COL32CM = 1.

During LOS, the device sends received data to the RPOS/RNEG pins (or RDATA in Unipolar Mode). LXT350 reports an LOS condition on the LOS pin in Hardware Mode. In Host Mode, the LOS bit in the Performance Status Register goes High to indicate an LOS condition and will interrupt the host controller if so programmed.

Alarm Indication Signal Detection (AIS)

The Alarm Indication Signal (AIS) is available only in Host Mode. The receiver detects an AIS pattern when it receives fewer than three 0s in any string of 2048 bits. The device clears the AIS condition when it receives three or more 0s in a string of 2048 bits.

The AIS bit in the Performance Status Register indicates AIS detection. When the AIS status changes, the TAIS bit in the Transition Status Register goes High. The change of status interrupts the host controller by pulling $\overline{\text{INT}}$ Low, unless the interrupt is masked. Writing a 1 to the ICR.CAIS bit masks the interrupt until the bit returns to 0.

Driver Failure Mode Open (DFMO)

In Host Mode a DFM Open (DFMO) bit is available in the Performance Status Register to indicate an open condition on the lines. DFMO can generate an $\overline{\text{INT}}$ to the host controller. The Transition Status Register bit DFMO indicates a transition in the status of the bit. Writing a 1 to ICR.CDFMO will clear or mask the interrupt.

Elastic Store Overflow/Underflow (ESOV/ESUNF)

When the bit count in the Elastic Store (ES) is within two bits of overflowing or underflowing the ES adjusts the output clock by $\frac{1}{8}$ of a bit period. In Host Mode, the ES provides an indication of overflow and underflow in the TRS.ESOVR and TSR.ESUNF. These are sticky bits and will stay set to 1 until the host controller reads the register. These interrupts can be cleared or masked by writing a 1 to the bits ICR.CESO and ICR.CESU, respectively.

OTHER DIAGNOSTIC MODES

Built-In Self Test (BIST)

LXT350/351 provides a Built-In Self Test (BIST) capability in Host Mode. The BIST exercises the internal circuits

by providing an internal QRSS pattern, running it through the encoders and the transmit drivers then looping it back through the receive equalizer, Jitter Attenuator and decoders to the QRSS pattern detection circuitry. If all the blocks in this data path work correctly, the receive pattern detector locks onto the pattern. It then pulls $\overline{\text{INT}}$ Low and sets the following bits High:

- TSR.QRSS
- PSR.QRSS
- PSR.BIST

The QPD pin (pin 12) also indicates completion status of the test. Starting the test forces this pin High. During the test, it remains High until the test finishes successfully at which time it goes Low.

OPERATING MODES

The LXT350/351 share many features. However, their control modes are very different.

- The LXT350 operates in either Hardware or (Serial Port) Host Mode
- The LXT351 operates in (Parallel Port) Host Mode only.

In the Hardware Mode (LXT350 only) individual pins control the transceiver.

The logic level at the MODE pin sets the LXT350 mode of operation. In Host Mode (LXT350/351), a microprocessor controls the device through a data interface. The LXT350 has a serial interface and the LXT351 uses a parallel interface.

Hardware Mode Operation (LXT350 Only)

The LXT350 operates in Hardware Mode when MODE is left open or set Low. In Hardware Mode individual pins access and control the transceiver. The outputs (RPOS/RNEG or RDATA) are valid on the rising edge of RCLK.

There are some advanced functions provided only in Host Mode. Interrupt ($\overline{\text{INT}}$), AIS detection indicator, DFM open indicator and CLKE functions are some of the features available in Host Mode.

Table 14: Control and Operational Mode Selection for LXT350 Transceiver

Input to Pin ¹		Mode
Mode	TRSTE	
Low	Low	Hardware - Bipolar
Low	High	Hardware - Tristate
Low	Open	Hardware - Unipolar
High	Low	Software ²
High	High	Software ² - Tristate All Outputs
High	Open	Software ²
Open	Low	Hardware - Unipolar (Encoder On)
Open	High	Hardware - Unipolar (Encoder On); Tristate All Outputs
Open	Open	Hardware - Unipolar (Encoder On)

1. Open is either a midrange voltage or the pin is floating
2. In Software Mode, the contents of register CR1 determine the operation mode.

Host Mode Operation

The LXT350 operates in Host Mode when MODE is set High. In Host Mode a microprocessor accesses and controls the transceiver through a data port using the internal registers. The outputs (RPOS/RNEG or RDATA) are valid on the rising edge of RCLK.

In Host Mode there are eight control and status registers—five read/write and three read-only registers. The LXT350 accesses them through its serial interface (SIO). The LXT351 provides this access using an 8-bit parallel interface (PIO).

The host processor/controller can completely configure the device as well as get a full diagnostic/status report through the SIO or PIO. Only the clocks and data for Bipolar Mode and BPV/Logic Error insertions for Unipolar or QRSS Mode need to be provided directly to the input pins. Similarly, the recovered clock, data, and BPV/Logic Error occurrences are available only at output pins. All other mode settings and diagnostic information are available through the data port.

Table 15 shows the address used by the SIO or PIO to access each register on the LXT350 or LXT351, respectively. Table 16 summarizes the control and status registers and labels each bit they contain. Tables 17 through 23 identify the bits in each register.

Table 15: Serial (LXT350) and Parallel (LXT351) Port Register Addresses

Register		Address ¹	
Name	Abbr	Serial Port (A7-A1)	Parallel Port (A7-A0)
Control #1	CR1	x010000	x010000x
Control #2	CR2	x010001	x010001x
Control #3	CR3	x010010	x010010x
Interrupt Clear	ICR	x010011	x010011x
Transition Status	TSR	x010100	x010100x
Performance Status	PSR	x010101	x010101x
Control #4	CR4	x010111	x010111x

1. x = "don't care".

Table 16: Register Addresses and Bit Names

Register		Type	Bit							
Name	Sym		7	6	5	4	3	2	1	0
Control #1	CR1	R/W	JASLE1	JASEL0	ENCEB	UNIENB	<i>reserved</i> ²	EC3	EC2	EC1
Control #2	CR2	R/W	RESET	EPAT1	EPAT0	ETAOS	<i>reserved</i> ²	EALOOP	ELLOOP	ERLOOP
Control #3	CR3	R/W	JA6HZ	PCLKE ¹	SBIST	EQZMON	<i>reserved</i> ²	ES64	ESCEN	ESJAM
Interrupt Clear	ICR	R/W	CESU	CESO	CDFMO	<i>reserved</i> ³	CQRSS	CAIS	<i>reserved</i> ²	CLOS
Transition Status	TSR	R	ESUNF	ESOVR	TDFMO	<i>reserved</i> ²	TQRSS	TAIS	<i>reserved</i> ²	TLOS
Performance Status	PSR	R	<i>reserved</i> ²	BIST	DFMO	<i>reserved</i> ²	QRSS	AIS	<i>reserved</i> ²	LOS
Control #4	CR4	R/W	<i>reserved</i> ²	<i>reserved</i> ²	<i>reserved</i> ²	<i>reserved</i> ²	COL32CM	LOS2048	ZEROV	CODEV

1. Bit CR3.PCLKE is available only in the LXT351; for the LXT350, set this bit to zero.
 2. In write registers, bits labeled *reserved* should be set to 0 (except as in note 3 below) for normal operation and ignored in read only registers.
 3. Write a 1 into this bit for normal operation.

Table 17: Control Register #1 Read/Write, Address (A7-A1) = x010000

Bit	Name	Function	Jitter Attenuation		
			JASEL0	JASEL1	Position
0	EC1	Set the Equalizer Control codes (see Table 12).	1	0	Transmit
1	EC2		1	1	Receive
2	EC3		0	X	disabled
3	—	<i>reserved, set this bit to 1, ignore when reading.</i>			
4	UNIENB	Enables Unipolar I/O Mode and insertion/detection of BPVs.			
5	ENCENB	Enables B8ZS/HDB3 encoders/decoders; device enters Unipolar Mode and pins 3, 4, 6 and 7 change to their unipolar functions.			
6	JASEL0	Jitter Attenuation Mode, selects jitter attenuation circuitry position in data path or disables it. See right hand section of table for values. ↗			
7	JASEL1				

Table 18: Control Register #2 Read/Write, Address (A7-A1) = x010001

Bit	Name	Function	Pattern		
			EPAT0	EPAT1	Selected
0	ERLOOP ¹	Enables Remote Loopback (RLOOP)	0	0	Transmit TPOS/TNEG
1	ELLOOP ¹	Enables Local Loopback (LLOOP)	0	1	Detect and transmit QRSS
2	EALOOP	Enables Analog Loopback (ALOOP)			
3	—	<i>reserved, set this bit to 0, ignore when reading.</i>			
4	ETAOS	Enables Transmit All Ones (TAOS)			
5	EPAT0	Enables internal data pattern transmission. See right hand section of table for values.			
6	EPAT1				
7	RESET	RESET = 1 resets device state and all registers.			

1. To enable Dual Loopback (DLOOP), set both ERLOOP = 1, ELLOOP = 1.

Table 19: Control Register #3 Read/Write, Address (A7-A1) = x010010

Bit	Name	Description
0	ESJAM	Disables Jamming of Elastic Store Read Out Clock ($1/8$ bit-time adjustment for over/underflow).
1	ESCEN	Centers ES pointer for a difference of 16 or 32 (depending on depth-clears automatically).
2	ES64	Increases ES depth from 32 to 64 bits.
3	—	<i>reserved—set to 0 for normal operation.</i>
4	—	<i>reserved—set to 0 for normal operation.</i>
5	SBIST	Starts Built-In Self Test.
6	PLCKE	This bit is meaningful only in the LXT351— <i>for LXT350, set this bit to 0.</i> PCLKE = 0 sets RPOS/RNEG valid on the rising edge of RCLK. PCLKE = 1 sets RPOS/RNEG valid on the falling edge of RCLK .
7	JA6HZ	When JA6HZ = 1, changes bandwidth of Jitter Attenuation Loop from 3 Hz (default) to 6 Hz.

Table 20: Interrupt Clear Register Read/Write, Address (A7-A1) = x010011

Bit	Name	Function ¹
0	CLOS	Clears/Masks LOS Interrupt.
1	—	<i>reserved, set this bit to 1 for normal operation.</i>
2	CAIS	Clears/Masks AIS Interrupt.
3	CQRSS	Clears/Masks QRSS Interrupt.
4	—	<i>reserved—set this bit to 1 for normal operation.</i>
5	CDFMO	Clears/Masks DFMO.
6	CESO	Clears/Masks ES Overflow Interrupt.
7	CESU	Clears/Masks ES Underflow Interrupt.

1. Leaving a one in any of these bits masks the associated interrupt.

Table 21: Transition Status Register Read Only, Address (A7-A1) = x010100

Bit	Name	Function
0	TLOS	Loss of Signal (LOS) has changed since last clear LOS interrupt occurred.
1	—	<i>reserved-ignore.</i>
2	TAIS	AIS has changed since last clear AIS interrupt occurred.
3	TQRSS	QRSS has changed since last clear QRSS interrupt occurred ¹ .
4	—	<i>reserved-ignore.</i>
5	TDFMO	DFMO has changed since last clear DFMS interrupt occurred.
6	ESOVR	ES overflow status sticky bit ² .
7	ESUNF	ES underflow status sticky bit ² .

1. A QRSS transition indicates receive QRSS pattern sync or loss. A simple error in QRSS pattern is not reported as a transition.
 2. Tripping the overflow or underflow indicator in the ES sets the ESOVR/ESUNF status bit(s). Reading the Transition Status Register clears these bits. Setting CESO and CESU in the Interrupt Clear Register masks these interrupts.

Table 22: Performance Status Register Read Only, Address (A7-A1) = x010101

Bit	Name	Function
0	LOS	Loss of Signal (LOS) Status.
1	—	<i>reserved-ignore.</i>
2	AIS	Alarm Indicator (AIS) Status.
3	QRSS	QRSS Pattern Detect Status.
4	—	<i>reserved-ignore.</i>
5	DFMO	Driver Open Indication.
6	BIST	Built-In Self Test Status.
7	—	<i>reserved-ignore</i>

Table 23: Control Register #4 Read/Write, Address (A7-A1) = x010111

Bit	Name	Function
0	CODEV	Enables detection of HDB3 code violation on the BPV pin along with bipolar violations and ZEROVs (as enabled).
1	ZEROV	Enables detection of four consecutive zeros (an HDB3 coding violation) on the BPV pin along with bipolar violation and ZEROVs (as enabled).
2	LOS2048	Changes LOS detection threshold from 32 consecutive zeros (for E1 operation) or 175 consecutive zeros (T1 operation) to 2048 consecutive zeros in either environment.
3	COL32CM	In E1 Mode, changes “clear LOS condition” criterion from 12.5% marks density (default) to receipt of 32 consecutive marks.
4	—	<i>reserved—set to 0 for normal operation; ignore when reading.</i>
5	—	<i>reserved—set to 0 for normal operation; ignore when reading.</i>
6	—	<i>reserved—set to 0 for normal operation; ignore when reading.</i>
7	—	<i>reserved—set to 0 for normal operation; ignore when reading.</i>

Serial Port Operation (LXT350 Only)

The LXT350 operates in Host Mode when the MODE pin is set High. Figure 12 shows the SIO data structure. The registers are accessible through a 16-bit word: an 8-bit Command/Address byte (bits R/W and A1-A7) and a subsequent 8-bit data byte (bits D0-7). Bit R/W determines whether a read or a write operation occurs. Bits A6-1 in the Command/Address byte address specific registers (the address decoder ignores bit A7). The data byte depends on both the value of bit R/W and the address of the register as set in the Command/Address byte.

Host Mode provides a latched interrupt output ($\overline{\text{INT}}$). A change in the state of any of the following bits in the Performance Status Register will drive $\overline{\text{INT}}$ Low: LOS, AIS, QRSS, or DFMO. An interrupt will also occur when there is an elastic store overflow or underflow. When the interrupt has occurred, the $\overline{\text{INT}}$ output pin is pulled Low. The output stage of each $\overline{\text{INT}}$ pin consists only of a pull-down device, so each one requires an external pull-up resistor. The interrupt is cleared when the interrupt condition no longer exists, and the host processor writes a 1 to the respective interrupt causing bit(s) in the Interrupt Register. Leaving a 1 in any of these interrupt status bits masks that interrupt.

Host Mode also allows control of the serial data and receive data output timing. The clock edge (CLKE) signal determines when the outputs are valid, relative to the Serial Clock (SCLK) or RCLK as shown in Table 24.

Table 24: CLKE Settings

CLKE	Output	Clock	Valid Edge
Low	RPOS	RCLK	Rising
	RNEG	RCLK	Rising
	SDO	SCLK	Falling
High	RPOS	RCLK	Falling
	RNEG	RCLK	Falling
	SDO	SCLK	Rising

Figure 12: LXT350 Serial Interface Data Structure

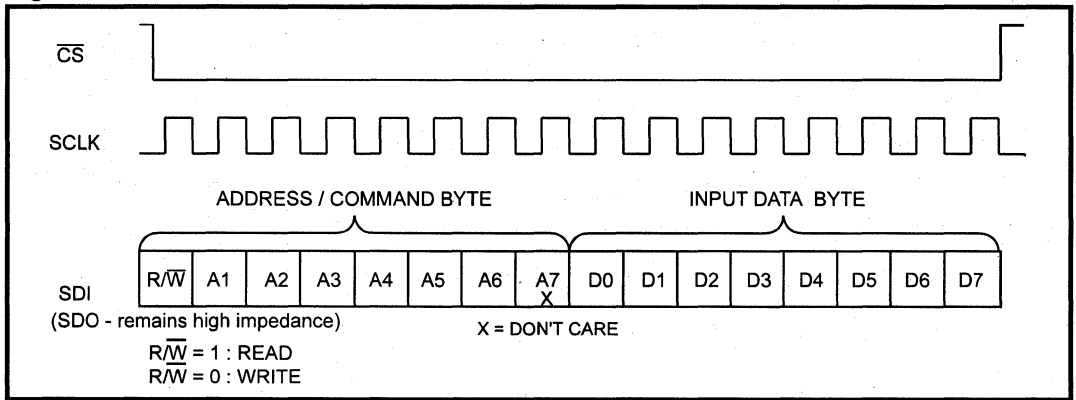

Parallel Port Operation (LXT351 Only)

The LXT351 address/control bus pins and control pins are compatible with both the Intel and Motorola address/data buses. See Figures 22 and 23 for the I/O timing diagram for each bus. The device automatically detects bus timing based on the Intel and Motorola microprocessor bus specifications. The maximum recommended processor speed for an Intel device is 20 MHz; for a Motorola device, 16.78 MHz. Table 17 summarizes the control and status registers for the LXT351. Tables 17 through 23 identify and explain the bits in the control registers.

The LXT351 provides a latched interrupt output (\overline{INT}). A change in the state of any of the following bits in the Performance Status Register will drive \overline{INT} Low: LOS, AIS, QRSS, DFMO. When the interrupt has occurred, the \overline{INT} output pin is pulled Low. The output stage of \overline{INT} pin consists only of a pull-down device, so each pin requires an external pull-up resistor. The interrupt is cleared when the interrupt condition no longer exists, and the host processor writes a 1 to the respective interrupt causing bit(s) in the Interrupt Register. Leaving a 1 in any of these interrupt status bits masks that interrupt.

The received data output is valid on the rising edge of RCLK, when bit CR3.PCLKE = 0. The data output is valid on the falling edge of RCLK when CR3.PCLKE = 1.

There are five read/write and three read-only registers. Only bits A6-1 in the address byte are valid. (The address decoder ignores bits A7 and A0.) Tables 17 through 23 show the register address bits A7-1, without regard to bit A0.

APPLICATION INFORMATION

NOTE

This application information is for design aid only.

Table 25 shows the specification for transmit return loss in E1 applications. (The G.703/CH PTT specification is a Swiss Telecommunications Ministry specification.)

Table 26 shows the transmit return loss values for T1 applications. Table 34 shows the receive return loss values.

Table 25: E1 Transmit Return Loss Requirements

Frequency Band	Return Loss	
	ETS 300 166	G.703/CH PTT
51-102 kHz	6 dB	8 dB
102-2048 kHz	8 dB	14 dB
2048 - 3072 kHz	8 dB	10 dB

Table 26: Transmit Return Loss (2.048 Mbps)

EC3-1	XfrmR/ Rt	Rload (Ω)	CI (pF)	Return Loss (dB)
000	1:2/ 9.1 Ω	75	0	14
			470	16
	120	0	12	
		470	13	
1:2.3/ 9.1 Ω	120	0	13	
		470	16	

2

Table 27: Transmit Return Loss (1.544 Mbps)

EC3-1	XfrmR/ Rt	Rload (Ω)	CI (pF)	Return Loss (dB)
000	1:2/ 9.1 Ω	100	0	16
			470	17
	1:1.15 ¹ / 0.0 Ω	100	0	2
			470	2

1. A 1:1.15 transmit transformer keeps the total transceiver power dissipation at a low level, a 0.47 μF DC blocking capacitor must be placed on TTIP or TRING.

Table 28: Transformer Specifications for LXT350/LXT351

Tx/ Rx	Frequency MHz	Turns Ratio	Primary Inductance μH (minimum)	Leakage Inductance μH (max)	Interwinding Capacitance pF (max)	DCR Ω (maximum)	Dielectric ¹ Breakdown V (minimum)
Tx	1.544	1:1.15	600	0.80	60	0.90 pri 1.70 sec	1500 VRMS
	2.048	1:2.3	600	0.80	60	0.70 pri 1.20 sec	1500 VRMS ² (3000 VRMS)
	1.544/2.048	1:2	600	0.80	60	1.0 pri 1.70 sec	1500 VRMS ² (3000 VRMS)
Rx	1.544/2.048	1:1	600	1.10	60	1.10 pri 1.10 sec	1500 VRMS ² (3000 VRMS)

1. Some ETSI applications may require a 2.3 kV dielectric breakdown voltage.
 2. Some applications require transformers to guarantee performance in extended temperature range (-40° to +85° C) ETSI applications require a dielectric breakdown voltage of 3000 VRMS.

LXT350/351 Integrated T1/E1 S/H Transceivers With Crystal-less Jitter Attenuation

Table 29: Recommended Transformers for LXT350/LXT351

Tx/Rx	Turns Ratio	Part Number	Manufacturer
Tx	1:1.15	PE-65388	Pulse Engineering
		PE-65770	
	1:2	PE-65351	
		PE-65771	
		0553-5006-IC	Bell-Fuse
		66Z-1308	Fil-Mag
		671-5832	Midcom
		67127370	Schott Corp
		67130850	
		TD61-1205G	HALO (combination Tx/Rx set)
	TD67-1205G		
	1:2.3	PE-65558	Pulse Engineering
Rx	1:1	FE 8006-155	Fil-Mag
		671-5792	Midcom
		PE-64936	Pulse Engineering
		PE-65778	
		67130840	Schott Corp
		67109510	
		TD61-1205	HALO (combination Tx/Rx set)
		TD67-1205G	

LXT350/351 Integrated T1/E1 S/H Transceivers With Crystal-less Jitter Attenuation

Figure 13 shows a typical LXT350 application in either T1 or E1 environment. See Tables 26 through 31 to select the transformers (T1 and T2), resistors (Rt and RL) and capacitors (CL) needed for this application.

NOTE

If the application includes surge protection, such as a varistor or sidactor on the TTIP/TRING lines, it may also require re-dimensioning the value of the capacitor CL or eliminating it completely. Excessive capacitance at CL will distort the transmitted signals.

2

Figure 13: Typical T1/E1 LXT350 Hardware Mode Application

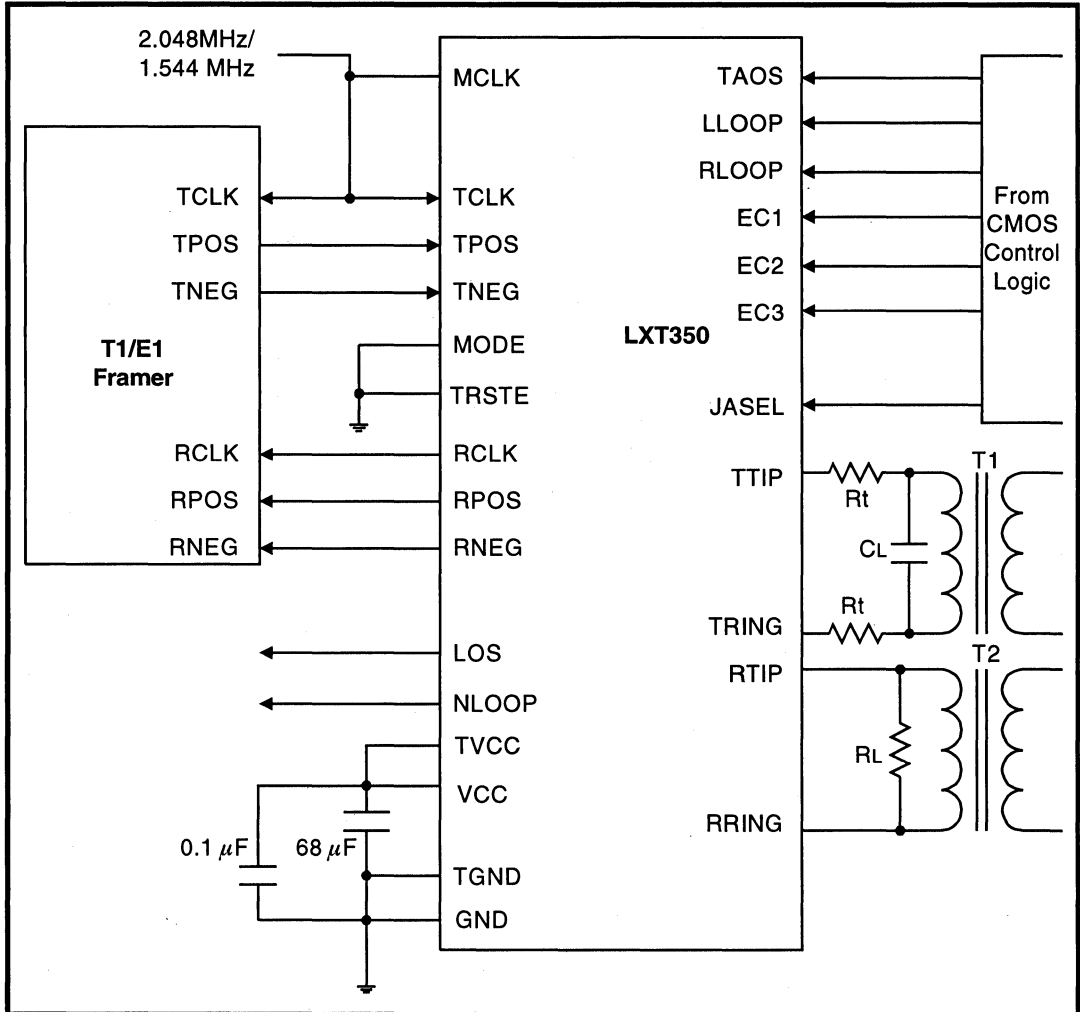

LXT350/351 Integrated T1/E1 S/H Transceivers With Crystal-less Jitter Attenuation

Figure 14 shows an application using the LXT350 in its Host Controlled Mode. See Tables 26 through 27 to select the transformers (T1 and T2), resistors (Rt and Rl) and capacitors (Cl) needed for this application.

NOTE

If the application includes surge protection, such as a varistor or sidactor on the TTIP/TRING lines, it may also require reducing the value of the capacitor CL or eliminating it completely. Excessive capacitance at CL will distort the transmitted signals.

Figure 14: Typical T1/E1 LXT350 Host Mode Application

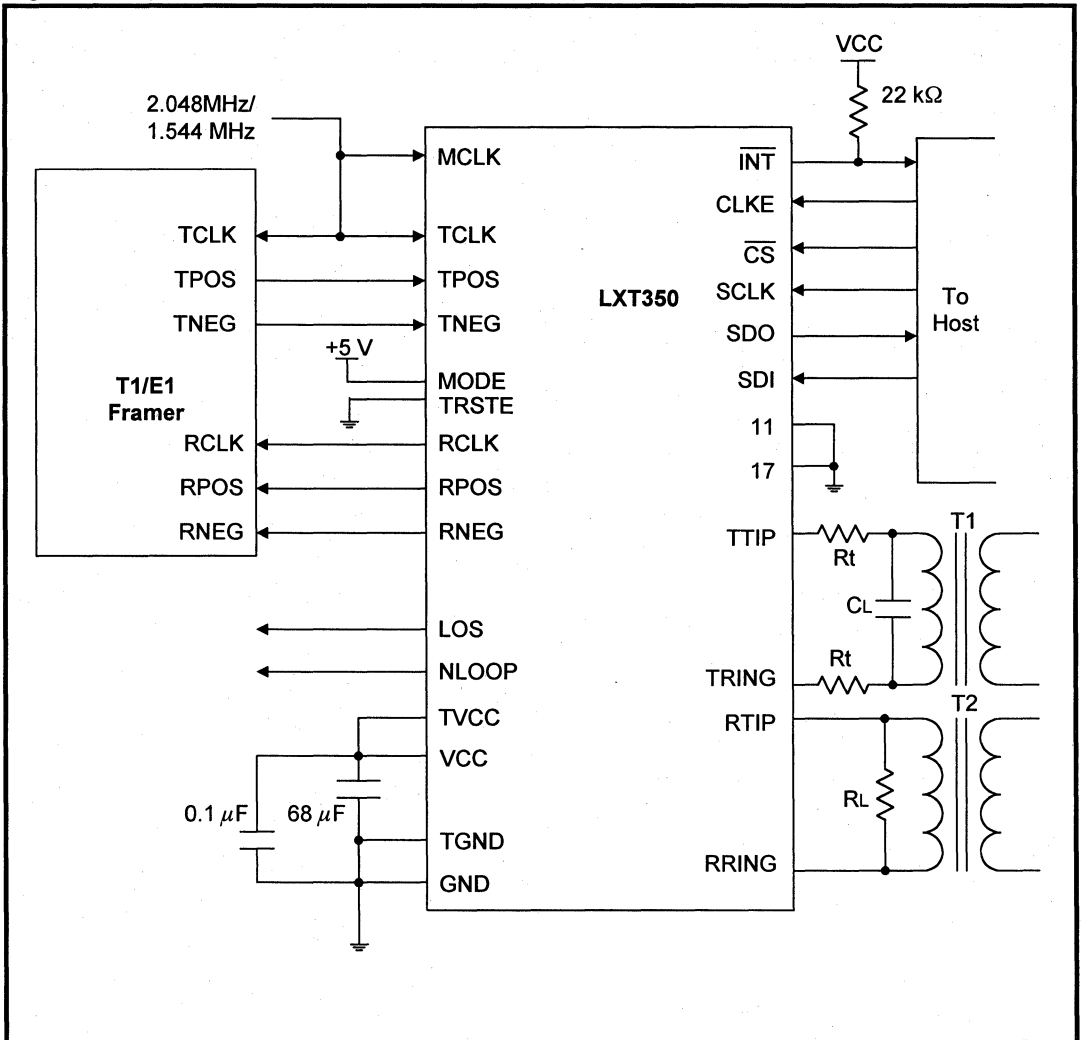

LXT350/351 Integrated T1/E1 S/H Transceivers With Crystal-less Jitter Attenuation

Figure 15 shows an application using the LXT351. See Tables 26 through 27 to select the transformers (T1 and T2), resistors (Rt and Rl) and capacitors (Cl) needed for this application.

NOTE

If the application includes surge protection, such as a varistor or sidactor on the TTIP/TRING lines, it may also require reducing the value of the capacitor CL or eliminating it completely.

Figure 15: Typical T1/E1 LXT351 Application

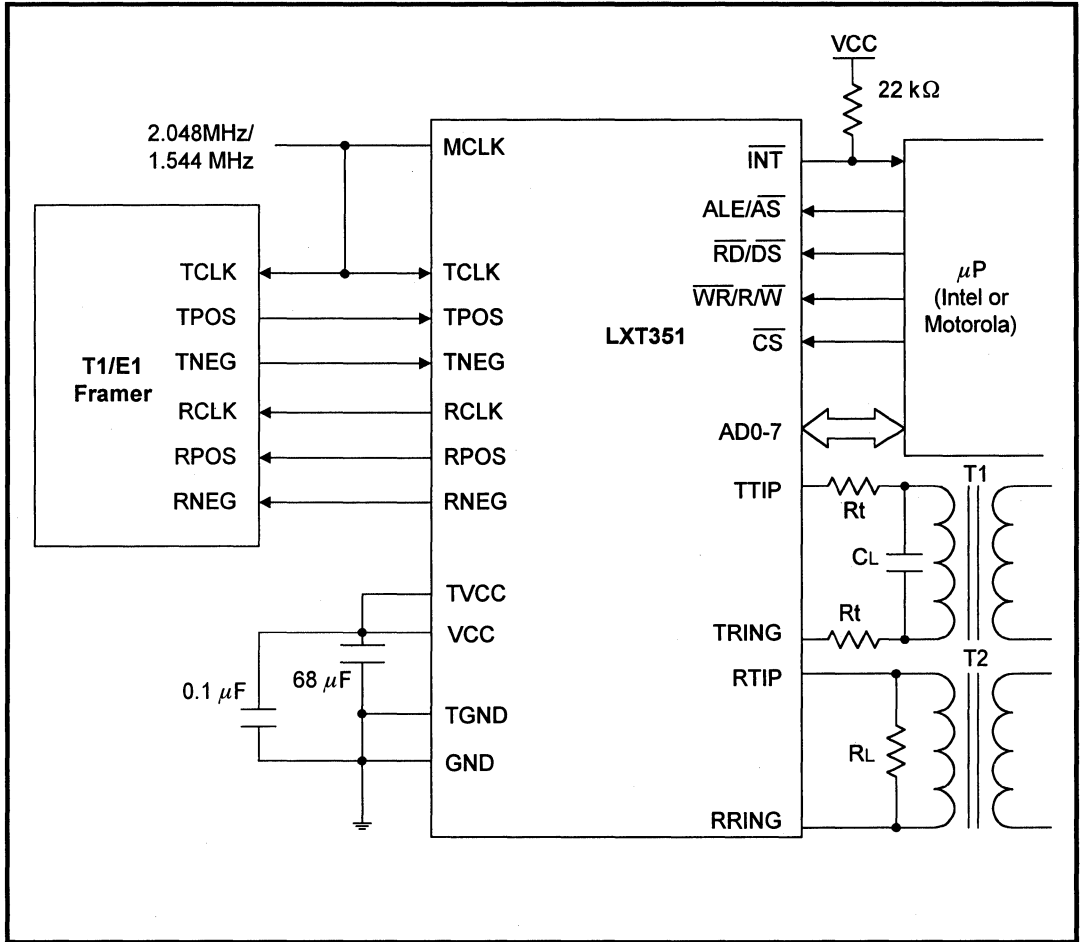

TEST SPECIFICATIONS

NOTE

The minimum and maximum values in Tables 30 to 42 and Figures 16 through 27 represent the performance specifications of the LXT350 and LXT351 and are guaranteed by test, except where noted by design.

Table 30: Absolute Maximum Ratings

Parameter	Sym	Min	Max	Units
DC supply (reference to GND)	VCC,TVCC	-	6.0	V
Input voltage, any pin ¹	V _{IN}	GND -0.3 V	VCC + 0.3 V	V
Input current, any pin ²	I _{IN}	- 10	10	mA
Storage Temperature	TSTG	-65	150	°C

CAUTION
Operation at these limits may permanently damage the device.
Normal operation at these extremes not guaranteed.

- TVCC and VCC must not differ by more than 0.3 V during operation. TGND and GND must not differ by more than 0.3 V during operation.
- Transient currents of up to 100 mA will not cause SCR latch-up. TTIP, TRING, TVCC, and TGND can withstand continuous currents of up to 100 mA.

Table 31: Recommended Operating Conditions

Parameter	Sym	Min	Typ ¹	Max	Units	Test Conditions	
DC Supply ²	VCC,TVCC	4.75	5.0	5.25	V		
Ambient Operating Temperature	T _A	- 40	25	85	°C		
Total Power Dissipation ³	T1	PD	-	310	380	mW	100% mark density
		PD	-	225	295	mW	50% mark density
	E1	PD	-	275	330	mW	100% mark density
		PD	-	215	270	mW	50% mark density

- Typical figures are at 25° C and are for design aid only; not guaranteed and not subject to production testing.
- TVCC and VCC must not differ by more than 0.3 V.
- Power dissipation while driving 75 Ω load over operating range for T1 operation or 60 Ω load for E1 operation. Includes power dissipation on device and load. Digital levels are within 10% of the supply rails and digital outputs driving a 50 pF capacitive load.

Table 32: LXT350 DC Electrical Characteristics (over recommended operating range)

Parameter	Sym	Min	Typ	Max	Units	Test Conditions
Digital I/O Pins						
High level input voltage ^{1,2} (pins 1-4, 23-25)	V _{IH}	2.0	–	–	V	
Low level input voltage ^{1,2} (pins 1-4, 23-25)	V _{IL}	–	–	0.8	V	
High level output voltage ^{1,2} (pins 6-8, 12, 23, 25)	V _{OH}	2.4	–	–	V	I _{OUT} = -400 μA
Low level output voltage ^{1,2} (pins 6-8, 12, 23, 25)	V _{OL}	–	–	0.4	V	I _{OUT} = 1.6 mA
Three-state leakage current ¹ (all outputs)	I _{3L}	0	–	±10	μA	
Mode Input Pins						
High level input voltage ³ (pins 5, 9, 11, 26-28)	V _{IH}	3.5	–	–	V	
Midrange output voltage ³ (pins 5, 9, 11, 26-28)	V _{OM}	2.3	–	2.7	V	
Low level input voltage ³ (pins 5, 9, 11, 26-28)	V _{IL}	–	–	1.5	V	
Input leakage current (pins 5, 9, 11, 26-28)	I _{LL}	0	–	±50	μA	
TTIP/TRING Leakage current	I _{TR}	–	–	1.2	mA	In power down and tristate
1. Functionality of pin 23 and 25 depends on mode. See Host Mode and Hardware Mode description 2. Output drivers will output CMOS logic levels into CMOS loads. 3. As an alternative to supplying 2.3 - 2.7 V to these pins, they may be left open.						

Table 33: LXT351 DC Electrical Characteristics (over recommended operating range)

Parameter	Sym	Min	Typ	Max	Units	Test Conditions
Digital I/O Pins						
High level input voltage ^{1,2} (pins 1-5, 9-12, 17, 23-28)	V _{IH}	2.0	–	–	V	
Low level input voltage ^{1,2} (pins 1-5, 9-12, 17, 23-28)	V _{IL}	–	–	0.8	V	
High level output voltage ^{1,2} (pins 6-8, 10, 11, 23, 28)	V _{OH}	2.4	–	–	V	I _{OUT} = -400 μA
Low level output voltage ^{1,2} (pins 6-8, 10, 11, 23, 28)	V _{OL}	–	–	0.4	V	I _{OUT} = 1.6 mA
Input leakage current	I _{LL}	–	–	±10	μA	
1. Functionality of pins 23 and 25 depends on mode. See Host Mode description. 2. Output drivers will output CMOS logic levels into CMOS loads.						

LXT350/351 Integrated T1/E1 S/H Transceivers With Crystal-less Jitter Attenuation

Table 34: Analog Characteristics (over recommended operating range)

Parameter		Min	Typ ¹	Max	Units	Test Conditions
Recommended output load on TTIP/TRING		50	–	200	Ω	
AMI Output Pulse Amplitudes	T1	2.4	3.0	3.6	V	RL = 100 Ω
	E1	2.7	3.0	3.3	V	RL = 120 Ω
Jitter added by the transmitter ²	10 Hz - 8 kHz ³	–	–	0.02	UI	
	8 kHz - 40 kHz ³	–	–	0.025	UI	
	10 Hz - 40 kHz ³	–	–	0.025	UI	
	Broad Band	–	–	0.05	UI	
Receiver Sensitivity		0	–	18	dB	@ 1024 kHz 1.431
Allowable consecutive zeros before LOS (T1)		160	175	190	–	
Allowable consecutive zeros before LOS (E1)		–	32	–	–	
Input jitter tolerance (T1)	10 kHz - 100 kHz	0.4	–	–	UI	0 dB line AT&T Pub 62411
	1 Hz ³	138	–	–	UI	
Input jitter tolerance (E1)	10 kHz - 100 kHz	0.2	–	–	UI	0 dB line ITU (G.823)
	1 Hz ³	37	–	–	UI	
Jitter attenuation curve corner frequency ⁴		–	3	–	Hz	selectable in data port
Driver Output Impedance		–	3	–	Ω	
Receiver Input Impedance		–	40	–	kΩ	RTIP to RRING
Receive Return Loss (E1)	51 kHz - 102 kHz ³	20	22	–	dB	
	102 kHz - 2.048 MHz ³	20	28	–	dB	
	2.048 MHz - 3.072 MHz ³	25	30	–	dB	

1. Typical figures are at 25° C and are for design aid only; not guaranteed and not subject to production testing.
2. Input signal to TCLK is jitter-free. The Jitter Attenuator is in the receive path or disabled.
3. Guaranteed by characterization; not subject to production testing.
4. Circuit attenuates jitter at 20 dB/decade above the corner frequency.

Figure 16: 2.048 Mbps E1 Pulse (See Table 35)

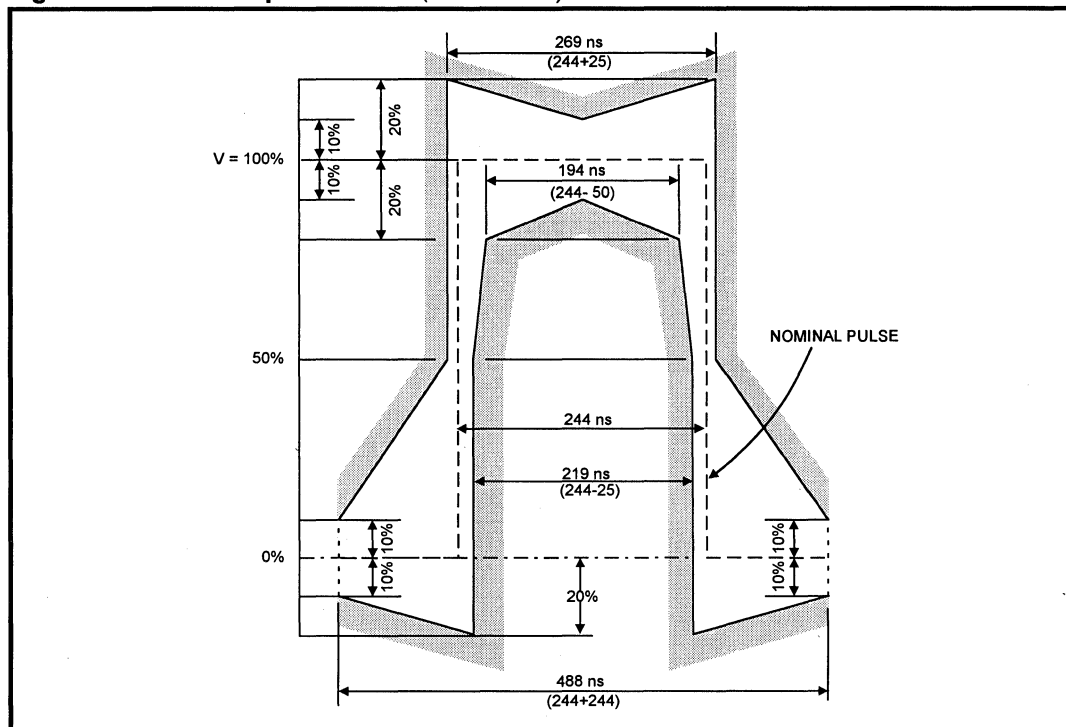

2

Table 35: 2.048 Mbps E1 Pulse Mask Specifications

Parameter	TPW	Coax	Unit
Test load impedance	120	75	Ω
Nominal peak mark voltage	3.0	2.37	V
Nominal peak space voltage	0 ± 0.30	0 ± 0.237	V
Nominal pulse width	244	244	ns
Ratio of positive and negative pulse amplitudes at center of pulse	95-105	95-105	%
Ratio of positive and negative pulse amplitudes at nominal half amplitude	95-105	95-105	%

Figure 17: 1.544 Mbps T1 Pulse (DSX-1) (See Table 36)

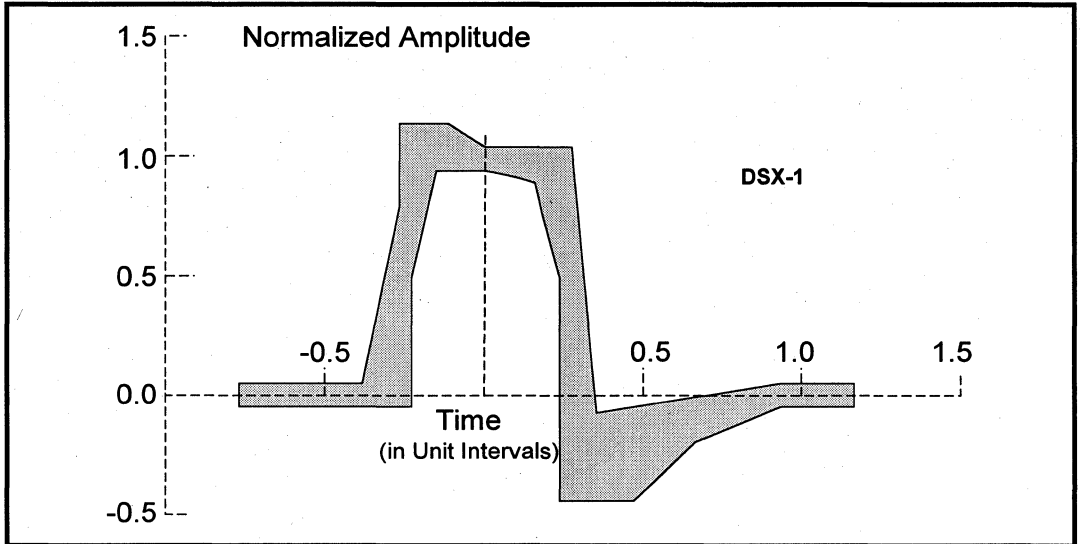

Table 36: 1.544 Mbps T1 (DSX-1) Pulse Mask Corner Point Specifications

DSX-1 Template (per ANSI T1. 102-1993)			
Minimum Curve		Maximum Curve	
Time (UI)	Amplitude	Time (UI)	Amplitude
-0.77	-0.05	-0.77	0.05
-0.23	-0.05	-0.39	0.05
-0.23	0.50	-0.27	0.80
-0.15	0.95	-0.27	0.80
0.0	0.95	-0.27	1.15
0.15	0.90	0.0	1.05
0.23	0.50	0.27	1.05
0.23	-0.45	0.35	-0.07
0.46	-0.45	0.93	0.05
0.66	-0.20	1.16	0.05
0.93	-0.05		
1.16	-0.05		

Table 37: Master and Transmit Clock Timing Characteristics for T1 Operation
(over recommended operating range) (see Figure 18)

Parameter	Sym	Min	Typ ¹	Max	Units	Notes
Master clock frequency	MCLK	–	1.544	–	MHz	must be supplied
Master clock tolerance	MCLKt	–	±32	–	ppm	
Master clock duty cycle	MCLKd	40	–	60	%	
Transmit clock frequency	TCLK	–	1.544	–	MHz	
Transmit clock tolerance	TCLKt	–	–	±100	ppm	
Transmit clock duty cycle	TCLKd	10	–	90	%	
TPOS/TNEG to TCLK setup time	tsUT	50	–	–	ns	
TCLK to TPOS/TNEG hold time	tHT	50	–	–	ns	

1. Typical figures are at 25° C and are for design aid only; not guaranteed and not subject to production testing.

Table 38: Master and Transmit Clock Timing Characteristics for E1 Operation
(see Figure 18)

Parameter	Sym	Min	Typ ¹	Max	Units	Notes
Master clock frequency	MCLK	–	2.048	–	MHz	must be supplied
Master clock tolerance	MCLKt	–	±32	–	ppm	
Master clock duty cycle	MCLKd	40	–	60	%	
Transmit clock frequency	TCLK	–	2.048	–	MHz	
Transmit clock tolerance	TCLKt	–	–	±100	ppm	
Transmit clock duty cycle	TCLKd	10	–	90	%	
TPOS/TNEG to TCLK setup time	tsUT	50	–	–	ns	
TCLK to TPOS/TNEG hold time	tHT	50	–	–	ns	

1. Typical figures are at 25° C and are for design aid only; not guaranteed and not subject to production testing.

Figure 18: Transmit Clock Timing

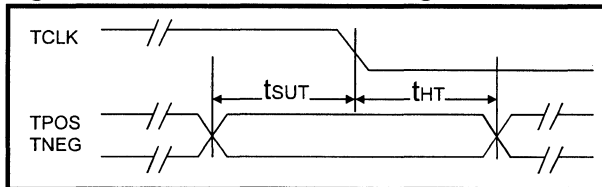

LXT350/351 Integrated T1/E1 S/H Transceivers With Crystal-less Jitter Attenuation

Table 39: Receive Timing Characteristics for T1 Operation (See Figure 19)

Parameter	Sym	Min	Typ ¹	Max	Units
Receive clock duty cycle ^{2,3}	RLCKd	40	50	60	%
Receive clock pulse width ^{2,3}	tpw	–	648	–	ns
Receive clock pulse width high	tpWH	–	324	–	ns
Receive clock pulse width low ^{1,3}	tpWL	260	324	388	ns
RPOS/RNEG to RCLK rising time	tsUR	–	274	–	ns
RCLK rising to RPOS/RNEG hold time	tHR	–	274	–	ns

1. Typical figures are at 25 °C and are for design aid only; not guaranteed and not subject to production testing.
 2. RCLK duty cycle widths will vary according to extent of received pulse jitter displacement. Max and Min RCLK duty cycles are for worst case jitter conditions.
 3. Worst case conditions guaranteed by design only.

Table 40: Receive Timing Characteristics for E1 Operation (See Figure 19)

Parameter	Sym	Min	Typ ¹	Max	Units
Receive clock duty cycle ^{2,3}	RLCKd	40	50	60	%
Receive clock pulse width ^{2,3}	tpw	–	488	–	ns
Receive clock pulse width high	tpWH	–	244	–	ns
Receive clock pulse width low ^{1,3}	tpWL	195	244	293	ns
RPOS/RNEG to RCLK rising time	tsUR	–	194	–	ns
RCLK rising to RPOS/RNEG hold time	tHR	–	194	–	ns

1. Typical figures are at 25 °C and are for design aid only; not guaranteed and not subject to production testing.
 2. RCLK duty cycle widths will vary according to extent of received pulse jitter displacement. Max and Min RCLK duty cycles are for worst case jitter conditions (0.4 UI clock displacement for 1.544 MHz.)
 3. Worst case conditions guaranteed by design only.

Figure 19: Receive Clock Timing

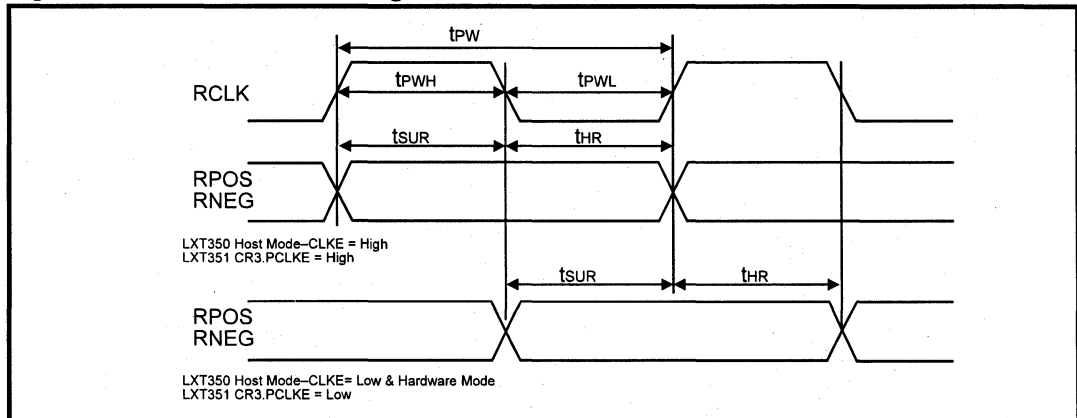

Table 41: LXT350 Serial I/O Timing Characteristics (See Figures 20 and 21)

Parameter	Sym	Min	Typ ¹	Max	Units	Parameter
Rise/fall time—any digital output	t _{RF}	–	–	100	ns	Load 1.6 mA, 50 pF
SDI to SCLK setup time	t _{DC}	50	–	–	ns	
SCLK to SDI hold time	t _{CDH}	50	–	–	ns	
SCLK low time	t _{CL}	240	–	–	ns	
SCLK high time	t _{CH}	240	–	–	ns	
SCLK rise and fall time	t _R , t _F	–	–	50	ns	
$\overline{\text{CS}}$ falling edge to SCLK rising edge	t _{CC}	50	–	–	ns	
Last SCLK edge to $\overline{\text{CS}}$ rising edge	t _{CCH}	50	–	–	ns	
$\overline{\text{CS}}$ inactive time	t _{CWH}	250	–	–	ns	
SCLK to SDO valid time	t _{CDV}	–	–	200	ns	
SCLK falling edge or $\overline{\text{CS}}$ rising edge to SDO high-Z	t _{CDZ}	–	100	–	ns	

1. Typical figures are at 25°C and are for design aid only; not guaranteed and not subject to production testing.

Figure 20: LXT350 Serial Data Input Timing Diagram

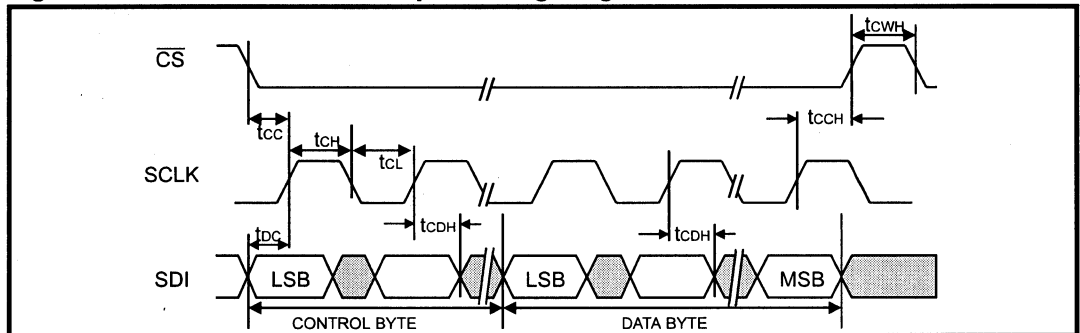

Figure 21: Serial Data Output Timing Diagram

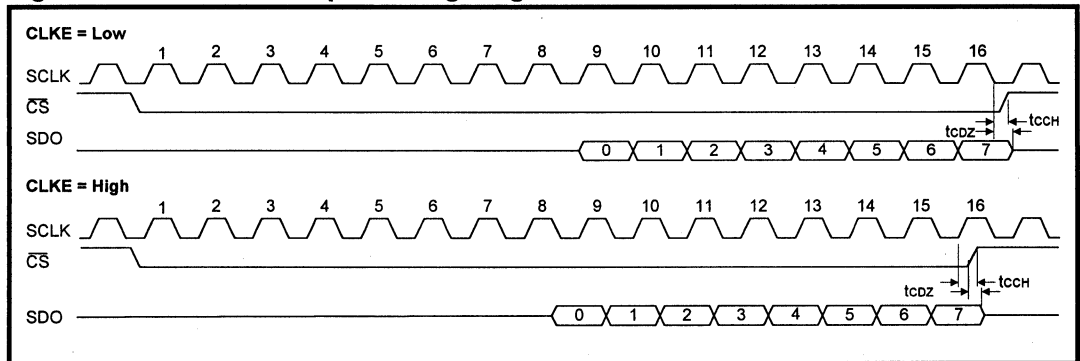

Table 42: LXT351 20 MHz Intel Bus Parallel I/O Timing Characteristics (See Figure 22)

Parameter	Sym	Min	Max	Units	Test Conditions
ALE pulse width	TLHLL	35	–	ns	
Address valid to ALE falling edge	TAVLL	10	–	ns	
ALE falling edge to address hold time	TLLAX	10	–	ns	
ALE falling edge to \overline{RD} falling edge	TLLRL	10	–	ns	
ALE falling edge to \overline{WR} falling edge	TLLWL	10	–	ns	
\overline{CS} falling edge to \overline{RD} falling edge	TCLRRL	10	–	ns	
\overline{CS} falling edge to \overline{WR} falling edge	TCLWL	10	–	ns	
\overline{RD} low pulse width	TRLRH	95	–	ns	
\overline{RD} falling edge to data valid	TRLDV	10	55	ns	
Data hold time after \overline{RD} rising edge	TRHDX	5	35	ns	
\overline{RD} rising edge to ALE rising edge	TRHLH	15	–	ns	
\overline{RD} rising edge to address valid	TRHAV	35	–	ns	
\overline{CS} low hold time after \overline{RD} rising edge	TRHCH	0	–	ns	
\overline{WR} low pulse width	TWLWH	95	–	ns	
Data setup time before \overline{WR} rising edge	TDVWH	40	–	ns	
Data hold time after \overline{WR} rising edge	TWHDX	30	–	ns	
\overline{WR} rising edge to ALE rising edge	TWHLH	15	–	ns	
\overline{CS} low hold time after \overline{WR} rising edge	TWHCH	15	–	ns	

Figure 22: LXT351 I/O Timing Diagram for Intel Address/Data Bus

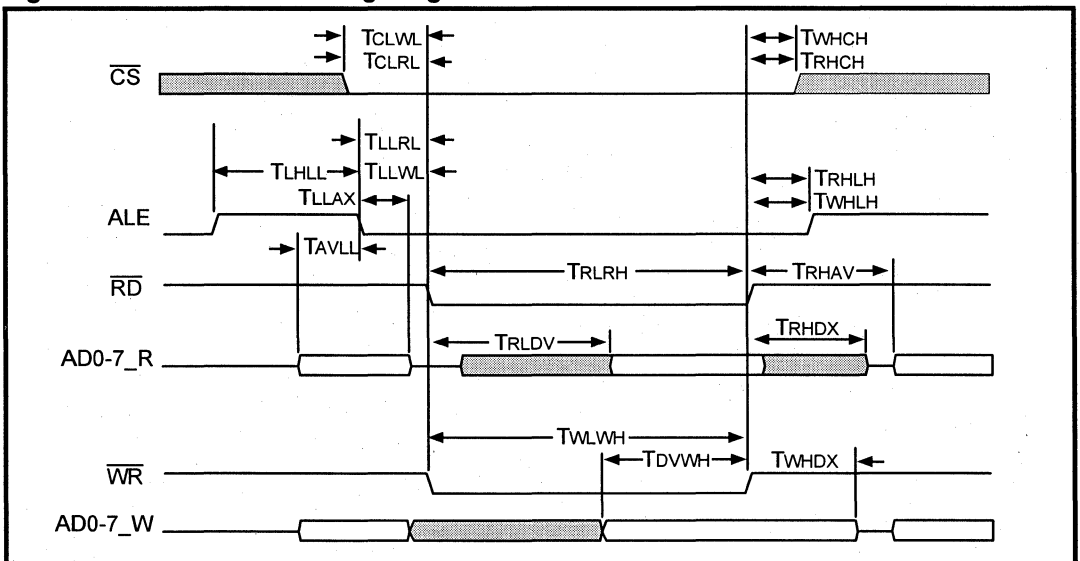

Table 43: LXT351 16.78 MHz Motorola Bus Parallel I/O Timing Characteristics
(See Figure 23)

Parameter	Sym	Min	Max	Units	Test Conditions
\overline{DS} rising edge to \overline{AS} rising edge	TDSHASH	15	–	ns	
\overline{AS} high pulse width	TASHASL	35	–	ns	
Address valid setup time at \overline{AS} falling edge	TAVASL	10	–	ns	
\overline{AS} falling edge to Address valid hold time	TASLAX	10	–	ns	
\overline{AS} falling edge to \overline{DS} falling edge	TASLDSL	20	–	ns	
\overline{CS} falling edge to \overline{DS} falling edge	TCSLDSL	10	–	ns	
\overline{DS} low pulse width	TDSLDSH	95	–	ns	
\overline{DS} falling edge to data valid	TDSL DV	10	55	ns	
Data hold time after \overline{DS} rising edge	TDSHDX	5	35	ns	
R/\overline{W} falling edge to \overline{DS} falling edge	TRWLDSL	10	–	ns	
Data setup time before \overline{DS} rising edge	TDVDSH	40	–	ns	
Data hold time after \overline{DS} rising edge	TDXDSH	30	–	ns	
R/\overline{W} low hold time after \overline{DS} rising edge	TDSHRWH	15	–	ns	
\overline{CS} low hold time after \overline{DS} rising edge	TDSHCSSH	15	–	ns	

2

Figure 23: LXT351 I/O Timing Diagram for Motorola Address/Data Bus

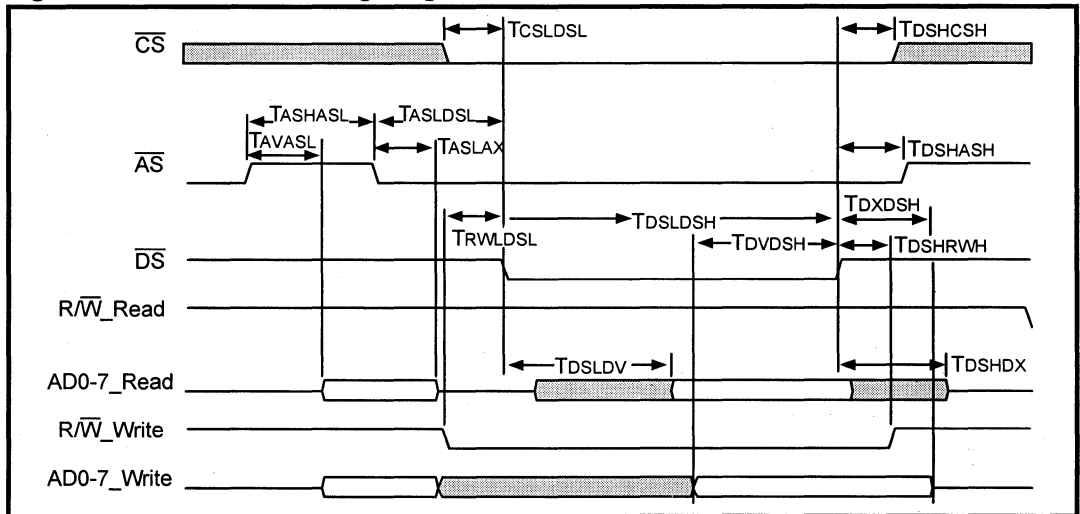

Figure 24: Input Jitter Tolerance (Typical)

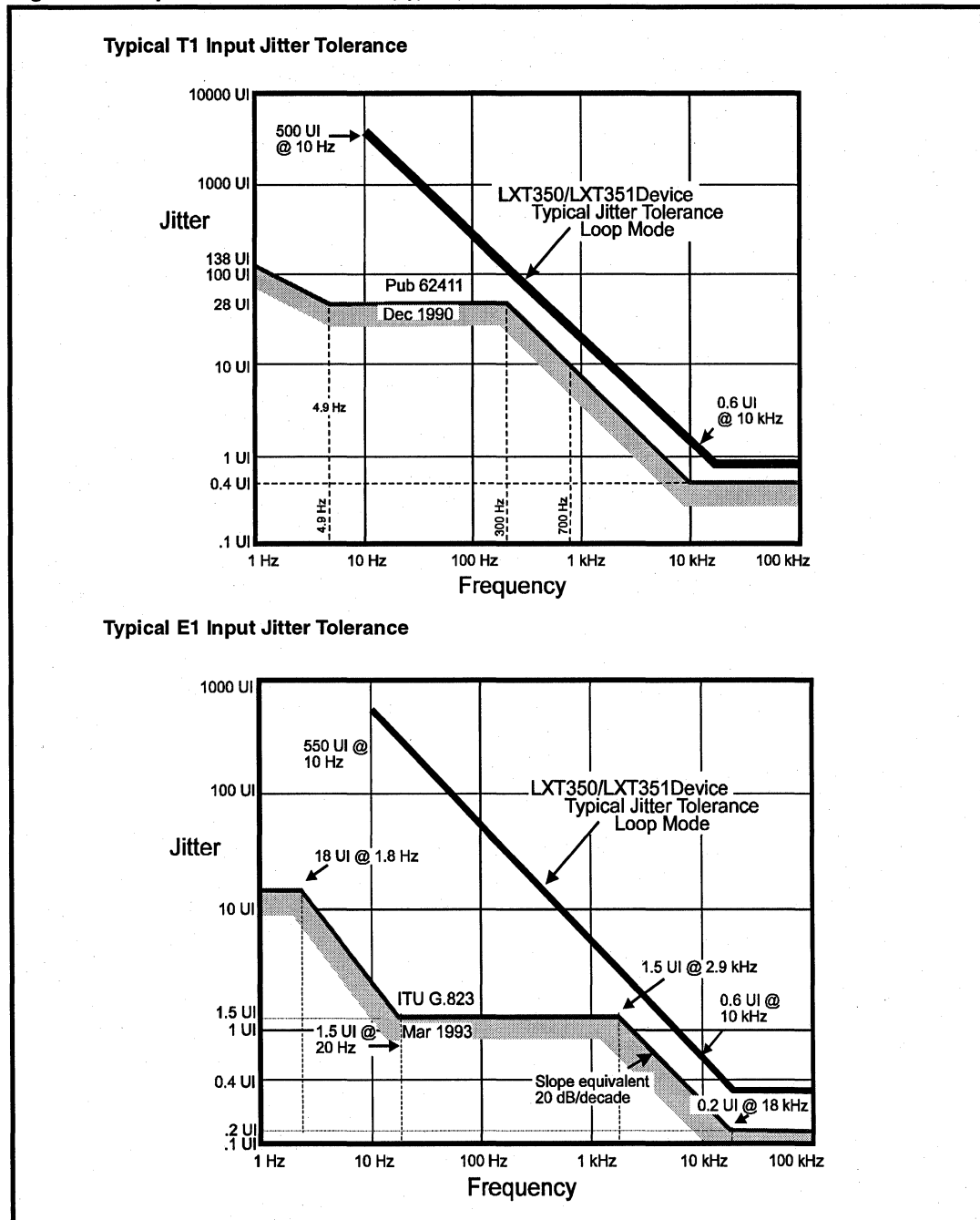

Figure 25: E1 Jitter Transfer Performance (Typical)

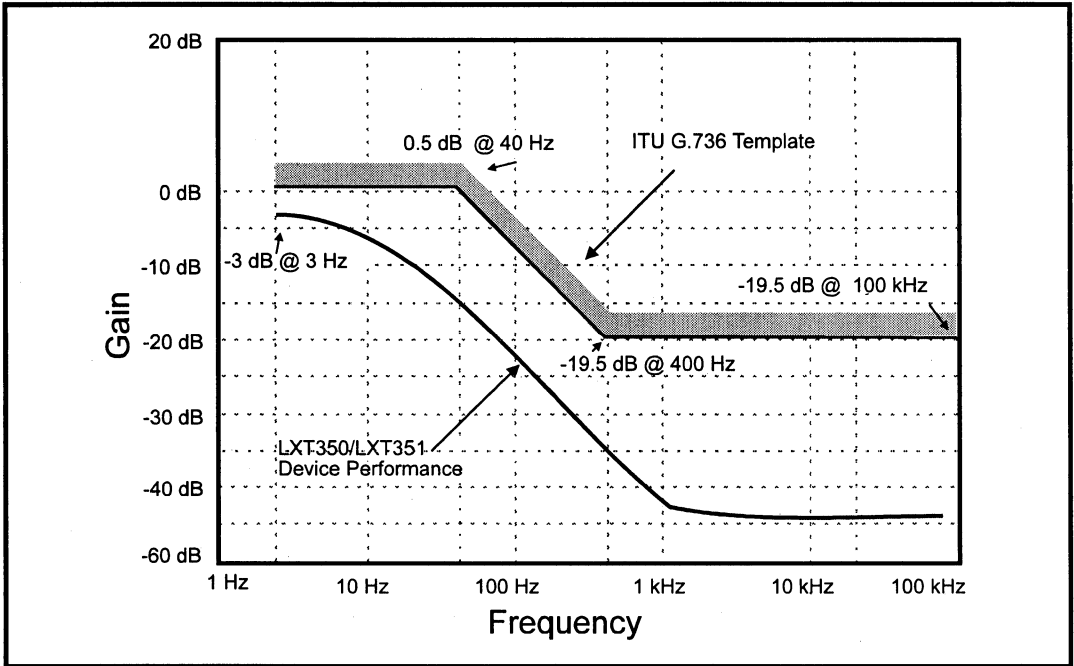
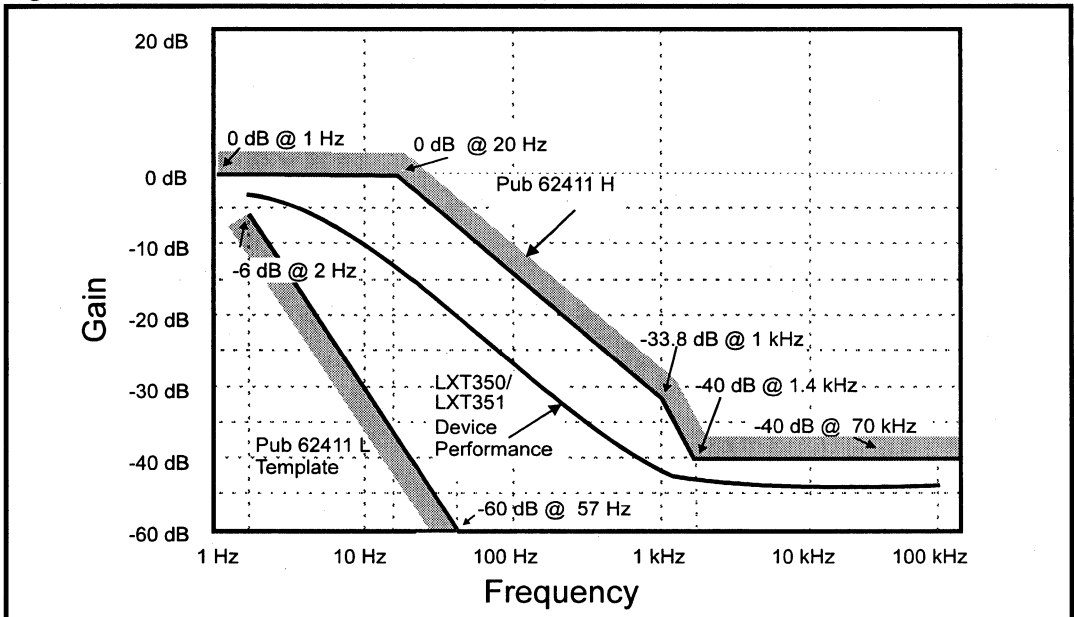

Figure 26: T1 Jitter Transfer Performance (Typical)



LXT350/351 Integrated T1/E1 S/H Transceivers With Crystal-less Jitter Attenuation

NOTES:

T1/E1 Clock Adapters

3



LXP600A, LXP602 and LXP604

Low-Jitter Clock Adapters (CLADs)

General Description

The LXP600A, LXP602 and LXP604 Clock Adapters (CLADs) incorporate Level One's patented frequency conversion circuitry. The LXP600A and LXP602 convert a 1.544 MHz input clock to a 2.048 MHz output clock, or vice versa. The LXP604 converts between 1.544 MHz and 4.096 MHz. Each CLAD produces two different high frequency output (HFO) clocks for applications which require a higher-than-baud rate backplane or system clock.

Level One's patented locking method enables the CLAD to perform frequency conversion with no external components, while generating very little jitter on the output clock. The conversion is digitally controlled so the output clock (CLKO) is as accurate as the input clock (CLKI), and the two clocks are frequency-locked together. When an input frame sync pulse (FSI) is provided, the CLAD also phase-locks CLKI and CLKO together, and locks the output frame sync pulse (FSO) to FSI.

Frequency Conversions

CLAD	CLKI	CLKO	HFO
LXP600A	1.544	2.048	6.144
	2.048	1.544	6.176
LXP602	1.544	2.048	8.192
	2.048	1.544	6.176
LXP604	1.544	4.096	8.192
	4.096	1.544	6.176

Features

- Generates a 1.544 MHz clock and its frame sync from a 2.048 MHz or 4.096 MHz clock and its frame sync, or vice versa
- Low output jitter meets AT&T Publication 62411 for 1.544 MHz, and ITU Recommendation G.823 for 2.048 MHz
- Digital control of frequency conversion process
- No external components
- Available in 8-pin plastic DIP
- Pin-selectable operation mode
- Advanced CMOS device requires only a single +5 V power supply

Applications

- Internal timing system for Channel Banks, Digital Loop Carriers, Multiplexers, Internal Timing Generators, PBX, etc.
- Conversion between 2.048 MHz or 4.096 MHz backplane rates and 1.544 MHz T1 clock rate
- Conversion between North American and International standards (T1 / E1 Converter)

LXP600A/602/604 Block Diagram

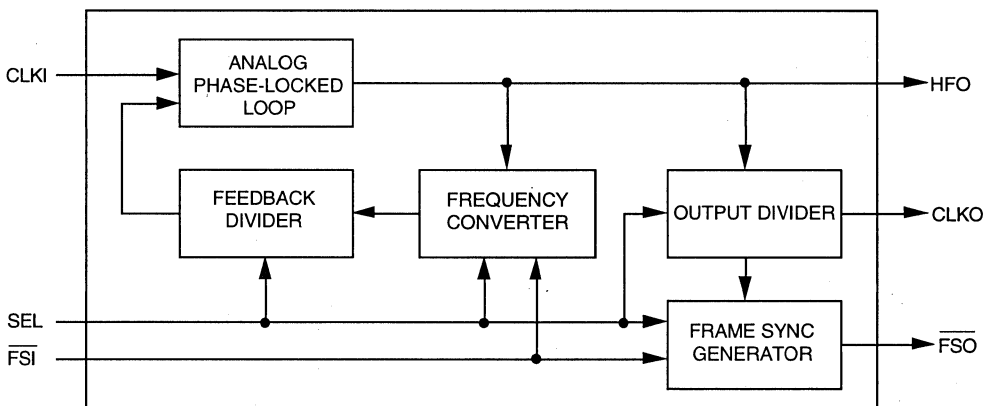

Figure 1: Pin Assignments

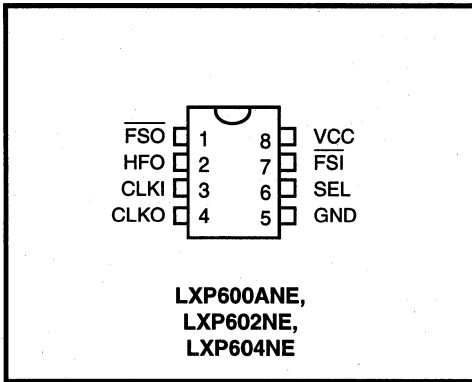

Table 1: Pin Descriptions

Pin #	Sym	I/O	Name	Description
1	$\overline{\text{FSO}}$	O	Frame Sync Output	Frame synchronization output at 8 kHz. $\overline{\text{FSO}}$ is synced to CLKO and to $\overline{\text{FSI}}$ (if $\overline{\text{FSI}}$ is provided).
2	HFO	O	High Frequency Output	HFO is used to derive CLKO. HFO can also clock external devices. HFO is always a multiple of CLKO (CLKO x2, x3, or x4). Actual frequencies are determined by device, CLKI and CLKO frequencies and Mode Select (SEL) input, as listed in Table 2.
3	CLKI	I	Clock Input	Input clock (1.544, 2.048 or 4.096 MHz) to be converted.
4	CLKO	O	Clock Output	Output clock (1.544, 2.048 or 4.096 MHz) derived from CLKI.
5	GND	-	Ground	Ground.
6	SEL	I	Mode Select	Controls frequency conversion as listed in Table 2. When SEL = High, higher frequency CLKI (2.048 for LXP600A and LXP602, or 4.096 MHz for LXP604) is converted to 1.544 MHz CLKO. When SEL = Low, 1.544 MHz CLKI is converted to higher frequency CLKO (2.048 for LXP600A and LXP602, or 4.096 MHz for LXP604).
7	$\overline{\text{FSI}}$	I	Frame Sync Input	8 kHz frame synchronization pulse. Tie High or Low if not used.
8	VCC	-	Power Supply	+5 V power supply input.

FUNCTIONAL DESCRIPTION

NOTE

This information is for design aid only.

The CLADs convert an input clock (CLKI) at a particular frequency to an output clock (CLKO) at a different frequency. They also produce a frame sync output (FSO) and a high frequency output (HFO) clock. The HFO is a multiple (2x, 3x, or 4x) of CLKO. The HFO and CLKI/CLKO conversion frequencies are different for each device, and controlled by the Mode Select input as listed in Table 2.

The LXP600A and LXP602 convert between 1.544 MHz and 2.048 MHz. When converting from 2.048 MHz to 1.544 MHz, both CLADs produce a 6.176 MHz HFO. However, when converting from 1.544 MHz to 2.048 MHz, the LXP600A produces a 6.144 MHz HFO and the LXP602 produces an 8.192 MHz HFO.

The LXP604 converts between 1.544 MHz and 4.096 MHz. When converting from 4.096 to 1.544 MHz the LXP604 HFO is 6.176. When converting from 1.544 MHz to 4.096 MHz, the LXP604 produces an 8.192 MHz HFO.

MODE SELECT

The Mode Select (SEL) input controls whether the device converts to a higher or lower frequency as described below:

- **2.048 or 4.096 to 1.544 MHz:** To produce a 1.544 MHz output clock from a 2.048 MHz or 4.096 MHz input clock, SEL must be set High. In this mode HFO = 6.176 MHz for all CLADs.
- **1.544 to 2.048 MHz or 4.096 MHz:** To produce a 2.048 MHz or 4.096 MHz output clock from a 1.544 MHz input clock, SEL must be set Low. In this mode the LXP600A HFO = 6.144 MHz, and the LXP602 and LXP604 HFO = 8.192 MHz.

In both frequency modes, CLKO is frequency-locked to CLKI. When $\overline{\text{FSI}}$ is applied, CLKO and CLKI are also phase-locked with FSO and FSI synchronized. Refer to Test Specifications for detailed timing.

When $\overline{\text{FSI}}$ is first asserted, the CLKI and CLKO rising edges will be aligned within a maximum of 500 ms.

If $\overline{\text{FSI}}$ is not provided, pin 7 should be tied High or Low. CLKO and $\overline{\text{FSO}}$ are still generated with the CLKO frequency-locked to CLKI.

OUTPUT JITTER

2.048 MHz or 4.096 MHz to 1.544 MHz

In this mode of operation, the CLADs meet the output jitter requirements of AT&T Publication 62411. When there is no jitter on input clock CLKI, the maximum jitter on CLKO is 0.020 UI pp with no bandlimiting, 0.010 UI pp over the range of 10 Hz to 40 kHz, and 0.012 UI pp in the 8 - 40 kHz band.

1.544 MHz to 2.048 MHz or 4.096 MHz

In this mode of operation, the CLADs meet the output jitter requirements of CCITT Recommendation G.823. When there is no jitter on input clock CLKI, the maximum jitter on CLKO is 0.035 UI pp over the range of 20 Hz to 100 kHz, and 0.025 UI pp in the 18 - 100 kHz band.

JITTER TRANSFER

The CLADs are sensitive to jitter on the input clock in certain frequency bands. The jitter transfer curve is determined by the frequency and amplitude of the input jitter. Test Specification Figures 4 and 5 show nominal jitter transfer measured in nanoseconds. These figures graph output jitter (less intrinsic jitter) divided by input jitter (0.25 UI). Jitter transfer from a 2.048 MHz CLKI to a 1.544 MHz CLKO is shown in Figure 4. In this mode, jitter in the critical 8 kHz band is slightly attenuated while jitter in the 18 - 70 kHz band is transferred with a small net gain. Jitter transfer from a 1.544 MHz CLKI to a 2.048 MHz CLKO is shown in Figure 5. In both modes, with an input jitter level of 0.25 UI, jitter transfer is held below a net gain of 1.110.

(Jitter transfer varies with input jitter. Performance in a specific application should be verified in the actual circuit.)

Table 2: CLAD Frequency Conversions

CLAD	CLKI	CLKO	HFO	SEL
LXP600A	1.544	2.048	6.144	0
	2.048	1.544	6.176	1
LXP602	1.544	2.048	8.192	0
	2.048	1.544	6.176	1
LXP604	1.544	4.096	8.192	0
	4.096	1.544	6.176	1

APPLICATION INFORMATION

POWER-UP

NOTE

This information is for design aid only.

Standard CMOS device precautions apply to the CLAD. Inputs must be applied either simultaneously with or after the power supply VCC. CLAD input signals include CLKI, FSI and SEL.

Figure 2: Typical CLAD Application Circuit

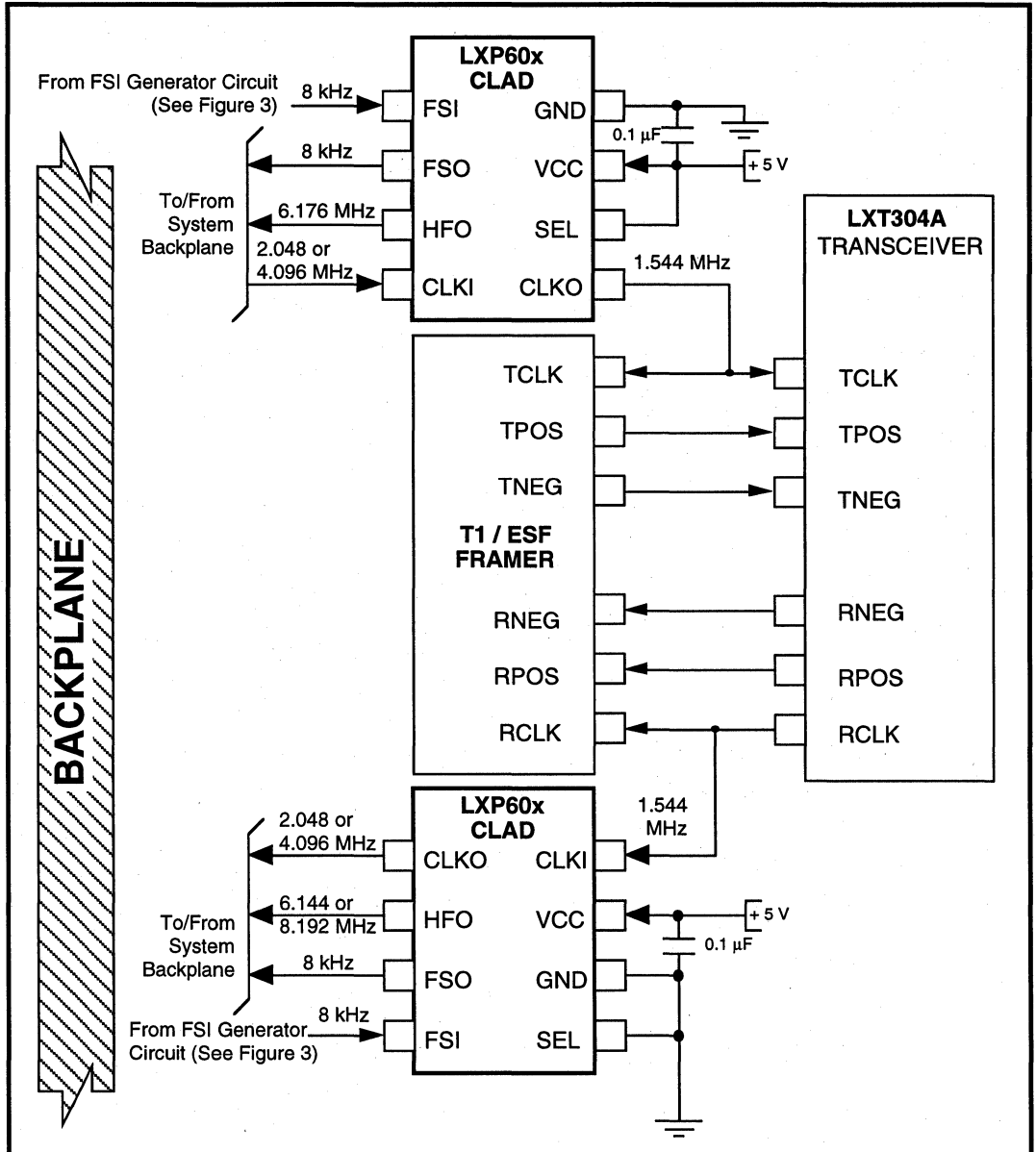

The CLAD internal circuitry takes a maximum of 200 ms to stabilize. There is an additional delay of 500 ms maximum for CLKO to be phase-locked to the incoming clock CLKI during frame synchronization FSI.

POWER SUPPLY DECOUPLING AND FILTERING

The CLADs are designed to meet AT&T Publication 62411 specifications for jitter in the range from 10 Hz to 100 kHz. Proper power supply decoupling is critical for meeting these specifications. As shown in Figure 2, a typical application with a pair of CLADs for backplane frequency conversion, a standard 0.1 μF bypass capacitor is recommended.

The CLADs are monolithic silicon devices which incorporate both analog and digital circuits. CLAD application circuit design may require closer attention to power supply filtering and bypassing than required for strictly digital devices.

Switching power supplies which operate below 100 kHz may produce noise spikes which can affect the analog sections of the CLAD. These spikes should be filtered with an RC network at the CLAD VCC pin.

FRAME SYNC GENERATION

A frame sync pulse is required to synchronize the input and output clocks. If a frame sync pulse is not provided on the backplane, one can be generated from the existing 2.048 MHz backplane clock. A typical FSI generation circuit is shown in Figure 3.

3

Figure 3: Frame Sync (FSI) Generation Circuit

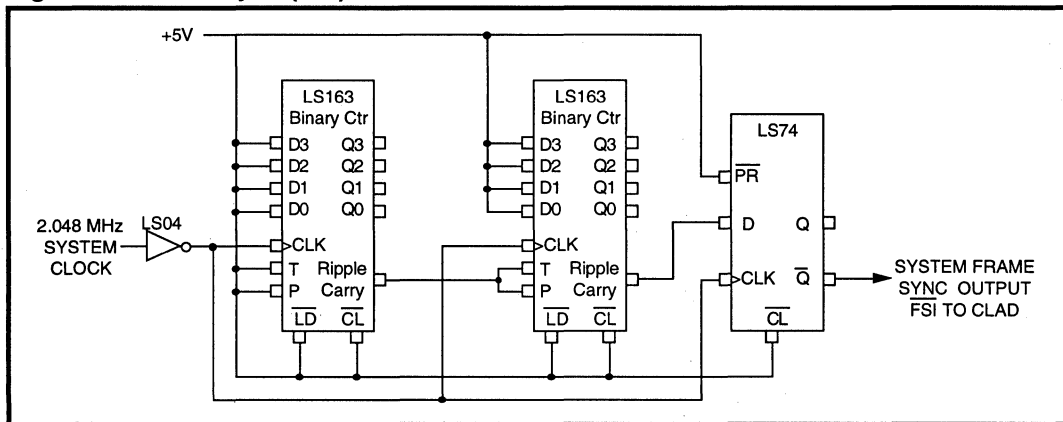

TEST SPECIFICATIONS

NOTE

Minimum and maximum values in Tables 3 through 8 and Figures 4 through 11 represent the performance specifications of the LXP600A/602/604 and are guaranteed by test except, as noted, by design.

Table 3: Absolute Maximum Ratings

Parameter	Sym	Min	Max	Units
DC supply (referenced to GND)	RV+, TV+	-0.3	7.0	V
Voltage, any I/O pin	V _{IO}	GND - 0.3	VCC + 0.3	V
Current, any I/O pin ¹	I _{IO}	-10	10	mA
Storage temperature	T _{STG}	-65	150	°C
Package power dissipation	P _D	–	340	mW
CAUTION				
Operations at or beyond these limits may result in permanent damage to the device. Normal operation not guaranteed at these extremes.				
1. Transient currents of up to 100 mA will not cause SCR latch-up.				

Table 4: Recommended Operating Conditions

Parameter	Symbol	Min	Typ	Max	Units	Test Conditions
Supply voltage ¹	V _{CC}	4.75	5.0	5.25	V	
Supply current	I _{CC}	–	–	8	mA	No TTL loading
	I _{CC}	–	–	14	mA	Full TTL loading
Operating temperature	T _{OP}	-40	–	85	°C	
1. Voltages are with respect to Ground unless otherwise specified.						

Table 5: Digital Characteristics (Over Recommended Range)

Parameter	Symbol	Min	Max	Units
Input Low voltage	V _{IL}	–	0.8	V
Input High voltage	V _{IH}	2.0	–	V
Output Low voltage (I _{OL} = +1.6 mA)	V _{OL}	–	0.4	V
Output Low voltage (I _{OL} < +10 μA)	V _{OL}	–	0.2	V
Output High voltage (I _{OH} = -0.4 mA)	V _{OH}	2.4	–	V
Output High voltage (I _{OH} < -10 μA)	V _{OH}	4.5	–	V
Input leakage current	I _{LL}	-10	10	μA

Table 6: Output Jitter Specifications

Parameter	Sym	Frequency	Spec ¹	Typ ²	Max	Units	Test Conditions
Output Jitter on CLKO CLKO = 1.544 MHz (All CLADs)	Tj1	No Bandlimiting	0.050	0.010	0.020	UI pp	CLKI = 2.048 or 4.096 MHz
		10 Hz to 40 kHz	0.025	0.005	0.010	UI pp	Jl = 0
		8 kHz to 40 kHz	0.025	0.006	0.012	UI pp	F _{SI} applied
Output Jitter on CLKO CLKO = 2.048 MHz (LXP600A and 602 Only)	Tj2	20 Hz to 100 kHz	1.500	0.025	0.035	UI pp	CLKI = 1.544 MHz, Jl = 0
		18 kHz to 100 kHz	0.200	0.015	0.025	UI pp	F _{SI} applied

1. Specifications from AT&T Publication 62411 and ITU Recommendations G.823 (for 1.544 MHz and 2.048 MHz, respectively).
2. Typical values are at 25 °C and are for design aid only; not guaranteed and not subject to production testing.

3

Figure 4: Nominal Jitter Transfer - 2.048 MHz CLKI to 1.544 MHz CLKO
(Input Jitter = 0.25 UI)

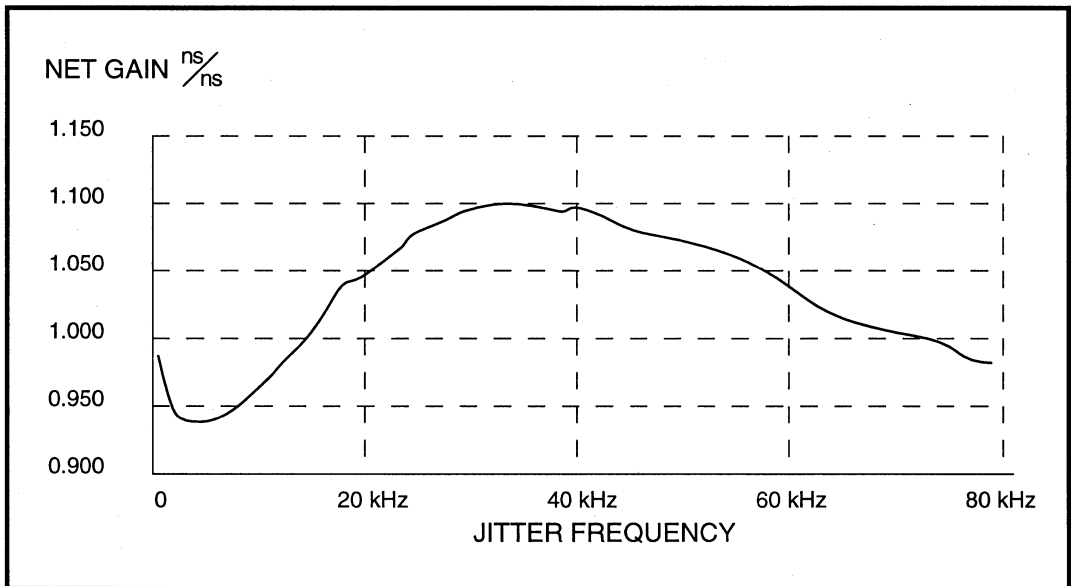

Figure 5: Nominal Jitter Transfer - 1.544 MHz CLKI to 2.048 MHz CLKO
(Input Jitter = 0.25 UI)

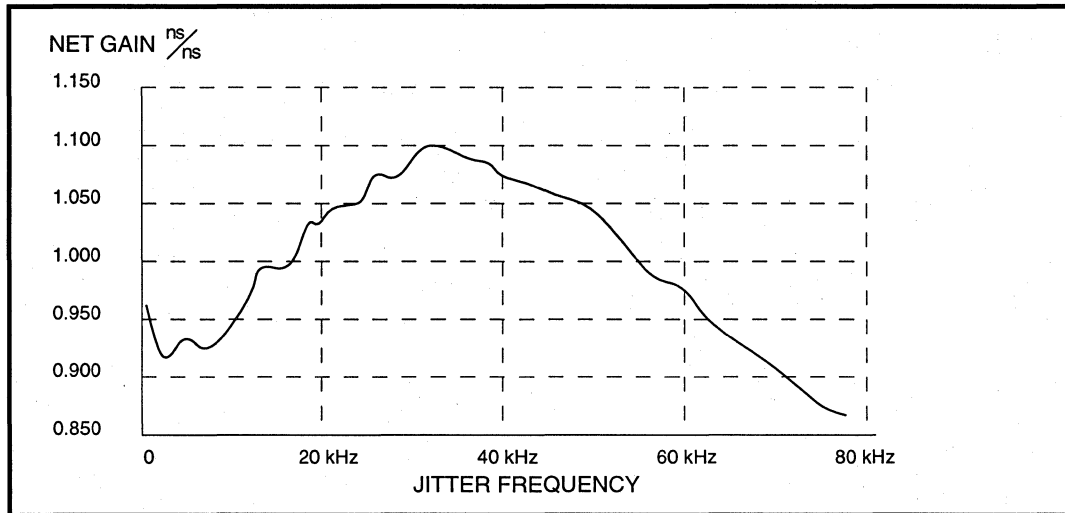

Table 7: Timing Values (see Figure 6)

Parameter	Symbol	Min	Max	Units
Capture range on CLKI	-	±10000	-	ppm
Lock range on CLKI	-	±10000	-	ppm
Input clock duty cycle	-	35	65	%
Rise/fall time on CLKI, \overline{FSI}	Trf	-	40	ns
Rise/fall time on CLKO, \overline{FSO} , HFO with a 25 pF load	Trf	-	40	ns

Figure 6: Rise and Fall Times

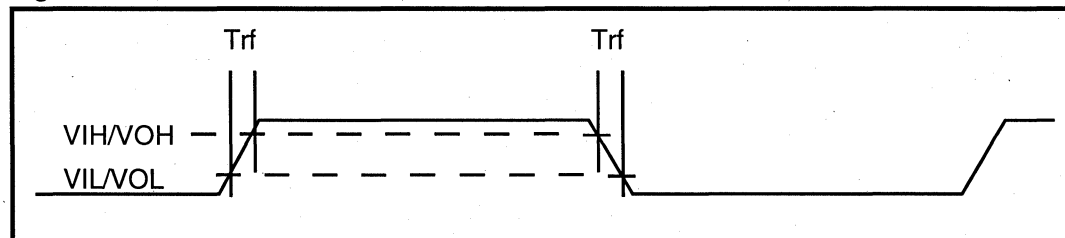

Table 8: Frame Sync Characteristics (see Figures 7 through 11)

Parameter	Symbol	Min	Typ ¹	Max	Units
\overline{FSI} setup time from CLKI rising	Tsui	46	–	–	ns
$\overline{FSI}/CLKI$ hold time	Thi	30	–	–	ns
\overline{FSI} pulse width (low)	Twi	76	–	TCLKI ²	ns
CLKO delay from CLKI	TdC	-15	0	+15	ns
CLKO duty cycle	Cdc	49	–	51	%
\overline{FSO} delay from HFO	TdF	-5	–	30	ns
\overline{FSO} pulse width (low)	Two	–	–	TCLKO ³	ns
CLKO delay from HFO	TdH	-15	–	+15	ns

1. Typical figures are at 25 °C and are for design aid only; not guaranteed and not subject to production testing.
 2. TCLKI is the period of CLKI.
 3. TCLKO is the period of CLKO.

Figure 7: LXP600A and LXP602 High to Low Frequency Conversion Frame Sync Alignment

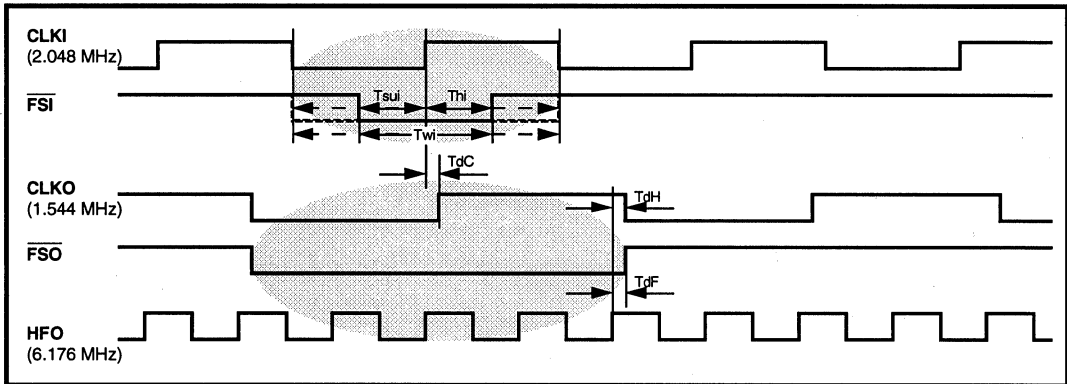

Figure 8: LXP604 High to Low Frequency Conversion Frame Sync Alignment

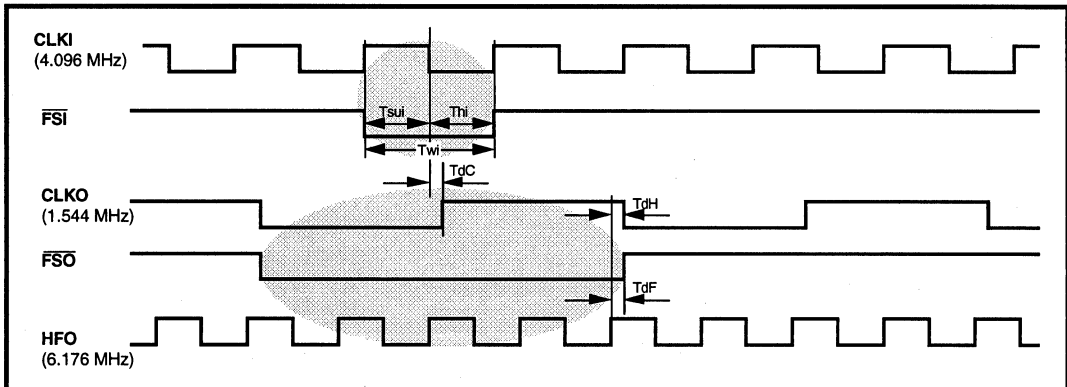

Figure 9: LXP600A Low to High Frequency Conversion Frame Sync Alignment

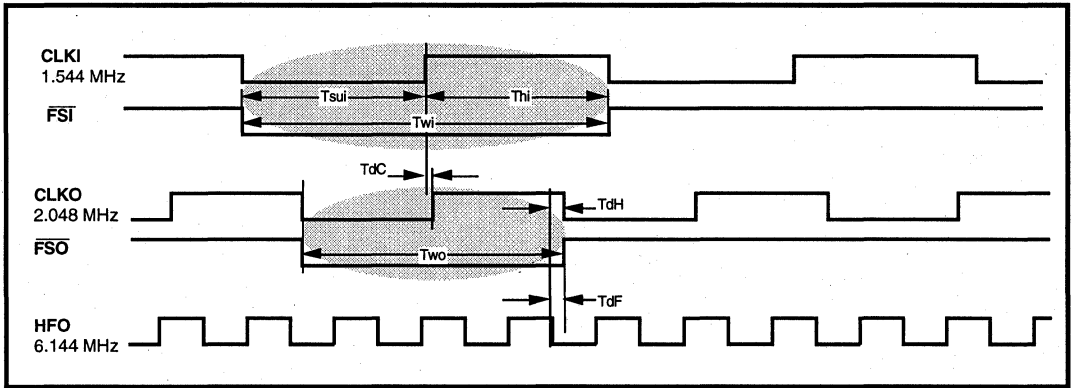

Figure 10: LXP602 Low to High Frequency Conversion Frame Sync Alignment

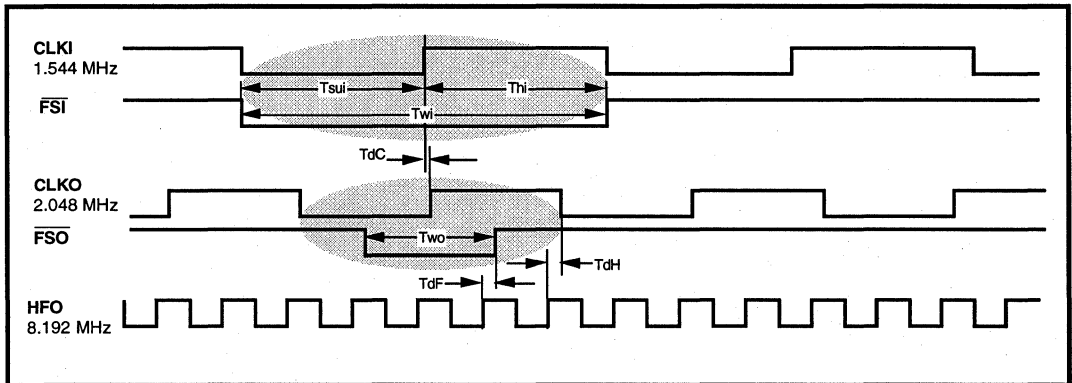
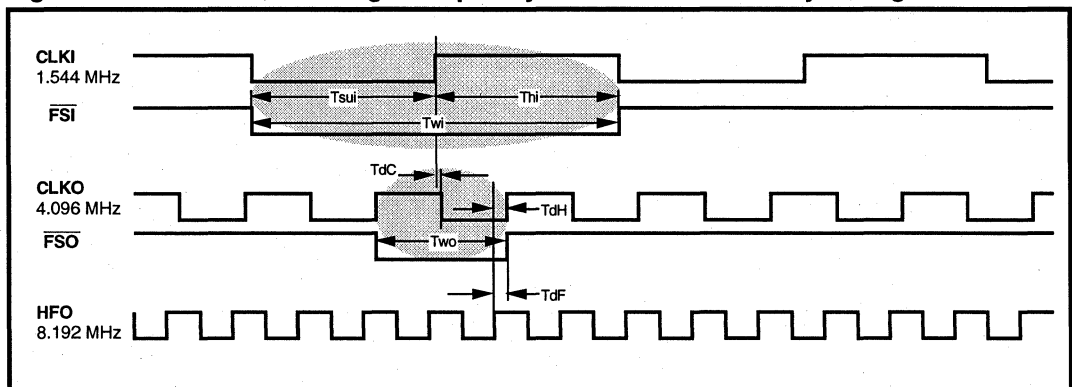

Figure 11: LXP604 Low to High Frequency Conversion Frame Sync Alignment



LXP610

Low-Jitter Multi-Rate Clock Adapter (CLAD)

General Description

The LXP610 Multi-Rate Clock Adapter (CLAD) offers pin-selectable frequency conversion between T1 and E1 rates as well as 8 additional rates from 1.544 MHz to 8.192 MHz. The output clock is frequency-locked to the input clock. When an input frame sync pulse is provided, the CLAD phase-locks the input and output clocks together, and locks the 8 kHz output frame sync pulse to the input frame sync pulse. The frame sync polarity is also pin-selectable.

Five different high frequency output clocks are available for applications which require a higher-than-baud rate backplane or system clock. The high frequency output (HFO) clock varies with the input clock frequency.

Level One's patented locking method enables the CLAD to perform frequency conversion with no external components, while generating very little jitter on the output clock. The conversion is digitally controlled so the output clock is as accurate as the input clock.

The CLAD is an advanced CMOS device. It requires only a single +5 V power supply.

Features

- Translates between 10 different frequencies. Generates basic and high frequency output clocks and frame sync from an input clock and its frame sync.
- High Frequency Output clock for higher-than-baud rate backplane systems
- Low output jitter meets AT&T Publication 62411 for 1.544 MHz, and CCITT Recommendation G.823 for 2.048 MHz
- Digital control of frequency conversion process
- No external components
- Pin-selectable operation mode
- Low-power 5 V only CMOS in 14-pin plastic DIP or 28-pin PLCC

Applications

- Internal timing system for Channel Banks, Digital Loop Carriers, Multiplexers, Internal Timing Generators, etc.
- Conversion between T1/E1 clock rates and higher frequency backplane rates (T1/E1 converter)
- Special backplane interfaces (e.g. NTI 2.56 MHz)

LXP610 Block Diagram

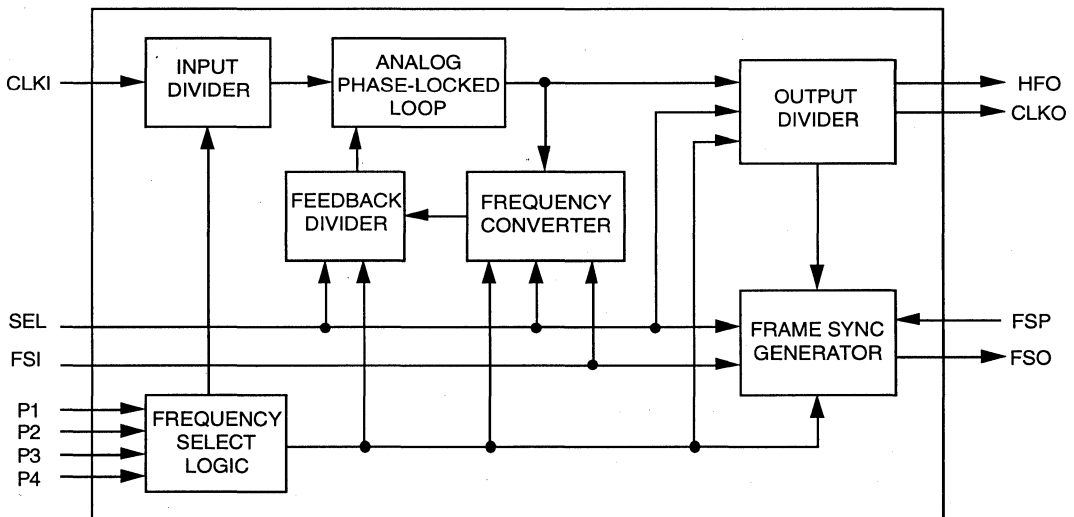

LXP610 Low-Jitter Multi-Rate Clock Adapter (CLAD)

Figure 1: Pin Assignments

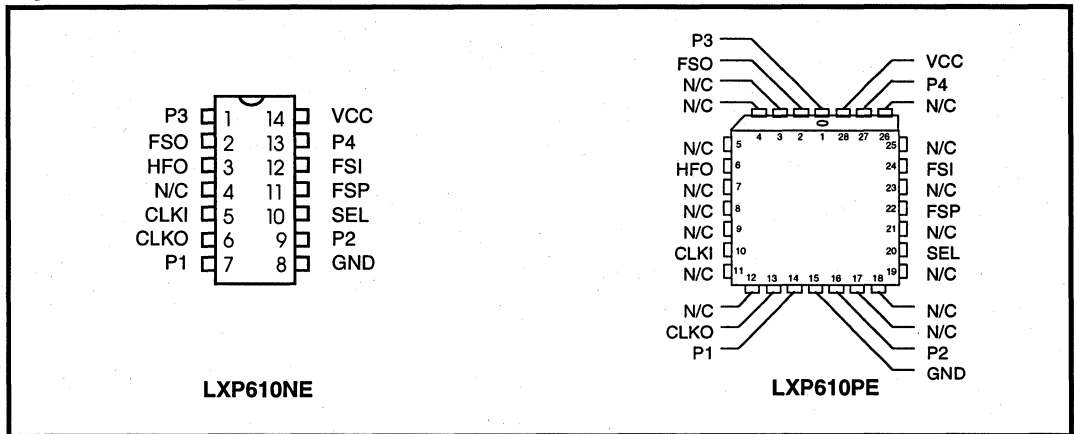

Table 1: Pin Descriptions

Pin #		Sym	I/O	Name	Description
DIP	PLCC				
1	1	P3	I	Program Pin 3	Program pins control frequency conversion and FSO pulse width in conjunction with the SEL pin as listed in Table 2.
7	14	P1	I	Program Pin 1	
9	16	P2	I	Program Pin 2	
13	27	P4	I	Program Pin 4	
2	2	FSO	O	Frame Sync Output	Frame synchronization output at 8 kHz. FSO is synced to CLKO and to FSI (if FSI is provided.) Active Low unless FSP = 1.
3	6	HFO	O	High Frequency Output	A high frequency output which can be used to clock external devices. HFO outputs are determined in accordance with Table 2.
5	10	CLKI	I	Clock Input	Primary rate clock to be converted.
6	13	CLKO	O	Clock Output	Primary rate clock derived from CLKI.
8	15	GND	-	Ground	Ground.
10	20	SEL	I	Mode Select	Controls frequency conversion and FSO pulse width in conjunction with Program pins 1-4, as listed in Table 2.
11	22	FSP	I	Frame Sync Polarity	When High, causes FSI and FSO to be active High pulses.
12	24	FSI	I	Frame Sync Input	Frame synchronization pulse (8 kHz or any substrate multiple). Active Low when FSP = 0. Active High when FSP = 1.
14	28	VCC	I	Power Supply Input	+5 V power supply input.

NOTE: The following pins are not connected (N/C): DIP pin 4 and PLCC pins 3, 4, 5, 7, 8, 9, 11, 12, 17, 18, 19, 21, 23, 25 and 26.

FUNCTIONAL DESCRIPTION

NOTE

This information is for design aid only.

The CLAD converts an input clock (CLKI) at a particular frequency to an output clock (CLKO) at a different frequency. It also produces a frame sync output (FSO) and a high frequency output clock (HFO). The HFO frequency is a multiple (2x, 3x, 4x, or 5x) of CLKO. The specific frequencies are determined by the Mode Select (SEL) and Program (P1 - P4) inputs. Tables 2 and 3 list the CLKO and HFO frequencies available with a given input CLKI. (Table 2 is keyed to Program Pin settings; Table 3 is keyed to CLKI frequencies.) Refer to Test Specifications for output frame sync alignments.

CLKO is always frequency-locked to CLKI. When a frame sync input (FSI) is supplied, CLKI and CLKO are also phase-locked. The CLAD accepts FSI pulses at 8 kHz, or at any sub-rate multiple (i.e., 1, 2 or 4 kHz). The frame sync output (FSO) pulse is synchronized to the FSI pulse.

When an 8 kHz FSI is first asserted, the CLKI and CLKO rising edges will be aligned within a maximum of 500 ms. For other FSI rates, the alignment period is correspondingly lengthened. For example, at 4 kHz, the FSI/FSO alignment is completed within a maximum of one second.

If an input frame sync pulse is not provided, the FSI pin should be tied High or Low. CLKO and FSO are still generated with the CLKO frequency locked to CLKI.

OUTPUT JITTER

The CLAD output jitter meets the following specifications:

- **2.048 MHz or 4.096 MHz to 1.544 MHz:** In this mode of operation, the CLAD meets the output jitter requirements of AT&T Publication 62411. When there is no jitter on input clock CLKI, the maximum jitter on CLKO is 0.020 UI pp with no bandlimiting, 0.010 UI in the 10 Hz - 40 kHz band, and 0.012 UI in the 8 - 40 kHz band.
- **1.544 MHz to 2.048 MHz or 4.096 MHz:** In this mode of operation when there is no jitter on input clock CLKI, the maximum jitter on CLKO is 0.035 UI pp over the range of 20 Hz to 100 kHz, and 0.025 UP pp in the 18-100 kHz band.

Table 2: Program Pin Functions

Mode Select P4 P3 P2 P1	SEL = 0				SEL = 1			
	CLKI	CLKO	HFO	FSO	CLKI	CLKO	HFO	FSO
0 0 0 0	1.544	2.048	6.144	Long (L)	2.048	3.088	6.176	L
0 0 0 1	3.088	2.048	8.192	Short (S)	2.048	3.088	6.176	L
0 0 1 0	1.544	2.048	6.144	L	2.048	1.544	6.176	L
0 0 1 1	1.544	2.048	8.192	S	2.048	1.544	6.176	L
0 1 0 0	1.544	2.560	7.680	L	2.560	1.544	7.720	L
0 1 0 1	6.176	4.096	8.192	L	8.192	3.088	6.176	L
0 1 1 0	1.544	2.560	7.680	L	2.560	1.544	7.720	L
0 1 1 1	6.176	2.048	8.192	S	8.192	1.544	6.176	L
1 0 0 0	3.088	2.048	6.144	L	2.048	3.088	6.176	L
1 0 0 1	3.088	4.096	8.192	L	4.096	3.088	6.176	L
1 0 1 0	3.088	2.048	6.144	L	2.048	3.088	6.176	L
1 0 1 1	1.544	4.096	8.192	L	4.096	1.544	6.176	L
1 1 0 0	6.176	2.560	7.680	L	2.560	1.544	7.720	L
1 1 0 1	6.176	4.096	8.192	L	8.192	3.088	6.176	L
1 1 1 0	6.176	2.560	7.680	L	2.560	1.544	7.720	L
1 1 1 1	6.176	4.096	8.192	L	8.192	1.544	6.176	L

JITTER TRANSFER

The CLAD is sensitive to jitter on the input clock in certain frequency bands. The jitter transfer curve is determined by the frequency and amplitude of the input jitter. Test Specification Figures 4 and 5 show nominal jitter transfer measured in nanoseconds. These figures graph output jitter (less intrinsic jitter) divided by input jitter (0.25 UI). Jitter transfer from a 2.048 MHz CLKI to a 1.544 MHz CLKO is shown in Figure 4. In this mode, jitter in the critical 8 kHz band is attenuated while jitter in the 18 - 70 kHz band is transferred with a small net gain. Jitter transfer from a 1.544 MHz CLKI to a 2.048 MHz CLKO is shown in Figure 5. In both modes, with an input jitter level of 0.25 UI, jitter transfer is held below a net gain of 1.110. (Jitter transfer varies with the input jitter level. Performance in a particular application should be verified in the actual circuit.)

Table 3: Input to Output Frequency Conversion Options

CLKI	CLKO	HFO	FSO	P4	P3	P2	P1	SEL
1.544	2.048	6.144	Long (L)	0	0	X	0	0
1.544	2.048	8.192	Short (S)	0	0	1	1	0
1.544	2.560	7.680	L	0	1	X	0	0
1.544	4.096	8.192	L	1	0	1	1	0
2.048	1.544	6.176	L	0	0	1	X	1
2.048	3.088	6.176	L	0	0	0	X	1
2.048	3.088	6.176	L	1	0	X	0	1
2.560	1.544	7.720	L	X	1	X	0	1
3.088	2.048	6.144	L	1	0	X	0	0
3.088	2.048	8.192	S	0	0	0	1	0
3.088	4.096	8.192	L	1	0	0	1	0
4.096	1.544	6.176	L	1	0	1	1	1
4.096	3.088	6.176	L	1	0	0	1	1
6.176	2.048	8.192	S	0	1	1	1	0
6.176	2.560	7.680	L	1	1	X	0	0
6.176	4.096	8.192	L	0	1	0	1	0
6.176	4.096	8.192	L	1	1	X	1	0
8.192	1.544	6.176	L	X	1	1	1	1
8.192	3.088	6.176	L	X	1	0	1	1

APPLICATION INFORMATION

NOTE

This information is for design aid only.

FRAME SYNC GENERATION

A frame sync pulse is required to synchronize the input and output clocks. If a frame sync pulse is not provided on the backplane, one can be generated from the existing 2.048 MHz backplane clock. A typical FSI generation circuit is shown in Figure 2.

POWER SUPPLY DECOUPLING AND FILTERING

The LXP610 CLAD is designed to meet AT&T Publication 62411 specifications for jitter in the range from 10 Hz to 100 kHz. Proper power supply decoupling is critical for meeting these specifications. As shown in Figure 3, a standard 0.1 μ F bypass capacitor is recommended.

The CLAD is a monolithic silicon device which incorporates both analog and digital circuits. CLAD application circuit design may require closer attention to power supply filtering and bypassing than required for strictly digital devices.

Switching power supplies which operate below 100 kHz may produce noise spikes which can affect the analog sections of the CLAD. These spikes should be filtered with an RC network at the CLAD VCC pin.

TYPICAL APPLICATION

Figure 3 shows a typical application circuit using a pair of LXP610 CLADs to convert between the 2.56 MHz backplane frequency and the 1.544 MHz T1 rate. The CLAD at the top of the figure provides the 1.544 MHz TCLK for the T1 framer and transceiver. For conversion from 2.56 MHz to 1.544 MHz, P1, P2, and P4 are tied Low; and P1 and SEL are tied High. In this configuration, the LXP610 HFO is 7.720 MHz.

The CLAD at the bottom of Figure 3 produces the 2.56 MHz backplane clock. For conversion from 1.544 MHz to 2.56 MHz, P1, P2, P3 and P4 are tied High; and SEL is tied Low. The HFO produced in this configuration is 7.680 MHz.

Figure 2: Frame Sync (FSI) Generation Circuit

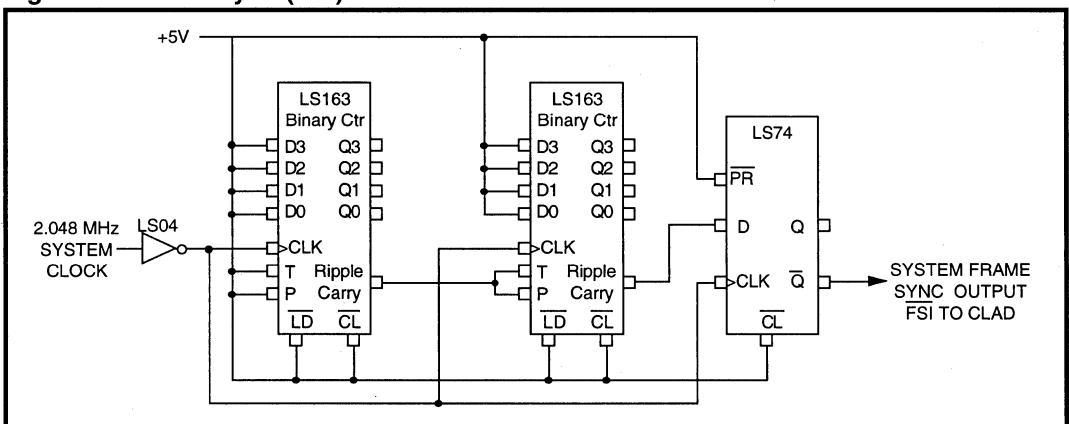

LXP610 Low-Jitter Multi-Rate Clock Adapter (CLAD)

Figure 3: Typical Application Circuit

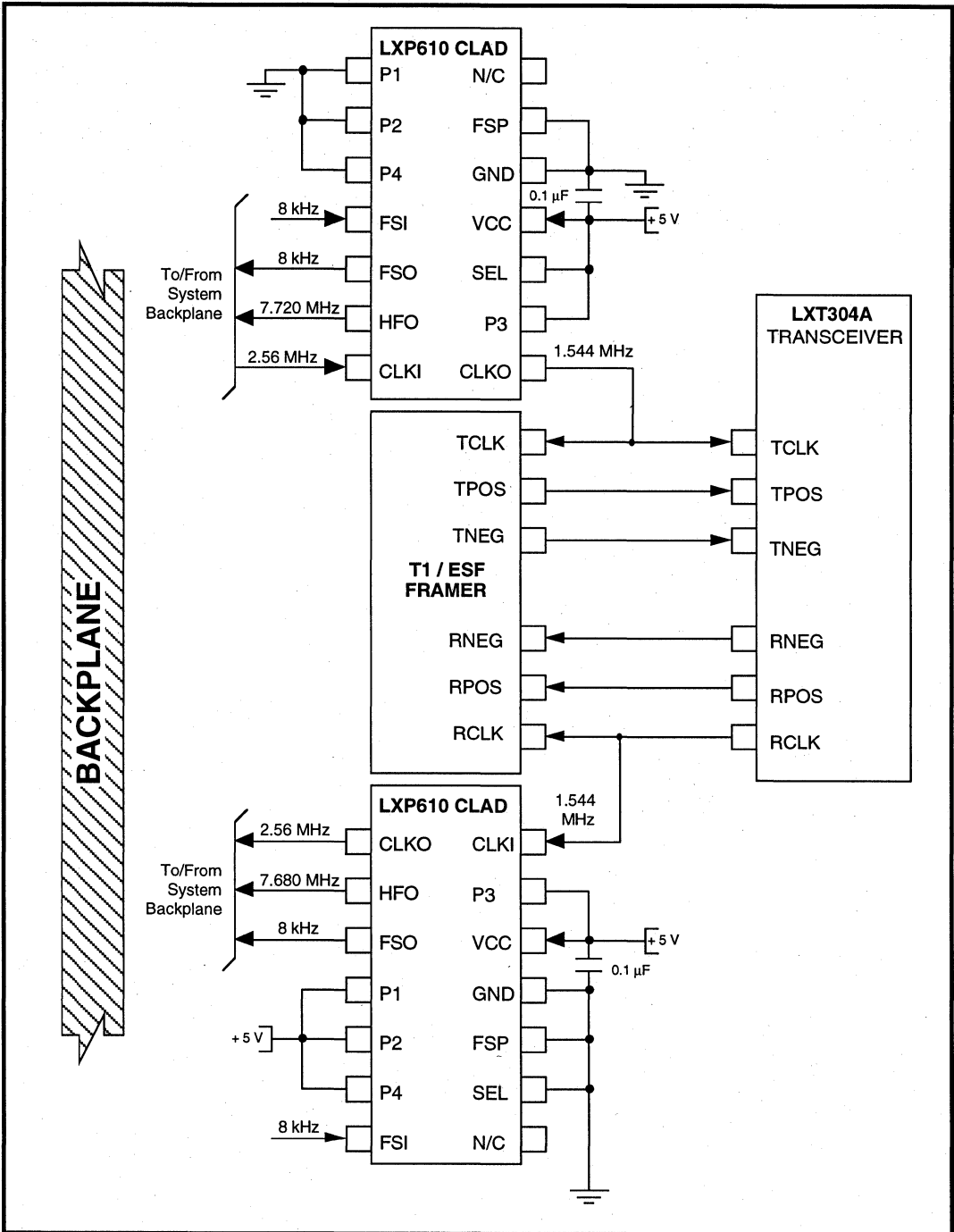

TEST SPECIFICATIONS

NOTE

Minimum and maximum values in Tables 4 through 9 and Figures 4 through 11 represent the performance specifications of the LXP610 and are guaranteed by test except, as noted, by design.

Table 4: Absolute Maximum Ratings

Parameter	Sym	Min	Max	Units
DC supply (referenced to GND)	RV+, TV+	-0.3	7.0	V
Voltage, any I/O pin	V _{IO}	GND - 0.3	VCC + 0.3	V
Current, any I/O pin ¹	I _{IO}	-10	10	mA
Storage temperature	T _{STG}	-65	150	°C
Package power dissipation	P _D	-	340	mW

CAUTION
Operations at or beyond these limits may result in permanent damage to the device.
Normal operation not guaranteed at these extremes.

1. Transient currents of up to 100 mA will not cause SCR latch-up.

3

Table 5: Recommended Operating Conditions

Parameter	Symbol	Min	Typ	Max	Units	Test Conditions
Supply voltage ¹	V _{CC}	4.75	5.0	5.25	V	
Supply current	I _{CC}	-	-	8	mA	No TTL loading
	I _{CC}	-	-	14	mA	Full TTL loading
Operating temperature	T _{OP}	-40	-	85	°C	

1. Voltages are with respect to Ground unless otherwise specified.

Table 6: Digital Characteristics (Over Recommended Range)

Parameter	Symbol	Min	Max	Units
Input Low voltage	V _{IL}	-	0.8	V
Input High voltage	V _{IH}	2.0	-	V
Output Low voltage (I _{OL} = +1.6 mA)	V _{OL}	-	0.4	V
Output Low voltage (I _{OL} < +10 μA)	V _{OL}	-	0.2	V
Output High voltage (I _{OH} = -0.4 mA)	V _{OH}	2.4	-	V
Output High voltage (I _{OH} < -10 μA)	V _{OH}	4.5	-	V
Input leakage current	I _{LL}	-10	10	μA

LXP610 Low-Jitter Multi-Rate Clock Adapter (CLAD)

Table 7: Output Jitter Specifications

Parameter	Sym	Frequency	Spec ¹	Typ ²	Max	Units	Test Conditions
Output Jitter on CLKO CLKO = 1.544 MHz	Tj1	No Bandlimiting	0.050	0.010	0.020	UI pp	CLKI = 2.048 or 4.096 MHz
		10 Hz to 40 kHz	0.025	0.005	0.010	UI pp	JI = 0
		8 kHz to 40 kHz	0.025	0.006	0.012	UI pp	FSI applied
Output Jitter on CLKO CLKO = 2.048 MHz	Tj2	20 Hz to 100 kHz	1.500	0.025	0.035	UI pp	CLKI = 1.544 MHz, JI = 0
		18 kHz to 100 kHz	0.200	0.015	0.025	UI pp	FSI applied

1. Specifications from AT&T Publication 62411 and ITU Recommendations G.823 (for 1.544 MHz and 2.048 MHz, respectively).
 2. Typical values are at 25 °C and are for design aid only; not guaranteed and not subject to production testing.

**Figure 4: Nominal Jitter Transfer - 2.048 MHz CLKI to 1.544 MHz CLKO
(Input Jitter = 0.25 UI)**

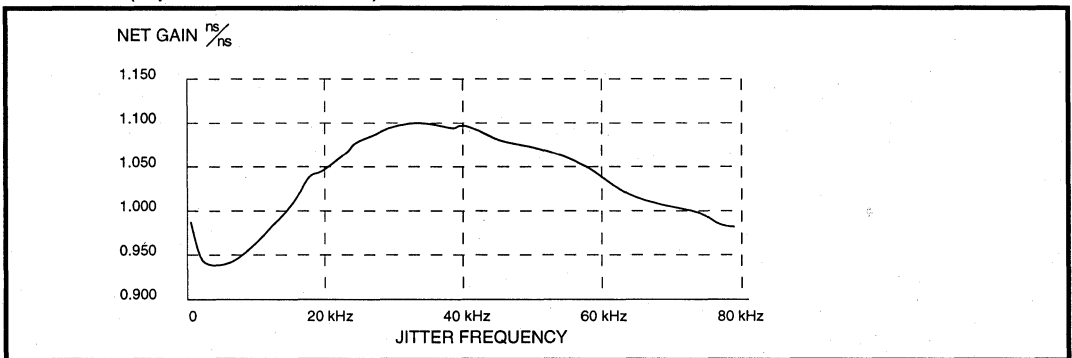

**Figure 5: Nominal Jitter Transfer - 1.544 MHz CLKI to 2.048 MHz CLKO
(Input Jitter = 0.25 UI)**

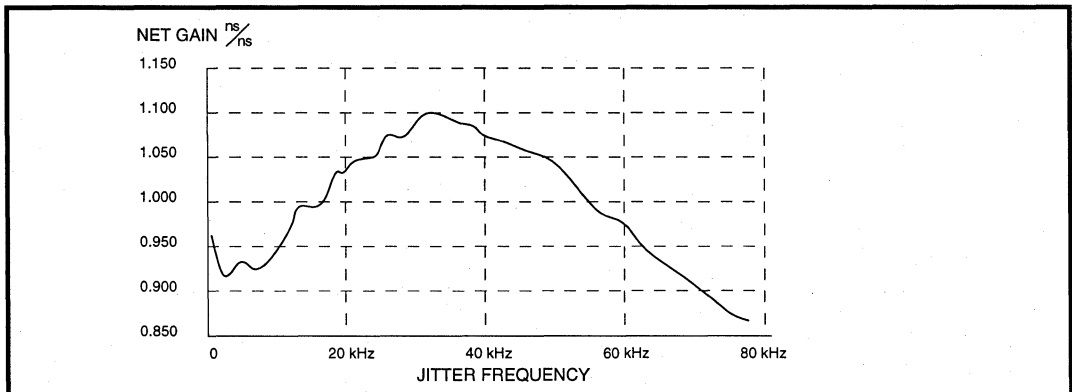

Table 8: Timing Values (see Figure 6)

Parameter	Symbol	Min	Max	Units
Capture range on CLKI	-	±10000	-	ppm
Lock range on CLKI	-	±10000	-	ppm
Input clock duty cycle	-	35	65	%
Rise/fall time on CLKI, FSI	Trf	-	40	ns
Rise/fall time on CLKO, FSO, HFO with a 25 pF load	Trf	-	40	ns

Figure 6: Rise and Fall Times

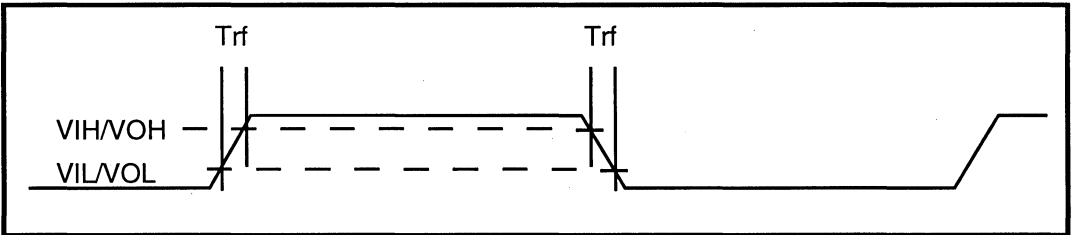

Table 9: Timing Values (see Figures 7 through 11)

Parameter	Symbol	Min	Typ	Max	Units
FSI setup time from CLKI rising	Tsui	46	-	-	ns
FSI/CKLI hold time	Thi	30	-	-	ns
FSI pulse width	Twi	76	-	TCLKI ¹	ns
CLKO delay from CLKI	TdC	-15	0	+15	ns
CLKO duty cycle	Cdc	49	-	51	%
FSO delay from HFO	TdF	-5	-	30	ns
FSO pulse width	Two	-	-	TCLKO ²	ns
CLKO delay from HFO	TdH	-15	-	15	ns

1. TCLKI is the period of CLKI.
 2. TCLKO is the period of CLKO.

Figure 7: Timing Relationships - FSI / CLKI to CLKO / FSO and HFO

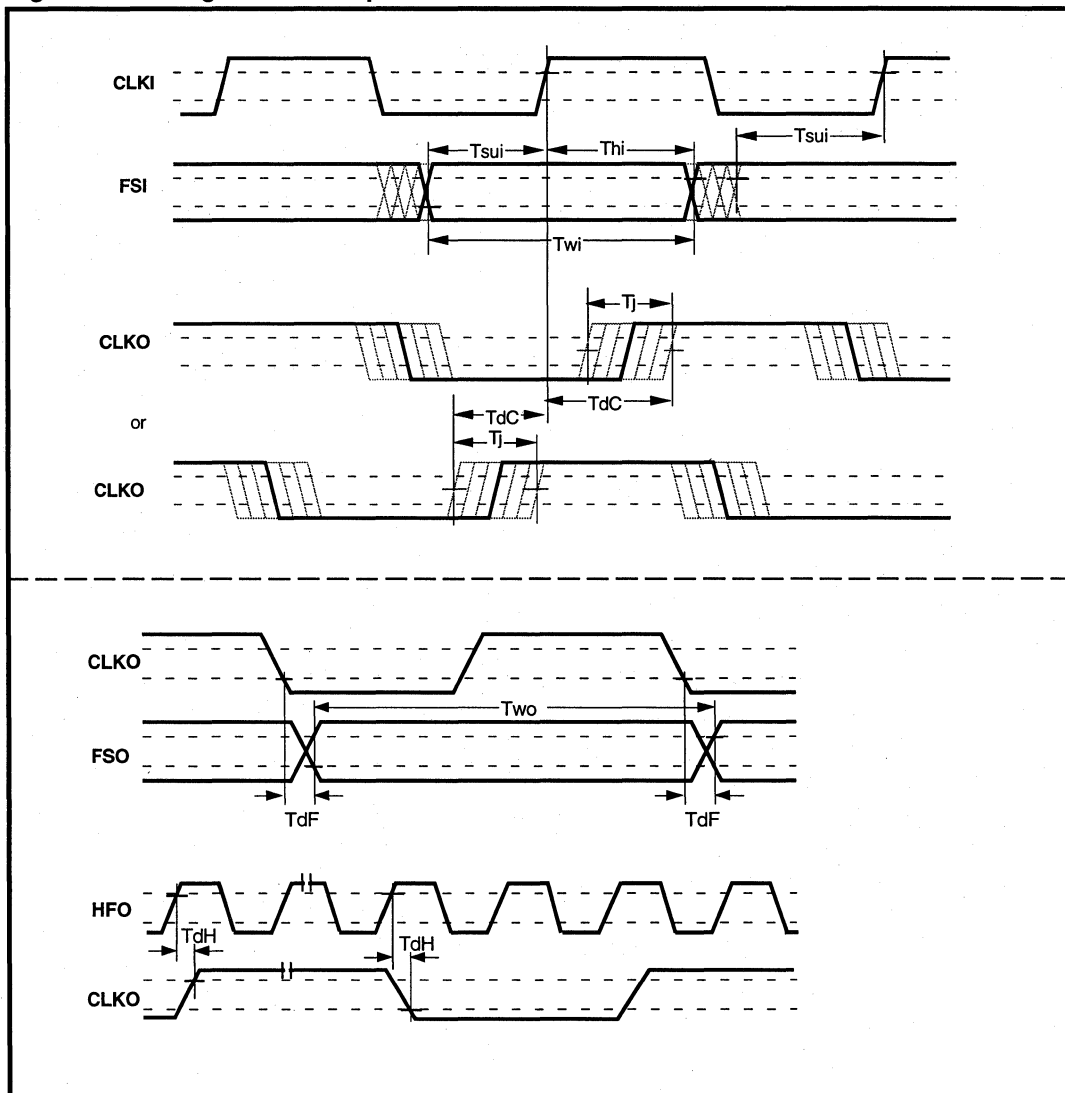
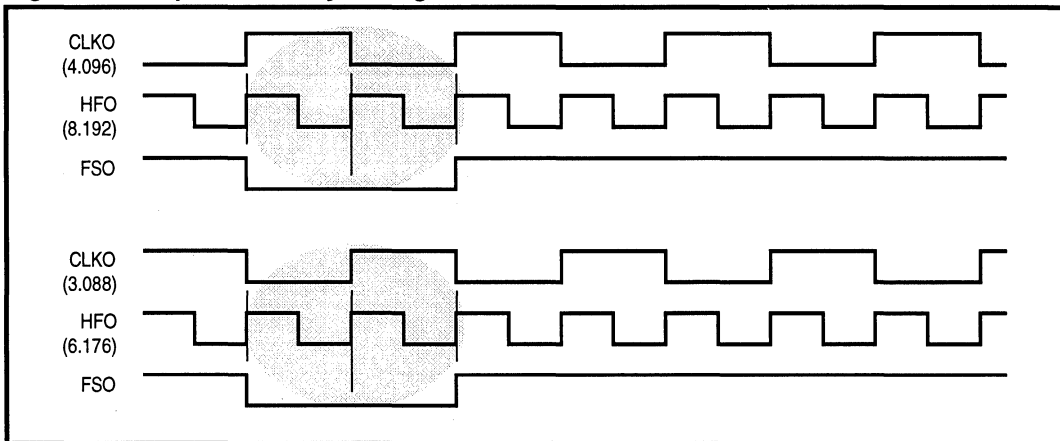

Figure 8: Output Frame Sync Alignment when HFO = 2 x CLKO



3

Figure 9: Output Frame Sync Alignment when HFO = 3 x CLKO

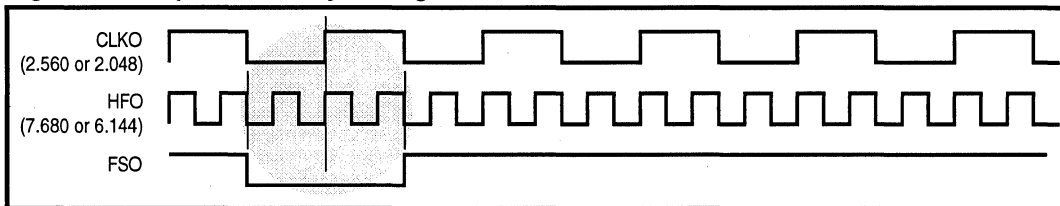

Figure 10: Output Frame Sync Alignment when HFO = 4 x CLKO

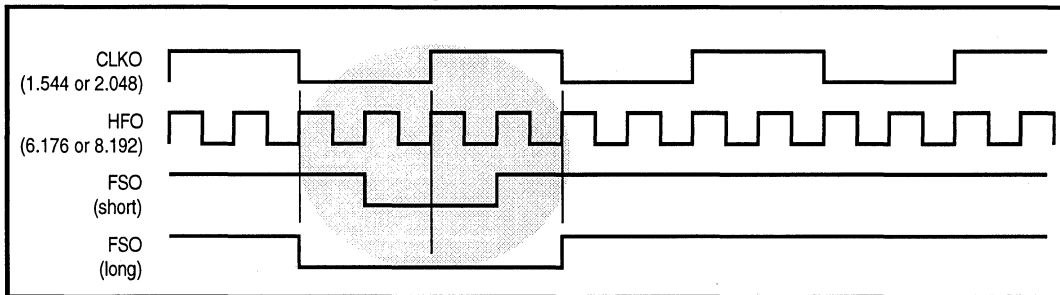
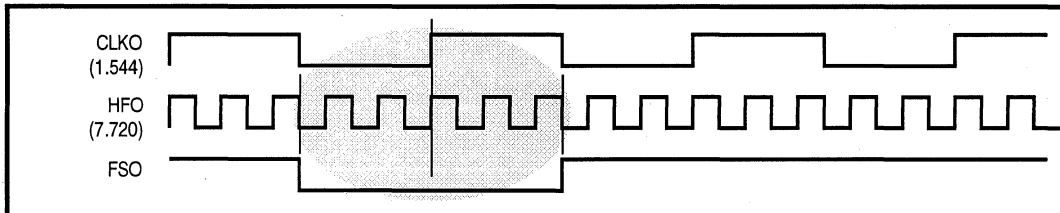

Figure 11: Output Frame Sync Alignment when HFO = 5 x CLKO



LXP610 Low-Jitter Multi-Rate Clock Adapter (CLAD)

NOTES:

T1/E1 Repeaters

4



LXT312 / LXT315

Low-Power T1 PCM Repeaters/Transceivers

General Description

The LXT312 and LXT315 are integrated repeater/transceiver circuits for T1 carrier systems. The LXT312 is a dual repeater/transceiver and the LXT315 is a single repeater/transceiver. The LXT312 and LXT315 are designed to operate as regenerative repeaters/transceivers for 1.544 Mbps data rate PCM lines. Each includes all circuits required for a regenerative repeater/transceiver system including the equalization network, automatic line build-out (ALBO), and a state-of-the-art analog/digital clock extraction network tuned by an external crystal.

The key feature of the LXT312 family is that it requires only a crystal and a minimum of other components to complete a repeater/transceiver design. Compared with traditional tuned coil-type repeaters/transceivers, they offer significant savings in component and labor costs, along with reduced voltage drop/power consumption, and improved reliability. To ensure performance for all loop lengths, the LXT312 and LXT315 are 100% AC/DC tested using inputs generated by Level One's proprietary transmission line and network simulator.

The LXT312 and LXT315 are advanced CMOS devices which require only a single 5-volt power supply.

Features

- Integrated repeater/transceiver circuit on a single CMOS chip
- On-chip equalization network
- On-chip ALBO
- Low power consumption
- No tuning coil
- On-chip Loopback
- Recovered Clock Output
- 0 to 36 dB dynamic range
- -11 dB interference margin
- Compatible with CB113/TA24 specifications
- Single 5 V only CMOS technology
- Available in 16-pin PDIP and 44-pin PLCC

LXT312 Block Diagram

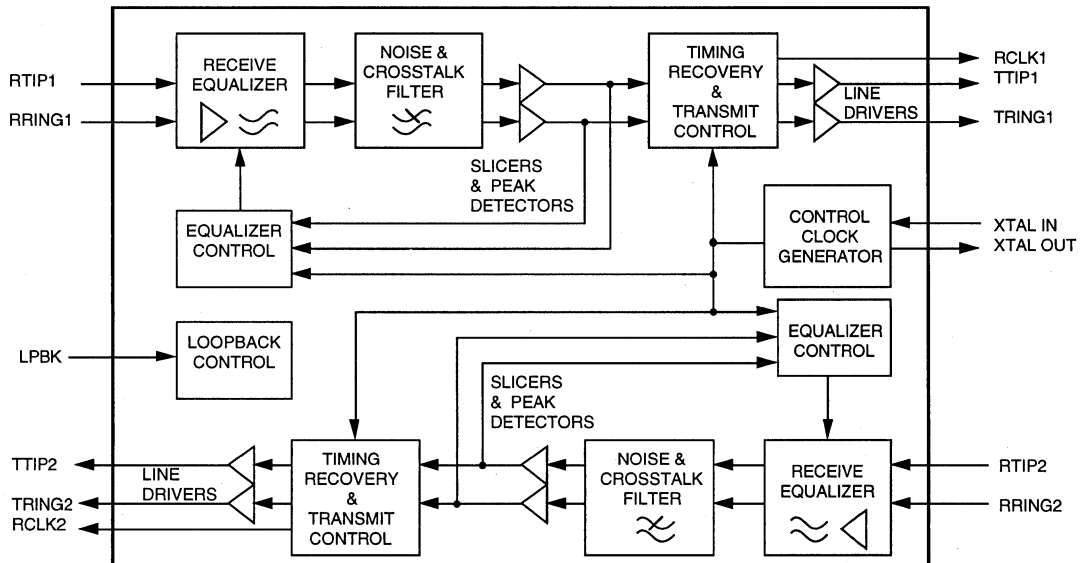

LXT312/315 Low-Power T1 PCM Repeater/Transceivers

Figure 1: LXT312/315 Repeater/Transceiver Pin Assignments

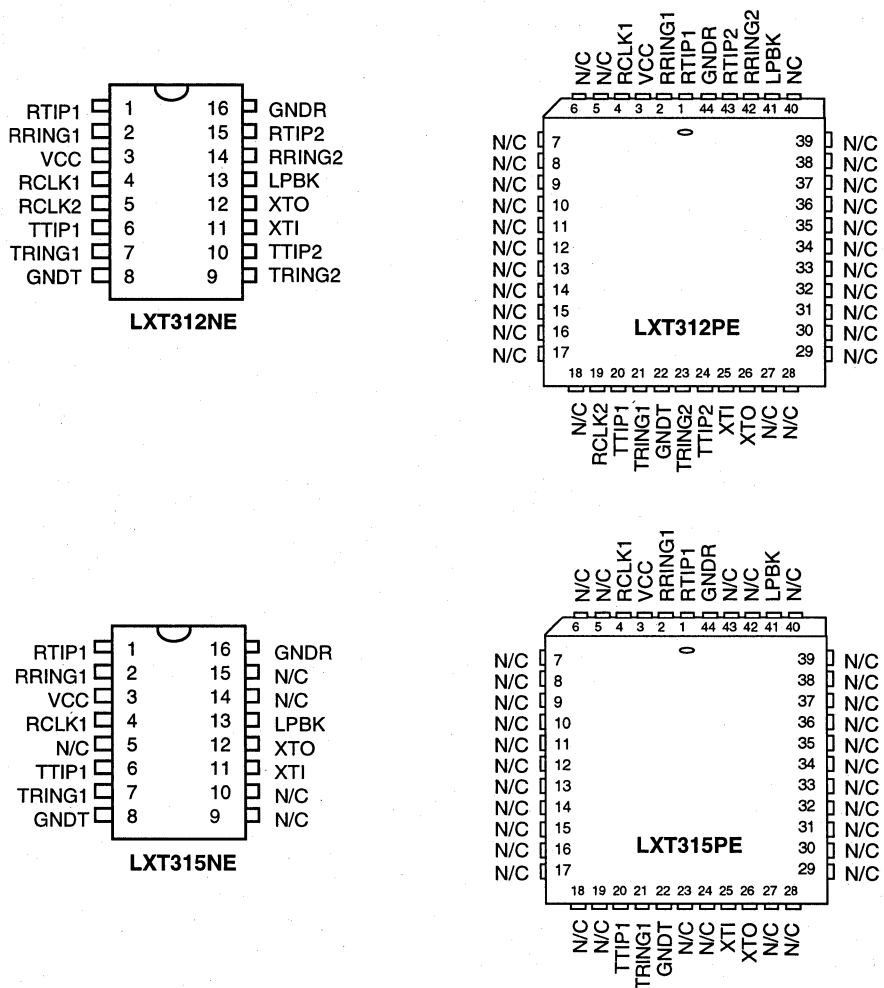

Table 1: Pin Descriptions

Pin # DIP / PLCC		Sym	I/O	Name	Description
1	1	RTIP1	I	Repeater Tip and	Tip and ring receive inputs for Channel 1.
2	2	RRING1	I	Ring Inputs	
4	4	RCLK1	O	Recovered Clock	Clock output recovered from Channel 1 receive input.
6	20	TTIP1	O	Repeater Tip and	Open-drain output drivers for Channel 1.
7	21	TRING1	O	Ring Outputs	
11	25	XTI	I	Crystal Oscillator	A 6.176 MHz crystal must be connected across these two pins.
12	26	XTO	O	Pins	
3	3	VCC	I	Power Supply	Power supply input for all circuits. +5 V (± 0.25 V)
8	22	GNDT	-	Transmit Ground	Ground return for transmit circuits.
16	44	GNDR	-	Receive Ground	Ground return for receive circuits.
9 ¹	23 ¹	TRING2	O	Side 2 Tip and Ring	On the LXT312 dual repeater/transceiver, these are open-drain output drivers for Channel 2.
10 ¹	24 ¹	TTIP2	O	Outputs	
14 ¹	42 ¹	RRING2	I	Side 2 Ring and Tip	On the LXT312 dual repeater/transceiver these are tip and ring receive inputs for Channel 2.
15 ¹	43 ¹	RTIP2	I	Inputs	
5 ¹	19 ¹	RCLK2	O	Recovered Clock	On the LXT312 dual repeater/transceiver, this is the recovered clock output for Channel 2.
13	41	LPBK	I	Loopback Control	On the LXT312, this pin controls Loopback Selection. High = Loopback side 1 data to side 2. Low = No Loopback. On the LXT315 single repeater/transceiver, this pin must be connected to GND.

1. On the LXT315NE and LXT315PE single repeater/transceiver, these pins are not connected (N/C).
 2. On the LXT312PE and LXT315PE pins 5 through 18 and 28 through 40 are not connected (N/C).

FUNCTIONAL DESCRIPTION

NOTE

This information is for design aid only.

PCM signals are attenuated and dispersed in time as they travel down a transmission line. Repeaters/transceivers are required to amplify, reshape, regenerate and retime the PCM signal, then retransmit it.

The LXT312 and LXT315 each contain all the circuits required to build a complete PCM repeater/transceiver. The operational range of the repeaters/transceivers is 0 to 36 dB of cable loss at 772 kHz (equal to 6300 feet of 22 gauge pulp-insulated cable between repeaters).

RECEIVE FUNCTION

The signal is received through a 1 : 1 transformer at RTIP and RRING and equalized for up to 36 dB of cable loss. The receive equalizer uses a proprietary on-chip adaptive filter technique which is equivalent to a 3-port ALBO equalizer design. The monolithic structure of the filter and the absence of external components provide excellent ISI and dispersion elimination, and accurate data transfer over temperature.

Receiver noise immunity is optimized by a proprietary crosstalk elimination filter which eliminates the unneeded high frequency components of the received signal.

Timing Recovery Function

The equalized signal is full wave rectified and used to generate information for the timing recovery circuit. This circuit uses a mixed analog/digital technique to provide a low-jitter PLL similar to a tuned tank with excellent jitter tracking ability. But unlike a tuned tank, the free running frequency of the PLL clock is accurately controlled by the external reference crystal. No adjustment is required. Refer to Application Information for crystal specifications.

Recovered clock signals are available on the RCLK pins for applications that require synchronization to the bit stream.

TRANSMIT FUNCTION

Recovered data is resynchronized to the recovered clock signal by the timing recovery and transmit control section. The data is then retransmitted to the network via two open-drain, high-voltage transistors.

LOOPBACK FUNCTION (LXT312 ONLY)

The LXT312 includes a loopback function for network diagnostics. With the LPBK pin Low, the repeater/transceiver operates in the normal mode. When the LPBK pin is pulled High, the data is looped back from side 1 to side 2.

APPLICATION INFORMATION

NOTE

This information is for design aid only.

Figure 2 shows a typical T1 dual repeater/transceiver application using an LXT312 repeater/transceiver with standard PCB edge connectors. It includes a jumper-selectable shorting option (dashed lines at connector pins 2 and 7) for the fault location circuitry. Table 2 gives the specifications for a typical crystal used with the LXT312 or LXT315 repeater/transceiver.

Table 2: LXT312/315 Crystal Specifications

Parameter	Specification
Frequency	6.176 MHz
Frequency tolerance ¹	± 50 ppm
Effective series resistance	40 Ω Maximum
Crystal cut	AT
Resonance	Parallel
Maximum drive level	2.0 mW
Mode of operation	Fundamental

1. @ 25 °C, C Load = 10 pF; and from -40 °C to + 85 °C (Ref 25 °C reading)

Figure 2: Typical T1 Dual Repeater/Transceiver Application Diagram

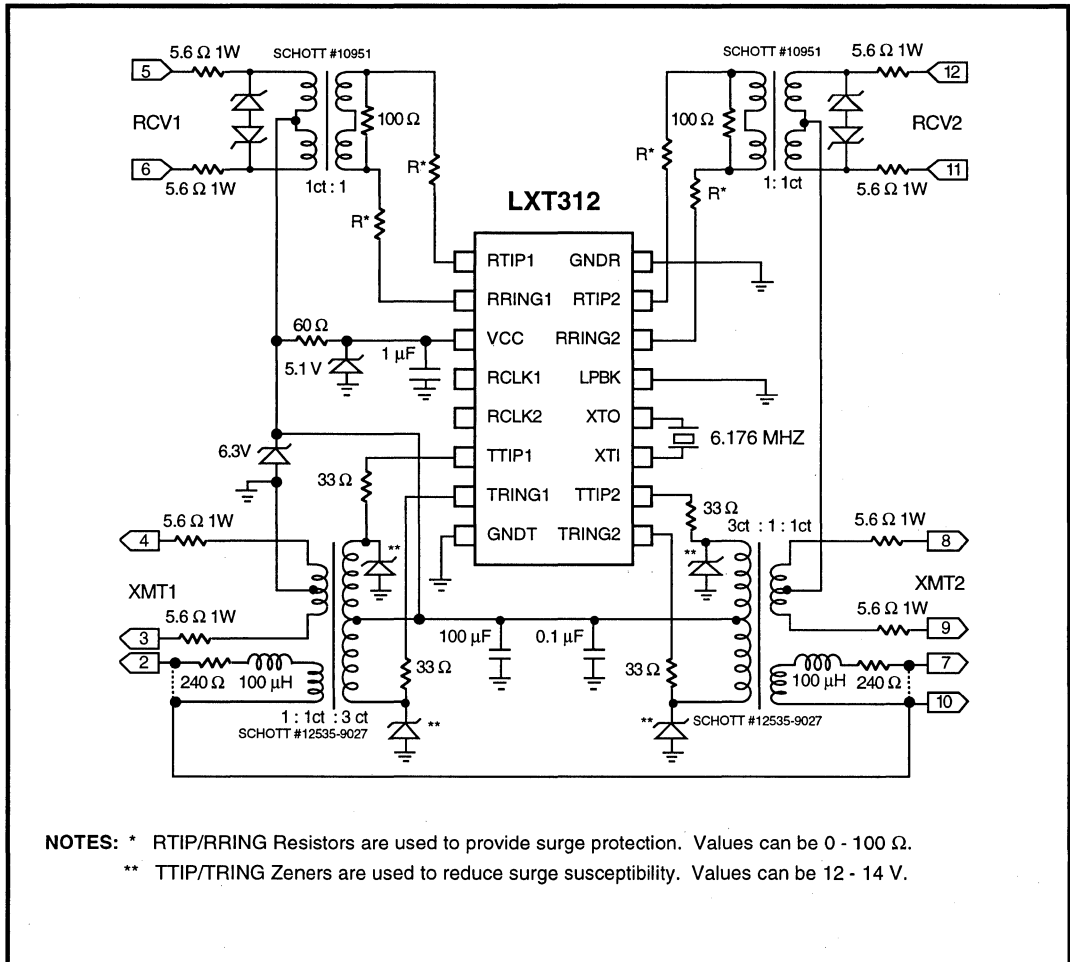

NOTES: * RTIP/RRING Resistors are used to provide surge protection. Values can be 0 - 100 Ω.
 ** TTIP/TRING Zeners are used to reduce surge susceptibility. Values can be 12 - 14 V.

TEST SPECIFICATIONS

NOTE

Minimum and maximum values in Tables 3 through 5 and Figures 3 through 11 represent the performance specifications of the LXT312/315 repeaters/transceivers and are guaranteed by test except, as noted, by design.

Figure 3: Digital Timing Characteristics

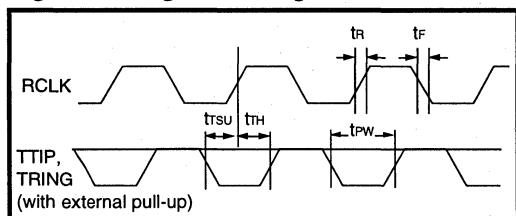

Table 3: Absolute Maximum Ratings

Parameter	Sym	Value
Supply Voltage (min to max)	VCC	-0.3 V to +6 V
Driver Voltage	VOH	18 V
Receiver Current	ICC	100 mA
Operating temperature (min to max)	TOP	-40 °C to +85 °C
Storage temperature (min to max)	TST	-65 °C to +150 °C

CAUTION

Exceeding these values may cause permanent damage. Functional operation under these conditions is not implied. Exposure to maximum rating conditions for extended periods may affect device reliability.

Table 4: Recommended Operating Conditions (Voltages are with respect to ground.)

Parameter	Symbol	Min	Typ	Max	Units
Supply voltage	VCC	4.75	5.0	5.25	V
Operating temperature	TOP	-40	-	85	°C

Table 5: Electrical Characteristics (Over Recommended Range)

Parameter	Symbol	Min	Typ ¹	Max	Units
Interference Margin	SNR	-11	-	-	dB
Receiver Dynamic Range	-	-36	-	0	dB
Digital Outputs - Low	(IOL = 1.6 mA)	VOL	-	0.4	V
	(IOL = 10 µA)	VOL	-	0.2	V
Digital Outputs - High	(IOH = 0.4 mA)	VOH	2.4	-	V
	(IOH < 10 µA)	VOH	-	4.5	V
Digital Inputs - High	VIH	2.0	-	-	V
Digital Inputs - Low	VIL	-	-	0.8	V
Supply Current (from VCC supply) ²	All zeros	ICC	15	22	mA
	All ones	ICC	-	23	mA
Driver Leakage Current (VDVR = 18 V)	ILL	-	-	100	µA
Driver Pulse Amplitude (Driver output IO = 20 mA)	AP	0.65	-	0.95	V
Driver Pulse Width	tpw	299	324	349	ns
Driver Pulse Imbalance	-	-	-	15	ns
Rise and Fall Time (any digital output ²)	tr / tf	-	-	18	ns
Setup Time - TTIP/TRING to RCLK	tSU	90	-	-	ns
Hold Time - TTIP/TRING from RCLK	tTH	90	-	-	ns

1. Typical values are at 25 °C and are for design aid only; not guaranteed and not subject to production testing.
2. Measured with CLOAD ≤ 10 pF, RLOAD > 100 kΩ.

TEST SETUPS

Both the LXT312 and LXT315 are fully tested (100% AC and DC parameters) using inputs generated by Level One's proprietary transmission line and network simulator. Device testing includes receiver jitter tolerance, jitter transfer and interference margin, and receiver immunity to gaussian and 60 Hz noise. Specifications and bench test setups are shown in Figures 4 through 11.

Receiver Jitter Tolerance Testing

Receiver jitter tolerance meets the template shown in Figure 4, when operated at line losses from 0 to 36 dB. Figure 5 shows the setup used for jitter tolerance testing.

Figure 4: Receiver Jitter Tolerance Template

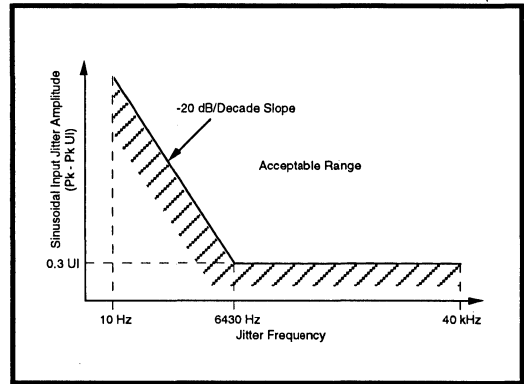

Figure 5: Receiver Jitter Tolerance Test Setup

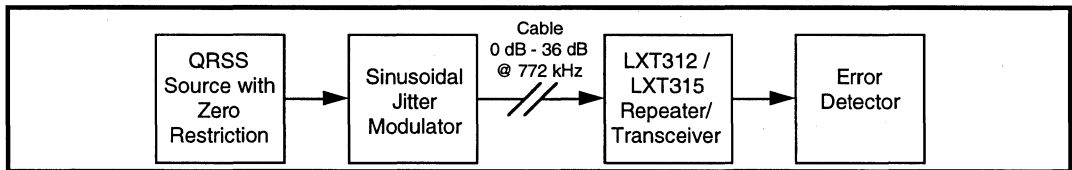
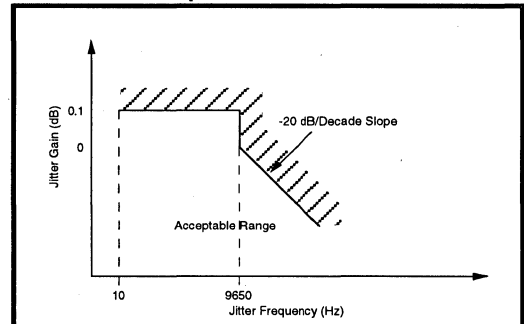

Figure 6: Receiver Jitter Transfer Template



Receiver Jitter Transfer Testing

Receiver jitter transfer meets the template shown in Figure 6, when operated with line losses from 0 to 36 dB and input jitter amplitude of 0.15 UI peak-to-peak. Jitter gain at a given frequency is defined as the difference between intrinsic jitter and additive jitter at the measurement frequency, divided by the amplitude of the input jitter. Figure 7 shows the setup used for jitter transfer testing.

Figure 7: Receiver Jitter Transfer Test Setup

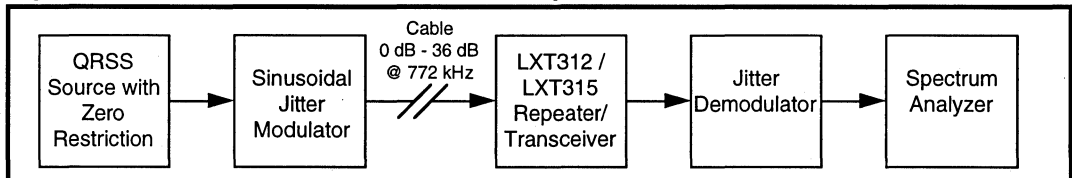

Interference Margin Testing

The LXT312 and LXT315 receiver noise interference margin is specified at a minimum of -11 dB for line losses from 0 dB to 36 dB. The test setup used to measure noise margin is shown in Figure 8.

Gaussian Noise Immunity Testing

Receiver immunity to gaussian noise is specified at a maximum BER of 10^{-7} for a quasi-random T1 signal at 1.544 MHz (± 130 ppm). The receiver must be immune to noise power expressed as $N_p = -(L + 4.7)$ dBm, where L corresponds to the line loss and is valid for 0 - 36 dB.

Figure 9 shows the setup used to test gaussian noise immunity. The noise source is gaussian to at least 6 sigma and filtered to simulate expected noise in a binder group (per AT&T TA #24/CB113).

60 Hz Pulse Modulation Immunity Testing

Receiver immunity to 60 Hz pulse amplitude modulation is specified using the gaussian noise source described in the previous paragraph on gaussian noise immunity. Pulse amplitude modulation is specified between 10% and 30% of the nominal amplitude (see AT&T TA #24/CB113 for details on the modulation envelope). Figure 10 shows the setup used for testing receiver immunity to 60 Hz pulse amplitude modulation. The following figures reflect noise power for 10^{-7} BER at each modulation level, where L corresponds to the line loss and is valid for 0 - 35 dB:

Modulation Level	Noise Power
10%	$N_p = -(L + 5.7)$ dBm
20%	$N_p = -(L + 6.7)$ dBm
30%	$N_p = -(L + 8.7)$ dBm

Receiver Timing Recovery Testing

Receiver timing recovery phase shift modulation for repetitive 8-bit patterns is specified at less than 0.07 UI. This is tested using any two out of 35 possible 8-bit patterns and measuring the change in output pulse timing from one pattern to the other (see AT&T TA #24 / CB113 for details on the patterns). Switching rate from one pattern to the other is specified at between 300 Hz and 500 Hz. The setup used to test receiver timing recovery phase shift modulation is shown in Figure 11.

Figure 8: Receiver Noise Interference Margin Test Setup

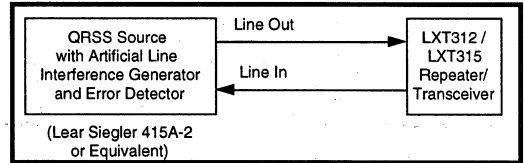

Figure 9: Receiver Gaussian Noise Immunity Test Setup

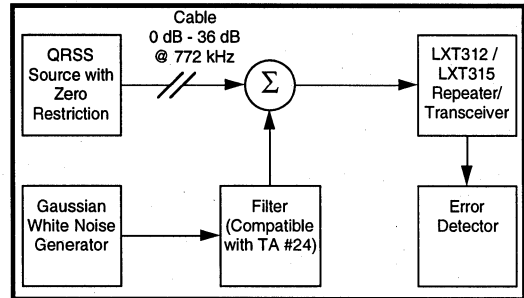

Figure 10: Receiver 60 Hz Pulse Amplitude Modulation Immunity Test Setup

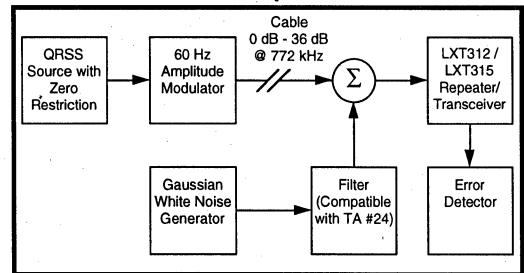
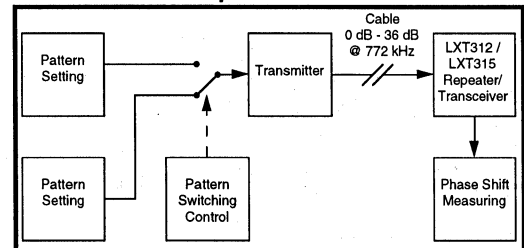

Figure 11: Receiver Timing Recovery Phase Shift Modulation Test Setup



LXT313 / LXT316

Low-Power E1 PCM Repeaters/Transceivers

General Description

The LXT313 and LXT316 are integrated repeater/transceiver circuits for E1 carrier systems. The LXT313 is a dual repeater/transceiver and the LXT316 is a single repeater/transceiver. The LXT313 and LXT316 are designed to operate as regenerative repeaters/transceivers for 2.048 Mbps data rate PCM lines. Each includes all circuits required for a regenerative repeater/transceiver system including the equalization network, automatic line build-out (ALBO), and a state-of-the-art analog/digital clock extraction network tuned by an external crystal.

The key feature of the LXT313 family is that it requires only a crystal and a minimum of other components to complete a repeater/transceiver design. Compared with traditional tuned coil-type repeaters/transceivers, they offer significant savings in component and labor costs, along with reduced voltage drop/power consumption, and improved reliability. To ensure performance for all loop lengths, the LXT313 and LXT316 are 100% AC/DC tested using inputs generated by Level One's proprietary transmission line and network simulator.

The LXT313 and LXT316 are advanced CMOS devices which require only a single 5-volt power supply.

Features

- Integrated repeater/transceiver circuit on a single CMOS chip
- On-chip equalization network
- On-chip ALBO
- Low power consumption
- No tuning coil
- On-chip Loopback
- Recovered Clock Output
- 0 to 43 dB dynamic range
- -14 dB interference margin
- Single 5 V only CMOS technology
- Available in 16-pin PDIP and 44-pin PLCC

LXT313 Block Diagram

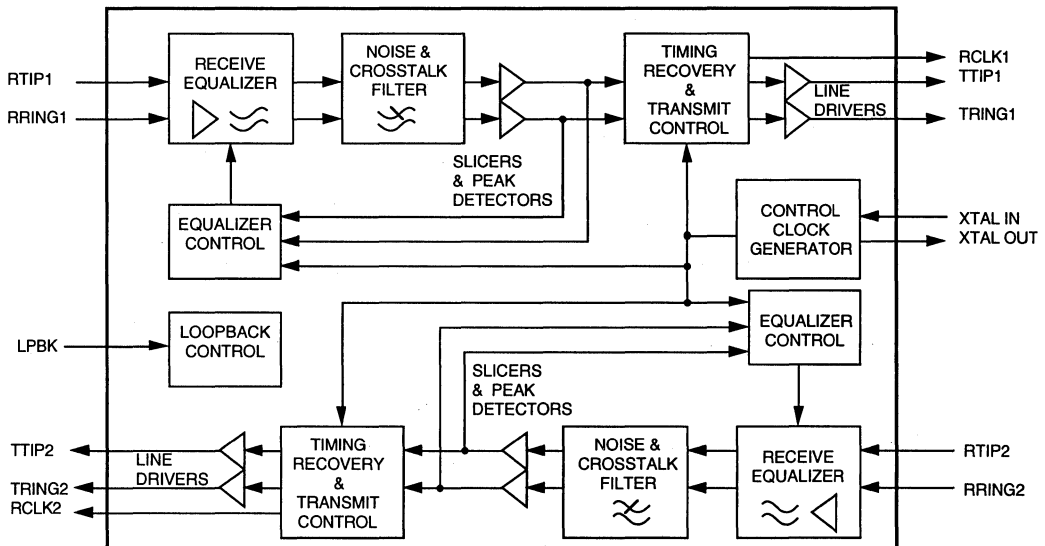

LXT313/316 Low-Power E1 PCM Repeaters/Transceivers

Figure 1: LXT313/316 Repeater/Transceiver Pin Assignments

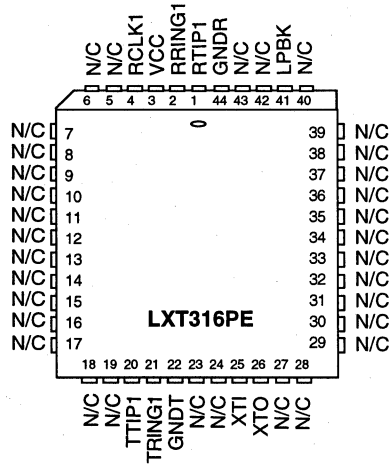
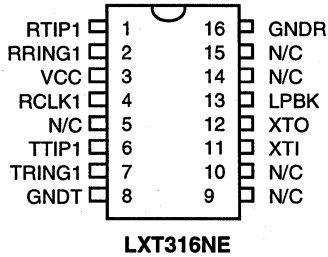
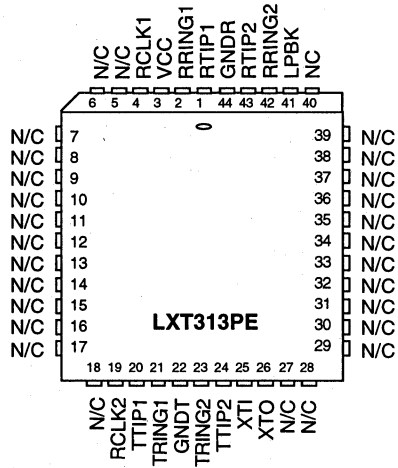
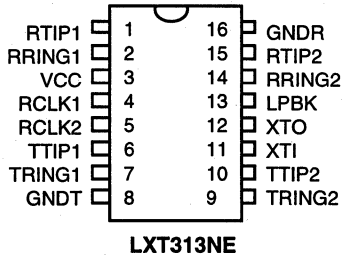

Table 1: Pin Descriptions

Pin # DIP / PLCC		Sym	I/O	Name	Description
1	1	RTIP1	I	Repeater Tip and	Tip and ring receive inputs for Channel 1.
2	2	RRING1	I	Ring Inputs	
4	4	RCLK1	O	Recovered Clock	Clock output recovered from Channel 1 receive input.
6	20	TTIP1	O	Repeater Tip and	Open-drain output drivers for Channel 1.
7	21	TRING1	O	Ring Outputs	
11	25	XTI	I	Crystal Oscillator	A 8.192 MHz crystal must be connected across these two pins.
12	26	XTO	O	Pins	
3	3	VCC	I	Power Supply	Power supply input for all circuits. +5 V (±0.25 V)
8	22	GNDT	-	Transmit Ground	Ground return for transmit circuits.
16	44	GNDR	-	Receive Ground	Ground return for receive circuits.
9 ¹	23 ¹	TRING2	O	Side 2 Tip and Ring	On the LXT313 dual repeater/transceiver, these are open-drain output drivers for Channel 2.
10 ¹	24 ¹	TTIP2	O	Outputs	
14 ¹	42 ¹	RRING2	I	Side 2 Ring and Tip	On the LXT313 dual repeater/transceiver these are tip and ring receive inputs for Channel 2.
15 ¹	43 ¹	RTIP2	I	Inputs	
5 ¹	19 ¹	RCLK2	O	Recovered Clock	On the LXT313 dual repeater/transceiver, this is the recovered clock output for Channel 2.
13	41	LPBK	I	Loopback Control	On the LXT313, this pin controls Loopback Selection. High = Loopback side 1 data to side 2. Low = No Loopback. On the LXT316 single repeater/transceiver, this pin must be connected to GND.
1. On the LXT316NE and LXT316PE single repeater/transceiver, these pins are not connected (N/C). 2. On the LXT313PE and LXT316PE pins 5 through 18 and 27 through 40 are not connected (N/C).					

4

FUNCTIONAL DESCRIPTION

NOTE

This information is for design aid only.

PCM signals are attenuated and dispersed in time as they travel down a transmission line. Repeaters/transceivers are required to amplify, reshape, regenerate and retime the PCM signal, then retransmit it.

The LXT313 and LXT316 each contain all the circuits required to build a complete PCM repeater/transceiver. The operational range of the repeaters/transceivers is 0 to 43 dB of cable loss at 1.024 MHz (equal to 2 km of 22 gauge pulp-insulated cable between repeaters/transceivers).

RECEIVE FUNCTION

The signal is received through a 1 : 1 transformer at RTIP and RRING and equalized for up to 43 dB of cable loss. The receive equalizer uses a proprietary on-chip adaptive filter technique which is equivalent to a 3-port ALBO equalizer design. The monolithic structure of the filter and the absence of external components provide excellent ISI and dispersion elimination, and accurate data transfer over temperature.

Receiver noise immunity is optimized by a proprietary crosstalk elimination filter which eliminates the unneeded high frequency components of the received signal.

Timing Recovery Function

The equalized signal is full wave rectified and used to generate information for the timing recovery circuit. This circuit uses a mixed analog/digital technique to provide a low-jitter PLL similar to a tuned tank with excellent jitter tracking ability. But unlike a tuned tank, the free running frequency of the PLL clock is accurately controlled by the external reference crystal. No adjustment is required. Refer to Application Information for crystal specifications.

Recovered clock signals are available on the RCLK pins for applications that require synchronization to the bit stream.

TRANSMIT FUNCTION

Recovered data is resynchronized to the recovered clock signal by the timing recovery and transmit control section. The data is then retransmitted to the network via two open-drain, high-voltage transistors.

LOOPBACK FUNCTION (LXT313 ONLY)

The LXT313 includes a loopback function for network diagnostics. With the LPBK pin Low, the repeater/transceiver operates in the normal mode. When the LPBK pin is pulled High, the data is looped back from side 1 to side 2.

APPLICATION INFORMATION

NOTE

This information is for design aid only.

Figure 2 shows a typical E1 dual repeater/transceiver application circuit using standard repeater/transceiver card edge connections. It includes a jumper-selectable shorting option for the fault location circuitry (dashed lines at connector pins 2 and 7). Table 2 gives the specifications for a typical crystal used with the LXT313 or LXT316 repeater/transceiver.

Table 2: LXT313/316 Crystal Specifications

Parameter	Specification
Frequency	8.192 MHz
Frequency tolerance ¹	± 50 ppm
Effective series resistance	30 Ω Maximum
Crystal cut	AT
Resonance	Parallel
Maximum drive level	2.0 mW
Mode of operation	Fundamental

1. @ 25 °C, C Load = 10 pF; and from -40 °C to + 85 °C (Ref 25 °C reading)

Figure 2: Typical E1 Dual Repeater/Transceiver Application Diagram

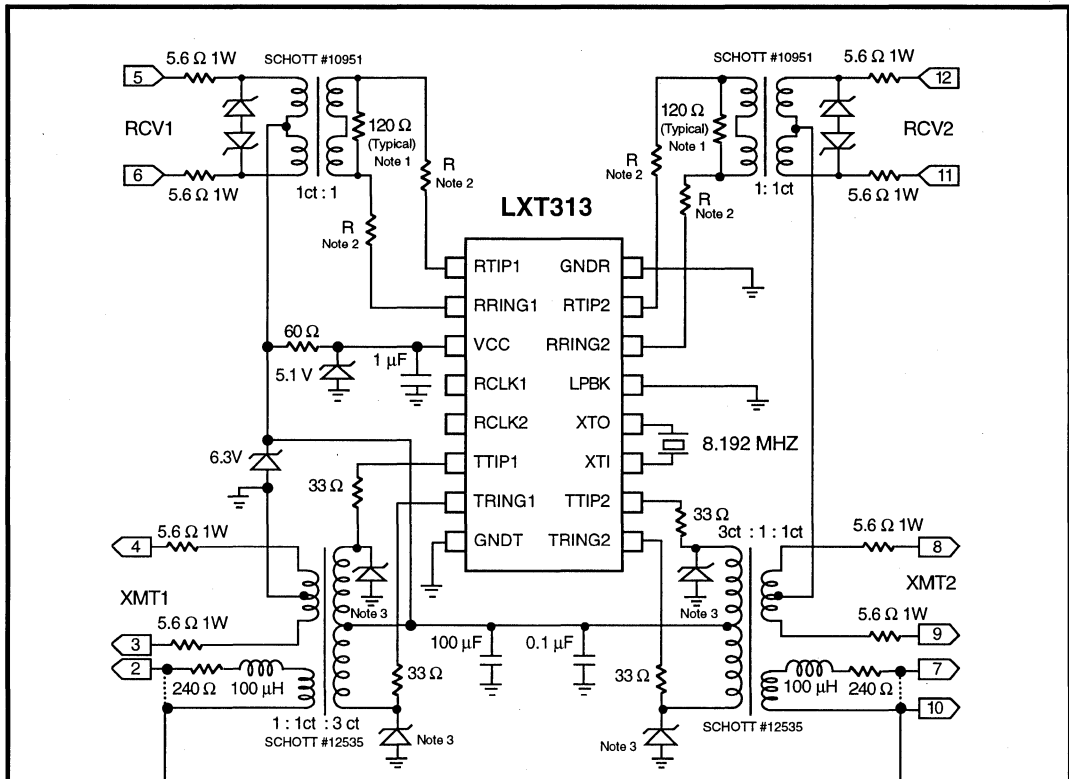

- NOTES: 1. Check cable impedance required by the approving telecom agency.
 2. RTIP/RRING Resistors are used to provide surge protection. Values can be 0 - 100 Ω.
 3. TTIP/TRING Zeners are used to reduce surge susceptibility. Values can be 12 - 14 V.

TEST SPECIFICATIONS

NOTE

Minimum and maximum values in Tables 3 through 5 and Figures 3 through 8 represent the performance specifications of the LXT313/316 repeaters/transceivers and are guaranteed by test except, as noted, by design.

Figure 3: Digital Timing Characteristics

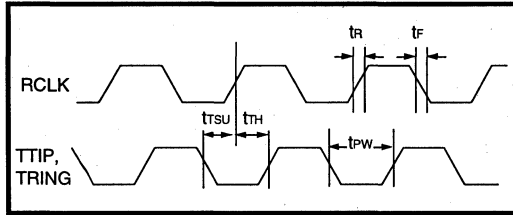

Table 3: Absolute Maximum Ratings

Parameter	Sym	Value
Supply Voltage (min to max)	VCC	-0.3 V to +6 V
Driver Voltage	VOH	18 V
Receiver Current	ICC	100 mA
Operating temperature (min to max)	TOP	-40 °C to +85 °C
Storage temperature (min to max)	TST	-65 °C to +150 °C

CAUTION

Exceeding these values may cause permanent damage. Functional operation under these conditions is not implied. Exposure to maximum rating conditions for extended periods may affect device reliability.

Table 4: Recommended Operating Conditions (Voltages are with respect to ground.)

Parameter	Symbol	Min	Typ	Max	Units
Supply voltage	VCC	4.75	5.0	5.25	V
Operating temperature	TOP	-40	-	85	°C

Table 5: Electrical Characteristics (Over Recommended Range)

Parameter	Symbol	Min	Typ ¹	Max	Units
Interference Margin	SNR	-14	-	-	dB
Receiver Dynamic Range	-	-43	-	0	dB
Digital Outputs - Low	(IOL = 1.6 mA)	VOL	-	0.4	V
	(IOL = 10 μA)	VOL	-	0.2	V
Digital Outputs - High	(IOH = 0.4 mA)	VOH	2.4	-	V
	(IOH < 10 μA)	VOH	-	4.5	V
Digital Inputs - High	VIH	2.0	-	-	V
Digital Inputs - Low	VIL	-	-	0.8	V
Supply Current (from VCC supply) ²	All zeros	ICC	15	23	mA
	All ones	ICC	-	25	mA
Driver Leakage Current (VDVR = 18 V)	ILL	-	-	100	μA
Driver Pulse Amplitude (Driver output Io = 20 mA)	AP	0.65	-	0.95	V
Driver Pulse Width	tpw	219	244	269	ns
Driver Pulse Imbalance	-	-	-	15	ns
Rise and Fall Time (any digital output ²)	tr / tf	-	-	25	ns
Setup Time - TTIP/TRING to RCLK	t _{SU}	90	-	-	ns
Hold Time - TTIP/TRING from RCLK	t _{TH}	90	-	-	ns

1. Typical values are at 25 °C and are for design aid only; not guaranteed and not subject to production testing.
2. Measured with C_{LOAD} ≤ 10 pF, R_{LOAD} > 100 kΩ.

TEST SETUPS

Both the LXT313 and LXT316 are fully tested (100% AC and DC parameters) using inputs generated by Level One's proprietary transmission line and network simulator. Device testing includes receiver jitter tolerance, jitter transfer and interference margin for line losses from 0 dB to 43 dB @ 1.024 MHz. Specifications and bench test setups are shown in Figures 3 through 7.

Receiver Jitter Tolerance Testing

Receiver jitter tolerance meets the template shown in Figure 4, when operated at line losses from 0 to 43 dB. Figure 5 shows the setup used for jitter tolerance testing.

Figure 4: Receiver Jitter Tolerance Template

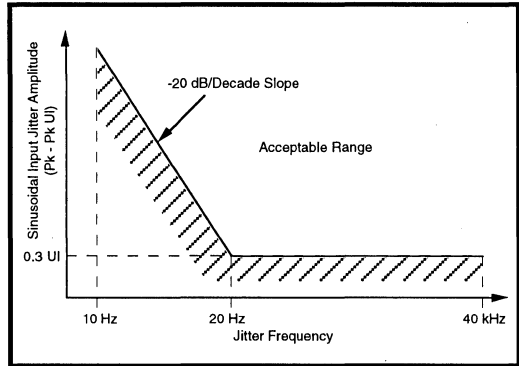
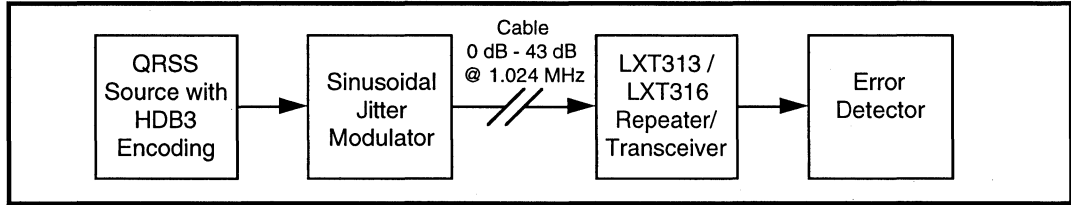

Figure 5: Receiver Jitter Tolerance Test Setup



Receiver Jitter Transfer Testing

Receiver jitter transfer meets the template shown in Figure 6, when operated with line losses from 0 to 43 dB and input jitter amplitude of 0.15 UI peak-to-peak. Jitter gain at a given frequency is defined as the difference between intrinsic jitter and additive jitter at the measurement frequency, divided by the amplitude of the input jitter. Figure 7 shows the setup used for jitter transfer testing.

Figure 6: Receiver Jitter Transfer Template

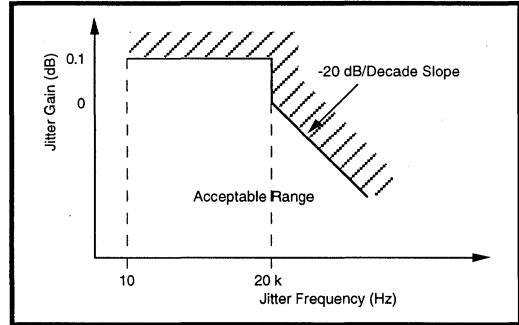
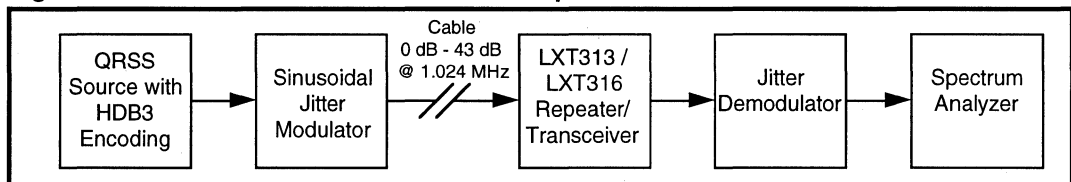

Figure 7: Receiver Jitter Transfer Test Setup



Interference Margin Testing

The LXT313 and LXT316 receiver noise interference margin is specified at a minimum of -14 dB for line losses from 0 dB to 43 dB. The test setup used to measure noise margin is shown in Figure 8.

Figure 8: Receiver Noise Interference Margin Test Setup

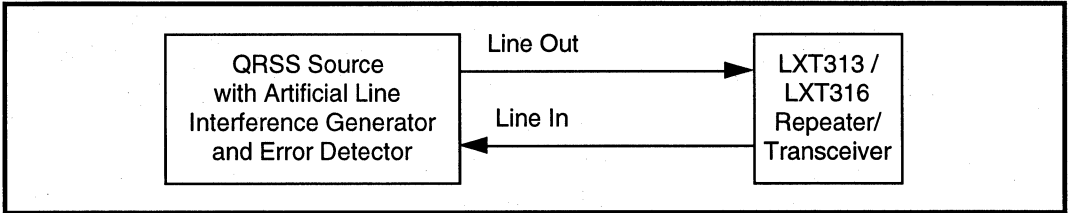

Switched 56/DDS Products

5



LXT400

All Rate Extended Range Switched 56 / DDS Transceiver

General Description

The LXT400 is an integrated line interface circuit for Switched 56 (SW 56) and Digital Data Service (DDS), compatible with any combination of 19 to 26 AWG cable. The LXT400 operates at any of 17 preset data rates from 2.4 kbps to 72.0 kbps, providing appropriate transmit pulse shaping, receive signal detection and timing recovery at the metallic interface between the carrier and the customer installation. The LXT400 offers a variety of diagnostic features including loopback, line status and equalizer monitor outputs, while conforming to AT&T, ANSI and Bellcore specifications.

The LXT400 transmit section includes switched capacitor filters, continuous reconstruction filters, and a 50% AMI encoder. The AMI pulse is synchronized with the transmit clock.

The LXT400 receive section performs line equalization, data extraction and timing recovery. The LXT400 has a BER of less than 10^{-7} with up to 49 dB of cable attenuation at the Nyquist frequency for 56, 64 and 72 kbps, and 40 dB at the lower rates. The LXT400 is an advanced CMOS device which requires only a single +5 V power supply.

Features

- Enhancements:
 - Three new data rates: 38.4, 51.2, and 64.0 kbps
 - Improved accuracy in line attenuation reporting
 - Simplified transmit digital timing
- Integrated transmitter, receiver and timing recovery on a single CMOS chip
- Transparent to framing and coding
- Receive equalizer filters allow data recovery from signals with up to 40 dB of attenuation at the Nyquist frequency at line rates below 56 kbps, and up to 49 dB at the 56, 64 and 72 kbps line rates
- Single 4.096 MHz crystal or master clock input
- Digital back-end loopback
- Equalizer output monitor pin
- Line status (loop length, RLOS, etc.) information available for maintenance purposes
- Low power consumption (200 mW typical)
- Available in 28-pin plastic DIP and PLCC
- Single 5 V only CMOS technology

5

LXT400 Block Diagram

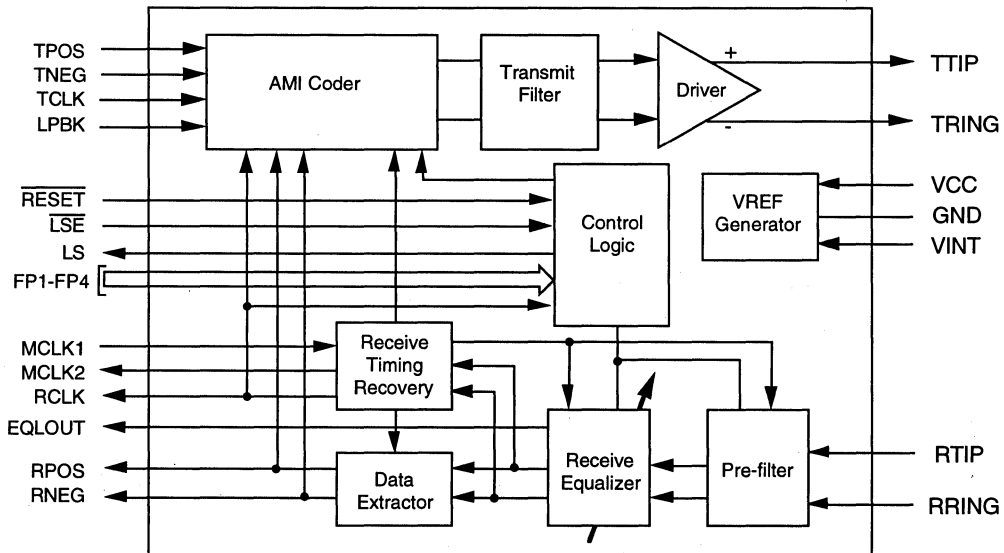

LXT400 All Rate Extended Range SW56/DDS Transceiver

Figure 1: Pin Assignments

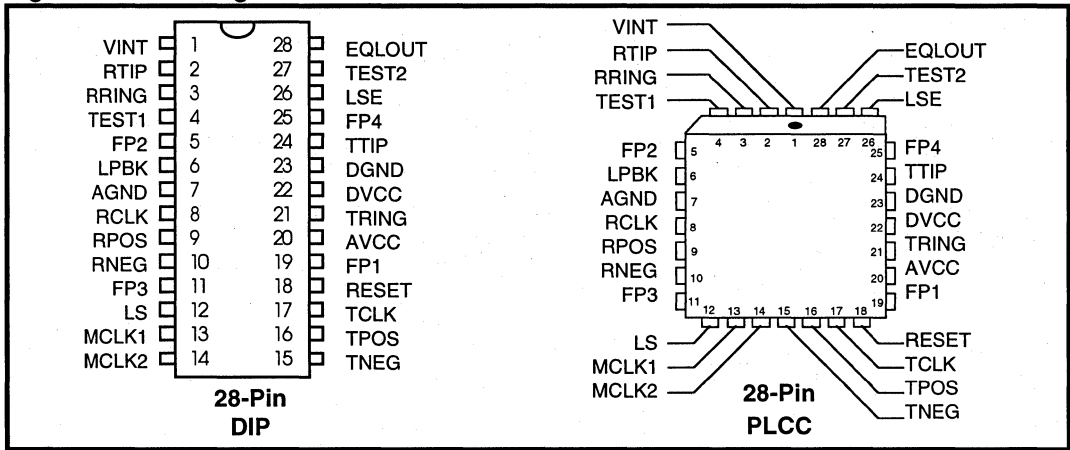

Table 1: Pin Descriptions

Pin #	Sym	I/O	Name	Description
1	VINT	I	Intermediate Voltage Reference	Reference voltage used for internal analog circuits. This pin must be connected through a 1 kΩ resistor (R _v) to the center node between the two termination resistors, R _r , as shown in Figure 8 and 9.
2 3	RTIP RRING	I	Receive Tip Receive Ring	Receive data input pair. RTIP and RRING are a fully differential input for the receive line interface.
4	TEST1	I	Test 1	Factory Test Pin. Leave unconnected.
5 19 11 25	FP2 FP1 FP3 FP4	I I I I	Frequency Programming Inputs 1 thru 4	The LXT400 data rate is set by the logic levels present at the FP1 through FP4 inputs as shown in Table 2. For operation at 38.4, 51.2, and 64.0 kbps, the RCLK output must be applied to the FP3 input.
6	LPBK	I	Loopback	When set High, activates digital back-end loopback.
7	AGND	-	IC Ground	IC ground for all circuits except the transmit driver.
8	RCLK	O	Recovered Clock	Clock recovered from signal input at RTIP and RRING, based on the data rate setting on the FP1 - FP4 inputs.
9 10	RPOS RNEG	O O	Receive Data Positive and Negative	Receive data outputs. A signal on RPOS corresponds to receipt of a positive pulse on RTIP and RRING. A signal on RNEG corresponds to a negative pulse on RTIP and RRING. Both outputs transition on the rising edges of RCLK, and are never High simultaneously.
12	LS	O	Line Status Output	A 16-bit serial word indicating activation state, line loss, and loss of signal (LOS). LS transitions occur on falling edges of RCLK. LS goes to a high impedance state when LSE is High. If LSE is tied Low, the LS output represents LOS only.

LXT400 All Rate Extended Range SW56/DDS Transceiver

Table 1: Pin Descriptions - continued

Pin #	Sym	I/O	Name	Description															
13	MCLK1	I	Master Clock 1	The required 4.096 MHz master clock may be provided by a crystal connected across these pins, or by a digital clock connected to MCLK1. If a clock is provided on MCLK1, MCLK2 must be left unconnected.															
14	MCLK2	O	Master Clock 2																
15	TNEG	I	Transmit Data Negative and Positive	Inputs are sampled on the falling edges of TCLK. AMI pulses are encoded as follows: <table style="margin-left: auto; margin-right: auto; border-collapse: collapse;"> <thead> <tr> <th style="text-align: center; border-bottom: 1px solid black;">TPOS</th> <th style="text-align: center; border-bottom: 1px solid black;">TNEG</th> <th style="text-align: center; border-bottom: 1px solid black;">Transmit Signal</th> </tr> </thead> <tbody> <tr> <td style="text-align: center;">0</td> <td style="text-align: center;">0</td> <td style="text-align: center;">Space</td> </tr> <tr> <td style="text-align: center;">0</td> <td style="text-align: center;">1</td> <td style="text-align: center;">Negative Pulse</td> </tr> <tr> <td style="text-align: center;">1</td> <td style="text-align: center;">0</td> <td style="text-align: center;">Positive Pulse</td> </tr> <tr> <td style="text-align: center;">1</td> <td style="text-align: center;">1</td> <td style="text-align: center;">Space</td> </tr> </tbody> </table>	TPOS	TNEG	Transmit Signal	0	0	Space	0	1	Negative Pulse	1	0	Positive Pulse	1	1	Space
TPOS	TNEG	Transmit Signal																	
0	0	Space																	
0	1	Negative Pulse																	
1	0	Positive Pulse																	
1	1	Space																	
16	TPOS	I																	
17	TCLK	I	Transmit Clock	Transmit clock at the data rate set by the FP1 - FP4 inputs.															
18	RESET	I	Reset	Hardware reset pin. Must be pulsed Low on power-up to initialize all internal circuits. Must also be pulsed Low after changing the data rate setting, and after forcing or releasing any loopback condition.															
20	AVCC	I	IC Power	IC power supply for all circuits except the transmit driver. +5 V ($\pm 5\%$).															
21	TRING	O	Transmit Ring Transmit Tip	Differential driver outputs. Designed to drive the 135 Ω twisted-pair cable through transmit line interface shown in application diagram, Figure 9.															
24	TTIP	O																	
22	DVCC	I	Driver Power	Transmit driver power supply. +5 V ($\pm 5\%$). Tie to AVCC, pin 20.															
23	DGND	-	Driver Ground	Transmit driver ground. Tie to AGND, pin 7.															
26	LSE	I	Line Status Enable	Active Low enable for the LS serial port. This pin must transition from High to Low to read LS serial data. LSE is sampled on the rising edges of RCLK.															
27	TEST2	I	Test 2	Analog test pin. Must be tied to ground.															
28	EQLOUT	O	Equalizer Output Monitor	Monitors Equalizer. Must be left open when not used.															

5

LXT400 All Rate Extended Range SW56/DDS Transceiver

FUNCTIONAL DESCRIPTION

NOTE

This information is for design aid only.

The LXT400 comprises three basic sections: transmit, receive and control logic.

The transmit section includes a 50% AMI encoder, a programmable switched-capacitor low-pass filter, a low-pass notch filter, a transmit timing resynchronizer and a continuous reconstruction filter. An on-chip CMOS driver is also incorporated to drive a 135 Ω line through a transformer.

The receive section includes pre-filters and line equalizers, and the timing recovery and data extraction blocks. An internal digital phase-locked loop (DPLL) is used in conjunction with the MCLK input to synchronize the recovered clock and data.

The control logic block initializes the transceiver, selects receive filters and reports status information on the serial port. Control logic inputs FP1 through FP4 determine the data rate in accordance with Table 2. The control logic executes the initialization procedure upon automatic resynchronization or external RESET. Filter selection optimizes the receive signal-to-noise ratio (SNR) by matching the filter in the equalizer section to the strength of the received signal (a function of loop length/line loss). The control logic block also reports receiver status, estimated line length (as indicated by filter selection) and a receive loss of signal (RLOS) alarm on the serial port.

INITIALIZATION

Upon power-up, or after changing the baud rate or loopback condition of the line interface, a RESET pulse is required to initialize the LXT400. On receipt of the RESET pulse, the LXT400 executes an iterative cycle of level detection and offset cancellation to select the appropriate equalizer settings for the received signal. Receiver initialization can be monitored on the serial channel. When received data has a 50% ones density, full operation is achieved within one second after RESET. Under the minimum ones density condition specified in Table 3, full operation is achieved within eight seconds after RESET. Correct initialization assumes the presence of an AMI-coded signal at the RTIP and RRING inputs. The LXT400 will not correctly initialize unless a stable signal which meets the network interface specifications of AT&T Pub 62310 is present at the RTIP and RRING inputs during the entire initialization process. The RPOS/RNEG outputs are not valid until full operation is achieved. During offset cancellation, the RPOS/RNEG

outputs do not adhere to the AMI rule. However, once initialized (assuming that a proper baud rate is selected), RPOS and RNEG outputs are never simultaneously High.

Reset

A hardware reset is required after any of the following changes in transceiver configuration:

1. A change in Data Rate setting
2. A change in the local analog loopback configuration
3. A local change in the line upon which the transceiver is communicating (for example, configurations for changing lines in a "1 for n" redundancy scheme)

Table 2: Data Rate Programming

FP4	FP3	FP2	FP1	Data Rate ¹
0	0	0	0	2.4 kbps
0	0	0	1	3.2 kbps
0	0	1	0	4.8 kbps
0	0	1	1	6.4 kbps
0	1	0	0	9.6 kbps
0	1	0	1	12.8 kbps
0	1	1	0	19.2 kbps
0	1	1	1	25.6 kbps
1	0	0	0	56.0 kbps
1	0	0	1	72.0 kbps
1	0	1	0	3.5 kbps
1	0	1	1	7.0 kbps
1	1	0	0	14.0 kbps
1	1	0	1	28.0 kbps
0	RCLK ¹	0	0	38.4 kbps
0	RCLK ¹	0	1	51.2 kbps
0	RCLK ¹	1	0	64.0 kbps

1. Three data rates are activated when the RCLK output on pin 8 is applied to the FP3 input on pin 11.

Table 3: Ones Density Requirements

Data Rate (kbps)	Minimum Average Ones Density
2.4, 4.8, 9.6, 19.2, 38.4	1 / 12
3.2, 6.4, 12.8, 25.6, 51.2	1 / 16
56.0	1 / 14
64.0	1 / 16
72.0	1 / 18
3.5, 7.0, 14.0, 28.0	≈ 1 / 16

Automatic re-initialization may be triggered by changes in received signal strength as follows:

- If received signal strength increases by more than about 6 dB after full operation is achieved, automatic re-initialization occurs.
- If received signal strength decreases by more than about 4 dB, re-initialization occurs. If the decrease in received signal strength exceeds 6 dB, the LXT400 reports an LOS condition and performs an automatic re-initialization.

The time required to achieve full operation after reinitialization, is the same as required for power-on initialization (i.e., 1 second max with 50% ones density, 8 seconds under minimum ones density conditions). Reinitialization is not triggered by impulse noise events.

TRANSMISSION

TPOS and TNEG must have transitions coincident with the rising edges of TCLK. The transmit section generates a 50% AMI pulse according to the pulse encoding rules, which is synchronized with the TCLK input. In DSU applications, RCLK is typically routed back into the TCLK input. The instantaneous baud period varies with the receive DPLL

phase adjustments, however, the pulse duty cycle is maintained at 50% of the nominal baud period by internal re-synchronization to TCLK. The AMI pulse is then processed through a set of frequency dependent filters.

Initial filtering at all rates is accomplished by a programmable, switched-capacitor, low-pass filter. This filter is a single-pole type with the pole set at 1.3 times the bit rate (as determined by inputs FP1 - FP4).

For data rates of 2.4, 3.2, 4.8, 6.4, 9.6 and 12.8 kbps, the filtered pulses go through an additional low-pass notch filter. The notch filter is required to protect other DDS services with specific band requirements, and provides the attenuation listed in Table 4. The additional rejection requirement is weighted within each band by "C-Message" weighting over double speech sidebands around a carrier in the middle of each band (28 kHz and 76 kHz). The C-Message weighting function is graphed in Figure 2. Depending on the data rate, the frequency template extends to different limits as shown in Table 5. (An alternate notch filter is used for data rates of 3.5 and 7.0 kbps.) The single pole, low-pass filter would maintain the frequency within $\pm 5\%$. The notch filter attenuation is added to this.

A continuous filter, common to all data rates, is the final stage. The continuous filter removes high frequency components which remain after processing by the low-pass filter stages. The pulse is then applied to the line driver for transmission onto the twisted-pair line.

Figure 2: C-Message Weighting

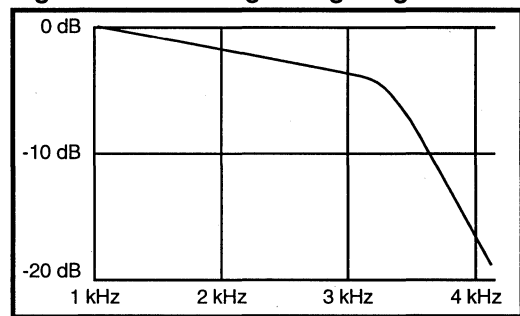

Table 4: Notch Filter Attenuation

OCU/Loop Data Rate (kbps)	Customer (Primary Channel) Data Rate (kbps)	Rejection Band	
		24 - 32 kHz	72 - 80 kHz
2.4 or 3.2	2.4	5 dB	1 dB
4.8 or 6.4	4.8	13 dB	9 dB
9.6 or 12.8	9.6	17 dB	8 dB

RECEPTION

RTIP and RRING inputs are differentially detected, then processed through the pre-filters and equalizer section. The continuous pre-filter removes high frequency noise and prevents aliasing problems for the switched capacitor (SC) line equalizers which follow. Pulse reshaping is achieved by the receive equalizer, which consists of an SC step equalizer and an adaptive decision feedback equalizer (DFE). The DFE eliminates residual inter-symbol interference (ISI) due to echoing by multiple bridged tap connections and the quantized frequency responses of the SC step filters. The DFE is continuously adapted to compensate for ISI due to time-varying line characteristics such as temperature, humidity and age. Nine different filter selections based on signal strength are available.

Changes in Received Signal Strength

During initialization, the LXT400 selects filters appropriate to the strength of the received signal. After initialization, the LXT400 continually monitors the receive signal strength to ensure the optimum signal/filter match. Data reception is not affected by impulsive noise events or by slow changes in signal amplitude, such as may be caused by temperature and humidity changes on the line. (The maximum constant rate of change which the LXT400 can track is 6 dB per minute.) However, instantaneous "step" changes (see Figure 3) may temporarily interfere with data reception. Step changes may be due to sudden changes in loop loss, far end transmitter output, etc.

After normal operation has been established, an instantaneous single-step change may cause one of three conditions, as shown in Figure 4.

Under Condition 1, the LXT400 automatically adapts to minor step changes in signal strength (assuming that the new input is a valid DDS signal).

Under Condition 3, the LXT400 responds to significant step changes by re-initializing.

Condition 2, while unlikely to occur in an actual DDS implementation, may be observed in the laboratory due to artificial line simulators. Condition 2, which results from a 6-20 dB step increase in received signal strength, may result in a signal/filter mismatch. This condition is characterized by excessive bipolar violations (BPVs) which can be observed on RPOS and RNEG. External signal quality detection circuitry can be used to detect excessive BPVs that are not recognized as standard DDS BPV code words. Upon detection of unrecognized BPVs, the user may force a reset on the LXT400 to resume error-free operation.

Under normal operating conditions, step changes in received signal strength are all under local control. Thus, the user can reset the LXT400 once the new receive signal has stabilized at the chip inputs. Remote changes typically involve disconnecting one line and re-connecting another line of different length. These changes trigger the RLOS report and automatic re-initialization. Any remote changes in line length or transceiver configuration are beyond the local user's control. Remote changes in data rate are not detected.

Table 5: Frequency Limits per Data Rate

Data Rate (kbps)	Upper Frequency Limit (kHz)
2.4 (3.2)	100
4.8 (6.4)	150
9.6 (12.8)	150
19.2 (25.6)	150
38.4 (51.2)	150
56.0 (72.0)	150
64.0	150
3.5	100
7.0	150
14.0	150
28.0	150

Figure 3: Step Changes in Received Signal Strength = $20 \log_{10} (A^2/A1) \text{ dB}$

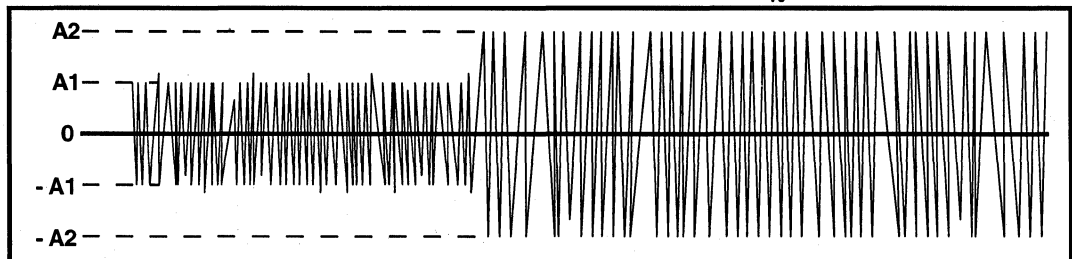

Receive Loss of Signal

RLOS goes High when more than 32 consecutive zeros are received, caused either by a true loss of signal, or a signal strength drop greater than 6 dB. The LXT400 automatically re-initializes when RLOS goes High, and 40 consecutive zeros are counted. Figure 5 shows the RTIP/RRING input and RLOS output timing relationships for a true loss of signal. When signal energy returns to the chip input, the

LXT400 executes one full activation cycle in the presence of this signal. The result is that RLOS will remain High for a period of time ($0.13 \text{ s} < t_H < 16 \text{ s}$) after signal energy reappears.

Figure 6 shows the RTIP/RRING input timing and RLOS output timing relationship for a signal strength decrease greater than 6 dB. In this case, RLOS will go High for a time $0.26 \text{ s} < t_P < 16 \text{ s}$.

Figure 4: Conditions Based on Changes in Received Signal Strength

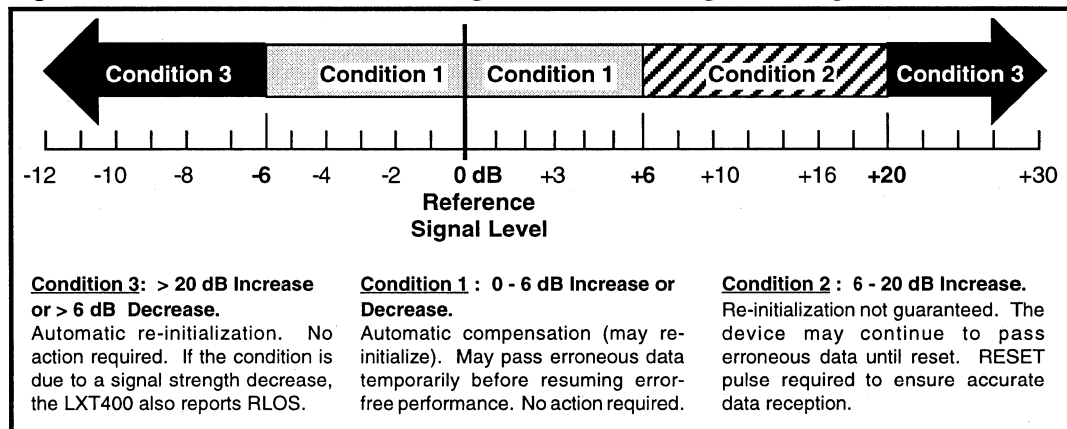

5

Figure 5: RLOS Timing for a True Loss of Signal

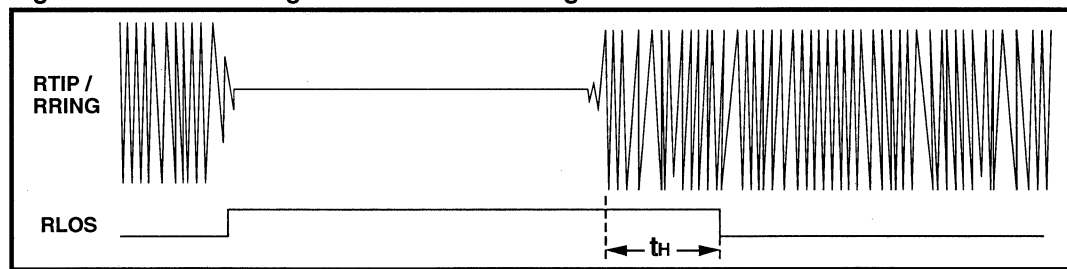
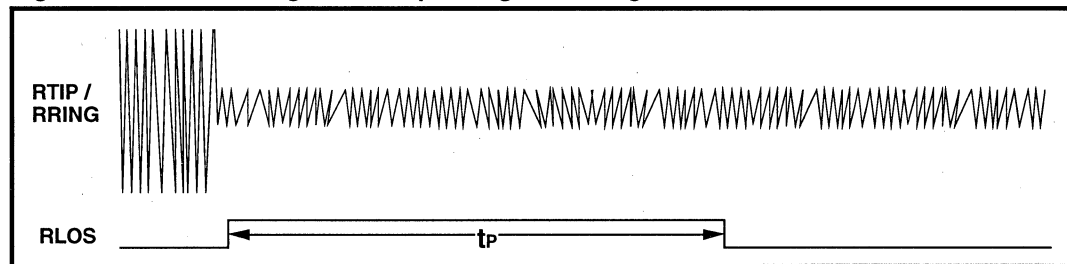

Figure 6: RLOS Timing for a Drop in Signal Strength > 6 dB



Timing Recovery

The timing recovery circuit uses a rate synchronizer to generate a high frequency internal clock from the MCLK input. A DPLL is used to synchronize this internal clock to the received data pulses. The output clock from the DPLL is divided down to generate RCLK and all other required clocks (except TCLK which is an external input).

Data Extraction

The data extraction block provides RPOS and RNEG outputs. A positive differential pulse received between RTIP and RRING results in a High on RPOS. A negative differential pulse between RTIP and RRING results in a High on RNEG. RPOS and RNEG are output at the received data rate and are valid on the falling edge of RCLK.

Receiver operation is not affected by the data patterns, provided the ones density requirements of Table 3 are met with no more than 26 consecutive zeros. RLOS is declared after 32 consecutive zeros. However, the RCLK output remains synchronized to the RTIP/RRING input for up to 40 consecutive zeros, after which re-initialization occurs. Bipolar violations are received properly. The bipolar violation coding rule that successive violations be of alternating polarity must be followed. However, if this rule is temporarily broken (due to channel noise, etc.), long term LXT400 data reception will not be adversely affected.

LOOPBACK OPERATION

When the LPBK pin is set High, the recovered data and clock are sent back through the transmit section and onto the line

interface, as well as being output on the RPOS/RNEG and RCLK pins. TPOS/TNEG and TCLK inputs are ignored in the loopback mode.

SERIAL PORT OPERATION

The line status (LS) output is an 8-bit or 16-bit serial word enabled by pulling LSE Low for 8 or 16 bit-periods as shown in Figures 12 and 13. Refer to Test Specifications for Serial Port Timing. Bit assignments are listed in Table 6. Approximate line loss and loop length (based on received signal strength/filter selection, assuming far-end pulse transmission compliant with AT&T Pub 62310 or T1E1/90-051) are reported via bits b0 through b3 as listed in Table 7. When combined with the receive signal magnitude bits in positions b8-b15, the line attenuation may be calculated to within ± 1 dB of actual value using the following equation:

$$\text{Insertion loss} = \left[\frac{\text{Insertion loss value in dB from Table 7 based on LL3-LL0 value.}}{\text{LL3-LL0 value.}} \right] + 20 \log_{10} \left(\frac{3C \text{ hex}}{\text{Mag} <7,0> \text{ hex}} \right) \text{ dB}$$

Bits b4 through b6 indicate the receiver activation state. Bit b7 is the RLOS alarm.

Figure 7 shows the serial output for a typical LXT400 initialization sequence. Bits b0 - b3 report filter selection and bits b4 - b6 report receiver status. Bit b6 toggles to indicate that the receiver is alternating between offset cancellation (b6 - b4 = 100) and receive level detection (b6 - b4 = 000). The receiver starts with the highest-gain filter (b3 - b0 = 0111), cancels systematic voltage offset at the

Figure 7: Typical Serial Port Output for Receive Activation @ 72 kbps

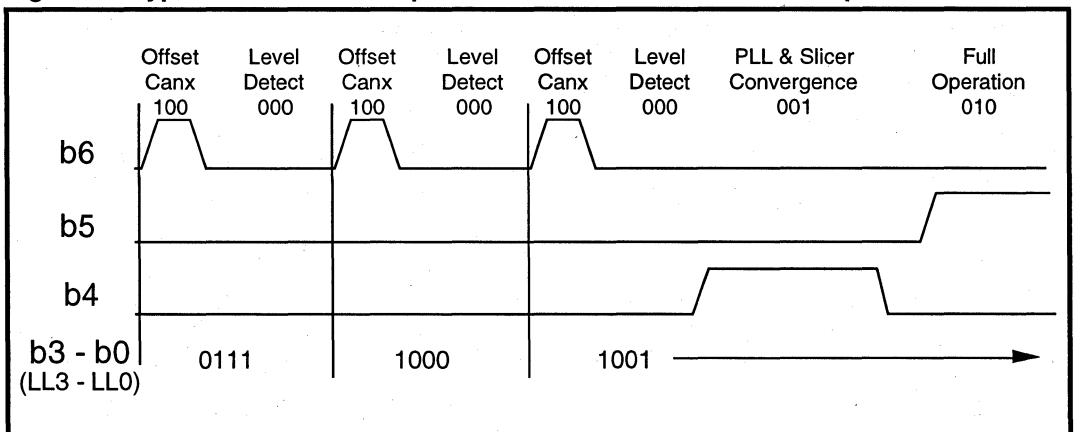

LXT400 All Rate Extended Range SW56/DDS Transceiver

filter output, and then detects the receive signal level at the filter output. If the signal exceeds the threshold for that filter, the LXT400 steps down to the filter with the next-highest gain ($b3 - b0 = 1000$). This process is repeated until the receive signal level does not exceed the filter threshold.

peak of the receive pulses and the slicer level adapts to the midway point between zero and the pulse peak voltage. Once convergence is complete, the LXT400 begins full operation ($b6 - b4 = 010$).

Once the appropriate filter is selected, the receiver phase-locked loop (PLL) and slicer levels converge to match the receive signal for optimum SNR. During receiver convergence ($b6 - b4 = 001$), the PLL adapts to sample the

Table 6: LS Word Bit Assignments

Bit #	Name	Description	Bit #	Name	Description
b0	LL0	Loop Length Indication, bit 0	b8	MAG0	Rx signal magnitude bit 0
b1	LL1	Loop Length Indication, bit 1	b9	MAG1	Rx signal magnitude bit 1
b2	LL2	Loop Length Indication, bit 2	b10	MAG2	Rx signal magnitude bit 2
b3	LL3	Loop Length Indication, bit 3	b11	MAG3	Rx signal magnitude bit 3
b4	S1	Receiver Converging when high	b12	MAG4	Rx signal magnitude bit 4
b5	S2	Full Operation when high	b13	MAG5	Rx signal magnitude bit 5
b6	S0	Level Detection when high	b14	MAG6	Rx signal magnitude bit 6
b7	RLOS	Receive Loss of Signal when high	b15	MAG7	Rx signal magnitude bit 7

5

Table 7: LS Loop Length Bits LL3 - LL0

Rate kbps	Insertion Loss @ $\tau_{1/2}$ in dB / Line Range in km (24 AWG PIC, no bridged taps) for LL3 - LL0								
	Values are for optimum receiver slicer level, with MAG7 - MAG0 = 3C hex								
	0111	1000	1001	1010	1011	1100	1101	1110	1111
2.4	N/A	42.3 / 23	36.0 / 19.2	30.0 / 15.3	24.2 / 11.5	20.0 / 8.6	15.5 / 5.0	10.6 / 2.4	3.4 / 0.8
3.2	N/A	42.0 / 19.9	36.0 / 16.9	30.7 / 14.3	25.2 / 11.6	20.0 / 7.8	15.0 / 4.9	10.3 / 2.4	3.0 / 0.7
4.8	N/A	42.3 / 17.3	36.3 / 14.7	30.5 / 12.0	24.7 / 9.3	18.8 / 6.7	13.5 / 4.0	9.3 / 2.0	3.1 / 0.7
6.4	N/A	42.4 / 15.4	36.5 / 13.2	31.2 / 11.0	25.6 / 8.8	20.0 / 6.6	15.0 / 4.4	10.0 / 2.2	3.3 / 0.7
9.6	N/A	40.0 / 12.5	35.0 / 10.7	29.6 / 8.9	24.2 / 7.1	18.9 / 5.4	13.8 / 3.6	9.0 / 1.8	2.5 / 0.5
12.8	N/A	42.3 / 11.7	36.2 / 10.0	30.7 / 8.3	25.0 / 6.7	19.3 / 5.0	13.8 / 3.3	8.8 / 1.7	2.6 / 0.5
19.2	N/A	42.2 / 10.0	36.2 / 8.6	30.5 / 7.1	24.9 / 5.7	14.0 / 4.3	13.0 / 2.9	7.7 / 1.4	1.0 / 0.2
25.6	N/A	42.0 / 9.0	36.0 / 7.7	30.2 / 6.4	24.5 / 5.1	18.4 / 3.9	13.6 / 2.6	7.5 / 1.3	0.5 / 0.1
38.4	N/A	42.5 / 8.4	36.5 / 7.1	30.7 / 6.0	25.0 / 4.7	18.9 / 3.6	14.0 / 2.4	7.4 / 1.2	1.0 / 0.2
51.2	N/A	43.0 / 7.7	37.0 / 6.6	31.2 / 5.5	25.5 / 4.4	19.4 / 3.3	14.0 / 2.2	7.4 / 1.1	0.5 / 0.1
56.0	50.5 / 8.5	44.4 / 7.5	38.4 / 6.4	32.3 / 5.3	26.0 / 4.2	19.7 / 3.2	13.6 / 2.1	7.3 / 1.1	0.0 / 0.0
72.0	50.7 / 8.0	45.0 / 7.0	38.8 / 6.0	32.5 / 5.0	26.3 / 4.0	20.0 / 3.0	14.0 / 2.0	7.4 / 1.0	0.0 / 0.0
64.0	50.0 / 8.3	44.0 / 7.2	38.0 / 6.2	32.0 / 5.3	26.0 / 4.1	19.7 / 3.1	14.0 / 2.1	7.4 / 1.1	0.0 / 0.0
3.5	N/A	43.0 / 20.4	37.4 / 17.3	31.5 / 14.2	26.0 / 11.2	20.2 / 8.1	15.0 / 5.0	10.3 / 2.5	4.1 / 1.0
7.0	N/A	43.8 / 15.4	37.8 / 13.2	32.3 / 11.0	26.4 / 8.8	20.5 / 6.6	15.0 / 4.4	10.0 / 2.2	3.6 / 0.8
14.0	N/A	43.0 / 11.7	37.5 / 10.1	31.9 / 8.34	25.6 / 6.67	19.8 / 5.0	13.9 / 3.3	8.5 / 1.7	2.5 / 0.5
28.0	N/A	43.7 / 9.0	37.5 / 7.7	31.9 / 6.4	25.7 / 5.1	19.5 / 3.9	13.0 / 2.6	7.5 / 1.3	0.5 / 0.1

NOTE: A MAG7 - MAG0 value of 3C hex represents a 1V slicer level at the point of receive data detection.

APPLICATION INFORMATION

NOTE

This information is for design aid only.

Figure 8 shows a typical LXT400 application circuit. A DSU crystal (4.096 MHz) is connected across MCLK1 and MCLK2, with two grounded loading capacitors. The line interface consists of a pair of 1:1 transformers, center-tapped on the line side, with appropriate load resistors. The R_s/C_s shunt network provides high frequency compensation for the transmit driver. The input signal is developed across the R_r/R_{in} network. R_v limits current into the low-impedance VINT driver during over-voltage conditions on the line. Table 8 lists external component recommendations.

CROSSTALK

It is important to prevent crosstalk between the transmitter and receiver circuits. Steps were taken to reduce this interference inside the LXT400, but precautions must be taken with the line interface circuitry outside the chip as well. Crosstalk is especially high when the idle pattern (alternate positive and negative pulses) is being transmitted because the transmit power is concentrated around the Nyquist frequency (half the baud rate).

Figure 8: Typical Application Circuit for 72 kbps Operation

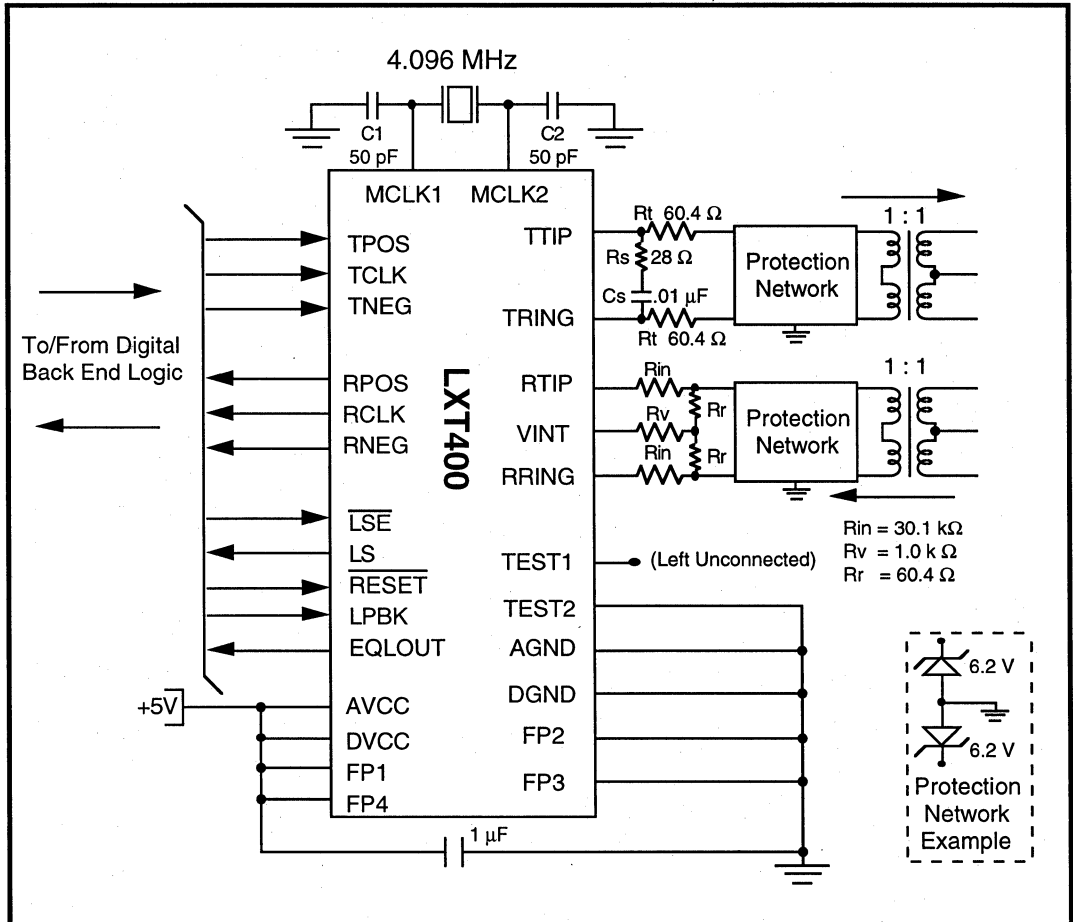

PCB LAYOUT

The external line interface circuit must be laid out to minimize coupling of other digital and analog signals into RTPIP and RRING (see Figure 9). These inputs, pins 2 and 3, are high impedance nodes which can pick up interference from adjacent PCB traces. The line interface circuit must be designed for loops with up to 50 dB of loss at the Nyquist frequency, even if the product will never be used on such long lines. When no receive signal is present, the LXT400 will switch to the highest gain filter, which at 56, 64 and 72 kbit/s produces an internal gain of about 50 dB. Unless precautions are taken, substantial interference coupling into RTPIP and RRING could exceed the internal slicer levels and prevent the RLOS report. Layout considerations for LXT400 application circuits include:

1. Minimum PCB trace lengths between the LXT400 and the 4.096 MHz crystal and loading capacitors.
2. Minimum PCB trace lengths between resistors Rin and the RTIP and RRING pins. Shield these connections with ground traces.
3. Minimum PCB trace lengths between the receive transformer and the receive termination network.

Even with good PCB layout practices, RLOS reporting can be unreliable if the twisted pair line cable is not connected to the OCU or CSU/DSU when the LXT400 is set for operation at 56, 64, or 72kbit/s. The unterminated receive lines can pick up enough noise to trip the data detectors and force RLOS low. However, equipment designers can safely assume that the highest-gain filter with 50dB of signal amplification will never be selected for normal operation on lines with up to 45dB of attenuation at the Nyquist frequency. Therefore, the status word on the LS output can be used as a secondary LOS indicator - the occurrence of RLOS=0 and LL3-0 = 0111 at 56, 64 or 72 kbps reliably indicates the loss of carrier condition.

The 50dB filters were designed for applications in which the line attenuation is 48dB or greater. The DDS specification requires an insertion loss at 56, 64, and 72kbit/s of 43dB or less. The LXT400 incorporates built-in headroom up to 45dB. So for standard applications, the highest-gain filter will never be selected. The critical element is operating frequency. The highest gain filter (50 dB) is only available at 56, 64, and 72kbit/s settings. At the lower operating frequencies, the highest-gain filter is about 44dB, well above the interference levels arising from unterminated lines.

5

Figure 9: Suggested LXT400 PCB Layout

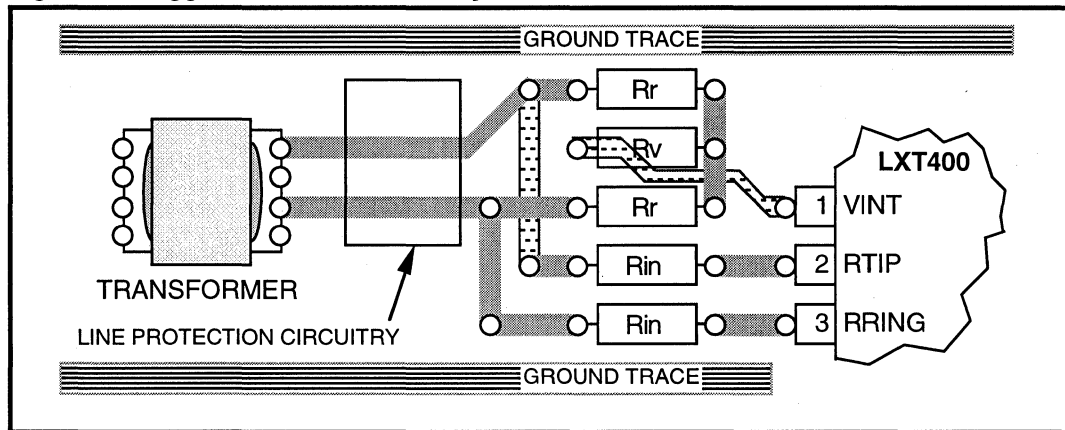

LXT400 All Rate Extended Range SW56/DDS Transceiver

Table 8: External Component Recommendations

Component	Parameter	Recommended Value
Line Transformer Suggested Manufacturers: Midcom - Phone 800/643-2661 Schott - Phone 615/889-8800	Turns ratio	1:1, $\pm 1\%$
	Structure	Center tapped (for line side)
	Primary Inductance	200 mH minimum
	Leakage Inductance	22 to 43 μ H maximum
	Interwinding Capacitance	350 pF maximum
	DC Resistance (Primary, Rwp)	7 to 15 Ω
	DC Resistance (Secondary, Rws)	7 to 15 Ω , See Rt, Rr calculation
Rin	Resistance, Tolerance, Rating	30.1 k Ω , $\pm 1\%$, 1/4 W
Rt, Rr	Resistance, Tolerance, Rating	$(135 \Omega - R_{wp} - R_{ws}) / 2$, $\pm 1\%$, 1/4 W
Rv	Resistance, Tolerance, Rating	1 k Ω , $\pm 5\%$, 1/4 W
DSU Crystal Suggested Manufacturers: Fox - Phone 813/693-0099 Monitor - Phone 815/432-5296	Nominal frequency	4.096 MHz
	Holder style	HC-49/U
	Operating Mode	Fundamental, parallel resonant
	Load Capacitance	28 pF nominal
	Tolerance	± 35 ppm @ 25 $^{\circ}$ C
	Range	± 50 ppm, -40 to 85 $^{\circ}$ C
	Aging	3 ppm per year maximum
	Maximum ESR	100 Ω
	Drive Level	1 mW maximum
DSU Crystal Loading Capacitors	Capacitance, Tolerance, Rating	50 pF, $\pm 5\%$, 10 V
	Construction	NPO ceramic or equivalent
Transmit Shunt Network		
Rs	Resistance, Tolerance, Rating	28 Ω , $\pm 5\%$, 1/4 W
Cs	Capacitance, Tolerance, Rating	0.01 μ F, $\pm 20\%$, 10 V

TEST SPECIFICATIONS

NOTE

Minimum and maximum values in Tables 9 through 13 and Figures 10 through 14 represent the performance specifications of the LXT400 and are guaranteed by test except, as noted, by design.

Table 9: Absolute Maximum Ratings

Parameter	Min	Max	Units
DC supply - AVCC referenced to AGND	- 0.3	+ 6.0	V
DVCC referenced to DGND	- 0.3	+ 6.0	V
DVCC referenced to AVCC	- 0.3	+ 0.3	V
DGND referenced to AGND	- 0.3	+ 0.3	V
Input voltage, any pin ^{1,2}	AGND - 0.3	AVCC + 0.3	V
Input or output diode current, any pin ²	-	± 20	mA
Continuous output current, any pin ²	-	± 25	mA
Continuous current, VCC or GND pins	-	± 60	mA
Storage temperature	- 40	+ 150	°C

CAUTION
Operations at or beyond these limits may result in permanent damage to the device.
Normal operation not guaranteed at these extremes.

1. TTIP and TRING are referenced to DVCC and DGND.
2. Except supply pins.

5

Table 10: Recommended Operating Conditions

Parameter	Sym	Min	Typ	Max	Units
DC supply	AVCC/DVCC	4.75	5.0	5.25	V
Ambient operating temperature	T _A	-40	-	+85	°C

Table 11: DC Electrical Characteristics

Parameter	Sym	Min	Typ ¹	Max	Units	Test Conditions
Supply current (transmitting spaces)	I _{CC}	-	40	60	mA	270 Ω resistor across TTIP and TRING
Supply current (transmitting all marks)	I _{CC}	-	47.5	60	mA	270 Ω resistor across TTIP and TRING
Input Low voltage	V _{IL}	-	-	0.8	V	Digital inputs
Input High voltage	V _{IH}	2.0	-	-	V	Digital inputs
Output Low voltage	V _{OL}	-	-	0.4	V	I _{OL} = 1.6 mA
Output Low voltage	V _{OL}	-	0.2	-	V	I _{OL} < 10 μA
Output High voltage	V _{OH}	2.4	-	-	V	I _{OH} = 0.4 mA
Output High voltage	V _{OH}	-	4.5	-	V	I _{OH} < 10 μA
Input leakage current	I _{IL}	-40	-	40	μA	0 < V _{IN} < V _{CC}

1. Typical figures are at 25 °C and are for design aid only; not guaranteed and not subject to production testing.

LXT400 All Rate Extended Range SW56/DDS Transceiver

Table 12: AC Electrical Characteristics

Parameter	Symbol	Min	Typ ¹	Max	Units
Input capacitance	C _{IN}	–	7	–	pF
TCLK jitter at DSU with respect to RCLK	t _{JIT}	–	–	2	% t _{PR} at DSU
RCLK isochronous distortion at DSU	t _{JIT}	–	–	5	% t _{PT} at OCU
Transmit output jitter with respect to TCLK	t _{OJIT}	–	–	3	% t _{PT} at DSU
Transmit pulse amplitude at TTIP/TRING ²					
- at 9.6 and 12.8 kbps	A _T	1.44	1.55	1.75	V
- at all other rates	A _T	2.56	2.74	2.92	V

1. Typical figures are at 25 °C and are for design aid only; not guaranteed and not subject to production testing.
2. The instantaneous peak amplitude of an isolated pulse (i.e.: a mark between two spaces) into a 270 Ω resistive load.

Table 13: Timing Characteristics

Parameter	Symbol	Min	Typ ¹	Max	Units	Notes
Receive Timing (Figure 10)						
RCLK period	t _{PR}	–	1/f _b	–	ns	
RCLK pulse width high	t _{RWH}	1/(2 f _b) - 150	1/(2 f _b)	1/(2 f _b) + 150	ns	
RPOS/RNEG delay from RCLK rising edge	t _{DP}	–	–	200	ns	2
Transition time on any digital output	t _{TO}	–	10	20	ns	2
Transmit Timing (Figure 11)						
TCLK period	t _{PT}	–	1/f _b	–	μs	
TCLK pulse width high	t _{TWH}	400	–	–	ns	
TPOS/TNEG setup to TCLK falling edge	t _{T_{SU}}	200	–	–	ns	
TPOS/TNEG hold time from the falling edge of TCLK	t _{T_H}	200	–	–	ns	
Transition time on any digital input	t _{TI}	–	–	40	ns	
TCLK frequency tolerance	f _{TTOL}	-50	0	+50	ppm	
LS Serial Port Timing (Figures 12 and 13)						
LS delay from RCLK falling edge	t _{LSP}	–	–	200	ns	2
LSE setup to RCLK rising edge	t _{LSU}	200	–	–	ns	
LSE hold time from RCLK rising edge	t _{LSH}	t _{RWH}	–	–	ns	
LSE low to low Z state	t _{LZ}	–	–	100	ns	
LSE high to high Z state	t _{HZ}	–	–	100	ns	
MCLK and Reset Timing (Figure 14)						
MCLK1 input frequency	f _{MCLK}	–	4.096	–	MHz	
MCLK1 frequency tolerance	f _{MTOL}	-100	0	+100	ppm	
MCLK1 pulse width high	t _{MWH}	98	122	146	ns	
RESET pulse width low	t _{RWL}	1000	–	–	ns	

1. Typical figures are at 25 °C and are for design aid only; not guaranteed and not subject to production testing.
2. Measured with 15 pF load.

Figure 10: Receive Digital Timing

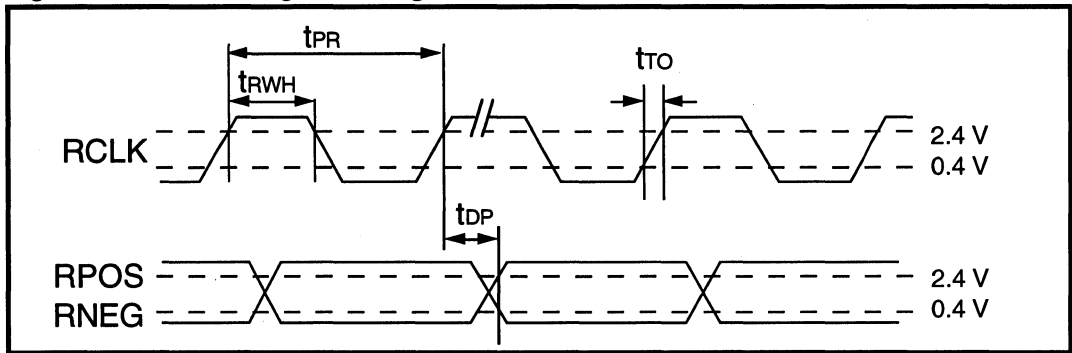

Figure 11: Transmit Digital Timing

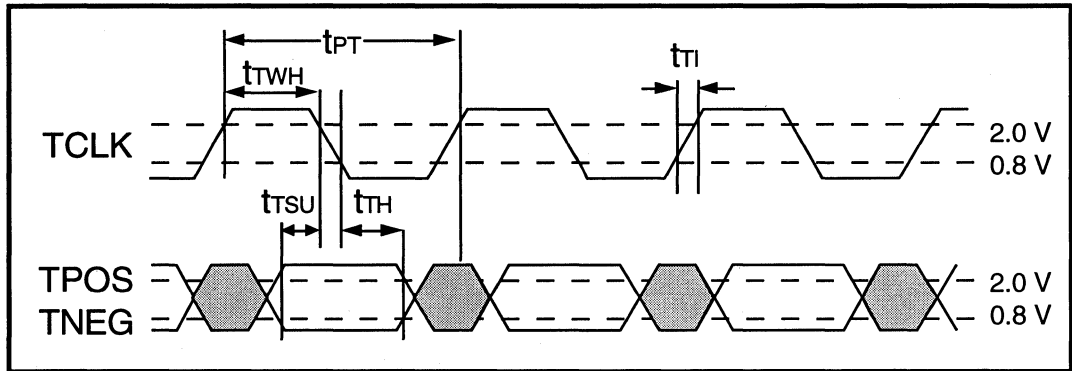

Figure 12: LS Serial Port Timing - 8-Bit Word

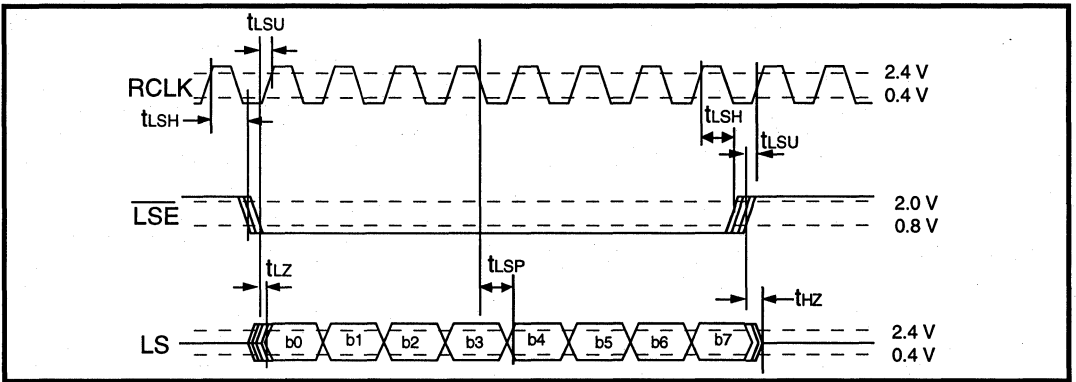

Figure 13: LS Serial Port Timing - 16-Bit Word

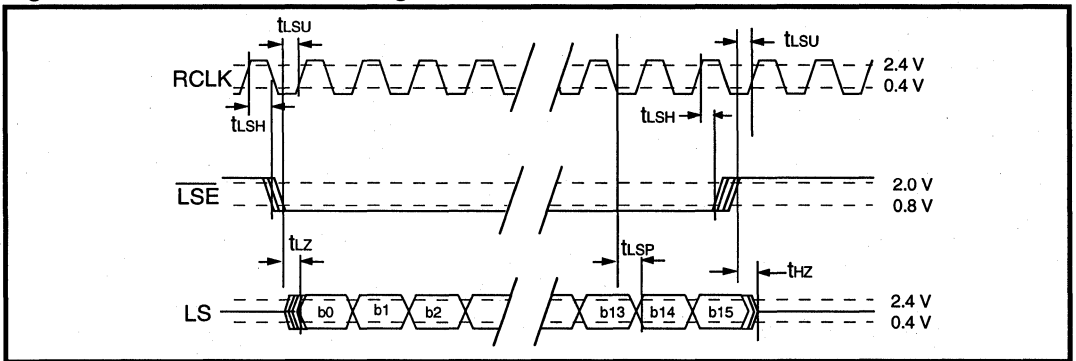
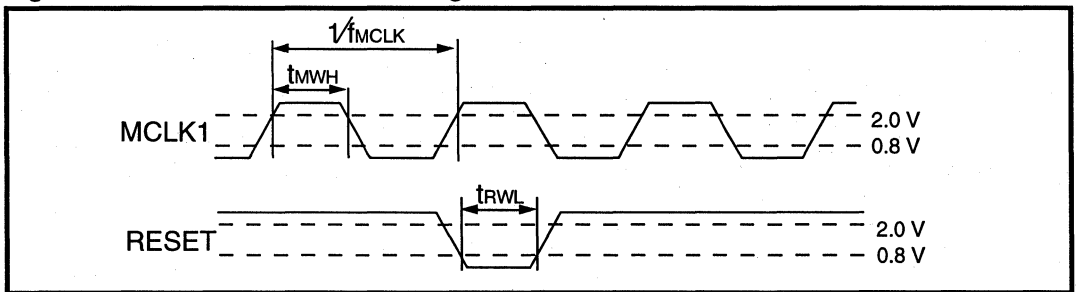

Figure 14: MCLK and RESET Timing



LXT441

Switched 56/DDS Integrated DSU/CSU

General Description

The LXT441 is an integrated transceiver and data formatter for Switched 56 (SW56) and Digital Data Service (DDS) Data Service Unit/Channel Service Unit (DSU/CSU) and Office Channel Unit (OCU) applications.

The LXT441 line interface section performs transmit pulse shaping and receive signal data and timing recovery at the user-network 4-wire metallic interface. The device operates at loop speeds of 56 kbps and 72 kbps, supporting SW56, 56 kbps DDS with or without secondary channel (SC) and 64 kbps clear channel DDS services.

The integrated DSU circuit provides a DCE interface and connects directly to terminal equipment (DTE) using standard EIA530 control leads. Data formatting includes DDS framing, control code handling, loop code generation and detection, and zero code suppression processing.

The LXT441 has an on-chip 8-bit microprocessor interface that simplifies device configuration, status reporting, and SW56 call processing, and may be used for parallel data transfer to and from the 4-wire physical link.

Features

- Available in 44-pin PLCC
- Single 8.192 MHz crystal or clock input
- 5 V only CMOS process technology
- Supports most popular data rates for new DSU/CSUs
 - Switched 56 and 56 kbps DDS (56 kbps loop speed)
 - 56 kbps DDS with secondary channel (72 kbps loop speed)
 - 64 kbps clear-channel DDS (72 kbps loop speed)
- Switched 56 Call Control via EIA control leads or microprocessor
- Receiver performance monitoring
- Idle Code Transmission (CMI, DMI)
- Transmit timing recovered from network or supplied by system
- Network Control Code Detection and Generation
- CSU and DSU latching and non-latching loopbacks

5

Applications

- Leased-line DDS and Switched 56 DSU/CSUs
- Internet Service Provider (ISP) Equipment
- Internal DSU for Routers, Bridges and PC add-in cards
- Frame Relay Access Devices (FRAD)
- OCU Cards for Channel Banks and DLC Systems

LXT441 Block Diagram

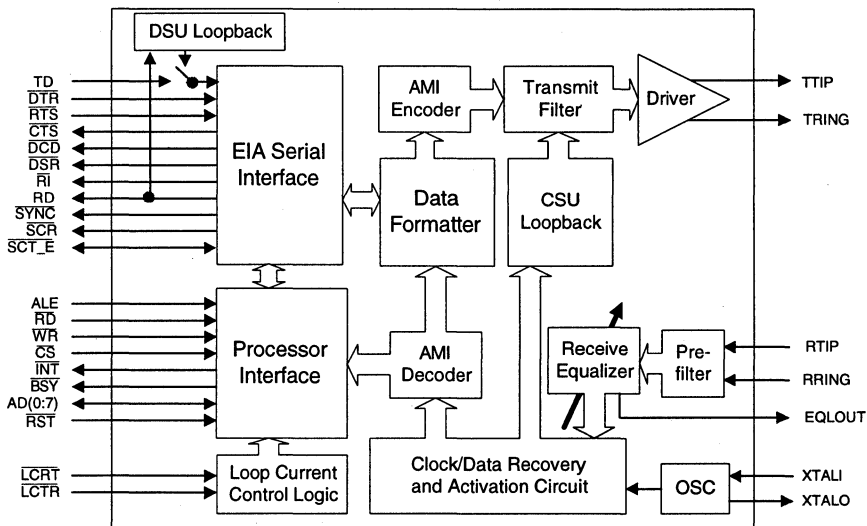

NOTES:

T1/E1 Long-Haul Transceivers

6



LXT310

T1 CSU/ISDN PRI Transceiver

General Description

The LXT310 is the first fully integrated transceiver for T1 CSU and ISDN Primary Rate Interface (ISDN PRI) applications at 1.544 Mbps. This transceiver operates over 6,000 feet of 22 AWG twisted-pair cable without any external components. To compensate for shorter lines, 7.5 dB, 15 dB, and 22.5 dB frequency-dependent transmit Line Build-Outs (LBOs) are provided.

The device offers selectable B8ZS encoding/decoding, and unipolar or bipolar data I/O. The LXT310 also provides jitter attenuation in either the transmit or receive direction starting at 6 Hz, and incorporates a serial interface (SIO) for microprocessor control.

The LXT310 offers a variety of diagnostic features including loopbacks and loss of signal monitoring. It uses an advanced double-poly, double-metal CMOS process and requires only a single 5-volt power supply.

Applications

- ISDN Primary Rate Interface (PRI) (ANSI T1.408)
- CSU Interface to T1 Service (Pub 62411)
- DS1 Metallic Interface (ANSI T1.403)
- T1 LAN bridge
- CPU to CPU Channel Extenders
- Digital Loop Carrier - Subscriber Carrier Systems
- T1 Mux
- Channel Banks

Features

- Fully integrated transceiver comprising: on-chip equalizer; timing recovery/control; data processor; receiver; and transmitter with Line Build-Out and digital control
- Meets or exceeds ANSI and ITU specifications including T1.403, T1.408, and AT&T Pub 62411
- Selectable Receiver Sensitivity. Fully restores the received signal after transmission through a cable with attenuation of either 0 to 26 dB, or 0 to 36 dB @ 772 kHz
- Selectable Unipolar or Bipolar data I/O
- Selectable B8ZS encoding/decoding
- Line attenuation indication output
- 138 UI jitter tolerance at 1 Hz
- Output short circuit current limit protection
- On-line idle mode for redundant systems
- 7.5 dB, 15 dB, and 22.5 dB transmit LBOs
- Local, remote and inband network loopback functions
- Receive monitor with Loss of Signal (LOS) output
- Jitter attenuation starting at 6 Hz, switchable to transmit or receive path
- Microprocessor controllable

LXT310 Block Diagram

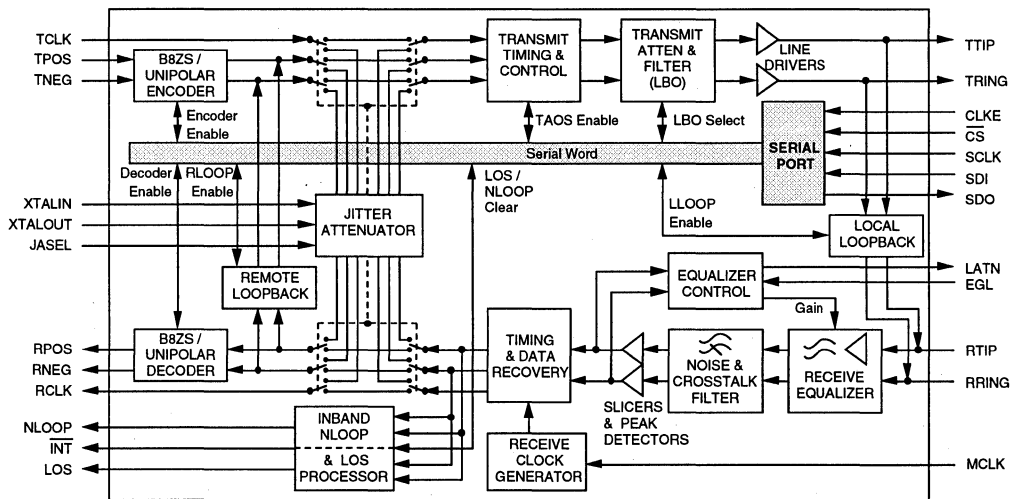

Figure 1: Pin Assignments

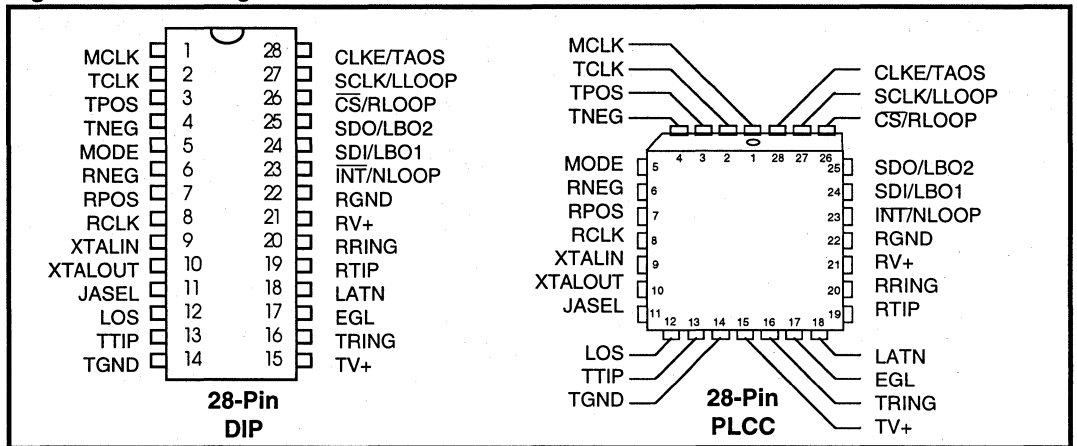

Table 1: Pin Descriptions

Pin #	Sym	I/O	Name	Description
1	MCLK	I	Master Clock	A 1.544 MHz clock input used to generate internal clocks. Upon Loss of Signal (LOS), RCLK is derived from MCLK. If MCLK is not applied, this pin should be grounded.
2	TCLK	I	Transmit Clock	Transmit clock input. TPOS and TNEG are sampled on the falling edge of TCLK.
3	TPOS/ TDATA	I	Transmit Data Input	Input data to be transmitted on the twisted-pair line. Normally, pin 3 is TPOS and pin 4 is TNEG, the positive and negative sides of a bipolar input pair. However, if pin 4 is held High for at least 16 TCLK cycles (equivalent to 15 successive bipolar violations), the LXT310 switches to a unipolar mode. The LXT310 returns to bipolar I/O when pin 4 goes Low.
4	TNEG/ UBS	I	Data Input/ Polarity Select	
5	MODE	I	Mode Select	Setting MODE High selects the Host Mode. In Host Mode, the serial interface is enabled for control and status reporting. Setting MODE Low selects the Hardware (H/W) Mode. In Hardware Mode the serial interface is disabled; hard-wired pins control configuration and report status. Tying MODE to RCLK enables Hardware Mode and the B8ZS encoder/decoder.
6	RNEG	O	Receive Data Negative	In Bipolar Data I/O Mode pins 6 and 7 are bipolar data outputs. A signal on RNEG corresponds to receipt of a negative pulse on RTIP/RRING, and a signal on RPOS corresponds to a positive pulse on RTIP/RRING. RNEG/RPOS outputs are Non-Return-to-Zero (NRZ). In Host Mode, CLKE determines the clock edge at which these outputs are stable and valid. In Hardware Mode both outputs are stable and valid on the RCLK rising edge
7	RPOS	O	Receive Data Positive	
6	BPV	O	Bipolar Violation	In Unipolar Data I/O Mode, pin 6 goes High to indicate receipt of a Bipolar Violation of the AMI code.
7	RDATA	O	Receive Data	In Unipolar Mode, data received from the twisted-pair line is output at pin 7.
8	RCLK	O	Receive Clock	This is the clock recovered from the signal received at RTIP and RRING.

Table 1: Pin Descriptions - continued

Pin #	Sym	I/O	Name	Description
9	XTALIN	I	Crystal Input	An external crystal (18.7 pF load capacitance, pullable) operating at 6.176 MHz (four times the bit rate) is required to enable the jitter attenuation function of the LXT310. These pins may also be used to disable the jitter attenuator by connecting the XTALIN pin to the positive supply through a resistor, and leaving the XTALOUT pin unconnected.
10	XTALOUT	O	Crystal Output	
11	JASEL	I	Jitter Attenuation Select	Selects jitter attenuation location. When JASEL is High, the jitter attenuator is active in the receive path. When JASEL is Low, the jitter attenuator is active in the transmit path.
12	LOS	O	Loss Of Signal	LOS goes High when 175 consecutive spaces have been detected. LOS returns Low when the received signal reaches a mark density of 12.5% (determined by receipt of four marks within 32 bit periods). Received marks are output on RPOS and RNEG even when LOS is High.
13	TTIP	O	Transmit Tip	Differential Driver Outputs. These outputs are designed to drive a 50 - 200 Ω load. Line matching resistors and transformer can be selected to give the desired pulse height.
16	TRING	O	Transmit Ring	
14	TGND	-	Tx Ground	Ground return for the transmit drivers power supply TV+.
15	TV+	I	Transmit Power Supply	+5 VDC power supply input for the transmit drivers. TV+ must not vary from RV+ by more than ± 0.3 V.
17	EGL	I	Equalizer Gain Limit	Input sets equalizer gain. When EGL is Low, up to 36 dB of equalizer gain may be added. When EGL is High, equalizer gain is limited to no more than 26 dB.
18	LATN	O	Line Attenuation Indication (See Figure 2)	Encoded output. Pulse width, relative to RCLK, indicates receive equalizer gain setting (line insertion loss at 772 kHz) in 7.5 dB steps. When LATN = 1 RCLK pulse, the equalizer is set at 7.5 dB gain, 2 pulses = 15 dB, 3 pulses = 22.5 dB and 4 pulses = 0 dB. Output is valid on the rising edge of RCLK.
19	RTIP	I	Receive Tip	The AMI signal received from the line is applied at these pins. A 1:1 transformer is required. Data and clock from the signal applied at these pins are recovered and output on the RPOS/RNEG and RCLK pins.
20	RRING	I	Receive Ring	
21	RV+	I	Receive Power Supply	+5 VDC power supply for all circuits except the transmit drivers. (Transmit drivers are supplied by TV+.)
22	RGND	-	Rx Ground	Ground return for power supply RV+.
23	NLOOP	O	Network Loopback (H/W Mode)	When High, indicates Inband Network Loopback has been activated by reception of 00001 pattern for five seconds. NLOOP is reset by reception of 001 for five seconds, or by activation of RLOOP or LLOOP.
	$\overline{\text{INT}}$	O	Interrupt (Host Mode)	This LXT310 Host Mode output goes Low to flag the host processor when LOS or NLOOP changes state. INT is an open-drain output and should be tied to power supply RV+ through a resistor. INT is reset by clearing the LOS or NLOOP register bit.

6

Table 1: Pin Descriptions - continued

Pin #	Sym	I/O	Name	Description
24	SDI	I	Serial Data In (Host Mode)	The serial data input stream is applied to this pin when the LXT310 operates in the Host Mode. SDI is sampled on the rising edge of SCLK.
	LBO1	I	Line Build-Out Select 1 (H/W Mode)	In Hardware Mode this input is used in conjunction with LBO2 to select the transmit line build-outs: 00 = 0 dB, 01 = 7.5 dB, 10 = 15 dB, and 11 = 22.5 dB.
25	SDO	O	Serial Data Out (Host Mode)	The serial data from the on-chip register is output on this pin in the LXT310 Host Mode. If CLKE is High, SDO is valid on the rising edge of SCLK. If CLKE is Low, SDO is valid on the falling edge of SCLK. This pin goes to a high-impedance state when the serial port is being written to and when \overline{CS} is High.
	LBO2	I	Line Build-Out Select 2 (H/W Mode)	The signal applied at this pin in the LXT310 Hardware Mode is used in conjunction with LBO1 to select the transmit line build-outs. 00 = 0 dB, 01 = 7.5 dB, 10 = 15 dB, and 11 = 22.5 dB.
26	\overline{CS}	I	Chip Select (Host Mode)	This input is used to access the serial interface in the Host Mode. For each read or write operation, \overline{CS} must transition from High to Low, and remain Low.
	RLOOP	I	Remote Loopback (H/W Mode)	This input controls loopback in the Hardware Mode. Setting RLOOP High enables Remote Loopback. During Remote Loopback, in-line encoders and decoders are bypassed. Setting both RLOOP and LLOOP High while holding TAOS Low causes a Reset. Setting both RLOOP and LLOOP with TAOS High (or tying RCLK to RLOOP) enables Network Loopback detection.
27	SCLK	I	Serial Clock (Host Mode)	This clock is used in the Host Mode to write data to or read data from the serial interface registers.
	LLOOP	I	Local Loopback (H/W Mode)	This input controls loopback functions in the Hardware Mode. Setting LLOOP High enables the Local Loopback Mode. Setting both LLOOP and RLOOP while holding TAOS Low causes a Reset.
28	CLKE	I	Clock Edge (Host Mode)	Setting CLKE High causes RPOS and RNEG to be valid on the falling edge of RCLK, and SDO to be valid on the rising edge of SCLK. When CLKE is Low, RPOS and RNEG are valid on the rising edge of RCLK, and SDO is valid on the falling edge of SCLK.
	TAOS	I	Transmit All Ones (H/W Mode)	When set High in the Hardware Mode, TAOS causes the LXT310 to transmit a stream of marks at the TCLK frequency. Activating TAOS causes TPOS and TNEG inputs to be ignored. TAOS is inhibited during Remote Loopback. Setting TAOS, LLOOP and RLOOP High simultaneously enables Network Loopback detection.

FUNCTIONAL DESCRIPTION

NOTE

This functional description is for design aid only.

The LXT310 is a fully integrated PCM transceiver for 1.544 Mbps (T1) applications. It allows full-duplex transmission of digital data over existing twisted-pair installations.

The LXT310 interfaces with two twisted-pair lines (one pair for transmit, one pair for receive) through standard pulse transformers and appropriate resistors.

The figure on the front page of this section is a block diagram of the LXT310. The transceiver may be controlled by a microprocessor through the serial port (Host Mode), or by individual pin settings (Hardware Mode). The jitter attenuator may be positioned in either the transmit or receive path.

POWER REQUIREMENTS

The LXT310 is a low-power CMOS device. It operates from a single +5 V power supply which can be connected externally to both the transmitter and receiver. However, the two inputs must be within $\pm .3$ V of each other, and decoupled to their respective grounds separately. Refer to Application Information for typical decoupling circuitry. Isolation between the transmit and receive circuits is provided internally.

Initialization and Reset Operation

Upon power up, the transceiver is held static until the power supply reaches approximately 3 V. Upon crossing this threshold, the device begins a 32 ms reset cycle to calibrate the transmit and receive delay lines and lock the Phase Lock Loop to the receive line. A reference clock is required to calibrate the delay lines. The transmitter reference is provided by TCLK. The crystal oscillator provides the receiver

reference. If the crystal oscillator is grounded, MCLK is used as the receiver reference clock.

The transceiver can also be reset from the Host or Hardware Mode. In Host Mode, reset is commanded by simultaneously writing ones to RLOOP and LLOOP, and a zero to TAOS. In Hardware Mode, reset is commanded by holding RLOOP and LLOOP High simultaneously for 200 ns while holding TAOS Low. In either mode, reset clears and sets all registers to 0.

RECEIVER

The twisted-pair input is received via a 1:1 transformer. Recovered data is output at RPOS/RNEG (RDAT in unipolar mode), and the recovered clock is output at RCLK. Refer to Test Specifications for receiver timing.

The signal received at RPOS and RNEG is processed through the receive equalizer. The Equalizer Gain Limit (EGL) input determines the maximum gain that may be applied at the equalizer. When set Low, up to 36 dB of gain may be applied.

When EGL is High, gain is limited to no more than 26 dB providing for increased noise margin in shorter loop operation. Insertion loss of the line in 7.5 dB steps, as indicated by the receive equalizer setting, is encoded in the LATN output as shown in Figure 2.

The equalized signal is filtered and applied to the peak detector and data slicers. The peak detector samples the inputs and determines the maximum value of the received signal. A percentage of the peak value is provided to the data slicers as a threshold level to ensure optimum signal-to-noise ratio. The threshold is set to 50% of the peak value. The receiver is capable of accurately recovering signals with up to 36 dB of cable attenuation (from 2.4 V).

After processing through the data slicers, the received signal is routed to the data and timing recovery section, then to the B8ZS decoder (if selected) and to the LOS processor. The

6

Figure 2: LATN Pulse Width Encoding

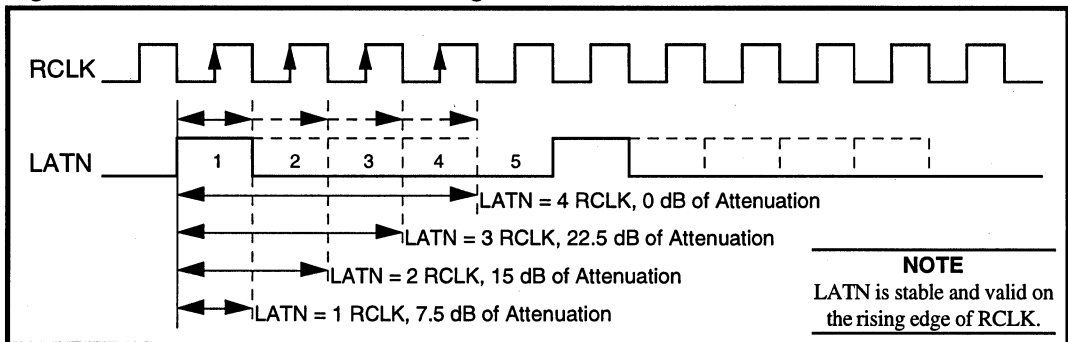

LOS Processor loads a digital counter at the RCLK frequency. The count is incremented each time a zero (space) is received, and reset to zero each time a one (mark) is received. Upon receipt of 175 consecutive zeros the LOS pin goes High, and a smooth transition replaces the RCLK output with the MCLK. (During LOS if MCLK is not supplied and JASEL = 1, the RCLK output is replaced with the centered crystal clock.)

Received marks will be output regardless of the LOS status, but the LOS pin will not reset until the ones density reaches 12.5 %. This level is based on receipt of at least 4 ones in any 32-bit period.

TRANSMITTER

Input data (bipolar or unipolar) for transmission onto the line is clocked serially into the device. Bipolar data is input at pin 3 (TPOS) and pin 4 (TNEG). Unipolar data is input at pin 3 (TDATA) only. (Unipolar mode is enabled by holding pin 4 high for 16 RCLK cycles). Input data may be passed through the Jitter Attenuator and/or B8ZS encoder, if selected. In Host Mode, B8ZS is selected by setting bit D3 of the input data byte. In Hardware Mode, B8ZS is selected by connecting the MODE pin to RCLK. Input synchronization is supplied by the transmit clock (TCLK). Timing requirements for TCLK and the Master Clock (MCLK) are defined in Test Specifications.

Idle Mode

The LXT310 incorporates a transmit idle mode. This allows multiple transceivers to be connected to a single line for redundant applications. TTIP and TRING remain in a high-impedance state when TCLK is not present (TCLK grounded). The high-impedance state can be temporarily disabled by enabling either TAOS, Remote Loopback or Network Loopback.

The transmitted pulse shape is determined by Line Build Out (LBO) inputs LBO1 and LBO2 as follows:

Line Build-Out (dB)	0	7.5	15	22.5
LBO1	0	1	0	1
LBO2	0	0	1	1

LBO settings are input through the serial port in the Host Mode. In the Hardware Mode, LBO inputs are applied through individual pins. Shaped pulses meeting the various T1 CSU and ISDN PRI requirements are applied to the AMI line driver for transmission onto the line at TTIP and TRING. Refer to Test Specifications for T1 pulse mask specifications.

Short Circuit Limit

The LXT310 transmitter is equipped with a short-circuit limiter. This feature limits to approximately 120 mA RMS the current the transmitter will source into a low-impedance load. The limiter trips when the RMS current exceeds the limit for 100 μ s (~ 150 marks). It automatically resets when the load current drops below the limit.

The LXT310 meets or exceeds FCC and AT&T specifications for CSU and NI applications, as well as ANSI T1E1, and CCITT requirements for ISDN PRI.

Line Code

The LXT310 transmits data as a 50% AMI line code as shown in Figure 3. Power consumption is reduced by activating the AMI line driver only to transmit a mark. The output driver is disabled during transmission of a space. Biasing of the transmit DC level is on-chip.

Figure 3: 50% AMI Coding Diagram

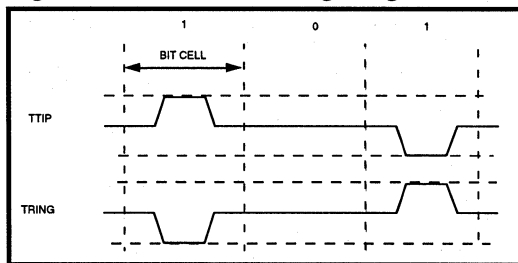

JITTER ATTENUATION

Jitter attenuation is provided by a Jitter Attenuation Loop (JAL) and an Elastic Store (ES). An external crystal oscillating at 4 times the bit rate provides clock stabilization. Refer to Table 6 for crystal specifications. The ES is a 32 x 2-bit register. When JASEL = 1, the JAL is positioned in the receive path. When JASEL = 0, the JAL is positioned in the transmit path.

Data (TPOS/TNEG / TDATA or RPOS/RNEG / RDATA) is clocked into the ES with the associated clock signal (TCLK or RCLK), and clocked out of the ES with the dejittered clock from the JAL. When the bit count in the ES is within two bits of overflowing or underflowing, the ES adjusts the output clock by 1/8 of a bit period. The ES produces an average delay of 16 bits in the associated path.

OPERATING MODES

The LXT310 can be controlled by a microprocessor through a serial interface (Host Mode), or through individual pins (Hardware Mode). The mode of operation is set by the MODE pin logic level.

Host Mode Operation

The LXT310 operates in the Host Mode when MODE is set High. The 16-bit serial word consists of an 8-bit Command/Address byte and an 8-bit Data byte. Table 3 lists the output data bit combinations. Figure 4 shows the serial interface data structure and timing. The Host Mode provides a latched Interrupt output ($\overline{\text{INT}}$) which is triggered by a change in the LOS or NLOOP bits. The Interrupt is cleared when the interrupt condition no longer exists, and the host processor writes a one to the respective bit in the serial input data byte.

Host Mode also allows control of the serial data and receive data output timing. The Clock Edge (CLKE) signal determines when these outputs are valid, relative to the Serial Clock (SCLK) or RCLK as listed in Table 2.

Table 2: CLKE Settings

Output	Clock	CLKE = 0	CLKE = 1
RPOS/RNEG SDO	RCLK SCLK	Rising Edge Falling Edge	Falling Edge Rising Edge

The LXT310 serial port is addressed by setting bit A4 in the Address/Command byte, corresponding to address 16. The LXT310 contains only a single output data register so no complex chip addressing scheme is required. The register is accessed by causing the Chip Select ($\overline{\text{CS}}$) input to transition from High to Low. Bit 1 of the serial Address/Command

Table 3: LXT310 Serial Data Output Bits (See Figure 4)

Bit D5	Bit D6	Bit D7	Status
0	0	0	Reset has occurred, or no program input
0	0	1	TAOS active
0	1	0	Local Loopback active
0	1	1	TAOS and Local Loopback active
1	0	0	Remote Loopback active
1	0	1	DPM has changed state since last Clear DPM occurred
1	1	0	LOS has changed state since last Clear LOS occurred
1	1	1	LOS and DPM have both changed state since last Clear DPM and Clear LOS occurred

6

Figure 4: LXT310 Serial Interface Data Structure

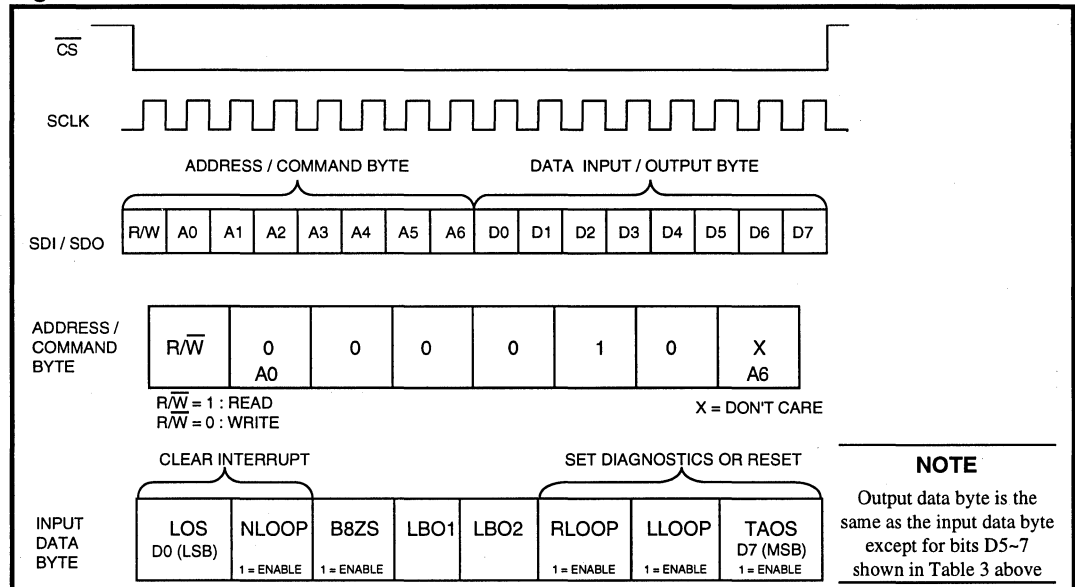

byte provides Read/Write control when the chip is accessed. A logic 1 indicates a read operation, and a logic 0 indicates a write operation. Serial data I/O timing characteristics are shown in Table 14, and Figures 11 and 12.

Hardware Mode Operation

In Hardware Mode the transceiver is accessed and controlled through individual pins. With the exception of the INT and CLKE functions, Hardware Mode provides all the functions provided in the Host Mode. In the Hardware Mode RPOS/RNEG or RDATA outputs are valid on the rising edge of RCLK. The LXT310 operates in Hardware Mode only when MODE is set Low or connected to RCLK.

Diagnostic Mode Operation

TRANSMIT ALL ONES

In Transmit All Ones (TAOS) Mode, the TPOS and TNEG inputs to the transceiver are ignored and the transceiver transmits a continuous stream of ones at the TCLK frequency. (If TCLK is not provided, TAOS is locked to the MCLK.) This can be used as the Blue Alarm Indicator (AIS). In Host Mode, TAOS is commanded by writing a one to bit D7 of the input data byte. In Hardware Mode, TAOS is commanded by setting pin 28 High. TAOS can be commanded simultaneously with Local Loopback, but is inhibited during Remote Loopback.

LOCAL LOOPBACK

Local Loopback (LLOOP) is designed to exercise the maximum number of functional blocks. During LLOOP operation, the RTIP/RRING inputs from the line are disconnected. Instead, the transmit outputs are routed back into the receive inputs. This tests the encoders/decoders, jitter attenuator, transmitter, receiver and timing recovery sections. In Host Mode, Local Loopback is commanded by writing a one to bit D6 of the input data byte. In Hardware Mode, Local Loopback is commanded by setting pin 27 High. If TAOS and LLOOP are both set, the All Ones pattern is transmitted

onto the line while the TPOS/TNEG input data is looped back to the RPOS/RNEG outputs.

REMOTE LOOPBACK

In Remote Loopback (RLOOP) Mode, the transmit data and clock inputs (TCLK and TPOS/TNEG or TDATA) are ignored, and the in-line encoders and decoders are bypassed. The RPOS/RNEG or RDATA outputs are looped back through the transmit circuits and output on TTIP and TRING at the RCLK frequency. Receiver circuits are unaffected by the RLOOP command and continue to output the RCLK and RPOS/RNEG or RDATA signals received from the twisted-pair line. In Host Mode, Remote Loopback is commanded by writing a one to bit D5 of the input data byte. In Hardware Mode, Remote Loopback is commanded by setting pin 26 High.

NETWORK LOOPBACK

Network Loopback can be commanded from the network when the Network Loopback detect function is enabled. In Host Mode, Network Loopback (NLOOP) detection is enabled by simultaneously writing ones to RLOOP, LLOOP and TAOS, then writing zeros in the next cycle. In Hardware Mode, Network Loopback detection is enabled by holding RLOOP, LLOOP and TAOS High simultaneously for 200 ns then bringing them Low, or by tying RCLK to RLOOP. NLOOP detection may be disabled by resetting the chip.

When NLOOP detection is enabled, the receiver monitors the input data stream for the NLOOP data patterns (00001 = enable, 001 = disable). When an NLOOP enable data pattern is repeated for a minimum of five seconds (with 10^{-3} BER), the device begins remote loopback operation. The LXT310 responds to both framed and unframed NLOOP patterns. Once remote network loopback detection is enabled at the chip and activated by the correct data pattern, it is identical to remote loopback initiated at the chip. NLOOP is reset by receiving the disable pattern for 5 seconds, or by activation of RLOOP. NLOOP is temporarily interrupted by LLOOP, but the NLOOP state is not reset.

APPLICATION INFORMATION

NOTE

This information is for design aid only.

Figure 5: Typical LATN Decoding Circuit

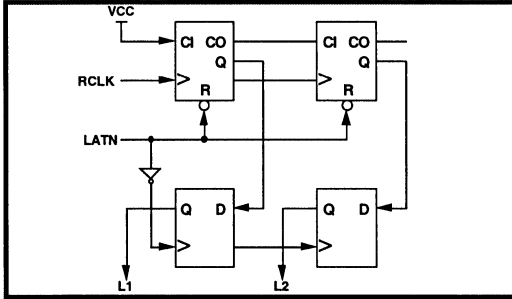

LATN Decoding Circuits and External Components

To conserve pins, the line attenuation output is encoded as a simple serial bit stream. Table 4 provides the decoded output for each equalizer setting. Figure 5 is a typical decoding circuit for the LATN output. It uses a 2-bit synchronous counter (half of a 4-bit counter) with synchronous reset, and a pair of flip-flops. Table 5 lists approved crystals and transformers.

Table 4: LATN Output Coding

L1	L2	Line Attenuation
0	0	0.0 dB
0	1	-7.5 dB
1	0	-15.0 dB
1	1	-22.5 dB

Table 5: Approved Crystals and Transformers

Component	Manufacturer	Part Numbers
Crystal (6.176 MHz)	M-Tron Monitor Products CTS Knights Valpey Fisher U.S. Crystal	MP-1 3808-010 / 4144-002 MSC1311-01B 6176-180 VF49A16FN1 U18-18-6176SP
Tx Transformer (1 : 2)	Bell Fuse FEE Fil-Mag Midcom Pulse Engineering Schott Corp HALO	0553-5006-IC 66Z1308 671-5832 65351, 65771 67127370 and 67130850 TD61-1205G and TD67-1205G (combo Tx/Rx)
Rx Transformer (1 : 1)	FEE Fil-Mag Midcom Pulse Engineering Schott Corp HALO	FE 8006-155 671-5792 64936 and 65778 67130840 and 67109510 TD61-1205G and TD67-1205G (combo Tx/Rx)

Table 6: LXT310 Crystal Specifications (External)

Parameter	Specification
Frequency	6.176 MHz
Frequency Stability	± 20 ppm @ 25 °C ± 25 ppm from -40 °C to 85 °C (Ref 25 °C reading)
Pullability	CL = 11 pF to 18.7 pF, +ΔF = 175 to 195 ppm CL = 18.7 pF to 34 pF, -ΔF = 175 to 195 ppm
Effective series resistance	40 Ω Maximum
Crystal cut	AT
Resonance	Parallel
Maximum drive level	2.0 mW
Mode of operation	Fundamental
Crystal holder	HC49 (R3W), CO = 7 pF maximum CM = 17 fF typical

LXT310 T1 CSU/ISDN PRI Transceiver

Host Mode Applications

Figure 6 shows a typical T1 CSU application with the LXT310 operating in the Host Mode (MODE pin tied high). A T1/ESF Framer provides the digital interface with the host controller. Both devices are controlled through the serial interface. In the Host Mode, the LOS alarm is reported via the serial port so the LOS pin is allowed to float.

An LXP600A Clock Adapter (CLAD) provides the 2.048 MHz system backplane clock, locked to the recovered 1.544 MHz clock signal. The 6.176 MHz crystal across XTALIN

and XTALOUT enables the JAL which is switched to the transmit side by the ground on JASEL. (Refer to Table 5 for approved crystals and transformers.) The power supply inputs are tied to a common bus with appropriate decoupling capacitors (68 μ F and 0.1 μ F) installed on each side.

The twisted-pair interfaces are relatively simple. A 100 Ω resistor across the input of a 1:1 transformer is used on the receive side, and a pair of 12.5 Ω resistors are installed in line with the 1:2 output transformer.

Figure 6: Typical LXT310 Host Mode T1/CSU Application

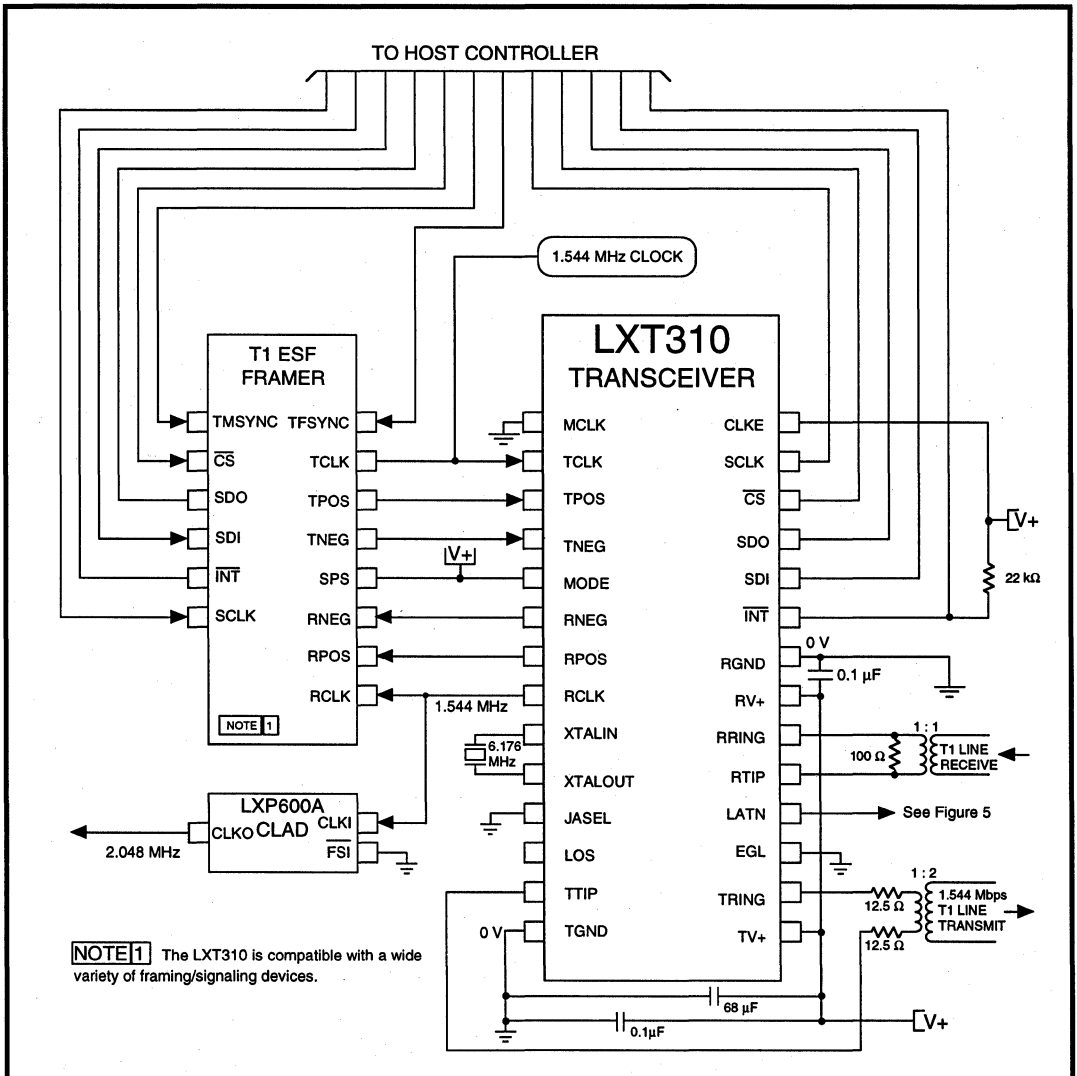

LXT310 Hardware Mode Applications

Figure 7 is a typical 1.544 Mbps ISDN PRI application with the LXT310, a T1/ESF framer and an LXP600A clock adapter. The LXT310 is operating in the Hardware Mode with B8ZS encoding enabled (MODE pin 5 tied to RCLK). As in the T1/CSU application, Figure 6, this configuration is illustrated with a single power supply bus. CMOS control

logic is used to set both LBO pins high, selecting the 22.5 dB LBO, and the EGL pin is tied low, allowing for full receiver gain. The TAOS, LLOOP and RLOOP diagnostic modes are individually controllable. The RCLK input to the OR gate at RLOOP allows for clocking of the RLOOP pin, which enables network loopback detection. The receive and transmit line interfaces are identical to the Host Mode application shown in Figure 6.

Figure 7: Typical LXT310 Hardware Mode Application

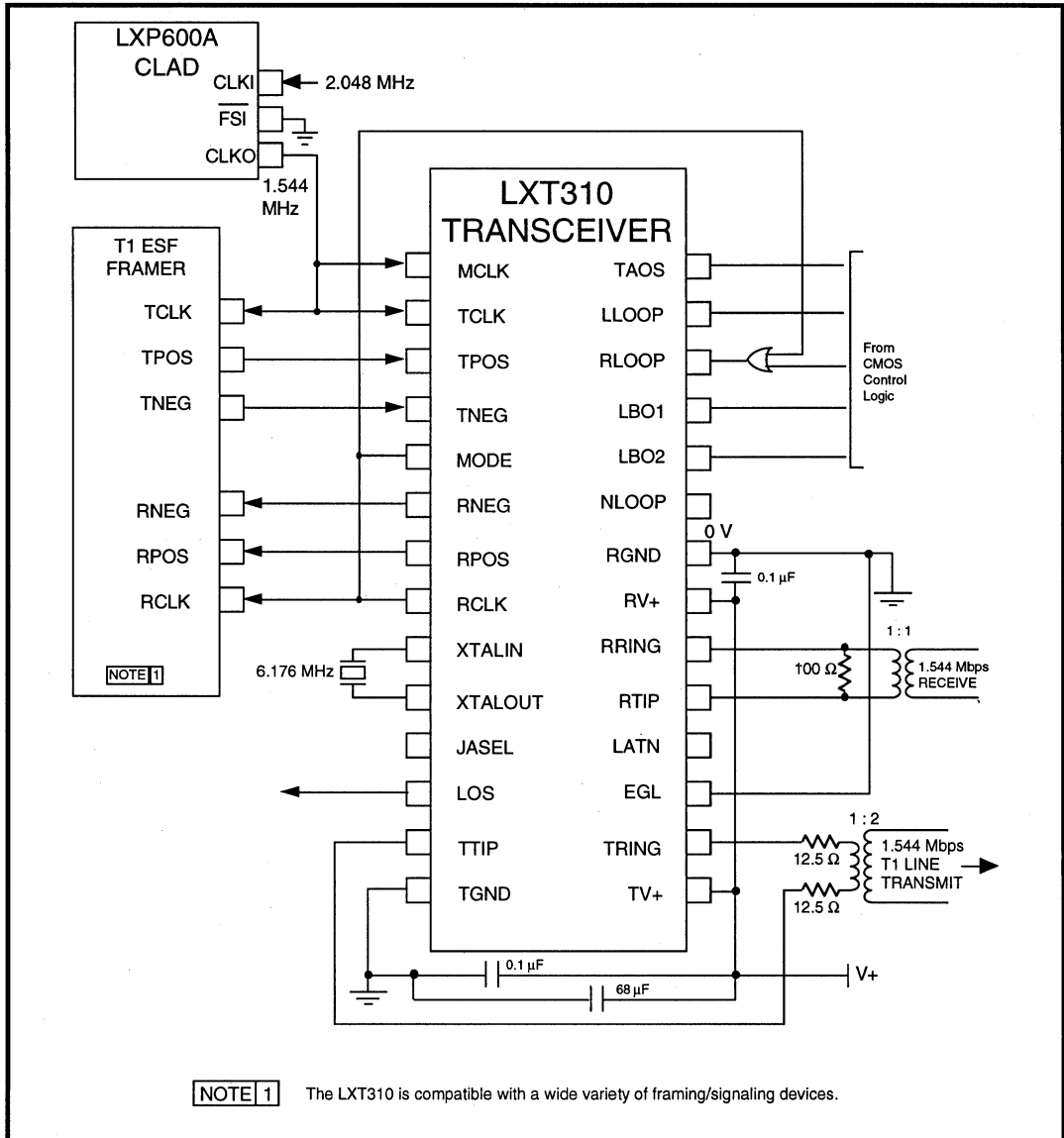

TEST SPECIFICATIONS

NOTE

Minimum and maximum values in Tables 7 through 14 and Figures 8 through 12 represent the performance specifications of the LXT310 and are guaranteed by test except, as noted, by design.

Table 7: Absolute Maximum Ratings

Parameter	Sym	Min	Max	Units
DC supply (referenced to GND)	RV+, TV+	-0.3	6.0	V
Input voltage, any pin	V _{IN}	RGND - 0.3	RV+ + 0.3	V
Input current, any pin ¹	I _{IN}	-10	10	mA
Ambient operating temperature	T _A	-40	85	°C
Storage temperature	T _{STG}	-65	150	°C

CAUTION

Operations at or beyond these limits may result in permanent damage to the device.
Normal operation not guaranteed at these extremes.

1. Transient currents of up to 100 mA will not cause SCR latch-up. TTIP, TRING, TV+ and TGND can withstand a continuous current of 100 mA.

Table 8: Recommended Operating Conditions

Parameter	Sym	Min	Typ	Max	Units	Test Conditions
DC supply ¹	RV+, TV+	4.75	5.0	5.25	V	
Ambient operating temperature	T _A	-	25	-	°C	

1. TV+ must not exceed RV+ by more than 0.3 V.

Table 9: Digital Characteristics (Over Recommended Range)

Parameter	Sym	Min	Typ ¹	Max	Units	Test Conditions
High level input voltage ^{2,3} (pins 1-5, 10, 23-28)	V _{IH}	2.0	-	-	V	
Low level input voltage ^{2,3} (pins 1-5, 10, 23-28)	V _{IL}	-	-	0.8	V	
High level output voltage ^{2,3} (pins 6-8, 11, 12, 23, 25)	V _{OH}	2.4	-	-	V	I _{OUT} = -400 μA
Low level output voltage ^{2,3} (pins 6-8, 11, 12, 23, 25)	V _{OL}	-	-	0.4	V	I _{OUT} = 1.6 mA
Input leakage current	I _{LL}	0	-	±10	μA	
Three-state leakage current ² (pin 25)	I _{3L}	0	-	±10	μA	
Driver power down current ⁴	I _{PD}	-	-	±1.2	mA	Direct connection to V _{CC} or GND
Total power dissipation ⁵	P _D	-	375	450	mW	100% ones density & maximum line length @ 5.25 V

1. Typical figures are at 25 °C and are for design aid only; not guaranteed and not subject to production testing.
2. Functionality of pins 23 and 25 depends on mode. See Host / Hardware Mode descriptions.
3. Output drivers will output CMOS logic levels into CMOS loads.
4. TTIP, TRING only in Idle or Power Down Mode.
5. Power dissipation while driving 25 Ω load over operating temperature range. Includes device and load. Digital input levels are within 10% of the supply rails and digital outputs are driving a 50 pF capacitive load.

Table 10: Analog Characteristics (Over Recommended Range)

Parameter	Min	Typ ¹	Max	Units	Test Conditions	
Recommended output load at TTIP and TRING	50	–	200	Ω		
AMI Output Pulse Amplitudes	2.4	3.0	3.6	V		
Jitter added by the transmitter ²	10 Hz - 8 kHz ³	–	–	0.01	UI	measured at the output with LBO1 = 0, and LBO2 = 0
	8 kHz - 40 kHz ³	–	–	0.02	UI	
	10 Hz - 40 kHz ³	–	–	0.02	UI	
	Broad Band	–	–	0.04	UI	
Receive signal attenuation range @ 772 kHz	Mode 1 (EGL = 1)	0	26	–	dB	
	Mode 2 (EGL = 0)	0	36	–	dB	
Allowable consecutive zeros before LOS	160	175	190	–		
Input jitter tolerance	10 kHz - 100 kHz	0.4	–	–	UI	0 dB line
	1 Hz	138	–	–	UI	
Jitter attenuation curve corner frequency ⁴	–	6	–	Hz		

1. Typical figures are at 25 °C and are for design aid only; not guaranteed and not subject to production testing.
2. Input signal to TCLK is jitter-free.
3. Guaranteed by characterization; not subject to production testing.
4. Circuit attenuates jitter at 20 dB/decade above the corner frequency.

6

Figure 8: 1.544 Mbps DS1 Pulse Mask (T1.403 - 1995)

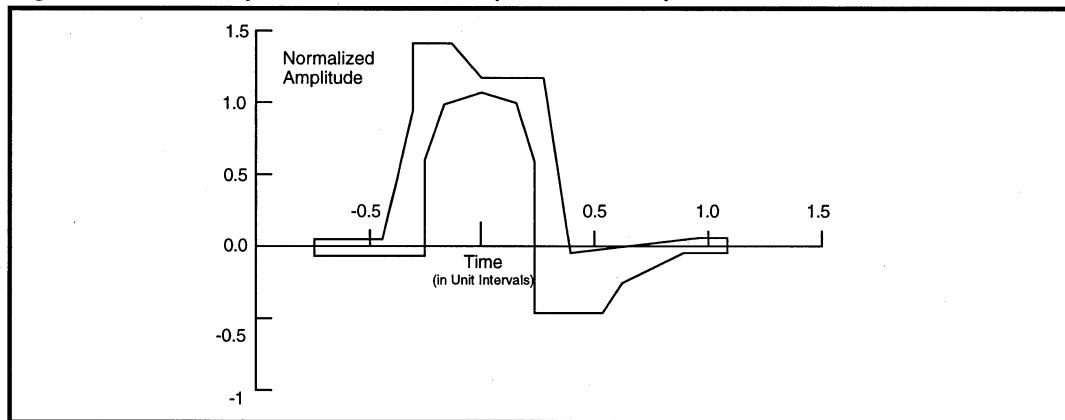

Table 11: Pulse Mask Corner Point Specifications

Maximum Curve		Minimum Curve	
Time (ns)	% V	Time (ns)	% V
0	5	0	-5
250	5	350	-5
325	80	350	50
325	120	400	90
425	120	500	95
500	105	600	90
675	105	650	50
725	5	650	-45
1100	5	800	-45
1250	5	896	-26
		1100	-5
		1250	-5

Table 12: LXT310 Receive Timing Characteristics (See Figure 9)

Parameter	Sym	Min	Typ ¹	Max	Units
Receive clock duty cycle ²	RCLKd	40	50	60	%
Receive clock pulse width ²	tpw	600	648	700	ns
Receive clock pulse width high	tpWH	–	324	–	ns
Receive clock pulse width low	tpWL	303	324	345	ns
RPOS / RNEG to RCLK rising setup time	tsUR	–	274	–	ns
RCLK rising to RPOS /RNEG hold time	tHR	–	274	–	ns

1. Typical figures are at 25 °C and are for design aid only; not guaranteed and not subject to production testing.
2. RCLK duty cycle widths will vary depending on extent of received pulse jitter displacement. Max and Min RCLK duty cycles are for worst case jitter conditions (0.4 UI clock displacement for 1.544 MHz).

Figure 9: LXT310 Receive Clock Timing Diagram

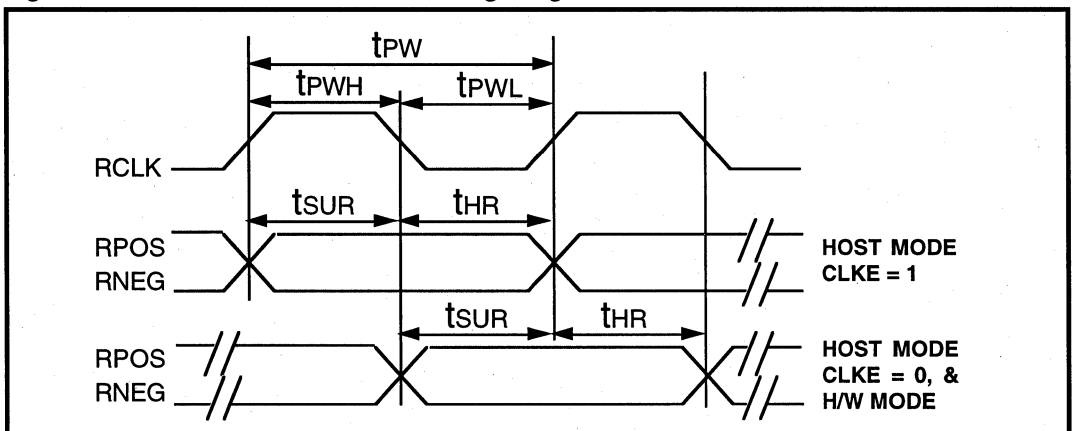

Table 13: LXT310 Master Clock and Transmit Timing Characteristics (See Figure 10)

Parameter	Sym	Min	Typ ¹	Max	Units	Notes
Master clock frequency	MCLK	–	1.544	–	MHz	
Master clock tolerance	MCLKt	–	±100	–	ppm	
Master clock duty cycle	MCLKd	40	–	60	%	
Crystal frequency	fc	–	6.176	–	MHz	LXT310 only
Transmit clock frequency	TCLK	–	1.544	–	MHz	
Transmit clock tolerance	TCLKt	–	–	±100	ppm	
Transmit clock duty cycle	TCLKd	10	–	90	%	
TPOS/TNEG to TCLK setup time	t _{SUT}	50	–	–	ns	
TCLK to TPOS/TNEG Hold time	t _{HT}	50	–	–	ns	

1. Typical figures are at 25 °C and are for design aid only; not guaranteed and not subject to production testing.

Figure 10: LXT310 Transmit Clock Timing Diagram

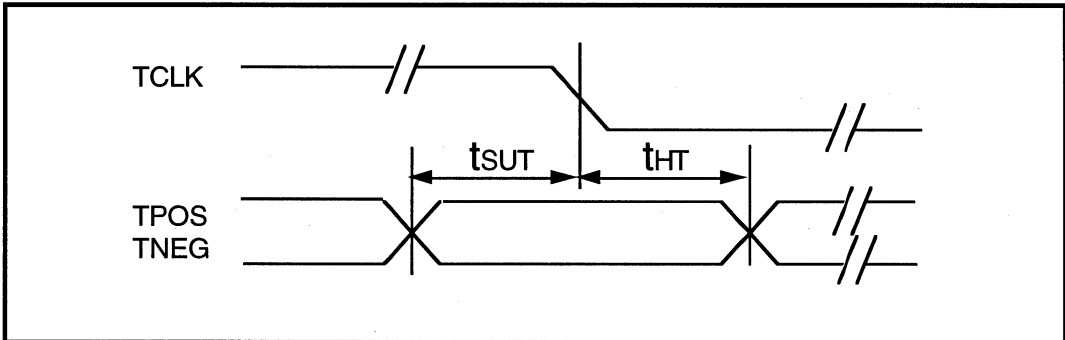

Table 14: LXT310 Serial I/O Timing Characteristics (See Figures 11 and 12)

Parameter	Sym	Min	Typ ¹	Max	Units	Test Conditions
Rise/Fall time - any digital output	trf	-	-	100	ns	Load 1.6 mA, 50 pF
SDI to SCLK setup time	t _{DC}	50	-	-	ns	
SCLK to SDI hold time	t _{CDH}	50	-	-	ns	
SCLK low time	t _{CL}	240	-	-	ns	
SCLK high time	t _{CH}	240	-	-	ns	
SCLK rise and fall time	t _r , t _f	-	-	50	ns	
\overline{CS} to SCLK setup time	t _{CC}	50	-	-	ns	
SCLK to \overline{CS} hold time	t _{CCH}	150	-	-	ns	
\overline{CS} inactive time	t _{CWH}	250	-	-	ns	
SCLK to SDO valid	t _{CDV}	-	-	200	ns	
SCLK falling edge or \overline{CS} rising edge to SDO high Z	t _{CDZ}	-	100	-	ns	

1. Typical figures are at 25 °C and are for design aid only; not guaranteed and not subject to production testing.

Figure 11: LXT310 Serial Data Input Timing Diagram

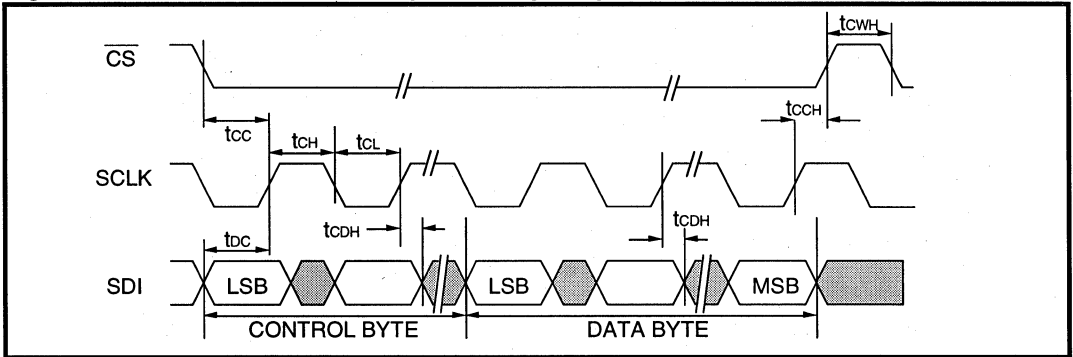
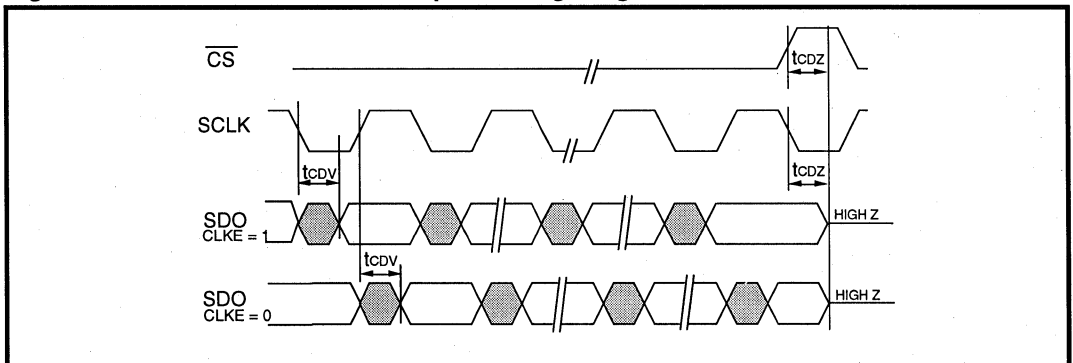

Figure 12: LXT310 Serial Data Output Timing Diagram



LXT317

DECT Twisted-Pair LIU Transceiver

General Description

The LXT317 is the first fully integrated, long-haul transceiver for Digital European Cordless Telephony (DECT) base station interface applications at 1.152 Mbps. The transceiver operates over twisted-pair cable to a maximum of 43 dB (3.5 km at 0.6 mm, 40 nF/km cable) with no external components.

The LXT317 offers selectable HDB3 encoding/decoding, and unipolar or bipolar data I/O. The LXT317 also offers a variety of diagnostic features including loopbacks and Loss of Signal monitoring.

Its advanced double-poly, double-metal CMOS process requires only a single 5-volt power supply.

Applications

- DECT base stations to switch/PBX interface
- NTU (interface to E1 Service)
- LAN bridge
- Private network data pump

Features

- Fully integrated transceiver comprising:
 - on-chip equalizer
 - timing recovery/control
 - data processor
 - receiver
 - transmitter
 - digital control
- Fully restores the received signal after transmission via a cable with attenuation of 43 dB @ 576 kHz
- Selectable Unipolar or Bipolar data I/O
- Selectable HDB3 encoding/decoding
- Output short circuit current limit protection
- On-line idle mode for testing or for redundant systems
- Local and remote loopback functions
- Receive monitor with Loss of Signal (LOS) output
- High input jitter tolerance
- Constant through-chip delay
- Available in 28-pin DIP and PLCC
- -40 °C to +85 °C operating temperature

6

LXT317 Block Diagram

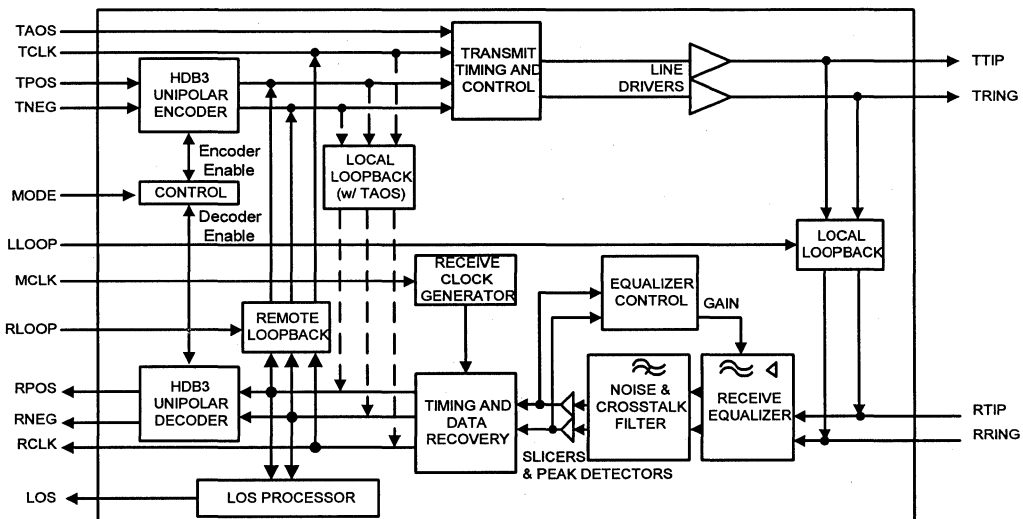

Preliminary Information: This product is not yet fully released to production. Some specifications may change and others may be added after production release.

LXT317 DECT Twisted-Pair LIU Transceiver

Figure 1: LXT317 Pin Assignments

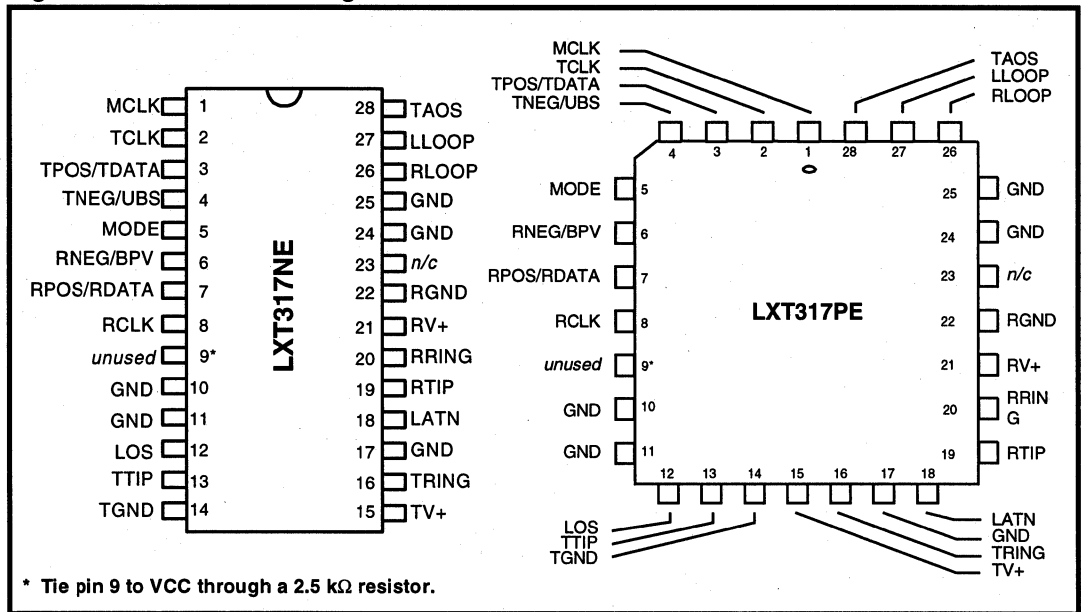

Table 1: Pin Descriptions

Pin #	Symbol	I/O	Description
1	MCLK	I	Master Clock. A 1.152 MHz clock input used to generate internal clocks. Upon Loss of Signal (LOS), RCLK is derived from MCLK. If MCLK is not applied tie this pin Low.
2	TCLK	I	Transmit Clock. Transmit clock input. TPOS and TNEG are sampled on the falling edge of TCLK. If TCLK is not supplied tie this pin Low.
3	TPOS/ TDATA	I	Transmit Data Input; Data Input/Polarity Select. Bipolar input for data to be transmitted on the twisted-pair line. Normally, pin 3 is TPOS and pin 4 is TNEG, the positive and negative sides of a bipolar input pair. However, when pin 4 is held High for at least 16 TCLK cycles (equivalent to 15 successive bipolar violations), the LXT317 switches to a unipolar mode. See Table 2 for Unipolar mode pin functions.
4	TNEG/ UBS	I	
5	MODE	I	Mode Select. Enables or disables zero suppression. Enables the HDB3 encoder/decoder when tied to RCLK. Disables HDB3 encoder/decoder when tied Low.
6	RNEG/ BPV	O	Receive Negative Data; Receive Positive Data. Bipolar data outputs. A signal on RNEG corresponds to receipt of a negative pulse on RTIP/RRING. A signal on RPOS corresponds to receipt of a positive pulse on RTIP/RRING. RNEG/RPOS outputs are Non-Return-to-Zero (NRZ). Both outputs are stable and valid on the rising edge of RCLK. In Unipolar mode, pin 6 output is a bipolar violation indicator and pin 7 is the unipolar data output. See Table 2 for Unipolar mode functions.
7	RPOS/ RDATA	O	
8	RCLK	O	Receive Clock. This is the clock recovered from the signal received at RTIP and RRING.
9	-	-	<i>not used.</i> Tie this pin to VCC through a 2.5 kΩ resistor.

Table 1: Pin Descriptions—continued

Pin #	Symbol	I/O	Description
10	GND	–	Ground. Tie this pin to ground.
11	GND	–	Ground. Tie this pin to ground.
12	LOS	O	Loss Of Signal. LOS goes High after 175 consecutive spaces and returns Low when the received signal reaches 12.5% mark density (minimum of four 1s within 32 bit periods, with no more than 15 consecutive 0s). Received marks are output on RPOS and RNEG even when LOS is High (during LOS condition).
13	TTIP	O	Transmit Tip; Transmit Ring. Differential Driver Outputs. These outputs are designed to drive a 50 - 200 Ω load. Line matching resistors and transformer can be selected to give the desired pulse height.
16	TRING	O	
14	TGND	–	Tx Ground. Ground return for the transmit drivers power supply TV+.
15	TV+	I	Transmit Power Supply. +5 VDC power supply input for the transmit drivers. TV+ must not vary from RV+ by more than ± 0.3 V.
17	GND	–	Ground. This pin must be tied to ground.
18	LATN	O	Line Attenuation Indication. Encoded output. Pulse width, relative to RCLK, indicates receive equalizer gain setting (line insertion loss at 1024 kHz). When LATN = one RCLK pulse, the equalizer is set at 10 dB of gain; two pulses = 21 dB; three pulses = 32 dB and four pulses = 0 dB. Output is valid on the rising edge of RCLK.
19	RTIP	I	Receive Tip; Receive Ring. The AMI signal received from the line is applied at these pins. A 1:1 transformer is required. Data and clock from the signal applied at these pins are recovered and output on the RPOS/RNEG, and RCLK pins.
20	RRING	I	
21	RV+	I	Receive Power Supply. +5 VDC power supply for all circuits except the transmit drivers. (Transmit drivers are supplied by TV+.)
22	RGND	–	Rx Ground. Ground return for power supply RV+.
23	–	–	<i>not used.</i> This pin is inactive—leave this pin floating.
24	GND	–	Ground. This pin is inactive—tie this pin to ground.
25	GND	–	Ground. This pin is inactive—tie this pin to ground.
26	RLOOP	I	Remote Loopback. This input controls remote loopback. Setting RLOOP High enables Remote Loopback. During Remote Loopback, inline encoders and decoders are bypassed. Setting both RLOOP and LLOOP High while holding TAOS Low causes a Reset.
27	LLOOP	I	Local Loopback. This input controls local loopback. Setting LLOOP High enables Local Loopback Mode. Setting both RLOOP and LLOOP High while holding TAOS Low causes a Reset. Allow 32 ms to recover from Reset.
28	TAOS	I	Transmit All Ones. This pin controls the TAOS function. When tied High, TAOS causes the LXT317 to transmit a stream of marks at the TCLK frequency. Activating TAOS causes TPOS and TNEG inputs to be ignored. TAOS is inhibited during Remote Loopback, but can be activated simultaneously with Local Loopback.

Table 2: Unipolar Data I/O Pin Descriptions¹

Pin #	Symbol	I/O	Description
3	TDATA	I	Transmit Data. Unipolar input for data to be transmitted on the twisted-pair line.
4	UBS	I	Unipolar/Bipolar Select. When pin 4 is held High for at least 16 TCLK cycles (equivalent to 15 successive bipolar violations), LXT317 switches to unipolar data I/O. The device immediately returns to bipolar I/O when pin 4 goes Low.
6	BPV	O	Bipolar Violation. Pin 6 goes High when a bipolar violation is received.
7	RDATA	O	Receive Data. Unipolar data output. RDATA is a Non-Return-to-Zero (NRZ) output. RDATA is stable and valid on the rising edge of RCLK.

1. Table 2 lists only those pins which are affected by the switch to unipolar data I/O.

FUNCTIONAL DESCRIPTION

NOTE

This functional description information is for design aid only

The LXT317 is a fully integrated PCM transceiver for 1.152 Mbps DECT applications. It allows full-duplex transmission of digital data over existing twisted-pair installations.

Table 1 lists the LXT317 pin assignments and signal descriptions. Table 2 lists the alternative pin assignments for unipolar data I/O mode. The LXT317 transceiver interfaces with two twisted-pair lines (one twisted-pair for transmit, one twisted-pair for receive) through standard pulse transformers and appropriate resistors.

The figure on the front of this Data Sheet shows a block diagram of the LXT317. Individual hard-wired pins control the transceiver. It can operate in either a bipolar (default) or unipolar data transmission mode. The LXT317 can also operate in one of several diagnostic modes, including Local Loopback, Remote Loopback and Transmit All Ones (TAOS).

TRANSMITTER

Input data (bipolar or unipolar) for transmission onto the line is clocked serially into the LXT317. The bipolar data inputs are at pin 3 (TPOS) and pin 4 (TNEG). The unipolar data input is at pin 3 (TDATA) only. Input data passes through the HDB3 encoder, if selected by connecting the MODE pin to RCLK. Input synchronization is supplied by the transmit clock (TCLK). Refer to the Test Specifications section for transmit timing.

Idle Mode

The LXT317 incorporates a transmit idle mode. This allows multiple transceivers to be connected to a single line for redundant applications or for testing purposes. TTIP and TRING remain in a high impedance state when TCLK is not present (TCLK grounded). Enabling Remote Loopback temporarily disables the high impedance state.

Short Circuit Limit

The LXT317 transmitter is equipped with a short-circuit limiter. This feature limits to approximately 120 mA RMS the current the transmitter will source into a low-impedance load. The limiter trips when the RMS current exceeds the limit for 120 μ s (~ 150 marks). It automatically resets when the load current drops below the limit.

Line Code

The LXT317 transmits data as a 50% AMI line code as shown in Figure 2. Biasing of the transmit DC level is on-chip. Shaped pulses meeting the DECT requirements are applied to the AMI line driver for transmission onto the line at TTIP/TRING. The pulse conforms to the mask defined in ITU G.703, with the time scale expanded by a factor of $16/9$ for a nominal pulse width of 434 ns. Refer to Figure 11 and Table 8 for 1.152 Mbps pulse mask specifications.

Figure 2: 50% Duty Cycle Transmit Pulse

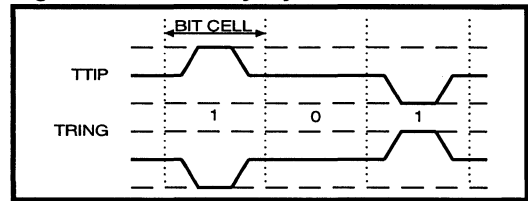

RECEIVER

The input from the twisted-pair is received via a 1:1 transformer. Recovered data is output at RPOS/RNEG (RDATA in unipolar mode), and the recovered clock is output at RCLK. Refer to the Test Specifications section for receiver timing.

The signal received at RTIP and RRING is processed through the receive equalizer which may apply up to 43 dB of gain. Insertion loss of the line, as indicated by the receive equalizer setting, is encoded in the LATN output as shown in Figure 5.

The equalized signal is filtered and applied to the peak detector and data slicers. The peak detector samples the inputs and determines the maximum value of the received signal. Fifty percent of the peak value is provided to the data slicers as a threshold level to ensure optimum signal-to-noise ratio.

The receiver is capable of accurately recovering signals with up to 43 dB of cable attenuation (from 2.7 V).

After processing through the data slicers, the received signal is routed to the data and timing recovery section, then to the HDB3 decoder (if selected) and to the LOS processor. The data and timing recovery sections provide an input jitter tolerance significantly better than required by ITU G.823, as shown in the Test Specifications section. The Test Specifications section also includes the jitter tolerance template.

If the incoming bit stream has jitter, the jitter transfer limit for the LXT317 is less than 1 dB up to 25 kHz; it then decreases by 20 dB per decade from 25 kHz to 100 kHz (using a 2^{15} -1 bit, PRBS signal). Refer to Figure 15 for the jitter transfer template.

LXT317 DECT Twisted-Pair LIU Transceiver

The LOS processor loads a digital counter at the RCLK frequency. The count is incremented each time a 0 (space) is received, and reset to 0 each time a 1 (mark) is received. Upon receipt of 175 consecutive 0s the LOS pin goes High, and a smooth transition replaces the RCLK output with the MCLK.

Received marks will be output regardless of the LOS status, but the LOS pin will not reset until the 1s density reaches 12.5% (receipt of at least four 1s in any 32-bit periods, with no more than 15 consecutive 0s).

SELECTING UNIPOLAR OR BIPOLAR DATA MODE

The LXT317 operates in Bipolar Data mode by default. To enable Unipolar Mode, hold pin 4 High for 16 TCLK cycles. To return to Bipolar Mode immediately, pull pin 4 Low. To enable the HDB3 encoder/decoder circuits, connect pin 5 to RCLK.

INITIALIZATION AND RESET OPERATION

Upon power up, the transceiver is held static until the power supply reaches approximately 3V. Upon crossing this threshold, the device begins a 32 ms reset cycle to lock the transmit and receive Phase Lock Loops. The transmitter reference is provided by TCLK; the receive reference is provided by MCLK. All PLLs are continuously calibrated.

Command reset by holding RLOOP and LLOOP High simultaneously for 200 ns while holding TAOS Low. When the reset conditions end, the device begins the 32 ms cycle to calibrate the transmit and receive PLLs.

DIAGNOSTIC MODE OPERATION

Transmit All Ones. See Figure 3. In Transmit All Ones (TAOS) mode the TPOS and TNEG inputs to the transceiver are ignored and the transceiver transmits a continuous stream of 1s at the TCLK frequency. If there is no TCLK provided, TAOS is locked to the MCLK. This can be used as the AIS Alarm Indicator (AIS also called the Blue Alarm). Command TAOS by setting pin 28 High. TAOS can be commanded simultaneously with LLOOP as shown in Figure 4, but is inhibited during Remote Loopback.

Figure 3: Transmit All Ones

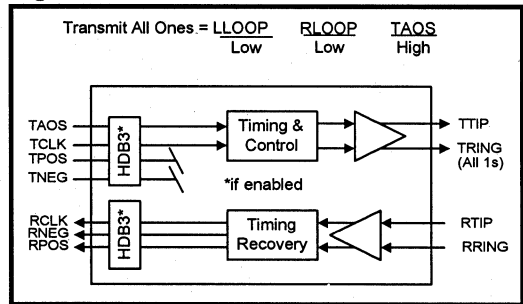

Figure 4: TAOS with LLOOP Data Path

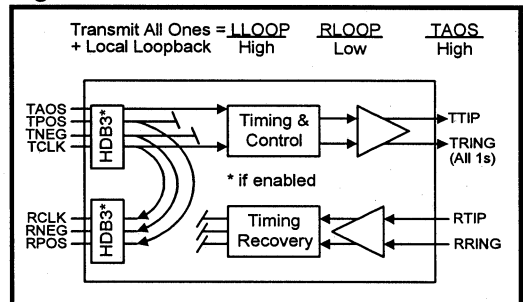
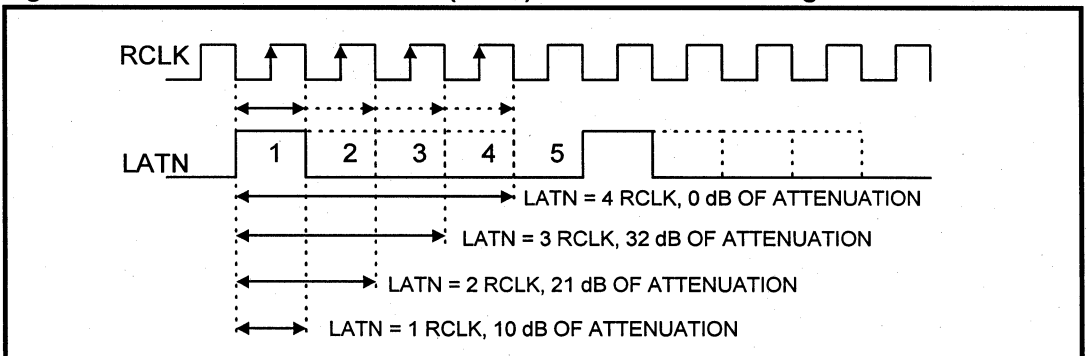
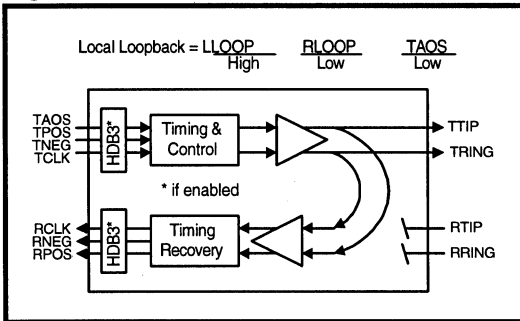

Figure 5: LXT317 Line Attenuation (LATN) Pulse Width Encoding



Local Loopback. See Figure 6. Local Loopback (LLOOP) is designed to exercise the maximum number of functional blocks. During LLOOP operation, the RTIP/RRING inputs from the line are disconnected. Instead, the transmit outputs are routed back into the receive inputs. This tests the encoders/decoders, transmitter, receiver and timing recovery sections. Enable Local Loopback by setting pin 27 High. If TAOS and LLOOP are both active, the All Ones pattern is transmitted onto the line while the TPOS/TNEG input data loops back to the RPOS/RNEG outputs.

Figure 6: Local Loopback



Remote Loopback. See Figure 7. In Remote Loopback (RLOOP) mode, the transmit clock and data inputs (TCLK and TPOS/TNEG or TDATA) are ignored, and the in-line encoders and decoders are bypassed. The RPOS/RNEG or RDATA outputs are looped back through the transmit circuits and output on TTIP and TRING at the RCLK frequency. Receiver circuits are unaffected by the RLOOP command and continue to output the RCLK and RPOS/RNEG or RDATA signals received from the twisted-pair line. Command Remote Loopback by setting pin 26 High.

Figure 7: Remote Loopback

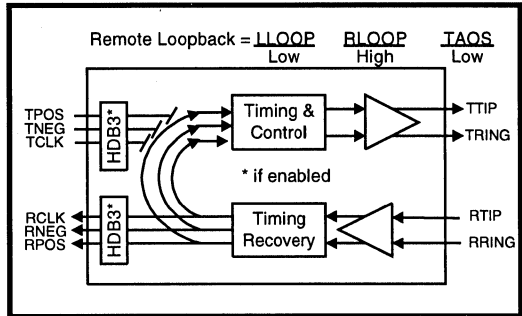

APPLICATION INFORMATION

NOTE

This application information is for design aid only.

LATN DECODING CIRCUITS AND EXTERNAL COMPONENTS

The line attenuation (LATN) output is encoded as a simple serial bit stream for use in line monitoring applications. Figure 8 is a typical decoding circuit for the LATN output. It uses a 2-bit synchronous counter (half of a 4-bit counter) with synchronous reset, and a pair of flip-flops. Table 3 provides the decoded output for each equalizer setting.

Figure 8: Typical LATN Decoding Circuit

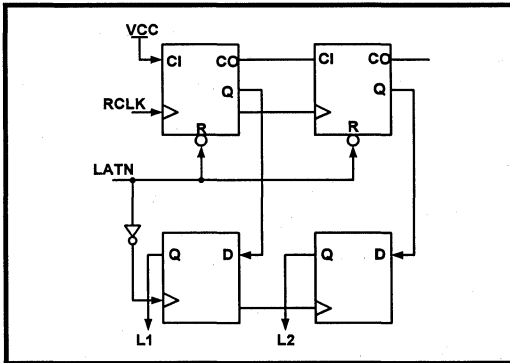
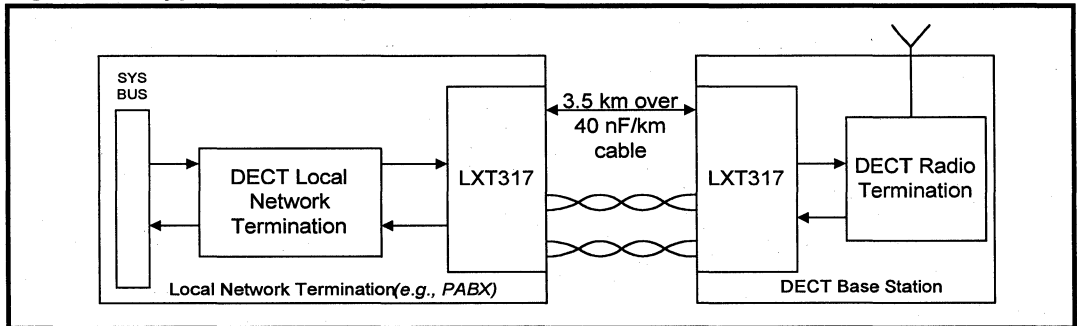

Table 3: Line Attenuation Decoding

L2	L1	Line Attenuation
0	0	0.0 dB
0	1	-10 dB
1	0	-21 dB
1	1	-32 dB

Figure 9: Typical DECT Application



POWER REQUIREMENTS

The LXT317 is a low-power CMOS device. It operates from a single +5 V power supply which can be connected externally to both the transmitter and receiver. However, the two inputs must be within ± 3 V of each other, and decoupled separately to their respective grounds, as shown in Figure 10. Isolation between the transmit and receive circuits is provided internally.

Table 4: Approved Transformers

Transformer Type	Manufacturer	Part Number	
Transmit (1:2)	Bell Fuse	0553-50061C	
	Fil-Mag	66Z1308	
	Midcom	671-5832	
	Pulse Engineering	PE 65351	
		PE65771	
	Schott Corp	67127370 67130850	
Receive (1:1)	Fil-Mag	FE 8006-155	
	Midcom	671-5792	
	Pulse Engineering	PE 64936 PE 65778	
	Schott Corp	67130840 67109510	
	Combination (Tx & Rx)	HALO	TD61-1205D2
		VALOR	PT5083

LXT317 CIRCUITRY

Figure 9 shows a typical DECT application with the LXT317. Figure 10 shows typical LXT317 circuit connections. The power supply inputs are tied to a common bus with appropriate decoupling capacitors (68 μ F and 1.0 μ F) installed on each side.

The line interfaces are relatively simple. A 120 Ω resistor (for TWP applications) across the input of a 1:1 transformer is used on the receive side, and a pair of 15 Ω resistors are installed in series with the 1:2 transmit transformer. (Table 4 lists approved transformers.)

Figure 10: Typical LXT317 DECT Application

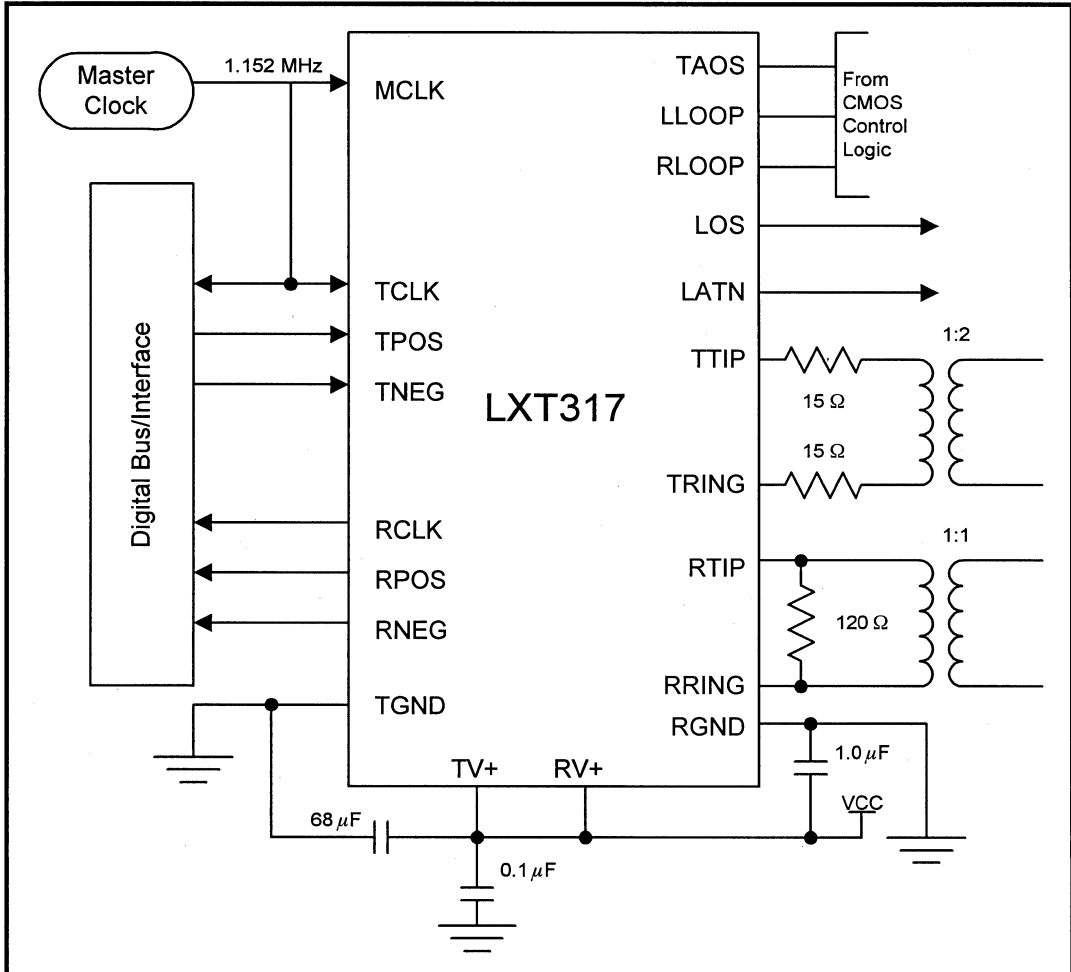

TEST SPECIFICATIONS

NOTE

The minimum and maximum values in Tables 5 through 11 and Figures 11 through 16 represent the performance specifications of the LXT317 and are not guaranteed by test, except where noted by design.

Table 5: Absolute Maximum Ratings

Parameters	Symbol	Min	Max	Units
DC supply (referenced to GND)	RV+, TV+	-	6.0	V
Input voltage, any pin	V _{IN}	RGND, -0.3	RV+, +0.3	V
Input current, any pin ¹	I _{IN}	-10	10	mA
Ambient operating temperature	T _A	-40	85	°C
Storage temperature	T _{STG}	-65	150	°C

CAUTION
Operation at or beyond these limits may permanently damage the device.
Normal operation is not guaranteed at these extremes.

1. Transient Currents of up to 100 mA will not cause SCR latch-up. TTIP, TRING, TV+, TGND can withstand continuous current of 100 mA.

Table 6: Recommended Operating Conditions and Characteristics

Parameter	Symbol	Min	Typ ¹	Max	Units	Test Conditions
DC supply ²	RV+, TV+	4.75	5.0	5.25	V	
Ambient operating temperature	T _A	-40	-	+85	°C	
Power dissipation ³	P _D	-	300	400	mW	100% ones density & maximum line length @ 5.25 V

1. Typical values are at 25 °C and are for design aid only; not guaranteed and not subject to production testing.
2. TV+ must not differ from RV+ by more than 0.3 V.
3. Power dissipation while driving 25 Ω load over operating temperature range. Includes device and load. Digital input levels are within 10% of the supply rails and digital outputs are driving a 50 pF capacitive load.

Table 7: Digital Characteristics (over the Recommended Range)

Parameter	Sym	Min	Typ	Max	Units	Test Conditions
High level input voltage (pins 1-5, 10, 26-28)	V _{IH}	2.0	-	-	V	
Low level input voltage (pins 1-5, 10, 26-28)	V _{IL}	-	-	0.8	V	
High level output voltage ¹ (pins 6-8, 12)	V _{OH}	3.8	-	-	V	I _{OUT} = -400 μA
Low level output voltage ¹ (pins 6-8, 12)	V _{OL}	-	-	0.4	V	I _{OUT} = 1.6 mA
Input leakage current	I _{LL}	0	-	±10	μA	
Driver Power Down Current ²	I _{PD}	-	-	±1.2	mA	direct connection to VCC or GND

1. Output drivers will output CMOS logic levels into CMOS loads.
2. TTIP, TRING only in Idle or Power Down Mode.

Figure 11: 1.152 Mbps Pulse Mask

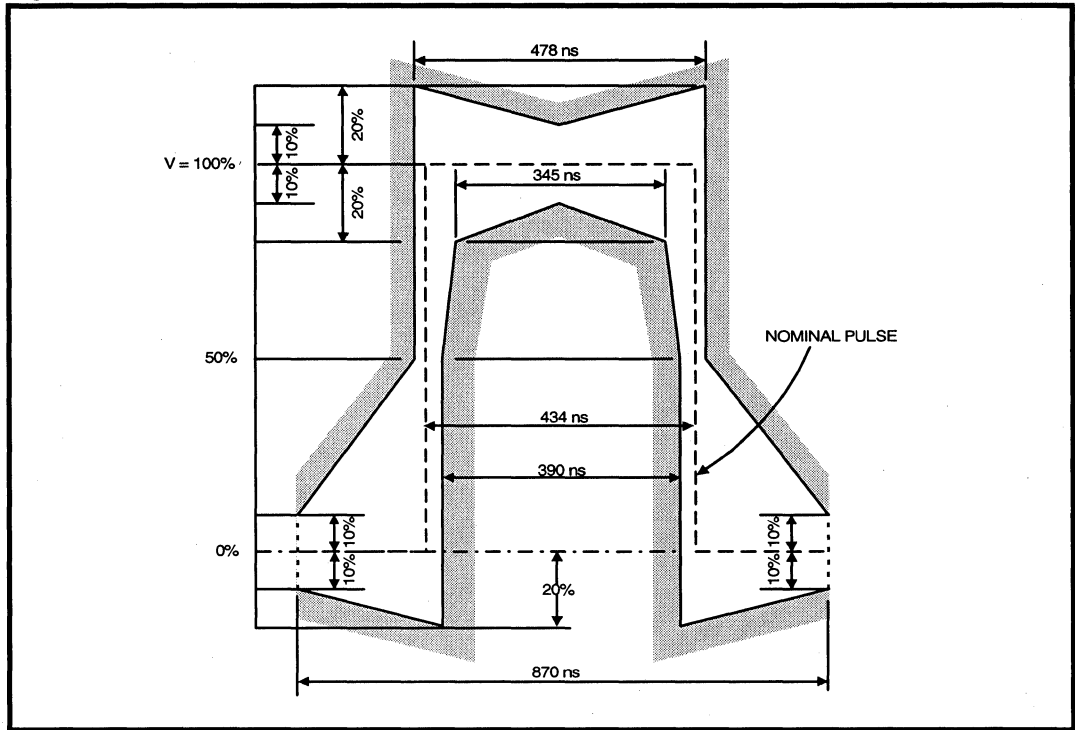

6

Table 8: 1.152 Mbps Pulse Mask Parameters

Parameter	TPW	Units
Test load impedance	120	Ω
Nominal peak mark voltage	3.0	V
Nominal peak space voltage	0 ± 0.30	V
Nominal pulse width	434	ns
Ratio of positive and negative pulse amplitude at center of pulse	95-105	%
Ratio of positive and negative pulse amplitudes at nominal half amplitude	95-105	%

LXT317 DECT Twisted-Pair LIU Transceiver

Table 9: Analog Characteristics (over the Recommended Range)

Parameter		Min	Typ ¹	Max	Units	Test Conditions		
Recommended output load at TTIP and TRING		50	120	200	Ω			
AMI output pulse amplitudes		2.7	3.0	3.3	V	Measured at the output		
Jitter added by the transmitter ² 20 Hz - 100 kHz		-	-	0.05	UI (pp)			
Input jitter tolerance	20 kHz - 100 kHz	0.2	0.3	-	UI	0 - 43 dB line		
	10 Hz	100	500	-	UI			
Round Trip Chip Data Delay ^{2, 3, 4}	TDATA to Transmitter	-	5.5	-	bits			
	Receiver to RDATA	-	7.0	-	bits			
Receive signal attenuation range @ 576 kHz		+1	-43.0	-	dB			
Allowable consecutive 0s before LOS declared		160	175	190				
Return loss ³		Transmit		Receive				
		Min	Typ	Min	Typ			
		29 kHz - 58 kHz		12	15	12	15	dB
		58 kHz - 1.152 MHz		15	16	16	18	dB
1.152 MHz - 2.304 MHz		14	18	14	18	dB		

1. Typical values are at 25 °C and are for design aid only, not guaranteed and not subject to production testing.
 2. Input signal to TCLK is jitter free.
 3. Guaranteed by characterization; not subject to production testing.
 4. Using HDB3 encoders and decoders in data path.

Table 10:LXT317 Master Clock and Transmit Timing Characteristics (See Figure 12)

Parameter	Sym	Min	Typ ¹	Max	Units	Notes
MCLK frequency	MCLK	-	1.152	-	MHz	
MCLK tolerance	MCLKt	-	-	±100	ppm	
MCLK duty cycle	MCLKd	40	-	60	%	
TCLK frequency	TCLK	-	1.152	-	MHz	
TCLK tolerance	TCLKt	-	-	±100	ppm	
TCLK duty cycle	TCLKd	10	-	90	%	
TPOS/TNEG to TCLK setup time	tSUT	50	-	-	ns	
TCLK to TPOS/TNEG hold time	tHT	50	-	-	ns	

1. Typical values are at 25 °C and are for design aid only; not guaranteed and not subject to production testing.

Figure 12: LXT317 Transmit Clock Timing

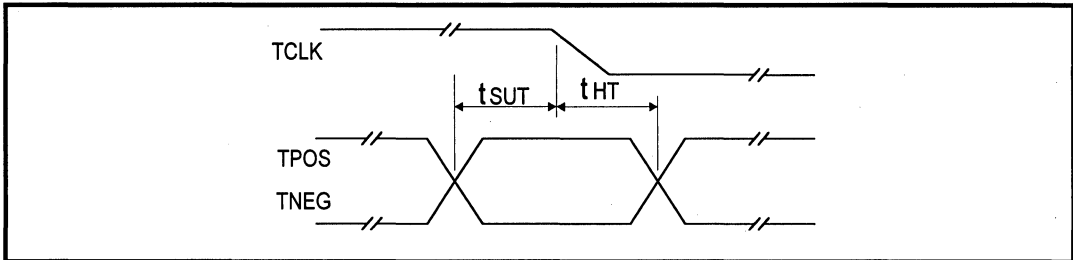

LXT317 DECT Twisted-Pair LIU Transceiver

Table 11: LXT317 Receive Timing Characteristics (see Figure 13)

Parameter	Sym	Min	Typ ¹	Max	Units	Notes
RCLK duty cycle ²	RCLKd	40	50	60	%	
RCLK width ²	tPW	–	868	–	ns	
RCLK pulse width high	tPWH	398	434	–	ns	
RCLK pulse width low	tPWL	398	434	470	ns	
RPOS/RNEG to RCLK rising setup time	tSUR	300	384	–	ns	
RCLK rising to RPOS/RNEG hold time	tHR	300	384	–	ns	

1. Typical values are at 25 °C and are for design aid only; not guaranteed and not subject to production testing.
2. RCLK duty cycle widths will vary depending on extent of received pulse jitter displacement. Max and min RCLK duty cycles are for worst case jitter conditions (0.4 UI clock displacement for 1.152 MHz.)

Figure 13: LXT317 Receive Clock Timing

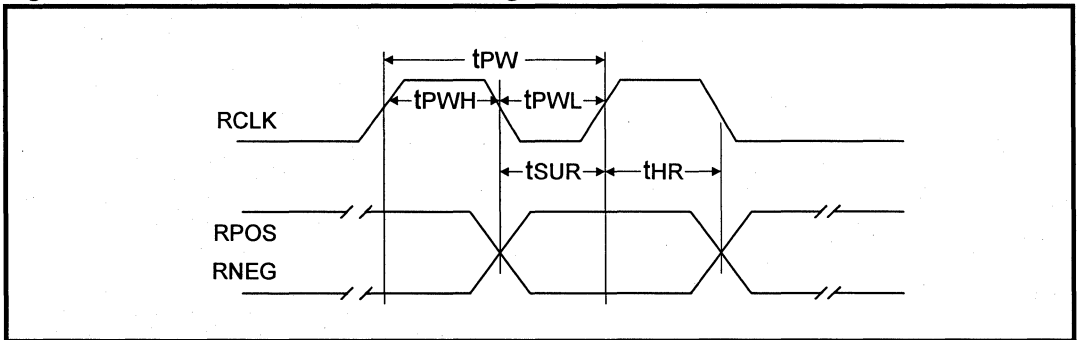
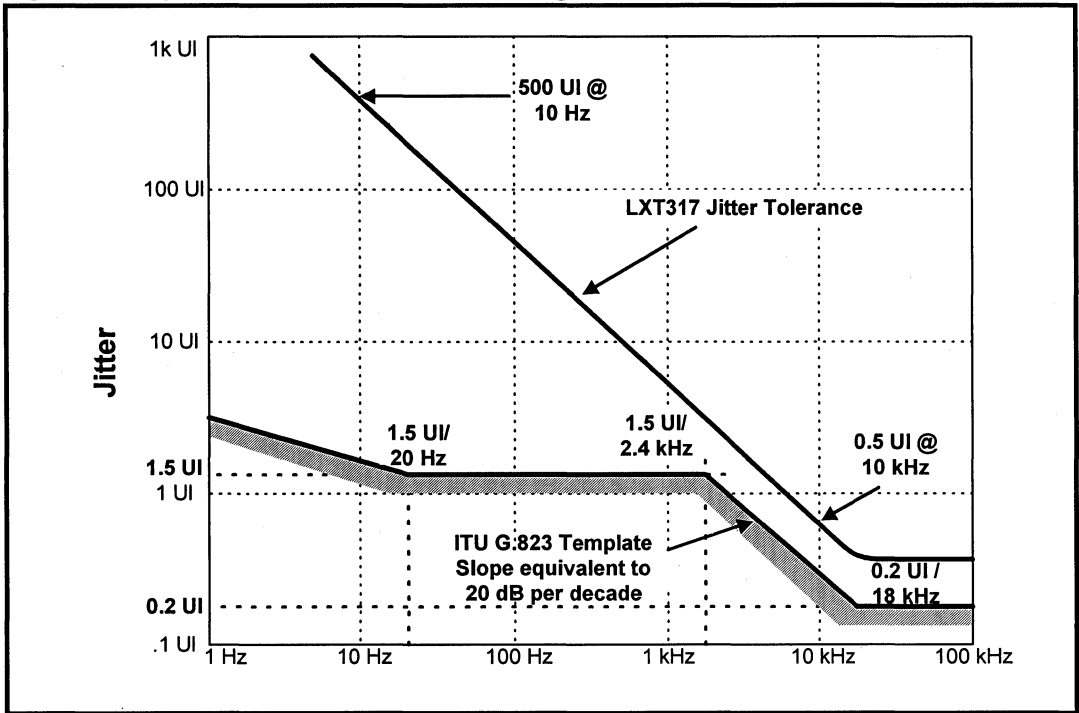
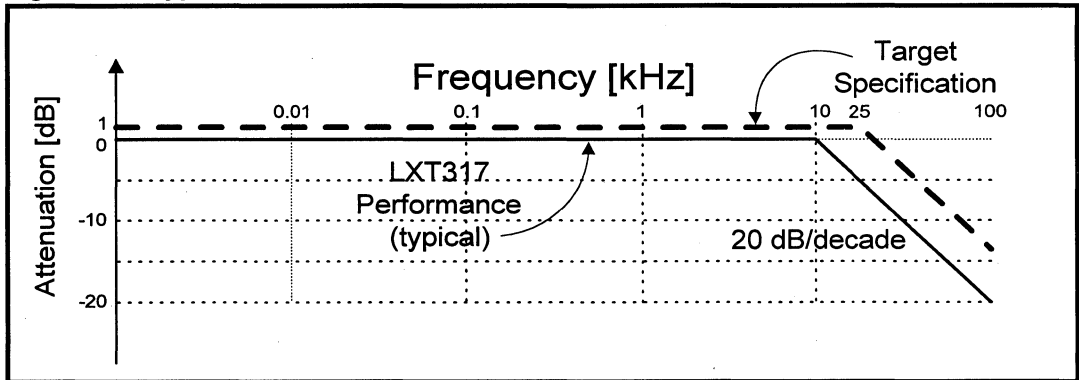

Figure 14: Typical LXT317 Jitter Tolerance @ 43 dB



6

Figure 15: Typical LXT317 Jitter Attenuation (Test Signal PRBS = 2¹⁵-1)



LXT317 DECT Twisted-Pair LIU Transceiver

NOTES:

LXT318

E1 NTU/ISDN PRI Transceiver

General Description

The LXT318 is the first fully integrated transceiver for E1 Network Termination Unit (NTU) and ISDN Primary Rate Interface (ISDN PRI) applications at 2.048 Mbps. The transceiver operates from 0.0 km to 2.6 km of 0.6 mm (22 AWG) twisted-pair cable with no external components.

The LXT318 offers selectable HDB3 encoding/decoding, and unipolar or bipolar data I/O. The LXT318 also provides jitter attenuation in either the transmit or receive direction starting at 3 Hz, and incorporates a serial interface (SIO) for microprocessor control.

The LXT318 offers a variety of diagnostic features including loopbacks and loss of signal monitoring. It is built using an advanced double-poly, double-metal CMOS process and requires only a single 5-volt power supply.

Applications

- PCM 30/ISDN PRI Interface (ITU G.703, I.431)
- NTU (interface to E1 Service)
- E1 Mux or LAN bridge - Campus Networking
- Wireless Base Stations/Networking
- CPU to CPU Channel Extenders
- Digital Loop Carrier — Subscriber Carrier Systems
- Channel Banks
- HDSL - E1 Extension

Features

- Fully integrated transceiver comprising: on-chip equalizer; timing recovery/control; data processor; receiver; transmitter and digital control
- Pin compatible with the LXT310 T1 CSU/ISDN PRI (1.544 Mbps) transceiver
- Meets or exceeds latest ITU specifications including G.703, G.736, G.823, and I.431
- Meets ETSI 300011 and 300233 standards
- Jitter attenuation starting at 3 Hz, switchable to transmit or receive path
- Exceeds ETSI TBR12/13 jitter transfer performance specifications
- Fully restores the received signal after transmission via a cable with attenuation of 43 dB @ 1024 kHz
- Selectable Unipolar or Bipolar data I/O
- Selectable HDB3 encoding/decoding
- Output short circuit current limit protection
- Meets 50 mARMS short-circuit current limit (per OFTEL OTR-001)
- On-line idle mode for testing or for redundant systems
- Local and remote loopback functions
- Receive monitor with Loss of Signal (LOS) output
- Microprocessor controllable
- Available in 28-pin DIP and PLCC
- Extended Temperature Range (-40° C to +85° C)

6

LXT318 Block Diagram

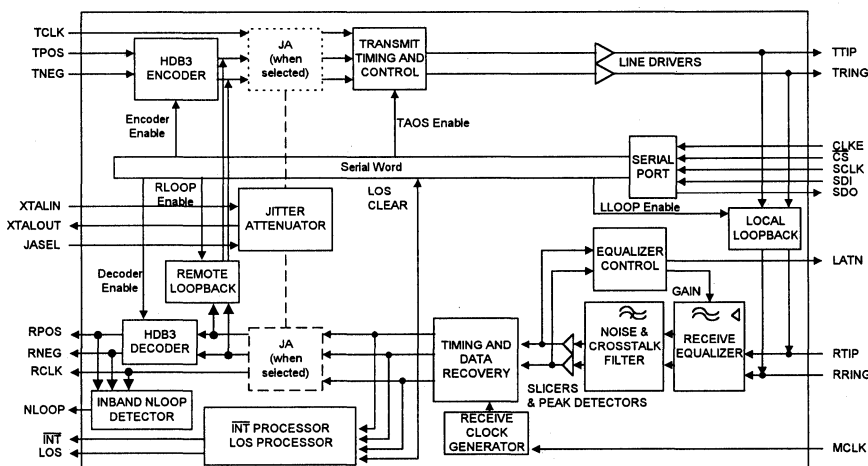

Figure 1: LXT318 Pin Assignments

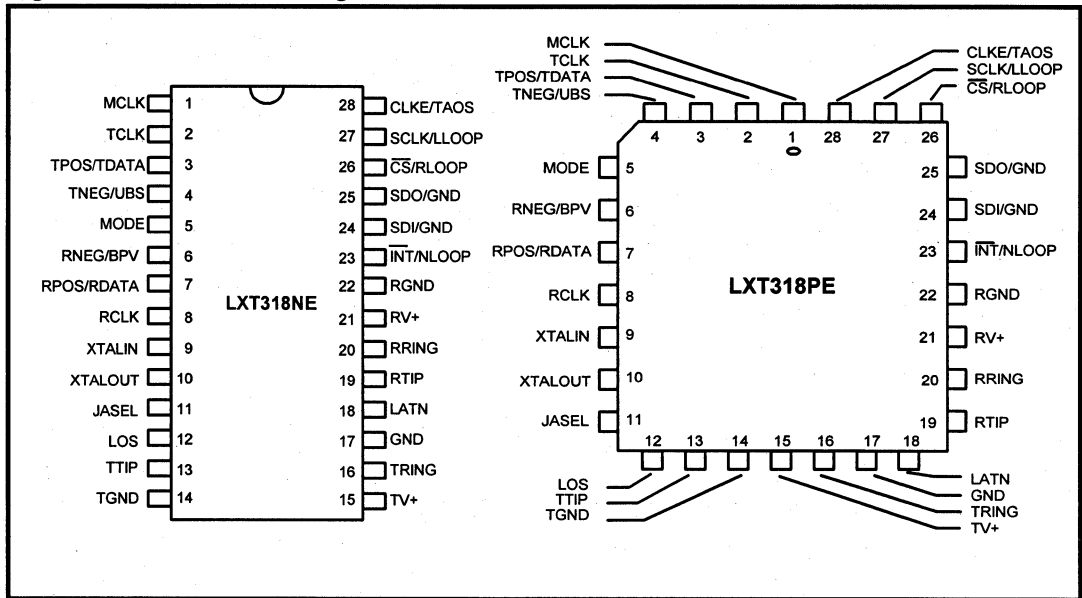

Table 1: Pin Descriptions

Pin #	Symbol	I/O	Description
1	MCLK	I	Master Clock. A 2.048 MHz clock input used to generate internal clocks. Upon loss of Signal (LOS), RCLK is derived from MCLK. If MCLK is not applied, this pin should be grounded.
2	TCLK	I	Transmit Clock. Transmit clock input. TPOS and TNEG are sampled on the falling edge of TCLK. Ground this pin if TCLK is not supplied.
3	TPOS/ TDATA	I	Transmit Data Input; Data Input/Polarity Select. Input for data to be transmitted on the twisted-pair line. Normally, pin 3 is TPOS and pin 4 is TNEG, the positive and negative sides of a bipolar input pair. However, when pin 4 is held High for at least 16 TCLK cycles (equivalent to 15 successive bipolar violations), the LXT318 switches to a unipolar mode. Unipolar mode pin functions are listed in Table 2.
4	TNEG/UBS	I	
5	MODE	I	Mode Select. Setting MODE High puts the LXT318 in the Host mode. In the Host mode, the serial interface is used to control the LXT318 and determine its status. Setting MODE Low puts the LXT318 in the Hardware (H/W) mode. In the Hardware mode the serial interface is disabled and hard-wired pins are used to control configuration and report status. Tying MODE to RCLK activates the Hardware mode and enables the HDB3 encoder/decoder.
6	RNEG/BPV	O	Receive Negative Data; Receive Positive Data. Bipolar data outputs. A signal on RNEG corresponds to receipt of a negative pulse on RTIP/RRING. A signal on RPOS corresponds to receipt of a positive pulse on RTIP/RRING. RNEG/RPOS outputs are Non-Return-to-Zero (NRZ). In Host mode, CLKE determines the clock edge at which these outputs are stable and valid. In Hardware mode both outputs are stable and valid on the rising edge of RCLK. In Unipolar mode, pin 6 output is a bipolar Violation indication and pin 7 is the unipolar data output. See Table 2 for Unipolar mode functions.
7	RPOS/ RDATA	O	

Table 1: Pin Descriptions – continued

Pin #	Symbol	I/O	Description
8	RCLK	O	Receive Clock. This is the clock recovered from the signal received at RTIP and RRING.
9	XTALIN	I	Crystal Input; Crystal Output. An external crystal (18.7 pF load capacitance, pullable) operating at four times the bit rate (8.192 MHz) is required to enable the jitter attenuation function of the LXT318. These pins may also be used to disable the jitter attenuator by connecting the XTALIN pin to the positive supply through a resistor, and leaving the XTALOUT pin unconnected or tied to ground.
10	XTALOUT	O	
11	JASEL	I	Jitter Attenuation Select. Selects jitter attenuation location. When JASEL is High, the jitter attenuator is active in the receive path. When JASEL is Low, the jitter attenuator is active in the transmit path.
12	LOS	O	Loss Of Signal. LOS goes High after 175 consecutive spaces and returns Low when the received signal reaches 12.5% mark density (minimum of four marks within 32 bit periods, with no more than 15 consecutive 0s). Received marks are output on RPOS and RNEG even when LOS is High.
13	TTIP	O	Transmit Tip. Differential Driver Outputs. These outputs are designed to drive a 50-200 Ω load. Line matching resistors and transformer can be selected to give the desired pulse height.
16	TRING		
14	TGND	–	Tx Ground. Ground return for the transmit drivers power supply TV+.
15	TV+	I	Transmit Power Supply. +5 VDC power supply input for the transmit drivers. TV+ must not vary from RV+ by more than $\pm 0.3V$.
17	GND	–	Ground. This pin must be tied to ground.
18	LATN	O	Line Attenuation Indication. Encoded output. Pulse width, relative to RCLK, indicates receive equalizer gain setting (line insertion loss at 1024 kHz) in 9.5 dB steps. When LATN is High for one RCLK pulse, the equalizer is set at 9.5 dB gain; 2 pulses = 19 dB; 3 pulses = 28.5 dB and 4 pulses = 0 dB. Output is valid on the rising edge of RCLK.
19	RTIP	I	Receive Tip; Receive Ring. The HDB3 signal received from the line is applied at these pins. A 1:1 transformer is required. Data and clock from the signal applied at these pins are recovered and output on the RPOS/RNEG, and RCLK pins.
20	RRING	I	
21	RV+	I	Receive Power Supply. +5 VDC power supply for all circuits except the transmit drivers. (Transmit drivers are supplied by TV+.)
22	RGND	–	Rx Ground. Ground return for power supply RV+.
23	$\overline{\text{INT}}$	O	Interrupt (Host Mode). In Host mode, this pin goes Low to flag the host processor when LOS changes state. $\overline{\text{INT}}$ is an open drain output and should be tied to power supply RV+ through a resistor. Reset $\overline{\text{INT}}$ by clearing the LOS register bit.
	NLOOP	O	Network Loopback Detection (H/W Mode). In Hardware mode, this pin indicates that inband network loopback is active by going High. To set this signal High, the device must receive the NLOOP activation pattern (00001) for five seconds. To reset it Low, either the device must receive the deactivation pattern (001) for five seconds or either RLOOP or LLOOP must be activated.
24	SDI	I	Serial Data In (Host Mode). The serial data input stream is applied to this pin when the LXT318 operates in the Host mode. SDI is sampled on the rising edge of SCLK.
	GND	–	Ground (H/W Mode). This pin is inactive in the Hardware mode and should be tied to ground.

Table 1: Pin Descriptions – continued

Pin #	Symbol	I/O	Description
25	SDO	O	Serial Data Out (Host Mode). In the Host mode, serial data from the on-chip register is output on this pin. If CLKE is High, SDO is valid on the rising edge of SCLK. If CLKE is Low, SDO is valid on the falling edge of SCLK. SDO goes to a high-impedance state when the serial port is being written to.
	GND	–	Ground (H/W Mode). This pin is inactive in the Hardware mode and should be tied to ground.
26	\overline{CS}	I	Chip Select (Host Mode). In the Host mode, this input is used to access the serial interface. For each read or write operation, \overline{CS} must transition from High to Low, and remain Low.
	RLOOP	I	Remote Loopback (H/W Mode). In the Hardware mode, this input controls remote loopback. Setting RLOOP High enables Remote Loopback. During Remote Loopback, inline encoders and decoders are bypassed. Setting both RLOOP and LLOOP while holding TAOS Low causes a Reset.
27	SCLK	I	Serial Clock (Host Mode). In the Host mode, this clock is used to write data to, or read data from the serial interface register.
	LLOOP	I	Local Loopback (H/W Mode). In the Hardware mode, this input controls local loopback. Setting LLOOP High enables Local Loopback Mode. Setting both RLOOP and LLOOP while holding TAOS Low causes a Reset.
28	CLKE	I	Clock Edge (Host Mode). In the Host mode, this pin controls transitions of the data outputs. Setting CLKE High causes RPOS and RNEG to be valid on the falling edge of RCLK, and SDO to be valid on the rising edge of SCLK. When CLKE is Low, RPOS and RNEG are valid on the rising edge of RCLK, and SDO is valid on the falling edge of SCLK.
	TAOS	I	Transmit All Ones (H/W Mode). In the Hardware mode, this pin controls the TAOS function. When set High, TAOS causes the LXT318 to transmit a stream of marks at the TCLK frequency. Activating TAOS causes TPOS and TNEG inputs to be ignored. TAOS is inhibited during Remote Loopback.

Table 2: Unipolar Data I/O Pin Descriptions¹

Pin #	Symbol	I/O	Description
3	TDATA	I	Transmit Data. Unipolar input for data to be transmitted on the twisted-pair line.
4	UBS	I	Unipolar/Bipolar Select. When pin 4 is held High for at least 16 TCLK cycles (equivalent to 15 successive bipolar violations), LXT318 switches to unipolar data I/O. The device immediately returns to bipolar I/O when pin 4 goes Low.
6	BPV	O	Bipolar Violation. Pin 6 goes High when a bipolar violation is received.
7	RDATA	O	Receive Data. Unipolar data output. RDATA is a Non-Return-to-Zero (NRZ) output. In Host mode, CLKE determines the clock edge at which RDATA is stable and valid. In Hardware mode RDATA is stable and valid on the rising edge of RCLK.

1. Table 2 lists only those pins which are affected by the switch to unipolar data I/O.

FUNCTIONAL DESCRIPTION

NOTE

This functional description is for design aid only.

The LXT318 is a fully integrated PCM transceiver for 2.048 Mbps (E1) applications. It allows full-duplex transmission of digital data over existing twisted-pair installations.

The LXT318 transceiver interfaces with two twisted-pair lines (one twisted-pair for transmit, one twisted-pair for receive) through standard pulse transformers and appropriate resistors.

The figure on the front page of this data sheet shows a block diagram of the LXT318. This transceiver may be controlled by a microprocessor through the serial port (Host Mode), or by individual pin settings (Hardware Mode). The jitter attenuator may be positioned in either the transmit or receive path, as determined by JASEL.

TRANSMITTER

Input data (bipolar or unipolar) for transmission onto the line is clocked serially into the LXT318. Bipolar data is input at TPOS and TNEG. Unipolar data is input at TDATA only (Unipolar mode is enabled by holding TNEG High for 16 RCLK cycles). Input data may be passed through the Jitter Attenuator and/or HDB3 encoder, if selected. In Host mode, HDB3 is selected by setting bit D2 of the input data byte. In Hardware mode, HDB3 is selected by connecting the MODE pin to RCLK. Input synchronization is supplied by the transmit clock (TCLK). Timing requirements for TCLK and the Master Clock (MCLK) are defined in the Test Specifications section. When TCLK is not supplied, the TCLK pin must be grounded.

Line Code

The LXT318 transmits data as a 50% HDB3 line code as shown in Figure 2. Biasing of the transmit DC level is on-chip. Shaped pulses meeting the various ITU requirements are applied to the HDB3 line driver for transmission onto the line at TTIP and TRING. Refer to Figure 22 and Table 15 for 2.048 Mbps pulse mask specifications.

Figure 2: 50% Duty Cycle Coding Diagram

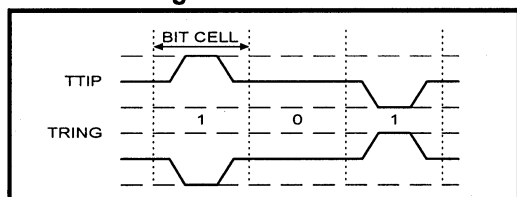

Idle Mode

The LXT318 incorporates a transmit idle mode. This allows multiple transceivers to be connected to a single line for redundant applications or for testing purposes. TTIP and TRING remain in a high impedance state when TCLK is not present (TCLK grounded). The high impedance state can be temporarily disabled by enabling Remote Loop-back.

Short Circuit Limit

The LXT318 transmitter is equipped with a short-circuit limiter. This feature limits to approximately 120 mA RMS the current the transmitter will source into a low-impedance load. The limiter trips when the RMS current exceeds the limit for 100 μ s (~ 150 marks). It automatically resets when the load current drops below the limit.

The LXT318 will meet or exceed the OFTEL OTR-001 short circuit limit (50 mARMS) when the design includes a 1:2 transmit transformer and 15 Ω resistors on TTIP and TRING. The device also meets or exceeds ITU specifications for NTU applications, as well as requirements for ISDN PRI.

RECEIVER

The receiver input from the twisted-pair is received via a 1:1 transformer. Recovered data is output at RPOS/RNEG (RDATA in unipolar mode), and the recovered clock is output at RCLK. Refer to the Test Specifications section.

The signal received at RTIP and RRING is processed through the receive equalizer which may apply up to 43 dB of gain. Insertion loss of the line, as indicated by the receive equalizer setting, is encoded in the LATN output as shown in Figure 3.

The equalized signal is filtered and applied to the peak detector and data slicers. The peak detector samples the inputs and determines the maximum value of the received signal. A percentage of the peak value is provided to the data slicers as a threshold level to ensure optimum signal-to-noise ratio. The threshold is set to 50% of the peak value. The receiver is capable of accurately recovering signals with up to 43 dB of cable attenuation (from 2.7 V).

After processing through the data slicers, the received signal is routed to the data and timing recovery section, then to the HDB3 decoder (if selected) and to the LOS processor. The data and timing recovery sections provide an input jitter tolerance significantly better than required by ITU G.823, as shown in the Test Specifications section.

The LOS Processor loads a digital counter at the RCLK frequency. The count is incremented each time a 0 (space)

LXT318 E1 NTU/ISDN PRI Transceiver

is received, and reset to 0 each time a one (mark) is received. Upon receipt of 175 consecutive 0s the LOS pin goes High, and a smooth transition replaces the RCLK output with the MCLK. (During LOS, if MCLK is not supplied and JASEL is High, the RCLK output is replaced with the centered quartz crystal frequency.)

Received marks will be output regardless of the LOS status, but the LOS pin will not reset until the ones density reaches 12.5%. This level is based on receipt of at least four 1s in any 32 bit periods, with no more than 15 consecutive 0s.

Jitter Attenuation

Jitter attenuation is provided by a Jitter Attenuation Loop (JAL) and an Elastic Store (ES). The Test Specifications show the LXT318 jitter attenuation performance compared with the jitter template specified by ITU G.736. The 3 dB corner frequency for the LXT318 is at 3 Hz. The performance complies with ETSI TBR-12 and TBR-13. An external crystal oscillating at four times the bit rate provides clock stabilization. The ES is a 32 x 2-bit register. When JASEL is High, the JAL is positioned in the receive path. When JASEL Low, the JAL is positioned in the transmit path.

Data (TPOS/TNEG or TDATA; or RPOS/RNEG or RDATA) is clocked into the ES with the associated clock signal (TCLK or RCLK), and clocked out of the ES with the dejittered clock from the JAL. When the bit count in the ES is within two bits of overflowing or underflowing, the ES adjusts the output clock by $\frac{1}{8}$ of a bit period. The ES produces an average delay of 16 bits in the associated path.

CONTROL MODES

The LXT318 transceiver can be controlled by a microprocessor through a serial interface (Host mode), or through individual hard-wired pins (Hardware mode). The mode of operation is determined by the input to MODE. With MODE set High, the LXT318 operates in the Host mode. With MODE set Low, the LXT318 operates in the Hardware mode. With MODE tied to RCLK, the LXT318 operates in the Hardware mode with the HDB3 encoder/

decoder enabled. The LXT318 can also be commanded to operate in one of several diagnostic modes.

Host Mode Control

The LXT318 operates in the Host mode when MODE is set High. In Host mode the LXT318 is controlled through the serial I/O port (SIO) by a microprocessor. The LXT318 provides a pair of data registers, one for command inputs and one for status outputs, and an interrupt output.

An SIO transaction is initiated by a High-to-Low transition on \overline{CS} . The LXT318 responds by writing the incoming serial word from the SDI pin into its command register. If the command word contains a read request, the LXT318 subsequently outputs the contents of its status register onto the SDO pin. The Clock Edge (CLKE) signal determines when the SDO and receive data outputs are valid, relative to the Serial Clock (SCLK) or RCLK as in Table 3.

The 16-bit serial word consists of an 8-bit Command/Address byte and an 8-bit Data byte as shown in Figures 4 and 5. SIO timing characteristics are shown in Table 14.

Table 3: CLKE Settings

CLKE	Output	Clock	Valid Edge
LOW	RPOS	RCLK	Rising
	RNEG	RCLK	Rising
	SDO	SCLK	Falling
HIGH	RPOS	RCLK	Falling
	RNEG	RCLK	Falling
	SDO	SCLK	Rising

Table 4: SIO Input Bit Settings (Figure 4)

Mode	RLOOP Bit D5	LLOOP Bit D6	TAOS Bit D7
RLOOP	1	0	n/a
LLOOP	0	1	n/a
TAOS	0	n/a	1
RESET	1	1	0

Figure 3: LXT318 Line Attenuation (LATN) Pulse Width Encoding

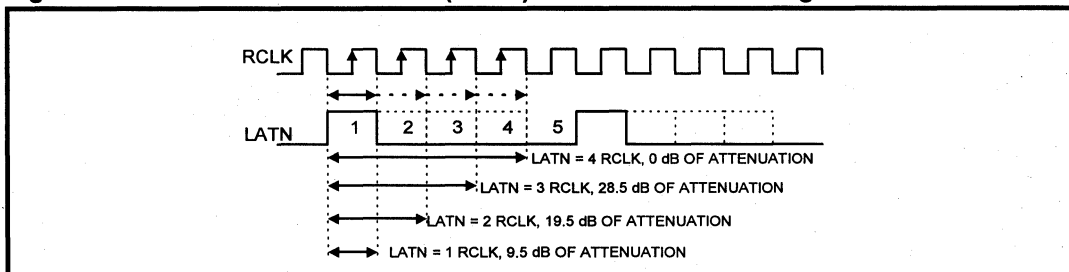

SERIAL INPUT WORD

Figure 4 shows the Serial Input data structure. The LXT318 is addressed by setting bit A4 in the Address/Command byte, corresponding to address 16. Bit 1 of the serial Address/Command byte provides Read/Write (R/W) control when CS is Low. The R/W bit is set to logic 1 to read the data output byte from the chip, and set to logic 0 to write the input data byte to the chip.

The Data Input byte is the second eight bits of a write operation. The first bit (D0) clears and/or masks LOS interrupts. The second bit (D1) clears and/or masks NLOOP detection interrupts. The third bit (D2) enables or disables HDB3 coding/decoding, and the last 3 bits (D5 - D7) control operating modes (normal and diagnostic) and chip reset. Refer to Table 4 for details on bits D5 - D7.

SERIAL OUTPUT WORD

Figure 5 shows the Serial Output data structure. When the Serial Input word has bit A0 = 1, the LXT318 drives the output data byte onto the SDO pin. The output data byte reports Loss of Signal (LOS) conditions, NLOOP detection status, HDB3 code setting, and operating modes (normal or diagnostic as shown in Table 5. The first bit (D0) reports LOS status. The second bit (D1) reports network loopback detection status. The third bit (D2) reports the HDB3 setting. The last 3 bits (D5 - D7) report operating modes and interrupt status.

The Host mode provides a latched Interrupt output pin, INT. An interrupt is triggered by a change in the LOS bit (D0 of the output data byte). If the INT line is High (no interrupt is pending), bits D5 - D7 report the operating

modes listed in Table 5. If the INT line is Low, the interrupt status overrides all other reports and bits D5 - D7 reflect the interrupt status as listed in Table 5.

Hardware Mode Operation

In Hardware mode the transceiver is accessed and controlled through individual pins. With the exception of the INT and CLKE functions, Hardware mode provides all the functions provided in the Host mode. In the Hardware mode RPOS/RNEG or RDATA outputs are valid on the rising edge of RCLK. The LXT318 operates in Hardware mode only when MODE is Low or connected to RCLK.

INITIALIZATION AND RESET OPERATION

Upon power up, the transceiver is held static until the power supply reaches approximately 3V. Upon crossing this threshold, the device begins a 32 ms reset cycle to calibrate the transmit and receive delay lines and lock the Phase Lock Loop to the receive line. A reference clock is required to calibrate the delay lines. The transmitter reference is provided by TCLK. The crystal oscillator provides the receiver reference. If the crystal oscillator is grounded, MCLK is used as the receiver reference clock. All PLLs are continuously calibrated.

The transceiver can also be reset from the Host or Hardware mode. In Host mode, command reset by simultaneously writing 1s to RLOOP and LLOOP, and a 0 to TAOS. In Hardware mode, reset by holding RLOOP and LLOOP High simultaneously for 200 ns while holding TAOS Low. In either mode, reset sets all registers to 0.

6

Table 5: LXT318 Serial Data Output Bit Coding (See Figure 5)

Bit			Status
D5	D6	D7	
Operating Modes			
0	0	0	Reset has occurred, or no program input.
0	0	1	TAOS active
0	1	0	LLOOP active
0	1	1	TAOS and LLOOP active
1	0	0	RLOOP active
Interrupt Status			
1	0	1	NLOOP has changed state since last Clear NLOOP occurred.
1	1	0	LOS has changed state since last Clear LOS occurred.
1	1	1	LOS and NLOOP have both changed state since last Clear NLOOP and Clear LOS occurred.

Figure 4: LXT318 Serial I/O Input Data Structure

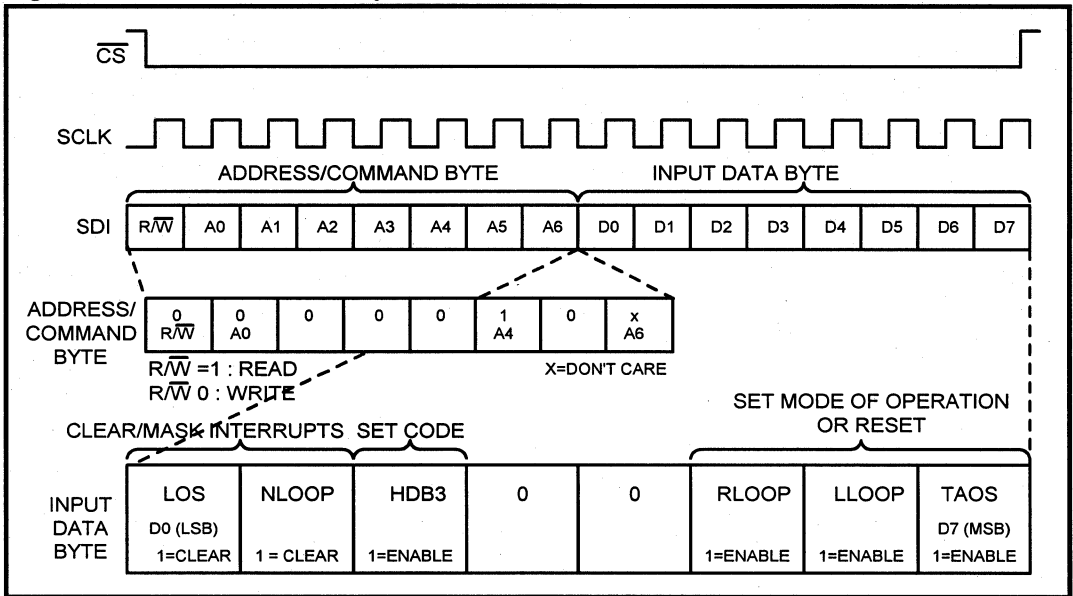
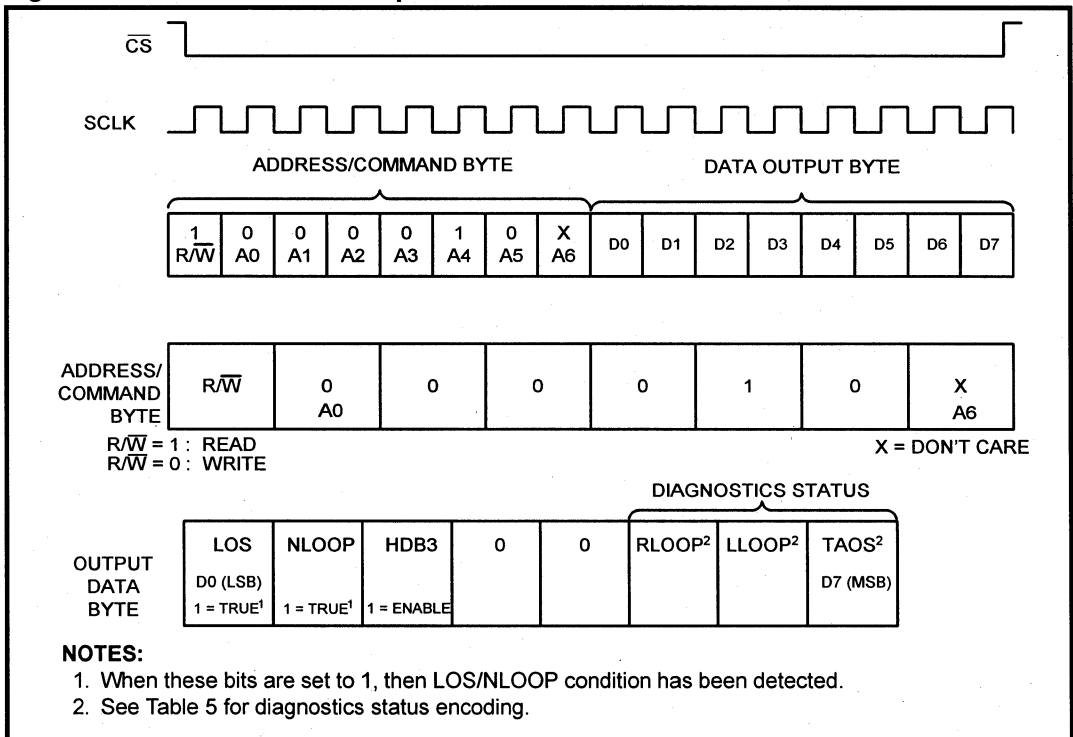

Figure 5: LXT318 Serial I/O Output Data Structure



Interrupt Handling

Figure 6 shows how to mask the interrupt generator by writing a one to the respective bit of the input data byte LOS (D0) or NLOOP (D1). Either interrupt pulls the $\overline{\text{INT}}$ output pin Low. The output stage of the $\overline{\text{INT}}$ pin consists only of a pull-down device which requires an external pull-up resistor for it to function. To clear either interrupt:

1. If either of the interrupt bits LOS (D0) and NLOOP (D1) of the output data byte is High, writing a one to the respective input bit (D0 or D1, of the input data byte) will clear the interrupt. Leaving a one in this bit position will effectively mask the interrupt. To re-enable the interrupt capability, reset D0 and/or D1 to 0.
2. If either the LOS or the NLOOP bit is Low, resetting the device will clear both interrupts. To reset the chip, set input bits D5 and D6 to one, and D7 to 0.

Figure 6: LXT318 Interrupt Handling

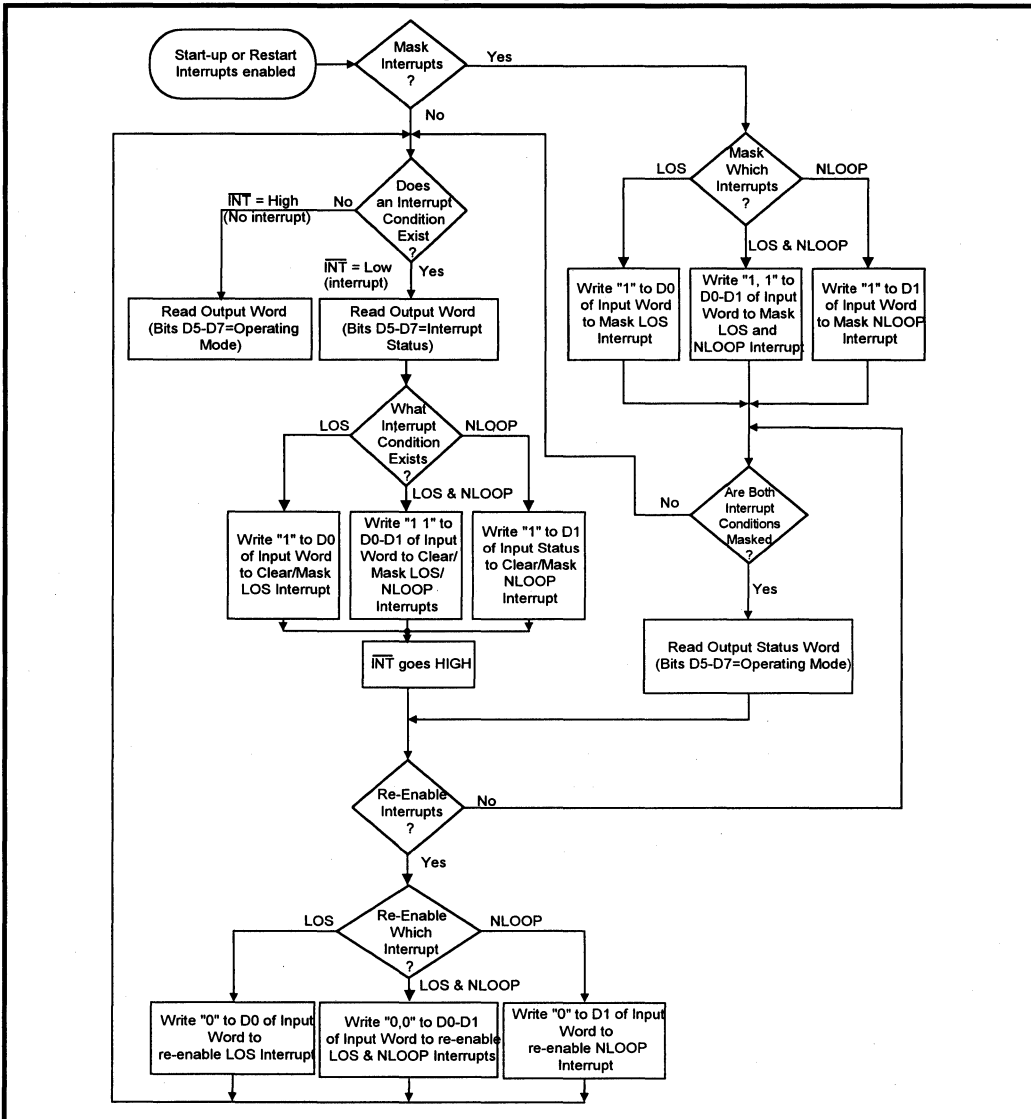

6

Diagnostic Mode Operation

Transmit All Ones. See Figure 7. In Transmit All Ones (TAOS) mode the TPOS and TNEG inputs to the transceiver are ignored and the transceiver transmits a continuous stream of 1s at the TCLK frequency. (In the LXT318 with JASEL set Low and TCLK not provided, TAOS is locked to the MCLK.) This can be used as the Blue Alarm Indicator (AIS). In Host mode, TAOS is commanded by writing a one to bit D7 of the input data byte. In Hardware mode, TAOS is commanded by setting TAOS High. TAOS can be commanded simultaneously with Local Loopback as shown in Figure 7B, but is inhibited during Remote Loopback.

Figure 7: Transmit All Ones

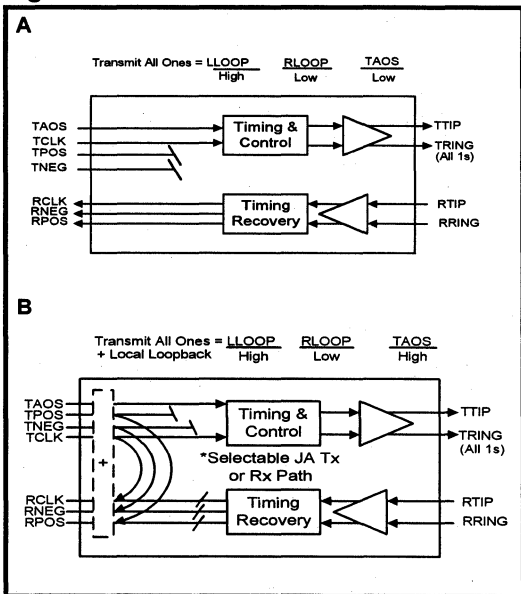
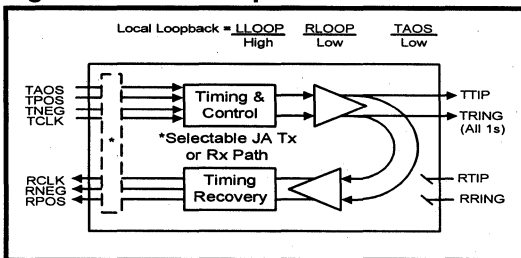

Figure 8: Local Loopback



Local Loopback. See Figure 8. Local Loopback (LLOOP) is designed to exercise the maximum number of functional blocks. During LLOOP operation, the RTIP/RRING inputs from the line are disconnected. Instead, the transmit out-

puts are routed back into the receive inputs. This tests the encoders/decoders, jitter attenuator, transmitter, receiver and timing recovery sections. In Host mode, writing a one to bit D6 of the input data byte commands Local Loopback. In Hardware mode, Local Loopback is commanded by setting LLOOP High. If TAOS and LLOOP are both active, the All Ones pattern is transmitted onto the line while the TPOS/TNEG input data loops back to the RPOS/RNEG outputs through the jitter attenuator.

Remote Loopback. See Figure 9. In Remote Loopback (RLOOP) mode, the transmit data and clock inputs (TCLK and TPOS/TNEG or TDATA) are ignored, and the in-line encoders and decoders are bypassed. The RPOS/RNEG or RDATA outputs are looped back through the transmit circuits and output on TTIP and TRING at the RCLK frequency. Receiver circuits are unaffected by the RLOOP command and continue to output the RCLK and RPOS/RNEG or RDATA signals received from the twisted-pair line. In Host mode, writing a one to bit D5 of the input data byte commands Remote Loopback. In Hardware mode, Remote Loopback is commanded by setting RLOOP High.

Figure 9: Remote Loopback

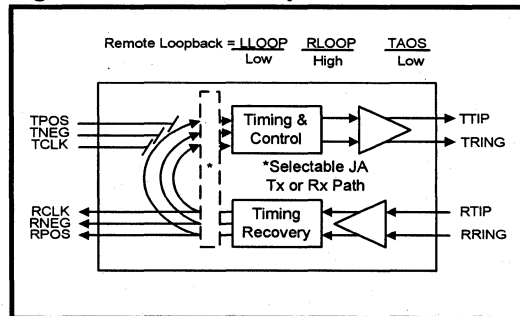

Network Loopback Detection. In Host mode, to start the Network Loopback detection mode, write a one to each of RLOOP, LLOOP, and TAOS simultaneously and write all 0s in the next cycle. In Hardware mode, hold RLOOP, LLOOP and TAOS High simultaneously for 200 ns, then pull them all Low. Alternatively, tying RLOOP to RCLK will enable NLOOP.

With NLOOP detection enabled, the receiver monitors the input data for the NLOOP enable data pattern (00001). When either pattern repeats for five seconds, the device begins remote loopback operation. The LXT318 responds to either framed or unframed NLOOP patterns. Once the device begins NLOOP operation, the function is identical to remote loopback. When it detects the disable pattern (001) for five seconds or if RLOOP is enabled, the chip resets NLOOP. Activating LLOOP interrupts NLOOP temporarily, but it does not reset NLOOP.

APPLICATION INFORMATION

NOTE

This application information is for design aid only.

LATN DECODING CIRCUITS AND EXTERNAL COMPONENTS

The line attenuation (LATN) output is encoded as a simple serial bit stream for use in line monitoring applications. Figure 10 is a typical decoding circuit for the LATN output. Table 6 provides the decoded output for each equalizer setting. It uses a 2-bit synchronous counter (half of a 4-bit counter) with synchronous reset, and a pair of flip-flops.

Figure 10: Typical LATN Decoding Circuit

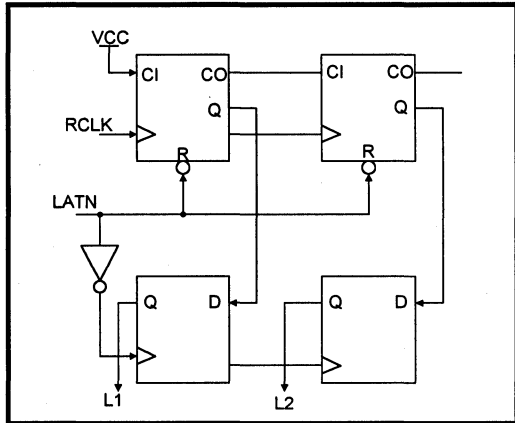

Table 6: Line Attenuation Decoding

L2	L1	Line Attenuation
0	0	0.0 dB
0	1	-9.5 dB
1	0	-19.5 dB
1	1	-28.5 dB

POWER REQUIREMENTS

The LXT318 is a low-power CMOS devices. It operates from a single +5 V power supply which can be connected externally to both the transmitter and receiver. However, the two inputs must be within $\pm 3V$ of each other, and decoupled to their respective grounds separately, as shown in Figure 11. Isolation between the transmit and receive circuits is provided internally.

JITTER ATTENUATION CIRCUITRY EXTERNAL CRYSTAL SPECIFICATIONS

Table 7 shows the minimum specifications for the external crystal used by the LXT318 jitter attenuation loop.

Table 7: LXT318 Crystal Specifications (External)

Parameter	Specification
Frequency	8.192 MHz
Frequency stability	± 20 ppm @ 25° C ± 25 ppm @ -40° to +85° C (ref 25° C reading)
Pullability (Pull range may be slightly asymmetrical)	CL = 19 pF to 37 pF, crystal should pull -95 ppm to -115 ppm from nominal frequency CL = 19 pF to 11.6 pF, crystal should pull +95 ppm to +130 ppm from nominal frequency
Effective series resistance	30 Ω maximum
Crystal cut	AT
Resonance	Parallel
Drive level	2.0 mW maximum
Mode of operation	Fundamental
Crystal holder	HC49 (R3W), Co = 7 pF maximum CM = 17 fF typical;

6

LXT318 E1 NTU/ISDN PRI Transceiver

LXT318 Host Mode Applications

Figure 11 shows a typical E1 NTU application with the LXT318 operating in the Host mode (MODE pin tied High). The E1/CRC Framer provides the digital interface with the host controller. Both devices are controlled through the serial interface. In the Host mode, the LOS alarm is reported via the serial port so the LOS pin is not used (although it still reports valid LOS status.)

The 8.192 MHz crystal across XTALIN and XTALOUT enables the JAL which is switched to the transmit side by the ground on JASEL. The power supply inputs are tied to a common bus with appropriate decoupling capacitors (68 mF and 0.1 μF) installed on each side.

The line interfaces are relatively simple. A 120 Ω resistor (for TWP applications) across the input of a 1:1 transformer is used on the receive side, and a pair of 15 Ω resistors are installed in series with the 1:2 transmit transformer.

Figure 11: Typical LXT318 Host Mode E1/NTU Application (120 Ω Twisted Pair)

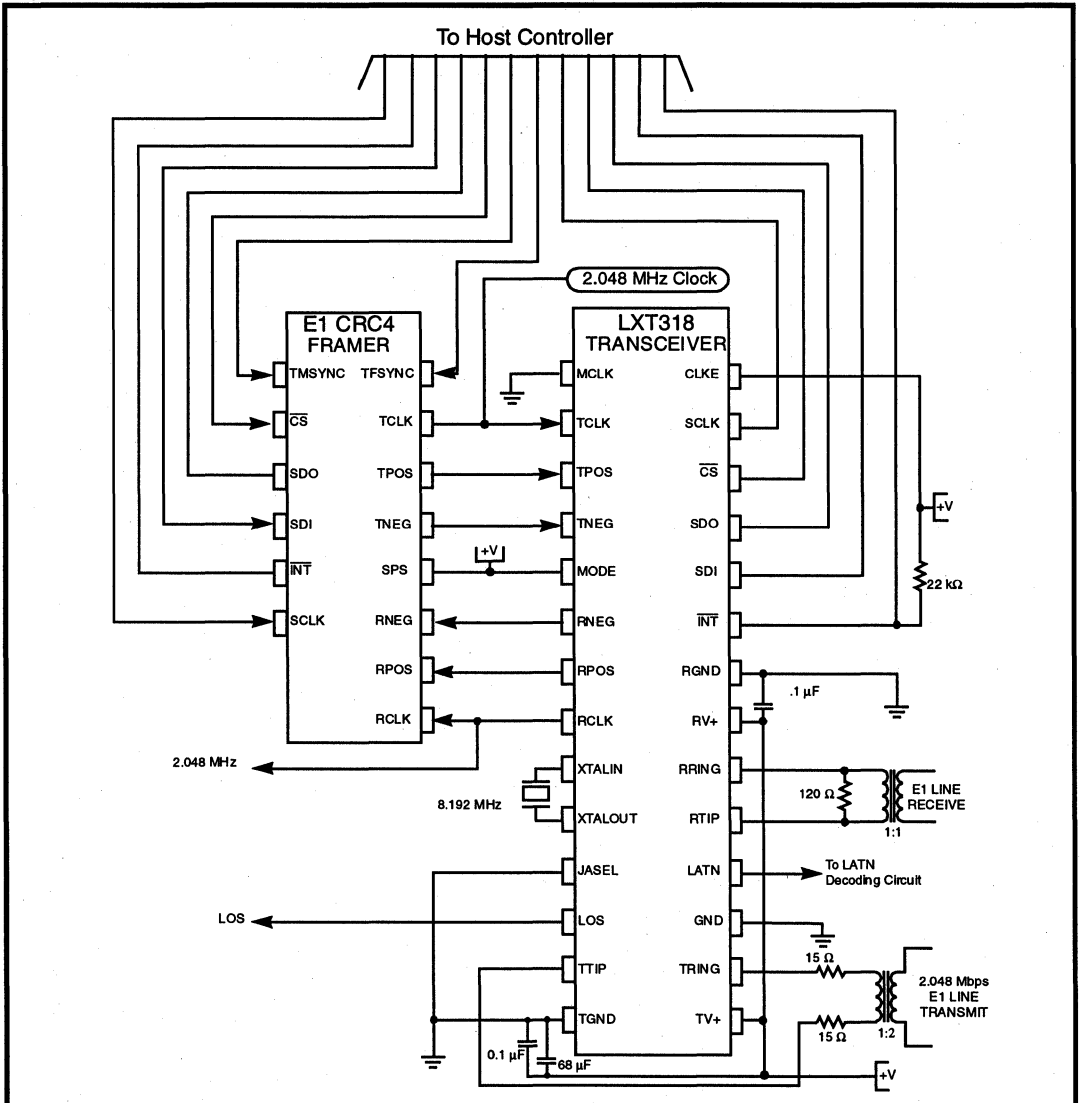

LXT318 Hardware Mode Applications

Figure 12 shows a typical 2.048 Mbps application with the LXT318 operating in the Hardware mode. This configuration is illustrated with a single power supply bus. CMOS control logic is used to set the TAOS, LLOOP and RLOOP

diagnostic modes individually. The RCLK output is tapped to clock the MODE pin, enabling HDB3 encoding. The receive and transmit line interfaces are identical to the Host mode application shown in Figure 11.

Figure 12: Typical LXT318 Hardware Mode Application (120 Ω Twisted Pair)

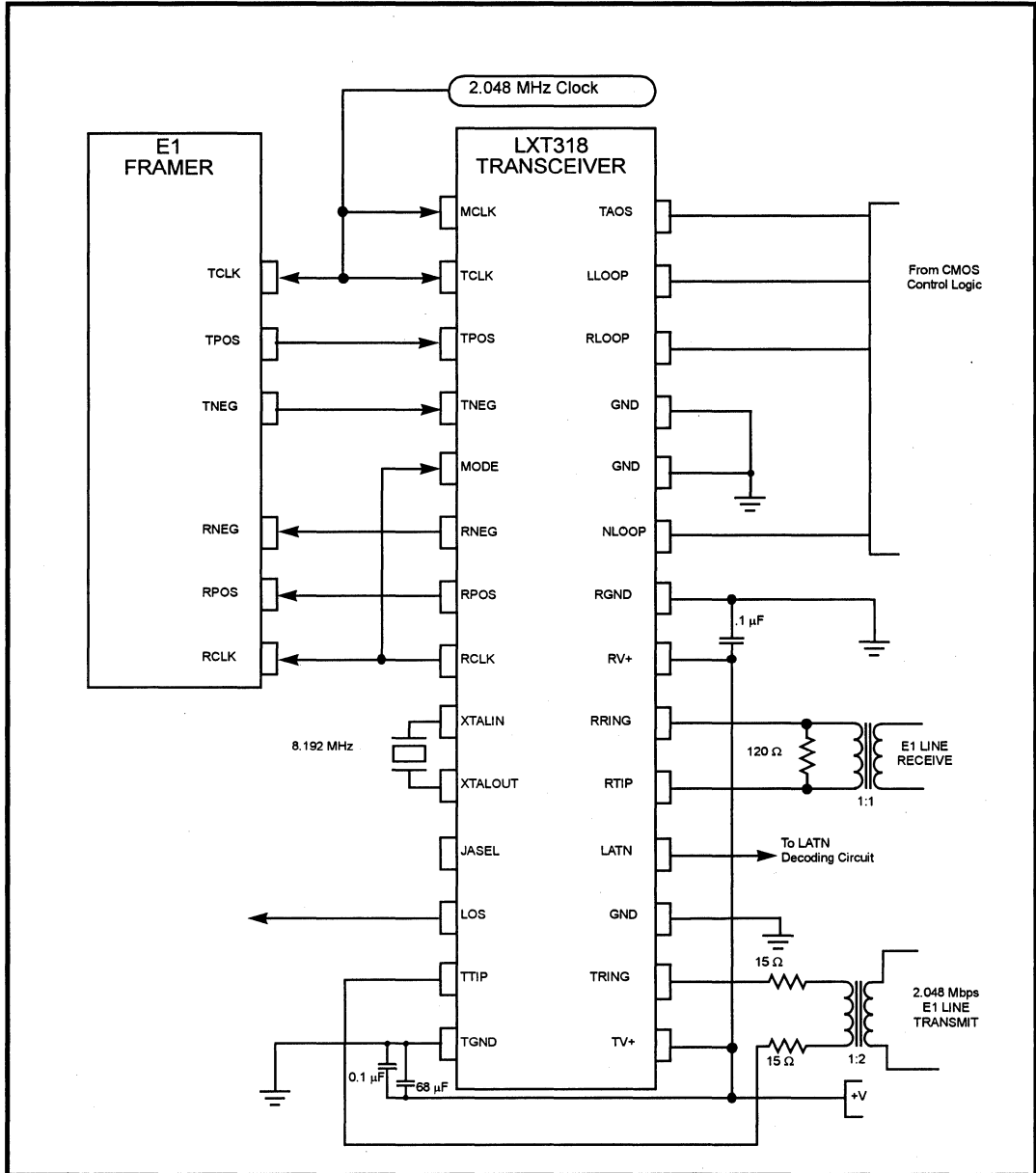
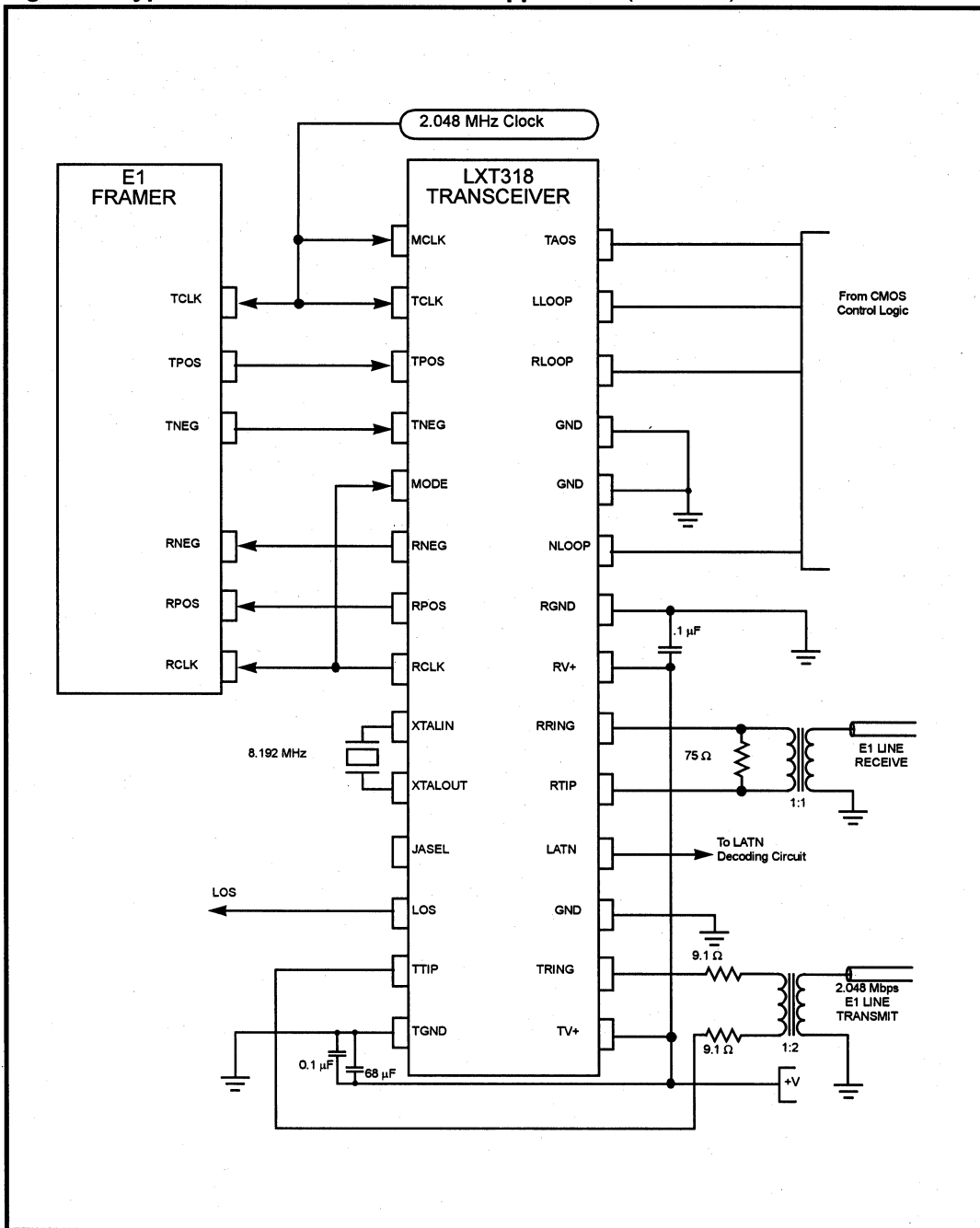

Figure 13: Typical LXT318 Hardware Mode Application (75 Ω Coax)



TEST SPECIFICATIONS

NOTE

The minimum and maximum values in Tables 8 through 14 and Figures 18 through 23 represent the performance specifications of the LXT318 and are guaranteed by test, except where noted by design.

Table 8: Absolute Maximum Ratings

Parameters	Symbol	Min	Max	Units
DC supply (referenced to GND)	RV+, TV+	–	6.0	V
Input voltage, any pin	V _{IN}	RGND, -0.3	RV+, +0.3	V
Input current, any pin ¹	I _{IN}	-10	10	mA
Storage temperature	TSTG	-65	150	°C

CAUTION
Operation at or beyond these limits may permanently damage the device. Normal operation not guaranteed at these extremes.

1. Transient Currents of up to 100 mA will not cause SCR latch-up. TTIP TRING, TV+, TGND can withstand continuous current of 100 mA.

6

Table 9: Operating Conditions and Characteristics

Parameter	Symbol	Min	Typ ¹	Max	Units	Test Conditions
DC supply ²	RV+, TV+	4.75	5.0	5.25	V	
Ambient operating temperature	TA	-40	-	+85	°C	
Power dissipation ³	PD	-	300	400	mW	100% ones density & maximum line length @ 5.25 V

1. Typical figures are at 25 °C and are for design aid only; not guaranteed and not subject to production testing.
2. TV+ must not differ from RV+ by more than 0.3 V.
3. Power dissipation while driving 25 Ω load over operating temperature range. Includes device and load. Digital input levels are within 10% of the supply rails and digital outputs are driving a 50 pF capacitive load.

Table 10: Digital Characteristics (TA = -40 to 85 °C, V+ = 5.0 V ±5%, GND = 0 V)

Parameter	Sym	Min	Typ	Max	Units	Test Conditions
High level input voltage ^{1,2} (pins 1-5, 10, 23-28)	V _{IH}	2.0	–	–	V	
Low level input voltage ^{1,2} (pins 1-5, 10, 23-28)	V _{IL}	–	–	0.8	V	
High level input voltage ^{1,2} (pins 6-8, 12, 23, 25)	V _{OH}	2.4	–	–	V	I _{OUT} = -400 μA
Low level input voltage ^{1,2} (pins 6-8, 12, 23, 25)	V _{OL}	–	–	0.4	V	I _{OUT} = 1.6 mA
Input leakage current	I _{LL}	0	–	±10	μA	
Three-state leakage current ¹ (pin 25)	I _{3L}	0	–	±10	μA	
Driver Power Down Current ³	I _{PD}	–	–	±1.2	mA	Direct connection to Vcc or GND

1. Functionality of pins 23 and 25 depends on mode. See Host/Hardware Mode descriptions.
2. Output drivers will output CMOS logic levels into CMOS loads.
3. TTIP, TRING only in Idle or Power Down Mode.

Table 11: Analog Characteristics (TA = -40 to 85 °C, V+ = 5.0 V ±5%, GND = 0 V)

Parameter		Min	Typ ¹	Max	Units	Test Conditions
Recommended output load at TTIP and TRING		50	120	200	Ω	
AMI output pulse amplitudes		2.7	3.0	3.3	V	Measured at the output
Jitter added by the transmitter ² 20 Hz - 100kHz ³		–	–	0.05	UI	
Input jitter tolerance	20 Hz - 100kHz	0.2	0.3	–	UI	0 - 43 dB line
	10 Hz	100	500	–	UI	
Jitter attenuation curve corner frequency ⁴		–	3	–	Hz	
Receive signal attenuation range		0	43	–	dB	
Allowable consecutive zeros before LOS		160	175	190	–	
Transmitter return loss ³	51 kHz - 102 kHz	–	18	–	dB	
	102 kHz - 2.048 MHz	–	24	–	dB	
	2.048 MHz - 3.072 MHz	–	22	–	dB	
Receiver return loss ^{3, 5}	51 kHz - 102 kHz	–	20	–	dB	
	102 kHz - 2.048 MHz	–	24	–	dB	
	2.048 MHz - 3.072 MHz	–	22	–	dB	

1. Typical figures are at 25 °C and are for design aid only, not guaranteed and not subject to production testing.
 2. Input signal to TCLK is jitter free.
 3. Guaranteed by characterization; not subject to production testing.
 4. Circuit attenuates jitter at 20 dB/decade above the corner frequency.
 5. Measured with 1:1 transformer terminated with 120 Ω resistance.

Table 12: LXT318 Master Clock and Transmit Timing Characteristics (See Figure 14)

Parameter	Sym	Min	Typ ¹	Max	Units	Notes
Master clock frequency	MCLK	–	2.048	–	MHz	
Master clock tolerance	MCLKt	–	±100	–	ppm	
Master clock duty cycle	MCLKd	40	–	60	%	
Crystal frequency	fc	–	8.192	–	MHz	
Transmit clock frequency	TCLK	–	2.048	–	MHz	
Transmit clock tolerance	TCLKt	–	–	±100	ppm	
Transmit clock duty cycle	TCLKd	10	–	90	%	
TPOS/TNEG to TCLK setup time	tsUT	50	–	–	ns	
TCLK to TPOS/TNEG hold time	tHT	50	–	–	ns	

1. Typical figures are at 25 °C and are for design aid only; not guaranteed and not subject to production testing.

6

Figure 14: LXT318 Transmit Clock Timing

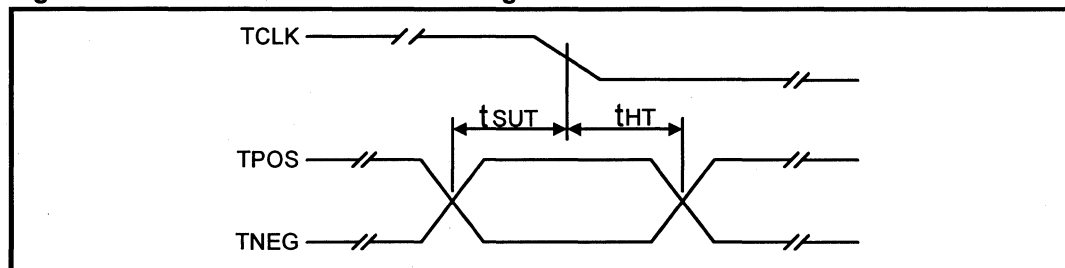

Figure 15: LXT318 Receive Clock Timing

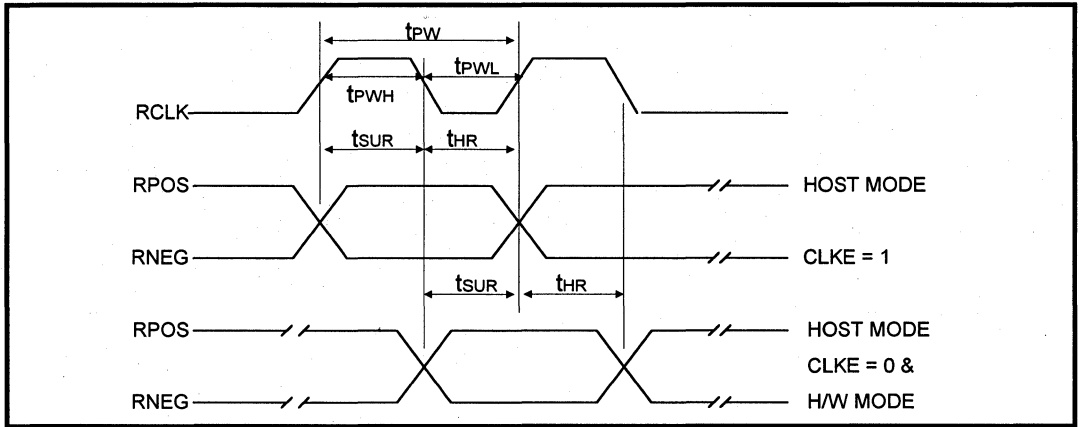

Table 13: LXT318 Receive Timing Characteristics (See Figure 15)

Parameter	Sym	Min	Typ ¹	Max	Units	Notes
Receive clock duty cycle ²	RCLKd	40	50	60	%	
Receive clock pulse width ²	tpw	-	488	-	ns	
Receive clock pulse width High	tpwh	-	244	-	ns	
Receive clock pulse width Low	tpwl	220	244	268	ns	
RPOS/RNEG to RCLK rising setup time	tsur	-	194	-	ns	
RCLK rising to RPOS/RNEG hold time	thr	-	194	-	ns	

1. Typical figures are at 25° C and are for design aid only; not guaranteed and not subject to production testing.
 2. RCLK duty cycle widths will vary depending on extent of received pulse jitter displacement. Max and min RCLK duty cycles are for worst case jitter conditions (0.4 UI clock displacement for 2.048 Mbps.)

Table 14: LXT318 Serial I/O Timing Characteristics (See Figures 16 and 17)

Parameter	Sym	Min	Typ ¹	Max	Units	Parameter
Rise/fall time—any digital output	t _{RF}	—	—	100	ns	Load 1.6 mA, 50 pF
SDI to SCLK setup time	t _{DC}	50	—	—	ns	
SCLK to SDI hold time	t _{CDH}	50	—	—	ns	
SCLK low time	t _{CL}	240	—	—	ns	
SCLK high time	t _{CH}	240	—	—	ns	
SCLK rise and fall time	t _R , t _F	—	—	50	ns	
$\overline{\text{CS}}$ falling edge to SCLK rising edge	t _{CC}	50	—	—	ns	
Last SCLK edge to $\overline{\text{CS}}$ rising edge	t _{CCH}	150	—	—	ns	
$\overline{\text{CS}}$ inactive time	t _{CWH}	250	—	—	ns	
SCLK to SDO valid time	t _{CDV}	—	—	200	ns	
SCLK falling edge or $\overline{\text{CS}}$ rising edge to SDO high-Z	t _{CDZ}	—	100	—	ns	

1. Typical figures are at 25 °C and are for design aid only; not guaranteed and not subject to production testing.

Figure 16: LXT318 Serial Data Input Timing Diagram

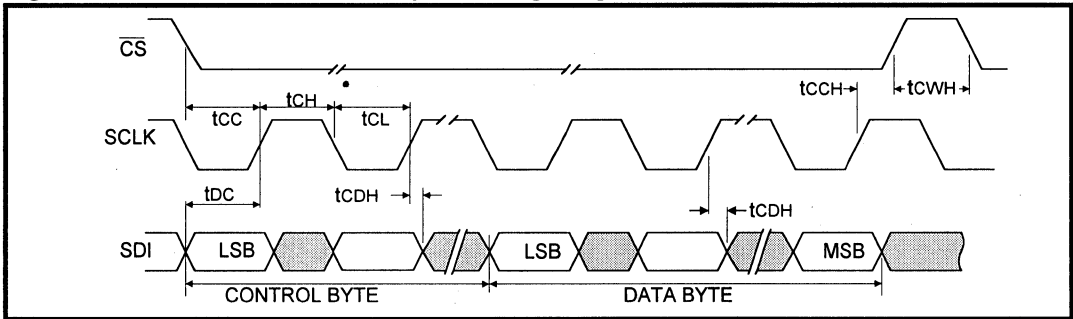

Figure 17: LXT318 Serial Data Output Timing Diagram

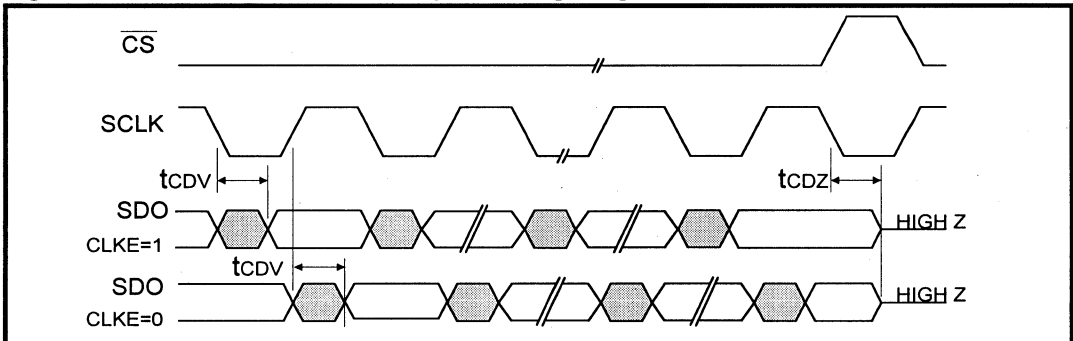

Figure 18: LXT318 Jitter Tolerance @ 43 dB (Typical)

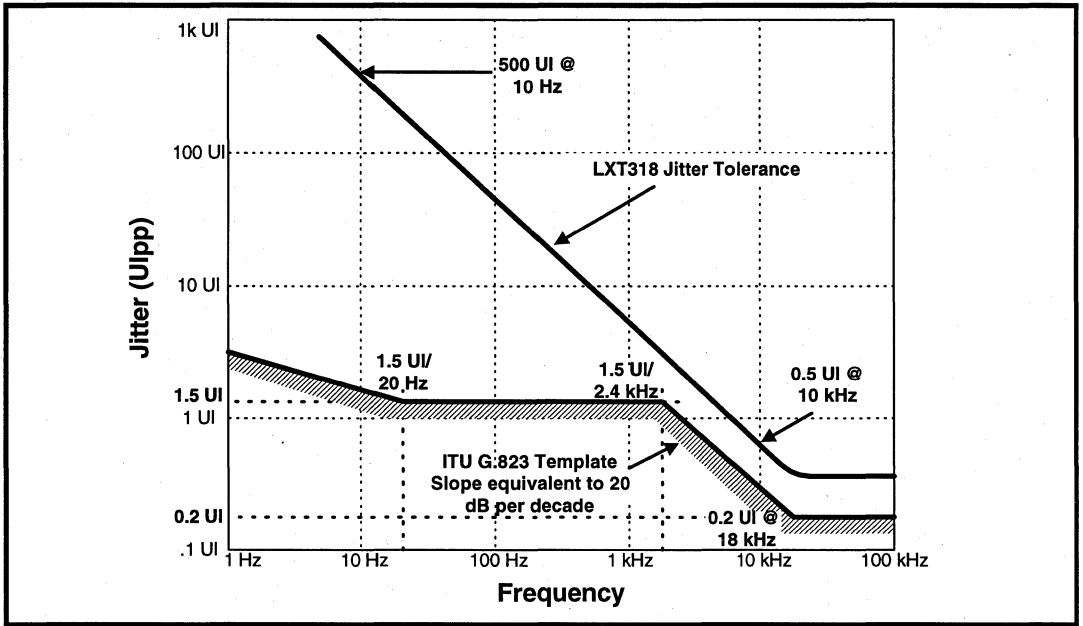

Figure 19: LXT318 Jitter Attenuation (Typical)

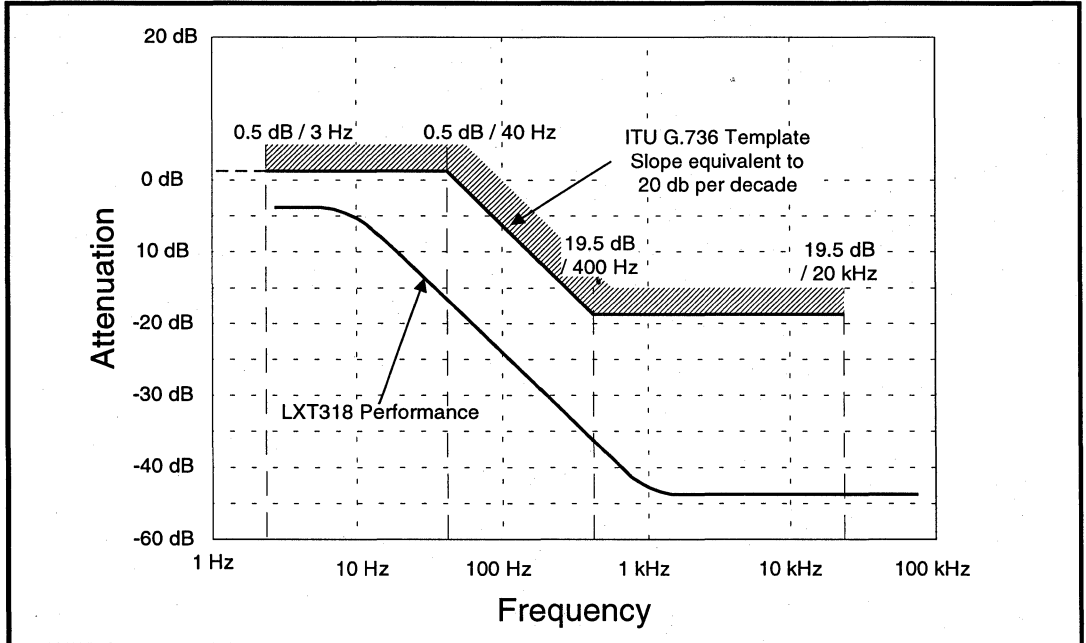
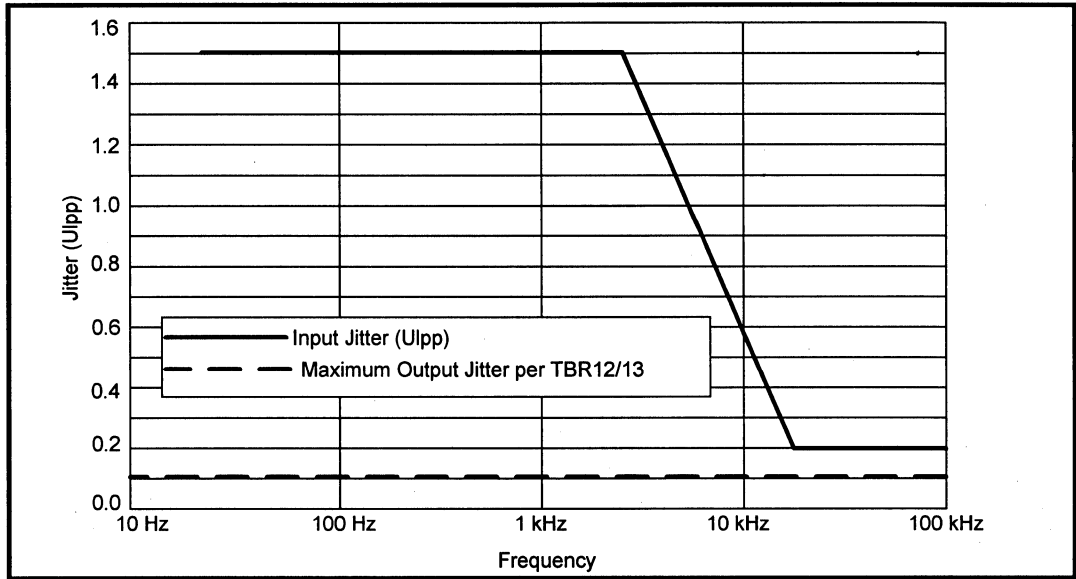

Figure 20: Input and Maximum Output Jitter Specified by TBR12/13



6

Figure 21: LXT318 Jitter Attenuation Performance (Typical-Measured Against TBR12/13)

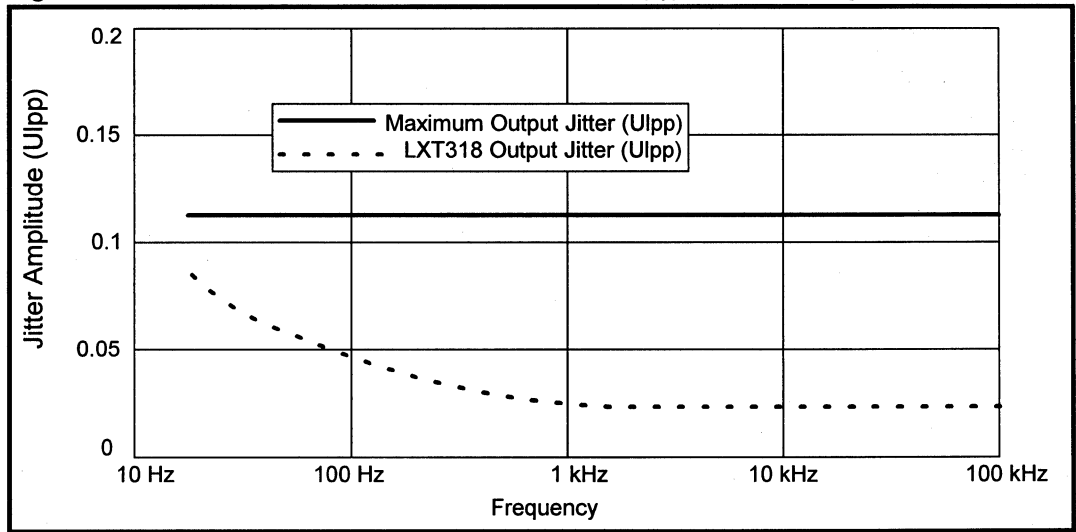

Figure 22: 2.048 Mbps Pulse Mask

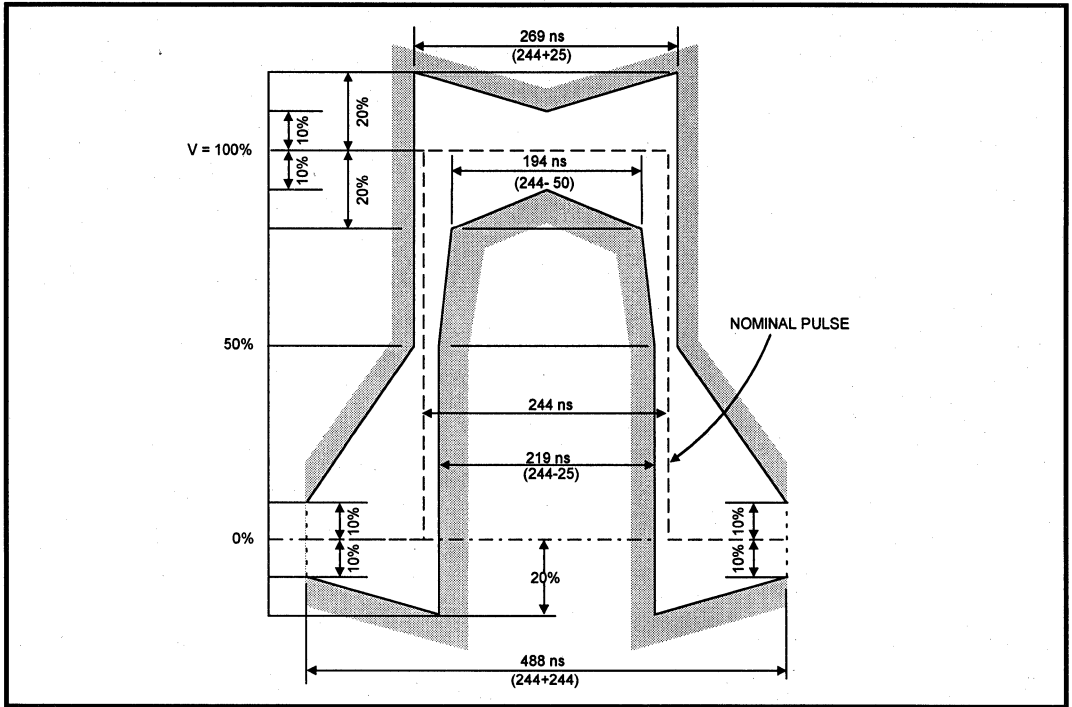

Table 15: 2.048 Mbps Pulse Mask Parameters

Parameter	TPW	Units
Test load impedance	120	Ω
Nominal peak mark voltage	3.0	V
Nominal peak space voltage	0 ± 0.30	V
Nominal pulse width	244	ns
Ratio of positive and negative pulse amplitude at center of pulse	95-105	%
Ratio of positive and negative pulse amplitudes at nominal half amplitude	95-105	%

LXT360/361 Integrated T1/E1 LH/SH Transceivers

for DS1/DSX-1/CSU or NTU/ISDN PRI Applications

General Description

The LXT360 and LXT361 are the first full-featured, fully integrated, combination transceivers for E1 ISDN Primary Rate Interface and T1 long- and short-haul applications. They operate over 0.63 mm (22 AWG) twisted-pair cables for 0 to 2 km (6 kft) and offer Line Build-Outs and pulse equalization settings for all T1 and E1 Line Interface Unit (LIU) applications.

The LXT360 and LXT361 are identical except for their control options. The LXT361 offers an Intel- or Motorola-compatible parallel port for microprocessor control. The LXT360 provides both a serial port for microprocessor control and a hardware control mode for stand alone operation. Both incorporate advanced crystal-less digital jitter attenuation in either the transmit or receive data path starting at 3 Hz. B8ZS/HDB3 encoding/decoding and unipolar or bipolar data I/O are available. Both LIUs provide loss of signal monitoring and a variety of diagnostic loopback modes.

The LXT360/361 uses an advanced double-poly, double-metal fabrication process and requires only a single 5-volt power supply.

Applications

- ISDN Primary Rate Interface (ISDN PRI)
- CSU/NTU interface to T1/E1 Service
- Wireless Base Station interface
- T1/E1 LAN/WAN bridge/routers
- T1/E1 Mux; Channel Banks
- Digital Loop Carrier - Subscriber Carrier Systems

Features

- Fully integrated transceivers for Long- or Short-Haul T1 or E1 interfaces
- Crystal-less digital jitter attenuation
 - Select either transmit or receive path
 - No crystal or high speed external clock required
- Meet or exceed specifications in ANSI T1.403 and T1.408; ITU G.703, G.736, G.775 and G.823; ETSI 300-166 and 300-233; and AT&T Pub 62411
- Support 75 Ω (E1 coax), 100 Ω (T1 twisted-pair) and 120 Ω (E1 twisted-pair) applications
- Selectable receiver sensitivity – Fully restores the received signal after transmission through a cable with attenuation of either 0 to 26 dB, or 0 to 36 dB @ 772 kHz and 0 to 43 dB @ 1024 kHz
- Five Pulse Equalization Settings for T1 short-haul applications
- Four Line Build-Outs for T1 long-haul applications from 0 dB to -22.5 dB
- Transmit/receive performance monitors with Driver Fail Monitor Open and Loss of Signal outputs
- Selectable unipolar or bipolar data I/O and B8ZS/HDB3 encoding/decoding
- Line attenuation indication output in 2.9 dB steps
- QRSS generator/detector for testing or monitoring
- Output short circuit current limit protection
- Local, remote, analog and inband network loopback generation and detection
- Multiple-register serial- or parallel-interface for microprocessor control
- Available in 28-pin DIP, 28-pin PLCC packages

6

LXT360 Block Diagram

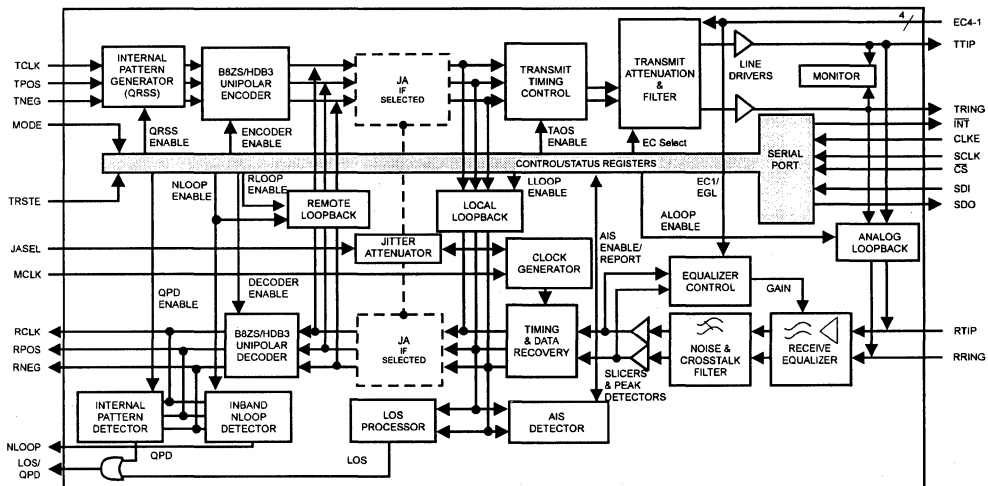

LXT360/361 Integrated T1/E1 LH/SH Transceivers

Figure 1: LXT360 Hardware Controlled Bipolar Mode Pin Assignments

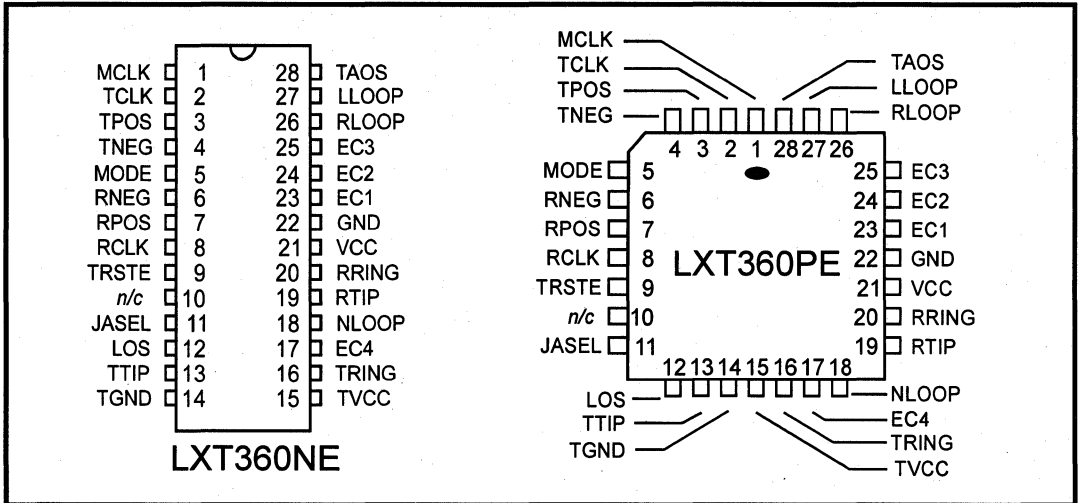

Table 1: LXT360 Clock and Data Pin Assignments by Mode¹

Pin #	External Data Modes		QRSS Modes	
	Bipolar Mode	Unipolar Mode	Bipolar Mode	Unipolar Mode
1	MCLK			
2	TCLK			
3	TPOS	TDATA	INSLER	
4	TNEG	INSBPV	INSBPV	
6	RNEG	BPV	RNEG	BPV
7	RPOS	RDATA	RPOS	RDATA
8	RCLK			
13	TTIP			
14	TGND			
15	TVCC			
16	TRING			
19	RTIP			
20	RRING			
21	VCC			
22	GND			

¹ Data pins change based on whether external data or internal QRSS mode is active. Clock pins remain the same in both Hardware and Host Modes.

Table 2: LXT360 Control Pins by Mode

Pin #	Hardware Modes		Host Modes		Pin #	Hardware Modes		Host Modes	
	Unipolar/ Bipolar	QRSS	Unipolar/ Bipolar	QRSS		Unipolar/ Bipolar	QRSS	Unipolar/ Bipolar	QRSS
5	MODE		MODE		25	EC3		SDO	
9	TRSTE		TRSTE		17	EC4		Low	
11	JASEL		Low		18	NLOOP		NLOOP	
12	LOS	LOS/ QPD	LOS	LOS/ QPD	26	RLOOP		\overline{CS}	
23	EC1		\overline{INT}		27	LLOOP		SCLK	
24	EC2		SDI		28	TAOS	QRSS	CLKE	

Table 3: LXT360 Hardware Controlled Bipolar Mode Signal Descriptions

Pin #	Symbol	I/O ²	Description
1 ¹	MCLK	DI	Master Clock. Connect to 1.544 MHz for T1 operation; to 2.048 MHz for E1. MCLK input requires an external, independent clock signal to generate internal clocks. Required accuracy is better than ± 32 ppm with a typical duty cycle of 50%. Upon Loss of Signal (LOS), RCLK is derived from MCLK.
2 ¹	TCLK	DI	Transmit Clock. 1.544 MHz or 2.048 MHz clock input. Transceiver samples TPOS and TNEG on the falling edge of TCLK
3 4	TPOS TNEG	DI	Transmit Data – Positive and Negative. In the Bipolar I/O mode, these pins are the positive and negative sides of a bipolar input pair. Data to be transmitted onto the twisted-pair line is input at these pins. Table 4 describes Unipolar Mode functions.
5 ¹	MODE	DI	Mode Select. Connecting MODE Low puts the LXT360 in the Hardware Mode. In Hardware Mode, the serial interface is disabled and hardwired pins are used to control configuration and report status. Connecting MODE to Midrange ³ activates the Hardware Mode and enables the B8ZS/HDB3 encoder/decoder and Unipolar Mode. Connecting MODE High puts the LXT360 in the Host Mode. In the Host Mode, the serial interface controls the LXT360 and displays its status.
6 7	RNEG RPOS	DO	Receive Data – Negative and Positive. In the Bipolar I/O mode, these pins are the positive and negative sides of a bipolar output pair. Data recovered from the line interface is output on these pins. A signal on RNEG corresponds to receipt of a negative pulse on RTIP/RRING. A signal on RPOS corresponds to receipt of a positive pulse on RTIP/RRING. RNEG/RPOS outputs are Non-Return-to-Zero. Both outputs are stable and valid on the rising edge of RCLK. Refer to Table 4 for Unipolar mode function descriptions.

1. These pins do not change function as the operating mode changes. Tables 4 through 6 do not describe these pins.
 2. I/O column entries: DI = Digital Input; DO = Digital Output; DI/O = Digital Input/Output; AI = Analog Input; AO = Analog Output.
 3. Midrange is a voltage level such that $2.3\text{ V} \leq \text{Midrange} \leq 2.7\text{ V}$ or the pin may float.

Table 3: LXT360 Hardware Controlled Bipolar Mode Signal Descriptions – continued

Pin #	Symbol	I/O ²	Description
8	RCLK	DO	Recovered Clock. The clock recovered from the line input signal is output on this pin. Under LOS conditions there is a smooth transition from RCLK signal (derived from the recovered data) to MCLK signal at the RCLK output.
9	TRSTE	DI	Tristate. Connecting TRSTE High forces all output pins to a high impedance state. Connecting TRSTE Low sets LXT360 to the Hardware Bipolar Mode. Connecting TRSTE to Midrange ³ enables the Unipolar Mode. (See Table 4 for Unipolar function descriptions.)
10	n/c	DO	<i>No connection. Leave this pin floating.</i>
11	JASEL	DI	Jitter Attenuation Select. Selects jitter attenuation location. Connecting JASEL High activates the jitter attenuator in the receive path. Connecting JASEL Low activates the jitter attenuator in the transmit path. Connecting JASEL to Midrange ³ disables JA.
12	LOS	DO	Loss of Signal Indicator. In T1 modes, LOS goes High on receipt of 175 consecutive spaces and returns Low when the received signal reaches a mark density of 12.5% (determined by receipt of 16 marks within a sliding window of 128 bits with fewer than 100 consecutive zeros). In E1 modes, LOS goes High on receipt of 32 consecutive spaces, and returns Low when the receiver detects 12.5% mark density (determined by receipt of 4 marks within a sliding window of 32 bits with fewer than 16 consecutive zeros). The transceiver outputs received marks on RPOS and RNEG even when LOS is High.
13 ¹ 16 ¹	TTIP TRING	AO	Transmit Tip and Ring. Differential Driver Outputs. These outputs are designed to drive a 50 - 200 Ω load. The transformer and line matching resistors should be selected to give the desired pulse height and return loss performance.
14 ¹	TGND		Ground return for the transmit drivers power supply TVCC.
15 ¹	TVCC	DI	+5 VDC Power Supply input for the transmit drivers. TVCC must not vary from VCC by more than ± 0.3 V.
17	EC4	DI	Equalization Control 4. Used with EC3-1 (pins 23-25) for pulse equalization and LBO settings.
18 ¹	NLOOP	DO	Network Loopback Detection. If the LXT360 is configured to detect Network Loopback (NLOOP) (by connecting the RLOOP pin to Midrange ³), this pin goes High when an Inband Network Loopback has been activated by the reception of a 00001 pattern for five seconds. NLOOP is reset by reception of 001 for five seconds, or by activation of RLOOP.
19 ¹ 20 ¹	RTIP RRING	AI	Receive Tip and Ring. The AMI signal received from the line is applied at these pins. A 1:1 transformer is required. Data and clock from the signal applied at these pins are recovered and output on the RPOS/RNEG, and RCLK pins.

1. These pins do not change function as the operating mode changes. Tables 4 through 6 do not describe these pins.
 2. I/O column entries: DI = Digital Input; DO = Digital Output; DI/O = Digital Input/Output; AI = Analog Input; AO = Analog Output.
 3. Midrange is a voltage level such that 2.3 V ≤ Midrange ≤ 2.7 V or the pin may float.

Table 3: LXT360 Hardware Controlled Bipolar Mode Signal Descriptions – continued

Pin #	Symbol	I/O ²	Description
21 ¹	VCC		+5 VDC Power Supply for all circuits except the transmit drivers. (Transmit drivers are supplied by TVCC.)
22 ¹	GND		Ground return for power supply VCC.
23 24 25	EC1 EC2 EC3	DI	Equalization Control 3-1. EC4-1 (including pin 17) define the Pulse Equalization, Line Build Outs and Equalizer Gain Limit settings. See Table 12 for additional details.
26	RLOOP	DI	Remote Loopback. When held High, the clock and data inputs from the framer (TPOS/TNEG or TDATA) are ignored and the data received from the twisted-pair line is transmitted back onto the line at the RCLK frequency. During remote loopback, the device ignores the in-line encoders/decoders. Connecting this pin to Midrange enables Network Loopback. See Figure 8.
27	LLOOP	DI	Local Loopback. When held High, the data on TPOS and TNEG loops back digitally to RPOS and RNEG outputs (through JA if enabled). Connecting this pin to Midrange ³ enables Analog Loopback (TTIP and TRING looped back to RTIP and RRING). See Figures 5, 6, and 7.
28	TAOS	DI	Transmit All Ones. When held High the transmit data inputs are ignored and the LXT360/361 transmits a stream of 1s at the TCLK frequency. (If TCLK is not supplied, MCLK is the transmit clock reference.) TAOS is inhibited during Remote Loopback. Connecting this pin to Midrange enables QRSS pattern generation and detection. See Figure 5, 10, and 11.
<p>1. These pins do not change function as the operating mode changes. Tables 4 through 6 do not describe these pins. 2. I/O column entries: DI = Digital Input; DO = Digital Output; DI/O = Digital Input/Output; AI = Analog Input; AO = Analog Output. 3. Midrange is a voltage level such that $2.3\text{ V} \leq \text{Midrange} \leq 2.7\text{ V}$ or the pin may float.</p>			

6

Table 4: LXT360 Hardware Controlled Unipolar Mode Signal Assignments

Pin #	Symbol	I/O ¹	Description
3	TDATA	DI	Transmit Data. Unipolar input for data to be transmitted onto the twisted-pair line.
4	INBPV	DI	Insert Bipolar Violation. This pin is sampled on the falling edge of TCLK to control Bipolar Violation Insertions in the transmit data stream. A Low-to-High transition is required to insert subsequent BPVs.
6	BPV	DO	Bipolar Violation. BPV goes High to report receipt of a bipolar violation from the line. This is an NRZ output, valid on the rising edge of RCLK.
7	RDATA	DO	Receive Data. RDATA is a unipolar NRZ output of data recovered from the line interface. In Hardware Mode RDATA is stable and valid on the rising edge of RCLK.
<p>1. I/O column entries: DI = Digital Input; DO = Digital Output; DI/O = Digital Input/Output; AI = Analog Input; AO = Analog Output.</p>			

Table 5: LXT360 Hardware Controlled QRSS Unipolar Mode Signal Assignments

Pin#	Signal Name	I/O ¹	Description
3	INSLER	DI	Insert Logic Error. When this pin goes from Low to High, the transceiver inserts a logic error into the transmitted QRSS data pattern. The error follows the data flow in whatever loopback mode is in effect. The LXT360 samples this pin on the falling edge of TCLK (or MCLK, if TCLK is not present).
4	INSBPV	DI	Insert Bipolar Violation. When this pin goes from Low to High, the transceiver inserts a bipolar violation error into the transmitted QRSS data pattern. A subsequent insertion requires another Low to High transition. The LXT360 samples this pin on the falling edge of TCLK (or MCLK, if TCLK is not present).
6	BPV ³	DO	Bipolar Violation. BPV goes High to report receipt of a bipolar violation from the twisted-pair line. This is an NRZ output, valid on the rising edge of RCLK.
7	RDATA ³	AO	Received Data. RDATA is a unipolar NRZ output of data recovered from the line interface. In hardware Mode, RDATA is stable and valid on the rising edge of RCLK.
12	LOS/QPD	DO	Loss of Signal/QRSS Pattern Detect. This pin acts as a QPD indicator as well as LOS indicator. The QRSS Pattern synchronization criterion is fewer than four errors in 128 bits. In this mode, as long as the transceiver does not detect a QRSS pattern QPD stays High. As soon as the device does detect a QRSS pattern, the pin goes Low; any bit errors cause QPD to go High for half a clock cycle. This output can trigger an external error counter. An LOS condition will also make this pin go High. See Figure 11.
28	QRSS	DI	QRSS. Setting this pin to Midrange ² , enables QRSS pattern generation and detection. The transceiver transmits the QRSS pattern at the TCLK rate (or MCLK, if TCLK is not present).

1. I/O column entries: DI = Digital Input; DO = Digital Output; D/I/O = Digital Input/Output; AI = Analog Input; AO = Analog Output.
 2. Midrange is a voltage level such that $2.3\text{ V} \leq \text{Midrange} \leq 2.7\text{ V}$ or the pin may float.
 3. In QRSS Bipolar Mode, pins 6 and 7 act as RNEG and RPOS, respectively.

Table 6: LXT360 Host Controlled Bipolar Mode Signal Assignments ^{1,2}

Pin #	Signal Name	I/O ³	Description
6 7	RNEG RPOS	DO	Received Data—Negative and Positive. In the Bipolar I/O Mode, these pins are the negative and positive sides of a bipolar output pair. The transceiver outputs the data recovered from the line interface on these pins. A signal on RNEG corresponds to receipt of a negative pulse on RTIP/RRING. A signal on RPOS corresponds to receipt of a positive signal on RTIP/RRING. RNEG/RPOS outputs are Non-Return-to-Zero (NRZ). CLKE determine the clock edge at which these outputs are stable and valid. See Figure 19.
9	TRSTE	DI	Tristate. Connecting TRSTE High forces all output pins to high-impedance state. Connect this pin Low for normal operation.
10	<i>none</i>	–	<i>Not connected.</i>
11	<i>none</i>	–	<i>Connect Low.</i>
17	<i>none</i>	–	<i>Connect Low.</i>
18	NLOOP		Network Loopback. This pin goes High when an Inband Network Loopback has been activated.
23	$\overline{\text{INT}}$	DO	Interrupt (Active Low—Maskable). $\overline{\text{INT}}$ goes Low to flag the host when any of the LOS, NLOOP, AIS, QRSS, DFMS or DFMO changes state or when there is an Elastic Store overflow or underflow. $\overline{\text{INT}}$ is an open drain output which requires a connection to power supply VCC through a resistor. Reset $\overline{\text{INT}}$ by writing a one to the respective bit in the Interrupt Clear Register.
24	SDI	DI	Serial Data Input. Input port for the 16-bit serial address/command and data word. LXT360 samples SDI on the rising edge of SCLK. See Figures 20 and 21.
25	SDO	DO	Serial Data Output. If CLKE is High, SDO is valid on the rising edge of SCLK. If CLKE is Low, SDO is valid on the falling edge of SCLK. This pin goes to a high-impedance state when the serial port is being written to or when $\overline{\text{CS}}$ is High. See Figure 21.
26	$\overline{\text{CS}}$	DI	Chip Select (Active Low). This input is used to access the serial interface. For each read or write operation, $\overline{\text{CS}}$ must transition from High to Low, and remain Low.
27	SCLK	DI	Serial Clock. This clock is used to write data to or read data from the serial interface registers. The clock frequency can be any rate up to 2.048 MHz.
28	CLKE	DI	Clock Edge. Setting CLKE High causes RPOS and RNEG to be valid on the falling edge of RCLK, with SDO valid on the rising edge of SCLK. Setting CLKE Low makes RPOS and RNEG valid on the rising edge of RCLK and SDO valid on the falling edge of SCLK.

1. For pins not described in this table, see Table 3. Pin out for data pins in Unipolar and QRSS Modes remains the same as in Tables 4 and 5. In Host Mode, the control pins (23-28) change as shown in Table 6.
 2. In QRSS Bipolar Mode, pins 6 and 7 seven act as RNEG and RPOS, respectively.
 3. I/O column entries: DI = Digital Input; DO = Digital Output; DI/O = Digital Input/Output; AI = Analog Input; AO = Analog Output.

Figure 2: LXT361 Bipolar Mode Pin Assignments

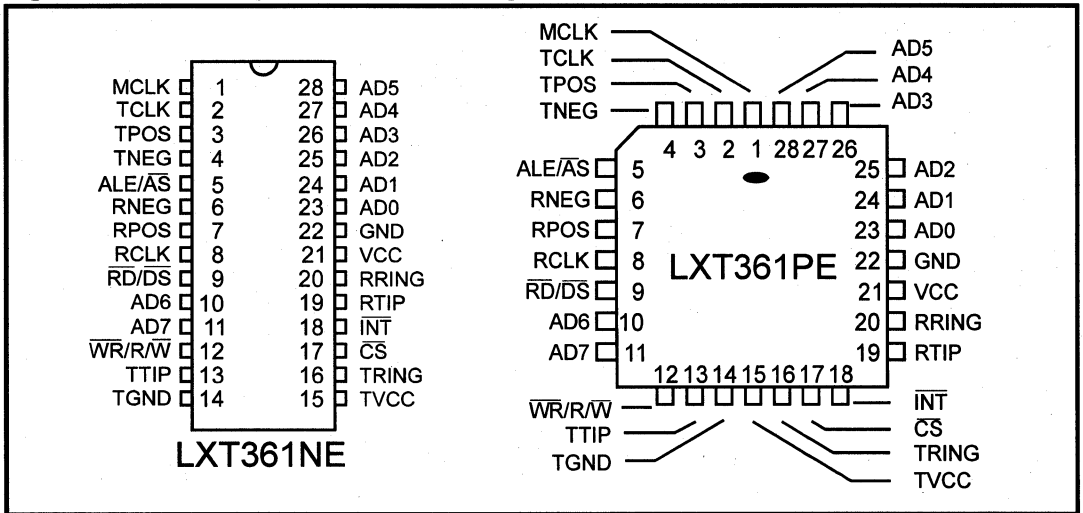

Table 7: LXT361 Clock and Data Pin Assignments by Mode¹

Pin #	External Data Modes		QRSS Modes	
	Bipolar Mode	Unipolar Mode	Bipolar Mode	Unipolar Mode
1	MCLK			
2	TCLK			
3	TPOS	TDATA	INSLER	
4	TNEG	INSBPV	INSBPV	
6	RNEG	BPV	RNEG	BPV
7	RPOS	RDATA	RPOS	RDATA
8	RCLK			
13	TTIP			
14	TGND			
15	TVCC			
16	TRING			
19	RTIP			
20	RRING			
21	VCC			
22	GND			

1. Data pins change based on whether external data or internal QRSS mode is active. These pins remain the same in both Hardware and Host Modes.

Table 8: LXT361 Processor Interface Pins

Pin #	Address/Data Bus Type		Pin #	Address/Data Bus Type	
	Intel	Motorola		Intel	Motorola
5	ALE	\overline{AS}	25	AD2	
9	\overline{RD}	\overline{DS}	26	AD3	
12	\overline{WR}	R/ \overline{W}	27	AD4	
17	\overline{CS}		28	AD5	
18	\overline{INT}		10	AD6	
23	AD0		11	AD7	
24	AD1		--	--	

Table 9: LXT361 Bipolar Mode Signal Assignments

Pin#	Symbol	I/O ¹	Description
1	MCLK	DI	Master Clock. Connect to 1.544 MHz for T1 operation; to 2.048 MHz for E1. MCLK requires an external, independent input to generate internal clocks. Required accuracy is ± 32 ppm with a typical duty cycle of 50%. Upon Loss of Signal (LOS), the transceiver derives RCLK from MCLK.
2	TCLK	DI	Transmit Clock. 1.544 MHz or 2.048 MHz bit rate clock input. The transceiver samples TPOS and TNEG on the falling edge of TCLK
3 4	TPOS TNEG	DI	Transmit Data – Positive and Negative. In the Bipolar I/O Mode, these pins are the positive and negative sides of a bipolar input pair. Data for transmission onto the twisted-pair line is input at these pins.
5	\overline{ALE} \overline{AS}	DI	Address Latch Enable/Address Strobe (Active Low). Connects to Intel (ALE) or Motorola (\overline{AS}) signal. On Motorola bus, this signal is Active Low. Leaving this pin floating forces all output pins into a high impedance state.
6 7	RNEG RPOS	DO	Receive Data – Negative and Positive. In the Bipolar I/O mode, these pins are the positive and negative sides of a bipolar output pair. Data recovered from the line interface is output on these pins. A signal on RNEG corresponds to receipt of a negative pulse on RTIP/RRING. A signal on RPOS corresponds to receipt of a positive pulse on RTIP/RRING. RNEG/RPOS outputs are Non-Return-to Zero. Both outputs are stable and valid on the rising edge of RCLK. Refer to Table 10 for Unipolar mode function descriptions.
8	RCLK	DO	Recovered Clock. The output on this pin is the clock recovered from the line input signal. Under LOS conditions there is a smooth transition from RCLK to MCLK output.

1. I/O column entries: DI = Digital Input; DO = Digital Output; DI/O = Digital Input/Output; AI = Analog Input; AO = Analog Output.

LXT360/361 Integrated T1/E1 LH/SH Transceivers

Table 9: LXT361 Bipolar Mode Signal Assignments – continued

Pin #	Symbol	I/O ¹	Description
9	\overline{RD} \overline{DS}	DI	Read (Active Low)/Data Strobe (Active Low). On an Intel bus, this signal, Read, goes Low to command a read operation. On a Motorola bus, this signal, Data Strobe, goes Low when data is being driven on the address/data bus. Data is valid on the rising edge of \overline{DS} .
10 11	AD6 AD7	DI/O DI/O	Address/Data bus lines 6 and 7. Used with pins 24-28 as the address/data bus.
12	\overline{WR} R/ \overline{W}	DI	
13 16	TTIP TRING	AO	Transmit Tip and Ring. Differential Driver Outputs. The design load for these outputs is 50 - 200 Ω . Select the transformer and line matching resistors to give the desired pulse height.
14	TGND		Ground return for the transmit drivers power supply TVCC.
15	TVCC		+5 VDC Power Supply input for the transmit drivers. TVCC must not vary from VCC by more than ± 0.3 V.
17	\overline{CS}	DI	Chip Select (Active Low). For each read or write on the Address/Data bus, this pin must go Low during the operation. See Figures 22 and 23 for timing requirements. In the case of a single processor controlling several chips, this is the line it uses to command a specific transceiver.
18	\overline{INT}	DO	Interrupt (Active Low). This pin goes Low to signal an interrupt on the chip. To identify the specific interrupt, read the Performance Status Register. To clear or mask an interrupt, write a one to the appropriate bit in the Clear Interrupt Register.
19 20	RTIP RRING	AI	Receive Tip and Ring. The AMI signal received from the line is applied at these pins. A 1:1 transformer is required. Data and clock from the signal applied at these pins are recovered and output on the RPOS/RNEG, and RCLK pins.
21	VCC		+5 VDC Power Supply for all circuits except the transmit drivers. (Transmit drivers are supplied by TVCC.)
22	GND		Ground return for power supply VCC.
23 24 25 26 27 28	AD0 AD1 AD2 AD3 AD4 AD5	DI/O	Address/Data Lines 0-5. (Also pins 10, 11-AD6 and 7) Conform to Intel and Motorola Address/Data bus specifications.

1. I/O column entries: DI = Digital Input; DO = Digital Output; DI/O = Digital Input/Output; AI = Analog Input; AO = Analog Output.

Table 10: LXT361 Unipolar Mode Signal Assignments¹

Pin #	Symbol	I/O ²	Description
3	TDATA	DI	Transmit Data. Unipolar data for transmission onto the twisted-pair line.
4	INSBPV	DI	Insert Bipolar Violation. Controls bipolar violation insertions, requires Low-to-High transition to insert each violation, the LXT361 samples the signal on the falling edge of TCLK.
6	BPV	DO	Bipolar Violation. BPV goes High on receipt of a bipolar violation from twisted-pair line. This is an NRZ output, valid on the rising edge of RCLK.
7	RDATA	DO	Received Data. RDATA is an NRZ output of the data recovered from the line interface. RDATA is valid on the rising edge of RCLK.

1. For the descriptions of pins not identified in this table, see Table 9: LXT361 Bipolar Mode Signal Assignments.
 2. I/O column entries DI = digital input; DO = digital output, DI/O = digital input and output; AI = analog input , AO = analog output.

Table 11: LXT361 QRSS Unipolar Mode Signal Assignments^{1,2}

Pin #	Symbol	I/O ³	Description
3	INSLER	DI	Insert Logic Error. When this pin goes from Low to High, the transceiver inserts a logic error into the transmitted QRSS data pattern. The error follows the data flow in whatever loopback mode is in effect. The LXT361 samples this pin on the falling edge of TCLK (or MCLK, if TCLK is not present).
4	INSBPV	DI	Insert Bipolar Violation. When this pin goes from Low to High, the transceiver inserts a bipolar violation error into the transmitted QRSS data pattern. A subsequent insertion requires another Low to High transition. The LXT361 samples this pin on the falling edge of TCLK (or MCLK, if TCLK is not present).
6	BPV	DO	Bipolar Violation. BPV goes High on receipt of a bipolar violation from twisted-pair line. This is an NRZ output, valid on the rising edge of SCLK.
7	RDATA	DO	Received Data. RDATA is an NRZ output of the data recovered from the line interface. RDATA is valid on the rising edge of RCLK.

1. For the descriptions of pins not identified in this table, see Table 9.
 2. In QRSS Bipolar Mode, pins 6 and 7 act as RNEG and RPOS, respectively.
 3. I/O column entries DI = digital input; DO = digital output, DI/O = digital input and output; AI = analog input, AO = analog output.

Figure 3: LXT361 Integrated T1/E1 Transceiver Block Diagram

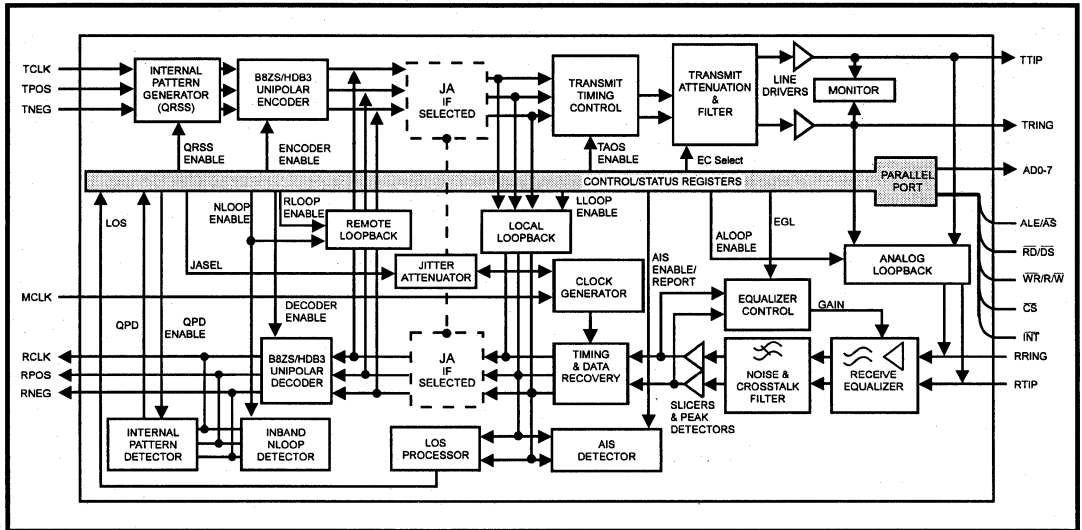

FUNCTIONAL DESCRIPTION

NOTE

This functional description is for design aid only.

The LXT360 and LXT361 are fully integrated, PCM transceivers for long- or short-haul, 1.544 Mbps (T1) or 2.048 Mbps (E1) applications allowing full-duplex transmission of digital data over existing twisted-pair installations. They interface with two twisted-pair lines (one pair each for transmit and receive) through standard pulse transformers and appropriate resistors.

The figure at the front of this Data Sheet shows a block diagram of the LXT360. Control of this chip is via either a serial microprocessor port or, in Hardware Mode, via individual pin settings. Figure 3 is a block diagram of the LXT361. The LXT361 has a parallel port for microprocessor control. Both transceivers provide a high-precision, crystal-less jitter attenuator. The user may place it in the transmit or receive path, or bypass it completely.

The transceivers meet or exceed FCC and AT&T specifications for CSU and DSX-1 applications, as well as ANSIT1/E1, and ITU and ETSI requirements for E1 ISDN PRI applications.

INITIALIZATION

During power up, the transceiver remains static until the power supply reaches approximately 3 V. On crossing this threshold, the device begins a 32 ms reset cycle to calibrate the Phase Lock Loops (PLL). The transceiver uses a reference clock to calibrate the PLL; the transmitter reference is TCLK, and the receiver reference clock is MCLK. MCLK is mandatory for chip operation.

Reset Operation

Reset clears and sets all registers to 0 and resets the status and state machines for the LOS, AIS, NLOOP, and QRSS blocks. In Hardware Mode, holding pins RLOOP, LLOOP and TAOS High for at least one clock cycle resets the device. Writing a 1 to the bit CR2.RESET commands reset in Host Mode. Allow 32 ms for the device to settle after removing all reset conditions.

TRANSMITTER

Digital Data Interface

Input data for transmission onto the line is clocked serially into the device at the TCLK rate. TPOS and TNEG are the bipolar data inputs. TDATA accepts unipolar data. (Setting the TRSTE pin to Midrange enables Hardware Unipolar Mode.)

Input data may pass through either the Jitter Attenuator or B8ZS/HDB3 encoder or both. Bit CR1.ENCENB = 1 enables B8ZS/HDB3 encoding in Host Mode. In Hardware Mode, connecting the MODE pin to Midrange selects zero suppression coding. With zero suppression enabled, the ECx inputs (see Table 12) determine the coding scheme (B8ZS for T1 or HDB3 for E1 mode). To select the HDB3 scheme, set EC4-1 to 1000, 1001 or 1010. Other ECx settings select the B8ZS option. The transmit clock (TCLK) supplies input synchronization. The Test Specifications section defines the transmit timing requirements for TCLK and the Master Clock (MCLK).

Short Circuit Limit

The transmitter includes a short circuit limiter. This limits the current sourced into a low impedance load. It automatically resets when the load current drops below the limit. The current is determined by the interface circuitry (total resistance on transmit side).

In Host Mode, the Performance Status Register flags open circuits in bit PSR.DFMO. A transition on DFMO will provide an interrupt and the transition sets bit TSR.DFMO = 1. Writing a 1 in bit ICR.CDFMO clears the interrupt; leaving a 1 in the bit masks that interrupt.

Output Drivers

The transceivers transmit data as a 50% line code as shown in Figure 4. Activating the line driver only during a mark reduces power consumption. The output driver is disabled during transmission of a space. Biasing of the transmit DC level is on-chip.

Figure 4: 50% Duty Cycle Coding Diagram

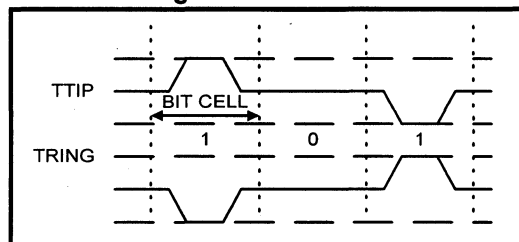

Idle Mode

Transmit Idle Mode is a normal operational mode (as opposed to modes) which allows multiple transceivers to be connected to a single line for redundant applications. TTIP and TRING remain in a high impedance state when TCLK is not present. Remote or Dual Loopback, TAOS or any internal transmit patterns temporarily disable the high impedance state as will detection of Network Loop Up code in the receive direction.

Pulse Shape

The Equalizer Control inputs (EC4-1) determine the transmitted pulse shape as in Table 12. In Host Mode, the I/O port controls the ECx values. For the LXT360 in Hardware Mode, four individual pins provide the ECx inputs.

Shaped pulses meeting the various T1, DS1, DSX-1 and E1 specifications are applied to the AMI line driver for transmission onto the line at TTIP and TRING. The transceivers produce DSX-1 pulses for short-haul T1 applications (settings from 0 dB to +3.0 dB), DS1 pulses for long-haul T1 applications (settings from 0 dB to -22.5 dB), and a G.703 pulse for E1 applications. Refer to the Test Specifications section for pulse mask specifications.

RECEIVER

A 1:1 transformer provides the interface to the twisted-pair line. Recovered data is output at RPOS/RNEG (RDATA in Unipolar Mode), and the recovered clock is output at RCLK. The Test Specifications section shows receiver timing.

Receiver Equalizer

The receive equalizer processes the signal received at RTIP and RRING. The equalizer gain is up to 43 dB in E1 long-haul applications. In T1 long-haul applications, the equalizer control (ECx) input pins or register bits determine the maximum gain applied at the equalizer. With EC1 Low, up to 36 dB of gain may be applied. When EC1 is High, 26 dB is the gain limit to provide an increased noise margin in shorter loop operations.

The receiver can accurately recover signals with up to 36 dB of cable attenuation (from 2.4 V) for T1 and up to 43 dB of cable attenuation (from 2.7 V) for E1 operation.

Data Recovery

The transceiver filters the equalized signal and applies it to the peak detector and data slicers. The peak detector samples the inputs and determines the maximum value of

the received signal. The data slicers are set at 50% of the peak value to ensure optimum signal-to-noise performance.

After processing through the data slicers, the received signal goes to the data and timing recovery section, then to the B8ZS/HDB3 decoder (if selected) and to the receive monitor. The data and timing recovery circuits provide input jitter tolerance significantly better than required by AT&T Pub 62411 and ITU G.823. See the Test Specifications section.

Digital Data Interface

In either Host or Hardware Control Mode the recovered data goes to the Loss of Signal (LOS) Monitor. In Host Control Mode, it also goes through the Alarm Indication Signal (AIS, Blue Alarm) Monitor. The jitter attenuator circuit may be enabled or disabled in the receive data path or the transmit path. Received data may go through either the B8ZS or HDB3 decoder or neither. Finally, the device may send the digital data to the framer as either unipolar or bipolar data.

When transmitting unipolar data to the framer, the device reports receiving bipolar violations by driving the BPV pin High. During E1 operation in Host Control Mode, the device can report HDB3 code violations and Zero Substitution Violations on the BPV pin. The diagnostics section explains these options in more detail.

Receiver Monitor Mode

The receive equalizer of the LXT360/361 can be used in Monitor Mode applications. Monitor Mode applications are those requiring a resistive attenuation of the signal in addition to a small amount of cable attenuation (less than 6 dB). Setting bit CR3.EQZMON = 1 configures the device to work in its Monitor Mode. The device must be in its long-haul receiver mode (set bits CR1.ECx = 0xx0 or 1001 or 1010) for Monitor Mode. This feature is not available in the LXT360 Hardware Mode.

With the device in Monitor Mode, the receive equalizer handles signals attenuated resistively by 20 to 30 dB, along with 0 to 6 dB of cable attenuation for both E1 and T1 applications.

JITTER ATTENUATION

A Jitter Attenuation Loop (JAL) with an Elastic Store (ES) provides jitter attenuation as shown in the Test Specifications section. The JAL requires no special circuitry, such as an external quartz crystal or high-frequency clock

(higher than the line rate). Its timing reference is the master clock, MCLK.

In Hardware Control Mode the ES is a 32 x 2-bit register. Setting the JASEL pin High places the JA circuitry in the received data path; setting JASEL Low places the JA in the transmit data path; tying it to Midrange disables the JA.

In Host Mode, bit CR1.JASEL0 enables or disables the JA circuit. With bit CR1.JASEL0 = 1, bit CR1.JASEL1 controls the JA circuit placement (see Table 16). The ES can be either a 32 x 2-bit or 64 x 2-bit register depending on the value of bit CR3.ES64 (see Table 18.)

The device clocks data into the ES using either TCLK or Receiver Recovered Clock depending on whether the JA circuitry is in the transmit or receive data path, respec-

tively. Data is shifted out of the elastic store using the dejittered clock from the JAL. When the FIFO is within two bits of overflowing or underflowing, the ES adjusts the output clock by 1/8 of a bit period. The ES produces an average delay of 16 bits (or 32 bits, with the 64-bit ES option selected in Host Control Mode) in the associated data path. When the Jitter Attenuator is in the receive path, the output RCLK transitions smoothly to MCLK in the event of an LOS condition.

The Transition Status Register bits TSR.ESOV and TSR.ESUNF indicate an overflow or underflow, respectively, in the ES. These are sticky bits: once set to 1, they remain set until the host reads the register. The ES can also provide a maskable interrupt on either overflow or underflow.

Table 12: Equalizer Control Input Settings

EC4	EC3	EC2	EC1 ¹	Function	Pulse	Cable	Gain	Coding ²
0	0	0	0	T1 Long Haul	0.0 dB pulse	100 Ω TP	36 dB	B8ZS
0	0	1	0	T1 Long Haul	-7.5 dB pulse	100 Ω TP	36 dB	B8ZS
0	1	0	0	T1 Long Haul	-15.0 dB pulse	100 Ω TP	36 dB	B8ZS
0	1	1	0	T1 Long Haul	-22.5 dB pulse	100 Ω TP	36 dB	B8ZS
0	0	0	1	T1 Long Haul	0.0 dB pulse	100 Ω TP	26 dB	B8ZS
0	0	1	1	T1 Long Haul	-7.5 dB pulse	100 Ω TP	26 dB	B8ZS
0	1	0	1	T1 Long Haul	-15.0 dB pulse	100 Ω TP	26 dB	B8ZS
0	1	1	1	T1 Long Haul	-22.5 dB pulse	100 Ω TP	26 dB	B8ZS
1	0	0	0	E1 Short Haul	ITU Rec G.703	120 Ω TP/75 Ω Coax	12 dB	HDB3
1	0	0	1	E1 Long Haul	ITU Rec G.703	120 Ω TP	43 dB	HDB3
1	0	1	0	E1 Long Haul	ITU Rec G.703	120 Ω TP/75 Ω Coax	43 dB	HDB3
1	0	1	1	T1 Short Haul	0-133 ft / 0.6 dB	100 Ω TP	12 dB	B8ZS
1	1	0	0	T1 Short Haul	133-266 ft / 1.2 dB	100 Ω TP	12 dB	B8ZS
1	1	0	1	T1 Short Haul	266-399 ft / 1.8 dB	100 Ω TP	12 dB	B8ZS
1	1	1	0	T1 Short Haul	399-533 ft / 2.4 dB	100 Ω TP	12 dB	B8ZS
1	1	1	1	T1 Short Haul	533-655 ft / 3.0 dB	100 Ω TP	12 dB	B8ZS

1. EC1 sets the receive equalizer gain (EGL) during T1 long-haul operation.
 2. When enabled.

DIAGNOSTIC MODE OPERATION

LXT360/361 offers multiple diagnostic modes as shown in Table 13. In Hardware Mode, the diagnostic modes are selected by a combination of pin settings. In Host Mode, the diagnostic modes are selected by writing appropriate bits in the Diagnostic Control Register.

Table 13: Diagnostic Mode Availability

Diagnostic Mode	Availability ¹		Host Mode ² Maskable
	H/W	Host	
Loopback Modes			
Local Loopback (LLOOP)	Yes	Yes	No
Analog Loopback (ALOOP)	Yes	Yes	No
Remote Loopback (RLOOP)	Yes	Yes	No
In-band Network Loopback (NLOOP)	Yes	Yes	Yes
Dual Loopback (DLOOP)	Yes	Yes	No
Internal Data Pattern Generation and Detection			
Transmit All Ones (TAOS)	Yes	Yes	No
Quasi-Random Signal Source (QRSS)	Yes	Yes	Yes
In-band Loop up/down Code Generator	No	Yes	No
Error Insertion and Detection			
Bipolar Violation Insertion (INSBPV)	Yes	Yes	No
Logic Error Insertion (INSLER)	Yes	Yes	No
Bipolar Violation Detection (BPV)	Yes	Yes	No
Logic Error Detection, QRSS (QPD)	Yes	Yes	No
HDB3 Code Violation Detection (CODEV)	No	Yes	No
HDB3 Zero violation Detection (ZEROV)	No	Yes	No
Alarm Condition Monitoring			
Receive Loss of Signal (LOS) Monitoring	Yes	Yes	Yes
Receive Alarm Indication Signal (AIS) Monitoring	No	Yes	Yes
Transmit Driver Failure Monitoring—Open (DFMO)	No	Yes	Yes
Elastic Store Overflow and Underflow Monitoring	No	Yes	Yes
Other Diagnostic Reports			
Receive Line Attenuation Indicator (LATN)	No	Yes	No
Built-In Self Test (BIST)	No	Yes	Yes

1. In Hardware Control Mode, a combination of pin settings selects the Diagnostics Modes; in Host Control Mode, writing appropriate bits in the Control Registers selects the Diagnostic Modes.

2. Host Control Mode allows interrupt masking by writing a "1" to the corresponding bit in the Interrupt Clear Register. Hardware Control Mode has no interrupt masking feature.

LOOPBACK MODES

NOTE

Hardware Mode pins discussed in this section refer to the LXT360 only.

Local Loopback

See Figures 5 and 6. In Hardware Mode, Local Loopback (LOOP) is selected by tying LLOOP High; in Host Mode, by setting CR2.ELLOOP to 1. LLOOP inhibits the receiver circuits. The transmit clock and data inputs (TCLK and TPOS/TNEG or TDATA) loop back through the jitter attenuator (if enabled) and show up at RCLK and RPOS/RNEG or RDATA. (During LLOOP, the JASEL input is strictly an Enable/Disable control; it does not affect the placement of the JAL. If JA is enabled, it is active in the loopback circuit. If JA is bypassed, it is not active in the loopback circuit.)

The transmitter circuits are unaffected by LLOOP. LXT360/361 transmits the TPOS/TNEG or TDATA inputs (or a stream of 1s if TAOS is asserted) normally. When used in this mode, the transceiver can function as a stand-alone jitter attenuator.

Figure 5: TAOS with LLOOP (JA Selected)

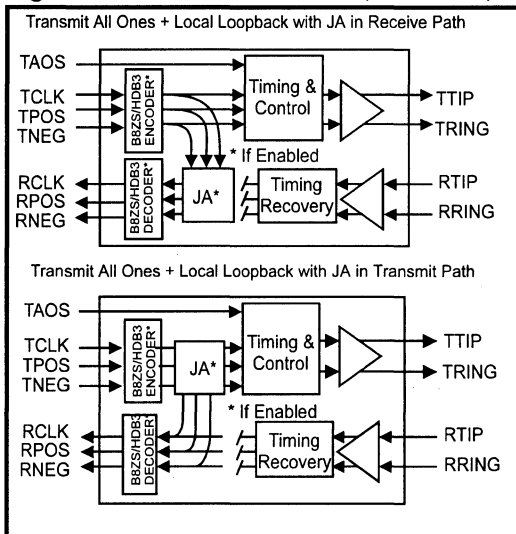
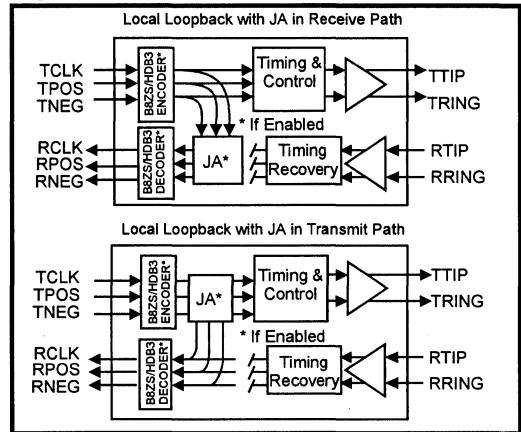

Figure 6: Local Loopback (JA Selected)



Analog Loopback

See Figure 7. Analog Loopback (ALOOP) exercises the maximum number of functional blocks. ALOOP operation disconnects the RTIP/RRING inputs from the line and routes the transmit outputs back into the receive inputs. This tests the encoders/decoders, jitter attenuator, transmitter, receiver and timing recovery sections. In Hardware Mode, tying pin 27 to Midrange commands Analog Loopback; in Host Mode, writing a 1 to bit CR2.EALOOP enables the function. The ALOOP function overrides all other loopback modes.

Figure 7: Analog Loopback (JA Selected)

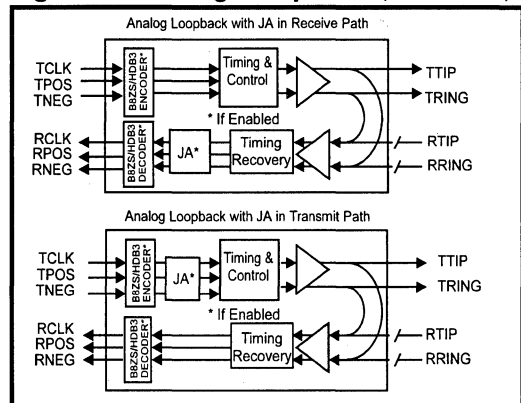

Remote Loopback

See Figure 8. In Remote Loopback (RLOOP) mode, the device ignores the transmit data and clock inputs (TCLK and TPOS/TNEG or TDATA), and bypasses the in-line encoders/decoders. The RPOS/RNEG or RDATA outputs loop back through the transmit circuits to TTIP and TRING at the RCLK frequency. The RLOOP command does not affect the receiver circuits which continue to output the RCLK and RPOS/RNEG or RDATA signals received from the twisted-pair line. In Host Mode, command RLOOP by writing a 1 to bit CR2.ERLOOP. In Hardware Mode, RLOOP is commanded by setting pin 26 High.

Network Loopback

Network Loopback (NLOOP) can be initiated only when the Network Loopback detect function is enabled. In Host Mode, writing a 1 to CR2.ENLOOP enables NLOOP detection. In Hardware Mode, setting RLOOP to Midrange enables Network Loopback detection.

With NLOOP detection enabled, the receiver looks for the NLOOP data patterns (00001 = enable, 001 = disable) in the input data stream. When the receiver detects an NLOOP enable data pattern repeated for a minimum of five seconds, the device enables RLOOP. The device responds to both framed and unframed NLOOP patterns. Once NLOOP detection is enabled at the chip and activated by the appropriate data pattern, it is identical to Remote Loopback (RLOOP). NLOOP is disabled by receiving the 001 pattern for five seconds, or by activating RLOOP or ALOOP, or by disabling NLOOP detection. The device goes into Dual Loopback Mode (DLOOP) in the case where it detects both the NLOOP and LLOOP functions.

Dual Loopback

See Figure 9. To select Dual Loopback (DLOOP), set both RLOOP and LLOOP High in Hardware Mode or set bits CR2.ERLOOP and CR2.ELLOOP to 1 in Host Mode. In DLOOP mode, the transmit clock and data inputs (TCLK and TPOS/TNEG or TDATA) loop back through the Jitter Attenuator (unless disabled) to RCLK and RPOS/RNEG or RDATA. The data and clock recovered from the twisted-pair line loop back through the transmit circuits to TTIP and TRING without jitter attenuation.

Figure 8: Remote Loopback (JA Selected)

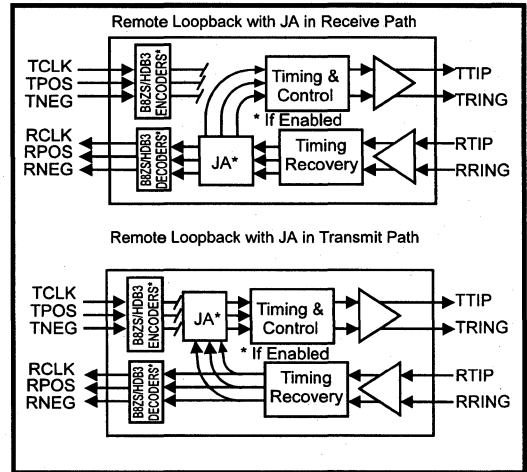
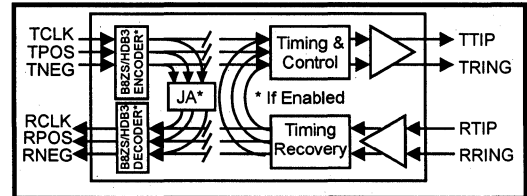

Figure 9: Dual Loopback



INTERNAL PATTERN GENERATION AND DETECTION

Transmit All Ones

See Figure 10. In Transmit All Ones (TAOS) Mode the transceiver ignores the TPOS and TNEG inputs and transmits a continuous stream of 1s at the TCLK frequency. (With no TCLK, the TAOS output clock is MCLK.) This can be used as the Alarm Indication Signal (AIS—also called the Blue Alarm). In Host Mode, TAOS is commanded by writing a 1 to bit CR2.ETAOS. In Hardware Mode setting pin 28 High does so. Both TAOS and Local Loopback can occur simultaneously as shown in Figure 5, but Remote Loopback inhibits TAOS. When both TAOS and LLOOP are active, TCLK and TPOS/TNEG loop back to RCLK and RPOS/RNEG through the jitter attenuator (if enabled), and an all ones pattern goes to TTIP/TRING.

Figure 10: TAOS Data Path

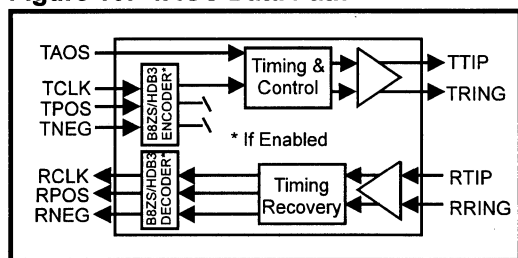

Quasi-Random Signal Source (QRSS)

See Figure 11. For T1 operation, the Quasi-Random Signal Source (QRSS) is a $2^{20}-1$ pseudo-random bit sequence (PRBS) with no more than 14 consecutive zeros. For E1 operation, QRSS is $2^{15}-1$ PRBS with inverted output.

Both Hardware and Host Modes allow QRSS Mode. The QRSS pattern is normally locked to TCLK; but if there is no TCLK, MCLK is the clock source. Bellcore Pub 62411 defines the T1 QRSS transmit format and ITU G.703 defines the E1 format.

Connecting TAOS (pin 28) Midrange enables QRSS transmission in Hardware Mode. In Host Mode, setting bits CR2.EPAT0 = 0 and CR2.EPAT1 = 1 enables this function.

With QRSS transmission enabled, it is possible to insert a logic error into the transmit data stream by causing a Low-to-High transition on INSLER (pin 3). However, if no logic or bit errors are to be inserted into the QRSS pattern, INSLER must remain Low. Logic Error insertion waits until the next bit if the current bit is “jammed”. (When there are more than 14 consecutive 0s, the output is jammed to a 1.)

Furthermore a bipolar violation in the QRSS pattern is possible by causing a Low-to-High transition on INSBPV (pin 4) without regard to whether the device is in bipolar or unipolar operating mode.

Figure 11: QRSS Mode

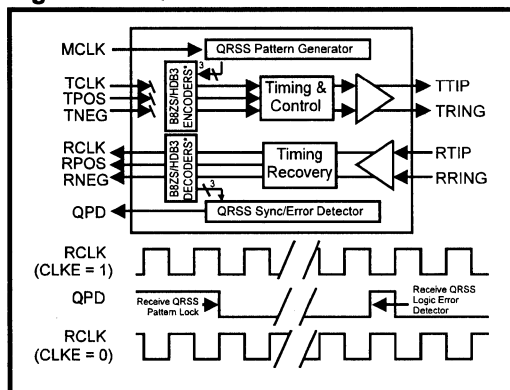

Choosing QRSS Mode also enables the QRSS Pattern Detection (QPD) in the receive path. The QRSS pattern is synchronized when there are fewer than four errors in 128 bits. After achieving synchronization the device drives QPD (pin 12) Low (QPD output is available on LXT360 only). The LXT361 does not support bit error detection in QRSS Mode. In the LXT360 QRSS Mode, any subsequent bit error in the QRSS pattern causes QPD to go High for half an RCLK clock cycle (the precise relationship to RCLK depends on the value of CLKE—when CLKE is Low, QPD goes High while RCLK is High; if CLKE is High, QPD goes High while RCLK is Low). This signal edge can serve as a trigger for an external bit-error counter. An LOS condition or a loss of QRSS synchronization will cause this output to go High continuously. In this case, and with either Unipolar Mode or the encoders/decoders enabled, the BPV pin indicates BPVs, CODEVs or ZEROVs as chosen.

Host Mode offers an additional interrupt to indicate that QRSS detection and synchronization have occurred, or that synchronization is lost. This interrupt is available when bit ICR.CQRSS = 0. If the QPD signal triggers a bit error counter, the interrupt could start or reset the counter.

Also in Host Mode, the PSR.QRSS bit provides an indication of the QRSS pattern synchronization. This bit goes Low with no QRSS pattern detected (*i.e.*, when there are more than four errors in 128 bits). The TQRSS bit in the Transition Status Register indicates that QRSS status has changed since the last QRSS Interrupt Clear command.

In-Band Network Loop Up or Down Code Generator

In Host Mode, LXT360/361 can transmit in-band Network Loop Up or Loop Down code. The Loop Up code is 00001; Loop Down code is 001. A Loop Up code transmission occurs when Control Register #2 bits EPAT0 = 1 and EPAT1 = 0. A Loop Down code transmission requires that both EPAT0 and EPAT1 = 1.

With this mode enabled, logic errors and bipolar violations can be inserted into the transmit data stream. Inserting a logic error requires a Low-to-High transition in INSLER (pin 3). (If there are no logic or bit errors to insert, INSLER must remain Low.) Inserting a bipolar violation requires a Low-to-High transition on INSBPV (pin 4), independent of Unipolar or Bipolar operation.

ERROR INSERTION AND DETECTION

Bipolar Violation Insertion (INSBPV)

In Unipolar Mode, both Hardware and Host Modes provide for Bipolar Violation Insertion (INSBPV). Choosing Unipolar Mode configures pin 4 as INSBPV. Bipolar violation insertion requires a Low-to-High transition on INSBPV. Sampling occurs on the falling edge of TCLK. When INSBPV goes High a BPV is inserted on the next available mark except in the four following situations:

- Zero suppression (HDB3 or B8ZS) is not violated
- If LLOOP and TAOS are both active, the BPV is looped back to RNEG/BPV indicator and the line driver transmits all ones with no violation.
- BPV insertion is disabled with RLOOP (remote loop-back) active.
- BPV insertion is disabled with NLOOP asserted (pin 10 High).

With the LXT360/361 configured to transmit internally generated data patterns (QRSS or NLOOP), a BPV can be inserted on the transmit pattern independent of whether the device is in the unipolar or bipolar mode of operation.

LOGIC ERROR INSERTION (INSLER)

When configured to transmit internally generated data patterns (QRSS or NLOOP Up/Down codes), the device can insert a logic error on the transmit data pattern when there is a Low-to-High transition on INSLER. In QRSS Mode, there is no logic error insertion on a jammed bit (a bit forced to one to suppress transmission of more than 14 consecutive zeros). The transceiver treats data patterns the same way it treats data applied to TPOS/TNEG, so the inserted logic error will follow the data flow path as defined by the loopback mode in effect.

Logic Error Detection (QPD) (LXT360 Only)

After receiving pattern synchronization when configured in the QRSS Mode, LXT360 reports logic errors on QPD (pin 12). To indicate a logic error, this pin goes High for half an RCLK cycle (during the High period of RCLK if CLKE is Low but during the Low RCLK period if CLKE is High). To tally logic errors, connect an error counter to QPD. A continuous logic one on this pin indicates loss of either the QRSS pattern lock or LOS condition. The QRSS section has additional details on QRSS pattern lock criteria.

Bipolar Violation Detection (BPV)

With the internal encoders/decoders enabled or when configured in Unipolar Mode, the LXT360/361 reports received Bipolar Violations at BPV (pin 6). The pin goes High for a full clock cycle to indicate receipt of a BPV. However, if the encoders/decoders are enabled, LXT360/361 does not report bipolar violations due to the line coding scheme.

HDB3 Code Violation Detection (CODEV)

LXT360/361 can detect HDB3 code violations in Host Mode with HDB3 encoders enabled. This requires CR1.ENCENB = 1 and CR1.EC4-1 = 100x or 1010, which establishes E1 operation. To enable CODEV, set bit CR4.CODEV = 1.

An HDB3 code violation (CODEV) occurs when the device receives two consecutive bipolar violations of the same polarity (refer to ITU O.161). With CODEV detection enabled, LXT360/361 reports a violation on the BPV pin along with received BPVs and ZEROVs (if these options are enabled). LXT360/361 forces the BPV pin High for a full RCLK cycle to report a CODEV.

HDB3 Zero Substitution Violation Detection (ZEROV)

With encoders/decoders enabled, the LXT360/361 can detect HDB3 zero substitution violations (ZEROV) in Host Mode. This requires CR1.ENCENB = 1 and CR1.EC4-1 = 100x or 1010, which establish E1 operation, and CR4.ZEROV = 1.

LXT360/361 forces the BPV pin High for a full RCLK cycle to report a ZEROV. An HDB3 ZEROV is the receipt of four or more consecutive zeros. This does not occur with correctly encoded HDB3 data unless there are transmission errors. With ZEROV detection enabled, the device reports a violation on the BPV pin along with received BPVs and CODEVs (if these options are enabled).

ALARM CONDITION MONITORING

Loss of Signal (LOS)

The LXT360/361 Loss of Signal (LOS) monitor function is compatible with ITU G.775 and ETSI 300233. The receiver LOS monitor loads a digital counter at the RCLK frequency. The count increments with each received 0 and the counter resets to 0 on receipt of a 1. When the count reaches “n” 0s, the LOS flag goes High, and the MCLK replaces the recovered clock at the RCLK output in a smooth transition. For T1 operations, the number of 0s, $n = 175$, and for E1 operations, $n = 32$. In Host Mode, either number can be changed to 2048 by setting bit CR4.LOS2048 to 1.

For T1 operation, when the received signal has 12.5% 1s (16 marks in a sliding 128-bit period, with fewer than 100 consecutive 0s), the LOS flag returns Low and the recovered clock replaces MCLK at the RCLK output in another smooth transition.

For E1 operation, the LOS condition is cleared when the received signal has 12.5% 1s density (four 1s in a sliding 32-bit window with fewer than 16 consecutive 0s). In Host Mode E1 operation, the out-of-LOS criterion can be modified from 12.5% marks density to 32 consecutive marks by setting bit CR4.COL32CM = 1.

During LOS, the device sends received data to the RPOS/RNEG pins (or RDATA in Unipolar Mode). LXT360 reports an LOS condition on the LOS pin in Hardware Mode. In Host Mode, the LOS bit in the Performance Status Register goes High to indicate an LOS condition and will interrupt the host controller if so programmed.

Alarm Indication Signal Detection (AIS)

The Alarm Indication Signal (AIS) is available only in Host Mode. The receiver detects an AIS pattern when it receives fewer than three 0s in any string of 2048 bits. The device clears the AIS condition when it receives three or more 0s in a string of 2048 bits.

The AIS bit in the Performance Status Register indicates AIS detection. When the AIS status changes, the TAIS bit in the Transition Status Register goes High. The change of status interrupts the host controller by pulling $\overline{\text{INT}}$ Low, unless the interrupt is masked. Writing a 1 to the ICR.CAIS bit masks the interrupt until the bit returns to 0.

Driver Failure Open Mode (DFMO)

In Host Mode a DFM Open (DFMO) bit is available in the Performance Status Register to indicate an open condition

on the lines. DFMO can generate an $\overline{\text{INT}}$ to the host controller. The Transition Status Register bit DFMO indicates a transition in the status of the bit. Writing a 1 to ICR.CDFMO will clear or mask the interrupt.

Elastic Store Overflow/Underflow (ESOV/ESUNF)

When the bit count in the Elastic Store (ES) is within two bits of overflowing or underflowing the ES adjusts the output clock by $\frac{1}{8}$ of a bit period. In Host Mode, the ES provides an indication of overflow and underflow in the TRS.ESOVR and TSR.ESUNF. These are sticky bits and will stay set to 1 until the host controller reads the register. These interrupts can be cleared or masked by writing a 1 to the bits ICR.CESO and ICR.CESU, respectively.

OTHER DIAGNOSTIC REPORTS

Receive Line Attenuation Indication (LATN)

The equalizer status register (ESR) provides an approximation of the line attenuation encountered by the device. The four most significant bits of the register (ESR.LATN7-4) indicate line attenuation in approximately 2.9 dB steps for both T1 and E1 operation of the receive equalizer. For instance, if ESR.LATN7-4 is 10 (decimal), then the receiver is seeing a signal attenuated by approximately 29 dB ($2.9 \text{ dB} * 10$) of cable loss.

Built-In Self Test (BIST)

LXT360/361 provides a Built-In Self Test (BIST) capability in Host Mode. The BIST exercises the internal circuits by providing an internal QRSS pattern, running it through the encoders and the transmit drivers then looping it back through the receive equalizer, Jitter Attenuator and decoders to the QRSS pattern detection circuitry. If all the blocks in this data path work correctly, the receive pattern detector locks onto the pattern. It then pulls $\overline{\text{INT}}$ Low and sets the following bits High:

- TSR.TQRSS
- PSR.QRSS
- PSR.BIST

The QPD pin (pin 12) also indicates completion status of the test. Starting the test forces this pin High. During the test, it remains High until the test finishes successfully at which time it goes Low.

The most reliable test will result with separate TCLK and MCLK and LBO = -22.5 dB (CR1.EC4-1 = 011x).

OPERATING MODES

The LXT360/361 share many features. However, their control modes are very different.

- The LXT360 operates in either Hardware or (Serial Port) Host Mode
- The LXT361 operates in (Parallel Port) Host Mode only.

In the Hardware Mode (LXT360 only) individual pins control the transceiver.

The logic level at the MODE pin sets the LXT360 mode of operation. In Host Mode (LXT360/361), a microprocessor controls the device through a data interface. The LXT360 has a serial interface and the LXT361 uses a parallel interface.

Hardware Mode Operation (LXT360 Only)

The LXT360 operates in Hardware Mode when MODE is set to Midrange or Low. In Hardware Mode individual pins access and control the transceiver. The outputs (RPOS/RNEG or RDATA) are valid on the rising edge of RCLK.

There are some advanced functions provided only in Host Mode. Interrupt (INT), AIS detection indicator, DFM open indicator and CLKE functions are some of the features available in Host Mode.

Host Mode Operation

The LXT360 operates in Host Mode when MODE is set High. In Host Mode a microprocessor accesses and controls the transceiver through a data port using the internal registers. The outputs (RPOS/RNEG or RDATA) are valid on the rising edge of RCLK.

In Host Mode there are eight control and status registers—five read/write and three read-only registers. The LXT360 accesses them through its serial interface (SIO). The LXT361 provides this access using an 8-bit parallel interface (PIO).

The host processor/controller can completely configure the device as well as get a full diagnostic/status report through the SIO or PIO. Only the clocks and data for Bipolar Mode and BPV/Logic Error insertions for Unipolar or QRSS Mode need to be provided directly to the input pins. Similarly, the recovered clock, data, and BPV/Logic Error occurrences are available only at output pins. All other mode settings and diagnostic information are available through the data port.

Table 14 shows the address used by the SIO or PIO to access each register on the LXT360 or LXT361, respectively. Table 15 summarizes the control and status registers and labels each bit they contain. Tables 16 through 23 identify the bits in each register.

Table 14: Serial (LXT360) and Parallel (LXT361) Port Register Addresses

Register		Address ¹	
Name	Abbr	Serial Port (A7-A1)	Parallel Port (A7-A0)
Control #1	CR1	x010000	x010000x
Control #2	CR2	x010001	x010001x
Control #3	CR3	x010010	x010010x
Interrupt Clear	ICR	x010011	x010011x
Transition Status	TSR	x010100	x010100x
Performance Status	PSR	x010101	x010101x
Equalizer Status	ESR	x010110	x010110x
Control #4	CR4	x010111	x010111x

1. x = "don't care".

Table 15: Register Addresses and Bit Names

Register		Type	Bit							
Name			7	6	5	4	3	2	1	0
Control #1	CR1	R/W	JASEL1	JASEL0	ENCEB	UNIENB	EC4	EC3	EC2	EC1
Control #2	CR2	R/W	RESET	EPAT1	EPAT0	ETAOS	ENLOOP	EALOOP	ELLOOP	ERLOOP
Control #3	CR3	R/W	JA6HZ	PCLKE ¹	SBIST	EQZMON	<i>reserved</i> ²	ES64	ESCCN	ESJAM
Interrupt Clear	ICR	R/W	CESU	CESO	CDFMO	<i>reserved</i> ³	CQRSS	CAIS	CNLOOP	CLOS
Transition Status	TSR	R	ESUNF	ESOVR	TDFMO	<i>reserved</i> ²	TQRSS	TAIS	TNLOOP	TLOS
Performance Status	PSR	R	<i>reserved</i> ²	BIST	DFMO	<i>reserved</i> ²	QRSS	AIS	NLOOP	LOS
Equalizer Status	ESR	R	LATN7	LATN6	LATN5	LATN4	<i>reserved</i> ²	<i>reserved</i> ²	<i>reserved</i> ²	<i>reserved</i> ²
Control #4	CR4	R/W	<i>reserved</i> ²	<i>reserved</i> ²	<i>reserved</i> ²	<i>reserved</i> ²	COL32CM	LOS2048	ZEROV	CODEV

1. Bit CR3.PCLKE is available only in the LXT361; for the LXT360, set this bit to zero.
 2. In write registers, bits labeled *reserved* should be set to 0 (except as in note 3 below) for normal operation and ignored in read only registers.
 3. Write a 1 into this bit for normal operation.

6

Table 16: Control Register #1 Read/Write, Address.(A7-A1) = x010000

Bit	Name	Function	Jitter Attenuation		
			JASEL0	JASEL1	Position
0	EC1	Set the Equalizer Control codes (see Table 12).	1	0	Transmit
1	EC2		1	1	Receive
2	EC3		0	X	disabled
3	EC4				
4	UNIENB	Enables Unipolar I/O Mode and insertion/detection of BPVs.			
5	ENCENB	Enables B8ZS/HDB3 encoders/decoders; device enters Unipolar Mode and pins 3, 4, 6 and 7 change to their unipolar functions.			
6	JASEL0	Jitter Attenuation Mode, selects jitter attenuation circuitry position in data path or disables it. See right hand section of table for values. ↗			
7	JASEL1				

LXT360/361 Integrated T1/E1 LH/SH Transceivers

Table 17: Control Register #2 Read/Write, Address (A7-A1) = x010001

Bit	Name	Function	Pattern		
			EPAT0	EPAT1	Selected
0	ERLOOP ¹	Enables Remote Loopback (RLOOP)	0	0	Transmit TPOS/TNEG
1	ELLOOP ¹	Enables Local Loopback (LLOOP)	0	1	Detect and transmit QRSS
2	EALOOP	Enables Analog Loopback (ALOOP)	1	0	In-band Loop Up Code 00001
3	ENLOOP	Enables Network Loopback Detection (NLOOP)	1	1	In-band Loop Down Code 001
4	ETAOS	Enables Transmit All Ones (TAOS)			
5	EPAT0	Enables internal data pattern transmission. See right hand section of table for values. ↗			
6	EPAT1				
7	RESET	RESET = 1 resets device state and all registers.			

1. To enable Dual Loopback (DLOOP), set both ERLOOP = 1, ELLOOP = 1.

Table 18: Control Register #3 Read/Write, Address (A7-A1) = x010010

Bit	Name	Description
0	ESJAM	Disables Jamming of Elastic Store Read Out Clock ($1/8$ bit-time adjustment for over/underflow).
1	ESCEN	Centers ES pointer for a difference of 16 or 32 (depending on depth-clears automatically).
2	ES64	Increases ES depth from 32 to 64 bits.
3	—	<i>reserved—set to 0 for normal operation.</i>
4	EQZMON	Configures Receiver Equalizer for Monitor Mode Application .
5	SBIST	Starts Built-In Self Test.
6	PLCKE	This bit is available only in the LXT361— <i>for LXT360, set this bit to 0.</i> PCLKE = 0 sets RPOS/RNEG valid on the rising edge of RCLK. PCLKE = 1 sets RPOS/RNEG valid on the falling edge of RCLK .
7	JA6HZ	When JA6HZ = 1, changes bandwidth of Jitter Attenuation Loop from 3 Hz (default) to 6 Hz.

Table 19: Interrupt Clear Register *Read/Write, Address (A7-A1) = x010011*

Bit	Name	Function ¹
0	CLOS	Clears/Masks LOS Interrupt.
1	CNLOOP	Clears/Masks NLOOP Interrupt.
2	CAIS	Clears/Masks AIS Interrupt.
3	CQRSS	Clears/Masks QRSS Interrupt.
4	—	<i>reserved—set to 1 for normal operation.</i>
5	CDFMO	Clears/Masks DFMO.
6	CESO	Clears/Masks ES Overflow Interrupt.
7	CESU	Clears/Masks ES Underflow Interrupt.

1. Leaving a one of in any of these bits masks the associated interrupt.

6

Table 20: Transition Status Register *Read Only, Address (A7-A1) = x010100*

Bit	Name	Function
0	TLOS	Loss of Signal (LOS) has changed since last clear LOS interrupt occurred.
1	TNLOOP	NLOOP has changed since last clear NLOOP interrupt occurred.
2	TAIS	AIS has changed since last clear AIS interrupt occurred.
3	TQRSS	QRSS has changed since last clear QRSS interrupt occurred ¹ .
4	—	<i>reserved—ignore.</i>
5	TDFMO	DFMO has changed since last clear DFMS interrupt occurred.
6	ESOVR	ES overflow status sticky bit ² .
7	ESUNF	ES underflow status sticky bit ² .

1. A QRSS transition indicates receive QRSS pattern sync or loss. A simple error in QRSS pattern is not reported as a transition.
 2. Tripping the overflow or underflow indicator in the ES sets the ESOVR/ESUNF status bit(s). Reading the Transition Status Register clears these bits. Setting CESO and CESU in the Interrupt Clear Register masks these interrupts.

Table 21: Performance Status Register *Read Only, Address (A7-A1) = x010101*

Bit	Name	Function
0	LOS	Loss of Signal (LOS) Status.
1	NLOOP	Network Loop (NLOOP) Status.
2	AIS	Alarm Indicator (AIS) Status.
3	QRSS	QRSS Pattern Detect Status.
4	—	<i>reserved—ignore.</i>
5	DFMO	Driver Open Indication.
6	BIST	Built-In Self Test Status.
7	—	<i>reserved—ignore</i>

Table 22: Equalizer Status Register *Read Only, Address (A7-A1) = x010110*

Bit	Name	Function
0	—	<i>reserved—ignore</i> (Least Significant Bit)
1	—	<i>reserved—ignore</i>
2	—	<i>reserved—ignore</i>
3	—	<i>reserved—ignore</i>
4	LATN4	Receive Line Attenuation Indicators. Convert this binary output to a decimal number and multiply by 2.9 dB to determine the approximate cable attenuation as seen by the receiver. For instance, if LATN7-4 = 1010 _{BIN} (= 10 _{DEC}), then the receiver is seeing a signal attenuated by approximately 29 dB (2.9 dB x 10) of cable.
5	LATN5	
6	LATN6	
7	LATN7	

Table 23: Control Register #4 Read/Write, Address (A7-A1) = x010111

Bit	Name	Function
0	CODEV	Enables detection of HDB3 code violation on the BPV pin along with bipolar violations and ZEROVs (as enabled).
1	ZEROV	Enables detection of four consecutive zeros (an HDB3 coding violation) on the BPV pin along with bipolar violation and ZEROVs (as enabled).
2	LOS2048	Changes LOS detection threshold from 32 consecutive zeros (for E1 operation) or 175 consecutive zeros (T1 operation) to 2048 consecutive zeros in either environment.
3	COL32CM	In E1 Mode, changes “clear LOS condition” criterion from 12.5% marks density (default) to receipt of 32 consecutive marks.
4	—	<i>reserved—set to 0 for normal operation; ignore when reading.</i>
5	—	<i>reserved—set to 0 for normal operation; ignore when reading.</i>
6	—	<i>reserved—set to 0 for normal operation; ignore when reading.</i>
7	—	<i>reserved—set to 0 for normal operation; ignore when reading.</i>

6

Serial Port Operation (LXT360 Only)

The LXT360 operates in Host Mode when the MODE pin is set High. Figure 12 shows the SIO data structure. The registers are accessible through a 16-bit word: an 8-bit Command/Address byte (bits R/W and A1-A7) and a subsequent 8-bit data byte (bits D0-7). Bit R/W determines whether a read or a write operation occurs. Bits A6-1 in the Command/Address byte address specific registers (the address decoder ignores bit A7). The data byte depends on both the value of bit R/W and the address of the register as set in the Command/Address byte.

Host Mode provides a latched interrupt output ($\overline{\text{INT}}$). A change in the state of any of the following bits in the Performance Status Register will drive $\overline{\text{INT}}$ Low: LOS, NLOOP, AIS, QRSS, or DFMO. An interrupt will also occur when there is an elastic store overflow or underflow. When the interrupt has occurred, the $\overline{\text{INT}}$ output pin is pulled Low. The output stage of each $\overline{\text{INT}}$ pin consists only of a pull-down device, so each one requires an external pull-up resistor. The interrupt is cleared when the interrupt condition no longer exists, and the host processor writes a 1 to the respective interrupt causing bit(s) in the Interrupt Register. Leaving a 1 in any of these interrupt status bits masks that interrupt.

Table 24: CLKE Settings

CLKE	Output	Clock	Valid Edge
Low	RPOS	RCLK	Rising
	RNEG	RCLK	Rising
	SDO	SCLK	Falling
High	RPOS	RCLK	Falling
	RNEG	RCLK	Falling
	SDO	SCLK	Rising

Host Mode also allows control of the serial data and receive data output timing. The clock edge (CLKE) signal determines when the outputs are valid, relative to the Serial Clock (SCLK) or RCLK as shown in Table 24.

LXT360/361 Integrated T1/E1 LH/SH Transceivers

Parallel Port Operation (LXT361 Only)

The LXT361 address/control bus pins and control pins are compatible with both the Intel and Motorola address/data buses. See Figures 22 and 23 for the I/O timing diagram for each bus. The device automatically detects bus timing based on the Intel and Motorola microprocessor bus specifications. The maximum recommended processor speed for an Intel device is 20 MHz; for a Motorola device, 16.78 MHz. Table 17 summarizes the control and status registers for the LXT361. Tables 16 through 23 identify and explain the bits in the control registers.

The LXT361 provides a latched interrupt output ($\overline{\text{INT}}$). A change in the state of any of the following bits in the Performance Status Register will drive $\overline{\text{INT}}$ Low: LOS, NLOOP, AIS, QRSS, DFMO. When the interrupt has occurred, the $\overline{\text{INT}}$ output pin is pulled Low. The output stage of $\overline{\text{INT}}$ pin consists only of a pull-down device, so

each pin requires an external pull-up resistor. The interrupt is cleared when the interrupt condition no longer exists, and the host processor writes a 1 to the respective interrupt causing bit(s) in the Interrupt Register. Leaving a 1 in any of these interrupt status bits masks that interrupt.

The received data output is valid on the rising edge of RCLK, when bit CR3.PCLKE = 0. The data output is valid on the falling edge of RCLK when CR3.PCLKE = 1.

There are five read/write and three read-only registers. Only bits A6-1 in the address byte are valid. (The address decoder ignores bits A7 and A0.) Tables 16 through 23 show the register address bits A7-1, without regard to bit A0.

Figure 12: LXT360 Serial Interface Data Structure

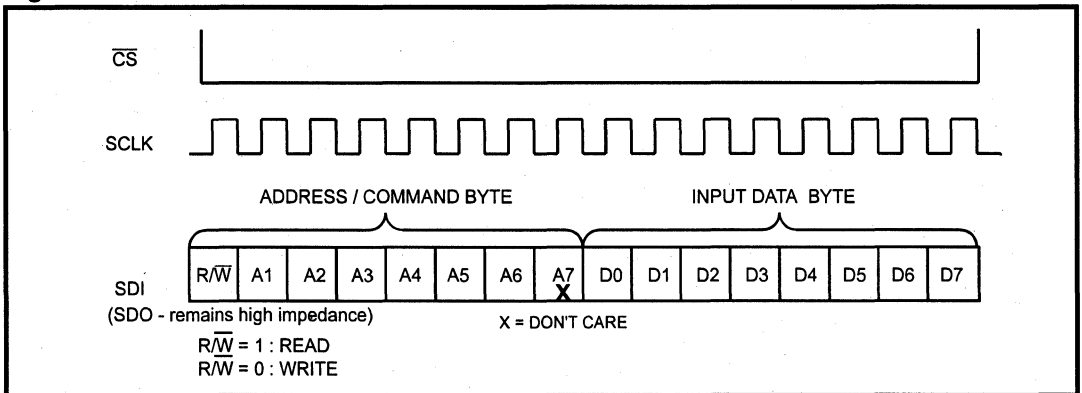

APPLICATION INFORMATION

NOTE

This application information is for design aid only.

Table 25 shows the specification for transmit return loss in E1 applications. (The G.703/CH PTT specification is a Swiss Telecommunications Ministry specification.)

Tables 26 through 29 show the transmit return loss values for E1 short- and long-haul and T1 applications. Table 36 shows the receive return loss values.

Table 25: E1 Transmit Return Loss Requirements

Frequency Band	Return Loss	
	ETS 300 166	G.703/CH PTT
51-102 kHz	6 dB	8 dB
102-2048 kHz	8 dB	14 dB
2048 - 3072 kHz	8 dB	10 dB

Table 26: Transmit Return Loss (2.048 Mbit/s–Short-Haul)

EC4-1	XfrmR/Rt	Rload (Ω)	CI (pF)	Return Loss (dB)
1000	1:2/ 9.1 Ω	75	0	14
			470	16
		120	0	12
			470	13
	1:2.3/ 9.1 Ω	120	0	13
			470	16

Table 30: Transformer Specifications for LXT360/LXT361

Tx/Rx	Frequency MHz	Turns Ratio	Primary Inductance μH (minimum)	Leakage Inductance μH (max)	Interwinding Capacitance pF (max)	DCR Ω (maximum)	Dielectric ¹ Breakdown V (minimum)
Tx	1.544	1:1.15	600	0.80	60	0.90 pri 1.70 sec	1500 VRMS
	2.048	1:2.3	600	0.80	60	0.70 pri 1.20 sec	1500 VRMS ²
	1.544/2.048	1:2	600	0.80	60	0.70 pri 1.20 sec	1500 VRMS ²
Rx	1.544/2.048	1:1	600	1.10	60	1.10 pri 1.10 sec	1500 VRMS ²

1. Some ETSI applications may require a 2.3 kV dielectric breakdown voltage.

2. Some applications require transformers with center tap (Long-Haul applications with DC current in the E1/T1 loop).

Table 27: Transmit Return Loss (2.048 Mbit/s–Long-Haul) High Return Loss Configuration

EC4-1	XfrmR/Rt	Rload (Ω)	CI (pF)	Return Loss (dB)
1001	1:2/ 15 Ω	120	0	19
			470	28
	1:1.53/ 15 Ω	75	0	18
			470	28

Table 28: Transmit Return Loss (2.048 Mbit/s–Long-Haul)

EC4-1	XfrmR/Rt	Rload (Ω)	CI (pF)	Return Loss (dB)
1010	1:2/ 9.1 Ω	120	0	12
			470	13
		75	0	16
			470	18

Table 29: Transmit Return Loss (1.544 Mbit/s–Long- or Short-Haul)

EC4-1	XfrmR/Rt	Rload (Ω)	CI (pF)	Return Loss (dB)
Refer to Table 12	1:2/9.1 Ω	100	0	16
			470	17
	1:1.15 ¹ / 0.0 Ω	100	0	2 dB
			470	2 dB

1. A 1:1.15 transmit transformer keeps the total transceiver power dissipation at a low level, a 0.47 μF DC blocking capacitor must be placed on TTIP or TRING.

LXT360/361 Integrated T1/E1 LH/SH Transceivers

Table 31: Recommended Transformers for LXT360/LXT361

Tx/Rx	Turns Ratio	Part Number	Manufacturer
Tx	1:1.53	PE-68663	Pulse Engineering
		PE-65388	
	1:1.15	PE-65770	Vitec
		16Z5952	
		16Z5952	
	1:2	PE-65351	Pulse Engineering
		PE-65771	
		0553-5006-IC	Bell-Fuse
		66Z-1308	Fil-Mag
		671-5832	Midcom
		67127370	Schott Corp
		67130850	
		TD61-1205G	HALO (combination Tx/Rx set)
		16Z5946	Vitec
		1:2.3	PE-65558
Rx	1:1	FE 8006-155	Fil-Mag
		671-5792	Midcom
		PE-64936	Pulse Engineering
		PE-65778	
		67130840	Schott Corp
		67109510	
		TD61-1205D	HALO (combination Tx/Rx set)
		16Z5936	Vitec
		16Z5934	

NOTE

Figure 13 shows a typical LXT360 application in either a T1 or E1 environment. See Tables 26 through 31 to select the transformers (T1 and T2), resistors (Rt and Rl) and capacitors (Cl) needed for this application.

NOTE

If the application includes surge protection, such as a varistor or sidactor on the TTIP/TRING lines, it may also require reducing the value of the capacitor CL or eliminating it completely. Excessive capacitance at CL will distort the transmitted signals.

Figure 13: Typical T1/E1 LXT360 Hardware Mode Application

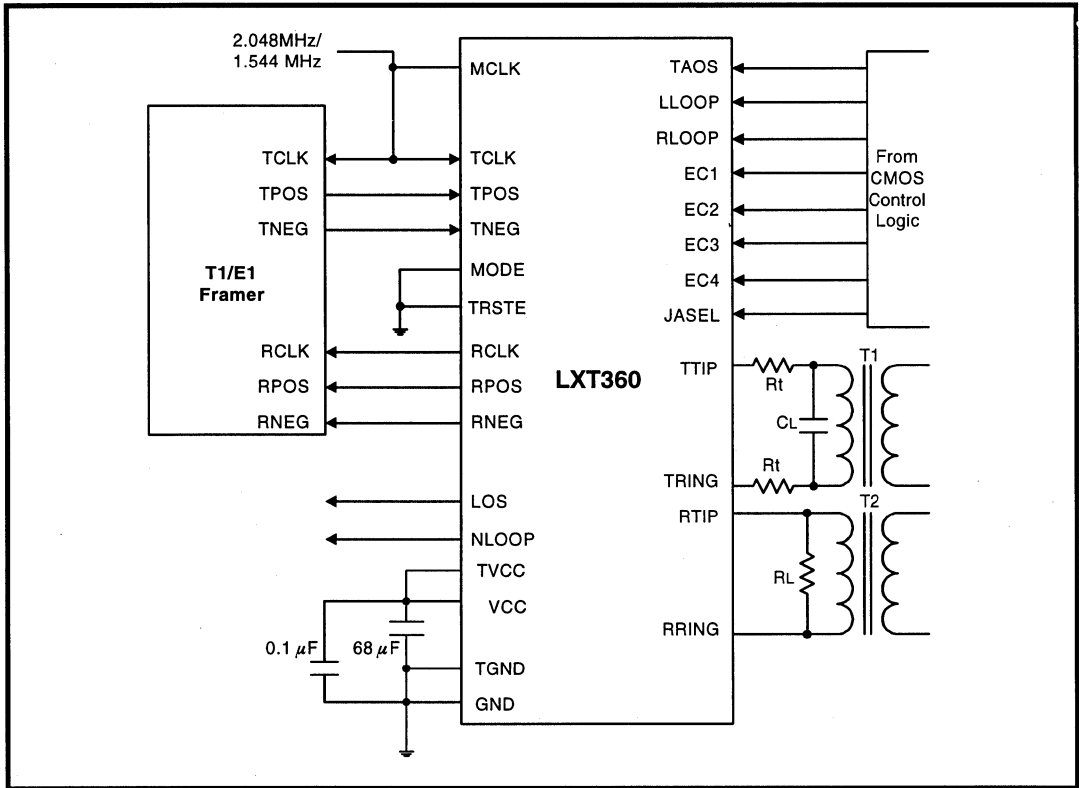

LXT360/361 Integrated T1/E1 LH/SH Transceivers

NOTE

Figure 14 shows an application using the LXT360 in its Host Controlled Mode. See Tables 26 through 29 to select the transformers (T1 and T2), resistors (Rt and Rl) and capacitors (Cl) needed for this application.

NOTE

If the application includes surge protection, such as a varistor or sidactor on the TTIP/TRING lines, it may also require reducing the value of the capacitor CL or eliminating it completely. Excessive capacitance at CL will distort the transmitted signals.

Figure 14: Typical T1/E1 LXT360 Host Mode Application

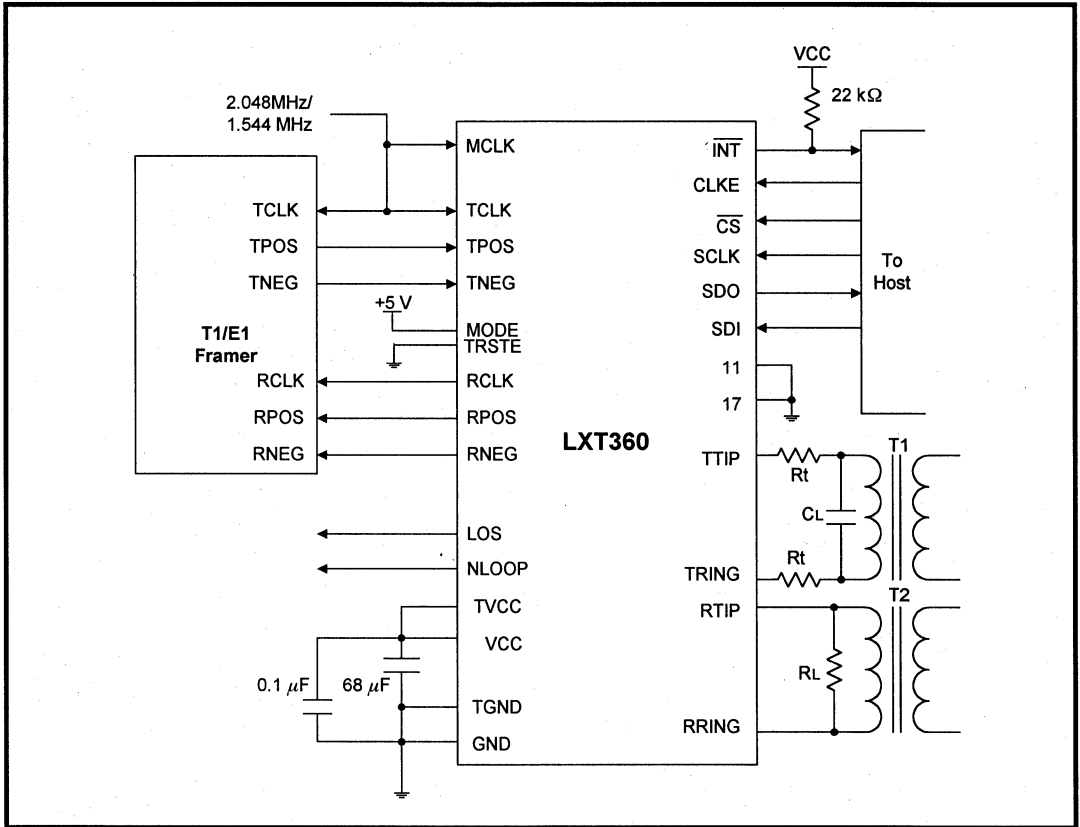

NOTE

Figure 15 shows an application using the LXT361. See Tables 26 through 29 to select the transformers (T1 and T2), resistors (Rt and Rl) and capacitors (Cl) needed for this application.

NOTE

If the application includes surge protection, such as a varistor or sidactor on the TTIP/TRING lines, it may also require reducing the value of the capacitor CL or eliminating it completely.

Figure 15: Typical T1/E1 LXT361 Application

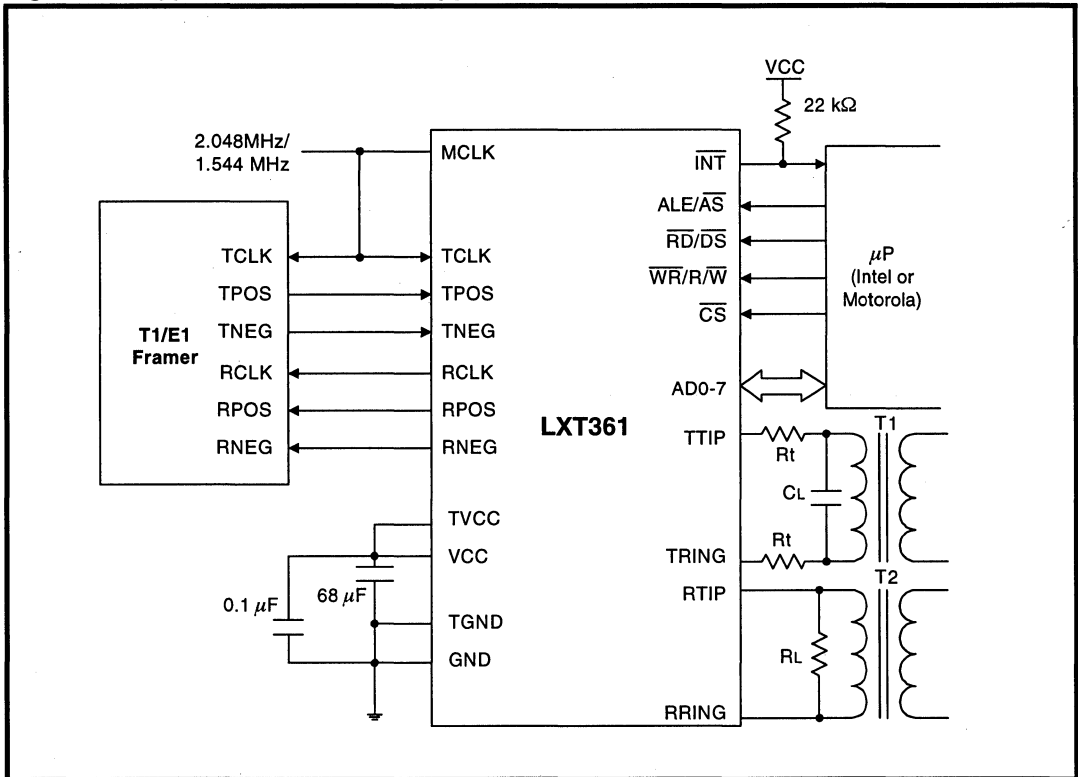

TEST SPECIFICATIONS

NOTE

The minimum and maximum values in Tables 32 to 44 and Figures 16 through 27 represent the performance specifications of the LXT360 and LXT361 and are guaranteed by test, except where noted by design.

Table 32: Absolute Maximum Ratings

Parameter	Sym	Min	Max	Units
DC supply (reference to GND)	Vcc, TVcc	-	6.0	V
Input voltage, any pin ¹	V _{IN}	GND -0.3 V	Vcc + 0.3 V	V
Input current, any pin ²	I _{IN}	- 10	10	mA
Ambient operating temperature	T _A	-40	85	°C
Storage Temperature	T _{STG}	-65	150	°C
CAUTION Operation at these limits may permanently damage the device. Normal operation at these extremes not guaranteed.				
1. TVCC and VCC must not differ by more than 0.3 V during operation. TGND and GND must not differ by more than 0.3 V during operation. 2. Transient currents of up to 100 mA will not cause SCR latch-up. TTIP, TRING, TVCC, and TGND can withstand continuous currents of up to 100 mA.				

Table 33: Operating Conditions/Characteristics

Parameter			Sym	Min	Typ ¹	Max	Units	Test Conditions
DC Supply ²			Vcc, TVcc	4.75	5.0	5.25	V	
Ambient Operating Temperature			T _A	-	25	-	°C	
Total Power Dissipation ³	T1	Short Haul	PD	-	310	380	mW	100% mark density
			PD	-	225	295	mW	50% mark density
		Long Haul	PD	-	245	325	mW	100% mark density
			PD	-	195	265	mW	50% mark density
	E1	Short Haul/ Long Haul	PD	-	275	330	mW	100% mark density
			PD	-	215	270	mW	50% mark density
1. Typical figures are at 25 °C and are for design aid only; not guaranteed and not subject to production testing. 2. TVCC and VCC must not differ by more than 0.3 V. 3. Power dissipation while driving 75 Ω load over operating range for T1 operation or 60 Ω load for E1 operation. Includes power dissipation on device and load. Digital levels are within 10% of the supply rails and digital outputs driving a 50 pF capacitive load.								

Table 34: LXT360 Digital Characteristics ($T_a = -40$ to 85 °C, $V_+ = 5.0$ V \pm 5%, $GND = 0$ V)

Parameter	Sym	Min	Typ	Max	Units	Test Conditions
High level input voltage ^{1,2} (pins 1-4, 17, 23-25)	V _{IH}	2.0	–	–	V	
Low level input voltage ^{1,2} (pins 1-4, 17, 23-25)	V _{IL}	–	–	0.8	V	
High level output voltage ^{1,2} (pins 6-8, 10, 12, 23, 25)	V _{OH}	2.4	–	–	V	I _{OUT} = 400 μ A
Low level output voltage ^{1,2} (pins 6-8, 10, 12, 23, 25)	V _{OL}	–	–	0.4	V	I _{OUT} = 1.6 mA
High level input voltage ³ (pins 5, 9, 11, 26-28)	V _{IH}	3.5	–	–	V	
Midrange input voltage ³ (pins 5, 9, 11, 26-28)	V _{IM}	2.3	–	2.7	V	
Low level input voltage ³ (pins 5, 9, 11, 26-28)	V _{IL}	–	–	1.5	V	
Input leakage current	I _{LL}	0	–	\pm 50	μ A	
Three-state leakage current ¹ (all outputs)	I _{3L}	0	–	\pm 10	μ A	
TTIP/TRING leakage current (pins 13, 16)	I _{TR}	–	–	\pm 1.2	mA	in Idle and Power Down

1. Functionality of pin 23 and 25 depends on mode. See Host Mode and Hardware Mode description
 2. Output drivers will output CMOS logic levels into CMOS loads.
 3. As an alternative to supplying 2.3 - 2.7 V to these pins, they may be left open.

6

Table 35: LXT361 Digital Characteristics ($T_a = -40$ to 85 °C, $V_+ = 5.0$ V \pm 5%, $GND = 0$ V)

Parameter	Sym	Min	Typ	Max	Units	Test Conditions
High level input voltage ^{1,2} (pins 1-5, 9-12, 17, 23-28)	V _{IH}	2.0	–	–	V	
Low level input voltage ^{1,2} (pins 1-5, 9-12, 17, 23-28)	V _{IL}	–	–	0.8	V	
High level output voltage ^{1,2} (pins 6-8, 10, 11, 23, 28)	V _{OH}	2.4	–	–	V	I _{OUT} = 400 μ A
Low level output voltage ^{1,2} (pins 6-8, 10, 11, 23, 28)	V _{OL}	–	–	0.4	V	I _{OUT} = 1.6 mA
Input leakage current	I _{LL}	–	–	\pm 50	μ A	

1. Functionality of pins 23 and 25 depends on mode. See Host Mode description.
 2. Output drivers will output CMOS logic levels into CMOS loads.

LXT360/361 Integrated T1/E1 LH/SH Transceivers

Table 36: Analog Characteristics ($T_a = -40$ to 85 °C, $V_+ = 5.0$ V \pm 5%, $GND = 0$ V)

Parameter		Min	Typ ¹	Max	Units	Test Conditions
Recommended output load on TTIP/TRING		50	–	200	Ω	
AMI Output Pulse Amplitudes	DSX-1, DS1	2.4	3.0	3.6	V	$R_L = 100 \Omega$
	CEPT (ITU)	2.7	3.0	3.3	V	$R_L = 120 \Omega$
Jitter added by the transmitter ²	10 Hz - 8 kHz ³	–	–	0.02	UI	
	8 kHz - 40 kHz ³	–	–	0.025	UI	
	10 Hz - 40 kHz ³	–	–	0.025	UI	
	Broad Band	–	–	0.05	UI	
Receiver sensitivity @ 772 kHz (T1)	Mode 1 (EC1 = 1) (T1 Long-Haul)	0	–	26	dB	See Table 12 for Gain Setting
	Mode 2 (EC1 = 0) (T1 Long-Haul)	0	–	36	dB	
	Mode 3 (EC4 = 1) (T1 Short-Haul)	0	–	13.6	dB	
Receiver Sensitivity @ 1024 kHz (E1 line loss)	Mode 1 (EC4-1 = 1000) (E1 Short-Haul/12 dB)	0	–	13.6	dB	
	Mode 2 (EC4-1 = 1001 or EC4-1 = 1010) (E1 Long-Haul/43 dB)	0	–	43	dB	
Allowable consecutive zeros before LOS (T1)		160	175	190	–	
Allowable consecutive zeros before LOS (E1)		–	32	–	–	
Input jitter tolerance (T1)	10 kHz - 100 kHz	0.4	–	–	UI	0 dB line AT&T Pub 62411
	1 Hz ³	138	–	–	UI	
Input jitter tolerance (E1)	10 kHz - 100 kHz	0.2	–	–	UI	0 dB line ITU (G.823)
	1 Hz ³	37	–	–	UI	
Jitter attenuation curve corner frequency ⁴		–	3	–	Hz	selectable in data port
Receive Return Loss (E1)	51 kHz - 102 kHz	–	22	–	dB	
	102 kHz - 2.048 MHz	–	28	–	dB	
	2.048 MHz - 3.072 MHz	–	30	–	dB	

1. Typical figures are at 25 °C and are for design aid only; not guaranteed and not subject to production testing.

2. Input signal to TCLK is jitter-free. The Jitter Attenuator is in the receive path or disabled.

3. Guaranteed by characterization; not subject to production testing.

4. Circuit attenuates jitter at 20 dB/decade above the corner frequency.

Figure 16: 2.048 MHz E1 Pulse (See Table 37)

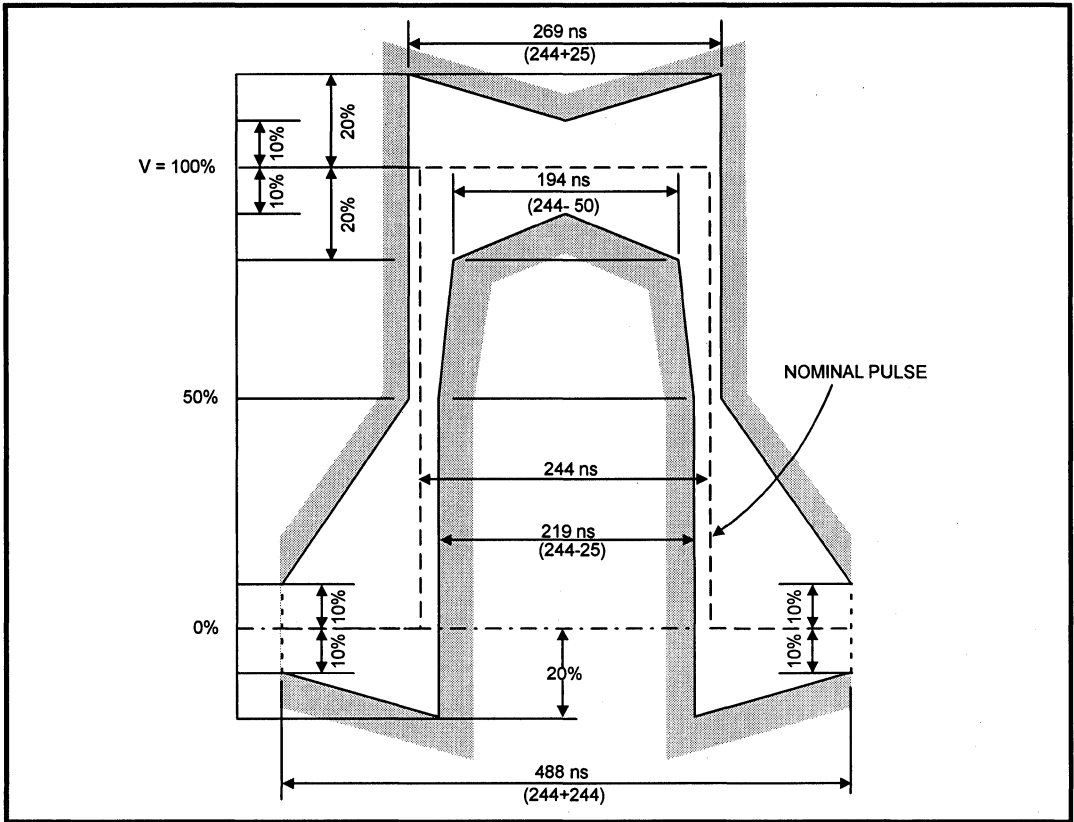

6

Table 37: 2.048 MHz E1 Pulse Mask Specifications

Parameter	TPW	Coax	Unit
Test load impedance	120	75	Ω
Nominal peak mark voltage	3.0	2.37	V
Nominal peak space voltage	0 \pm 0.30	0 \pm 0.237	V
Nominal pulse width	244	244	ns
Ratio of positive and negative pulse amplitudes at center of pulse	95-105	95-105	%
Ratio of positive and negative pulse amplitudes at nominal half amplitude	95-105	95-105	%

Figure 17: 1.544 MHz T1 Pulse (DS1 and DSX-1) (See Table 38)

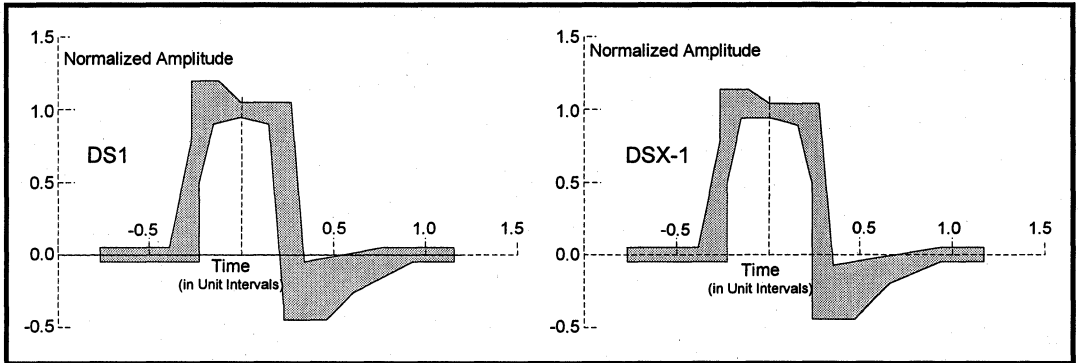

Table 38: 1.544 MHz T1 Pulse Mask Corner Point Specifications

DS1 Template (per ANSI T1. 403-1995)				DSX-1 Template (per ANSI T1. 102-1993)			
Minimum Curve		Maximum Curve		Minimum Curve		Maximum Curve	
Time (UI)	Amplitude	Time (UI)	Amplitude	Time (UI)	Amplitude	Time (UI)	Amplitude
-0.77	-0.05	-0.77	0.05	-0.77	-0.05	-0.77	0.05
-0.23	-0.05	-0.39	0.05	-0.23	-0.05	-0.39	0.05
-0.23	0.50	-0.27	0.80	-0.23	0.50	-0.27	0.80
-0.15	0.90	-0.27	1.20	-0.15	0.95	-0.27	0.80
0.0	0.95	-0.12	1.20	0.0	0.95	-0.27	1.15
0.15	0.90	0.0	1.05	0.15	0.90	0.0	1.05
0.23	0.50	0.27	1.05	0.23	0.50	0.27	1.05
0.23	-0.45	0.34	-0.05	0.23	-0.45	0.35	-0.07
0.46	-0.45	0.77	0.05	0.46	-0.45	0.93	0.05
0.61	-0.26	1.16	0.05	0.66	-0.20	1.16	0.05
0.93	-0.05			0.93	-0.05		
1.16	-0.05			1.16	-0.05		

Table 39: Master and Transmit Clock Timing Characteristics (T1 Operation) (Figure 18)

Parameter	Sym	Min	Typ ¹	Max	Units	Notes
Master clock frequency	MCLK	–	1.544	–	MHz	must be supplied
Master clock tolerance	MCLKt	–	±32	–	ppm	
Master clock duty cycle	MCLKd	40	–	60	%	
Transmit clock frequency	TCLK	–	1.544	–	MHz	
Transmit clock tolerance	TCLKt	–	–	±100	ppm	
Transmit clock duty cycle	TCLKd	10	–	90	%	
TPOS/TNEG to TCLK setup time	tsUT	50	–	–	ns	
TCLK to TPOS/TNEG hold time	tHT	50	–	–	ns	

1. Typical figures are at 25 °C and are for design aid only; not guaranteed and not subject to production testing.

6

Table 40: Master and Transmit Clock Timing Characteristics (E1 Operation) (Figure 18)

Parameter	Sym	Min	Typ ¹	Max	Units	Notes
Master clock frequency	MCLK	–	2.048	–	MHz	must be supplied
Master clock tolerance	MCLKt	–	±32	–	ppm	
Master clock duty cycle	MCLKd	40	–	60	%	
Transmit clock frequency	TCLK	–	2.048	–	MHz	
Transmit clock tolerance	TCLKt	–	–	±100	ppm	
Transmit clock duty cycle	TCLKd	10	–	90	%	
TPOS/TNEG to TCLK setup time	tsUT	50	–	–	ns	
TCLK to TPOS/TNEG hold time	tHT	50	–	–	ns	

1. Typical figures are at 25 °C and are for design aid only; not guaranteed and not subject to production testing.

Figure 18: Transmit Clock Timing

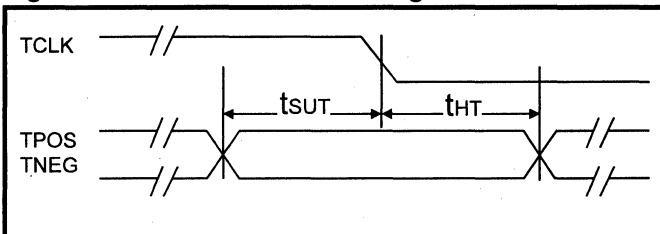

Table 41: Receive Timing Characteristics for T1 Operation (See Figure 19)

Parameter	Sym	Min	Typ ¹	Max	Units
Receive clock duty cycle ^{2, 3}	RLCKd	40	50	60	%
Receive clock pulse width ^{2, 3}	tpw	–	648	–	ns
Receive clock pulse width high	tpwh	–	324	–	ns
Receive clock pulse width low ^{1,3}	tpwl	260	324	388	ns
RPOS/RNEG to RCLK rising time	tsur	–	274	–	ns
RCLK rising to RPOS/RNEG hold time	tthr	–	274	–	ns

1. Typical figures are at 25 °C and are for design aid only; not guaranteed and not subject to production testing.
 2. RCLK duty cycle widths will vary according to extent of received pulse jitter displacement. Max and Min RCLK duty cycles are for worst case jitter conditions.
 3. Worst case conditions guaranteed by design only.

Table 42: Receive Timing Characteristics for E1 Operation (See Figure 19)

Parameter	Sym	Min	Typ ¹	Max	Units
Receive clock duty cycle ^{2, 3}	RLCKd	40	50	60	%
Receive clock pulse width ^{2, 3}	tpw	–	488	–	ns
Receive clock pulse width high	tpwh	–	244	–	ns
Receive clock pulse width low ^{1,3}	tpwl	195	244	293	ns
RPOS/RNEG to RCLK rising time	tsur	–	194	–	ns
RCLK rising to RPOS/RNEG hold time	tthr	–	194	–	ns

1. Typical figures are at 25 °C and are for design aid only; not guaranteed and not subject to production testing.
 2. RCLK duty cycle widths will vary according to extent of received pulse jitter displacement. Max and Min RCLK duty cycles are for worst case jitter conditions (0.4 UI clock displacement for 1.544 MHz.)
 3. Worst case conditions guaranteed by design only.

Figure 19: Receive Clock Timing

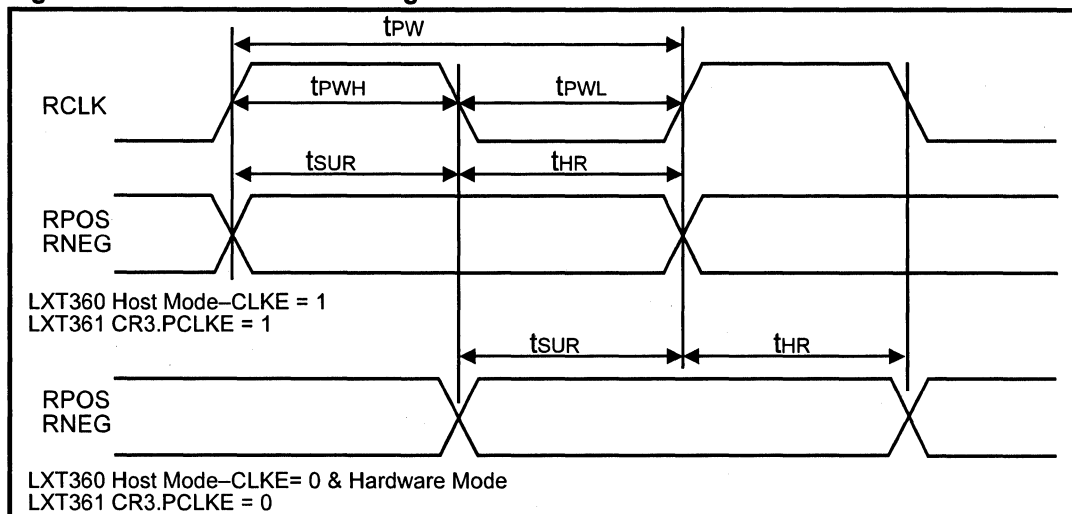

6

Table 43: LXT360 Serial I/O Timing Characteristics (See Figures 20 and 21)

Parameter	Sym	Min	Typ ¹	Max	Units	Parameter
Rise/fall time—any digital output	t _{RF}	–	–	100	ns	Load 1.6 mA, 50 pF
SDI to SCLK setup time	t _{DC}	50	–	–	ns	
SCLK to SDI hold time	t _{CDH}	50	–	–	ns	
SCLK low time	t _{CL}	240	–	–	ns	
SCLK high time	t _{CH}	240	–	–	ns	
SCLK rise and fall time	t _R , t _F	–	–	50	ns	
\overline{CS} falling edge to SCLK rising edge	t _{CC}	50	–	–	ns	
Last SCLK edge to \overline{CS} rising edge	t _{CCH}	50	–	–	ns	
\overline{CS} inactive time	t _{CWH}	250	–	–	ns	
SCLK to SDO valid time	t _{CDV}	–	–	200	ns	
SCLK falling edge or \overline{CS} rising edge to SDO high-Z	t _{CDZ}	–	100	–	ns	

1. Typical figures are at 25 °C and are for design aid only; not guaranteed and not subject to production testing.

Figure 20: LXT360 Serial Data Input Timing Diagram

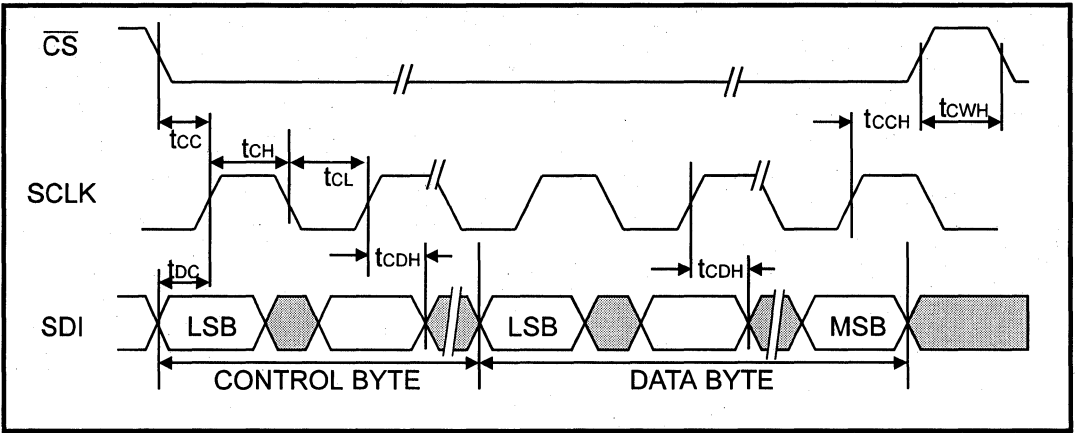

Figure 21: LXT360 Serial Data Output Timing Diagram

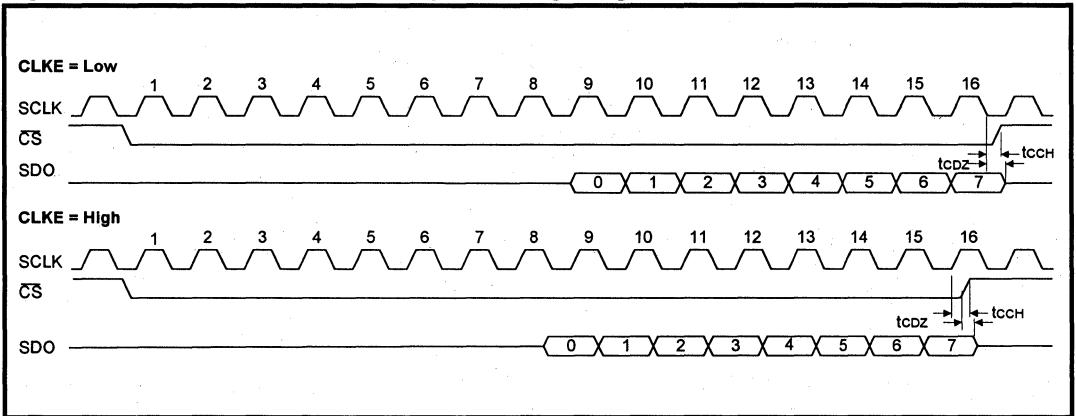

Table 44: LXT361 20 MHz Intel Bus Parallel I/O Timing Characteristics (See Figure 22)

Parameter	Sym	Min	Max	Units	Test Conditions
ALE pulse width	TLHLL	35	–	ns	
Address valid to ALE falling edge	TAVLL	10	–	ns	
ALE falling edge to address hold time	TLLAX	10	–	ns	
ALE falling edge to \overline{RD} falling edge	TLLRL	10	–	ns	
ALE falling edge to \overline{WR} falling edge	TLLWL	10	–	ns	
\overline{CS} falling edge to \overline{RD} falling edge	TCLRL	10	–	ns	
\overline{CS} falling edge to \overline{WR} falling edge	TCLWL	10	–	ns	
\overline{RD} low pulse width	TRLRH	95	–	ns	
\overline{RD} falling edge to data valid	TRLDV	10	55	ns	
Data hold time after \overline{RD} rising edge	TRHDX	5	35	ns	
\overline{RD} rising edge to ALE rising edge	TRHLH	15	–	ns	
\overline{RD} rising edge to address valid	TRHAV	35	–	ns	
\overline{CS} low hold time after \overline{RD} rising edge	TRHCH	0	–	ns	
\overline{WR} low pulse width	TWLWH	95	–	ns	
Data setup time before \overline{WR} rising edge	TDVWH	40	–	ns	
Data hold time after \overline{WR} rising edge	TWHDX	30	–	ns	
\overline{WR} rising edge to ALE rising edge	TWHLH	15	–	ns	
\overline{CS} low hold time after \overline{WR} rising edge	TWHCH	15	–	ns	

6

Figure 22: LXT361 I/O Timing Diagram for Intel Address/Data Bus

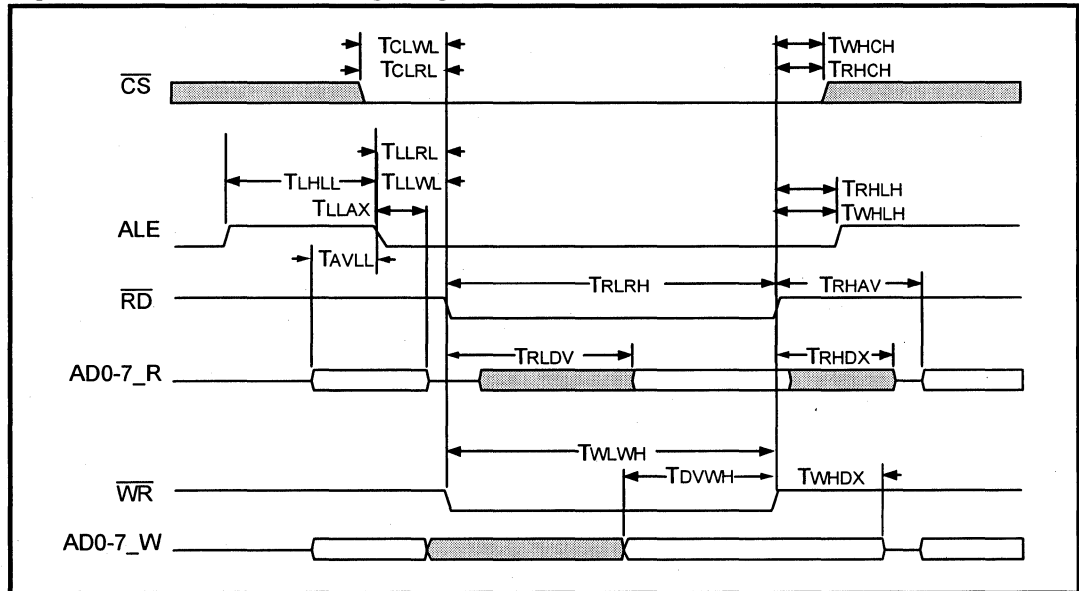

Table 45: LXT361 16.78 MHz Motorola Bus Parallel I/O Timing Characteristics
 (See Figure 23)

Parameter	Symbol	Min	Max	Units	Test Conditions
\overline{DS} rising edge to \overline{AS} rising edge	TDSHASH	15	–	ns	
\overline{AS} high pulse width	TASHASL	35	–	ns	
Address valid setup time at \overline{AS} falling edge	TAVASL	10	–	ns	
\overline{AS} falling edge to Address valid hold time	TASLAX	10	–	ns	
\overline{AS} falling edge to \overline{DS} falling edge	TASLDSL	20	–	ns	
\overline{CS} falling edge to \overline{DS} falling edge	TCSLDSL	10	–	ns	
\overline{DS} low pulse width	TDSLDSH	95	–	ns	
\overline{DS} falling edge to data valid	TDSL DV	10	55	ns	
Data hold time after \overline{DS} rising edge	TDSHDX	5	35	ns	
R/\overline{W} falling edge to \overline{DS} falling edge	TRWLDSL	10	–	ns	
Data setup time before \overline{DS} rising edge	TDVDSH	40	–	ns	
Data hold time after \overline{DS} rising edge	TDXDSH	30	–	ns	
R/\overline{W} low hold time after \overline{DS} rising edge	TDSHRWH	15	–	ns	
\overline{CS} low hold time after \overline{DS} rising edge	TDSHC SHV	15	–	ns	

Figure 23: LXT361 I/O Timing Diagram for Motorola Address/Data Bus

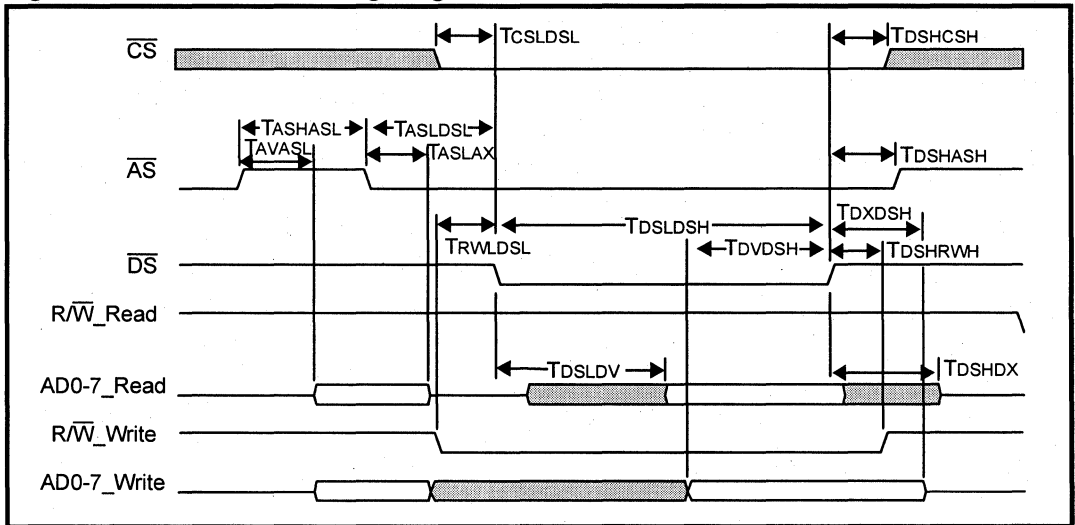

Figure 24: Jitter Tolerance (Typical)

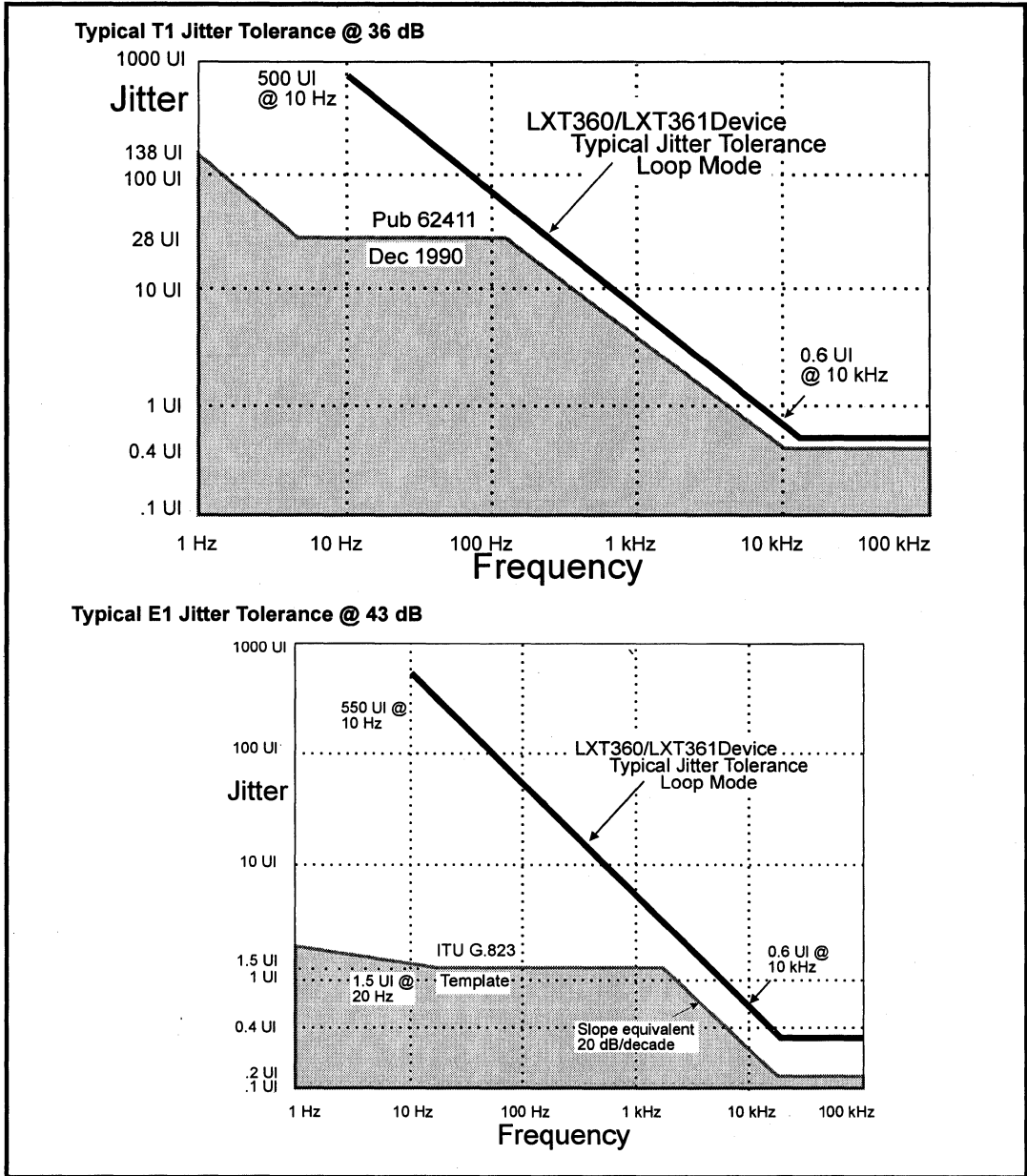

Figure 25: E1 Jitter Attenuation (Typical)

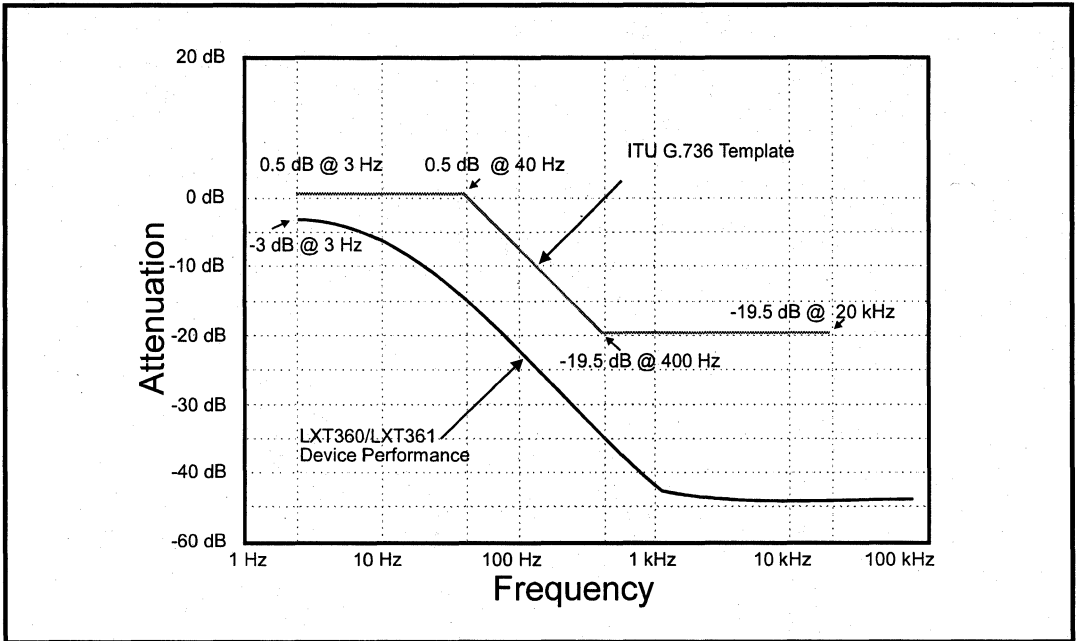
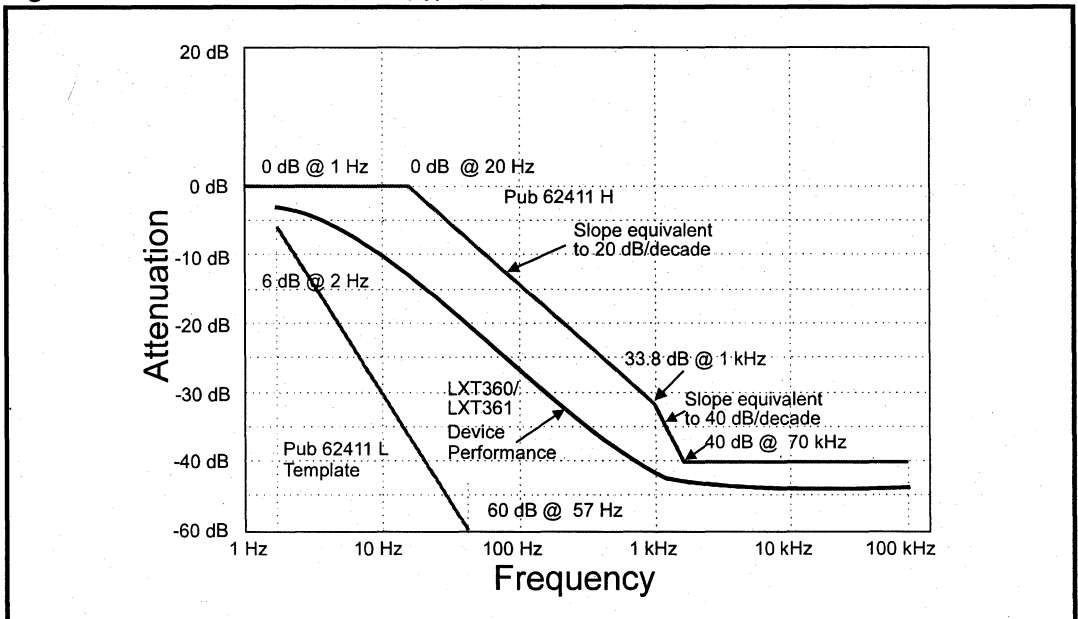

Figure 26: T1 Jitter Attenuation (Typical)



Digital Subscriber Line (DSL) Products



SK70704/SK70706

784 kbps HDSL Data Pump Chip Set

General Description

The HDSL Data Pump is a chip set consisting of the following two devices:

- SK70704 Analog Core Chip (ACC)
- SK70706 HDSL Digital Transceiver (HDX)

The HDSL Data Pump is a 2-wire transceiver which provides echo-cancelling and 2B1Q line coding. It incorporates transmit pulse shaping, filtering, line drivers, receive equalization, timing and data recovery to provide 784 kbps, clear-channel, "data pipe" transmission. The Data Pump provides Near-End Cross-Talk (NEXT) performance in excess of that required over all ANSI and ETSI test loops. Typical transmission range on 26 AWG (0.4 mm) cable exceeds 13 kft (4 km) in a noise-free environment or 9.5 kft (2.9 km) with ANSI-specified noise levels.

The Data Pump meets the requirements of Bellcore TA-NWT-001210, ANSI T1 Technical Report No. 28-1994 and ETSI ETR-152. It provides one end of a single-channel HDSL transmission system from the twisted pair interface back to the Data Pump/HDSL data interface. The Data Pump can be used at either the HTU-R or the HTU-C end of the interface.

Applications

- T1 (2-pair) and fractional T1 transport
- N-channel digital pair-gain
- Wireless base station to switch interface
- Campus and private networking
- High-Speed digital modems

Features

- Fully integrated, 2-chip set for interfacing to 2-wire HDSL lines at 784 kbps
- Single +5 V supply
- Integrated line drivers, filters and hybrid circuits result in greatly reduced external logic and simplified support circuitry requirements
- Simple line interface circuitry, via transformer coupling, to twisted pair line
- Internal ACC voltage reference
- Converts serial binary data to scrambled 2B1Q encoded data
- Self-contained activation/start-up state machine for simplified single loop designs
- Programmable for either central office (HTU-C) or remote site (HTU-R) applications
- Compliant with:
 - Bellcore TA-NWT-001210
 - ANSI HDSL Technical Report No. 28-1994
 - ETSI ETR-152 (1995)
- Design allows for operation in either Software Control or stand alone Hardware Control mode
- Typical power consumption less than 1.0 W allowing remote power feeding for repeater and HTU-R equipment
- Input or Output Reference Clock of 12.544 MHz
- Digital representation of receive signal level and noise margin values available for SNR controlled activation.

7

HDSL Data Pump Block Diagram

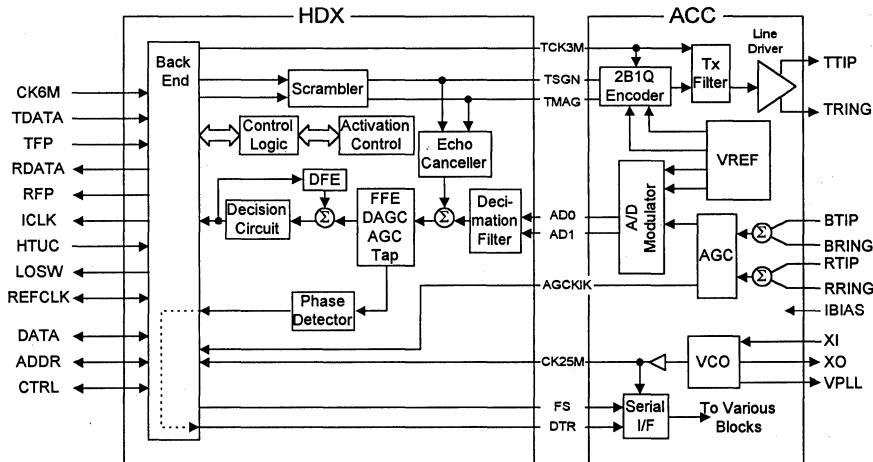

SK70704/SK70706 784 kbps HDSL Data Pump Chip Set

Order Information

Part Number	Package	Temperature Range
SK70704PE	28-pin PLCC	-40 °C to +85 °C
SK70706PE	44-pin PLCC	-40 °C to +85 °C
SK70706PH	44-pin PLCC	-5 °C to +85 °C

DATA PUMP PIN ASSIGNMENT AND SIGNAL DESCRIPTIONS

The ACC is packaged in a 28-pin PLCC. Figure 1 shows the ACC pin locations. Table 1 lists signal descriptions for each pin, except pins 18 and 19, which are not connected.

Figure 1: SK70704 ACC Pin Locations

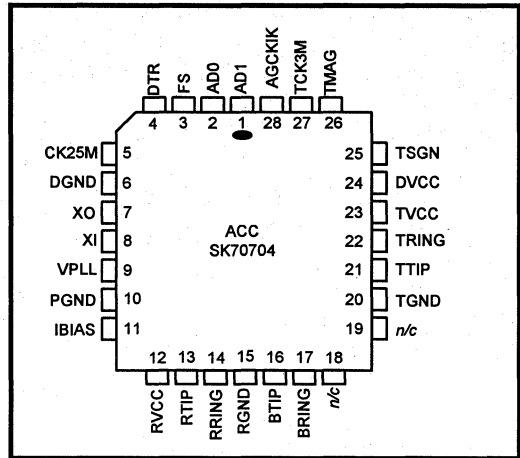

Table 1: SK70704 ACC Pin Assignments/Signal Descriptions

Group	Pin #	Symbol	I/O	Description
Line	13	RTIP	I	Receive Tip and Ring inputs. Connect these pins to the line transformer per network requirements.
	14	RRING	I	
	16	BTIP	I	Bias Tip and Ring. Inputs provide a bias setting for the receiver. Provide balanced network inputs.
	17	BRING	I	
	21	TTIP	O	Transmit Tip and Ring. Line driver outputs.
	22	TRING	O	
PLL	7	XO	O	Crystal Oscillator. Connect a 25.088 MHz crystal across these two pins.
	8	XI	I	
	9	VPLL	O	PLL Voltage Control. Supplies control voltage to the VCXO.
Power	10	PGND	I	PLL Ground. 0 V.
	12	RVCC	I	Receive Power supply. +5 V (± 5%).
	23	TVCC	I	Transmit Power supply. +5 V (± 5%).
	24	DVCC	I	Digital Power Supply. +5 V (± 5%).
	6	DGND	I	DVCC Ground. 0 V.
	15	RGND	I	RVCC Ground. 0 V.
	20	TGND	I	TVCC Ground. 0 V.

Table 1: SK70704 ACC Pin Assignments/Signal Descriptions – continued

Group	Pin #	Symbol	I/O	Description
Clock and Control	3	FS	I	392 kHz Clock Input. From HDX FS.
	4	DTR	I	Serial Control Data. Input from HDX at 12.544 Mbps.
	5	CK25M	O	25.088 MHz HDSL Reference Clock. Used as the receive timing reference for the HDX. Tie to HDX CK25M.
	27	TCK3M	O	3.136 MHz Clock. Input from HDX TCK3M.
Data Input and Output	28	AGCKIK	O	AGC Adjust Signal. Output to HDX AGCKIK.
	1	AD1	O	A-to-D Converter Data Line 1. Connect to HDX AD1.
	2	AD0	O	A-to-D Converter Data Line 0. Connect to HDX AD0.
	25	TSGN	I	Transmit Quat Sign. Input from HDX.
	26	TMAG	I	Transmit Quat Magnitude. Input from HDX.
Analog Input	11	IBIAS	I	Input Bias. Provides input bias current.

Figure 2: SK70706 HDX Pin Assignments

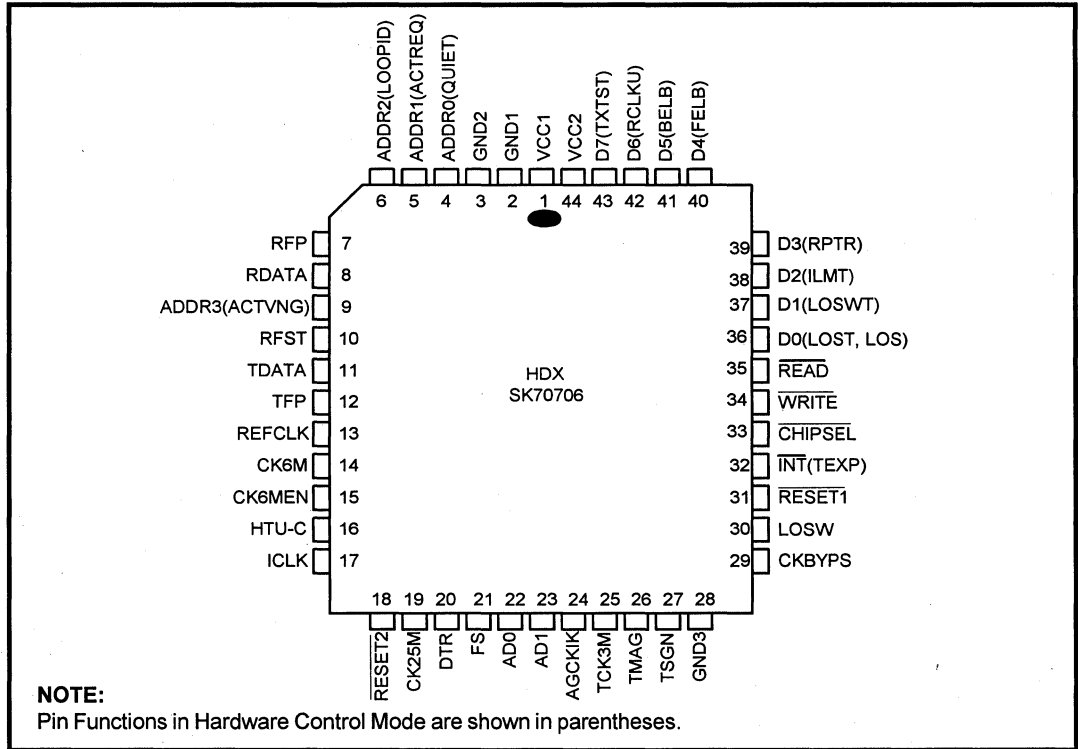

SK70704/SK70706 784 kbps HDSL Data Pump Chip Set

Table 2: SK70706 HDX Pin Assignments/Signal Descriptions

Group	Pin#	Symbol	I/O	Description
Power	1	VCC1	I	Logic supply input (Refer to Table 24)
	44	VCC2	I	I/O supply input
	2	GND1	I	Ground Return
	3	GND2	I	Ground Return
	28	GND3	I	Ground Return
Misc	29	CKBYP5	I	Test signal only, may be tied Low or not connected.
User Port	10	RFST	O	Receive Frame and Stuff Bit Indicator. Goes High for 18 consecutive ICLK periods to indicate four stuffing bits (b4703 - 4706) and 14 frame bits (b1-14) on RDATA.
	13	REFCLK	I ¹ O	12.544 MHz HDSL Reference Clock. In HTU-C Mode, this clock generates transmit and receive timing and must have ± 32 ppm accuracy. In HTU-R Mode, this output is derived by dividing CK25M by two.
	16	HTU-C	I	Operation Mode Select. When HTU-C is High, the Data Pump operates in HTU-C mode; when HTU-C is Low, the Data Pump operates in HTU-R mode. Tied to internal pull-up device.
	17	ICLK	O	Bit Rate Clock. Nominally 784 kHz, REFCLK is the source of ICLK in HTU-C Mode. CK25M is the source of ICLK in HTU-R Mode.
	30	LOSW	O	Loss of Sync Word Indicator. Normally Low in Active States, goes High to indicate receipt of six consecutive mismatched frame synch words. LOSW is logic High in all states except Active States.
	8	RDATA	O	Receive HDSL Data Stream. Output data to HDSL framer at 784 kbps: HDSL payload of Loop 1 or Loop 2 bytes plus the F-bits, eoc, crc, losd, febe, ps, bpv, hrp, inde/indr and uib bits, Sync bits for frame positions b1-14, Stuff bits for frame positions b4703 - 4706. RDATA bits are forced high in all states except the Active State.
	7	RFP	O	Receive Frame Pulse. Low for one ICLK cycle during the last bit of the current HDSL receive frame on RDATA, either b4702 or b4706. Period is within one baud time of 6 ms. ² RFP is valid when LOSW transitions Low.
	11	TDATA	I ¹	Transmit HDSL Data Stream. Input data from HDSL framer at 784 kbps: HDSL payload of Loop 1 or Loop 2 bytes plus the F-bits, eoc, crc, losd, febe, ps, bpv, hrp, inde/indr and uib bits, Sync bits for frame positions b1-14, Stuff dummy bits; may be 1s or 0s. Tied to internal pull-up device. When ACTIVE, the Data Pump is transparent and the HDSL framer must generate the appropriate bits on TDATA as shown in Table 5.
12	TFP	I ¹	Transmit Frame Pulse. Should be Low for one ICLK cycle during last bit of the current HDSL frame on TDATA, either b4702 or b4706. Period is within one baud time of 6 ms. ² If TFP is pulled Low and is Low again three ICLK cycles later, all digital outputs of the User Port go to tri-state. Tied to internal pull-up device.	

1. This input is a Schmidt Triggered circuit and includes an internal pull-up device.
 2. The period is 6 ms $\pm 1/302$ ms.
 3. This input is a Schmidt Triggered circuit and includes an internal pull-down device.

Table 2: SK70706 HDX Pin Assignments/Signal Descriptions – continued

Group	Pin#	Symbol	I/O	Description
Hardware Interface (Hardware Control Mode)	4	QUIET	I ³	Quiet Mode Enable. Pull High to force HDX into Deactivated State. Any later transition to Low will not return HDX to Active State. See ACTREQ.
	5	ACTREQ	I ³	Activation Request (HTU-C mode) or no function (HTU-R mode). Tie this pin Low in HTU-R mode. If QUIET is Low, a rising edge on this pin initiates activation, but the signal is ignored after activation. See QUIET.
	6	LOOPID	I ³ /O	Loop Number Control (HTU-C mode) or Loop Number Indicator (HTU-R mode). Low = loop 1; High = loop 2. Input Signal for HTU-C mode, output for HTU-R mode. In HTU-R mode valid only when LOSW is Low. <i>Note: The ETSI recommendation uses overhead bits for loop identification.</i>
	9	ACTVNG	O	Activating State Indication. High when the HDX is in the Activating State.
	18	RESET $\bar{2}$	I ¹	Reset Pulse. Pull Low on power up to initialize circuits and stop all clocks.
	31	RESET $\bar{1}$	I ¹	Reset Pulse. Pull Low to initialize internal circuits.
	32	TEXP	O	Timer Expiry. Goes High to indicate 30 second timer expiration in all states.
	33	CHIPSEL	I ³	Chip Select <i>Assert these three pins Low to activate Hardware Control Mode. When any of them goes High, the HDX reverts immediately to Software Control Mode.</i>
	34	WRITE	I ³	
	35	READ	I ³	
	36	LOST (HTU-C)	O	Loss of Signal Timer Expiration. In HTU-C mode, LOST goes High when the Data Pump enters the Inactive State. The transition from the Deactivated to the Inactive State occurs 1 second after the end of transmission by the HTU-R when deactivation began from either the Active-1 or Active-2 State. When the Data Pump transitions from the Activating State to the Deactivated State it may immediately enter the Inactive State without waiting for HTU-R transmission to cease. (See Figure 6.)
		LOS (HTU-R)	O	Loss of Signal Energy Indicator. In HTU-R mode LOS goes High to indicate loss of signal energy on entering the Inactive State. (See Figure 8.)
	37	LOSWT	O	Loss of Sync Word Timer. LOSWT goes High when LOSW is sustained for longer than 2 sec.
	38	ILMT	I ¹	Insertion Loss Measurement Test. Set High to transmit a framed & scrambled, “all 1s”, 2B1Q pulse sequence. Pulse sequence will have a valid sync word. In the HTU-R configuration, when the ILMT mode is selected, the Data Pump may begin activation.
	39	RPTR	I ¹	Repeater Mode Enable. When in HTU-C mode, ICLK output phase is aligned to the TFP input pulse width. Ignored in HTU-R mode.
40	FELB	I ¹	Front-End Loopback (HTU-C only). In Inactive State, set High to cause the ACC to loopback. The returned signal activates the HDX which receives its own transmitted data. The system ignores incoming data from HTU-R during loopback irrespective of status.	
41	BELB	I ¹	Back-End Loopback. In Active State a High forces an internal, transparent loopback with RDATA connected to TDATA and RFP connected to TFP.	

1. This input is a Schmidt Triggered circuit and includes an internal pull-up device.
 2. The period is 6 ms ± 1/392 ms.
 3. This input is a Schmidt Triggered circuit and includes an internal pull-down device.

SK70704/SK70706 784 kbps HDSL Data Pump Chip Set

Table 2: SK70706 HDX Pin Assignments/Signal Descriptions – continued

Group	Pin#	Symbol	I/O	Description
Hardware Interface <i>(Hardware Control Mode) -cont'd</i>	42	RCLKU	O	Receive Baud Rate (392 kHz) Clock. Aligned with ICLK in HTU-R mode, phase synchronous with receive pulse stream. However, during Activating State, the clocks may not be aligned. In the HTU-C mode RCLKU has a constant, arbitrary, phase relationship with ICLK in Active State.
	43	TXST	I ¹	Transmit Test. Set high to enable isolated transmit pulse generation. The time between pulses is approximately 6 ms. TDATA controls the sign and TFP controls the magnitude of the transmitted quat pulses according to the 2B1Q encoding rules. In the HTU-R configuration, when the TXST mode is selected, the Data Pump may begin activation.
Processor Interface <i>(Software Control Mode)</i>	36	D0	I ¹ /O	Data bit 0. Eight-bit, parallel data bus.
	37	D1	I ¹ /O	Data bit 1
	38	D2	I ¹ /O	Data bit 2
	39	D3	I ¹ /O	Data bit 3
	40	D4	I ¹ /O	Data bit 4
	41	D5	I ¹ /O	Data bit 5
	42	D6	I ¹ /O	Data bit 6
	43	D7	I ¹ /O	Data bit 7
	4	ADDR0	I ³	Address bit 0. Four-bit address, selects read or write register.
	5	ADDR1	I ³	Address bit 1
	6	ADDR2	I ³	Address bit 2
	9	ADDR3	I ³	Address bit 3
	18	$\overline{\text{RESET2}}$	I ³	Reset Pulse. Pull Low on power up to initialize circuits and stop all clocks.
	31	$\overline{\text{RESET1}}$	I ¹	Reset Pulse. Pull Low to initialize internal circuits. ICLK continues.
	32	$\overline{\text{INT}}$	O	Interrupt Output. Open drain output. Requires an external 10 k Ω pull up resistor. Goes Low on interrupt.
33	$\overline{\text{CHIPSEL}}$	I ³	Chip Select. Pull Low to read or write to registers.	
34	$\overline{\text{WRITE}}$	I ³	Write Pulse. Pull Low to write to registers.	
35	$\overline{\text{READ}}$	I ³	Read Pulse. Pull Low to read from registers.	

1. This input is a Schmidt Triggered circuit and includes an internal pull-up device.
 2. The period is 6 ms $\pm 1/392$ ms.
 3. This input is a Schmidt Triggered circuit and includes an internal pull-down device.

Table 2: SK70706 HDX Pin Assignments/Signal Descriptions – continued

Group	Pin #	Symbol	I/O	Description
Clock and Control	14	CK6M	I ³	6.272 or 12.544 MHz Reference Clock. Mandatory in HTU-R mode. Tie High or Low in HTU-C Mode. Clock input requires ± 32 ppm accuracy.
	15	CK6MEN	O	CK6M Enable. Active High enable for CK6M clock. In HTU-R mode, this pin goes Low to indicate the PLL is tracking the input signal from the HTU-C. Not used in HTU-C.
	19	CK25M	I	Receive Timing Clock (25.088 MHz). Tie to CK25M on ACC.
	20	DTR	O	Serial Control Data Link. Transfers data at 12.544 Mbps. Tie to DTR on ACC.
	21	FS	O	392 kHz Clock . Derived from CK25M. Tie to FS on ACC.
	22	AD0	I	Analog to Digital Converter input pin. Tie to AD0 on ACC
	23	AD1	I	Analog to Digital Converter input pin. Tie to AD1 on ACC
	24	AGCKIK	I	AGC Adjust Signal. Controls analog gain circuit. Tie to AGCKIK on ACC.
	25	TCK3M	O	Transmit Clock. Tie to TCK3M on ACC.
	26	TMAG	O	Transmit Magnitude Bit. Tie to TMAG on ACC.
	27	TSGN	O	Transmit Sign Bit. Tie to TSGN on ACC.

1. This input is a Schmidt Triggered circuit and includes an internal pull-up device.
 2. The period is 6 ms ± 1/392 ms.
 3. This input is a Schmidt Triggered circuit and includes an internal pull-down device.

FUNCTIONAL DESCRIPTION

NOTE

This functional description is for design aid only.

The HDSL Data Pump is a fully-integrated, two-chip solution (see Figure 3) which includes an SK70704 Analog Core Chip (ACC) and an SK70706 HDSL Digital Transceiver (HDX).

Transmit: The transmit data stream is supplied to the HDX at the TDATA input in a binary fashion. The HDX scrambles and 2B1Q encodes the data and adds the sync word and stuff quats based on the TFP frame pulse position. The injected stuff quats in a frame are equal to the last scrambled data symbol in that frame. The 2B1Q encoded transmit quat data stream (TSGN / TMAG) is then passed to the ACC which filters and drives it onto the line. For additional details on the transmit function, refer to Component Description.

Receive: The composite waveform of the receive signal plus trans-hybrid echo is filtered and converted to digital words at a rate of 392 k-words/second in the ACC. The ACC passes the digitized receive quat stream (AD0 and AD1) to the HDX. The HDX performs digital filtering, linear echo cancellation, frame recovery and descrambling. The HDX uses the transmit quat stream to generate the echo estimates and estimate error values. Using this error and the delayed transmit quat stream, the echo canceller coefficients are updated. The recovered, decoded and descrambled data is then output to the framer-mux from the HDX RDATA pin. For additional details on the receive function, refer to Component Description.

Control: The Data Pump offers two control modes - Hardware Mode and Software Mode. In Hardware mode the HDX receives control inputs via individually designated pins. In Software mode the HDX control data is supplied via an 8-bit parallel port. In either mode, communication between the HDX and the ACC is established via a unidirectional serial port (DTR).

Figure 3: HDSL Data Pump Block Architecture

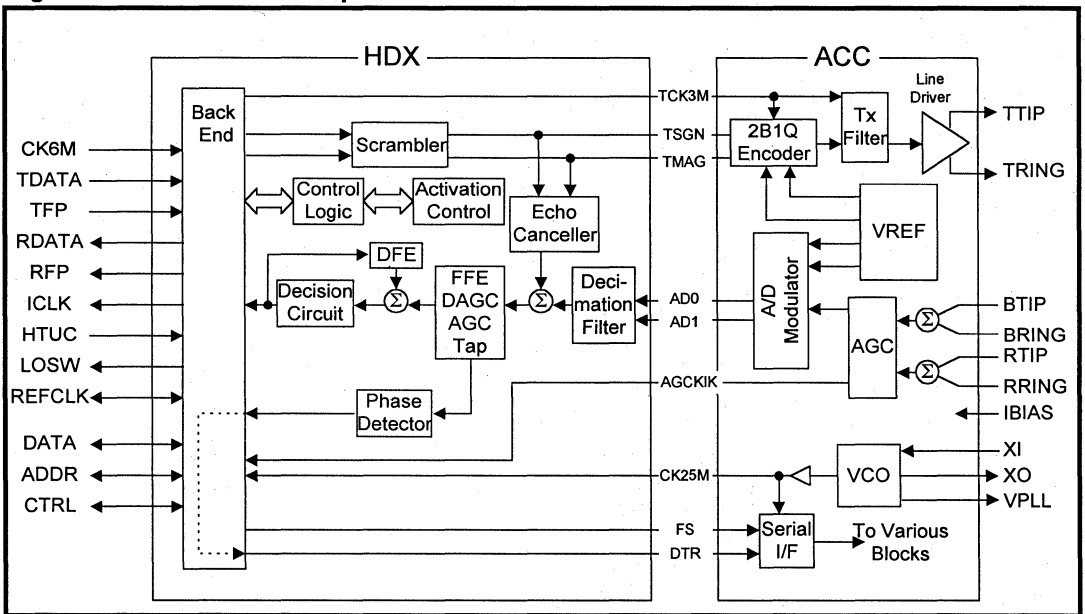

COMPONENT DESCRIPTION

The following paragraphs describe the chip set components individually with reference to internal functions and the interfaces between Data Pump components.

Analog Core Chip (ACC)

The ACC incorporates the following analog functions:

- the transmit driver
- transmit and receive filters
- Phase-Locked Loop (PLL)
- hybrid circuitry analog-to-digital converter.

The ACC provides the complete analog front end for the HDSL Data Pump. It performs transmit pulse shaping, line driving, receive A/D, and the VCO portion of the receiver PLL function. Transmit and receive controls are implemented through the serial port. The ACC line interface uses a single twisted pair line for both transmit and receive. Table 1 lists the ACC pin descriptions. Refer to Test Specifications for ACC electrical and timing specifications.

ACC TRANSMITTER

The ACC performs the pulse shaping and driving functions. The ACC transmitter generates a 4-level output of $1/(8 \cdot f(TCK3M))$ defined by TMAG and TSGN. Table 3 lists 2B1Q pulse coding parameters. Refer to Test Specifications for frequency and voltage templates.

ACC RECEIVER

The ACC receiver is a sophisticated sigma-delta converter. It sums the differential signal at RTIP/RRING minus the signal at BTIP/BRING. The first A/D signal comes out of AD0 at a bit stream rate of 12.544 MHz. The second stage of the A/D samples the noise of the first and generates the AD1 bit stream at 12.544 MHz.

Receiver gain is controlled by the HDX via the AGC2-0 bits in the DTR serial control stream. The AGCKIK output from the ACC is normally Low. It goes High when the signal level in the sigma delta A/D is approaching its clipping level, signaling the HDX to lower the gain.

The VCO is part of a phase-locked loop (PLL) locked to the receive data baud rate using an external phase detector.

The VCO frequency is varied by pulling an external crystal with external varactor diodes that are controlled by the VPLL output. The VPLL output is, in turn, controlled by the serial port VCO and PLL bits.

HDSL Digital Transceiver (HDX)

The HDX incorporates the following digital functions:

- bit-rate transmit and receive signal-processing
- adaptive Echo-Cancelling (EC)
- adaptive decision feedback-equalization (DFE) using the receive quat stream and the internal error signal
- fixed and adaptive digital-filtering functions
- activation/start-up control and the microprocessor interface to the HDSL framer.

The HDX also provides the Data Pump Back-End interface for the customer defined/developed HDSL framer via serial data channels and clock signals. A simple, parallel 8-bit microprocessor interface on the HDX allows high-speed access to control, status and filter coefficient words. Table 2 lists the HDX pin descriptions. Refer to Test Specifications for HDX electrical and timing specifications.

The microprocessor interface on the HDX provides bit flags for signal presence, synchronization, activation completion, and loss of synchronization for a time greater than two seconds. Single-byte words representing receive signal level and the noise margin of the transceiver are also available on the microprocessor interface. One control byte allows the user to start the Data Pump activation sequence. The HDX controls the complete activation/start-up sequence, allowing flexible, single-loop, fractional applications.

Table 3: ACC Transmit Control

TSGN	TMAG	Output Symbol (quat)
1	0	+3
1	1	+1
0	1	-1
0	0	-3

HDX/ACC Interface

The ACC provides the 25.088 MHz master clock, CK25M, to the HDX. The serial control stream framing signal FS is sampled inside the ACC with the CK25M rising edge. The serial control stream, DTR, is sampled inside the ACC by the rising edge of an internally-generated clock at $f(CK25M)/2$. This ACC internal clock has the same phase relationship with a similar clock inside the HDX, as established by the FS signal. In the HDX, the half-rate clock CK25M/2 and FS transition on the rising edge of CK25M, and DTR transitions coincide with the falling edge of CK25M/2. The output REFCLK in HTU-R Mode is equal to CK25M/2.

The A/D converter outputs, AD0 and AD1, are clocked out of the ACC with CK25M, having transitions coincidental with the rising edge of CK25M/2. The HDX samples AD0 and AD1 with the falling edge of its internal CK25M/2.

Transmit data, represented by TSGN and TMAG, is clocked from the HDX using the falling edge of TCK3M, the 3.136 MHz ($f(REFCLK)/4$) transmit time base clock. The ACC uses the rising edge of TCK3M to sample TSGN and TMAG. TSGN and TMAG change state at the baud rate, or every 8 cycles of TCK3M. Figure 4 shows relative timing for the HDX/ACC interface.

HDX/ACC Serial Port

The HDX continually writes to the ACC serial port. This serial stream consists of two 16-bit words as shown in Table 4. The data flows from the HDX to the ACC at a rate of $f(CK25M)/2$. Refer to the Test Specifications section for serial port timing relationships and electrical parameters.

LINE INTERFACE

The Data Pump line interface consists of three differential pairs. The transmit outputs TTIP and TRING, receive inputs RTIP and RRING, and the balance inputs BTIP and BRING, all connect through a common transformer to a single twisted-pair line (see Figures 12 and 13). The transmit outputs require resistors in series with the transformer. A passive prefilter is required for the receive inputs. The balance inputs feed the transmit signals back to the Data Pump providing passive echo cancellation. Protection circuitry should be inserted between all Data Pump line interface pins and the transformer. Refer to the Applications section for typical schematics.

Table 4: HDX/ACC Serial Port Word Bit Definitions (See Figure 3)

Bit	Word A (on DTR)	Word B (on DTR)
15	INIT	COR4
14	<i>n/a</i>	COR3
13	<i>n/a</i>	COR2
12	TXOFF	COR1
11	TXDIS	COR0
10	TXTST	VCO2
9	AGC2	VCO1
8	AGC1	VCO0
7	AGC0	PLL7
6	FELB	PLL6
5	<i>n/a</i>	PLL5
4	PTR4	PLL4
3	PTR3	PLL3
2	PTR2	PLL2
1	PTR1	PLL1
0	PTR0	PLL0

Figure 4: HDX/ACC Interface – Relative Timing

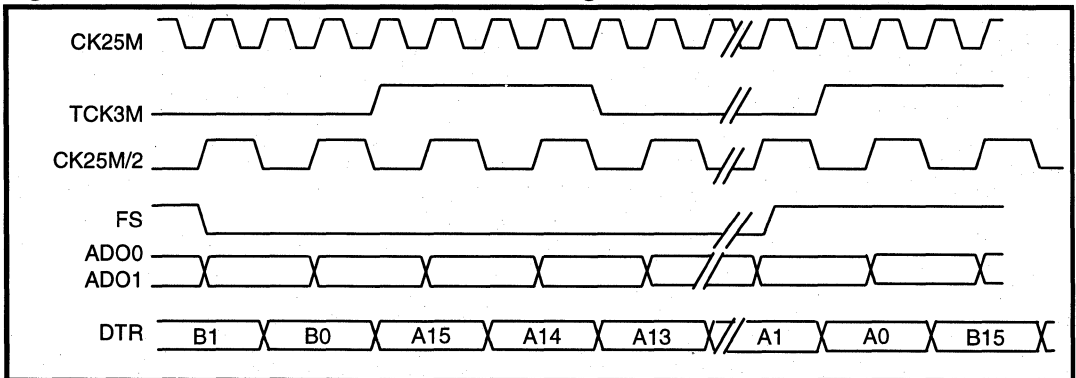

HDSL DATA INTERFACE

The HDSL data interface includes the transmit and receive binary data streams, transmit and receive frame pulses, the 784 kHz clock (ICLK) and the receive frame and stuff quat indicator (RFST). Figure 5 shows relative timing for the framer interface. Refer to Test Specifications section for details on the Data Pump/framer interface. Figure 6 shows

a complete HDSL system with both the remote HTU-R and central office HTU-C HDSL framer interfaces illustrated. Table 5 shows the TDATA requirements for the framer interface through the activation sequence. Once the ACTIVE 0-to-1 transition occurs, the Data Pump becomes transparent. Therefore, the HDSL framer must supply appropriate data to TDATA. Table 5 summarizes this requirement.

Figure 5: HDX/ACC Framer Interface – Relative Timing

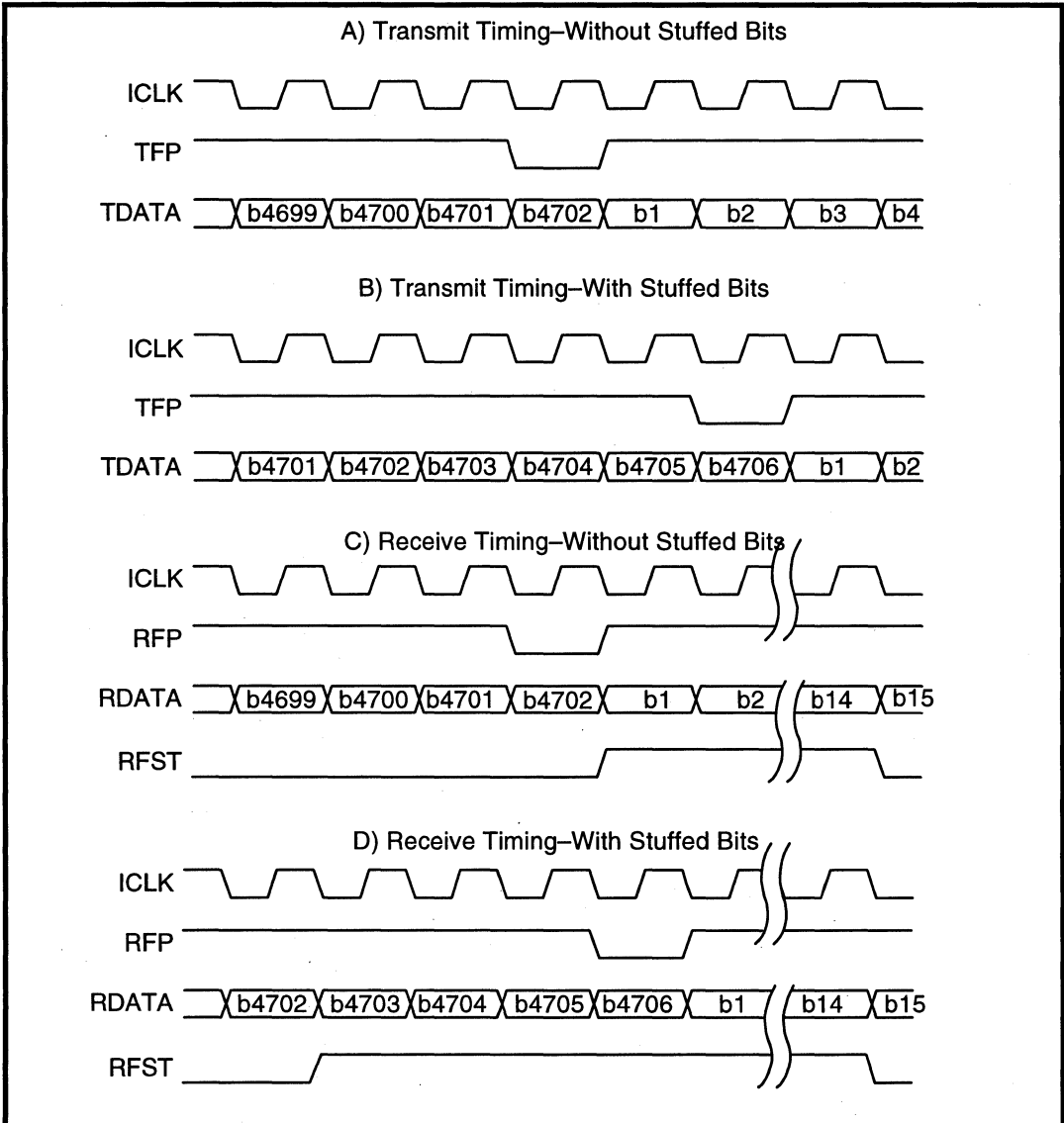

Table 5: HDSL Framer TDATA Requirements

Activation Process		TDATA	
Framer	Data Pump	Overhead	Data
Idle	Activating	<i>don't care</i>	<i>don't care</i>
Idle	Active 1	live	all 1s
Active-R	Active 1	live	all 1s
Active-T	Active 1	live	live
Link Active	Active 1	live	live
Link Active	Active 2	live	live

The HDSL framer interface is subject to the following rules:

1. When frame sync is not present (LOSW is High), all RDATA bits are set to 1.
2. If frame sync is lost on both Data Pump-R1 and Data Pump-R2, both units will fall back on the local reference frequency with ± 32 ppm tolerance, and stuff bits will be injected in their RDATA streams on every other frame.
3. If frame sync is lost on either Data Pump-C1 or Data Pump-C2, both unit's receiver will fall back on the reference clock with ± 32 ppm or ± 5 ppm tolerance, and inject stuff bits in the RDATA stream on every other frame.
4. If either T1-R or T1-C loses sync or signal, it is assumed that the corresponding T1 receiver will fall back on a local reference with ± 32 ppm tolerance, and that transmit bit-stuffing control will still be applied through the TFP signal from the HDSL framer.
5. The HDSL framer should provide TFP signal with a period of 6 ms $\pm 1/392$ ms prior to an activation request for the HTU-C Data Pump(s). The framer should provide a valid TFP after power-up, before or immediately after LOS goes Low for the HTU-R Data Pump(s).

Figure 6: Model for HDSL Data Pump and HDSL Framer Applications

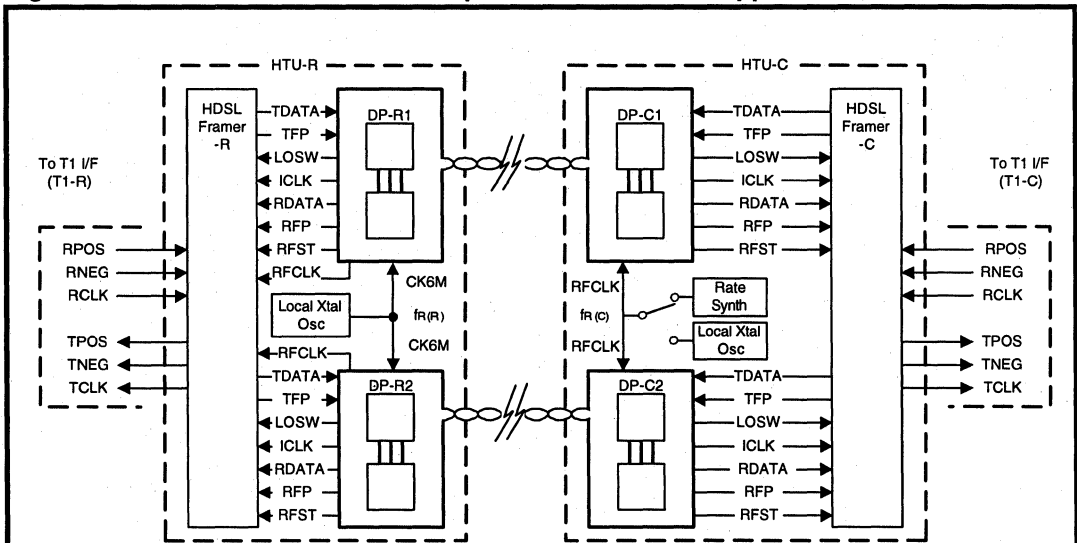

Frequency Relationships

1. $f_{TCLK} (DS1-C) = (DS1-R)$; tolerance = ± 32 ppm, even with loss of signal on DS1-R.
2. $f_{TCLK} (DS1-R) = (DS1-C)$; tolerance = ± 32 ppm, even with loss of signal on DS1-C.
3. $f_{ICLK} (C) = \frac{f_{R(C)}}{16}$; tolerance = ± 32 ppm if sourced by local crystal oscillator (stratum 4),
 = ± 5 ppm if sourced by office clock (stratum 3).
4. $f_{ICLK} (R) = f_{ICLK} (C)$ if loop is activated with receive frame sync acquired,
 = $\frac{f_{R(R)}}{16}$ if receive sync is lost; tolerance = ± 32 ppm. ($f_{R(R)} = 12.544$ MHz)
 = $\frac{f_{R(R)}}{8}$ if $f_{R(R)} = 6.272$ MHz.

If for any reason the TFP signal from the HDSL framer is inactive (always High or unconnected), then the Data Pump will inject stuff bits in the TDATA stream in every other frame, although the Data Pump will not be synchronized to the HDSL framer. When a new TFP is provided the Data Pump will immediately re-set the transmit frame alignment, typically causing loss of alignment at the other end.

7. A simultaneous $\overline{\text{RESET2}}$ to all HTU-C Data Pumps which use a common REFCLK eliminates phase shift between the ICLK outputs which may exist after power-up.

The ICLK outputs of all HTU-R Data Pumps may have an arbitrary phase difference even using a common CK6M reference.

MICROPROCESSOR INTERFACE (HDX)

Three primary control pins, $\overline{\text{CHIPSEL}}$ (Chip Select), $\overline{\text{READ}}$ and $\overline{\text{WRITE}}$, execute the Software Mode which also uses an interrupt output pin to report status changes. Four additional pins are used for the parallel bus addressing and eight pins for data I/O. Refer to Test Specifications for μ processor interface timing in Software Mode.

Control Pins

Chip Select: The Chip Select ($\overline{\text{CHIPSEL}}$) pin requires an active Low signal to enable Data Pump read or write transfers over the data bus. To enable Hardware Mode hold this pin Low, along with $\overline{\text{READ}}$ and $\overline{\text{WRITE}}$.

Data Read: The Data Read pin ($\overline{\text{READ}}$) requires an active Low pulse to enable a read transfer on the data bus. When $\overline{\text{READ}}$ is pulled Low, the Data Pump data bus lines go from tristate to active and output the data from the register addressed by ADDR0-ADDR3. To avoid reading data during register updates, reads should be synchronized to the falling edge of FS. Alternatively, each read should be repeated until the same data is read twice within one baud time.

Data Write: The Data Write pin ($\overline{\text{WRITE}}$) requires an active Low pulse to enable a write transfer on the data bus. Data transfer is triggered by the rising edge of the $\overline{\text{WRITE}}$ pulse. To ensure data is written to the register addressed by ADDR0-ADDR3, valid data must be present on the HDX data bus lines before $\overline{\text{WRITE}}$ goes High.

Interrupt: The Interrupt pin ($\overline{\text{INT}}$) is an open drain output requiring an external pull-up resistor. The $\overline{\text{INT}}$ output is pulled active Low when an internal interrupt condition occurs. $\overline{\text{INT}}$ is latched and held until Main Status Register RD0 is read. An internal interruption results from a Low-to-High transition in any of four status indicators: ACTIVE, LOSW, LOSWT or TEXP. Any transition on LOS will also generate an interrupt. If an interrupt mask bit

in register WR2 is set, any transition of the corresponding status bit will not trigger the $\overline{\text{INT}}$ output.

Register Access

Write

To write to an HDX register, proceed as follows:

1. Drive $\overline{\text{CHIPSEL}}$ Low.
2. Drive an address (0000, 0010, or 0011) onto ADDR0-ADDR3.
3. Observe address setup time.
4. Set 8-bit input data word on D0-D7.
5. Pull $\overline{\text{WRITE}}$ Low, observing minimum pulse width.
6. Pull $\overline{\text{WRITE}}$ High, observing hold time for data and address lines.

Read

Procedures for reading the HDX registers vary according to which register is being read. Accessing registers RD0, RD1, RD2, RD5 and RD6 is relatively simple. Reading registers RD3 and RD4 is more complex. *Unless parallel port reads are synchronized with the falling edge of FS, all read operations should be repeated until the same data is read twice within one baud time.*

To read register RD0, RD1, RD2, RD5 or RD6 proceed as follows:

1. Drive $\overline{\text{CHIPSEL}}$ Low.
2. Drive the desired address onto ADDR0-ADDR3.
3. Pull $\overline{\text{READ}}$ Low, observing minimum pulse width.
4. Pull $\overline{\text{READ}}$ High to complete the read cycle.

Registers RD3 and RD4 hold the coefficient values from the DFE, EC, FFE and AGC as shown in Table 9. Register RD3 holds the lower byte value and register RD4 holds the upper byte value. To reconstruct the complete 16-bit word, concatenate the least significant and most significant bytes.

To read registers RD3 and RD4 proceed as follows:

1. Select the desired coefficient by writing the appropriate code from Table 9 to register WR3.
2. Enable the Coefficient Read Register by writing a 1 to bit b0 (CRD1) in register WR2.
3. Perform standard register read procedure listed in steps 1 through 6 above to read the lower byte from RD3 and the upper byte from RD4.
4. Concatenate the RD3 and RD4 to obtain the complete 16-bit word.

SK70704/SK70706 784 kbps HDSL Data Pump Chip Set

Registers

Three write registers and seven read registers are available to the user. Table 6 lists these registers and the following paragraphs describe them in more detail.

Some of the registers contain *reserved* bits. Software must deal correctly with reserved fields. For reads, software

must use appropriate masks to extract the defined bits and not rely on reserved bits being any particular value. In some cases, software must program reserved bit positions to a particular value. This value is defined in the individual bit descriptions.

After asserting the $\overline{\text{RESET1}}$ or $\overline{\text{RESET2}}$ signal, the Data Pump initializes its registers to the default value.

Table 6: Register Summary

ADDR A3-A0	Write Registers			Read Registers		
	WR#	Name	Table	RD#	Name	Table
0000	WR0	Main Control	7	RD0	Main Status	10
0001		<i>reserved</i>	<i>n/a</i>	RD1	Receiver Gain Word	11
0010	WR2	Interrupt Mask	8	RD2	Noise Margin	12
0011	WR3	Read Coefficient Select	9	RD3	Coefficient Read Register (lower byte)	13
0100		<i>reserved</i>		RD4	Coefficient Read Register (upper byte)	13
0101		<i>reserved</i>		RD5	Activation Status	14
0110		<i>reserved</i>		RD6	Receiver AGC and FFE Step Gain	15
0111-1001		<i>reserved</i>			<i>reserved</i>	

WR0—MAIN CONTROL REGISTER

Address: A3-0 = 0000

Default 00h

Attributes: Write Only

Control Register bits serve the same purpose in Software Mode as the like-named individual pins in Hardware Mode. Table 7 lists bit assignments for the WR0 register.

Table 7: Main Control Register WR0

Bit	Description
b7	Transmit Test Pattern Enable (TXTST). Set TXTST to 1 to enable isolated transmit pulse generation. The time between pulses is 6 ms. TDATA controls the sign and TFP controls the magnitude of the transmitted symbols according to the 2B1Q encoding rules. In the HTU-R configuration when the TXTST mode is selected, the Data Pump may begin activation.
b6	Back-End Loop Back (BELB). In the Active State, set BELB to 1 to enable an internal, transparent loopback of the HDX RDATA to TDATA and RFP to TFP.
b5	Front End Loop Back (FELB). In the HTU-C mode with the Data Pump in the Inactive State, set FELB to 1 to enable an ACC front-end loopback. The Data Pump will begin activation and transmission on the line, but will ignore any signal from the HTU-R instead synchronizing to its own transmit signal.
b4	Repeater Mode (RPTR). The RPTR bit is set to 1 and the HTU-C pin is pulled High to program the Data Pump for operation on the side of the HDSL repeater driving the remote HTU-R. RPTR is set to 0 and the HTU-C pin is tied Low to program the Data Pump for operation on the side of the repeater driven by the central office HTU-C.
b3	Loop Control (LOOPID). For 2-pair ANSI HDSL applications, LOOPID defines the frame sync word format to encode the loop number in HTU-C mode. Set LOOPID to 0 for Loop1 or to 1 for Loop2. The Data Pump transmits a 7-quat, time-reversed, double-Barker code on Loop2. For 3-pair ETSI HDSL applications, LOOPID should be set to 0 on all loops because the loop number is encoded in the HDSL overhead using the Z bits.
b2	Insertion Loss Measurement Test (ILMT). Set ILMT to 1 to enable transmission of a scrambled all ones insertion loss measurement test pattern. In the HTU-R configuration when the ILMT mode is selected, the Data Pump may begin activation.
b1	Quiet Mode (QUIET). Set QUIET to 1 to force the Data Pump into the De-Activated State with the transmitter silent. Setting QUIET to 0 will not cause the Data Pump to reactivate. In the HTU-R mode, the Data Pump will not respond to an S0 signal from the HTU-C when QUIET is set to 1, but may activate after QUIET is set to 0 even if the HTU-C transmission has already ceased.
b0	Activation Request (ACTREQ). In the HTU-C mode when the Data Pump is in the Inactive State and Quiet is set to 0, setting the ACTREQ bit to 1 will initiate an activation sequence. Because ACTREQ is a level- rather than an edge-triggered signal, it should be reset to 0 again within approximately 25 seconds to prevent the immediate start of another activation cycle if the current activation attempt fails. If an activation attempt fails, the processor should allow the Data Pump to remain in the Inactive State where the transmitter is silent for 32 seconds before generating another activation request to allow the HTU-R to return to the Inactive State. It is possible to shorten this quiet period following a failed activation by implementing additional algorithms described in the section entitled “Activation State Machines.”

7

WR2—INTERRUPT MASK REGISTER

Address: A3-0 = 0010
 Default: 00h
 Attributes: Write Only

Table 8 shows the various interrupt masks provided in register WR2.

Table 8: Interrupt Mask Register WR2

Bit	Description
b7:6	<i>Reserved. Must be set to 0.</i>
b5	LOSMSK. 1=Masked. 0=Not Masked. Interrupt mask for the LOS condition
b4	LSWTMSK. 1=Masked. 0=Not Masked. Interrupt mask for the LOSWT condition
b3	LSWMSK. 1=Masked. 0=Not Masked. Interrupt mask for the LOSW condition
b2	ACTMSK. 1=Masked. 0=Not Masked. Interrupt mask for the TEXP condition and the ACTIVE condition
b1	<i>Reserved. Must be set to 0.</i>
b0	Enable coefficient read register (CRD1). 1=Enable. 0=Disable. Used in conjunction with WR3 for reading coefficient values.

WR3—READ COEFFICIENT SELECT REGISTER

Address: A3-0 = 0011
 Default: 00h
 Attributes: Write Only

Table 9 lists the bit maps used to select the coefficient read from the HDX.

Table 9: Read Coefficient Select Register WR3

Hex Value	Selected Registers	Description
00-07	DFE1-DFE8	DFE coefficients
08-0F	EC1-EC8	Echo Cancellation
10-15	FFE1-FFE6	FFE coefficients 1-6
16-19	<i>reserved</i>	
1A	AGC Tap	AGC Tap
1B-FF	<i>reserved</i>	

RD0—MAIN STATUS REGISTER

Address: A3-0 = 0000
 Default: xxh (x=undefined)
 Attributes: Read Only

Status Register bits serve the same purpose in Software Mode as the like-named individual pins in Hardware mode. Table 10 lists the bit assignments in this register.

Table 10: Main Status Register RD0

Bit	Active Description
b7	Timer Expiry (TEXP). Set to 1 to indicate 30-second timer expiration in the Active State. <ul style="list-style-type: none"> • Causes interrupt on changing from 0 to 1; masked by ACTMSK = 1. • Latched event; reset on read, with persistence while in the Active State.
b6	TIP/RING polarity reversed (INVERT). 0 = polarity reversal. Valid only in Active State.
b5	Change Of Frame Alignment (COFA). Indicates that re-acquisition of frame sync is in a different position with respect to the last frame position. Does not cause interrupt. Latched event; reset on read
b4	Loss Of Signal for HTU-R (LOS). 1 = loss of line signal energy on entering Inactive State. Loss of Signal Timer Expiration for HTU-C (LOST). 1 = loss of signal for 1 second on entering Inactive State. <ul style="list-style-type: none"> • Causes interrupt on transitions from 0 to 1 or 1 to 0 that are masked by LOSMSK = 1. • LOS/LOST is not a latched event.
b3	Loop Number Control (LOOPID). 0 = loop 1; 1 = loop 2. Valid only in Active States, 0 in all others <i>Note: This bit is used only for ANSI systems. The ETSI recommendation defines overhead bits for loop identification.</i>
b2	Loss of Sync Word Timer Expiry (LOSWT). Indicates two seconds of LOSW. <ul style="list-style-type: none"> • Causes interrupt on changing from 0 to 1; masked when LSWTMSK = 1. • Latched event; reset on read; with persistence while in the Deactivated State.
b1	Loss of Sync Word (LOSW). <ul style="list-style-type: none"> • Causes interrupt on changing from 0 to 1; masked by LSWMSK = 1. • Latched event; reset on read; with persistence while in the Pending Deactivation State.
b0	Active State (ACTIVE). 1 = Completion of layer 1 activation. <ul style="list-style-type: none"> • Causes interrupt on changing from 0 to 1; masked by ACTMSK = 1. • Latched event; reset on read with persistence if still in the Active State.

7

RD1—RECEIVER GAIN WORD REGISTER

Address: A3-0 = 0001
 Default: xxh (x=undefined)
 Attributes: Read Only

The 8-bit word in this register is the eight most significant bits of the main FFE AGC tap, which, along with the AGC and DACG values (RD6), represent the receiver gain required to compensate for line loss, and to normalize the receive 2B1Q pulses to a fixed threshold. Bit b7 (sign bit, always 0) is the MSB with bit b0 the LSB. The AGC tap value is determined as follows:

$$AGC\ Tap = \sum_{i=0}^6 b_i * 2^{i-6}$$

Table 11: Receiver Gain Word Register

Bit	Description
b7-b0	FFE AGC Tap Value (eight most significant bits).

RD2—NOISE MARGIN REGISTER

Address: A3-0 = 0010
 Default: xxh (x=undefined)
 Attributes: Read Only

The noise margin of the received signal is an input to the HDSL framer’s Activation State Machine. The noise margin must reach a threshold level before the HDSL framer can transition to the fully Active State. The HDX provides a calculated, logarithmic noise margin value used by the HDSL framer. This eight-bit word, stored in register RD2, is available every baud, although updated only every 64 baud. Table 12 shows the noise margin coding. To calculate the SNR, use this equation:

$$\text{SNR} = \text{Noise Margin} + 21.5 \text{ dB}$$

Error propagation in the DFE and de-scrambler may introduce some fractional errors in this formula, however, the relationship between the SNR and the noise margin remains valid as long as the noise follows a Gaussian distribution.

Since the average period of the calculation is very short (64 baud = 163 μs), the recommended procedure for evaluating transmission quality is to average at least 1000 samples over a 163 ms period.

**Table 12: Noise Margin Register RD2
 (Noise Margin Coding)**

MSB				LSB				Noise Margin
b7	b6	b5	b4	b3	b2	b1	b0	
0	0	1	1	0	1	0	1	+26.5
0	0	1	0	1	1	1	1	+23.5
0	0	1	0	1	0	1	1	+21.5
0	0	1	0	1	0	0	1	+20.5
0	0	1	0	0	1	1	1	+19.5
0	0	1	0	0	1	0	1	+18.5
0	0	1	0	0	1	0	0	+18.0
0	0	1	0	0	0	1	0	+17.0
0	0	1	0	0	0	0	0	+16.0
0	0	0	1	1	1	1	0	+15.0
0	0	0	1	1	1	0	0	+14.0
0	0	0	1	1	0	1	0	+13.0
0	0	0	1	1	0	0	0	+12.0
0	0	0	1	0	1	1	0	+11.0
0	0	0	1	0	1	0	0	+10.0
0	0	0	1	0	0	1	0	+9.0
0	0	0	0	1	0	0	0	+8.0
0	0	0	0	1	1	1	0	+7.0
0	0	0	0	1	1	0	0	+6.0
0	0	0	0	1	0	1	0	+5.0
0	0	0	0	1	0	0	0	+4.0
0	0	0	0	0	1	1	0	+3.0
0	0	0	0	0	1	0	0	+2.0
0	0	0	0	0	0	1	0	+1.0
0	0	0	0	0	0	0	0	0.0
1	1	1	1	1	1	1	0	-1.0
1	1	1	1	1	1	0	0	-2.0
1	1	1	1	1	0	1	0	-3.0
1	1	1	1	1	0	0	0	-4.0
1	1	1	1	0	1	1	0	-5.0
1	1	1	1	0	1	0	0	-6.0

RD3 (LSB), RD4 (MSB)—COEFFICIENT READ REGISTER

Address: RD3 (A3-0 = 0011)
 RD4 (A3-0 = 0100)
 Default: xxh (x=undefined)
 Attributes: Read Only

Coefficient Read Word (read from the HDX) comes from the location configured in the Read Coefficient Select Register (WR3, Address A3-0 = 0011). The HDX updates this word on the rising edge of the receive clock, FS. Read register RD3 is the lower byte, and RD4 is the upper byte.

Table 13: Coefficient Read Register

Bit	Description
b7-b0	Coefficient Word Value. RD3 contains the lower byte; RD4 the upper byte.

RD5—ACTIVATION STATUS REGISTER

Address: A3-0 = 0101
 Default: xxh (x=undefined)
 Attributes: Read Only

The ACT bits indicate the current state of the HDX transceiver during the Activating State as listed in Table 14. (For any state other than the Activating State, the ACT bits will be “0000”.)

Table 14: Activation Status Register RD5

ACT Bits 3-0	State in HTU-C Mode	State in HTU-R Mode
0000	Inactive	Inactive
0001	Pre-AGC	Wait
0010	Pre-EC	AAGC
0011	SIGDET	EC
0100	AAGC	PLL1
1001	EC	PLL2
1010	PLL	4LVLDDET
1011	4LVLDDET	FRMDET
1000	FRMDET	-

SK70704/SK70706 784 kbps HDSL Data Pump Chip Set

RD6—RECEIVE STEP GAIN REGISTER

Address: A3-0 = 0110

Default: xxh (x=undefined)

Attributes: Read Only

This 8-bit register represents AGC and FFE gain coefficients (GAGC and GFFE, respectively). Bit assignments are listed in Table 15. The approximate line loss (LL) can be determined using these values in the following equation:

$$LL = 20\log_{10}(GFFE * AGC \text{ tap}) + GAGC + 28 \text{ dB}$$

GFFE corresponds to DAGC in the HDX and GAGC is from the ACC. Bits ST0-ST2 indicate the Data Pump activation states as shown in Figures 7 and 9 and Table 16.

Table 15: Receiver AGC and FFE Step Gain Register RD6

Bit	Description																		
b7	ST2. Data Pump Activation State-bit 2																		
b6	ST1. Data Pump Activation State-bit 1																		
b5-b4	GFFE1, GFFE0. Digital Gain Word-bit 1 and Digital Gain Word-bit 0. <table border="1" style="margin-left: 20px;"> <thead> <tr> <th>Bits [5:4]</th> <th>GFFE Value</th> </tr> </thead> <tbody> <tr> <td>00</td> <td>$2^0 = 1$</td> </tr> <tr> <td>01</td> <td>$2^1 = 2$</td> </tr> <tr> <td>10</td> <td>$2^2 = 4$</td> </tr> <tr> <td>11</td> <td>$2^3 = 8$</td> </tr> </tbody> </table>	Bits [5:4]	GFFE Value	00	$2^0 = 1$	01	$2^1 = 2$	10	$2^2 = 4$	11	$2^3 = 8$								
Bits [5:4]	GFFE Value																		
00	$2^0 = 1$																		
01	$2^1 = 2$																		
10	$2^2 = 4$																		
11	$2^3 = 8$																		
b3	ST0. Data Pump Activation State-bit 0																		
b2-b0	GAGC2-GAGC0. Analog Gain Word-bit 2,1 and 0. <table border="1" style="margin-left: 20px;"> <thead> <tr> <th>Bits[2:0]</th> <th>GAGC Value (db)</th> </tr> </thead> <tbody> <tr> <td>000</td> <td>-12</td> </tr> <tr> <td>001</td> <td>-10</td> </tr> <tr> <td>010</td> <td>-8</td> </tr> <tr> <td>011</td> <td>-6</td> </tr> <tr> <td>100</td> <td>-4</td> </tr> <tr> <td>101</td> <td>-2</td> </tr> <tr> <td>110</td> <td>0</td> </tr> <tr> <td>111</td> <td>+2</td> </tr> </tbody> </table>	Bits[2:0]	GAGC Value (db)	000	-12	001	-10	010	-8	011	-6	100	-4	101	-2	110	0	111	+2
Bits[2:0]	GAGC Value (db)																		
000	-12																		
001	-10																		
010	-8																		
011	-6																		
100	-4																		
101	-2																		
110	0																		
111	+2																		

ACTIVATION STATE MACHINES

The Data Pump Activation/Start-Up circuitry is compatible with ANSI T1E1.4/94-006. Full HTU-C activation is partitioned between the Data Pump and the framer. Figure 7 represents the HTU-C Data Pump Activation State Machine, and Figure 8 shows the HTU-C framer activation state machine. Figures 9 and 10 present the corresponding HTU-R state machines. Table 16 lays out the correspondence between the Data Pump and Framer state machines. In Software Mode, the ST_n bits in Read Register 6 (ADDR 0110) show the current status of the state machine.

HTU-C Data Pump Activation

When the HTU-C Data Pump is powered up and reset is applied, the chip is in the Inactive State as shown at the top of Figure 7. Starting at the Inactive State, the device progresses in a clockwise direction through the Activating, Active-1, Active-2, Pending De-Activation and De-Activated States.

In the hardware mode when the Data Pump is in the Inactive State and the QUIET pin is Low, a Low-to-High transition on the ACTREQ pin initiates activation of the link. In the software mode when the Data Pump is in the Inactive State and the QUIET bit is set to 0, setting the ACTREQ bit to 1 initiates activation of the link. Because the ACTREQ control bit is level sensing, it should be set to 1 and then reset to 0 again within 25 seconds to generate a single activation request.

During the Activating State, the echo canceller, equalizer and timing recovery circuits are all adapting during the simultaneous transmission and reception of the framed, scrambled-ones data transmitted as a two-level code (S0) or as the four-level code (S1). If the receive frame sync word is not detected in two consecutive frames within 30 seconds, the timer expires and the device moves to the De-Activated State and ceases transmission. It will then immediately transition to the Inactive State (setting LOST regardless of whether HTU-R transmission has ceased). Another activation request should not be generated for 32 seconds allowing the HTU-R to timeout, detect LOS and move from the De-Activated to the Inactive State. In microprocessor-based systems, this time may be shortened by implementing a processor routine to reset the HTU-R Data Pumps which are in the Activating State when no HTU-C signal is present.

Successful detection of the sync word drives the State machine to the Active-1 State. This is indicated by a 0-to-1 transition of the ACTIVE bit (Software Mode). If the HTU-C Data Pump remains locked to the sync word until the Activation Timer expires, the device transitions to the Active-2 (fully active) State. If sync is lost, as indicated by

a 0-to-1 transition on LOSW, the HTU-C Data Pump transitions to the Pending De-Activation State.

In Pending De-Activation, the HTU-C Data Pump progresses to the De-Activated and Inactive States with the expiration of the respective timers. If the sync word is detected before the LOSW timer expires, the HTU-C Data Pump returns to either Active 1 or Active-2. (The HTU-C Data Pump returns to whichever state it occupied before transitioning to Pending De-Activation.)

The HTU-C Data Pump will exit the Active-2 State in one of two ways. A Low-to-High transition on the QUIET pin (Hardware Mode) or the QUIET bit (Software Mode), forces the HTU-C Data Pump directly to the De-Activated State. The only other means of exiting the Active State is through a loss of receive sync word (LOSW). LOSW is set when six consecutive frames occur without a sync word match. The LOSW event puts the HTU-C Data Pump into the Pending De-Activation State.

The HTU-C Data Pump remains in the Pending De-Activation State for a maximum of two seconds. If a sync word is detected within two seconds after the LOSW event, the HTU-C Data Pump re-enters the Active State. If the LOSW condition exceeds two seconds, an LOSWT event occurs which sends the chip to the De-Activated State. When the De-Activated State is reached from Pending De-Activation, the HTU-C Data Pump returns to the Inactive State and declares LOST when it detects no signal from the HTU-R for one second. The Data Pump should remain in the Inactive State for 15 seconds before another activation attempt.

Table 16: Data Pump/Framer Activation State Machine Correspondences

ST2	ST1	ST0	Data Pump State	Framer State
0	0	0	Inactive	Idle
0	0	1	Activating – 30 s timer running	Idle
0	1	0	Active – 30 s timer running (Active-1) ¹	Idle, Active-R or Active-T, or Link Active
0	1	1	Active – 30 s timer running (Active-2)	Link Active
1	0	0	Pending De-Activation ¹	Link Active or Active-R or Active-T
1	0	1	De-Activated ¹	Idle
1	1	0	unused	unused
1	1	1	unused	unused

1. TDATA is transparent to line output in states 010, 011 and 100

HTU-C Framer Activation

Figure 8 shows the activation state machine for the HTU-C HDSL framer. Transition to the Link Active stage from the Idle stage (upper left) requires successful exchange of a pair of indicator bits, *indc* and *indr*. (“INDC” and “INDR” are internal status signals within the HDSL framer; “*indc*” and “*indr*” are bits in the overhead channel.) The HTU-C device transmits the *indc* bit, and the HTU-R device transmits the *indr* bit. The overhead frame carries these indicator bits during transmission of the S1 training pattern.

Figure 8 illustrates the two partially active states (Active-R and Active-T) which may serve as transitions between the Idle and Link Active States. If the HTU-C device reaches the SNR threshold, its framer sets the INDC bit and the device transitions to the Active-R State. If the HTU-R device reaches the SNR threshold, it will transmit the *indr* bit to the HTU-C. The HTU-C will then transition to the Active-T State. From either of the partially Active States, the devices transition to the full Link Active State only with both Indication bits set.

Upon entering the Active States (Active-R, Active-T or Link Active), the chip will open up the full duplex communication link with the HTU-R. Only the Active and Pending De-Activation States allow full payload transmission. In all states except Active-1 and Active-2, the RDATA output is clamped High.

Figure 7: HTU-C Data Pump Activation State Machine

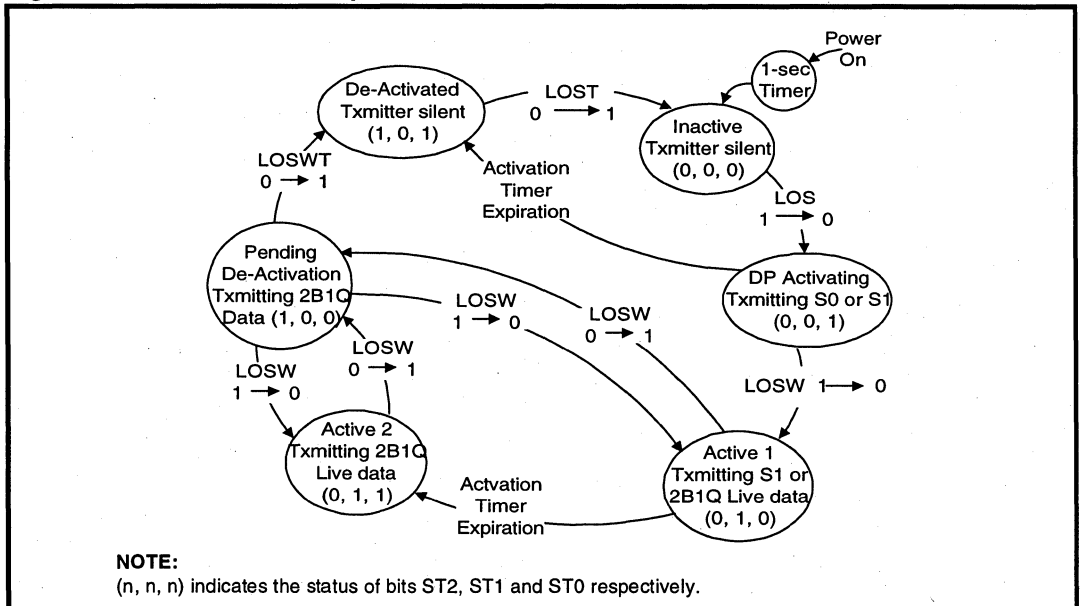
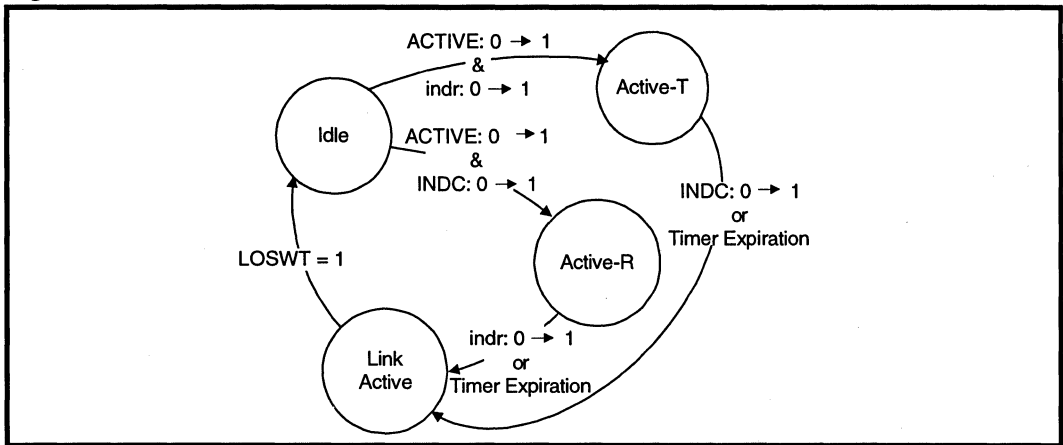

Figure 8: HTU-C HDSL Framer Activation State Machine



HTU-R Data Pump Activation

HDSL Synchronization State Machine

Figures 9 and 10 represent the HTU-R Data Pump Activation State Machine and the HTU-R HDSL Framer State Machine. The activation state machines for HTU-R and HTU-C devices are similar. Both Data Pump machines start at the Inactive State and progress clockwise through the Activating, Active-1, Active-2, Pending De-Activation, and De-Activated States. One difference between them is in the initial condition required to exit from the Inactive State. The HTU-C Data Pump responds to the Activation Request (ACTREQ) signal. The HTU-R device responds only to the presence of signal energy on the link. Thus, only an active HTU-C device can bring up the link. Once the HTU-C begins transmitting, the HTU-R device will automatically activate and attempt synchronization.

The other difference between the Data Pump state machines is the impetus for the change from the De-Activated to the Inactive State. In the HTU-C Data Pump, expiration of a one-second loss of signal timer (LOST) causes the transition. In the HTU-R the transition occurs immediately on Loss of Signal (LOS).

HTU-R Framer Activation

The HDSL framer activation state machines for HTU-C and HTU-R are also similar. The difference is in the indicator bits which cause the transition to either the Active-T or Active-R State. On the HTU-R side, the INDR bit causes the transition to the Active-R State, and the INDC bit causes the transition to the Active-T State. From either partially active state, receipt of the remaining indicator bit or timer expiry causes the transition to the full Link Active State.

Figure 11 shows the HDSL Synchronization State Machine incorporated in the HDX. It applies to both HTU-C and HTU-R devices. Table 17 lists the correspondence between the Synchronization states and Activation states. The Sync state machine is clocked by the receive signal framing. Starting at the initial Out-of-Sync condition (State 0), the device progresses in a clockwise direction through State 1 until Sync is declared in State 2. Two consecutive frame sync word matches are required to achieve synchronization.

Once the In-Sync condition is declared, six consecutive frame sync mismatches will cause the device to transition through States 3 through 7 and declare an Out-of-Sync condition in State 8. From State 8, the device will return either to State 2 or to State 0. If the 2-second timer expires without re-establishing frame sync (LOSWT = 1) or if the receive signal is lost entirely (LOS = 1), the device returns directly to State 0.

If frame sync is re-established, the device will return to the In-Sync condition (State 2) through State 9 if two consecutive frames are received without any change of frame alignment (COFA = 0). If a change of frame alignment does occur (COFA = 1), two consecutive matches are required to transition through State 10 back to State 2.

Table 17: Activation – Synchronization

Activation State	Synchronization States
Inactive	State 0
Activating	State 1
Active	States 2, 3, 4, 5, 6, and 7
Pending De-Activation	States 8, 9, and 10

Figure 9: HTU-R Data Pump Activation State Machine

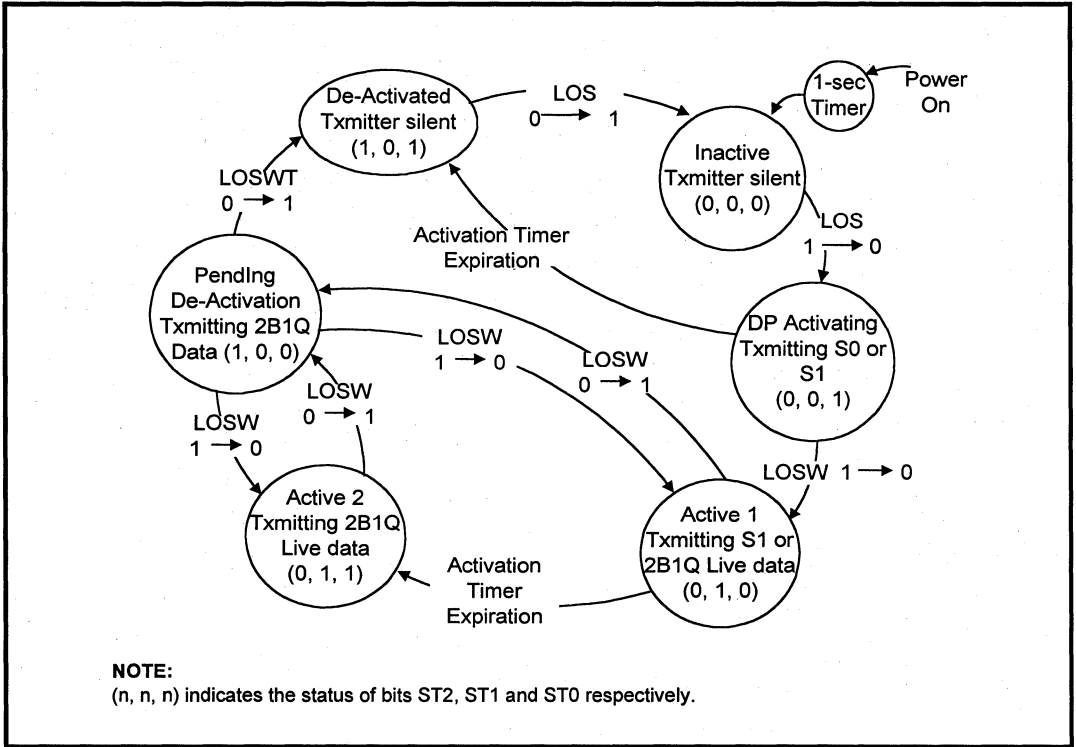

Figure 10: HTU-R HDSL Framer Activation State Machine

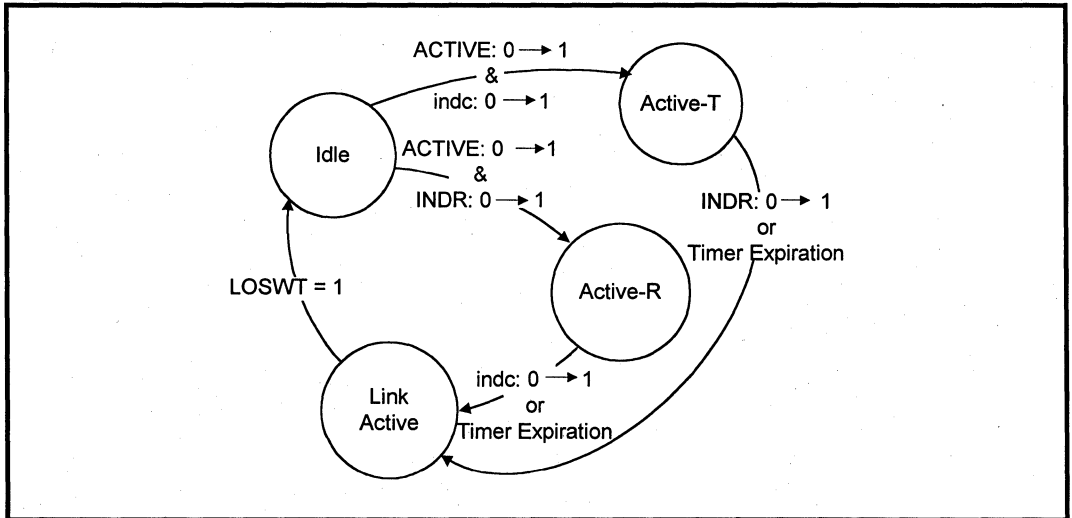
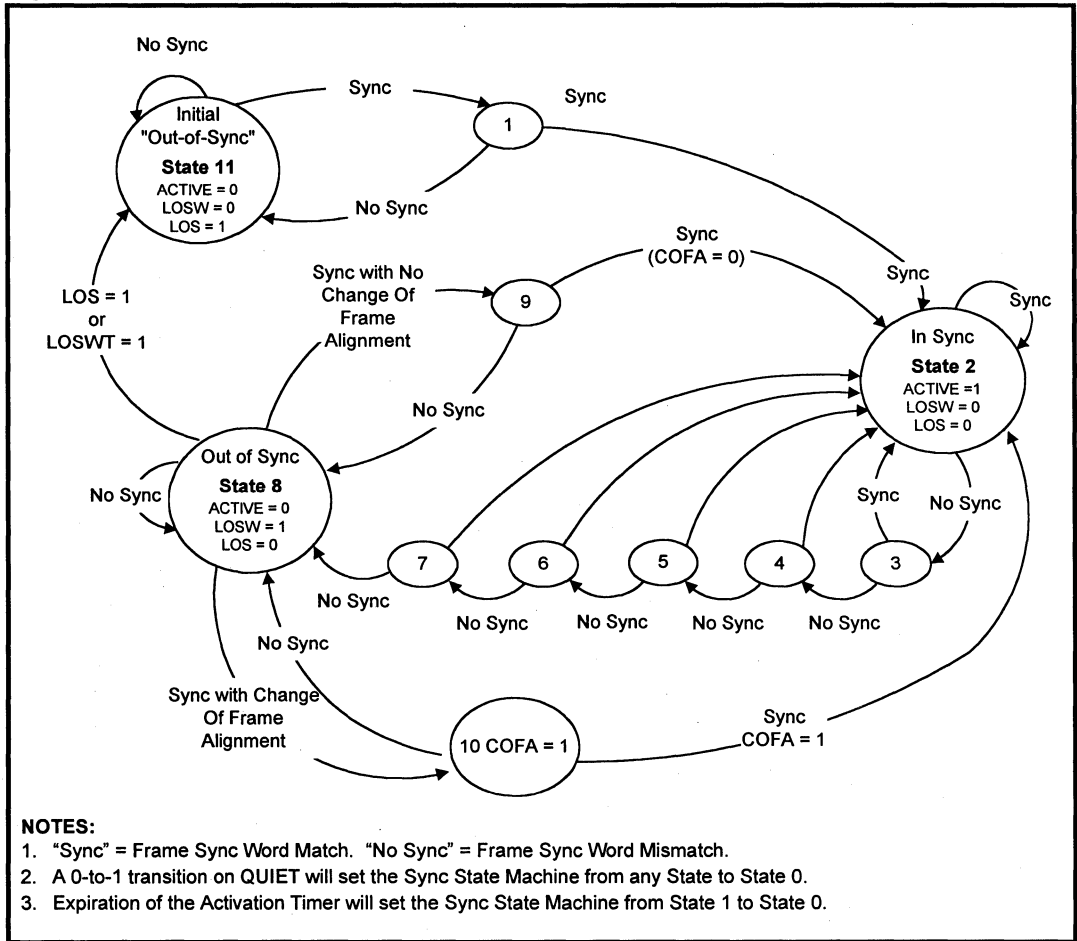

Figure 11: HDSL Synchronization State Machine



APPLICATION INFORMATION

NOTE

This application information is for design aid only.

HDSL FRAMER STATE MACHINE DESIGN

Because of data transparency characteristics of the Data Pump, two issues impact on implementing the HDSL Framer Activation State machines for both HTU-C and HTU-R devices:

1. Once the ACTIVE 0-to-1 transition occurs, the Data Pump becomes transparent. Therefore, the HDSL framer must put appropriate data in TDATA. Table 5 summarizes this requirement.
2. The link indicator bits (*indc* and *indr*) must stabilize before the device makes the transition from the Idle to the Active-T State. Thus, the HDSL framer design may detect 6 consecutive matches for the indication bit transition. This is particularly important for non-CSA loops where a lower SNR may be experienced.

PCB LAYOUT

The following are general considerations for PCB layout using the HDSL Data Pump chip set:

- Refer to Figures 12 and 13, and Table 18. Keep all shaded components close to the pins they connect to.
- Use a four-layer or more PCB layout, with embedded power and ground planes.
- Break up the power and ground planes into the following regions. Tie these regions together at the common point where power connects to the circuit:
 - Digital Region
 - Analog Region
 - VCXO subregion
 - ACC, Line I/F, and IBIAS subregion
- Use larger feedthroughs ("vias") and tracks for connecting the power and ground planes to the power and ground pins of the ICs than for signal connections. Place the decoupling capacitors right at the feed-through power/ground plane ties, or on the tracks to the IC power/ground pins as close to the pins as possible.
- On the User Interface Connector, route digital signals to avoid proximity to the TIP, RING, and CT lines.
- Provide at least 100 μF or more of bulk power supply decoupling at the point where power is connected to the Data Pump circuit.

Digital Section

- Keep all digital traces separated from the analog region of the Data Pump layout.
- Provide high frequency decoupling capacitors (0.01 μF ceramic or monolithic) around the HDX as shown in Figures 12 and 13. The capacitor on the HDX VCC1 pin (pin 1) should be on the IC side of the diode.
- It is possible to replace the NAND gate (shown in Figures 12 and 13) with an AND gate.

Analog Section

The analog section of the PCB consists of the following subsections:

1. ACC and power supply decoupling capacitors
2. Bias Current Generator
3. Voltage Controlled Crystal Oscillator
4. Line Interface Circuit

- Keep Section (3) as far from Sections (2), and (4) as possible, but close to Section (1).
- Keep Section (2) close to Section (1).
- In Section (1), use three 0.1 μF decoupling capacitors placed as close as possible to ACC pins 12, 23, and 24 and connected to the ground plane.
- Route digital signals ADO, AD1, FS, DTR, TSGN, TMAG, TCK3M, and AGCKIK on the solder side of the PCB, and route all analog signals on the component side as much as possible.
- Route the following signal pairs as adjacent traces:
 - TTIP/TRING
 - BTIP/BRING
 - RTIP/RRINGbut keep the pairs separated from each other as much as possible.
- Do not run the analog ground plane under the transformer line side to maximize high voltage isolation.

User Interface

The REFCLK and CK6M signals are sensitive to capacitive loading and rise time. Keep the rise time (from 10%-90%) for these signals less than 5 ns.

Figure 12: Typical Support Circuitry for HTU-C Applications

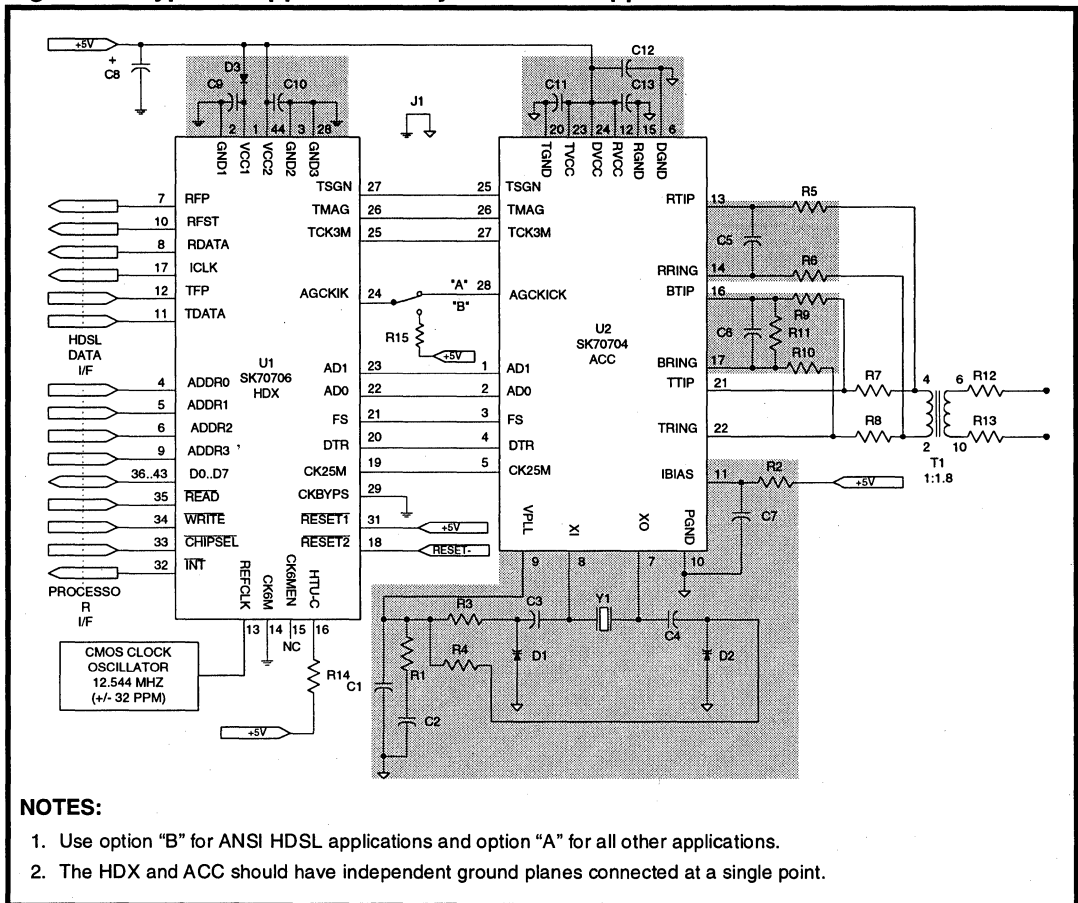

Table 18: Components for Suggested Circuitry (See Figures 12 and 13)

Ref	Description	Ref	Description	Ref	Description
C1, 9, 10	0.01 μ F, ceramic, 10%	R1	5.11 k Ω , 1%	R12, 13	5.6 Ω , line feed fuse resistor (ALFR-2-5.6-1 IRC)
C2	100 μ F, electrolytic, 20% low leakage $\leq 5 \mu$ A @ 25 $^{\circ}$ C	R2	35.7 k Ω , 1%	D1, 2	Varicap diode (Motorola MV209)
C3, 4	1000 pF, ceramic, 20%	R3, 4	20.0 k Ω , 1%	D3	Silicon rectifier diode (1N4001)
C5, 6	470 pF, COG or mica, 10%	R5, 6	301 Ω , 1%	Y1	25.088 MHz crystal (Hy-Q International 80546/1)
C7, 11-13	0.1 μ F, ceramic, 10%	R7, 8 ¹	18.2 Ω , 1%	T1	1:1.8 (Midcom 671-7376 or Pulse Engineering PE-68614)
C8	100 μ F, electrolytic, 20%	R9, 10	604 Ω , 1%		
		R11	909 Ω , 1%		
		R14, R15	10.0 k Ω , 1%		

1. R7, R8 should be 20 Ω when R12 and R13 (the 5.6 Ω fuse links) are not used.

SK70704/SK70706 784 kbps HDSL Data Pump Chip Set

Table 19: Transformer Specifications
(Figures 12 and 13, Reference T1)

Measure	Value	Tolerance
Turns Ratio (IC:Line)	1:1.8	±1%
Secondary Inductance (Line Side)	2.75 mH	±6%
Leakage Inductance	≤ 50 μH	
Interwinding Capacitance	≤ 60 pF	
THD	≥ -70 dB	
Longitudinal Balance	≥ 50 dB	5-196 kHz
Return Loss	≥ 20 dB	40-200 kHz
Isolation	2000 VRMS	
Primary DC Resistance	≤ 3.2 Ω	
Secondary DC Resistance	≤ 6.0 Ω	
Operating Temperature	-40 to +85° C	

Table 20: Crystal Specifications
(Figures 12 and 13, Reference Y1)

Measure	Value	Tolerance
Calibration Frequency	25.088 MHz @ CL = 20pF	+0-+40 ppm
Mode	Fundamental, Parallel Resonance	
Pullability (CL = 24 pF ⇔ 16 pF)	≥ +160 ppm	
Operating Temperature	-40-+85° C	
Temperature Drift	≤ ±30 ppm	
Aging Drift	≤ 5 ppm/year	
Series Resistance	≤ 15 Ω	
Drive Level	0.5 mW	
Holder	HC-49	

Figure 13: Typical Support Circuitry for HTU-R Applications

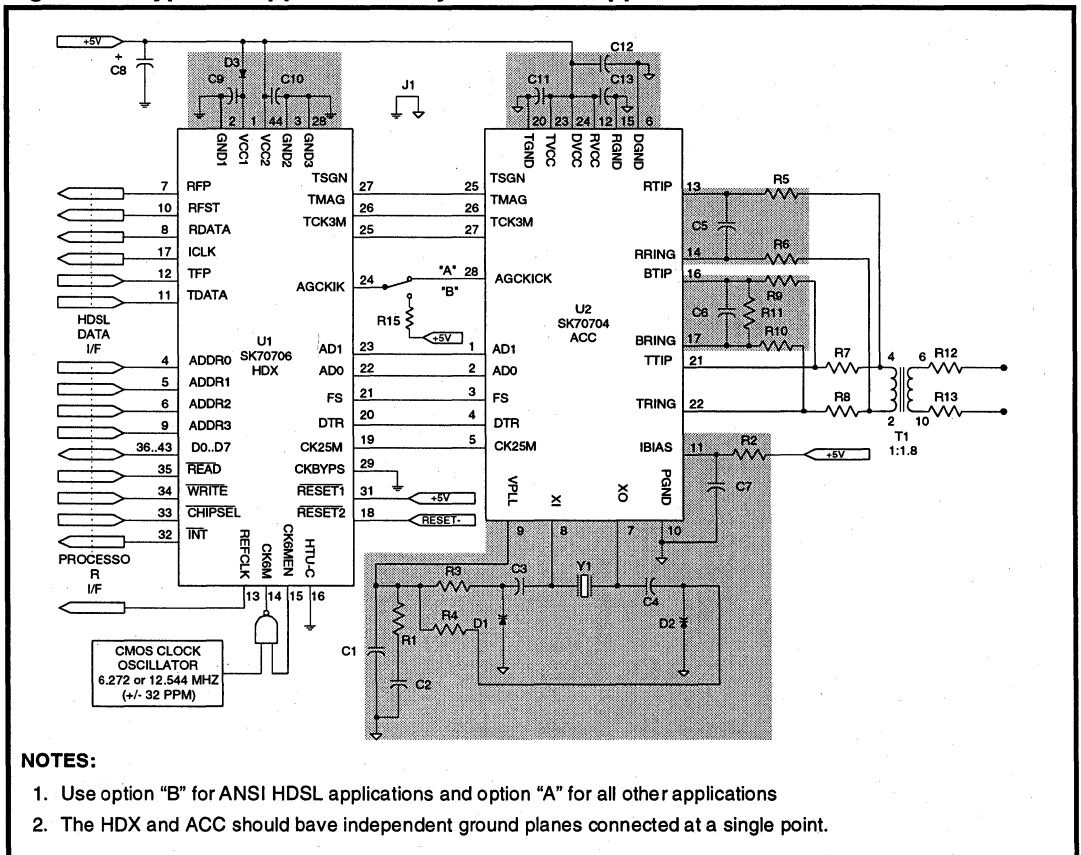

TEST SPECIFICATIONS

NOTE

The minimum and maximum values in Tables 21 through 31 and Figures 14 through 20 represent the performance specifications of the Data Pump and are guaranteed by test, except where noted by design.

Table 21: ACC Absolute Maximum Ratings

Parameter	Symbol	Min	Max	Units
Supply Voltage ¹ Reference to ground ²	TVCC, RVCC, DVCC	-0.3	+6.0	V
Input Voltage ^{2, 3} , any input pin	TVCC, RVCC, DVCC	-0.3V	VCC + 0.3	V
Continuous Output Current, any output pin	–	–	±25	mA
Storage Temperature	T _{STOR}	-65	+150	°C

CAUTION

Operations at the limits shown may result in permanent damage to the Analog Core Chip. Normal operation at these limits is neither implied nor guaranteed

1. No supply input may have a maximum potential of more than ±0.3 V from any other supply input.
 2. TGND = 0V; RGND = 0V; DGND = 0V.
 3. TVCC = RVCC = DVCC = VCC.

Table 22: ACC Recommended Operating Conditions

Parameter	Symbol	Min	Typ	Max	Units
DC Supply	TVCC, DVCC, RVCC	4.75	5.0	5.25	V
Ambient Operating Temperature	TA	-40	+25	+85	°C

Table 23: ACC DC Electrical Characteristics (Over Recommended Range)

Parameter	Sym	Min	Typ ¹	Max	Unit	Test Conditions
Supply current (full operation)	ICC	–	92	120	mA	83 Ω resistor across TTIP and TRING
DVCC Current		–	3	6	mA	
RVCC Current		–	26	33	mA	
TVCC Current		–	63	79	mA	Normal Mode 8+3, 8-3, 8+3, ...
		–	38	48	mA	Off Mode
Input Low Voltage	V _{IL}	–		0.5	V	I _{IL} < 40 μA
Input High Voltage	V _{IH}	4.5		–	V	I _{IL} < 40 μA
Output Low Voltage	V _{OL}	–	–	0.2	V	I _{OL} < 40 μA
Output High Voltage	V _{OH}	4.5	–	–	V	I _{OH} < 40 μA
Input Leakage Current	I _{IL}	–	±40	–	μA	0 < V _{IN} < V _{CC}
Input capacitance (individual pins)	C _{IN}	–	12	–	pF	
Load Capacitance (REFCLK output)	CLREF	–	–	20	pF	

1. Typical values are at 25° C and are for design aid only; not guaranteed and not subject to production testing.

7

Table 24: ACC Transmitter Electrical Parameters (Over Recommended Range)

Parameters	Sym	Min	Typ	Max	Unit	Test Conditions
Isolated Pulse height at TTIP, TRING		+2.455	+2.640	+2.825	Vp	TDATA High, TFP Low (+3)
		-2.825	-2.640	-2.455	Vp	TDATA Low, TFP Low (-3)
		+0.941	+0.880	+0.818	Vp	TDATA High, TFP Low (+1)
		-0.818	-0.880	-0.941	Vp	TDATA Low, TFP High (-1)
Setup Time (TSGN, TMAG)	ttSMSU	5	-	-	ns	
Hold Time (TSGN, TMAG)	ttSMH	12	-	-	ns	

1. Pulse amplitude measured across a 135 Ω resistor on the line side of the transformer using the application circuit shown in Figure 12 and Table 18.

Figure 14: ACC Normalized Pulse Amplitude Transmit Template

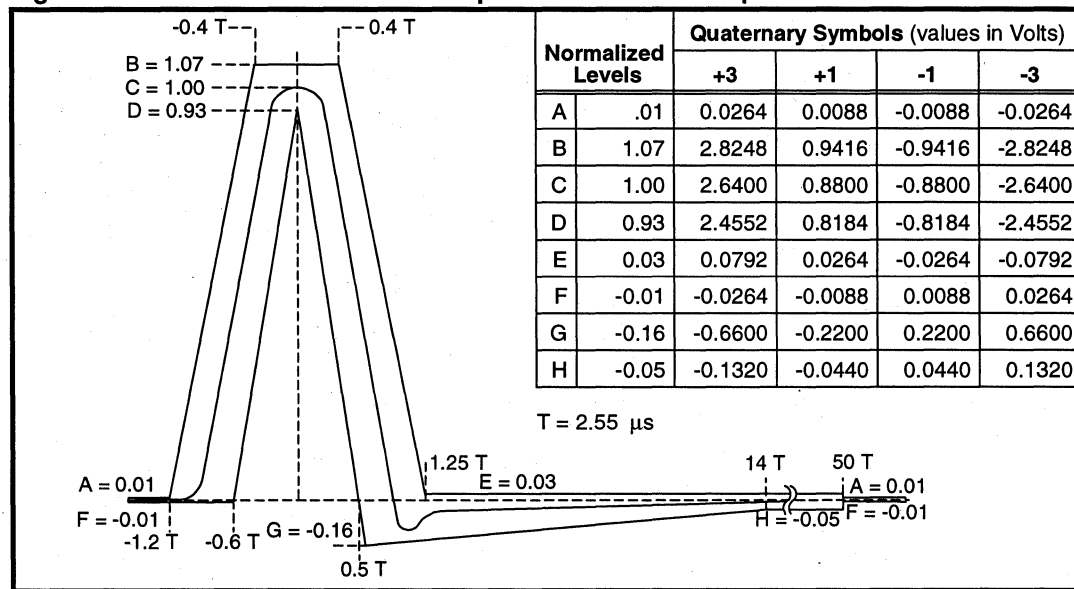

Figure 15: ACC Transmitter Timing

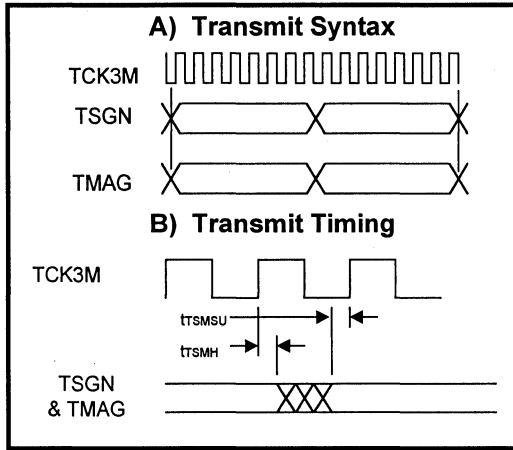

Figure 16: ACC Transmit Power Spectral Density

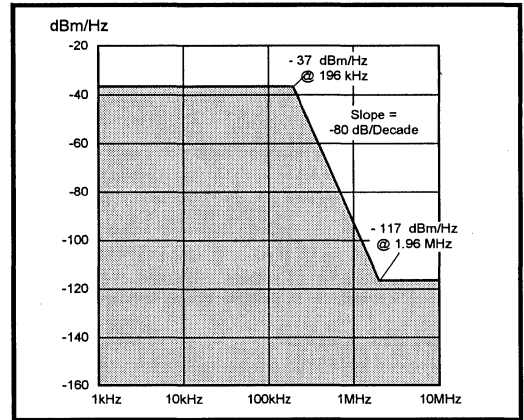

Table 25: ACC Receiver Electrical Parameters (Over Recommended Range)

Parameter	Sym	Min	Typ	Max	Unit	Test Conditions
Propagation Delay (AD0, AD1)	tADD	-	-	25	ns	
Total Harmonic Distortion		-	-80	-	dB	V(RTIP, RRING) = 3 Vpp @ 50 kHz
RTIP, RRING, to BTIP, BRING Gain Ratio		-	1.0	1%	V/V	

7

Figure 17: ACC Receiver Syntax and Timing

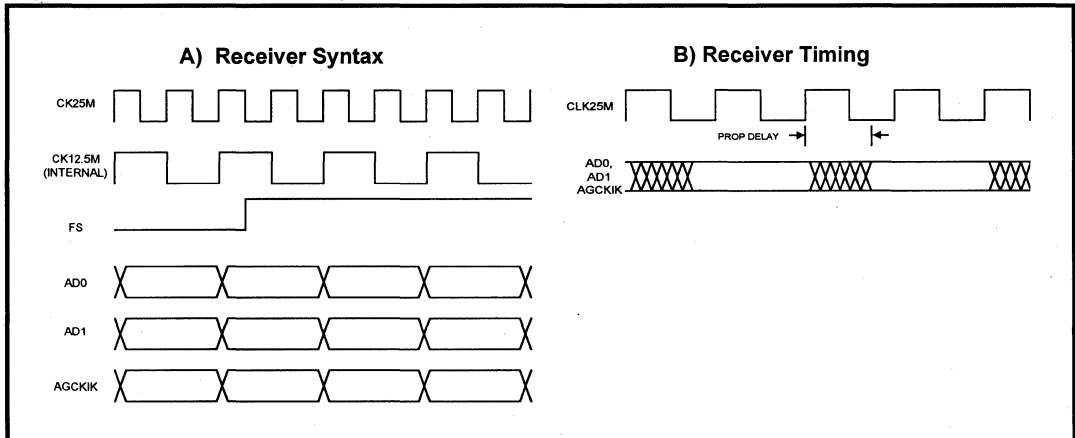

Table 26: HDX Absolute Maximum Ratings

Parameter	Symbol	Min	Max	Units
Supply Voltage ¹ Reference to ground ²	VCC2, VCC1	-0.3	+6.0	V
Input Voltage ² , any input pin	-	- 0.3	VCC2 + 0.3	V
Continuous Output Current, any output pin	-	-	±25	mA
Storage Temperature	TSTOR	-65	+150	° C

CAUTION

Operations at the limits shown may result in permanent damage to the HDXL Digital Transceiver (HDX).
Normal operation at these limits is neither implied nor guaranteed

1. The maximum potential between VCC2 and VCC1 must never exceed ±1.2 V.
2. GND3 = 0V; GND2 = 0V; GND1 = 0V.

Table 27: HDX Recommended Operating Conditions

Parameter	Symbol	Min	Typ	Max	Units
DC Supply	VCC1 ¹	3.95	4.25	4.55	V
	VCC2	4.75	5.0	5.25	V
	VCC2-VCC1	0.6	-	0.9	V
Ambient Operating Temperature	SK70706PE	TA	-40	+85	° C
	SK70706PH	TA	-5	+85	° C

1. To derive this supply, connect a 1N4001 (or equivalent) diode between VCC2 and VCC1 as shown in Figures 12 and 13.

Table 28: HDX DC Electrical Characteristics (Over Recommended Range)

Parameter	Sym	Min	Typ ¹	Max	Unit	Test Conditions
Supply current (full operation)		-	100	135	mA	
Input Low Voltage	VIL	-	-	0.5	V	IIL < 40 µA
Input High Voltage	VIH	4.0	-	-	V	IIH < 40 µA
Output Low Voltage	VOL	-	-	GND +0.3	V	IOL < 40 µA
Output High Voltage	VOH	VCC2-0.5	-	-	V	IOH < 40 µA
Input Leakage Current	IIL	-	±40	-	µA	
Tristate Leakage Current	IIL	-	±10	-	µA	
Input capacitance (individual pins)	CIN	-	12	-	pF	
Load Capacitance (REFCLK output)	CLREF	-	-	15	pF	

1. Typical values are at 25° C and are for design aid only; not guaranteed and not subject to production testing.

Table 29: HDX/HDSL Data Interface Timing Specifications (See Figure 18)

Parameter	Symbol	Min	Typ ¹	Max	Unit
ICLK Frequency	f _{ICLK}	–	784	–	kHz
REFCLK Frequency	f _{REFCLK}	–	12.544	–	MHz
REFCLK Frequency tolerance (HTU-C Mode)	tol _{RCLK}	-32	0	+32	ppm
CK6M Frequency tolerance (HTU-R Mode) ²	tol _{CK6M}	-32	0	+32	ppm
ICLK Pulse width high	t _{IPW}	–	638	–	ns
Transition Time on any Digital Output ³	t _{TO}	–	5	10	ns
Transition Time on any Digital Input	t _{TI}	–	–	25	ns
TDATA, TFP Setup Time to ICLK Rising Edge	t _{TSU}	100	–	–	ns
TDATA, TFP Hold Time from ICLK Rising Edge	t _{TH}	100	–	–	ns
RDATA, RFP, RFST delay from ICLK Falling Edge	t _{TD}	0	–	150	ns
TFP Pulse Width ⁴	t _{TFPW}	1248	1276	1304	ns
TFP Falling Edge to ICLK Rising Edge ⁴	t _{TFIR}	480	–	610	ns
TFP Setup Time to REFCLK Rising Edge ⁴	t _{TSUR}	25	–	–	ns

1. Typical values are at 25° C and are for design aid only; not guaranteed and not subject to production testing.

2. CK6M must meet this tolerance about an absolute frequency of 6.272000 MHz or 12.544000 MHz in HTU-R mode

3. Measured with 15 pF load.

4. These parameters apply only to an HTU-C mode Data Pump programmed for repeater applications as shown in Figure 18.

Figure 18: HDX/HDSL Data Interface Timing

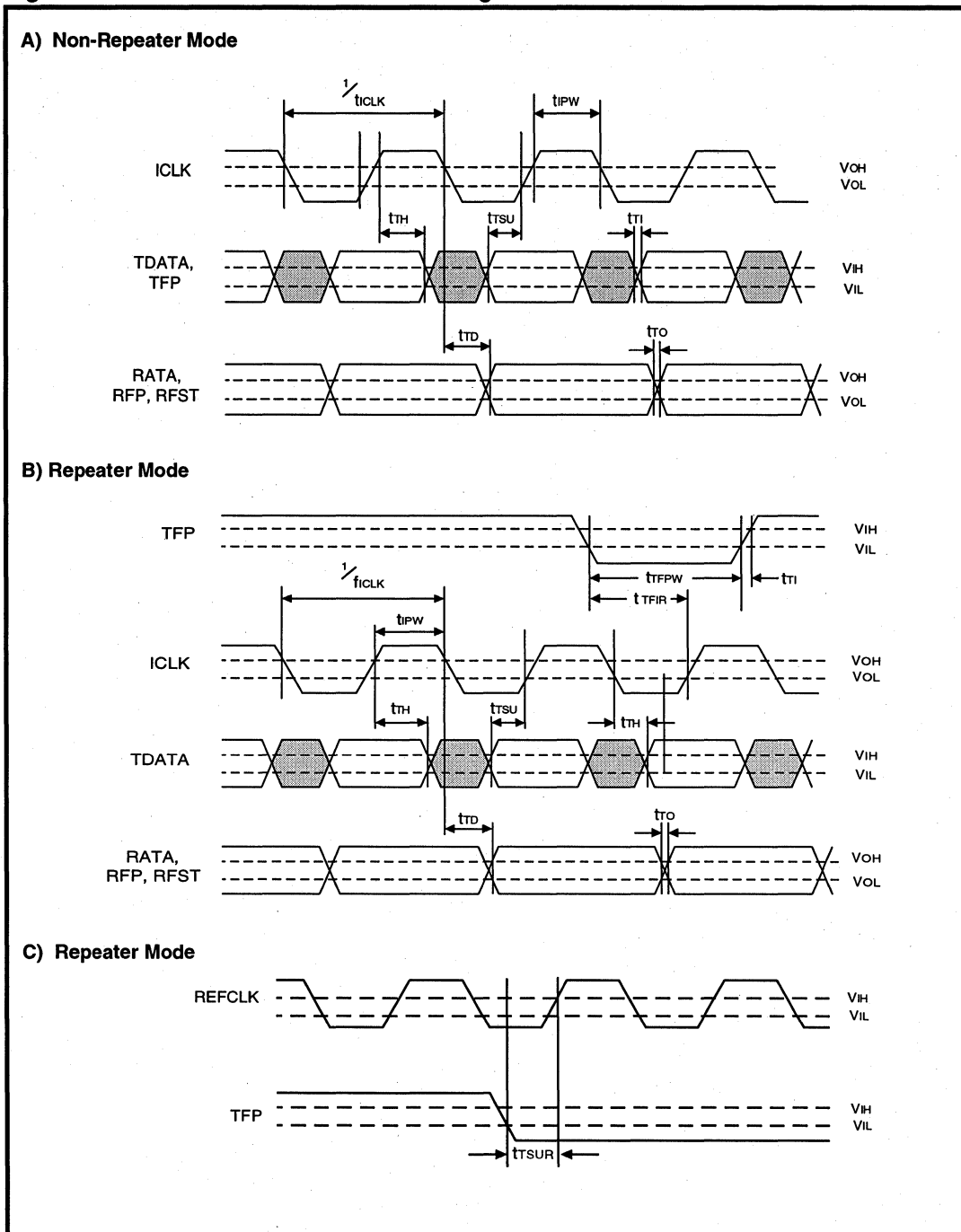

Table 30: HDX/Microprocessor Interface Timing Specifications (See Figures 19 and 20)

Parameter	Symbol	Min	Typ	Max	Unit
RESET2 pulse width Low	tRPWL	0.1	–	1,000	μs
RESET2 to INT clear (10 kΩ resistor from INT to VCC2)	tINTH	–	–	300	ns
RESET2 to data tristate on D0-7	tDTHZ	–	–	100	ns
CHIPSEL pulse width Low	tCSPWL	200	–	–	ns
CHIPSEL Low to data active on D0-7	tCDLZ	–	–	80	ns
CHIPSEL High to data tristate on D0-7	tCDHZ	–	–	80	ns
READ pulse width Low	tRSPWL	100	–	–	ns
READ Low to data active	tRDLZ	–	–	80	ns
READ High to data tristate	tRDHZ	–	–	80	ns
Address to Valid Data	tPRD	–	–	80	ns
Address setup to WRITE Rising Edge	tASUW	20	–	–	ns
Address hold from WRITE Rising Edge	tAHW	10	–	–	ns
WRITE pulse width Low	tWPWL	100	–	–	ns
Data setup to WRITE Rising Edge	tDSUW	20	–	–	ns
Data hold from WRITE Rising Edge	tDHW	10	–	–	ns
READ High to INT clear when reading register RD0	tINTR	–	–	400	ns

1. Timing for all outputs assumes a maximum load of 30 pF.
 2. "Address" refers to input signals CHIPSEL, A0, A1, A2, and A3. "Data" refers to I/O signals D0, D1, D2, D3, D4, D5, D6, and D7.

7

Table 31: General System and Hardware Mode Timing

Parameter	Min	Typ ¹	Max	Unit	
Throughput delay	TDATA to TTIP/TRING	–	10.2	12.5	μs
	RTINP/RRING to RDATA	–	53.6	72	μs
Hardware Mode	"ACTREQ" input transitional pulse width (High or Low)	5	–	–	μs
	"QUIET" transitional pulse width (High-to-Low)	5	–	–	μs

1. Typical values are at 25 °C and are for design aid only; not guaranteed and not subject to production testing.

Figure 19: RESET and INTERRUPT Timing (μ P Control Mode)

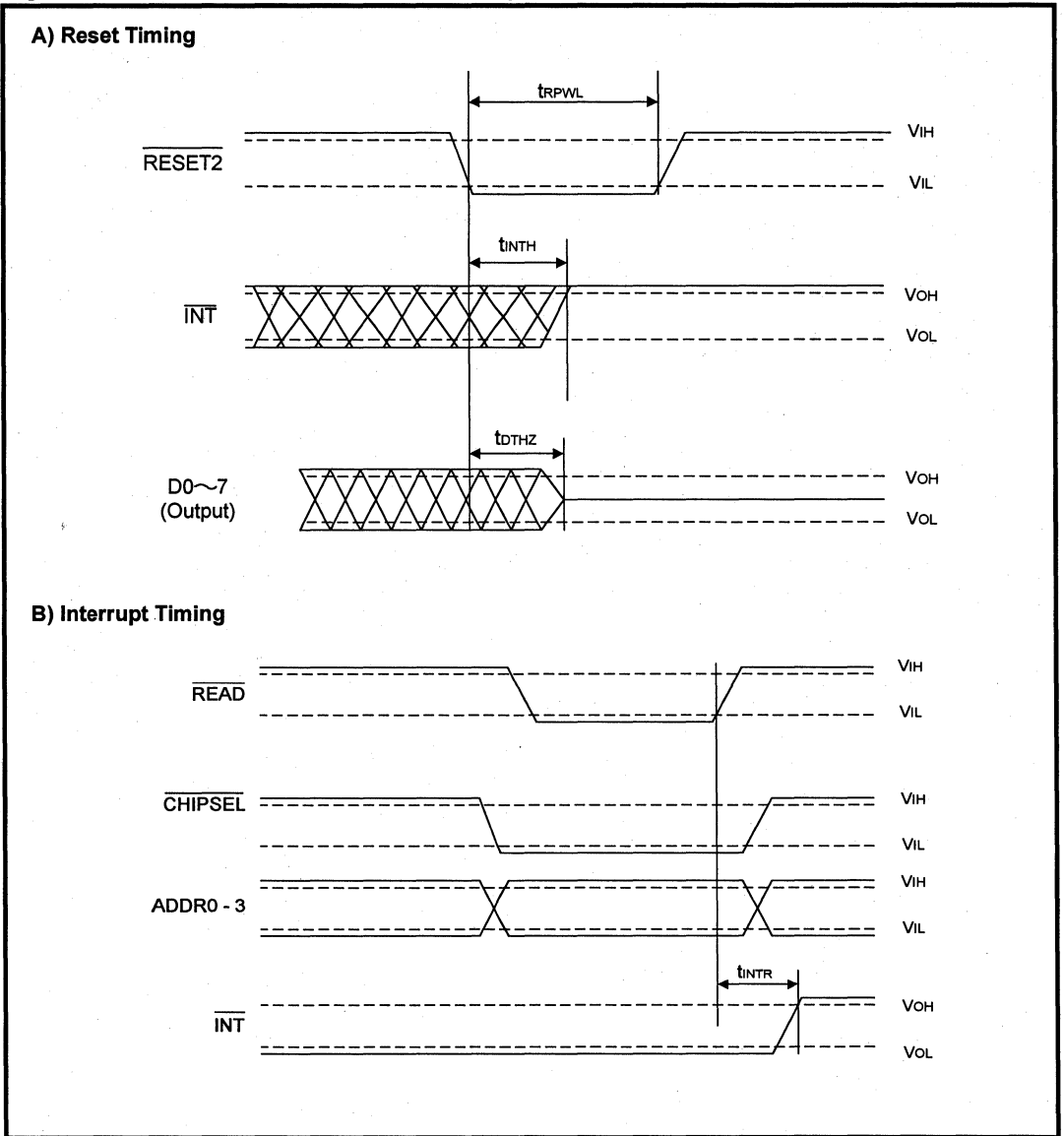
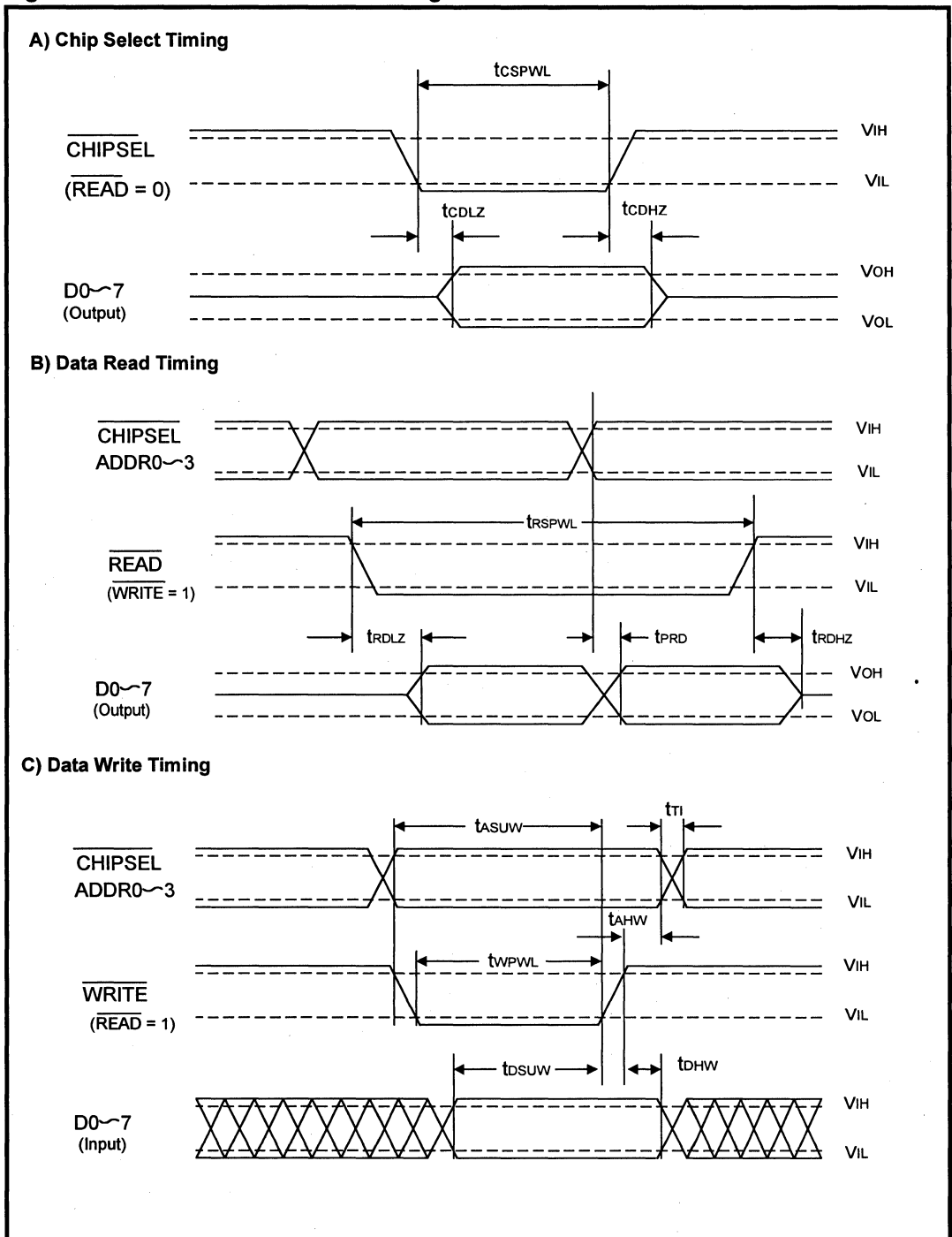

Figure 20: Parallel Data Channel Timing



NOTES:

SK70704/SK70707

1168 kbps HDSL Data Pump Chip Set

General Description

The HDSL Data Pump is a chip set consisting of the following two devices:

- SK70704 Analog Core Chip (ACC)
- SK70707 HDSL Digital Transceiver (HDX)

The HDSL Data Pump is a 2-wire transceiver which provides echo-cancelling and 2B1Q line coding. It incorporates transmit pulse shaping, filtering, line drivers, receive equalization, timing and data recovery to provide 1168 kbps, clear-channel, "data pipe" transmission. The Data Pump provides Near-End Cross-Talk (NEXT) performance in excess of that required over all ETSI test loops. Typical transmission range on 0.4 mm cable exceeds 3.6 km in a noise-free environment or 2.8 km with a 0 dB margin over $10 \mu\text{V}/\sqrt{\text{Hz}}$ ETSI noise.

The Data Pump meets the requirements of ETSI ETR-152. It provides one end of a single-channel HDSL transmission system from the twisted pair interface back to the Data Pump/HDSL data interface. The Data Pump can be used at either the NTU or the LTU end of the interface.

Applications

- E1 (2-pair) and fractional E1 transport
- N-channel digital pair-gain
- Wireless base station to switch interface
- Campus and private networking
- High-Speed digital modems

Features

- Fully integrated, 2-chip set for interfacing to 2-wire HDSL lines at 1168 kbps
- Single +5 V supply
- Integrated line drivers, filters and hybrid circuits result in greatly reduced external logic and simplified support circuitry requirements
- Simple line interface circuitry, via transformer coupling, to twisted pair line
- Internal ACC voltage reference
- Integrated VCXO circuitry
- Converts serial binary data to scrambled 2B1Q encoded data
- Self-contained activation/start-up state machine for simplified single loop designs
- Programmable for either line termination (LTU) or network termination (NTU) applications
- Compliant with ETSI ETR-152 (1995)
- Design allows for operation in either Software Control or stand alone Hardware Control mode
- Typical power consumption less than 1.2 W allowing remote power feeding for repeater and NTU equipment
- Input or Output Reference Clock of 18.688 MHz
- Digital representation of receive signal level and noise margin values available for SNR controlled activation

HDSL Data Pump Block Diagram

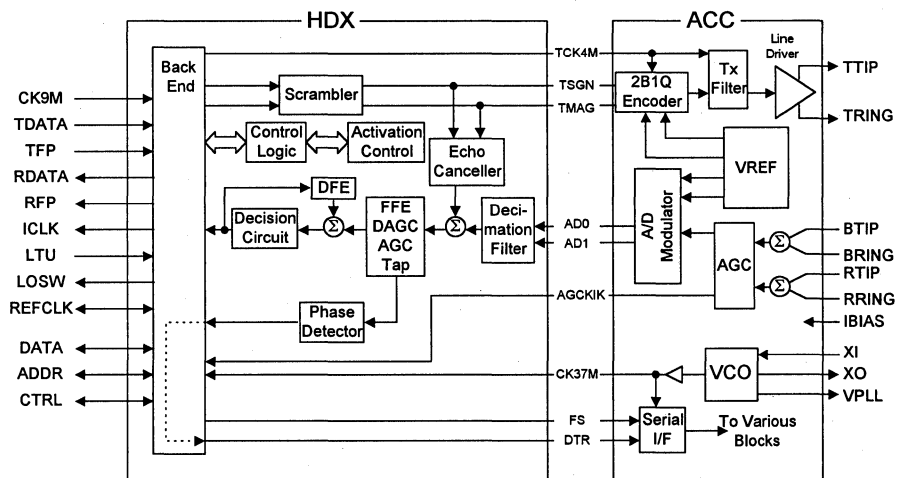

Order Information

Part Number	Package	Temperature Range
SK70704PE	28-pin PLCC	-40 °C to +85 °C
SK70707PE	68-pin PLCC	-40 °C to +85 °C
SK70707PH	68-pin PLCC	-5 °C to +85 °C

DATA PUMP PIN ASSIGNMENT AND SIGNAL DESCRIPTION

The ACC is packaged in a 28-pin PLCC. Figure 1 shows the ACC pin locations. Table 1 lists signal descriptions for each pin, except pins 18 and 19 which are not connected.

Figure 1: SK70704 ACC Pin Locations

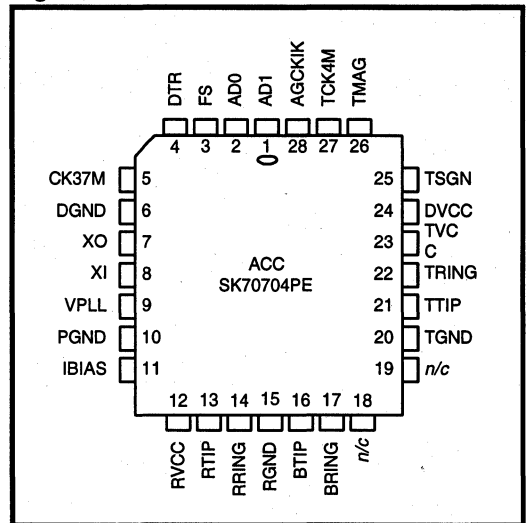

Table 1: SK70704 ACC Pin Assignments/Signal Descriptions

Group	Pin #	Symbol	I/O	Description
Line	13	RTIP	I	Receive Tip and Ring. Connected these input pins to the line transformer per network requirements.
	14	RRING	I	
	16	BTIP	I	Bias Tip and Ring. Inputs provide a bias setting for the receiver. Provide balanced network inputs.
	17	BRING	I	
	21	TTIP	O	Transmit Tip and Ring. Line driver outputs.
	22	TRING	O	
PLL	7	XO	O	Crystal Oscillator. Connect a 37.376 MHz crystal across these two pins.
	8	XI	I	
	9	VPLL	O	PLL Voltage Control. Supplies control voltage to the VCXO.
Power	10	PGND	I	PLL Ground. 0 V.
	12	RVCC	I	Power supply. + 5 V (± 5%).
	23	TVCC	I	Power supply. + 5V (± 5%).
	24	DVCC	I	Digital Power Supply. +5 V (± 5%).
	6	DGND	I	DVCC Ground. 0V.
	15	RGND	I	RVCC Ground. 0V.
	20	TGND	I	TVCC Ground. 0V.

Table 1: SK70704 ACC Pin Assignments/Signal Descriptions – continued

Group	Pin #	Symbol	I/O	Description
Clock and Control	3	FS	I	584 kHz clock. Input from HDX FS.
	4	DTR	I	Serial control data. Input from the HDX at 18.688 Mbps.
	5	CK37M	O	37.376 MHz HDSL Reference Clock. Used as the receive timing reference for the HDX. Tie to HDX CK37M.
	27	TCK4M	O	4.672 MHz Clock. Input from HDX TCK4M.
Data Input and Output	28	AGCKIK	O	AGC adjust signal. Output to HDX AGCKIK.
	1	AD1	O	A-to-D converter data line 1. Connect to HDX AD1.
	2	AD0	O	A-to-D converter data line 0. Connect to HDX AD0.
	25	TSGN	I	Transmit quat sign. Input from HDX.
	26	TMAG	I	Transmit quat magnitude. Input from HDX.
Analog Input	11	IBIAS	I	Input BIAS. Provides input bias current.

Figure 2: SK70707 HDX Pin Assignments

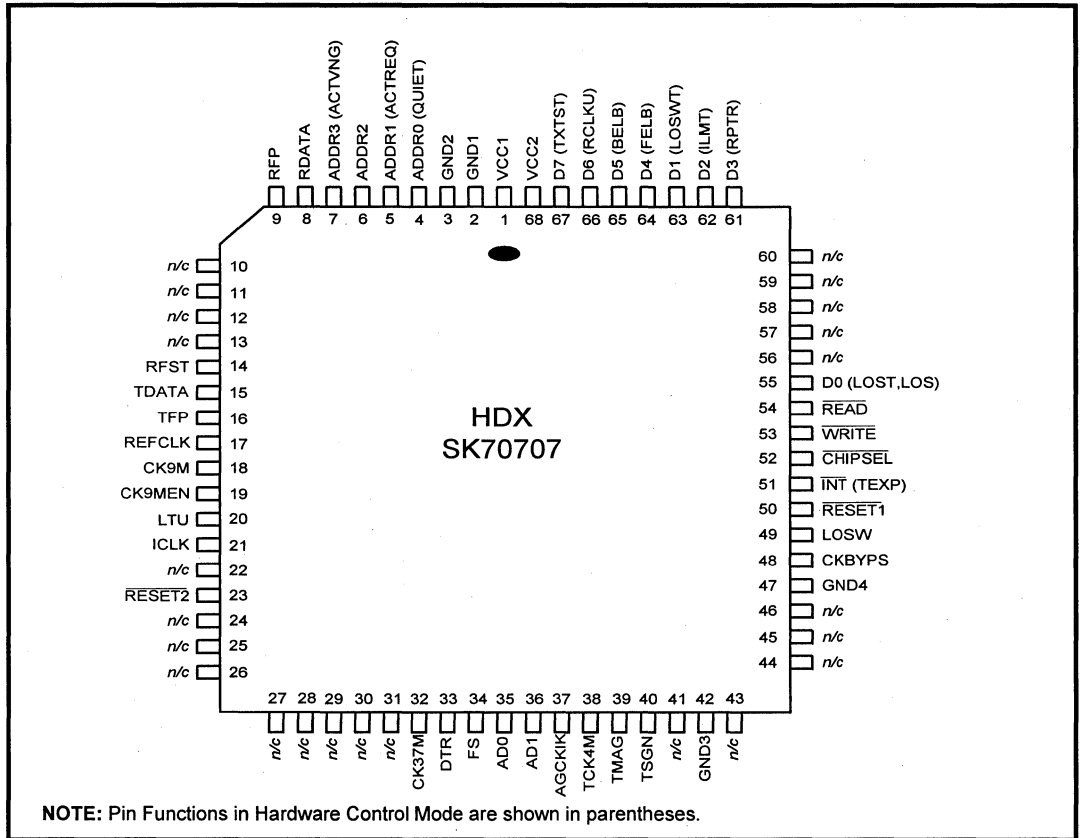

SK70704/SK70707 1168 kbps HDSL Data Pump Chip Set

Table 2: SK70707 HDX Pin Assignments/Signal Descriptions

Group	Pin #	Symbol	I/O	Description
User Port	14	RFST	O	Receive Frame and Stuff Bit Indicator. Goes High for 18 consecutive ICLK periods to indicate four stuffing bits (b7007 - 7010) and 14 frame bits (b1-14) on RDATA.
	17	REFCLK	I ¹ O	18.688 MHz HDSL Reference Clock. In LTU Mode, this clock generates transmit and receive timing and must have ±32 ppm accuracy. In NTU Mode, this output is derived by dividing CK37M by two.
	20	LTU	I	Operation Mode Select. When LTU is High, the Data Pump operates in LTU mode; when LTU is Low, the Data Pump operates in NTU mode. Tied to internal pull-up device.
	21	ICLK	O	Bit Rate Clock. Nominally 1168 kHz, REFCLK is the source of ICLK in LTU Mode. CK37M is the source of ICLK in NTU Mode.
	49	LOSW	O	Loss of Sync Word Indicator. Normally Low in Active States, goes High to indicate receipt of six consecutive mismatched frame synch words. LOSW is logic High in all states except Active States.
	8	RDATA	O	Receive HDSL Data Stream. Output data to HDSL framer at 1168 kbps: HDSL payload of Loop 1 or Loop 2 bytes plus the Z-bits, eoc, crc, losd, febe, ps, bpv, hrp, indc/indr and uib bits, Sync bits for frame positions b1-14, Stuff bits for frame positions b7007 - 7010. RDATA bits are forced high in all states except the Active State.
	9	RFP	O	Receive Frame Pulse. Low for one ICLK cycle during the last bit of the current HDSL receive frame on RDATA, either b7006 or b7010. Period is within one baud time of 6 ms. ² RFP is valid when LOSW transitions Low.
	15	TDATA	I ¹	Transmit HDSL Data Stream. Input data from HDSL framer at 1168 kbps: HDSL payload of Loop 1 or Loop 2 bytes plus the Z-bits, eoc, crc, losd, febe, ps, bpv, hrp, indc/indr and uib bits, Sync bits for frame positions b1-14, Stuff dummy bits; may be 1s or 0s. Tied to internal pull-up device. When ACTIVE, the Data Pump is transparent and the HDSL framer must generate the appropriate bits on TDATA as shown in Table 5.
16	TFP	I ¹	Transmit Frame Pulse. Should be Low for one ICLK cycle the during last bit of the current HDSL frame on TDATA, either b7006 or b7010. Period is within one baud time of 6 ms. ² If TFP is pulled Low and is Low again three ICLK cycles later, all digital outputs of the User Port go to tri-state. Tied to internal pull-up device.	

1. This input is a Schmidt Triggered circuit and includes an internal pull-up device.
2. The period is 6 ms ±1/584 ms.
3. This input is a Schmidt Triggered circuit and includes an internal pull-down device.

Table 2: SK70707 HDX Pin Assignments/Signal Descriptions – continued

Group	Pin #	Symbol	I/O	Description	
Hardware Interface <i>(Hardware Control Mode)</i>	4	QUIET	I ³	Quiet Mode Enable. Pull High to force HDX into Deactivated State. Any later transition to Low will not return HDX to Active State. See ACTREQ.	
	5	ACTREQ	I ³	Activation Request (LTU mode) or no function (NTU mode). Tie this pin Low in NTU mode. If QUIET is Low, a rising edge on this pin initiates activation, but the signal is ignored after activation. See QUIET.	
	6	<i>reserved</i>	–	<i>Pull Low in LTU mode, ignore in NTU mode.</i>	
	7	ACTVNG	O	Activating State Indication. High when the HDX is in the Activating State.	
	23	$\overline{\text{RESET2}}$	I ¹	Reset Pulse. Pull Low on power up to initialize circuits and stop all clocks.	
	50	$\overline{\text{RESET1}}$	I ¹	Reset Pulse. Pull Low to initialize internal circuits.	
	51	TEXP	O	Timer Expiry. Goes High to indicate 30 second timer expiration in all states.	
	52	$\overline{\text{CHIPSEL}}$	I ³	Chip Select <i>Assert these three pins Low to activate Hardware Control Mode. When any of them goes High, the HDX reverts immediately to Software Control Mode.</i>	
	53	$\overline{\text{WRITE}}$	I ³		Write Pulse
	54	$\overline{\text{READ}}$	I ³		Read Pulse
	55	LOST (LTU)	O	Loss of Signal Timer Expiration. In LTU mode, LOST goes High when the Data Pump enters the Inactive State. The transition from the Deactivated to the Inactive State occurs 1 second after the end of transmission by the NTU when deactivation began from either the Active-1 or Active-2 State. When the Data Pump transitions from the Activating State to the Deactivated State it may immediately enter the Inactive State without waiting for NTU transmission to cease. (See Figure 7.)	
		LOS (NTU)	O	Loss of Signal Energy Indicator. In NTU mode LOS goes High to indicate loss of signal energy on entering the Inactive State. (See Figure 9.)	
	63	LOSWT	O	Loss of Sync Word Timer. LOSWT goes High when LOSW is sustained for longer than 2 sec.	
	62	ILMT	I ¹	Insertion Loss Measurement Test. Set High to transmit a framed & scrambled, “all 1s”, 2B1Q pulse sequence. Pulse sequence will have a valid sync word. In the NTU configuration, when the ILMT mode is selected, the Data Pump may begin activation.	
	61	RPTR	I ¹	Repeater Mode Enable. When in LTU mode, ICLK output phase is aligned to the TFP input pulse width. Ignored in NTU mode.	
64	FELB	I ¹	Front-End Loopback (LTU only). In Inactive State, set High to cause the ACC to loopback. The returned signal activates the HDX which receives its own transmitted data. The system ignores incoming data from NTU during loopback irrespective of status.		
65	BELB	I ¹	Back-End Loopback. In Active State a High forces an internal, transparent loopback with RDATA connected to TDATA and RFP connected to TFP.		

7

1. This input is a Schmidt Triggered circuit and includes an internal pull-up device.
 2. The period is 6 ms ±¹/₅₈₄ ms.
 3. This input is a Schmidt Triggered circuit and includes an internal pull-down device.

SK70704/SK70707 1168 kbps HDSL Data Pump Chip Set

Table 2: SK70707 HDX Pin Assignments/Signal Descriptions – continued

Group	Pin #	Symbol	I/O	Description
Hardware Interface <i>(Hardware Control Mode -cont'd)</i>	66	RCLKU	O	Receive Baud Rate (584 kHz) Clock. Aligned with ICLK in NTU mode, phase synchronous with receive pulse stream. However, during Activating State, the clocks may not be aligned. In the LTU mode RCLKU has a constant, arbitrary, phase relationship with ICLK in Active State.
	67	TXTST	I ¹	Transmit Test. Set high to enable isolated transmit pulse generation. The time between pulses is approximately 6 ms. TDATA controls the sign and TFP controls the magnitude of the transmitted quat pulses according to the 2B1Q encoding rules. In the NTU configuration, when the TXTST mode is selected, the Data Pump may begin activation.
Processor Interface <i>(Software Control Mode)</i>	55	D0	I ¹ /O	Data bit 0. Eight-bit, parallel data bus.
	63	D1	I ¹ /O	Data bit 1
	62	D2	I ¹ /O	Data bit 2
	61	D3	I ¹ /O	Data bit 3
	64	D4	I ¹ /O	Data bit 4
	65	D5	I ¹ /O	Data bit 5
	66	D6	I ¹ /O	Data bit 6
	67	D7	I ¹ /O	Data bit 7
	4	ADDR0	I ³	Address bit 0. Four-bit address, selects read or write register.
	5	ADDR1	I ³	Address bit 1
	6	ADDR2	I ³	Address bit 2
	7	ADDR3	I ³	Address bit 3
	23	$\overline{\text{RESET2}}$	I ³	Reset Pulse. Pull Low on power up to initialize circuits and stop all clocks.
	50	$\overline{\text{RESET1}}$	I ¹	Reset Pulse. Pull Low to initialize internal circuits. ICLK continues.
	51	$\overline{\text{INT}}$	O	Interrupt Output. Open drain output. Requires an external 10 k Ω pull up resistor. Goes Low on interrupt.
52	$\overline{\text{CHIPSEL}}$	I ³	Chip Select. Pull Low to read or write to registers.	
53	$\overline{\text{WRITE}}$	I ³	Write Pulse. Pull Low to write to registers.	
54	$\overline{\text{READ}}$	I ³	Read Pulse. Pull Low to read from registers.	
<p>1. This input is a Schmidt Triggered circuit and includes an internal pull-up device. 2. The period is 6 ms $\pm 1/584$ ms. 3. This input is a Schmidt Triggered circuit and includes an internal pull-down device.</p>				

Table 2: SK70707 HDX Pin Assignments/Signal Descriptions – continued

Group	Pin #	Symbol	I/O	Description
Clock and Control	18	CK9M	I ³	9.344 or 18.688 MHz Reference Clock. Mandatory in NTU mode. Tie High or Low in LTU Mode. Clock input requires ± 32 ppm accuracy.
	19	CK9MEN	O	CK9M Enable. Active High enable for CK9M clock. In NTU mode, this pin goes Low to indicate the PLL is tracking the input signal from the LTU. Not used in LTU.
	32	CK37M	I	Receive Timing Clock (37.376 MHz). Tie to CK37M on ACC.
	33	DTR	O	Serial Control Data Link. Transfers data at 18.688 Mbps. Tie to DTR on ACC.
	34	FS	O	584 kHz Clock. Derived from CK37M. Tie to FS on ACC.
	35	AD0	I	Analog to Digital Converter input pin. Tie to AD0 on ACC
	36	AD1	I	Analog to Digital Converter input pin. Tie to AD1 on ACC
	37	AGCKIK	I	AGC Adjust. Controls analog gain circuit. Tie to AGCKIK on ACC.
	38	TCK4M	O	Transmit Clock. Tie to TCK4M on ACC.
	39	TMAG	O	Transmit Magnitude Bit. Tie to TMAG on ACC.
	40	TSGN	O	Transmit Sign Bit. Tie to TSGN on ACC.
Power	1	VCC1	I	Logic supply input (Refer to Table 27)
	68	VCC2	I	I/O supply input
	2	GND1	I	Ground
	3	GND2	I	Ground
	42	GND3	I	Ground
	47	GND4	I	Ground
Misc	48	CKBYPS	I	Test signal only, may be tied Low or not connected.

1. This input is a Schmidt Triggered circuit and includes an internal pull-up device.
 2. The period is 6 ms ± 1/584 ms.
 3. This input is a Schmidt Triggered circuit and includes an internal pull-down device.

7

FUNCTIONAL DESCRIPTION

NOTE

This functional information is for design aid only.

The HDSL Data Pump is a fully-integrated, two-chip solution (see Figure 3) which includes an SK70704 Analog Core Chip (ACC) and an SK70707 HDSL Digital Transceiver (HDX).

Transmit: The transmit data stream is supplied to the HDX at the TDATA input in a binary fashion. The HDX scrambles and 2B1Q encodes the data and adds the sync word and stuff quats based on the TFP frame pulse position. The injected stuff quats in a frame are equal to the last scrambled data symbol in that frame. The 2B1Q encoded transmit quat data stream (TSGN/TMAG) is then passed to the ACC which filters and drives it onto the line. For additional details on the transmit function, refer to Component Description.

Receive: The composite waveform of the receive signal plus trans-hybrid echo is filtered and converted to digital words at a rate of 584 k-words/second in the ACC. The ACC passes the digitized receive quat stream (AD0 and AD1) to the HDX. The HDX performs digital filtering, linear echo cancellation, frame recovery and descrambling. The HDX uses the transmit quat stream to generate the echo estimates and estimate error values. Using this error and the delayed transmit quat stream, the echo canceller coefficients are updated. The recovered, decoded and descrambled data is then output to the framer-mux from the HDX RDATA pin. For additional details on the receive function, refer to Component Description.

Control: The Data Pump offers two control modes - Hardware Mode and Software Mode. In Hardware mode the HDX receives control inputs via individually designated pins. In Software mode the HDX control data is supplied via an 8-bit parallel port. In either mode, the HDX and the ACC communicate via a unidirectional serial port (DTR).

Figure 3: HDSL Data Pump Block Architecture

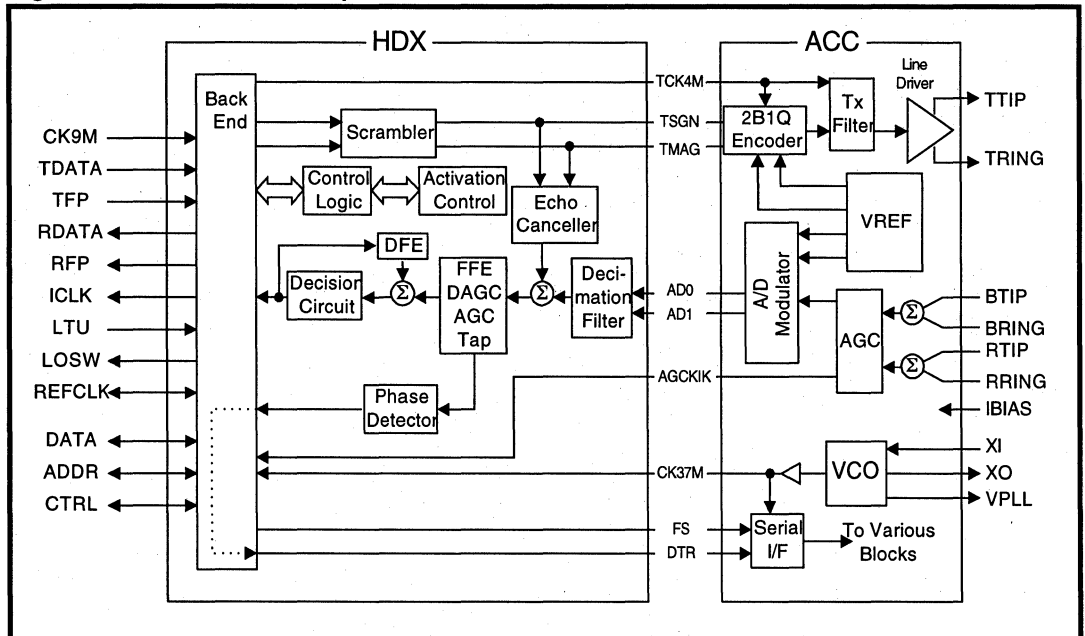

ACC AND HDX OVERVIEW

The following paragraphs describe the chip set components individually with reference to internal functions and the interfaces between Data Pump components.

Analog Core Chip (ACC)

The ACC incorporates the following analog functions:

- the transmit line driver
- transmit and receive filters
- Phase-Locked Loop (PLL), including VCXO
- hybrid circuitry analog-to-digital converter.

The ACC provides the complete analog front end for the HDSL Data Pump. It performs transmit pulse shaping, line driving, receive A/D, and the VCO portion of the receiver PLL function. Transmit and receive controls are implemented through the serial port. The ACC line interface uses a single twisted pair line for both transmit and receive. Table 1 lists the ACC pin descriptions. Refer to Test Specifications for ACC electrical and timing specifications.

ACC TRANSMITTER

The ACC performs the pulse shaping and driving functions. The ACC transmitter generates a 4-level output of $1/(8 \cdot f(\text{TCK4M}))$ defined by TMAG and TSGN. Table 3 lists 2B1Q pulse coding parameters. Refer to Test Specifications for frequency and voltage templates.

ACC RECEIVER

The ACC receiver is a sophisticated sigma-delta converter. It sums the differential signal at RTIP/RRING minus the signal at BTIP/BRING. The first A/D signal comes out of AD0 at a bit stream rate of 18.688 MHz. The second stage of the A/D samples the noise of the first and generates the AD1 bit stream at 18.688 MHz.

Receiver gain is controlled by the HDX via the AGC2-0 bits in the DTR serial control stream. The AGCKIK output from the ACC is normally Low. It goes High when the signal level in the sigma-delta A/D is approaching its clipping level, signaling the HDX to lower the gain.

The VCO is part of a phase-locked loop (PLL) locked to the receive data baud rate using an external phase detector. The VCO frequency is varied by pulling an external crystal with external varactor diodes that are controlled by the VPLL output. The VPLL output is, in turn, controlled by the serial port VCO and PLL bits.

HDSL Digital Transceiver (HDX)

The HDX incorporates the following digital functions:

- bit-rate transmit and receive signal-processing
- adaptive echo-cancelling (EC)
- adaptive decision feedback-equalization (DFE) using the receive quat stream and the internal error signal
- fixed and adaptive digital-filtering functions
- activation/start-up control and the microprocessor interface to the HDSL framer.

The HDX also provides the Data Pump Back-End interface for the customer defined/developed HDSL framer via serial data channels and clock signals. A simple, parallel 8-bit microprocessor interface on the HDX allows high-speed access to control, status and filter coefficient words. Table 2 lists the HDX pin descriptions. Refer to Test Specifications for HDX electrical and timing specifications.

The microprocessor interface on the HDX provides bit flags for signal presence, synchronization, activation completion, and loss of synchronization for a time greater than two seconds. Single-byte words representing receive signal level and the noise margin of the transceiver are also available on the microprocessor interface. One control byte allows the user to start the Data Pump activation sequence. The HDX controls the complete activation/start-up sequence, allowing flexible, single-loop, fractional applications.

Table 3: ACC Transmit Control

TSGN	TMAG	Output Symbol (quat)
1	0	+3
1	1	+1
0	1	-1
0	0	-3

HDX/ACC Interface

The ACC provides the 37.376 MHz master clock, CK37M, to the HDX. The serial control stream framing signal FS is sampled inside the ACC with the CK37M rising edge. The serial control stream, DTR, is sampled inside the ACC by the rising edge of an internally-generated clock at $f(\text{CK37M})/2$. This ACC internal clock has the same phase relationship with a similar clock inside the HDX, as established by the FS signal. In the HDX, the half-rate clock $\text{CK37M}/2$ and FS transition on the rising edge of CK37M, and DTR transitions come on the falling edge of $\text{CK37M}/2$. The output REFCLK in NTU Mode equals $\text{CK37M}/2$.

SK70704/SK70707 1168 kbps HDXL Data Pump Chip Set

The A/D converter outputs, AD0 and AD1, are clocked out of the ACC with CK37M, having transitions coincidental with the rising edge of CK37M/2. The HDX samples AD0 and AD1 with the falling edge of its internal CK37M/2.

Transmit data, represented by TSGN and TMAG, is clocked from the HDX using the falling edge of TCK4M, the 4.672 MHz ($f(\text{REFCLK})/4$) transmit time base clock. The ACC uses the rising edge of TCK4M to sample TSGN and TMAG. TSGN and TMAG change state at the baud rate, or every 8 cycles of TCK4M. Figure 4 shows relative timing for the HDX/ACC interface.

HDX/ACC Serial Port

The HDX continually writes to the ACC serial port. This serial stream consists of two 16-bit words as shown in Table 4. The data flows from the HDX to the ACC at a rate of $f(\text{CK37M})/2$. Refer to the Test Specifications section for serial port timing relationships and electrical parameters.

LINE INTERFACE

The Data Pump line interface consists of three differential pairs. The transmit outputs TTIP and TRING, receive inputs RTIP and RRING, and the balance inputs BTIP and BRING, all connect through a common transformer to a single twisted-pair line (see Figures 13 and 14). The transmit outputs require resistors in series with the transformer. A passive prefilter is required for the receive inputs. The balance inputs feed the transmit signals back to the Data Pump providing passive echo cancellation. Protection circuitry should be inserted between all Data Pump line interface pins and the transformer. Refer to the Applications section for typical schematics.

Table 4: HDX/ACC Serial Port Word Bit Definitions (See Figure 4)

Bit	Word A (on DTR)	Word B (on DTR)
15	INIT	COR4
14	<i>n/a</i>	COR3
13	<i>n/a</i>	COR2
12	TXOFF	COR1
11	TXDIS	COR0
10	TXST	VCO2
9	AGC2	VCO1
8	AGC1	VCO0
7	AGC0	PLL7
6	FELB	PLL6
5	<i>n/a</i>	PLL5
4	PTR4	PLL4
3	PTR3	PLL3
2	PTR2	PLL2
1	PTR1	PLL1
0	PTR0	PLL0

Figure 4: HDX/ACC Interface – Relative Timing

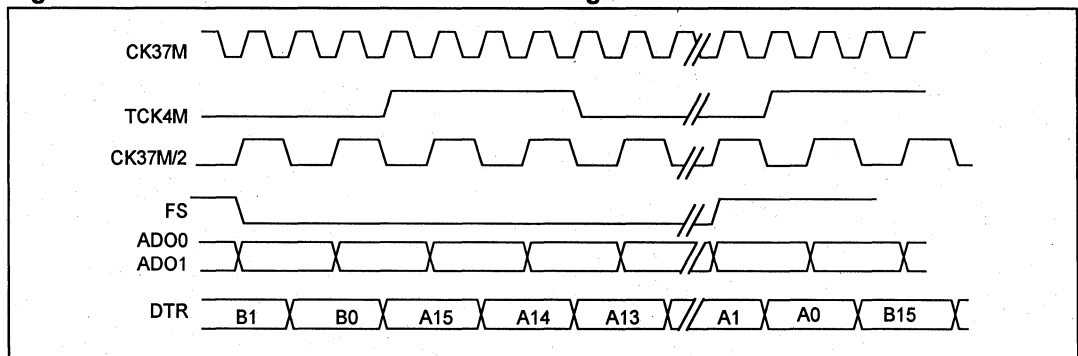

HDSL DATA INTERFACE

The HDSL data interface includes the transmit and receive binary data streams, transmit and receive frame pulses, the 1168 kHz clock (ICLK) and the receive frame and stuff quat indicator (RFST). Figure 5 shows relative timing for the framer interface. Refer to Test Specifications section for details on the Data Pump/framer interface. Figure 6 shows a complete HDSL system with both the remote NTU and central office LTU HDSL framer interfaces illustrated. Table 5 shows the TDATA requirements for the framer interface through the activation sequence. Once the ACTIVE Low-to-High transition occurs, the Data Pump

becomes transparent. Therefore, the HDSL framer must supply appropriate data to TDATA. Table 5 summarizes this requirement.

The HDSL framer interface is subject to the following rules:

1. When frame sync is not present (LOS is High), all RDATA bits are set to 1.
2. If frame sync is lost on both Data Pump-R1 and Data Pump-R2, both units will fall back on the local reference frequency with ± 32 ppm tolerance, and stuff bits will be injected in their RDATA streams on every other frame.

Figure 5: HDX/ACC Framer Interface – Relative Timing

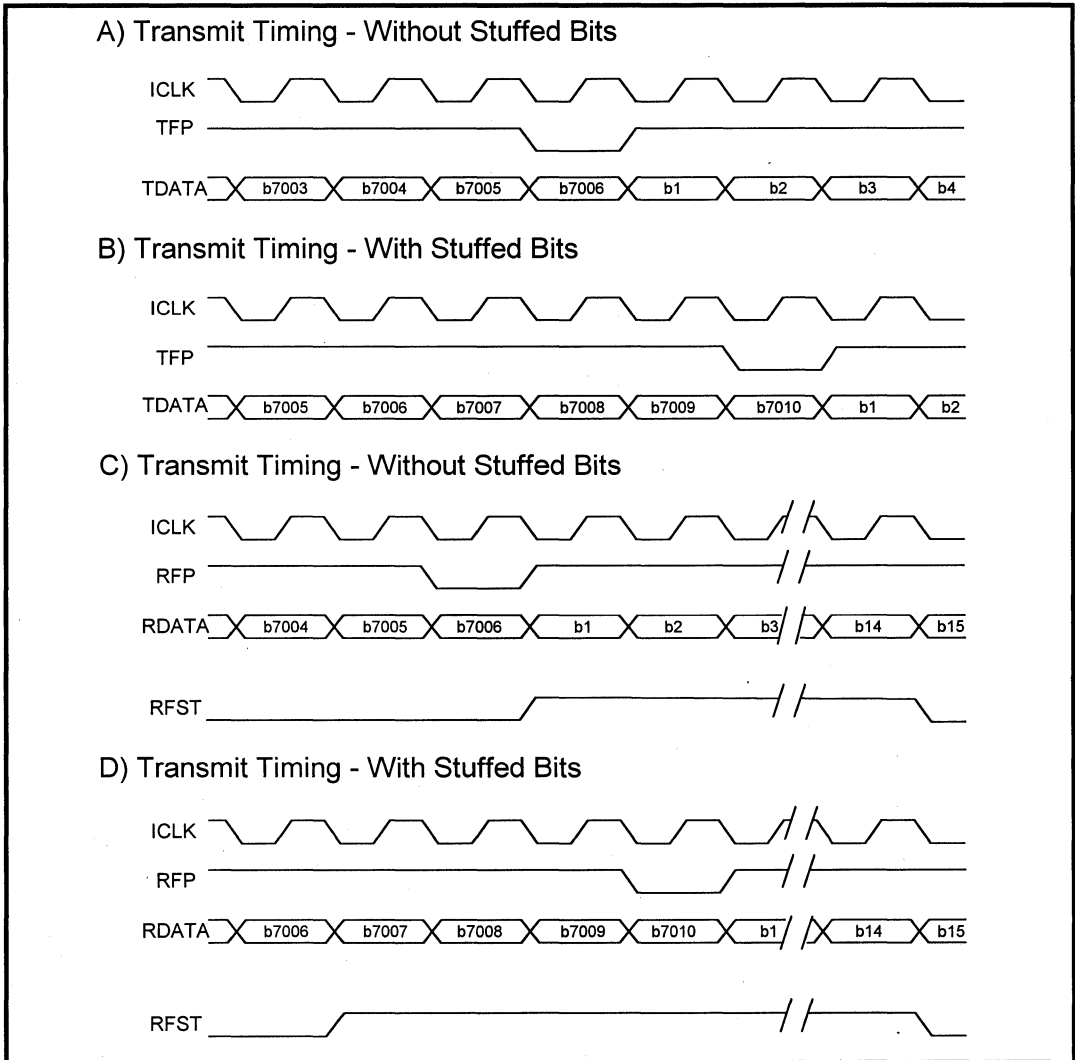

Table 5: HDSL Framer TDATA Requirements

Activation Process		TDATA	
Framer	Data Pump	Overhead	Data
Idle	Activating	<i>don't care</i>	<i>don't care</i>
Idle	Active 1	live	all 1s
Active-R	Active 1	live	all 1s
Active-T	Active 1	live	live
Link Active	Active 1	live	live
Link Active	Active 2	live	live

- If frame sync is lost on either Data Pump-R1 or Data Pump-R2, that unit can be made to fall back on the REFCLK from the Data Pump-R which is still in frame sync, and stuff bits will be injected in the RDATA stream on every other frame of the out-of-frame Data Pump-R.
- If frame sync is lost on either Data Pump-C1 or Data Pump-C2, both unit's receiver will fall back on the reference clock with ± 32 ppm or ± 5 ppm tolerance, and inject stuff bits in the RDATA stream on every other frame.

- If either E1-R or E1-C loses sync or signal, it is assumed that the corresponding T1 receiver will fall back on a local reference with ± 32 ppm tolerance, and that transmit bit-stuffing control will still be applied through the TFP signal from the HDSL framer.
- The HDSL framer should provide TFP signal with a period of $6 \text{ ms} \pm 1/584 \text{ ms}$ prior to an activation request for the LTU Data Pump(s). The framer should provide a valid TFP after power-up, before or immediately after LOS goes Low for the NTU Data Pump(s).

If the TFP signal from the HDSL framer is inactive (always High or unconnected), the Data Pump will inject stuff bits in the TDATA stream in every other frame, although the Data Pump will not be synchronized to the HDSL framer. When a new TFP is provided, the Data Pump will immediately reset the transmit frame alignment, typically causing loss of alignment at the other end.

- A simultaneous $\overline{\text{RESET2}}$ to all LTU Data Pumps which use a common REFCLK eliminates phase shift between the ICLK outputs which may exist after power-up. The ICLK outputs of all NTU Data Pumps may have an arbitrary phase difference even using a common CK9M reference.

Figure 6: Model for HDSL Data Pump and HDSL Framer Applications

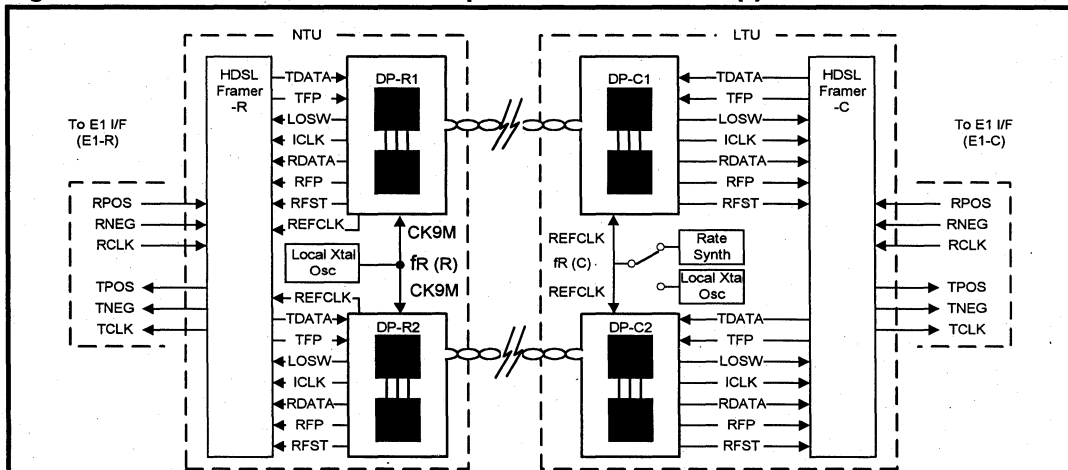

Frequency Relationships

- $f_{TCLK} (E1-C) = (E1-R)$; tolerance = ± 32 ppm, even with loss of signal on E1-R.
- $f_{TCLK} (E1-R) = (E1-C)$; tolerance = ± 32 ppm, even with loss of signal on E1-C.
- $f_{ICKL} (C) = f_{R(C)}/16$; tolerance = ± 32 ppm if sourced by local crystal oscillator (stratum 4), ± 5 ppm if sourced by office clock (stratum 3).
- $f_{ICKL} (R) = f_{ICKL} (C)$ if loop is activated with receive frame sync acquired,
 $= f_{R(R)}/16$ if receive sync is lost; tolerance = ± 32 ppm ($f_{R(R)} = 18.688 \text{ MHz}$).
 $= f_{R(R)}/8$ if $f_{R(R)} = 9.344 \text{ MHz}$.

MICROPROCESSOR INTERFACE (HDX)

Three primary control pins, $\overline{\text{CHIPSEL}}$ (Chip Select), $\overline{\text{READ}}$ and $\overline{\text{WRITE}}$, execute the Software Mode which also uses an interrupt output pin to report status changes. Four additional pins are used for the parallel bus addressing and eight pins for data I/O. Refer to Test Specifications for μ processor interface timing in Software Mode. The following control pins are used during register access.

Control Pins

Chip Select: The Chip Select ($\overline{\text{CHIPSEL}}$) pin requires an active Low signal to enable Data Pump read or write transfers over the data bus. To enable Hardware Mode hold this pin Low, along with $\overline{\text{READ}}$ and $\overline{\text{WRITE}}$.

Data Read: The Data Read pin ($\overline{\text{READ}}$) requires an active Low pulse to enable a read transfer on the data bus. When $\overline{\text{READ}}$ is pulled Low, the Data Pump data bus lines go from tristate to active and output the data from the register addressed by ADDR0-ADDR3. To avoid reading data during register updates, reads should be synchronized to the falling edge of FS. Alternatively, each read should be repeated until the same data is read twice within one baud time.

Data Write: The Data Write pin ($\overline{\text{WRITE}}$) requires an active Low pulse to enable a write transfer on the data bus. Data transfer is triggered by the rising edge of the $\overline{\text{WRITE}}$ pulse. To ensure data is written to the register addressed by ADDR0-ADDR3, valid data must be present on the HDX data bus lines before $\overline{\text{WRITE}}$ goes High.

Interrupt: The Interrupt pin ($\overline{\text{INT}}$) is an open drain output requiring an external pull-up resistor. The $\overline{\text{INT}}$ output is pulled active Low when an internal interrupt condition occurs. $\overline{\text{INT}}$ is latched and held until Main Status Register RD0 is read. An internal interruption results from a Low-to-High transition in any of four status indicators: ACTIVE, LOSW, LOSWT or TEXP. Any transition on LOS will also generate an interrupt. If an interrupt mask bit in register WR2 is set, any transition of the corresponding status bit will not trigger the $\overline{\text{INT}}$ output.

Register Access

Write: To write to an HDX register, proceed as follows:

1. Drive $\overline{\text{CHIPSEL}}$ Low.
2. Drive an address (0000, 0010, or 0011) onto ADDR0-ADDR3.
3. Observe address setup time.
4. Set 8-bit input data word on D0-D7.
5. Pull $\overline{\text{WRITE}}$ Low, observing minimum pulse width.
6. Pull $\overline{\text{WRITE}}$ High, observing hold time for data and address lines.

Read: Procedures for reading the HDX registers vary according to which register is being read. Accessing registers RD0, RD1, RD2, RD5 and RD6 is relatively simple. Reading registers RD3 and RD4 is more complex. *Unless parallel port reads are synchronized with the falling edge of FS, all read operations should be repeated until the same data is read twice within one baud time.*

To read register RD0, RD1, RD2, RD5 or RD6 proceed as follows:

1. Drive $\overline{\text{CHIPSEL}}$ Low.
2. Drive the desired address onto ADDR0-ADDR3.
3. Pull $\overline{\text{READ}}$ Low, observing minimum pulse width.
4. Pull $\overline{\text{READ}}$ High to complete the read cycle.

Registers RD3 and RD4 hold the coefficient values from the DFE, EC, FFE and AGC as shown in Table 9. Register RD3 holds the lower byte value and register RD4 holds the upper byte value. To reconstruct the complete 16-bit word, concatenate the least significant and most significant bytes.

To read registers RD3 and RD4 proceed as follows:

1. Select the desired coefficient by writing the appropriate code from Table 9 to register WR3.
2. Enable the Coefficient Read Register by writing a 1 to bit b0 (CRD1) in register WR2.
3. Perform standard register read procedure listed in steps 1 through 6 above to read the lower byte from RD3 and the upper byte from RD4.
4. Concatenate the RD3 and RD4 to obtain the complete 16-bit word.

Registers

Three write registers and seven read registers are available to the user. Table 6 lists these registers and the following paragraphs describe them in more detail.

Some of the registers contain *reserved* bits. Software must deal correctly with *reserved* fields. For reads, software must use appropriate masks to extract the defined bits and not rely on *reserved* bits being any particular value. In some cases, software must program *reserved* bit positions to a particular value. This value is defined in the individual bit descriptions.

After asserting the $\overline{\text{RESET1}}$ and $\overline{\text{RESET2}}$ signals, the Data Pump initializes its registers to the **default** value.

Table 6: Register Summary

ADDR		Write Registers		Read Registers		
A3-A0	WR#	Name	Table	RD#	Name	Table
0000	WR0	Main Control	7	RD0	Main Status	10
0001		<i>reserved</i>		RD1	Receiver Gain Word	11
0010	WR2	Interrupt Mask	8	RD2	Noise Margin	12
0011	WR3	Read Coefficient Select	9	RD3	Coefficient Read Register (lower byte)	13
0100		<i>reserved</i>		RD4	Coefficient Read Register (upper byte)	13
0101		<i>reserved</i>		RD5	Activation Status	14
0110		<i>reserved</i>		RD6	Receiver AGC and FFE Step Gain	15
0111-1001		<i>reserved</i>			<i>reserved</i>	

WR0—MAIN CONTROL REGISTER

Address: A3-0 = 0000
 Default: 00h
 Attributes: Write Only

Control Register bits serve the same purpose in Software Mode as the like-named individual pins in Hardware Mode. Table 7 lists bit assignments for the WR0 register.

Table 7: Main Control Register WR0

Bit	Description
b7	Transmit Test Pattern Enable (TXTST). Set TXTST to 1 to enable isolated transmit pulse generation. The time between pulses is 6 ms. TDATA controls the sign and TFP controls the magnitude of the transmitted symbols according to the 2B1Q encoding rules. In the NTU configuration when the TXTST mode is selected, the Data Pump may begin activation.
b6	Back-End Loop Back (BELB). In the Active State, set BELB to 1 to enable an internal, transparent loopback of the HDX RDATA to TDATA and RFP to TFP.
b5	Front End Loop Back (FELB). In the LTU mode with the Data Pump in the Inactive State, set FELB to 1 to enable an ACC front-end loopback. The Data Pump will begin activation and transmission on the line, but will ignore any signal from the NTU instead synchronizing to its own transmit signal.
b4	Repeater Mode (RPTR). The RPTR bit is set to 1 and the LTU pin is pulled High to program the Data Pump for operation on the side of the HDSL repeater driving the remote NTU. RPTR is set to 0 and the LTU pin is tied Low to program the Data Pump for operation on the side of the repeater driven by the central office LTU.
b3	<i>reserved. This bit must be set to 0.</i>
b2	Insertion Loss Measurement Test (ILMT). Set ILMT to 1 to enable transmission of a scrambled all ones insertion loss measurement test pattern. In the NTU configuration when the ILMT mode is selected, the Data Pump may begin activation.
b1	Quiet Mode (QUIET). Set QUIET to 1 to force the Data Pump into the De-Activated State with the transmitter silent. Setting QUIET to 0 will not cause the Data Pump to reactivate. In the NTU mode, the Data Pump will not respond to an S0 signal from the LTU when QUIET is set to 1, but may activate after QUIET is set to 0 even if the LTU transmission has already ceased.

Table 7: Main Control Register WR0 – continued

Bit	Description
b0	Activation Request (ACTREQ). In the LTU mode when the Data Pump is in the Inactive State and Quiet is set to 0, setting the ACTREQ bit to 1 will initiate an activation sequence. Because ACTREQ is a level- rather than an edge-triggered signal, it should be reset to 0 again within approximately 25 seconds to prevent the immediate start of another activation cycle if the current activation attempt fails. If an activation attempt fails, the processor should allow the Data Pump to remain in the Inactive State where the transmitter is silent for 32 seconds before generating another activation request to allow the NTU to return to the Inactive State. It is possible to shorten this quiet period following a failed activation by implementing additional algorithms described in the section entitled “Activation State Machines.”

WR2—INTERRUPT MASK REGISTER

Address: A3-0 = 0010
 Default: 00h
 Attributes: Write Only

Table 8 shows the various interrupt masks provided in register WR2.

Table 8: Interrupt Mask Register WR2

Bit	Description
b7-b6	<i>Reserved. Must be set to 0.</i>
b5	LOSMSK. 1=Masked. 0=Not Masked. Interrupt mask for the LOS condition
b4	LSWTMSK. 1=Masked. 0=Not Masked. Interrupt mask for the LOSWT condition
b3	LSWMSK. 1=Masked. 0=Not Masked. Interrupt mask for the LOSW condition
b2	ACTMSK. 1=Masked. 0=Not Masked. Interrupt mask for the TEXP condition and the ACTIVE condition
b1	<i>Reserved. Must be set to 0.</i>
b0	CRD1. Enable coefficient read register. Used in conjunction with WR3 for reading coefficient values.

WR3—READ COEFFICIENT SELECT REGISTER

Address: A3-0 = 0011
 Default: 00h
 Attribute: Write Only

Table 9 lists the bit maps used to select the coefficient read from the HDX.

Table 9: Read Coefficient Select Register WR3

Hex Value	Selected Registers	Register Description
00-07	DFE1-DFE8	DFE coefficients
08-0F	EC1-EC8	Echo Cancellation
10-15	FFE1-FFE6	FFE coefficients 1-6
16-19	<i>reserved</i>	
1A	AGC Tap	AGC Tap
1B-FF	<i>reserved</i>	

7

SK70704/SK70707 1168 kbps HDSL Data Pump Chip Set

RD0—MAIN STATUS REGISTER

Address: A3-0 = 0000
 Default: xxh (x=undefined)
 Attribute: Read Only

Status Register bits serve the same purpose in Software Mode as the like-named individual pins in Hardware mode. Table 10 lists the bit assignments in this register

Table 10: Main Status Register RD0

Bit	Active Description
b7	Timer Expiry (TEXP). Set to 1 to indicate 30-second timer expiration in the Active State. <ul style="list-style-type: none"> Causes interrupt on changing from 0 to 1; masked by ACTMSK = 1. Latched event; reset on read, with persistence while in the Active State.
b6	TIP/RING polarity reversed (INVERT). 0 = polarity reversal. Valid only in Active State.
b5	Change Of Frame Alignment (COFA). Indicates that re-acquisition of frame sync is in a different position with respect to the last frame position. Does not cause interrupt. Latched event; reset on read
b4	Loss Of Signal (NTU) (LOS). 1 = loss of line signal energy on entering Inactive State.
	Loss of Signal Timer Expiration (LTU) (LOST). 1 = loss of signal for 1 second on entering Inactive State. <ul style="list-style-type: none"> Causes interrupt on transitions from 0 to 1 or 1 to 0 that are masked by LOSMSK = 1. LOS/LOST is not a latched event.
b3	<i>reserved. This bit should be ignored.</i>
b2	Loss of Sync Word Timer Expiry (LOSWT). Indicates two seconds of LOSW. <ul style="list-style-type: none"> Causes interrupt on changing from 0 to 1; masked when LSWTMSK = 1. Latched event; reset on read; with persistence while in the Deactivated State.
b1	Loss of Sync Word (LOSW). <ul style="list-style-type: none"> Causes interrupt on changing from 0 to 1; masked by LSWMSK = 1. Latched event; reset on read; with persistence while in the Pending Deactivation State.
b0	Active State (ACTIVE). 1 = Completion of layer 1 activation. <ul style="list-style-type: none"> Causes interrupt on changing from 0 to 1; masked by ACTMSK = 1. Latched event; reset on read with persistence if still in the Active State.

RD1—RECEIVER GAIN WORD REGISTER

Address: A3-0 = 0001
 Default: xxh (x=undefined)
 Attributes: Read Only

The 8-bit word in this register is the eight most significant bits of the main FFE AGC tap, which, along with the AGC and DAGC values (RD6), represent the receiver gain required to compensate for line loss, and to normalize the receive 2B1Q pulses to a fixed threshold. Bit b7 (sign bit, always 0) is the MSB with bit b0 the LSB. The AGC tap value is determined as follows:

$$\text{AGC Tap} = \sum_{i=0}^6 b_i * 2^{i-6}$$

Table 11: Receiver Gain Word Register

Bit	Description
b7-b0	FFE AGC Tap Value (eight most significant bits).

RD2—NOISE MARGIN REGISTER

Address: A3-0 = 0010
 Default: xxh (x=undefined)
 Attributes: Read Only

The noise margin of the received signal is an input to the HDSL framer's Activation State Machine. The noise margin must reach a threshold level before the HDSL framer can transition to the fully Active State. The HDX provides a calculated, logarithmic noise margin value used by the HDSL framer. This eight-bit word, stored in register RD2, is available every baud, although updated only every 64 baud. Table 12 shows the noise margin coding. To calculate the SNR, use this equation:

$$\text{SNR} = \text{Noise Margin} + 21.5 \text{ dB}$$

Error propagation in the DFE and de-scrambler may introduce some fractional errors in this formula, however, the relationship between the SNR and the noise margin remains valid as long as the noise follows a Gaussian distribution.

Since the average period of the calculation is very short (64 baud = 110 μs), the recommended procedure for evaluating transmission quality is to average at least 1000 samples over a 110 ms period.

Table 12: Noise Margin Register RD2
 Noise Margin Coding

MSB				LSB				Noise Margin
b7	b6	b5	b4	b3	b2	b1	b0	
0	0	1	1	0	1	0	1	+26.5
0	0	1	0	1	1	1	1	+23.5
0	0	1	0	1	0	1	1	+21.5
0	0	1	0	1	0	0	1	+20.5
0	0	1	0	0	1	1	1	+19.5
0	0	1	0	0	1	0	1	+18.5
0	0	1	0	0	1	0	0	+18.0
0	0	1	0	0	0	1	0	+17.0
0	0	1	0	0	0	0	0	+16.0
0	0	0	1	1	1	1	0	+15.0
0	0	0	1	1	1	0	0	+14.0
0	0	0	1	1	0	1	0	+13.0
0	0	0	1	1	0	0	0	+12.0
0	0	0	1	0	1	1	0	+11.0
0	0	0	1	0	1	0	0	+10.0
0	0	0	1	0	0	1	0	+9.0
0	0	0	0	1	0	0	0	+8.0
0	0	0	0	1	1	1	0	+7.0
0	0	0	0	1	1	0	0	+6.0
0	0	0	0	1	0	1	0	+5.0
0	0	0	0	1	0	0	0	+4.0
0	0	0	0	0	1	1	0	+3.0
0	0	0	0	0	1	0	0	+2.0
0	0	0	0	0	0	1	0	+1.0
0	0	0	0	0	0	0	0	0.0
1	1	1	1	1	1	1	0	-1.0
1	1	1	1	1	1	0	0	-2.0
1	1	1	1	1	0	1	0	-3.0
1	1	1	1	1	0	0	0	-4.0
1	1	1	1	0	1	1	0	-5.0
1	1	1	1	0	1	0	0	-6.0

RD3(LSB), RD4(MSB)—COEFFICIENT READ REGISTER

Address: RD3 (A3-0 = 0011)
 RD4 (A3-0 = 0100)
 Default: xxh (x=undefined)
 Attributes: Read Only

Coefficient Read Word (read from the HDX) comes from the location configured in the Read Coefficient Select Register (WR3, Address A3-0 = 0011). The HDX updates this word on the rising edge of the receive clock, FS. Read register RD3 is the lower byte, and RD4 is the upper byte.

Table 13: Coefficient Read Register

Bit	Description
b7-b0	Coefficient Word Value. RD3 contains the lower byte; RD4 the upper byte.

RD5—ACTIVATION STATUS REGISTER

Address: A3-0 = 0101
 Default: xxh (x=undefined)
 Attributes: Read Only

The ACT bits indicate the current state of the HDX transceiver during the Activating State as listed in Table 14. (For any state other than the Activating State, the ACT bits will be “0000”.)

Table 14: Activation Status Register RD5

ACT Bits 3-0	State in LTU Mode	State in NTU Mode
0000	Inactive	Inactive
0001	Pre-AGC	Wait
0010	Pre-EC	AAGC
0011	SIGDET	EC
0100	AAGC	PLL1
1001	EC	PLL2
1010	PLL	4LVLDDET
1011	4LVLDDET	FRMDET
1000	FRMDET	-

RD6—RECEIVE STEP GAIN REGISTER

Address: A3-0 = 0110
 Default: xxh (x=undefined)
 Attributes: Read Only

This 8-bit register represents AGC and FFE gain coefficients (GAGC and GFFE, respectively). Bit assignments are listed in Table 15. The approximate line loss (LL) can be determined using these values in the following equation:

$$LL = 20\log_{10} (GFFE * AGC \text{ tap}) + GAGC + 28 \text{ dB}$$

GFFE corresponds to DAGC in the HDX and GAGC is from the ACC. Bits ST0-ST2 indicate the Data Pump activation states as shown in Figures 7 and 9 and Table 16.

Table 15: Receiver AGC and FFE Step Gain Register RD6

Bit	Description																		
b7	Data Pump Activation State-bit 2 (ST2).																		
b6	Data Pump Activation State-bit 1 (ST1).																		
b5-b4	Digital Gain Word-bit 1 and 0 (GFFE1,0). <table border="1" style="margin-left: 20px;"> <thead> <tr> <th>Bits [5:4]</th> <th>GFFE Value</th> </tr> </thead> <tbody> <tr> <td>00</td> <td>$2^0 = 1$</td> </tr> <tr> <td>01</td> <td>$2^1 = 2$</td> </tr> <tr> <td>10</td> <td>$2^2 = 4$</td> </tr> <tr> <td>11</td> <td>$2^3 = 8$</td> </tr> </tbody> </table>	Bits [5:4]	GFFE Value	00	$2^0 = 1$	01	$2^1 = 2$	10	$2^2 = 4$	11	$2^3 = 8$								
Bits [5:4]	GFFE Value																		
00	$2^0 = 1$																		
01	$2^1 = 2$																		
10	$2^2 = 4$																		
11	$2^3 = 8$																		
b3	Data Pump Activation State-bit 0 (ST0).																		
b2-b0	Analog Gain Word-bit 2,1 and 0 (GAGC2,1,0). <table border="1" style="margin-left: 20px;"> <thead> <tr> <th>Bits[2:0]</th> <th>GAGC Value (db)</th> </tr> </thead> <tbody> <tr> <td>000</td> <td>-12</td> </tr> <tr> <td>001</td> <td>-10</td> </tr> <tr> <td>010</td> <td>-8</td> </tr> <tr> <td>011</td> <td>-6</td> </tr> <tr> <td>100</td> <td>-4</td> </tr> <tr> <td>101</td> <td>-2</td> </tr> <tr> <td>110</td> <td>0</td> </tr> <tr> <td>111</td> <td>+2</td> </tr> </tbody> </table>	Bits[2:0]	GAGC Value (db)	000	-12	001	-10	010	-8	011	-6	100	-4	101	-2	110	0	111	+2
Bits[2:0]	GAGC Value (db)																		
000	-12																		
001	-10																		
010	-8																		
011	-6																		
100	-4																		
101	-2																		
110	0																		
111	+2																		

ACTIVATION STATE MACHINES

The Data Pump Activation/Start-Up circuitry is compatible with ETSI ETR-152. Full LTU activation is partitioned between the Data Pump and the framer. Figure 7 represents the LTU Data Pump Activation State Machine, and Figure 8 shows the LTU framer activation state machine. Figures 9 and 10 present the corresponding NTU state machines. Table 16 lays out the correspondence between the Data Pump and Framers state machines. In Software Mode, the ST n bits in Read Register 6 (ADDR 0110) show the current status of the state machine.

LTU Data Pump Activation

When the LTU Data Pump is powered up and reset is applied, the chip is in the Inactive State as shown at the top of Figure 7. Starting at the Inactive State, the device progresses in a clockwise direction through the Activating, Active-1, Active-2, Pending De-Activation and De-Activated States.

In the hardware mode when the Data Pump is in the Inactive State and the QUIET pin is Low, a Low-to-High transition on the ACTREQ pin initiates activation of the link. In the software mode when the Data Pump is in the Inactive State and the QUIET bit is set to 0, setting the ACTREQ bit to 1 initiates activation of the link. Because the ACTREQ control bit is level sensing, it should be set to 1 and then reset to 0 again within 25 seconds to generate a single activation request.

During the Activating State, the echo canceller, equalizer and timing recovery circuits are all adapting during the simultaneous transmission and reception of the framed, scrambled-ones data transmitted as a two-level code (S0) or as the four-level code (S1). If the receive frame sync word is not detected in two consecutive frames within 30 seconds, the timer expires and the device moves to the De-Activated State and ceases transmission. It will then immediately transition to the Inactive State (setting LOST regardless of whether NTU transmission has ceased). Another activation request should not be generated for 32 seconds allowing the NTU to timeout, detect LOS and move from the De-Activated to the Inactive State. In microprocessor-based systems, this time may be shortened by implementing a processor routine to reset the NTU Data Pumps which are in the Activating State when no LTU signal is present.

Successful detection of the sync word drives the State machine to the Active-1 State. This is indicated by a 0-to-1 transition of the ACTIVE bit (Software Mode). If the LTU Data Pump remains locked to the sync word until the Activation Timer expires, the device transitions to the Active-2 (fully active) State. If sync is lost, as indicated by

a 0-to-1 transition on LOSW, the LTU Data Pump transitions to the Pending De-Activation State.

In Pending De-Activation, the LTU Data Pump progresses to the De-Activated and Inactive States with the expiration of the respective timers. If the sync word is detected before the LOSW timer expires, the LTU Data Pump returns to either Active 1 or Active-2. (The LTU Data Pump returns to whichever state it occupied before transitioning to Pending De-Activation.)

The LTU Data Pump will exit the Active-2 State in one of two ways. A Low-to-High transition on the QUIET pin (Hardware Mode) or the QUIET bit (Software Mode), forces the LTU Data Pump directly to the De-Activated State. The only other means of exiting the Active State is through a loss of receive sync word (LOSW). LOSW is set when six consecutive frames occur without a sync word match. The LOSW event puts the LTU Data Pump into the Pending De-Activation State.

The LTU Data Pump remains in the Pending De-Activation State for a maximum of two seconds. If a sync word is detected within two seconds after the LOSW event, the LTU Data Pump re-enters the Active State. If the LOSW condition exceeds two seconds, an LOSWT event occurs which sends the chip to the De-Activated State. When the De-Activated State is reached from Pending De-Activation, the LTU Data Pump returns to the Inactive State and declares LOST when it detects no signal from the NTU for one second. The Data Pump should remain in the Inactive State for 15 seconds before another activation attempt.

Table 16: Data Pump/Framer Activation State Machine Correspondences

ST2	ST1	ST0	Data Pump State	Framer State
0	0	0	Inactive	Idle
0	0	1	Activating – 30 s timer running	Idle
0	1	0	Active – 30 s timer running (Active-1) ¹	Idle, Active-R or Active-T, or Link Active
0	1	1	Active – 30 s timer running (Active-2)	Link Active
1	0	0	Pending De-Activation ¹	Link Active or Active-R or Active-T
1	0	1	De-Activated ¹	Idle
1	1	0	unused	unused
1	1	1	unused	unused

1. TDATA is transparent to line output in states 010, 011 and 100

LTU Framer Activation

Figure 8 shows the activation state machine for the LTU HDSL framer. Transition to the Link Active stage from the Idle stage (upper left) requires successful exchange of a pair of indicator bits, **indc** and **indr**. (“INDC” and “INDR” are internal status signals within the HDSL framer; “**indc**” and “**indr**” are bits in the overhead channel.) The LTU device transmits the **indc** bit, and the NTU device transmits the **indr** bit. The overhead frame carries these indicator bits during transmission of the S1 training pattern.

Figure 8 illustrates the two partially active states (Active-R and Active-T) which may serve as transitions between the Idle and Link Active States. If the LTU device reaches the SNR threshold, its framer sets the INDC bit and the device transitions to the Active-R State. If the NTU device reaches the SNR threshold, it will transmit the **indr** bit to the LTU. The LTU will then transition to the Active-T State. From either of the partially Active States, the devices transition to the full Link Active State only with both Indication bits set.

Upon entering the Active States (Active-R, Active-T or Link Active), the chip will open up the full duplex communication link with the NTU. Only the Active and Pending De-Activation States allow full payload transmission. In all states except Active-1 and Active-2, the RDATA output is clamped High.



Figure 7: LTU Data Pump Activation State Machine

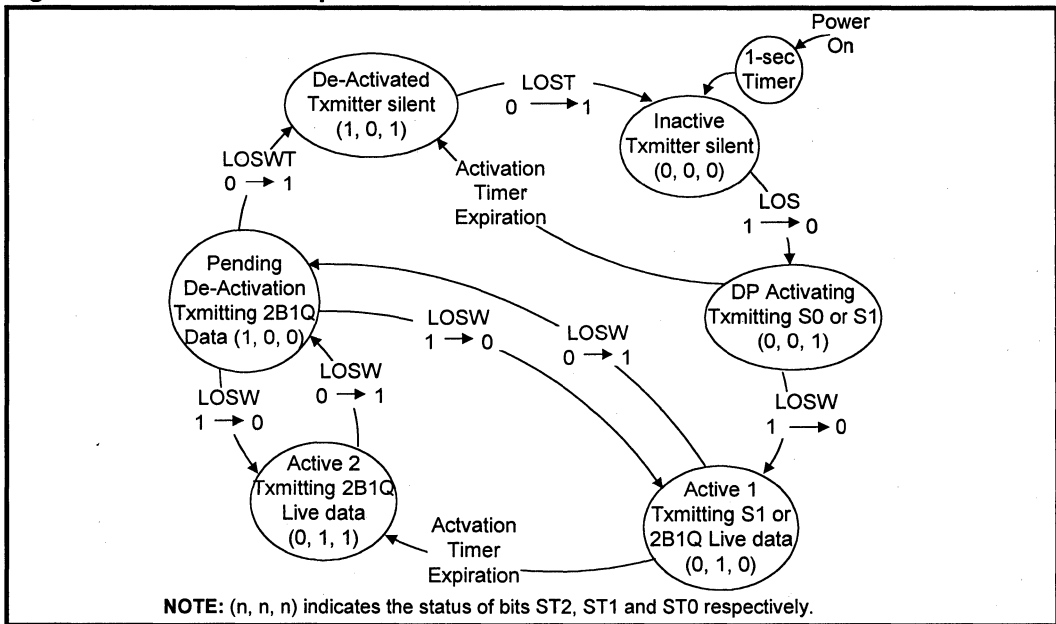
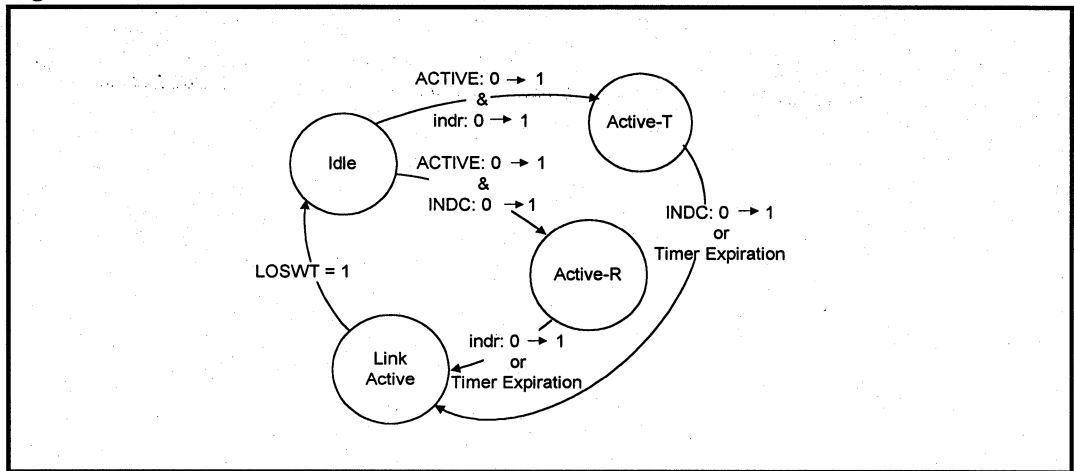

Figure 8: LTU HDSL Framer Activation State Machine



NTU Data Pump Activation

Figures 9 and 10 represent the NTU Data Pump Activation State Machine and the NTU HDSL Framer State Machine. The activation state machines for NTU and LTU devices are similar. Both Data Pump machines start at the Inactive State and progress clockwise through the Activating, Active-1, Active-2, Pending De-Activation, and De-Activated States. One difference between them is in the initial condition required to exit from the Inactive State. The LTU Data Pump responds to the Activation Request (ACTREQ) signal. The NTU device responds only to the presence of signal energy on the link. Thus, only an active LTU device can bring up the link. Once the LTU begins transmitting, the NTU device will automatically activate and attempt synchronization.

The other difference between the Data Pump state machines is the impetus for the change from the De-Activated to the Inactive State. In the LTU Data Pump, expiration of a one-second loss of signal timer (LOST) causes the transition. In the NTU the transition occurs immediately on Loss of Signal (LOS).

NTU Framer Activation

The HDSL framer activation state machines for LTU and NTU are also similar. The difference is in the indicator bits which cause the transition to either the Active-T or Active-R State. On the NTU side, the INDR bit causes the transition to the Active-R State, and the INDC bit causes the transition to the Active-T State. From either partially active state, receipt of the remaining indicator bit or timer expiry causes the transition to the full Link Active State.

HDSL Synchronization State Machine

Figure 11 shows the HDSL Synchronization State Machine incorporated in the HDX. It applies to both LTU and NTU devices. Table 17 lists the correspondence between the Synchronization states and Activation states. The Sync state machine is clocked by the receive signal framing. Starting at the initial Out-of-Sync condition (State 0), the device progresses in a clockwise direction through State 1 until Sync is declared in State 2. Two consecutive frame sync word matches are required to achieve synchronization.

Once the In-Sync condition is declared, six consecutive frame sync mismatches will cause the device to transition through States 3 through 7 and declare an Out-of-Sync condition in State 8. From State 8, the device will return either to State 2 or to State 0. If the 2-second timer expires without re-establishing frame sync (LOSWT = 1) or if the receive signal is lost entirely (LOS = 1), the device returns directly to State 0.

If frame sync is re-established, the device will return to the In-Sync condition (State 2) through State 9 if two consecutive frames are received without any change of frame alignment (COFA = 0). If a change of frame alignment does occur (COFA = 1), two consecutive matches are required to transition through State 10 back to State 2.

Table 17: Activation – Synchronization

Activation State	Synchronization States
Inactive	State 0
Activating	State 1
Active	States 2, 3, 4, 5, 6, and 7
Pending De-Activation	States 8, 9, and 10

Figure 9: NTU Data Pump Activation State Machine

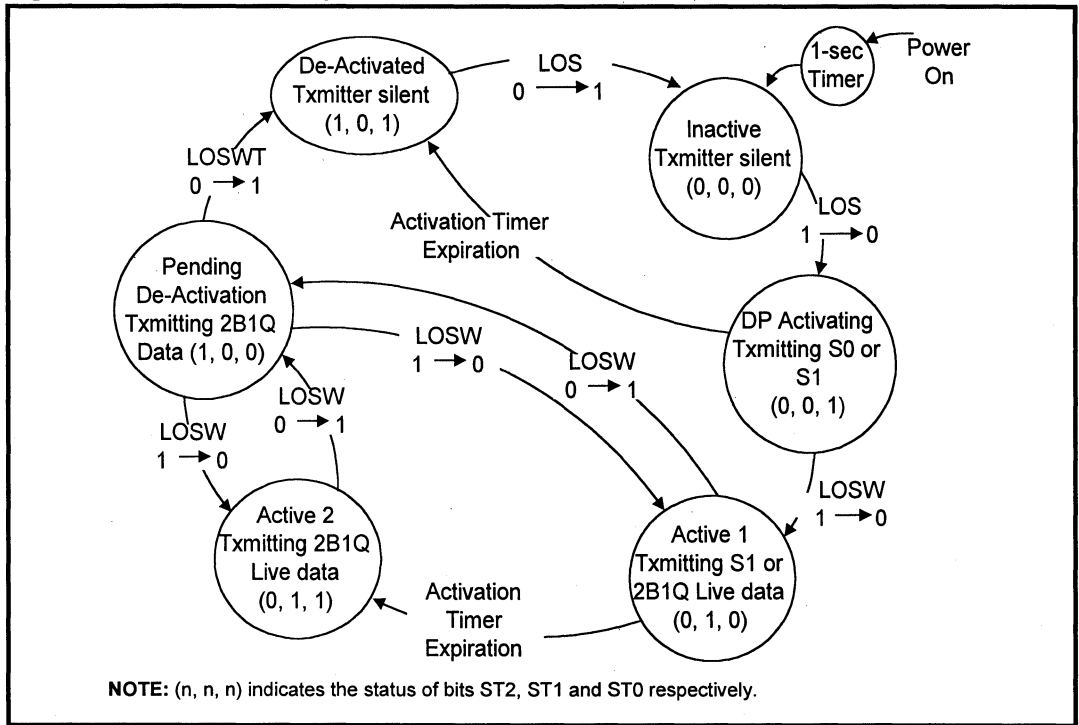

7

Figure 10: NTU HDSL Framing Activation State Machine

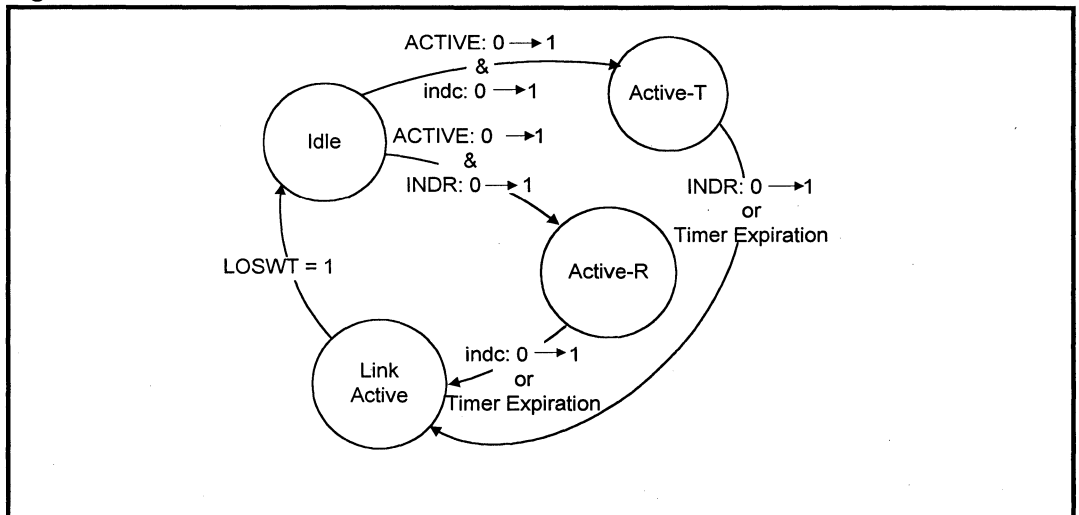
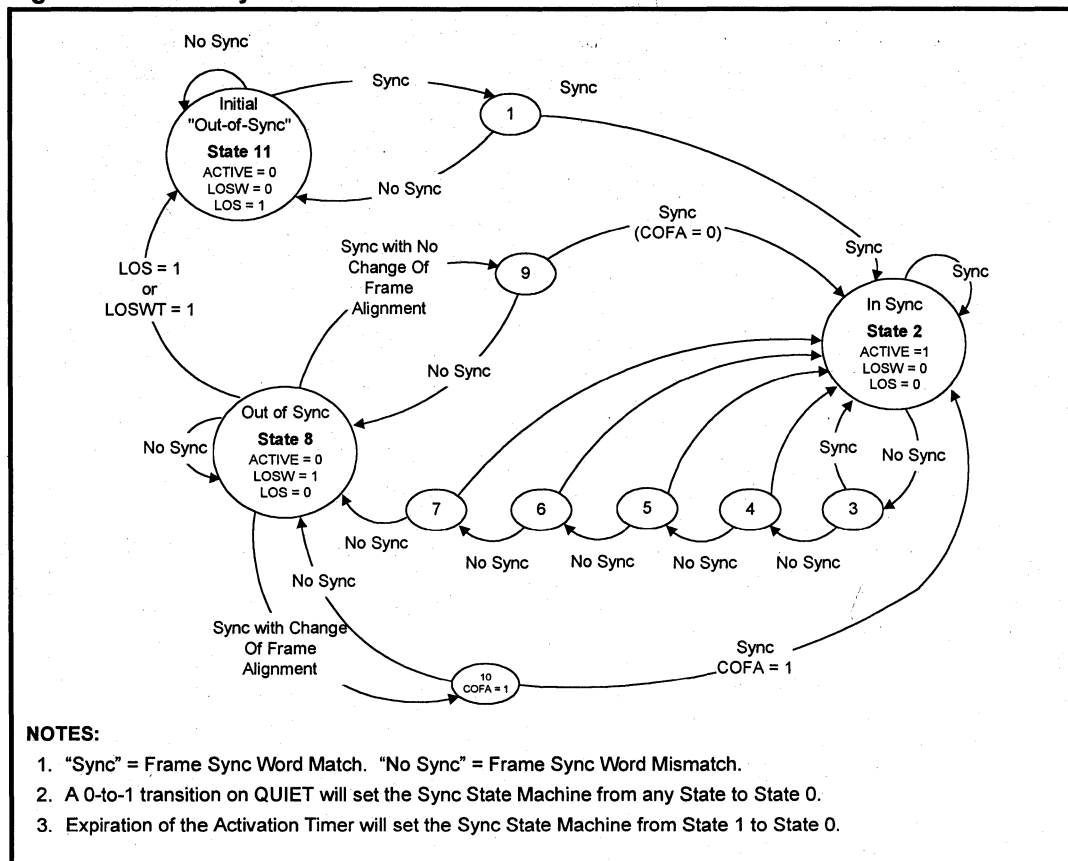

Figure 11: HDSL Synchronization State Machine



NOTES:

1. "Sync" = Frame Sync Word Match. "No Sync" = Frame Sync Word Mismatch.
2. A 0-to-1 transition on QUIET will set the Sync State Machine from any State to State 0.
3. Expiration of the Activation Timer will set the Sync State Machine from State 1 to State 0.

APPLICATION INFORMATION

NOTE

This application information is for design aid only.

HDSL FRAMER STATE MACHINE DESIGN

Because of data transparency characteristics of the Data Pump, two issues impact on implementing the HDSL Framer Activation State machines for both LTU and NTU devices:

1. Once the ACTIVE 0-to-1 transition occurs, the Data Pump becomes transparent. Therefore, the HDSL framer must put appropriate data in TDATA. Table 5 summarizes this requirement.
2. The link indicator bits (**indc** and **indr**) must stabilize before the device makes the transition from the Idle to the Active-T State. Thus, the HDSL framer design may detect 6 consecutive matches for the indication bit transition. This is particularly important for non-CSA loops where a lower SNR may be experienced.

PCB LAYOUT

The following are general considerations for PCB layout using the HDSL Data Pump chip set:

- Refer to Figures 12, 13 and 14, and Table 18. Keep all shaded components close to the pins they connect to.
- Use a four-layer or more PCB layout,
- with embedded power and ground planes.
- Break up the power and ground planes into the following regions, and tie these regions together at the common point where power connects to the circuit:
 - Digital Region
 - Analog Region
 - VCXO subregion
 - ACC, Line I/F, and IBIAS subregion
- Use larger feedthroughs (“vias”) and tracks for connecting the power and ground planes to the power and ground pins of the ICs than for signal connections. Place the decoupling capacitors right at the feedthrough power/ground plane ties, or on the tracks to the IC power/ground pins as close to the pins as possible.
- On the User Interface Connector, route digital signals to avoid proximity to the TIP, RING, and CT lines.
- Provide at least 100 μF or more of bulk power supply decoupling at the point where power is connected to the Data Pump circuit.

User Interface

The REFCLK and CK9M signals are sensitive to capacitive loading and rise time. Keep the rise time (from 10%-90%) for these signals less than 5 ns.

Digital Section

- Keep all digital traces separated from the analog region of the Data Pump layout.
- Provide high frequency decoupling capacitors (0.01 μF ceramic or monolithic) around the HDX as shown in Figures 13 and 14. The capacitor on the HDX VCC1 pin (pin 1) should be on the IC side of the diode.
- It is possible to replace the NAND gate (shown in Figures 13 and 14) with an AND gate.

Analog Section

The analog section of the PCB consists of the following subsections:

1. ACC and power supply decoupling capacitors
2. Bias Current Generator
3. Voltage Controlled Crystal Oscillator
4. Line Interface Circuit
 - Keep Section (3) as far from Sections (2), and (4) as possible, but close to Section (1).
 - Keep Section (2) close to Section (1).
 - In Section (1), use three 0.1 μF decoupling capacitors placed as close as possible to ACC pins 12, 23, and 24 and connected to the ground plane.
 - Route digital signals AD0, AD1, FS, DTR, TSGN, TMAG, TCK4M, and AGCKIK on the solder side of the PCB, and route all analog signals on the component side as much as possible.
 - Route the following signal pairs as adjacent traces:
 - TTIP/TRING
 - BTIP/BRING
 - RTIP/RRING
 but keep the pairs separated from each other as much as possible.
 - To maximize high voltage isolation, do not run the analog ground plane under the transformer line side.

7

Figure 12: PCB Layout Regions

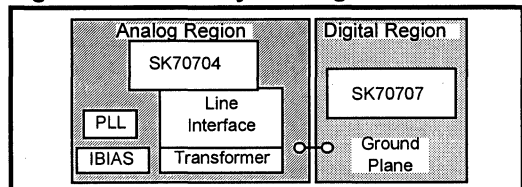

Figure 13: Typical Support Circuitry for LTU Applications

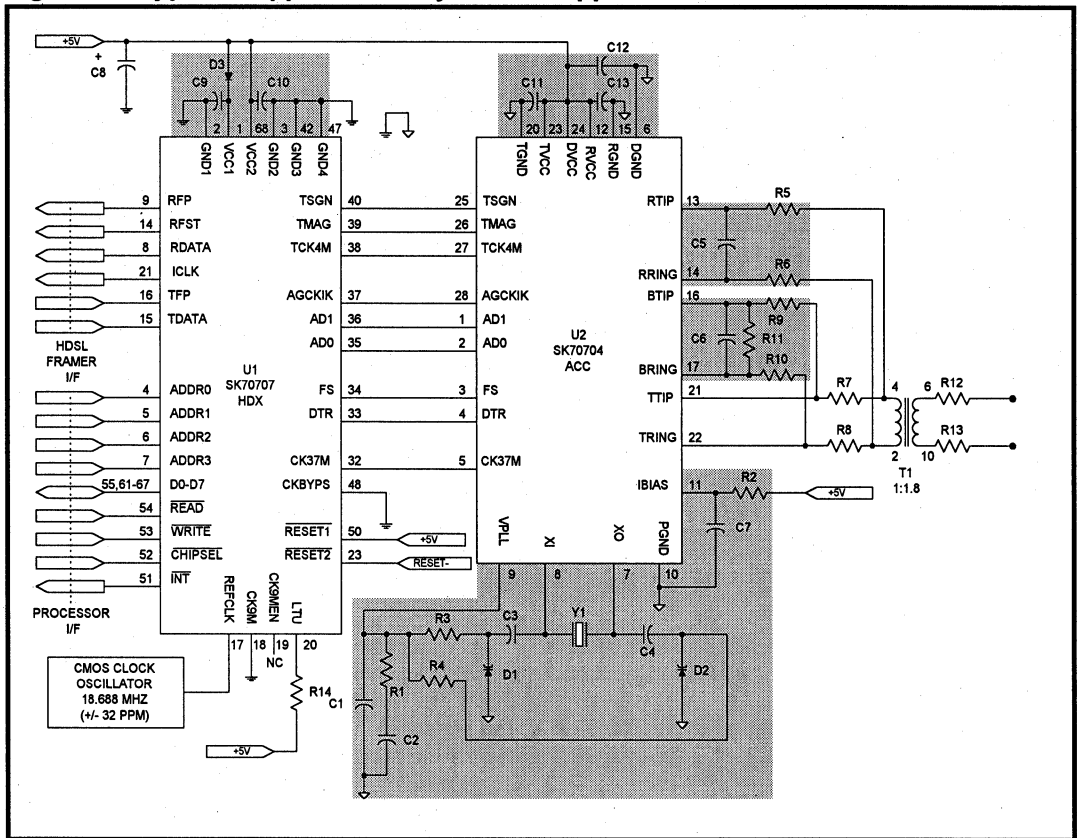

Table 18: Components for Suggested Circuitry (See Figures 13 and 14)

Ref	Description	Ref	Description	Ref	Description
C1, 9, 10	0.01 μ F, ceramic, 10%	R1	10.0 k Ω , 1%	R12, 13	5.6 Ω line feed fuse resistor (ALFR-2-5.6-1 IRC)
C2	33 μ F, electrolytic, 20% low leakage $\leq 5 \mu$ A @ 25 $^{\circ}$ C	R2	35.7 k Ω , 1%	D1, 2	Varicap diode (Motorola MV209)
C3, 4	1000 pF, ceramic, 20%	R3, 4	20.0 k Ω , 1%	D3	Silicon rectifier diode (1N4001)
C5, 6	470 pF, COG or mica, 10%	R5, 6	301 Ω , 1%	Y1	37.376 MHz crystal (Hy-Q International 81256/1)
C7, 11-13	0.1 μ F, ceramic, 10%	R7, 8 ¹	18.2 Ω , 1%	T1	1:1.8 (Midcom 671-7671 or Pulse Engineering PE-68650)
C8	100 μ F, electrolytic, 20%	R9, 10	604 Ω , 1%		
		R11	1.43 k Ω , 1%		
		R14	10.0 k Ω , 1%		

1. R7, R8 should be 20 Ω , when R12 and R13 (the 5.6 Ω fuse links) are not used.

Table 19: Transformer Specifications
(Figures 13 and 14, Reference T1)

Measure	Value	Tolerance
Turns Ratio (IC:Line)	1:1.8	±1%
Secondary Inductance (Line Side)	2.05 mH	±6%
Leakage Inductance	≤ 50 μH	
Interwinding Capacitance	≤ 60 pF	
THD	≥ -70 dB	
Longitudinal Balance	≥ 50 dB	5-292 kHz
Return Loss	≥ 20 dB	40-200 kHz
Isolation	2000 VRMS	
Primary DC Resistance	≤ 2.0 Ω	
Secondary DC Resistance	≤ 4.0 Ω	
Operating Temperature	-40 to +85 °C	

Table 20: Crystal Specifications
(Figures 13 and 14, Reference Y1)

Measure	Value	Tolerance
Calibration Frequency	37.376 MHz @ CL = 20 pF	0 to +40 ppm
Mode	Fundamental, Parallel Resonance	
Pullability (CL = 24 pF ⇔ 16 pF)	≥ +160 ppm	
Operating Temperature	-40 to +85 °C	
Temperature Drift	≤ ±30 ppm	
Aging Drift	≤ 5 ppm/year	
Series Resistance	≤ 15 Ω	
Drive Level	0.5 mW	
Holder	HC-49	

Figure 14: Typical Support Circuitry for NTU Applications

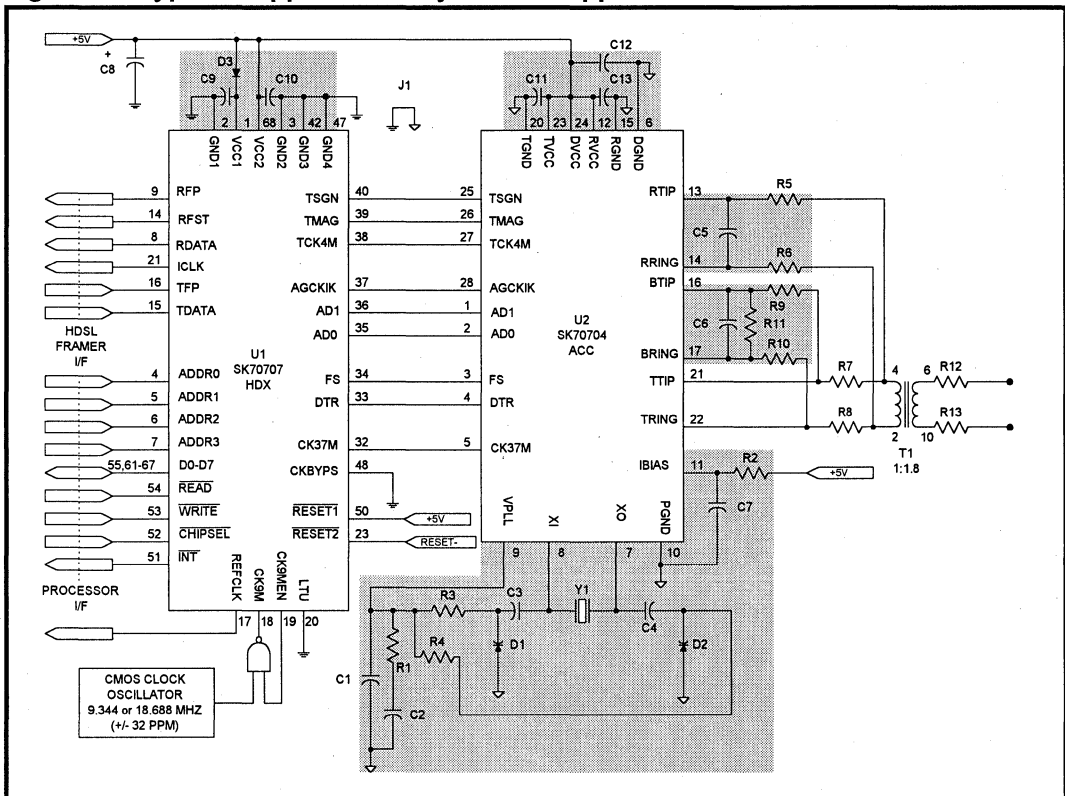

TEST SPECIFICATIONS

NOTE

The minimum and maximum values in Tables 21 through 31 and Figures 15 through 21 represent the performance specifications of the Data Pump and are guaranteed by test, except where noted by design.

Table 21: ACC Absolute Maximum Ratings

Parameter	Symbol	Min	Max	Units
Supply Voltage ¹ Reference to ground ²	TVCC, RVCC, DVCC	-0.3	+6.0	V
Input Voltage ^{2,3} , any input pin	TVCC, RVCC, DVCC	- 0.3V	VCC + 0.3	V
Continuous Output Current, any output pin	–	–	±25	mA
Storage Temperature	TSTOR	-65	+150	°C

CAUTION

Operations at the limits shown may result in permanent damage to the Analog Core Chip. Normal operation at these limits is neither implied nor guaranteed

1. No supply input may have a maximum potential of more than ±0.3 V from any other supply input.
 2. TGND = 0V; RGND = 0V; DGND = 0V.
 3. TVCC = RVCC = DVCC = VCC.

Table 22: ACC Recommended Operating Conditions

Parameter	Symbol	Min	Typ	Max	Units
DC Supply	TVCC, DVCC, RVCC	4.75	5.0	5.25	V
Ambient Operating Temperature	TA	-40	+25	+85	°C

Table 23: ACC DC Electrical Characteristics (Over Recommended Range)

Parameter	Sym	Min	Typ ¹	Max	Unit	Test Conditions
Supply current (full operation)	ICC	–	102	137	mA	83 Ω resistor across TTIP and TRING
DVCC Current		–	7	12	mA	
RVCC Current		–	30	50	mA	
TVCC Current		–	65	75	mA	Normal Mode 8+3, 8-3, 8+3, ...
		–	38	48	mA	Off Mode
Input Low Voltage	VIL	–		0.5	V	IIL < 40 μA
Input High Voltage	VIH	4.5		–	V	IIL < 40 μA
Output Low Voltage	VOL	–	–	0.2	V	IOL < 40 μA
Output High Voltage	VOH	4.5	–	–	V	IOH < 40 μA
Input Leakage Current	IIL	–	±40	–	μA	0 < VIN < VCC
Input capacitance (individual pins)	CIN	–	12	–	pF	
Load Capacitance (REFCLK output)	CLREF	–	–	20	pF	

1. Typical values are at 25° C and are for design aid only; not guaranteed and not subject to production testing.

Table 24: ACC Transmitter Electrical Parameters (Over Recommended Range)

Parameters	Sym	Min	Typ	Max	Unit	Test Conditions
Isolated Pulse height at TTIP, TRING		+2.455	+2.640	+2.825	Vp	TDATA High, TFP Low (+3)
		-2.825	-2.640	-2.455	Vp	TDATA Low, TFP Low (-3)
		+0.941	+0.880	+0.818	Vp	TDATA High, TFP Low (+1)
		-0.818	-0.880	-0.941	Vp	TDATA Low, TFP High (-1)
Setup Time (TSGN, TMAG)	tTMSU	5	—	—	ns	
Hold Time (TSGN, TMAG)	tTSMH	12	—	—	ns	

1. Pulse amplitude measured across a 135 Ω resistor on the line side of the transformer using the application circuit shown in Figure 13 and Table 18.

Figure 15: ACC Normalized Pulse Amplitude Transmit Template

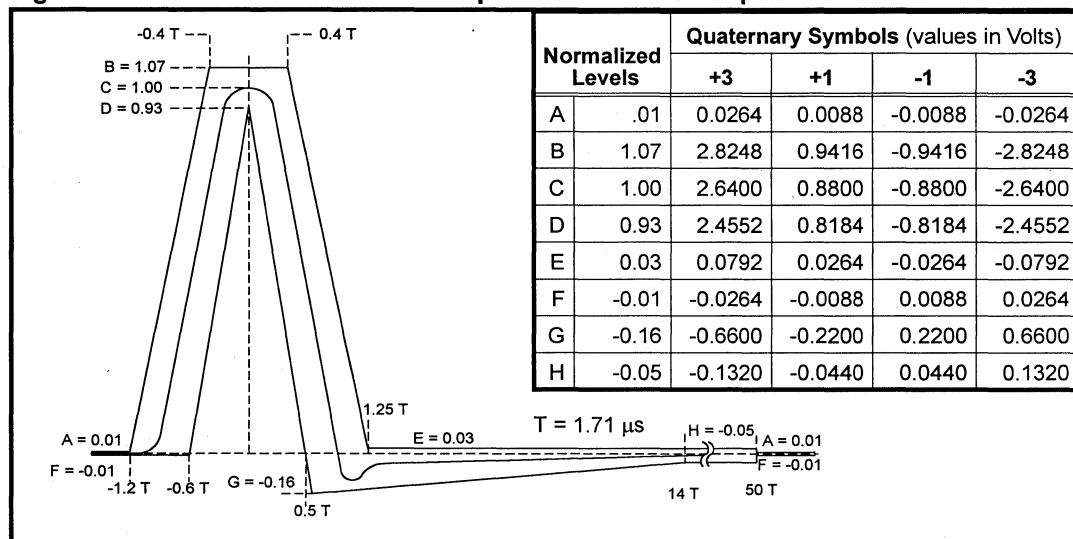

Figure 16: ACC Transmitter Timing

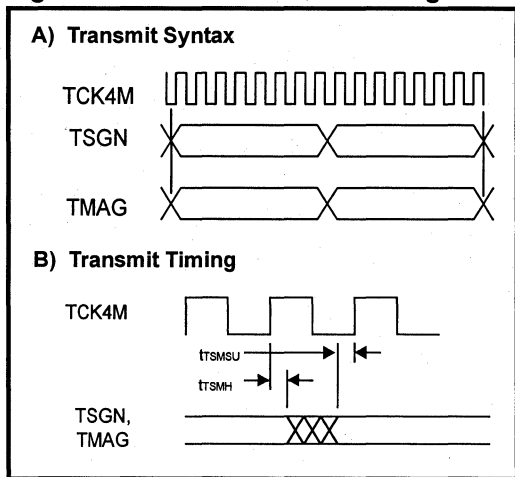

Figure 17: Transmit Power Spectral Density

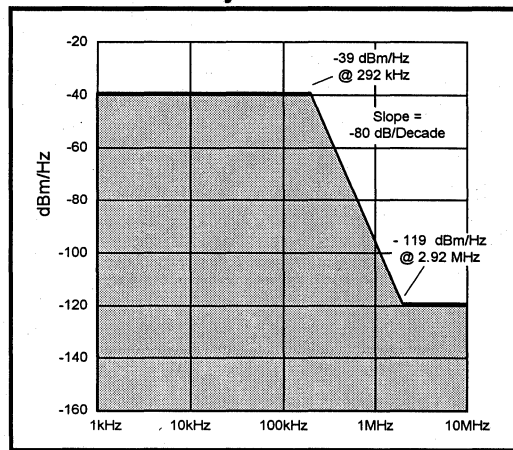

Table 25: ACC Receiver Electrical Parameters (Over Recommended Range)

Parameter	Sym	Min	Typ	Max	Unit	Test Conditions
Propagation Delay (AD0, AD1)	tADD	-	-	25	ns	
Total Harmonic Distortion		-	-80	-	dB	V(RTIP, RRING) = 3 Vpp @ 50 kHz
RTIP, RRING, to BTIP, BRING Gain Ratio		-	1.0	1%	V/V	

Figure 18: ACC Receiver Syntax and Timing

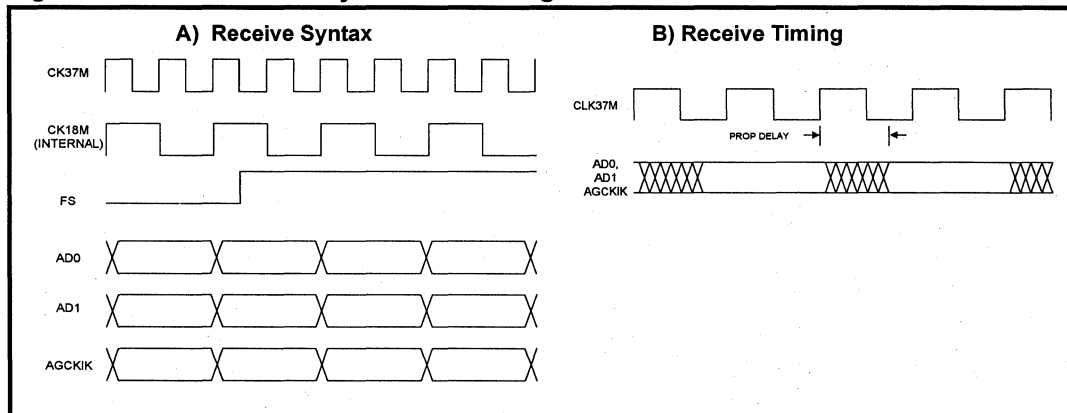

Table 26: HDX Absolute Maximum Ratings

Parameter	Symbol	Min	Max	Units
Supply Voltage ¹ Reference to ground ²	VCC2, VCC1	-0.3	+6.0	V
Input Voltage ² , any input pin	-	-0.3	VCC2 + 0.3	V
Continuous Output Current, any output pin	-	-	±25	mA
Storage Temperature	T _{STOR}	-65	+150	°C
CAUTION				
Operations at the limits shown may result in permanent damage to the HDSL Digital Transceiver (HDX). Normal operation at these limits is neither implied nor guaranteed				
1. The maximum potential between VCC2 and VCC1 must never exceed ±1.2 V.				
2. GND4 = GND3 = 0V; GND2 = 0V; GND1 = 0V.				

Table 27: HDX Recommended Operating Conditions

Parameter	Symbol	Min	Typ	Max	Units	
DC Supply	VCC1 ¹	3.95	4.25	+4.55	V	
	VCC2	4.75	5.0	+5.25	V	
	VCC2-VCC1	0.6	-	0.9	V	
Ambient Operating Temperature	SK70707PE	T _A	-40	-	+85	°C
	SK70707PH	T _A	-5	-	+85	°C
1. To derive this supply, connect a 1N4001 (or equivalent) diode between VCC2 and VCC1 as shown in Figures 13 and 14.						

7

Table 28: HDX DC Electrical Characteristics (Over Recommended Range)

Parameter	Sym	Min	Typ ¹	Max	Unit	Test Conditions
Supply current (full operation)	I _{CC}	-	125	175	mA	
Input Low Voltage	V _{IL}	-	-	0.5	V	I _{IL} < 40 μA
Input High Voltage	V _{IH}	4.0	-	-	V	I _{IH} < 40 μA
Output Low Voltage	V _{OL}	-	-	GND +0.3	V	I _{OL} < 40 μA
Output High Voltage	V _{OH}	VCC2-0.5	-	-	V	I _{OH} < 40 μA
Input Leakage Current	I _{IL}	-	±40	-	μA	
Tristate Leakage Current	I _{IL}	-	±10	-	μA	
Input capacitance (individual pins)	C _{IN}	-	12	-	pF	
Load Capacitance (REFCLK output)	CL _{REF}	-	-	15	pF	
1. Typical values are at 25 °C and are for design aid only; not guaranteed and not subject to production testing.						

Table 29:HDX/HDSL Data Interface Timing (See Figure 19)

Parameter	Symbol	Min	Typ ¹	Max	Unit
ICLK Frequency	f _{ICLK}	–	1168	–	kHz
REFCLK Frequency	f _{REFCLK}	–	18.688	–	MHz
REFCLK Frequency tolerance (LTU Mode)	tol _{RCLK}	-32	0	+32	ppm
CK9M Frequency tolerance (NTU Mode) ²	tol _{CK6M}	-32	0	+32	ppm
ICLK Pulse width high	t _{IPW}	–	428	–	ns
Transition Time on any Digital Output ³	t _{TO}	–	5	10	ns
Transition Time on any Digital Input	t _{TI}	–	–	25	ns
TDATA, TFP Setup Time to ICLK Rising Edge	t _{TSU}	100	–	–	ns
TDATA, TFP Hold Time from ICLK Rising Edge	t _{TH}	100	–	–	ns
RDATA, RFP, RFST delay from ICLK Falling Edge	t _{TD}	0	–	150	ns
TFP Pulse Width ⁴	t _{TFPW}	828	856	884	ns
TFP Falling Edge to ICLK Rising Edge ⁴	t _{TFIR}	300	–	400	ns
TFP Setup Time to REFCLK Rising Edge ⁴	t _{TSUR}	25	–	–	ns

1. Typical values are at 25 °C and are for design aid only; not guaranteed and not subject to production testing.
 2. CK9M must meet this tolerance about an absolute frequency of 9.344000 MHz or 18.688000 MHz in NTU mode.
 3. Measured with 15 pF load.
 4. These parameters apply only to an LTU mode Data Pump programmed for repeater applications as shown in Figure 19.

Figure 19: HDX/HDSL Data Interface Timing

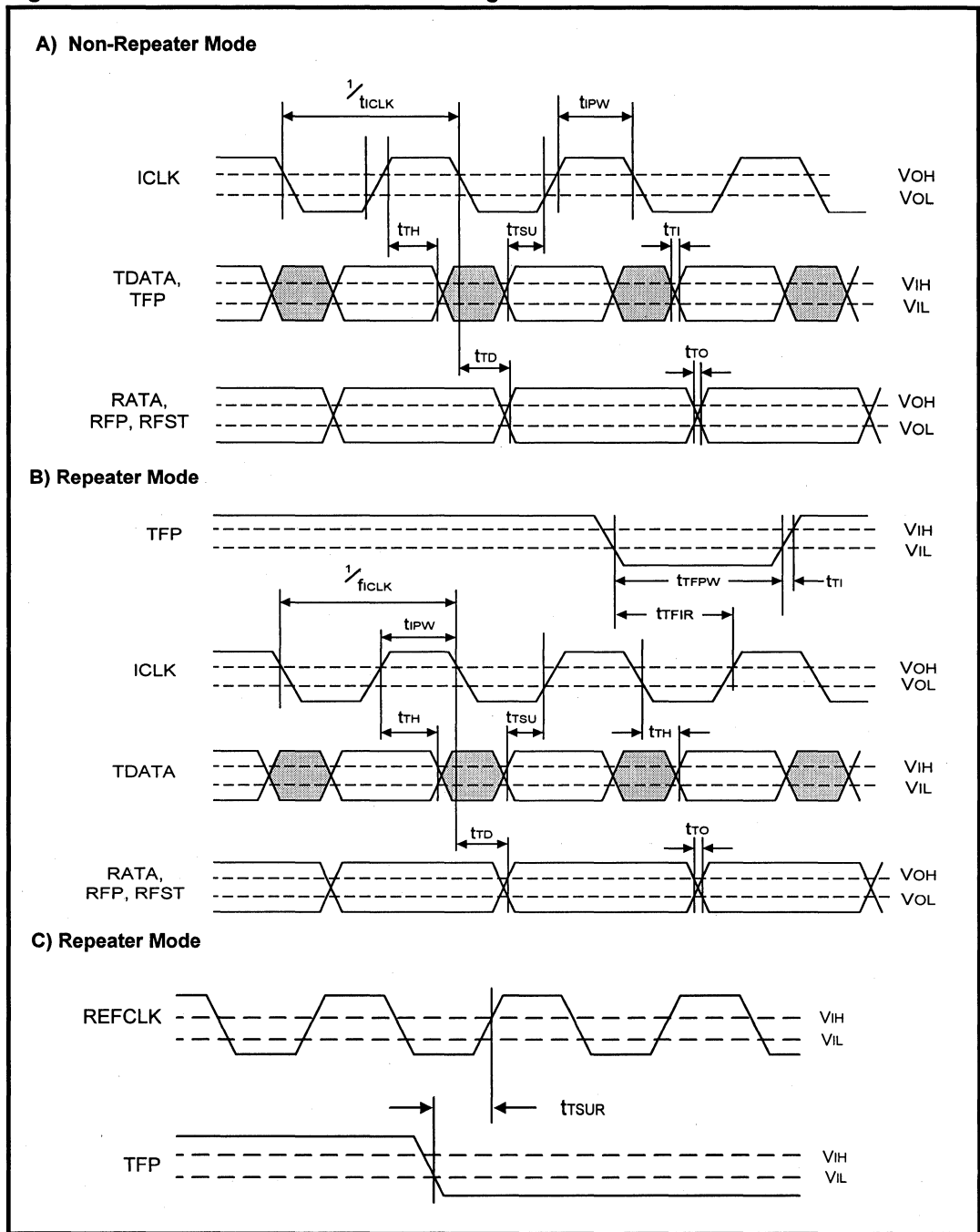

Table 30: HDX/Microprocessor Interface Timing Specifications (See Figures 20 and 21)

Parameter	Symbol	Min	Typ	Max	Unit
RESET2 pulse width Low	tRPWL	0.1	–	1,000	μs
RESET2 to INT clear (10 kΩ resistor from INT to VCC2)	tINTH	–	–	300	ns
RESET2 to data tristate on D0-7	tDTHZ	–	–	100	ns
CHIPSEL pulse width Low	tCSPWL	200	–	–	ns
CHIPSEL Low to data active on D0-7	tCDLZ	–	–	80	ns
CHIPSEL High to data tristate on D0-7	tCDHZ	–	–	80	ns
READ pulse width Low	tRSPWL	100	–	–	ns
READ Low to data active	tRDLZ	–	–	80	ns
READ High to data tristate	tRDHZ	–	–	80	ns
Address to Valid Data	tPRD	–	–	80	ns
Address setup to WRITE Rising Edge	tASUW	20	–	–	ns
Address hold from WRITE Rising Edge	tAHW	10	–	–	ns
WRITE pulse width Low	tWPWL	100	–	–	ns
Data setup to WRITE Rising Edge	tDSUW	20	–	–	ns
Data hold from WRITE Rising Edge	tDHW	10	–	–	ns
READ High to INT clear when reading register RD0	tINTR	–	–	400	ns

1. Timing for all outputs assumes a maximum load of 30 pF.
 2. "Address" refers to input signals CHIPSEL, A0, A1, A2, and A3. "Data" refers to I/O signals D0, D1, D2, D3, D4, D5, D6, and D7.

Table 31: General System and Hardware Mode Timing

Parameter	Min	Typ ¹	Max	Unit	
Throughput delay	TDATA to TTIP/TRING	–	6.85	12.5	μs
	RTINP/RRING to RDATA	–	36.0	72	μs
Hardware Mode	"ACTREQ" input transitional pulse width (High or Low)	5	–	–	μs
	"QUIET" transitional pulse width (High-to-Low)	5	–	–	μs

1. Typical values are at 25° C and are for design aid only; not guaranteed and not subject to production testing.

Figure 20: RESET and INTERRUPT Timing (μ P Control Mode)

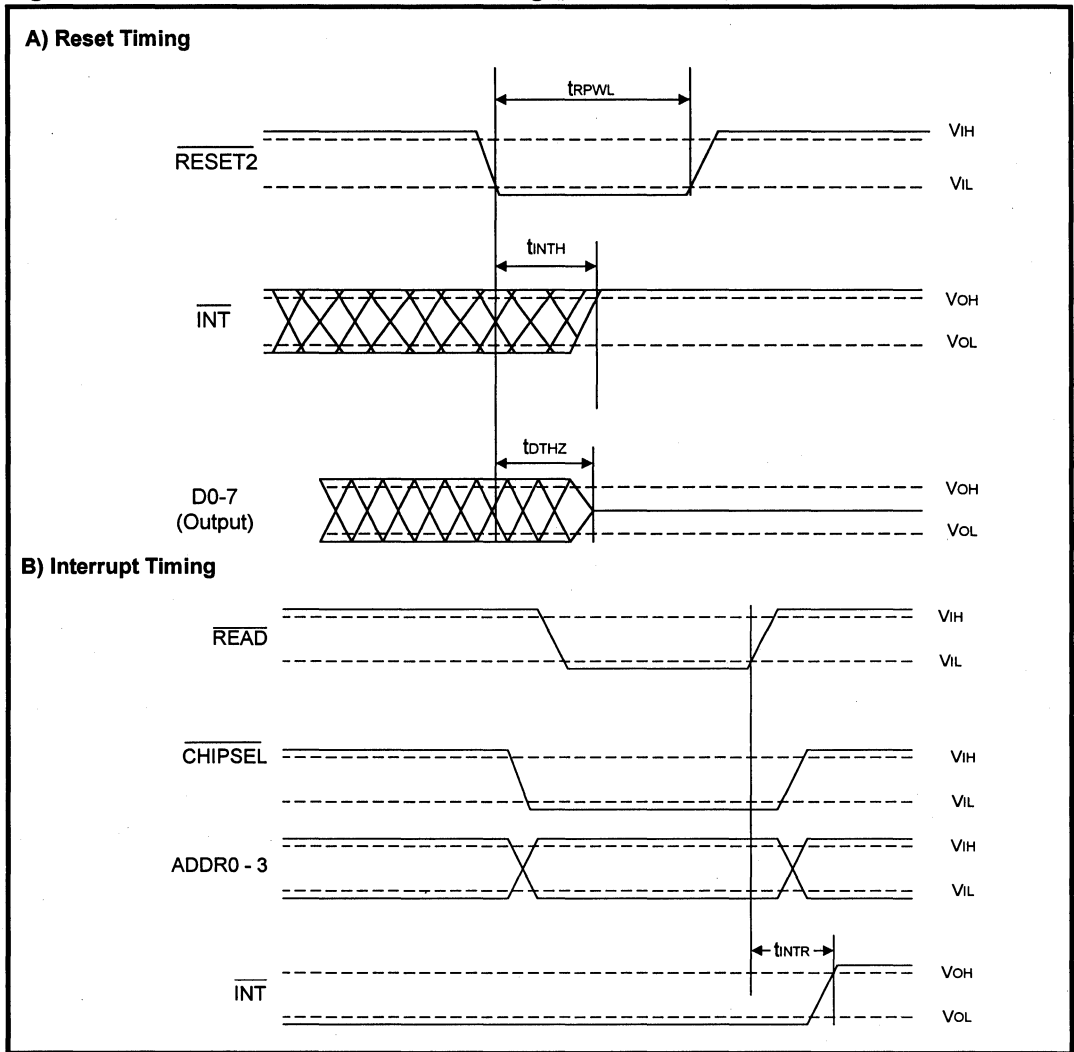
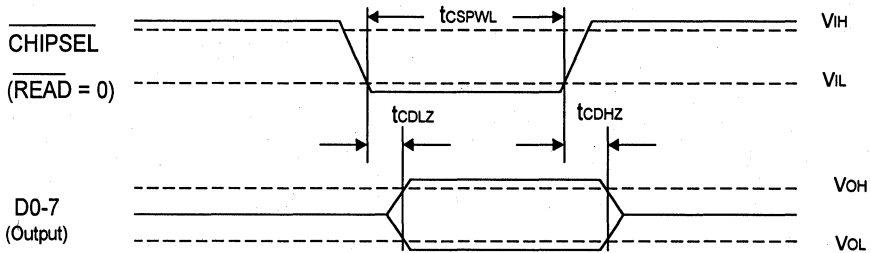
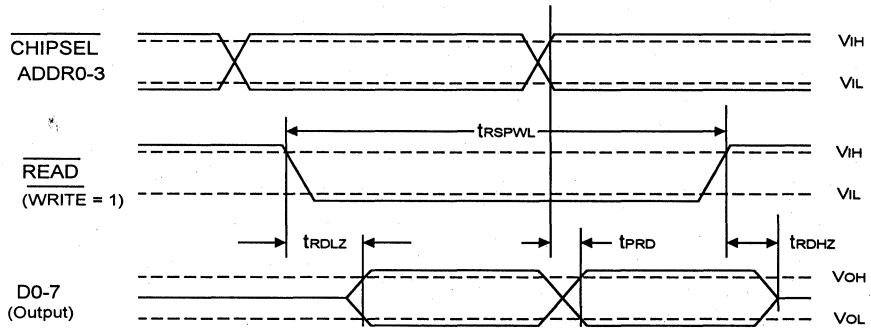

Figure 21: Parallel Data Channel Timing

A) Chip Select Timing



B) Data Read Timing



C) Data Write Timing

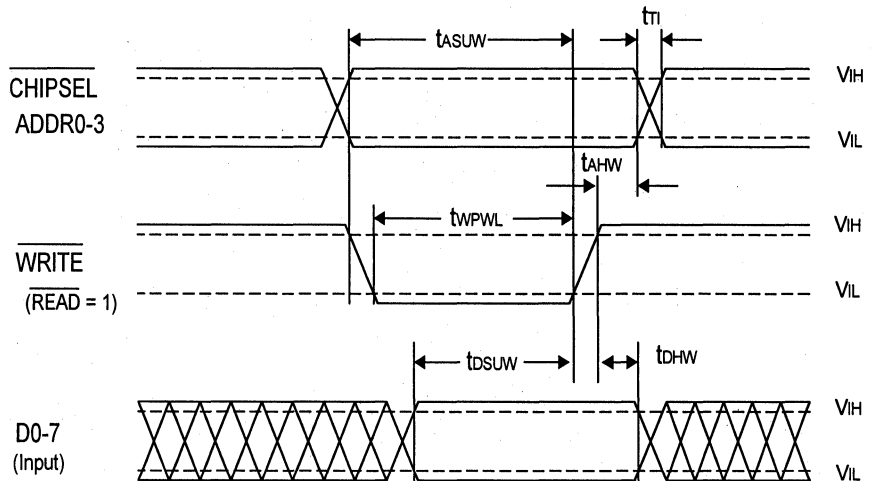

PDH Multiplexers



SXT6234

E-Rate Multiplexer

General Description

The SXT6234 E-Rate Multiplexer is a single-chip solution for multiplexing four tributary channels into a single high speed data stream and for demultiplexing a high speed data stream back to four tributary channels. All of the necessary circuitry is integrated into the SXT6234 E-Rate Multiplexer; there is no need for an external framing device.

The SXT6234 E-Rate Multiplexer conforms to both the (ITU) G.742 and (ITU) G.751 multiplexing formats defined by the International Telecommunications Union (ITU; formerly known as CCITT): G.742 recommendation for multiplexing four E1 channels into an E2 frame; and the G.751 recommendation for multiplexing four E2 channels into an E3 frame.

The SXT6234 E-Rate Multiplexer also encodes and decodes HDB3 zero suppression line coding used on E1, E2, and E3 signals. The coder and decoder input/output pins are externally accessible, allowing either HDB3 or NRZ (non-return-to-zero) I/O to the multiplexer. The SXT6234 E-Rate Multiplexer can also serve as a five channel HDB3 coder and decoder.

Applications

- E1/E2 Multiplexer (2/8 Mbit/s)
- E2/E3 Multiplexer (8/34 Mbit/s)
- E1/E3 Multiplexer (2/34 Mbit/s)

Features

- Performs four-E1 to one-E2, or four-E2 to one-E3 multiplexing. Five ICs will implement a sixteen-E1 to one-E3 Multiplexer.
- Fully compliant with the G.742 and G.751 ITU recommendations. Fully compliant with G.703 when used with LXT305/332 Line Interface.
- A robust frame-acquisition and frame-holding algorithm minimizes frame slippage, acquires and holds frame below 10^{-2} bit error rate.
- Four auxiliary low speed data or flag channels are available via the Stuffing Bits on each tributary channel.
- Access to the Alarm bit and the National bit. These can be used as recommended by ITU or for proprietary use.
- Five independent HDB3 CODECs allow Multiplexer I/O in either HDB3 or NRZ formats. The SXT6234 can also function as a stand alone five-channel HDB3 transcoder.

NOTE

The SXT6234 will not be available in India until June, 1997.

SXT6234 Block Diagram

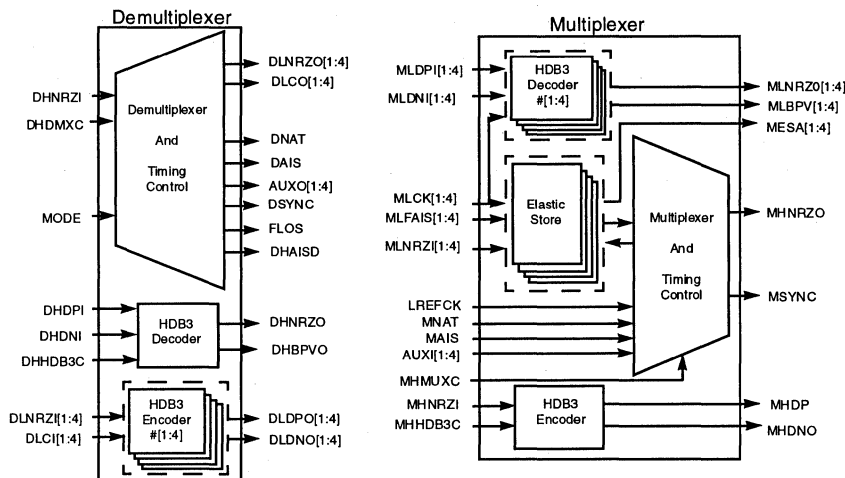

Figure 1: SXT6234 Pin Assignment

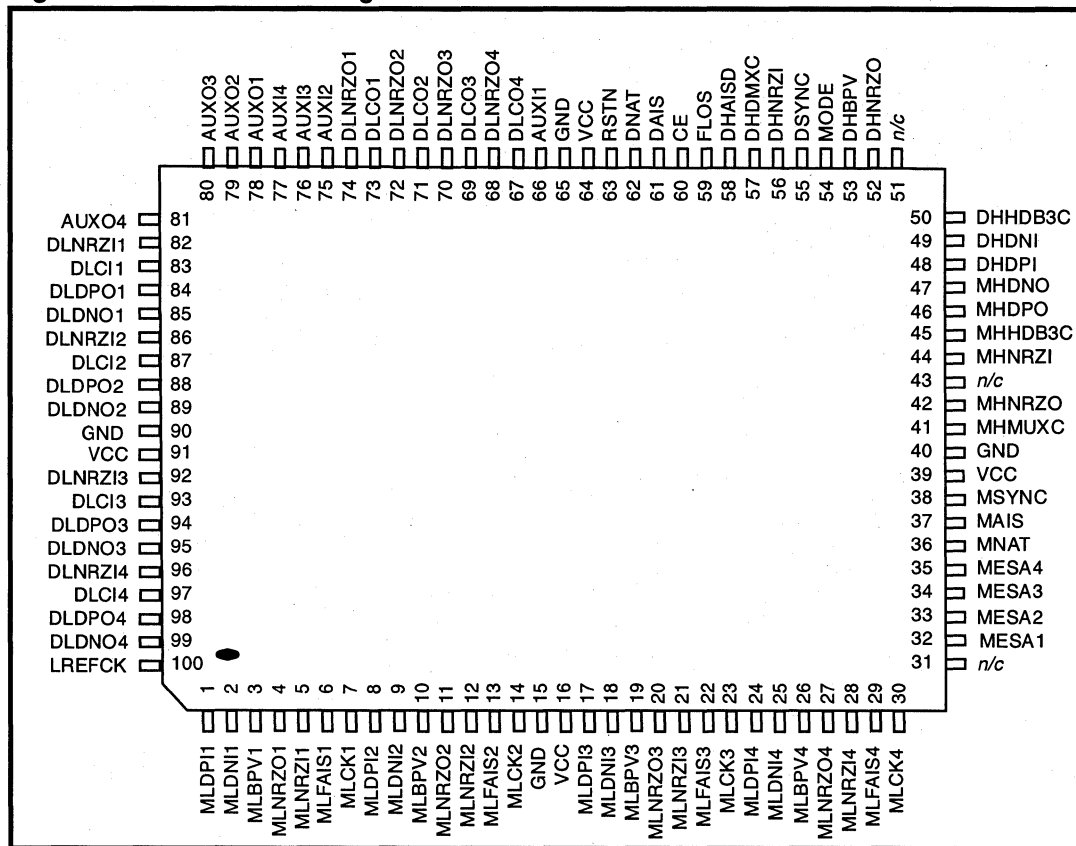

Table 1: Input Signals

Pin #	Sym	Description
1	MLDP1	HDB3 Decoder #1 Positive Data Input. HDB3 Decoder #1 positive rail input clocked on the positive transitions of the clock signal MLCK1.
2	MLDN1	HDB3 Decoder #1 Negative Data Input. HDB3 Decoder #1 negative rail input clocked on the positive transitions of the clock signal MLCK1.
8	MLDP2	HDB3 Decoder #2 Positive Data Input. HDB3 Decoder #2 positive rail input clocked on the positive transitions of the clock signal MLCK2.
9	MLDN2	HDB3 Decoder #2 Negative Data Input. HDB3 Decoder #2 negative rail input clocked on the positive transitions of the clock signal MLCK2.
17	MLDP3	HDB3 Decoder #3 Positive Data Input. HDB3 Decoder #3 positive rail input clocked on the positive transitions of the clock signal MLCK3.
18	MLDN3	HDB3 Decoder #3 Negative Data Input. HDB3 Decoder #3 negative rail input clocked on the positive transitions of the clock signal MLCK3.



Table 1: Input Signals—continued

Pin #	Sym	Description
24	MLDPI4	HDB3 Decoder #4 Positive Data Input. HDB3 Decoder #4 positive rail input clocked on the positive transitions of the clock signal MLCK4.
25	MLDNI4	HDB3 Decoder #4 Negative Data Input. HDB3 Decoder #4 negative rail input clocked on the positive transitions of the clock signal MLCK4.
7	MLCK1	Multiplexer Tributary #1 Clock Input. Clock input for Multiplexer side tributary channel #1. This clock is used by both the associated HDB3 decoder and the Multiplexer. For standard rate applications, this clock must have a frequency of ± 50 ppm for 2048 kbit/s operation and ± 30 ppm for the 8448 kbit/s operation as per ITU G.703.
14	MLCK2	Multiplexer Tributary #2 Clock Input. Idem as MLCK1 with tributary #2 in.
23	MLCK3	Multiplexer Tributary #3 Clock Input. Idem as MLCK1 with tributary #3 in.
30	MLCK4	Multiplexer Tributary #4 Clock Input. Idem as MLCK1 with tributary #4 in.
5	MLNRZI1	Multiplexer Tributary #1 NRZ Data Input. Multiplexer tributary NRZ input clocked on the falling edge of the clock signal MLCK1.
12	MLNRZI2	Multiplexer Tributary #4 NRZ Data Input. Multiplexer tributary NRZ input clocked on the falling edge of the clock signal MLCK2.
21	MLNRZI3	Multiplexer Tributary #3 NRZ Data Input. Multiplexer tributary NRZ input clocked on the falling edge of the clock signal MLCK3.
28	MLNRZI4	Multiplexer Tributary #4 NRZ Data Input. Multiplexer tributary NRZ input clocked on the falling edge of the clock signal MLCK4.
6	MLFAIS1	Force AIS on Multiplexer Tributary #1. Active high signal to force AIS (all 1's) data and LREFCK clock on Multiplexer tributary #1.
13	MLFAIS2	Force AIS on Multiplexer Tributary #2. Active high signal to force AIS (all 1's) data and LREFCK clock on Multiplexer tributary #2.
22	MLFAIS3	Force AIS on Multiplexer Tributary #3. Active high signal to force AIS (all 1's) data and LREFCK clock on Multiplexer tributary #3.
29	MLFAIS4	Force AIS on Multiplexer Tributary #4. Active high signal to force AIS (all 1's) data and LREFCK clock on Multiplexer tributary #4.
66	AUXI1	Auxiliary Flag/Data #1 Input. The signal on this pin is clocked into the frame at the stuffing bit location (J1) when justification is such that tributary data is NOT placed at this location. A high on alarm signal MESA1 indicates this condition during the current frame.
75	AUXI2	Auxiliary Flag/Data #2 Input. See AUXI1 Description. MESA2 is relevant indication signal.
76	AUXI3	Auxiliary Flag/Data #3 Input. See AUXI1 Description. MESA3 is relevant indication signal.
77	AUXI4	Auxiliary Flag/Data #4 Input. See AUXI1 Description. MESA4 is relevant indication signal.
36	MNAT	National Bit Input. National Bit input that is placed in the 12th bit of the frame as per ITU G.742, G.751 specifications.
37	MAIS	AIS/Error Bit Input. AIS Bit input that is placed in the 11th bit of the frame, as per ITU G.742, G.751 specifications.

SXT6234 E-Rate Multiplexer

Table 1: Input Signals—continued

Pin #	Sym	Description
41	MHMUXC	High speed Multiplexer Clock Input. Clock input for Multiplexer functions and NRZ high speed data output. For standard rate applications, this clock must have a frequency of ± 30 ppm for the 8448 kbit/s operation and ± 20 ppm for the 34368 kbit/s operation as per ITU G.703.
44	MHNRZI	HDB3 Encoder #5 NRZ Input. HDB3 Encoder #5 (High speed) NRZ input clocked on the rising edge of MHHDB3C.
45	MHHDB3C	HDB3 Encoder #5 Clock Input. When used in conjunction with the Multiplexer, this pin should be tied to the high speed Multiplexer Clock, MHMUXC, P41.
48	DHDPI	HDB3 Decoder #5 Positive Data Input. HDB3 Decoder #5 (High Speed) positive rail input clocked on the rising edge of DHHDB3C.
49	DHDNI	HDB3 Decoder #5 Negative Data Input. HDB3 Decoder #5 (High Speed) positive rail input clocked on the rising edge of DHHDB3C.
50	DHHDB3C	HDB3 Decoder #5 Clock Input. When used in conjunction with the Demultiplexer, this pin should be tied to the high speed Demultiplexer Clock, DHMUXC, P57.
56	DHNRZI	Demultiplexer NRZ Data Input. Demultiplexer NRZ input clocked on rising edge of DHD-MXC.
57	DHDMXC	High speed Demultiplexer Clock Input. Clock input for Demultiplexer functions and NRZ high speed data in. For standard rate applications, this clock must have a frequency of ± 30 ppm for the 8448 kbit/s operation and ± 20 ppm for the 34368 kbit/s operation as per ITU G.703.
82	DLNRZI1	HDB3 Encoder #1 NRZ Data Input. HDB3 Encoder #1 NRZ input clocked on rising edge of DLCI1.
86	DLNRZI2	HDB3 Encoder #2 NRZ Data Input. HDB3 Encoder #2 NRZ input clocked on rising edge of DLCI2.
92	DLNRZI3	HDB3 Encoder #3 NRZ Data Input. HDB3 Encoder #3 NRZ input clocked on rising edge of DLCI3.
96	DLNRZI4	HDB3 Encoder #4 NRZ Data Input. HDB3 Encoder #4 NRZ input clocked on rising edge of DLCI4.
83	DLCI1	HDB3 Encoder #1 Clock Input. Clock input for HDB3 Encoder #1.
87	DLCI2	HDB3 Encoder #2 Clock Input. Clock input for HDB3 Encoder #2.
93	DLCI3	HDB3 Encoder #3 Clock Input. Clock input for HDB3 Encoder #3.
97	DLCI4	HDB3 Encoder #4 Clock Input. Clock input for HDB3 Encoder #4.
54	MODE	E12/E23 Mode Select. Mode selection for multiplexer/demultiplexer operation. A low signal selects 4E1/E2 multiplexing. A high signal selects 4E2/E3 multiplexing.
100	LREFCK	Tributary Reference Clock. This clock is used as a reference for the Force AIS functions (See Pin 6 Description). For standard rate applications, this clock must have a frequency of ± 50 ppm for the 2048 kbit/s operation and ± 30 ppm for the 8448 kbit/s operation as per ITU G.703.
60	CE	Chip Enable. A high signal forces all outputs into tri-state; used for PCB Testing. This signal should be low for normal operation.
63	RSTN	Reset. An active low reset pin. Must be pulsed low on power up to initialize all internal circuits after V_{cc} and clocks are stable.



Table 1: Input Signals—continued

Pin #	Sym	Description
15, 40 63, 90	GND	Ground. Ground Reference.
16, 39 64, 91	V _{CC}	Voltage. 5-volt supply voltage.

Table 2: Output Signals

Sym	Pin #	Description
MLNRZO1	4	HDB3 Decoder #1 NRZ Output. HDB3 Decoder #1 NRZ output clocked on the rising edge of MLCK1.
MLNRZO2	11	HDB3 Decoder #2 NRZ Output. HDB3 Decoder #2 NRZ output clocked on the rising edge of MLCK2.
MLNRZO3	20	HDB3 Decoder #3 NRZ Output. HDB3 Decoder #3 NRZ output clocked on the rising edge of MLCK3.
MLNRZO4	27	HDB3 Decoder #4 NRZ Output. HDB3 Decoder #4 NRZ output clocked on the rising edge of MLCK4.
MLBPV1	3	HDB3 Decoder #1 Bipolar Violation Alarm. This open collector output pulses every time a bipolar violation occurs in the decoding process.
MLBPV2	10	HDB3 Decoder #2 Bipolar Violation Alarm. This open collector output pulses every time a bipolar violation occurs in the decoding process.
MLBPV3	19	HDB3 Decoder #3 Bipolar Violation Alarm. This open collector output pulses every time a bipolar violation occurs in the decoding process.
MLBPV4	26	HDB3 Decoder #4 Bipolar Violation Alarm. This open collector output pulses every time a bipolar violation occurs in the decoding process.
MESA1	32	Multiplexer Tributary #1 Elastic Store Alarm Indication. Multiplexer justification status for tributary #1. A high indicates bit stuffing on the current frame. A low indicates an information bit. When externally filtered, this signal can be used to indicate elastic store failure or incorrect tributary frequency.
MESA2	33	Multiplexer Tributary #2 Elastic Store Alarm Indication. Idem as MESA1 with tributary channel 2.
MESA3	34	Multiplexer Tributary #3 Elastic Store Alarm Indication. Idem as MESA1 with tributary channel 3.
MESA4	35	Multiplexer Tributary #4 Elastic Store Alarm Indication. Idem as MESA1 with tributary channel 4.
MHNRZO	42	High speed Multiplexer NRZ Output. Multiplexer NRZ data clocked out on the rising edge of MHMUXC.
MHDPO	46	HDB3 Encoder #5 Positive Data Output. HDB3 Encoder #5 Positive rail clocked out on the rising edge of MHHDB3C.
MHDNO	47	HDB3 Encoder #5 Negative Data Output. HDB3 Encoder #5 Negative rail clocked out on the rising edge of MHHDB3C.
DLNRZO1	74	Demux Tributary #1 NRZ Output. This signal is clocked out on the rising edge of DHD-MXC and transitions are coincident with the falling edge of DLCO1.

Table 2: Output Signals—continued

Sym	Pin #	Description
DLNRZO2	72	Demux Tributary #2 NRZ Output. This signal is clocked out on the rising edge of DHD-MXC and transitions are coincident with the falling edge of DLCO2.
DLNRZO3	70	Demux Tributary #3 NRZ Output. This signal is clocked out on the rising edge of DHD-MXC and transitions are coincident with the falling edge of DLCO3.
DLNRZO4	68	Demux Tributary #4 NRZ Output. This signal is clocked out on the rising edge of DHD-MXC and transitions are coincident with the falling edge of DLCO4.
DLCO1	73	Demux Tributary #1 Clock Output. Demultiplexer side recovered clock of tributary #1. This clock has a duty cycle of 75% and is gapped at points in the frame where tributary data is not present (i.e., frame word). The maximum gap is 3 clocks at the frame word location. The frequency will match that of the far end multiplexer tributary input. This signal is clocked out on the rising edge of DHDMXC.
DLCO2	71	Demux Tributary #2 Clock Output. Demultiplexer side recovered clock of tributary #2. See DLCO1 description.
DLCO3	69	Demux Tributary #3 Clock Output. Demultiplexer side recovered clock of tributary #3. See DLCO1 description.
DLCO4	67	Demux Tributary #4 Clock Output. Demultiplexer side recovered clock of tributary #4. See DLCO1 description.
DLDP01	84	HDB3 Encoder #1 Output +. HDB3 Encoder #1 positive rail output clocked out on the rising edge of DLCI1.
DLDN01	85	HDB3 Encoder #1 Output -. HDB3 Encoder #1 negative rail output clocked out on the rising edge of DLCI1.
DLDP02	88	HDB3 Encoder #2 Output +. HDB3 Encoder #2 positive rail output clocked out on the rising edge of DLCI2.
DLDN02	89	HDB3 Encoder #2 Output -. HDB3 Encoder #2 negative rail output clocked out on the rising edge of DLCI2.
DLDP03	94	HDB3 Encoder #3 Output +. HDB3 Encoder #3 positive rail output clocked out on the rising edge of DLCI3.
DLDN03	95	HDB3 Encoder #3 Output -. HDB3 Encoder #3 negative rail output clocked out on the rising edge of DLCI3.
DLDP04	98	HDB3 Encoder #4 Output +. HDB3 Encoder #4 positive rail output clocked out on the rising edge of DLCI4.
DLDN04	99	HDB3 Encoder #4 Output -. HDB3 Encoder #4 negative rail output clocked out on the rising edge of DLCI4.
DHNRZO	52	HDB3 Decoder #5 NRZ Data Output. HDB3 Decoder #5 NRZ data clocked out on the rising edge of DHHDB3C.
DHBPV	53	HDB3 Decoder #5 Bipolar Violation Alarm. This active high signal pulses every time a bipolar violation occurs in the decoding process.
AUX01	78	Auxiliary Flag/Data #1 Output. Auxiliary Data #1 output that contains data value input on AUXI1. See AUXI1 Description.
AUX02	79	Auxiliary Flag/Data #2 Output. Auxiliary Data #2 output that contains data value input on AUXI2. See AUXI1 Description.



Table 2: Output Signals—continued

Sym	Pin #	Description
AUXO3	80	Auxiliary Flag/Data #3 Output. Auxiliary Data #3 output that contains data value input on AUXI3. See AUXI1 Description.
AUXO4	81	Auxiliary Flag/Data #4 Output. Auxiliary Data #4 output that contains data value input on AUXI4. See AUXI1 Description.
DNAT	62	National Bit Output. Updated every frame based on the contents of the 12th bit in the frame as per ITU G.742, G.751
DHAISD	58	Demultiplexer Input AIS Detect. Active high alarm occurs when an all 1's condition (AIS) is detected at the DHNRZI input. This alarm will not occur if the input is a framed signal (i.e. all tributaries are AIS on multiplexer side).
FLOS	59	Demultiplexer Loss of Frame Alarm. Active high Frame Loss Alarm that occurs when the Demux has not detected the Frame word.
MSYNC	38	Multiplexer Frame Sync Pulse. Pulse of one high speed clock cycle synchronous with the last bit of the frame (just before the frame word of the next frame).
DSYNC	55	Dmx Frame Sync Pulse. Pulse of one high speed clock cycle synchronous with the first bit of the frame word of the high speed incoming signal.
DAIS	61	AIS Error Bit Output. Updated every frame based on the contents of the 11th bit in the frame as per ITU G.742 and G.751.
NC	31, 43 51	Not Connected. These pins must be left unconnected.

FUNCTIONAL DESCRIPTION

NOTE

This Functional Description is for design aid only

The SXT6234 E-Rate Multiplexer consists of a multiplexer block, a demultiplexer block, five HDB3 decoders, and five HDB3 encoders. If the HDB3 codecs are used, the signal flow would be as follows:

Multiplexer: Four tributaries of data feed HDB3 decoders one through four. The NRZ outputs of the decoders are connected to the multiplexer tributary inputs. Within the multiplexer, the justification or stuffing for each tributary is determined; the frame word is added; and the high speed NRZ data sent out. The multiplexer output is connected to HDB3 encoder five where it is encoded and sent out as Positive Data Output (MHDPO) and Negative Data Output (MHDNO).

Demultiplexer: High speed encoded data feeds the HDB3 decoder five and is output as NRZ data. The decoder output is connected to the demultiplexer input where it enters both the frame search circuitry and the demultiplexing circuitry. Once the frame is detected, the NRZ data is demultiplexed into the four tributaries and the justification is removed. Tributary data is then sent out in NRZ format. These tributary outputs, both Clock Output (DLCO_x) and NRZ Output (DLNRZO_x), are connected to HDB3 encoders one through four, encoded, and output as Positive Data (MHDPO) and Negative Data (MHDNO).

FRAME FORMAT

The multiplexer and demultiplexer share the Mode Select (MODE) control pin. When MODE is low, the multiplexer conforms to the ITU G.742 format for four-E1 to E2 (Figure 2). An E2 frame is 848 bits long, with 205 data bits and one justification bit for each E1 tributary. When MODE is high, the multiplexer conforms to the ITU G.751 format for four-E2 to E3 (Figure 3). This E3 frame is 1536 bits long, with 377 data bits and one justification bit for each E2 tributary.

In both E2 and E3 formats, there are two flag bits per frame: the AIS bit and the National bit. The four justification bits may also be used as additional flag bits.

HDB3 CODECS

Five HDB3 codecs are included within the SXT6234 to allow easy integration with a wide range of line interface circuits. There are four low speed codecs for the tributary

streams and one high speed codec to process the high speed output data. All five codecs are identical and all I/O pins are externally accessible for each device. All codecs can be operated at the maximum operating speed if the chip is used as a stand alone HDB3 transcoder. Note that the "low speed" decoders share a clock with the multiplexer tributary clocks.

Each HDB3 decoder is provided with Positive Data, Negative Data, and clock; they decode the data into a single NRZ bit stream. The HDB3 encoders are provided with NRZ data and clock; they produce the Positive Data and Negative Data bit streams.

HDB3 DECODER ALARMS

A Bipolar Violation Alarm (MLBPV_x, DHBPV) associated with each HDB3 decoder indicate detection of a coding violation error within the data. Coding violations include Bipolar Violations, a string of more than four zeros in a row, or encoding violations. The active high alarm is one clock cycle in duration.

MULTIPLEXER

The multiplexer formats four low speed NRZ tributaries into a single high speed bit stream. Tributary data rates are synchronized via internal elastic store memories using a positive justification process as specified in the ITU recommendations.

Data enters a first-in/first-out (FIFO) elastic store block. The FIFO receives the data along with the tributary clock and a pointer generated from the timing control. The output of the elastic store block is clocked by the tributary enable pulses from the timing control, and the data is finally processed by the multiplexer. Processing normally places the output data bit into the high speed bit stream during the tributary enable. An once-per-frame exception occurs during justification. During this event the location of the pointer in the FIFO is determined and a decision made for justification. If the elastic store is less than half full, a justification bit (used for the auxiliary flag channels) is placed in the bit stream and the MESA_x pin is set high. When the elastic store becomes over half full, a tributary bit is clocked out from the FIFO, placed in the bit stream, and the MESA_x pin set low. There are three justification indicators spread throughout the frame to show the status of the justification bit to the demultiplexer. Finally, the National and AIS bits are added at the beginning of each frame, and the bit stream is clocked out on MHNZRZO.

The multiplexer timing control receives a high speed clock and generates the frame structure and timing control according to the bit length of each frame. This is 848 bits



for an E2 frame, and 1536 bits for an E3 frame. MODE provides for either E2 or E3 selection.

In case of tributary transmission failure or the loss of a signal, tributary data can be forced to an all 1's state. For each tributary this function is controlled at the MLFAISx pin.

Flag Bits

Two flag bits, defined as the National Bit (MNAT) and AIS/Error Bit (MAIS) are transmitted with each frame. At the appropriate time the bit values of the MNAT and MAIS inputs are inserted into the frame. There are also four auxiliary flag channels available (AUXLx) that use the justification bit. These flags are placed in the frame approximately 40% of the time, depending on the ratio of the tributary clock to the multiplexer clock. A high on MESAx indicates that the AUXLx flag will be inserted into the current frame.

Multiplexer Alarms

An indicator bit (MESAx) for each tributary monitors the status of the elastic store memory. This pin provides the justification status of the tributary. Under normal conditions this pin toggles at the frame rate with a 40% duty cycle. Large variation of the duty cycle indicates the tributary clock frequency is out of specification. Loss of clock would cause MESA to assume a rail value.

For use as a frequency alarm this signal should be filtered by a single-pole RC filter far below the frame frequency, and connected to a pair of voltage comparators. The unfiltered alarm signal can be used to clock the auxiliary data channel inputs.

Figure 2: E2 Frame

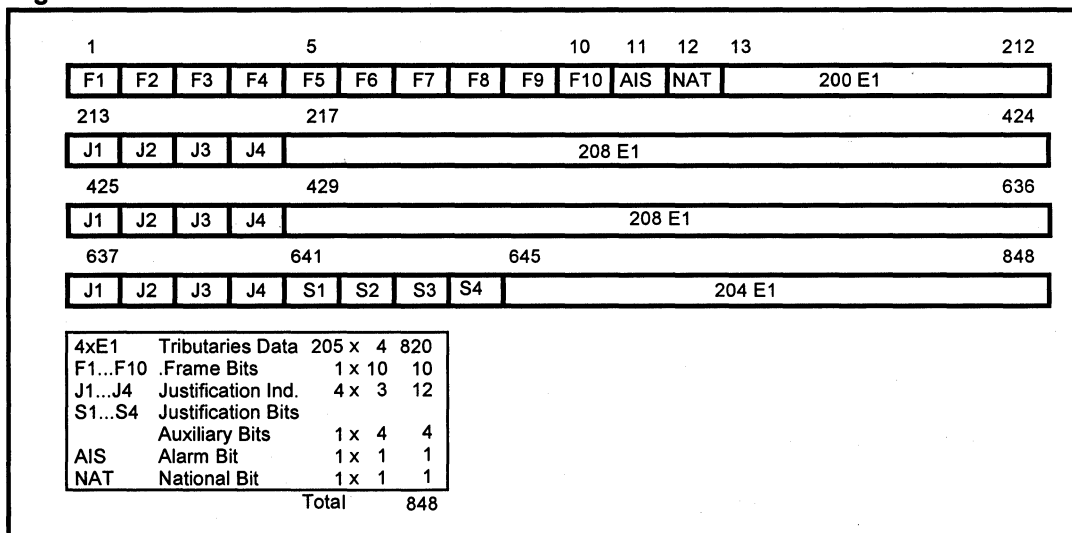

DEMULTIPLEXER

Data entering the demultiplexer is sent to both the demultiplexing block and the framer. The framer, using a Sieve algorithm, examines the incoming data to find the framing word. A frame is declared found when three passes show the frame word has been found at the same location within the frame. The timing module is then synchronized to the incoming data frame and the Frame Loss Alarm turns off.

Valid tributary data can be extracted after the frame is found. For each tributary, three justification indicator bits are stored. A majority-rule determination decides whether the justification bit is sent as tributary data (with clock) or as an auxiliary bit (with no clock).

The DNAT and DAIS flag bits are updated for each frame and sent to their dedicated pins. The auxiliary flag bits AUXOx are updated when they are available on the frame.

Demultiplexer Alarms

The demultiplexer has two active-high alarms: Frame Loss (FLOS), and Demultiplexer Input AIS Detect (DHAISD).

- FLOS is active at power-up and clears after three consecutive frames are detected. During normal operation FLOS becomes active after missing four consecutive frames.
- DHAISD activates after 768 consecutive 1's pass through the high speed NRZ data stream. DHAISD will occasionally glitch if four tributaries are all 1's and the justification of all four channels is identical. This glitch is filtered with a single-pole RC filter.

APPLICATION INFORMATION

NOTE

This application information is for design aid only.

E1/E3 MULTIPLEXER BLOCK DIAGRAM

Figure 4 is a block diagram of the E1/E3 Multiplexer.

E1 Line Interface

- Receive clocks from the pulse data.
- Pass either HDB3 encoded signals to the E-Rate Multiplexer as clock and RZ data or as NRZ data¹. (Both positive and negative RZ data.)

SXT6234, E1/E2 Stage

- The SXT6234 may interface with either HDB3 or non-HDB3 coded signals. Data from an LIU that does not perform HDB3 decoding must be connected to the HDB3 inputs on the SXT6234. These are the clock (MLCK_x) and decoder data input signals (both positive - MLDP_x and negative - MLDN_x). When receiving data from an LIU which does perform HDB3 decoding, the NRZ data is connected to the MLNRZ_x input and the clock connects to the MLCK_x in on the SXT6234

- The four tributaries are interleaved into a single, intermediary E2 rate data stream. An on-board crystal oscillator drives the data output frequency from the mux at the E2 rate of 8.448 MHz. A bit stuffing algorithm implemented in the SXT6234 ensures tributary rate integrity at the output. The SXT6234 contains elastic store buffers to manage bit-stuffing process.
- The NRZ data is sent to a tributary of the E-Rate Multiplexer, stage E2/E3.

SXT6234, E3 Stage

- The multiplexer portion of the SXT6234 interleaves four asynchronous E2 rate NRZ data streams into a single E3 data stream. Depending on the configuration, either an on-board crystal oscillator or an external reference clock drives the data output frequency from the mux at the rate of 34.368 Mbps. The bit stuffing algorithm implemented in the SXT6234 ensures tributary rate integrity at the output.
- If the LIU provides HDB3 encoding, then the NRZ data and clock are passed to the E3 line interface.
- If the LIU does not provide HDB3 encoding, then encoding is done by the SXT6234 and data is output as positive and negative data. An activity monitor provides tributary fail notification when necessary.

See Application Note 9501 for additional information.

1. If the HDB3 decoder is on the line interface unit (LIU).

Figure 4: E1/E3 Multiplexer

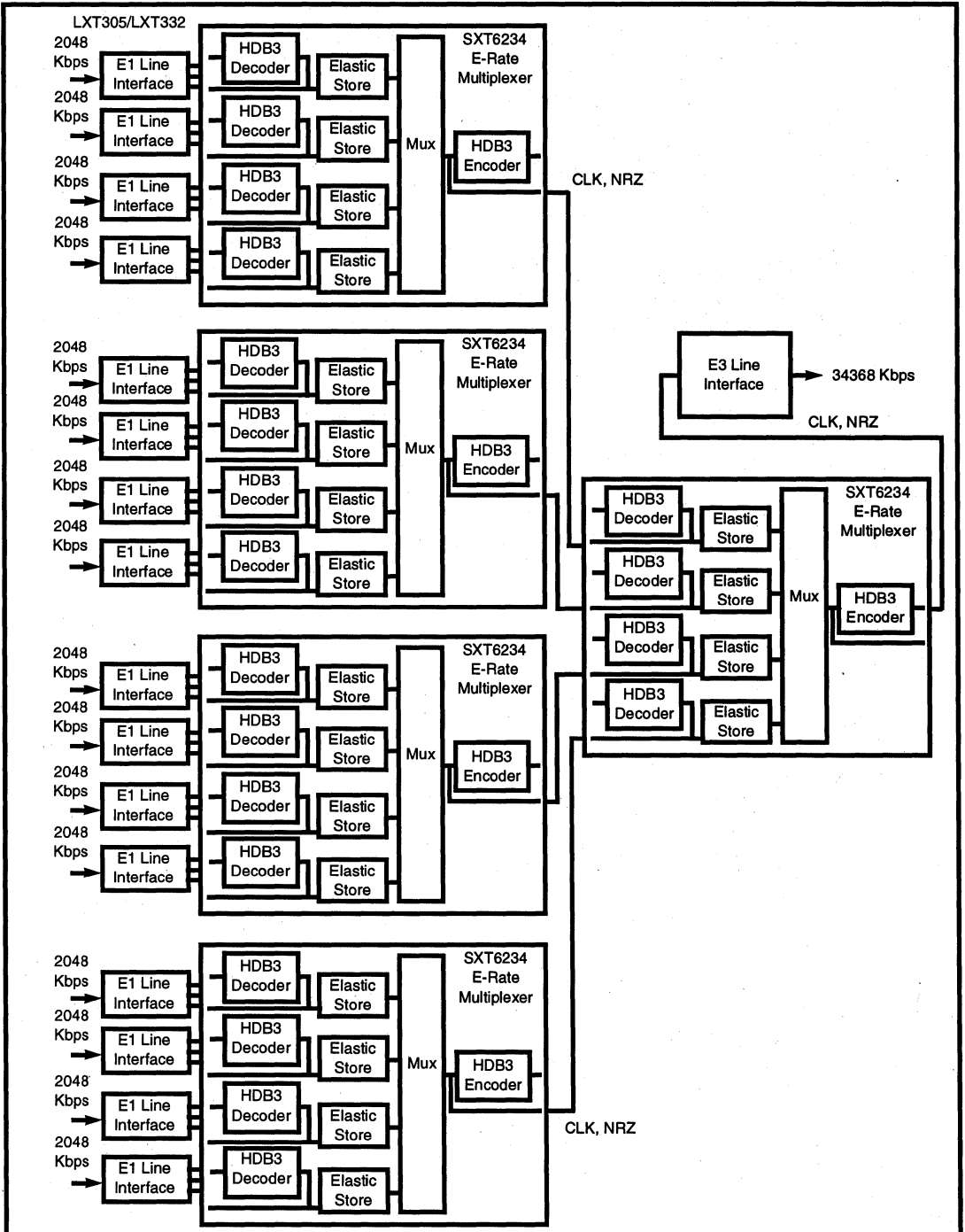

TEST SPECIFICATIONS

NOTE

Minimum and maximum values in Tables 3 through 9 and Figures 5 through 10 represent the performance specifications of the SXT6234 E-Rate Multiplexer and are guaranteed by test except, where noted, by design. Typical values are not subject to production testing.

The SXT6234 E-Rate Multiplexer, fabricated with 1.2-micron CMOS technology, is currently available in a 100-pin plastic quad flat pack package (EIAJ standard 100PQFP). All device I/O comply with 5V CMOS standards. A list of input and output signals is provided with this data sheet. There are 46 input signals and 43 output signals. In addition, there are four V_{CC} power pins and four Ground power pins.

A Chip Enable is provided to facilitate board level, in-circuit testing during the PCB manufacturing process. The SXT6234 E-Rate Multiplexer is fully tested before shipment.

Table 3: Absolute Maximum Ratings

Parameter	Symbol	Min	Max	Units
DC Supply Voltage	V_{CC}	-0.3	7.0	V
Input Voltage on any Pin	V_{IN}	0	$V_{CC} + 0.3$	V
Input Current	I_{IN}	--	10	μA
Ambient Operating Temperature	T_{AM}	0	+70	$^{\circ}C$
Storage Temperature	T_{STOR}	-55	+150	$^{\circ}C$

CAUTION

Exceeding these values may cause permanent damage. Functional operation under these conditions is not implied. Exposure to absolute maximum rating conditions for extended periods may affect device reliability.

Table 4: DC Characteristics ($T_A=0$ to $70^{\circ}C$, $V_{CC}=\pm 5\%$, $GND=0V$)

Parameter	Symbol	Min	Typ	Max	Units	Test Conditions
High Level Input Voltage	V_{IH}	70	--	--	% of V_{CC}	
Low Level Input Voltage	V_{IL}	--	--	30	% of V_{CC}	
High Level Output Voltage	V_{OH}	2.4	4.5	--	V	$I_{OH} = 4\text{ mA}$ $V_{DD} = 4.75\text{ V}$
Low Level Output Voltage	V_{OL}	--	0.2	0.4	V	$I_{OH} = 4\text{ mA}$ $V_{DD} = 4.75\text{ V}$
Input Leakage Current	I_{IL}	--	--	10	μA	$V_{DD} = 5.25\text{ V}$
Three State Leakage Current	I_{HZ}	-10	1	10	μA	$V_{DD} = 5.25\text{ V}$
Power Dissipation 4E1/E2 mode 4E2/E3 mode	PD		100 500		mW mW	$V_{DD} = 5.25\text{ V}$ $V_{DD} = 5.25\text{ V}$
Static Current	I_{DD}	--	1	20	μA	$V_{DD} = 5.25\text{ V}$

AC TIMING SPECIFICATIONS

NOTE

Unless otherwise specified, all timing specifications are referenced at ambient condition as $T_{Ambient} = 0^{\circ}$ to 70°C , $V_{CC} = \pm 5\%$, $GND = 0V$.

Figure 5: HDB3 Encoder and Decoder Timing (Refer to Table 5)

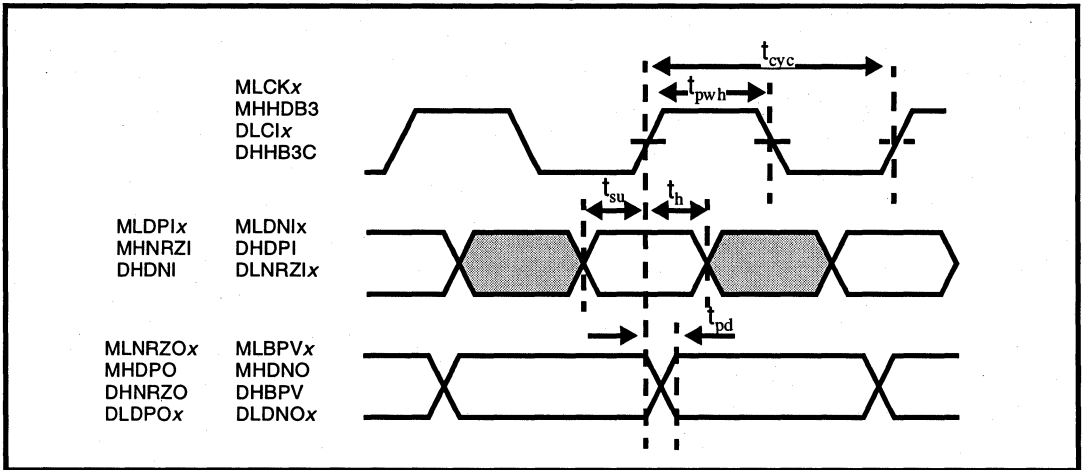

Table 5: HDB3 Encoder and Decoder (Refer to Figure 5)

Parameter	Symbol	Min	Typ	Max	Unit
Clock Duty Cycle	tPWH	40	--	60	%
Data to Clock Setup Time	tSU	5	--	--	ns
Data to Clock Hold Time	tH	6	--	--	ns
Clock to Data Propagation Time (50pF Capacitive Load)	tPD	--	15	30	ns

Figure 6: Multiplexer Tributary Input Timing (Refer to Table 6)

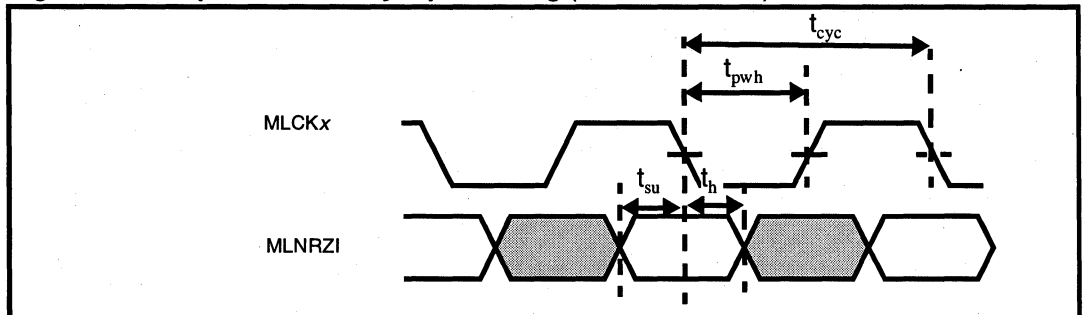

Table 6: Multiplexer Tributary Input (Refer to Figure 6)

Parameter	Symbol	Min	Typ	Max	Unit
Clock Duty Cycle	tpWH	40	--	60	%
Data to Clock Setup Time (Falling Edge)	tsU	5	--	--	ns
Data to Clock Hold Time (Falling Edge)	th	5	--	--	ns

Figure 7: High Speed Multiplexer Input & Output Timing (Refer to Table 7)

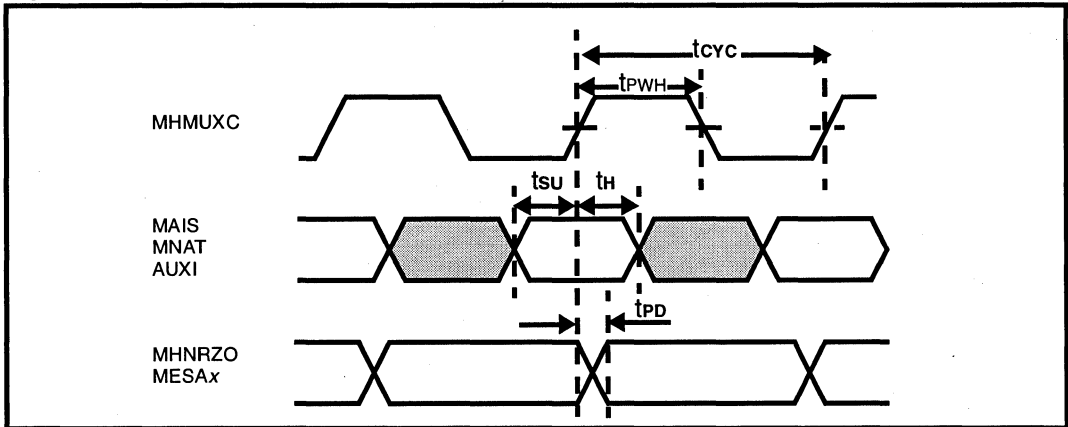

Table 7: High Speed Multiplexer Input & Output (Refer to Figure 7)

Parameter	Symbol	Min	Type	Max	Unit
Clock Duty Cycle	tpWH	40	--	60	%
Data to Clock Setup Time	tsU	5	--	--	ns
Data to Clock Hold Time	th	6	--	--	ns
Clock to Data Propagation Time	tPD	--	20	30	ns

Figure 8: High Speed Demultiplexer Input & Output Timing (Refer to Table 8)

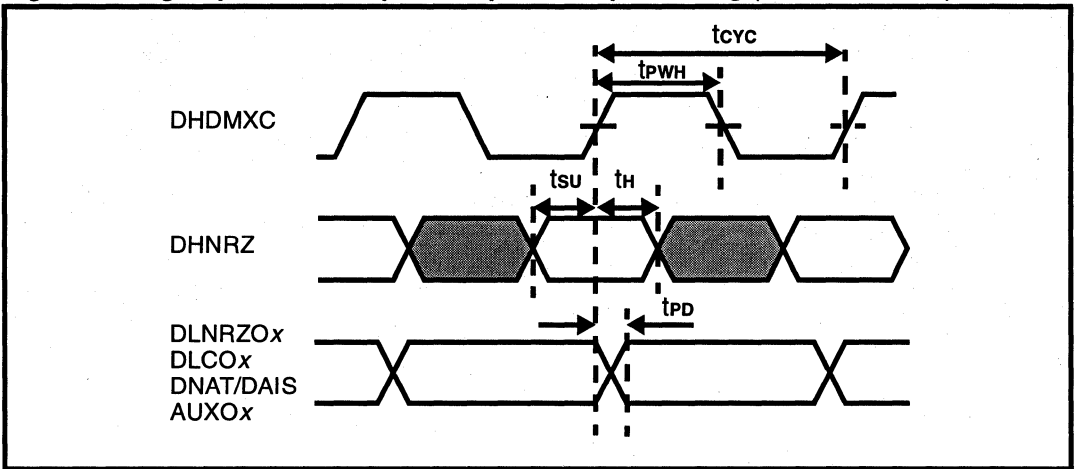

Table 8: High Speed Demultiplexer Input & Output (Refer to Figure 8)

Parameter	Symbol	Min	Type	Max	Unit
Clock Duty Cycle	t_{pwh}	45	--	60	%
Data to Clock Setup Time	t_{su}	8	--	--	ns
Data to Clock Hold Time	t_h	5	--	--	ns
Clock to Data Propagation Time	t_{pd}	--	20	30	ns

Figure 9: Chip Enable Timing (Refer to Table 9)

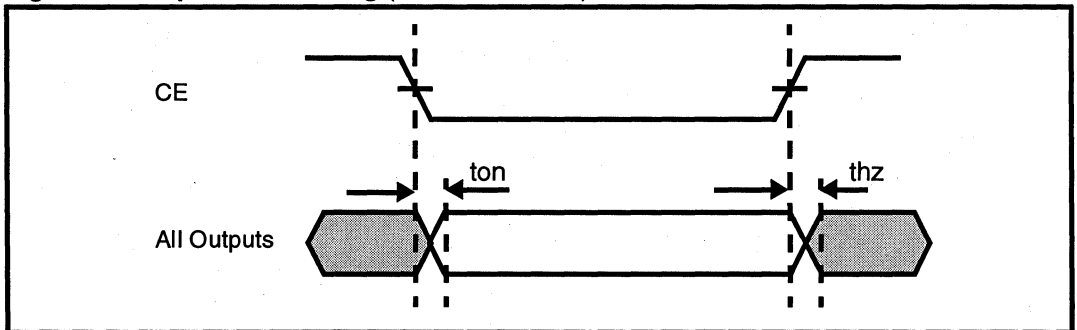

Table 9: Chip Enable (Refer to Figure 9)

Parameter	Symbol	Min	Type	Max	Unit
CE to Outputs Enabled	t_{on}		20	30	ns
CE to Outputs High Impedance	t_{pwh}		20	30	ns

Transmission Application Notes



LXT304A Transceiver

D4 Channel Bank Applications

General Description

Existing D4 Channel Bank architectures frequently employ: (1) a plug-in card for T1 pulse generation (6.0 V peak); and (2) a separate card for pulse shaping and Line Build-Out (LBO). The LXT304A integrates the functions of both cards on a single chip producing a DSX-1 compatible, 3.0 V peak output pulse with a standard transformer. In new designs, the LXT304A can replace two cards with one. However, the LXT304A is also compatible with existing dual-card architectures. With an appropriate output transformer, the LXT304A can produce full 6.0 V peak amplitude pulses suitable for D4 Channel Bank applications with separate pulse shaping/LBO cards.

Line Interface Circuitry

To achieve the 6.0 V peak output, the FCC Part 68-010 Equalizer Code setting is used. (EC = 010.) With the standard 1:1.15 transformer, this code produces a 3.0 V peak pulse. However, doubling the transformer turns ratio to 1:2.30 produces the desired 6.0 V peak pulse.

The Application Diagram shows a D4 Channel Bank application circuit using the correct Equalizer Code setting and transformer. Transformer specifications are listed in Table 1.

Note: Typical pulse undershoot = 30% ($\pm 10\%$).

Application Diagram

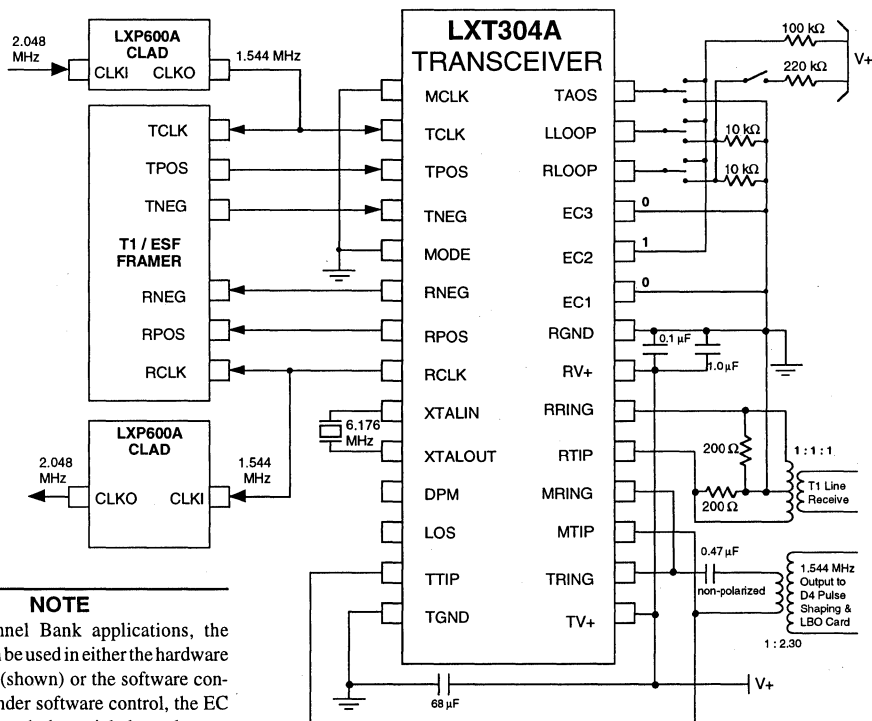

NOTE

For D4 Channel Bank applications, the LXT304A can be used in either the hardware control mode (shown) or the software control mode. Under software control, the EC code is set through the serial channel.

LXT304A Transceiver - D4 Channel Bank Applications

Table 1: Transformer Specifications

Parameter	Value
Turns Ratio	1:2.3 ($\pm 2\%$)
Primary Inductance	1.2 mH min
Leakage Inductance	0.5 μ H max
Interwinding Capacitance	25 pF max
Series Resistance	1.0 Ω PRI

Vendors supplying suitable transformers include Pulse Engineering, Bel Fuse, Midcom and Schott.

Application circuit functionality was confirmed using a Pulse Engineering PE65558 transformer.

LXT300 and LXT310 Interchangeability

Adapting Short-Haul T1 Boards to Long-Haul Applications

General

While the LXT300 is designed for short-haul (up to 200 m) T1/E1 applications and the LXT310 is designed for long-haul (up to 2 km) T1 applications, these transceivers are quite similar in function. There are only minor differences in line interfaces and pin configurations. Therefore, T1 equipment designed for short-haul applications (using the LXT300) can easily be adapted to provide long-haul capability (using the LXT310) as an option. This application note describes the steps necessary to adapt a single design so that it can be used for both long-haul and short-haul applications.

Functional Differences

- In the Hardware Mode, three Equalizer inputs on the LXT300 are replaced by two LBO inputs and an NLOOP output on the LXT310. These pins are identical in the Software Mode, but the bit register is defined differently.
- The LXT300 uses two inputs and an output for the Driver Performance Monitor (DPM) function. On the LXT310, these pins are replaced by inputs for Jitter Attenuation Select (JASEL) and Equalizer Gain Limitation (EGL), and an output for Line Attenuation (LATN).
- The LXT300 uses a 1:2 transformer for both the Tx and Rx line interfaces. The LXT310 uses a 1:2 transformer with two 12.5 Ω series resistors for the Tx line interface; it uses a 1:1 transformer for the Rx line interface.

Circuit Modifications

To adapt an LXT300 board to accommodate the LXT310, modify the circuit as follows:

1. Cut the DPM output trace from LXT300 pin 11, and tie the LXT310 JASEL input to VCC.
2. Cut the MTIP and MRING inputs to LXT300 pins 17 and 18. Reconfigure the LXT310 input at pin 17 to allow EGL switching, or simply tie pin 17 to ground. Connect the LXT310 output from pin 18 to a LATN decoding circuit.
3. Cut the EC1 input to LXT300 pin 23, and connect the LXT310 output from this pin to NLOOP monitoring circuitry.

Line Interface Modifications

On the transmit side, both the LXT300 and LXT310 use a 1:2 transformer. The LXT300 transformer connects directly to the chip as shown in Figure 1a. The LXT310 requires two 12.5 Ω serial resistors in line with the transformer, as shown in Figure 1b.

On the receive side, the LXT300 uses a 1:2 transformer with 400 Ω termination, as shown in Figure 2a. The LXT310 uses a 1:1 transformer with 100 Ω termination, as shown in Figure 2b.

(A 1:2 CT transformer can be used for both devices. For LXT310 boards, connect only one of the secondary windings, an effective 1:1 ratio.)

Figure 1: Transmit Line Interface

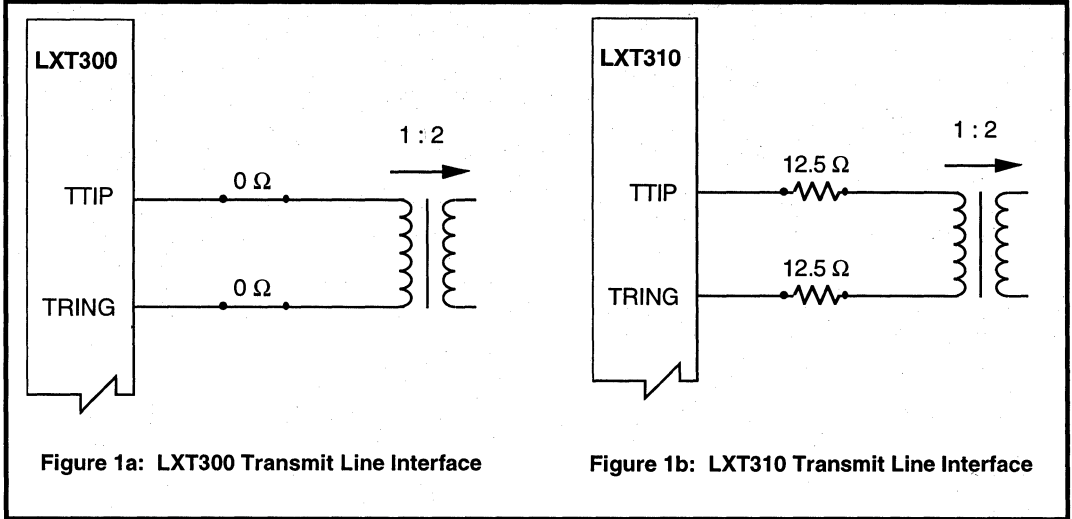

Figure 1a: LXT300 Transmit Line Interface

Figure 1b: LXT310 Transmit Line Interface

Figure 2: Receive Line Interface

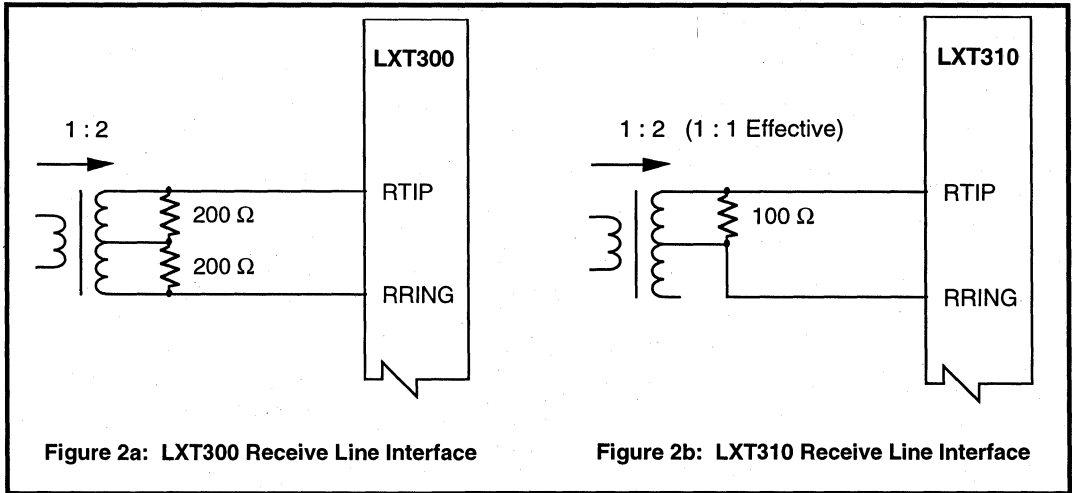

Figure 2a: LXT300 Receive Line Interface

Figure 2b: LXT310 Receive Line Interface

LXT310 Line Protection Circuitry

Application Guidelines

General Information

This application note provides guidelines for line protection circuitry required in network channel termination equipment (NCTE) Channel Service Units (CSU) and WAN network interfaces, typical LXT310 applications. NCTE is installed at the customer premises end of T1 lines. As these lines run between the customer facilities and the central office, they are subject to overvoltage/overcurrent stresses from lightning strikes, power crosses, and other noise impairments. Protection circuitry is required to protect the line from injected impairments and the termination equipment (CSU, mux, PBX, etc.) from overload stresses.

NCTE protection requirements are specified in FCC Part 68 (lightning hazards), UL 1459 (AC hazards), Bellcore TR-TSY-000007 and AT&T Pub 62411. These documents differentiate between longitudinal stress (differential between tip/ring and ground) and metallic stress (differential between tip and ring). Longitudinal stresses are more common and include impulsive noise events such as lightning induced surges. Metallic stresses are less likely and are usually caused by power crosses during maintenance activity.

Since T1 acceptance testing does not meet formal FCC and safety requirements, the final board design should undergo this FCC testing at an approved lab.

Protective Circuitry

The figure below shows a typical LXT310 line interface.

- Resistors R1, 2, 3, 12, 13 (in the transmit and receive lines) values are selected to match the line impedance. They also provide some current limitation
- Positive Temperature Co-efficient Resistors (PTCs) (R10, 11, 16, 17) permit "healing" after an overvoltage event
- 5.6 Ω resistors and PTCs matched to T1 Line requirements using receive resistor pad and 2:1 transformers
- Line transformers T1 and T2 breakdown ratings should be a minimum of 1.5 kV
- Varistors must have sufficient stand-off voltage to allow normal operation (approximately 4 volts), with low off-state capacitance (< 50 pF)
- Final values for RF chokes, L1, 2, will vary with board design
- Interconnect the line side center taps of the line transformers if sealing currents are present
- No power or ground planes should be located on the circuit board in the area T1 Line connector back to the transformers

Suggested component values are listed in Table 1.

LXT310 Protection Circuitry

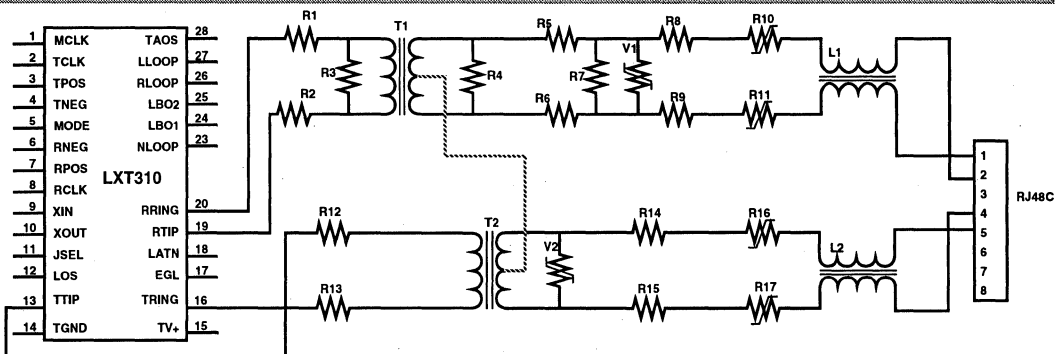

LXT310 Line Protection Circuitry

Table 1: Component Values

Ref #	Description
R1,2	100 Ω
R3	402 Ω ,1%
R4	301 Ω ,1%
R5, 6	22 Ω ,2W
R7	232 Ω
R8, 9	5.6 Ω ,1W
R10, 11	8.5 Ω ,600 V, Positive Temperature Co-efficient Resistor –
R16, 17	typical: Raychem 21214B
R12, 13	6.8 Ω , $\frac{1}{2}$ W
R14, 15	5.6 Ω ,1 W
V1, 2	Stand-off voltage 4–4.5 V, off-state capacitance < 50 pF – typical: EDAL Industries B529-2
T1, 2	Line transformer, 1:2 turns ratio – typical: Pulse Engineering PE65351
L1, 2	RF Choke, value varies by board design, approximately 33 μ H – typical: BH Electronics 500-1164

Table 2: Suppliers

Company	Telephone Number
Raychem, Inc.	(800) 272-2436 ext 6900
Pulse Engineering	(619) 674-8130
EDAL Industries	(203) 467-2591
BH Electronics	(612) 894-9590

LXT30x Transceiver / Framer Interface

Application Guidelines for Use with Mitel MT8976 and MT8979 Framers

General Description

This application note provides guidelines for interfacing the Level One LXT300 series (LXT300, 301, 305, 304A and 305A) transceivers with Mitel framers in both T1 and E1 applications. Only minimal circuitry is required to implement the interface. For T1 (1.544 Mbps) applications, the transmit data pins may be connected directly between the two chips as shown below. A single 4-gate NAND package provides the signal inversion required on the receive side.

Receive-side signal inversion is also required for E1/CEPT (2.048 Mbps) applications. A similar setup using NAND gates in an E1 application is shown in Figure 1. Additional circuitry is also required to synchronize the transmit data stream in E1 applications. This synchronization is easily implemented with a pair of D-flip-flops, clocked by the common 2.048 MHz transmit clock.

LXT30x Interface to MT8976 T1 ESF Framer

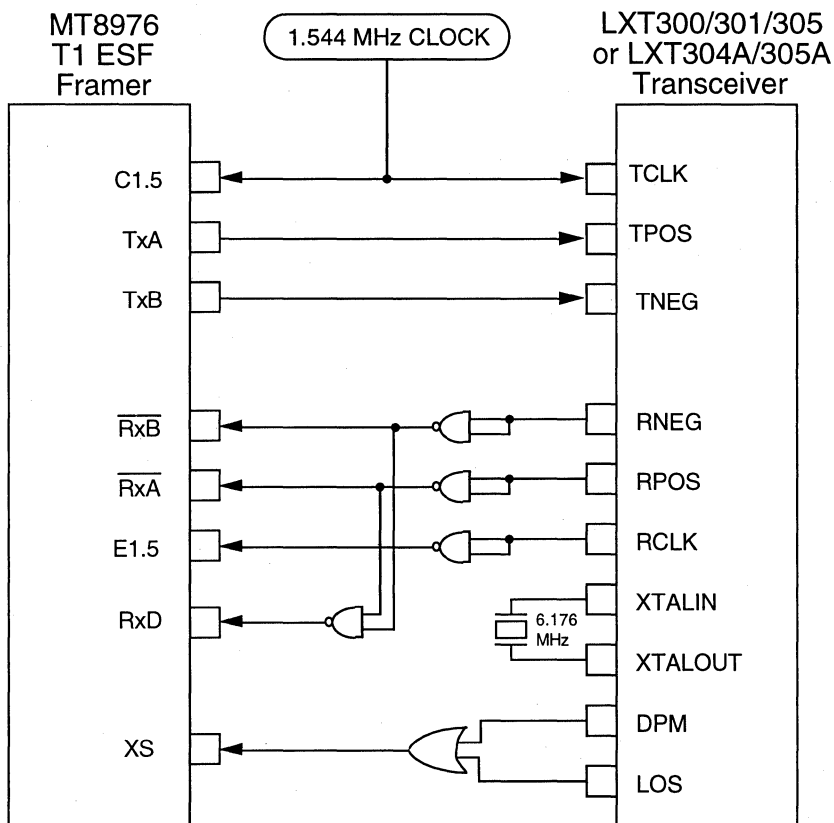
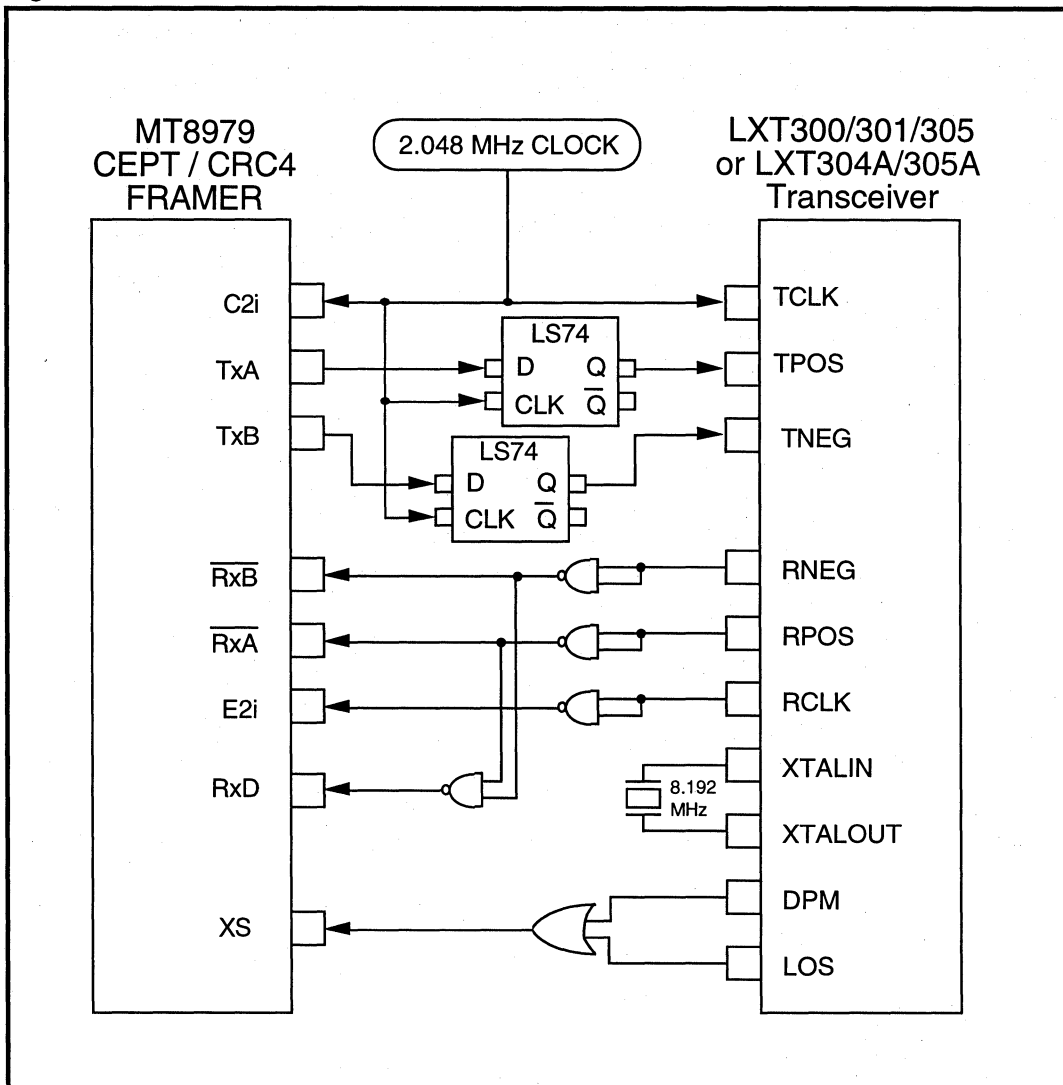

Figure 1: LXT300 Interface to MT8979 E1 CRC Framer



LXT318 Long-Haul E1 Transceiver Solution

Migration from Dual-Chip (LXT304A/LXT316) to Single-Chip (LXT318) Implementation

Introduction

This application note provides manufacturers of long-haul E1 (2.048 Mbps) transmission equipment with a smooth transition from Level One's LXT304A/316 dual-chip long-haul E1 solution to an advanced single-chip implementation, the LXT318.

This application note describes the steps necessary to modify a dual-chip design for use with the LXT318. Both solutions use the same transformers. The modification involves removing the repeater and associated circuitry (shown in the shadowed area of the figure below).

There are only minor differences in the line interfaces for single- and dual-chip solutions. Therefore, E1 equipment designed around the dual-chip solution (using the LXT304A and LXT316) can easily be adapted to take advantage of the fully integrated LXT318.

Long-Haul E1 2-Chip Solution

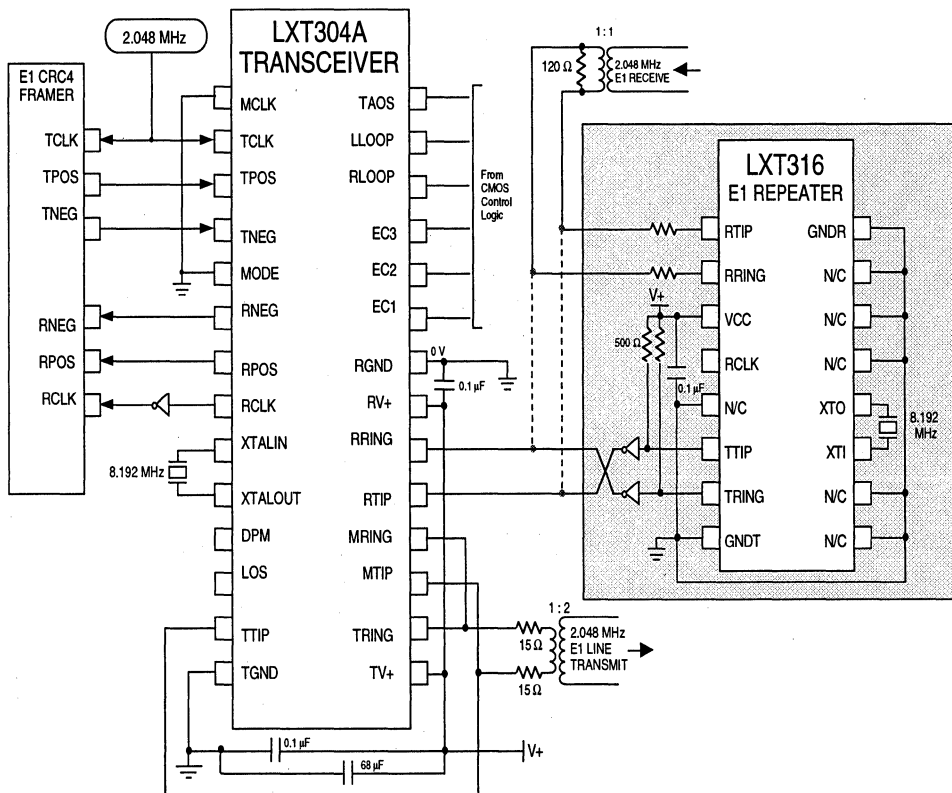

FUNCTIONAL DIFFERENCES

- In Hardware Mode, the LXT304A uses three Equalizer Control inputs (EC1, EC2 and EC3), and two transmit driver monitor inputs (MTIP and MRING). These functions are not provided on the LXT318. On the LXT318, pins 17, 23, 24 and 25 must be tied to ground. LXT318 pin 18 is now the coded line attenuation (LATN) output.
- On the LXT318, pin 11 is used as an input for Jitter Attenuation Select (JASEL). It should be tied to VCC or ground, as desired.

CIRCUIT MODIFICATIONS

- To modify a 2-chip long-haul PCB for use with the LXT318, cut the EC1, 2 and 3 inputs to LXT304A (pins 23, 24 and 25). Tie these three pins to ground.
- Cut the MTIP and MRING inputs to LXT304A pins 17 and 18. Tie pin 17 to ground. Tie pin 18 to an LATN decoding circuit or let it float.
- Cut the DPM output trace from LXT304A pin 11, and tie the LXT318 JASEL input to VCC (for receive jitter attenuation) or to ground (for transmit jitter attenuation).
- Remove all the circuitry shown in the shadowed area of Figure 1, and connect the receive transformer to pins 19 and 20 of the LXT318.

Figure 1: Long-Haul E1 1-Chip Solution (LXT318)

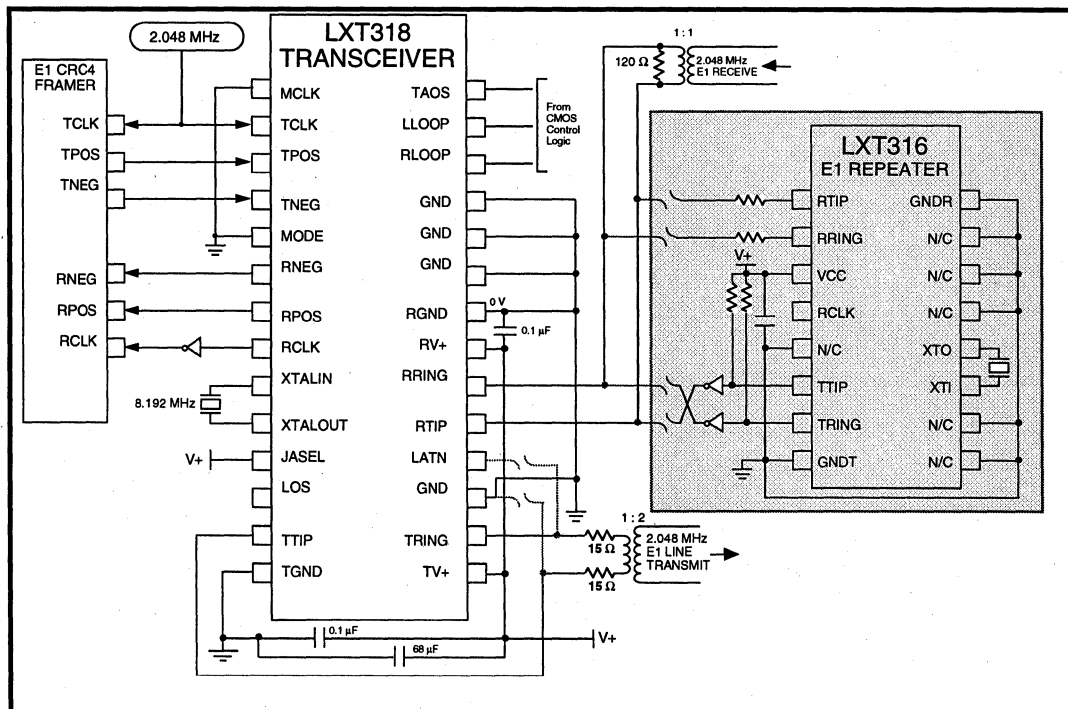

T1 Jitter Performance Measurement

AT&T Pub 62411 Certification

General Description

This application note provides a brief definition of jitter and then summarizes jitter performance requirements and measurement techniques specified for T1 (1.544 Mbps) Customer Premises Equipment (CPE).

Requirements for T1 systems are specified by AT&T Publication 62411, December 1990 - Accunet T1.5 Service Description and Interface Specification. (Similar requirements for E1 systems are specified by CCITT G.823 - The Control of Jitter and Wander within Digital Networks.)

Understanding Jitter

T1 signals are composed of square-wave pulses as shown below. A "1" is represented by a positive or negative pulse (the pulses alternate in polarity). A "0" is represented by the absence of a pulse. To enhance timing and data recovery, the duration of a "1" pulse is constrained to $\frac{1}{2}$ of the bit rate period. Deviations in time between when the pulse transitions occur and when the decoding circuits expect them to occur are referred to as jitter. Very low-frequency deviations (< 10 Hz) are referred to as wander. These deviations are equivalent to unintentional phase modulation. Any pulse that is phase-shifted by more than 50% will be sampled incorrectly.

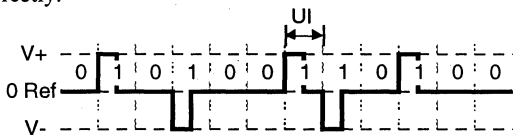

Jitter is measured in Unit Intervals (UIs). A UI is equal to the bit rate period. A UI is, therefore, the reciprocal of the frequency. For T1 service, a UI equals 648 ns, while the "1" pulse duration is 324 ns. Jitter amplitude is measured in UI pp (peak-to-peak). Jitter specifications have both an amplitude component and a frequency component; that is, for a given jitter parameter, performance will be specified at a particular amplitude (in UI pp) within a particular frequency band.

TYPES OF JITTER

There are three parameters of jitter performance which are specified and measured:

1. Input Jitter Tolerance (Jitter Accommodation)
2. Output Jitter Generation (Intrinsic Jitter)
3. Jitter Transfer (Jitter Attenuation)

Input Jitter Tolerance. Input jitter tolerance is defined as a system's ability to recover input data correctly in the presence of jitter. This value indicates how much input jitter a system or device can handle before bit errors occur. Individual devices should have as high a tolerance value as possible because the system's jitter tolerance is limited to the tolerance of its most restrictive element. Input jitter tolerance is also referred to as jitter accommodation.

Output Jitter Generation. Output jitter is defined as the amount of jitter generated in the system output when zero jitter is present in the input. Essentially, it is a measure of how "noisy" the system is. Individual system elements should have as low a value as possible because output jitter is additive. Each device in a system adds its own intrinsically generated jitter to the system total, hence the term "jitter budget." Output jitter is also referred to as intrinsic jitter or additive jitter.

Jitter Transfer. Jitter transfer, frequently referred to as jitter attenuation (JA), is defined as the percentage of input jitter which is present in the system output, expressed in dBs. While a certain amount of jitter attenuation is desirable, excessive jitter attenuation can cause problems with frame slippage and synchronization. Therefore, jitter attenuation specifications define an acceptable range of values for a given jitter frequency. (Jitter attenuation circuits typically use an elastic store as a buffer between input and output. Buffer size is directly related to throughput delay. Oversize buffers intended to maximize jitter attenuation may cause equipment to fail requirements for maximum throughput delay.)

AT&T PUB 62411 COMPLIANCE TESTING

Jitter performance is strongly related to the transmitted bit pattern. AT&T Publication 62411 defines a standard quasi-random test signal (QRTS) used for jitter testing at 1.544 Mbps. The QRTS bit pattern is designed to simulate typical transmission patterns. Jitter performance testing should be conducted in a noise-free environment to eliminate, as far as possible, the effect of other factors on the performance of the device under test.

Input Jitter Tolerance Testing

The input jitter tolerance of a DTE is characterized by determining the level of jitter required to induce bit errors in a 60-second interval. At frequencies up to 10 kHz, one bit error is allowed. At higher frequencies, up to 5 errored bits are allowed in a 60-second period. (Synchronizers, which provide a system master clock, are held to a tighter spec. They are characterized by determining the level of jitter required to induce a loss of synchronization.) Jitter tolerance is tested at a number of spot frequencies to ensure full characterization across the spectrum. Figure 1A shows the jitter tolerance template for DTE. Figure 1B shows the jitter tolerance template for synchronizers.

Figure 1: Input Jitter Tolerance Specified by AT&T Publication 62411

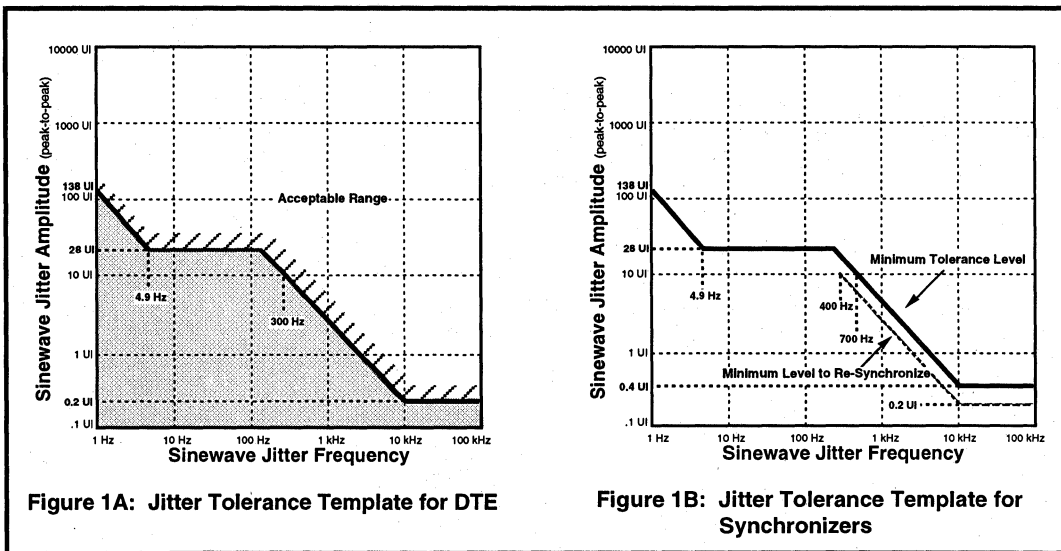

Jitter Tolerance Test Procedures

1. Connect the test equipment as shown in Figure 2.
2. Configure the device under test for remote loopback.
3. With its modulation input turned off, configure the RF signal generator for an appropriate output level to drive the external clock input of the BER, through an AC-coupled driver as shown in Figure 2. Test this jitter-free external clocking of the BER with the unit under test.
4. Enable the External FM Modulation mode of operation on the HP8656B.
5. Set the Frequency Synthesizer to the first jitter frequency to be tested. Set the amplitude of this sine wave frequency such that the high/low input LEDs on the HP8656B are off (approximately 2.1 V pp).
- 6a. DTE Testing. While observing the transmission tester for bit error indications, adjust the modulation index on the signal generator to the level required to produce the minimum error level. (For example, if the synthesizer is set for a jitter frequency of 10 Hz, adjust the modulation index as required to produce no more than one bit error in any 60-second period.)

- 6b. Synchronizer Testing. While observing the transmission tester for clock slips (loss of sync), adjust the modulation index on the signal generator to the level required to produce the loss of sync. Then, reduce the modulation index to the level required to achieve resynchronization. Record **both** values.
7. Determine the jitter tolerance using the formula:

$$UI_{pp} = \frac{\Delta f}{\pi f_m}$$

where f_m = Jitter Frequency (synthesizer modulation frequency), and where Δf = FM Modulation Index (as set on the signal generator).

for example,

$$38 \text{ kHz} / \pi \cdot 10 \text{ Hz} = 1209 \text{ UI}_{pp} @ 10 \text{ Hz}$$

8. Repeat steps 5 through 7 for additional frequencies to be tested and plot the results as shown in Figure 3.

Figure 2: Input Jitter Tolerance Test Setup

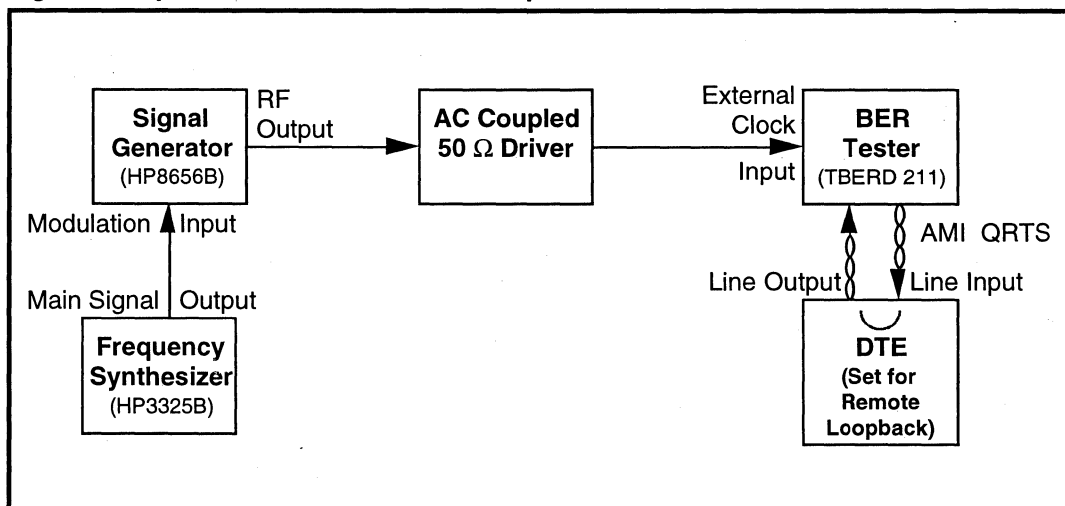

Figure 3: Charting Input Jitter Tolerance Test Results

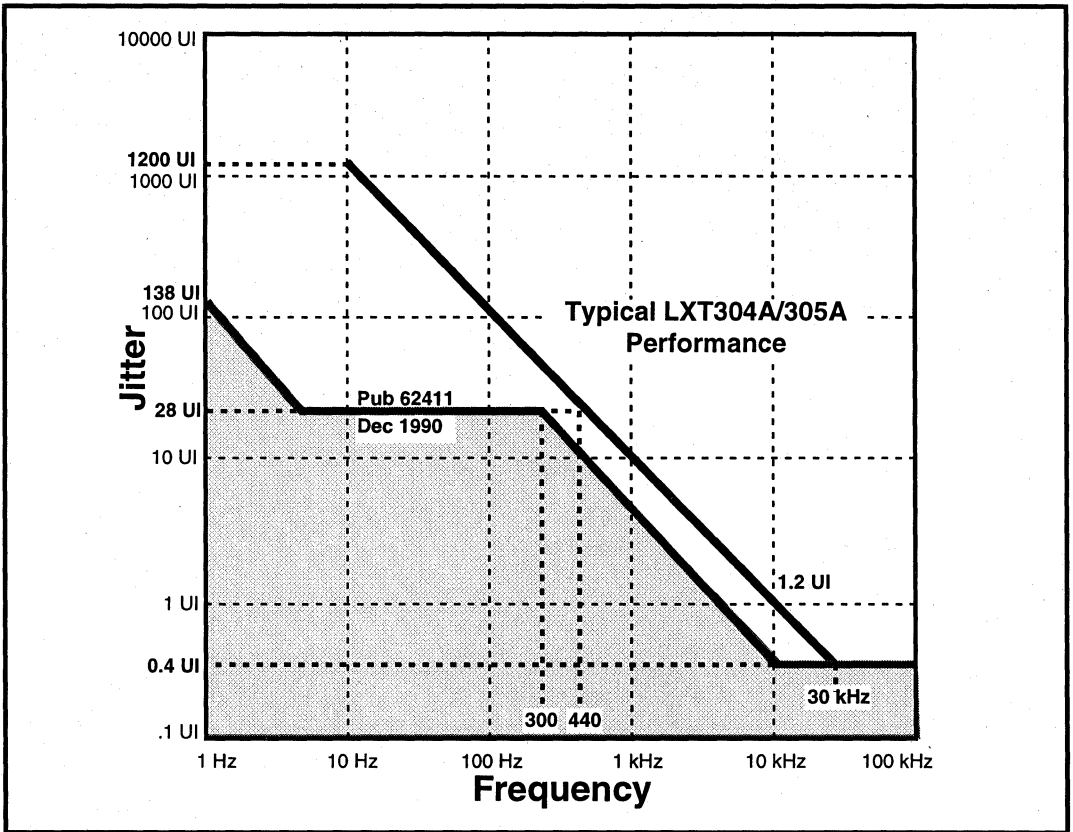
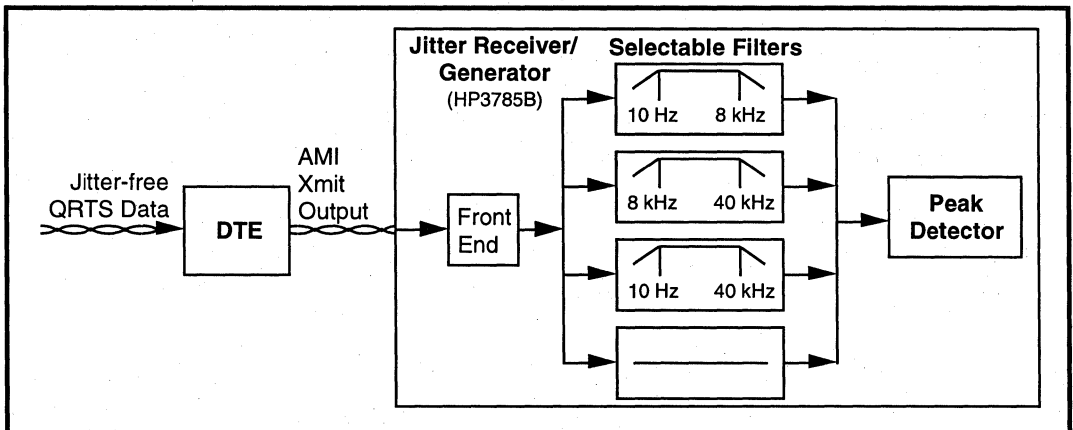

Figure 4: Output Jitter Generation Test Setup



Output Jitter Generation Testing

The intrinsic jitter generated by a DTE is characterized by configuring the device for remote loopback and then monitoring the line output when no jitter is present in the line input. AT&T Publication 62411 lists maximum output jitter values for three separate frequency bands, as well as a fourth value for the unlimited broadband output. Output jitter may be measured with a variety of instruments including peak detectors, true RMS voltmeters and spectrum analyzers. Figure 4 shows a typical test setup. Table 1 lists the maximum generated jitter allowed in each frequency band, as well as sample test measurements.

OUTPUT JITTER GENERATION TEST PROCEDURES

1. Connect a frequency synthesizer, signal generator and telecom tester to produce a jitter-free QRTS output. Figure 2 may be used as a reference.
2. Select the filters in the HP3785B as shown in Figure 4 and monitor the first frequency band.
3. Measure and record the output jitter peak values.
4. Repeat steps 2 and 3 for each remaining band.

Table 1: Output Jitter Generation Specification

Frequency Band	62411 Specified Maximum		Typical 304A Performance
10 Hz - 8 kHz	0.02 UI	(0.8 mV rms)	0.002 UI
10 Hz - 40 kHz	0.025 UI	(1.25 mV rms)	0.016 UI
8 kHz - 40 kHz	0.025 UI	(1 mV rms)	0.014 UI
No Bandlimiting	0.05 UI	(2 mV rms)	0.025 UI

Jitter Attenuation Testing

Jitter attenuation is defined as the percentage of input jitter which is present in the system output, expressed in dBs. While a certain amount of jitter attenuation is desirable, excessive jitter attenuation can cause problems with frame slippage and synchronization. Therefore, jitter attenuation specifications define an acceptable range of values for a given jitter frequency as shown in Figure 5. (Jitter attenuation circuits typically use an elastic store as a buffer between input and output. Buffer size is directly related to throughput delay. Oversize buffers may cause equipment to fail requirements for maximum throughput delay.) Jitter attenuation is also referred to as jitter transfer.

Figure 5: Jitter Transfer Template

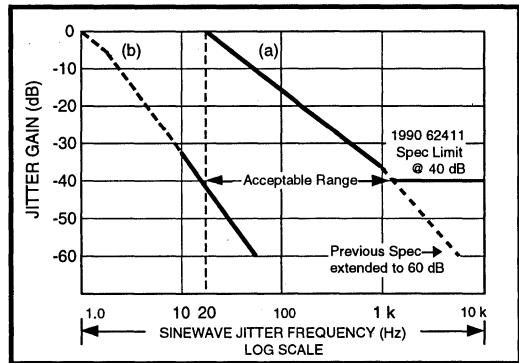

T1 Jitter Performance Measurement

JITTER ATTENUATION TEST PROCEDURES

1. Connect the test equipment as shown in Figure 6.
2. Set the frequency synthesizer to produce a square wave reference clock at 1.544 MHz.
3. Set the jitter generator as follows:
 - a. Frequency: lowest frequency to be tested
 - b. Amplitude : 75% of the level shown in Figure 1 (use appropriate DTE or Synchronizer template.)
4. Set the spectrum analyzer as follows:
 - a. Center Frequency: same as 3a.
 - b. Frequency Span: 200 Hz - 500 Hz.
5. Set the reference level (UI_{INP}) on the spectrum analyzer by temporarily connecting the BERT transmit output directly into the data input of the jitter receiver/generator.
6. Re-connect the test equipment as shown in Figure 6 and set the synthesizer to the first jitter frequency to be tested.
7. Observe the spectrum analyzer (Figure 7) and record the difference between the reference level, UI_{INP} , and the DTE line output level, UI_{OUT} .
8. Repeat steps 3 through 7 for each frequency to be tested and plot the results as shown in Figure 8.

Figure 6: Jitter Attenuation Test Setup

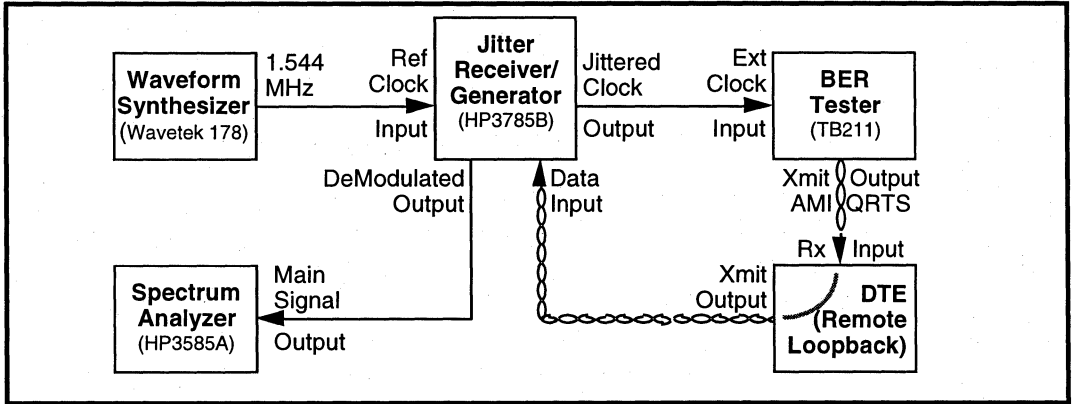

NOTE: The test setup shown in Figure 6 is used to measure jitter amplitudes less than 10 UI (the limit of the HP3785B). Alternate test setups should be used for other jitter amplitudes or amplitude/frequency combinations.

Figure 7: Spectrum Analyzer Display

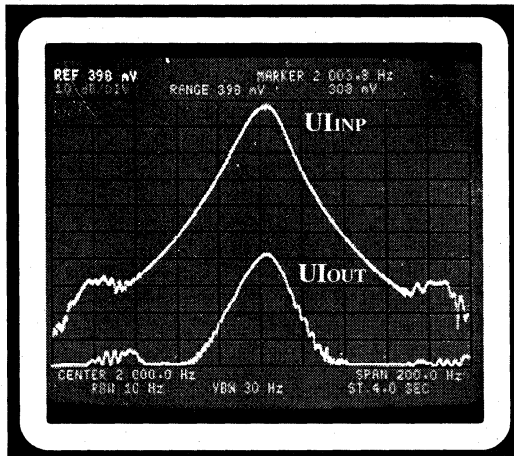
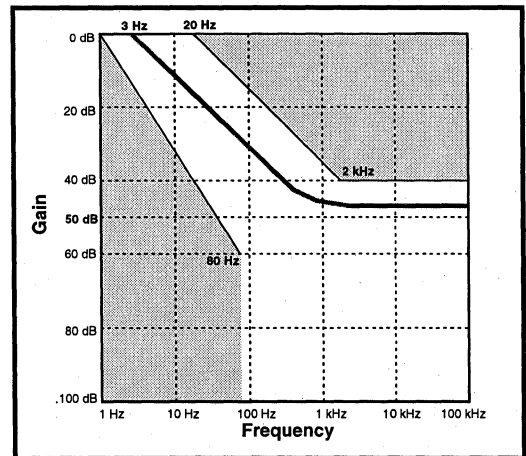

Figure 8: Typical LXT304A JA Performance



LXT30x and LXT318 Interchangeability

Adapting Short-Haul T1/E1 Boards to Long-Haul Applications

General Description

While the LXT300, 304A and 305A are designed for short-haul T1/E1 applications (up to 14 dB) and the LXT318 is designed for long-haul E1 applications (up to 43 dB), these transceivers are quite similar in function. There are only minor differences in line interfaces and pin configurations. Therefore, E1 equipment designed for short-haul applications (using LXT30x series transceivers) can easily be adapted to provide long-haul capability (using the LXT318). This application note describes the steps necessary to adapt a short-haul design so that it can be used for both long-haul and short-haul applications. (The LXT318 can support both E1 long-haul and E1 short-haul applications.)

Functional Differences

- The LXT30x uses three Equalizer inputs in the Hardware Mode. These pins are not used by the 318 and should be tied to ground. These pins are identical in the Software mode, but the bit register is defined differently.
- The LXT30x uses two inputs and an output for the Driver Performance Monitor (DPM) function. On the LXT318, these pins are replaced by an input for Jitter Attenuation Select (JASEL) and an output for Line Attenuation (LATN).
- The LXT30x uses a 1:2 transformer for both the Tx and Rx line interfaces. The LXT318 uses a 1:2 transformer with two 15 Ω series resistors for the Tx line interface, and a 1:1 transformer for the Rx line interface.

Circuit Modifications

To adapt an LXT30x board to accommodate the LXT318, modify the circuit as follows:

1. Cut the DPM output trace from LXT30x pin 11 and tie the LXT318 pin 11 (JASEL) to VCC (to select receive jitter attenuation), or to GND (to select transmit jitter attenuation).
2. Cut the MTIP and MRING inputs to LXT30x pins 17 and 18. Connect the LXT318 input at pin 17 to ground. Connect the LXT318 output from pin 18 to a LATN decoding circuit.
3. For Hardware Mode, cut the EC inputs to LXT30x (pins 23, 24 and 25), and connect these LXT318 pins to ground.

Line Interface Modifications

On the transmit side, both the LXT30x and LXT318 use a 1:2 transformer. The LXT30x transformer connects directly to the chip as shown in Figure 1a. The LXT318 requires two 15 Ω series resistors in line with the transformer, as shown in Figure 1b.

On the receive side, the LXT30x uses a 1:2 transformer with 480 Ω termination, as shown in Figure 2a. The LXT318 uses a 1:1 transformer with 120 Ω termination for TWP applications, as shown in Figure 2b.

(A 1:2 CT transformer can be used for both devices. For LXT318 boards, connect only one of the secondary windings, an effective 1:1 ratio.)

Adapting Short-Haul T1/E1 Boards to Long-Haul Applications

Figure 1: Transmit Line Interface

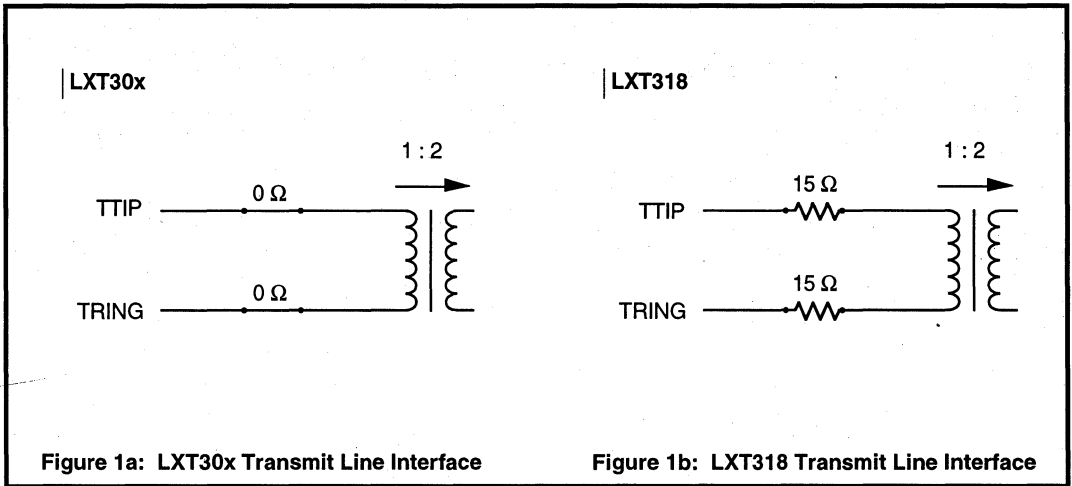

Figure 1a: LXT30x Transmit Line Interface

Figure 1b: LXT318 Transmit Line Interface

Figure 2: Receive Line Interface

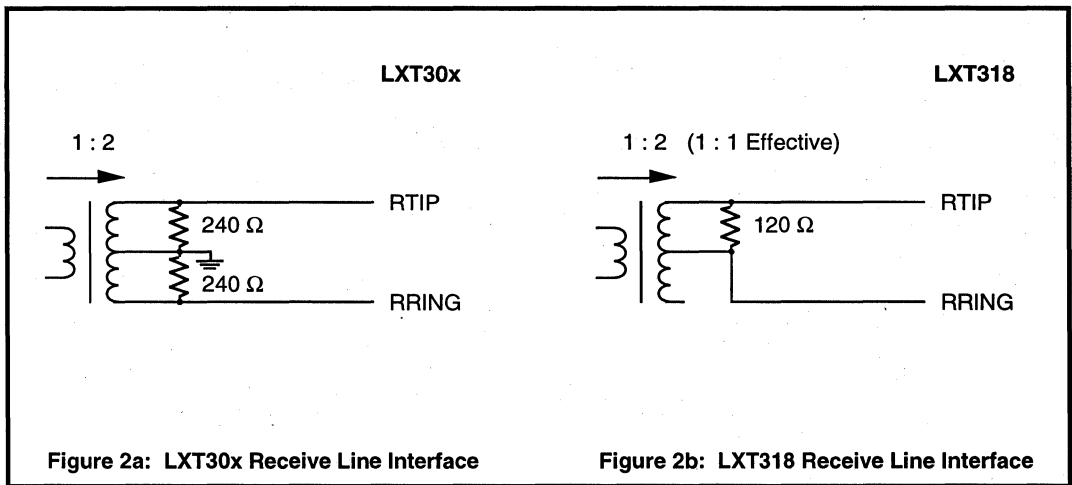

Figure 2a: LXT30x Receive Line Interface

Figure 2b: LXT318 Receive Line Interface

LXT318 Long-Haul E1 Transceiver

Line Interface Design Guide

General Description

This application note describes a standard line interface for the LXT318 transceiver in a long-haul E1 environment. The interface uses two Pulse Engineering transformers designed specifically for this transceiver.

The design is simple and robust and will reduce in-house engineering and testing time.

Refer to the current LXT318 data sheet for complete information on the LXT318 transceiver.

Transmit Line Interface

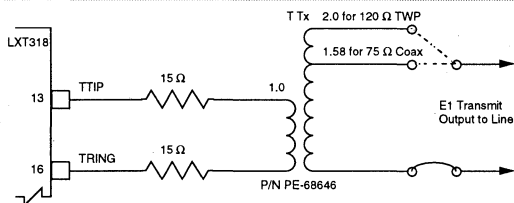

Transmit Line Interface

The transmit line interface uses the following parts:

1. Pulse Engineering transformer, P/N PE68646 - 1:1.58:2 (one per transceiver)
2. 15 Ω resistors (two per transceiver)

Connect them to the Transmit Tip and Ring inputs (pins 13 and 16) of the transceiver as shown above.

Twisted-Pair Cable (120 Ω)

For a twisted-pair cable, use the full 1:2 step-up ratio provided at the end tap. This gives the required 120 Ω impedance.

$$Z = \Omega \times (\text{step-up ratio})^2 = (15 \Omega + 15 \Omega) \times 2^2 = 120 \Omega$$

Coaxial Cable (75 Ω)

For a coaxial cable, connect the circuit at the transformer center tap. The 1:1.58 step-up ratio gives a value within 0.2% of the 75 Ω impedance required.

$$Z = \Omega \times (\text{step-up ratio})^2 = (15 \Omega + 15 \Omega) \times 1.58^2 = 74.89 \Omega$$

Line Interface Features

- Provides correct impedance match for both 75 Ω coaxial and 120 Ω twisted-pair cables
- Meets 3 kV isolation requirement of many PTT ministries
- Standard interface requires one-time design
- Laboratory engineered and proven design requires minimal in-house testing
- Readily available parts make building fast and easy

Receive Line Interface

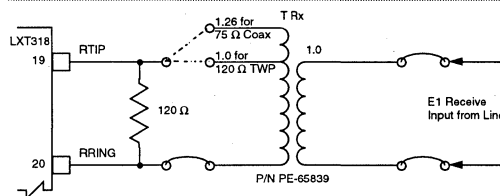

Receive Line Interface

The receive line interface uses the following parts:

1. Pulse Engineering transformer, P/N PE65839 - 1:1:1.26 (one per transceiver)
2. 120 Ω resistors (one per transceiver)

Connect them to the Receive Tip and Ring inputs (pins 19 and 20) of the transceiver as shown above.

Twisted-Pair Cable (120 Ω)

For a twisted-pair cable, use the 1:1 step-down ratio provided at the center tap. This gives the required 120 Ω impedance.

$$Z = \frac{\Omega}{(\text{step-down ratio})^2} = \frac{120 \Omega}{(1)^2} = 120 \Omega$$

Coaxial Cable (75 Ω)

For a coaxial cable, connect the circuit at the transformer center tap. The 1:1.26 step-down ratio gives a value within 1% of the 75 Ω impedance required.

$$Z = \frac{\Omega}{(\text{step-down ratio})^2} = \frac{120 \Omega}{(1.26)^2} = 75.59 \Omega$$

NOTES:

LXT332 Dual Channel T1/E1 Transceiver Solution

Migration from Dual-Chip (Siemens PEB 2236) to Single-Chip (LXT332) Implementation

Introduction

This application note provides manufacturers of multi-channel T1/E1 transmission equipment with a smooth upgrade from two Siemens PEB 2236 single-channel devices to an advanced implementation using a single LXT332 Dual Line Interface Unit (DLIU) integrated dual-channel device. This application note discusses Hardware Mode only.

There are some differences between the two devices in the back end and line interfaces. However, existing PEB 2236 designs can easily be adapted to take advantage of the fully integrated dual-channel LXT332 DLIU.

Upgrade Issues

Upgrading from the PEB 2236 to the LXT332 DLIU requires minor framer interface modifications and some simple changes to the control circuitry. Specifically, the conversion requires removing the inverters on the data and control lines. In addition, the LXT332 DLIU includes internal jitter attenuation; any existing JA circuitry may not be necessary. The following paragraphs describe other differences between the two devices.

Tristate Output

The Tristate control forces all output pins to a high-impedance state. This is an especially valuable feature in applications such as in-circuit testing. The Siemens transceiver offers no similar operation.

AIS Generation

The LXT332 generates an AIS Alarm Signal when either TAOS0 or TAOS1 = 1. The PEB 2236 provides no comparable feature.

Reset Condition

On initial power up, the transceiver clears all internal registers, and does not require any external components or software control to establish a reset. The PEB 2236 requires one of three complex reset procedures.

Operating Temperatures

The LXT332 operates in the temperature range of 40 to 85 °C, exceeding the PEB 2236 operating range of 0 to 70 °C.

Advantages

- Meets or exceeds industry specifications including ANSI T1.403, ITU G.703 and AT&T Pub 62411
- Simplifies board design
- Crystal-less Jitter Attenuation
- Saves real estate
- Reduces inventory costs
- Improved jitter tolerance performance
- Improved return loss on both transmit and receive lines
- Reads switch settings dynamically in Hardware Mode
- No complicated reset conditions
- Transparent to ternary codes
- Single transformer turns ratio for both T1 and E1 applications
- Lower per-channel power consumption
- Additional features with Host Mode Serial I/O

Return Loss

LXT332 device return loss for both the transmitter (if the design includes a capacitor) and receiver will exceed 20 dB. The Siemens device meets only minimum return loss specifications.

Line Length/Pulse Shape Control

Both the LXT332 and the PEB 2236 use 3-input codes to determine pulse shapes for various line lengths. Tables 1A and 1B show the two coding schemes.

Loopback Control

Both the LXT332 and the PEB 2236 provide RL and LL as shown in Tables 2A and 2B. The LXT332 has an additional dual loopback capability.

Loss of Signal (Receive Line)

Both the LXT332 and the PEB 2236 provide Loss of Signal (LOS) outputs on the receive side. The internal detection circuitry which determines when an LOS condition exists is functionally different. The LXT332 provides both digital and analog LOS detection.

Transmit Driver Monitor

The LXT332 provides a single Driver Fail Monitor for both channels. The DFM output reports short conditions. The PEB 2236 does not include such a feature for the transmit circuit.

Dual Channel T1/E1 Transceiver Solution - Migration from PEB 2236 to LXT332

Table 1A: PEB 2236 Line Length Codes

LS 2	LS 1	LS 0	Line Length PIC/PULP Cable
0	0	1	0 ~ 50 m-24 AWG
0	1	0	20 ~ 80 m-24 AWG
0	1	1	60 ~ 130 m-24 AWG
1	0	0	110 ~ 200 m-24 AWG
1	0	1	140 ~ 230 m-24 AWG
1	1	0	210 ~ 290 m-24 AWG
1	1	1	270 ~ 320 m-24 AWG
0	0	0	CEPT

Table 2A: PEB 2236 Loopback Codes

Mode	LOOPA	LOOPB
RLOOP	1	0
LLOOP	0	1

Table 1B: LXT332 Line Length Codes

LEN 2	LEN 1	LEN 0	Line Length	Cable Loss
0	1	1	0 ~ 41 m-22 AWG	0.6 dB
1	0	0	41 ~ 81 m-22 AWG	1.2 dB
1	0	1	81 ~ 122 m-22 AWG	1.8 dB
1	1	0	122 ~ 162 m-22 AWG	2.4 dB
1	1	1	162 ~ 198 m-22 AWG	3.0 dB
0	0	0	75 Ω ITU	
0	0	1	120 Ω G.703	
0	1	0	FCC Part 68, Option A	

Table 2B: LXT332 Loopback Codes

Mode	RLOOP	LLOOP	TAOS
RLOOP	1	0	n/a
LLOOP	0	1	n/a
DLOOP	1	1	1
TAOS	0	n/a	1
RESET	1	1	0

Line Interface Modifications

The line interface must be modified when upgrading from the PEB 2236 to the LXT332. The T1 line interfaces are shown in Figures 1A and 1B. The E1 line interfaces for 120 Ω twisted-pair are shown in Figures 2A and 2B. The E1 line interfaces for 75 Ω coax are shown in Figures 3A and 3B.

The applications illustrated here do not optimize return loss values. Instead they simplify design requirements. To design an application with the best possible return loss, see the LXT332 Dual Line Interface Unit Data Sheet for optimized R_t and transformer values.

Figure 1: 100 Ω T1 Line Interface Upgrade

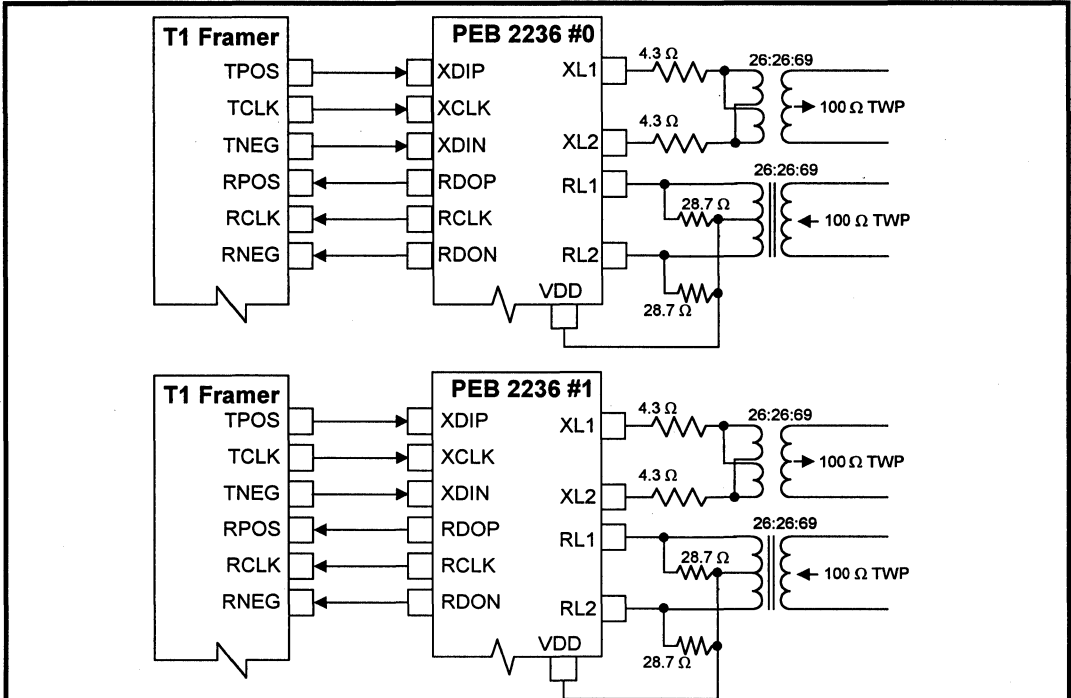

Figure 1A: PEB 2236 100 Ω T1 Line Interface

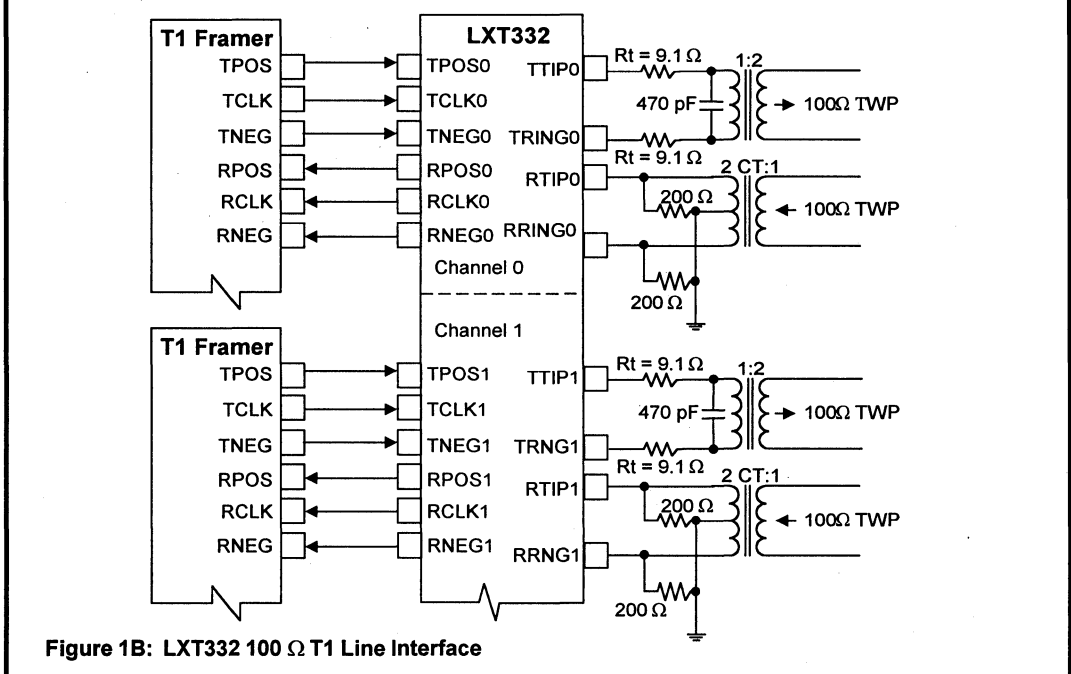

Figure 1B: LXT332 100 Ω T1 Line Interface

Dual Channel T1/E1 Transceiver Solution - Migration from PEB 2236 to LXT332

Figure 2: 120 Ω E1 Line Interface Upgrade

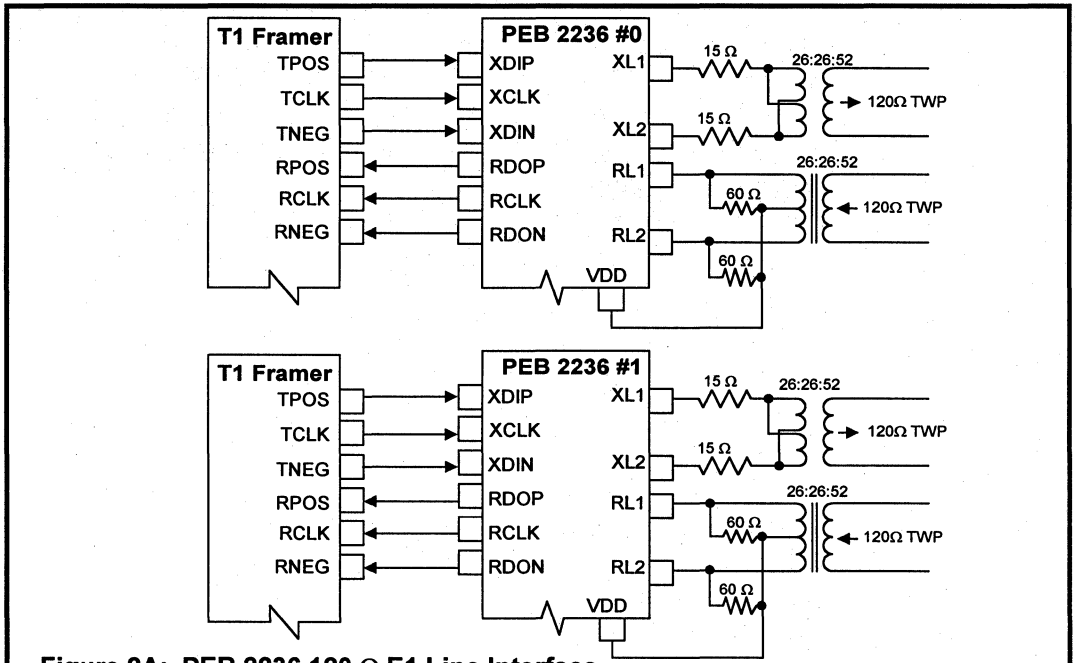

Figure 2A: PEB 2236 120 Ω E1 Line Interface

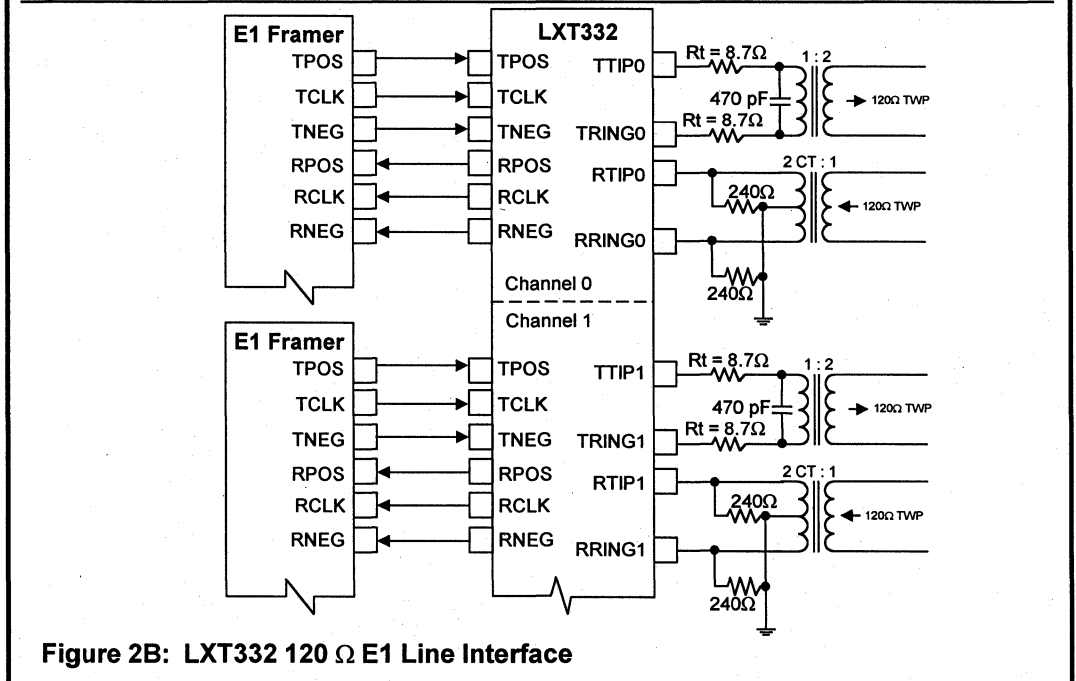

Figure 2B: LXT332 120 Ω E1 Line Interface

Figure 3: 75 Ω E1 Line Interface Upgrade

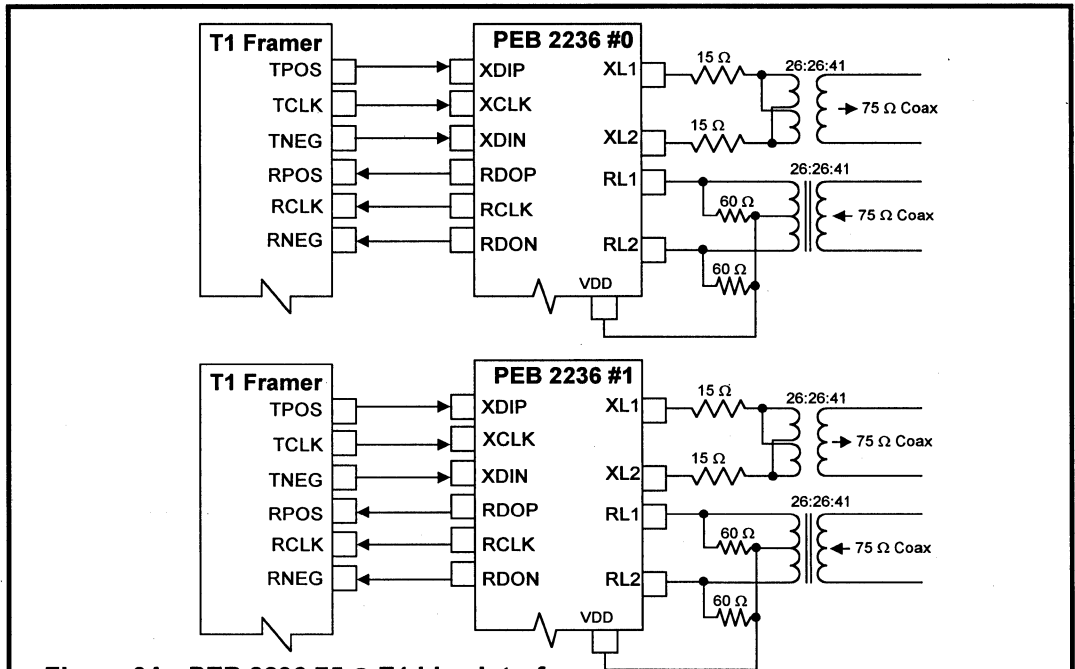

Figure 3A: PEB 2236 75 Ω E1 Line Interface

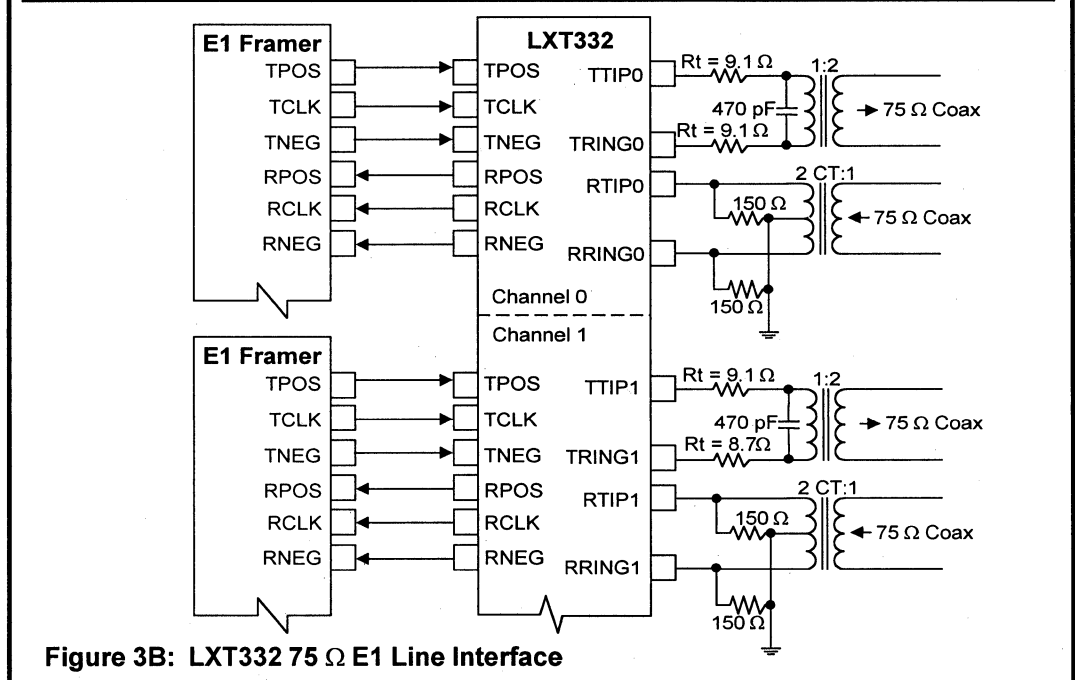

Figure 3B: LXT332 75 Ω E1 Line Interface

Dual Channel T1/E1 Transceiver Solution - Migration from PEB 2236 to LXT332

Typical LXT332 Application

A switchable interface board design is possible using the LXT332 device. Figure 4 shows a simplified application design for either T1 or E1 equipment which only requires changing the MCLK and Line Length inputs, and selecting appropriate resistors for R_t and R_r .

This application does not optimize return loss values. See the LXT332 Dual Line Interface Unit Data Sheet for R_t and transformer specifications for other possible components.

Figure 4: LXT332 Switchable T1/E1 Line Interface (Hardware Mode)

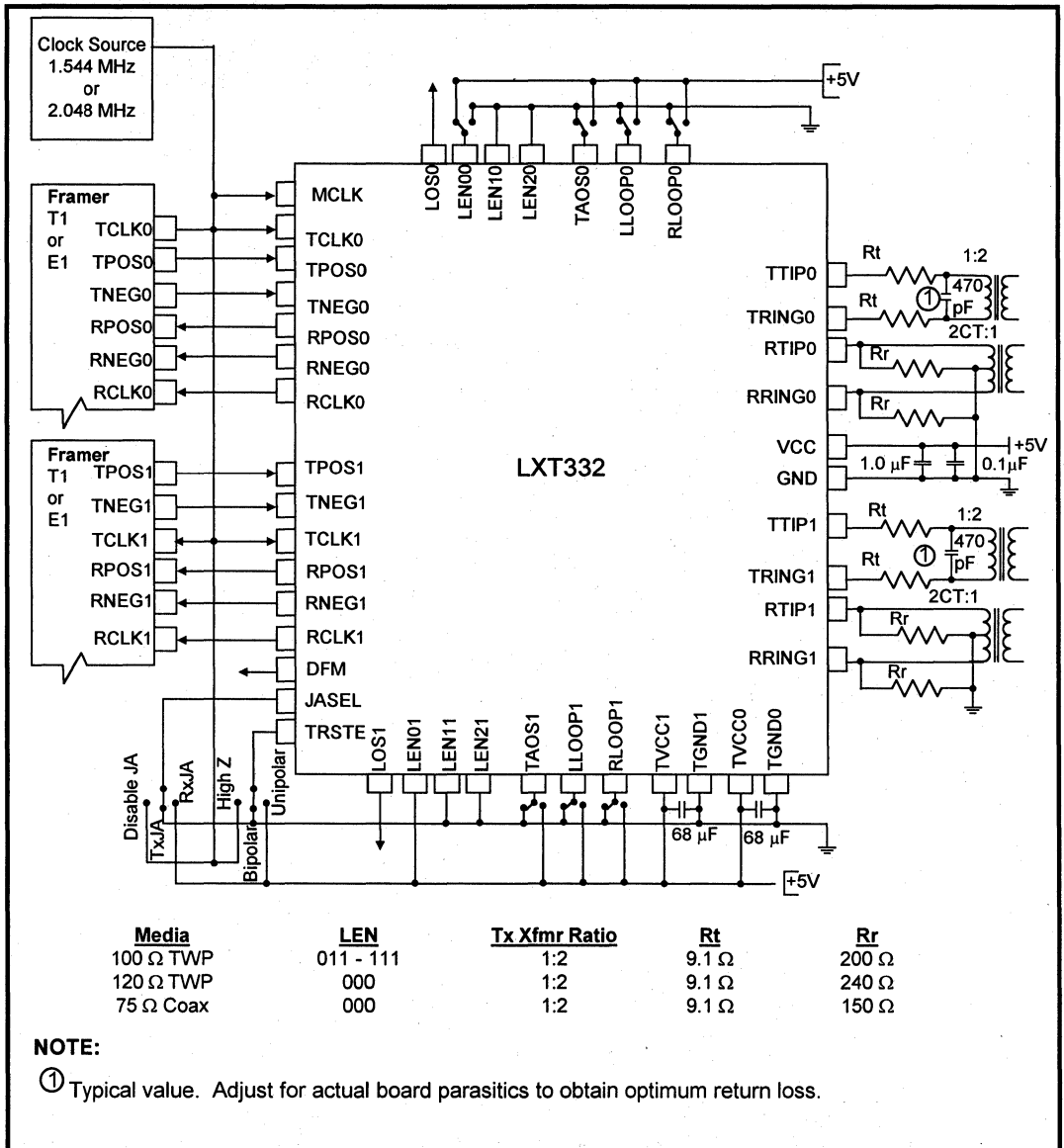

LXT332 Dual Channel T1/E1 Transceiver Solution

Migration from Dual-Chip (AT&T T7290) to Single-Chip (LXT332) Implementation

Introduction

This application note provides manufacturers of multi-channel T1/E1 transmission equipment with a smooth upgrade from a pair of AT&T T7290 single-channel devices to an advanced implementation using a single LXT332 integrated dual-channel device. This app note discusses Hardware Mode only. (No Host Mode is available in the T7290.)

There are some differences between the two devices in the back end and line interfaces. However, existing T7290 designs can easily be adapted to take advantage of the fully integrated dual channel LXT332.

Advantages

- Simplifies board design
- Single transformer turns ratio for both T1 and E1 applications
- Saves real estate
- Improves jitter performance
- No external crystal required
- Reduces inventory costs
- Additional features with Host Mode Serial I/O

Framer and Control Interface

No framer interface changes are required to upgrade from the T7290 to the LXT332. However, minor modifications to the control circuitry are required. There are also minor differences in the LOS and Transmit Driver monitor outputs.

Jitter Attenuation Select

The LXT332 JA circuitry is controlled by the JASEL and MCLK inputs. This function is implemented through the Mode 1 and Mode 2 pins on the T7290. Refer to Tables 1A and 1B for details.

Tristate Output

The Tristate control inputs on the two devices function similarly, but with inverted polarity. The T7290 TRI input is an active low; the LXT332 TRSTE input is an active high. To provide compatibility with existing designs, an inverter must be added to the existing TRI input.

Line Length/Pulse Shape Control

Both the LXT332 and the T7290 use 3-input codes to determine pulse shapes for various line lengths. The two coding schemes are shown in Tables 2A and 2B.

Loopback Control

Both the LXT332 and the T7290 provide various diagnostic loopbacks. The control codes for executing the various loopbacks are slightly different as shown in Tables 3A and 3B.

Loss of Signal

Both the LXT332 and the T7290 provide Loss of Signal (LOS) outputs. The internal detection circuitry which determines when an LOS condition exists is functionally different.

Transmit Driver Monitor

Both the LXT332 and the T7290 provide Driver Monitor detectors. The LXT332 DFM output reports short conditions. The T7290 TSC output differentiates between shorts to power supply, shorts to ground and shorts together.

Elastic Store Overflow

The T7290 provides an output to report ES overflow conditions. The LXT332 does not report overflow conditions.

Dual Channel T1/E1 Transceiver Solution Migration from AT&T T7290 to LXT332

Table 1A: AT&T JA Codes

JA Placement	Mode 1	Mode 2
Bypass	0	0
Transmit Path	0	1
Receive Path	1	0
Test Mode*	1	1

* Not used in normal operation.

Table 1B: LXT332 JA Codes

JA Placement	JASEL
Bypass	MCLK*
Transmit Path	0
Receive Path	1

* JA is bypassed when JASEL is tied to MCLK.

Table 2A: AT&T T7290 Line Length Codes

EC 3	EC 2	EC 1	Line Length	Cable Loss
1	0	0	0 - 131 ft ABAM	0.6 dB
0	1	0	131 - 262 ft ABAM	1.2 dB
1	1	0	262 - 393 ft ABAM	1.8 dB
0	0	1	393 - 524 ft ABAM	2.4 dB
1	0	1	524 - 655 ft ABAM	3.0 dB
0	1	1	75 Ω ITU	
1	1	1	120 Ω G.703	
0	0	0	FCC Part 68, Option A	

Table 2B: LXT332 Line Length Codes

LEN 2	LEN 1	LEN 0	Line Length	Cable Loss
0	1	1	0 - 133 ft ABAM	0.6 dB
1	0	0	133 - 266 ft ABAM	1.2 dB
1	0	1	266 - 399 ft ABAM	1.8 dB
1	1	0	399 - 533 ft ABAM	2.4 dB
1	1	1	533 - 655 ft ABAM	3.0 dB
0	0	0	75 Ω ITU	
0	0	1	120 Ω G.703	
0	1	0	FCC Part 68, Option A	

Table 3A: AT&T Loopback Codes

Mode	LOOPA	LOOPB	TBS
RLOOP	1	0	N/A
LLOOP	0	1	1 or 0
TBS	N/A	N/A	1
Full Local Loop	1	1	1 or 0

Table 3B: LXT332 Loopback Codes

Mode	RLOOP	LLOOP	TAOS
RLOOP	1	0	N/A
LLOOP	0	1	N/A
DLOOP	1	1	1
TAOS	0	N/A	1
RESET	1	1	0

Line Interface Modifications

The line interface must be modified when upgrading from the T7290 to the LXT332. The T1 line interfaces are shown in

Figures 1A and 1B. The E1 line interfaces for 120 Ω twisted-pair are shown in Figures 2A and 2B. The E1 line interfaces for 75 Ω coax are shown in Figures 3A and 3B.

Figure 1: 100 Ω T1 Line Interface Upgrade

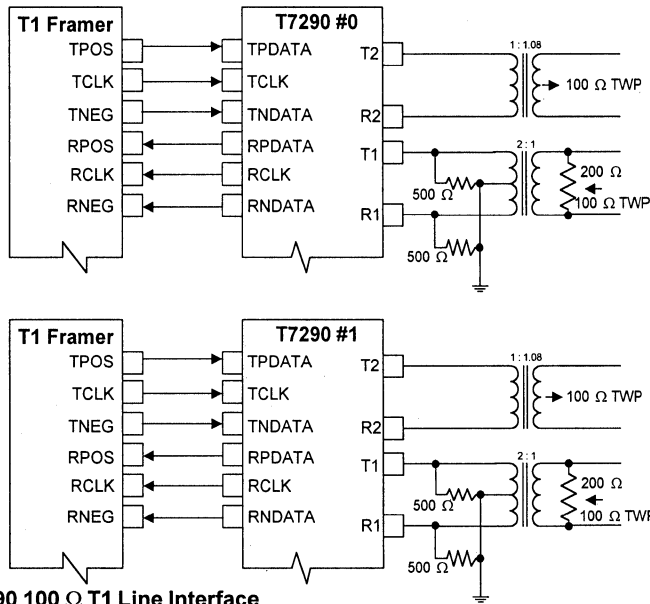

Figure 1A: T7290 100 Ω T1 Line Interface

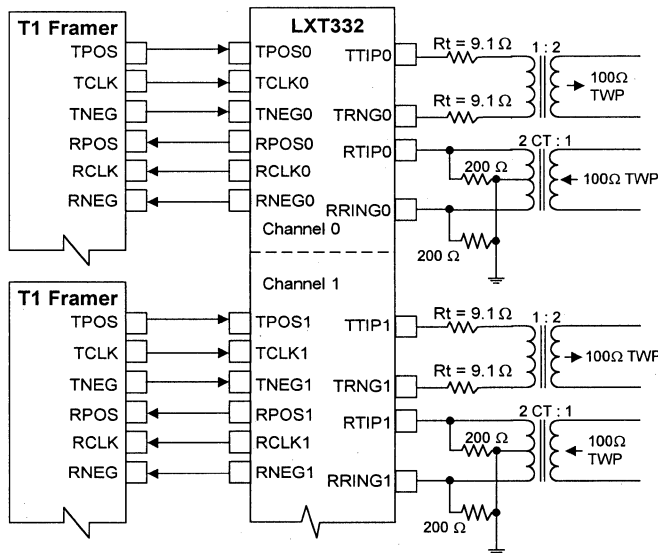

Figure 1B: LXT332 100 Ω T1 Line Interface

Figure 2: 120 Ω E1 Line Interface Upgrade

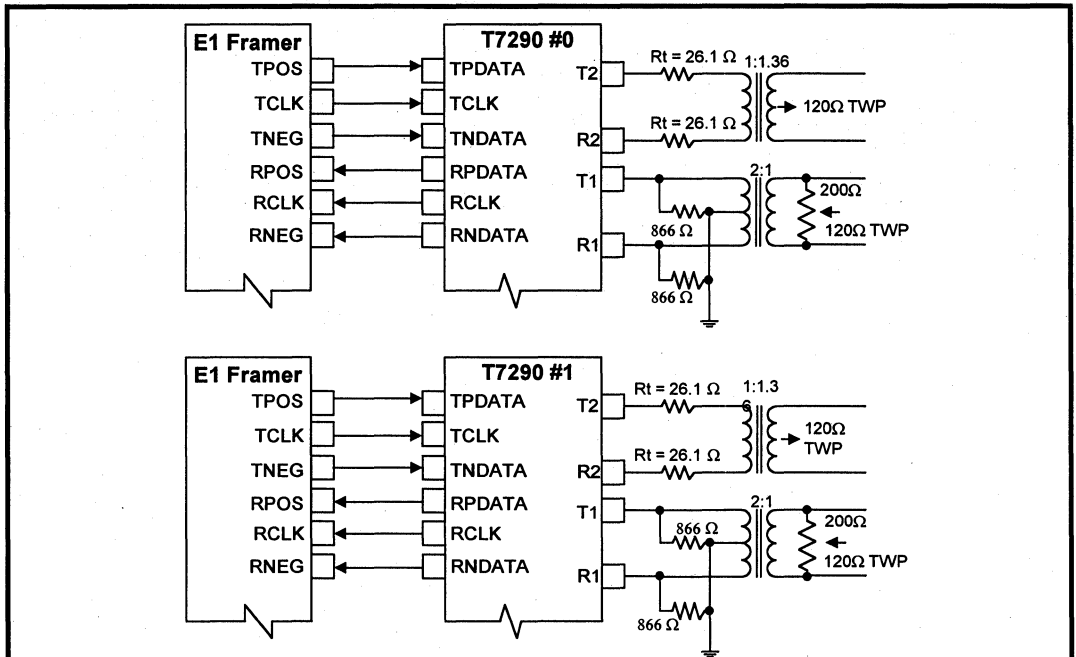

Figure 2A: T7290 120 Ω E1 Line Interface

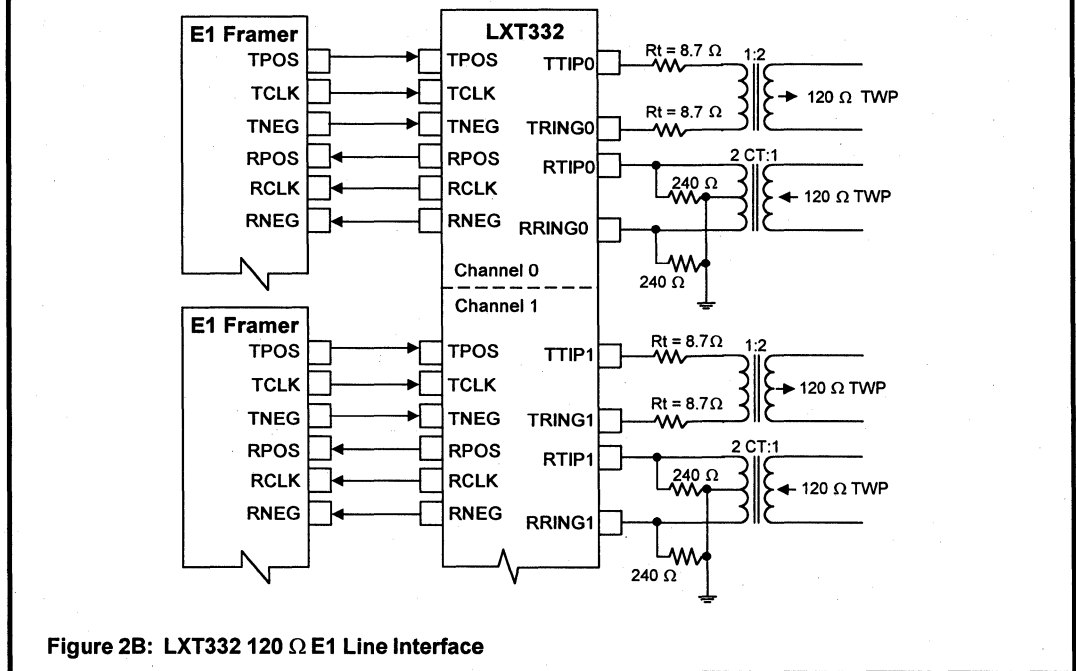

Figure 2B: LXT332 120 Ω E1 Line Interface

Figure 3: 75 Ω E1 Line Interface Upgrade

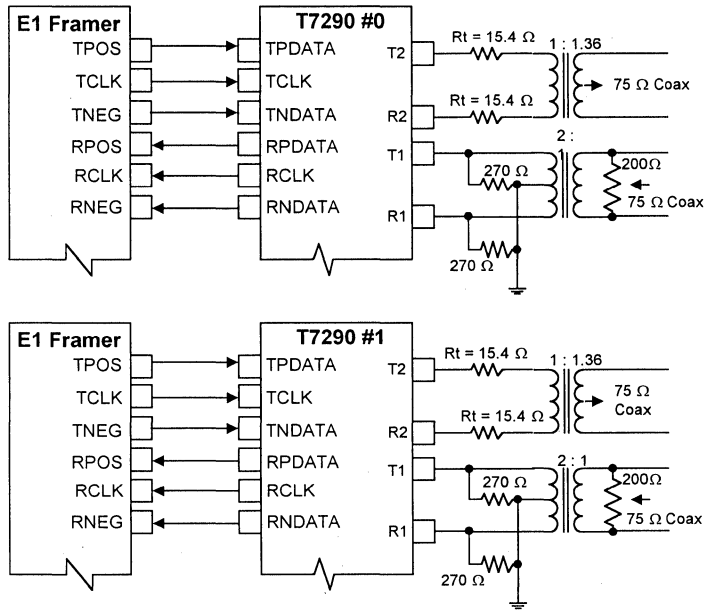

Figure 3A: T7290 75 Ω E1 Line Interface

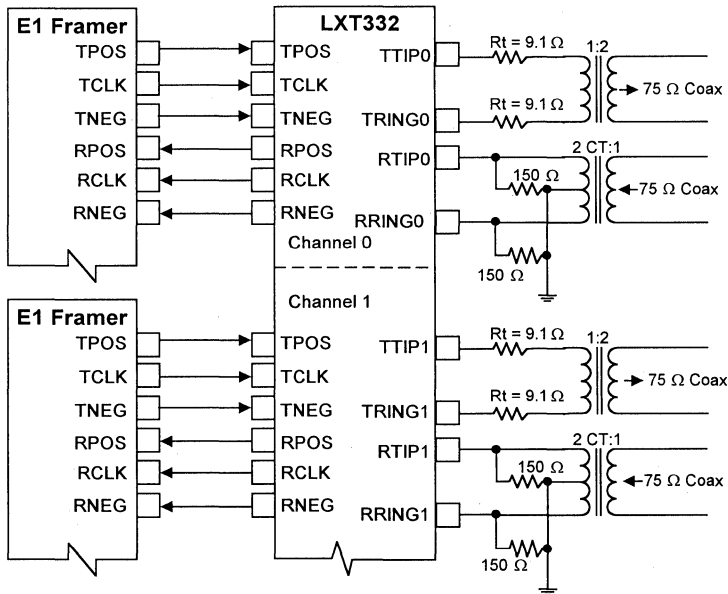
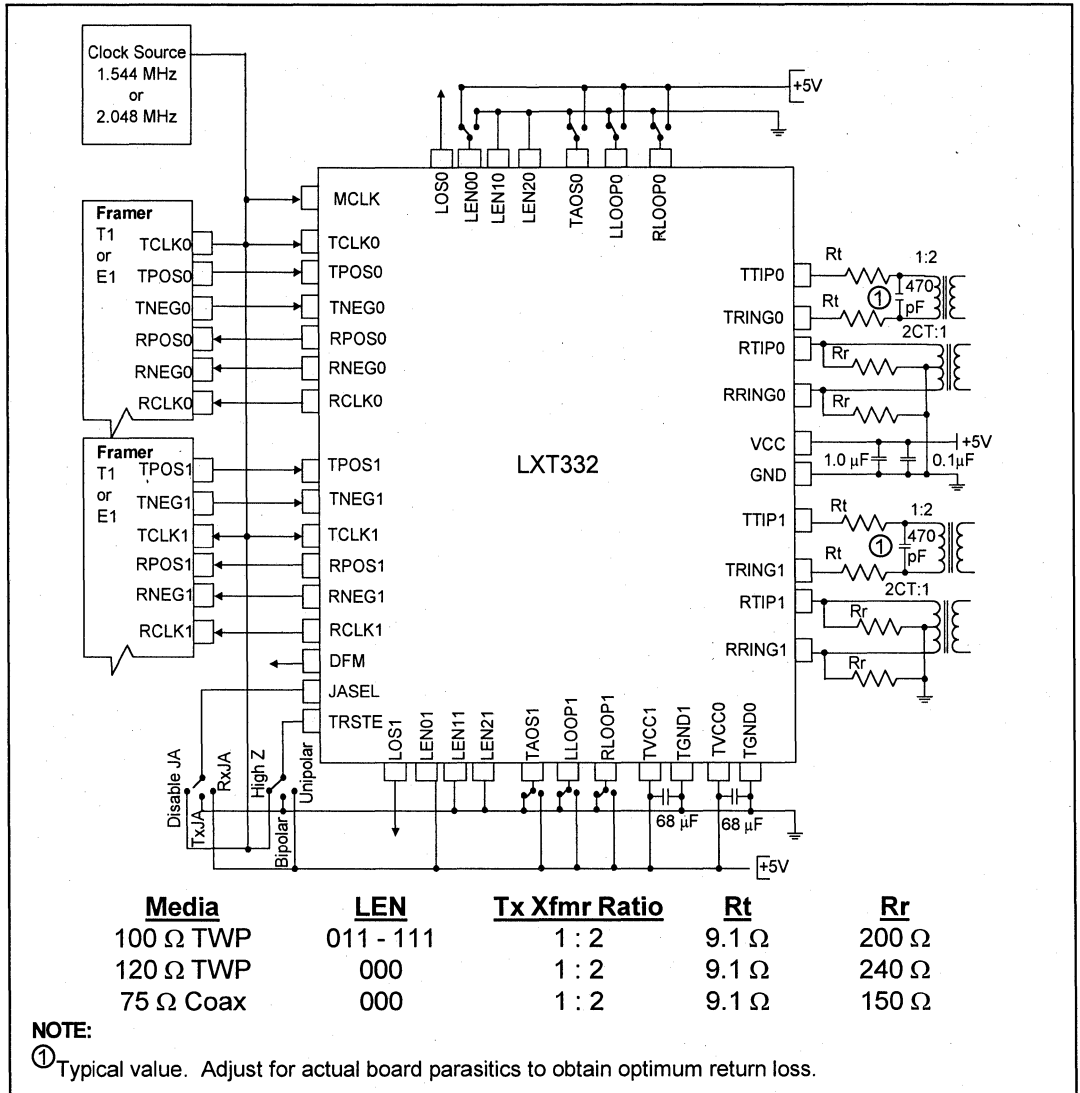

Figure 3B: LXT332 75 Ω E1 Line Interface

Dual Channel T1/E1 Transceiver Solution Migration from AT&T T7290 to LXT332

Using the LXT332, it is possible to design a switchable interface board. Figure 4 shows a simplified application which can be used for either T1 or E1 equipment by changing the MCLK and Line Length inputs, and selecting appropriate resistors for R_t and R_r .

Figure 4: LXT332 Switchable T1/E1 Line Interface (Hardware Mode)



Level One Short-Haul Devices and ITU G.775 LOS Criteria Compliance

General Description

This application note documents the compliance of Level One Communications' line of short-haul transceivers to ITU Recommendation G.775 for detecting and clearance of a loss of signal (LOS) condition. For purposes of illustration, data presented here are from the LXT304A transceiver. The logic circuitry related to LOS in the LXT304A is identical to that of all Level One short-haul transceivers.

To clarify the implementation of LOS detection and clearance, this application note explains ITU Recommendation G.775. The recommendation gives the criteria for the detection and clearance of both LOS and AIS defects at the intra-station interfaces conforming to recommendation G.703.

Recommendation G.775

Section 4.2 of ITU G.775 dated September 1993 states:

A LOS defect at 2048 kbit/s interface is detected when the incoming signal has "no transitions", *i.e.*, when the signal level is less than or equal to a signal level of Q dB below nominal, for N consecutive pulse intervals, where $10 \leq N \leq 255$.

The LOS defect is cleared when the incoming signal has "transitions", *i.e.*, when the signal level is greater than or equal to a signal level of P dB below nominal, for N consecutive pulse intervals, where $10 \leq N \leq 255$.

Refer to the figure on this page. The signal level P is (maximum cable loss +3 dB) dB below the nominal signal level. For a 2.048 Mbps transmission, P = 9 dB. The signal level Q is greater than the maximum expected cross talk level (Q = 35 dB).

G.775 LOS Tolerance Range with Receiver Sensitivity

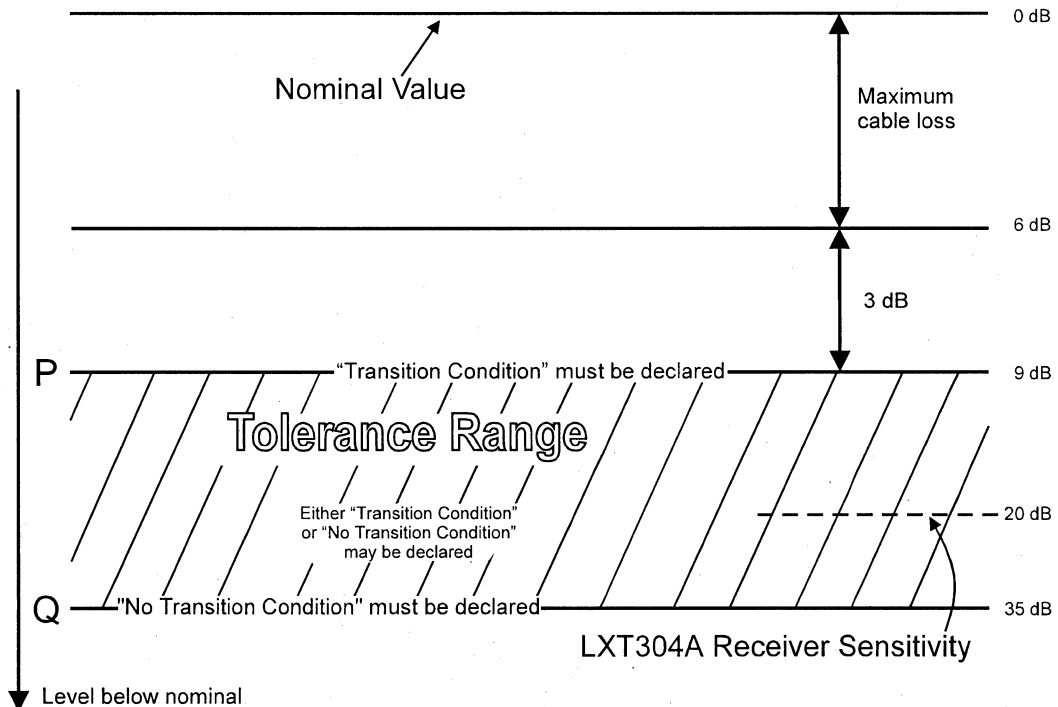

Level One Short-Haul Device Compliance with Recommendation G.775

Declaring the LOS Condition

Recommendation G.775 sets parameters for both signal levels and consecutive pulse period conditions. With reference to declaring the LOS Condition, it states, “when the signal level without transition is less than or equal to Q dB below nominal, for N consecutive pulse intervals, where $10 \leq N \leq 255$, a LOS must be declared.”

This means if the signal level is below P yet still within the tolerance range, either LOS or clear from LOS is acceptable. However, the transceiver must declare LOS if the signal level falls below Q dB.

Level One transceivers use a digital-and-analog detection scheme to comply with the recommendation. If the signal level falls below 20 dB, the LXT304A¹ begins to count consecutive bit times and declares LOS after approximately 175 (160 to 190) consecutive zeros. This is in compliance with the recommendation. Refer to Table 1. Since the recommendation requires the receiver to have a minimum sensitivity of 9 dB, the 20 dB sensitivity provided by the Level One devices falls within the tolerance range.

Clearing the LOS Condition

In discussing clearing the LOS Condition, the recommendation says,

The LOS defect is cleared when the incoming signal has “transitions”, *i.e.*, when the signal level is greater than or equal to a signal level of P dB below nominal, for N consecutive pulse intervals, where $10 \leq N \leq 255$.

The receiver must clear the LOS Condition above P dB if the pulse density falls within the window of N consecutive pulse intervals, where $10 \leq N \leq 255$.

Level One transceivers meet these criteria by clearing LOS with a three step process: The signal level must first exceed the 20 dB signal level. Then a 32-bit repeating window checks for 12.5% ones density (to meet this parameter, there must be at least 4 ones out of the 32 bits in the window), and finally, there must be no more than 15 consecutive zeros. Figures 1 and 2 show this in graphic form.

Table 1: G.775 Requirements and Level One Implementation of LOS Detection

Condition	G.775 Recommendation	Level One Implementation
Detect LOS	Signal with no transitions ¹ less than or equal to signal level of Q below nominal for N consecutive intervals where $10 \leq N \leq 255$.	Signal level below 20 dB and no consecutive transitions for 160 to 190 pulse intervals.
Clear LOS	Signal has transitions ¹ and level greater than or equal to P dB below nominal for N consecutive pulse intervals where $10 \leq N \leq 255$.	Signal level above 20 dB with bit density greater than 12.5% for 32 bit positions, but with fewer than 15 consecutive zeros.

¹ A signal with “transitions” corresponds to a G.703 compliant signal.

Figure 1: G.775 Recommendation and Level One Transceiver Implementation to Clear the LOS Condition

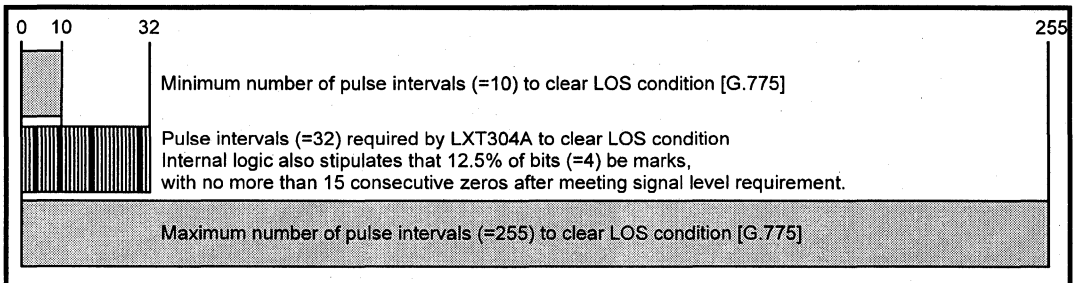

¹ This document uses the LXT304A as an example. The LXT305, LXT305A and LXT332 transceivers meet the standard using the same LOS circuit design.

The window in these transceivers closes every time the 32 bits fail to include four marks. The window also closes any time the detector circuitry senses 16 consecutive zeros. It will only reopen when the circuitry detects a mark even if that mark was part of a window closed because of 16 consecutive zeros. This opening mark starts a new search for a pattern that will allow clearing the LOS condition. See Figure 2.

If the signal in the 32-bit sliding window meets the constraints described in this note, the transceiver will clear the LOS condition. This design is in compliance with ITU G.775 since the window of 32 bits fits within the N consecutive bits defined by $10 \leq N \leq 255$.

Figure 2: Level One Transceiver Requirements for Clearing the LOS Condition

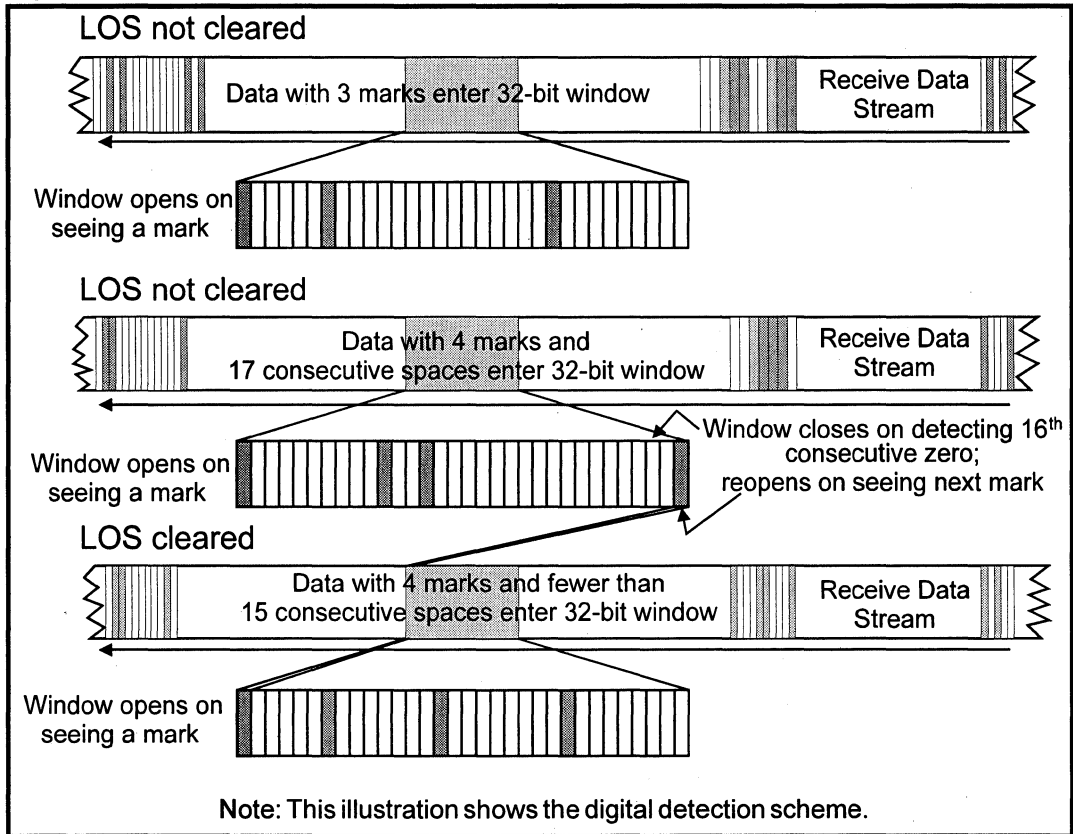

Level One Short-Haul Device Compliance with Recommendation G.775

NOTES:

Crystal-less T1 Long-Haul Solutions

LXT310/360 Universal Line Interface Unit Design Guide

Introduction

This note describes applications for the crystal-less LXT360 transceiver in newer generation network access equipment. Use this application note as a guide when upgrading designs using the LXT360. Before designing a circuit using this new device, refer to the data sheets for both devices for complete information.

The LXT360 provides several advanced features. While the LXT360 provides for both T1 (1.544 Mbps) and E1 (2.044 Mbps) operation, this application note focuses only on hardware-controlled, T1 designs. Additional application notes detail migration paths for T1 and E1 design using other LXT360 features.

Identifying Major LXT360 Design Improvements

Jitter Attenuation Circuitry

- The LXT310 device requires a pullable 6.176 MHz crystal to provide selectable jitter attenuation. The jitter attenuation circuitry may be in either the transmit or the receive path, depending on the application.
- The LXT360 requires only the MCLK signal to provide the same selectable jitter attenuation functions since it uses digital JA circuitry. It needs no crystal or high-frequency external clock for jitter attenuation.

External Clock Requirements

- The MCLK input signal in the LXT310 is optional. If used, the clock must have an accuracy of ± 100 ppm.
- The MCLK input signal in the LXT360 is mandatory. The clock must be a stand alone reference with an accuracy of ± 32 ppm or better at 1.544 MHz for T1 applications.

Applications

- The LXT310 is a long-haul T1 transceiver only.
- The LXT360 operates as either a short- or long-haul transceiver in T1 or E1 applications.

Available Line Coding Schemes

- The LXT310 allows B8ZS encoding in either Unipolar or Bipolar mode.
- The LXT360 transceiver offers B8ZS line encoding only in the Unipolar Mode.

Reset Operation

- Reset on the LXT310 occurs when both LLOOP and RLOOP inputs are pulled High while TAOS is pulled Low for at least 200 ns.
- Reset on the LXT360 occurs when LLOOP, RLOOP and TAOS are pulled High simultaneously for at least 200 ns.

Output Control

- The LXT310 provides a high-impedance state option for the TTIP/TRING outputs only when TCLK is grounded.
- The LXT360 provides high-impedance state limited to the TTIP/TRING outputs when TCLK is pulled High. An additional high-impedance state option is available for all output pins when TRSTE is pulled High.

Line Attenuation Indication

- The LXT310 provides Line Attenuation Indication (LATN) in both Hardware and Host Modes.
- The LXT360 provides LATN in Software Mode only.

NLOOP Detection

- For the LXT310 transceiver, holding RLOOP, LLOOP and TAOS High simultaneously for 200 ns and then pulling all three Low enables the NLOOP detection function. Alternatively, tying RCLK to RLOOP also enables NLOOP. Resetting the device disables NLOOP detection.
- In the LXT360 setting the RLOOP input to 2.5 V ± 0.2 V ("Midrange") enables NLOOP detection. Setting RLOOP Low or High disables NLOOP detection.

Loss of Signal Detection and LOS Clear Criteria

- The LXT310 device declares a Loss Of Signal (LOS) condition when it detects 175 consecutive spaces. It clears the LOS condition when the receiver detects 12.5% mark density (*i.e.*, 4 marks within a 32-bit period) with no more than 15 consecutive 0s.
- The LXT360 transceiver also declares the LOS condition when it detects 175 consecutive spaces. It clears the LOS condition when the receiver detects 12.5% mark density (determined by 16 marks in a sliding 128-bit period) with fewer than 100 consecutive 0s.

DIAGNOSTIC FUNCTIONS

The LXT360 provides several diagnostic features not provided on the LXT310 transceiver. These are Dual Loop-back function, Error Insertion and Detection, AIS Condition Monitoring and Elastic Store Pointer Monitoring. The LXT360 data sheet has details on these functions.

In addition, the LXT360 provides both a Quasi-Random Signal Source and a Detector for diagnostic procedures.

Three-State Input Pins

The LXT310 uses two-state (High and Low) configuration inputs but some LXT360 control inputs recognize three states. Typical values for these states are:

- High - $V_{IN} > 3.5 V$.
- Midrange - $2.3 V \leq V_{IN} \leq 2.7 V$ (or floating).
- Low - $V_{IN} < 1.5 V$.

The control for three-state inputs may be a standard tri-state buffer. Figure 1 shows a typical driver circuit for these inputs. Setting the output buffer to its high-impedance state places the three-state input into its Midrange state.

Application designers must take into account the current drawn by the internal resistors (part of each three-state input) before choosing a buffer to drive these inputs to their High or Low states.

Figure 1: Typical Circuit for LXT360 Three-State Inputs

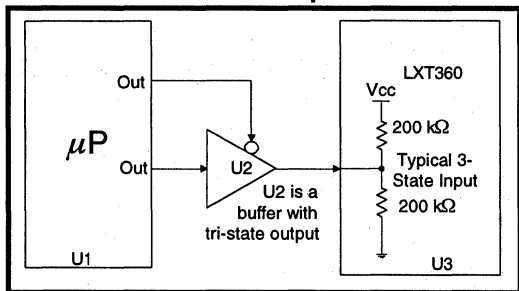

Line Interface Considerations

To improve transmit return loss, add a capacitor (CTX) to the transmit side as shown in Figures 2 through 4. This capacitor is typically 470 pF, but may vary depending on the resistor and transformer values, the board layout and the parasitics of the protection diodes.

Table 1 shows the combinations of transformers, resistors and capacitors needed for the transmit side as shown in

these applications. Table 2 lists transformers that met Level One Communications specifications when tested with the LXT360 device.

Table 1: Transmit Return Loss (1.544 Mbit/s—Long- or Short-Haul)

EC4-1	Xfrmr/ Rt	Xmission Line	CTX (pF)	Return Loss
Refer to the LXT360 Data Sheet	1:2/ 9.1 Ω	100 Ω Twisted Pair	0	16 dB
			470	17 dB
	1:1.15 ¹ / 0.0 Ω	100 Ω Twisted Pair	0	2 dB
			470	2 dB

1. A 1:1.15 transmit transformer keeps the total transceiver power dissipation at a low level, a 0.47 μF DC blocking capacitor must be placed on TTIP or TRING.

Table 2: Recommended Transformers for LXT360/LXT361

Tx/ Rx	Turns Ratio	Part Number	Manufacturer
Tx	1:1.15	PE-65388	Pulse Engineering
		PE-65770	
	1:2	PE-65351	Bell-Fuse
		PE-65771	
		0553-5006-IC	Fil-Mag
		66Z-1308	Midcom
		671-5832	Schott Corp
		67127370	
67130850	HALO (combination Tx/ Rx set)		
TD61-1205G			
TD67-1205G			
Rx	1:1	FE 8006-155	Fil-Mag
		671-5792	Midcom
		PE-64936	Pulse Engineering
		PE-65778	
		67130840	Schott Corp
		67109510	
		TD61-1205G	HALO (combination Tx/ Rx set)
		TD67-1205G	

Bipolar Mode with AMI Line Coding (without Zero Suppression)

Most pins on LXT360 have the same names and functions as those on the LXT310, although some differ. This section describes the modifications needed to change from the LXT310 to the LXT360 in Hardware Control Mode. The LXT360 pins not included in this discussion have the same connections and signal level requirements as those on the LXT310. Table 3 is a summary of the pins whose functions change when moving from LXT310 to LXT360.

The 6.176 MHz crystal required by the LXT310 must be deleted when migrating to the LXT360. The functions on pins 17, 18, and 23 on the LXT310 change pin locations on the LXT360 transceiver. **Pay particular attention to the new locations for these signals.** Figure 2 shows the connection differences between the two transceivers for this configuration.

Pin 1: The LXT360 requires an independent, external clock called MCLK. The MCLK input signal must have a nominal rate of 1.544 MHz and an accuracy of ± 32 ppm or better. The LXT310 uses the same nominal frequency, but requires no better accuracy than ± 100 ppm.

Pin 5: In the LXT310, pin 5 is called MODE. This pin can be pulled High or Low, or it can be tied to the RCLK pin. The RCLK signal at the MODE pin enables the B8ZS encoders and decoders.

In the LXT360, the MODE pin is a three-state input pin: High, Low or Midrange. Setting the pin to Midrange enables the B8ZS encoders and decoders in LXT360 for T1 applications (and also forces the transceiver into unipolar operation).

Pin 9: In LXT360, pin 9 is called TRSTE. It is a three-state input. With TRSTE pulled High all LXT360 device output pins go into a high-impedance state. In conjunction with MODE (pin 5), this pin also sets the operational mode of the transceiver.

To enable T1, Long-Haul, Bipolar, Hardware Control Mode, the TRSTE pin must be pulled Low. See the data sheet for a complete description of the operating modes.

Pin 10: This pin is the XTALOUT input on the LXT310. Leave this pin not connected on the LXT360.

Pin 17: Move the LXT310 signal (EGL) to pin 23 on the LXT360. In the LXT360, pin 17 is EC4 and must be pulled Low to enable T1, Long-Haul operation.

Pin 18: The LXT310 pin 18 signal (NLOOP) appears on pin 23 of the LXT360.

The LATN signal, which is on pin 18 of the LXT310, is not available in the Hardware Mode on the LXT360. However, a binary encoded equivalent to LATN is provided in the LXT360 Software Mode.

Pin 23: The EGL signal, which appears on pin 17 of the LXT310 appears on the LXT360 pin 23 (EC1).

The NLOOP signal, which appears on pin 23 of the LXT310, is available on pin 18 of the LXT360.

Pins 24 and 25: These pins retain their functions from the LXT310, but the names of the signals change. In the LXT310, pin 24 is LBO1 and pin 25 is LBO2. The LXT360 uses the names EC2 (pin 24) and EC3 (pin 25). The functions and connection remain the same. See the LXT360 Data Sheet for details.

Figure 2: Bipolar Mode Using AMI Line Coding (without Zero Suppression)¹

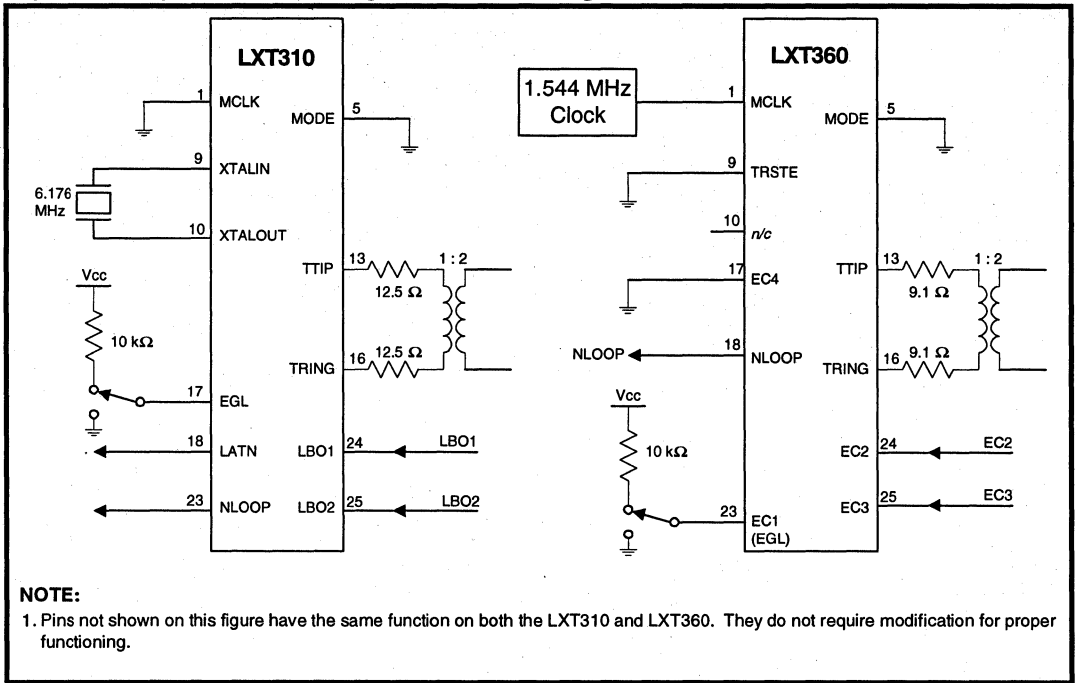

Table 3: Bipolar Mode using AMI Line Coding (without Zero Suppression)

Pin#	LXT310		LXT360		Comments
	Name	Function/State	Name	Function/State	
1	MCLK ¹	1.544 MHz/GND	MCLK	1.544 MHz	Mandatory in LXT360 applications
5	MODE	Low	MODE	Low	MODE and TRSTE set operation mode
9	XTALIN	6.176 MHz Crystal	TRSTE	Low	Crystal not used in LXT360
10	XTALOUT	6.176 MHz Crystal	—	n/c	No function assigned to this pin.
17	EGL	Input	EC4	Input-Low	EC4 = Low for T1 long-haul operation.
18	LATN	Output	NLOOP	Output	LATN not supported on LXT360 in Hardware Control Mode. NLOOP changes location.
23	NLOOP	Output	EC1	Set to select the Xmit line build-outs, including EC4, pin 17.	Refer to Table 12 in LXT360 Data Sheet.
24	LBO1	Set to select the Xmit line build-outs.	EC2	EC4, pin 17.	
25	LBO2		EC3		

¹. MCLK is optional in LXT310 applications. With the LXT310, if MCLK is not supplied, pin 1 must be grounded.

Using B8ZS Encoding/Decoding

The LXT310 supports B8ZS encoding/decoding in both Unipolar and Bipolar Modes. The LXT360 configures itself in Unipolar mode (*i.e.*, TPOS becomes TDATA and TNEG becomes INSBPV) when B8ZS is enabled. To

enable B8ZS encoders and decoders, set the MODE pin to Midrange. Other connections are the same as for AMI line coding. Figure 3 shows the changes needed in connections for LXT310 and LXT360. See Table 4 for a summary of the modifications needed to adapt an LXT310 application to the LXT360.

Figure 3: Unipolar Mode (with B8ZS Zero Suppression)¹

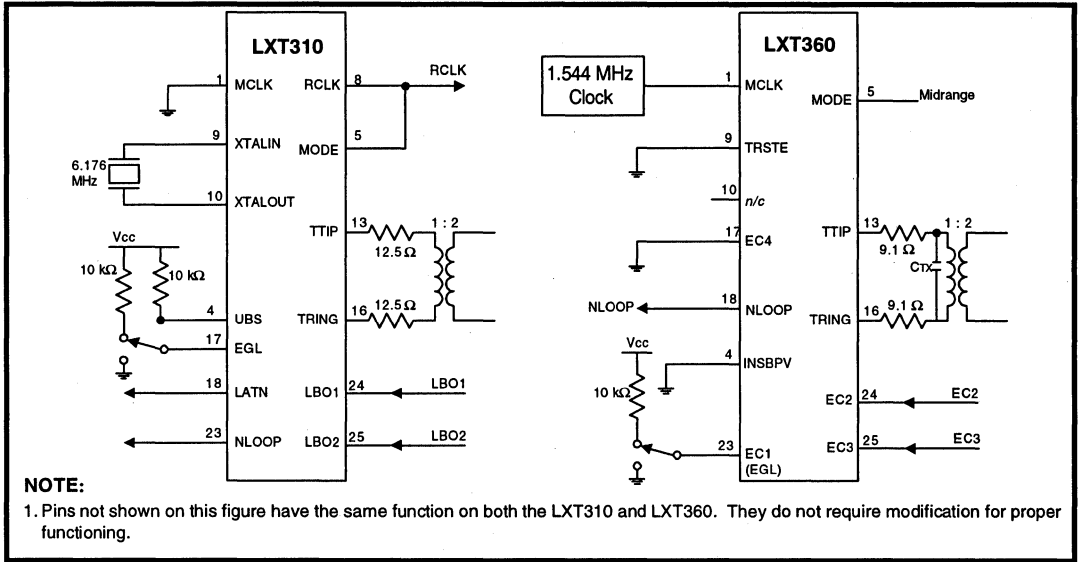

Table 4: Unipolar Mode (B8ZS Zero Suppression Enabled)

Pin #	LXT310		LXT360		Comments
	Name	Function/State	Name	Function/State	
1	MCLK ¹	1.544 MHz/GND	MCLK	1.544 MHz	Mandatory in LXT360 applications
5	MODE	Tie to RCLK	MODE	Midrange ²	MODE and TRSTE set operation mode
4	UBS	High	INSBPV	Low	Refer to Data Sheet
9	XTALIN	8.152 MHz Crystal	TRSTE	Low	Crystal not used in LXT360
10	XTALOUT	8.152 MHz Crystal	—	n/c	
17	EGL	Input	EC4	Input-Low	EC4 = Low for T1 long-haul operation.
18	LATN	Output	NLOOP	Output	LATN not supported on LXT360 in Hardware Control Mode. NLOOP changes location. Refer to Table 12 in LXT360 Data Sheet.
23	NLOOP	Output	EC1	Set to select the Xmit Line Build Outs and receiver range.	
24	LBO1	Set to select the Xmit Line Build Outs.	EC2		
25	LBO2		EC3		

1. MCLK is optional in LXT310 applications. If MCLK is not supplied to the LXT310, pin 1 must be grounded.
2. "Midrange" means leave the pin unconnected or tie it to 2.5 V.

Crystal-less T1 Long-Haul Solutions

Enabling NLOOP Detection

Tying the RCLK output to the RLOOP input enables Network Loop detection (NLOOP) on the LXT310 transceiver. NLOOP detection is also enabled by holding

RLOOP, LLOOP and TAOS all High simultaneously for 200 ns and then bringing them Low. To enable NLOOP detection on the LXT360 transceiver, tie the RLOOP input pin to Midrange as in Figure 4.

Figure 4: Bipolar Mode (with NLOOP Detection Enabled)¹

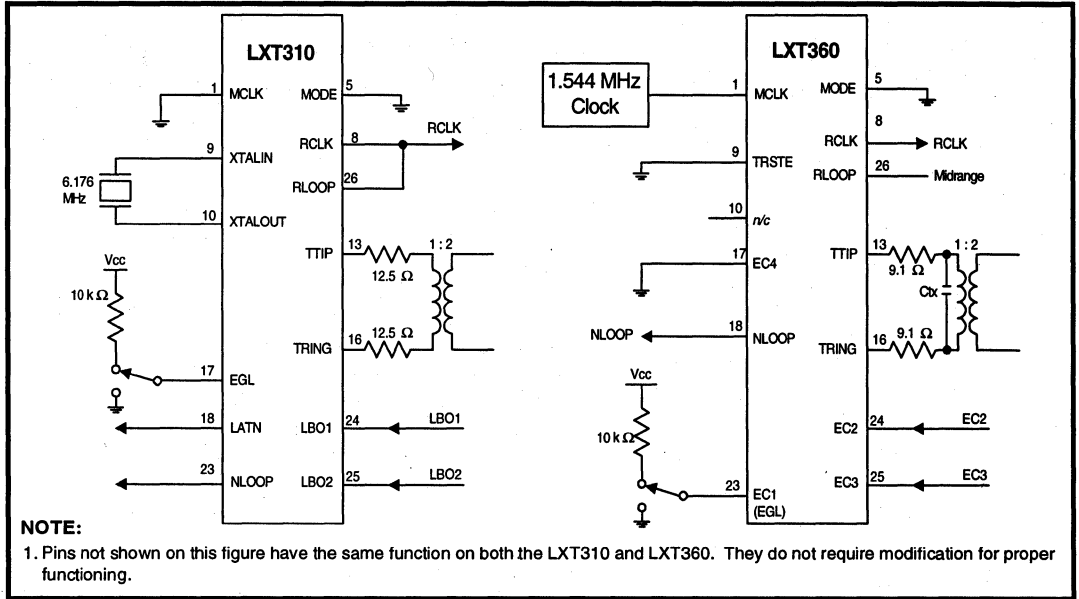

Jitter Performance Requirements for E1 Leased Lines

ETSI TBR-12 & TBR-13 Conformance Testing

Introduction

This application note summarizes the new jitter performance requirements and appropriate conformance testing procedures for E1 (2.048 MHz) terminal equipment designed to attach to harmonized leased lines throughout the European Economic Community (EEC).

Directive 91/263/EEC implements a harmonized market for telecommunications equipment throughout the EEC by establishing unified procedures for testing, certification, marking and quality assurance. This allows vendors and service providers to market and use the same equipment in the public networks of all EEC member states. The Open Network Provision (ONP) directive 92/44/EEC mandates member states to provide leased lines having harmonized technical characteristics to facilitate inter-network operability across the EEC.

The European Telecommunications Standards Institute (ETSI) drafts two types of standards that define these harmonized requirements. The first, for which compliance is voluntary, is the European Telecommunications Standard (ETS). An ETS completely describes all details of the specified interface or equipment. The second standard, for which compliance is mandatory, is the Technical Basis for Regulation (TBR). A TBR defines the minimum necessary technical requirements for the interface or equipment and allows for no national deviations. The TBR technical requirements are combined with regulatory provisions to form a Common Technical Regulation, or CTR.

In Europe there are two categories of 2048 kbps leased-line service: *unstructured* and *structured*. ETS 300-248 fully describes the unstructured service interface and TBR-12 (December 1993) defines the necessary technical requirements. Unstructured service provides a usable bit rate of 2048 kbps with no network-provided timing or framing support.

Structured service provides a usable bit rate of 1984 kbps with network framing support. ETS 300-420 fully describes this interface. The current draft of TBR-13 (June 1994) defines the necessary technical requirements. (By the end of 1995, CTR-13 should include the provisions of TBR-13.) Compliance with TBR-13 also insures compliance with TBR-12.

Maximum Output Jitter Specifications

TBR-12 and TBR-13 (draft) include a common Output Jitter section (5.2.1.4). For terminal equipment, this section defines a maximum output jitter of 0.11 UIpp in the band from 40 Hz to 100 kHz.

The output jitter limit applies to equipment in configurations where output timing is derived locally as well as configurations where output timing is derived from one or more leased lines. For such "loop-timed" applications these requirements also imply minimum jitter transfer requirements because they apply when the maximum allowed input jitter is present at all line inputs. These requirements also apply with a data rate offset of up to ± 50 ppm from 2.048 MHz.

Figure 1 shows the input jitter amplitude and the maximum output jitter amplitude over frequency when measured across a 40 Hz - 100 kHz bandwidth. These specifications require loop-timed equipment to provide a significant amount of jitter attenuation at 20 Hz because the standards specify that conformance testing be done using a 40 Hz, first-order high pass filter which still allows the measurement of a significant portion of the 1.5 UIpp input jitter applied at 20 Hz.

At 20 Hz the terminal equipment must provide approximately 15 dB of jitter attenuation to insure that 1.5 UIpp is attenuated to 0.11 UIpp when measured using the first-order 40 Hz, high-pass filter providing approximately 7 dB of attenuation at 20 Hz. This will be the case as long as the equipment does not transfer significant components of the 20 Hz the input jitter to higher frequencies. Designs which do not have linear jitter transfer at 20 Hz with an input amplitude of 1.5 UIpp may shift jitter to higher frequencies inside the filter passband and thus fail to comply at this frequency.

CONFORMANCE TESTING

Terminal equipment is tested in configurations where it does and does not derive timing from an input (if it has the capability to do so). One way to configure a single line system for loop timing is to enable the line interface line-side (*i.e.*, remote) loopback function.

Table 1 lists useful equipment for TBR-12 and TBR-13 characterization and conformance testing. Figure 2 illustrates the recommended test configuration using this equipment.

The HP3785A measures output jitter with an external 40 Hz RC high-pass filter and the 100 kHz internal low-pass filter. The high-pass filter consists of a 4 μ F capacitor connected between the DEMOD output and the MEASURE input on the back of the HP3785A. The external 4 μ F capacitor and the internal 1 k Ω input termination resistor in the MEASURE input combine to form the filter.

NOTE

Prior to testing, use the HP3785A to calibrate the filter by adjusting the capacitor to achieve a 40 Hz, -3 dB corner frequency.

The filter should be calibrated with a network analyzer with high impedance inputs to prevent loading or with an audio oscillator and RMS voltmeter (as shown in Figure 3). Figure 4 illustrates the transfer function of a properly calibrated high pass filter implemented with a 4 μ F capacitor in series with the MEASURE input of the HP3785A.

Configure the HP3785A jitter generator to generate a jittered clock using the clock input from the external clock synthesizer (*e.g.*, the Stanford Research DS345). In addition, set the switch on the back of the HP3785A to enable the MEASURE input. Connect the jittered clock from the HP3785A so it clocks the Fireberd 6000A pattern generator which generates the HDB3 encoded, framed, $2^{15}-1$ PRBS input signal for the equipment under test.

The tested output port connects directly to the HP3785A jitter receiver input. Read the output jitter directly from the HP3785A front panel meter using the 1 UIpp input range. The reading will be from 40 Hz to 100 kHz. Test each output port on the equipment at several input jitter points along the curve in Figure 1. Adjust the data rate offset at each frequency and to obtain the largest measured output jitter. At all frequencies and data rate offsets, the output jitter amplitude must be less than 0.11 UIpp.

Figure 1: Input and Maximum Output Jitter

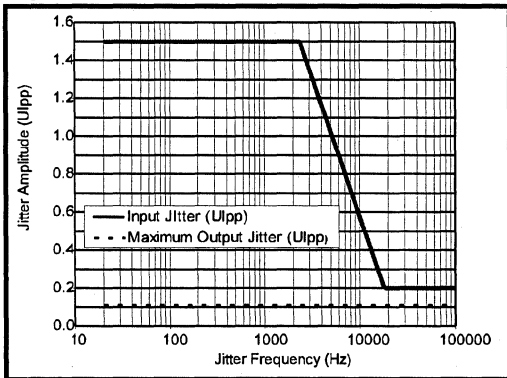

Figure 2: Conformance Test Configuration

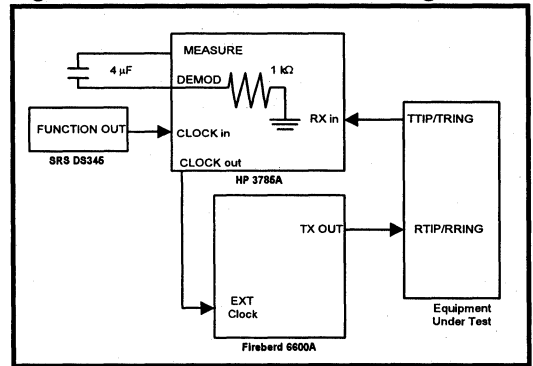
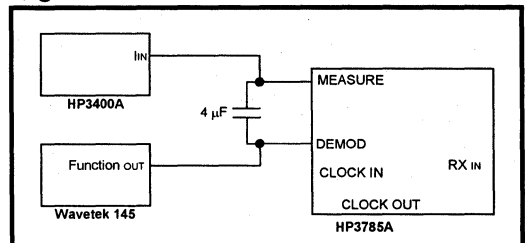

Table 1: Recommended Equipment for Jitter Conformance Testing

MODEL #	DESCRIPTION
Wavetek 145	Function Generator
HP3400A	RMS Voltmeter
HP3785A	Jitter Generator/Receiver
TTC Fireberd 6000A	E1 Pattern Generator
TTC 41800	2.048M interface module
Stanford Research DS345	Synthesized Function Generator

Figure 3: Filter Calibration



TYPICAL PERFORMANCE OF LEVEL ONE LINE INTERFACE ICs

The Level One LXT300Z, LXT304A, LXT305A and LXT318 transceivers provide the jitter attenuation needed to satisfy the TBR-12 and -13 requirements. These devices begin jitter attenuation at approximately 3 Hz insuring adequate margin against the TBR-12 and TBR-13 output jitter limit with 1.5 UIpp input at 20 Hz. Table 2 and Figure 5 present the data measured using the procedure outlined above with the LXT304A. The LXT304A meets the TBR-12 and TBR-13 requirements throughout the required frequency range. These data are also typical of the performance of the LXT300Z, LXT305A and LXT318.

Table 2: LXT304A Measured Performance

Jitter Frequency (Hz)	Measured Output (UIpp)	Jitter Frequency (Hz)	Measured Output (UIpp)
20	0.075	2400	0.008
50	0.053	5000	0.008
100	0.035	10000	0.008
250	0.019	15000	0.008
500	0.013	18000	0.007
750	0.012	25000	0.007
1000	0.011	50000	0.007
1500	0.008	75000	0.007
2000	0.008	100000	0.007

Figure 4: Transfer Function of a Properly Calibrated External Filter

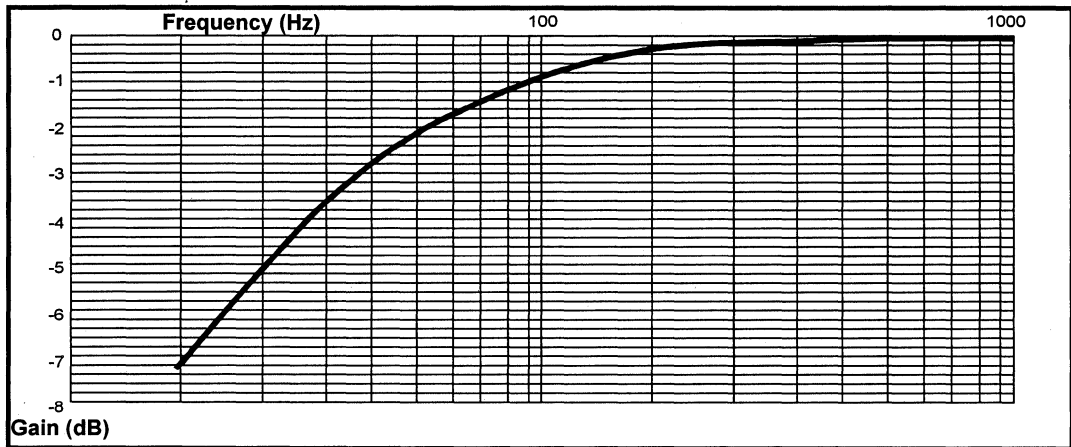
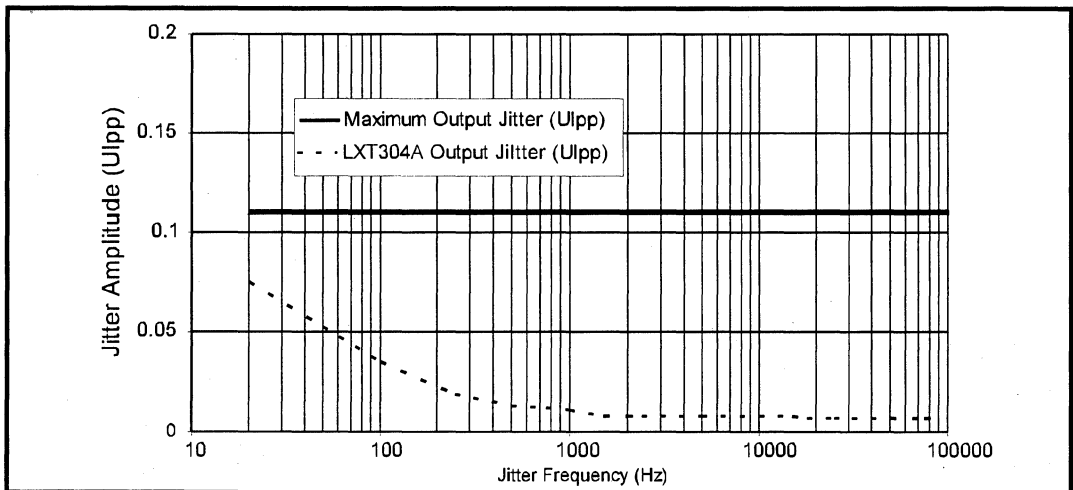

Figure 5: Typical LXT304A Jitter Attenuation Performance



TBR-12 and TBR-13 Conformance Testing

NOTES:

LXT300/300Z/304A/305A Integrated Short-Haul Transceivers

Crystal Layout Guidelines

General Description

Level One transceivers are designed for robust operation. Good PCB design practices also contribute to overall application reliability. This application note reminds design engineers of PCB layout considerations that will make LXT300, LXT300Z, LXT304A and LXT305A transceiver applications even more effective.

The PCB designs should lay out the crystal input to any of these transceivers to minimize coupling of other digital and analog signals into XTALOUT and XTALIN. See the figure below. These inputs (pins 9 and 10 for all products included in this note) are high impedance nodes which can pick up interference from adjacent PCB traces and other components on the board. Adhering to these considerations will help ensure proper operation.

Before beginning a PCB design for any of the LXT300-series family transceivers, consider the following points:

- Use a crystal that meets the recommended crystal specifications (see the appropriate Data Sheet)
- Minimize the trace lengths between the transceiver and the 6.176 or 8.192 MHz crystal (typically less than 0.25 in or 6 mm)
- Shield these connections and the area around the crystal with ground planes
- Keep other high speed system clocks away from crystal leads and traces
- Locate all magnetic components well away from the crystal, its leads and traces
- Keep all high energy signals away from crystal leads and traces connected to pins 9 and 10

Crystal Layout for LXT300-Family Transceivers

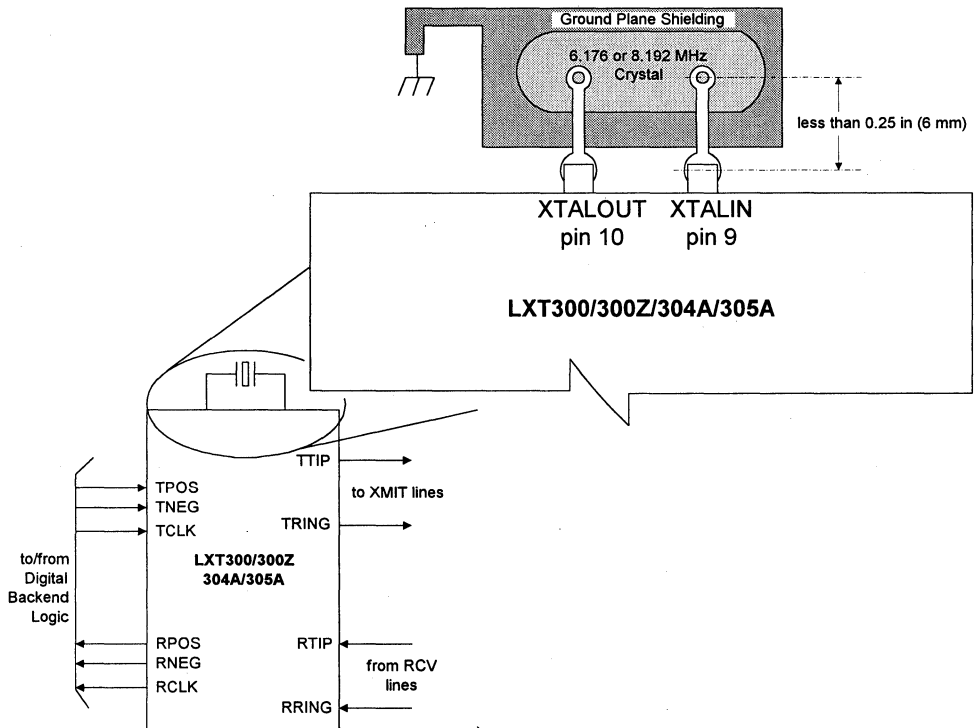

NOTES:

LXT360/361 Line Protection Circuitry

General Description

This application note provides guidelines for line protection circuitry required in typical LXT360/361 applications such as Network Channel Termination Equipment (NCTE), Channel Service Units (CSUs) and Wide Area Network (WAN) interfaces. NCTE is installed at the customer premises end of the T1 or E1 lines. As these lines run between the customer facilities and the central office, they are subject to overvoltage/overcurrent stresses from lightning strikes, power crosses and other noise impairments. Protection circuitry is required to protect the line from injected impairments and to protect the terminal equipment (CSU, NTU, mux, PBX, etc.) from overload stresses.

Protection requirements for T1 equipment are specified in FCC Part 68 (lightning hazards), UL 1459 (AC hazards), Bell Core TR-TSY-000007 and AT&T Pub 62411. These documents differentiate between longitudinal stress (differential tip/ring and ground) and metallic stress (differential between tip and ring). Longitudinal stresses are more common and include impulsive noise events such as lightning induced surges. Metallic stresses are less likely and are usually caused by power crosses during maintenance activity.

Similar protection circuitry is suggested for E1 applications of the LXT360/361. The network described in this application note targets compliance with ETS 300 046-3 and ITU K17-K20.

To ensure compliance with all applicable requirements, the final design should undergo appropriate testing at an approved lab.

Protective Circuitry Discussion

- No power or ground planes should be located on the circuit board in the area near the T1/E1 Line connector and back to the transformers.
- Select resistors R_{Tx} to match the line impedance. Their values impact the amplitude of the transmitted signal and the transmit return loss.
- Positive Temperature Coefficient Resistors (PTCs) permit healing after an overvoltage event. Their pre-trip resistance is specified at between 4 and 7 Ω .
- The PTCs will slightly reduce the amplitude of the transmitted signal. When using a 1:2 transformer, carefully selecting the series resistors (see Table 1) may negate this effect.
- The breakdown voltage of the line transformers (T1 and T2) must be at least 1.5 kV. (E1 designs may require a breakdown voltage of 3.0 kV.)
- Some harmful signal voltage from the interface lines will cross the T1/E1 transformer to the IC side; the recommended varistor (V1) with sufficient stand off voltage will provide additional protection to the LIU.
- Sidactors SD1 and SD2 provide the primary protection against bidirectional transient voltages on the transmit and receive sides.
- The final board design determines the values for the RF chokes (L1 and L2).
- Join the line side center taps of the Transmit and receive line transformers only for applications requiring a DC path for sealing currents (*i.e.*, some T1 CSU applications).
- The RJ48C configuration shown is recommended for T1 CSU applications.

LXT360/LXT361 Line Protection Circuitry

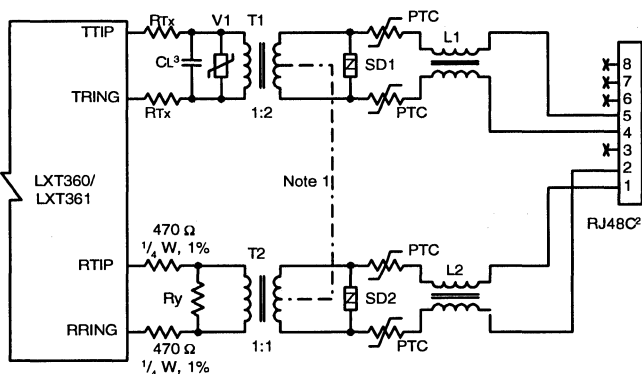

NOTES

1. Interconnection of transformers T1 and T2 is optional to support current in the E1/LI1 loop.
2. Connections at RJ48C jack are for T1 CSU applications only. For E1 applications, refer to ITU standards.
3. Assign a space for Capacitor CL. CL can be installed to improve the Tx return loss if needed.

LXT360/361 Line Protection Circuitry

Table 1: Component Selection Guide—LXT360/LXT361 (E1/T1, Long-Haul/Short-Haul Applications)

Application	Rtx ¹ [Ω] 1.0% 1/8 Ω	Ry [Ω] 1.0% 1/2 Ω	Transmit Transformer ²	Receive Transformer	EC4-1 ³			
					4	3	2	1
T1 Long-Haul 100 Ω twisted-pair lines (with line protection)	9.1	100	1:2	1:1	0	x	x	x
T1 Short-Haul 100 Ω twisted-pair lines (without line protection)	9.1	100	1:2	1:1	1 1	0 1	1 x	1 x
E1 Short-Haul 75 Ω coax lines (without line protection)	9.1	75	1:2	1:1	1	0	0	0
E1 Short-Haul 120 Ω twisted-pair lines (without line protection)	9.1	120	1:2	1:1	1	0	0	0
E1 Long-Haul 120 Ω twisted-pair/ 75 Ω coax (with line protection)	9.1	120/75	1:2	1:1	1	0	1	0
E1 Long-Haul 120 Ω twisted-pair lines (with line protection)	15	120	1:2	1:1	1	0	0	1
E1 Long-Haul 75 Ω coax lines (with line protection)	15	75	1:1.53	1:1	1	0	0	1

1. The protection circuit reduces the amplitude of the transmitted signal. Use a lower value for R_{Tx} to restore the amplitude to its nominal value. The lower value compensates for resistance of the protection resistors on the line side (PTC 4 Ω to 7 Ω used in this example).

2. The transmit and receive transformers must have a center tap (1:2 CT, 1:1 CT) to support simplex current in the E1/T1 loop if required.

3. "x" in the EC4-1 columns indicates "don't care". Refer to LXT360/361 Data Sheet for full description of transmit equalizer codes.

Table 2: Common Components for LXT360/LXT361 Applications

Ref #	Description	Typical Part (Manufacturer)	
SD1, SD2	Sidactor—Instantaneous clamping voltage 65 - 80 V TO-92 packaging	PO720EA70 (TECCOR Electronics)	
PTC	Positive Temperature Coefficient Resistors - 4 - 7 Ω, 600 V	TR600-160-RA-B-0.5-.130 (Raychem)	
LFR	Line Feed Resistor—Thermal, fused, 5.6 Ω	LFR-2-5.6-1 (IRC)	
V1	MSV Varistor—Stand-off voltage 3.7 V, Off-state capacitance ≤ 470pF	MSV701A (Microsemi)	B529-2 (EDAL Industries)
CL	Ceramic capacitor—0-470 pF, radial leaded, 50 V	any manufacturer (e.g., KEMET, AVX)	
L1, L2	RF Choke—Varies based on board design typically 33 mH	500-1164 (BH Electronics)	

Figure 1: Enhanced Line Protection Circuitry

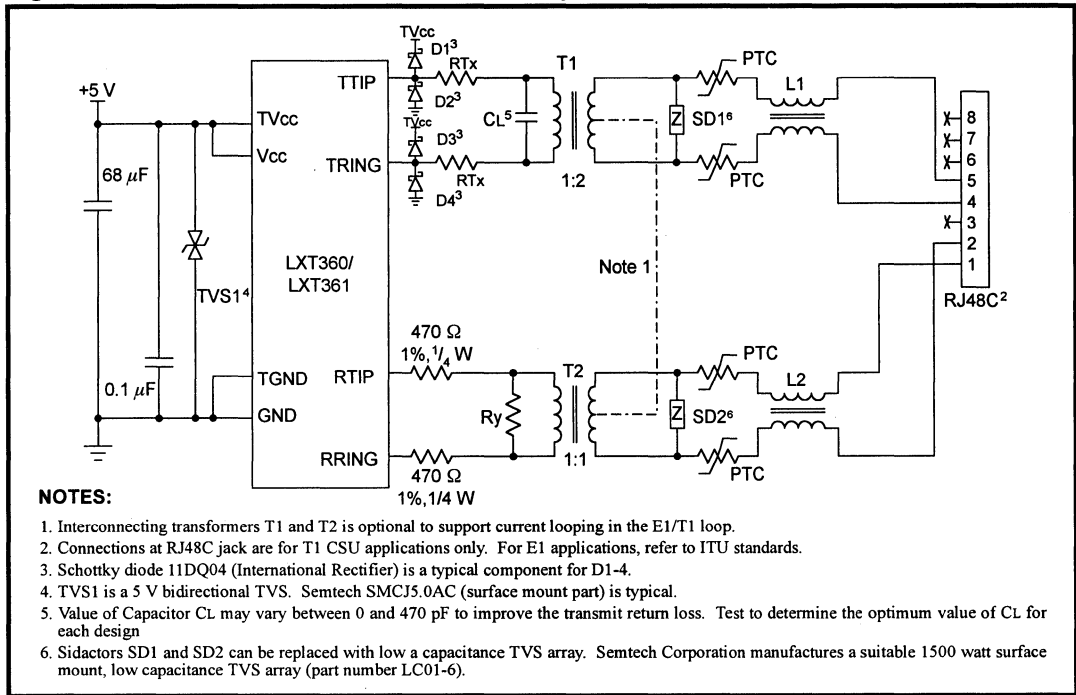

Figure 1 shows an enhanced version of the protection circuit for the LXT360/361 shown on the first page of this data sheet. Please notice that the circuit requires additional components, including Schottky diodes D1-4 and a 5 V bidirectional TVS (TVS1). The enhanced circuit provides better protection from metallic stresses and from surges coupled to VCC. However, these advantages come at the price of increased component count, PCB space, and a higher unit cost.

PTCs have the advantage of recovering from a stress condition once the condition disappears. Many similar designs use a Line Feed Resistor (LFR) like the **LFR-2-5.6.1** from **IRC, Inc.** An LFR is a combination precision resistor (5.6 Ω, 1%) and a thermal fuse. The primary benefit of the LFR is its stable resistance over temperature variances. However, it opens permanently and must be replaced. The affected line must be switched to a redundant circuit until the primary circuit is restored.



Table 3: Manufacturers Mentioned in this Note

Company	Contact Information	Company	Contact Information
BH Electronics	12219 Wood Lake Drive Burnsville, MN 55337 (612) 894-9590 / Fax: (612) 894-9380	Raychem Corp	300 Constitution Drive Menlo Park, CA 94025-1164 (800) 227-2040 / Fax: (800) 227-4866
EDAL Industries	4 Short Beach Road East Haven, CT 06512 (203) 467-2591 / Fax: (203) 469-5928	SEMTECH Corp	652 Mitchell Road Newburg Park, CA 91320 (805) 498-2111 / Fax: (805) 498-3804
IRC, Inc	P.O. Box 1860 Boone, NC 28607 (704) 264-8861 / Fax: (704) 262-1972	TECCOR Electronics	1801 Hurd Drive Irving, TX 75038 (214) 580-1515 / Fax: (214) 550-1309
Microsemi Corp	8700 E. Thomas Road Scottsdale AZ 85251 (602) 941-6300 / Fax: (602) 947-1503		

NOTES:

SCR Latch-up Model

Preventing Latch-up in Level One Transceivers

General Description

The purpose of this application note is to familiarize designers in the use of Level One CMOS transceivers. Level One devices are designed to meet, but not to exceed the absolute maximum specifications for Silicon Controlled Rectifier latch-up. SCR latch-up in CMOS devices is a condition that can cause maximum specifications to be exceeded. This application note provides the necessary design considerations to avoid SCR latch-up.

Application Overview

Once triggered, an SCR latch-up condition turns on a parasitic SCR internal to CMOS circuits that creates a low resistance path from VCC to ground. The resulting internal high currents can damage the devices.

Modeled as a cross coupled transistor, the SCR has two basic trigger mechanisms; one forces current into its gate and the other places a large voltage between anode and cathode. When forward biasing a diode, current injected into the base of Q2 turns this transistor on and the collector current (beta times its base current) flows into the base of Q1. This causes Q1 to be amplified by beta and fed back into the base of Q2, where the current is again amplified. If the beta of both transistors is greater than 1, the current gain continues until the transistors saturate and the SCR is triggered. Once the regenerative condition occurs, a large anode current flows. The SCR remains on after the gate current is removed, if enough anode current flows to sustain latch-up.

In the case of large voltages on its anode and cathode, a trigger condition can occur even if no current is applied to the gate. In the forward blocking state a small leakage current is present but will not trigger the SCR. If the voltage is increased to allow a significant leakage current, then a

Following these design guidelines will:

- Avoid exceeding maximum transceiver ratings
- Simplify application maintenance
- Reduce SCR latch-up related downtime in systems
- Improve System reliability

SCR could trigger. The beta of the NPN and PNP must be greater than one for the latch condition to occur.

There are a number of scenarios that can cause a SCR trigger to occur at inputs and outputs (latch condition) including insertion and removal of a circuit card from a powered system. To be effectively controlled (either when integrated or at the system level) designers must have a clear understanding of the causes of SCR latch-up.

Design Guidelines

1. If the circuit card design includes "hot-swapping" capability, insure that power reaches the devices (transceivers, PALs, etc.) before applying any voltages to the input or output pins (*i.e.*, power and ground pins make contact before input and output pins).
2. With multiple power supplies feed the same device, arrange the pins so the supplies connect in ascending order. Thus, if a circuit card requires +5 V, +12 V, and -12 V, the +5 V pins should connect first, the +12 V pins next and finally the -12 V pins. In any event, before any voltage pins make contact, the ground should connect first to insure that the positive supplies do not pull the negative supplies or visa versa.

SCR Latch-Up Model

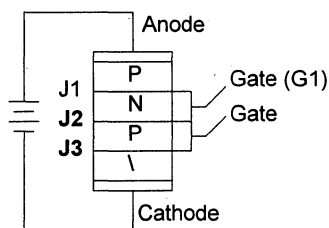
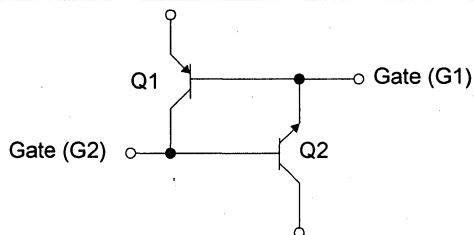

SCR Latch-up Model

- When devices drive other devices on separate boards be aware that large amounts of local decoupling can cause power supply ramps to be slower on some boards than others.
- Insure that the voltages to the input/output pins do not exceed the supply voltage. Clamping circuits are needed to reduce the input voltage.
- Insure that the input current does not exceed the absolute maximum rating of 100 mA. If this is expected, current limiting is necessary to prevent the SCR latching condition.
- Never allow the output driver to drive another output driver in applications of redundancy (Figure 1). This can be accomplished only if a break before make connection of the two drivers is observed. These drivers are high current drivers, capable of exceeding the triggering currents necessary for a SCR latch condition.

Figure 1: Applications of Redundancy

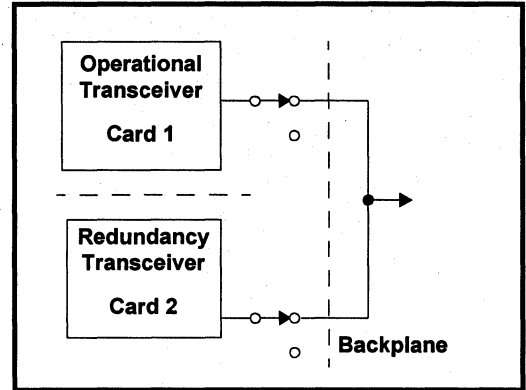

Crystal-less E1 Long-Haul Solutions

LXT318/360 Universal Line Interface Unit Design Guide

Introduction

This note describes applications for the crystal-less LXT360 transceiver in newer generation network access equipment. Use this application note as a guide when upgrading designs using the LXT360. Before designing a circuit using this new device, refer to the data sheets for both devices for complete information.

The LXT360 provides several advanced features. While the LXT360 provides for both T1 (1.544 Mbps) and E1 (2.044 Mbps) operation, this application note focuses only on hardware-controlled, E1 designs. Additional application notes detail migration paths for T1 and E1 design using other LXT360 features.

Identifying Major LXT360 Design Improvements

Jitter Attenuation Circuitry

- The LXT318 device requires a pullable 8.192 MHz crystal to provide selectable jitter attenuation. The jitter attenuation circuitry may be in either the transmit or the receive path, depending on the application.
- The LXT360 requires only the MCLK signal to provide the same selectable jitter attenuation functions since it uses digital JA circuitry. It needs no crystal or high-frequency external clock for jitter attenuation.

External Clock Requirements

- The MCLK input signal in the LXT318 is optional. If used, the clock must have an accuracy of ± 100 ppm.
- The MCLK input signal in the LXT360 is mandatory. The clock must be a stand alone reference with an accuracy of ± 32 ppm or better at 2.048 MHz for E1 applications.

Applications

- The LXT318 is a long-haul E1 transceiver only.
- The LXT360 operates as either a short- or long-haul transceiver in E1 or T1 applications.

Available Line Coding Schemes

- The LXT318 allows HDB3 encoding in either Unipolar or Bipolar mode.
- The LXT360 transceiver offers HDB3 line encoding only in the Unipolar Mode.

Reset Operation

- Reset on the LXT318 occurs when both LLOOP and RLOOP inputs are pulled High while TAOS is pulled Low for at least 200 ns.
- Reset on the LXT360 occurs when LLOOP, RLOOP and TAOS are pulled High simultaneously for at least 200 ns.

Output Control

- The LXT318 provides a high-impedance state option for the TTIP/TRING outputs only when TCLK is grounded.
- The LXT360 provides high-impedance state limited to the TTIP/TRING outputs when TCLK is pulled High. An additional high-impedance state option is available for all output pins when TRSTE is pulled High.

Line Attenuation Indication

- The LXT318 provides Line Attenuation Indication (LATN) in both Hardware and Host Modes.
- The LXT360 provides LATN in Software Mode only.

NLOOP Detection

- For the LXT318 transceiver, holding RLOOP, LLOOP and TAOS High simultaneously for 200 ns and then pulling all three Low enables the NLOOP detection function. Alternatively, tying RCLK to RLOOP also enables NLOOP. Resetting the device disables NLOOP detection.
- In the LXT360 setting the RLOOP input to 2.5 V ± 0.2 V ("Midrange") enables NLOOP detection. Setting RLOOP Low or High disables NLOOP detection.

Loss of Signal Detection and LOS Clear Criteria

- The LXT318 device declares a Loss Of Signal (LOS) condition when it detects 175 consecutive spaces. It clears the LOS condition when the receiver detects 12.5% mark density (*i.e.*, 4 marks within a 32-bit period) with no more than 15 consecutive 0s.
- The LXT360 transceiver declares the LOS condition when it detects 32 consecutive spaces. It clears the LOS condition when the receiver detects 12.5% mark density (*i.e.*, 4 marks within a 32-bit period) with no more than 15 consecutive 0s.

DIAGNOSTIC FUNCTIONS

The LXT360 provides several diagnostic features not provided on the LXT318 transceiver. These are Dual Loop-back function, Error Insertion and Detection, AIS Condition Monitoring and Elastic Store Pointer Monitoring. Refer to the LXT360 data sheet for details on these functions.

In addition, the LXT360 provides both a Quasi-Random Signal Source and a Detector for diagnostic procedures.

Three-State Input Pins

The LXT318 uses two-state (High and Low) configuration inputs but some LXT360 control inputs recognize three states. Typical values for these states are:

- High— $V_{IN} > 3.5 \text{ V}$.
- Midrange— $2.3 \text{ V} \leq V_{IN} \leq 2.7 \text{ V}$ (or floating).
- Low— $V_{IN} < 1.5 \text{ V}$.

The control for three-state inputs may be a standard tri-state buffer. Figure 1 shows a typical driver circuit for these inputs. Setting the output buffer to its high-impedance state places the three-state input into its Midrange state.

Application designers must take into account the current drawn by the internal resistors (part of each three-state input) before choosing a buffer to drive these inputs to their High or Low states.

Figure 1: Typical Circuit for LXT360 Three-State Inputs

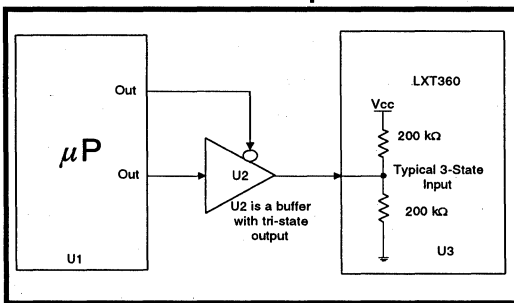

Line Interface Considerations

To improve transmit return loss, add a capacitor (CTX) to the transmit side as shown in Figures 2 through 4. This capacitor is typically 470 pF, but may vary depending on the resistor and transformer values, the board layout and the parasitics of the protection diodes.

Tables 1 through 3 show the combinations of transformers, resistors and capacitors needed for the transmit side as shown in these applications. Table 4 lists transformers that meet Level One Communications specifications when tested with the LXT360 device.

Table 1: Transmit Return Loss (2.048 Mbit/s—Short-Haul 12 dB)

EC4-1	Xfrmr/ Rt	Xmission Line	CTX (pF)	Return Loss (dB)
1000	1:2/ 9.1 Ω	75 Ω Coax	0	14
			470	16
	1:2.3/ 9.1 Ω	120 Ω Twisted Pair	470	13
			0	13
		470	16	

Table 2: Transmit Return Loss (2.048 Mbit/s—Long-Haul 43 dB) High Return Loss Configuration

EC4-1	Xfrmr/ Rt	Xmission Line	CTX (pF)	Return Loss (dB)
1001	1:2/ 15 Ω	120 Ω Twisted Pair	0	19
			470	28
	1:1.53/ 15 Ω	75 Ω Coax	0	18
			470	28

Table 3: Transmit Return Loss (2.048 Mbit/s—Long-Haul 43 dB)

EC4-1	Xfrmr/ Rt	Xmission Line	CTX (pF)	Return Loss (dB)
1010	1:2/ 9.1 Ω	120 Ω Twisted Pair	0	12
			470	13
		75 Ω Coax	0	16
			470	18

Table 4: Recommended Transformers for LXT360

Transmit Side			Receive Side		
Transformer Turns Ratio	Manufacturer	Part Number	Transformer Turns Ratio	Manufacturer	Part Number
1:2	Fil-Mag	FE 66Z1308	1:1	Fil-Mag	FE 80006-155
	HALO	TD 61-1205G		HALO	TD 61-1205G
		TD 67-1205G			TD 67-1205G
	Midcom	671-5832		Midcom	671-5792
	Pulse Engineering	PE-65351		Pulse Engineering	PE-64936
		PE-65771			PE-65778
Schott Corp	67127370	Schott Corp	67109150		
	67130850		67130840		
1:1.53	Pulse Engineering	PE 68663			

Bipolar Mode with AMI Line Coding (without Zero Suppression)

Most pins on LXT360 have the same names and functions as those on the LXT318, although some differ. This section describes the modifications needed to change from the LXT318 to the LXT360 in Hardware Control Mode. The LXT360 pins not included in this discussion have the same connections and signal level requirements as those on the LXT318. Table 5 is a summary of the pins whose functions change when moving from LXT318 to LXT360.

The 8.192 MHz crystal required by the LXT318 must be deleted when migrating to the LXT360. The functions on pins 17, 18, and 23 on the LXT318 change pin locations on the LXT360 transceiver. **Pay particular attention to the new locations for these signals.** Figure 2 shows the connection differences between the two transceivers for this configuration.

Pin 1: The LXT360 requires an independent, external clock called MCLK. The MCLK input signal must have a nominal rate of 2.048 MHz and an accuracy of ± 32 ppm or better. The LXT318 uses the same nominal frequency, but requires no better accuracy than ± 100 ppm.

Pin 5: In the LXT318, pin 5 is called MODE. This pin can be pulled High or Low, or it can be tied to the RCLK pin. The RCLK signal at the MODE pin enables the HDB3 encoders and decoders.

In the LXT360, the MODE pin is a three-state input pin: High, Low or Midrange. Setting the pin to Midrange enables the HDB3 encoders and decoders in LXT360 for E1 applications (and also forces the transceiver into uni-polar operation).

Pin 9: In LXT360, pin 9 is called TRSTE. It is a three-state input. With TRSTE pulled High all LXT360 device output pins go into a high-impedance state. In conjunction with MODE (pin 5), this pin also sets the operational mode of the transceiver.

To enable E1, Long-Haul (43 dB), Bipolar, Hardware Control Mode, the TRSTE pin must be pulled Low. See the data sheet for a complete description of the operating modes.

Pin 10: This pin is the XTALOUT input on the LXT318. Leave this pin not connected on the LXT360.

Pin 17: Pin 17 is grounded in LXT318 applications. In the LXT360, pull pin 17 (EC4) High to enable E1 long-haul operation.

Pin 18: The LXT318 pin 18 signal (NLOOP) appears on pin 23 of the LXT360.

The LATN signal, which is on pin 18 of the LXT318, is not available in the Hardware Mode on the LXT360. However, a binary encoded equivalent to LATN is provided in the LXT360 Software Mode.

Pin 23: The NLOOP signal, which appears on pin 23 of the LXT318, is available on pin 18 of the LXT360.

Pins 24 and 25: In the LXT318, pins 24 and 25 are both grounded. The LXT360 uses these pins and gives them the names EC2 (pin 24) and EC3 (pin 25). EC4-1 control the equalizers on the LXT360. See the LXT360 Data Sheet for details.

Figure 2: Bipolar Mode Using AMI Line Coding (without Zero Suppression)¹

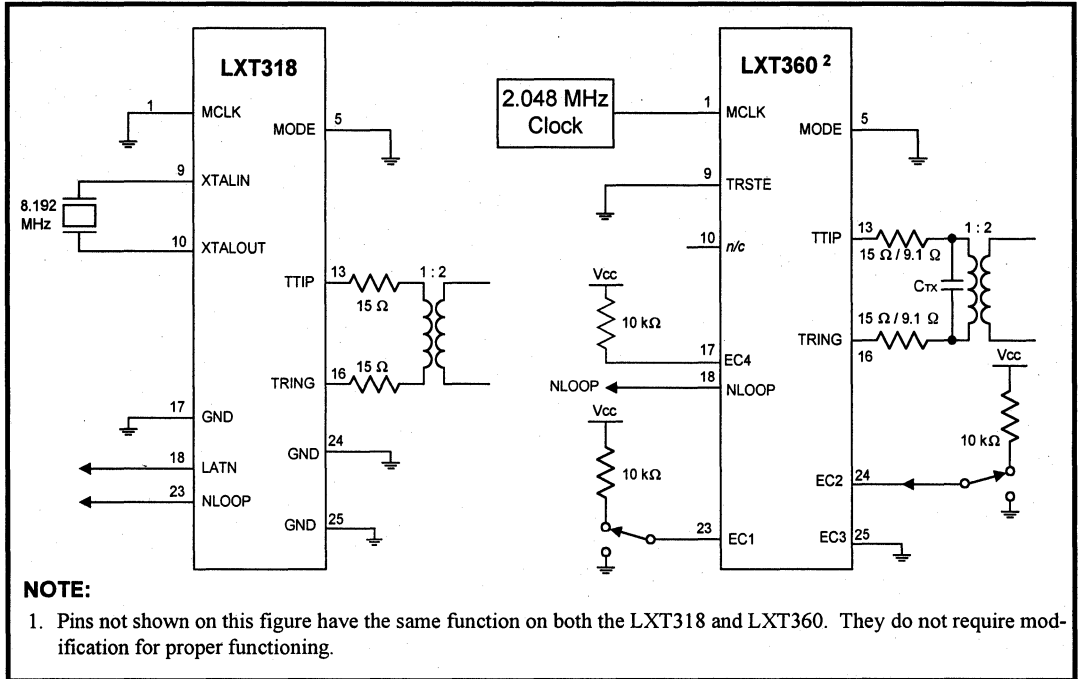

Table 5: Bipolar Mode using AMI Line Coding (without Zero Suppression)

Pin#	LXT318		LXT360		Comments
	Name	Function/State	Name	Function/State	
1	MCLK ¹	2.048 MHz/GND	MCLK	2.048 MHz	Mandatory in LXT360 applications
5	MODE	Low	MODE	Low	MODE and TRSTE set operation mode
9	XTALIN	8.192 MHz Crystal	TRSTE	Low	Crystal not used in LXT360
10	XTALOUT	8.192 MHz Crystal	—	n/c	No function assigned to this pin.
17	GND	—	EC4	Input-High	EC4 = High for E1 operation.
18	LATN	Output	NLOOP	Output	LATN not supported on LXT360 in Hardware Control Mode. NLOOP changes location.
23	NLOOP	Output	EC1	Input	
24	GND	Low	EC2	Input	Refer to Table 12 in LXT360 Data Sheet.
25	GND	Low	EC3	Input/Low	

1.MCLK is optional in LXT318 applications. With the LXT318, if MCLK is not supplied, pin 1 must be grounded.

Using HDB3 Encoding/Decoding

The LXT318 supports HDB3 encoding/decoding in both Unipolar and Bipolar Modes. The LXT360 configures itself in Unipolar mode (*i.e.*, TPOS becomes TDATA and TNEG becomes INSBPV) when HDB3 is enabled. To

enable HDB3 encoders and decoders, set the MODE pin to Midrange. Other connections are the same as for AMI line coding. Figure 3 shows the changes needed in connections for LXT318 and LXT360. See Table 6 for a summary of the modifications needed to adapt an LXT318 application to the LXT360.

Figure 3: Unipolar Mode (with HDB3 Zero Suppression)¹

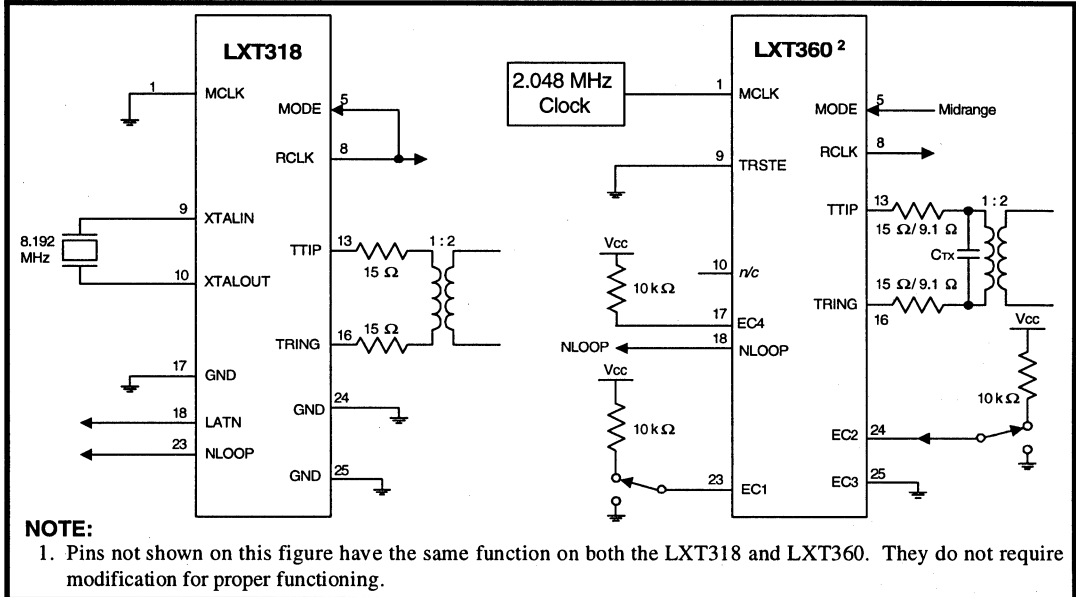

Table 6: Unipolar Mode with HDB3 Zero Suppression Enabled

Pin#	LXT318		LXT360		Comments
	Name	Function/State	Name	Function/State	
1	MCLK ¹	2.048 MHz/GND	MCLK	2.048 MHz	Mandatory in LXT360 applications
5	MODE	Tie to RCLK	MODE	Midrange ²	MODE and TRSTE set operation mode Crystal not used in LXT360
9	XTALIN	8.192 MHz Crystal	TRSTE	Low	
10	XTALOUT	8.192 MHz Crystal	—	n/c	
17	GND	—	EC4	Input-High	EC4 = High for E1 operation
18	LATN	Output	NLOOP	Output	LATN not supported on LXT360 in Hardware Control Mode. NLOOP changes location.
23	NLOOP	Output	EC1	Input	
24	GND	Low	EC2	Input	Refer to Table 12 in LXT360 Data Sheet.
25	GND	Low	EC3	Input/Low	

1. MCLK is optional in LXT318 applications. With the LXT318, if MCLK is not supplied, pin 1 must be grounded.
2. "Midrange" means leave the pin unconnected or tie it to 2.5 V.

Enabling NLOOP Detection

Tying the RLOOP and MODE inputs to the RCLK output enables Network Loop detection (NLOOP) on the LXT318 transceiver. NLOOP is also enabled by holding LLOOP,

RLOOP, and TAOS all High simultaneously for 200 ns and pulling them Low. To enable NLOOP on the LXT360 transceiver, tie the RLOOP input pin to Midrange as in Figure 4. This function is available only in Bipolar Mode.

Figure 4: Bipolar Mode¹

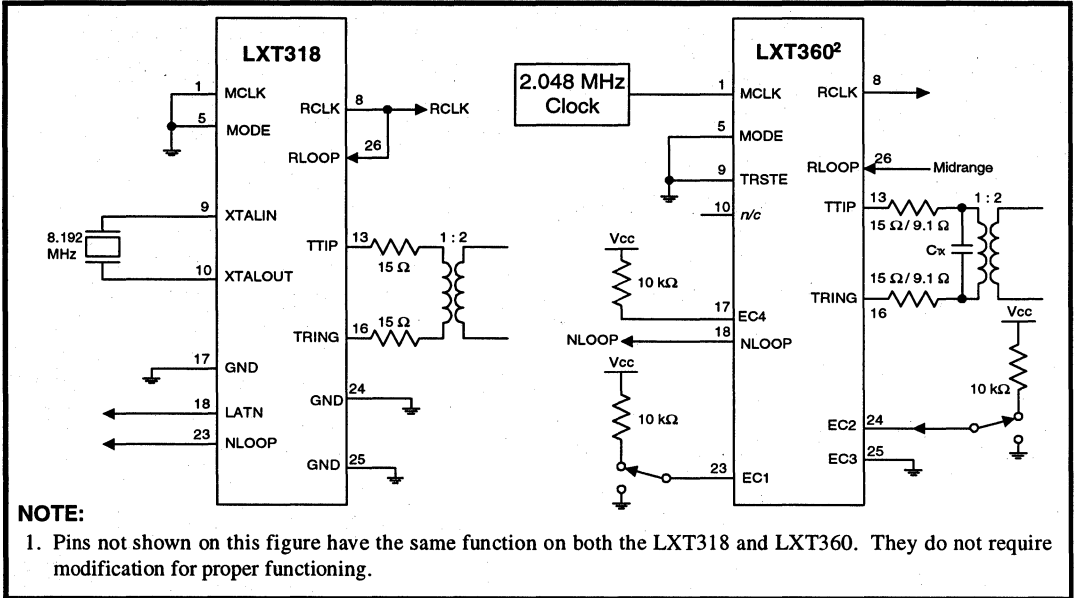

SXT6234 E-Rate Multiplexer

For 16-E1/E3 Multiplexer/Demultiplexer

Introduction

The SXT6234 E-Rate Multiplexer offers a simple and economic approach to building E1/E2, E2/E3 and E1/E3 multiplexers and demultiplexers. This application note provides the system designer with a 16E1/E3 multiplexer/demultiplexer design example.

A brief overview of fundamental E1/E3 protocol is included to establish a common reference with readers. For additional information, refer to the ITU-T General Aspect of Digital Transmission Systems, Recommendations G.700-G.772. Related documentation includes the SXT6234 Data Sheet and the SDB6234 E1/E3 Demo Board User Guide.

E Standards

The International Telecommunication Union - Telecommunication Standardization Sector (ITU-T) standardized the E1, E2, and E3 specifications. The ITU-T was formerly known as the Consultative Committee for International Telephone and Telegraph (CCITT).

E Standard European Hierarchy

To accommodate higher transmission speeds, carriers developed the hierarchy levels shown in Table 1.

Table 1: E Standard Hierarchy

Level Number	System	Number of Voice Circuits	Bit rate Mbps
1	E1	30	2.048
2	E2	120	8.448
3	E3	480	34.368
4	E4	1920	139.264

E1 Standard

The E1 standard was designed to support transmission of thirty digitized voice channels. Analog-Digital conversion of each channel is based on the Nyquist sampling theory. This theory says that to digitize an analog signal so that it contains sufficient information to allow an accurate analog reconstruction, the signal must be sampled at a frequency that is at least twice the channel bandwidth. Sampling 8,000 per second is the industry-accepted rate. This rate allows the accurate reproduction of a voice-grade 4-kHz bandwidth channel.

The 8 kHz sampling produces a series of narrow pulses with a 125 microseconds (μsec) period. The magnitude or height of each analog sample is digitally encoded as an 8 bit binary value. Furthermore, the sampling pulse has a duration of less than 4 μsec during the 125 μsec period. Consequently, it is possible to interleave sampled pulses from other signals within the 125 μsec period. The E1 standard interleaves thirty-two channels; Thirty channels transmit digitized analog signals, and the remaining two channels send signaling and synchronization information. As shown in Table 2, each channel is assigned a specific time-slot.

Table 2: E1 Frame

Time slot	Type of information
0	Synchronization
1-15	Speech
16	Signaling
17-32	Speech

1. Frame length = 256 bits
2. Frame duration = 125 μsec
3. The 32 time slots constitute a frame. Each slot is 8 bits. Consequently one frame is:
4. 8 bits x 32 time slots = 256 bits/frame
5. Since 8000 frames are transmitted each second, the bit rate is: 256 bits /frame x 8000 frames/second = 2.048 Mbps.

E2 Standard

The second level is the E2 standard. The E2 standard multiplexes four E1 channels into a single 8.448 Mbps channel (4 X 2.048 Mbps = 8.448 Mbps). Two recommendations, defined in ITU-T G.742 and G.745, exist for this multiplexing. The G.742 for the SXT6234 is shown in Table 3. The G.742 uses positive justification and is intended for digital paths between countries.

Table 3: E2 Frame Bit Assignments

Bit Number	Bit Number by Set	Type of Information
1-10	1-10	Frame alignment
11	11	Alarm indication signal to the remote multiplex equipment
12	12	Bit reserved for national use
13-212	13-212	Bits from tributaries
213-216	1-4	Justification control bits Cj1
217-424	5-212	Bits from tributaries
425-428	1-4	Justification control bits Cj2
429-636	5-212	Bits from tributaries
637-640	1-4	Justification control bits Cj3
641-644	5-8	Bits from tributaries available for justification
645-848	9-212	Bits from tributaries available for negative justification

Table 4: E2 Frame

Standard	G 742
Bit rate	8.448 Kbits/s
Frame length	848 bits
Frame duration	100.39 μ sec
Bits per tributaries	205 bits
Maximum justification rate per tributaries	10 Kbit/s

Table 6: E2 Frame Bit Usage

# of bits	10	1	1	200	4	208	4	208	4	4	204
Usage	Frame	AIS	NAT	E1	Jus	E1	Jus	E1	Jus	Aux	E1

Table 7: E3 Frame Bit Usage

# of bits	10	1	1	372	4	380	4	380	4	4	376
Usage	Frame	AIS	NAT	E2	Jus	E2	Jus	E2	Jus	Aux	E2

E3 Standard

The third level is the E3 standard. The nominal bit-rate of 34.368 Mbps is the result of the multiplexing of four 8.448 Mbps E2 channels.

Table 5: E3 Frame Bit Assignments

Bit Number	Bit Number by Set	Type of Information
1-10	1-10	Frame alignment
11	11	Alarm indication to remote digital multiplex equipment
12	12	Bit reserved for national use
13-384	13-384	Bits from tributaries
385-388	1-4	Justification service bits Cj1
389-768	5-384	Bits from tributaries
769-772	1-4	Justification service bits Cj2
773-1152	5-384	Bits from tributaries
1153-1156	1-4	Justification service bits Cj3
1157-1160	5-8	Bits from tributaries available for justification
1161-1536	9-384	Bits from tributaries

Multiplexing Method

The multiplexing method uses cyclic bit interleaving in the tributary numbering order. This conforms with the positive justification recommendation of ITU-T G.742 and G.751.

Table 8: E3 Frame

Standard	G.751
Bit rate	34 368 kbit/s
Frame length	1536 bits
Frame duration	44.7 μ sec
Bits per tributaries	378 bits
Maximum justification rate per tributary	22.375 kbit/s

Justification

Justification is the process of changing the data rate of a digital signal from its inherent rate to a different rate without loss of information. Positive justification is a method by which the data rate used to convey a signal has a higher bit-rate than the original signal. Positive justification is normally achieved by assigning some time-slots per frame to handle the additional information that may result from justification. If signal justification is unnecessary, these time-slots may contain regular channel information or they might remain empty. The justification service digits indicate if these time-slots contain information digits or justifying digits. The justification control signal in E standard is defined by the C_{jn} bits (see E2 and E3 frame tables). Three bits are used to show the type of justification; the fourth bit is the stuffing bit.

The E-Rate Multiplexer

The SXT6234 is a single-chip solution for multiplexing four tributaries into one high speed bit stream and the demultiplexing of the high speed bit stream back into four tributaries. All required circuitry has been integrated into the SXT6234; there is no need for an external framer.

The SXT6234, fabricated with 1.2-micron CMOS technology, is packaged in a 100-pin PQFP package. This device consists of the multiplexer block, the demultiplexer block, four HDB3 Encoder/Decoders for each tributary, and one HDB3 Encoder/Decoder for the high speed stream.

- The SXT6234 supports two multiplexing formats: One multiplexes four E1 channels into one E2 channel. The other format multiplexes four E2 channels into one E3 channel. Both are fully compliant with ITU-T recommendations, G.742 and G.751 respectively.

- All CODEC I/O pins are externally accessible, allowing either HDB3 or NRZ I/O to the multiplexer and demultiplexer. Alternatively, the SXT6234 can be used as a 5-channel HDB3 CODEC.
- Access is provided to the Alarm Indication Signal (AIS) and the National Bit.
- Four auxiliary low speed data or flag channels are available via the stuffing bits on each tributary channel.

Figure 1: SXT6234 E-Rate Multiplexer

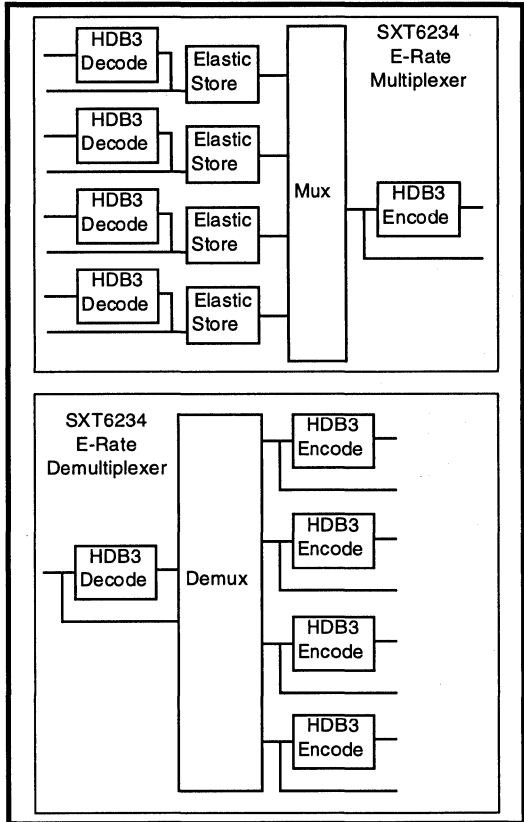

E1/E3 Multiplexer Block Diagram

The block diagram of the E1/E3 Multiplexer is shown in Figure 2.

E1 LINE INTERFACE

- Receive clocks from the pulse data.
- Accepts either HDB3 encoded signals (clocks along with positive and negative RZ data), or NRZ data (clock and data). This depends on whether the Line Interface Unit (LIU) performs HDB3 coding.

SXT6234 E-Rate Multiplexer For 16-E1/E3 Multiplexer/Demultiplexer

Figure 2: E1/E3 Multiplexer

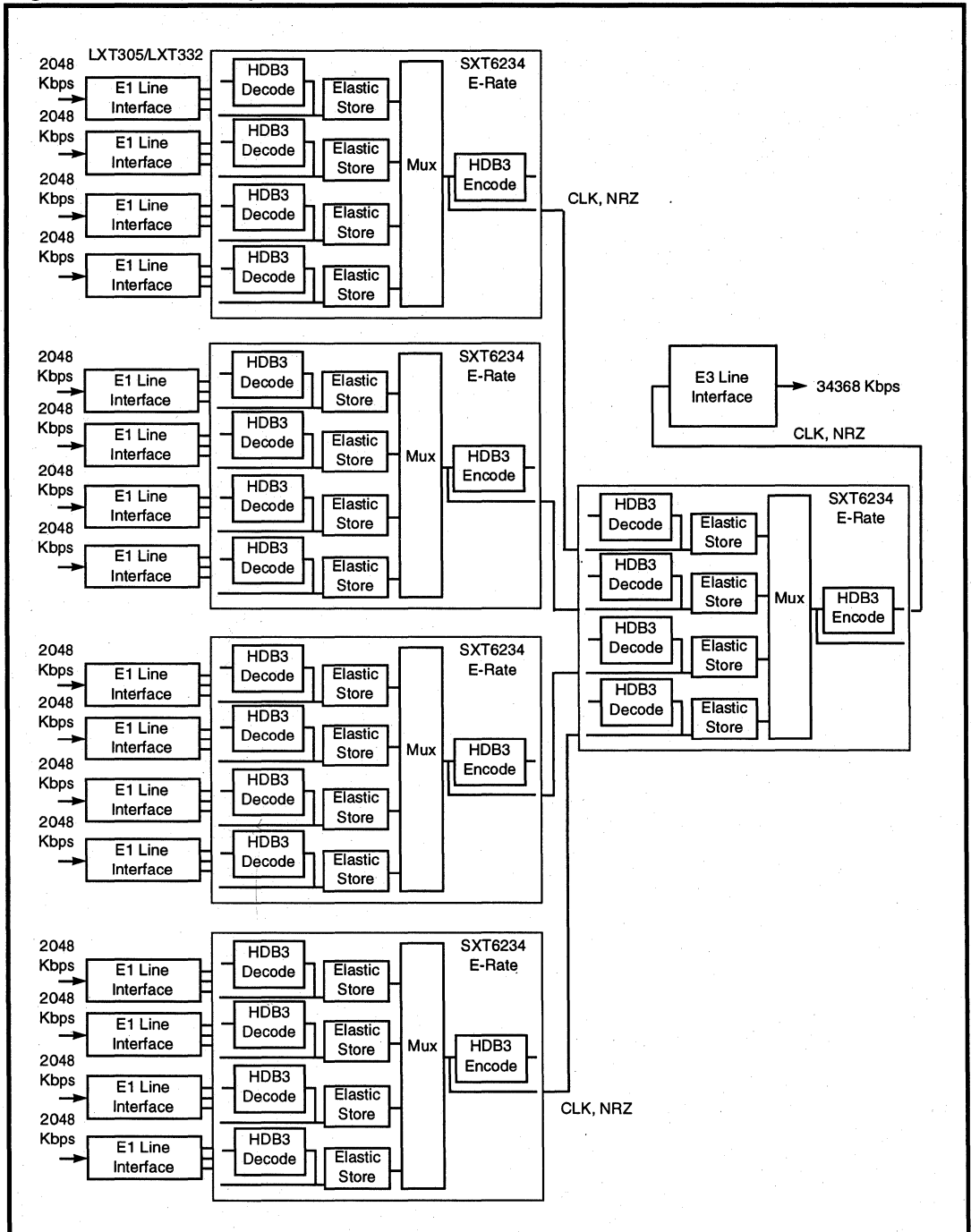

SXT6234, E1/E2 STAGE

- If the tributary LIU does not perform HDB3 decoding, then the signals are routed to the SXT6234 onboard HDB3 decoder. The inputs are the clock and the decoder data input signals (both positive and negative). The onboard HDB3 decoder then outputs NRZ data and clock to the Elastic Store of the multiplexer portion of the SXT6234.
- If the LIU provides HDB3 decoding, then the NRZ data and clock are sent directly to the elastic store of the multiplexer portion of the SXT6234 via the external pin.
- Each four-tributary group is interleaved into a single, intermediary E2 data stream. An onboard crystal oscillator drives the data from the multiplexer at the E2 rate of 8.448 MHz. A bit stuffing algorithm implemented in the SXT6234 ensures tributary rate integrity at the output. The SXT6234 contains elastic store buffers to manage the bit-stuffing process.
- The NRZ data is sent to a tributary of the E-Rate Multiplexer, stage E2/E3.

SXT6234, E3 STAGE

- If the tributary LIU does not provide HDB3 encoding, then encoding is performed in the SXT6234; positive and negative data output is provided. An activity monitor provides tributary fail notification when necessary.
- If the LIU provides HDB3 encoding, the NRZ data and clock are passed to the multiplexer input.
- The multiplexer portion of the SXT6234 interleaves the four asynchronous E2 rate NRZ data streams into a single E3 data stream. Depending on the user configuration, either an onboard crystal oscillator or an external reference clock drives the data output frequency from the multiplexer at the rate of 34.368 Mbps. The bit stuffing algorithm implemented in the SXT6234 ensures tributary rate integrity at the output.

E Multiplexer Block Diagram

The block diagram in Figure 3 shows the I/O used on the SXT6234 to accomplish the multiplexing function. Only I/O for tributary #1 has been referenced. I/O for tributaries #2, #3, and #4 are omitted for clarity, but they are the same as tributary #1.

Figure 3: SXT6234 Multiplexing Function

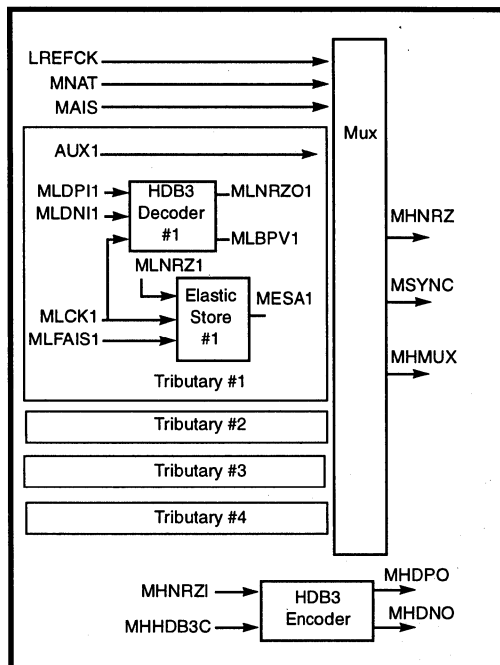

E1/E3 Demultiplexer Block Diagram

The block diagram of the E1/E3 demultiplexer is shown in Figure 4.

E3 LINE INTERFACE

- Receive clocks from the pulse data.
- If the LIU does not provide HDB3 decoding, then the LIU passes HDB3 encoded signals to the SXT6234. These signals consist of the clock and (positive and negative) RZ data.
- If the LIU does provide HDB3 decoding, then the LIU passes the NRZ data and clock to the SXT6234.

SXT6234 E-Rate Multiplexer For 16-E1/E3 Multiplexer/Demultiplexer

SXT6234, E3/E2 STAGE

- If the LIU does not do HDB3 decoding then the signals are routed to the SXT6234 onboard HDB3 decoder. The inputs are the clock and the decoder data input signals (both positive and negative). The onboard HDB3 decoder then outputs NRZ data and clock to the Elastic Store of the multiplexer portion of the SXT6234.
- If the LIU provides HDB3 decoding, NRZ data and clock are received by the demultiplexer portion of the SXT6234.
- The Four E2 rate data streams are recovered from the E3 NRZ data and are sent from the SXT6234 as four tributaries.

SXT6234, E2/E1 STAGE

- The demultiplexer portion of the SXT6234 recovers four E1 data streams from the E2 intermediary stream.
- If the LIU does not provide HDB3 encoding, the streams are HDB3 encoded and sent out as positive and negative voltages to the E1 line interface. (LXT305 or LXT332)
- If the LIU provides HDB3 encoding the stream is sent out as NRZ data to the E1 line interface.

Figure 4: E1/E3 Demultiplexer

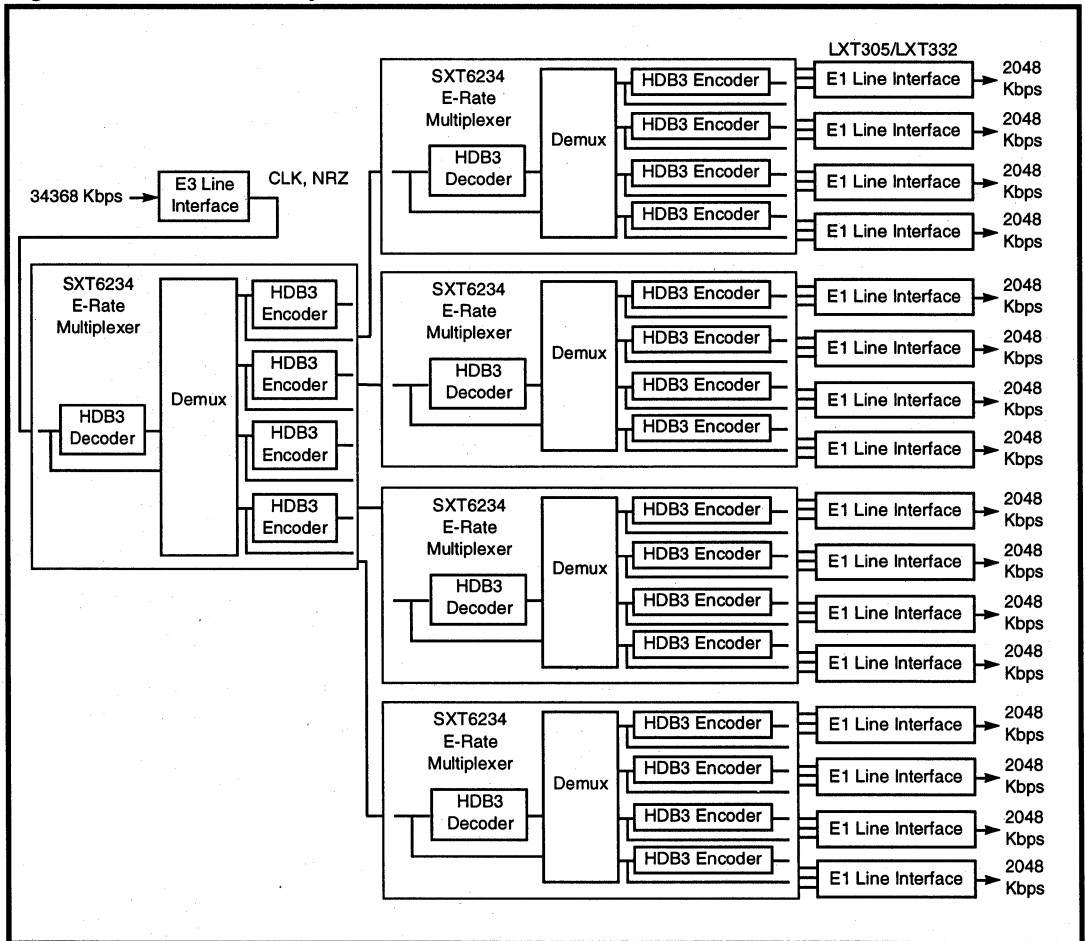

E Demultiplexer Block Diagram

Figure 5 shows the I/O used on the SXT6234 to perform the demultiplexing function. Only I/O for tributary #1 has been referenced. I/O for tributaries #2, #3, and #4 are omitted for clarity, but they are the same as tributary #1.

Figure 5: SXT6234 Demultiplexing Function

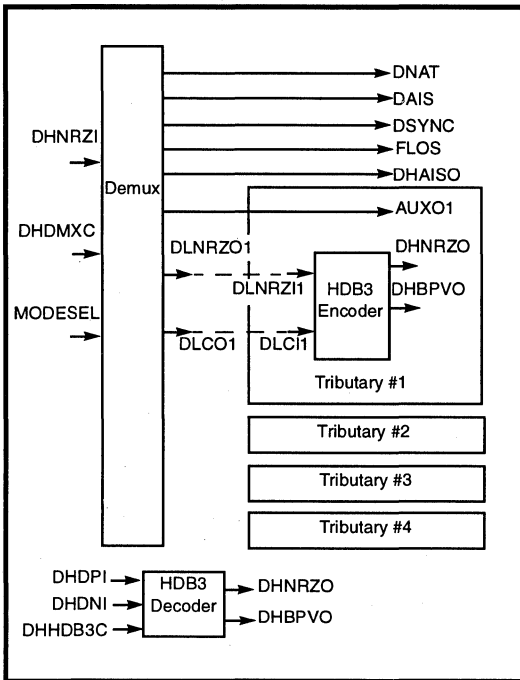

Alarms

The multiplexer and demultiplexer sides contain the following alarm provisions:

- Input Loss Alarms at all receive line interfaces.
- Output Fail Alarms at all transmit line interfaces.
- Frame Loss Alarm line.

With ME for multiplexer and DE for demultiplexer:
i = 1 to 16 for E1
j = 1 to 4 for E2

Alarm equations are:

$$ME1FAIS_i = MELOS_i$$

$$DE1FAIS_i = DE2AISD_j + DE2FLOS_j + DE3LOS + DE3FLOS + DE3AISD$$

$$ME2FAIS_j = ME2LOS_j$$

$$DE2FAIS_j = DE3LOS + DE3FLOS + DE3AISD$$

$$ME3AIS = DE3LOS + (DE3FLOS \& \sim DE3LOS) + DEAISD$$

Auxiliary Channels

Within the E2 and E3 standards, there are four extra bits used for justification (bits 641-644 in the E2 frame, and bits 1157-1160 in the E3 frame). These bits may be used as four auxiliary channels that would provide an E2 rate of 10 KHz, or an E3 rate of 22 KHz.

Two examples how these may be used are:

- Voice Channel Maintenance.
- Data Counter implemented with a parity circuit that would count data bits during one frame of the incoming stream.

National and AIS Bits

The bits are accessible for compliance with the ITU-T recommendation. However, these two bits can also be used as auxiliary channel at the rate of 10 KHz for E2 or 22 KHz E3.

Microcontroller

E1/E3 multiplexer design can be improved by using a microcontroller to control the alarms and other settings. An 8 bit microcontroller, such as an Intel 87C51 is sufficient. The microcontroller could monitor alarms, provide an alarm history, update a control panel and even sound an audible alert if necessary. This microcontroller could monitor switches for loop-back instructions, test and update the National Bit, and check the configuration jumpers for E1/E2 or E2/E3 functions.

SXT6234 E-Rate Multiplexer For 16-E1/E3 Multiplexer/Demultiplexer

Table 9: Multiplexer Pin Description

Mux Input	
LFRECK	Reference clock for tributary data is used as reference for the AIS functions.
MNAT	National Bit Input.
MAIS	AIS bit input.
MHMUXC	High speed multiplexer clock input.
Tributary #1 Input	
AUX1	Auxiliary data input #1. The signal on this pin is clocked into the frame at the stuffing bit location (J1) when justification is such that tributary data is not placed at this location. A high on alarm signal MESA1 indicates this condition during the current frame.
MLDPI1	Positive data input. Clocked on the positive transition of the clock MCKL1.
MLDNI1	Negative data input. Clocked on the positive transition of the clock MCKL1.
MCKL1	Clock input for tributary channel 1.
MLFAIS1	Force AIS on tributary 1. Active high signal forces AIS (all 1) data and LREFCK clock.
Tributary #1 Output	
MLNRZO1	HDB3 decoder #1 NRZ output clocked on the rising edge of MCKL1.
MLNRZ1	Multiplexer tributary NRZ input clocked on the falling edge of the clock signal MLCK1.
MLBPV1	HDB3 decoder #1 bipolar violation alarm. This open collector output pulses when a bipolar violation occurs in the decoding process.
MESA1	Multiplexer justification status for tributary #1. A high indicates bit stuffing on the current frame. A low indicates an information bit. When externally filtered, this can be used to indicate elastic store failure or incorrect tributary frequency.
Mux Output	
MHRZO	Multiplexer NRZ output data is clocked out on the rising edge of MHMUXC.
MSYNC	Multiplexer frame synchronization pulse is one high speed clock cycle synchronous with the last bit of the frame.
HDB3 Decoder	
MHNRZI	HDB3 encoder #5 NRZ input clocked on the rising edge of MHHDB3C.
MHHDB3C	HDB3 encoder #5 clock input. When used in conjunction with the multiplexer, this pin should be tied to the multiplexer clock (MHMUXC).
MHDPO	HDB3 encoder #5 positive data output. Positive rail clocked out on the rising edge of MHHDB3C.
MHDNO	HDB3 encoder #5 negative data output. Negative rail clocked out on the rising edge of MHHDB3C.



Table 10: Demultiplexer Pin Description

Demultiplexer Input	
DHNRZI	NRZ input clocked on the rising edge of DHDMXC.
DHDMXC	Clock input.
MODESEL	Mode selection for multiplexer / demultiplexer operation. A low selects 4E1/E2 multiplexing. A high selects 4E2/E3 multiplexing.
HDB3 Decoder	
DHDPI	HDB3 decoder #5 positive rail input clocked on the rising edge of DHHDB3C.
DHDNI	HDB3 decoder #5 negative rail input clocked on the rising edge of DHHB3C.
DHHDB3C	Clock input for HDB3 decoder # 5. When used in conjunction with the demultiplexer this pin should be tied to the demultiplexer clock DHMUXC.
DHNRZO	HDB3 decoder #5 NRZ data clocked out on the rising edge of DHHDB3C.
DHBPVO	HDB3 decoder #5 bipolar violation alarm. This active high signal pulses when a bipolar violation occurs in the decoding process.
HDB3 Encoder	
DLNZO1	Tributary #1 NRZ output. This signal is clocked out on the rising edge of DHDMXC and transitions are coincident with the falling edge of DLCO1.
DLCO1	Demultiplexer side recovered clock of tributary #1. This clock has a duty cycle of 75% and is gapped at points in the frame where tributary data is not present. The maximum gap is 3 clocks at the frame word will match that of the far end multiplexer tributary input. This signal is clocked out on the rising edge of DHDMXC.
DLNRZI1	HDB3 encoder #1 NRZ input clocked on the rising edge of DLCI1.
DLCI1	Clock input for HDB3 encoder #1.
Multiplexer Output	
DNAT	National Bit output.
DAIS	AIS bit output.
DSYNC	Pulse of one high speed clock cycle synchronous with the last bit of the frame.
FLOS	Loss of frame alarm. Active high frame loss alarm that occurs when the demux has not detected the frame word.
DHAIS	Input AIS detect. Active high alarm occur when an all 1's condition (AIS) is detected at the DHNRZI input. This alarm does not trip if the input is a frame signal (i.e., all tributaries are AIS on the multiplexer side).
Auxiliary #1 Output	
AUXO1	Auxiliary flag data #1 output that contains data value input on AUX1.
DLDP01	HDB3 encoder #1 positive rail output clocked out on the rising edge of DLCI1.
DLDN01	HDB3 encoder #1 negative output clocked out on the rising edge of DLCI1.

SXT6234 E-Rate Multiplexer For 16-E1/E3 Multiplexer/Demultiplexer

NOTES:



Transformer Specifications

for Level One Transceiver Applications

Transformer Specifications

Txcvr	Frequency (kHz)	Turns Ratio ($\pm 2\%$)	Inductance ($\mu\text{H} - \text{Min}$)	Leakage Inductance ($\mu\text{H} - \text{Max}$)	Interwinding Capacitance (pF - Max)	Resistance ($\Omega - \text{Typ}$)	Dielectric Breakdown (V - Min)
LXT300 LXT301 Rx & Tx	1544 / 2048	1 : 2 CT	600 Pri	0.75 Pri	50	1.0 Pri 1.0 Sec	500
LXT304A LXT305A Rx	1544 / 2048	1 : 2 CT	600 Pri	0.75 Pri	50	1.0 Pri	500
LXT304A LXT305A Tx	1544 / 2048	1 : 1.15, 1 : 2 CT 1 : 1 1 : 1.126	600 Pri	0.75 Pri	50	1.0 Pri 1.0 Sec	500
LXT310 LXT318 Rx	1544 / 2048	1 : 1 CT	600 Pri	0.75 Pri	50	1.0 Pri 1.0 Sec	1000
LXT310 LXT318 Tx	1544 / 2048	1 : 2 CT	600 Pri	0.75 Pri	50	1.0 Pri 1.0 Sec	1000
LXT324 LXT325 Rx Only	1544 / 2048	1 : 2 : 2	600 Pri	0.75 Pri	50	1.0 Pri 1.0 Sec	500
LXT312/15 LXT313/16 Rx	1544 / 2048	1 : 1 CT	1000 Pri	1.0 Pri	25	1.0 Pri 1.0 Sec	1000
LXT312/15 LXT313/16 Tx	1544 / 2048	1:1 CT:3 CT	1000 Pri	1.0 Pri	25	1.0 Pri 1.0 Sec	1000
LXT400 Rx & Tx	2.4 to 72	1 : 1	700 Pri	22 - 43 Pri	350	15.0 Pri 15.0 Sec ($\pm 1 \Omega$)	1000

Transformer Specifications

Transformer Manufacturers

Transceiver	Application	Part Number	Manufacturer
LXT300/301 LXT304A/5A LXT305	Tx	PE-64931, PE-64951 67112060, 67115100 0553-5006-IC 671-5832 6500-07-011 FE 8006-55, 8006-85 16Z5946	Pulse Schott Corp. Bell Fuse Midcom Nova Magnetics Fil-Mag Vitec
LXT310/318	Tx (1 : 2)	0553-5006-IC 66Z1308 671-5832 65351, 65771 67127370 and 67130850 TD61-1205G and TD67-1205G (combo Tx/Rx) 16Z5946	Bell Fuse Fil-Mag Midcom Pulse Schott Corp. HALO Vitec
LXT310/318	Rx (1 : 1)	FE 8006-155 671-5792 64936 and 65778 67130840 and 67109510 TD61-1205G and TD67-1205G (combo Tx/Rx) 16Z5934	Fil-Mag Midcom Pulse Schott Corp. HALO Vitec
LXT312/315	Tx	12535 FE 8006-175	Schott Corp. Fil-Mag
LXT312/315	Rx	10951 FE 8006-155	Schott Corp. Fil-Mag
LXT332	Tx Rx (1 : 2) (1 : 2 CT)	PE65351 16Z5946	Pulse Vitec

Quartz Crystals for T1/E1 Transceivers

General Information

The Level One LXT300, LXT305, LXT304A, LXT305A, LXT310, and LXT318 transceivers require quartz crystals as companion devices. For the convenience of our customers, Level One buys crystals in volume from a qualified vendor, stocks them and resells them at reasonable prices in conjunction with Level One transceivers.

The LXC6176 is used in T1 applications and the LXC8192 is used in E1 applications. Specifications for the LXC6176 and LXC8192 crystals are listed below.

Level One has evaluated and qualified several crystal vendors for the benefit and convenience of our customers. We believe customers prefer to have multiple approved sources. Quartz crystals qualified for use with Level One transceivers are listed on the next page. We suggest that customers establish relations with one or more of these approved crystal suppliers and buy direct.

Crystal Specifications

Parameter	T1	E1
Frequency	6.176 MHz	8.192 MHz
Frequency stability	±20 ppm @ 25 °C ±25 ppm from -40 °C to + 85 °C (Ref 25 °C reading)	±20 ppm @ 25 °C ±25 ppm from -40 °C to + 85 °C (Ref 25 °C reading)
Pullability	CL = 11.7 - 19.0 pF, +ΔF = 175 - 250 ppm CL = 19 - 34 pF, -ΔF = 175 - 250 ppm	CL = 19 pF to 37 pF, crystal should pull -95 ppm to -115 ppm from nominal frequency CL = 19 pF to 11.6 pF, crystal should pull +95 ppm to +130 ppm from nominal frequency
Effective series resistance	40 Ω Maximum	30 Ω Maximum
Crystal cut	AT	AT
Resonance	Parallel	Parallel
Maximum drive level	2.0 mW	2.0 mW
Mode of operation	Fundamental	Fundamental
Crystal holder	HC49 (R3W), Co = 7 pF maximum C _M = 22 fF typical	HC49 (R3W), Co = 7 pF maximum C _M = 13 fF typical

Crystals for T1/E1 Transceivers

Qualified Quartz Crystals

Manufacturer	Part Number	Frequency
M-Tron	MP-1 3808-010 / 4144-002	6.176 MHz
Monitor Products	MSC-1311-01B-6.176	6.176 MHz
Monitor Products	MSC-1311-01B-8.192	8.192 MHz
CTS Knights	6176-180	6.176 MHz
CTS Knights	8192-100	8.192 MHz
Valpey Fisher	VF49A16FN1-6.176	6.176 MHz
Valpey Fisher	VF49A16FN1-8.192	8.192 MHz
US Crystal	U18-18-6176SP	6.176 MHz
US Crystal	U18-18-8192SP	8.192 MHz

Transmission Product Evaluation Boards



For information regarding pricing and availability of Transmission Product Evaluation Boards, please contact your local Level One sales representative.

LDB300

Evaluation Board for T1/E1 Transceivers

General Description

The LDB300 Evaluation Board is a versatile evaluation tool for Level One Communications short-haul and long-haul T1/E1 transceivers. The Evaluation Board works with any of the following:

<u>Short-Haul Transceivers</u>	<u>Long-Haul Transceivers</u>
LXT300/LXT301/LXT305	LXT310 (T1)
LXT300Z/LXT301Z	LXT318 (E1)
LXT304A/LXT305A	

This data sheet describes using the Evaluation Board with the LXT300 transceiver in both T1 (North American) and E1 (European) environments. We have also included information to set it up with the other short-haul transceivers.

A later section has similar information describing applications in a long-haul environment using both the LXT310 and LXT318 transceivers.

To use this document, have the current data sheet for the chosen transceiver to insure having the correct information available.

Features

- Board design permits fast set-up, ease of use and clear visibility of application settings
- On board sockets accept either 6.176 or 8.192 MHz crystal for jitter attenuation
- Flexible design for numerous termination schemes
- On-board switches for Hardware Mode operation
- Ribbon-cable, serial-interface connector for Host Mode operation
- Banana jacks for quick TP and power connections
- BNC connectors allow tracing signals with oscilloscope
- LEDs indicate LOS, BPV and DPM conditions
- Design supports either short- or long-haul transceiver
- On-board sockets for both DIP and PLCC package

LDB300 Evaluation Board Layout

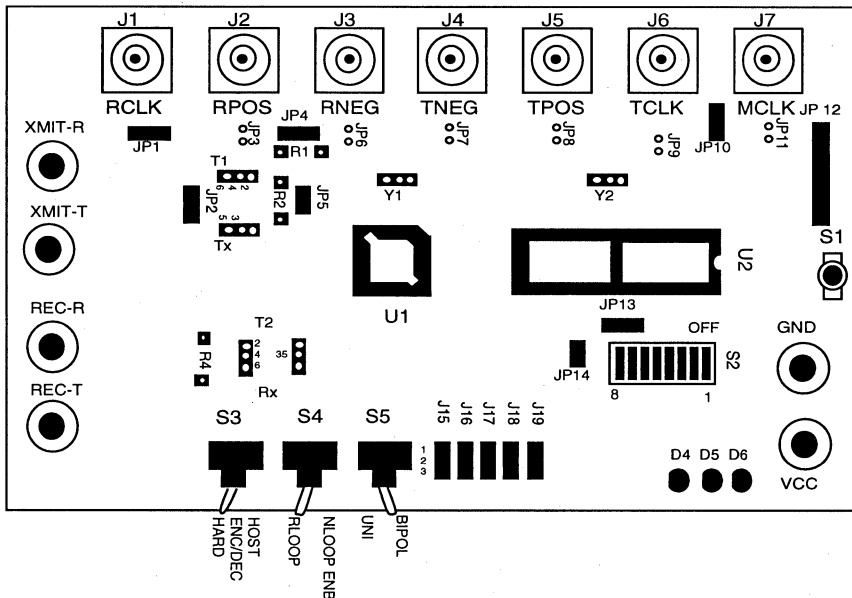

10

LDB332

Evaluation Board for T1/E1 Applications

General Description

The LDB332 Evaluation Board is a versatile evaluation tool for engineers involved in designing T1/E1 short haul applications. It uses an LXT332 Dual Line Interface Unit (DLIU) and incorporates all supporting circuitry for either T1 or E1 applications using the DLIU.

The Evaluation Board provides banana jacks for the line interface and BNC connectors for the framer interface. A bit error rate tester (BERT) or framer/mux may be used to provide the external signal needed for evaluation.

This document describes typical Evaluation Board setup procedures for both T1 (North American) and E1 (International) environments.

Before using the Evaluation Board, review the current LXT332 DLIU data sheet for complete information about this transceiver. A Evaluation Board schematic is also available.

Features

- Board design permits quick setup, ease of use and clear visibility of application settings
 - Local DLIU testing
 - Complete system evaluation
 - Individual circuit isolation
- Exploits crystal-less jitter attenuation of DLIU
- Jitter attenuation switchable into either transmit or receive data path
- Two twisted-pair line interfaces and all related digital signals available for analysis and testing
- Banana jacks for twisted-pair line interface
- BNC connectors for clock and framer interface
- LEDs indicators for DFM and LOS
- Design supports both E1 and T1 evaluation
- Switches emulate stand-alone Hardware Mode

LDB332 Evaluation Board

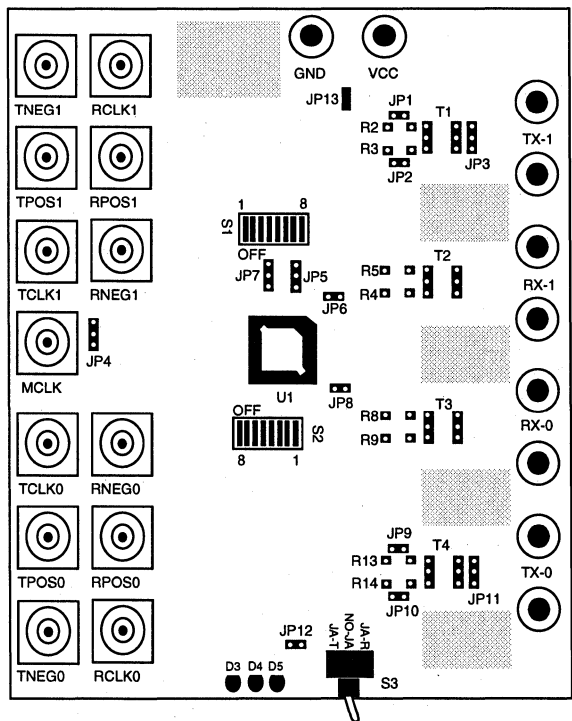

LDB360 Evaluation Board

for T1/E1 Short- and Long-Haul Applications

General Description

The LDB360 Evaluation Board (Eval Board) is a versatile tool for engineers involved in designing T1/E1 short- or long-haul applications. It uses an LXT360 or LXT361 Line Interface Unit (LIU) and incorporates all supporting circuitry for either T1 or E1 applications.

The LDB360 provides connector jacks for the line interface and BNC connectors for the framer interface. A bit error rate tester (BERT) or framer/mux may be used to provide the external signals needed for evaluation.

This document describes typical Eval Board setup procedures for both T1 and E1 environments.

Before using the Eval Board, review the latest LXT360/361 LIU data sheet for the most current information about these transceivers.

Features

- Quick setup, ease of use and clear visibility of application settings for:
 - Local LIU testing
 - Complete system evaluation
 - Individual circuit isolation
- Exercises crystal-less jitter attenuation of LIU
- Jitter attenuation switchable into either transmit or receive data path
- Twisted-pair line interface and all related digital signals available for analysis and testing
- Connector jacks for twisted-pair line interface
- BNC connectors for clock and framer interface
- LED indicators for major features
- Design supports both E1 and T1 evaluation
- Switches emulate stand-alone Hardware Mode and Software Mode with Serial Interface to the Host (for the LXT360)
- The LXT361 is controlled exclusively via an 8-bit parallel interface to the Host

LDB360/361 Evaluation Board

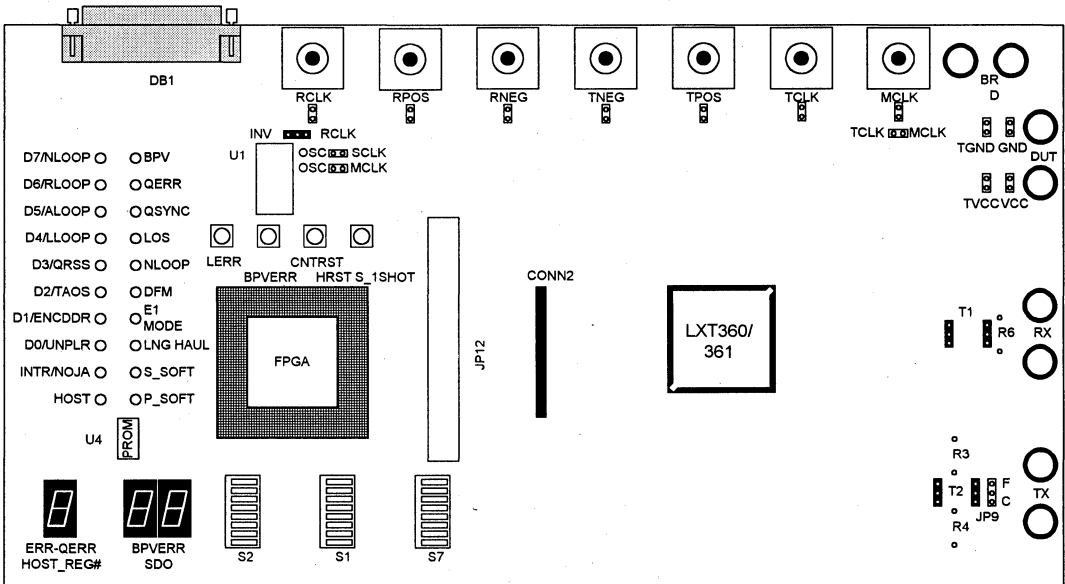

SDB6234

Evaluation Board for the SXT6234

General Description

The SDB6234 Evaluation Board is a versatile, full featured evaluation tool designed specifically for engineering evaluation of the SXT6234 E-Rate Multiplexer. This tool uses two SXT6234 circuits and includes all supporting circuitry for E1, E2, and E3 multiplexer/demultiplexer applications.

The Evaluation Board provides banana jacks for power (J3) and ground (J2). BNC connectors are provided for input and output signals. DIP switch S1 selects various functions and connector J4 provides a convenient way to monitor signals.

This document describes configurations for both E1-to-E2 and E1-to-E3 multiplexing with setup details for each. Note that each SXT6234 E-Rate multiplexer chip on the board is configured to use only one of the four tributary inputs.

Before using the Evaluation Board, review the current SXT6234 data sheet for the most current information about this product.

Features

- Board design permits quick set-up, ease of use and clear visibility of application settings
- Complete system evaluation including Line Interface Units
- Test points for both NRZ data and Sync
- Banana jacks for V_{CC} and ground
- LED indicators for power
- LED indicators for signal loss
- BNC connectors for input and output signals
- DIP switch for easy configuration set-up
- Eighteen-pin connector for monitoring the National, AIS, and Aux flag bits, and alarms
- Design supports:
 - E1 to E2 multiplexing/demultiplexing
 - E1 to E3 multiplexing/demultiplexing

SDB6234 Evaluation Board

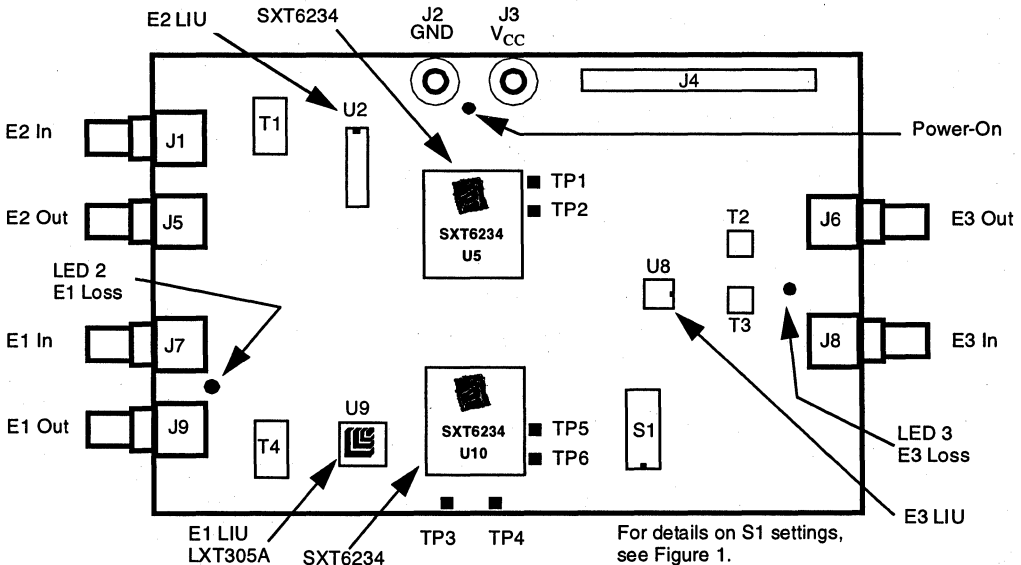

LDB70206

HDSL Evaluation Kit for 784 kbps Applications

General Description

The HDSL Evaluation Kit is a versatile tool for design engineers working with 784 kbps HDSL communications applications. The Development Kit for the Data Pump incorporates all the supporting circuitry needed for end-to-end testing of one HDSL line without external hardware or software. The Development Kit also supports connections to an external HDSL framer/mux and microprocessor to facilitate the development of a complete 2- or 3-loop HDSL system.

The Evaluation Kit includes two printed circuit boards that connect to each other through two PGA sockets:

- The HDSL Data Pump Development Board includes the power, signal, and digital data interfaces
- The HDSL Board contains the Data Pump and its supporting circuitry

The Evaluation Kit uses either of the two Data Pump control options:

- Hardware Control Mode (set up with DIP switches)
- Host Control Mode (set up through an external microprocessor)

Standard cable connectors and pin headers permit connection to signal analyzers, bit error rate testers (BERT), line emulators, and other instrumentation.

The Evaluation Kit design includes an RS422 interface for customized setups and RS449 interfaces for BERT connections.

Features

- Includes two complete Data Pumps and all supporting circuitry
- Facilitates system-wide design and evaluation
- RS449 connectors for BERT attachments
- RS422 connections for customized testing
- RJ45 connectors for twisted pair connections
- Hardware Mode operation uses DIP switches to control Data Pumps
- Host Mode operation using an external processor
- Basic error rate testing using all ones data requires only received clock and received data signals.
- Link Active indicator LEDs
- Independent reset switches for each loop

HDSL Data Pump Board

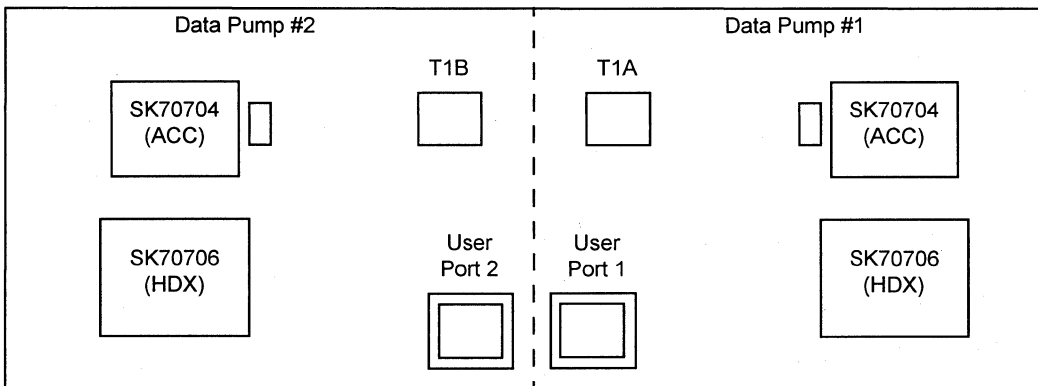

LDB70207

HDSL Evaluation Kit for 1168 kbps Applications

General Description

The HDSL Evaluation Kit is a versatile tool for design engineers working with 1168 kbps HDSL communications applications. The Evaluation Kit for the Data Pump incorporates all the supporting circuitry needed for end-to-end testing of one HDSL line without external hardware or software. The Evaluation Kit also supports connections to an external HDSL framer/mux and microprocessor to facilitate the development of a complete 2-loop HDSL system.

The Evaluation Kit includes two printed circuit boards that connect to each other through two PGA sockets:

- The HDSL Data Pump Development Board includes the power, signal, and digital data interfaces
- The HDSL Board contains the Data Pump and its supporting circuitry

The Evaluation Kit uses either of the two Data Pump control options:

- Hardware Control Mode (set up with DIP switches)
- Host Control Mode (set up through an external microprocessor)

Standard cable connectors and pin headers permit connection to signal analyzers, bit error rate testers (BERT), line emulators, and other instrumentation.

The Evaluation Kit design includes an RS422 interface for customized setups and RS449 interfaces for BERT connections.

Features

- Includes two complete Data Pumps and all supporting circuitry
- Facilitates system-wide design and evaluation
- RS449 connectors for BERT attachments
- RS422 connections for customized testing
- RJ45 connectors for twisted pair connections
- Hardware Mode operation uses DIP switches to control Data Pumps
- Host Mode operation using an external processor
- Basic error rate testing using all ones data requires only received clock and received data signals
- Link Active indicator LEDs
- Independent reset switches for each loop

HDSL Data Pump Board

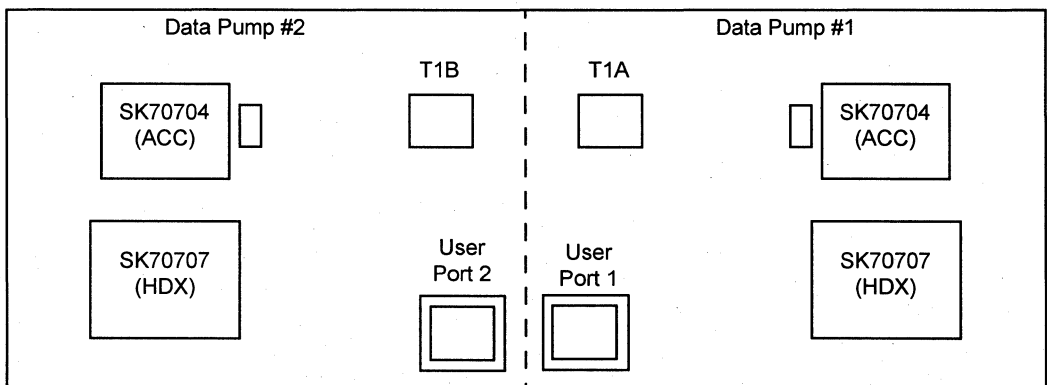

Ethernet PHY Products



LXT901

Universal Ethernet Interface Adapter (Internal MAU) with Integrated 10BASE-T MAU, EnDec, AUI and Filters

General Description

The LXT901 Universal Ethernet Interface Adapter is designed for IEEE 802.3 physical layer applications. It provides all the active circuitry to interface most standard 802.3 controllers to either the 10BASE-T media or Attachment Unit Interface (AUI). In addition to standard 10 Mbps Ethernet, the LXT901 also supports full-duplex operation at 20 Mbps.

LXT901 functions include Manchester encoding/decoding, receiver squelch and transmit pulse shaping, jabber, link testing and reversed polarity detection/correction. The LXT901 can be used to drive either the AUI drop cable or the 10BASE-T twisted-pair cable with only a simple isolation transformer. Integrated filters simplify the design work required for FCC compliant EMI performance. Selectable termination impedance allows the LXT901 to be used with either shielded or unshielded twisted-pair cable.

The LXT901 is fabricated with an advanced CMOS process and requires only a single 5 volt power supply.

Applications

- Laptop/Palmtop portables (PCMCIA compatibles)
- Computer/workstation 10BASE-T LAN adapter boards

Features

Functional Features

- Integrated Filters - Simplifies FCC Compliance
- Integrated Manchester Encoder/Decoder
- 10BASE-T compliant Transceiver
- AUI Transceiver
- Supports Standard and Full-Duplex Ethernet

Convenience Features

- Automatic/Manual AUI/RJ45 Selection
- Automatic Polarity Correction
- Programmable Impedance Driver
- Power Down Mode and four loopback modes
- Available in 64-pin TQFP and 44-pin PLCC packages

Diagnostic Features

- Four LED Drivers
- AUI/RJ45 Loopback
- Remote Signaling of Link Down and Jabber conditions

LXT901 Block Diagram

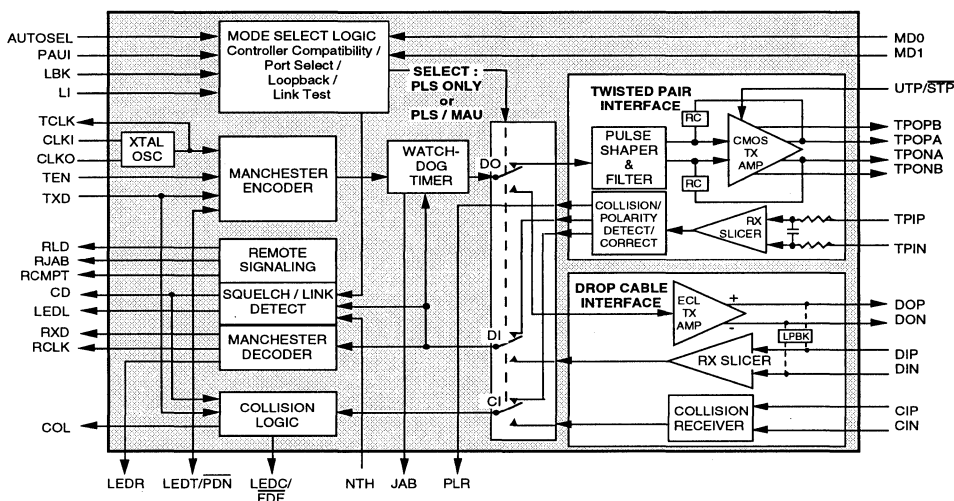

LXT901 Universal Ethernet Interface Adapter

Figure 1: LXT901 Pin Assignments

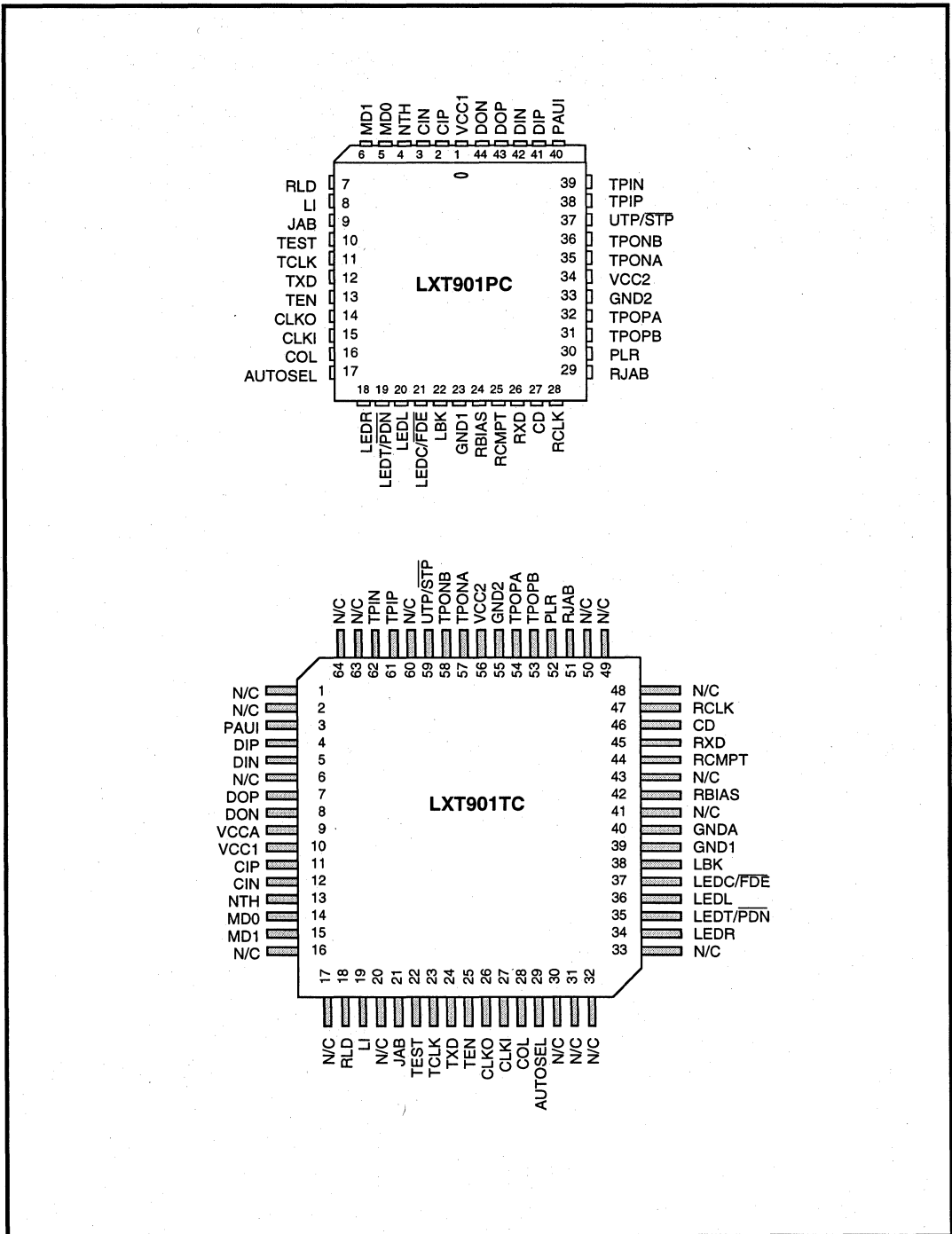

Table 1: LXT901 Pin Descriptions

P L C C	T O F P	Sym	I/O	Name	Description
1 34 –	10 56 9	VCC 1 VCC 2 VCCA	I I I	Power Inputs 1, 2 and A (TQFP only)	+ 5 volt power supply inputs.
2 3	11 12	CIP CIN	I I	AUI Collision Pair	Differential input pair connected to the AUI transceiver CI circuit. The input is collision signaling or SQE.
4	13	NTH	I	Normal Threshold	When NTH is High, the normal TP squelch threshold is in effect. When NTH is Low, the normal TP squelch threshold is reduced by 4.5 dB.
5 6	14 15	MD0 MD1	I I	Mode Select 0 Mode Select 1	Mode select pins determine controller compatibility mode in accordance with Table 2.
7	18	RLD	O	Remote Link Down	Output goes high to signal to the controller that the remote port is in link down condition.
8	19	LI	I	Link Test Enable	Controls Link Integrity Test; enabled when High, disabled when Low.
9	21	JAB	O	Jabber Indicator	Output goes high to indicate Jabber state.
10	22	TEST	I	Test	This pin must be tied High.
11	23	TCLK	O	Transmit Clock	A 10 MHz clock output. This clock signal should be directly connected to the transmit clock input of the controller.
12	24	TXD	I	Transmit Data	Input signal containing NRZ data to be transmitted on the network. TXD is connected directly to the transmit data output of the controller.
13	25	TEN	I	Transmit Enable	Enables data transmission and starts the watchdog timer. Synchronous to TCLK (see Test Specifications for details).
14 15	26 27	CLKO CLKI	O I	Crystal Oscillator	A 20 MHz crystal must be connected across these pins, or a 20 MHz clock applied at CLKI with CLKO left open.
16	28	COL	O	Collision Detect	Output which drives the collision detect input of the controller.
17	29	AUTO SEL	I	Automatic Port Select	When High, automatic port selection is enabled (the 901 defaults to the AUI port only if TP link integrity = Fail). When Low, manual port selection is enabled (the PAUI pin determines the active port).
18	34	LEDR	O	Receive LED	Open drain driver for the receive indicator LED. Output is pulled Low during receive.
19	35	LEDT/ PDN	O I	Transmit LED/ Power Down	Open drain driver for the transmit indicator. Output is pulled Low during transmit. If externally tied Low, the LXT901 goes to power down state.
20	36	LEDL	O I	Link LED	Open drain driver for link integrity indicator. Output is pulled Low during link test pass. If externally tied Low, internal circuitry is forced to "Link Pass" state and 901 will continue to transmit link test pulses.
21	37	LEDC/ FDE	O I	Collision LED	Open drain driver for the collision indicator pulls Low during collision. If externally tied Low, the LXT901 disables the internal TP loopback and collision detect circuits for full-duplex operation or external TP loopback.

LXT901 Universal Ethernet Interface Adapter

Table 1: Pin Descriptions - continued

P L C C	T Q F P	Sym	I/O	Name	Description
22	38	LBK	I	Loopback	Enables internal loopback mode. Refer to Test Specifications for details.
23 33 -	39 55 40	GND1 GND2 GNDA	- - -	Ground Returns 1, 2 and A (TQFP only)	Grounds.
24	42	RBIAS	I	Bias Control	A 12.4 k Ω 1% resistor to ground at this pin controls operating circuit bias.
25	44	RCMPT	O	Remote Compatibility	Output goes High to signal the controller that the remote port is compatible with the LXT901 remote signaling features.
26	45	RXD	O	Receive Data	Output signal connected directly to the receive data input of the controller.
27	46	CD	O	Carrier Detect	An output to notify the controller of activity on the network.
28	47	RCLK	O	Receive Clock	A recovered 10 MHz clock which is synchronous to the received data and connected to the controller receive clock input.
29	51	RJAB	O	Remote Jabber	Output goes High to indicate that the remote port is in Jabber condition.
30	52	PLR	O	Polarity Reverse	Output goes High to indicate reversed polarity at the TP input.
31 36 32 35	53 58 54 57	TPOPB TPONB TPOPA TPONA	O O O O	Twisted-Pair Transmit Pairs A & B	Two differential driver pair outputs (A and B) to the twisted-pair cable. The outputs are pre-equalized; no external filters are required. Two pairs are used to provide compatibility with both 100 Ω load cable and 150 Ω load cable.
37	59	UTP/ STP	I	UTP / STP Select	When UTP is Low, 150 Ω termination for shielded TP is selected. When UTP is High, 100 Ω termination for unshielded TP is selected.
38 39	61 62	TPIP TPIN	I I	Twisted-Pair Receive Pair	A differential input pair from the twisted-pair cable. Receive filter is integrated on-chip.
40	3	PAUI	I	Port/AUI Select	In Manual Port Select mode (AUTOSEL Low), PAUI selects the active port. When PAUI is High, the AUI port is selected. When PAUI is Low, the TP port is selected. In Auto Port Select mode, PAUI must be tied to ground.
41 42	4 5	DIP DIN	I I	AUI Receive Pair	Differential input pair from the AUI transceiver DI circuit. The input is Manchester encoded.
43 44	7 8	DOP DON	O O	AUI Transmit Pair	A differential output driver pair for the AUI transceiver cable. The output is Manchester encoded.

FUNCTIONAL DESCRIPTION

NOTE

This information is for design aid only.

The LXT901 Universal Ethernet Interface Transceiver performs the physical layer signaling (PLS) and Media Attachment Unit (MAU) functions as defined by the IEEE 802.3 specification. It functions as a PLS-Only device (for use with 10BASE-2 or 10BASE-5 coaxial cable networks) or as an Integrated PLS/MAU (for use with 10BASE-T twisted-pair networks). In addition to standard 10 Mbps operation, the LXT901 also supports full-duplex 20 Mbps operation.

The LXT901 interfaces a back end controller to either an AUI drop cable or a twisted-pair (TP) cable. The controller interface includes transmit and receive clock and NRZ data channels, as well as mode control logic and signaling. The AUI interface comprises three circuits: Data Output (DO), Data Input (DI) and Collision (CI). The twisted-pair interface comprises two circuits: Twisted-Pair Input (TPI) and Twisted-Pair Output (TPO). In addition to the three basic interfaces, the LXT901 contains an internal crystal oscillator and four LED drivers for visual status reporting.

Functions are defined from the back end controller side of the interface. The LXT901 Transmit function refers to data transmitted by the back end to the AUI cable (PLS-Only mode) or to the twisted-pair network (Integrated PLS/MAU mode). The LXT901 Receive function refers to data received by the back end from the AUI cable (PLS-Only) or from the twisted-pair network (Integrated PLS/MAU mode). In the integrated PLS/MAU mode, the LXT901 performs all required MAU functions defined by the IEEE 802.3 10BASE-T specification such as collision detection, link integrity testing, signal quality error messaging, jabber control and loopback. In the PLS-Only mode, the LXT901 receives incoming signals from the AUI DI circuit with ± 18 ns of jitter and drives the AUI DO circuit.

CONTROLLER COMPATIBILITY MODES

The LXT901 is compatible with most industry standard controllers including devices produced by Advanced Micro Devices (AMD), Intel, Fujitsu, National Semiconductor, Seeq and Texas Instruments. Four different control signal timing and polarity schemes (Modes 1 through 4) are required to achieve this compatibility. Mode select pins (MD0 and MD1) determine Controller compatibility modes as listed in Table 2. Refer to Test Specifications for a complete set of timing diagrams for each mode.

TRANSMIT FUNCTION

The LXT901 receives NRZ data from the controller at the TXD input as shown in the first diagram, and passes it through a Manchester encoder. The encoded data is then transferred to either the AUI cable (the DO circuit) or the twisted-pair network (the TPO circuit). The advanced integrated pulse shaping and filtering network produces the output signal on TPO_N and TPO_P, shown in Figure 2. The TPO output is pre-distorted and prefiltered to meet the 10BASE-T jitter template. **An internal continuous resistor-capacitor filter is used to remove any high-frequency clocking noise from the pulse shaping circuitry. Integrated filters simplify the design work required for FCC compliant EMI performance.** During idle periods, the LXT901 transmits link integrity test pulses on the TPO circuit (if LI is enabled and integrated PLS/MAU mode is selected). The UTP pin controls LXT901 termination impedance.

When UTP/ $\overline{\text{STP}}$ is Low, the LXT901 is set for shielded TP (150 Ω). When UTP/ $\overline{\text{STP}}$ is High, the LXT901 is set for unshielded TP (100 Ω).

Figure 2: LXT901 TPO Output Waveform

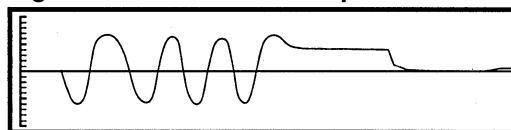

Table 2: Controller Compatibility Mode Options

Controller Mode:	Setting:	
	MD1	MD0
Mode 1 - For Advanced Micro Devices AM7990 or compatible controllers	Low	Low
Mode 2 - For Intel 82596 or compatible controllers	Low	High
Mode 3 - For Fujitsu MB86950, MB86960 or compatible controllers (Seeq 8005) ¹	High	Low
Mode 4 - For National Semiconductor 8390 or compatible controllers (TI TMS380C26)	High	High

1. SEEQ controllers require inverters on CLKI, LBK, RCLK and COL.

JABBER CONTROL FUNCTION

Figure 3 is a state diagram of the LXT901 Jabber control function. The LXT901 on-chip watchdog timer prevents the DTE from locking into a continuous transmit mode. When a transmission exceeds the time limit, the watchdog timer disables the transmit and loopback functions, and activates the JAB pin. Once the LXT901 is in the jabber state, the TXD circuit must remain idle for a period of 0.25 to 0.75 seconds before it will exit the jabber state.

SQE FUNCTION

In the integrated PLS/MAU mode, the LXT901 supports the signal quality error (SQE) function as shown in Figure 4. After every successful transmission on the 10BASE-T network, the 901 transmits the SQE signal for $10BT \pm 5BT$ over the internal CI circuit which is indicated on the COL pin of the device. When using the 10BASE-2 port of the 901, the SQE function is determined by the external MAU attached.

RECEIVE FUNCTION

The LXT901 receive function acquires timing and data from the twisted-pair network (the TPI circuit) or from the AUI (the DI circuit). Valid received signals are passed through the on-chip filters and Manchester decoder then output as decoded NRZ data and receive timing on the RXD and RCLK pins, respectively.

An internal RC filter and an intelligent squelch function discriminate noise from link test pulses and valid data streams. The receive function is activated only by valid data streams above the squelch level and with proper timing. If the differential signal at the TPI or the DI circuit inputs falls below 75% of the threshold level (unsquelched) for 8 bit times (typical), the LXT901 receive function enters the idle state. If the polarity of the TPI circuit is reversed, LXT901 detects the polarity reverse and reports it via the PLR output. The LXT901 automatically corrects reversed polarity.

Figure 3: Jabber Control Function

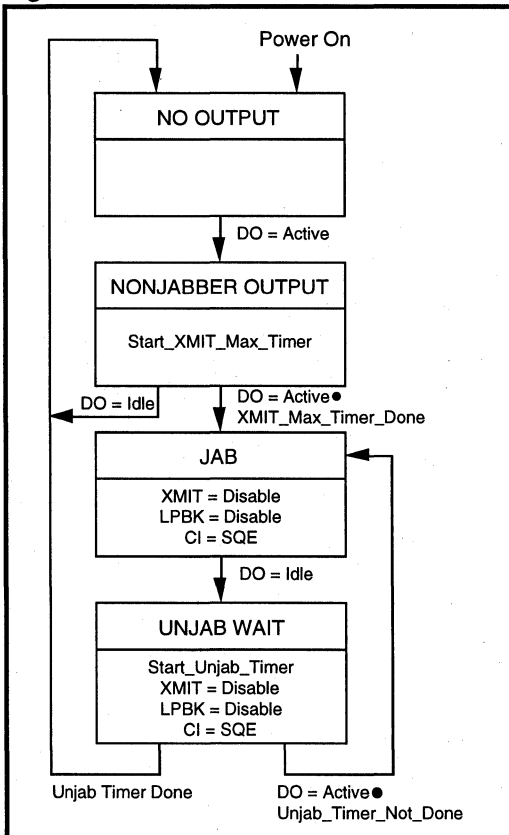
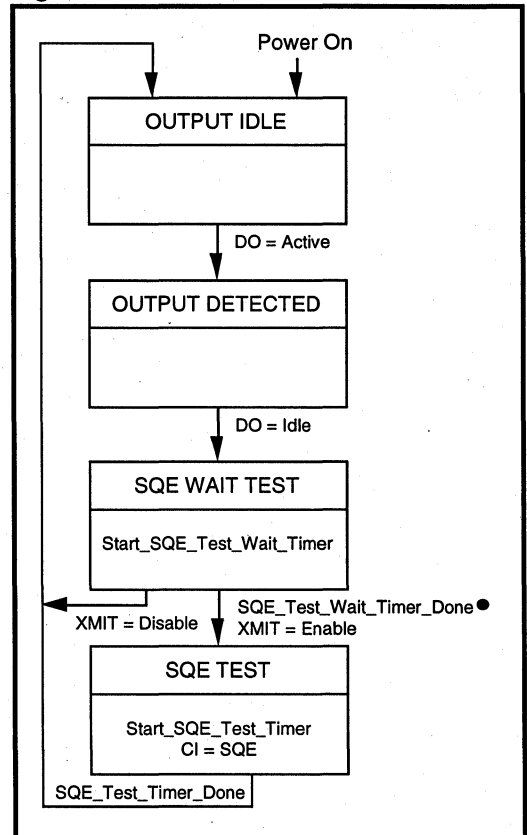

Figure 4: SQE Function



POLARITY REVERSE FUNCTION

The LXT901 polarity reverse function uses both link pulses and end-of-frame data to determine polarity of the received signal. A reversed polarity condition is detected when eight opposite receive link pulses are detected without receipt of a link pulse of the expected polarity. Reversed polarity is also detected if four frames are received with a reversed start-of-idle. Whenever a correct polarity frame or a correct link pulse is received, these two counters are reset to zero. If the LXT901 enters the link fail state and no valid data or link pulses are received within 96 to 128 ms, the polarity is reset to the default non-flipped condition. (If Link Integrity Testing is disabled, polarity detection is based only on received data.) Polarity correction is always enabled.

COLLISION DETECTION FUNCTION

The collision detection function operates on the twisted-pair side of the interface. For standard (half-duplex) 10BASE-T operation, a collision is defined as the simultaneous presence of valid signals on both the TPI circuit and the TPO circuit. The LXT901 reports collisions to the back-end via the COL pin. If the TPI circuit becomes active while there is activity on the TPO circuit, the TPI data is passed to the back-end over the RXD circuit, disabling normal loopback. Figure 5 is a state diagram of the LXT901 collision detection

function. Refer to Test Specifications for collision detection and COL/CI output timing (NOTE: For full-duplex operation, the collision detection circuitry must be disabled.)

LOOPBACK FUNCTION

The LXT901 provides the normal loopback function specified by the 10BASE-T standard for the twisted-pair port. The loopback function operates in conjunction with the transmit function. Data transmitted by the back-end is internally looped back within the LXT901 from the TXD pin through the Manchester encoder/decoder to the RXD pin and returned to the back-end. This "normal" loopback function is disabled when a data collision occurs, clearing the RXD circuit for the TPI data. Normal loopback is also disabled during link fail and jabber states.

The LXT901 also provides three additional loopback functions. An external loopback mode, useful for system-level testing, is controlled by pin 21 (LEDC/FDE). When LEDC/FDE is tied Low, the LXT901 disables the collision detection and internal loopback circuits, to allow external loopback.

"Forced" TP loopback is controlled by pin 22 (LBK). When the TP port is selected and LBK is High, TP loopback is "forced", overriding collisions on the TP circuit. When LBK is Low, normal loopback is in effect.

Figure 5: Collision Detection Function

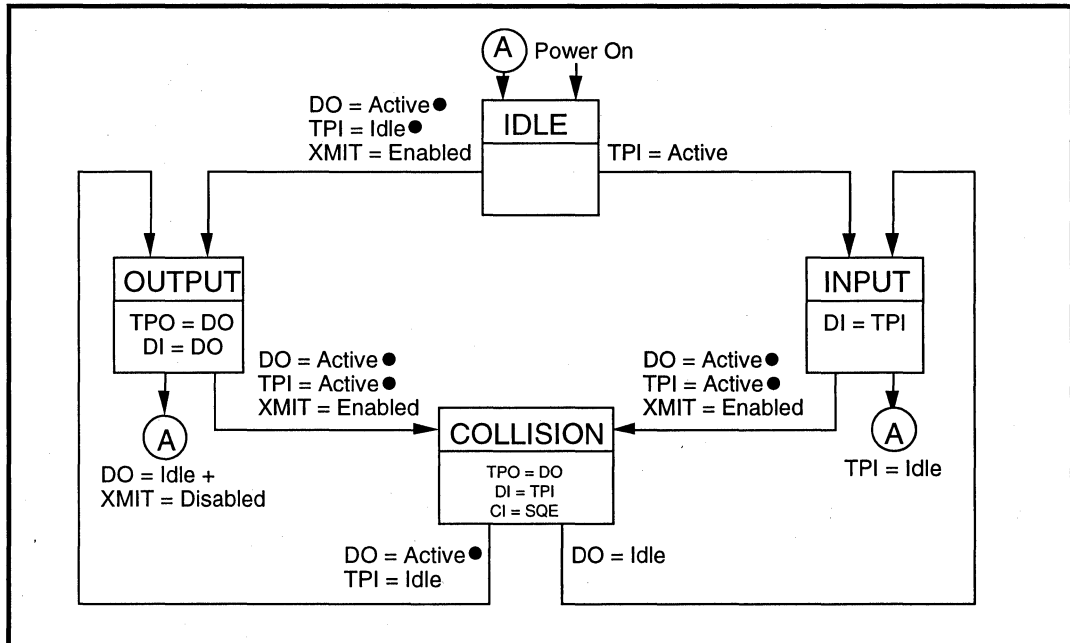

AUI loopback is also controlled by the LBK pin. When the AUI port is selected and LBK is High, data transmitted by the back-end is internally looped back from the TXD pin through the Manchester encoder/decoder to the RXD pin. When LBK is Low, no AUI loopback occurs.

LINK INTEGRITY TEST

Figure 6 is a state diagram of the LXT901 Link Integrity test function. The link integrity test is used to determine the

status of the receive side twisted-pair cable. Link integrity testing is enabled when pin 8 (LI) is tied High. When enabled, the receiver recognizes link integrity pulses which are transmitted in the absence of receive traffic. If no serial data stream or link integrity pulses are detected within 50 - 150 ms, the chip enters a link fail state and disables the transmit and normal loopback functions. The LXT901 ignores any link integrity pulse with interval less than 2 - 7 ms. The LXT901 will remain in the link fail state until it detects either a serial data packet or two or more link integrity pulses.

Figure 6: Link Integrity Test Function

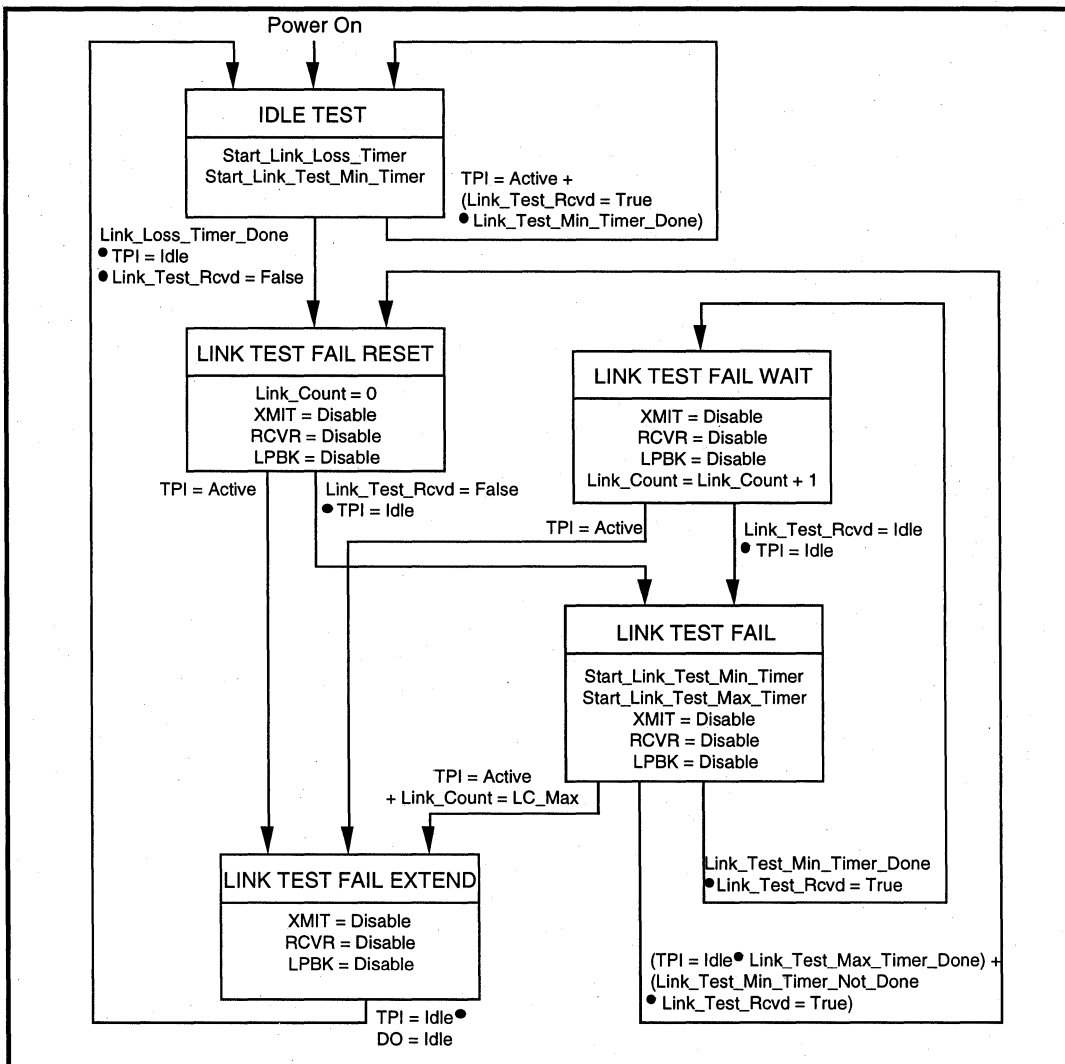

REMOTE SIGNALING

The LXT901 transmits standard link pulses which meet the 10BASE-T specification. However, the LXT901 encodes additional status information into the link pulse by varying the link pulse timing. This is referred to as remote signaling. Using alternate pulse intervals, the LXT901 can signal three local conditions: link down, jabber, and remote signaling compatibility. Figure 7 shows the interval variations used to signal local status to the other end of the line. The LXT901 also recognizes these alternate pulse intervals when received from a remote unit. Remote status conditions are reported to the controller over the RLD, RJAB and RCMPPT output pins.

Figure 7: Remote Signaling Link Integrity Pulse Timing

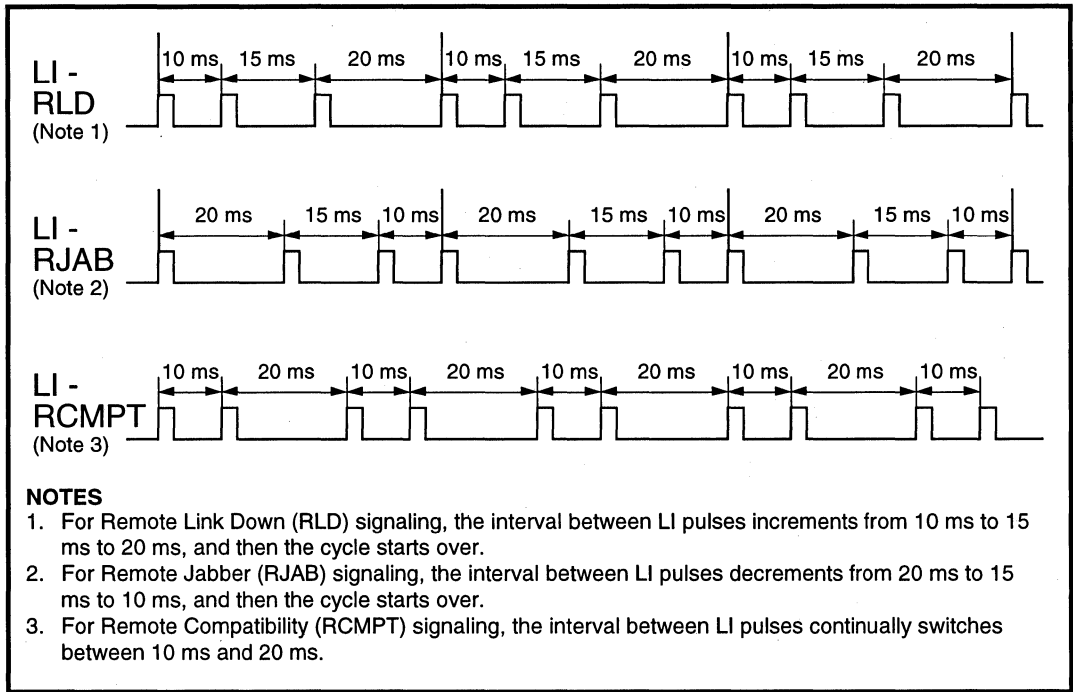

APPLICATION INFORMATION

NOTE

This information is for design aid only.

Figures 8 through 15 show typical LXT901 applications.

AUTO PORT SELECT WITH EXTERNAL LOOPBACK CONTROL (FIGURE 8)

Figure 8 is a typical LXT901 application. The diagram is arranged to group similar pins together; it does not represent the actual LXT901 pinout. The controller interface pins (transmit data, clock and enable; receive data and clock; and the collision detect, carrier detect and loopback control pins) are shown at the top left.

Programmable option pins are grouped center left. The PAUI pin is tied Low and all other option pins are tied High. This set-up selects the following options:

- Automatic Port Selection (PAUI Low and AUTOSEL High)
- Normal Receive Threshold (NTH High)
- Mode 4 (compatible with National NS8390 controllers) (MD0 High, MD1 High)
- 100 Ω termination for unshielded TP cable (UTP/ $\overline{\text{STP}}$ High)
- Link Testing Enabled (LI High)

Status outputs are grouped at lower left. Local status outputs drive LED indicators and remote status indicators are available as required.

Power and ground pins are shown at the bottom of the diagram. A single power supply is used for both VCC1 and VCC2 with a decoupling capacitor installed between the power and ground busses.

The TP and AUI interfaces are shown at upper and lower right, respectively. Impedance matching resistors are installed in each I/O pair but no external filters are required. Suitable transformers are listed in notes 2 and 3.

DUAL NETWORK SUPPORT - 10BASE T AND TOKEN RING (FIGURE 9)

Figure 9 shows the LXT901 with a Texas Instruments 380C26 CommProcessor. The 380C26 is compatible with Mode 4 (MD0 and MD1 both High). When used with the 380C26, both the LXT901 and a TMS38054 Token Ring transceiver can be tied to a single RJ45 allowing dual network support from a single connector. The LXT901 AUI port is not used.

MANUAL PORT SELECT WITH LINK TEST FUNCTION (FIGURES 10 AND 11)

With MD0 Low and MD1 tied High, the LXT901 logic and framing are set to Mode 3 (compatible with Fujitsu MB86950 and MB86960, and SEEQ 8005 controllers). Figure 10 shows the setup for Fujitsu controllers. Figure 11 shows the four inverters required to interface with the SEEQ 8005 controller. As in Figure 8, both these Mode 3 applications show the LI pin tied High, enabling Link Testing; and the UTP/ $\overline{\text{STP}}$ and NTH pins are both tied High, selecting the standard receiver threshold and 100 Ω termination for unshielded TP cable. However, in these applications AUTOSEL is tied Low, allowing external port selection through the PAUI pin. The remote status outputs are inverted to drive LED indicators.

150 Ω SHIELDED TWISTED-PAIR ONLY (FIGURE 12)

Figure 12 shows the LXT901 in a typical twisted-pair only application. The DTE is connected to a 10BASE-T network through the twisted-pair RJ45 connector. (The AUI port is not used.) With MD0 tied High and MD1 Low, the LXT901 logic and framing are set to Mode 2 (compatible with Intel 82596 controllers).





A 20 MHz system clock input at CLKI is used in place of the crystal oscillator. (CLKO is left open.) The LI pin externally controls the link test function. The UTP/ $\overline{\text{STP}}$ and NTH pins are both tied Low, selecting the reduced receiver threshold and 150 Ω termination for shielded TP cable. The switch at LEDT/ $\overline{\text{PDN}}$ manually controls the power down mode.

THREE MEDIA APPLICATION (FIGURE 13)

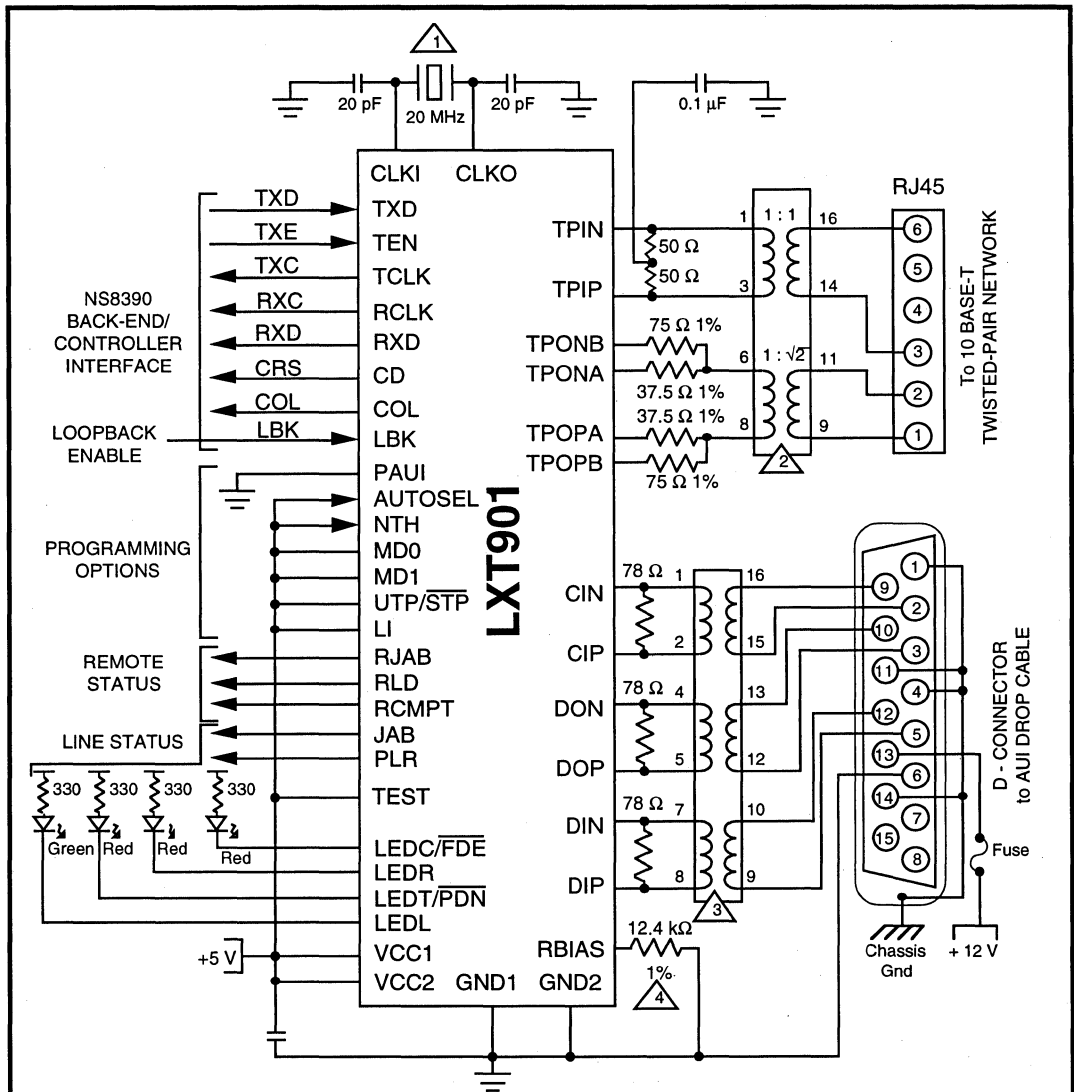
Like Figure 12, Figure 13 shows the LXT901 in Mode 2 (compatible with Intel 82596 controllers) with the same options and twisted-pair interface. However, Figure 13 adds a pair of connections to the AUI port which was not used in Figure 12. Two transformers are used to couple the AUI port to either a D-connector or a BNC connector. (A DP8392 coax transceiver with PM6044 power supply are required to drive the thin coax network through the BNC.)

Figure 8: LAN Adapter Board - Auto Port Select with External LPBK Control



-  Suitable crystals include the MTRON MP-1 and MP-2.
-  Suitable TP transformers include the Fil-Mag 23Z128, and 23Z128SM; Valor PT4069 and ST7011; Belfuse S553-0716 and A553-0716; and Halo Electronics TD42-2006Q and TG42-2006WH1.
-  Suitable AUI transformers include the Fil-Mag 23Z90 and 23Z90SM; Valor LT6030 and ST7030; and Halo Electronics TD01-0756K and TG01-0756W.
-  Bias resistor RBIAS should be located close to the pin and isolated from other signals.

LXT901 Universal Ethernet Interface Adapter

Figure 9: LXT901/380C26 Interface for Dual Network Support of 10BASE-T and Token Ring

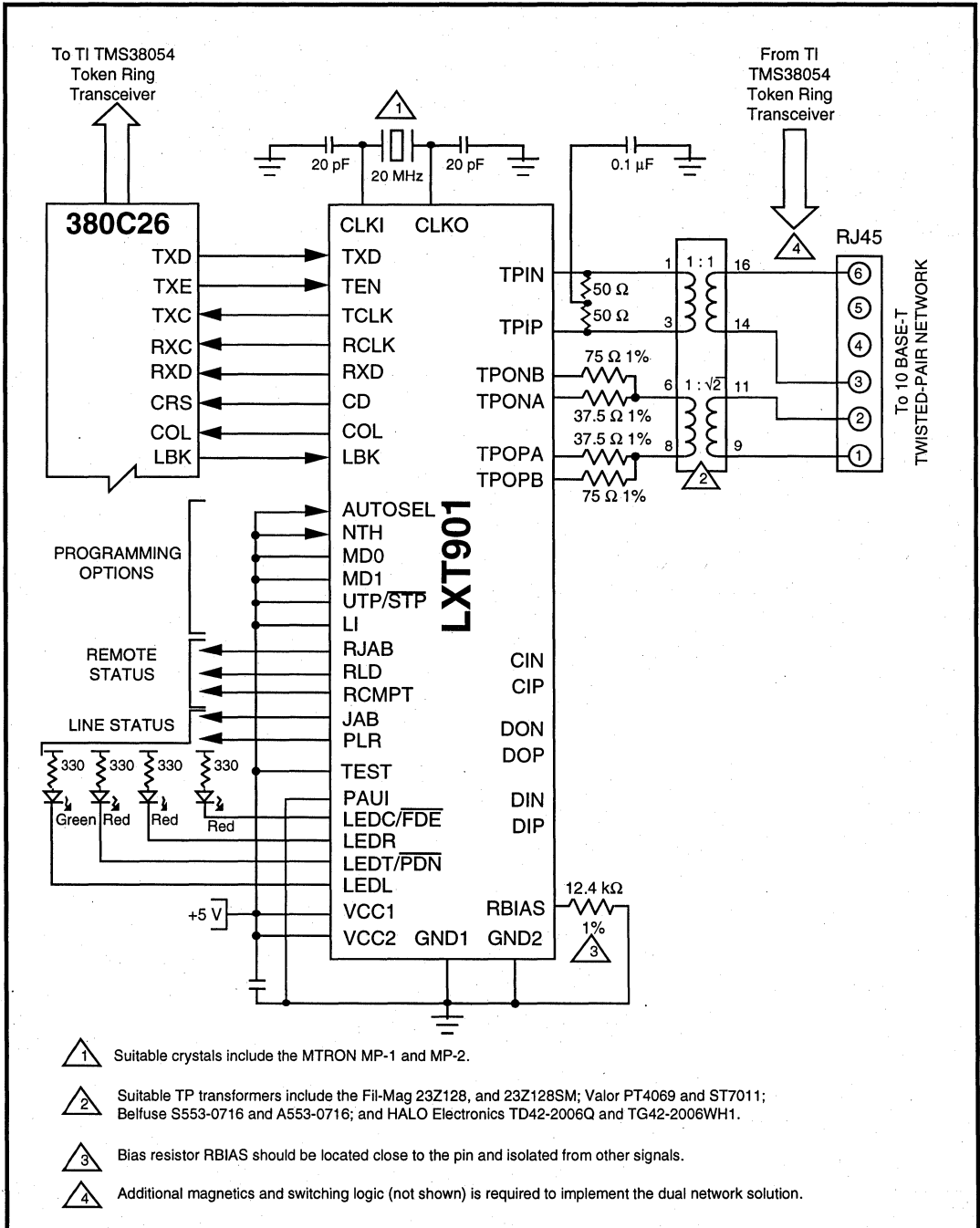
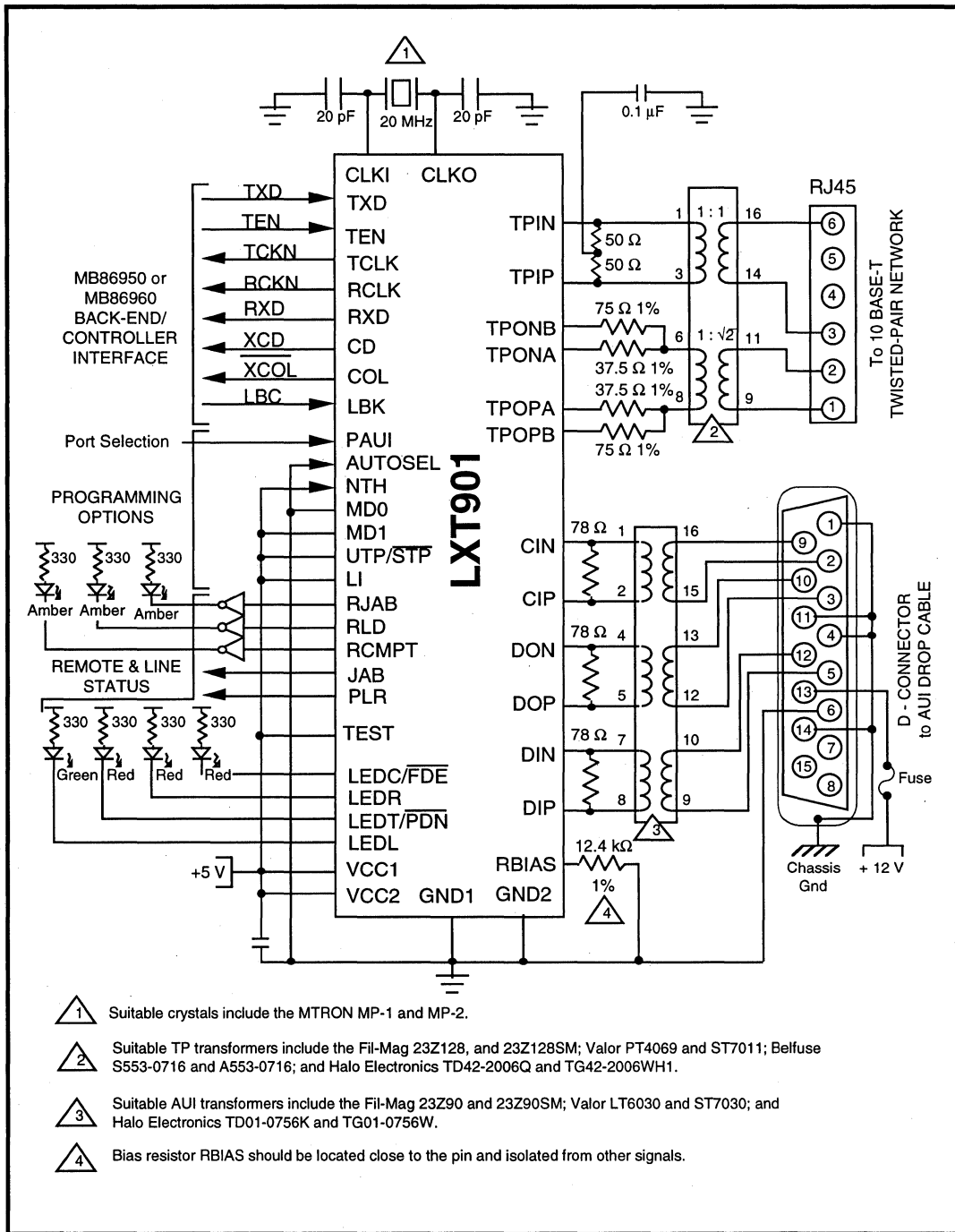

Figure 10: LAN Adapter Board - Manual Port Select with Link Test Function



LXT901 Universal Ethernet Interface Adapter

Figure 11: Manual Port Select with Seqq 8005 Controller

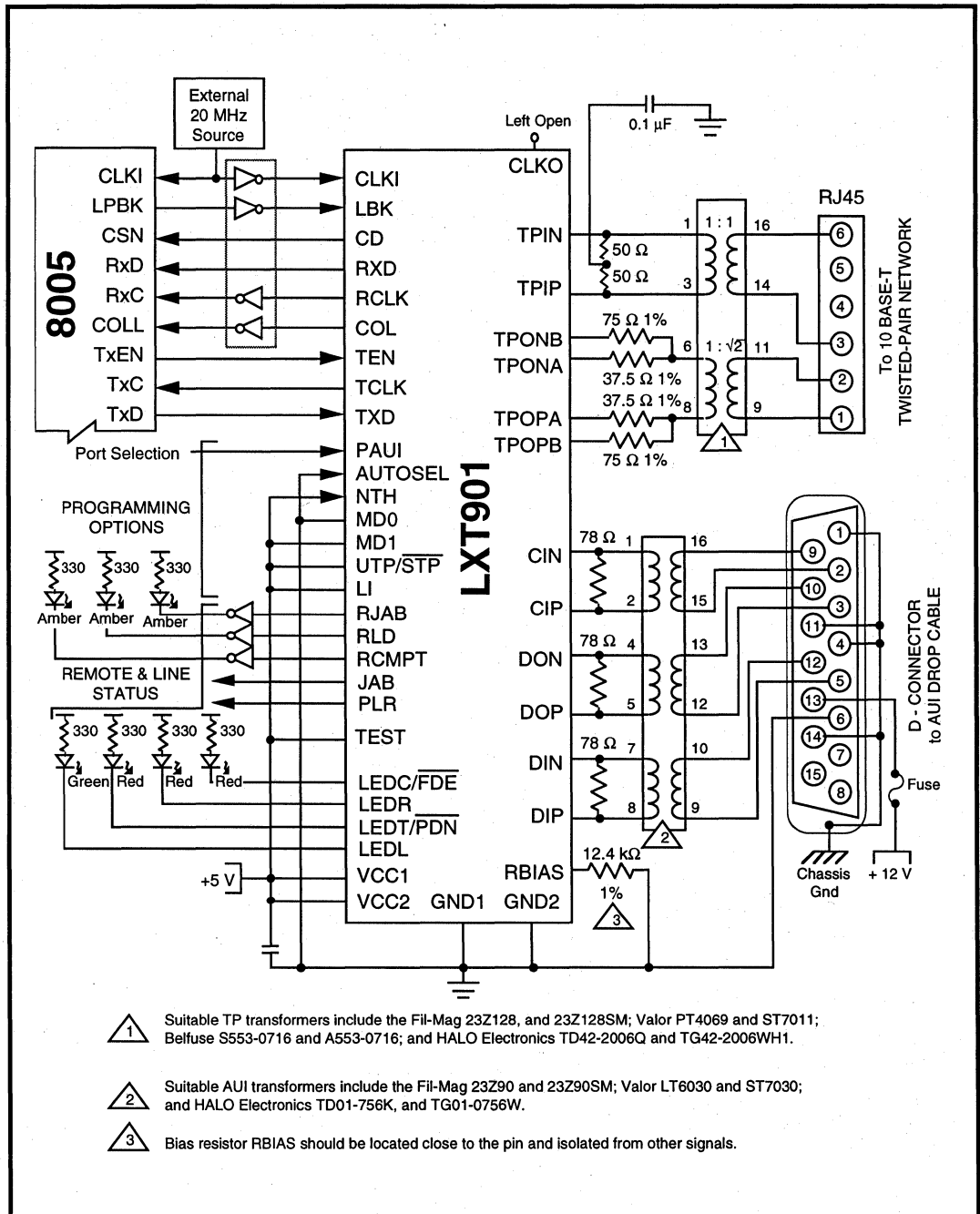

Figure 12: 150 Ω Shielded Twisted-Pair Only Application

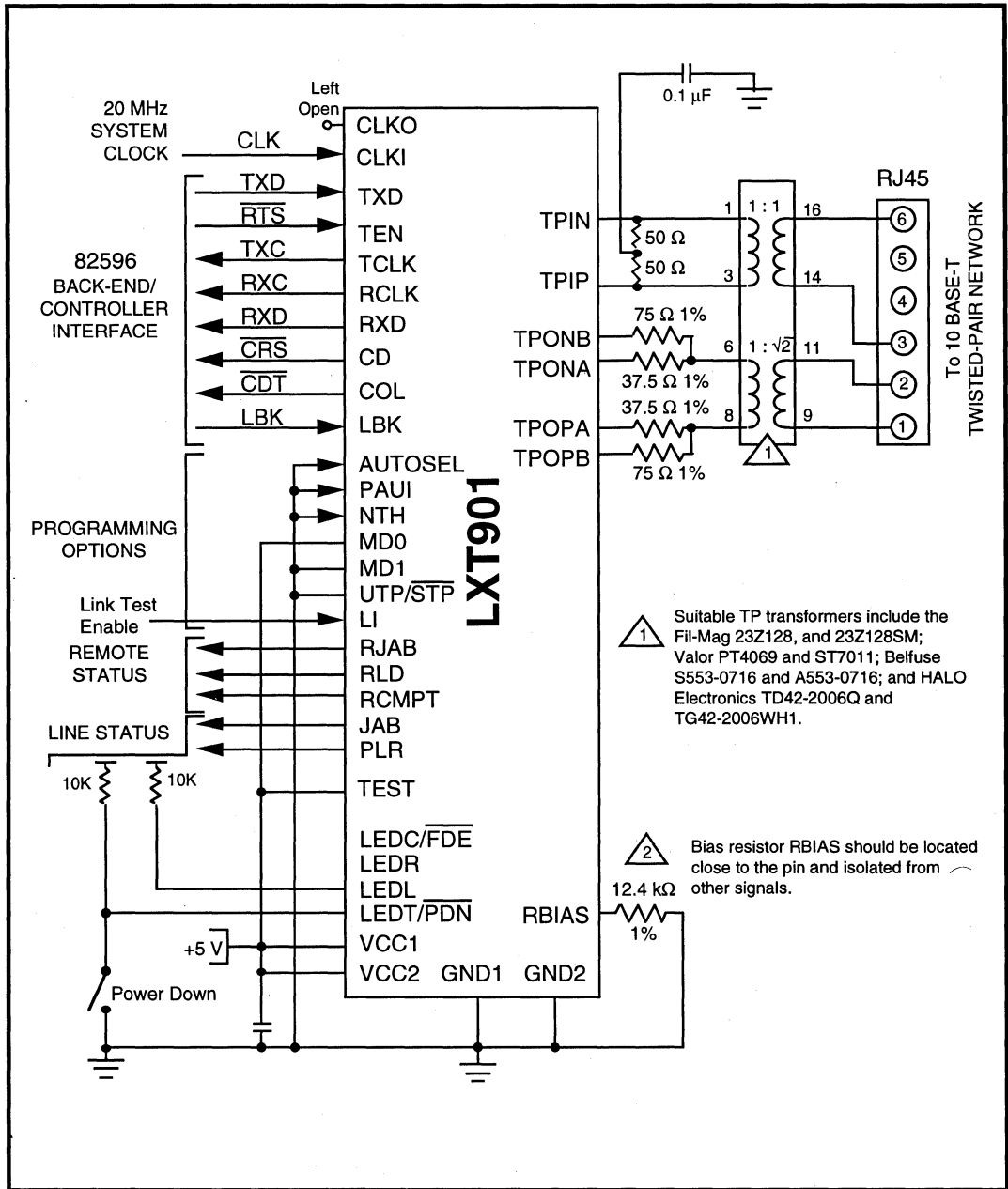
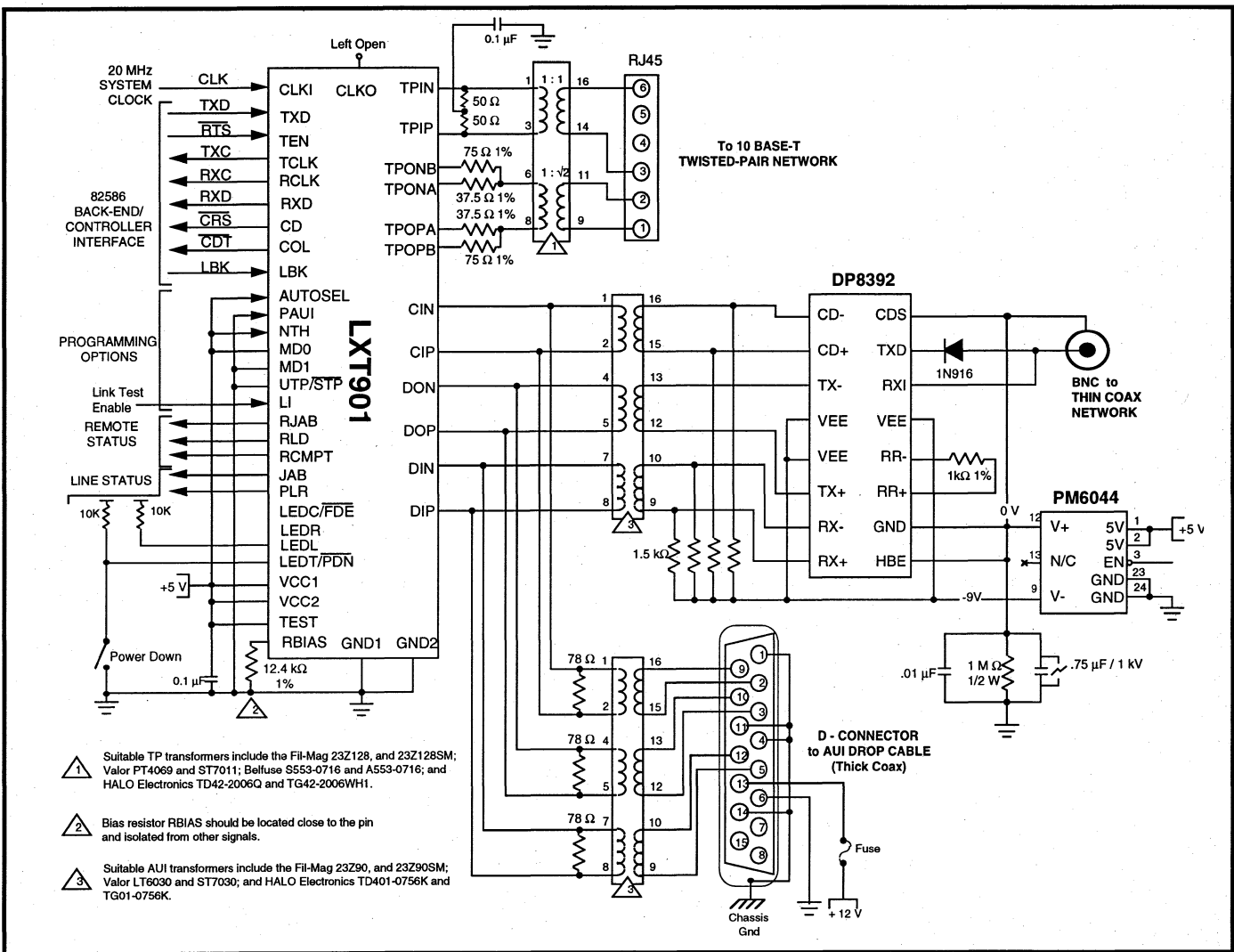

Figure 13: Three Media Application



**AUI ENCODER/DECODER ONLY
(FIGURE 14)**

In this application the DTE is connected to a coaxial network through the AUI. AUTOSEL is tied Low and PAUI is tied High, manually selecting the AUI port. The twisted-pair

port is not used. With MD1 and MD0 both Low, the LXT901 logic and framing are set to Mode 1 (compatible with AMD AM7990 controllers). The LI pin is tied Low, disabling the link test function. The LBK input controls loopback. A 20 MHz system clock is supplied at CLKI with CLKO left open.

Figure 14: AUI Encoder/Decoder Only Application

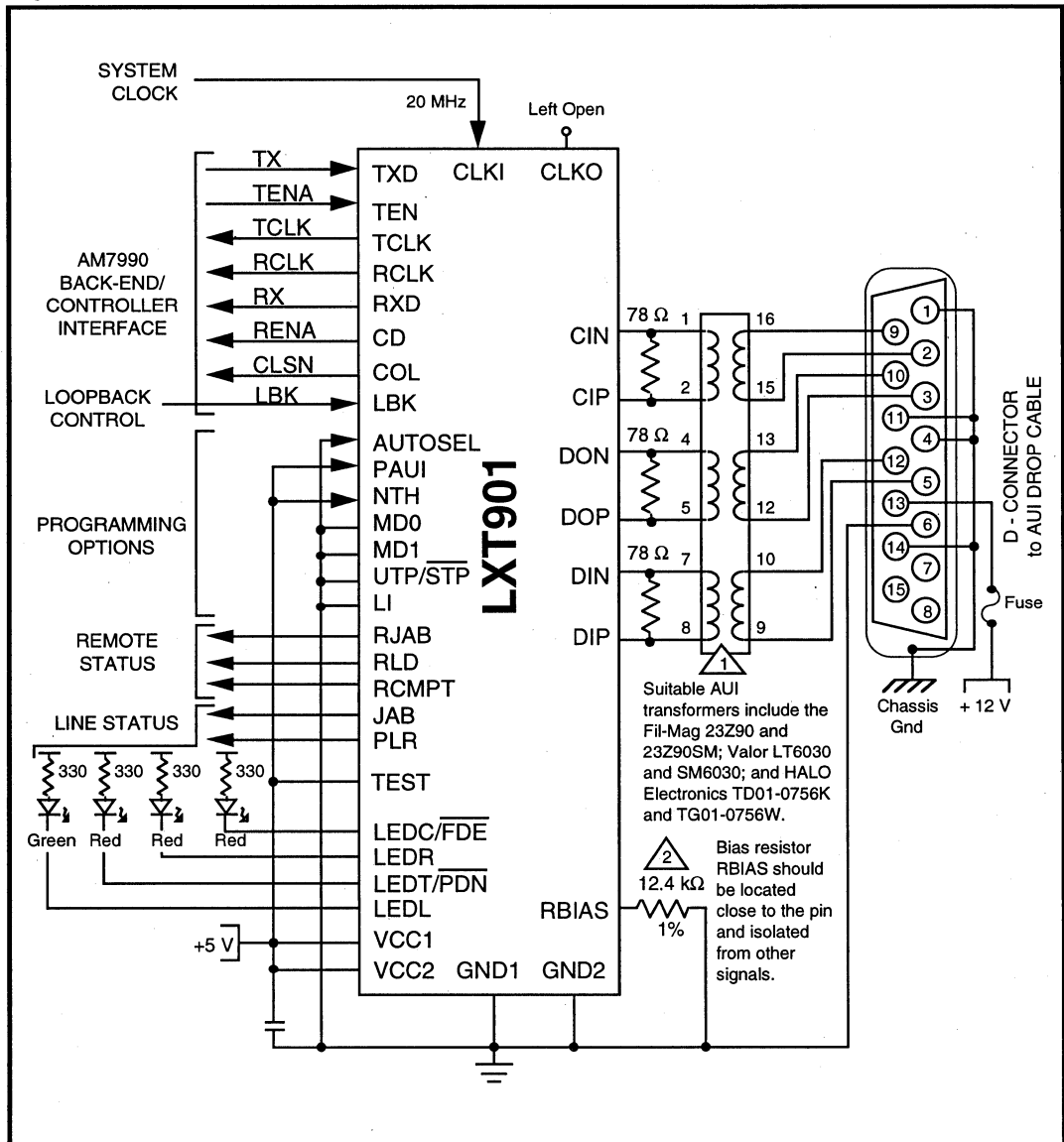

LXT901 Universal Ethernet Interface Adapter

FULL DUPLEX SUPPORT (FIGURE 15)

Figure 15 shows the LXT901 with a Texas Instruments 380C24 CommProcessor. The 380C24 is compatible with Mode 4 (MD0 and MD1 both High). When used with the

380C24 or other full duplex-capable controller, the LXT901 supports full-duplex Ethernet, effectively doubling the available bandwidth of the network. In this application the LXT901 AUI port is not used.

Figure 15: Full-Duplex Application

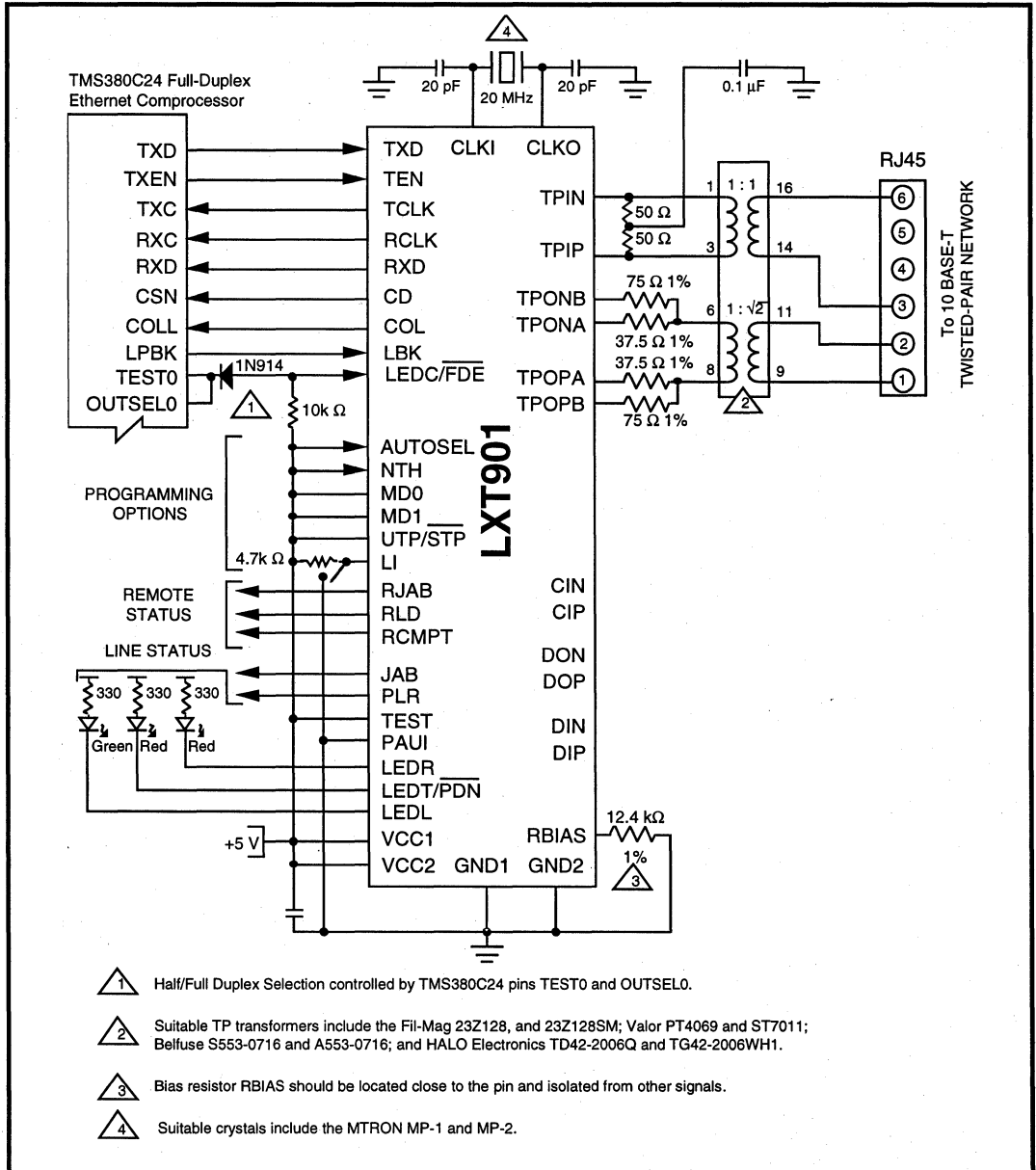

TEST SPECIFICATIONS

NOTE

Minimum and maximum values in Tables 3 through 12 and Figures 16 through 39 represent the performance specifications of the LXT901 and are guaranteed by test except, as noted, by design.

Table 3: Absolute Maximum Ratings

Parameter	Sym	Min	Max	Units
DC supply (referenced to GND)	V _{CC}	-0.3	6.0	V
Ambient operating temperature	T _A	0	75	°C
Storage temperature	T _{STG}	-65	150	°C

CAUTION

Operations at or beyond these limits may result in permanent damage to the device.
Normal operation not guaranteed at these extremes.

Table 4: Recommended Operating Conditions

Parameter	Symbol	Min	Typ	Max	Units	Test Conditions
Recommended supply voltage ¹	V _{CC}	4.75	5.0	5.25	V	
Recommended operating temperature	T _{OP}	0	-	70	°C	

1. Voltage with respect to ground unless otherwise specified.

Table 5: I/O Electrical Characteristics (Over Recommended Range)

Parameter	Symbol	Min	Typ ¹	Max	Units	Test Conditions	
Input Low voltage ²	V _{IL}	-	-	0.8	V		
Input High voltage ²	V _{IH}	2.0	-	-	V		
Output Low voltage	V _{OL}	-	-	0.4	V	I _{OL} = 1.6 mA	
Output Low voltage	V _{OL}	-	-	10	% V _{CC}	I _{OL} < 10 μA	
Output Low voltage (Open drain LED Driver)	V _{OLL}	-	-	0.7	V	I _{OLL} = 10 mA	
Output High voltage	V _{OH}	2.4	-	-	V	I _{OH} = 40 μA	
Output High voltage	V _{OH}	90	-	-	% V _{CC}	I _{OH} < 10 μA	
Output rise time	CMOS	-	3	12	ns	C _{LOAD} = 20 pF	
TCLK & RCLK	TTL	-	2	8	ns		
Output fall time	CMOS	-	3	12	ns	C _{LOAD} = 20 pF	
TCLK & RCLK	TTL	-	2	8	ns		
CLKI rise time (externally driven)	-	-	-	10	ns		
CLKI duty cycle (externally driven)	-	-	50/50	40/60	%		
Supply Current	Normal mode	I _{CC}	-	65	85	mA	Idle Mode
		I _{CC}	-	90	110	mA	Transmitting on TP
		I _{CC}	-	70	90	mA	Transmitting on AUI
	Power Down Mode	I _{CC}	-	0.75	2	mA	

1. Typical values are at 25 °C and are for design aid only; not guaranteed and not subject to production testing.

2. Limited functional tests are performed at these input levels. The majority of functional tests are performed at levels of 0V and 3V.

Table 6: AUI Electrical Characteristics (Over Recommended Range)

Parameter	Symbol	Min	Typ ¹	Max	Units	Test Conditions
Input Low current	I _{IL}	-	-	-700	μA	
Input High current	I _{IH}	-	-	500	μA	
Differential output voltage	V _{OD}	± 550	-	± 1200	mV	
Differential squelch threshold	V _{DS}	150	220	350	mV	5 MHz square wave input
1. Typical values are at 25 °C and are for design aid only; not guaranteed and not subject to production testing.						

Table 7: TP Electrical Characteristics (Over Recommended Range)

Parameter	Symbol	Min	Typ ¹	Max	Units	Test Conditions
Transmit output impedance	Z _{OUT}	-	5	-	Ω	
Transmit timing jitter addition ²	-	-	± 6.4	± 10	ns	0 line length for internal MAU
Transmit timing jitter added by the MAU and PLS sections ^{2,3}	-	-	± 3.5	± 5.5	ns	After line model specified by IEEE 802.3 for 10BASE-T internal MAU
Receive input impedance	Z _{IN}	-	20	-	kΩ	Between TPIP/TPIN, CIP/CIN & DIP/DIN
Differential squelch threshold (Normal threshold : NTH = 1)	V _{DS}	300	420	585	mV	5 MHz square wave input
Differential squelch threshold (Reduced threshold : NTH = 0)	V _{DS}	180	250	345	mV	5 MHz square wave input
1. Typical values are at 25 °C and are for design aid only; not guaranteed and not subject to production testing.						
2. Parameter is guaranteed by design; not subject to production testing.						
3. IEEE 802.3 specifies maximum jitter additions at 1.5 ns for the AUI cable, 0.5 ns from the encoder, and 3.5 ns from the MAU.						

Table 8: Switching Characteristics (Over Recommended Range)

Parameter	Symbol	Min	Typ	Max	Units
Jabber Timing:					
Maximum transmit time	-	20	-	150	ms
Unjab time	-	250	-	750	ms
Link Integrity Timing:					
Time link loss receive	-	50	-	150	ms
Link Min receive	-	2	-	7	ms
Link Max receive	-	50	-	150	ms
Link Transmit period	-	8	10	24	ms

Table 9: RCLK/Start-of-Frame Timing (Over Recommended Range)

Parameter		Symbol	Minimum	Typical ¹	Maximum	Units
Decoder acquisition time	AUI	tDATA	–	900	1100	ns
	TP	tDATA	–	1300	1500	ns
CD turn-on delay	AUI	tCD	–	50	200	ns
	TP	tCD	–	400	550	ns
Receive data setup from RCLK	Mode 1	trDS	60	70	–	ns
	Modes 2, 3 and 4	trDS	30	45	–	ns
Receive data hold from RCLK	Mode 1	trDH	10	20	–	ns
	Modes 2, 3 and 4	trDH	30	45	–	ns

Table 10: RCLK/End-of-Frame Timing (Over Recommended Range)

Parameter	Type	Symbol	Mode 1	Mode 2	Mode 3	Mode 4	Units
RCLK after CD off	Minimum	trC	5	1	27	5	bt
Rcv data throughput delay	Maximum	trD	400	375	375	375	ns
CD turn off delay ²	Maximum	tCDOFF	500	475	475	475	ns
Receive block out after TEN off	Typical ¹	tTFG	5	50	–	–	bt

2. CD Turnoff delay measured from middle of last bit, so timing specification is unaffected by the value of the last bit.

Table 11: Transmit Timing (Over Recommended Range)

Parameter	Symbol	Minimum	Typical ¹	Maximum	Units
TEN setup from TCLK	tEHCH	22	–	–	ns
TXD setup from TCLK	tDSCH	22	–	–	ns
TEN hold after TCLK	tCHEL	5	–	–	ns
TXD hold after TCLK	tCHDU	5	–	–	ns
Transmit start-up delay - AUI	tSTUD	–	200	450	ns
Transmit start-up delay - TP	tSTUD	–	350	450	ns
Transmit through-put delay - AUI	tTPD	–	–	300	ns
Transmit through-put delay - TP	tTPD	–	338	350	ns

11

Table 12: Collision, COL/CI Output and Loopback Timing (Over Recommended Range)

Parameter	Symbol	Minimum	Typical ¹	Maximum	Units
COL turn on delay	tCOLD	–	–	500	ns
COL turn off delay	tCOLOFF	–	–	500	ns
COL (SQE) Delay after TEN off	tSQED	0.65	–	1.6	μs
COL (SQE) Pulse Duration	tSQEP	500	–	1500	ns
LBK setup from TEN	tKHEH	10	25	–	ns
LBK hold after TEN	tKHEL	10	0	–	ns

1. Typical values are at 25 °C and are for design aid only; not guaranteed and not subject to production testing.

Figures 16 through 21 - Timing Diagrams for Mode 1 (MD1 = 0, MD0 = 0)

Figure 16: Mode 1 RCLK/Start-of-Frame Timing

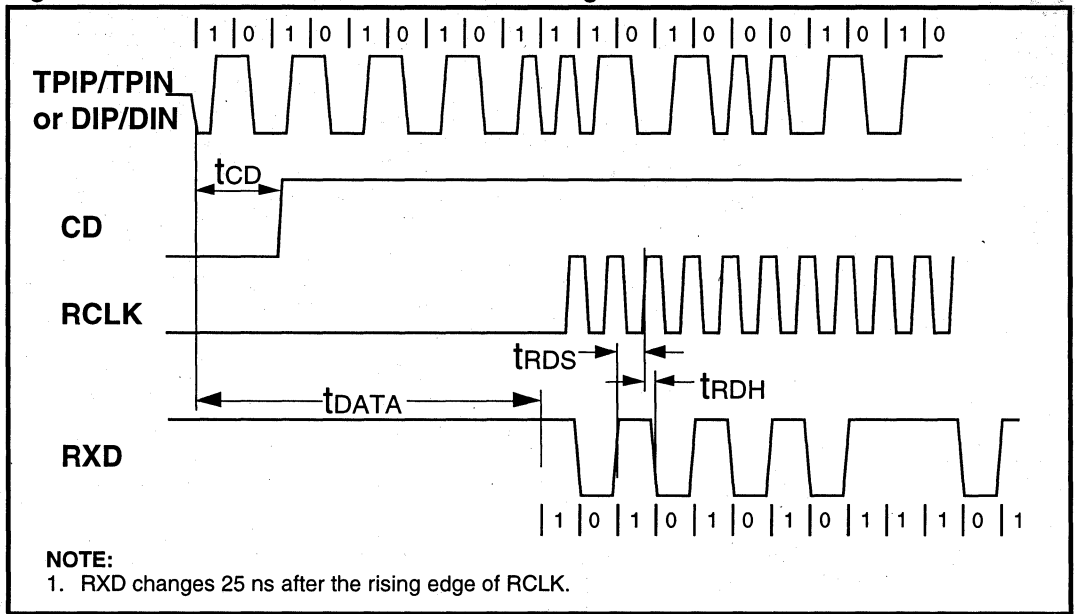

Figure 17: Mode 1 RCLK/End-of-Frame Timing

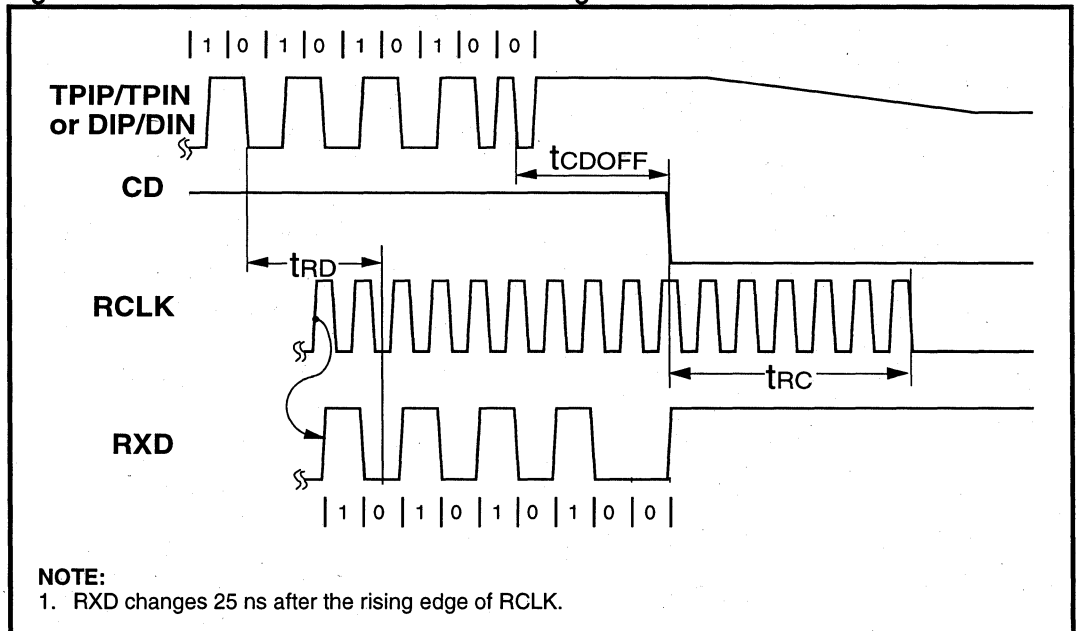

Figure 18: Mode 1 Transmit Timing

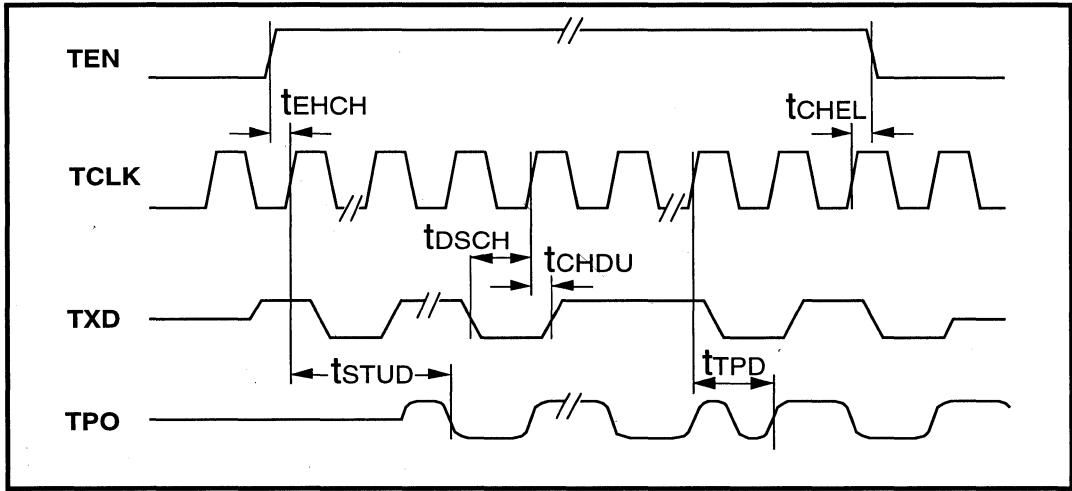

Figure 19: Mode 1 Collision Detect Timing

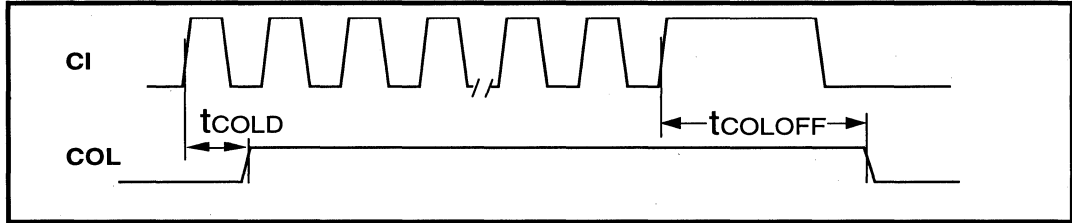

Figure 20: Mode 1 COL/CI Output Timing

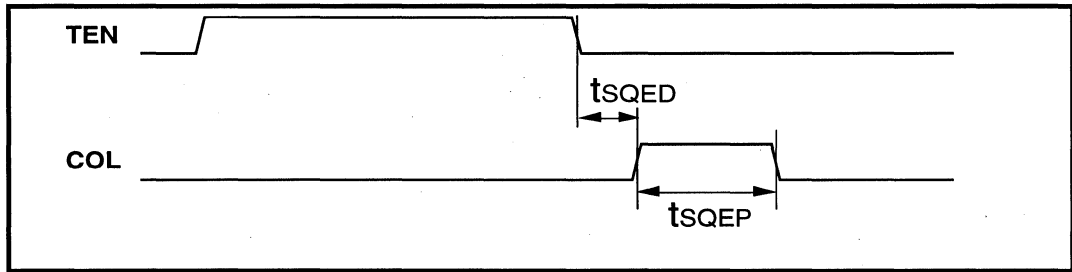
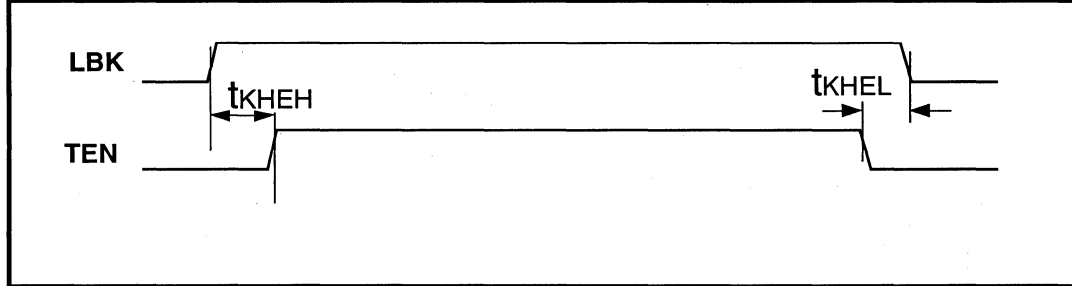

Figure 21: Mode 1 Loopback Timing



Figures 22 through 27 - Timing Diagrams for Mode 2 (MD1 = 0, MD0 = 1)

Figure 22: Mode 2 RCLK/Start-of-Frame Timing

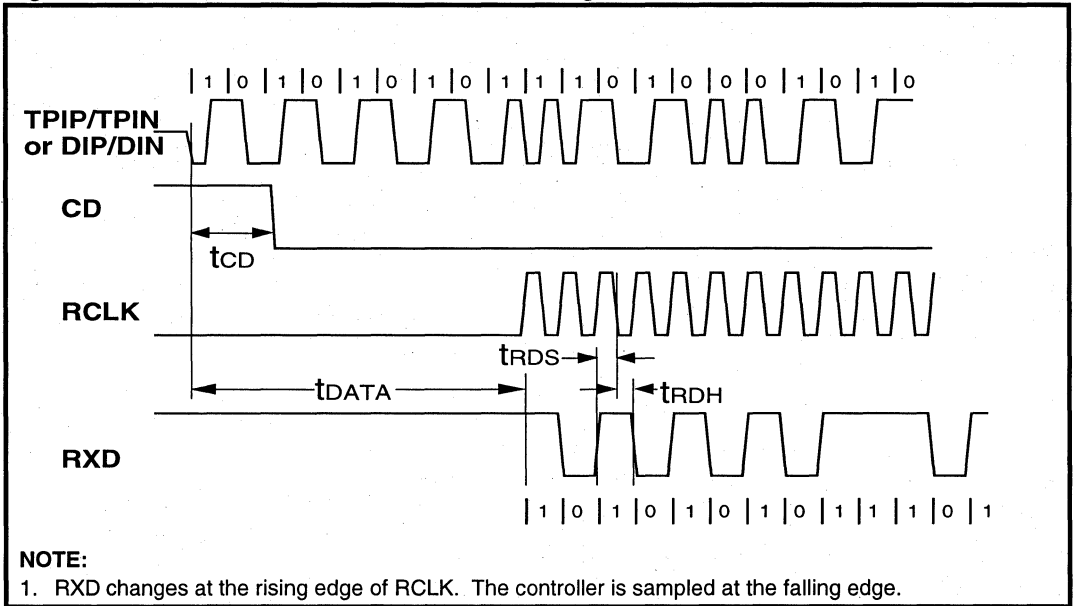

Figure 23: Mode 2 RCLK/End-of-Frame Timing

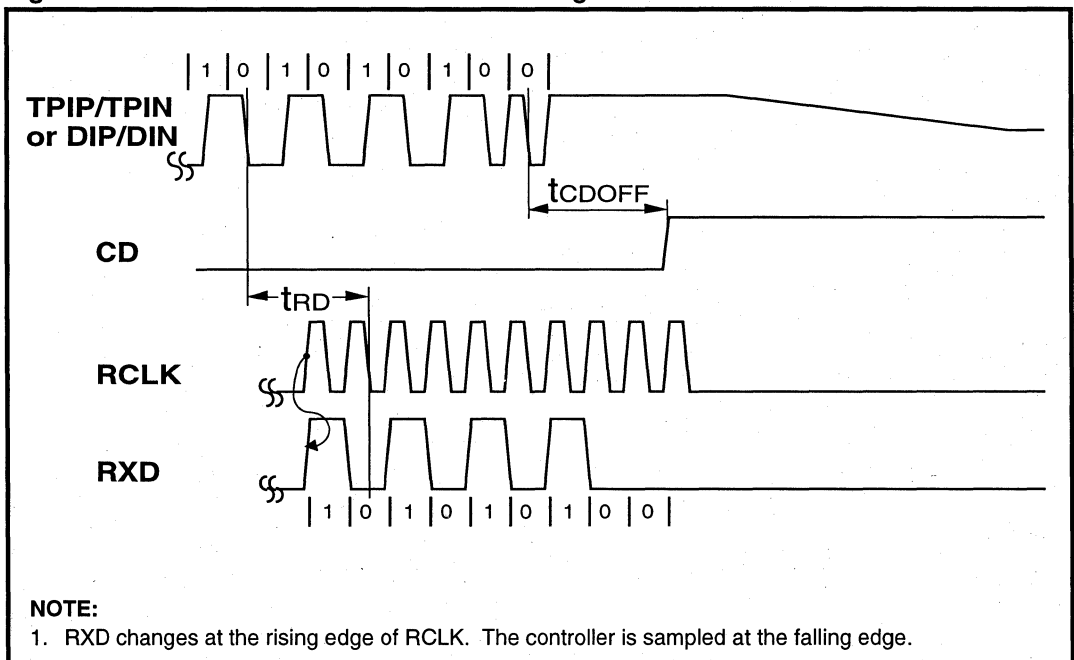

Figure 24: Mode 2 Transmit Timing

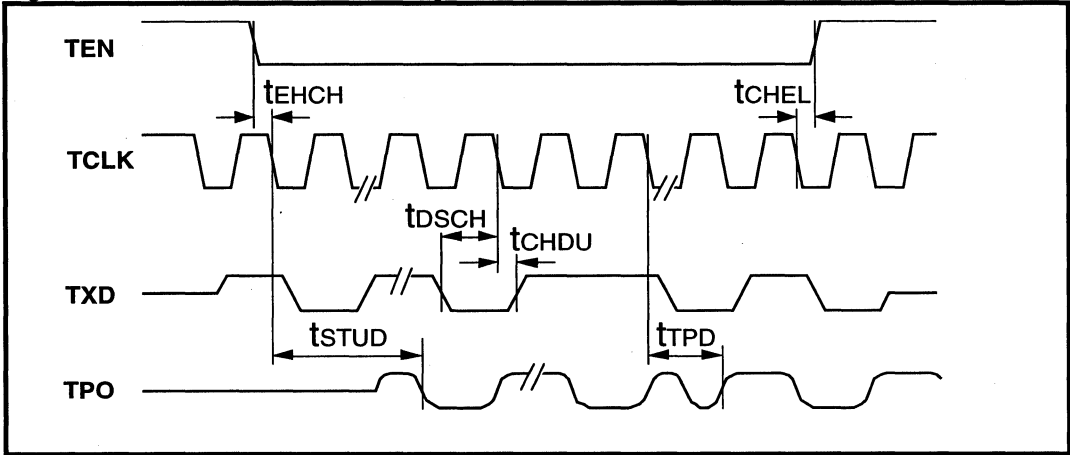

Figure 25: Mode 2 Collision Detect Timing

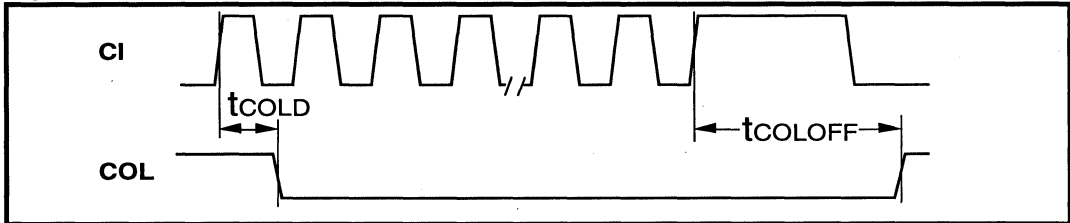

Figure 26: Mode 2 COL/CI Output Timing

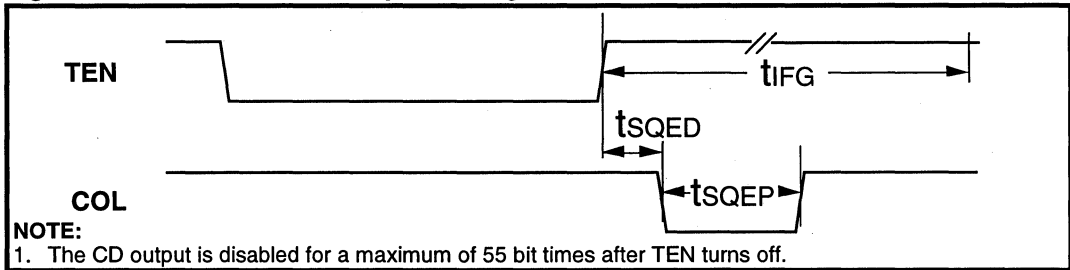
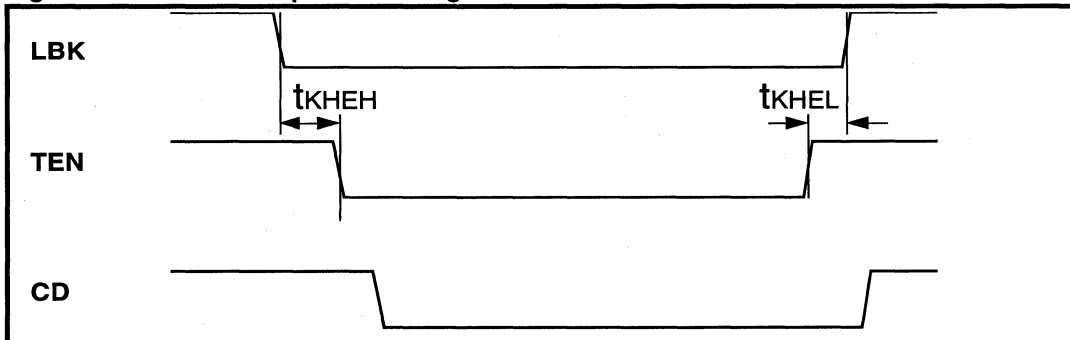

Figure 27: Mode 2 Loopback Timing



Figures 28 through 33 - Timing Diagrams for Mode 3 (MD1 = 1, MD0 = 0)

Figure 28: Mode 3 RCLK/Start-of-Frame Timing

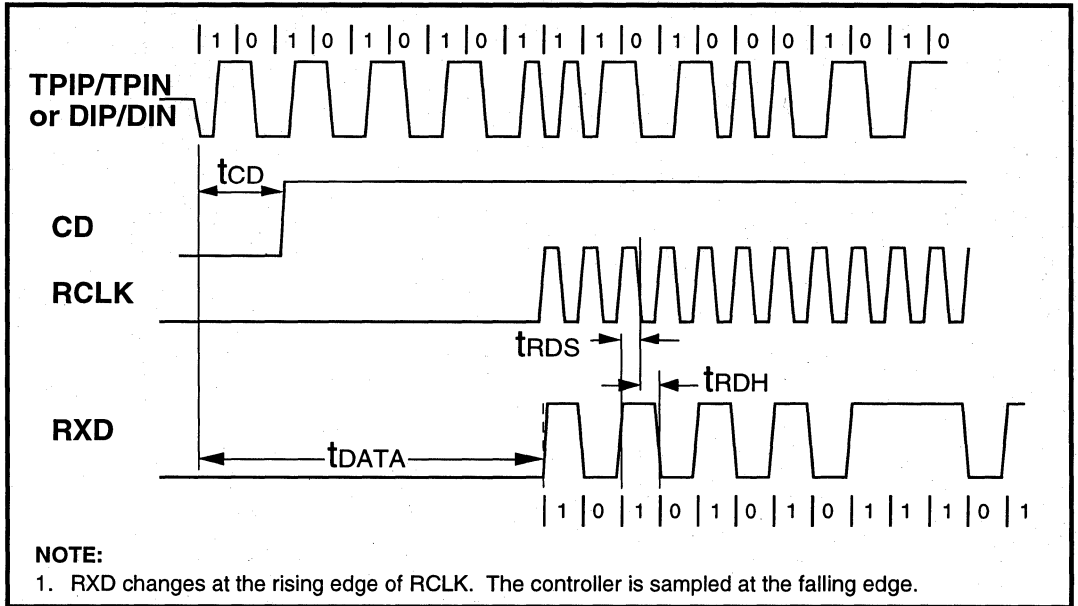

Figure 29: Mode 3 RCLK/End-of-Frame Timing

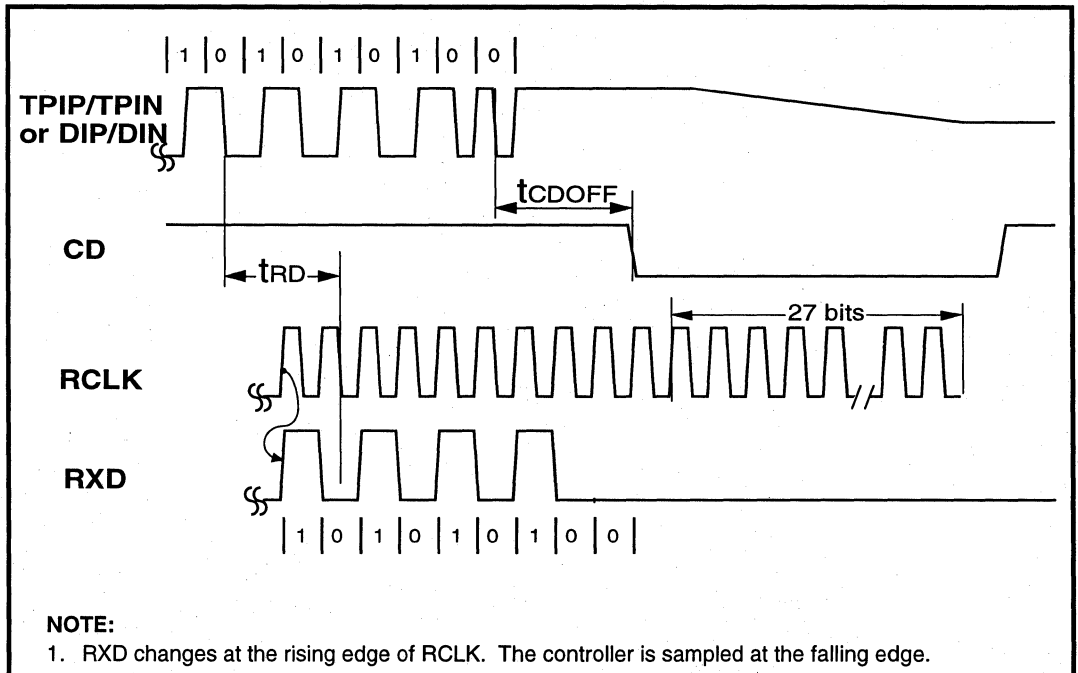

Figure 30: Mode 3 Transmit Timing

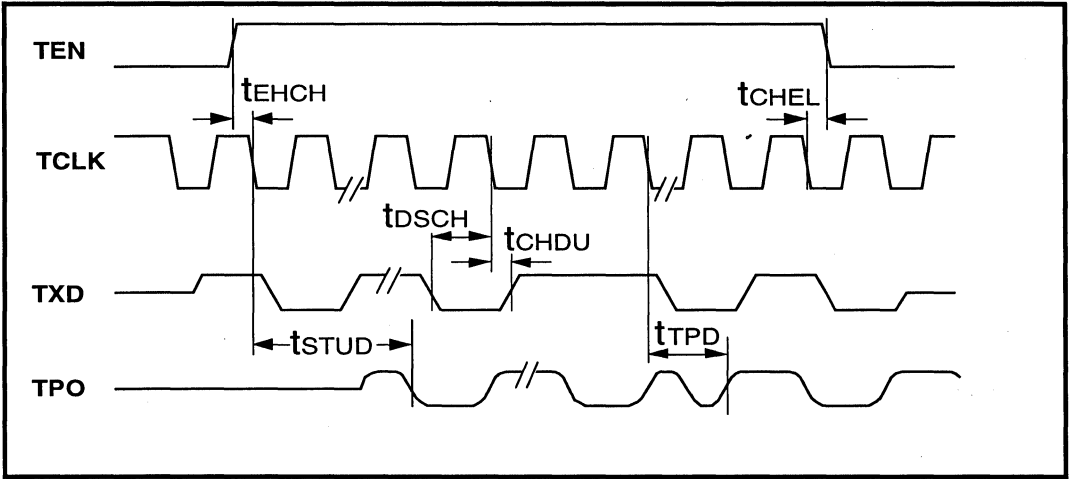

Figure 31: Mode 3 Collision Detect Timing

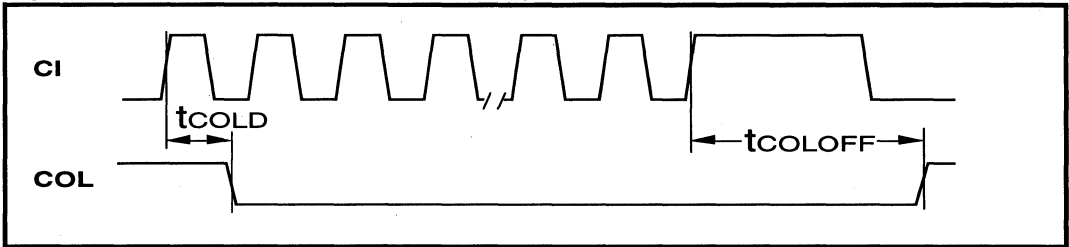

Figure 32: Mode 3 COL/CI Output Timing

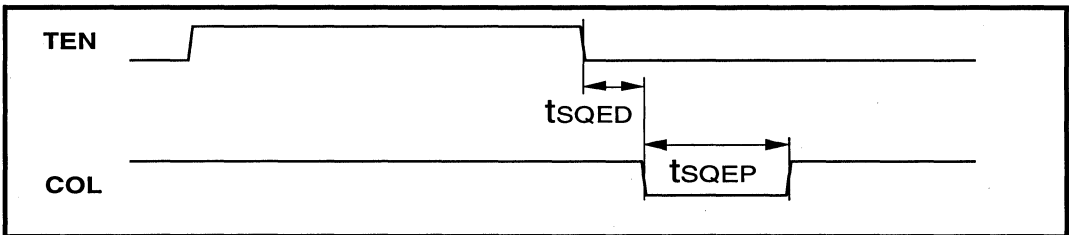
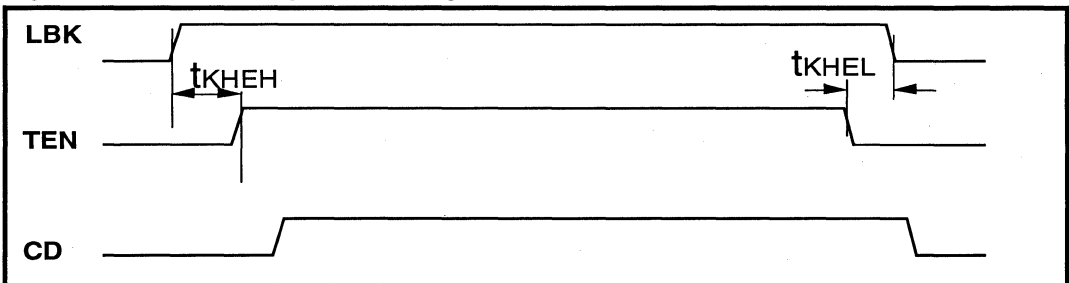

Figure 33: Mode 3 Loopback Timing



Figures 34 through 39 - Timing Diagrams for Mode 4 (MD1 = 1, MD0 = 1)

Figure 34: Mode 4 RCLK/Start-of-Frame Timing

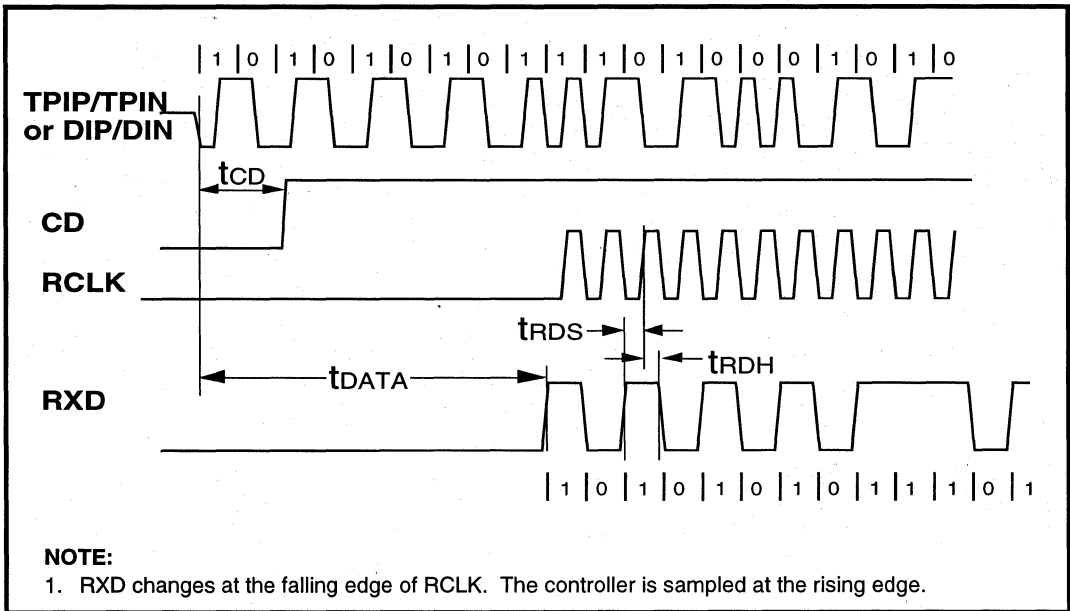

Figure 35: Mode 4 RCLK/End-of-Frame Timing

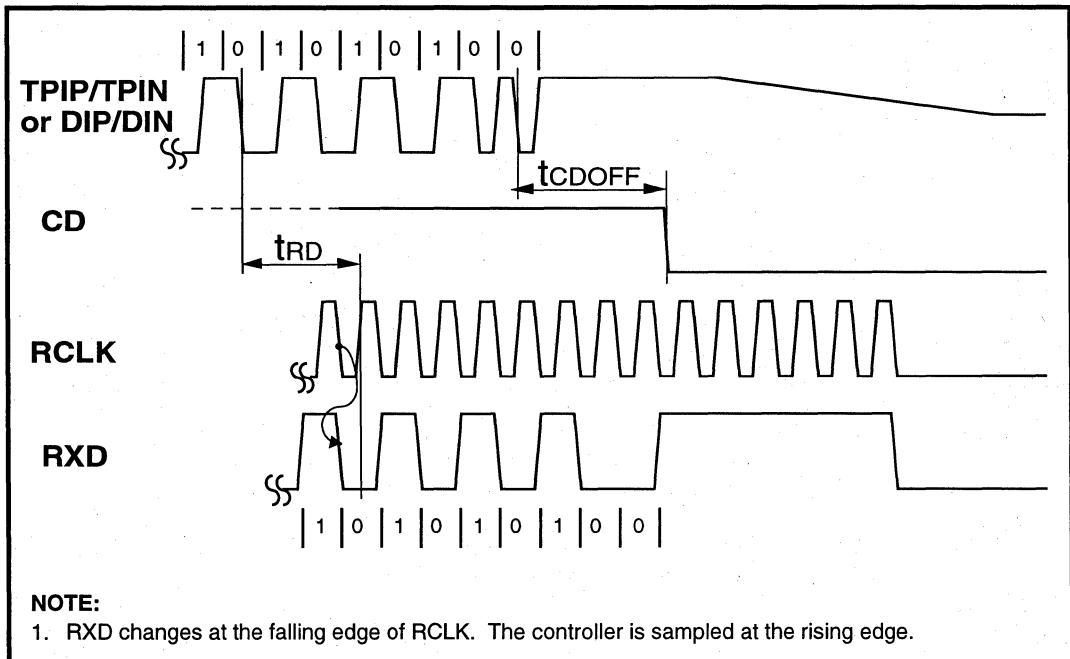

Figure 36: Mode 4 Transmit Timing

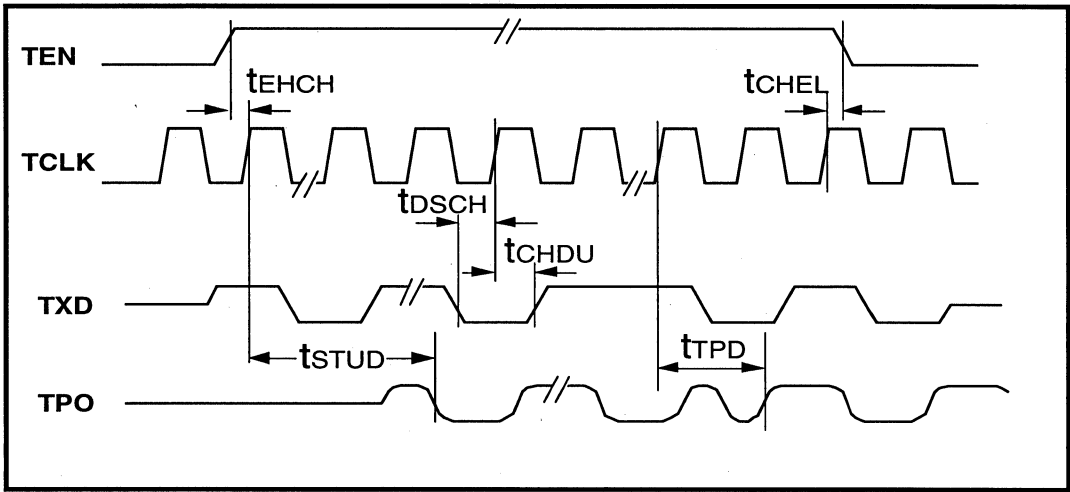

Figure 37: Mode 4 Collision Detect Timing

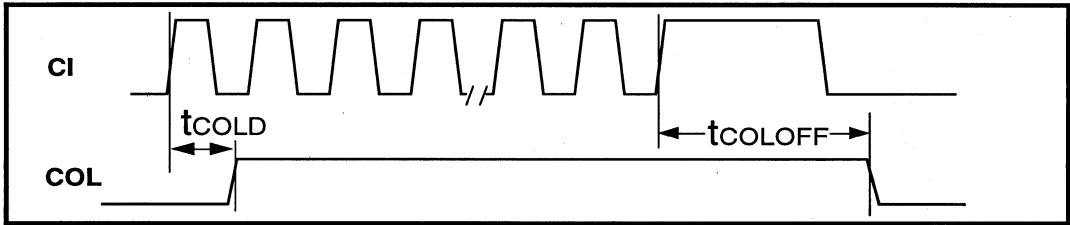

Figure 38: Mode 4 COL/CI Output Timing

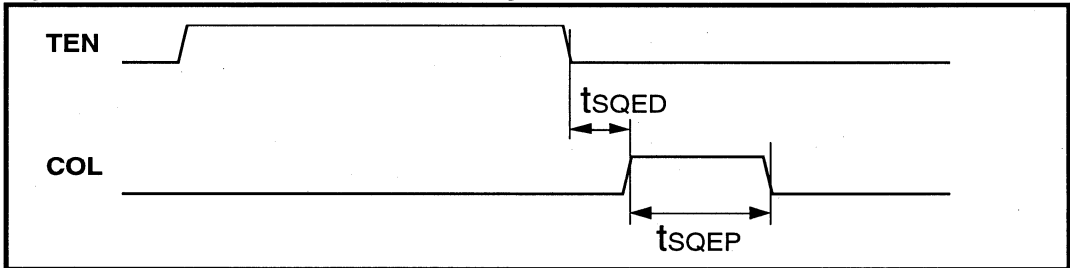
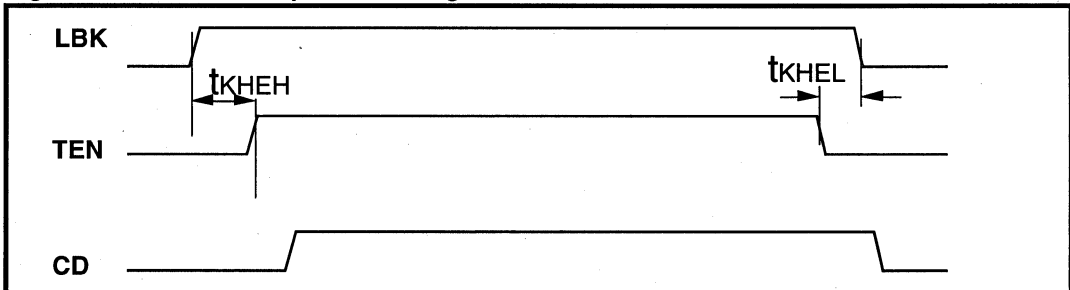

Figure 39: Mode 4 Loopback Timing



LXT901 Universal Ethernet Interface Adapter

NOTES:

LXT902

Ethernet Twisted-Pair Media Attachment Unit

General Description

The LXT902 twisted-pair Media Attachment Unit (TP-MAU) is designed to allow Ethernet connections to use the existing twisted-pair wiring plant through an Ethernet Attachment Unit Interface (AUI). The LXT902 provides the electrical interface between the AUI and the twisted-pair wire.

LXT902 functions include level-shifted data pass-through from one transmission media to another, collision detection, Signal Quality Error (SQE) testing and automatic correction of polarity reversal on the twisted pair input. It also includes LED drivers for transmit, receive, jabber, collision, reversed polarity detect and link functions.

The LXT902 is an advanced CMOS device and requires only a single 5-volt power supply.

Applications

- Computer/workstation interface boards
- LAN repeater
- External 10BASE-T transceiver (MAU)

Features

- Meets or exceeds IEEE 802.3 standards for AUI and 10BASE-T interface
- Direct interface to AUI and RJ45 connectors
- Automatic AUI/RJ45 selection
- Internal predistortion generation
- Internal common mode voltage generation
- Jabber function
- Selectable link test, SQE test disable
- Twisted-pair receive polarity reverse detection and selectable polarity correction
- LED driver for transmit, receive, jabber, collision, link and reversed polarity indicators or for flashing status indicator
- Single 5 V supply, CMOS technology
- Available in 28-pin DIP or PLCC

LXT902 Block Diagram

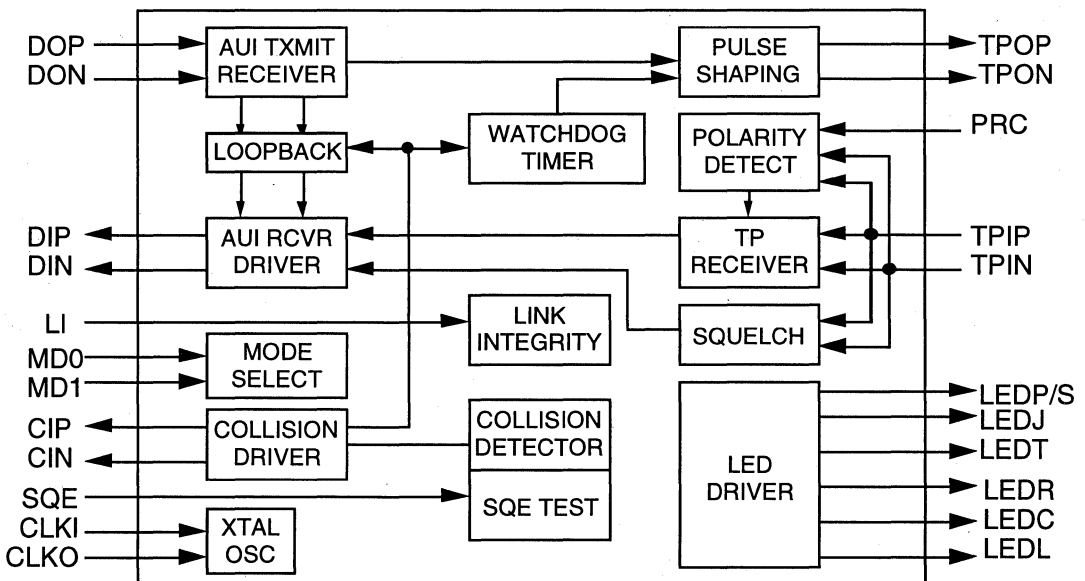

Figure 1: Pin Assignments

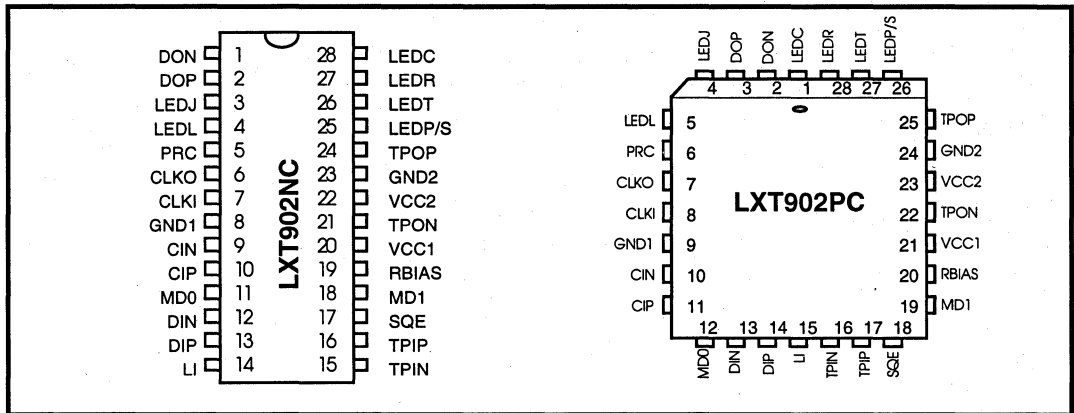

Table 1: Pin Descriptions

Pin #		Sym	I/O	Name	Description
DIP	PLCC				
1	2	DON	I	Data Out Negative	Differential input pair connected to the AUI transceiver DO circuit.
2	3	DOP	I	Data Out Positive	
3	4	LEDJ	I/O	Jabber LED Driver	Open drain driver for the Jabber indicator LED. Output goes active ¹ when watchdog timer begins jab, and stays active until end of the unjab wait period (491 - 525 ms) . When tied to ground, causes LEDP/S to act as a multi-function blinking status indicator.
4	5	LEDL	O	Link LED Driver	Open drain driver for the Link indicator LED. Output is active except during Link Fail or when Link Integrity Test is disabled.
5	6	PRC	I/O	Polarity Reverse Correction	The LXT902 automatically corrects reversed polarity at TPI when PRC is tied high. In Test mode, this pin is a 10 MHz output.
6	7	CLKO	-	Crystal Oscillator	The LXT902 requires either a 20 MHz crystal (or ceramic resonator) connected across these pins, or a 20 MHz clock applied at CLKI.
7	8	CLKI	-		
8	9	GND1	-	Ground 1	Ground.
9	10	CIN	O	Collision Negative	Differential driver output pair tied to the collision presence pair of the Ethernet transceiver AUI cable. The collision presence signal is a 10 MHz square wave. This output is activated when a collision is detected on the network, during self-test by the SQE sequence, or after the watchdog timer has expired to indicate the transmit wire pair has been disabled.
10	11	CIP	O	Collision Positive	
11	12	MD0	I	Mode Select 0	Selects operating modes in conjunction with MD1. See Table 2 for mode select options.
12	13	DIN	O	Data In Negative	Differential driver pair connected to the AUI transceiver DI circuit.
13	14	DIP	O	Data In Positive	

1. LED drivers pull Low when active.

Table 1: Pin Descriptions - continued

Pin # DIP PLCC		Sym	I/O	Name	Description
14	15	LI	I	Link Integrity Test Enable	Link integrity testing is enabled when this pin is tied high. With link test enabled, the LXT902 sends the link integrity signal in the absence of transmit traffic. It also recognizes received link test pulses, indicating the receive wire pair is present in the absence of transmit traffic.
15 16	16 17	TPIN TPIP	I I	Twisted Pair Receive Inputs	Differential receive inputs from the twisted pair input filter.
17	18	SQE	I/O	Signal Quality Error Test Enable	SQE is enabled when this pin is tied High. When enabled, the LXT902 sends the signal quality error test sequence to the CI of the AUI cable after every successful transmission to the media. In Test mode, SQE becomes a 20 MHz output.
18	19	MD1	I	Mode Select 1	Selects operating modes in conjunction with MD0. (See Table 2.) MD1 clock input between 2.0 and 2.5 MHz enables Test mode.
19	20	RBIAS	-	Resistor Bias Control	Bias control pin for the operating circuit. Bias set from external resistor to ground. External resistor value = 12.4 k Ω (\pm 1%).
20	21	VCC1	I	Power Supply 1	+5 V power supply.
21 24	22 25	TPON TPOP	O O	Twisted Pair Transmit Outputs	Transmit drivers to the twisted-pair output filter. The output is Manchester encoded and pre-distorted to meet the 10BASE-T template.
22	23	VCC2	I	Power Supply 2	+5 V power supply.
23	24	GND2	-	Ground 2	Ground.
25	26	LEDP/S	O	Polarity/Status LED Driver	Open drain LED driver. In normal mode, LEDP/S is active when reversed polarity is detected. If LEDJ is tied to ground, the output LEDP/S indicates multiple status conditions as shown in Figure 11. On solid = Normal, 1 Blink = Link Down, 2 Blinks = Jabber, 5 Blinks = Polarity Reversed.
26	27	LEDT	O	Transmit LED Driver	Open drain driver for the Transmit indicator LED. Output is active during transmit.
27	28	LEDR	O	Receive LED Driver	Open drain driver for the Receive indicator LED. Output is active during receive.
28	1	LEDC	O	Collision LED Driver	Open drain driver for the Collision indicator LED. Output is active when a collision occurs.
1. LED Drivers pull Low when active.					

FUNCTIONAL DESCRIPTION

NOTE

This information is for design aid only.

The LXT902 Media Attachment Unit (MAU) interfaces the Attachment Unit Interface (AUI) to the unshielded twisted pair cables, transferring data in both directions between the two. The AUI side of the interface comprises three circuits: Data Output (DO), Data Input (DI) and Control Interface (CI). The twisted pair network side of the interface comprises two circuits: Twisted Pair Input (TPI) and Twisted Pair Output (TPO). In addition to the five basic circuits, the LXT902 contains an internal crystal oscillator, separate power and ground pins for analog and digital circuits, various logic controls and six LED drivers for status indications.

Table 2: Mode Select Options

MD1	MD0	Mode
0	0	10BASE-T compliant MAU
0	1	Reduced squelch level
1	0	Half current AUI driver
1	1	DO, DI & CI ports disabled
1	Clock	Test Mode, Jabber on
0	Clock	Test mode, Jabber Disabled

Figure 2: LXT902 TPO Output Waveform

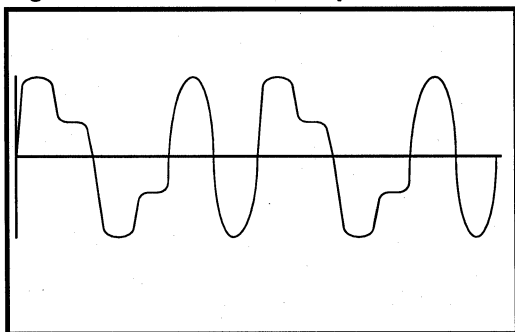

Functions are defined from the AUI side of the interface. The LXT902 Transmit function refers to data transmitted by the Data Terminal Equipment (DTE) through the AUI and MAU to the twisted pair network. The LXT902 Receive function refers to data received by the DTE through the MAU and AUI from the twisted pair network. In addition to basic transmit and receive functions, the LXT902 performs all required functions defined by the IEEE 802.3 10BASE-T MAU specification such as collision detection, link integrity testing, Signal Quality Error (SQE), jabber control and loopback.

TRANSMIT FUNCTION

The LXT902 transfers Manchester encoded data from the AUI port of the DTE (the DO circuit) to the twisted pair network (the TPO circuit). The output signal on TPO and TPOP is pre-distorted to meet the 10BASE-T jitter template, and filtered to meet FCC requirements. The output waveform (after the transmit filter) is shown in Figure 2. If the differential inputs at the DO circuit fall below 75% of the threshold level for 8 bit times (typical), the LXT902 transmit function will enter the idle state. During idle periods, the LXT902 transmits link integrity test pulses on the TPO circuit.

RECEIVE FUNCTION

The LXT902 receive function transfers serial data from the twisted pair network (the TPI circuit) to the DTE (over the DI circuit of the AUI). An internal squelch function discriminates noise from link test pulses and valid data streams. Only valid data streams activate the receive function. If the differential inputs at the TPI circuit fall below 75% of the threshold level (unsquelched) for 8 bit times (typical), the LXT902 receive function will enter the idle state. The TPI threshold can be reduced by approximately 3 dB to allow for longer loops in low-noise environments. The reduced threshold is selected when MD1 = 0 (Low) and MD0 = 1 (High).

POLARITY REVERSE FUNCTION

The LXT902 polarity reverse function uses both link pulses and end-of-frame data to determine polarity of the received signal. A reversed polarity condition is detected when eight opposite receive link pulses are detected without receipt of a link pulse with the expected polarity. Reversed polarity is also detected if four frames are received with a reversed start-of-idle. Whenever polarity is reversed, these two counters are reset to zero. If the LXT902 enters the link fail state and no data or link pulses are received within 96 to 128 ms, the polarity is reset to the default non-flipped condition. (If Link Integrity is disabled, polarity detection is based only on received data pulses.)

COLLISION DETECTION FUNCTION

The collision detection function operates on the twisted pair side of the interface. A collision is defined as the simultaneous presence of valid signals on both the TPI circuit and the TPO circuit. The LXT902 reports collisions to the AUI by sending a 10 MHz signal over the CI circuit. The collision report signal is output no more than 9 bit times (BT) after the chip detects a collision. If the TPI circuit becomes active while there is activity on the TPO circuit, the TPI data is passed to the DTE over the DI circuit, disabling the loopback. Figure 3 is a state diagram of the LXT902 collision detection function (refer to IEEE 802.3 10BASE-T specification).

LOOPBACK FUNCTION

The LXT902 loopback function operates in conjunction with the transmit function. Data transmitted by the DTE is internally looped back within the LXT902 from the DO pins to the DI pins and returned to the DTE. The loopback function is disabled when a data collision occurs, clearing the DI circuit for the TPI data. Loopback is also disabled during link fail and jabber states.

Figure 3: Collision Detection Function

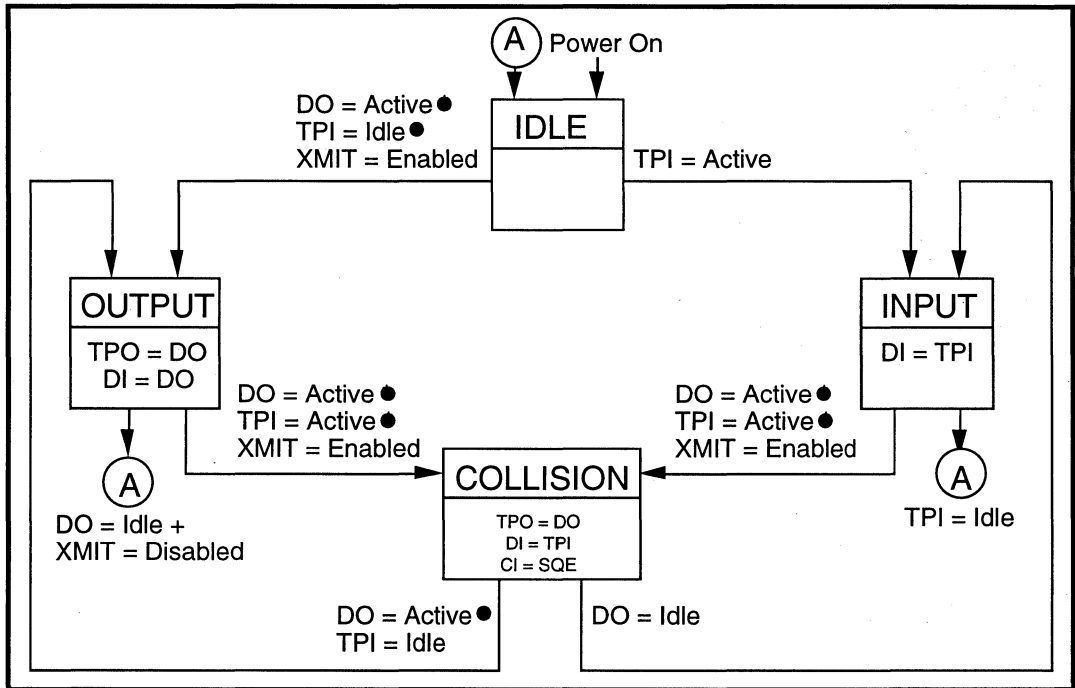

SQE TEST FUNCTION

Figure 4 is a state diagram of the SQE Test function. The SQE test function is enabled when the SQE pin is tied High. When enabled, the SQE test sequence is transmitted to the controller after every successful transmission on the 10BASE-T network. When a successful transmission is completed, the LXT902 transmits the SQE signal to the AUI over the CI circuit for 10 BT ± 5 BT. The SQE function can be disabled for hub applications by tying the SQE pin to ground.

Figure 4: SQE Test Function

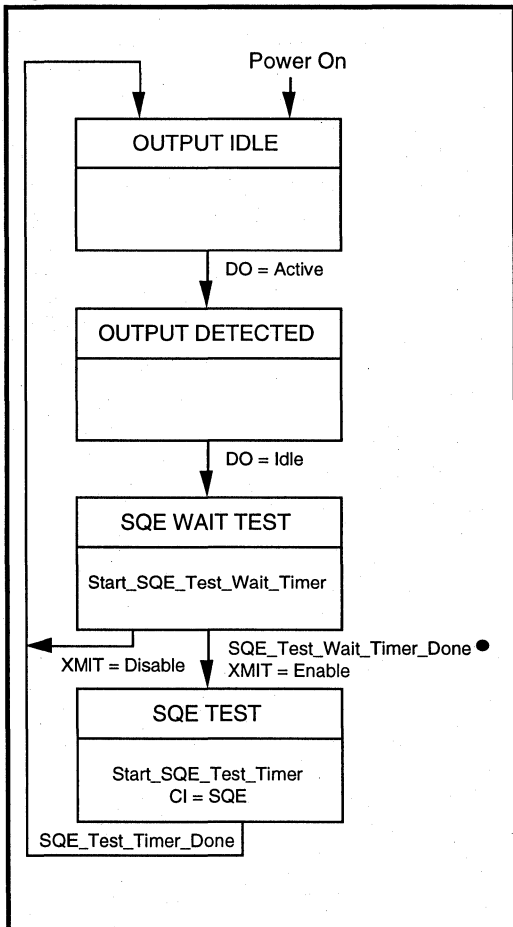

JABBER CONTROL FUNCTION

Figure 5 is a state diagram of the LXT902 Jabber control function. The LXT902 on-chip watchdog timer prevents the DTE from locking into a continuous transmit mode. When a transmission exceeds the time limit, the Watchdog timer disables the transmit and loopback functions, and sends the SQE signal to the DTE over the CI circuit. Once the LXT902 is in the jabber state, the DO circuit must remain idle for a period of 491 to 525 ms before it will exit the jabber state.

Figure 5: Jabber Control Function

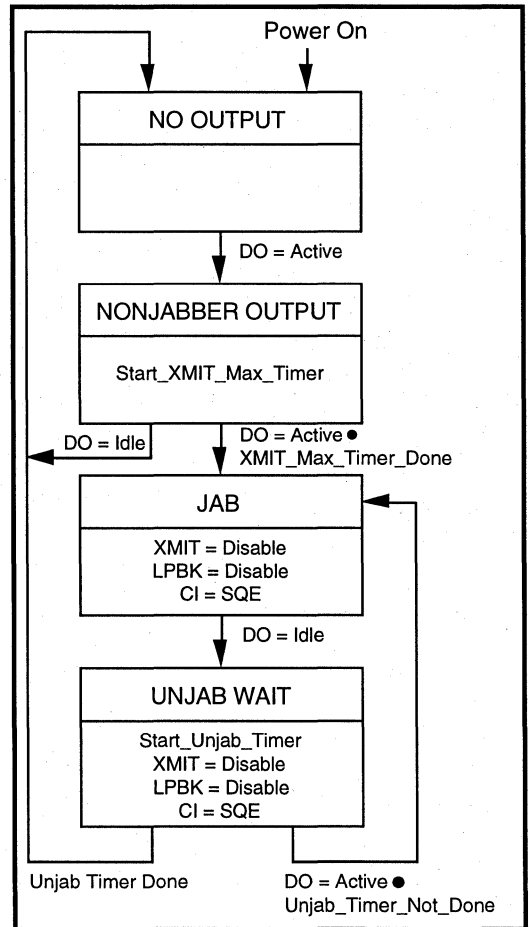

LINK INTEGRITY TEST FUNCTION

Figure 6 is a state diagram of the LXT902 Link Integrity Test Function. The Link Integrity Test is used to determine the status of the receive side twisted pair cable. The link integrity test is enabled when the LI pin is tied high. When enabled, the receiver recognizes link integrity pulses which are transmitted in the absence of receive traffic. If no serial data stream or link integrity pulses are detected within 50 - 150 ms, the chip enters a link fail state and disables the transmit and loopback functions. The LXT902 ignores any link integrity pulse with interval less than 2 - 7 ms. The LXT902 will remain in the link fail state until it detects either a serial data packet or two or more link integrity pulses.

TEST MODE

The LXT902 Test mode is selected when a 2 - 2.5 MHz clock is input on the MD0 mode select pin. Test mode sets the internal counter chains to run at 1024 times their normal speed. The maximum transmit time, unjab time, Link Integrity timing and LED timing are reduced by a factor of 1024. During test operation, 10 MHz and 20 MHz signals are output on the PRC and SQE pins, respectively. When Test mode is selected, the SQE function cannot be disabled. In Test mode the PRC function can be disabled by the LI pin. Jabber can be disabled by setting MD1 Low.

Figure 6: Link Integrity Test Function

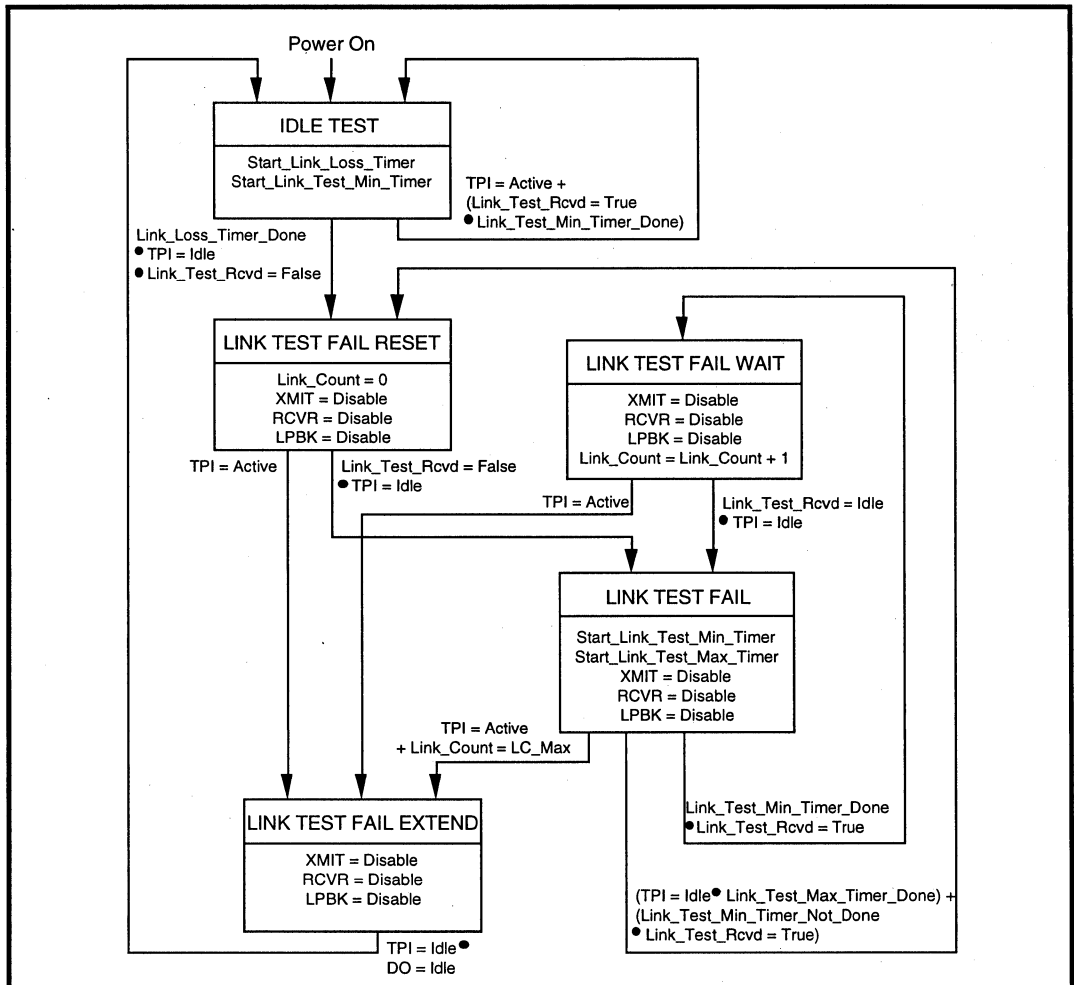

APPLICATION INFORMATION

NOTE

This information is for design aid only.

EXTERNAL MAU

Figure 7 shows the LXT902 in a typical external MAU application, interfacing between an AUI and the RJ45 connectors of the twisted pair network. A 20 MHz crystal (or ceramic resonator) connected across CLKI and CLKO provides the required clock signal. Transmit and receive filters are required in the TPO and TPI circuits. Details of the transmit and receive filters are shown in Figures 8 and 9, respectively. (Differential filters are also recommended.)

INTERNAL MAU

Figure 10 shows an internal MAU application which takes advantage of the LXT902's unique AUI/10BASE-T switching feature to select either the D-connector (AUI) or the RJ45 connector (10BASE-T). No termination resistors are used on the LXT902 side of the AUI interface to prevent impedance mismatch with the drop cable. The half current drive mode is used to maintain the same voltage levels in the absence of termination resistors. This application uses capacitive coupling instead of transformer coupling. MD1 is tied High so MD0 functions as the mode control switch.

When MD0 is Low, the half current drive mode is selected. When MD0 is High, the LXT902 is effectively removed.

Figure 7: LXT902 External MAU Application Diagram

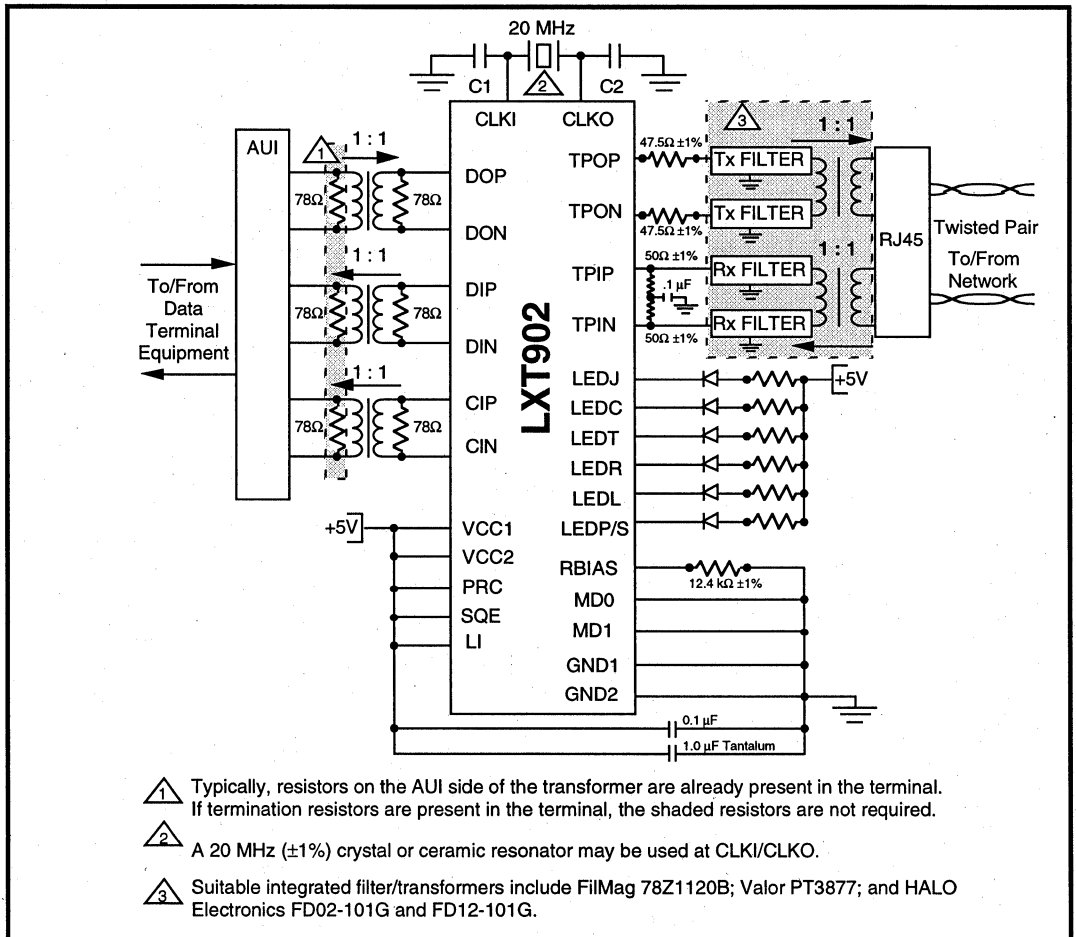

from the circuit. The 902 AUI ports (DO, DI and CI) are disabled isolating the LXT902 from the AUI. The LXT902 DI and CI ports go to a high impedance state and the DO port is ignored.

To implement an auto-select function, LEDL can be tied to MD0. This activates the 902/AUI interface when the TP link is active (data or link integrity pulses) and disables it when the link is inactive.

Figure 8: Transmit Filter Diagram

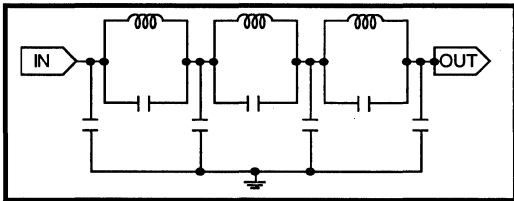

Figure 9: Receive Filter Diagram

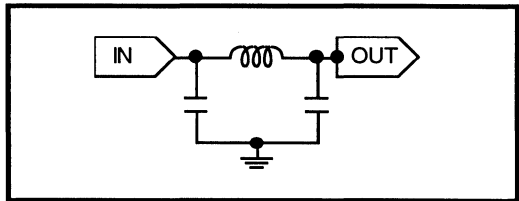
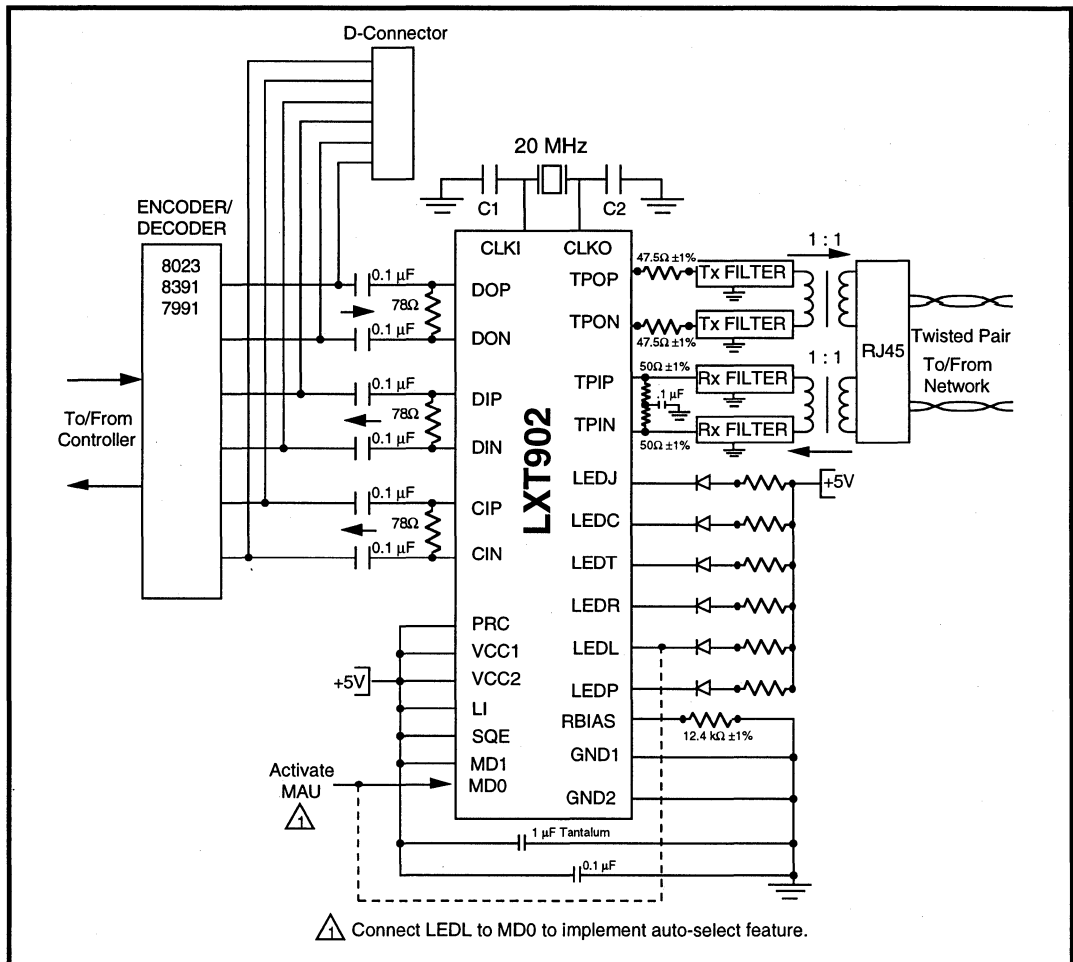

Figure 10: LXT902 Internal MAU Application Diagram



TEST SPECIFICATIONS

NOTE

Minimum and maximum values in Tables 3 through 9 and Figure 11 represent the performance specifications of the LXT902 and are guaranteed by test except, as noted, by design.

Table 3: Absolute Maximum Ratings

Parameter	Symbol	Min	Max	Units
DC supply (referenced to GND)	V _{CC}	-0.3	6.0	V
Ambient operating temperature	T _A	0	70	°C
Storage temperature	T _{STG}	-65	150	°C

CAUTION

Operations at or beyond these limits may result in permanent damage to the device.
Normal operation not guaranteed at these extremes.

Table 4: Recommended Operating Conditions

Parameter	Symbol	Min	Typ	Max	Units
Supply voltage ^{1,2}	V _{CC}	4.75	5.0	5.25	V
Operating temperature	T _{OP}	0	–	70	°C

1. Voltages are with respect to ground unless otherwise specified.
2. Maximum voltage differential between VCC1 and VCC2 must not exceed 0.3V.

Table 5: I/O Electrical Characteristics (Over Recommended Range)

Parameter	Symbol	Min	Typ ¹	Max	Units	Test Conditions
Input Low voltage ²	V _{IL}	–	–	0.8	V	
Input High voltage ²	V _{IH}	2.0	–	–	V	
Output Low voltage (Open drain LED Driver)	V _{OLL}	–	–	0.7	V	I _{OLL} = 10 mA
Supply current (V _{CC1} = V _{CC2} = 5.25 V)	I _{CC}	–	60	70	mA	Line Idle
		–	125	140	mA	Line Active, transmitting all ones
Input leakage current ³	I _{LL}	–	±1	±10	µA	Input between VCC and GND
Three state leakage current (high Z)	I _{TS}	–	±1	±10	µA	Output between VCC and GND

1. Typical figures are at 25 °C and are for design aid only; not guaranteed and not subject to production testing.
2. MD0, MD1, SQE, PRC and LI pins. MD0 clock (test mode) must be CMOS level input.
3. Not including TPIN, TPIP, DOP or DON.

Table 6: AUI Electrical Characteristics (Over Recommended Range)

Parameter	Symbol	Min	Typ ¹	Max	Units	Test Conditions
Input Low current	I _{IL}	–	–	-700	μA	
Input High current	I _{IH}	–	–	500	μA	
Differential output voltage	V _{OD}	± 550	–	± 1200	mV	
Differential squelch threshold	V _{DS}	–	220	–	mV	
Receive input impedance	R _Z	–	20	–	kΩ	Between DOP and DON

1. Typical figures are at 25 °C and are for design aid only; not guaranteed and not subject to production testing.

Table 7: Transmit Characteristics (Over Recommended Range)

Parameter	Symbol	Min	Typ ¹	Max	Units	Test Conditions
Transmit output impedance	Z _{OUT}	–	5	–	Ω	
Transmit timing jitter addition ²	–	–	–	± 8	ns	After Tx filter, 0 line length
Transmit timing jitter addition ²	–	–	–	± 3.5	ns	After Tx filter and line model specified by IEEE 802.3 for 10BASE-T

1. Typical figures are at 25 °C and are for design aid only; not guaranteed and not subject to production testing.
2. Parameter is guaranteed by design; not subject to production testing.

Table 8: Receive Characteristics (Over Recommended Range)

Parameter	Symbol	Min	Typ ¹	Max	Units	Test Conditions
Receive input impedance	Z _{IN}	–	20	–	kΩ	Between TPIP/TPIN
Differential squelch threshold	V _{DS}	–	420	–	mV	
Reduced squelch threshold	V _{DSR}	–	300	–	mV	
Receive timing jitter ²	–	–	–	1.5	ns	

1. Typical figures are at 25 °C and are for design aid only; not guaranteed and not subject to production testing.
2. Parameter is guaranteed by design; not subject to production testing.

Table 9: Switching Characteristics (Over Recommended Range)

Parameter	Min	Typ ¹	Max	Units
Jabber Timing				
Maximum transmit time ²	98.5	–	131	ms
Unjab time ²	491	–	525	ms
Time from Jabber to CS0 on CIP/CIN ³	0	–	900	ns
Link Integrity Timing				
Time link loss ²	65	–	66	ms
Time between Link Integrity Pulses ²	9	–	11	ms
Interval for valid receive Link Integrity Pulses ²	4.1	–	65	ms
Collision Timing				
Simultaneous TPI/TPO to CS0 state on CIN/CIP	0	–	900	ns
DO loopback to TPI on DI ³	300	–	900	ns
CS0 state delay after TPI/DO idle	–	–	900	ns
CS0 high pulse width	40	–	60	ns
CS0 low pulse width	40	–	60	ns
CS0 frequency	–	10	–	MHz
SQE Timing				
SQE signal duration	500	–	1500	ns
Delay after last positive transition of DO	0.6	–	1.6	µs
LED Timing				
LEDC, LEDT, LEDR on time ²	100	–	–	ms
LEDP/S on time ² (See Figure 1)	–	164	–	ms
LEDP/S period ² (See Figure 1)	–	328	–	ms
General				
Receive start-up delay	0	–	500	ns
Transmit start-up delay	0	–	200	ns
Loopback start-up delay	0	–	500	ns
1. Typical figures are at 25 °C and are for design aid only; not guaranteed and not subject to production testing. 2. Switching times reduced by a factor of 1024 during Test mode. 3. Parameter is guaranteed by design; not subject to production testing.				

Figure 11: LEDP/S Status Indication Timing

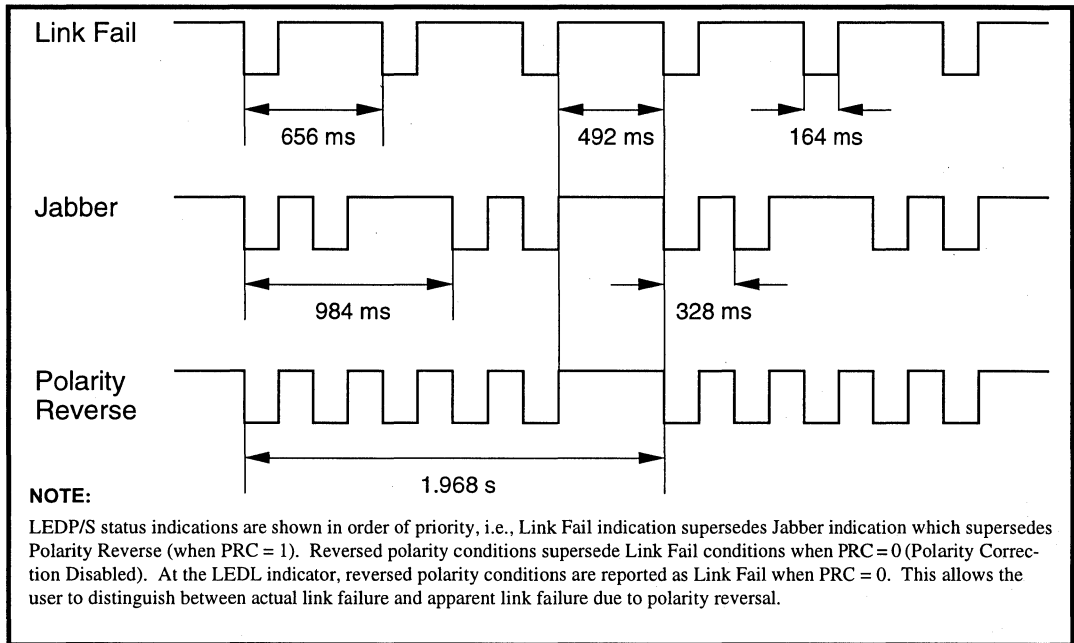

NOTES:

LXT904

Ethernet Interface Adapter with EnDec and AUI

General Description

The LXT904 Ethernet Interface Adapter is designed for IEEE 802.3 applications. It provides all the active circuitry to adapt most standard 802.3 controllers to the Attachment Unit Interface (AUI). The LXT904 is a pin-compatible replacement for the LXT901 in applications that do not require a twisted-pair port. In addition to standard 10 Mbps Ethernet, the LXT904 also supports full-duplex operation at 20 Mbps.

LXT904 functions include Manchester encoding/decoding and AUI driving/receiving. The LXT904 can also be used to drive the AUI drop cable.

The LXT 904 is fabricated using an advanced CMOS process and requires only a single 5-volt power supply.

Features

- Integrated Manchester Encoder/Decoder
- AUI Transceiver
- Supports Standard and Full-Duplex Ethernet
- Power Down Mode
- AUI Loopback mode for better testing
- Three LED Drivers
- Available in 44-pin PLCC package
- Part Number LXT904PC

Applications

- Bridges, routers and Ethernet-to-WAN access equipment
- Computer/workstation LAN adapter boards

LXT904 Block Diagram

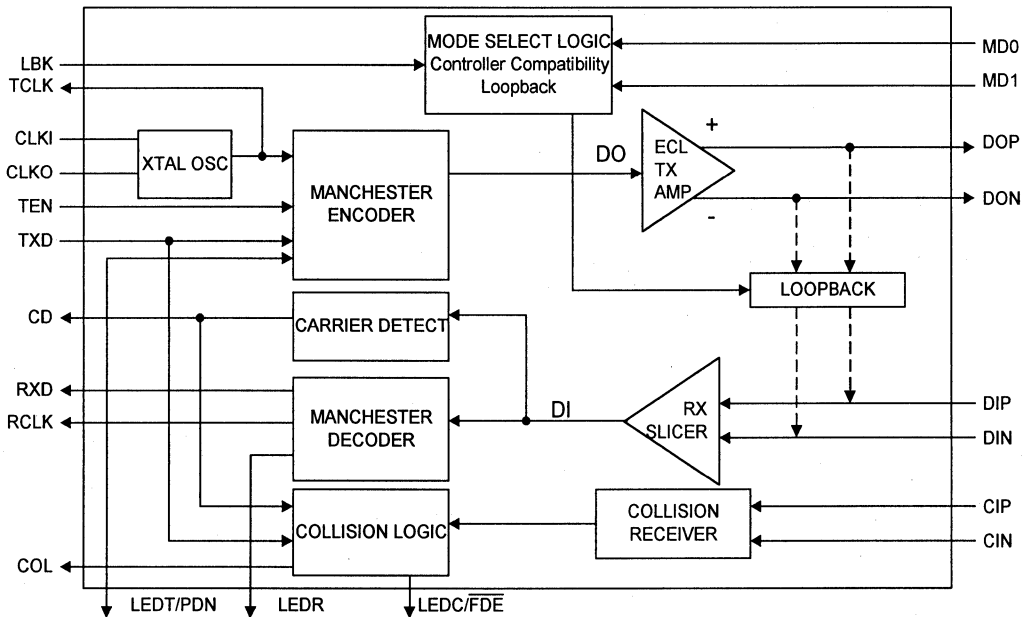

LXT904 Ethernet Interface Adapter with EnDec and AUI

Figure 1: Pin Assignments

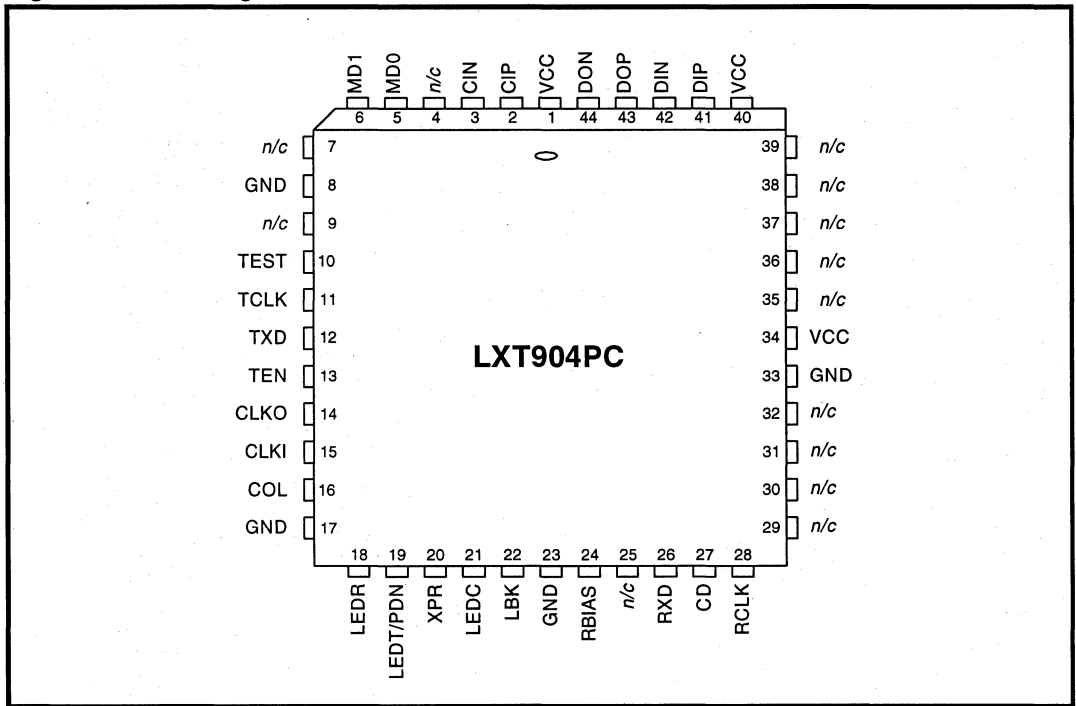

Table 1: Pin Descriptions

Pin #	Sym	I/O	Description
1	VCC	I	Power Input. + 5 volt power supply input.
2	CIP	I	AUI Collision Pair. Differential input pair connected to the AUI transceiver CI circuit. The input is collision signaling or SQE.
3	CIN	I	
4	n/c	-	No connection. This pin must be left floating.
5	MD0	I	Mode Select 0; Mode Select 1. Mode select pins determine controller compatibility mode in accordance with Table 2.
6	MD1	I	
7	n/c	-	No connection. This pin must be left floating.
8	GND	-	Ground. Ground return.
9	n/c	-	No connection. This pin must be left floating.
10	TEST	I	Test. This pin must be tied High.
11	TCLK	O	Transmit Clock. A 10 MHz clock output. This clock signal should be directly connected to the transmit clock input of the controller.
12	TXD	I	Transmit Data. Input signal containing NRZ data to be transmitted on the network. TXD is connected directly to the transmit data output of the controller.
13	TEN	I	Transmit Enable. Enables data transmission and starts the watchdog timer. Synchronous to TCLK (see Figures 5, 11, 17 and 23 for details).

LXT904 Ethernet Interface Adapter with EnDec and AUI

Table 1: Pin Descriptions – continued

Pin #	Sym	I/O	Description
14	CLKO	O	Crystal Oscillator. A 20 MHz crystal must be connected across these pins, or a 20 MHz clock applied at CLKI with CLKO left open.
15	CLKI	I	
16	COL	O	Collision Detect. Output which drives the collision detect input of the controller.
17	GND	–	Ground. Ground return.
18	LEDR	O	Receive LED. Open drain driver for the receive indicator LED. Output is pulled Low during receive.
19	LEDT/ PDN	O I	Transmit LED/Power Down. Open drain driver for the transmit indicator. Output is pulled Low during transmit. If externally tied Low, the LXT904 goes to power down state.
20	XPR	–	External Pull Up. Requires an external pull-up resistor.
21	LEDC	O	Collision LED. Open drain driver for the collision indicator pulls Low during collision.
22	LBK	I	Loopback. Enables internal loopback mode. See Figure 8 (Mode 1), Figure 14 (Mode 2), Figure 20 (Mode 3) and Figure 26 (Mode 4) for details.
23	GND	–	Ground. Ground Return.
24	RBIAS	I	Bias Control. A 12.4 kΩ 1% resistor to ground at this pin controls operating circuit bias.
25	<i>n/c</i>	–	No connection. This pin must be left floating.
26	RXD	O	Receive Data. Output signal connected directly to the receive data input of the controller.
27	CD	O	Carrier Detect. An output to notify the controller of activity on the network.
28	RCLK	O	Receive Clock. A recovered 10 MHz clock which is synchronous to the received data and connected to the controller receive clock input.
29	<i>n/c</i>	–	No connection. These pins must be left floating.
30	<i>n/c</i>	–	
31	<i>n/c</i>	–	
32	<i>n/c</i>	–	
33	GND	–	Ground. Ground Return.
34	VCC	I	Power Input. + 5 volt power supply input.
35	<i>n/c</i>	–	No connection. These pins must be left floating.
36	<i>n/c</i>	–	
37	<i>n/c</i>	–	
38	<i>n/c</i>	–	
39	<i>n/c</i>	–	
40	VCC	I	Power Input. + 5 volt power supply input.
41	DIP	I	AUI Receive Pair. Differential input pair from the AUI transceiver DI circuit. The input is Manchester encoded.
42	DIN	I	
43	DOP	O	AUI Transmit Pair. A differential output driver pair for the AUI transceiver cable. The output is Manchester encoded.
44	DON	O	

FUNCTIONAL DESCRIPTION

NOTE

This functional information is for design aid only.

The LXT904 Ethernet Interface Transceiver performs the physical layer signaling (PLS) functions as defined by the IEEE 802.3 specification. It functions as a PLS-Only device for use with 10BASE-5 or 10BASE-2 coaxial cable networks. In addition to standard 10 Mbps operation, the LXT904 also supports full-duplex 20 Mbps operation.

Refer to the block diagram on the first page of this data sheet. The LXT904 interfaces a back end controller to an AUI drop cable. The controller interface includes transmit and receive clock and NRZ data channels, as well as mode control logic and signaling. The AUI interface comprises three circuits: Data Output (DO), Data Input (DI) and Collision (CI). In addition to these basic interfaces, the LXT904 contains an internal crystal oscillator and three LED drivers for visual status reporting.

Functions are defined from the back end controller side of the interface. The LXT904 Transmit function refers to data transmitted by the back end to the AUI cable. The LXT904 receive function refers to data received by the back end from the AUI cable. The LXT904 receives incoming signals from the AUI DI circuit with ± 18 ns of jitter and drives the AUI DO circuit. The CI pins are monitored for collision status.

TRANSMIT FUNCTION

The LXT904 receives NRZ data from the controller at the TXD input, and passes it through a Manchester encoder. The encoded data is then transferred to the AUI cable (the DO circuit).

RECEIVE FUNCTION

The LXT904 receive function acquires timing and data from the AUI (the DI circuit). Valid received signals are passed through the on-chip decoder then output as decoded NRZ data and receive timing on the RXD and RCLK pins, respectively.

The receive function is activated only by valid data streams above the squelch level with proper timing. If the differential signal at the DI circuit inputs falls below 75% of the threshold level (unsquelched) for 8 bit times (typical), the LXT904 receive function enters the idle state.

LOOPBACK FUNCTION

Loopback is controlled by the LBK pin. When LBK is High, data transmitted by the back-end is internally looped back from the TXD pin through the Manchester encoder/decoder to the RXD pin. When LBK is Low, no AUI loopback occurs.

CONTROLLER COMPATIBILITY MODES

The LXT904 is compatible with most industry standard controllers including devices produced by Motorola, Advanced Micro Devices (AMD), Intel, Fujitsu, National Semiconductor, Seeq and Texas Instruments. Four different control signal timing and polarity schemes (Modes 1 through 4) are required to achieve this compatibility. Mode select pins (MD0 and MD1) determine controller compatibility modes as listed in Table 2.

A complete set of timing diagrams and specifications for each mode is provided in the Test Specifications section.

Table 2: Controller Compatibility Modes

Controller Mode	Settings	
	MD1	MD0
Mode 1—For Motorola 68EN360, Advanced Micro Devices AM7990 or compatible controllers	Low	Low
Mode 2—For Intel 82596 or compatible controllers	Low	High
Mode 3—For Fujitsu MB86950 or MB86960, Seeq 8005 or compatible controllers ¹	High	Low
Mode 4—For National Semiconductor 8390, Texas Instruments TMS380C26 or compatible controllers	High	High

¹. Seeq Controllers require inverters on CLKI, LBK, RCLK, and COL.

APPLICATION INFORMATION

NOTE

This application information is for design aid only.

Figure 2 is a typical LXT904 application. The diagram is arranged to group similar pins together; it does not represent the actual LXT904 pinout. The controller interface pins (transmit data, clock and enable; receive data and clock; and the collision detect, carrier detect and loopback control pins) are shown at the top left.

With MD1 and MD0 both Low, the LXT904 logic and framing are set to Mode 1 (compatible with AMD AM7990 controllers). The LBK input controls loopback. A 20 MHz system clock is supplied at CLKI with CLKO left open.

Figure 2: Typical LXT904 Application

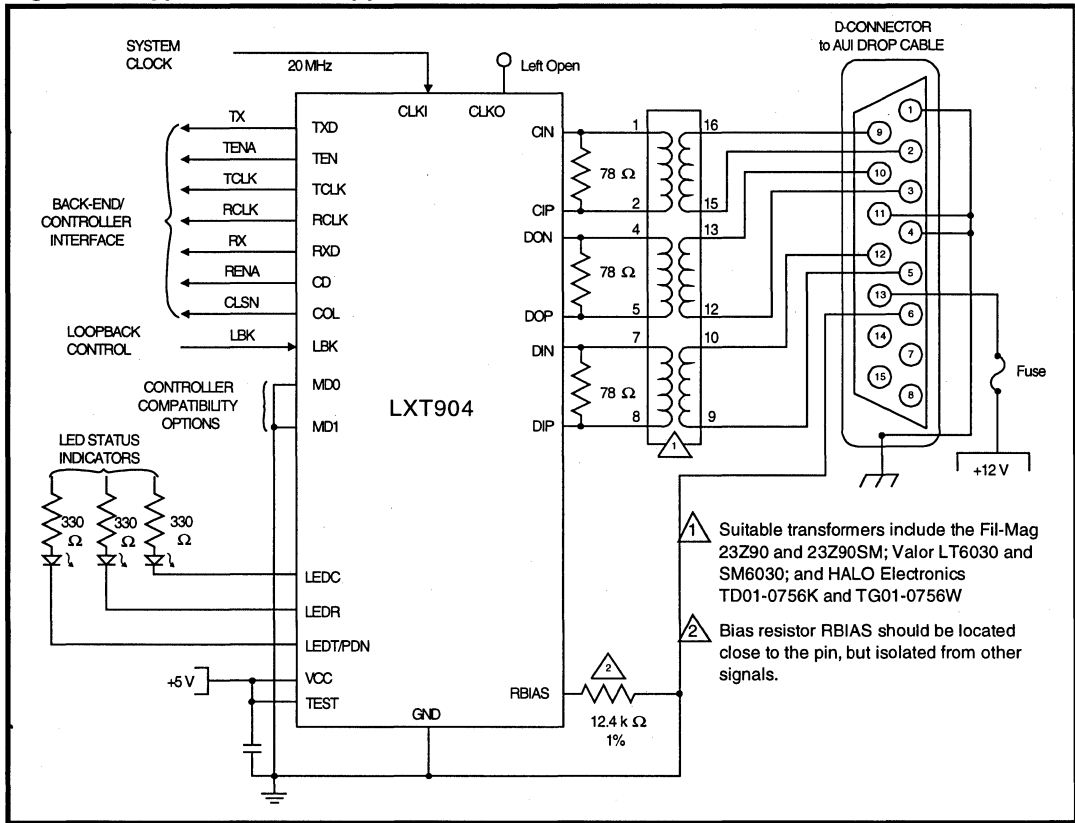

TEST SPECIFICATIONS

NOTE

The minimum and maximum values in Tables 3 through 9 and Figures 3 through 26 represent the performance specifications of the LXT904 and are guaranteed by test, except where noted by design.

Table 3: Absolute Maximum Ratings

Parameter	Symbol	Min	Typ	Max	Units
Supply Voltage	V _{CC}	-0.3	-	6	V
Operating Temperature	T _{OP}	0	-	70	°C
Storage Temperature	T _{ST}	-65	-	150	°C

CAUTION

Exceeding these values may cause permanent damage. Functional operation under these conditions is not implied. Exposure to maximum rating conditions for extended periods may affect device reliability.

Table 4: Operating Conditions (Voltage with respect to ground unless otherwise specified.)

Parameter	Symbol	Min	Typ ¹	Max	Units	Test Conditions
Recommended supply Voltage	V _{CC}	4.75	5.0	5.25	V	
Recommended operating temperature	T _{OP}	0	-	70	°C	

1. Typical values are at 25° C and are for design aid only; not guaranteed and not subject to production testing.

Table 5: Electrical Characteristics (Over Recommended Range)

Parameter	Symbol	Min	Typ ¹	Max	Units	Test Conditions	
Input Low Voltage ²	V _{IL}	-	-	0.8	V		
Input High Voltage ²	V _{IH}	2.0	-	-	V		
Output Low Voltage	V _{OL}	-	-	0.4	V	I _{OL} = 1.6 mA	
	V _{OL}	-	-	10	%V _{CC}	I _{OL} < 10µA	
Output Low Voltage (Open drain LED Driver)	V _{OLL}	-	-	0.7	V	I _{OLL} = 10mA	
Output High Voltage	V _{OH}	2.4	-	-	V	I _{OH} = 40µA	
	V _{OH}	90	-	-	%V _{CC}	I _{OL} < 10µA	
Supply current	Normal mode	I _{CC}	-	65	85	mA	Idle mode
		I _{CC}	-	70	90	mA	Transmitting on AUI
	Power Down mode	I _{CC}	-	0.75	2	mA	

1. Typical values are at 25° C and are for design aid only; not guaranteed and not subject to production testing.
 2. Limited functional test patterns are performed at these input levels. The majority of functional tests are performed at levels of 0 V and 3 V.

Table 6: Clock Timing (Over Recommended Range)

Parameter		Sym	Min	Typ ¹	Max	Units	Test Conditions
Output Rise Time TCLK & RCLK	CMOS	-	-	3	12	ns	CLOAD = 20 pF
	TTL	-	-	2	8	ns	
Output Fall Time TCLK & RCLK	CMOS	-	-	3	12	ns	CLOAD= 20 pF
	TTL	-	-	2	8	ns	
CLKI rise time (externally driven)		-	-	-	10	ns	
CLKI duty cycle (externally driven)		-	-	50/50	40/60	%	

1. Typical values are at 25° C and are for design aid only; not guaranteed and not subject to production testing.

Table 7: AUI Electrical Characteristics (Over Recommended Range)

Parameter	Symbol	Min	Typ ¹	Max	Units	Test Conditions
Input Low Current	IIL	-	-	-700	mA	
Input High Current	IiH	-	-	500	mA	
Differential Output Voltage	VOD	±150	-	±1200	mV	
Differential Squelch Threshold	VDS	150	220	350	mV	5 MHz square wave input

1. Typical values are at 25° C and are for design aid only; not guaranteed and not subject to production testing.

Table 8: RCLK/Start-of-Frame Timing

Parameter	Symbol	Minimum	Typical ¹	Maximum	Units	
Decoder acquisition time	tDATA	-	900	1100	ns	
CD turn-on delay	tCD	-	50	200	ns	
Receive data setup from RCLK	Mode 1	tRDS	60	70	-	ns
	Modes 2, 3 and 4	tRDS	30	45	-	ns
Receive data hold from RCLK	Mode 1	tRDH	10	20	-	ns
	Modes 2, 3 and 4	tRDH	30	45	-	ns

1. Typical values are at 25° C and are for design aid only; not guaranteed and not subject to production testing.

11

Table 9: RCLK/End-of-Frame Timing

Parameter	Type	Sym	Mode 1	Mode 2	Mode 3	Mode 4	Units
RCLK after CD off	Minimum	tRC	5	1	27	5	bit times
Rx data throughput delay	Maximum	tRD	400	375	375	375	ns
CD turn off delay ²	Maximum	tCDOFF	500	475	475	475	ns
Receive block out after TEN off	Typical ¹	tIFG	5	50	-	-	bit times

1. Typical values are at 25° C and are for design aid only; not guaranteed and not subject to production testing.
 2. Limited functional test patterns are performed at these input levels. The majority of functional tests are performed at levels of 0 V and 3 V. This applies to all inputs except DIP and DIN.

Table 10: Transmit Timing

Parameter	Symbol	Minimum	Typical ¹	Maximum	Units
TEN Setup from TCLK	tEHCH	22	-	-	ns
TXD Setup from TCLK	tDSCH	22	-	-	ns
TEN Hold after TCLK	tCHEL	5	-	-	ns
TXD Hold after TCLK	tCHDU	5	-	-	ns
Transmit Start-up Delay - AUI	tSTUD	-	200	450	ns
Transmit Through-put Delay - AUI	tTPD	-	-	300	ns

1. Typical values are at 25° C and are for design aid only; not guaranteed and not subject to production testing.

Table 11: Collision and Loopback Timing

Parameter	Symbol	Minimum	Typical ¹	Maximum	Units
COL turn on delay	tCOLD	-	-	500	ns
COL turn off delay	tCOLOFF	-	-	500	ns
COL (SQE) Delay after TEN off	tSQED	0.65	-	1.6	µs
COL (SQE) Pulse Duration	tSQEP	500	-	1500	ns
LBK setup from TEN	tKHEH	10	25	-	ns
LBK hold after TEN	tKHEL	10	0	-	ns

1. Typical values are at 25° C and are for design aid only; not guaranteed and not subject to production testing.

TIMING DIAGRAMS FOR MODE 1 (MD1 = Low, MD0 = Low)

Figure 3: Mode 1 RCLK/Start-of-Frame Timing

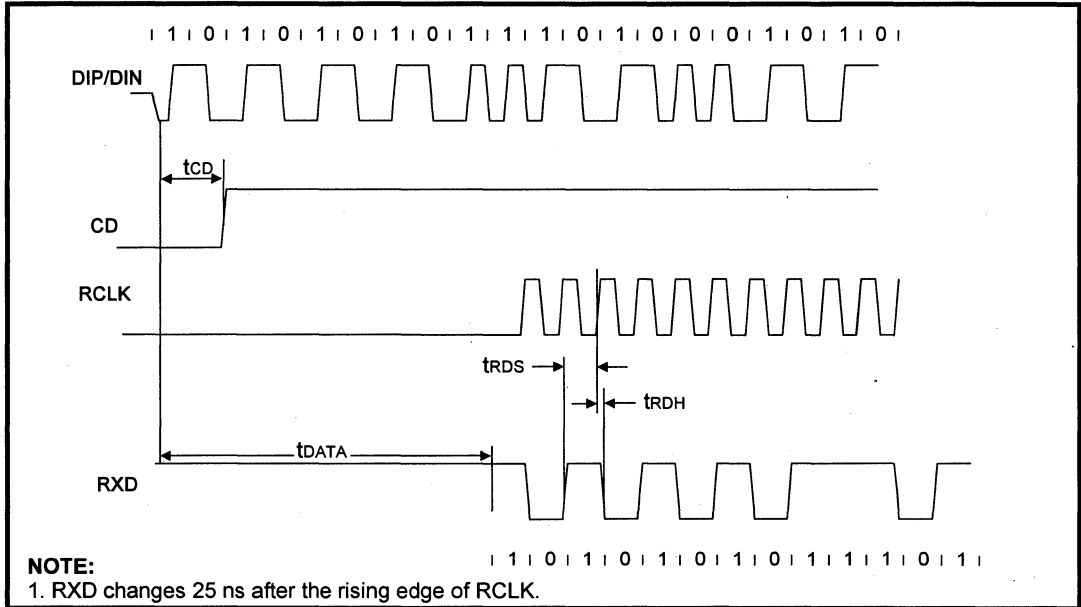

Figure 4: Mode 1 RCLK/End-of-Frame Timing

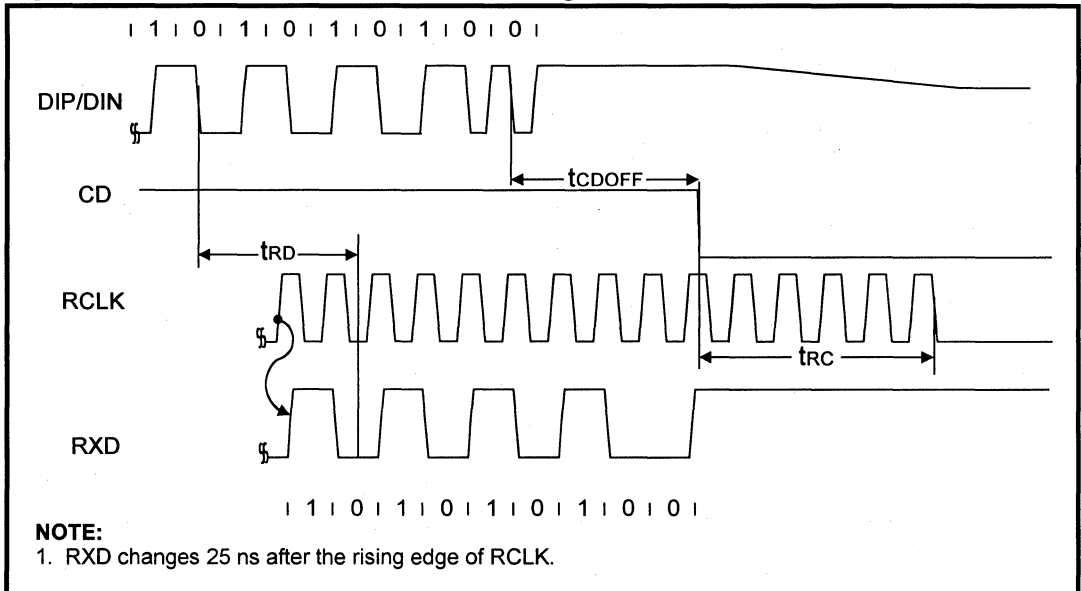

Figure 5: Mode 1 Transmit Timing

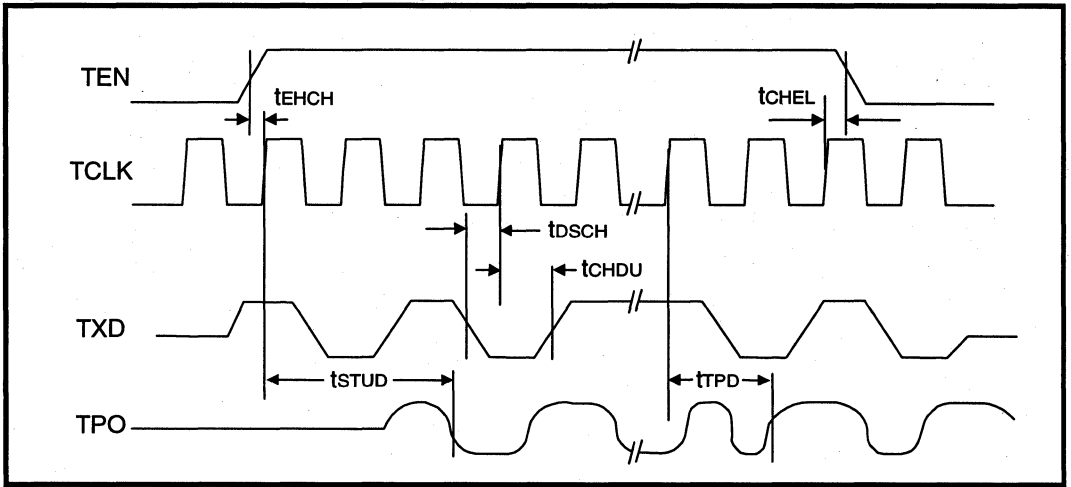

Figure 6: Mode 1 Collision Detect Timing

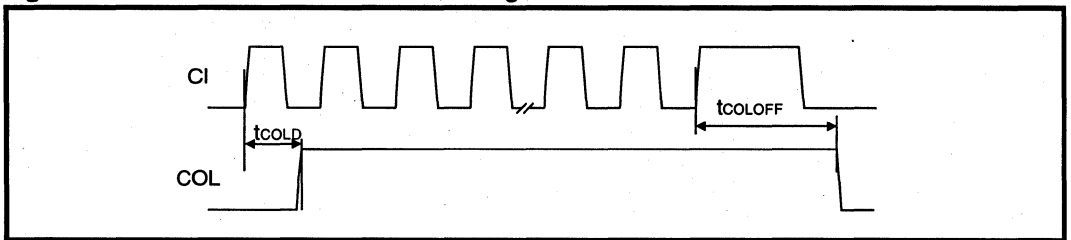

Figure 7: Mode 1 COL/CI Output Timing

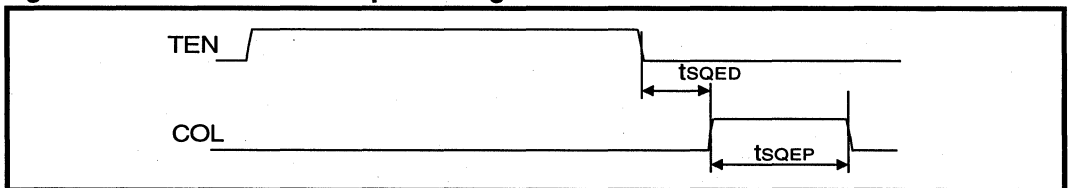
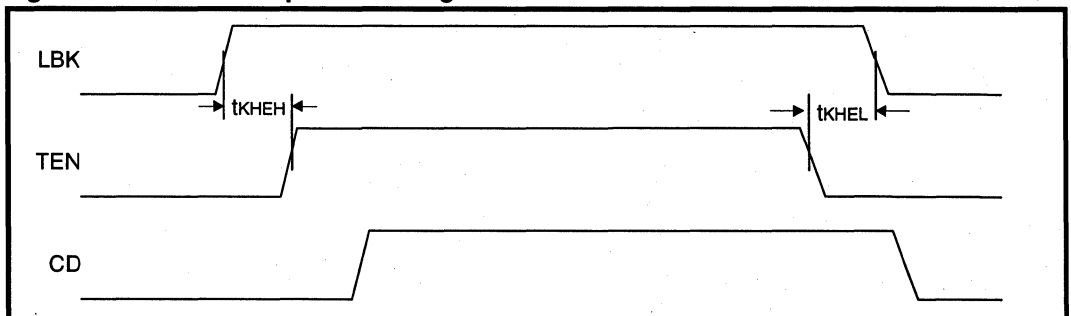

Figure 8: Mode 1 Loopback Timing



TIMING DIAGRAMS FOR MODE 2 (MD1 = Low, MD0 = High)

Figure 9: Mode 2 RCLK/Start-of-Frame Timing

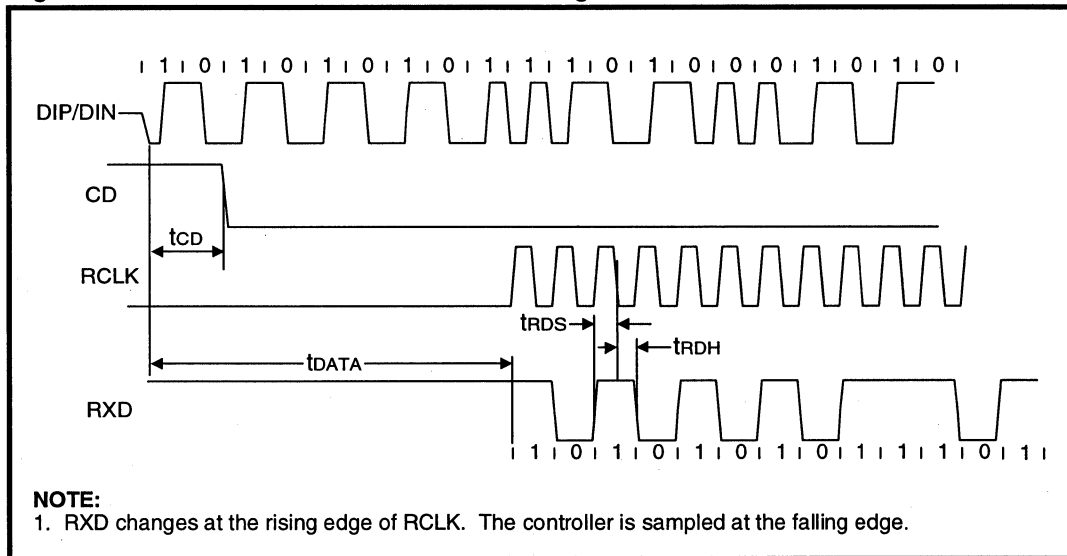

Figure 10: Mode 2 RCLK/End-of-Frame Timing

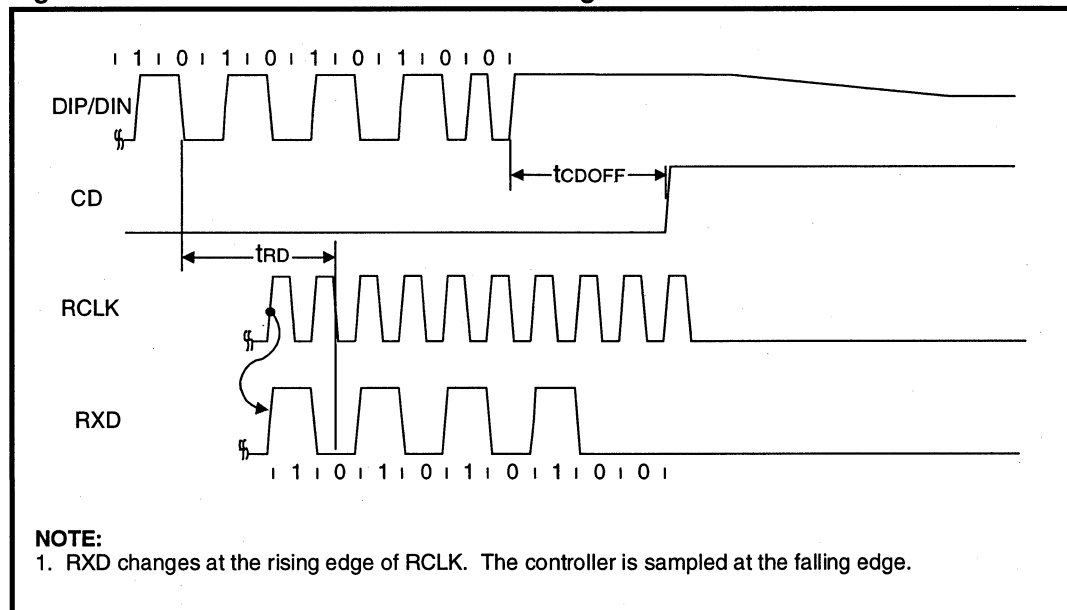

Figure 11: Mode 2 Transmit Timing

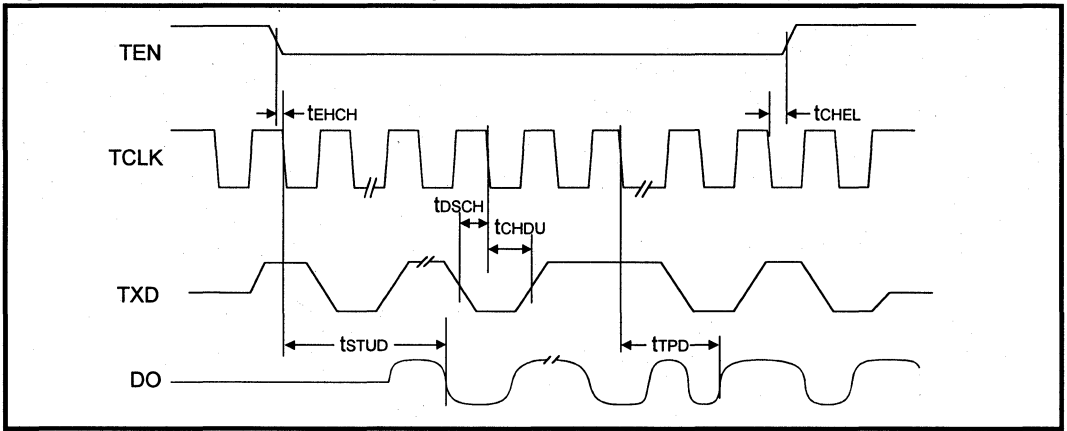

Figure 12: Mode 2 Collision Detect Timing

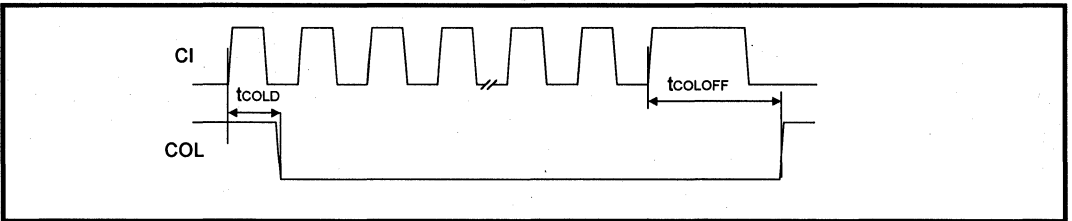

Figure 13: Mode 2 COL/CI Output Timing

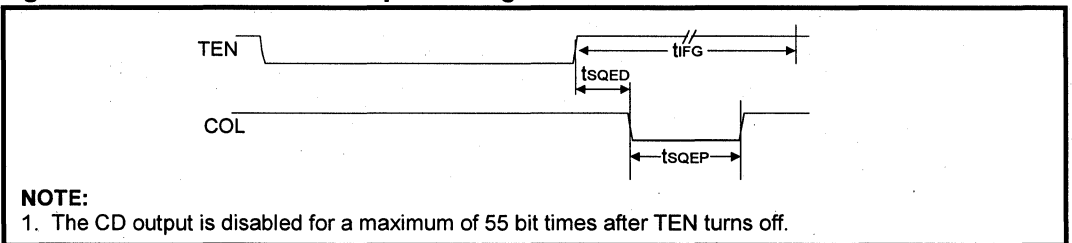
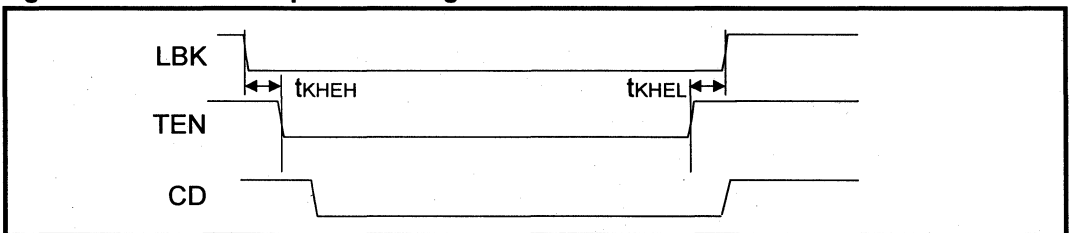

Figure 14: Mode 2 Loopback Timing



TIMING DIAGRAMS FOR MODE 3 (MD1 = High, MDO = Low)

Figure 15: Mode 3 RCLK/Start-of-Frame Timing

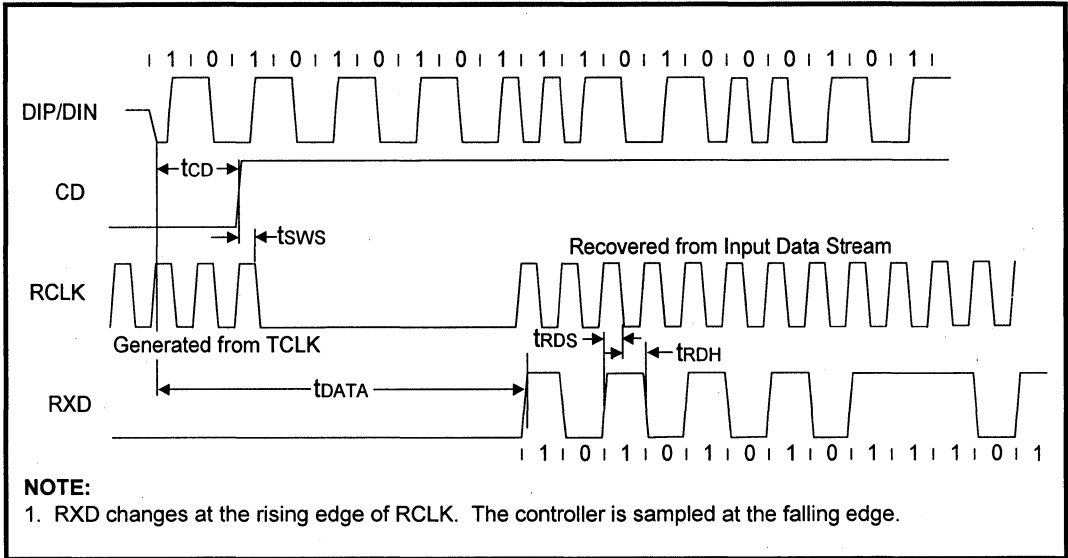

Figure 16: Mode 3 RCLK/End-of-Frame Timing

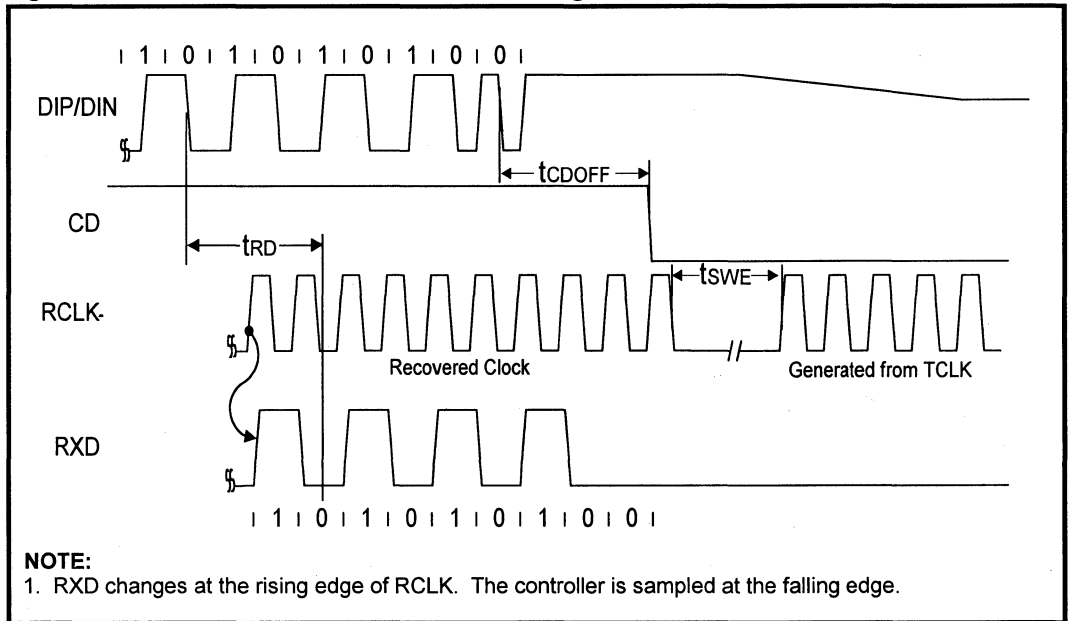

Figure 17: Mode 3 Transmit Timing

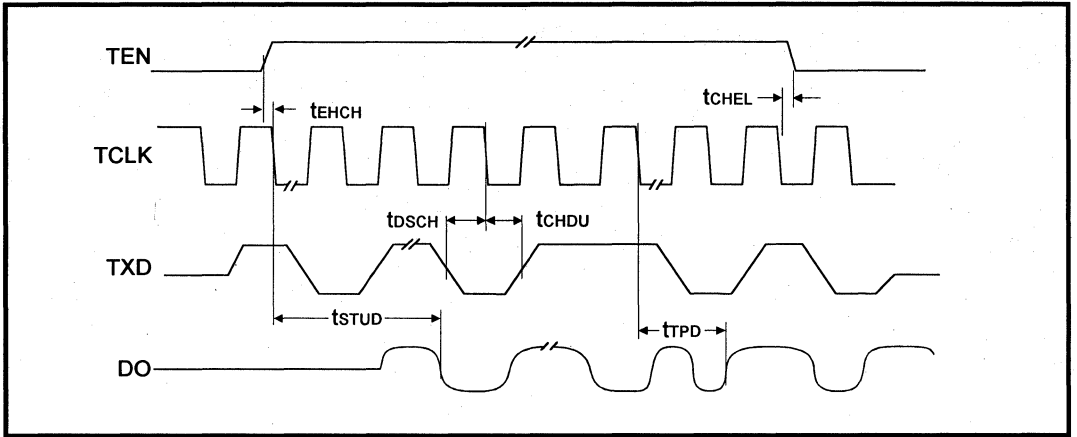

Figure 18: Mode 3 Collision Detect Timing

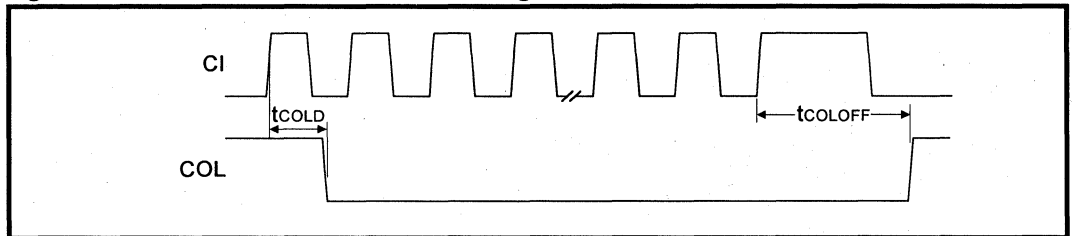

Figure 19: Mode 3 COL/CI Output Timing

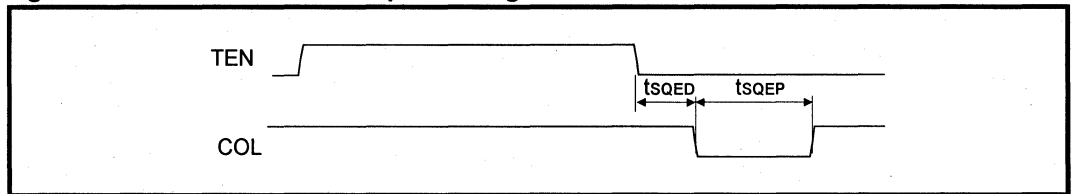
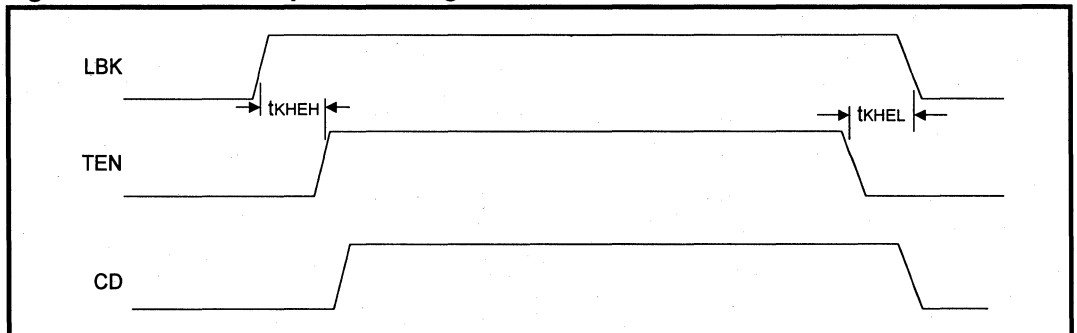

Figure 20: Mode 3 Loopback Timing



TIMING DIAGRAMS FOR MODE 4 (MD1 = High, MDO = High)

Figure 21: Mode 4 RCLK/Start of Frame Timing

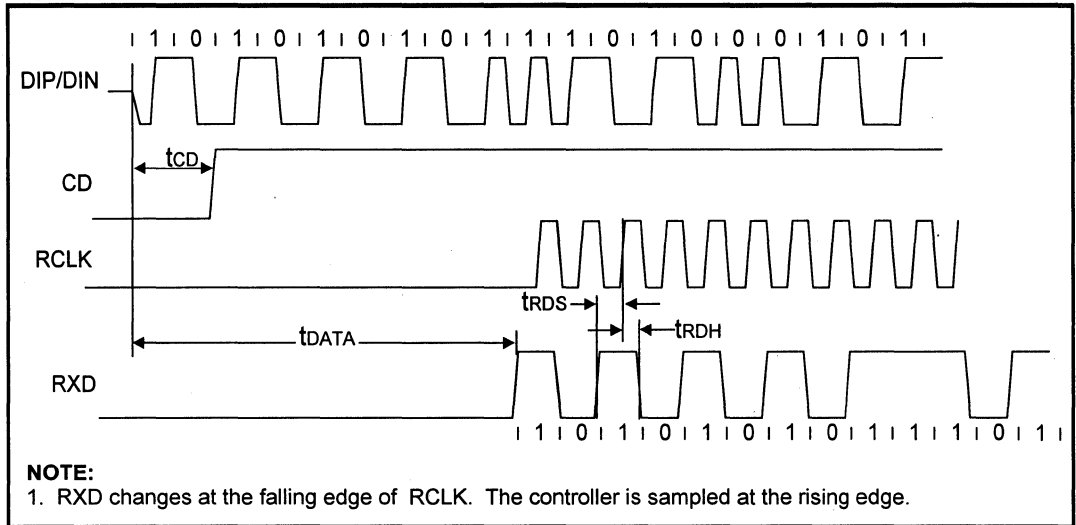

Figure 22: Mode 4 RCLK/End of Frame Timing

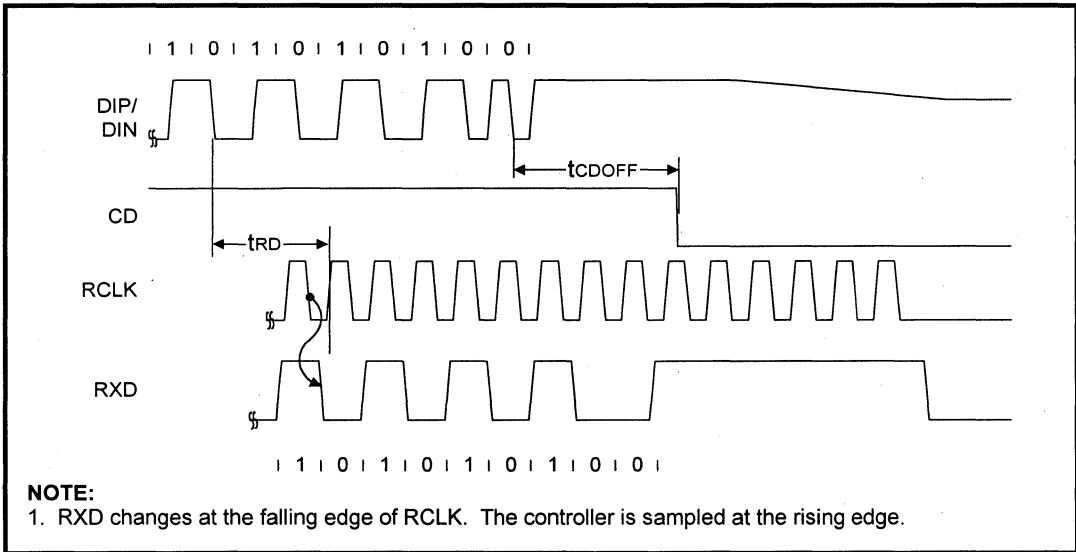

Figure 23: Mode 4 Transmit Timing

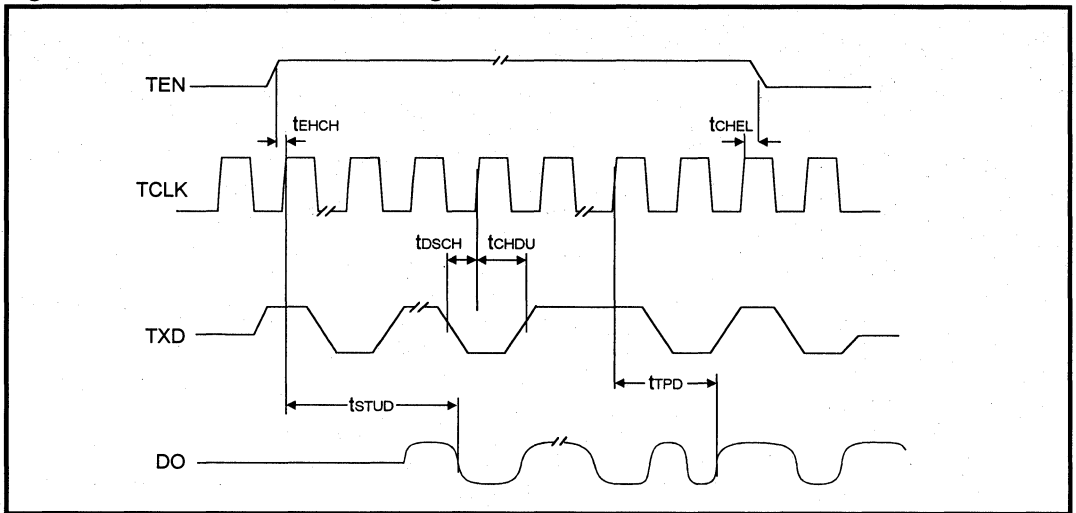

Figure 24: Mode 4 Collision Detect Timing

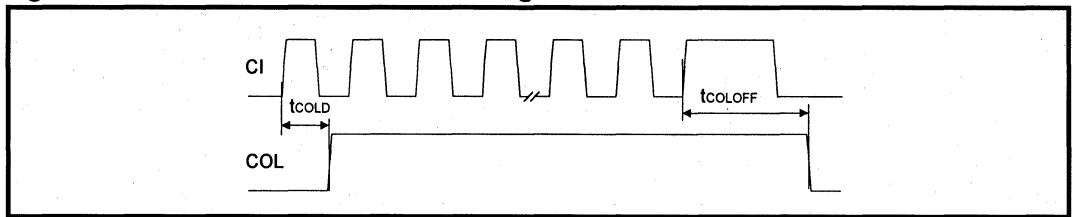

Figure 25: Mode 4 COL/CI Output Timing

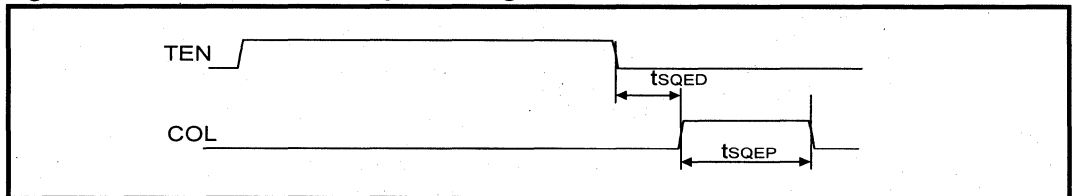
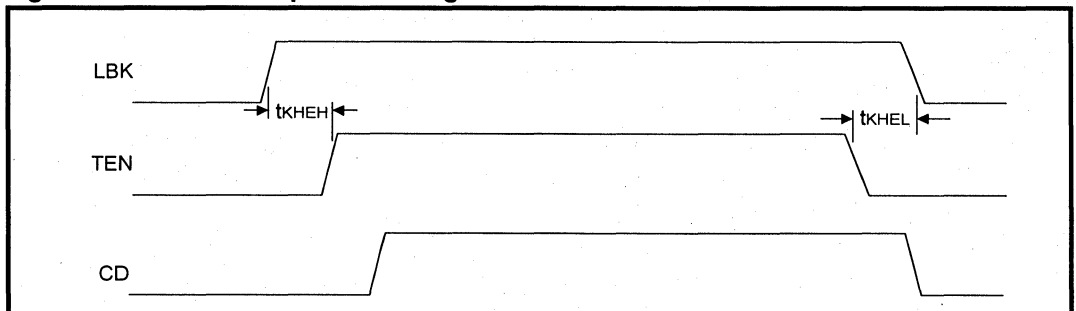

Figure 26: Mode 4 Loopback Timing



LXT905

Universal Ethernet Interface Adapter (Internal MAU) with Integrated 10BASE-T MAU, EnDec and Filters

General Description

The LXT905 Universal Ethernet Interface Adapter is designed for IEEE 802.3 physical layer applications. It provides, in a single CMOS device, all the active circuitry for interfacing most standard 802.3 controllers to 10BASE-T media.

LXT905 functions include Manchester encoding/decoding, receiver squelch and transmit pulse shaping, jabber, link integrity testing and reversed polarity detection/correction. The LXT905 drives the 10BASE-T twisted-pair cable with only a simple isolation transformer. Integrated filters simplify the design work required for FCC compliant EMI performance.

The LXT905 is fabricated with an advanced process and requires only a single 5 or 3.3 volt power supply.

Applications

- Hub/Switched Dedicated LANs for 10BASE-T
- Computer/workstation 10BASE-T LAN adapter boards
- Laptop and Portable applications

Features

- Transparent 3.3 V or 5 V operation
- Integrated filters – Simplifies FCC compliance
- Integrated Manchester encoder/decoder
- 10BASE-T compliant transceiver
- Automatic polarity correction
- Available in 28-pin PLCC and 32-pin TQFP packages
- SQE enable/disable
- Four LED drivers
- Full duplex capability
- Power-down mode with tristate

LXT905 Block Diagram

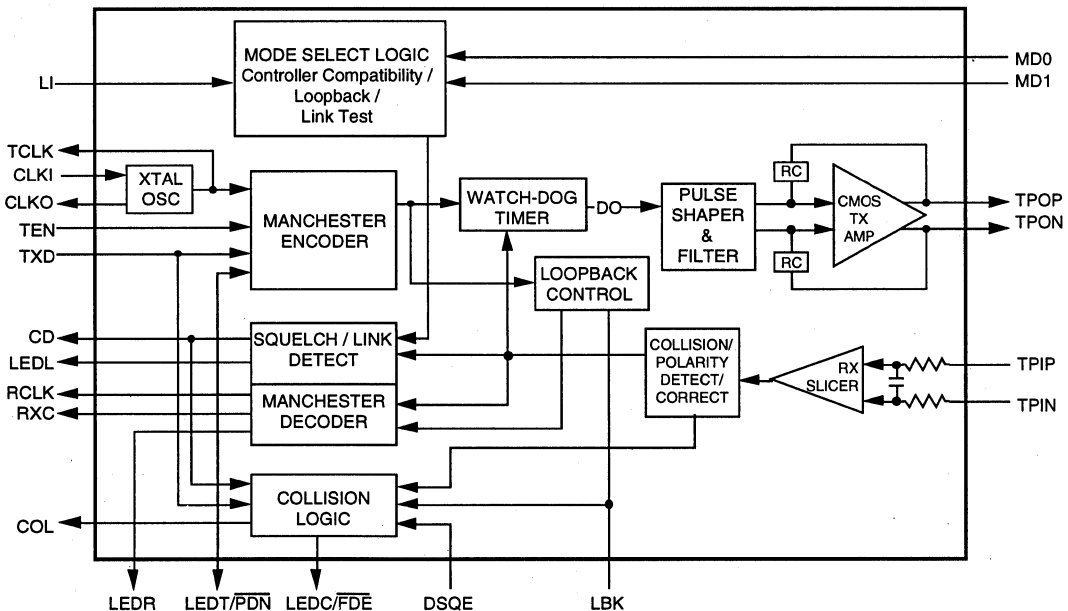

Figure 1: Pin Assignments

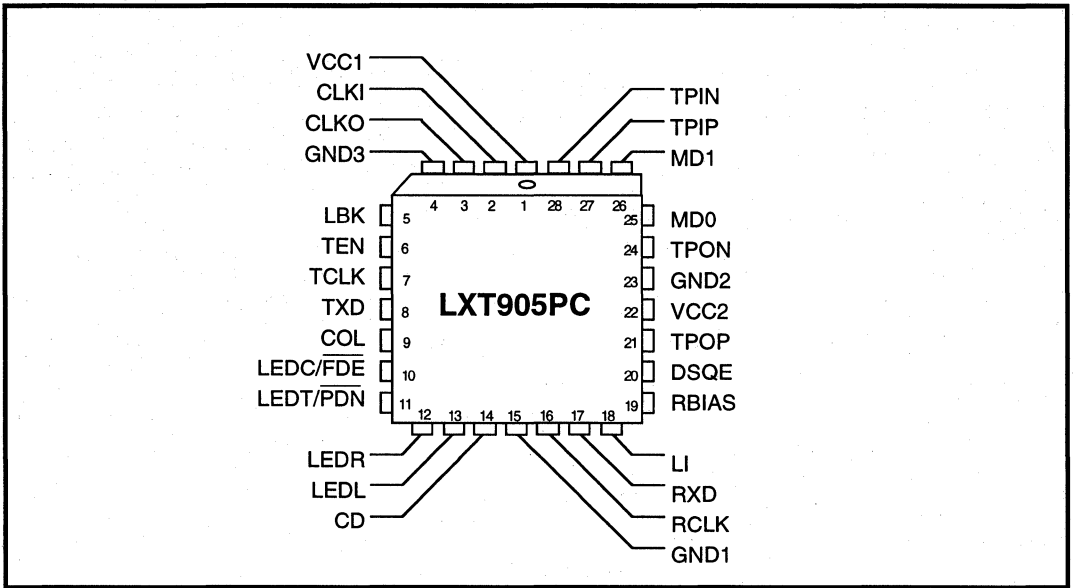

Table 1: Pin Descriptions

Pin #	Sym	I/O	Name	Description
1 22	VCC1 VCC2	— —	Power Input 1 Power Input 2	Power supply inputs: +5 volt or +3.3 volt.
2 3	CLKI CLKO	I O	Crystal Oscillator	A 20 MHz crystal must be connected across these pins, or a 20 MHz clock applied at CLKI with CLKO left open.
4 15 23	GND3 GND1 GND2	— — —	Ground 3 Ground 1 Ground 2	Ground.
5	LBK	I	Loopback	When High, forces internal loopback. Disables collision and the transmission of both data and link pulses. Pulled Low internally.
6	TEN	I	Transmit Enable	Enables data transmission and starts the watchdog timer. Synchronous to TCLK. Pulled Low internally.
7	TCLK	O	Transmit Clock	A 10 MHz clock output. This clock signal should be directly connected to the transmit clock input of the controller.
8	TXD	I	Transmit Data	Input signal containing NRZ data to be transmitted on the network. TXD should be connected directly to the transmit data output of the controller. Pulled Low internally.
9	COL	O	Collision Signal	Output that drives the collision detect input of the controller.

Table 1: Pin Descriptions - continued

Pin #	Sym	I/O	Name	Description
10	LEDC/ FDE	O I	LED Collision or Full Duplex Enable	Open drain driver for the collision indicator pulls Low during collision. LED "on" (<i>i.e.</i> , Low output) time is extended by approximately 100 ms. Enables full duplex mode (external loopback) if tied Low externally. Pulled high internally.
11	LEDT/ PDN	O I	LED Transmit or Power Down	Open drain driver for the transmit indicator. LED "on" (<i>i.e.</i> , Low output) time is extended by approximately 100 ms. Output is pulled Low during transmit. If externally tied Low, the LXT905 goes to power down state. In Power-down Mode, all logic inputs and outputs are tristated.
12	LEDR	O	LED Receive	Open drain driver for the receive indicator LED. LED "on" (<i>i.e.</i> , Low output) time is extended by approximately 100 ms. Output is pulled Low during receive. Pulled High internally.
13	LEDL	O	LED Link	Open drain driver for link integrity indicator. Output is pulled Low during link test pass. Pulled High internally.
14	CD	O	Carrier Detect	An output for notifying the controller that activity exists on the network.
16	RCLK	O	Receive Clock	A recovered 10 MHz clock which is synchronous to the received data and connected to the controller receive clock input.
17	RXD	O	Receive Data	Output signal connected directly to the receive data input of the controller.
18	LI	I	Link Enable	Controls link integrity test; enabled when LI = 1, disabled when LI = 0. Pulled High internally.
19	RBIAS	I	Bias Circuitry	A 7.5 k Ω 1% resistor to ground at this pin controls operating circuit bias.
20	DSQE	I	SQE Disable	When DSQE = 1, the SQE function is disabled. When DSQE = 0, the SQE function is enabled. SQE should be disabled for normal operation in Hub/Switch/Repeater applications. Pulled Low internally.
21 24	TPOP TPON	O O	Twisted Pair Output Pair	Differential outputs to the twisted-pair cable. The outputs are pre-equalized.
25 26	MD0 MD1	I I	Mode Select 0 Mode Select 1	Mode select pins determine controller compatibility mode in accordance with Table 2. Pulled Low internally.
27 28	TPIP TPIN	I I	Twisted-Pair Receive Pair	A differential input pair from the twisted-pair cable. Receive filter is integrated on-chip. No external filters are required.

FUNCTIONAL DESCRIPTION

NOTE

This information is for design aid only.

The LXT905 Universal Ethernet Interface Transceiver performs the physical layer signaling (PLS) and Media Attachment Unit (MAU) functions as defined by the IEEE 802.3 specification. It functions as an integrated PLS/MAU for use with 10BASE-T twisted-pair networks.

The LXT905 interfaces a back end controller to a twisted-pair (TP) cable. The controller interface includes transmit and receive clock and NRZ data channels, as well as mode control logic and signaling. The twisted-pair interface comprises two circuits: Twisted-Pair Input (TPI) and Twisted-Pair Output (TPO). In addition to the two basic interfaces, the LXT905 contains an internal crystal oscillator and four LED drivers for visual status reporting.

Functions are defined from the back end controller side of the interface. The LXT905 Transmit function refers to data transmitted by the back end to the twisted-pair network. The LXT905 Receive function refers to data received by the back end from the twisted-pair network. The LXT905 performs all required functions defined by the IEEE 802.3 10BASE-T MAU specification such as collision detection, link integrity testing, signal quality error messaging, jabber control and loopback.

CONTROLLER COMPATIBILITY MODES

The LXT905 is compatible with most industry standard controllers including devices produced by Advanced Micro Devices (AMD), Intel, Fujitsu, National Semiconductor, Seeq, Motorola and Texas Instruments. Four different control signal timing and polarity schemes (Modes 1 through 4) are required to achieve this compatibility. Mode select

pins (MD0 and MD1) determine controller compatibility modes as listed in Table 2. Refer to the Test Specifications section for timing diagrams and parameters.

TRANSMIT FUNCTION

The LXT905 receives NRZ data from the controller at the TXD input as shown in the block diagram, and passes it through a Manchester encoder. The encoded data is then transferred to the twisted-pair network (the TPO circuit). The advanced integrated pulse shaping and filtering network produces the output signal on TPON and TPOP, shown in Figure 2. The TPO output is pre-distorted and prefiltered to meet the 10BASE-T jitter template. An internal continuous resistor-capacitor filter is used to remove any high-frequency clocking noise from the pulse shaping circuitry. Integrated filters simplify the design work required for FCC compliant EMI performance. During idle periods, the LXT905 transmits link integrity test pulses on the TPO circuit (if LI is enabled and LBK is disabled).

JABBER CONTROL FUNCTION

Figure 3 is a state diagram of the LXT905 jabber control function. The LXT905 on-chip watchdog timer prevents the DTE from locking into a continuous transmit mode. When a transmission exceeds the time limit, the watchdog timer disables the transmit and loopback functions and activates the COL pin. Once the LXT905 is in the jabber state, the TXD circuit must remain idle for a period of 0.25 to 0.75 seconds before it will exit the jabber state.

Figure 2: LXT905 TPO Output Waveform

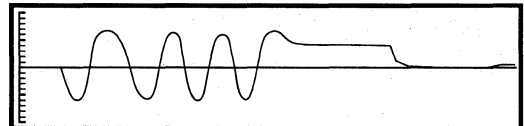

Table 2: Controller Compatibility Mode Options

Controller Mode:	Setting:	
	MD1	MD0
Mode 1 - For Advanced Micro Devices AM7990 or compatible controllers	Low	Low
Mode 2 - For Intel 82596 or compatible controllers ¹	Low	High
Mode 3 - For Fujitsu MB86950, MB86960 or compatible controllers (Seeq 8005 ²)	High	Low
Mode 4 - For National Semiconductor 8390 or compatible controllers (TI TMS380C26)	High	High

1. Refer to Level One Application Note 51 when designing with Intel controllers.
 2. SEEQ controllers require inverters on CLKI, LBK, RCLK and COL.

SQE FUNCTION

The LXT905 supports the signal quality error (SQE) function as shown in Figure 4. After every successful transmission on the 10BASE-T network, the LXT905 transmits the SQE signal for 10 bit times (BT) \pm 5BT on the COL pin of the device.

The SQE can be disabled for repeater/switch applications. When DSQE = 1, the SQE function is disabled. When DSQE = 0, the SQE function is enabled.

RECEIVE FUNCTION

The LXT905 receive function acquires timing and data from the twisted-pair network (the TPI circuit). Valid received signals are passed through the on-chip filters and Manchester decoder then output as decoded NRZ data and receive timing on the RXD and RCLK pins, respectively.

An internal RC filter and an intelligent squelch function discriminate noise from link test pulses and valid data streams. The receive function is activated only by valid data streams above the squelch level and with proper timing. If the differential signal at the TPI circuit inputs falls below 85% of the threshold level (unsquelched) for 8 bit times (typical), the LXT905 receive function enters the idle state. The LXT905 automatically corrects reversed polarity on the TPI circuit.

POLARITY REVERSE FUNCTION

The LXT905 polarity reverse function uses both link pulses and end-of-frame data to determine polarity of the received signal. A reversed polarity condition is detected when eight consecutive opposite receive link pulses are detected without receipt of a link pulse of the expected polarity. Reversed polarity is also detected if four consecutive frames are

Figure 3: Jabber Control Function

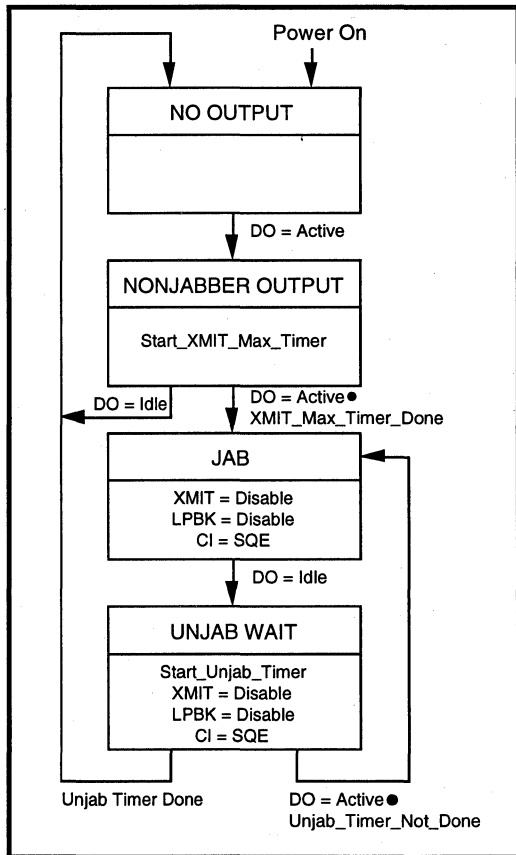
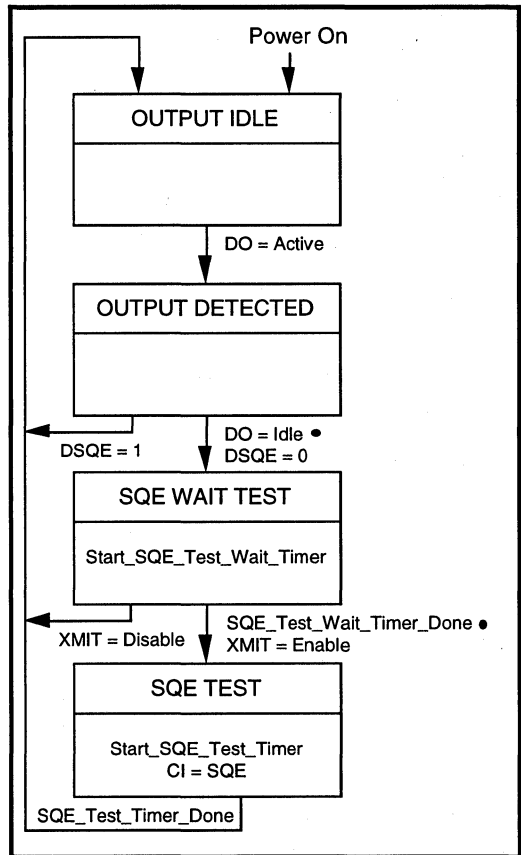

Figure 4: SQE Function



received with a reversed start-of-idle. Whenever a correct polarity frame or a correct link pulse is received, these two counters are reset to zero. If the LXT905 enters the link fail state and no valid data or link pulses are received within 96 to 128 ms, the polarity is reset to the default non-flipped condition. (If Link Integrity testing is disabled, polarity detection is based only on received data.) Polarity correction is always enabled.

COLLISION DETECTION FUNCTION

A collision is defined as the simultaneous presence of valid signals on both the TPI circuit and the TPO circuit. The LXT905 reports collisions to the back-end via the COL pin. If the TPI circuit becomes active while there is activity on the TPO circuit, the TPI data is passed to the back-end over the RXD circuit, disabling normal loopback. Figure 5 is a state diagram of the LXT905 collision detection function.

LOOPBACK FUNCTION

The LXT905 provides the normal loopback function specified by the 10BASE-T standard for the twisted-pair port, as well as a forced loopback function. The loopback function operates in conjunction with the transmit function. Data transmitted by the back-end is internally looped back within the LXT905 from the TXD pin through the Manchester encoder/decoder to the RXD pin and returned to the back-end. This "normal" loopback function is disabled when a data collision occurs, clearing the RXD circuit for the TPI data. Normal loopback is also disabled during link fail, jabber, and full duplex states. Loopback is always enabled during the forced loopback state.

The LXT905 provides an additional loopback function. External loopback mode, useful for system-level testing, is controlled by the LEDC/FDE pin. With both LEDC/FDE and LBK low, the LXT905 device:

- disables internal loopback circuits
- disables SQE
- disables Collision Detection
- enables Full Duplex Mode

This allows external loopback testing.

Figure 5: Collision Detection Function

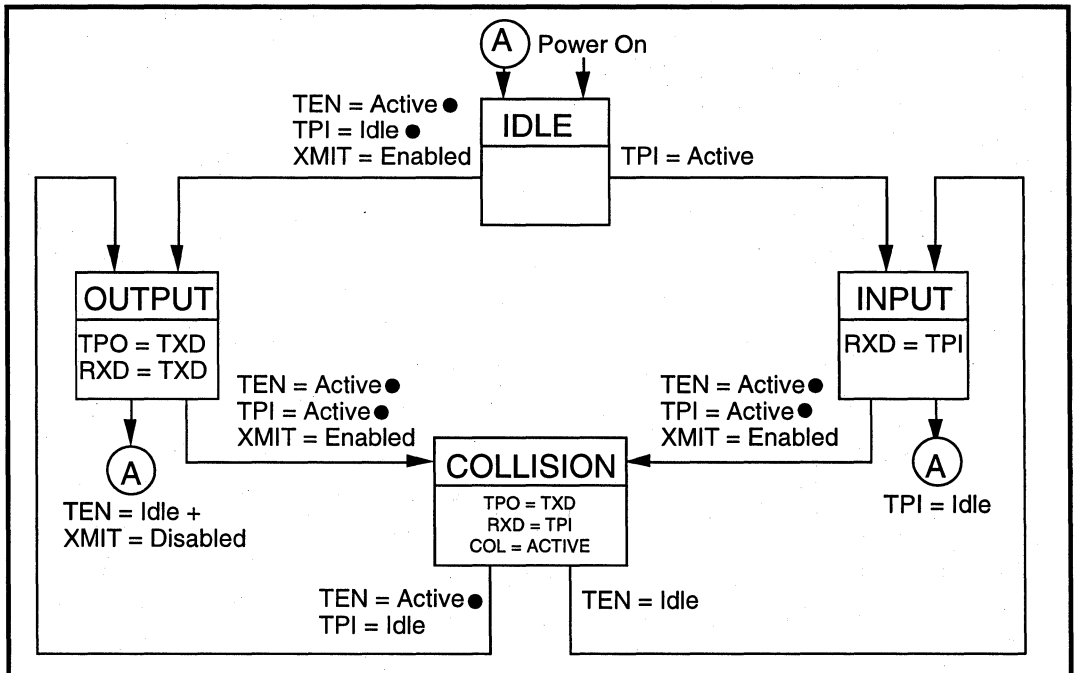

LINK INTEGRITY TEST FUNCTION

Figure 6 is a state diagram of the LXT905 Link Integrity test function. The link integrity test is used to determine the status of the receive side twisted-pair cable. Link integrity testing is enabled when pin 18 (LI) is tied high. When enabled, the receiver recognizes link integrity pulses which are transmitted in the absence of receive traffic. If no serial

data stream or link integrity pulses are detected within 50~150 ms, the chip enters a link fail state and disables the transmit and normal loopback functions. The LXT905 ignores any link integrity pulse with interval less than 2~7 ms. The LXT905 will remain in the Link Fail State until it detects either a serial data packet or two or more link integrity pulses.

Figure 6: Link Integrity Test Function

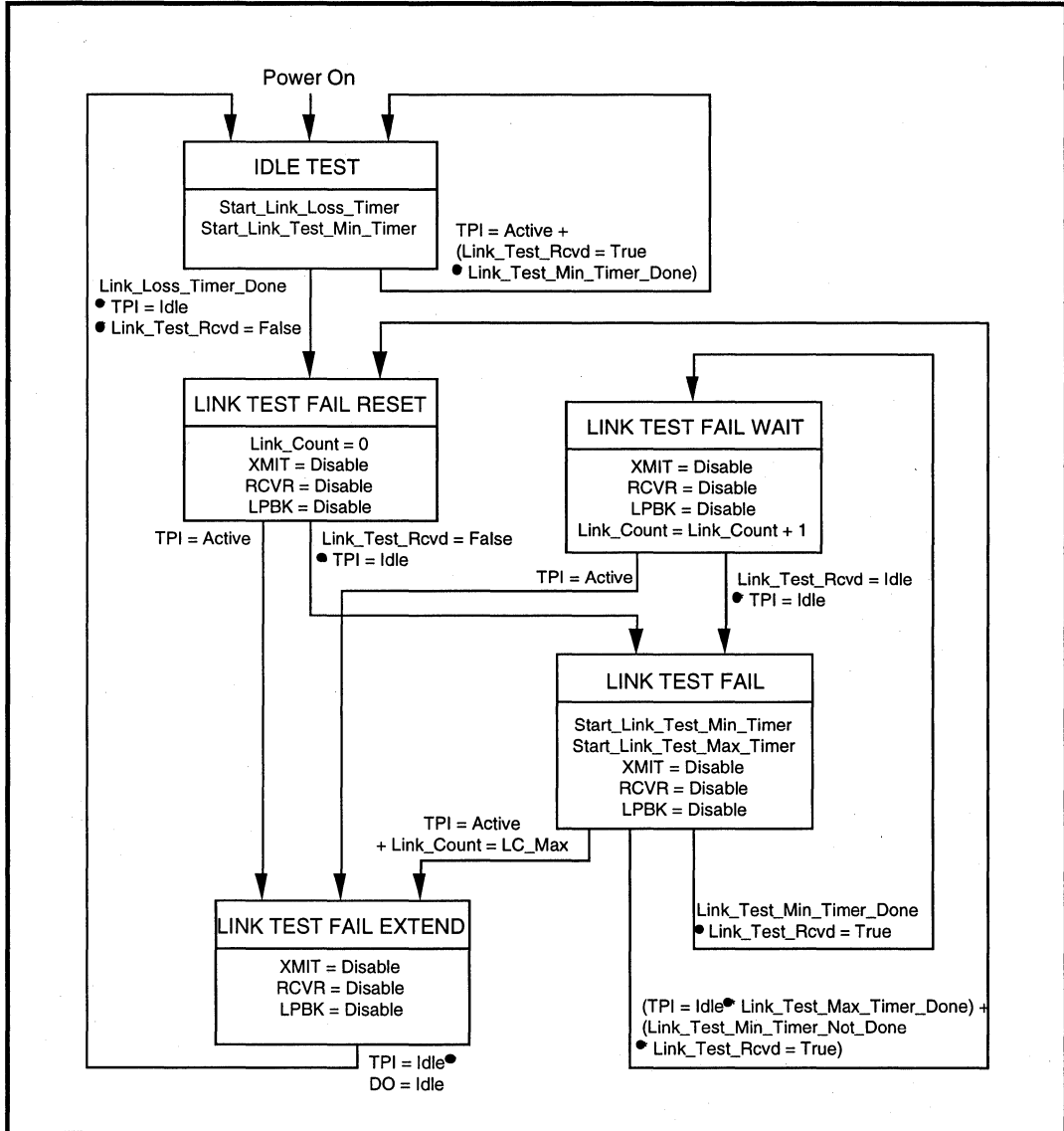

APPLICATION INFORMATION

NOTE

This information is for design aid only.

These diagrams group similar pins; they do not portray the actual chip pinout. The controller interface pins (transmit data, clock and enable; receive data and clock; and the collision detect and carrier detect pins) are at the upper left.

Power and ground pins are at the bottom of each diagram. VCC1 and VCC2 use a single power supply with decoupling capacitors installed between the power and ground busses.

The TP interfaces are at the upper right. The I/O pairs have impedance matching resistors but require no external filters.

Transformers for these designs are available from various manufacturers including Valor, FilMag, HALO and Nanopulse. Contact supplier for current part numbers. Test transformer for correct values. Verify 10BASE-T compliance of system design.

TYPICAL 10BASE-T APPLICATION

Figure 7 is a typical LXT905 application. The DTE is connected to a 10BASE-T network through the twisted-pair RJ45 connector. With MD0 tied high and MD1 grounded, the LXT905 logic and framing are set to Mode 2 (compatible with Intel 82596 controllers*). Connect 20 MHz system clock input at CLKI. (Leave CLKO open.) The LI pin externally controls the link test function.

* Refer to Level One Application Note 51 when designing with Intel controllers.

Figure 7: Intel Controller Application (Mode 2)

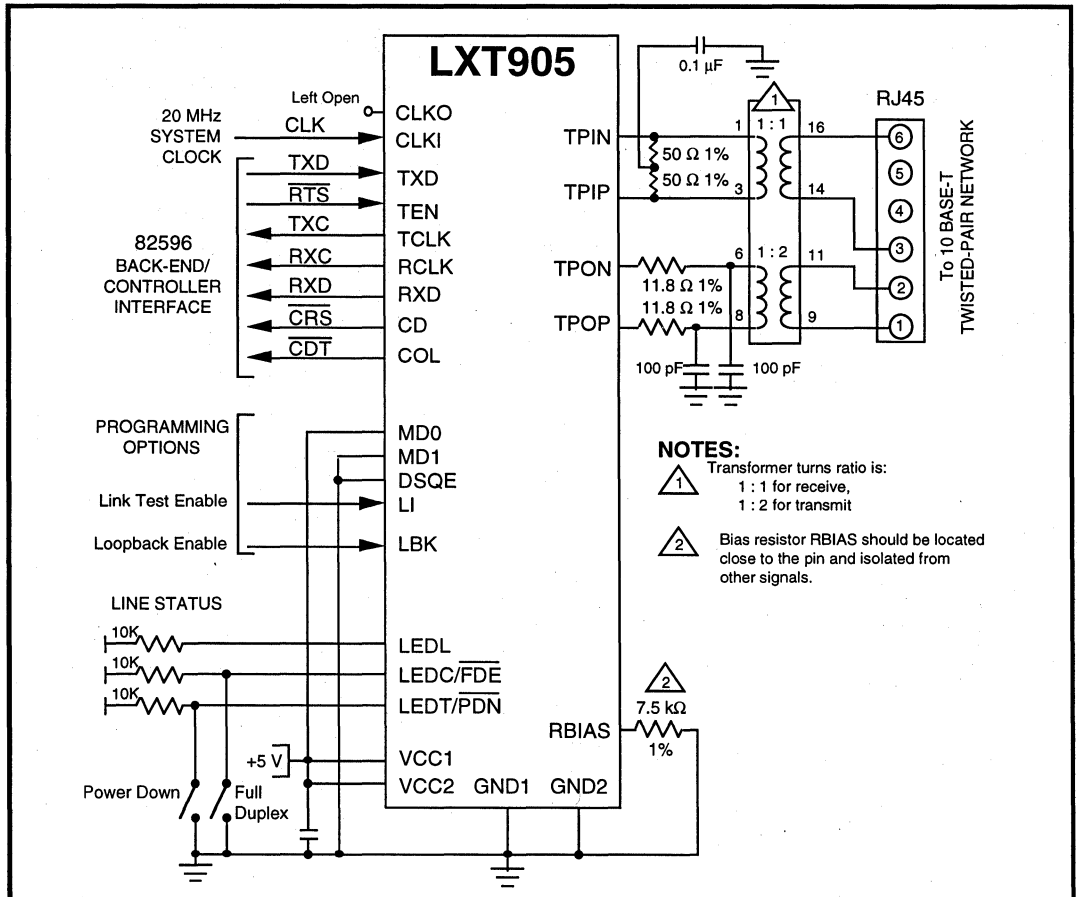

LXT905 Universal Ethernet Interface Adapter

SIMPLE 10BASE-T CONNECTION

Figure 9 shows a simple 10BASE-T application using an LXT905 transceiver and a Motorola MC68EN360. The MC68EN360 is compatible with Mode 1 (MD0 and MD1 both low).

Figure 9: LXT905/MC68EN360 Interface for Full Duplex 10BASE-T (Mode 1)

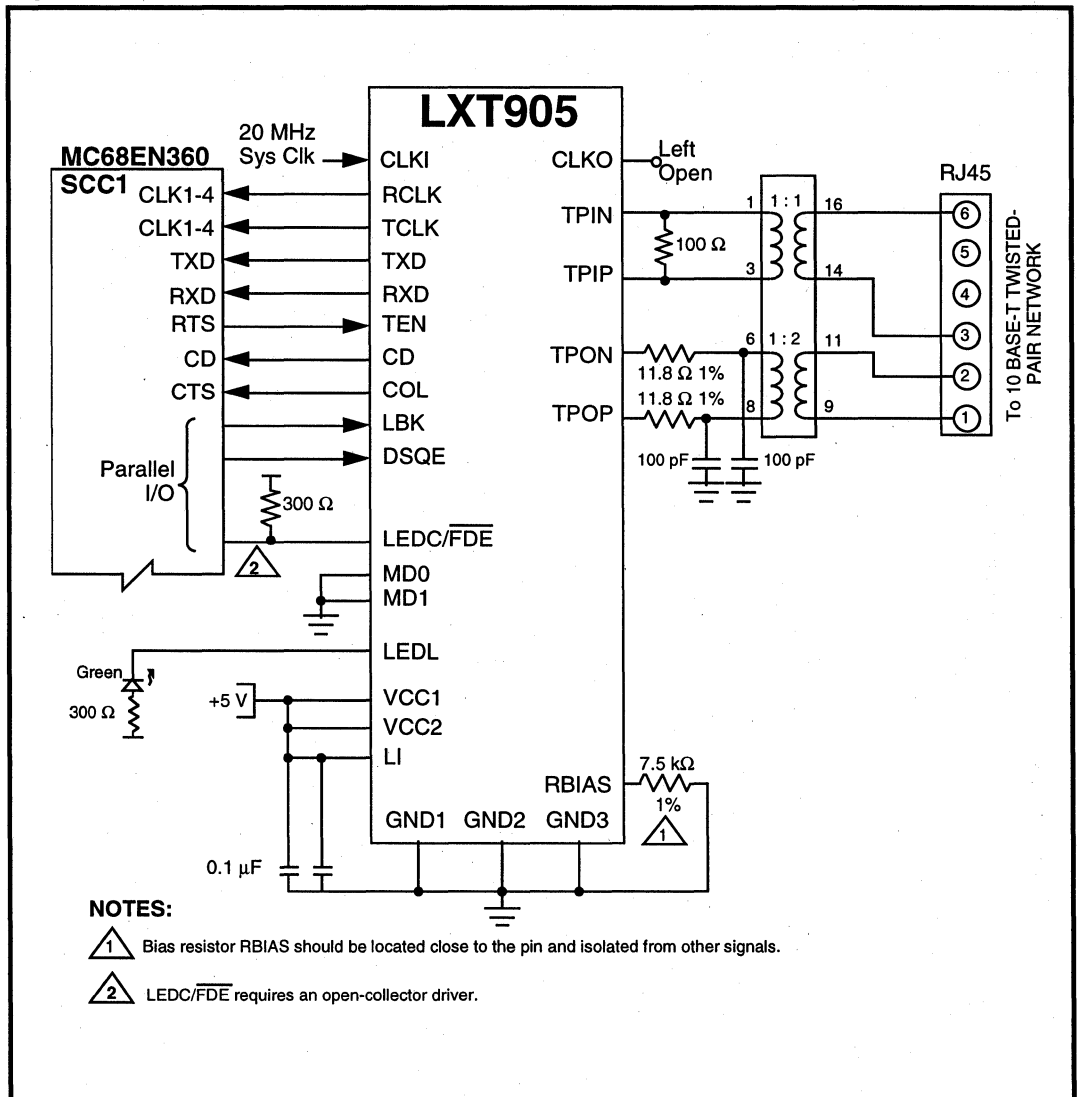

TEST SPECIFICATIONS

NOTE

Minimum and maximum values in Tables 3 through 11 and Figures 10 through 25 represent the specifications of the LXT905 and are guaranteed by test except, as noted, by design.

Table 3: Absolute Maximum Ratings

Parameter	Symbol	Min	Max	Units	Comments
Supply Voltage	V _{CC}	-0.3	+6	V	
Operating temperature	T _{OP}	0	+70	°C	
Storage temperature	T _{ST}	-65	+150	°C	

CAUTION

Exceeding these values may cause permanent damage. Functional operation under these conditions is not implied. Exposure to maximum rating conditions for extended periods may affect device reliability.

Table 4: Recommended Operating Conditions

(Voltage with respect to ground unless otherwise specified)

Parameter	Symbol	Min	Typ ¹	Max	Units	Test Conditions
Recommended supply voltage	V _{CC}	3.135	5.0	5.25	V	
Recommended operating temperature	T _{OP}	0	—	70	°C	

1. Typical figures are at 25 °C and are for design aid only; not guaranteed and not subject to production testing.

Table 5: I/O Electrical Characteristics (Under Recommended Operating Conditions)

Parameter	Symbol	Min	Typ ¹	Max	Units	Test Conditions	
Input low voltage ²	V _{IL}	—	—	0.8	V		
Input high voltage ²	V _{IH}	2.0	—	—	V		
Output low voltage	V _{OL}	—	—	0.4	V	I _{OL} = 1.6 mA	
Output low voltage	V _{OL}	—	—	10	% V _{CC}	I _{OL} < 10 μA	
Output low voltage (Open drain LED Driver)	V _{OLL}	—	—	0.7	V	I _{OLL} = 10 mA	
Output high voltage	V _{OH}	2.4	—	—	V	I _{OH} = 40 μA	
Output high voltage	V _{OH}	90	—	—	% V _{CC}	I _{OH} < 10 μA	
Output rise time	CMOS	—	—	3	ns	C _{LOAD} = 20 pF	
TCLK & RCLK	TTL	—	—	2	ns		
Output fall time	CMOS	—	—	3	ns	C _{LOAD} = 20 pF	
TCLK & RCLK	TTL	—	—	2	ns		
CLKI rise time (externally driven) ²	—	—	—	10	ns		
CLKI duty cycle (externally driven) ²	—	—	50/50	40/60	%		
Supply current	Normal Mode	I _{CC}	—	40	80	mA	Idle Mode
		I _{CC}	—	70	100	mA	Transmitting on TP
	Power Down mode	I _{CC}	—	0.01	1	μA	

1. Typical figures are at 25 °C and are for design aid only; not guaranteed and not subject to production testing.

2. Limited functional test patterns are performed at these input levels. The majority of functional tests are performed at levels of 0 V and 3 V. This applies to all inputs except TPIP and TPIN.

LXT905 Universal Ethernet Interface Adapter

Table 6: TP Electrical Characteristics (Under Recommended Operating Conditions)

Parameter	Symbol	Min	Typ ¹	Max	Units	Test Conditions
Transmit output impedance	Z _{OUT}	–	2	–	Ω	
Transmit timing jitter addition ²	–	–	± 6.4	± 10	ns	0 line length for internal MAU
Transmit timing jitter added by the MAU and PLS sections ^{2,3}	–	–	± 3.5	± 5.5	ns	After line model specified by IEEE 802.3 for 10BASE-T internal MAU
Receive input impedance	Z _{IN}	–	24	–	kΩ	Between TPIP/TPIN
Differential squelch threshold	V _{Ds}	300	420	585	mV	5 MHz square-wave input

1. Typical figures are at 25 °C and are for design aid only; not guaranteed and not subject to production testing.
 2. Parameter is guaranteed by design; not subject to production testing.
 3. IEEE 802.3 specifies maximum jitter additions at 0.5 ns from the encoder, and 3.5 ns from the MAU.

Table 7: Switching Characteristics (Under Recommended Operating Conditions)

Parameter	Symbol	Minimum	Typical ¹	Maximum	Units
Jabber Timing:					
Maximum transmit time	–	20	–	150	ms
Unjab time	–	250	–	750	ms
Link Integrity Timing:					
Time link loss receive	–	50	–	150	ms
Link Min receive	–	2	–	7	ms
Link Max receive	–	50	–	150	ms
Link Transmit period	–	8	10	24	ms

1. Typical figures are at 25 °C and are for design aid only; not guaranteed and not subject to production testing.

Table 8: RCLK/Start-of-Frame Timing (Under Recommended Operating Conditions)

Parameter	Symbol	Minimum	Typical ¹	Maximum	Units	
Decoder acquisition time	t _{DATA}	—	1300	1500	ns	
CD turn-on delay	t _{CD}	—	400	550	ns	
Receive data setup from RCLK	Mode 1	t _{RDS}	60	70	—	ns
	Modes 2, 3 and 4	t _{RDS}	30	45	—	ns
Receive data hold from RCLK	Mode 1	t _{RDH}	10	20	—	ns
	Modes 2, 3 and 4	t _{RDH}	30	45	—	ns
RCLK shut off delay from CD assert (Mode 3)	t _{SWS}	—	± 100	—	ns	

1. Typical figures are at 25 °C and are for design aid only; not guaranteed and not subject to production testing.

Table 9: RCLK/End-of-Frame Timing (Under Recommended Operating Conditions)

Parameter	Type	Symbol	Mode 1	Mode 2	Mode 3	Mode 4	Units
RCLK hold after CD off	Min	trCH	5	1	—	5	bit times
Recv data throughput delay	Max	trD	400	375	375	375	ns
CD turn off delay ²	Max	tcDOFF	500	475	475	475	ns
Receive block out after TEN off ³	Typ ¹	tIFG	5	50	—	—	bit times
RCLK switching delay after CD off	Typ ¹	tsWE	—	—	120 (±80)	—	ns

1. Typical figures are at 25 °C and are for design aid only; not guaranteed and not subject to production testing.
 2. CD Turnoff delay measured from middle of last bit; timing specification is unaffected by the value of the last bit.
 3. Blocking of Carrier Detect is disabled during full duplex operation.

Table 10: Transmit Timing (Under Recommended Operating Conditions)

Parameter	Symbol	Minimum	Typical ¹	Maximum	Units
TEN setup from TCLK	tEHCH	22	—	—	ns
TXD setup from TCLK	tDSCH	22	—	—	ns
TEN hold after TCLK	tCHEL	5	—	—	ns
TXD hold after TCLK	tCHDU	5	—	—	ns
Transmit start-up delay	tSTUD	—	350	450	ns
Transmit throughput delay	tTPD	—	338	350	ns

1. Typical figures are at 25 °C and are for design aid only; not guaranteed and not subject to production testing.

Table 11: Miscellaneous Timing (Under Recommended Operating Conditions)

Parameter	Symbol	Minimum	Typical ¹	Maximum	Units
COL (SQE) Delay after TEN off ²	tsQED	0.65	—	1.6	µs
COL (SQE) Pulse Duration ²	tsQEP	500	—	1500	ns
Power Down recovery time	tPDR	—	25	—	ms

1. Typical figures are at 25 °C and are for design aid only; not guaranteed and not subject to production testing.
 2. When SQE is enabled (DSQE=0).

Figures 10 through 13 - Timing Diagrams for Mode 1 (MD1 = 0, MD0 = 0)

Figure 10: Mode 1 RCLK/Start-of-Frame Timing

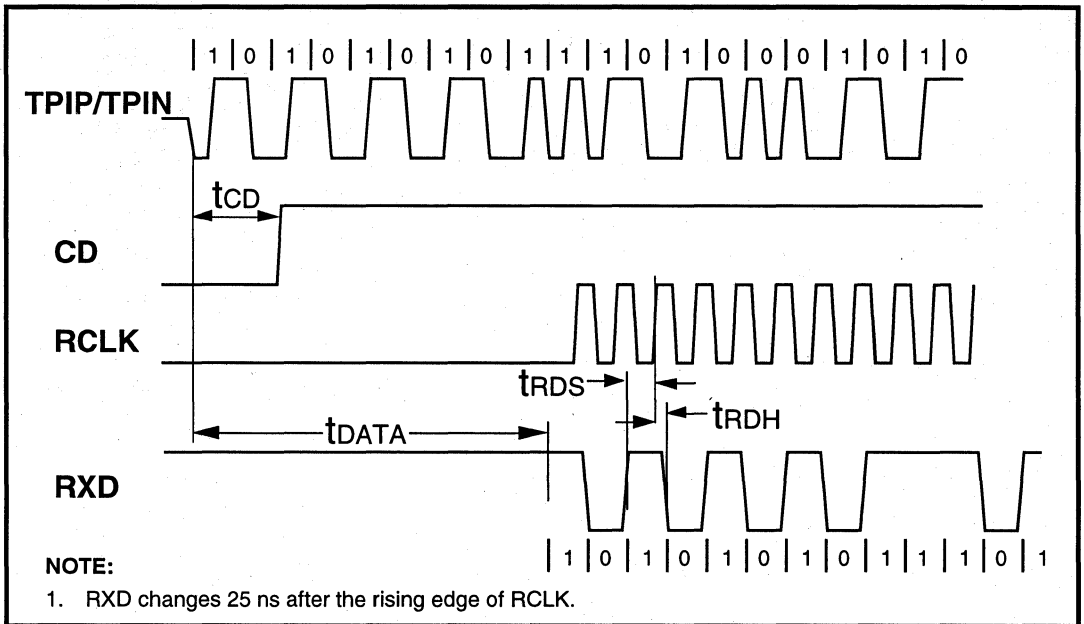

Figure 11: Mode 1 RCLK/End-of-Frame Timing

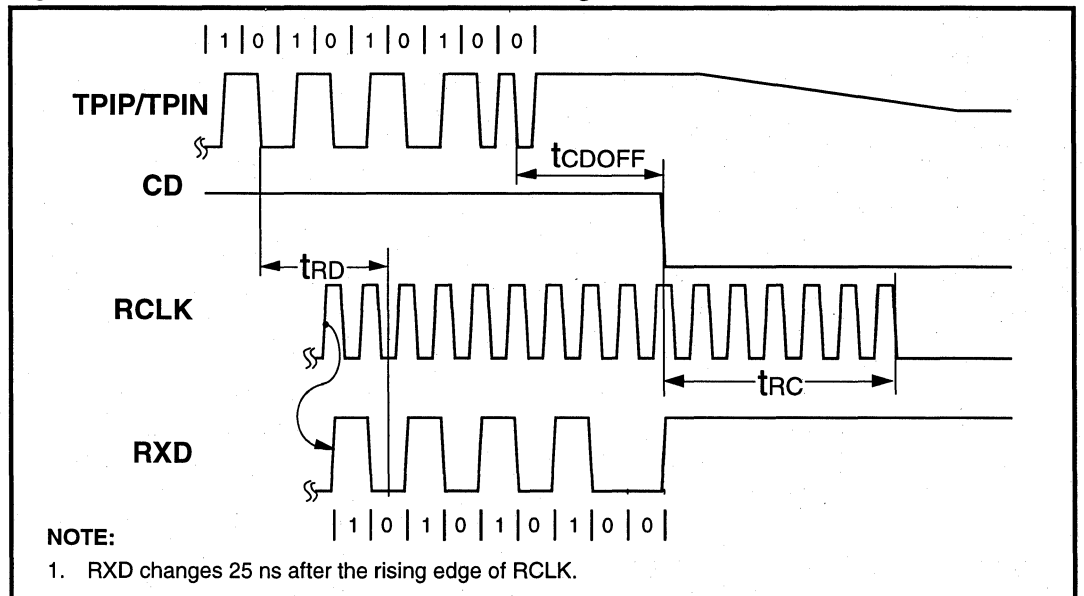

Figure 12: Mode 1 Transmit Timing

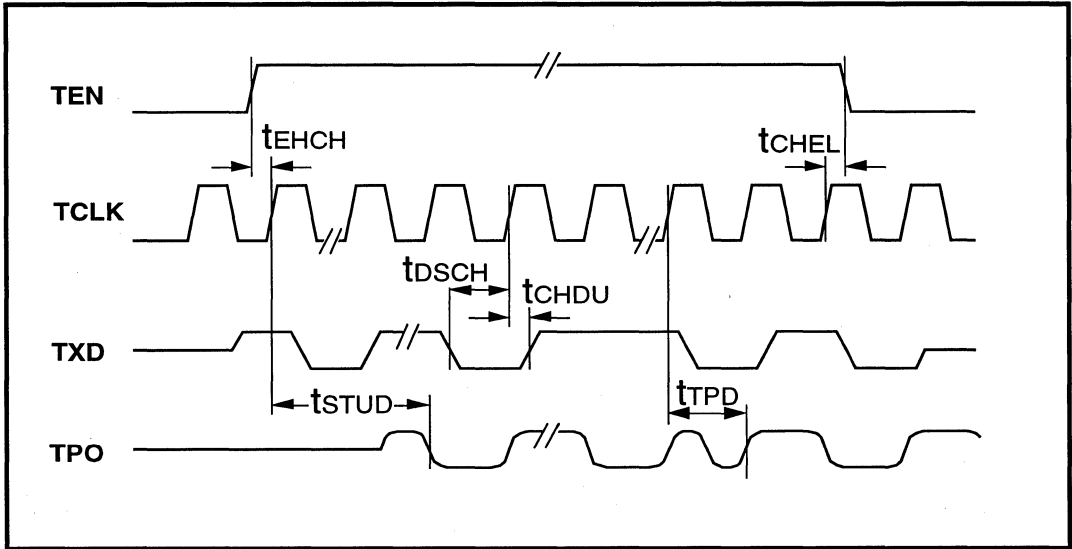
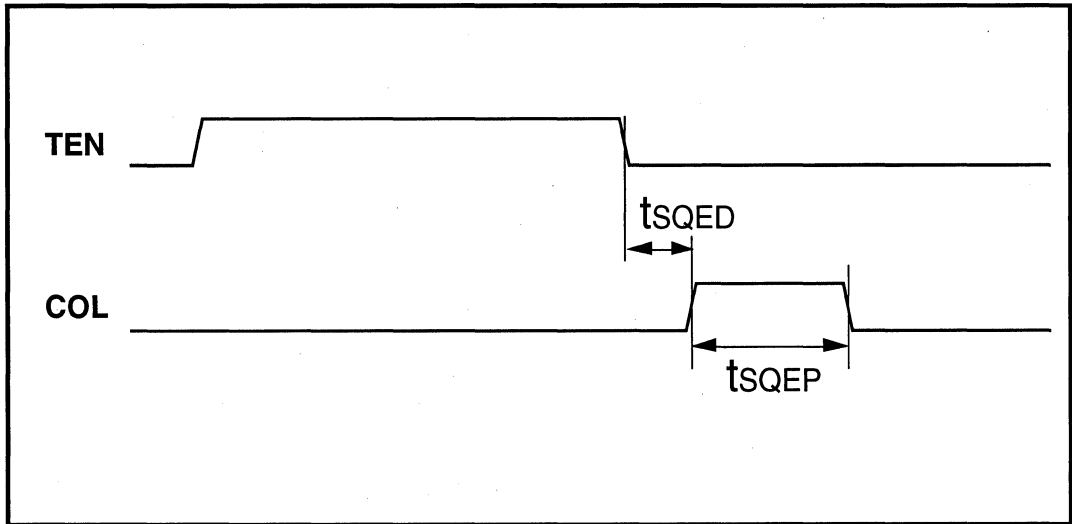

Figure 13: Mode 1 COL Output Timing



Figures 14 through 17 - Timing Diagrams for Mode 2 (MD1 = 0, MD0 = 1)

Figure 14: Mode 2 RCLK/Start-of-Frame Timing

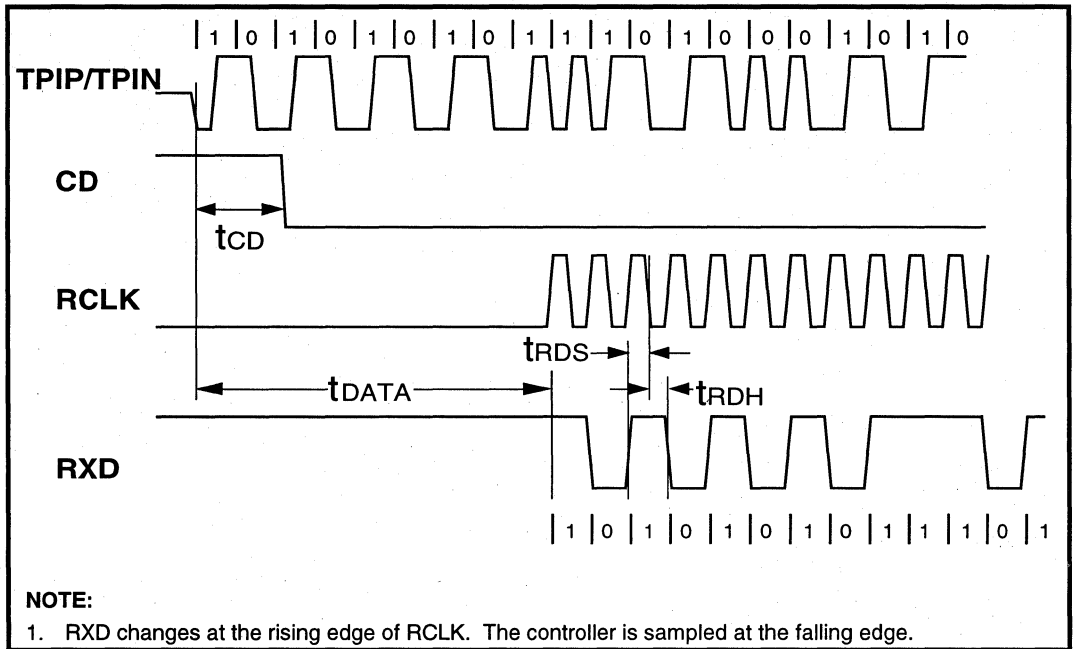

Figure 15: Mode 2 RCLK/End-of-Frame Timing

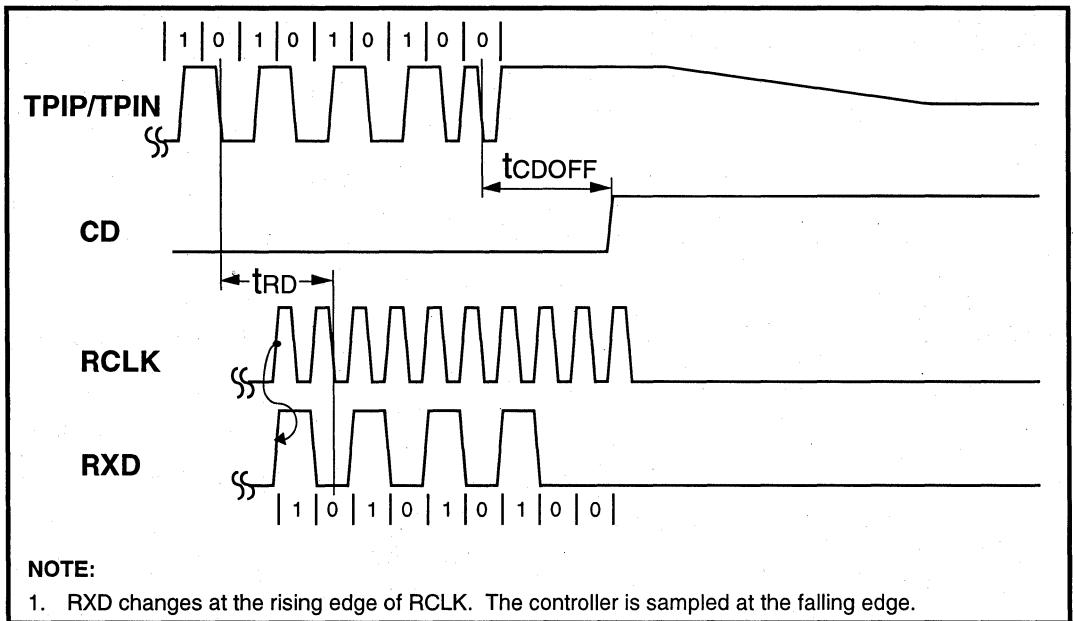

Figure 16: Mode 2 Transmit Timing

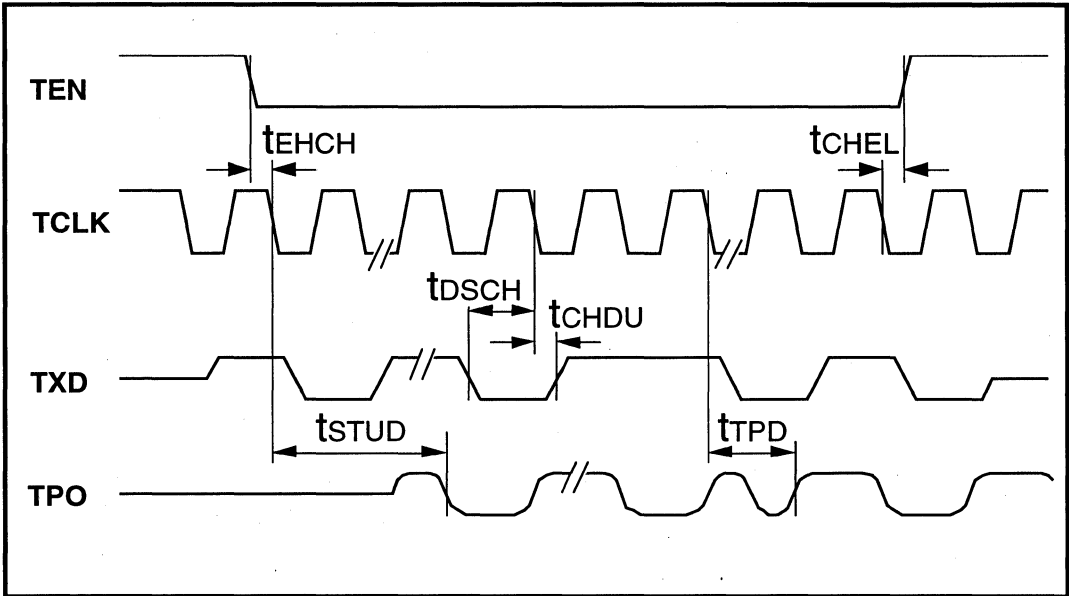
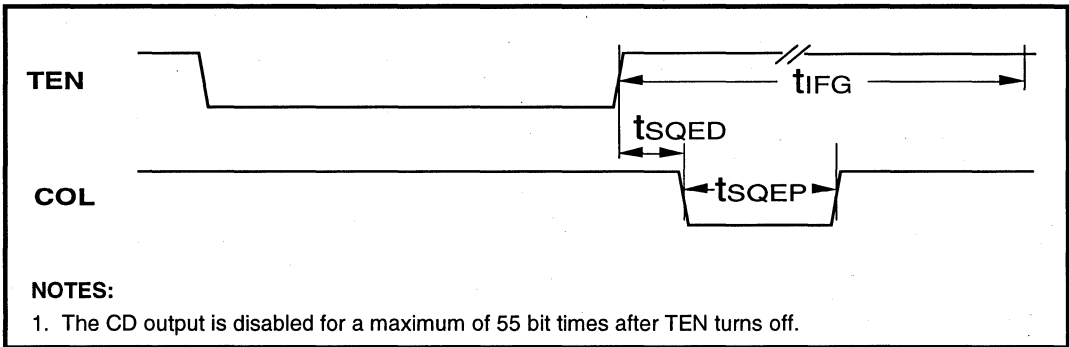

Figure 17: Mode 2 COL Output Timing



Figures 18 through 21 - Timing Diagrams for Mode 3 (MD1 = 1, MD0 = 0)

Figure 18: Mode 3 RCLK/Start-of-Frame Timing

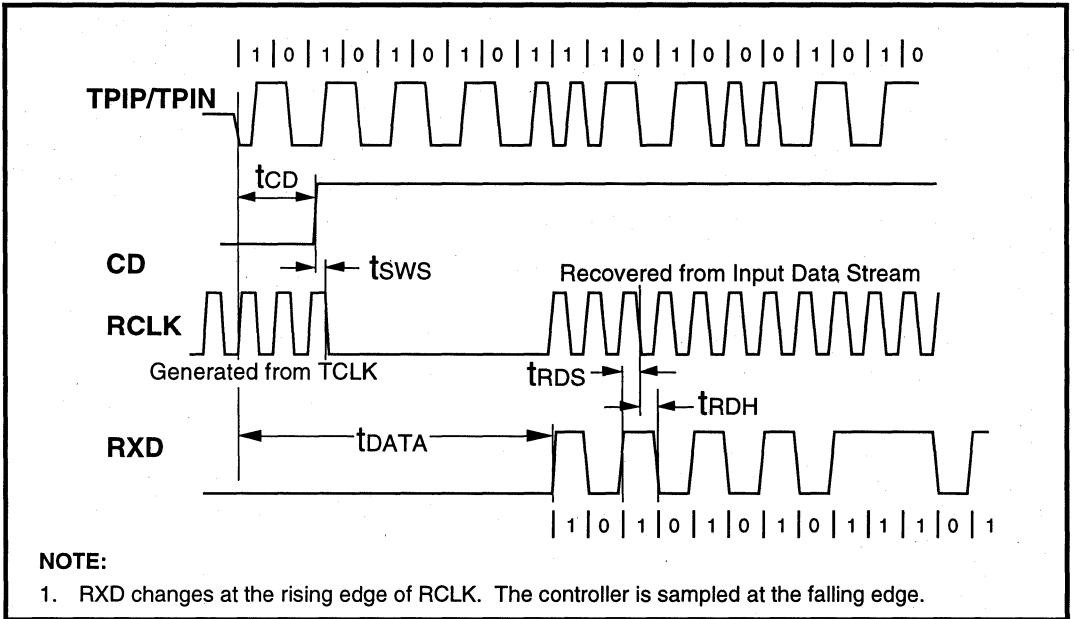

Figure 19: Mode 3 RCLK/End-of-Frame Timing

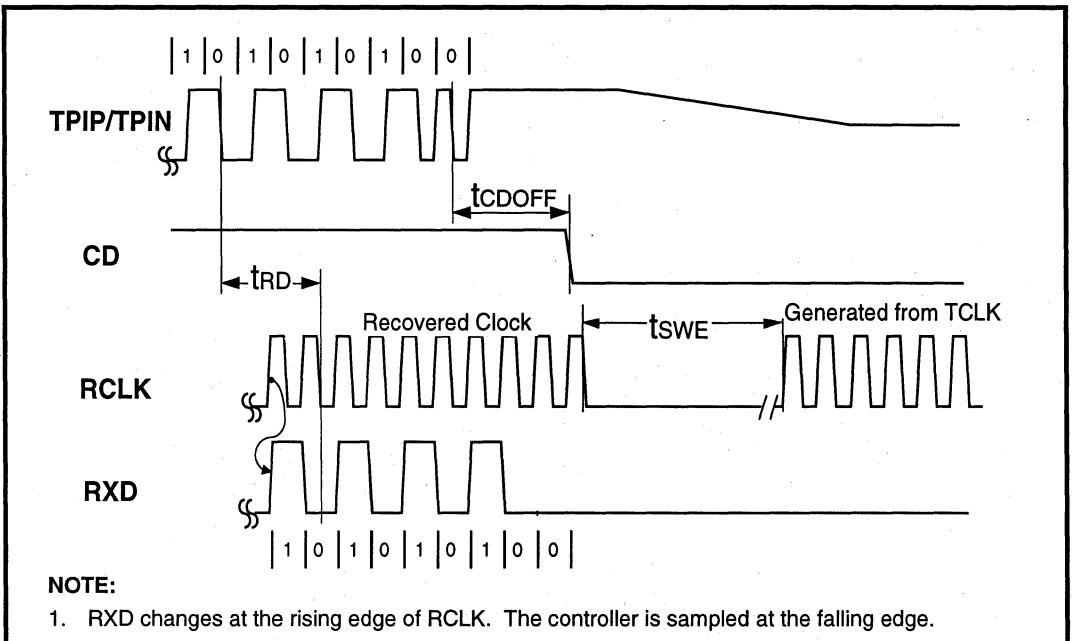

Figure 20: Mode 3 Transmit Timing

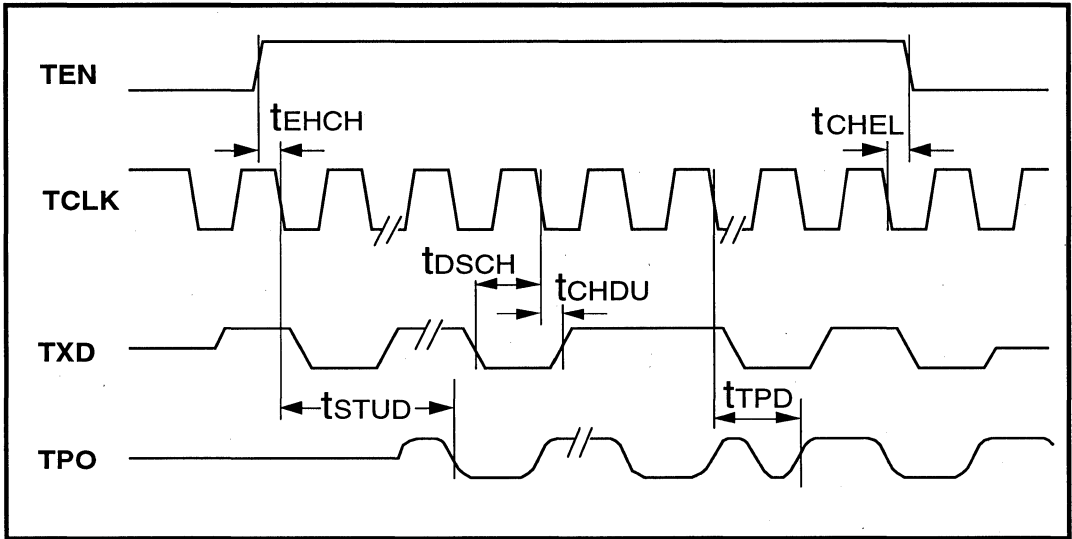
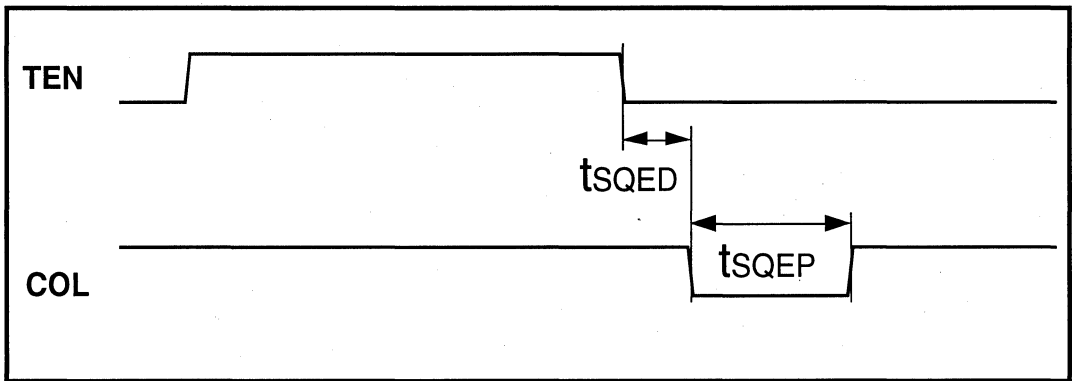

Figure 21: Mode 3 COL Output Timing



Figures 22 through 25 - Timing Diagrams for Mode 4 (MD1 = 1, MD0 = 1)

Figure 22: Mode 4 RCLK/Start of Frame Timing

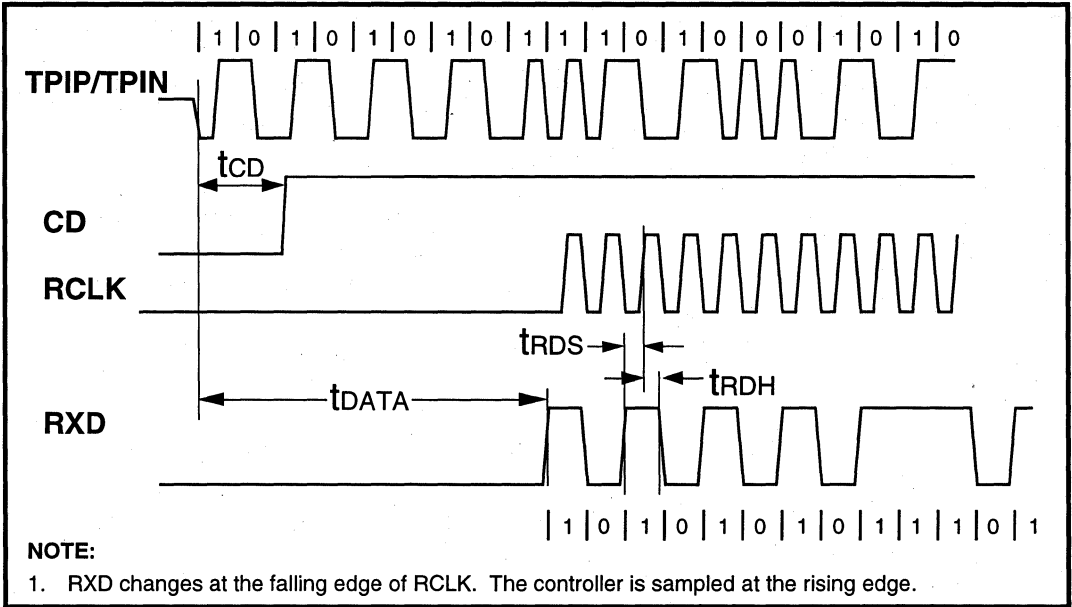

Figure 23: Mode 4 RCLK/End of Frame Timing

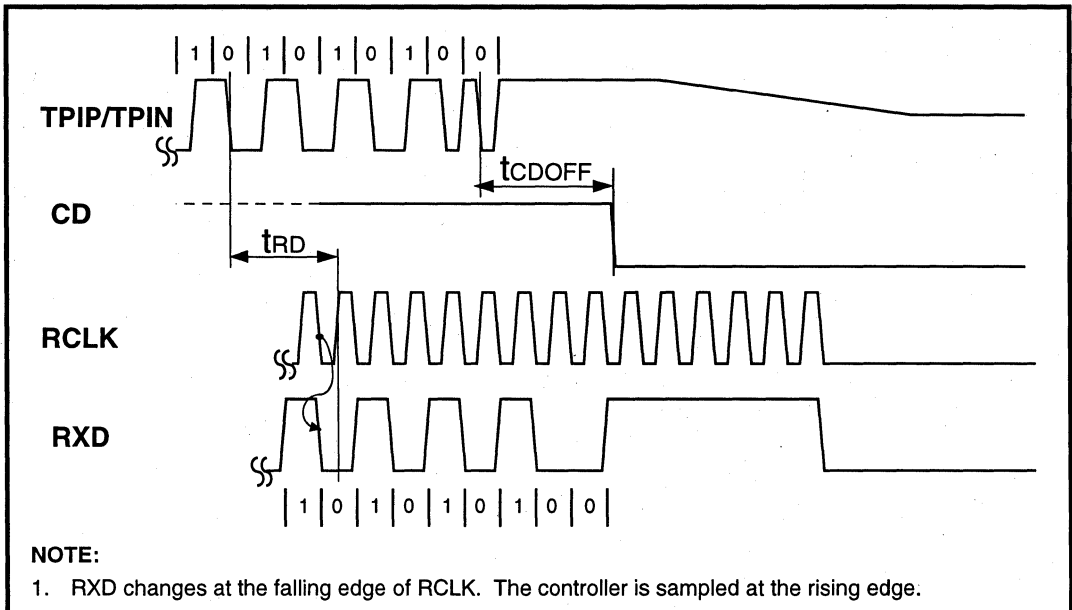

Figure 24: Mode 4 Transmit Timing

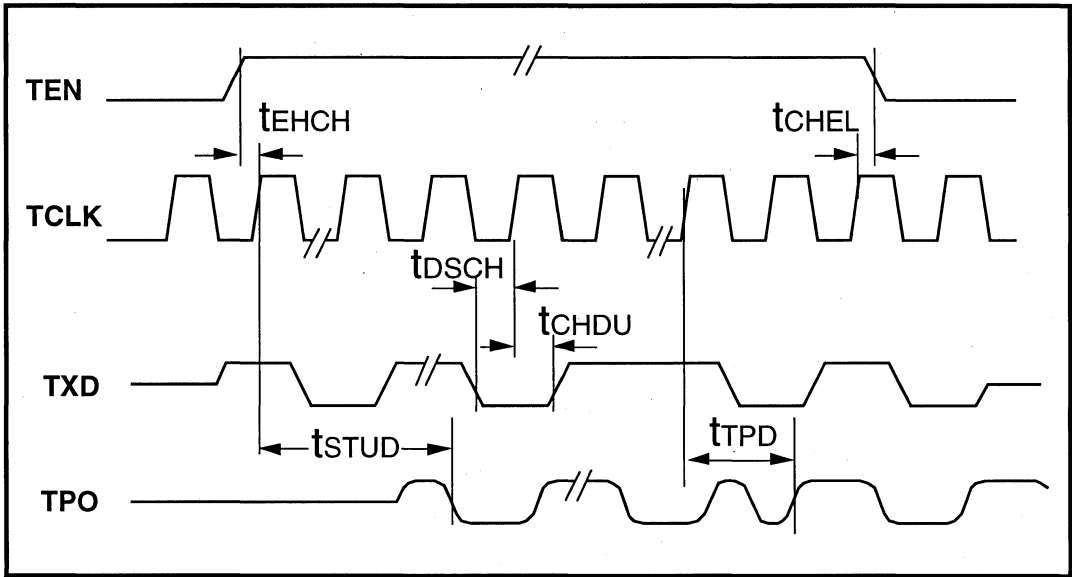
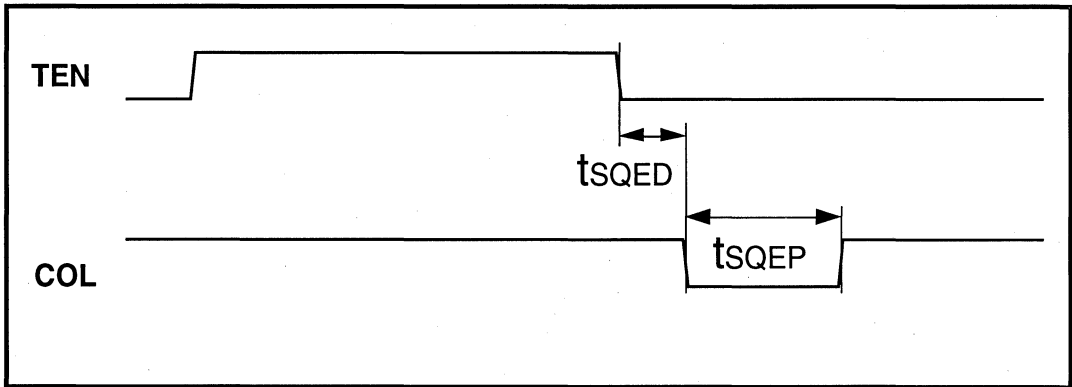

Figure 25: Mode 4 COL Output Timing



LXT905 Universal Ethernet Interface Adapter

NOTES:

LXT906

Ethernet Twisted-Pair/Coax Adapter

General Description

The LXT906 Twisted-Pair/Coax Adapter is designed to allow a cost effective Ethernet implementation in a mixed media environment. Combined with a coax transceiver such as the DP8392, the LXT906 offers a complete adapter solution.

LXT906 functions include level-shifted data pass-through from one transmission media to another, collision detection and propagation, and automatic correction of polarity reversal on the twisted pair input. It also includes LED drivers for jabber, coax receive and collision, twisted pair receive and collision, reversed polarity detect and link indication functions.

The LXT906 is an advanced CMOS device and requires only a single 5 volt power supply.

Applications

- 10BASE-T to Coax (10BASE5 or 10BASE2) converter

Features

- Direct interface to Coax transceiver and to RJ45 connector
- Collision detection and propagation
- Internal predistortion generation
- Internal common mode voltage generation
- Selectable link test
- Twisted-Pair receive polarity reverse detection and correction
- LED drivers for TP and coax receive; TP and coax collision; jabber, link active and reversed polarity indicators
- Single 5 V supply, CMOS technology
- Available in 28-pin PLCC

LXT906 Block Diagram

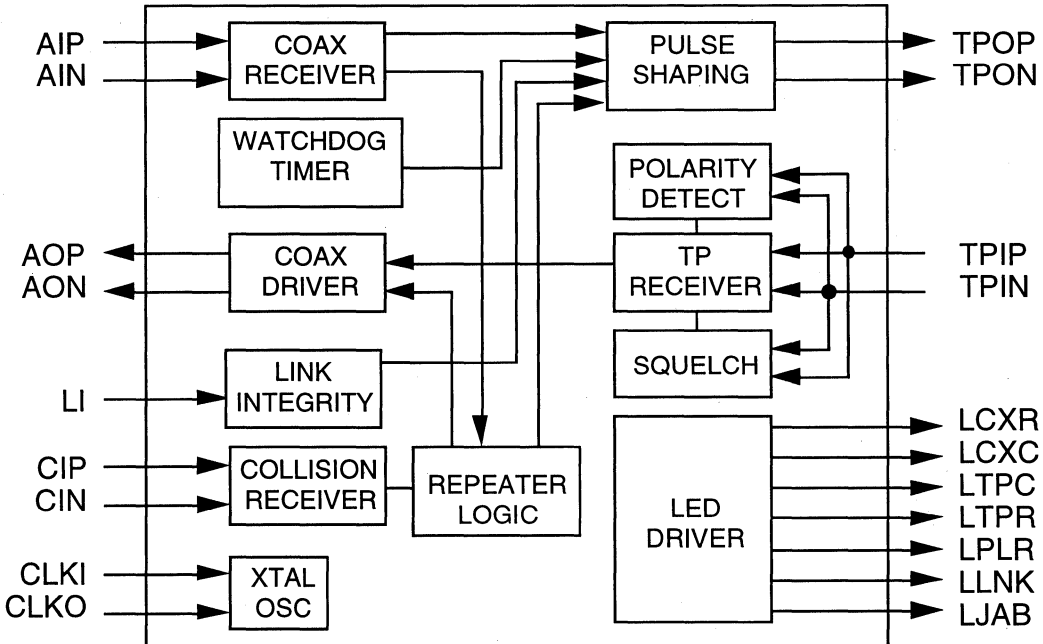

LXT906 Ethernet Twisted-Pair/Coax Adapter

Figure 1: LXT906 Pin Assignments

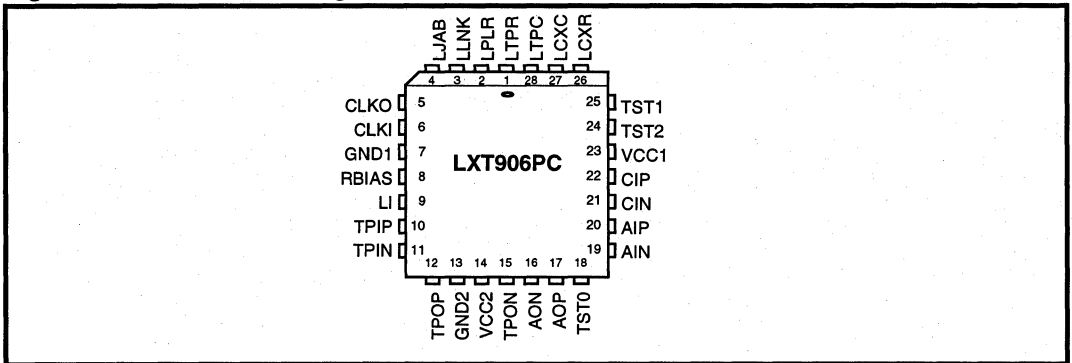

Table 1: Pin Descriptions

Pin #	Sym	I/O	Name	Description
1	LTPR	O	TP Receive LED Driver	Open drain driver for the TP Receive indicator LED. Output pulls Low whenever TP receiver is active.
2	LPLR	O	TP Reverse Polarity LED Driver	Open drain driver for the TP Reversed Polarity indicator LED. Output pulls Low whenever reversed polarity is detected.
3	LLNK	O	TP Link LED Driver	Open drain driver for the TP Link indicator LED. Output goes High whenever link is active.
4	LJAB	O	Jabber LED Driver	Open drain driver for the Jabber indicator LED. Output pulls Low whenever LXT906 is in a jabber condition.
5	CLKO	I/O	Crystal Oscillator	The LXT906 requires either a 20 MHz crystal (or ceramic resonator) connected across these pins, or a 20 MHz clock applied at CLKI.
6	CLKI			
7	GND1	-	Ground 1	Ground.
8	RBIAS	I	Resistor Bias Control	Bias control pin for the operating circuit. Bias set from external resistor to ground. External resistor value = 12.4 kΩ (± 1%).
9	LI	I	Link Integrity	Enables Link Integrity Testing when tied High.
10	TPIP	I	Twisted-Pair Receive Inputs	Differential receive inputs from the TP input filter.
11	TPIN	I		
12	TPOP	O	Twisted-Pair Transmit Outputs	Transmit drivers to the TP output filter. The output is Manchester encoded and pre-distorted to meet the 10BASE-T template.
15	TPON	O		
13	GND2	-	Ground 2	Ground.
14	VCC2	I	Power Supply 2	+5 V power supply input.
16	AON	O	AUI Out Negative AUI Out Positive	Differential driver output pair connected to the Coax AUI.
17	AOP	O		
18	TST0	-	Test Pin 0	Test pin for factory use. This pin must be left unconnected.

Table 1: Pin Descriptions - continued

Pin #	Sym	I/O	Name	Description
19 20	AIN AIP	I I	AUI In Negative AUI In Positive	Data input pair from the Coax AUI.
21 22	CIN CIP	I I	Collision Negative Collision Positive	Differential input pair tied to the collision presence pair of the Ethernet Coax transceiver.
23	VCC1	I	Power Supply 1	+5 V power supply.
24 25	TST2 TST1	- -	Test Pin 2 Test Pin 1	Test pins reserved for factory use. These pins must be left unconnected.
26	LCXR	O	Coax (AUI) Receive LED Driver	Open drain driver for the Coax Receive indicator LED. Output pulls Low whenever coax receiver is active.
27	LCXC	O	Coax Collision LED Driver	Open drain driver for the Coax Collision indicator LED. Output pulls Low whenever a collision is detected on the coax circuit.
28	LTPC	O	TP Collision LED Driver	Open drain driver for the TP Collision indicator LED. Output pulls Low whenever a collision is detected on the TP line.

FUNCTIONAL DESCRIPTION

NOTE

This information is for design aid only.

The LXT906 interfaces the coaxial transceiver (AUI) to the unshielded twisted-pair cables, transferring data in both directions. The AUI side of the interface comprises three circuits: Data Input (AIP and AIN to the coax receiver), Data Output (AOP and AON from the coax driver), and Collision Interface (CIP and CIN to the collision receiver). The twisted-pair network side of the interface comprises two circuits: Twisted-Pair Output (TPOP and TPON from the pulse shaper) and Twisted-Pair Input (TPIP and TPIN to the TP receiver). In addition to the five basic circuits, the LXT906 contains an internal crystal oscillator, various logic controls and seven LED drivers for status indications.

COAX TO TP FUNCTION

The LXT906 receives data from the coax transceiver on the AI circuit and transmits it to the twisted-pair network on the TPO circuit. The output signal on TPOP and TPOP is pre-distorted to meet the 10BASE-T jitter template. The output waveform (after the transmit filter) is shown in Figure 2. If the differential inputs at the AI circuit fall below 75% of the threshold level for 8 bit times (typical), the LXT906 TP transmit function will enter the idle state. During idle periods, the LXT906 transmits link integrity test pulses on the TPO circuit.

Figure 2: LXT906 TPO Output Waveform

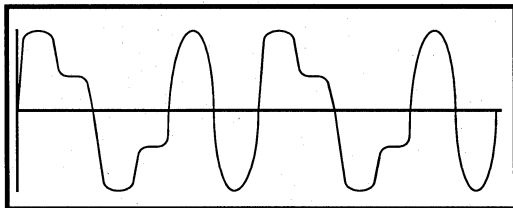

TP TO COAX FUNCTION

The LXT906 receives data from the twisted pair network on the TPI circuit and transmits it to the coax transceiver on the AO circuit. An internal squelch function discriminates noise from link test pulses and valid data streams. Only valid data streams activate the TP receive function. If the differential inputs at the TPI circuit fall below 75% of the threshold level (unsquelched) for 8 bit times (typical), the LXT906 TP receive function will enter the idle state. The Coax-to-TP data path is disabled when the TP-to-Coax path is active.

The Coax-to-TP path is enabled 9 bit times after end of TP-to-Coax transmission.

POLARITY REVERSE FUNCTION

The LXT906 polarity reverse function uses both link pulses and end-of-frame data to determine polarity of the received signal. A reversed polarity condition is detected when eight link pulses of the opposite (unexpected) polarity are received without receipt of a link pulse with the expected polarity. Reversed polarity is also detected if four frames are received with a reversed start-of-idle. Whenever polarity is reversed, these two counters are reset to zero. If the LXT906 enters the link fail state and no data or link pulses are received within 96 to 128 ms, the polarity is reset to the default non-flipped condition. (If Link Integrity is disabled, polarity detection is based only on received data pulses.) The LXT906 automatically corrects for reversed polarity.

JABBER FUNCTION

The LXT906 interrupts its output if it has transmitted continuously for longer than 5 ms on TPOP/TPON or AOP/AON. During jab the repeater state machine is disabled. Transmission is re-enabled when no activity has been detected on TPIP/TPIN or AIP/AIN for 6.4 μ s.

LINK INTEGRITY TEST FUNCTION

Figure 3 is a state diagram of the LXT906 Link Integrity Test Function. The Link Integrity Test is used to determine the status of the twisted pair cable. Link integrity testing is enabled when the LI pin is tied High. When enabled, the receiver recognizes link integrity pulses which are transmitted in the absence of receive traffic. If no serial data stream or link integrity pulses are detected within 50 - 150 ms, the chip enters a link fail state and disables the transmit function and the repeater state machine. The LXT906 ignores any link integrity pulse with interval less than 2 - 7 ms. The LXT906 will remain in the link fail state until it detects either a serial data packet or two or more link integrity pulses.

COLLISION PROPAGATION FUNCTION

A TP collision is defined as the simultaneous presence of valid signals on both the TPI circuit and the TPO circuit. A Coax collision is detected when a valid collision signal is present at CIP/CIN. If a collision is detected the appropriate collision LED (TP or coax) is activated and a Jam frame is transmitted as described in Figure 4. The Jam length is always a minimum of 96 bits: 64 bits of alternating 1's and 0's, followed by an all 1's pattern.

Figure 3: Link Integrity Test Function

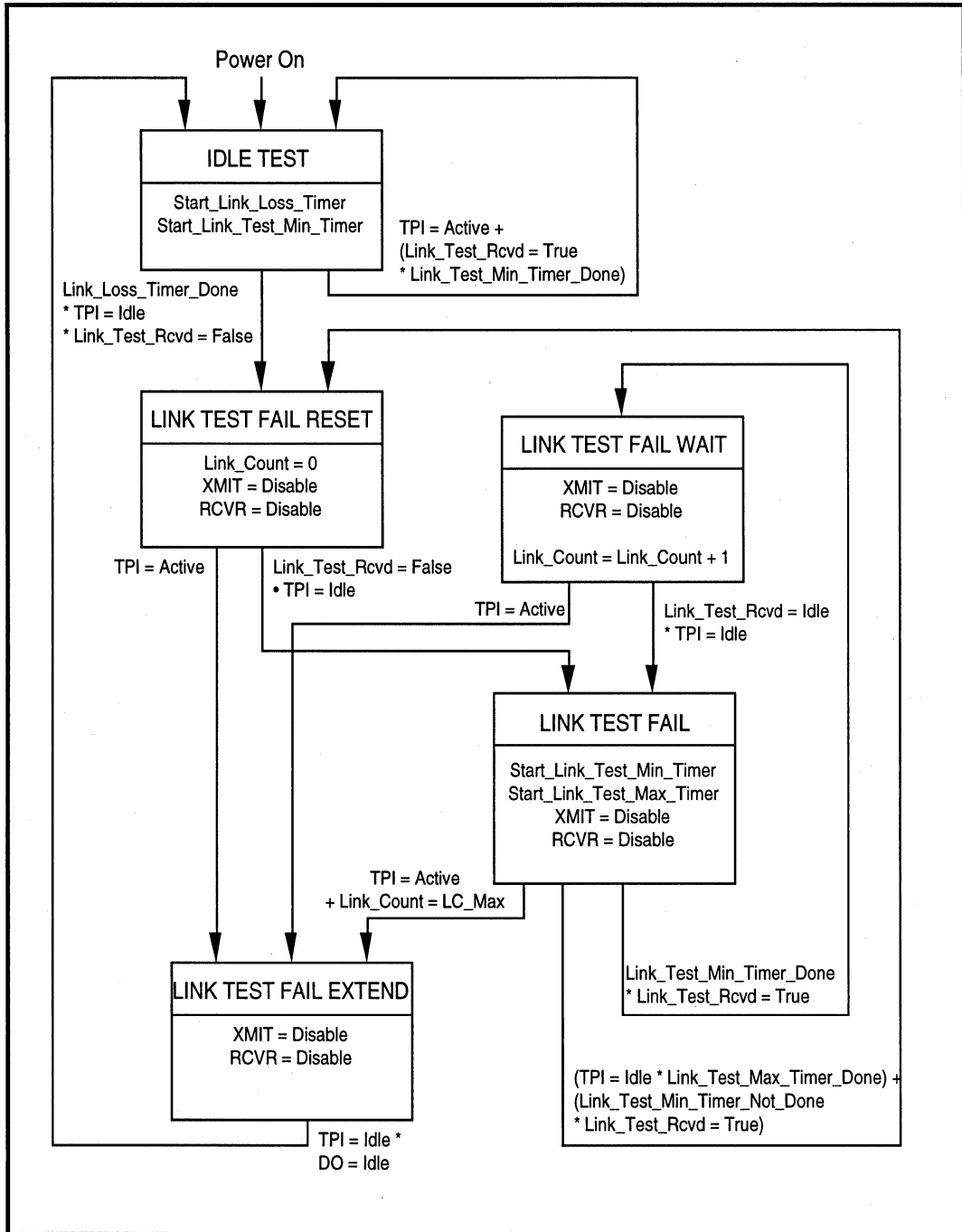

LXT906 STATE DIAGRAM

The state diagram, Figure 4, describes the operation of the LXT906. It is similar to a repeater state diagram, however the LXT906 does not provide retiming, preamble regeneration or fragment extension. The LXT906 avoids fragment generation by using a minimum Jam size of 96 bits. Since the TP side does not have a receive collision detection it is not considered in this implementation.

Description of State diagram variables :

- cXcoll : Coax collision active
- TPcoll : TP collision active
- cXact : Coax data active
- TPact : TP data active
- Tw1 : 9 bit time
- Tw2 : 3 bit time
- Jam : Minimum 96 bit time

Figure 4: LXT906 State Diagram

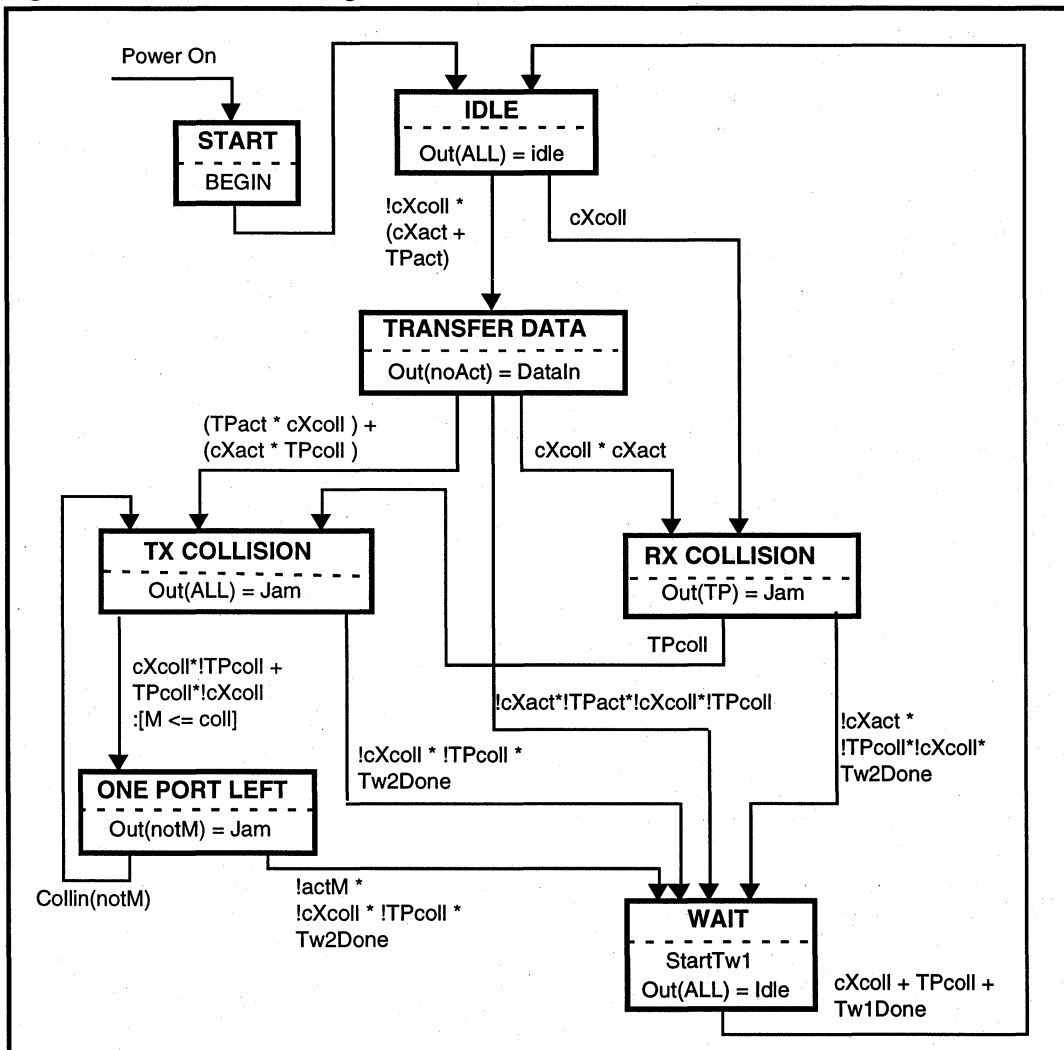

TEST SPECIFICATIONS

NOTE

Minimum and maximum values in Tables 2 through 8 represent the performance specifications of the LXT906 and are guaranteed by test except, as noted, by design.

Table 2: Absolute Maximum Ratings

Parameter	Symbol	Min	Max	Units
DC supply (referenced to GND)	V _{CC}	-0.3	6.0	V
Ambient operating temperature	T _A	0	70	°C
Storage temperature	T _{STG}	-65	150	°C

CAUTION
Operations at or beyond these limits may result in permanent damage to the device.
Normal operation not guaranteed at these extremes.

Table 3: Recommended Operating Conditions (Voltages are with respect to ground.)

Parameter	Symbol	Min	Typ	Max	Units
Supply voltage	V _{CC}	4.75	5.0	5.25	V
Operating temperature	T _{OP}	0	-	70	°C

Table 4: I/O Electrical Characteristics (Under Recommended Operating Conditions)

Parameter	Symbol	Min	Typ ¹	Max	Units	Test Conditions
Input low voltage	V _{IL}	-	-	0.8	V	
Input high voltage	V _{IH}	2.0	-	-	V	
Output low voltage (Open drain LED Driver)	V _{OLL}	-	-	0.7	V	I _{OLL} = 10 mA
Supply current (V _{CC1} = V _{CC2} = 5.25 V)	I _{CC}	-	60	80	mA	Line Idle
		-	125	150	mA	Line Active, transmitting all ones
Input leakage current ²	I _{LL}	-	± 1	50	µA	Input between V _{CC} and GND

1. Typical figures are at 25 °C and are for design aid only; not guaranteed and not subject to production testing.
2. Not including TPIN, TPIP, AIP, AIN, CIP or CIN.

Table 5: AUI Electrical Characteristics (Under Recommended Operating Conditions)

Parameter	Symbol	Min	Typ ¹	Max	Units	Test Conditions
Input low current	I _{IL}	-	-	-700	µA	
Input high current	I _{IH}	-	-	500	µA	
Differential output voltage	V _{OD}	± 550	-	± 1200	mV	
Differential squelch threshold	V _{DS}	-	220	-	mV	
Receive input impedance	R _Z	-	20	-	kΩ	Between AIP and AIN, and between CIP and CIN

1. Typical figures are at 25 °C and are for design aid only; not guaranteed and not subject to production testing.

Table 6: Switching Characteristics (Under Recommended Operating Conditions)

Parameter	Min	Typ ¹	Max	Units
Jam Timing				
Transmit time	96	–	–	bit
Link Integrity Timing				
Time link loss ²	65	–	66	ms
Time between Link Integrity Pulses ²	9	–	11	ms
Interval for valid receive Link Integrity Pulses ²	3.9	–	65	ms
Collision Timing				
End of collision to end of jam	–	–	1200	ns
Jabber Timing				
Maximum transmit time	–	–	5.1	ms
Unjab time	–	6.4	–	us
LED Timing				
LED on time	100	–	–	ms
General				
Transmit recovery time	–	–	12	bit
Carrier recovery time	–	–	3	bit
TP receive to AUI transmit	0	–	500	ns
AUI receive to TP transmit	0	–	200	ns

1. Typical figures are at 25 °C and are for design aid only; not guaranteed and not subject to production testing.
 2. Switching times reduced by a factor of 1024 during Test mode.

Table 7: TP Transmit Characteristics (Under Recommended Operating Conditions)

Parameter	Symbol	Min	Typ ¹	Max	Units	Test Conditions
Transmit output impedance	Z _{OUT}	–	5	–	Ω	
Transmit timing jitter addition ²	–	–	–	± 8	ns	After Tx filter, 0 line length

1. Typical figures are at 25 °C and are for design aid only; not guaranteed and not subject to production testing.
 2. Parameter is guaranteed by design; not subject to production testing.

11

Table 8: TP Receive Characteristics (Under Recommended Operating Conditions)

Parameter	Symbol	Min	Typ ¹	Max	Units	Test Conditions
Receive input impedance	Z _{IN}	–	20	–	kΩ	Between TPIP/TPIN
Differential squelch threshold	V _{DS}	–	420	–	mV	
Receive timing jitter ²	–	–	–	1.5	ns	

1. Typical figures are at 25 °C and are for design aid only; not guaranteed and not subject to production testing.
 2. Parameter is guaranteed by design; not subject to production testing.

NOTES:

LXT907

Universal Ethernet Interface Adapter (Internal MAU) with Integrated 10BASE-T MAU, EnDec, AUI and Filters

General Description

The LXT907 Universal Ethernet Interface Adapter is designed for IEEE 802.3 physical layer applications. It provides all the active circuitry to interface most standard 802.3 controllers to either the 10BASE-T media or Attachment Unit Interface (AUI). In addition to standard 10 Mbps Ethernet, the LXT907 also supports full-duplex operation at 20 Mbps.

LXT907 functions include Manchester encoding/decoding, receiver squelch and transmit pulse shaping, jabber, link testing and reversed polarity detection/correction. The LXT907 can be used to drive either the AUI drop cable or the 10BASE-T twisted-pair cable with only a simple isolation transformer. Integrated filters simplify the design work required for FCC compliant EMI performance. Selectable termination impedance allows the LXT907 to be used with either shielded or unshielded twisted-pair cable.

The LXT907 is fabricated with an advanced CMOS process and requires only a single 5 volt power supply.

Applications

- 10BASE-T hub and switching products
- Computer/workstation 10BASE-T LAN adapter boards

Features

Functional Features

- Integrated Filters - Simplifies FCC Compliance
- Integrated Manchester Encoder/Decoder
- 10BASE-T compliant Transceiver
- AUI Transceiver
- Full-Duplex Capable (20 Mbps)

Convenience Features

- Automatic/Manual AUI/RJ45 Selection
- Automatic Polarity Correction
- SQE Disable/Enable function
- Power Down Mode and four loopback modes
- Available in 44-pin PLCC package

Diagnostic Features

- Four LED Drivers
- AUI/RJ45 Loopback
- Remote Signaling of Link Down and Jabber conditions

LXT907 Block Diagram

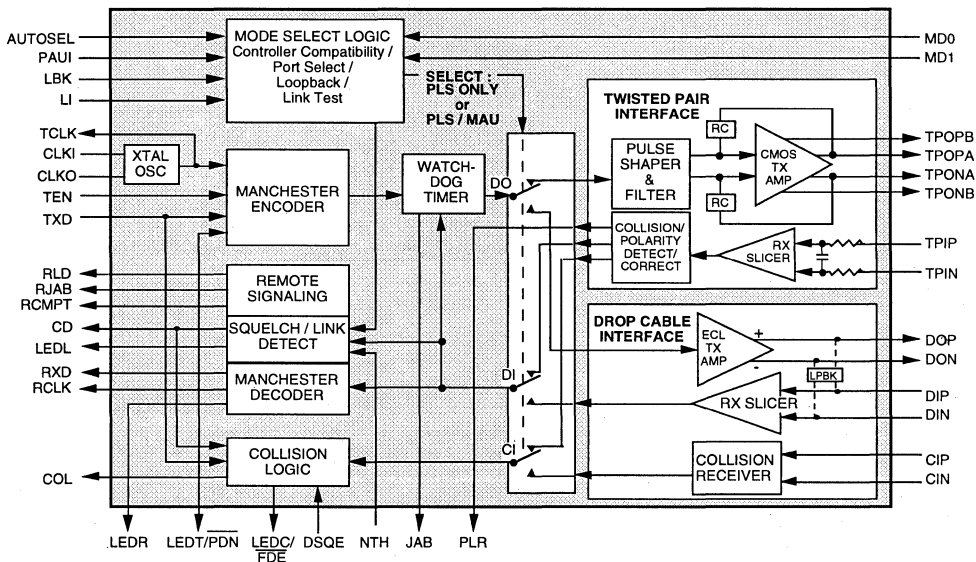

LXT907 Universal Ethernet Interface Adapter

Figure 1: LXT907 Pin Assignments

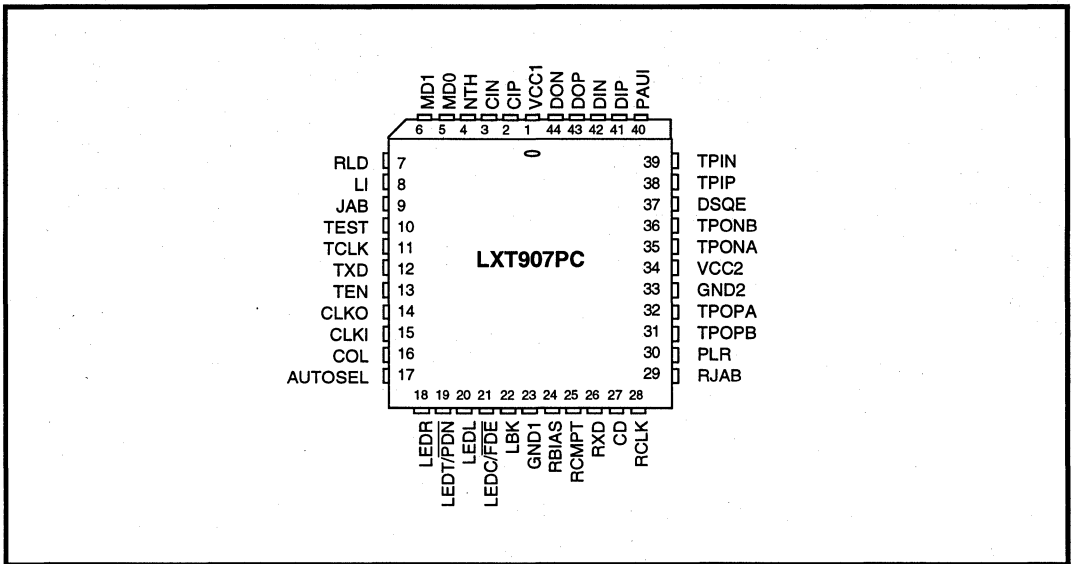

Table 1: Pin Descriptions

Pin #	Sym	I/O	Name	Description
1 34	VCC1 VCC2	I I	Power Inputs 1 and 2	+5 volt power supply inputs.
2 3	CIP CIN	I I	AUI Collision Pair	Differential input pair connected to the AUI transceiver CI circuit. The input is collision signaling or SQE.
4	NTH	I	Normal Threshold	When NTH = High, the normal TP squelch threshold is enabled. When NTH = Low, the normal TP squelch threshold is reduced by 4.5 dB.
5 6	MD0 MD1	I I	Mode Select 0 Mode Select 1	Mode select pins determine controller compatibility mode in accordance with Table 2.
7	RLD	O	Remote Link Down	Output goes High to signal to the controller that the remote port is in link down condition.
8	LI	I	Link Test Enable	Controls Link Integrity Test; enabled when LI = High, disabled when LI = Low.
9	JAB	O	Jabber Indicator	Output goes High to indicate Jabber state.
10	TEST	I	Test	This pin must be tied High.
11	TCLK	O	Transmit Clock	A 10 MHz clock output. This clock signal should be directly connected to the transmit clock input of the controller.

Table 1: Pin Descriptions - continued

Pin #	Sym	I/O	Name	Description
12	TXD	I	Transmit Data	Input signal containing NRZ data to be transmitted on the network. TXD is connected directly to the transmit data output of the controller.
13	TEN	I	Transmit Enable	Enables data transmission and starts the watchdog timer. Synchronous to TCLK (see test specifications for details).
14 15	CLKO CLKI	O I	Crystal Oscillator	A 20 MHz crystal must be connected across these pins, or a 20 MHz clock applied at CLKI with CLKO left open.
16	COL	O	Collision Detect	Output which drives the collision detect input of the controller.
17	AUTO SEL	I	Automatic Port Select	When AUTOSEL is High, automatic port selection is enabled. (The LXT907 defaults to the AUI port only if TP link integrity = Fail). When AUTOSEL is Low, manual port selection is enabled (the PAUI pin determines the active port).
18	LEDR	O	Receive LED	Open drain driver for the receive indicator LED. Output is pulled Low during receive, except when data is being looped back to DIN/DIP from a remote transceiver (external MAU). LED "On" (i.e., Low output) time is extended by approximately 100 ms.
19	LEDT/ PDN	O I	Transmit LED/ Power Down	Open drain driver for the transmit indicator LED. Output is pulled Low during transmit. LED "On" (i.e., Low output) time is extended by approximately 100 ms. If externally tied Low, the LXT907 goes to power down state.
20	LEDL	O I	Link LED	Open drain driver for link integrity indicator LED. Output is pulled Low during link test pass. If externally tied Low, internal circuitry is forced to "Link Pass" state and LXT907 will continue to transmit link test pulses.
21	LEDC/ FDE	O I	Collision LED/Full Duplex Enable	Open drain driver for the collision indicator LED pulls Low during collision. LED "On" (i.e., Low output) time is extended by approximately 100 ms. If externally tied Low, the LXT907 enables full duplex operation by disabling the internal TP loopback and collision detection circuits in anticipation of external TP loopback or full duplex operation.
22	LBK	I	Loopback	Enables internal loopback mode. See test specifications for details.
23 33	GND1 GND2	— —	Ground Returns 1 and 2	Grounds.
24	RBIAS	I	Bias Control	A 12.4 kΩ 1% resistor to ground at this pin controls operating circuit bias.
25	RCMPT	O	Remote Compatibility	Output goes High to signal the controller that the remote port is compatible with the LXT907 remote signaling features.
26	RXD	O	Receive Data	Output signal connected directly to the receive data input of the controller.

LXT907 Universal Ethernet Interface Adapter

Table 1: Pin Descriptions - continued

Pin #	Sym	I/O	Name	Description
27	CD	O	Carrier Detect	An output to notify the controller of activity on the network.
28	RCLK	O	Receive Clock	A recovered 10 MHz clock which is synchronous to the received data and connected to the controller receive clock input.
29	RJAB	O	Remote Jabber	Output goes High to indicate that the remote port is in Jabber condition.
30	PLR	O	Polarity Reverse	Output goes High to indicate reversed polarity at the TP input.
31 36 32 35	TPOPB TPONB TPOPA TPONA	O O O O	Twisted-Pair Transmit Pairs A & B	Two differential driver pair outputs (A and B) to the TP cable. The outputs are pre-equalized. Two pairs must be shorted together with 24.9 Ω 1% resistors to match impedance of 100 Ω UTP.
37	DSQE	I	Disable SQE	When DSQE is High, the SQE function is disabled. When DSQE is Low, the SQE function is enabled. SQE must be disabled for normal operation in Hub/Switch applications.
38 39	TPIP TPIN	I I	Twisted-Pair Receive Pair	A differential input pair from the TP cable. Receive filter is integrated on-chip. No external filters are required.
40	PAUI	I	Port/AUI Select	In Manual Port Select mode (AUTSEL Low), PAUI selects the active port. When PAUI is High, the AUI port is selected. When PAUI is Low, the TP port is selected. In Auto Port Select mode, PAUI must be tied to ground.
41 42	DIP DIN	I I	AUI Receive Pair	Differential input pair from the AUI transceiver DI circuit. The input is Manchester encoded.
43 44	DOP DON	O O	AUI Transmit Pair	A differential output driver pair for the AUI transceiver cable. The output is Manchester encoded.

FUNCTIONAL DESCRIPTION

NOTE

This information is for design aid only.

The LXT907 Universal Ethernet Interface Transceiver performs the physical layer signaling (PLS) and Media Attachment Unit (MAU) functions as defined by the IEEE 802.3 specification. It functions as a PLS-Only device (for use with 10BASE-2 or 10BASE-5 coaxial cable networks) or as an Integrated PLS/MAU (for use with 10BASE-T twisted-pair networks). In addition to standard 10 Mbps operation, the LXT907 also supports full-duplex 20 Mbps operation.

The LXT907 interfaces a back end controller to either an AUI drop cable or a twisted-pair (TP) cable. The controller interface includes transmit and receive clock and NRZ data channels, as well as mode control logic and signaling. The AUI interface comprises three circuits: Data Output (DO), Data Input (DI) and Collision (CI). The twisted-pair interface comprises two circuits: Twisted-Pair Input (TPI) and Twisted-Pair Output (TPO). In addition to the three basic interfaces, the LXT907 contains an internal crystal oscillator and four LED drivers for visual status reporting.

Functions are defined from the back end controller side of the interface. The LXT907 Transmit function refers to data transmitted by the back end to the AUI cable (PLS-Only mode) or to the twisted-pair network (Integrated PLS/MAU mode). The LXT907 Receive function refers to data received by the back end from the AUI cable (PLS-Only) or from the twisted-pair network (Integrated PLS/MAU mode). In the integrated PLS/MAU mode, the LXT907 performs all required MAU functions defined by the IEEE 802.3 10BASE-T specification such as collision detection, link integrity testing, signal quality error messaging, jabber control and loopback. In the PLS-Only mode, the LXT907 receives incoming signals from the AUI DI circuit with ± 18 ns of jitter and drives the AUI DO circuit.

CONTROLLER COMPATIBILITY MODES

The LXT907 is compatible with most industry standard controllers including devices produced by Advanced Micro Devices (AMD), Intel, Fujitsu, National Semiconductor, Seeq and Texas Instruments. Four different control signal timing and polarity schemes (Modes 1 through 4) are required to achieve this compatibility. Mode select pins (MD0 and MD1) determine Controller compatibility modes as listed in Table 2. Refer to Test Specifications for a complete set of timing diagrams for each mode.

TRANSMIT FUNCTION

The LXT907 receives NRZ data from the controller at the TXD input as shown in the block diagram on the first page of this Data Sheet, and passes it through a Manchester encoder. The encoded data is then transferred to either the AUI cable (the DO circuit) or the twisted-pair network (the TPO circuit). The advanced integrated pulse shaping and filtering network produces the output signal on TPON and TPOP, shown in Figure 2. The TPO output is pre-distorted and prefiltered to meet the 10BASE-T jitter template. **An internal continuous resistor-capacitor filter is used to remove any high-frequency clocking noise from the pulse shaping circuitry.** Integrated filters simplify the design work required for FCC compliant EMI performance. During idle periods, the LXT907 transmits link integrity test pulses on the TPO circuit (if LI is enabled and integrated PLS/MAU mode is selected). External resistors control the termination impedance.

Figure 2: LXT907 TPO Output Waveform

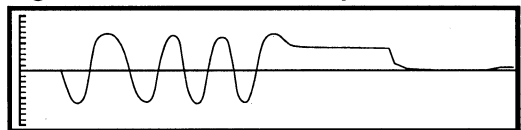

Table 2: Controller Compatibility Mode Options

Controller Mode:	Setting:	
	MD1	MD0
Mode 1 - For Advanced Micro Devices AM7990 or compatible controllers	Low	Low
Mode 2 - For Intel 82596 or compatible controllers	Low	High
Mode 3 - For Fujitsu MB86950, MB86960 or compatible controllers (SEEQ 8005) ¹	High	Low
Mode 4 - For National Semiconductor 8390 or compatible controllers (TI TMS380C26)	High	High

1. SEEQ Controllers require inverters.

JABBER CONTROL FUNCTION

Figure 3 is a state diagram of the LXT907 Jabber control function. The LXT907 on-chip watchdog timer prevents the DTE from locking into a continuous transmit mode. When a transmission exceeds the time limit, the watchdog timer disables the transmit and loopback functions, and activates the JAB pin. Once the LXT907 is in the jabber state, the TXD circuit must remain idle for a period of 0.25 to 0.75 seconds before it will exit the jabber state.

SQE FUNCTION

In the integrated PLS/MAU mode, the LXT907 supports the signal quality error (SQE) function as shown in Figure 4, although the SQE function can be disabled. After every successful transmission on the 10BASE-T network when SQE is enabled, the LXT907 transmits the SQE signal for $10BT \pm 5BT$ over the internal CI circuit which is indicated on the COL pin of the device. When using the 10BASE-2

port of the LXT907, the SQE function is determined by the external MAU attached. SQE must be disabled for normal operation in hub and switch applications. The SQE function is disabled when DSQE is set High, and enabled when DSQE is Low.

RECEIVE FUNCTION

The LXT907 receive function acquires timing and data from the twisted-pair network (the TPI circuit) or from the AUI (the DI circuit). Valid received signals are passed through the on-chip filters and Manchester decoder then output as decoded NRZ data and receive timing on the RXD and RCLK pins, respectively.

An internal RC filter and an intelligent squelch function discriminate noise from link test pulses and valid data streams. The receive function is activated only by valid data streams above the squelch level and with proper timing. If

Figure 3: Jabber Control Function

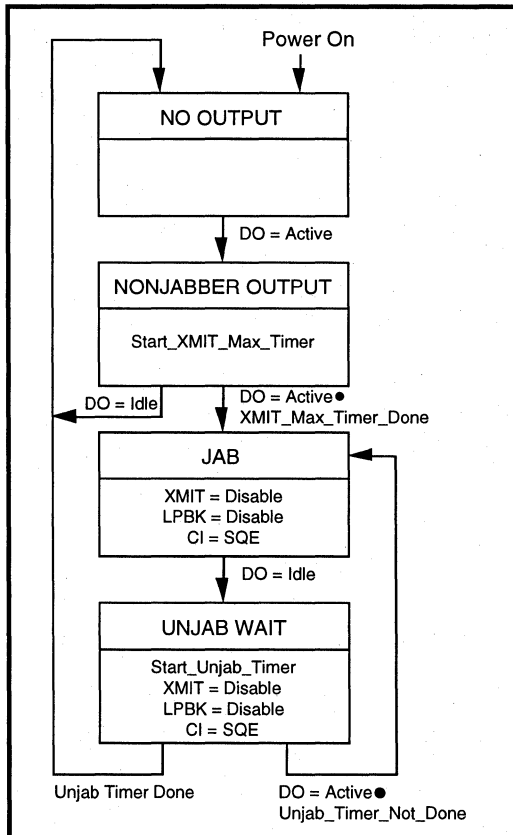
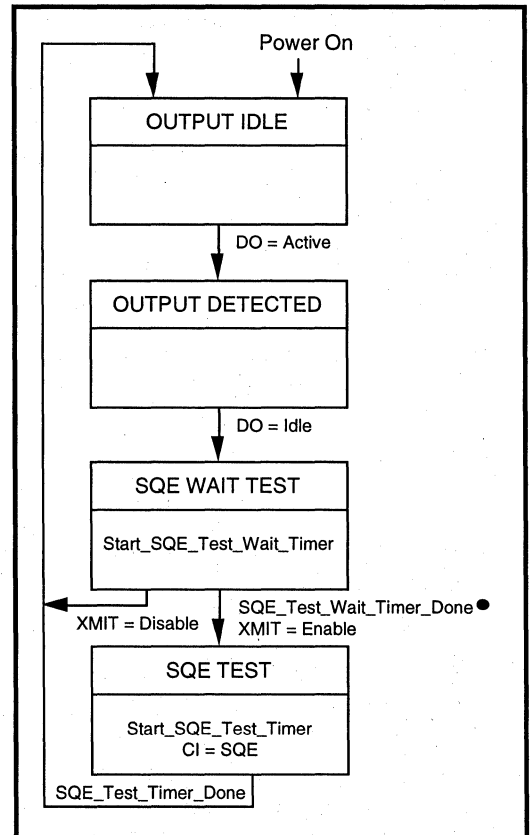

Figure 4: SQE Function



the differential signal at the TPI or the DI circuit inputs falls below 75% of the threshold level (unsnatched) for 8 bit times (typical), the LXT907 receive function enters the idle state. If the polarity of the TPI circuit is reversed, LXT907 detects the polarity reverse and reports it via the PLR output. The LXT907 automatically corrects reversed polarity.

POLARITY REVERSE FUNCTION

The LXT907 polarity reverse function uses both link pulses and end-of-frame data to determine polarity of the received signal. A reversed polarity condition is detected when eight opposite receive link pulses are detected without receipt of a link pulse of the expected polarity. Reversed polarity is also detected if four frames are received with a reversed start-of-idle. Whenever a correct polarity frame or a correct link pulse is received, these two counters are reset to zero. If the LXT907 enters the link fail state and no valid data or link pulses are received within 96 to 128 ms, the polarity is reset to the default non-flipped condition. (If Link Integrity Testing is disabled, polarity detection is based only on received data.) Polarity correction is always enabled.

COLLISION DETECTION FUNCTION

The collision detection function operates on the twisted pair side of the interface. For standard (half-duplex) 10BASE-T

operation, a collision is defined as the simultaneous presence of valid signals on both the TPI circuit and the TPO circuit. The LXT907 reports collisions to the back-end via the COL pin. If the TPI circuit becomes active while there is activity on the TPO circuit, the TPI data is passed to the back-end over the RXD circuit, disabling normal loopback. Figure 5 is a state diagram of the LXT907 collision detection function. Refer to Test Specifications for collision detection and COL/CI output timing (NOTE: For full-duplex operation, the collision detection circuitry must be disabled.)

LOOPBACK FUNCTION

The LXT907 provides the normal loopback function specified by the 10BASE-T standard for the twisted-pair port. The loopback function operates in conjunction with the transmit function. Data transmitted by the back-end is internally looped back within the LXT907 from the TXD pin through the Manchester encoder/decoder to the RXD pin and returned to the back-end. This "normal" loopback function is disabled when a data collision occurs, clearing the RXD circuit for the TPI data. Normal loopback is also disabled during link fail and jabber states.

The LXT907 also provides three additional loopback functions. An external loopback mode, useful for system-level testing, is controlled by pin 21 (LEDC). When LEDC is tied

Figure 5: Collision Detection Function

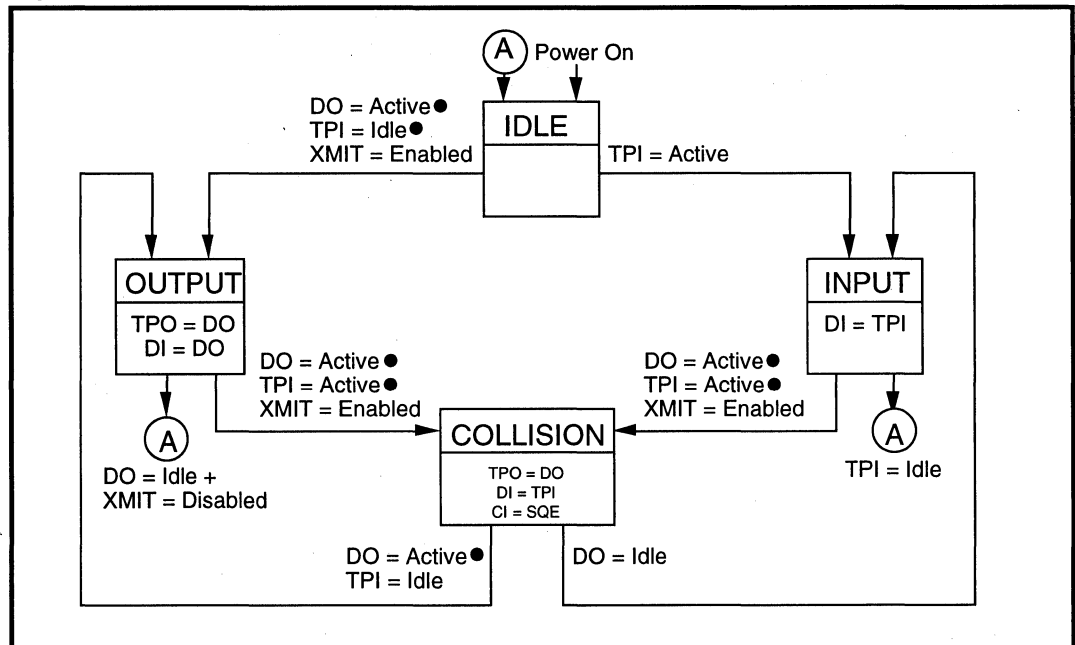

LXT907 Universal Ethernet Interface Adapter

Low, the LXT907 disables the collision detection and internal loopback circuits, to allow external loopback.

"Forced" TP loopback is controlled by pin 22 (LBK). When the TP port is selected and LBK is High, TP loopback is "forced", overriding collisions on the TP circuit. When LBK is Low, normal loopback is in effect.

AUI loopback is also controlled by the LBK pin. When the AUI port is selected and LBK is High, data transmitted by the back-end is internally looped back from the TXD pin through the Manchester encoder/decoder to the RXD pin. When LBK is Low, no AUI loopback occurs.

Figure 6: Link Integrity Test Function

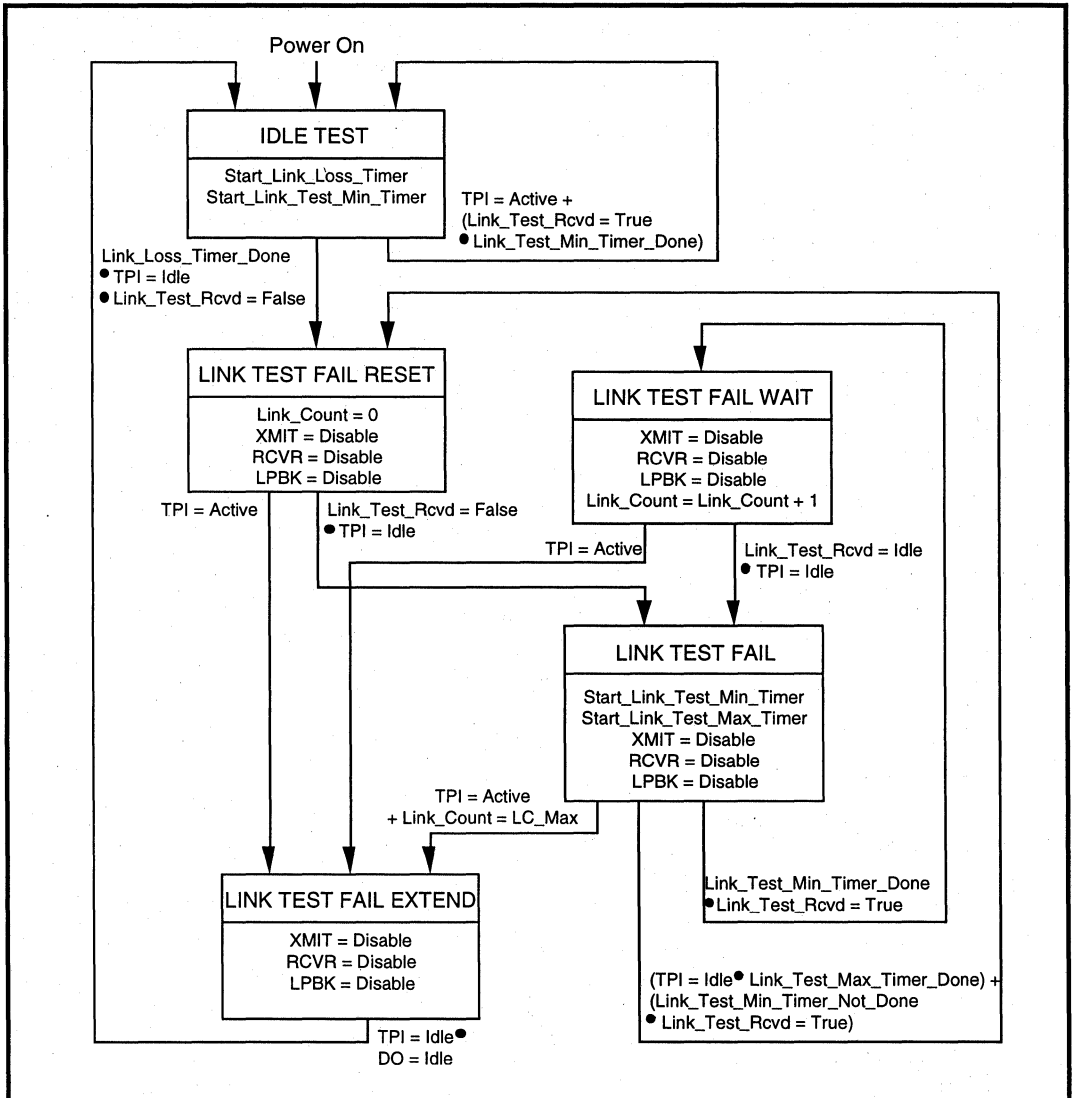

LINK INTEGRITY TEST

Figure 6 is a state diagram of the LXT907 Link Integrity test function. The link integrity test is used to determine the status of the receive side twisted-pair cable. Link integrity testing is enabled when pin 8 (LI) is tied High. When enabled, the receiver recognizes link integrity pulses which are transmitted in the absence of receive traffic. If no serial data stream or link integrity pulses are detected within 50 - 150 ms, the chip enters a link fail state and disables the transmit and normal loopback functions. The LXT907 ignores any link integrity pulse with interval less than 2 - 7 ms. The LXT907 will remain in the link fail state until it detects either a serial data packet or two or more link integrity pulses.

REMOTE SIGNALING

The LXT907 transmits standard link pulses which meet the 10BASE-T specification. However, the LXT907 encodes additional status information into the link pulse by varying the link pulse timing. This is referred to as remote signaling. Using alternate pulse intervals, the LXT907 can signal three local conditions: link down, jabber, and remote signaling compatibility. Figure 7 shows the interval variations used to signal local status to the other end of the line. The LXT907 also recognizes these alternate pulse intervals when received from a remote unit. Remote status conditions are reported to the controller over the RLD, RJAB and RCMP output pins.

Figure 7: Remote Signaling Link Integrity Pulse Timing

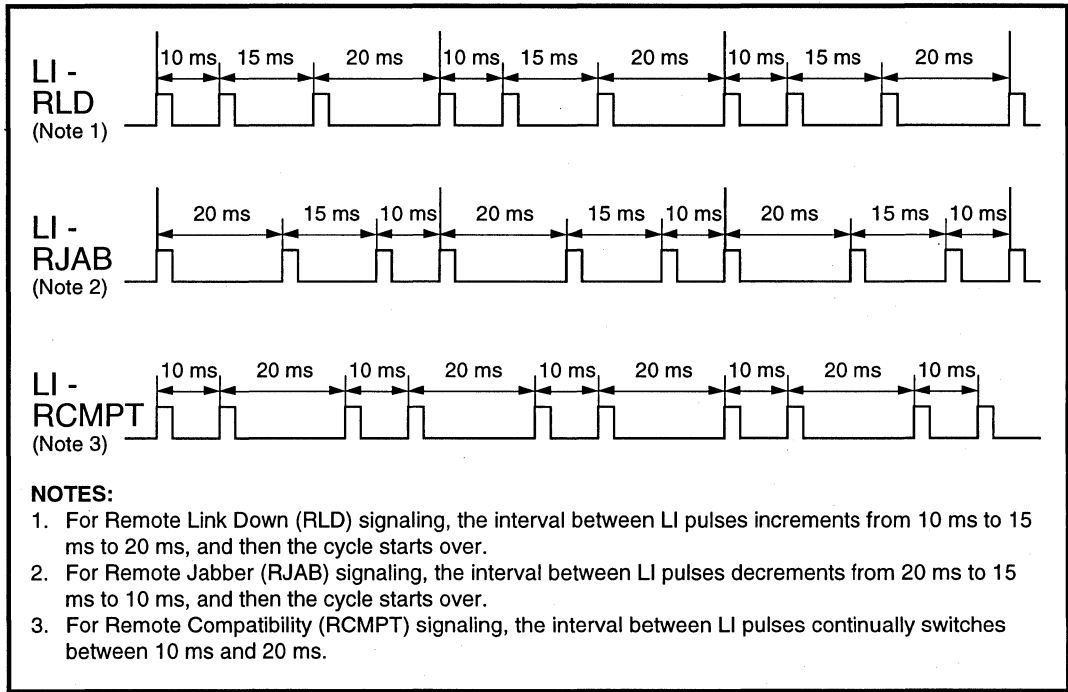

APPLICATION INFORMATION

NOTE

This information is for design aid only.

Figures 8 through 14 show typical LXT907 applications.

AUTO PORT SELECT WITH EXTERNAL LOOPBACK CONTROL (FIGURE 8)

Figure 8 is a typical LXT907 application. The diagram is arranged to group similar pins together; it does not represent the actual LXT907 pinout. The controller interface pins (transmit data, clock and enable; receive data and clock; and the collision detect, carrier detect and loopback control pins) are shown at the top left.

Programmable option pins are grouped center left. The PAUI pin is tied Low and all other option pins are tied High. This set-up selects the following options:

- Automatic Port Selection (PAUI Low and AUTOSEL High)
- Normal Receive Threshold (NTH High)
- Mode 4 (compatible with National NS8390 controllers) (MD0 High, MD1 High)
- SQE Disabled (DSQE High)
- Link Testing Enabled (LI High)

Status outputs are grouped at lower left. Local status outputs drive LED indicators and remote status indicators are available as required.

Power and ground pins are shown at the bottom of the diagram. A single power supply is used for both VCC1 and VCC2 with a decoupling capacitor installed between the power and ground busses.

The TP and AUI interfaces are shown at upper and lower right, respectively. Impedance matching resistors for 100 UTP are installed in each I/O pair but no external filters are required. Suitable transformers are listed in notes 2 and 3.

FULL DUPLEX SUPPORT (FIGURE 9)

Figure 9 shows the LXT907 with a Texas Instruments 380C24 CommProcessor. The 380C24 is compatible with Mode 4 (MD0 and MD1 both High). When used with the 380C24 or other full duplex-capable controller, the LXT907 supports full-duplex Ethernet, effectively doubling the available bandwidth of the network. In this application the SQE function is enabled (DSQE tied Low), and the LXT907 AUI port is not used.

DUAL NETWORK SUPPORT - 10BASE T AND TOKEN RING (FIGURE 10)

Figure 10 shows the LXT907 with a Texas Instruments 380C26 CommProcessor. The 380C26 is compatible with Mode 4 (MD0 and MD1 both High). When used with the 380C26, both the LXT907 and a TMS38054 Token Ring transceiver can be tied to a single RJ45 allowing dual network support from a single connector. The LXT907 AUI port is not used.

MANUAL PORT SELECT WITH LINK TEST FUNCTION (FIGURES 11 AND 12)

With MD0 Low and MD1 tied High, the LXT907 logic and framing are set to Mode 3 (compatible with Fujitsu MB86950 and MB86960, and Seeq 8005 controllers). Figure 10 shows the setup for Fujitsu controllers. Figure 11 shows the four inverters required to interface with the Seeq 8005 controller. As in Figure 8, both these Mode 3 applications show the LI pin tied High, enabling Link Testing; and the UTP and NTH pins are both tied High, selecting the standard receiver threshold and 100 Ω termination for unshielded TP cable. However, in these applications AUTOSEL is tied Low, allowing external port selection through the PAUI pin. The remote status outputs are inverted to drive LED indicators.

THREE MEDIA APPLICATION (FIGURE 13)

Figure 13 shows the LXT907 in Mode 2 (compatible with Intel 82596 controllers) with additional media options for the AUI port. Two transformers are used to couple the AUI port to either a D-connector or a BNC connector. (A DP8392 coax transceiver with PM6044 power supply are required to drive the thin coax network through the BNC.)

AUI ENCODER/DECODER ONLY (FIGURE 14)

In this application the DTE is connected to a coaxial network through the AUI. AUTOSEL is tied Low and PAUI is tied High, manually selecting the AUI port. The twisted-pair port is not used. With MD1 and MD0 both Low, the LXT907 logic and framing are set to Mode 1 (compatible with AMD AM7990 controllers). The LI pin is tied Low, disabling the link test function. The DSQE pin is also Low, enabling the SQE function. The LBK input controls loopback. A 20 MHz system clock is supplied at CLKI with CLKO left open.

Figure 8: LAN Adapter Board - Auto Port Select with External LPBK Control

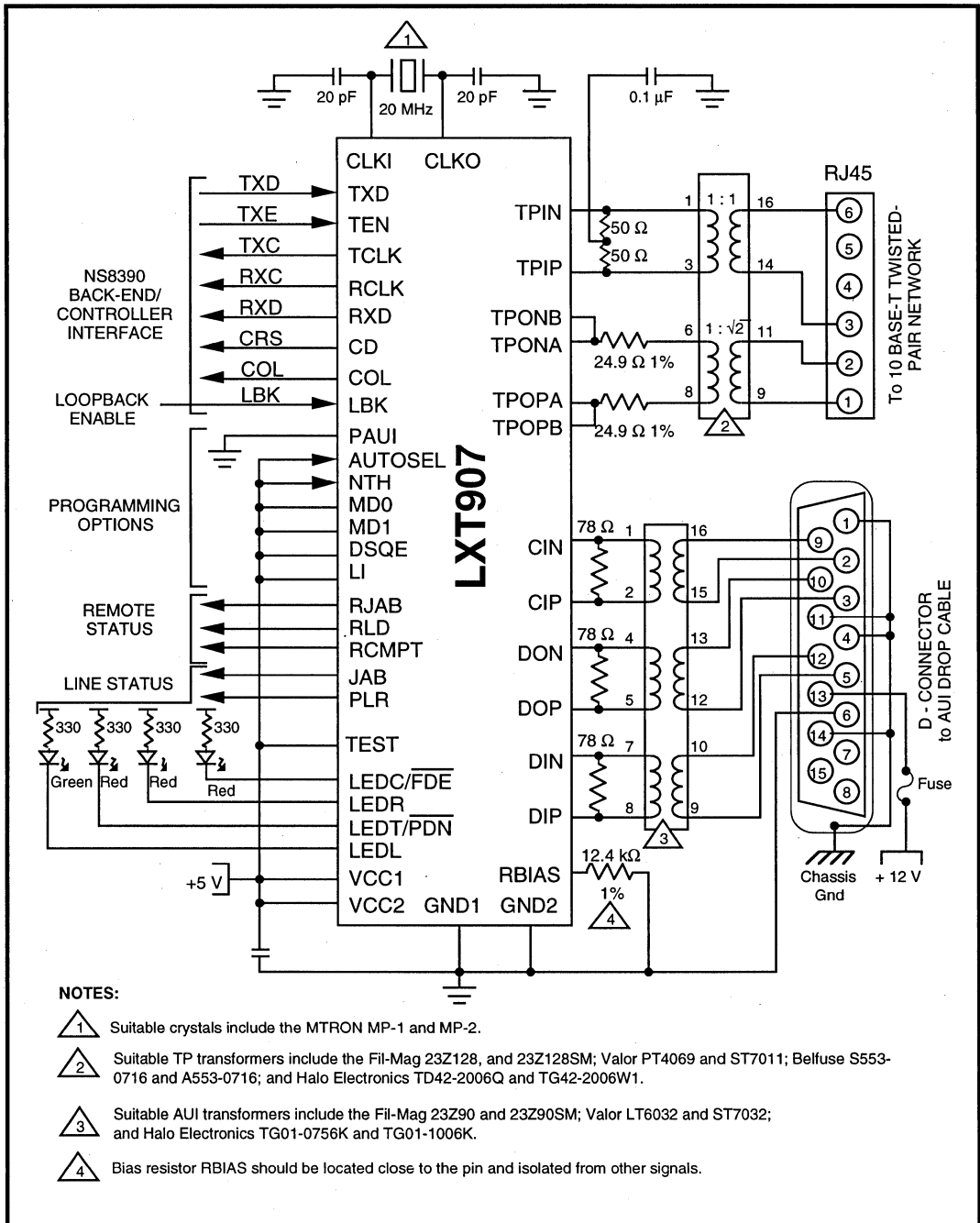

NOTES:

- 1 Suitable crystals include the MTRON MP-1 and MP-2.
- 2 Suitable TP transformers include the Fil-Mag 23Z128, and 23Z128SM; Valor PT4069 and ST7011; Belfuse S553-0716 and A553-0716; and Halo Electronics TD42-2006Q and TG42-2006W1.
- 3 Suitable AUI transformers include the Fil-Mag 23Z90 and 23Z90SM; Valor LT6032 and ST7032; and Halo Electronics TG01-0756K and TG01-1006K.
- 4 Bias resistor RBIAS should be located close to the pin and isolated from other signals.

Figure 10: LXT907/380C26 Interface for Dual Network Support of 10BASE-T and Token Ring

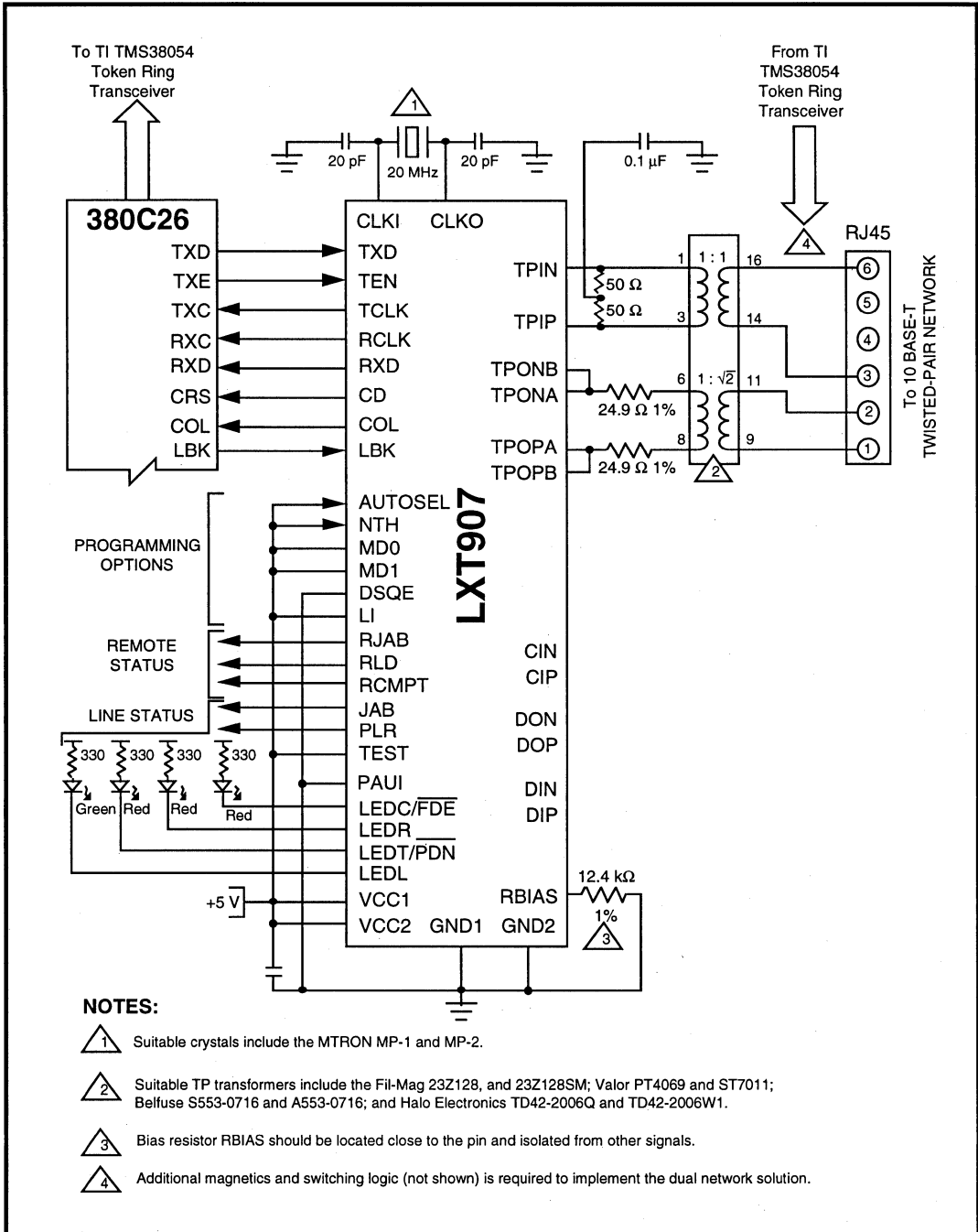

LXT907 Universal Ethernet Interface Adapter

Figure 11: LAN Adapter Board - Manual Port Select with Link Test Function

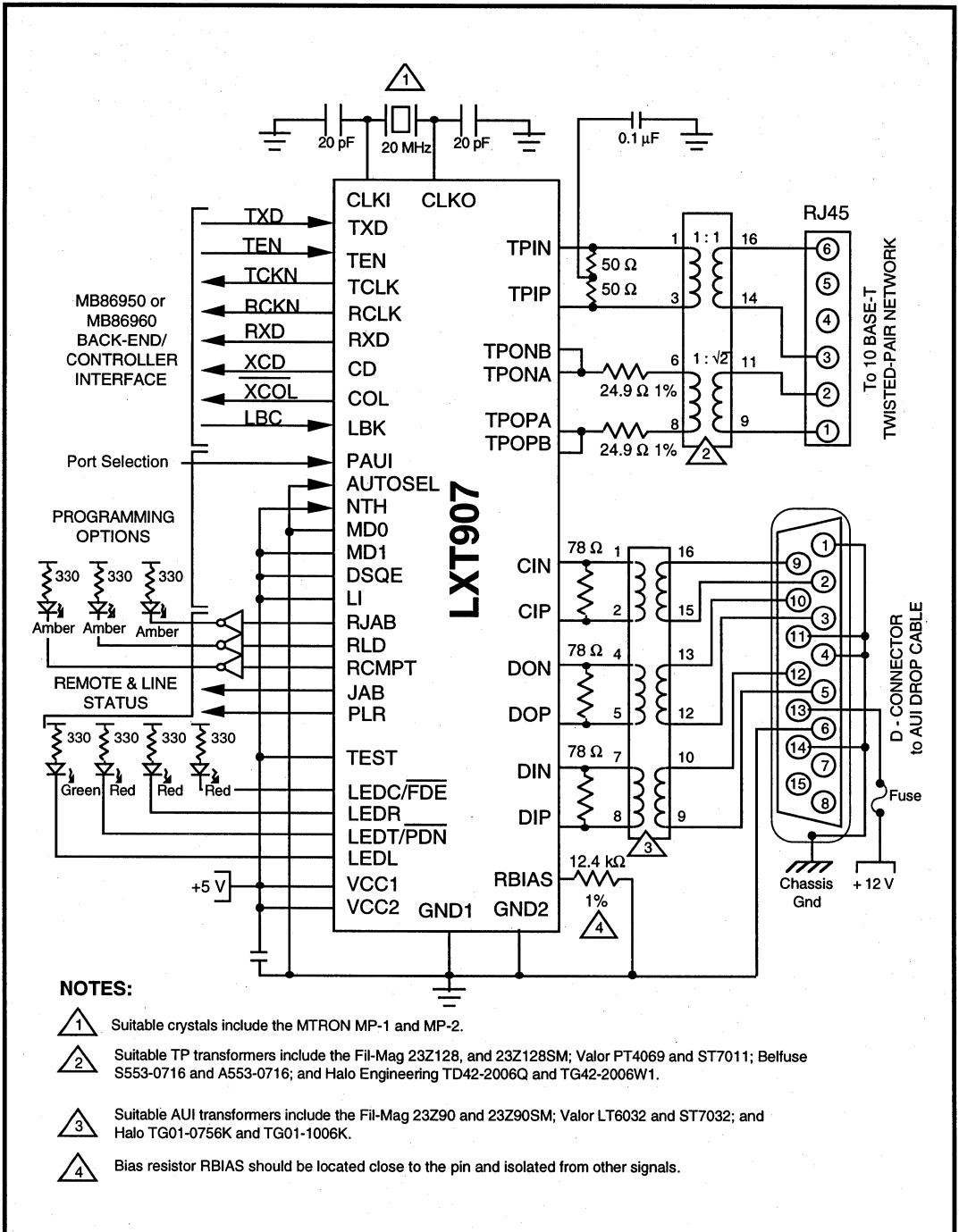

NOTES:

- ① Suitable crystals include the MTRON MP-1 and MP-2.
- ② Suitable TP transformers include the Fil-Mag 23Z128, and 23Z128SM; Valor PT4069 and ST7011; Belfuse S553-0716 and A553-0716; and Halo Engineering TD42-2006Q and TG42-2006W1.
- ③ Suitable AUJ transformers include the Fil-Mag 23Z90 and 23Z90SM; Valor LT6032 and ST7032; and Halo TG01-0756K and TG01-1006K.
- ④ Bias resistor RBIAS should be located close to the pin and isolated from other signals.

Figure 12: Manual Port Select with Seeq 8005 Controller

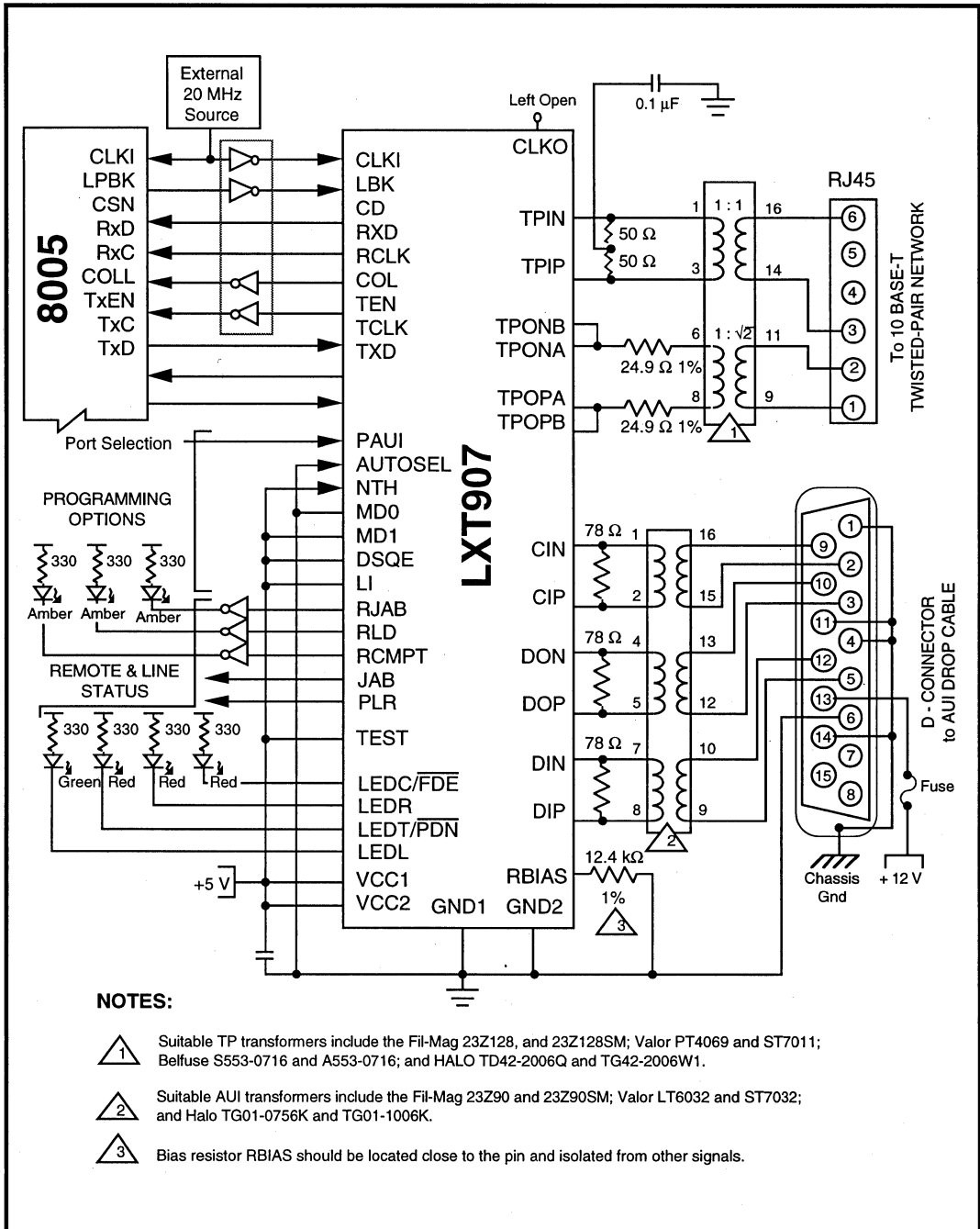

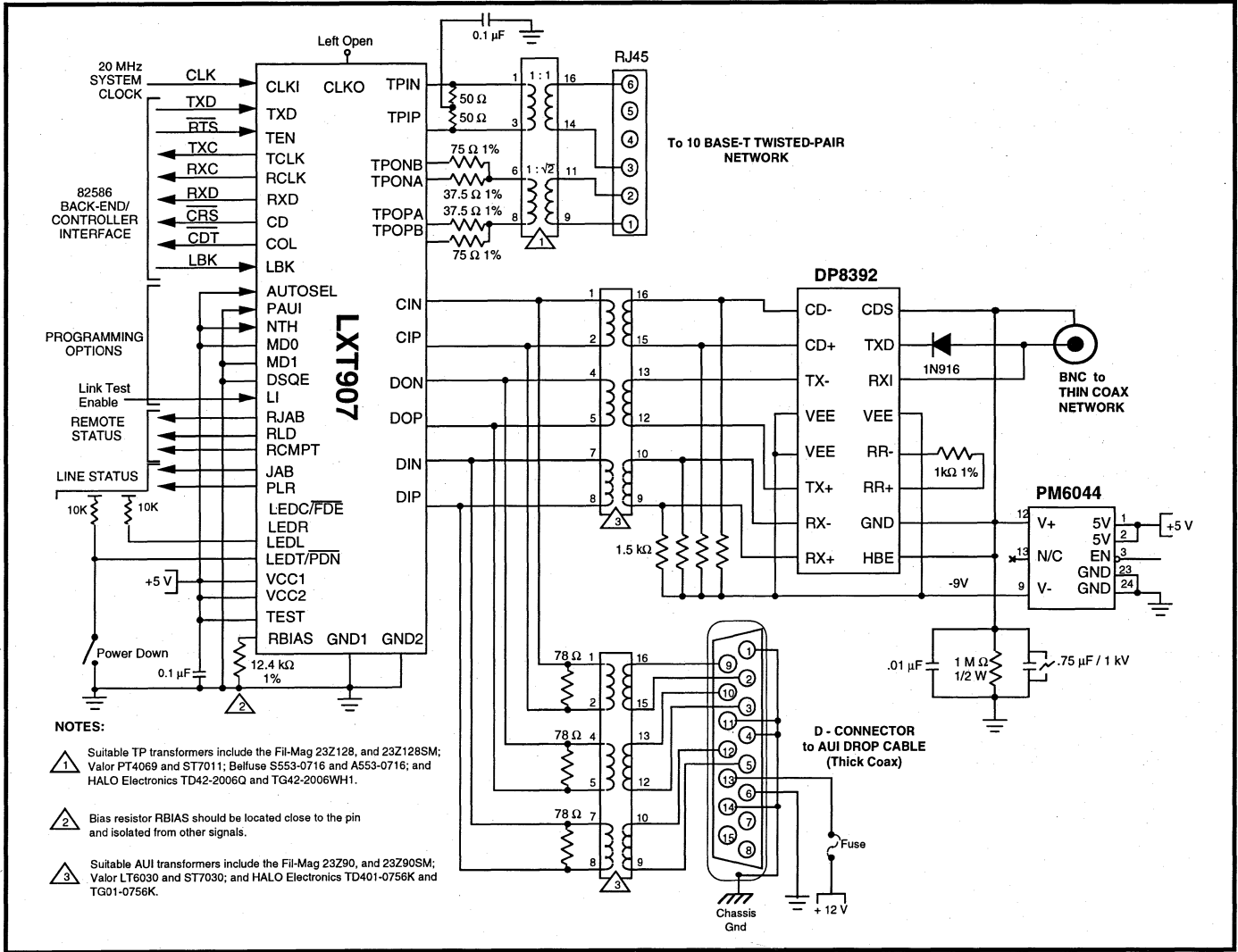
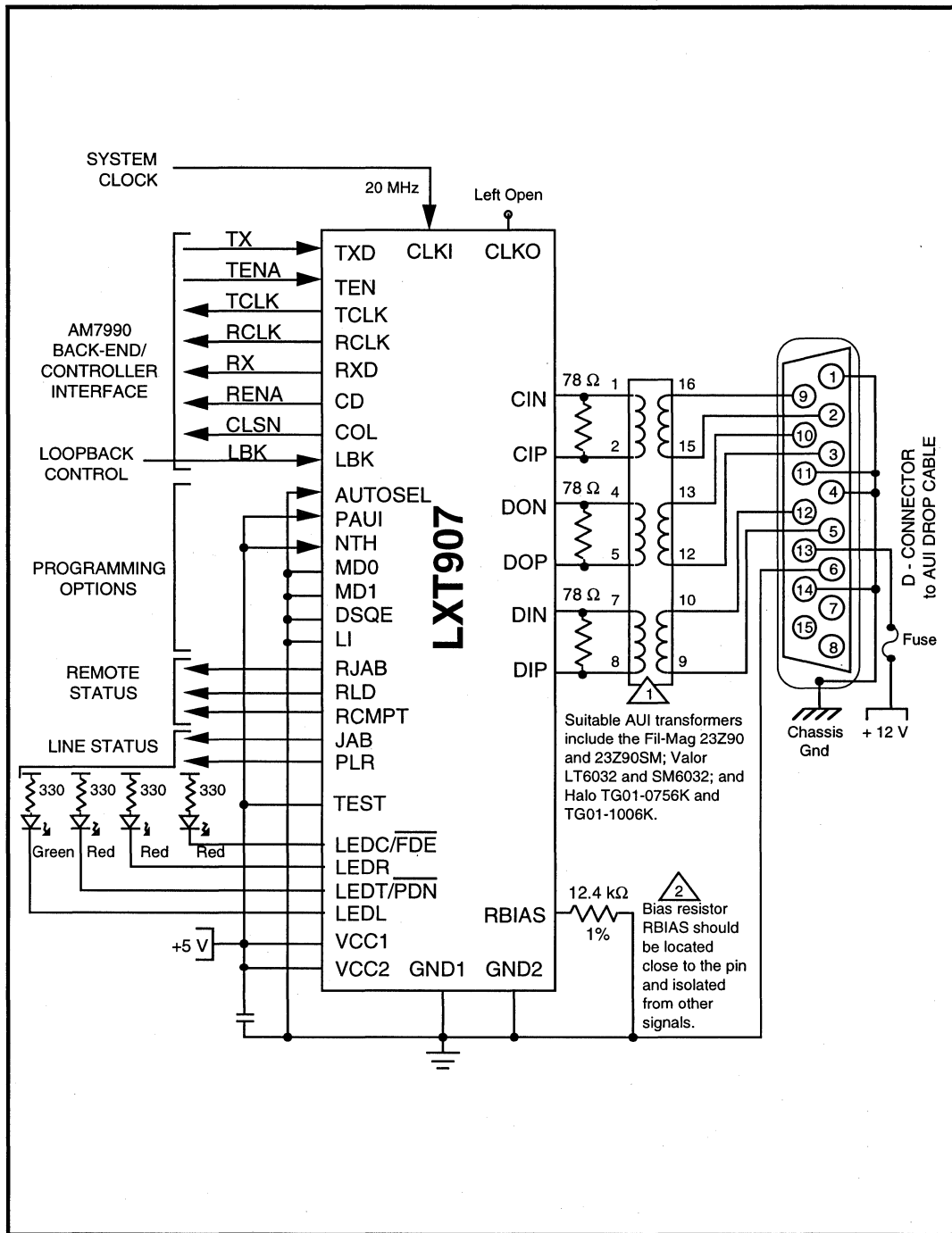

Figure 13: Three Media Application

LXT907 Universal Ethernet Interface Adapter



Figure 14: AUI Encoder/Decoder Only Application



LXT907 Universal Ethernet Interface Adapter

TEST SPECIFICATIONS

NOTE

Minimum and maximum values in Tables 3 through 12 and Figures 15 through 38 represent the performance specifications of the LXT907 and are guaranteed by test except, as noted, by design.

Table 3: Absolute Maximum Ratings

Parameter	Symbol	Min	Max	Units
DC supply (referenced to GND)	V _{CC}	-0.3	6.0	V
Ambient operating temperature	T _A	0	70	°C
Storage temperature	T _{STG}	-65	150	°C

CAUTION

Operations at or beyond these limits may result in permanent damage to the device.
Normal operation not guaranteed at these extremes.

Table 4: Recommended Operating Conditions

Parameter	Symbol	Min	Typ	Max	Units	Test Conditions
Recommended supply voltage ¹	V _{CC}	4.75	5.0	5.25	V	
Recommended operating temperature	T _{OP}	0	-	70	°C	

1. Voltage with respect to ground unless otherwise specified.

Table 5: I/O Electrical Characteristics (Over Recommended Range)

Parameter	Symbol	Min	Typ ¹	Max	Units	Test Conditions	
Input Low voltage ²	V _{IL}	-	-	0.8	V		
Input High voltage ²	V _{IH}	2.0	-	-	V		
Output Low voltage	V _{OL}	-	-	0.4	V	I _{OL} = 1.6 mA	
Output Low voltage	V _{OL}	-	-	10	% V _{CC}	I _{OL} < 10 μA	
Output Low voltage (Open drain LED Driver)	V _{OLL}	-	-	0.7	V	I _{OLL} = 10 mA	
Output High voltage	V _{OH}	2.4	-	-	V	I _{OH} = 40 μA	
Output High voltage	V _{OH}	90	-	-	% V _{CC}	I _{OH} < 10 μA	
Output rise time TCLK & RCLK	CMOS	-	-	3	12	ns	C _{LOAD} = 20 pF
	TTL	-	-	2	8	ns	
Output fall time TCLK & RCLK	CMOS	-	-	3	12	ns	C _{LOAD} = 20 pF
	TTL	-	-	2	8	ns	
CLKI rise time (externally driven)	-	-	-	10	ns		
CLKI duty cycle (externally driven)	-	-	-	40/60	%		
Supply current	Normal Mode	I _{CC}	-	65	85	mA	Idle mode
		I _{CC}	-	90	110	mA	Transmitting on TP
		I _{CC}	-	70	90	mA	Transmitting on AUI
	Power Down Mode	I _{CC}	-	0.75	2	mA	

1. Typical values are at 25 °C and are for design aid only; not guaranteed and not subject to production testing.

2. Limited functional tests are performed at these input levels. The majority of functional tests are performed at levels of 0V and 3V.

Table 6: AUI Electrical Characteristics (Over Recommended Range)

Parameter	Symbol	Min	Typ ¹	Max	Units	Test Conditions
Input Low current	I _{IL}	–	–	-700	μA	
Input High current	I _{IH}	–	–	500	μA	
Differential output voltage	V _{OD}	± 550	–	± 1200	mV	
Differential squelch threshold	V _{DS}	150	220	350	mV	5 MHz square wave input

1. Typical values are at 25 °C and are for design aid only; not guaranteed and not subject to production testing.

Table 7: TP Electrical Characteristics (Over Recommended Range)

Parameter	Symbol	Min	Typ ¹	Max	Units	Test Conditions
Transmit output impedance	Z _{OUT}	–	5	–	Ω	
Transmit timing jitter addition ²	–	–	± 6.4	± 10	ns	0 line length for internal MAU
Transmit timing jitter added by the MAU and PLS sections ^{2,3}	–	–	± 3.5	± 5.5	ns	After line model specified by IEEE 802.3 for 10BASE-T internal MAU
Receive input impedance	Z _{IN}	–	20	–	kΩ	Between TPIP/TPIN, CIP/CIN & DIP/DIN
Differential squelch threshold (Normal threshold : NTH = 1)	V _{DS}	300	420	585	mV	5 MHz square wave input
Differential squelch threshold (Reduced threshold : NTH = 0)	V _{DS}	180	250	345	mV	5 MHz square wave input

1. Typical values are at 25 °C and are for design aid only; not guaranteed and not subject to production testing.
 2. Parameter is guaranteed by design; not subject to production testing.
 3. IEEE 802.3 specifies maximum jitter additions at 1.5 ns for the AUI cable, 0.5 ns from the encoder, and 3.5 ns from the MAU.

Table 8: Switching Characteristics (Over Recommended Range)

Parameter	Symbol	Min	Typ	Max	Units
Jabber Timing:					
Maximum transmit time	–	20	–	150	ms
Unjab time	–	250	–	750	ms
Link Integrity Timing:					
Time link loss receive	–	50	–	150	ms
Link Min receive	–	2	–	7	ms
Link Max receive	–	50	–	150	ms
Link Transmit Period	–	8	10	24	ms

Table 9: RCLK/Start-of-Frame Timing (Over Recommended Range)

Parameter		Symbol	Minimum	Typical ¹	Maximum	Units
Decoder acquisition time	AUI	tDATA	–	900	1100	ns
	TP	tDATA	–	1300	1500	ns
CD turn-on delay	AUI	tCD	–	50	200	ns
	TP	tCD	–	400	550	ns
Receive data setup from RCLK	Mode 1	trDS	60	70	–	ns
	Modes 2, 3 and 4	trDS	30	45	–	ns
Receive data hold from RCLK	Mode 1	trDH	10	20	–	ns
	Modes 2, 3 and 4	trDH	30	45	–	ns
RCLK shut off delay from CD assert (Mode 3)		tsWS	–	±100	–	ns

1. Typical values are at 25 °C and are for design aid only; not guaranteed and not subject to production testing.

Table 10: RCLK/End-of-Frame Timing (Over Recommended Range)

Parameter	Type	Symbol	Mode 1	Mode 2	Mode 3	Mode 4	Units
RCLK after CD off	Min	trC	5	1	27	5	bt
Rev data throughput delay	Max	trD	400	375	375	375	ns
CD turn off delay ²	Max	tCDOFF	500	475	475	475	ns
Receive block out after TEN off	Typ ¹	tIFG	5	50	–	–	bt
RCLK switching delay after CD off	Typ ¹	tsWE	–	–	120 (±80)	–	ns

1. Typical values are at 25 °C and are for design aid only; not guaranteed and not subject to production testing.

2. CD Turnoff delay measured from middle of last bit, so timing specification is unaffected by the value of the last bit.

Table 11: Transmit Timing (Over Recommended Range)

Parameter	Symbol	Minimum	Typical ¹	Maximum	Units
TEN setup from TCLK	tEHCH	22	–	–	ns
TXD setup from TCLK	tDSCH	22	–	–	ns
TEN hold after TCLK	tCHEL	5	–	–	ns
TXD hold after TCLK	tCHDU	5	–	–	ns
Transmit start-up delay - AUI	tSTUD	–	200	450	ns
Transmit start-up delay - TP	tSTUD	–	350	450	ns
Transmit through-put delay - AUI	tTPD	–	–	300	ns
Transmit through-put delay - TP	tTPD	–	338	350	ns

1. Typical values are at 25 °C and are for design aid only; not guaranteed and not subject to production testing.

Table 12: Collision, COL/CI Output and Loopback Timing (Over Recommended Range)

Parameter	Symbol	Minimum	Typical ¹	Maximum	Units
COL turn on delay	tCOLD	–	–	500	ns
COL turn off delay	tCOLOFF	–	–	500	ns
COL (SQE) Delay after TEN off	tSQED	0.65	–	1.6	μs
COL (SQE) Pulse Duration	tSQEP	500	–	1500	ns
LBK setup from TEN	tKHEH	10	25	–	ns
LBK hold after TEN	tKHEL	10	0	–	ns

1. Typical values are at 25 °C and are for design aid only; not guaranteed and not subject to production testing.

Figures 16 through 21 - Timing Diagrams for Mode 1 (MD1 = 0, MD0 = 0)

Figure 15: Mode 1 RCLK/Start-of-Frame Timing

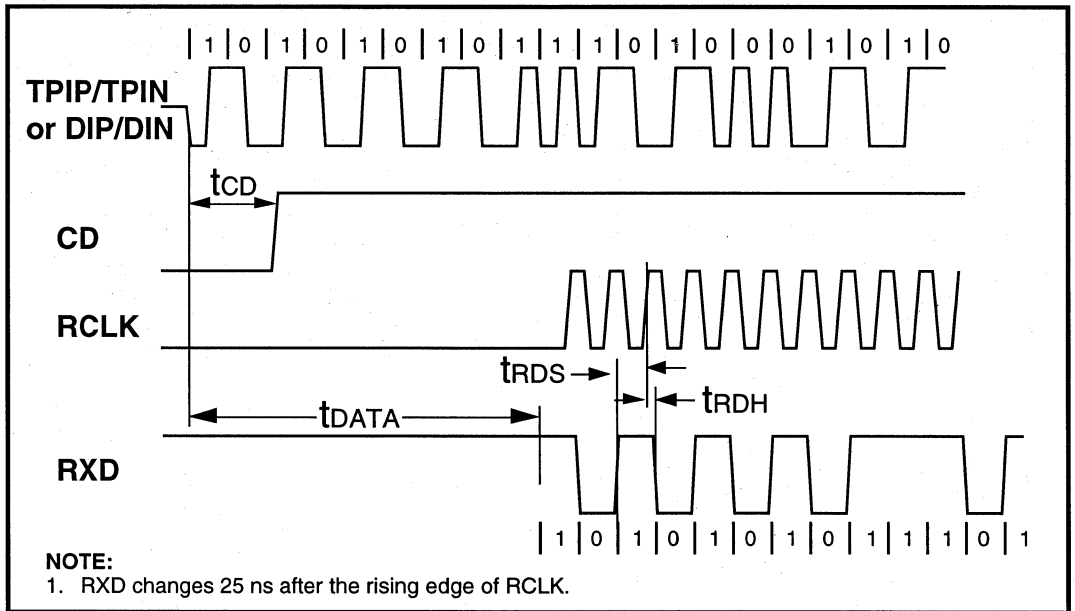

Figure 16: Mode 1 RCLK/End-of-Frame Timing

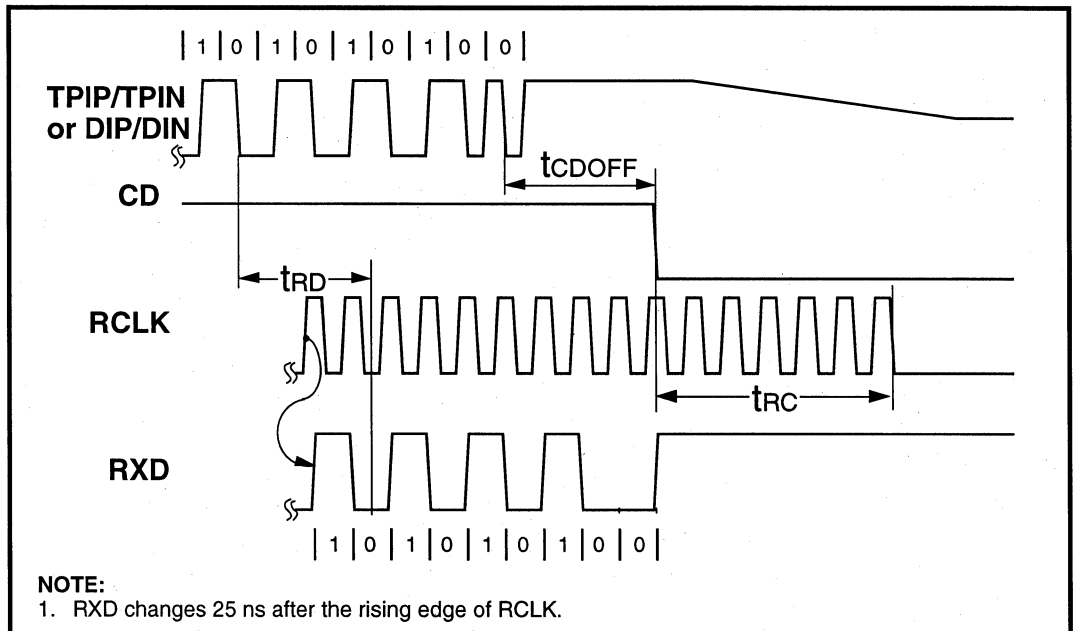

Figure 17: Mode 1 Transmit Timing

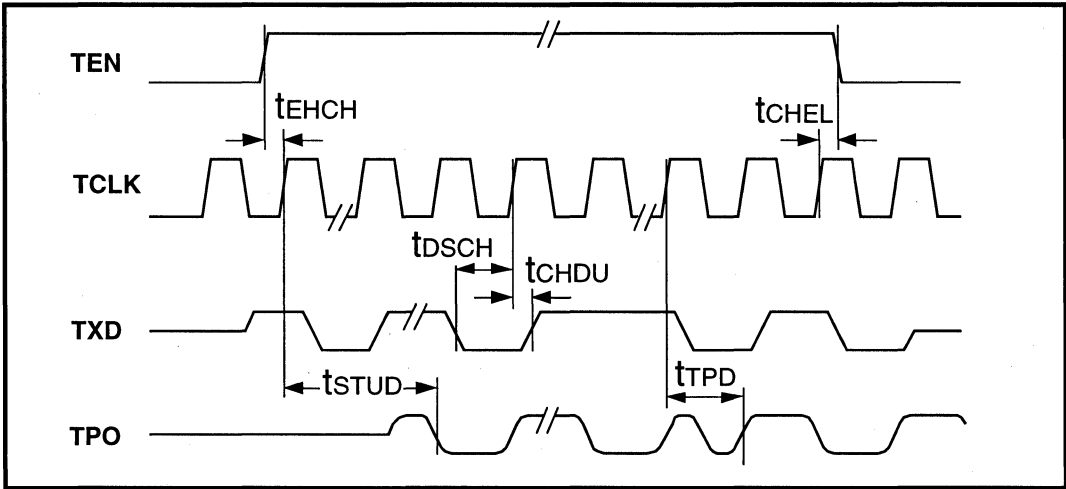

Figure 18: Mode 1 Collision Detect Timing

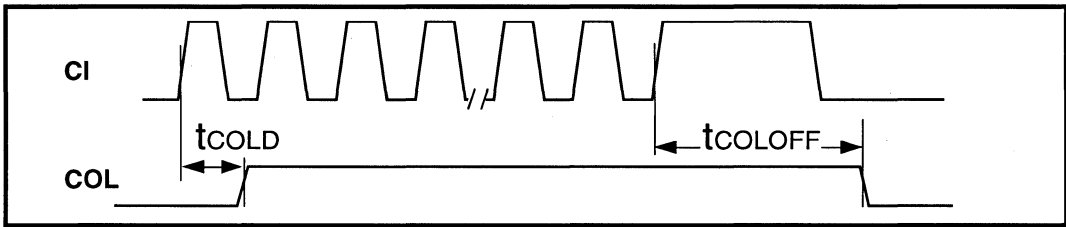

Figure 19: Mode 1 COL/CI Output Timing

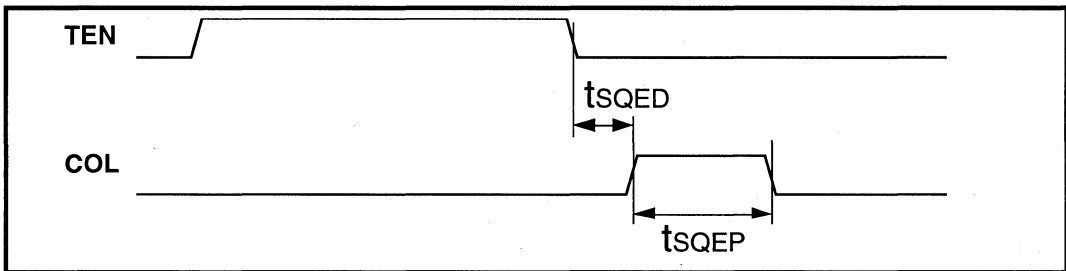
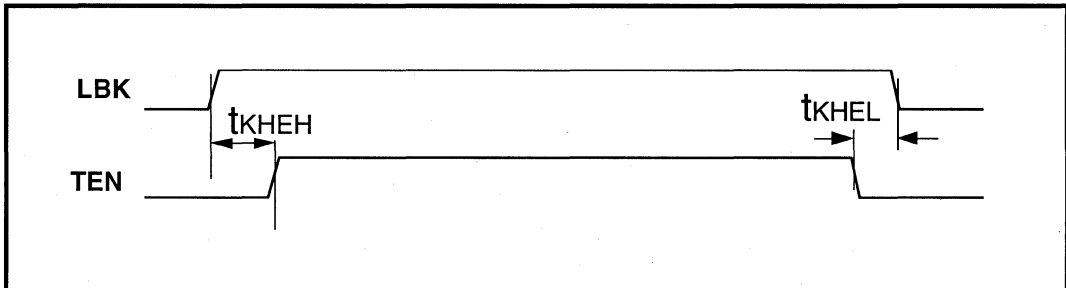

Figure 20: Mode 1 Loopback Timing



Figures 22 through 27 - Timing Diagrams for Mode 2 (MD1 = 0, MD0 = 1)

Figure 21: Mode 2 RCLK/Start-of-Frame Timing

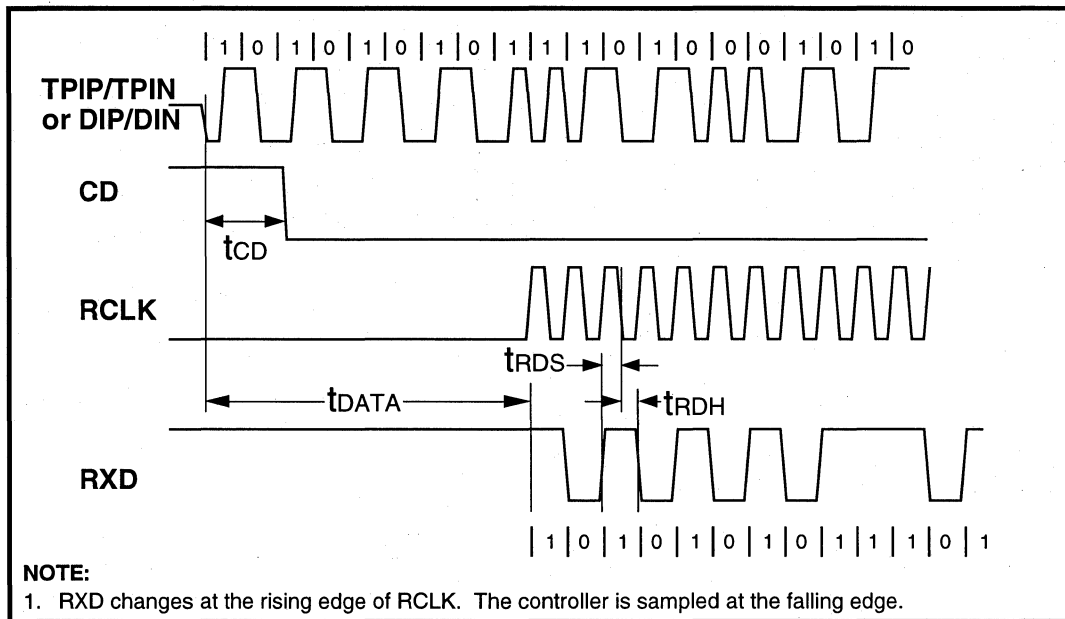

Figure 22: Mode 2 RCLK/End-of-Frame Timing

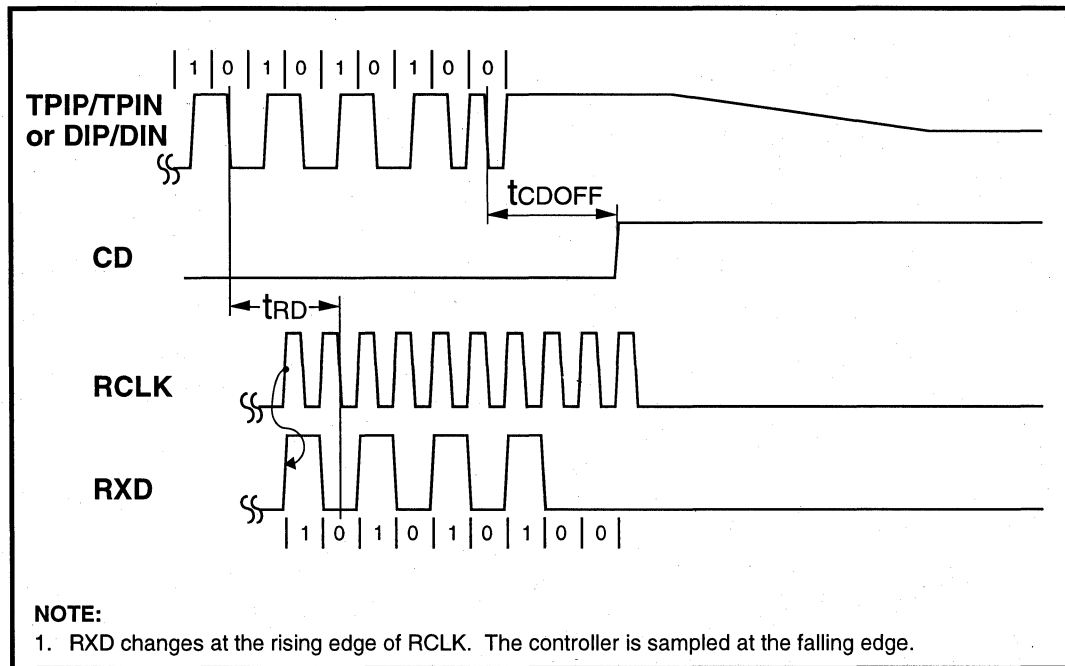

Figure 23: Mode 2 Transmit Timing

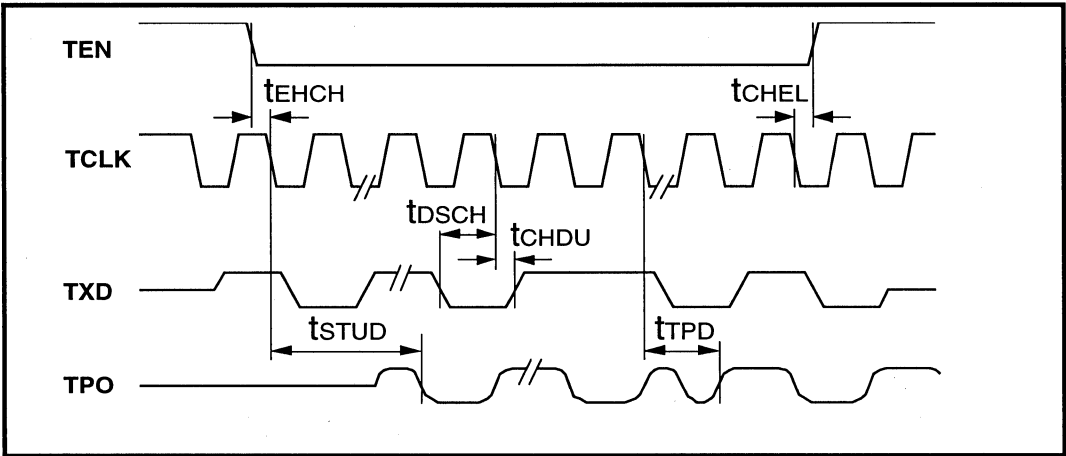

Figure 24: Mode 2 Collision Detect Timing

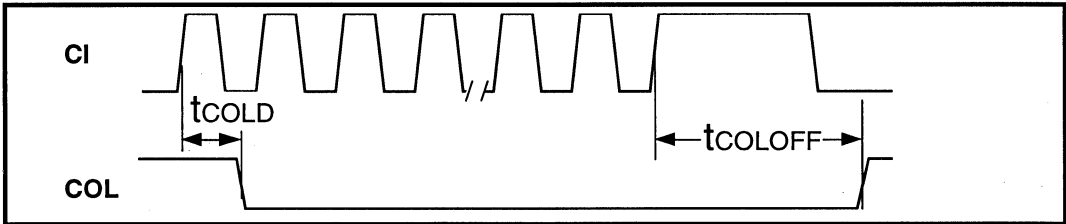

Figure 25: Mode 2 COL/CI Output Timing

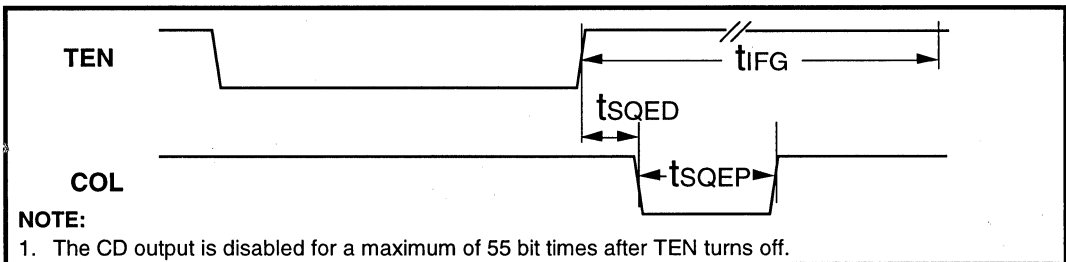
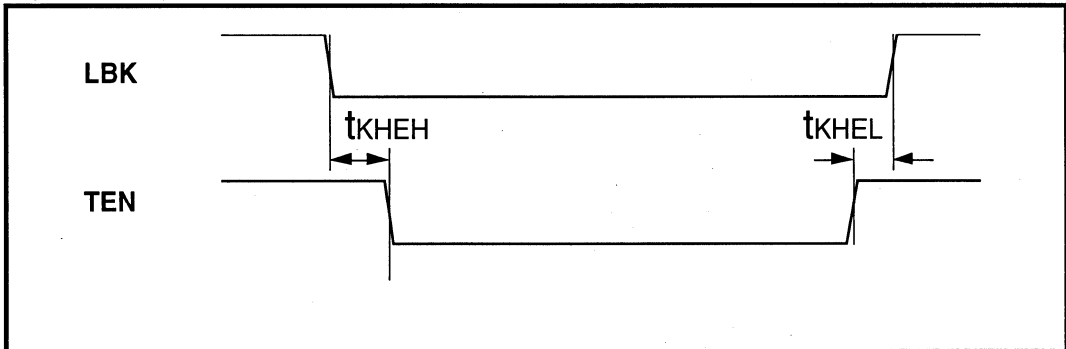

Figure 26: Mode 2 Loopback Timing



Figures 28 through 33 - Timing Diagrams for Mode 3 (MD1 = 1, MD0 = 0)

Figure 27: Mode 3 RCLK/Start-of-Frame Timing

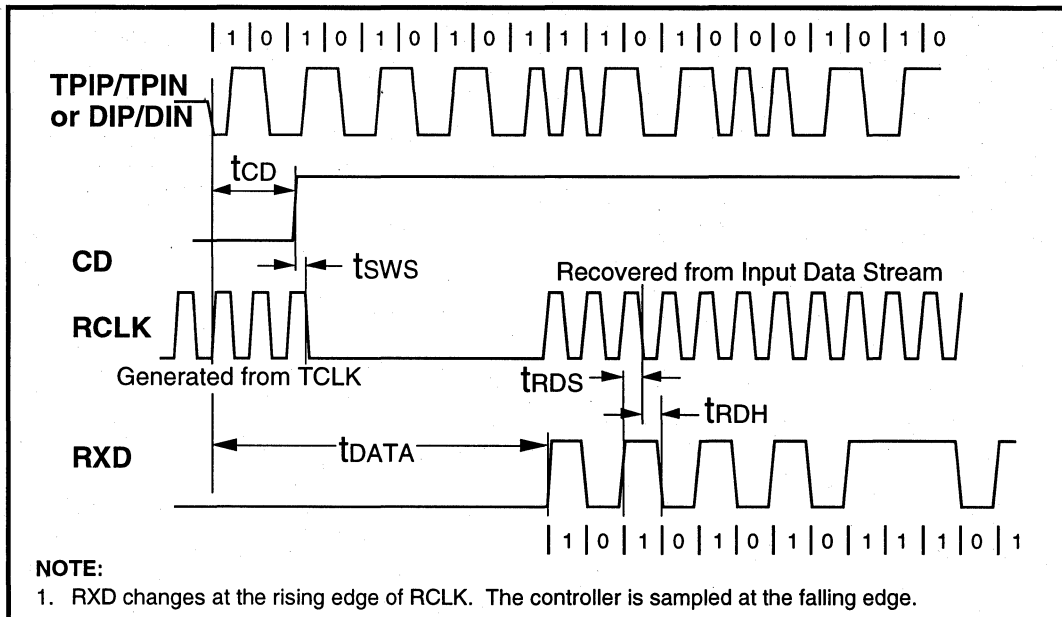

Figure 28: Mode 3 RCLK/End-of-Frame Timing

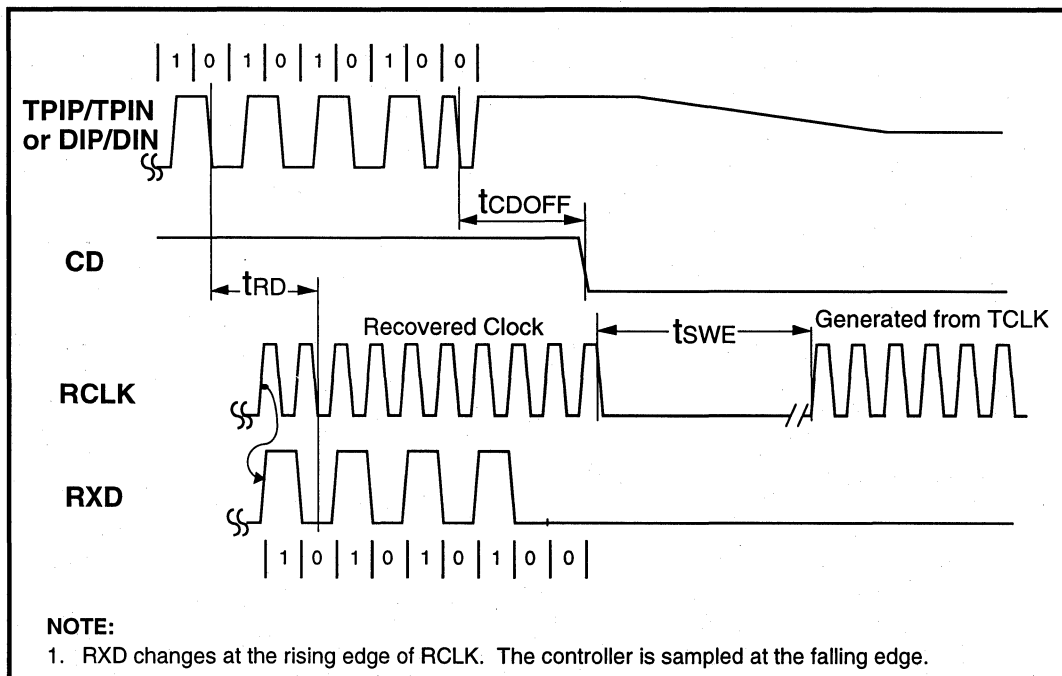

Figure 29: Mode 3 Transmit Timing

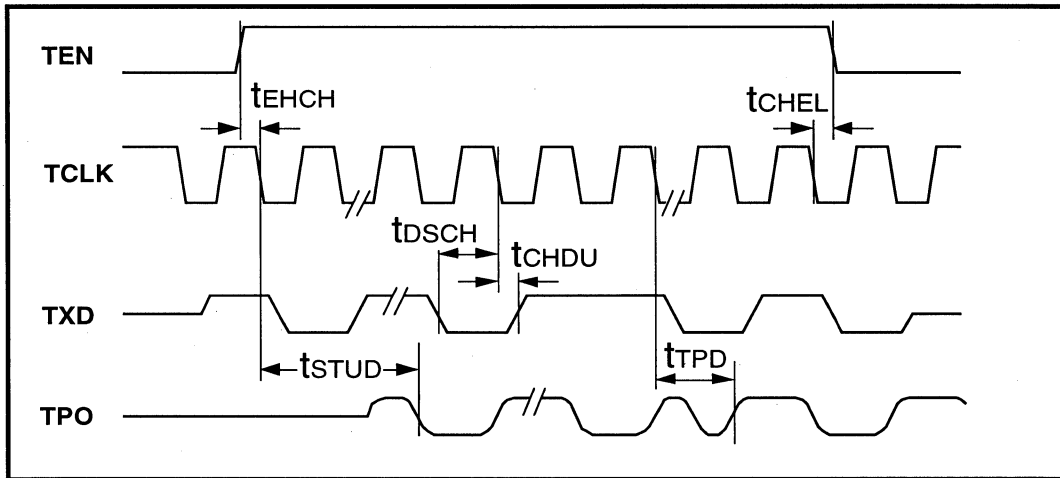

Figure 30: Mode 3 Collision Detect Timing

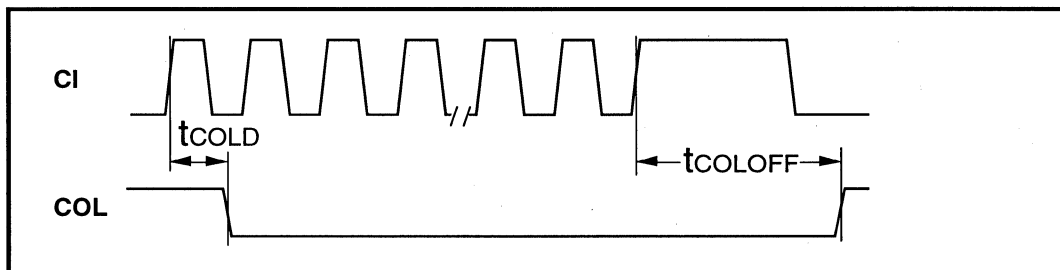

Figure 31: Mode 3 COL/CI Output Timing

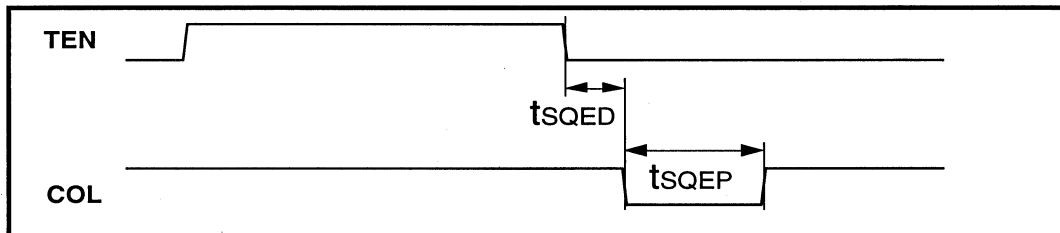
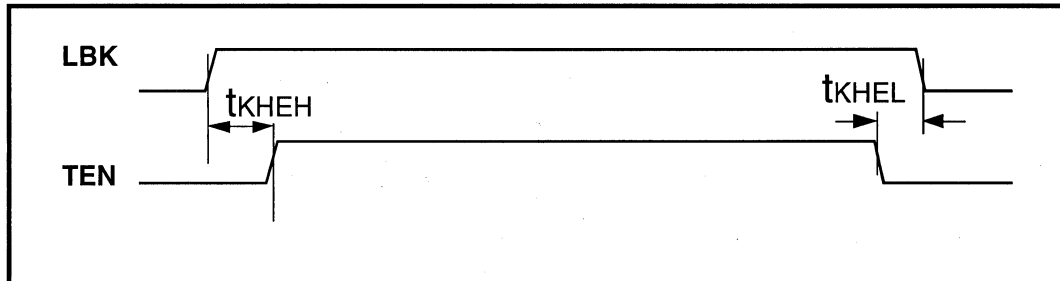

Figure 32: Mode 3 Loopback Timing



Figures 34 through 39 - Timing Diagrams for Mode 4 (MD1 = 1, MD0 = 1)

Figure 33: Mode 4 RCLK/Start-of-Frame Timing

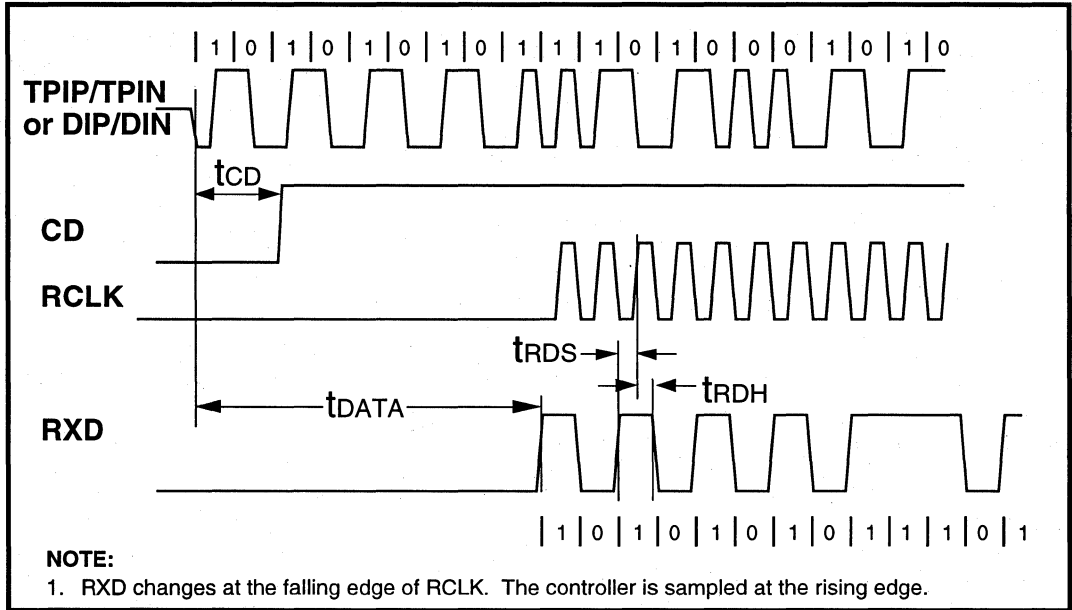

Figure 34: Mode 4 RCLK/End-of-Frame Timing

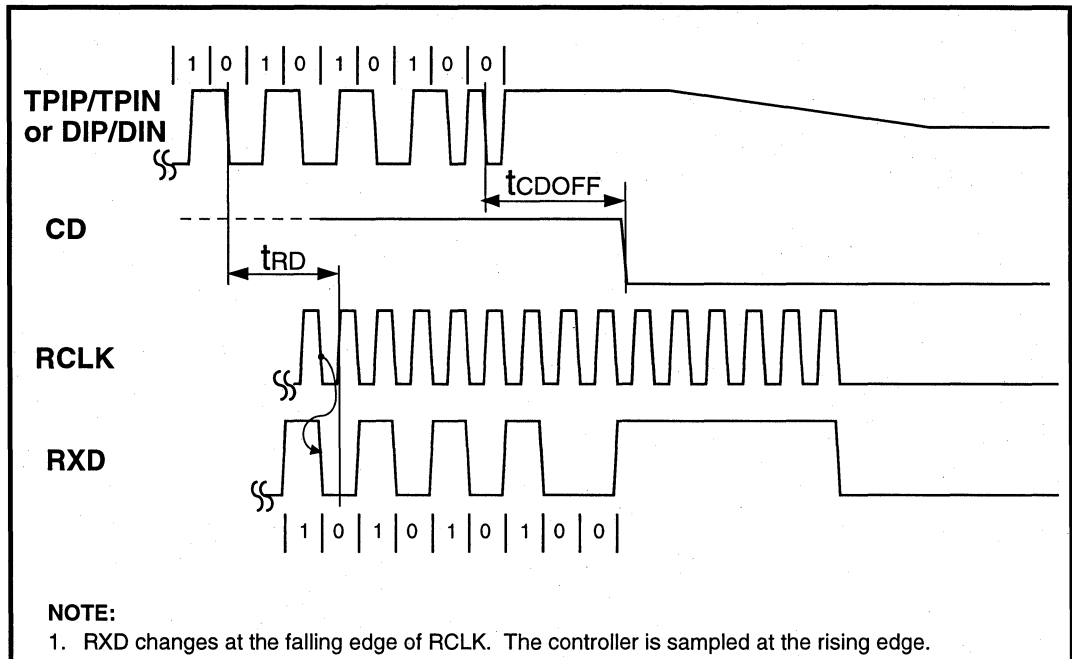

Figure 35: Mode 4 Transmit Timing

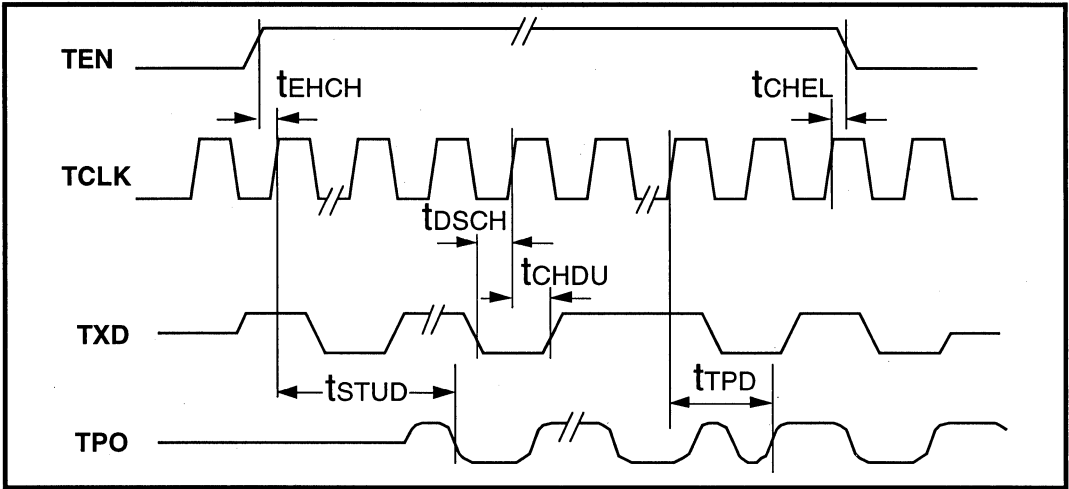

Figure 37: Mode 4 Collision Detect Timing

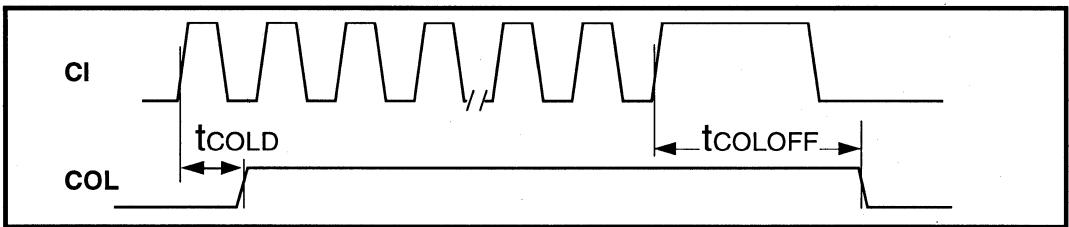

Figure 37: Mode 4 COL/CI Output Timing

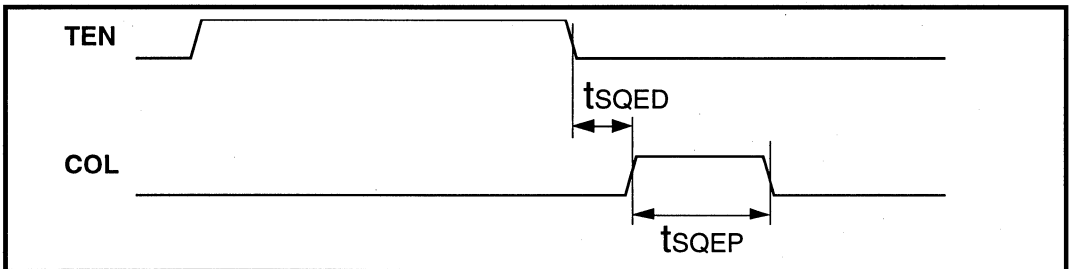
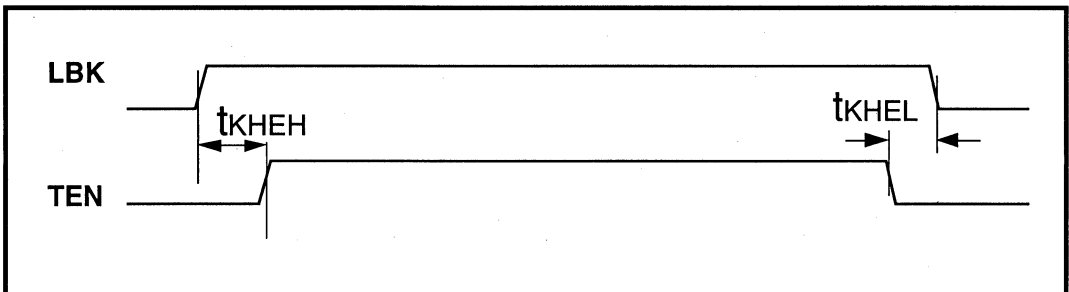

Figure 38: Mode 4 Loopback Timing



NOTES:

LXT944 Universal Quad Ethernet Interface Adapter

(Internal MAU) with Four Integrated 10BASE-T MAUs, EnDec and Filters

General Description

The LXT944 is the first quad 10BASE-T transceiver device with integrated filters. The LXT944 Quad Universal Ethernet Adapter is designed for IEEE 802.3 physical layer applications. This single CMOS device includes all of the active circuitry for interfacing most standard 802.3 controllers to 10BASE-T media.

The LXT944 includes four Manchester encoders/decoders, receiver squelch and transmit pulse shaping, jabber, link integrity testing and reversed polarity detection and correction per port. The LXT944 drives four independent 10BASE-T twisted-pair cables with only isolation transformers. Integrated filters simplify the design work required for FCC compliant EMI performance.

- Quad Independent 10BASE-T compliant transceivers with Integrated filters
- Quad Integrated Manchester encoder/decoder
- Power-down mode with tri-stated outputs
- Automatic Polarity Detection & Correction
- Global SQE enable/disable
- Four LED drivers per port
- Full duplex capability per port
- External Loopback with port disable
- Available in 100-pin Plastic Quad Flat Pack

Applications

- Hub/switched Dedicated LANs for 10BASE-T
- Multi-port 10BASE-T Server products

LXT944 Block Diagram

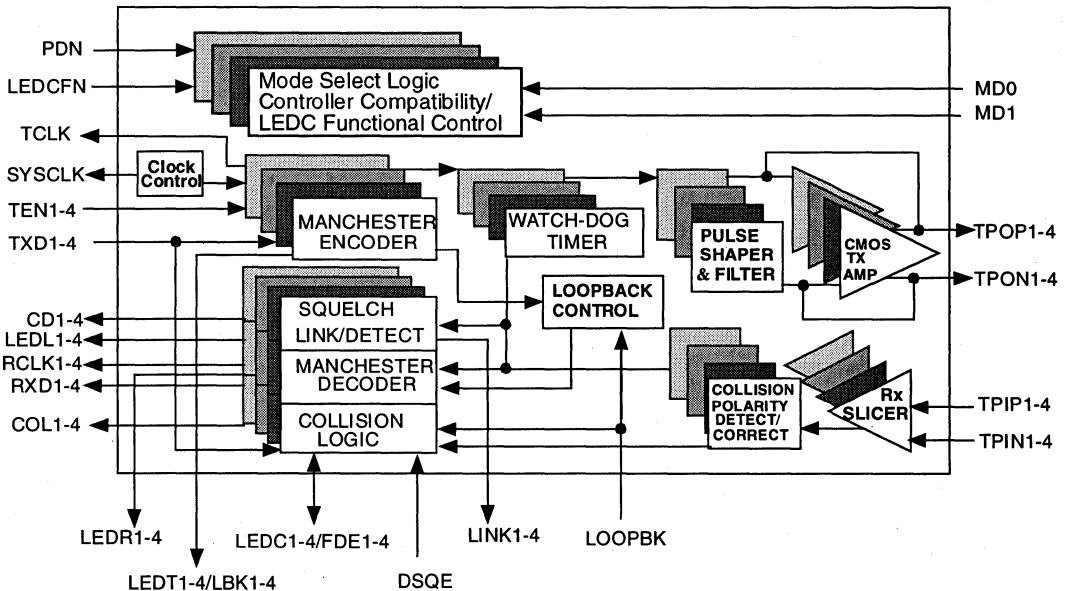

11

LXT944 Universal Quad Ethernet Interface Adapter

Figure 1: LXT944 Pin Assignments

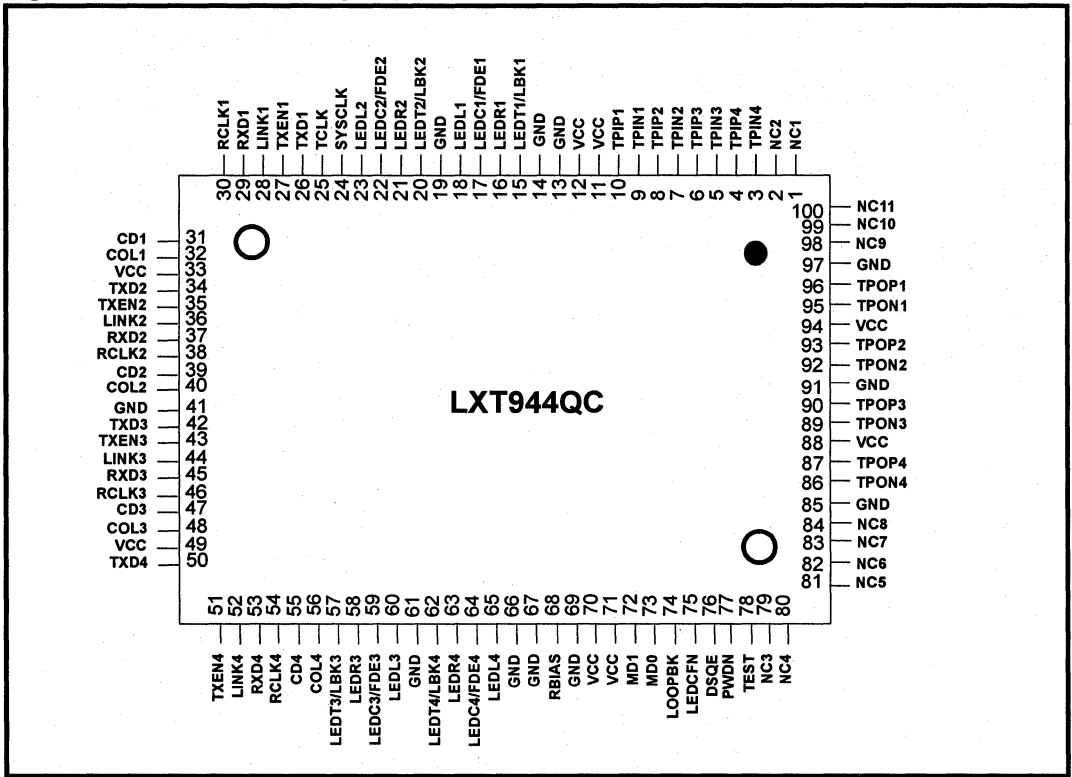

Table 1: Power, Clock, and I/O Pin Descriptions

Pin #	Symbol	I/O	Description
11,12,33,49,70,71,88,94	VCC	I	Power Input. Power supply input of +5 volts.
13,14,19,41,61,66,67,69,85,91,97	GND	I	Ground. These pins are intended for external connection to the ground plane.
1, 2,79,80-84,98,99,100	NC1-11	-	No Connects. These pins should be left unconnected.
68	RBIAS	I	Bias. Bias current for internal circuitry. This pin should be connected to ground through an external 7.5 kΩ 1% resistor.
78	TEST	I	Test. Factory use only. This pin should be tied to ground .
24	SYCLK	I	SystemClock. A 20 MHz clock input is required at this pin.
25	TCLK (global)	O	Transmit Clock. 10 MHz clock output. This clock signal should be directly connected to the transmit clock input of each controller.

Table 1: Power, Clock, and I/O Pin Descriptions – continued

Pin #	Symbol	I/O	Description
73 72	MD0 MD1 <i>(global)</i>	I	Mode Select 0 (MD0), Mode Select 1 (MD1). Mode select pins determine the controller compatibility mode in accordance with Table 2. Default is mode 3.
77	PWDN <i>(global)</i>	I	Power Down. When driven High the component enters power down state with all outputs tri-stated. When Low the device is in operational mode.
76	DSQE <i>(global)</i>	I	SQE Disable. When this pin is pulled High the SQE function is disabled. When this pin is driven Low or floated the SQE function is enabled. This pin controls the SQE function for all four TP ports.
75	LEDCFN <i>(global)</i>	I	LEDC Function Select. When driven Low or floated the LEDC1–4/FDE1–4 pins are bidirectional. When driven High the LEDC1–4/FDE1–4 pins are TTL inputs only.
74	LOOPBK <i>(global)</i>	I	Global Loopback. When Low all ports are forced to internal loopback, disabling collision and the transmission of both data and link pulses. When High the loopback function is controlled on a per port basis using the LEDT1–4/LBK1–4.
26 34 42 50	TXD1 TXD2 TXD3 TXD4	I I I I	Transmit Data (ports 1–4). These pins are input signals containing NRZ data to be transmitted on the network. The TXD pins should be tied directly to the data output of the respective controller. Pulled Low internally.
27 35 43 51	TXEN1 TXEN2 TXEN3 TXEN4	I I I I	Transmit Enable (ports 1–4). These pins enable data transmission from the respective controller and start the watch dog timers. The signals are synchronous to TCLK. Pulled Low internally.
28 36 44 52	LINK1 LINK2 LINK3 LINK4	O O O O	Link Status.(ports 1–4). These four signals indicate link status for each port. Low = link test pass. High = link test fail. The link status is valid for both half and full duplex modes.
29 37 45 53	RXD1 RXD2 RXD3 RXD4	O O O O	Receive Data (ports 1–4). These are the output signals and should be connected directly to the data input of the respective controller.
30 38 46 54	RCLK1 RCLK2 RCLK3 RCLK4	O O O O	Receive Clock (ports 1–4). These pins provide recovered 10MHz clocks which are synchronous to the receive data from the respective port. These pins should be connected to the receive clock input of the respective controller.
31 39 47 55	CD1 CD2 CD3 CD4	O O O O	Carrier Detect (ports 1–4). Outputs for notifying the controller that activity exists on the respective network.
32 40 48 56	COL1 COL2 COL3 COL4	O O O O	Collision Detect (ports 1–4). Outputs for driving their respective collision detect input of the controller.
15 20 57 62	LEDT1/ LBK1 LEDT2/ LBK2 LEDT3/ LBK3 LEDT4/ LBK4	O I O I O I O I	Transmit LED drivers (ports 1–4) . Open drain drivers for the transmit indicators. The output is pulled Low and the pulse is extended for 100 ms to indicate transmit activity. Loopback (ports 1–4). If Externally tied Low, the port is forced to Internal Loopback, disabling collision detection and the transmission of both data and link pulses. (See Loopback.) These pins are internally pulled up.

LXT944 Universal Quad Ethernet Interface Adapter

Table 1: Power, Clock, and I/O Pin Descriptions – continued

Pin #	Symbol	I/O	Description
16 21 58 63	LEDR1 LEDR2 LEDR3 LEDR4	O O O O	Receive LED drivers (ports 1–4). Open drain drivers for the receive indicators. The output is pulled Low and the pulse is extended for 100 ms to indicate receive activity.
17 22 59 64	LEDC1/ FDE1 LEDC2/ FDE2 LEDC3/ FDE3 LEDC4/ FDE4	O I O I O I O I	Transmit LED drivers (ports 1–4). Open drain drivers for the collision indicators. The output is pulled Low and the pulse is extended for 100ms to indicate collision. Loopback (ports 1–4). If Externally tied Low, the respective port is forced into Full Duplex Mode. These pins are internally pulled up.
18 23 60 65	LEDL1 LEDL2 LEDL3 LEDL4	O O O O	Link LED drivers (ports 1–4). These tri-level LED drivers indicate Link status for each port. The outputs are pulled Low to indicate half duplex link pass state. The outputs are driven High to indicate full duplex link pass state. When in link fail state the driver is tri-stated.
10 9 8 7 6 5 4 3	TPIP1 TPIN1 TPIP2 TPIN2 TPIP3 TPIN3 TPIP4 TPIN4	I I I I I I I I	Twisted Pair Data Inputs, Positive & Negative (ports 1–4). These pins are the positive and negative twisted-pair data input pins for ports 1 - 4, respectively.
96 95 93 92 90 89 87 86	TPOP1 TPON1 TPOP2 TPON2 TPOP3 TPON3 TPOP4 TPON4	O O O O O O O O	Twisted Pair Data Outputs, Positive & Negative (ports 1–4). These pins are the positive and negative twisted-pair data output pins for ports 1 - 4, respectively. The outputs are pre-equalized; no external filters are required.

Table 2: Controller Compatibility Modes

Ethernet Controllers Supported	Mode	MD1	MD0
Advanced Micro Devices AM7990, Motorola 68EN360, and compatible controllers	Mode 1	0	0
Intel 82596 and compatible controllers ¹	Mode 2	0	1
Fujitsu MB86950, MB86960, Seeq 8005, and compatible controllers ²	Mode 3	1	0
National Semiconductor 8390, Texas Instruments TMS380C26, and compatible controllers	Mode 4	1	1

1. Refer to Level One Application Note 51 when designing with Intel controllers.
2. Seeq controllers require inverters on CLKI, LBK, RCLK and COL.

FUNCTIONAL DESCRIPTION

NOTE

This functional information is for design aid only.

The LXT944 Quad Universal Ethernet Transceiver performs the physical layer signaling (PLS) and Media Attachment Unit (MAU) functions as defined by the IEEE 802.3 specification. It functions as an integrated PLS/MAU for use with four 10BASE-T twisted-pair networks.

The LXT944 interfaces between four independent back end controllers and four twisted-pair (TP) cables. The controller interfaces includes transmit and receive clock and NRZ data channels, as well as mode control logic and signaling. The twisted-pair interfaces are comprised of Twisted-Pair Input (TPI±) and Twisted-Pair Output (TPO±) pairs. In addition to the two basic interfaces, the LXT944 has a 20 MHz system clock input; a single 10 MHz TCLK output to all four controllers; LED drivers for Collision, Receive, Transmit, and Link Status of each port; independent or global internal loopback; full duplex operation on a per port basis; and four TTL link status outputs.

LXT944 functions are defined from the back end controller side of the interface. The LXT944 Transmit function refers to data transmitted by the back end controllers to the twisted-pair network. The LXT944 receive function refers to the data received by the back end controllers from the twisted-pair networks. The LXT944 performs all required MAU functions defined by the IEEE 802.3 10BASE-T specification such as collision detection, link integrity testing, signal quality error messaging, jabber control and loopback.

CONTROLLER COMPATIBILITY MODES

The LXT944 is compatible with most industry standard controllers including devices produced by Advanced Micro Devices (AMD), Fujitsu, Intel¹, Motorola, National Semiconductor, Seeq², Texas Instruments. Four different control signal timing and polarity schemes (modes 1 through 4) are required to achieve this compatibility. The Mode select pins (MD1 & MD0) determine the controller compatibility mode as listed in Table 1. Controller compatibility mode is selected globally. Each of the four independent controller inputs (one per port) is configured to operate in the same mode. The user must select a single controller operating 1. Refer To Level One Application Note 51 when designing with Intel controllers.

2. Seeq controllers require inverters on SYSCLK, LBK1-4, RCLK1-4, and COL1-4.

mode for all four ports. Refer to the Test Specification section for the timing parameters.

Transmit Function

The LXT944 receives NRZ data from the controller at the TXD input (as shown in the block diagram on the first page of the data sheet) and passes it through a Manchester encoder. The encoder data is then transferred to the twisted-pair network (the four TPO circuits). The advanced integrated pulse shaping and filtering network produces the output signal on TPO_{Nx} and TPO_{Px}, shown in Figure 2. The TPO output is pre-distorted and prefiltered to meet the 10BASE-T jitter template. An internal, continuous, resistor-capacitor filter removes high frequency clocking noise from the pulse shaping circuitry. Integrated filters simplify the design work required for FCC compliant EMI performance. During idle periods the LXT944 transmits link integrity test pulses on the TPO_x circuits (if the Loopback function is disabled).

Figure 2: LXT944 TPO Output Waveform

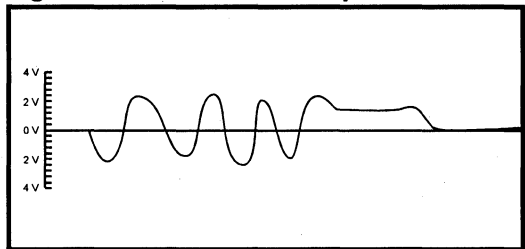

JABBER CONTROL FUNCTION

Figure 3 is a state diagram of the LXT944 jabber control function per port. The LXT944 on-chip watchdog timer prevents the DTE from locking into a continuous transmit mode. When a transmission exceeds the time limit, the watchdog timer disables the transmit and loopback functions and activates the COL_x pins. Once the LXT944 is in jabber state, the TXD circuit must remain idle for a period of 0.25 to 0.75 seconds before it will exit the jabber state.

Figure 3: LXT944 Jabber Control Function

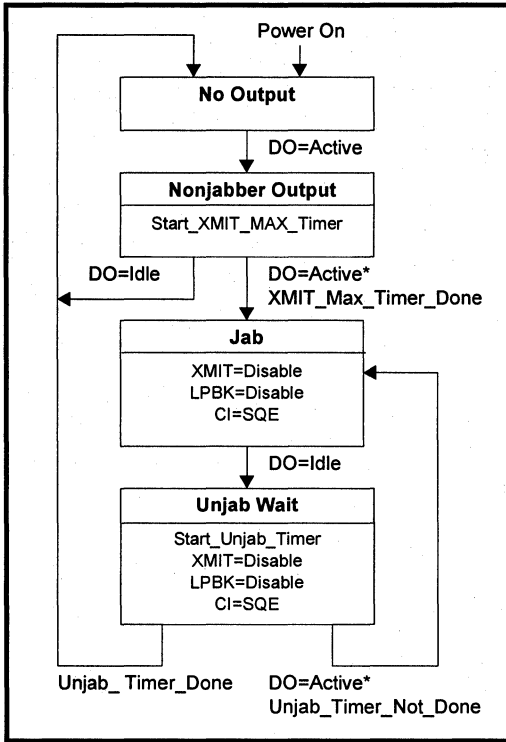

SQE FUNCTION

The LXT944 supports the Signal Quality Error (SQE) function as shown in Figure 4. After every successful transmission on the 10BASE-T network, the LXT944 transmits the SQE signal for 10 bit times (BT) ± 5 BT on the COLx pins of the device.

The SQE function can be disabled for repeater or switch applications. When the DSQE pin = 1, the SQE function is disabled. When DSQE=0, the SQE function is enabled. The pin has an internal pull down enabling the SQE function when unconnected.

RECEIVE FUNCTION

The LXT944 receive function acquires timing and data from the twisted-pair network (the TPLx circuits). Valid receive signals are passed through the on-chip filters and Manchester decoder then output as decoded NRZ data receive timing on the RXD RCLK pins, respectively.

An internal RC filter and an intelligent squelch function discriminates noise from link test pulses and valid data streams. The receive function is activated only by valid data streams above the squelch level and with proper timing. If the differential signals at the TPLx circuit inputs fall below 85% of the threshold level (unsquelched) for 8 bit times (typical), the LXT944 receive function enters the idle state. The LXT944 automatically corrects reversed polarity on the TPLx circuits.

Figure 4: Signal Quality Error

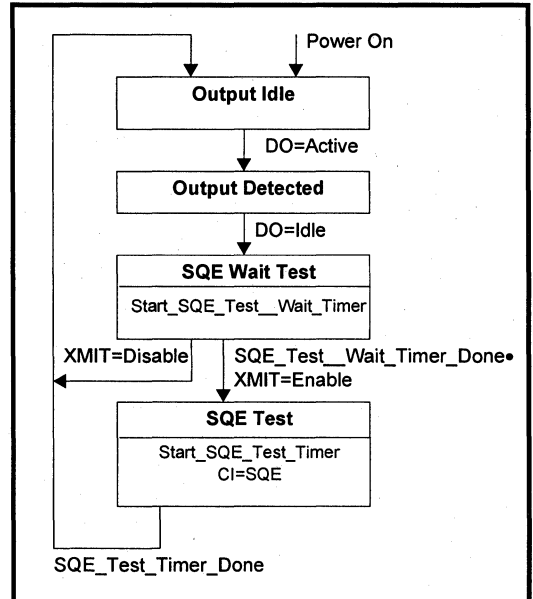

POLARITY REVERSE FUNCTION

The LXT944 supports auto polarity detection and correction. The polarity reverse function uses both the link pulses and the end-of-frame data to determine polarity of the received signal. A reversed polarity condition is detected when eight consecutive opposite receive link pulses are detected without receipt of a link pulse of the expected polarity. Reversed polarity is also detected if four consecutive frames are received with a reversed start-of-idle. Whenever a corrected polarity frame is received, these two counters are reset to zero. If the LXT944 enters the link fail state and no valid data or link pulses are received within 96 to 128 ms, the polarity is reset to the default non-flipped condition. (If Link Integrity testing is disabled, polarity detection is based only on receive data.) Polarity correction is always enabled.

COLLISION DETECTION FUNCTION

A collision is defined as the simultaneous presence of valid signals on both the TPLx circuits and the TPOix circuits. The LXT944 reports collisions to the back-end via the COLx pins. If the TPLx circuits become active while there is activity on the TPOx circuits, the TPLx data is passed to the back-end over the RXD circuit, disabling normal loopback. Figure 5 is a state diagram of the LXT944 collision detection function per port.

Figure 5: LXT944 Collision Detection State Machine

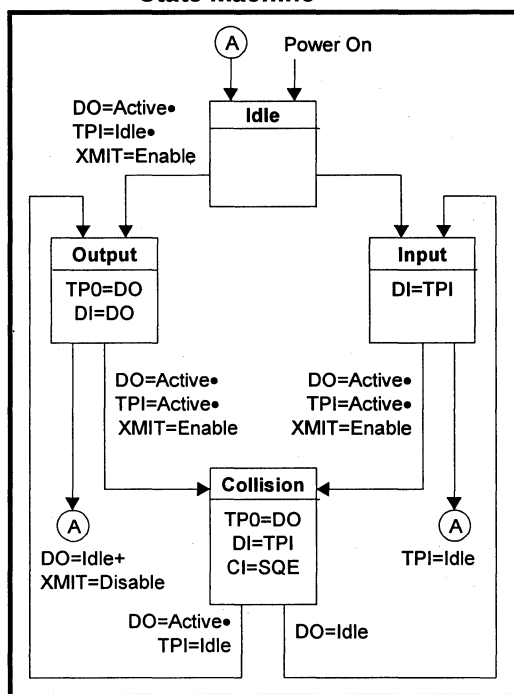

LOOPBACK FUNCTION

The LXT944 provides the normal loopback function specified by the 10BASE-T standard for the twisted-pair port, as well as a forced loopback function. The loopback function operates in conjunction with the transmit function. Data transmitted by the back-end is internally looped back within the LXT944 from the TXDx pins through the Manchester encoder/decoder to the RXD1-4 pins and returned to the back-end. This “normal” loopback function is disabled when a data collision occurs, clearing the RXDx circuits for the TPLx data. Normal loopback is also disabled during link fail, jabber, and full duplex states. Loopback is always enabled during the forced loopback state.

The LXT944 provides an additional loopback function. **External loopback mode**, useful for system-level testing, is controlled by the LEDCx/FDEx pins. With both LEDCx/FDEx, and LEDTx/LBKx, or the global Loopback pins Low, the LXT944 device:

- disables internal loopback circuits
- disables SQE
- disables the collision detection circuitry
- enables full duplex mode

This allows for external loopback testing. This can be controlled on a per port basis using the individual port controls or globally by using the “Loopback” pin.

FULL DUPLEX OPERATION

Full duplex operation is enabled by driving the LEDCx/FDEx pins with an open collector driver. The LEDCFN pin when enabled will disable the collision LED driver and allow the LEDCx/FDEx pin to be driven by a TTL driver to enable or disable the full duplex operation of the TP ports.

LINK INTEGRITY TEST FUNCTION

Figure 6 is a state diagram of the LXT944 Link Integrity Test function. The link integrity test is used to determine the status of the receive side twisted-pair cable. Link integrity testing is always enabled unless the loopback function is enabled (LBK or Loopback = 1). When enabled, the receiver recognizes link integrity pulses which are transmitted in the absence of receive traffic. If no serial data stream or link integrity pulses are detected within 50-150 ms, the device enters a link fail state and disables the transmit and normal loopback functions. The LXT944 ignores any link integrity pulse with an interval less than 2-7 ms. The LXT944 will remain in the Link Fail state until it detects either a serial data packet or two or more link integrity pulses.

LED DRIVER FUNCTIONS

The LXT944 supports individual LED drivers for each port. Per-port LED drivers include link (both half & full duplex), receive, transmit, and collision. The signal pulse widths on all activity outputs (receive, transmit, and collision) are a minimum of a 100 ms to increase visual recognition of the LED status.

The LINKx signals are TTL level outputs indicating link pass state for both half and full duplex operation. The signal is active Low and can be read as a status bit or be used to activate port link LEDs.

Figure 6: LXT944 Link Integrity Test Function State Machine

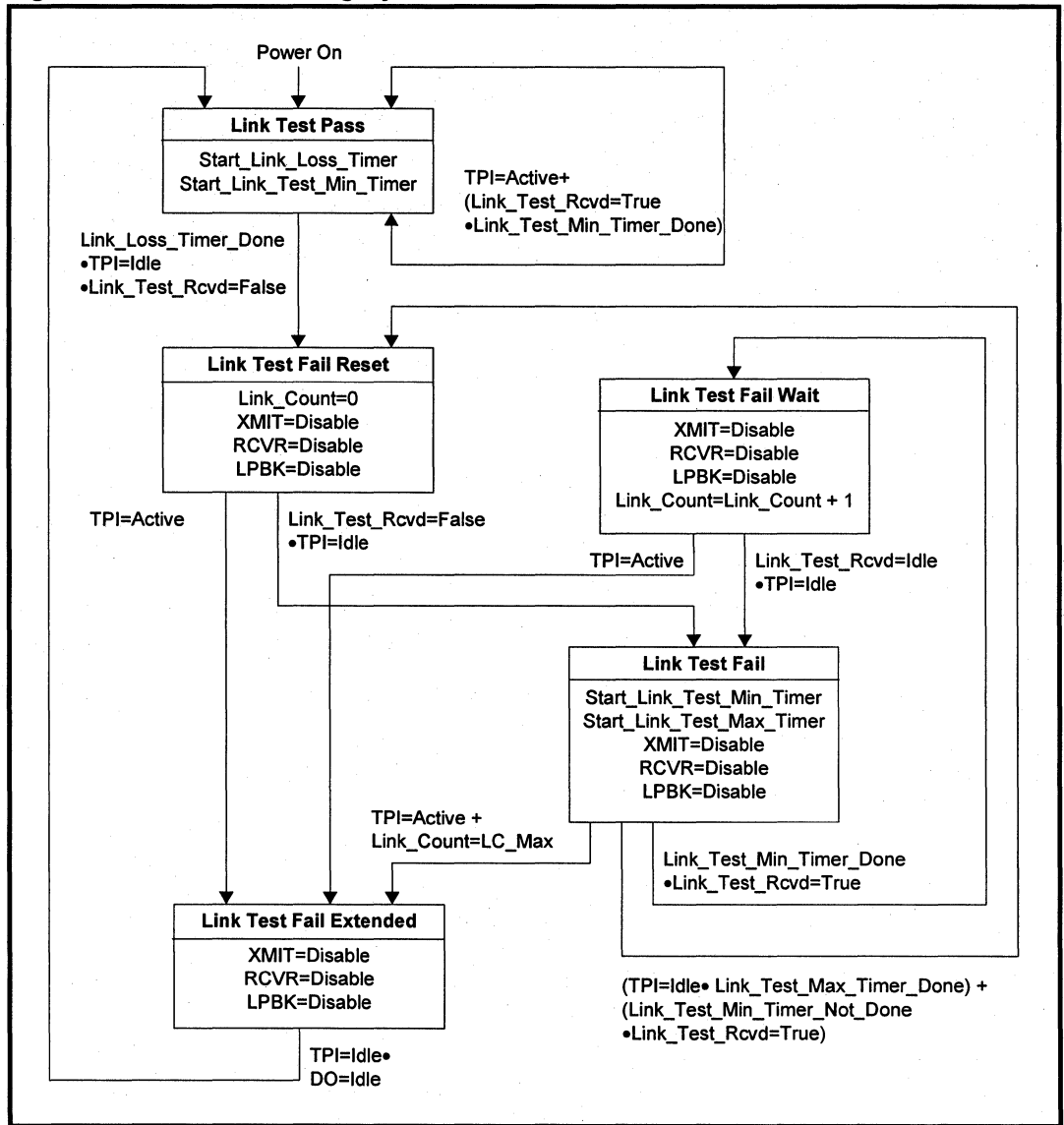

APPLICATION INFORMATION

NOTE

This application information is for design aid only.

The following diagrams group similar pins; they do not portray the actual chip pinout. The controller interface pins (transmit, data, clock, and enable; receive data and clock; and the collision detect and carrier detect pins) are at the upper left.

The VCC and GND pins are at the bottom of each diagram. All VCC pins use a single power supply with decoupling capacitors installed between the VCC and GND pins and their respective planes.

MAGNETICS INFORMATION

The LXT944 requires a 1:1 ratio for the receive transformers and a $1:\sqrt{2}$ ratio for the transmit transformers. The LXT944 uses the same magnetics which are currently used on the LXT914 Quad Repeater. Various front end design options are available: a simple per port Rx/Tx pair configuration (see Figure 7), the receive quad and the transmit quad (see Figure 8), and the new single 40 pin octal transformer configuration (see Figure 9).

Transformers for these designs are available from various manufacturers. Table 3 is a list of available Quad and Single port transformers with manufacturers and their part numbers. This information was valid as of the printing date of this document. Before committing to a specific component, designers should test and validate all specifications of the magnetics used in all applications.

LAYOUT REQUIREMENTS

The Twisted Pair Interface

The four, twisted-pair output circuits are identical. Each TPDOP/TDPON signal has a $24.9\ \Omega$, 1%, series resistor and a 120 pF capacitor differentially across the positive and negative outputs. These signals go directly to a $1:\sqrt{2}$ transformer creating the necessary $100\ \Omega$ termination for the cable. The TPDIP/TPDIN signals have a $100\ \Omega$ resistor across the positive and negative input signals to terminate the $100\ \Omega$ signal received from the line. To calculate the impedance on the output line interface, use:

$$(24.9\ \Omega + 24.9\ \Omega) * \sqrt{2}^2 \approx 100\ \Omega.$$

The layout of the twisted-pair ports is critical in complex designs. Run the signals directly from the device to the discrete termination components (located close to the transformers).

The transformer isolation voltage should be rated at 2 kV to protect the circuitry from static voltages across the connectors and cables. The signals running from the transformers to the connector should run in close pairs directly to the connector. Be careful not to cross the transmit and receive pairs. One way to avoid a problem is to run the receive pairs on the component side and the transmit pairs on the solder side. Careful planning during the schematic and layout stages can avoid these problems.

The PCB layout should have no ground or power planes between the transformers and the connectors. The data signals should be the only traces in this area. Place the chassis ground for the connectors near the edge of the PCB, away from the signals, connecting the connector shield with the chassis.

Table 3: Manufacturers Magnetics List

Mfgr	Quad Transmit	Quad Receive	Tx/Rx Pairs
Bell Fuse	S553-5999-02	S553-5999-03	
Fil-Mag	23Z338	23Z339	
HALO	TD54-1006L1 TG54-1006N2	TD01-1006L1 TG01-1006N2	TD42-2006Q TD43-2006K TG42-1406N1 TG43-1406N TG44-S010NX
(Octal)			
Kappa	TP4003P	TP497P101	
Nan-opulse	5976	5977	
PCA	EPE6009	EPE6010	
VALOR	PT4116	PT4117	PT4069N1 PT4068N1 ST7011S2 ST7010S2

The RBIAS Pin

The RBIAS signal sets the levels for the output drivers of the LXT944. Any emissions or common mode noise entering the device here could be measured on the twisted-pair output signals.

The LXT944 requires a $7.5\ k\Omega$, 1% resistor directly connected between pin 68 and ground. These traces should be as short as possible. The ground signals from pins 67 & 69 should come directly off of the device to enclose the resistor and pin forming a shielded area between the RBIAS connection and the switching signals on the PCB.

Figure 7: Simple Receiver/Transmit on Each Port Application

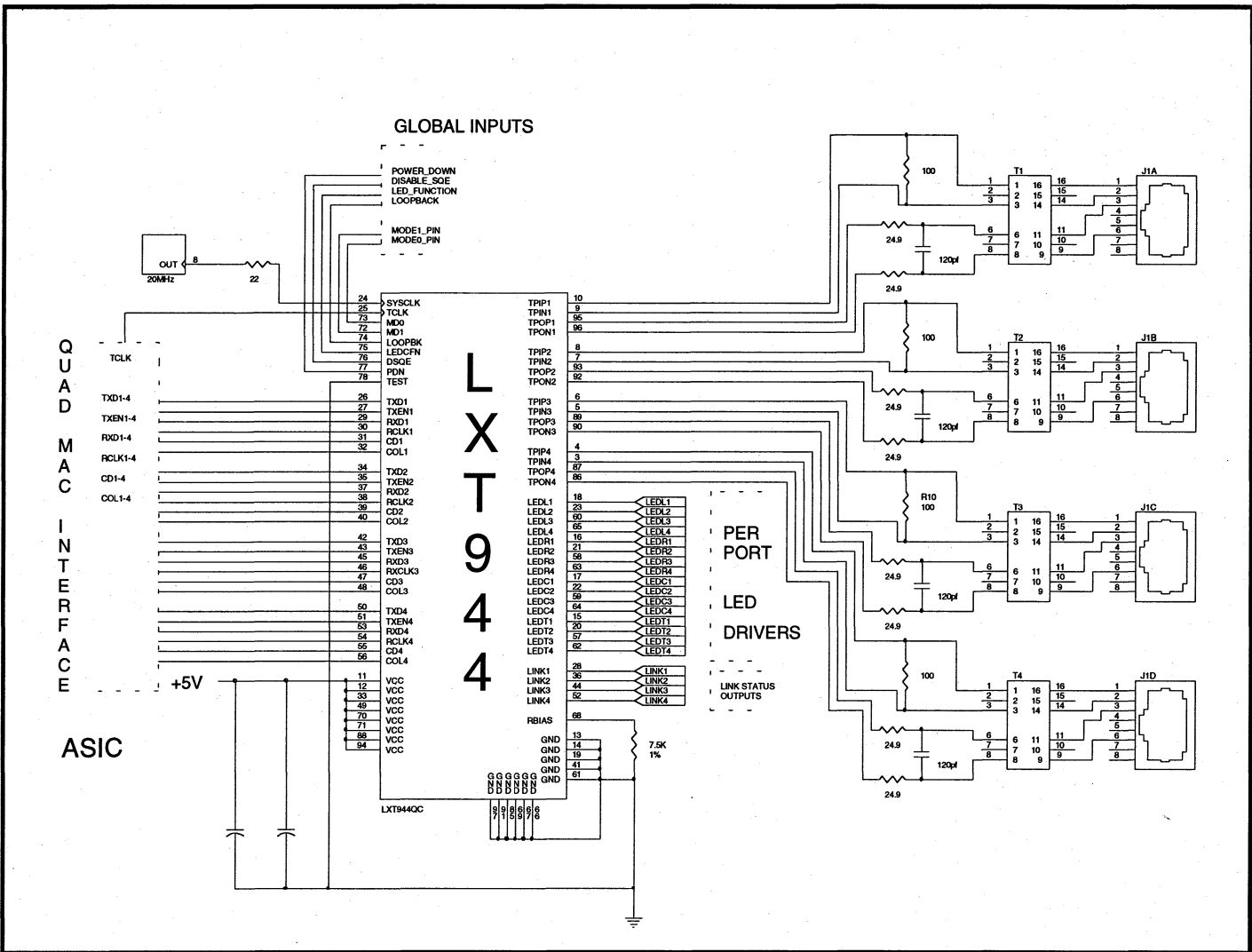
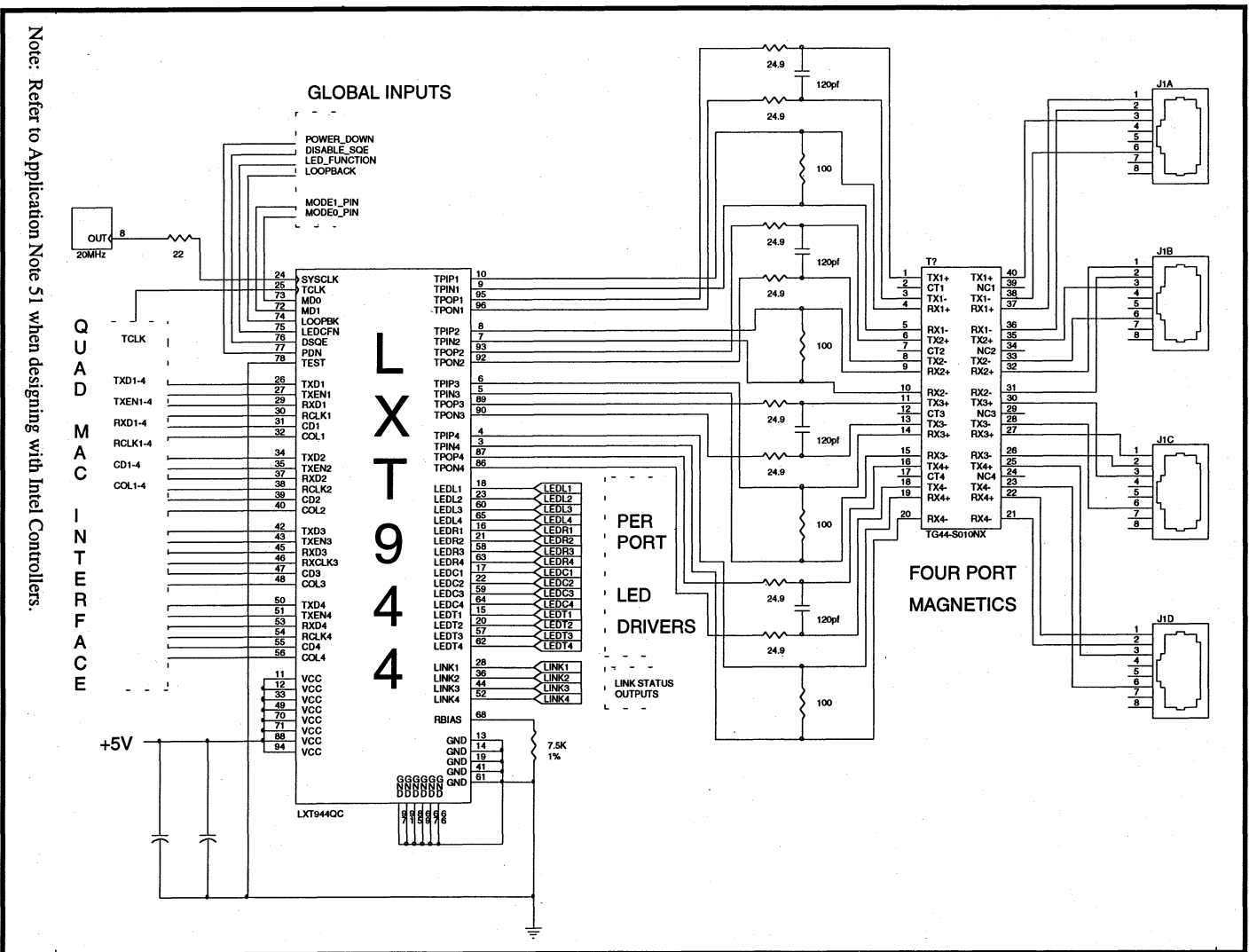

Figure 9: Single, 40-pin Octal Transformer Application



Note: Refer to Application Note 51 when designing with Intel Controllers.

TEST SPECIFICATIONS

NOTE

The minimum and maximum values in Tables 4 through 10 and Figures 10 through 26 represent the performance specifications of the LXT944 and are guaranteed by test, except where noted by design.

Table 4: Absolute Maximum Values

Parameter	Symbol	Min	Max	Units
Supply Voltage	VCC	-0.3	6	V
Operating Temperature	TOP	0	70	°C
Storage Temperature	TST	-65	+150	°C

CAUTION

Exceeding these values may cause permanent damage. Functional operation under these conditions is not implied. Exposure to maximum rating conditions for extended periods may affect device reliability.

Table 5: Operating Conditions

Parameter	Symbol	Min	Typ	Max	Units	Test Conditions
Recommended Supply Voltage ¹	VCC	4.75	5.0	5.25	V	
Recommended Operating Temperature	TOP	0	-	70	°C	

1. Voltages with respect to ground unless otherwise specified.

Table 6: I/O Electrical Characteristics (Over Recommended Range)

Parameter	Sym	Min	Typ ¹	Max	Units	Test Conditions	
Input Low voltage	VIL	-	-	0.8	V		
Input High voltage	VIH	2.0	-	-	V		
Output Low voltage	VOL	-	-	0.4	V	IOL = 1.6 mA	
	VOL	-	-	10	%VCC	IOL < 10 μA	
Output Low voltage - LEDs	VOLL	-	-	1.0	%VCC	IOLL = 5 mA	
Output High voltage	VOH	2.4	-	-	V	IOH = 40 μA	
	VOH	90	-	-	%VCC	IOH < 10 μA	
Output High voltage - LEDs	VOLH	2.4	-	-	V	IOHL = -5 mA	
Input low current	IIL	-	-	2	mA	VOL = .4 V	
Output Rise Time TCLK & RCLK	CMOS	-	3	15	ns	CLOAD = 20 pF	
	TTL	-	2	15	ns		
Output Fall Time TCLK & RCLK	CMOS	-	3	15	ns	CLOAD = 20 pF	
	TTL	-	2	15	ns		
CLKI rise time (externally driven)	-	-	-	10	ns		
CLKI duty cycle (externally driven)	-	-	50/50	40/60	%		
Supply Current	Normal Mode	ICC	0	140	200	mA	Idle
	Normal Mode	ICC	0	160	220	mA	Transmitting on TP
	Power Down Mode	ICC	-	0.1	100	μA	

1. Typical values are at 25 °C and are for design aid only; not guaranteed and not subject to production testing.

LXT944 Universal Quad Ethernet Interface Adapter

Table 7: TP Electrical Characteristics (Over Recommended Range)

Parameter	Symbol	Min	Typ ¹	Max	Units	Test Conditions
Transmit output impedance	Z _{OUT}	–	2	–	Ω	
Transmit timing jitter addition ²	–	–	±6.4	±10	ns	0 line length for internal MAU
Transmit timing jitter added by the MAU and PLS sections ^{2, 3}	–	–	±3.5	±5.5	ns	After line model specified by IEEE 802.3 for 10BASE-T internal MAU
Receive input impedance	Z _{IN}	–	24	–	kΩ	Between TPIP/TPIN
Differential Squelch Threshold	V _{DS}	300	420	585	mV	5 MHz square wave input

1. Typical values are at 25 °C and are for design aid only; not guaranteed and not subject to production testing.

Table 8: Switching Characteristics (Over Recommended Range)

Parameter	Symbol	Minimum	Typical ¹	Maximum	Units
Jabber Timing	Maximum Transmit Timing	-	20	-	150 ns
	Unjab Timing	-	250	-	750 ns
Link Integrity Timing	Time Link Loss Receive	-	50	-	150 ns
	Link Min Receive	-	2	-	7 ns
	Link Max Receive	-	50	-	150 ns
	Link Transmit Period	-	8	10	24 ns

1. Typical values are at 25 °C and are for design aid only; not guaranteed and not subject to production testing.

Table 9: RCLK/Start-Of-Frame Timing (Over Recommended Range)

Parameter	Symbol	Minimum	Typical ¹	Maximum	Units
Decoder acquisition time	t _{DATA}	-	900	1100	ns
CD turn-on delay	t _{CD}	-	50	200	ns
Receive data setup from RCLK	Mode 1	t _{RDS}	60	70	- ns
	Modes 2, 3 and 4	t _{RDS}	30	45	- ns
Receive data hold from RCLK	Mode 1	t _{RDH}	10	20	- ns
	Modes 2, 3 and 4	t _{RDH}	30	45	- ns
RCLK shut off delay from CD assert (Mode 3)	t _{SWS}	-	±100	-	ns

1. Typical values are at 25 °C and are for design aid only; not guaranteed and not subject to production testing.

Table 10: RCLK/End-of-Frame Timing (Over Recommended Range)

Parameter	Type	Sym	Mode 1	Mode 2	Mode 3	Mode 4	Units
RCLK after CD off	Minimum	tRC	5	1	27	5	bit times
Rx data throughput delay	Maximum	tRD	400	375	375	375	ns
CD turn off delay ¹	Maximum	tCDOFF	500	475	475	475	ns
Receive block out after TEN off ²	Typical ³	tIFG	5	50	-	-	bit times
RCLK switching delay after CD off	Typical ³	tSWE	-	-	120 (±80)	-	bit times

1. CD Turnoff delay measured from middle of last bit; timing specification is unaffected by the value of the last bit.

2. Blocking of Carrier Detect is disabled during full duplex operation.

3. Typical values are at 25° C and are for design aid only; not guaranteed and not subject to production testing.

Table 11: Transmit Timing (Over Recommended Range)

Parameter	Symbol	Minimum	Typical ¹	Maximum	Units
TEN Setup from TCLK	tEHCH	22	-	-	ns
TXD Setup from TCLK	tDSCH	22	-	-	ns
TEN Hold after TCLK	tCHEL	5	-	-	ns
TXD Hold after TCLK	tCHDU	5	-	-	ns
Transmit Start-up Delay	tSTUD	-	350	450	ns
Transmit Through-put Delay	tTPD	-	338	350	ns

1. Typical values are at 25° C and are for design aid only; not guaranteed and not subject to production testing.

Table 12: Miscellaneous Timing (Over Recommended Range)

Parameter	Symbol	Minimum	Typical ¹	Maximum	Units
COL (SQE) Delay after TEN off	tSQED	0.65	-	1.6	µs
COL (SQE) Pulse Duration	tSQEP	500	-	1500	ns
Power Down recovery time	tPDR	-	TBD	-	ms

1. Typical values are at 25° C and are for design aid only; not guaranteed and not subject to production testing.

TIMING DIAGRAMS FOR MODE 1 (MD1 = Low, MD0 = Low)—FIGURE 10 THROUGH FIGURE 13

Figure 10: Mode 1 RCLK/Start of Frame Timing

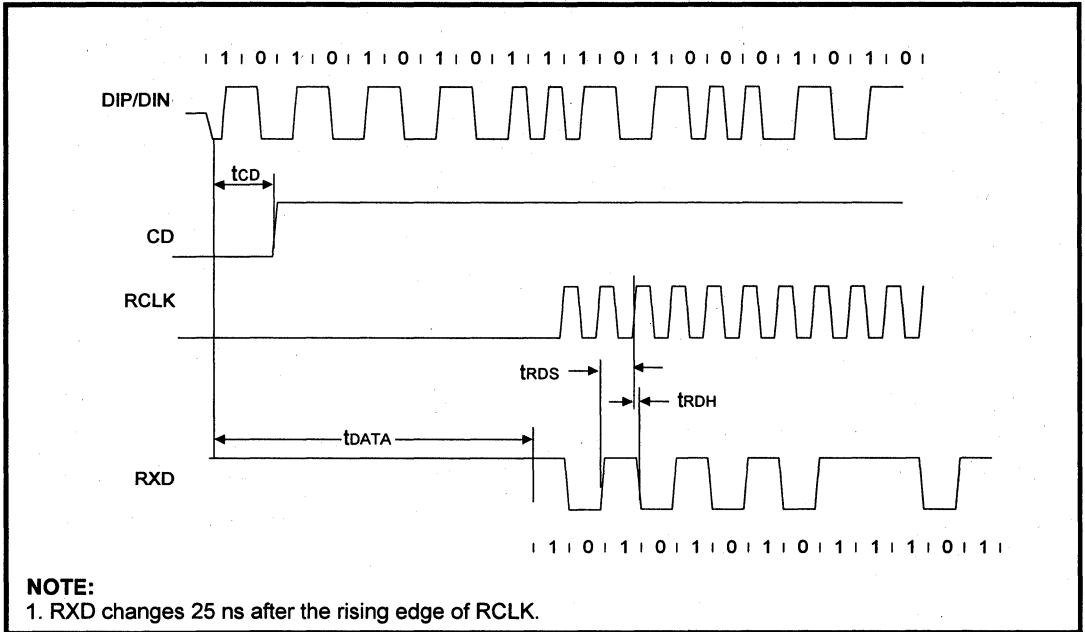

Figure 11: Mode 1 RCLK/End of Frame Timing

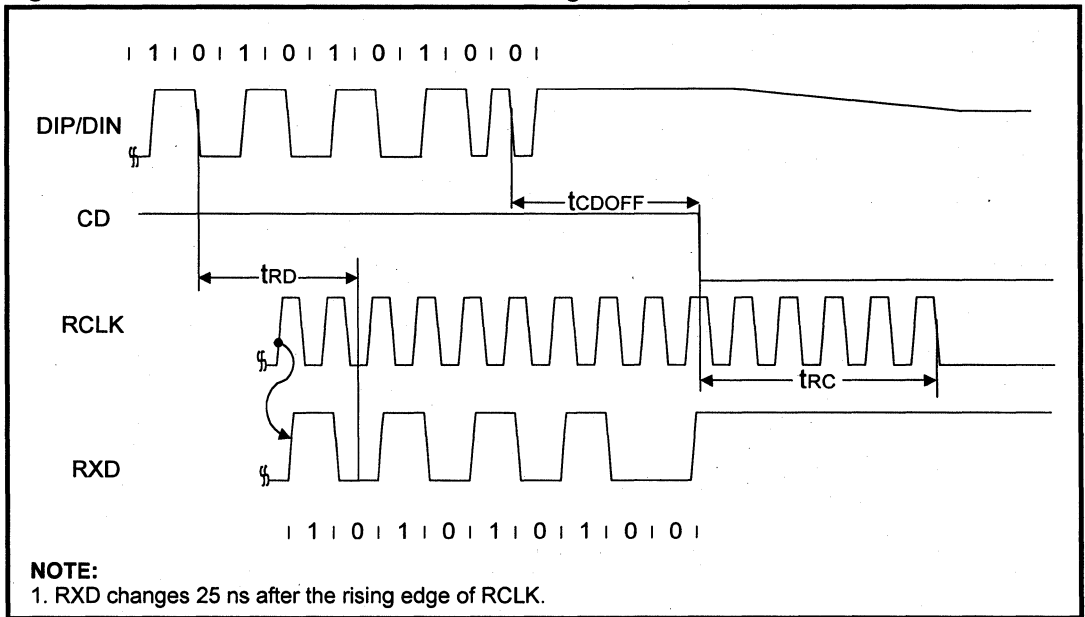

Figure 12: Mode 1 Transmit Timing

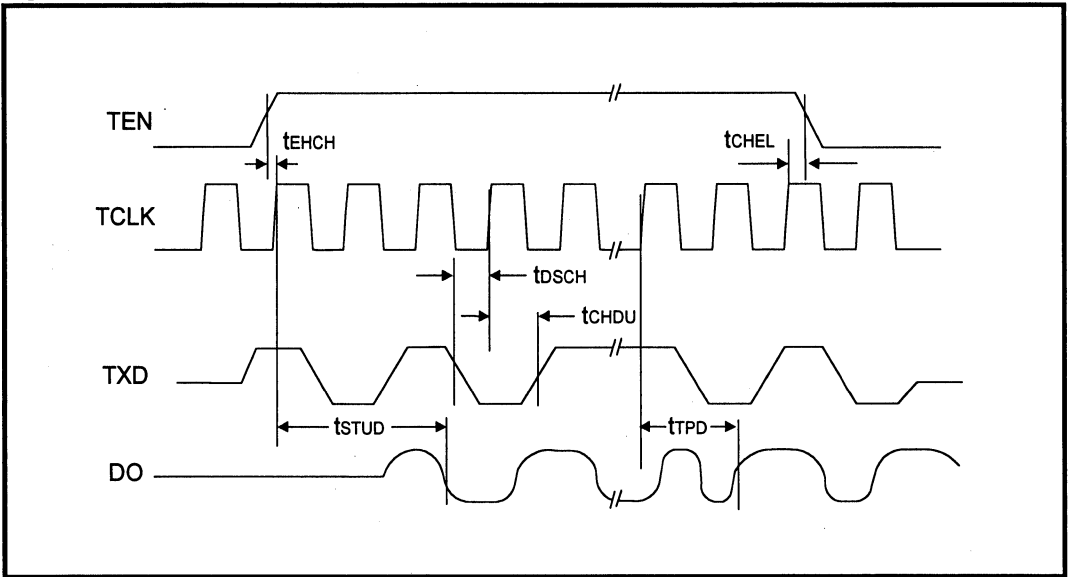
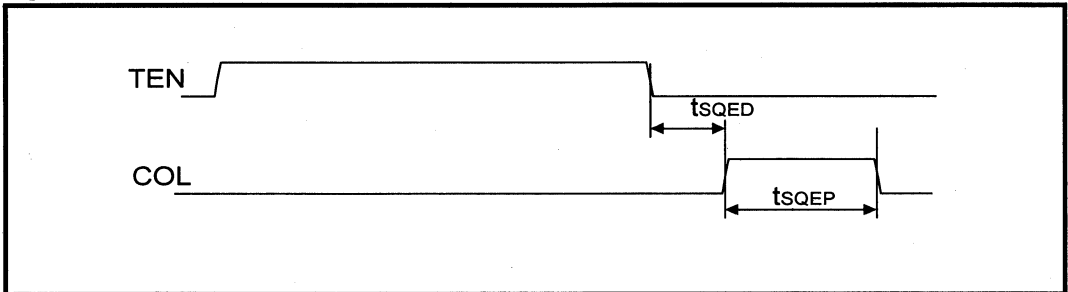

Figure 13: Mode 1 COL Output Timing



TIMING DIAGRAMS FOR MODE 2 (MD1=Low, MD0=High)—FIGURE 14 THROUGH FIGURE 17

Figure 14: Mode 2 RCLK/Start-of-Frame Timing

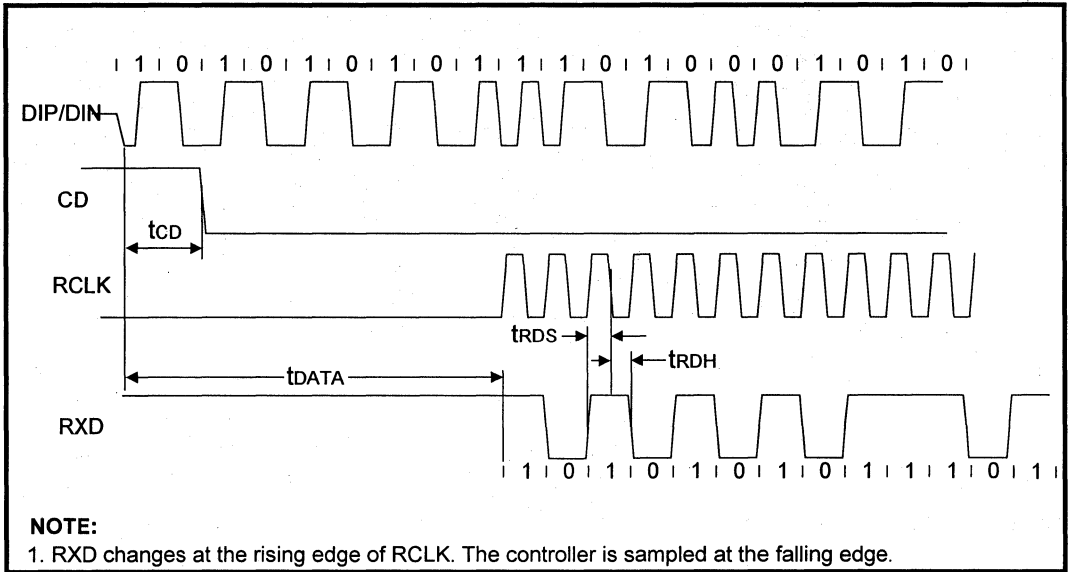

Figure 15: Mode 2 RCLK/End-of-Frame Timing

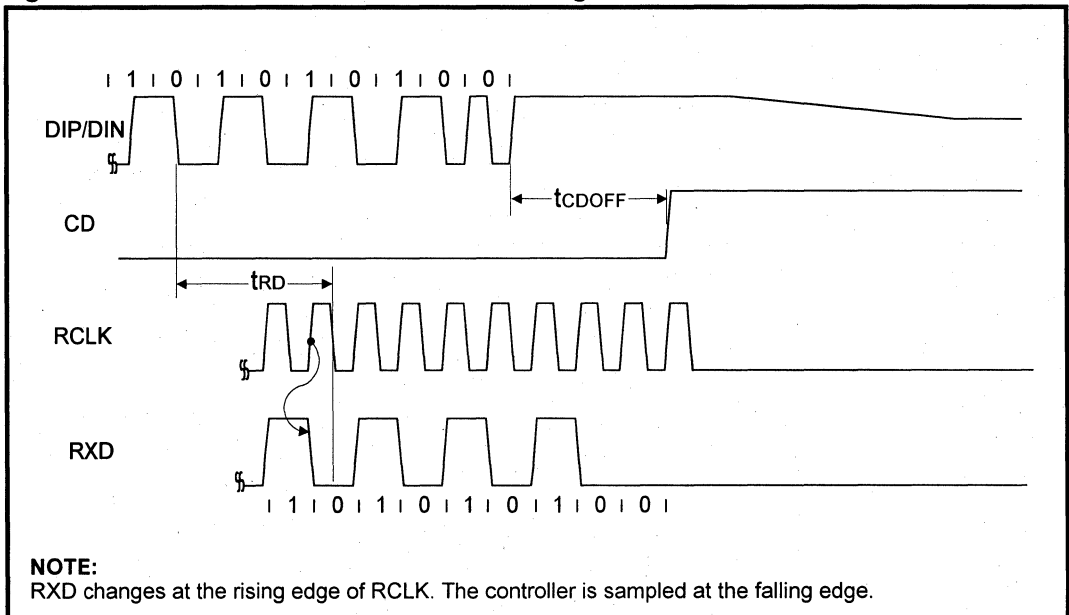

Figure 16: Mode 2 Transmit Timing

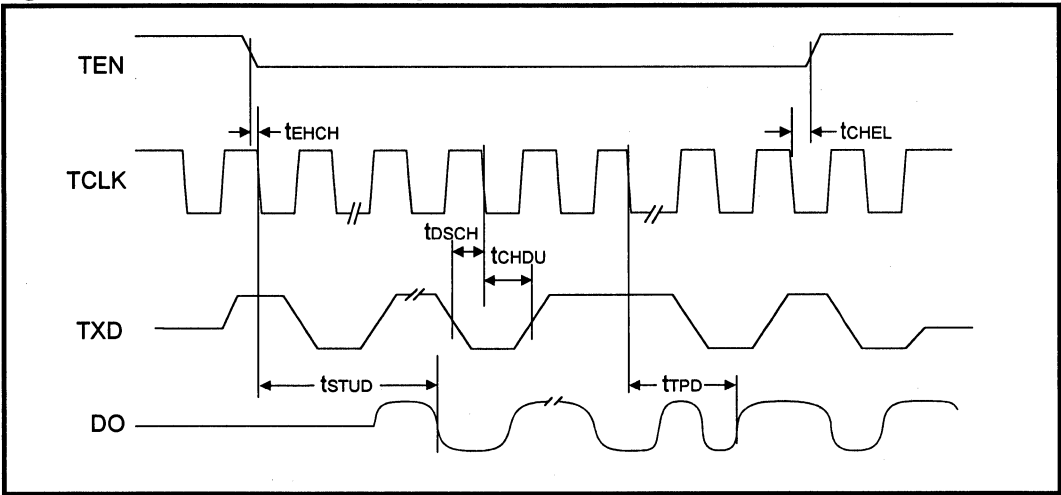
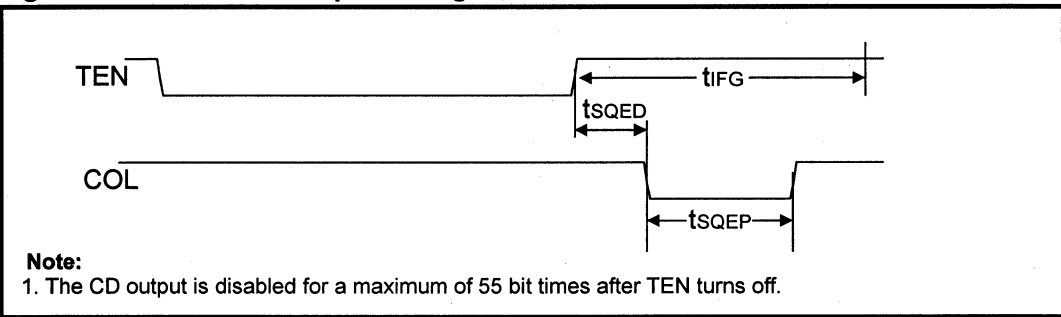

Figure 17: Mode 2 COL Output Timing



TIMING DIAGRAMS FOR MODE 3 (MD1 = High, MDO = Low)—FIGURE 18 THROUGH FIGURE 21

Figure 18: Mode 3 RCLK/Start-of-Frame Timing

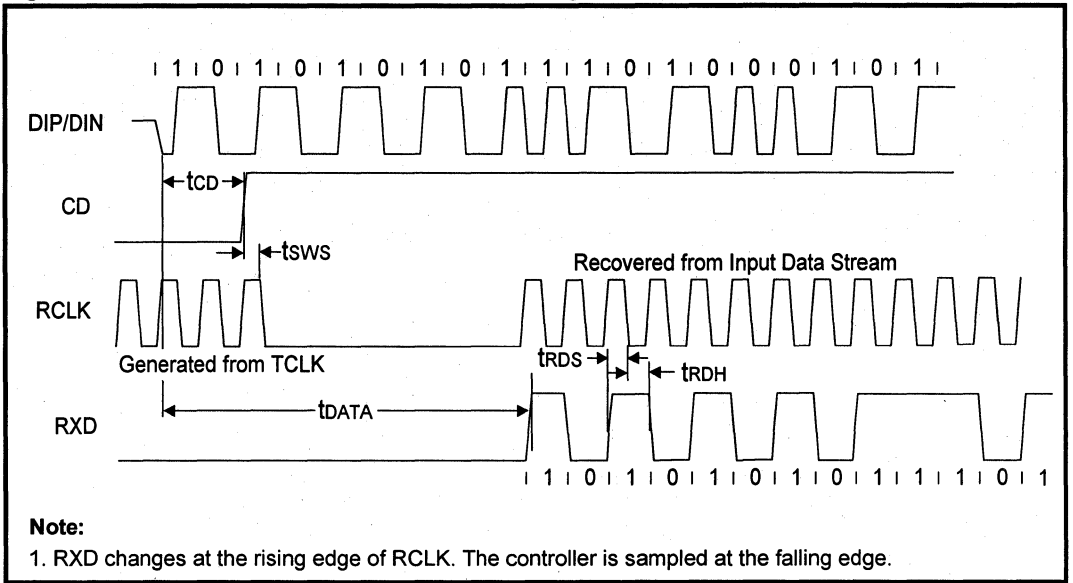

Figure 19: Mode 3 RCLK/End-of-Frame Timing

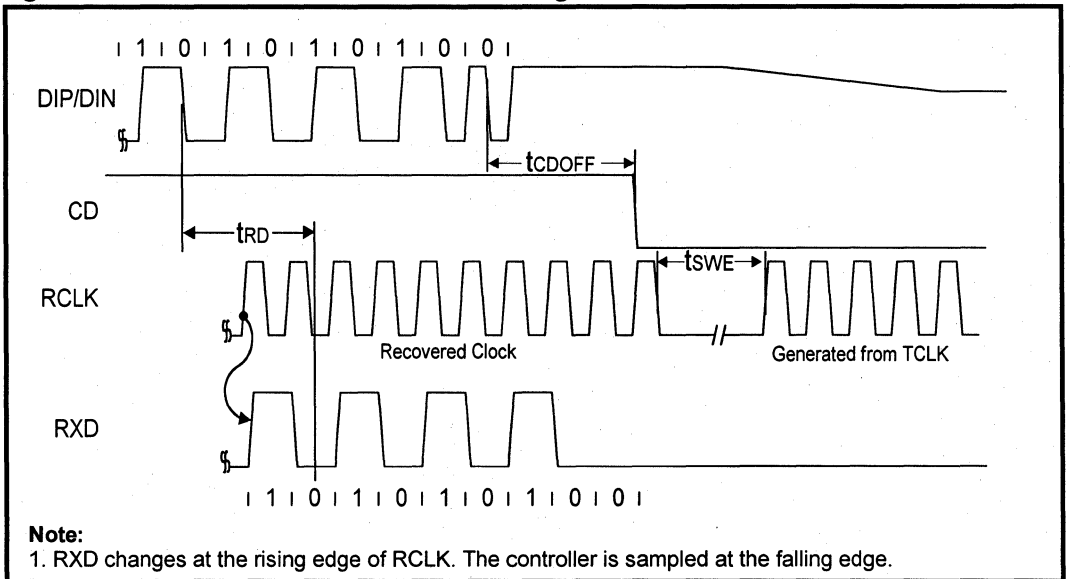

Figure 20: Mode 3 Transmit Timing

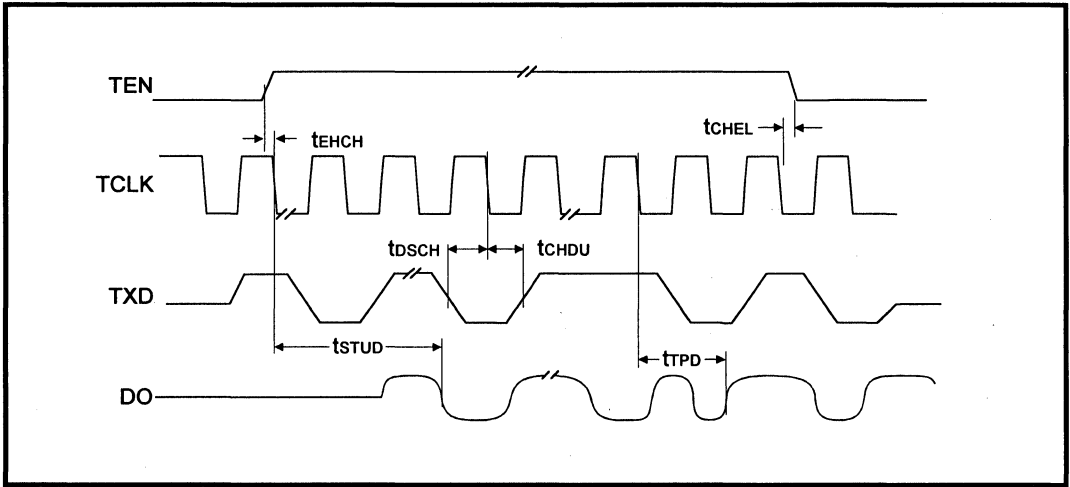
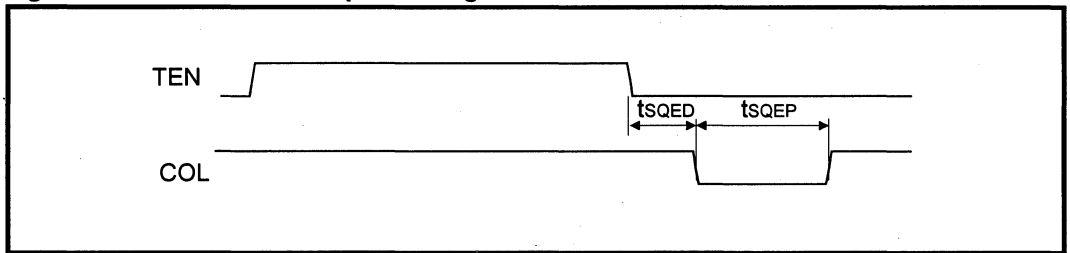

Figure 21: Mode 3 COL Output Timing



TIMING DIAGRAMS FOR MODE 4 (MD1 = High, MDO = High) FIGURE 22 THROUGH FIGURE 25

Figure 22: Mode 4 RCLK/Start of Frame Timing

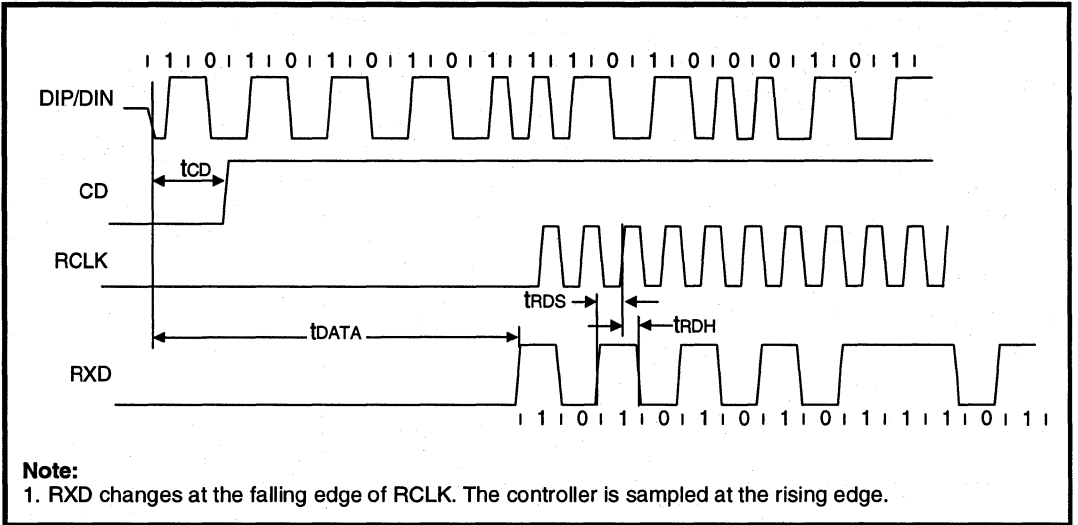

Figure 23: Mode 4 RCLK/End of Frame Timing

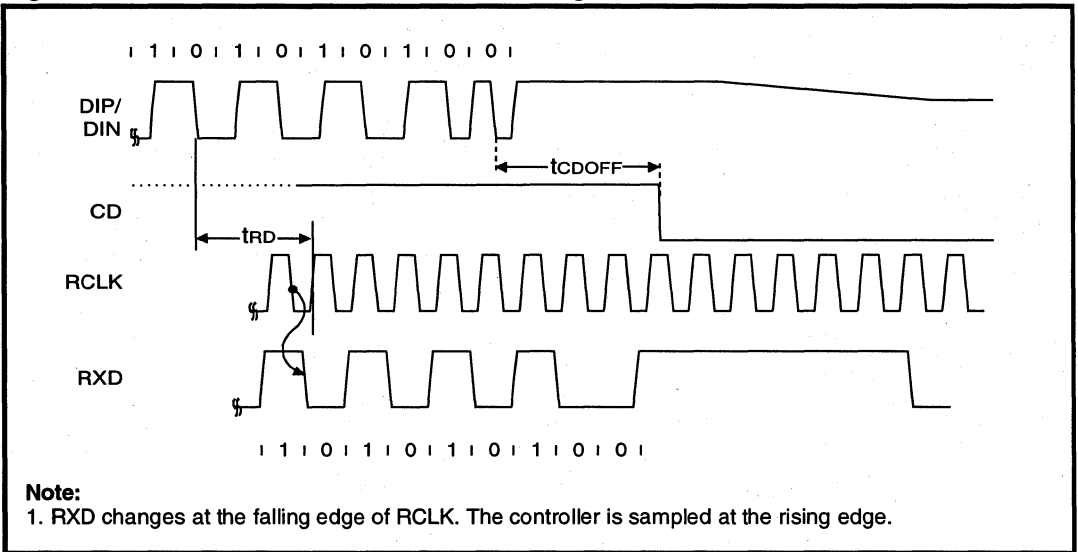

Figure 24: Mode 4 Transmit Timing

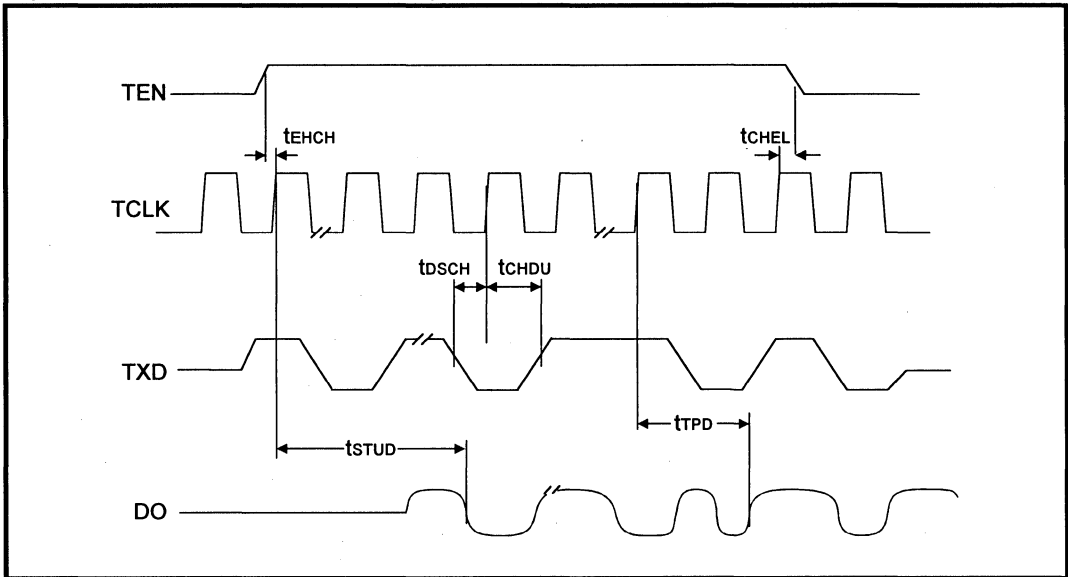
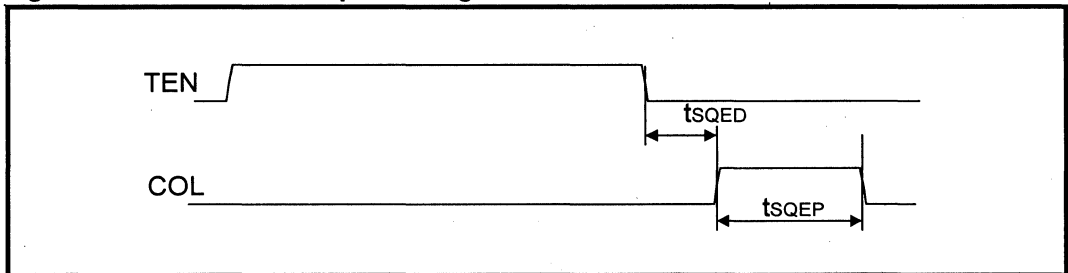

Figure 25: Mode 4 COL Output Timing



NOTES:

Ethernet Hub and Repeater Products



LXT914

Flexible Quad Ethernet Repeater

General Description

The LXT914 is an integrated multi-port repeater designed for mixed-media networks. It provides all the active circuitry required for the repeater function in a single CMOS device. It includes one Attachment Unit Interface (AUI) port and four 10BASE-T transceivers. The AUI port is mode selectable: DTE mode allows connection of an external transceiver (10BASE2, 10BASE5, 10BASE-T or FOIRL) or a drop cable. MAU mode creates a MAU output allowing direct connection to another DTE interface. The 10BASE-T transceivers are entirely self-contained with internal filters which simplify the design work required for FCC-compliant EMI performance.

An inter-repeater backplane interface allows 128 or more 10BASE-T ports to be cascaded together. In addition, a serial port provides information for network management.

The LXT914 requires only a single 5-volt power supply due to its advanced CMOS fabrication process.

Applications

- LAN Repeaters
- Integrated Repeaters
- Switched Repeater Clusters

Features

- Four integrated 10BASE-T transceivers and one AUI transceiver on a single chip
- Programmable DTE/MAU interface on AUI port
- Seven integrated LED drivers with four unique operational modes
- On-chip transmit and receive filtering
- Automatic partitioning of faulty ports, enabled on an individual port basis
- Automatic polarity detection and correction
- Programmable squelch level allows extended range in low-noise environments
- Synchronous or asynchronous inter-repeater backplane supports "hot swapping"
- Inter-repeater backplane allows cascaded repeaters, linking 128 or more 10BASE-T ports
- Serial port for selecting programmable options
- Packaged in 68-pin PLCC or 100-pin PQFP

LXT914 Block Diagram

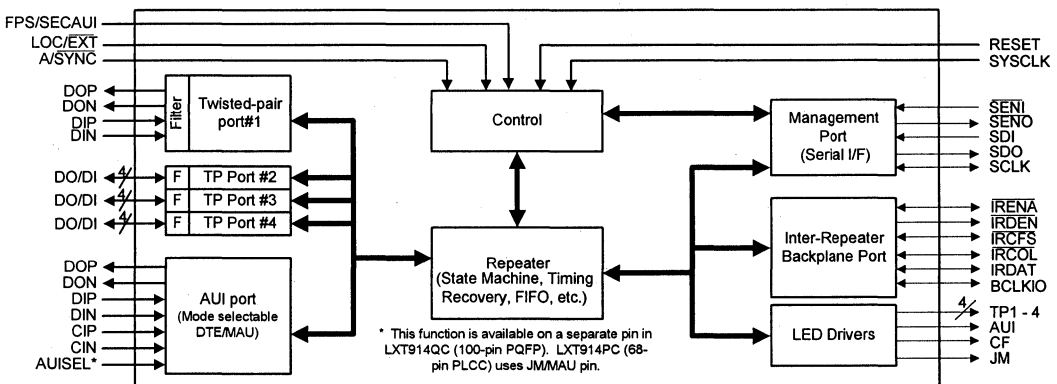

12

LXT914 Flexible Quad Ethernet Repeater

Figure 1: LXT914 Pin Assignments

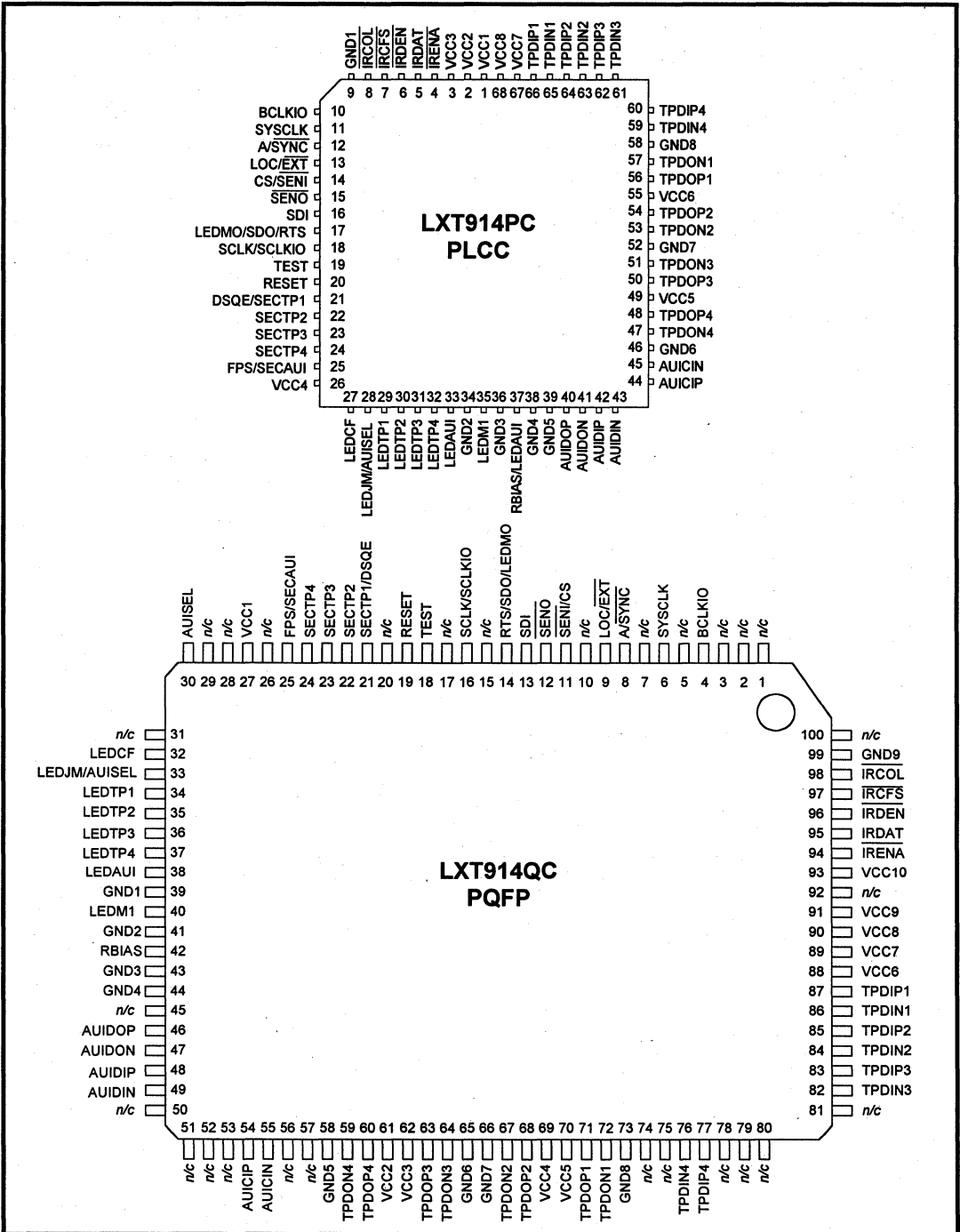

Table 1: Common Power, Ground and Clock Signal Description

Pin #		Symbol	I/O	Description
PLCC	PQFP			
1	27	VCC1	—	Power Supply Inputs. These pins each require a +5 VDC power supply input. The various inputs may be supplied from a single power source, but special decoupling requirements may apply. Each VCC input must be within ±0.3 V of every other VCC input.
2	61	VCC2	—	
3	62	VCC3	—	
26	69	VCC4	—	
49	70	VCC5	—	
55	88	VCC6	—	
67	89	VCC7	—	
68	90	VCC8	—	
	91	VCC9	—	
	93	VCC10	—	
9	39	GND1	—	Ground. These pins provide ground return paths for the various power supply inputs.
34	41	GND2	—	
36	43	GND3	—	
38	44	GND4	—	
39	58	GND5	—	
46	65	GND6	—	
52	66	GND7	—	
58	73	GND8	—	
	99	GND9	—	
37	42	RBIAS	—	Bias. This pin provides bias current for the internal circuitry. The 100 µA bias current is provided through an external 12.4 kΩ resistor to ground.
10	4	BCLKIO	I/O	Backplane Clock. This 10 MHz clock synchronizes multiple repeaters on a common backplane. In the synchronous mode, BCLKIO must be supplied to all repeaters from a common external source. In the asynchronous mode, BCLKIO is supplied only when a repeater is outputting data to the bus. Each repeater outputs its internally recovered clock when it takes control of the bus. Other repeaters on the backplane then sync to BCLKIO for the duration of the transmission.
11	6	SYCLK	I	System Clock. The required 20 MHz system clock is input at this pin. Clock must have a 40-60 duty cycle with < 10 ns rise time.

Table 2: Inter-Repeater Backplane Signal Description

Pin #		Symbol	I/O	Description
PLCC	PQFP			
4	94	$\overline{\text{IRENA}}$	I/O	Inter-Repeater Backplane Enable. This pin allows individual LXT914 repeaters to take control of the Inter-Repeater Backplane (IRB) data bus (IRDAT). The $\overline{\text{IRENA}}$ bus must be pulled up locally by a 330 Ω resistor. ¹
5	95	IRDAT	I/O	IRB Data. This pin is used to pass data between multiple repeaters on the IRB. The IRDAT bus must be pulled up locally by a 330 Ω resistor. ¹
6	96	$\overline{\text{IRDEN}}$	O	IRB Driver Enable. The $\overline{\text{IRDEN}}$ pin is used to enable external bus drivers which may be required in synchronous systems with large backplanes. This is an active low signal, maintained for the duration of the data transmission. $\overline{\text{IRDEN}}$ must be pulled up locally by a 330 Ω resistor.
7	97	$\overline{\text{IRCFS}}$	I/O	IRB Collision Flag Sense ($\overline{\text{IRCFS}}$). And IRB Collision ($\overline{\text{IRCOL}}$). These two pins are used for collision signalling between multiple LXT914 devices on the Inter-Repeater Backplane (IRB). Both the $\overline{\text{IRCFS}}$ bus and the $\overline{\text{IRCOL}}$ bus must be pulled up globally with 330 Ω resistors. ¹ ($\overline{\text{IRCFS}}$ requires a precision resistor [$\pm 1\%$].) ²
8	98	$\overline{\text{IRCOL}}$	I/O	

1. The $\overline{\text{IRENA}}$ and IRDAT can be buffered between boards in multi-board configurations. Where buffering is used, a 330 Ω pull-up resistor can be used on each signal, on each board. Where no buffering is used, the total impedance should be no less than 330 Ω .

2. The $\overline{\text{IRCFS}}$ and $\overline{\text{IRCOL}}$ cannot be buffered. In multi-board configurations, the total impedance on $\overline{\text{IRCOL}}$ should be no smaller than 330 Ω . $\overline{\text{IRCFS}}$ should be pulled up only once, by a single 330 Ω , 1% resistor.

Table 3: Mode Select and Control Signal Descriptions

Pin #		Symbol	I/O	Description
PLCC	PQFP			
12	8	$\overline{\text{A/SYNC}}$	I	Backplane Synch Mode Select. This pin selects the backplane synch mode. When this pin is left floating an internal pull-up defaults to the Asynchronous mode ($\overline{\text{A/SYNC}}$ High). In the asynchronous mode 12 or more LXT914s can be connected on the backplane, and an external 10 MHz backplane clock source is not required. When the synchronous mode is selected ($\overline{\text{A/SYNC}}$ tied Low), 32 or more LXT914s can be connected to the backplane and an external 10 MHz backplane clock source is required.
13	9	$\overline{\text{LOC/EXT}}$	I	Management Mode Select. This pin selects the management mode. When this pin is left floating, an internal pull-up defaults to the Local management mode ($\overline{\text{LOC/EXT}}$ High). In the Local mode, setup parameters are downloaded from an EEPROM during installation. Once initialized with the setup parameters, the repeater functions independently.
28	33	LEDJM/ AUISEL	I/O	LED Driver or DTE/MAU Select. At reset, this pin selects the mode of the AUI port. If left floating, an internal pull-down device forces it to DTE mode. If pulled High with an external resistor, the port changes to a MAU, in which case the functions of the LEDJM pin are disabled and the default LED mode is not available.
—	30	AUISEL	I	DTE/MAU Select. This pin changes the mode of the AUI port independent of the condition at reset. This function is available only in the 100-pin PQFP package.
17 35	14 40	LEDM0 LEDM1	I/O I/O	LED Mode 0 & 1 Select. These two pins select one of four possible LED modes of operation. The Functional Description section describes the four modes.

Table 4: Serial Port Signal Descriptions—External Management Mode

Pin #		Symbol	I/O	Description
PLCC	PQFP			
14	11	$\overline{\text{SEN1}}$	I	Serial Enable Input. This active low input is used to access the LXT914 serial interface. To write to the serial input (SDI), the External Management Device (EMD) must drive this pin from High to Low. The input must be asserted Low concurrent with the appearance of data on SDI and remain Low for the duration of the serial input transaction.
15	12	$\overline{\text{SEN0}}$	O	Serial Enable Output. This active low output is used to access the serial interface of the EMD. When the LXT914 sends a data stream to the EMD through the serial port (SDO), this output transitions from High to Low and remains Low for the duration of the serial transmission.
16	13	SDI	I	Serial Data Input. This pin is the input for the serial interface with the EMD. Setup and operating parameters are supplied to the LXT914 in a serial data stream from the EMD through this port.
17	14	SDO	I/O	Serial Data Output. After each packet transmission or interrupt event, the LXT914 reports status information to the EMD in a serial data stream through this port.
18	16	SCLK	I	Serial Clock. This 10 MHz clock synchronizes the serial interface between the LXT914 and the EMD. Both devices must be supplied from the same clock source. In synchronous mode, SCLK and BCLK may be tied together.

Table 5: Serial Port Signal Descriptions—Local Management Mode

Pin #		Symbol	I/O	Description
PLCC	PQFP			
14	11	CS	O	Chip Select. The LXT914 is designed for use with an EEPROM or similar device which may be used to store setup parameters and serially download them to the LXT914 during initialization. In a single-device application or in the first device of a daisy chain application, this pin is an active high Chip Select output used to enable the EEPROM.
		$\overline{\text{SEN1}}$	I	Serial Enable Input. In subsequent devices of a daisy-chain configuration, a High-to-Low transition on this pin enables the serial input port (SDI). The input must be asserted concurrent with the appearance of data on SDI and remain Low for the duration of the serial input transaction.
15	12	$\overline{\text{SEN0}}$	O	Serial Enable Output. During initialization, the LXT914 accepts 48 bits of setup data through the SDI port. After the 48th bit, the LXT914 asserts this pin Low. When multiple LXT914 devices are connected in a daisy-chain, this output is tied to the $\overline{\text{SEN1}}$ input of the next device in the chain. Thus each device in the chain is serially enabled by the previous device until all the devices have read in their 48 bits of setup data.

Table 5: Serial Port Signal Descriptions—Local Management Mode—continued

Pin #		Symbol	I/O	Description
PLCC	PQFP			
16	13	SDI	I	Setup Data Input. This pin is the serial input port for the setup parameters (48 bits). This pin should be tied Low if no EEPROM is present.
17	14	RTS	I/O	Request To Sent. In a single-device application or in the first device of a daisy chain application, this pin outputs a 9-bit, active high sequence. This pin must be tied to the EEPROM DI input to trigger the EEPROM to download its stored data. In subsequent devices this pin is not used.
18	16	SCLKIO	I/O	Serial Clock. A 1 MHz clock provided by the first LXT914 in the chain to all subsequent repeaters and the EEPROM. In the Local mode all repeaters have their SCLKIO pins tied together.

Table 6: Miscellaneous Control Signal Description

Pin #		Symbol	I/O	Description
PLCC	PQFP			
19	18	TEST	I	Test Mode Select. This pin must be tied Low for normal operation. A High on this pin enables the Factory Test mode.
20	19	RESET	I	RESET. This pin resets the LXT914 circuitry when pulled High for $\geq 1 \mu s$.
21	21	DSQE (Local)	I	DSQE Invert. When High in Local Mode, DSQE disables the SQE function of the AUI port. When Low in Local Mode, this pin enables the SQE function.
21	21	SECTP1	I	Security Mode Select (TP Ports 1-4). In External Mode, these pins enable the security mode for the respective twisted-pair ports (TP1 through TP4). When pulled High, the LXT914 JAMs the affected port. The SEC pins must be tied Low if external security control is not required. This is only enabled when SECAUI is enabled during External Management Mode.
22	22	SECTP2	I	
23	23	SECTP3	I	
24	24	SECTP4 (External)	I	
25	25	FPS (Local)	I	First Position Select. In the Local mode this pin identifies the first device in a daisy chain configuration. When tied High (First position), the LXT914 controls the local EEPROM by providing clock and handshaking. When tied Low (Not First), the LXT914 will accept CLK and data in its turn from previous LXT914s in the data chain.
		SECAUI (External)	I	Security Mode Select (AUI Port). In the External mode this pin enables the security mode for the AUI port. When pulled High, the LXT914 JAMs the AUI port. The security feature is available only in External management mode.

Table 7: LED Driver Signal Description

Pin #		Symbol	I/O	Description
PLCC	PQFP			
27	32	LEDCF	O	Collision & FIFO Error LED Driver. This tri-state LED driver pin reports collisions and FIFO errors. It pulses Low to report collisions, and pulses High to report FIFO errors. When this pin is connected to the anode of one LED and to the cathode of a second LED, the LXT914 will simultaneously monitor and report both conditions independently.
28	33	LEDJM	O	Jabber/MJLP & Manchester Code Violation LED Driver. This tri-state LED driver pin reports jabber and code violations. It pulses Low to report MAU Jabber Lockup Protection (MJLP), and pulses High to report Manchester code violations. When this pin is connected to the anode of one LED and to the cathode of a second LED, the LXT914 will simultaneously monitor and report both conditions independently.
29 30 31 32	34 35 36 37	LEDTP1 LEDTP2 LEDTP3 LEDTP4	O O O O	TP Port LED Drivers. These tri-state LED drivers use an alternating pulsed output to report TP port status. Each pin should be tied to a pair of LEDs (to the anode of one LED and the cathode of a second LED). When connected this way, each pin reports five separate conditions (receive, transmit, link integrity, reverse polarity and auto partition).
37	38	LEDAUI	O	AUI Port LED Driver. This tri-state LED driver uses an alternating pulsed output to report AUI port status. This pin should be tied to a pair of LEDs (to the anode of one LED and the cathode of a second LED). When connected this way, this pin reports five separate conditions (receive, transmit, receive jabber, receive collision and auto partition).

Table 8: Repeater Port Signal Description

Pin #		Symbol	I/O	Description
PLCC	PQFP			
40 41	46 47	AUIDOP AUIDON	O O	AUI Data Out Pos & Neg. These pins are the positive and negative data outputs for the AUI Port. In MAU Mode these pins are connected to the DI pins of the DTE.
42 43	48 49	AUIDIP AUIDIN	I I	AUI Data In Pos & Neg. These pins are the positive and negative data inputs for the AUI Port. In MAU Mode, these pins are connected to the DO pins of the DTE.

Table 8: Repeater Port Signal Description—continued

Pin #		Symbol	I/O	Description
PLCC	PQFP			
44 45	54 55	AUICIP AUCIN	I/O I/O	AUI Collision Pos & Neg. These pins are the positive and negative Collision inputs for the AUI Port in DTE Mode. In MAU Mode, these pins output a collision indication to the DTE.
56 57 54 53 50 51 48 47	71 72 68 67 63 64 60 59	TPDOP1 TPDON1 TPDOP2 TPDON2 TPDOP3 TPDON3 TPDOP4 TPDON4	O O O O O O O O	Twisted-Pair Data Outputs Positive and Negative. These pins are the positive and negative outputs from the line drivers for the respective twisted-pair ports.
66 65 64 63 62 61 60 59	87 86 85 84 83 82 77 76	TPDIP1 TPDIN1 TPDIP2 TPDIN2 TPDIP3 TPDIN3 TPDIP4 TPDIN4	I I I I I I I I	Twisted-Pair Data Inputs Positive & Negative. These pins are the positive and negative data inputs to the respective twisted-pair ports.

FUNCTIONAL DESCRIPTION

NOTE

This functional description is for design aid only.

The LXT914 is an integrated hub repeater for 10BASE-T networks. The hub repeater is the central point for information transfer across the network. The LXT914 offers multiple operating modes to suit a broad range of applications ranging from simple 4-port stand-alone hubs or attachments for print and file servers, up to intelligent 128-port enterprise systems with microprocessor/gate array management.

The main functions of the LXT914 hub repeater are data recovery and retransmission and collision propagation. Data packets received at the AUI or 10BASE-T ports are detected and recovered by the port receivers before being passed to the repeater core circuitry for retiming and retransmission. Data packets received through the IRB port are essentially passed directly to the core for retransmission. After recovery of a valid data packet, the repeater broadcasts it to all enabled stations, except the originator station.

EXTERNAL INTERFACES

The LXT914 includes four 10BASE-T ports with internal filters. The LXT914 also includes an Attachment Unit Interface (AUI) port, a serial port and an Inter-Repeater Backplane (IRB) port. The serial port allows an external device such as an EEPROM to download setup parameters to the repeater. In more complex designs the serial port can also be used to monitor repeater status. The IRB port enables multiple LXT914 devices to be cascaded, creating a large, multi-port repeater.

10BASE-T Ports

The four 10BASE-T transceiver ports are completely self-contained. Since the transmitters and receivers include the required filtering, only simple, inexpensive transformers are required to complete the 10BASE-T interface. Each individual Twisted-Pair (TP) port is implemented in accordance with the IEEE 802.3 10BASE-T standard.

AUI Port

The AUI port mode is selectable (DTE mode or MAU mode). With DTE mode selected the AUI port allows connection of an external transceiver (10BASE2, 10BASE5, 10BASE-T or FOIRL) or a drop cable. With MAU mode

selected, the AUI port establishes a MAU output allowing direct connection to another DTE interface.

Serial Port

The serial port provides the management interface to the LXT914. Refer to Test Specifications for serial port timing. The serial port can be either unidirectional or bidirectional, depending on the management mode selected. In the Local management mode the serial port is unidirectional (input only), and is used only to download setup parameters during initialization. The Local mode is intended for use with a simple EEPROM, but the serial port may be tied Low if an EEPROM is not required.

In the External management mode, the serial port is bidirectional (input for setup parameters, output for status reports). The External mode is intended for use with an External Management Device (EMD) and a Media Access Controller (MAC). The EMD (typically a gate array) communicates with a microprocessor (e.g., Intel 8051) and can control up to three LXT914 repeaters. This simplifies design of a relatively standard 12-port repeater on a single printed circuit board.

Inter-Repeater Backplane

The Inter-Repeater Backplane (IRB) allows several LXT914s to function as a single repeater. Refer to Test Specifications for IRB timing. The IRB also allows several multi-repeater boards to be integrated in a standard rack and to function as a single unit. The IRB supports "hot swapping" for easy maintenance and troubleshooting. Each individual repeater distributes recovered and retimed data to other repeaters on the IRB for broadcast on all ports simultaneously. This simultaneous rebroadcast allows the multi-repeater system to act as a single large repeater unit. The maximum number of repeaters on the IRB is limited by bus loading factors such as parasitic capacitance. The IRB can be operated synchronously or asynchronously.

SYNCHRONOUS IRB OPERATION

In the synchronous mode, a common external source provides the 10 MHz backplane clock (BCLKIO) and the 20 MHz system clock (SYSCLK) to all repeaters. (BCLKIO must be synchronous to SYSCLK and may be derived from SYSCLK using a divide-by-two circuit.) In the synchronous mode 32 or more LXT914 repeaters may be connected on the IRB, providing 128 10BASE-T ports and 32 AUI ports.

ASYNCHRONOUS IRB OPERATION

In the asynchronous mode an external BCLKIO source is not required. The repeaters run independently until one takes control of the IRB. The transmitting repeater then outputs its own 10 MHz clock onto the BCLKIO line. All other repeaters sync to that clock for the duration of the transmission. In the asynchronous mode 12 or more LXT914 devices may be connected to the IRB, providing 48 10BASE-T ports and 12 AUI ports.

NOTE

The maximum number of repeaters which may be linked on the backplane is limited by board design factors. The numbers listed above are engineering estimates only. Stronger drivers and reduced capacitive loading in PCB layout may allow an increased device count.

INTERNAL REPEATER CIRCUITRY

The basic repeater circuitry is shared among all the ports within the LXT914. It consists of a global repeater state machine, several timers and counters and the timing recovery circuit. The timing recovery circuit includes a FIFO for retiming and recovery of the clock which is used to clock the receive data out onto the IRB.

The shared functional blocks of the LXT914 are controlled by the global state machine (Figure 2). This diagram and all associated notations used are in strict accordance with section 9.6 of the IEEE 802.3 standard.

The LXT914 also implements the Partition State Diagram as defined by the IEEE 802.3 standard and shown in Figure 3. The value of CCLimit as implemented in the LXT914 is 64.

The CCLimit value sets the number of consecutive collisions that must occur before the port is subjected to automatic partitioning. Auto-partition/reconnection is also supported by the LXT914 with Tw5 conforming to the standard requirement of 450 to 560 bit times.

INITIALIZATION

The following description applies to the initial power-on reset and to any subsequent hardware reset. When a reset occurs (RESET pin pulled High for $> 1 \mu\text{s}$), the device senses the levels at the various control pins (see Table 3) to determine the correct operating modes for Management, LEDs, and the AUI port functions.

Local Management Mode Initialization

An internal pull-up causes the LXT914 to default to the Local management mode unless the LOC/EXT pin is tied Low. In the Local mode the serial port is a unidirectional interface used only to download setup parameters from an external device.

In a Locally managed multiple-repeater (daisy chain) configuration, the first repeater in the chain performs special functions. The First Position Select (FPS) pin is used to establish position (FPS High = First, FPS Low = Not First). After establishing the Hardware mode, each LXT914 monitors the FPS pin to determine its position.

Figure 2: Global State Machine

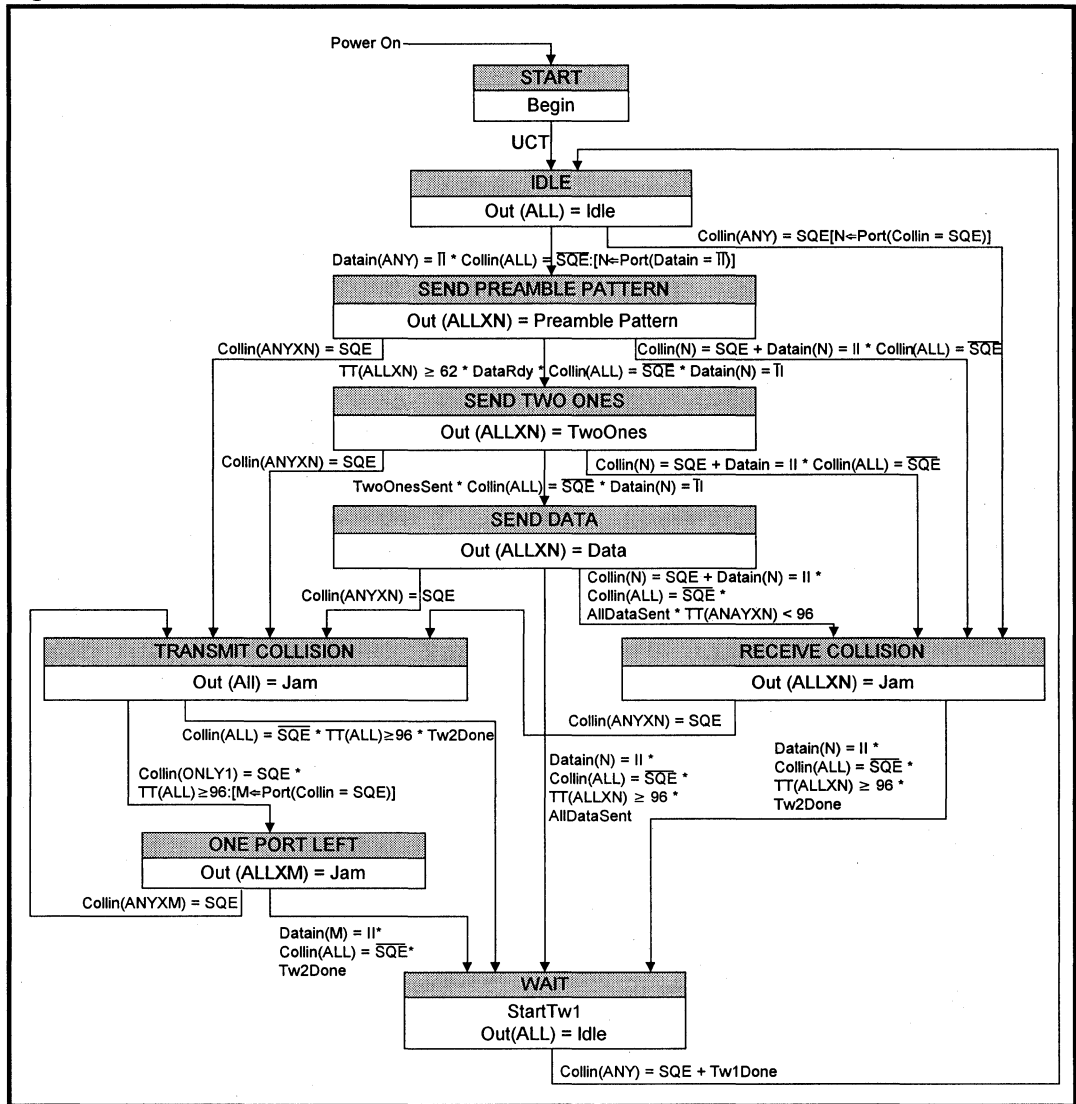
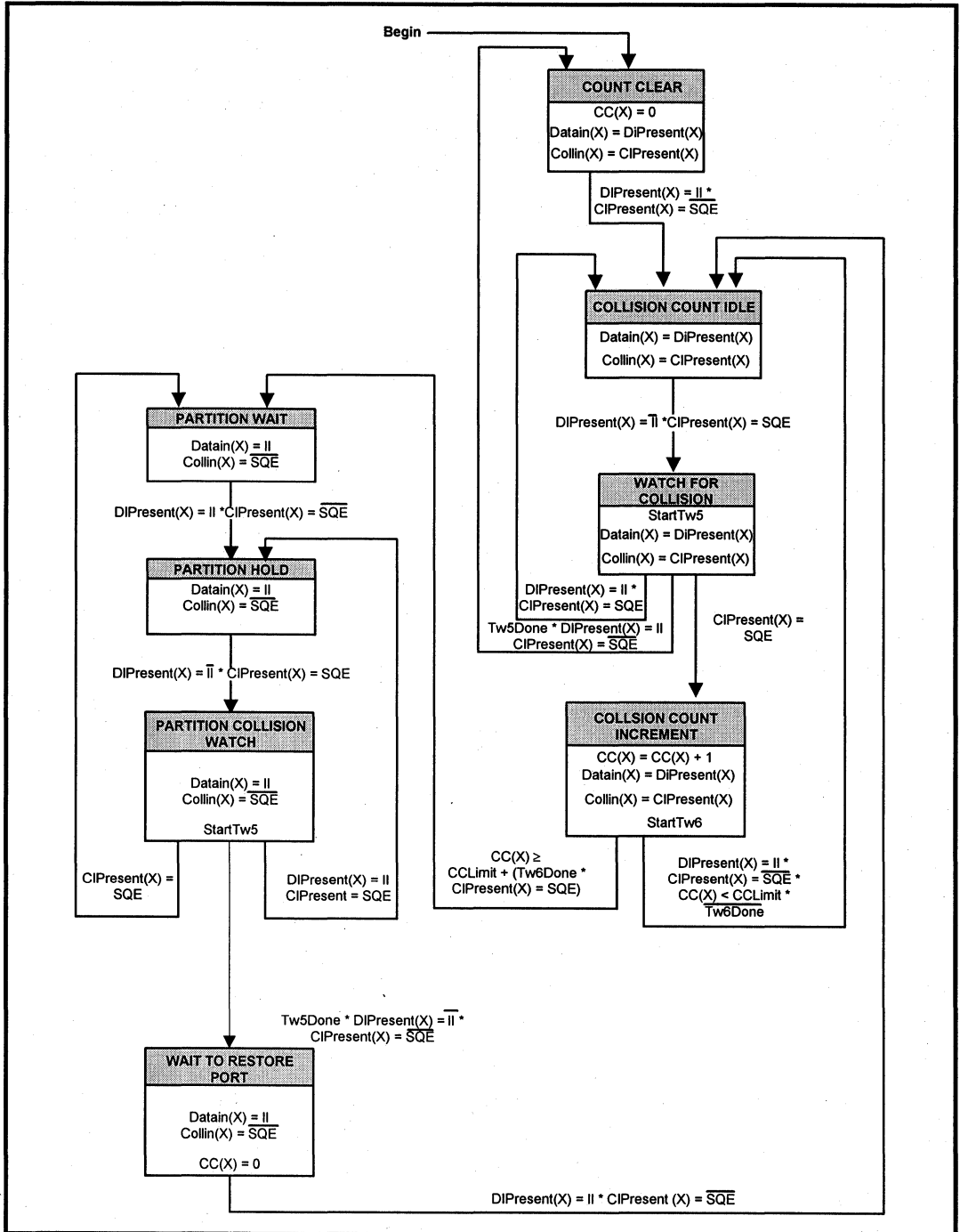

Figure 3: Partitioning State Diagram



If FPS is High (First Position), the repeater performs the following functions:

1. Outputs a 1 MHz Serial Clock (SCLK). SCLK is derived from the 20 MHz SYSCLK input in ASYNC mode and from BCLKIO in SYNC mode; it is supplied to the SCLK inputs of all other repeaters on the bus and to the EEPROM.
2. Asserts Chip Select (CS) High to enable the EEPROM.
3. Outputs a serial 9-bit request-to-send (RTS) strobe. (The programmable device responds to the RTS strobe with a serial data stream containing the setup parameters for all repeaters in the chain.)
4. Clocks the first 48 serial data input (SDI) bits from the EEPROM into its setup register. Refer to Table 9 and Table 10 for Setup Register bit assignments.
5. Asserts Serial Enable Output ($\overline{\text{SENO}}$) Low to enable the next repeater in line.

The second repeater has FPS tied Low and Serial Enable Input ($\overline{\text{SENI}}$) connected to the Serial Enable Output ($\overline{\text{SENO}}$) of the first repeater. When enabled by a Low on $\overline{\text{SENI}}$, each repeater downloads its portion of the stream, then stops accepting data and asserts $\overline{\text{SENO}}$ Low. The $\overline{\text{SENO}}$ pin is linked to the $\overline{\text{SENI}}$ input of the next repeater. This enables the next repeater to clock in its 48-bit word and so on.

If FPS is Low (Not First Position), the repeater performs the following functions:

1. Syncs to the 1 MHz Serial Clock (SCLK) input. SCLK is supplied by the First Position repeater.
2. Responds to $\overline{\text{SENI}}$ Low by enabling the SDI port.
3. Clocks 48 bits from the EEPROM into its setup register through the SDI port.
4. Asserts $\overline{\text{SENO}}$ Low to enable the next repeater in line.

Table 9: Setup Register Bit Assignments

	D7	D6	D5	D4	D3	D2	D1	D0
SR(0)	DISLI3	DISLI2	DISLI1	DISAP4	DISAP3	DISAP2	DISAP1	DISAPA
SR(1)	DISTX2	DISTX1	DISTXA	DPRC4	DPRC3	DPRC2	DPRC1	DISLI4
SR(2)	ERSQ1	DISRX4	DISRX3	DISRX2	DISRX1	DISRXA	DISTX4	DISTX3
SR(3)	DFIFOE	DPFRM	DSQE	DMCV	ERXJAB	ERSQ4	ERSQ3	ERSQ2
SR(4)	RES	RES	RES	RES	RES	RES	RES	RES
SR(5)	RES	RES	RES	RES	RES	RES	RES	RES

Table 10: Setup Register Bit Definitions

BIT	DEFINITION
DISAP _x	1 = Disable Auto-Partitioning on Port <i>x</i>
DISLI _x	1 = Disable Link Integrity on Port <i>x</i> (Twisted-pair ports only)
DPRC _x	1 = Disable Polarity Reverse detection and Correction on Port <i>x</i> (Twisted-pair ports only)
DISTX _x	1 = Disable Transmit on Port <i>x</i>
DISRX _x	1 = Disable Receive on Port <i>x</i>
ERSQ _x	1 = Enable Reduced Squelch on Port <i>x</i> (Twisted-pair ports only)
ERXJAB	1 = Enable Receive JAB (Long Packet) (Global)
DMCV	1 = Disable entering Tx Collision state on reception of Manchester Code Violation
DSQE	1 = Disable Signal Quality Error to provide heartbeat (AUI port only)
DPFRM	1 = Disable End-of-Frame checking for polarity correction (Global)
DFIFOE	1 = Disable entering Tx Collision state on FIFO over/underflow condition (Global)
DMJLP	1 = Disable MJLP counter (Global)
RES	Reserved. Must be set to 0.

External Management Mode Initialization

The LXT914 operates in the External management mode when the LOC/EXT pin is tied Low. In the External mode, the serial port is a bidirectional interface between the LXT914 and an external management device (EMD). The serial port is used to download initial setup parameters to the repeater and to monitor status reports from the repeater. The LXT914 setup parameters can be changed at any time by the EMD. The initialization process for each repeater in a managed mode configuration is the same, regardless of its position; each repeater is connected directly to the EMD. Each LXT914 initializes as follows:

1. Syncs to the 10 MHz Serial Clock (SCLK) input. SCLK must be supplied from an external source.
2. Responds to $\overline{\text{SEN1}}$ Low by enabling the SDI port.
3. Clocks 48 bits from the EMD into its setup register through the SDI port.
4. Once initialized, the LXT914 reports its status in a 48-bit serial stream after every packet transmission or interrupt event. Refer to Table 11 and Table 12 for packet status register bit assignments and definitions.

Table 11: Packet Status Register Bit Assignments

	D7	D6	D5	D4	D3	D2	D1	D0
PSR(0)	COL2	COL1	COLA	RX4	RX3	RX2	RX1	RXA
PSR(1)	PR2	PR1	LLS4	LLS3	LLS2	LLS1	COL4	COL3
PSR(2)	SPA	AP4	AP3	AP2	AP1	APA	PR4	PR3
PSR(3)	LP3	LP2	LP1	LPA	SP4	SP3	SP2	SP1
PSR(4)	RXJABA	MJLP	LCOL4	LCOL3	LCOL2	LCOL1	LCOLA	LP4
PSR(5)	RES	RXCOL	MANCV	FIFOER	RXJAB4	RXJAB3	RXJAB2	RXJAB1

Table 12: Packet Status Register Bit Definitions

BIT ¹	DEFINITION
RX _x	Received Packet on Twisted-Pair Port 1-4 or on AUI Port
COL _x	Transmit Collision of Twisted -Pair Port 1-4 or on AUI Port
LLSC _x	Link Loss State on Twisted-Pair Port 1-4 or on AUI Port
PR _x	Polarity reversed on Twisted-Pair Port 1-4 or on AUI Port
AP _x	Auto-Partition circuit isolated Twisted-Pair Port 1-4 or the AUI Port
SP _x	Short Packet (less than 74 bits) on Twisted-Pair Port 1-4 or on AUI Port
LP _x	Long Packet (more than 1.3 ms) on Twisted-Pair Port 1-4 or on AUI Port
LCOL _x	Late Collision on Twisted-Pair Port 1-4 or on AUI Port
MJLP	MAU Jabber Lockup Protection
RXJAB _x	Receive Jabber Lockup Protection
FIFOER	FIFO overflow/underflow
MANCV	Manchester Code Violation
RXCOL	Receive Collision on the AUI Port
<i>reserved</i>	<i>not used</i>

1. The notation ABCD_x means bit ABCD associated with port x, which can be any of the four Twisted-Pair Ports or the AUI-Port

10BASE-T PORT OPERATION

10BASE-T Reception

Each LXT914 10BASE-T port receiver acquires data packets from its twisted-pair input (DIP/DIN). An internal RC filter and an intelligent squelch function discriminate noise from link test pulses and valid data streams. The receive function is activated only by valid data streams (above the squelch level and with proper timing). If the differential signal at the DI circuit inputs falls below 75% of the threshold level (unsquelched) for eight bit times (typical), the port receiver enters the idle state.

Programmable Internal Squelch Level

The 10BASE-T port receivers have two squelch levels: a normal level or default setting and a reduced level squelch (-4.5 dB) selected when the ERSQx is set in the Setup register. When used with Low noise media such as shielded twisted-pair cabling, the reduced squelch level allows longer loop lengths in the network.

Polarity Detection and Correction

The LXT914 10BASE-T ports detect and correct for reversed polarity by monitoring link pulses and end-of-frame sequences. A reversed polarity condition is declared when the port receives sixteen or more incorrect link pulses consecutively, or four frames with reversed start-of-idle sequence. In these cases the receiver reverses the polarity of the signal and thereby corrects for this failure condition. If the port enters the link fail state and no valid data or link pulses are received within 96 to 128 ms, the polarity is reset to the default non-flipped condition. (If Link Integrity Testing is disabled, polarity detection is based only on received data.)

10BASE-T Transmission

Each LXT914 10BASE-T port receives NRZ data from the repeater core and passes it through a Manchester encoder. The encoded data is then transmitted to the twisted-pair network (the DO circuit). The advanced integrated pulse shaping and filtering network produces the pre-distorted and pre-filtered output signal to meet the 10BASE-T jitter template. **An internal continuous resistor-capacitor filter is used to remove any high-frequency clocking noise from the pulse shaping circuitry. Integrated filters simplify the design work required for FCC compliant EMI performance.** During idle periods, the LXT914 10BASE-T ports transmit link integrity test pulses in accordance with the 802.3 10BASE-T standard.

Data packets transmitted by the LXT914 contain a minimum of 56 preamble bits before the start of frame delimiter (SFD). In the Asynchronous mode, preamble regeneration takes place on the transmit side. In the Synchronous mode, the preamble is regenerated on the receive side and distributed via the IRB. If the total packet is less than 96 bits including the preamble, the LXT914 extends the packet length to 96 bits by appending a Jam signal (1010...) at the end.

10BASE-T Link Integrity Testing

The LXT914 fully supports the 10BASE-T Link Integrity test function. The link integrity test determines the status of the receive side twisted-pair cable. Link integrity testing is enabled unless disabled via the DISLIX bit in the Setup register. When enabled, the receiver recognizes link integrity pulses transmitted in the absence of data traffic. With no data packets or link integrity pulses within 100 (± 50) ms, the port enters a link fail state and disables its transmitter. The port remains in the link fail state until it detects three or more data packets or link integrity pulses.

AUI PORT OPERATION

AUI Reception

The LXT914 AUI port receiver acquires data packets from the network (DIP/DIN). Only valid data streams above the squelch level activate the receive function. If the differential signal at the DI circuit inputs falls below 75% of the threshold level (unsquelched) for 8 bit times (typical), the AUI receiver enters the idle state.

AUI Transmission

The LXT914 AUI port receives NRZ data from the repeater core, and passes it through a Manchester encoder. The encoded data then goes out on the network (DOP/DON).

AUI Mode Selection (DTE/MAU)

The LXT914 allows the user to change the mode of the AUI from a DTE to a MAU interface. This option is available on both 68- and 100-pin versions except as follows:

- When using the LEDJM/AUISEL pin to select the AUI interface mode the following is true: After reset the state of the LEDJM/AUISEL pin is sensed for the correct mode. The LEDJM/AUISEL pin when floated or pulled Low will select the DTE interface and the LEDJM/AUISEL output is still available. When the LEDJM/AUISEL pin is pulled High the MAU interface is selected and the LEDJM/AUISEL function is unavailable.

LXT914 Flexible Quad Ethernet Repeater

- The 100-pin PQFP has an additional pin, AUISEL (pin 30). When using this pin to select the AUI interface mode the LEDJM/AUISEL pin is still a functional LED driver. The AUISEL pin is not latched after reset and is actively polled to determine which AUI interface mode is to be used. Refer to Table 13.

Table 13: AUI Mode Selection (DTE/MAU)

App #	PQFP	PLCC & PQFP	AUI Mode	Available LED Modes
	AUISEL	LEDJM/AUISEL		
1	0	0	DTE	default, 1-3
2	0	1	MAU	1-3
3 ¹	1	0	MAU	default, 1-3
4	1	1	MAU	1-3

1. Application 3 is valid only when using the 100-pin PQFP.

COLLISION HANDLING

A collision occurs when two or more repeater ports receive simultaneously, or when the AUI CIP/CIN signal is active. The LXT914 fully complies with the IEEE 802.3 collision specifications, both in individual and multi-repeater applications. In multiple-repeater configurations, collision signaling on the IRB allows all repeaters to share collision parameters, acting as a single large repeater.

$\overline{\text{IRCOL}}$ is a digital open-drain pin. $\overline{\text{IRCFS}}$ is an analog/digital port. The $\overline{\text{IRCOL}}$ and $\overline{\text{IRCFS}}$ lines are pulled up globally (*i.e.*, each signal requires one pull-up resistor for all boards). If there are eight 3-repeater boards in the system, all eight boards share a single pull-up resistor for $\overline{\text{IRCOL}}$ and a single pull-up resistor for $\overline{\text{IRCFS}}$. The global pull-up may be located on one of the boards, or on the backplane. The $\overline{\text{IRCFS}}$ line requires a precision ($\pm 1\%$) resistor.

The $\overline{\text{IRENA}}$, $\overline{\text{IRDAT}}$ and $\overline{\text{IRDEN}}$ lines are each pulled up locally (one pull-up resistor per board) if external bus drivers are used. If no bus drivers are used then only one global pull-up per signal is used.

SECURITY MODE

The LXT914 security mode is fully transparent to the user. In the External management mode, the security feature is available for all four TP ports and the AUI port. In the Local mode, security is available for the TP ports only. (The SECAUI input is reassigned as FPS). The security inputs are normally held Low to disable the security feature. Any input can independently be pulled High to scramble the respective port for any given length of time. For applications which do not require security control, the SEC pins must be tied Low.

The security mode pins are real time response inputs. This allows the board designer to screen the destination address with an application specific device and (on match of the destination address) to assert the security input to jam the respective port for the given frame. This real time detection and jam assertion method provides the flexibility to implement customer specific solutions. The destination address decoding and security signal assertion functions can be integrated into the external management device.

LED DISPLAY

The LED display interface consists of seven integrated LED drivers, one for each of the five network ports and two for common functions. Each pin provides a three-state pulsed output (+5 V, high Z, and 0 V) which allows multiple conditions to be monitored and reported independently. Table 14 shows the LED Mode selected with each LEDM1 and LEDM0 combination. Figure 4 shows the LED Driver output conditions and Table 15 through Table 18 lists the repeater states associated with each of the five conditions.

NOTE

If LED mode 0 is selected and the LEDJM/AUISEL pin is High (which selects MAU Mode), the device defaults to LED Mode 1. Only LED Modes 1-3 are available when LEDJM/AUISEL is pulled High.

Table 14: LED Mode Selection

	LEDM1	LEDM0	LED Mode Selected
PLCC pin	35	17	
PQFP pin	40	14	
	0	0	0 (default) ¹
	0	1	1
	1	0	2
	1	1	3

1. This mode is not available when using the LEDJM/AUISEL pin to select a MAU interface in the AUI port. In this case, the LED Mode defaults to LED Mode 1.

LED Mode 0 (Default). This mode is selected when LEDM1 and LEDM0 are floating or pulled Low. Refer to Table 15. This mode is not available when using the LEDJM/AUISEL pin to select a MAU interface in the AUI port. In this case, the LED Mode defaults to Mode 1.

LED Mode 1. This mode is selected when LEDM1 is tied, floating or pulled Low and LEDM0 is pulled High by a pull-up resistor. Refer to Table 16.

LED Mode 2. This mode is selected when LEDM1 is pulled High by a pull-up resistor and LEDM0 is floating or pulled Low. Refer to Table 17.

LED Mode 3. This mode is selected when LEDM1 is pulled High by a pull-up resistor and LEDM0 is also pulled High by a pull-up resistor. Refer to Table 18.

Table 15: Mode 0 (Default) LED Truth Table

Condition	LEDTP 1-4	LEDAUI	LED CF	LEDJM
1	Rx Link Pulse	N/A	FIFO Error	Manchester Code Violation
2	Tx Packet	Tx Packet	N/A	N/A
3	Reversed Polarity	N/A	Collision	MAU Jabber Lockup Protection (MJLP)
4	Rx Packet	Rx Packet	N/A	N/A
5	Partitioned Out	Partitioned Out	N/A	N/A

Table 16: Mode 1 LED Truth Table

Condition	LEDTP 1-4	LEDAUI	LED CF	LEDJM
1	Rx Link Pulse	N/A	MAU Jabber Lockup Protection (MJLP)	N/A
2	N/A	N/A	N/A	N/A
3	N/A	N/A	Collision	N/A
4	Rx Packet	Rx Packet	N/A	N/A
5	N/A	N/A	N/A	N/A

Table 17: Mode 2 LED Truth Table

Condition	LEDTP 1-4	LEDAUI	LED CF	LEDJM
1	Rx Link Pulse	N/A	MAU Jabber Lockup Protection (MJLP)	N/A
2	Partitioned Out	Partitioned Out	N/A	N/A
3	N/A	N/A	Collision	N/A
4	Rx Packet	Rx Packet	N/A	N/A
5	N/A	N/A	N/A	N/A

Table 18: Mode 3 LED Truth Table

Condition	LEDTP 1-4	LEDAUI	LED CF	LEDJM
1	Rx Link Pulse	N/A	MAU Jabber Lockup Protection (MJLP)	N/A
2	Rx Packet	Rx Packet	N/A	N/A
3	Partitioned Out	Partitioned Out	Collision	N/A
4	N/A	N/A	N/A	N/A
5	N/A	N/A	N/A	N/A

Figure 4: Integrated LED Driver Indications

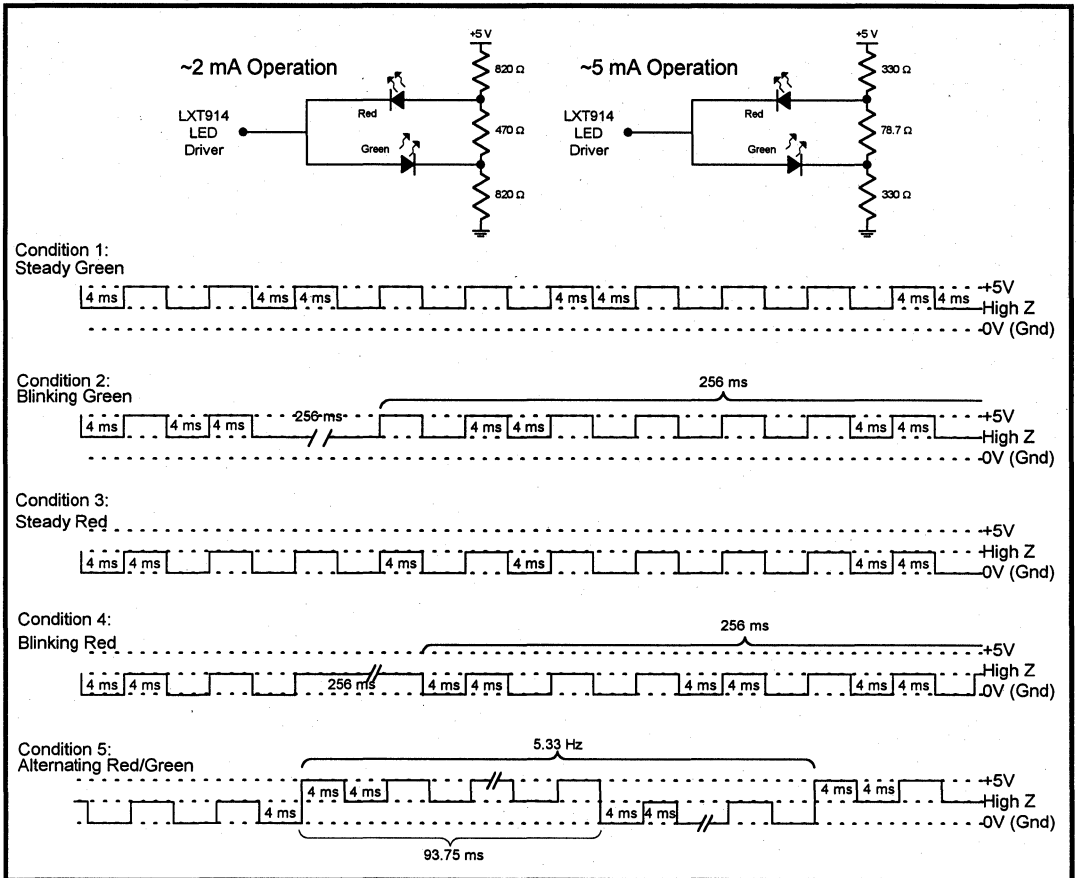

12-PORT HUB REPEATER

Figure 5 (Sheets 1 through 4) shows a simple 12-port hub repeater application with 3 LXT914s. This application also provides two additional AUI ports—one DB-15 connector and one coaxial port. The application shown uses the asynchronous backplane mode so no external backplane clock source is required.

Figure 5 (Sheet 1) shows the XL93C46 EEPROM which downloads the setup parameters for all the LXT914 devices at initialization. (This EEPROM could be replaced with a simple pull down resistor on the SDI pin. This will select the default conditions of the set up register.) A single 20 MHz crystal provides the SYSClk for all three LXT914 chips. The LXT914 hub repeater on Sheet 1 provides the AUI DB-15 connector as well as four twisted-pair ports. Table 19 lists transformers suggested for use with the LXT914.

Figure 5 (Sheet 2) shows a second LXT914 hub repeater with four TP ports and a coaxial port. The MD-001 coax transceiver is used to implement the port. Sheet 3 shows the third LXT914 device with its four TP ports and indicator LEDs. The AUI port of the third LXT914 hub repeater is not used. Sheet 4 of the schematic shows the LEDs for the remaining LXT914 devices, along with the LED operation table.

Table 19: Manufacturers Magnetics List

Mfr	Quad Transmit	Quad Receive	Tx/Rx Pairs
Bell Fuse	S553-5999-02	S553-5999-03	
Fil-Mag	23Z338	23Z339	
HALO	TD54-1006L1 TG54-1006N2	TD01-1006L1 TG01-1006N2	TD42-2006Q TD43-2006K TG42-1406N1 TG43-1406N (Octal) TG44-S010NX
Kappa	TP4003P	TP497P101	
Nan-opulse	5976	5977	
PCA	EPE6009	EPE6010	
Pulse Eng.	PE68810	PE68820	PE65745 PE65994 PE65746 PE65998 (Octal) PExxxx
VALOR	PT4116	PT4117	PT4069N1 PT4068N1 ST7011S2 ST7010S2

8-PORT PRINT OR FILE SERVER APPLICATION

Figure 6 (Sheets 1 and 2) shows an eight-port repeater attachment for an existing single port AUI or 10BASE5 interface. This application can be added to a current design with an existing AUI or 10BASE5 interface. This circuit allows increased connectivity without the need for another external remote hub. The application shown is a 68-pin PLCC, an asynchronous backplane with both LXT914s in the first position.

In Figure 6 (Sheet 1) the LXT914 is set up with the LEDs in Mode 1 with one LED per port and a single collision LED. The twisted pair port LEDs display link integrity only. (Refer to Table 16.) LED Mode 1 is selected by pulling LEDM0 High with a 1 kΩ resistor on pin 17 and pulling LEDM1 Low with pin 35 attached to ground.

Figure 6 (Sheet 2) has the same configuration, mode of operation and LED Mode as used in Sheet 1. However, the AUI port has been configured as a MAU interface. This is selected when LEDJM/AUISEL on pin 28 is pulled up through a 1 kΩ resistor. This mode disables the LEDJM pin as an LED driver. (See Table 13.) The MAU interface now configured on the LXT914 allows the AUI port to attach to a DTE interface. This application increases connectivity to any existing single-port Ethernet design.

This unique application allows the designer to integrate an external hub, eliminating the need for additional external equipment.

Figure 5: 12-Port Application Schematic using 68-Pin PLCC Package (Sheet 2 of 4)

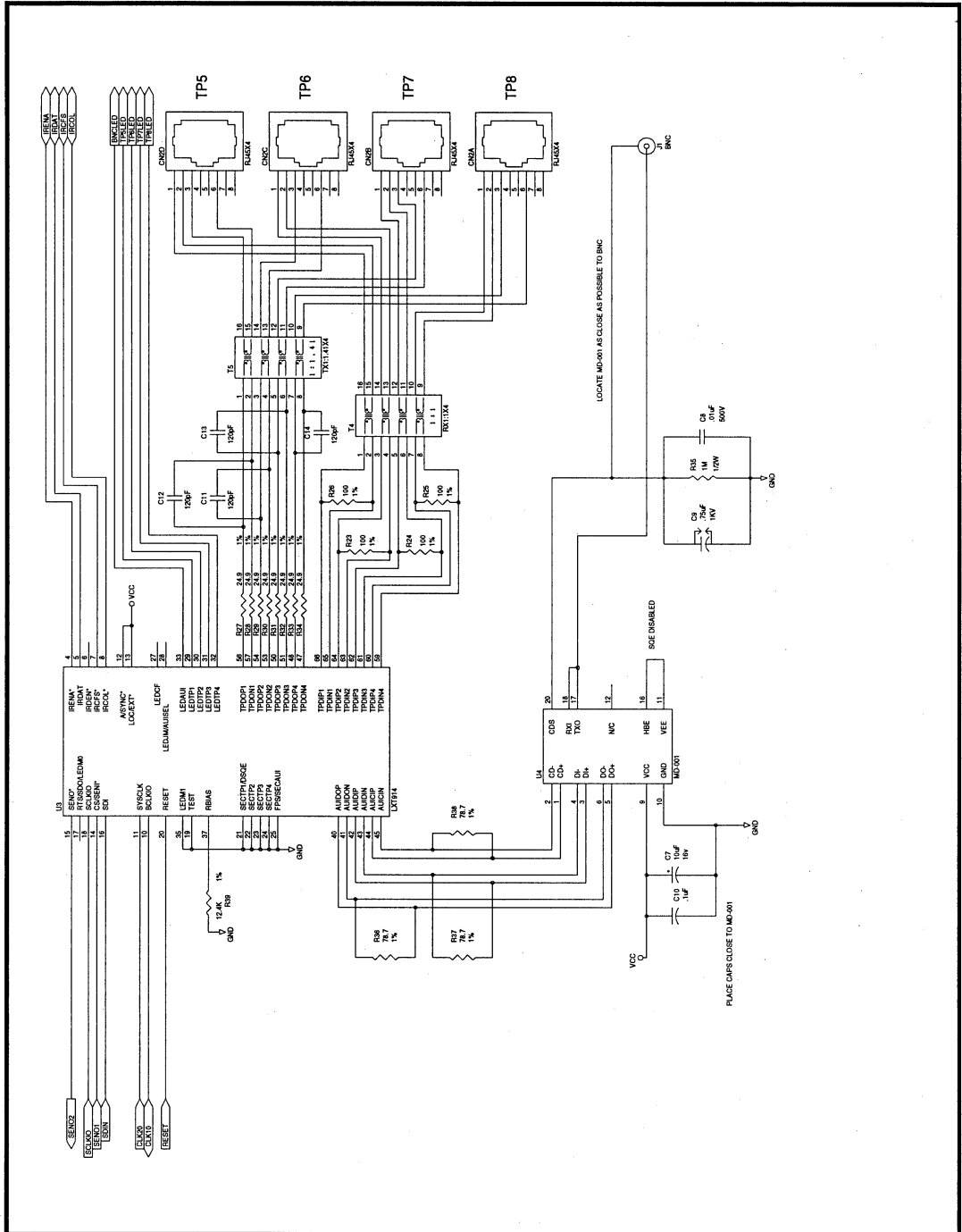

Figure 5: 12-Port Application Schematic using 68-Pin PLCC Package (Sheet 3 of 4)

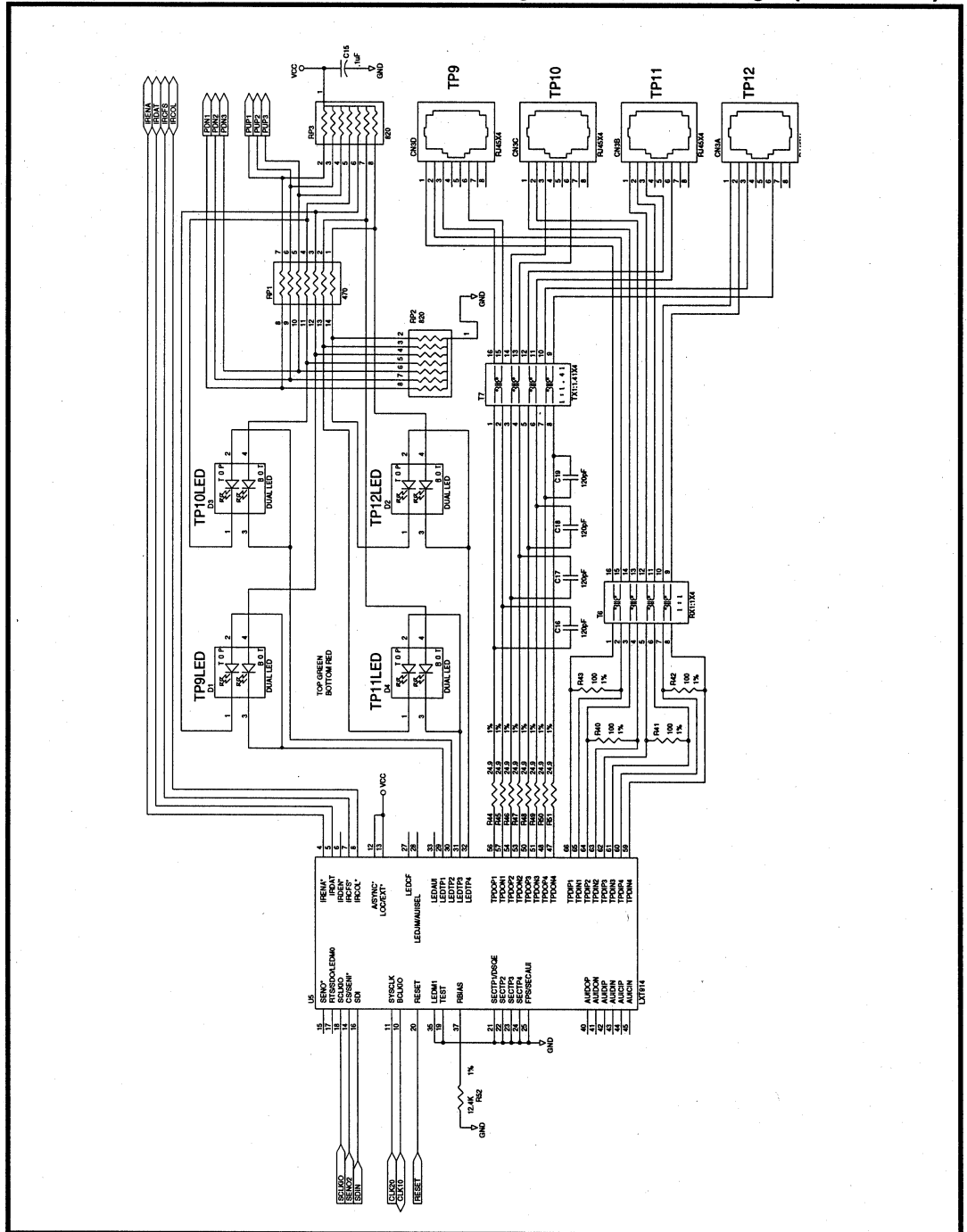

Figure 5: 12-Port Application Schematic using 68-Pin PLCC Package (Sheet 4 of 4)

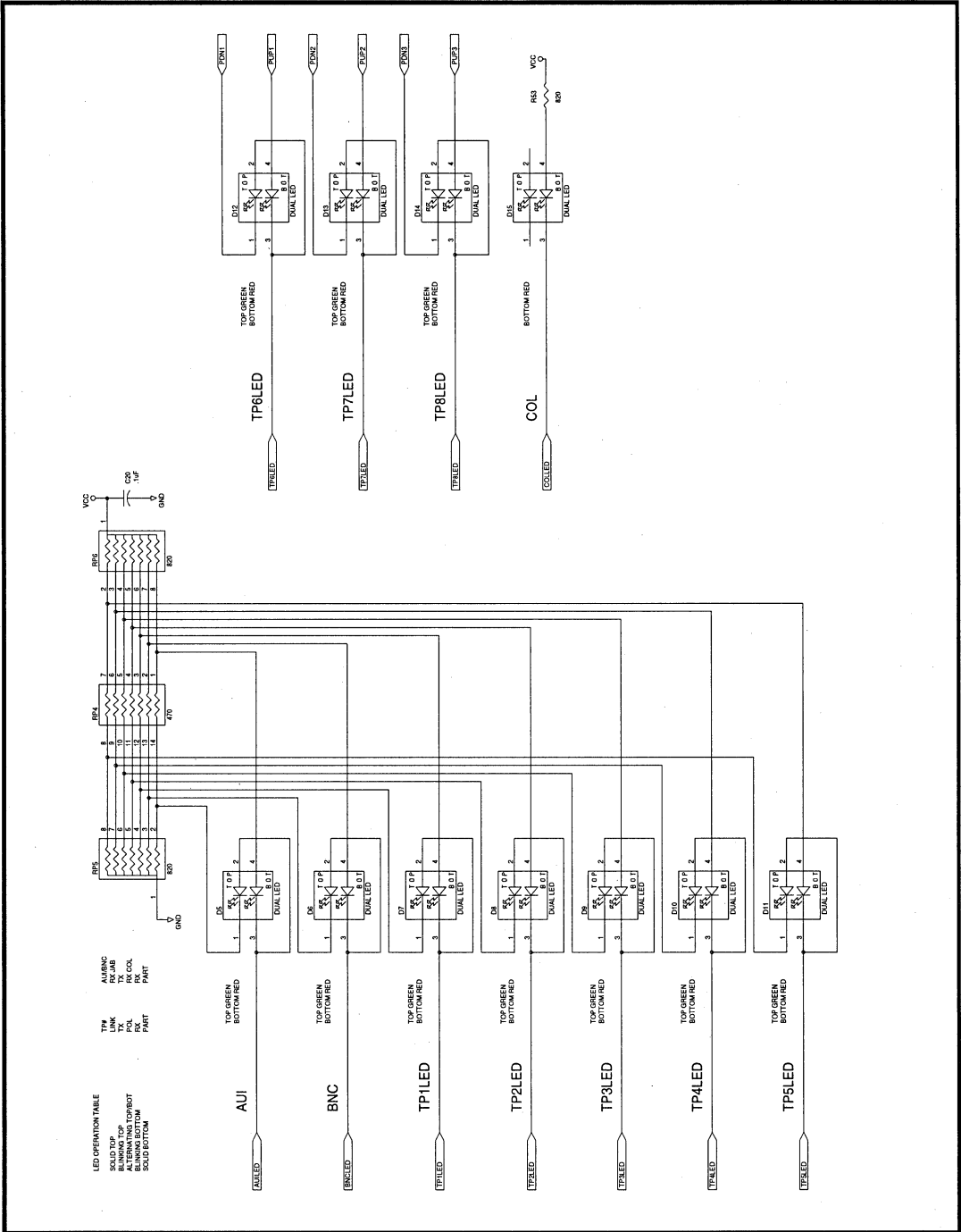
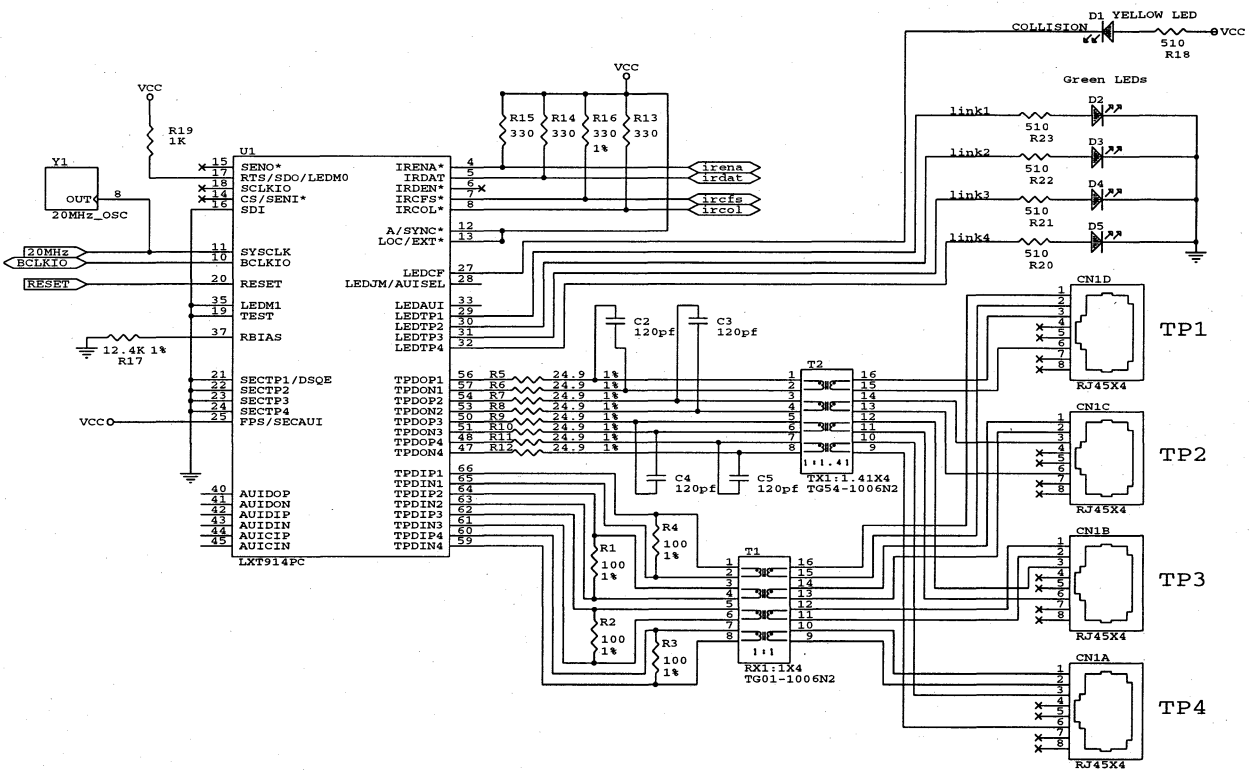

Figure 6: 8-Port Application Schematic, LED Mode 1 with AUISEL = MAU (Sheet 1 of 2)



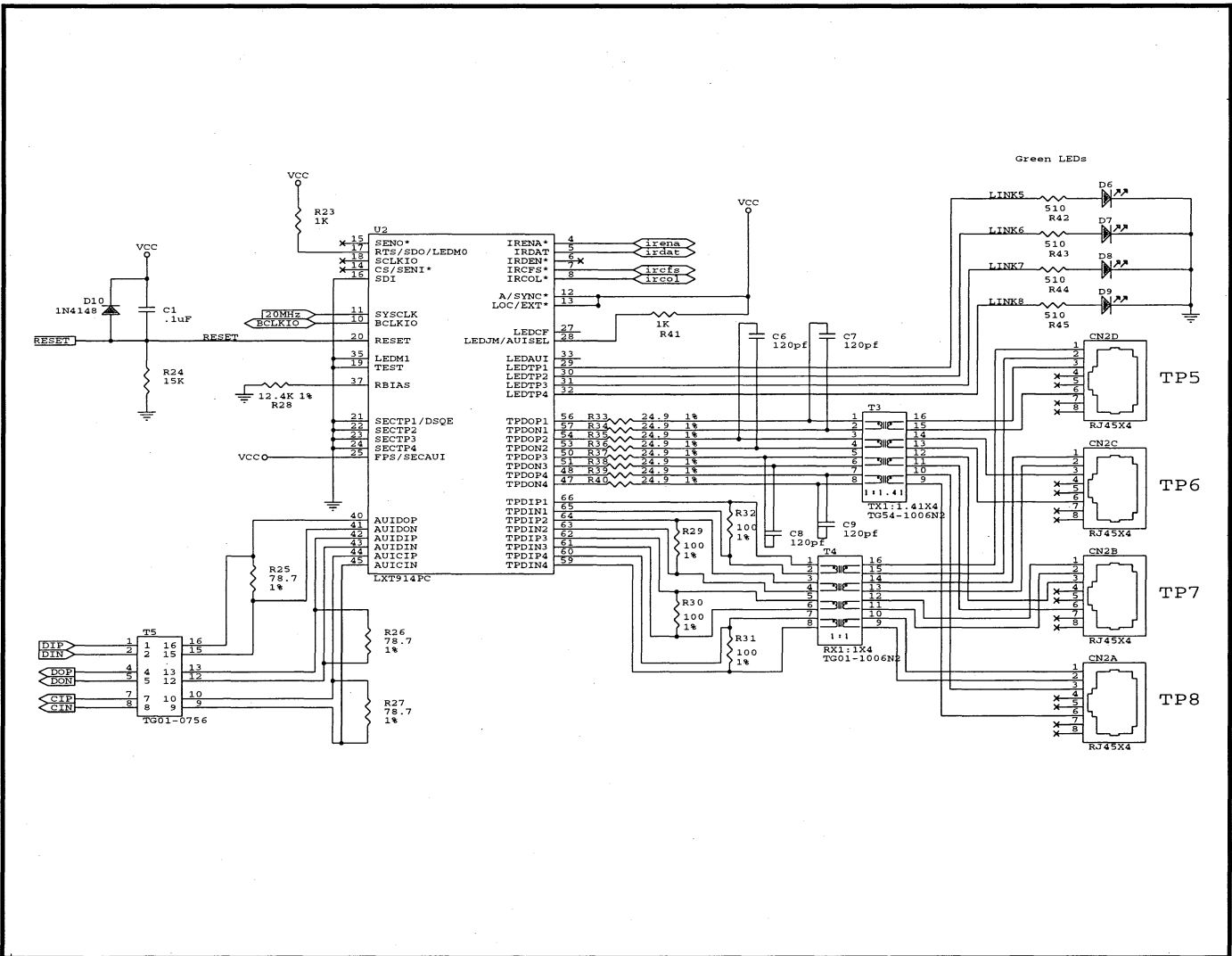

Figure 6: 8-Port Application Schematic, LED Mode 1 with AUISEL = MAU (Sheet 2 of 2)

TEST SPECIFICATIONS

NOTE

The minimum and maximum values in Tables 20 through 28 and Figures 7 and 8 represent the performance specifications of the LXT914 and are guaranteed by test except, where noted, by design.

Table 20: Absolute Maximum Ratings

Parameter	Symbol	Min	Typ	Max	Units
Supply voltage	VCC	-0.3	—	6	V
Operating temperature	TOP	0	—	+70	°C
Storage temperature	TST	-65	—	+150	°C

CAUTION
Exceeding these values may cause permanent damage. Functional operation under these conditions is not implied. Exposure to maximum rating conditions for extended periods may affect device reliability.

Table 21: Recommended Operating Conditions

Parameter	Symbol	Min	Typ	Max	Units
Recommended supply voltage	VCC	4.75	5.0	5.25	V
Recommended operating temperature	TOP	0	—	70	°C

Table 22: I/O Electrical Characteristics (over recommended range)

Parameter	Symbol	Min	Typ ¹	Max	Units	Test Conditions
Supply current	ICC	—	—	180	mA	
Input Low voltage	VIL	—	—	0.8	V	
Input High voltage	VIH	2.0	—	—	V	
Output Low voltage	VOL	—	—	0.4	V	IOL = 1.6 mA
Output Low voltage	VOL	—	—	10	% VCC	IOL < 10 μA
Output Low voltage (LED)	VOLL	—	—	1.0	V	IOLL = 5 mA
Output High voltage	VOH	2.4	—	—	V	IOH = 40 μA
Output High voltage	VOH	90	—	—	% VCC	IOH < 10 μA
Output High voltage (LED)	VOHL	4	—	—	V	IOHL = -5 mA
Input Low current	IIL	—	—	2	mA	VOL = .4 V
Output rise / fall time	—	—	3	8	ns	CLOAD = 20 pF

1. Typical values are at 25° C and are for design aid only; they are not guaranteed and not subject to production testing.

Table 23: AUI Electrical Characteristics (over recommended range)

Parameter	Symbol	Min	Typ ¹	Max	Units	Test Conditions
Input Low current	IIL	–	–	-700	μA	
Input High current	IiH	–	–	500	μA	
Differential output voltage	VOD	±550	–	±1200	mV	
Receive input impedance	ZIN	–	20	–	kΩ	Between CIP/CIN & DIP/DIN
Differential squelch threshold	VDS	–	220	–	mV	

1. Typical values are at 25° C and are for design aid only; they are not guaranteed and not subject to production testing.

Table 24: TP Electrical Characteristics (over recommended range)

Parameter	Symbol	Min	Typ ¹	Max	Units	Test Conditions
Transmit output impedance	ZOUT	–	5	–	Ω	
Peak differential output voltage	VOD	3.3	3.5	3.7	V	Load = 100 W at TPOP and TPON
Transmit timing jitter addition	–	–	± 6.4	± 10	ns	0 line length
Transmit timing jitter added by the MAU and PLS sections ²	–	–	± 3.5	± 5.5	ns	After line model specified by IEEE 802.3 for 10BASE-T
Receive input impedance	ZIN	–	20	–	kΩ	Between TPIP/TPIN
Differential squelch threshold (Normal threshold: ERSQ _x = 0)	VDS	300	420	565	mV	5 MHz square wave input
Differential squelch threshold (Reduced threshold: ERSQ _x = 1)	VDSL	180	250	345	mV	5 MHz square wave input

1. Typical values are at 25° C and are for design aid only; they are not guaranteed and not subject to production testing.
 2. IEEE 802.3 specifies maximum jitter additions at 1.5 ns for the AUI cable, 0.5 ns from the encoder, and 3.5 ns from the MAU.

Table 25: IRB Electrical Characteristics (over recommended range)

Parameter	Symbol	Minimum	Typical ¹	Maximum	Units
Output Low voltage	VOL	–	.3	.6	V
Output rise or fall time	Tf	–	4	12	ns

1. Typical values are at 25° C and are for design aid only; they are not guaranteed and not subject to production testing.

LXT914 Flexible Quad Ethernet Repeater

Table 26: Switching Characteristics (over recommended range)

Parameter	Minimum	Typical ¹	Maximum	Units
Jabber Timing:				
Maximum transmit time	5.0	–	5.5	ms
Unjab time	–	9.6	–	μs
Link Integrity Timing:				
Time link loss	–	60	–	ms
Time between Link Integrity Pulses	10	–	20	ms
Interval for valid receive Link Integrity Pulses	4.1	–	30	ms

1. Typical values are at 25° C and are for design aid only; they are not guaranteed and not subject to production testing.

Table 27: Serial Port Timing (External Mode)

Parameter	Symbol	Minimum	Typical ¹	Maximum	Units
SLCKIO High to $\overline{\text{SEN}}\overline{\text{I}}$ Low (active)	ts1	0	–	50	ns
SCLKIO High to SDIN data valid	ts2	0	–	50	ns
SCLKIO High to $\overline{\text{SEN}}\overline{\text{O}}$ Low (active)	ts3	5	–	15	ns
SCLKIO Low to SDOUT data valid	ts4	5	–	15	ns

1. Typical values are at 25° C and are for design aid only; they are not guaranteed and not subject to production testing.

Figure 7: Serial Port Timing

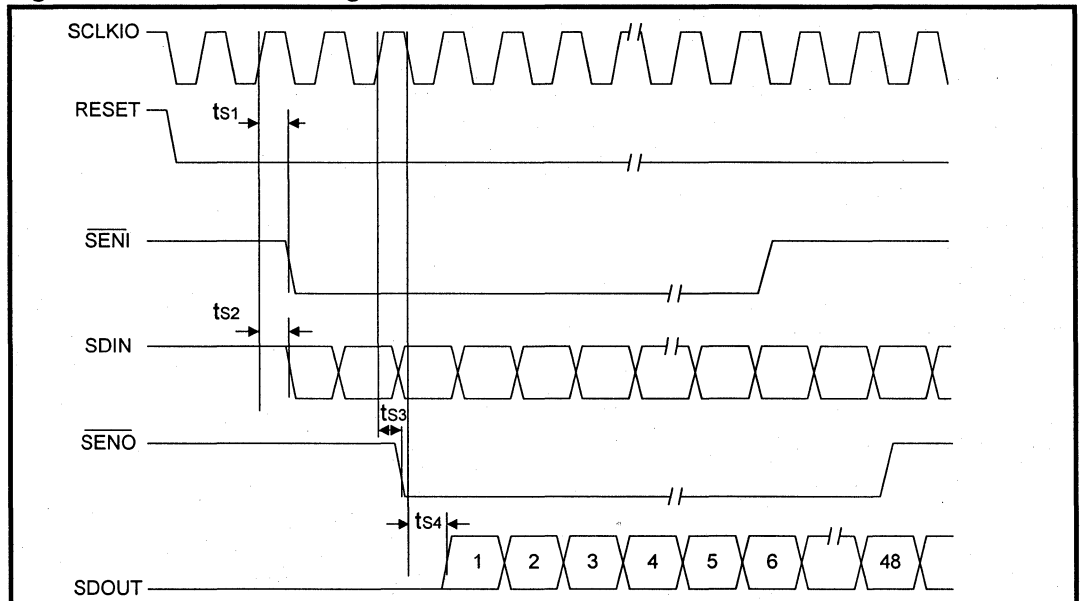
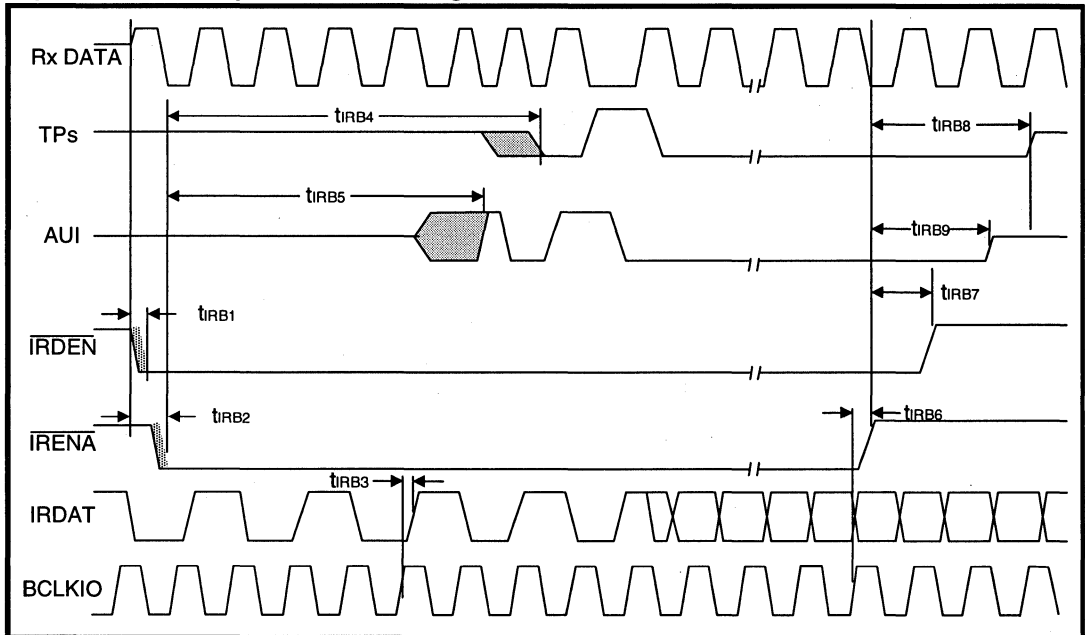

Table 28: Inter-Repeater Bus Timing

Parameter	Symbol	Minimum	Typical ¹	Maximum	Units
Start of Frame to $\overline{\text{IRDEN}}$ Low (active)	t_{IRB1}	10	–	150	ns
Start of Frame to $\overline{\text{IRENA}}$ Low (active)	t_{IRB2}	125	–	225	ns
BCLKIO to IRDAT valid (Synchronous mode)	t_{IRB3}	5	–	30	ns
BCLKIO to IRDAT valid (Asynchronous mode)	t_{IRB3}	–	50	–	ns
$\overline{\text{IRENA}}$ Low (active) to TP outputs active	t_{IRB4}	525	–	600	ns
$\overline{\text{IRENA}}$ Low (active) to AUI output active	t_{IRB5}	475	–	525	ns
End of Frame clock to $\overline{\text{IRENA}}$ High (inactive)	t_{IRB6}	5	–	30	ns
$\overline{\text{IRENA}}$ High (inactive) to $\overline{\text{IRDEN}}$ High (inactive)	t_{IRB7}	95	–	105	ns
$\overline{\text{IRENA}}$ High (inactive) to TP outputs inactive	t_{IRB8}	575	–	600	ns
$\overline{\text{IRENA}}$ High (inactive) to AUI output inactive	t_{IRB9}	425	–	450	ns

1. Typical values are at 25° C and are for design aid only; they are not guaranteed and not subject to production testing.

Figure 8: Inter-Repeater Bus Timing



NOTES:

LAN Application Notes



LXT902 and 906

Impedance Matching for Shielded and Unshielded Twisted-Pair Lines

General

The LXT902 Media Attachment Unit (MAU) and LXT906 Twisted-Pair/Coax (TP-CX) Adapter both require impedance matching with the network media. This application brief provides a short explanation of the impedance matching networks required for shielded and unshielded twisted-pair lines. This information applies to both the LXT902 and the LXT906

Transmit Line Matching

On the transmit side, the LXT902 and LXT906 use resistors in line with the output as shown in the figure on the left. To provide an optimum match, the total impedance of the resistors and the filter should equal the line impedance:

$$RL1 + RL2 + ZF = ZL$$

Receive Line Matching

On the receive side the LXT902 and LXT906 use a pair of resistors across the input with the center node tied to ground through a capacitor as shown in the figure on the right. To provide an optimum impedance match, use the same formula as used for the transmit side:

$$RL1 + RL2 + ZF = ZL$$

Typical Examples

For example, when the network media is 100 Ω UTP and the filter impedance is 5 Ω , each resistor value should be 47.5 Ω . When the network media is 150 Ω STP and the filter impedance is 0 Ω , each resistor value should be 75 Ω . This simple formula works for both devices and for both the transmit and receive line interfaces.

Transmit Line Interface

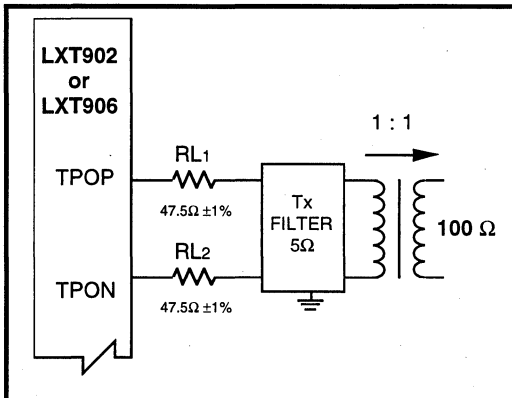

Receive Line Interface

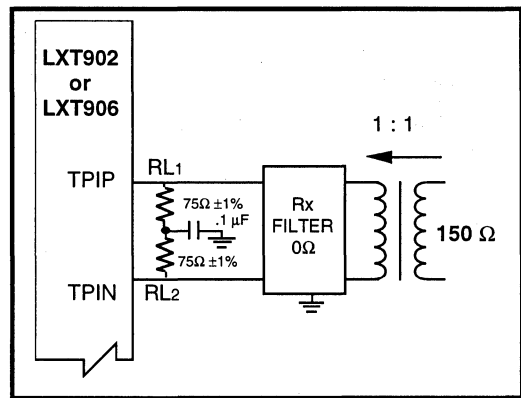

NOTES:

Design Guide for LXT901/907 Ethernet Interface Connection to Motorola MC68EN360 Controller

General Description

This application note describes a method for connecting the LXT901 or LXT907 Ethernet Interface Adapter to the Motorola MC68EN360 Quad Integrated Communications Controller (QUICC) with Ethernet capability.

The LXT901 and LXT907 devices have advanced features that make design and fabrication faster and cheaper than typical competitors' products. These two devices meet all of the Motorola QUICC design requirements with minimal external circuitry needed to use the MC68EN360 features. Either of these devices gives the lowest cost, highest performance possible with the Motorola QUICC.

LXT901/LXT907 Device Features

- Glueless interface to the MC68EN360 QUICC controller in 10 Mbps Ethernet/IEEE 802.3 LAN with either twisted-pair connection or AUI transceiver
- Integrated filters make design faster, fabrication cheaper
- Integrated LED drivers for operation monitoring
- Supports full duplex operation
- Automatic port selection makes choosing between the twisted-pair and AUI options seamless

Applications

The QUICC/LXT901 device combination makes designing routers, bridges, print servers and other, similar products simple and fast.

This application note addresses the Ethernet LAN side of the circuit only. To connect to a T1 or E1 network, use a Level One LXT301/305 family or an LXT310 or LXT318 transceiver.

Typical LXT901/LXT907 Device and MC68EN360 QUICC Connection

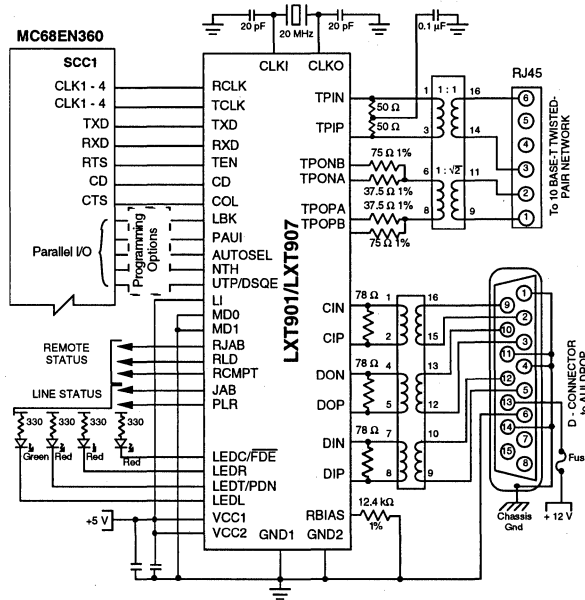

NOTE

The placement of signals in this figure does not represent the physical location of the pins on either chip.

LXT901/LXT907 Ethernet Interface Adapter to Motorola Controller

Connectivity to the QUICC

The LXT901 device is available in either a 44-pin PLCC format or a 64-pin TQFP package. The LXT907 device is available in the 44-pin PLCC form. The two PLCC packages are pin compatible except for pin 37. This pin is UTP (unshielded/shielded twisted-pair select) on the LXT901 and DSQE (Disable SQE) on the LXT907 device.

The following pins on the LXT901 or LXT907 device connect to the MC68EN360 SCC1 signals as shown.

Table 1: Pin Connections

LXT901/LXT907 Device			Motorola QUICC
PLCC Pin	TQFP Pin	Signal	MC68EN360 SCC1 Signal
28	47	RCLK	CLK1-4 ¹
11	23	TCLK	CLK1-4 ¹
12	24	TXD	TXD
26	45	RXD	RXD
13	25	TEN	RTS ²
27	46	CD	CD ²
16	28	COL	CTS ²
22	38	LBK	Connect these bits to the Parallel I/O bus on the QUICC ³ and program as needed.
40	3	PAUI	
17	29	AUTOSEL	
4	13	NTH	
37	59	UTP (901)	
37		DSQE (907)	

1. The design must provide separate clocks for TCLK and RCLK. Any of the clocks on the QUICC will do.
2. These signals are active high in this application.
3. Please check the Motorola specification for the connections needed for the desired result.

The LXT901/LXT907 device requires a 20 MHz clock and several resistors, diodes and capacitors. This example uses the following parts:

1. 20 MHz crystal (one each, or external 20 MHz clock)
2. 300 Ω, 1% resistor (four each)
3. 50 Ω, 1% resistor (two each)
4. 75 Ω, 1% resistor (two each)
5. 78 Ω, 1% resistor (three each)
6. 37.5 Ω, 1% resistor (two each)
7. 12.4 kΩ, 1% resistor (one each)
8. 0.1 μF capacitor (three each)
9. 20 pF capacitor (two each, not required if using clock)
10. 18 pF capacitor (one each)
11. Red LED (three each, optional)
12. Green LED (one each, optional)

The application also requires two DIP transformer packages for isolation and impedance matching on the AUI or twisted-pair transmit and receive lines. Recommended parts are listed in Table 2.

Table 2: Transformer Manufacturers

Supplier	Part Number	TP/AUI
Bel Fuse	S553-0716/A553-0716	TP
	A553-0756/S553-0756	AUI
Fil-Mag	23Z128/23Z128	TP
	23Z90/23Z90SM	AUI
HALO Electronics	TD42-2006Q	TP
	TG42-2006WH1	AUI
	TD01-0756K	
	TG01-0756W	
Valor	PT4069/SM4069	TP
	LT6030/SM6030	AUI

Fabricate the circuit as shown in the diagram on the first page of this document.

Take care to isolate the bias circuit at RBIAS and locate the resistor close to the pin. If this resistor is not positioned properly it acts as an antenna and causes erratic performance. Keep it away from other components or signal traces, and do not run any signals under the resistor.

Be sure to use a bypass capacitor at each VCC pin.

Setting QUICC Parameters

Refer to the *Motorola MC68360 Quad Integrated Communications Controller User's Manual* for settings required to make the QUICC function. Here are some points to be aware of:

Only SCC1 has Ethernet communications capability. Use SCC1 for the LAN connection, and use another SCC (or a parallel) port for the other side of the connection.

Bypass both the Digital Phase-Locked Loop (DPLL) and Manchester Encoding/Decoding function for Ethernet operation.

The TCI (Time Clock Invert) bit must be High to allow the QUICC to clock the data out to the LXT901 or LXT907 device on the rising edge of the clock pulse. This improves data setup time at the 10 Mbps speed used by Ethernet. TCI is bit 28 of the General SCC Mode Register (GSMR).

LXT901/LXT907 Ethernet Interface Adapter to Motorola Controller

The MODE bits (0-3) must be set to 1, 1, 0, 0. The Transparent Receiver (TRX) and Transparent Transmitter bits (TTX), bits 43 and 44, must both be 0 (normal operation) or 1 (transparent operation). Do not mix TRX and TTX values. The 0 setting is recommended; in transparent mode, the QUICC does not manipulate protocols in the data stream.

The Transmit FIFO Length (TFL) bit should be 0. TFL is bit 38 in the GSMR. The Receive FIFO Width (RFW) bit, bit 37, should also be 0.

GSMR bits 19 and 20 are the Transmit Preamble Pattern (TPP) bits. For Ethernet operation, set them to 0, 1 to transmit a repeating 10 pattern as a preamble.

Figure 1 shows a typical set up for a full duplex 10BASE-T LAN connection, using the LXT907 device. This application requires only the TP transformer, two 18 pF capacitors, two 330 Ω resistors, two 24.9 Ω 1% resistors, one 12.4 kΩ 1% resistor, and a green LED. The 20 MHz clock signal is common in all 10BASE-T applications, so no crystal is required. All QUICC parameters remain the same.

This completes the Ethernet/IEEE802.3 LAN side of the circuit setup. There are other steps in designing a working circuit that go beyond the scope of this application note.

Figure 1: Typical Full Duplex 10BASE-T Connection

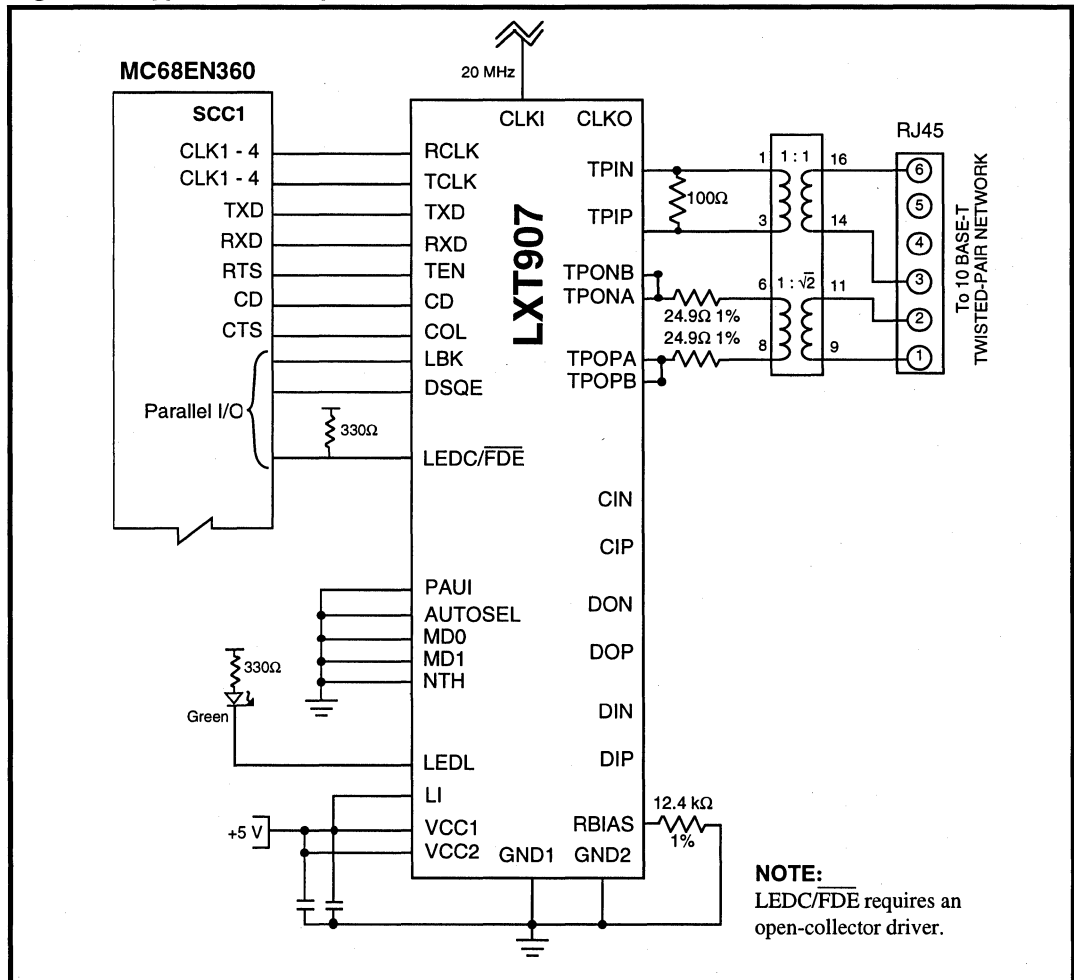

LXT901/LXT907 Ethernet Interface Adapter to Motorola Controller

NOTES:

Design Guide for LXT914 Quad Ethernet Repeater with the LXT901/4/7 and Motorola MC68EN360

General Description

This application note describes a method for integrating the LXT914 Quad Ethernet Repeater into existing and new architectures using the MC68EN360 (QUICC) device. It also includes the design notes for the MC68EN360 and the LXT901/7 found in Application Note 35 for new users of Level One devices who also use the QUICC interface. The LXT914 has a new advanced feature set which allows integration of the repeater function with existing QUICC/LXT901/7 designs.

The QUICC/LXT90X/LXT914 device combination demonstrates Level One's commitment to supplying highly integrated solutions to meet our customers' ever increasing requirements for advanced new products.

Application Overview

The LXT914 Flexible Quad Ethernet Repeater can be used to increase the connectivity of your current and future designs, including Routers, Bridges, Print Servers, etc. Any single port Ethernet design can be upgraded to a multi-port repeated network simply and easily using the LXT914 device with the new advanced feature set.

The LXT914's advanced feature set includes three new LED modes and the selectable AUI interface (DTE/MAU).

LXT914 Advanced Feature Set

- Three new LED operating modes
- Selectable AUI interface (DTE/MAU)
- Four integrated 10BASE-T transceivers
- Integrated transmit and receive filters
- Seven integrated LED drivers
- Synchronous or Asynchronous inter-repeater backplane operation
- Inter-repeater backplane supports glueless cascading of repeater devices for maximum port count
- Serial port interface for initial port configuration
- Packaged in both 68-pin PLCC and 100-pin PQFP

The LXT914 AUISEL pin allows the designer to select the MAU interface mode of operation. The MAU mode allows for the connection of the DTE interface of the LXT901/4/7 with the MAU interface of the LXT914. This application will increase the connectivity of the product from one port to 4, 8, or 12 TP ports. The LXT914 advanced feature set also allows for growth from LED managed to a fully managed solution.

LXT914 Integrated Ethernet Repeater Block Diagram

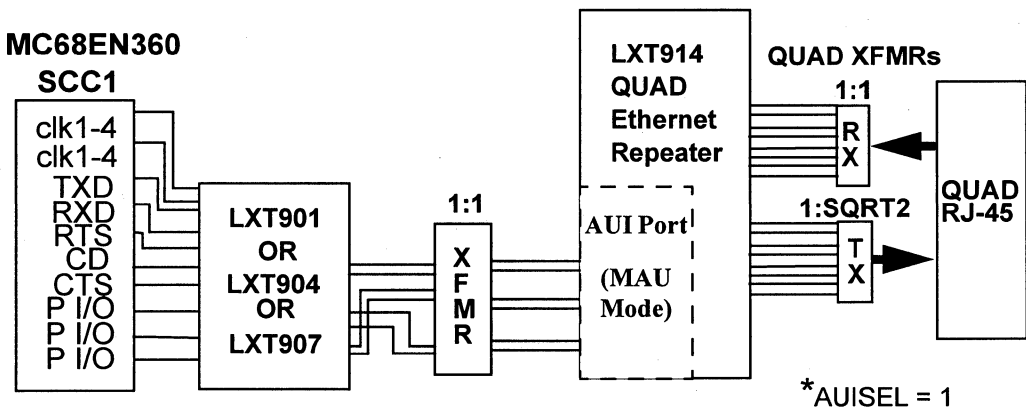

DESIGN REQUIREMENTS

LXT90X to the Motorola QUICC

The LXT901, LXT904 and LXT907 devices are each available in a 44-pin PLCC package. There are functional differences between the three devices, but each product has all of the features required for this application. The LXT907, for example, uses pin 37 for the DSQE function, allowing the designer to make SQE a programmable option in the design. The LXT901 uses pin 37 for UTP/STP media selection. These device-specific options apply to the use of the TP port which is unused in this application. The LXT904 device has only the single AUI port—the only port required for this application. Refer to the Level One data sheet for the specific device to fit your individual requirements.

The LXT901/4/7 device should be set up in a fixed mode of operation. This fixed mode of operation reduces the number of required programmable pins. The mode selected for operation with the LXT914 is: Autoselect disabled, LI disabled, and PAUI set (for AUI only operation).

The actual connection between the LXT901/4/7 and the LXT914 is shown in Figures 1 and 2, which detail the two interface options: capacitive coupling and isolation transformers, respectively. Capacitive coupling is used for like-biased devices. Some devices will require transformers. The AUI circuitry has voltage biasing on all lines and requires isolation when transmitting between devices. Either option also requires the 78.7 Ω termination resistors on both sides of the transformer or the capacitive coupling as shown in Figures 1 and 2.

NOTE

Some existing designs may require reprogramming. The programmable pins should be set as follows:
 AUTOSEL = Low: Auto Port Select disabled
 LI = Low: Link Integrity Test disabled
 PAUI = High: AUI Port selected
 MD0 = Low: Controller Mode 1 selected
 MD1 = Low: Controller Mode 1 selected

The following pins on the LXT901/4/7 connect to MC68EN360 SCC1 signals.

Table 1: Connections to QUICC SCC1

LXT90X Pin #	LXT90X Signal Name	Motorola QUICC MC68EN360 SCC1 Signal
28	RCLK	CLK1-4 ¹
11	TCLK	CLK1-4 ¹
12	TXD	TXD
26	RXD	RXD
13	TEN	RTS
27	CD	CD
16	COL	CTS
22	LBK	PI/O1 ²
4	NTH	PI/O2 ²
37	UTP(901)	PI/O3 ²
37	DSQE(907)	PI/O3 ²

1 The design must provide separate clocks for TCLK & RCLK. Any of the clocks on the QUICC will do.
 2 Please refer to the Motorola specification for the correct connections and desired results. These pins should be programmable output pins for use with TTL inputs. Check the pin's state at reset and power up for compatibility with Level One devices.

Setting QUICC Parameters

Refer to the Motorola MC68EN360 Quad Integrated Communications Controller User's Manual for settings required to operate the QUICC properly. Here are some points to be aware of when setting up the QUICC's internal registers:

- Use SCC1 for the LAN connection, and use another SCC or a parallel port for another remote connection. (Only the SCC1 has Ethernet communications capability.)
- Bypass both the Digital Phase -Locked Loop (DPLL) and Manchester Encoding/Decoding functions for Ethernet operations (This is integrated into the LXT901/4/7).
- Set the TCI (Time Clock Invert) bit high to allow the QUICC to clock the data out to the LXT901 or LXT907 device on the rising edge of the clock pulse. This improves data setup time at the 10 Mbps speed used by Ethernet. TCI is bit 28 of the General SCC Mode Register (GSMR).
- Set the MODE bits (0-3) must to 1, 1, 0, 0. Set both the Transparent Receiver (TRX) and Transparent Transmitter (TTX), bits 43 & 44, to 0 for Normal Operation, or a 1 for Transparent Operation. Do not mix the two signals, set them for the same mode. We recommend the 0 setting: In this mode the QUICC does not manipulate the protocols in the data stream.
- Set the Transmit FIFO Length (TFL) bit & the Receive FIFO Width (RFW) bits to 0.
- Set the bits to 0, 1 (Ethernet operation) for a repeating (1,0,1,0,...) pattern as a preamble. GSMR bits 19-20 are Transmit Preamble Pattern (TPP) bits.

Figure 1: AUI Capacitive Coupling Interface

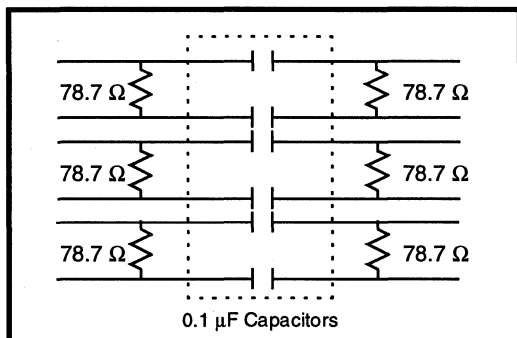

LXT914 Configuration

The following is a complete list of the settings as shown in Figure 3. Some of these settings are optional and you will have to select the settings which will be best for the product.

- $\overline{\text{LOC/EXT}}$: Set this bit High (1) for Local Management. (Use External Management to meet the requirement for managed TP port statistics, SNMP protocol or RMON operation with a EMD device.)
- $\overline{\text{A/SYNC}}$: Select Asynchronous mode High (1) to eliminate the need for an external clock source. The Asynchronous and Synchronous modes of operation determine the relationship between the System Clock and the IRB Clock. The IRB clock is internally generated in Asynchronous mode only.
- $\overline{\text{AUISEL/LEDJM}}$: Pull this pin High (1) for this application. (This pin can be an external LED driver or used as an input to select MAU mode for the AUI port.)
- $\overline{\text{LEDM1/0}}$: Set these pins for one of four possible LED modes. The available modes are shown in Table 2. In the MAU configuration, Mode 0 and the LEDJM driver are not available with the PLCC package.
- $\overline{\text{DSQE}}$: Set the disable SQE pin High (1) to disable the SQE function or Low (0) to enable the SQE function.
- $\overline{\text{FPS}}$: Set the first position pin High (1).
- $\overline{\text{SDI}}$: Tie this pin Low for the default settings of the internal setup register used here. (Use an external EEPROM to customize the port settings. Refer to the LXT914 data sheet for further information.)
- $\overline{\text{SCLKIO}}$, $\overline{\text{SEN0}}$, $\overline{\text{SEN1}}$: Leave the remaining serial management pins floating.
- $\overline{\text{TEST}}$: Tie this pin Low (0).

Figure 2: Isolation Transformer Interface

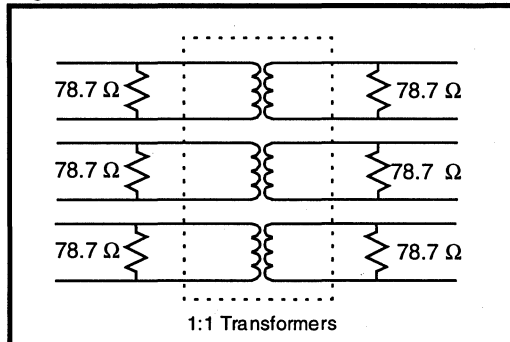

Design Guide for LXT914 Quad Ethernet Repeater

Table 2: LED Modes Available in the LXT914

Condition (LEDM0, 1)	LEDTP 1-4	LEDAUI	LEDCF
MODE 1 (0, 1)			
1 Steady High	Rx Link Pulse	n/a	MJLP
2 Blink High	n/a	n/a	n/a
3 Steady Low	n/a	n/a	Collision
4 Blink Low	Rx Packet	Rx Packet	n/a
MODE 2 (1, 0)			
1 Steady High	Rx Link Pulse	n/a	MJLP
2 Blink High	Partition Out	Partition Out	n/a
3 Steady Low	n/a	n/a	Collision
4 Blink Low	Rx Packet	Rx Packet	n/a
MODE 3 (1, 1)			
1 Steady High	Rx Link Pulse	n/a	MJLP
2 Blink High	Rx Packet	Rx Packet	n/a
3 Steady Low	Partition Out	Partition Out	Collision
4 Blink Low	n/a	n/a	n/a

Inter-Repeater Bus (IRB)

The IRB connects multiple LXT914 devices on a single repeated segment. Each repeater device distributes recovered and retimed data to other repeaters on the IRB simultaneously. This simultaneous rebroadcast allows the multiple devices to act as a single large repeated segment.

- $\overline{\text{IRENA}}$, $\overline{\text{IRDAT}}$, $\overline{\text{IRCOL}}$, $\overline{\text{IRCFS}}$: These four signals must each be pulled up through a single 330 Ω 1% resistor.
- $\overline{\text{IRDEN}}$: This signal controls the transceivers for synchronous mode of operation. The synchronous mode is required for a fully managed solution.

Table 3: Four TP Port BOM (see Figure 3)

#	Qty	Description
1	6	.1 μF caps <i>AC Coupling only</i>
2	4	120 pF capacitors
3	8	24.9 Ω 1% resistor
4	4	100 Ω resistors
5	4	330 Ω resistors
6	2	12.4 k Ω resistors
7	4	1 k Ω resistors
8	1	1:1 XFMR, <i>No AC coupling</i>
9	1	1:1 Rx XFMR (quad)
10	1	1:1.41 Tx XFMR (quad)
11	1	20 MHz Oscillator (or 20 MHz system clock)
12	-	LEDs, user defined

Layout Requirements

The Twisted-Pair Interface

The four twisted-pair output circuits are identical. Each TPDO/TPDON output pair has a 24.9 Ω, 1% resistor in series at each output pin and a 120 pF capacitor across the output lines. These signals go directly to a 1:√2 transformer creating the necessary 100 Ω termination for the cable. The TPDIP/TPDIN signals have a 100 Ω resistor across the differential pairs to terminate the 100 Ω signal from the line. To calculate the impedance on the output line interface, use the formula:

$$(24.9 \Omega + 24.9 \Omega) * \sqrt{2} \approx 100 \Omega.$$

Table 4 lists available quad and single port transformers with manufacturers and their part numbers. This information was valid as of the printing date of this document. Before committing to a specific component, designers should review the specifications for any device to be used in the design.

The layout of the twisted-pair ports is critical in complex designs. Run the differential pairs directly from the device to the discrete termination components (located close to the transformers).

The transformer isolation voltage rating should be 2 kV to protect the circuitry from static voltages across the connec-

tors and cables. The signals running from the transformers to the connector should run in close pairs directly to the connector. Be careful not to cross the transmit and receive pairs. One way to avoid a problem is to run the receive pairs on the component side and the transmit pairs on the solder side.

The PCB layout should have no ground or power planes from the transformers to the connectors. The receive and transmit signals should be the only traces in this area. Place the chassis ground for the connectors near the edge of the PCB, away from the signals, connecting the connector shield within the wide etch of the chassis ground.

RBIAS Pins

The RBIAS resistor for the LXT901/4/7 devices should be placed as close to the pin as possible with no vias between the device and the resistor (SMT). The other side should share the via with GND1 (pin 23). There should be no other signals running through or under this area. The RBIAS signal sets the levels for the output drivers of the device. Emissions or common mode noise entering the device here will be seen on the output signals.

Lay out the LXT914 device with a 12.4 kΩ, 1% resistor directly connected to pin 37. The ground signals from pins 36 & 38 should come directly off of the device to surround the resistor and pin forming a partition between the RBIAS resistor and the other signals on the PCB.

Table 4: Manufacturers Magnetics List

Manufacturer	Quad Transmit	Quad Receive	Tx/Rx Pairs
Bell Fuse	S553-5999-02	S553-5999-03	
Fil-Mag	23Z338	23Z339	
HALO (Octal)	TD54-1006L1 TG54-1006N2	TD01-1006L1 TG01-1006N2	TD42-2006Q TD43-2006K TG42-1406N1 TG43-1406N TG44-S010NX
Kappa	TP4003P	TP497P101	
Nanopulse	5976	5977	
PCA	EPE6009	EPE6010	
VALOR	PT4116	PT4117	PT4069N1 PT4068N1 ST7011S2 ST7010S2

MAC Interface Design Guide

Interfacing Level One Ethernet Transceivers to Intel Controllers

General Description

This application note describes operation of the Intel 82596 LAN coprocessor with Level One Ethernet transceivers for IEEE 802.3 10BASE-T and AUI connections. The 82596 can be used with a variety of Level One devices including the LXT901, LXT904, LXT905, LXT907 and LXT944. The 82596 performs the Medium Access Control (MAC) functions, while the Level One transceivers perform the Physical (PHY) layer functions of Manchester encoding/decoding, receiver squelch and transmit pulse shaping, jabber, link integrity testing, reversed polarity detection and correction, and AUI driving and receiving. This note details the transceiver-to-controller interface. It also describes the Carrier Sense mode settings required for compatibility between Level One LXT905 and LXT944 transceivers and the Intel 82596 LAN controller.

Features

- Integrated filters - No external filters required
- Integrated Manchester encoders/decoders
- 10BASE-T compliant transceivers
- AUI transceivers
- Automatic /Manual AUI/RJ45 Selection
- Automatic polarity correction
- SQE enable/disable
- Integrated LED drivers
- Full duplex capability

Consult individual product data sheets for specific product feature sets.

Application Overview

CSMA/CD or Full-Duplex Ethernet

The above listed Level One transceivers are capable of full duplex operation. This makes them an excellent choice for use with the Intel 82596. The 82596 has two link management algorithms. One of these is Carrier Sense Multiple Access with Collision Detection (CSMA/CD) for compliance with the IEEE 802.3 standard. In CSMA/CD operation, the presence of activity on the serial link delays any data transmission until the link is clear. Collisions can be detected internally or externally to the 82596. With external collision detection, the 82596 is notified of collisions by the COL output of the Level One transceiver.

In addition to CSMA/CD, the 82596 is capable of full-duplex communication. In full-duplex operation, the 82596

uses the $\overline{\text{RTS}}$ output to enable data transmission through the TEN input of a Level One transceiver. In order for Level One transceivers to operate in full duplex mode, the transceiver collision detect circuits must be disabled. Collision detection disable is performed through the LEDC pin on the transceiver. In half-duplex operation (for CSMA/CD), the LEDC pin is an output for driving a collision indicator LED. Externally tying the LEDC pin low disables internal twisted-pair loopback and collision detect, enabling full-duplex communication.

Full-duplex operation effectively doubles the bandwidth of an Ethernet connection, without any change in the physical media.

TRANSCEIVER TO CONTROLLER INTERFACE

Level One transceivers use an 8-pin interface to connect with LAN controllers. Table 1 describes the connections between Level One transceivers and the 82596. Note that the CD output from the transceiver is not used with the 82596 controller.

Table 1: Transceiver Pin Description and 82596 Connections

Transceiver Pin Name	I/O	Signal Name	Signal Description	82596 Pin Name
TXD	I	Transmit Data	Input signal containing NRZ data to be transmitted on the network. TXD is connected directly to the transmit data output of the controller.	TXD
TEN	I	Transmit Enable	Enables data transmission and starts the watchdog timer. Synchronous to TCLK.	$\overline{\text{RTS}}$
TCLK	O	Transmit Clock	10 MHz clock output. This clock signal should be directly connected to the transmit clock input of the controller.	$\overline{\text{TXC}}$
RCLK	O	Receive Clock	Recovered 10 MHz clock which is synchronous to the received data and connected directly to the receive clock input of the controller.	$\overline{\text{RXC}}$
RXD	O	Receive Data	Output signal connected directly to the receive data input of the controller.	RXD
CD	O	Carrier Detect	Output to notify the controller of activity on the network. Do not connect when using an Intel 82596 with either an LXT905 or LXT944.	$\overline{\text{CRS}}$
COL	O	Collision Detect	Output which drives the collision detect input of the controller.	$\overline{\text{CDT}}$
LBK	I	Loopback	Enables internal loopback mode. ¹	$\overline{\text{LPBK}}$

1. Loopback is an optional connection. Both devices recognize Loopback, but it is not necessary for normal operation.

Carrier Sense Mode Settings

The Intel 82596 LAN controller offers two modes for the carrier sense function: Internal and External. Mode compatibility is listed in Table 2. The LXT901, LXT904 and LXT907 can be used with either mode. The LXT905 and LXT944 can be used with the Internal Mode only.

In the Internal Carrier Sense mode the external carrier sense on the 82596 $\overline{\text{CRS}}$ pin is ignored. Instead, the presence of the receive clock is interpreted as Carrier Sense active. Therefore, the Carrier Detect output from the transceiver is not required and should not be connected to the controller. To set the 82596 controller to the Internal Carrier Sense mode, use the configure command to set the 82596 configuration parameter CARRIER SENSE SOURCE (Byte 9, Bit 3) to 1.

In the External Carrier Sense mode the controller looks at the Carrier Detect signal from the transceiver. In the LXT905 and LXT944, the delay between the end of frame and the de-assertion of Carrier Detect can cause the 82596 to mis-read several bits. Selecting the Internal Carrier Sense mode eliminates this condition.

Table 2: Carrier Sense Mode Compatibility

Transceiver	Internal	External
LXT901	Yes	Yes
LXT904	Yes	Yes
LXT905	Yes	No
LXT907	Yes	Yes
LXT944	Yes	No

Transformer Manufacturers

for Level One Network Product Applications

Transformer Manufacturers

Product	Application	Part Number	Manufacturer
LXT901 LXT907	TP	23Z128, 23Z128SM S553-0716, A553-0716 TD42-2006Q, TG42-2006WH1	Fil-Mag Bell Fuse HALO Electronics
LXT901 LXT902 LXT907 LXT914	AUI	23Z90, 23Z90SM LT6030, SM6030 TD01-0756K, TG01-0756W	Fil-Mag Valor HALO Electronics
LXT902 LXT906	TP	78Z1122B-01, 78Z1122D-01 PT3877 FD02-101G, FD12-101G	Fil-Mag Valor HALO Electronics
LXT905	TP	23Z441, 23Z441SM TD75-1406Q, TD76-1406W	Fil-Mag HALO Electronics
LXT914	TP - Quad Tx	A553-5999-01 23Z339, 23Z339SM TD54-1006L1 5977 6038 PT34116	Bel Fuse Fil-Mag HALO Electronics Nanopulse PCA Valor
LXT914	TP - Quad Rx	A553-5999-00 23Z338, 23Z338SM TD01-1006L1 5976 6037 PT34117	Bel Fuse Fil-Mag HALO Electronics Nanopulse PCA Valor

Transformer Manufacturers

NOTES:

Package Specifications and Ordering Information



This section contains a summary of the Package Specifications for
Level One products.
In case of a conflict, the latest issue of the JEDEC publication #95 shall take
precedence over these drawings.

Plastic Dual In-Line Package (8-pin, 14-pin, 16-pin, 24-pin, 28-pin, 40-pin DIP)

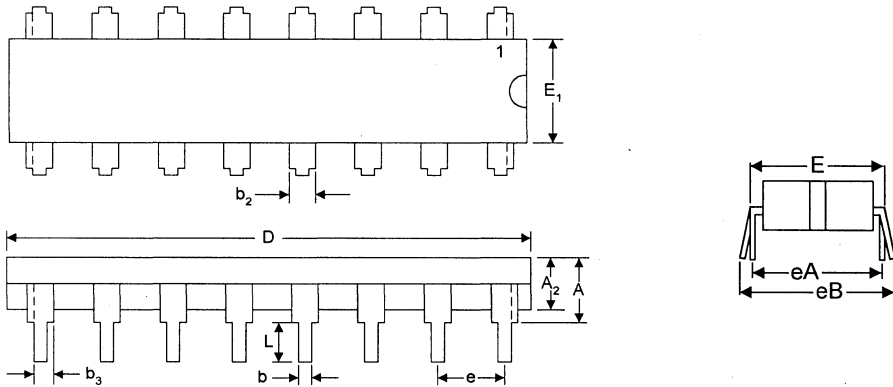

Dual In-Line Packages (dimension D in lower tables)

Dim	300 mil DIP				600 mil DIP			
	Inches		Millimeters		Inches		Millimeters	
	Min	Max	Min	Max	Min	Max	Min	Max
A	—	0.210	—	5.334	—	0.250	—	6.350
A ₂	0.115	0.195	2.921	4.953	0.125	0.195	3.175	4.953
b	0.014	0.022	0.356	0.559	0.014	0.022	0.356	0.559
b ₂	0.045	0.070	1.143	1.778	0.030	0.070	0.762	1.778
b ₃ ¹	0.030	0.045	0.762	1.143	—	—	—	—
E	0.300	0.325	7.620	8.255	0.600	0.625	15.240	15.875
E ₁	0.240	0.280	6.096	7.112	0.485	0.580	12.319	14.732
e	0.100 BSC ² (Nominal)		2.540 BSC ² (Nominal)		0.100 BSC ² (Nominal)		2.540 BSC ² (Nominal)	
eA	0.300 BSC ² (Nominal)		7.620 BSC ² (Nominal)		0.600 BSC ² (Nominal)		15.240 BSC ² (Nominal)	
eB	—	0.430	—	10.922	—	0.700	—	17.780
L	0.115	0.150	2.921	3.810	0.115	0.200	2.921	5.080

Length of 300 mil Packages

Package Type	Dim D	8-pin DIP		14-pin DIP		16-pin DIP		24-pin DIP	
		Min	Max	Min	Max	Min	Max	Min	Max
Full Lead	Inch	—	—	0.735	0.775	0.780	0.800	1.230	1.280
	mm	—	—	18.669	19.685	19.812	20.320	31.242	32.512
1/2 Lead	Inch	0.355	0.400	—	—	0.735	0.775	1.160	1.195
	mm	9.017	10.160	—	—	18.669	19.685	29.464	30.353

Length of 600 mil Packages

Dim D	28-pin DIP		40-pin DIP	
	Min	Max	Min	Max
Inch	1.380	1.565	1.980	2.095
mm	35.052	39.751	50.292	53.213

NOTES:

- b₃ is for 1/2 lead only
- BSC — Basic Spacing between Centers

Package Outlines and Ordering Information

Plastic Leaded Chip Carrier (28-pin PLCC; 44-pin PLCC; 68-pin PLCC)

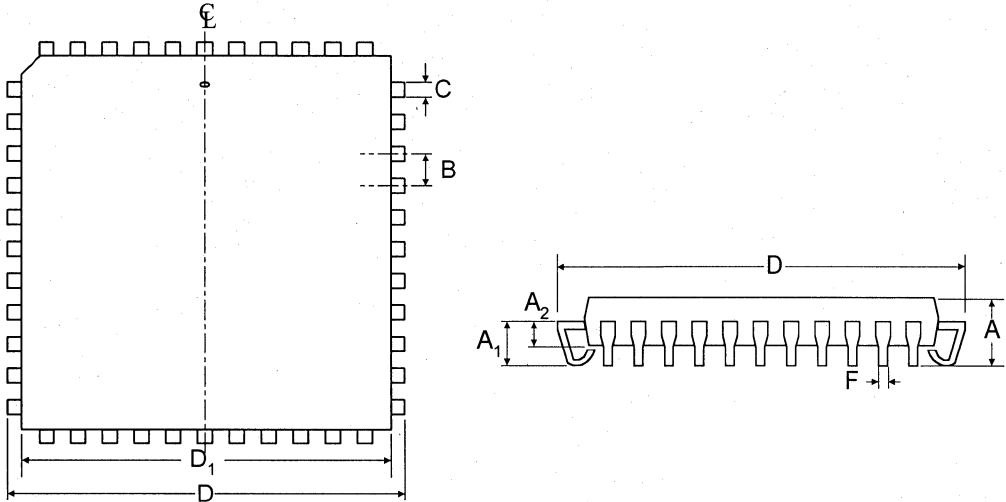

Plastic Leaded Chip Carriers

Dim	Inches		Millimeters	
	Min	Max	Min	Max
A	0.165	0.180	4.191	4.572
A1	0.090	0.120	2.286	3.048
A2	0.062	0.083	1.575	2.108
B	0.050	–	1.270	–
C	0.026	0.032	0.660	0.813
D	See table below		See table below	
D1	See table below		See table below	
F	0.013	0.021	0.330	0.533

Outside Package Size (Dimensions D and D₁)

Dim	28-pin PLCC				44-pin PLCC				68-pin PLCC			
	Inch		Millimeter		Inch		Millimeter		Inch		Millimeter	
	Min	Max	Min	Max	Min	Max	Min	Max	Min	Max	Min	Max
D	0.485	0.495	12.319	12.573	0.685	0.695	17.399	17.653	0.985	0.995	25.019	25.273
D ₁	0.450	0.456	11.430	11.582	0.650	0.656	16.510	16.662	0.950	0.958	24.130	24.333

Plastic Quad Flat Pack (44-pin QFP)

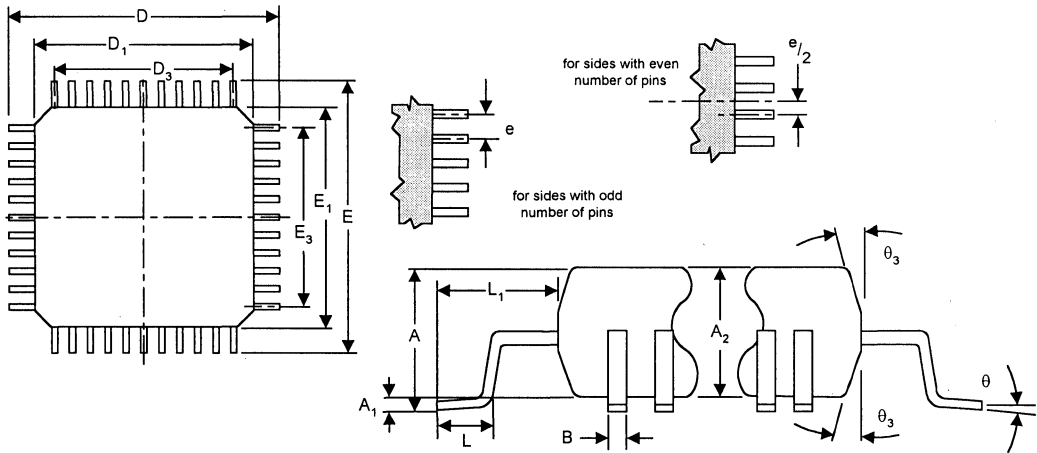

44-Pin Plastic Quad Flat Packs

Dim	Inches		Millimeters	
	Min	Max	Min	Max
A	—	0.096	—	2.45
A ₁	0.010	—	0.25	—
A ₂	0.077	0.083	1.95	2.10
B	0.012	0.018	0.30	0.45
D	0.510	0.530	12.95	13.45
D ₁	0.390	0.398	9.90	10.10
D ₃	0.315 BSC ¹ (Nominal)		8.00 BSC ¹ (Nominal)	
E	0.510	0.530	12.95	13.45
E ₁	0.390	0.398	9.90	10.10
E ₃	0.315 BSC ¹ (Nominal)		8.00 BSC ¹ (Nominal)	
e	0.031 BSC ¹ (Nominal)		0.80 BSC ¹ (Nominal)	
L	0.029	0.041	0.73	1.03
L ₁	0.063 REF (Nominal)		1.60 REF (Nominal)	
θ ₃	5°	16°	5°	16°
θ	0°	7°	0°	7°

NOTE:

1. BSC — Basic Spacing between Centers

Plastic Quad Flat Pack (100-pin PQFP)

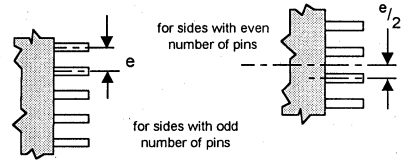
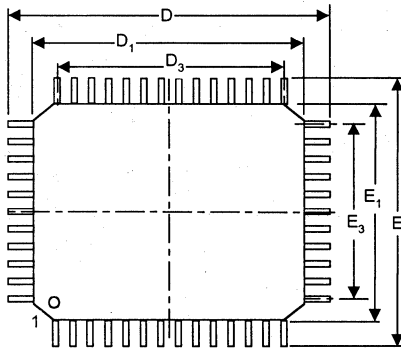

D Side pin count = 30 pins
E Side pin count = 20 pins

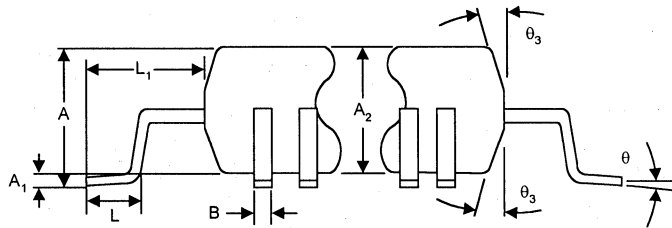

100-Pin Plastic Quad Flat Packs

Dim	Inches		Millimeters	
	Min	Max	Min	Max
A	—	0.134	—	3.40
A ₁	0.010	—	0.25	—
A ₂	0.100	0.120	2.55	3.05
B	0.009	0.015	0.22	0.38
D	0.931	0.951	23.65	24.15
D ₁	0.783	0.791	19.90	20.10
D ₃	0.742 REF		18.85 REF	
E	0.695	0.715	17.65	18.15
E ₁	0.547	0.555	13.90	14.10
E ₃	0.486 REF		12.35 REF	
e	0.026 BSC		0.65 BSC	
L	0.026	0.037	0.65	0.95
L ₁	0.077 REF		1.95 REF	
θ_3	5°	16°	5°	16°
θ	0°	7°	0°	7°

Thin Quad Flat Pack (64-pin TQFP)

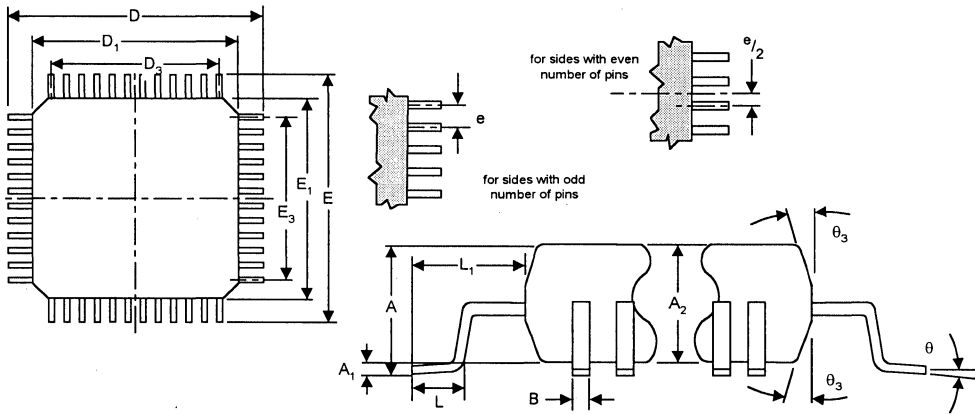

64-pin Thin Quad Flat Pack

Dim	Inches		Millimeters	
	Min	Max	Min	Max
A		.063	—	1.60
A ₁	.002	.006	0.05	0.15
A ₂	.053	.057	1.35	1.45
b	.007	.011	0.17	0.27
D	0.472 BSC ¹		12.00 BSC ¹	
D ₁	0.394 BSC ¹		10.00 BSC ¹	
E	0.472 BSC ¹		12.00 BSC ¹	
E ₁	0.394 BSC ¹		10.00 BSC ¹	
e	0.020 BSC ¹		0.50 BSC ¹	
L	0.018	0.030	0.45	0.75
L ₁	0.039 REF		1.00 REF	
θ_3	11°	13°	11°	13°
θ	0°	7°	0°	7°

NOTE:

1. BSC — Basic Spacing between Centers

Notes:

Ordering Information

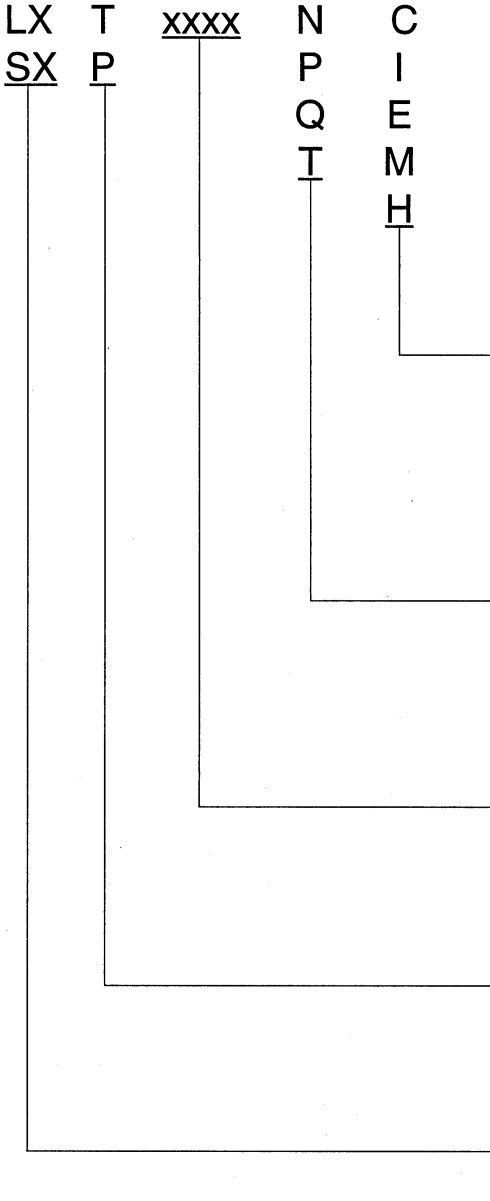

Temperature Range:

- C = Commercial range (0° to 70° C)
- I = Industrial range (-25° to +85° C)
- E = Extended range (-40° to +85° C)
- M = Military specification (-55° to +125° C)
- H = Intermediate range (-5° to +85° C)

Package Type:

- N = Plastic Dual In-line Package (DIP)
- P = Plastic Leaded Chip Carrier (PLCC)
- Q = Quad Flat Pack (QFP)
- T = Thin Quad Flat Pack (TQFP)

Product Code: 3-5 alpha-numeric digits

Product type:

- T = Transceivers
- P = Peripherals

Company ID:

- LX = Level One Communications
- SX = San Francisco Telecom

NOTES:



Literature Request Form

Company _____
 Address _____
 City; State; Zip _____
 Phone _____ Fax _____

Number/Title	Product / Description	Pages	Pub. Date	Quantity
--------------	-----------------------	-------	-----------	----------

Data Sheets - Short Haul T1/E1 Transceivers

.XT300/301	Single Transceiver with Receive JA	20	4/96	
.XT300Z/301	Advanced Single Transceiver with Receive JA	24	4/96	
.XT304A	Low Power Single Transceiver with Receive JA	16	4/96	
.XT305	Single Transceiver with Transmit JA	20	4/96	
.XT305A	Low Power Single Transceiver with Transmit JA	16	4/96	
.XT307	Low Power E1 Integrated Short Haul Transceiver	24	4/96	
.XT325	Quad Receiver with LOS Output	8	4/96	
.XT332	Dual Transceiver with Crystal-less JA	28	4/96	
.XT350	T1/E1 Transceiver	44	4/96	

Data Sheets - Long Haul T1/E1 Transceivers

.XT310	Single T1 Transceiver with Selectable JA	20	4/96	
.XT317	DECT Twisted Pair LIU Transceiver	16	4/96	
.XT318	Single E1 Transceiver with Selectable JA	20	4/96	
!K70704/70706	784 kbps HDSL Data Pump Chip Set	36	4/96	
!K70704/70707	1168 kbps HDSL Data Pump Chip Set	36	4/96	

Data Sheets - Long Haul/Short Haul T1/E1 Transceivers

.XT360/361	Integrated LH/SH T1/E1 Transceivers	44	4/96	
------------	-------------------------------------	----	------	--

Data Sheets - T1/E1 Repeaters

.XT312/315	Low Power T1 PCM Repeaters	8	4/96	
.XT313/316	Low Power E1 PCM Repeaters	8	4/96	

Bold Indicates new product

Fax or Mail Literature Requests to:
 Phone: 916/854-1155
 Fax: 916/854-1192

Level One Communications, Inc.
 c/o MarCom
 9750 Goethe Road
 Sacramento, CA 95827



Literature Request Form

Company _____

Address _____

City; State; Zip _____

Phone _____ Fax _____

Number/Title	Product / Description	Pages	Pub. Date	Quantity
--------------	-----------------------	-------	-----------	----------

Data Sheets - Clock Adapters

LXP600A/2/4	1.544 - 2.048 - 4.096 MHz Adapter	12	4/96	
LXP610	Multi-Rate Selectable Adapter	12	4/96	

Data Sheets - Networking Products

LXT400	Switched 56 / DDS 4-Wire Transceiver	16	4/96	
LXT901	Universal 10BASE-T Ethernet Interface	28	4/96	
LXT902	10BASE-T Ethernet Media Attachment Unit	16	4/96	
LXT904	10BASE-T Ethernet Media Attachment Unit	20	4/96	
LXT905	10BASE-T Transceiver	24	4/96	
LXT906	Ethernet Twisted-pair to Coax Adapter	12	4/96	
LXT907	Ethernet Interface Transceiver	28	4/96	
LXT914	Flexible Quad Hub Repeater	32	4/96	

Data Sheets - San Francisco Telecom Products

LXT944	Quad 10BASE-T Transceiver	28	4/96	
SXT6234	E-Rate Multiplexer	20	4/96	

Application Notes

AN21	LXT304A - D4 Channel Bank Applications	2	4/96	
AN23	LXT902/906 - Line Impedance Matching	2	4/96	
AN25	LXT30x/310 - Long-Haul/Short-Haul Commonality	2	4/96	
AN26a	LXT310 - Circuit Protection	2	4/96	
AN28	LXT304A/310 - DS-1/DSX-1 CSU Applications	2	4/96	

Bold Indicates new product

Fax or Mail Literature Requests to:

Phone: 916/854-1155

Fax: 916/854-1192

**Level One Communications, Inc.
c/o MarCom
9750 Goethe Road
Sacramento, CA 95827**



Literature Request Form

Company _____

Address _____

City; State; Zip _____

Phone _____ Fax _____

Number/Title	Product / Description	Pages	Pub. Date	Quantity
<i>Appication Notes (Continued)</i>				
AN29	LXT3xx - Mitel Frammer Interface Applications	2	4/96	
AN31a	LXT318 - Migration to Single-chip Long Haul E1 Aps	2	4/96	
AN32	LXT3xx - T1 Jitter Measurement	8	4/96	
AN34	LXT30x/318 - Migration from Short to Long Haul E1	2	4/96	
AN35	LXT901/907 - 68EN360 Controller Applications	4	4/96	
AN36	LXT318 - Long-Haul E1 Line Interface Design	2	4/96	
AN38	LXT332 - Migration from Siemens PEB2236	8	4/96	
AN39	LXT332 - Migration from AT&T 7290	8	4/96	
AN41	Short-Haul Devices - Compliance w/ITU G.775 LOS	4	4/96	
AN42	LXT360/310 - Crystal-less T1 Long Haul Solutions	8	4/96	
AN44	E1 Devices - Compliance w/ETSI TBR-12/13	4	4/96	
AN45	LXT914 - 68EN360 Controller Applications	8	4/96	
AN47	LXT360/361 - Line Protection Circuitry Guide	4	4/96	
AN50	LXT318/360- Crystal-less T1 Long Haul Solutions	8	4/96	
AN51	Ethernet Transceivers - MAC Interface Design Guide to Intel Controllers			
AN9501	SXT6234 - E1/E3 Mux/Demux Applications	12	4/96	

14

Bold Indicates new product

Fax or Mail Literature Requests to:

Phone: 916/854-1155

Fax: 916/854-1192

Level One Communications, Inc.

c/o MarCom

9750 Goethe Road

Sacramento, CA 95827



Literature Request Form

Company _____
 Address _____
 City; State; Zip _____
 Phone _____ Fax _____

Number/Title	Product / Description	Pages	Pub. Date	Quantity
--------------	-----------------------	-------	-----------	----------

T1/E1 Demo Board User Guides

LDB300	For all single channel LXT3xx family transceivers	12	4/96	
LDB332	For LXT332 Dual Line Interface	12	4/96	
LDB360/361	For LXT360/361 - Demonstration/Evaluation Kit	24	4/96	
SDB6234	For SXT6234 E-Rate Multiplexer	16	4/96	
LDB70206/ 70207	HDSL Development Kits	2 ea.	4/96	

Quality and Reliability

Reliability	Periodic report covers all Level One products	32	4/96	
Qualification	Individual reports - Order by product/package type	various	various	

General Information

Fact Sheet	Corporate Backgrounder	8	2/96	
Sales Locations	Level One Sales, Distributor and Corporate offices	4	3/96	
Product Reference Guide	Short Form Catalogue of Level One products	52	4/96	
1996 DATABOOK	Complete collection of all Level One technical documentation	800	4/96	

Bold Indicates new product
 Fax or Mail Literature Requests to:
 Phone: 916/854-1155
 Fax: 916/854-1192

Level One Communications, Inc
 c/o MarCom
 9750 Goethe Road
 Sacramento, CA 95827

Sales Offices



Level One Corporate Offices

Corporate Headquarters

9750 Goethe Road
Sacramento, California 95827
Telephone: (916) 855-5000
Fax: (916) 854-1102

North American Offices

Western Area Headquarters

3375 Scott Blvd., Suite 338
Santa Clara, California 95054
Telephone: (408) 496-1950
Fax: (408) 496-1955

South Central Regional Office

2340 E. Trinity Mills Road, Ste. 306
Carrollton, Texas 75006
Telephone: (214) 418-2956
Fax: (214) 418-2985

South Western Regional Office

28203 Cabot Road, Suite 300
Laguna Niguel, California 92677
Telephone: (714) 365-5655
Fax: (714) 365-5653

Eastern Area Headquarters

115 Route 46, Suite F1000
Mountain Lakes, New Jersey 07846
Telephone: (201) 316-6088
Fax: (201) 316-8173

North Central Regional Office

One Pierce Place, Suite 500E
Itasca, Illinois 60143
Telephone: (708) 250-6044
Fax: (708) 250-6045

Northeastern Regional Office

486 Totten Pond Road
Waltham, Massachusetts, 02154
Telephone: (617) 487-7070
Fax: (617) 487-7474

Southeastern Regional Office

3191 Coral Way, Suite 601
Miami, Florida 33145
Telephone: (305) 444-2966
Fax: (305) 444-4650

International Offices

Northern Europe

Torshamnsgatan 35
164 40 Kista/Stockholm, Sweden
Telephone: +46 8 750 39 80
Fax: +46 8 750 39 82

Central and Southern Europe

Forum House, Stirling Road
Chichester, West Sussex
PO19 2EN United Kingdom
Telephone: +44 1243 538822
Fax: +44 1243 773144

Asia / Pacific

101 Thomson Road
United Square #08-01
Singapore 307591
Telephone: +65 353-6722
Fax: +65 353-6711

Central Asia Regional Office

6F, No. 126 Min-Chu W. Road
Taipei, Taiwan
Telephone: +886 2 586 8727
Fax: +886 2 586 0746

Latin / South America

9750 Goethe Road
Sacramento, California USA 95827
Telephone: (916) 854-4326
Fax: (916) 854-1102

Level One Sales Locations

Level One Sales Locations

Sales Representatives (USA)

Alabama

M Squared, Inc.
4950 Corporate Drive, Suite 105B
Huntsville, Alabama 35805
Telephone: (205) 830-0498
Fax: (205) 837-7049

Arkansas

Mil-Rep Associates, Inc.
Telephone: (214) 644-6731
Fax: (214)644-8161

California

First Rep
143 Triunfo Canyon Rd., #222
Westlake Village, California 91361
Telephone: (805) 373-0887
Fax: (805) 495-1317

California

S C Cubed, Inc.
6390 Greenwich Drive, Suite 180
San Diego, California 92122
Telephone: (619) 546-3730
Fax: (619) 546-3731

Trinity Technologies, Inc.
1261 Oakmead Parkway
Sunnyvale, California 94086
Telephone: (408) 733-9000
Fax: (408) 733-9970

Colorado

Thorson Rocky Mountain, Inc.
7108 South Alton Way, Building D
Englewood, Colorado 80112
Telephone: (303) 773-6300
Fax: (303) 773-6302

Connecticut

NRG Limited
63 Duka Avenue
Fairfield, Connecticut 06430
Telephone: (203) 384-1112
Fax: (203) 335-2127

Delaware

S-J Mid-Atlantic, Inc.
Telephone: (609) 866-1234
Fax: (609) 866-8627

District of Columbia

Third Wave Soutlions, Inc.
Telephone: (410) 290-5990
Fax: (410) 381-5846

Florida

EIR, Inc.
1057 Maitland Center Commons
Maitland, Florida 32751
Telephone: (407) 660-9600
Fax: (407) 660-9091

Georgia

M Squared, Inc.
3000 Northwoods Pkwy, Suite 110
Norcross, Georgia 30071
Telephone: (770) 447-6124
Fax: (770) 447-0422

Idaho

Thorson Rocky Mountain, Inc.
1937 E.Cypress Point Drive
Eagle, Idaho 83616
Telephone: (208) 939-4345
Fax: (208) 939-4107

Illinois (Northern)

Beta Technology Sales, Inc.
1009 Hawthorn Drive
Itasca, Illinois 60143
Telephone: (708) 250-9586
Fax: (708) 250-9592
Change scheduled for August '96:
Telephone: (603) 250-9586
Fax: (603) 250-9592

Illinois (Southern)

QDC Industries
Telephone: (913) 894-1386
Fax: (913) 894-0726

Iowa

QDC Industries
9601 W. 103rd Terrace
Overland Park, Kansas 66212
Telephone: (913) 894-1386
Fax: (913) 894-0726

Sales Representatives (USA) cont.

Kansas (Northern)

QDC Industries
9601 W. 103rd Terrace
Overland Park, Kansas 66212
Telephone: (913) 894-1386
Fax: (913) 894-0726

Kansas (Southern)

QDC Industries
216 Koob Lane
Andover, Kansas 67002
Telephone: (316) 733-9756
Fax: (316) 733-8105

Louisiana (Northern)

Mil-Rep Associates, Inc.
Telephone: (214) 644-6731
Fax: (214) 644-8161

Louisiana (Southern)

Mil-Rep Associates, Inc.
Telephone: (713) 444-2557
Fax: (713) 444-2751

Maine

New Tech Solutions, Inc.
Telephone: (617) 229-8888
Fax: (617) 229-1614

Maryland

Third Wave Solutions, Inc.
8335H Guilford Road
Columbia, Maryland 21046
Telephone: (410) 290-5990
Fax: (410) 381-5846

Massachusetts

New Tech Solutions, Inc.
111 South Bedford St., Suite 102
Burlington, Massachusetts 01803
Telephone: (617) 229-8888
Fax: (617) 229-1614

Michigan

Greiner Associates, Inc.
15324 East Jefferson Avenue
Grosse Pointe Park, Michigan 48230
Telephone: (313) 499-0188
Fax: (313) 499-0665

Minnesota

Russell and Associates
8030 Cedar Ave. South, Suite 114
Minneapolis, Minnesota 55425
Telephone: (612) 854-1166
Fax: (612) 854-6799

Mississippi

M Squared, Inc.
4950 Corporate Drive, Suite 105B
Huntsville, Alabama 35805
Telephone: (205) 830-0498
Fax: (205) 837-7049

Missouri (Northern)

QDC Industries
9601 W. 103rd Terrace
Overland Park, Kansas 66212
Telephone: (913) 894-1386
Fax: (913) 894-0726

Missouri (Southern)

QDC Industries
216 Koob Lane
Andover, Kansas 67002
Telephone: (316) 733-9756
Fax: (316) 733-8105

Nebraska

QDC Industries
9601 W. 103rd Terrace
Overland Park, Kansas 66212
Telephone: (913) 894-1386
Fax: (913) 894-0726

Nevada

Trinity Technologies, Inc.
Telephone: (408) 733-9000
Fax: (408) 733-9970

New Hampshire

New Tech Solutions, Inc.
Telephone: (617) 229-8888
Fax: (617) 229-1614

New Jersey (Northern)

S-J Mid-Atlantic, Inc.
131-D Gaither Drive
Mount Laurel, New Jersey 08054
Telephone: (609) 866-1234
Fax: (609) 866-8627

Level One Sales Locations

Sales Representatives (USA) *cont.*

New York

Parallax
734 Walt Whitman Road
Melville, New York 11747
Telephone: (516) 351-1000
Fax: (516) 351-1606

S-J Upstate New York
7353 Victor-Pittsford Road
Victor, New York 14564
Telephone: (716) 924-1720
Fax: (716) 924-1728

S-J Upstate New York
179 Pierce Hill Road
Vestal, New York 13850
Telephone: (607) 785-1185
Fax: (607) 785-5099

North Carolina

M Squared, Inc.
1200 Trinity Road
Raleigh, North Carolina 27607
Telephone: (919) 851-0010
Fax: (919) 851-6620

North Dakota

Russell and Associates
Telephone: (612) 854-1166
Fax: (612) 854-6799

Ohio

Great Lakes Group
33610 Solon Road, Suite 5
Solon, Ohio 44139
Telephone: (216) 349-2700
Fax: (216) 349-2701

Great Lakes Group
2038 Heritage Point Drive.
Kettering, Ohio 45409
Telephone: (513) 298-7322
Fax: (513) 298-7323

Great Lakes Group
7760 Olentangy River Rd., Suite 119
Columbus, Ohio 43235
Telephone: (614) 885-6700
Fax: (614) 885-6701

Oklahoma

Mil-Rep Associates, Inc.
Telephone: (214) 644-6731
Fax: (214) 644-8161

Oregon

Luscombe/Matrex Electronics Group
11140 S.W. Barbur Blvd., Suite 100
Portland, Oregon 97219-8639
Telephone: (503) 245-8080
Fax: (503) 246-1848

Pennsylvania (Eastern)

SJ Mid-Atlantic, Inc.
Telephone: (609) 866-1234
Fax: (609) 866-8627

Pennsylvania (Western)

Great Lakes Group
33610 Solon Road, Suite 5
Solon, Ohio 44139
Telephone: (216) 349-2700
Fax: (216) 349-2701

Puerto Rico

EIR, Inc.
Telephone: (407) 660-9600
Fax: (407) 660-9091

Rhode Island

New Tech Solutions, Inc.
Telephone: (617) 229-8888
Fax: (617) 229-1614

South Carolina

M Squared, Inc.
1200 Trinity Road
Raleigh, North Carolina 27607
Telephone: (919) 851-0010
Fax: (919) 851-6620

South Dakota

Russell and Associates
Telephone: (612) 854-1166
Fax: (612) 854-6799

Tennessee (Eastern)

M Squared
3000 Northwoods Pkwy, Suite 110
Norcross, Georgia 30071
Telephone: (770) 447-6124
Fax: (770) 447-0422

Sales Representatives (USA) *cont.*

Tennessee (Western)

M Squared
4950 Corporate Drive, Suite 105B
Huntsville, Alabama 35805
Telephone: (205) 830-0498
Fax: (205) 837-7049

Texas

Mil-Rep Associates, Inc.
1755 N. Collins, #215
Richardson, Texas 75080
Telephone: (214) 644-6731
Fax: (214) 644-8161

Mil-Rep Associates, Inc.
13810 Champion Forest Dr.
Suite 145
Houston, Texas 77069
Telephone: (713) 444-2557
Fax: (713) 444-2751

Mil-Rep Associates, Inc.
9009 Mountain Ridge Drive
Suite 230
Austin, Texas 78759
Telephone: (512) 346-6331
Fax: (512) 346-1975

Utah

Thorson Rocky Mountain, Inc.
5505 So. 900 E., Suite 140
Salt Lake City, Utah 84117
Telephone: (801) 264-9665
Fax: (801) 264-9881

Vermont

New Tech Solutions, Inc.
Telephone: (617) 229-8888
Fax: (617) 229-1614

Virginia

Third Wave Solutions, Inc.
Telephone: (410) 290-5990
Fax: (410) 381-5846

Washington

Luscombe/Matrex Electronics Group
12729 NE 20th Street, Suite 1
Bellevue, Washington 98005-1935
Telephone: (206) 688-0448
Fax: (206) 451-7708

Wisconsin (Eastern)

Beta Technology Sales, Inc.
150 N. Sunnyslope Road, Suite 365
Brookfield, Wisconsin 53005
Telephone: (414) 797-7977
Fax: (414) 797-8051

Wisconsin (Western)

Russell and Associates
8030 Cedar Ave. South, Suite 114
Minneapolis, Minnesota 55425
Telephone: (612) 854-1166
Fax: (612) 854-6799

Wyoming

Thorson Rocky Mountain, Inc.
Telephone: (303) 773-6300
Fax: (303) 773-6302

Level One Sales Locations

Sales Representatives (Canada)

Alberta

Electro Source Inc.
2635 37th Avenue NE, Suite 245
Calgary, Alberta T1Y 5Z6
Telephone: (403) 735-6230
Fax: (403) 735-0599

British Columbia

Electro Source Inc.
6875 Royal Oak Avenue
Burnaby, British Columbia V5J 4J3
Telephone: (604) 435-2533
Fax: (604) 435-2538

Ontario

Electro Source Inc.
230 Galaxy Boulevard
Rexdale, Ontario M9W 5R8
Telephone: (416) 675-4490
Fax: (416) 675-6871

Electro Source Inc.
300 March Road, Suite 203
Kanata, Ontario K2K 2E2
Telephone: (613) 592-3214
Fax: (613) 592-4256

Quebec

Electro Source Inc.
6600 Trans-Canada Hwy, #420
Pointe Claire, Quebec H9R 4S2
Telephone: (514) 630-7486
Fax: (514) 630-7421

Sales Representatives (Europe)

France

- Distributor

MISIL Technologies
2, Rue de la Couture, Silic 301
Rungis Cedex, 94588
Telephone: +33 1-45 60 0021
Fax: +33 1-45 60 0186

- Sales Representative

Rep'tronic, sa
1 Bis, Rue Marcel Paul
Bat. B, Z.I La Bonde
91742 Massy, Cedex
Telephone: +33 1-69 53 6720
Fax: +33 1-6013 9198

Germany

- Stocking Representative

Scantec GmbH
Behringstrasse 10
D-82152 Planegg/Munchen
Telephone: +49 89-89 91 43-0
Fax: +49 89-857 65 74
Internet-Homepage: www.scantec.de
Email: info@scantec.de

- Sales Representatives

Scantec GmbH
Armbruststrasse 26
73230 Kirchheim/Teck
Telephone: +49 7021-97 93 21
Fax: +49 07021-97 92 62

Scantec GmbH
Fliedersteig 28
D-90607 Ruckersdorf / Nurnberg
Telephone: +49 911-9578037
Fax: +49 911-9578039

Scantec GmbH
D-71394 Kernen / Stuttgart
Rommelesweg 28
Telephone: +49 7151-947940
Fax: +49 7151-947941

Topas Electronic GmbH
Fliegerstrasse 1
D-30179 Hannover
Telephone: +49 511-968 64-0
Fax: +49 511-968 64-64

Topas Electronic GmbH
Max Weber-Strasse 16
D-25456 Quickborn/Hamburg
Telephone: +49 4106-73097
Fax: +49 4106-73378

Israel

- Stocking Representative

Seg Tec
3 Hametsuda St., Industrial Park
P.O. Box 11468, Azur 58001
Telephone: +972 3-556-7458
Fax: +972 3-556-9490

Italy

- Stocking Representative

Consystem
Viale Lombardia 20
20095 Cusano Milanino
Milano
Telephone: +39 2664 00153
Fax: +39 2664 00339

Netherlands

- Stocking Representative

Tekelec Airtronic B.V.
Postbus 63, Industrieweg 8A
2700AB Zoetermeer
Telephone: +31 79 3 310 100
Fax: +31 79 3 417 504

Belgium

- Stocking Representative

Tekelec Airtronic B.V.
J.F. Kennedyplein 8
B1930 Zaventem
Telephone: +32 2 715 90 20
Fax: +32 2 725 10 83

Switzerland

- Stocking Representative

Eurodis Electronic AG
Bahnstrasse 58/60
CH-8105 Regensdorf
Telephone: +41 1 843 31 11
Fax: +41 1 843 34 75

Level One Sales Locations

Sales Representatives (Europe) *continued*

United Kingdom

- Sales Representative

Cedar Technologies
Unit One Old Barns
Rycote Lane Farm
Milton Common
Oxfordshire OX9 2NZ
Telephone: +44 1844 278278
Fax: +44 1844 278378

- Sales Representative

Cedar Technologies
Unit 32, Enterprise House
Springkerse Business Park
Stirling, Scotland FK7 7UF
Telephone: +44 1786 446220
Fax: +44 1786 446223

- Distributor

Manhattan Skyline Ltd.
Manhattan House, Unit 1
The Switchback, Gardner Road
Maidenhead, Berkshire SL6 7RJ
Telephone: +44 (0) 1628 778686
Fax: +44 (0) 1628 782812

Scandinavia

Denmark

- Stocking Representative

C-88 AS
Kokkedal Industripark 101
Kokkedal, DK-2980
Telephone: +45 42 24 4888
Fax: +45 42 24 4889

Finland / Baltics / Russia

- Stocking Representative

Bexab Finland OY
Asemakuja 2 A
Fin-02770, Espoo
Telephone: +358 0 6135 2690
Fax: +358 0 6135 2655

Sweden

- Stocking Representative

EGEVO Elektronik AB
Box 8100
Fagerstagatan 4
S-163 08 Spanga
Telephone: +46 08 795 9650
Fax: +46 08 795 7883

**Sales Representatives
(Asia / Pacific)**

Australia / New Zealand

- Representative

Multi Electronics
18 Coombes Drive
Penrith, NSW 2750
Telephone: +61 47-31-6533
Fax: +61 47-31-3735

Hong Kong

- Representative

Leadertronics Co. / HK
Unit 1706-07, 17/F, Hewlett Centre
54 Hoi Yuen Road
Kwun Tong, Kowloon
Hong Kong
Telephone: +852 2 389-0800
Fax: +852 2 797-8429
Email: ltrhk@HK.Super.NET

India

- Representatives

SES Computers & Technology
605A, Ansal Chamber - II
6, Bhikaji Cama Place
New Dehli, 110066
Telephone: +91 11 688 8664
Fax: +91 11 688 8664

SES Computers & Technology
G-3, Cunningham Apartments
5, Edwards Road
Bangalore - 560 052
Telephone: +11 80 334 8481
Fax: +11 80 334 3685

New Number-scheduled for April 1

Telephone: +91 80 2259469
Fax: +91 80 2200281

SES Computers & Technology,
PVT LTD
Arvind Chambers,
194 Andheri Kurla Road
Andheri (E), Bombay 400069
Telephone: +91 22-8380055, 8341584
Fax: +91 22-8380266

SES Computers & Technology, PVT LTD
95C Siddemsetty Complex,
Park Lane
S D Road Secunderabad 500 003
Telephone: +91 40-812378, 847838
Fax: +91 40-815321

Japan

- Representatives & Distributors

Macnica
Utsunomiya Ekimae Bldg.,
4-2-10 Odori, Utsunomiya City, 320
Telephone: +81 286-27-5231
Fax: +81 286-27-5274

Macnica
Shin-Osaka Kimura Daiichi Bldg.
5-11-8 Nishi-Nakashima,
Yodogawa-Ku, Osaka City, 532
Telephone: +81 6-300-0810
Fax: +81 6-300-0848

Macnica
Chikusa First Bldg., Kato
3-23-10, Aoi, Higashi-Ku
Nagoya City, 461
Telephone: +81 52-933-4541
Fax: +81 52-933-4542

Macnica
Hakusan High-Tech Park
1-22-2 Hakusan, Midori-Ku
Yokohama City, 226
Telephone: +81 45-939-6140
Fax: +81 45-939-6141

Korea

- Representative

Uniquet Corporation
Suite 401 Doo Jin Bldg.
158 Samsung-Dong
Kangnam-Ku, Seoul
Telephone: +82 562 8805
Fax: +82 562 6646

Level One Sales Locations

Sales Representatives (Asia) *cont.*

PRC

-Representatives

Leadertronics / Xian
RM 409, Hang Tian Building
87 South Chang An Road
Xian, P.R.C. 710061
Telephone: +86 29 526-4300, ext. 2409
Fax: +86 29 523-1093

Leadertronics / Shenyang
4/F., Zhong Hang Building
Hemu Road, No. 36 Dadon District
Shenyang, P.R.C. 110043
Telephone: +86 24 483-0843, ext. 4427
Fax: +86 24 483-0364

Taiwan

- Representative

Jeritronics, Ltd.
Floor 7B, No. 267, Sec. 3
Cheng-Teh Road, Taipei
Telephone: +886 2-5851636
Fax: +886 2-5864736

Sales Representatives (South America)

Brazil

- Distributor

Etek Electronics Corporation
6353 West Rogers Circle, Suite 3
Boca Raton, Florida 33487
Telephone: (407) 997-6277
Fax: (407) 997-5467

- Representative

Hitech el. Ind. Com. Ltda.
Rua Branco de Morais, 489
04718-010 Sao Paulo - SP
Telephone: +55 11 882 4000
Fax: +55 11 882 4100

Distributors (USA)

Alabama

Pioneer-Standard Electronics, Inc.
4835 University Square, #5
Huntsville, Alabama 35816
Telephone: (205) 837-9300
Fax: (205) 837-9358

Alaska

QuickShelf
Telephone: (800) 616-5000

Arizona

QuickShelf
Telephone: (800) 616-5000

Arkansas

Pioneer-Standard Electronics, Inc.
Telephone: (800) 522-5290

California

QuickShelf
P.O. Box 278148
Sacramento, California 95827
Telephone: (800) 616-5000
Fax: (916) 854-1108

Colorado

QuickShelf
Telephone: (800) 616-5000

Connecticut

Phase 1 Technology Corporation
36A Padanaram Road
Danbury, Connecticut 06811
Telephone: (203) 791-9042
Fax: (203) 790-6128

Delaware

Pioneer-Standard Electronics, Inc.
Telephone: (301) 921-0660

District of Columbia

Pioneer-Standard Electronics, Inc.
Telephone: (301) 921-0660
Fax: (301) 670-6746

Florida

Pioneer-Standard Electronics, Inc.
674 South Military Trail
Deerfield Beach, Florida 33442
Telephone: (954) 428-8877
Fax: (954) 481-2950

Pioneer-Standard Electronics, Inc.
337 S. Northlake Blvd., #1000
Altamonte Springs, Florida 32701
Telephone: (407) 834-9090
Fax: (407) 834-0865

Georgia

Pioneer-Standard Electronics, Inc.
4250 C Rivergreen Parkway
Duluth, Georgia 30136
Telephone: (770) 623-1003
Fax: (770) 623-0665

Hawaii

QuickShelf
Telephone: (800) 616-5000

Idaho

QuickShelf
Telephone: (800) 616-5000

Illinois

All American
1930 N. Thoreau, Suite 200
Schaumburg, Illinois 61173
Telephone: (708) 303-1995
Fax: (708) 303-1996

Indiana

Sager Electronics
Telephone: (800) 724-3780

Iowa

Voyager Electronics
Telephone: (612) 571-7766

Kansas

Sager Electronics
Telephone: (800) 724-3780

Level One Sales Locations

Distributors (USA) *continued*

Louisiana

Pioneer-Standard Electronics, Inc.
8641 United Plaza Blvd., Suite 105
Baton Rouge, Louisiana 70809
Telephone: (504) 923-0015
Fax: (504) 923-0463

Maine

Sager Electronics
Telephone: (800) 724-3780

Maryland

Pioneer-Standard Electronics, Inc.
9100 Gaither Road
Gaithersburg, Maryland 20877
Telephone: (301) 921-0660
Fax: (301) 670-6746

Massachusetts

Sager Electronics
60 Research Road
Hingham, Massachusetts 02043
Telephone: (800) 724-3780
Fax: (617) 749-3842

Massachusetts

Sager Electronics
100 Burt Road, Suite 100
Andover, Massachusetts 01810
Telephone: (800) 724-3780
Fax: (508) 475-4568

Michigan

All American
39201 Schoolcraft Road, Suite B-20
Livonia, Michigan 48150
Telephone: (313) 464-2202
Fax: (313) 464-2433

Minnesota

Voyager Electronics Corporation
5201 East River Road, Suite 300
Fridley, Minnesota 55421
Telephone: (612) 571-7766
Fax: (612) 571-9519

Mississippi

Pioneer-Standard Electronics, Inc.
Telephone: (205) 837-9300

Missouri

Sager Electronics
Telephone: (800) 724-3780

Montana

QuickShelf
Telephone: (800) 616-5000

Nebraska

Sager Electronics
Telephone: (800) 724-3780

Nevada

QuickShelf
Telephone: (800) 616-5000

New Hampshire

Sager Electronics
Telephone: (800) 724-3780

New Jersey

Phase 1 Technology Corporation
295 Molnar Drive
Elmwood Park, New Jersey 07407
Telephone: (201) 791-2990
Fax: (201) 791-2552

Phase 1 Technology Corporation
560 Fellowship Rd., Suite 205
Mount Laurel, New Jersey 08054
Telephone: (609) 234-3232
Fax: (609) 234-5012

New Mexico

QuickShelf
Telephone: (800) 616-5000

New York

Phase 1 Technology Corporation
46 Jefryn Boulevard
Deer Park, New York 11729
Telephone: (800) 683-0068
Telephone: (516) 254-2600
Fax: (516) 254-2693

Sager Electronics
1200-C Scottsville Road, Suite 105
Rochester, New York 14624
Telephone: (800) 724-3780
Fax: (716) 436-3138

Distributors (USA) *continued*

North Carolina

Pioneer-Standard Electronics, Inc.
2200 Gateway Centre Blvd., Ste. 215
Morrisville, North Carolina 27650
Telephone: (919) 460-1530
Fax: (919) 460-1540

North Dakota

Voyager Electronics
Telephone: (612) 571-7766

Ohio

Sager Electronics
3601 Green Road, Suite 103
Beachwood, Ohio 44122
Telephone: (800) 724-3780
Fax: (216) 831-5583

Sager Electronics
7494 Webster Street
Dayton, Ohio 45414
Telephone: (800) 724-3780
Fax: (513) 898-4455

Oklahoma

Pioneer-Standard Electronics, Inc.
9717 E. 42nd Street, Suite 105
Tulsa, Oklahoma 74146
Telephone: (918) 665-7840
Fax: (918) 665-1891

Oregon

QuickShelf
Telephone: (800) 616-5000

Pennsylvania (Eastern)

Phase 1 Technology Corporation
560 Fellowship Road, Suite 205
Mt. Laurel, New Jersey 08054
Telephone: (609) 234-3232
Fax: (609) 234-5012

Pennsylvania (Western)

Sager Electronics
1000 Gamma Dr., RIDC Plaza
Suite 517
Pittsburgh, Pennsylvania 15238
Telephone: (800) 724-3780
Fax: (412) 772-3845

Puerto Rico

Pioneer-Standard Electronics, Inc.
Telephone: (800) 421-6108
Rhode Island

Sager Electronics
Telephone: (800) 724-3780

South Carolina

Pioneer-Standard Electronics, Inc.
Telephone: (404) 623-1003

South Dakota

Voyager Electronics
Telephone: (612) 571-7766

Tennessee

Pioneer-Standard Electronics, Inc.
Telephone: (919) 460-1530

Texas

Pioneer-Standard Electronics, Inc.
1826-D Kramer Lane
Austin, Texas 78758
Telephone: (512) 835-4000
Fax: (512) 835-9829

Pioneer-Standard Electronics, Inc.
13765 Beta Drive
Dallas, Texas 75244
Telephone: (214) 419-5500
Fax: (214) 490-6419

Pioneer-Standard Electronics, Inc.
10530 Rockley Road, Suite 100
Houston, Texas 77099
Telephone: (713) 495-4700
Fax: (713) 495-5642

Pioneer-Standard Electronics, Inc.
8200 Interstate 10 W #705
San Antonio, Texas 78230
Telephone: (210) 377-3440
Fax: (210) 378-3626

Utah

QuickShelf
Telephone: (800) 616-5000

Vermont

Sager Electronics
Telephone: (800) 724-3780

Level One Sales Locations

Distributors (USA) *continued*

Virginia

Pioneer-Standard Electronics, Inc.
Telephone: (301) 921-0660

Washington

QuickShelf
Telephone: (800) 616-5000

West Virginia (Western)

All American
Telephone: (800) 573-2727

West Virginia (Eastern)

Pioneer-Standard Electronics, Inc.
Telephone: (301) 921-0660

Wisconsin

All American
1540 River Highland Drive
Oconomowoc, Wisconsin 53066
Telephone: (414) 569-1034
Fax: (414) 569-1017

Wyoming

QuickShelf
Telephone: (800) 616-5000

Distributors (Canada)

Ontario

Valtrie Marketing, Inc.
270 Galaxy Boulevard
Rexdale, Ontario M9W 5R8
Telephone: (416) 798-2555
Fax: (416) 798-2560



Level One Communications, Inc.

9750 Goethe Road

Sacramento, CA 95827

Phone: (916) 855-5000

Fax: (916) 854-1101

Web: <http://www.level1.com>



TRINITY TECHNOLOGIES, INC.

1261 Oakmead Parkway
Sunnyvale, CA 94086

Fax: 408-733-9970

408-733-9000